

The Leading Magazine in Radio

RADIO NEWS

WITH

New!

FEATURES
WRITERS &
GADGETS

AND SHORT WAVE

In This Issue:

HOW TO BE A
RADIO ANNOUNCER



1 Homebuilt
TELEVISION
TRANSMITTER



DOES YOUR VOICE
HAVE "UMPH"



GOSSIP
PEOPLE
LINKS
INGO



WIL BAKER'S HECKLER
SEE PAGE 40

APRIL
25c



With This Issue

The New

RADIO NEWS

Takes Its Bow

NEW DRESS

NEW FEATURES

NEW TREATMENT

with an inspiring new outlook on this modern radio world . . . up-to-the-minute news . . . colorful personalities . . . unusual radio gossip . . . "inside dope" . . . latest television circuits and developments . . . authoritative experiments . . . short wave programs . . . latest trade news . . . helpful hints for the serviceman, amateur and professional. . . .

But— this is only the beginning—wait until you see the big May issue!

MORE INTERESTING FEATURES—
NEWS—PICTURES—DIAGRAMS—
EXPERIMENTS—CHARTS—
PERSONALITIES—RADIO GOSSIP

Watch
for the

Big

MAY

Issue

ON SALE AT ALL NEWSSTANDS APRIL 10th

1938



Be a Radio Expert

Many make \$30 \$50 \$75 a week

I will train you at home for many Good Spare Time and Full Time Radio Jobs

J. E. SMITH, President, National Radio Institute
Established 1914

The man who has directed the home study training of more men for the Radio Industry than any other man in America.



Set Servicing

Spare time set servicing pays many \$5, 10, \$15 a week extra while learning. Full time servicing pays as much as \$30, \$50, \$75 a week.

Broadcasting Stations

Employ managers, engineers, operators, installation and maintenance men for fascinating jobs and pay up to \$5,000 a year.



Loud Speaker Systems

Building, installing, servicing, operating public address systems is another growing field for men well trained in Radio.



HERE'S PROOF THAT MY TRAINING PAYS



\$80 Monthly in Spare Time

"I work on Radio part time, still holding my regular job. Since enrolling seven years ago, I have averaged around \$80 every month." JOHN B. MORISSETTE, 809 Valley St., Manchester, N. H.



Makes \$50 to \$60 a Week

"I am making between \$50 and \$60 a week after all expenses are paid, and I am getting all the radio work I can take care of, thanks to N. R. I." H. W. SPANGLER, 126 1/2 S. Gay St., Knoxville, Tenn.



Operates Public Address System

"I have a position with the Los Angeles Civil Service, operating the Public Address System in the City Hall Council. My salary is \$170 a month." R. H. HOOD, R. 136, City Hall, Los Angeles, Calif.

Lesson on Radio Servicing Tips—FREE

I'll prove that my Training gives practical, money-making information, that it is easy to understand—that it is just what you need to master Radio. My sample lesson text, "Radio Receiver Troubles—Their Cause and Remedy" covers a long list of Radio receiver troubles in A.C., D.C., battery, universal, auto, T. R. F., superheterodyne, all-wave, and other types of sets. And a cross-reference system gives you the probable cause and a quick way to locate and remedy these set troubles. A special section is devoted to receiver checking, alignment, balancing, neutralizing and testing. Get this lesson FREE. No obligation. Just mail coupon.



Do you want to make more money? Radio offers you many opportunities for well-paying spare time and full time jobs. You don't have to give up your present job, leave home or know anything about radio or electricity, spend a lot of money to become a Radio Expert.

Many Radio Experts Make \$30, \$50, \$75 a Week

Radio broadcasting stations employ engineers, operators, station managers and pay up to \$5,000 a year. Spare time Radio set servicing pays many \$200 to \$500 a year—full time jobs with Radio jobbers, manufacturers, dealers, as much as \$30, \$50, \$75 a week. Many Radio Experts operate their own full time or part time Radio sales and service businesses. Radio manufacturers and jobbers, employ testers, inspectors, foremen, engineers, servicemen, paying up to \$6,000 a year. Radio operators on ships get good pay, see the world besides. Automobile, police, aviation, commercial Radio and loud speaker systems are newer fields offering good opportunities now and for the future. Television promises to open many good jobs soon. Men I trained have good jobs in these branches of Radio. Read their letters in "Rich Rewards in Radio." Mail the coupon.

There's a Real Future in Radio for Well-Trained Men

Radio already gives jobs to more than 300,000 people. In 1937 Radio enjoyed one of its most prosperous years. Nearly \$500,000,000 worth of sets, tubes and parts were sold. Over 5,000,000 home Radios were sold—25,000,000 homes (4 out of 5 in the U. S.) now have one or more sets. Over 1,800,000 auto Radios were sold—5,000,000 cars now have Radios. Every year millions of sets go out of date, are replaced with newer models. Every year millions of dollars are spent on transmitting equipment, Television developments, etc. The \$30, \$50, \$75 a week jobs have grown from a few hundred 20 years ago to thousands today. And Radio is still a young industry—developing fast.

Many Make \$5, \$10, \$15 a Week Extra in Spare Time While Learning

Almost every neighborhood needs a good spare time serviceman. The day you enroll I start sending you Extra Money Job Sheets. They show you how to do Radio repair jobs, how to cash in quickly. Throughout your training I send you plans and ideas that

have made good spare time money—from \$200 to \$500 a year—for hundreds of fellows. I send you special Radio equipment and show you how to conduct experiments and build circuits, which illustrate important Radio principles. My Training gives you PRACTICAL EXPERIENCE while learning.

I Give You a Professional Servicing Instrument

Here is the instrument every Radio expert needs and wants—an All-Wave, All-Purpose Set Servicing Instrument. It contains everything necessary to measure A.C. and D.C. voltages and current; test tubes, resistance; adjust and align any set, old or new. It satisfies your needs for professional servicing after you graduate—can help you make extra money servicing sets while training.



You Get a Money-Back Agreement

I am sure I can train you successfully. I will agree in writing to refund every penny you pay me if you are not satisfied with my Lessons and Instruction Service when you finish. I'll send you a copy of this agreement with my Free Book.

Find Out What Radio Offers You

Act Today. Mail the coupon now for "Rich Rewards in Radio." It's free to any fellow over 16 years old. It points out Radio's spare time and full time opportunities and those coming in Television; tells about my training in Radio and Television; shows you letters from men I trained, telling what they are doing and earning. Find out what Radio offers YOU! MAIL THE COUPON in an envelope, or paste on a postcard—NOW!

J. E. SMITH, Pres., National Radio Institute
Dept. 8DR
Washington
D. C.

THIS FREE BOOK HAS HELPED HUNDREDS OF MEN MAKE MORE MONEY



This Coupon is Good for . . . One FREE Copy of My Book

J. E. SMITH, President, Dept. 8DR
National Radio Institute, Washington, D. C.

Dear Mr. Smith: Without obligation, send me free the Sample Lesson and your 64-page Book "Rich Rewards in Radio," telling about spare time and full time Radio opportunities, and how I can train for them at home in spare time. (Please write plainly.)

NAME..... AGE.....

ADDRESS

CITY..... STATE.....



HEREWITH a new RADIO NEWS, with new features from cover to cover, compiled and written by new authors, with a new Art Department and an entirely new editorial and engineering staff. We believe that RADIO NEWS now is the magazine that the radio public has been looking for. We have tried to please everyone, not only the amateur and the serviceman, but also those who are in any way interested in radio. It has been a hard job, and we are really very proud of the results.

* * *

HERETOFORE, radio could haunt you with its memories. Once a word was said, a note sung, or an impression given, it was a matter of recollection as to just exactly what had happened. This issue we reveal for the first time that the engineers have changed all this, and now the spoken word, the song, and the impression can be permanently recorded on a strip of film. These films are developed and a picture results which accurately shows the voice or the film as it was given over the radio. In passing, we wonder just exactly how that Mae West skit would look if reduced by this means to something that you could see. Would it have the same svelte lines of the star, and would it have that "come-hither expression" for which she is so justly famous?

* * *

WE HAVE authentic information that the American Radio Relay League members will gather in Chicago for their annual convention on September third to fifth. This brings to a final culmination the long battle between the Westerners and the Easterners to have Hartford Headquarters bow to the greater weight of their members west of New England. It seems like a step in the right direction, too. A very hot debate is expected among the delegates, on the now famous "Direct Representation Referendum." Many A.R.R.L. hams have long felt that they are not truly represented under the present system. So far, steam roller tactics in headquarters have prevented the control from getting into the hands of the majority where it belongs. This has then been

in effect nothing less than a miniature benevolent dictatorship. It would seem that with the present strength of vote behind the referendum that this minority is about to lose the stranglehold which it has held for over twenty years.

* * *

BECAUSE the average convention-goer likes to be at business on a Monday morning, the Radio Parts Manufacturers' Show, scheduled for the Stevens Hotel in Chicago, June 8th to 11th, will close, for the first time in its history, on a Saturday night. The exhibition will be laid out as a radio parts city with the aisles named after famous personages in radio. We'll be seeing you at the corner of Edison and Ohm!

* * *

IN THIS issue we break a column headed by "X-73-88". The gentleman prefers to remain incognito, so as to be able to talk with greater latitude on the subjects he discusses. He is a man well versed in all phases of radio from Hamdom to Broadcast. It is said he has a long nose for news, and very wide open ears. His shoes will penetrate the inner offices of many a broadcasting station, and his shadow will fall across many a manufacturers' desk. The material can be relied on to be accurate and the story will always be the one "behind the story." We encourage you to write to him in care of RADIO NEWS telling of injustices, deep dark secrets or anything that will best be aired. You will find it in X-73-88's column before you see it elsewhere.

* * *

SOMEWHERE in this issue you will find a statement by Commander McDonald on the subject of television. He says it won't be here for a long time. It is the opinion of the president of a great radio company. But—believe it or not,—that same radio company has applied to the Government for a license for a television station. Thus, do great corporations work their miracles, of saying one thing to the public and doing another.

* * *

TWO years ago RADIO NEWS had a letter from one Thomas D. Gootee who was reporting DX conditions in war-torn Spain. Operator Gootee

boasted that he was becoming an expert bullet-dodger. We have not heard from him since. If Tom Gootee reads this, will he please write us at once? If anyone knows of his whereabouts, will they tell us? It seems to us that a bullet-dodger like Gootee cannot have come to a foul end, but we are curious to get his story, for ourselves as well as for our readers.

* * *

TWO amateurs in Chicago have been tinkering with television and finally got around the use of the seemingly invaluable tube—the "Iconoscope." Their article is featured in this issue. They are trail-blazers in whose path the rest of the fraternity can follow and make television real, everyday and practical. The encouraging thing about the whole matter is that they learned how to circumvent the RCA Iconoscope at the RCA Institute.

* * *

AT THE recent National Aviation Show, radio divided even honors with the planes. Hardly does one think of planes and one realizes, that, without radio, planes would not fly across the evening sky, nor would our mail be delivered with the regularity that we now receive it. Radio, starting behind aviation, has not only come up even with it, but aviation is now almost wholly dependent on radio for everything except the gas to run the motor and the lift to raise the ship. It is quite conceivable that aviation might some day become a subsidiary to radio. After all, what travels faster than a radio signal?

* * *

WITH this issue Larry Cockaday retires as Editor and joins the Navy in which he holds the rank of Lieutenant-Commander. Our loss is Navy's gain, and we cannot think of any finer gentleman than old "L.C." Since radio was in knee pants L.C. has known it and grown up with it. He did a bang-up job as Editor for us, and his shoes will be swimmingly large to fill. Lots of luck, Larry, and 73 from all the gang.

* * *

SCOOP! Mutual's WGN station of Chicago is dickering for a hundred-acre tract of land east of their
(Continued on page 62)

APRIL
1938

RADIO NEWS

AND SHORT WAVE RADIO

★
VOLUME 19
Number 10

contents



Look for this picture in full colors on the cover of the next issue of RADIO NEWS. Posed especially for this magazine by Miss Claire Trevor, movie and radio star.



PUBLISHED MONTHLY BY
ZIFF-DAVIS PUBLISHING COMPANY
at 608 So. Dearborn St., Chicago, Ill.
New York Office, 381 Fourth Ave., New York City
William B. Ziff, Publisher; B. G. Davis, Editor

Karl A. Kopetzky, Managing Editor
Herman R. Bollin, Art Director

CONTRIBUTIONS: Contributors are advised to retain a copy of their manuscripts and illustrations and to include return postage. Contributions will be handled with reasonable care, but this magazine assumes no responsibility for their safety. Any copy accepted is subject to revision or changes to meet the requirements of this publication. Payment for manuscript and photographs will be made at our current rates. In making payment illustrations will be considered part of the manuscript unless otherwise specified.

SUBSCRIPTION RATES: \$2.50 per year, single copies 25 cents; foreign postage \$1.00 per year extra, except Canada. Entry as second-class matter applied for at the Post Office, Chicago, Ill., under the act of March 3, 1879

Within Earshot of the Editor	4
Has Your Voice Got "Umph"?	6
Broadcast Lingo	9
Radio Sign Language	11
Hot News on the Air	12
Hook, Line and Radio	15
Is Television Here?	16
A Home Built Transmitter for \$20.00	18
The "Pigeon Cooker"	21
Personalities	22
Want a Job as Radio Announcer?	24
You Must Have Talent!	26
Power Pack Rectifiers	29
Mobile Pickup	30
An Amateur's Television Transmitter	32
No: for Rebroadcast	36
Can They Hear You?	37
A Homebuilt 5 Tube Receiver	39
An Amateur's Dual Receiver	41
Studio Briefs	42
The TZ-40 Modulator	43
The Mizpah—Amateur Transmitter	44
Radio Gadgets	46
Ham Shack	47
World Short-Wave Time-Table	49
What's New in Radio	52
Questions and Answers	55
Special DX Programs	56
Radio Physics Course	71

Copyright, 1938
ZIFF-DAVIS PUBLISHING COMPANY
Member of the Audit Bureau of Circulations



President Roosevelt, whose "My friends" practically assured his election. The publication of Pres. Roosevelt's graph is forbidden, as is a recording of his voice. The President, himself, made the rule.

Has Your

by DOC SCHNURMACHER

Since radio audiences cannot see the speakers, science has long sought the reason for one man's popularity over another's. Radio News reveals for the first time that engineers have devised a means to reduce the spoken word to an all-revealing graph.

A NOTED statesman may make a speech of international importance into the microphone and be dialed out of millions of homes by radio listeners who figuratively turn thumbs down with the damning words: "For Pete's sake, turn that guy off and get something else!"

An obscure actor may read a passage from Shakespeare which is so familiar to radio listeners that they can repeat the words with him. Yet they may keep their set dialed in on him while there are several other excellent programs on the air.

What has one man's voice got over the ether that another's lacks? Why

can some people hold an interested audience when appearing before them personally and fail to hold them when broadcasting? The answer is in that indefinable word UMPH. Either you have it or you don't!

Of all the celebrities who have broadcast during the past few years probably the ones whose voices were most dissimilar to one another were President Roosevelt's, the late Huey Long's, Father Coughlin's, The Duke of Windsor's and General Hugh Johnson's. Yet all five have held millions of radio listeners spell bound. And again, why?

To answer these questions, as well

as to take voices apart to see what makes 'em tick, science developed the intricate and delicate oscillograph which makes a photograph of a person's voice as he broadcasts and the resulting oscillogram, when carefully studied, reveals many interesting things about that person's speech.

The oscillograph is to the electrical engineer what the stethoscope is to the doctor who listens to your heart. With it we can now see the "heart beats" of the voice.

It shows the relative emphasis which a speaker places on various syllables

T H E S E P I E D



The late Huey Long whose dynamic voice made him a feared man in the U. S. A.

. C O O O O O O O

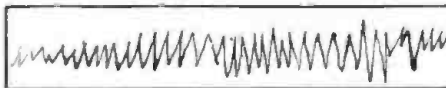

Beatrice Lillie (Lady Peel) whose "COOO" above shows the voice of a singer.

. . H U G H J O H N S O N

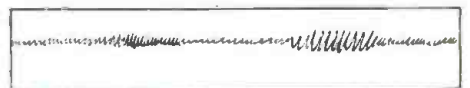

General Hugh Johnson whose powerful delivery clearly shows in his voice-graph.

Voice Got "UMPH"?

T H E W O M A N I L O V E

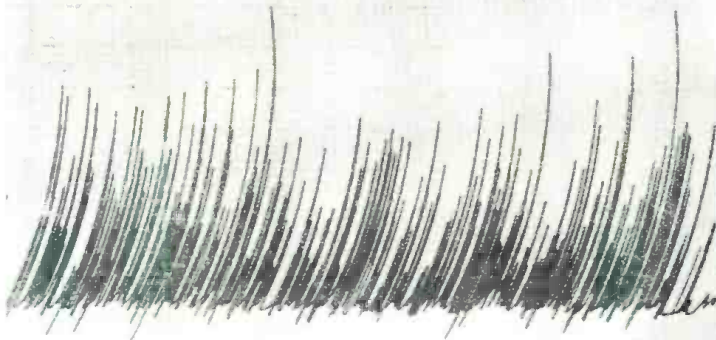

The Duke of Windsor's famous words, "The Woman I Love." The graph shows great suppressed emotion.

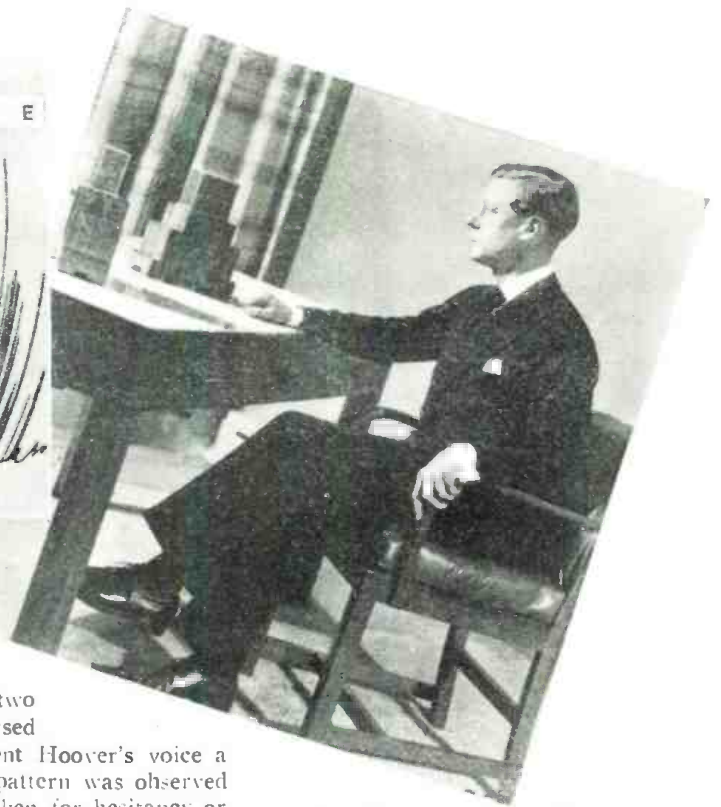

and reveals something of the frequency structure of the individual's voice. As the voice appears on the oscillogram in the form of a wavering, compact track, it expands and contracts vertically.

The contracted parts generally show that the consonant sounds and the expanded parts, known as the higher amplitudes, correspond with the vowel sounds. Suppressed emotion is shown by the width of the graph.

One of the best known voices on the air belongs to President Roosevelt. During one of his fire side chats, scientists made an oscillogram of his greeting, "My friends." When they analyzed the resulting pattern, they found that his mike speech had a well-developed fundamental frequency of about 240 cycles, showing a pleasing, resonant, smooth and well rounded voice.

When the same two words were analysed in former President Hoover's voice a wide variance in pattern was observed which might be taken for hesitancy or indecision. Strangely enough Mr. Hoover's oscillogram might be compared to General Johnson's and several similarities noted although the General's was more abrupt and stronger. Johnson is the better speaker.

Both of these speakers, as shown by their voice patterns would have a greater difficulty in holding a radio audience than did the late Huey Long or Father Coughlin. The Senator's oscillogram revealed to scientists that he had a very flexible voice, although it was basically low pitched. It was

this flexibility which could not only hold, but excite a mass audience. Great durability was also revealed in his voice and, most amazing of all, had he lived to witness the current popularity of Edgar Bergen and Charley McCarthy, he himself might have become a very fair ventriloquist had he so desired.

Smother than Huey Long's voice was that of Father Coughlin. The radio priest's oscillogram showed educated suavity together with a pleasing roundness which would cause the listener either to believe in its sincerity or mistrust it because it seemed too sincere.

Surprising in its evenness and suppressed emotion was the oscillogram of the Duke of Windsor made on the occasion of his renunciation of the throne. Far from being an excellent speaker, what the former Prince of Wales had to say was greatly dramatized by the way in which he said it on this occasion. The words "The woman I love" formed a pattern of intense restraint. If oscillograms ever become museum pieces, this one will probably go down in radio history as "Exhibit A".

One of scientific advantages of the
(Continued on next page)



Former Premier Edouard Herriot of France, whose voice had great persuasive powers.



The late Ramsay MacDonald, whose vocal "umph" easily swung the greatest empire.



Dr. Hjalmar Schacht, arriving aboard the official Distinguished Visitors Launch, accepts a welcome from New York City.



Guido Jung's voice has particularly persuasive powers. His delivery is forceful, as is that of many foreign dignitaries.

oscillograph—although it may also prove an embarrassing disadvantage to an occasional radio speaker, is that observers may plug in on any speech or debate that is being broadcast, unknown to those involved. When this is done, a moving pencil of light is reflected on a rapidly revolving mirror first transforming the sound into light, then permanently recording it in visible form upon an ordinary photographic negative film which may be printed like an ordinary snapshot. [Neon tubes are often used as a source of light. Ed.]

While all of the possibilities of the oscillogram have not yet been explored, some radio engineers believe that, like a man's finger-prints it may be able to differentiate between the spurious and the real. If, for example, one man imitated another's voice on the radio, while the imitator's voice might ring true to thousands of listeners, yet a comparison of oscillograms of the two people involved would show several differences.

Abroad, both in Europe and the near East where nations are bombarding one another with short wave propaganda, radio engineers are now doing considerable research work with the oscillograph to prevent just such contingencies. It is conceivable, for example, for a person adroitly imitating Haile Selassie's voice to be put on the air by an interested nation. "He" might deliver a message telling "his people" that "he" has formally renounced his throne and bid them pledge allegiance to the conquerors. Of course, it is problematical just how convinced the less educated inhabitants of Ethiopia would be by a comparison of oscillograms of the real Haile Selassie and the pretender, but the discrepancies would be readily apparent to the scientists and engineers.

European statesmen, on the whole, are able to hold radio audiences better than American politicians. They are aided by the number of vowels
(Continued on page 65)



Father Coughlin addresses an audience at Cleveland, Ohio, Aug., 1936. There are 13 microphones before him. The number must have been unlucky, because Fr. Coughlin collapsed near the end of his speech from heat and indignation.

Do You Know Your Radio?

1. What buxom lass with a refreshing singing style is receiving a big build-up by NBC?
2. How old is Uncle Ezra, the old caper-cutter from Rosedale?
3. Who is the "Lady Next Door"?
4. A direct descendant of the man who invented the steamboat is heard on the Columbia network Monday through Friday. Who is he?
5. Who plays the rôle of Pepper Young on the air?
6. Who's Who in the cast of One Man's Family?
7. What is the real name of Lulu Belle?
8. Who is The Woman in White?
9. "And I Do Mean You" is the aerial trademark of what columnist?
10. Who conducts the orchestra on the "Double Everything" program?
11. What Chicago announcer is president of a cosmetic company?
12. Who writes the songs sung by Joe Penner?
13. What is the "Hobby Lobby"?
14. Who is the organist on the program with Arthur Godfrey?
15. Who is "Aunt Jenny"?
16. What is the real name of "Park-yakarkas"?
17. Who writes the popular script shows, Bachelor's Children and We Are Four?
18. Who is the Dean of Ballad Singers?
19. Who is Alexander Smallens?
20. With whose orchestra is Terry Shand a vocalist?

[Answers on page 63]

Television Transmission Schedules

THE Don Lee Broadcasting System operating station W6XAO will transmit daily television programs excepting Sunday and Holidays starting at 6:30 P.M., P.C.T. In addition, daylight programs will be transmitted on the following schedules: Monday—9 to 10 A.M. Wednesday—11 to 12 A.M. Saturday—2 to 3 P.M.

The Video signal is transmitted on a frequency of 45 megacycles, and the audio on 54.3 megacycles. The image is 300 lines with a frame repetition frequency of 24 per second. Interlacing is avoided and successful reception can be had on either 50 or 60 cycle electric line power.

According to information at RADIO NEWS office, neither NBC nor CBS maintain regular television schedules. NBC and CBS use a 441 line frequency interlacing every 240 frames.

RADIO NEWS will be interested in receiving reports of television reception of any one of the three systems.

BROADCAST LINGO

by TED LEITZELL

Author and Radio Continuity Writer

Broadcasters have a picturesque flow of slang. The author has gathered a few of the thousands of words now in general use. When put together, broadcast lingo seems like a foreign language.

"MARY was just a piece of white meat on the beach when the Rover Boy found her and turned her over to a flesh peddler. He put her in a one shot who-dunit, but the Scout-master said she was a creeper. That gave her clientitis. Then she was in a sustaining cliff-hanger on the cuff, but finally the flesh peddler sold her to a fairy godfather in a variety show that was across the board.

"A couple o' woodsheds put the show on the head. On opening night the fairy godfather brought a bunch of pests to the fish bowl. Then everything went haywire. An old sexton turned out to be a spreader, and when the gelatin did a schmalz that bent the needle, everybody knew it was a turkey. One of the canaries was flirting with a grasshopper, and when she tried to kiss it she laid an egg. The squeak stick was sour, which burned the sick waver, and then the fairy godmother grew a beard and cued the godbox instead of the eighty-eight. The adenoid was a mike-mugger, and the woodchopper fluffed. Madame Cadenza got lock-jaw and began to fight the music. Then the spieler began drooling and pulled an offside.

"Mary went cut in the alley to cry, but the skit turned out all right even if she did ham the O. Henry. She stayed with that show for a couple of months until it ended and then got on as spieler in the dawn patrol with a pancake turner and platters."

Does that sound like an insane man's version of a melodrama? Well, it isn't, if you know your radio slang. Here is the translation:

"Mary was just an actress out of a job when the advertising agency minor executive found her and turned her over to a talent salesman. He put her in a radio mystery that was not part of a regular series, but the major executive from the advertising agency said she was in the habit of working up toward



Using sign language, William Spier directs The March of Time program.

the microphone during the broadcast, and the sponsor did not like her. Then she was in an unsponsored adventure serial which did not pay her anything, but finally the talent salesman sold her to an easy going sponsor in a variety show that was scheduled for the same time every day, five days a week.

"A couple of stiff rehearsals made the show run right on time. On opening night the sponsor brought a number of fans to the clients' observation booth; then everything went wrong. A base soloist took up more time than was allowed, and when the tenor with a thin, quavery voice sentimentalized a love song so close to the microphone that volume was too great, everybody knew the show was a tremendous flop. One of the sopranos was flirting with a young chap from the agency, and when she tried to hit an accented note, she muffed it completely. The clarinet was off tune, which made the orchestra leader very angry, and then the dumb musical director made a bad blunder and cued the organ instead of the piano. The tight voiced tenor sang too close to the microphone, and the xylophonist missed his cue. A flighty soprano sang as if she were tired and then forced her singing. Then the announcer began talking to fill time, and pulled a gag that was not suitable for radio.

"Mary went out of range of the microphone to cry, but the skit turned out all right, even if she did overact the climax. She stayed with that show for

a couple of months until it ended, and then got a job as announcer for an early morning program with a record turner and phonograph records."

It is not likely that anybody would include so much radio slang as this in one short account, but every slang term employed is in common usage in studios. Some radio jargon is technical, some of it is adapted for other professions, and some has only local significance.

There are some, such as NBC's "PUM" as a

signal to end the program with chimes, that can be considered as code, and are not used universally. Others, based on local slang, never spread very far. For example, a Boston term for swelled head is "squash." It so happens that a person's voice does not sound nearly so pleasing to others as to himself. Hence, if a "squash" comes into a New England studio and is too insistent about his remarkable voice, he is taken into the recording room and a record is made of his voice, speaking or singing as the case may be. The play-back is usually disconcerting; hence, the recorder is called a "squash reducer."

Gestures play a very important part in radio production. The production man is in a booth outside of the studio where he can watch the performance through glass. To communicate with the announcer or others in the studio, and for communication between various performers in the studio, an elaborate sign code has been developed. This has been developed to the point where Columbia has had drawings made for use in a booklet to be distributed to performers, production men, etc.

Every engineer, production man and performer is supposed to memorize these signs which are the most used tools in the production of any program.

Studio visitors are often amazed at the gestures used, and a new radio performer will occasionally misinterpret. A well known singer at NBC looked up

(Continued on next page)

at the production booth during his first broadcast, and saw the production man's finger at his nose. The singer got furious, thinking this was a signal that the music smelled. Actually, it said that the show was "on the nose"; in other words, that the program was exactly on schedule.

GLOSSARY

Across the board: A program booked at the same time every day, five days a week.

Ad lib: Impromptu talking, playing, or singing.

Adenoid: Tight voiced tenor.

Accent: Change of emphasis in sentence or group to emphasize meaning.

Arrangement: A special way of playing or singing a musical number.

Arsenic: A dead program.

Audition: A studio test of performers.

Background: Music or sound effects in background of main performance.

Balance: Blending different kinds of sound to get balanced volume; also proper placing of different instruments to secure best balance.

Bang 'em: Hit the notes of musical number hard.

Beam: Angle of sensitivity of a microphone.

Beards: Errors in performance of program. See "Fluffs."

Belcher: An actor, singer, or other performer whose voice catches.

Bend the needle: To work so close to the microphone or use so much volume that program volume is too high.

Big name: Well known star.

Birdie: Squealing sound sometimes heard on long distance transmission lines.

Bit: Small part in cast—usually just a few lines.

Bite it off: Cut the music.

Blast: To overload the microphone.

Blinker: Light operated from control room to call attention of performers.

Blue gag: Same as "offside"—a gag line not proper for radio.

Blurb: Publicity statement.

Bridge: Music or sound for transition from one dramatic scene to another.

Bring it up: Increase volume.

Bugs: Concealed trouble in equipment, defects. "It's full of bugs."

Build up: Campaign to increase popularity or prestige of artist, program, etc.

Bye-bye: "We leave our studio."

Canary: Soprano.

Canned music: Phonograph records.

Cans: Earphones.

Carbon mike: A microphone with metal diaphragm and carbon granules.

(Continued on page 79)

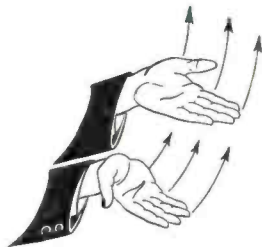

Step it up, louder.
(Move hands up.)

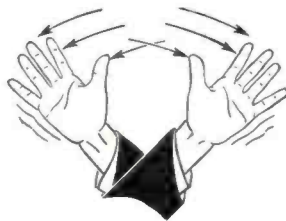

End—stop—silence.
(Hands are wigwagged.)

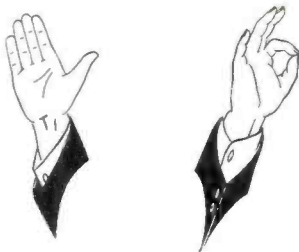

(Left) Announcer signalling for mike.
(Right) Program is okay.

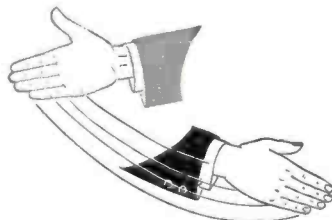

Take it away.

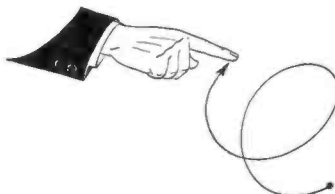

Pick it up. Speed up show.

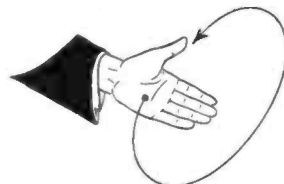

Continue with program.
(Arm movement.)

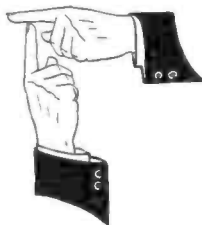

Theme.

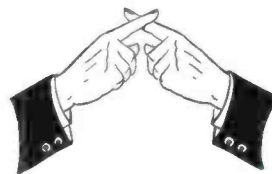

Dead Mike.
(Both fingers are diagonal.)

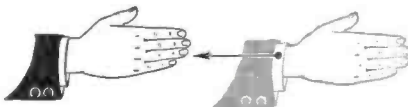

Slow up performance.
(Hands drawn slowly apart.)





Speak more clearly.

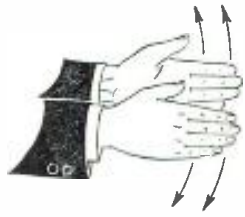

Move away from mike.
(Hands are slowly drawn apart.)

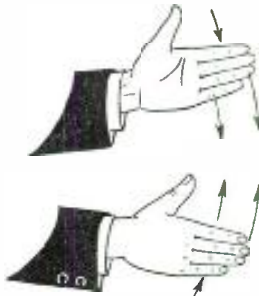

Move closer to mike.
(Hands are brought slowly together.)

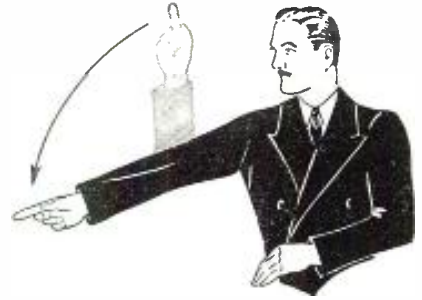

Start program.



On the nose—program running on time.
(This may be used as question and answer.)

RADIO SIGN LANGUAGE

Since it is impossible to converse during a program, Columbia Broadcasting Company's engineers have standardized a system of signals. Some of these have grown up with radio, while others have been arbitrarily invented. The sign for "cut" is used by aviators to request the pilot to turn off the ignition, and by movie directors to stop the filming of a scene. The sign for "end, stop, silence" is used by the Army's field artillery to order the stopping of tractors.



Bye-bye. "We leave our studio."



On the Head--Show ends exactly or time.



Segue. ("You follow next.")

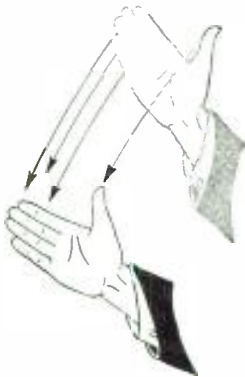

Signal to take away mike or switch.
(Move hand downward.)

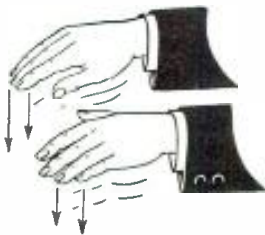

Softer, quieter.
(Move hands down.)



Half minute to go.
(Note that one finger is vertical.)



One minute to go.



Electrical transcription.

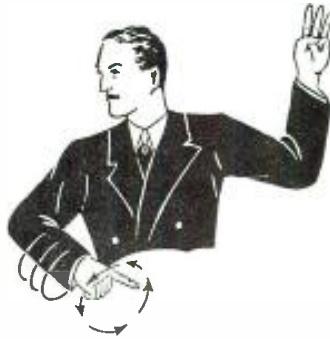

Speed up performance.



Cut.

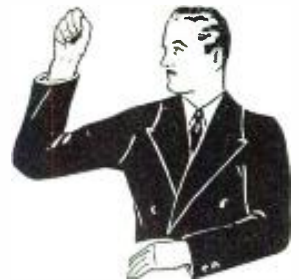

Finish.



The shortwave pack transmitter used by NBC for parachute work.

Hot News ON THE AIR

by ABE SCHECTER
Director of Special Events Dept. NBC
as told to EMILE C. SCHNURMACHER

WHEN an important news story has broken, a newspaper reporter can write his story from interviews with eye witnesses and it is still hot news when the average citizen reads about it in his daily newspaper.

But with the fast paced development of special events radio broadcasting, the reporter of the airplanes has to be Johnny-on-the-spot while events are still happening; and despite hell and high water, the equipment which broadcasts his voice throughout the country must be there too.

The broadcasting of special events, whereby with the twist of a dial, you can tune in on a roaring volcano, the abdication speech of a king, the crash of a dirigible has undergone many scientific improvements since 1929. Previous to that time, radio announcers covering an assignment of news interest, could go just as far as the telephone lines which piped their voices into the broadcasting studios. If there were no telephone lines, there was no story—as far as radio was concerned.

With the development of mobile short wave sets in swiftly moving trucks, of small back pack sets which the announcers may carry on their backs, and of even smaller short wave sets

which have successfully been used in high silk hats and other apparel, hot news may be broadcast from any place, at any time and the previous technical difficulties have been overcome.

Special events broadcasting today falls into two general groups. The first are scheduled features, which we know about ahead of time and for which we can make preparations a long time in advance.

An outstanding broadcast of this group occurred on June 8th last year when from tiny, uninhabited Canton Island in the South Seas, George Hicks, NBC Special Events announcer, broadcast a complete description of the longest eclipse of the sun in 1,200 years.

To make the broadcast possible Hicks and two engineers were sent to the South Seas for almost three months and transported almost four tons of broadcasting equipment to convert the lonely atoll into a complete broadcasting station.

Of all the "unpredictable" special events broadcasts of 1937 which were carried over the NBC networks the work done during the Ohio River floods, early in the winter, probably

was outstanding. The broadcasts offered the greatest problems to the engineers and technicians, and the greatest hazards to the announcers and field men who bore the brunt of the colossal task.

In comparison, describing the air journey of an entire village, broadcasting a running description of the annual Indianapolis Speedway classic, covering track meets and gold cup matches, bringing the voice of a diver from a hitherto unreachable depth and describing an army plane roaring through the sub-stratosphere seemed almost like child's play.

The great flood came in late January, 1937. The Ohio river, swollen by thaws and rains went out of its banks like an angry beast destroying all in its path. Thousands of persons in the river valley were made homeless. Property worth millions of dollars was swept away, leaving scores upon scores of small farmers destitute.

Worst of all, power plants failed, telephone lines were washed out and the fertile territory was suddenly as isolated from the world as it was in the days when Daniel Boone led a

Flood, fires; receptions, riots; wherever anything happens you'll find the broadcast engineers and announcers on the spot reporting the news while it's hot.

From a restaurant in Hopewell, N. J., the news of the Lindbergh kidnaping goes over the air. This was before the now famous trial.

With minute transmitter, and the famous "beer mug" mike, two NBC men describe the Chicago Open Golf Tournament, 1937.



group of hard pioneers into the wilderness that is now Kentucky.

When NBC hurried to the aid of the stricken area the engineers were faced with the difficult task of establishing a broadcast schedule, then finding the best means of maintaining that schedule. Engineers and announcers fought their way into the heart of the devastated area and the series of broadcasts describing the suffering and horror of a flood were begun.

A receiving station was established in Vincennes, Ind., and to this the first general description of the flood short-waved from an airplane was achieved. The standard equipment in the plane was used with the addition of the NBC audio equipment. The broadcast was picked up on the usual airplane band and piped into Chicago, where it was put on the air from their studios. The entire broadcast was conducted with a one-way hookup, with the announcer in the plane taking his cues from standard broadcasts.

The second broadcast from a plane, using the same equipment and the same receiving point, was planned for a two-way hookup. At the last minute it was discovered the ground crew, perched upon one of the few dry roofs in the area, was in a dead spot. The plane could hear the men on the ground, but they could receive nothing from the plane. The broadcast went ahead, Menser doing as Prandt had done earlier, taking his cues from standard broadcasts.

As the flood waters swelled and more and more square miles of land went under water difficulties increased. So did the need for communication. A gasoline engine was sent from Chicago to Evansville where headquarters had been established in a hotel. When the local power plant failed the engine was used to charge batteries and keep the temporary station functioning.

When it was possible the broadcasts were piped into Chicago in a dozen roundabout ways. When this wasn't possible the programs were short-waved to Vincennes, Ind., on a 110 meter band and piped from there.

But the need of getting first hand information added to the troubles of the crew.

To get this information men were sent out in boats and stationed here and there about the area. To pick up the programs, getting them to Vincennes and thence to Chicago, three engineers and three announcers were used. The announcers were equipped with compact transmitter sets that were built to be carried on the back.

These low powered sets were many times more efficient than any mobile units could have been. They were taken almost anywhere the carrier went, and their power was so low, and their frequency so varied that many operated in the same locality without interference. The "beer-mug" transmitters which were small enough to be carried in the hand were especially useful in saving lives and directing the rescue ships.

While the engineers stood by at the central station, in an Evansville hotel, and listened to the complaints about the noise the gas engine made, the an-

noncers journeyed about with transmitters, telling of what they saw.

Another interesting Special Events broadcast was the description of the trip by air of all 20 residents of Ex-line, Ill. The American Airlines invited the residents of the village to fly to Chicago and back home. All ac-

(Continued on next page)



With pressure so great that a special mike had to be used, Max Gene Nohl prepares to announce from the bottom of Lake Michigan. The broadcast had to be picked up in Wisconsin to get on the air in Chicago.

While a soldier stands guard, the announcer describes all that was left of the proud Hindenburg after it crashed at Lakehurst. An assistant carries the pack transmitter.

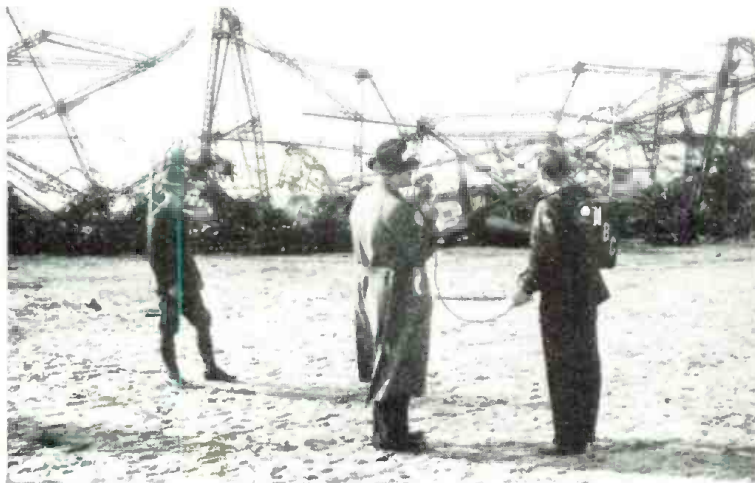

Announcer Barry & Engineer MacCornack report flood conditions in Evansville, Ind. Short and long wave radio saved countless lives during the Ohio Flood of 1937.





A walking station. Wrist watch mike; walking-stick antenna and transmitter; binocular case — batteries. Behind him an engineer monitors the transmission.

cepted. The huge airliner flew from Chicago to the village, circled and returned with its load of travelers. Norman Barry was aboard. At Exline was the NBC Mobile Unit, ready to act as a receiving station and here Hal Totten was all set to do the announcing. The band used was 110 meters, and NBC audio equipment was installed in the plane. Because of interference at the Chicago Studios a special short-wave station was set up in a nearby building. This station was operated on a 140 meter band and had two kilowatts power. The broadcast was picked up by the Mobile Unit and piped to the studios. There it was put on the network and re-piped to the short-wave station. The men at the short-wave station kept in contact with the plane, maintaining the two-way hookup throughout the program.

Another two-way hookup by short-wave for a network broadcast was achieved when two window washers, one clinging to a narrow window ledge at Radio City, New York, and the other to a window in the NBC Studios, Chicago, carried on a mutual interview. The window washers were equipped with pack-sack transmitters working on a seven-meter band. The short-waves were picked up by 50-watt portable stations on the roofs of the buildings and fed to the studios on an eight-meter band.

The Indianapolis Automobile race offered some interesting problems for the engineers. The area to be covered was great and the only solution the engineers could hit upon was to have a number of pick-up points. They established five stationary points and a sixth in an Eastern Airlines plane.

With the duty of describing the race falling to Charles Lyon and Graham

McNamee, the broadcast opened. Outside the grounds the Mobile Unit was parked to act as receiving station. Working on a nine-meter band, using the "beer mug" portable transmitter with a power of five-tenths watt, Charles Lyon moved from point to point giving his descriptions.

The description was picked up in the judge's pagoda and piped to the Chicago studios. The Mobile Unit served as the tie-in for the two-way hookup and operated on a 140-meter band. The four broadcast points from which the announcer with the "beer mug" was heard were the starter's platform, the timer's platform, the pits, the Victory Lane wire. All the equipment used, including that aboard the plane, was



"Pig Boat" broadcasts are not uncommon. Note the old fashioned mike. The newer types are too delicate to stand vibration.

standard NBC audio and transmitter equipment.

The A.A.U. track meet in the Marquette Stadium, Milwaukee, offered no difficulty to the engineers. Announcers toured the field with the "beer mug" and the short-wave from that was picked up by the Mobile Unit, where other announcers were stationed. From there the program was fed over telephone lines to the studios and so to the networks, an eight-meter band being used for the cue channel.

In July, two announcers used a portable set as the cue channel hookup on the broadcast of the Medinah Country Club Open Golf Championship play. Another announcer with the "beer

mug" was in a tent near the clubhouse. There he interviewed players and, on the final day moved to the last hole to describe the play. The program was piped from the course directly to the studios.

The Mobile Unit could not be used in this broadcast because it had been moved to Shawneetown, Ill., for another Special Events broadcast that day. This program, consisted of a tour of the town that had been so ruined that plans were being perfected to move it to higher ground. The program was picked up by a temporary station in a bank building and piped to Chicago.

In September the Gold Cup Boat Races at Detroit offered some problems in placing equipment. It was necessary to follow the racers to give a good description of what went on and this meant portable short-wave. An audio station was set up on the Detroit Yacht clubhouse on Belle Isle, an audio and receiving station on the roof of the Tower apartments and a short-wave station on a yacht in the Detroit river.

When time for the broadcast of the Annual National Cornhusking Championship came along some real problems presented themselves. The use of 27 pieces of major equipment was involved.

A diesel-powered tractor was built for the occasion. Specifications of NBC engineers were used in the construction to reduce interference and vibration and a special short-wave transmitter was built into the machine. It was felt necessary to have the tractor because of the muddy conditions which prevail in cornfields at that time of the year.

Next a tower was erected in the center of the 45-acre field where the con-

(Continued on page 57)

Asbestos protecting the mike, NBC broadcasts the eruption of Mt. Kilauea, Hawaii.



HOOK, LINE and RADIO

by J. L. GOLDBY

Veteran Wireless Operator and Author

The most exciting job in radio is that of the operator aboard the tuna fleet. Danger, adventure and good fishing is a part of his daily routine at sea.



When the tuna run, the radioman joins his shipmates on the submerged "fan-tail."

IT'S those darn tuna boat operators again! If they don't quit busting in I'll report them to the commission or somebody," cried an operator while standing a watch at WSL handling traffic. "Just a happy-go-lucky kid with a bug in his fist and unlimited power to get breezy over the air!"

And that is about as good a thumbnail sketch of the radio operator who hangs his ticket upon the wall of a shack on a tuna boat barge as any. Occasionally some one does report them to the commission and then the District Radio Inspector will write a letter to the skipper or owners of the boat, who will show the report to their radioman which, in turn, will quiet him until the next time the urge comes on again.

The apparatus aboard one of these vessels is cut down to a minimum due to the premium put upon space, but in a shack just a hop and skip off the main deck, usually near the wheel house, is the whole imposing array of equipment. On the table in a corner is the high frequency transmitter which is a tuned plate, tuned grid push-pull in a modified Hartley or Colpitts circuit and using two 85.2 tubes. This is fed by a high voltage d. c. 2000 volt generator. On some ships they use instead a 500 cycle alternator stepped up by a transformer.

The small oblong box on the wall houses the frequency meter which has recently incorporated an AT cut crystal and which aids the operator in getting as close to his operating frequency as he may desire, although permitted a one-tenth percent deviation off either way. The small receiver is the usual type three-tube National shortwave job and is very efficient, seldom giving any trouble. The frequencies which are used and maintained by this unique fleet are 48, 36, 24, and 18 meters, even though they are permitted to use the whole range.

For continuous traffic work the tuna boat operators use 36 meters and it is a simple matter for them to shift to any of the other frequencies if that channel is cluttered up. These little transmitters have an output of almost 200 watts power and nightly work KOK from as far south as the Galapagos Group, a distance of about 2600 miles, and during good atmospheric conditions they have been heard as far away as four thousand miles. So when that WSL operator squawked, he had good reason.

The tuna boat operator is indeed a much abused and little known chap neither interested in strikes nor the glamorous uniforms or careers pictured

in other operating billets. He is satisfied to take care of his shack, stand the few watches, if any, and help in various other ways cooperating with the crew while fishing for the elusive tuna out on the broad Pacific, or in catching bait in the coves that dot the West coast from Magdalena Bay to the Galapagos. When they leave port, they do not know their destination nor the length of time they may be gone. Ralph Williams, formerly of the Mayflower and now the repairman for all radios at the Campbell Boat Works, tells a story of having left port with all intentions of fishing for tuna at their usual fishing banks, but ending up in the Hawaiian Islands searching for albacore, which brings a greater price.

To compare the tuna boat operator with the average radioman is practically impossible. He is practically a law unto himself, being greatly respected for his specialized training by the whole crew from the skipper down to the lowly cabin boy. The usual commercial license to operate as set forth in the regulations of the Federal Communications Commission is required of him. In addition to standing watches, he as-

(Continued on page 54)



The radioman's summons brings a Coast Guard hospital plane to the Tuna fleet.

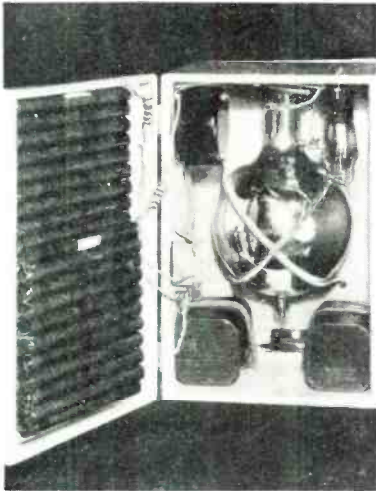

The huge television "eye" used in the whirling disk system. On the left are batteries.

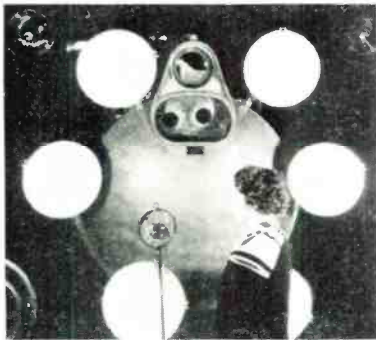

An actor's view of the whirling disk camera. The six white disks are powerful spot lights.

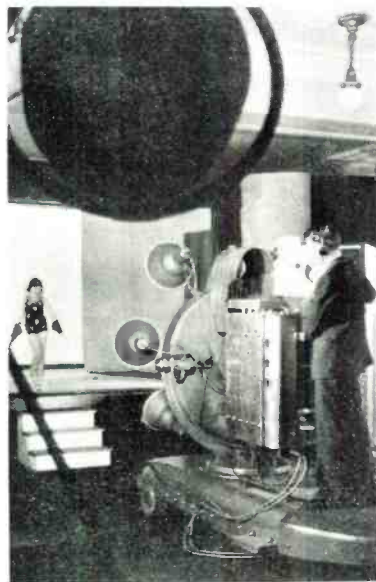

The heavy whirling disk camera successfully televises a diminutive actress in Chicago.

IS Television

For years, Television has been "just around the corner." For years Television has been promised us as America's great new industry. What is really the truth about these reports? In this important symposium of opinion, much is revealed, little solved.

YES . . . says U. A. SANABRIA
Vice-President of American Television Institute,
and leading television engineer.

DURING years that I have been working in television I have had occasion to meet most of the important engineers and inventors in the field. Some have had more agreeable personalities than others, but behind each one I could feel a common driving force which appeared to focus into the words, "No matter what be the obstacles, we must have television."

Consider for a moment the motivating force behind these thoughts. These are men who were not supported by the Government or any benevolent society during the years they forced television from nothing into the highly developed systems we see today. All of them learned that the task was too vast and the industry too great for any individual to attempt to obtain more than a small share of the financial profit that goes to a pioneer. Yet, none of them slackened in their efforts to give us television. Basically, this hard work continues because television engineers

have come to understand that whole groups of people can only continue to live together in harmony through greater mass educational mediums. They believe that the greatest mass educator will be television.

The huge capacity of a television system for exhausting the entertainment resources of producers will demand that subjects of greater mental interest will occupy more time and attention as television grows in national use. Television will be the greatest of all forces for the dissemination of information and propaganda. It shall be the responsibility of present television engineers to see that their work is not misused. I am convinced that beginning with this year, this same driving energy will direct itself toward the solution of removing the comparatively simple business barriers which remain to oppose national television service.

Some of those executives who casually print the story of their inability to find

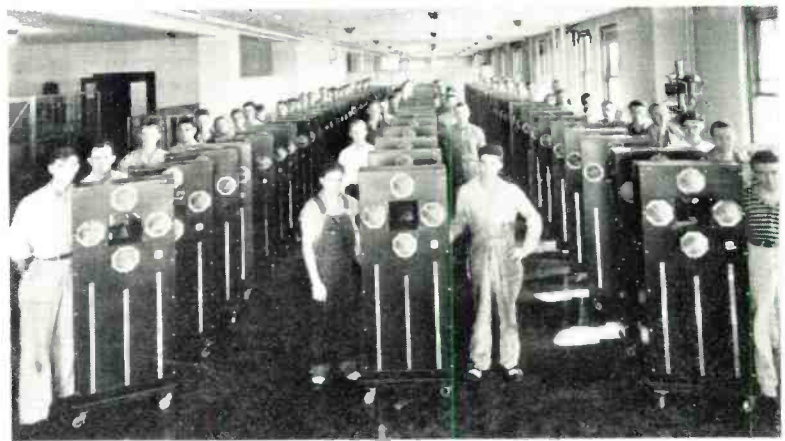

100 television-telephones for commercial use; 100 trained men ready to service them. Why have they not been put to use? What is holding up the U. S. on this last frontier?

Here?

Under the RCA system, this is the type of picture you will receive on your television receiver.



NO . . . says **COMMANDER E. F. McDONALD**
President, Zenith Radio Corp.

"Television is just around the corner—but only for stock salesmen and deluded investors. It is time the public is told the truth. Television is coming, but serious technical and economic difficulties are delaying its introduction. Even with the finest laboratory equipment, experts have been unable to project clear pictures more than twenty-seven miles. Changes in television transmitting apparatus have been so rapid and so continuous that television receivers sold only one year ago are now obsolete. Two thousand transmitters would be needed to give adequate coverage of the United States and would require ninety thousand miles of special cable costing nearly *one billion dollars*. Television is likely to find its first application over telephone wires instead of by means of wireless television transmitters. The American Telephone and Telegraph Company subsidiaries are having television privileges included in their franchises. Television is coming, but it is *not* 'just around the corner.'"



Two high power television tubes. The plates become so hot that water cooling is needed.

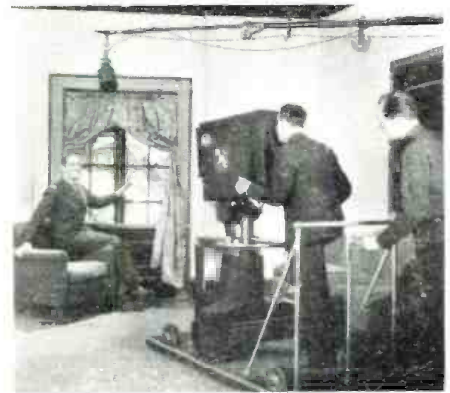

Michael Bartlett, screen star, is televised by The RCA Iconoscope. The engineer looks into the camera watching the performance.



The television receiver of the future. Less complicated than a modern broadcast receiver.

a good financial solution to launching national television service, have said. "Show us how to raise a Billion Dollars and we will give you national television service tomorrow."

I can remember when they said, "Show us television and we'll worry about the rest." Well, the time to worry is now, or the doubt of their sincerity will follow.

Where is American business acumen, if it cannot solve the comparatively sim-

ple problem of financing television?

Wouldn't our financial geniuses of yesterday blush with shame to see some of our most notable business executives actually printing the story of this unbelievably difficult task of financing an invention already more perfected than any heretofore launched? Certainly these men are not serious; they have not really tried to think out a good financial solution for television service;

(Continued on page 69)



NBC Empire State Bldg. Studio television control room. A lot of equipment, but only intermittent programs. When will this equipment get regular use?

A HOMEBUILT Transmitter for

by HOWARD SULLIVAN,
W9QGS

For the amateur who wishes to give phone a whirl, and yet not pay out a lot for the equipment, this transmitter is the answer. It can WAC on 10 meters.

WHEN I first got my "ticket" on November 19, 1937 I could only afford a 6L6 crystal oscillator. When installed in my station, this gave excellent service, and I soon made many friends, both local and DX. As I continued to be on the air longer, I got the urge to go from CW to fone. On Christmas I received a present of \$20, and immediately proceeded to delve into my junk box in quest of parts with which to build a fone rig for 160M. Since \$20.00 would buy only a few small parts here and there, I dug down to the very bottom.

The transmitter you see in the illustrations is the result of all my digging. As for cost, it won't set you back nearly as much as you might think. I paid \$20.32 for everything on the transmitter chassis and under it. All parts are brand new—and in case you are skeptical, I make three claims for the rig.

Economy—if you cut out some of the more elaborate parts and substitute plainer, cheaper ones, you should be able to build the rig absolutely complete excluding power supply and the mike. for between \$13 and \$15.

Reliability—No trouble has ever been experienced with this little rig—it works like a charm, and all you need do is plug in the mike, flip the switches and you are on the air.

Ruggedness—Obviously, the transmitter can be readily converted into a portable job with a minimum of work. You don't have to worry about it taking the bumps. It will take plenty of tough knocks, and the "edges won't even get frayed."

And now to get down to the actual description, construction, and operation of the rig. The crystal oscillator is a type '76 tube. It is a good stable oscillator and just about any crystal will give complete satisfaction. More than enough output is available from the '76

because the '77 buffer doesn't need much juice. The '77 buffer was thought advisable to provide some sort of isolation between oscillator and final stage in order to maintain good frequency stability. As a matter of fact a buffer is required by law if the set be used on the 20 meter band. No neutralization is needed, and the current drain is low.

The final is a 6L6G. This bottle was chosen for several reasons. It is very easy to neutralize; it requires very little excitation, and it is more efficient than any other receiving type tube that might be eligible for use in this circuit.

The microphone I am using is a Western Electric single button, type 337. This mike, although it sounded almost like a peach can on a string,

gave very good service. Provision is made for either single or double button input. The mike is transformer coupled to a 6C5 speech amplifier. The 6C5 is resistance coupled to a 6L6 class "A" modulator which gives very excellent service, and modulates the final at 15 watts input to a full 100%.

Incidentally, the quality of the audio channel is limited only by the type of microphone used. Both the speech and modulator tubes are biased and bypassed. As a Class A modulator, the 6L6 output declines rapidly as the tube is overloaded.

One power supply is used, giving good quality and stability.

The entire unit thus far described, except for power supply, is built on a cadmium plated chassis and crackle fin-

Behind the panel of the \$20 rig. A neat, clean-cut arrangement of parts.

Black Box Foto

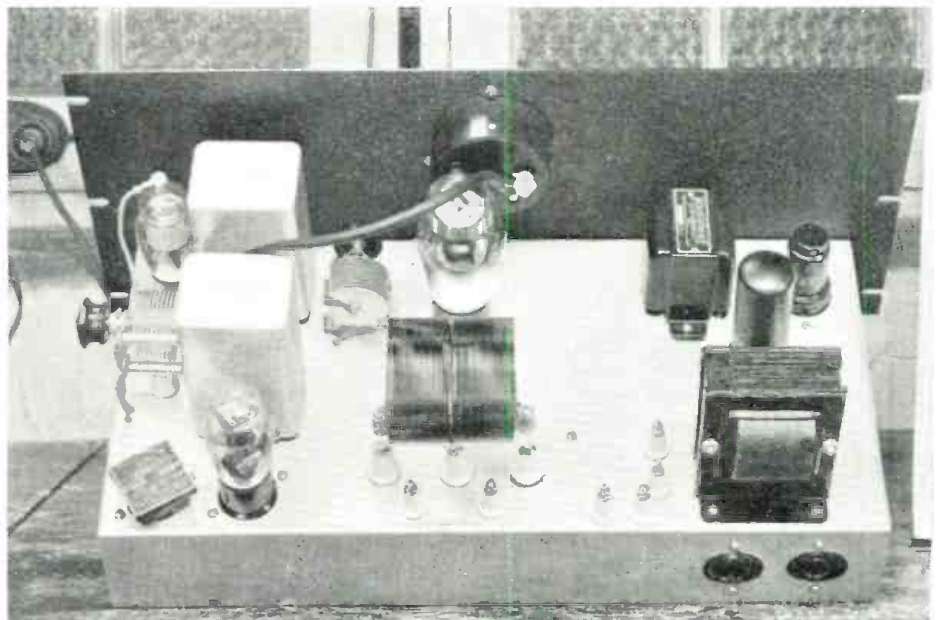



Black Box Foto

The Author tries out the transmitter in his shack. Note that the rig is smaller than the RCA receiver on which it rests. The transmitter should be able to WAC on 10 or 20 meters with a good antenna and location.

ished metal panel. The chassis is 17"x8 $\frac{3}{8}$ "x3". The panel is 19"x8 $\frac{3}{8}$ ". Both are standard for relay rack construction.

If the chassis and panel, while looking at it from the front, is divided into three parts, it will be seen that the

third to the right holds the audio system, and the two thirds to the left supports the R.F. In the rear left hand corner is the crystal. Directly alongside it and against the back edge is the '76 oscillator.

Directly in front of the crystal is its

plate tank tuning condenser. In front of the '76, and along-side the condenser is the National P.B.10 oscillator plate tank in its coil shield.

In front of the oscillator condenser and directly behind the panel is the '77 buffer. Alongside it, and behind the panel is the buffer coil assembly and to its right is its tuning condenser.

In the middle of the chassis and against the back edge is the final tank coil. In front of this coil is the 6L6G final amplifier.

This layout comprises the R.F. section. It is advised that this arrangement of parts be used because shorter leads will result. The minimum of interaction takes place between stages; and the appearance and operation of this arrangement leaves nothing to be desired.

The audio channel is very simple. On the panel and below the chassis are the microphone jack and gain control. On the chassis is the mike transformer and the 6C5 speech amplifier tube.

Midway between these two units and to the rear is the 6L6 modulator. Along the back edge of the chassis and in the corner is the modulation choke of 25 henries at 50 milliamperes.

Metering in the circuits is accom-
(Continued on page 20)

The underside of the chassis shows the correct wiring for short wave work. Fancy bends and leads are to be avoided. All stages are properly isolated.

Black Box Foto

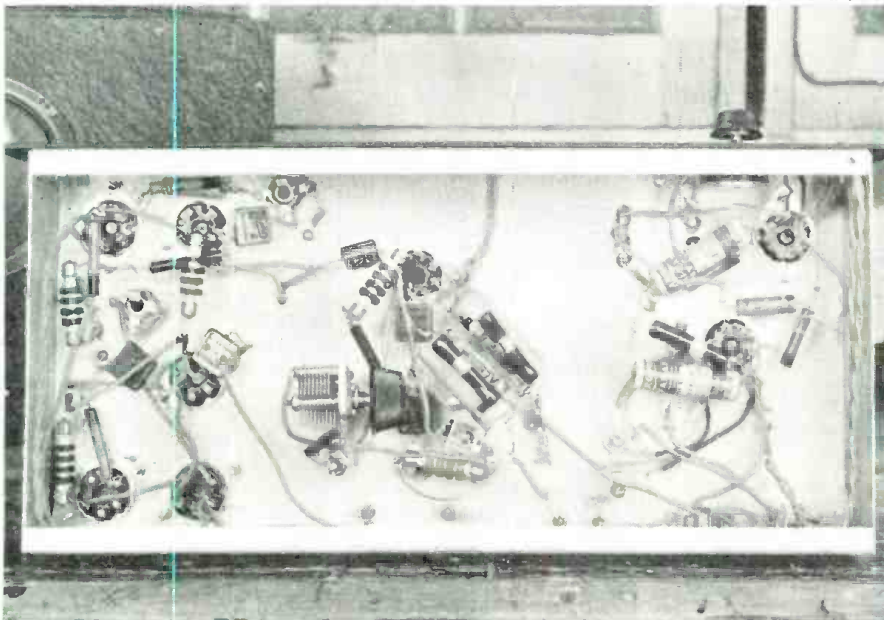

plished by a plug and jack system behind the panel.

On the back of the chassis are two sockets. The one to the right supplies the filaments to the two 6L6's, and B+ and "ground." The one to the left supplies filament and reduced plate voltage. For the best results this should be followed.

I will not go into a technical description because I feel that any amount of that stuff is to be found in contemporary literature. However, I do feel that a few precautions are advisable.

First—keep leads as short as possible. Don't go in for fancy curves, twists, and corners. A visitor may be very much impressed by the looks of the rig, but his impression can easily be ruined if the other station (when you do hook one) comes back and says that something is "haywire" and that you ought to get off the air.

Second—keep each circuit by itself. The units on top of the chassis are all grouped by each individual requirement. It is logical to keep the parts under the chassis that way.

Third—be absolutely sure that each connection is correct before you make it. It is, for instance, only too easy to get the cathode and plate prongs reversed on a '76 socket. Don't apply the solder until you are sure—then go ahead and you'll save yourself plenty of headaches later on.

Near the modulation choke, and to its left, will be seen four feed-through stand-off insulators; two alongside the choke and two along the back. The two along side the choke are connected across it. The other two are in series with the power lead and between the final tank coil and the modulation choke. When it is desired to work CW it is advantageous to short out the choke for higher input. For phone operation the link across the choke is removed and the one in series with the power lead is connected.

If it is desired to modulate, say, a five meter transmitter, merely remove both links and run a wire from the insulator on the plate side of the 6L6 modulator to the B+ of the 5 meter

A "junk-box special" power supply that gave excellent service.

Black Box Foto

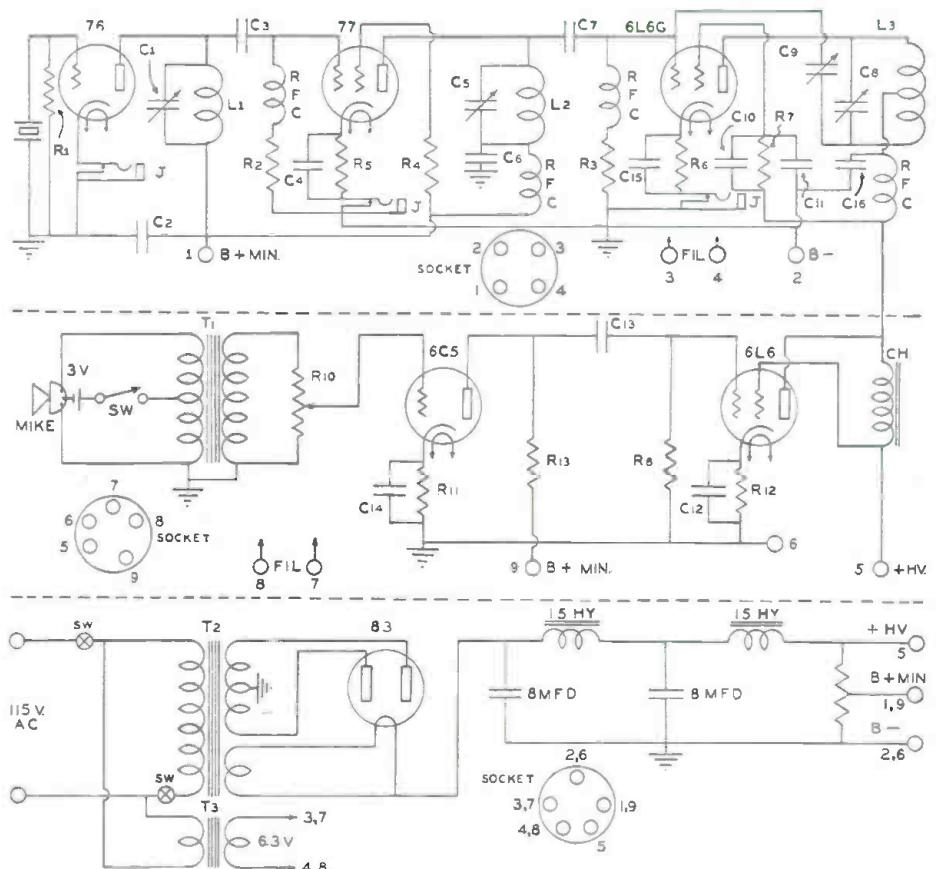
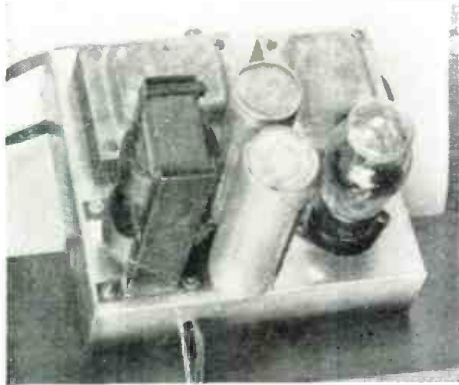

The complete transmitter circuit.

- C₁—140 mmfd. variable
- C₂—0.01 mfd. mica
- C₃—0.001 mfd. mica
- C₄—0.01 mfd. 400 volt paper
- C₅—140 mmfd. variable
- C₆—0.02 mfd. mica
- C₇—0.001 mfd. mica
- C₈—140 mmfd. variable
- C₉—Hammarlund "Mex"
- C₁₀—5 mfd. 400 volt paper
- C₁₁—0.05 mfd. mica
- C₁₂—10 mfd. 50 volt paper
- C₁₃—0.01 mfd. 400 volt paper
- C₁₄—10 mfd. 25 volt
- C₁₅—10 mfd. 50 volt
- C₁₆—0.02 mfd. mica
- CH—18 henry 150 ma. choke
- L₁, L₂—(160M.) 60 T. \approx 20 EC 1 1/2 dia.

- L₃—(160M.) 60 T. \approx 20 EC 2 1/4 dia. (Brown and Williams Coil)
- R₁—25,000 ohm 1 w
- R₂—50,000 ohm 1 w
- R₃—50,000 ohm 1 w
- R₄—3000 ohm 1 w
- R₅—300 ohm 1 w
- R₆—350 ohm 10 w
- R₇—20,000 ohm 10 w
- R₈—500,000 ohm 1 w
- R₉—100,000 ohm 1 w
- R₁₀—250,000 ohm pot.
- R₁₁—2000 ohm 1 w
- R₁₂—200 ohm 10 w
- R₁₃—50,000 ohm 1 w
- RFC—2.5 mh. choke
- T₁—Microphone transformer (Thordarson 5837)

R.F. stage and connect negative of this modulator to B- of the 5 meter job.

To tune, first apply all voltages except the plate voltage to the final and buffer. Plug the meter into J₁ and rotate the oscillator plate tuning condenser 'til the meter dips suddenly. Leave the condenser set slightly past the lowest current reading, but not at the highest reading. The crystal is now oscillating.

Plug the meter into J₂ and set the condenser to a point where lowest current reading is obtained, having turned on the juice to the buffer. Now, with some form of sensitive R.F. indicator, such as a neon bulb, set the little "Mex" neutralizing condenser to a point where no R.F. is produced in the final tank coil L₃ when the final tank condenser is rotated through its complete arc. This is shown by the neon glow going out. Up until this point, remember, no plate

voltage has been applied to the 6L6.

Then hook on the B supply so that voltage is applied to the final and adjust the final tank tuning condenser to give lowest current reading. Now plug in the microphone and turn up the gain control, which is across the mike transformer, until the meter which has been plugged into J₃ moves slightly when you talk into the mike in a fairly loud voice.

Couple the antenna to L₂ and load the final amplifier to 50 milliamperes by adjusting the coupling. Since there are so many ways this can be done, I suggest the reading of any handbook on the procedure.

No further adjustment is necessary except that it might be advisable to set the gain control to an optimum value. That point is best determined by another amateur listening to the signal in his receiver.

(Concluded on page 73)

The "Pigeon Cooker"

by J. E. BROWN, Engineer.

Reports that homing pigeons were being slowed up by radio towers, sent the Navy into a fury of activity. Independently Engineer Brown undertook a similar survey, with the interesting results described in this article.

HOMING pigeons were used as a means of communication long before radio was in existence. Now under the present Signal Corps Plan of the U. S. Government, they are still continued as a necessary adjunct to the communications of the military forces.

Occasional reports have filtered through from time to time of the homing instinct of pigeons being disturbed when released in the vicinity of radio transmitting stations. One of these reports covers tests conducted by the Navy Department of Lakelurst, New Jersey, and shows quite conclusively that the pigeons were affected. Those exposed to radio waves at the antenna of the A T & T transmitter at Ocean Gate, New Jersey, took much longer to return home than did those birds released at the same location, but not exposed.

In order to find out if possible what the effects of radio waves on pigeons were, a 100-watt oscillator was constructed in the laboratories of the Zenith Radio Corporation and a series of experiments conducted at many different wave lengths on homing pigeons. This 100-watt oscillator was nicknamed the *Pigeon Cooker*. All tests were conducted at the site of the former WJAZ radio station near Mt. Prospect, Illinois. The oscillator was arranged to have large tank coils so that the pigeons could be placed in a strong field. The oscillator covered the range of 5 to 50 meters.

The first tests were conducted last Fall, using 50 pigeons borrowed from various pigeon lofts in Chicago. The

pigeons were released one at a time at suitable intervals. The tests were carefully arranged so that only those pigeons intended to be exposed to radio frequency were exposed. The remainder were kept $\frac{1}{2}$ mile away from the oscillator, inside a steel bodied truck. The following results were obtained:

EXPOSED TO RADIO FREQUENCY

Wavelength	Number of Pigeons	Flying Time
11 Meters	5	17 4/5 Min.
13 Meters	5	17 3/5 Min.
15 Meters	4	20 3/4 Min.
20 Meters	6	23 2/3 Min.
30 Meters	2	17 Min.

NOT EXPOSED TO RADIO FREQUENCY

Number of Pigeons	Flying Time
21	25 1/2 Min.

According to these tests those pigeons not exposed to the oscillator took longer to return home than did those exposed to the oscillator. This was at variance with reports, but there were irregularities in the tests. The pigeons flew the same distance in both cases to the same destination. The only difference in treatment was that those exposed to the oscillator were held in the operator's hand for three minutes in the field of the oscillator; those not exposed were held in hand for a fraction of a minute only, that is, the time actually involved in removing it from its cage and tossing it in the air.

In order to eliminate this irregularity in all future tests, all pigeons, both exposed and unexposed, were held in the

hand and in position in the coil of the oscillator for the same period of time. The period of three minutes of holding was decided upon since exposure times as great as ten minutes did not show any different reaction on the pigeon.

The tests previously outlined led to some doubt in the timing of the pigeon's arrival at the home loft. To remove this possibility of error it was decided to limit the number of birds used to those from one or two lofts so that observers could be stationed at these lofts to secure accurate timing.

Another series of tests were run a few weeks later using 8 birds from one loft. Four were exposed to radio frequency, 4 were not exposed. Unfortunately the observer at the loft failed to make any accurate record of the pigeon's arrival and hence the test was valueless. Another test was then made with these same birds and from the same loft in which test birds were released in groups, 4 exposed and released simultaneously; 4 unexposed and released simultaneously. In this test a wavelength of 20 meters was used and the exposed birds took 38 minutes to get home, the unexposed 50 minutes to get home.

These tests were still at great variance with the reports that pigeons were actually slowed up by exposure to radio waves. *The careful check on the pigeons revealed that they did not go straight home, but stopped to cat, loiter, go out of their way, visit with other pigeons and do whatever pigeons do when "not on the job."* Of the birds that were exposed to radio waves, those that were doing this visiting and eating found themselves so disturbed by exposure that they actually flew straight

(Continued on page 60)

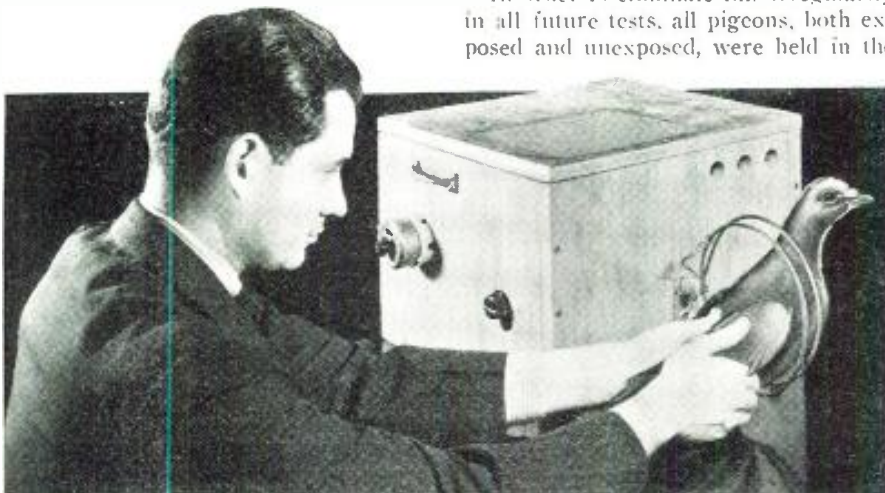

In the experiments, the pigeon was placed in the radio field coil of a small transmitter. In war times the enemy might be able to attract our pigeons over to their side by short wave beams.



Key Kyser, originator of the College of Musikal Knowledge, placed FIRST in a West Coast Popularity poll.



Engineer Frank Lester, designer of the Les-tet circuit and a new all band transmitter for Wholesale Radio Service Co.



Samuel Poncher, who started in radio in 1931, now controls one of Chicago's oldest radio stores, Newark Electric Co.

PERSONALITIES



Banjo-eyed Eddie Cantor and sensations, Bobby Breen and Deanna Durbin. Cantor has much to show for his talent scouting.



Silly Watson, Fibber McGee's Man Friday, goes by the name of Hugh Studebaker, and is famed for his Negro imitations.



Jane Rhodes, NBC child singer still has to go to school five days each week. She is now in Hollywood appearing in pictures.



Those Kraft Music Hall Aces—Piano, John Scott Trotter; Bazooka, Robin (Bob) Burns; Voice, Harry Lillis (Bing) Crosby.



Stancor's prexy Jerry Kahn whose firm moves to new quarters. Kahn is an ardent home movie addict.



A. D. Davis, President of Allied Radio Corp. Entered that firm 1927 and became its chief officer in 1933.

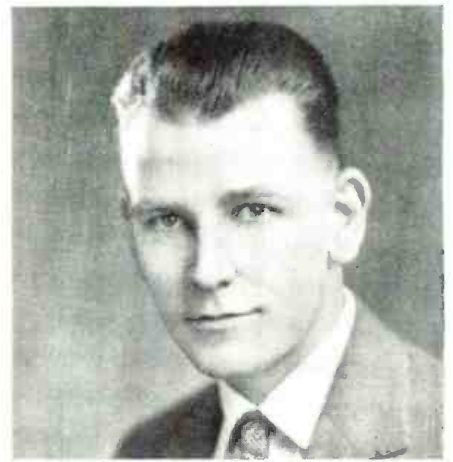

Fred Hinds, the head of one of the country's oldest radio mail order houses. Hinds' hobby is model trains.



The musical director of WOR, Alfred Wallenstein, who was one of America's leading young conductors.



Our own Kate Smith of the golden voice who exercises on the slopes of Lake Placid. Kate is athletically inclined.



Tizzie Lish of the impossible recipes. The inspirations come from any cook book, and "her" name is really William Compton.

Senior Announcer Everett Mitchell, Chicago, conducting the NBC Announcers School. Tom Casey, now junior announcer NBC, Chicago, is first person in back row. Jack Simpson (2nd l. to r.), Bill Layden (last in front row), is now at WCFL, Chicago. Most would-be announcers for NBC must attend this school.



as RADIO ANNOUNCER?

by WALLY RODDA
Announcer and Managing Editor
WKZO Press Bureau

If you can't attend the school for announcers, this article will help you materially towards being an announcer. An exacting profession, it cannot be entered in a haphazard manner. The author describes some of the things to expect and the pitfalls to avoid.

SO you are really determined that you want to be a radio announcer? You've thought it all over carefully and have come to the conclusion you shall not live a happy moment until you have stepped before that little black robot (microphone to you) and have voiced your bit on the endless waves of



Announcer Truman Bradley picked by Ford to "do" the Ford Sunday Evening Hour. Sponsors pick many Announcers.



Don Wilson who was lifted to stardom last year by Jack Benny. Don was MC of the show during the summer of 1936.



Ken Carpenter, who holds the distinction of dramatizing the NBC chimes. He did it on the Kraft Music Hall hour.

other received daily through millions of loud speakers.

Well, it's a very noble aim. But first, remember, there will be a long period of preparation before you are ready to approach the General Manager, Personnel Director or whatever he may be titled. You might as well start tonight. Let's develop your imagination first. You'll need it later, anyway, while trying to read some of the continuity placed before you.

The question is: Deep down inside of you, do you want to be a radio announcer? Have you listened to the radio and built castles around your imagination alone? Have you been unfortunate enough to see the radio performer and announcer glorified in the cinema to the extent that you think it must be a glorious existence? If so, I'm sorry. I sometimes wish I had had the picture painted for me more vividly. I would, without a doubt, be selling shoes somewhere, or have a chicken ranch all my own instead of spending the past eight years as a radio announcer.

Let's find out if you really are ready for the radio industry. You want to show me how well you can read and what a lovely voice you have? That's the last thing required of a new man in some hundred watt stations. Of course, you should start there. You'll never regret it. The farther up you go, the easier it will seem.

Can you eat lunch in five minutes without suffering from acute indigestion? Can you break the same postponed date for five nights in a row and then on the sixth night call her with a calm voice and say, "Honey, I have to work again tonight"? Can you come to work in the morning so sick with a headache that you would much rather lie down and expire in your



Radio Columnist Margaret McBride who describes such excellent recipes over the air, tries one of them on Announcer Kenneth Roberts who seems to enjoy it.

tracks and still be the cheerful morning earful that you are billed as being? Can you take a bawling out from the boss on an empty stomach and then dash hurriedly into the studio and read a spot ad without sounding as though you wanted to chew the ears off everyone listening and strangle the "Mike" for good measure? If you have passed the test thus far and still want to be a radio man, then you're one in a million.

Let us assume you've passed the first barrier, and are to be given a

trial. You will probably be turned over to the Chief announcer, who will put you through your training period and give you a schedule. It will probably be all night work for a while, until the other boys get rested up a bit. What's that you say? How much what? Oh, yes, money! I'd forgotten it entirely.

Well, I'll tell you, if you're doing as well six months from today as I feel you will: if you aren't late mornings and work hard; if you can get along

(Continued on page 66)



Announcer Howard Claney is an expert at oil painting in his spare hours. Will only paint wearing his coat and hat.



Fort Pierson, Ace Commentator-Announcer, whose word pictures have made news realistic and vivid to us.



Ken Ellington, Ace CBS announcer, whose cool head has helped him rise far above the average "mike-juggler."



Lots of talent in small space. Dorothy Lamour kisses Charlie McCarthy to the amusement of Edgar Bergen. Don Ameche watches.

by NORMAN D. MODELL
Author and Talent Scout

RADIO, like the movies, is constantly on the search for new voices. In the recesses of some unsuspecting throat may lie a gold mine waiting to be exploited as soon as its owner acts on his wild urge to "try out for radio."

Contrary to the general opinion, you do not have to be a first cousin of a radio station's vice-president to get your chance at the studios. Whether you are sweating behind a plow in Iowa, pushing a cart that shrieks a staccato whistle as you yell "Peanuts!" or taking Mrs. Schultze's complicated grocery order over the telephone—your chances are just as good as if you were born with a microphone in your mouth. But you must have talent!

Behind the outside door of every Class A broadcast station is a "seeing eye": not a photoelectric cell but a corps of talent scouts every bit as efficient in detecting the presence of unknowns who show possibilities of becoming outstanding radio artists.

These scouts venture into the tank-towns to cast a discriminating eye over the semi-monthly vaudeville acts and lend an ear to the efforts of the home talent. They tune their radio sets to the wavelengths of the hundred waters scattered around the countryside almost as numerous as silos. They listen in on the amateur hours. They watch observantly the finalists in "unknown singer"

You MUST

You may have the makings of a first class radio star. Daily thousands try to get into radio . . . they can if they have that elusive thing called TALENT.



Mercedes, heroine of "Don Winslow of the Navy" series . . . dear to the hearts of the young people. Her real name, Betty Lou Gerson.

contests. They attend Broadway shows, Little Theatre productions, the motion pictures, keeping their eagle eyes peeled for the voice that might thrill millions. And as though this were not enough, they hold a general audition once a week at the studios for the hundreds of singers, announcers, and actors who think they possess the talent radio is seeking.

Perhaps you have heard Mildred Stanley sing over the air. She isn't famous like Grace Moore, but down at the studios they expect her to hit high C on the scale of radio success. Not long ago Miss Stanley was only an amateur. She entered an amateur contest conducted by the King's Jesters at the Hotel LaSalle, Chicago. Alex Robb, assistant manager of the Artists Service in NBC Central Division, heard her sing. After the performance, he introduced himself and asked her over for an audition. That moment, when her heart beat like a frenzied Congo drum, may have been the beginning of a great radio career.

Lulu Belle, star of National Barn Dance Hour. She was 1936 Radio Queen.



Have Talent!

Marian and Jim Jordan, beloved by many as Fibber McGee and Molly.



Vivian Della Chiesa had an inherited talent for music. Her grandfather was a symphony conductor in Italy, her mother an accomplished pianist. Her break came after years of study under prominent Chicago voice instructors and at the Chicago Musical College.

A formal musical education is not indispensable, though, to become famous over the ether. One name you all know started out in life with a passion for corn bread, a back porch that overlooked the Blue Ridge Mountains in North Carolina, and a mother who taught her most of the songs she sings today—none other than Lulu Belle, who titillates rural America every Saturday night on the National Barn Dance.

As to blues singers, Gale Page has an astonishing biography. She got into radio by way of boredom. The daughter of a Spokane banker and the wife of a Chicago investment banker, she became so disgusted with afternoons of bridge that she sang over radio for a lark. NBC scouts heard her make her debut on Chicago's old KYW and three weeks later gave her a contract. Now she's in the movies.

From the other end of the economic ladder came Little Jackie Heller. At fifteen he sold papers in the lobby of a Pittsburgh hotel. Then a cafe owner heard his voice and hired him at \$40 a week. He wasn't singing four months in Pittsburgh night clubs when he was introduced to Eddie Cantor, who taught him his present style of singing and sent him to New York, where he became a hit. Later Ben Bernie heard him and signed him for a long engagement. Jackie's only sixty-one inches tall, a miniature no less, but he packs more personality per square inch than any tenor in radio.

Kenny Baker got into radio through the movies. A talent scout for 20th Century-Fox discovered him singing in the choir of a Long Beach, California, church. At a preview of his first picture, "King of Burlesque", he was spotted by Jack Benny and signed for the Jell-O hour. That was in 1935. Since then he has soared to an enviable position in the galaxy of radio stars.

For every singer that comes to the



(Above) Few people know that Kenny Baker writes many arrangements and songs. He always works with his hat on.

(Right) Diminutive singer Jackie Heller, supports Hi-de-ho Martha Raye . . . but only for this picture. Both are tops in their respective fields.



network auditions there are half a dozen actors. Time and time again you have heard these names mentioned as part of the cast: Laurette Fillbrandt, Macdonald Carey, Loretta Poynton, Carl Weber, Merrill Fugit, Arthur Kohl, Betty Winkler, Betty Lou Gerson, Philip Lord, Carlton Brickert, and Fred Sullivan. Every one of them got on the NBC dramatic staff through general auditions.

Philip Lord and Carlton Brickert came to Chicago in stage plays and graduated to radio after successful auditions. In fact, the path to radio dramatics in a majority of cases follows a course from the footlights to the microphone.

Don Ameche, the "man of a thousand voices", who does his bit to help Charlie McCarthy emcee the Chase and Sanborn Hour, began as a campus idol in University of Wisconsin dramatics. A last minute alarm sent out by a touring stock company, which was minus a

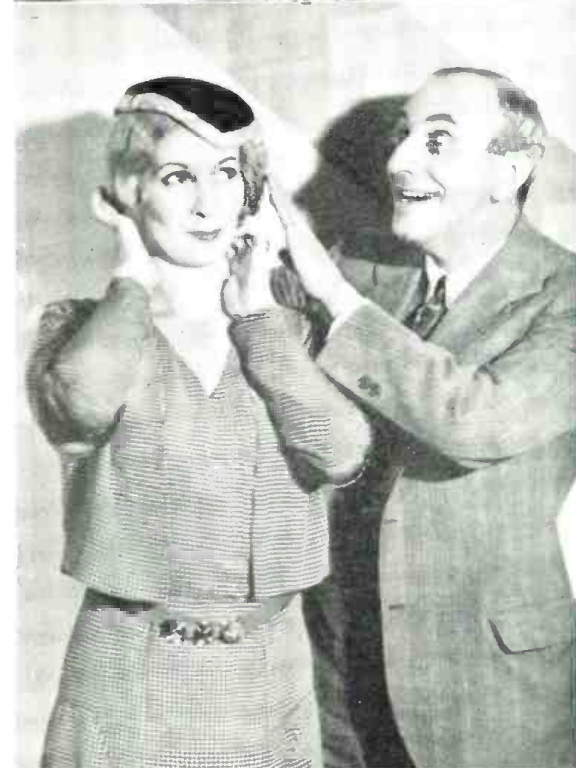

Arthur Van Harvey and Bernadine Flynn, entertain with their "Vic and Sade" sketches over NBC-WJZ net works.

leading man because of an automobile accident, dragged Don from his law books. After the first performance he was awarded a 20-weeks contract. Then followed unemployment, a part in "Jerry, For Short", more stock company labor, vaudeville, another short run play and again unemployment. A radio audition for a program called "Empire Builders" attracted him. He threw his cap into the ring and came out winner. His name came to be a household word as leading man in the "Grand Hotel" and "First Nighter" series. It even penetrated the home of Darryl F. Zanuck, who liked him and brought him to Hollywood for 20th Century-Fox.

Bernadine Flynn, whom the radio public knows better as Sade of "Vic and Sade", is also a product of University of Wisconsin dramatics. Zona Gale, the famous authoress, recommended her to Broadway, where she became understudy to Muriel Kirkland in "Strictly Dishonorable" and played with George Jessel in "Joseph." In the spring of 1930, just half a year after she left Madison, she auditioned at NBC for a part that required a French accent. The accent she had learned from her mother won her the role, and since then her career has been hit after hit until now she has the recognition of playing one of the best comedy roles in radio.

Marian and Jim Jordan, who fell in love over a hymn book in a Peoria church choir, received their theatrical education when they organized a concert company and toured the Midwest. They played tanktowns, opera houses and churches until vaudeville called them a few years later. In 1924, while visiting friends in Chicago they were dared to take their vaudeville singing act into radio for a trial. The dare resulted in a \$10-a-week job at WIBO. Soon they were at NBC, where their talent for comedy was recognized and they were encouraged to develop a comedy show. They originated the "Smackout" series, which started them on their way to fame as gagsters. Today they are the stars of what is known as the shortest half hour comedy show on the air, "Fibber McGee and Molly."

Anne Seymour, whose theatrical lineage traces back to more than 200 years ago, made a success of radio only after years on the stage with such stars as Ethel Barrymore. A little less of her indomitable ambition to keep up the

family precedent, and she would have pursued a career behind a Remington. Theatre Guild officials told her to give up acting. But instead she enrolled in another dramatic school, from which she graduated with honors after winning a scholarship. Her first appearance on the stage was made when she was only twelve years old. Seven years later, in 1928, she attracted public attention by her performance in Channing Pollock's "Mr. Moneybags." Anne came to WLW in 1932, played in more than 200 radio shows, returned to the stage for a few months, and in the fall of 1933 was back again in radio, this time as the lead in "Grand Hotel". Now she is heard daily in the title



A rabid ball fan, Comedian Hugh Studebaker gets to play even if he has to use the microphone as a bat.

role of "The Story of Mary Marlin."

Betty Winkler, too, was not long out of her swaddling clothes before she made her stage debut. At the age of four she sang "Margie", tears of fright running down her blackface makeup because she had seen her ebony image in a mirror. At Hyde Park High School, Chicago, she was the pride and joy of the Senior Dramatics teacher. She graduated at seventeen, and almost immediately was engaged as a member of the Cleveland Playhouse Repertory Company. Within a year she was playing leads in stock companies in Akron, Ohio and neighboring cities. "The Trial of Vivian Ware", broadcasted

over WTAM, Cleveland, gave Betty her first chance in radio. In spite of an attack of influenza, she won the audition contest and the leading role. After a few months at WTAM, she returned to Chicago to try her luck at NBC. A general audition proved that she stood head and shoulders above the other hopeful artists. She was cast in one role after another until she is the dramatic star of the serial show "Girl Alone."

A background of curtain calls and stage makeup, however, is not a prerequisite for a successful career in radio acting. To Ransom Sherman the stage was just a platform a little higher than the audience. The one quality he had which marked him for success as a radio comedian was the irrepressible penchant for looking at the world through topsyturvy spectacles. Everything was funny. And so Ransom Sherman was funny too when he started to emit giggle waves over the radio in 1923. One of the original Three Doctors, he put thousands of fans into hysterics with his extemporaneous nonsense. Today he is master of ceremonies on the Club Matinee Broadcast, and NBC officials expect him to become a nation-wide favorite.

Hugh Studebaker, whose first job was carrying papers in Kansas City, Kansas, at a salary of \$1 a week, has become one of the outstanding character actors in radio without any stage preparation. You hear him as Silly Watson on the "Fibber McGee and Mollie" program, as well as on University Broadcasting Council productions and "Curtain Time" plays on WGN.

A philosophy of life brought Betty Lou Gerson to radio. She believed that "one's career should come before all other emotions and desires." She was teaching dramatics when suddenly she realized that this was only another way of expressing her love of acting. She wanted to act. She gave up her pupils and came to the station for an audition in 1934. Her success was immediate. She's been playing dramatic roles ever since.

Radio has been very democratic in its selection of artists. There is only one requirement: Talent—and don't forget the capital T! Just in case you should be bitten by the bug to journey to radio's Mecca, take one last look at your equipment and make sure you aren't missing the one requirement.

POWER PACK RECTIFIERS

by LOUIS J. GAMACHE

Development Engineer, Standard Transformer Corp.

To every serviceman the topic of power pack rectifiers should be interesting and valuable.



The author who is probably one of the country's outstanding power pack and filter system engineers, describes the technicalities of the rectifier.

POWER packs are universally used in converting the alternating current of the house lines to direct current. The voltage and current derived from the power pack without the filter is pulsating d.c. Every radio station, every receiving set makes use of the power pack. Theoretically, even a battery comes under this heading, although in the profession it is not commonly so known.

Every electrical power pack, excepting a battery, contains a rectifier of one sort or another, and before the subject of power packs can be fully understood, it is necessary to comprehend the use of the rectifier itself.

The most common of all power packs

is that used with the small radio receiver. The rectifier used is of the high vacuum thermionic type. Such is the type 80 tube, which is the most popular and has been used in 90% of all the radios developed in the last ten years. The disadvantages of this rectifier are: poor regulation, a high voltage drop, and a low limit of overload.

In other words, these tubes are designed to operate at a medium voltage such as 350 volts a.c. and to pass 125 milliamperes maximum current. It is not uncommon to find a voltage drop of 100 volts in this type of rectifier; figuring the voltage drop on the secondary of the high voltage transformer and the internal resistance of the tube.

In sets requiring greater current for operation, the rectifier is the mercury vapor type, such as the type 83, and in medium and low powered transmitters, the type '66. The voltage drop across these tubes is limited to approximately 15 volts because mercury vapor gas is a good electrical conductor. In this type tube, we find that the voltage drop in the tube remains fairly constant, whereas in the thermionic tube mentioned above, the voltage drop in the tube itself increases with the load. However, the limiting factor in a mercury vapor rectifier is inverse current. Another disadvantage of mercury vapor rectifiers, is that the filament of the tubes must heat the mercury in the en-

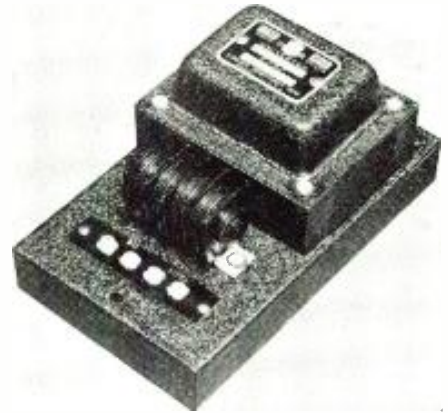

Commercial power pack used for the operation of small games, trains, etc.

velope before the plate or high voltage is applied.

The third rectifier in general popularity is the copper oxide rectifier. This rectifier is used in meters, railroad dispatching systems; for ringing chimes, charging batteries, etc., where a source of low d.c. voltage and medium current is required. However, the copper oxide rectifier is unstable in its operation. The rectifier depreciates along indefinite proportions during its life, and leaves much to be desired in regulation. The efficiency of a copper oxide rectifier, considering the voltage

(Continued on page 76)

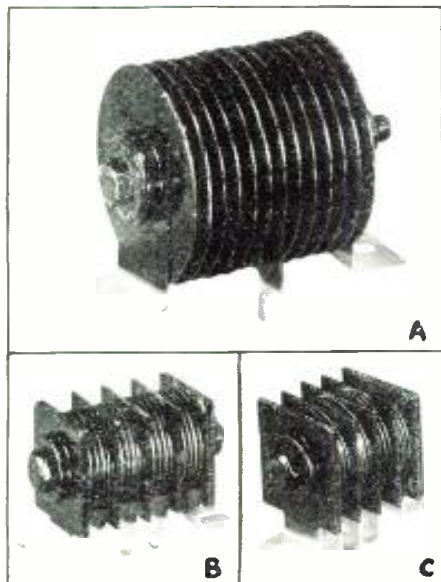

A. High current, low voltage magnesium cupric sulphide rectifier. Note large cooling fins. Balance of center connections are behind the rectifier and do not show.

B. Low current, low voltage magnesium cupric sulphide rectifier.

C. Very low current and voltage rectifier.

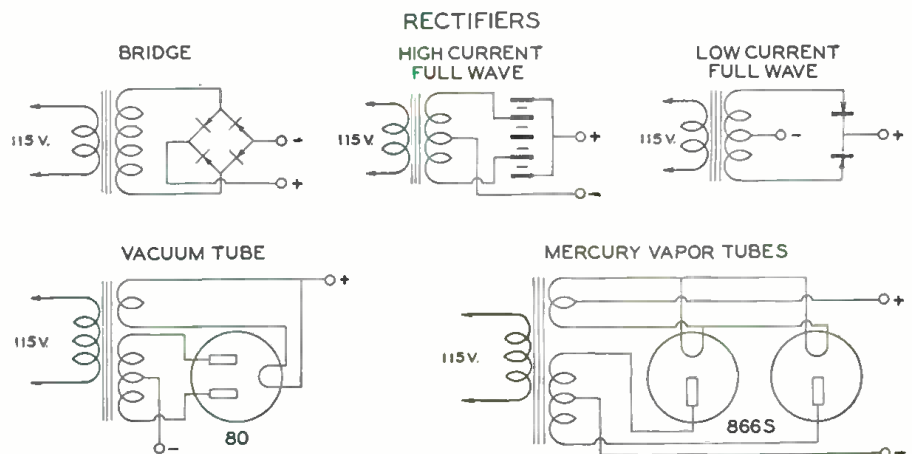

The circuits of various rectifiers all of which are fully treated in the text.



(Top) Sitting on the roof of WBBM's unit, the announcer describes the latest spot news.



(Lower) Engineer R. Norene watches spot news being recorded for future transmission.



California's Highway Patrol station KAPA which relays valuable police information to headquarters KADJ in Sacramento. A 50 watt transmitter used.

Mobile

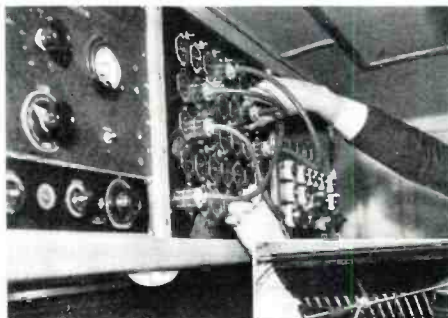

Many plugs, many connections (called "patches"), cross-connect the various circuits so that the program goes into the proper channel and to the right net work. The panel is in the mobile unit. At the extreme left is the audio monitoring control board.

The special 110v. AC 600w. fan-belt driven generator supplies power where lines are unavailable. →

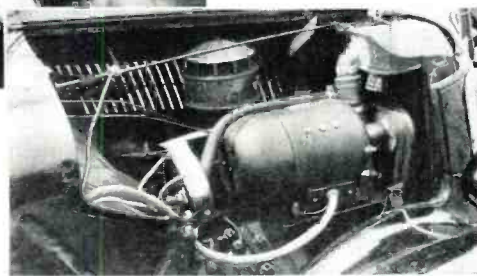

NBC's mobile television transmitter with special antenna to transmit the programs direct to the Empire State Building for re-transmission.

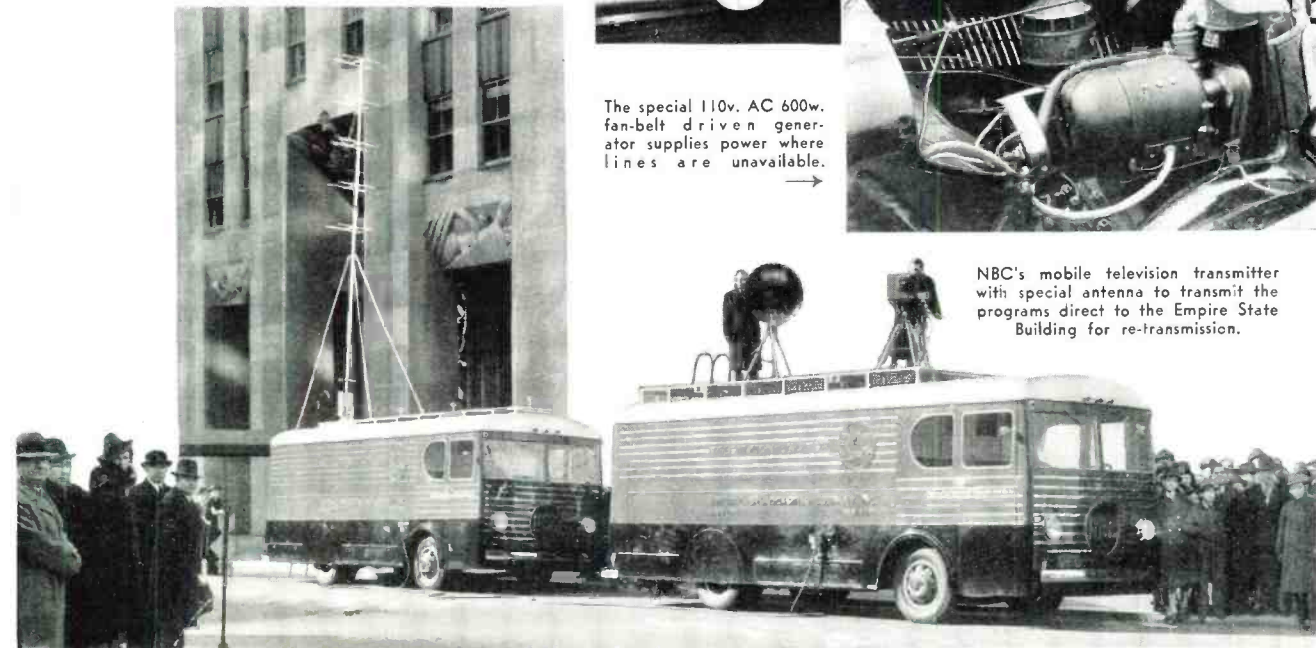

Engineers McMahon and Whitam demonstrate the Cleveland mobile unit. One carries a full pack short wave transmitter, while the other is monitoring him on a small portable receiver. In the truck is a medium powered transmitter, amplifier, etc.

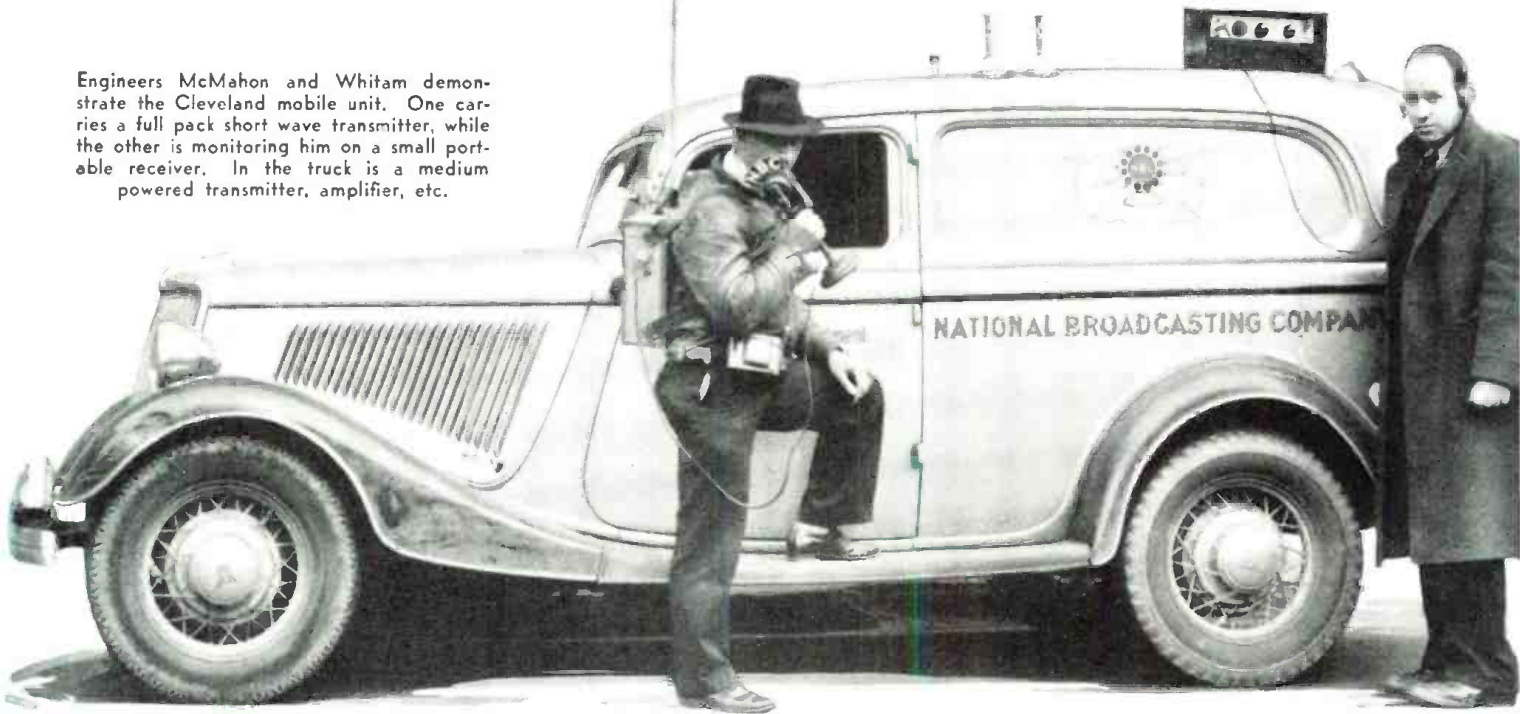

Pickup

IN THE comfort of our homes, little do we realize the extent to which the broadcast companies go to bring us the story from the location where it happens. Their equipment is growing day by day. It is practically impossible for anything to happen in a place where the station cannot send its men or trucks for the spot news. All operators of mobile units have to be licensed by the Government if they operate a transmitter itself.

WKY of Oklahoma City, Okla., the only mobile unit with its own antenna. The four poles and antenna can be installed in bumper sockets in less than four minutes.

(Lower) An RCA transmitter and full associated equipment. A regular auto receiver is used to hear the home station.



(Top) Rear view of New York mobile unit showing transmitter panel and set

(Bottom) The motor generator furnishes power. Control panel next to it, is for voltage regulation and the high voltage power supplies.



An AMATEUR'S TELEVISION

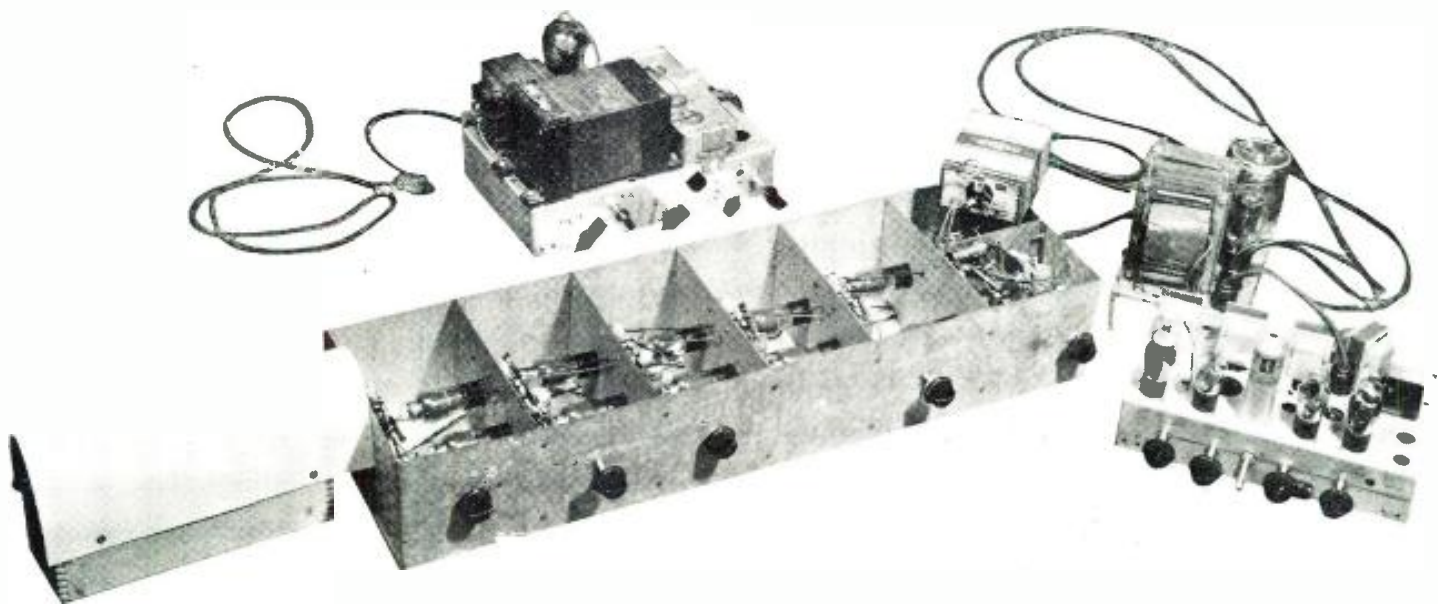

The complete Video Section hooked up ready to transmit a picture. The radio frequency section is not shown.

Black Box Fotos

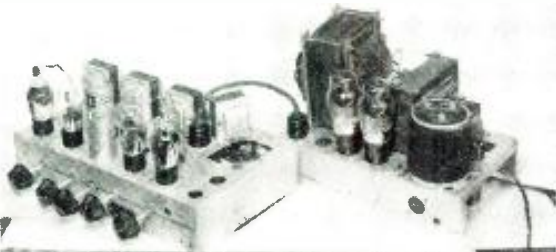
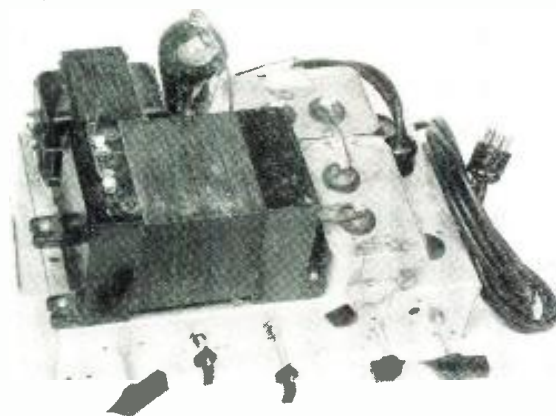

THERE are two general television transmission systems in use today. First, is by means of the whirling disk and the second by means of tubes. The second classification is divided between the Iconoscope, used by RCA, and the Dissector, used by Farnsworth on the West Coast. Neither of these latter tubes are available to the amateur.

There were three of us who became interested in the subject of television: George Sharp of Sioux City, Iowa; Ernest Kokoska of Cicero, Illinois; and myself. We discussed the designing of an experimental wired television system that would operate on the same basis as the commercial. Later put it on the air. However, we knew that we were not able to obtain an Iconoscope and that is where our difficulties began.

Close inspection of the Iconoscope revealed that it is in effect a cathode ray tube with a metal plate placed in such a manner that it will be scanned by the electron ray. The ordinary cathode tube shoots the electron ray up against a coated glass screen at the end of the tube and the ray, when hitting the screen, heats it to a sufficient extent to make it luminous. Our problem, therefore, was to construct either an Iconoscope or a tube which could be used in its place. We soon gave up the tube construction idea and concentrated on using the available tubes that are on the

market today. Television transmitter described below is the result of our experiment. While it will not televise a living person, it will transmit pictures from film negatives or it could be used to transmit motion picture film.

The system of transmission of the negative is quite unique in that it incorporates the cathode ray tube as the heart. The difference between our system and the Iconoscope was that while the Iconoscope scans an image inside of the tube, we were able to scan an image outside of the cathode ray screen. This was done by placing a negative flat against the end of the cathode ray tube and transmitting the ray through the glass and the film, collecting it in an Eby cell upon which it had been focused by means of a series of lenses. This then would be our "Iconoscope." The lens we used was an ordinary photographic convex type which can be purchased in any supply store. Our system had one drawback. There was not enough light hitting the Eby cell to operate the modulator for the ordinary speech input.

Our second big problem, therefore, was to design an amplifier which would amplify the very small amount of energy obtained from the Eby cell sufficient to modulate a small transmitter.

A lot of different things had to be taken into consideration. Firstly, the amplifier had to pass a very wide range of frequencies, from 20 to 1,500,000 cycles with a constant output over the entire frequency rate. We determined we had to have at least a 60-volt output from the amplifier in order to adequately excite the drivers and the modulators of the transmitter.

In order to avoid distortion, the ca-

(Top) The Cathode Ray tube high voltage power supply with its 866.

(Middle) The Cathode Ray sweep circuit low voltage and filament supplies.

(Bottom) The complete Video amplifier section. Modulators and drivers not shown.

TRANSMITTER

by ANTHONY KOWALEWSKI, W9VCU

Without whirling disks, Iconoscope or Dissector, the author has designed a television transmitter which works. Radio News is first to publish a complete circuit diagram. The Amateur again leads the way

capacity of all of the parts had to be very small. The amplifier had to be hum-free, and each stage would have to be shielded so that there would be no interaction between them.

Forgetting for the moment the video or transmission of television signals, we concentrated on the design of an amplifier suitable for our purpose. Before going into the actual construction itself, it might be well to state a few axioms of television. The simple basis of comparison with television is the ordinary broadcast transmission and reception. An ideal broadcast or phone transmitter is one which can follow transmitted variations in one ten-thousandth part of a second. This will not do for television. In picture transmission it is necessary that the transmitter follow a variation from light to dark in almost a millionth part of a second.

In order to televize a picture properly, a number of conditions must be satisfied. A beam of electrons must be produced and made to strike the screen of the cathode ray so as to furnish the scanning material, electric though it may be, for the purpose of televising. Next, the beam must be made to scan the picture area in proper sequence. That is, it must go along from right to

left in the proper order so that the received signal at the other end will also come out exactly as transmitted. The density of the beam must be variable, at the rate of one million times per second. Ordinary television transmission contains, also, in addition to the above, DC modulation, vision modulation, synchronizing modulation, line synchronizing signals, and frame synchronizing signals.

At the onset, it seemed almost hopeless for us to produce all of these things in one small amateur transmitter, and as we worked along the problems more or less solved themselves. The picture brightness is transmitted as amplitude modulation so that definite carrier value can be associated with definite brightness. This is the DC modulation mentioned and has no fixed value of average carrier. The average carrier varies with the picture brightness. The term "visual modulation" is mod-

ulation applied in the direction which represents the increase in carrier corresponding to the increase in picture brightness. Vision signals occupy values between 30% and 100% of the total modulation of the total speech carrier.

All of the signals transmitted below 30% of the speech carrier represent the synchronizing modulation signals. Line synchronizing signals are those which are transmitted to permit the beam to fly back so as to start scanning the next line. Frame synchronizing signals are those signals which are transmitted which cause the line to scan downward and not to repeat over the same line previously scanned.

In our transmitter the total numbers of lines in the complete picture was 240 scanned sequentially, and horizontally 24 picture transversals per second or 24 complete frames per second. The line frequency of our transmitter then was 5,760 cycles horizontal deflection, and frame frequency of 24 pictures per second. Later we were able to push out scanning lines up to 300 with some distortion and our horizontal deflection ran 7,200 cycles. This distortion was noticeable and not pleasing to the eye.

Before commencing the construction of the amplifier it would be better to construct the oscilloscope and its associated circuits. If two 908 oscilloscope tubes are available, one may be used with which to transmit, and the other one to check the entire system by receiving the image. They may be hooked



The author seated at the controls of his television station W9VCU.

(Below) The modest home in which the author made his far-reaching experiments.

Black Box Fotos



SIMPLE FILM TELEVISION TRANSMITTER

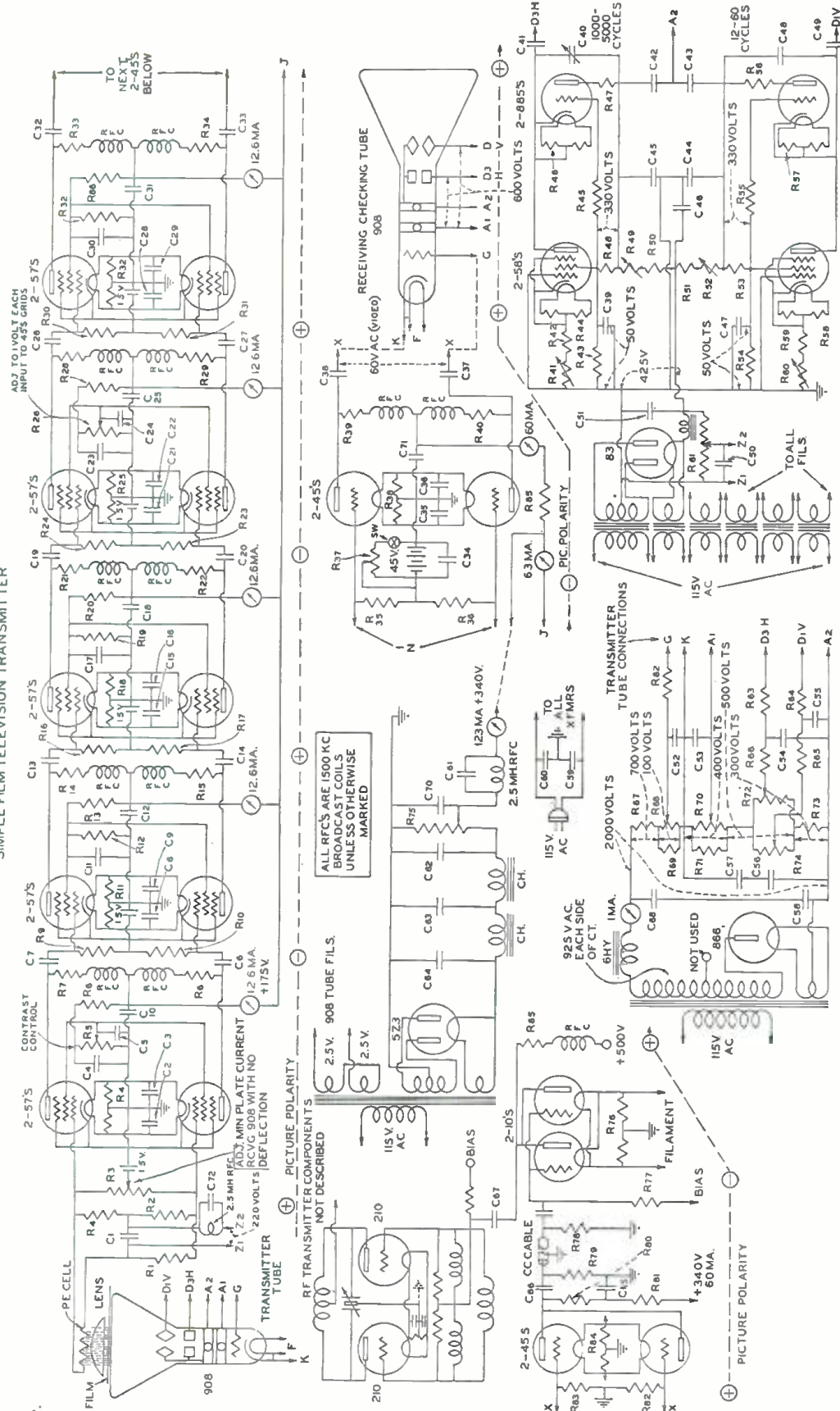

Components

- C1—8 mfd, 300 v. elect.
- C2—.05 mfd paper
- C3—.05 mfd paper
- C4—.25 mfd paper
- C5—.25 mfd paper
- C6—.1 mfd paper
- C7—.1 mfd paper
- C8—.05 mfd paper
- C9—.05 mfd paper
- C10—.25 mfd paper
- C11—.25 mfd paper
- C12—.25 mfd paper
- C13—.1 mfd paper
- C14—.1 mfd paper
- C15—.05 mfd paper
- C16—.05 mfd paper
- C17—.25 mfd paper
- C18—.25 mfd paper
- C19—.1 mfd paper
- C20—.1 mfd paper
- C21—.05 mfd paper
- C22—.05 mfd paper
- C23—.25 mfd paper
- C24—.25 mfd paper
- C25—.25 mfd paper
- C26—.1 mfd paper
- C27—.1 mfd paper
- C28—.05 mfd paper
- C29—.05 mfd paper
- C30—.25 mfd paper
- C31—.25 mfd paper
- C32—.2 mfd paper
- C33—.2 mfd paper
- C34—.25 mfd paper
- C35—.05 mfd paper
- C36—.05 mfd paper
- C37—.1 mfd paper
- C38—.1 mfd paper
- C39—.8 mfd, elect.
- C40—.0001 mfd, var.
- C41—.1 mfd paper
- C42—.1 mfd paper
- C43—.1 mfd paper
- C44—.8 mfd, elect.
- C45—.8 mfd, elect.
- C46—.8 mfd, elect.
- C47—.8 mfd, elect.
- C48—.1 mfd paper
- C49—.1 mfd paper
- C50—.8 mfd, elect.
- C51—.8 mfd, elect.
- C52—.75 mfd paper
- C53—.1 mfd paper
- C54—.1 mfd paper
- C55—.1 mfd paper
- C56—.25 mfd paper
- C57—.25 mfd paper
- C58—.1 mfd, 2000p.
- C59—.2 mfd, 500p.
- C60—.2 mfd, 500p.
- C61—.0053 mfd, mica
- C62—.0053 mfd, mica
- C63—.4 mfd, 500p.
- C64—.4 mfd, 500p.
- C65—1000 mfd, 400v.
- C66—1000 mfd, 400v.
- C67—1000 mfd, 500v.
- C68—.4 mfd, 2000p.
- Input to modulators,

- R1—5000 ohms 1 w.
- R2—5000 ohms 1 w.
- R3—1000 ohms 1 w.
- R4—1000 ohms 1 w.
- R5—1000 ohms 1 w.
- R6—1000 ohms 1 w.
- R7—1000 ohms 1 w.
- R8—1000 ohms 1 w.
- R9—1000 ohms 1 w.
- R10—1000 ohms 1 w.
- R11—1000 ohms 1 w.
- R12—1000 ohms 1 w.
- R13—1000 ohms 1 w.
- R14—1000 ohms 1 w.
- R15—1000 ohms 1 w.
- R16—1000 ohms 1 w.
- R17—1000 ohms 1 w.
- R18—1000 ohms 1 w.
- R19—1000 ohms 1 w.
- R20—1000 ohms 1 w.
- R21—1000 ohms 1 w.
- R22—1000 ohms 1 w.
- R23—1000 ohms 1 w.
- R24—1000 ohms 1 w.
- R25—1000 ohms 1 w.
- R26—1000 ohms 1 w.
- R27—1000 ohms 1 w.
- R28—1000 ohms 1 w.
- R29—1000 ohms 1 w.
- R30—1000 ohms 1 w.
- R31—1000 ohms 1 w.
- R32—1000 ohms 1 w.
- R33—1000 ohms 1 w.
- R34—1000 ohms 1 w.
- R35—1000 ohms 1 w.
- R36—1000 ohms 1 w.
- R37—1000 ohms 1 w.
- R38—1000 ohms 1 w.
- R39—1000 ohms 1 w.
- R40—1000 ohms 1 w.
- R41—1000 ohms 1 w.
- R42—1000 ohms 1 w.
- R43—1000 ohms 1 w.
- R44—1000 ohms 1 w.
- R45—1000 ohms 1 w.
- R46—1000 ohms 1 w.
- R47—1000 ohms 1 w.
- R48—1000 ohms 1 w.
- R49—1000 ohms 1 w.
- R50—1000 ohms 1 w.
- R51—1000 ohms 1 w.
- R52—1000 ohms 1 w.
- R53—1000 ohms 1 w.
- R54—1000 ohms 1 w.
- R55—1000 ohms 1 w.
- R56—1000 ohms 1 w.
- R57—1000 ohms 1 w.
- R58—1000 ohms 1 w.
- R59—1000 ohms 1 w.
- R60—1000 ohms 1 w.
- R61—1000 ohms 1 w.
- R62—1000 ohms 1 w.
- R63—1000 ohms 1 w.
- R64—1000 ohms 1 w.
- R65—1000 ohms 1 w.
- R66—1000 ohms 1 w.
- R67—1000 ohms 1 w.
- R68—1000 ohms 1 w.
- R69—1000 ohms 1 w.
- R70—1000 ohms 1 w.
- R71—1000 ohms 1 w.
- R72—1000 ohms 1 w.
- R73—1000 ohms 1 w.
- R74—1000 ohms 1 w.
- R75—1000 ohms 1 w.
- R76—1000 ohms 1 w.
- R77—1000 ohms 1 w.
- R78—1000 ohms 1 w.
- R79—1000 ohms 1 w.
- R80—1000 ohms 1 w.
- R81—1000 ohms 1 w.
- R82—1000 ohms 1 w.
- R83—1000 ohms 1 w.
- R84—1000 ohms 1 w.
- R85—1000 ohms 1 w.
- R86—1000 ohms 1 w.
- R87—1000 ohms 1 w.
- R88—1000 ohms 1 w.
- R89—1000 ohms 1 w.
- R90—1000 ohms 1 w.
- R91—1000 ohms 1 w.
- R92—1000 ohms 1 w.
- R93—1000 ohms 1 w.
- R94—1000 ohms 1 w.
- R95—1000 ohms 1 w.
- R96—1000 ohms 1 w.
- R97—1000 ohms 1 w.
- R98—1000 ohms 1 w.
- R99—1000 ohms 1 w.
- R100—1000 ohms 1 w.

in parallel insofar as the power circuits go.

High voltage power supply for the cathode tube can be seen directly behind the amplifier in the picture at the top of the page. It uses a single 866 rectifier and operates on the half-wave rectification system. The current drain from this power supply is one millampere and it will not cause any voltage fluctuation in the power supply when this is used. A full-wave system could be used, but the cost would be exorbitant. The diagram fully explains the component parts and their hook-up. It also gives the necessary voltages for checking.

After the high voltage supply has been completed, the sweep circuits should next be commenced. The cathode ray sweep circuit and its associated power supply is shown. The controls in the front of the panel are from left to right the horizontal amplitude control, the horizontal frequency control, blocking control, frequency control and the vertical amplitude control. This sweep circuit operates the horizontal and vertical amplifiers of the cathode ray oscilloscope. It utilizes two 885 discharge tubes and two '58 tubes. The associated power supply to which it is connected by means of a cable and plug arrangement contains a power transformer a type 5Z3 chokes and the condensers in filter arrangement. Two power supplies are mounted on this chassis, one for the sweep circuits and the other for the amplifier. The transformers are mounted along the rear side of the sweep circuit chassis and 2½ volt filament transformers are used to light all of the heaters in the transmitter.

After the oscilloscope power supply and sweep circuits have been completed it will be well to test them with an oscilloscope. In the event that the sine wave input is not available for test purposes, 60 cycle current may be put upon horizontal or vertical plate through a .002 mfd. mica condenser. If everything is in order, the oscilloscope should operate as is customary.

The amateur is now ready for the construction of the difficult part, the amplifier. Component parts are all listed in the diagram itself. Procure a chassis 35 inches long, 10 inches wide and 6 inches high. Divide this into six compartments, each of approximately 6 x 10 inches in size. The tubes should be mounted in each compartment as is shown in the photograph, making certain that all wiring is as short as possible. Do not purchase anything but the very best parts. Check each resistor at the time of the purchase, and be sure that the values are exact and use the ohmmeter as a reference rather than the printed label upon the part. A few ohms difference in the various resistors might

unbalance the amplifier and will make a great deal of difference in the performance of the finished product. Mount the Eby cell on the outside of the chassis to the extreme left and proceed with the wiring and construction as is indicated jointly by the diagram and the photograph.

After the amplifier has been completed tubes should be inserted and it should be checked for hum by turning on all of the filaments and the voltage to each tube. If any hum is present, it will show on the cathode ray tube in the receiving position. Hum must be removed before the amplifier can be put into television operation.

By means of the lenses, focus the beam of the transmitting cathode ray tube upon the Eby cell. If everything is in order, a square frame of light should appear on the receiving tube at the other end of the amplifier. Both cathode ray



(Black Box Foto)

Checking transmitter's Video section shows a good, clear picture coming through. Note the typical amateur's mounting. The cover is cardboard.

tubes are connected in parallel as is indicated in the diagram. If the diagrams, pictures and hints herein contained, have been followed, and the apparatus tests ok, a picture can now be televised. Place a sharp contrast negative up against the end of the cathode ray in the transmitting position. Turn on all filaments and tubes. If everything is working right, a positive reproduction should appear on the receiving C. R. tube screen. You are now ready to put the television transmitter on the air.

Because of the wide frequency range of video signals, it is impossible through

a transformer plate to modulate any transmitter. Grid modulation, therefore will have to be resorted to. The modulator and driver should now be constructed. We used a pair of 10's as modulators and a pair of 10's as RF final amplifiers.

Feeding the output of the amplifier at points x-x into a pair of 45's in push-pull as is indicated in the diagram, we fed that to 2 10's operating in Class A. Here again the diagram is self-explanatory. The output of the 45 drivers is fed through a low impedance network to the modulators. These, in turn, grid modulate another pair of 10's acting as final RF amplifiers. The crystal and exciter circuit in the RF section has not been drawn since it is well-known to almost every amateur.

In order that amateurs who have different types of receiving sets, as well as any short wave listeners who might be equipped to give you a report, can tune you in, the following procedure is one we adopted with considerable success.

Fire up your regular transmitter, call "CQ Television," or "CQ Video." Do not turn on the Video transmitter. When you make a contact, inform the person receiving, that you wish to transmit a video signal. The person receiving will need the following information. First, the wavelength in KC upon which you expect to transmit your video signal; second, the horizontal scanning frequency, and third, the vertical frequency of the image.

Actually in practice, it works out something like this. W9 . . . calls CQ on 59.9 MC. Receiving a reply, he advised the recipient to watch for the video signal on 58 MC and gave him the horizontal scanning frequency of 5760 cycles and the vertical frequency of 24 cycles. The recipient then tunes his television receiver to 58 MC and set his cathode ray sweep circuit to the horizontal frequency of 5760 cycles and the vertical frequency of 24 cycles. By doing this, the transmitter and the receiver were in synchronization. Transmitted signal and picture came through with considerable clarity. Audio or voice transmission must be at least 1.5 MC removed from the video signal.

The transmitter we described does not transmit any signal of a synchronizing nature, but it does enable the amateur to start on his way with television. As we see it, in the future amateurs will call "CQ Video" and receiving an answer, will transmit their video signals. The receiving amateur will set up the necessary components in his receiving oscilloscope to synchronize with the transmission. Wide variation from 60 cycles on the A.C. line will prevent the picture from being received properly.

Not For REBROADCAST

by "X-73-88"

The author is one of the best-informed men on radio in the country, withholding his identity in order to maintain complete freedom of comment.

FIBBER McGEE has been ordered to cease closing his broadcasts with the touching little phrase, "Goodnight, Molly!"

Reason, of course, is that actor Jim Jordan's words, addressed to his sick wife, come under the classification of direct communication. NBC wants to take no chances with the Federal Communications Commission.

The rule is also being applied to John Charles Thomas who has made it a practice to close his concerts with "Goodnight, Mother."

BENNY FINKLE is the gent who puts the "evil eye" on boxers, causing them to lose fights. He explained it all when he appeared as mike-side guest of Robert Ripley.

"Business is SO good," volunteered the optical jinxer, "that I've had to hire a bodyguard!"

MORE jobs for radio men . . . Adoption of the five-day week in Chicago network studios during the past month opened 40 new jobs . . . NBC added 14 engineers, 4 announcers . . . CBS: 6 engineers, 4 announcers . . . Mutual: 8 mikemen and knob twirlers.

New York and Los Angeles (Hollywood) studios long ago began operating on the five-day work week.

"dots and dashes and lots of flashes from border to border and coast to coast" . . . Walter Winchell, away from a keyhole.



REASON "Queen" Marjorie Whitney left the King's Jesters was a salary squabble. Those who ought to know say the boys were paying her but \$50 a week . . . Lum and Abner will have left their malted milk sponsor by the time you read this. Reason: company economy.

Federal radio supervisors spotted a bootleg broadcast station operating in the heart of Chicago, couple of weeks ago. It used the call letter "WHAN" . . . Believe it or Rip: Success drove one comedy team off the air! The team boosted the sponsor's product, tripled sales. Then the sponsor died. Heirs to his estate had to scrape up heavy inheritance taxes. Resulting slash took in the sponsor's favorite funny men!

SINGER-COMPOSER PINKY ("The Love Bug Will Get You") Tomlin is to altar his bachelor ways. The young lady is Joan Alcorn of Ponca City, Okla . . . Add to airfolk who are hams: Capt. Frank Hawks, guitarist Andy Sanella and ½ of Amos 'n' Andy. (Name withheld on request.) . . . At least a dozen fans I know have sworn off buying certain toothpastes and coffee because the announcer turns panhandler and closes with, "By buying our products you help these stars stay on the air!" Nice of the sponsor, eh?

Those "dots and dashes and lots of flashes" that Winchell bugs from border-to-border-and-coast-to-coast don't spell a thing when deciphered . . . On the other hand, those an operator transmits for Jimmy Fidler spell "Jim" and "Fidler". Latter improvement was at the suggestion of a ham Fidler has never given credit for the suggestion. (The ham has a letter from J. F. to show it!) . . . Strange to relate, Fidler who laughs at Simone Simon's double talk name, has the operator transmit "Jim Jim."

WHILE current talk is all of television, there are some indications that the older, cheaper art of transmission of still photos and printed pages by radio or wire might yet grow to be a healthy—and moneyed—yongster.

Already, New York, Chicago, Nashville and other cities' 50,000 watt
(Concluded on page 60)

FREE BULLETINS & CATALOGS

Aerovox Corporation, 70 Washington Street, New York City. A new handy industrial capacitor manual dealing with ratings, required capacities, power factors and other engineering and servicing aspects of motor-starting condensers. Available to jobbers.

Amperite Company, 561 Broadway, New York City. A new bulletin listing the complete line of Amperite velocity microphones and other products. Issued to all jobbers and servicemen.

Philco Radio and Television Corporation, Philadelphia, Pa. A 52-page manual with listings of test equipment, aerials, amplifiers and accessories. Prepared especially for distributors and dealers.

Stromberg-Carlson Manufacturing Company, Rochester, New York. A 32-page 1938 radio parts catalog listing all standard replacement parts for their receivers. The booklet also describes and illustrates a number of new products, including a new record player, headphone kit, etc. For dealers, servicemen and amateurs.

Stancor Amplimannual, 3rd Edition. Size 8½ by 11 inches. Published by Standard Transformer Corp., 850 Blackhawk St., Chicago, Ill. New 22-page audio-amplifier manual for the serviceman, sound engineer and experimenter. Contains constructional information and circuit diagrams on 10 complete sound systems. There is a helpful information page and a section with specifications on all types of transformers. Free to Servicemen.

Stancor Hamannual, 3rd Edition. Size 8½ by 11 inches. Published by Standard Transformer Corporation, 850 Blackhawk Street, Chicago, Illinois. A large size manual with wide appeal for all amateurs. The book includes 16 different transmitter circuits, from 5 to 1000 watts input, complete with detailed constructional information. There is a tube filament transformer chart, and a section devoted to "Ham" gadgets. Free to amateurs.

Coming—

A THRILLING EXPOSÉ ON

★ Short Wave Propaganda

BY A LEADING NEWS-
PAPER'S RADIO EDITOR

IN THE MAY ISSUE OF RADIO NEWS

CAN THEY HEAR YOU?

By ALEXANDER MAXWELL, W9BRE
Evanston, Illinois

Whether radio stations cover an area or not is of utmost importance. The survey engineer can tell exactly how far the signal reaches.

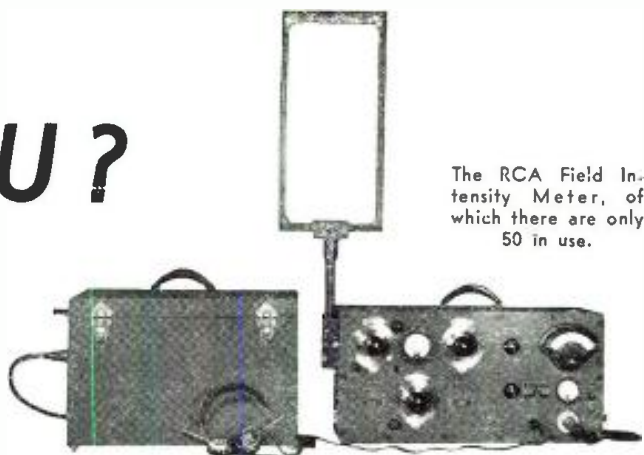

The RCA Field Intensity Meter, of which there are only 50 in use.

JUST send your name and address to this station and you will receive a beautiful gift absolutely free—.” Several years ago that was the only way a station could prove it really was reaching its market.

Mail trucks backed up to the broadcast studio and ton after ton of postcards and letters were carried in. These letters were all gratefully acknowledged and a dot placed on a map for each one received. This dotted map then became the closing argument when selling time to new accounts. It was proudly displayed, and the advertising manager always concluded, “—this shows conclusively the territory we are covering—.” But did it?

Today we know the answer. In some cases

it was yes, in others it was badly under or overestimated. An accurate method of determining just how much signal a station was laying down in a certain area became of extreme importance, both to the station and to the advertiser.

One by one, individuals appeared on the scene with home made measuring instruments, as none were on the market. They made surveys, and while the work was crude and elementary, surprising facts were discovered. Radio waves were supposed to radiate from the transmitter like ripples when a stone is tossed in still water. Instead of the

coverage of a station being a perfect circle it was warped and distorted, often with long lobes sticking out, or deep dents, or dead spots. This bit of startling information threw a monkey wrench in all the carefully worked out coverage diagrams. Stations at once became worried. They wanted an exact answer.

One of the first of the field intensity surveyors was E. C. Page (now of Page, Davis & Co.), a designer of broadcast transmitters. After putting a station into existence, he was naturally concerned about what results he was getting. More for his own satisfaction, than any thought of starting a new business, he designed and built a pair of field intensity meters. With these he could check the stations he had built and determine once and for all just where those stations were placing their signals. Knowing what was happening, he could make changes and modifications while still on the job. As a result his stations reached out more consistently than some others. He was no longer groping in the dark, relying upon guess-work, but armed with measuring instruments he applied engineering principles and knew the answer at once.

It wasn't long till stations he had not built asked him to come and measure their transmitters and make recommendations or alterations. In the meanwhile RCA had developed an instrument which exceeded the fondest dreams of the dozen or so men who had struggled and perspired while putting together instruments of their own making. Today the RCA TMV 75 B is the world recognized standard of intensity meter design. The meters are expensive, so the use of them is mostly confined to engineers and government monitoring stations, both in the U. S. and abroad. All told, RCA reports having sold only fifty of the instruments.

Measuring a station's coverage is a long drawn out, monotonous process. It may take two weeks or longer, and there are no short cuts. Like all engi-

(Continued on next page)



The map shows the coverage of WJJD. It is used as a basis for advertising rates and to convince the Government.

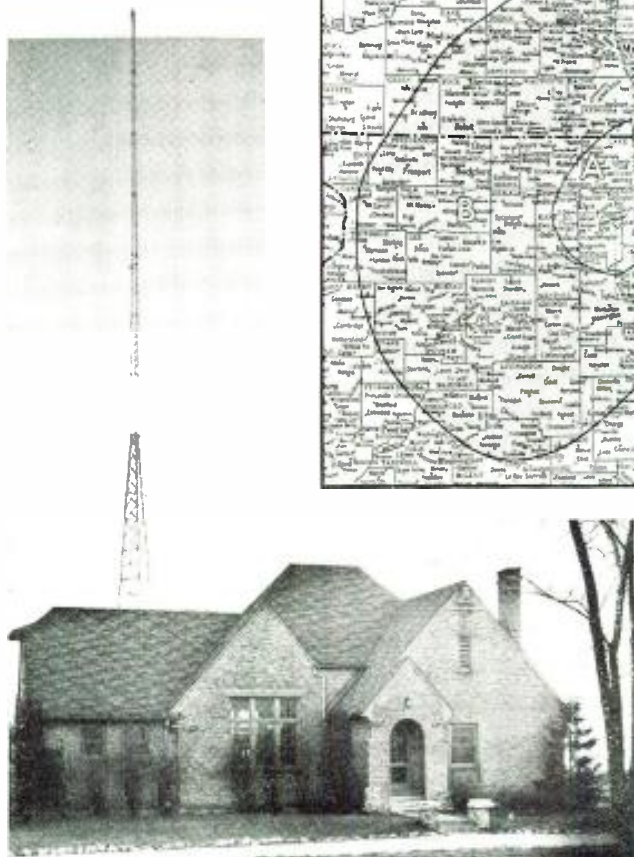

This low rambling suburban home is the station. The tower in the rear is a vertical steel antenna of the latest type.

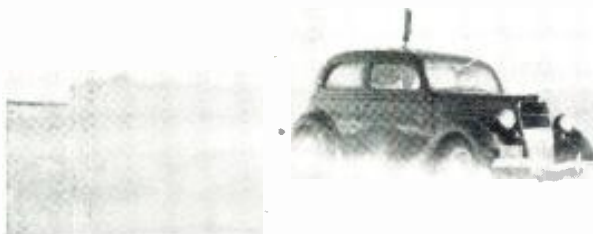

Blizzards do not keep the survey engineer from his appointed rounds. The loop can be seen sticking out through the roof of the car. Snow does not affect its operation.

neering problems, it must be done correctly and completely to be of any value.

For a specific example let us take the case of WJJD, a splendid example of the typical independent broadcaster. When purchased by its present owners, the transmitter was moved from Mooseheart, Ind., to a location five miles west of Evanston, Ill., and modernized throughout. The landscaping had not yet been done when Page arrived on the scene with his survey car.

The intensity meter comes in three parts for easy portability, the battery box, the meter and the loop. Ordinarily the loop is carried in the battery box, but Page has his built into the roof of the car. First a hole was cut and a

walnut bushing installed, then the loop was mounted in a brass tube which acted as a bearing. On the underside of the roof, a wrought iron hanger was placed. From this was suspended the intensity meter. When the meter was in place, the loop could be dropped down through the bushing and into the socket provided for it. This arrangement enabled the meter to be used just as it came from the factory, with no modification whatsoever.

To operate, all the driver had to do was stop the car, turn in his seat and make the adjustments. The dome light gave ample illumination at night and the battery box, which weighs 90 pounds when full of heavy duty B batteries,

and the six volt storage battery for tube filaments, rest on the floor in the back of the car.

The whole meter assembly can be removed from the car in less than a minute. First the loop is drawn up, then two wingnuts are loosened, releasing the meter. Pulling the battery cables completes the operation and the units can be lifted out one at a time. The meter rides securely in its hanger, but because it obscures the rear view mirror it is only hung when doing actual measuring. At other times it rides on the rear seat and a cork plugs the loop bushing.

Three Ford V8s were selected to serve as field cars, mainly because the tops contained wooden members to which the hanger could be bolted, and when the cars were to be traded in, all that had to be done was replace the cloth top, inside and out. In addition to the field strength equipment, each car has a Motorola radio, used to keep a constant check on the station being measured.

The function of the survey car is to radiate in all directions like the spokes of a wheel from the station, so when the survey is completed there will be a spiderweb of data cast over the entire service area. At any time the exact signal strength in any particular city or town may be determined at a glance.

Lake Michigan occupies a large portion of the service area, so to start, Page chose the road maps of Northern Illinois and Wisconsin and laid out a radial following the shore line. Of all the maps available, those made for motorists were the easiest to use, for with them it was possible to select a route in almost a straight line from the station. This may take the survey car over highway, byway and country lane, but getting lost or missing identifying landmarks is minimized. Every half mile he stopped and took a measurement, checking his distances by the speedometer and putting a dot on the map. In addition a note was made, such as, "Measurement 1A, 300 ft. North Schultze's tavern," followed by the meter readings for that spot. The map was then keyed "1A" to identify and double check the reading. This may sound involved, but when one realizes a thousand readings may be taken, it comes in handy when the chart is later made up on the basis of county population.

The most disconcerting feature of survey work is the presence of power and light wires alongside every main road. Measurements within 500 ft. of a line are likely to be inaccurate, so while the engineer is watching his map, the speedometer, and the road, he must also look for a chance to get away from the

(Continued on page 72)



When the weather is pleasant surveys are sometimes made outside the car. The field survey meter can be dismantled and assembled outside in less than one minute.

A HOME BUILT 5 TUBE RECEIVER

By LLOYD MOORE

Moore's Radio Shop, Chariton, Iowa.

For the broadcast fan outside the power line limit, this receiver will be the answer.

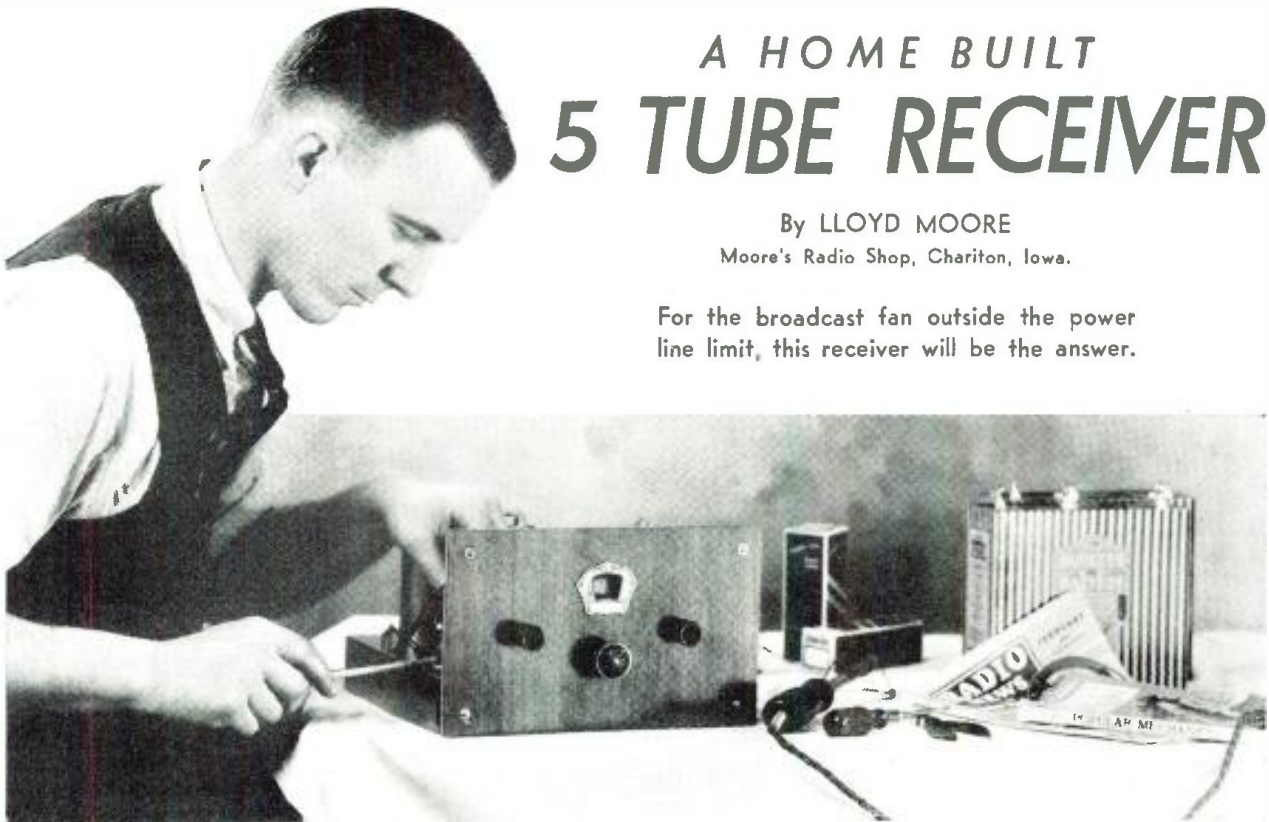

THE radio fan beyond the electric power lines seems to be the forgotten man. Radio magazines are full of designs and constructional articles for building electric receivers, but there are very few articles on practical battery sets; because of this, I have worked out a very efficient A-battery set, easy to build, and not too expensive.

The circuit is very sensitive, and in the Middle West [the author lives in Chariton, Ia.—Ed.] received up to 1,000 miles in the daytime and both coasts at night. It has a very good automatic volume control which holds distant stations at an even volume without fading. It is selective enough to give good station separation and yet the tone will satisfy the most critical.

This set is easy to build because it has such few parts and they are mounted on a chassis which is large enough to make the location of the parts and the wiring easy. The chassis can be built at home or purchased already formed.

It is very economical to operate. It uses only two "B" batteries, no "C" battery. The bias or "C" voltage for the power tube is obtained from the voltage drop across the 500-ohm resistor in the "— B" lead to the ground on the chassis. One two-volt storage cell is used for the "A" power. Air cell or dry batteries may be used for the "A" power if suitable resistors are used with them to reduce the voltage to the proper value for the two-volt tubes. The author however recommends the two-volt storage cell for best results and long tube life.

The chassis used in the original model was 10x12x2 inches. This gives plenty of room for the parts without any crowding. The positions of the various parts should be located and all the necessary holes drilled before any parts are mounted in place. This saves any chance of injury to a part already mounted while drilling holes for the next piece. The sockets are fixed into place first. Next the I.F. transformers and the volume and tone controls. The tuning condenser is mounted into place last. All parts should be mounted on this chassis before starting to wire the set. This enables the constructor to

make a much shorter and neater looking job.

In hooking up the set it is best to begin with the filament circuit. The +A wire in the battery cable makes direct connections with all the +A terminals of the five sockets. The other filament terminal of each socket is connected directly to the chassis. The — A wire in the battery cable is run to the switch; from the opposite side of the switch to the chassis. When the switch is on, the — A is then connected to the chassis completing the circuit and lighting the tubes. Do not expect much visible light as two-volt tubes

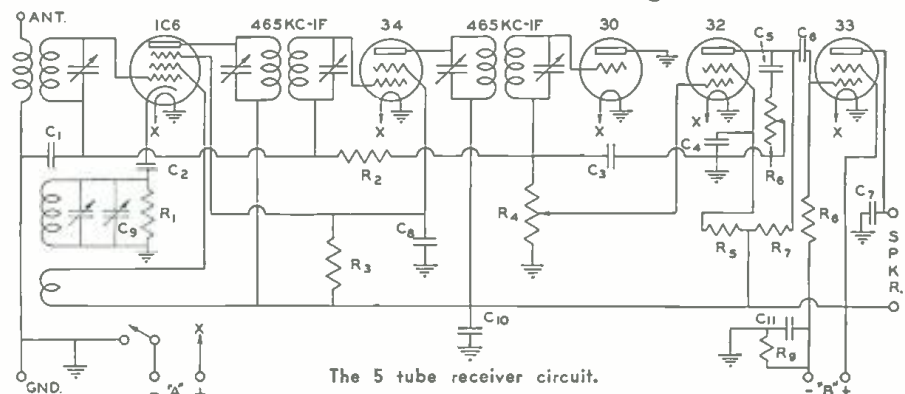

The 5 tube receiver circuit.

C₁ —.05 mfd. 600 v. paper condenser
 C₂ —.0001 mfd. mica condenser
 C₃ —.0005 mfd. mica condenser
 C₄ —.05 mfd. 600 v. paper condenser
 C₅ —.01 mfd. 600 v. paper condenser
 C₆ —.01 mfd. 600 v. paper condenser
 C₇ —.0005 mfd. mica condenser
 C₈ —.05 mfd. 600 v. paper condenser
 C₉ —padding condenser to match ant. coil
 C₁₀ —1. mfd. 250 v. paper condenser
 C₁₁ —10 mfd. 50 v. electrolytic condenser

R₁ —50,000 ohms 1 watt resistor
 R₂ —2 megohms 1 watt resistor
 R₃ —10,000 ohms 1 watt resistor
 R₄ —500,000 ohms potentiometer
 R₅ —500,000 ohms 1 watt resistor
 R₆ —500,000 ohms potentiometer
 R₇ —100,000 ohms 1 watt resistor
 R₈ —1 megohm 1 watt resistor
 R₉ —500 ohms 10 watt resistor
 SW—Battery switch on potentiometer

such as are used in this set make very little when they are on.

The —B lead wire enters the set through a 500-ohm resistor. This resistor provides the bias voltage for the '33 power tube. This resistor is shunted by a 10 mfd. electrolytic condenser. This condenser is polarized and it is necessary to connect the negative pole of the condenser to that connection of the resistor where the —B wire is connected. The other pole of this condenser is connected to the opposite end of the 500 ohm resistor which is connected to the chassis. The +B wire in the battery cable is run to an *insulated* central point and all voltage for the set is tapped from there.

The rest of the set is wired as shown in the diagram. It is not advisable to make any changes in the circuit as quite a period was spent in experimentation to work it out. About the only possible trouble would be in connecting the oscillator coil. Sometimes these coils are packed without a chart showing their connections. In such cases, if data cannot be obtained, it will be necessary to determine the hook-up by the trial method. Take care not to run the +B connection through to the chassis as this will ruin the coil and maybe the "B" batteries. The set will not work if the plate section of the coil is connected the wrong way. If the set does not work when finished try reversing these two wires.

Just a word about the parts used in this set. All condensers, except the low voltage electrolytic, are of the 600-volt type. This forestalls any chance of battery leakage, which is a common fault with many battery sets. The resistors are of the highest quality and protected against moisture. Dampness ruins more resistors than current does. The intermediate transformers used in this model are iron core type. These transformers, when compared with air core type, show a big gain in sensitivity and better selectivity. There are so few parts to buy in this set, that a saving will result if the highest quality parts are bought; and in that way the set becomes all the more efficient. The circuit is very simple, and if care is used in the construction, the results will satisfy the most critical.

After construction the set may need some adjustment to make it operate at its best. If the builder does not have the necessary oscillator and output meter to do the job right he had better take it to a good radio repairman who does have this equipment. If it is impossible to have the set adjusted by an oscillator it can be done fairly well by the following method.

Before beginning the actual adjustment of the set something should be

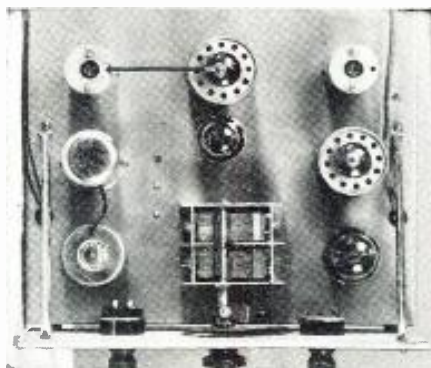

So neatly designed that it looks commercial, is the 5 tube special.

said about the dial. Most dials sold for the home builder are marked O—100 and not in kilocycles. This marking can be easily removed with a little soap or cleaner. The new kilocycle marking is made after the set has been adjusted or balanced.

Now for the balancing itself. Volume control is turned to maximum for all adjustments. If this makes the signal too loud use a shorter antenna. Most I.F. transformers are adjusted at the factory. The wiring of this set will detune them little, if any at all.

Leave the adjustment of the I.F. transformers till the last. Begin by tuning in a station around 600 kilocycles. Now adjust the padding condenser for maximum volume while slowly turning the tuning condenser back and forth through the station. An insulated tool must be used for this adjustment.

Next, tune in a station at about 1300 kilocycles and adjust the trimmer on the antenna section of the tuning condenser. The trimmer on the oscillator section of the tuning condenser is left alone unless the high frequency end of the broadcast band does not come in right on the dial. You should be able
(Continued on page 73)

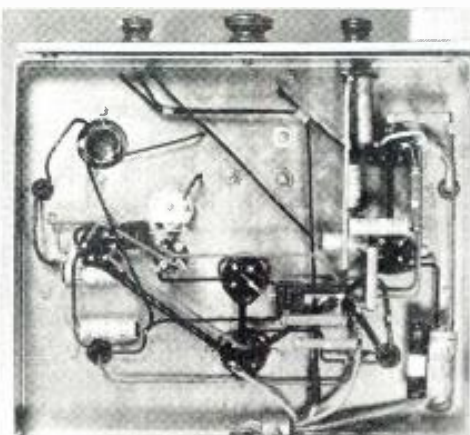

Underside the chassis. A cleanly wired receiver works better.

ON THE COVER WE HAVE . . .

LUCILLE BALL, whose picture appears on this month's cover, is Phil Baker's attractive feminine heckler who works with him on his Sunday night broadcasts from 7:30 to 8 p. m. EST over the ABC Columbia Network. Miss Ball, who would not give us her exact age, was born in Butte, Montana, on a certain August 6th.

Her family moved to Jamestown, New York, where she was educated in public schools. Later she went to the Chautauqua Musical Institute. Graduating from this institute, she took a drama course at John Murray School in New York City. Her first theater job was in the chorus of Ziegfeld's RIO RITA, followed by many other performances in musical productions. She has also posed for commercial ads, and was chosen as the Chesterfield Girl. It was natural that she would end up in Hollywood. There she appeared in many motion picture productions under the RKO banner.

Lately she has developed herself as a first class comedienne and appears regularly before the microphone for CBS. Five and a half feet tall, she weighs 120 lbs., is athletic, and expert at handling her private plane and roadster.

The photograph was made by Ted Allen, West Coast photographer for the Columbia network. He took the picture in the Hollywood studio, with a Contax camera and Zeiss f2 lens. Miss Ball was lighted with three 500-watt spotlights placed four feet from the subject, and a 250-watt ceiling floodlight. One of the spots was used as a key light, one as a backlight, and the third to illuminate the background.

FIRE BOAT FREQUENCIES

WITH the new radio fireboat patrol in the City of New York Harbor, many have written in requesting information on what frequencies these ships operate and what their call-letters are. The fireboats, their call letters and their names are listed below. They operate on a frequency of 35.6 megacycles with an input of 50 watts.

W2XNA—James Duane.

W2XNB—Thomas Willett.

W2XNC—Wm. Strong.

W2XND—Geo. McClellan.

W2XNE—Wm. Gaynor.

W2XNF—John P. Mitchell.

W2XNG—Abram Hewitt.

W2XNH—John Harvey.

W2XNI—Cornelius Lawrence.

W2XNJ—Capt. Connell. tender.

AN AMATEUR'S DUAL RECEIVER

by FRANK A. JONES, CO6OM
Tuinucu, Cuba

A famous amateur of Cuba describes a simple solution to a difficult problem.
A Dual-Superheterodyne that brings in the DX.

WITH the static situation in Cuba acute, eliminating many stations from contact, I felt that I needed a news receiver which would furnish extreme selectivity. Nor was this all. I could not afford to sacrifice the signal strength to noise level, and I certainly did not want to have more than one dial to tune. It became apparent that a dual IF receiver would be the answer. Several of these are on the market, but at exorbitant prices, and I have not been too successful in receiver construction. The solution was to use two commercial receivers so adapted that the first would have a different IF freq. than the second. When the National Company brought out their 1560 kc. IF receiver I knew I had the answer if I were to combine this with the usual superheterodyne with 456 kc. IF stages.

In the new composite receiver the basic idea is very simple. Put a signal through a National NC-81-X and take the signal after conversion out at 1560 kc., then run this signal to the input of an HRO with RF coils inserted to handle 1560 kc. This really gives 5 stages of 1RF on 1560 kc. and then conversion again to 456 kc., and finally the audio demodulation and output through the audio stages to the speaker.

A new 3-stage pre-selector in "HRO CLOTHES" gives lots of TRF gain to first detector of the NC-81-X, which all contributes to quietness and plenty of sensitivity.

The photos and circuit diagrams are almost self-explanatory, so I shall only outline the general arrangements of the parts and the concentric line "link" intercouplings.

Everything was mounted

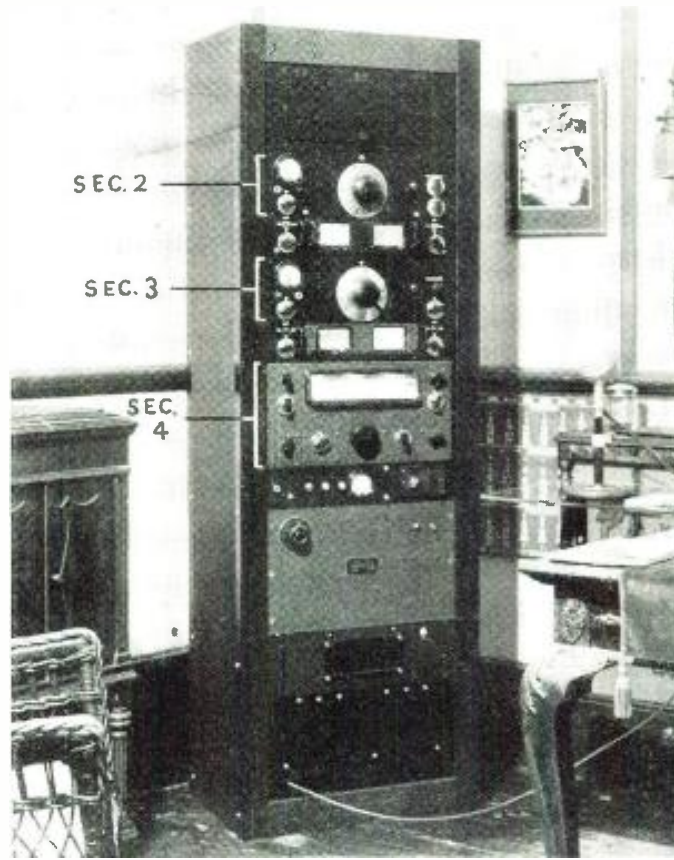

When mounted in a rack the Dual Receiver looks fine and, once adjusted, has one control tuning.

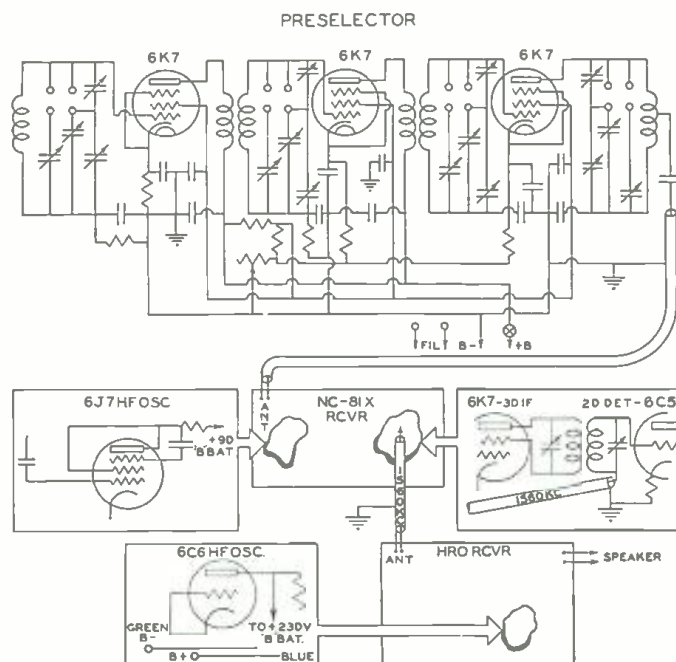

The circuit of the Dual Receiver.
Component parts are standard and discussed in the text.

in relay rack style in a Par-Metal DeLuxe cabinet with back door and latches and ventilation grilles at the back.

Power lines, transmitter control circuits, etc., come up through the floor into the bottom of the cabinet in lead covered cables.

A table relay rack could be used if only the NC-81-X, the HRO, and the pre-selector were mounted in the rack.

Two antennas are available on the receiver at the flip of an antenna switch operated change over relay, and these antennas come into the receiver through "Bassett" concentric feeder lines which have the outer conductors grounded.

Going down, the next panel section (2) contains a 3-stage pre-selector designed around an HRO panel; HRO coil forms, 4-gang condenser and National wide band spread dial. This 3-stage selector has very high gain with *no regeneration* and is stable on all bands. A reference to the circuit will show that the first three sections of the gang condenser tune the grids of the metal tubes 6K7, and the fourth coil and fourth section of the gang condenser, tune the plate circuit or the 3rd stage. Standard HRO coils were used, but the fourth coil in the regular HRO assembly is normally used for the IF oscillator, so this coil was slightly cut down so as to gang properly with the three grid circuits.

As this original oscillator coil had a tap a few turns from the low RF end, this made a low impedance line for output, possible at this point with no difficulty at all. The concentric link line was made out of "Brush" single conductor microphone shielded cable

(Continued on page 77)

"STUDIO BRIEFS"

By SAMUEL KAUFMAN

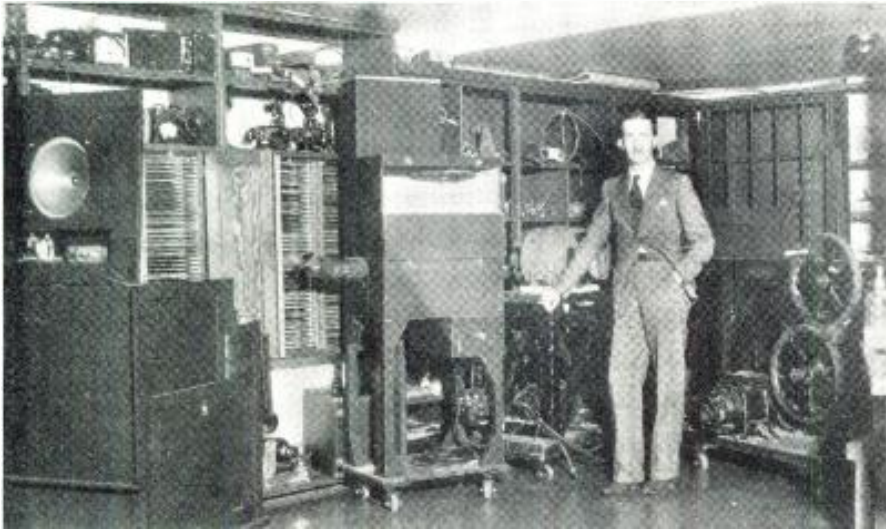

Chief Sound Effects Man Ray Kelly poses with his many contraptions.

A "Sound" Business

SOUND effects in radio have developed into a fine art. Back in the early days of broadcasting, the trap-drummer of the studio orchestra was depended on to supply all background sounds deemed essential to provide a program with authentic atmosphere. What a long cry from the modern technique! Large staffs, expensive equipment, huge record libraries and busy laboratories are provided by network and station executives to find means of reproducing those

noises that can satisfactorily convey the full meaning of dramatic action.

At one time, sound effects were virtually limited to horses hoofs, door slams and pistol shots. But today, every gesture in a dramatic program is audibly performed even though the actors merely stand still at the mike calmly reading their lines while the listener visualizes a terrific battle-to-the-death, a motor boat race or a tender love scene.

Sound effects are the props of radio; they're comparable to, but even more important than, the settings of a stage

play. An announcer can't break into the middle of a script and say "That's a door creaking!" or "A dish just broke!" The sound must define itself and must be so carefully interwoven between the spoken lines that the listener will readily know what's taking place.

The Columbia Workshop programs on Sundays emphasized the importance of sound effects in radio drama. True, the phase had considerable progress before. But the Workshop plays, directed by Irving Reis (who won such fame through them that he was signed by Paramount Pictures) employed sounds as they were never used before. Reis would use a single continuous note to provide a psychological background for the cast.

Now, we find that NBC foresees the need for national standardization of sound effects and has appointed Ray Kelly, recent head of the network's New York sound division, as manager of the new department which will serve all NBC managed and operated stations under the pretentious name of Sound Effects Development and Maintenance Division.

Following a tour of some NBC stations, Kelly remarked that many of the outlets are not equipped physically to produce network programs and, under the new plan, the stations will be supplied with equipment comparable to that now in use in the Radio City studios.

Kelly is acknowledged to be one of the leading radio sound technicians in the world. He headed the network's New York sound effects division since 1929 when the department was created.

And he can always boast that regardless of the trend business takes elsewhere, his is one trade that is always "sound."

Bernie Drops Fiddle

BEN BERNIE, famed far and wide as "The Old Maestro" disregards that cognomen in the role he has in the new Wednesday CBS series sponsored by a subsidiary of the United States Rubber Company. Bernie is now a full-fledged comedian rather than a musician, and he ignores conducting entirely. He is supported by an all-star radio cast including Lew Lehr, the dialect Fox Movietone commentator, and vocalists Jane Pickens and Buddy Clark.

Although Bernie doesn't go on the air until Wednesday, he stages a dress rehearsal before a capacity audience at one of the CBS Radio Playhouses on the preceding Monday. He finds that he can gauge audience reaction by his non-broadcast performance and make

(Continued on page 68)

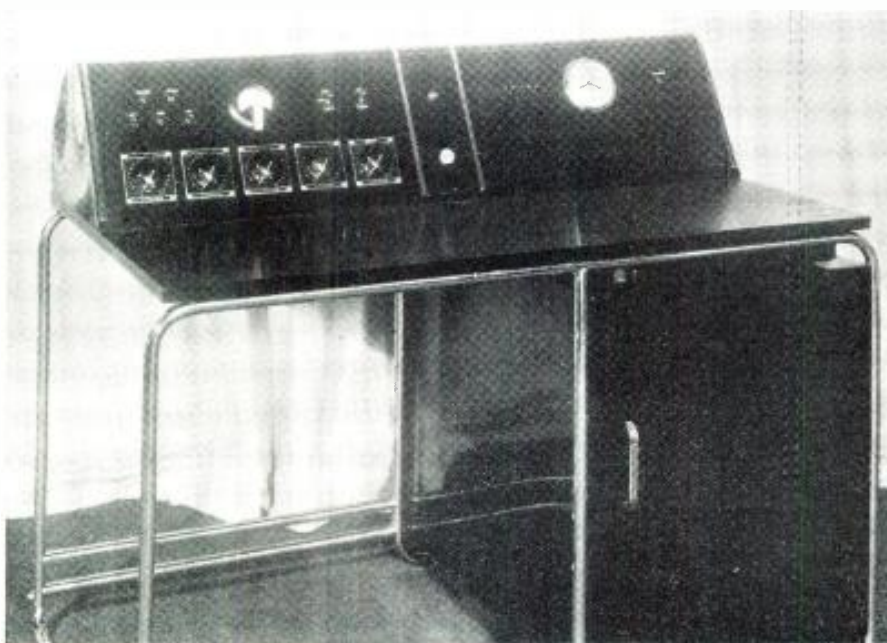

And now the streamlined Studio Control Board. The latest in equipment installed at WMCA. It was designed by Chief Engineer Frank Marx, built by RCA.

THE TZ-40 MODULATOR

by EDMUND P. KELLY, JR., W9HPW and A. J. LOUIS

The authors, well-known in "ham" circles, describe a simple modulator using the new tubes.

RADIO telephony is considerably more complicated than CW work.

Not only in the amount of apparatus needed but also in its technical aspects. The phone transmitter must have radio frequency equipment similar to a good CW set, plus excellent audio frequency equipment to accomplish the modulation. In designing the modulator described in this article, these facts were taken into consideration, plus the item of cost, which heretofore has been prohibitive in the matter of a 150 watt modulator, because of the price of the tube. With the advent of the T-40 and TZ-40 tubes, a cheap 150 watt-175 watt modulator was brought within the reach of every amateur.

The modulator is divided into three sections. The speech input section, the driver section and the modulator section. The speech section contains all the audio stages between the microphone and the driver, while the driver's sole function is to push the Class B modulator tube to modulate the RF load.

The speech section is resistance coupled; the driver, transformer coupled; and the modulator, of course, the same. In general, resistance coupling is preferable in the speech stages, and resistance coupling must be used in non-power pentodes and high- μ triodes. Transformers may be used for the same purpose but they are generally found unsuitable because of the difficulty of securing a high load resistance with the ordinary construction. They introduce magnetic feed-back and other difficulties. Resistance coupling is not without its troubles either, but by careful construction and by following the diagram, no "bugs" should be encountered in building this 150 watt modulator.

In the speech section the microphone is coupled to a 6F5 tube which, in turn, is resistance coupled to 6C5. This in turn, is resistance coupled to a 6F6, triode connected. If the amateur does not have 6 volt tubes available and wishes

The TZ-40 Modulator mounted, ready to operate. A panel can be mounted in front.

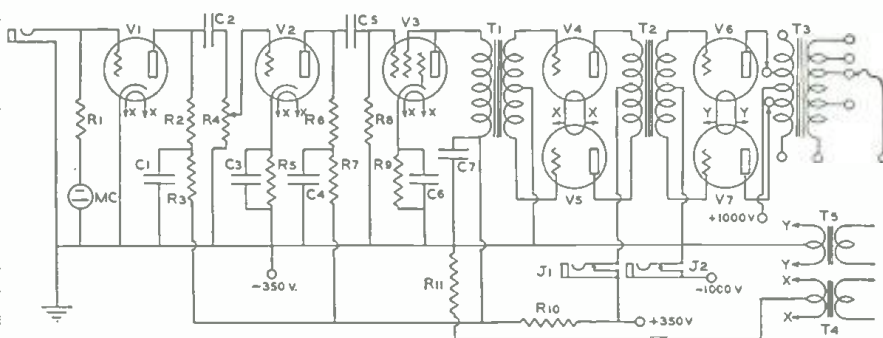

The circuit of the TZ-40 modulator.

C_1 —10 mfd. 50 volt paper
 C_2 —01 mfd. 400 volt paper
 C_3 —10 mfd. 25 volt electro
 C_4 —10 mfd. 50 volt paper
 C_5 —01 mfd. 400 volt paper
 C_6 —10 mfd. 25 volt paper
 C_7 —2 mfd. 450 volt electro
Is-Jacks
 R_1 —500,000 ohm 1 ω
 R_2 —250,000 ohm 1 ω
 R_3 —100,000 ohm 1 ω
 R_4 —500,000 ohm potentiometer
 R_5 —2000 ohm 1 ω
 R_6 —50,000 ohm 1 ω

R_7 —50,000 ohm 1 ω
 R_8 —500,000 ohm 1 ω
 R_9 —650 ohm 10 ω
 R_{10} —1000 ohm 10 ω
 R_{11} —800 ohm 10 ω
SW—A.C. switch
 T_1 —Input transformer (Stancor A4405)
 T_2 —Driver transformer (Stancor A4404)
 T_3 —Modulation transformer (Stancor A3829)
 T_4 —2.5 or 6.3 ω . A.C. transformer (Stancor P3024 or P4019)
 T_5 —7.5 ω . A.C. transformer (Stancor P4091)

to use the 2 volt tubes he may use the following: A 2A6 triode connected for the 6F5, a 56 for the 6C5, a 2A5 for the 6F6 and a 2A3 for the 6A3.

Output of the speech section is transformer coupled to driver 6A3 tubes.

The TZ-40 is primarily designed as a zero bias Class B tube and no bias is required with voltages up to 1000 volts. The T-40 requires a bias of 22½ volts to limit the static current to just 22 MA per tube. In all other respects the T-40 and the TZ-40 are identical. When used in Class B, either tube will modulate up to 300 watts and with different supply voltages, up to 350 watts.

In the left hand picture the controls mounted on the front panel are, reading from left to right, the microphone jack, gain control, the jack for reading the plate current of the driver tube, the jack for reading the plate current of the modulator tubes, the AC switch for turning on the filament and last, the jewel pilot light connected across the filament to indicate when they have been turned on. The chassis used is standard 10" x 17" x 3". The filament transformers have been mounted underneath the chassis and close by to reduce voltage drop in the heavy filament current circuit. While any symmetrical layout will be acceptable, it is suggested that the pictures be followed closely.

First step in the construction is to drill all holes and install the sockets, jacks,

switch, gain control, stand-off insulators and transformers, following the picture as nearly as possible. Then wire in all of the filament circuits. Starting at the beginning of the modulator, wire the microphone jack to the grid of the first tube, using shielded cable as it passes from the top of the chassis to the top of the tube. This will prevent any feed-back. The cable should be grounded.

Next, connect the plate circuit of this tube; following with the coupling condenser to the grid of the 6C5. Wire the plate circuit, and the grid circuit of the 6F6. Connect the plate circuit of the 6F6 to the push-pull input transformer, being careful to connect the leads as indicated by the manufacturer. Wire in the grids of the 6A3 driver tubes and connect up the plate circuit.

(Continued on page 82)

Underside the modulator chassis. The two filament transformers should mount there.

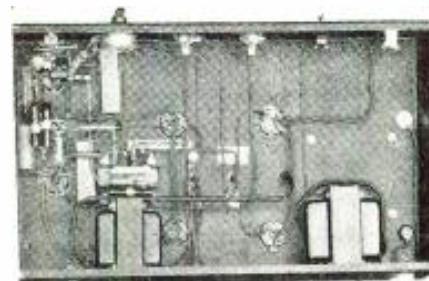

THE MIZPAH-AMATEUR TRANSMITTER

by G. E. GUSTAFSON

Chief Engineer, Zenith Radio Corp.



Commander McDonald watches as his Captain shows how to shift frequency.

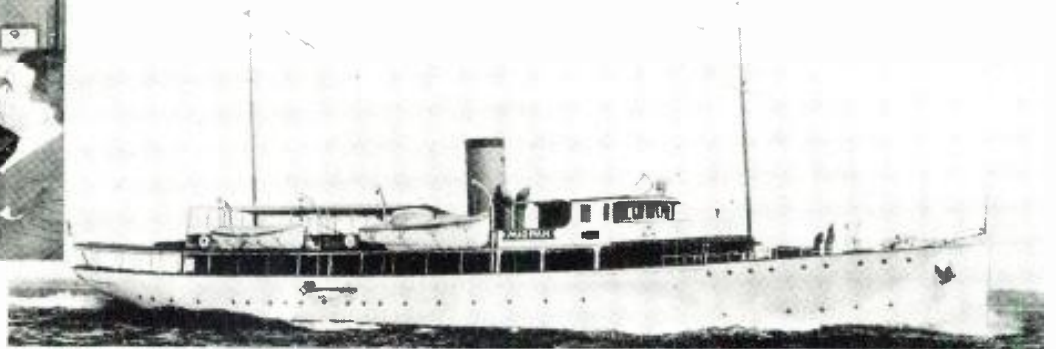

The *MIZPAH*, a veritable floating radio laboratory capable of keeping in touch with the world by radiophone. She is second only to the late Marconi's Electra in equipment.

A commercial transmitter adapted to the amateurs' needs. For the advanced builder who wants a professional transmitter, the author reveals an unusual method of rapid band switching.

THE yacht *Mizpah*, has been recently equipped with a new radio transmitting installation which, because of several innovations and new practices, will be of intense interest to amateurs.

Inasmuch as the *Mizpah* is frequently used in exploration work in remote parts of the world, much depends on good radio communication operable over long distances and under severe conditions.

Of special interest to amateurs is the fact that this transmitter has available 17 frequencies between the range of 22,080 and 375 kilocycles, any one of which is selected merely by turning a control wheel on the front panel which operates all frequency changing switches. The transmitter is used for radio telegraph and radio telephone transmission, having available seven radio telephone frequencies ranging from 17,640 kilocycles to 2100 kilocycles, and provides 1000 watts of radio telegraph power and 750 watts of radio telephone power.

It is possible with this installation to communicate from the *Mizpah* with radio telephony to a shore radio telephone station where the output of the receiver is connected to the land telephone lines and thence to any telephone anywhere.

The entire transmitter is enclosed in a frame 36" x 36" x 76" high. It will be observed that a minimum of controls are used in this installation; as a matter of fact, the only actual controls are the frequency selector wheel, observable on the left side of the transmitter, start-and-stop switch and a

push-button switch near it for testing purposes which shorts out the radio telegraph key circuit directly at the transmitter. On the right hand side of the transmitter will be observed another control wheel which selects high power and low power C W and I C W as well as radio telephony and a test position on extreme low power. The transmitter operates from motor generators which are driven from the ship's supply of 110 volts DC. These motor generators supply 220 volts AC and 110 volts AC. All power supplies, including rectifier tubes, filter circuits and transformers, are enclosed directly in the transmitter unit.

Inasmuch as a wide frequency range has to be covered, it was felt that neutralizing was to be avoided; therefore, the use of screen grid tubes will be noted throughout. The tube lineup consists of a 6V6G crystal oscillator tube; an RK48 driver following the crystal, which in turn is followed by an 861 tube used as a final modulated amplifier.

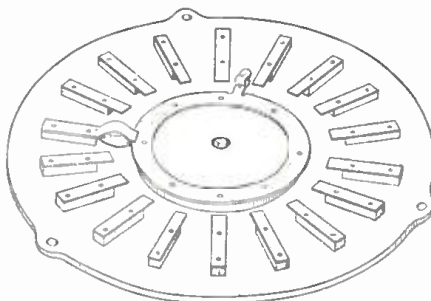

The *Mizpah's* Selector Switch. Easy to build, efficient and inexpensive.

The audio circuit of the transmitter starts with a 6C8 tube used as a first amplifier and in which is fed the output of the microphone. This tube feeds two 6L6's in push-pull, acting as a driver for two Taylor 822 tubes working as class B modulators which modulate the plate and screen circuit of the 861 tube used as the final radio frequency amplifier.

In order to provide all of the frequencies required for this installation, it was felt that the use of the individual crystal oscillators for each frequency was justified. This is of interest particularly to amateurs building transmitters having several different frequencies in them. It permits the installation of a system not involved in long crystal leads where switching of the crystal is used. Further, it eliminates problems incidental to tank circuit adjustments of the crystal oscillator. A further justification of the use of separate crystal oscillators is the fact that in general these oscillators are made up largely of standard receiver parts which are relatively inexpensive and which are easily obtainable.

When the transmitter is in operation, only one crystal oscillator unit is turned on, that being the one used for the frequency involved—all others are turned off, both as respects filament and plate supplies. [*Amateurs might leave all their filaments on, since they do not depend on motor generators, as does the Mizpah.—Ed.*]

In shifting frequency, as is done in Marine Radio operation for calling and working, it is necessary that some thought be given to the amount of time involved in making the shift. A solution for the problem of quickly warming up the 6V6's was found in first

(Continued on page 58)

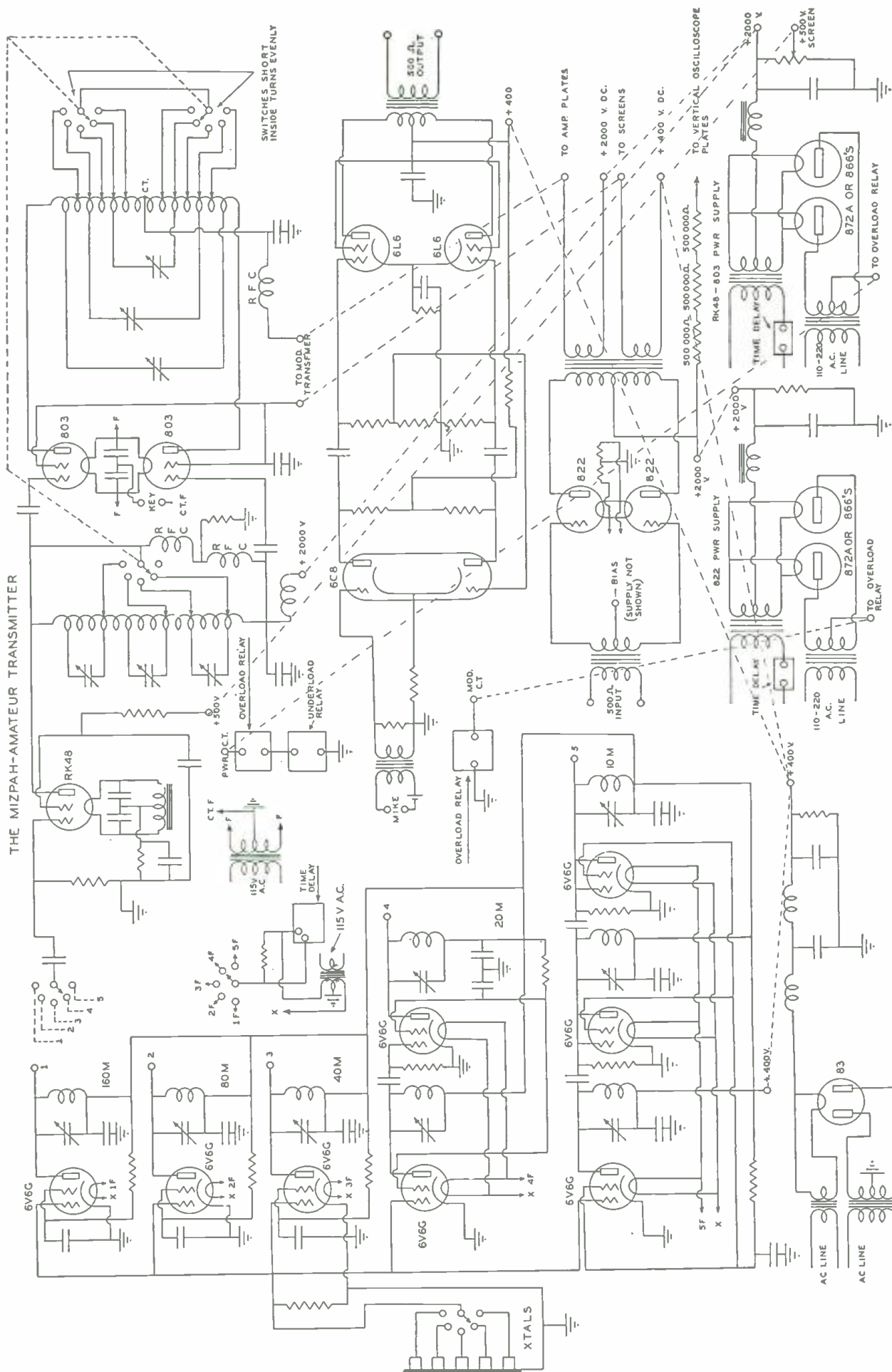

THE MIZPAH-AMATEUR TRANSMITTER

(Note: Suppressor and screen of 803 tied together at socket.)

"RADIO Gadgets"

Single Tube Announcer

Designed for simplicity and economy, this announcing system employs a 12A7 type tube in a conventional pentode amplifier and half-wave rectifier arrangement. A 350 ohm line-cord resistance is used to obtain the correct filament

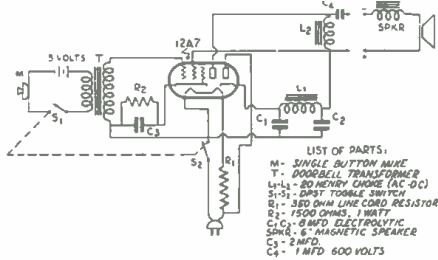

- LIST OF PARTS:
 M- SINGLE BUTTON SWITCH
 T- JENSEN TRANSFORMER
 L1- 50 HENRY CHOKE (A.C.-D.C.)
 S1-S2- DIAL TOMBAC SWITCH
 R1- 350 OHM LINE CORD RESISTOR
 R2- 1500 OHMS, 1 WATT
 C1- .0005 MFD ELECTROLYTIC
 C2- 6" MAGNETIC SPEAKER
 C3- 2 MFD, 600 VOLTS

voltage. As only fair quality response covering the voice frequencies is desired any inexpensive single-button carbon microphone may be used. Sufficient power is provided to drive a small loud speaker with plenty of volume for the job.

Measuring Power Output

The standard equipment required for lining up a receiver generally comprises a modulated oscillator and an output meter. An experimenter may have the first instrument or can borrow one, but very often his measuring apparatus does not include the second device; that is, the output meter. As a simple substitution for the output meter you can use a Mazda flashlight bulb or a 110-volt, 8-watt pilot lamp to provide visual indication of power. Using the flashlight bulb, it is necessary to disconnect the voice coil of the speaker and connect the lamp across the secondary side of the output transformer. Keep the input voltage down; that is, the applied signal from the oscillator, so as to prevent burning out the lamp. The 10-watt lamp can be connected in series with a 2 mfd. condenser, ahead of the output transformer. The voice coil circuit should be open for this test.

Speaker Troubles

Intermittent blasting of dynamic speakers is very often traceable to the presence of minute metal particles. These particles generally collect in the air gap between the moving coil and the field magnet and become magnetized. To remove the particles simply disconnect the field supply and pass a thin piece of magnetized iron around the air gap.

Improving Quality

Even with the best of ordinary baffling, the range, both in quality and vol-

ume, of small dynamic speakers is rather limited. By adapting a discarded exponential horn as a baffle the ability of the speaker may be improved considerably. These horns—generally made of fibre—may be obtained quite cheaply from any obsolete orthophonic victrola.

The throat of the horn should be cut off at a point where the cross-sectional area, regardless of its shape, is approximately equal to the cone of the speaker. It may then be attached to the speaker with small brackets. A small section of the original baffling should be retained, however, to prevent distortion.

Another Soldering Iron Tip

By mixing a little powdered graphite with a drop of oil and applying it on the screw threads of the soldering iron tip it will prevent the tip from sticking. The graphite also helps to prevent corrosion.

Neon Lamp Substitute

Neon test lamps cost from 50c up, but if you will search around the five and ten cent store you may be able to pick up one or more of the little carbon filament lamps that sell for 10c. These lamps are even more sensitive to r.f. current than a neon bulb. For use in a wave meter the filament can be used either intact or "blown." With a whole filament the usual glow is produced just as with a neon. With a blown filament the tuning is sharper. Operating in series will produce a broader glow point than if the lamp is shunted across the circuit. The filament can be blown by shooting about 500 volts through it.

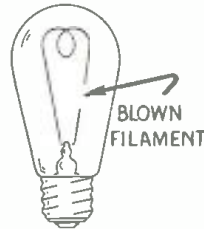

A.C.-D.C. Receiver Tube Tester

To quickly locate an open circuit in a.c.-d.c. receivers, a handy tester is a small neon light with two rubber covered electric wire probes soldered to the base and side of the bulb base.

Method of Testing

Placing one probe to negative, which is usually the chassis, move the other as follows:

To the high side of the line cord, then to the filament resistor that is wound in the cord. (If a ballast tube is used, move probe to each live prong on the ballast tube.) The cord and filament resistor are checked this way for continuity.

Placing one probe to negative, move

the other probe to each filament prong of the tubes, starting at the rectifier, and then on through all the other tubes.

This step checks the continuity of the tube filaments.

Placing one probe to the high side of the line cord, and the other probe to each contact of the dial lights, if they are 6-volt lights and are insulated from the chassis (or to the live side of the bulbs if they are 110-volt lights) check the continuity of the bulb filaments.

The a.c.-d.c. cord should be plugged in and the switch turned on for all tests.

Whenever the neon bulb does not glow, there is the open tube, light or resistance, as the case may be.

Replacing the Magnetic Speaker

There are a great many radio beginners who would like to replace their magnetic speaker with an electrodynamic type. They hesitate because they think it is an involved procedure. Purchase an output choke or transformer of suitable impedance for the dynamic speaker. Connect this in series with the field supply which in turn is shunted by a 4 mfd. condenser. Connect this field in turn in series with the plate terminal of the output tube. The circuit then will run from the plate of the output tube to the matching output transformer, from the matching output transformer to the field circuit just described, and from the field circuit to the positive lead of the power supply of the receiver.

A Few Cents Builds This C. P. Oscillator

The search for a simple code practice oscillator still continues and here is one that anyone can build in a few minutes. It employs the fewest possible parts and costs but little to construct. A quarter watt neon test lamp is connected in series with a .001 mfd. condenser as shown in the drawing. One side of the condenser also connects to one side of a telegraph key, the other side of the key then connects to the

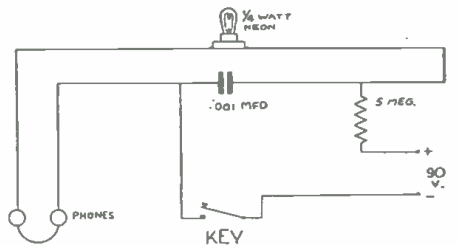

minus side of a 90 volt B battery or eliminator. Then an 0 to 5 megohm variable grid leak is connected between the plus side of the power source and the remaining side of the condenser.

Pressing the key completes the circuit between lamp, phones and resistor and causes the lamp to oscillate. For normal use set the resistor at about 1 1/2 megohms. Lowering or raising the resistance will alter the pitch of the signal.

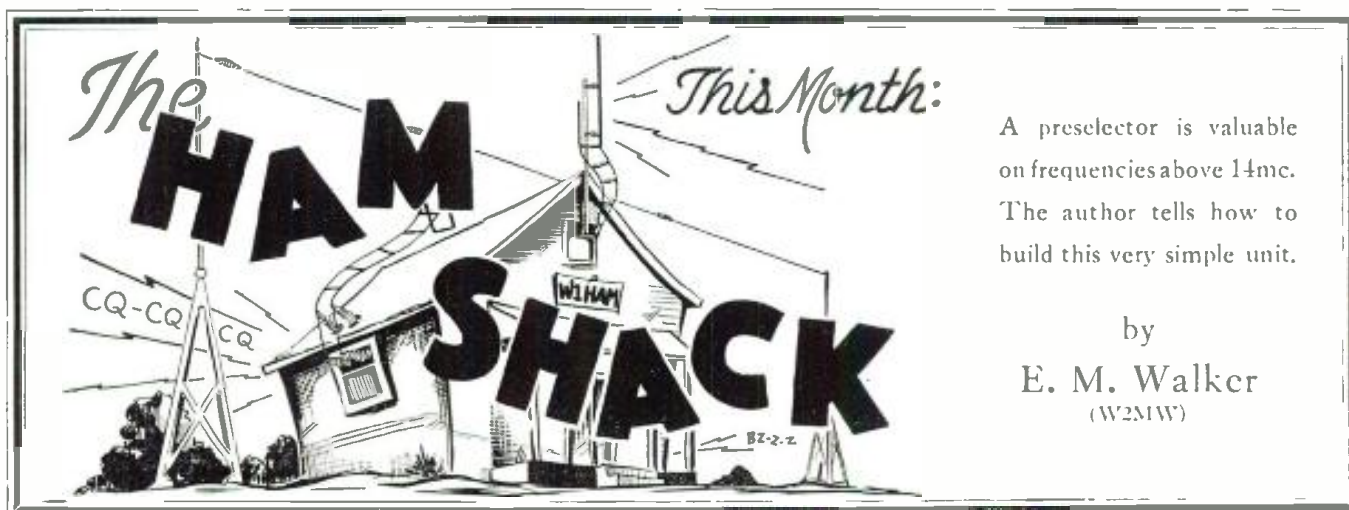

A preselector is valuable on frequencies above 14mc. The author tells how to build this very simple unit.

by
E. M. Walker
(W2M W)

SUCCESSFUL operation on high frequency bands is more dependent on a good receiver than anything else. Regardless how good a transmitter may be, "you can't work 'em, if you can't hear 'em" is still a good axiom.

Most receivers on the market designed for amateur stations are as nearly perfect as modern engineering permits. They are excellent on frequencies below about 9,000 kilocycles. They are good performers up to about 16,000 kilocycles but because of the high circuit losses above this frequency, their efficiency does not compare with the high efficiency obtained at lower frequencies. By the same token, if these same manufacturers were to design a receiver capable of performing as well on the high frequency bands, it would not be adaptable to operation on the lower frequency bands. The result has been that designers have sought a unit that is a compromise capable of performing over the short wave spectrum and the standard broadcast band.

My own "shack" contains perhaps one of the better types of receivers available for communication purposes. It is equipped with noise suppression, noise limitation, crystal filter and electrical band spread. Its performance is beyond criticism on all bands save the ten meter one. It even operates satisfactorily here, but due to circuit losses

and other conditions, its performance is somewhat below its par of the other bands.

On ten meters signals could be heard frequently, slightly below the noise level, but not understood. At the same time it was noticed that just as many signals were heard as other operators in our locality heard, and at about the same signal strength, according to the reports they were giving on stations worked. This, too, with a receiver equipped with two stages of preselection and a fairly efficient doublet antenna.

On the theory that a highly efficient unit ahead of the receiver would boost

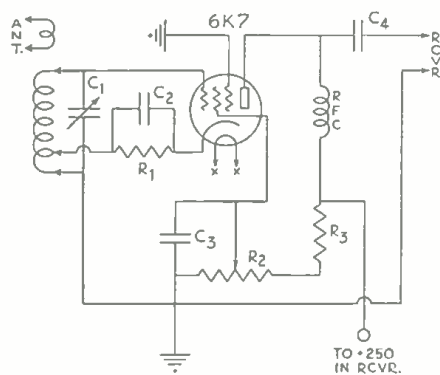

The One Tube Preselector.
C1—35 mufd var. cond.
C2—.0001 mfd mica cond.
C3—.01 mfd mica cond.
C4—.1 paper cond. 250 v.
R1—500 ohm 1 watt res.
R2—50,000 ohm pot.
R3—25,000 ohm 2 watt res.
RFC—Radio Frequency Ch.

the signal input to the first tube in the receiver to a point above the inherent tube noise level; another preselector stage was designed especially for high frequencies.

Regeneration was used in order to gain every possible degree of efficiency at 10 meters. Without the use of regeneration the added gain from such a unit would hardly be enough to bring the signals out of the noise level. A low grid input impedance at 28 mc. prevents much gain without regeneration.



The author, in his own shack bringing in the DX with the one tube preselector he describes.

The regenerative preselector stage was connected ahead of the receiver. A double-pole-double-throw switch was used in the circuit so that the preselector could be connected in or out of the circuit quickly for the purpose of making comparisons.

Results were surprising! While a large number of these signals were of domestic origin, it was surprising to discover how many actually were among the rare "DX" catches, that few other stations were hearing, let alone working. Furthermore, the preselector unit added considerably to the effectiveness of the receiver on signals that already were being heard. Even on louder signals it increased the signal input to the first tube in the receiver to a point where the noise level was considerably reduced.

The preselector unit is extremely simple and may be constructed at small cost. As a matter of fact it is exactly the same as one of the preselector stages already in the receiver, except regeneration has been added to the circuit. It is adjustable by means of a screen voltage control of the same type used in regenerative detector circuits employing screen grid tubes.

The whole unit is mounted in a cabinet
(Continued on page 61)

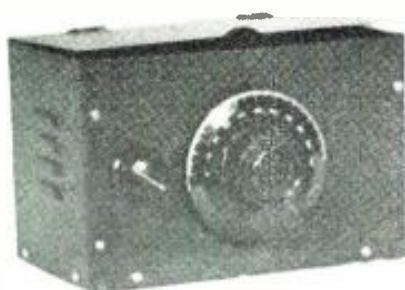

The little Preselector that pushes the hard ones on 10 meters right into your receiver.

SHORT WAVE FLASHES

BY CHARLES A. MORRISON

EACH month this department will feature short wave flashes showing the very latest news of DX broadcasts. This is information which has been received after the issue has gone to press. The station reports have been double checked for accuracy.

All frequencies in the column are given in *megacycles* and the time is *Eastern Standard Time*.

RADIO NEWS will be interested in hearing from observers reporting any unusual or different DX stations than those which regularly appear here. Be sure to give the time and the frequency as exactly as you can determine.

SPECIAL DX BROADCASTS: On Tues., March 22, 9-11 p. m., from HC2RL (6.635), Guayaquil, Ecuador; on Saturday, March 26, 10:45-11:45 p. m., from YV1RB (5.845), Maracaibo, Venezuela.

NEW SHORT-WAVE STATIONS: (Under Construction): two 40 kw. transmitters at Daventry, England, for Spanish broadcasts to Latin America. . . HAR4 (60 kw.) in Lithuania which will test on various frequencies between 6 and 7 a. m.) . . . A 50 kw. transmitter at Vienna, Austria . . . CB1185 (11.85), 2½ kw., at Santiago, Chile. . .

(ON THE AIR): CHANNEL ISLANDS: French station (6.00), owned by Alderney Radio Ltd., Alderney Island, testing daily 7-8 a. m.; will soon inaugurate a high-power transmitter . . . **COLOMBIA:** HJ4ABU (8.65), Medellin, first noted on Jan. 24, is now being heard evenings until 10 p. m. or later . . . **DOMINICAN REPUBLIC:** HI8J (6.388), "La Voz de la Provencia," La Vegas, being heard near 5 to 6 p. m.; signs-off with a march selection . . . **ECUADOR:** HC1GQ (9.175), P. O. Box 159, Nariz del Diablo, Quito, operates Mon., Wed. and Sat., 8-10:30 p. m. English announcements. Signs-off with "Blue Danube Waltz"; HC1RB (7.87), "Diario-Hablado" or "La Voz de Quito," Carrera Calda 146, Quito, operates from approximately 8:30 to 11:30 p. m.; HC1B4 (7.41), believed to be in Quito, being heard irregularly through bad CW QRM. . . **GERMANY:** DJF (11.78), reported to be relaying program to Africa daily, starting at 12:05 a. m. . .

GUATEMALA: TGQA (6.44), "La Voz de Quetzaltenango," relays broadcast station TGQ, Quetzaltenango, irregularly 8-10:10 p. m. Station heard recently, and for several days thereafter testing with experimental call TG1X; TG25 (5.77), mobile transmitter, heard broadcasting from Hualtenango at 11 p. m. Requested reports to be sent to "Casa Presidencial," Guatemala City, Guatemala. . . **INDIA:** VUD2 (9.59), All-India Radio, Delhi, power 10 kw., now being heard nightly from 9:30 to fade-out near 11 p. m. Broadcast opens at 9:30 p. m. with a soft-toned clock striking 8 a. m. (Delhi time). A one hour program of oriental music and chanting, with announcements in Hindustani follows. An announcement at 10:40 p. m.—"This is Delhi," is followed by news in English. Also licensed to operate on 15.29, 15.16, 11.87 and 6.085 . . . **ITALY:** IQY (11.9), Rome, is now relaying 2RO3 (9.635), with IRF (9.83), daily 6-9 p. m. . . **PITCAIRN:** VD6A (7.245 and 14.346), 60 watts, should be testing now. Will originate programs for NBC pick-up during March and April, which will probably be radiated on either 12.862 or 17.31 . . . **MEXICO:** XEBC, or XEVC (6.53), Veracruz, is testing irregularly in the evenings . . . **ST. KITTS:** VP2LO (6.384), owned by ICA Radio Sales & Service, P. O. Box 88, St. Kitts, B.W.I., power 500 watts, tests irregularly 4:30-5:30 and 8-9 p. m. . . **SPAIN:** "Radio Malaga (14.44), "Malaga, relays Salamanca programs late afternoons" . . . **STRAIT SETTLEMENT:** ZHP (9.53), Singapore, reported as heard 5:30-7 a. m. and ZHL (6.085), as operating 4-10 a. m. . . **U. S. A.:** W9XDH (12.862), Press Wireless Inc, Elgin, Ill., is testing with phonograph records afternoons to 5 p. m.

NEW FREQUENCIES (in megacycles) in use at press time: CB1170, Santiago, Chile, on 11.7; COBZ, Havana, Cuba, on 9.02; HC2CW, Guayaquil, Ecuador, on 9.28; HJ1ABE, Cartagena, Colombia, on 4.8; HJ4ABP, Medellin, Colombia, on 4.88; HS8PJ, Bangkok, Siam, on 9.5; OAX5C, Ica, Peru, variable

(Continued on page 78)

U. S. A. Airline Radio Frequencies

IN response to numerous inquiries from our readers, we hercunder publish the list of Aviation Radio frequencies. On these frequencies can be heard the airplane stations on the ground as well as those in the air.

Airline Frequencies in Kilocycles

AMERICAN AIRLINES, INC.

Day	Night	Route
5652.5	3232.5	New York—Boston— Montreal — Cleveland —Boston
5612.5	3232.5	New York—Buffalo— Chicago
5632.5	3257.5	New York—Los Angeles
5602.5	3242.5	Cleveland — Nashville —Washington — Chicago — Chicago — Ft. Worth

BOSTON-MAINE AIRWAYS

5887.5	2946	Boston—Burlington— Bangor
--------	------	------------------------------

BRANIFF

5042.5	3452.5	Chicago—Brownsville
--------	--------	---------------------

CHICAGO & SOUTHERN

5682.5	3485	Chicago—New Orleans
--------	------	---------------------

CONTINENTAL

5582.5	3172.5	Denver—El Paso
--------	--------	----------------

DELTA

5707.5	2854	Charleston—Dallas
--------	------	-------------------

EASTERN

4122.5	2922	New York—New Orleans — Chicago — Miami
6590		New York—Miami

HANFORD

5887.5	2994	Tulsa — Bismarck — Minneapolis
--------	------	-----------------------------------

NATIONAL AIRLINES SYSTEM

5652.5	2946	Miami—Jacksonville
--------	------	--------------------

NORTHWEST

5377.5	3005	Chicago—Seattle
--------	------	-----------------

PENNA.-CENTRAL

5697.5	4335	Milwaukee—Washington
--------	------	----------------------

TRANS-CANADA AIRWAYS

5642.5	3212.5	
	3105.0	(Canada only)

TWA

4967.5	3088	Pittsburgh—Chicago Kansas City
4947.5	3072.5	Kansas City—Los Angeles— San Francisco
4937.5	3088	New York—Pittsburgh

UNITED

5572.5	3162.5	New York—Chicago
5662.5	3322.5	Chicago—Salt Lake
5122.5	3147.5	Salt Lake—Oakland— Portland—Vancouver
5592.5	3182.5	San Diego—Oakland

WESTERN AIR EXPRESS

5692.5	2906	San Diego—Los Angeles— Salt Lake—Helen
--------	------	---

PRIVATE FLYERS

3105	6210	
------	------	--

A SERVICEMAN'S DIARY

by JOHN H. POTTS

A car, radio, and a blonde; two servicemen learn about women from the combination.

WEDNESDAY—A big, gray Cadillac pulled up in front of the store and we heard the horn honking.

"Somebody wants service," Jerry said, maliciously. He knows how sore I get when these lazy customers won't even get out of their cars to tell you what they want. After all, we're running a sales and service shop for radios, not a filling station.

"Somebody wants to buy a postage stamp," I told him. Selling is his end, not mine.

Neither of us budged. Pretty soon we saw the car window slide downward and a pretty, blonde head poked itself out. Both of us made a mad dash for the car, but I beat him to it by a split second.

"Sorry to keep you waiting," I told her. "We were just arguing over who should have the privilege of serving you." Jerry gave me a mean look and walked slowly back into the store.

"Better jump inside," she said, sliding over to the driver's seat. "It's chilly this morning and I don't want you to catch cold on my account." (She was nice. Her round, fur hat was cocked over one side of her head, just missing an eyebrow. Her dark, brown eyes were laughing as she motioned me to sit by her side.)

I hopped in and closed the door. She pointed her foot toward a Stromberg-Carlson installed beneath the cowl. It seemed peculiarly difficult to keep my attention on the radio.

"The radio at the house hasn't worked for days," she continued. "But we just didn't think to call you. Now, this morning, this one stopped working, too. Just when I really need a radio. You know how it is." (Yes, indeed, I know how it is. Everyone waits till the last moment before calling for service.)

"Now this afternoon at 5:00 one of the girls of the club is going to appear on a radio program and I did so want to hear her. Do you think you can have at least one of the radios in working order by that time?"

"You'll hear the program," I assured her. "And you won't have to sit out in the car to listen to it. If it's something hard to fix, I'll have a loan set ready and operating in your home in time."

I collected together my tool kit, tubes and tester and rode out with her, telling Jerry I'd be back by noon and not to make any appointments after five o'clock. I planned on driving her car back to the shop so I could go over the set more conveniently.

She lived in a rather small Colonial house 'way over by the woods. It took about ten minutes to get there but she kept up such a running fire of conversation that it didn't seem that long. Women are either very good or very rotten drivers and I noted she handled



"I wish you'd let me croon a little, Sarge . . . The boys are getting mighty tired of just police calls!"

the car beautifully. She was naturally mechanically inclined, she told me, and had even fixed her vacuum cleaner all by herself. I asked her why her husband didn't fix it. She was rather vague about that. Radio was such a dark mystery—and yet one of her girl friends could actually work a sending station. Could I teach her how, too? Boy, this was getting interesting! Of course I could and I would.

She introduced me to her mother and together we examined the house radio, a rather old Stromberg 642. I switched it on and started to test it but turned it off quickly—one sniff was enough—a burnt-out power transformer. None in stock, either, for that particular model. What to do? Of course, I could still bring over the loan set but she seemed to have so much confidence in me that I had better find some way of getting it ready in time for her program. Then she'd think I was good.

I carted out the chassis and dumped it in the car. Ran over to Bill's service shop, fifteen miles away, and borrowed a replacement transformer for the job.

Delayed my lunch to get the transformer installed and put the set on operating test. Then started in on the car radio. Fortunately, the sole trouble there was a blown fuse and I got it working right off the bat. The alignment wasn't all that could be desired, however, so I put a little more time on it to add pep to the lower end of the band.

Meanwhile the Stromberg on the bench stopped working. A pink glow in the 80 rectifier indicated a blown filter condenser to add to the misery. Installed a replacement and got it going again. Whew! What a strain. Then went out for lunch.

"That dame's sure got you hypnotized," Jerry said. "You haven't snapped out of it so well for over a month." He scarcely waited until I had taken my coat off.

"You can just leave her out of any arguments," I warned him. "She's been looking for a good radio man for a long time and now she's found one."

"Oh, yeah?" he said. I didn't like the way he said it.

At four o'clock I put the chassis in the car and drove the Cadillac back to her house.

"How did you make out?" she asked, anxiously.

"Both sets are in perfect working order," I told her proudly.

"Goody, goody, I win!" she cried.

"You win what?" But she had disappeared upstairs.

I put the chassis back in the cabinet, lined up the dial and made out the bill, knocking off a couple of dollars as a matter of goodwill. She reappeared with her purse, and I collected.

She drove me back to the shop. I tried to make a date to teach her the code so she could learn how to send messages but she said she wanted to think it over first.

At the store, we found Jerry talking to a big, middle-aged fellow. She poked her head in the door and called to him.

"Both radios are fixed, Walter," she said, smiling.

"You're a great little manager," he replied. They walked out together.

I looked at Jerry. He was laughing. "What's eating you?" I demanded.

"That fellow is stuck for a new dress on account of you. He bet that no one could get those two radios fixed the same day and you did it."

"Who is he, anyhow, her uncle?"

"Nope. He's her husband!"

What's **NEW** in Radio

Bendix Radio Corp., Washington, D. C., announces the 1938 radio equipment available to the aviation industry. Includes a type TA-2 series transmitter



rated at 100-watts on either cw. icw. or phone transmissions; also new receivers, high power transmitters with a power output of 1000-watts; a radio compass and other products.

Sprague Products Co., North Adams, Mass., has a new plug-in type radio noise filter. They point out that tests proved it to reduce radio interference caused by electric razors, heating pads, and hair dryers.



RCA Victor, Camden, N. J., new model 86T-2 is a dual wave set; tuning range 530-1720 kc., 2300-22,000 kc. 4.5 watts audio output.

Replacement vibrator two-section mica condensers for Motorola models 65 and 70, are now offered by Aerovox Corp., Brooklyn, N. Y. They consist of two postage-stamp mica condensers held together by twisting and solder-dipping two of their leads to form one terminal, while the remaining two leads provide the other two terminals. Each mica section is rated .0008 mfd., 1000-volt d.c. test.

To meet more completely the requirements for all types of tubes, Jefferson Electric Co. of Bellwood, Ill., has added three new filament transformers to its line.

P. R. Mallory & Co., Indianapolis, Ind., announces a new line of mica condensers, mechanically strong and mois-



ture proof. Lead wires are soft tinned metal which can be bent or twisted without breaking.

Howard Radio Co., 1731 Belmont Ave., Chicago, Ill., recently announced a new communication receiver. A new four channel i.f. unit provides for increased band width in the five and ten meter bands, broad tuning for improved tone quality where extreme selectivity is not required, normal sharp tuning, and a crystal filtered channel.

The new RCA Victor model 87T-2 seven tube set, features electric tuning, and a tuning range of 530 to 1720 kc., and 2300 to 22,000 kilocycles. Tube complement; 6A8, 6K7, 6H6, 6F5, 5W4, 6U5.

The Solar Mfg. Corp., 599 Broadway, N. Y. C., announces a new line of "Transmica" high-voltage, heavy-current carrying transmitting condensers.

An announcement has just been made by Bell Sound Systems, Inc., 61 E. Goodale St., Columbus, O., of their

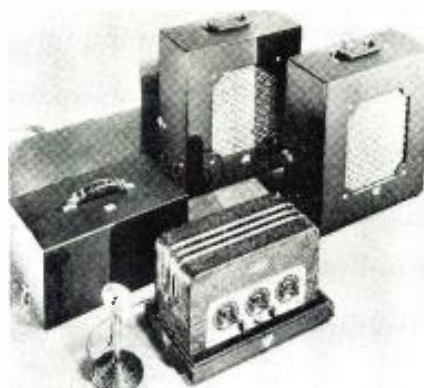

model 424 portable public-address system. It is streamlined, and available in a choice of colors. Power output: 24-watts.

The Webster Co., 5622 Bloomingdale Ave., Chicago, Ill., announces a new sound system model JS-118. This new school model features an all-wave radio, master call, return speech, etc.

The Lafayette 15-20 watt portable sound system has a rated gain of 140 db. Three high and low gain channels are provided. Wholesale Radio Service Co., 100 6th Ave., N. Y. C.

Universal Signal Appliances, 64 W. 22nd St., New York City, announces a new telegraph recorder, Model V-5. It is designed to record words effectively at a speed up to 200 words per minute.

The new 1938 Galvin Motorola auto radio receivers feature automatic push-button network tuning. A red push-button identifies the NBC network, green for Columbia and yellow for the Mutual system. An electric motor drives the variable condenser when a

button is depressed and contact made. The "Golden Voice" model is an 8 tube set using an 8 inch external P.M. speaker.

Cornell-Dubilier, South Plainfield, N. J., has designed the type BR etched-foil electrolytics to a physical size one-



fifth that of corresponding types. They are available in single sections only, in capacities from 4 to 40 mfd. at 150 volts d.c.

General Electric, Schenectady, N. Y., has announced a new line of small radio transmitter capacitors designed particularly for use under severe conditions of humidity and temperature. Very small in size, these capacitors are treated and filled with Pyranol, a nonflammable, nonexplosive liquid dielectric, then hermetically sealed in metal containers to resist corrosion.

The ball type dynamic microphone made by the Transducer Corp., N. Y. C., is housed in a 3 inch spherical metal case. It is equipped with a swivel bracket and can be used as either a directional or non-directional microphone. Output level—52dB. The unit has excellent frequency response to 10,000 cps.



Mallory-Yaxley, Indianapolis, Ind., has just brought out a line of multiple push-button switches for use in automatic station selector tuning devices, inter-office communication systems, tube checkers, etc. Pushing any button automatically releases the button which

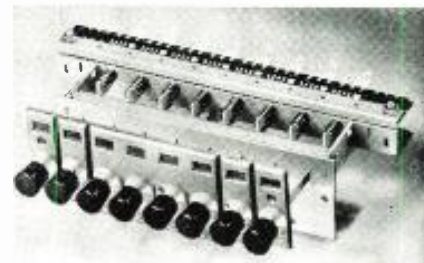

has previously been depressed. The switches are available in two distinct circuit combinations—one designed for circuit closings applications, and the other for circuit transfer applications. Special folder on request.

(Concluded on page 65)

GET YOUR NEW GUIDE TO RADIO! SEE EVERY NEW DEVELOPMENT

ALLIED'S NEW CATALOG

for Spring and Summer



Now Ready!

164 PAGES

NEW KITS!
NEW TESTERS!
NEW PARTS!

NEW SETS!



55 AMAZING VALUES—THIS KNIGHT 6 TUBE PUSH-BUTTON ELECTRIC MOTOR MODEL ONLY \$19.95!

NEW SOUND SYSTEMS!

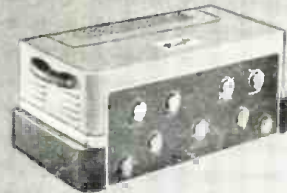

COMPLETE KNIGHT NEW LINE, NEW FEATURES THROUGHOUT; A.V.C.; A.V.E.; INVERSE FEED-BACK; MASTER GAIN CONTROLS; DUAL TONE COMPENSATION; SPEAKER SELECTOR SWITCH; 4 MIKE INPUT; DUAL PHONO INPUT.

NEW HAM GEAR!

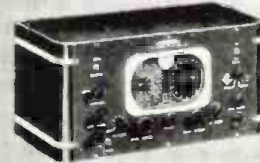

NEW AMATEUR RECEIVERS—NEW X-MITTING AND RECEIVING KITS—NEW HAM PARTS.

PACKED WITH NEWS FOR EVERY RADIO MAN!

Everything New in Radio!

Dealers!

See ALLIED'S tremendous radio set offering, 62 new "Knight" models: each a value that stands alone. The new "Knight" line brings you every latest feature, including 20 new Push-Button Tuning models (a 6-tuber with electric-motor tuning at only \$19.95), new Auto Radios (as low as \$14.95), new Bakelite compact models, phono-radio combinations, universal 6 volt-110 volt farm radio, portable models at less than \$10. And other pace-setting developments such as Hush-a-Tone attachment, Remote Control units, etc. "Knight" offers a radio for every purpose; models from 5 to 16 tubes for AC, AC-DC, 6-volt, 32-volt, Battery, and Auto operation. Every set is priced to bring you volume sales and big profits. See them all in ALLIED'S new Spring Catalog!

Service Men!

See Radio's most elaborate test instrument and parts listings. Latest tube-checkers, set-testers, analyzers, oscillographs, meters. All standard lines, including brand new Hickok and Triumph equipment. Over 12,000 exact duplicate and replacement parts to service practically any set in existence. ALLIED'S "Knight" brand parts (quality-made, economy-priced). Plus—books, tools, accessories. Every service need brought to your finger tips in this new Catalog. Everything in Radio priced so that you'll save and profit more!

Sound Men!

See remarkable new developments in Public Address: new "Knight" Integrated Sound Systems—completely new in engineering and styling. Systems from 10 to 80 watts, with latest features for better coverage and greater operating convenience. New mobile units—new phono-players, portable phonographs, and a complete selection of recording equipment. Here is the most extensive P. A. listing equipment in history!

Amateurs!

See exciting new Amateur equipment in the big Ham section of the new ALLIED Catalog. Brand new Hallicrafters and Howard communications sets, new RCA Television Tubes, new RTL Hi-Frequency gear, new "Knight" Transmitter kits. And a complete selection of receivers, transceivers, and transmitters, as well as parts, books, etc. ALLIED brings you the "low-down" on everything new and important—arranged for quick reference—and offered at the lowest prices in years!

Set Builders!

See Radio's finest Kit selection—every type from beginner's 1-tuber to 14-tube superhet. Latest circuits and many new additions. ALLIED offers matched kits for any circuit in any magazine. Write for Free Parts Lists.

Just off the press! ALLIED'S big new Spring and Summer Catalog. 164 pages with everything new in radio. Whether you service, build, or sell radios, sell or rent sound equipment, or operate an Amateur station—you'll WANT this new Book! It shows you what's new, keeps you up-to-the-minute. It's the outstanding Radio Buying Guide with an all-inclusive listing of Radio Sets, parts, sound systems, kits, test equipment, Ham gear, books, tools, and accessories for every purpose. All leading lines of high quality equipment (including ALLIED'S new "Knight" brand parts—the value leaders). You'll always find what you want in ALLIED'S new Catalog—it's easy to read and easy to order from. Your copy of the new Spring and Summer Catalog is ready for you. It's FREE. Send coupon today!

Why Your Dollar Buys More at ALLIED

With so many thousands of steady customers, ALLIED can buy in huge quantities and pass the savings on to you (check ALLIED'S prices and you will see). Under one roof, ALLIED stocks radio's greatest selection of standard, dependable merchandise—tested for performance and priced to save you money. The ALLIED organization is geared up for fastest service. That's why your dollar always buys more at ALLIED—why you save time, money, and effort every time you order from ALLIED'S Catalog. Write today for the new Spring and Summer edition.

FREE SEND COUPON

ALLIED RADIO CORPORATION
833 West Jackson Blvd. Dept. 1-D-8
Chicago, Illinois

Send me your new Spring and Summer Radio Catalog.

Name.....

Address.....

City.....State.....

ALLIED RADIO CORP.

833 W. JACKSON BLVD., CHICAGO, ILL.

Hook, Line and Radio

(Continued from page 15)

sists in fishing and working about the boat.

It is difficult to present a résumé of a tuna boat operator's day, as he has no fixed schedules unless he should collaborate with a group of other boats which leave port together and help in locating good fishing banks and bait "bunks." This group is called "Code Boats" and he makes up the code and schedules with the other operators upon leaving port. Outside of this he does not have to keep any regular watch at sea. No special weather reports or press or traffic schedules or any other type of watch usually stood by the regular line boats are necessary. Of course, he does listen in occasionally to hear what is going on, and, if he is conscientious, he will try to copy the code messages being flashed out by other Code Boat groups. If he can decipher these codes and find their special "bunks" for tuna fishing or bait, then he is indeed honored by his crew. It has been done, but very seldom can one of those codes be broken. They are only used when absolutely necessary.

Outside of special duties assigned to him, his day is spent scanning the horizon looking for tuna. In accordance with his agreement or arrangement made before shipping out with the owners of the boat, he may stand extra watches or perform duties outside of his regular radio operating work. Special duties may consist of handling a "wheel" watch or standing an engine-room watch or working with the crew as one of them in hauling in fish or catching bait or, in other words, making himself thoroughly useful.

An operator is not rated for his ability to handle a watch, but on the manner and experience he may have with a pole and line when the tuna strike. This insures his wage on one of the following four prefixed arrangements: A. Straight salary, usually around \$100 per month. B. Straight salary, plus a bonus which varies from 25¢ to \$1.00 per ton and he works with the crew in

handling the fish but does not stand any other watches outside of the radio shack. C. Half share or 50% of whatever the crew may receive of their share of the catch.

In agreement "C" the operator must work with the crew and stand special watches but does not have to help in ship's overhaul when such is necessary after docking of the boat. And still another arrangement is full-share or sharing equally with the crew in the moneys received by them which is a division of 50% of the whole amount received by the owners of the boat, less the expenses incurred during the trip.

There is no distinction made between

crew, but also by the owners of the vessel. This is the first time in the writer's knowledge that both radio and a radio operator are requested by the owners and the crew before sailing. They realize that their chances for succor during trouble would be negligible. They usually operate outside of the regular shipping lanes and, because of their construction, are but playthings for the usual hazards encountered by ships at sea. Then, too, the owners spend a small fortune for the purchase of their boat and find it difficult to get a crew to man her without such protection aboard. In addition, insurance rates are greatly lowered when radio is installed.

But all is not Beer and Skittels for the boys making big money, which quite often exceeds \$300 a trip. Each trip will take from twenty to forty days, depending upon the length of time it takes to

get a full load. That is why an experienced radio fisherman is more in demand and receives higher wages than the ordinary and usual run of radio operator. The radio-fisherman must also be able to perform any of the duties of the regular crew, such as deck work, engine room watch, wheel watch, catching bait or fish-

ing for tuna, and this latter ceases to be fun or sport when the fish start biting.

There are two methods used to catch tuna—"purseigning" or the throwing out aft off the fantail of a huge net to wait until a school of fish decide to roost in it, and the regular method of pole and line fishing, which is the most important of the routine jobs performed by the radioman. The latter is the preferred method, which entails the following procedure.

When a school of tuna fish is sighted, large platforms hung on hinges attached to the ship's side at gunwhale height are dropped down around the ship from stem to stern. There is then terrific tension, but the action is smooth without any undue or unnecessary hustle and bustle on the part of the crew, as

(Continued on page 74)

(Right) Radio room of a tuna fleet boat. Northern Radio Co. provides equipment.

(Below) Baby clipper, "Sun Harbor," 75'x21'. Note ice house in front and a "fan-tail" where tuna are stored.



the skipper, engineer, cook, navigator, radioman or deckhands when tuna money is divided. This may sound unfair, due to the extra services rendered by the specialized men, but the only rating recognized aboard one of these small diesel-powered overgrown whale-boats is the ability to haul in tuna. Under this last agreement he must help in overhaul and in any way to speed up sending the ship out again for another trip. In addition, he must act as the ship's doctor in mild cases of illness or, as often happens, in cauterizing and sterilizing of wounds caused by fish hooks imbedded into the heads and backs of luckless members of the crew.

In spite of this seeming indifference accorded the radioman in regards to his wages, he is considered the greatest asset aboard the ship, not only by the

QUESTIONS and ANSWERS

J. D. F., Brooklyn, N. Y.: Is there any charge for an amateur operator's license?

Answer: There is no charge for an amateur license other than the notary fee of 25c for attesting to the validity of the answers on the station and operator's applicant blank.

* * *

W. D. B., Chicago, Ill.: I am just a beginner in Radio and in reading the different articles in RADIO NEWS, I am constantly running across the different electrical symbols for resistance, audio frequency and capacity. I am not always sure of the correct abbreviations. Please help me on this.

Answer: The symbols for the electrical terms you inquire about is only a small part of those used in every day radio. We suggest that you obtain a radio textbook showing the complete list of these symbols. The A. R. R. L. Handbook, or RADIO Handbook, are excellent for this purpose.

* * *

J. H. J., Boston, Mass.: Is it necessary to have an amateur operator's license if you only transmit across a room?

Answer: You must be a licensed amateur operator to do any transmitting whatsoever no matter how short the distance or how weak the transmission.

* * *

O. B. S., Los Angeles, Cal.: In making a repair to my dynamic speaker I noticed a small external coil in addition to the regular field winding. What is this coil and please explain its function.

Answer: The winding you have reference to is the hum bucking coil and its purpose is to eliminate any hum from a poorly filtered field supply.

* * *

R. A. R., Denver, Col.: My receiver is over 10 years old, battery operated, using the old 201A tubes throughout. I am all set to purchase a new electric radio, and I would like to know if I should buy a receiver covering only the broadcast band or one of the new all-wave sets.

Answer: To obtain the ultimate from present day reception you should have a receiver that covers both our broadcast range and the short-wave bands. There are a great many fine programs on the shorter wavelengths, particularly on the 25, 31 and 49 meter bands.

* * *

D. A. P., Phoenix, Ariz.: Every time I turn on my set, a blue light flashes in the tubes. As far as I can determine, it has no effect on reception. What is this condition?

Answer: This is caused by the inert gas content of the tube and has no material bearing on the operation of your receiver. Pay no attention to it.

* * *

J. C., Washington, D. C.: Sometimes I hear voices on my radio calling CQ, W, something or other, and I am sure

they are not part of the regular program. How can I eliminate this background interference?

Answer: Tune your receiver to a low wavelength (high frequency) and you will probably find a spot where this interfering voice will come in the loudest and you will be able to get the complete call which you will no doubt find to be an amateur's call. Write to the Federal Communications Commission, Washington, D. C., and offer to cooperate with the amateur you heard to eliminate the interference. Amateurs are always interested in preventing this type of interference and ready to show you how it can be eliminated.

* * *

M. E. F., Newark, N. J.: I have a dual-wave receiver and would like to listen in on our local two-way police calls. Where can I find them on the dial?

Answer: The police calls in your city are transmitted on approximately 7½ meters (36-41 mc.). This is in the high frequencies, and is not covered by your set.

* * *

J. H. F., Lima, Ohio: My set has complete coverage from 550 kilocycles to 18 megacycles and I would like to tune in on the air lanes. Can you advise the various frequencies assigned to these calls?

Answer: The following are the assigned frequencies under 1500 kc. for aircraft and airports: 2600 to 3500 kc. and 4900 to 5700 kilocycles.

* * *

J. H. D., Buffalo, N. Y.: My receiver employs metal tubes in all stages. Can these tubes be replaced with glass tubes? Would there be any advantage?

Answer: There are octal glass equivalent type tubes for practically all the metal tubes. There is no advantage to the average receiver, though some engineers prefer one to the other type.

* * *

S. J. F., Chicago, Ill.: I own a fine all-wave, receiver. Is a special antenna necessary to receive foreign short wave broadcasts?

Answer: No. A piece of No. 18 D.C.C. wire about 25 ft. long obtainable at any dime store will usually do. It should be installed outside the building, though, for best results.

* * *

S. G. R., Detroit, Mich.: I am located in a building using d.c. current. My reception is spoiled by all sorts of noises from apparatus such as elevators, sewing machines, razors, and the like. Can anything be done to clear this up?

Answer: It is difficult to clear the condition completely. A good line filter, such as is sold by a reputable store, installed at the light line socket to the receiver, should help a great deal.

* * *

A. D. K., New York.: My car radio runs down my battery while driving. What should I do?

Answer: Have the regular agency of the make of the car raise the charging rate on the generator so that with all lights lit brightly, and the radio on, the ammeter shows either zero discharge or a charge of 1 to 3 amperes.

CHATTERING VIBRATIONS

**FROM
GIANT GUNS!**



**BUT
RAYTHEONS
CAN "TAKE" IT!**

The ear-splitting roar of giant guns . . . shattering vibrations that fairly rock the earth . . . these are the daily conditions under which Raytheon's tubes go through with "flying colors" in army communications!

That's because Raytheons are built *right* . . . built to stand up and "take" it! Built by the greatest engineers in the country—and with best materials available! A fact known by engineers of leading licensed set manufacturers who constantly use Raytheons as standard equipment—and by "hams" all over the world. Consider Raytheons for your rigs or replacements.

RAYTHEON

CHICAGO SAN FRANCISCO
ATLANTA NEW YORK
 NEWTON, MASS.



WORLD'S LARGEST EXCLUSIVE RADIO TUBE MANUFACTURERS

Hear the New Scott Sixteen

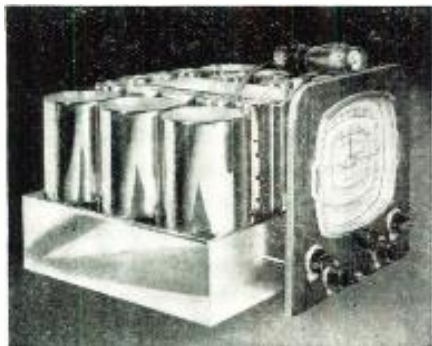

A scientific, precision instrument, custom built BY HAND, from the finest materials, in one of the world's foremost radio Research Laboratories. It represents the results of 14 years constant developing, perfecting, inventing . . . years of intense specialization in producing the finest radio receivers. Sold with a money-back guarantee to outperform mass-produced radios. Yet, this amazing instrument costs no more than many production-type receivers.

COMPARE THESE FEATURES

- Selectivity 10 Kc. at 37 times field strength
- Frequency Range 30 to 7,500 cycles plus or minus 5 db. continuously variable
- Continuously Variable Bass Resonator System which does not impair high frequencies
- Two Automatic Gain Control Systems
- Adjustable Sensitivity Control
- Three Stage I.F. Amplifier (Scott Patents Applied for)
- Sensitivity 0.6 microvolts
- Inverse Feedback System
- Five Year Guarantee
- I.F. Band-Pass System (Scott Patents Applied for)
- One Stage R.F. Amplification
- High Fidelity Loud Speaker with curvilinear cone and high frequency sound diffusion
- Finished in permanent mirror-finish chromium
- Super-shield Antenna Coupling System (Scott Patents Applied for)
- Signal-to-noise ratio at 2 microvolts input, 5-1
- Weakest signal providing good tuning indication—under 1 microvolt
- A.G.C. action within plus or minus 10 db. from 0.6 to 2,000,000 microvolts
- Automatic Sensitivity Compensation for each wave band
- Many other equally advanced features.

30 DAYS' HOME TRIAL!



and Budget Payments anywhere in U.S.A. NOT SOLD THROUGH STORES. Laboratory built on order only. Mail the coupon for special offer during next 30 days.

• SPECIAL LIMITED OFFER! • MAIL COUPON FOR ALL DETAILS

E. H. SCOTT RADIO LABORATORIES, INC.
4440 Ravenswood Ave., Dept. 5F8, Chicago Ill.

Send all the facts, order blank, and Special Offer. No obligation.

Name

Address

City & State

**STUDIOS: NEW YORK, CHICAGO
LOS ANGELES, LONDON**

SPECIAL BROADCAST PROGRAMS FOR THE DX FAN

HERE are the special and periodical DX broadcasts which are dedicated to RADIO NEWS and the various DX organizations.

Tune in on these RADIO NEWS special programs and do not fail to send in your report to the station. Give them

complete information, reporting the station's signal strength, quality, fading, etc. Practically all of the stations listed will be pleased to verify reports.

The schedule is shown in Eastern Standard Time and all hours are A.M. unless otherwise indicated.

MARCH

Day	Hour	Call	State	Kc.	Kw.	Dcd.
10	2-6	CMHJ	Cuba	1160	.175	RADIO NEWS
10	3:30-3:50	WSAJ	Pa.	1310	.1	RADIO NEWS
10	5-5:20	WTRC	Ind.	1310	.1	RADIO NEWS
10	5:10-5:30	WWAE	Ind.	1200	.1	RADIO NEWS
11	4:20-4:40	WMFG	Minn.	1210	.1	RADIO NEWS
11	5-5:20	WEBQ	Ill.	1210	.1	RADIO NEWS
12	3:10-3:30	KWYO	Wyo.	1370	.1	RADIO NEWS
12	3:40-4	WFOR	Miss.	1370	.1	RADIO NEWS
12	4:30-4:50	KUJ	Wash.	1370	.1	RADIO NEWS
12	4:40-5	WGTM	N. Car.	1310	.1	RADIO NEWS
12	5-5:20	KIT	Wash.	1250	.5	RADIO NEWS
13	3-4	WCKY	Ky.	1490	.5	IDA
14	4-4:20	WAGF	Ala.	1370	.1	RADIO NEWS
14	4:50-5:10	WLAK	Fla.	1310	.1	RADIO NEWS
14	5:40-6	KGMB	T. H.	1320	.1	RADIO NEWS
27	2-4	WJBO	La.	1120	.5	RADIO NEWS
27	3-4	KFOR	Nebr.	1210	.1	IDA

APRIL

Day	Hour	Call	State	Kc.	Kw.	Dcd.
1	4-4:30	WPAY	Pa.	1370	.1	RADIO NEWS
8	3:30-3:50	WRAC	Wyo.	1370	.1	RADIO NEWS
8	5:30-5:45	KWYO	Ohio	1370	.1	RADIO NEWS
9	3:30-5:30	WGAR	Ohio	1450	.5	RADIO NEWS
12	4:05-4:20	WCLE	Ohio	610	.5	RADIO NEWS
12	6:10-6:25	KOOS	Ore.	1200	.1	RADIO NEWS

MAY

Day	Hour	Call	State	Kc.	Kw.	Dcd.
1	4-4:30	WPAY	Ohio	1370	.1	RADIO NEWS
8	3:30-3:50	WRAC	Pa.	1370	.1	RADIO NEWS
10	6:10-6:25	KOOS	Ore.	1200	.1	RADIO NEWS
22	3-4	KWYO	Wyo.	1370	.1	RADIO NEWS

PERIODIC

Mondays—
9:15-9:30 p.m., 690 kc., CJCJ, Calgary, Alta., Canada, .1 kw. (tips).

Wednesdays—
12:30 a.m., 1390 kc., KOY, Phoenix, Ariz., 1 kw. (tips).
1:45-2 p.m., 780 kc., WTAR, Norfolk, Va., 1 kw. (URDNC) (tips).

Saturdays—
1-1:10 a.m., 1390 kc., KLRA, Little Rock, Ark., 1 kw.
10:30 a.m., 830 kc., WIEU, Reading, Pa., 1 kw. (tips).

Sundays—
12:45-1 a.m., 1280 kc., KLS, Oakland, Calif., .25 kw. (URDNC) (tips).
2:45-3 a.m., 1010 kc., CKWN, Vancouver, B. C., Canada, .1 kw.
3-3:30 a.m., 1410 kc., CKMO, Vancouver, B. C., Canada, .1 kw.
3:30-3:45 a.m., 570 kc., KMTR, Los Angeles, Calif., 1 kw. (tips).

Monthly—
1st day of each month, 3-4 a.m., 1260 kc., WTOG, Savannah, Ga., 1 kw.
1st Sunday of each month, 4-4:30

a.m., 1340 kc., KGDY, Huron, S. Dak., 25 kw.

2nd Tuesday of each month, 5-5:30 a.m., 1370 kc., KRMC, Jamestown, N. Dak., 1 kw.

2nd Friday of each month, 4-4:20, 1370 kc., WBTM, Va., .1 kw.

—30—

A Free Forwarding Service

The fact that you might not know the address of the manufacturer in whose product or literature you might be interested, need not be any drawback. Write your letter, address it *directly* to the manufacturer % RADIO NEWS, 608 South Dearborn Street, Chicago, Illinois, and he will receive it promptly.

**COMING MAY ISSUE! "GUESS WHO!"
AN AMUSING PICTURE GAME TO TEST
YOUR OBSERVATION POWERS.**

Hot News on the Air
(Continued from page 14)

test was to be held. In this a receiving set was installed.

Next another receiving station was set up in the Chamber of Commerce Building, Marshall, Mo., the nearest town to the field. The Mobile Unit, on the day of the broadcast, was stationed at the base of the tower.

Operating on four channels, nine meters, 275 meters, 110 meters, and 140 meters, the broadcast went on the air. The announcers on the tractor, broadcast on the nine-meter channel. This was picked up at the tower and re-broadcast by shortwave on the 110-meter channel to the station in Marshall. There it was piped to the NBC studios in Chicago and fed to the networks. For cues and directions between the station in Marshall, the Mobile Unit and the tractor the 275-meter channel was used. The 140-meter channel was held for emergency.

A Special Events broadcast that offered thrills to the announcer and lots of problems to the engineers was the record dive in Lake Michigan, made by Max Gene Nohl, youthful Milwaukee scientist and inventor on December 1, 1937. The dive was to be made from the Coastguard Cutter Antietam so the problem of a short-wave station at that point was no problem at all. The Antietam is equipped with radio and the only installation necessary was the NBC audio. But a receiving point was something else.

Searching the shore of Lake Michigan for a likely spot, engineers discovered a church at Port Washington, Wis.

Here they set up a receiving station and had the lines to the Chicago studios tied in. When the broadcast went on the air with Nohl starting his descent the program was short-waved from the Antietam on a 110-meter channel, picked up at the church and fed to the telephone lines and to the Mobile Unit which worked the cue channel. An attempt to install a ribbon microphone in Nohl's helmet was abandoned because of space and a carbon mike was used. This was affected somewhat by the pressure when the diver reached the maximum depth of 420 feet, but Nohl's words were understandable over the airways.

Interference from man-made devices created the greatest problem when a broadcast from the sub-stratosphere was planned. Because of the limitations of the radio equipment in the plane, a regulation 15-watt army set, it was deemed impossible to receive the broadcast in the downtown area.

NBC engineers installed standard audio equipment for the announcer. The short-wave station in a Chicago building was called into service and the Mobile Unit was made the connecting tie-up. The broadcast opened with the announcer describing the plane and the sensation of flying 20,000 feet above the earth. His words were picked up by the Mobile Unit, which was parked in a sparsely settled portion of Chicago, from whence it was piped to the

studios and to the other building where the short-wave station maintained the cue channel, keeping in constant contact with the plane.

And so the Special Events broadcasts go on. Each presents its problems. Each problem is solved and the engineers continue to insist, after the broadcast is all over, that it's all in a day's work and really was no problem at all.

-30-

THE RCA TUBE TWINS SAY...

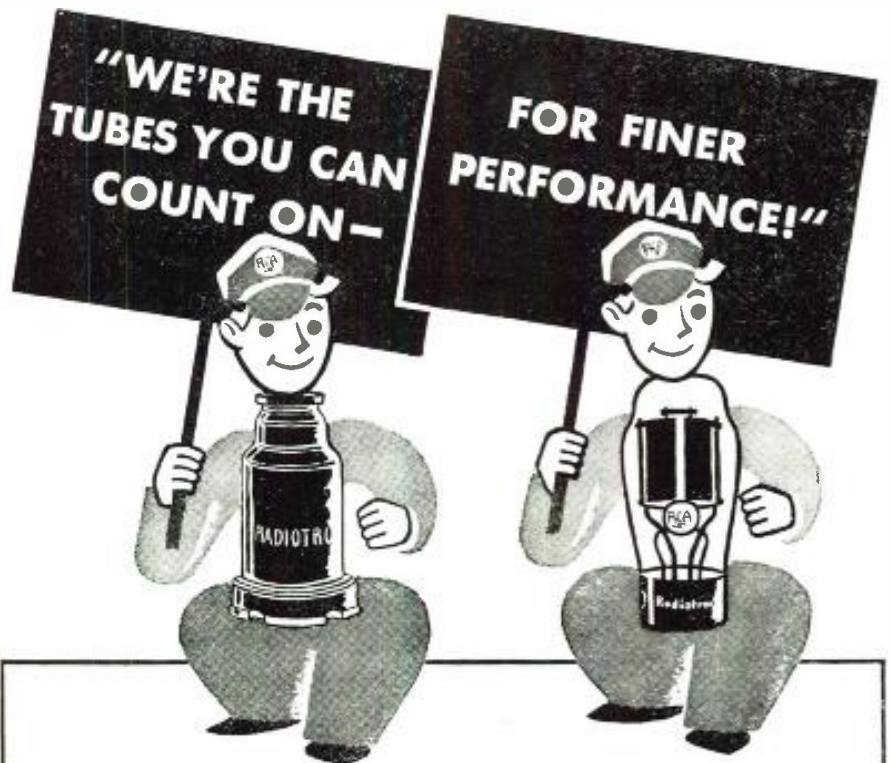

THE best evidence of the *quality* that's built into every RCA radio tube is the fact that over 300 million of them have been bought by radio users.

For better radio reception, better tone, better volume—ask for RCA radio tubes. Built by the world's foremost radio organization, RCA radio tubes offer you

the extra advantages of (1) the unmatched experience of RCA engineers in every phase of radio, (2) the unmatched research and manufacturing facilities of the only company making everything in radio.

No wonder RCA radio tubes are "the tubes of unquestioned quality"! No wonder they'll do a better job for you at low cost!

Ask your distributor, or send 10 cents to Camden, N. J., for a commemorative advertisement on RCA's television tube announcement.

RCA presents the "Magic Key" every Sunday, 2 to 3 p. m., E. S. T. on NBC Blue Network



Radio Tubes

RCA Manufacturing Company, Inc., Camden, New Jersey
A Service of the Radio Corporation of America



"RIDER'S..... Out Front Again"

Says Service Manager of
Leading Set Manufacturer

"That HOW IT WORKS section in RIDER MANUAL Volume VIII, certainly puts Rider out front again! It makes clear the underlying theory you must understand when working on complicated 1938 receivers."

In addition to 64 pages on HOW IT WORKS, plus the 128-page INDEX, Volume VIII includes 1650 pages on essential service data on 1715 models of over 100 manufacturers. Yet, the price is the same as last year's Volume—\$10.00!

RIDER BOOKS BANISH Bewilderment

Radio Technicians get a sure grasp of the underlying theory of modern sets by using up-to-date Rider Books.

AUTOMATIC FREQUENCY CONTROL SYSTEMS

With Automatic Frequency Control Circuits in most new higher-priced models, knowledge of "AFC" means money in your pocket! Learn the practical facts, from these easy-to-understand explanations. Get your copy today. Cash in on a profitable "AFC" work. Hard covers. 144 pp. \$1.00.

THE CATHODE-RAY TUBE

Written especially so you can understand the subject. With introduction of new, cheaper Cathode-Ray Tubes, this book is even more indispensable for its complete practical information on Oscillographs, etc. 336 pp. 450 illustrations. \$2.50

SERVICING SUPERHETERODYNES

Changes, changes, changes! That has been the history of the superheterodyne circuit. Make repairs quickly by analyzing the different parts of the circuit quickly. Rider shows you how in this revised edition which has 288 profusely illustrated pages. \$1.00

"AN HOUR A DAY WITH RIDER" BOOKS —60¢ each

ON AUTOMATIC VOLUME CONTROL will speed up your AVC work. 96 pp. 65 illus. ON RESONANCE & ALIGNMENT. You need this! 96 pp. 48 illus. ON D.C. VOLTAGE DISTRIBUTION IN RADIO RECEIVERS. How d-c voltages are led to tube elements, etc. 96 pp. 69 illus. ON ALTERNATING CURRENTS IN RADIO RECEIVERS—with drawings and diagrams.

JOHN F. RIDER, PUBLISHER
1440 Broadway, New York City

YOU NEED ALL 8
Rider
MANUALS

The Mizpah—Amateur Transmitter

(Continued from page 44)

applying automatically 9 volts to the filament of the 6V6 in question each time the frequency was changed or the transmitter turned on. This voltage automatically dropped after 8 seconds to 6 volts, giving short warming up time and not appreciably shortening the life of the tube.

The motor generator and filament systems, since not applicable to amateur radio, will not be discussed.

It will be observed in the circuit diagram that use has been made of relays for control and safety purposes. Overload relays are provided in each of the two high power supplies. An underload relay is located in the radio frequency high voltage power supply, which does not allow modulation of the transmitter unless the radio frequency tubes are actually operating in normal fashion.

A time delay circuit is also provided in order that high voltage will not be applied to the 872A rectifier tubes until they have been lighted for 8 seconds. This was found safe and sufficient. [Amateurs may provide for 872A or 866 filaments to run continuously.—Ed.] Since the transmitter operates with voltages as high as 4000 volts (2000 volts for the amateur), it is apparent that switching operations must be conducted with extreme care.

In order to obviate any troubles from this source, all switching is done with the transmitter "cold." Whenever either one of the control wheels are turned, before any action takes place in the nature of switching, the high voltage power supplies are immediately automatically turned off. This is done by means of special contractors and relays associated with the two control wheels.

The actual operation is that with the transmitter set at any particular radio telephone frequency, unless the small push "to talk" button is pressed, transmission does not take place and receiving normally occurs when the button is not pressed. "Duplex" operation can be used whenever desired.

Reasonable LC ratio in the tank circuits was obtained at all frequencies and the maximum of efficiency. The solution was to divide the frequencies up into groups—number one group consists of 375, 410, 425, 454, 468 and 500 kilocycles. Number two group contains switching positions in the range of 2100 to 2200 kilocycles, 2738 kilocycles, 4412 kilocycles and 5520 kilocycles. The third group consists of 8280, 8820, 11,040 and 13,210 kilocycles. The fourth group contains 16,560, 17,640

and 22,080 kilocycles. [Amateurs could use 1800-2000KC, 3500-4000KC, 7000-14,250KC and 28,000-30,000KC.—Ed.] In practice it has been found that this grouping of frequencies is successful and that actual switching can be arranged with circuits which allow a reasonable efficiency.

It is apparent that to switch in this manner, two switches operating together are required for each stage—one of which selects the individual frequency in this band. The individual frequency is selected by shorting out portions of the coil.

Only one tank condenser is used for each group of frequencies. Fundamentally, this amounts to the use of four separate tank circuits covering the range of 375 to 22,080 kilocycles and each of these tanks has individually selectable in it, the various frequencies which have been outlined.

[This means that with the tank condenser set for the center of any group, the proper resonant point is obtained by tapping the tank.—Ed.]

Such a system might find ready application in amateur transmitters. For instance, it would be entirely possible to use one tank circuit having 160 and 80 meters, another tank circuit 40 and 20, and still another having 10 meters. With this division, a reasonable LC ratio would be maintained and good efficiency secured.

The tuning of such a circuit is not complicated and involves itself in the selection of a coil and a condenser having the values necessary for the frequencies in use. Actually, what is done is to select a condenser having a value of capacity which is reasonable at the highest frequency in the group and thereafter to make use of the shorting provision in the tank circuit.

In the Mizpah transmitter, a condenser having a value of 50 mmfd. was used for the 22,080 to 16,560 K.C. group; 100 mmfd. for the 13,210 to 8,280 K.C. group and 150 mmfd. for the 5,520 to 2,100 K.C. group. One crystal each for some frequency in the 160, 80, 40 and 20 meter band is used. By means of the master switch this transmitter may be practically instantly switched to any one of the three bands.

[Any combination of crystals and doublers can be used to hit desired frequencies. It is all a question of which is cheaper and easier — fundamental crystals for 40 and 20 meters, or doublers for use with 80 meter crystals. Ed.] The switches for the filaments and R.F. outputs of the crystal oscillator and doubler circuits can be of the conventional type used in all wave radio receivers. Or the switch may be copied from that used on the Mizpah. This may be ganged with the

(Concluded on next page)

other switches described so that all are thrown together.

The doublers used in this circuit should be compact and simple of construction. Ordinarily, receiver variable condensers of any reasonable size up to .00025 mfd. can be used with success. No shielding is required and components should be spaced close together. The units containing a crystal oscillator and two doublers in the *Mizpah* transmitter occupied a total space of only 10" x 8" x 6" and are entirely satisfactory.

It is a very desirable provision, in an amateur transmitter, to have several crystal frequencies available in each band. A switch is shown in the crystal circuit, so that one or more crystals may be used. For the sake of simplicity this switch should not be ganged with the band changing switch. Ordinarily a change in frequency of 10 or 15 kilocycles is all that is desired. Experimentation revealed that a frequency change of even more than this amount is allowable, without any loss of efficiency being noted in the operation of the transmitter; even though the succeeding circuits are not returned.

The actual switches used in the final stage and in the driver stage of the *Mizpah* transmitter were bakelite discs some 12" in diameter on which were located radially 19 micalex blocks some 3" long by 1/2" thick by 1" high. On the tops of these blocks were mounted silvered phosphor bronze contactors which projected. The rotating arm which makes contact to each of these units is of the split type which makes contact on the top and on the bottom of each contactor.

The switch is, in fact, a large edition of the type used in multi-band receivers for wave band selection. As finally developed for the *Mizpah* installation, the switch consisted of 8 sections used as follows: (1) Crystal filament and dial light indicators; (2) crystal plate voltage; (3) crystal unit selector; (4) RK48 tank selector; (5) RK48 tank shorting; (6) 861 plate tank selector; (7) 861 tank shorting; (8) antenna switch.

The lineup of a 6V6G crystal oscillator, an RK48 driver and an 861 final amplifier was used for all frequencies below 6 megacycles. [*Amateurs might use 2-803's, tetrode connected, in place of the expensive 861.*—Ed.]

For frequencies higher than this, it was necessary to use doublers. For instance, to secure the frequency of 8,820 kilocycles, the crystal actually operates at 4,410 K.C., which drives a doubler at 8,820 K.C., which then feeds the RK48 and the 861, both operating at 8,280 K.C. In the case of the highest frequency, 22,080 K.C., the crystal operated at 5,520 kilocycles—is doubled

from there to 11,040 K. C., and is doubled again to 22,080 from where it feeds the RK48, where again feeds the final 861 tube. [*A similar 7 MC-14 MC-28 MC system could be used by amateurs for 10-meter operation.*—Ed.]

It might be said that the design of this transmitter was made possible due to the RK48 which requires a very minimum of driving power to secure a relatively large amount of output. The 6V6G tube as a crystal oscillator and as a doubler also assisted materially in the design. These tubes are highly efficient and have been found to be very successful for applications of this type.

Careful shielding was used throughout with the result that at no time was any difficulty experienced with oscillation either R.F. or A.F. The audio amplifier system is located only one foot away from the final radio frequency stage whose power output is 750 watts and no trouble encountered.

The crystal units are all contained in a large copper box with individual shielded compartments. The units are removable from the side of the transmitter individually by removing two screws and disconnecting three wires on the front and one on the back. By this means a crystal oscillator or doubler unit may be taken from the transmitter for examination or repair.

The entire operation of the transmitter is accomplished from a small control panel placed on the operator's desk. On this panel switches; microphone input; receiver output; and such other facilities as are necessary for complete operation of the transmitter. In the course of normal operation, it is only necessary that the operator leave the control panel to change frequencies.

When using radio telephony volume levels are checked through a V.I. meter located on the control panel and by means of a cathode ray tube mounted permanently in one of the meter panels of the transmitter. [*Amateurs may use a DB or an AC output meter in place of the V.I. meter.*—Ed.]

The cathode ray tube operates with a 60 cycle sweep on the horizontal deflector plates and with modulated radio frequency on the vertical deflector plates. It is so arranged that it is turned on automatically whenever radio telephony is used.

An indication of the efficiency of the transmitter might best be made by saying that radio telephone and radio telegraph communication has been consistently maintained over a considerable period of time with stations on both the Atlantic and Pacific Oceans while the *Mizpah* was located on the Great Lakes. Amateurs with their fixed locations and superior antennas should be able to work anywhere on the globe.



YAXLEY Switches

*... and the
difference between
shorting and non-
shorting types*

Many of our customers have written, asking that we explain the difference between shorting and non-shorting types of switches.

On a shorting type switch, the moving arm overlaps each contact, so that when the switch shaft is rotated from one position to another, the second circuit is closed before the first circuit is opened. This type of construction is used in band change switches to prevent an annoying noise in the loudspeaker which otherwise would occur when the grid circuits were momentarily opened during the operation of the switch.

Non-shorting switches do not have this overlap, and are preferred for test equipment service. In this type switch adjacent circuits are not momentarily contacted during the rotation of the switch.

Write us for information on your switch problems. Yaxley Switches are sold by leading radio parts distributors.

P. R. MALLORY & CO., Inc.
INDIANAPOLIS INDIANA

Cable Address—PELMALLO



RADIO COURSES
 RADIO OPERATING: Prepare for Gov't License Exam • RADIO SERVICING Including Short Wave • AMATEUR CODE • ELECTRONICS • TELEVISION • Day and Evening Classes Booklet Upon Request
NEW YORK Y. M. C. A. SCHOOLS
 7 W. 63rd Street, New York City

OVER 1500 CASE HISTORIES TO SPEED UP YOUR SERVICE WORK

Get the world's greatest collection of "Case Histories" — in Ghirardi's time-saving "loose-leaf" RADIO FIELD SERVICE DATA Book. Each one tells you exactly which part in the set is causing the trouble—and how to remedy it! No fussing, no cursing—you get directly to the seat of the trouble in a few moments! Think of the work you'll save by having these servicing short-cuts at your elbow. Once you get into the habit of first referring to Ghirardi's "Case Histories" before starting every service job, you may save over 30% of the time you are now spending in trouble-shooting. But that's just one feature of this great Data Book. You'll also get the 116 of experience, 56 Car-Wiring Diagrams, Auto-Radio Installation and Ignition system interference data for all cars, and over 25 other indispensable tables and charts for shop and job reference. This book is kept always up-to-the-minute by a regular supplement Sheet Service.

Get the servicing text, too!
 Get the DATA Book together with Ghirardi's famous MODERN RADIO SERVICING — a clearly complete and comprehensive explanation of everything about modern servicing instruments and practice. It gives you a whole big 420-page section on Test Instruments (theory, operation, construction, wiring diagrams, etc.), Trouble-Shooting and Repair methods, Noise Elimination, Auto-Radio Installation and Servicing, AVC and QAVC Circuits, Aligning Super-hets, etc., etc. All "117 Essentials" of successful radio service work are explained fully — and illustrated! — in this amazing collection of practical quick-use servicing information. These 2 books give you "the whole works" — shop reference data and knowledge you really have to have. Get them today! Sent Postpaid Anywhere!

MODERN RADIO SERVICING
RADIO FIELD SERVICE DATA BOOK
 1800 PAGES 813 ILLUS. \$6
 Both Books for **6**

MODERN RADIO SERVICING

ORDER NOW! MONEY BACK GUARANTEE

To: Radio & Tech. Publ. Co., Dept. RN-48, 45 Astor Pl., New York, N. Y.
 Here is \$6 for MODERN RADIO SERVICING and RADIO FIELD SERVICE DATA (including Jan.-June '37 Supplements in Data Book) postpaid (\$6.50 for foreign).
 Please send free descriptive literature about these 2 books.

NAME _____
 STREET _____
 CITY _____ STATE _____

SPEED UP
 Your Service Work with GHIRARDI'S GADGETS

In a flash these amazing Pocket Trouble Shooters speed over 800 different set troubles—give you exact TESTS and REMEDIES. One each for HOME and AUTO radios. 5-day Trial. Free Circular—no obligation! Write: RADIO & TECH. PUBL. CO., 45 Astor Pl., N. Y. Dept. RN-48

NOT FOR REBROADCAST
 (Continued from page 36)

broadcast stations are toying with the various facsimile models . . . Some visionary engineers and commercialists foresee the day when you and I will wake up in the morning, go over to the radio and tear off the morning newspaper.

That day might or might not come—but you might keep an eye on the art so you won't get caught napping if it does.

WONDER if hams will ever succeed in closing the air to the minority in their ranks who insist on telling traveling salesmen and farmer's daughter jokes by radio?

Now that hundreds of thousands of all-wave receivers tune daily to the ham phone bands, complaints from BCLs are increasing.

Latest to reach this column is from C. J. Stanisjewski, 3033 N. Troy, Chicago . . . Mr. S. objects particularly to a story aired by a Midwest kilocycler—a yarn concerning the President and the WPA.

PURELY PERSONAL.
 Little Jackie Heller, pint-sized tenor, and night club dancer Ruth H. Greeley were wed the last week in February . . . Basic salaries of network announcers (five-day week) now runs about \$50 per week in main studios. More if they handle commercials . . . Jack Benny is in bad with newspaper radio eds from coast to coast. It started when Benny changed his scripts at last minute, airing sketches totally different from those he had scheduled earlier and which the scribes had published . . . Maestro Marek Weber speaks no English (his first violinist interprets for him, whispering above the orchestral din).

 After discussing the many celebrities and songs he has started to fame, Rudy Vallee said to this scribe, "I regard myself as a sort of human guinea pig. They try new things out on me—and some of them work!"

NEXT ISSUE!

The unknown hero is the airline radio-man. Many would like to enter this fascinating profession. Read "Qualifications for Airline Radio Operator" by a T.W.A. official in the big May issue.

PIGEON COOKER
 (Continued from page 21)

home, giving them better time than heretofore. Pigeons were then chosen which were true homing pigeons, that is, they were perfect specimens, which actually flew straight to their "home" loft.

There was still some question as to the accuracy of the timing of arrival of the pigeons and in order to eliminate fully all doubt on this score, the pigeon loft and services of Mathew Manka, 2815 N. Fairfield Avenue, Chicago, Ill., was hired. As a further precaution a member of the Engineering Department was stationed at the loft to check the pigeons' return time. In all tests thereafter, careful watch calibration was maintained and the element of possible time inaccuracy removed.

Tests were resumed under these conditions at Mount Prospect, Illinois, with the following result:

EXPOSED TO RADIO FREQUENCY

Wavelength	Number of Pigeons	Flying Time
5 Meters	1	33 Min.
11.5 Meters	3	29 Min.
15 Meters	4	27 Min.
20 Meters	5	27 Min.
30 Meters	3	31 Min.
40 Meters	4	32 Min.
50 Meters	3	28 Min.

NOT EXPOSED TO RADIO FREQUENCY

Number of Pigeons	Flying Time
2	24½ Min.
2	24½ Min.
3	30 Min.
2	23 Min.
3	37 Min.
2	24 Min.
3	21 Min.

Average Time—29½ Min.
 NOT EXPOSED TO RADIO FREQUENCY
 Average Time—26½ Min.
 Flight Course—25.6 miles.

About 125 pigeons flown during entire tests.
 Above compilation covers 40 pigeons. It appears from these figures that homing pigeons exposed to radio frequency are affected by the exposure and in some way their ability to return home definitely slowed up. Here then was confirmation of the reports. The difference in time used to return home between the exposed and the unexposed birds is not very great; however, it must be borne in mind that the power of the oscillator is not great and its radiated field is very much restricted by comparison with what would exist around a high power radio transmitter. In this respect the results obtained are significant.
 During the course of these experiments
 (Concluded on next page)

ments many other tests were conducted. In some cases fixed permanent magnets were hung around the necks of pigeons. This was done to determine whether the pigeon's homing instinct might be affected by the earth's magnetic lines of force or as has been suggested (since there exist no two places on the earth's surface having the same magnetic field strength) these birds might seek that field strength which exists at the home lofts. It was found that the magnet on the pigeon's neck did not seem to affect his homing ability at all. Further tests of this type might produce more conclusive evidence; however, the present tests indicate that the flying time is the same both with and without the magnet.

It has been reported that homing pigeons having their ears blocked up fail to return to the home loft. A reference to this test is an article by Mr. Lincoln of the Wild Fowl Division of the U. S. Department of Agriculture. Mr. Lincoln states that pigeons whose ears are filled with wax, fail to return home. He also states that the use of wax in the ears seems to irritate greatly the pigeon. In order to make this test under conditions where the pigeon would not be irritated in any way and normal in every respect, excepting that his hearing would be stopped, the ears were completely filled with vaseline. The feathers all around and over the ears were also smeared with vaseline.

The temperature on the day of the tests was around 45 degrees and the vaseline quite solid at this temperature. The pigeon so treated, returned home faster than it had ever been known to do so before with the vaseline still in its ears. It is possible that further tests might develop additional information; however, the fact that the pigeon returned home is very much at variance with the other reports which indicate the pigeon loses his homing instinct entirely when his ability to hear is removed.

Several tests were also conducted when an antenna was coupled to the oscillator and a half wave antenna tuned to the transmitter frequency was tied to the pigeon's leg so that there was actual contact to the leg. This seemed to slow the bird's flight up somewhat and it is difficult to say whether the slowing up was due to the drag of the antenna or the resultant application of more radio frequency to the pigeon through the medium of the antenna.

This test would be of real merit in the vicinity of a regular transmitter having considerable power. The antenna fastened on the pigeon consisted of a No. 41 wire which is very small in order to introduce the minimum possible drag on the bird. Tests with head and foot wires were not attempted then because of difficulty with the birds.

The facts produced from the experi-

ments would indicate: that the pigeons' organs of hearing apparently are not connected with the homing instinct; that the homing instinct is not affected by magnetic fields such as the earth's field; that radio radiations do affect the homing instinct; that the homing instinct is not appreciably affected by any particular wavelength in the short wavelength ranges, any wavelength producing about the same result.

It is of interest to note that exposure to radio frequencies in the ranges tested frequently seemed to make the pigeon restless and that at 20 meters the respiration and heartbeat seemed to increase a noticeable degree, and to an extent much more noticeable than at any other wavelength in the range used.

It will be extremely interesting to follow developments along these lines. Conceivably, in time of war, the enemy, through radio interference could destroy the effectiveness of any carrier pigeons the country might employ, or actually divert the winged messengers into their own camps.

Whether or not "contra" radio waves might be sent out to nullify the effect of the enemy's beams, is the question of conjecture upon which, to date, nothing has been done. In any event, the tests open up a large field of research which should be made before the subject is finally dropped.

-50-



BUILT FOR "DX"

HAMMARLUND components built into your receiver means greater "DX". The "MC" midgut condensers, together with the "SWK" (17-270 meter) "X1-53" low-loss coil set, and the type "S" Isolantite socket are matched parts "built for 'DX'."—Send coupon for 1938 catalog.

HAMMARLUND MFG. CO., Inc
424-438 W. 33rd St., N. Y. City

Please mail me new "38" catalog.

Name _____

Address _____

City _____ State _____

RN



HAMMARLUND

**THIS POCKET
VOLT-OHM-
MILLIAMMETER
DOES ALL YOUR
D.C. TESTING**

**PRECISION
BUILT
\$10.80**

*Ask Your Jobber to Show You
The Difference*

• A Model 735 has a Triplett D'Arsonval type precision instrument with easily readable scales. Ranges are 15-150-750 volts at 1000 ohms per volt; 1½-15-150 M. A.; ½-1000 low ohms; 0-100,000 high ohms at 1½ volts. Provisions for external batteries for higher resistance measurements. Has selector switch for all ranges and individual zero adjustment for resistance measurements. Now with silver and black etched panel.



**ASK YOUR JOBBER
WRITE FOR CATALOG**

Readrite Meter Works
415 College Ave., Bluffton, Ohio

Without obligation please send me more information on Model 735
I am also interested in _____

Name _____

Address _____

City _____ State _____

Model
735
Accuracy 2%
Battery,
Test Leads and
Accessories
Included

Within Earshot of the Editor

(Continued from page 4)

present transmitter site. They plan a public park and a new 500,000-watt transmitter, feeding one of those vertical towers. The location is at Itasca, Illinois. Although we tried to obtain more information on this subject, it was all very "hush-hush." Nevertheless, our informant tells us that the dope is the McCoy.

* * *

AS WE go to press word reaches us that the three broadcast sys-

tems, are about to engage in a high-power fight. We do not know if they are jealous of WLW with its 500 kilowatts or not, nevertheless, the three stations situated in the Middle West will shortly begin negotiations and hearings before the Federal Communications Commission for the granting of licenses of similar power to each of them. The only joker in the whole situation is that should the Federal Communications Commission grant this license, and should they finally have the power they are seeking, each will have to use a directional antenna so as to keep the East and West Coasts clear of their signal. It is hard to understand why a greater power increase is sought when,

after all is said and done, they are adequately covering the area at present.

* * *

OVER in Europe on short-waves, England, Germany, Italy and France are engaging in a propaganda war. Every day from morning 'til morning the short waves carry the various —isms, creeds and ideas to the remote corners of the world. This is done by means of short-wave directional beam antennas. For instance, Germany is interested in promulgating her theories in South America and in the United States. Italy, on the other hand, is interested in and around Ethiopia. France is working on the northern part of Africa, and England is doing her best to keep India under control. Because they have no centralized Communications Commission as has the United States, and because most of them who are signatories to the Madrid pact do not find themselves in the least hindered on short wave, the poor uneducated, ignorant colonist in South Africa, South America and India is finding his radio set full of all sorts of new theories, ideas and —isms which are contrary to those of the government under whose control he lives. How much this short-wave propaganda will affect the map remains to be seen. Each of the nations involved is in deadly earnest. So earnest were the Italians that they furnished the Indians and some of the people around the Red Sea with radio sets that could only receive the Italian stations. The English have retaliated by doing a similar stunt in India.

* * *

RADIO NEWS will shortly join those who use the sponsored broadcast. In the near future arrangements will be made with one of the leading networks for an hour a month to be sponsored by RADIO NEWS. We expect to broadcast those subjects which will be suggested by the readers themselves. We urge you to write to us and tell us what you would like to have us do over the air. Something has already been suggested. In the news staff we have the makings of an excellent musical organization. Perhaps some of our readers would like to hear the Radio News Orchestra swing out on "Shake That Thing."

* * *

SMALL things often change an entire life. When we were very little and very good, our parents took us to the corner candy store and treated us to an ice cream soda. We knew of no greater pleasure than to blow bubbles through the straw. Against this somewhat noisy procedure, our parents objected. Perhaps that was their mistake, because a very popular orchestra

(Concluded on next page)





LEE DE FOREST LABORATORIES
RADIO ELECTRONICS
1200 N. MICHIGAN AVE.
CHICAGO, ILL.
JANUARY 21, 1938

Mr. McMurdo Silver
8900 So. Michigan Bldg.
Chicago, Ill.
Dear McMurdo:

"MASTERPIECE VI
EMBODIES MERITORIOUS FEATURES TO MY
KNOWLEDGE FOUND IN NO OTHER ONE RECEIVER"

Lee de Forest.

● Among the illustrious names on the roster of Masterpiece VI owners, none carries more significance in the world of Radio than Dr. Lee de Forest... inventor of the Audion Vacuum Tube... father of modern radio broadcasting. Commenting on the performance of the Masterpiece VI in the music room of his Hollywood home, Dr. de Forest said:

"To properly appreciate and enjoy the best that Radio can offer, those gifted with culture and refined taste must listen to its interpretation by such an excellent instrument as this one of yours.

"... today's radio-tastes have been so far advanced, by our better musical programs and by such adequate interpreters as your Masterpiece that new and exacting criteria, unknown heretofore, demand compliance.

"This superfine Masterpiece VI nearly meets them all: controlled fidelity and selectivity... wide vol-

ume range with expander... both bass and treble controls... universal frequency-coverage... extreme sensitivity... tremendous power... rich reproduction of tone... A.V.C., of course... and other meritorious features to my knowledge found in no other one Receiver. You have done a job here of which you and your staff may well be justly proud."

If you want unlimited, adequate radio reception, you owe it to yourself to investigate McMurdo Silver's Masterpiece VI. Here is radio that assures true interpretation of fine symphonies, thrilling arias... which, with uncanny "reach" goes to the earth's four corners to snare unique and unusual programs. Thirty-six distinctive technical features are responsible for its "Years Ahead" performance... performance that has won the acclaim of Europe's noble families, America's social leaders, internationally famous musicians, technical schools, laboratories, and radio distance receiving champions. Send for details.

MCMURDO SILVER CORPORATION

2900-A South Michigan Avenue, Chicago, Illinois

leader and an organization are famous today for just that sort of thing. We wonder whether or not, had we been permitted to continue our musical blowing through this straw, we too might not have become a famous orchestra leader.

IN THE September issue of Radio News a small article appeared concerning the amateur station W9FEL which was powered by means of a Wincharger. We are in receipt of a letter from the owner of that station. He complains: "Daily, I get letters from all over the U.S. about my layout, and it is utterly impossible for me to answer all of them." He asks us please do something about this. Heeding to his request, may we ask that our readers do not write further to W9FEL, so that the gentleman may get caught up on some of his badly-needed sleep.

THE Federal Communications Commission has established a band between 41,000 kc. and 42,000 kc. for educational broadcasts. This classification provides for noncommercial educational broadcast stations on which no sponsored or commercial program will be allowed. The power of the stations will range from 100 to 1,000 watts. The programs will be directly similar to those used in schools and will provide regular courses of instruction for the general public. We can see some difficulty with Junior in preventing him from tuning out these stations and turning to some other program more to his liking. Just another problem for the worried housewife.

SOMETIMES publicity agents go haywire. We are in receipt of an amusing release which tells us that a certain engineer in Uruguay is running two 245 oscillator tubes modulated by two Class A 250 modulator tubes. This gentleman uses a two-stage microphone amplifier with 56 type tubes. The grandest thing about our South American friend is that he is able to obtain a 500-watt output from a set of tubes operating as a self-excited oscillator. The RCA manual tells us that the maximum input to a pair of 45s is 37 watts when used as an audio amplifier. Personally, we have used a pair of 45s with inputs as high as 50 and 60 watts, but 500 watts is a little hard to believe. The release goes on to say that he uses 6v. wet storage batteries as a source of power and a 6-volt vibrator booster which gives him the 500 watt output. Using the slip-stick a little, we find that this gentleman is drawing over 100 amperes from his storage batteries, assuming better than a 50% efficiency. This miraculous electrical system is kept charged by a Wincharger of a 6-volt type whose maximum output would not

be in excess of 30 amperes. It seems a pity that a corporation as large as the one which released this amusing document could not be more careful.

AND so we come to the end of our stint. We hope that through this page we will come to know our many readers so that with this knowledge will come the ability to interest them and keep them informed of the goings-on in this fastest moving of all things on the face of this globe—RADIO.

—50—

Radio Quiz (Questions on page 8)

1. Amanda Snow.
2. Fitty.
3. Madge Tucker.
4. Jack Fulton.
5. Curtis Arnall.
6. J. Anthony Smythe (Henry Barbour); Minetta Ellen (Fannie Barbour); Michael Raftetto (Paul); Bernice Berwin (Hazel); Kathleen Wilson (Claudia); Barton Yarborough (Clifford); Paige Gilman (Jack); Winifred Wolfe (Teddy); Helen Muselman (Ann); Walter Patterson (Nicky); Ann Shelley (Joan).
7. Myrtle Cooper Wiseman.
8. Luise Barclay.
9. Jimmy Fidler.
10. Carl Hohengerten.
11. Truman Bradley.
12. Rev. Hal Raynor, an Episcopal minister.
13. A program on which interesting people appear to tell of their hobbies or lobby for their hobby.
14. John Salb.
15. Mento Everitt.
16. Harry Einstein.
17. Bess Flynn.
18. Henry Burr.
19. Music director of the Rising Musical Star program.
20. Freddy Martin.

THE NEW NATIONAL NC80X and NC81X

SUPERHET RECEIVERS
 NOW IN STOCK FOR IMMEDIATE SHIPMENT
 Either above receiver complete with tubes, crystal and speaker chassis.
NET PRICE \$99.00 COMPLETE
CAMERADIO
 963 LIBERTY AVE. • 30 TWELFTH ST.
 PITTSBURGH, PA. • WHEELING, W. VA.
 Established 1919

LES Correspondence Courses in
RADIO and ELECTRICAL ENGINEERING
ELECTRICAL ENGINEERING Get a good grasp of wide electrical field. Prepare yourself, at Low Cost, for secure future. Modern course. No simplified anyone can understand quickly.
RADIO ENGINEERING Extra fine course in radio, public address, photo-electric work trains you to be super-service man, real vacuum-tube technician. Experiments kits furnished. Diploma on completion. Tuition ONLY \$25, either course. Deferred payment plan available.
FREE! Send name quick for free copies of school catalogs, student magazines, complete details. **SEND NOW!**
 LINCOLN ENGINEERING SCHOOL, Box 931-74, Lincoln, Nebr.

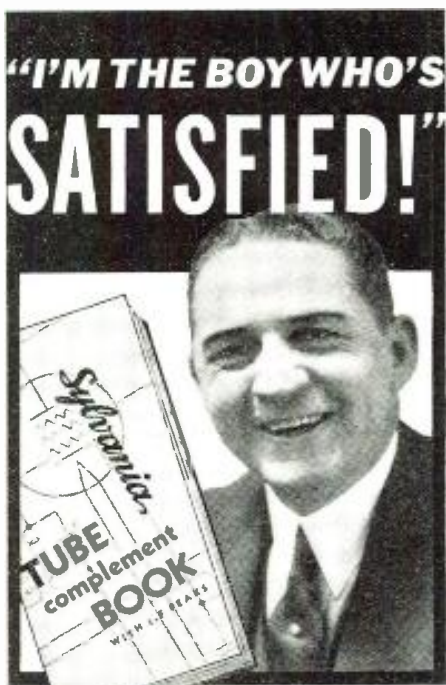

"I paid 25c for a tube complement book that has already repaid its cost many times!"

The Sylvania Tube Complement Book can save you money, too. For this manual tells before you leave to service a set, just what tubes you need to take. That means no return trips to the shop . . . no wasted gasoline . . . no loss of valuable time.

Servicemen like this tube complement book. It gives the tube complements of 10,386 radio models . . . contains the most complete and largest compilation of i-f peaks available . . . names and addresses of all active radio receiver manufacturers . . . helpful articles dealing with tube selling, etc.

And there are lots of other features too—all designed to be of help to servicemen. Send 25c and the coupon below for your copy of the Sylvania Tube Complement Book. Or get it from your local jobber.

Hygrade Sylvania Corp. Also Manufactures the Famous Hygrade Lamp Bulbs

SYLVANIA
 Set-Tested Radio Tubes

HYGRADE SYLVANIA CORPORATION
 Emporium, Pa. RN-48

Enclosed please find 25c. Send me my copy of your new Tube Complement Book right away.

Name

Address

City State

Dealer Service Man
 Amateur Experimenter

NOW!

PUSH BUTTON TUNING for EVERY Radio



Every customer you have is a prospect for a push button installation. This device makes ANY radio a modern, up-to-the-minute push button set. Installed in a few minutes. Increase your profits by selling this compact, fool-proof unit! Write today for complete details!

Model 86 for 2 Gang Var. Cond. Receivers LIST \$660 Serviceman's Net Price \$395	Model 86JA for 3 and 4 Gang Var. Cond. Receivers LIST \$725 Serviceman's Net Price \$425
---	---

- Only 3 leads to connect.
- 6 Push Buttons.
- Compact 5½" wide, 1½" high, 2½" deep.
- Adaptable for remote control.
- Manual control of receiver as well as push button control.
- Completely shielded by metal container.
- Unit complete with instructions, case, tube, station tabs, hardware, etc.

AUTOMATIC DEVICE MANUFACTURERS
Dept. 4A, 4243 West Ogden Ave., Chicago, U. S. A.

The Ham Shack

(Continued from page 47)

net 9 by 5 by 6 inches, equipped with a chassis 8½ by 4¾ by 1½ inches. The tube used is a 6K7 triple grid variable amplifier. Two plug-in coils are used, with a 35 mmfd. midget variable condenser for tuning. Regeneration is controlled by means of a 50,000 ohm potentiometer connected in the screen grid circuit. These are the only two controls on the front panel.

The chassis layout is extremely simple. The tube is mounted at the right front corner of the chassis and the coil socket one-half inch back of the middle of the center of the chassis. This arrangement facilitates short leads. All of the component parts and all wiring except the leads to the condenser and regeneration control are mounted underneath the chassis.

I constructed coils for both 10 and 20 meter bands. These are wound on standard five prong coil forms 1½ inches in diameter. Both the antenna coupling coil and secondary coil are wound on the same form. However, it is necessary to space the two coils at least ¾ inch, otherwise the degree of coupling will be too tight with most antennas, and regeneration unstable.

Four turns are used for the antenna coil on both the 10 and 20 meter coils. These turns are wound with No. 18 E.C. wire at the top edge of the coil, without spacing between turns. The secondary coil is wound by starting at the bottom end of the form and in the same direction as the antenna coil. Both secondary coils have a tap at about ¼ of a turn from the grounded end to provide the regeneration. The 10 meter coil has five turns of No. 18 E.C. wire with spacing of about three times the diameter of the wire between turns. The 20 meter coil is wound with the same size wire, but has 11 turns with the same spacing between turns.

For the sake of efficiency it is advisable to wind the coils so that the grid connection is made at the bottom end of the coil. This keeps the grid circuit away from the antenna circuit, thus reducing its effect on the regenerative action of the tube. Bias for the 6K7 is obtained through a cathode resistor of 500 ohms bypassed by a .01 mfd. mica condenser. The suppressor grid of the tube is grounded. The screen voltage is obtained from a voltage divider consisting of the 50,000 ohm potentiometer in series with a 25,000 ohm 2 watt resistor connected across the plate voltage supply. The potentiometer is bypassed by a .1 mfd. paper condenser. A high-frequency radio-frequency isolation choke coil is connected in the plate circuit of the 6K7 soldered directly to the plate terminal at the socket.

Coupling to the receiver is done through a .0001 mfd. mica condenser connected to the plate of the 6K7 and from the common ground point under the preselector chassis. A good grade shielded "twisted-pair" connects the unit with the receiver in order to minimize pick-up between the r.f. unit and the receiver.

Both filament and plate power for the preselector may be obtained either from a separate power supply or from the receiver itself. Little power is required to operate the unit, so no harm will be done by tapping the receiver power supply, 250 volts at 13 ma. being adequate.

Tuning should be carefully done, advancing regeneration control until a slight "plop" or hiss is heard. Reduce regeneration and tune for signal, on hearing signal, advance regeneration to threshold of oscillation or for loudest signal. A little practice will be required to enable fast tuning, but the results will be worth while in more stations heard.

NEW! — AN A. C. OSCILLATOR THAT HOLDS ITS ACCURACY

(Individually hand calibrated dials)

● **ACCURATE** frequency calibration assured by large 330° fully visible *hand calibrated* dial (No troublesome trimmers or padders used.)

● **UNIFORM** output level regardless of frequency assured by new WESTON A.A.C. circuit. Tuning oscillator or shifting frequency band does not increase or decrease signal strength.

● **CONSTANT** signal free from drift or shift in frequency assured by A.A.C. circuit which automatically regulates mutual conductance of oscillator tube.

● **COMPLETE** attenuation of signal on all bands assured by new WESTON design, thorough double shielding, and elimination of line feedback.

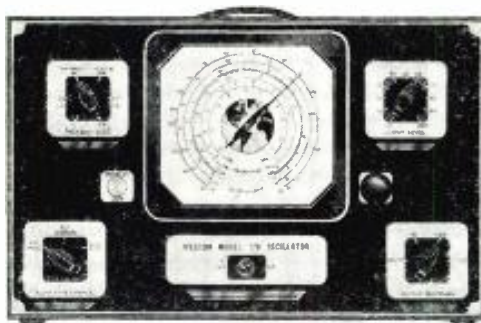

The above 4 features, heretofore available only in high priced laboratory oscillators . . . yet recognized as essential for thorough radio servicing . . . now are available *for the first time* in a practical service oscillator, at a *serviceman's price*.

The new WESTON Model 776 Oscillator gives you all "four", plus 12 additional features and refinements. In addition, it has been styled to match other recent and widely popular instruments in the WESTON line.

You will want all the facts on Model 776 . . . a serviceman's oscillator that fully meets WESTON's high standards of accuracy and durability. The coupon will bring you complete literature.

WESTON
Instruments

Weston Electrical Instrument Corporation
615 Frelinghuysen Ave., Newark, New Jersey

Send data on Model 776 Oscillator.

Name.....

Address.....

City.....State.....

Does Your Voice Have Umph?

(Continued from page 8)

they use and the flexibility of their voices. Oscillograms were made of the voices of former Premier Edouard Herriot of France, the late Ramsay MacDonald of England, Dr. Hjalmar Schacht and Guido Jung. German and Italian statesmen show natural radio voices around the 240 cycle mark with even flow of pattern in marked contrast to the voice patterns of many prominent American speakers.

Just how greatly the coldly scientific oscillogram record of a radio speech differs from the impression received when both the eye and the ear are appealed to, was recently demonstrated by several scientists who were divided into two groups for the experiment.

One group went to New York's Town Hall to see and hear three speakers in person. The other group listened to the speeches on the radio. After they had heard the broadcast they compared notes with the following results:

SEEN IN PERSON	HEARD ON THE AIR
1. Speaker B.	1. Speaker C.
2. Speaker A.	2. Speaker A.
3. Speaker C.	3. Speaker B.

When they examined the oscillograms of the three speakers, they realized the reason for the divergence of opinion. The voice pattern of Speaker C's was by far the best. But those who had seen as well as heard Speaker B. had been impressed by his personality and delivery—visual aids which had failed to go out over the air.

All of which explains why the star or celebrity who may go over big in a personal appearance may disappoint you on the air. The oscillograph discounts the glamor and personality and, like your ears records only what is heard.

In other words, you may have "umph" in your personal appearance, in your personality—but you definitely may not have it in your voice. But if it's in your voice, the oscillogram will show it up. Thus when a studio is seeking a good announcer they may make a test oscillogram of Jimmy Wallington's voice and try out only those applicants whose voices actually record a graph similar to Jimmy's. Similarly, Kate Smith's voice record may be classified as *this one has umph*, and then be on the lookout for any obscure voice that graphs likewise.

Next month! A prominent engineer discusses the Photocell, its operation, construction and various uses.

What's New in Radio

(Continued from page 52)

The Micamold Radio Corp., Brooklyn, N. Y., offers a tiny molded condenser, measuring only $\frac{1}{2}$ by $\frac{1}{4}$ by $\frac{3}{16}$ inch. The condenser section is made up of metal plates that are integral with the lead terminals and mica films. Any capacity from 2.5 mmf. to 50 mmf. can be supplied.

A dual-wave trap, type 813, consisting of both a series and a parallel resonant circuit, using the iron core type of radio-frequency coil to obtain a sharp resonance curve and tuning to two different carrier frequencies simultaneously is manufactured by J. W. Miller Co., 5917 S. Main St., Los Angeles, Calif.

Phileo Radio & Television Co., of Philadelphia, Pa., is placing four new auto-radio models on the market at competitive prices. The model 920 will feature greater freedom from interference.

Raytheon Production Corp., Chicago, Ill., offers four new RK tubes for use as power amplifiers, oscillators, or frequency multipliers. Specifically designed for the amateur for long life and the ability to withstand heavy surges. Type RK-11 is a triode power amplifier with a mu. of 20. The RK-12 is a zero bias modulator tube offering extremely low distortion. Output rating of both tubes 55 watts. RK-51 is a triode designed for use as a power amplifier. 170 watts output. Amplification factor 20. RK-52 is a high mu. zero bias triode having low idling current. Power output 135 watts.

One of the latest receiving tubes to be brought out by RCA is the type 6K8, a multi-unit all metal tube intended primarily for use as a converter in superheterodynes. A triode and a hexode unit are incorporated in the one metal shell. Typical operation: Heater voltage 6.3, current 0.3 amp. Hexode—P.V. 250, S.V. 100, C.G.V.—3v., P.C. 2.7 ma. Triode P.V. 100, P. C. 3.5 ma.

Eitel-McCullough, Inc., San Bruno, Calif., announces two new rectifiers, types RX 21 mercury-vapor rectifier and a KY 21 mercury-vapor grid-control tube. Operating characteristics for both tubes as follows: Filament voltage 2.5 volts, filament current 10, amperes, peak inverse voltage 11,000 volts, peak plate current 3, amperes.

The Automatic Devices Manufacturers, 4243 W. Ogden Ave., Chicago, Ill., introduces an automatic push-button tuner of anti-capacity variety with specially designed condensers. In operation the push-button switches connect these to the oscillator and antenna circuits of the radio receiver.

Step Into a Good PAYING JOB in RADIO

I Can Train You AT HOME

to make \$35.00 to \$75.00 Per Week



I'LL PROVE IT!

Actually Set You Up For A Profitable Business

Here's the greatest opportunity you've ever had to enter the fast moving Radio Industry. Thousands making jobs for properly trained men. If you are an ambitious fellow, I can train you for a good paying full time or part time job . . . with a big future ahead. My training is distinctly new and different. It not only teaches all phases of Radio . . . it equips you fully for an actual start in your own Radio business.



Professional Outfit Given

Positively the finest equipment offered with any Radio Course is available to every Sprayberry student. Consists of All-Wave All-Purpose Analyzer, Rider Manuals (7,076 pages), Tool Kit, Electric Eye Outfit, Experimental Apparatus.

No Experience Needed Earn While You Learn



Sprayberry lessons are intensely interesting and easy to understand . . . thoroughly cover all branches and phases of Radio. Right at the beginning of your training, I show you how to get profitable spare time Radio service work. Moreover, I show you how to do this work efficiently. Thus you gain real practical experience and add easy cash to your bank account while you're learning.

THESE FELLOWS Made Good . . . So Can You!

Cleared \$150 in Spare Time
"Since enrolling I have cleared a net profit of more than \$150 in spare time alone. . . . And I am not one-half through the course yet. Finally, I cannot understand how you can give so much 'spare' for so little money." A. E. Landon, Northbridge, Mass.

Earn \$25 Monthly Spare Time
"I am now doing spare time service work as a result of your training. Make around \$25 per month in selling auto Radio receivers." George Herrington, B. C., Canada.

Don't "Wish" For More Money Train For It Now!

Wouldn't you like to be your own boss with a regular cash income? Why envy those fellows who have good paying jobs . . . who are building toward future security? They are no smarter than you. All that it takes is initiative.

Iron-Clad Money Back Agreement

You must be satisfied that my Course is exactly as represented . . . or it will cost you nothing. Why not cash in now in the spare time or full time job is waiting for properly trained men? Hundreds of fellows have made good. I cannot urge you too strongly to get started immediately in Radio.

Mahoney Got Job With Sears
"I found that after three months of study I was able to service sets in a much more professional manner. Business certainly showed an increase. I recently received an offer from Sears Roebuck which I could not have accepted without having had your training." Joseph Mahoney, Rhode Island.

SPECIAL SERVICEMAN'S COURSE

. . . Of an advanced nature for men already in Radio work. Explains newest methods, circuits and short cuts. Terms low as \$25.00 per month.

GET THE FACTS!

Mail Coupon Now

Sprayberry Academy of Radio, F. L. Sprayberry, Pres., 125-D University Place, N. W., Washington, D. C.

Please send me free copy of "More Money in Radio".

Name Age

Address

City State

Mail in envelope or paste coupon on postcard. If interested in Service Course, check here ().



TIME and MONEY

SAVE BOTH WITH THIS GREAT CATALOG

HERE'S the book that shows you how to save! 180 pages crammed full of the greatest "Buys" in radio today—parts, tubes, test instruments, ham rigs, and public address equipment, plus the famous Lafayette "line of 70" radio models for '38. In all, over 50,000 items completely described at prices you cannot beat. Write for **FREE** parts lists for any circuit described in this magazine. Send for your **FREE** copy of this catalog **NOW!**

WHOLESALE RADIO SERVICE CO., INC.
 NEW YORK, N. Y. • CHICAGO, ILL. • ATLANTA, GA.
 120 SIXTH AVENUE • 101 W. JACKSON BLVD. • 255 PEACOCK STREET
 BOSTON, MASS. • BROOKLYN, N. Y. • NEWARK, N. J. • JAMAICA, L. I.

WHOLESALE RADIO SERVICE CO., INC.
 301 W. JACKSON BLVD., CHICAGO, ILL. • 180 SIXTH AVENUE, NEW YORK, N. Y.
 (Mail to nearest warehouse)
 Rush **FREE** general Catalog No. 69-208 Reserve **NEW**
SPRING Catalog No. 71-209 Send **FREE** parts lists for.....

Name.....
 Address.....
 City..... State.....

PASTE COUPON ON PENNY POST CARD

Want a Job
(Continued from page 25)

with your fellow workers without getting the "cub itch" (that feeling that comes after the first time you make an announcement without getting called on the carpet). If you're doing O.K. then, why, we'll give you five a week. No, not five hundred. I said five—1-2-3-4-5!

It's true, but it's really not as bad as it sounds in print, so don't let it discourage you.

If you are sincerely enthusiastic about radio and want to be something in the industry, I think your own common sense will tell you whether or not you can deliver the goods. You'll have to love radio and everything about it. You'll have to be willing to work night and day, if necessary. In most independent stations your day will range anywhere from eight to fifteen hours. You must be willing to cast aside many of your outside interests for the sake of your work. You must be versatile, for announcing is only a small part of the duties demanded. If you want to win a place of distinction, you should be able to write, produce, direct, act and any of a hundred and one other items that will be expected of you if you are to be a valuable man and an asset to your staff. The money isn't always big, but if you're making your living the way you want to and if you're happy in your work, what more can you ask?

Let's go into the qualification angle a bit more in detail. I've told you what to expect, but I haven't offered much advice as to how to go about preparing yourself early in life for this chosen vocation.

The first item, of course, would be the voice. The tonal quality is not too necessary, although that is of importance.

I once worked with a lad who we shall know as Jimmy O'Shea. He had far from the best voice on the air from a standpoint of quality, but I think Jimmy will forgive me for saying that, when I add, he bubbled over with wit and personality, like a true Irishman. What his voice lacked in quality, it more than made up with a homely appeal that struck a note of friendship into the heart of every listener. His voice was interesting and his cheery manner made you want to know him as a friend.

Jimmy, the boy everyone said would never make a radio announcer, drew more mail than any other member of the staff, in spite of quality shortcomings. He had delivery, a friendly appeal and was one of the best ad-lib men in radio.

Jimmy was also ingenious. I recall one instance when he came in to open up the station in the morning. There had always been a designated spot in the reception room for the studio key and this particular morning the key was gone. The station opened with a commercial musical clock. At about three minutes before sign-on time Jimmy skidded into the reception room on one heel, making it right on the nose, as most announcers do on the dawn shift. The key was gone and the station had to go on. What to do?

The engineer set up an emergency mike in the audio control room and Jimmy ad-libbed a program about nothing in particular for 40 minutes! No script to work from, he gave his commercials from memory, talked about the weather, called upon some of his Irish wit and, best of all, held his audience throughout the entire period, until a key arrived to opened the studio and affairs returned to a state of normalcy. That's what radio men call batting "1000" under fire. Your true worth is judged by your actions during moments of emergency.

It is imperative that you speak clearly, bring out every syllable, without slighting a single one, and develop a smooth flow or delivery. Speech impediments, no matter how slight, are a great drawback for the aspiring announcer. The microphone seems to amplify any unusual characteristics. Stuttering has unfortunately prevented many young men, who were otherwise fully qualified, from becoming a part of the industry they loved most.

Education for announcerial ambitions plays an important role in overcoming many barriers along the way. I have been in radio for eight years and never has my knowledge of mathematics been of any notable assistance. Yet, on the other hand, languages, history, literature, drama and music are the very basis of every-day duties in any station.

It can be done, for I have seen many examples of self-educated men in radio today. One chap in particular, who left high school, furthered his education through merely his own efforts. He possessed a firm desire to enter radio as his life work. Today, after several years of hard work, he is a prominent member of a staff operating one of this country's finer radio stations.

Announcing is only a part of what will be expected of you. To seriously consider this vocation as his life's work, you should be interested in writing, program writing, advertising copy, dramatic scripts; this, and the capacity to be original and creative, makes the announcer all the more valuable to his employer.

Many of the aspirants think in terms



TIME PAYMENTS ON EVERYTHING WE SELL

Have all the radio equipment you want when you want it! A few dollars down will bring you the latest and finest equipment. Everything for the "Ham", Service Man and Experimenter. All at rock-bottom prices—ALL sold on convenient Time Payments. Send for your **FREE** copy of Wards 1938 Radio Catalog **NOW!**

MONTGOMERY WARD

Sound Systems, Inter-Office Communication Systems, Radio-Phonographs, Auto Radios, Etc.
 Testing Instruments, "Ham" Transmitters and Receivers, Kits, Parts, Accessories, Tools, Etc.

MONTGOMERY WARD
 Dept. RN-14, CHICAGO
 Please send me my **FREE** copy of Wards 1938 Radio Catalog. I have checked items above in which I am especially interested.

NAME.....
 ADDRESS.....
 CITY..... STATE.....

of special events announcing, mainly sports broadcasts from the scene of action. This type of announcing is merely being capable of painting a word picture of that which is being enacted before you. Naturally, it calls for a full knowledge of the particular type of event and a mind quick to observe. You must be able to translate what you see into a word picture to the extent that it comes through the loud speakers a vivid living story which never for a minute loses its sequence.

So many young chaps think of specializing in a single type of announcing. What they fail to realize is that of the vast industry, of which they desire to become a part, almost 85% are connected with either independent or network outlet stations. These range from 100 watts up. Only a small percentage are in a position to specialize. Even those who do now, without a doubt, attained that position by gradually working up from the bottom and the only factor that ever advanced them was their versatility, thus boosting their own stock over the single type announcer.

In fitting yourself for a position along this line I can't stress too much the necessity of always keeping cool when caught in tight spots on programs.

I recall one instance when I was sent to the roof of the building in which our studios were located. We had strung a line up there and it was my assignment to give a description of three airplanes that were scheduled to perform stunts over the main part of town.

I had just signed off a dance remote from a local cocktail-grill and ran all the way back to the studio to make it on time. The dance job wound up at 6:30 P.M. and at 6:45 P.M. on a scorching summer afternoon I was perched on the uppermost point of the Commerce Building.

The engineer gave me the signal and I began the unusual program. A gust of wind tore the continuity out of my hands, leaving me entirely on my own. This was only the beginning. The planes flew down over the main part of town, then swiftly headed westward out over the bay—and *out of sight*, leaving me with 15 minutes of scheduled time to report the thrills of airplane stunting!

For fifteen of the longest minutes I have ever experienced on the air, I described an imaginary picture of the sun and what I knew the planes were supposed to be doing. Harold Roess, the man on the control board downstairs, sensed the predicament and added a little atmosphere by fading in an airplane sound effect to back me up. That's an example of the difficulties sometimes

faced in broadcasting, and when I say that it's working under pressure, I mean just that.

There isn't a business in the world where a group of people are more closely associated than in the radio business. You are all working under the same roof and under a constant nervous strain. A tension from morning 'til night. If you only do an ordinary job on the air, but are tolerant and understanding with those about you, you can be sure of a long-time job.

There's not a great amount of glamour to the work. The glamour of it all ceases after the first few weeks. How-

ever, it's replaced with something finer than the original. You feel perhaps as you read a script gag, somewhere a lonely heart has been brightened and a bit of sunshine and laughter may have found its way into a depressed soul. As you read news bulletins that may shock or bring joy to the world, you have that feeling of telling the world the one thing they are waiting to hear. In short, radio announcing is a man's business, serious, vital and necessary. It's a long trip to the top, but, for that matter, so is any profession. Do not be discouraged, the reward of success will justify the hard climb.

-30-

GOVERN YOUR NEXT INSTRUMENT PURCHASE BY THE OPINION OF Men Who Know!

Read what 6 famous radio engineers have to say of Supreme instruments! Then—see these very same instruments at your parts jobbers. Look them over carefully. Test them to your heart's content—We know you'll be a Supreme booster, too, after that!

EASIEST INSTALLMENT TERMS!
And, remember, you can buy any Supreme instrument on Supreme S. I. C. terms—the world's easiest installment terms! See your jobber!

JUST OFF THE PRESS!
FREE ILLUSTRATED 1938 CATALOG. Write for it.

SUPREME INSTRUMENTS CORP.
GREENWOOD, MISSISSIPPI, U. S. A.
Export Dept., Association Exporters Co., 145 West 45th St., New York City
Cable Address: LOPREH, New York.

Testimonials and Engineer Photos:
 - **LEE DE FORREST**: "Model 502 has almost super-human ability to separate 'Good' or 'Bad' tubes regardless of type, number of elements, or filament termination."
 - **KARL W. MILES**, Chief Engineer, The Hallicrafters, Inc.: "I am particularly glad to see SUPREME introduce so efficient and reliable an instrument as the Model 541 Set Tester."
 - **McMURDO SILVER**, President, McMurdo Silver Corp.: "I was really amazed at the excellence and flexibility of Model 551 Analyzer considering its very low price."
 - **HENRY L. ARGENTO**, Field Engineer, Raytheon Production Corp.: "Supreme is to be congratulated on the fine instrument they have built in the Model 501 Tube Tester."
 - **ALFRED A. GHIRARDI**, Radio Technical Consultant, Radio & Technical Publishing Co.: "Model 581 Signal Generator is a distinct and important contribution to rapid, intelligent and scientific radio service work."
 - **WM. L. DUNN**, Chief Engineer, Belmont Radio Corp.: "I have found that the Supreme Model 546 Oscilloscope is one of the most complete, accurate, perfectly engineered service instruments I have ever used."

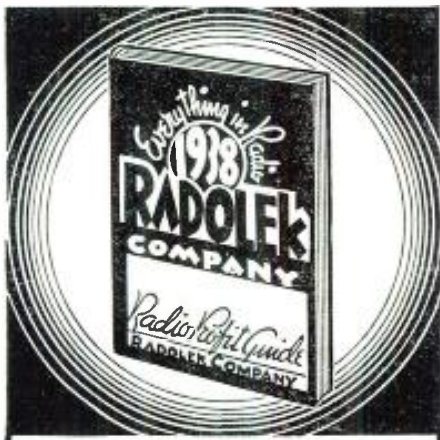

Everything you need in radio. It's all in this new **RADOLEK RADIO PROFIT GUIDE**. Every repair part for every receiver. Newest radio receivers. New 1938 model public address amplifiers, outputs for 5 to 100 watts. New model public address speakers. Test instruments. Technical books. Special equipment. Leading standard brands. Every item guaranteed. It must be right or we make it right.

And everything under one roof. You get what you want promptly, and exactly what you want. Radolek's immense stock plus Radolek's efficient organization insures you fastest service. 25,000 service men depend on this service and benefit by Radolek's lowest prices. Send now for your copy of Radolek's Radio Profit Guide. It will help you make more money.

---RADOLEK---

601 W. Randolph, Chicago, Dept. B-16

Send me the 1938 Radolek Radio Profit Guide FREE.

Name

Address

Serviceman? Dealer? Experimenter?

ELGIN PRESENTS ...
1938's Outstanding Line
Model 801 Volt-Ohmmeter

A handy pocket tester that has proved indispensable to many servicemen and experimenters. Makes use of a rugged D'Arsonval moving coil meter with 2% guaranteed accuracy. Accurately tests: 0.5 50 500 and 1000 volts D.C. Resistance measurements in two steps 0.500 500000 ohms. 0-1 Milliamperes foundation meter. Serviceman's Net Price **\$5.75**



Model 950 All-Purpose Unit



Probably the greatest value ever offered in test equipment. Offers a complete and accurate value test of all tubes released to date, plus volt-ohm and milliamperes tests. Servicemen who are looking for this type of instrument cannot afford to pass up this wonderful buy. Tube Tester Highlights: Neon short test; separate section tests: "Good"—"Bad"—Test A.C. and D.C. readings similar to Model 801A described above. Serviceman's Net Price **\$19.95** in portable case.

Send for General Catalog

TRY-MO RADIO COMPANY, INC.
85 Cortlandt St., New York City, N. Y.
"This Is Our Only Outlet"

Studio Briefs

(Continued from page 42)

changes before taking to the air Wednesday night.

He isn't the first one to use it. Eddie Cantor used it when his CBS programs originated in New York and it's quite likely someone else did it before that. But Bernie, like Cantor, believes that regardless of the trouble and expense, it pays to take every precaution against the program providing a single dull moment.

WMCA Streamline Equipment

STATION WMCA'S new studios on New York's famous Broadway boasts of "streamlined control equipment" said to mark the latest step in technical design. The highlight of the new equipment, manufactured by RCA from the station's own specifications, is a style of studio control desk which holds all of the technical apparatus.

The material encased within the desk itself includes amplifiers, relays, power supplies, switches, "talk-back" telephones and the inevitable clock. An extension provides working space for a production man who desires to check the script and make notes. The volume indicators are illuminated and a light signal system replaces the more cumbersome telephones for communication with the master control chamber.

Movie-Radio Merger

THE interchange of talent between radio and the talkies seems to be bringing about a partial merger of the two great entertainment mediums that may lead to still closer ties with the approach of television. Two movie firms—Warner Brothers and Metro-Goldwyn-Mayer—are producing radio shows for commercial sponsors.

William B. Lewis, program chief of CBS, speaking on the talkies' invasion of radio, said:

"We are both in the business of providing popular, large-scale entertainment. Beyond that, you cannot say that we are in a competitive business. Because we are engaged in the same

general work, we are in an ideal position to work together for the betterment of the particular entertainment each of us tries to produce. We want to continue to use Hollywood 'big names', Hollywood stories, and Hollywood music. On our part we are glad to see radio talent given its 'chance in the movies'. And we are particularly anxious that, through intelligent cooperation, we may improve the quality of the work that both of us are striving to do."

Radio Goes Intellectual

BOTH NBC and CBS have taken big steps towards improving educational radio programs. The NBC signed Dr. James Rowland Angell, former president of Yale University, as educational counsellor and followed that honor by electing him to the network's board of directors.

CBS formed an adult education board which includes some of the foremost pedagogical names in the United States. Professor Lyman Bronson, of Teachers College, Columbia University, heads the CBS board as chairman.

Just what results these moves will gain stands to be seen. Many observers have felt that radio education must be fed in sugar-coated doses and should not carry the label of "education" at all to achieve greatest listener appeal. Educators have often complained that broadcasters show considerable shortcomings in their educational programs and, likewise, broadcasters were none too pleased with the manner in which classroom instructors handled a microphone. Perhaps with closer cooperation the two elements will find some harmony and practical results.

Stars Change Sponsor

WHEN Amos 'n' Andy change sponsors, that's news!

It's several weeks since the blackface pair switched from Pepsodent to Campbell's Soup and listeners are still amazed at the fact that no change took place in the program. Usually, when a series switches sponsors, the new backer brings his own ideas to the show and demands drastic alterations.

The new sponsors of Amos 'n' Andy were wise enough to know that listeners would resent any change or break in the series that will be nine years old next August. Even Bill Hay, the original announcer, remained with the air show which continues to be heard at the old time.

Freeman Gosden and Charles Correll, who respectively portray Amos 'n' Andy, certainly occupy a prominent place in the line of suggested candidates for radio's hall of fame. It's nice to see a new sponsor keep their original program intact. No listener would have wanted it otherwise.

Send for your copy TODAY

Do You Like RADIO

TELEVISION, SOUND & ELECTRICITY

You men who want to know the true facts about employment opportunities and requirements in radio and related industries should have National's new book—40 pages of information and illustrations.



NATIONAL SCHOOLS

NATIONAL SCHOOLS

Dept. RN-4 4000 So. Figueroa Street, Los Angeles, Calif.

Please Send Free Book

NAME _____ AGE _____
ADDRESS _____
CITY _____ STATE _____

Is Television Here?

(Continued from page 17)

they have not stopped to think that it is now time for them to do their share.

America needs men to give it the split-second television service it will soon have on a national scale.

**England Far Ahead in Television,
Says Noel B. Gerson**

TELEVISION isn't something for the future to be dreamed of in the Sunday supplements. Television is here—today. But that's the whole trouble—it isn't here at all. It's in England.

For more than a year two daily television programs of one hour each have been broadcast from London by the British Broadcasting Company. Thousands of Englishmen have television sets in their homes, and the number is increasing daily.

The average Londoner is as complacent about television as he is about a regular B.B.C. broadcast, or about his daily ride to his office on the bus or the underground. He is amazed to learn that American television is still in the "experimental" stage.

The English public was introduced to regular telecasting in August, 1936, although some telecasting was done as early as 1932. The first programs, which were naturally rather crude, consisted of short vaudeville and variety acts, lectures, news-reel films and excerpts from American and British movies. Production has since been polished, and the scope greatly broadened. At the present, mobile units record special events as they occur, such as the Coronation of King George VI. or the tennis matches at Wimbledon.

In February of last year the London station at Alexandra adopted a single set of technical standards for public transmissions. This was the beginning of television in its present phase. The Palace was selected for the transmitter site because it stands three hundred feet above sea level, and still is in the heart of the city. Over fifty-five thousand square feet of space are utilized for television broadcasts. Masts erected on the roof gave the top aerial a height of six hundred feet. There are two aerials—one imposed on top of the other, the lower being the regular radio broadcasting unit.

Between five and ten thousand persons in London own sets. As the price of the receiving apparatus decreases, the audience is expected to increase proportionately. A good set may be purchased for a minimum of \$200 to \$320. Costs may be reduced below the \$100 mark in the next year or so. When that day comes, mass reception will begin. All of which adds up to one thing: tele-

vision is no longer a novelty or a freak—it is big business. And the television people in England will tell you that they are playing for keeps.

At the present time the B.B.C. presents one hour of television in the afternoons and one hour in the evenings. There is a great clamor for more, but so far there are too few "viewers," and the cost remains prohibitive. Nevertheless the Corporation continues its relentless research for improvements.

Among the most important of the recent developments has been the mobile unit. This consists of three vehicles, each about the size of a large motor bus. The most important of these contains the control room equipment, and is similar to the control room at Alexandra Palace. The unit has three cameras. When a television picture has been obtained in the mobile control room it must still be conveyed to the Palace and broadcast in the usual way. Consequently it was found necessary to lay a specially designed cable in the center of London.

Authorities and luminaries beg for a chance to telecast. With a pardonable tone of pride in his voice Mr. Frost said that, "Everybody in the Empire who is anybody has been on."

Television is still an extremely expensive proposition (although costs are less in England than they would be here). Scenery, costume and other production expenses double the normal cost of broadcasting. It must be remembered that this is not only radio, but audition PLUS vision. The operators of the only public television service in the world ruefully admit that the cost will always be greater. Even so, the public is paying approximately what it did for radio ten years ago.

The British disagree with us that television is only effective for very short distances. Being conservative, they guarantee reception for only a twenty-five mile radius, but privately admit that a decent set can almost always pick up programs at a distance of at least seventy miles. They said cautiously, that the big buildings of New York, Chicago, Philadelphia and San Francisco could increase the range even more. Recently, for instance, California police television type signals, said to have a range of only ten miles, have been badly interfering with police reception in Princeton, N. J.

The B.B.C. has two "freaks" on its record books—cases where programs, telecast in London, were picked up thousands of miles away, once in New York, and once in Johannesburg, South Africa. It would be hard to draw any conclusions from these phenomena, but one might hazard a fairly accurate guess that if such distance can be achieved accidentally, it won't be long

All the Latest Features **FOR QUICK, ACCURATE SET TESTING**



MODEL 1601 DeLUXE SET TESTER \$45.33 IN METAL CASE

Has modern front illuminated instrument . . .

A great advance in Set Testers is achieved by Triplett's new DeLuxe Model 1601 . . . has all the latest features, including many exclusive with Triplett . . . Plug-in type Copper-Oxide Rectifier . . . 25,000 ohms per volt D.C. . . . Large 4-inch square instrument with front illumination (a great aid for more accurate readings).

- D.C. Volts at 25,000 Ohms per Volt. A.C. Volts at 1,000 Ohms per Volt. Reads to 2,000 Volts A.C. and D.C. in 6 Ranges.
- Resistance Measurements to 20 Megohms. Condenser Tester to 30 Mfds.
- 50 Microamperes to 20 Amperes in 9 Ranges.
- New Single Zero Adjustment for Ohmmeter. All A.C. Operated—No Batteries Used.

Also available in attractive leatherette case with compartment for accessories. Net price \$49.33.



THE TRIPLETT ELECTRICAL INSTRUMENT CO.

154 Harmon Dr., Bluffton, Ohio

Please send me more information on Model 1601

Name

Address

City..... State.....

TRAIN FOR RADIO

IN 12 WEEKS
at COYNE



I will finance your training

Mail coupon today for all details of my plan whereby you can get training first and pay for it in easy monthly payments after your training period is over. *H. C. Lewis*
PRESIDENT

Actual Shop Practice



Here at Coyne you are trained on real equipment by the famous Coyne "learn by doing" method—under expert instructors—on a wonderful outlay of receivers, transmitters, testers and other Radio equipment. No books, recitations or useless theory.

Many Earn While Learning



I aid my students in finding a part time job by which they can help pay their living expenses while here. Send coupon for all details.

Lifetime Employment Aid

After you graduate you get lifetime employment help and in addition to this I give you a lifetime advisory and review service.

ELECTRIC REFRIGERATION

Training Included Without Extra Cost
This combination training (Radio and Refrigeration) can be of great value to you. Whether you go into business for yourself or get a job working for a Radio Sales and Service organization, the fact that you are trained in servicing Electric Refrigerators will be profitable to you. Many Radio manufacturers also make Electric Refrigerators and men with this combination training are much more valuable to these employers. You can NOW get this training without extra cost.

GET ALL THE FACTS

Send coupon today for all details of my amazing plan where you can get training first—then pay for it in small monthly payments spread over a 12 month period starting 60 days after your 12-week training period—Send coupon for details.

SEND NOW FOR BIG FREE BOOK

H. C. LEWIS, President
Radio Division, Coyne Electrical School
500 S. Paulina St., Dept. 48-3K, Chicago, Ill.
Dear Mr. Lewis: Please send me your Big FREE Book, and details of your Pay-After-Graduation Plan.

Name

Address

City State

MILLION TUBE TESTER

FEATURES

1. Emission
2. Metal Tubes
3. Shorts Hot
4. Leakage Hot
5. Resistance
6. Electrolytics
7. By-Pass Condensers
8. D'Arsonval Meter

MODEL CP

\$13.95 NET

Model TM—\$16.95 NET

3 1/2" square meter and continuous line voltage adjustment.
Deposit and the name of your jobber required on all direct orders.

MILLION RADIO AND TELEVISION LABORATORIES
577 N. UNION ST., CHICAGO, ILL.

before distance-televasting is perfected.

A normal television set costing \$300 has a screen ten by sixteen inches, although the new models have screens of almost twice that size. The screen itself is set on a slant, with a plate of glass in front of it, and on one's line of vision when seated. Incidentally, from sixteen to twenty persons can view a program comfortably seated in front of one machine. Furthermore, the lights need not be totally extinguished—as long as they are dim in the immediate vicinity of the receiving unit, that is sufficient.

The average afternoon London program when viewed might be as follows:

At exactly three o'clock, Big Ben, as he always does, would flash on the screen, chiming the hour. A pretty brunette in a finely patterned but clearly visible black lace dress would be introduced by an announcer. The screen shows them in black and white, although it is possible to get a machine with sepia tints, too. Most amazing of all is that the figures are seen clearly in three dimensions. The perspective and depth was something that is not expected.

The girl executes a series of Spanish dances. Next the head of Mme. Tussaud's Museum gives an illustrated lecture on clay modeling. Here is television at its finest. Such a talk on the radio alone might become dull. But during the speech, two assistants model a bust of Prime Minister Neville Chamberlain, and one can actually see what the man is talking about. So an ordinary lecture is turned into a living document.

For the third item, a full fifteen-minute British Movietown News-reel is shown. The last portion of the program is devoted to a production of an operetta by John Gay. Because of the smallness of the screen it is still difficult to show more than six characters on the stage at once. Television has already developed a technique of its own for lighting, make-up and scenery, so it is probable that the problem of exhibiting a large number of characters simultaneously will soon be solved, too.

The most vital question about television is this: the British have it: why can't we? Unfortunately there are a number of very sound reasons. The most obvious is the difference in the respective sizes of the British Isles and the United States. It is cheaper and simpler to erect stations in a country which measures its distances in hundreds of miles than one which must cope with thousands. One-fourth of the British population is concentrated in the London area.

Observers both in this country and in England have declared with remarkable unanimity that there is a grave obstacle

in the path of American television. This hurdle is the motion picture industry. Such an antipathetic attitude is logical—and only too human. Once television comes, Hollywood will be no more. The daily televised news-reels are sufficient proof of that.

It is comparatively simple for the B.B.C. to inaugurate a service like television because of the Corporation's unique character. There are no commercial broadcasts reaching the air-waves through the facilities of the B. B.C. Although privately owned and controlled, the company is closely affiliated with the government—our nearest comparison would be the relationship between Washington and the TVA. As a result there is full backing and a fat wallet behind any B.B.C. enterprise.

The Corporation gets most of its revenue from two sources, the listener being the most lucrative. Every owner of a radio or television set must pay the government an annual license tax. The various publications of the Company are also big money-makers. In this country television depends on the whims of commercial sponsors, and it stands to reason that these interests will not invest their money until they are sure of a safe margin of return. Which means that the problem of distance must be solved and the price of sets reduced appreciably before mass reception will make sponsorship profitable to the cigarette and chewing gum manufacturers.

Experiments in the United States led to the successful transmission of simple outlines in 1925. Two years later the American Telegraph and Telephone Company demonstrated the transmission of a picture by wire over a distance of two hundred and fifty miles. This was repeated by wireless shortly afterwards. There are three television "experimenters" in America right now—RCA, the Philco Radio and Television Corporation, and the remarkable Philo T Farnsworth.

RCA, which has transmitters on the top of the Empire State Building, and receivers in Radio City, put on a show for newspapermen just one year ago. The program was much like the one described a little earlier in this story. Vision was good, and the press came away from the demonstration enthusiastic. This ardor has been dampened somewhat by the subsequent lack of action. Your correspondent, for one, would like to know why nothing has happened here.

In 1929 and 1930 the British took the lead and are now thundering down the home stretch with not an American horse in sight. The Germans are planning on starting public telecasts in the near future. The French are already dabbling. How much longer must America wait?

RADIO PHYSICS COURSE

ALFRED A. GHIRARDI

High-resistance voltmeter. The function of a voltmeter is to measure the difference of potential existing between two points in a circuit. It should not influence in any way, the circuit or device across which the difference of potential exists. Since every voltmeter will draw some current from the circuit across which it is connected, this current really puts a load on the circuit or device being measured. If the circuit or device has quite some resistance, the meter current flowing through it may produce an additional appreciable fall of potential through it. In this case, the voltage indicated by the meter, is really *lower* than the actual voltage which exists across the circuit normally when the meter is not connected to it.

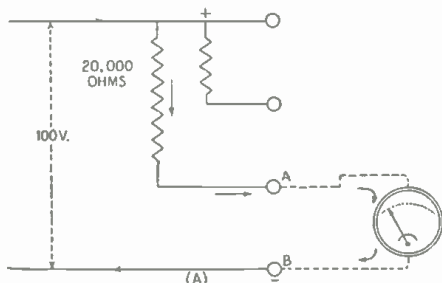

High-resistance Voltmeter

Thus in (A), suppose we are to measure the output voltage across the B battery eliminator circuit at A - B. An e.m.f of say 100 volts is applied to the circuit by the rectifier tube, and a resistor of 20,000 ohms is in series with the voltage tap we are connecting the voltmeter across. Suppose the voltmeter has a range of 150 volts and a total resistance of 1,000 ohms. The current actually flowing through the resistor and the voltmeter may be found by Ohm's law. Since the 20,000 ohm resistor and the voltmeter resistance are now in series we have:

$$I = \frac{E}{R} = 100 \div (20,000 + 1,000) = .0048 \text{ amperes, or } 4.8 \text{ milliamperes.}$$

This current flowing through the 20,000 ohm resistance causes a voltage drop across it of $E = I \times R = .0048 \times 20,000 = 96$ volts.

The voltage actually recorded on the meter then, is the difference between the applied circuit voltage and the drop across the 20,000 ohm resistor or,

$$\text{Voltage at A B} = E - (I \times R) = 100 - 96 = 4 \text{ volts.}$$

Thus the meter is not indicating the true voltage of the circuit, since it is drawing so much current from the circuit that the circuit voltage drops when it is connected. The meter reads 4 volts, whereas the voltage of this circuit when the meter is not connected, is 100 volts. Of course this is an exaggerated case.

The remedy for this condition is to use a *high-resistance* voltmeter, that is, one having a high resistance connected in series with its moving coil. Suppose the meter has a resistance of 1,000 ohms for each volt range of its scale (1000 ohms per-volt), then its total resistance is $150 \times 1000 = 150,000$ ohms. The current from the circuit just considered would be:

$$I = \frac{E}{R} = 100 \div (20,000 + 150,000) = .0006 \text{ amperes, or } .6 \text{ milliamperes,}$$

and the $I \times R$ drop across the circuit resistor is,

$$E = I \times R = .0006 \times 20,000 = 12 \text{ volts}$$

and the voltage read at A B would be $100 - 12 = 88$ volts.

This shows that the high resistance voltmeter gives a reading of 88 volts which is much nearer the true open-circuit or no-load voltage of 100 volts than before.

Since a voltmeter having a high resistance takes very little current from the line, the meter itself must be very sensitive, that is, it must require very little current to move its coil and pointer over full scale deflection. This means that either the permanent magnet must be stronger than in the usual meter, or else more turns of wire must be wound on the moving coil to obtain the same ampere-turn effect at a smaller value of amperes. The latter method is used in the construction of high resistance voltmeters used in radio work. The moving coil has several layers of exceedingly thin copper wire in order to produce the necessary magnetic field strength. Such meters have a resistance as high as 1000 ohms-per-volt. The term *ohms-per-volt* may be understood by considering the specific case of a 1000 ohms-per-volt meter having three ranges, 7.5, 150, and 750 volts. Then the resistance in series with the 7.5-volt terminal is 7.5×1000 or 7,500 ohms; that in series with the 150-volt terminal is $150 \times 1000 = 150,000$ ohms; that in series with the 750-volt terminal is $750 \times 1000 = 750,000$ ohms.

The "ohms-per-volt" value or R_{pv} is equal to the total resistance R_t of the meter divided by the maximum voltage E_t marked upon the scale considered, or

$$R_{pv} = \frac{R_t}{E_t}$$

Voltmeters having a resistance of 1000 ohms-per-volt are used extensively for voltage measurements in radio receiver power packs. Voltmeters having an ohms-per-volt value as low as 100 are used in ordinary electrical work, since the few milliamperes of current taken by the meter is not objectionable here.

It should be remembered that it is not possible to make a high-resistance voltmeter of the same range from an ordinary low resistance voltmeter by simply connecting a resistance in series with it, for this would reduce the current which flows through the meter, and would therefore reduce the deflections of the pointer. High-resistance voltmeters are more sensitive than the ordinary low-resistance type.

MAKES RADIO AS *Easy*

AS **ABC**

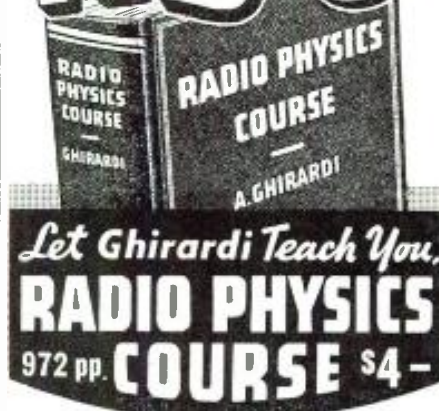

Let Ghirardi Teach You. **RADIO PHYSICS COURSE** 972 pp. \$4-

EASY as "rolling off a log" is this new double-quick Ghirardi method of mastering radio. No "lessons." No correspondence. Instead, a COMPLETE course on RADIO, ELECTRICITY, and SOUND—now available to you in one big 972-page home-study book. You just read it like you would a story. Ghirardi makes everything so clear and to the point, that you understand it perfectly the first time—even with no previous electrical training. His 508 specially-prepared diagrams and illustrations are marvelous for making important facts and explanations clear! It's as simple as A B C. Ghirardi gives you all there is to know about radio—yes, the equal of at least 36 ordinary books all rolled up in one! It's "the book of a million radio facts"—the world's radio knowledge between 2 covers!

WHAT YOU WILL LEARN FROM THIS BOOK!

- Sound, Speech and Music . . . Electrons . . . Electric Current
- . . . Electric Units and Circuits . . . Resistance . . . Ohm's Law
- . . . Batteries . . . Magnetism . . . Electromagnetism . . . Transformers . . . Inductance . . . Capacitors . . . Alternating Current Circuits . . . Filters . . . Electrical Measuring Instruments
- . . . Radio Waves and Radiations . . . Broadcast Stations . . . Receiving Equipment . . . Vacuum Tubes . . . Radio and Audio Frequency Amplification . . . Superheterodynes . . . Loud Speakers . . . Battery Operated Receivers . . . Power Supply Units . . . Electric Receivers . . . Automobile and Aircraft Receivers . . . Phonograph Pickups . . . P. A. Systems . . . Short-Wave Receivers . . . Photoelectric Cells . . . Television
- . . . Antennas and Grounds . . . Testing and Servicing Receivers . . . Sound Motion Pictures . . . Appendices . . . 856 Review Questions for Self-Study . . . AND LOTS MORE!

Ghirardi's **RADIO PHYSICS COURSE** is used in the courses of more radio schools than any other radio book in the world! It costs you only \$4. EVERY PENNY of your money back if not fully satisfied! GET IT NOW and start your radio training AT ONCE! It's EASY this way!

Snip this Coupon out!
-MAIL IT NOW!

RADIO & TECHNICAL PUBLISHING CO.
 45 Astor Place, New York, N. Y.
 Dept. RN-48

Send my RADIO PHYSICS COURSE (972 pp.) for \$4.00. (Please include postage.)

Send free circular describing this book.

Name _____ State _____
 Street _____
 City _____

MONEY-BACK GUARANTEE!

LEARN RADIO TELEVISION

Midland's **RADIO TELEVISION** Color-Coded Extension Training fits you for better radio jobs—prepares for future television opportunities. Backed by 5000-watt Columbia base network broadcasting station, KMKR, graduates qualified to take Government operator's license exams. Lifetime employment service. All necessary equipment for "home laboratory" experiments furnished! 90 illustrated lessons, 19 laboratory manuals. After "home training," bus tickets to Kansas City for 4 weeks' intensive training in laboratories. Get facts—write for free catalog. **MIDLAND TELEVISION, Inc., Power & Light Bldg., 110-D W. 14th St., Kansas City, Mo.**

PRICES REDUCED

on two Brush micro-phones—BR2S and B-1. If your jobber can't supply you, write us.

THE BRUSH DEVELOPMENT CO.
 3311 PERKINS AVE., CLEVELAND, OHIO

Amazing!... MIDWEST'S ELECTRIC TOUCH BUTTON TUNING...

FACTORY-TO-YOU SAVES 50%

SHOW MONEY WHILE WORKING IN A STATION

ELECTRIC MOTOR DOES YOUR TUNING

20-TUBES
6 WAVE BANDS
only \$49.95 LESS TUBES
NEW LOW BASE PRICE CHASSIS

30 DAYS FREE TRIAL

TERMS AS LOW AS 50¢ A WEEK.

ONLY Midwest offers split-second Motorized tuning. Just touch a button on top of radio and FLASH!... your station comes in perfectly tuned, in one second. World-wide reception up to 12,000 miles. Super power and 101 advanced features bring in weak distant stations like locals and assure glorious crystal-clear concert realism. Famous Midwest Factory-To-You plan enables you to buy at wholesale price... to save up to 50%... to enjoy 30 days' FREE home trial... to pay as little as 50 cents a week.

Send for FREE 1938 Catalog
MIDWEST RADIO CORPORATION
Dept. PP11 Cincinnati, Ohio

PASTE COUPON ON 14 POSTCARD... OR WRITE TODAY!

MIDWEST RADIO CORPORATION
Dept. PP11, Cincinnati, O

Name _____ Address _____
Town _____ State _____

Send me your new 1938 catalog and complete details of your liberal 30-day FREE trial offer. (Special offer and prices prevail only when dealing direct with factory by mail.)

User-Agents Make Easy Extra Money. Check Here for details. Check Here for 1938 BATTERY catalog

Can They Hear You
(Continued from page 38)

wires. Turning into private drives, cemeteries and hayfields to make measurements sometimes results in lengthy explanations. But as a rule people are considerate, and when told what is being done are more helpful than antagonistic. Work in the city is largely confined to cruising from ball park to cemetery, then through the public parks, large vacant lots and the suburban areas. City work is never accurate, but a ring around the town will give a good idea of what to expect.

Steel buildings cast a shadow. On the side toward the station the signal intensity will be great, on the other side almost nothing, while a block or two farther beyond it will again be normal. In a large city this means the continued blocking of the signal finally results in a dead spot. Notice how the area directly southeast of Chicago gets practically no signal from WJJD, due to the absorption of the Loop.

Watercourses and some veins of soil prove highly conductive, resulting in a long finger of high intensity leading out. Several radiating areas such as this may give the field pattern the shape of a star.

Page kept driving northward, making his measurements until the intensity dropped well below .5 millivolt, which is considered the minimum for satisfactory reception. This took him almost to Manitowoc, Wisconsin. He now turned westward till he reached the end of the next radial he had laid out, then turning on this, he drove back to WJJD, measuring as he came. Reaching the station he turned and went out on the next radial, and so on. At last he found himself on the eastern shore of Lake Michigan, having gone as far around the circle as it was possible.

Zig-zagging back and forth across Wisconsin, Illinois, Indiana and Michigan to make one WJJD survey accounted for 2,000 miles of road work. This did not include the distances traveled going to points where work was started or left off each day.

Some stations want daylight surveys, others night, some both. Others require more complicated measurements by means of automatic recorders set up at predetermined points and run till the desired information is obtained.

The operation of the intensity meter itself is involved enough, for first it must be turned on till the tubes heat. The loop and heterodyne controls are adjusted till the desired signal is picked up. Headphones may be used for this, but where possible it is best to use the car radio. When the meter is in resonance with the signal it heterodynes the radio, which is rather hard on nearby reception, but lasts only a few seconds. The loop is now rotated till signal pickup is at a minimum. Next the calibrated oscillator is turned on and adjusted to receiver frequency.

To standardize operation it is adjusted till the input reads 200. The attenuator, which is a bank of resistances, is set to its maximum, 50,000 ohms. The gain is adjusted till the output meter reads 150. The oscillator is then turned off. The loop is rotated till the signal is picked up and the attenuator is adjusted till the output meter shows a convenient value.

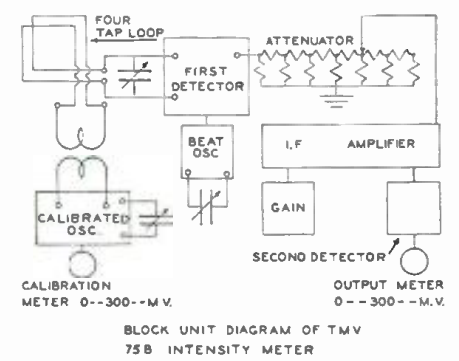

CODE CHAMPIONS AGREE!

"One week of Candler Training is worth months of undirected practice!"

Quick Results When You Practice Right!

You've got what it takes to be a speedy operator. Your sound consciousness has to be developed—that's all. Then you can snap out speedy code, and take it as fast as the best of them can send it. But you can't learn just by pounding a key! Ask any skilled operator. It's mental training you need. After just a few hours of Candler Personalized instruction, you'll know you're on the right track. You'll see why Candler-trained McElroy is World's Champion. You'll see why a 9 year old girl won the Class E championship with Candler training. You'll see why Candler men are so speedy on the air, and why they get the good jobs in radio. Don't deprive yourself of the thrill and success that comes with really "knowing your stuff."

FREE—Valuable Code Book

All you have to do to get the facts is write for Candler's FREE Book. Don't put it off. You may forget. This might easily be the turning point in your radio career if you write today!



L. H. McDONALD, WBCW Winner, A. R. R. L. C. Contest, Detroit, Convention Sept. 6, 1937 by copying 80 wpm without error. "Practice alone of any kind will not develop a fast operator. Candler makes available to all operators the Menzies training formerly associated by only a few, and then by a few."



Walter H. Candler "the man who knows the short cuts to true code skill."

CANDLER SYSTEM CO. Dept. N-4 ASHEVILLE, N. C.

bill, or would it be better to divide time among several smaller ones. If he desired to cover Northern Indiana, WJJD would admittedly be a poor bet. He would do much better to tie up with WIND in Gary. If on the other hand his interest lay in the dairying region of Northern Illinois and Southern Wisconsin, then by all means sign up with WJJD because the chart shows adequate coverage.

As long as a broadcaster "stays put" only one survey is needed. Modern transmitters are regulated as accurately as a watch. They never depart from the assigned frequency and the power is kept right on the line. Until repairs or alterations demand, there is no need of the field engineer returning, save for his customary inspection and checkup visits. A dozen engineers can easily handle all of the 600 stations now on the air. This is the most highly specialized branch of radio work and the hardest to enter because the requirements are so great only a few make the grade. Four years ago there were eight men practicing this engineering; today there are twelve.

The value of field intensity work is not confined to the getting of business alone. Sometimes the very existence of a station depends upon the engineer's word, and he must appear in court and testify as to his findings. In cases of lawsuits involving an action to close a station which appears to be unneeded because of overlap with another, or a suit by one party who claims he can better serve an area than the existing station, the evidence presented by engineers frequently decides the issue.

The engineer may well be compared to the old family doctor. He brings the station into the world, sits up with it nights, gets it organized and then makes periodic visits to see that it stays in good condition. Like doctors, most engineers keep their suitcases packed, know all the plane and train schedules and keep the gas tanks of their cars filled. Any hour of the day or night a call may come from a station in distress. It may cost the station five hundred dollars an hour to be shut down. Whatever the engineer may charge, it will be less than the revenue lost. He must come at once.

In the early days of radio every station operator was his own engineer. As the industry skyrocketed, the demand for specialized men became so great they could not afford to give their time to routine work, hence was born the new profession of radio consultant. Having grown up with radio, he knew it inside and out, experience had taught him more than books. This experience and reliability has made this small group an indispensable element.

-30-

Five Tube Special

(Continued from page 40)

to receive stations at 1500 kilocycles when the tuning condenser is turned so the plates are almost out of mesh. The oscillator trimmer takes care of this adjustment. Remember that each new position of the oscillator trimmer requires a new adjustment of the antenna trimmer. After completing these adjustments go back over them and make sure the set is working at its peak. The I.F. transformers may now be adjusted by tuning in a station at about 1300 kilocycles and turning the balancing screws on the transformers till the signal is the loudest. Go over this adjustment slowly two or three times to insure reaching the highest peak. If you receive stations twice on the dial it is a sign that these transformers are incorrectly adjusted, and you must start over.

After the set has been adjusted, and both ends of the broadcast band are coming in on the dial, it may be calibrated. This can be done by using an oscillator or if none is at hand by tuning in stations of known frequency and making the kilocycle markings on the dial with drawing ink. If a little time and care are used a very good looking job can be done. Some people prefer to mark the call letters of the stations themselves directly on the dial.

The speaker used with this set was a 12-inch cone of the permanent magnetic type. It should have 7000 ohms impedance to match the '33 power tube. A little experimenting with different speakers may result in much better tone. The speaker should be mounted in a suitable cabinet or baffle to allow it to reproduce the lower notes properly.

-30-

\$20 Transmitter

(Continued from page 20)

The little fone transmitter certainly was successful: with 9-watts input I worked all over Chicago, Gary, Hammond, Oak Park, Berwyn and Maywood. I even contacted an amateur in Advance, Mo. It was a pleasure to talk to the friends I had made with CW and I felt that the work necessary to build the rig was more than repaid by the enjoyment I got from it. After consulting further with "Chet" Horton, W9YQH and "Harry" Harrison, W9LIX, who had helped me in the design and construction, I felt that as soon as my year was up and I could get my Class A license, I would have no trouble in making WAC on 10 or 20 meter phone.

-30-

"LET ME TRAIN YOU at home FOR A GOOD RADIO JOB"



Get in Line for Big Money!

Radio is growing fast. Modern receivers require thoroughly trained experts for service and maintenance. You can become such an expert . . . right at home . . . through R.T.A. methods and begin earning money almost from the start of your course. In a very short time you will

Be the ONE Man in 1,000

who understand everything there is to know in order to give quick "strut-the" service to all kinds of receivers. You can be the one man who can take the service business away from the old-time radio "tinker."

No Experience Needed

Even though you know nothing about Radio now, you can quickly qualify the R.T.A. way to step right into a well paying position or start your own profitable business. Use your spare time and

LEARN AT HOME

Most R.T.A. members start making money right from the beginning. The special servicing equipment which is supplied without extra cost makes it possible. Don't wait, get started now. Write today for our interesting Radio Book FREE.

Don't Put It Off—Send Coupon Now

RADIO TRAINING ASSOCIATION OF AMERICA
4525 Ravenswood Ave., Dept. RN-48, Chicago, Ill.

RADIO TRAINING ASSN. of AMERICA
Dept. RN-48, 4525 Ravenswood Ave., Chicago, Ill.

Gentlemen: Send me details of your Enrollment Plan and information on how to learn to make real money in radio quick

Name

Address

City..... State.....

INCLUDED WITH OUR TRAINING



This efficient time-saving trouble-finding Circuit Analyzer and Resistance Tester helps you to make money without delay.

HANDEE
Tool of 1001 Uses

A Whole Shop Full of Tools in One

Grinds, polishes, routs, drills, cuts, carves, sands, saws, sharpens, engraves. Use 100 accessories. For home, shop or take to job. Plugs in any socket AC or DC 110V, 13,000 r.p.m.

Get A Demonstration at Hardware, Dept. Stores, Tool Dealers or order on 10 Day Money-Back Trial, \$10.75 and up postpaid, 3 Accessories Free, De Luxe Model \$18.50, with 6 Accessories. Catalog Free.

CHICAGO WHEEL & MFG. CO., 1101 W. Monroe St. Dept. AB, Chicago

New CRAFTSMAN Project Book—Learn more and profit with a Handee. Easy working plans for making many interesting and unusual projects 25c, stamp or coin.

For Faster Better Jobs

Ask your JOBBER for the NEW STANCOR "HAMANUAL"

16 NEW TRANSMITTERS 5 WATTS TO 1000 WATTS

STANDARD TRANSFORMER CORPORATION
850 BLACKHAWK STREET, CHICAGO

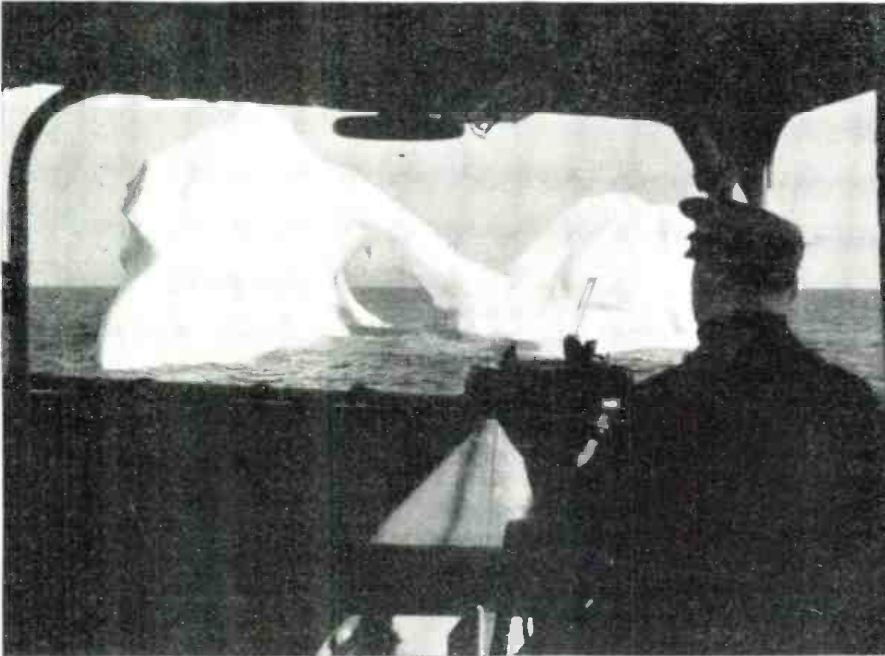

WITH THE ICE PATROL

*Don't
Miss!*

**THIS
THRILLER
IN THE
APRIL ISSUE**

Huge, silent, drifting icebergs, though the greatest hazard to ships in the North Atlantic, are among the most beautiful and exciting photographic subjects that a bountiful nature provides. Lieut. Comdr. N. G. Ricketts, U. S. Coast Guard, presents a vivid story of his thrilling experiences on Ice Patrol duty . . . supplemented with sensational pictures caught by his camera lens.

PLUS MANY OTHER BIG FEATURES

- **PORTRAIT LIGHTING FOR THE BEGINNER**—illustrated with many photographs and diagrams.
- **CECIL BEATON**—the famous "Peck's Bad Boy" of photography presents his own fascinating story about his bizarre photography.
- **GETTING THE EXPRESSION**—how to capture successfully those life-like expressions in portraits.
- **SALON SECTION**—a diversified selection of dramatic pictures caught by the modern rapid-fire camera.

THESE FEATURES AND DOZENS MORE APPEAR IN THE GREAT APRIL ISSUE

GET YOUR COPY AT THE NEWSSTAND NOW

MAIL COUPON BELOW

Popular Photography

POPULAR PHOTOGRAPHY, 608 South Dearborn Street, Chicago, Ill.

Enclosed find \$1. Enter my subscription for the special introductory offer of 6 issues of Popular Photography for \$1. Start subscription with _____ issue.

NAME _____ CITY _____

ADDRESS _____ STATE _____

I prefer a one year subscription at \$2.50 two years at \$4 \$1.00 extra foreign postage per year.

Hook, Line & Radio

(Continued from page 54)

every man knows before-hand his exact position on the stages, or the special duty assigned to him.

One man feeds the bait over the side and another is assigned to remain on the deck to unhook the fish as they come in. Then the remainder of the crew grab a "squid" which is a large, barbless hook covered with a cat skin, in the bottom of which are stuck a few white feathers. The whole is attached to a one foot piece of wire, which is then tied to a quarter inch line about ten feet long extending from the end of a bamboo pole.

When the fish are of small size, about seven to twenty pounds in weight, it is a simple matter to pull them up on deck, but when they are heavier it requires from two to four men to haul them in. When two men holding two poles attached to a single hook haul in tuna, this is called "two pull." Then there is "three pull" for weights from fifty to one hundred pounds, and "four pull" for heavier weights. It can therefore be seen that a technique developed only after many years of such work is necessary in order to gain that combination of speed and ease of handling.

This hauling up of large tuna is no easy matter, as the men must work fast and catch as many as possible in the short space of time the fish remain biting. There is a knack in heaving fish on deck in a manner which fills up the holds more rapidly than just hauling or pulling them up on deck. This is accomplished more by a delicate sense of touch and automatic action than by actual design or education. At the moment the fish strikes the hook the pole is snapped up and the continual motion takes on the semblance of an arc over the head of the fisherman landing them on the deck with a swish. The tuna is immediately unhooked by the deck man and the hook goes back into the briny deep.

After the fish are landed comes the task of salting them down and packing them rightly. The radioman continues to aid with this until he is ready to

CODE—TAPES FOR EVERY NEED



You can easily learn or improve your Radio or Morse Code—typical messages are sent you by the INSTRUCTOGRAPH, at any speed. Senior model with 10 tapes and Book of Instructions—\$20.25. (Shipped at low cost.) Junior model with 5 tapes and Book of Instructions—\$12.00 (Not rented). Complete oscillator equipment, lease battery, \$0.50. Send for full information today!

INSTRUCTOGRAPH CO., Dept. NR-4, 912 Lakeside Pl., Chicago, Ill. Representatives for Canada: Radio College of Canada, 863 Bay St., Toronto.

Buy on Cash or Terms—**HALLICRAFTER** and **R.M.E. SHORT WAVE RECEIVERS—SPEED-X** and **VIBROPLEXES.**

transmit the approximate time of return to the cannery and amount of catch. The average size boat holds about 125 tons of fish, although the smaller boats don't carry more than 50 tons.

The average size boat fishing for tuna runs from 40 feet in length by 10 feet in the beam to 100 feet in length by 30 feet in the beam and can easily be prey for the terrific tropical Chubasco storms which are prevalent around the usual fishing banks. Fires, because of lack of proper firefighting apparatus and improper life saving equipment, such as watertight doors or automatic alarms, are another hazard. When hit with any of the usual vagaries which boats sometimes encounter during their life, there is little chance of saving the smaller boats. At such times, the radio operator must display rare courage in the face of certain destruction because of the impossibility of repairing damages or fighting fire.

One such case is the "Belle Isle," which has never been heard from since it left the port of San Diego, California, with a crew of twelve men almost four years ago. There is the chance they may still be alive and living on one of the numerous small islands which dot the south Pacific and are very seldom visited by the regular boats. It is believed that she went through one of those Chubasco hurricanes (a term coined by the Portuguese tuna fishermen) in the Gulf of Tehuantepec, which is directly west of Acapulco on the coast of southern Mexico.

Living on an island for the rest of their lives was almost the fate of the crew of the "Continental" with radioman MacIntosh aboard. The boat caught fire and burnt to the water's edge somewhere off the coast of Cocos Island. After sending out his SOS signals which were dispatched literally in a raging inferno, he, with the rest of the crew, jumped into the one and only life boat. After almost two days of continual rowing the nearly exhausted crew managed to make a landing on one of those verdant tropical islands of the Cocos group. Although far from funny at the time was the incident when the life boat was pulling away from the ship's stern, they kept pulling for a quarter of an hour, making no headway from the blistering heat of the flaming holocaust, until Mac noticed the rope was still attached to the ship's sterning and cut loose!

The island on which they landed was well stocked with all kinds of game and edible plants, but the men suffered greatly from exposure and their clothing was in shreds by the time a party of British naturalists rescued them. Amongst them was a Canadian amateur operator who set up his equipment

and transmitted their plight to the United States Naval Station at Balboa, Canal Zone, who in turn sent out a destroyer which picked them up and returned them to their home port.

Then there was the "Enterprise," with Operator Vernon Hadley at the controls, which went aground off Point Tosca, close by the end of Lower California. After transmitting his distress signals, Hadley stuck to his ship although it was in imminent danger of being broken up on the coral reefs by the pounding ocean breakers. He was answered by one of the Dollar boats, which was too far away to reach them before the small vessel was pounded to splinters. In the meantime, one of the Japanese fishermen crew went over the side with a line in his teeth and with powerful strokes made the beach through the boiling surf. The others followed by pulling themselves along this line. They were later saved, as the radio had given out their position.

We could go on and on telling of the heroism of these men in their hazardous calling and their clear thinking without thought of self in the performance of their duty. Occasionally an operator has to pull himself out of a hole, which happened to James (Smitty) Smith, operator on the Japanese tuna boat "Columbus."

With the usual duties assigned to him as in the case of a full-share wage earner, "Smitty" was cleaning the ice-machine while at sea in heavy weather. His hand caught in the gears and was completely severed before he could pull it out or stop the machine. He immediately ran up to the radio shack, his stump bleeding badly, and transmitted the message which was picked up by KPH, who relayed it to the Coast Guard station. They dispatched a plane to the vessel and brought him back to the hospital. They did the same thing for Brother Cecil Johnson, who had his toe yanked off in a water pump below decks. In this instance, the Coast Guard plane made a flight of six hundred miles south

to pick him up for hospitalization.

Although lots of new gadgets are being invented to lighten the burden of the operators on tankers and passenger liners and in other radio operating billets, there do not seem to be any new ideas in the offing making the duties aboard a tuna boat more attractive.

You couldn't drag the tuna boat operator away from his boat with a team of horses; and if you'd say, "Want to swap?" he'd more than likely answer with a slow drawl, "Go peddle your fish up some other alley. I'm satisfied."

-30-

Here's what it takes



to insure dependable sound reproduction



Veteran, inventive engineers working with the finest materials and facilities obtainable produce AmerTran

Transformers. Clear, natural, dependable amplification under all circumstances is the result.

Bulletin No. 1002 describes our complete line in detail. Write

AMERICAN TRANSFORMER CO.
178 Emmet St. Newark, N. J.



NEW AUTOMATIC PUSH-BUTTON TUNER

TWO TYPES, FOR MOUNTING ON FRONT OR TOP OF CABINET

"HETRO - MATIC
Modernizes Tuning"

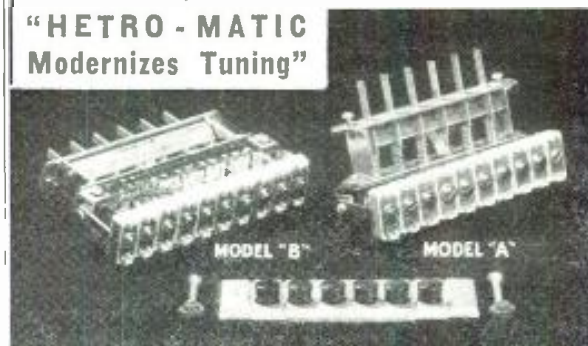

A Remarkable Value

ONLY \$3.75 Net Post-paid Anywhere in U. S. A.

Install on Any Radio

Quickly modernizes any superheterodyne radio to an Automatic Push-Button Tuner. Only 3 wires to connect. Isolating trimmers. Mounts on either top or front of cabinet.

Big Profits for You

Costs you only \$3.75 COMPLETE. You can easily sell it for \$15.00. Thousands will buy it!

Model "A" for TOP Mounting

Model "B" for FRONT Mounting

Specify which model you want. Free literature on request. Write or cable

HETRO ELECTRICAL INDUSTRIES, INC.
4611 RAVENSWOOD, CHICAGO, U. S. A.

FASTEST WAY TO LEARN **CODE**

Easy, Fascinating, LEARN by EAR
To Be a GOOD OP.



The New All Electric Master Teleplex Code Teaching Machine is exactly what thousands are looking for. No experience needed. Ideal for beginners - steps up WPM for ALL Ops. There is no guess work with Master Teleplex, because it records your sending in visible dots and dashes. You SEE and HEAR exactly how you are making your signals. You learn code the way you'll be using it - by SOUND. Complete course included at no extra charge. Used by many schools for teaching code. Low cost; easy terms. **MONEY BACK GUARANTEE.** Send now for booklet RN4, no obligation. Post card will do.

TELEPLEX CO.

72-76 Cortlandt St., New York, N. Y.

RADIO ENGINEERING TRI-STATE COLLEGE DEGREE IN 2 YEARS.

Complete Radio Engineering Course in 96 weeks. Bachelor of Science Degree. Radio (television, talking pictures and the vast electronic field) offers unusual opportunities for trained radio engineers. Courses also in Civil, Electrical, Mechanical, Chemical, Aeronautical Engineering; Business Administration and Accounting. Low tuition, low living costs. World famous for technical two-year courses. Those who lack high school may make up work. Students from all parts of the world. 35th year. Enter September, January, March, June. Write for catalog. 1648 College Avenue, Angola, Ind.

QUALITY recommends

Condensers

WET... DRY
PAPER
MICA... TRIMMER

Please Write for Details

SOLAR MFG. CORP. 593-401 Broadway
New York City



RADIO in Combat Aviation!

EVERY RADIO ENTHUSIAST WILL BE AROUSED BY THIS ARTICLE AND SHOULD NOT MISS THE

APRIL ISSUE

Remember the old blooper-dyne radio sets furnished by the government to wartime gunners and observers? Gone are those days forever. Today radio plays just as much an important part to Combat Aviation as it does to the average citizen who enjoys it in his everyday life.

The author, William A. Lentz, Jr., of the 21st Reconnaissance Sqdn., GHQ Air Force, Langley Field, Va., takes you on a typical flight, showing the importance of radio in Combat Aviation and just why the pilot's best friend is his radio.

POPULAR AVIATION 25¢

NOW ON SALE AT NEWSSTANDS EVERYWHERE

Power Pack Rectifiers

(Continued from page 29)

and the current applied, versus the voltage and current available from the d.c. terminals, is rather low. Overloads damage CuO rectifiers very rapidly.

A rectifier, more often used in modern power packs for supplying the above named applications, is the magnesium cupric sulphide rectifier. It is used in power packs for supplying power to operate pin games, coin machines, supplying power to miniature railroads; also with relays for controlling the shutter and flashing mechanism of cameras, and numerous other uses where a source of low d.c. voltage, high current carrying capabilities are required from the regular 115 volt a.c. mains. This unit contains the good features of the above with less of their disadvantages, and is approximately half the size of a copper oxide rectifier, of the same rating.

It has a lower internal voltage drop than any of the above rectifiers, better efficiency, and a much greater safety factor. Its depreciation may be calculated over a certain period of time. The active life of the magnesium cupric sulphide rectifier is approximately 10,000 hours, if the unit is not overloaded for long periods of time.

In a magnesium cupric sulphide, as well as in a copper oxide rectifier, ventilation is very important. These rectifiers work on the principle of allowing the current to flow one way, and then resisting the current in the opposite direction. Resistance creates heat, which must be dissipated in and

around the rectifier itself. The maximum rectifier temperature is a $90^{\circ} C.$ rise, over a 40° Ambient room, and exceeding this temperature materially reduces the life of the rectifier. Excessive voltage also creates an undue amount of heat, which is destructive.

Copper oxide rectifiers are used in bridge and full wave circuits. In a bridge circuit each unit has four junctions, very similar to a Wheatstone bridge. Two legs are used for a.c. and two for d.c. The smallest of these units has four sections. In a full wave circuit there are 5 junctions. 3.75 volts a.c. applied across this smallest of the units is the highest possible voltage. To increase the applied voltage, larger units with sections in series are used. This permits the application of higher voltages so that the next type bridge would have two sections in each leg of the bridge, or eight sections; and the next would be twelve, sixteen, twenty, etc. The number of these sections or disks, as they are called, also determines the amount of current that may be drawn from these units, while the size or area, the amount of voltage. Radiator fins are used on larger units so that more area is exposed to the atmosphere for cooling.

Magnesium cupric sulphide units are used as full wave rectifiers. Generally they are subject to the same conditions regarding current and voltage as the copper oxide units.

In all power packs used from usual mains, a transformer is required to convert this voltage to a voltage and current suitable for operating the load. The primary is designed for 110-115 v. a.c. operation, while the secondary should be designed for 130% of the expected voltage output. Overloads of approximately 500% can be momentarily used without bad effects. Therefore, the wire size in these transformers must be large, and the regulation should be good.

This article has concerned itself solely with rectifiers which are the heart of any power pack system. Of equal importance, naturally, are the transformers necessary to activate the rectifiers and depending upon the uses, the filter system.

In a future article soon to appear in RADIO NEWS, the transformer problem will be discussed. Meanwhile careful study of rectifiers in contemporary literature and textbooks is warranted because this article merely touches upon the high-lights of this fascinating subject.

A Dual Receiver
(Continued from page 41)

of 1/2" outside diameter. The outer conductor is grounded and connects to the input coil of the NC-81-X.

The pre-selector has only manual RF gain control, and is not on the AVC circuit of either the HRO or the NC-81-X.

Also in this pre-selector section is a wave-trap coupled to the first 6K7 and tunable by the lower left dial. This is useful for duplex work to minimize blanketing of the band by the transmitter only 30 feet away.

Of course this section can be used alone, but is ordinarily used in the combination. A few minor changes were made. A small bakelite panel was bolted to the left, upper back of the shield box covering two of the one inch ventilation holes. The square hole on the left usually used for antenna input, was blanked off by a square piece of sheet iron fastened with screws.

A special Faraday screen coupler was made up and bolted inside, just over the old square hole. The output 4-turn pancake coil of the Faraday screen coupler goes to the original antenna binding posts. The input 4-turn pancake coil with center point tapped and grounded goes to the jack C-1 which is a diagram of back of panel inter-section connections. Jack C-2 goes direct to the original antenna binding posts.

These two jacks make it possible to feed through Faraday screen or not as desired.

The audio output of the HRO, is the audio output of the entire composite receiver.

A slight change in the hf oscillator plus "B" supply of the HRO section was made. This oscillator is very stable after about 10 to 15 minutes warm up, but I needed something a little extra, so I used either a bank of 5-45 volt "B" batteries or the voltage regulated "B" supply that I made from an extra National power pack available with the addition of a couple of tubes in recently described regulator circuits for amateur use. Either the batteries or the regulated power are connected to the hf oscillator. With this change, the hf oscillator is extremely stable, even when the load on the regular HRO power supply is fluctuating widely due to a rapidly varying incoming signal.

With this change you can run the audio gain to loud speaker wide open if desired with no motor-boating even when using single or double crystal

filter for maximum selectivity. A similar change is made in the NC-81-X section.

Of course, it will be plain, that when using the entire circuit combination, the HRO section (3) is acting as two further stages of 1560. kc. IRF, and then two more stages of IRF on 456 kc., as in this composite operation, the input to the HRO section (3) is on 1560 kc. coming from the NC-81-X section (4) now to be described. All interconnections between the various sections are through low impedance concentric feeder link coupling lines with shielded plugs and the external conductors of the concentric lines are grounded.

The NC-81-X section (4) is the main tuning control of the entire composite receiver, as the HRO once set with its coil combination for 1560 KC. does not have to be touched. The large tuning knob of the NC-81-X is desk high and very conveniently located.

The output of the pre-selector section (2) goes direct to the antenna binding posts on the right end of the NC-81-X section through a plug and jack combination that was installed at right, back, on chassis.

The 1560 kc. output is taken as shown in the circuit. The ground return of the 6C5 (second detector of NC-81-X grid coil was unsoldered from its ground clip under chassis. A 1/2" hole was cut in bottom plate under chassis and a concentric cable line introduced into the chassis at this point. The outer conductor was grounded and the inner conductor connected to the lower end of the grid coil of the 6C5.

The coil trimmer condenser was re-adjusted for perfect alignment and it proved to be all very simple.

As the audio output of the NC-81-X was not used the speaker posts were shorted through a 500 ohm 20 watt resistor, all the tubes have to be in their sockets as all filaments are in series.

The second little switch operates a relay near the bottom of cabinet at back to change antennas. At the extreme right of control panel is the master switch for entire panel rack within its

(Concluded on next page)

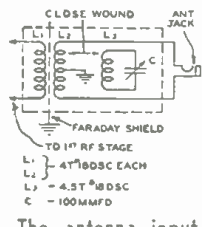

The antenna input.



... THE DIFFERENCE between a "Future" and "Just a Job" is ... TECHNICAL TRAINING

Of course you want to get your share of the opportunities that Radio offers. But, "good intentions" are not enough. You MUST be equipped with modern training to cope with modern problems. Right now is the time to start.

CREI home-study and residence courses are planned only for serious-minded men who know that it takes Training to qualify for, and to hold, the big jobs and salaries that go with them. Let us suggest the course best suited for you and the easy ways of paying for it.

Write for the CREI "TESTED PLAN"

Send free to serious-minded Radionics on request. Fully illustrated and examined with information. Write for your copy now.

CAPITOL RADIO Engineering Institute



RIGHT NOW—WRITE NOW!

CAPITOL RADIO ENGINEERING INSTITUTE
Dept. RN-4, 14th & Park Rd., Washington, D. C.
Please send me complete details and illustrated 48-page booklet—"A Tested Plan for a Future in PRACTICAL RADIO ENGINEERING."

Name
Address
City RN-4

CAN YOU REPAIR ANY MAKE OF RADIO SET?



"Yes Ma'm!"

...is your answer if you get FREE EQUIPMENT the

EASY NATIONAL UNION WAY

No need to wish you might have the fine modern equipment you see advertised... you can have it. National Union will give it to you with purchases of National Union radio tubes and condensers. It's easier now than ever with both tubes and condensers to apply against your purchase agreement. Find out... Ask your distributor. If you don't know who your nearest N. U. distributor is, send coupon or write - right now!

N. U. TUBES and CONDENSERS ARE QUALITY PRODUCTS

Thousands of top notches in the Radio Service Engineering profession are depending on National Union quality. It's the kind of precision and value that makes good friends for you. National Union quality will never let you down... The National Union guarantee is your assurance.

National Union Radio Corporation
570 Lexington Avenue
New York City RN-438

Who is the nearest N. U. distributor?
Name
Address
City..... State.....

RADIO ENGINEERING

RCA Institutes offer an intensive course of hi-h standard embracing all phases of Radio and Television. Practical training with modern equipment at New York and Chicago schools. Also specialized courses and Home Study Courses under "No obligation" plan. Catalog Dept. RN-38.

RCA INSTITUTES, Inc.
A Radio Corporation of American Service
75 Varick St., New York 1154 Merchandise Mart, Chicago

WANTED.. YOUR TOUGHEST RESISTOR JOBS!



IRC
INTERNATIONAL
RESISTANCE COMPANY

TRANSMITTING WIRE WOUNDS

They'll stand the overloads. No breakdowns, "opens" or coating cracks. No damage by moisture.

For more than five years, IRC Cement Coated Power Wire Wounds have been proving their superiority. Today you'll find them specified for the most difficult industrial, aircraft, naval and communications applications—jobs where there must be no resistor failures. Write for IRC Catalog No.42.

INTERNATIONAL RESISTANCE COMPANY

401 N. Broad St., Philadelphia, Pa.

RADIO'S LATEST SENSATION HARBRAYS AUTOMATIC PUSH BUTTON TUNING UNIT

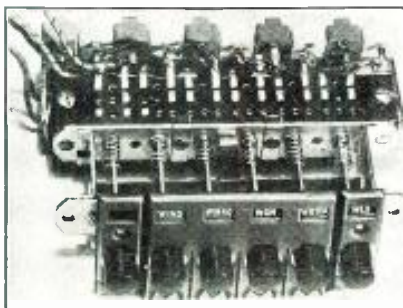

Modernize Radio Receivers

Easy to install, only a few wires to connect—Can be used on any Superheterodyne—Compact in size—Complete instructions and set of Call Letters for all Broadcasting Stations in the U. S. A. with every kit.

JOBBERS

Protected Territory Now Being Allotted
DEALERS—Modernize Your Inventory

Sample Unit will be sent
Prepaid for \$3.97. \$7.50
Send Check or M.O. List

HARBRAYS COMPANY

Exponents in
Radio, Television and Kindred Lines
4701-13 N. Sheridan Rd., Chicago

80 8th Avenue, New York
Tel. WAtkins 9-8125

main pilot light. Each section also has its own individual pilot light.

Panel section (7) is an HRO relay rack style power pack for section (3).

Panel section (8) at extreme bottom is a 7" panel with two National type 5886 table model power packs bolted to the back of this panel. The one on the left (from front) supplies the pre-selector section panel (2).

The one on the right was redesigned for automatic voltage regulation (see recent articles on automatic voltage regulated power supplies for amateur receivers.) This pack is used for the hf oscillators in place of the alternate "B" batteries. No other load is on this power supply.

Tuning the receiver is very simple.

The pre-selector is ordinarily set at mid-band. Section (3) is peaked on 1560 kc. and left alone. A signal is tuned in on section (4.) That's all there is to it.

Then just turn section 4 to maximum selectively and if there are bad heterodynes you can phase out the worst one with the phasing control of section (4.)

And if a heterodyne appears on the other side from the first, why just phase it out in section (3.)

Ordinarily, there is so much usable IRF gain usefully available that the RF gain of the section (4) is only set on point 4 to 5.

Also note that two AVC circuits in tandem are in use at all times which levels out signals in very nice shape all the time.

For DX, peak the pre-selector and advance the various RF gains. You'd be surprised how a quarter micro-volt signal can be brought up to "R-9 plus-plus," minus the usual noise.

Once again, you will notice that this composite receiver successfully uses *two crystal filters* effectively in series with the attendant double phasing possibilities which ordinarily can drop interfering signals on *both* sides of the wanted signal right down and out of the picture.

—50—

Short Wave Flashes

(Continued from page 50)

near 9.62; TGWA, Guatemala City, Guatemala, now broadcasting evenings on 9.685; TI4NRH, Heredia, C.R., testing on 9.55; TIWS (formerly T18WS), Puntarenas, C.R., on 6.37; YNLG, Managua, Nicaragua, on 6.61, and YNPR, Managua, Nicaragua, on 8.58 . . . W1XAL, Boston, Mass., has been granted additional frequencies of 11.73 and 15.13, while G. E. stations at Schenectady, N. Y., have been granted additional frequencies of 9.55 and 21.5, respectively.

TRANSMISSIONS OF INTEREST: For North America, over OLR2B (6.03), Prague, Czechoslovakia, Mon., Wed. and Fri., 8-10:35 p. m. . . Catholic broadcasts for America over PCJ (9.59), Hilversum, Holland, Sundays 8-9 p. m. . . English program over "Radio Fort-de-France," Martinique, Mondays 6:30 p. m. . . "DX Chatter Box" over W8XWJ (41), Detroit, Mich., Thursdays at 10:15 p. m. . . For North America, over HBL (9.345) and HBP (7.797), Geneva, Switzerland, Mondays 6:45-8 p. m. . . "Friendship Hour" in English, over HC1JB (14.43) and HCJB2 (8.84), Quito, Ecuador, Sundays 9-10 p. m. . . NBC pick-up from TGWA (9.685), Guatemala City, Guatemala, on Wed., March 30, 6:15-6:30 p. m. . . For North America, over EAR (9.488), Madrid, Spain (Loyalist), nightly 7:30 p. m. and Mon., Tues. and Thurs., at 9:30 p. m. . . for North America, over "Radio Nacional (10.37), Salamanca, Spain (Nationalist), nightly 9-10 p. m.

LAST MINUTE NOTES:

NEME (7.05), Merida, Mexico, off the air . . . COCH (9.42), Havana, Cuba, will soon inaugurate a new 5 kw transmitter . . . According to inside information, "Radio del Pueblo" (7.09), the unlicensed 200 watt station at Guadalajara, Mexico, will soon be forced to close down . . . HS8PJ, Bangkok, Siam, is again verifying reception. The attractive tri-colored new cards have the Siamese flag and emblem on them . . . ZIK2 (10.6), Belize, British Honduras, will soon issue verifications, according to announcements . . . E8SAK (14.02 and 14.24), Santa Cruz de la Palma, Canary Islands, retransmits EAJ43 at 3 p. m., Sevilla at 5 p. m. and Radio Nacional at 5:45 p. m. . . The new experimental transmitter of "Radio Coloniale" at Essarts, France, is now testing on 9.55 almost every Sunday from 9:30 to 11 p. m. . . The popular "Hawaii Calls" program, broadcast by KKH (7.52) and KIO (11.68), both of Kahuku, Hawaii, which was resumed on Sunday, February 27, is now being heard every Sunday at 9 p. m. EST . . . W1XAL, Boston, Mass., has a new identification signal consisting of the first six notes from the "Star Spangled Banner." . . . HAS3 (15.37), Budapest, Hungary, uses an aerial beamed on New Zealand.

COMING!

Microphone Manners—a feature article revealing the peculiar habits, good and bad, of radio personalities. In the BIG MAY issue of RADIO NEWS. Don't Miss It!

Broadcast Lingo
(Continued from page 9)

Cast: The performers of a show, or used as a verb, to select the performers.

Cat: A swing musician.

CGM: (NBC) Chimes are to be given in Chicago.

Character: Actor or actress with older voice who can do characterization; also, a role requiring characterization.

Clamaroo: Same as Clambake.

Clambake: A big show that falls apart or flops.

Clean it up: Command to rehearse a musical number or dramatic cast until production is perfect.

Clear a number: Get permission to use a musical number.

Clear a station: Make sure station is licensed to use specific music scheduled for program.

Cleared channel: Frequency assigned exclusively to one station.

Cliff-hanger: Adventure serial.

Clientitis: Trouble with sponsor.

Coaches: Instructors in voice or drama.

Cold programs: One that begins with no preliminaries or build up.

Cold drama: Dramatic sketch with no music.

Coming up: Ten seconds and we're on the air.

Commercial: A sponsored program.

Condenser mike: More modern than carbon, has two diaphragms close together that act as condenser, transferring sound, by vibration, to electrical impulses which changes capacity of condenser.

Control Room: Room separated by glass from studio. Program is directed from here.

Continuity: Text read by announcer. Sometimes used to mean written script for entire program.

Corn: Unsophisticated acting, playing, or singing. (Adjective is "Cornie.") Same as "Off the Cob."

Corn-fed: Performers notable for crudeness.

Corn-on-the-cob: Mouth organ.

Crock: Animal imitator.

Credit: Advertisers' message about product, also called "Plug."

Credits: Acknowledgements for material used on program.

Credit writer: The one who writes the credit or plug.

Creep: A performer who works up closer to the microphone during the show.

Cross Fade: Where one portion of a program fades out while another fades in.

Cross talk: Words picked up from telephone line or other source outside of studio.

Cue: Signal for music or actor, either by sign or verbally. As a verb, to signal performer to begin.

Cushion: Theme or other musical number, or commercial credit, that can be lengthened or shortened or omitted entirely to make the show finish on time.

Cut: Deletion of material to fit program time. Also, an order to cut show from air. Some orchestra leaders use it to stop music in cushion.

Dampen: Stop echoes in studio with sound absorbers.

Dawn patrol: Personnel of early morning broadcasts.

Dead book: Used continuity kept on file. Corresponds somewhat to newspaper "Morgue."

Dead mike: A microphone that is not connected.

Dead spot: Period of silence when program is supposed to be on air. Also called "White space."

Definition: Focus of tone.

Delight box: Instrument board in studio operated by announcer.

Dress: Final rehearsal, corresponding to dress rehearsal on stage.

Drooling: Filling time on program with talk. Usually by announcer who sees show will be short.

Dynamic mike: A microphone with 180° beam that operates on principle of reversing a dynamic loud speaker, sound moving the diaphragm, which moves a floating coil or wire in a magnetic field.

Echo chamber: Small room with sound reflecting walls used to give hollow sound in some broadcasts. The show is run into room with a loudspeaker, and picked up by broadcasting mike.

Eight ball: A round, black microphone, having 360 degree beam. It is often used for orchestra broadcasts by hanging directly over orchestra.

Electrical transcription: A high fidelity recording made on sixteen inch disc for broadcasting. Operating speed is 33½ r.p.m.

Engineer: Radio technician.

Facsimile: Transmission of drawings or text by radio.

Fade: To reduce volume of program by having performers slowly back away from microphone, or by reducing volume electrically. Also used in some studios to increase volume by "fading in."

Fader: Instrument used by engineer in reducing volume.

Fades: Signs to fade in or out.

Fairy godfather: A sponsor who is easy to please and doesn't interfere with show.

(Continued on next page)

COMMERCIAL HEADSETS
IDEAL FOR
Amateurs and commercial operators, ruggedly constructed, yet extremely lightweight. Write Dept. R-24 for information.
TRIMM RADIO MFG. CO.
1770 W. Berteau Ave. Chicago, Ill.

TRIAD
Radio Tubes
Triple Checked for Quality
TRIAD MFG CO., INC.
Pawtucket, R. I.
The Quality Name in Radio

6-VOLT UNIVERSAL POWER PACK
At Less Than Price of 6-Troun Synchronous Vibrator!
LISTS \$15.00 Operates 2 volt set from 6 volt storage battery, also operates 6 Volt house sets, auto sets, S.W. transmitters and receivers. Output, 180 Volts at 50 M.A. On 4 Volt cell supplies 120 Volts at 50 M.A. Housed in case 3"X4"X6 1/2". Shipping Wt. 6 lbs. **ONLY \$3.95 NET**
ARROW SALES COMPANY
Chicago, Ill.
27 S. Jefferson St.

FREE TO SERVICEMEN RADIO PROFITS
TELEPHON PHILCO EROSLY RCA Victor Grammer Emerson
BUY WHOLESALE—SELL RETAIL
Send for sales data TODAY! Sell 1938 nationally advertised radios for big profits. ACT AT ONCE! WRITE
RADIO DISTRIBUTING COMPANY
1065 NORTH HALSTED STREET CHICAGO, ILL. 4000
COMPLETE DISCOUNT SALES PLAN SENT

Centralab conquers 8 months of Rain!

... "climatic conditions here are severe ... and we recommend Centralab 100%."

H. H. WRIGHT, Gen. Mgr., DAY & NIGHT GARAGE CORP., Panama City, Rep. of Panama.

Down in Panama City where Mr. Wright is manager of the DAY AND NIGHT GARAGE CORP. it rains 8 months in the year ... and the humidity plays havoc with radios. That's why Old Man Centralab is happy to quote from Mr. Wright's letter.



Centralab
DIVISION OF GLOBE UNION, INC.
MILWAUKEE, WIS.

British Centralab, Ltd
Canterbury Rd., Kilburn
London N. W. 6, England

French Centralab Co., 118 Avenue LeFré-Rollin, Paris XI, France

Classified

Rate 16c per word, Minimum, 10 words.

BOOKS

FOUR new radio books—latest servicing methods. Complete technical reference library. Servicing instruments, fault location methods, trouble analysis. Indispensable. Sensational savings—four volumes, only \$1.95. (Regularly \$2.50.) Electronic Publishing Co., Box 323-A11, Lincoln, Nebr.

CORRESPONDENCE COURSES

USED Correspondence Courses and Educational Books sold or rented. Inexpensive. Money-back guarantee. Write for Free Catalog listing 4000 bargains. (Courses Bought.) Lee Mountain, Pisgah, Alabama.

DETECTIVES

DETECTIVES—Make Secret Investigations. Write George Wanger, 2640-R, Broadway, New York.

FOR SALE OR TRADE

WESTERN Electric 625A microphone, \$5, new. Box B, Radio News, 608 S. Dearborn, Chicago.

VACUUM tube hearing aid complete with trim headphone. Under \$50. R. Dorf, 2297 Sedgwick Ave., N. Y. C.

FOR SALE—Midwest 1936 receiver, 18 tubes, 12 inch speaker, perfect order, M. E. Fraser, 2485 Creston Ave., N. Y. C.

PATENT ATTORNEYS

PATENTS. Instruction "How to Establish Your Rights" and form. "Evidence of Conception" sent Free! Lancaster, Allwine & Rommel, 114 Bowen Building, Washington, D. C.

PATENTS—Advice and booklet free. Highest references, best results. Promptness assured. Watson E. Coleman, Patent Lawyer, 121 9th Street, Washington, D. C.

PATENTS AND INVENTIONS WANTED

INVENTIONS Commercialized. Patented or unpatented. Write Adam Fisher Company, 278 Enright, St. Louis, Missouri.

PERSONAL

WANTED original poems, songs, for immediate consideration. Send poems to Columbian Music Publishers, Ltd., Dept. 293, Toronto, Can.

FREE—Introductory sample De Cyr Face Powder and \$1.00 Personal Analysis by Jeanne French, famous Graphologist. Send handwriting and stamped envelope. De Cyr Co'y., 1514 CC, Prospect, Cleveland, O.

RADIO

RADIO Engineering, broadcasting, aviation and police radio, servicing, marine and Morse telegraphy taught thoroughly. All expenses low. Catalog free. Dodge's Institute, Elm St., Valparaiso, Ind.

QSL'S—New designs, \$30 for \$1.75. Samples. Wilbur Printers, Sec. 3, 732 Federal St., Chicago, Ill.

MALE & FEMALE HELP WANTED

M. M. Earned \$267, three weeks, raising mushrooms in cellar! Exceptional, but your cellar, shed perhaps suitable. We buy crops. Book free. United, 3848 Lincoln Ave., Dept. 279, Chicago.

SALESMEN WANTED

WANTED County Distributors. Excellent opportunity for earnings. Nationally advertised product. Large company. Dept. 257, Fry-Fyter Company, Dayton, Ohio.

"WANTED"

WANTED—Home 2-way telephone, for low battery operation. Aviation Products Co. 619 S. Federal, Chicago.

SPECIAL RATES FOR READERS

A special classified rate is now offered for readers (non-commercial) who wish to buy, sell, or exchange radio sets, transmitters or parts; 10 words for \$1.00. Extra words 16c. Payable in advance.

Fairy godmother: Dumb musical director.

Fake: Same as "ad lib."

Fight the music: To make hard work of singing.

Fill: Extra material added to program.

Fill in: A substitute program read in case of emergency.

Fish bowl: Observation booth for clients.

Flesh peddler: Talent salesman.

Fluff: To miss a cue or make other error in program.

Free lance: Writer or performer not under contract to one studio. Similar to free lance writer or painter.

Frying: Hissing sound.

Fuzzy: Program with poor definition or voice lacking in clarity.

Gag: Comedy line.

Gain: Volume increase from amplifier.

Gelatin: Thin, uncertain tenor voice.

Godbox: Organ.

Goose-neck: Microphone stand with flexible neck. Also, saxophone.

Grasshopper: Unimportant employee of advertising agency.

Grief: Trouble of any kind. Use about the same as in orthodox slang.

Groan box: Accordion.

Guide sheet: Program schedule.

Ham: Amateur radio operator.

Ham (verb): To overact.

Hambone: Second rate blackface impersonator.

Ham-fest: Talk session of actors.

Haywire: Defective equipment. Anything gone wrong, as "mike went haywire."

Heartbreaker: Audition of show before sponsor who is considering it.

Hold it down: Less volume.

Hot mike: Microphone that is turned on.

Hot switch: Quick transfer from one program source to another.

In the beam: In sensitive range of microphone.

In the mud: Dead, uninteresting delivery. Also sound of voice which has been spoken into a dead microphone and picked up faintly by a live microphone some distance away.

Ingenue: Actress with youthful voice, indicating age of 17 to 24.

International: Foreign short wave broadcast.

Jam session: Hot ad lib performances of popular music.

Juvenile: Actor with youthful voice, indicating age of 17 to 24.

Key station: Station where chain program originates.

Kill the mike: To turn off a microphone.

Kiss it: To hit an accented note.

Lady Macbeth: Tragedienne.

Lay an egg: To give a very poor performance.

Lead: An important role. Also, character with good voice to indicate age of 25-35.

Leg: One unit of several stations in a network.

Let: NBC code to indicate local transcription program.

Level: To test a voice to determine proper distance from microphone for best results. Also, electrical measure of volume.

Lick: Ad lib change in song.

Lid: A newcomer to radio operating.

Light and shade: Alternation in emphasis and volume to prevent monotonous program.

Line: A network.

Lines, lay: To arrange for outside pickups.

Live mike: Same as hot mike.

Live studio: Studio connected with transmitter.

Local: One station program.

Lock jaw: Used to denote singer whose voice sounds tired.

Log: Detailed account of every minute of broadcasting.

Long underwear: Sheet music; a long underwear gang is an orchestra playing from stereotyped music, as against a band which has its own arrangement.

Loss: Decrease in volume.

Madame Cadenza: Temperamental soprano.

Make system: To announce the network by name.

Make local: To announce local station's call letters.

MC: Master of ceremonies.

Middle breaks: To identify station near middle of program.

Mike: A microphone.

Mike hog: A performer who crowds closer to the microphone than other performers.

Mike mugger: Performer who works too close to the microphone.

Mike wise: Used to describe artist who knows microphone technic.

Mix: To blend sounds from two or more microphones.

Mixer: Panel for control of mixing.

More wax: Cut down the volume; sing softer.

Mushy: Poor definition. Similar to "in the mud."

Nemo: Program originating outside of studio.

Network show: Program broadcast over two or more stations.

Neutral: Musical background for announcements.

Nick 'em: Hit notes staccato.

NON: NBC code for "No Chimes."

Noodling: Tuning instruments, usually characterized by practice runs.

O. Henry: The climax sentence in a dramatic sequence, or the final speech of a scene or play. Also called "tag line."

Off: Sound not directed at microphone.

Off side: Gag not proper for radio, same as "blue gag."

Off the cob: Same as "Cornie"; unsophisticated performance.
 Old sexton: Bass soloist.
 On the air: Period show is being broadcast.
 On the beach: Out of a job.
 On the button: Same as "on the nose"; show running exactly on time.
 On the cuff: Appearing on program without payment.
 On the head: Show finishes exactly on time.
 On the nose: Show is running exactly on time; same as "on the button."
 One and one: One verse and one chorus of musical number.
 One and two: One verse and two choruses of musical number.
 One shot: Single program, not part of scheduled series. Same as "one timer."
 One timer: Same as "one shot."
 Out in the alley: Beyond range of microphone.
 On: Sound directed at microphone from point in microphone's beam.
 Outside job: Program from another studio brought to transmitter by telephone wires. Same as "nemo."
 Over: Program that runs longer than allotted time.
 P.A.: Public address system.
 Pancake turner: One who operates device for playing transcriptions or phonograph records.
 Peacock: An orchestra leader, to peacock a band—to lead an orchestra.
 Peak: High point in volume as shown by volume indicator.
 Pace: Speed of delivery.
 Pests: Radio fans in studio.
 Phonograph record: Sound recorded on ten or twelve inch disc, operated at 78 R.P.M. Lower in fidelity than transcription.
 Pick up: Point where broadcasts originate. Device for picking up sounds from moving record or transcription and converting them to electrical impulses. Sound value of program.
 Pick it up: Speed up show.
 Pick up a cue: Begin your lines as soon as preceding speaker finishes.
 Pipe: To transmit program over telephone wires.
 Platter: Transcription or phonograph record.
 Playback: Playing a fresh recording. Often done by performers who re-broadcast same show later in day to check on weak points.
 Play ons: Background music during introduction of performers.
 Plops: What happens when P and B are spoken too loud by performer.
 Plug: Mention of advertiser's product. As a verb, to build up a person or product by favorable publicity.
 Pound brass: To operate a key for

transmitting radio by code.
 Production: The complete job of building, organizing, and presenting a show.
 Production director: The one who is responsible for every portion of the program.
 PUM: NBC code indicating that show is to end with elixirs.
 Putty blower: Trombone.
 Ready: Unnatural acting or speaking which gives impression of reading instead of talking.
 Reading high hat: Reading script in a conceited or "high hat" manner.
 Record audition: Audition of recorded program, or making transcription of audition.
 Remote control: Program controlled by engineer outside the regular studio.
 Ride the gain: Control volume of output manually.
 Ride it: Ad lib, swing music.
 RM: NBC code for remote control.
 Rover Boy: Minor executive from advertising agency.
 Rmover: When program goes past scheduled time for ending.
 Schmaltz: Highly sentimental performance of musical number.
 Scoop: To get a first or exclusive on an important program or event. Same use as in newspapers.
 Scooper: Singer who slurs notes.
 Scoutmaster: Major executive from advertising agency.
 Script: The written text of a radio program. Contains full directions for sound effects, etc.
 Set up: Arrangement of microphones and performers for show. As verb, to prepare for transmission.
 Segue: Going from one musical number to another without break or announcement.
 Show: The entire broadcast program.
 Short: Program that does not fill scheduled time.
 Short voice: One without wide range.
 Signature: The music or sound that identifies a program. Same as "theme."
 Sneak it in: Start music or sound effect very softly and gradually increase volume.
 Sneak it out: Fade music or music slowly.
 Sock: Same as "tag line" or "O. Henry."
 Sound effects: Sounds produced by phonograph records or other means to create effects demanded by script.
 Sound man: Person who produces sound effects.
 Sound table: Table with props for sound effects.
 Song plugger: Publisher's representative who promotes use of music pub-

(Concluded on next page)

RADIO ENGINEERING DEGREE IN 2 YEARS

Intensive, specialized course, including strong basis in mathematics and electrical engineering, and advanced Radio Theory and Design. Modern laboratory, thorough instruction. Low tuition. Self-help opportunities. Also 2-year courses in Aeronautical, Chemical, Civil, Electrical and Mechanical Engineering. Terms open September, December, March, June. Catalog.

INDIANA TECHNICAL COLLEGE
 247 East Washington Blvd., Fort Wayne, Indiana

RADIO ENGINEERING.

broadcasting, aviation and police radio, servicing, marine radio telegraphy and telephony. Morse telegraphy and railway arcourt ne taught thoroughly. Engineer ne course of nine months' duration equivalent to three years of college radio work. School established 1874. All expenses low. Catalog free.

Dodge's Institute, Oak St., Valparaiso, Indiana



INKOGRAPH Pencil Pointed Fountain Pen

Point perfect for any style of writing. Excellent for carbon, ruling, and rapid work. 14K Solid Gold Point. Fully guaranteed. Only \$1.00 postage paid.

SEVAN CO., Dept. 18, 7 E. 42 St., New York City

RADIO IN IT S ENTIRETY!

"It's All" serves the trade with every need in radio—complete 160-page catalog of nationally known radio receivers, public address, parts, supplies and equipment. Orders shipped same day received.



COMPLETE CATALOG AVAILABLE

BURSTEIN-APPLEBEE CO. 1812-14 McGEE ST. KANSAS CITY, MO.

BREAKING ALL RECORDS

for price and performance Model 407
AC-DC MULTITESTER \$9.95

Write for Catalog N.

RADIO CITY PRODUCTS CO.

88 PARK PLACE NEW YORK CITY

Experimental Television

INVITES PIONEERS

• Still in its infancy, no one doubts the future of television—and if you would like to be in on the ground floor of a development that's bound to revolutionize American life, here is a course of study that will equip you to go ahead with it. Ask for information.

INTERNATIONAL CORRESPONDENCE SCHOOLS

Box 8283-T, Scranton, Penna.

Send me—free—information on subject checked:

Experimental Television

Radio Radio Service Man
 Radio Operator Electrical Engineer

Name.....

Address.....

How would YOU Like to SAVE up to 40% on Nationally Advertised RADIOS

Selling Nationally advertised Radios, such as Stromberg-Carlson—R. C. A.—Philco—Zenith—G. E.—Grunow—Emerson—Fada—Gard—Kadette—Crosley—DeLo and many other makes, is as easy as "rolling off a log."

With our new and enlarged 1938 Radio Catalog (Spring and Summer Edition) you have over 400 different models of Radio sets for home, farm and auto to offer, at prices ranging from \$7.95 to \$1,500.

In addition to all the standard Radios made by the leading manufacturers, this new spring and summer edition giant Catalog contains many electrical conveniences for the home and gift items. Special savings on Electric Irrigators, Vacuum Cleaners, Electric Clocks, Toasters, Food Mixers, Electric Razors, Air Conditioners and hundreds of other items that we know you'll be interested in. Send AT ONCE for your copy FREE OF CHARGE before the supply is exhausted....

Get This New 1938 Catalog FREE

also our plan on how you may make big weekly commissions in spare or full time. Experience is not necessary as our catalog describes fully each set and the instructions we furnish will help you make sales more readily. The discounts our salesmen make are as high as 40% off the list price and every set is shipped in a factory sealed carton, with a 3 year written guarantee.

Here is an offer open to you NOW. Pick the set you want and we will give you the salesman's big discount. This special inducement is offered so that you may have at least one set in your home or shop for display and demonstration purposes.

MODELL'S is the only Radio organization in the U. S. selling Standard make Nationally known Radio Sets in every market, town, farm. We have been in business for almost 50 years and have been selling radios for about 20 years, so you see you are doing business with a concern of responsibility and reputation.

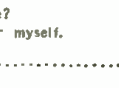

lished by his employer.

Sour: Off pitch.

Spiel: The advertiser's copy.

Split channel: Different sections of same network using different programs at the same time. Example: Red and blue networks of NBC.

Sponsor: The advertiser who pays for a commercial show.

Sponsored program: Show paid for by advertiser.

Spot broadcasting: Using one or more local stations for commercial broadcast by either transcriptions or local talent.

Spreader: Performer who takes more time during show than allowed in rehearsal.

Squash reducer: Recorder for making transcriptions.

Stand-by: Substitute program ready in case of emergency. Same as "Fill in." Also a warning to performers that show is about to begin.

Spieler: Announcer or commentator.

Squeak stick: Clarinet.

Station break: Announcing local station call letters after network program. Same as "Make the local."

Stick waver: Orchestra conductor.

Step it up: Increase volume. (Note difference from "pick it up" to increase speed.)

Stretch: Slow up to make show finish on time.

Sustaining program: Show sponsored and paid for by station or network, such as Columbia's weekly broadcast of Philharmonic Symphony Orchestra.

Tag line: Last line in scene or play, or climax sentence of dramatic sequence.

Take it away: Cue to begin program.

Talk in his beard: To speak with a muffled voice.

Talk down: Condescension on part of announcer. Similar to "writing down" by conceited writers.

TC: Columbia code for transcontinental broadcast.

Tear jerker: A sad play.

Theme: Same as "signature."

Thick: Poor definition of group of singers or instrumentalists.

Tight: A program which runs a few seconds over allotted time when rehearsed.

Town crier: Singer or speaker with too much volume.

Transition: Changing from one scene to another in show by change in music, description of new setting, etc.

Turkey: Very pretentious show which is a very pretentious flop.

Tying-in: Joining a network program already in progress.

Under: A program that does not fill allotted time. Same as "short."

Unilateral mike: Ribbon microphone sensitive on only one side.

Velocity mike: Same as "ribbon mike."

Video: In television, the sight channel.

Visual: A show with studio audience.

Wax: A record. See "recording."

Web: A network.

West of Denver: Unexplainable technical troubles or "bugs."

White meat: actress.

Whodunit: Mystery show.

Wood pile: Xylophone.

Wood chopper: Xylophonist.

Wood shed: Hard rehearsal.

Woof: Sound used by engineers in checking peaks.

Woof in cheap clothing: Announcer's term for engineer.

Wow: Distortion of sound on transcription or record.

-30-

TZ-40 Modulator

(Continued from page 43)

Connect the grids of the TZ-40 tube to the transformer. Since the plates of the modulator tubes are brought out through the tops of their respective envelopes, they will require two large grid caps similar to the ones used for type 866 tubes. The output of the modulation transformer is then wired to two standoff insulators, to which to connect the class C stage. The output impedances of this transformer are 3300, 4400, 5000 and 5880 Ohms. Class C stage must be run at such a current and voltage value as to accurately match one of these impedances.

The modulator is now ready for test. It has sufficient gain to operate directly from a crystal microphone. Connect a crystal microphone to the input channel. Disconnect the high voltage supply to the modulator tubes, and turn on the power to the speech and driver tubes. Place a pair of earphones across the output of the driver tube (the grids of the TZ-40). Advance the gain approximately to the half-way mark. Touch the grid of the 6F5. A hum should be present in the earphone. Speech should be heard without any difficulty and should be crisp, clear and without distortion.

If the pre-amplifier (speech input and driver section) is working properly, it is now safe to insert the modulator tubes in their sockets, and connect the modulator to the Class B stage. Load the Class B stage to the proper impedance as heretofore described, and with a monitor or with a receiver check the quality when the transmitter is actually put into operation.

If the diagrams and the suggestions herein contained have been fully complied with, the modulator quality will be excellent and a first-class audio system will result.

-30-

W. F. HALL PRINTING CO.

MAIL COUPON OR SEND POSTCARD TODAY TO OUR ADDRESS NEAREST YOU

Modell's

Since 1889

NEW YORK, N. Y.
58 Cortlandt St.

CHICAGO, ILL.
56 W. Washington St.

ATLANTA, GA.
57 Forsyth St.



MODELL'S, Dept. G-12,
58 Cortlandt St., New York City, N. Y.

Send me your New Spring and Summer 1938 catalog.

How may I increase my income?

I wish to purchase a Radio for myself.

NAME

ADDRESS

CITY..... STATE.....

PASTE COUPON ON PENNY POSTCARD

Read What TRI-TOWN RADIO AMATEUR CLUB Says About Their A. T. I. TELEVISION OUTFIT

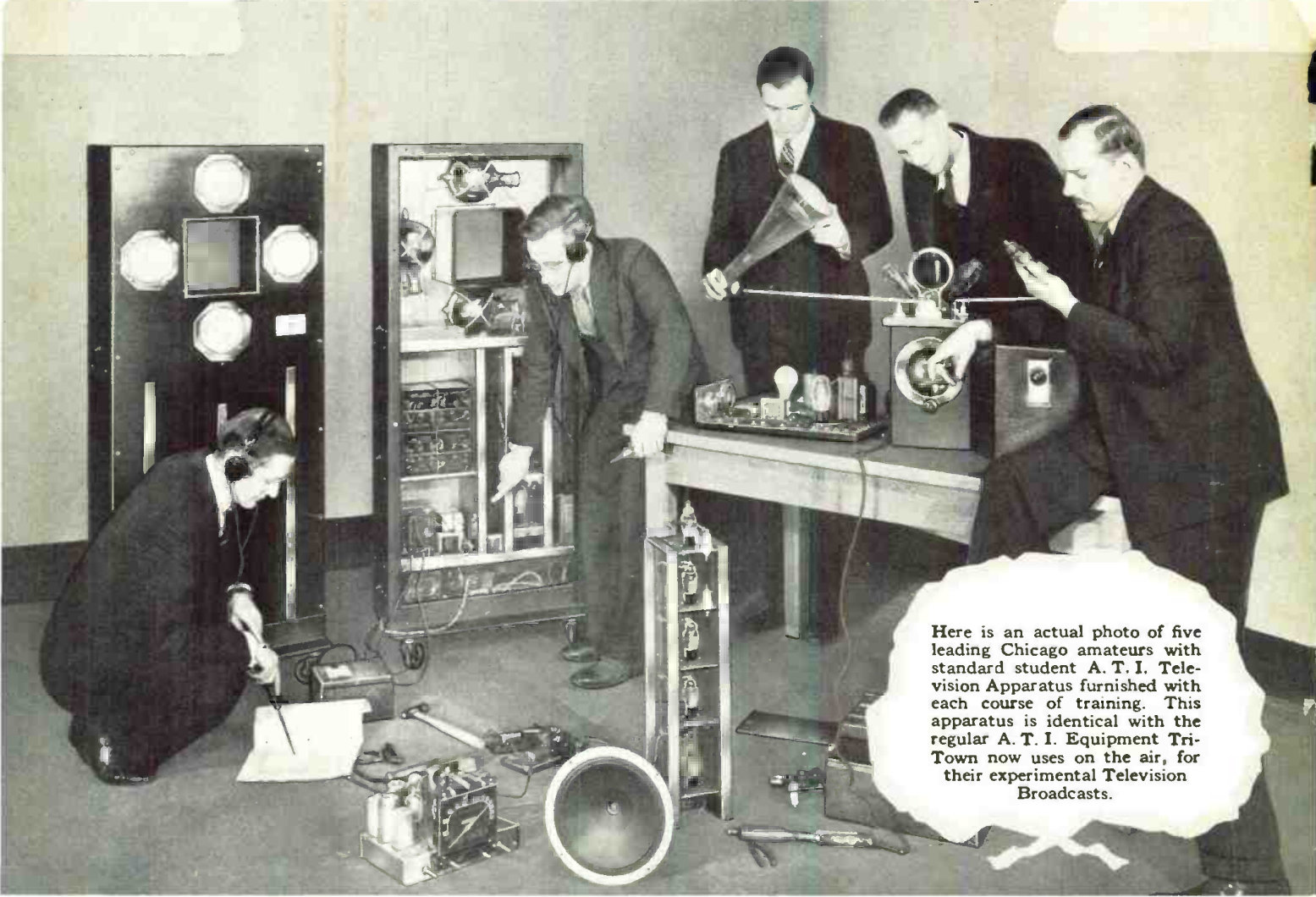

Here is an actual photo of five leading Chicago amateurs with standard student A. T. I. Television Apparatus furnished with each course of training. This apparatus is identical with the regular A. T. I. Equipment Tri-Town now uses on the air, for their experimental Television Broadcasts.

Dr. Norman F. Ellemeir says, "As an optical expert, I find the A.T.I. equipment in line with the finest precision standards. It produces an exceptionally good image. The sensitivity is remarkable."



Edward Gibbons, W9TAK, says, "I have worked with A.T.I. equipment. It lends itself perfectly to experimental work and hundreds of tests which give you a first hand practical knowledge of television."



E. F. Wiechmann, W9LKA, says, "I am tremendously impressed by the size and quality of your equipment. The cathode ray tube and four photo electric cells alone are worth the entire price you ask for the complete machine and training."



Mr. A. G. Roberts, W9YMF, says, "I favor A.T.I. television equipment because it is thoroughly modern. Every part is as good as any experimenter would want."



G. L. Dostand, W9TSM, says, "This equipment is practical and lends itself admirably to experimental uses and the study of television."

We Invite All Men to Write to Us

The Tri-Town Radio Amateur Club, W9MWJ, of Ridge Park, Chicago, is the only Amateur Club, we believe, that has its own Television Experimental Laboratories. Their television test broadcasts on the air will mark the beginning of local amateur cooperation dedicated to the progress and perfecting of Television. The enthusiasm these "hams" show over their A.T.I. Television Equipment, and their appreciation of the cooperation A.T.I. Engineers have extended to them is well reflected in their statements. We have hundreds of letters from A.T.I. men throughout the nation, expressing their enthusiasm about A.T.I. Equipment and A.T.I.'s new method of learning Television at home, with practical equipment. The American Television Institute cordially invites all men who are interested in Television to write for complete information on the new A.T.I. method of training at home with actual working apparatus.

A. T. I. Equipment Includes:

Complete television transmitter and receiver, cathode ray tube with large 7" screen, sweep circuits, photo electric cells, gas arcs, 50 watt radio transmitter, super-heterodyne receiver, hi-gain transmission amplifier, projector, Mazdas, lenses, loud speaker, meters, phones, and complete RCA tubes. Large five foot steel rack and panels with separate television receiver. Complete text books and technical manuals. Television can not be properly learned from texts alone, that's why all this equipment is sent to you at home, and is yours to keep. You learn by actually doing television work with your own equipment at home under our direction. We give you a full engineering course in Radio, Television and Electronics with final training in our laboratory in Chicago under the direction of internationally famous television engineers. Employment service given to graduates.

You Can Make 350 Experiments . . .

With this A.T.I. Equipment you can make over 350 amazing, interesting experiments right in your own home. You can produce your own Television program for a local audience . . . transmitting and receiving the faces of your friends. You can build complete Television Transmission and Reception Systems, Television Amplifiers, Radio Transmitters, Television Pick-ups, Photo-Electric Relays, Light Beam Telephone, Magic Lantern, Grid-Glow Alarms, Sound Amplifiers, Photo-Electric Photometers. You can make hundreds of comparison tests that show you Television and Radio in a quick, simple way . . . much easier to understand than just mere words in a book. The entire A.T.I. course with all above equipment is remarkably low in price and on terms arranged to suit you. It costs you nothing to thoroughly investigate. SEND Coupon Now!

A. T. I. TRAINING WITH COMPLETE EQUIPMENT IS AVAILABLE ON AMAZINGLY LOW EASY MONTHLY PAYMENTS

Free LESSONS in TELEVISION
THIS OFFER GOOD FOR A LIMITED TIME ONLY!
DON'T DELAY! SEND THE COUPON NOW!

AMERICAN TELEVISION INSTITUTE

433 E. Erie St., Dept. RN 438, Chicago, Ill.

I am interested in your special offer of 4 free lessons in Television. Please send literature and complete details. No obligation.

Name..... Age.....

Address.....

City..... State.....



Infinite image rejection
with the **SKY CHALLENGER II**

The INFINITE IMAGE REJECTOR* is just one of the features of the NEW SKY CHALLENGER II that makes it unique among communications receivers. Where ordinary amateur receivers are designed to reduce image ratio to the minimum level, the Hallicrafters have gone a step further, and provided the means to *completely* eliminate image interference. Any amateur can appreciate the value of this new Hallicrafters circuit, especially when working the 10 and 20 meter bands. Combined with the 1000° Spiral Band Spread, its razor-sharp selectivity, and rigid, smooth-operating, mechanical superiority, this feature accounts for the instantaneous popularity and acceptance of the New Sky Challenger II by the amateur radio world. See it at your dealer's or write for complete information.

*Pat. Applied for

- ★ 5 Tubes
- ★ Infinite Image Rejector
- ★ 1000° Spiral Band Spread
- ★ Extreme Selectivity
- ★ 38 MC to 540 KC (7.9 to 545 meters)
- ★ Recessed Main Tuning Dial
- ★ "S" Meter Terminals
- ★ Iron Core IF's

All Hallicrafters Receivers available on Liberal Time Payments

The Super Skyrider



The Super Skyrider is universally accepted as the highest development in communications receivers. Its brilliant performance has made it the most talked of receiver in the entire amateur world. ●

Leading Sports Announcer Uses Super Skyrider
Johnnie O'Hara, W9OP, of KWK, St. Louis, and one of the leading sports announcers of the country, says this of his Super Skyrider: "This is the only receiver on the market that has the rigid, business-like build and the performance of a commercial job."



the hallicrafters inc.

2603 Indiana Ave., Chicago, U. S. A. • Cable Address "Hallicraft" Chicago

"WORLD'S LARGEST BUILDERS OF AMATEUR COMMUNICATIONS RECEIVERS"