

BUILD YOUR OWN CITIZENS BAND TRANSCEIVER

RADIO & TV NEWS

Soon To Be

ELECTRONICS WORLD

MARCH, 1959
50 CENTS

V. H. F. TV SPECTRUM AND INTERFERENCE CHART
(A Special Feature for Service Technicians and Radio Amateurs)

TESTING ELECTROSTATIC LOUDSPEAKERS

THREE-BAND MOBILE CONVERTER

HOW RING COUNTERS WORK

INFRARED —
A NEW FIELD
OF ELECTRONICS
(See Pages 37 & 41)

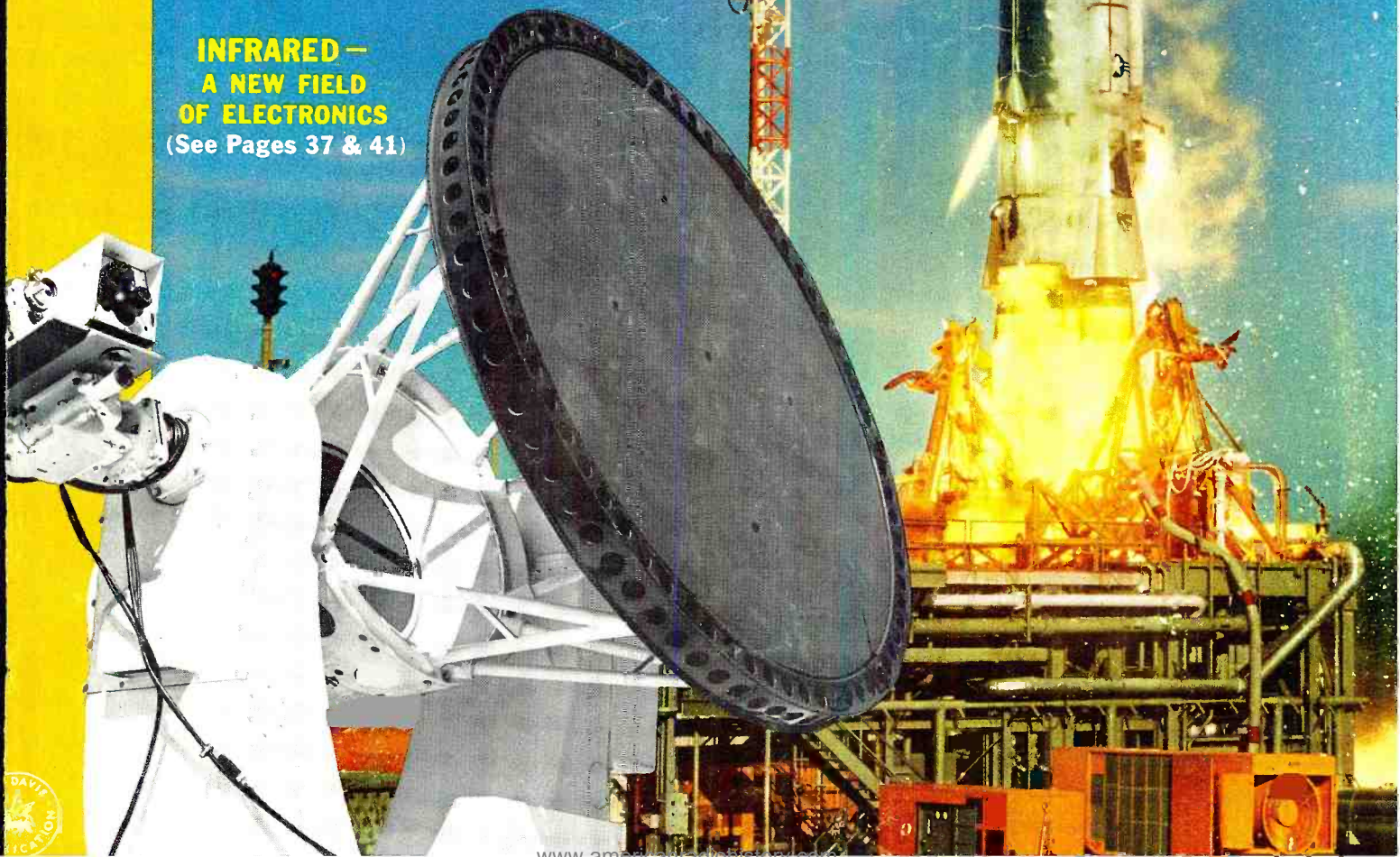



3 sound reasons why



is your

BEST RECORDING TAPE BUY!

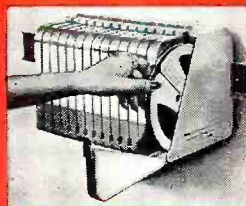

CASE:

Shatterproof plastic container for permanent protection against dirt, dust, abuse. Vertical storage eliminates reel warpage and "Wow." Easy access, flip of finger opens case—tape rolls forward.

INDEXING:



Applies quickly to front and side of container—permits you to keep typewritten tabs on all recordings.

Unique Sonoramic indexing system on colorful pressure sensitive labels is included in every package.

REEL: Exclusive V-slot, self threading Selection Finder with large write-on surface for notations. Fumble-proof V-slot permits jiffy-quick threading. Easy-to-read Selection Finder numbers permanently moulded into reel. Aligns with tape-time ruler.



2
3

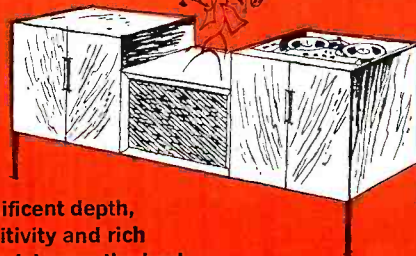

...and of course, **QUALITY**

Sonoramic offers music lovers and sound enthusiasts the ultimate in brilliant reproduction. For magnificent depth, unsurpassed sensitivity and rich startling realism, insist upon the best—insist upon Sonoramic professional recording tape.

FREE Sonoramic Tape-Time ruler. Gives you footage and recording time on reel. Write Dept. N3

Ferraro dynamics CORPORATION, LODI, NEW JERSEY

For a Successful Career in Radio-Television

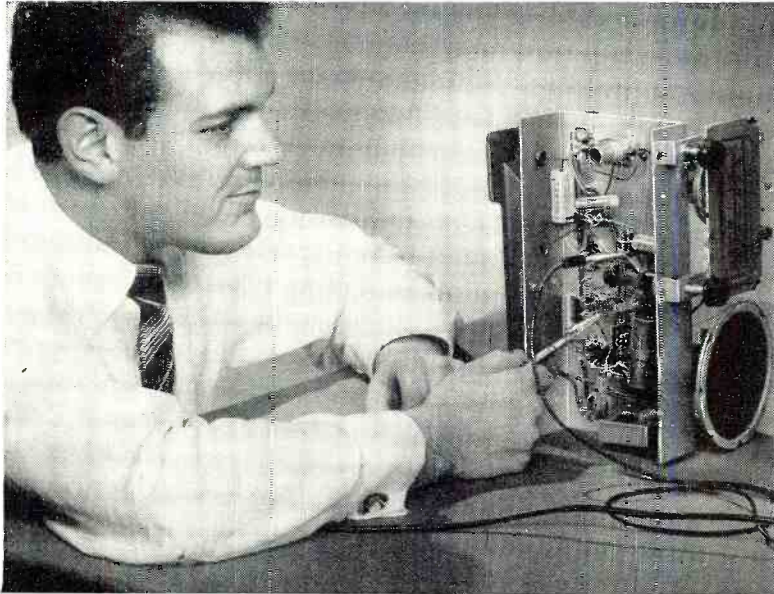

Train at Home in Spare Time with N. R. I. **OLDEST and LARGEST** Home Study Radio-Television School

N.R.I. Trained These Men

ENGINEER STATION WHPE

"Thanks to NRI, I operated a successful Radio repair shop. Now I am an engineer for WHPE." VAN W. WORKMAN, HIGH POINT, NORTH CAROLINA



QUICK SPARE TIME CASH

"Knew nothing about Radio-TV when I enrolled. After 15 lessons started repairing sets. My future looks bright." DONALD B. ACKERMAN, MINNEAPOLIS, MINNESOTA



HAS OWN TV BUSINESS

"Quit my job to do Television work full time. I love it and do all right financially." WILLIAM F. KLINE, CINCINNATI, OHIO



Prosperous Fast Growing Industry Offers You GOOD PAY-BRIGHT FUTURE-SUCCESS

It's the trained man who gets ahead—gets the better job, drives a better car, lives in a better home, is respected for what he knows and can do. For a job with a future—find out how you can train at home for Radio-Television.

TODAY'S OPPORTUNITY FIELD

Training PLUS OPPORTUNITY is the ideal combination for success. And today's OPPORTUNITY field is Radio-Television. Over 125 million home Radios plus 30 million sets in cars, plus 40 million TV sets mean big money for trained Technicians. More than 4,000 Radio and TV broadcasting stations offer interesting and important positions. Color television, portable TV sets, Hi-Fi, assure future growth. Find out about NRI. Since 1914—for more than 40 years—NRI has been training ambitious men

at home in spare time for Radio-TV. With NRI 50-50 method, you study basic principles AND learn by practicing with actual equipment NRI furnishes. You learn with your hands and your head. You get dependable training, backed up by the reputation of the oldest and largest home study Radio-TV school.

ADD TO YOUR INCOME SOON \$10-\$15 A WEEK IN SPARE TIME

Soon after enrolling many start earning extra money fixing sets. Many open their own full time Radio-TV shops after getting NRI Diploma. MAIL COUPON. Get FREE Sample Lesson and 64-page Catalog showing equipment supplied, outlines of courses, opportunities in Radio-TV. Price is low—terms easy. Address: NATIONAL RADIO INSTITUTE, Dept. 9CE, Washington 16, D. C.

You Learn Servicing-Broadcasting at Home-By Practicing with Kits N.R.I. Sends



Nothing takes the place of practical experience. That's why NRI training is Learning-by-Doing. With Servicing Course you build Radio shown at top and other equipment. With Communications Course you build Transmitters at left and other equipment. Catalog shows all equipment you get.

Available To **VETERANS** Under G.I. Bills



SAMPLE LESSON AND CATALOG FREE

MAIL COUPON TODAY

National Radio Institute

Dept. 9 CE, Washington 16, D. C.

Mail me Sample Lesson and 64-Page Catalog FREE. (No salesman will call. Please write plainly.)

Name _____ Age _____

Address _____

City _____ Zone _____ State _____

ACCREDITED MEMBER, NATIONAL HOME STUDY COUNCIL

RADIO & TV NEWS is published monthly by Ziff-Davis Publishing Company, William B. Ziff, Chairman of the Board (1946-1953), at 434 S. Wabash Ave., Chicago 5, Ill. Second-class postage at Chicago, Illinois. Authorized by Post Office Department, Ottawa, Canada, as second-class matter. SUBSCRIPTION RATES: one year U. S. and possessions, and Canada \$4.00; Pan American Union Countries \$4.50; all other foreign countries \$5.00.

March, 1959

RADIO & TV NEWS

Reg. U. S. Pat. Off.

First in radio-television-audio-electronics

Average Net Paid Circulation 236,101

Radio & Television News • Radio News • Television News Trademarks Reg. U. S. Pat. Off.

CONTENTS

MARCH, 1959

VOL. 61 ■ NO. 3

Publisher

OLIVER READ, D. Sc., WIETI

Editor

WM. A. STOCKLIN, B.S.

Technical Editor

MILTON S. SNITZER, W2QYI

Service Editor

SIDNEY C. SILVER

Associate Editor

P. B. HOEFER

Assistant Editor

J. JUSTER

Television Consultant

WALTER H. BUCHSBAUM

Art Editor

MILTON BERWIN

Art and Drafting Dept.

**J. A. GOLANEK
JAMES A. ROTH
MILTON WHELPLEY**

Advertising Director

JOHN A. RONAN, JR.

Midwest Adv. Manager

W. ROBERT WOLFE

Western Adv. Manager

JAMES R. PIERCE



ZIFF-DAVIS PUBLISHING COMPANY
William Ziff, President; W. Bradford Briggs, Executive Vice-President; Michael Michaelson, Vice-President and Circulation Director; Hershel B. Sorbin, Secretary; Howard Stoughton, Jr., Treasurer; Albert Gruen, Art Director.

Editorial and Executive Offices
One Park Avenue
New York 16, N. Y. OR. 9-7200



Member
Audit Bureau of
Circulations

MEMBER
INSTITUTE OF



BRANCH OFFICES: Midwestern Office, 434 S. Wabash Ave., Chicago 5, Ill.; Western Office, Room 412, 215 W. 7th St., Los Angeles 14, Calif.; James R. Pierce, manager.

FOREIGN ADVERTISING REPRESENTATIVES: D. A. Goodall Ltd., London; Albert Milhado & Co., Antwerp and Dusseldorf.

ELECTRONICS—GENERAL

Satellites, Security & Space (Editorial).....	W. Stocklin	8
Spot News.....	Washington Editor	33
Infrared—A New Field of Electronics and Optics.....	Paul Bernard & Nathan Buitenkant	37
Cover Story.....		41
IGY—an eighteen-month report.....		42
How Ring Counters Work.....	Ed Bukstein	44
Synthetic Quartz Produced in Pilot Plant.....		120
Record Number of Sets in Use During '58.....		136
"Atlas" Satellite Uses Special Radio System.....		138
Transistors Produced by Automatic Line.....		140
Calendar of Events.....		163

HIGH FIDELITY AND AUDIO

A New idea in a Stereo Preamp (RADIO & TV NEWS Lab Tested).....		46
Hi-Fi Product Test Report (RADIO & TV NEWS Lab Tested).....		61
Testing Electrostatic Loudspeakers.....	Arthur A. Janszen	62
Tips on FM Alignment.....	John M. Doyle	66
The Case for a Third Channel.....	Leonard Feldman	70
Hi-Fi—Audio Product Review.....		92
Outboard Amplifier for Transistor Portable.....	T. C. Lawson	100
Certified Record Revue.....	Bert Whyte	122
Sound on Tape.....	Bert Whyte	126
Dynamic Sideband Regulation Used in New Tuner.....	Robert Berkovitz	132

TELEVISION-RADIO

Promoting a Small Business.....	William Leonard	48
Mac's Service Shop.....	John T. Frye	52
V.H.F. TV Spectrum and Interference Chart.....		53-54
Problems in TVI Localization.....		55
Quarter-Wave Matching Section (Nomograph).....		56
Get the Most out of Your Service Data.....	Bob Eldridge	60
New TV Projector Makes Giant Color Picture.....		65
Replacement Parts—Standard or Special?.....	Walter H. Buchsbaum	72
Association of the Month (TEA of San Antonio, Texas).....		90
Service Notes.....		129
Service Industry News.....		146
Test Bench Puzzler: No. 5.....	Bob Eldridge	164

TEST EQUIPMENT

Test New Tubes on Old Checkers (Part 2).....	Jack Darr	68
Test Equipment Teaser (Crossword Puzzle).....	John A. Comstock	137

AMATEUR AND COMMUNICATIONS

Build This Citizens Band Transceiver.....	Donald L. Stoner	49
Three-Band Mobile Converter.....	Joseph L. Reiffin, W5CWP	57
Simple "Tune-Operate" Switching for the Ham Transmitter.....	Howard S. Pyle, W7OE	114

DEPARTMENTS

Letters from Our Readers.....	14	Technical Books.....	110
Within the Industry.....	22	What's New in Radio.....	141
		Manufacturers' Literature.....	162

Copyright © 1959 by Ziff-Davis Publishing Company. All rights reserved.
SUBSCRIPTION SERVICE: Forms 3579 and all subscription correspondence should be addressed to Circulation Department, 434 South Wabash Avenue, Chicago 5, Illinois. Please allow at least four weeks for change of address. Include your old address as well as new—enclosing if possible an address label from a recent issue.

CONTRIBUTIONS: Contributors are advised to retain a copy of their manuscripts and illustrations. Contributions should be mailed to the New York Editorial Office and must be accompanied by return postage. Contributions will be handled with reasonable care, but this magazine assumes no responsibility for their safety. Any copy accepted is subject to whatever adaptations and revisions are necessary to meet the requirements of this publication. Payment covers all author's, contributor's, and contestant's rights, title, and interest in and to the material accepted and will be made at our current rates upon acceptance. All photos and drawings will be considered as part of the material purchased.

SOMETHING NEW* HAS BEEN ADDED TO THE DEVRY TECH TRAINING PROGRAM

Prepare in Spare Time At Home for a

JOB THAT PAYS REAL MONEY

in TELEVISION-RADIO-ELECTRONICS

Many DeVry-trained men who now hold good jobs paying real money were once looking for opportunity, yet wondering if they needed advanced schooling, special experience, or higher math. They clipped a DeVry Tech coupon, mailed it in—and were pleasantly SURPRISED! Now they work in one of today's fastest-growing fields—TELEVISION-RADIO-ELECTRONICS. Many have their own profitable service shops. DeVry Tech's "Learn-by-Seeing," "Learn-by-Reading," "Learn-by-Doing" training made the difference! You, too, may train at home the DeVry Tech way with wonderful, helpful movies, clear texts and valuable home laboratory equipment—or in our well-equipped Chicago or Toronto Training Centers.

Now something NEW* has been added to help you learn more by "doing." You can choose to build and keep your own top quality 6-speaker STEREOPHONIC SOUND SYSTEM that will provide thrilling enjoyment for years to come. Plans are furnished so that you can also build your own speaker cabinets—or we can tell you where to buy them. DeVry Tech's specially designed Stereo System includes:

- Turntable with Stereo cartridge
- Stereo Amplifier
- Stereo Pre-Amplifier
- 2 Cross-Over Networks
- Six Speakers: two 12-in., two 8-in., two 3-in.

When you build your own equipment, you learn about the working parts. You can repair, adjust, maintain. You learn by doing—the DeVry Tech way. You put basic principles into "on-the-job" practice.



VACUUM TUBE VOLT METER

5 INCH WIDE BAND OSCILLOSCOPE

GET 2 FREE BOOKLETS!

Clip the coupon now for two booklets that answer many questions about your chances for success in this field. "Electronics and YOU" and the remarkable "Pocket Guide to Real Earnings" (just off the press) are yours without obligation.

***NEW!**
Build Your Own
6-Speaker
HIGH FIDELITY
STEREOPHONIC
SOUND SYSTEM

... another wonderful DeVry advantage

Special SHORT COURSE in High Fidelity Sound Reproduction including Stereophonic Systems also available. Ideal for hobbyists, music lovers and those wanting to ADD to their incomes.

MANY OPTIONS!

NOW . . . DeVry Tech men can take their choice of any or all of the quality equipment shown above: The Stereo System . . . the Scope and Meter . . . a 21-inch TV Set (not pictured) . . . or ALL THREE. But no matter which way you do it, you get practical home training at its best . . . the kind you need to get started in the fast-moving Electronics field. Send coupon for details.

"One of North America's Foremost Electronics Training Centers"

Accredited Member of National Home Study Council



DEVRY TECHNICAL INSTITUTE

4141 BELMONT • CHICAGO 41, ILL. • Formerly DeFOREST'S TRAINING, Inc.

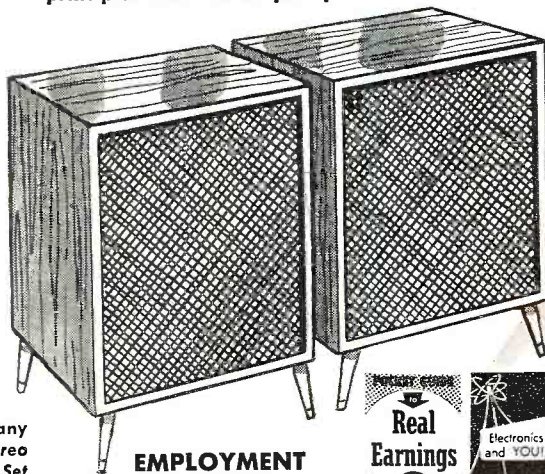

EMPLOYMENT SERVICE

DeVry Tech offers real, down-to-earth employment service to help you toward a good job after graduation — even provides help in starting your own servicing business.

MAIL TODAY FOR FREE FACTS

DeVry Technical Institute
4141 Belmont Ave., Chicago 41, Ill., Dept. RN-3-P
Please give me your two FREE booklets, "Pocket Guide to Real Earnings" and "Electronics and You," and tell me how to prepare to enter one or more branches of Electronics.

NAME _____ AGE _____

PLEASE PRINT

STREET _____ APT. _____

CITY _____ ZONE _____ STATE _____

Check here if subject to military training.

DeVry Tech's Canadian Training Center is located at
2053 626 Roselawn Avenue, Toronto 12, Ontario

Use Delco Radio Service Parts!

DS501—Highest power transistor used in auto radios.

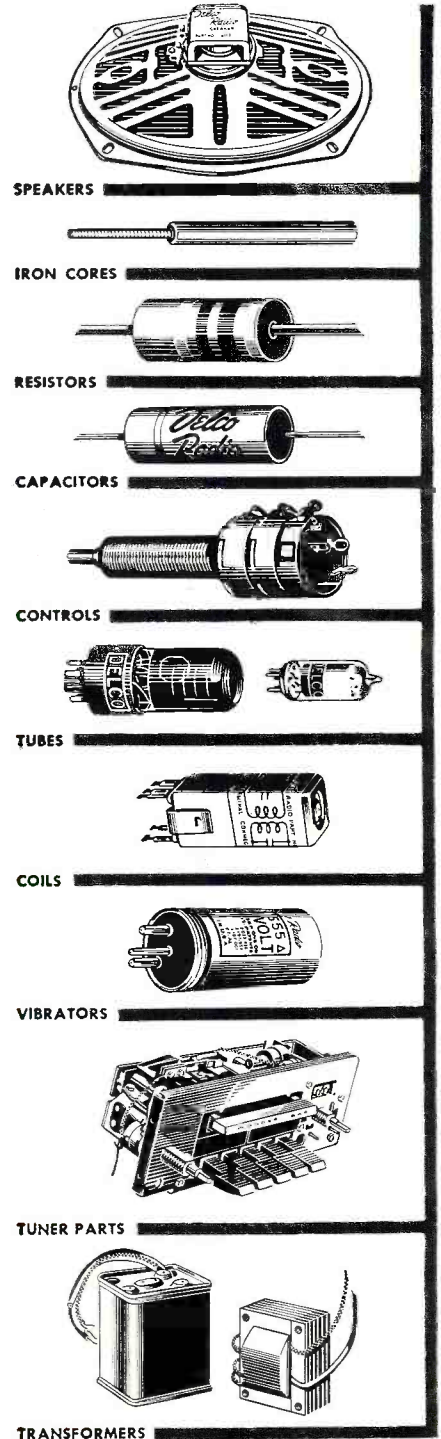

SPEAKERS

IRON CORES

RESISTORS

CAPACITORS

CONTROLS

TUBES

COILS

VIBRATORS

TUNER PARTS

TRANSFORMERS

Your Delco Radio Electronic Parts Distributor carries the complete line, giving you fast, dependable service on the items you'll need for Delco Radio—and other radio—service work. Delco Radio also provides:

- Wide selection of special application parts
- Complete technical training program
- Effective warranty program
- Dealer identification signs

Get the facts today on this truly profitable dealer setup, and grow with General Motors!

Available everywhere through Electronic Distributors associated with . . .



DELCO RADIO

DIVISION OF GENERAL MOTORS, KOKOMO, INDIANA

RADIO & TV NEWS

NOW the Columbia (LP) Record Club offers **BOTH**
STEREOPHONIC
and MONAURAL RECORDS
 at Tremendous Savings!



1. Johnny sings What'll I Do, Warm, White We're Young, 9 more



2. This vivid musical painting has become an American classic



3. 16 favorites—Sweet Violets, Down by the Old Mill Stream, etc.



4. Pianistic fireworks abound in these two romantic scores



5. Where or When, The Way You Look Tonight, Be My Love, 9 more

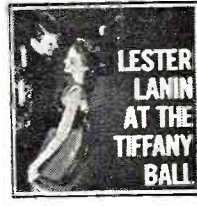

6. 43 hits for listening and dancing—in the smooth Lanin style

FREE ANY 3

OF THESE SUPERB
COLUMBIA and EPIC RECORDS

(AVAILABLE IN STEREOPHONIC SOUND OR MONAURAL HIGH FIDELITY)

If you join the Columbia (LP) Record Club now—and agree to purchase 4 selections during the coming 12 months

Yes, now you can acquire the world's finest stereophonic AND high-fidelity monaural recordings — at truly substantial savings! And as a dramatic demonstration of the Columbia (LP) Record Club's money-saving Bonus Plan — you may have, at once, ANY 3 of the sixteen records shown here, FREE . . . available in your choice of stereophonic sound OR monaural high fidelity!

HOW THE CLUB SAVES YOU MONEY

Your only membership obligation is to purchase four selections from the almost 200 Columbia and Epic records to be offered in the coming 12 months. Thus you receive seven records for the price of four — a saving of more than one-third on your record purchases.

Furthermore, after buying four selections you receive your choice of a Columbia or Epic Bonus record (stereo or monaural) free for every two additional selections you buy.

HOW THE CLUB OPERATES

You enroll in any one of the six Club Divisions: If you have stereo equipment you enroll in either the Stereo Classical or Stereo Popular Division.

If you have monaural equipment you enroll in any one of four Divisions: Classical; Listening and Dancing; Broadway, Movies, Television and Musical Comedies; Jazz.

Each month the Club's staff of musical experts selects outstanding recordings from every field of music. These selections are described in the Club Magazine, which you receive free each month.

You may accept or reject the selection for your Division, take any of the other records offered (stereo or monaural), or take NO record in any particular month. You may discontinue membership at any time after purchasing four records.

The records you want are mailed and billed to you at the regular list price: Popular Monaural Selections, \$3.98; Classical Monaural, \$4.98; all Stereo Records, \$5.98 — plus a small mailing charge.

To receive your three stereo or monaural records FREE, fill in and return the coupon today!

COLUMBIA (LP) RECORD CLUB
 Terre Haute, Indiana

March, 1959



7. The ingratiating Miss Holliday in her biggest Broadway hit

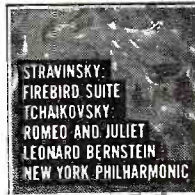

8. Bernstein's exciting performances of two colorful scores



9. The finest performance ever of the Duke's masterpiece



10. A truly magnificent performance of this majestic symphony



11. The great tunes from Rodgers and Hammerstein's fabulous hit



12. The two fiery Rumanian Rhapsodies—plus 2 more works

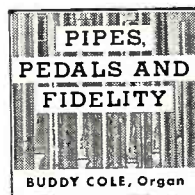

13. Organist Buddy Cole plays 11 tunes—Mine, Caravan, Carioca, etc.



14. Cugat's greatest hits—Besame Mucho, Tico-Tico, Brazil, 9 more



15. The most popular of Tchaikovsky's lovely, melodic symphonies

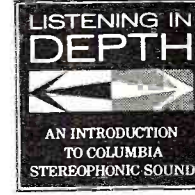

16. Available in stereo only. 16 popular and classical selections

FREE — ANY 3 — MAIL COUPON NOW

COLUMBIA (LP) RECORD CLUB, Dept. 247-1
 Terre Haute, Indiana

Please send me as my FREE gift the 3 records whose numbers I have circled at the right — and enroll me in the following Division of the Club: (check one box only)

MONAURAL DIVISIONS		STEREO DIVISIONS
<input type="checkbox"/> Classical	<input type="checkbox"/> Broadway, Movies, Television and Musical Comedies	<input type="checkbox"/> Stereo Classical
<input type="checkbox"/> Listening & Dancing		<input type="checkbox"/> Stereo Popular
<input type="checkbox"/> Jazz		

I agree to purchase four selections from the almost 200 stereophonic and monaural records to be offered during the coming 12 months, at regular list price plus small mailing charge. For every two additional selections I accept, I am to receive a Columbia or Epic Bonus record (stereo or monaural) of my choice FREE.

Name
 (please print)
 Address

City..... Zone..... State.....

CANADA: prices slightly higher, address 11-13 Soho St., Toronto 2B
 If you want this membership credited to an established Columbia or Epic record dealer, authorized to accept subscriptions, fill in below:

Dealer's Name.....
 Dealer's Address..... 215

© "Columbia," (E), "Epic," (M) Marcas Reg. © Columbia Records Sales Corp., 1959

CIRCLE 3 NUMBERS BELOW:

(Indicate here whether you want your 3 records in Stereo or Monaural):

STEREO L-50 MONAURAL L-49

1. Johnny Mathis — Warm
2. Grofe: Grand Canyon Suite
3. Sing Along With Mitch Miller
4. Grieg Piano Concerto; Rachmaninoff Rhapsody
5. 'S Marvelous — Ray Conniff
6. Lester Lanin at the Tiffany Ball
7. Bells Are Ringing — Original Broadway Cast
8. Firebird; Romeo and Juliet
9. Black, Brown and Beige
10. Beethoven: Eroica Symphony
11. Percy Faith Plays "South Pacific"
12. Rumanian Rhapsodies 1, 2; plus two more works
13. Pipes, Pedals and Fidelity
14. Cugat Cavalcade
15. Tchaikovsky: Pathétique Symphony
16. Listening in Depth (Available in stereo only)

short description of a
Small Efficient TV System...

1 antenna ... IN
8 set lines ... OUT
10 db signal ... GAIN



DISTRIBUTION AMPLIFIER MODEL DA8-B

Ideal for garden apartments, motels, TV showrooms, deluxe home installations and other small TV systems. The DA8-B is a broadband, all-channel unit that requires no tuning, impedance matching devices, preamps or other special fittings. Provides 8 isolated TV outlets from one 75 or 300 ohm input.

Features and Specifications:

- Low noise all-triode circuit
- More than 10 db gain on all VHF channels
- Inter-set isolation in excess of 22 db
- Provision for 75-ohm cable or 300-ohm twin lead
- Prevents overload through 10:1 gain control range
- Built-in power supply
- Designed for continuous duty operation

NOTE: For larger systems, Blonder-Tongue will furnish Free planning service on request.

List **\$94⁵⁰**

Sold by Radio-TV
Parts Distributors and Jobbers



**BLONDER-TONGUE
LABORATORIES, INC.**

9 Alling St., Newark 2, N. J.
Dept. RTN-3

In Canada: Teleequipment Mfg. Co., Ltd., London, Ont.
export: Morhan Export Corp., N.Y. 13, N.Y.

hi-fi components • UHF converters • master TV systems
industrial TV cameras • FM-AM radios

...for the Record

ELECTRONICS
WORLD



By **W. STOCKLIN**
Editor

SATELLITES, SECURITY, & SPACE

DESPITE the fact that the new Federal budget, as proposed by President Eisenhower, calls for reduced appropriations to a number of agencies and a discontinuance of certain military projects, it is heartening to note that it calls for an increase in the number of ICBM squadrons from 13 to 20 and an implementing of our current satellite and space activities.

Although many senior officers feel that total reliance on guided missiles is foolhardy and that to base our entire defense program on these push-button-controlled devices is ostrich-like, the fact remains that an ever-growing percentage of our defense dollar will have to be spent for research, development, and production of such projectiles.

The contributions of the electronics industry to this fantastic program are limitless. Not only are the laboratories and production lines of our companies working full speed ahead on triggering and control mechanisms but they are developing new and more sensitive equipment to be carried by the missiles for homing, guidance, and reporting. In addition to this particular phase, these same organizations are concerned with anti-missile defense equipment as well as protection of the anti-missile type.

Nor are many of these systems the exclusive province of the military. The more sophisticated equipment will be adapted to handle the increasing number of satellites which will hurtle into space, while others will be "ganged" to provide the tremendous thrust that will be required to project instrumented and man-carrying rockets into the outer atmosphere.

Those of us in the electronic industry have reason to be proud of our "profession." We are part of a "team" dedicated to a task which staggers the human imagination. Who could have anticipated, on the basis of the primitive bi-planes of World War I, that a mere forty years later not only would jet planes be hurtling across the ocean between breakfast and dinner but that our solar system would acquire new "moons" at a casual rate.

Much as it hurts our national pride to admit that we are not presently No. 1 in the space race, credit should be given the U.S.S.R. for its impressive achievement in launching and orbiting its "Lunik" solar satellite. Undoubtedly some, if not all, of the information radioed back by the instru-

ments before the batteries went dead will be shared with scientists throughout the world and provide another boost in the sum total of man's knowledge about his universe.

Although there are undoubted drawbacks in living at the accelerated pace demanded by these never-ending developments and many nostalgically long for "the good old days," "Age of Anxiety" or no, this is an exciting time to be alive as most people will agree upon careful consideration. With the International Geophysical Year, formally closed but informally continuing, and the unceasing probing into Outer Space, most of us will live to see interplanetary travel as casually accepted and enjoyed as the "Spend a Weekend in Europe" promotions of the airlines today.

Some scientists and military men have been willing to "stick their necks out" to the extent of predicting that 1959 will find man whirling through the atmosphere in a space vehicle—while the more conservative set 1960 as the target date.

JUST A REMINDER

By now most of our readers have been introduced to our new name and logotype, ELECTRONICS WORLD, which is scheduled to take effect with our May issue. Last month's issue and this carry, in miniature, a reproduction of the title under which you will find RADIO & TV NEWS on the newsstand two months from now.

We sincerely hope that our readers will like our new name and style and that it will soon become as familiar to all as have our predecessor titles RADIO NEWS and RADIO & TV NEWS. Our new name, like those in the past, will continue to stand for the newest and best in electronics.

Last month you also had a chance to verify the usefulness of the first of the series of Gatefolds which will appear regularly. This month the second such insert is included—this one designed especially for television service technicians and radio amateur operators. We hope you will find it and the subsequent Gatefolds we have planned for you of particular help in your work or hobby. We would appreciate hearing your reactions if you will be good enough to take time to write us. After all, this is YOUR magazine and we want it to be the type of magazine YOU find most useful!

free! ALLIED'S 1959

value-packed 452-page
ELECTRONIC SUPPLY CATALOG

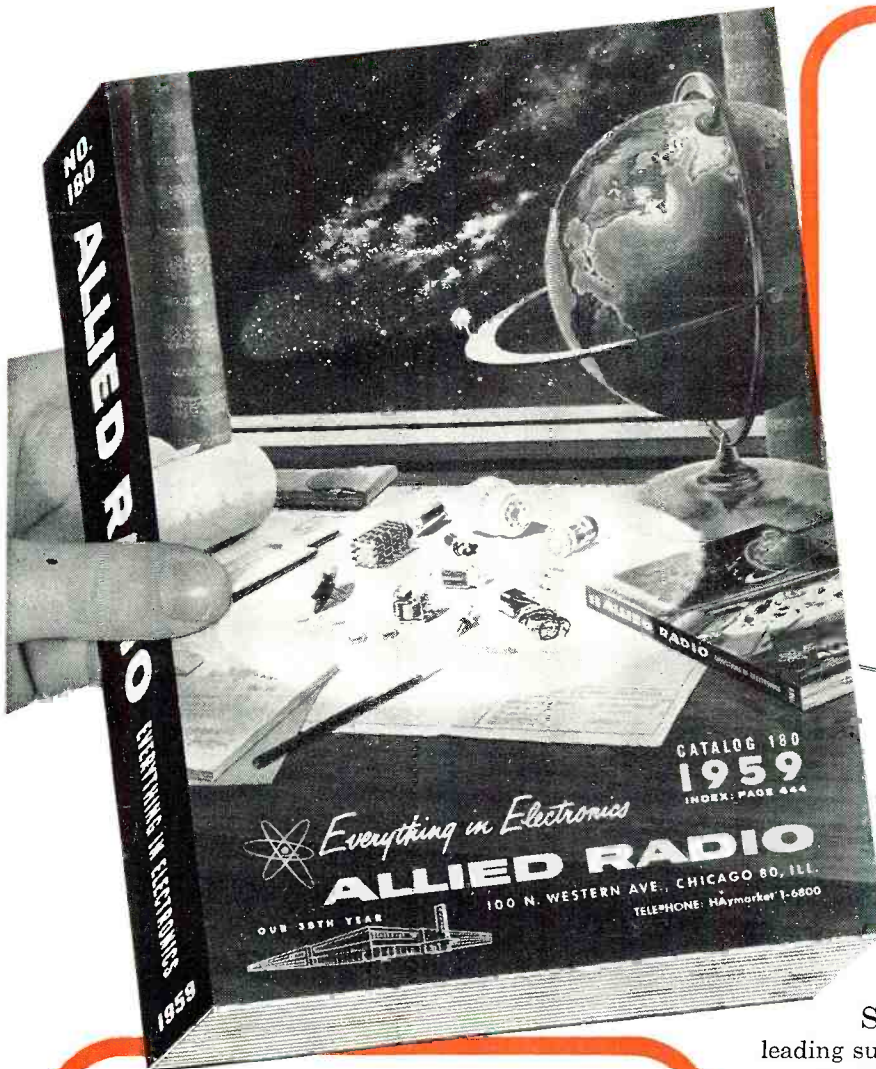

the only COMPLETE guide
to everything in electronics

WORLD'S LARGEST STOCKS

- Latest Stereo Hi-Fi Systems—
Everything in Hi-Fi Components
- Money-Saving, Build-Your-Own
KNIGHT-KITS—Latest Models
- Values in Recorders and Supplies
- Latest Public Address Systems,
Paging and Intercom Equipment
- Amateur Receivers, Transmitters
and Station Gear
- Test & Laboratory Instruments
- Specialized Electronic Equipment
for Industrial Application
- TV Tubes, Antennas, Accessories
- Huge Listings of Parts, Tubes,
Transistors, Tools, Books



featuring:

MONEY-SAVING knight-kits: Finest electronic equipment in money-saving kit form. Complete selection of latest Hi-Fi amplifier, tuner and speaker kits (new Stereo units); Hobbyist kits; Test Instruments and Amateur kits. KNIGHT-KITS are an exclusive ALLIED product.

HI-FI! STEREO! See the world's largest selection of quality Hi-Fi music systems and famous name components. First with the latest in STEREO! Save on ALLIED-recommended complete systems. Own the best in Hi-Fi for less!

EASY PAY TERMS: Only 10% down; available on orders of \$20 or more. Fast handling—no red tape.

ALLIED RADIO

 our 38th year
World's Largest Electronic Supply House

Send for ALLIED'S 1959 Catalog—it's the leading supply guide—452 pages packed with the world's largest selection of quality electronic equipment at lowest, money-saving prices. Get every buying advantage at ALLIED: fastest shipment, expert personal help, lowest prices, guaranteed satisfaction...

send for the leading
electronic supply guide

FREE!

ALLIED RADIO CORP., Dept. 1-C9
100 N. Western Ave., Chicago 80, Ill.

Send FREE 452-Page 1959 ALLIED Catalog

Name _____

Address _____

City _____ Zone _____ State _____

New Mallory *Diffused*



Type T . . . for most economical replacement. Encapsulated in Mallo-Seal*, this lowest-priced model can stand 500 hours in boiling water. Available in handy packs of five each for mounting by leads, and in kits using plug-in rectifiers, with mounting hardware. 400 and 365 volt ratings, 0.5 ampere. Also available from 50 to 600 P.I.V. inclusive.

*Trademark of P. R. Mallory & Co. Inc.



Type P . . . for plug-in replacement. Fuse model fits sets already converted to this type of silicon unit. Available in 5-packs, and as conversion kits for half-wave, full-wave or doubler application, with fuse clip and mounting hardware. 400 and 365 volt ratings, 0.5 ampere. Also available from 50 to 600 P.I.V. inclusive.



Type E . . . for higher reliability. Military grade "top hat" rectifier, hermetically sealed for jobs where you want the absolute peak in life and dependability. Two to a pack; rating is 400 volts, 0.75 ampere. Also available from 50 to 600 P.I.V. inclusive.

Junction Silicon Rectifiers

A completely new concept in silicon rectifier design gives these new Mallory models reliability never before possible. At the heart of each is a unique diffused junction silicon element, product of extensive Mallory research in semi-conductors, which has these characteristics:

Low reverse leakage.....less than 250 microamperes

Low forward drop.....less than 0.5 volt

Exceptional life.....takes over 2000 hours at 85 C, with 1.5 million switching operations without failure

Moisture-proof.....exceeds humidity requirements by four times (MIL 202A)

High reliability.....100% testing eliminates premature failures, protects you against call-backs

Three different models, each designed for specific service applications, are now available to fit all television and radio circuits as replacements for metallic rectifiers.

See this display on your Mallory distributor's counter—a complete assortment—in handy see-through packs—of the full line of Mallory silicon rectifiers.

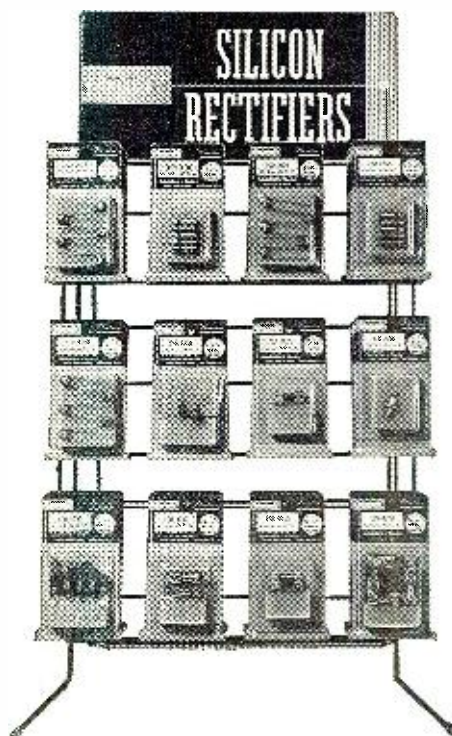

NOW FROM RCA...TWO

ALL-NEW

RCA Silverama®

SILVERAMA is RCA's premium tube—and that means tops in the industry! Manufactured with all-new glass and parts, it's the finest picture tube made—for the customer who prefers top-quality. RCA SILVERAMA—a premium tube that merits a premium price—and commands premium profits for you!

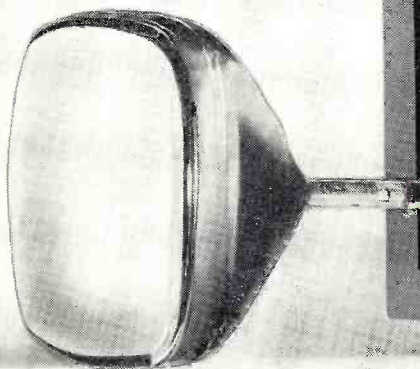

RCA is telling every TV owner the facts about RCA's BIG 21IN PICTURE TUBES in the most informative and hard-hitting advertising campaign ever undertaken in the tube industry—directing all sales to you, the independent TV service technician.

GET THE PRICE AND PROFIT STORY

LINE OF PICTURE TUBES

FACTORY-REBUILT



RCA Monogram

RCA MONOGRAM is the finest rebuilt picture tube made. Factory-rebuilt by RCA to high quality standards, this tube assures dependable performance and fewer call-backs. It is backed by a brand name you sell with confidence—a brand name they buy with confidence. RCA MONOGRAM is economy-priced for the economy-minded buyer.

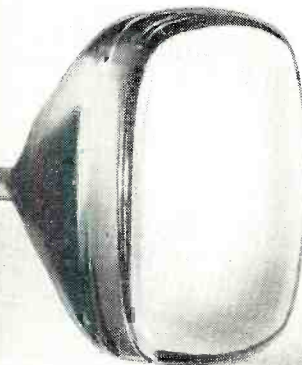

NOW you will be able to offer your customers a choice between an ALL-NEW, PREMIUM RCA SILVERAMA TUBE, the finest tube in the business, and an RCA MONOGRAM, the best REBUILT made. Yes, RCA manufactures both—and warrants both for a full year. Satisfy the needs of every customer with the right tube for virtually every set on the market.

Now, you call the signals. Now, you supply the very best tube in both price ranges—all-new or factory-rebuilt! Both lines of tubes now available from your RCA Distributor.

FROM YOUR RCA DISTRIBUTOR TODAY



RADIO CORPORATION OF AMERICA

Electron Tube Division

Harrison, N. J.

Perfect for CUSTOM STEREO SYSTEMS

QUALITY COMPONENTS

by

Pilot

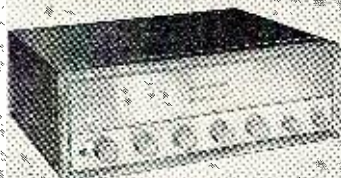

SP-210 • Stereo Preamplifier

\$89.50 less power supply
P-10 Power Supply: \$19.50

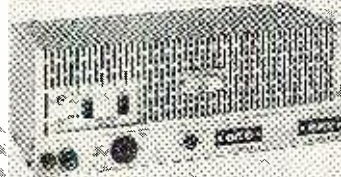

SA-232 • Basic Stereo Amplifier

Total Power Output:
80 watts peak
Has power tap-off for SP-210

\$89.50



SA-260 • Basic Stereo Amplifier

Total Power Output:
140 watts peak
Has power tap-off for SP-210

\$129.50

prices slightly higher in West

Pilot Radio Corporation

37-10 36th St., L. I. C. 1, New York

Please send literature covering
Pilot Stereo Components.

NAME _____

ADDRESS _____

CITY _____ ZONE _____ STATE _____

Electronics manufacturer
for over 39 years.

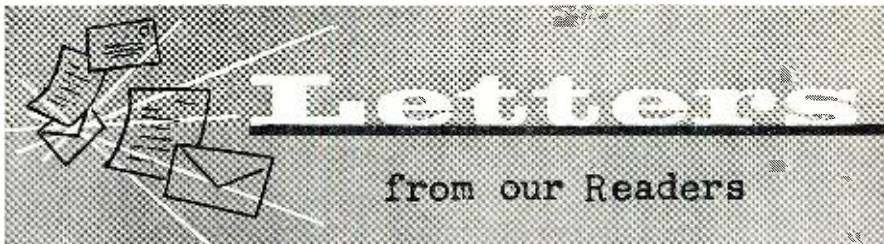

Letters

from our Readers

NEW LOOK IN TV

To the Editors:

In your December, 1958 issue, you published an article entitled "New Look in TV."

I am calling this article to the attention of all 700 members of ESFETA, Inc. in the December issue of "ESF-ETAN," our monthly association newsletter. This article is highly commendable, and speaking unofficially at this time, I am quite sure that all of independent service will be most happy to see an article of this sort gracing the pages of one of our leading magazines.

GEORGE CARLSON, Secretary
Empire State Federation of
Electronic Technicians Ass'ns,
Inc.

Jamestown, New York

Thanks very much for your very kind comments on the article. Our goal, of course, as always, has been to help the service technician and the industry as a whole.—Editors.

* * *

"WHAT IS IT?" REPLIES

To the Editors:

Regarding the "whatzit" in your January, 1959 "Letters" column, I believe it is a hoax. The writer has wireless books back as far as 1907 and wireless magazines from 1910. There is nothing in them that faintly resembles the "whatzit." The writer was a ham in 1909, went to sea as a wireless operator from 1911 to 1921, and he has seen nothing that resembles this thing. As for the RCA, I do not think that it even means *Radio Corp. of America*.

Perhaps I am 100 per-cent wrong, but that is one man's opinion.

H. Y. B.

Manhattan Beach, California

To the Editors:

The "whatsis" made by RCA looks very much like an antique power supply for an equally antique gas-filled x-ray tube. It must date about 1900. The cable reels are the key.

GEORGE H. HUFF, Engineer
Terado Company
St. Paul, Minnesota

To the Editors:

I am including complete instructions for the unit photographed in your "Letters from our Readers" column. My machine was used by a dentist for x-rays until just a few years ago. It will deliver about a 6-inch spark between the terminals. I had the x-ray tube too, but it got broken.

I would guess that the equipment was built around 1910 or 1915 by

Victor. It stands in a case and measures about 5 feet to the top of the ball.

BILL DWINELLE
Radio and Television Service
Denver, Colorado

To the Editors:

It is a piece of medical apparatus, and probably the Tesla coil portion of a larger instrument adapted to an old-time gas x-ray tube that could be used with it.

S. THERON JOHNSTON, M. D.
Appleton, Wisconsin

We certainly appreciate all the answers that we got on the piece of equipment shown in our January "Letters from our Readers" column. Special thanks to Reader Dwinelle for sending us a copy of the instruction book for the "Victor No. 7 High Frequency Outfit." This shows the complete drawing with all the important parts labeled. The unit was designed to be used with a special ultraviolet lamp, and would also produce x-rays for medical purposes.

Thanks also to Dr. T. H. Lipscomb, roentgenologist, who pointed out that the unit was manufactured by the Victor X-ray Corp., which later became the General Electric X-ray Corp.—Editors.

* * *

"CONSUMER REPORTS" ON SPEAKERS

To the Editors:

In assigning ratings to various loudspeakers in their article in the December, 1958 issue of "Consumer Reports," *Consumers Union* has shown a willingness to give consumer guidance based on judgments in a field in which such judgments have been scrupulously avoided in the past by all reputable laboratories. The question needs to be asked whether *CU* has capabilities beyond those that are to be found anywhere else and whether their capabilities are sufficient for the assignment of valid figures of merit to loudspeakers and loudspeaker systems.

In this connection, the following can be said of at least one portion of their report. Many of the statements concerning our *Janszen* electrostatic are contrary to the general consensus regarding the performance capabilities of push-pull electrostatics and contrary to the findings of independent test laboratories. Also, their relative rating of our product is contrary to the conclusions that have been reached on the basis of extensive tests on unselected samples of the two rated electrostatics. These tests were made at *Janszen Laboratory, Inc.*, Cambridge, Mass., and the results will be published soon, to-

Learn Electronics

PREPARE FOR YOUR F. C. C. LICENSE—YOUR TICKET TO A BETTER JOB AND HIGHER PAY!

F.C.C. LICENSE—THE KEY TO BETTER JOBS

An F.C.C. *commercial* (not amateur) license is your ticket to higher pay and more interesting employment. This license is Federal Government evidence of your qualifications in electronics. Employers are eager to hire *licensed* technicians.

WHICH LICENSE FOR WHICH JOB?

The **THIRD CLASS** radiotelephone license is of value primarily in that it qualifies you to take the second class examination. The scope of authority covered by a third class license is extremely limited.

The **SECOND CLASS** radiotelephone license qualifies you to install, maintain and operate most all radiotelephone equipment except commercial broadcast station equipment.

The **FIRST CLASS** radiotelephone license qualifies you to install, maintain and operate every type of radiotelephone equipment (except amateur) including all radio and television stations in the United States, its territories and possessions. This is the highest class of radiotelephone license available.

GRANTHAM TRAINING PREPARES YOU

The Grantham Communications Electronics Course prepares you for a **FIRST CLASS** F.C.C. license, and it does this by **TEACHING** you electronics. Each point is covered simply and in detail, with emphasis on making the subject easy to understand. The organization of the subject matter is such that you progress, step-by-step, to your specific objective—a first class F.C.C. license.

CORRESPONDENCE OR RESIDENCE CLASSES

Grantham training is available by correspondence or in resident classes. Either way (residence or correspondence), we train you quickly and well—no previous training required. Even a beginner may qualify for his first class license in a relatively short time.

THREE COMPLETE SCHOOLS: *To better serve our many students throughout the entire country, Grantham School of Electronics maintains three complete schools—one in Washington, D.C., one in Hollywood, Calif., and one in Seattle, Wash. All schools offer the same rapid courses in F.C.C. license preparation, either home study or resident classes.*

This booklet
FREE!

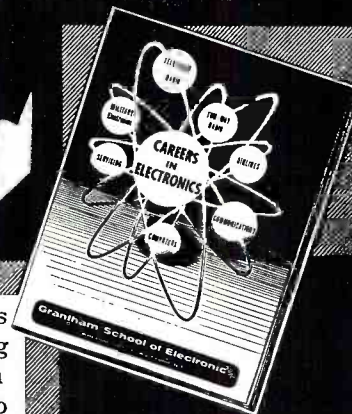

This free booklet gives details of our training and explains what an F.C.C. license can do for your future.

Upgrade Your Income with a First Class F. C. C. LICENSE

HERE'S PROOF...

that Grantham students prepare for F.C.C. examinations in a minimum of time. Here is a list of a few of our recent graduates, the class of license they got, and how long it took them:

	License	Weeks
Donald E. Mason, 2659 Centinella, Santa Monica, Calif.	1st	12
Everett T. Bozard, 411 N. Wash. St., Alexandria, Va.	1st	12
Henry M. Best, 1003 Vermont St., Fremont, N. C.	1st	11
Harold V. Jones, P.O. Box 705, Alamogordo, N. M.	1st	13
Michael F. Aperio, 916 Townsend St., Chester, Pa.	1st	12
Earl A. Stewart, 3918 Modesto Dr., San Bernardino, Calif.	1st	14
Donald L. Leebug, Box 1075, Anchorage, Alaska	1st	12
J. Milton Condit, 1312 N. 78th Street, Seattle, Wash.	1st	8
John R. Bahrs, 72 Hazelton St., Ridgefield Park, N. J.	1st	12
Richard Baden, 4226 - 37th St., N.W., Washington, D.C.	1st	12
James F. Stewart, 2618 1/2 Prospect Ave., La Crescenta, Calif. ...	1st	12
Nerman R. Cook, 130 Olive Street, Neodeska, Kans.	1st	12

GRANTHAM SCHOOL OF ELECTRONICS

WASHINGTON
D.C.

821 - 19th Street, N.W.
Washington, D.C. (ST 3-3614)

HOLLYWOOD
CALIF.

1505 N. Western Ave.
Hollywood, Calif. (HO 7-7727)

SEATTLE
WASH.

408 Marion Street
Seattle, Wash. (MA 2-7227)

MAIL COUPON TO SCHOOL NEAREST YOU

(Mail in envelope or paste on postal card)

To: **GRANTHAM SCHOOL OF ELECTRONICS**

821-19th, NW Washington • 1505 N. Western Hollywood • 408 Marion Seattle



Gentlemen:

Please send me your free booklet telling how I can get my commercial F.C.C. license quickly. I understand there is no obligation and no salesman will call.

Name _____ Age _____

Address _____

City _____ State _____

I am interested in: Home Study, Resident Classes **96C**

a quarter-century of **PRECISION*** know-how
is now yours in



quality electronic equipment in KIT FORM

FOR:

electronic hobbyists
and amateur radio

hi-fi custom building
and service

science education and
technical schools

industrial testing and
quality control

PACO is the only line of test instrument kits engineered and produced under the auspices of a leading test equipment and meter manufacturer.

and, you pay nothing extra for the convenience of buying PACO kits directly from your own local parts distributor.

COMPARE PACO against any other kits for performance, appearance, ruggedness, ease of operation and simplicity of assembly and wiring.

COMPARE PACO's superbly detailed, step-by-step instruction manuals and giant size wiring diagrams, against any you have ever seen.

SEE HOW PACO sets an entirely new standard in electronic instrument kit design and kit assembly instruction.

► Available and on display at leading electronic parts distributors.

► Write for free descriptive bulletin.

 <p>MODEL B-10 Battery Eliminator Kit • less than 0.3% ripple output • no external filters required Kit Net Price:\$41.95 Factory Wired:\$49.50</p>	 <p>MODEL S-55 Wideband 5" Oscilloscope • response DC to 5 Mc • push-pull V and H amplifiers Kit Net Price:\$87.50 Factory Wired:\$139.50</p>
 <p>MODEL C-20 Res-Cap-Ratio Bridge Kit • 10 mfd to 2000 mfd • 1/2 ohm to 200 megs Kit Net Price:\$20.95 Factory Wired:\$31.50</p>	 <p>MODEL T-60 Tube Checker Kit • full free-point lever selector system • built-in roll chart Kit Net Price:\$38.75 Factory Wired:\$54.50</p>
 <p>MODEL G-30 RF Signal Generator Kit • 160 Kc to 240 Mc in 8 bands • 120 Mc fundamental output Kit Net Price:\$28.50 Factory Wired:\$39.95</p>	 <p>MODEL T-65 Transistor and Crystal Diode Tester Kit • tests I_{cbo} gain, leakage, etc. • tests both p-n-p and n-p-n types Kit Net Price:\$39.95 Factory Wired:\$59.50</p>
 <p>MODEL M-40 High Sensitivity V-O-M Kit • 20,000 ohms/volt DC • 10,000 ohms/volt AC Kit Net Price:\$31.50 Factory Wired:\$37.50</p>	 <p>MODEL V-70 Vacuum Tube Voltmeter Kit • wide-range • peak-to-peak Kit Net Price:\$31.50 Factory Wired:\$47.50</p>
 <p>MODEL S-50 5" Cathode Ray Oscilloscope Kit • push-pull vertical and horizontal amplifiers Kit Net Price:\$49.50 Factory Wired:\$84.50</p>	 <p>MODEL Z-80 RF-AF Signal Tracer Kit • high gain RF and AF amplifier • visual and audible indicator Kit Net Price:\$29.50 Factory Wired:\$42.50</p>



ELECTRONICS CO., INC.

70-31 84th Street, Glendale 27, L. I., New York
Export: 458 B'way, N. Y. 13, U.S.A., Canada: Atlas Radio Corp., Toronto 19.

* A DIVISION OF **PRECISION** APPARATUS COMPANY, INC.

gether with information on procedures and equipment that were used.

It seems highly significant that *CU* did not publish adequate information on the test methods and equipment employed in their tests. It should not, however, be surprising, since loud-speaker testing requires more exacting and time-consuming measurements than any other high-fidelity component, if the tests are to serve as any indication of the ability of the loudspeaker to perform its proper function in a high-fidelity system.

FRANCIS D. WETHERILL, Pres.
Neshaminy Electronic Corp.
Neshaminy, Pennsylvania

An article containing the results referred to above appears in this month's issue under the title "Testing Electrostatic Loudspeakers."—Editors.

THE VARISTOR

To the Editors:

In your November issue there was a brief article entitled "The 'Istor' Story." In the story the term "varistor" was explained as "a network of four carefully selected and matched diodes." I have always been under the impression that a varistor was a form of variable resistor, and that there are three types; rectifier, symmetrical, and thermistor.

FRANK C. TIRIMACCO
Alameda, California

According to Author Graf who wrote the original article, the official ASA and IRE definition of a varistor is "A two-electrode semiconductor device having a voltage-dependent nonlinear resistance." This is a more general description of such a device than the one given in the article. The description given there is of a 1N71 varistor manufactured by Sylvania. Other manufacturers' varistors have different characteristics. For example, General Electric manufactures a "Thyrite" varistor, which is used to protect, stabilize, and control various circuits.—Editors.

ELECTRO-MELODEON

To the Editors:

I have had some comments from readers who have been experiencing an undesirable echo effect with the Electro-Melodeon I described in the September, 1958 issue.

I would suggest that anyone having any problems with an undesired echo reread the second column on page 62 of the issue. This material will help to point out the reason for the echo. When one of the push-buttons is partially depressed, the C and D switch springs make contact and V_{2A} produces a tone. Even though the A and B springs are not yet touching, a minute amount of energy from V_{2A} will reach the grid of V_3 . Some of this signal gets to V_2 by way of C_{11} and the internal capacity existing between the two halves of V_2 . The rest of it is picked up on the rather long lead running from the variable arm of R_{17} to pin 1 of V_3 , and on the

NOW!
at a price
you can afford!

MAKE MORE MONEY in TELEVISION RADIO-ELECTRONICS

**BETTER...MORE COMPLETE...LOWER COST...
WITH NATIONAL SCHOOLS SHOP-METHOD
HOME TRAINING!**

BETTER... Training that is proved and tested in Resident School shops and laboratories, by a School that is the **OLDEST** and **LARGEST** of its kind in the world.

MORE COMPLETE... You learn **ALL PHASES** of *Television-Radio-Electronics*.

LOWER COST... Other schools make several courses out of the material in our **ONE MASTER COURSE . . .** and you pay more for less training than you get in *our course* at **ONE LOW TUITION!**

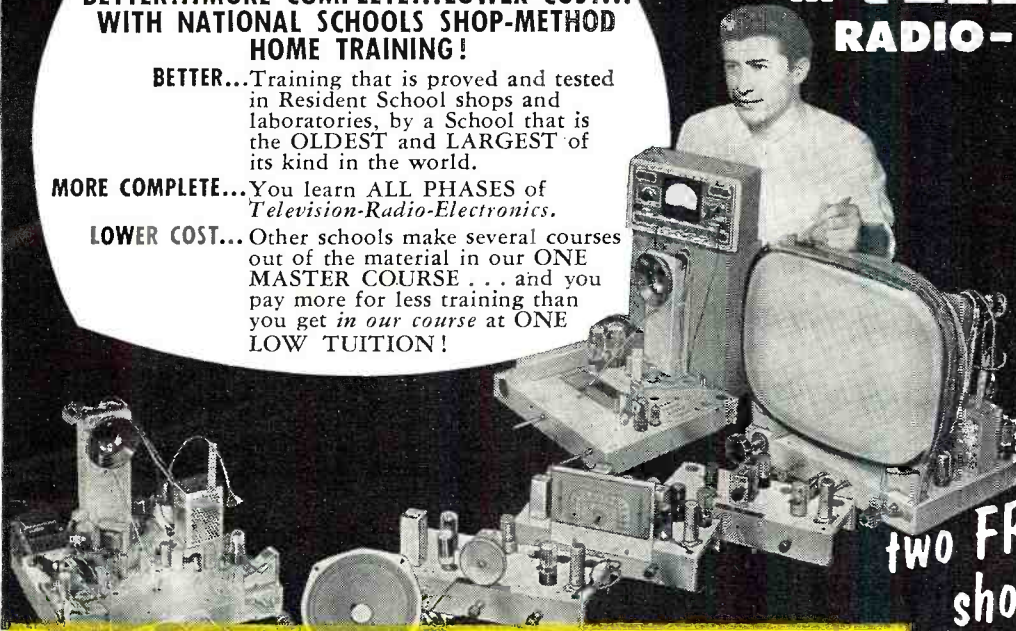

These **FREE** books will show you how!

You get all information by mail . . . You make your own decision . . . at home! **NO SALESMAN WILL CALL**

**TOP PAY... UNLIMITED OPPORTUNITIES
LIFETIME SECURITY CAN BE YOURS!**

You are needed in the Television, Radio, and Electronics industry! Trained technicians are in growing demand at excellent pay—in **ALL PHASES**, including Servicing, Manufacturing, Broadcasting and Communications, Automation, Radar, Government Missile Projects.

NATIONAL SCHOOLS SHOP-METHOD HOME TRAINING, with newly added lessons and equipment, trains you in your spare time at home, for these unlimited opportunities, including many technical jobs leading to supervisory positions.

YOU LEARN BY BUILDING EQUIPMENT WITH KITS AND PARTS WE SEND YOU. Your National Schools course includes thorough *Practical* training—**YOU LEARN BY DOING!** We send you complete standard equipment of professional quality for building various experimental and test units. You advance step by step, perform more than 100 experiments, and you build a complete TV set from the ground up, that is yours to keep! A big, new TV picture tube is included at no extra charge.

EARN AS YOU LEARN. We'll show you how to earn extra money right from the start. Many of our students pay for their course—and more—while studying. So can you!

LESSONS AND INSTRUCTION MATERIAL ARE UP-TO-DATE, PRACTICAL, INTERESTING. Every National Schools Shop-Method lesson is made easy to understand by numerous illustrations and diagrams. All instruction material has been developed and tested in our own Resident School Shops, Laboratories and Studios.

SEND FOR INFORMATION TODAY . . . it can mean the difference between **SUCCESS** and failure for you! Send for your **FREE BOOK** "Your Future in Television-Radio-Electronics" and **FREE Sample Lesson.** Do it **TODAY**, while you are thinking about your future. It doesn't cost you anything to investigate!

**GET THE BENEFITS OF OUR OVER
50 YEARS EXPERIENCE**

Approved for
GI Training



NATIONAL SCHOOLS
Los Angeles 37, Calif.

YOU GET...

- 19 Big Kits—**YOURS TO KEEP!**
- Friendly Instruction and Guidance
- Job Placement Service
- Unlimited Consultation
- Diploma—Recognized by Industry
- **EVERYTHING YOU NEED FOR SUCCESS!**

**SHOP-METHOD HOME TRAINING
COVERS ALL PHASES OF INDUSTRY**

1. Television, including Color TV
2. Radio AM & FM
3. Electronics for Guided Missiles
4. Sound Recording and Hi-Fidelity
5. FCC License
6. Automation and Computers
7. Radar & Micro-Waves
8. Broadcasting and Communications

NATIONAL TECHNICAL SCHOOLS
WORLD-WIDE TRAINING SINCE 1905

MAIL NOW TO

**NATIONAL SCHOOLS, Dept RH-39
4000 S. FIGUEROA ST. LOS ANGELES 37, CALIF.**

Rush free TV-Radio "Opportunity" Book and sample lesson. No salesman will call.

NAME _____ AGE _____
ADDRESS _____
CITY _____ ZONE _____ STATE _____

Check if interested **ONLY** in Resident School training at Los Angeles
VETERANS: Give date of Discharge _____

RESIDENT TRAINING AT LOS ANGELES

If you wish to take your training in our Resident School at Los Angeles, the world's TV capital, start **NOW** in our big, modern Shops, Labs and Radio-TV Studios. Here you work with latest Electronic equipment - - professionally installed - - finest, most complete facilities offered by any school. Expert, friendly instructors. Personal attention. Graduate Employment Service. Help in finding home near school - - and part time job while you learn. Check box in coupon for full information.

FIRST TIME . . . a versatile

DUAL

HEAT SOLDERING GUN

FOR ONLY
\$7.95
LIST
Model 122B.C.K.



...and best of all,
it's a new

Weller®

Here from Weller, long time leader in the soldering field, is the newest and finest soldering gun value on the market.

WELLER DUAL HEAT FEATURE saves time, gives greater convenience and greatly increases tip life. A touch of your finger on the Triggermatic control switches heat to high (125 watts) or low (90 watts) as your job requires. It adapts instantly to varying needs, and you use high heat only when necessary.

HIGH EFFICIENCY WELLETIP utilizes copper for superior heat transfer and soldering efficiency, plus iron plating for durability. Flat cross-section design gives added strength and rigidity.

NEWEST DESIGN with sturdy plastic housing that resists hard knocks. Compact "feel" and comfortable balance aid precision soldering. Like all other Weller guns, this new model features instant heat, and a spotlight illuminates your work.



KIT INCLUDED

In addition to the Dual Heat Soldering Gun you get:

- Wire Bristle Cleaning Brush
- Soldering Aid for opening old joints, twisting wires
- All-purpose Solder

On sale now at your
Electronic Parts Distributor

WELLER ELECTRIC CORP. • 601 Stone's Crossing Rd., Easton, Pa.

wire from the top of R_{17} to C_{11} . Little can be done to eliminate the stray coupling between the two halves of V_2 . However, grounded metallic shield braid threaded over the wires running to R_{17} will reduce the echo effect to insignificance.

In practice, the echo effect is unnoticeable when the instrument is properly played. I've been using the prototype described in the article, with no shielding, for over a year-and-a-half without difficulty. I'm sure that with a little practice anyone can achieve the same results. Use a snappy fingering technique. Don't depress or release the keys slowly, and don't allow your fingers to rest on unused keys.

HARTLAND B. SMITH
Birmingham, Michigan

We are glad to pass along this useful information from Author Smith who designed this unit.—Editors.

* * *

CITIZENS BAND RADIO

To the Editors:

Can you tell me whether or not considerable use is being made of the Citizens Radio Band, which I believe uses a frequency of about 460 mc.? Are there any articles in back issues of RADIO & TV NEWS which discuss this band and the equipment required?

G. W. BLOEMENDAL
Oak Park, Illinois

To the Editors:

Here is a report of some DX I have worked on the new 27 mc. Citizens Band.

On December 25th, I worked 11WØ-822 at Lakewood, California, a distance of about 1700 miles from St. Charles, Illinois, using a power input of less than 5 watts to a vertical, 300-ohm folded dipole antenna. We are exchanging verifications.

M. ARTHUR LAVERTY
St. Charles, Illinois

For an excellent article on the status of the 460 mc. Citizens Band, we refer you to the article "Citizens Radio Faces the Future" in our November, 1958 issue. For information on the new 27 mc. Class D Citizens Service, we refer you to the article "Build This Citizens Band Transceiver" (page 49) in this issue.—Editors.

* * *

"TINY TIM" THERMISTOR

To the Editors:

In the parts list for the "Tiny Tim" Portable P.A. Amplifier" (December, 1958 issue), you list R_{16} as a 130-ohm thermistor, Veco type 21W1. In my catalogues, this number is rated as a 100-ohm thermistor. Now which is correct, the model number you give or the resistance value shown?

WALTER PROKUSKI
Peru, Illinois

The correct thermistor is actually a 21W1 with a resistance value of 100 ohms.—Editors.

—50—

JUST OFF THE PRESS!



NEWLY REVISED AND UP-TO-DATE

WHERE
Would You
be Today
in Radio-TV
Electronics
IF...

you had sent for
this FREE Valuable Booklet 12 Months Ago

TAKE A MINUTE TO MAIL THIS COUPON FOR FREE BOOKLET!

Thousands of men did send for it. They read it. And now they are a full year ahead in their march toward:

- a better job
- better pay
- promotion
- greater security
- greater confidence
- better living for self and family

All these benefits can be yours . . . if you act now to see what the rapidly expanding field of Electronics offers you. Take that first big step this minute. No obligation whatsoever. Mail coupon today, or write: Capitol Radio Engineering Institute, 3224 16th St., N.W., Washington 10, D. C.

CAPITOL RADIO ENGINEERING INSTITUTE

ECPD Accredited Technical Institute Curricula • Founded 1927
3224 16th St., N.W. Washington 10, D. C.

JA

113-F

Please send me your course outline and FREE illustrated Booklet "Your Future in the New World of Electronics" . . . describing opportunities and CREI home study courses in Electronic Engineering Technology.

- CHECK FIELD OF GREATEST INTEREST
- Radar, Servo and Computer Engineering Technology
 - Electronic Engineering Technology
 - Broadcast (AM, FM, TV) Engineering Technology
 - Television Engineering Technology
 - Aeronautical Electronic Engineering Technology
 - Automation and Industrial Electronics Engineering Technology

Name.....Age.....

Street.....

City..... Zone..... State.....

Check: Home Study Residence School Korean Veteran

To obtain fast immediate service and to avoid delay it is necessary that the following information be filled in:

EMPLOYED BY.....

TYPE OF PRESENT WORK.....

EDUCATION: YEARS HIGH SCHOOL.....

OTHER

ELECTRONICS EXPERIENCE.....

CREI prepares you quickly for success in

The future is in your hands!

The signs are plain as to the future of the trained men in the electronics industry. It is a tremendous industry, but—when there's a choice between a trained and untrained applicant, the trained man will get the job. Your biggest problem is to decide on—and begin—the best possible training program.

**CREI Home Study . . .
The Quick Way to Get There.**



Since 1927, CREI has given thousands of ambitious young men the technical knowledge that leads to more money and security. The time-tested CREI procedure can help *you*, too—if you really want to be helped. CREI lessons are prepared by experts in easy-to-understand form. There is a course of instruction geared to the field in which you want to specialize. You study at *your* convenience, at *your* rate of speed. Your CREI instructors guide you carefully through the material, and grade your written work personally (not by machine).

Industry Recognizes CREI Training.

CREI courses are prepared, and taught with an eye to the needs and demands of industry, so your CREI diploma can open

many doors for you. Countless CREI graduates now enjoy important, good-paying positions with America's most important companies. Many famous organizations have arranged CREI group training for their radio-electronics-television personnel. To name a few: All-American Cables and Radio, Inc.; Canadian Broadcasting Corporation; Columbia Broadcasting System; Gates Radio Company; Federal Electric Corporation; The Martin Company; Douglas Aircraft Co.; U.S. Information Agency (Voice of America); Trans-Canada Air Lines; United Air Lines. Their choice for training of their own personnel is a good cue for *your* choice of a school.

Benefits Felt Right Away.

Almost immediately you feel the benefits of CREI training. Your employer, when informed of your step toward advancement (only at your request), is certain to take new interest in you and in your future. What you learn in CREI Home Study can start helping you do a better job immediately.

CREI also offers Residence Training in Washington, D. C.

. . . at the same high technical level. Day and evening classes start at regular intervals. Qualified residence school graduates earn degree as "Associate in Applied Science." Check reply card if you prefer resi-

- BROADCASTING, AM, FM, TV
- MILITARY, NAVY CAA ELECTRONICS
- COMMUNICATIONS
- ELECTRONICS MANUFACTURING
- GUIDED MISSILES
- SERVO-MECHANISMS
- AUTOMATION
- COMPUTERS
- AERONAUTICAL ELECTRONICS

dence or home study information . . . or write Capitol Radio Engineering Institute, 3224 16th St., N.W., Wash. 10, D. C.

BRAND NEW COURSE ADDED: AUTOMATION & INDUSTRIAL ELECTRONICS ENGINEERING TECHNOLOGY. Complete course, covers all phases of automation. Special emphasis on theory, functioning and applications of servo-mechanisms and computers. Also note-worthy: Lessons on machine control, instrumentation, data-processing, and telemetry.

ELECTRONIC TECHNICIANS

Growing Peninsula Co. has openings for 1st class electronic technicians to work directly with engineering in development of new products. Only those with CREI or equal training and 3 years minimum commercial experience will be considered. Top salaries to qualified applicants. Call Mr. McQueeney, DA. 4-4733 for appointment. ALTO SCIENTIFIC Co., Inc. 855 COMMERCIAL ST. PALO ALTO

ENGINEERING AIDES

AND
TECHNICAL
Immediate Position Available
CREI or other to electronic training desirable.
Experienced in read schematics, breadboard construction of electronic circuits and chassis preparation.

EMERSON RESEARCH

Industry Calls for CREI Training by Name So Should You!

Here you see actual help wanted ads—one from a San Francisco newspaper, another seen in Washington. They are just two of many which specify "CREI or equal" education. This shows that industry approves CREI training, even insists on it. Experience has taught many, many companies that CREI students are taught what industry needs and wants them to know. Let this be your cue when you choose your educational program.

**Send card today for
this fact-packed
booklet. It's free.**



Take 2 minutes to send for this booklet right now. We'll promptly send your copy. The rest—your future—is up to you.

1st Class
Permit No. 288-R
Washington, D. C.

BUSINESS REPLY CARD
No Postage Stamp Necessary If Mailed in United States

4¢ Postage Will Be Paid By



3224 SIXTEENTH STREET, N.W.
WASHINGTON 10, D. C.

FREE

With Your Purchase of RCA Receiving Tubes

NEW
ALL-METAL
RCA
TREASURE CHEST



RCA's "TREASURE CHEST"—the handy way to have more than 260 RCA receiving tubes with you at all times, and all in one easy-to-carry, durable *steel* carrying case! This All-Metal RCA Treasure Chest can carry a wide selection of tube types and sizes, with all type numbers in full view when the case is opened. It has a handsome finish, is well braced and strongly hinged. Measurements—21 $\frac{3}{4}$ " x 16" x 8 $\frac{3}{8}$ ".

ALL-NEW
RCA SERVICE INFO KIT



RCA SERVICE PARTS INFO KIT! Valuable servicing data in one easy-to-use package for work right on the job! Contains: (1) the New Service Parts Directory for RCA Victor 1955, 1956 and 1957 TV Receivers—features service information on more than 250 color and black-and-white TV receiver models, circuit diagrams, parts lists, top-and-bottom chassis views and comprehensive index; (2) New RCA Victor Radio and Record Service Parts Directory—features major replacement parts for TV and radio receivers, phonograph cartridge guide and comprehensive index.

TO GET THE NEW RCA ALL-METAL TREASURE CHEST AND THE RCA SERVICE PARTS INFO KIT ASK YOUR RCA TUBE DISTRIBUTOR FOR FULL DETAILS... TODAY!



A BIG HAND
From RCA to You...
In Honor of 5th Annual
**NATIONAL TELEVISION
TECHNICIANS' WEEK**
March 23-28



RADIO CORPORATION OF AMERICA

Electron Tube Division

Harrison, N. J.

NEW

from

Tarzian



F-4

Lowest priced 750 mil. silicon rectifier available . . . Ten in a handy pack—rated at 0.75 amps. dc, 400 P.I.V. . . . For use in radio, television and electronics.

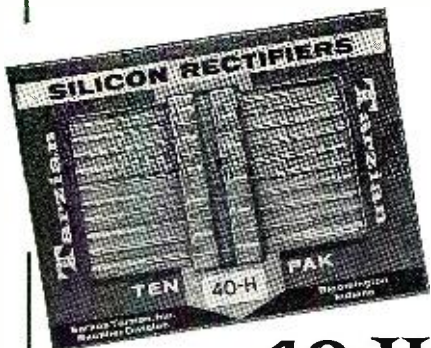

40-H

Industry standard top hat hermetically sealed silicon rectifier rated at 0.75 amps. dc, 400 P.I.V.

Send for prices and complete information

Sarkes Tarzian, Inc.

RECTIFIER DIVISION

DEPT. N-2, 415 N. COLLEGE AVE.
BLOOMINGTON, INDIANA

IN CANADA: 700 WESTON RD., TORONTO 9
TEL. ROGER 2-7535
EXPORT: AD AURIEMA, INC., NEW YORK CITY

Win in the Industry

ROBERT E. LEWIS has been elected president of *Sylvania Electric Products Inc.*



Previously he was a senior vice-president of the company.

Mr. Lewis was president of *Argus Cameras, Inc.*, an independent company, prior to its combination with *Sylvania* in 1957. Before this, he was a consulting management engineer with *Sanderson & Porter*. Earlier, he had been treasurer and a director of *American Steel & Wire Co.*, a *U. S. Steel* subsidiary; president of *Cleveland Wire Spring Co.*; and controller and assistant to the president of *Batten, Barton, Durstine and Osborn*, New York advertising agency.

THE REPRESENTATIVES has changed its name to the Electronic Representatives Association after an overwhelming deluge of "yes" votes from members.

In announcing the official tally of 265 to 16 it was added that the organization would now be known as ERA. This clearly identifies the group as electronic representatives.

ED FLAXMAN has been appointed vice-president in charge of sales for *Service Instruments Corporation* of Addison, Illinois.



He was previously sales manager of *Waldom Electronics* and is well known throughout the electronic industry.

Mr. Flaxman's new responsibilities will include complete charge of nineteen "Sencore" representative organizations and the development of a new sales organization for the company's special products division.

AMPHENOL ELECTRONICS CORPORATION and **THE GEORGE W. BORG CORPORATION** have received approval from their stockholders for the consolidation of the two companies into **AMPHENOL-BORG ELECTRONICS CORPORATION** . . . Controlling interest in **THE BOBBS-MERRILL COMPANY** has been acquired by **HOWARD W. SAMS & CO., INC.** According to the firm, the former company will retain its present identity and will continue with its educational, legal, and trade book departments . . . **AMERICAN TELEVISION & RADIO COMPANY** has announced the purchase of **ECKSTEIN RADIO AND TELEVISION COMPANY** and is taking over the manufacturing of this

line immediately . . . **ARKAY RADIO KITS, INC.** has moved to new quarters at 88-06 Van Wyck Expressway, Richmond Hill, Queens, N. Y.

HOWARD T. HARWOOD has been named chairman of the advertising section of the Electronic Parts and Equipment Manufacturers Association. The group has a membership of about 120 manufacturers throughout the Middle West.

Mr. Harwood is advertising manager of *Shure Brothers, Inc.*, Evanston, Ill.

JOHN D. MICHAEL has been named to the executive sales staff of the distributor division of *Quam Nichols Company*.



Mr. Michael comes to the speaker and electronic components manufacturing company with seven years' experience in the installation of sound systems

in industrial, school, and institutional applications.

In his new post he will assist the manager of the company's distributor division.

ELECTRONICS INDUSTRIES ASSOCIATION's board of directors has established a National Stereophonic Radio Committee with authorization to develop a set of standards for stereophonic radio broadcasting for recommendation to the FCC.

The responsibility of this committee would be to develop a set of standards which, in the opinion of the industry, as represented by the Association, represents the most economical method of serving the public. The standards must permit full compatibility to the extent economically feasible; that is, all reasonable systems of multiplexing plus regular FM transmissions.

Operations will be directed by an administrative committee headed by Dr. W. R. G. Baker and with David B. Smith of *Philco Corporation* as vice-chairman. The operating committee will be headed by Graydon Lloyd of *General Electric Company*.

WILLIAM H. ATTSCHULER has been appointed to the newly created position of factory manager of *Pentron Corporation* . . . *Switchcraft, Inc.* has named **THOMAS L. DOWELL** as distributor sales manager . . . *Raytheon Manufacturing Company* has named **JOHN H. BEEDLE** as head of its new equipment and systems division and **J. PENN RUTHERFORD** as manager of the new industrial apparatus division . . . **GEORGE W. DE-**

ownership of a **PHOTOFACT** SERVICE DATA LIBRARY SPELLS SUCCESS FOR SERVICE TECHNICIANS

here's actual proof from the men who know

"Cuts service time in half. There's no way to accurately judge the great amount of time saved by PHOTOFACT in locating replacement parts and the many other services furnished by PHOTOFACT."

—Julius L. Burke,
Dallas, Texas

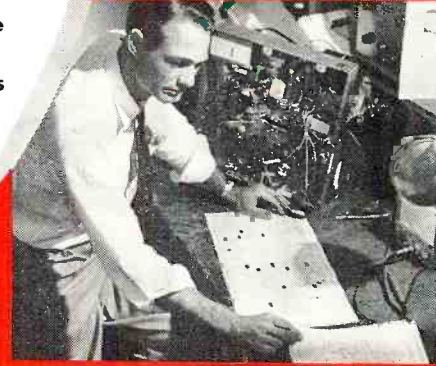

Mr. Burke is a Sams distributor and a Sams customer. He is also a Sams Manager. See how you can enjoy PHOTOFACT today.



HERE'S MORE PROOF...FROM COAST-TO-COAST

"Since I have used PHOTOFACT my business has increased about 50%, and they have taught me a lot about service work."

—Leland Moyer, Fort Plain, N. Y.

"PHOTOFACT is a great aid to expedite servicing and a handy complete reference material."

—E. A. Allen, Coffeeville, Ala.

"I couldn't do any business without PHOTOFACT. I just wish I could have afforded all of them before."

—Albert Bishop, Brevard, N. C.

"With my Sams PHOTOFACT Library I feel I can lick most any problem I'm likely to run into, in an efficient, profitable manner."

—Herbert L. Till, Iuka, Miss.

"It would be very difficult to service some sets without Sams PHOTOFACT; they make the tough ones easy to service."

—W. D. Johnson, Tavares, Fla.

"It is used for every bench job we work on."

—Edison R. Haviland,
Garfield Heights, Ohio

"PHOTOFACT means faster and better service."

—Ray W. Nichols, Seymour, Ind.

"I believe PHOTOFACT is the only way for fast service on TV. I couldn't give good service without them."

—Henry Ingham, Tetum, Texas

(These are just a few of hundreds of "Success with PHOTOFACT" letters in our files)

OWN A PHOTOFACT LIBRARY —
see your Sams Distributor today or write
to Howard W. Sams for full details



HOWARD W. SAMS & CO., INC.
2203 E. 46th St., Indianapolis 6, Ind.

- Send me Free booklet "Your Guide To Maximum Profits"
 I'm a Service Technician: full-time; part-time

My Distributor is: _____

Shop Name: _____

Attn: _____

Address: _____

City: _____ Zone: _____ State: _____

NEW EASY-BUY PLAN! It's the money-saving way to build your complete profit-making PHOTOFACT Library! NO INTEREST—NO CARRYING CHARGE—AS LITTLE AS \$10 DOWN **FREE!** Valuable steel file cabinets for PHOTOFACT monthly subscribers and Library purchasers.



Valuable booklet shows you how PHOTOFACT boosts your profit-capacity

FREE!

Send for it!



Integrated Data Processing For Military Weapons Systems

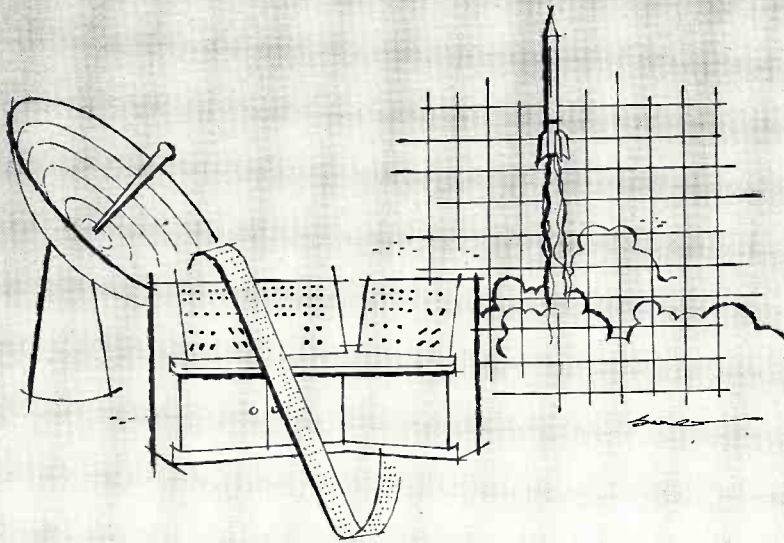

Technicians — An electronics future for you at BURROUGHS Military Field Service Division adds up to challenging work on important ATLAS and SAGE programs, advancement based on individual performance and a fine career in the field of tomorrow: Digital Computation.

BURROUGHS, consistent with its recognized leadership in equipment, skills and manpower, is providing the answers for complex military weapons systems through automatic suprahuman computation.

Qualified applicants will receive: 1) Formal 16 or 22-week training program in Data Processing Systems. 2) Starting salary commensurate with experience and ability. 3) Full salary while training. 4) Fine fringe benefits including educational assistance in addition to your training program. 5) Current field assignments include Western and Midwestern areas, when your training program is concluded.

If you are a graduate of an accredited Technical School and/or have military training in radar or communications equipment, plus at least 2 years' experience in electronics, you are invited to address your inquiries to Personnel Department, Military Field Service Division, Burroughs Drive, Radnor, Pa. (a suburb of Philadelphia).



Burroughs Corporation

"NEW DIMENSIONS" / in electronics and data processing systems

SOUSA has been named vice-president in charge of marketing for the semiconductor division of *Hoffman Electronics Corp.* . . . **DR. JAMES B. FISK** has been elected president of *Bell Telephone Laboratories* . . . **STAN NEUFELD** has joined *Brand Products, Inc.* as vice-president in charge of sales . . . **J. GERALD MAYER** has been named president of *Radio Receptor Co., Inc.*, subsidiary of *General Instrument Corp.* . . . **JACK KARNIS** has resigned as vice-president of *Recoton Corporation*. At the same time, **ALFRED WISH**, formerly secretary of the firm, has been elected vice-president . . . *Raytheon Manufacturing Company* has appointed **RICHARD E. SEIFERT** as sales planning manager for the semiconductor division and **NATHANIEL H. SPERBER** as publicity manager for the firm . . . **HARVEY W. HARPER**, founder and chairman of the board of directors of *Tung-Sol Electric Inc.* died at the age of 80 . . . **DR. CHARLES G. SMITH**, one of the three founders of *Raytheon Manufacturing Company*, has retired from that company at the age of 70.

MOGENS E. CHRISTIANSEN has been appointed general sales manager of the *Mallory Battery Company* of Cleveland, a division of *P. R. Mallory & Co. Inc.*



Mr. Christiansen has been employed in battery manufacturing, engineering, and sales for nineteen years. He came to this country from Denmark in 1940 and joined *General Dry Batteries, Inc.* where he served in production, quality control, engineering, and sales capacities.

Prior to his new appointment he was assistant general sales manager of the firm.

INSTITUTE OF HIGH FIDELITY MANUFACTURERS has re-elected Joseph N. Benjamin as president. Mr. Benjamin is president of the *Bogen-Presto Division* of the *Siegler Corporation*.

Philip Gundy, president of *Ampex Audio Inc.*, was elected as Institute vice-president; Saul Marantz, president of *Marantz Company*, was named secretary; and Milton D. Thalberg, president of *Audiogersh Corporation*, was re-elected treasurer.

Mr. Benjamin and Mr. Thalberg were renamed to the board of directors for two year terms along with the following: L. J. Epstein, formerly director of sales and merchandising, *University Loudspeakers Inc.*; William S. Grommes, the president of *Grommes Division* of *Precision Electronics Corporation*; and Walter O. Stanton, president of *Pickering and Company*.

The Institute, formed with 23 firms in 1955 to set industry standards and educate the public about component high-fidelity, now numbers more than 120 manufacturers, recording companies, and publishers throughout the country.

How to Pass FCC License Exams

find out how an FCC license means...



1 More income for you every week

2 A more interesting job in electronics

The average person spends over 50% of his waking hours on the job (or going to and from the job). Therefore doesn't it make sense to have a job that is really interesting and also pays well?

The chances are very good that if you are reading this magazine you can qualify for the really good jobs in electronics . . . and it won't take long to do it. Your past training and experience in basic electronics (such as radio and TV repair, armed forces electronics, ham operations, etc.) can be the foundation for a profitable career as an "across-the-board" electronics technician.

Whether you run your own shop or work for someone else, the real money, the interesting work, is available to the man who can effectively handle the more complex electronic gear. Home receiver repair can provide a good living, but it can't match the opportunities open to a skilled electronics technician.

The booklets shown below will show you how you can qualify for a government certificate of competency . . . a commercial FCC License . . . and acquire a really fine technical education. Find out how your success with the FCC examination is guaranteed . . . or your money back.

You will also find out where technicians are needed . . . what a technician needs to know about electronics . . . and many other facts about opportunities for you in electronics.

It will cost you only the price of a postage stamp to get all of the facts. If you are in any type of electronics work . . . or if you have had previous training or experience in electronics . . . you owe it to yourself to ask us to send you information on profitable careers in electronics.

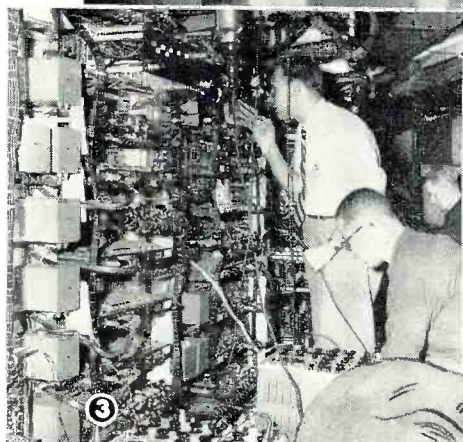
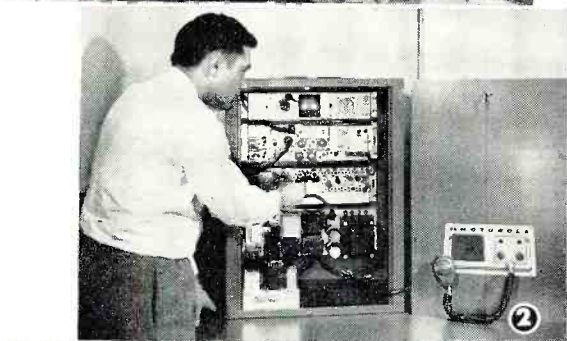

CLEVELAND INSTITUTE OF RADIO ELECTRONICS

Desk RN -27 4900 Euclid Ave.

Cleveland 3, Ohio

1. Collins Radio Company
2. Motorola Communications & Electronics, Inc.
3. Raytheon Manufacturing Company



CLEVELAND INSTITUTE OF RADIO ELECTRONICS

Desk RN -27 4900 Euclid Ave., Cleveland 3, Ohio

Please send FREE Booklets prepared to help me get ahead in Electronics. I have had training or experience in Electronics as indicated below:

- | | |
|---|---|
| <input type="checkbox"/> Military | <input type="checkbox"/> Broadcasting |
| <input type="checkbox"/> Radio-TV Servicing | <input type="checkbox"/> Home Experimenting |
| <input type="checkbox"/> Manufacturing | <input type="checkbox"/> Telephone Company |
| <input type="checkbox"/> Amateur Radio | <input type="checkbox"/> Other _____ |

In what kind of work are you now engaged? _____

In what branch of Electronics are you interested? _____

Name _____ Age _____

Address _____

City _____ Zone _____ State _____

RN-27

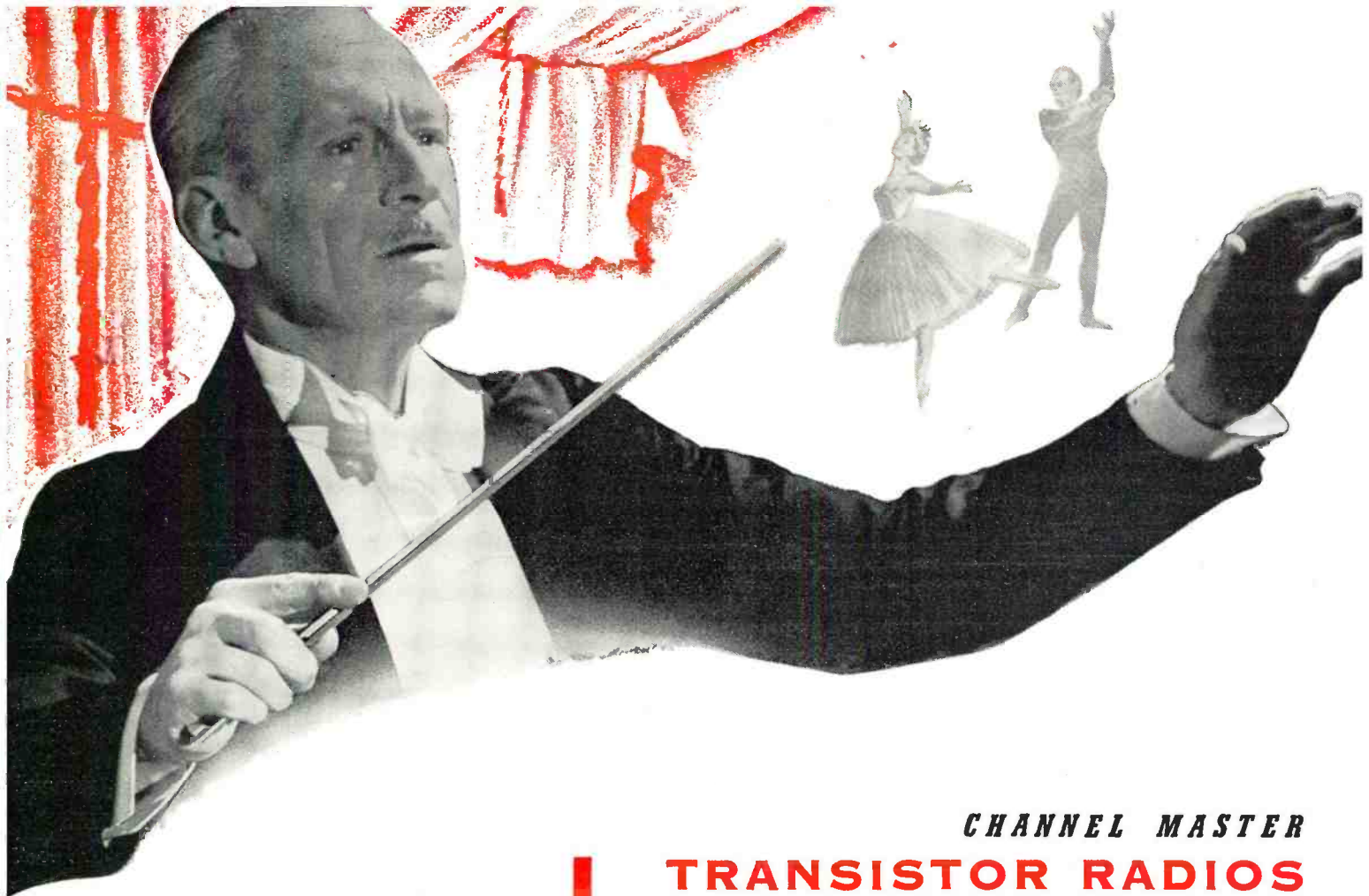

CHANNEL MASTER TV ANTENNAS

Dealers sell more T-W's than any other fringe-area antenna—by far. The powerful T-W delivers the highest gains and front-to-back ratios of any all-channel VHF antenna. Its rugged construction provides more years of peak performance. And it's nationally advertised on network TV and in leading magazines. Recommend a T-W for your next installation—and help your business grow.

CHANNEL MASTER **T-W** The World's Most Powerful TV Antenna

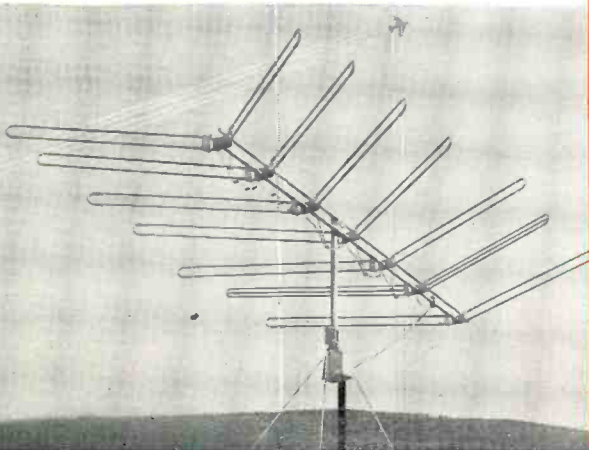

CHANNEL MASTER TRANSISTOR RADIOS

Personal Portable Radio

6 transistors, plus 1 diode and 1 thermistor. 5 $\frac{3}{4}$ " x 3" x 1 $\frac{3}{4}$ "
Model No. 6506 \$49⁹⁵ list
including accessories



Pocket Portable Radio

6 transistors, plus 1 diode.
4 $\frac{5}{8}$ " x 2 $\frac{3}{4}$ " x 1 $\frac{1}{4}$ "
Model No. 6501 \$34⁹⁵ list



Never before have any radios made such an instant hit with the American public. And no wonder! These electronic gems are unmatched in sensitivity — even by larger, much more expensive radios. Their smart, modern design... rich tone... and low price make Channel Master transistor radios America's #1 value.

CHANNEL MASTER

works wonders in
Sight and Sound

New! CHANNEL MASTER HIGH FIDELITY COMPONENTS

New components with a new idea: the "Practical Approach!" Channel Master's new hi-fi line is designed to eliminate confusion by directing the customer's attention to the 5 basic, practical considerations which apply to the selection of any high fidelity system: Performance, Ease of Operation, Versatility, Styling, and Cost.

The Channel Master line eminently satisfies each of these requirements. These are instruments of superb quality and striking appearance, offered at moderate prices. They reproduce with astonishing accuracy the entire audible spectrum with an absolute minimum of manual controls. The result is a true high fidelity system which satisfies the most discriminating audiophile... and yet can be used and enjoyed by virtually everyone.

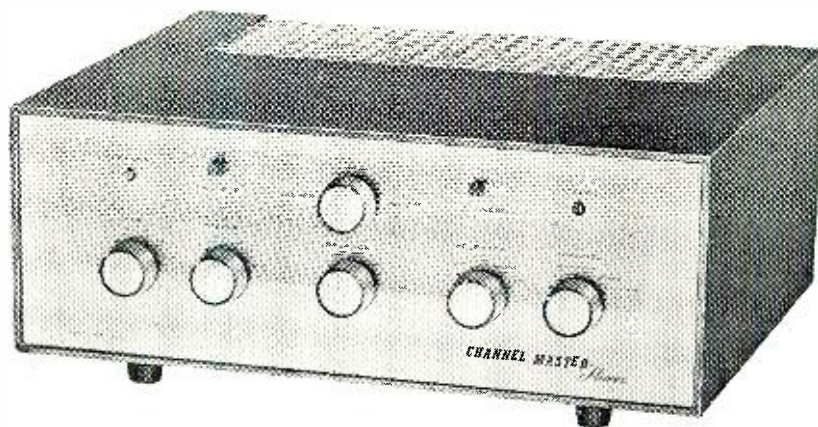

Stereophonic Amplifier

Model No. 6600

audiophile net \$119⁹⁵ without cabinet

The Channel Master 6600 stereophonic amplifier is an instrument of flawless electronic craftsmanship, embodying every advanced technical feature for full-range stereophonic sound reproduction. 16 watts on each channel (32 watt peak). Solid brass face panel.

Cabinets available
in wood or metal.

Tiny Minstrel Speaker System brings concert hall realism to the home

Now, for the first time, full dynamic realism is achieved in a miniature enclosure only 9" x 9" x 16". Through the patented new "Acoustic Transformer" principle the entire air chamber becomes a phase matching air transformer which produces clear, undistorted sound from 50 to 15,000 cycles. The big sound and small size of Channel Master Minstrels make them ideal for flexible, space-saving, low-cost stereo installations.

audiophile net \$29⁹⁵

Monaural Amplifier Model No. 6620

audiophile net \$79⁹⁵ without cabinet

This superb 20 watt (40 watt peak) amplifier faithfully reproduces every sound audible to the human ear. Modern feed-back circuitry assures minimum distortion and full-frequency range. Special adapter jacks make conversion to a stereo system simple and economical. Solid brass face panel.

AM/FM Tuner Model No. 6100

audiophile net \$84⁹⁵ without cabinet

This outstanding tuner provides fine performance, pinpoint station selectivity and effortless flywheel tuning. Automatic Gain and Volume Controls on FM and AM prevent overloading by strong signals and maintain constant sound levels. Special multiplex output permits tuner to be adapted for stereophonic FM broadcasting. Solid brass face panel.

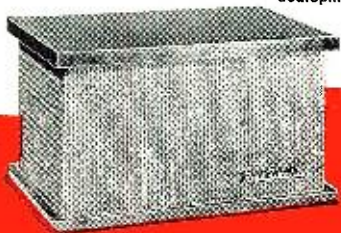

for product literature contact your CM Distributor or write to

CHANNEL MASTER CORP.

ELLENVILLE, NEW YORK

From Bell Telephone Laboratories . . .

Brainpower

for the brawny

Nike-Hercules

The Army's newest surface-to-air guided missile—the lethal Nike-Hercules—is now operational. Because it is, no unfriendly plane will be able to fly sufficiently high, fast or evasively to escape a fatal rendezvous with it.

For Hercules has a “brain”—an intellect that makes it a prodigy among today's electronic robots. Bell Telephone Laboratories developed it. Western Electric (prime contractor for the entire missile system) is producing it. Douglas Aircraft Company is giving it its body.

This “brain” is a fully integrated guidance system, almost entirely land-based. Only the vital signal-receiving apparatus is expendable within the missile itself. Other highly practical features: it defies “jamming,” is completely mobile, is designed in separate “building block” units which are replaceable in seconds—and is deadly accurate.

Bell Labs scientists and engineers designed the world's largest and most intricate telephone communications network for the Bell System. They developed about half of the Armed Forces' radar equipment during World War II. And they pioneered the nation's *first* successful air defense guided missile system—Nike-Ajax.

They were eminently qualified to give Hercules the brainpower it needed.



BELL TELEPHONE LABORATORIES

World center of communications research and development

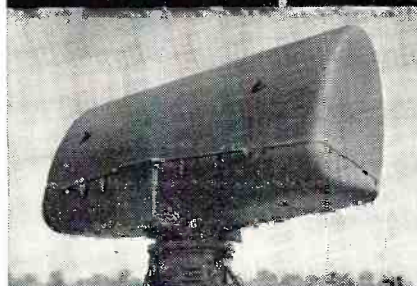

Vigilant acquisition radar for Nike-Hercules first detects approach of distant aircraft, pinpoints its location and instantly signals to battery control.

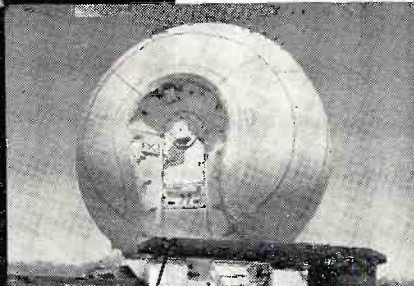

Two tracking-radar antennas, housed in radomes, take over. One feeds target azimuth, elevation, range data to computers; other tracks Hercules.



Two sets of radar data are electronically computed and plotted. Hercules is “steered” by radio signals, then detonated at precise point of interception.



LET RCA TRAIN YOU IN ELECTRONICS

RCA Institutes celebrates Fifty Years of Electronic Training by introducing its newest Home Study Course . . .

ELECTRONICS FOR AUTOMATION

. . . Now you have four comprehensive courses for your electronic training . . . from basic electronic theory to the more advanced principles of color TV and Automation.

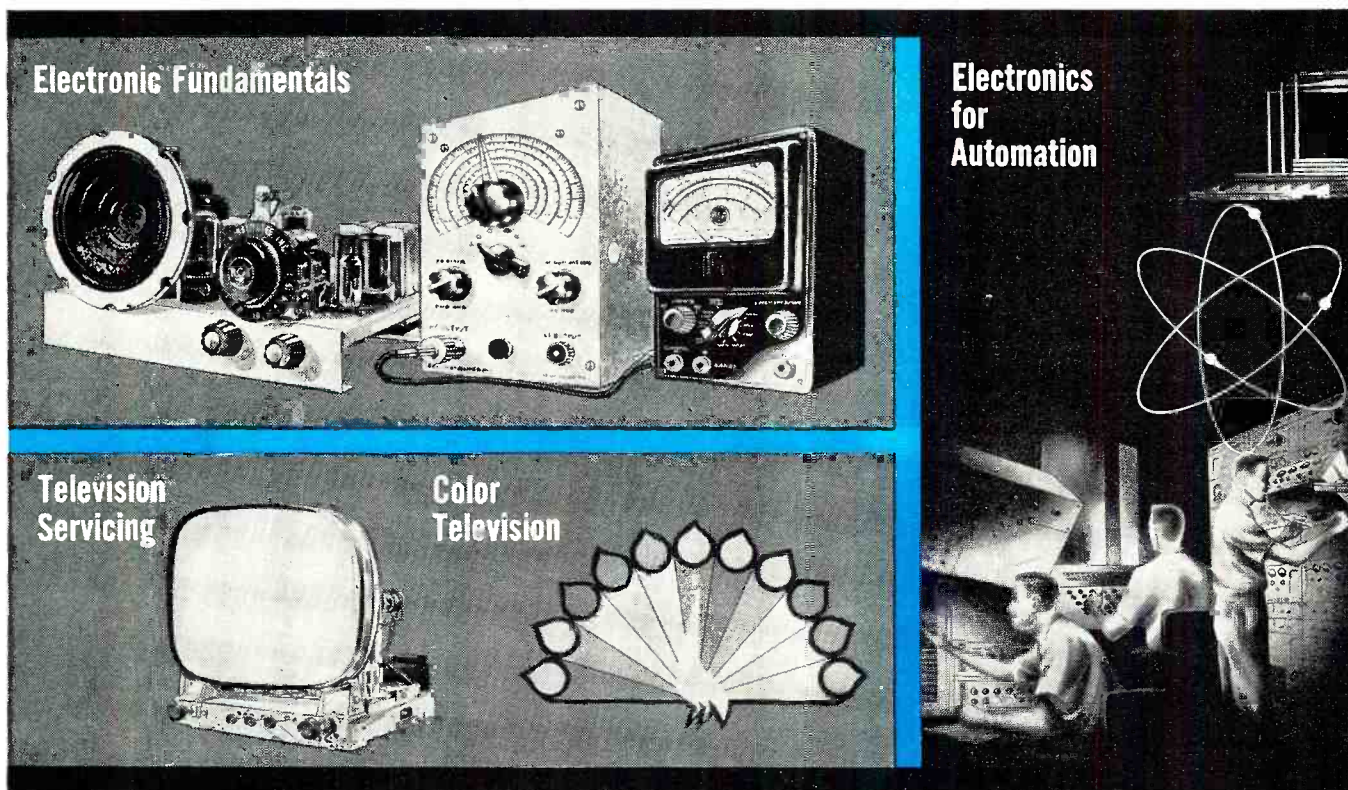

Send for our
64 page Home
Study Catalog

FREE!

RESIDENT SCHOOL offers Technical Institute and Vocational School Courses in Electronics. Day and Evening classes start 4 times each year. Resident School Catalog sent free on request.

March, 1959

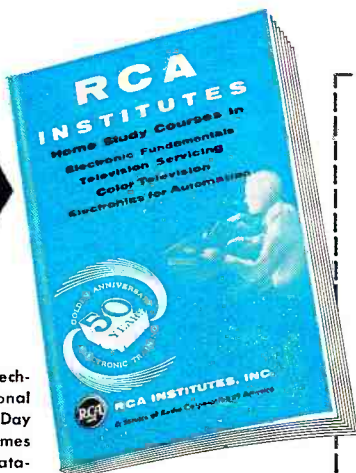

Practical work with the very first lesson. Pay-as-you-learn. You need pay for only one study group at a time.

RCA INSTITUTES, Inc. Home Study School, Dept. RN-39

A Service of Radio Corporation of America

350 West Fourth Street, New York 14, N. Y.

Without obligation, send me the FREE catalog of Home Study Courses. No salesman will call.

Name Please print

Address

City Zone State

Korean Vets! Enter Discharge Date.....

CANADIANS — Take advantage of these same RCA courses at no additional cost. No postage, no customs, no delay. Send coupon to:
RCA Victor Company, Ltd., 5001 Cote de Liesse Rd., Montreal 9, Quebec
To save time, paste coupon on postcard.

Get big-speaker performance in a "stereo-compact" enclosure



General Electric's LH-12 "Stereo Classic" Speaker System combines enclosure compactness with full, smooth response over the entire audio frequency range. The complete unit — with woofer, tweeter and crossover network — occupies only two cubic feet of space.

But small size is gained through no sacrifice in sound. G.E.'s new Extended Bass design puts out *four times* as much power (+6db) at low frequencies as standard 12" speakers in the same enclosure. For superb stereo sound, we invite you to compare this system with all others, *regardless of size*.

Complete LH-12 Speaker System in four most wanted finishes at **\$129.95***. LC-12 and LK-12 Speakers available for separate mounting at **\$89.95***.

OUTSTANDING NEW BASS PERFORMANCE

The woofer's high excursion cone and long voice coil quadruple power-handling ability. Treated cloth cone suspension increases compliance. Aluminum base voice coil for fast, efficient heat dissipation. All-steel welded construction.



Woofer



Crossover network



Tweeter

LH-6 Bookshelf Speaker System

Only 9" high, 17 $\frac{3}{8}$ " wide and 8 $\frac{3}{8}$ " deep, yet provides better low-frequency response than speakers tested in enclosures up to twice the size. Perfect solution to problem of getting high quality performance in a limited space. May be positioned on side or end, as shown at right. Also offered as kit without enclosure. From **\$49.95 to \$57.50*** (Kit form, **\$29.95**).

New EN-50 5-cu. ft. enclosure for 12" speakers available in four finishes. **\$69.95***

There's a full line of General Electric speakers at your High Fidelity dealer's. Finest performance—sensibly priced.

*Manufacturer's suggested resale prices.

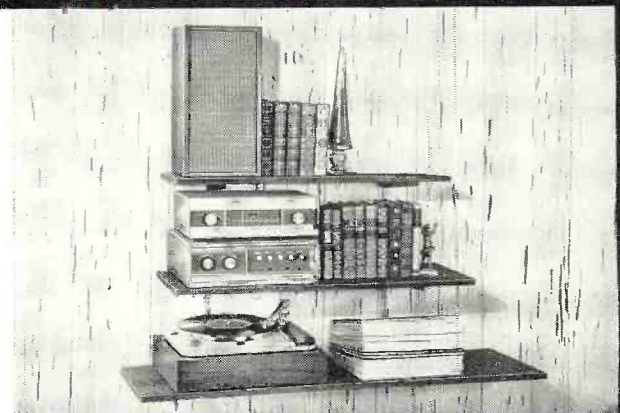

See and hear all the new G-E "Stereo Classic" components at your Hi-Fi dealer's now. For more information and the name of your nearest dealer, write General Electric Company, Specialty Electronic Components Dept., 45J3, W. Genesee St., Auburn, New York.

GENERAL  ELECTRIC

**WE'RE MAKING IT EASIER THAN EVER TO BECOME A WELL PAID
RADIO-TELEVISION SERVICE TECHNICIAN**

**NOW - Just \$6 Starts You Training in
RADIO-TELEVISION
the SPRAYBERRY "Learn-by-Doing" Way . . .**

**25 BIG, COMPLETE KITS
of PARTS & EQUIPMENT**

To help you learn fast the practical side of Radio-Television, we send you expertly engineered training kits to test and assemble for interesting, valuable shop-bench practice!

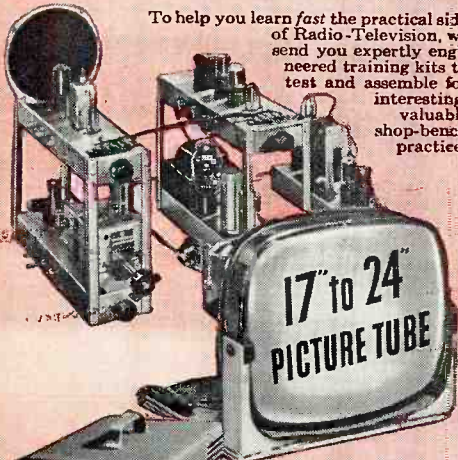

• The new Sprayberry Training Television Receiver, built and tested in 5 sections.

• Now offered . . . this fine modern oscilloscope.

• You build this powerful two-band superheterodyne radio receiver.

**Big New
CATALOG
AND
Sample Lesson
FREE!**

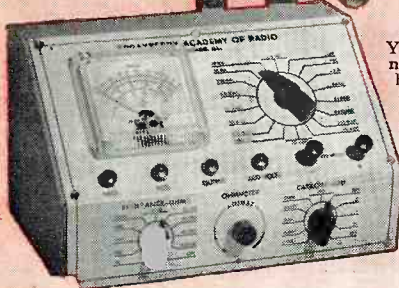
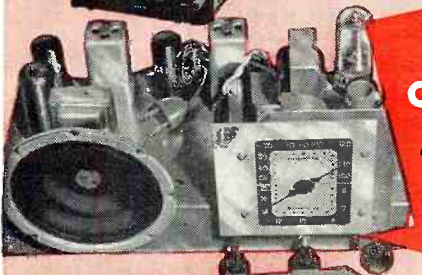

You build the new Sprayberry tester—a complete 18-range Volt-Ohm-Milliammeter test meter.

*** This great industry is begging for trained men . . . to step into good paying jobs or a profitable business of their own! Our new plan opens the doors of Radio-Television wide to every ambitious man who is ready to act at once!

Men by the thousands . . . trained Radio-Television Service Technicians . . . are needed at once! Perhaps you've thought about entering this interesting, top paying field, but lack of ready money held you back. Now—just \$6 enrolls you for America's finest, most up to date home study training in Radio-Television! Unbelievable? No, the explanation is simple! We believe Radio-Television *must* have the additional men it needs as quickly as possible. We are willing to do our part by making Sprayberry Training available for less money down and on easier terms than ever before. This is your big opportunity to get the training you need . . . to step into a fine job or your own Radio-Television Service Business.

Complete Facts Free—Act Now; Offer Limited

Only a limited number of students may be accepted on this liberal and unusual basis. We urge you to act at once . . . mail the coupon below and get complete details plus our big new catalog and an actual sample lesson—all free. No obligation . . . no salesman will bother you.

HOME STUDY TRAINING IN SPARE TIME

Under world-famous 27-year old Sprayberry Plan, you learn entirely at home in spare time. You keep on with your present job and income. You train as fast or as slowly as you wish. You get valuable kits of parts and equipment for priceless shop-bench practice. And everything you receive, lessons and equipment alike, is all yours to keep.

LET US PROVE HOW EASILY YOU CAN LEARN!

Radio-Television needs YOU! And Sprayberry is ready to train you on better, easier terms, that any ambitious man can afford. *Just \$6 starts you!* Mail coupon today . . . let the facts speak for themselves. You have everything to gain. Let us prove the kind of opportunity that's in store for you!

SPRAYBERRY Academy of Radio-Television
1512 Jarvis Avenue, Dept. 25-S, Chicago 26, Illinois

Mail This Coupon Now—No Salesman Will Call

Sprayberry Academy of Radio-Television
Dept. 25-S, 1512 W. Jarvis Ave., Chicago 26, Ill.

Please rush all information on your ALL-NEW Radio-Television Training Plan. I understand this does not obligate me and that no salesman will call upon me. Include New Catalog and Sample Lesson FREE.

NAME..... Age.....

ADDRESS.....

CITY..... ZONE..... STATE.....

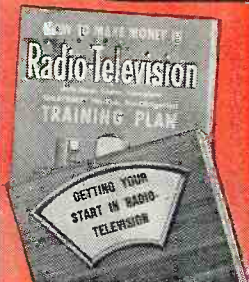



FAMOUS MEN OF MUSIC CHOOSE UNIVERSITY

Metropolitan Opera Star Leonard Warren, often referred to as the world's foremost baritone, has been acclaimed in most of today's great opera houses from Italy's La Scala to Buenos Aires' Teatro Colon and Moscow's Bolshoi Theatre. For his stereo system, Mr. Warren converted his full-range "Troubadour" quickly, easily and inexpensively with a compact Stereoflex-2.



WIDEST SELECTION OF HIGHEST QUALITY "ADD-ON" SPEAKERS...

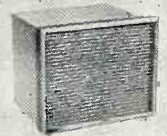

STEREOFLEX-1



MODEL SLC

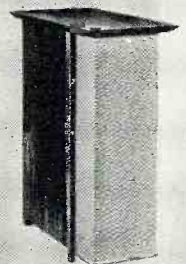

STEREOFLEX-2

NEW... for cost and space-saving stereo

UNIVERSITY SLC* and STEREOFLEX*

"ADD-ON" SPEAKERS



*Trademark. Patent Pending.

Whether converting or starting from scratch . . .

For those who already possess a full-range monophonic speaker system, or plan to buy one now with an eye to stereo conversion later . . . University can "add" superb stereo at low cost, even in rooms with "no" space for a second speaker. *Here's how:*

Because bass frequencies below 150 cps are strictly non-directional and do not contribute to the stereo effect, they can be reproduced by one woofer—that of the main system. In this case, the system supplies the *combined* bass of *both* channels as well as the full mid and high range of one channel. The mid and high range of the second channel is then provided by one of the three University "add-on" speakers. Because such "add-ons" are not required to produce low bass, they are small in size, easy to place for optimum stereo and decor effect, and priced most modestly. You also save the cost of a second woofer and large enclosure!

How University uses one woofer for two channel bass

This can be achieved in two ways, depending upon the kind of woofer you have. A conventional woofer—with a single voice coil—can receive these frequencies only after they are combined by the special stereo adapter network Model A-1. However, with University's exclusive DUAL VOICE COIL WOOFER† . . . containing two electrically separate voice coils . . . no such network is required. Instead, the stereo amplifiers can simply be connected one to each voice coil, thus feeding the full bass directly to this unique woofer.

Starting from scratch, another attractive and flexible approach would be to use a dual voice coil woofer in an enclosure along with one "add-on," the combination making a very fine monophonic speaker system. Later, you can convert to stereo with a duplicate "add-on," as shown at left. Now, since the woofer's position for stereo is not critical, you can place it almost anywhere in the room . . . and the two compact "add-ons" can easily be positioned for perfect decor and stereo effects . . . regardless of where the woofer has been placed.

Whichever approach you choose, University "add-ons" put you on the cost and space-saving road to true high fidelity stereo.

†University woofers having dual voice coils are models: C-15W, C-12SW, C-15HC and C-12HC. These are employed in speaker systems: Debonaire-12 S-3S; Senior S-5S; Master S-6, S-6S; Dean S-7, S-7S; Classic S-8, S-8S; S-9, S-9S; Ultra Linear S-10, S-10S; S-11, S-11S; Troubadour S-12, S-12S. (System models in light type are fully stereo adapted. System models in bold type, or any home built system with a dual voice coil woofer, can be easily and inexpensively prepared for stereo with kit SK-1. User net: \$5.95)

MODEL SLC is housed in an attractive fibreglas shell of charcoal grey with gold anodized grille and adjustable stand, STEREOFLEX-1, in a handsome wooden cabinet with fine woven grille cloth. Each occupies less than one cubic foot, making them easy to place on bookshelf, "lite-pole," or wall. Double horn-loaded, with 6" mid-range driver and 2000 cps crossover wide-angle tweeter. User net: Model SLC—\$43.50. Stereoflex-1—Mahogany—\$54.50, Blond or Walnut—\$56.50.

STEREOFLEX-2 is a slim, elegant unit, with matched woven grille cloth, designed for floor placement and makes an excellent end table. Double horn-loaded with heavy duty compression driver and extended air column for mid-range. Wide-angle driver/horn tweeter with "BRILLIANCE" control, 3000 cps crossover. 25½" x 10" x 19½" d User net: Mahogany—\$110.00, Blond or Walnut—\$113.00.

MODEL A-1 ADAPTER NETWORK: Required only with speaker systems not having dual voice coil woofer. User net: \$30.00.



FREE Guide to high fidelity stereo and monophonic speaker systems and components

You'll find complete information on how to select the above and other major types of stereo speaker systems . . . how to adapt your present system to stereo . . . how to choose a monophonic system now for efficient conversion to stereo later . . . how to plan economical "do-it-yourself" monophonic/stereo speaker systems. See your dealer, or write Desk S-11, University Loudspeakers, Inc., White Plains, N. Y.

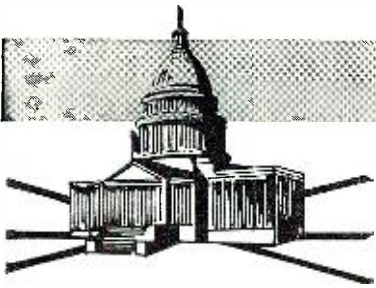

Latest Information
on the Electronic Industry



By RADIO & TV NEWS'
WASHINGTON EDITOR

ELECTRONIC BOOM YEAR PREDICTED BY GOVERNMENT EXPERTS—In their annual projection review, the U. S. Department of Commerce, Business, and Defense Services Administration, Electronics Division, said that 1959 will be healthiest on record for electronics. They estimated that home-type radio and television receiver and related-product output would reach a top of \$1.5 billion and the output of electronic components, other than tubes and semiconductors, would rise to the same new high. About \$250-million would be spent for semiconductor devices, the forecast continued, and about \$850-million would be channeled to tubes.

ATLAS RELAY SUCCESS LAYING GROUNDWORK FOR COURIER SATELLITE CONTACT—The orbiting communications relay inside the Atlas missile is the first step toward courier satellites for military communications, the Department of the Army announced recently. The relay was said to show promising advantages in helping to solve the growing traffic jam in the radio-wave spectrum in ground-to-ground military contacts. In addition, it was pointed out, the system suggests a means of eventually using satellite relays to store large numbers of messages, carry them thousands of miles, and release them, on call, to ground stations around the world. To obtain stored messages from the relay in the Atlas, a ground station triggered off the relay transmitter by electronic command. The relay consisted of a pair of transmitters, receivers, and recorders using erasable loops of magnetic tape. The transmitter produced 8 watts of power and used zinc-silver oxide batteries with an estimated life of four to six weeks.

AIRCRAFT RADARS COSTING OVER \$10-MILLION ORDERED—Large-scale procurement of radars for civil aircraft has been authorized by Washington. Ten of the radar systems, known as Airport Surface Detection Equipment, costing \$1,786,124, have been ordered from Airborne Instrument Labs for installation at some of the nation's busiest airports, including the new jet airport for Washington, D.C. at Chantilly, Va. Another contract calls for \$3,022,147 worth of microwave link installations from Collins Radio Company which will include links for civil and military long-range radar and repeater stations. Another order issued covered purchase of 39 basic scan-conversion systems—a \$5,729,116 contract to Admiral—to provide daylight displays of long-range radar information for air-traffic control. The equipment features a memory tube with the capability of retaining radar targets on the display for up to 30 minutes and showing a trailing blip on the screen indicating previous positions on the radar target.

NBS DEVELOPS APPARATUS FOR INTERCOMPARISON OF SMALL CAPACITORS—As part of its continuing program to improve the precision and reliability of electrical standards and measurements, the National Bureau of Standards has recently completed apparatus for the precise intercomparison of small capacitors. The apparatus employs a special 3-winding transformer and a bank of very stable capacitors which are combined to balance the unknown capacitance. This apparatus improves both the sensitivity and precision of capacitance measurements made by Bureau laboratories.

FCC REPORTS RECORD YEAR—The annual year-end report of the Federal Communications Commission has revealed that 1958 was a banner year for all phases of the radio and TV industry. Every facet of this burgeoning business set new records—from the number of sets in use to the number of broadcasting and telecasting stations on the air. For complete details on the "health" of the industry, refer to the article "Record Number of Sets in Use During '58" which appears elsewhere in this issue. This should serve as an effective rebuttal to the "gloom-merchants" who are always predicting the imminent collapse of the radio-TV industry.

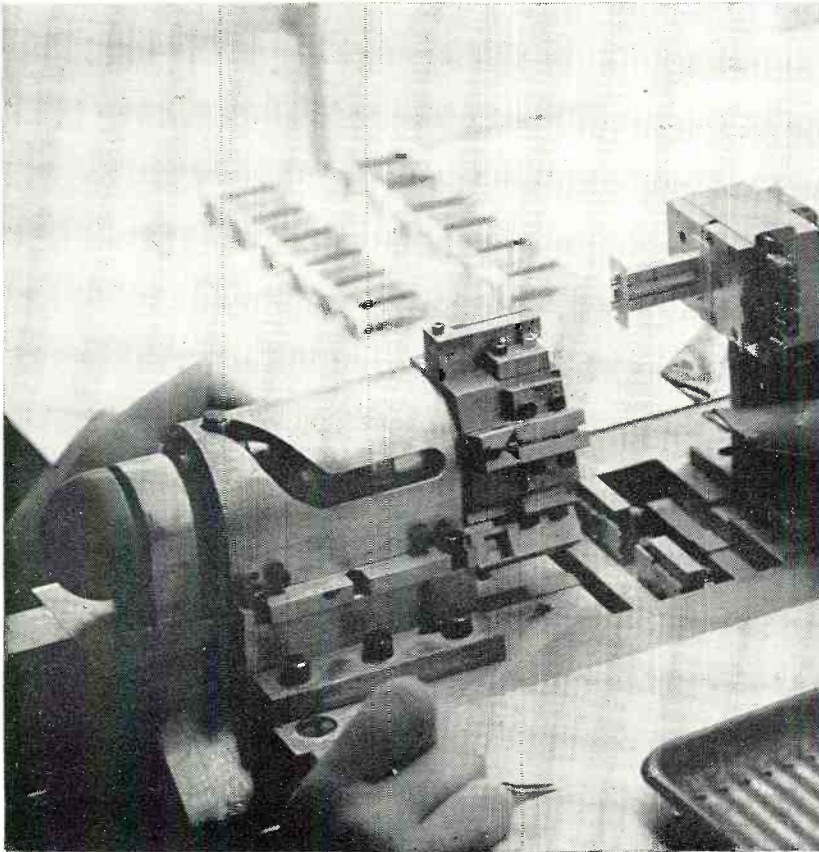

Large illustration shows operator completing the critical assembly work on a 6V6GTA mount in new CBS-Hytron automatic rotary assembly machine. Strip photos (top to bottom) catch six progressive steps: cathode positioned for insertion into bottom mica . . . cathode being inserted . . . A grid, B grid, and beam plate ready for assembly . . . top mica being added to complete the mount cage.

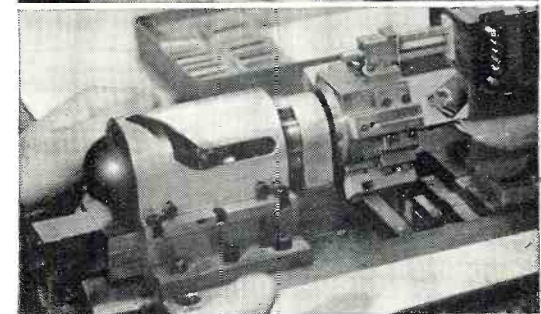
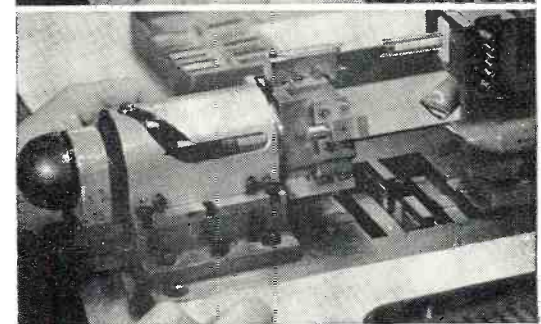
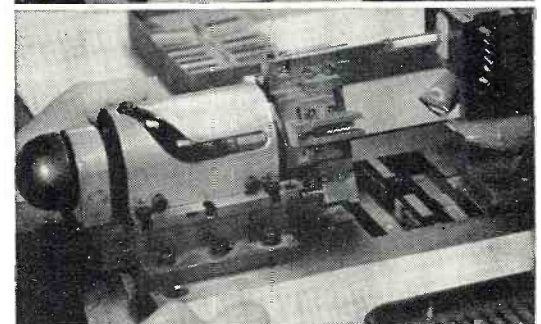
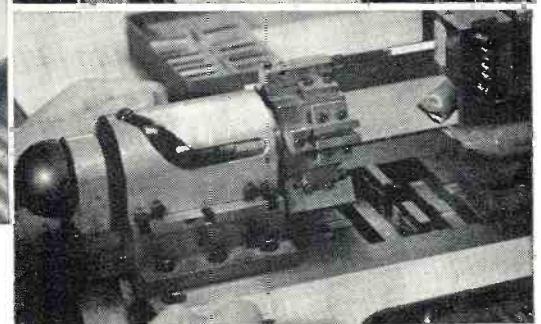
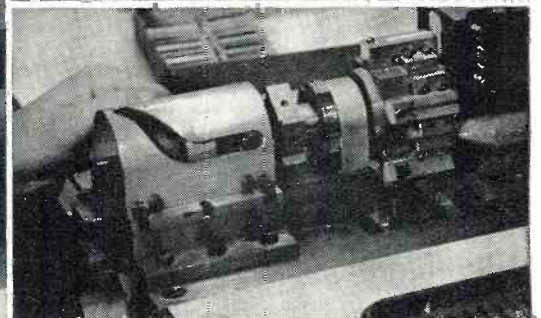
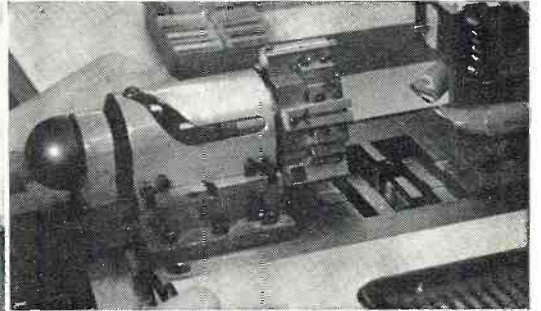

Automatic tube assembly can cut your call-backs

"Quality always equal . . . or better" is not just a catch phrase at CBS-Hytron. It stems from a determination to prevent troublesome, expensive call-backs. And it is based on building in quality, not trying to test it in.

Here automatic assembly builds in better performance. Operator feeds in each part; presses foot pedal; machine moves part forward and precisely into position. No handling contaminates, distorts or misassembles the parts. Potential failure headaches for you are automatically avoided.

Take advantage of CBS-Hytron quality. You, too, will find it is always equal . . . or better . . . at all times more trouble-free. Ask for CBS-Hytron.



*More reliable products
through
Advanced-Engineering*

CBS-HYTRON, Danvers, Massachusetts
A Division of Columbia Broadcasting System, Inc.

**STEREO
STEREO
AND
MONAURAL**

the
experts
say...
in HI-FI
the best buys are

EICO®

World-famous
EICO advantages
guarantee your complete satisfaction:

- Advanced engineering • Finest quality components
- "Beginner-Tested," easy step-by-step instructions
- LIFETIME service & calibration guarantee
- IN STOCK — Compare, then take home any EICO equipment—right "off the shelf"—from 1900 neighborhood EICO dealers.



Stereo Preamplifier HF85



FM Tuner HFT90



Stereo
Amplifier-Preamp
HF81



Monaural Integrated Amplifiers:
50, 30, 20, and 12-Watt
(use 2 for Stereo)



Bookshelf
Speaker System
HFS1



Speaker System HFS2
36" H x 15 1/4" W x 11 1/2" D



Monaural Power Amplifiers:
60, 50, 35, 30, 22 and 14-Watt
(use 2 for Stereo)



Monaural Preamplifiers:
HF65, HF61
(stack 2 for Stereo)



Over 1 MILLION EICO instruments in use throughout the world.

NEW STEREOGRAPHIC EQUIPMENT

HF85: Stereo Dual Preamplifier is a complete stereo control system in "low silhouette" design adaptable to any type of installation. Selects, preamplifies, controls any stereo source—tape, discs, broadcasts. Superb variable crossover, feedback tone controls driven by feedback amplifier pairs in each channel. Distortion borders on unmeasurable even at high output levels. Separate lo-level input in each channel for mag. phono, tape head, mike. Separate hi-level inputs for AM & FM tuners & FM Multiplex. One each auxiliary A & B input in each channel. Independent level, bass & treble controls in each channel may be operated together with built-in clutch. Switched-in loudness compensator. Function Selector permits hearing each stereo channel individually, and reversing them; also use of unit for stereo or monophonic play. Full-wave rectifier tube power supply. 5-12AX7/ECC83, 1-6X4. Works with any 2 high-quality power amplifiers such as EICO, HF14, HF22, HF30, HF35, HF50, HF60. Kit \$39.95. Wired \$64.95. Includes cover.

HF81: Stereo Dual Amplifier-Preamplifier selects, amplifies & controls any stereo source—tape, discs, broadcasts—and feeds it thru self-contained dual 14W amplifiers to a pair of speakers. Monophonically: 28 watts for your speakers; complete stereo preamp. Ganged level controls, separate focus (balance) control, independent full-range bass & treble controls for each channel. Identical Williamson-type, push-pull EL84 power amplifiers, excellent output transformers. "Service Selector" switch permits one preamp-control section to drive the internal power amplifiers while other preamp-control section is left free to drive your existing external amplifier. "Its performance is excellent, and the operation is uncomplicated."—HI-FI MUSIC AT HOME. "Excellent"—SATURDAY REVIEW. Kit \$69.95. Wired \$109.95. Incl. cover.

MONAURAL PREAMPLIFIERS (stack 2 for Stereo)
NEW HF65: superb new design, inputs for tape head, microphone, mag-phono cartridge & hi-level sources. IM distortion 0.04% @ 2V out. Attractive "low silhouette" design. HF65A Kit \$29.95, Wired \$44.95. HF65 (with power supply) Kit \$33.95, Wired \$49.95.
HF61: "Rivals the most expensive preamps" — Marshall, AUDIOCRAFT. HF61A Kit \$24.95, Wired \$37.95, HF61 (with power supply) Kit \$29.95, Wired \$44.95.

**MONAURAL POWER AMPLIFIERS
(use 2 for STEREO)**

HF60: 60-Watt Ultra Linear Power Amplifier with Acro TO-330 Output Xfmr.; "One of the best-performing amplifiers extant; an excellent buy." AUDIOCRAFT Kit Report. Kit \$72.95. Wired \$99.95. Cover E-2 \$4.50.

HF50: 50-Watt Ultra Linear Power Amplifier with extremely high quality Chicago Standard Output Transformer. Identical in every other respect to HF60, same specs at 50W. Kit \$57.95. Wired \$87.95. Cover E-2 \$4.50.

NEW HF35: 35-Watt Ultra-Linear Power Amplifier. Kit \$47.95. Wired \$72.95. Cover E-2 \$4.50.

HF30: 30-Watt Power Amplifier. Kit \$39.95. Wired \$62.95. Cover E-3 \$3.95.

NEW HF22: 22-Watt Power Amplifier. Kit \$38.95. Wired \$61.95. Cover E-2 \$4.50.

NEW HF14: 14-Watt Power Amplifier. Kit \$23.50. Wired \$41.50. Cover E-6 \$4.50.

**MONAURAL INTEGRATED AMPLIFIERS
(use 2 for STEREO)**

HF52: 50-Watt Integrated Amplifier with complete "front end" facilities & Chicago Standard Output Transformer. "Excellent value"—Hirsch-Houck Labs. Kit \$69.95. Wired \$109.95. Cover E-1 \$4.50.

HF32: 30-Watt Integrated Amplifier. Kit \$57.95. Wired \$89.95. Both include cover.

HF20: 20-Watt Integrated Amplifier. "Well-engineered" — Stocklin, RADIO TV NEWS. Kit \$49.95. Wired \$79.95. Cover E-1 \$4.50.

HF12: 12-Watt Integrated Amplifier. "Packs a wallop"—POP. ELECTRONICS. Kit \$34.95. Wired \$57.95.

SPEAKER SYSTEMS (use 2 for STEREO)

HFS2: Natural bass 30-200 cps via slot-loaded 12-ft. split conical bass horn. Middles & lowers highs: front radiation from 8 1/2" edge-damped cone. Distortionless spike-shaped super-tweeter radiates omni-directionally. Flat 45-20,000 cps, useful 30-40,000 cps. 16 ohms. HWD 36", 15 1/4", 11 1/2". "Eminently musical; would suggest unusual suitability for stereo."—Holt, HIGH FIDELITY. Completely factory-built: Walnut or Mahogany. \$139.95; Blonde, \$144.95.

HFS1: Bookshelf Speaker System, complete with factory-built cabinet. Jensen 8" woofer, matching Jensen compression-driver exponential horn tweeter. Smooth clean bass; crisp extended highs. 70-12,000 cps range. Capacity 25 w. 8 ohms. HWD: 11" x 23" x 9". Wiring time 15 min. Price \$39.95.

FM TUNER

HFT90: surpasses wired tuners up to 3X its cost. Pre-wired, pre-aligned, temperature-compensated "front end"—drift-free. Precision "eye-tronic" tuning. Sensitivity 1.5 uv for 20 db quieting — 6X that of other kit tuners. Response 20-20,000 cps ±1 db. K-follower & multiplex outputs. "One of the best buys you can get in high fidelity kits." — AUDIOCRAFT KIT REPORT. Kit \$39.95*, Wired \$65.95*. Cover \$3.95.

BEFORE YOU BUY, COMPARE:

You may examine the complete EICO line at any of 1900 neighborhood EICO distributors coast to coast. Compare critically with equipment several times the EICO cost—then you judge. You'll see why the experts recommend EICO, kit or wired, as your best buy.

EICO, 33-00 NORTHERN BLVD., L. I. C. 1, N. Y.
Fill out coupon on other side for FREE CATALOG

Copyright 1958 by Electronic Instr. Co., Inc. 33-00 N. Blvd., L. I. C. 1, N. Y.

Add 5% in the West.

© EICO COVER, F. C. T. INCL.

the specs prove it . . .
your **BEST BUY** is



for COLOR & Monochrome TV servicing

FREE CATALOG

shows you **HOW TO SAVE 50%**
on 50 models of top quality
professional test equipment.
MAIL COUPON NOW!



NEW!
**TV-FM SWEEP
GENERATOR &
MARKER #368**

KIT \$69⁹⁵ WIRED \$119⁹⁵

Entirely electronic sweep circuit (no mechanical devices) with accurately-biased inductor for excellent linearity. Extremely flat RF output; new AGC circuit automatically adjusts osc. for max. output on each band with min. ampl. variations. Exceptional tuning accuracy: edge-lit hairlines eliminate parallax. Swept Osc. Range 3-216 mc in 5 fund. bands. Variable Marker Range 2-75 mc in 3 fund. bands; 60-225 mc on harmonic band. 4.5 mc Xtal Marker Osc., xtal supplied. Ext. Marker provision. Sweep Width 0-3 mc lowest max. deviation to 0-30 mc highest max. dev. 2-way blanking. Narrow range phasing. Attenuators: Marker Size, RF Fine, RF Coarse (4-step decade). Cables: output, 'scope horiz., 'scope vertical. Deep-etched satin aluminum panel; rugged grey wrinkle steel cabinet.

**NEW! RF
SIGNAL GENERATOR
#324**

KIT \$28⁹⁵ WIRED \$39⁹⁵



150 kc to 435 mc with ONE generator! Better value than generators selling at 2 or 3 times its cost! Ideal for IF-RF alignment, signal tracing & trouble-shooting of TV, FM, AM sets; marker gen.; 400 cps audio testing; lab. work. 6 fund. ranges: 150-400 kc, 400-1200 kc, 1.2-3.5 mc, 3.5-11 mc, 11-37 mc, 37-145 mc; 1 harmonic band 111-435 mc. Freq. accurate to $\pm 1.5\%$; 6:1 vernier tuning & excellent spread at most important alignment freqs. Etched tuning dial, plexiglass windows, edge-lit hairlines. Colpitts RF osc. directly plate-modulated by K-follower for improved mod. Variable depth of int. mod. 0-50% by 400 cps Colpitts osc. Variable gain ext. amplifier: only 3.0 v needed for 30% mod. Turret-mounted coils slug-tuned for max. accuracy. Fine & Coarse (3-step) RF attenuators. RF output 100,000 uv; AF sine wave output to 10 v. 50-ohm output Z. 5-way jack-top binding posts for AF in/out; coaxial connector & shielded cable for RF out. 12AU7, 12AV7, selenium rectifier; xmfr-operated. Deep-etched satin aluminum panel; rugged grey wrinkle steel cabinet.

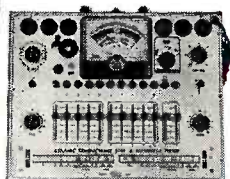

**NEW! DYNAMIC
CONDUCTANCE
TUBE & TRANSISTOR
TESTER #666
KIT \$69⁹⁵ WIRED \$109⁹⁵**

COMPLETE with steel cover and handle.

SPEED, ease, unexcelled accuracy & thoroughness. Tests all receiving tubes (and picture tubes with adapter). Composite indication of Gm, Gp & peak emission. Simultaneous sel of any 1 of 4 combinations of 3 plate voltages, 3 screen voltages, 3 ranges of continuously variable grid voltage (with 5% accurate pot). New series-string voltages: for 600, 450, 300 ma types. Sensitive 200 ua meter. 5 ranges meter sensitivity (1% shunts & 5% pot). 10 SIX-position lever switches: freepoint connection of each tube pin. 10 pushbuttons: rapid insert of any tube element in leakage test circuit & speedy sel. of individual sections of multi-section tubes in merit tests. Direct-reading of inter-element leakage in ohms. New gear-driven rollechart. Checks n-p-n & p-n-p transistors: separate meter readings of collector leakage current & Beta using internal dc power supply. Deep-etched satin aluminum panel; rugged grey wrinkle steel cabinet. CRA Adapter \$4.50

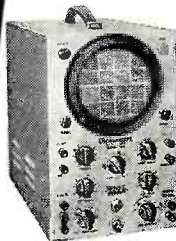

COLOR

**and Monochrome
DC to 5 MC LAB & TV
5" OSCILLOSCOPE
#460**

KIT \$79⁹⁵ WIRED \$129⁵⁰

• Features DC Amplifiers!

Flat from DC-4.5 mc, usable to 10 mc. VERT. AMPL.: sens. 25 rms mv/in; input Z 3 megs; direct-coupled & push-pull thruout; K-follower coupling bet. stages; 4-step freq-compensated attenuator up to 1000:1. SWEEP: perfectly linear 10 cps-100 kc (ext. cap. for range to 1 cps); pre-set TV V & H positions; auto. sync. ampl. & lim. PLUS: direct or cap. coupling; bal. or unbal. inputs; edge-lit engraved lucite screen; dimmer; filter; bezel fits std photo eqpt. High intensity trace CRT. 0.06 usec rise time. Push-pull hor. ampl., flat to 400 kc, sens. 0.6 rms mv/in. Built-in volt. calib. Z-axis mod. Sawtooth & 60 cps outputs. Astig. control. Retrace blanking. Phasing control. 5" PUSH-PULL Oscilloscope = 425: Kit \$44.95, Wired \$79.95. 7" PUSH-PULL Oscilloscope = 470: Kit \$79.95, Wired \$129.50.



New!
Series/Parallel
R-C COMBINATION
BOX #1140
KIT \$13.95
WIRED \$19.95



**TUBE TESTER
#625**
KIT \$34.95
Wired \$49.95
• tests 600
mil series
string type
tubes
• illuminated
roll-chart

Pix Tube Test Adapter\$4.50



**6V & 12V BATTERY
ELIMINATOR
& CHARGER #1050**
KIT \$29.95
WIRED \$38.95
Extra-filtered for
transistor equip.
= 1060 KIT \$38.95
WIRED \$47.95



New!
Miniaturized
MULTI-SIGNAL
TRACER #145A
KIT \$19.95
WIRED \$28.95



**20,000 Ohms/Volt
V-O-M #565**
KIT \$24.95
Wired \$29.95



**1000 Ohms/Volt
V-O-M #536**
KIT \$12.90
Wired \$14.90



Reads 0.5 ohms
-500 megs, 10
mmfd-5000 mfd,
power factor.

**KIT \$19.95
Wired \$29.95**

**R-C BRIDGE & R-C-L COMPARATOR
#950B**



**NEW! PEAK-to-PEAK
VTVM #232 & UNI-
PROBE (pat. pend.)**

KIT \$29⁹⁵ WIRED \$49⁹⁵

Half-turn of probe tip selects DC or AC-Ohms.

Uni-Probe - exclusive with EICO - only 1 probe performs all functions!

Latest circuitry, high sensitivity & precision, wide ranges & versatility. Calibration without removing from cabinet. New balanced bridge circuit. High Z input for negligible loading. 4 1/2" meter, can't burn-out circuit. 7 non-skip ranges on every function. 4 functions: +DC Volts, -DC Volts, AC Volts, Ohms. Uniform 3 to 1 scale ratio for extreme wide-range accuracy. Zero center. One zero-adj. for all functions & ranges. 1% precision ceramic multiplier resistors. Measure directly peak-to-peak voltage of complex & sine waves: 0-4, 14, 42, 140, 420, 1400, 4200. DC/RMS sine volts: 0-1.5, 5, 15, 50, 150, 500, 1500 (up to 30,000 v. with HVP probe & 250 mc with PRF probe). Ohms: 0.2 ohms to 1000 megs. 12AU7, 6AL5, selenium rectifier; xmfr-operated. Deep-etched satin aluminum panel, rugged grey wrinkle steel cabinet.

TURN PAGE
FOR MORE
EICO VALUES



Send for
FREE CATALOG
now

33-00 Northern Blvd., R-3
EICO, L.I.C., N. Y. Show me **HOW TO SAVE 50%** on Test Instruments Hi-Fi Ham Gear. Send me **FREE Catalog**, name of neighborhood dealer.
Name.....
Address.....
City..... Zone..... State.....

Prices 5% higher on West Coast.

L.I.C., N.Y.

INFRARED

— A New Field of Electronics and Optics



By **PAUL BERNARD**
and
NATHAN BUITENKANT
Barnes Engineering Co.
Stamford, Connecticut

Taking pictures in total darkness, tracking missiles with extreme accuracy and at close ranges—these are but a few of the many uses of IR radiation.

INFRARED radiation has been known for almost 160 years. In the year 1800 William Herschel placed thermometers along a spectrum of the sun's rays which had been dispersed by a glass prism. The thermometers were heated not only in the visible portions of the spectrum but also at the end of the spectrum beyond the visible red. It was as if energy from the sun were present here too, even though invisible. This invisible energy "below red," became known as infrared radiation. But the properties of this remarkable portion of the spectrum were not put to use until more than a century later. Then, from 1920 to 1935, a number of infrared instruments were developed for identifying unknown materials and analyzing chemical compounds.

World War II brought the need for extensive military applications of infrared and such devices as the "sniperscope" and "snooperscope" were developed. These were "active" infrared devices in the sense that they required their targets to be illuminated or irradiated by self-contained infrared spotlights. After World War II the major developments in infrared devices were in the field of "passive" equipment requiring no form of illumination.

Such equipment makes use of the fact that all objects at temperatures above absolute zero (-273°C) emit radiation, and can be detected and located by means of sensitive detectors.

Passive infrared systems have been employed by the military in air-to-air, air-to-ground, ground-to-ground, and ground-to-air applications. Such equipment can search, detect, warn, identify, track, and guide. Infrared thermograph equipment has been built that will print pictures of people and objects in total darkness (Fig. 1).

Tracking is an extremely important application of infrared, which takes over from radar at close range to provide very high resolution results. The U. S. Navy "Sidewinder" is an example of an infrared-guided air-to-air missile which can detect an enemy aircraft at a distance of seven miles, track it down at twice the speed of sound, and make a direct hit. The high-resolution infrared tracker shown on the cover and in Fig. 3 is designed to track high-speed airborne targets in daylight or in complete darkness.

Infrared provides much better definition than radar. The resolving power of a radar antenna or infrared optical system increases as its diameter is

INCREASING FREQUENCY



INCREASING WAVELENGTH



Fig. 1. Infrared photo (thermograph) taken in total darkness. In this view black areas are at a temperature of 75 degrees F or colder, and white areas are at 133 degrees or hotter. Note that the pipe bowl is the hottest object in the photograph.

made larger. Since useful infrared wavelengths are on the order of 1000 times shorter than those of the latest radars, infrared systems provide detail that is unobtainable with radar. For example, a microwave radar operating at 8 millimeter wavelength and with an antenna 12 inches in diameter cannot identify targets at 5-mile range as being separate unless they are laterally separated by more than $\frac{1}{4}$ mile. On the other hand an infrared system with a 4-inch mirror can easily identify the individual engines on a plane at the same range.

There are also many industrial uses of infrared. Infrared radiometers can monitor and control the temperatures of plastics, elastomers, ceramics, textiles, paper, glass, and metals, in all physical states and forms; and measure

the temperature distributions of moving and rotating objects. Other infrared applications include non-destructive testing, machine maintenance, and aircraft and missile testing. An interesting new application is the use of infrared to detect "hot boxes" on railroad freight cars moving at speeds up to 80 miles an hour and to signal ahead to the next station the presence of hot boxes which may cause stoppage or derailment. Such hot box detectors can save many thousands of hours annually by eliminating the need to stop trains for manual inspection.

Infrared has many vitally important uses in industrial and scientific laboratories. For example, the infrared spectrometer is used to analyze chemical substances and identify unknown material. Infrared thermographs showing

temperature distributions over the human body are being used in cancer research. Agriculture experts are using infrared to investigate temperature differences over supposedly uniform areas of plant life. Meteorologists are using infrared devices to measure the temperatures of sky, air, earth, and sea water; the results promise to be of great value in long-range weather prediction.

Infrared Radiation

Radiant energy is energy which is propagated through space, at the speed of light, by transfer of electromagnetic vibrations. There is a continuous spectrum of possible frequencies of these vibrations. *Gamma* rays, x-rays, ultraviolet, light, infrared, microwaves, and radio waves are all forms of radiant energy, and their location in the electromagnetic spectrum can be determined only by their frequencies. They all exhibit wave properties. High-frequency radiation is of short wavelength and low-frequency radiation is of long wavelength. (Refer to chart at bottom of the previous page.)

The infrared portion of the spectrum covers the wavelengths from about 0.75×10^{-6} meter to about 1000×10^{-6} meter (Fig. 4.). These wavelengths are so short that a smaller unit of length, the *micron* (equals 10^{-6} meter), is commonly used. Thus the infrared spectrum covers the range from about 0.75 micron to about 1000 microns. For convenience this band is said to consist of the near infrared (0.75 to 1.2 microns), intermediate infrared (1.2 to 7 microns) and far infrared (7 to 1000 microns) regions.

The molecules making up all matter are in a state of constant motion. This motion increases as the object's temperature is raised and decreases as the

Fig. 2. Black body radiation curves at various temperatures. Note the shift of the peak of maximum radiation that occurs.

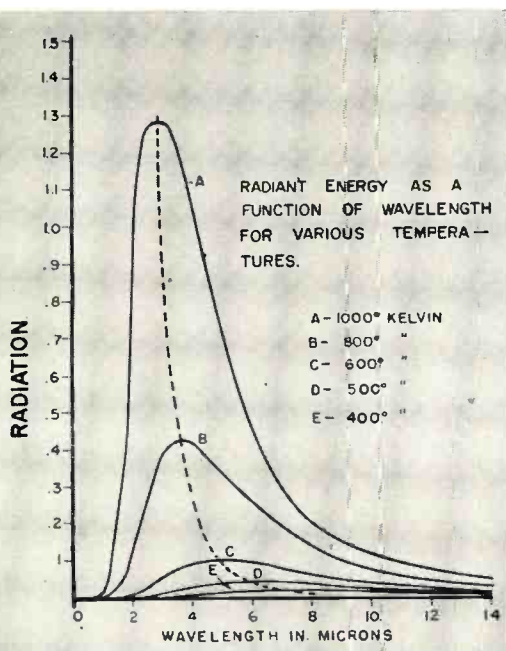
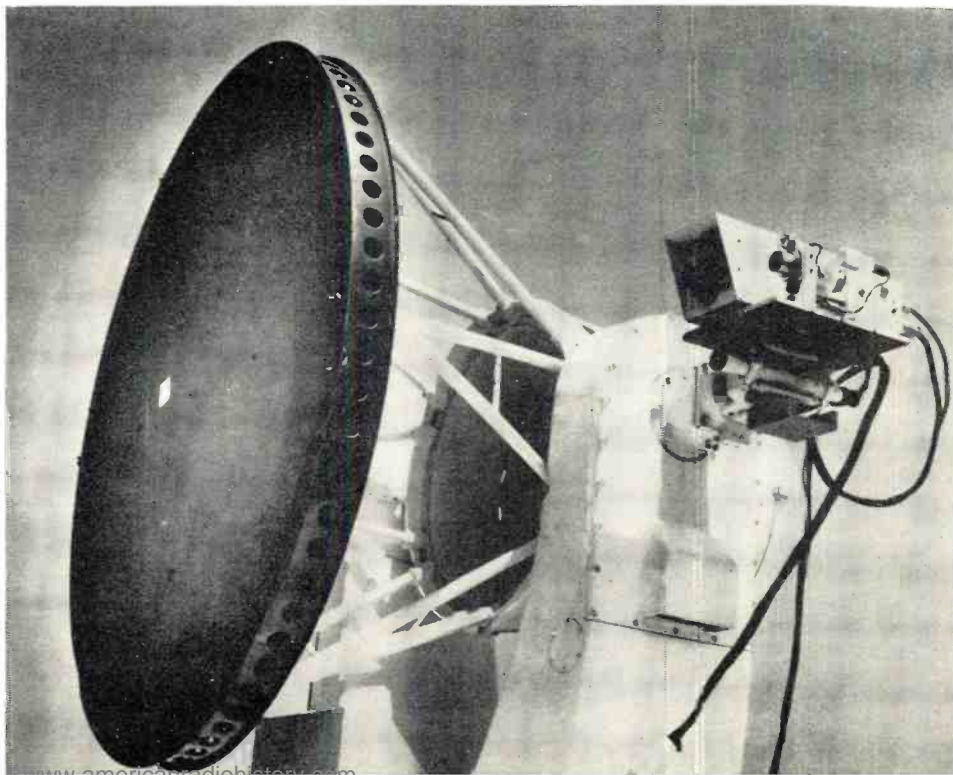

Fig. 3. High-resolution infrared tracker installed at Patrick Air Force Base. Photo shows extreme compactness of infrared system compared to antenna of tracking radar on which it is mounted and with which it moves. See text for details.



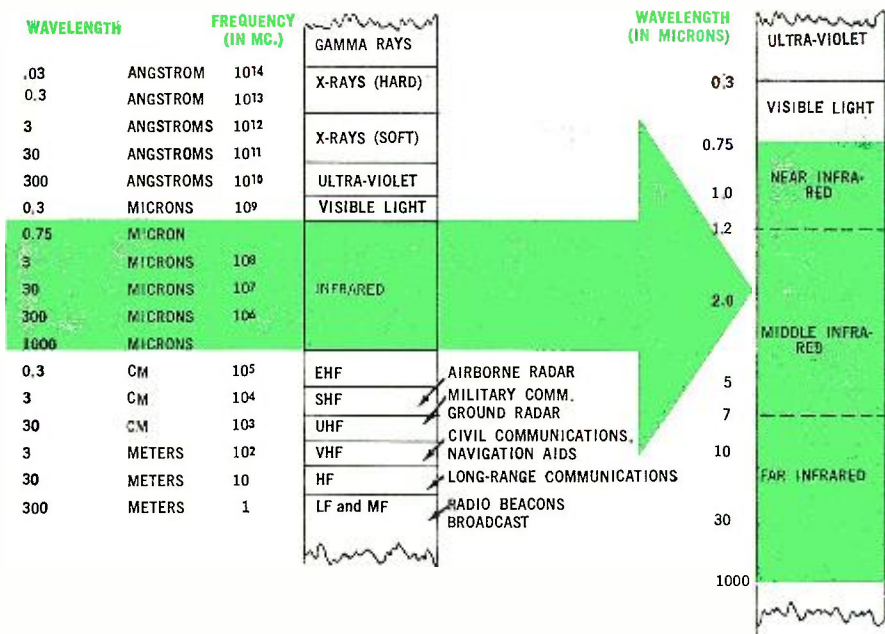

Fig. 4. Diagram of the known electromagnetic spectrum showing the near, intermediate or middle, and far infrared bands located between visible light and microwaves.

temperature is lowered. At the lowest temperature possible (-273°C), all molecular motion stops. Since all molecules are made up of electrical charges, the oscillations of these molecules cause the radiation of electromagnetic energy. The intensity, frequency, and wavelength of this electromagnetic energy are controlled by the temperature and size of the source and by an interesting property known as the *emissivity* of the material.

When the electromagnetic energy emitted by a source reaches another body, part may be reflected, part may be transmitted, and part may be absorbed to cause heating. Thus infrared radiation is intimately connected with heat, but cannot itself be called heat waves, because it is fundamentally similar to radio waves and light and can be transmitted through vacuum. Other means of heat transmission, such as conduction and convection, require physical media, such as air, or physical contact between the source and the receiver.

The standard used in infrared work is the "black body." The black body is an ideal emitter for which the total radiated energy and the spectral distribution of this energy are known. Since the black body is an ideal, it provides only a theoretical relationship between the temperature and radiation. In order to measure practically the relation between temperature and radiation, we need a practical black body which simulates the desired characteristics. Black-body simulators are usually electrically heated, insulated cavities with small apertures. The black-body simulator and its precision temperature controller comprise a radiation reference source that links measurable temperatures and emitted radiation.

The infrared energy radiated by a black body covers a wide range of fre-

quencies and wavelengths. The wavelength at which the maximum or peak radiation occurs is determined by the temperature of the black body as shown in Fig. 2. As the temperature increases, the peak radiation shifts to shorter wavelengths and the total amount of the radiated energy increases.

Emissivity is an extremely important property. It is defined as the ratio of the radiation emitted by an object to the radiation that would be emitted by a black body at the same temperature. The emissivity of a black body is 1 and the emissivity of all practical materials is less than 1. This property depends on the material and its finish. Dielectrics and insulators in general have high emissivities and metals and other conductors have low emissivities. Polished surfaces have lower emissivities than matte surfaces. The emissivity of a mirrored silver surface is approximately 0.02 and the emissivity of matte lampblack is about 0.95.

Transmission of Infrared

All electromagnetic radiation is transmitted in accordance with the inverse-square law. This states that the intensity of the energy radiated by a source varies inversely as the square of the distance from the source. Thus the energy at 2 miles from a source would be $\frac{1}{4}$ of the energy which would exist at a distance of 1 mile from the source. These statements hold true only in a vacuum and do not take into account the effect of the atmosphere.

The atmosphere modifies the transmission of infrared radiation quite markedly. Over short distances, such as used in measuring radiation in laboratories, atmospheric attenuation is negligible. However, over the greater distances which separate military infrared devices from their targets, the problems of infrared transmission

through the atmosphere become rather serious.

Atmospheric attenuation is caused by water vapor, carbon dioxide, and other gases present in the air, as well as by particles of dust and other substances. There is less attenuation at increasing altitude and especially with lowered water content. The reason for this is that the atmosphere becomes thinner at higher altitudes; so that at altitudes above about 100,000 feet there is comparatively little attenuation. At still greater altitudes, such as those traversed by satellites, atmospheric attenuation of infrared is almost non-existent, because the atmosphere itself is almost non-existent. As shown in Fig. 5, the atmosphere does not absorb all infrared wavelengths uniformly. Instead most absorption occurs quite definitely at the wavelengths at which

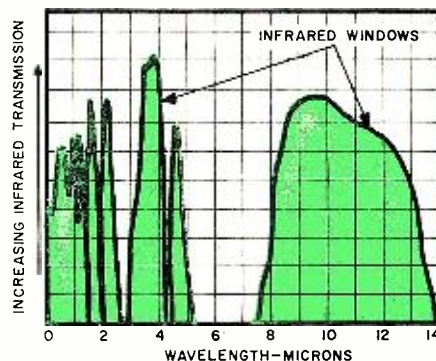

Fig. 5. The atmosphere does not transmit infrared uniformly at all wavelengths. Windows are regions of high transmission.

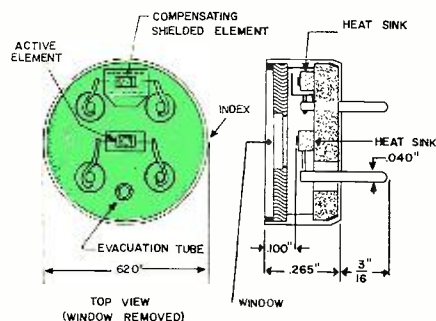
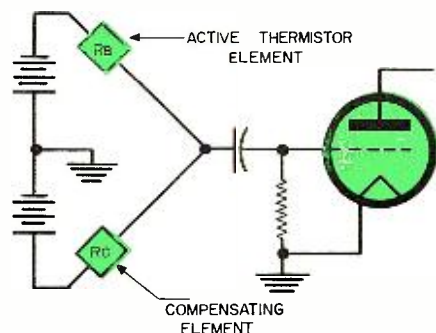

Fig. 6. Construction of typical thermistor bolometer detector. The "active" flake is mounted so that it can be exposed to radiation, while the "compensating" flake is shielded from radiation and is used to keep arrangement balanced.

Fig. 7. Circuit of the thermistor bolometer bridge, showing preamp coupling.



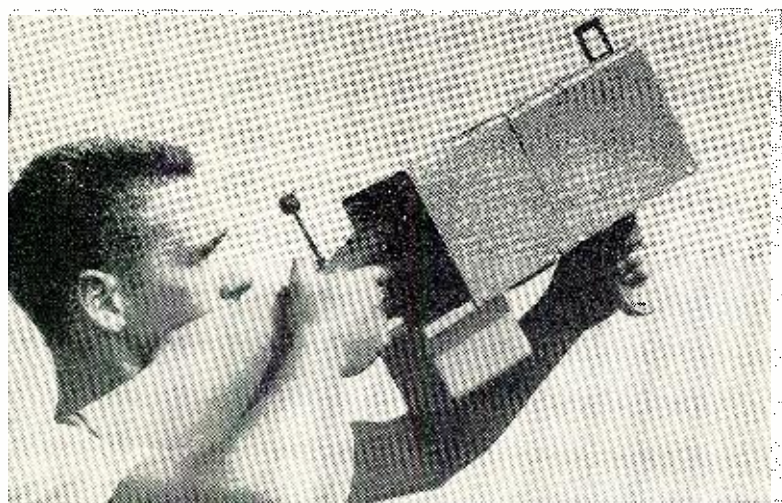

Fig. 8. Hand-held radiometer is employed to measure radiation from intercontinental ballistic missile re-entering atmosphere.

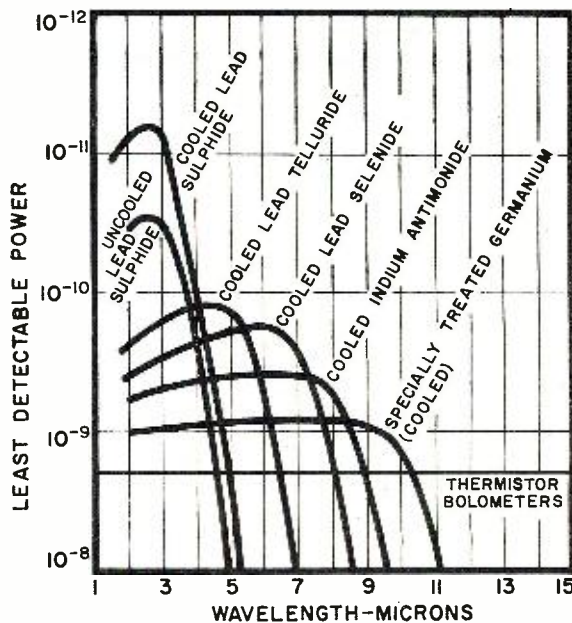

Fig. 9. Curves shown at the right illustrate the relative sensitivities of various infrared detectors in common usage.

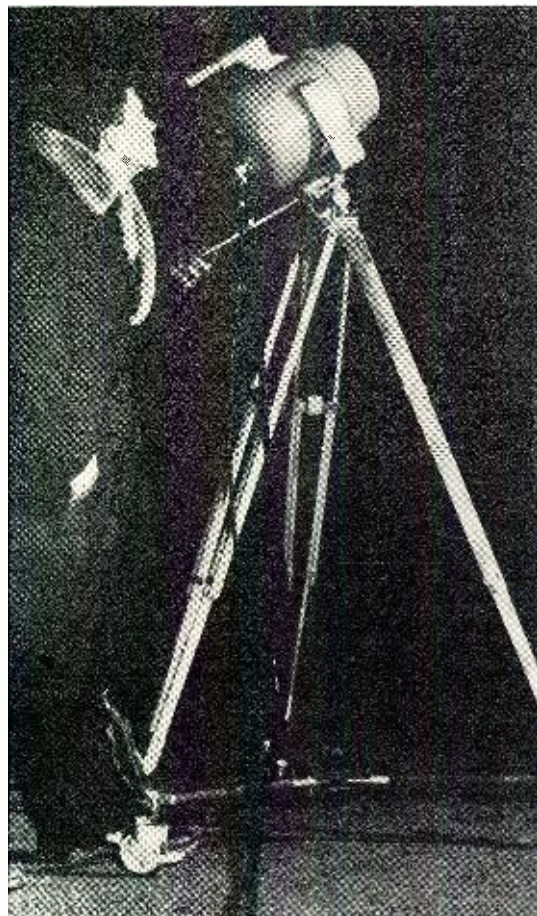
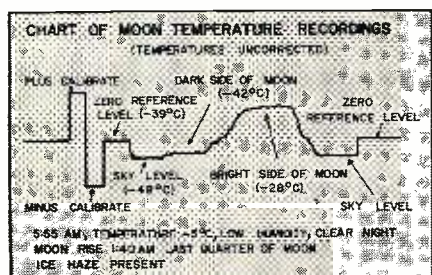

Fig. 10. Measuring moon's temperature (above) along with chart of actual recording.



the molecules of water vapor, carbon dioxide, and other atmospheric gases resonate and absorb energy from the infrared radiation which passes through. This highly selective absorption of infrared radiation causes a "window" effect. These windows occur at wavelength regions where absorption by carbon dioxide and water vapor is at a minimum. Depending upon altitude and weather conditions, these windows can be used by employing filters which transmit only at the window wavelengths.

The principles described so far are fully exploited in modern infrared equipment that is able to perform near miracles of accurate tracking and detection at close ranges. Such equipment uses both the sciences of optics and electronics to do its job. Now let us probe a little deeper into the details of the type of components and systems needed in this type of equipment and its expanding applications.

Optical Systems

Most infrared devices use special optical systems along with special detectors. The performance of infrared detectors improves as the detectors are made smaller. Therefore very small detectors are used (on the order of

1 millimeter by 1 millimeter square) and the radiation lost because of this tiny size is recovered by placing the detector at the focal point of an optical collecting system. The field of view, or that portion of space which is seen by the detector, is determined by the area of the detector and by the diameter and focal length of the optical system. Optical systems in infrared are like antennas in microwave receivers. The optical gain of an optical system is equal to the ratio of its effective area to the effective area of the detector. Gains of 20,000 times or more are easily obtained with compact optical systems; such optical gain is completely free of the noise which is characteristic of electronic amplification.

Between the source and the detecting device there is not only the atmosphere and one or more optical systems, but infrared-transmitting elements such as windows or domes in airplanes to shield or protect infrared devices from high-speed air currents.

When radiation strikes solid materials, some of it may be reflected, some may be absorbed, and some may be transmitted. For example, glasses transmit most of the visible energy which impinges upon them; they reflect less, and absorb still less. The

Fig. 11. The block diagram shown below is that of a basic radiometer system.

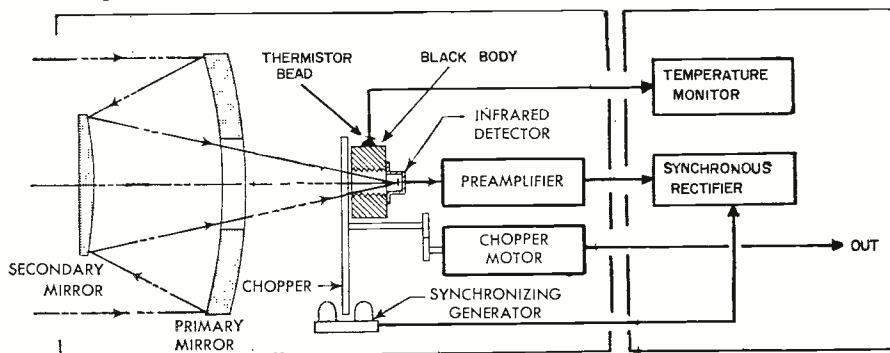

properties of glasses and most other materials are usually quite different at infrared wavelengths than they are at visible wavelengths. Many materials which are transparent in the visible spectrum are opaque to infrared wavelengths; while some substances which are opaque to the visible are transparent to infrared wavelengths. Most glass transmits up to 2.0 or 2.5 micron, just beyond the visible spectrum. Quartz transmits out to about 4 microns. Rock salt and potassium bromide, which transmit out to 15 and 40 microns respectively, have been used for many years in instruments such as infrared spectrometers. During and since World War II, new materials have been developed and the long-wavelength properties of older materials have been discovered. These materials include the German-developed KRS-5, arsenic trisulfide, sapphire, magnesium oxide, high-purity germanium and silicon, indium antimonide, and certain new glasses. While many new materials with remarkable infrared properties are yet to come, there is a wide enough variety of existing materials to permit the design of new scientific instruments, industrial devices, and military systems.

To eliminate as a factor from optical systems the infrared transmission properties of materials, front-surfaced mirrors are used. Mirrors uniformly reflect wavelengths from ultraviolet out through the far infrared. They are unlike lenses, in this regard, since these do not transmit radiation equally at all wavelengths. A large number of high-performance optical mirror systems are in use in infrared equipment; many of them were developed earlier for astronomical telescopes.

Infrared Detectors

Infrared detectors are used to obtain information from radiation picked up by infrared gear. Such a detector converts incident radiant energy into another form of energy which can be displayed and/or measured. The outputs most frequently used are electrical signals, which can easily be processed, displayed, and measured. Since two of the major effects of radiation on matter are the thermal effect and the photoelectric effect, the two major groups of radiation detectors are thermal detectors and photodetectors.

Thermal detectors respond to heating effects which are usually caused by infrared radiation of longer wavelengths. Thermal detectors are power detectors: their output is proportional to the total energy of the absorbed radiation. These detectors are usually blackened to increase the absorption of incident radiation and to reduce reflection and transmission. Thermal detectors make use of the thermal effects of radiation in several ways. Thermocouples and thermopiles employ the effect whereby voltages are generated when junctions of dissimilar metals are heated. Pneumatic cells employ the expansion of gases heated by radiation to move diaphragms. Bolometers em-

COVER STORY



OUR cover and Fig. 3 show a high-resolution infrared tracker in use at the Air Force Missile Test Center's firing range, Cape Canaveral, Patrick Air Force Base. It was developed and installed for the U.S. Air Force by Barnes Engineering Company of Stamford, Connecticut. A recent launch of an "Atlas" is shown. The equipment is used to track missiles during launching and early flight. It provides the range safety officer with the information he must have to prevent the missile from passing outside the firing range limits as well as providing very important trajectory data to missile designers.

These vital functions cannot be accomplished by other existing equipment. During launching and early flight, radar screens are completely cluttered by multiple reflections from surrounding structures and from the ground itself. Optical and photographic equipment frequently cannot be used because of the enormous amounts of obscuring dust and smoke that are present.

Considering the functions it performs, the infrared tracker is extremely compact: the photos clearly show the size of its optical head compared to the radar antenna upon which it is mounted. The weight of the optical unit is only 22 pounds; a small control panel and oscilloscope display unit are mounted inside the radar van.

In use, the tracker is trained upon the missile before take-off. Then the exhaust flame appears, the tracker locks onto it and automatically follows the flame throughout powered flight, to ranges in excess of ten miles. As the missile attains high altitudes and long ranges, tracking is manually or automatically switched to the radar, which is used only for such long-range tracking. The infrared tracking is so precise that, in the display unit of the closed-circuit TV system, provided as an accessory to the tracker, the missile flame remains locked at the exact center of the

screen. If tracking is purposely deflected by the operator, the infrared system quickly re-acquires the target and brings it back to the center of the screen.

The infrared tracker supplies electrical azimuth and elevation signals to a tracking servo system. In addition, it provides similar signals to its own display system, which graphically shows the operator the accuracy with which tracking is being performed both by the infrared and radar systems. The tracker has a $4^\circ \times 4^\circ$ acquisition field. Once a target is brought within this field, the tracker generates coarse azimuth and elevation error signals to drive the tracking servo at maximum slewing rate and to bring the target rapidly to the center of the field of view. When the target enters the central (3 mil x 3 mil) field of view, proportional control azimuth and elevation signals are transmitted to the tracking servo. The tracker is quickly centered on the target and tracking continues with an accuracy of 0.25 angular mil (1 angular mil = $1/6400$ of 360°) or better. There is less than 400 microseconds delay between the time that a tracking error takes place and a proportional correcting signal occurs. This assures accurate tracking of high-speed evasive targets.

The tracker is of such light, compact, and rugged construction that it is suitable for use in aircraft. In such installations it can be used to track missiles, drones, and other aircraft in flight with an accuracy many times superior to radar. In aircraft or on shipboard the tracker can be used as downrange equipment to track the re-entering nose cones of missiles, because sufficient heat is generated by re-entry to provide adequate infrared energy for tracking.

-30-

(Cover: Official U.S. Air Force photo)

ploy the changes in resistance of solids when heated or cooled.

An extremely important group of thermal detectors are thermistor bolometers. Thermistors are heat sensitive resistors which exhibit large changes of resistance with temperature. When used as radiation detectors, they are made in small and very thin flakes and are solidly backed by heat sinks of high thermal conductivity for fast response to changes in radiation. A thermistor bolometer is constructed by using a closely matched pair of such flakes in an arrangement like that shown in Fig. 6. The detector assembly is quite rugged and resistant to the vibration, shock, temperature variations, high humidity, and other extreme environmental conditions found in industrial and military applications.

The bolometer is usually operated in a bridge circuit as shown in Fig. 7, with the two flakes equally and oppositely biased. The output terminal,

which is the junction of the two flakes, is thus maintained near ground potential to reduce noise and microphonics. Since the two flakes are closely matched, there is little voltage drift of the output terminal with changes in ambient temperatures. When the bolometer is exposed to radiation, the active flake is heated; its temperature rises, and its resistance decreases. Since the compensating flake is shielded, its resistance is unaffected by the radiation. The output voltage at the junction of the two flakes therefore changes by an amount which is precisely proportional, over a tremendous dynamic range, to the power of the incident radiation.

Photodetectors respond to infrared radiation of shorter wavelengths. Fig. 9 shows that while thermal detectors respond almost equally to radiation at all wavelengths, most photodetectors have some long-wavelength limit be-

(Continued on page 151)

IGY

an eighteen-month report

The recently concluded "International Geophysical Year" was an outstanding example of the tremendous results which can be achieved when nations band together to tackle a common problem. The data obtained during IGY holds out hopes for a safer, more comfortable future for us and our descendants.

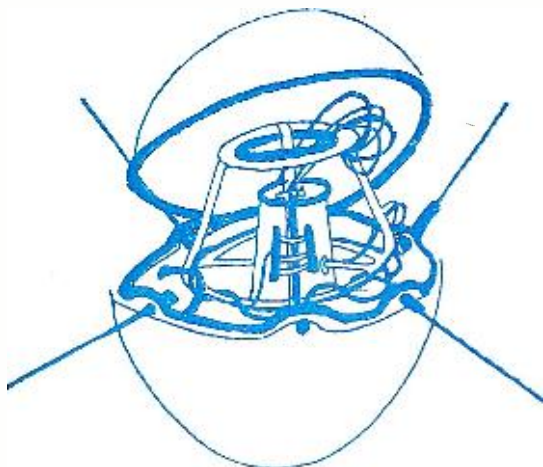
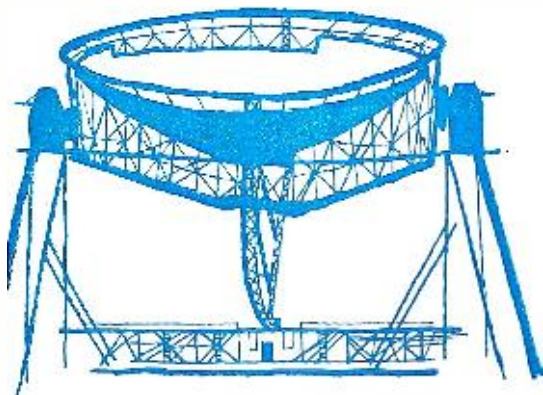

AS the Old Year drew to its close so did the massive cooperative scientific project known as the "International Geophysical Year"—a period which actually covered eighteen months. Although formally "closed," many of the projects and accumulation of data will continue on a semi-permanent and/or permanent basis.

Some 30,000 scientists and technicians in 66 countries contributed to this unprecedented program of global observation and experiment, seeking greater understanding of the earth's interior, oceans, atmosphere, and the space around it. There were 4000 principal stations scattered throughout the globe with several thousand additional temporary and volunteer sites and stations which could be called upon for specific data.

It has been estimated that the U. S. contribution to the program entailed an expenditure of about \$100,000,000 excluding logistic support. The worldwide program may have cost about \$750,000,000. Including logistic support, the total effort may bring this total up to a billion and a half dollars!

What did this vast sum "buy"? Although it may be years before all the results can be completely evaluated, certain findings have emerged which are of immediate interest and application.

Constant surveillance of the sun during the greatest activity in its known history permitted the calling of about 40 world-wide "alerts" during which scientists intensified their observations of the many and varied effects of great solar flares. The scientists were able to collect unprecedented data on the interrelationships of upper atmosphere phenomena when the earth passed through a remarkably intense solar cloud on February 11, 1958 causing the best-observed aurora in history. They also had the opportunity of observing the first man-made aurora in history at Apia, Samoa on August 1, 1958—a phenomenon evidently related to nuclear testing at the time.

Electronics & Radio

In the field of electronics and radio propagation several interesting effects were noted which may serve as new transmission media in the future. The fact that a variety of rockets was available to researchers—both as test instruments themselves and as vehicles for launching satellites and other high-

altitude equipment—cannot be underestimated. That so much new and interesting data is now available can be directly attributed to the fact that these giants, basically military weapons, could be harnessed to the gathering of vital facts about the upper atmosphere.

Probably one of the most significant on-board satellite experiments appears to be the work of Dr. James A. Van Allen of Iowa in establishing the existence of *equatorial electrojet*, a narrow band girdling the earth's magnetic equator and flowing eastward when the sun is overhead. Data obtained from balloon rockets sent through the electrojet seemed to indicate that the jet consists of two currents, one atop the other. The lower extended from 60 to 69 miles above the earth while the bottom of the second current was 73 miles above the earth with the top of the band out of the range of the "rockoons." This radiation was interpreted as corpuscular in nature and led to the conclusion that this great radiation belt around the earth consisted of charged particles, temporarily trapped in the earth's magnetic field. The scientists conjectured that the aurora is related to this trapped radiation and is caused by particle leakage from the belt. This suggests that solar plasma is the source of particles. These studies, combined with other results obtained during IGY, begin to relate a variety of atmospheric and spatial phenomena in an exciting and meaningful way, suggesting that major advances are in the process of being made and formulated.

Also of interest were the special studies made regarding the nature of the ionosphere close to the geographical poles during periods of prolonged solar absence. At the South Pole Stations, for instance, the ionosphere is subjected to extended exposure and to solar ionizing radiations during the long summer day while it is screened for several months during the polar night. This phenomenon might be considered to have an adverse effect on year-around communications—such as the two-way radio service required by the trans-polar flights of commercial aircraft. Surprisingly enough, the IGY investigators found that the ionization reached a summer saturation of about 4.5×10^5 electrons per cubic centimeter which was capable of supporting trans-polar communications up to 22 mc. Throughout the winter night it was

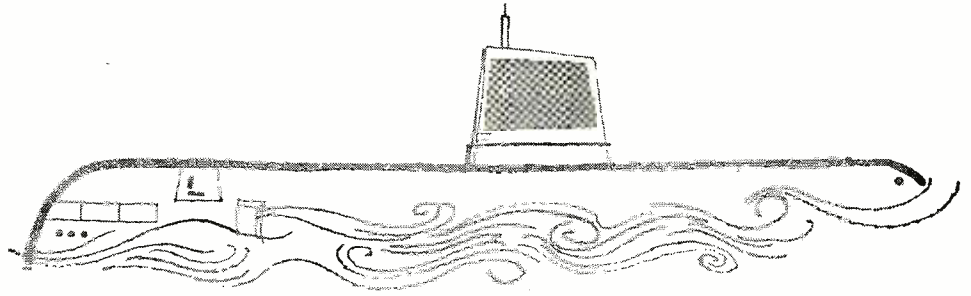

found that the F-layer persists but that this usually rather uniform layer appeared to break up into cloud formations. Despite this, a density of 2×10^5 electrons per cubic centimeter—a typical reading—was sufficient to support trans-polar communications up to 14 mc. in the absence of ionospheric storms.

Considerable work was also done on the subject of backscatter—both that requiring reflections continuously from large regions and that where reflection geometry requires the backscatter oblique-incidence technique. Analysis of the data obtained revealed that tilts in the F-region permit radio-wave propagation over great distances without ground reflections. Tilts or horizontal gradients allow the propagation of radio waves over long distances by successive reflections from the curved F-layer until a particular tilt directs the energy to earth. Propagation over distances in excess of 6000 miles was a frequently observed phenomenon.

Another interesting project concerned “whistlers.” The data gathered seems to point to a marked dependence on the frequency of occurrence from place to place. Activity appeared to increase northward from none at all at Huancayo, Peru up to Hanover, N. H., where a variety of very-low-frequency phenomena were recorded, and then diminishes nearly to the vanishing point at Frobisher Bay and Thule, Greenland.

Another group reported a peculiar signal enhancement on a 49.84 mc. circuit operating between the Philippines and Okinawa—a circuit which had been set up to measure sporadic-E. The enhancement of the signal strength commenced about 2 hours after sunset and continued until about midnight, being particularly strong during the autumnal equinox. This phenomenon seemed to be attributable to F-region scatter. Studies carried out on the circuit seemed to indicate F-region reflections from the path midpoint at 187 miles. The returned echo appeared to be similar to those returned from extensive aurora curtains and may represent blobs of ionization oriented along the earth’s magnetic field.

Other Results

Among other results obtained by the scientists was evidence that magnetic fields associated with sunspots revealed

them to be as much as 8000 times greater than at the earth’s equator; that the cosmic-ray intensity cycle runs opposite to and somewhat behind the sunspot cycle; while the existence of magnetic fields in space was due to the fact that cosmic rays do not approach the earth’s magnetic field as expected but instead show a bias to the west; and that radio signals caused by lightning flashes curve far out through space to the opposite hemisphere, indicating the existence of an ionized medium in space denser than anticipated and possibly consisting of the sun’s corona—greatly attenuated.

Information gathered by the satellites in orbit during the period the IGY studies were under way revealed that the interior satellite temperatures were controllable within limits of easy human tolerance and that micrometeorite density was not the problem originally anticipated. Such satellite observations suggested that the upper atmosphere is at least ten times denser than previously thought on the basis of ground observations. The satellite trackers detected an antipodal “echo” of satellite signals, coming from the side of the earth opposite the satellite, due to the unexpected “ducting” of the signals by the ionosphere.

In the weeks, months, and even years that lie ahead, scientists throughout the civilized world will be referring to the reams of priceless data patiently garnered by thousands of skilled specialists stationed throughout the globe—from the icy wastes of the arctic to the steaming jungles of the tropics. The information they have been able to collate from instruments soaring high above the earth’s surface and miles down on the ocean floor promises a better and more comfortable existence for mankind—both in our generation and in the future.

Improved radio communications, more knowledge about weather forecasting, more information about the space surrounding our earth in preparation for putting man in space will all grow out of some of the IGY findings.

An additional bonus in the form of freely extended international cooperation between “traditional enemies” may have a far-reaching effect which can’t be evaluated on the data-processing machines but may make itself felt in the slackening of international tensions and a freer exchange of data among the world’s scientists. —30—

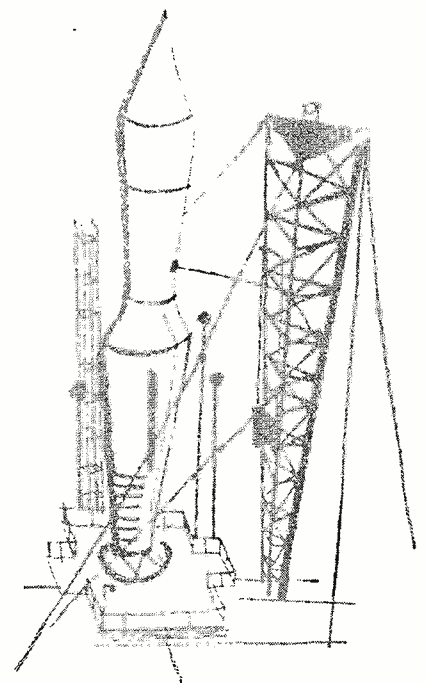

Unlike the binary, the ring yields a linear count; is used in many tallying and sensing applications.

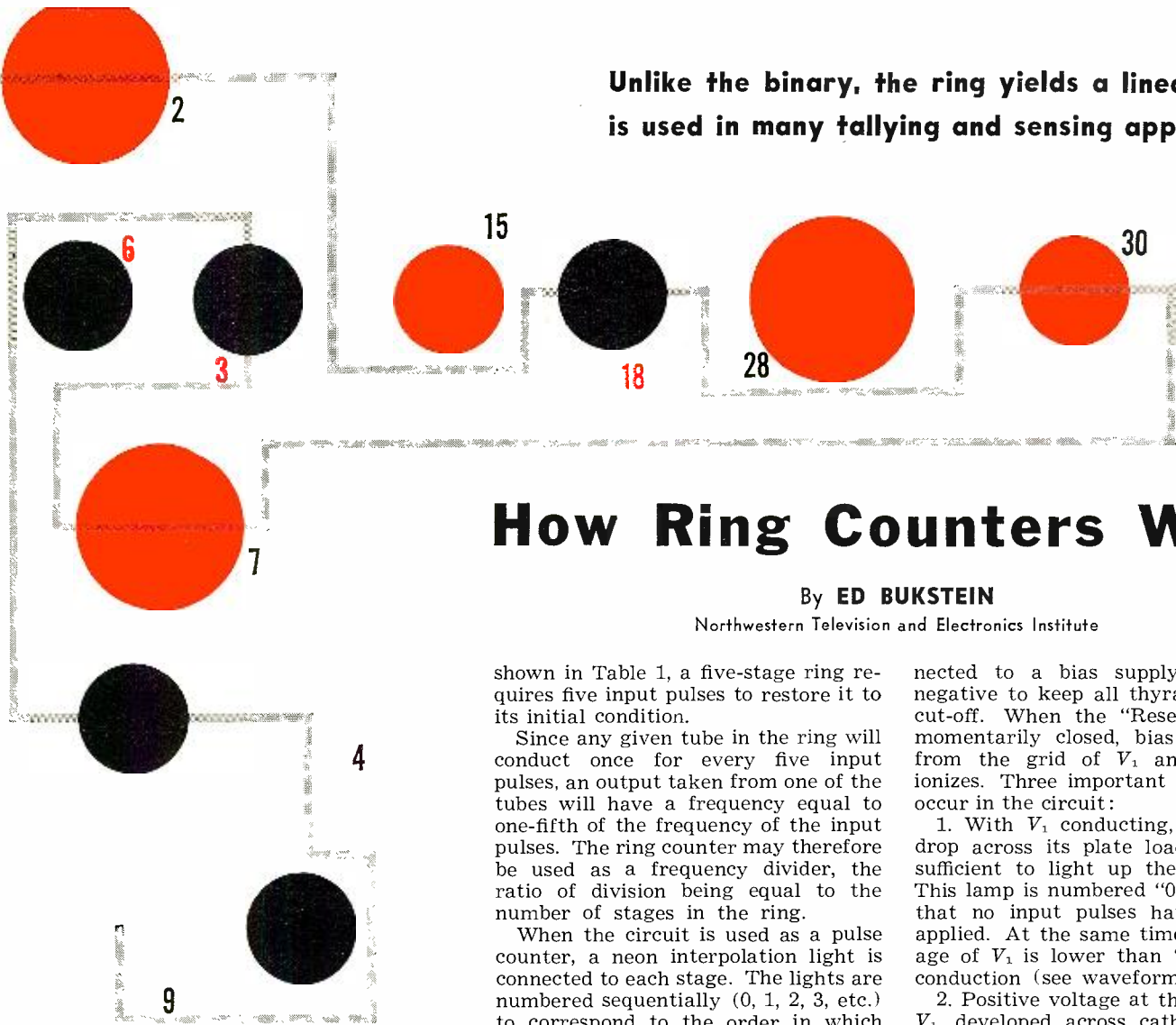

How Ring Counters Work

By ED BUKSTEIN

Northwestern Television and Electronics Institute

shown in Table 1, a five-stage ring requires five input pulses to restore it to its initial condition.

Since any given tube in the ring will conduct once for every five input pulses, an output taken from one of the tubes will have a frequency equal to one-fifth of the frequency of the input pulses. The ring counter may therefore be used as a frequency divider, the ratio of division being equal to the number of stages in the ring.

When the circuit is used as a pulse counter, a neon interpolation light is connected to each stage. The lights are numbered sequentially (0, 1, 2, 3, etc.) to correspond to the order in which they light up when input pulses are applied. Mounted on the front panel of the instrument, the lights therefore provide an indication of the number of input pulses.

So much for *what* the ring counter does. We may now consider *how* it performs its function. The circuit diagram of a ring counter using thyratron tubes appears in Fig. 1. For simplicity, only three stages are shown, but the circuit can be extended to include a greater number. The grid of each stage is con-

nected to a bias supply sufficiently negative to keep all thyratrons below cut-off. When the "Reset" switch is momentarily closed, bias is removed from the grid of V_1 and this tube ionizes. Three important changes now occur in the circuit:

1. With V_1 conducting, the voltage drop across its plate load resistor is sufficient to light up the neon lamp. This lamp is numbered "0" to indicate that no input pulses have yet been applied. At the same time, plate voltage of V_1 is lower than "B+" during conduction (see waveforms of Fig. 1).

2. Positive voltage at the cathode of V_1 , developed across cathode resistor R_1 , causes capacitor C_1 to charge to the polarity shown. Charging electrons flow up from ground through resistor R_2 .

3. A portion of the positive voltage at the cathode of V_1 is applied to the grid of V_2 through a dropping resistor (see Fig. 1). The circuit is designed so that this voltage is *not* quite enough to overcome the negative voltage keeping V_2 cut off. However, this positive voltage is enough to cancel out most of the cut-off bias, so that V_2 is now just be-

INPUT PULSES	STAGE CONDUCTING	STAGES CUT OFF
Start	1st	2nd, 3rd, 4th, 5th
1	2nd	1st, 3rd, 4th, 5th
2	3rd	1st, 2nd, 4th, 5th
3	4th	1st, 2nd, 3rd, 5th
4	5th	1st, 2nd, 3rd, 4th
5	1st	2nd, 3rd, 4th, 5th

Table 1. Sequence of switching action in a five-stage ring-counting circuit.

THE RING counter, as the name implies, consists of a number of stages connected as a complete ring or loop. Initially, one of the stages is conducting and all other stages are cut off. When an input pulse is applied to the circuit, the stage previously conducting is driven to cut-off and the following tube in the ring becomes conductive. Since the conducting condition advances around the ring one stage at a time, the circuit is sometimes referred to as a *linear* counter.

Table 1 shows the switching actions which occur in a five-stage ring counter. Because each input pulse transfers the conducting condition to the following stage of the ring, the number of input pulses required to restore the circuit to its initial condition is equal to the number of stages in the ring. As

Fig. 1. A thyratron ring counter using three stages. The tubes ionize in succession as input pulses are applied. The circuit may be extended to a greater number of stages. Input and single-stage waveforms are at the right.

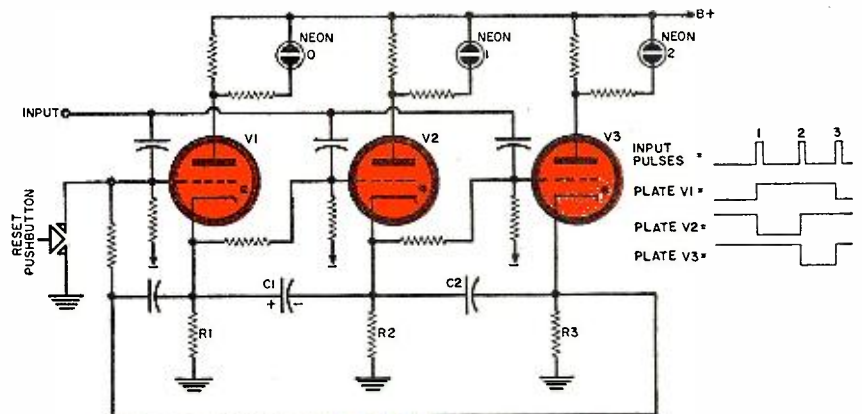

low the point at which tube will fire. So much for the initial conditions. If a positive pulse is now applied to the input terminal of the entire circuit, the second tube in the ring (V_2) will become conductive, the tube previously conducting (V_1) will become cut off, and the final tube (V_3) will remain cut off. This action occurs as follows:

1. Since initial circuit action biased V_2 just below the firing point, it will ionize when the positive input pulse reaches its grid.

2. As a result of current drawn by V_2 , a voltage drop appears across its cathode resistor, R_2 . This voltage, adding in series with the previously accumulated charge on C_1 , is applied to the cathode of V_1 . The positive potential at the V_1 cathode is now higher than the potential at the V_1 plate. V_1 therefore de-ionizes.

3. Since V_2 is now conducting, the neon lamp in its plate circuit will glow. This lamp is numbered "1" to indicate that one pulse has been applied to the entire circuit.

4. The input pulse has not been strong enough to overcome the high negative bias of V_3 (see waveforms of Fig. 1 for conditions of plate voltage at all three tubes). However, a portion of the positive voltage at the cathode of V_2 is now applied to the grid of V_3 , biasing it, in turn, just below its firing point. Also, capacitor C_2 is charged by current flowing up from ground through R_3 .

The circuit action already described continues from stage to stage successively as each pulse is applied. Because V_3 is biased just below the firing point, it will ionize when the next positive pulse is applied to the input terminal.

INPUT PULSES	STAGES							
	1st	2nd	3rd	4th	5th	6th	7th	8th
Start	0	1	1	1	1	1	1	1
1	1	0	1	1	1	1	1	1
2	1	1	0	1	1	1	1	1
3	1	1	1	0	1	1	1	1
4	1	1	1	1	0	1	1	1
5	1	1	1	1	1	0	1	1
6	1	1	1	1	1	1	0	1
7	1	1	1	1	1	1	1	0
8	0	1	1	1	1	1	1	1

A voltage drop will then appear across resistor R_3 and this drop will add in series with the charge on C_2 . As a result, the cathode of V_2 will be more positive than its plate, and V_2 will de-ionize. Because the next (second) input pulse causes V_3 to ionize, neon lamp number 2 will glow to indicate that two input pulses have now been applied to the input terminal.

Thyratron V_1 follows V_3 in this continuous circle or ring. Accordingly, when the third input pulse is applied, V_1 will ionize and V_3 will return to cut-off. The circuit will now be back to its initial condition. As indicated by the waveforms in Fig. 1, the plate voltage of a thyratron is high when the gas is de-ionized and low when the tube is conducting. The waveforms are idealized in that they do not show such distortions as the rounding of the leading

corners that may result if the stray capacitance of the circuit is excessive. It is of interest to note that an output taken from the plate of any of the tubes will have a frequency that is one-third the frequency of the input pulses.

Because the ring-of-three circuit has three stable states, it is sometimes referred to as a *ternary* circuit. The Walkirt Co. ternary counter shown in Fig. 2 uses vacuum tubes and is therefore capable of higher switching speeds than the thyratron ring counter.

Each plate of this circuit is resistively coupled to the grids of the other two tubes through 270,000-ohm resistors. As a result, only one tube at a time can conduct. When V_1 is conducting, for example, its plate voltage will be low and the grids of V_2 and V_3 will also be at a low potential. Tubes V_2 and V_3 are therefore cut off when V_1 conducts.

The initial condition of the circuit (V_1 conducting) is established by applying a positive pulse to the "Reset" terminal. If a negative pulse (in this type of ternary) is now applied to the "Input" terminal of the circuit, tube V_1 will cut off and tube V_2 will become conductive. This action occurs as follows:

The negative input pulse is applied, through the plate-load and coupling resistors, to all three grids. Since V_1 is the only tube conducting at this time, it is the only tube affected by the input pulse. Tube V_1 therefore cuts off and its plate voltage increases. This increase is coupled to the grids of V_2 and V_3 .

Only V_2 becomes conductive, however, because the coupling to its grid is accomplished through a parallel

(Continued on page 158)

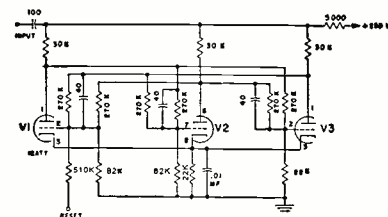

ALL TUBES 1/2 12AT7

Fig. 2. Each plate in this ternary is connected to the grids of the other tubes so that only one at a time can conduct.

Fig. 3. Each flip-flop stage (A) in this counter is a separate plug-in unit. All are interconnected as in (B).

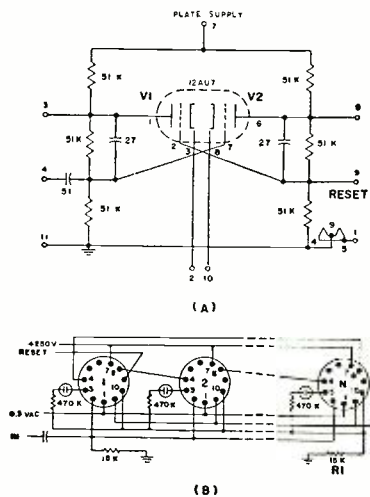

INPUT PULSES	RING STAGES					Binary
	1st	2nd	3rd	4th	5th	
Start	0	1	1	1	1	0
1	1	0	1	1	1	0
2	1	1	0	1	1	0
3	1	1	1	0	1	0
4	1	1	1	1	0	0
5	0	1	1	1	1	1
6	1	0	1	1	1	1
7	1	1	0	1	1	1
8	1	1	1	0	1	1
9	1	1	1	1	0	1
10	0	1	1	1	1	0

Table 3. Sequence in counter of Fig. 5.

Table 2. Switching action in 8-stage ring circuit of type shown in Fig. 3.

Fig. 4. How a ring counter (blocks at the top) may be used to control gate tubes (below). Pulses applied to the gates appear in succession at output.

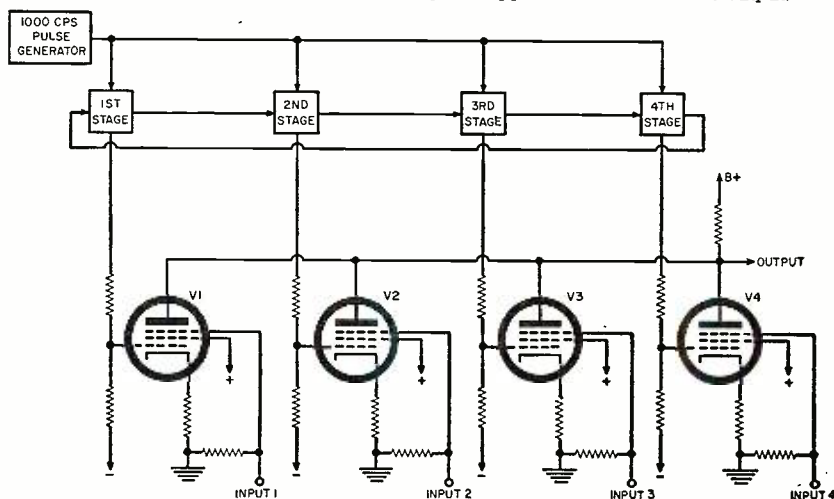



Over-all view of the Heath Model SP-2 high-fidelity stereo preamplifier.

a NEW idea in a Stereo Preamp

An unusual design—
a monophonic unit now
which can be later
converted to stereo.

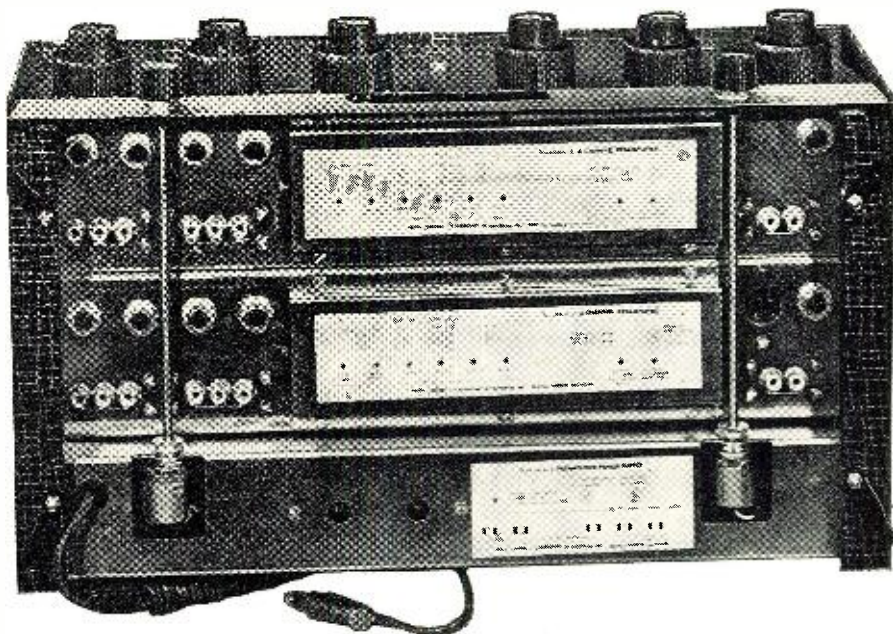

Bottom view of preamp. All of the input and output jacks and level controls are mounted in special areas at the bottom of the unit.

A RELATIVE newcomer to the field of high-fidelity components is the *Heath* Model SP-2 monophonic-stereo preamplifier. There are several unusual features incorporated in this design. As shown above, all of the non-operating controls and jacks are mounted at the bottom rather than the rear as is more conventional. Instead of making all interconnections from the rear, it is only necessary to lift the preamplifier from the front and make the required adjustments and connections. The other feature is more of a convenience for the consumer who would prefer a monophonic system at the present time and probably would like to convert to stereo at a later date.

The *Heath Company* has made available a Model SP-1 which in all respects looks the same as the unit shown at the top of this page but is solely for monophonic use. Instead of dual knobs for the operating controls, single knobs

are used. If at a later date stereo operation is desired, a conversion kit (Model C-SP-1) is available. This kit contains all of the necessary components for converting the monophonic unit to the stereo mode.

Another feature which is rather unique is the use of a 20-foot shielded extension cable with a balance control at its end. This makes possible a more accurate balance adjustment between the left and right channels from an ideal position in the listening area. This cable is just an added feature for those who may find it useful. However, it can be removed from the chassis and balance adjustment then made directly at the preamplifier. We disliked the idea of tripping over the cable but must admit that a more accurate balance adjustment can be made from the center of the room than at the preamplifier itself.

As pointed out in previous articles,

preamplifiers or master control units require separate power amplifiers to complete a system. This, of course, differs from an integrated set-up where the preamplifier and power amplifier are combined on a single chassis. Since economy was the keynote in the design of this unit, only the basic function controls are provided. Each channel has an eight-position selector switch, bass, treble, level, and loudness control. In addition, a scratch filter for Channel A and a four-position function switch for either monophonic or stereo operation is provided.

There are other preamplifiers on the market at a much higher price which include additional controls or switches not provided in the *Heath* unit. For example, phase reversal, reverse channels, level indicators, special pilot lights, and provision for a third channel are not included in the SP-2. These controls may be considered added con-

PROMOTING a Small Business

By WILLIAM LEONARD

Successful promotion for small service dealers is best accomplished with specialized methods.



THE SUCCESSFUL management of any business, irrespective of its size, in our present-day economic system, requires a lot of physical endurance and a good measure of merchandising skill and business acumen. There is a constant parade of small businesses opening and closing in practically every business center. Each of these businesses was started with a great deal of confidence and enthusiasm. When the curtain fell on them at the end of two months, six months, or a year, the disillusioned proprietors had whole batteries of reasons to explain the failures of their ventures. It is seldom that the real reason for failure is included in such a catalogue of excuses.

The controlling factor in the success or failure of any such venture is the volume of profitable business it is able to develop and maintain. In a conventional retail establishment, this means the sale of merchandise. It means the sale of enough merchandise at a sufficient gross profit to pay all of the overhead and operating expenses, and to provide the owner with an adequate salary for himself.

An electronic service business differs from a conventional retail store in that its major commodity is time, knowledge, and skill. Knowledge and skill are intangible products. A customer may marvel at a technician's ability to comprehend the complex wiring of a TV set, yet gripe at paying a reasonable price for that ability to fix her set. While *time* is a very tangible commodity to a service dealer who must pay for it, it has a low dollars-and-cents value in the eyes of the average customer. This also applies to the high cost of the transportation required in providing TV service in the home. In brief, the major income of a service business must be developed from the sale of intangibles that people dislike having to pay for.

A very interesting facet of human behavior is that we like good showmanship and are inclined to give secondary consideration to the cost of products that are presented to us in an atmosphere of adroit and subtle showmanship. This normal, human factor is quite important in the merchandising of a service business. It is the door to consistently good customer relations when it is woven into the fabric of the

everyday operations of an electronic service business.

It is elemental that, while the electronic service industry has sharp seasonal variations, the service dealer must meet his overhead, operating, and living expenses with clock-like regularity fifty-two weeks every year. Where a merchandising-wise retailer can build his cash reserves by pushing the fast-selling seasonal items in his field, the service dealer has only a limited number of hours each day that he can sell. He cannot realize the same percentage of increase in the sale of his time during seasonal booms that the retail merchant can with the specialized products he handles.

Another factor that the service dealer must constantly bear in mind is that the main product he sells—service—is one the average customer neither plans for nor wants to buy. The need for service usually happens unexpectedly. It disturbs the family members because the breakdown may have deprived them of enjoying some of their favorite programs. Also, it may have occurred at a time when the family's cash reserves were at a very low point. These two factors establish the "normal" psychological atmosphere in which the dealer must transact business with his customers.

In the light of its seasonal variations and the psychological factors involved in selling service, it is apparent that some types of promotion and advertising are superior to others in the merchandising of a service business. The limited amount of money the service dealer has available for advertising makes it necessary for him to spend these few available dollars on types of promotions that are especially suited to his type of business.

The most important element in the promotion of any business that deals directly with the public is the appearance and demeanor of the owner and

his employees. While a service dealer may feel sometimes that all of his customers are ungrateful chisellers, he must constantly guard against allowing this feeling to creep into his conversation. A technician's personal appearance and the procedure he uses when working on sets in the home may seem unimportant to the technician himself, but they are very important in the set owner's appraisal of what he is getting for the dollars he pays for the service.

The second important element in good sales promotion is the appearance of the business establishment. Does it look like a successful business? People like to deal with successful businesses. The store front and show windows will pay dividends in profitable business if they are utilized intelligently by the service dealer.

Maintaining a good front is vitally important in promoting service. Included in this good front are the personal appearance and demeanor of the owner and his employees, the use of a studied service procedure in the home, an attractive-looking store front, and window displays that indicate a dynamic, successful business. While these things are not expensive to do, they are elements of merchandising that must be woven into the everyday pattern of the business operation. They can be incorporated into a business only through careful planning of a long-range program.

In this era of intense competition, shifting population, and mass promotions, the owner of any small business must be both an opportunist and an imaginative promotor to keep his name and business facilities before a substantial number of potential customers. Although every home is a prospective customer for TV service on an average of once a year, a dealer must maintain some type of regular communication with them to get a fair share of this business.

(Continued on page 161)

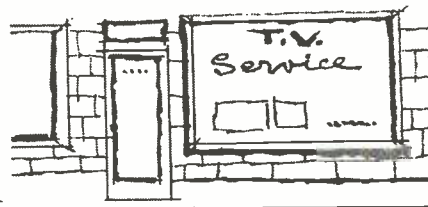

By DONALD L. STONER

The recent FCC decision to open the 11-meter band for Citizens Band operation makes it possible for anyone to own and operate a transmitting and receiving station. Here is complete construction information for simple low-power station that permits voice communications.

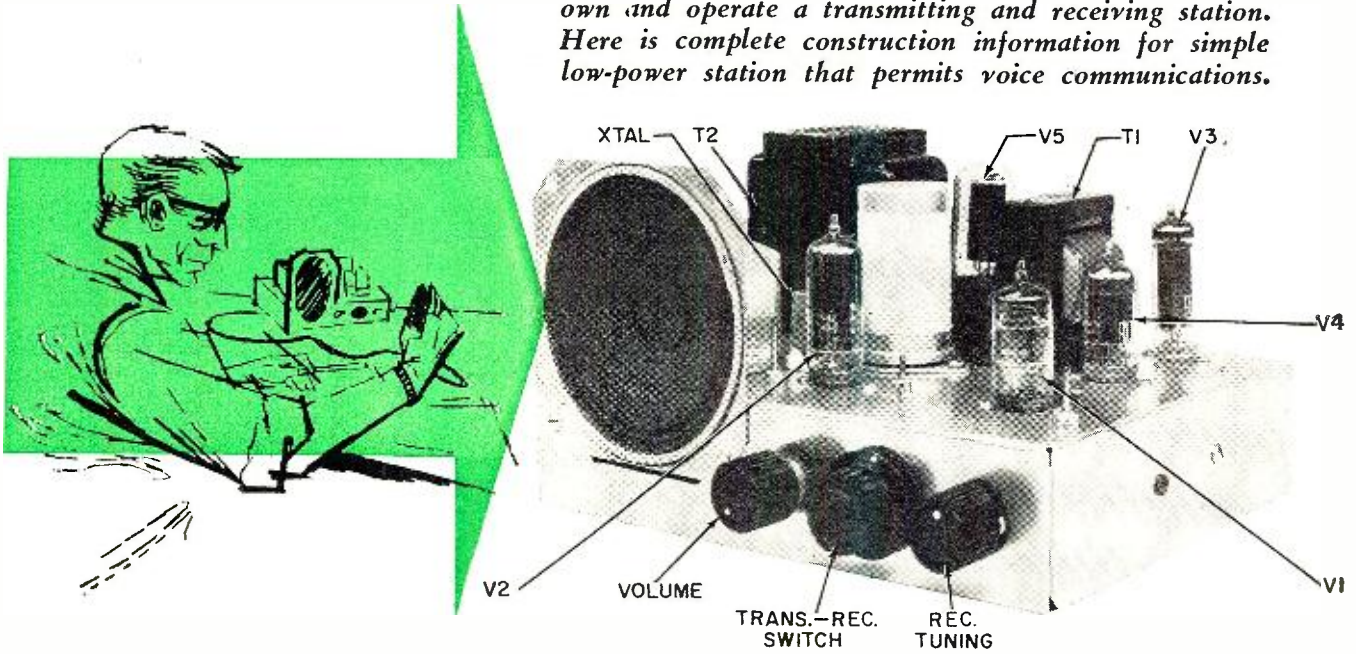

Over-all view of the complete Citizens Band transceiver is shown in this photo.

Build This Citizens Band Transceiver

DID you know that now you can build a radiotelephone transceiver and talk on a short-wave band *without* having to obtain an amateur radio license? The recent FCC decision to open the 11-meter band to Class D Citizens Band operation makes it possible for *anyone* (except those under 18 and aliens) to own and operate a short-wave transmitting and receiving station!

Up to the time of the new ruling, the Citizens Band was located between 460 and 470 mc. If you were operating on this band, you might be fortunate enough to talk clear across the city with the help of lofty antennas at each end of the "circuit"! Not only that, but you *had* to use commercially built equipment. The FCC would not license home-made equipment unless such gear had "type approval." A type approval test would not be made on less than 100 production units. Obviously the experimenter couldn't do this just to get on the air!

The recent 11-meter ruling has changed everything. Hams and SWL's know from experience that signals on the 11-meter band can travel to the far corners of the earth. It is not at all uncommon to hear stations coming in from clear across the country *every day* during the winter and on most days during the summer.

Twenty-two channels have been assigned for voice communication in this new band plus six more for radio-control applications. These frequencies are shown in the chart of Fig. 1.

Although you are limited to a maxi-

mum power input of 5 watts, don't "pooh-pooh" this Citizens Band transceiver as a "peanut-whistle." Even with 5 watts, it is perfectly capable of transmitting and receiving over distances of 3000 miles or more when Old Mother Nature has the ionosphere in good working order.

Even though you do not have to go through the rigors of obtaining an amateur license to operate on the 11-meter band, you do have to register your station with the FCC. Obtaining a Class D station permit is merely a formality. Simply send a card or letter to your local FCC field office and re-

quest the "Revised Form 505." When you receive this form, fill it out (describing this transceiver) and return it to the Federal Communications Commission, Washington 25, D.C. Do not send the form to the local field office, but directly to Washington. Allow enough time for FCC personnel to process your application and send your permit.

The transceiver uses a total of five tubes. A 12AX7 and a 6AQ5 are used in the combination amplifier and modulator. The transmitter and receiver are simplified to the point where only one tube is used in each circuit. The fifth

Fig. 1. Frequency allocation chart showing the channels in the Citizens Band.

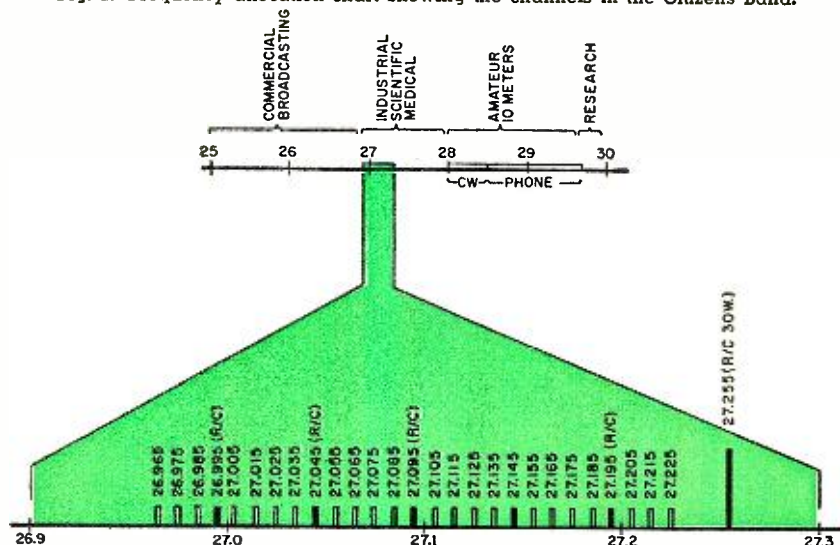

tube, a 5Y3, is used as a rectifier in the power supply. The entire transceiver is built on a 7" x 9" x 2" aluminum chassis and includes the speaker and power supply. The construction of a cabinet (preferably of wood) to house the unit is left up to the builder.

How It Works

The unit is called a transceiver because the power supply and audio amplifier are common to both transmitter and receiver. This type of circuitry conserves tubes and components by making them do "double duty." (Fig. 2)

Eleven-meter signals are picked up on the antenna and fed to the transceiver through a connector on the rear apron of the chassis. One section of the "transmit-receive" switch, S_1 , transfers the antenna from the receiving to the transmitting mode.

The receiver is an extremely sensitive one-tube circuit, consisting of a type 6AN8 pentode-triode. The pentode section of the 6AN8 is connected as a radio-frequency amplifier; the triode section of the tube is connected as a superregenerative detector. Even though the circuit is relatively uncomplicated, it is capable of detecting signals as weak as one microvolt. The

audio recovered from the detector is applied to the volume control. A regeneration control (on the rear apron) sets the proper operating point for the detector and is adjusted for maximum sensitivity.

A small portion of the audio-frequency voltage on the volume control, R_{17} , is fed to the audio-frequency amplifier which consists of one half of a 12AX7 as a voltage amplifier and a 6AQ5A power amplifier. These two stages amplify the audio output of the detector to a level that is sufficient to operate the speaker.

The voltage produced by the crystal mike is even less than the signal coming from the detector. Therefore, a speech amplifier is used when transmitting. This circuit (the other half of the 12AX7) amplifies the tiny microphone voltage about 20 times. The signal is further amplified by the 12AX7-6AQ5A circuits until it is strong enough to modulate the transmitter.

The transmitter section also consists of a simplified one-tube circuit. A type 6AU8 triode-pentode is used as a crystal-controlled oscillator and power amplifier. The crystal is a third overtone type and its frequency is selected to fit one of the Class D chan-

nels shown in Fig. 1. The Federal Communications Commission rules for Citizens Band operation require that the transmitter have a frequency stability of at least .005%. The crystal used in this circuit must have this frequency tolerance. When used in a conservative circuit, such as this, the overall transmitter stability will be within the FCC specifications.

The oscillator uses the triode section of the 6AU8 and is the circuit recommended by the crystal manufacturer. The plate circuit is tuned to the crystal frequency (one of the Class D channels) and the radio-frequency energy from this stage drives the power amplifier. The power amplifier stage boosts the power to just slightly less than the legal power limit of five watts. The modulated power output of this stage is coupled to the antenna through L_4 , a link coil, and switch S_1 . When a "dummy antenna," such as a #47 pilot lamp, is connected to the antenna jack, the r.f. energy will light the bulb to full brilliance.

Regarding the maximum power input, the regulations go something like this: The maximum plate power input to the anode circuit of the electron tube or tubes which supply power to

Fig. 2. Complete schematic diagram of the transceiver. Note that V_3 , V_4 , and V_5 are used both on transmit and receive.

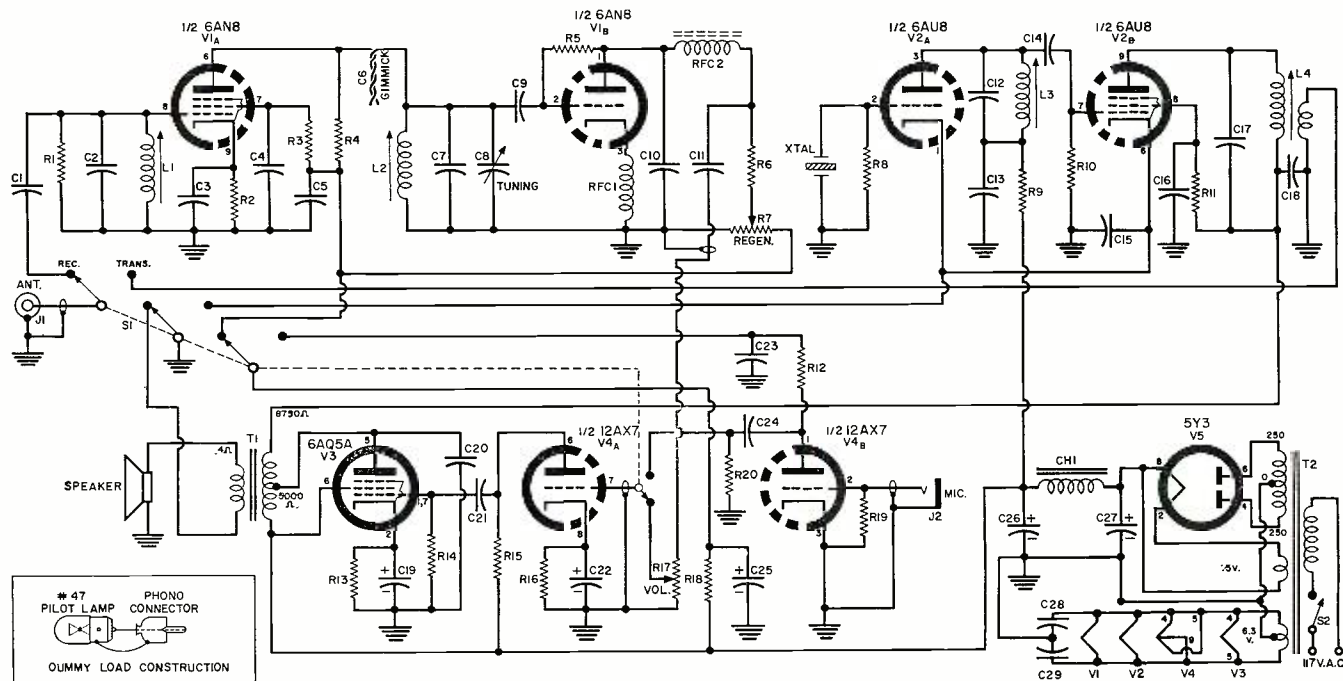

- R_1 —2700 ohm, $\frac{1}{2}$ w. res.
- R_2 —470 ohm, $\frac{1}{2}$ w. res.
- R_3, R_{10} —220,000 ohm, $\frac{1}{2}$ w. res.
- R_4 —4700 ohm, $\frac{1}{2}$ w. res.
- R_5, R_{19} —10 megohm, $\frac{1}{2}$ w. res.
- R_6 —180,000 ohm, $\frac{1}{2}$ w. res.
- R_7 —250,000 ohm linear taper pot
- R_8 —47,000 ohm, $\frac{1}{2}$ w. res.
- R_9, R_{11} —22,000 ohm, 2 w. res.
- R_{10} —22,000 ohm, $\frac{1}{2}$ w. res.
- R_{12} —470,000 ohm, $\frac{1}{2}$ w. res.
- R_{13} —500 ohm, 10 w. wirewound res.
- R_{14} —270,000 ohm, $\frac{1}{2}$ w. res.
- R_{16} —3300 ohm, $\frac{1}{2}$ w. res.
- R_{17} —1 megohm audio taper pot (with switch S_2)
- R_{18} —10,000 ohm, 1 w. res.
- R_{20} —1 megohm, $\frac{1}{2}$ w. res.
- C_1 —3.3 μ fd. disc or mica capacitor
- C_2, C_{17} —15 μ fd. disc or mica capacitor
- $C_3, C_4, C_{16}, C_{11}, C_{13}, C_{15}$ —0.01 μ fd. disc ce-

- ramic capacitor
- $C_5, C_{15}, C_{16}, C_{23}, C_{24}, C_{28}, C_{29}$ —0.05 μ fd. disc ceramic capacitor (C_{28} and C_{29} should be mounted directly at the filament pins of the 6AN8 to ground)
- C_6 —Gimmick (see text)
- C_7, C_{12} —10 μ fd. disc or mica capacitor
- C_8 —2-8 μ fd. variable capacitor (three plates of E. F. Johnson #157-1 7J12 or equiv.)
- C_9 —100 μ fd. disc or mica capacitor
- C_{11} —4.7 μ fd. disc or mica capacitor
- $C_{19}, C_{21}, C_{26}, C_{27}$ —20/20/20/20 μ fd., 25/450/450/450 v. elec. capacitor
- C_{20}, C_{22} —0.1 μ fd., 600 v. capacitor
- C_{23} —25 μ fd., 25 v. tubular elec. capacitor
- CH_1 —8 hy., 75 ma. filter choke (Stancor C1355)
- L_1, L_2, L_3 —16 t. #24 en. closewound on $\frac{1}{4}$ " slug-tuned coil form (Miller #4500)
- L_4 —Same as L_1 but with 2 t. link of #22 plas-

- tic covered wire
- J_1 —Antenna jack (RCA type phono connector)
- J_2 —Jack to match microphone used
- RFC_1 —50 t. #36 en. scramble-wound on 10 megohm, $\frac{1}{2}$ w. res.
- RFC_2 —75 mhy. iron-core choke (Miller #959)
- S_1 —4-pole d.t. wafer switch (Centralab PA-1011)
- S_2 —S.p.s.t. switch (part of R_{17})
- T_1 —Modulation/output trans. 5000 ohms, 6750 ohms, 4 ohms at 10 watts (Triad M4Z)
- T_2 —Power trans. 250-0-250 v. @ 70 ma.; 5 v. @ 2 amps; 6.3 v. c.t. @ 2.5 amps (Stancor PC-8403)
- $XTal.$ —27,005 mc. third-overtone-type crystal, .005% tolerance (International FA-9)
- $Spkr.$ —4", 3.2 ohm voice-coil speaker
- 1—7" x 9" x 2" chassis
- V_3 —6AQ5A tube
- V_1 —6AN8 tube
- V_4 —12AX7 tube
- V_2 —6AU8 tube
- V_5 —5Y3 tube

the antenna shall not exceed five watts, except on the radio-control channel of 27.255 mc., where the maximum power limit is 30 watts. The method of checking and determining the power input is explained in the adjustment section.

There is another regulation of which you should be aware. A permanently installed antenna system may not exceed 20 feet in height above any man-made structure (or natural formation) on which it is mounted nor shall the feedline be more than 25 feet long. This precludes the possibility of mounting the antenna high in the air, or placing the transmitter remotely from the operating location.

Construction

Referring to the photographs, you will note that the power-supply components are mounted in the left-rear corner of the chassis, with the exception of the filter choke which is mounted under the chassis and below the speaker. The front-left portion of the

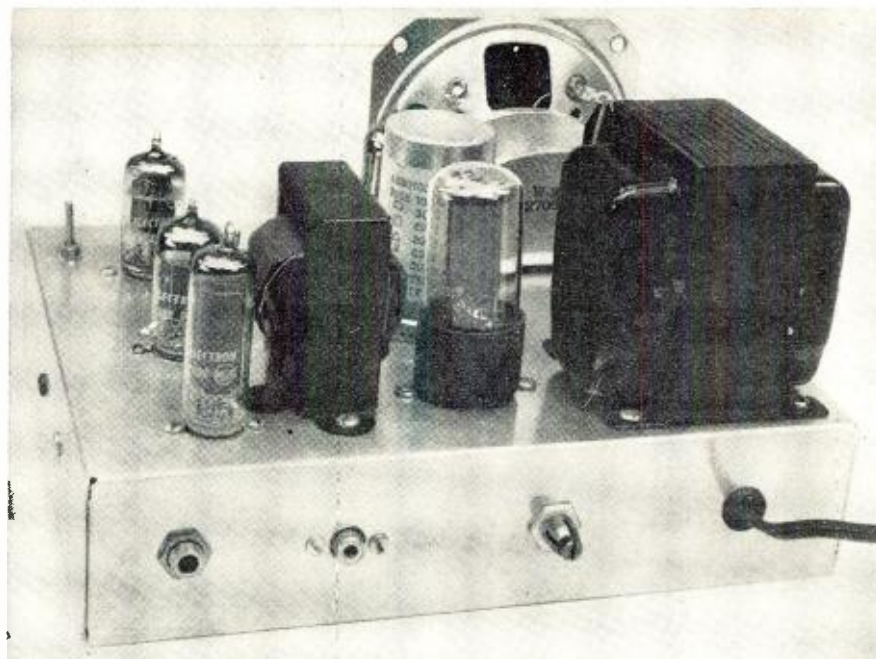

Rear view of the unit shows regeneration control, antenna, and microphone jacks.

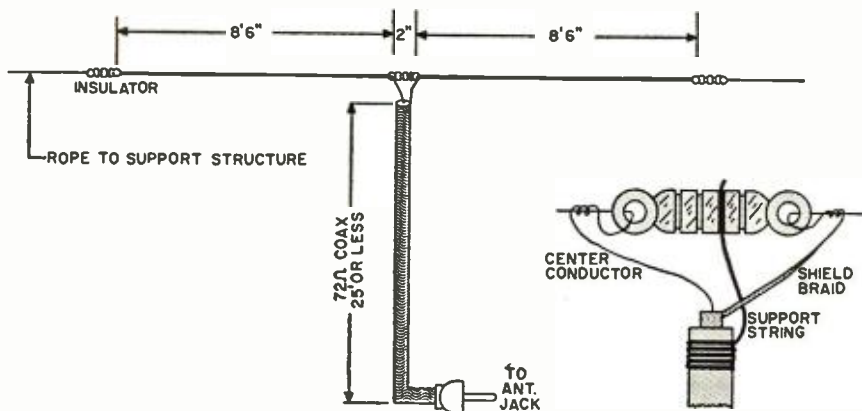

Fig. 3. Shown above are all the construction details on a simple dipole antenna that may be used with the transceiver. Note detailed view of the middle insulator.

chassis has been notched out so that the speaker will set down on the chassis, almost flush with the front apron. The 6AN8, 12AX7, and 6AQ5A are mounted in a line, at the right side of the chassis, and the audio output transformer is located between the 6AQ5A and the 5Y3 rectifier tube. The transmitter circuitry is in the area just forward of the power-supply filter capacitor. The components associated with a particular section are tightly grouped around the tube socket. The close-up views of the equipment should reveal the location of most components.

The filter choke is secured to the side of the chassis with $\frac{9}{32}$ hardware. It is necessary to mount the choke first to gain access to the nut, through the speaker cut-out. A five-lug terminal strip is mounted under the centermost transformer mounting bolt and is used for the power transformer primary circuit, filament and high-voltage winding center-taps, and speaker lead tie-point. A four-lug terminal strip is mounted under the front audio output transformer mounting screw. This serves as a tie point for R_3 , R_4 , C_5 , R_{12} , and C_{22} . A third terminal strip is mounted on the side apron just behind RFC_2 and

is used to secure R_6 and C_{11} . The rest of the components are self-supporting by their leads or lugs. For convenience in grounding components, sockets with four ground lugs should be used.

The connections to R_7 are important if this control is to work according to the instructions which follow. Looking at the rear of this control, with the lugs up, the left terminal should be grounded while the right terminal is connected to "B+" with a short length of wire. Naturally, the center lug goes to R_6 . For proper operation of the volume control (R_{17}) the left terminal should also be ground when observed in the same manner as resistor R_7 .

Once the transceiver is wired, testing should be carried out in a logical fashion. Before the unit is plugged in, measure the resistance across the power-line
(Continued on page 148)

Bottom view shows placement of the components. Note positions of the various coils.

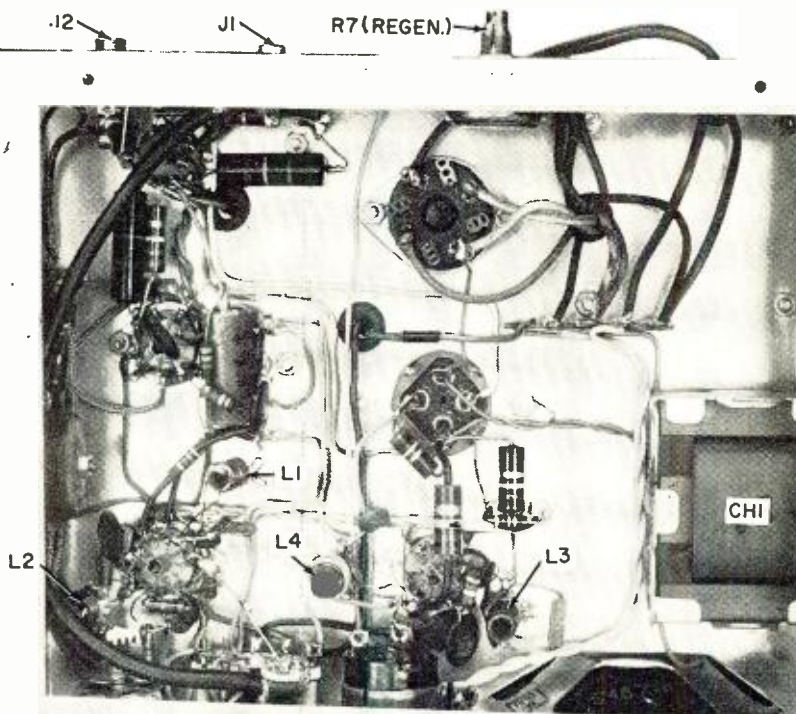

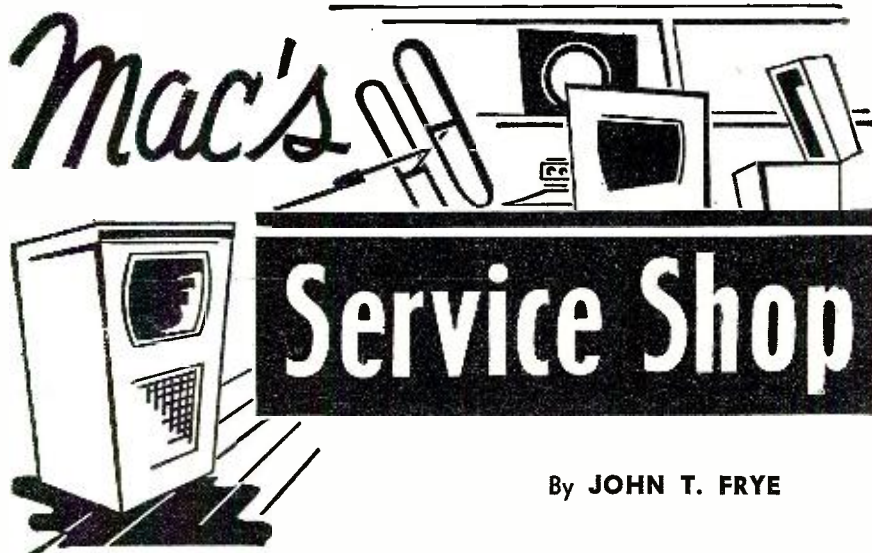

By JOHN T. FRYE

NO HANDS, NO HEAD

AS BARNEY entered the front door of Mac's Service Shop he could hear his employer talking back in the service department; but when the youth stepped through the service department door, no one was in sight. Mac was standing at the bench cleaning a TV tuner and saying, "All right, Mrs. Carter, I'll send Barney over right after lunch."

"I knew it had to happen; I knew it, I knew it!" Barney said over his shoulder as he got his shop coat out of the locker. "Sooner or later everyone in this wacky business flips his wig and starts talking to himself. I do it all the time. I'll say this, though: you're different. I always talk to the set that's giving me a hard time, but you talk to imaginary customers. Guess that's because you have business worries while I just have service headaches."

"So who was talking to himself?" Mac grunted. "I was talking on the telephone."

"Yeah-h-h!" Barney snorted derisively, "with the phone five or six feet away and with the handset resting on the cradle?"

"That's right. Take a good long look at the telephone. If you don't notice something different, turn in your Boy Scout badge. You're not observant."

Barney walked over to the telephone resting on the end of the bench.

"Hey, we do have a new phone!" he exclaimed; "and it's a weirdy. What are these 'on' and 'off' buttons down here below the dial for? What's this little knob with the arrow on it? Is this a dial light? What's behind this little chrome hole plug in the base? Has that little plastic box that looks like a housing for a three-inch speaker got anything to do with it?"

"Whoa! Down, boy. Take it easy. This is a Loud-speaking Telephone. It can be used without lifting the handset from the cradle. To make a call or answer the telephone, you just push that 'on' button. The sound comes out of the speaker in this little plastic case.

Your voice goes into a dynamic microphone behind that hole plug. The pilot light tells you the phone is on. The little knob in the upper right-hand corner adjusts the volume coming out of the speaker. When the conversation is over, you simply push the 'off' button, and the pilot light goes out. You can pick up the handset at any time and transfer automatically to normal telephone operation."

"How come you had it put in?"

"The telephone installer talked me into it when he was in here the other day to pick up a tape recorder I had repaired for him. He says it will be just the thing when you call in for some information on a set and I have to look it up and give it to you. This 'no-hands' telephone will allow me to talk to you from anywhere in the room while I'm leafing through service literature, checking to see if we have an item in stock, looking through the customer file, and so on. Furthermore, when a customer calls with a description of symptoms, we can both listen while we keep right on working. I agreed to give it a trial for a couple of months and see if it was worth the extra cost."

"Do you know how it works?"

"Sure. I told the installer I wouldn't have any electronic equipment in this room that I didn't savvy; so he let me look at the technical bulletin on it. If you've got any questions, shoot."

"It must have amplifiers in it. Where are they and how are they powered?"

"It has two printed-circuit vacuum-tube amplifiers. Each amplifier consists of a CK-512AX hearing-aid-tube voltage amplifier and a 3V4 output tube. Power for the tubes is taken from the 117-volt line. One amplifier builds up the output of the microphone before putting it on the line. The other amplifier builds up the voice currents from the line so they can drive the speaker."

"Surely all that stuff isn't crammed inside the telephone."

"Nope. There's a small 'control unit'

about 4" x 7" x 10" fastened up under the bench. Leads from it go to the telephone, this little speaker, the telephone line, and to the house wiring."

"Why don't you get feedback from the speaker through the microphone?"

"That's a good question and it worried me, too. You actually can get feedback if you turn up the speaker volume too high or if you place the speaker too close to the microphone; but with the speaker three or four feet from the telephone and properly positioned, there's no problem. A hybrid coil inside the control box does the trick. This hybrid coil is a clever gadget that connects microphone signals to the line but not to the loudspeaker amplifier. I haven't time to go into hybrid coil theory now, but you won't be far off if you think of a hybrid coil as a device that represents a sort of bridge circuit forcing one signal to buck itself out while another signal is allowed to pass freely."

"Well, that's the end, the absolute end!" Barney said admiringly as he stroked the telephone.

"Oh no it's not," Mac disagreed with a grin. "Nothing is ever the end in electronics. Someone is always coming up with something a little better. Already they have a Transistor Speaker Phone that has some advantages over this model."

"Such as what?"

"The small power requirements of the transistors are supplied right from the d.c. current in the telephone line itself; so no connection to the house current is needed. Miniaturization afforded by transistors permits all the extra equipment to be housed inside the telephone and the little speaker case, thus doing away with the need for the 'control box.' That means the Transistorized Speaker Phone is portable and can be carried about and plugged in at different locations in the house or office. Transistors, unlike tubes, should last just as long as any other parts of the telephone. Furthermore, they spring into action instantly and do not need the second or so of filament warm-up time required by the tubes."

"Those telephone guys are right on the ball," Barney said.

"They *did* invent the transistor," Mac said quietly. "Don't ever underestimate telephone engineers. Radio engineers have borrowed very freely from them in the past and will continue to do so in the future. The telephone boys have done marvelous research work in the fields of sound, microwave transmission, semiconductors, multiplexing, and many others. When they talk, I listen."

"Suppose you listen to me a bit," Barney said as he picked up the little a.c.-d.c. receiver he had been working on at quitting time the day before. "Ain't it funny how identical troubles come in bunches in service work? This set has exactly the same difficulty as the last one: a dead oscillator. That one I fixed yesterday had an open wind-

(Continued on page 88)

PROBLEMS IN TVI LOCALIZATION

The quantity of information on the accompanying chart covering v.h.f. TV and other radio frequencies will be useful in a variety of applications, including some never considered by the compiler. However, it will be most helpful in solving TV interference problems, for which it was designed.

A major difficulty when TVI occurs is that, out of a seemingly infinite set of paths to pursue, one seldom knows where to begin. Such related but quite separate factors may be involved as the frequency of the interfering source, its nature, its location, the frequency on which it enters the receiver, the portion of the set through which it makes its entry, and the techniques best suited to reducing its effects. Often one of these factors is better to start with than another, but it is seldom easy to tell which at the outset, when this information is most needed. Anything that can narrow down the vast range of possibilities is useful.

No single source can provide quick, ready-made answers. However, when properly applied, the INTERFERENCE CHART can save much time by narrowing down possibilities sharply. It will do this in the majority of cases, although it cannot cover every one of them. Conversely, it will highlight important, additional possibilities that are easily overlooked. But the technician will still have to think.

One of its chief functions is that of determining the frequencies on which the interference may be entering the receiver. The "entering frequency" is not necessarily the same as the frequency of origin, or "source frequency," but must usually be determined first. When either of these is already known, the chart may be used to determine what specific service and/or point of origin is involved. This will be covered later.

Where TVI appears to exist on just one channel, or two, it is still not correct to assume that it is simply entering through the antenna in the r.f. bandwidth of that channel. It may be beating against or near the local-oscillator frequency of the set for that channel. It may be an image, as much above the local oscillator as the received signal is below the latter.

The "source frequency" itself may be some sub-multiple of the one

on which TVI is actually entering. For example, a nearby industrial plant may have r.f. heating equipment that operates on 33.5 mc. The eighth harmonic, 268 mc., is an image frequency that may disturb a TV receiver with a 41-mc. i.f. strip when the latter is tuned to receive on channel 7 or 8.

In the matter of harmonic interference, it is recognized that requirements for suppressing harmonic radiation are fairly rigid. Even so, harmonic interference is easily produced in the receiver itself. Take the case just mentioned. The heating equipment in the nearby plant may put out a very "clean" 33.5-mc. However, TV tuner circuits are quite non-linear. They can act as excellent harmonic generators for an entering 33.5-mc. or other signal, especially if that signal is strong enough to cause overload. Nevertheless, the cure involves suppression of the fundamental.

The source of interference may be the TV receiver itself, with one circuit providing unwanted signal for another. As a corollary, one TV receiver may be the interference generator for another, especially if they or their antennas are adjacent, or if they are fed by a common signal distribution system.

For example, the video detector (a nonlinear circuit element) has been known to act as a harmonic generator for signals within the i.f. bandwidth that are fed to it. Thus the 4th or higher harmonics of 41-47 mc. i.f. signals can interfere with reception on channels 7 to 13. Also the 13th harmonic (46.54 mc.) of the subcarrier oscillator (3.58 mc.) in some color sets has been known to interfere on all channels of its own or nearby receivers.

Whenever interference appears to exist on many or all channels received, instead of one or two, the probability is that entrance is through the fixed-tuned circuits (video i.f. for picture hash, audio i.f. for garbled sound, 3.58-mc. oscillator for loss of color sync or color). This fact is helpful in determining the portion of the receiver that is affected. While antenna and r.f. circuits are thought of as the most susceptible points of entry, no possibilities should be overlooked. In addition to those already noted, there is always the power line.

How to Use the Chart

To identify probable "source" frequencies of TVI, locate the possible "entrance" frequencies on that portion of the chart marked below as "A" ("Receiver Frequencies"). Using the two "F" scales, align a straight edge so that it intersects the possible entering frequencies, working with one such frequency at a time. (Refer to the note entitled PINPOINTING TVI in the upper portion of the chart.)

"Source" frequencies whose fundamentals or harmonics may be suspected will be intersected on the intermediate scales (F, F/2, etc., in section "B"). Although harmonics above the 20th have been known to result in TVI, the most likely ones are given by the chart. Subharmonics up to the 10th may be found mentally by moving the decimal point one place to the left on the "F" scale.

The "Allocations" portion of the chart (section "C" below) is then used to see what interfering services may be involved, between 1 and 300 mc., as indicated on the "F" scales. While this may still leave numerous possibilities, common sense and slight effort will provide further, drastic narrowing down. Few of the indicated services are likely to be possibilities in any one area. For example, there is little likelihood of TVI from maritime services in an inland location. Away from airports or

airlines, this source can be ignored. A check with the regional office of the FCC will assist in determining what services are active in a given area and what frequencies they use.

Remembering that the receiver itself or other sets may be implicated, the cautious technician will examine section "A" of the chart for sources at the same time that he uses section "C."

In another application of the locator chart, let us assume that the source and originating frequency are already known. For example, the transmission is readily identifiable as originating from a local airport. To apply proper suppression, we must determine how the interference enters the TV receiver. We now start out with the known frequency, on the "F" and fractional "F" scales in section "B," and determine entering frequencies in section "A."

Since it is not a magic wand, the locator chart is intended to supplement rather than replace other known weapons in the war against TVI. Such devices as interference probes will still be useful. Knowledge of available types of interference filters and their uses, as well as data for fabricating them, is still essential. Also, nothing can replace the ability to think.

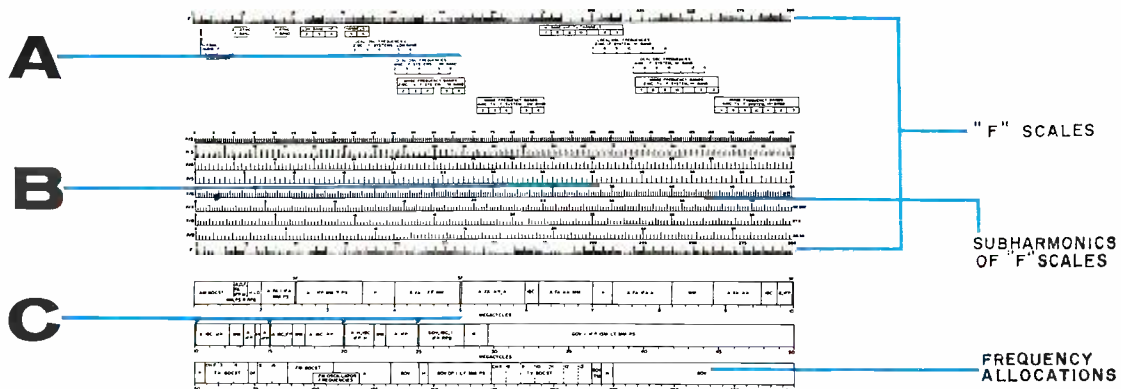

QUARTER-WAVE MATCHING SECTION

This chart is used to obtain the surge impedance of a $\frac{1}{4} \lambda$ matching section used as an impedance transformer from one real impedance to another.

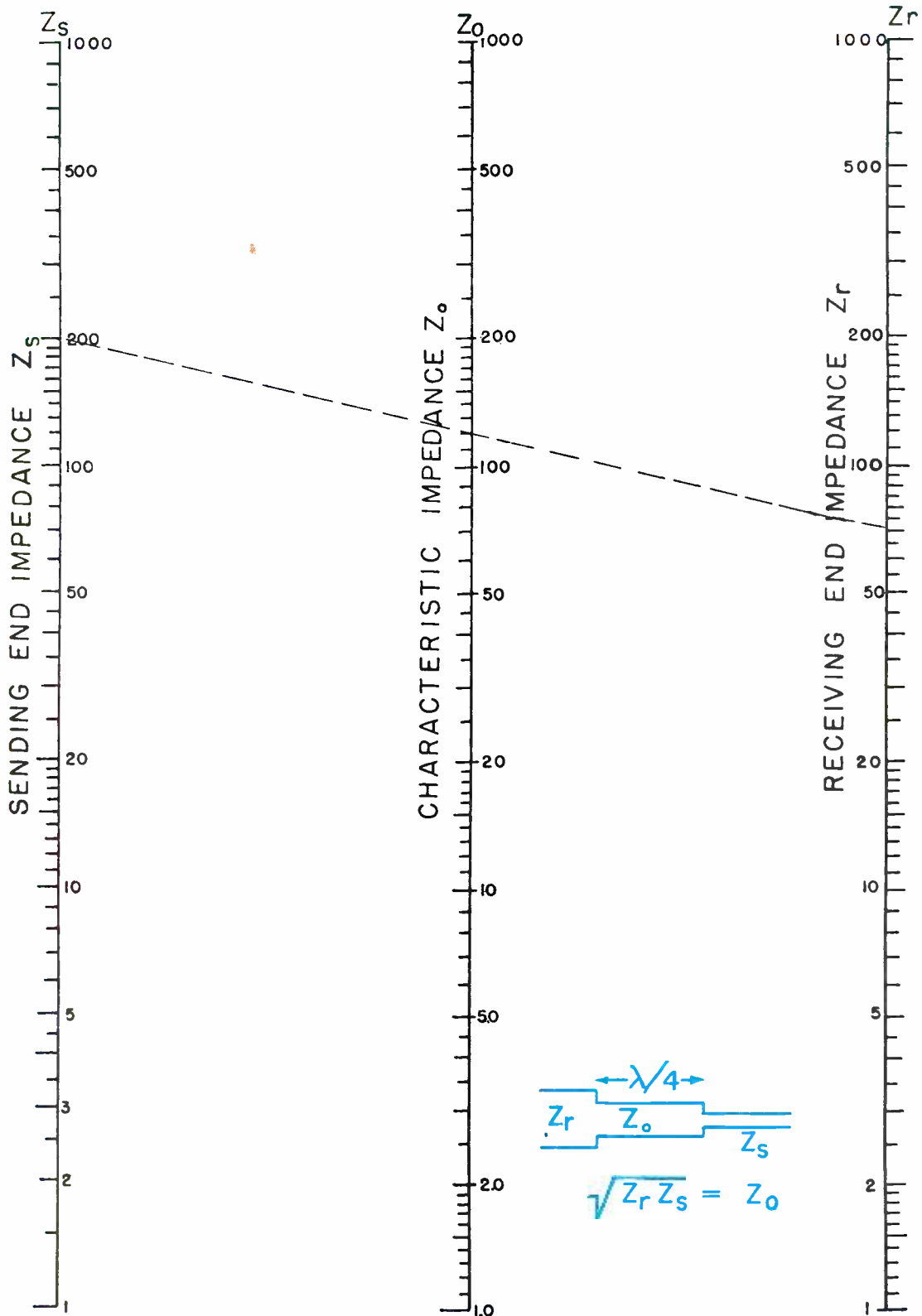

Three-Band Mobile Converter

By JOSEPH L. REIFFIN, W5CWP

Inexpensive to build, small enough to be hidden away in the car, this single-crystal converter unit has more "bring 'em in" power than the mobile ham can employ.

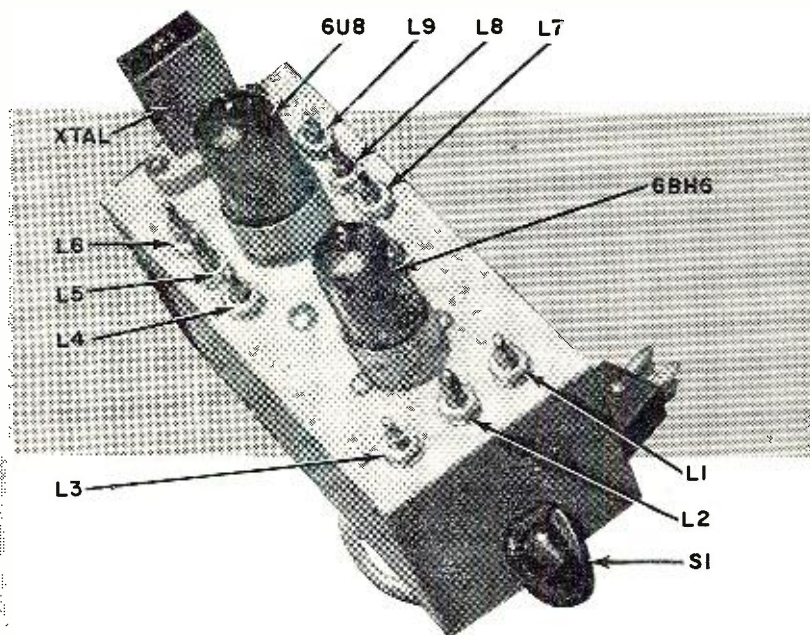

Top view of the crystal-controlled converter is shown here.

YOU certainly don't have to be an Old Timer to remember when operating mobile was strictly a one-band affair. For one thing, the problem of getting an antenna to radiate with at least a semblance of efficiency on more than one band without the use of the rather recently developed "Hi-Q" loading coils and traps, proved to be a big stumbling block. The average mobile installation consisted of a one-band converter, a one-band transmitter, and a single-band antenna to match.

With the advent of efficient multi-band antennas, mobile operation is now conveniently possible on the three most popular bands—10, 15, and 20 meters, without the need for making any adjustments to the antenna and without the need to even leave the front seat of the car. The one-band installation is now just about obsolete and multi-band operation from the family car is becoming as commonplace as multi-band operation from the shack.

Perhaps the greatest obstacle to multi-band operation in the car is the high cost of suitable receiving equipment. There are several very fine all-band receivers designed for mobile installations available, but paying out about \$300 for such a receiver is pretty difficult to justify to the XYL, who already holds a dim view of the loss of leg room around the front seat.

The three-band, crystal-controlled converter described here may be the answer to that problem. It is inexpensive to build, small enough to be hidden away practically unnoticed, and has more "bring 'em in" power than you can actually use in your car. In fact, working into a good broadcast receiver,

it can make many a full-fledged communications receiver sit up and take notice. It is designed for the 10-, 15-, and 20-meter bands which many hams consider to be the best of our bands for mobile use. This works hand-in-glove with the new mobile antennas that are designed to operate on those three bands without any loading coil tap changes or adjustments of any kind.

Circuit

From a circuit standpoint, this converter represents little departure from accepted practices for broadbanded, crystal-controlled converters designed to operate into a tunable broadcast frequency i.f. system. The one new twist is the use of a single crystal for all three bands. By choosing a frequency in the region of 7525 kc. and making use of the 2nd, 3rd, and 4th overtones, this single crystal can perform the oscillator function for all three bands to be covered. The oscillator frequency is on the high side of the signal in all cases. The triode section of a 6U8 tube performs very well as the crystal oscillator. The circuit values are not particularly critical and the values given in the parts list have produced ample output on all overtones, from every crystal tried, for adequate mixing voltage for good i.f. output to the broadcast receiver. All the crystals tested were of the "surplus" type costing approximately 50 cents each.

One problem of band coverage for 10 meters is present here as it is in all converter systems of this type. With the average car receiver tuning 550 kc. to 1600 kc., the coverage of the 10-meter band is limited to about 1050 kc.

To cover the entire 10-meter band, a frequency range of 1700 kc. is required. This situation calls for some compromise. By using a crystal frequency of 7525 kc. the portion of the 10-meter band covered will be from 28,500 kc. to 29,550 kc. This clips 150 kc. off the top end of the band and eliminates the entire foreign DX portion from 28,000 kc. to 28,500 kc. It is a simple matter, however to plug in another crystal at 7400 kc. and then the 28,000 kc. to 29,050 kc. portion of the band will be covered. In the same way, the top end of the band could be covered by using a crystal frequency of 7565 kc. A bonus feature of the oscillator circuit is that no re-tuning is necessary when these other crystals are plugged into the mobile converter unit.

Most broadcast receivers do cover a bit more of the frequency range than the absolute broadcast-band edges so that the situation isn't quite as sharply cut-off as indicated. With a 7525 kc. crystal just about all of the American phone band is covered with a little overlap into the DX portion.

Covering the 15- and 20-meter bands presents no problem whatsoever. By using the 7525 kc. crystal that gives the best coverage of the 10-meter band, full coverage of the 15- and 20-meter bands is automatic.

The 6BH6 tube used as the r.f. amplifier is a good choice for this application. It provides good gain, is quite tolerant of physical layout, and shows no sign of instability. There was a strong temptation to use a 6AH6 tube as the r.f. amplifier in order to simplify the operation of this converter when installed in a car with a 12-volt battery system.

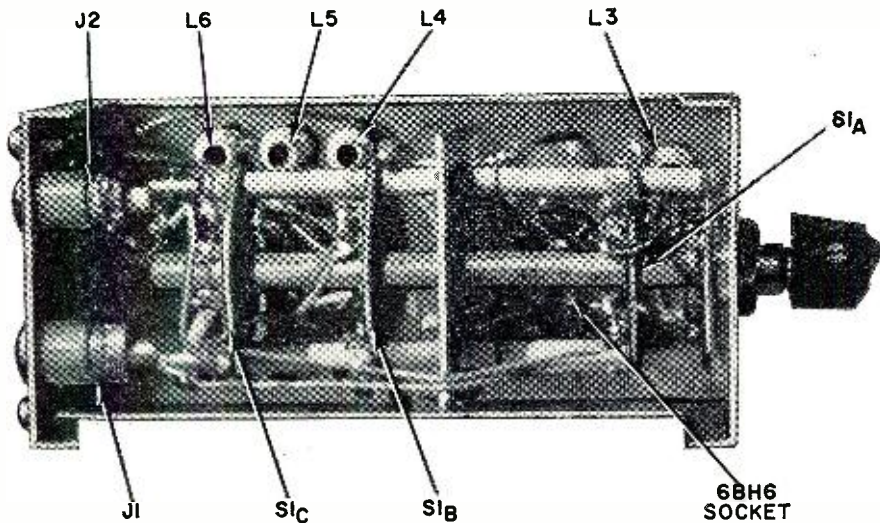

This bottom view shows locations of some of the coils with respect to switch. Other coils, not labeled, are not visible in this particular view of the unit.

The 6AH6 tube has the same heater current as the 6U8 tube—450 amp.—and all that is necessary for 12-volt operation, is to run the heaters in series. The 6BH6 tube draws only .300 amp. of heater current. This makes it necessary to parallel a 42-ohm resistor across the heater terminals of this tube when it is run in series with the 6U8 tube. The 6AH6 tube, due to its exceptionally high G_m , was very unstable and extremely critical of physical layout, shielding, and antenna loading.

Broadbanding is accomplished by using slug-tuned coils with no capacitance across them other than the stray capacity of the wiring and the inter-electrode capacity of the tubes. In addition, a low value of plate load resistor is used for the 6BH6 and 6U8 tubes, R_3 and R_6 , further degrading the “ Q ” of the tuned circuits, resulting in the broadbanding necessary for this type of circuit.

The opposite is true in the case of the coil used in the plate circuit of the crystal oscillator stage. Here we are interested in a single frequency, the 2nd, 3rd, or 4th overtone of the crystal frequency, and capacitor C_6 is used across the coil in order to aid in increasing the “ Q ” of this circuit. However, the “ Q ” is still not very high as evidenced by the fact that retuning is not necessary when different crystals are used for different band coverage.

No attempt was made to apply the broadcast receiver's a.v.c. voltage to the grid of the 6BH6 tube. This would necessitate digging into the broadcast receiver's innards which many hams do not like to do. The advantages gained by applying a.v.c. to the r.f. stage in the converter are quite marginal. The usual high noise level of a mobile installation would probably keep the a.v.c. bias voltage developed in the broadcast receiver at a continuously high level. If this were applied to the grid of the converter r.f. tube—it would tend to reduce the over-all sensitivity

to a marked degree. It will be argued that the weaker signals picked up by the “wide open” 6BH6 r.f. tube will be masked by the high noise level, but there will be many weaker signals that will get through which would have been shut out entirely by the a.v.c. voltage. The only real justification for applying a.v.c. voltage to the r.f. tube is to prevent that tube from being overloaded by a strong incoming signal. Signals that strong may be present in your mobile installation, but they will certainly be few and far between.

Should it be desired, a.v.c. voltage can easily be applied to the 6BH6 tube. All that is necessary is to remove the ground from the bottom end of L_1 , L_2 , and L_3 , connect them together and feed the a.v.c. voltage from the broadcast receiver through a 470,000-ohm, $\frac{1}{2}$ -watt resistor, bypassed at the coil end with a .002 μ fd. capacitor. If this is done, be sure to ground the cold end of the antenna coil winding.

Construction

The converter is built in a $2\frac{3}{4} \times 5$ inch Mini-Box. This is rather small for a three-band converter but actually there is no overcrowding of the components and wiring is not too much of a problem. By utilizing the layout shown, there is ample room for all the coils, capacitors, resistors, and bandswitch. Wiring is strictly point-to-point and long leads are almost automatically eliminated. The wiring of the chassis should be completed before the bandswitch is mounted. The coils should be wound and mounted in place and short lengths of wire should be soldered to the terminals. When the bandswitch is mounted, it becomes a simple matter to solder the proper leads from the coils to the proper switch terminals.

The bandswitch is made up of three sections of *Centralab* PA-33 miniature switch sections mounted on a PA-301 shaft and index assembly. These switch

assemblies are very easy to construct and are extremely flexible in their application. An aluminum partition is used between the first section of the bandswitch and the other two. This serves a dual purpose. It acts as a shield between the 6BH6 r.f. stage and the 6U8 mixer-oscillator stage and also helps to support the bandswitch rigidly. A feedthrough bushing (*National* type TPB) is mounted on the partition to feed the output of the 6BH6 to the 6U8 tube.

The bandswitch is assembled to the following dimensions, using the spacers provided with the PA-301 shaft and index assembly. The first wafer section (section A on the schematic) is spaced $\frac{1}{2}$ inch from the index. The partition is mounted $1\frac{1}{4}$ inches from the first section. The second wafer section (section B) is mounted $\frac{1}{2}$ inch from the partition and the last wafer section (section C) is mounted 1 inch from section B. The excess length of the long threaded mounting rods should be clipped off. Each wafer section has two poles and five positions for each pole. Only four of these positions are used and the indexing ring supplied allows for this arrangement very conveniently.

In switch position #1, the “off” position, the antenna is switched to the broadcast receiver directly so that it operates normally. In this switch position, the filament voltage is not applied to the converter tubes. In switch positions #2, #3, and #4, the proper coils are switched into the circuit, the antenna is connected to the converter, and the output of the converter is connected to the broadcast receiver antenna input. In these three switch positions, the filament voltage is applied to the tubes in the converter. The “B plus” voltage is not switched since that would require another switch section. In the “off” position, with the filament voltage removed, there is no “B plus” current drain at all and there is actually no need to switch the “B plus” voltage at all.

The power requirements of the converter are 6.3 volts at .750 amp. or 12 volts at .450 amp. for the tube heaters and any “B plus” voltage from 100 volts to 250 volts is satisfactory. The “B plus” current drain varies with the amount of voltage applied. With 180 volts, the total current drain is about 15 ma. Most car receivers can spare that much current so it is a simple matter to obtain the “B plus” voltage from a convenient point. Be sure to take this voltage from a supply point such as the screen voltage of the audio amplifier tube—never from the plate terminal of any tube. The heater voltage should also be taken from the broadcast receiver. In that way you can be sure that everything is turned off when you switch the broadcast receiver off.

This converter can also be used with the newer transistor car radios. In this case you cannot take the “B plus” voltage necessary from the car receiver. It would then be necessary to power the converter from a small vibrator supply or even batteries.

Alignment of the converter is greatly simplified if a signal generator or grid-dipper is available. However, it is not too difficult a job even without the use of either of these instruments. It is also very helpful if an a.c. power supply is available for the initial testing and alignment. Most communications receivers have an accessory socket that provides suitable external voltages.

Alignment

The first step is to make sure that the crystal oscillator stage is operating properly. If your converter is wired for 6-volt-battery operation, it will only be necessary to have the 6U8 tube in the socket for this test. However, if you are wired for 12-volt-battery operation, you will have to have both tubes in the converter in order to complete the series filament circuit. In any event, the check-out procedure is the same. With a milliammeter—zero to 50 ma. range will do fine—in the "B plus" lead, note the current drawn with the crystal out of the circuit and then note the difference in the current drawn when the crystal is inserted in the socket. There should be a marked reduction in the current with the crystal in if the circuit is operating properly. If a v.t.v.m. is available, oscillation can be checked by reading the voltage present on the grid of the triode section of the 6U8 tube, pin #9. With proper oscillation there will be a negative voltage on the grid and this negative voltage will disappear if the crystal is removed. If the coils are wound according to the specifications given in the parts list, there is very little danger of the wrong overtone being generated in the oscillator. The tuning range of these coils is quite limited and if oscillation is taking place, the frequency of the overtone selected by the bandswitch should be correct. This can be checked, if desired, by tuning a communications receiver to the frequency selected and listening for the oscillator signal. Be sure you are not tuned to an image frequency when making this test. If the receiver has an "S"-meter, it can be used to peak the oscillator plate coils. Just adjust the slugs in these coils for maximum "S"-meter reading.

The converter should now be connected to a broadcast receiver for the final phase of alignment and check-out. A communications receiver with broadcast-band coverage makes an ideal setup for this operation because the "S"-meter provides a visual means of peaking the coils. A short length of coax cable—RG-59-U or RG-58-U will do very nicely—should be used to connect the output of the converter to the antenna terminals of the broadcast receiver. Coax or shielded wire must be used for this connection to eliminate any leak-through of broadcast-station signals. Length of the cable is not critical but should be kept as short as conveniently possible. When the converter is installed in the car and connected to the car radio, it would be well to use the special type of coax cable that is

used for auto antenna lead-in extensions. This is a special low-capacity type of coax and its use prevents the antenna circuit of the car radio being detuned by the high capacity of the standard coax cable. This special cable is inexpensive and usually comes with the proper plugs already attached to each end.

An antenna should now be connected to the converter and the bandswitch set for 20-meter operation. With a 7525 kc. crystal plugged in, the 20-meter amateur band will be found between 700 and 1050 kc. on the broadcast-band dial. If a signal generator is available, it should be set at a frequency of approximately 14,200 kc. This signal should be heard at approximately 800 kc. on the receiver dial. The slugs in the 20-meter coils— L_3 and L_6 —should be adjusted for maximum output. If a signal generator is not available, the peaking of these coils can be done on any good signal that will be heard in the 20-meter phone band. Choose a signal that has a minimum of fading on it, preferably a local or one of the "California Kilowatts" that always seem to be present on this band.

The same procedure should be followed for each band. The 15-meter band will be found between 1125 and 1575 kc. on the broadcast-band dial and the 10-meter band will be found on the

entire broadcast-band dial, as explained earlier.

By peaking the coils at approximately the center frequency of each band, the entire band is covered with little or no loss at either end.

It will be noted that by using the broadcast receiver as a tunable i.f. system, the tuning of the amateur bands is reversed. When the broadcast receiver is tuned to the low end of the broadcast band—around 550 kc.—the high end of the amateur band is located and when the broadcast receiver is tuned to the high end—around 1600 kc.—the low end of the amateur band will be received. This takes a little getting used to—but after a few excursions up and down the bands it becomes an easy thing to put up with a minimum of confusion.

The performance of this little hand-ful is really a revelation. The crystal oscillator provides a measure of stability that is certainly appreciated in a mobile installation, or even at a fixed location for that matter. Naturally, the ability to separate the stations on the bands is a function of the selectivity of the broadcast receiver used. The converter performs its half of the job—that of bringing in the 10-, 15-, and 20-meter bands to the input of the broadcast receiver—with apologies to no one.

Complete schematic diagram and parts listing for the three-band mobile converter.

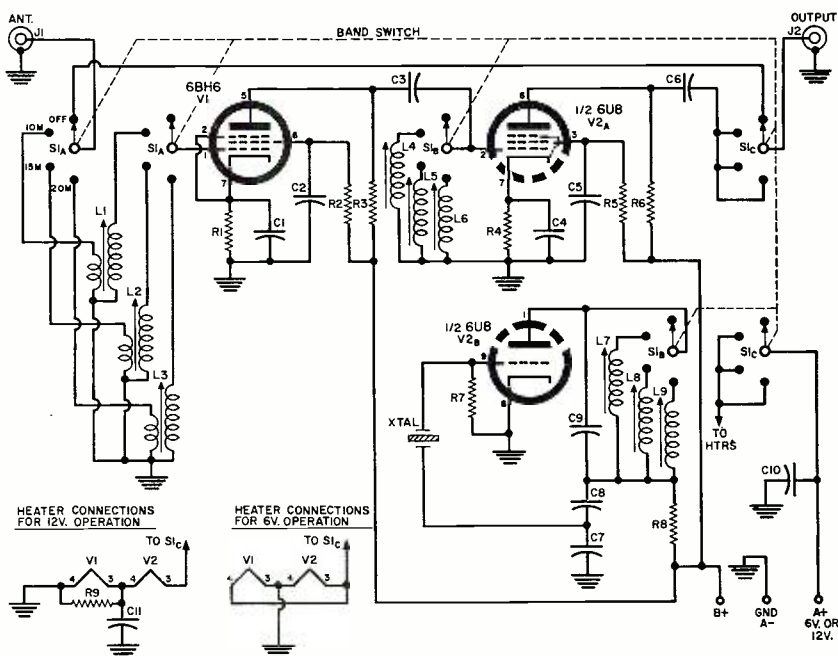

- R_1 —220 ohm, $\frac{1}{2}$ w. res.
 R_2, R_5 —33,000 ohm, $\frac{1}{2}$ w. res.
 R_3, R_6 —10,000 ohm, $\frac{1}{2}$ w. res.
 R_4, R_8 —1000 ohm, $\frac{1}{2}$ w. res.
 R_7 —47,000 ohm, $\frac{1}{2}$ w. res.
 R_9 —42 ohm, 2 w. res.
 C_1, C_4 —4700 μ fd. ceramic capacitor
 C_2, C_5 —002 μ fd. ceramic capacitor
 C_3, C_6 —50 μ fd. ceramic capacitor
 C_7 —100 μ fd. ceramic capacitor
 C_8 —560 μ fd. ceramic capacitor
 C_9 —10 μ fd. ceramic capacitor
 C_{10}, C_{11} —01 μ fd. ceramic capacitor
 J_1, J_2 —Auto radio antenna chassis-type socket
 S_1 —Bandswitch (made up of Centralab PA-301 shaft and index assembly with three Centralab PA-33 wafer sections, see text)
 X_{tal} —7525 kc. crystal (see text)

- L_1 —18 t. #28 en., (antenna winding) 2 t. at cold end
 L_2 —25 t. #28 en., (antenna winding) 3 t. at cold end
 L_3 —42 t. #28 en., (antenna winding) 4 t. at cold end
 L_4 —16 t. #28 en.
 L_5 —23 t. #28 en.
 L_6 —40 t. #28 en.
 L_7 —15 t. #28 en.
 L_8 —20 t. #28 en.
 L_9 —37 t. #28 en.
 Note: All coils are wound on $\frac{1}{4}$ " diameter ceramic slug-tuned coil forms (Cambridge Thermionic Co. LS6 forms). All coils are closewound. The antenna windings on L_1, L_2 , and L_3 are close-coupled at the cold end of the grid windings.
 V_1 —6BH6 tube
 V_2 —6U8 tube

EDITOR'S NOTE: For shops that handle only a few locally popular brands of TV, the procedures described here can be invaluable. For others that rely on one of the commercially available service-data services, the job of organizing material is done by experts. Nevertheless, these establishments will find helpful suggestions here.

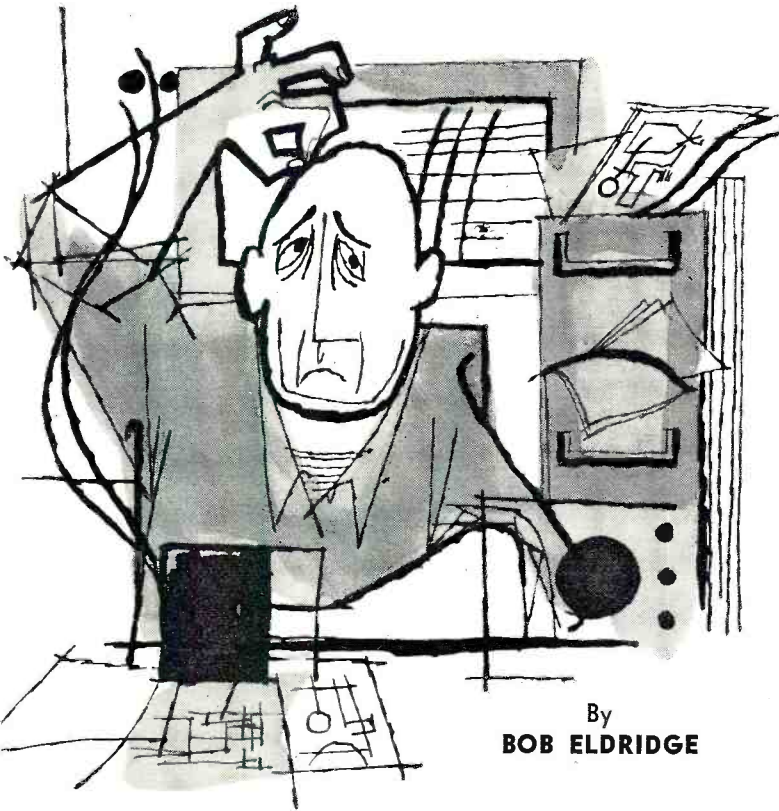

By
BOB ELDRIDGE

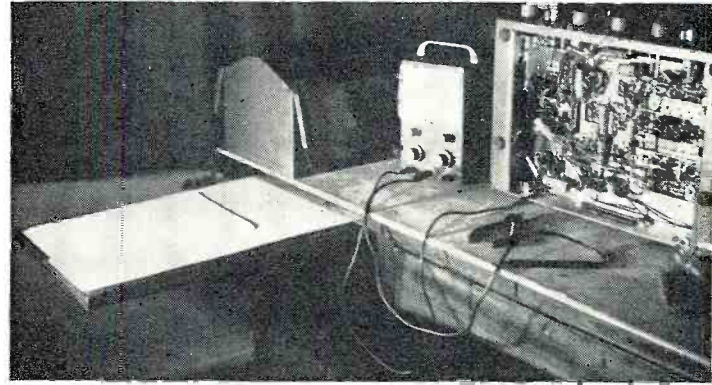

Fig. 1. The use of a sliding shelf keeps your schematics handy, but away from the working surface of the shop bench.

Systematic handling of schematics and other data pays off in faster service.

Get the Most out of Your Service Data

TIME is the most valuable commodity in any service shop, yet few factors waste more of it than the failure to organize and file service information for easy and rapid reference. In the shop that is not well organized, the situation becomes progressively worse as the reference material accumulates; yet, if the technician is reproved on this score, the answer is always, "I want to get it squared up, but I just haven't got the time to do it."

The truth is, he really hasn't the time *not* to do it!

There will be individual preferences as to how the system should be or-

ganized, but there are certain features that will be desirable in most systems:

1. It must be easy to determine whether a given, needed schematic is or is not on hand.
2. Data should be easy to find and extract.
3. There must be a quick way of finding such auxiliary information as related manufacturers' letters, factory modifications, service hints, and the like.
4. There should be provision for the addition of special information on a particular model.
5. It must be simple to return the data to its proper place.
6. The schematics must be protected against abuse.

Requirement 1 calls for an index. This should be as large as possible, preferably drawn up on stiff, white paper so that it can be affixed to the wall above or beside the filing cabinet. In drawing up this index, there should be liberal provision for blank spaces under each heading. This takes subsequent additions into account.

Foresight will result in labeling each group of data with a number rather than a manufacturer's name. This helps accommodate the fact that, quite frequently, one schematic will cover sets made under several different trade-names. Under the system described here, the different trade-names listed on the main index refer the searcher to the same single schematic in the actual file. Time is saved, as well as space, because there is no duplication.

For example, part of the RCA Victor index might read:

17T200 23-12 (group 23, folder #12)

17T201 23-12

17T202 23-12

17T211 23-12

17T220 23-12

17T301/U 23-13

17T302 23-13

KCS72 23-12

KCS78/B 23-13

If we now want the schematic for Model 17T220, we go straight to section 23 of folder 12—no thumbing over, no

(Continued on page 128)

Fig. 2. A typical schematic folder. Helpful notes (left) have been added.

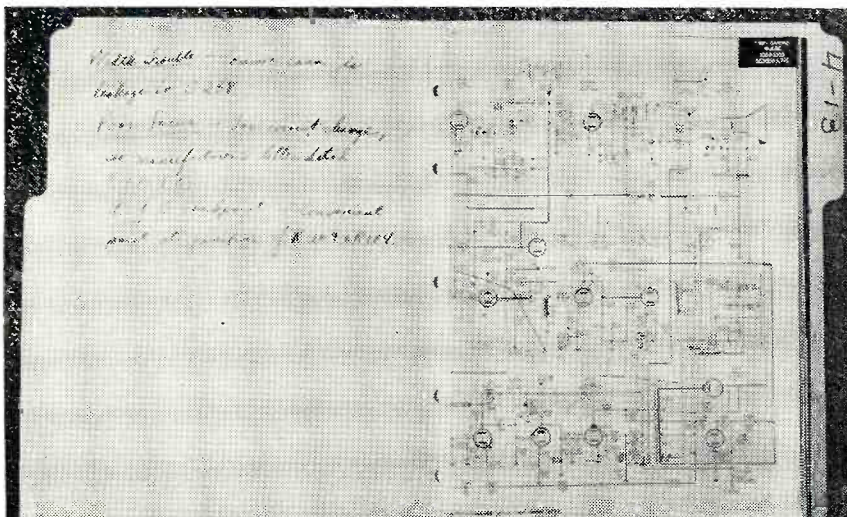

Hi-Fi Product Test Report

The RIAA equalizing network which is to be used between the cartridge and any high-level preamp input circuit.

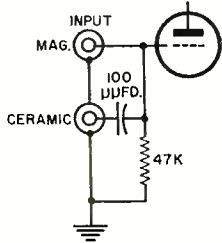
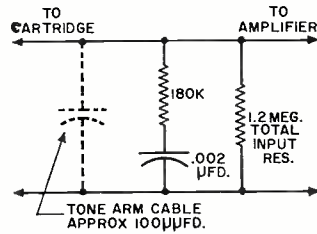

There are a few preamps that have provisions for a ceramic input cartridge wired internally as shown. If not, capacitor and resistor must be outboarded or input circuit converted as shown in figure.

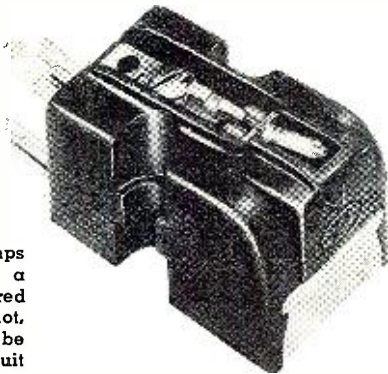

CBS-HYTRON STEREO CARTRIDGE

WE HAVE always been of the opinion that if sufficient care were taken in design, a ceramic cartridge could perform as well as magnetic versions. We were pleasantly surprised when we tested the *CBS-Hytron Model SC-1* to find that it comes close to justifying our contention in this respect.

This cartridge has a diamond stylus .0008" in radius which is to be used at a recommended pressure of 5 to 8 grams. According to the manufacturer, the cartridge frequency response is ± 2.5 db from 30 to 16,000 cps. In our tests we used a pressure of 6 grams and input network recommended by the manufacturer. We obtained an output voltage of .21 volt at 1000 cps (5 cm/sec.). The hum at the output of the network was low. The IM distortion was somewhat lower on the left channel than on the right but both compared favorably with other manufacturers' cartridges we have tested. We were extremely pleased with the relative uniformity of response between the channels; the over-all frequency response that we obtained was within ± 2.4 db from 30 to 15,000 cps with the exception of a dip at 11,500 cps. At this dip response was down 5.2 db. Since most stereo records that are on the market today drop off rapidly above 10,000 cps, the dip should not affect the performance of the cartridge.

When using this cartridge in connection with a high-level input, a special RIAA equalizing network, shown in the diagram, must be used. There is another alternative which

may prove somewhat simpler. We found that a 100- μ fd. capacitor with a 47,000-ohm resistor connected as shown in the diagram can give excellent results when used in conjunction with the low-level magnetic input jack of your preamp. In fact we found the frequency response more uniform using this method than with the special RIAA network recommended.

The channel separation for the cartridge measured 20.5 db at 1000 cps. Listening tests certainly proved that a well-designed ceramic cartridge can give excellent performance.

SHURE M7D STEREO CARTRIDGE

THE stereo cartridge industry is moving at an extremely rapid pace. New companies are entering the field and established companies are coming out with new models and improved versions of some of their previous types. In line with this trend *Shure Brothers* has just announced a new addition to its line, the Model M7D. With the exception of a new external housing this cartridge is basically the same as the M3D which was covered in our last month's issue. Since the price of this new cartridge is almost half the cost of the previous one, it seems like a rather odd situation. However, there is a reason for it. The more costly unit, the M3D, is manufactured under laboratory conditions. All the characteristics of this stereo cartridge were held to much closer tolerances, thus assuring uniformity of performance and providing the utmost in high-fidelity reproduction. The M7D is produced under normal controlled production methods. It is possible that one might obtain a lower priced unit whose quality is equal to the higher priced version. However, this is not guaranteed.

The M7D which we tested showed a gradual drop in response of 5 db (± 2.5 db) from 1000 to 6000 cps, then a rise to -3.8 db at 10,000 cps, and then flat out to 15,000 cps, the limit of our test. The amplitude output of the two channels was relatively similar with a maximum difference of 1.0 db. Channel separation at 1000 cps was approximately 21 db. The hum pickup was low and compares with the M3D previously reported. The actual figure is of no specific consequence in that it indicates those conditions that apply with the particular combination of turntable and arm used in our test.

All-in-all, it is a cartridge that will provide truly high-fidelity performance and should be of interest to anyone who is economically minded. For the pro, of course, where cost is no object, the M3D still remains *Shure's* top stereo cartridge.

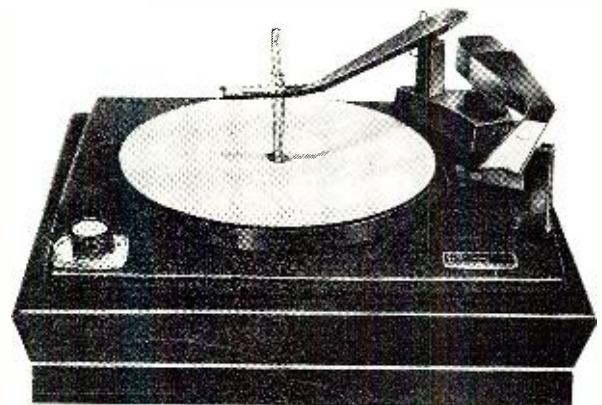
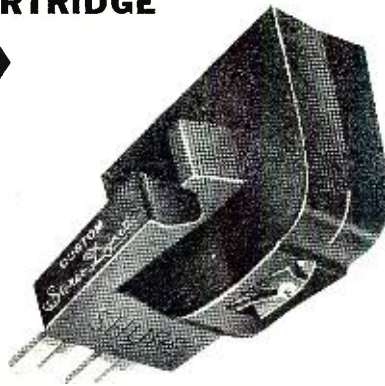

NEW GS RECORD CHANGER

ANOTHER new addition to the component field is *Glaser Steers'* modernized version of its Model Seventy-Seven stereo record changer. Functionally, it is identical to their previous model which was described in our January 1958 issue but, in addition to conversion to stereo operation and improved over-all design, it has several new features. In the conventional monophonic (Continued on page 97)

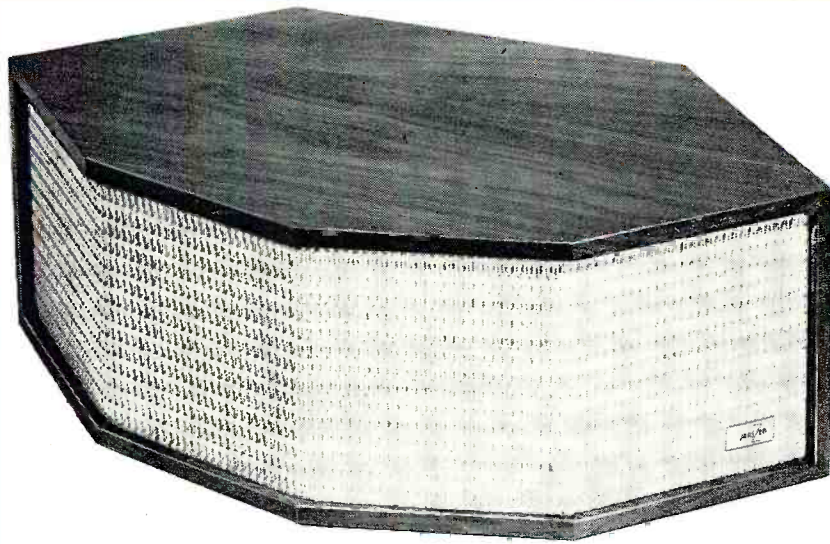

By **ARTHUR A. JANSZEN**
Janszen Laboratory, Inc.

**Listening tests versus
laboratory measurements
—what's the right way
to assign a figure of
merit to a hi-fi speaker?**

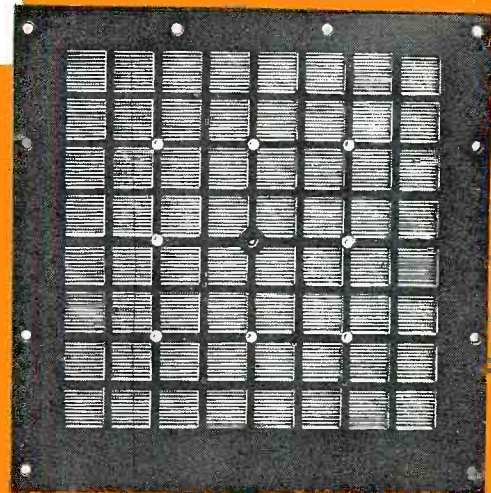

Fig. 1. JansZen Model 130 (above) uses 4 radiators of type shown (right).

Testing Electrostatic Loudspeakers

IT APPARENTLY is still fashionable to refer to loudspeakers as the "weakest links" in the chain of components in high-fidelity systems. The obvious inference to draw from such statements is that in every high-fidelity system, the loudspeaker is the most deficient of all components in the performance of its assigned role. This is not true. There are *some* loudspeakers that introduce less over-all distortion than *some* pickup cartridges, tape playback systems, preamplifiers, power amplifiers, and tuners. Despite the effort that has gone into investigations of the design parameters that make one loudspeaker "good" and another "bad," the problem of loudspeaker evaluation is still with us; for there is no measurement or set of measurements that can be used to predict accurately whether a "typical" listener will prefer speaker *A* over speaker *B*. It may be possible in the future, after extensive bio-acoustical experiments have been completed and the data evaluated, to make a prediction of listener preference, based on objective measurements, that will be valid for *most* listeners in *most* situations. At the present time, how-

ever, such a statistical prop is not available and there is only one way to find out whether speaker *A* or speaker *B* is to be preferred in a given situation, and that way is to try *A versus B* under the conditions in which listening is to be done.

Listening Tests

The assignment of a "figure of merit" to a loudspeaker can be valid only under highly specific conditions. This is because one's listening response

depends not only on the speaker's actual performance, but also on the acoustical environment in which the listening is done, on the performance of associated equipment, and on subjective factors that defy definition. Judgments of loudspeaker performance based on listening tests can be valid only for one panel of listeners, in the particular listening room, for the particular positions of the listeners and loudspeakers within the room, and for the particular program material used, in conjunction with a particular set of associated equipment. For example, a preference for one loudspeaker over another can sometimes be reversed by simply using a different amplifier.

Objective Measurements

Although objective measurements do not permit the assignment of definitive figures of merit to loudspeakers, there *are* several performance factors, which *are* susceptible of objective measurement, that are important in determining critical listener preference, even though they may not represent *all* of the pertinent factors. These are: (1) the range of frequency

Table 1. Total harmonic distortion in acoustic power output of a single unselected radiator at various frequencies with 5 volts applied to the 8-ohm input.

FREQUENCY (in cps)	% TOTAL HARMONIC DISTORTION
750	0.47
1000	0.4
1500	0.35
2000	0.23
4000	0.16
5000	0.38
6000	0.47
7500	0.5
10,000	0.45

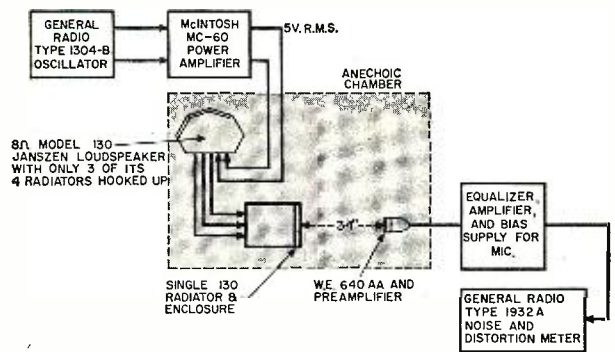
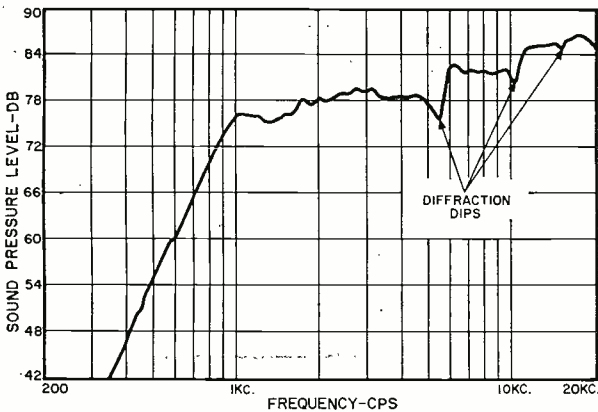
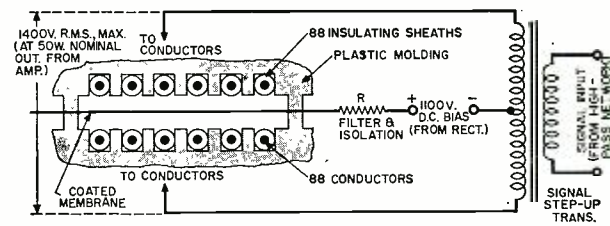

Fig. 2. (Top left) Electrical connections and construction of electrostatic radiator described in text. Circuit for the 1100-volt bias supply (derived from the a.c. line) and the high-pass LRC filter network required is not shown in drawing.

Fig. 3. (Top) Test setup for distortion measurements. The radiator being checked was mounted in a separate enclosure one-quarter the volume of main enclosure. All 4 radiators were connected for proper amplifier loading but radiation from the 3 radiators not under test was prevented by disconnecting bias.

Fig. 4. (Left) Axial pressure response of a single radiator with 2 volts input at 8 ohms. Note slight diffraction dips.

response; (2) the "trend" or shape of the curve of the frequency response curve, *i.e.*, whether some bands of frequencies are emphasized or de-emphasized with respect to other bands; (3) the "smoothness" of the frequency response curve, *i.e.*, the presence or absence of sharp dips and peaks in the curve; (4) the linearity of response, *i.e.*, whether a linear relationship exists between the instantaneous values of input voltage and output pressure over the entire a.c. signal cycle at each frequency within the bandpass, which can be determined by a measurement of total harmonic distortion; (5) the transient response of the system, which can be inferred from the frequency response but which can be more directly investigated by applying "tone bursts" of various carrier frequencies within the passband to the input terminals and photographing the output of a microphone as oscillograms; (6) the distribu-

tion of acoustic pressure in both vertical and horizontal planes as a function of the angular position with respect to the axis of the loudspeaker; and (7) the impedance frequency characteristic, which affects the ability of the associated power amplifier to supply the required output voltage frequency characteristic at the required voltage levels.

These then represent the objective measurements that can be made.

It must be stressed that the listener's ability to detect differences in performance between one loudspeaker and another, will depend greatly on the performance of the associated equipment. It is incumbent upon the manufacturer of loudspeakers that are capable of excellent performance to be specific in making recommendations concerning the other components in the system. For example, if another component (or components) is generating a lot of har-

monic distortion at 4000 cps, it is likely that a loudspeaker whose response is restricted to frequencies below 8000 cps would be chosen over one whose response extends to 20 kc.

Since a loudspeaker should convert complex electrical waveforms into acoustical counterparts without distortion, it would seem desirable to make this conversion *directly*, without membranes, cones, domes, or horns. Such a system would be of ultimate simplicity. If the acoustic output varied directly with the input voltage, and if the area of the air front at the radiating boundary were large enough to prevent non-linear response of the air itself, then one would have a loudspeaker free of waveform distortion. If the area were made appropriate to the range of frequencies to be radiated, then the power output could be made independent of frequency (for a constant input voltage), and the electro-acoustical tran-

Fig. 5. Tone bursts at a repetition rate of 30 per second for 1 kc., 3.5 kc., 7 kc., and 20 kc. respectively. In each pair of waveforms the electrical input is shown directly underneath the waveform showing the acoustic output of the speaker.

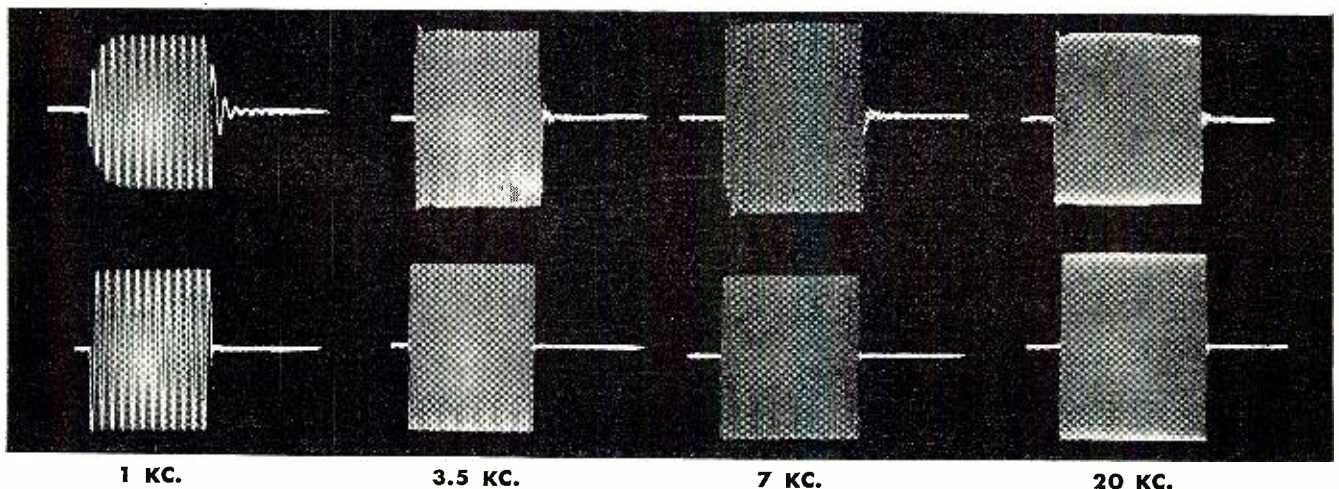

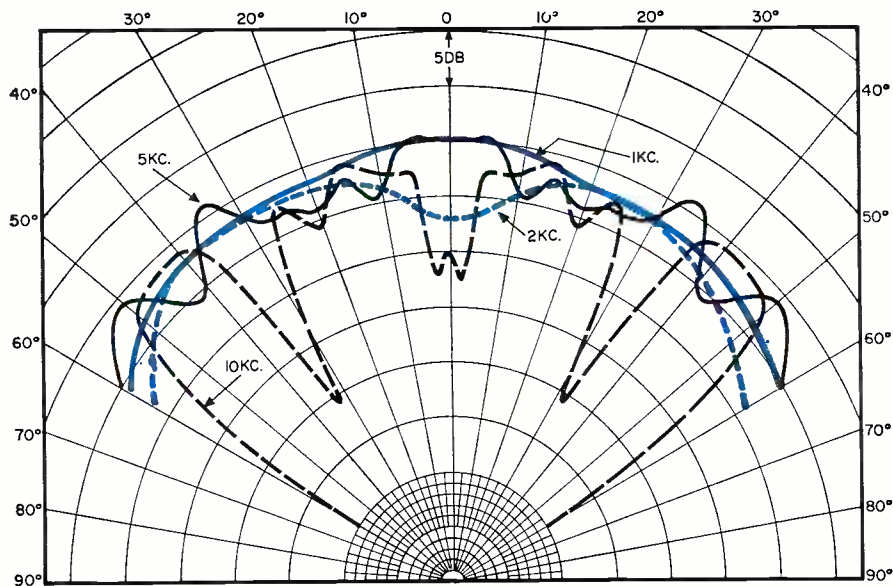

Fig. 6. Polar charts of acoustic pressure at various frequencies with all 4 radiators operating. Measurements were taken in anechoic chamber at distance of 10 ft.

sient response would be without flaw.

Such an ideal loudspeaker is not yet practical and all speakers on the market at present have one or more mechanical and/or acoustical coupling elements which tend to introduce resonances and which, in turn, cause a degradation of transient response. In the radiating elements used in the speaker shown in Fig. 1, an attempt has been made to achieve the greatest degree of simplicity and the nearest approach to the ideal electro-acoustical system. These elements are push-pull, constant-*q* electrostatic radiators, in which the vibrating elements are made of plastic membranes so light and thin that over most of their frequency range they operate almost as if the membrane were absent. Through the application of a very high, constant d.c. charge (*q*) between the membrane and the two stationary electrodes, a high degree of

linearity can be achieved with a high per-unit-area acoustic power output.

Test Results

Fig. 2 shows the electrical connections to a segment of a radiator. Signal voltage is applied to the outer electrodes and bias voltage is applied between the conducting coating of the membrane and the outer electrodes by means of a resistor *R*. An analysis of this constant-*q* system, in which the electric charge deposited by the bias supply is kept constant during variations in signal voltage by the presence of the high resistance, leads to the conclusion that if perfect symmetry is preserved, there is no harmonic distortion. If *R* is made large enough, electrode asymmetry, within limits that can be maintained in production, causes only very small amounts of distortion. The degree of excellence with

respect to distortion that can be achieved in production is shown in Table 1.

Fig. 3 shows a diagram of the test setup used in the measurements. Data gathered in an anechoic chamber on a multiple array of radiators defies interpretation, so measurements were made on a single radiator. The response of the microphone used was equalized by means of a multiple *LRC* network so that the over-all system response was flat to within 1 db up to 20 kc.

A pressure frequency response curve, taken on axis, is shown in Fig. 4. This was obtained with the test setup of Fig. 3, except that a power level recorder, mechanically linked with the oscillator, was substituted for the distortion meter. The rising pressure response tends to keep the acoustic power output more nearly constant than it would be if the curve were flat. The average reverberant living room translates this rising pressure characteristic, which is accompanied by increased directivity, into a more nearly constant pressure response.

Although the transient response of a loudspeaker can be inferred from its pressure frequency response, tone bursts provide a more direct test. Fig. 5 shows oscillograms of bursts of various carrier frequencies within the passband of the radiator. As one would expect, the 1000 cps bursts, at the lower end of the passband, were not as good replicas of the electrical signal as the remainder of the bursts. The absence of "hang-over" is indicative of the effectiveness of a "nearly absent" vibrating element.

Fig. 6 shows the acoustic pressure at various angles off-axis of a Model 130 with all four radiators in operation, at several frequencies. At frequencies below about 8 kc., the response in the horizontal plane is quite uniform over a total angle of about 120°. At 10 kc. and above, there are sharp dips in the

(Continued on page 139)

Fig. 7. Measured impedance of the electrostatic unit alone and in combination with a matching woofer.

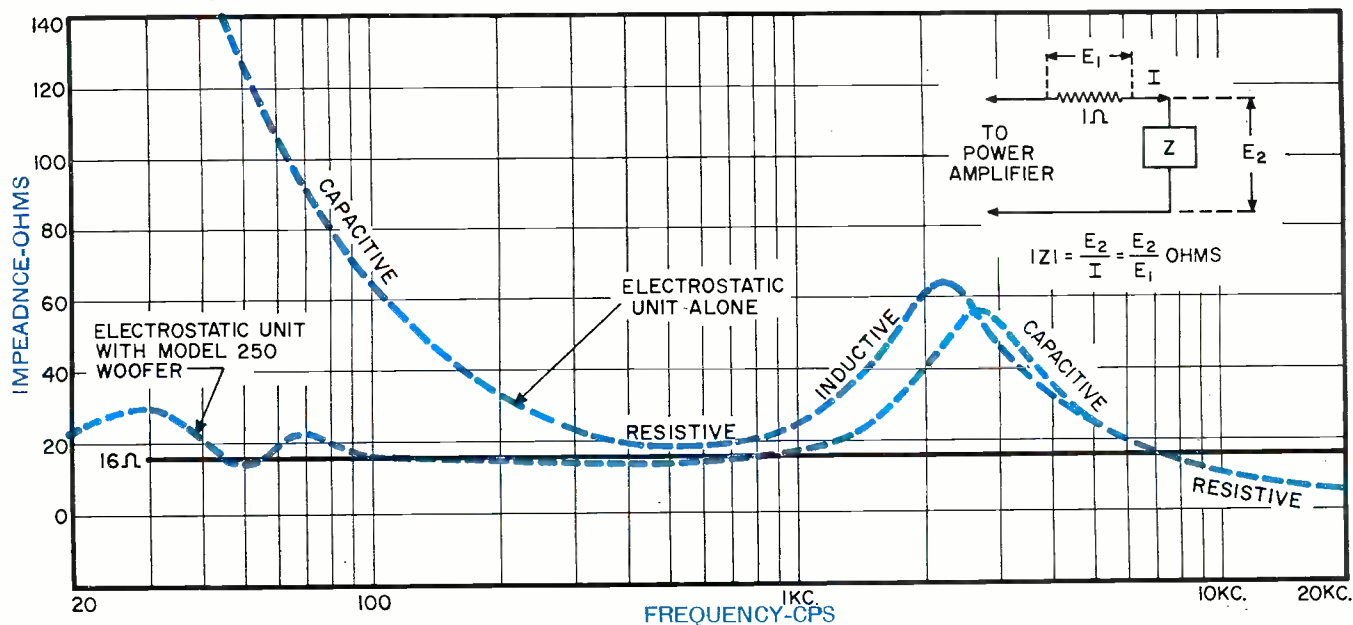

New TV Projector Makes Giant Color Picture

A new closed-circuit TV projector which is able to produce 12 by 16 foot picture.

A NEW closed-circuit television projector, which produces a bright and sharp 12 by 16 foot color picture, was unveiled recently at the annual session of the American Association for the Advancement of Science in Washington, D. C. *CIBA Pharmaceutical Products Inc.* of Summit, New Jersey, sponsored the live, closed-circuit color telecast and is backing work on the projector. Projecting a large, theater-sized color picture, the demonstration presaged the system's future usefulness in presenting telecasts, live and in color, to large professional audiences in hospitals, universities, and at scientific meetings as a public service. The projector can also be used for black-and-white pictures up to 24 by 32 feet on a metallized screen.

For color reproduction the field sequential system is employed. Utilizing color wheels in the camera and projector, the sequential system adds considerably to the accuracy of the color image produced.

Tradenamed "Eidophor" (a Greek word meaning "image bearer"), the new projector uses a control-layer process to produce the brightly colored pictures. In this process electrical impulses from the camera control an electron beam which bombards, and thus modifies, the surface of a film

A large professional audience is shown viewing color picture on live telecast.



of oil on a concave mirror. Light passing through the resulting "wrinkles" in the oil film is projected through a special grating onto the screen.

The control layer projection system differs fundamentally from the Schmidt system that is more common in projection television. In this latter system a high-intensity television tube is used. Rather than using the electronic generation of the projection light, the Eidophor system employs an electro-optical control of the light beam from an outside source to produce the picture. It is therefore a relay system, the light output of which is limited mainly by the power of the carbon arc or xenon arc light source.

Special television cameras were made for *CIBA* by *General Electric*. Similar color cameras are now used for monitoring missile sites at Cape Canaveral.

Production models of the color projector are expected to cost about \$16,000. The custom-built motor trailer which houses all the other electronic equipment required is the world's largest color television mobile unit, and costs \$366,000. A crew of four cameramen, two video operators, one audio engineer, and one projector engineer operate the entire closed-circuit system.

-30-

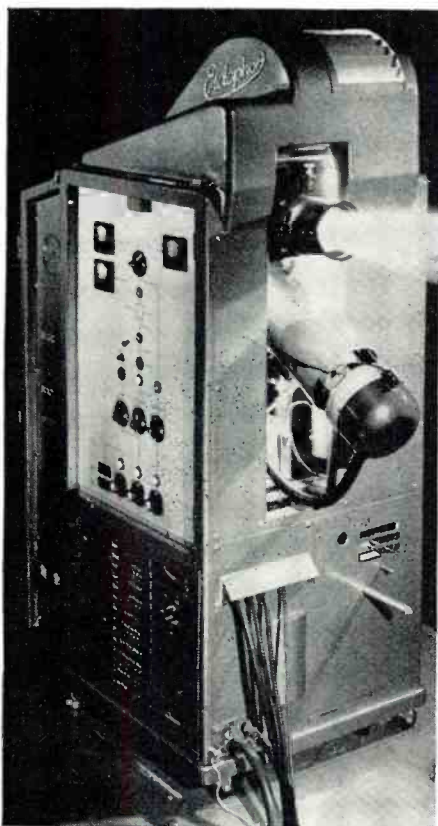

The 5-foot projector weighs 800 pounds; projects a 12 x 16 foot color picture.



This 35-foot-long motor trailer houses all the closed-circuit TV gear needed.

Interior of the mobile unit, with its 4 TV cameras, 2 projectors, p.a. system, 2 large screens, and control equipment.

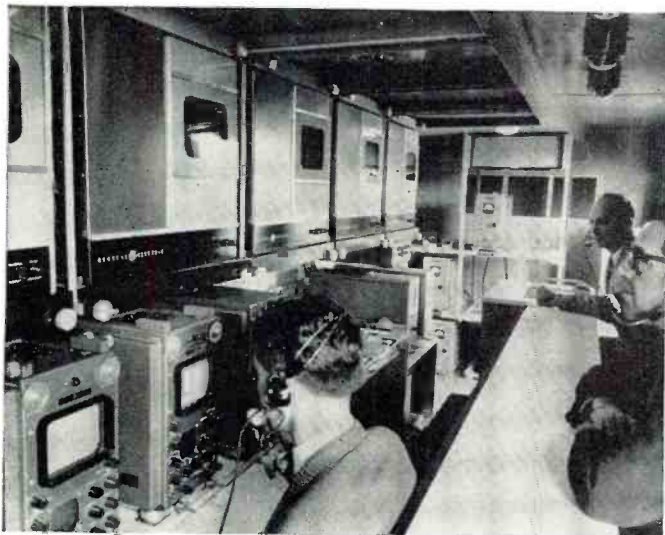

By JOHN M. DOYLE

Tips on FM Alignment

Circuits using various types of detectors each have their own bugaboos. Practical techniques.

SINCE MUCH has been written about the alignment of FM receivers, there is not much point in simply reviewing well-known procedures. Therefore, specific problems peculiar to certain types of FM circuits will be our main concern. It will be convenient to concentrate on the various detector circuits, but consideration will be given to related alignment procedures. Considered in order will be discriminator-type detectors, ratio detectors (balanced and unbalanced), locked-in oscillator detectors, and gated-beam detectors.

Before any test equipment is connected to the tuner, the latter should be adjusted to a point where no signal is received. This is done because shorting out of the oscillator in an FM receiver cannot usually be accomplished reliably. Since the inductance of the jumper used is likely to approach that of the oscillator coil, oscillator operation tends to continue, although at a different frequency.

For the initial phases of alignment, it is often more practical to forego a sweep generator in favor of a more conventional r.f. generator—one that has been set to the i.f. with 400-cps amplitude modulation. The latter type of signal will be found to provide good accuracy and convenience, especially in indicating exact center frequency during detector alignment. The audio signal also comes in handy for such other purposes as checking AM rejection and detecting oscillation by its ef-

fect on the receiver's audio output.

Connection of the signal-generator leads to the receiver chassis in the vicinity of the detector or the final i.f. stage frequently results in the development of standing waves. As a result of these, oscillation may be encountered when i.f. adjustments are attempted. To eliminate this effect, generator leads often have to be re-dressed carefully.

Refer now to Fig. 1, which is the schematic for one version of the discriminator-type detector. The primary of the discriminator transformer is adjusted first, for maximum output. Ordinarily the indicating instrument is connected from the center tap of the

scale, this will be convenient in making the adjustment. A slight movement of the adjustment in one direction will then result in a negative reading, while over-adjustment in the other direction will result in a quick swing through zero to a positive reading.

For final alignment, the sweep generator is brought into play. While a discussion of the conventional setting of generator controls is not intended here, it should certainly be pointed out that sweep width should be increased to the maximum that is consistent with convenient observation of the trace. If sweep is not wide enough, there are several difficulties that can mask the proper alignment point. To mention some, misalignment of the i.f. channel, regeneration, spurious response from the tuner, and standing waves can all obscure the scope pattern to some extent. When the sweep is, for example, 450 kc. wide, the trace on the screen will show the whole response curve and indicate such troubles. If the sweep is too narrow, we may also end up by setting the crossover point on one side of the i.f. response curve.

Occasionally the connection of an oscilloscope to the receiver may result in pickup of external signals, noise, or hum voltages. Internal regeneration or oscillation may also result. These conditions cause modulation or distortion of the observed pattern. To guard against these annoyances, the lead to

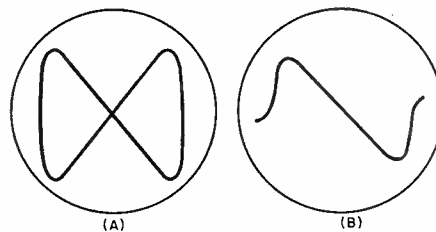

Fig. 2. Swept detector response with scope synced at (A) 120 and (B) 60 cps.

secondary to ground, across the load resistor of the secondary. In most versions of the discriminator, this is easy to locate. In this case, the v.t.v.m. is connected from point "A" to ground.

The meter is then transferred to the output of the de-emphasis network (point "B") for the adjustment of the discriminator-transformer secondary. The desired reading here is zero d.c. volts. As the proper setting of the secondary is reached, the meter pointer drops from a definite amount of deflection to zero almost instantaneously. Also the audio modulation from the generator will almost completely disappear at the same point. We therefore have two indicators, one visual and the other aural, for accurately determining the proper point.

If the v.t.v.m. has a zero-center

Fig. 1. A version of the discriminator.

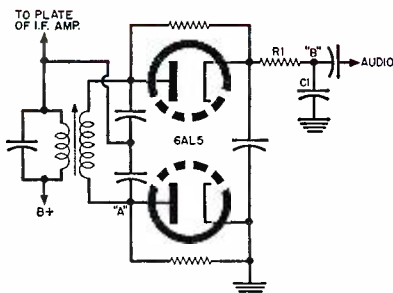
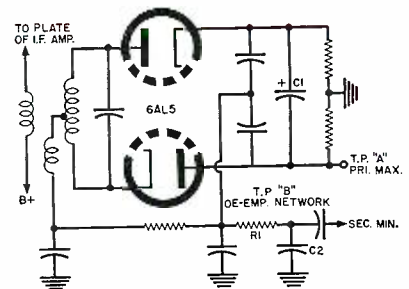

Fig. 3. Ratio detector, balanced type.



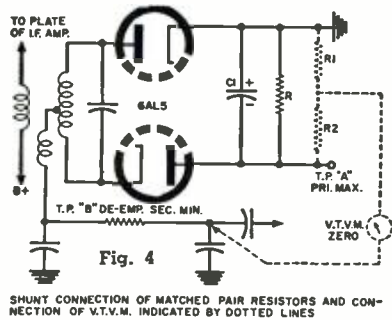

Fig. 4

SHUNT CONNECTION OF MATCHED PAIR RESISTORS AND CONNECTION OF V.T.V.M. INDICATED BY DOTTED LINES

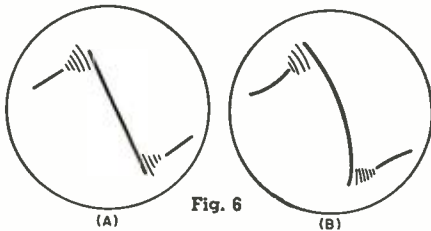

Fig. 6

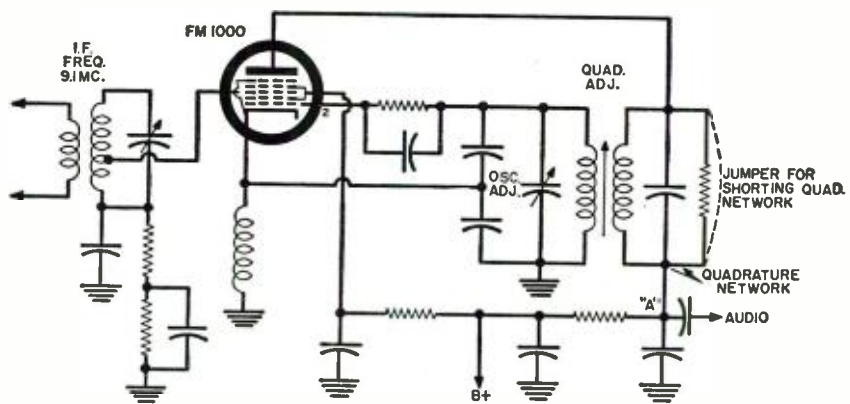

Fig. 5

Fig. 4 (Upper left). One version of the unbalanced ratio detector.

Fig. 5 (Above). Locked-in oscillator-detector found in Philco sets.

Fig. 6. Correct (A) and poor (B) response for oscillator-detector.

the vertical-input terminals should be kept as short as possible and well shielded. If these troubles persist, a resistor in the range between 50,000 and 100,000 ohms may be placed in series with the vertical-input lead of the oscilloscope. In the circuit of Fig. 1, for example, this is necessary to avoid detuning. Keep this resistor as close as possible to the point of contact in the receiver.

A few words are necessary here concerning the final alignment of the i.f. section. When adjusting the frequency setting of the sweep generator, always make certain that the response curve displayed is for the proper intermediate frequency rather than for a harmonic. It is easier to make a mistake of this kind than one might expect, especially if one happens to be working with an instrument that is not completely familiar. However, a simple check eliminates this possibility of error.

With the response curve showing on the screen of the scope, move the receiver tuning control back and forth. If the frequency setting of the generator is correct, the pattern will remain stationary; if not, the pattern will move off the screen as the tuning knob of the receiver is turned.

The reason for this movement lies in the design of those sweep generators where this difficulty is likely to occur. The FM is imposed on an oscillator of fixed frequency, usually in the range between 25 and 60 mc. This signal then beats against another variable r.f. oscillator, providing sweep around the desired frequency by heterodyne action. However, more than one heterodyne output is produced.

For example, assume that the fixed swept oscillator is operating around 45 mc. and that it is beating with a variable oscillator adjusted to 55.7 mc. By adding these two we get 100.7 mc. By subtraction we get 10.7 mc., the desired signal. In addition, the second harmonic of the 45-mc. output is at 90

mc. Thus, there are at least three sweep signals available in this case to which circuits in the receiver may respond, although only one of them is desirable.

If the trace observed on the oscilloscope is the result of either the 90-mc. or the 100.7-mc. signal, it will move off the screen as the receiver's tuning control is rotated because these signals beat with the local oscillator in order to enter the i.f. section. On the other hand, if it is the true 10.7-mc. output, it will stay put. Furthermore, this does not take into account such other adverse effects as image response.

Assuming that i.f. alignment is correct, final oscilloscope alignment of the discriminator is performed by first connecting the scope to point "A" of Fig. 1, as already noted, for the primary adjustment, in which maximum amplitude of the response curve is sought. The scope lead is then moved to the de-emphasis network (point "B") to obtain the crossover pattern, which is adjusted for maximum symmetry, particularly at the crossover point. The sweep frequency of the scope may be set to 120 cps, in which case the pattern should resemble that of Fig. 2A. If the scope is synced at 60 cps, the

pattern of Fig. 2B will be obtained.

We will now consider the ratio detector, both balanced and unbalanced types. Information previously given for signal-generator settings and attachment of instrument leads applies equally well here. We first connect the v.t.v.m. across electrolytic capacitor C_1 (point "A" in both Figs. 3 and 4) and ground to adjust the primary of the detector transformer for maximum curve amplitude and to make the i.f. adjustments as well. In the balanced type, we next connect the v.t.v.m. to the de-emphasis network, between point "B" (R_1, C_2 in Fig. 3) and ground, and then adjust the secondary for the rapid zero reading previously described.

To make this adjustment in the unbalanced type, a pair of high-value, matched resistors—100,000 ohms or more—is usually shunted across R in Fig. 4. Connection of the meter is then made between the usual point in the de-emphasis network and the junction of these two temporarily added resistors. To avoid this bothersome procedure, the secondary may be adjusted by ear for minimum audio as previously described, using a conventional r.f. generator with a 400-cycle amplitude-

(Continued on page 154)

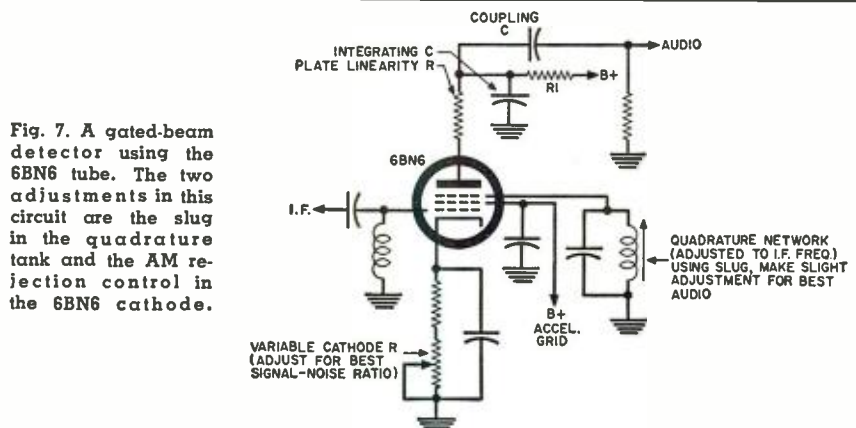

Fig. 7. A gated-beam detector using the 6BN6 tube. The two adjustments in this circuit are the slug in the quadrature tank and the AM rejection control in the 6BN6 cathode.

Tes New Tubes on Old Checkers



By JACK DARR

Part 2. Recording developed test settings. How to handle odd-voltage and controlled-warmup types.

TO KEEP a record of the settings found for new tube types, it may be somewhat handier if a small file card is made out for each, rather than trying to keep this information on a single sheet of paper. A small box of appropriate size can be fastened to the top of the tube-tester and the cards filed in numerical order. This makes them easy to find and new cards may be added at any time without disturbing the order.

The gas test of the tester may be used just as it was before. This is merely a resistor switched into the grid circuit of the tube: a button marked "Gas-1" is pushed on the Hickok and the "Bias" dial is turned to bring the meter reading down to 100 micromhos. Holding "Gas-1" down, another button, "Gas-2," is pushed, and the meter deflection noted. The second button opens a shunt across the resistor: if there is any gas current flowing in the grid circuit, it will cause the meter to deflect upward. Upward deflection of more than another 100 micromhos indicates that the tube is too gassy for use in critical circuits. This test is especially useful for sync clipper and separator tubes, a.g.c. amplifiers, and oscillators.

Odd-Voltage Tubes

Quite a number of new tubes have been brought out in the last few years with heater voltages which seem very odd to those old-timers accustomed to the familiar 6- and 12-volt types. New tubes may be found with almost any rating from 2.0 volts on up! Some of these may not be found on the voltage selector of the tester; 20 volts, for example, or 19 volts.

The best way to set these up is by a direct measurement. For instance, if a 19AU4 tube is to be tested, say a 19AU4, then the selector is set at 25 volts. An a.c. voltmeter is inserted into the filament holes of an unused socket,

and the "Line-Adjust" rheostat set to bring the filament voltage down to the correct level. In the case mentioned, the 19AU4 would be plugged into the octal socket: the voltmeter could be inserted into #1 and #8 of the local socket for example. This type of com-

pensation may necessitate some extrapolation: the "Line-Adjust" rheostat also raises and lowers the applied plate voltage: however, the results may be interpreted with sufficient accuracy.

Controlled-Warmup Tubes

The development of the 600-ma. series of tubes with their controlled-warmup time, for use in TV sets with series heater strings, has also posed a few new problems for tube testers. For an accurate test, these tubes should be set up so that the correct current is flowing through their heaters, and then the voltage across them checked. One very elusive trouble in these TV sets is caused by the tube with abnormal filament resistance, causing it to assume more or less than its rightful share of the voltage. To add to the complications, this trouble may be intermittent!

Some late-model testers have provisions for measuring this current, and checking the heater voltage during the test. This provision may be added easily to older testers. A circuit is shown in Fig. 4. A 0-1 a.c. ammeter is connected in series with the heater supply and a suitable a.c. voltmeter is connected across the heater terminals.

The a.c. voltmeter may be connected across the sliders of the heater-selector switches, as shown in Fig. 5. Because of the low heater voltage of many new tubes, a 0-10 voltmeter was chosen. This was raised to an extra range of 0-30 volts by a series multiplier resistor. To avoid accidental damage to the voltmeter, both the basic and extended ranges were selected by a spring-return switch. Other ranges may be added if desired, and a push-button switch used. Although a single s.p.d.t. spring-return switch was used here, any type of switch may be used, depending upon what type of meter and other parts are on hand. As shown

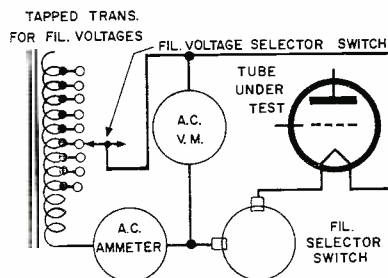
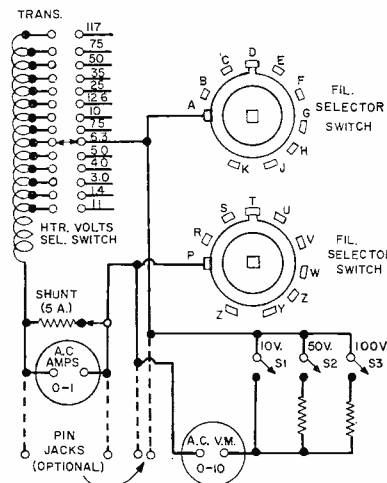

Fig. 4. General arrangement for meters added to filament circuit of a tester.

Fig. 5. Specific wiring for adding meters to Hickok 532. Optional wiring for using external meters also shown.



in Fig. 5, a set of pin-jacks may be added instead of this a.c. voltmeter, and the bench v.o.m. may be used, to save the expense of the added meter.

For current measurements, the a.c. ammeter is connected in one leg of the heater supply; it makes no difference which side, of course. The normal 0-1 ampere range is very good for most tubes, especially in the 600-ma. series: the reading falls in the most accurate portion of the scale. For testing rectifier and other high-drain tubes, a very good shunt is needed to protect the meter movement. In the writer's tester, another spring-return switch was used.

A word of caution here: this switch must be of a high quality with *very low contact resistance*. Because of the very small shunting resistance, any contact resistance across the meter will cause it to be overloaded should the switch fail to close cleanly. It might be better to use a d.p.d.t. heavy-duty switch of the type used for portable electric tools, with the contacts in parallel, to avoid this. On the other side of the switch a shunt was worked out by the "cut and try" method, which raised the range of the meter to 0-3 amperes. This is ample for all receiving-type tubes, even the larger rectifiers. The spring normally stays in this position for safety.

The meters shown are mounted on a small piece of thin *Masonite*, but any other thin material may be used. It should be strong enough to hold the switches and brackets, in service. Any suitable wire will serve to connect the meters into the circuit; we used a scrap of 8-conductor "rotator cable," with two conductors paired in the ammeter circuit to avoid voltage drop.

To make the tests mentioned, plug the tube into its socket after setting up the tester. Leave the line switch turned off. Check the time necessary for the tube to warm up, using a sweep-second hand watch, after turning the power on. According to the specifications for these tubes, they should reach almost full operation within 11 seconds after power is applied. More than 10% deviation from this time should be checked carefully. For in-

stance, if a tube required 20 seconds to reach operating temperature, it would probably give trouble in a few weeks and should be replaced.

While running shorts tests, waiting for the tube to warm up, the ammeter should be watched very carefully. Any flickering or variation may mean an intermittent connection inside the heater itself. Probably the best method of evaluating the performance of the filament would be to set the *current* at exactly 600 ma., and then measure the voltage across it; if there is any large variation from normal, the tube should probably be replaced. Fig. 6 shows a test being made on a type 5U8; note the 5 volts indicated on the voltmeter, while the ammeter shows the correct 600 ma. Fig. 7 is a close-up view of the meter mounting and switches. A tube is in the tester, showing 600 ma. on the ammeter, but the voltmeter switch is not being operated.

Another handy test is possible with this set-up. When checking a set of tubes, much time can be wasted waiting for a dead tube to warm up! If you'll glance at the ammeter when a tube is plugged into the socket, it will tell you immediately whether or not the filament is open. Even this small trick can save many minutes of time in a day.

Connecting the Meters

To make the internal connections to the tester, remove the instrument from its case. Check the instruction book and schematic diagram for the location of the various terminals and switches. Locate the filament-voltage selector switches and find the "slider" connections on each: this will generally be the easiest place to make the voltmeter connection. Either of these connections may be opened so that the ammeter leads may be wired in series. Fortunately, most instrument manufacturers are very nice about color-coding the wiring, making it fairly easy to trace.

Low-Voltage Tubes

We inevitably run into a type of tube that cannot be accommodated. These are the ones used in hybrid tube-trans-

sistor auto radios using the same potential (12 volts) on both filament and plate. Often identified as the "12K5" type, from one important version in this series, they use a closely spaced "grid" near the cathode that is actually an accelerator rather than a conventional control grid.

While you cannot test the tubes in this family on your old checker, you are no worse off than people buying new testers today, until special circuits are worked out. Tube manufacturers themselves caution against conventional tests for these types. Both *Delco* and *Motorola*, major users of these tubes in their hybrid auto radios, even caution technicians against tapping the tubes for noise or intermitents: a heavy jolt could cause a short between the closely spaced electrodes. The entire chassis should be jarred instead. The only present test for these tubes is direct substitution.

Saving the Sockets

Since replacement of worn-out sockets in a tester gets to be quite annoying, "adapter" sockets should be used in those positions that correspond to the most popular tube types. In many instances, ready-built adapters are available at parts supply houses. They are the types used for in-circuit testing, with terminals brought out at the sides for easy test-equipment connections, but will serve nicely here. Or else, acceptable units can be made up, each consisting of a socket and a tube base wired together "straight through;" that is, with pin 1 connected to pin 1, and so on.

The author began to use such adapters years ago after becoming irritated over the fact that tester sockets "wore out so darn fast." A check of service records and some elementary arithmetic showed the reason: even back in the days of radio, we were testing something like 10,000 tubes a year. With adapters, all the wear is taken by the upper sockets. When these are depleted, they are simply discarded and new ones are plugged in. There is no need to spend time in disassembly and tracing out of wires. -50-

Fig. 6. A 5U8 is in the noval socket (not shown). The ammeter (upper left) indicates the proper 600 ma., while the voltmeter (upper right) correctly shows a 5-volt reading.

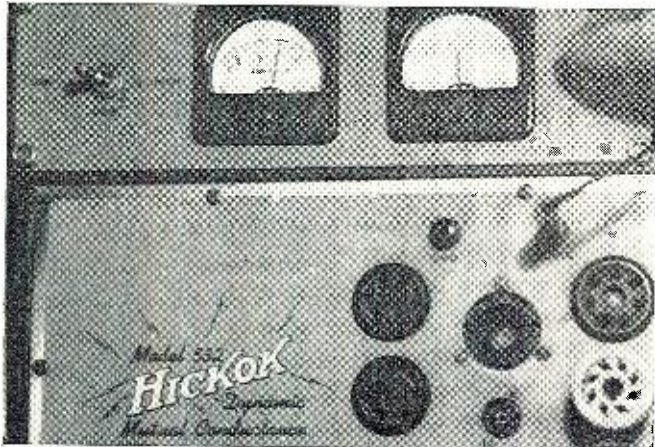
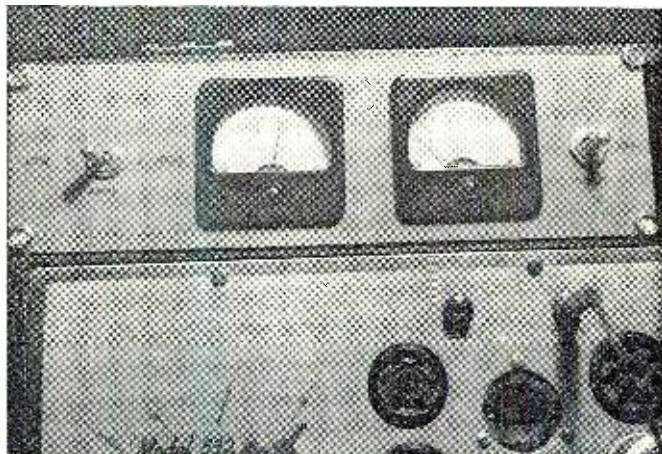

Fig. 7. Close-up of the meter mounting and meter switches. A 600-ma. tube is in the tester (see the ammeter reading), but the switch for the voltmeter is in the "Off" position.



By **LEONARD FELDMAN**

President, Madison Fielding Corp.

Results of listening tests when a third channel is added to an already set up stereophonic music system.



The Case for a Third Channel

AFTER answering consumer questions on stereophonic sound for nearly two years, certain recurring queries served to create a serious doubt as to the validity of some of the accepted axioms of stereophonic reproduction of sound in the home. The problem stems from the nature of the evolution of stereo from its predecessor, binaural sound. Those of us involved in binaural sound, years ago, will always remember dual-headphone listening as a rewarding if somewhat impractical means of achieving spatial realism. We remember, too, that six to eight inches between pick-up microphones translated to headphone two-channel listening resulted in virtually perfect spatial visualization on the part of the hearer. The theory advanced then by *Bell Telephone Laboratories* (and there is no reason to believe that human hearing has changed materially in twenty-five years) was that the closely spaced microphones served as individual "extensions" of our two ears, placed in the "best orchestra seat in the house."

There exists even today a hard core of individualists who do the bulk of their two-channel listening *via* headphones. Unfortunately, there is no longer any source material with which to satisfy their binaural craving. Yes, we know that there are nearly a thousand stereo disc titles available (and probably an equal or greater number of stereo tapes), but not one of them was recorded binaurally. The headphone listener is therefore deluding himself—hoping to hear a listening

sensation that remains confined to the laboratory.

So much for a few die-hards. The far more alarming question is: are the thousands of newly indoctrinated two-channel stereo listeners equally deluding themselves. Let's examine a typical stereo recording session in detail and see. The first anomaly to strike the observer is the microphone arrangement. If, indeed, the number of channels in the studio pick-up is dictated by the number of ears per person, then the session we are about to witness is intended for outer space consumption, where three-eared Martians dwell. Yes, there are distinctly three microphone channels; a left, a right, and a middle. (There may be more than three actual microphones in a symphonic recording session, but several may be operating to serve only one of the three channels—in effect "compressing" the area of stage-left, stage-right, and center-stage.)

Investigation of this puzzling state of affairs yields two explanations: 1. The recording session is being made monophonically and stereophonically at one and the same time. 2. As long as the center microphone channel is there, why not "blend in" a bit of its output into both the left and right tracks, to eliminate that "hole-in-the-middle" which has so sorely afflicted the listening public? Indeed, why not? Certainly, the "ping-pong" effect originally foisted upon the public to stimulate interest in stereophony is fast disappearing from present-day, sophisticated orchestral recordings. If a fusion or

"wall" of sound is the aim, then it would seem to be justifiable to use any technique available in the studio to create that fusion. But what of the home listener? Equipped with two channels, two speakers, two amplifiers, etc., does it follow that he will derive any benefit from the three-channel recording technique? Or, will speaker placement, maladjustment of controls, and room acoustics create a still more objectionable effect—that of *two* orchestras playing at opposite corners of the room. If the latter results (and we have heard numerous installations which do nothing more), then we are spending vast sums of money on superfluous electronic gear when all we really needed was a second speaker. So prevalent is this particular state of confusion that there is not one of us in the field who has not been asked "Is the only requirement for stereo the addition of a second speaker?"

Somewhere between the "ping-pong" effect and "one-channel" stereo lies a happy compromise, which we set out to find. To subject observers to musical listening alone seemed insufficient in the case of three-channel listening. For one thing, the choice of musical selections would, perforce, be arbitrary. The exact technique used in recording would introduce an even greater variable. Our compromise decision, then, was to combine controlled, single-tone experiments with musical auditioning *via* two and three channels.

The Listening Test

Our population sampling, while small compared with some of the monumental works compiled by pioneers in the field, consisted of ten adult listeners. Six males and four females were chosen. Of the six males, two have had some professional dealings with the reproduction of sound. Two were non-professionals who had heard stereo before and two had never heard any

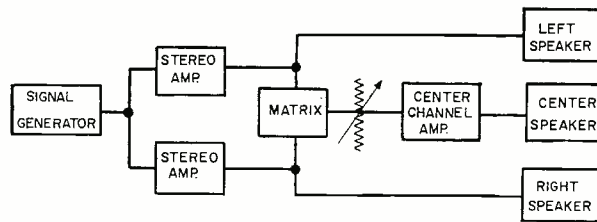

Fig. 1. Block diagram shown here is of the three-channel setup that was employed for the listening tests.

stereo before the tests. All the ladies had heard stereo, but none were professionally involved in hi-fi. All the subjects were tested first for reasonably equal hearing response in both ears.

Since our answers were intended to have meaning in terms of home conditions, we elected to conduct the experiments in an average living room rather than in some specially treated sound chamber. In order to eliminate such side effects as "standing waves" and "nulls," each subject was tested from two points in the room. The diagrammatic layout of the test set-up is shown in Fig. 2. In the first series of tests, the same frequency was fed to two loudspeakers and balanced electrically. Unbalance was then introduced, to emphasize either the sound from the left or right speaker. The observer was never told where the emphasis would take place in advance and was asked to indicate when the sound shifted from "center" stage to either the right or the left. This simple objective test was repeated at 10 frequencies, ranging from 50 cycles to 15,000 cycles and at three different levels of intensity. Frankly, after testing the first two observers, we were ready to abandon the project entirely on the basis of such wide divergencies of opinion. As we proceeded with more observers however, a very definite pattern came into focus. The *average* results of this two-channel test are given in Table 1.

The second series of tests involved the use of a third channel. Much has been written about "three-speaker"

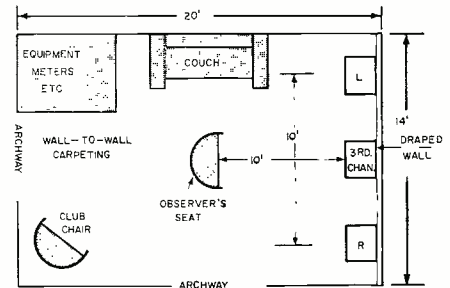

Fig. 2. Room layout in which the two- and three-channel tests were conducted.

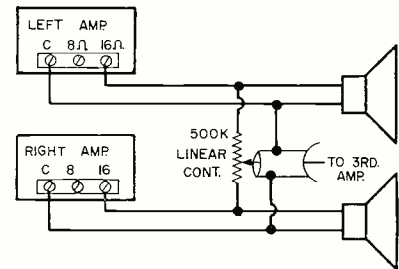

Fig. 3. Matrixing or mixing circuit used.

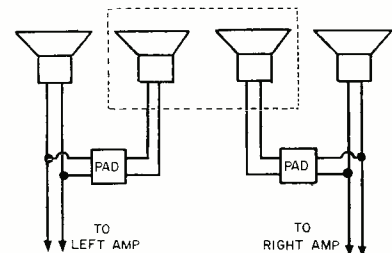

Fig. 4. Creating third channel by paralleling two speakers from left and right channels and positioning them between the outer two. No additional amplifier is needed.

INTENSITY	FREQUENCIES (in cps)											
	50	100	200	400	800	1000	2000	4000	6000	8000	Above	
Low	N _L	N _L	5.1 db	3 db	4 db	3 db	3 db	6 db	N _L	N _L	N _L	
Medium	N _L	7 db	5.3 db	2 db	3.2 db	2 db	3 db	5 db	N _L	N _L	N _L	
Loud	N _L	5 db	4 db	3 db	3.3 db	2 db	3.5 db	5 db	10 db	N _L	N _L	

NOTES: Reading of decibels are "average left or right channel emphasis" detected by observers.
 N_L = Readings completely random and erroneous, confirming conclusion that low frequencies are essentially non-directional because of long wavelength.
 N_R = Readings in these high-frequency ranges, while taken, are deemed inconclusive since errors in judgment of direction were in the majority. At high frequencies, a mere turning of the head will cause the listener to believe that sound has shifted from one side to the other even when sound intensity from one side is as much as 20 db greater than from the other side.

Table 1. Average level differences detected by listeners in two-channel setup.

Table 2. Average level differences detected by listeners in three-channel setup.

INTENSITY	FREQUENCIES (in cps)											
	50	100	200	400	800	1000	2000	4000	6000	8000	Above	
Low	N _L	N _L	7 db	8 db	6 db	4 db	6.1 db	7.8 db	8 db	N _L	N _L	
Medium	N _L	7.3 db	6 db	6.2 db	6 db	4.8 db	7 db	7.3 db	7 db	10 db	N _L	
Loud	N _L	8 db	6.4 db	6 db	7 db	4.3 db	6 db	8 db	7.7 db	10 db	N _L	

NOTES: Readings taken in same manner as in Table 1. In addition to increase in one-sided intensity for positive identification of source of sound, it is interesting and somewhat unexpected to note that the range of frequencies over which it becomes possible to determine source of sound is actually extended by the addition of a third channel. It is believed that the center channel serves as a positive "starting point" or mental "anchor point," making phase cancellations less confusing.

stereo, so that perhaps a definition of our "third channel" is in order at this point. We did *not* use a left and right "tweeter" and a center "woofer" channel, for this is still basically two-channel reproduction. We did *not* use one, wide-range center channel and two "end" tweeters or mid-range tweeters. We *did* employ two wide-range systems at the ends and a somewhat less expensive, but nevertheless full-range, system for the center channel. The center channel itself was fed an equal mixture of the left and right channels (the same procedure used in three-channel microphone mixing discussed earlier). The electrical set-up is shown in Fig. 1.

In execution, the second series of tests was identical to the two-channel test, that is, tones of equal intensity and frequency were fed to the left- and right-speaker systems. A mixture of

(Continued on page 104)

Replacement Parts—

STANDARD or SPECIAL?

By **WALTER H. BUCHSBAUM**
Television Consultant, RADIO & TV NEWS

Even with many resistors and capacitors, certain characteristics must be considered.

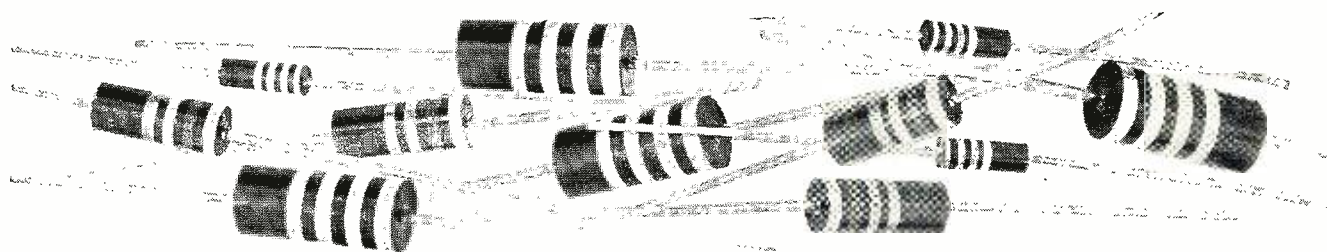

Fig. 1. Standard carbon composition resistors in an assortment of popular 1/2-, 1-, and 2-watt sizes.

THE PROBLEM of replacing a defective part in a TV receiver often boils down to deciding whether to use a standard component that is on hand or whether to get the manufacturer's exact replacement part. In the case of tubes, diodes, and similar components, an exact replacement is either in the technician's stock or else directly available from the local parts distributor. However, when one section of a multi-section electrolytic goes bad, or if the deflection yoke has a partial short, the difference between using an available replacement off the shelf or ordering the special component from the manufacturer means the difference between a day or weeks of waiting. For both service technicians and customer, the quick repair job possible with a standard part is always preferable to having to wait until the special replacement part arrives, whenever it is possible.

One should know where standard components can be used, where modifications are possible to use a standard component, and where an exact replacement cannot be avoided. In many instances, the local distributor carries parts which could be used provided the technician knows the important characteristics which seem to stamp the defective parts as "specials." Some hints on adapting standard parts to replace a "special" component are also discussed. Only resistors and capaci-

tors are considered here but, in a subsequent article, coils and transformers will be covered.

Composition Resistors

In general, it is a safe assumption that any defective carbon resistor can be replaced by a standard unit. Typical 1/2-, 1-, and 2-watt resistors are shown in Fig. 1. Resistance values, tolerances, markings and sizes have been sufficiently standardized so that practically all values will be readily available in the technician's own stock or else from the local jobber. It is important to consider the tolerances of the replaced resistor, especially when it is used in such circuits as the horizontal oscillator, a.f.c., or some audio feedback network. It is safe to replace a 10% resistor with a 5% one, but never the other way around.

As concerns the power rating of a resistor, some technicians feel that there can be no harm in using a 1-watt replacement for a 1/2-watt resistor, but in some circuits this can lead to trouble. In the tuner and i.f. sections, for example, the 1-watt resistor, which has more capacity than its smaller cousin, is likely to cause misalignment. In some other circuit, the 1/2-watt resistor may have become defective because more than 1/2-watt of power was handled. Substituting a larger resistor may now obscure the real defect; the excess current continues and, after

a while, some other, more expensive component in that circuit may become damaged.

Film Type Resistors

Most film type resistors are used either for high-voltage circuits or else as precision resistors, usually with 1% tolerance. They must be replaced by other film type resistors in either case. Most jobbers carry a line of film types in stock, but the technician has to know the exact resistance, tolerance, and wattage rating in order to get the right replacement. There are some varistors and thermistors which look like film type resistors, but their temperature and current coefficients are quite different.

Potentiometers

Many manufacturers use their own code for marking potentiometer values, and reference to the circuit diagram is therefore often necessary to make sure of the resistance value. Replacing a defective potentiometer may mean a search for the correct replacement part because of the many characteristics that must be considered. Resistance values are standardized and most potentiometers are 1/2- to 2-watt composition types, unless they are wire-wound units, like the focus and centering controls found in earlier-model TV receivers. What complicates the selection of a standard-replacement potentiometer

Fig. 2. These high-voltage filter capacitors are available in various voltage ratings and types of terminal.

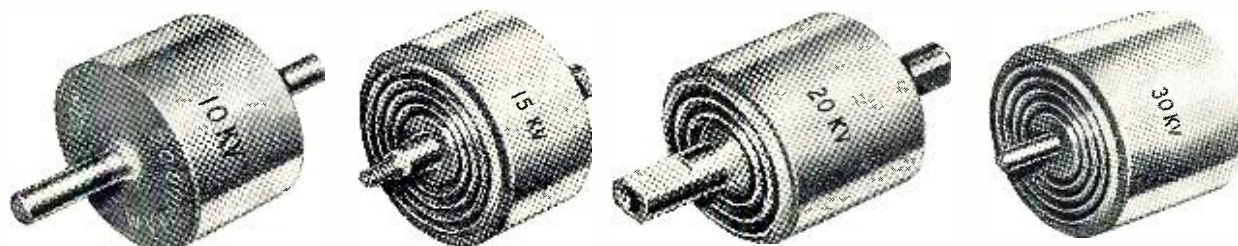

is usually the mechanical arrangement of the defective part with another, concentric potentiometer, or with a switch, and the shaft dimensions. Fig. 3 shows an assortment of typical 2-watt potentiometer combinations.

The taper of a potentiometer is also important to know. This characteristic depends on the rate at which part of the total resistance is tapped off as the potentiometer's shaft is rotated. If the unit has a linear taper, this means that, when the shaft is turned exactly halfway between its two extremes of rotation, exactly half of the total resistance will appear on either side of the tap. When the shaft is turned so that it is a quarter of a turn from one extreme, one quarter of the total resistance will appear on one side of the tap and three quarters of the total will appear on the other.

For audio controls, linear tapers are not usually desirable. Apparent loudness to the human ear does not have a direct linear relationship to increases or decreases in audio voltage. A linear-taper potentiometer would make a volume control appear "bunched up" at one end and spread out at the other. For this reason, a special audio taper is used on all volume controls, and on many tone-control potentiometers as well. This taper "bunches" resistance together at one end of the potentiometer rotation so as to accommodate the logarithmic characteristic of the human ear. There are other types of tapers available, but the most commonly used in radio and TV receivers are the linear taper for TV controls and the audio taper for audio controls.

Another complicating factor in replacing some potentiometers is the location of taps on the fixed resistance. Such taps often are used on the volume, tone, and contrast or gain controls; and the replacement part must have the same taps, at the same resistance points.

The problem of matching the shaft length of the replacement and of making it fit the front-panel knob is usually not severe, since most replacement potentiometers are furnished with an extra-long shaft that can easily be cut down with a hacksaw. Most jobbers stock either a large variety of potentiometers or offer universal replacement kits, which permit the technician to assemble almost any desired combination of resistance, taper, shaft, and concentric combination. Because of their versatility, these kits increase the likelihood of quick availability with low inventory.

While the majority of potentiometers in radio and TV receivers can be replaced by standard parts available from jobbers' stock, there are some potentiometers, especially those using taps, concentric-control arrangements, and possibly special tapers, that must be obtained from the set manufacturer. In some earlier TV sets and in current color sets, special high-voltage insulated potentiometers are used in the h.v. cage. While it is always a good idea to check with the local jobber

first, some of these special components may also have to be obtained from the manufacturer.

Power Resistors

Most power resistors used in TV receivers are of the wire-wound type and, since they are made in standard resistance and wattage ratings, they can usually be replaced from the local jobber's stock. In this instance, it is perfectly acceptable to replace a resistor with one of greater power rating provided the replacement fits into the same space. In many TV sets, the power resistors are contained in a single strip assembly, which is often riveted to the chassis. To replace a single section, the new part can simply be wired across the old terminals if an open circuit is the defect. If the defect consists of a short to the chassis, then the replacement will require using different terminal points.

Here, caution is recommended. Power resistors that are bolted to the chassis often use the chassis to dissipate some of their heat. Thus they do not need to have as great a power rating as if they were suspended from their terminals only, thus being required to radiate their dissipated heat into the surrounding air. For this reason, the pigtail type replacement resistor should use the next higher wattage rating than the flat, chassis-mounted resistor it replaces.

Many technicians feel that, instead of getting the correct resistance in the replacement part, it is easier to use a slide-wire type of adjustable resistor and set it to the correct value. This is permissible if the reduction in power dissipation is considered when only a fraction of the entire resistor body is used. It is poor practice to use such a variable resistor at less than half its total resistance setting, unless the power rating is correspondingly increased.

In general, it is a safe assumption that any power resistor can be replaced from jobber's stock, even if the physical appearance is not the same, or if a

variable resistor or a combination of several has to be used. The technician should never attempt to replace a wire-wound power resistor by a combination of parallel or series carbon resistors, since their construction may not permit continuous, full, power dissipation without resistance change and eventual deterioration.

Electrolytic Capacitors

At first glance, the large variety of replacements available at most distributors seems to indicate that any electrolytic capacitor can be replaced by its exact duplicate. This is true for most capacitors. Occasionally some slight differences appear that complicate the replacement problem.

A good example is the instance where the parts distributor has an un-insulated metal-can replacement for a defective electrolytic capacitor that has exactly the same capacitance and voltage ratings, but is insulated by a cardboard tube. The un-insulated capacitor can certainly be used as replacement, provided that its shell is carefully covered with several layers of insulating tape and the capacitance values are clearly marked on the outside.

Another instance is the case where only one section of a multiple-section capacitor is defective. Either because an exact replacement for the entire can is not in stock or because of the difference in cost, the technician may decide to replace only the defective section by a smaller, pigtail-mounted capacitor. Fig. 5 shows typical, cardboard-insulated, electrolytic, single-section capacitors suitable for such replacement work. While the original capacitor can may be mounted above the chassis, the smaller replacement may be mounted underneath, at convenient terminal points. Caution is required here to locate the new part at the coolest, best-ventilated spot, since excessive heat will shorten the capacitor's life.

Ratio detectors use small, low-voltage, electrolytic capacitors. When one of these is replaced, it is important that

Fig. 3. Some of the many available TV potentiometer combinations.

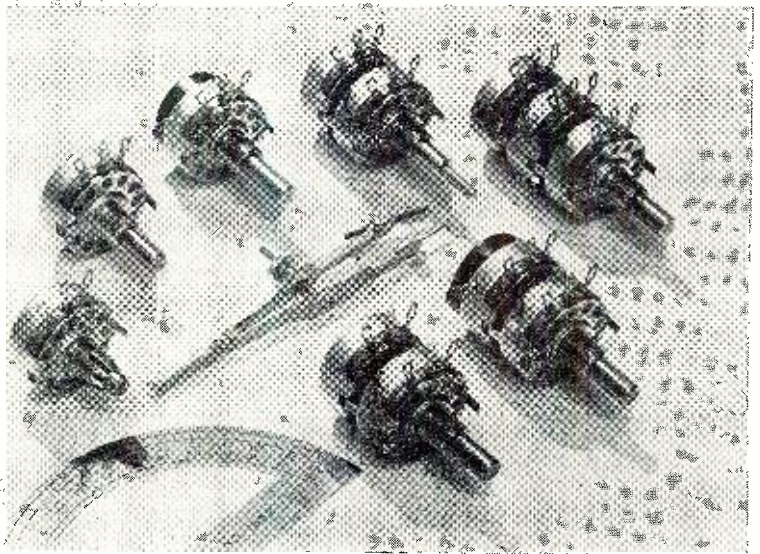

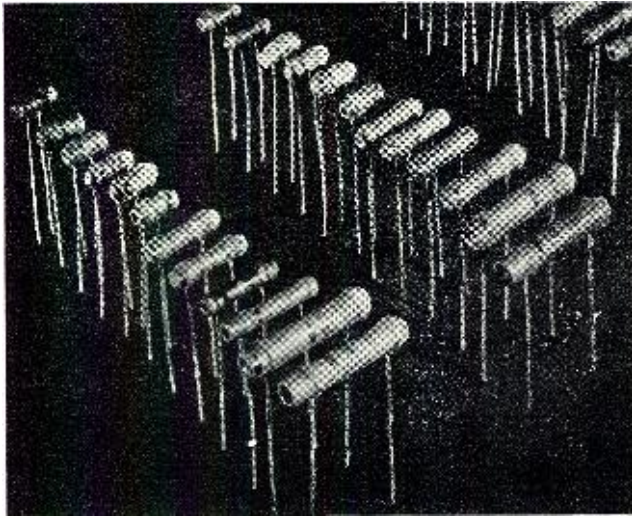

◀ Fig. 4. Ceramic capacitors are available in a variety of types and sizes. Units with controlled temperature characteristics are used to stabilize various circuits.

the correct polarity be observed and that the outer shell be insulated. An exact replacement value is not necessary, but the nominal capacitance of the replacement should not be less than that of the original and not more than 20% higher.

Since capacitances of electrolytics are not usually critical, a somewhat larger unit can usually be used; but when a 40- μ fd. filter input capacitor is replaced with an 80- μ fd. unit, this may raise the "B+" voltage and the initial current surge sufficiently to shorten the life of other components in the set. In the case of transformerless TV sets, the electrolytics that are part of the doubler and filter-input circuit should be replaced only with very similar capacitors.

Paper Tubular Capacitors

Generally standard items carried in every jobber's stock, paper tubular capacitors are also usually found among the spare parts of the service technician. In most cases, tubular capacitors can be replaced by ceramic disc capacitors or any other type having the same value.

Since many ceramic capacitors have much greater tolerances than the tubular types, it can happen that a $\pm 10\%$ tubular in the horizontal oscillator is replaced by a ceramic capacitor that has a +100, -20% tolerance. This might make adjustment of the horizontal oscillator difficult. Therefore caution is required in replacing tubular capacitors in such critical circuits.

Voltage ratings are important only in that the new part should never have a lower working voltage than that of the defective part. Although in the majority of the circuits the polarity of the capacitor is not important, the replacement tubular type should always be connected just as the original was. The outer winding terminal, indicated by a line around the capacitor body, should go closest to a.c. ground.

Ceramic and Mica Units

Invariably mica and ceramic capacitors are used in standard values that are available at the distributor. Direct

factory replacements of these types is hardly ever needed. The important thing about getting a replacement from a jobber is to make sure that all the characteristics of the capacitor are known. Capacitance, voltage rating, and tolerance are almost always stated either through the color code or else on the circuit diagram or parts list. If voltage rating is not given, it is safe to assume that it should be at least 30% higher than the highest d.c. voltage in the set.

The characteristic that is often overlooked is the variation of capacitance with temperature. Bypass and coupling capacitors in the i.f., video, and deflection circuits are not critical in this respect; but capacitors in the tuner oscillator, the horizontal a.f.c., and the vertical oscillator often have special temperature characteristics. Where mica capacitors are used, the silver-mica type is usually called for to maintain stability over wide ranges of temperature. This is indicated by the color dot in the second row, left, which corresponds to a letter giving temperature characteristics. For example, an orange dot stands for characteristic D, which means $\pm 3\%$ change over a range of $\pm 100^\circ$ C.

Ceramic capacitors (Fig. 4) are similarly marked at the color band nearest to the lead. Instead of special stability with temperature, some capacitors also have negative temperature coefficients to compensate for other circuit changes due to heating. If the exact temperature characteristic of the defective capacitor cannot be obtained from jobber's stock, the replacement may have to be gotten from the set manufacturer; but such instances are rare.

High-Voltage Capacitors

In most TV sets, the values and voltage ratings of the h.v. filter capacitors are limited to such values as 500 and 1000 μ fd. and 10, 15, 20 and 30 kv. As Fig. 2 shows, however, the physical arrangement of the terminals varies. To accommodate any terminal combination, some manufacturers offer screw-in kits to enable the technician to make up the terminals as needed.

Fig. 5. Various sizes of cardboard-insulated, pigtail, single-section, electrolytic capacitors. They are useful replacements when part of a multiple unit goes bad.

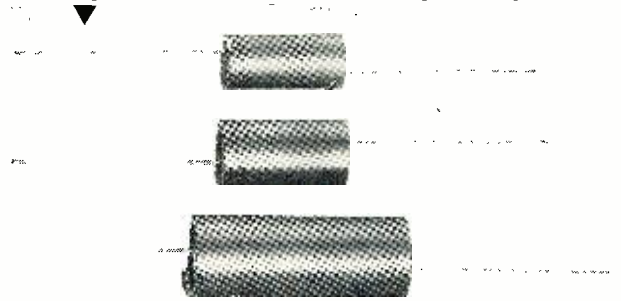

Other parts manufacturers offer a variety of h.v. capacitors designed to replace any type. Generally h.v. capacitors can be replaced from jobber's stock and rarely present any sort of problem.

Variable Capacitors

The trimmer capacitors used in some horizontal-deflection circuits occasionally are made up to manufacturers' specifications and are therefore not directly obtainable from the jobber. Since these capacitors are of the compression type, it is often possible to repair them by taking them apart carefully, clearing the short, and re-assembling them. If the ceramic frame is cracked, especially on dual and triple units, it may be necessary to turn to the set manufacturer for a correct replacement part. Trimmer capacitors used on most TV tuners are standard parts and can be had from jobber's stock. Sometimes the exact physical duplicate is not available, and then the technician must determine whether the available part can be fitted into the space occupied by the defective one. Mechanical work on the tuner must be done with great care, since it is easily possible to damage contacts, switch sections, or coils accidentally.

The variable capacitors that make up the fine-tuning control on the TV tuner almost always must be exact factory replacements. In this connection, it may be mentioned that most jobbers carry an assortment of parts for *Standard Coil*, *RCA* and other widely used tuners.

Conclusion

The point in preparing an article of this type is that many technicians still do not realize *all* the possibilities that can be explored in obtaining replacements for apparently special parts, or *all* of the factors that should be considered in determining just how special a component may be. Some factors have been explored here already. In a subsequent issue, the matter of replacing coils, transformers, deflection yokes and other inductances used in TV receivers will be treated.

SAVE $\frac{1}{2}$ THE TIME

Make Twice The Profit!

in TV Trouble-Shooting

THIS EASY
SIGNAL INJECTION
POINT-TO-POINT
DIRECT VIEWING
WAY—

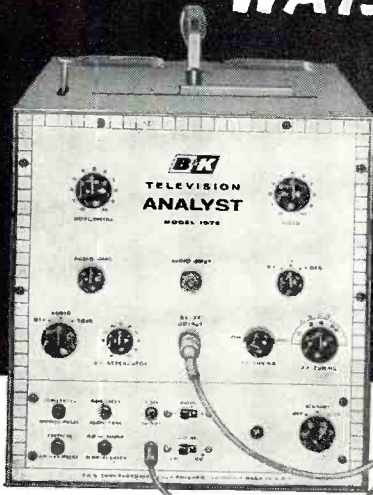

MODEL 1075



TELEVISION ANALYST

New Technique Makes TV Servicing Easier, Faster, More Profitable

Thousands of service technicians already save thousands of hours every day with the amazing B&K TELEVISION ANALYST. Enables you to inject your own TV signal at any point and watch the resulting test pattern on the picture tube itself. Makes it quick and easy to isolate, pin-point, and correct TV trouble in any stage throughout the video, audio, r.f., i.f., sync, and sweep sections of black & white and color television sets—including *intermittents*. Makes external scope or wave-form interpretation unnecessary. Enables any serviceman to cut servicing time in half, service more TV sets in less time really satisfy more customers, and make more money. Color generator provides both rainbow pattern and color bars.

MODEL 1075 TELEVISION ANALYST. Complete with standard test pattern, white dot, white line, and color-bar slide transparencies, and one clear acetate. Net, **\$259⁹⁵**

See your B&K Distributor or Write for Bulletin ST21-N

B & K MANUFACTURING CO.
3726 N. Southport Ave. • Chicago 13, Illinois
Canada: Atlas Radio Corp., 50 Wingold, Toronto 10, Ont.
Export: Empire Exporters, 458 Broadway, New York 13, U.S.A.

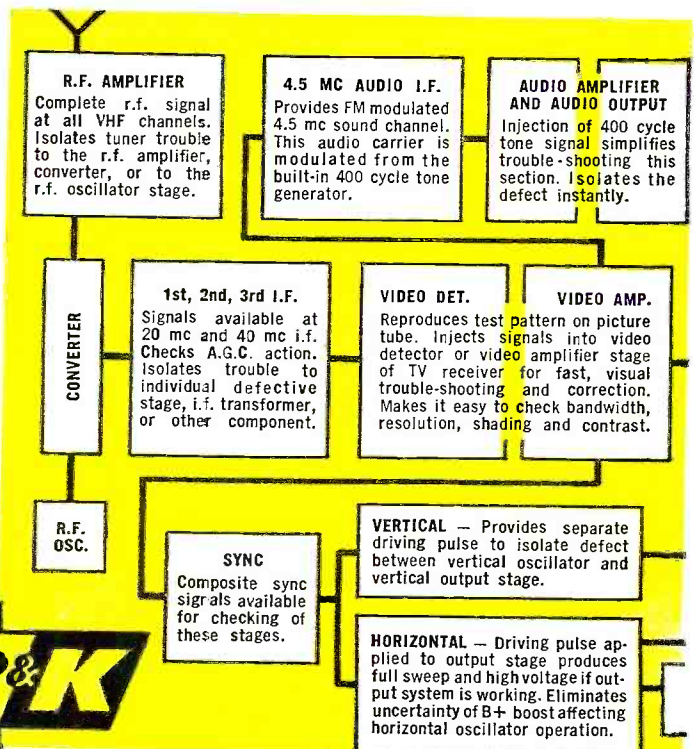

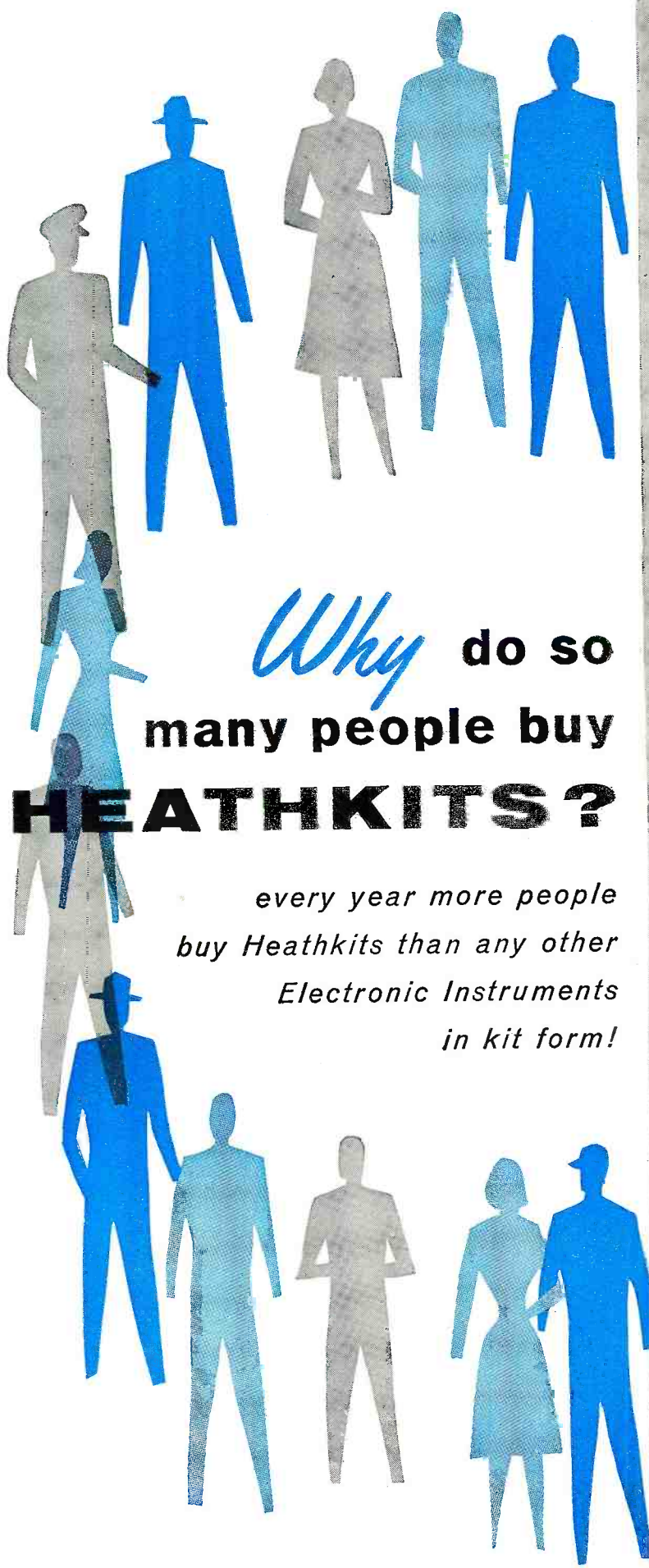

Why do so many people buy **HEATHKITS?**

every year more people buy Heathkits than any other Electronic Instruments in kit form!

Here are a few reasons why...

EASY TO BUILD

Heathkits are engineered for easy kit construction. You need no electronic or kit building experience whatsoever to successfully complete your own kit. Use of printed circuit boards and pre-wired, pre-aligned assemblies cut construction time. Manuals are carefully prepared, employing step-by-step instructions written in simple, non-technical language. Large pictorial diagrams and photographs show you exactly where each part goes.

LASTING QUALITY

Only top quality components go into Heathkits, assuring you of a finished product that is unsurpassed in performance, dependability and endurance. Rigid quality control standards are maintained at the Heath factory to see that each component lives up to its advertised specifications. Heathkits are conservatively rated. No performance claims are made that are not thoroughly proven and tested under the most stringent laboratory conditions.

ADVANCED ENGINEERING

Progress in electronics engineering never stands still at Heath. The latest developments in circuit design and components are exploited by Heath engineers, offering you superior performance at lower costs. New advances in all fields of electronics are carefully watched by Heath engineers to keep abreast of the rapidly growing industry. The modern, up-to-date styling of Heathkits make them a handsome addition to your home or workshop.

WORLD-WIDE REPUTATION

A pioneer in do-it-yourself electronics, Heath Company, over more than a decade, has established public confidence in its products both in the United States and abroad. Today, as the world's largest manufacturer of electronic kits, Heath stands as the leader in its field.

GREATER SAVINGS

Do-it-yourself Heathkits save you up to 1/2 the cost of equivalent ready-made equipment. Direct factory-to-you selling, eliminating middle-man profit, plus the tremendous Heath purchasing power mean even further savings to you. And the convenient Heath Time Payment Plan allows you to use and enjoy your Heathkit NOW, while you pay for it in easy installments.



HEATH COMPANY
Benton Harbor 15, Michigan

 a subsidiary of Daystrom, Inc.

TRANSISTOR PORTABLE RADIO KIT

Fun for the whole family, this easy-to-build 6-transistor portable radio is ready to go wherever you go. The modern molded plastic case with pull-out carrying handle and fully enclosed back add beauty and convenience to this splendid kit. Six name-brand (Texas Instrument) transistors are used for good sensitivity and selectivity. The 4" x 6" PM speaker with heavy magnet provides "big set" tone quality. Use of this large speaker and roomy chassis make it unnecessary to crowd components adding greatly to the ease of construction. Transformers are prealigned making the radio ready for use as soon as kit is assembled. A built-in rod-type antenna assures good reception in all locations. Six standard flashlight batteries are used for power, providing extremely long battery life (between 500 and 1,000 hours) and they can be purchased anywhere. Stylish cabinet is two-tone blue molded plastic with gold inlay and measures 9" L. x 7" H. x 3 3/4" D. Shpg. Wt. 6 lbs.

MODEL XR-1L: Identical to XR-1P except in handsome leather case instead of plastic case. Leather carrying strap included. Shpg. Wt. 7 lbs.

LEATHER CASE: Can be purchased separately if desired. Fits all XR-1P and earlier XR-1 chassis. No. 93-1. Shpg. Wt. 3 lbs. \$6.95.

HEATHKIT
MODEL XR-1P
\$29⁹⁵



MODEL XR-1L **\$34⁹⁵**

NAVIGATE BY PORTABLE RADIO

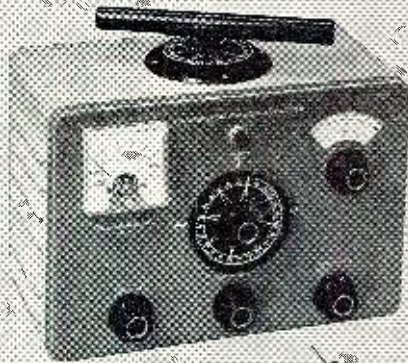

HEATHKIT
MODEL DF-2

\$69⁹⁵

2-BAND TRANSISTOR PORTABLE RADIO DIRECTION FINDER KIT

Enjoy the safety, convenience and entertainment of this self-contained, self-powered, six-transistor superheterodyne radio direction finder. It receives aeronautical and marine beacons as well as standard band broadcasts with startlingly clear tone reproduction over a long range. Covering the beacon band from 200 to 400 kc and broadcast band from 540 to 1620 kc, the DF-2 is designed to take directional "fixes" on both aircraft and marine beacons as well as standard broadcast stations, while providing the entertainment of a high quality transistor portable radio. You are able to receive aircraft weather reports every thirty minutes and constant Coast Guard beacons on the 200 to 400 kc band. A dial-light is provided for night operation. Power is supplied by six standard flashlight batteries which will last you up to one year under normal operation. Shpg. Wt. 9 lbs.

POWER CONVERTER KIT

Now you can operate your TV set, radio, razor, and other AC electrical equipment directly from your 12-volt boat or car battery. With the Heathkit Power Converter you can enjoy the convenience of home electricity whether boat cruising or on automobile trips. Two power transistors are employed for years of trouble-free, dependable service. No moving parts to wear out, no tubes to replace. Shpg. Wt. 8 lbs.



MODEL PC-1

\$24⁹⁵

ELECTRONIC IGNITION ANALYZER KIT

Ideal for use on automobiles, boats, aircraft engines, etc., the IA-1 checks ignition systems with the engine in operation (400 to 5,000 RPM). Shows the condition of coil, condenser, points, plugs and ignition wiring. Shows complete engine cycle or just one cylinder at a time. Two test leads are supplied, each 10' long, which will enable you to reach either the breaker points or the spark plug wires. Shpg. Wt. 20 lbs.

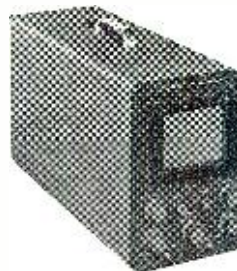

MODEL IA-1

\$59⁹⁵

ELECTRONIC TACHOMETER KIT

Useful on inboard and outboard boats, as well as in automobiles, the TI-1 operates directly from the spark impulse of the engine. Use on any spark ignited 2 or 4 cycle engine of any number of cylinders. Completely transistorized, it works with 6, 8, 12, 24 or 32 volt DC systems. Indicates revolutions-per-minute from 0 to 6,000. Calibration control provided for adjusting to engine type. Easy-to-build and easy-to-install. Shpg. Wt. 4 lbs.



MODEL TI-1

\$25⁹⁵

PROFESSIONAL OSCILLOSCOPE KIT

Everything you could possibly want in an oscilloscope is found in the new Heathkit model OP-1. Featured are DC coupled amplifiers and also DC coupled CR tube un-blanking. The triggered sweep circuit will operate on either internal or external signals and may be either AC or DC coupled. The polarity of the triggering signal may also be selected, and any point on the waveform may be selected for the start of the sweep by using the "triggering level" control. An automatic position is also provided, in which the sweep recurs at 50 cycle rate, but can be driven over a wide range of frequencies with no additional adjustment. Prewired terminal boards are used for rapid, easy assembly of all critical circuits. Power supply is transformer operated utilizing silicon diode rectifiers and is fused for protection. Handsome cabinet features silver anodized front panel with red and black lettering and matching knobs. Shpg. Wt. 34 lbs.

HEATHKIT
MODEL OP-1

\$179⁹⁵



VARIABLE VOLTAGE REGULATED POWER SUPPLY KIT

Invaluable in experimental and design work, the PS-4 eliminates the need for building up a separate power supply for each new circuit tried. It provides a convenient source of variable regulated B+, variable bias voltage and filament voltage for labs and work shops. The PS-4 supplies regulated B+ output continuously variable from 0 to 400 volts DC at up to 100 ma, bias voltage variable from 0 to -100 volts DC at 1 ma, and filament voltage of 6.3 volts AC at 4 amps. Separate panel meters continuously monitors voltage and current output. Rugged, top-rated components used throughout for long, reliable service. Shpg. Wt. 16 lbs.



HEATHKIT
MODEL PS-4

\$54⁹⁵

Your best
dollar value...



HEATH COMPANY • Benton Harbor 15,
Michigan
a subsidiary of Daystrom, Inc.

"EXTRA DUTY" 5" OSCILLOSCOPE KIT

Laboratory quality at utility scope price makes this instrument an unusual value. The Heath patented sweep circuit functions from 10 CPS to better than 500 kc in five steps, giving you five times the usual sweep obtained in other scopes. Vertical frequency response extends from 3 CPS to 5 mc +1.5 db -5 db without extra switching. An automatic sync circuit with self-limiting cathode follower provides excellent linearity and lock-in characteristics. Extremely short retrace time and efficient blanking action are characteristic of this scope. Frequency response of the horizontal amplifier is within ±1 db from 1 CPS to 200 kc. Horizontal sensitivity is 0.3 volts RMS-per-inch. Construction is simplified through the use of two etched metal circuit boards and pre-cut, cabled wiring harness. Complete step-by-step instructions and large pictorial diagrams are supplied for easy assembly. An ideal scope for all service applications as well as in standard or color TV servicing. Shpg. Wt. 22 lbs.

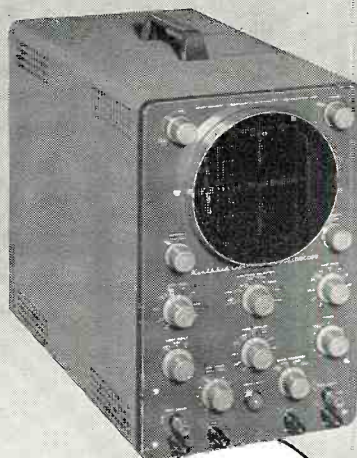

HEATHKIT
MODEL O-12

\$65⁹⁵



HEATHKIT
MODEL TO-1

\$16⁹⁵

TEST OSCILLATOR KIT

Provides the test frequencies most often used by servicemen in repairing and aligning modern broadcast receivers. Five fixed-tuned frequencies (262 kc, 455 kc, 465 kc, 600 kc and 1400 kc) are quickly selected for troubleshooting or alignment of the IF frequency and high and low end of the broadcast band for proper tracking. Shpg. Wt. 4 lbs.



MODEL SG-8 \$19⁵⁰

RF SIGNAL GENERATOR KIT

A "must" for any beginning serviceman, this indispensable instrument is used for aligning tuned circuits quickly and tracing signals in faulty RF, IF and audio circuits. Covers 160 kc to 110 mc on fundamentals in five bands and from 110 mc to 220 mc on calibrated harmonics. Coils are pre-wound and calibrated. Complete with output cable and instructions. Shpg. Wt. 8 lbs.



MODEL AG-9A \$34⁵⁰

AUDIO SIGNAL GENERATOR KIT

This unique generator uses three rotary switches to select two significant figures and a multiplier to determine audio frequency, allowing return to the exact frequency previously measured when making multiple frequency measurements. Covers 10 CPS to 120 kc with less than .1 of 1% distortion between 20 and 20,000 CPS. Shpg. Wt. 10 lbs.



MODEL TS-4A \$49⁵⁰

TV ALIGNMENT GENERATOR KIT

TV service technicians will appreciate the outstanding features found in this sweep generator. Provides essential facilities for aligning FM, monochrome TV or color TV sets. The all-electronic sweep circuit employs a trouble-free controllable inductor which varies frequency by magnetic means. An unusual buy at this low price. Shpg. Wt. 16 lbs.



MODEL CD-1 \$59⁹⁵

COLOR BAR AND DOT GENERATOR KIT

The CD-1 combines the two basic color servicing instruments, a color bar and white dot generator in one versatile and portable unit, which has crystal controlled accuracy and stability for steady lock-in patterns. (Requires no external sync leads.) Easy-to-build and easy-to-use. No other generator on the market offers so many features at such a great price saving. Shpg. Wt. 13 lbs.

tuner (R-1), stereo preamplifier (R-1 & 2), and record changer (R-P-3). Record changer chassis pulls out easily for convenient loading and unloading. Adequate space is provided for record storage and a pair of matching Heathkit power amplifiers (from 12 to 70 watts). The stereo wing speaker enclosures are open backed, cloth grilled cabinets designed to hold the Heathkit SS-2 or similar speaker systems. The cabinets are available in beautifully grained 3/4" solid core Philippine mahogany or select birch plywood suitable for the finish of your choice. The matched grain sliding tape deck access door on top pops-up flush when closed. Entire top features a shaped edge. Hardware and trim of brushed-brass and gold finish. Rich toned grille cloth is hecked in gold and black. No woodworking experience required. All parts pre-cut and predrilled for easy assembly. Maximum overall dimensions (all 3 pieces): 82 3/4" W. x 36 1/2" H. x 20" D. Center Cabinet: 47 1/2" W. x 36 1/2" H.

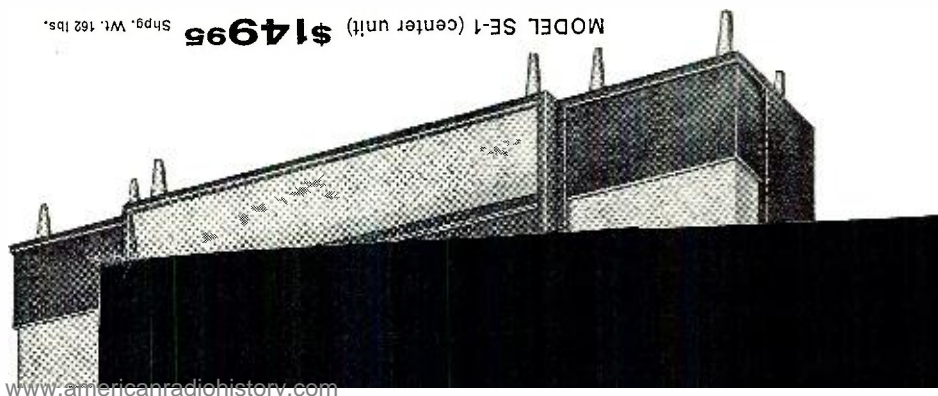

MODEL SE-1 (center unit) \$14995 Shpg. Wt. 162 lbs.
 MODEL SC-1 (speaker enclosure) \$3995 each Shpg. Wt. 42 lbs.

Plan your own Hi-Fi System...
HEATHKIT
 A subsidiary of Daystrom, Inc. • Benton Harbor 15, Michigan



HIGH FIDELITY RECORD CHANGER KIT
 \$6495
 MODEL RP-3
 HEATHKIT

Every outstanding feature you could ask for in a record changer is provided in the Heathkit RP-3, the most advanced changer on the market today. The unique turntable pause during the change cycle saves wear and tear on your records by eliminating the grinding action caused by records dropping on a moving turntable or disk. Record groove and stylus wear are practically eliminated through proper weight distribution and low pivot point friction of the tone arm. Clean mechanical simplicity and precision parts give you turntable performance with the automatic convenience of a record changer. Flutter and wow, a major problem with automatic changers, is held to less than 0.18% RMS. An automatic speed selector position allows intermixing 3 1/3 and 45 RPM records regardless of their sequence. Four speeds provided: 16, 33 1/3, 45 and 78 RPM. Changer is supplied complete with GE VR II cartridge with diamond LP and sapphire 78 stylus, changer base, stylus pressure gauge and 45 RPM spindle. Shpg. Wt. 19 lbs.

CHAIRSIDE ENCLOSURE KIT

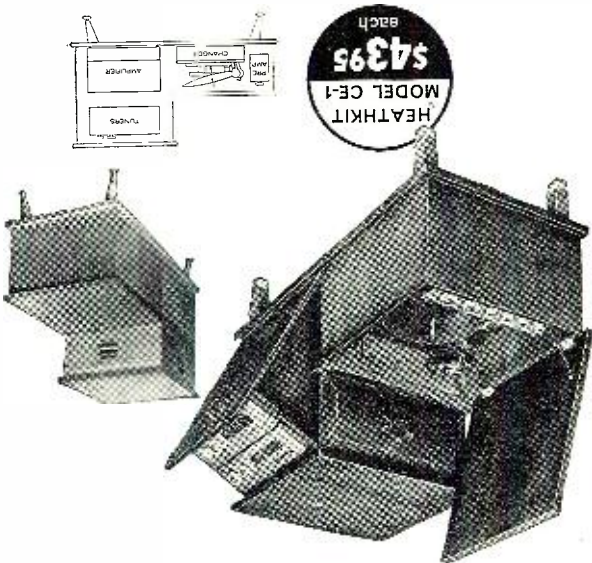

HEATHKIT MODEL CE-1
 \$7395 each

Combine all of your hi-fi equipment into one compact control center and, at the same time add a beautiful piece of furniture to your home. The CE-1 is designed to house AM and FM tuners (BC-1A and FM-3A) and the WA-P2 preamplifier along with the majority of record changers which will fit in the space provided. Changer compartment measures 17 3/4" L. x 16" W. x 9 1/2" D. Adequate space is provided in the rear of the unit to house any of the Heathkit amplifiers designed to operate with the WA-P2. Good ventilation is achieved through properly placed slots in the bottom and back of the enclosure. Overall dimensions are 18" W. x 24" H. x 35 1/2" D. All parts are pre-cut and predrilled for easy assembly. The temporary cabinet is available in either mahogany or birch, and the Traditional cabinet is available in mahogany suitable for the finish of your choice. Beautiful hardware supplied. Shpg. Wt. 46 lbs.

Far below the cost of crystals to obtain the same frequency coverage this VFO covers 160, 80, 40, 20, 15, 11 and 10 meters with three basic oscillator frequencies. Better than 10 volts RF output on fundamental. Requires only 250 volts DC at 15 to 20 ma, and 6.3 VAC at 0.45 a. Illuminated dial reads direct. Shpg. Wt. 7 lbs.

VARIABLE FREQUENCY OSCILLATOR KIT

MODEL VF-1 \$19.50



This easy-to-build device gives instant warning and cuts AC power to your transmitter when a monitored station goes "off-the-air". Use with any radio receiver having an AVC circuit. A sensitivity control adjusts to various AVC levels. Incorporates a heavy duty six-ampere relay and a manual "reset" button to reactivate the transmitter. Complete instructions provided for connection to receiver. Shpg. Wt. 4 lbs.

"ALARM KIT"

"AUTOMATIC" CONRAD

MODEL CA-1 \$13.95



Use with any receiver with IF frequency between 450 and 460 kc to add additional selectivity for separating two signals or to reject one signal and eliminate heterodyne. A great help on crowded phone and CW bands. Not for use with AC-DC type receivers. Simple to connect with cable and plugs supplied. Shpg. Wt. 3 lbs.

"Q" MULTIPLIER KIT

MODEL QF-1 \$9.95

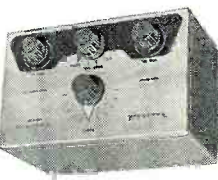

This unique device lets you switch from receiver to transmitter merely by talking into your microphone. Provision is made for receiver and speaker connections and also for a 117 volt antenna relay. Adjustable to all conditions by sensitivity and variable time delay controls provided. Shpg. Wt. 5 lbs.

ELECTRONIC VOICE CONTROL KIT

MODEL VX-1 \$23.95



Unbalanced coax lines can be matched to balance lines of either 75 or 300 ohms by using this balun coil kit. Use without adjustment from 80 through 10 meters at power up to 200 watts. May be located any distance from transmitter or antenna. Protective cover included. Shpg. Wt. 4 lbs.

BALUN COIL KIT

MODEL B-1 \$8.95



Brand new in every respect, the model VHF-1 "Seneca" is the latest addition to our line of ham transmitters. This self-contained 6 and 2 meter transmitter features built-in VFO, modulator, and dual power supply. A pair of 6146 tubes are employed in the push-pull final amplifier stage and features up to 120 watts input on phone and 140 watts input on CW in the 6 meter band. Slightly less in the 2 meter band to prolong amplifier tube life. Panel controls allow VFO or crystal control, phone or CW operation on both amateur bands. Four switch-selected crystal positions. Complete RF shielding to minimize TVI. Spotting rule type dial features edge-lighting and vernier tuning. An ideal transmitter for the ham who wants to extend operation into the VHF region. Shpg. Wt. 56 lbs.

"SENECA" VHF TRANSMITTER KIT

- Prewired and Aligned Coil/Bandswitch Assembly
- Crystal Controlled Oscillators for Drift-Free Reception

\$274.95

HEATHKIT MODEL RX-1



Many more important features are provided in this outstanding receiver for dependable and effective amateur communications. Ruggedly constructed with well rated components throughout. Shpg. Wt. 66 lbs. Matching accessory speaker kit; optional extra. Model AK-5, \$9.95. Shpg. Wt. 8 lbs.

"BASIC RANGE" HI-FI SPEAKER SYSTEM KIT

The popularity of this modestly priced speaker system attests to its high fidelity performance. The SS-2 provides an ideal basic speaker for your home hi-fi system. Flexibility of design allows it to be used as a table top model or as an attractive console table with optional legs. May also be used as a supplementary speaker in more advanced systems or as replacement speaker for TV sets, etc. The specially designed tweeter horn rotates 90 degrees allowing you to use the speaker in an upright position if desired, as in the Heathkit stereo wing speaker enclosures. Total frequency range is from 50 to 12,000 cycles-per-second. An 8" mid-range woofer covers from 50 to 1,600 CPS while a compression-type tweeter with flared horn covers 1,600 to 12,000 CPS. Both speakers are by Jensen. A variable balance control allows level adjustment of the high frequency speaker. Power rating is 25 watts. Constructed of 1/2" veneer-surfaced plywood suitable for light or dark finish. All wood parts are pre-cut and pre-drilled for simple, quick assembly. An added feature of the SS-2 is that, although an outstanding performer in its own right, it may be combined with the SS-1B "range extending" speaker system later to extend the frequency range at the high and low ends of the audio range. Build in just one evening for many years of listening enjoyment. Shpg. Wt. 26 lbs.

ATTRACTIVE BRASS TIP ACCESSORY LEGS convert SS-2 into handsome console table. 14" legs screw into brackets provided. All hardware included. Shpg. Wt. 3 lbs. No. 91-26. \$4.95.

Assemble it in

Just One Evening



HEATHKIT
MODEL SS-2
\$39⁹⁵

OPTIONAL LEGS
NO. 91-26 \$4.95

DIAMOND STYLUS HI-FI PICKUP CARTRIDGE

MODEL MF-1 \$26⁹⁵

Replace your present pickup with the MF-1 and enjoy the fullest fidelity your library of LP's has to offer. Designed to Heath specifications to offer you one of the finest cartridges available today. Nominally flat response from 20 to 20,000 CPS. Shpg. Wt. 1 lb.



"RANGE EXTENDING" HI-FI SPEAKER SYSTEM KIT

Designed exclusively for use with the SS-2, the SS-1B employs a 15" woofer and a super tweeter horn to extend the range of the SS-2 to an overall response of ± 5 db from 35 to 16,000 CPS. When used together the two units form an integrated four-speaker system and are designed to combine into a single piece of attractive furniture. Impedance of the SS-1B is 16 ohms and power rating 35 watts. A control is provided to limit the output of the super tweeter. Constructed of beautiful 3/4" veneer-surfaced plywood suitable for light or dark finish of your choice. All parts are pre-cut and pre-drilled for simple assembly. No woodworking experience required. All hardware included. Shpg. Wt. 80 lbs.

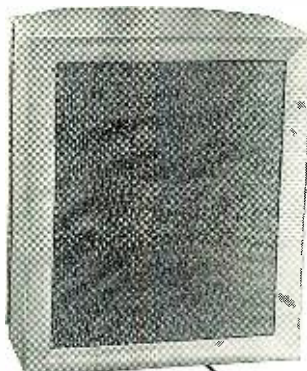

HEATHKIT
MODEL SS-1B
\$99⁹⁵

Extended
Frequency Range
for Your SS-2

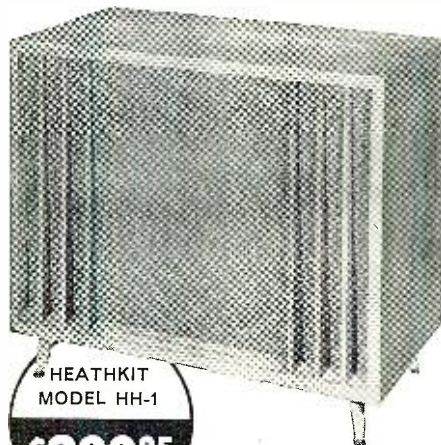

HEATHKIT
MODEL HH-1
\$299⁹⁵

"LEGATO" HI-FI SPEAKER SYSTEM KIT

It is difficult to describe in words the performance of this magnificent speaker system. You may never find absolute perfection in reproduced sound, but the Legato comes as close to achieving it as anything yet devised. Perfect balance, precise phasing, and adequate driver design combine to produce the superb quality of reproduction inherent in this instrument. The crisp, clear high frequencies and rich full bass engulf you in a sea of life-like tone. Two 15" Altec Lansing low frequency drivers cover frequencies from 25 to 500 CPS while a specially designed exponential horn with high frequency driver covers 500 to 20,000 CPS. The unique crossover network is built-in making electronic crossovers unnecessary. The Legato emphasizes simplicity of line and form to blend with modern or traditional furnishings. Constructed of 3/4" veneer-surfaced plywood in either African mahogany or white birch suitable for light or dark finishes of your choice. All parts are pre-cut and pre-drilled for easy assembly. Shpg. Wt. 195 lbs.

Easy to buy...

Easy to build

Easy to use...



**HEATH
COMPANY**

Benton Harbor 15,
Michigan

High Fidelity AM
and FM reception
in a Single Set



Professional Stereo-Monaural AM-FM Tuner Kit

Enjoy stereophonic broadcasts as well as outstanding individual AM and FM radio reception with this deluxe 16-tube AM-FM-stereophonic tuner combination. Features include three etched circuit boards for high stability and ease of construction, prewired and prealigned FM front end, built-in AM rod antenna, tuning meter, FM-AFC (automatic frequency control) with on-off switch, and flywheel tuning. A multiplex jack is also provided. AM and FM circuits are tuned individually making it ideal for stereo applications since both AM and FM can be used at the same time. A switch selected tuning meter functions on either AM or FM. Cathode follower outputs with individual level controls are provided for both AM and FM. Other features include variable AM bandwidth, 10 kc whistle filter, tuned-cascade FM front end, FM AGC and amplified AVC for AM. Anywhere from 1 to 4 limiters or IF's assure smooth, non-flutter reception on weak or strong stations alike. The silicon diode power supply is conservatively rated and is fuse-protected assuring long service life. Flywheel tuning combined with new edge-lighted slide-rule dial provide effortless tuning. Use of three printed circuit boards greatly simplifies construction. Vinyl-clad steel cover is black with inlaid gold design. Shpg. Wt. 20 lbs.

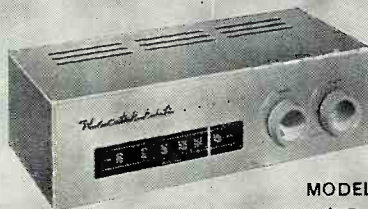

MODEL FM-3A
\$26.95

HIGH FIDELITY FM TUNER KIT

The Heathkit FM-3A Tuner will provide you with years of inexpensive hi-fi enjoyment. Features broad-banded circuits for full fidelity and better than 10 uv sensitivity for 20 db of quieting. Covers the complete FM band from 88 to 108 mc. Stabilized, temperature-compensated oscillator assures negligible drift after initial warmup. Employs a high gain cascode IF amplifier and has AGC. Power supply is built-in. IF and ratio transformers are prealigned as is the front end tuning unit. Two outputs provided, one fixed, one variable, with extra stage of amplification. Shpg. Wt. 8 lbs.

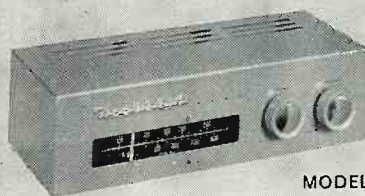

MODEL BC-1A
\$26.95

HIGH FIDELITY AM TUNER KIT

The BC-1A incorporates many features not usually expected in an AM circuit particularly in this low price range. It features a special detector using crystal diodes and broad band-width IF circuits for low signal distortion. Audio response is ± 1 db from 20 CPS to 9 kc with 5 db of pre-emphasis at 10 kc to compensate for station rolloff. Covers the complete broadcast band from 550 to 1600 kc. Prealigned RF and IF coils eliminate the need for special alignment equipment. Incorporates AVC, two outputs, two antenna inputs and built-in power supply. Shpg. Wt. 9 lbs.



MODEL W-6 \$109.95

**"HEAVY DUTY" 70 WATT
HI FI AMPLIFIER KIT**

Designed for "rugged duty" called for by advanced hi-fi systems and P.A. networks. Silicon diode rectifiers assure long life and heavy duty transformer provides excellent power supply regulation. Variable damping control provides optimum performance with any speaker system. Quick change plug selects 4, 8 and 16 ohm or 70 volt output and the correct feedback resistance. Shpg. Wt. 52 lbs.



MODEL W-5 \$59.75

**25 WATT HI FI
AMPLIFIER KIT**

Enjoy the distortion-free high fidelity sound from one of the most outstanding hi-fi amplifiers available today. Features include a specially designed Peerless output transformer and KT66 tubes. Frequency response is ± 1 db from 5 to 160,000 CPS at 1 watt and within 2 db 20 to 20,000 CPS at full 25 watts output. Hum and noise are 99 db below 25 watts. Shpg. Wt. 31 lbs.



MODEL W-4AM \$39.75

**SINGLE CHASSIS 20 WATT
HI FI AMPLIFIER KIT**

A true Williamson-type high fidelity circuit, the W-4AM features 5881 push-pull output tubes and a special Chicago-Standard output transformer to guarantee you full fidelity at minimum cost. Harmonic distortion is 1.5% and IM distortion is below 2.7% at full 20 watt output. Hum and noise are 95 db below full output. Taps for 4, 8 or 16 ohm speakers. Shpg. Wt. 28 lbs.



MODEL W-3AM \$49.75

**DUAL CHASSIS 20 WATT
HI FI AMPLIFIER KIT**

Another famous Williamson-type high fidelity circuit, the W-3AM features the famous Acrosound TO-300 "ultralinear" output transformer and 5881 tubes. The power supply and main amplifier are on separate chassis for installation flexibility. Harmonic distortion is less than 1% and IM distortion is less than 1.2% at 20 watts. Shpg. Wt. 29 lbs.



HEATHKIT
MODEL SP-2
(STEREO)
\$56⁹⁵

Monaural-Stereo Preamplifier Kit (2-Channel Mixer)

This unique kit allows you to purchase it in the monaural model if desired and then add the second or stereo channel later. The SP-2 features 12 separate inputs, six on each channel, with input level controls. Six dual concentric controls consist of: two 8-position selector switches, two bass, two treble, two volume level and two loudness controls, a scratch filter switch and a 4-position function switch. A separate on-off switch is provided. The function switch provides settings for stereo, 2-channel mix, channel A or B for monaural use. Inputs consist of tape, mike, mag phono and three high-level inputs. NARTB equalization and RIAA, LP, 78 record compensation are provided. A remote balance control is included. Printed circuit boards for easy assembly. Built-in power supply. Shpg. Wt. 15 lbs.

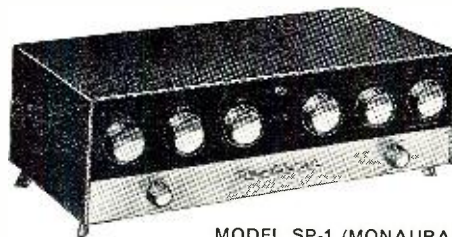

MODEL SP-1 (MONAURAL)
\$37⁹⁵ Shpg. Wt. 13 lbs.

MODEL C-SP-1 (CONVERTS SP-1 TO SP-2)
\$21⁹⁵ Shpg. Wt. 5 lbs.



HEATHKIT
MODEL WA-P2
\$19⁷⁵

"MASTER CONTROL" PREAMPLIFIER KIT

Control your hi-fi system with this compact unit. Features 5 switch-selected inputs to accommodate a record changer, tape recorder, AM tuner, FM tuner, TV receiver, microphone, etc., each with level control. Provision also for a tape recorder output. Equalization for records through separate turnover and rolloff switches for LP, RIAA, AES and early 78's. Shpg. Wt. 7 lbs.

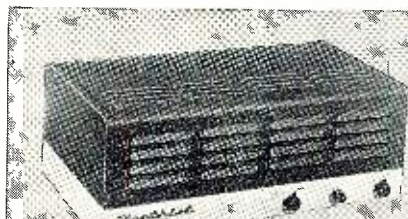

MODEL W-7M
\$54⁹⁵

"EXTRA PERFORMANCE" 55 WATT HI-FI AMPLIFIER KIT

Enjoy this high fidelity power amplifier at less than a dollar per watt. Full audio output and maximum damping is conservatively rated at 55 watts from 20 CPS to 20 kc with less than 2% total-harmonic distortion throughout the entire range. Features famous "bas-bal" circuit, EL-14 output tubes and special 70 volt output. Shpg. Wt. 28 lbs.



MODEL UA-1
\$21⁹⁵

"UNIVERSAL" 12 WATT HI-FI AMPLIFIER KIT

The versatility and economy of this fine kit make it a truly "universal" hi-fi amplifier. An ideal basic amplifier for any hi-fi system or a perfect addition to gear your present hi-fi system to stereo sound. Uses 6BQ5 EL84 push-pull output tubes for less than 2% harmonic distortion throughout the entire audio range. Shpg. Wt. 13 lbs.

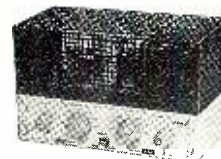

MODEL
XO-1
\$18⁹⁵

ELECTRONIC CROSSOVER KIT

This unique instrument separates high and low frequencies and feeds them through 2 amplifiers into separate speakers. Located ahead of the main amplifier, it virtually eliminates IM distortion and matching problems. Note: Not for use with Heathkit Legato speaker system. Shpg. Wt. 6 lbs.



MODEL A-9C **\$35⁵⁰**

GENERAL-PURPOSE 20 WATT AMPLIFIER KIT

Designed for home installation as well as for PA requirements, the A9-C combines a preamplifier, main amplifier and power supply all on one chassis. Four switch-selected inputs are provided as well as separate bass and treble tone controls offering 15 db boost and cut. Detachable front plate allows for custom installation. Shpg. Wt. 23 lbs.



MODEL SW-1 **\$24⁹⁵**

SPEEDWINDER KIT

A real timesaver; the SW-1 leaves your tape recorder free for operation while rewinding tape at the rate of 1200 feet in 40 seconds. Prevents unnecessary wear to the tape and recorder. Handles up to 10½" tape reels. Handles 800' reels of 8 and 16 millimeter film as well. Automatic shutoff prevents whipping at end of rewind. Shpg. Wt. 12 lbs.



NO. 401-6
\$7⁵⁰

12" UTILITY SPEAKER KIT

Replace inferior speakers in radio or TV sets to obtain better tone quality or set up an auxiliary speaker for testing purposes with this convenient, high quality speaker. The speaker will handle up to 12 watts with a frequency response of ±5 db from 50 to 9,000 CPS. Speaker impedance is 8 ohms and has a 6.8 oz. magnet. An outstanding dollar value. Shpg. Wt. 7 lbs.

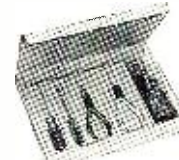

MODEL TK-1 **\$9⁹⁵**

COMPLETE TOOL SET

These basic tools are all you need to build any Heathkit. The pliers, diagonal side cutters, 2 screwdrivers, and soldering iron are all of top quality case hardened steel for hard duty and long life. Pliers and side cutters are equipped with insulated rubber handles for safety. A good example of just how easy Heathkit building really is. Shpg. Wt. 3 lbs.

HIGH FIDELITY TAPE RECORDER KIT

The model TR-1A tape deck and preamplifier combination provides all the facilities you need for top quality monaural recording/playback with fast forward and rewind functions. $7\frac{1}{2}$ and $3\frac{3}{4}$ IPS tape speeds are selected by changing belt drive. Flutter and wow are held to less than 0.35%. Frequency response at $7\frac{1}{2}$ IPS ± 2.0 db 50-10,000 CPS, at $3\frac{3}{4}$ IPS ± 2.0 db 50-6,500 CPS. Both units may be mounted together or separately affording high flexibility in every application. Features include NARTB playback equalization—separate recording and playback gain controls—cathode follower output and provision for mike or line input. Signal-to-noise ratio is better than 45 db below normal recording level with less than 1% total harmonic distortion. A filament balance control allows adjustment for minimum hum level. Complete instructions provided for easy assembly. Overall dimensions of tape deck and preamp is $15\frac{1}{2}$ " W. x $13\frac{1}{2}$ " H. x 8" D. Shpg. Wt. 24 lbs.



Includes tape deck assembly, preamplifier and roll of tape.



HEATHKIT
TE-1
\$39.95

Tape preamplifier sold separately if desired. Shpg. Wt. 10 lbs.



Many more Heathkits to choose from

hi-fi: Amplifiers—Preamplifiers—Speaker Systems—AM/FM Tuners—Equipment Cabinets—Record Player—Tape Recorder—Electronic Crossover—Stereo Equipment.

test: Oscilloscopes—Voltmeters—RF Signal Generators—AF Generators—Analyzers—Battery Eliminators—Tube Checkers—Condenser Checkers—Computer—Color Bar & Dot Generator—Sweep Generator—Impedance Bridge—Power Supplies—Probe Kits—R/C Decade & Substitution Kits.

ham radio: Transmitters—Receivers—Antenna Accessories—Voice Control—Conelrad Alarm—Variable Frequency Oscillator—SSB Adapter—"Q" Multiplier.

marine: Direction Finders—Marine Converter—Rudder Position Indicator—Fuel Vapor Detector—Charge Indicator—Power Meter.

general: Tool Set—6-Transistor Portable Radio—Radiation Counter—Electronic Timer—Crystal Receiver—Superheterodyne Receiver.

Send for Catalog describing over 100 easy-to-build electronic instruments in kit form. Complete specifications and detailed information on Hi-Fi—Test—Ham and Marine kits.

Save with Heathkits...the quality name in kit form electronics.



'BOOKSHELF' 12 WATT AMPLIFIER KIT

Here are a few of the reasons why this attractive amplifier is such a tremendous dollar value. You get rich, full range, high fidelity sound reproduction with low distortion and noise . . . plus "modern styling". The many features include full range frequency response 20 to 20,000 CPS ± 1 db with less than 2% distortion over this range at full 12 watt output—its own built-in preamplifier with provision for three separate inputs: mag phono, crystal phono, and tuner—RIAA equalization—separate bass and treble tone controls—special hum control—and it's easy-to-build. Complete instructions and pictorial diagrams show where ever part goes. Cabinet shell has smooth leather texture in black with inlaid gold design. Cabinet measures 12½" W. x 8¾" D. x 4¾" H. Output transformer has taps at 4, 8 and 16 ohms to match the speaker of your choice. An ideal unit to convert your present hi-fi system to stereo sound. Shpg. Wt. 15 lbs.

An Amplifier, Preamplifier

all in one!



HEATHKIT
EA-2
\$28⁹⁵

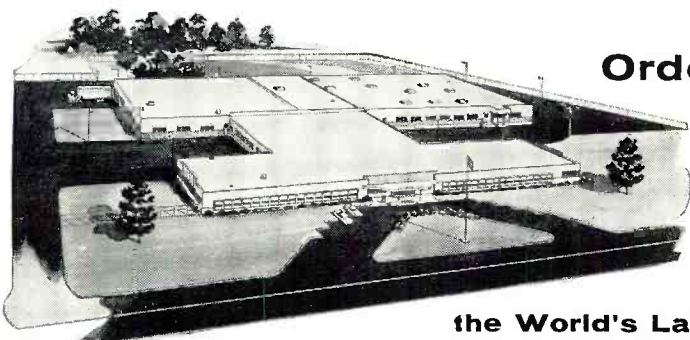

Order direct by mail...

Save ½ or more over equivalent ready-made products by buying direct and assembling them yourself. Heathkit Style, Performance and Quality are unsurpassed!

the World's Largest Manufacturer
of Electronic Instruments in Kit Form



HEATH COMPANY BENTON HARBOR 15, MICH.

H a subsidiary of Daystrom, Inc.

NOTE: all prices and specifications subject to change without notice.

Enclosed find () check () money order. Please ship C.O.D. ()

On Express orders do not include transportation charges—they will be collected by the express agency at time of delivery.

On Parcel Post Orders include postage for weight shown. All prices are NET F.O.B. Benton Harbor, Michigan, and apply to Continental U.S. and Possessions only. 20% Deposit required on all C.O.D. orders.

Name _____
 Address _____
 City & Zone _____ State _____
(PLEASE PRINT)

SHIP VIA
 Parcel Post
 Express
 Freight
 Best Way

QUANTITY	ITEM	MODEL NO.	PRICE
<input type="checkbox"/> SEND FREE HEATHKIT CATALOG		POSTAGE	
		TOTAL	

HEATHKITS are also available at your Dealer

see listing on next page



Authorized **HEATHKIT** Dealers

Convenient "over-the-counter" delivery



... is now available through any of the Authorized Heathkit Dealers listed below. Although you will find the price of Heathkits slightly higher when buying locally, we're sure you'll agree that this increase is justified. Your dealer absorbs all transportation charges, carries a complete stock of kits for immediate delivery, provides demonstration facilities, offers you a reliable source for parts and fast service... and stands ready to counsel or advise you on any problem that might arise.

This new service does not affect your continued privilege to buy directly from Heath Company if you prefer.

NOW READY TO SERVE YOU...

CALIFORNIA
zackIT CORPORATION
 2002 University Avenue
 Berkeley 4, California
DUNLAP RADIO & TV
 928 Main Street
 Chico, California
TELRAD ELECTRONICS
 128 East Main Street
 El Cajon, California
DUNLAP RADIO & TV
 2617 Tulare Street
 Fresno, California
BUSHNELL SOUND CORP.
 12024 Wilshire Boulevard
 Los Angeles, California
KIERULFF SOUND CORP.
 820 West Olympic Boulevard
 Los Angeles, California
DUNLAP RADIO & TV
 5th & "J" Street
 Marysville, California
DUNLAP RADIO & TV
 419 10th Street
 Modesto, California
DUNLAP RADIO & TV
 234 West 17th Street
 Merced, California
TELRAD ELECTRONICS
 639 National
 National City, California
ZACK RADIO SUPPLY
 654 High Street
 Palo Alto, California
DUNLAP RADIO & TV
 1800 22nd Street
 Sacramento, California
TELRAD ELECTRONICS
 3453 University Avenue
 San Diego, California
ZACK RADIO SUPPLY
 1422 Market Street
 San Francisco, California
DUNLAP RADIO & TV
 27 North Grant Street
 Stockton, California
VALLEY SOUND CORPORATION
 18841 Ventura Boulevard
 Tarzana, California
DUNLAP RADIO & TV
 1725 Mooney Avenue
 Visalia, California

DELAWARE
RADIO ELECTRIC SERVICE
 Third & Tenth Streets
 Wilmington, Delaware

FLORIDA
THUROW DISTRIBUTORS, INC.
 540 St. Johns Street
 Cocoa, Florida
THUROW DISTRIBUTORS, INC.
 1800 Northwest 23rd Street
 Miami, Florida

INDIANA
GOLDEN EAR, INCORPORATED
 15 East 18th Street
 Indianapolis, Indiana
GOLDEN EAR, INCORPORATED
 24 West Washington
 Indianapolis, Indiana
GOLDEN EAR, INCORPORATED
 108 Northwestern
 West Lafayette, Indiana

KENTUCKY
GOLDEN EAR, INCORPORATED
 610 Third Street
 Louisville, Kentucky

LOUISIANA
STERLING RADIO PROD., INC.
 1005 Cameron Street
 LaFayette, Louisiana

MARYLAND
RADIO ELECTRIC SERVICE
 736 South Salisbury Blvd.
 Salisbury, Maryland

MASSACHUSETTS
AUDIONICS, INCORPORATED
 1348 Boylston Avenue
 Boston 15, Massachusetts

MICHIGAN
VOLTA ELECTRONICS
 6716 Park Avenue
 Allen Park, Michigan
HIGH FIDELITY WORKSHOP
 16400 West Seven Mile Road
 Detroit 35, Michigan

MINNESOTA
AUDIO KING COMPANY
 913 West Lake Street
 Minneapolis 8, Minnesota

NEW JERSEY
RADIO ELECTRIC SERVICE
 452 North Albany Avenue
 Atlantic City, New Jersey
RADIO ELECTRIC SERVICE
 513 Cooper Street
 Camden, New Jersey
FEDERATED PURCHASER, INC.
 1021 U.S. Route #22
 Mountainside, New Jersey
FEDERATED PURCHASER, INC.
 114 Hudson Street
 Newark, New Jersey

NEW YORK
CROSS ISLAND ELEC., INC.
 247-40 Jericho Turnpike
 Bellerose, New York
ACME ELECTRONICS, INC.
 59 Willoughby Street
 Brooklyn, New York
GEM ELECTRONICS, INC.
 34 Hempstead Turnpike
 Farmingdale, New York
BEAM ELECTRONICS, INC.
 101-10 Queens Boulevard
 Forest Hills, New York
GEM ELECTRONICS
 236 Broadway
 Hicksville, New York
ARROW ELECTRONICS, INC.
 525 Jericho Turnpike
 Mineola, New York
DAVIS RADIO DIST. INC.
 70 East Third Street
 Mt. Vernon, New York
ARROW ELECTRONICS, INC.
 65 Cortlandt Street
 New York, New York
HARVEY RADIO COMPANY
 103 West 43rd Street
 New York, New York

OREGON
ECCLES ELECTRIC CO.
 237 Northeast Broadway
 Portland, Oregon
CECIL FARNES COMPANY
 440 Church Street, Northeast
 Salem, Oregon

Careful selection of reliable qualified dealers is a slow process... so please bear with us if your area has not been covered. Thank you.

PENNSYLVANIA
FEDERATED PURCHASER, INC.
 1115 Hamilton Street
 Allentown, Pennsylvania
FEDERATED PURCHASER, INC.
 925 Northampton Street
 Easton, Pennsylvania
AUSTIN ELECTRONICS, INC.
 1421 Walnut Street
 Philadelphia, Pennsylvania
RADIO ELECTRIC SERVICE
 701 Arch Street
 Philadelphia, Pennsylvania
RADIO ELECTRIC SERVICE
 3412 Germantown Avenue
 Philadelphia, Pennsylvania
RADIO ELECTRIC SERVICE
 5930 Market Street
 Philadelphia, Pennsylvania
RADIO ELECTRIC SERVICE
 29 York Road
 Willow Grove, Pennsylvania
RADIO ELECTRIC SERVICE
 1114 Roosevelt Ext.
 York, Pennsylvania

RHODE ISLAND
AUDIONICS, INCORPORATED
 790 North Main Street
 Providence, Rhode Island

TEXAS
STERLING RADIO PROD., INC.
 1160 Laurel Street
 Beaumont, Texas
STERLING RADIO PROD., INC.
 2615 Texas Avenue
 Bryan, Texas
HILLCREST RECORDS, INC.
 6309 Hillcrest Avenue
 Dallas, Texas
SOUND EQUIPMENT, INC.
 2506 Crawford Street
 Houston, Texas
STERLING RADIO PROD., INC.
 1616 McKinney Avenue
 Houston, Texas
STERLING RADIO
 428 Atkinson Street
 Lufkin, Texas

VIRGINIA
KEY ELECTRONICS, INC.
 126 South Wayne Street
 Arlington, Virginia

WASHINGTON
SEATTLE RADIO SUPPLY
 2117 Second Avenue
 Seattle 1, Washington

WISCONSIN
HI-FI CORNER
 401 State Street
 Madison, Wisconsin
SATTERFIELD ELEC., INC.
 1900 South Park
 Madison, Wisconsin
HI-FI CENTER, INC.
 4236 West Capitol Drive
 Milwaukee, Wisconsin
NETZOW'S
 2630 North Downer Avenue
 Milwaukee, Wisconsin

Mac's Service Shop (Continued from page 52)

ing in the oscillator coil and I had to replace the coil. This coil must be bad, too, although the windings show continuity. Guess it must have shorted turns or something.

"What really bugs me though is that the owner said the pilot lamp went out and the set quit playing. That makes sense, for the filament of the output tube was open. But when I put in a new tube the set still wouldn't play and then I found the oscillator wasn't working. It's kind of a coincidence that the coil and the tube should go out at the same time. The owner had been into it, for some of the tubes were in the wrong socket. Maybe he fouled up the oscillator coil by putting the wrong tube in the socket. Anyway, I've put in a new oscillator coil; so let's hear it play."

Barney turned on the receiver, but no sound came from the speaker except a low hum. "What do you know! Guess it wasn't the coil after all," he said in chagrin.

"How about the mixer tube and the oscillator grid capacitor?" Mac asked helpfully.

"Both OK," Barney said promptly. "I checked them before taking out the old coil."

Mac looked down at the receiver on the bench for a minute and then reached over and gently pulled on a wire that ran from the loop antenna on the back of the receiver to the ganged tuning capacitor. The end of the wire flipped loose from the tuning capacitor and the set began to play at once.

"OK, you smart aleck, what did you do?" Barney demanded.

"Just what you asked me to do: I listened to you," Mac said blandly.

"What did I say that gave you a clue?"

"You said the owner had been into the set. I tried to put myself in his place and look at the receiver. I know non-technical people are always looking for a 'loose wire' in a radio. To such a person, the short external antenna lead on the loop would seem to be just such a loose wire. When he looked for the point from which the wire might come, he spied that empty little eyelet connection on one end of the stator of the oscillator section of the tuning capacitor and he thrust the bared end of the wire through the hole. That failed to restore the receiver to operation; so he bundled the set up and brought it to us with the wire still in place."

"And I, like a big dope, never saw it," Barney finished bitterly.

"Don't be too hard on yourself. Your judgment was still fogged by the memory of the recent dead-oscillator set you had repaired and you couldn't think of anything but another bad coil. We all tend to expect recent experiences to repeat themselves in servicing.

HEATH COMPANY
 Benton Harbor, Mich.

A Subsidiary of **Daystrom, Inc.**

Some technicians carry this to an extreme and insist on replacement of certain components in radio and TV sets right off without making sufficient checks to make sure these components are bad. If this fails to restore proper operation, then they go ahead to find what actually is wrong. As a result I have known technicians called 'Resistor Ralph,' 'Picture Tube Paul,' 'Filter Capacitor Frank,' 'Transformer Tom,' and so on. Just make sure I don't have 'Bad Coil Barney' working for me."

"Oakie doakie, Boss," Barney said with a sheepish smile. "I'll watch it. But I'm convinced you do a better job of 'no-hands' telephoning than I do of 'no-head' servicing!"

MARS SCHEDULES FOR MARCH

THE FIRST Army MARS SSB Technical Net, which operates on 4030 kc. upper sideband, Wednesdays at 9 p.m. (EST), has announced the following speakers for March.

March 4—"Frequency Measurements" by Herbert D. Tanzman, Project Engineer, Frequency Control Div., U.S. Army Signal Research and Development Laboratory, Ft. Monmouth.

March 11—"Principles of Radio Direction Finding" by Paul G. Hansel, Engineer-in-Charge, Radio Engineering Dept., Servo Corp. of America.

March 18—"Some Aspects of Grounded Grid Amplifiers" by George Grammer, Technical Director, ARRL.

March 25—"Antennas" by Michael D. Ercolino, President and Chief Engineer, Telrex, Inc.

* * *

THE WESTERN Technical Net of Air Force MARS offers the following program of speakers for March with transmissions on 7832.5 and 3295 kc. and 143.46 mc. Sundays from 2 to 4 p.m. (PST).

March 1—"Environmental Testing of Electronic Equipment and Components" by Eric Edberg, Chief Test Engineer, Varian Associates.

March 8—"Microwave Radiometers" by Don Harris, G-E Microwave Laboratories.

March 15—"Navcom 100 V.H.F. Aircraft Navigation and Communication Radio System" by Kenneth M. Miller, K6BNJ, Chief Engineer, LearCal Div., Lear, Inc.

March 22—"Miniaturization of Amateur Equipment" by W. R. Barstow, Lockheed Aircraft Corp.

March 29—"Equipment Utilization, Conversion Information and Project Reports" by USAF MARS Western Technical Net Members.

ANNUAL RTTY DINNER

THE SIXTH Annual Amateur Radio-Teletype Dinner will be held in New York City the evening of March 23. Technical discussions and demonstrations of teleprinter equipment are planned.

Reservations must be made in advance. Details are available from Clay Cool, W2EBZ, 443 West 47th St., New York 36, N. Y.

The RTTY dinner is held each year during the IRE National Convention, making it convenient for a maximum number of amateurs to attend.

Last year's event drew hams from as far away as Alaska and New Zealand.

-30-

March, 1959



FOR

GREATER

"SMALL-TUBE"



reliability

... replace with RCA

"Premiums" and

"Special Red" Tubes

Recommended wherever increased reliability of small-tube circuitry is important. Characteristics are uniform throughout useful life. Rigid controls and rigorous tests weed out "early failures". Designed and built to give dependable performance under conditions of shock and vibration. Available at RCA Industrial Tube Distributors.



RADIO CORPORATION OF AMERICA

Electron Tube Division

Harrison, N. J.

Handy data book RIT-104-A includes the tube characteristics you need to know when you install RCA "Premium" and "Special Red" Tubes. Free, from your RCA Industrial Tube Distributor.



prepare for your career in
ELECTRONICS
RADIO-TV
COMPUTERS

and other fields of
ELECTRICAL ENGINEERING



At MSOE, you can equip yourself for a career in many exciting, growing fields: **MISSILES • RADAR AUTOMATION • RESEARCH DEVELOPMENT • ELECTRICAL POWER • AVIONICS ROCKETRY**

When you graduate from the Milwaukee School of Engineering, you are prepared for a dynamic career as an Electrical Engineer or Engineering Technician. Under a faculty of specialists, you gain a sound technical education in modern, completely equipped laboratories and classrooms. As a result, MSOE graduates are in great demand and highly accepted by industries nationally.

At MSOE you will meet men from all walks of life and all parts of the country—some fresh out of high school or prep school, others in their twenties—veterans and non-veterans.

You can start school in any one of four quarters and begin specializing immediately. Engineering technicians graduate in 2 years with an Associate in Applied Science degree. For a Bachelor of Science degree in Engineering, you attend 4 years. A 3-month preparatory course also is available.



FREE CAREER BOOKLET!

If you're interested in any phase of electronics, radio or television, be sure to look into the programs of study offered by the Milwaukee School of Engineering. Just mail the coupon.

MS-114

MILWAUKEE SCHOOL OF ENGINEERING

Dept. RT 359, 1025 N. Milwaukee St.
 Milwaukee, Wisconsin

Please send FREE Career Booklet. I'm interested in Electronics Electrical Power Television Mechanical Engineering Radio Electrical Engineering Computers Industrial Electronics

Name..... Age.....
 PLEASE PRINT

Address.....

City..... Zone..... State.....

I'm eligible for veterans education benefits

Service Association of the Month



TEA OF SAN ANTONIO, TEXAS

MEMBERS of the electronics service industry in Texas have won themselves a nationwide reputation for "getting things done." The statewide Texas Electronics Association, for example, has gained considerable recognition for its well managed annual electronics fair. One of its member groups, TEA of San Antonio, has run true to the regional flair for successful action.

Shrewdly acknowledging the power of womankind, it chartered a ladies' auxiliary, which is itself no insignificant body. Membership of the auxiliary is about three-quarters that of the association—an impressive figure when one considers that not all of the 28 San Antonio members have "auxiliary ladies!" In any case, this TEA affiliate is not likely to run into the distaff opposition that faces so many active association people in other parts of the country because their efforts take them away from their firesides. In other words, if you can't beat them—let them join you!

Faced with the common, touchy problem of customers who want credit, the group makes up a retail credit report, available to members on a monthly basis. Technicians looking for work and shop owners looking for help find the employment assistance service set up by TEA of San Antonio a valuable function. An investigating committee to facilitate action on any industry problems that may arise keeps the group on a standby basis, ready to act when the situation calls for action. Of great value in establishing confidence with the public is the consumer protection committee, which handles grievances of set owners. Recognition of the difficulties that service people experience everywhere in connection with business and financial matters has led

to the formation of a system of group bookkeeping. In addition to these efforts, TEA of San Antonio has done an exhaustive job of recording "fringe" service dealers who operate out of their homes in residential areas and reporting them to the Chief Building Inspector for violation of zoning regulations. This activity has received publicity in the San Antonio newspapers.

Prospective members must have state store licenses. They must also conduct their businesses in areas zoned for commercial use and satisfy the organization as a whole as to their good character and possession of satisfactory shop equipment. TEA of San Antonio takes its code of ethics quite seriously. Members are required to sign a legal form pledging that they will abide by the code and also adhere to the group's by-laws.

Located at 810 E. Commerce St. in San Antonio, this association boasts its own monthly, "SARTA News," which is edited by Kurt Wertheim. It holds two meetings every month, one for business matters and the other of an educational nature. Results of the annual election of officers for 1959 had not yet been reported at the time this was written. Officers for 1958 included C. W. Schertz, president; O. O. Brigman, vice-president; Donald Van Der Brugen, secretary; Tom Boyd, treasurer; and directors Roland Mueller and Ralph McCoy.

As its publication name indicates, the San Antonio organization was initially known as the San Antonio Radio & Television Association. The original seems to stick, although it has chosen to identify itself more closely with the state group with its present name. Organized in 1949, this body has been incorporated.

-30-

Would you like us to feature your association here? Send in the coupon!

Service Editor
 RADIO & TV NEWS
 1 Park Avenue
 New York 16, New York

We want to tell you more about our association. Please send us your questionnaire.

Name of Association.....

Mailing Address.....

Name of President or Corresponding Sec'y.....

How Rad'o-TV Serv'cemen are increasing their Annual Income \$2,000 to \$10,000

HERE'S YOUR KEY...A.S.P.G.

Throughout the country, ever-increasing numbers of service technicians like yourself are realizing increased business and profits, *without* additional effort or expense, through membership in the **APPLIANCE SERVICEMEN'S PURCHASING GROUP**. This dynamic, new merchandising group can help you increase *your* annual income too, easily, simply, with no interference with your regular service calls.

WHY IT'S "GOOD BUSINESS" TO BELONG TO A.S.P.G.

There's no magic formula to A.S.P.G., no secrets, no gimmicks. IT'S THIS SIMPLE! Through the tremendous purchasing power created by you and your numerous fellow servicemen, you are able to offer your *present* customers **NATIONALLY ADVERTISED APPLIANCES** (such as those you service) **AT SUBSTANTIAL SAVINGS**. Your mass purchasing power, through one central source (A.S.P.G.) enables you to buy for less, create customer good will by selling for less, and assures healthy profits for yourself on every sale!

SELLING IS EASY... THE A.S.P.G. WAY

When you make your normal service calls, simply inform your customers that you can offer them any and all nationally advertised appliances at substantial discounts. Show your customer the **MASTER A.S.P.G. catalog**, impressing the point that your professional experience can help her make a wiser decision. (REMEMBER, YOUR SALE IS 90% COMPLETED BEFORE YOU START... YOU ALREADY HAVE THE CUSTOMER'S CONFIDENCE!) Now, give her a chance to sell herself while you proceed with your repair work.

QUALITY AND DEPENDABILITY

ARE ALWAYS ASSURED... THE A.S.P.G. WAY

The **MASTER A.S.P.G. CATALOG**, which is included with your membership, lists the biggest, most accepted names in the appliance industry. You sell only the best... all nationally advertised, "pre-sold" merchandise that denotes quality and dependability... made by famous manufacturers who make your selling job easier by advertising in newspapers, radio, television and magazines. Such household appliances as refrigerators, ranges, washers, dryers, television receivers, radios, stereophonic hi-fi's, etc., that carry internationally-known brand names like Westinghouse, RCA, G.E., Grundig Majestic, Admiral, Zenith, Hotpoint, Philco, Sunbeam, Motorola, etc., are already known by your customers. **YOU SELL MORE CONFIDENTLY BECAUSE THE CUSTOMER HAS MORE CONFIDENCE IN THE PRODUCTS YOU SELL!**

A.S.P.G. FULL REFUND PRIVILEGE

If, after receiving the current copy of the Master A.S.P.G. Catalog and your Confidential Cost Book, you are not 100% satisfied with the A.S.P.G. program, return the catalog and cost book within 10 days. **A.S.P.G. GUARANTEES TO RETURN YOUR MEMBERSHIP FEE IMMEDIATELY.**

HERE'S HOW YOU JOIN A.S.P.G.

FILL OUT THIS MEMBERSHIP APPLICATION AND RETURN TO A.S.P.G. WITH YOUR MEMBERSHIP FEE... TODAY!

PROFITS COME EASY... THE A.S.P.G. WAY

With your membership, you receive the **CONFIDENTIAL A.S.P.G. DEALER PRICE LIST**, which shows you **YOUR COST** on the more than 1,500 items contained in the master catalog. *You* determine your own profit margin on each sale... and you collect directly from your customers.

HERE'S WHAT HAPPENS WHEN YOU JOIN A.S.P.G.

- You get the giant **A.S.P.G. CATALOG**, showing brand names, model numbers, descriptions, manufacturers' suggested retail list prices, and beautiful photographs of the entire nationally-advertised pre-sold appliances.

TWO ISSUES ARE PUBLISHED EVERY 12 MONTHS, SO THAT YOU AND YOUR CUSTOMERS CAN KEEP ABREAST OF THE LATEST STYLES AND MODELS AVAILABLE.

- You get the **MASTER A.S.P.G. CONFIDENTIAL COST BOOK**, showing your actual net cost on all merchandise displayed in the A.S.P.G. catalog. **THIS COST BOOK IS ISSUED TWICE A YEAR IN CONJUNCTION WITH THE CATALOG.**

- **YOU BENEFIT FROM A.S.P.G.'s** collective purchasing power, whether you buy one item at a time or a hundred. You deal with one—and only one source of supply, with no inventory to worry about!

- Your service business is not disturbed—you don't stock any inventory—you make no capital investment—you have no extra overhead, expend no extra effort.

- You sell only the best products—all backed by name-brand manufacturers.

- You set your own profit margins—you collect from your own customers.

- You receive all necessary sales "tools" to help your program—you are guided in all sales efforts by A.S.P.G.

A-S-P-G

MEMBERSHIP APPLICATION

Gentlemen: Enclosed please find my check or money order for full membership fee in A.S.P.G.

PLEASE CHECK ONE Three Years \$25.00 One Year \$10.00

Name _____

Company Name (if any) _____

Address _____

City _____ Zone _____ State _____

Signature _____

FILL OUT—MAIL TODAY—FOR IMMEDIATE RESULTS
Appliance Servicemen's Purchasing Group
469 E. Ohio St., Chicago 11, Ill.

APPLIANCE SERVICEMEN'S PURCHASING GROUP 469 E. Ohio St., Chicago 11, Ill.

March, 1959

91

JansZen*



sound without fury in 3 easy steps

Here's a compact, do-it-yourself speaker system that delivers realistic, transparent reproduction without the fury of bass or treble exaggerations. Perfectly matched Electrostatic mid/high range speakers and a dynamic woofer give measurably flat response over the entire audio spectrum. What's more, you need not be an expert cabinet maker. You create high fidelity at a sensible, do-it-yourself cost.

1

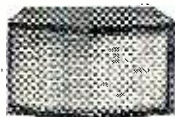

ELECTROSTATIC MID/HIGH RANGE SPEAKER

Model 65, illustrated, uses two JansZen electrostatic elements with a built-in power supply and high-pass filter. Each element contains 176 perfectly balanced, sheathed conductors to give absolutely clean response from 700 to beyond 30,000 cycles. Furnished complete in cabinet at \$86-\$91.50, depending on finish. Slightly higher in West.

Better yet . . . Model 130—considered as THE mid/high range speaker—contains four elements for a broad, 120° sound source. \$161-\$188, depending on finish. Slightly higher in West.

2



DYNAMIC WOOFER DRIVER

Specifically designed to complement the delicate clarity of JansZen Electrostatic Mid/High Range Speakers, the Model 350 Dynamic Woofer offers clean, honest bass, devoid of coloration, false resonances, hangover or boom. It is the only separately available woofer to give such clean response in so small an enclosure—only 2.2 cu. ft. Response is uncannily flat from 40 to 2000 cycles with excellent output to 30 cycles. Only \$44.50. Slightly higher in West.

3



DO-IT-YOURSELF WOOFER ENCLOSURE

Working with the plans we furnish with each woofer, you'll be able to build your own enclosure with basic tools. The enclosure is a sturdy, yet simple, totally enclosed cabinet. There are no tricky baffle arrangements or adjustments. Size without legs: 19" high x 25" wide x 13" deep. Cost of all materials should run about \$12 to \$18.

Discover JansZen clarity for yourself. Write for literature on JansZen's complete speaker systems and the name of your nearest dealer.

*including designs by Arthur A. Janszen and made only by NESHAMINY ELECTRONIC CORP. Neshaminy, Pa.

Export Div.: 25 Warren St., New York 7, N. Y.
Cable: Simontrice, N. Y.



"KNIGHT" 3-WAY SPEAKERS

Allied Radio Corporation, 100 N. Western Ave., Chicago 80, Ill. has added two new deluxe three-way speakers to its "Knight" line of audio gear.

Made in England especially for the company, the new speaker features massive magnet structures, compression-type tweeters, and vacuum-formed woofer cones with high-compliance suspension. The mid-frequency radiator cones are mounted coaxial to the woofers.

The Model KN-812 is a 12" unit which employs a 3½ pound magnet, has a frequency response of 30 to 20,000 cps, and a power handling capacity of 35 watts. The Model KN-815 is a 15" speaker with a 6¼ pound magnet, a frequency response of 25 to 20,000 cps, and power handling capacity of 50 watts. Both speakers are 7⅞" deep and have 16-ohm impedance. Each speaker has a high-frequency L-pad level control on a 30" cable. Frames are of extra heavy die-cast metal.

Write the company direct for prices and further details.

G-E'S DUAL PREAMP

The Speciality Electronic Components Department, General Electric Company, West Genesee St., Auburn, N. Y. has announced the development of a new dual stereophonic high-fidelity preamplifier, the "Stereo Classic" Model MF-1.

Featuring high sensitivity, low hum and noise, high channel separation, and individual switching for each channel to select phono or tape input, the new

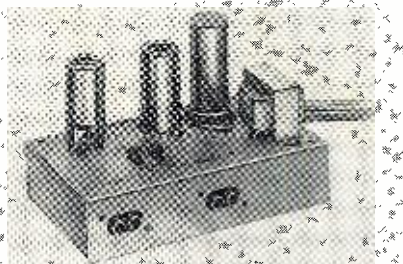

unit was designed for use primarily with magnetic stereo cartridges, for conversion of existing ceramic cartridge stereo systems where the necessary preamplification is not available in the system.

The MF-1 is also equipped for use with stereo tape heads. In addition to

providing two stages of preamplification in each channel, it offers proper feedback-type circuit equalization for discs and tape for very low distortion. It may also be used as a stereo headphone amplifier for individual listening and, with a minor circuit modification, as a high gain, monaural or stereo tape recorder microphone preamp. Its low impedance output of less than 10,000 ohms at 100 cps allows the use of an output cable up to 50 feet long.

Complete specifications are available from the manufacturer on request.

STEREO CONVERSION KITS

Fanon Electric Company, Inc., 98 Berriman St., Brooklyn, N. Y. has announced the availability of three new stereo conversion kits which permit the low cost modification of any monaural phonograph to play stereo disc recordings.

Each kit includes a self-contained amplifier and dual speaker system,

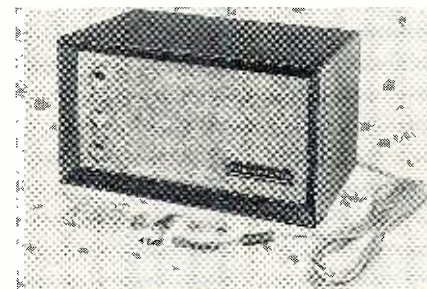

stereo turnover cartridge, and the necessary mounting accessories. Each has separate bass, treble, and volume controls.

The lowest priced conversion kit is the STK-4 which has a three-tube amplifier and two matched 4" phased speakers in a two-tone fabric-finished cabinet. A stereo cartridge kit and 15 feet of cable are included. The STK-10 has a 5-tube push-pull amplifier with separate bass, treble, and volume controls and a coax two-speaker system consisting of one 8" woofer and one 3" tweeter. This system comes in a hand-rubbed mahogany, walnut, or blonde cabinet and includes the stereo cartridge, accessories, and extension cable. This same 5-tube system is available in a two-tone fabric covered cabinet as the Model STK-5.

All of the units can be supplied, at reduced cost, without the stereo cartridge and mounting accessories.

GROMMES STEREO LINES

Grommes, Division of Precision Electronics Inc., 9101 King St., Franklin Park, Ill. is now offering two new

stereo series in its high-fidelity equipment line.

The "Premiere" series consists of the Model 40PG stereo amplifier, the Model 209 stereo preamp, the Model 240 basic stereo amplifier, the Model 103GT AM-

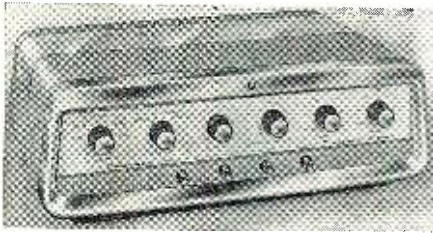

FM tuner, and Model 120GAT tuner-amplifier. The 212B preamplifier and 260A 60-watt basic amplifier are also included in the new series.

The "Custom" series consists of the Model 24PG stereo preamp, Model 214 stereo preamp, Model 101GT FM tuner, and Model 102GT FM-AM tuner.

The new lines have been distinctively designed in gold and white in leatherette cases. Modern pedestal styling contributes to the streamlined appearance of the units.

For specifications on any or all of the new units in either line, write the manufacturer direct.

BULK TAPE ERASER

Lafayette Radio, 165-08 Liberty Ave., Jamaica 33, N. Y., is now offering a professional-type bulk eraser for all magnetic recording tape applications.

The ML-120 is a heavy-duty degausser which will handle any reel up to and including 10½" in diameter. The field generator is strong enough to erase any tape without rewinding or flopping the reel.

In operation, the reel is placed over the spindle on the degausser, rotated until each segment of the reel passes over the field area several times, then lifted off slowly to a distance of six or more feet. The demagnetizer is then switched off and the tape is ready for



re-recording. The unit is also recommended for processing new tapes before being used in critical recording applications.

The circuit employs two transformers, drawing 6 amps at 117 volts a.c.; has an "on-off" switch and power-line fuse. The unit measures 6¼ x 7⅞ x 3½". Shipping weight is 14 pounds.

PERFORMANCE-MATCHED TUBES

Tung-Sol Electric Inc., Newark, N. J., is now performance-matching its 6550

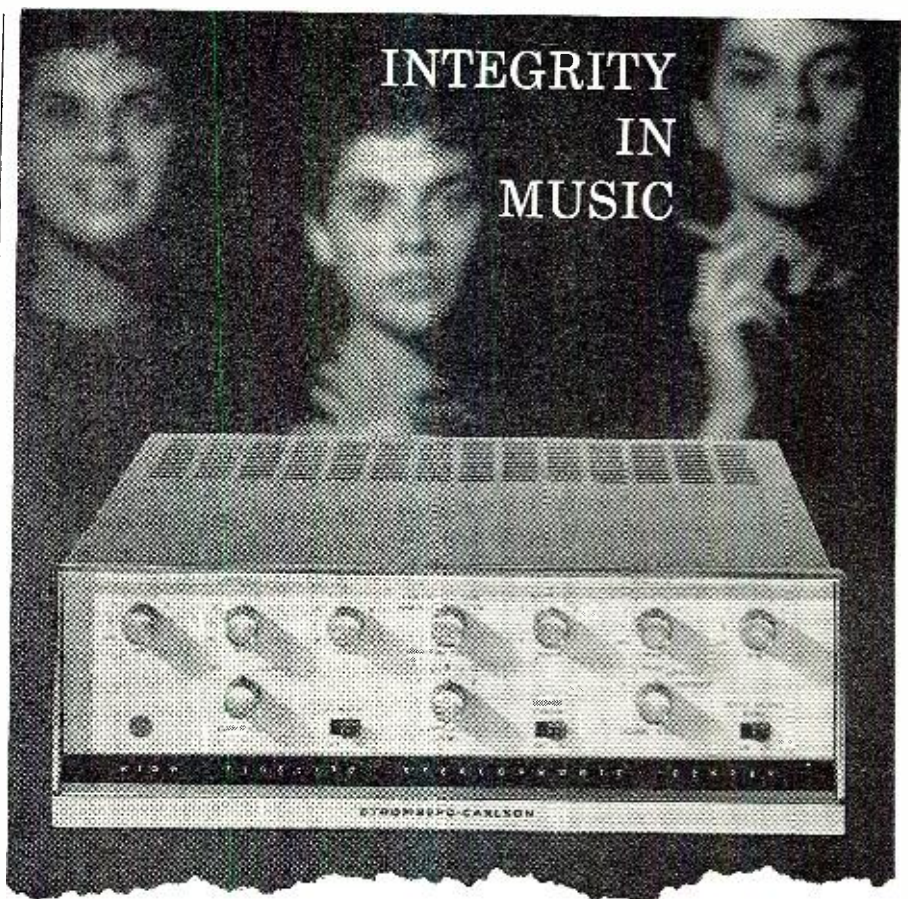

NEW 60-WATT STEREO AMPLIFIER BY STROMBERG-CARLSON

WITH EXCLUSIVE "STEREO TONE BALANCE" SIGNAL

Here is a new dual-channel amplifier with performance and control features that add up to the best value in the field.

Each channel gives you 30 watts of clean, balanced power. Balance is the key to bona fide stereo. Exclusive Stromberg-Carlson "Stereo Tone Balance" lets you balance the two channels by a signal tone. You set up to what you actually hear.

Each channel has its own complete set of controls: loudness/volume, bass and treble—plus a master gain control.

For complete details and specifications see your dealer or write to us for literature. Find your dealer in the Yellow Pages, under "High Fidelity."

ASR-444 dual-channel stereo amplifier

POWER OUTPUT: 60 watts (2 30-watt channels). FREQUENCY RESPONSE: 20-20,000 cycles \pm .9 db. HARMONIC DISTORTION: Less than .7% at 30 watts each channel. NOISE LEVEL: 70 db down. INPUTS: Magnetic Phono, Ceramic Phono, Tape Head, Tuner and Aux. Tape. IM DISTORTION: Less than 1% program level (60 and 7000 cps at 4:1 ratio). AMPLIFIER OUTPUTS: 4, 8, 16 ohms. PREAMPLIFIER OUTPUTS: Dual Tape Out; Output for external second-channel amplifier. LOUDNESS CON-

TROL: In-out, continuously variable. TONE CONTROLS: Bass 15 db droop, 15 db boost; Treble 14 db droop, 12 db boost. EQUALIZATION: RIAA Mag. Phono. NARTB Tape Head. TUBES: 2-12AX7/7025, 2-6AV6, 2-6U8, 4-7027. CHANNEL SELECTOR: Channel "A," Channel "B," Stereo, Monaural, Crossover (at 3000 cycles). CHANNEL REVERSE. TWO AC CONVENIENCE OUTLETS. DIMENSIONS: 13½" W, 13¾" D, 4⅝" H. \$169.95. (Audiophile Net, Zone 1.)

STROMBERG-CARLSON
A DIVISION OF GENERAL DYNAMICS CORPORATION
1477C N. GOODMAN STREET • ROCHESTER 3, N. Y.



TUBE PROBLEM:

An amplifier manufacturer was plagued by noise, microphonics and hum that developed in the high gain stages of his amplifiers. Sonotone engineers were consulted on the problem.

SONOTONE SOLVES IT:

Sonotone engineers discovered that they could correct *all three* complaints by redesigning just *one* tube.

RESULTS:

The heater element was changed to a coil heater, eliminating the hum. And rigid controls on the mount structure and processing reduced microphonics and noise. This resulted in the Sonotone reliable type 7025. It's now available for initial equipment and replacement purposes.

Let Sonotone help solve *your* tube problem, too.

Sonotone

Electronic Applications Division, Dept. TN-39
ELMSFORD, NEW YORK

Leading makers of fine ceramic cartridges, speakers, microphones, tape heads, electron tubes.

In Canada, contact Atlas Radio Corp., Ltd., Toronto

and 5881 beam power amplifier tubes and twin-packing them in pairs to eliminate one of the most time-consuming operations encountered by the builder of audio gear.

Matching, which eliminates much of the higher order distortion and makes

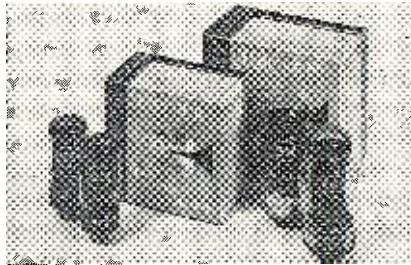

possible the best sound reproduction of which the equipment is capable, is a critical criterion with both hi-fi enthusiasts and design engineers.

The 5881's are for service in amplifiers rated at up to 50 watts while the 6550's are used in amplifiers and commercial sound equipment of up to 100 watt power.

NEW MULLARD TUBE

International Electronics Corp., 81 Spring St., New York 12, N. Y., U. S. distributor of *Mullard* tubes, has announced the availability of the ECF80/6BL8, a nine-pin miniature triode-pentode which functions as a high-gain a.f. amplifier and phase inverter.

Specially constructed center-tapped heater windings provide unusually low hum characteristics, according to the company. The heater windings may also be grounded for additional balance and hum reduction. The basing and element construction are such that coupling between the two sections is non-existent, making this tube suitable for integrated stereo amplifiers.

Additional engineering data and circuit information will be supplied by the U. S. distributor upon request.

"ISOPHON III"

The *Isophon Speaker Division of Arnhold Ceramics, Inc.*, 1 E. 57th St., New York 22, N. Y. has announced the availability of a new four-speaker, three-channel combination unit—the "Isophon III."

Consisting of the firm's P30/37 bass speaker, a mid-range folded-horn com-

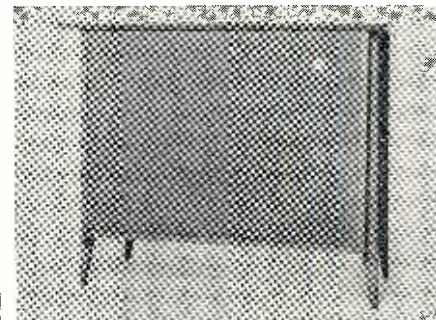

pression speaker, and two four-inch high-frequency tweeters, the system includes a multi-matching universal transformer and special divider network.

Designed for either monophonic or stereo applications, the new system is housed in a West Indian mahogany cabinet which is available in a number of finishes as well as in a utility cabinet with non-acoustic baffle board.

An illustrated catalogue on this and other units in the company's line is available on request.

SPEAKER CROSSOVER NET

Vidaire Electronics Mfg. Corp. of Baldwin, N. Y. is now offering a high-fidelity speaker crossover network, the Model CN-6.

Designed for use with most high-fidelity speakers, the new unit is of the constant-impedance LCR type. A treble control is included for varying the treble response of the high-frequency speaker over a range of 9 db. Crossover frequency is 1500 cps with 6 db-per-octave attenuation.

The Model CN-6 may be used with



either 8- or 16-ohm speakers. It comes assembled on a gold-embossed brass plate for mounting on the hi-fi equipment or speaker enclosure.

"TRIMENSIONAL" SPEAKER

University Loudspeakers, Inc., 80 S. Kensico, White Plains, N. Y. has announced the development of an integrated, single-cabinet speaker system for both stereo reproduction and monaural-stereo effect.

The "Trimensional" unit measures 30" wide x 25" high x 12½" deep overall. The system utilizes the reflections from the walls of the listening room to provide broad virtual sound sources with good separation. Compactness is achieved through use of the company's dual-voice-coil woofer which reproduces the bass ranges of both stereo channels. According to the company, full response is obtained down to below 30 cps, for both channels, with an enclosure of only 2 cubic feet for the bass speaker.

The mid-frequency and high-frequency ranges are covered, respectively, by Model C-8W eight-inch direct radiator speakers and Model HF-206 "Hypersonic" tweeters.

A data sheet giving specifications and recommended operational details will be furnished by the company on request.

STEREO CONTROL CENTER

Arkay, Inc., 88-06 Van Wyck Expressway, Richmond Hill 18, N. Y. has just announced the availability of a new hi-fi stereo control center which incorporates dual 14-watt amplifiers and provides full 28-watt output for monaural use.

Offered in either kit or factory wired

form, the CS-28 has all of its inputs and outputs of the dual variety. In addition the circuit includes a reverse stereo switch for interchanging chan-

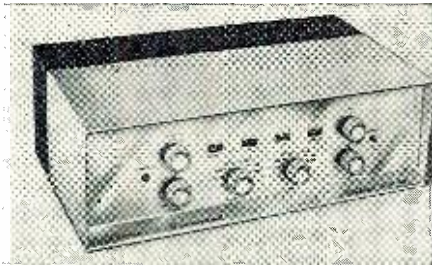

nels, a balance control for providing compensation in each channel for the speaker system or room acoustics, and a ganged gain control which governs volume on both channels simultaneously.

Frequency response is 20 to 20,000 cps; IM distortion 60 and 6000 cps (4:1) is 1% at 14 watts and .5% at 10 watts; harmonic distortion is less than 1% from 30 to 20,000 cps at rated output while hum and noise on the low-level inputs is -70 db and -80 db on high-level inputs. Speaker impedances of 4, 8, 16, and 32 ohms are provided. The circuit uses a total of ten tubes.

For complete details and prices, write the manufacturer direct.

HEATH AMPLIFIER KIT

Heath Company of Benton Harbor, Mich. has just added a 55-watt amplifier to its line of audio equipment in kit form.

The Model W-7M provides frequency coverage from 20 to 20,000 cps at less than 2% total harmonic distortion throughout the entire range. Unique terminal output connections permit instant switch selection of "unity" or "maximum" damping factors for all 4-, 8-, or 16-ohm speakers, with an individually optimized output for each of these impedances. Each output has a separate current feedback circuit for

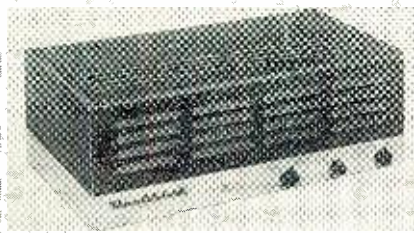

unity damping. This circuit is entirely shorted out when not in use in order to obtain the highest possible damping factor.

Other features include level control and "on-off" switch right on the chassis plus provisions for remote control for preamps, etc. The company's "bas-bal" circuit conveniently balances the EL-34 output tubes. These heavy duty push-pull tubes operate into a high-quality tapped screen transformer designed especially for this unit by Chicago Standard Transformer. A 70-volt output on the transformer provides for p.a. or large music systems.

The unit is housed in a black and



We'll give you nine reasons for buying Audiotape;

1. AUDIOTAPE has excellent response at high and low frequencies—assures most faithful reproduction of all sounds.
2. AUDIOTAPE has exceptionally low background noise, through better dispersion of finer oxide particles.
3. AUDIOTAPE has increased output and reduced distortion because the oxides are magnetically oriented.
4. AUDIOTAPE has unequalled uniformity of output—guaranteed not to exceed $\pm 1/4$ db within the reel and $\pm 1/2$ db from reel to reel.
5. AUDIOTAPE is continuously monitored in production for output, uniformity and freedom from distortion.
6. AUDIOTAPE has no oxide rub-off because an improved drier-type formula prevents it, even on dirty heads.
7. AUDIOTAPE is on the C-slot reel—fastest-threading reel ever developed.
8. AUDIOTAPE assures you of smooth, quiet tape travel—even under hot, humid conditions—because of a special moisture-repellent binder.
9. AUDIOTAPE has exceptionally low surface friction—reduces wear on heads.

For even more reasons—see your Audiotape dealer today

Manufactured by AUDIO DEVICES, INC.
444 Madison Ave., New York 22, New York
Offices in Hollywood & Chicago.

audiotape
TRADE MARK

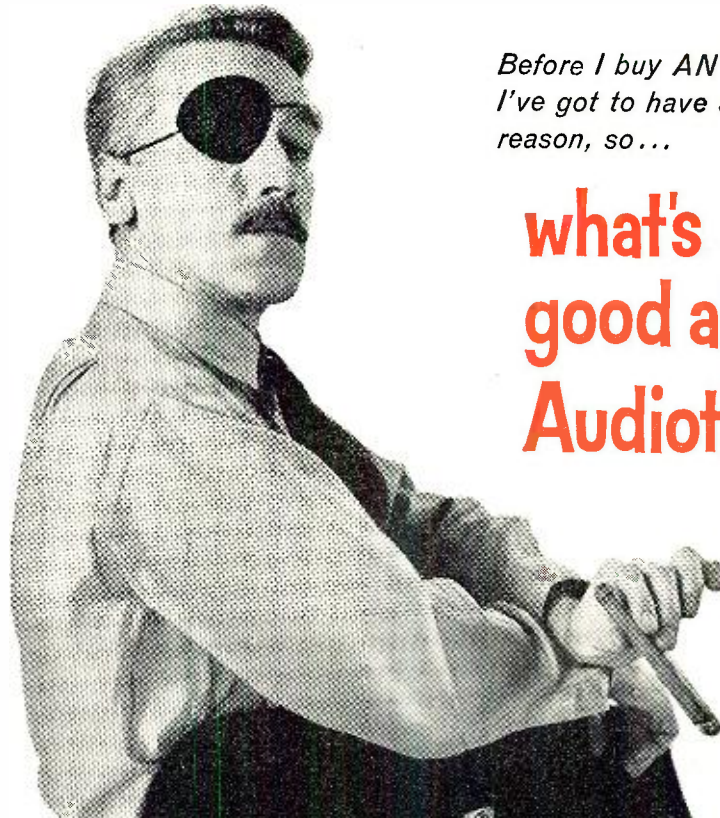

*Before I buy ANYTHING,
I've got to have a
reason, so...*

**what's so
good about
Audiotape?**

From the pioneer in ceramics for electronics

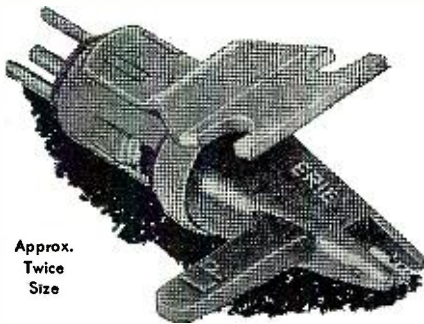

Approx.
Twice
Size

STEREO

the new single
ceramic element
Stereophonic
cartridge

DYNAMIC BALANCING MAKES THE DIFFERENCE

DYNAMIC BALANCING during manufacture provides full stereo reproduction. SINGLE ELEMENT DESIGN offers balanced outputs; excellent separation of 20 db over full audio-frequency range, with equal outputs from both channels. Compatible with stereo and monophonic discs.

SPECIFICATIONS

RESPONSE: 20 to 16,000 cps. **OUTPUT VOLTAGE:** 0.5 vrms at 1 KC each channel. **COMPLIANCE:** 3×10^{-6} cm/dyne, vertical & lateral. **RECOMMENDED LOAD:** 2 megohms. **RECOMMENDED TRACKING PRESSURE:** 5-6 grams. **CHANNEL SEPARATION:** 20 db. **STYLUS:** Dual tip; 0.7 mil diamond or sapphire, and 3 mil sapphire. **MOUNTING DIMENSIONS:** EIA Standard $\frac{7}{16}$ " & $\frac{1}{2}$ " centers.

For additional information, see your Authorized ERIE Distributor



PURCHASING A HI-FI SYSTEM?

Send Us
Your
List Of
Components
For A
Package
Quotation

WE WON'T BE
UNDERSOLD!

All merchandise
is brand new, fac-
tory fresh & guar-
anteed.

AIREX RADIO

CORPORATION

64-R Cortlandt St., N. Y. 7, CO 7-2137

PARTIAL LIST OF BRANDS IN STOCK

Altec Lansing
Electrovoice
Jensen
Hartley
University
Acoustic Research
Janszen
Wharfedale
Karlson
Viking
Concertone
Bell • G.E.
Weathers
Harman-Kardon
Eico • Pilot
Sherwood
Acrosound
Fisher
Bogen • Leak
Dynakit
H. H. Scott
Pentron
Ampro • VM
Revere
Challenger
Wallensak
Garrard
Miracord
Glaser-Steers
Rek-O-Kut
Components
Norelco
Fairchild
Pickering • Gray
Audio Tape

Full Line of
Cabinets

IF YOU PRIZE IT... KRYLON-IZE IT!
Completely seals electronic
parts with no delay



CRYSTAL-CLEAR ACRYLIC SPRAY

Radio, TV and hi-fi equipment need Krylon Crystal-Clear, the protective coating with high dielectric strength and weatherproof qualities that seal the surface indefinitely.

- Prevents corona in high voltage section
- Keeps lead-in connections tight
- Prevents rusting and pitting of antenna
- Goes on in seconds—DRIES IN MINUTES

At your favorite radio-TV repair shop.

Use Krylon Spray Paints (22 colors) for
quick, easy, professional touch-up jobs

IF YOU PRIZE IT... KRYLON-IZE IT!

gold case measuring 6" x 8½" x 15". Write the company direct for additional particulars on this medium-power amplifier.

BRITISH COAX SPEAKERS

Ercona Corporation's Electronic Division, 16 West 46th St., New York 36, N. Y. is now handling the U. S. distribution of a new line of British coaxial speakers, made by *Reproducers & Amplifiers, Ltd.* of Wolverhampton, England.

Known as the R & A Series 700, the line features coaxial construction, easily removable magnet assembly, plus wide, smooth frequency response up to 10,000 cps. The Model 780 is an 8" unit which will handle 15 watts; the Model 7100 is a 10" version designed for 20-watt applications, while the Model 7120 is a 25-watt, 12" unit. All of the units have voice-coil impedances of 8 ohms. In all instances, the magnet strength is 12,000 gauss.

For full details on price and additional specifications on this new line, write the U. S. distributor direct at the above address.

TAPE REEL CLIPS

Toyco Products' Audio Division, 1712 W. Florence Ave., Los Angeles 47, Calif. is marketing an inexpensive and efficient tape clip under the name "Reel-Neat."

Precision engineered of high-quality polished stainless steel, the clips are

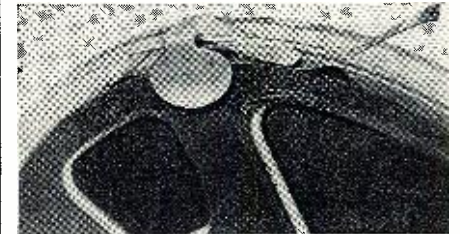

guaranteed to eliminate tape unreeling. The clip snaps on the reel and involves no elaborate or complex operations.

For additional information and price on these new tape-reel clips, write the manufacturer direct at the above address.

AUDIO CATALOGUES

STEREO TAPES & DISCS

Allied Radio Corporation, 100 N. Western Ave., Chicago 80, Ill. has just released a new stereophonic record and tape catalogue listing over 200 of the latest stereo disc releases and almost 500 stereo tapes.

Divided into two major sections and sub-divided into categories of music, the catalogue lists classical records and tapes alphabetically by composer. Popular, jazz, and other types of music are listed by performing artists, group, orchestra, and disc or tape title. In almost every case a complete rundown of selections is given.

Dept. PR832 of the company will mail a copy on request. Please specify Stock No. 68 R 566.

—50—

Hi-Fi Test Report

(Continued from page 61)

record players rumble wasn't as serious a problem in that vertical compliance of monophonic cartridges was considerably damped. However, this is not true for stereo reproduction where high vertical compliance is required. The new model has been redesigned to eliminate this problem in that it has negligible rumble, wow, and flutter. It incorporates an improved motor design and changes were made in the mechanical operation of the changer to allow for smoother performance and operation.

A stereo-monophonic switch has been added which serves an important purpose under certain conditions. When playing monophonic records with a stereo cartridge, it is necessary to connect the left and right channels of the cartridge together. In most hi-fi systems this is done in the preamplifier section and in this case the switch serves no particular function. However, there are many installations that do not provide the paralleling connection, in which case the added switch, which does this job, is important to provide this additional flexibility.

In addition, a dual-channel muting switch and a quick-change cartridge holder have been incorporated. Although designed with stereo in mind, the changer can be used with ordinary monophonic cartridges simply by using only one of the output cartridge cables provided.

There are certainly advantages and disadvantages in using a record changer in place of a manual turntable. If one does not want the inconvenience of changing records then, of course, the changer is the answer. For ultimate quality of sound reproduction the preference is usually in favor of the manual turntable. There are two other factors that must be considered: variation in stylus pressure and the vertical angle of the stylus when playing a record singly or on top of a 10-record stack. The stylus pressure on this unit showed only a 1-gram variation and there was no noticeable change in the sound reproduction with the slight vertical angle stylus variation that occurred in use.

Like its predecessor model, this new changer has four speeds. The turntable comes to rest during the change cycle to eliminate unnecessary record wear. The motor is an improved four-pole, hum-shielded type with balanced rotor for smooth, constant-speed, shock-mounted operation. The turntable also incorporates automatic shut-off after the last record on the spindle has been played.

Regarding the performance of this new changer, we are sure that only the most critical listener would detect any difference between the sound reproduced by this changer and that emanating from some of the better turntables.

-30-

An important announcement for everyone considering a small-space wide-range speaker system . . . monaural or stereo

ACTUAL TESTS PROVE

University RRL*

ULTRA LINEAR RESPONSE SYSTEMS SUPERIOR

Compared with competitive widely publicized high compliance small-space systems



RRL systems use a specially designed acoustic coupler to load the new University high compliance woofer, enabling it to radiate tremendous bass energy with only small cone excursions. This achieves greater linearity and virtually eliminates distortion. Tweeter response, carefully matched to the woofer's acoustic output, is smooth and flat to beyond 20,000 cps. Result: better bass, cleaner treble, smoother response than any competitive small-space, high compliance units based on totally sealed enclosures using "air spring" capacitance loading.

*RRL - Radiation Resistance Loading

ONLY FROM UNIVERSITY . . . A FULL LINE OF RRL ULTRA LINEAR RESPONSE SYSTEMS AND KITS

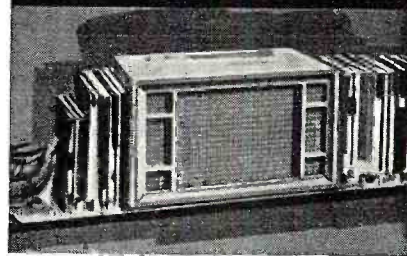

Outstanding for monaural—ideal as a stereo pair

Model S-10S 2-SPEAKER SYSTEM

Available as highboy or lowboy

Components of the S-10S comprise the new 12" C-12HC high compliance, dual voice coil woofer, employed with the UL/HC 2500 cps tweeter and the special matched-level HC-2 crossover network. Separate "BASS" and "BRILLIANCE" controls permit adjustment to room acoustics. Also includes the Program Distortion Filter to correct for stridency of inferior radio programs, worn records, tapes, etc. The enclosure is constructed of extra heavy 3/4" furniture hardwoods. Gracefully styled to harmonize with any decor. Without removable base, either model is perfect for shelf, bookcase, or built-in applications. 24" x 14" x 14 1/2" deep. Shpg. wt., 51 lbs. User net: Mahogany—\$154.00, Blond or Walnut—\$158.00.

...And greater efficiency, greater RRL advantages

Model S-11S 3-SPEAKER SYSTEM

Available as highboy or lowboy

The S-11S truly stands alone in its field! It cannot be compared with any other existing high compliance system . . . but only with the most elaborate speaker systems, such as University's famed "Classic." Its handsome, compact RRL enclosure houses the new heavy duty high compliance 15" C-15HC dual voice coil woofer. The new HC-3 network provides 500 cps crossover to the Diffusicone-8 Diffaxial for mid-range and 2500 cps crossover to the special UL/HC Hypersonic Tweeter for response to beyond audible limits. The unique Program Distortion Filter and separate treble and mid-range controls complete this magnificent system. 26 7/8" x 19 1/2" x 17 1/2" deep. Shpg. wt., 80 lbs. User net: Mahogany—\$260.00, Blond or Walnut—\$264.00.

FOR EVEN GREATER SAVINGS . . .

Ultra Linear component kits CUL-10, CUL-11

Enjoy the satisfaction of assembling your own superb Ultra Linear Response system along with the added savings thus made possible. Speaker kit CUL-10 comprises the identical components of Model S-10S; speaker kit CUL-11, the components of Model S-11S. Both kits are furnished with all wiring cables and complete easy-to-follow instructions for building and installing your own RRL enclosure. User net: CUL-10—\$98.75, Shpg. wt., 15 lbs. CUL-11—\$164.50, Shpg. wt., 37 lbs.

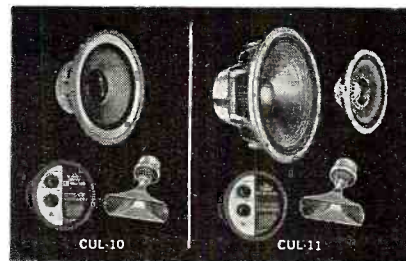

UNIVERSITY LOUDSPEAKERS, INC., WHITE PLAINS, N.Y.

How far can you go in electronics without a degree?

A few years ago, Lincoln E. Kitchin had no formal degree and knew nothing about electronic computers.

He still doesn't have a degree, yet today, he is a Field Engineer on one of America's biggest electronics projects. He helps maintain one of the largest computers in the world. He's doing work ordinarily done by engineers—an opportunity usually denied to men without a degree. This is a story of unusual significance to every technician who feels himself handicapped by lack of a formal degree.

"It all started back at the Base," Link recalls, "about two years ago. We were having lunch. One of my fellow Aircrewmembers described an interview he had just had—with IBM.

"It sounded good to me—particularly the field engineering aspects. I wasn't anxious to start my civilian electronics career stuck in a corner of some plant. Here was a chance to work in the field—with all the advantages of a permanent location. I made a note to add IBM to the companies I was considering for civilian work."



Taking notes in IBM Field Engineering class

Discussing a SAGE display console

Front view of computer frame

Interviewed by IBM

A month later, Link sat across the desk from an IBM interviewer. "Frankly," confesses Link, "I was scared at the thought of this interview. I didn't know the difference between an analog and a digital computer. I didn't expect to get the job."

The interviewer put Link quickly at his ease. A check of his background revealed Link's Service training—28 weeks of Class "A" aviation electronics plus Class "C" schooling in LORAN, RADAR and SONAR. He took a test, which indicated excellent aptitude for computer work.

Then Link learned how IBM would train him in electronics—for five months at full salary—to become a Field Engineer on the SAGE Program. He learned about SAGE, part of our nation's radar defense net, which is built around giant IBM computers—each containing 50,000 vacuum tubes plus 170,000 diodes. He heard about IBM's excellent company benefits, especially interesting to Link who had a wife and child. By the time the interview was over, Link had decided that IBM and the SAGE Program were what he was looking for. He decided then and there that he wanted to come with IBM.

Receives 20 weeks' training

Link reported to Kingston, N. Y., for training. In the IBM "school," he studied basic computer circuits, com-

puter logic and programming, card punch machines—all part of the twenty-week course a Computer Units Field Engineer takes. "The instruction was excellent," he recalls. "Our teachers, experienced field men, often made points not in the textbooks." Formal classroom lectures accounted for half his time, the other half being spent in the laboratories, where he worked on actual computer equipment for SAGE. During his training period, Link received a living allowance in addition to his salary.

Assigned to site in home state

His twenty weeks' training completed, Link was assigned to the SAGE site at Topsham, Maine. "IBM makes every effort to assign you to a location of your choice wherever possible," Link, who is a native State-o'-Mainer, points out.

At Topsham, Link has completed the installation phase of the computer. Now, his work consists of preventive maintenance and "keeping the customer happy"—the customer, in this case, being the Air Force personnel who man and operate the computer. "Installing this giant computer was a significant engineering feat," Link recalls. "First we ran 2,509 cables from 4 to 300 feet long. Then we bolted the computer sections together and hooked up the cables. Next came the testing phase in anticipation of Air Force acceptance tests.

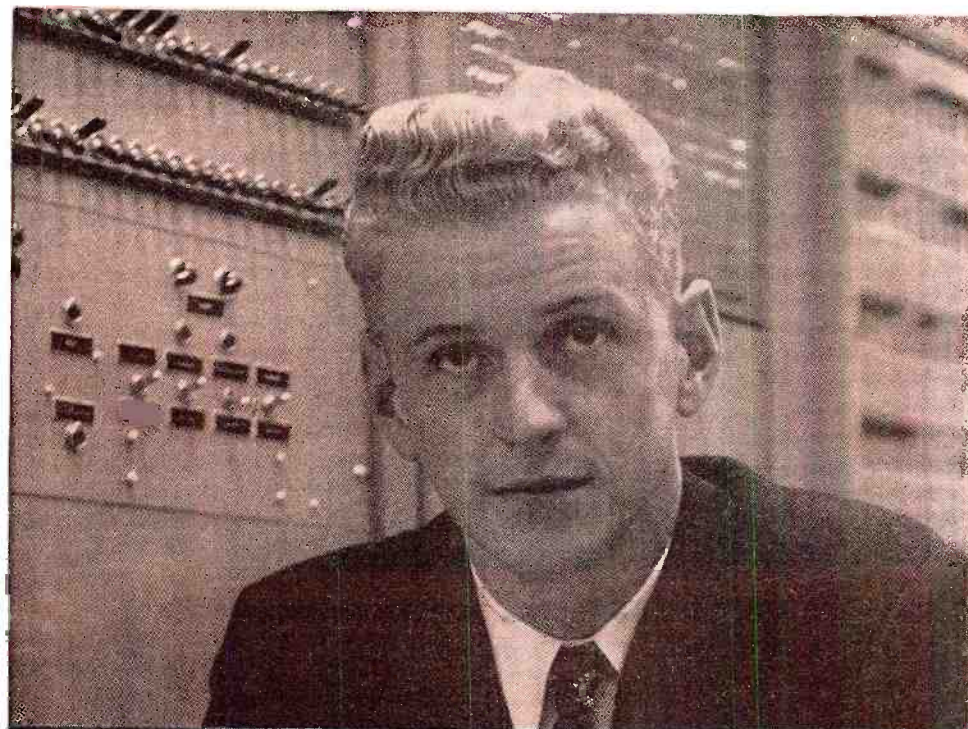

A problem in pluggable units

Working on manual input board of SAGE computer

Recording data on main core memory unit

"I'm in the Display Group," Link continues, "which has responsibility for over one hundred display consoles. Each of these has a 19-inch and a 5-inch cathode ray tube (similar to a TV tube) plus associated circuits. The knowledge of complex circuitry which we learned in the IBM school is essential for this work. We also maintain our own test equipment—oscilloscopes, meters, signal generators and specially designed pluggable unit test equipment."

What does the future hold?

Link looks forward to a rewarding career as a Computer Units Field Engineer. Promotion-wise, he could become, with further training, a Computer Systems Field Engineer, a Group Supervisor or Group Manager. Most important, however, he believes, is the excellent electronics background he's acquiring for the years ahead. "I've had a new engineering dimension added to my career—thanks to IBM's willingness to spend time and money training technicians to assume engineering responsibilities."

A career for you with IBM?

Since Link Kitchin joined IBM and the SAGE Program, opportunities are more promising than ever. This long-range program is destined for increasing national importance and IBM will invest thousands of dollars in the right men to insure its success.

If you have a minimum of 3 years' technical schooling—or equivalent experience—you may be eligible for advanced training for 5 months as a Computer Units Field Engineer. While training, you receive full pay plus living allowance before assignment to a permanent location. You are paid a salary, not hourly wages, plus overtime.

From then on, you can go as far as your abilities and ambition will take you. IBM is the leader in a field that offers you unlimited horizons. And, as you may already know, at IBM you receive company-paid benefits that set standards for industry today.

Mr. N. H. Heyer, Room 650C

**WRITE TODAY TO: Military Products Division
IBM Corp., Kingston, N. Y.**

You will receive a prompt reply. Personal interviews arranged in all areas of the U. S.

IBM[®]
MILITARY PRODUCTS



The personal portable fits neatly into a recessed opening in the carrying case housing the added amplifier and loudspeaker.

Outboard Amplifier for Transistor Portable

By T. C. LAWSON

Applications Engineer, Philco Corporation

Convert your personal set to a "Big Little Portable" with this detachable transistor amplifier and larger speaker.

IN this transistor age, the small, personal portable radio has become a reality. In these receivers some compromises in audio reproduction and output level became necessary due to the small speakers and battery supplies available.

There are times when it would be desirable to be able to increase the power output and to improve the fidelity of such receivers, as when on a crowded beach or at home. By incorporating an amplifier and a larger speaker in a cabinet, the tiny personal

radio can become a 1-watt output receiver of improved fidelity.

In order to build an amplifier of relatively high output while retaining its "portable" feature, a class B push-pull circuit was used. In class B operation, power consumption is minimum and distortion is quite low. The power consumption is low enough so that four size "D" flashlight batteries are adequate for the power supply.

The amplifier, shown schematically in Fig. 3, uses a conventional push-pull, transformer-coupled circuit. Base bias is developed by the voltage divider R_1 and R_2 . By making R_1 small, the base bias circuit may be left unbypassed with only negligible loss in gain. The audio response of amplifiers of this type is usually determined mainly by the quality of transformers used. The typical cut-off frequency of the transistors used (*Philco 2N353*) is 16 kc., but the degeneration introduced by the unbypassed emitter resistor raises this cut-off frequency considerably. (The cut-off frequency is defined as the frequency at which the current gain of the transistor falls off 3 db.)

Fig. 1 shows that the response is down only 3 db at 30 kc. with the low frequency response beginning to fall off between 100 and 200 cps and down

Fig. 1. Audio frequency response curve of the transistorized amplifier is shown.

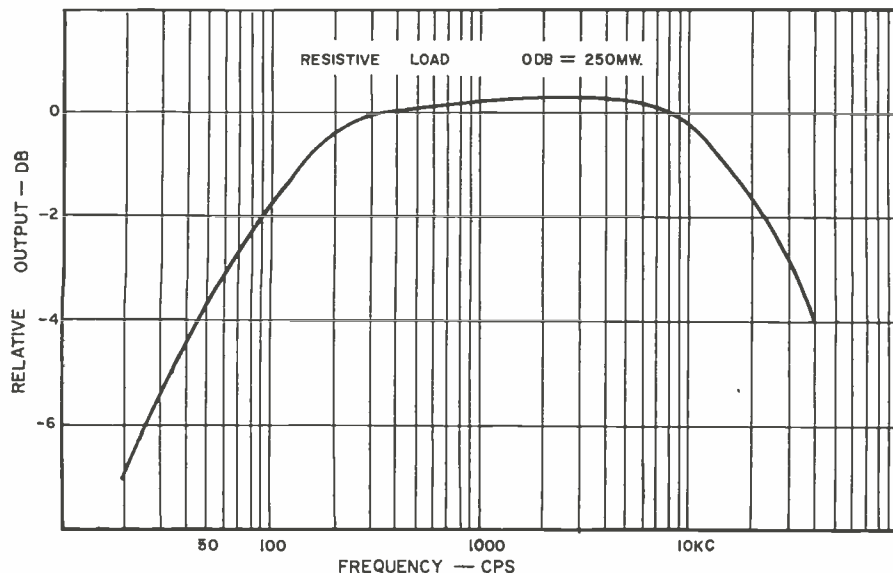

3 db at 60 cps. The curve was taken with a resistive load connected in place of the speaker. When the speaker is connected, its resonant frequency, usually close to 100 cps, will bring the low end up. Tone control could be added to the circuit but if the amplifier alone is fairly flat, then the response of the receiver will be reproduced. The gain of the amplifier is 23 db at 400 cps. This means that any receiver which will supply at least 5 mw. of output power will be able to drive the amplifier to its full output capabilities.

The maximum power which can be delivered to a resistive load was measured at 1.5 watts. Clipping sufficient to give 10 per-cent distortion occurred at an output of 915 milliwatts. The distortion at 250 milliwatts was 2.4%.

Battery life will depend on the manner in which the amplifier is used. Since it is a class B stage, the power required from the battery depends on the listening level. At full output, the total battery current is 335 ma. while at 250 milliwatt output, which is still a good listening level, the current is 150 ma. The "no signal" current is 16 ma. For the average listener, battery

life expectancy should be 100 to 200 hours. With supply voltages as low as 4 volts the output will fall off, but the amplifier will still perform well at low listening levels.

Although temperature usually has an important role in the design of transistor circuitry, the use of power transistors at these output levels requires no special consideration. Heat sinks are not needed. The amplifier performs very well at 55 degrees C (131 degrees F) where the "no signal" current rises to about 30 ma. At this temperature the maximum power output falls off slightly.

The amplifier and speaker are enclosed in a cabinet which measures 10½" x 6½" x 5½". The top is recessed to hold the personal receiver. The size of the recess will of course depend upon the receiver used. In the author's unit, the receiver was a *Philco* Model T-4. Electrical connection of the receiver to the amplifier is made through the "private listening" jack which is provided on most receivers. If the particular radio being considered does not have one, it is a simple matter to install one. Fig. 2 shows how this can

be done by a simple wiring change.

The male plug is spring-mounted in the side of the recess to permit the receiver to slide into place. The amplifier case is constructed of ¼" Polyvinyl Chloride board (*Colonial Plastics Mfg. Co.*, 8007 Grand Ave., Cleveland, Ohio), commonly called "Van-Cor". This board is very easily worked and its softness adds to the audio response. The handle is made from 1" polystyrene rod. The photographs show the parts layout used by the author. The tube in the bottom of the set is the battery holder. This type of holder makes it possible to change batteries without opening the amplifier case. Also, the danger of destruction of the amplifier due to leaky batteries is eliminated. The holder is polarized so that it is impossible to insert the batteries in the wrong direction.

The "Big Little Portable" described has been used both at home and on Florida beaches in the blazing sun. Performance was very good and many hours of entertainment have been enjoyed in situations where the small portable alone would have been unusable.

-30-



The interior view of the carrying case clearly shows the mounting of parts as well as placement of four flashlight cells.

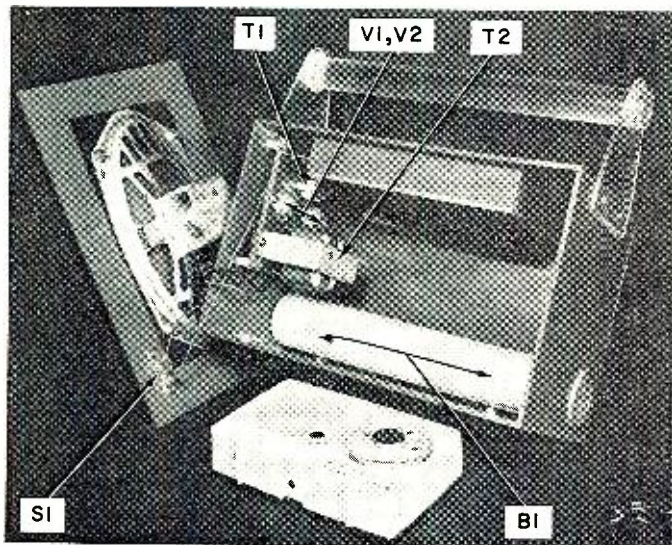

As the personal portable is placed into the recessed opening, the spring-mounted plug in the side of the opening is fitted into the set's private listening jack. Refer to text.

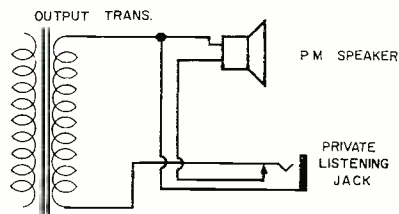
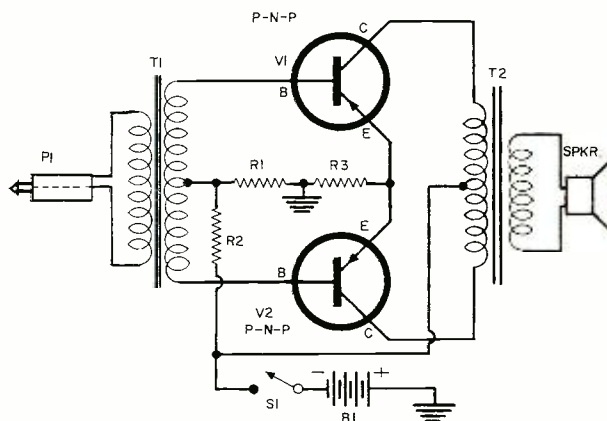

Fig. 2. Method that can be employed to add private listening jack to set.

Fig. 3. Schematic of the added amplifier.



- R₁—56 ohm, ½ w. res.
- R₂—2200 ohm, ½ w. res.
- R₃—1 ohm, ½ w. res.
- P₁—Subminiature phone plug
- S₁—S.p.s.t. slide switch
- B₁—6-volt battery (four "D" flashlight cells)
- T₁—Input trans., 12 ohms to 100 ohms center-tapped (Chicago Standard TA-39)
- T₂—Output trans., 48 ohms to 16 ohms (Chicago Standard TA-11)
- Spkr.—16-ohm speaker, 3½" x 7½"
- Battery Holder—Mayfair Molded Products #624-L
- V₁, V₂—"p-n-p" transistor (Philco 2N353)

SHIPPED ON APPROVAL

an IN-CIRCUIT CONDENSER TESTER THAT DOES THE WHOLE JOB!

The CT-1 actually steps in and takes over where all other in-circuit condenser testers fail. The ingenious application of a dual bridge principle gives the CT-1 a tremendous range of operation . . . and makes it an absolute 'must' for every serviceman.

IN-CIRCUIT CONDENSER TESTER Model CT-1

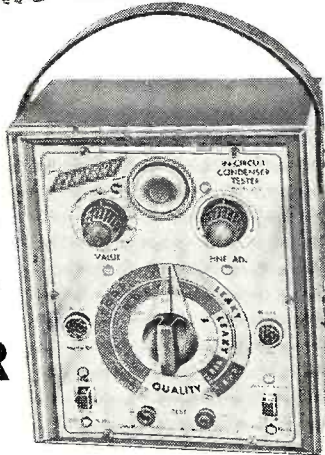

Model CT-1—housed in sturdy hammertone finish steel case complete with test leads...only **\$34.50** Net

in-circuit checks:

- ✓ Quality of over 80% of all condensers even with circuit shunt resistance present . . . (leakage, shorts, opens, intermittents)
- ✓ Value of all condensers from 200 mmfd. to .5 mfd.
- ✓ Quality of all electrolytic condensers (the ability to hold a charge)
- ✓ Transformer, socket and wiring leakage capacity

out-of-circuit checks:

- ✓ Quality of 100% of all condensers . . . (leakage, shorts, opens and intermittents)
- ✓ Value of all condensers from 50 mmfd. to .5 mfd.
- ✓ Quality of all electrolytic condensers (the ability to hold a charge)
- ✓ High resistance leakage up to 300 megohms
- ✓ New or unknown condensers . . . transformer, socket, component and wiring leakage capacity

OUTSTANDING FEATURES

- Ultra-sensitive 2 tube drift-free circuitry
- Multi-color direct scale precision readings for both quality and value . . . (in-circuit or out of circuit)
- Simultaneous readings of circuit capacity and circuit resistance
- Built-in hi-leakage indicator sensitive to over 300 megohms
- Cannot damage circuit components
- Electronic eye balance indicator for even greater accuracy
- Isolated power line

TRANSISTOR TESTER Model TT-2

Every day more and more manufacturers are using transistors in home portable and car radios . . . in hearing aids, intercoms, amplifiers, industrial devices, etc. Since transistors go bad the need for TRANSISTOR TESTER is great. They can

develop excessive leakage, poor gain, shorts or opens. The TT-2 is an inexpensive quality instrument designed for accurate and dependable tests of all transistors and diodes — quickly and accurately.

OUTSTANDING FEATURES

- Checks all transistors, including car radio, power output, triode, tetrode and unijunction types for current gain, leakage, opens, shorts, cut-off current
- Checks all diodes for forward to reverse current gain
- All tests can be made even if manufacturers' rated gain is not available
- Less than half a minute required for tests of either transistors or diodes
- Large 3" meter is extremely sensitive yet rugged . . . with multi-color scales designed for quick easy readings
- Power is supplied by an easy to replace 6-volt battery — current drain so small, service life almost equal to shelf life. Battery cannot be drained due to accidental shorting of test leads
- Cannot burn-out its own meter or damage transistor or diode under test
- Long test leads and insulated test clips enable tests without entirely removing transistor from circuit
- Test leads are identified by E.I.A. color code so that connection to the correct terminal is assured
- Comes complete with replaceable transistor set-up chart that fits into a special rear compartment.

IMPORTANT FEATURE: The TT-2 cannot become obsolete as the circuitry is engineered to enable you to check all new type transistors as they are introduced. New listings will be furnished at no cost.



Model TT-2 — housed in sturdy hammertone finish steel case complete with test leads . . . only

\$24.50 Net

Check all power rectifiers in-circuit

whether SELENIUM, GERMANIUM, SILICON, etc.

with the **IN-CIRCUIT RECTIFIER TESTER** Model SRT-1



Model SRT-1—housed in sturdy hammertone finish steel case complete with test leads . . . only

\$29.50 Net

With the growing trend towards compactness, portability and low price, TV manufacturers are resorting more and more to producing series-string TV sets employing selenium, germanium or silicon power rectifiers. Now the need for an in-circuit rectifier tester is greater than ever.

THE SRT-1 CHECKS ALL POWER RECTIFIERS IN-CIRCUIT AND OUT-OF-CIRCUIT WITH 100% EFFECTIVENESS FOR:

- ✓ Quality ✓ Fading ✓ Shorts ✓ Opens ✓ Arcing ✓ Life Expectancy

OUTSTANDING FEATURES

- Checks all types of power rectifiers rated from 10 ma. to 500 ma. (selenium, germanium, silicon, etc.) both in-circuit or out-of-circuit.
- Will not blow fuses even when connected to a dead short.
- Large 3" highly accurate multi-color meter . . . sensitive yet rugged.
- Separate meter scales for in-circuit and out-of-circuit tests.
- Cannot damage or over heat rectifier being tested.

SIMPLE TO OPERATE

Just clip SRT-1 test leads across rectifier under test right in the circuit without disconnecting rectifier from circuit. Press test switch and get an instant indication on the easy-to-read three-color meter scales . . .

ALL CENTURY INSTRUMENTS ARE GUARANTEED FOR ONE FULL YEAR

The extremely low prices are made possible because you are buying direct from the manufacturer.

EASY TO BUY IF SATISFIED
see order form on facing page

FOR 10 DAY FREE TRIAL

try them for 10 days before you buy . . . only then, when satisfied, pay in easy-to-buy monthly installments — without any financing or carrying charges added.

STILL THE BEST SELLING TUBE TESTER IN THE FIELD FAST-CHECK TUBE TESTER

Model FC-2

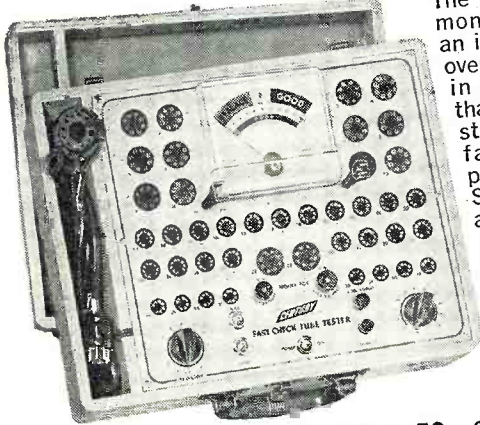

The greatest testimonial ever paid an instrument . . . over 20,000 sold in a little more than a year—and still selling as fast as we can produce them. See for yourself at no risk why so many servicemen choose the FAST-CHECK above all other tube testers—regardless of price.

Model FC-2 — housed in hand-rubbed oak carrying case complete with CRT adapter . . . only

\$69.50
Net

SIZE: W: 14 5/8"
H: 11 1/4" D: 4 3/8"

Just 2 settings on the FAST-CHECK TUBE TESTER tests over 700 tube types completely, accurately — AND IN SECONDS!

PICTURE TUBE TEST ADAPTER INCLUDED WITH FAST-CHECK

Enables you to check all picture tubes (including the new short-neck 110 degree type) for cathode emission shorts and life expectancy . . . also to rejuvenate weak picture tubes.

No other tube tester made at any price can match the value of the FAST-CHECK.

RANGE OF OPERATION

- ✓ Checks quality of over 700 tube types, employing the time proven dynamic cathode emission test. This covers more than 99% of all tubes in use today, including the newest series-string TV tubes, auto 12 plate-volt tubes, OZ4s, tubes, auto 12 plate-volt tubes, special magic eye tubes, gas regulators, special purpose hi-fi tubes and even foreign tubes.
- ✓ Checks for inter-element shorts and leakage.
- ✓ Checks for gas content.
- ✓ Checks for life-expectancy.

IMPORTANT FEATURES

- No time consuming multiple switching . . . only two settings are required instead of banks of switches on conventional testers
 - No annoying roll chart checking . . . tube chart listing over 700 tube types is located inside cover. New listings are added without costly roll chart replacement
 - Checks each section of multi-section tubes and if only one section is defective the tube will read "Bad" on the meter scale
 - 41 phosphor bronze beryllium tube sockets never need replacement
 - 7-pin and 9-pin straighteners mounted on panel
 - Large 4 1/2" D'Arsonval type meter is the most sensitive available, yet rugged — fully protected against accidental burn-out
 - Special scale on meter for low current tubes
 - Compensation for line voltage variation
 - 12 filament positions
 - Separate gas and short jewel indicators
 - Line isolated — no shock hazards
 - Long lasting etched aluminum panel.
- NOTE: The Fast-Check positively cannot become obsolete . . . circuitry is engineered to accommodate all future tube types as they come out. New tube listings are furnished periodically at no cost.

NEW . . . For those looking for a real ECONOMY MULTIPLE SOCKET TUBE TESTER without sacrificing ACCURACY, SPEED and VERSATILITY MINI-CHECK TUBE TESTER

Model MC-1

Here is a multiple socket tube tester designed to meet limited budgets. Although low in price it boasts a unique circuitry that enables you to check over 600 tube types — and has a range of operation that far exceeds others in its price class.

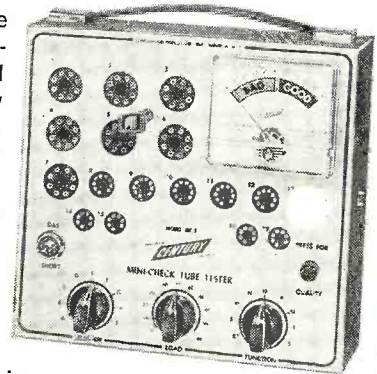

Model MC-1 — housed in sturdy wrinkle finish steel case . . . only

\$39.50
Net

SIZE: W: 9"
H: 8 1/2"
D: 2 3/4"

OUTSTANDING FEATURES

- Checks emission, inter-element shorts and leakage of over 600 tube types. This covers OZ4s, series-string TV tubes, gas regulators, auto 12 plate volt, hi-fi and foreign tubes
- 3 settings enable a test of any tube in less than 10 seconds
- Employs dynamic cathode emission test principle
- D'Arsonval type meter — most accurate type available . . . its greater sensitivity means more accuracy . . . its 3 1/2" means longer life
- 17 long lasting phosphor bronze tube sockets
- Combination gas and short jewel indicator
- 9 filament positions
- Handy tube chart contained in special back compartment
- New tube listings furnished periodically at no cost
- Detachable line cord

plus these BONUS FEATURES . . . found in no other low price tube tester

- ✓ Checks for cathode to heater shorts
- ✓ Checks for gas content
- ✓ Checks all sections of multiple purpose tubes . . . will pickup tubes with one "Bad" section
- ✓ Line isolated — no shock hazard
- ✓ Variable load control enables you to get accurate results on all tubes
- ✓ Positively cannot become obsolete as new tube types are introduced.

CONVENIENT TIME PAYMENT PLAN — NO INTEREST OR FINANCING CHARGES

CENTURY ELECTRONICS CO., INC.

CHECK INSTRUMENTS DESIRED

- | | | |
|--------------------------|--|---------|
| <input type="checkbox"/> | Model CT-1 In-Circuit Condenser Tester | \$34.50 |
| | \$9.50 within 10 days. Balance \$5 monthly for 5 months. | |
| <input type="checkbox"/> | Model SRT-1 In-Circuit Rectifier Tester | \$29.50 |
| | \$4.50 within 10 days. Balance \$5 monthly for 5 months. | |
| <input type="checkbox"/> | Model TT-2 Transistor Tester | \$24.50 |
| | \$4.50 within 10 days. Balance \$5 monthly for 4 months. | |
| <input type="checkbox"/> | Model FC-2 Fast-Check Tube Tester | \$69.50 |
| | \$14.50 within 10 days. Balance \$11 monthly for 5 months. | |
| <input type="checkbox"/> | Model MC-1 Mini-Check Tube Tester | \$39.50 |
| | \$9.50 within 10 days. Balance \$6 monthly for 5 months. | |

Prices Net F.O.B. Mineola, N. Y.

111 Roosevelt Avenue, Dept. 203, Mineola, New York

Please rush the instruments checked for a 10 day free trial. If satisfied I agree to pay the down payment within 10 days and the monthly installments as shown. If not completely satisfied I will return the instruments within 10 days and there is no further obligation. It is understood there will be NO INTEREST or FINANCING charges added.

Name _____ Please print clearly

Address _____

City _____ State _____

LAMPKIN METERS

+ FCC LICENSE = HIGHER INCOME!



Over a million mobile-radio installations need regular, high-grade maintenance and measurements per FCC regulations!



LAMPKIN 105-B MICROMETER FREQUENCY METER

Range 0.1 to 175 mc. (to 3,000 mc. by checking multipliers). Gives error from assigned frequencies. VHF CW signal generator. Weight 13 lbs., width 13". \$220.00

LAMPKIN 205-A FM MODULATION METER

Reads peak FM voice deviation ± 12.5 kc. and ± 25 kc., tunes 25-500 mc. in one band. Relative field-strength meter. Speaker. Jack for oscilloscope. Weight 13 lbs., width 12". \$240.00.

LAMPKIN LABORATORIES, INC.
BRADENTON, FLORIDA

This means money... steady income... right in your own area.

LAMPKIN METERS are the preferred test equipment!

Send for free booklet... "HOW TO MAKE MONEY IN MOBILE-RADIO MAINTENANCE". No charge... just use coupon below.

LAMPKIN LABORATORIES, INC.
MFM Division, Bradenton, Florida

At no obligation to me, please send

Free booklet Data on Lampkin meters.

Name _____
Address _____
City _____ State _____

BC-645 XMTR Receiver LIKE NEW 19.95

435 to 500 mc. BRAND NEW 1.49

Control Box for above. BRAND NEW 1.49

PE-101C Dynamotor. BRAND NEW 5.95

0-500 Microamps (Basic Movement) 3/4 Aircraft Meter. Marked fuel Air Ratio mfd. by Cambridge Instrument. ... 2 for 3.00; 1.59 ea.

0-100 Microamps 3" rd. 5.85

Variable Capacitor Glass Dielectric Concentric Type 1-8 MMFD. 6 for 1.00; 100 for 15.00

2AP1 tube w/socket. 1.95

Dynamotor 14V in-output 172V/138MA used with BC-652). NEW 2.95-2 for 5.00

Dynamotor-Eicor 6/0 Volts in-output 600V/150MA. NEW 6.95-2 for 12.90

Power Supply Unit PE-110-B 115V/60 cyc. (used with BC-669). LIKE NEW 49.95

Test Set TS-945/up Echo Box 1150 T. 1350 mc w/accessories & manual. 39.95

BC-652 Receiver 2-6mc w/tubes & dyn. Like New 14.95

Less tubes & dyn. Good Cond. 7.95

BC-344 Receiver 150-1500 KC (w/115 VAC Power Supply RA-20). LIKE NEW 29.95

BC-610 Tuning Unit. LIKE NEW 2.75

BC-1305 XMTR Receiver. Complete w/tubes 3800-6500 KC CW-Voice. 29.75

BC-638A Freq. Meter 100-150 mc Comprises fixed freq. crystal-controlled osc. for calibrating Receiver BC639 24.95

APN-1 420-365 mc Complete w/tubes & dyn. 9.95

1 MFD 5000V Industrial Oil Condenser. NEW 2.95

1 MFD 2000 volts Sprague oil cond. NEW 98c

8 MFD 150 volts Pyramid oil cond. NEW 59c

Power Trans PRI. 115V or 220V 60 cyc. Sec. 1400 VCT 300 MA (Conservative) 6.3V-4A/6.3V-1A/5V-4A. Mfd. by W. E. Co. Body dim 7 21/32 h x 6 23/32 br. 5 15/16 wd. 7.95; 2 for 15.00

Power Trans 115V 60 cyc. Sec. 800 V.C.T. 150 MA. 6.3V-4A. CT/5V-3A C.T. Very neat. 4.95; 2 for 9.00

Heavy Duty Choke. 13.7 Hx 450 MA (600MA Conservative) Mfd. by Merit. 3200 V.H.M.S 120 DCR. 6.95

Variable Cond. Split Stator Dual 250mmfd 1.00

6000 Volts 6.95

5.5 B. Transformer. 1.00

Micropositioner/Barber Colman. NEW 9.95

Carbon Chestmike w/single ear phone. 1.95

DZ-2 Direction Finder 15 KC-1780 KC. LIKE NEW 49.95

Radio Transmitter T-59/CRN-4. NEW 14.95

Plug-in Tuning unit. A unit of Model GP-7 Freq. Range 800-1500 KC. NEW 4.95

Global non-inductive resistor 600 ohms 118 Watts NEW 98c-12 for 10.00

Portable Amplifying Megaphone. complete w/electric megaphone and microphone, pistol grip and trigger switch additional hand microphone and switch portable tripod stand comb. amplifier and battery case. BRAND NEW 39.95

Filter Choke—SHVS—500 ma 91 ohms DCR Hi Pot 2000 V.H.M.S (small) 1.00

Amplifier BC-686-A—unit line termination. 19.95

Sorenson Regulator—input 95-130 volts/output 115 at 1 KVA. USED 59.95

Vertical flight gyro type C-1 autopilot. 29.95

SPARKS RADIO SUPPLY
194 GENESEE ST., BUFFALO 3, N.Y.

PROMPT DELIVERY ASSURED

GLOBE ELECTRONICS

A World of Values!

R111/APR-5A RECEIVER

2S VDC. Single phase. 1000/3100 MC or 3000/6000 MC. 80-115 VAC; 60/2600 cycles **\$39.95**

AC. Like brand new. Only.....

NEW SPEAKERS! NEW LOW PRICES!

4 x 6" P.M. 1.47 ounce magnet. Only... \$1.89

4" P.M. 1.47 ounce magnet. Just... 1.39

5" P.M. 1.47 ounce magnet. Special... 1.49

5 1/2" P.M. 2.5 ounce magnet. Heavy duty for cars. 1.99

3" TWEETER. Hard cone. Can't be beat... 1.49

CONTROLLER

Open type. 50-60 cycles. C/o one 100 amp, 220 V., 3-pole magnetic contactor with mercury relay attached. 3 second delay; coil to operate on 220 V., 50/60 cycles. Original cost \$382.00. **\$9.95**

Brand new. YOUR COST ONLY.....

AN/APX-2 TRANSMITTER-RECEIVER

Brand new! Tubes alone list at over \$100.00! Look at them: 19-6C4; 11-6A65; 7-6B6; 1-3Y3G; 1-2D21; 1-VR-150; 1-2C26; 3-900G! Plus motors, AB controls, relays AND MANY OTHER PARTS. Original govt. cost approx. \$300.00. A Globe Electronics Lead-Off Special!..... **\$14.95**

BRAND NEW! OIL CONDENSERS!

1 MFD @ 25,000 V. General Electric. \$9.85

Each 95

2 MFD @ 1,000 V. Each 69

4 MFD @ 50 V. for cross-over network. 50

Each 49

4 MFD @ 60 V. Each 69

5 MFD @ 440 VAC. Each 99

15 MFD @ 330 VAC. Each 2.95

650 MFD @ 50 V. Each 99

MOTOR STARTER. 130-157 MFD. 110 V/60 cyc. Each 59

6 x 9" HI FI CO AX SPEAKER

Heavy Alnico V magnet. With 3" tweeter. Built-in crossover. New. Terrific buy! Ea... **\$5.95**

G.E. THERMOSTAT

A raft of uses limited only by your ingenuity! Range 65-135 degrees F. DC 115 V.. 5 amps; 230 VDC .25 amps; AC 220 V., 25 amps. Brand new. Only..... **\$2.95**

PANEL METER: Westinghouse or G.E. 0-50 milliamper. 3" Square. New. SPECIAL..... **\$1.49**

25% Deposit. Bal. C.O.D. Min. order \$3.00. Items FOR Los Angeles. Prices subj. to change without notice. Calif. residents add 4% tax.

GLOBE ELECTRONICS
7978 Melrose Ave., Los Angeles 46, Calif.
PHONE: OLIVE 3-7993

Case for a Third Channel

(Continued from page 71)

the left and right outputs was fed to the center speaker at a voltage level equal to one of the end speakers (or, in other words, 3 db lower than the total power of both end speakers). The sound of one channel was increased in intensity until the observer could state with certainty that the sound seemed to be coming from a particular direction. The average results of this second series is shown in Table 2. By comparing equivalent average measurements between the two series of tests, one immediate conclusion can be drawn with respect to three channel. It takes *more* change of emphasis of either left or right channels before the listener can definitely "fix" the source of sound. For example, at medium sound level of 1000-cycle tones, the listener felt a shift from center to either left or right with a change of only 2 db. In the three-channel set-up, a change of 4 db was required before the observer detected the "shift" of location. The conclusion is that it is *far* more difficult to achieve true balance in a two-channel stereo set-up than in three channel. In fact, we seriously doubt if balance can be maintained or adjusted for a given point in the room without instruments. This does not mean that under musical conditions stereo illusion is lost. It does mean, though, that in two-channel stereo the vocalist or soloist originally at center stage may alternately appear to be at stage-right or stage-left by a mere shifting of the listener in his chair. This did, in fact, take place in the musical tests which followed.

Musical Corroboration

To translate the tabulations into further meaningful conclusions, we selected vocal and instrumental discs and tapes and subjected the listeners to them. In all ten cases, the listeners preferred having the third channel in use in this form of musical presentation. (Of course, the listeners were never told whether the third channel was in or out and *over-all* sound level at the listener's seat was maintained constant. As the third channel was faded in, end channels were reduced proportionately, to maintain equal *total* sound at all times.) In the case of solo or vocal music surrounded by an orchestral background, the reason given for the preference of third channel was essentially "I find that I don't have to concentrate on *where* the soloist is standing." In purely orchestral music, only six out of ten preferred a third channel. Two experienced no perceptible difference between two and three channels and two actually preferred the two-channel arrangement. It is interesting to note that these latter two were the two gentlemen who work professionally in the audio field. It is possible that the extensive stereo listening these men have done recently

may be partly responsible for their subjective answers as to preference.

Whence the Third Channel?

If your interest is aroused at this point, and if you would like to draw your own conclusions, it is not difficult to duplicate the set-up we used. The third channel was derived right at the speaker terminals of the left and right channels. The "hot" lead to each of the end speakers was fed to a 500,000-ohm potentiometer (one lead to an end terminal of the potentiometer, the other speaker lead to the other end terminal of the potentiometer). The arm of the pot was then used to feed a third basic power amplifier and speaker. By rotating the shaft of the potentiometer (which had a linear resistance element) half way, equal amounts of left and right signal were picked off at the arm of the pot. A schematic of the arrangement is shown in Fig. 3. All grounds (from left and right speakers and shield of cable going to third amplifier) were tied together. It is extremely important that the third speaker be phased properly with respect to the other two. If increasing the level control on the third amplifier seems to *reduce* the total level of sound in the room, you can be certain the third speaker is phased incorrectly and a simple reversal of the leads to that speaker will correct the situation. It goes without saying that the left and right speakers should also be phased properly.

Several preamplifiers currently available for stereo set-ups feature provisions for a third power amplifier connection. These include *Madison Fielding* Model 340, *Scott* Model 130, and *Lafayette* Model KT-600. In these preamplifiers, the necessary "blending" is accomplished electronically, providing the user with a "mixed" left and right signal for just this application. Undoubtedly, others will be marketed.

Still a third method of achieving three channels suggests itself. In this last method, no third amplifier is required, but two more wide-range speakers are involved. The set-up is shown in Fig. 4. Here, a third wide-range speaker is paralleled across the left speaker and a fourth speaker is paralleled across the right speaker. Physically, however, the two extra speakers are mounted in one enclosure, which is positioned between the other two enclosures. If you have a pair of speakers currently doing stereo duty in another room, this might be the most inexpensive way to perform the three-channel experiment without additional expenditure until you decide whether or not you like the effect.

As for our own situation, there will be no rest until I replace the speaker system I "temporarily" stole from our bedroom and am unwilling to return—I happen to have decided in favor of three-channel stereo in the living room. For the time being, our bedroom TV set will have to subsist on its own 4" low-fi unbaflled "squeaker."

NEW SURPLUS!
for SPRING

METERS
G.E.—WESTINGHOUSE—W.E.—WESTON, Etc.

<p>2" R.F. Amp. 0 To 3A 2.95 0 To 9A 1.95</p> <p>2" Milliamperes 0 To 3 DC 2.50 0 To 10 DC 2.50 0 To 100 DC 2.50 0 To 200 DC 2.50 0 To 250 AC 2.50</p> <p>2" Volt Meters 0 To 15 AC 1.50 0 To 25 AC 2.50 0 To 150 AC 2.95 0 To 300 DC 2.95</p> <p>3" Volt Meters 0 To 15 AC 2.50 0 To 150 AC 3.50 200-0-200 DC 3.50 0 To 500 DC 2.50 0 To 750 DC 3.50</p> <p>3" DC Kilovolt Meters: All 1 MA Full Scale Movements. Use with external multipliers— 0 To 1.5: 0 To 3: 0 To 4: 0 To 5. Ea. \$2.95</p>	<p>3" Milliamperes 0 To 1 DC 3.50 (Blank Face) 3.50 0 To 25 DC 2.95 0 To 50 DC 2.95 80-0-80 DC 2.95 0 To 100 DC 2.95 0 To 150 DC 2.95 0 To 200 DC 2.95 0 To 250 DC 2.95 0 To 500 DC 2.95</p> <p>3" Amp. Meters 0 To 1.5 DC \$2.95 0 To 4 DC 2.50 0 To 15 DC 2.95 0 To 10 RF 2.95 0 To 15 RF 2.95</p> <p>3" Microampere 0 To 50 DC 4.95 0 To 100 DC 6.95 0 To 200 DC 4.95</p> <p>2" Decibel Meters 2.50 3" 3.50</p>
--	--

UHF SIGNAL GENERATOR
Type 1X-1 Later Version of type 804 signal generator. Frequency Range 8 MC to 310 MC. Output adjustable from 1 Milliwatt to 30 Milliwatts. Modulated non-modulated Video or IIF output. **\$125.00**
Like New Cond.

12 VOLT JEEP GENERATOR
Once again you can offer this outstanding piece of surplus equipment. 12 Volt 55 Amp. DC output generator complete with 55 Amp. Regulator and Meter. Minimum 250 RPM for operation. Pulley drives. Ideal for Mobile or Trucks or Boats. **\$49.95**
New Cond.

24 VOLT JEEP GENERATOR
Same as above only output of 24 Volt DC **\$49.95**
@ 30 Amp. New

SELSYN MOTORS
110 V. 60 Cycle Selsyns. All types. Size 5 available including 37, 50, 5 CT, 5DG, Etc. Lowest Price in the world @ **\$8.95**
Per Pair

See our previous ad for Special Surplus Items. All Prices F.O.B. S. F., Calif. Calif. orders add 3% Sales Tax. 20% Disp. on all C.O.D. purchases under \$5.00 send full amount. Items subject to prior sale.

STANDARD SURPLUS
1230 Market St., San Francisco 3, Calif.
Telephone HElock 1-3106

News of SUPREME Radio & TV Manuals

18 RADIO VOLUMES

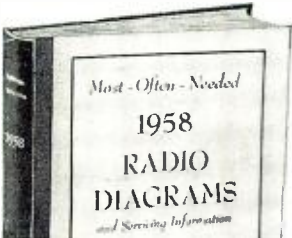

RADIO DIAGRAMS

Supreme is your best source for all needed RADIO diagrams and service data. Covers everything from the most recent 1958 radios to pre-war old-timers; home radios, auto sets, combinations, changers, HI-FI, FM, and portables. Sensational values. Only \$2 for many volumes. Every manual has extra large schematics, all needed alignment facts, parts lists, voltage values, trimmers, dial stringing, and helpful hints. Volumes are large in size, 8 1/2 x 11 inches, about 190 pages. See coupon below for a complete list of these low-priced manuals.

Just Out

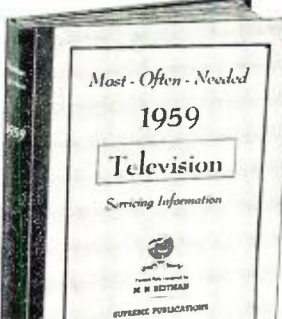

New 1959 TV manual covers all important sets of every make. Includes all data needed for faster TV servicing. Amazing bargain. A whole year of service material for only \$3.

ALL NEEDED TV DATA

Use Supreme TV manuals for faster, easier repairs. All needed material on every popular TV set of every important make. Easy-to-use, practical, factory-prepared data simplify TV servicing and adjustment. These giant TV manuals have complete, large double-page schematics, all needed alignment facts, printed board views, recommended changes, waveforms, voltage charts, etc. Only \$3 per large volume. The choice of 126,000 wise servicemen.

AMAZING BARGAIN

Here are your error-free service instructions to help you do expert work quicker; and priced at only \$3 for a mammoth yearly manual. Greatest bargain in service data. Repair any TV model ever made by having in your shop all 14 volumes listed in coupon. Special price for all 14, only \$40. Or try the new 1959 TV manual for only \$3. See no risk coupon below.



TELEVISION SERVICING COURSE

Let this new course help you in TV servicing. Amazing bargain complete, only \$3, full price for all lessons. Giant in size, mammoth in scope, topics just like a \$200.00 correspondence course. Lessons on picture faults, circuits, adjustments, short-cuts, UHF, alignment facts, hints, antenna problems, trouble-shooting, test equipment, picture analysis. Special, only **\$3**

SIMPLIFIED RADIO SERVICING BY COMPARISON

Fix any radio easily. New, different COMPARISON method finds faults quickly. Covers every radio set—new and old models. Introductory training included. Simple picture suggestions tell you where to look for faults. No testers needed for most jobs. Data on all tubes. Manual form, 96 large pages, 8 1/2 x 11". Special price, only... **\$1.50**



RADIO SERVICING COURSE

Here is your most amazing bargain in radio training. For only \$2.50 (full price) you can obtain a practical radio course of 22 easy-to-follow lessons. Covers every topic in radio. Review fundamentals, learn new servicing tricks, prepare for television. Compares lesson-by-lesson with the best \$150.00 home-study correspondence courses. With self-testing questions. Large size: 8 1/2 x 11". New 1959 edition. Amazing value at only... **\$2.50**

Supreme Publications
Sold by All Leading Parts Jobbers

NO-RISK TRIAL ORDER COUPON

SUPREME PUBLICATIONS, 1760 Balsam Rd., Highland Park, Ill.

Rush RADIO and TV manuals checked in coupon.

New Television Servicing Course, complete... **\$3.50**

Simplified Radio Servicing by Comparison... **\$1.50**

Radio Servicing Course (all 22 lessons)... **\$2.50**

New 1959 Television Servicing Manual, only... **\$3.**

1958 Television Manual, \$3. Early 1957 TV, \$3.

Additional 1957 TV, \$3. 1956 TV Manual, \$3.

Early 1955 TV, \$3. Additional 1955 TV, \$3.

1954 TV, \$3. 1953 TV, \$3. 1952 TV, \$3.

1951 TV, \$3. 1950 TV, \$3. 1949 TV, \$3.

1948 TV, \$3. 1957-58 RCA Victor TV, \$1.50

I am enclosing \$..... Send postpaid.

Send C.O.D. I am enclosing \$..... deposit.

Name:

Address:

- Radio Diagram Manuals
- 1958 Radio Diagrams, \$2.50
 - 1957 Radio Manual, \$2.50
 - 1956 Radio Diagrams, \$2.50
 - 1955 Radio Manual, only \$2
 - 1954
 - 1953
 - 1952
 - 1951
 - 1950
 - 1949
 - 1948
 - 1947
 - 1946
 - 1942
 - 1941
 - 1940
 - 1939
 - 1926-1938 Manual, \$2.50
 - radio & TV Master INDEX, 25c
- These annual RADIO volumes specially priced at only **\$2.50** each... **\$2**
- THIS GROUP ONLY \$2 EACH**

Build the Best... build **knight-kits**

A PRODUCT OF ALLIED RADIO

with exclusive "CONVENIENCE ENGINEERING" for easiest building

SAVE UP TO

50%

KNIGHT-KIT design goes beyond handsome styling, advanced circuitry and guaranteed specifications. KNIGHT-KIT "convenience engineering" means just that... it goes deep-down, with special attention to those small but vital details that count... details such as carded and identified resistors, plastic-bagged hardware, precut and stripped wire—details that make assembly far easier, that assure absolute accuracy, and finally reward you with proud enjoyment of the superior performance designed into your KNIGHT-KIT.

America's Low-Cost HI-FI anyone can afford—THERE'S NOTHING FINER

STEREO High Fidelity...build your own at great savings



Tremendous Value! ONLY

\$44.50

NEW 20-Watt Stereo Amplifier Kit

Newest complete Stereo high-fidelity amplifier at an amazing low \$44.50. Includes built-in magnetic cartridge preamps. Tandem controls for simplified operation. Single switch selects phono, tuner or auxiliary stereo inputs, plus stereo reverse on each; also switches monaural input to both amplifier channels. Bass and treble controls boost and attenuate. Special clutch-type concentric volume control permits adjusting balance on each channel, then controls overall volume. Total output is 20 watts (10 watts per channel at less than 1½% distortion). Response, 20-20,000 cps, ± 1.5 db. Four pairs of stereo inputs: magnetic cartridge, ceramic cartridge, tuner, auxiliary. Hum-free (DC on preamp tube filaments). Custom case, 4¼ x 13¼ x 9". Shpg. wt., 27 lbs.

Model Y-773. Net only.....

Easy Terms: Only \$4.45 Down



Stereo Preamp Control Center kit

In a class by itself—a control center that will do **anything** and **everything** you want. Features complete input flexibility—5 Stereo inputs (including tape heads), additional 4 inputs for monaural. Six record equalizations for monaural; RIAA for Stereo. Volume, bass and treble controls on concentric shafts with special clutch for both individual channel and overall control. Single switch selects straight Stereo; Stereo Reverse, either channel separately, or either channel into monaural output. Continuously variable loudness control; hum-free (DC on all tube filaments); cathode follower output and special recorder output. Exclusive printed-circuit switches and boards. Custom styled case, 4¼ x 13 x 8". Shpg. wt., 17½ lbs.

Model Y-776. Net only.....

Easy Terms: Only \$6.25 Down

60-Watt Stereo Basic Amplifier Kit

Absolutely the finest dual amplifier you can build—equal to highest-priced factory-built units. Ideal for use with the KNIGHT-KIT preamp, either as two 30-watt stereo amplifiers or 60-watt monaural amplifier. Exceptional response from 10 cps to 42,000 cps. Phenomenal 0.08% distortion at full 60 watts. Includes static plate current balancing adjustments for each channel; absolute stability under all operating conditions; custom-quality transformers. Also has special built-in circuitry, with easy external adjustment, for precise balance of gain on each channel to achieve perfect monaural performance. Two printed-circuit boards for easy assembly. Beautiful black and chrome; 9 x 14 x 8¼". (Cover extra, \$6.50.) 36 lbs.

Model Y-777. Net only (less cover)...

Easy Terms: Only \$8.45 Down

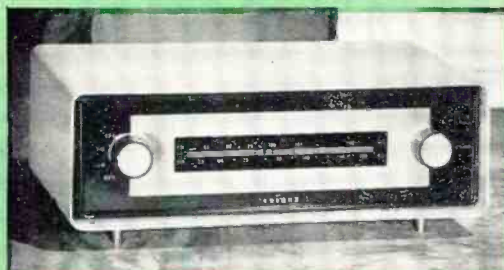

NOW WITH JACK FOR FM STEREO MULTIPLEX ADAPTORS

\$49.95

Only \$5.00 Down

Deluxe FM-AM Hi-Fi Tuner Kit at Lowest Cost

The best-looking, best-performing FM-AM tuner kit for the money. You'll enjoy building and owning it. FM sensitivity is a remarkable 2.5 microvolts for 20 db of quieting. AM is 3 microvolts for 10 db signal-to-noise ratio. Outstanding features include: single large printed-circuit board with most critical wiring already done; AFC (with disabling feature); flywheel tuning; precisely pre-aligned RF and IF coils—no further alignment needed; tuned RF stage on FM; drift-compensated oscillator; neon glow tuning pointer; cathode follower output; rotatable built-in AM antenna. Beautiful French-gray case, 4¼ x 13¼ x 8". Shpg. wt., 12 lbs.

Model Y-787. Deluxe FM-AM Hi-Fi Tuner Kit. Net only.....

\$49.95

Top-Value 12-Watt Complete Amplifier Kit... Best Buy in Hi-Fi

True Hi-Fi for only
\$19.95

(less cover)

Only \$2.00 Down

Never before has there been so much solid hi-fi value and quality performance at such low cost. Features smooth, clean output for truly rich reproduction. **Guaranteed specifications:** frequency response, 30-15,000 cps ± 1½ db at half power; less than 1% distortion at full power. Has 15 db of inverse feedback. Has preamp stage equalized for magnetic cartridges; inputs for phono and tuner; separate bass and treble controls with both boost and attenuation, push-pull EL84 output tubes; virtually hum-free performance. Size with cover, 5 x 9¼ x 7". (Cover extra, \$3.95.) 7½ lbs.

Model Y-784. 12-Watt Amplifier Kit, less cover. Net only.....

\$19.95

EASY TERMS ON knight-kit ORDERS AS LOW AS \$20

the kits with the GU RANTEED* specifications

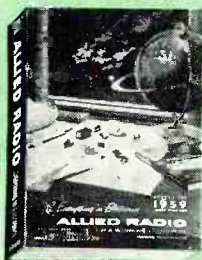

SEE ALLIED'S 1959 CATALOG FOR COMPLETE DETAILS

For full descriptions of the KNIGHT-KITS below, see the 452-page 1959 ALLIED Catalog. If you haven't a copy, send for it today—use coupon on following page.

there's a money-saving knight-kit for every quality Hi-Fi need



Universal Stereo Control Kit

Provides full centralized stereo control (volume, balance and channel selection) for use with any two amplifiers. Handles up to 20 watts program material. Unit simply connects between speakers and output terminals of amplifiers (no amplifier re-wiring needed). Lets you balance speaker system volume; provides master gain control for overall volume (can be used remotely); lets you play either channel monaurally through one or both speakers; provides channel reversal; phase reversal switch for best overall performance. 4½ x 7¼ x 4" 3½ lbs.

Model Y-778. Net only . . . \$9.95

*MONEY-BACK GUARANTEE

Every KNIGHT-KIT meets or exceeds published specifications, or we refund your money in full.



18-Watt Hi-Fi Amplifier Kit

Superb hi-fi specifications; deluxe custom styling. Includes 8 inputs for every desired signal source; full equalization; printed-circuit switches and boards for easy assembly. Shpg. wt., 15 lbs.

Model Y-797. Net only \$39.95



30-Watt Hi-Fi Amplifier Kit

Linear-deluxe Williamson-type circuit. Clear, rich 30 watts output; full equalization; 8 inputs; level and loudness controls; DC on filaments of preamp tubes; rumble filter; variable damping. Exclusive printed-circuit switches and boards. Custom-styled. 32 lbs.

Model Y-762. Net only \$76.95



Deluxe Hi-Fi Preamplifier Kit

Quality audio control center. 16 combinations of equalization; 8 inputs including tape head; DC on all tube filaments; printed-circuit switches and boards. Custom-styled. 12½ lbs.

Model Y-754. Net only \$39.95



25-Watt Hi-Fi Basic Amplifier Kit

Williamson-type circuit. Response, ±0.5 db, 9-70,000 cps at half power. Includes balance control; calibrated damping control; potted output transformer. Shpg. wt., 25 lbs.

Model Y-793. Net only \$44.50



Hi-Fi Basic FM Tuner Kit

Authentic Hi-Fi FM response. Includes AFC; flywheel tuning; pre-aligned RF and IF coils. 4 microvolt sensitivity guaranteed. With jack for FM stereo multiplex adaptors. Printed circuit board. Shpg. wt., 12 lbs.

Model Y-751. Net only \$38.95



2-Way "Ducted Port" Hi-Fi Speaker System Kit

Pre-finished enclosure; easy to assemble. Hi-fi response, 45-14,000 cps. Includes 12" woofer and horn-type tweeter. Available in mahogany, blonde or walnut (specify finish). 26 x 29 x 14". Shpg. wt., 33 lbs.

Model Y-789. Net only \$49.95



Deluxe "Ducted Port" 3-Way Speaker System Kit

Pre-finished enclosure, ready for quick assembly. Includes famous KNIGHT 3-way, 12" speaker. Response, 35-15,000 cps. Features "ducted port" for excellent bass response. Available in mahogany, blonde or walnut finish (specify). Shpg. wt., 47 lbs.

Model DZ-262. Net only \$73.45

knight-kits for the Radio Amateur

with designed-in value *Ham*s appreciate

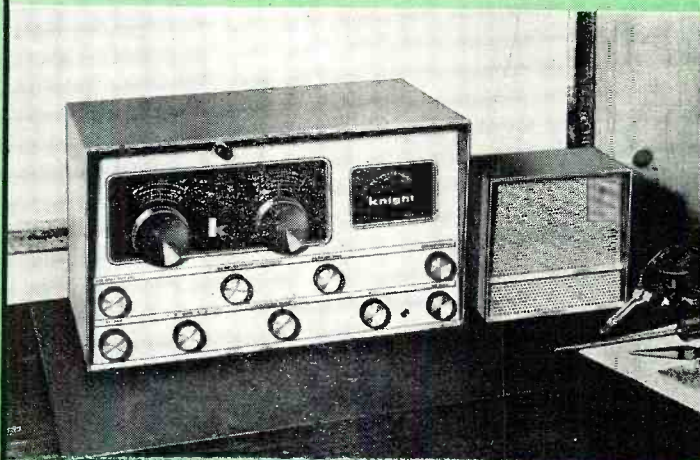

Amateur Communications Receiver Kit

IT'S THE BEST • BUILD IT YOURSELF AND SAVE!

Has all the selectivity, sensitivity and features of high-priced commercial units. Covers 540 kc to 31 mc in 4 ranges; calibrated, electrical bandspread on 80-10 meter Ham bands; slug-tuned Hi-Q coils; continuous, VR tube-regulated B+ applied to HF oscillator; built-in Q-multiplier; delayed AVC; provision for Y-256 crystal calibrator (below). Sensitivity, 1.5 microvolts for 10 db signal-to-noise ratio. Selectivity: variable from 300 cps to 4.5 kc at 6 db down. Exalted BFO injection for SSB. Controls: Main tuning, bandspread, band selector, BFO pitch, RF gain, AF gain, BFO-MVC-AVC-ANL, off-stby-rec-cal, ant. trim.—plus Q mult. controls; null-off-peak, selectivity, tune. Phone jack on front panel. Exclusive printed-circuit bandswitch; printed-circuit boards. Handsome metal cabinet, 10 x 10 x 16½". (Less speaker and S-meter.) 23 lbs.

Model Y-726. Net only

\$104.50

Easy Terms: Only \$10.45 Down

Y-727. S-Meter Kit for above. 1 lb. Net \$10.75

Y-728. 4" speaker in matching cabinet. 3½ lbs. Net . . \$7.50

POPULAR AMATEUR knight-kit VALUES!

50-Watt CW Transmitter Kit

Ideal for the novice. Convenient band-switching, 80 through 10 meters. Efficient pi-network antenna coupler; effective TVI suppression. Uses 807 in final. Shpg. wt. 18 lbs.

Model Y-255. Net only \$38.95



Self-Powered VFO Kit

With built-in power supply. High stability; excellent keying; full TVI suppression. Planetary vernier drive. Calibrated for 80, 40, 20, 15 and 10 meters; output on 80 and 40 meters. Shpg. wt., 11 lbs.

Model Y-725. Net only \$29.50

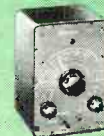

Z-Bridge Kit

Accurately measures SWR from 1 mc to 150 mc. Also measures antenna impedance. Has coax input and output. Invaluable for attaining peak antenna efficiency. Shpg. wt., 1½ lbs.

Model Y-253. Net only \$5.85



100-kc Crystal Calibrator Kit

Crystal frequency standard for any receiver, at very low cost. Gives marker every 100 kc up to 32 mc. Trimmer for zero-beating with WWV. With crystal. Shpg. wt. 1 lb.

Model Y-256. Net only \$10.95



Fascinating knight®-kits for Hobbyists

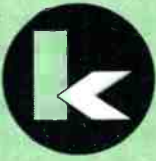

Fun to build... with performance you'll proudly demonstrate
 KNIGHT-KITS are the first choice of hobbyists, experimenters and students because they're truly "convenience-engineered" for easiest assembly, absolute dependability and finest performance. You'll have more building fun, you'll have more enjoyable performance, you'll save more with KNIGHT-KITS.



with exclusive
"Convenience Engineering"
 for assured
 build-your-own
 success...

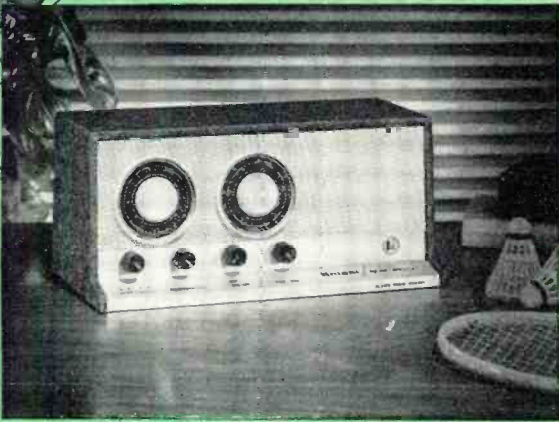

"Span-Master" 4-Band World-Wide Receiver Kit

Imagine the thrill of hearing overseas broadcasts on a precision receiver you've built yourself! At the flip of the bandswitch, you tune in the world—continuous 4-band coverage from Broadcast to 30 mc—fascinating foreign broadcasts, ships-at-sea, aircraft, police and marine radio, amateur reception on 80, 40, 20, 15 and 10 meters—all this wonderful short-wave, plus enjoyable local broadcast reception. Features sensitive regenerative circuit; easy bandspread tuning; built-in 4" Alnico V speaker; head-phone terminals; speaker cutout switch. Controls: Main Tuning, Bandspread, Bandswitch, Volume, Coarse and Fine Regeneration. Easy to build from marvelous instruction manual. Handsome cabinet; 6 1/4" x 13 3/4" x 6 1/4". For 110-125 v. AC. Shpg. wt., 7 lbs. **\$2495**
 Model Y-258. Net only

Easy Terms: Only \$2.50 Down

Widest choice of quality Hobbyist Kits

"Ranger III" AC-DC Radio Kit



Superhet broadcast band receiver. Built-in antenna; AVC; Alnico V speaker. Black plastic cabinet. AC or DC. Shpg. wt., 4 1/2 lbs.
 Model Y-736. Net only... \$16.95

"Ocean Hopper" Receiver Kit



Regenerative receiver for broadcast, long wave and short wave reception from 155 kc to 35 mc. With coil for broadcast band. For AC or DC. Shpg. wt., 7 lbs.
 Model Y-749. Net only... \$15.95
 Y-748. Set of plug-in long wave and short wave coils. Net... \$2.95

"Ranger III-PC" AC-DC Radio Kit



Printed-circuit broadcast band superhet. Easy to assemble. Has AVC, built-in loop antenna, Alnico V speaker. Ivory plastic cabinet. AC or DC. Shpg. wt., 4 lbs.
 Model Y-738. Net only... \$18.95

"Ranger" Radio-Intercom Kit



It's a broadcast band radio—it's an efficient 2-way intercom—both in one! Ivory plastic case for Master station/Radio; smartly styled Remote station. With 50-ft. cable. AC or DC. Shpg. wt., 8 lbs.
 Model Y-739. Net only... \$27.50

"Trans-Midge" Radio Kit



Tiny 1-transistor radio for local broadcast reception. Works for months from single penlight cell supplied. Handsome plastic case. Fascinating to build. (Requires headphones and antenna.) 8 oz.
 Model Y-767. Net only... \$2.45

10-Circuit Transistor Lab Kit

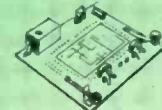

Builds any of 10 favorite projects. Entire kit on a printed circuit board. Just plug in leads to change from project to project. 3 lbs.
 Model Y-299. Net only... \$15.75

1-Transistor Radio Kit

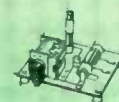

Offers fine local broadcast head-phone reception. Printed circuit board for easy assembly. Works for months from penlight cell supplied. (Antenna and headphones required.) Shpg. wt., 1 lb.
 Model Y-765. Net only... \$3.95

"Space Spanner" Receiver Kit

Thrilling 2-band receiver, easy to build, fun to operate—a terrific value. Bandswitch selects exciting short-wave, including foreign broadcasts, amateur, aircraft, police and marine radio (6.5 to 17 mc), and standard broadcast. Highly sensitive regenerative circuit. Built-in 4" PM speaker and beam-power output for strong volume. Has head-phone jacks and switch to cut out speaker. Easy to assemble from step-by-step instructions. Handsome cabinet, 7 x 10 1/2 x 6". AC or DC operation. Shpg. wt., 7 1/2 lbs.
\$1895
 Model Y-259. Net only

"Ranger" Clock-Radio Kit

You'll be proud of the performance of this easy-to-build clock-radio. Provides wonderful broadcast band reception. Includes Telechron clock with sleep-switch timer plus automatic radio wake-up/alarm switch. Radio automatically shuts off at night and wakes you in morning; also turns on appliances automatically. Module plug-in circuits and printed-circuit board for quick, easy assembly. Beautiful blue and white plastic cabinet. 6 x 9 1/8 x 5 3/8". For 60 cycle AC only. Shpg. wt., 5 lbs. **\$2495**
 Model Y-737. Net only
 Easy Terms: Only \$2.50 Down

12-In-1 Electronic Lab Kit

Fascinating way to learn electronics—build any one of 12 practical circuits! Change circuits just by relocating a few wires. Safety-designed; no voltage exceeds 25v. Makes any one of the following: AM radio, amplifier, code oscillator; home "broadcaster"; electronic timer, switch or flasher; voice-operated, capacity-operated or photoelectric relay; CW "transmitter"; light control oscillator. With all parts, mike, phototube, instructions for each project. For 110-125v. AC. Shpg. wt., 3 1/2 lbs. **\$1495**
 Model Y-272. Net only

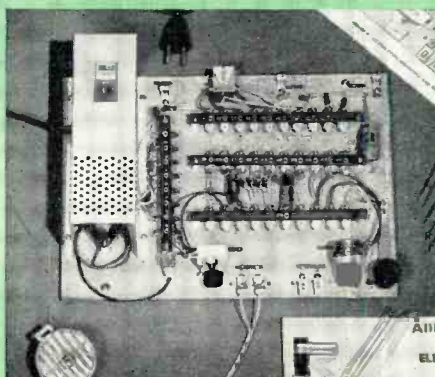



MONEY-BACK GUARANTEE

Every KNIGHT-KIT meets or exceeds published specifications—or we refund your money in full.

EASY TERMS on orders as low as \$20

5-Transistor Superhet Radio Kit



Quality personal portable. Printed circuit for easy assembly. Built-in antenna; 3 1/2" speaker; prealigned IF's; phono jack; 200-hour battery playing life. Handsome ivory and gold styling. Less battery (\$1.43). 2 lbs.

Model Y-771. Net only \$25.95

2-Transistor Pocket Radio Kit



Excellent for local broadcast reception. Newest printed-circuit board for easy assembly. Built-in antenna; miniature dynamic earphone; plays for months from single battery. In handsome carrying case; only 4 x 3 3/4 x 1 1/2". Less battery (\$1.25). 1 1/2 lbs.

Model Y-263. Net only \$11.50

2-Way Intercom System Kit

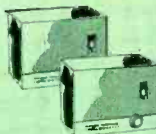

Complete 2-station system; low-cost, easy to assemble. High gain, clear toned, sensitive. Has 2-stage amplifier and 4" PM speakers. Handsome metal cabinets. Includes master, remote and 50-ft. cable. AC or DC. 8 lbs.

Model Y-297. Net only \$14.95

Electronic Photoflash Kit



Fast 1/700th-of-a-second flash; 50 watt/second output. Synchronizes with any camera with X or O shutter. Less battery. Shpg. wt., 4 lbs.

Model Y-244. Net only \$29.50

Wireless Broadcaster—Amplifier Kit



Play music or make announcements through your radio set, using mike or phono—no connection to set needed. Use also as audio amplifier. Has built-in preamp. AC or DC. Shpg. wt., 3 lbs.

Model Y-706. Net only \$11.95

Transistor Code Practice Kit



Ideal for beginners learning code. 500 cps tone. Single penlight cell supplied operates unit for months. Jacks for headphones; screw terminals for key. Shpg. wt., 1 lb.

Model Y-239. Net only \$3.95

Crystal Set Kit



Gives clear headphone reception of local broadcast stations. Sensitive crystal diode; efficient "Hi-Q" coil. (Antenna and headphone required.) Shpg. wt., 1 lb.

Model Y-261. Net only \$2.35

Photoelectric Relay Kit

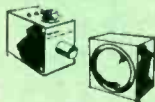

Ultra-sensitive relay at very low cost. Fine for automatic control of lights, door openers, as a burglar alarm, etc. Shpg. wt., 3 1/2 lbs.

Model Y-702. Net only \$13.50

Y-703. Light Source only \$ 6.75

Free! **1959 452-PAGE ALLIED CATALOG**

See pages 241-273 for detailed descriptions of all KNIGHT-KITS: Hi-Fi, Hobby, Test Instrument, Amateur. The 1959 Allied Catalog is your complete Buying Guide to the world's largest stocks of everything in Electronics.

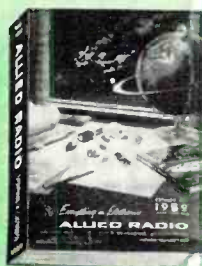

38 years of experience in electronic kit design

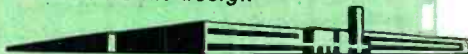

Vacuum Tube Voltmeter Kit

Top buy in a quality VTVM. Entire chassis is printed-circuit board—easy to assemble. Balanced-bridge, push-pull circuit; 1% film-type resistors; 200 μ movement; 4 1/2" meter; includes zero center scale and direct-reading db scale. Polarity reversing switch. Input Res.: 11 megs. DC and AC rms, 0-1.5-5-15-50-150-500-1500; AC Peak-to-Peak, 0-4-14-40-140-400-1400-4000; Response, 30 cycles to 3 mc; Ohms, 0-1000-10K-100K and 0-10-100-1000 megs; db, -10 to +5. Includes battery and test leads. For 110-125v., 50-60 cycles. Shpg. wt., 6 lbs.

Model Y-125. Net only **\$25⁷⁵**

Easy Terms: Only \$2.58 Down



Lowest Cost Tube Checker Kit

A really tremendous value in a quality tube checker. Checks over 400 tubes. Features "Flip-Card" charts with tube settings in loss-proof pull-out storage drawer. Has sockets for 7-pin miniature, 9-pin miniature, octal and loctal base tubes. Checks for cathode emission, filament continuity, shorted elements. Meter has "Replace-Good" scale and special scale for checking diodes. With quick-setting, universal-type selector slide switches. Includes "Hi-Lo" line-voltage regulator switch. Compact and light—use anywhere. With tube charts. 6 1/2 lbs.

Model Y-707. Net only **\$19⁹⁵**

Easy Terms: Only \$2.00 Down

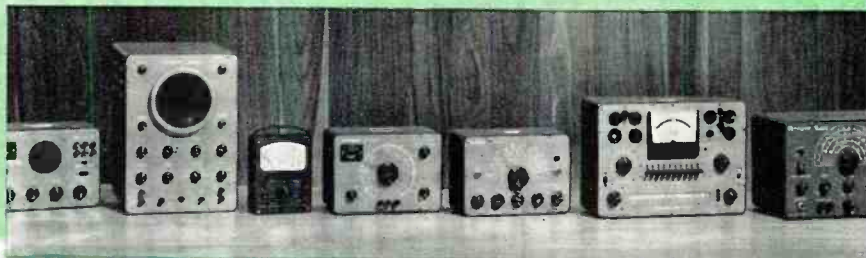

there is a knight-kit to fill every test equipment need

For detailed descriptions, see the 1959 Allied Catalog.

5" Wide-Band "Scope Kit	\$65.75	High-Gain Signal Tracer Kit	\$26.50
5" General Purpose "Scope Kit	42.00	Audio Generator Kit	32.95
20,000 Ohms/Volt VOM Kit	29.50	Resistor-Capacitor Tester	19.50
1,000 Ohms/Volt VOM Kit	16.95	"In-Circuit" Capacitor Checker Kit	12.50
"Scope Voltage Callibrator Kit	12.75	Flyback Checker Kit	19.50
Counter Tube Checker Kit	29.75	Transistor & Diode Checker Kit	8.50
Portable Tube Checker Kit	34.75	Resistance Substitution Box Kit	5.95
TV-FM Linear Sweep Generator	44.95	Capacitance Substitution Box Kit	5.95
RF Signal Generator Kit	19.75	6V-12V Battery Eliminator Kit	32.95

ORDER BLANK

ALLIED RADIO Dept. 131-C9
100 N. Western Ave., Chicago 80, Ill.

Ship me the following KNIGHT-KITS:

Quantity	Description	Model No.	Price

\$..... enclosed. (For parcel post include postage; express is shipped collect.) All prices Net F. O. B. Chicago

My Down Payment in the amount of \$..... is enclosed. Send Time Payment form

Send FREE
452-Page 1959
Allied Catalog

Name _____
Address _____
City _____ Zone _____ State _____

UNBEATABLE!

SPAULDING "STRATO-TOWER"

FEATURING THE

ALL NEW SCREW ANCHOR BASE

1. No Concrete Necessary
2. Completely Self-Supporting
3. Unconditionally Guaranteed
(Base more satisfactory than concrete or your money back)
4. Absolutely No Hole To Dig
5. Fast Installation . . . Base in 15 Min., Tower in 90 Min. (2 men)
6. One Base Fits All Tower Sizes To 48 Ft.
7. Tower Completely Galvanized
8. All Riveted Construction
9. Beaded Channel Leg (Will not rust inside like tubular type towers)

No. X40B (ILLUSTRATED)
40 FT. HIGH LIST **\$99.95**

OTHER MODELS FROM 8 FT. TO 64 FT.

U. S. Patent No. 2806560

How Tower Mounts On Screw Anchor Base

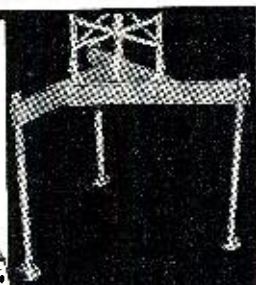

WRITE

today for complete literature and details on where to get Spaulding Strato-Towers for TV—Ham—Civil Defense—Industrial Communications.

SPAULDING PRODUCTS COMPANY

550 West Barner Street • Frankfort, Indiana

IN CANADA: Delhi Metal Products Co., Delhi, Ontario

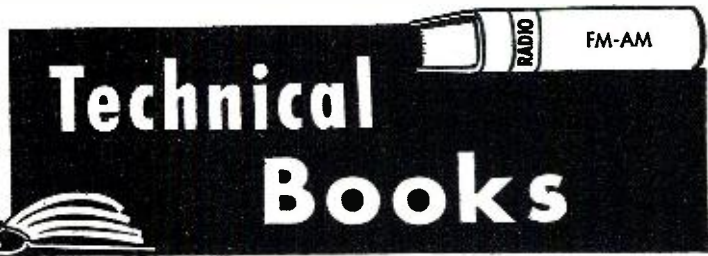

"NEW SIDEBAND HANDBOOK" by Don Stoner, W6TNS. Published by Cowan Publishing Corp., 300 W. 43rd Street, New York 36, N. Y. 215 pages plus catalogue section. Price \$3.00. Paper bound.

This is a "how-to" book for the radio amateur who operates SSB and those who have been "thinking it over" and are as yet undecided as to whether to hop on the bandwagon or not. The author, a dyed in the wool "sidewinder," is a mighty persuasive salesman so be forewarned!

The book is divided into eight informal and chatty chapters covering a definition of sideband, balanced modulators, the filter system, phasing system, double sideband, linear amplifiers, how to receive sideband, and accessories for sideband shacks.

Parts of the text are humorous but this treatment is incidental to a sound and thorough discussion of the subject. The author "knows his stuff" and is happy to share his knowledge with his audience. Line drawings, photographs of commercial equipment, schematics, and graphs are lavishly used to amplify the text material. A bibliography at the end of each chapter is provided for those who wish to delve deeper into some particular phase of the subject although this volume is complete in itself.

Hams seeking greater operating convenience and pleasure will undoubtedly want to investigate the possibilities of SSB while those already a member of the "fraternity" will be interested in sharpening their operating practices.

"INTERNATIONAL RADIO TUBE ENCYCLOPAEDIA" by Bernard B. Babani. Published by *Bernards (Publishers) Limited, London*. Available in the U. S. from *Joseph Plasencia, Inc.*, 401 Broadway, New York 13, N. Y. Price \$15.00 postage prepaid in the U. S., its possessions, and territories. Third Edition.

Listings of over 27,500 tubes of all types are included in the newest edition of this well-known reference volume. Since the appearance of the second edition in 1954 more than 9000 tubes have been added by electronic manufacturers throughout the world.

The Encyclopaedia is divided into ten sections covering radio receiving tubes, triode transmitting tubes, tetrode and pentode transmitting tubes, rectifiers, thyratrons, regulator and control tubes, tuning indicators, cathode-ray tubes, photo tubes, and rare tubes and their equivalents.

Instructions for using the charts and tables are printed in 14 languages in addition to English, fully justifying the

"International" in the title. Tubes made in Great Britain, U. S., France, Germany, Italy, Holland, Switzerland, Poland, Czechoslovakia, Belgium, Japan, South American countries, Australia, Spain, Canada, and the U.S.S.R. appear along with comprehensive data on each type. Of particular interest to those who have purchased various items of surplus military gear is the section on tube types used in the equipment of the British, U. S., Russian, and European Armed Forces.

There are completely cross-indexed equivalents tables covering every receiving tube produced in the world, enabling the user to substitute tubes where required. A numerical-alphabetical index, a section showing the various types of tube bases, a listing by tube purpose, and a manufacturer's index with trade-names and complete addresses are all "plus" features which will be warmly appreciated by those who have occasion to consult such a reference source.

"MOST-OFTEN-NEEDED 1959 TELEVISION SERVICING INFORMATION" compiled by M. N. Beitman. Published by *Supreme Publications*, Highland Park, Ill. 192 pages. Price \$3.00. Soft binding. Vol. TV-15.

This is the fifteenth in this publisher's series of servicing data books and follows the same pattern of presentation as the earlier volumes.

Sets made by *Admiral, Emerson, General Electric, Hotpoint, Montgomery Ward, Motorola, Packard-Bell, Philco, RCA, Sylvania, Westinghouse, and Zenith* are covered. All of the essential material needed for a quick servicing job has been included. Double-page diagrams, alignment tips, waveforms, voltage values, parts location diagrams, factory revisions, and service hints are provided.

An index which lists the receivers by maker and chassis and model numbers is included to facilitate location of the required material.

"FUNDAMENTALS OF TRANSISTORS" by Leonard Krugman. Published by *John F. Rider Publisher, Inc.*, New York, 164 pages. Price \$3.50. Paper bound. Second Edition.

The progress of the transistor art has been so rapid that a second edition of this volume (originally published in 1954) was warranted. Large portions of the original text have been rewritten and additional material included to bring the reader up to date on technological developments.

New material includes the theory, construction, and operation of semi-

conductor devices such as surface barrier, intrinsic, drift, avalanche, and capacitor types. Illustrative circuits and design theory applicable to amplifiers, oscillators, and high-frequency usage indicate the current state of the art.

To make this volume suitable for home-study and classroom use, each chapter carries review questions plus a bibliography for further study. Those seeking a compact, up-to-date reference on transistors would do well to consider this volume. A practical working knowledge of mathematical processes would be helpful.

* * *

"LAYMAN'S GUIDE TO HI-FI" by Byron Wels. Published by *American Electronics Co.*, 1203 Bryant Ave., New York 59, N. Y. 72 pages. Price \$1.25. Paper bound.

In this non-technical discussion of high-fidelity equipment, the author covers turntables, record changers, tone arms, and pickups; FM and AM tuners; amplifiers; speakers, cabinets, and enclosures; the assembling of kits; and the installation of a hi-fi system using pre-assembled components.

Additional chapters present an introduction to high-fidelity, a discussion of the components comprising a high-fidelity system; how to listen to high-fidelity program material; and the future of hi-fi. A glossary and index complete the volume.

The language is simple and schematics and graphs have been eliminated in favor of block diagrams. Each type of component discussed is illustrated with a photograph of a commercial unit.

For the technically inclined or the "old hand," the author's treatment is overly simplified but for the real tyro this text should prove helpful.

* * *

"GUIDE TO MOBILE RADIO" by Leo G. Sands. Published by *Gernsback Library, Inc.*, New York. 160 pages. Price \$2.85. Paper bound.

Despite the fact that mobile radio has become a 79-95 million-dollar-a-year-business, there is surprisingly little information in print about available equipment, how to install it, and troubleshooting procedures.

While this book isn't the complete answer to the lack of literature on the subject it is a step in the right direction. Obviously a subject this comprehensive and covering so many different types of equipment cannot be exhaustively treated in a book this size but it helps.

The twelve chapters cover mobile radio in general, the mobile unit and base station, receivers, transmitters, power supplies, antenna systems, remote control, portable equipment, selective calling, maintenance, licensing, and conducting a field survey. Graphs, schematics, polar patterns, and photographs of commercial units all help to amplify the text.

The book will be of interest to radio technicians, mobile equipment sales personnel as well as those who buy and operate such gear.

March, 1959

KIT-OF-THE-YEAR!

A new
RCA-WV-77E(K)
VoltOhmyst[®]
for only
\$29.95*

Also available
factory-wired
and calibrated—
RCA-WV-77E
VOLTOHMYST—
only \$49.95*
*User Price (optional)

FREE—New Booklet
"Servicing Is Easy With
An RCA VoltOhmyst"
offered with the purchase
of a WV-77E(K)
or WV-77E (\$1 value)



Hams! Hobbyists! Service Technicians!—Here's the new RCA VoltOhmyst Kit you've been hearing about ... combining dependable electronic performance and ease of assembly!

Look what you get—ohms-divider network protected by fuse—ultra-slim probes and flexible leads for getting into those tight spots—leads, probes, and power cord can be stored in sleeve attached to handle for increased portability—separate scales for 1 1/2 volts rms and 4 volts peak-to-peak maintain instrument accuracy on low ac measurements—all lettering on front panel acid-etched to last the life of the unit!

You can get the new RCA VTVM Kit at your local RCA Test Equipment Distributor today—it's available "off-the-shelf"! For literature, visit your nearest RCA Distributor, or write RCA Commercial Engineering, Section C-41-W, Harrison, N. J.

SPECIFICATIONS

Measures:

DC Volts—0.02 volt to 1500 volts in 7 overlapping ranges

AC Volts (RMS)—0.1 volt to 1500 volts in 7 overlapping ranges

AC Volts (peak-to-peak)—0.2 volt to 4000 volts in 7 overlapping ranges

Resistance—from 0.2 ohm to 1000 megohms in 7 overlapping ranges. Zero-center indication for discriminator alignment

Accuracy—±3% of full scale on dc ranges; ±5% of full scale on ac ranges

Frequency Response—flat within ±5%, from 40 cycles to 5 Mc on the 1.5, 5, and 15-volt rms ranges and the 4, 14 and 40-volt peak-to-peak ranges

DC Input Resistance—standard 11 megohms (1 megohm resistor in probe)



RADIO CORPORATION OF AMERICA

Electron Tube Division

Harrison, N. J.

NEW! "Do-It-Yourself" LAFAYETTE Kits



LAFAYETTE'S
1959 CATALOG
260 GIANT-SIZE
PAGES
FREE!

Complete listings of the NEWEST in Stereo and Monaural Hi-Fi, Short Wave, Audio, Transistor, and many other Lafayette electronics kits as well as thousands upon thousands of standard brand nationally advertised kits and electronic parts and components are described in LAFAYETTE'S GIANT NEW 260-PAGE CATALOG. SEND FOR IT—IT'S FREE! Just fill in coupon below and present it at any Lafayette store, or paste it on a postcard and send it to us. THAT'S ALL YOU HAVE TO DO to get your FREE 1959 LAFAYETTE CATALOG!

LAFAYETTE RADIO ELECTRONIC KITS

- Include the very latest electronic advances.
- Are constantly being modernized by Lafayette's own Engineering Department, by a leading consulting engineering firm, and by your own recommendations.
- Are a product of Lafayette's 38 years of Electronic Leadership.

EDUCATIONAL

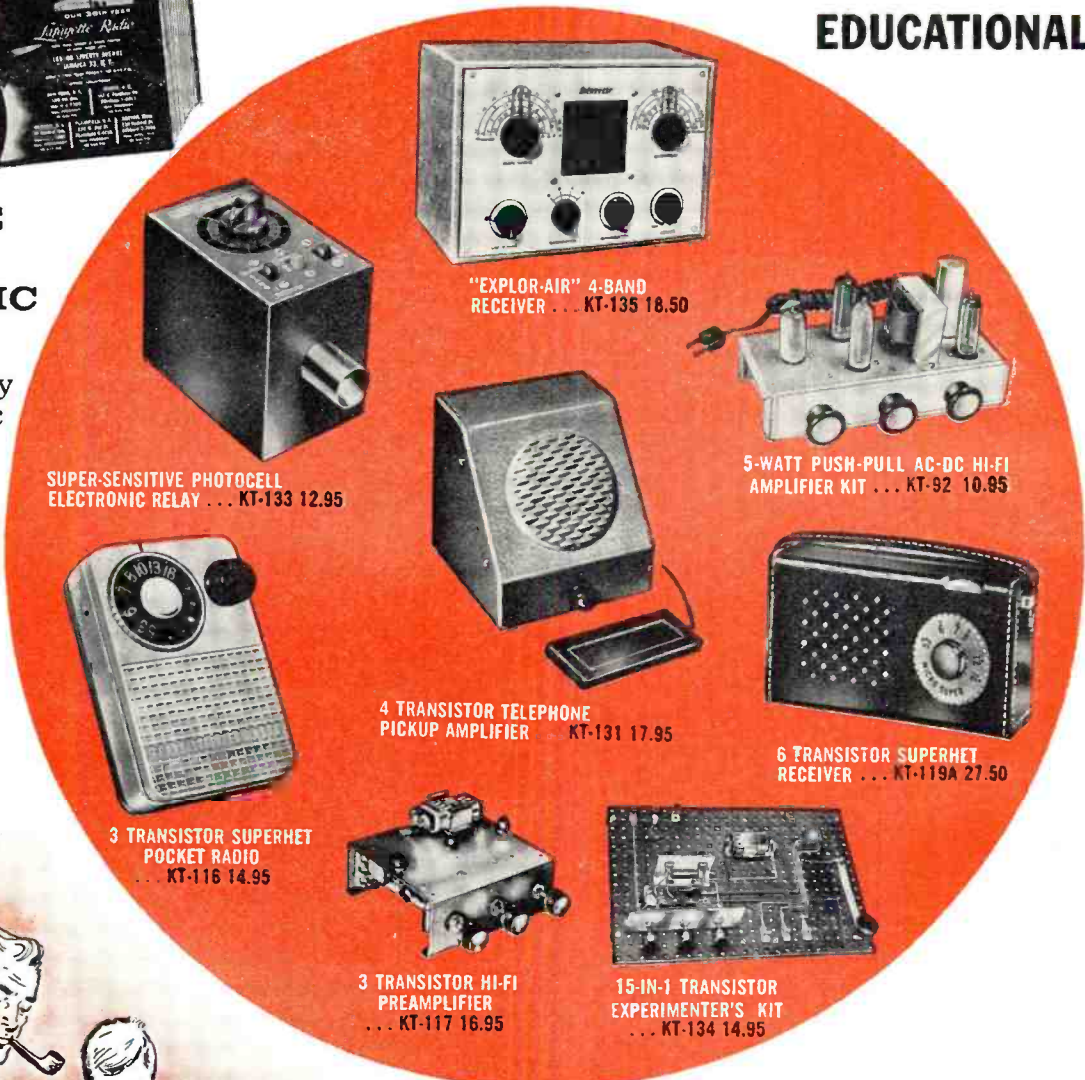

SUPER-SENSITIVE PHOTOCCELL ELECTRONIC RELAY ... KT-133 12.95

"EXPLOR-AIR" 4-BAND RECEIVER ... KT-135 18.50

5-WATT PUSH-PULL AC-DC HI-FI AMPLIFIER KIT ... KT-92 10.95

4 TRANSISTOR TELEPHONE PICKUP AMPLIFIER ... KT-131 17.95

6 TRANSISTOR SUPERHET RECEIVER ... KT-119A 27.50

3 TRANSISTOR SUPERHET POCKET RADIO ... KT-116 14.95

3 TRANSISTOR HI-FI PREAMPLIFIER ... KT-117 16.95

15-IN-1 TRANSISTOR EXPERIMENTER'S KIT ... KT-134 14.95

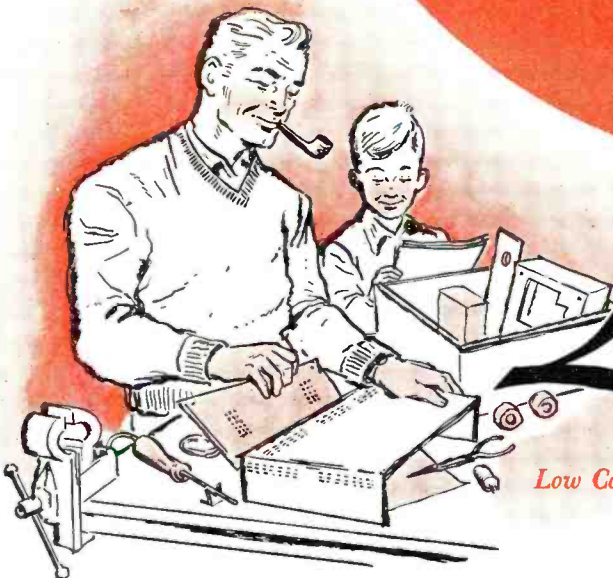

Low Cost Kits For Everyone!

Lafayette Radio

LAFAYETTE Kits Are FUN To Build!

LEARN ELECTRONICS BY BUILDING A LOW COST LAFAYETTE KIT

KITS FOR BEGINNERS • 10-In-1 Lab Kit • Transistor Code Practice Oscillator • AC-DC Broadcast Receiver • 3-Way Broadcast Receiver • 5-Watt Push-Pull AC-DC Amplifier • 7-In-1 Radio Lab Kit • 2-In-1 Kit • Germanium Diode Radio • 1-Transistor Pocket Radio • 2-Transistor Pocket Radio

HI-FI KITS • Stereo Master Audio Control Center & Preamplifier • Stereo Remote Control Center—Electronic Stereo Adapter • 36-Watt Basic Stereo Amplifier • AM-FM Stereo Tuner • Preamp-Audio Control Center • 70-Watt Power Amplifier • 4-Watt Stereo Amplifier • Speaker Enclosure Kits

ADVANCED KITS • Broadcast-Shortwave Receiver • Electric Brain Kit • 10-Watt Push-Pull Hi-Fi Amplifier • 15-In-1 Transistor Experimenter's Kit • 4-Band Broadcast-Shortwave Receiver • Photocell Electronic Relay • 6-Transistor Superhet Receiver • 3-Transistor Pocket Radio • 3-Transistor Hi-Fi Preamplifier • 2-Transistor Reflex Radio with Sun Battery • Transistor Code Practice Oscillator • Radio Control Transmitter • Transistor-Diode Checker • Multitester-Semi-Kit • 4-Transistor Telephone Pickup Amplifier

PRACTICAL

EASY-TO-BUILD LAFAYETTE KITS

Enjoy and Save

LAFAYETTE KITS SAVE YOU REAL MONEY. You save up to 50% or more when you build a low-cost Lafayette kit as against factory-wired units of equal or even lesser quality. You save also because Lafayette manufactures these kits and sells them *direct to you*, eliminating the usual dealer's markup.

LAFAYETTE KITS ARE YEARS AHEAD. Every latest advance in electronics finds its way into educational and practical Lafayette Kits. Lafayette was **FIRST** in TRANSISTORS, and Lafayette is now **FIRST** in STEREO HI-FI!

LAFAYETTE KITS ARE EASY TO BUILD. Whether you are a beginner or an engineer, a novice or advanced amateur, there are Lafayette kits you can build, learn from, and use. Detailed instructions with clear, large blow-ups and dozens of illustrations describe minutely every step of the kit assembly so that there are seldom any questions.

LAFAYETTE KITS ARE AVAILABLE ON OUR EASY PAY PLAN. SEE OUR FREE GIANT-SIZED 260-PAGE 1959 CATALOG FOR DETAILS.

ASK FOR THE FREE 260-PAGE GIANT NEW 1959 LAFAYETTE CATALOG

Fill in and present the coupon below at any Lafayette store for your FREE Catalog, or simply paste the coupon on a postcard and mail it to the address on the coupon. Our catalog is FREE for the asking!

FREE



CUT
OUT
AND
PASTE
ON
POST
CARD

LAFAYETTE RADIO, Dept. RC9
P.O. Box 511, Jamaica 31, N. Y.

SEND FOR THE WORLD'S LEADING ELECTRONICS,
RADIO, T.V., INDUSTRIAL, AND HI-FI GUIDE

Send FREE LAFAYETTE Catalog 590

Name

Address

City..... Zone.... State.....



36-WATT STEREO BASIC POWER
AMPLIFIER KT-310 47.50

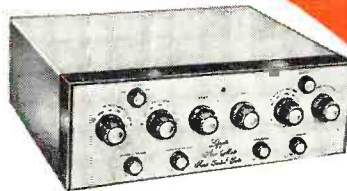

STEREO MASTER AUDIO CONTROL
CENTER-PREAMP KT-600 79.50

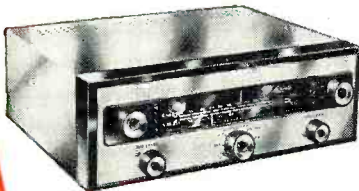

STEREO AM-FM HIGH FIDELITY
TUNER KT-500 74.50

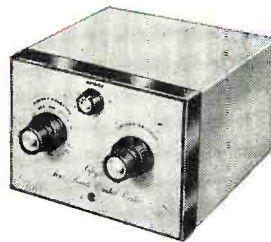

STEREO REMOTE CONTROL CENTER
ELECTRONIC STEREO ADAPTER
.... KT-315 27.50



70-WATT DELUXE
BASIC AMPLIFIER
.... KT-400 69.50

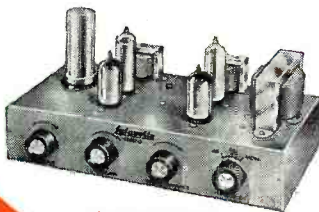

4-WATT STEREO
PHONO AMPLIFIER
.... KT-126 18.95

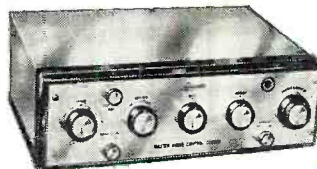

DELUXE MASTER AUDIO CONTROL
CENTER-PREAMPLIFIER
.... KT-300 39.50

LAFAYETTE RADIO STORE LOCATIONS

JAMAICA 33, N. Y.
165-08 Liberty Ave.
AXtel 1-7000
Open FRIDAY
'till 8:45 P.M.

NEW YORK 13, N. Y.
100 6th Ave.
WOrth 6-5300
Open THURSDAY
'till 8:45 P.M.

BRONX 58, N. Y.
542 E. Fordham Rd.
Fordham 7-8813
Open THURSDAY
'till 8:45 P.M.

NEWARK 2, N. J.
24 Central Ave.
Market 2-1661
Open WEDNESDAY
'till 8:45 P.M.

PLAINFIELD, N. J.
139 W. 2nd St.
Plainfield 6-4718
Open THURSDAY
'till 8:45 P.M.

BOSTON 10, Mass.
110 Federal St.
Hubbard 2-7850
Open MON.-WED.
'till 8:45 P.M.



POWER TOOLS
are "job-matched" for
easier handling, trustier performance!

Pick up a Wen tool. It fits in your hand like it grew there! Lightweight, streamlined Wen designs are extra easy-handling . . . quality-engineered to do the job right. Ask any Wen tool user. Your best dollar-for-dollar buy, too!



2-SPEED POWER DRILL
3/8" capacity in steel, up to 3/4" in hardwood. Smooth easy speed change, high torque motor. **\$29⁹⁵**



TOTE KIT
Perfect supplement to drill. 35 pieces including drill holder, Tote Box with tray. A whole workshop, only **\$9⁹⁵**



SOLDERING GUN KIT
Includes 4 tips for wide variety of uses, solder. "Quick-Hot" gun heats in only 2 1/2 seconds. A buy at **\$9⁹⁵**

See complete line of Wen power tools at your favorite dealer! RT-3

WEN PRODUCTS, INC.
5810 Northwest Highway • Chicago 31, Illinois

Simple "Tune-Operate" Switching for the Ham Transmitter

By HOWARD S. PYLE, W7OE

Provides protection for transmitting tubes and components while tuning up and permits reduced power operation of the rig for local contacts.

PRACTICALLY all radio transmitters built for military and commercial services are provided with what is designated a "tune-operate" switch which permits reduction of the power input during tuning adjustments thereby protecting tubes, meters, and other components from dangerous overloads.

Seldom does such a simple and practical safeguard appear in *amateur* radio transmitting equipment whether of commercial manufacture or of the "home-brewed" type. In addition to the protective feature provided for the components, a "tune-operate" switch, such as described here, permits instant switching from "high" to "low" power for those short contacts within your local area, reducing the interference problem and earning you the gratitude of other nearby hams!

Installation of such an arrangement is simple in existing rigs; more simple still to incorporate in one you may be planning or building. The cost is small and the circuit uses standard, readily obtainable parts. If these parts are purchased new your cost will run less than five dollars. Your own station junk box will no doubt produce most or all of the required components.

Such an arrangement as described and illustrated here is adaptable to any amateur station of any legal power, with one exception; those using a common filament and plate supply transformer in the final stage. These latter appear only in the "low power" category . . . below 100 watts . . . where such a protective device is less essential. Combination plate and filament transformers are rarely available in secondary voltages greater than 600-0-600 a.c., producing a d.c. voltage in the neighborhood of 500. For the higher-powered rigs requiring 750 to 1000 volts and more, separate plate and filament transformers are invariably used.

To lower the a.c. output voltage of the final amplifier plate transformer, which drops the d.c. voltage proportionately, it is merely necessary to decrease the a.c. *input* voltage at the primary terminals. The most satisfactory method of accomplishing this is to insert the *primary* of an additional small transformer of the same input voltage (usually 117 volts) in *series*

with the primary of the *plate* transformer, with provision for switching this second primary in or out of the circuit. This is readily accomplished by wiring a single-pole, single-throw toggle switch of appropriate carrying capacity directly across the second primary.

The second transformer can well be an ordinary filament type with a 117-volt primary winding. The secondary voltage is immaterial although we shall use it, whether it is 2.5, 5.0, or 6.3 volts. For what? Merely connect a pilot light of appropriate voltage across it, behind a panel jewel of whatever color you select (the author used amber) and when the pilot light is illuminated you are on "low power" . . . when it is extinguished by throwing the "tune-operate" toggle switch to "operate" or "high" position, you are back on normal power! Approximately fifty percent reduction in power input and consequent r.f. output will result with the switch in the "tune" or "low" position.

It should be possible to find sufficient chassis space in any rig on which to mount the second transformer. Any panel will most certainly accommodate a small toggle switch and a pilot light bracket and jewel. Appropriate labelling with neat little decals will add a suitable "professional" touch.

This simple and positive little protective feature is shown schematically in the accompanying diagram. —30—

Circuit diagram of switching arrangement.

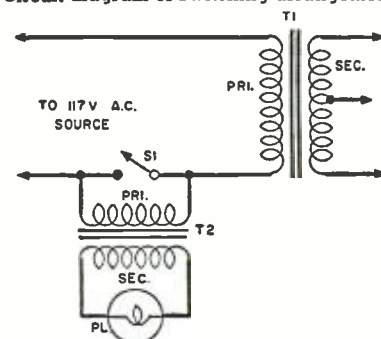

T1—FINAL AMP. PLATE TRANS.
T2—CONVENTIONAL FIL. TRANS.
PL—PILOT LAMP (VOLTAGE TO MATCH SEC. VOLTAGE OF T2)

NOT USED, NOT PULLED OUT OF OLD SETS

Brand New TUBES

**BETTER
THAN
70%
OFF!**

**BETTER
THAN
70%
OFF!**

**and RAD-TEL'S FIRST QUALITY!
REMEMBER... ALL RAD-TEL TUBES
GUARANTEED ONE FULL YEAR**

Ask for Types Not Listed - Send for New Free Tube & Parts Catalog

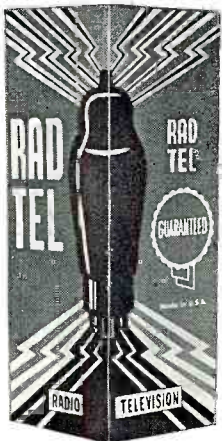

RAD-TEL TUBES

Individually Boxed!
NOT USED, NOT PULLED
OUT OF OLD SETS
Every Rad-Tel Tube Is
BRAND NEW
Guaranteed 1 Full Year!

Type	Price	Type	Price	Type	Price	Type	Price	Type	Price	Type	Price
1AX2	.62	5BQ7	.97	6BC5	.54	6CU6	1.08	12AF6	.49	12V6GT	.53
1B3GT	.79	5CG8	.76	6BD6	.51	6CY7	.71	12AQ5	.52	12W6	.69
1S5	.51	5CL8	.76	6BE6	.55	6DE6	.58	12AT6	.43	17AX4	.67
1U4	.57	5J6	.68	6BF6	.44	6DG6GT	.59	12AT7	.76	17BQ6	1.09
1U5	.50	5T8	.81	6BG6G	1.66	6DQ6	1.10	12AU6	.50	19AU4	.83
1X2B	.82	5U4GB	.60	6BH8	.87	6DT6	.53	12AU7	.60	19BG6	1.39
2AF4	.96	5U8	.81	6BK7	.85	6J5GT	.51	12AV6	.41	19T8	.80
2BN4	.60	5V6	.56	6BN4	.57	6J6	.67	12AV7	.75	25BQ6GT	1.11
3AL5	.42	5X8	.78	6BN6	.74	6K6GT	.58	12AX7	.63	25C5	.53
3AU6	.51	5Y3GT	.46	6BQ/		6L6	.84	12AZ7	.86	25CD6	1.44
3AV6	.41	6AB4	.46	CU6	1.25	6S4	.48	12B4	.63	25CU6	1.11
3BZ6	.55	6AC7M	.96	6BQ5	.65	6SK7GT	.74	12BD6	.50	25L6	.57
3BY6	.55	6AF4	.97	6BQ6GT	1.05	6SN7GT	.65	12BE6	.53	35C5	.51
3CB6	.54	6AG5	.65	6BQ7	.95	6T4	.99	12BH7	.73	35Z5GT	.60
3CF6	.60	6AH6	.99	6BR8	.78	6T8	.80	12BQ6GT		50B5	.60
3DT6	.50	6AK5	.95	6BY6	.54	6U8	.78		1.06	50C5	.53
3V4	.58	6AL5	.47	6BZ6	.54	6V6GT	.54	12BY7	.74	50L6GT	.61
4BN6	.75	6AM8	.78	6BZ7	.97	6W4GT	.57	12C5	.56		
4BQ7	.96	6AN8	.85	6C4	.43	6W6GT	.69	12CU5	.58	All Tube Prices	
4DT6	.55	6AQ5	.50	6CB6	.54	6X4	.39	12CU6	1.06	Subject To Change	
4BZ7	.96	6AT6	.43	6CD6	1.42	6X8	.77	12DQ6	1.04	Without Notice!	
4CB6	.59	6AT8	.79	6CF6	.64	6Y6G	.65	12F8	.66	NOT	
5AM8	.79	6AU4GT	.82	6CG7	.60	8AU8	.83	12K5	.65	AFFILIATED	
5AN8	.86	6AU6	.50	6CG8	.77	8AW8	.93	12L6	.58	WITH ANY	
5AQ5	.52	6AU8	.87	6CM7	.66	11CY7	.75	12SA7M	.86	OTHER MAIL	
5AT8	.80	6AV6	.40	6CN7	.65	12A4	.60	12SK7GT	.74	ORDER	
5BK7A	.82	6BA6	.49	6CS6	.57	12AD6	.57	12SN7GT	.64	TUBE CO.	

RAD-TEL TUBE CO.

Est. 1945

55 Chambers Street
Newark 5, N. J.
Mitchell 2-3147

TERMS: A 25% deposit must accompany all orders—balance C.O.D. All shipments F.O.B. Newark warehouse. Orders under \$5—50c Handling Charge. Subject to prior sale. No C.O.D.'s outside continental U.S.A.

SUPERIOR'S NEW MODEL 77

VACUUM TUBE VOLTMETER

WITH NEW 6" FULL-VIEW METER

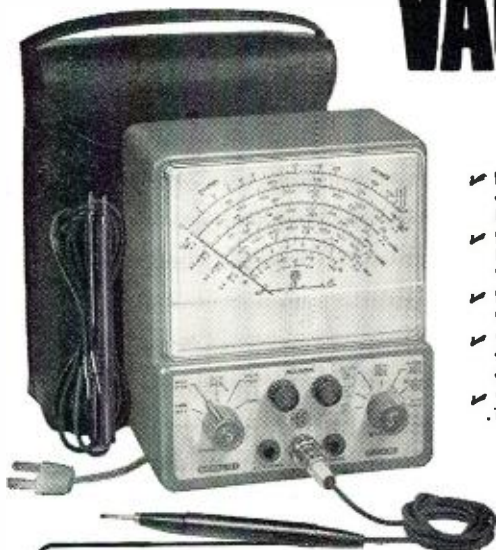

Model 77—VACUUM TUBE VOLTMETER . . . Total Price \$42.50—Terms: \$12.50 after 10 day trial, then \$6.00 monthly for 5 months if satisfactory. Otherwise return, no explanation necessary!

- Compare it to any peak-to-peak V. T. V. M. made by any other manufacturer at any price!
- ✓ Model 77 completely wired and calibrated with accessories (including probe, test leads and portable carrying case) sells for only \$42.50.
 - ✓ Model 77 employs a sensitive six inch meter. Extra large meter scale enables us to print all calibrations in large easy-to-read type.
 - ✓ Model 77 uses new improved SICO printed circuitry.
 - ✓ Model 77 employs a 12AU7 as D.C. amplifier and two 9006's as peak-to-peak voltage rectifiers to assure maximum stability.
 - ✓ Model 77 uses a selenium-rectified power supply resulting in less heat and thus reducing possibility of damage or value changes of delicate components.
 - ✓ Model 77 meter is virtually burn-out proof. The sensitive 400 microampere meter is isolated from the measuring circuit by a balanced push-pull amplifier.
 - ✓ Model 77 uses selected 1% zero temperature coefficient resistors as multipliers. This assures unchanging accurate readings on all ranges.

AS A DC VOLTMETER: The Model 77 is indispensable in Hi-Fi Amplifier servicing and a must for Black and White and color TV Receiver servicing where circuit loading cannot be tolerated.

AS AN AC VOLTMETER: Measures RMS values if sine wave, and peak-to-peak value if complex wave. Pedestal voltages that determine the "black" level in TV receivers are easily read.

AS AN ELECTRONIC OHMMETER: Because of its wide range of measurement leaky capacitors show up glaringly. Because of its sensitivity and low loading, intermittents are easily found, isolated and repaired.

Model 77 comes complete with operating instructions, probe and test leads. Use it on the bench—use it on calls. A streamlined carrying case, included at no extra charge, accommodates the tester, instruction book, probe and leads. Operates on 110-120 volt 60 cycle. Only

SPECIFICATIONS

• DC VOLTS — 0 to 3/15/75/150/300/750/1,500 volts at 11 megohms input resistance. • AC VOLTS (RMS) — 0 to 3/15/75/150/300/750/1,500 volts. • AC VOLTS (Peak to Peak) — 0 to 8/40/200/400/800/2,000 volts. • ELECTRONIC OHMMETER — 0 to 1,000 ohms/10,000 ohms/100,000 ohms/1 megohm/10 megohms/100 megohms/1,000 megohms. • DECIBELS — -10 db to +18 db, +10 db to +38 db, +30 db to +58 db. All based on 0 db = .006 watts (6 mw) into a 500 ohm line (1.73v). • ZERO CENTER METER — For discriminator alignment with full scale range of 0 to 1.5/7.5/37.5/75/150/375/750 volts at 11 megohms input resistance.

\$42⁵⁰
NET

SUPERIOR'S NEW MODEL 79

SUPER-METER — WITH NEW 6" FULL-VIEW METER

A Combination VOLT-OHM MILLIAMMETER.

Plus CAPACITY, REACTANCE, INDUCTANCE AND DECIBEL MEASUREMENTS.

Also Tests SELENIUM AND SILICON RECTIFIERS, SILICON AND GERMANIUM DIODES.



Model 79—SUPER-METER . . . Total Price \$38.50—Terms: \$8.50 after 10 day trial, then \$6.00 per month for 5 months if satisfactory. Otherwise return, no explanation necessary!

The Model 79 represents 20 years of continuous experience in the design and production of SUPER-METERS, an exclusive SICO development. In 1938 Superior Instruments Co. designed its first SUPER-METER, Model 1150. In 1940 it followed with Model 1250 and in succeeding years with others including Models 670 and 670-A. All were basically V.O.M.'s with extra services provided to meet changing requirements. Now, Model 79, the latest SUPER-METER includes not only every circuit improvement perfected in 20 years of specialization, but in addition includes those services which are "musts" for properly servicing the ever increasing number of new components used in all phases of today's electronic production. For example with the Model 79 SUPER-METER you can measure the quality of selenium and silicon rectifiers and all types of diodes—components which have come into common use only within the past five years, and because this latest SUPER-METER necessarily required extra meter scale, SICO used its new full-view 6-inch meter.

Model 79 comes complete with operating instructions and test leads. Use it on the bench—use it on calls. A streamlined carrying case included at no extra charge accommodates the tester, instruction book and test leads. Only

Specifications

D.C. VOLTS: 0 to 7.5/15/75/150/750/1,500.
A.C. VOLTS: 0 to 15/30/150/300/1,500/3,000.
D.C. CURRENT: 0 to 1.5/15/150 Ma. 0 to 1.5/15 Amperes.
RESISTANCE: 0 to 1,000/100,000 Ohms. 0 to 10 Megohms.
CAPACITY: 001 to 1 Mfd. 1 to 50 Mfd.
REACTANCE: 50 to 2,500 Ohms, 2,500 Ohms to 2.5 Megohms.
INDUCTANCE: .15 to 7 Henries, 7 to 7,000 Henries.
DECIBELS: -6 to +18, +14 to +38, +34 to +58.

The following components are all tested for QUALITY at appropriate test potentials. Two separate BAD-GOOD scales on the meter are used for direct readings.

All Electrolytic Condensers from 1 MFD to 1000 MFD.
All Selenium Rectifiers. All Germanium Diodes.
All Silicon Rectifiers. All Silicon Diodes.

\$38⁵⁰
NET

SHIPPED ON APPROVAL
NO MONEY WITH ORDER — NO C.O.D.

Try for 10 days before you buy! If completely satisfied, send down payment after trial and pay balance at indicated monthly rate — NO INTEREST OR FINANCE CHARGES ADDED. If not completely satisfied, return to us, no explanation necessary.

See page 119 for complete details

MOSS ELECTRONIC, INC.

3849 TENTH AVE., NEW YORK 34, N. Y.

For the first time ever: ONE TESTER PROVIDES ALL THE SERVICES LISTED BELOW!

**SUPERIOR'S NEW
MODEL 76**

ALL PURPOSE BRIDGE

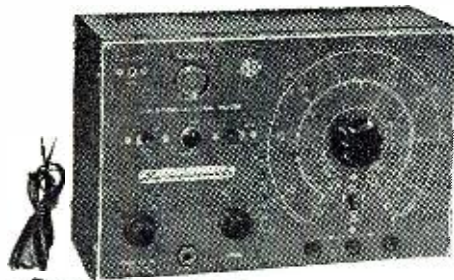

IT'S A
CONDENSER BRIDGE

with a range of .00001 Microfarad to 1000 Microfarads (Measures power factor and leakage too.)

IT'S A
SIGNAL TRACER

which will enable you to trace the signal from antenna to speaker of all receivers and to finally pinpoint the exact cause of trouble whether it be a part or circuit defect.

IT'S A
RESISTANCE BRIDGE

with a range of 100 ohms to 5 megohms

IT'S A
TV ANTENNA TESTER

The TV Antenna Tester section is used first to determine if a "break" exists in the TV antenna and if a break does exist the specific point (in feet from set) where it is.

SPECIFICATIONS:

CAPACITY BRIDGE SECTION

4 Ranges: .00001 Microfarad to 1000 Microfarads. Will also locate shorts, and leakages up to 20 megohms. Measures the power factor of all condensers from .1 to 1000 Microfarads. (Power factor is the ability of a condenser to retain a charge and thereby filter efficiently.)

TV ANTENNA TESTER SECTION

Loss of sync., snow and instability are only a few of the faults which may be due to a break in the antenna, so why not check the TV antenna first? 2 Ranges: 2' to 200' for 72 ohm coax and 2' to 250' for 300 ohm ribbon.

SIGNAL TRACER SECTION

With the use of the R.F. and A.F. Probes included with the Model 76, you can make stage gain measurements, locate signal loss in R.F. and Audio stages, localize faulty stages, locate distortion and hum, etc. Provision has been made for use of phones and meter if desired.

Model 76 Bridge...Total Price \$26.95—Terms: \$6.95 after 10 day trial, then \$5.00 monthly for 4 months if satisfactory. Otherwise return, no explanation necessary!

RESISTANCE BRIDGE SECTION

2 Ranges: 100 ohms to 5 megohms. Resistance can be measured without disconnecting capacitor connected across it. (Except, of course, when the R C combination is part of an R C bank.)

Model 76 comes complete with all accessories including R.F. and A.F. Probes; Test Leads and operating instructions. Nothing else to buy. Only

**\$26⁹⁵
NET**

SUPERIOR'S NEW MODEL TV-50A

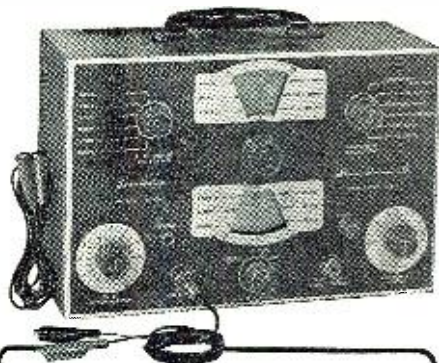

Model TV-50A GENOMETER . . . Total Price \$47.50—Terms: \$11.50 after 10 day trial, then \$6.00 monthly for 6 months if satisfactory. Otherwise return, no explanation necessary!

GENOMETER

7 Signal Generators in One!

- ✓ R.F. Signal Generator for A.M.
- ✓ Bar Generator
- ✓ R.F. Signal Generator for F.M.
- ✓ Cross Hatch Generator
- ✓ Audio Frequency Generator
- ✓ Color Dot Pattern Generator
- ✓ Marker Generator

A versatile all-inclusive GENERATOR which provides ALL the outputs for servicing:
A.M. Radio • F.M. Radio • Amplifiers • Black and White TV • Color TV

Specifications

R. F. SIGNAL GENERATOR: The Model TV-50A Genometer provides complete coverage for A.M. and F.M. alignment. Generates Radio Frequencies from 100 Kilocycles to 60 Megacycles on fundamentals and from 60 Megacycles to 180 Megacycles on powerful harmonics.

VARIABLE AUDIO FREQUENCY GENERATOR: In addition to a fixed 400 cycle sine-wave audio, the Model TV-50A Genometer provides a variable 300 cycle to 20,000 cycle peaked wave audio signal.

BAR GENERATOR: The Model TV-50A projects an actual Bar Pattern on any TV Receiver Screen. Pattern will consist of 4 to 16 horizontal bars or 7 to 20 vertical bars.

THE MODEL TV-50A comes absolutely complete with shielded leads and operating instructions.

CROSS HATCH GENERATOR: The Model TV-50A Genometer will project a cross-hatch pattern on any TV picture tube. The pattern will consist of non-shifting, horizontal and vertical lines interlaced to provide a stable cross-hatch effect.

DOT PATTERN GENERATOR (FOR COLOR TV) Although you will be able to use most of your regular standard equipment for servicing Color TV, the one addition which is a "must" is a Dot Pattern Generator. The Dot Pattern projected on any color TV Receiver tube by the Model TV-50A will enable you to adjust for proper color convergence.

MARKER GENERATOR: The Model TV-50A includes all the most frequently needed marker points. The following markers are provided: 189 Kc., 262.5 Kc., 456 Kc., 600 Kc., 1000 Kc., 1400 Kc., 1600 Kc., 2000 Kc., 2500 Kc., 3579 Kc., 4.5 Mc., 5 Mc., 10.7 Mc., (3579 Kc. is the color burst frequency)

**\$47⁵⁰
NET**

**SHIPPED ON APPROVAL
NO MONEY WITH ORDER — NO C.O.D.**

Try for 10 days before you buy! If completely satisfied, send down payment after trial and pay balance at indicated monthly rate — NO INTEREST OR FINANCE CHARGES ADDED. If not completely satisfied, return to us, no explanation necessary.

See page 119 for complete details

MOSS ELECTRONIC, INC.

3849 TENTH AVE., NEW YORK 34, N. Y.

SUPERIOR'S NEW MODEL TW-11

STANDARD PROFESSIONAL TUBE TESTER



Model TW-11—TUBE TESTER . . . Total Price \$47.50—Terms: \$11.50 after 10 day trial, then \$6.00 per month for 6 months if satisfactory. Otherwise return, no explanation necessary!

- ★ Tests all tubes, including 4, 5, 6, 7, Octal, Lock-in, Hearing Aid, Thyatron, Miniatures, Sub-miniatures, Novals, Sub-minars, Proximity fuse types, etc.
- ★ Uses the new self-cleaning Lever Action Switches for individual element testing. Because all elements are numbered according to pin-number in the RMA base numbering system, the user can instantly identify which element is under test. Tubes having tapped filaments and tubes with filaments terminating in more than one pin are truly tested with the Model TW-11 as any of the pins may be placed in the neutral position when necessary.
- ★ The Model TW-11 does not use any combination type sockets. Instead individual sockets are used for each type of tube. Thus it is impossible to damage a tube by inserting it in the wrong socket.
- ★ Free-moving built-in roll chart provides complete data for all tubes. All tube listings printed in large easy-to-read type.
- ★ NOISE TEST: Phono-jack on front panel for plugging in either phones or external amplifier will detect microphonic tubes or noise due to faulty elements and loose internal connections.

EXTRAORDINARY FEATURE

SEPARATE SCALE FOR LOW-CURRENT TUBES. Previously, on emission-type tube testers, it has been standard practice to use one scale for all tubes. As a result, the calibration for low-current types has been restricted to a small portion of the scale. The extra scale used here greatly simplifies testing of low-current types.

The Model TW-11 operates on 105-130 Volt 60 Cycles A.C. Comes housed in a beautiful hand-rubbed oak cabinet complete with portable cover.

\$47⁵⁰ NET

SUPERIOR'S
NEW MODEL 83

C.R.T. TESTER

Tests and Rejuvenates ALL PICTURE TUBES

ALL BLACK AND WHITE TUBES

From 50 degree to 110 degree types—from 8" to 30" types.

ALL COLOR TUBES



Model 83—C.R.T. TUBE TESTER . . . Total Price \$38.50—Terms: \$8.50 after 10 day trial, then \$6.00 monthly for 5 months if satisfactory. Otherwise return, no explanation necessary!

Test ALL picture tubes—in the carton—out of the carton—in the set!

- ✓ Model 83 is not simply a rehashed black and white C.R.T. Tester with a color adapter added. Model 83 employs a new improved circuit designed specifically to test the older type black and white tubes, the newer type black and white tubes and all color picture tubes.
- ✓ Model 83 provides separate filament operating voltages for the older 6.3 types and the newer 8.4 types.
- ✓ Model 83 employs a 4" air-damped meter with quality and calibrated scales.
- ✓ Model 83 properly tests the red, green and blue sections of color tubes individually—for each section of a color tube contains its own filament, plate, grid and cathode.
- ✓ Model 83 will detect tubes which are apparently good but require rejuvenation. Such tubes will provide a picture seemingly good but lacking in proper definition, contrast and focus. To test for such malfunction, you simply press the rej. switch of Model 83. If the tube is weakening, the meter reading will indicate the condition.

Model 83 comes housed in handsome portable Saddle Stitched Texon case—complete with sockets for all black and white tubes and all color tubes. Only

\$38⁵⁰

Rejuvenation of picture tubes is not simply a matter of applying a high voltage to the filament. Such voltages improperly applied can strip the cathode of the oxide coating essential for proper emission. The Model 83 applies a selective low voltage uniformly to assure increased life with no danger of cathode damage.

SHIPPED ON APPROVAL
NO MONEY WITH ORDER—NO C.O.D.

Try for 10 days before you buy! If completely satisfied, send down payment after trial and pay balance at indicated monthly rate — **NO INTEREST OR FINANCE CHARGES ADDED.** If not completely satisfied, return to us, no explanation necessary.

See following page for complete details

MOSS ELECTRONIC, INC.

3849 TENTH AVE., NEW YORK 34, N. Y.

Multi-Socket Type

TUBE TESTER

TEST ANY TUBE IN 10 SECONDS FLAT

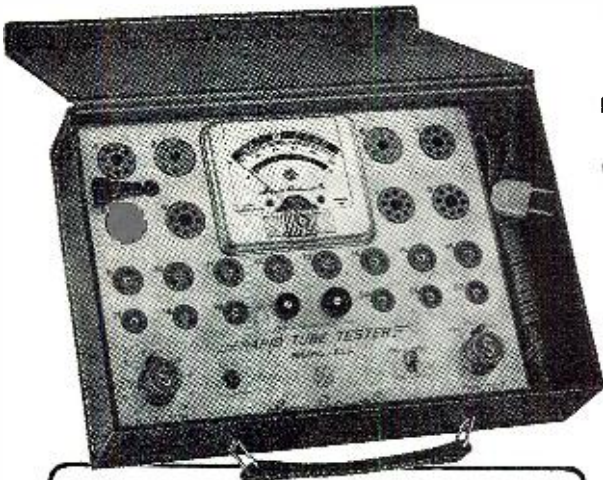

Model 82A — TUBE TESTER ... Total Price \$36.50 — Terms: \$6.50 after 10 day trial, then \$6.00 monthly for 5 months if satisfactory. Otherwise return, no explanation necessary.

- ① Turn the filament selector switch to position specified.
- ② Insert tube into a numbered socket as designated on our chart (over 600 types included).
- ③ Press down the quality button —

THAT'S ALL!

Read emission quality direct on "BAD-GOOD" meter scale.

Specifications

- Tests over 600 tube types
- Tests OZ4 and other gas-filled tubes
- Employs new 4" meter with sealed air-damping chamber resulting in accurate vibrationless readings
- Use of 22 sockets permits testing all popular tube types and prevents possible obsolescence
- Dual Scale meter permits testing of low current tubes
- 7 and 9 pin straighteners mounted on panel
- All sections of multi-element tubes tested simultaneously
- Ultra-sensitive leakage test circuit will indicate leakage up to 5 megohms

Model 82A comes housed in handsome, portable Saddle-Stitched Texon case. **\$36.50 NET** Only.....

Production of this Model was delayed a full year pending careful study by Superior's engineering staff of this new method of testing tubes. Don't let the low price mislead you! We claim Model 82A will outperform similar looking units which sell for much more — and as proof, we offer to ship it on our examine before you buy policy.

To test any tube, you simply insert it into a numbered socket as designated, turn the filament switch and press down the quality switch — THAT'S ALL! Read quality on meter. Inter-element leakage if any indicates automatically.

SHIPPED ON APPROVAL NO MONEY WITH ORDER — NO C. O. D.

MOSS ELECTRONIC, INC.
Dept. D-583 3849 Tenth Ave., New York 34, N. Y.

Please send me the units checked on approval. If completely satisfied I will pay on the terms specified with no interest or finance charges added. Otherwise, I will return after a 10 day trial positively cancelling all further obligation.

Name
Address
City Zone State.....
All prices net. F.O.B., N. Y. C.

- Model 77 Total Price \$42.50
\$12.50 within 10 days. Balance \$6.00 monthly for 5 months.
- Model 79 Total Price \$38.50
\$8.50 within 10 days. Balance \$6.00 monthly for 5 months.
- Model 76 Total Price \$26.95
\$6.95 within 10 days. Balance \$5.00 monthly for 4 months.
- Model TV-50A Total Price \$47.50
\$11.50 within 10 days. Balance \$6.00 monthly for 6 months.
- Model TW-11 Total Price \$47.50
\$11.50 within 10 days. Balance \$6.00 monthly for 6 months.
- Model 83 Total Price \$38.50
\$8.50 within 10 days. Balance \$6.00 monthly for 5 months.
- Model 82A Total Price \$36.50
\$6.50 within 10 days. Balance \$6.00 monthly for 5 months.

NEW

HICKOK

Low-Cost TUBE TESTER and TRANSISTOR CHECKER



Model 800

NEW LEAKAGE AND SHORTS TEST—Checks leakage between tube elements up to 10 megohms.

INCLUDES TRANSISTOR AND DIODE CHECK

HIGH SPEED SERIES-STRING TEST—A new filament continuity test is provided to greatly speed the testing of series-string tubes.

METER REVERSE—A push-button control reverses the meter for testing special tubes such as the 117N7 types.

TUBE SOCKETS—4, 5, 6, 7-pin, octal, loctal, noval and 7-pin miniature. Top cap jacks are built into the panel and leads are included.

MICROMHO SCALES—Hickok Mutual Conductance circuits test tubes under simulated operating conditions and accurately evaluate all popular tubes encountered in electronic work. 0-3,000, 6,000, 15,000 micromhos are directly indicated on the meter dial.

COMPLETE, ACCURATE TEST—A new grid current (gas) test is very sensitive and will indicate even the slightest amount of gas.

BUILT-IN ROLL CHART—A time saving tube reference chart contains test data for all popular tubes in a new, faster-to-use group system.

The 800 will pay for itself in a short time . . . and give you many years of accurate, dependable service.

\$159⁵⁰ NET

**Now is the time to...
TRADE UP TO A HICKOK**

Ask for a demonstration of the new 800 from your Authorized Hickok Distributor.

THE HICKOK ELECTRICAL INSTRUMENT CO.
10514 Dupont Ave. • Cleveland 8, Ohio

Synthetic Quartz Produced in Pilot Plant

Large crystals are being grown for use in communication equipment of the Bell System.



The crystals shown are all synthetic quartz which has been grown at Western Electric's Merrimack Valley Works in No. Andover, Mass. Such crystals will replace natural quartz crystals, obtained mainly from Brazil, in communication equipment.

DETAILS of pilot plant production of synthetic quartz crystals for telephone communication purposes were disclosed recently. Large crystals are now being grown in limited quantities at *Western Electric's Merrimack Valley Works* in North Andover, Mass. The process being used is an outgrowth of one that had been employed experimentally at the *Bell Telephone Laboratories*.

Synthetic quartz provides a number of advantages over natural quartz in addition to its availability in any quantity and size. Seeds can be cut to provide grown crystals which can be sawed in the most efficient manner. Also, synthetic quartz has natural crystal faces, which allow easier orientation of the stock for cutting into crystal units. It has none of the foreign inclusions which usually occur in natural quartz and it can be produced without either optical or electrical twinning.

The crystals are grown in a long, narrow autoclave mounted vertically and filled with a solution of sodium hydroxide. Small pieces of readily available natural quartz are then placed in the bottom of the vessel to provide the nutrient. Future production will use even less costly and more readily available material such as high-quality sand as the nutrient. Seed plates cut from either natural quartz or synthetic crystals, are hung from a rack in the upper section of the vessel. After sealing, the autoclave is heated to the required temperature and maintained under a constant temperature differential from bottom to top for the required processing time. This period has varied from a week to several weeks.

Economical growth rate much in excess of 60 thousandths of an inch per day has been achieved. During the process the nutrient dissolves in the hotter lower region and is carried by convection currents to the cooler upper region. The lower temperature here leads to a supersaturated condition in the nutrient solution, which causes the dissolved quartz to redeposit onto the seed plates in single crystal form. The high temperature and pressure requirements are among the most severe encountered in any process industry.

—30—

R. A. Sullivan (left) and R. A. Laudise are shown behind the top of a high-pressure autoclave used in growing synthetic quartz. Sullivan holds large crystal grown in large autoclave, while Laudise holds smaller crystal and experimental vessel that was used in early research.



RADIO & TV NEWS

RADIO SHACK STUNS THE HI-FI WORLD!

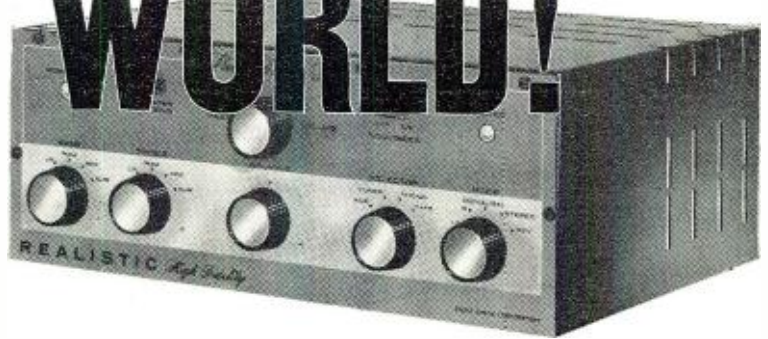

REALISTIC STEREO-36

ONLY 36-WATT HI-FI AMPLIFIER UNDER \$100!!!

RADIO SHACK EXCLUSIVE!
by the makers of the famous **REALISTIC Electrostat-3 Electrostatic Super-Tweeter**

Hi-Fi Monaural / Hi-Fi Stereo
36-Watts / 18-Watts

REGULAR VALUE
~~\$129.95~~

\$69.50
\$7 Down
\$7 Monthly

INCLUDING CABINET

Technically Minded? Read These Specs!

Never before has there been a 36-watt amplifier within a mile of this REALISTIC low \$69.50 price! And it performs with the finest! Yes, this new REALISTIC "STEREO-36" is the ideal choice whether you're "stereo" or "monaurally" inclined. It delivers a full 36 watts (72 watts peak!) when used in a monaural system . . . yet, just a twist of the Channel Mode Selector turns it into a full-fledged dual 18-watt (36 watts peak!) stereo amplifier and dual pre-amp Stereo Control Center! It's Exclusive at Radio Shack, because cost-conscious Radio Shack knows how to use its 36 years of experience to produce the finest in high fidelity at its lowest possible cost! It's not done with mirrors . . . it's done with enormous purchases and the manufacturing "know-how" of Radio Shack's staff of design and production engineers. The new REALISTIC "STEREO-36" is one of the finest stereo monaural amplifiers on the market today! We guarantee it to be equal or superior, in specifications, performance and appearance to any similar amplifier costing up to \$130.00 or your money back!

Laboratory-verified specifications! Power Output: 18 watts per channel (36 watts peak!). Freq. Response: 20-20,000 cps ± 0.5 db. Hum and Noise: 80 db down. Distortion: less than 1% at full rated output! Separate wide-range (± 12 db) bass and treble controls: Twin-section, single-action master volume control with loudness off-on switch. Channel balance control: Variable equalization control: Channel mode selector with indicator lights and rumble reduction setting for use on monaural records; 4-position input selector. Has 4, 8 and 16 ohm outputs for each channel. 10 tubes, 140 watts, 115-volts AC. Measures only 5 1/4" h. x 14 3/4" w. x 11 1/2" d. Order No. R-33CX505Y Ship. wt. 18 lbs.

BUY IT AT EITHER STORE OR BY MAIL — ONLY 10% DOWN!

SALE! RADIO SHACK 36-WATT STEREO SYSTEMS AT TERRIFIC SAVINGS!



Realistic Stereo-36 Hi-Fi Amplifier	Reg. Value	
British Monarch Hi-Fi Changer		\$129.95
G-E Diamond Stereo GC-7 Cartridge		54.50
2-Realistic Solo Speakers in Cabinets		23.47
		39.90
Total Reg. Value		\$247.82

SAVE \$118.32 **\$129.50**

Order No. RX-SS7MY, Ship. Wt. 70 lbs.
\$13 DOWN, \$10 MONTHLY

Base for Changer, R-5900B Wt. 4 lbs. Net \$3.49



Realistic Stereo-36 Hi-Fi Amplifier	Reg. Value	
Garrard RC-121 II Stereo Changer		\$129.95
G-E Diamond Stereo GC-7 Cartridge		41.65
2-E-V SP12B Hi-Fi 12" Coax Speakers		23.47
		68.60
Total Reg. Value		\$263.67

SAVE \$103.72 **\$159.95**

Order No. RX-SS8GY, Ship. Wt. 65 lbs.
\$16 DOWN, \$12 MONTHLY

Base for Garrard, 15C785 Wt. 4 lbs. Net \$4.51

ABSOLUTELY FREE!

Radio Shack's Big BARGAIN BULLETIN

Lists thousands of exclusive Radio Shack Bargains in high fidelity, amateur gear, test equipment, tools, hobby materials, kits, records, etc.

RADIO SHACK CORP. Dept. 3F
730 Commonwealth Avenue, Boston 17, Mass.

Please send me:

- Realistic 36 amplifier
 RX-SS7MY system RX-SS8GY system
 Include changer base for system checked.
 Check or money order is enclosed.

NAME _____

ADDRESS _____

CITY _____ ZONE _____ STATE _____



RADIO SHACK CORP.

- 730 Commonwealth Avenue, Boston 17, Mass.
- 167 Washington Street, Boston 8, Mass.
- 230-240 Crown Street, New Haven 10, Conn.

From
any Point of View,
more Experts choose
ACROSOUND
ULTRA-LINEAR II
60 watt amplifier

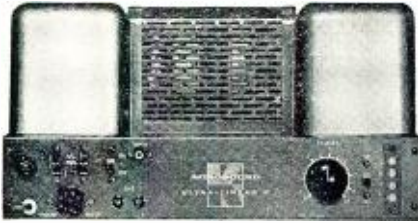

DESIGN The combination of patented ULTRA-LINEAR circuitry—plus new HYBRID FEEDBACK principle—VARIABLE DAMPING control, and ULTRA STABILITY, represents a new high in the art of amplifier design... an example of ACROSOUND'S latest achievement in AMERICAN Know-How. This superiority of design now enables anyone with or without any previous knowledge of electronics to assemble for himself or herself... (yes! it's that easy!)... the finest of amplifiers and at a most reasonable cost, in only two hours!



PERFORMANCE By listening test, or by instruments... second to none in clarity and frequency response. Normal level distortion is virtually unmeasurable—IM 1% or less at 60 watts, 120 watts peak. Completely stable... unaffected by loads, perfect square waves.



QUALITY Every part going into the assembly of critical and even non-critical circuitry is tested and checked to allow no more than $\pm 1/2\%$ variation from ACROSOUND'S standards. Specialized test equipment unavailable commercially was designed in ACROSOUND'S laboratories to achieve this result. Every printed circuit board is placed in trial operation on a laboratory amplifier. Output tubes are matched by trial and double checked.



COMPONENTS ACRO'S newest TO-600 output transformer with special hybrid winding—separates functions of output circuit and feedback circuit. Heavy duty, completely assembled, and thoroughly tested, printed circuit board assures uniformity of performance. Low distortion EL34 output tubes are operated well within their ratings ensuring long tube life and optimum performance.

PRICE In preassembled kit form so that you may save money, learn while doing, and have the proud satisfaction you built the best for only \$79.50 net... or if you feel you would prefer it laboratory assembled it still represents a bargain at \$109.50 net.

HEAR IT AT YOUR DEALER NOW!

BE READY FOR ACROSOUND DISTORTIONLESS PRE-AMP DESIGNED FOR THE STEREO-PHILE

Experts know why ACRO is best!
Others... Learn why! Write to

ACRO PRODUCTS
369 SHURS LANE
PHILA. 28, PA.

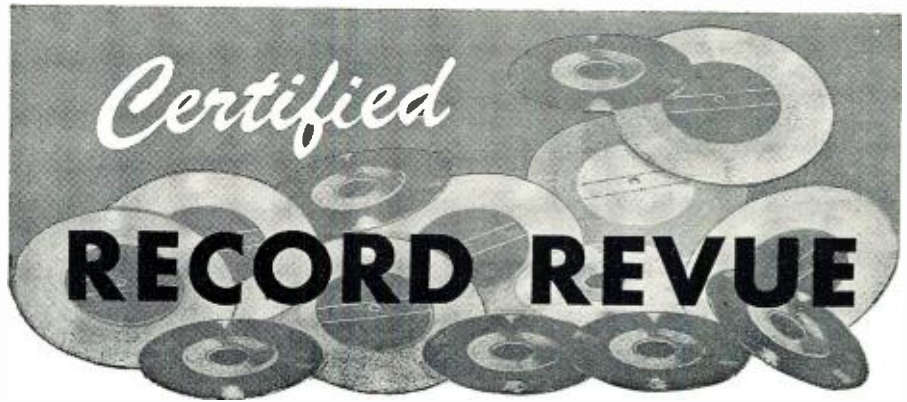

By **BERT WHYTE**

AS I have said before in these pages, the stereo disc, even at this early stage of development, has become a generally reliable proposition. In other words, one can purchase a stereo disc with a reasonable degree of assurance as far as quality is concerned. Of course, as with monophonic discs, there is great variation among record companies and, in fact, there is often variation in quality among discs from a single company. Now don't get me wrong... I'm not looking at the stereo disc through rose-colored glasses... in fact let me hasten to add that I still feel that even the very best stereo disc cannot equal the best of $7\frac{1}{2}$ ips stereo tape. In terms of frequency response and dynamic range, at least, the best monaural discs surpass the best stereo discs. But... and this a *big but*... neither is the stereo disc as poor as many people would have you believe.

The stereo disc is often maligned unjustly, for the real culprit, it is becoming more and more apparent, is the stereo disc playback equipment. There are many things that can go wrong and contribute to general dissatisfaction with the quality of the stereo disc. The biggest offender is the stereo playback cartridge. Some of these are so poor that if stereo discs were twice as good as they are the results would still be ghastly. There are many types and brands on the market now and of these there are few that can honestly qualify as acceptable for hi-fi use. Nor is price the ultimate criterion in this field. The old adage of "you get what you pay for," operates to a certain degree, but it is by no means a guarantee of high quality. I strongly urge any of you who have been dissatisfied with the results obtained from the stereo disc to investigate the pickup field. If you can, go to a reputable hi-fi component dealer and, armed with a record that has had favorable reviews from a number of critics in responsible journals, listen to it with the various stereo cartridges. Listen particularly for the degree of instrumental separation, and how effective are the directional characteristics. As reproduced through the better quality pre-amps which have volume controls fairly accurately calibrated, notice if one channel or the other seems to require an inordinate amount of boost or cut in order to balance to stereo. Generally if large amounts of boost are required in one channel, this is usually the effect of a cartridge with extremely poor vertical compliance. Listen also for general over-all smoothness of response and note particularly on recordings of concertos if the solo instrument "stays put" in a given place between the speakers or appears to "jump" suddenly from one channel to the other. Sometimes this is an inherent fault in the recording itself, but more often than not it is a sign of a cartridge with a very limited degree of interchannel separation.

For optimum results, once you have found a cartridge that seems to perform properly,

close attention must be paid to the arm in which it is mounted and also to the type and quality of turntable which will be used. You must remember that the stylus of a stereo cartridge is only 0.7 mil and if this smaller area is subjected to stylus pressures on the same order of magnitude as the monophonic types, the result will be rapidly ruinous wear to your stereo discs. An arm should be chosen that is so carefully balanced that stylus pressures are at a maximum of 2 to 4 grams for perfect tracking. Since good stereo pickups have excellent vertical compliance any turntable or changer that has poor rumble characteristics will have this factor accentuated.

Finally in the quest for good stereo disc reproduction, once the proper cartridge, arm, and turntable have been secured, they must be mounted most carefully. First make sure that the turntable is perfectly level by means of a small spirit level. Then follow to the split millimeter the manufacturer's arm mounting instructions especially in regard to distance between turntable center pin and the center of the arm pivot and degree of stylus overhang. Lastly, and of absolutely vital importance... the stylus must be positively perpendicular to the plane of the record. This means neither left nor right oriented as viewed from the front, nor canting forwards or backwards as viewed from the side... perfectly vertical is what we want! Having accomplished this, and carefully examining the records you purchase for eccentric spindle holes and warpage, you will find that most of the odd "swish-swash" and other types of spurious modulations will have disappeared and with any reasonably well cut "45-45" vertical-lateral stereo disc you should enjoy the beauty of stereo music.

This triumvirate of good stereo cartridge, arm, and turntable is quite the most important part of any stereo disc system and if I were starting from scratch to build a system... this consideration would take precedence over fancy amplifiers and fancy speakers. Those can always come in due time, but at least with a good pickup, arm, and turntable at the very beginning, you won't ruin your precious stereo discs and you will be able to enjoy them when you move up to the better speakers, etc.

SIBELIUS
SONGS

Kirsten Flagstad, soprano, with London Symphony Orchestra conducted by Oivin Fieldstad. London Stereo OS-25005. Price \$4.98.

Those who feel that stereo is wasted on a solo voice, even if accompanied by an orchestra, are directed to this *London* recording.

The opinions expressed in this column are those of the reviewer and do not necessarily reflect the views or opinions of the editors or the publishers of this magazine.

This was a fine monophonic recording but now hearing Madame Flagstad's glorious voice in the rounded fullness and beauty of stereo, there just isn't any comparison. True, the glaring spotlight of stereo also throws into relief some of the faults that the inroads of age have made on this great voice, but there is still so much that is pure gold, that the faults are ignored.

The Sibelius songs fit her voice like a glove and *London* has thoughtfully provided a text so we can follow them. Countryman Fjeldstad affords sympathetic accompaniment from the London Symphony. For the most part Flagstad is heard *via* the center "ghost channel" and the stereo effects of the orchestral background add to the superb realism.

CHADWICK
SYMPHONIC SKETCHES

Eastman Rochester Symphony Orchestra conducted by Howard Hanson. Mercury Stereo SR90018. Price \$4.98.

Outstanding as a monophonic disc and as a stereo tape, we now have Chadwick's delightful score on stereo disc and it is one of the major successes in this field. For one thing there is no diminution of level, nor is this level accomplished at the expense of bass response, as is so often the case. Rather percussion here is as solid, especially in the big bass drum wallops, as one could desire. The over-all sound is very clean with no tendency for the bright brass to "splatter." The stereo virtues are bountifully exhibited . . . fine directionality, good instrumental separation, excellent ghost channel "fill."

This comes off in comparison to the stereo tape very respectably . . . there is wider frequency range and dynamic scope on the tape, while on the other hand the disc is actually a bit quieter than the tape. Given a choice I'd still vote for the tape, but this is certainly a step in the right direction.

FALLA
THREE CORNERED HAT, SUITES
#1 AND #2

TURINA
SINFONIA SEVILLANA
Orquesta Nacional de Espana conducted by Ataúlfo Argenta. London Stereo CS6050. Price \$4.98.

I gave rave notices to the monophonic version and now plaudits are equally deserved by this stereo edition. Argenta is completely masterful with this music and with the blandishments of stereo, this music is positively irresistible. The colorful orchestration is particularly suitable for stereo and is much benefited by the increase in clarity and realism. Nice clean strings here, bright brass in the Spanish manner and sharply accented, beautifully articulate percussion. Good directionality and excellent depth from the astutely handled acoustics. Don't miss this!

BEAT TROPICALE

Jose Bethancourt and his orchestra with Harry Coons and Richard Campbell on drums. Concert-Disc Stereo CS-33. Price \$4.98.

Here is an innocuous appearing item which is a real stereo sizzler. Side one of the disc is devoted to Jose Bethancourt and his orchestra in some tasty Spanish-inspired bonbons. Among these are "Inspiration," "La Cumparsa," and a wild piece entitled "Chacha Flamenco." There is much use of xylophone here and it comes through with brilliant clarity. Anyone who thinks that stereo discs can't reproduce sharp transients should listen to this.

The other side is really fantastic. The two above-named skin-beaters take on a wild session with quasi-African rhythms, replete with a huge variety of modern and primitive

*For stereo
and monaural,
people who know
high fidelity recom-
mend this changer!*

**Confirm this with any
experienced dealer!**

The Garrard changer reproduces music *precisely as recorded*, without introducing any distorting factors such as rumble or wow. A Garrard changer is actually a superb turntable combined with a scientifically engineered all-aluminum tone arm. This tracks at the *correct* stylus pressure without undesirable resonances.

When considering the claims of changers "specifically designed for stereo" or turntables "to play stereo properly", it is well to remember that for years Garrard changers have had all the qualities necessary for this type of sensitive reproduction.

Standard Garrard
Tone arm with Stereo
Cartridge (underside
view through a
translucent record).



Garrard
The World's Finest

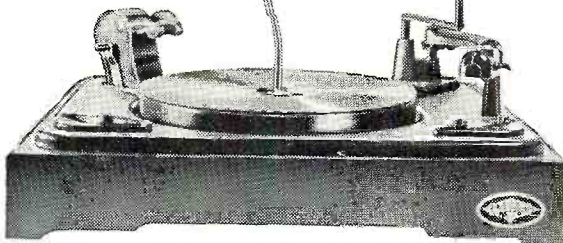

There's a Garrard for every high fidelity system . . . all fully wired for stereo and monaural records. Six models: \$32.50 to \$89.00.

Mail this coupon for free Garrard Comparator Guide.

Garrard Sales Corp.,

Dept. GC-49, Port Washington, N.Y.

Please send free Garrard Comparator Guide which compares all Garrard players and their advanced features.

Name

Address

City Zone State

**DEPENDABLE TV-RADIO
TUBES**



Tubes for TV-Radio Servicemen, Dealers, Experimenters.

Nationally sold ZALYTRON Tubes are BRAND NEW Quality Tubes, priced low to help you meet competition in your area — and guaranteed to perform as well and as long as tubes much higher priced. Why pay more? Try them once, you'll buy them always. Every tube we ship is covered by our Full Refund Guarantee . . . YOU be the judge! Send today for new Price List "RN"

BE YOUR OWN BOSS
RUN A SELF-SERVICE TUBE BUSINESS

Get This Modern Sturdy Tube Tester

FREE

with "Package Deal" order for nationally sold ZALYTRON Quality Brand Receiving Tubes. We'll show you how to start a successful Tube Tester Route, and get YOUR share of today's Big Profits in Self-Service Tube Sales! This is no "Get-Rich-Quick" scheme but a solid, proven business that will reward you well — if you WORK at it. But, INVESTIGATE before you INVEST! Get full details on the best "Deal" now being offered, send today for our Booklet "R"



ZALYTRON TUBE CORP.
220 West 42nd St.,
New York 36, N. Y.

**FAST!
ACCURATE!**

SECO Test Equipment

**Saves time . . . makes
more money for you!**

WRITE TODAY FOR COMPLETE
SPECIFICATIONS AND FEATURES!

- Outstanding Reliability and Performance!
- Unique, Time-Saving Features!
- Low First Cost Makes You Money From the Start!

107 TUBE TESTER—

Outstanding performance and accuracy—provides 3 important tests: amplifier types tested for gain by Dynamic Mutual Conductance method—power types tested for cathode current by Cathode Emission method—all types tested for shorts and grid error by Grid Circuit Test developed and patented by Seco. Dynamic Mutual Conductance Test pre-wired to eliminate elaborate set-up. Cathode Emission Test done by free point pin-selector method—will not be obsolete. Completely self-contained in portable carrying case. Furnished with handy flip chart for fast tube set-up data.

MODEL 107 \$139.50 NET



GCT-8 GRID CIRCUIT TUBE TESTER

—Perfect companion to any tester—checks critical “control grid” condition of vacuum tubes fast, accurately. Electron eye tube indicates faults at a glance. As many as eleven simultaneous checks—automatically.

MODEL GCT-8—Kit \$19.95 NET

MODEL GCT-8—Wired & tested 29.95 NET



208VVTM—“Fool-proof”—many new features! Easy-to-read 4½” 200 microamp meter mounted on sloping panel—7 DC, 7 AC, 7 ordinary Ohm ranges, plus RETMA (EIA) Ohm scale to check standard color-coded resistance values and tolerance limits. Specially designed “shift-lever” type function switch identifies and automatically connects proper probe. With stand, 40” leads, and common lead with clip.

MODEL 208 \$74.50 NET

Leather, felt-lined carrying case. . \$9.95 NET



PS-2 BATTERY ELIMINATOR

—Compact unit takes place of battery normally used to operate and service low-powered transistorized equipment. Supplies clean, filtered DC—can't be damaged

by a short. Quickly spots faulty batteries by substitution. Output continuously variable from 0 to 15 V.—ideal for experimenters. Complete with jacks, leads, and clips.

MODEL PS-2 \$13.95 NET

FB-4 FLYBACK CIRCUIT AND INDUCTANCE ANALYZER—Quick “yes” or “no” answer on condition of flyback transformer and yoke—100% accuracy!

MODEL FB-4 \$38.95 NET

NEW! HC-6 CURRENT CHECKER

Provides positive, on-the-spot method of checking TV horizontal output circuits—fast, accurate way to adjust horizontal drive and linearity. Easy to use—can be placed in circuit in seconds—compact size. Complete, ready to use.

MODEL HC-6 \$12.95 NET

Get the complete story on Seco's exciting line of test equipment. See your distributor—or write for complete information today!

SECO MANUFACTURING CO.



5015 Penn Avenue So.
Minneapolis, Minn.

percussion instruments. Their fast and furious drumming is breathtaking and so are the fabulous sounds they evoke from their instruments. At several places some oversized toms are used and if your speaker system is capable enough you'll hear some mighty low frequency whumps, which at the same time effectively refute the argument that you can't get real lows in a stereo disc. Later on there is some trick sound-on-sound overdubbing which is ear-popping in stereo.

Contrary to what you might expect, the stereo effect here is not all “left and right” but intelligent use is made of the “ghost channel” and there is even some “panning” between the speakers that is quite effective. A sleeper this record and an item worthy of hi-fi fanciers.

GRIEG

PEER GYNT (INCIDENTAL MUSIC)

London Symphony Orchestra conducted by Oivin Fjelstad. London Stereo CS-6049. Price \$4.98.

Another stereo winner from London, whose consistency in this field is amazing. This time the ever popular music from “Peer Gynt,” here given a crisp assured performance, that doesn't quite match the mastery of Beecham, but which need how to none other. The stereo is splendid throughout and adds greatly to this score, revealing many details which are not apparent in the monophonic versions. Depth effect here is superb.

MOZART

SERENADE FOR WIND INSTRUMENTS IN B FLAT MAJOR, #10

Eastman Wind Ensemble conducted by Frederick Fennell. Mercury MG50176. Price \$3.98.

Mozart on a monophonic disc of surpassing excellence. There is still great work being done via the single channel, and although one awaits eagerly the stereo disc that is sure to follow, it will be reassuring to those who are not stereo equipped that high standards are being maintained. This is something of a “first” for the versatile Fennell, who heretofore has made our living rooms tremble to the mighty Sousa and the thunder of drums and fife. In this beautiful “Serenade,” which calls for the utmost virtuosity from every player, Fennell demonstrates he knows how to turn a Mozartean phrase with the best of them. The performance is superbly modeled . . . a just right blend of ebullience and erudition that puts this near the top of the list in company with some formidable Mozartean.

In terms of sound, it is “no contest” as Mercury has lavished on this recording the same clarity and brilliance, the same fine

balance and acoustic perspective afforded Mr. Fennell in his more athletic recordings. Highly recommended.

BLAST OFF!

The Gus Bivona Band. Warner Bros. W1219. Price \$3.98.

As noted in a recent column, Warner Bros. has entered the record business with a bang and is releasing prodigious quantities of material, mostly of the pop variety. What I have received so far is mostly monaural and a sprinkling of stereo. As might be expected from a company whose name is so closely linked with the beginnings of sound movies, they are doing a fair job of recording. I don't think they have reached their full potential yet, but this big-band recording gives evidence that they are getting there. In such items as “C-Jam Blues,” “Fugue for Tim-horns,” and “Where Are You,” this proves to be an easy swinging yet solidly rounded outfit that has a fine sax section and a first-rate rhythm section.

Throughout the sound was very clean, wide in range, and recorded with spacious but not overdone acoustic perspective. Of its type, a pleasant recording.

VIVALDI

CONCERTO GROSSO IN D MINOR

MOZART

EINE KLEINE NACHTMUSIK

BACH

PRELUDE IN E MAJOR

Musical Arts Symphony Orchestra conducted by Leonard Sorkin. Concert Disc Stereo CS-31. Price \$4.98.

Not unexpectedly, with the advent of the stereo disc, most of the bigger companies have concentrated on the more spectacular symphonic repertoire. For those whose taste runs more conservatively, there has been very little issued on stereo disc. Thus this fine coupling of Vivaldi, Mozart, and Bach should be eagerly welcomed by people in that group.

This is exemplary music-making on all points. The performances are all first rate, done with taste and with considerable verve and *brío*. The playing of the orchestra is most expert and I rather suspect the personnel is recruited from the Chicago Symphony. Leonard Sorkin is, of course, the same gentleman whose Stradivarius heads up the well-known Fine Arts Quartet.

The sound is exceptionally bright and clean, and yet there is never any “wiriness” to the strings. Directionality was excellent as was instrumental separation and an acoustic perspective was chosen which lends smoothness and roundness to the sound without loss of detail.

—50—

New Shure “Ten-Four” mobile communications microphones are dragged behind auto for more than three miles during series of “torture tests” to determine ruggedness of new lightweight plastic “Armo-Dur” housing. This housing is a high-impact thermoplastic resin of uniform molecular structure. Similar substances are used in football helmets, roller skate wheels, and artillery shell casings. An estimated 35,000 separate shock-impacts did not affect microphones' frequency response or mechanical functioning. The housing proved more rugged than conventional metal housings in experiments that included exposure to high temperatures and corrosive fumes.

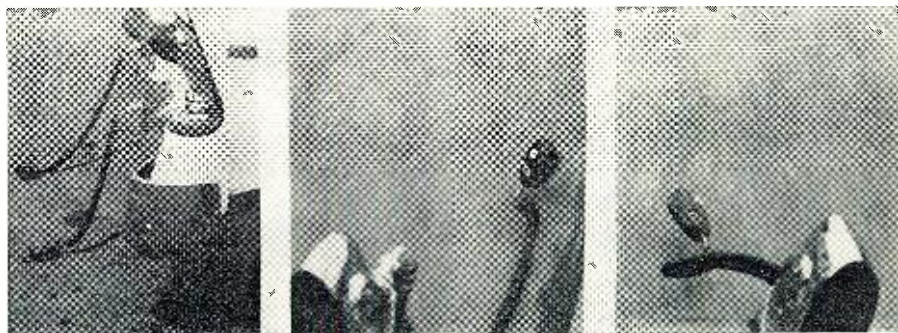



Leopold Stokowski



Sir Adrian Boult



Sir Eugene Goossens



Walter Susskind

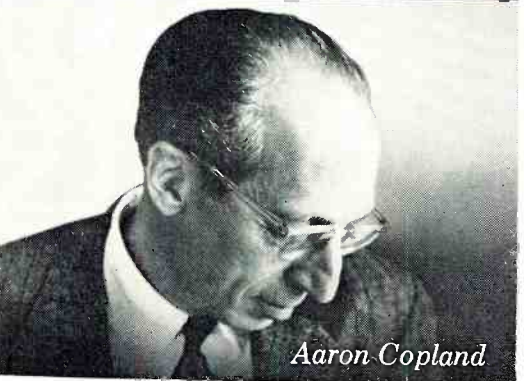

Aaron Copland

THE MAGIC OF GREAT CONDUCTORS ...IN EVEREST SOUND

Great music acquires a warm vitality in the hands of these masters. Everest is honored to bring you their new performances . . . to capture their inspirations in compelling monaural and stereo sound, on both discs and tapes. When you long for magic and color . . . for a vivid musical experience . . . listen to these and other fine Everest records.



Shostakovich: Symphony No. 5 in D Major, Op. 47. Leopold Stokowski, the Stadium Symphony Orch. of N. Y.
LPBR-6010 SDBR-3010†

Vaughan Williams: Symphony No. 9 in E Minor. Premier recording. Sir Adrian Boult, the London Philharmonic Orch.
LPBR-6006 SDBR-3006†

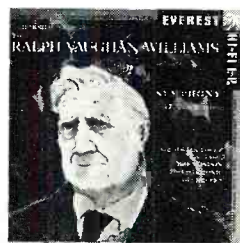

Tchaikovsky: Francesca da Rimini; Hamlet Overture. Leopold Stokowski, the Stadium Symphony of New York.
LPBR-6011 SDBR-3011†



Mahler: Symphony No. 1 in D Major—Sir Adrian Boult conducting the London Philharmonic Orchestra.
LPBR-6005 SDBR-3005†



Respighi: Feste Romane; Rachmaninoff: Symphonic Dances, Op. 45—Sir Eugene Goossens, the London Symphony Orch. **
LPBR-6004 SDBR-3004†

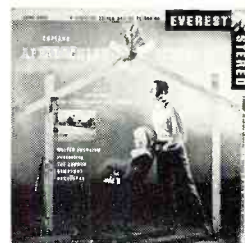

Copland: "Appalachian Spring"; Gould: "Spirituals"—Walter Susskind, the London Symphony Orchestra.
LPBR-6002 SDBR-3002†

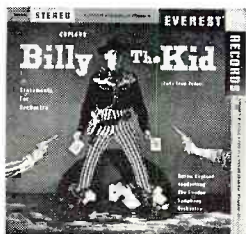

Copland: Billy the Kid (Suite); Statements For Orchestra—Aaron Copland, conducting the London Symphony Orch.
LPBR-6015 SDBR-3015†

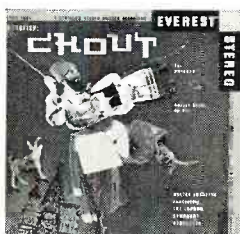

Prokofiev: "Chout" (the Buffoon) Ballet Suite—Walter Susskind conducting the London Symphony Orchestra.
LPBR-6001 SDBR-3001†



Stravinsky: Ebony Concerto (Woody Herman); Symphony in Three Movements. Sir Eugene Goossens, the London Sym. Orch. LPBR-6009 SDBR-3009†

EVEREST RECORDS

Photo of Mr. Susskind: Anni Landes, Tel-Aviv. †Stereo recording *T.M. **Two-disc set

Product of Belock Recording Co., Division of Belock Instrument Corp.

DYNACO

STEREODYNE PHONO PICK UP

This new, unique pickup is made in Denmark by Bang and Olufsen. It features a push pull magnetic principle (patent pending) which permits realization of the full potentialities of the most modern recording techniques. The special attributes which make the Stereodyne an outstanding stereo pickup make it equally exceptional for monophonic discs. On any type of record the Stereodyne offers smooth and natural sound—firm clean bass and sparkling treble—while its light tracking pressure insures negligible record wear.



BEST in every way . . .

- **Wide frequency response**
Smooth peak free response from 30 cps to over 15 Kc
- **True Stereo**
Highest channel separation over entire audio spectrum—better than 22 db.
- **Precision balance**
Both channels identical
Same high compliance (5×10^{-6} cm/dyne) in all directions
- **No hum pickup**
Balanced coil structure plus low impedance plus complete shielding eliminate hum from external fields
- **High output**
7 millivolts per channel even on low level stereo discs provides gain to spare
- **No magnetic pull**
Special magnetic circuit eliminates attraction to steel turntables
- **Easy installation**
Compact size and standard mounting centers simplifies mounting. 4 terminals to avoid hum loops
- **Low price**
Only \$29.95 net including .7 mil diamond stylus (replaceable in 2 seconds)

Available from leading high fidelity dealers everywhere

DYNACO INC.

Dept. RT, 617 N. 41st St., Phila. 4, Pa.
Export Division: 25 Warren St., New York, N. Y.

Sound on Tape

By BERT WHYTE

AS I reported in my last column, the New York Audio Fair was distinguished by the lack of any production models of the four-channel magazine-load tape machine. I suppose, like everything else, it will just be a question of time before such machines will actually appear. But evidently, there are a few people who feel that this time will be inordinately long. These are the people who are espousing the cause of what may turn out to be the best compromise after all, namely a four-channel, $3\frac{3}{4}$ ips tape machine, utilizing standard reels instead of magazines or cartridges.

First in the field and principal proponent of this scheme is *AmpeX*, which has had its universal-type 900 machine, which is capable of handling the reel-type four-channel sound, on the market for some time. Now several other companies appear to be following suit and perhaps before very long, four-channel tape, at least in the reel form, will be a commercial entity.

This approach to four-channel "half-track" stereophonic sound, would appear to be basically sound. After all, it would be impossible to equip existing stereophonic tape machines with some means of handling cartridge or magazine-load tape, whereas it is not difficult to imagine simple head conversion kits and the necessary electronic gear which would enable the user to play the reel-type of four-channel sound.

I have said at the end of this column for the past several months that new stereophonic tapes were becoming increasingly scarce and hence there hasn't been much to review. Naturally, this has been an almost direct consequence of the appearance of the commercially successful stereophonic disc.

Logic and just plain old common-sense tell me that there are many thousands of people who own perfectly good reel-type stereophonic machines, for which they have paid good money, and I cannot believe they are very happy about the current tape situation. It was less than a year ago that the stereo tape market was becoming an important sales factor for many companies and at the time the stereophonic disc was as yet an unrealized dream. All this activity was pegged at an admittedly high price level, yet despite this, people were buying tapes. Now, these people have invested their money in these machines and while many of them may have subsequently invested

in stereophonic disc playback equipment, you can't tell me that . . . (a) they don't feel a twinge in the region of their pocketbooks every time they look at said tape machine and (b) if you offered these people a relatively inexpensive four-channel conversion head kit and they have the prospects of being able to enjoy the superior quality of stereophonic tapes, at a price almost comparable to that of the stereo disc, they wouldn't jump at the chance.

Evidently a few of the manufacturers are beginning to think along these lines and not only has there been, at long last, some new releases in the normal $7\frac{1}{2}$ ips mode, but production plans are under way for the introduction of four-channel reel-type stereo tapes. There is even some original thinking being done by these proponents of reel tape and one outfit has developed a less troublesome method of handling and loading reel-type tapes. There is even talk of incorporating in some new production what is, in essence, a tape reel changer, although this would seem to be more in the province of the tape cartridge.

In any case, it all adds up to the fact that while stereo tape may be down at the moment, it certainly isn't out, and I feel that the longer the magazine-type machine is delayed and the more aware people become that even on the best of terms the stereo disc cannot equal a top stereo tape, there will be a resurgence of interest in the manufacture of "normal" stereo tape. I hope to be able to bring you a report on some new developments in reel-type tape technology. In the meanwhile, here are a few new tapes that have come my way.

WILLSON, MEREDITH **THE MUSIC MAN**

Hollywood Radio City Orchestra conducted by Tom Davis. Omegatape Stereo ST 3033. Price \$9.95.

This, of course, is a potpourri of tunes from the hit Broadway musical, "Music Man." It is not the first of these to appear, but it has much to recommend it in the way of sound quality. The Hollywood Radio City group is a better-than-average "pop" ensemble and with the able assistance of Conductor Davis, they tackle this work with great gusto and in the sparkling stereo sound which follows, they sound like they are enjoying themselves.

This tape was made at a very high level and is characterized by fine di-

At Your Service...
at big savings

arkay

Hi-Precision
TEST INSTRUMENTS
Kits and Wired

Designed and engineered in the Arkay tradition of highest professional quality at lowest cost.

NEW! ARKAY VT-10 6-INCH
MULTI-PURPOSE
VACUUM TUBE VOLTMETER



Advanced design and precision features make the Arkay VT-10 a truly sensational buy, unmatched at this price. You get exclusive larger 6-INCH 400 ua meter movement, within 2% accuracy, and edge-lighted for easier reading. 1% precision multiplier resistors are used throughout the range switch. There are 7 AC (RMS) and DC ranges, 0 to 1500 volts; also 7 AC (peak-to-peak) ranges, 0 to 2000 volts. Resistance of 0 to 1000 megohms, db and other essential ranges also included. Circuitry features 12AU7 for DC ranges, 6AL5 for AC, meter diodes rectifiers, and transformer operated selenium rectifier. Handsome durable plastic case.

Easy-to-build Kit **\$25.95**
Wired and tested **\$47.95**



**ARKAY AV-20 6-INCH
AUDIO VTVM
PRE-AMPLIFIER**

An Audio Vacuum Tube Voltmeter of extreme sensitivity, engineered for accurate measurements of RMS voltages.

Easy-to-build Kit **\$29.95**
Wired and tested **\$49.95**



**ARKAY AW-30 6-INCH
DIRECT READING
AUDIO WATTMETER**

Measures Audio Power Output with speed and precision. 0 to 500 watts in 6 ranges. For laboratory and general use.

Easy-to-build Kit **\$29.95**
Wired and tested **\$49.95**



**ARKAY CAP-40 6-INCH
DIRECT READING
CAPACITY METER**

1% precision calibration capacitors and 6-inch 200 ua meter movement provide accurate readings. 0 to 1 mfd. in 6 ranges.

Easy-to-build Kit **\$29.95**
Wired and tested **\$49.95**



**ARKAY MT-50 6-INCH
20,000 OHMS
PER VOLT METER**

A completely portable multitester of high accuracy. Sensitivity is 20,000 ohms per volt DC, 5,000 ohms per volt AC.

Easy-to-build Kit **\$29.50**
Wired and tested **\$42.95**

All prices 5% higher west of Mississippi

See ARKAY completely wired Test Instruments at your dealer. Write for detailed specifications and catalog. Dept. RT



March, 1959

rectivity, good instrumental separation, and big close-up, very full sound. Overall balance was well maintained and judicious use was made of hall acoustics to heighten the illusion of depth. As to the music itself, outside of the amusing and rollicking "76 Trombones" I find it a crashing bore, in which overworked clichés have been further done to death, and it all comes out sounding like freshly popped hot buttered corn. However, maybe I'm just getting old and grouchy and gosh knows it must have something or it wouldn't have been on Broadway this long.

If you are a lover of show tunes and similar ilk, this will probably furnish a nice evening's entertainment. Certainly it will be hard to fault in matters of sound and this may just be the thing you're looking for.

BACKGROUND FOR BRANDO

Elmer Bernstein and his orchestra. Omegatape Stereo ST 3020. Price \$9.95.

Obviously this tape is intended for fans of Marlon Brando. If this does not apply to you, read no further. I must confess I'm one . . . I like the guy. He's got a lot of genuine talent and certainly the wide scope of his roles has proved the versatility of his acting. Since he almost always appears in big productions, he generally has the benefit of some pretty good background music written by some of Hollywood's most able themesters. So here we have various moods, reflections, and points of action that have accompanied Brando's histrionics.

There is "Music for Condemning Brutus" from Julius Caesar, "Music to Accompany Wild Motorcycle Rides" from The Wild Ones, "Music for Making Love Japanese Style" from Sayonara, to say nothing of "Music to Get Beat Up By" from Water Front, and many other musical backgrounds which have made Brando's efforts more memorable.

All kidding aside, strictly as a vehicle for background listening, this is a very good tape, with the talented Elmer Bernstein conducting a group of excellent instrumentalists. It has all the stereo attributes and is an especially clean, well-balanced tape. Nothing earth-shaking here, but certainly among fellow Brando *aficionados*, a good stimulus for conversation about their favorite boy.

**GERSHWIN
RHAPSODY IN BLUE**

Eugene List, pianist, with Eastman Rochester Symphony Orchestra conducted by Howard Hanson. Mercury Stereo MWS 5-47. Price \$6.95.

Here is a companion piece to the same artists' recent "Concerto in F" and it is every bit as enjoyable as that memorable tape. Eugene List gives a fine idiomatic performance which, for my money, is the best since the old San Roma performance of so many years ago. His technique is very assured and facile, but apart from these considerations he imparts a great deal of expression and feeling to the music

Pleasure Unlimited

... WHEN YOU BUY IT
... BUILD IT ... HEAR IT

arkay STEREO

**TODAY'S GREATEST VALUE IN
HI-FI KITS AND WIRED**

Comparison proves Arkay is the best value on the market today for advanced hi-fi engineering, styling and performance. Arkay means STEREO at its best, within your budget.

NEW! MUSIC MASTERPIECE!

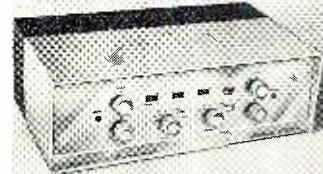

**ARKAY CS-28 STEREO AMPLIFIER
STEREO PRE-AMPLIFIER
COMPLETE CONTROL CENTER**

Presenting . . . the ultimate in total stereo! The versatile CS-28 is a superb product of Arkay's 20 years of advanced electronic engineering, with beauty of design that won the Fashion Foundation's coveted Gold Medal.

Identical dual 14 watt amplifiers convert to 28 watts for monaural operation. Full 28 watts, at flick of a switch, may be joined with an existing monaural amp for extended stereo, operated with the dual pre-amplifier.

"Reverse Stereo" switch interchanges channels. Balance Control compensates each channel for speaker system, room acoustics, etc. Gain Control operates both channels simultaneously.

Power Rating: 28 watts (two 14 watt channels); 60 watts peak. Frequency Response: 20-20,000 CPS. IM Distortion, 4 to 1. Harmonic Distortion, less than 1%. 30-20,000 CPS. Pre-amp Outputs 2V. Tape Recorder Outputs 10V. Speaker Outputs: 4, 8, 16 and 32 ohms.

Wired and tested **\$99.95** Easy-to-build Kit **\$64.95**

PERFECT COMPANION FOR THE CS-28



**ARKAY ST-11
AM-FM
STEREO TUNER**

Unmatched by units costing twice the price, the Arkay ST-11 provides wide-range AM and FM tuning of remarkable clarity and drift-free stability. "Miracle Ear" sensitivity in FM channel, 4 uV. (2 uV. in AM) for 20 db quieting. Two distinctive receivers in one, for use singly in monaural reception or simultaneously for stereo broadcasts.

Wired and tested **\$74.50** Easy-to-build Kit **\$49.95**



**ARKAY CS-12
STEREO PRE-AMP
AND AMP**

12 watts of clean power. Operates from ceramic or crystal cartridge, tape, tuners, auxiliary equipment.

Easy-to-build Kit **\$35.95**



**ARKAY SPA-55
STEREO AMP**

Two 27½ watt distortion-free hi-fi amplifiers. Or use as 55 watt monaural amplifier.

Easy-to-build Kit **\$64.95**
Wired and tested **\$79.95**

**ARKAY SP-6
STEREO
CONTROL CENTER**



Completely self-powered sensitive dual pre-amp with unparalleled flexibility. Reverse position, hi lo filters, etc. Prices less cover.

Wired and tested **\$62.95** Easy-to-build Kit **\$39.95**

All prices 5% higher west of Mississippi

See and hear completely wired ARKAY Kits at your dealer. Write for detailed specifications & catalog. Dept. RT



You learn more from SAMS BOOKS

OVER 1,200,000 IN USE

JUST OUT!

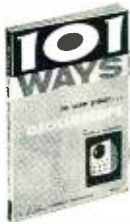

"101 Ways to Use Your Oscilloscope"

by Bob Middleton

A practical and invaluable guidebook for anyone using oscilloscopes. Covers all standard uses of this instrument as well as many uncommon ones. Describes connections required, equipment

needed, proper test procedures and evaluation of results for each scope use. Over 400 illustrations of waveforms and test setups are included. Invaluable for technicians, engineers, students and experimenters. 180 pages, 5½ x 8½". Only\$2.50
(Companion to Middleton's "101 Ways to Use Your Sweep Generator")

"Tape Recorder Manual"—Vol. 3



Complete analysis of 22 tape recorders produced in 1957-58, including Ampex, Geloso, Knight, RCA, Revere, Silvertone, Webcor, Wilcox-Gay, Wollensak. Includes general description, operation data, troubleshooting and maintenance facts, parts lists, diagrams, etc. Has special editorial section on basic types of tape transport mechanisms; with cumulative index. 160 pages, 8½ x 11". Only\$2.95

"Servicing Hi-Fi" Series



SERVICING HI-FI AM-FM TUNERS. Complete service data analysis of 18 AM-FM tuners produced in 1957-58. Thorough coverage: diagrams, photo views, troubleshooting, parts lists, etc. Includes special editorial section "Highlights on FM", covering FM signal, AFC circuits, alignment. 160 p., 8½ x 11". Only\$2.95



SERVICING HI-FI PREAMPS AND AMPLIFIERS. Covers 33 leading models made in 1957-58. Full technical analysis of each model (schematic, photos, charts, parts lists); special section on "Service Facts About Preamps and Amplifiers." 160 p., 8½ x 11". Only\$2.95

HOWARD W. SAMS & CO., INC.

Order from your Sams Distributor today, or mail to Howard W. Sams & Co., Inc., Dept. C-19 2201 E. 46th St., Indianapolis 6, Ind.

Send me the following books:

- "101 Ways to Use Your Oscilloscope" (TEM-2)
 "Tape Recorder Manual" (TR-3)
 "Servicing Hi-Fi AM-FM Tuners" (HF-3)
 "Servicing Hi-Fi Preamps & Amplifiers" (HF-4)
 \$.....enclosed. Send Free Book List

Name.....

Address.....

City.....Zone.....State.....

(outside U.S.A. priced slightly higher)

and you feel that he genuinely enjoys playing the piece.

Fortunately, neither he nor Dr. Hanson try to engage in any phony jazzifications which have been the bane of so many recordings of the "Rhapsody in Blue." There is no denying that the "Rhapsody in Blue" is jazz-derived, but this should not be a license for some of the tawdry and vulgar expositions I have heard of this score.

Dr. Hanson, for his part, plays it straightforwardly, and while his sense of rhythm and syncopation, if you must, is excellent, he never lets things get out of hand. Soundwise, this is fine concerto stereo, meaning that the piano stays just left of center in the ghost channel and does not wander between the speakers.

One thing I cannot for the life of me understand, is that I have read several reviews of this tape, in which the critics complained of a "lack of room resonance and dry acoustics." How they reach this conclusion, I'll never know, for although the recording is made close-up and is highly detailed, there is no paucity of hall reverberation and while I would not say that this has an over-powering sense of depth, it certainly has some and it adds considerably to the over-all realism.

Incidentally, here is one more instance where you champions of stereo tape can compare tape with the same piece on disc. Good as the disc is, it isn't in the same league with the tape!

-30-

Your Service Data (Continued from page 60)

peering—just one extraction. The index will also enable you to see at a glance that you do not have a particular schematic on file at all; so there is no time wasted in fruitlessly searching through the file.

Requirement 2: To be easy to find and extract, the service data should be in folders of uniform size and with stiff covers. The most useful are the manila folders of standard letter-filing size. One is shown in Fig. 2. There are "left-tab" and "right-tab" types and it is convenient to have a quantity of each. Thus odd-group numbers can be scanned on the left side and the even-group numbers on the right. This further simplifies the operation of finding a folder. When a folder gets dog-eared or limp, throw it away—folders are cheaper than your time.

Requirements 3 and 4: How do you deal with the various service letters, modification sheets, service hints, etc. that come in the mail from manufacturers? It is a fact that most of these invaluable sources of information are "filed" away and promptly forgotten. Here is a way to make good use of this "dope" without trying to pack it away in your already overburdened head.

Inside each folder, staple a blank sheet of paper. When a letter comes in, make a note on the appropriate flyleaf as a reminder in the future. If it is a

simple reference, like: "For better vertical lock replace C_{205} with a 220- μ fd. mica capacitor" it is easily entered as just stated. If it is more complex, a note such as, "To eliminate buzz in audio, see G-E letter 2nd Jan. 1957" is better. You will find yourself adding odd scraps of useful information on this flyleaf: " C_{36} , .03 μ fd., shorts—no H. V. Normal across video load resistor, Channel 2, 2.5 volts."

What's more, if your experience follows ours, you will find yourself scanning the flyleaf for help before servicing the set. After a couple of years of accumulating data, a large proportion of shop repairs will be handled "straight out of the book." If a technician leaves the shop to plow a furrow elsewhere, he leaves behind, in black and white, a goodly slice of the experience he has gained for the benefit of his successor.

Requirement 5: This is met by the provision of the numbered system described and by the use of stiff, uniform-sized folders. Beside the index should be hung a sheet of paper on which a note can be made of missing schematics. It is not often convenient to drop a job to write asking for service data, but a note to that effect should be made immediately and the necessary letter can be sent off at some more suitable time.

It is also a good idea to have a blank space in one corner of the index sheet, or a sheet attached, on which helpful notes relative to schematics can be written, such as: "RCA 17T705 is like 799 except for horizontal oscillator," or "Space Challenger much like 23-12."

Using the Schematic

Do you find that the set under repair, the test equipment, and the schematic have to compete for space on the bench? There is a simple and effective way to accommodate schematics just off the bench: incorporate a sliding shelf, similar to that used in many office desks. The shelf should be at least 12" wide and about 20 to 24 inches should project from the front edge of the bench when drawn out. The total length, including the hidden portion, should be as long as possible—the longer it is, the more stable and level will the surface be when it is withdrawn for use, as shown in Fig. 1.

The use of this device not only speeds up work, it also helps to protect valuable schematics from abuse. (**Requirement 6.**) A simple time and motion study will also prove that the bench technician can be spared much unnecessary movement and fatigue when the schematic is readily accessible.

There is a regrettable tendency, in TV service operations, to treat lightly such "details" as filing systems and labor-saving devices, but it definitely pays off to give some serious thought to these aspects of the business. The summer season will usually provide some opportunities to implement projects like this, resulting in a workshop better equipped to meet the rush of Fall business.

-30-

Service Notes

RCA: TVI FROM TUNERS

Field reports show that second-harmonic radiation from the oscillator in the KRK11 tuner, when it is on certain v.h.f. channels, may produce interference on certain u.h.f. channels. Specifically, when the KRK11 is tuned to channel 10, 11, 12, or 13, second harmonics of its oscillator will fall in the bandwidth of channel 15, 17, 19, or 21 respectively.

The simplest way of dealing with this problem is to connect a .001- μ fd. disc ceramic capacitor between terminal 4 on the rear of the tuner and ground. The ground connection must be made to the rear shield of the tuner, *not* on the outside case. Capacitor leads should be kept as short as possible. The oscillator tube shield must be securely grounded and held in place with the spring wire clip. The tuner top shield cover must be securely grounded too. If necessary, the spring edges should be bent inward to obtain better grounding.

In severe cases, this method may not work. A decoupling network (C_{30} and L_{66} in Fig. 1A) will then have to be installed. C_{30} , 1500 μ fd., is RCA Stock No. 75166. Inductor L_{66} is Stock No.

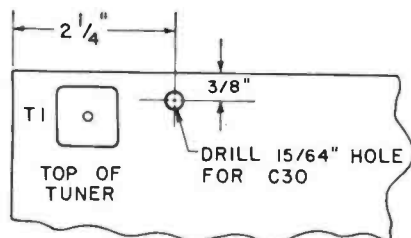
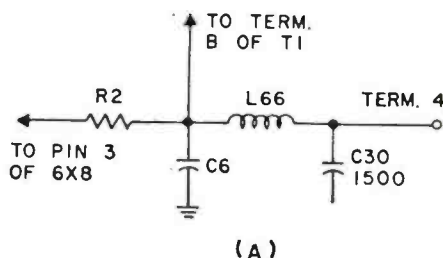

Fig. 1

77153. To mount the capacitor, drill a hole in the top of the tuner chassis as shown in Fig. 1B. A mounting clip for C_{30} , Stock No. 76143, should be used. The inductor is mounted inside the tuner chassis between C_{30} and terminal B of T_1 . As with the first method mentioned, make sure that the tube shield and the tuner top shield are securely grounded. Later versions of this tuner—KRK11A and —B—have this decoupling circuit already incorporated in

FREE

GIANT ALL NEW 1959

B-A CATALOG

WITH THE BIGGEST SAVINGS ANYWHERE

A COMPLETE BUYING GUIDE FOR EVERYTHING IN

RADIO TV

ELECTRONICS

BA 1959

ANNUAL CATALOG 591

SINCE 1927

180 KING-SIZED PAGES

EVERYTHING IN RADIO TV AND ELECTRONICS

100'S OF NEW ITEMS LISTED HERE FOR 1ST TIME

21 PAGES OF BARGAINS NOT IN ANY OTHER CATALOG

Guarantee
We guarantee everything in the Catalog to be of the quality and value represented. We can form exactly to the dimensions and description. We will make in the manner and give the care indicated for each apparatus.

RUSH COUPON TODAY!

BURSTEIN-APPLEBEE CO. Dept. 2M,
1012-14 McGee St., Kansas City 6, Mo.

Send Free 1959 B-A Catalog No. 591.

NAME _____

ADDRESS _____

CITY _____ STATE _____

SUPER POWERED SINGLE CHANNEL AMPLIFIER

Minimum 20V—5 Watts on All Channels

This all new super powered unit has the highest output of any TV channel amplifier with sufficient power to cover large communities with ample signal voltage and deliver a strong signal thru many miles of cable. The unit was designed specifically for community television and is the only unit of its kind that does not produce power in fractions of a watt. For full rated output a high-powered commercial transmitting tube is used.

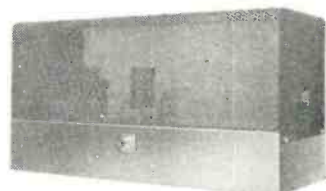

- C. C. S. Service
- 26 db min. gain
- 6-8 mcs. band width
- Channels 2-13 as specified
- Requires only 1 V input
- Co-axial input and output connectors for 75 OHM Line
- Linear class A operation
- Low Power Drain (1 Amp.)

MODEL SPA
\$350

Write for details today

SEG Electronics • 1778 Flatbush Ave., Brooklyn 10, New York

Dynamic Sideband Regulation Used in New Tuner

By **ROBERT BERKOVITZ**

Allied Radio Corp.

Overmodulation effects are reduced and weak signals are improved by circuit that wobbles local oscillator.

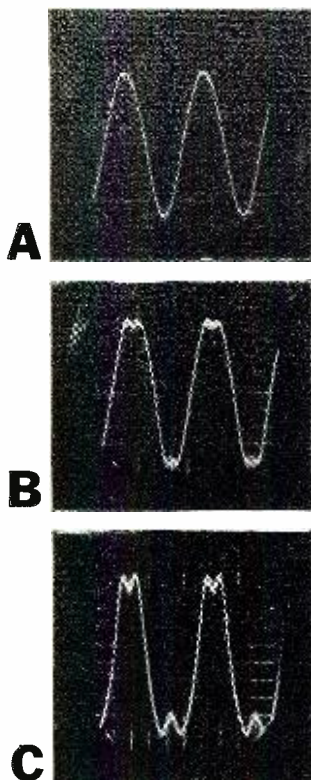

Fig. 1. The "Knight" stereo tuner that uses the D.S.R. circuit is shown here. The scope trace at (A) is the discriminator output of the tuner with an input signal having a deviation of ± 150 kc. (B) shows the output with D.S.R. circuit switched out. (C) is the output of another tuner without D.S.R.

THERE is an interesting problem associated with high-fidelity FM broadcast reception. Between the setting of the audio level at the transmitter and the volume control at the output of the FM tuner in the listener's home, there has until now been no way to adjust the amplitude of the transmitted program material. The very nature of FM transmission makes the problem a knotty one, since the audio information consists of frequency changes in the transmitted r.f., rather than the amplitude changes of AM, which can be dealt with in comparatively simple ways. As a result of this situation, volume peaks in the transmitted program can cause momentary high levels of distortion in comparatively good FM

example illustrated, the amount of frequency swing, or deviation, is plus-and-minus 75 kilocycles on either side of the center frequency. The deviation is proportional to the amplitude of the program material being transmitted, and is controlled at the transmitter, where changes in amplitude in the program are converted to changes in frequency of the carrier. To pass this transmission without distortion, an FM tuner would have to have an over-all bandpass of at least 150 kc. in those parts of the circuit preceding the detector. Actually, according to the higher mathematical analysis of FM transmission suggested by the theory of FM sidebands, the bandpass may have to be as great as 240 kc. Because of the ex-

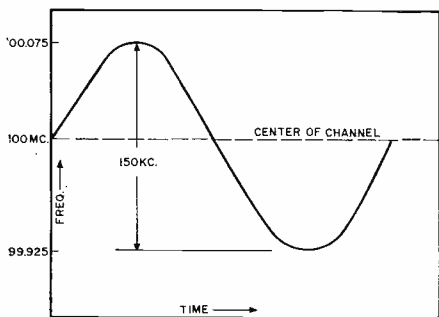
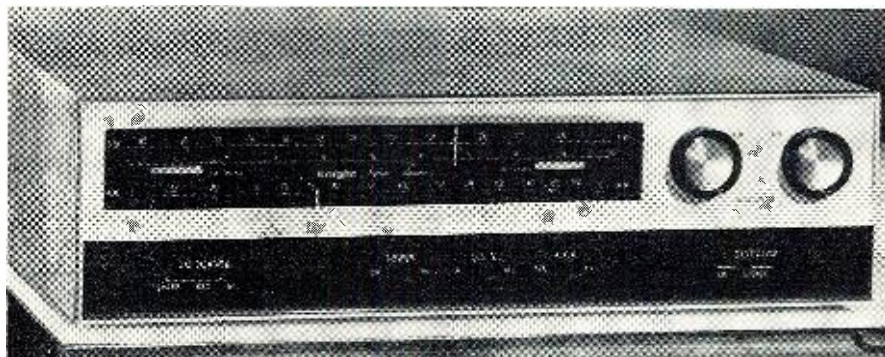
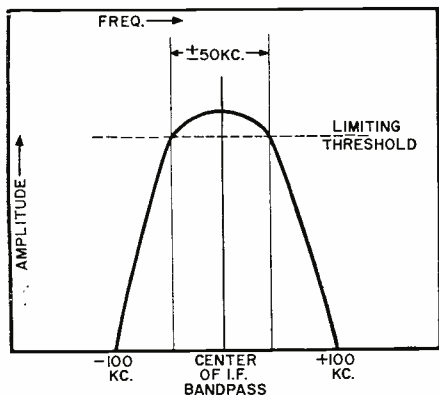

Fig. 2. Maximum carrier frequency swings.

Fig. 3. A typical i.f. amplifier response.



tuners. Moreover, signals which are too weak to produce good limiting action may be seriously distorted by the narrowed tuner bandwidth which results. A new FM tuner circuit development, Dynamic Sideband Regulation* (D.S.R.), has been devised by engineer Richard Medal to cope with these problems. Commercially available in a newly designed FM-AM stereo tuner, the D.S.R. circuit is claimed to provide very listenable reception at double the maximum modulation level permitted by the FCC, at signal levels of as little as 20 or 30 microvolts. Applicable to any good tuner with an a.f.c. circuit, the additional components required for D.S.R. consist of a triode cathode-follower and a few resistors and capacitors.

Deviation and Bandwidth

Stated most simply, D.S.R. works by reducing the deviations in frequency of the incoming FM carrier. Before going into the details of the circuit itself, it will be well to explain why this serves to reduce the distortion. Fig. 2 represents the maximum changes in frequency which may take place in the FM carrier during a broadcast; in the

tended high-frequency response required by some methods of FM multiplex broadcasting, this figure may need to be even larger. Few commercially available FM tuners attain these figures, and it may well be that only a perfectionist would demand that they do, since the usual deviation during most FM broadcasts rarely requires the theoretically necessary bandpass.

Musical program material, however, appears to be obedient only to the laws of art and of statistical probability. Unless the FM broadcasting station engineer chooses to operate at relatively low audio levels—which a little dial-spinning shows to be rare—his only choice would be to audition each performance or recording to be broadcast alongside an accurately calibrated oscilloscope. There is another alternative, the limiting amplifier, which can trim down the audio automatically by electronic means whenever overmodulation is likely, but this begins to make serious inroads against the whole idea of high-fidelity broadcasting with full dynamic range, an idea which has become an important part of the satisfaction listeners expect from FM. For these reasons, as several anonymous

* Patent applied for.

NOW *****
STEREO
EQUALIZATION
MADE
EASY



With The New NCB "Signature" Master Professional Alignment, Inspection and Equalization Tape! Whether you

RECORD—DUPLICATE
—SERVICE—EXPERIMENT
—CONVERT—OR . . . LISTEN!
 you'll get

BRILLIANT RESULTS
 from your Stereo or Monaural equipment when you use THIS PRECISION MASTER, CUSTOM-RECORDED COMPLETE ALIGNMENT TAPE!

Ten useful functions in six clearly announced chapters feature "Step-Sweeps" for easy, accurate equalization; each tape master recorded from original signals to NARTB professional standards. Exquisite azimuth accuracy.

Finest, full-length Mylar, on 7" large hub reel in air-tight metal storage can. Full instructions included. A "must" for conversions. Use the coupon. Order today.

For Full, Dual, or 4 Track Recorders

NCB
 Laboratories
 Box 491 Ithaca, N.Y.

Enclosed is \$ _____

Ship _____ 7 1/2" /sec. @ \$14.95 ea.
 _____ 15" /sec. @ 16.95 ea.

Name _____

Address _____

City _____ State _____

ferent mainly because deviation in the carrier due to interference has also been reduced.

Effectiveness of D.S.R.

The effectiveness of D.S.R. may be gauged by an examination of the three photographs in Fig. 1. The oscilloscope trace in (A) shows the discriminator output of the tuner incorporating D.S.R. when a 107-megacycle carrier is frequency-modulated plus-and-minus 150 kc., at an r.f. input of 18 microvolts. Photograph (B) was made under identical conditions, but with the D.S.R. switched out of the circuit. The third photograph was made under the same conditions, with an excellent, well-aligned tuner without D.S.R., which is deservedly well-respected for its high sensitivity and effective limiting.

Block Diagram

Fig. 6 is the block diagram of an FM tuner incorporating the D.S.R. circuit. The normal output of the discriminator in an FM tuner consists of two voltages: an a.c. voltage, which is the audio signal being transmitted, superimposed upon a d.c. voltage, which is produced by slightly detuning the receiver, and eliminated by accurate retuning. In a conventional a.f.c. circuit, the audio component of the discriminator output is filtered out and the remaining d.c., if any is present due to mistuning, is applied to the grid of a triode which is used as a variable reactance in the local oscillator circuit. This alters the frequency of the local oscillator, raising or lowering it according to the polarity of the discriminator d.c., until the receiver is retuned and the d.c. is no longer present.

For D.S.R. operation, a portion of the a.c. audio voltage is also applied to the reactance tube grid. This causes the oscillator frequency to vary in the same manner as in a conventional a.f.c. circuit, but at a much faster rate, of course. The result is frequency modulation of the local oscillator in-phase with the frequency variations of the incoming FM carrier, since the audio voltage controlling the oscillator frequency is derived from the frequency variations of the carrier. Because of the low impedance presented by the grid of the reactance tube, a cathode-follower triode is used after the discriminator to supply the D.S.R. control voltage at low impedance. In addition to its function in the D.S.R. circuit, the cathode-follower provides a multiplex output at low impedance, a highly useful by-product in view of the extended high-frequency response that may be required for a multiplex transmission system.

Circuit Used

In the schematic shown in Fig. 7, a 6BJ8 dual-diode triode serves both as discriminator and cathode-follower. From A, the discriminator output, the a.f.c. line proceeds through its a.c. bypass network and switch to F, the re-

SURPLUS BUYS

POWERSTAT, Variac—Input 115 or 230V—Output 0-270V—6 Kv A—0-270 Dial Calibration—with Case, Cord, Plug—New . . . \$16.95
 MURDOCK Headphones, New . . . 10,000 Ω w/plug \$3.49

Variable Condensers with Shafts
 140 Mmfd.—(Hammar) 2 for \$2.00
 35 Mmfd.—(Hammar) 2 for 1.00
 25 Mmfd.—(Hammar) 2 for 1.00

POWER SUPPLY (115VAC-60 Cy) for MAR equipment. Complete with 1 case of Brand New spares. (40 lbs.) Brand New—Special \$12.95
 SPERTI-VACUUM SWITCH—For ART-13 \$2.95

OIL CONDENSERS
 2 Mf.—600VDC—B'tub. \$.25 2 Mf.—1 Kv.—Rect. \$.75
 4 Mf.—600VDC—Rect. .50 4 Mf.—1 Kv.—Rect. 1.50
 8 Mf.—600VDC—Rect. .85 10 Mf.—1 Kv.—Rect. 2.50
 10 Mf.—600VDC—Rect. 1.29 4 Mf.—3 Kv.—Rect. 6.95

DYNAMOTORS
 BD-77 Input 12 VDC—Output 1,000 VDC . . \$9.95
 EICOR—Input 12 VDC—Output 440 VDC—200 Ma. Constant—300 Ma Intermittent—1" x 7/8" New \$2.95
 HALLICRAFTER Cabinet and 10" Speaker . . \$9.45
 GUNGER Xformer—100QPri.; 125,000 Ω sec. 2/51.00

2 1/2" ROUND MILLIAMMETERS
 0-300 Mils—New, boxed. \$2.95
 0-500 Mils—New, boxed. \$2.95

SPECIAL OIL CONDENSER BUY 24 Mfd (3 x 8) 600 VDC. 4 Insulated terminals W/Mtg. Brackets. Brand New—Only \$1.95
 2 CATHODE RAY TUBE—2API—New—Boxed . . \$1.95
 SOCKET with Harness for above69

RELAYS
 115 V AC—Allied #BKA-A DPST—10 A. Cont. \$1.95
 115 V AC—Allied 4 PDT—10A. Cont. New . . 3.50
 5-6 V AC—Allied A33A—SPDT 1.50
 12 V DC—Allied Isolantite Insul. 3 PDT. 10 A. Cont. New, Boxed. A Super Value 2.50
 12 V DC Auto Elett. DPDT. Hold Contact . . . 1.00

MINIATURE METER—1 1/2" Sq. 0-100 Microamps—De Jur. Etc. New \$3.95

VACUUM CONDENSERS
 50 Mmfd—3000 VDC—New \$2.25
 50 Mmfd—32000 VDC—New 7.95
 25 Mmfd—10000 VDC—New 12.00
 100 Mmfd—20 Kv 107 Speaker . . . 12.00

POWER FILAMENT XFORMER—Pri—105/115V-60 Cy. Sec. 300-0-300V—100 Ma; 12.6 VCT-3A; 12.6V-3A; 5.0V-3A. Open Frame—Compact—Useful as 12 or 24 Volt Transf. for Surplus Gear (U/W RA-20 B.S.) New \$2.49
 SLIDER BLEEDER—100,000 Ohm, 100W . . . 3/52.00
 25,000 Ohm, 100W 2/51.00
 ERIE Ceramic Variable, 3-12 Mmfd. 6/51.00
 OHMITE RHEOSTAT, 15 Ohm, 100W 3/55.00
 15 Ohm, 75W 2/53.00
 OCTAL Saddle Loss Sockets 4/51.00
 ICA Phone Plugs (PL-55 Type) 4/51.00
 AHH DPST Toggle (Ball Hand) New 3/51.00
 RF CHOKE—RF wound—1 Amp 3/51.00
 MAGNAL Sockets (Stearite) CR Tubes 3/51.00
 3 FT. RG8/U—w/2 Male Coax Conn. 3/52.00

REX RADIO SUPPLY CO.
 88 Cortlandt St.
 New York 7, N. Y.
 In the Heart of New York's Radio Row

comprehensive home study courses in

ELECTRONICS ENGINEERING

Each course is written by an eminent authority in his field and includes the standard recognized textbooks. Personal and individual attention is given to the student through our proved method of instruction. For complete information and a syllabus of each course, mail the coupon.

Choose from among these complete courses

- Advanced Radio and Electronics Engineering
- Electronics Engineering
- General Radio Engineering
- Radio Servicing, Maintenance and Repair
- Television
- Television, Maintenance and Servicing
- General Technical Training
- Special Advanced Electrical Engineering Course for Professional Engineers Examination
- General Electrical Engineering
- Electrical Installation and Wiring
- Electrical Draftsmanship
- Circuit Mathematics
- Electricity Supply
- Telephony

Canadian Institute of Science & Technology Ltd.
 720 Century Bldg., 4125th St. N.W., Washington, D. C.
 Gentlemen: Please forward free of cost or obligation information on your Electronics Engineering Courses.

Name _____
 Address _____
 City _____ State _____
 In Canada: Canadian Institute of Science and Technology Ltd., 720 Garden Building, 263 Adelaide St., West Toronto 1, Ontario.

actance tube grid. Also from *A*, the audio output of the discriminator is applied to the grid of the triode in the 6BJ8 through a d.c. blocking capacitor. In order for the frequency variations introduced by the D.S.R. to accurately reflect the deviation of the incoming carrier, the audio must not be allowed to pass through the de-emphasis network, where high-frequency response is pared down. From the cathode-follower, the D.S.R. control voltage passes to a voltage divider at *B*, where it is picked off below the multiplex output and the lead to a second cathode-follower which provides the final audio output of the tuner.

A ganged D.S.R. on-off switch is required for several reasons. Since the D.S.R. control voltage variations must be in-phase with the incoming signal, detuning must be avoided to prevent the noisy results of regenerative feedback. This requires that the a.f.c. and D.S.R. switching be arranged in such a way that the a.f.c. cannot be switched off when the D.S.R. is on, and this is accomplished by the switch circuit shown in the schematic (*C*, *D*, and *E*.) A second requirement in the switching is brought about by frequency response correction which takes place at an earlier point in the tuner, intended to flatten response which may not be perfectly linear due to slight irregularity of the discriminator frequency response. When the D.S.R. is switched into the circuit, the resulting frequency response is so linear that the corrective network must be "un-corrected," a task accomplished by the capacitor running from the audio signal line to ground through switch gang *E*. At the grid of the reactance-tube half of the 12AT7, the a.f.c., and D.S.R. lines meet.

Just as in a feedback audio amplifier, the degree of audio fed back through the D.S.R. circuit has an optimum maximum value. Too much feedback introduces instability, as well as decreasing the audio output of the tuner too much. Too little feedback, of course, fails to accomplish the results for which the circuit is intended. In the circuit illustrated, the voltage divider at *B* feeds back a voltage approximately one-fifth that of the output at the multiplex jack. Although noticeable, the drop in output level which results is easily compensated by a slight turn of the volume control on the amplifier to which the tuner is connected. Where the D.S.R. has been switched on to tame a station which is overmodulating, the listener is compensated for the volume loss by the fact that the audio level is now where it should be, were the transmission being properly monitored. Both under these conditions, and in the case of weak signals, D.S.R. adds a degree of quality to FM reception which makes pleasant listening possible under conditions which would otherwise make it quite difficult. The D.S.R. circuit shown is used in the new "Knight" KN-120 Stereo FM-AM tuner, a product of *Allied Radio Corp.*, Chicago, Illinois.

-30-

March, 1959

Announcing . . . A BRAND-NEW Home Study Program
— Equips you to enter the exciting, new and booming field of

AUTOMATION

and Industrial ELECTRONICS

Engineering Technology

Automation: "Second industrial revolution" . . . latest and most exciting development in our amazing world of electronics. Current needs: 3,000 specialists per year, well-trained in automation and industrial electronics . . . to fill new jobs and draw top pay.

CREI's new complete home study course covers all phases of automation and industrial electronics, including fundamentals of electronic engineering technology and a specialization in: Machine control systems . . . Data processing systems . . . Instrumentation techniques . . . Digital and Analogue Computers . . . Servomechanism systems . . . Telemetry systems . . . Industrial processes.

Leads to jobs like these:

NOW A TELEMETRY TECHNICIAN AT RCA MISSILE TEST PROJECT . . . "On December 31 I will be working for RCA at the Missile Test Project in Florida as a Telemetry Technician. I don't mind telling you that CREI

and your encouragement helped a lot in getting this job."—John S. Trefl, Box 133, Beulah, Mississippi

NOW ASSISTANT CHIEF ENGINEER OF RADAR INSTRUMENTATION STATION . . . "Five years ago I started to work for my present employer as a Radio Repairer and Installer. I also started my CREI course at this time. Three years later I was a supervisory electronic engineer and a year later I was promoted to the position I now hold as assistant chief engineer of a large radar instrumentation station at White Sands Proving Grounds."—Ralph Leo Gagnon, 1255 Gardner Ave., Las Cruces, N. M.

If you have had a high school education, and experience in electronics—and realize the need of high-level technical knowledge to make good in the better electronic jobs — you can qualify for this brand-new CREI Home Study course. Write to Capitol Radio Engineering Institute, Dept. 113X, 3224-16th St., N.W., Wash. 10, D. C.

MAIL THIS COUPON FOR FREE BOOKLET!

CAPITOL RADIO ENGINEERING INSTITUTE

ECPD Accredited Technical Institute Curricula • Founded 1927
Dept. 113-X, 3224 - 16th Street, N.W., Washington 10, D. C.

Please send me without cost or obligation your brochure describing your brand-new home study course in Automation and Industrial Electronics Engineering Technology.

Name..... Age.....
Street.....
City..... Zone..... State.....

To obtain fast, immediate service and to avoid delay, it is necessary that the following information be filled in:

Employed By.....
Type of Present Work.....
Education:
Yrs. High School.....
Other.....
Electronics Experience.....



**SEND
RADIO &
TV NEWS
EVERY
MONTH**

Check one: 3 years for \$10
 2 years for \$7
 1 year for \$4

In the U. S., its possessions, and Canada.

Foreign rates: Pan American Union countries, add .50 per year; all other foreign countries, add \$1.00 per year.

name.....
address.....
city..... zone..... state.....

Mail to: **RADIO & TV NEWS**
Dept. R-3-9
434 S. Wabash Ave., Chicago 5, Ill.

RADIO ELECTRONIC SURPLUS



BC683 FM RECEIVER
27-39 mc. Equipped with 10 push buttons for selecting channels. Cont. variable tuning over the entire range. Unit complete with tubes, built-in loud speaker, squelch circuit, head phone jacks, schematic diagram on bottom of case. Approx. weight 34 lbs. **\$19.95**
12- or 24-volt D.C. Dynamotoreach **\$3.95**

BC603 FM RECEIVER

Same description as BC683 except that range is 20-27 mc. This unit complete with tubes.
Like New.....each **\$9.95**
Manual with schematic for BC603 & BC604**\$1.00** each
CRYSTALS (set of 80) for BC604 transmitter... **\$5.00**

RCA 18-WATT AMPLIFIER

Input 105-125 volts A.C., 50/60 cycles, 180 watts. Output with 117 volts on 120 volt tap, power trans. 5% max. R.M.S. harmonic distortion at 400 cycles, 18 watts. Available amp. loading impedance 4, 8, or 15 ohms. Tube complement: input 6J7, voltage amp. 6J5, amplifier-phase inverter 6N7, output 2 6L6, rectifier 5U4G, field supply rectifier 5U4G, oscillator 6F6. This is high quality amp., built to Gov't. specs., used normally with 15mm sound projector. Case is steel painted black. Approx. dim. 9" x 20" x 8". Schematic furnished. Shipping wt. approx. 50 lbs.... **\$24.95** ea.



TEST SCOPE—SYNCHROSCOPE—PULSE ANALYZER



ID-59/APA-11. Late production. Modular subassembly construction. Video amplifier is flat to 4 mc. 3BP1 presentation. Test-scope sawtooth 25-20,000 cy. Has all normal test-scope controls. As synchroscope and pulse analyzer, accepts positive or negative pulses. Video delay circuit permits leading edge of pulse to be seen. Calibrated-dial horizontal shift measures pulse durations from 0.5 to 100 microseconds. Sine-wave-oscillator calibrator measures recurrence rates from 200 to 6000 pps accurate within 0.4%. Built-in power supply requires 115v, 400 cy, 196 watts. External 60 cy power supply may be made to furnish plus 350 and -1300 vdc and 6.3 vac. In excellent condition, with all 19 tubes, schematic with parts values, parts-location pictures, operating instructions, theory explanation, and maintenance charts. Shipping weight 60 lbs. Used, good. Price each **\$16.95**

NEW 1 1/4 H.P. GASOLINE ENGINE



Made by Jacobsen! 1 1/4 h.p. 3600 rpm, 2-cycle, ball-bearing crankshaft, 2" bore, 1 1/2" stroke. Complete with carburetor. With addition of flywheel and ignition system (not included), makes an ideal engine for generators, pumps, lawn mowers, midget cars, etc. Price **\$10.00**

RG 8U COAX CABLE

52 ohm, approx. 15 1/2 ft. long with PL259 plugs on each end. **\$1.50** each, postpaid.



30-40 MC FM RECEIVER R-435/VRC-2X



Single channel, crystal controlled, covering police and fire department freq. Double conversion superhet (455 kc and 4.3 mc. I.F.'s); both oscillator and crystal control. Noise squelch, double limiter stages, loud speaker output. Contains vibrator supply, operates on 24 volts D.C. Removable cover. Approx. dimensions: 9" X 12" X 1 1/2". Unused, good condition. Price..... **\$19.50**

PE120 POWER SUPPLY

6, 12 or 24 volt (specify voltage) Used with BC659 and 620..... **\$6.95** each

NO C.O.D.'s. REMIT FULL AMOUNT WITH ORDER. ALL PRICES F.O.B. PASADENA.

C & H SALES CO.

2176 E. Colorado St. - Pasadena 8, Calif.

Record Number of Sets in Use During '58

FCC issues year-end report showing big radio-TV gains

AT year end the FCC issued an annual report on the "health" of the radio industry and, to nobody's surprise, it indicates that the "patient" is robust and growing phenomenally.

During 1958 radio permits and licenses increased by about 200,000 for a total of more than 2,100,000 current authorizations in the radio field alone, with some 1,500,000 transmitters in actual use—250,000 more than at the close of 1957. Holders of licenses range from individual citizens to business, industry, and public agencies.

The 40 groups in the Safety and Special Radio Services account for some 465,000 authorizations covering more than 1,400,000 fixed and mobile transmitters. Over 300,000 of these units are operated by public bodies in connection with safeguarding life and property.

Private industry operating in this category account for nearly 420,000 transmitters which are used in a wide variety of applications.

Amateur radio stations involve the use of approximately 185,000 transmitters with radio usage by individual citizens accounting for 125,000 of the transmitter licenses outstanding.

Broadcast Services

Thirteen categories of broadcast authorizations are approaching an all-time-high total of 9500. Of this number more than 5100 are stations offering programs and the remainder are auxiliaries.

Interestingly enough, the nation now has more broadcast receivers than it has people and almost three times as many sets as automobiles. The industry estimates that there are more than 200,000,000 receivers in use — 150,000,000 radios and 50,000,000 TV sets.

Of the nearly 670 commercial TV stations authorized (about 470 v.h.f. and nearly 200 u.h.f.) more than 500 are on the air (430 v.h.f. and nearly 80 u.h.f.). In addition, the programs of some of these stations are being picked up and re-transmitted locally by about 200 translator stations.

Today, over 90 per-cent of the population is within range of at least one operating TV station and 75 per-cent is in the service areas of two or more TV stations. About 85 per-cent of all homes have one or more TV receivers.

Commercial FM broadcast stations continued the numerical upturn that began in 1957. Of nearly 690 commercial FM broadcast authorizations, more than 570 are on the air. They hold about 100 authorizations for subsidiary services as well.

There are some 3400 AM stations authorized with over 3300 of these in actual service.

Licensed Operators

More than 1,500,000 commercial radio operator permits of different grades are held by those who operate the ever-increasing number of non-Government transmitters for a livelihood as distinguished from "hams" who operate their amateur stations as a hobby without monetary return.

QUALITY CUT QUAR Z

FOR EVERY SERVICE

All crystals made from Grade "A" imported quartz—ground and etched to exact frequencies. Unconditionally guaranteed! Supplied in:



FT-243 holders. Pin spacing 1/2". Pin diameter .093.

DC-34 holders. Pin spacing 3/4". Pin diameter .156.

MC-7 holders. Pin spacing 3/4". Pin diameter .125.

FT-171 holders. Pin spacing 3/4". Banana pins.

MADE TO ORDER CRYSTALS

1001KC to 2500KC:
.01% Tolerance...\$2.00 .005% Tolerance...\$2.75
2501KC to 9000 KC: .005% Tolerance...\$2.50
9001KC to 12,000 KC: .005% Tolerance...\$3.00
Specify holder wanted

ANY AMATEUR, NOVICE TECHNICIAN BAND CRYSTALS

80 meters 3701-3749 KC .01% Tolerance
15 to 30 meters 7152-7198 KC\$3.85 ea.
15 meters 7034-7082 KC\$4.10 ea.
6 meters 8335-8650 KC (within 1 KC)\$4.50 ea.
\$150 each

NEW CITIZEN BAND CLASS D CRYSTALS

Following Frequencies in Stock (Frequencies Listed in Megacycles) **\$2.50** each

26.965	27.035	27.115	27.185
26.975	27.055	27.125	27.205
26.985	27.065	27.135	27.215
27.005	27.075	27.155	27.225
27.015	27.085	27.165	
27.025	27.095	27.175	

ASK YOUR LOCAL PARTS DISTRIBUTOR FOR TEXAS CRYSTALS... LOOK FOR YELLOW & RED DISPLAY BOARD. IF HE DOES NOT STOCK TEXAS CRYSTALS—ORDER DIRECT FROM FACTORY.

SEALED OVERTONE CRYSTALS supplied in metal HC/6U holders—pin spacing .486, diameter .050.
15 to 30 MC. .005 tolerance.....\$3.85 ea.
30 to 45 MC. .005 tolerance.....\$4.10 ea.
45 to 60 MC. .005 tolerance.....\$4.50 ea.

FUNDAMENTAL FREQ. SEALED CRYSTALS
In HC/6U holders from 1400KC-10,000KC any frequency .005 tolerance.....\$3.50 ea.

MARINE FREQUENCY CRYSTALS

All marine frequencies from 2000-3200KC .005 tolerance.....\$2.50 (Supplied in either FT-243, MC-7, or FT-171 holders.)

RADIO CONTROL CRYSTALS

26.995 MC, 27.045 MC, 27.095 MC, 27.145 MC, 27.195 MC, 27.255 MC sealed crystals (1/2" pin spacing) . . . specify pin diameter .093 or .050. In stock for immediate delivery.....\$2.50 ea.

Stock crystals in FT-243 holders from 5675KC to 8650KC in 25KC steps.....75c or 3 for \$2.00

FT-241 lattice crystals in all frequencies from 370KC to 540KC (All except 455KC and 500KC).....50c Matched pairs ±15 cycles \$2.50 per pair.

200KC Crystals...\$2.00 100KC Frequency
455KC Crystals...\$1.50 Standard Crystals...\$4.50
500KC Crystals...\$1.50

1000KC Frequency Standard Crystals.....\$3.50
Dual Socket for FT-243 Crystals.....\$.15
Ceramic socket HC/6U Crystals.....\$.15

(Add 5c per crystal for postage and handling.)

WRITE FOR FREE CRYSTAL CATALOG COMPLETE WITH OSCILLATOR CIRCUITS

TEXAS CRYSTALS

8538 W. GRAND AVENUE • RIVER GROVE, ILL.
ALL PHONES—GLADSTONE 3-3555

Terms: All items subject to prior sale and change of price without notice. All crystal orders MUST be accompanied by check, cash or M.O. WITH PAYMENT IN FULL. NO C.O.D.'s. Postpaid shipments made in U.S. and possessions only. Add 5c per crystal for postage and handling charge.

SAY YOU SAW IT IN RADIO & TV NEWS

ELECTRONICS

PREPARE FOR A GOOD JOB!
BROADCAST ENGINEER
RADIO SERVICING AUTOMATION

TELEVISION SERVICING
BLACK & WHITE—COLOR

APPROVED FOR VETERANS AND SURVIVORS OF VETERANS
BUILDING AIR CONDITIONED
SEND FOR FREE LITERATURE

BALTIMORE TECHNICAL INSTITUTE
1425 EUTAW PLACE, BALTIMORE 17, MD.

es equipment teaser

By JOHN A. COMSTOCK

EVERY electronic service technician should be familiar with the various test instruments associated with his profession and the terminology of his trade. How do you score in this respect? Work this anagram to determine the depth of your electronic test instrument "know how" then check your answer on page 166.

ACROSS

1. Resistor used to increase voltmeter's range.
5. Type of frequency meter.
8. The indication that a meter gives.
10. Maximum instantaneous value of an a.c. current or voltage.
12. Letters symbol for voltage measured across a resistance.
13. Type of color-TV test signal generator.
14. Type of connector used at end of test lead.
15. Amplifying device used in a v.t.v.m.
19. Resistor used in conjunction with an ammeter to increase its range.
20. Type of TV alignment signal generator.
22. Letters symbol for voltage measured on tube's screen grid.
26. To line up circuits or bring them into tune.
27. This, too, should be considered before one buys a test instrument.
28. Short for a type of variable resistance.
29. Some service technicians prefer to build their own instruments from a _____ to save on the purchase price.
32. An electromagnetic device for locating shorted coils in dynamos, generators, and motor armatures.

33. A meter's deflection mechanism which converts electrical currents or voltages into needle deflections.

DOWN

1. Type of TV signal generator used for visual alignments.
2. The device to which power is delivered.
3. Type of test jack.
4. A small test coil used for measuring magnetic fields.
6. Type of resistance box containing a precision variable resistance.
7. When one a.c. wave follows behind another, it is said to _____.
9. Type of bridge.
11. Device often used with a signal tracer.
16. Application of a test signal to the input of a circuit.
17. Test instrument protective device.
18. Type of audio measuring meter. (Abbr.)
21. Indicates the reading given by a test meter.
23. How much a given amplifier can raise the input signal.
24. Letters symbol for grid voltage.
25. One should _____ a tube to determine if it is microphonic.
30. Volt ohmmeter. (Abbr.)
31. Voltmeter. (Abbr.)

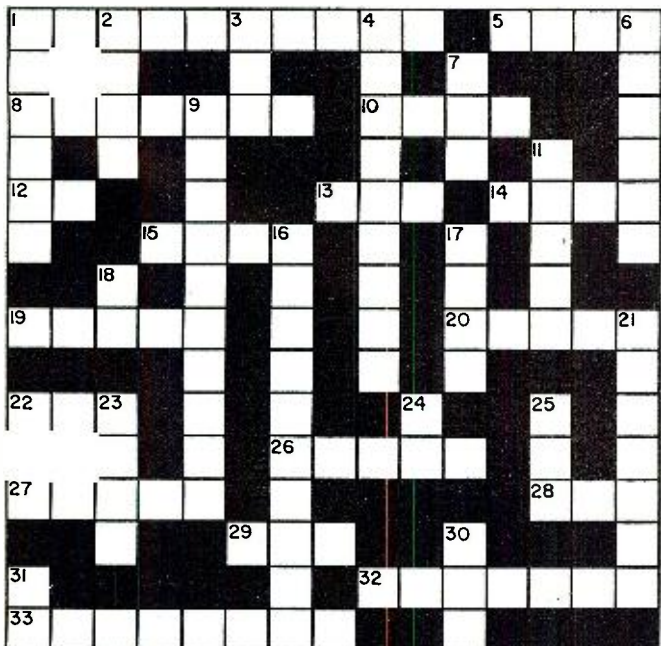

March, 1959

LEARN HOW TO BECOME A TECHNICIAN FOR ONLY \$22.95



Reg. U.S.
Pat. Off.

Build 16 Radio and
Electronic Circuits
At Home—ALL
Guaranteed to Work

Progressive Radio
"EDU-KIT"

NOW INCLUDES

- ★ 12 RECEIVERS
- ★ TRANSMITTER
- ★ SIGNAL TRACER
- ★ SIGNAL INJECTOR
- ★ CODE OSCILLATOR

- ★ No Knowledge of Radio Necessary
- ★ No Additional Parts or Tools Needed
- ★ Excellent Background for TV
- ★ School Inquiries Invited
- ★ Attractively Gift Packed

FREE EXTRAS

- SET OF TOOLS • RADIO & ELECTRONICS TESTER • ELECTRIC SOLDERING IRON • TESTER INSTRUCTION MANUAL • MEMBERSHIP IN RADIO-TV CLUB • CONSULTATION SERVICE • HI-FI GUIDE • QUIZZES • TV BOOK • FCC AMATEUR LICENSE TRAINING • RADIO BOOK • PRINTED CIRCUITRY • PLIERS-CUTTERS • ALIGNMENT TOOL • WRENCH SET • CERTIFICATE OF MERIT • VALUABLE DISCOUNT CARD

WHAT THE "EDU-KIT" OFFERS YOU

The "Edu-Kit" offers you an outstanding PRACTICAL HOME RADIO COURSE at a rock-bottom price. Our kit is designed to train Radio & Electronics Technicians, making use of the most modern methods of home training. You will learn radio theory, construction, servicing, basic Hi-Fi and TV repairs, code, FCC amateur license requirements.

You will learn how to identify radio symbols, how to read and interpret schematics, how to mount and layout radio parts, how to wire and solder, how to operate electronic equipment, how to build radios. Today it is no longer necessary to spend hundreds of dollars for a radio course. You will receive a basic education in radio, worth many times the small price you pay, only \$22.95 complete.

THE KIT FOR EVERYONE

The Progressive Radio "Edu-Kit" was specifically prepared for any person who has a desire to learn Radio. The "Edu-Kit" has been used successfully by young and old in all parts of the world, by many Radio Schools and by those in this country and abroad. It is used for training and rehabilitation of Armed Forces Personnel and Veterans throughout the world.

The Progressive Radio "Edu-Kit" requires no instructor. All instructions are included. Every step is carefully explained. You cannot make a mistake.

PROGRESSIVE TEACHING METHOD

The Progressive Radio "Edu-Kit" is the foremost educational radio kit in the world, and is universally accepted as the standard in the field of electronics training. The "Edu-Kit" uses the modern educational principle of "learning by doing". Therefore, you will construct radio circuits, perform jobs and conduct experiments to illustrate the principles which you learn.

You begin by examining the various radio parts included in the "Edu-Kit." You then learn the function, theory and wiring of these parts. Then you build a simple radio. With this first set you will enjoy listening to regular broadcast stations, learn theory, practice testing and troubleshooting. Then you build a more advanced radio, learn more advanced theory and techniques. Gradually, in a progressive manner and at your own rate, you will find yourself constructing more advanced multi-tube radio circuits, and doing work like a professional Radio Technician.

Included in the "Edu-Kit" course are sixteen Receiver, Transmitter, Code Oscillator, Signal Tracer and Signal Injector circuits. These are not unprofessional "breadboard" experiments, but genuine radio circuits, constructed by means of construction known as "Printed Circuitry." These circuits operate on your regular AC or DC house current.

In order to provide a thorough, well-integrated and easily-learned radio course, the "Edu-Kit" includes practical work as well as theory; troubleshooting in addition to construction; training for all, whether your purpose in learning radio is for hobby, business or job; progressively-arranged material, ranging from simple circuits to well-advanced topics in Hi-Fi and TV. Your studies will be further aided by Quiz materials and our well-known FREE Consultation Service.

THE "EDU-KIT" IS COMPLETE

You will receive all parts and instructions necessary to build 16 different radio and electronic circuits, each guaranteed to operate. Our Kits contains tubes, tube sockets, variable, electrolytic, mica, ceramic and paper dielectric condensers, resistors, tie strips, coils, hardware, tubing, punched metal chassis, Instruction Manuals, hookup wire, solder, etc.

In addition, you receive Printed Circuit materials, including Printed Circuit chassis, special tube sockets, hardware and instructions. You also receive a useful set of tools, a professional electric soldering iron, and a self-powered Dynamic Radio & Electronics Tester. The "Edu-Kit" also includes Code Instructions and the Progressive Code Oscillator, in addition to the F.C.C.-type Questions and Answers for the Progressive Signal Tracer and the Progressive Signal Injector, and a High Fidelity Guide and Quiz Book. Everything is yours to keep.

J. Statistis, of 25 Poplar Pl., Waterbury, Conn., writes: "I have repaired several sets for my friends, and made money. The "Edu-Kit" paid for itself. I was ready to spend \$240 for a Course, but I found your ad and sent for your Kit."

UNCONDITIONAL MONEY-BACK GUARANTEE

The Progressive Radio "Edu-Kit" has been sold to many thousands of individuals, schools and organizations, public and private, throughout the world. It is recognized internationally as the ideal radio course.

By popular demand, the Progressive Radio "Edu-Kit" is now available in Spanish as well as English.

It is understood and agreed that should the Progressive Radio "Edu-Kit" be returned to Progressive "Edu-Kits" Inc., for any reason whatever, the purchase price will be refunded in full, without question, and without delay.

The high recognition which Progressive "Edu-Kits" Inc. has earned through its many years of service to the public is due to its unconditional insistence upon the maintenance of perfect engineering, the highest instructional standards, and 100% adherence to its Unconditional Money-Back Guarantee. As a result, we do not have a single dissatisfied customer throughout the entire world.

ORDER FROM AD—RECEIVE FREE BONUS RESISTOR AND
CONDENSER KITS WORTH \$7.00

- Send "Edu-Kit" Postpaid. I enclose full payment of \$22.95.
 - Send "Edu-Kit" C.O.D. I will pay \$22.95 plus postage.
 - Send me FREE additional information describing "Edu-Kit." Also send FREE Radio, TV & Hi-Fi Books worth \$1.50. No obligation.
- Name
- Address

Progressive "EDU-KITS" Inc. 1186 Broadway, Dept. 87E
Hewlett, New York



NEW HALLIDRAFTERS SSB LINE AT HARVEY

SX-101 Mark IIIA Receiver \$395.00

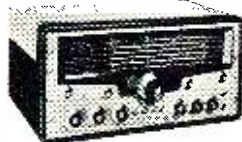

Provides full frequency coverage of five ham bands plus a 2 and 6 meter conv. band—80, 40, 20, 15, 10 meters. Every technical advantage and feature needed for years to come.

HT-32A Transmitter \$675.00



The world's cleanest signal—provided by a 5.0 mc quartz crystal filter system for rejection of unwanted sideband. Down 50 db or more. Bridged tee modulator. Five band output (80, 40, 20, 15, 10 meters). All modes of transmission—CW, AM, SSB.

HT-33A Linear Amplifier \$795.00

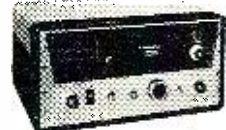

Complete efficient coverage of amateur bands; 80, 40, 20, 15, 10 meters. Conservatively rated at the maximum legal input. Third and fifth order distortion products down in excess of 30 db. Built-in rf output meter simplifies tune-up. Maximum harmonic suppression obtained through pi-network.

Trade in at Harvey
Trade UP to Hallicrafters

**MAIL ORDERS SHIPPED
SAME DAY AS RECEIVED**
Include with your payment a generous allowance for shipping charges — the excess will be promptly refunded.

HARVEY Estab. 1927
RADIO CO., INC.
103 West 43rd Street JU 2-1500
New York 36, N.Y.

“Atlas” Satellite Uses Special Radio System

Communications relay inside the missile includes a compact magnetic tape storage-playback system.

THE communications relay inside the “Atlas” missile that is circling the earth uses a special radio system developed by RCA for the U. S. Army. The system includes an array of lightweight communications and control equipment in the satellite itself, and complementary equipment of a more conventional type in the ground stations situated at points beneath the satellite's orbit. The service employs v.h.f. and code communications hitherto unattainable at these frequencies over distances of a thousand or more miles without intermediate relay stations. The success of this experiment opens up the early prospect of revolutionary communications techniques, such as international television and microwave voice and code services on a global basis, using satellite relays capable of spanning the oceans.

Among the elements aboard the satellite are the following: Two transistorized receivers, each weighing 10 ounces, for receiving messages from the ground stations. These receivers are enclosed in special shock-resistant coverings and employ ruggedized assemblies. Two 8-watt transmitters, each weighing 2½ pounds, to relay the messages on command to another ground station. Two electronic control units,

of ¾ pound each, which respond to commands from the ground to activate the receivers, transmitters, or the magnetic tape system that stores the radio messages until time for their delivery to a ground station. Two beacon transmitters, ¾ pound each, which send out a steady signal for tracking and temperature recording. These operate at the 108-mc. frequency adopted for satellite tracking and are picked up by the IGY “Minitrack” stations as well as the ground stations in the system.

Each of the five Army mobile ground stations includes a 1-kw. transmitter, a 250-watt standby transmitter, two receivers, and a control unit. The ground equipment, mounted in vans, also includes a beacon receiver and a tape recorder.

The Army Signal Laboratory was responsible for developing the beacon equipment and the tape recording gear both in the satellite and on the ground as well as handling the supervision of over-all completion of the entire communications system.

The RCA elements of the Army System were developed and largely produced at the engineering and production plant of the company's Astro-Electronic Products Division at Princeton, New Jersey.

The communications relay system installed in the Signal Corps Orbital Relay Experiment satellite includes the equipment shown here. Being held at right is transistorized receiver. Behind it is the control unit. Large unit at center is the transmitter. At left is a power converter for the transmitter. Round unit in foreground is beacon transmitter. Two of each of units shown are in satellite. Not shown are special tape recorder along with the battery power supply units.

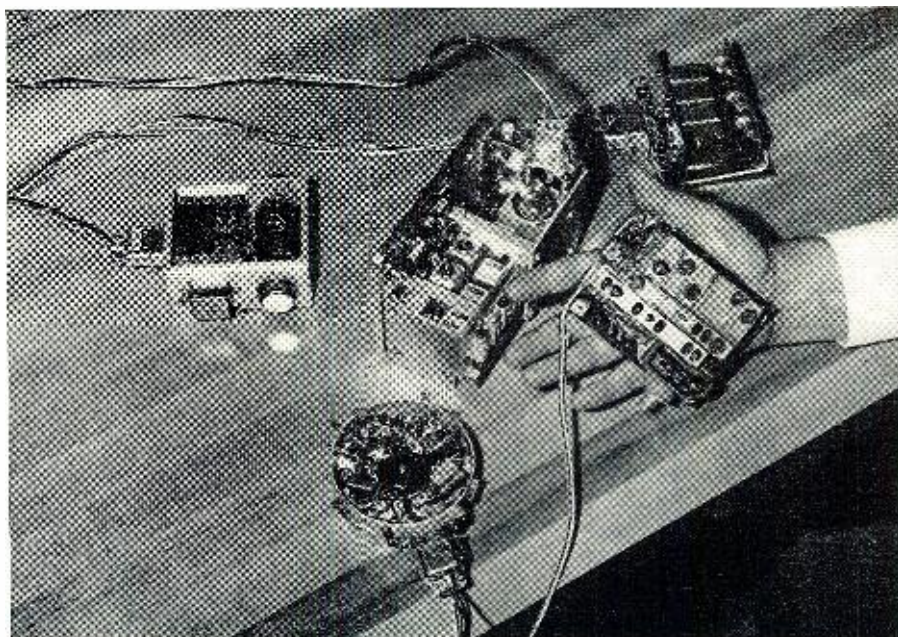

Testing Electrostatic Speakers

(Continued from page 64)

polar pressure between the beams of the individual radiators. The reverberation of the listening room must be relied upon to smooth these out.

The impedance-frequency curve is important in determining the "power" transfer of an amplifier for a given distortion. Maximum undistorted power transfer can be attained generally when the amplifier load is resistive and equal to the nominal output impedance of the amplifier. The loudspeaker carries nominal impedance ratings of 8 ohms or 16 ohms. The actual impedance, as in most loudspeakers, deviates considerably from the nominal rating. Fig. 7 shows the measured input impedance of a randomly selected unit. The impedance is near the rated value in two frequency regions, around 600 cps and around 7000 cps. At the lower frequency, the impedance is primarily resistive, while at the higher frequency it is primarily capacitive.

To obtain the desired pressure response from the unit, as indicated in Fig. 4, it is essential that the signal voltage applied to the radiators be constant within the passband. Therefore, only power amplifiers with a high damping factor (low source impedance) are recommended. Such amplifiers deliver a constant voltage to the input terminals of the speaker over a

wide frequency range. Speaker impedance variations then are important only as they affect the ability of the amplifier to deliver undistorted and constant voltage. The undistorted power that a good amplifier can deliver into a 2-ohm resistive load at 20 kc. from its 8-ohm terminals is usually not greater than about 10 per-cent of its rated power output. But since the power-per-cycle in music is maximum in the region between about 100 and 500 cps and falls off rapidly above 1000 cps, the impedance mismatch that occurs at the extreme high end of the hearing range does not normally degrade the performance.

Since only the upper 50 per-cent of the musical scale is reproduced by the electrostatic unit, it must be used with a low-frequency loudspeaker, or woofer. Several are readily available. The power transfer capabilities of the amplifier are more important for the combination of woofer and tweeter than for the tweeter alone, since it is the combination that acts as load on the amplifier. Fig. 7 also shows the combined impedance of a typical 16-ohm dynamic woofer with the tweeter. The upper end of the impedance curve is almost identical with the curve for the electrostatic unit alone, while in the region of maximum music power density (100 to 500 cps), the impedance is within the limits of 13.2 and 16 ohms.

The electrostatic radiators described in this article are covered by patents issued and pending to the author. -50-

GET INTO ELECTRONICS

TODAY'S TOP OPPORTUNITY FIELD

ELECTRICITY - ELECTRONICS TELEVISION RADIO - ELECTRONICS

TRAIN IN THE NEW SHOP-LABS OF

COYNE OLDEST, BEST
EQUIPPED SCHOOL
OF ITS KIND IN U.S.

in Chicago—Electronic Center of the World. Prepare for a better job and a successful future in TOP OPPORTUNITY FIELD. Train on real equipment—no advanced education or previous experience needed. Lifetime employment service to graduates. Finance Plan—enroll now, pay most of tuition later. Part time employment help to students.

FREE BOOK—Mail Coupon or write to address below for Big Free Illustrated Book—"Guide to Careers." Whether you prefer ELECTRICITY-ELECTRONICS, TELEVISION-RADIO ELECTRONICS OR COMBINED ELECTRONICS TRAINING, this book describes all training offered.

Information comes by mail. No obligation and NO SALESMAN WILL CALL.

B. W. Cooke, Jr., Pres.

Founded 1899

COYNE ELECTRICAL SCHOOL

Chartered as an Educational Institution Not for Profit
1501 W. Congress Pkwy., Chicago 7, Ill., Dept. 39-6A

Coyne Electrical School
New Coyne Building, Dept. 39-6A
1501 W. Congress Pkwy., Chicago 7, Ill.

Send FREE book "Guide to Careers" and details of all training you offer.

Name _____
Address _____
City _____
State _____
(I understand no Salesman will call)

MICRO

ELECTRON TUBE

INTRODUCES FOR THE FIRST TIME
ANYWHERE A SELECT STOCK OF USED
TUBES AT A FABULOUS LOW PRICE

37¢

ea.

FOR any TUBE LISTED

Jan Surplus Tubest

\$35 PER
HUNDRED
ASSTD.

ALL TUBES SENT POSTAGE PAID

Please send 25c handling for orders under \$5 Send 25% deposit on C.O.D. orders. Send approximate postage on Canadian and foreign orders.

MICRO

ELECTRON TUBE CO.

P.O. BOX 55 Park Station, Paterson 3, N. J.

- Each and every tube is tested in our own laboratory for mutual conductance and life test.
- We guarantee FREE replacement for one year of any tube purchased from us which fails to function efficiently under any or all operating conditions. Prompt refunds are made on any defective merchandise.
- The advertised tubes are not necessarily new, but may be electrically perfect factory seconds or used tubes—each is clearly so marked.

0A2	5X8	6BH6	6SF5	7Z4	19BG6G
0Z4	5Y3GT	6BJ6	6SF7	12A8	19J6
1A7GT	5Y3GT	6BK5	6S17	12A8S	19T8
1B3GT	6A7	6BK7	6SK7	12A76	24A
1W4G	6A8	6BL7GT	6SL7GT	12A77	25AV5
1H5GT	6A84	6BN6	6B06GT	12A06	25BQ6
1L4	6AC7	6BQ7	6BQ7	12A07	25DN6
1L6	6AF4	6BZ6	6BZ6	12A07	25L6GT
1N5GT	6AG5	6BZ7	6C4	12AV6	25W4GT
1Q5GT	6AC7	6C4	6C4	12AV7	25Z5
1R5	6A7	6C5	6C5	12AX7	25Z6
1S5	6AH4GT	6C6	6C6	12AX7	26
1T4	6AH6	6C86	6C86	12B4	35A5
1U4	6AK5	6CD6G	6C6	12BA6	35B5
1U5	6AL5	6CF6	6C7	12BA7	35C5
1V2	6AL7	6CG7	6C16	12BE6	35L6GT
1X2	6AM8	6C16	6C16	12BF6	35W4
2A3	6AN8	6CM7	6C16	12BH7	35Y4
2AF4	6AQ5	6CN7	6C16	12BQ6	35Z5GT
3BC5	6AQ6	6CS6	6C16	12BY7	37
3BN6	6AQ7GT	6C6	6C16	12C85	39/44
3BZ6	6AR5	6C6	6C16	12J5	42
3CB6	6AS5	6C7	6C16	12K7	43
3CF6	6AT6	6C6	6C16	12L6	45
3CS6	6AT8	6C6	6C16	12Q7	50A5
3LF4	6AU4GT	6C6	6C16	12SA7	50B5
3Q4	6AUSGT	6C6	6C16	12SG7	50C5
3S4	6AUS	6C6	6C16	12SJ7	50L6GT
3V4	6AV5GT	6C6	6C16	12SK7	50X6
4BQ7A	6AV6	6C6	6C16	12SN7GT	56
4BZ7	6AV6	6C6	6C16	12SQ7	57
5AS8	6AW8	6C6	6C16	12SVGT	58
5AT8	6AX4GT	6C6	6C16	12W6GT	71A
5AV8	6AX5GT	6C6	6C16	12X4	75
5AW4	6B8	6C6	6C16	12Z3	76
5BK7	6BA6	6C6	6C16	14A7/12B7	77
5J6	6BC5	6C6	6C16	14B6	78
5T8	6BC8	6C6	6C16	14Q7	80
5U4G	6BD6	6C6	6C16	14R6	84/6Z4
SUB	6BE6	6C6	6C16	14S7	117Z3
5V4G	6BF5	6C6	6C16	14T7	
5V6GT	6BF6	6C6	6C16	14U7	
	6BG6G	6C6	6C16	14V7	
		6C6	6C16	14W7	
		6C6	6C16	14X7	
		6C6	6C16	14Y7	
		6C6	6C16	14Z7	
		6C6	6C16	15A7	
		6C6	6C16	15B7	
		6C6	6C16	15C7	
		6C6	6C16	15D7	
		6C6	6C16	15E7	
		6C6	6C16	15F7	
		6C6	6C16	15G7	
		6C6	6C16	15H7	
		6C6	6C16	15I7	
		6C6	6C16	15J7	
		6C6	6C16	15K7	
		6C6	6C16	15L7	
		6C6	6C16	15M7	
		6C6	6C16	15N7	
		6C6	6C16	15O7	
		6C6	6C16	15P7	
		6C6	6C16	15Q7	
		6C6	6C16	15R7	
		6C6	6C16	15S7	
		6C6	6C16	15T7	
		6C6	6C16	15U7	
		6C6	6C16	15V7	
		6C6	6C16	15W7	
		6C6	6C16	15X7	
		6C6	6C16	15Y7	
		6C6	6C16	15Z7	
		6C6	6C16	16A7	
		6C6	6C16	16B7	
		6C6	6C16	16C7	
		6C6	6C16	16D7	
		6C6	6C16	16E7	
		6C6	6C16	16F7	
		6C6	6C16	16G7	
		6C6	6C16	16H7	
		6C6	6C16	16I7	
		6C6	6C16	16J7	
		6C6	6C16	16K7	
		6C6	6C16	16L7	
		6C6	6C16	16M7	
		6C6	6C16	16N7	
		6C6	6C16	16O7	
		6C6	6C16	16P7	
		6C6	6C16	16Q7	
		6C6	6C16	16R7	
		6C6	6C16	16S7	
		6C6	6C16	16T7	
		6C6	6C16	16U7	
		6C6	6C16	16V7	
		6C6	6C16	16W7	
		6C6	6C16	16X7	
		6C6	6C16	16Y7	
		6C6	6C16	16Z7	
		6C6	6C16	17A7	
		6C6	6C16	17B7	
		6C6	6C16	17C7	
		6C6	6C16	17D7	
		6C6	6C16	17E7	
		6C6	6C16	17F7	
		6C6	6C16	17G7	
		6C6	6C16	17H7	
		6C6	6C16	17I7	
		6C6	6C16	17J7	
		6C6	6C16	17K7	
		6C6	6C16	17L7	
		6C6	6C16	17M7	
		6C6	6C16	17N7	
		6C6	6C16	17O7	
		6C6	6C16	17P7	
		6C6	6C16	17Q7	
		6C6	6C16	17R7	
		6C6	6C16	17S7	
		6C6	6C16	17T7	
		6C6	6C16	17U7	
		6C6	6C16	17V7	
		6C6	6C16	17W7	
		6C6	6C16	17X7	
		6C6	6C16	17Y7	
		6C6	6C16	17Z7	
		6C6	6C16	18A7	
		6C6	6C16	18B7	
		6C6	6C16	18C7	
		6C6	6C16	18D7	
		6C6	6C16	18E7	
		6C6	6C16	18F7	
		6C6	6C16	18G7	
		6C6	6C16	18H7	
		6C6	6C16	18I7	
		6C6	6C16	18J7	
		6C6	6C16	18K7	
		6C6	6C16	18L7	
		6C6	6C16	18M7	
		6C6	6C16	18N7	
		6C6	6C16	18O7	
		6C6	6C16	18P7	
		6C6	6C16	18Q7	
		6C6	6C16	18R7	
		6C6	6C16	18S7	
		6C6	6C16	18T7	
		6C6	6C16	18U7	
		6C6	6C16	18V7	
		6C6	6C16	18W7	
		6C6	6C16	18X7	
		6C6	6C16	18Y7	
		6C6	6C16	18Z7	
		6C6	6C16	19A7	
		6C6	6C16	19B7	
		6C6	6C16	19C7	
		6C6	6C16	19D7	
		6C6	6C16	19E7	
		6C6	6C16	19F7	
		6C6	6C16	19G7	
		6C6	6C16	19H7	
		6C6	6C16	19I7	
		6C6	6C16	19J7	
		6C6	6C16	19K7	
		6C6	6C16	19L7	
		6C6	6C16	19M7	
		6C6	6C16	19N7	
		6C6	6C16	19O7	
		6C6	6C16	19P7	
		6C6	6C16	19Q7	
		6C6	6C16	19R7	
		6C6	6C16	19S7	
		6C6	6C16	19T7	
		6C6	6C16	19U7	
		6C6	6C16	19V7	
		6C6	6C16	19W7	
		6C6	6C16	19X7	
		6C6	6C16	19Y7	
		6C6	6C16	19Z7	
		6C6	6C16	20A7	
		6C6	6C16	20B7	
		6C6	6C16	20C7	
		6C6	6C16	20D7	
		6C6	6C16	20E7	
		6C6	6C16	20F7	
		6C6	6C16	20G7	
		6C6	6C16	20H7	
		6C6	6C16	20I7	
		6C6	6C16	20J7	
		6C6	6C16	20K7	
		6C6	6C16	20L7	
		6C6	6C16	20M7	
		6C6	6C16	20N7	
		6C6	6C16	20O7	
		6C6	6C16	20P7	
		6C6	6C16	20Q7	
		6C6	6C16	20R7	
		6C6	6C16	20S7	
		6C6	6C16	20T7	
		6C6	6C16	20U7	
		6C6	6C16	20V7	
		6C6	6C16	20W7	
		6C6	6C16	20X7	
		6C6	6C16	20Y7	
		6C6	6C16	20Z7	
		6C6	6C16	21A7	
		6C6	6C16	21B7	
		6C6	6C16	21C7	
		6C6	6C16	21D7	
		6C6	6C16	21E7	
		6C6	6C16	21F7	
		6C6	6C16	21G7	
		6C6	6C16	21H7	
		6C6	6C16	21I7	
		6C6	6C16	21J7	
		6C6	6C16	21K7	
		6C6	6C16	21L7	
		6C6	6C16	21M7	
		6C6	6C16	21N7	

MOBILE RADIO EQUIPMENT
Reconditioned—Mfd. by LINK

SPECIAL! MOTOROLA RECEIVER—Type FMRW-1GV
75 MC Range, Excellent for 2 Meter Conversion.
6V Vibrator Power Supply, good condition
with tubes, as is. Less controls & cables. **\$14.95**

Trans. modified in accordance with latest FCC Reg. for 20F3 emission.

MODEL 2210
152-162 MC
FM MOBILE TRANS.
& REC.—6 VOLTS

Complete with antenna, cables, control head, mike & crystals ground to your specific frequency. Unit as outlined complete for immediate installation. Specially priced **\$139.50**

MODEL 2210—same as above, for operation on 12 Volts. **\$162.50**

Trans. modified in accordance with latest FCC Reg. for 20F3 emission.

MODEL 2365
25-40 or 30-50 MC
FM MOBILE TRANS.
& REC.—6 VOLTS

Complete with antenna, cables, control head, mike & crystals ground to your specific frequency. Ready for immediate installation at this terrific price. **\$119.50**

MODEL 2365—same as above, for operation on 12 Volts. **\$149.50**

Trans. modified in accordance with latest FCC Reg. for 20F3 emission.

MODEL FMTR 30-50 MC
FM MOBILE TRANS. & REC.—6 VOLTS

Unit complete with Peak Modulation, control head, mike, antenna, cables & crystals ground to your specific frequency. Ready for immediate installation. A sensational buy at **\$109.95**

MODEL FMTR—same as above, for operation on 12 Volts. **\$149.95**

SPECIAL! Link 30-50MC Receiver
Motorola 152-174 MC Receiver
Above receivers crystal control complete with crystals, control head, cable & speaker. To your frequency. Commercial-type. Reconditioned.
6V—\$65.50 12V—\$78.50

NARROW-BAND BAND PASS FILTERS
Adapted to sets for latest FCC Regulations. Advise us as to frequency & type of set when ordering this filter. **\$29.95**

BC-221 FREQUENCY METER
Real value! QUANTITY IS LIMITED—so first come, first served. They are just like new, with original calibration charts. Range 125-20,000 KC with crystal check points in all ranges. Complete with crystal and tubes **\$99.50**
MODULATED TYPE... **\$139.50**
MODULATED TYPE with AC Power Supply **159.50**
These Frequency Meters are factory tested, checked for frequency alignment and GUARANTEED.

SPECIAL! CBS—Jobber Packed
—807 TUBE **\$1.95**

COMMAND EQUIPMENT

BC-457 Trans., 4 to 5.3 mc, good used **\$3.95**
BC-458 Trans., 5.3 mc to 7 mc, excellent, like new... **\$3.95**
BC-602 Control head for SCR-522, new **\$5.79**
Plugs for Above Command Sets, PL-152-A or PL-156-A... **\$0.55**

SPECIAL! 17 LBS. of ASSORTED RADIO PARTS. Now at a give-away price of **\$1.59** only

RETAIL DEPT. OPEN SATURDAYS
Immediate delivery. Include 25% deposit with order—balance C.O.D. 50c HANDLING CHARGE ON ALL ORDERS UNDER \$5.00. All shipments F.O.B. our warehouse, N.Y.C.

PLATT ELECTRONICS CORP.
20 MURRAY ST., NEW YORK 7, N. Y.
Telephone: COrtlandt 7-2575

Transistors Produced by Automatic Line

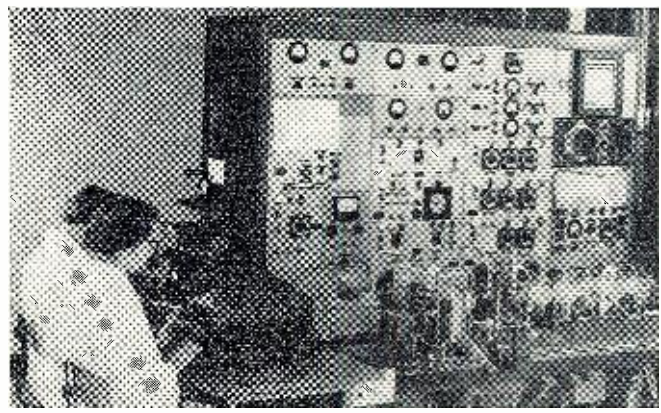

Two operators are stationed at beginning unit of the new Fast Automatic Transfer series of machines developed for high-speed transistor production. This is the etch-plate unit which prepares the transistor blank by electrochemical techniques.

A HIGHLY automated production line that can produce 450 transistors an hour at low cost is now operating at Philco's Lansdale Tube Co. division. The transistors being produced are entertainment types that may make possible in the near future the transistorization of FM tuners and TV sets. The transistors are not only being made for use in Philco products, but will also be made available to other manufacturers as well.

Tiny germanium blanks, about 1/16" square, are soldered to tabs which are held by a small drill-chuck-like assembly on a carrier block. These carriers move the blanks through the automated line from one automatic operation to another.

The line etches and plates the germanium blank to extremely precise measurements. It forms and attaches the fine electrode wires, and chemically cleans, washes, and dries the assembly. It checks itself through control points that feed back corrective information to previous operations. With some manual assistance, it vacuum dries the assembly and pressure-welds the tops. Several tests are applied to the transistors as they are moving along the line. Results of these tests are in the form of cathode-ray tube displays. About the only thing that the line does not do is to plate, final-test, brand, and pack the finished transistors for shipment.

The complete setup of the automated production line used to produce transistors.

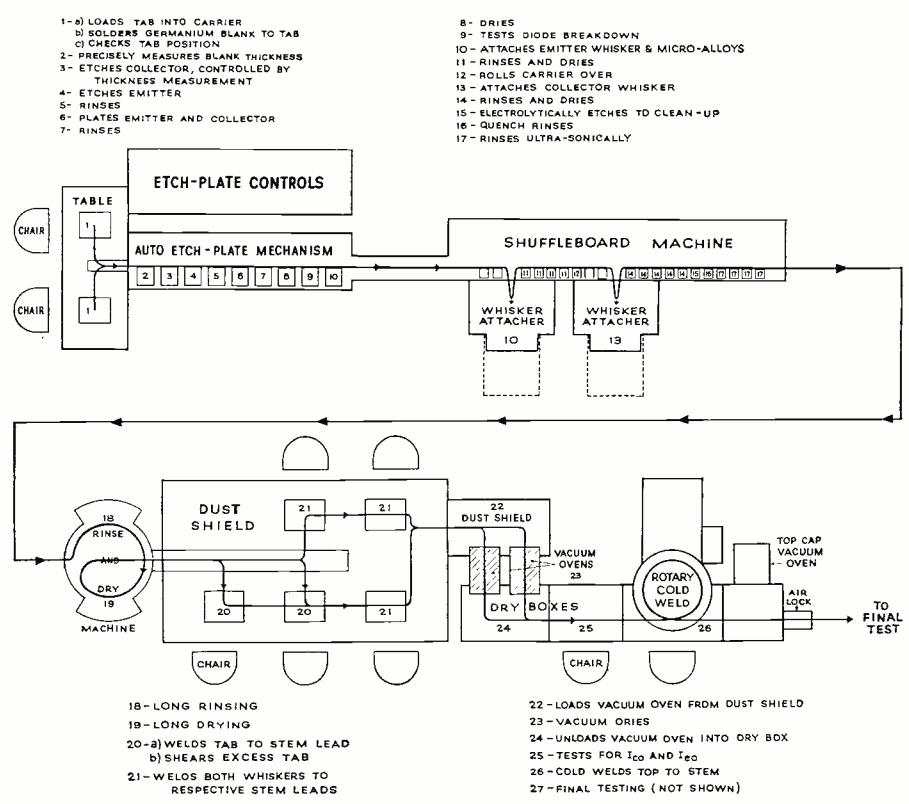

What's



New in Radio

TV I.F. PENTODE

Three heater versions of a wide-band, high-frequency pentode are now being offered by *CBS-Hytron* of Danvers, Mass.

The sharp cut-off types 3DK6, 4DK6, and 6DK6 are especially designed for use as i.f. amplifiers in TV receivers and feature a high transconductance of 9800 micromhos.

The 3DK6 and 4DK6 are designed for use in 600 ma. and 450 ma. series-string sets respectively while the 6DK6 is for parallel-heater operation.

Data on the three types is available in Bulletin E-315 which the company's Advertising Service, Parker Street, Newburyport, Mass. will supply on request.

NEW TRIPLETT TESTER

The *Triplet Electrical Instrument Co.* of Bluffton, Ohio is now marketing a new tube tester which provides fast, accurate tests with maximum flexibility as its Model 3414.

All switch settings can be made before the tube warms up, making it extremely fast in operation. Burned out tubes are rejected instantly without waiting for the filaments to heat. The

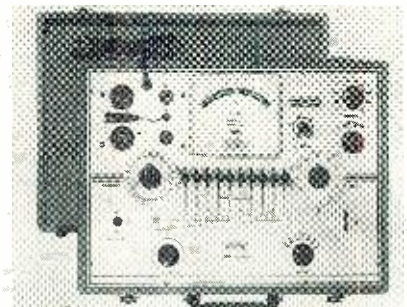

neon indicator shorts test is new, fast, and accurate, according to the manufacturer.

The tester will handle receiving types, gaseous rectifiers, series filament, resistor and ballast tube continuity, etc. The continuity test circuit may also be used to check electrical appliances for shorts and open circuits.

For complete specifications and price on the Model 3414, write the manufacturer direct.

MICROMINIATURE MERCURY CELL

Mallory Battery Company, a division of *P. R. Mallory & Co. Inc.*, 13000 Athens Ave., Cleveland, Ohio has developed a new mercury battery which is said to be the smallest ever made for commercial use.

A mere .300 inch in diameter and .125 inch high, the new battery is designed to fit the dimensional require-

ments of the military micro-module program. Its indicated uses include extremely small hearing aids, portable radiation detectors, and other miniaturized electronic devices.

Designated as the RM-312, the cell's energy life is approximately 36 ma.-hrs.

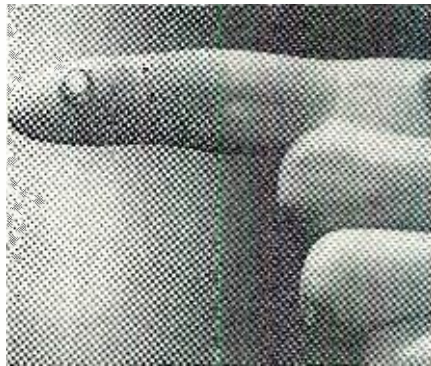

at a discharge of 2 ma. at 1.22 average volts. Like all mercury batteries, the cell features flat discharge. Voltage remains substantially constant out to the end of its useful life. It can be stored for periods in excess of one year without appreciable loss of capacity.

Complete technical data and production samples are available from the manufacturer.

POCKET-SIZED V.O.M.

A new low-cost portable v.o.m. for all servicing applications has been announced by *The Hickok Electrical Instrument Co.*, 10524 Dupont Ave., Cleveland 8, Ohio as its Model 457.

The 5" meter has easy to read scales and a time-saving single "function-range" control. The outstanding design feature is the inclined panel whereby the new instrument lies flat in normal use position eliminating the universal hazard of knocking over and breaking



which is so prevalent with these lightweight test instruments.

Sensitivity is 20,000-ohms-per-volt d.c. and 1000-ohms-per-volt a.c. Voltage ranges include six for a.c. (0-1200) and six for d.c. (0-1200). Resistance is measured in four ranges covering from

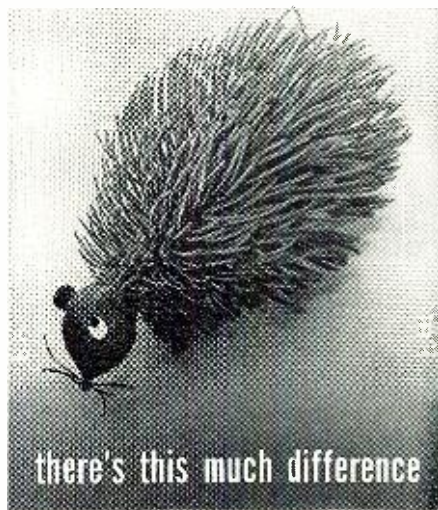

there's this much difference

in tape surface too!



ONLY SOUNDCRAFT TAPES ARE MICROPOLISHED SMOOTH

Unpolished tape surfaces contain microscopic irregularities which prevent intimate tape to head contact. It takes about 10 plays before these irregularities are smoothed out. During this period you lose high frequencies and force your recorder head to do the job of polishing the tape surface. This results in excessive head wear. Only Soundcraft Tapes are MICROPOLISHED to assure a mirror-smooth surface. The tape makes immediate intimate contact with your recorder head, guaranteeing high frequency response right from the first play! Only Soundcraft Tapes are MICROPOLISHED for your protection. Buy Soundcraft Tape—write for free catalog RS58-10R.

Ask About Soundcraft's 2-Reel Premium Pack—at your dealer now!



Dept. RT, Great Pasture Rd., Danbury, Conn.
342 N. La Brea, Los Angeles 36, Calif.
Canada: 700 Weston Rd., Toronto 9, Ont.

COMPLETE TRAINING FOR BETTER RADIO-TV SERVICE JOBS

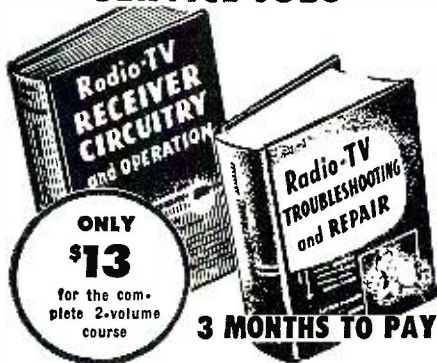

Let these two world-famous Ghirardi training books teach you to handle all types of AM, FM and TV service jobs by approved professional methods—and watch your efficiency and earnings soar!

Completely modern, profusely illustrated and written so you can easily understand every word, these books pave the way to fast, accurate service on any type of radio and TV set ever made. Each book contains the latest data on the latest methods and equipment—NOT a re-hash of old, out-of-date material. Each is co-authored by A. A. Ghirardi whose famous RADIO PHYSICS COURSE and MODERN RADIO SERVICING were, for 20 years, more widely used for military, school and home study training than any other books of their type!

THE NEW Ghirardi RADIO-TV SERVICE LIBRARY

Almost 1500 pages and over 800 clear illustrations show step-by-step how to handle every phase of modern troubleshooting and servicing.

1—Radio and Television Receiver TROUBLESHOOTING AND REPAIR

A complete guide to profitable Professional methods. For the beginner, it is a comprehensive training course. For the experienced serviceman, it is a quick way to "brush up" on specific jobs, to develop improved techniques or to find fast answers to puzzling service problems. Includes invaluable "step-by-step" service charts. 820 pages, 417 illus., price \$7.50 separately. (Outside U.S.A. \$8.00.) See combination offer below!

2—Radio and Television Receiver CIRCUITRY AND OPERATION

This 669-page volume is the ideal guide for servicemen who realize it pays to know what really makes modern radio-TV receivers "tick" and why. Gives a complete understanding of basic circuits and circuit variations; how to recognize them at a glance; how to eliminate guesswork and useless testing in servicing them. 417 illus. Price separately \$6.75 (outside U.S.A. \$7.25).

New low price...you save \$1.25!

If broken into lesson form and sent to you as a "course," you'd regard these two great books as a bargain at \$50 or more! Together, they form a complete modern servicing library to help you work faster, more efficiently and more profitably. Completely indexed so you can look up needed facts in a jiffy.

Under this new offer, you save \$1.25 on the price of the two books—and have the privilege of paying in easy installments while you use them! No lessons to wait for. You learn fast—and you learn right!

STUDY 10 DAYS FREE!

Dept. RN-39, RINEHART & CO., Inc.
232 Madison Ave., New York 16, N. Y.

Send book(s) checked below for 10-day FREE EXAMINATION. In 10 days, I will either remit price indicated (plus postage) or return books postpaid and owe you nothing.

Radio & TV Receiver TROUBLESHOOTING & REPAIR (Price \$7.50 separately)

Radio & TV Receiver CIRCUITRY & OPERATION (Price \$6.75 separately)

Check here for MONEY-SAVING COMBINATION OFFER. Save \$1.25. Send both of above big books at special price of only \$13.00 for the two (Regular price \$14.25) . . . you save \$1.25. Payable at rate of \$4 (plus postage) after 10 days if you decide to keep books and \$3 a month thereafter until \$13 has been paid.

Name

Address

City, Zone, State

Outside U.S.A.—\$8 for TROUBLESHOOTING & REPAIR; \$7.25 for CIRCUITRY & OPERATION; \$14 for both. Cash with order only, but same 10 day return privilege.

0 to 100 megohms. There are center-scale ranges of 5, 500, 5000, and 500,000 ohms. Current measurements include 50 μ a., 1, 10, 100, and 1000 ma., and 10 amps. The decibel scale covers -18 to +57 in five ranges.

The circuit is frequency compensated for accurate readings over the entire audio range. The instrument is battery operated, uses a full-wave rectifier circuit, and comes complete with test leads.

NEW T/R SWITCH

Barker & Williamson, Inc. of Bristol, Pa. has developed a new transmit-receive switch with selectable bandswitching and capacity to handle the full legal-limit power for ham transmitters.



The Model 381 T/R switch covers the 80 through 10 meter bands and is suitable for AM, DSB, SSB, and c.w. It has been designed especially for high-power transmitting applications. It provides a safety margin when used with antennas not in the ideal category with respect to s.w.r. conditions and freedom from the effects of intermodulation from strong local radio and TV stations. Under s.w.r. conditions not exceeding 1.5:1 it will handle more than 1 kw. AM phone and up to 5 kw. on SSB and c.w. when 72-ohm coaxial line is in use and higher power with 52-ohm lines.

The switch has a "fail-safe" design and keeps the transmitter connected to the antenna in case the unit is not energized or its tubes fail. It matches 52-75 ohm coaxial lines and is completely self-contained in a cabinet measuring 4 3/4" x 4" x 4 1/2".

A descriptive bulletin on this new accessory is available from the manufacturer upon request.

LOW-COST CITIZENS GEAR

Radio Corporation of America has announced the development of a low-cost Citizens Band transceiver which is tradenamed the "Radio-Phone."

Capable of two-way voice transmission over a distance of several miles, the new radio is expected to find wide application among small-boat enthusiasts, hunters, fishermen, farmers, etc.

The unit weighs less than 10 pounds and measures 9" x 7" x 5". It operates from a 6- or 12-volt battery or from a standard 117-volt a.c. power source. First of these units were previewed early this year.

4-BAND RECEIVER KIT

Allied Radio Corporation, 100 N. Western Ave., Chicago 80, Illinois is now offering a new 4-band receiver in kit form as its "Knight-Kit Span Master."

Providing world-wide short-wave coverage in addition to the standard broadcast band, this new unit will re-

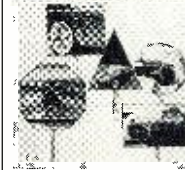

NEW SCI DIRECTORY is now on sale

Imagine having access to the largest, most complete sports car showroom in the world—where sports and economy cars of every make and model are waiting for your inspection. A unique showroom—with no fancy talk, but plenty of good, solid facts. A place where you can browse for hours on end and check out just about every car available—

That, in effect, is what the SPORTS CARS ILLUSTRATED DIRECTORY represents. It's the world's most complete guide to the buying and servicing of sports and economy cars. On sale now at newsstands all over the country, the 1959 edition of the SPORTS CARS ILLUSTRATED DIRECTORY has 160 pages of valuable, helpful information like:

ROAD TESTS OF THE EIGHT MOST POPULAR SPORTS CARS—Alfa Romeo, Austin-Healey, Corvette, Jaguar XK 150 S, Mercedes-Benz 190 SL, MGA Coupe, Porsche Coupe, and the Triumph TR3 A.

BUYER'S GUIDE TO READILY AVAILABLE SPORTS CARS (complete with spec sheets)—A.C., Arnolt-Bristol, Aston-Martin, Berkeley, Borgward, Elva, Ferrari, Lancia, Lotus, Maserati, Mercedes-Benz 300 SL, Morgan, OSCA, SAAB GT, Sprite.

BUYER'S GUIDE TO LIMITED PRODUCTION CARS (complete with spec sheets)—Abarth, Allard, BMW, Bristol, Cisitalia, Cooper, Dellow, DB, DKW, Elva, Facel Vega, Fairthorpe, Frazer-Nash, Gordini, Gregoire, Jensen, Jomar, Kieft, Lister, Lotus Elite, Moretti, Nardi, Pegasso, Salmson, Stanguellini, Talbot-Lago, Turner.

BUYER'S GUIDE TO LIGHT CARS (complete with spec sheets)—Alfa, Austin, Borgward, Citroen, DKW, English Ford, Fiat, Hillman, MG Magnette, Metropolitan, Morris, Opel, Panhard, Peugeot, Rambler, Riley, Renault, SAAB 93B, Simca, Sunbeam, Taunus, Triumph, Vauxhall, Volkswagen, Volvo.

PLASTIC SPORTS CAR BODIES BUYER'S GUIDE—Alken, Almquist, Devin, Victress, etc.

SPORTS CAR ACCESSORIES AND TIRES—a thorough round-up of new products in the field.

SERVICE DIRECTORY—a complete listing of dealers all over the United States who service sports cars and stock spare parts.

Once you see the 1959 SCI DIRECTORY, you'll agree that it's the greatest showroom of all—a breathtaking panorama of the wonderfully exciting world of imported cars! Sports car fans won't want to miss this Ziff-Davis publication.

THE SPORTS CARS ILLUSTRATED DIRECTORY
is now on sale—only \$1.00.

ceive foreign broadcasts, ships-at-sea, aircraft, time signals, amateur radio stations on the 80-, 40-, 20-, 15-, and 10-meter bands, as well as local AM stations.

The sensitive regenerative circuit also features bandspread dial and fine

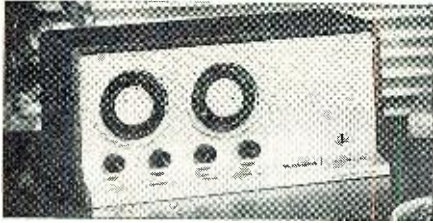

regeneration control to simplify critical tuning. Each band coil has its own antenna winding for maximum sensitivity. Additional features include headphone terminals and a speaker cut-out switch to permit private headphone reception.

The kit is supplied with a fabrikoid-covered cabinet measuring 6 3/4" x 13 1/16" x 6 3/16". It comes complete with tubes, all parts, wire, solder, instruction manual, and a world-wide listing of stations. Write Dept. PR837 of the company for further details.

A.C.-D.C. MULTITESTER

Olson Radio Warehouse, 260 S. Forge St., Akron, Ohio has released a compact 2000-ohm-per-volt multi-tester in its "Shield" line as the Model TE-117.



Featuring a 2 1/2" rectangular meter and 1% precision shunts and resistors, the instrument has seven a.c. and d.c. ranges (0-10-50-250-500-2500 volts); d.c. current ranges 0-500 μ a. and 0-50-500 ma.; and ohms ranges 0-10,000 ohms and 0-1 megohm; the instrument is housed in a durable grey crackle finished metal case which measures 3 1/4" x 1 1/8" x 4 3/4". Ranges are selected by means of pin jacks on the front of the meter case.

The multitester is supplied with test leads and operating instructions.

TUNG-SOL'S SILICON RECTIFIERS

Tung-Sol Electric Inc., Newark, N. J. has announced the availability of a new line of eight silicon rectifiers ranging from a peak inverse voltage of 50 to 500 volts.

Designed for radio and TV set applications, the new units have been assigned type numbers 1N2072 through 1N2079. The components are of the diffused junction type enclosed in epoxy resin cases with flexible pigtail leads. In configuration they closely resemble small capacitors.

The 1N2078, with a peak inverse voltage of 400 volts, has wide application as a radio and TV replacement. It provides the low forward voltage drop and low leakage current characteristics of silicon. The resulting higher output voltage, coupled with the ability to

SUPER PRO RECEIVER BC-779

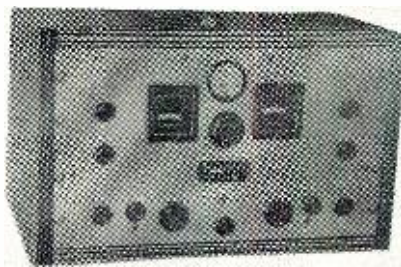

This is one of the best Receivers ever offered! Frequency range 100 to 400 KC & 2.5 to 20 MC. Main and Band Spread Tuning, Crystal Selectivity, Phasing, Limiter, Beat Oscillator, CW and Audio Gain Controls. Also "S" Meter, IF 465 KC. 16 Tubes. Voltage required: 6.3 VAC & 225 VDC 135 MA. Complete with Tubes, No Cabinet, 19" Rack Mounting. Prices:

USED: **\$69.50** USED, CHECKED: **\$79.50**

FM COMMUNICATION EQUIPMENT



BC-604
USED: \$4.95
RE-NEW: \$7.95
BC-603
RE-NEW: \$14.95

BC-603 RE-CEIVER FM—20 to 27.9 MC. 10 Tubes continuous tuning, 10 pre-set channels; Squelch Control, Speaker, etc. Re-New: \$14.95
DM-34 DYN. F/BC-603-683—12 Volt:

Used: \$2.95; Re-New: \$4.95
AC POWER SUPPLY F/BC-603-683; mounts same place as Dyn.; uses Tube Rectifier:

FT-346 Receiver Mounting Rack..... Re-New: \$4.95
Battery Cable & Female Plug f/rear of Receiver... \$2.75

BC-604 TRANSMITTER FM—30 Watt, 20 to 27.9 MC; Crystal Control; on 10 pre-set channels; complete with tubes, output meter, relays, etc. Also can be used as a mobile Amplifier..... Used: \$4.95—Re-New: \$7.95
DM-35 DYN. F/BC-604-684—12 Volt:

Used: \$7.95; Re-New: \$9.95
FT-237 MTG. F/BC-604 & BC-603..... Re-New: \$4.95

BC-659
\$9.95
Re-New

PE-117
Power Supply
\$7.95 Re-New

BC-659 TRANSMITTER-RECEIVER
FM—5 Watt, 27 to 38.9 MC;

Crystal Control on Two pre-set channels. Complete with tubes & speaker. Re-New: \$9.95—Ex. Used: \$6.95.

MANUAL—\$2.00..... BA-41 Battery. N: \$4.95
PE-117 POWER SUPPLY for BC-659, vibrator type, 6 or 12 Volts..... Re-New: \$7.95—Used: \$4.95
Manual \$2.00.

AN-29 Telescoping Antenna for BC-659..... \$2.95
BC-620 TRANS.-RECEIVER FM—20 to 27.9 MC—Same as BC-659 except no speaker:

Re-New: \$9.95—Used: \$6.95
PE-120 POWER SUPPLY F/BC-620—Specify 6 or 12 Volts—Prices..... Re-New: \$7.95—Used: \$4.95
AN-45 Telescoping Antenna..... New: \$1.95
BC-1000 FM Rec.-Trans.—40 to 48 MC w/tubes. U: \$38.95

AN-131 ANTENNA (for above)—12 Ft..... 1.95
AN-130 ANTENNA—3 Ft..... 1.00

TG-34 KEYS

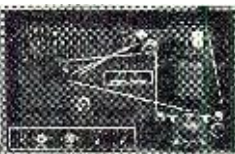

Used **\$22.95**

Code Practice TAPES—

SETS @ **\$16.95**

Automatic Unit for reproducing audible code practice signals previously recorded in

ink on paper tapes—Complete with speaker and phone jack for plugging into headset. Variable speed motor control to 25 WPM. Keying oscillator for use with hand key. 115 V 50/60 cycle. Complete—in portable carrying case. Checked for operation. Price: Re-New: **\$22.95** CODE PRACTICE TAPES—15 lessons to a set—in wood case. Tapes 3/8" inked paper, for use with TG-34. KY-127, and TG-10 Keyers..... \$16.95 per Set Or \$2.00 each individual Reel.

New CATALOG

New CATALOG F-59—Everyone who received our previous catalog will get this new one soon! Others please write for your FREE copy!

Address Dept. RN • \$5.00 Order Minimum, & 25% Deposit on C.O.D.'s • Prices are F.O.B. Lima, Ohio

COLLINS ART-13 TRANSMITTER \$49.50

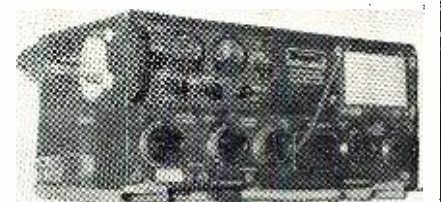

2 TO 18.1 MC—100 WATT—PHONE, CW, MCW

The most desired Set on the surplus market—Easily converted to 10 Meters (See Surplus Conversion Manual No. 2—\$2.50). Automatic Tuning for selection of 11 Channels in the Freq. Range. Tube Line-Up: 1/837, 1/213, 2/1625, 1/12SL7, 2/6V6, 2/811, 2/12SL7, 1/12SA7. AC Power Supply requirements: 28 VDC/10 A, 400 VDC/225 MA & 1250 VDC/250 MA. Size: 23 3/8" x 16 x 11 3/8". Wt.: 70 lbs.

Price—Used, Excellent..... **\$49.50**
DY-12/ART-13 24 Volt Dynamotor w/Filter & Relays. Used: \$12.95

BC-1306 REC.-TRANS.

BC-1306—3800 to 6500 KC. Voice 15 Miles, CW 30 Miles, MO or Crystal Control, Crystal Calib. and Net Controls..... Used: \$29.95

PE-237 POWER SUPPLY

Vibrator type, used to operate BC-1306 & RT-77, 6-12 or 24 VDC input; output 525/95, 105/42, 6.5/2, 6/500, 1.35/450 & 130/17. U: 14.95
CABLES for Power Supply to Receiver-Transmitter..... Ea.: \$4.95

ALL BAND RECEIVER



NAVY ARB/CRV 46151—190 to 9050 KC—Four Band, 6 Tube Superhet—Local & remote tuning and band change; illuminated dial, sharp & broad tuning; AVC, CW, provisions for operation of DU-1 Loop. Complete with Tubes: 1/12SA7, 1/12A6, 4/12SF7, & 24 Volt Dynamotor. Size: **\$17.95**
8 x 7 x 16"..... Used:

ABOVE—Converted to 12 Volt, with Dynamotor (No electric band change)..... \$24.95
Conversion for 115 V 60 cycle with Spin Dial, Phone Jack, CW, —KIT of Parts with Instructions..... \$10.00

Volume Control, On & Off Switch (All on front panel)
Conversion—as Above—for 12 Volt DC—KIT of Parts, with Dynamotor..... 10.00

Remote Control Box: \$2.00—Remote Control Shaft: 1.50
Remote Control Head..... 2.00

Tuning Knob for large splined shaft..... 1.00

T-Shaft Adapter for remote and local tuning..... 1.50

PLUGS only—for Receiver or Control Box, Each: 1.00

HIGH FREQUENCY RECEIVER



Used for Remote Control in the 65.9 to 92.8 MC Band. Variable Condenser for tuning 4 pre-set Channels. Complete with Tubes: 6/6AG5, 3/6J6, 1/6AL5; 24 VDC Dynamotor—output 250 VDC 60 MA. Relays. Band Filter, etc. Size: 10 x 12 x 6". USED: **\$6.95**; UNUSED: **\$8.95**

DYNAMOTORS:

		USED: RE-NEW:	
12 VDC	625 VDC 225 MA	DM-35	\$ 7.95 \$ 9.95
12 VDC	220 VDC 80 MA	DM-34	2.95 4.95
12 VDC	375 VDC 150 MA	BD-83	4.95 6.95
12 VDC	540 VDC 450 MA	DA-12	12.95 14.95
12 VDC	425 VDC 163 MA	WE-377	6.95 9.95
12 VDC	225 VDC 100 MA	D-402	4.95 6.95
12 VDC	250 VDC 80 MA	DM-32/12 V	4.95 6.95
12 VDC	275 VDC 130 MA	DM-64	4.95 6.95
12 VDC	185 VDC 210 MA	DM-40	1.95 2.95
12 VDC	1000 VDC 350 MA	BD-77	9.95
12 VDC	300 VDC 260 MA		
12 VDC	150 VDC 10 MA	PE-98	12.95 19.95
6 or 12	500 VDC 100 MA	PE-103	19.95
6 VDC	640 VDC 280 MA	Reconditioned by G.E.	\$12.95
6 VDC	420 VDC 260 MA	Reconditioned by G.E.	9.95
6 VDC	275 VDC 60 MA	DM-9450	6.95 9.95

AC POWER SUPPLIES:



AC POWER SUPPLY PS-603
Output: 220 VDC 80 MA & 24 AC 2 Amps. Tube Rectification; mounts on rear PLUG of BC-603-683. Can be adapted to other Receivers—

KIT: \$10.00—Wired: \$14.95
RA-34 AC Power Supply F/BC-191—output 1000 VDC 350 MA; 12 VAC 14 A & 12 VDC 2.4 A—Used: \$50.50

MISCELLANEOUS:

SCR-522 REC.-TRANS. 100 to 156 MC..... U: \$29.95
RT-18/ARC-1 Rec.-Trans. 100 to 156 MC..... U: 59.50
CD-2042 Vibrator Power Supply..... New: 7.95
Macy Phone Patch Conversion Unit: U: 1.95—N: 2.95
EE-8 Field Telephone—Used, Checked..... 12.95
BD-71 Switchboard, 6 lines: N: 24.95..... U: 14.95
BD-72 Switchboard—12 line..... U: 24.95
TS-9 Handset: N: 4.95—U: 2.95—TS-13..... U: 2.95
H-22 Handsets—with Retractable Cord..... New: 3.95
T-17 Microphones..... New: 6.95—U: 3.95
T-26 Microphone F-1 Button..... New: 1.95—U: 1.25

FAIR RADIO SALES 132 SOUTH MAIN ST. LIMA, OHIO

"ONE DOLLAR" buys

As much as \$15 worth — Everything Brand New and sold to you with a money back guarantee.

DEDUCT 10% ON ANY ORDER OF \$10 OR OVER
Plus a FREE SURPRISE PACKAGE

- \$15 — "JACKPOT" TELEVISION PARTS...\$1
- 4 — RCA #1U4 TUBES also serves as a 174...\$1
- 1 — RCA 70° FLYBACK TRANS. #75240...\$1
- 1 — \$11 TODD 60° DEFLECTION YOKE...\$1
- 6 — DEFLECTION YOKE MOUNTING HOODS...\$1
- 40 — ASST. PRECISION RESISTORS best sizes...\$1
- 35 — ASST. DISC CERAMICS best numbers...\$1
- 1 — 5" PM SPEAKER amnico #5 magnet...\$1
- 20 — TUBULAR CONDENSERS .05-600v...\$1
- 50 — ASSORTED FUSES popular sizes...\$1
- 100 — ASST. 1/2 WATT RESISTORS some 5%...\$1
- 70 — ASSORTED 1 WATT RESISTORS...\$1
- 35 — ASSORTED 2 WATT RESISTORS...\$1
- 50 — ASST. TUBULAR CONDENSERS...\$1
- 10 — 6' ELECTRIC LINE CORDS with plugs...\$1
- 10 — TV CHEATER CORDS with both plugs...\$1
- 4 — 50' SPOOLS HOOK-UP WIRE 4 colors...\$1
- 50 — STRIPS ASST. SPAGHETTI best sizes...\$1
- 100 — ASST. RUBBER GROMMETS best sizes...\$1
- 100' — TWIN LEAD-IN WIRE 300Ω heavy duty...\$1
- 50' — FLAT 4-CONDUCT. WIRE many purposes...\$1
- 25' — INSULATED SHIELDED WIRE...\$1
- 1 — \$7 INDOOR TV ANTENNA hi-gain 3 section...\$1
- 20 — ASST. TV KNOBS, ESCUTCHEONS, Etc...\$1
- 3 — ASST. TOGGLE SWITCHES spst, dpdt, etc...\$1
- 4 — BAKELITE KNIFE SWITCHES dpdt...\$1
- 15 — ASST. ROTARY SWITCHES \$15 worth...\$1
- 100' — FINEST NYLON DIAL CORD best size...\$1
- 200 — SELF TAPPING SCREWS #8 x 1/2"...\$1
- 35 — ASST. RADIO KNOBS screw and push-on...\$1
- 100 — KNOB SPRINGS standard size 3/8" x 1/2"...\$1
- 100 — ASSORTED KNOB SET-SCREWS...\$1
- 25 — ASSORTED CLOCK RADIO KNOBS...\$1
- 600 — ASST. H'DWARE screws, nuts, rivets, etc...\$1
- 50 — ASST. SOCKETS octal, noval and miniature...\$1
- 20 — ASSORTED TUBE SHIELDS best sizes...\$1
- 50 — ASST. MICA CONDENSERS some in 5%...\$1
- 50 — ASST. CERAMIC CONDENSERS...\$1
- 10 — ASST. VOLUME CONTROLS less switch...\$1
- 5 — ASST. VOLUME CONTROLS with switch...\$1
- 100 — VOLUME CONTROL HEX NUTS...\$1
- 20 — ASST. PILOT LIGHTS popular types...\$1
- 10 — PILOT LIGHT SKTS. bayonet type, wired...\$1
- 50 — ASST. TERMINAL STRIPS 1, 2, 3, 4 lug...\$1
- 10 — ASST. RADIO ELECTRO. CONDENSERS...\$1
- 5 — ASST. TV ELECTROLYTIC CONDENSERS...\$1
- 25 — ASST. MICA TRIMMER CONDENSERS...\$1
- 2 — ELECTROLYTIC COND. 40/40-450v...\$1
- 30 — FP CONDENSER MOUNTING WAFERS...\$1
- 3 — ELECTROLYTIC COND. 80-450v...\$1
- 3 — ELECTROLYTIC COND. 50/30-150v...\$1
- 10 — HV TUBULAR CONDENSERS .001-600v...\$1
- 10 — HV TUBULAR CONDENSERS .005-3000v...\$1
- 35 — MICA COND. 20-100 mmf & 15-270 mmf...\$1
- 35 — MICA COND. 20-470 mmf & 15-680 mmf...\$1
- 35 — MICA COND. 20-820 mmf & 15-1000 mmf...\$1
- 35 — CERAMIC COND. 20-5 mmf & 15-10 mmf...\$1
- 35 — CERAMIC COND. 20-25 mmf & 15-47 mmf...\$1
- 35 — CERAMIC COND. 20-56 mmf & 15-82 mmf...\$1
- 35 — CERAMIC COND. 20 100 mmf & 15-150 mmf...\$1
- 35 — CERAMIC COND. 20-270 mmf & 15-470 mmf...\$1
- 35 — CERAMIC COND. 20-1000 mmf & 15-1500 mmf...\$1
- 35 — CERAMIC COND. 20-2000 mmf & 15-5000 mmf...\$1
- 50 — 100Ω 1/2 WATT RESISTORS 5%...\$1
- 75 — 470KΩ 1/2 WATT RESISTORS 10%...\$1
- 10 — ASST. WIRE'ND RES. 5, 10, 20 watt...\$1
- 3 — AUDIO OUTPUT TRANS. SOLE type...\$1
- 3 — AUDIO OUTPUT TRANS. 6K6 or 6V6 type...\$1
- 3 — I.F. COIL TRANSFORMERS 456 kc...\$1
- 3 — I.F. COIL TRANSFORMERS 10.7 mc FM...\$1
- 4 — OVAL LOOP ANTENNAS ass't hi-gain types...\$1
- 3 — LOOPSTICK ANT. new ferrite adjustable...\$1
- 12 — RADIO OSCILLATOR COILS 456 kc...\$1
- 3 — 1/2 MEG VOLUME CONTROLS with switch...\$1
- 5 — 50K VOLUME CONTROLS less switch...\$1
- 10 — SURE GRIP ALLIGATOR CLIPS...\$1
- 1 — GOLD GRILLE CLOTH 14"x14" or 12"x18"...\$1
- 5 — SETS SPEAKER PLUGS wired...\$1
- 10 — SETS PHONO PLUGS and PIN JACKS...\$1
- 2 — \$2.50 SAPPHIRE NEEDLES 4000 playings...\$1
- 5 — DIODE CRYSTALS 2-1N21 2-1N22 1-1N64...\$1
- 3 — DIODE CRYSTALS 1-1N60, 1-1N64, 1-1N69...\$1
- 2 — SELENIUM RECTIFIERS 1-65 ma & 1-150 ma...\$1
- 15 — ASST. TV COILS sync, peakinz, width, etc...\$1
- 1 — TV VERT. OUTPUT TRANS. 10 to 1 ratio...\$1
- 5 — TV CRT. SOCKETS with 18" leads...\$1
- 5 — HI-VOLT. ANODE LEADS with 18" leads...\$1
- 1 — SET TV KNOBS standard type incl. decals...\$1
- 1 — LB. SPOOL ROSIN CORE SOLDER 40/60...\$1
- 6 — SPIN TIGHT SOCKET SET 3/16" to 7/16"...\$1
- 3 — TV ALIGNMENT TOOLS assortment #2...\$1
- 3 — TV ALIGNMENT TOOLS assortment #3...\$1
- 3 — TV ALIGNMENT TOOLS assortment #4...\$1
- 3 — TV ALIGNMENT TOOLS assortment #5...\$1

HANDY WAY TO ORDER—Simply tear out advertisement and pencil mark items wanted (X in square is sufficient); enclose with money order or check. You will receive a new copy of this ad for re-orders.
ON SMALL ORDERS—Include stamps for postage, excess will be refunded. Larger orders shipped express collect.

BROOKS RADIO & TV CORP.
 84 Vesey St., Dept. B, New York 7, N. Y.

withstand heavy current surges, assures reliable operation of the equipment, according to the company.

For specifications on this new line, write the manufacturer direct.

DUAL-PURPOSE POWER SUPPLY

Electro Products Laboratories, 4500 N. Ravenswood Ave., Chicago 40, Ill. is now offering a new dual-purpose d.c. power supply as its Model PS-2.

Designed for servicing all transistor and hybrid circuits as well as 12- and 6-volt auto radio receivers, this well-filtered unit provides two output ranges, each with its own output current meter and output terminals. The transistor radio output range is 0 to 20 volts at a rating of 75 ma. Minute variations in transistor current can be detected on the 0-75 ma. meter for this range. Transistor protection is pro-



vided by an exposed, panel-mounted fuse in the secondary circuit.

The auto radio output range is 0 to 16 volts with a continuous rating of 5 amperes with 10 amperes handled for periods up to 8 minutes. The current meter for this output has a range of 0-10 amps.

The Model PS-2 is housed in an 18-gauge steel blue-grey wrinkle finished cabinet with recessed panel, carrying handle, and rubber feet. It measures 8 1/2" x 8" x 6" and weighs 13 pounds.

STEPDOWN TRANSFORMERS

A complete line of low-power transformers for remote control and signal circuits has been announced by *Ander-son Controls, Inc.*, Franklin Park, Ill.

Among the features offered in the new line are windings insulated from the core with nylon plastic, low heat rise, small size, high temperature plastic and metal shells, screw terminal molded into the plastic case, and moisture-proofing. The units are available with various mounting arrangements and connection facilities. Two power ratings of 10 va. and 23 va. in five outputs from 6 volts to 24 volts are standard. This new line carries UL approval.

For complete descriptive literature and diagrams, write the manufacturer direct at 9959 Pacific Ave. in Franklin Park, Ill.

PRINTED-CIRCUIT RESIST

Screen Process Laboratories, 5-33 48th Avenue, Long Island City 1, N. Y. has developed a new plating and etching resist for the production of printed circuits.

According to the company, the new resist prints easily and very sharply

with a minimum of drag. It will resist the usual plater's cleaning solutions and etchants. It can be easily and completely removed from the copper laminate in a perchlorethylene, trichloroethylene, or carbon tet vapor degreasing system or with mineral spirits. It will force dry in about 15 minutes at 150 degrees F and air dry in about an hour.

The new resist is dimensionally stable, expanding about .0005 inch as compared with the usual .005 inch. It is not affected by humidity or other atmospheric conditions and will not break down through the evaporation of solvents. No strong solvents are necessary to clean screens. The resist is non-toxic and almost odorless.

Interested manufacturers may obtain free quart samples on request.

TRANSISTOR AM-FM PORTABLE

Delmonico International, 42-24 Orchard, Long Island City, N. Y. is handling the U. S. distribution of the new AM-FM all-transistor portable being manufactured by *Sony Corporation* of Tokyo.

The Model TFM-151 uses 15 transistors, 4 germanium diodes, and 1 varistor. The set covers the 88-108 mc. FM band and the AM band from 535 to 1605 kc. Switching is accomplished by a single knob and tuning is by means of a slide-rule dial. The circuit includes a.f.c.

The receiver has a built-in 4" x 6" dynamic speaker and telescopic antenna. A 75-ohm terminal is also provided for connecting an external antenna if desired. The set operates on four self-contained flashlight cells. The FM section has 8 transistors and 2 diodes which function as r.f. amplifier,



local oscillator, mixer, four-stage i.f. amplifier, d.c. amplifier for a.f.c., and discriminator. Frequency response is 20 to 20,000 cps ± 1 db and signal-to-noise ratio is 50 db. The AM circuit has 4 transistors and 2 diodes while the audio amplifier portion has two stages and push-pull output stage. Output power is 180 mw.

The set measures 3" x 8 1/4" x 9" and weighs 5 1/2 pounds.

PHONO-PIN PLUG

DeRo Electronics, 134 Nassau Road, Roosevelt, Long Island, N. Y. has recently introduced a new phono-pin plug as the "Grip-A-Lip" Model PPP-1.

The new component features an outwardly flanged bead at the open end of

the plug which provides positive finger grip for inserting and removing the pin plug. In addition, the unit includes a means whereby the attachment and soldering of the cable shield is considerably simplified.

Currently available at jobbers, the plug is being sold in packages of 4 and 8.

TUBE CHECKER KIT

A new tube checker in easy-to-build kit form has been announced by *Allied Radio Corporation*, 100 N. Western Ave., Chicago 80, Ill. as the "400" in its "Knight-Kit" line.

The "400" will check for filament continuity, shorted elements, and cathode emission on 400 tubes, including the most commonly used hi-fi, radio,

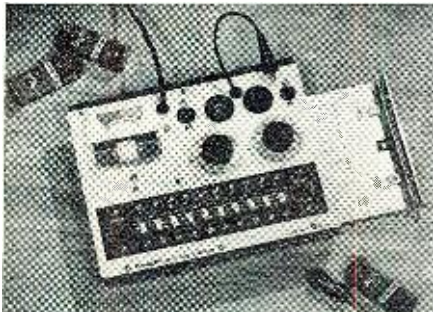

and TV receiving tubes. The unit has sockets for 7-pin miniature, 9-pin miniature, octal, and loctal tubes. A red-green "Replace-Good" scale shows condition of the tube at a glance. In addition, there is a special scale for check-

ing diodes. The "400" employs universal-type selector slide switches which are used in conjunction with Flip-Cards for the rapid selection of any combination of tube-base pin connections.

The kit has a metal case finished in grey with front panel of ivory. Over-all dimensions are 2 $\frac{3}{8}$ " x 9 $\frac{1}{2}$ " x 8". Weight is 5 $\frac{1}{4}$ pounds. The kit comes complete with all parts, wire, solder, and instructions. It is catalogued as the No. 83 Y 707.

PYRAMID RC BRIDGE

The Jobber Division of *Pyramid Electric Company*, North Bergen, N. J. has introduced a new resistance-capacity-ratio bridge as its Model RC-1 portable tester for the servicing field.

The circuit incorporates a special 3-volt amplifier for checking electrolytics used in miniaturized equipment; features capacity ranges from 10 μ fd. to 2000 μ fd.; resistance coverage from .5 ohm to 200 megohms; and ratio test ranges (reactance ratio between any two capacitors, inductors, or resistors) between .05:1 and 20:1. It will also test leakage of micas, paper, and electrolytics.

The tester is designed to operate from any 60-cps, 117-volt power source and draws about 25 watts.

The portable case is of ripple finished steel with an easy-to-read multicolor panel. It measures 7" x 11 $\frac{1}{2}$ " x 5".

Complete technical data will be supplied by the manufacturer upon written request.

HOW TO GET AHEAD IN RADIO-ELECTRONICS!

The most important training of all!

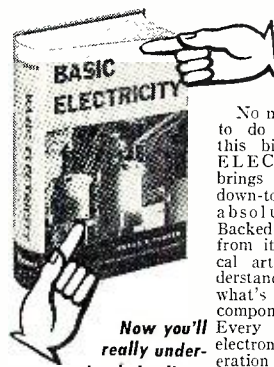

Now you'll really understand circuits—

components—equipment!

No matter what you want to do in radio-electronics, this big 396-page BASIC ELECTRICITY manual brings you the kind of down-to-earth training you absolutely must have. Backed with what you learn from it, you'll read technical articles with new understanding. You'll know what's what about circuits, components, and equipment. Every detail of electric-electronic procedure and operation will be far clearer to you than ever before.

BASIC ELECTRICITY covers the entire field—from circuits and currents to polyphase and 'phone principles . . . from tubes to transistors . . . from batteries, instruments and measurements to motors, generators, transformers and all the rest. More than 300 pictures and set-up diagrams make subjects doubly clear. Then, to top things off, it includes an easily understood 61-page INTRODUCTION TO ELECTRONICS. Read it for 10 days at our risk!

—10-DAY FREE EXAMINATION—

Dept. RN-39, RINEHART & CO., INC.
232 Madison Ave., New York 16, N. Y.

Send BASIC ELECTRICITY home training manual for 10-day free examination. If book is what I want, I will then send you \$6.50 (plus postage) in full payment. Otherwise I will return book and owe you nothing. (Save! Send \$6.50 with order and we pay postage. 10-day money-back guarantee.)

Name

Address

City, Zone, State.....
OUTSIDE U.S.A. \$7.00 cash. 10-day money back guarantee.

-30-

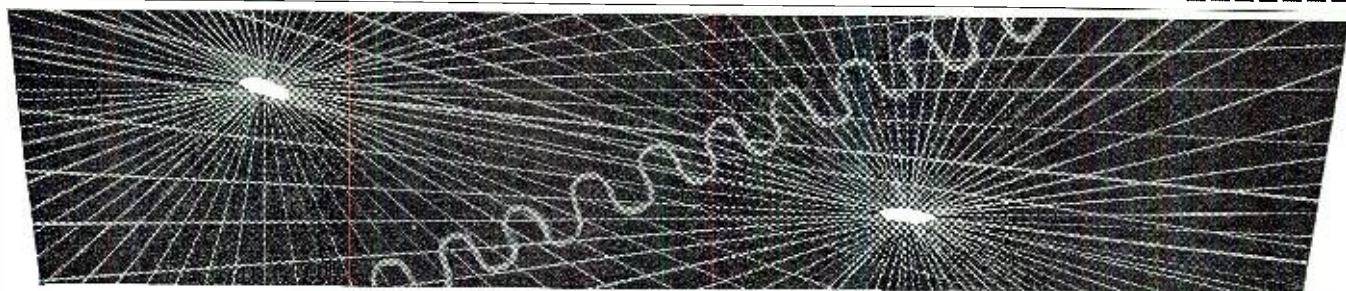

ELECTRONIC FIELD ENGINEERS FIELD SERVICE TECHNICIANS

Act fast for new, challenging assignments in U.S., Europe, Mediterranean, Far East, Alaska, Iceland and South America... including openings in

SPACE EXPLORATION PROGRAM

ELECTRONIC FIELD ENGINEERS

Engineering degree or equivalent experience in electronic systems required.

FIELD SERVICE TECHNICIANS

Technical school, plus three years experience required. Military service acceptable.

EXPERIENCED IN RADAR, GROUND COMMUNICATIONS, COMPUTERS, GCA

Obtain these advantages: • Prestige of representing the leader in its field • Opportunity for professional development and advancement • Excellent salary • Liberal field allowance • Both U.S. & overseas assignments

Drop us a line, briefly outlining your education and experience. Mail replies to MR. O. A. BOWMAN, DEPT. R, FIELD ENGINEERING.

"Our Laboratory... the Universe"

Bendix Radio

DIVISION OF BENDIX AVIATION CORP.
Owings Mills, Maryland

NEW SKL TV-900 EQUIPMENT LINE

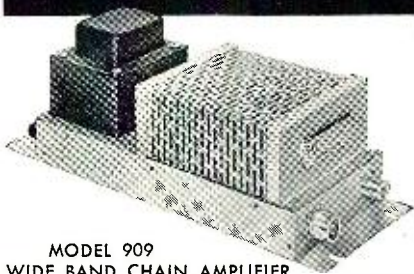

MODEL 909
WIDE BAND CHAIN AMPLIFIER

Model 909 Wide Band Chain Amplifier. Bandwidth 20-220 mc. Gain 28 db at Channel 13. Manual gain control range 10 db. Recommended multi-channel output level 46 dbmv. Input and output impedance matched to 75 ohms. Integrated power supply. Distributed circuit permits continued operation even after tube outage. No realignment necessary with tube aging or replacement. **\$235.00 LIST.**

SKL's TV-900 Line also includes:
Single channel amplifiers
Channel pass filters
Channel combiners with plug-in attenuators
Hi-Lo combiners
Hybrid splitters
Directional coupler line taps

SETS THE STANDARDS OF
TOP QUALITY — TOP RELIABILITY

In TV Distribution Systems for
Hotels, Hospitals,
Apartments, Stores,
Housing Developments

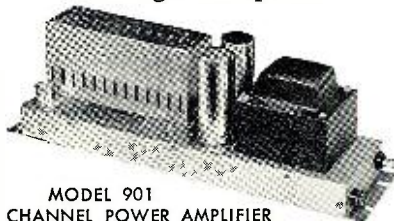

MODEL 901
CHANNEL POWER AMPLIFIER

Model 901 Channel Power Amplifier. 10 volts maximum output; 5 volts with less than 1% distortion. Minimum 35 db gain. Impedance matched to 75 ohms at input and output. Full 6 mc bandwidth. Available for Channels 2-13. Self-contained power supply. Delivers full fidelity monochrome or color pictures for all high level signal requirements. **\$325.00 LIST.**

Write today
for full information

**SKL SPENCER-KENNEDY
LABORATORIES, INC.**
1320 SOLDIERS FIELD ROAD
BOSTON 35, MASS.

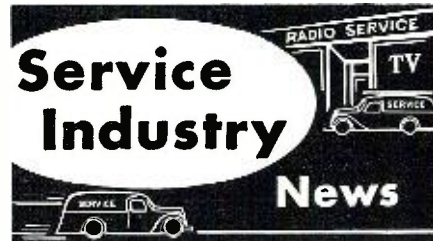

SEVERAL recent developments indicate that the efforts of electronic service associations to gain a voice for independent service dealers in plans and programs that affect the service business are bearing fruit. In times past, both industry and political sessions called to study the problems of TV consumer service were held without representatives of the independent service industry. This odd state of affairs usually led to a complete stalemate in finding a workable solution to the service problems under discussion.

One significant and encouraging development in this direction occurred recently in New York City. Representatives of both local and statewide service associations were named to serve on a committee formed to study ways and means of combatting fraud in TV service and components. One objective of this committee is to determine whether legislation will be necessary to promote fair practices and ethical standards in the television supply and repair industries.

The men named to serve on this body and their industry affiliations are: Samuel E. Ewing, *Radio Corporation of America*; Irving Sarnoff, *Bruno-New York Distributors*; Harry Esdale, staff member of the National Electronic Distributors Association; Gerald Sohne, National Tube Tester's Association; Robert Larsen, president of the Empire State Federation of Electronic Technicians' Associations; Arthur Startz, Better Business Bureau, Inc., of New York; and Martin Boxer of the Associated Radio & TV Servicemen of N. Y.

At its first meeting the Committee agreed on the three fundamental issues upon which any program to combat fraud must be based. They also agreed that the objectives to be achieved in any program evolved by the committee would have to provide satisfactory solutions to the following questions:

1. How can the TV industry and its supply channels insure greater competence on the part of the TV service technician? 2. What can be done to further limit deceptive advertising practices in soliciting TV repair business? 3. What can be done to cope with the problem involved in the sale of rejected or defective tubes as new tubes?

Arthur Startz of the Better Business Bureau, Inc., of New York, was elected temporary chairman of the committee.

Another significant development was the action of the Service Committee of the Electronic Industries Association in approving a program designed to stimulate and achieve over-all industry cooperation between EIA and the na-

COYNE
TRAINS YOU
IN SPARETIME
AT HOME

COYNE
QUALITY
TRAINING
AT LOWEST
COST

TELEVISION
RADIO-COLOR TV

Only from famous COYNE do you get this modern up-to-the minute TV Home Training. Easy to follow instructions—fully illustrated with 2150 photos and diagrams. Not an old Radio Course with Television tacked on. Includes UHF and COLOR TV. Personal guidance by Coyne Staff. *Practical Job Guides* to help you EARN MONEY QUICKLY IN A TV-RADIO SALES AND SERVICE BUSINESS—part time or full time. COSTS MUCH LESS—pay only for training—no costly "put together kits."

SEND COUPON FOR FREE BOOK

SEND COUPON BELOW for Free Book and full details including EASY PAYMENT PLAN. NO COST OR OBLIGATION—NO SALESMAN WILL CALL.



B. W. COOKE, Jr., Pres. **COYNE** FOUNDED 1899
ELECTRICAL SCHOOL

CHARTERED AS AN EDUCATIONAL INSTITUTION NOT FOR PROFIT
1501 W. Congress Pkwy., Dept. 39-H6, Chicago 7, Ill.

COYNE Television Home Training Div.
New Coyne Building, Dept. 39-H6
1501 W. Congress Pkwy., Chicago 7, Ill.

Send FREE BOOK and details of your Television Home Training offer.

Name _____
Address _____
City _____ State _____

**ELECTRO-MAGNETIC
SET COUPLER
WIZARD 300***

BRILLIANT RECEPTION ON AT LEAST
20 TV-FM SETS INCLUDING COLOR

FROM ONE ANTENNA
WITHOUT AMPLIFICATION
IN NORMAL SIGNAL AREAS

EASY TO INSTALL

SLIDES APART SLIDES TOGETHER CONNECT TO SET

CONTACT YOUR DISTRIBUTOR OR WRITE

**CHARLES
ENGINEERING, INC.**
6053 MELROSE AVENUE
LOS ANGELES, CALIFORNIA

tion's independent electronic technicians. The new program was outlined in a report of the Service Industry Relations Subcommittee, under chairman S. R. Mihalic of the *General Electric Co.* The report stated:

"EIA, from its inception, has endeavored to provide the electronic service industry with training and other technical information to aid in providing the best possible service to the products of the industry. EIA now recognizes that it has an opportunity to make an additional contribution by working to increase the prestige of the service technician.

"While many segments of the industry have taken advantage of the opportunities presented by rapid growth, some have failed to realize the business changes that must be made and the industry-wide responsibilities that must be accepted under conditions of growth and maturity. This maturity of electronics has resulted in new and unexpected problems. The solution of these problems can best be achieved by mutual effort of the independent service industry, individual manufacturers, and EIA. The EIA Service Committee stands ready to work and cooperate with all segments of the electronic service industry, in the knowledge that mutual benefits and improvements can come only by working together.

"For its part, the EIA Service Committee plans, within its limits as a trade association, to supplement its basic and advanced vocational training program, now widely accepted by the technical and vocational schools of the nation, with a program of:

"1. Welcoming opportunities for discussions of mutual problems with electronic service leaders. 2. Being represented at service association conventions. 3. Promoting press articles and public relations publications which will enhance the prestige, reputation, and public understanding of the independent service industry. 4. Providing and distributing articles of technical, professional, and business interest to independent service.

"The independent electronic service industry, individual manufacturers, and EIA—working together—will insure the success of this program."

The third significant development during the closing months of 1958, was the acceptance of the program developed by the Independent Dealers Emergency Action Committee (IDEA) on the part of both dealers and associations as they became acquainted with the precepts of the plan. Karl Heinzman, president of TSA of Michigan, was elected chairman of the IDEA Committee at a national meeting of the newly formed organization held in Kansas City.

In accepting the chairmanship, Mr. Heinzman again stressed the fact that the IDEA plan was *not* a national association and the Committee had no intention of building it into a national association. He said that, "the IDEA program must not get involved in association politics. It represents the



"Can't beat it for sensitivity and selectivity... a beautiful receiver... this is it."

J. P. Broderick, 151 W. 105th, N. Y. City

"The receivers are indeed an excellent buy."

Dr. H. W. Curtis, E. E. Dept., Dartmouth

"This is truly a sensational receiver..."

Bob Elmore, 524 E. Markham, Little Rock, Ark.

Specifications:

6 bands: 55-1.6, 1.6-3, 3-5.8, 5.8-11, 11-21, 21-43 mc. Large translucent back-lighted dial. Vernier knob takes plenty turns per mc; or switch motor on and let it tune slowly back and forth. You set automatic-reversing limit stops. Drift: Manual says less than 1% from cold start, but it's really much less. The separate 65A7 osc. gets regulated voltage from a VR-150. Sensitivity: Manual says better than 10 uv at 10 db s/n on all bands for 50 mw out; actually is much better. 6B7 and 2 6SK7's amplify RF; separate 6SA7 mixer; and 2 6SK7's are 455 kc I.F. Add Hallcrafters know-how. Selectivity: Manual shows curves ranging from

100 cy to 10 kc pass; 3 crystal and 3 I.F.-pass (6 total) switch positions. Also Crystal Phasing control. 5-Meter; 6 db/unit; adjustable. AVC-MVC control. CW-MCW switch; Separate 6J5 osc. Pitch Control on panel. Audio: 6H6 det-avc-noise limiter. Noise Limiter switch on panel. 6SQ7 ampl. 6V6 feeds 600 to 8000 ohm phones. Video: 50 plug from Cathode ray tube lower in 6V6 ckt shows sound on only test scope. Panoramic: 50 plug feeds any 455 kc Panadapter. Case: 10 7/16" wd, 19 3/4" deep, 7 3/4" high. Power supply 5" wd, 8 1/4" ht, 13" dp. With schematic and illustrated alignment and adjustment instructions.

BRAND NEW HALLICRAFTERS ALL-BAND COMMUNICATIONS RECEIVER
R-45/ARR-7
In Factory-Sealed Overseas Cartons. Factory Aligned and Ready to Use.
With 120V, 50/60 cy Power Supply Furnishing All Voltages, Including DC for the Automatic Tuning Motor. Gov't Cost \$750.00. OUR CASH PRICE is only **\$149.50** (80 lbs fob Stockton, Cal.)
Or on Time-Pay Plan: SEND US ONLY... **\$14.95** and pay \$12.55/mo. for 12 mos.

BIG DISCOUNT SALE ON RCA! SLASH \$8,541 OFF THE REGULAR PRICE!

MAR. 200-400 mc (nominally 225-390 mc) Receiver-Transmitter. AM voice and mcw. 10 W to antenna. 10 crystals plug into front panel. Each controls one channel for both rcvr & xmtr. One knob on front panel selects xtl and Autotone mechanism. Works on any of the following: 12, 24, 110, 230 v dc and 115 or 230 v, 60 cy. Use it in a truck, boat, home, or Airport. All you need are xtls, a carbon mike, phones, antenna. Metered tune-up. 52 ohm antenna 50 plug. 1 W, 600 ohm phone. Jack. 4 IF stages. Adjustable Squelch. Complete with all 24 tubes. 829B final. Pair 6L6G mod. to 100%. Very late design. In 3 waterproof aluminum cases, each 2 1/4" wd, 18 3/4" ht; total stacked height 30". With schematics, operating, and tune-up instructions. Shpg wt 190 lbs fob Los Angeles. Used, but in exc. condition. Acquisition **\$89.50** cost \$8,640.00. You pay only.....

ARB RECEIVER \$14.95
CRV-46151, RCA's BuAer Receiver, Bands: 195-560, 560-1500, 1500-4500, and 4500-9050 kc. AM Voice, CW, and MCW. 125F7 RF, 125A7 converter, 2-125F7's IF, 125F7 det-avc-bfo-AF, and 12A6 output to 600 or 4000 ohm phones. Requires external power supply for ac use. A great favorite for Marine. Use the 24 v dynamotor in it or change to 12 v and rewire the heater string. Very sharp, very hot. In exceptionally clean used condition. With schematic, step-by-step ac conversion instructions, and instructions for restringing the heater ckt. FOB Los Angeles. Shpg. wt. 30 lbs. **LOWEST PRICE ANYWHERE.** While they last **\$14.95**

a TERRIFIC BARGAIN in a

SOLA CONSTANT-VOLTAGE TRANSFORMER
Ends fluctuating line voltage!
Big Discount Off

the factory price. 60 cy. Output 115.0v at 85% PF. If load is resistive, output is fixed at a value close to the more modern standard of 120v. Holds to 1% at inputs 95-125 v, to 2% at 92-138 v. Used, clean, checked out to ratings; no moving parts or tubes. 250/300 lbs. FOB Los Angeles. **\$125.00**
2 KVA output 0-17.4 A, Sola 30974.....
3 KVA output 0-26.1 A, Sola 30973..... \$150.00

SCHEMATICS—CONVERSIONS FOR SURPLUS GEAR

Send stamped addressed envelope for NEW List E; has many new items. Includes many Tech Manuals. Add 25¢ for chart explaining AN Nomenclature. **DO IT TODAY!**

California Buyers Add 4% Sales Tax

R. E. GOODHEART CO. P. O. BOX 1220-A BEVERLY HILLS, CALIFORNIA

THERMO-ELECTRONICS
Successor to
Thermo-electricity

Change heat to electricity DIRECTLY—no acids, chemicals, liquids, sunlight or moving parts!
Build or buy a thermoelectric battery.
Information and sample thermoelectric alloy...25¢
Heat Battery Fundamentals (paper).....\$1.00
Both, ordered at the same time.....\$1.00

HERMON E. COTTER
Dept. P
15766 Blackstone, Detroit 23, Michigan

LAB-STANDARD 400 CYCLES PLUS POWER
Ready to use. The heart of this set is a \$90.00-plus Am. Time, 1/2" form, sealed Tuning Unit with tickler and output coils, accurate to better than 1/4% (400 ± 1 cy) on a sub-coils with 2 6AU6 in a varistor-compensated osc. ckt supplied by VR-150 Voltage-Regulated power supply. Sinusoidal 6 v is fed to a 6V6GT amp. thru a Gain Control. Output xfrmr provides High-Z, 16, 8, and 4 ohms Z at approx. 5 watts. The \$27.50 power transformer is Grade A Class 5H with sufficient additional power available from the 5U4GB to provide panel output of filtered 250 vdc ± approx. 25% as set by panel rheostat at 125 ma. Panel ac outputs are 6.3 at 4 A, 7 1/2 at 1 1/2 A, and a second 7 1/2 v at 3/4 A. All controls and outputs on front panel 9" high, only 6" wide. Case 14" deep. Power xfrmr 50/60 cy pri. is tapped at 95, 117, 130, 190, 210, 234, and 260 v to match any 115/230 v line condition. Tested and guaranteed. With schematic Shpg. wt. 35 lbs. NEW. **\$97.50**
FOB Los Angeles, only.....

MEASUREMENTS CORP. MOD. 80 STANDARD MICROVOLTER SIG. GEN. CHECKED AND GUARANTEED ON CALIBRATION
by local Standards Lab. You get 2-400 MC to 1/2%, Barreter-bridge-metered CALIBRATED 50-ohm output ±1 to ±1.1% less than 1 uv. Mod. method 0-300, int. 400 & 1000 cy & ext. square to 100% mod. or sine 50-10,000 cy mod. Works on 117 v, 50/60 cy. Net wt 53 lbs; shpg wt 75 lbs fob Los Angeles. Used, but exc. condition & appearance & COMPLETELY CHECKED to factory standards. Currently \$590.00. Here's one to be proud of at only..... **\$249.50**

BRAND NEW UHF MICROVOLTER SIG. GEN.
LAE-1. 520-1300 MC to 1%; less than .1% drift. Bolometer-bridge-metered CALIBRATED 50-ohm output. 1 to 1.1% less than 1 uv. Ext. pulse or sine mod., or int. rect-wave mod. 0-100%, 2-30 u-sec wd, 60-2500 cy. May also use ext. sync before adj. delay 3-300 u-sec before sync fire int. wave. May also be used to sync external eqpt. Works on 105-125 v, 50/60 cy. IN ORIGINAL CARTONS w/Maint. Book, calib. charts, tubes. 80 lbs fob Los Angeles. **\$79.50**
Only.....

HEWLETT-PACKARD LOW-FREQUENCY STANDARD
100-A. Crystal-controlled 100 mc, 10 kc, 1 kc, 100 cy. Extremely pure sine output, mt. 3 into open ckt. Max. temp. var. 3 cy/mc/°C. Locking panel adjusts ±.8 cy to beat with primary standard. Used, but checked & set to Pri. std. in local Standards Lab. Shpg wt 60 lbs fob Los Angeles. Only **\$99.50**

METERED DUMMY LOAD
I-83 Dynamotor Test Set may be used as-is or changed to check any power supply. Has 5 matched 3 1/2" meters 0-35v, 0-10A, 0-750v, 0-500 ma, 0-2v ac, 0-2v at 10k ohms/v; two 150 W rheostats, ripple step-up xfrmr, 7-position precision L-pad ripple-voltage meter multiplier, etc. With explanatory schematic. Panel 12 1/2" x 15". New. Shpg. wt. 50 lbs. FOB Chicago, only..... **\$24.50**

Easy-to-buy payment plan:
Buy anything at 10% down if it's new, 25% if it's used. If it's for your business, new or used, pay 25% down. Pay 9 1/3% of the balance per month for 12 months. Minimum financeable balance is \$62.50.

Hot Off The Press!
NEW 68-PAGE ARROW SALES CATALOG NO. 118
Thousands of electronic items at terrific moneysaving prices!
ORDER YOUR FREE COPY TODAY!
ARROW SALES, INC.
Mailing address: BOX 3007
NORTH HOLLYWOOD, CALIFORNIA
Western: 7035 Laurel Canyon, No. Hollywood, Cal.
Central: 2534 So. Michigan Ave., Chicago 16, Ill.

"TAB" Tubes Tested, Inspected, Boxed

Six Months Guarantee!! No Rejects!
NEW & Used Gov't & Mfrs. Surplus!
 Orders \$10 or more. Receiving types only ppd.
 48 states.

0A2	.80	6B1G	.72	12AT6	.59	18S1	1.00
0B2	.72	6BK7	.99	12AT7	.89	11Z76	1.10
0C3	.84	6BL7	1.05	6X4	.63	6AS4	16.00
0D3	.80	6BN6	1.08	12AU7	.69	2D21	.68
0Z4	.50	6BQ6	1.19	12AX7	.79	3D23	5.00
1A7	1.00	6CZ5	1.18	6Z5	.72	7A	5.25
1B3	.78	6C4	1.49	12BA7	.99	4-125	29.00
1R5	.78	6CS	.89	12BD6	.59	4-250	35.00
1S4	.78	6CSE	.80	12BE6	.59	4E27	7.00
174	.78	6CF6	1.49	12BF6	.59	4PR60	29.50

Send 25c for catalog!
 1U4 4/S1 6BH7 .59 12BH7 1.00 4X150 7.50
 1U5 .89 6J5 .59 12BH7 1.00 4X250 35.00
 1X2A .68 6J6 .59 12BH7 .99 4X500 38.00
 3C4 .68 6J7 .59 12C6 .48 58P1 4.98
 3G5 .86 6K7 .79 12SA7 1.29 58P4 4.98
 3E4 .68 6L6 1.19 12SG7 .89 35T 4.00
 3V4 .94 6L7 .79 12SG7 .89 58P1 4.98
 5M4 1.25 6SS .99 12S7 .75 250T 20.00
 5U4 .59 6SA7 .69 12SK7 .94 388A 1.00
 5V4 .89 6SA7 1.19 12SK7 .94 415A 24.00

Wanted surplus electronics from Schools & U!
 5Y3 .59 6SC7 .89 198G6 2.15 450T 43.00
 6A4 .59 6SC7 .89 19T6 1.16 807 1.29
 6AC7 .79 6SL7 .69 250W4 .77 404 8.42
 6AH6 .99 6SL7 .69 250W4 .77 4-400A 8.42
 6AK5 .69 6SL7 .69 250W4 .77 4-400A 8.42
 6AL5 .59 6SN7 2/S1 252G .75 812 3.00
 6AQ5 .69 6SR7 .79 EL34 3.49 813 9.00
 6A76 .49 6T8 .98 35L6 .59 815 3.95

TUBES WANTED! WE BUY! SELL & TRADE!

TRANSISTORIZED "TABSTAT" kit or built hi-efficiency DC to DC 12VDC to 430VDC continuous duty power supply! !! Output 450W/TAP 250VDC at up to 150MA/Up to 70 Watts 50% efficiency; Ripple 0.2%; Low idle current; AMP silicon rectifiers, oil condensers, toroid transformer, fused & short circuit proof. Regulation 3% at 200% load. Small in size! Quiet! Light Wgt! Low Priced! GTD "TABSTAT" TR1245CB built \$35, Pre-Assembled U-Built Kit TR1245CC ONLY \$30.

NEW DC POWER for TRANSISTORS!!

New low-cost 35 volt one amp filtered 1% Ripple Power Supply. Same as specified in Transistor Manuals G.E., RCA, CBS. Ideal for powering transistor circuits. Rugged & small in size! Preassembled kit U-build B25V1ACK \$10, or assembled B25V1ACB \$12.

Transistors! Filtered Power Supply Kit used to power transistor circuits, amplifiers, etc. Delivers 12VDC at 2 AMPS filtered at 100% ripple or 28VDC at 1A TFSK2 Kit \$18; TFS2W assembled & wired \$24. 115VAC Input Transformer & Full Wave Bridge Rectifier for 12VDC @ 2AMPS, or RECTAN KIT RT115 \$15. RT1W Assembled & Wired \$4.50

BATTERY CHARGER KIT 2 to 4 Amps. Charges 2-4-6 & 12 Volt Batteries. KIT BCK-1 \$11, Built \$12.75.

5" USN-MUMETAL SCOPE SHEILD \$4.00
 AN-ARR2 RCVR AS IS/GOOD FOR PARTS \$1.89
 RDZ/USN RCVR 200 to 400mc's LESS TUBES \$39
 RAN/MPN RCVR COVERS 4 BANDS 1.5 to 9Mc's. 5 TUBES HAS BFO-SUPERHET \$24

"ERIN" FINEST HI-FI RECORDING TAPE
 SO GOOD! WE CANNOT USE THE MFRS!
 TRUE NAME!

1200 Ft.—7" Reel \$1.45 ea. Lots Money Back Gtd. Singly \$1.59. Add 15c each Postpaid 48 States. New 1st Quality "Mylar" 2400 Ft.—7" Reel Ferro Erin Sheen Process Recording tape \$4.49, 3 for \$12

NEW SILICON 500MA/100°C/280VAC /400 p.i.v. Rectifier H'mt Sealed. \$1.50 @, 5 for \$6.50, 40 for \$46, 100/\$105.

SELENIUM RADIO & TV RECTIFIERS! GTD. 65MA 45c, @, 5 for \$2; 100MA 59c @, 10/\$5, 100/\$45; 250MA 79c @, 10/\$7, 100/\$60; 300MA 88c @, 10/\$8, 100/\$65; 400MA 1.10 @, 10/\$10, 100/\$85; 500MA 1.00/\$11, 100/\$90.

NEW "TEKSEL" SELENIUM FULL WAVE BRIDGE RECTIFIERS, ONE YEAR GTD!

AMP CONT.	18VDC	28VDC	36VAC	72VAC	144VAC	144VAC
1AMP	\$ 1.30	\$ 2.00	\$ 4.90	\$ 9.45	\$ 12.30	\$ 16.75
2AMP	2.15	3.00	6.25	12.30	16.75	21.20
3AMP	2.90	4.00	8.60	16.75	21.20	25.65
6AMP	4.15	6.00	18.75	36.15	48.90	61.65
10AMP	6.10	12.15	26.30	48.90	61.65	74.40
15AMP	9.90	19.00	40.00	68.60	87.45	106.20
24AMP	15.00	29.45	57.50	108.45	138.30	171.15

KITS! "TAB" THE BEST KITS!

- All Kits Contain Most Popular Values & Sizes
- Kit 2 Eng. Parallel P/S's
- Kit 35 Precision Resistors
- Kit 10 Switches
- Kit 75 Resistors 1/2, 1/1, 2W
- Kit 150 Carbon Resistors
- Kit 25 Panel Lamps
- Kit 12 Electrolytic Cond's
- Kit 15 Volume Controls
- Kit 56 Tube Sockets
- Kit 65 Tubular Condensers
- Kit 500 Lugs & Eyelets
- Kit 20 Bathtub Oil Cond's
- Kit 5 lbs. Surprise Package
- Kit 10 Xmttr. Mica Cond's.
- Kit Glyptal & Cement
- Kit 3 Phone/Patch Xfms
- Kit 4 AN/Reflector Lites
- Kit 6 Ins'd Tuning Tools
- Kit 6 AN plugs & connectors
- Kit 3 Searchlights
- Kit Circular Slide Rule
- Kit 12 Alligator clips asstd
- Kit 2 Bakelite Panels 6x12"
- Kit 5 Pcs. Wrench Set
- Kit 40 Standoff Insulators
- Kit 35 Power Resistors
- Kit 75 Mica Condensers
- Kit 5 Crystal Diodes
- Kit 100 Fuses, Assorted
- Kit 100 C-250 Connectors
- Kit 50 Coil Forms
- Kit 5 FT243 Xtal Holders
- Kit 2 Vduktor Antennas
- Kit 5 Microswitches
- Kit 10 Wheat Lamps
- Kit 10 Light Bulbs
- Kit 8 Xtal Osc-Blanks
- Kit 4 Asstd Rectifiers
- Kit 2 Vduktor Antennas
- Kit 100 Self/Tap Screws
- Kit 8x25 Ft Hookup Wire
- Kit 2 Vduktor Antennas
- Kit 2 Computer Toroids
- Kit 8 Pc. Nut Driver Set
- Kit 12 Light Bulbs
- Kit 5 Jeweler Screwdr.'s
- Kit 6 ea. Phone Plugs, Jaks

BUY 10 KITS—GET ONE FREE! EACH KIT 99c

"TAB" TERMS: Money Back Guarantee! Our 14th year. \$2 min. order F.O.B. N.Y.C. Add shpg charges for O.D. 25% sep. Prices shown subject to change.
 111-Vc LIBERTY ST., N.Y. 6, N.Y.
 Send 25c PHONE: RECTOR 2-6245 for Catalog

voice of all associations without regard to their local, state, regional or national affiliations as well as that of those high-minded service dealers who currently are not members of any service association. IDEA is the unified effort of all service elements to raise the prestige and to insure the stability of electronic service as a business."

Product Testing

The Federation of Radio & TV Service Associations of Pennsylvania recently expanded its policing program to include a continuing review of advertising claims for the quality, performance, and range of hi-fi equipment.

Claiming that "various producers and dealers are making exaggerated claims concerning the performance of their products," the Federation has established a research division which, it is said, will check the performance features of all hi-fi and stereo units, covering all parts from the cartridge to the speaker. The FRTSAP research division is now functioning in Wilkes-Barre under the supervision of the Luzerne County Service Dealers Assn., P.O. Box 309, Wilkes-Barre, Pa. -30-

Citizens Band Transceiver
 (Continued from page 51)

plug. It should measure infinity with the volume control switch off and about 20 ohms with the switch on. Measure the resistance from pin 8 of the 5Y3 to ground. It should show a very low resistance until the filter capacitors charge up. The ohmmeter should stop moving upwards somewhere above 20,000 ohms.

If these simple tests are satisfactory, plug in the 5Y3 and the line cord, then turn the unit on. Next measure the voltage from pin 8 of the 5Y3 to ground. It will be almost 370 volts. Place the "transmit-recv" switch in the "receive" position.

Plug in the 6AQ5A and the 12AX7 tubes. They should light up immediately. After they have warmed up, in a minute or so, turn the volume control up and touch pin 7 of the 12AX7 with an insulated screwdriver. You should hear a click and buzz in the loudspeaker of the unit.

Once all these checks have been performed, we can proceed further.

The next step is to insert the 6AN8 detector tube. Turn the regeneration control to the full counterclockwise position and allow the tube time to warm up. Turn the volume control on and slowly advance the regeneration control. At one point, the detector will break into a rushing sound which will resemble the noise of escaping steam. The regeneration control should be set to the point where the rushing sound just starts. If the detector does not want to "take-off," the "gimmick" may be twisted too tightly. For those of you not familiar with this term, a "gimmick" is two pieces of wire (in this case one-inch long) twisted together to

**AN/ART-13
 100 WATT TRANSMITTER**



Designed to provide radio communication by voice, (MCW) or CW telegraphy. Class "B" audio modulator system capable of modulating the carrier at least 90% on voice or MCW. Incorporates automatic tuning mechanism which may be used to select any one of 11 frequencies, range 2000 KC to 18,100 KC. Frequencies 200 KC to 1500 KC range is provided by addition of oscillator 0-16/ART-13A. Excellent. With 0-16 Low frequency oscillator coil \$45.00 \$49.50

GET ON 2 THE EASY WAY!!

AN/ARC-4, a complete 2-meter xmttr/rcvr using an 832 in the final. The receiver is xtl controlled and uses 10 tubes. The Xmttr uses standard 6000 kc xtls, and multiplies 24 times up to 2 meters. Originally designed to operate from 12/24vdc, the unit is easily converted for 110 vac operation. All units are in used, excellent condition, less tubes, dynamotor, crystals. With conversion data \$12.50

PANORAMIC ADAPTER

A complete panoramic receiver and RF scope, ideal for the VHF man and satellite monitor. Sweeps a bandwidth of 10 mc centered on 30 mc. Also has dual-range sawtooth sweep up to 1500 cps for analyzing the modulation on RF envelopes in the pass-band of the pan-adapter. Controls: Gain/Cent. Freq/Sweep-width/Int/Focus/Hor. Pos/Vert Pos/Pan/PRF1/PRF2. Sensitivity: 0.001v for 1/4" deflection. Sweep rate on PAN: 30cps. Uses 12 tubes, including CRT. Originally designed to operate from a 400 cy supply, we furnished 60 cy conversion kit and simple instructions. Use like new, with all tubes. Complete schematic diagram, conversion kit \$22.50 All prices are FOB Brooklyn, N. Y. Send check or M.O. Shipping charges COD.

COMMUNICATIONS EQUIP. CO.
 343 Canal St., New York 13, N. Y.
 Phone: WOrth 6-4045

**terado Tray-Electric
 MOBILE POWER CONVERTERS**



Give You 110 A.C. HOUSE CURRENT ANYWHERE You Drive or Cruise

NO INSTALLATION Just plug into cigar lighter on dash of car, truck, or boat—and away we go

- OPERATE PORTABLE TV
- SMALL DO-IT-YOURSELF
- TOOLS WHEREVER NEEDED
- One of the great conveniences of our electronic age

101 USES ALL ELECTRIC SHAVERS DO-IT-YOURSELF HOBBY TOOLS See Your Electronic Parts Dealer or Jabber

terado COMPANY
 DESIGNERS & MFRS. OF ELECTRONIC EQUIPMENT SINCE 1927
 1058 RAYMOND AVE., ST. PAUL 14, MINNESOTA
 IN CANADA: ATLAS RADIO-CORPORATION LTD.-ONTARIO

form a "capacitor." The number of twists determines the capacity between the two wires. If this capacity is excessive the detector may not work properly. The final setting of the regeneration control should be made (with the transceiver connected to an antenna) for best reception.

If the detector is functioning properly, you should start hearing "things" as soon as the antenna is connected. The receiver is tuned by varying the capacity of C_s . The setting of coil L_2 will determine what frequencies may be received by adjusting C_s . Thus coil L_2 will have to be adjusted experimentally to find the 11-meter Citizens Band. With the slug all the way out you should hear 10-meter amateur stations and with the slug all the way in you will receive commercial teletypewriter, telephoto, and other broadcasts. Somewhere in between these extremes lies the 11-meter band. You will probably hear a lot of tone modulation signals, the raspy buzz of diathermy machines and, if you are lucky, possibly some conversations. As soon as you have the unit tuned up to receive the 11-meter band, adjust coil L_1 for maximum signal strength. The adjustment will be quite broad.

The final step is to tune up the transmitter. A pilot lamp "antenna" (dummy load) will be very useful for the tune-up operation. The dummy load can be made by wiring a #47 pilot lamp to a mating connector for the antenna jack. Plug in the dummy load, the 6AU8 tube, and the crystal. After warm-up, place the "transmit-receive" switch in the "transmit" position. Connect a vacuum-tube voltmeter to pin 7 of the 6AU8 and measure the voltage while varying the slug in L_s . The negative voltage on this grid will be very low, then at one point will rise to 5 or 10 volts. If you are lucky the dummy load may start to glow. The increase in grid voltage indicates that the oscillator circuit is working properly and "according to Hoyle."

As soon as you are sure that the oscillator is functioning correctly, adjust coil L_1 for maximum brilliance of the bulb. Adjust L_s and L_1 alternately for maximum brilliancy. To make sure that the oscillator is stable, turn the "transmit-receive" switch on and off several times. The bulb should light up each time. If it does not, turn the slug in L_s a half turn counterclockwise and repeat the "on-off" test until a point is reached where the bulb comes on each time. Next, connect a crystal mike to the transceiver and modulate the rig. The bulb will decrease in brilliancy as you talk but this is normal with this type of circuit. When an antenna is connected to the transceiver, this effect will not be noticed.

There is one more test that must be made before the transceiver is ready for use. You must establish that the power input to the final amplifier is within the 5-watt FCC specification. Be very careful when making the following tests for there will be high voltage (250 volts) on the wires you will

WALTER ASHE SAYS— WE NEED YOUR USED* EQUIPMENT RIGHT NOW.

Today's king size Walter Ashe "Surprise" Allowances prove you get the deal of a lifetime . . . if you trade now!

*Made since 1945

Tell us what you want . . . and what you have to trade! The coupon brings our top "Surprise" Allowance on the newest models of famous brand equipment!

Your used equipment is just like money in the bank . . . only now it's worth a lot more in trade with Walter Ashe. Choose any item you want from the brand new 1959 Ashe catalog . . . your choice of Amateur Equipment, Test Equipment or High Fidelity. But whether you have a trade or not . . . you can always count on worthwhile savings when you "order from Ashe." Make us your "One Stop Supermarket" for everything in Radio, Television and Electronics. Our stocks of replacement or original parts, receivers, transmitters, amplifiers and associate equipment were never more complete. Of course, our experienced staff is always ready to help you and speed along your orders.



FREE! 1959 Catalog

New 144-page catalog ready now . . . mail the coupon for your FREE copy! You'll find everything you need at lowest money saving prices. Here are the very latest in receivers, transmitters, tubes, books, test instruments, amplifiers and components . . . In stock for prompt shipment. Send today for your complete Radio—TV—Hi-Fi Buyers Guide Catalog!

AMATEUR GEAR



The newest from Collins, Hammarlund, National and all the other top names. Best terms, always!

TEST EQUIPMENT

We've been servicemen's equipment headquarters for over 37 years. See all the latest Radio-TV Test equipment first in our new catalog.



HI-FI COMPONENTS



Trade your present speakers, amplifiers or tuners for new monaural or stereo equipment. Ask for our big "Surprise" Allowance.

ASK ABOUT TIME PAY PLAN

"SURPRISE TRADE-IN" COUPON

TRADE BIGGER—TRADE NOW

Walter Ashe

RADIO CO.

ONE STOP SUPERMARKET

1125 Pine Street—St. Louis 1, Mo.

WALTER ASHE RADIO CO.
YOUR ONE-STOP SUPERMARKET
Dept. R-3-59 • St. Louis 1, Mo. In Our 37th Year

- Rush New Catalog
 Send latest lists of guaranteed Used Equipment
 Rush "Surprise Trade-in" offer on my _____

For _____ (Show make and model of equipment desired)
Name _____
Address _____
City _____ Zone _____ State _____



LOOK

NO FURTHER . . . IF YOU'RE UNHAPPY WITH "HI" HI-FI PRICES. WRITE FOR OUR UNUSUAL AUDIO CATALOG.

KEY ELECTRONICS CO.
120-C Liberty St., N.Y. 6,
Phone EV 4-6071

BARGAIN HUNTING? TV SERVICEMEN!

Write for SENSATIONAL CATALOG

HENSHAW RADIO SUPPLY
3619 TROOST KANSAS CITY, MO.

GET INTO ELECTRONICS

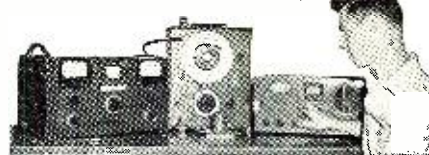

V.T.I. training leads to success as technicians, field engineers, specialists in communications, guided missiles, computers, radar and automation. Basic and advanced courses in theory and laboratory. Associate degree in electronics in 29 months. B.S. in electronic engineering obtainable. ECPD accredited. G.I. approved. Graduates in all branches of electronics with major companies. Start September, February. Dorms, campus. High School graduate or equivalent. Catalog.

VALPARAISO TECHNICAL INSTITUTE
Dept. RD Valparaiso, Indiana



**Amazing New Handbook
Takes The "Headache"
Out of TV Trouble Shooting**

**Pin Point
TV TROUBLES
IN
10 MINUTES**



**SAVES TIME . . .
ELIMINATES GUESSWORK!**

Now, a simple, practical way to accurately spot the cause of trouble in any TV set, FAST! Quick, easy-to-understand tests tell you in which of 5 TV set sections to find the cause of trouble. Fool-proof Check Charts help you locate the exact trouble spot at once, from as many as 700 possibilities. Book fits easily into your tool kit for handy on-the-job use. Over 300 spiral bound fast reference pages with 50 time-saving Check Charts; dozens of easy to understand diagrams and tests; explanations of circuits and designs. The hours and aggravation this amazing handbook can save you on a single servicing job more than pay its low price!

USE IT ON 7 DAYS FREE TRIAL!

Send no money, just the coupon. We'll rush your copy on FREE TRIAL. After 7 days, send only \$3.95 plus postage or return the book and owe nothing. Act NOW!

MAIL COUPON NOW!

Educational Book Publishing Div.
COYNE ELECTRICAL SCHOOL, Dept. 39-RT
1501 W. Congress Pkwy., Chicago 7, Ill.

Rush TV handbook for 7 days FREE TRIAL per offer.

Name Age

Address

City Zone State

Check here if \$3.95 enclosed. We pay postage. 7-day money-back guarantee.

be working with. Before making any adjustments, pull the power plug from the outlet and short out pin 8 of the 5Y3 tube to the chassis.

The power input of the transceiver may be checked in the following manner: Disconnect the wire between T₁ (audio transformer) and coil L₄ and insert a 0-25 ma. meter in the circuit. Note the current reading which should be something less than 20 ma. Now reconnect the wire and measure the voltage between this wire and ground. Also make a note of this reading. It will be in the vicinity of 250 volts. To find the power input, multiply the voltage by the current (in amperes). In a typical unit you may get readings of 250 volts and 18 ma. (.018 ampere). Multiplying these figures, we find that the power input is 4.5 watts. If either the voltage exceeds 250 volts or the current is more than 20 ma., you can loosen the coupling between coil L₄ and the antenna link to reduce the plate current in order to bring the total power input below five watts. These measurements should be made with the antenna connected.

Antenna

A permanently installed antenna system cannot exceed 20 feet in height above its mounting structure and the coaxial transmission line cannot be more than 25 feet long, according to the FCC rules.

You can construct a very satisfactory antenna using Fig. 3 as a guide. It

consists of a 25-foot length of RG-58/U or RG-8/U coaxial cable connected to two 8-foot, 6-inch lengths of copper antenna wire, forming a dipole antenna. Three insulators are used in the antenna. There is one at each end of the dipole elements to insulate the wire from the rope. The third insulator is used at the center of the dipole for the coax connections. Note that a short length of stout cord is used to support the weight of the coax. It is tied between the coax and the insulator. The distance between the two elements (two inches) is not critical and can be varied to accommodate available insulators.

Operation

The FCC requires that the registered serial number appearing on each Citizens Radio station license shall be the assigned call sign. This call is to be given at the beginning and end of all communications as well as at ten minute intervals during messages lasting longer than 10 minutes.

As far as operation of the transceiver is concerned, you simply switch to "transmit" and talk into the microphone. When you have finished transmitting, turn back to "receive" and tune stations on the right-hand knob, adjusting the volume to suit yourself. It's as simple as that.

I wonder who will be the first to issue a certificate for "Worked All States—Citizens Band (WASCB)?"

-30-

TUBES

Used Tubes! Electrically Perfect Factory Seconds! Brand New Factory Seconds! New and Used Jan Surplus Tubes!

- INDIVIDUALLY BOXED!
- GUARANTEED ONE YEAR!
- FACTORY BOXED
- FACTORY IRREGULARS
- NEW JAN SURPLUS
- EQUIPMENT TUBES

**ALWAYS 1000
TYPES IN STOCK**

EXPORT ORDERS MANUFACTURERS
INVITED ORDERS INVITED

**PROMPT DELIVERY
ONE YEAR MONEY
BACK GUARANTEE**

**FREE
12" TV SET**

with every receiving tube order of \$100.00 or more!

**FREE
16" TV SET**

with every receiving tube order of \$200.00 or more!

Bonus TV sets are shipped complete with cabinet and picture tube F.O.B. our warehouse. With slight adjustments and minimum labor they can be restored like new.

**Below Is A Partial List—Send For
FREE Complete List and Order Form**

QZ4	.42	5AT8	.79	6BK7	.75	7A4	.46	12J5	.39
1A7GT	.42	5J6	.79	6BL7GT	.74	7AS	.52	12L6	.59
1B3GT	.42	5Y3	.79	6C6	.57	7B5	.47	12SA7	.47
1CSGT	.40	5U4G	.48	6EQ6GT	.79	7A7	.44	12SG6T	.54
1C6	.25	5U8	.79	6EQ7	.75	7A8	.44	12SJ7	.44
1C7G	.57	5V4G	.48	6F5	.57	7B7	.44	12SK7	.47
1D5GP	.42	5V6GT	.49	6BZ7	.75	7B4	.43	12SL7GT	.59
1H4G	.45	5X8	.79	6C4	.36	7B5	.40	12SN7GT	.56
1J6GT	.46	5Y2	.79	6C6	.50	7B6	.40	12S07	.39
1L6	.54	5Z3	.44	6C8	.42	6CD6G	1.17	12V6GT	.44
1LA4	.55	6A7	.56	6D6	.47	7C7	.44	12W6	.59
1LA6	.46	6A8	.46	6E5	.37	7C7	.44	14Q7	.44
1LB4	.58	6AB4	.44	6F5	.36	7C5	.41	14A7	.44
1LC5	.48	6AC7	.66	6F6	.37	7C7	.44	14B6	.44
1LC6	.46	6AF4	.75	6H6	.49	7E5	.44	14Q7	.44
1LD5	.56	6AG5	.49	6J4	1.59	7E6	.44	19B6GG	1.17
1LE3	.56	6AG7	.68	6J5	.38	7E7	.48	25BQ5GT	.84
1LH4	.63	6AH4G2	.69	6J6	.48	7F7	.58	25CA5	.79
1LNS	.46	6AM6	.70	6K6GT	.38	7F8	.65	25C06	1.29
1NSGT	.49	6AK5	.53	6K7	.38	7G7	.74	25C06	.99
1RS	.50	6ALS	.41	6L6	.67	7N7	.57	25L6GT	.46
1S5	.45	6AM8	.79	6N7	.59	7Q7	.58	25W4GT	.42
1T4	.50	6AN8	.79	6Q7	.39	7X7	.64	25Z6	.36
1U4	.46	6AQ5	.45	6S8GT	.70	7Z4	.39	27	.24
1U5	.45	6AQ5	.45	6S8GT	.70	7Z4	.39	35B5	.47
1V2	.70	6AS7G	2.25	6SA7	.47	12A4	.59	35C5	.47
1X2	.66	6AT6	.38	6SB7Y	.75	12A6	.59	35D5	.46
2A2	.79	6AT8	.42	6SC7	.47	12AB5	.59	35E6T	.46
2A7	.54	6AU4GT	.64	6RG7	.40	12A05	.49	35W4	.38
2D21	.95	6AUSGT	.60	6SH	.40	12AT6	.60	35Y4	.38
3A4	.50	6AUC	.42	6S17	.42	12AT7	.65	35Z3	.40
3A5	.50	6AUB	.79	6SK7	.49	12A06	.42	35Z3	.40
3AL5	.52	6AV5GT	.64	6SL7GT	.58	12A07	.41	39/44	.25
3AU6	.52	6AV6	.38	6SN7GT	.68	12A07	.41	50A5	.47
3B26	.57	6AW8	.89	6S07	.40	12A07	.62	50B5	.47
3BC5	.57	6AX4GT	.56	6S17	.40	12AX7	.62	50C5	.47
3BN6	.57	6AX5GT	.56	6T8	.67	12A27	.62	50L6GT	.44
3C56	.57	6BA6	.46	6U5	.54	12B4	.67	50L6GT	.44
3Q4	.55	6BC5	.46	6U8	.54	12B6	.45	84/6Z4	.45
3Q5GT	.36	6BC8	.89	6V3	.79	12B7	.59	117L7GT	1.25
3V4	.55	6BD5GT	.52	6V6GT	.45	12B6	.59	117N7GT	1.25
4B27	.75	6BF5	.39	6W4G	.39	12B7	.63	117R7GT	1.25
4B27	.75	6BF5	.39	6W6GT	.52	12B7Y	.63	117Z3	.36
5AM8	.79	6BH6	.50	6X4	.38	12CA5	.59	117Z6T	.36
5AN8	.79	6BJ6	.46	6X8	.74	12DQ6	.79	117Z6T	.36
5A95	.49	6BK5	.67						

FREE! TWO SET COUPLER WITH EVERY TUBE ORDER OF \$8.50 OR MORE!!

FREE POSTAGE! On All Orders Shipped in U. S. A., Territories and A.P.O.'s. Send 25c for handling on orders under \$5.00. Please send approx. postage on Canadian and foreign orders. Excess will be refunded.

STANDARD LINE

ELECTRIC COMPANY

432 HARRISON AVENUE, HARRISON, N. J. • Phone: HUmboldt 4-4997

Infrared

(Continued from page 41)

yond which their response falls off. Of the various photoelectric effects the one most common for infrared detection is the photoconductive effect. As a result of this effect, the conductivity of certain solid materials changes when radiation is encountered. Photoelectric effects are usually considerably greater than thermal effects, so that special precautions are not usually taken to reduce temperature effects in most photodetectors. The usual circuit for photoconductive detectors is similar to that for the thermistor bolometer detector, except that instead of a compensating element a fixed dropping resistor is used. Some of the most common photoconductive detectors are lead sulfide, lead telluride, lead selenide, indium antimonide, and specially treated germanium. Most photoconductive detectors require cooling to extremely low temperatures for efficient operation.

Basic Infrared Radiometer

The infrared radiometer can be considered to be the basis of most infrared instrumentation. If the operation of a radiometer is understood, more complex arrangements can be readily followed. Radiometers receive infrared radiation from sources in their fields of view and transform the received energy into electrical signals which can be measured, recorded, and interpreted. Infrared radiometers do not require physical contact with sources being measured; in addition, they have great sensitivity, measuring range, and speed of response.

A basic infrared radiometer includes an optical system, chopper, detector, reference source, synchronizing signal generator, and electronics system. A typical arrangement is shown in Fig. 11, while Figs. 8 and 10 show portable radiometers.

The optical system is frequently a mirror telescope consisting of concave primary and convex secondary mirrors. Each mirror is aluminized and hard coated. Focusing is usually accomplished by moving the secondary mirror along the optical axis. An infrared detector is located at the focal point of the optical system. Thermistor bolometer detectors are most frequently used because of their very uniform response.

A black-body radiation reference source is used as a standard against which target radiation is continuously compared. In the most basic arrangement, the detector is mounted behind a thick metal block and receives incoming radiation through a cylindrical aperture in that block. The aperture has serrated and blackened walls so that it forms a black-body cavity when closed by a reflecting surface. The cavity wall temperature is accurately monitored by a thermistor bead.

A mirror-surfaced sector-disc shut-

T-47/ART-13 TRANSMITTER

100 watt 2-18 MC autotune exec. cond. with tubes. **\$59.00**



FOB CONN.—MICH.
Will ship from your nearest point (Full payment with your order please).
LIMITED QUANTITIES—GET YOURS NOW

SCR-274 COMMAND EQUIPMENT

ALL COMPLETE WITH TUBES		
Type	Description	Used Like NEW
BC-453	Receiver 190-550 KC.	\$14.95 \$16.95
BC-454	Receiver 3-8 Mc.	9.95 12.95
BC-455	Receiver 6-9 Mc.	10.95 13.50
BC-450	3-Receiver Control Box.	1.49 1.95
BC-457—TRANSMITTER—4-5.3 Mc. complete with all tubes and crystal. BRAND NEW... \$7.88		
BC-458 TRANSMITTER—5.3 to 7 Mc. Complete with all tubes and crystal. BRAND NEW... \$7.88		
BC-459 TRANSMITTER—7-9.1 Mc. complete with all tubes and crystal. BRAND NEW... \$12.95		
ARC-5/T-19 TRANSMITTER—3 to 4 Mc. BRAND NEW complete with all tubes & crystal... \$8.88		

AN/APN-9 LORAN SYSTEM

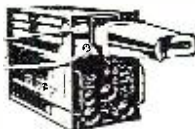

\$89.50

Used in ships and aircraft. Exc. Used.

AN/ARC-1 Airborne radiophone ground to plane Revr-Xmitter. 10-channel xtal controlled, easily converted to 20 or 30 channel VHF 100 to 156 Mc AM. Complete with tubes, mtg rack, dynamotor. Exc. **OUR LOW PRICE \$89.50**

SCR-522 2-METER SET

Terrific buy! VHF Transmitter-receiver, 100-156 Mc. 4 channels. Xtal-controlled. Amplitude modulated voice. They're going fast! Excellent condition.
SCR-522 Transmitter-Receiver, complete with all 18 tubes, top rack and metal case. COMBINATION Special \$33.33

SCR-522 AC-POWER SUPPLY parts consisting of genuine original power xformer and copper oxide rectifier and receptacles as on RA-62 schematic furnished. **\$17.50**

I-152-AM SCOPE indicator. Has 3" CRT tube with associated amplifier as new... **\$13.00**

RECEIVER MICROWAVE R-111/APR-5

Frequency range 2000-4000 mc, fully metered power 110v/60/1 ph. self contained, one unit, **\$49.00** used, exc.

THE GREATEST SURPLUS BARGAINS! —SEND for FREE CATALOG
\$5.00 Order Minimum, & 25% Deposit on C.O.D.'s • Prices are F.O.B. New Haven, Conn.
133 HAMILTON ST. NEW HAVEN, CONN.



INFRARED SNOOPERSCOPES

SEE IN TOTAL DARKNESS... UNDETECTED!

FOR: **Research • Crime Detection • Wildlife Study**

Army Model M-2

Now available... Complete Snooperscopes... PRICED \$50 TO \$85

LAMPS • OPTICS • TUBES • PARTS

Write today for FREE Infrared Catalog... Contains amazing low prices of assembled units... individual parts. Also, detailed description and applications. We have one of the world's largest stocks of Infrared parts and equipment.

MCNEAL ELECTRIC & EQUIPMENT CO.
4736 Olive St., Dept. R-3, St. Louis 8, Mo.

MICROPHONES

Model	Description	Excellent Used	BRAND NEW
T-17	Carbon Hand Mike	\$4.95	\$7.45
T-30	Carbon Throat Mike	.39	.79
T-45	Army and Navy Lip Mike	1.25	1.33
T-24	Carbon Mike	3.95	8.00
F-3	Handset	2.79	4.95
RS-38	Navy Type		

HEADPHONES

Model	Description	Excellent Used	BRAND NEW
HS-23	High Impedance	\$2.25	\$4.75
HS-33	Low Impedance	2.79	4.75
HS-30	Low Imp. (featherwt.)	1.25	1.99
H-16/U	High Imp. (2 units)		7.95
TELEPHONICS—600 ohm HEADSETS			
BRAND NEW—PER PAIR			
CD-307A	Cords, with PL55 plug and JK26 Jack.		.99
Earphone Cushions for above—pair... .50			
HI-FI HEADSET. Rubber Ear pads to obtain spacing for correct acoustical load. GIVES FINEST MUSIC REPRODUCTIONS! Imp.: 300 Ohms per unit or 600 Ohms when wire series.			
Brand New \$7.95			



MOBILE-MARINE DYNAMOTOR

Input 12V DC. Output: 625 V DC @ 225 Ma., for press-to-talk intermittent operation. Shpg. wt. 14 lbs.

DM-35 NEW... \$14.95

OTHER DYNAMOTOR VALUES:			Excellent Used	BRAND NEW
Type	Input	Output		
DA-19-A	28V 11A	400V 400A		\$6.95
DM-28	28V	224V 07A	\$2.95	4.95
DM-32A	28V 1.1A	250V .05A	2.95	4.95
DM-33A	28V 5A	575V .16A		3.95
	28V 7A	540V .25A		5.50
DM-34D	12V 2A	220V .080A	4.25	5.95
DM-37	25.5V 9.2A	625V .225A	5.95	8.95
DM-53A	28V 1.4A	220V .080A	3.95	5.95
PE-73C	28V 20A	1000V .350A		11.50
PE-86	28V 1.25A	250V .050A	2.95	5.24
PE-186	28V 11A	400V 400A		6.95
2880	14V 2.4A	250V .060A		5.95

MOBILE DYNAMOTORS

WINCHARGER 4156 regulated, Input 13v/13a. Output ±1: 240v/60ma—Output ±2: 300v/225 ma. Regulation zero load to full load, appr. 3%. **\$14.95** extremely stable, brand new.....

WINCHARGER 505S, Input 12v/15a; output 400v/200 a., can also be used on 24 volts, **\$14.95** brand new.....



SYNCHROSCOPE MODEL TS-34/AP

Utilizes a 2" cathode ray tube with a optical magnifier. It may be used for observing pulsed information of 1/4 microsecond to 30,000 microseconds duration. May also be used for observing sine waves from 30 cycles to 1 megacycle. This unit is supplied with carrying case and accessory cables. Condition is excellent. All equipment has been checked **\$95.00** (TE-028)

ENGINEERING

B.S. DEGREE IN 27 MONTHS

Prepare for unlimited opportunities of the Electronic Age!

Students study engineering under accelerated program leading to B.S. degree in 27 mo.; or standard 4-yr. program leading to B.E. degree in 36 mo. B.S. degree (30 mo.) in Math., Chem., Physics. Your-round classes. Comprehensive training in electronics, television, advanced radio theory and design, math., nuclear physics and elec. engineering. Also prep courses. Low rate. Earn board G.I. approved. Enter March, June, Sept., Dec. Catalog.

INDIANA TECHNICAL COLLEGE

939 E. Washington Blvd., Fort Wayne 2, Indiana

Please send me free information on B.S. ENGINEERING DEGREE IN 27 MONTHS as checked.

- | | | |
|--|--|---------------------------------------|
| <input type="checkbox"/> Electronics | <input type="checkbox"/> Chemical | <input type="checkbox"/> Aeronautical |
| <input type="checkbox"/> Civil | <input type="checkbox"/> Mechanical | <input type="checkbox"/> Electrical |
| B.E. DEGREE IN 36 MO. in: | | |
| <input type="checkbox"/> Aeronautical | <input type="checkbox"/> Mechanical | |
| <input type="checkbox"/> Civil | <input type="checkbox"/> Electrical (Power or Electronics) | |
| <input type="checkbox"/> Chemical | <input type="checkbox"/> Metallurgical | |
| B.S. DEGREE IN 36 MO. IN <input type="checkbox"/> Math. <input type="checkbox"/> Chem. <input type="checkbox"/> Physics | | |

Name
Address

ANNIVERSARY SALE!

Lektron's Biggest-Ever

DOUBLE-BONUS OFFER!



BUY ANY TEN POLY-PAKS^C AND GET BOTH OF THESE BONUSES . . . FREE!

- 1** YOUR CHOICE OF ANY POLY-PAK IN THIS AD FREE WHEN YOU BUY 10!
- 2** SPECIAL ASSORTMENT \$15 WORTH OF RADIO PARTS . . . FREE!

BOTH BONUSES FREE WITH EVERY 10 POLY-PAKS!

FREE!

★ Anniversary Gift Free With EVERY Order!
★ 24-page "Family Shopper"

BELOW WHOLESALE PRICES ON HI-FI, ELECTRONICS, GIFTS FOR EVERYONE!

- 10 RCA PLUG-N-JACK**
SETS, matched. Most pop. amps, tuners. 88¢
- WIRE STRIPPER**
Strips & cuts hook-up wire. #16 thru #22. Wt. 1 lb. 88¢
- 70 TUBULAR COND'S RS**
Paper, molded, oil pores. .5mf to 1000V. 2 lbs. Reg. \$14. 88¢
- 0-15 VAC MINI-METER**
Hundreds of uses! Only 1 3/4" dia. Wt. 1 1/2 lb. Reg. \$3.50. 88¢
- 0-60 MIN. TIMER**
For darkroom, lab, shop, kitchen. Loud alarm. 2 lbs. Reg. \$6. 88¢
- SUN BATTERY**
Similar to famed B2M. 1 1/2" long. Reg. 88¢
- 2 VARI-LOOPSTICKS**
Adj. 540-1500 KCS. Transistor radios. 88¢
- 2 P-N-P TRANSISTORS**
Popular make. Dozens of uses! \$3 value. 88¢
- 2 N-P-N TRANSISTORS**
Used in many pop. make radios. Worth 88¢
- 2 TRANSISTOR IF'S**
Double-tuned. Only 1 1/2" square. 45¢ 88¢
- TEN 3-SECOND TIMER**
Mechanisms. Precision geared. 2 lbs. Reg. \$30. 88¢
- 5" HOBBY SPEAKER**
For radios, code osc., intercoms. Wt. 2 lbs. Reg. \$5. 88¢
- 60 SUB-MINI RESISTORS**
1/4" long. 20 values. 1/3W to 10 meg. 88¢
- 10 PANEL SWITCHES**
Asstd. 115VAC, power, multi-circuit & SPST, DPST, DPDT. 2 lbs. 88¢
- 15 INSTR. KNOBS**
Knurled black bakelite, w/pointer; brass inserts, set-screws. Reg. 88¢
- 5-IN-1 DRILL BIT**
Reams, saws, shapes, drills, copes. Hand or electric drill. 88¢
- 20 PILOT LITES**
6V. Mini bayonet for panels, radios. 88¢
- 15 ROTARY SWITCHES**
Asstd. gangs. 3 88¢
- 30 MOLDED CONDENSERS**
Asstd. Finest made! 88¢
- 100 HALF-WATTERS**
Asstd. value carbon resistors, incl. 5%-. 88¢
- 300-FT. HOOKUP WIRE**
Tinned, asstd. sizes, colors. 2 lbs. Reg. 88¢
- 65 COILS, CHOKES**
IF, RF, Ant.; slug-tuned, reg. too. 3 lbs. 88¢
- 70 TERMINAL STRIPS**
Solder lug & binding; to 20 terms. 2 lbs. 88¢
- 6-PC. HACKSAW SET**
Includes 6 assorted blades. 1 lb. 88¢
- 1500 PCS HARDWARE**
Nuts, screws, washers, etc. 1 1/2 lbs. Reg. 88¢
- 7 ROLLS WIRE**
25-ft. each. #18 thru #22. Asstd. insulation, stranding, colors. 2 lbs. Reg. \$5. 88¢
- 60 CONDENSER SPECIAL!**
Molded, paper, ceramic, oil mica, discs. 88¢
- 75 RESISTOR SPECIAL!**
WW, precision, carbon, variable. 1 lb. 88¢
- 15-PC. DRILL SET**
1/16" thru 1/4" by 64ths, w/calibrated case. Reg. \$3. 88¢
- 75 MICA CONDENSERS**
.00025 to .01 to 1200 V; silver, too. 25 88¢
- 20 ARTISTS BRUSHES**
100% pure bristle, sizes 1-6. Reg. \$2.50. 88¢
- 10 TUB'LR ELECTROS**
Asstd. paper types; AC, DC, Hobby. 3 lbs. 88¢
- 4 POWER WOOD BITS**
Hi-Q steel. 3/8, 1/2, 3/4, 1". 5" long. 88¢
- 60 RADIO-TV KNOBS**
Asstd. colors, insulation. Some worth 88¢
- 10 ELECTROLYTICS**
Radio, TV. 10-500 mf to 450VDC. 3 lbs. Reg. 88¢
- 75-FT. TV TWINLEAD**
300-ohm; tinned. 3 lbs. Reg. \$3.50. 88¢
- 9-PC. WRENCH SET**
3/16 thru 7/16" steel wrenches for shop and auto use. Reg. \$8. 88¢
- POSTAGE STAMP MIKE**
Crystal. 100 to 8,000 cps. 1 lb. Reg. 88¢
- 4 OUTPUT XFMRs.**
50L6, etc. 3 lbs. 88¢
- HEARING-AID PHONE**
Crystal, w/cord set and plug. Reg. 88¢
- 70 HI-Q RESISTORS**
Carbon, IRC, Ohmite, 10% to 1/2, 1 & 2W; 10 ohms to 10 meg. 88¢
- HOBBY BENCH VISE**
Clamp type. Fits tables, too. Steel. 88¢
- SYLVANIA TV MIRROR**
10 x 12" stainless steel. 2 lbs. Reg. 88¢
- 100 RADIO PARTS**
Wide variety resistors, condensers, pots. 88¢
- 2 MIKE XFMRs.**
Carbon, 100 to 100K ohms impedance. Leads, enclosed. 2 lbs. Reg. 88¢
- 5 ROLLS MICRO WIRE**
#24 thru #32; for transistor, sub-mini cir. 88¢
- 40 HI-Q CONDENSERS**
Finest porcelain; NPO's too! 1 lb. Reg. 88¢
- 35 POWER RESISTORS**
WW. 5 to 50W to 10,000 ohms. Vitreous, too. 3 lbs. Reg. 88¢
- 70 ONE-WATTERS**
Asstd. value carbon resistors. 5% too! 88¢
- 15 VOLUME CONTROLS**
Incl. duals; some w/switch. To 1 meg. 88¢
- TV PIC BOOSTER**
Parallel, 6-wire. Extends picture tube life. 1 lb. 88¢
- 8-PC. NUTDRIVER SET**
\$3 value! Plastic handle; 3/16" 7/16" socket wrenches. 1 lb. 88¢
- 4 SUB-MINI VARIABLE**
Condensers. 1/2" sq. 1" shaft. All transistor, sub-mini work. 1 lb. Reg. \$3. 88¢
- 0-6 AMP MINI-METER**
A.C. 1 3/4" dia. 1 88¢

- 6 SILICON DIODES**
Sylvania IN23. 88¢
- \$25 SURPRISE PACK**
Cans, varied assortment, radio. 88¢
- 60 PLUGS 'N' RECEPTALS**
Audio, power, line, battery, speaker. 3 lbs. Reg. \$7. 88¢
- 8 SCREWDRIVER SET**
With wall rack. Asstd. drivers, plastic handle, dies. 1 lb. List \$3.50. 88¢
- 40 SUB-MINI CONDENSERS**
For transistor, printed circuit work. 1 lb. 88¢
- 8 SUB-MINI SOCKETS**
Mica-filled; for 88¢
- 40-RECORD CADDY**
Wrought iron. Holds 40 records or albums. 88¢
- MINI-RADIO KIT**
World's smallest! 2 x 1 x 1". Loopstick, jacks, diode, etc. w/instructions. 1 lb. Reg. \$3. 88¢
- 3 AC-DC CHOKES**
For power supplies. 50 to 200 ma. Open frame. 3 lbs. Reg. \$9. 88¢

Anniversary Special!
LOWEST PRICE EVER—ANYWHERE!
TRANSISTOR RADIO
REG. \$14.95
ONLY \$9.95

READY TO PLAY! INCLUDING BATTERIES & PHONE

By special arrangement with the manufacturer, Lektron offers this superb transistor radio at the lowest price it's ever been sold for, or is likely to be sold for again! VEST POCKET SIZE, only 3 3/8" x 2 3/8" x 1 1/2", this strikingly designed set has wonderful tone, amazing volume! Precision reflex circuit operates from single battery (no penlite cell) interchangeable with Eveready 213, etc. And it comes all ready to play, complete with battery and sensitive hearing-aid type phone.

HOW TO ORDER Check items wanted. Return entire ad w/check or M.O. including sufficient postage; excess returned. C.O.D. Orders, 25% down; rated, net 30 days. Print name, address, amount, money enclosed, in margin. (Canada postage, 48¢ 1st lb., 28¢ ea. add'l lb.)

LEKTRON 133 Everett Ave. CHELSEA 50, MASS.

ter, or optical chopper, is driven by a motor and rotates in front of the black-body aperture. As the aperture is opened and closed by the chopper blades, the detector alternately senses target radiation and black-body radiation. Detector output is an alternating signal, the peak-to-peak voltage of which is precisely proportional to the difference between target radiation and the known radiation from the black body.

The synchronizing signal generator develops a square-wave signal which drives a phase-sensitive rectifier in the electronics system. As the blades of the optical chopper rotate, they interrupt the light beam between a small bulb and a phototransistor, which generates a square-wave signal of exactly the same frequency as the detector output signal. The synchronizing signal generator can be moved so as to adjust the phase of its output.

A preamplifier located close to the detector amplifies the detector output signal to an amplitude and impedance level suitable for transmission through a cable to a remote signal-processing system. The simple signal-processing system shown uses an electromechanical synchronous rectifier. This is a magnetically actuated single-pole, double-throw switch driven by the synchronizing signal and functioning as a keyed full-wave rectifier. It demodulates the preamplifier output, producing a d.c.-output signal exactly proportional to the difference between the radiation from the target and the known radiation from the reference black body. The polarity of the output signal indicates whether the target is hotter or colder than the reference source. Variations in the output signal are precisely proportional to variations in target radiation; so that the d.c. signal can be connected to a voltmeter, calibrated recorder, or control system for continuous radiation or temperature monitoring or control.

Other circuits and devices can be added to the basic radiometer. Thus the arrangement can be developed to a form suitable for making thermal photographs, making spectral analyses of materials, tracking a plane or missile, or directing a missile towards a target. All-in-all, this remarkable branch of science which combines electronics and optics promises even more useful and fascinating applications in the future.

MARS NET ANNIVERSARY
The First Army MARS SSB Technical Net has just rounded out its first year of operation with an enviable 97.5% record of transmission reliability for the 37 talks presented during 1958.

Telephone patch techniques were used to permit speakers in distant cities to talk to members of the net through the stations of net members near New York City. Engineers from Cedar Rapids, Chicago, and Dayton were brought on channel using this technique.

The net has attracted a listening audience within a 1000 mile radius of New York City, with one report arriving from the Azores!

servicemen everywhere insist on the GENUINE "NO NOISE"

big 3 Beware Of Cheap Substitutes!

NO-NOISE RUBBER COAT SPRAY
6 Oz. Spray Can \$3.25
• Insulates where applied
• Protects indefinitely
• Prevents arcing, shorting, corrosion
• Waterproof, thoroughly non-flammable
• Contains no plastic

NO-NOISE TUNER-TONIC With PERMA-FILM
6 Oz. Aerosol Can \$3.25
• Economical—a little does a lot.
• Cleans, lubricates, restores all tuners, including water type.
• Non-toxic, non-inflammatory
• Use for TV, radio and FM

NO-NOISE VOLUME CONTROL and CONTACT RESTORER
• Cleans • Lubricates • Protects
NOT A CARBON TET SOLUTION

2 Oz. Bottle \$1.00
6 Oz. Spray Can \$2.25

ELECTRONIC CHEMICAL CORP. 813 Communipaw Avenue Jersey City 4, N. J.

BC-929 3-INCH SCOPE



Low cost station monitor and/or bench scope. Has Horiz., focus, sweep, intensity controls. Tubes: 2-6SN7, 2-6H6, 1-6X5, 1-6G6, 1-2X2, 3BP1 CR Tube. Voltage req. 115V 400 cy. and 24VDC. Complete with tubes, exc. **\$12.95**

used BRAND NEW **\$14.95**
Conversion instructions for 110V 60 cyc AC... **65c**

ARC-5/R28 RECEIVER



2-meter Superhet. 100 to 156 Mc in 4 crystal channels. Complete with 10 tubes. BRAND NEW **\$24.45**
110V AC Power Sup. Kit for above **\$9.75**

ARC-5/T-23 TRANSMITTER

100-150 Mc Includes 2-832A, 2-1625 Tubes. BRAND NEW **\$21.50**
SPECIAL Limited quantity ARC-5/T23 transmitters. BRAND NEW, less tubes... **\$7.95**
OFFER! Excellent Used, less tubes... **\$5.95**

ARC-5 MARINE RECEIVER-TRANSMITTER

Navy Type Comm. Receiver 1.5 to 3 Mc BRAND NEW with 4 tubes... **\$16.95**

Navy Type Comm. Transmitter 2.1-3 Mc BRAND NEW with 4 tubes and Xtal MODULATOR for above, new with tubes... **\$12.45**
MODULATOR for above, new with tubes... **\$4.95**

LORAN R-65/APN-9 RECEIVER & INDICATOR



Used in ships and aircraft. Determines position by radio signals from known xmitters. Accurate to within 1% of distance. Complete with tubes and crystal. Exc. used. Value **\$1200.00**.
Our Price... **\$88.50**

BC-620 FM TRANSCEIVER, 20-28 Mc. BRAND NEW **\$9.95**
PE-120 6-12V POWER SUPPLY, with Tubes and Vib, NEW **\$11.95**
Shock Mt. Rack, NEW **\$2.95**

LORAN APN-4 FINE QUALITY NAVIGATIONAL EQUIPMENT



Determine exact geographic position of your boat or plane. Indicator and receiver complete with all tubes and crystal.
INDICATOR ID-68/APN-4, and RECEIVER R-9B/APN-4, complete with tubes. Exc. used **\$42.50**
Receiver-Indicator as above, BRAND NEW **\$59.50**
Complete Kit of Accessories for Above: PE-206 Inverter, Set of Plugs, Visor for Indicator, Operation Manual, ALL BRAND NEW... **\$49.50**

LORAN APN-4 OSCILLOSCOPE



Easily converted for use on radio-TV service bench.
Completely Assembled
LIKE NEW! Supplied with 5" Scope, type 5CR only... **\$14.95**
Brand New... **\$19.50**

DYNAMIC BOOM MIKE M-33 A/C. Low impedance. With mounting bracket for attachment to headsets. A REAL VALUE at... **\$3.95**
DYNAMIC HANDMIKE, with "Press-to-talk" Switch on handle, cord and plug—BRAND NEW, only... **\$2.95**
DYNAMIC HANDMIKE, aircraft, made by Telephonics Corp. Press-to-talk switch on mike. BRAND NEW... **\$4.95**

Hi-Fi DYNAMIC HEADSET with Cushions

Freq. Range: 40-14000 CPS. No Distortion. BRAND NEW **\$7.95**

MICROPHONES

Model	Description	Excellent Used	BRAND NEW
T-17	Carbon Hand Mike	\$4.95	\$6.95
T-30	Carbon Throat Mike	.39	.79
T-45	Army and Navy Lip Mike	1.33	1.95
T-24	Carbon Mike	5.95	8.95
TS-9	Handset	3.88	4.95
RS-38	Navy Type	2.79	4.95

HEADPHONES

Model	Description	Excellent Used	BRAND NEW
HS-23	High Impedance	\$2.79	\$4.75
HS-33	Low Impedance	2.79	4.75
HS-30	Low Imp. (featherwt.)	1.25	1.95
H-16/U	High Imp. (2 units)	3.75	7.95

TELEPHONICS—600 ohm Low Impedance HEADSETS, BRAND NEW, PER PAIR... **\$3.45**
CD-307A Cords, with PL55 plug and JK26 Jack... **.99**
Earphone Cushions for above—pair... **.50**
FL-5 FILTER... **.75c**
FL8 Filter... **\$2.45**

WILLARD 6-VOLT MIDGET STORAGE BATTERY



3 Amp. Hour. BRAND NEW. 3 5/8" x 1-13/16" x 2 3/8". Uses Standard Electrolyte... Only **\$2.69**

2 VOLT BATTERY "PACKAGE"



1-2V. 20 Amp. Hr. Willard Storage **\$2.79**
1-2V. 7 prong Synchronous Plug-in Vibrator **1.49**
1-Quart Bottle Electrolyte (for 2 cells) **1.45**
ALL BRAND NEW!
Combination Price **\$5.45**

AN/ART-13 100-WATT XMTR



11 CHANNELS **\$4850** Complete with Tubes
200-1500 Kc
2 to 18.1 Mc

Famous Collins Autotune Aircraft Transmitter, AM, CW, MCW. Quick change to any of ten preset channels or manual tuning. Speech amplifier/clipper uses carbon or magnetic mike. Highly stable, highly accurate VFO. Built in Xtal controlled calibrator. FFS11s modulate 813 in final up to 90% class "B." A Real "HOT" Ham buy at our low price! Original cost \$1800.
Exc. Used... **\$49.50**
0-16 Low Freq. Osc. Coil for ART-13... **7.95**
24V Dynamotor for ART-13... **11.95**

AN/APA-38 PANORAMIC ADAPTER

And Wave Analyzer. 30 Mc Center Frequency, 2Mc Band Width. Total scan 10 Mc at one clip. Regular saw-tooth sweep. Variable sweep freq. control 1600 cycles. Use it as regular service scope! Including 11 tubes and 3" scope tube type 3DP1. BRAND NEW... **\$19.50**

ASB-5 SCOPE INDICATOR



BRAND NEW, including all tubes, together with 5BP1 Scope Tube. Originally used in Navy Aircraft RADAR equipment. Easily converted for AC operation.
VALUE \$250.00!
OUR LOW PRICE **\$15.95**

BC-733 VHF 10-TUBE AIRCRAFT RECEIVER.

6-channel xtal control. Freq. 108.3 to 110.3 Mc. Dual filter range. Easily converted for tracking Sputniks!
Exc. used... **\$9.95**
Exc. used... **\$12.95**
Dynamotor for above 12/24 V... New **\$5.95**

AN/APR-4 RECEIVER only.

38 to 4000 Mc in 5 tuning unit ranges. High precision laboratory instrument used to monitor or indicate frequency of any signals within its range. Includes wide and narrow band IF strip selected from panel. Outputs provided for attachments to pulse analyzer, panadapter, etc.
Input 115 V 60 cy. LIKE NEW **\$69.50**
Tuning Units for above—each... **\$39.50**

AN/ARN-5A AIRCRAFT RECEIVER.

11 tube superhet, 3-crystal control UHF for static-free reception.
Exc. used with tubes... **\$16.95**
BRAND NEW... **\$19.95**

BC-645 XMTR RECEIVER



15 Tubes 435 To 500 MC
Can be modified for 2-way communication, voice or code, on ham band 420-450 mc, citizens radio 460-470 mc, fixed and mobile 450-460 mc, television experimental 470-500 mc. 15 tubes (tubes alone worth more than sale price!): 4-7F7, 4-7H7, 2-7E6, 2-6F6, 2-955 and 1-WE316A. Now covers 460 to 490 mc. Brand new BC-645 with tubes, less power supply in factory carton. Shipping weight 25 lbs. **\$29.50**
PE-101C DYNAMOTOR for BC-645, has 12-24V input (easy to convert for 6V Battery operation) only **\$7.95**
UHF ANTENNA ASSEMBLY, for BC-645... **\$2.45**
Complete set of 10 Plugs for BC-645 **\$5.50**
CONTROL BOX for above... **\$2.25**
SHOCK MOUNT for above... **1.25**
CONVERSION BOOKLET, Instructions for most useful surplus rigs... **\$2.50**

BC-659 TRANSMITTER & RECEIVER

27 to 38.9 Mc F.M. Two preselected channels crystal controlled. 5 to 10 watts. Complete with speaker, tubes. Brand New **\$11.95**
Exc. Used... **\$7.95**
Vibrator Supply for 6-12-24 Volts, NEW... **\$9.95**

Please include 25% Deposit with order—Balance C.O.D. 50c Handling Charge on all orders under \$5.00. All shipments F.O.B. Our Warehouse, N.Y.C.

G & G Radio Supply Co.

Telephone: CO 7-4605
51 Vesey St., New York 7, N. Y.

TG-34A CODE KEYS



Self-contained automatic unit, reproduces code practice signals recorded on paper tape. By use of built-in speaker, provides code-practice signals to one or more persons at speeds from 5 to 25 WPM.
BRAND NEW, in original carton. **\$16.88**
Set of Code Practice Tapes (15 lessons), 3/8" inked paper... **\$15.95**

SCR-522 2-METER RIG!

Terrific buy! VHF Transmitter-receiver, 100-156 Mc. 4 channels. Xtal-controlled. Amplitude modulated voice. They're going fast! Excellent condition.
SCR-522 Transmitter-Receiver, complete with all 18 tubes, top rack and metal case. Special COMBINATION... **\$33.33**
Receiver only, with all tubes... **\$19.50**
Transmitter only, with all tubes... **\$22.25**
Accessories for above available.

ARB Receiver 4 band 195-9050 Kc, with all Tubes, Like New... **\$17.95**
Brand New, with Tubes and Dynamotor... **\$34.50**

MOBILE-MARINE DYNAMOTOR



Input 12V DC. Output: 625 V DC @ 225 Ma. for press-to-talk intermittent operation. Shpg. wt. 14 lbs. **\$6.45**
OUR LOW PRICE... **\$6.45**

OTHER DYNAMOTOR VALUES:	Excellent Used	BRAND NEW
DA-19-A 28V 11A	400V.400A \$4.99	\$6.95
DM-28 28V	224V.07A	2.95 4.95
DM-32A 28V 1.1A	250V.05A	2.95 4.45
DM-33A 28V 5A	575V.16A	
DM-34D 12V 2A	220V.080A	4.25 5.50
DM-53A 28V 1.4A	220V.080A	3.95 5.95
PE-73C 28V 20A	1000V.350A	8.50 11.50
PE-86 28V 1.25A	250V.050A	2.95 5.24

SCR-274 COMMAND EQUIPMENT

ALL COMPLETE WITH TUBES

Type	Description	Used	Like NEW
BC-453	Receiver 190-550 KC	\$14.95	\$16.95
BC-454	Receiver 5-8 Mc	9.95	12.95
BC-455	Receiver 8-9 Mc	10.95	13.50
BC-450	3-Receiver Control Box	1.49	1.95

110 Volt AC Power Supply Kit, for all 274-N and ARC-5 Receivers. Complete with metal case, instructions. Complete with metal case. Factory wired, tested, ready to operate... **\$11.50**
SPLINED TUNING KNOB for 274-N and ARC-5 RECEIVERS. Fits BC-453, BC-454 and others. Only... **49c**

BC-457 TRANSMITTER—4-5.3 Mc. complete with all tubes and crystal. BRAND NEW... **\$7.85**
BC-458 TRANSMITTER—3.3 to 7 Mc. Complete with all tubes and crystal. BRAND NEW... **\$7.85**
BC-459 TRANSMITTER—7-9.1 Mc. complete with all tubes and crystal. BRAND NEW... **\$12.95**
ARC-5 T-19 TRANSMITTER—3 to 4 Mc. BRAND NEW complete with all tubes & crystal... USED 3.45 NEW 4.95
BC-451 Transmitter Control Box... 1.25 NEW 1.49
POWER SUPPLY KIT, for All Command Transmitters. Provides all needed voltages. A quality kit, only... **\$29.50**
(See full description above)

BC-906 FREQ. METER—SPECIAL!



Cavity type. 145 to 235 Mc. BRAND NEW, complete with antenna. Manual included.
OUR LOW PRICE... **\$9.88**

BC-603 FM RECEIVER

10-channel push button tuning or continuous tuning. 20-28 Mc. Complete with speaker, tubes, switch, BRAND NEW... **\$14.95**
Exc. Used... **\$9.95**
12 or 24V Dynamotor for Above... **1.25**
Exc. Used \$4.25... BRAND NEW **\$5.50**

AC POWER SUPPLY FOR BC603, 683

Interchangeable, replace dynamotor. Has On-Off Switch. NO RECVR. CHANGE NEEDED. Provides 220VDC @ 80 Ma, 24VAC @ 2 Amps. Complete kit, with easy instructions... **\$8.45**
Wired... **\$10.49**
Complete 240-page Technical Manual for BC-603, 604... **\$2.95**

BC-221 FREQUENCY METER

SPECIAL BUY! This excellent frequency standard is equipped with original calibration charts, and has ranges from 125 Kc to 20,000 Kc with crystal check points in all ranges. At our smashing low price it's FIRST COME FIRST SERVED! Hurry, quantity is limited. Like New... **\$88.88**
BC-221 Modulated Type... **\$129.50**
Original 1000 Kc Crystal for BC-221... **\$8.45**
BRAND NEW... **\$8.45**

SCHEMATIC DIAGRAMS For any equipment on this page, each... **65c**

Tips on FM Alignment
(Continued from page 67)

modulated signal. This time saver is particularly acceptable if final alignment will be completed with the oscilloscope anyhow.

When the FM generator and scope are brought into play, remember that we rely on the latter to indicate amplitude changes during adjustment of the detector primary and the i.f. channel. Therefore limiting action in the detector is disabled temporarily by disconnecting electrolytic capacitor C_1 in Figs. 3 and 4 and making the scope connection at this same point. In the balanced circuit, it is satisfactory to remove either end of the capacitor. In the unbalanced version, the negative terminal should be removed.

When i.f. adjustments have been completed, reconnect C_1 and transfer the scope to the de-emphasis network, as already noted, to adjust the transformer secondary for maximum symmetry of the crossover pattern. In some sets, it will be necessary to re-adjust the primary to a very small degree at this time to get the crossover point to straighten up.

The locked-in oscillator-detector employing the FM1000 tube was developed by Philco. Refer to Fig. 5. The oscillator grid, pin 2, is first grounded which causes the section to operate as an AM detector. The i.f. frequency used here is 9.1 mc. The output indicating instrument is connected either to point "A" or to any other audio-frequency signal point. Alignment of the i.f. section is then made by employing the same procedure as given for the discriminator detector. When the i.f. adjustments have been completed, the ground jumper on the oscillator grid is removed, and the quadrature circuit is short-circuited, as shown in the schematic, to disable the locking action of the plate feedback into the oscillator section. With the signal generator set for 400-cycle AM output at 9.1 mc., adjust the oscillator trimmer until a beat note is heard in the loudspeaker. This audio note results from the heterodyning of the oscillator and i.f. signals. Continue to adjust the oscillator trimmer until a condition of zero beat is obtained (a null between two low-pitched growls).

When the short circuit is removed from the quadrature circuit, the audio signal will again be heard. Reduce the signal generator output to the lowest value at which a usable signal can be heard. Re-adjust the tuning slug in the quadrature circuit until a zero beat is again obtained. Repeat the entire operation as necessary until the removal of the short from the quadrature circuit has minimum effect on the zero-beat condition obtained when the oscillator trimmer is adjusted. When the jumper is removed from the quadrature circuit, the complete response curve can be observed on the screen of the scope with FM sweep. The

For my Money
XCELITE Tools are the Finest!

... Superbly made and designed for Radio, T.V. and Electronic Technicians. See your Distributor ... only one quality ... the finest — whether you choose individual items or the handy kits ...

Use the Tools the Professionals use!

XCELITE, INCORPORATED
ORCHARD PARK, NEW YORK
Canada: Charles W. Pointon, Ltd., Toronto

XCELITE
Quality Hand Tools
PREFERRED BY THE EXPERTS

GET MORE WORK OUT OF YOUR OSCILLOSCOPE!

Learn to service ANY radio or TV easier and faster!

Here, in an enlarged 2nd edition, is THE book that really shows you how to use oscilloscopes on every job! Clearly as A-B-C, MODERN OSCILLOSCOPES AND THEIR USES tells you exactly when, where and how. You learn to locate either AM or FM radio or television troubles in a jiffy. Even tough realignment jobs are made easy. No involved mathematics! Every detail is clearly explained—from making connections to adjusting circuit components and setting the oscilloscope controls. And you learn to analyze patterns fast and RIGHT!

'SCOPES IN COLOR TV!

Includes up-to-the-minute data on quantitative measurements—the slickest method of diagnosing many color TV troubles and aligning sets properly. Also covers 'scopes in industrial electronics, teaching . . . and even in atomic energy work. Over 400 pages and more than 400 clear pictures. Dozens of pattern photos make things doubly clear.

PRACTICE 10 DAYS FREE!

Dept. RN-39, RINEHART & CO., Inc.
232 Madison Ave., New York 16, N. Y.

Send big 2nd edition of MODERN OSCILLOSCOPES AND THEIR USES for 10-day examination. If I like book, I will then send \$6.50 (plus postage) in full payment, or return book postpaid and owe you nothing. (SAVE! Send \$6.50 with order and we pay postage. Same return privilege with money refunded.)

Name

Address

City, Zone, State

OUTSIDE U.S.A.—Price \$7.00, cash with order only. Money back if you return book in 10 days.

KEEP CANDEE HANDEE!

MODEL 80 MEASUREMENTS CORP. SIGNAL GENERATOR

- ★ Frequency range: 2-400 MC in 6 bands. Freq. accuracy $\pm 0.5\%$. Output accuracy: 0.1 V. $\pm 10\%$ from 2-200 MC and from 200-400 MC @ 0.1 V. $\pm 15\%$. Output voltage continuously variable from 0.1-100,000 microvolts.
- ★ Output impedance 50 ohms. Amplitude modulation is continuously variable from 0-30%.
- ★ Power supply 117 V., 50/60 cycles, 70 W. Dim.: 11 1/2" x 19 1/2" x 11 3/4". Excellent cond. Approx. shipping wt. 70 lbs. **\$295.00**

MODEL 84 MEASUREMENTS CORP. SIGNAL GENERATOR

- ★ Frequency 300-1000 MC in one band. Individually calibrated direct reading dials. Frequency accuracy $\pm 0.5\%$. Output voltage continuously variable from 0.1-100,000 microvolts. Output impedance 50 ohms. Modulation 0-30%.
- ★ Choice of 400, 1000, 2500 cycles. Pulse frequency 60-100 kc. in three ranges: 60-1,000, 600-10,000; and 6,000-100,000 pulses per second. Power supply 117 V., 50/60 cycles.
- ★ Dim.: 13 x 26 x 12 1/4". Approx. 50 lbs. shipping wt. 160 lbs. Excellent. **\$249.00**

SAVE BY BUYING BOTH MODELS FOR \$525.00

G.E. PYRALAN OIL-FILLED CONDENSERS
Cat. No. 18F209. 120 MFD @ 3,000 VDC. F.B. for hams. Makes good component for arc welder. Excellent cond. Sold at fraction of original cost. ONLY **\$69.95**

BC-611 HANDIE TALKIE CHASSIS
The buy of the month! New! Boxed! Crystal controlled. 3-6 MC. With antenna, less coils, crystals and tubes. EACH \$3.95 TWO FOR ONLY **\$6.95**

HICKOK MOD. 547 TUBE CHECKER
Mutual conductance. With chart. Also tests special purpose tubes. A terrific buy! EXCEL. **\$69.95**

T85/APT-5 TRANSMITTER
Has lighthouse tube 3C29 oscillator in tunable cavity modulated by two type 829B tubes powered by 931 noise generating photocell. Output approx. 30 W. CW @ 115 V, 400 cycles. Excellent cond. **\$49.95**

RAX-T RECEIVER
4-band, 4 1/2" dial, AVC, MCW, 1/2" phone jack and volume control. Voltage required 24VDC and 200V @ 80 ma. Complete with 7 tubes. All excellent. Unit No. 1: 200-1500 kc.; unit No. 2: 1500-9,000 kc.; Unit No. 3: 7,000-27,000 kc. Specify which unit you want. Each. **\$17.95**
Buy all 3 for only \$49.95

110 VAC POWER SUPPLY: For BC-603 and BC-683 Recvrs. All wired. No conversion needed. Just plug in. Brand new. Special! **\$11.95**

All items FOB, Burbank, Calif., subject to prior sale. In Calif. add 4%. Min. order \$3.95.

J. J. CANDEE CO. Dept. R
509 No. Victory Blvd., Burbank, Calif.
Phone: Victoria 9-3053

A... Always
B... Buy
C... Columbia

WHY BUY ELSEWHERE WHEN COLUMBIA UNDERSELLS EVERYBODY!!

MEASUREMENTS CORP.

MODEL 80 SIGNAL GENERATOR
Freq. 4-400 MC. ± one hand, accurate to ±0.5%. Output voltage continuously variable from 0.1 to 100,000 microvolts. Amplitude mod. is continuously variable from 0 to 30%. **70 W. ORIGINAL COST WAS \$625.00! Dim.: 11 1/2 x 19 3/8 x 11 3/8". Excellent cond. Wt. 75 lbs. \$295.00 ONLY**

MEASUREMENTS CORP.

MODEL 84 SIGNAL GENERATOR
Freq.: 300-1000 MC. ± one hand, direct reading dial. Freq. accurate to ±0.5%. Output voltage continuously variable from 0.1 to 300,000 microvolts! Output impedance 50 ohms. Modulation 0.0 to 30%. Choice of 400, 1000 to 2500 cycles. Pulse freq.: 40 to 100 kc in 10 ranges: 600-1,000, 600-10,000, and 6,000-100,000 pulses per second. Power supply 117 V. 50-60 cycles. **ORIGINAL COST WAS \$1,900.00! Dim.: 13 x 26 x 10". Excellent cond. Wt. 150 lbs. ONLY \$250.00**

COMBINATION DEAL!

BOTH ABOVE UNITS! Save \$20.00! ONLY \$525.00

HICKOK TUBE TESTER

Portable Model 547-A. Mutual conductance tester. Will test most types of receiving tubes including sub-minatures. Has built-in roll chart. Orig. cost \$300.00. **\$59.50**

MOBILE-EERS! THIS IS FOR YOU!

DM-35 MOBILE DYNAMOTOR: Output 620 V. @ 225 MA. In like new condition. This is a depot re-pack **\$9.95 for ONLY**

6 V. MOBILE EICOR DYNAMOTOR: Output 425 V. @ 375 mA. Excellent cond. **\$7.95**

MOTOROLA FM MOBILE TRANSMITTER: Models FMTU15 and 30D. 6 VDC input. Freq. 150-170 MC. 20 W. output. Excel. cond. ONLY **\$29.95**

RC4 AUDIO OSCILLATOR

Model 134. 27-39 MC. Output imp. 250, 500 and 1,500 ohms. **\$14.95**

TRIMM-COMMERCIAL HEADSET: 18,000 ohm. Magnetic super sensitive. New. Boxed. SPECIAL AT ONLY **\$4.95**

T-17 MICROPHONES

Standard mil. hand mike with push-to-talk button. 6 ft. cable. PL-68 plug. Lo imp. hi out. new cond. **\$3.50**

BC-611 HANDIE-TALKIE: Complete. Less batteries. 3885 or 3995 kc. New condition. Only **\$39.95**

CHASSIS ONLY: New. Less tubes, crystal, coil **3.95**

CRYSTAL & COIL SET for above chassis. **2.95**

BC-659 TRANSCEIVER

27-39 MC. Crystal control with internal speaker & power supply. New cond. **\$10.95**

HAND SET: For above. New. **2.95**

15 FT. WHIP ANTENNA: For above. Each **2.95**

MAINTENANCE KIT: For above. With crystals **1.95**

BC-312 COMMUNICATION RECEIVER

1.8-18 MC in 6 bands. 2 stages RF. **\$39.95**

12 VDC. Good condition.

LM FREQUENCY METERS

125-20,000 kc. With modulation. Excellent. Complete with calibration book. None better or lower priced! Ea. **\$39.95**

BC-221 FREQUENCY METER

Same as above. Army version. Like new. **\$9.00**

Each **\$9.00**

Same as above, but not modulated. Excel. **\$69.95**

Each **\$69.95**

All Orders FOB Los Angeles. 25% deposit required. All items subject to prior sale. NOTE: MINIMUM ORDER \$3.00. WRITE TO DEPT. R.

Columbia ELECTRONICS S
2251 W. WASHINGTON BLVD.
LOS ANGELES 18, CALIFORNIA

ORDER by MAIL and SAVE!
TV PICTURE TUBES

10BP4	\$ 7.95	17BP4	\$10.95	21AMP4	\$19.95
12LP4	8.95	17CP4	17.00	21ATP4	20.95
14B/CP4	9.95	17GP4	17.60	21AUP4	20.95
16DP4	14.95	17HP4	13.60	21EP4	14.95
16EP4	15.90	17LP4	13.60	21FP4	15.95
16GP4	15.90	17QP4	11.95	21WP4	17.30
16KP4	10.95	17TP4	19.30	21YP4	15.95
16LP4	10.95	19AP4	19.30	21ZP4	14.95
16RP4	10.95	20CP4	13.90	24CP4	23.95
16WP4	15.20	20HP4	17.95	24DP4	26.95
16TP4	10.95	21AP4	22.10	27EP4	39.95
17AVP4	15.20	21ALP4	20.95	27R74	39.95

27"-6 month guarantee—all others 1 year. Aluminized Tubes \$5.00 more than prices. These prices are determined to include the return of an acceptable similar tube under vacuum.

ALL PRICES FOB CHICAGO, ILLINOIS. Deposit required, when old tube is not returned, refundable at time of return. 25% deposit required on COD shipments. Old tubes must be returned prepaid. We ship anywhere.

WRITE FOR COMPLETE LIST.

PICTURE TUBE OUTLET
3032 MILWAUKEE AVE.
CHICAGO 18, ILLINOIS
Dickens 2-2048

quadrature slug is then adjusted for maximum linearity. Fig. 6A shows a proper response curve, while that of Fig. 6B is poor.

Once the detector is properly aligned, the oscillator grid is again grounded and the receiver front end adjusted in the usual manner.

In receivers employing the 6BN6 type of gated-beam detector, Fig. 7, alignment of the i.f. stages is accomplished by measuring the r.f. voltage at the signal grid of the detector. A suitable probe is therefore required with the indicating instrument.

Attach the r.f. probe to the detector signal grid and adjust the i.f. transformer for maximum r.f. voltage reading. Next, tune in a local FM station for maximum indication and adjust the quadrature circuit coil for best audio results. Finally, tune in a weak signal accompanied by a large amount of noise and adjust the variable control in the cathode circuit for the best signal-to-noise ratio. It may be necessary to disconnect the antenna and do some juggling with the degree of coupling to the receiver input in order to maintain the noise level sufficiently high so that changes can be detected readily. A slight re-adjustment of the quadrature coil may then improve fidelity.

The main point to remember is that poor alignment can cover up an otherwise skillful repair job. When in doubt, go over all adjustments. It only takes a few minutes to get the difference between mediocre and satisfying results and the concomitant approval of your musically oriented customers. —30—

STEREO SOUND FOR TV

At a press preview held recently, Motorola Inc. premiered, by closed-circuit transmission from WGN, Chicago, a compatible stereo sound system for television. Viewers of prototype equipment heard dual-channel stereo sound from two separate speaker systems while watching a corresponding taped segment of a regular TV show.

To produce the stereo effect, FM multiplexing of the sound carrier was used in conjunction with the "sum and difference" technique. The left plus right sound signal frequency modulated the TV sound transmitter; the left minus right signal frequency modulated a 23.6-kc. subcarrier. This frequency was picked since it is above the audible frequency range and it falls exactly between the fundamental and second harmonic of the horizontal scanning frequency. A 5-kc. top limit and a 5-kc. deviation were employed for the subcarrier.

A conventional TV receiver will respond only to the sum signal, a complete monophonic transmission. From this viewpoint, then, the system is fully compatible. The stereo TV set differs from the conventional set only in the audio circuits following the sound detector. These circuits recover both the sum and difference signals and combine them in such a way that the original separate left and right signals are reproduced.

It must be emphasized that the equipment shown were laboratory prototypes, unveiled to dramatize for the trade and the public products that may become available in the future. —30—

REALIZE YOUR DREAM

Become a graduate Electronics Engineer. Share rewards awaiting college men . . . higher income, rapid advancement. Important firms interview seniors here regularly.

Electrical Engineer in 27 months

B.S. degree in Electrical (Electronics or Power major), Mechanical, Civil, Chemical, Aeronautical Engineering. In 36 Months a B.S. in Business Administration (General Business, Accounting, Motor Transport Management majors). For earnest, capable students. Small classes. More professional class hours. Mature students. Well-equipped labs. Modest costs. Veteran approved. Year-round operation. Enter June, Sept., January, Mar. Write J. H. McCarthy, Director Admissions, for Catalog and "Your Career in Engineering and Commerce" Book.

TRI-STATE COLLEGE
1639 College Avenue, Angola, Indiana

CODE SENDING SPEED
CODE RECEIVING SPEED



Be a "key" man. Learn how to send and receive messages in International Morse code. Communicate with operators around the globe. Learn at home quickly through famous Candler System. Used by best operators. Qualify for Amateur or Commercial License. Write for FREE BOOK. **CANDLER SYSTEM CO., Dept. 2-C, Box 9226, Denver 20, Colo., U.S.A.**

HIT THE TOP IN

TV Engineering

BIG OPPORTUNITIES are waiting for the man who masters television theory, design, transmission. Now, this complete 2,300 page library tells you everything you must know to succeed in this profitable, fast-growing field.

THE MCGRAW-HILL
Practical
Television
ENGINEERING LIBRARY

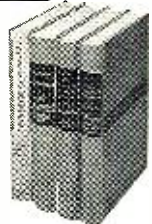

Four Giant Volumes, With More Than 1,600 Illustrations.

FREE
\$9.50 book
Wentworth's **COLOR TV ENGINEERING**
A valuable handbook will be sent at no extra cost. Covers color from A to Z!

This complete technical library can help you become an expert in servicing, engineering research, circuit design, or TV transmission. Leading engineers explain—simply and clearly—everything from basic theory to advanced circuit design. 2,300 pages and 1,600 illustrations show you the answers to your questions, give you the practical working knowledge you need to get ahead in TV. The coupon below will bring you all four volumes for free ten day trial. Mail it today!

- **Television Fundamentals.** By K. Fowler and H. Lippert of General Electric.
- **Television Engineering.** By D. Fink, Philco Corp.
- **Theory and Design of Television Receivers.** By S. Deutch, Polytechnical Research and Devel. Co.
- **Color Television Standards.** By D. Fink, Philco Corp.

10 DAYS FREE TRIAL

McGraw-Hill Book Co.
Dept. RTN-3

327 West 41st St., New York 36, N. Y.

Send the 4-volume Practical Television Engineering Library plus Color Television Engineering for FREE EXAMINATION. I will send \$6.00 within 10 days and only \$6 monthly until low price of \$36 is paid. Otherwise I will return all 5 books postpaid and owe nothing.

Name

Address

City

Zone

State

Employed by

Employed by

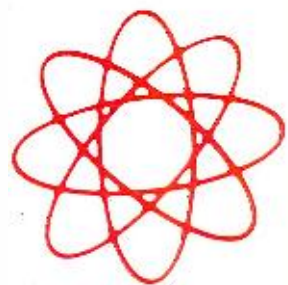

next month in RADIO & TV NEWS!

Special Service Features for the Pro, Small Shop or Home Workshop!

*In May, the name of
RADIO & TV NEWS
officially becomes
ELECTRONICS WORLD.*

In addition to all regular articles, April RADIO & TV News will include more than a dozen exclusive features on radio and TV repair. You'll find helpful, practical tips and information in each of these special articles:

NEW TV DESIGNS FOR 1959 — Here's a rundown on circuitry in the newest TV sets. Tells of layout problems you'll face, unusual new features, innovations, design trends.

SCHEMATICS OF 1959 TV SETS — Six pages of valuable diagrams of latest TV receivers.

1959 TUBE INVENTORY FOR SERVICE SHOPS — What tubes should you stock to keep up with changing requirements, new designs and models? Here's RADIO & TV News' annual guide to tubes for servicemen—with valuable recommendations on keeping your inventory flexible and efficient.

ANTENNA INSTALLATIONS: FACTS AND FICTION — There are a lot of "old wives' tales" concerning antenna installations still circulating. In this exclusive feature,



expert Jack Beever of Jerrold Electronics reveals how too many technicians are wasting time, effort, and money by sticking to outmoded antenna techniques.

TEST EQUIPMENT—Featured are three extensive articles—complete guides to basic test equipment, additional equipment needed when you expand, and special test instruments.

All in all, you'll find a wealth of information in April **RADIO & TV NEWS**. What's more, you can subscribe right now and save up to 44% on the new newsstand price of 50c per copy. If you're not already a subscriber, it's a good idea to act today—before subscription rates go up!

CURRENT SUBSCRIPTION RATES:

One year **\$4** Two years **\$7** Three years **\$10**

**plus all these features
scheduled for April, too.**

- **LOUDSPEAKERS FOR STEREO, Part I**
A survey of all speaker manufacturers resulting in a compilation of the various methods and ideas for stereo speaker operation, placement and design principles.
- **CROSSOVER NETWORKS, Part I**
Complete, how-to-do-it article on the design and construction of two and three-way speaker crossover networks. Part 2, to follow in the May issue; will be accompanied with a 4-page gatefold pertaining to design charts for crossover networks. Don't miss the beginning of this 2-part series next month.
- **TRANSISTORIZED DOUBLE SIDE-BAND SUPPRESSED-CARRIER TRANSMITTER**

A simple suppressed-carrier transmitter that can operate on the 20, 15, and 10-meter amateur bands and that can be driven by means of a small, low-power r.f. unit such as the "Mighty Milliwatt" described in our September 1958 issue.

- DRIFT & A.F.C. IN FM
- 20 CPS TAPE RECORDER SWITCH
- CERTIFIED RECORD REVUE
- SOUND ON TAPE
- HI-FI—AUDIO PRODUCT REVIEW
- ELECTRONICS IN NIGERIA
- DEFECTS IN THE HORIZONTAL OSCILLATOR
- SAVE TIME ON TROUBLESHOOTING TRANSISTOR RADIOS
- HINTS ON TWO-WAY RADIO SERVICE
- AN AUTOMATIC "TALK SQUELCHER" FOR YOUR RADIO

ZIFF-DAVIS PUBLISHING COMPANY
ONE PARK AVENUE, NEW YORK 16, N. Y.

**A Wire-Stripping Notch
That REALLY WORKS!**

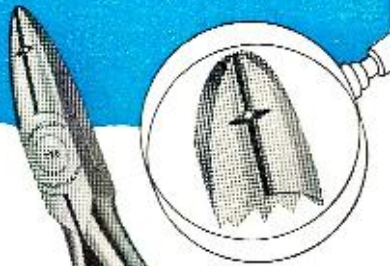

#728
LONG-REACH
DIAGONAL CUTTER
(Patent Pending)

Specially Designed

CHANNEL LOCK

ELECTRONICS PLIERS

You'll do hundreds of electronics jobs easier, faster with these specially designed pliers by Channellock. You'll like the l-o-n-g reach . . . the precision-matched jaws . . . the hand-honed, specially hardened cutting edges . . . the easy-to-handle "feel" of the blue plastic grips. And you'll appreciate the quality of Channellock pliers . . . they're forged from high grade steel, properly heat treated. Ask your Electronics Equipment Supplier for Channellock Electronics Pliers . . . or write us direct for further information.



#718 LONG-REACH FLAT-NOSE PLIER



#738 LONG-REACH ROUND-NOSE PLIER



#748 LONG-REACH END CUTTER

Channellock Pliers are made only by

CHAMPION DEPARTMENT TOOL COMPANY
Meadville, Pennsylvania

How Ring Counters Work

(Continued from page 45)

combination of resistance and capacitance (270,000 ohms and 40 μ fd.) This permits a faster transfer of signal to the grid of V_2 than to the grid of V_3 . (The transfer is faster because the RC combination acts as a differentiating or peaking circuit that produces a pulse with a sharp leading edge. The normal rounding off of the pulse applied to the grid of V_3 , produced by stray circuit capacitance, constitutes a slight delay.) Furthermore, when V_2 becomes conductive, its plate voltage decreases and lowers the potential of the grid of V_3 , preventing conduction.

The grid of V_2 actually receives two input signals: the negative pulse applied to the "Input" terminal and the positive pulse from the plate of V_1 . Of these two signals, the positive pulse from V_1 predominates because of its greater amplitude (due to the gain of tube V_1). The waveforms shown in Fig. 1 also apply to the circuit of Fig. 2, and neon lamps can be connected in the same manner. The basic action just described continues from stage to stage with each new input pulse.

A ring counter capable of still greater switching speeds is shown in Fig. 3. This *Walkirt Co.* linear counter will operate at input frequencies up to 250 kc. Each stage of this ring counter is a dual triode connected as a flip-flop (Fig. 3A). Interstage connections are shown in Fig. 3B. In the latter, numbers refer to the terminals around the edges of Fig. 3A, rather than to pin numbers of the tubes. Only one stage is in the zero condition (V_1 cut off and V_2 conducting), and all other stages are in the one condition (V_1 conducting and V_2 cut off). As shown in Table 2, each input pulse transfers the zero condition to the following stage of the ring.

The initial condition of the circuit (first stage in the zero condition) is established by applying a negative pulse to the reset terminal. This negative pulse cuts off the left-hand triode of the first stage, forcing this stage into the zero condition. The value of the cathode bias resistor, R_1 (Fig. 3B), is such that the plate current of the right-hand triode of the first stage develops sufficient bias to cut off the right-hand triodes of all other stages (V_2 in each). The other stages are therefore forced into the one condition.

The input terminal is connected to all of the left-hand cathodes. When a negative pulse is applied to the input terminal, the left-hand cathode of the

Fig. 5. Decade counter consisting of a ring-of-five followed by a binary.

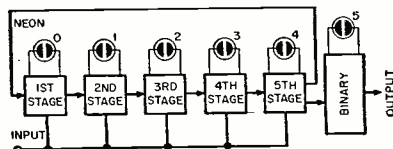

**get more
enjoyment
out of your Hi-Fi
for only \$1.00!**



photo courtesy Electro-Voice, Inc.

Now—just \$1 can show you how to get more listening pleasure from your hi-fi set! That's the cost of the new 1959 edition of the **HI-FI GUIDE & YEARBOOK**—the authoritative Ziff-Davis Annual that covers every facet of high fidelity enjoyment. Besides telling you how to use your equipment for the best possible reproduction, the 1959 HI-FI GUIDE & YEARBOOK presents a round-up of the trends in the hi-fi fields . . . tells you how to save on repairs . . . guides you in the selection of records . . . gives you tips on tapes. It's actually like getting two big books for the price of one!

GUIDE

Section 1: **IMPROVING YOUR HI-FI**—Strange Allergies of hi-fi. Square Waves Check Tone Controls. Give Your Pickup a Chance. Getting the Most from Your Tweeters. MX means Multiplex. Your Stereo Listening Area.

Section 2: **INSTALLING YOUR HI-FI SYSTEM**—Hiring the Fi to the Suburbs. Index Your Music. Ceiling Mounted Speaker.

Section 3: **TAPE RECORDING**—Getting the Most From Your Tape Records. Tips and Techniques. Don't Let Your Tapes Hiss at You. Make Your Own Stereo Tape Recordings.

YEARBOOK SECTION

TRENDS IN HI-FI: developments in 1958 and what the future holds.

CRITICS' CHOICE OF RECORDINGS: a conductor, a music critic, and a sound engineer tell what records (classical and jazz) they would select—and why.

THE ULTIMATE IN FM STATIONS: here's how an FM station in Chicago really caters to its hi-fi listeners—in what could be a nationwide trend in programming! Also gives you a listing of FM stations throughout the country.

STEREO: the latest report on what is happening in this big, exciting field. PLUS a photo story showing what can be done to fit more equipment into less space.



All told, the **HI-FI GUIDE & YEARBOOK** brings you a wealth of information to help you get the most out of your hi-fi listening hours. Only \$1.00 (\$1.25 outside U.S.A.), it's a fabulous buy! On sale soon—make sure you reserve your copy now at your newsstand.

ZIFF-DAVIS PUBLISHING COMPANY

434 South Wabash Avenue, Chicago 5, Illinois

RADIO & TV NEWS

first stage will be driven negative. Since a negative pulse applied to the cathode is equivalent to a positive pulse applied to the grid, the left-hand triode of the first stage will now conduct. As the first stage switches to the *one* condition, the right-hand triode (V_2) cuts off and its plate voltage increases. This increase, coupled to the right-hand grid of the second stage, forces the second stage into the *zero* condition, with V_2 conducting.

It can be seen that the second stage actually receives two signals: the negative input pulse applied to its left-hand cathode and the positive pulse (from the first stage) applied to its right-hand grid. The negative pulse at the left-hand cathode produces no change because this tube is already conducting at the time the pulse is applied. The positive pulse from the first stage arrives after the negative input pulse is completed and therefore switches the second stage to the *zero* condition.

Ring counters are sometimes used in combination with binary circuits for pulse counting applications. A ring-of-five, for example, may be connected in cascade with a single binary stage, as shown in Fig. 5. This *decade* counter has a scaling factor of ten: ten input pulses applied to the ring will produce one output pulse from the binary. The neon lamps in this circuit indicate the number of pulses applied to the input terminal. After eight input pulses for example, neon lamps 3 and 5 will be on. When the tenth input pulse is applied, the entire circuit will be back to its initial condition and the binary stage will produce an output pulse. (See Table 3.) This output pulse can be fed into another similar decade counter.

For two decades in cascade, the total counting capacity will be 10^2 or 100. If three decades are connected in cascade, the counting capacity will be 10^3 or 1000. Fig. 6 shows the neon lamps for four cascaded decades of the type shown in Fig. 5 after 3947 input pulses. Lighted indicators are shown in grey. Circuits of this type have been used for counting pulses produced by Geiger and scintillation counters.

Although ring circuits are sometimes used in pulse counting applications, they are not economical in terms of the number of stages required. The decade counter of Fig. 5, for example, requires *six* dual triodes. This compares un-

Fig. 6. The neon lamps lit on these four cascaded decades indicate that a total of 3947 pulses have been applied.

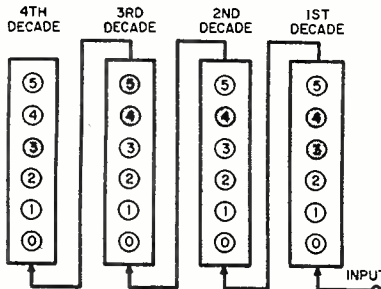

DX-16 Super Deluxe TV KIT

70° or 90° — operating all 17", 21", 24" and 27" PICTURE TUBES



Dimensions 17 1/2" W x 16" D
Shipping weight 40 lbs.

NEW IN DESIGN—Mounts Horizontally or Vertically

- ★ Produces a 16-Tube Chassis with 30-Tube performance.
- ★ Latest Intercarrier Circuitry and Multi-section Tubes.
- ★ Standard Neutrode Tuner for Selectivity & Fine Definition.
- ★ 5 Microvolts Sensitivity (20V peak to peak at CRT grid).
- ★ Fast Action AGC for Drift-Free Steady and Clear Pictures.
- ★ 3 Hi-gain Video I.F. Stages for fine Contrast and Details.
- ★ AGC Level Control, for adjusting reception to signal area.
- ★ All Video and I.F. Coils factory pre-aligned and tuned.
- ★ Large 250ma Power Transformer for dependable service.
- ★ 12" Speaker or Twin-cone 6" x 9" Speaker.

Includes **LIFE-SIZE** step-by-step Building Instructions
Most Up-To-Date and Practical Course in Television

COMPLETE KIT with SET of WESTINGHOUSE TUBES

4-6CB6 and 6U8, 6T8, 6C4, 12B117, 6SN7, 6BO6, 6W4, 6K6, 1X2B, 5U4, 6BN4, and 6CG8 included in the Tuner (less CRT)

\$79.97

COMPLETE KIT Including WESTINGHOUSE PICTURE TUBE

17" 70° =17HP4B \$99.42 21" 70° =21YP4A \$108.96 24" =24DP4A \$126.51
90° =17AVP4A 90° =21ALP4A

Also sold on **EASY-PAYMENT-PLAN**—buy LIFE-SIZE Instructions \$2.49 — and buy Parts as you build.



BUILD YOUR OWN CABINET FOR ANY TV CHASSIS

Comparable to the type that Top Mfrs. use on high priced TV sets.

CABINET KIT with 90% of the job done, includes—

FRONT SECTION in Solid Mahogany, Walnut or Blond Korina. **TOP, SIDES, BACK, MASK, SAFETY GLASS, ETC.**

And **EASY-TO-FOLLOW ASSEMBLY INSTRUCTIONS**

Front, Top and Sides supplied in a beautiful Piano Finish • Knob panel undrilled • For matching Mask specify type or number of CRT used. Same price—Mahogany, Walnut or Blond. (Shipping weight 36 lbs.)

21" CABINET KIT

\$24.95

26" H, 25" W, 22" D

FRONT SECTION Only

for WALL INSTALLATIONS Includes Mask, Safety Glass, Decals and Illustrated Instructions. Complete as pictured (undrilled), ready to install—in Mahogany, Walnut, Blond or unfinished. For your own color application to match the decor of the room.

PULSE KEYED AGC KIT

Finest, most accurate and the easiest Kit to install—in any make TV RECEIVER. Complete incl. 6AU6 Tube & Instructions. **\$4.59**

TV PLASTIC OPEN MASKS

21"—Rectangular 18" x 22 1/2" \$2.38
24"—Rectangular 21" x 26" 4.93
27"—Rectangular 21" x 26" 4.93
On 21" specify type number of CRT used

TV SAFETY GLASS in HANDY SIZES

16" x 20" \$3.94 20 1/4" x 25" \$5.47
18" x 22 1/2" 5.16 21" x 26" 5.87

90° CONVERSION KIT

Convert any Size, any make TV RECEIVER to operate the 24" or ANY 90° PICTURE TUBE

COMPLETE SET OF ESSENTIAL PARTS includes matched set of 90° YOKE & 18kv FLYBACK, 30kv FILTER, 6AX4 TUBE, BRACKETS, WIDTH CONTROL, CONDENSERS, RESISTORS, ETC.

Your \$15.98

List Price \$39.75

Incl. CONVERSION MANUAL with Step-by-Step Instructions & Diagrams

Similar Kit for any 70° CRT . . . \$13.97

CARBON RESISTORS—Regular factory stock in Stackpole, I.R.C., Speer, etc.

1/2 WATT 10%	10, 39, 37, 100, 120, 150, 270, 330, 390, 470, 560, 680, 820, 1k, 1800Ω . . .	2¢ ea.
1/2 WATT 10%	2700, 3300, 3900, 4700, 5600, 6800, 8200, 10k, 15k, 18k, 22k, 27k, 33kΩ . . .	2¢ ea.
1/2 WATT 10%	39k, 47k, 50k, 56k, 68k, 82k, 100k, 120k, 150k, 180k, 220k, 270k, 330kΩ . . .	2¢ ea.
1/2 WATT 10%	390k, 470k, 560k, 680k, 820kΩ	1, 1.2, 1.5, 2.2, 6.8, 10, 15 MEGΩ . . .
1 WATT 10%	3.3, 10, 39, 100, 120, 150, 330, 470, 560, 680, 820, 1k, 1800, 2700, 4700Ω . . .	3¢ ea.
1 WATT 10%	6800, 10k, 15k, 22k, 27k, 33k, 39k, 47k, 68k, 82k, 100k, 150k, 470k, 680kΩ . . .	3¢ ea.
2 WATT 10%	3.9, 18, 22, 82, 100, 180, 2200, 4700, 6800, 8200, 18k, 22k, 100k, 470kΩ . . .	4¢ ea.

BROOKS RADIO & TV CORP. AMAZING! EXCITING! CATALOG—FREE
84 Vesey St. Dept. B, New York 7, N. Y.

WANTED!



**EQUIPMENT,
COMPONENTS
OR PARTS!**

The more than 236,000 readers of RADIO & TV NEWS are always in the market for a good used equipment buy. So, if you have something to sell, let RADIO & TV NEWS readers know about it in our classified section. It costs very little: just 50¢ a word, including name and address. Minimum message: 10 words. For further information, write:

Martin Lincoln
RADIO & TV NEWS
One Park Avenue
New York 16, New York

**SPECIAL
PRE-PUBLICATION OFFER
SAVES YOU \$3.00**

ENCYCLOPEDIA ON CATHODE-RAY OSCILLOSCOPES & THEIR USES

(2nd edition)

by JOHN F. RIDER &
SEYMOUR USLAN

On May 1st, 1959, the second edition of this famous book—completely revised, updated and expanded—will be available. The price will be \$21.95 for this 1100 page (8½x11") 'bible' of oscilloscopes. However, you pay only \$18.95 a savings of \$3.00 by reserving your copy at your bookstore, jobber or at the publisher before April 30, 1959. The second edition of the fabulously successful book—the first was considered a classic of useful oscilloscope information by engineers, educators, lab technicians and service technicians—has been greatly expanded to include many new types of oscilloscopes and their applications. *It is completely up-to-date!*

Whatever your field—geophysics, aviation, automotive, medical research, television, audio, computers, automatic control or any other branch of industrial and communication electronics—you'll find the cathode-ray oscilloscope today's basic instrument. The newly revised 2nd edition of this best-selling classic begins with cathode-ray tube construction and theory, then carries you through a thorough analysis of modern oscilloscope circuitry, commercial scope types and maintenance, to a detailed treatment of how the scope is operated for all applications.

The 2nd edition includes more than twice as many new scope applications. It covers the latest in special purpose cathode-ray tubes, new data on probes, related information on scope photography. A new section on pulse measurements has been added and also a new illustrated section on square wave testing. The chapter on "Commercial Oscilloscopes and Maintenance" covers the latest commercial types.

COVERS EVERY PHASE OF OSCILLOSCOPES

Cathode-ray tubes—theory of operation and basic construction—
Basic Characteristics of Cathode-Ray Tubes; Principles of Focusing and Deflection; Deflection Systems in Cathode-Ray Tubes; Screens of Cathode-Ray Tubes.

Oscilloscope Circuitry and Operation—
The Basic Oscilloscope; Vertical and Horizontal Amplifiers; Time Bases; Sweep Circuits; Synchronization; Power Supplies; Auxiliary Equipment and Accessories; Commercial Cathode-Ray Oscilloscopes and Maintenance; Special Purpose Cathode-Ray Tubes.

Oscilloscope Applications—
Basic Signal Observation and Pulse Measurement; Phase and Frequency Measurements; Audio Frequency Circuit Testing; Transmitter Testing; Visual Alignment of A-M, F-M, and Television Receivers; Waveform Observation in Television Receivers; Electrical Testing; Medical, Scientific and Engineering Applications; Oscilloscope Photography.

Waveform Analysis—
Complex Waveforms; Square Waveforms.

Reserve your copy by April 30th at your jobber, bookstore or at the publisher—and pay only \$18.95, a saving of \$3.00.

JOHN F. RIDER PUBLISHER, INC. RTN-3
116 West 14th Street, N. Y. 11, N. Y.

Enclosed is \$ _____. Please send me _____ copies at \$18.95 each.

ENCYCLOPEDIA ON CATHODE-RAY
OSCILLOSCOPES & THEIR USES (2nd
edition, revised) by Rider & Uslan.

Pre-publication price of \$18.95 good until April 30,
1959. After that date, \$21.95. All books returnable
within 10-days for full refund.

Name.....

Address.....

City.....Zone.....State.....

in Canada 5% higher; add state & city taxes where applicable

favorably with the type of decade counter employing four dual-triode binary stages and appropriate feedback networks (see "Basic Decade Counters," RADIO & TV NEWS, August 1958 issue).

The primary area of usefulness of the ring circuit is in gating or commutating applications. In such uses, the ring circuit replaces a multi-position, motor-driven, rotary switch. Not only does the ring counter operate at much higher switching rates than a mechanical switch, but it also eliminates problems of contact wear.

A gating circuit for use with a four-stage ring is shown in Fig. 4. The control grids of the gate tubes (V_1 , V_2 , V_3 , and V_4) are connected to a negative supply which biases them below cut-off. However, one gate tube at a time becomes conductive as the ring circuit switches from stage to stage. The control grid of each gate tube is connected to the left-hand plate of the corresponding ring stage. The ring circuit here is assumed to be of the type shown in Fig. 3.

When a ring stage switches into the zero condition, its left-hand tube is cut off and the plate voltage increases. This increase, coupled to the grid of the gate above cut-off by overcoming the negative bias applied. When, for example, the second stage of the ring is in the zero condition, the grid of the second gate tube (V_2) will be above cut-off. The signal applied to the suppressor (used as a control grid) of V_2 will now appear at the common output.

When the zero condition transfers to the third stage of the ring, gate V_2 drops below cut-off and gate V_3 becomes conductive. At this time, the input signal applied to V_3 will appear at the output. Four different signals may therefore be applied to the inputs of the four gate tubes, and these signals will appear in succession at the common output terminal. Only four stages are shown in Fig. 4, but the circuit can be extended to a greater number of stages.

Circuits of the type shown in Fig. 4 are particularly useful in multiplexing operations because they permit a number of separate signals to be fed through a single transmission channel. In telemetering equipment, for example, the signals from pressure-sensing, temperature-sensing, speed-sensing, or other pickup elements may be fed into gate tubes like those shown in Fig. 4. The output, which will consist of successive samples of the signals from the sensing elements, can then be used to frequency-modulate an oscillator for subsequent transmission to a receiver. For a 1000-cps pulse waveform applied to the ring circuit, as shown in Fig. 4, each gate tube will open for one-thousandth of a second and then close for three-thousandths of a second while the other three gates open in succession. This sampling interval may be changed by varying the frequency of the input pulses to the ring circuit.

NOW ON SALE!



POPULAR PHOTOGRAPHY'S BRAND NEW GUIDE to 35-MM PHOTOGRAPHY!

Here for the first time is a complete guide to 35-MM, prepared by the editors of POPULAR PHOTOGRAPHY, the world's largest selling photo magazine. If you now own a 35-mm camera or plan to buy one soon, this new Annual will be invaluable to you. In it you'll find everything you want to know about 35-MM photography in six big sections covering

THE 35-MM CAMERA—What can you get for \$100? Rangefinder vs. Reflex. What you should know about interchangeable lenses. How good are coupled exposure meters? How to test a 35-MM camera. Buyer's guide.

THE 35-MM TECHNIQUE—Are you getting the most from 36 exposures? How fast is your draw? How to be a human tripod. Professional tips on 35-MM developing and printing. Developing by inspection.

THE COLOR CAMERA—Understanding color filters. A slide show is a picture story. Adding sound. Buyer's guide to slide projectors.

THE 35-MM CAMERA AT WORK—Text and pictures by outstanding photographers, demonstrating the 35-MM camera's amazing versatility.

35-MM ACHIEVEMENTS—A portfolio of outstanding 35-MM pictures showing the best and latest work being done with a miniature camera today. Each picture is accompanied by complete technical data and critical analysis.

FACTS FOR REFERENCE—Charts, tips, data, and tables designed for clipping and filing—all covering important 35-MM subjects.

PLUS: BOB SCHWALBERG ON 35-MM—a 40-page complete guide to miniature photography by the leading writer and technician in the field.

**The POPULAR PHOTOGRAPHY
35-MM ANNUAL**

is now on sale. Only \$1.00
(\$1.25 outside U.S.A.)

Be sure to pick up your copy today!

ZIFF DAVIS PUBLISHING COMPANY
434 South Wabash Avenue, Chicago 5, Illinois

RADIO & TV NEWS

Promoting a Business

(Continued from page 48)

Most dealers have found that service advertising in newspapers does not produce results commensurate with the cost. The most consistent users of newspaper space in advertising TV service are dealers who make a play for business on price. The type of business developed by that kind of advertising is neither stable nor profitable for an ethical dealer. The set owners who fall for "price advertising" usually are looking for something for nothing. They represent a type of business that is neither honestly profitable nor pleasant to handle.

Many small dealers spend too much of their limited advertising monies on telephone directory advertising. While telephone directories are used as a sort of buyer's guide by some people, the average person would rather deal with a business he knows something about than to call in a stranger picked at random from a business directory. When a dealer fails to maintain his lines of communication with customers, however, he will not develop the kind of personal relationship that ties service types of businesses to their customers.

The maintenance of communications with customers between calls for service should be of primary concern to every small dealer. One proven plan is to use a "Thank You for Calling Us" card, which is mailed to every customer a day or two after a service call is completed. This is followed at two- or three-month intervals by inexpensive service mailing pieces—just to keep the dealer's name alive in the minds of his old customers.

Then, the dealer has the constant problem of developing new customers. Static management will rely entirely on customer referrals, chance, and phone directory advertising for new business. Dynamic management will use a systematic mailing program to solicit new business within the economical working area of the dealer's store. All of the receiving-tube manufacturers make available professionally prepared, business-promotion cards that are very effective if they are used systematically. These cards are inexpensive. With a planned system of mailing, a dealer can maintain his lines of communication with his old customers and develop new business. He can do it by devoting only about an hour per week to addressing the cards and mailing them out.

Set manufacturers who solicit service work on their TV sets keep a steady flow of direct mail promotions going out to owners who have filed their warranty cards. Small dealers can profitably take a leaf from their notebooks by using direct mail to solicit business on all brands. It is the least expensive type of business promotion and, when used regularly, will produce the best results.

-30-

"Never Before—So Much!"

IN A GENERAL COVERAGE RECEIVER
FOR AS LOW A PRICE, AS IN THE NEW
HAMMARLUND HQ-145

ONLY
\$15.50 PER MO.
\$26.90 DOWN



or \$269.00 Net Cash

- ★ General Coverage — 540 KCS to 30.0 MCS in four bands. Electrical bandspread on all ham bands within frequency range of receiver.
- ★ Dual conversion from 10.0 to 30.0 MCS.
- ★ Unique combination of adjustable 60 db slot filter and six-position selective crystal filter for endless tuning techniques.
- ★ 11-tube superheterodyne with improved, automatic noise limiter.
- ★ 0.5 microvolt sensitivity on CW with 10:1 signal-to-noise ratio.
- ★ Hammarlund quality design and construction throughout.
- ★ Optional plug-in type 100 KCS crystal calibrator.

Telechron Clock-timer, optional, \$10 extra.
Plug-in 100 KCS crystal calibrator, \$15.95 extra

Write for Detailed Brochure Today!



Please send me Free Catalog . . . and complete info on the Hammarlund line.

RTV/3

NAME: _____

ADDRESS: _____

CITY & STATE: _____

Says
LEO I. MYERSON,
WØGFQ
from the
"World's Largest Distributor
of Amateur Radio Equipment"



- ✓ Easy pay plan — only 10% down.
- ✓ Personalized service
- ✓ Prompt shipment
- ✓ Late serial number stocks of all leading lines of equipment
- ✓ 25 hams to serve you.

FREE 1959 CATALOG

Just off the press, this colorful new catalog contains hundreds of bargains for the amateur, hi-fi enthusiast, experimenter and dealer-serviceman. Send for yours right now.



"Data-Prints" Still Available

A recent inventory check reveals that we have on hand a limited quantity of RADIO & TV NEWS "Data-Prints" (numbers 2 and 3) which originally appeared in this magazine during 1952.

Data-Print #2, entitled "Loudspeaker Enclosure Design Data," covers complete how-to-do-it details on constructing your own high fidelity speaker enclosure. The infinite baffle, corner folded horn, bass reflex, and labyrinth types are all included. In addition, the Data-Print includes a decibel table for both power and voltage ratios which should be of interest to the audiophile.

Data-Print #3, entitled "Television Signal Strength Calculation Charts," gives complete details on how one can predict the signal strength from a TV station. It is extremely helpful in determining the proper antenna to be used. In addition, this Data-Print includes a nomograph for determining multi-layer coil inductance. It is of particular interest to those who design coils to specific inductance.

Since our supply is limited this offer is open on the basis of first-come, first-served. In requesting these reprints include 10¢ per copy to cover the cost of handling and postage. Address your requests to Radio & TV News, Box 2045, Church Street Station, New York 8, New York.

HEADPHONES

Brand new Murdock phones. HI-impedance 10,000 ohm, with standard phone plug Ea. **\$3.45**

POWER TRANSFORMER

Pri. 110V. 60 Cy. Sec. 300-0-300 V. 125 Ma. 12 Volt CT @ 2 Amps. 12 Volts @ 3 Amps; 5V @ 2 Amps/Replacement Transf. for BC 342 Rec. (also for 24V. Use) ea. **\$2.50**
 Pri. 115V. Secs. 320-0-320V. @ 150 Ma. 5V. @ 2 Amps. 2.3V. @ 3 Amps. **\$2.95**
 Pri. 115 or 230V. Secs. 450-0-450 @ 250 Ma. 5V. @ 3 Amps. 6.3V. @ 8 Amps **\$5.95**
 Write for quantity prices

FILAMENT TRANSFORMERS

Pri. 115V. 60 cy. Sec. 6.3V. @ 20 Amps. H-41/4" x W-4" x D-3 1/2" ea. **\$3.50**
 Primary 110V. 60 cy. Sec. 5V. @ 10 Amps. Ins. 10,000 V. Small size. 2 for \$7.50 Each **\$3.95**
 Pri. 115 V. or 230 V. 60 cy. sec. 6.3 000" @ 5 amps **\$1.50**
 Primary 110 volts 60 cycle. Secondary 2 1/2 V. 10 Amps. 10,000 V. Insulation. Suitable for pair of 866 Tubes **\$3.95**

CHOKES—FULLY CASED

10 HENRY 80 Mil (unshielded) 90c
 6 HENRY 150 Mil **\$1.50**
 5 HENRY 200 Mil 1.25
 5 HENRY @ 250 Ma. 2.25
 10 HENRY 315 Mil 3.95
 12 HENRY 500 Mil 5.95
 3 HENRY 630 Mil 3.95
 4 HENRY 900 Mil 12.95
 6 HENRY 600 Mil 8.95

VACUUM CONDENSERS

50 MMF 5KV **\$1.75**
 25 MMF 10KV 2.25
 25 MMF 32KV 5.95
 50 MMF 32KV 7.95
 100 MMF 20KV **\$11.95**

BRAND NEW OIL CONDENSERS

2 MFD 500 VDC .50	1 MFD 3000 VDC .85
3 MFD 600 VDC .60	2 MFD 3000 VDC 1.50
4 MFD 600 VDC .75	4 MFD 2000 VDC 3.50
5 MFD 600 VDC .80	6 MFD 2000 VDC 5.95
8 MFD 600 VDC .95	8 MFD 2000 VDC 5.95
8 MFD 600 VDC .95	2 MFD 3500 VDC 2.50
10 MFD 600 VDC 1.19	2 MFD 3000 VDC 1.85
12 MFD 600 VDC 1.50	2 MFD 4000 VDC 3.50
1 MFD 1000 VDC .60	4 MFD 3000 VDC 6.95
2 MFD 1000 VDC .85	1 MFD 4000 VDC 3.25
4 MFD 1000 VDC 1.35	2 MFD 4000 VDC 6.25
8 MFD 1000 VDC 1.95	4 MFD 4000 " 13.95
10 MFD 1000 VDC 2.50	1 MFD 7500 VDC 6.95
12 MFD 1000 VDC 2.95	5 MFD 7500 VDC 2.95
15 MFD 1000 VDC 3.50	1 MFD 12,500 " 24.95
1 MFD 1200 VDC .45	1 MFD 15,000 " 34.50
1 MFD 1500 VDC .75	.02 MFD 15,000 " 5.50
2 MFD 1500 VDC 1.10	10 MFD 330 AC. 1.95
4 MFD 1500 VDC 1.95	15 MFD 440 AC. 2.50

REDMOND BLOWER

110V. 60 cyc. .3 Amp. 1600 Rpm. 3 3/4" Blower wheel—Outlet 2" Diameter. ea. **\$7.95**
 2 for **\$15.00**

SIGMA 5F RELAY

16,000 ohm in dual 8,000 ohm coils. (Can be paralleled) SPDT adjustable silver contacts. Adjustable armature tension. Operates on 500 microamperes or less ea. **\$3.95**
 Write for quantity prices.

RELAYS

Allied Relay 110 V. AC. DPST ea. **\$1.35**
 Allied 110V. AC 4PDT 10 amp contacts **\$2.50**
 Claire Telephone Type 11,300 ohm coil DPDT cont. 10 amp 125V. Sens. AMA. ea. **\$3.95**
 Hermetically Sealed Relay Coil 110V AC 60 cy SPDT Contacts 5 Amps **\$1.50**
 Sigma Sens. Plug H. S. 16,000 ohms 1 mil. — 1 pole SPDT. #2 pole SPST. ea. **\$1.95**
 6 Volt DC DPDT H.S. **99c**
 12 Volt DPDT DC Relay **\$1.35**
 12 Volt DPST Advance Relay ea. **\$1.05**
 12V. TPDT Ant. relay. Ceramic Ins. ea. **\$1.75**
 G.E. Plug in Relay 5 prong 10,000 ohm coil 1 mil. SPDT ea. **\$2.50**
 G.E. Relay control, contains 8000 ohm relay, sensitivity 2 mils. 10 for \$9.25. ea. **\$1.10**

MINIATURE MICROAMMETER

1 1/2" Square 0-100 Micro. Suitable for grid dipper field strength. S meter. A BARGAIN AT ea. **\$3.95**

PANEL METERS

G.E. WESTINGHOUSE, W.E. SIMPSON, etc. 2" METERS
 0-50 Micro (0-5 scale) 4.95
 0-500 Micro DC 3.50
 0-200 Mil DC 2.95
 0-500 Mil DC 2.95
 0-10 Amps DC 2.95
 0-25 Amps DC 2.95
 18-36 Volts DC 1.99
 0-150 V. AC 3.49
 0-4 Amps RF 2.95
 0-50 Micro 5.95
 0-1 Mil DC (0-3 1/2 KV scale). 3.95

MISCELLANEOUS SPECIALS

N.E. 51 NEON LAMPS. Box of 10 **\$1.00**
 36 OHM 50 Watt Clear Non-Ind. Res. 2 for **\$1.00**
 Replacement 6" phone cord for Standard Headsets **35c**
 UTC OUNCER TRANS. Pri. 100 ohm. Sec. 125,000 ohm. Idea for mike or phone patch—2 for **\$1.00** ea. **59c**
 CUTLER-HAMMER TOGGLE SWITCH SPDT (ST42D) 4 for **\$1.00** ea. **29c**
 Write for quantity prices on all special items

All merchandise sold on a 10 day money back guarantee basis

Min. Order \$3.00—25% with Order—F.O.B. New York
PEAK
 ELECTRONICS COMPANY
 66 W. Broadway, New York 7, N. Y., WO-2-5439

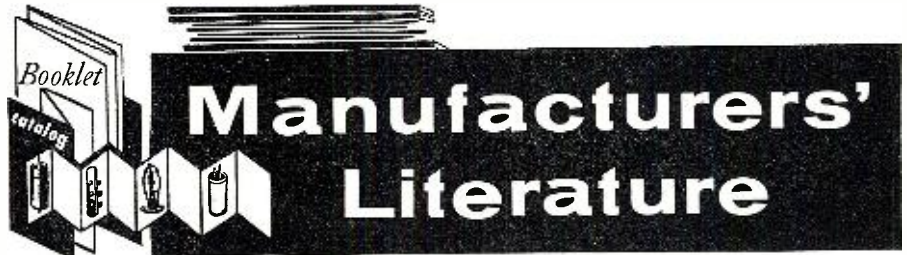

Manufacturers' Literature

COLD DRAWN WIRES

Sylvania Electric Products Inc., Parts Division, has made available a new booklet describing the properties and applications of a wide variety of cold drawn fine wires.

Listing both the physical and chemical properties of the company's alloy, plated, and clad wires, the booklet analyzes factors which determine the most economical and efficient wires for specific applications.

Copies of this new brochure may be obtained from the company, Warren, Pennsylvania.

PORTABLE TV ANTENNAS

JFD Electronics Corp., 6101 Sixteenth Ave., Brooklyn 4, N. Y., is offering a compilation of all portable TV sets, past and present, by model, year manufactured, screen size, and exact duplicate antenna catalogue number.

This new brochure facilitates servicing and installation by quick identification of the proper antenna to match the portable TV set electrically and mechanically. Dealers desiring the catalogue should address their requests to the company.

SILICON CONTROLLED RECTIFIER

General Electric Company, Semiconductor Products Dept., Syracuse, N. Y., has published a 17-page booklet, "Application Notes For ZJ-39A Silicon Controlled Rectifier," which describes circuit fundamentals for the use of the newly developed controlled rectifier.

The publication, ECG-327, covers general circuit design consideration, firing circuit design, and typical applications for the rectifier. It is available free upon request from the company.

HARVEY CATALOGUE

Harvey Radio Company, 103 W. 43rd St., New York 36, N. Y., has just published a new 304-page comprehensive catalogue of electronic products.

The catalogue contains listings of industrial, service, high-fidelity, commercial sound, and broadcast components and equipment. Detailed descriptions, including specifications and prices, are given for all items listed.

Copies of this publication may be obtained by writing to the company.

TRANSISTOR PRIMER

RCA's Semiconductor Products Division has published a new 48-page booklet, "Transistor Fundamentals and Applications," which contains basic information on transistor theory and circuit applications.

Subjects covered in the 16-section brochure include transistor physics,

p-n, p-n-p, and n-p-n junction transistors, the point-contact transistor, transistor characteristics, types of transistors, transistor amplifiers, power amplifiers, servicing transistor circuits, and many other features.

Copies of the booklet, Form No. 4T37, are available through the company's tube and semiconductor distributors.

NEW BUD CATALOGUE

Bud Radio, Inc., 2118 E. 55th St., Cleveland 13, Ohio, is offering its new catalogue.

The brochure is profusely illustrated and describes the firm's entire line of components. In addition, special fabrication facilities are outlined. To insure ease of selection and ordering, complete sizing information is given on each product. Suggestions for uses and applications are also included.

Copies may be obtained by writing to the company.

NEW PLUGS

Cannon Electric Company, 3208 Humboldt Street, Los Angeles 31, Calif., has published a new catalogue describing its line of r.f. plugs.

Catalogue ALRF-1 covers 17 pages and is very well illustrated. It describes the firm's new line of coaxial plugs and cable adapters.

This free brochure may be obtained by writing to the firm's advertising department at the above-mentioned address.

SCIENCE CATALOGUE

Herbach & Rademan, Inc., Industrial Products Division, 1204 Arch Street, Philadelphia 7, Pa., is offering a new, 24-page brochure containing hundreds of products and components for use in electronics, science, engineering, biology, and astronomy.

In addition, the catalogue contains telephone, radio and intercom equipment for use in plants, warehouses, and offices.

Write to the firm for free copies.

ANTENNA SYSTEMS CATALOGUE

Andrew Corporation, 363 E. 75th St., Chicago 19, Ill., has released Catalogue 22, a 96-page product and facility book as a reference for antenna system planners and engineers.

It covers the antennas, antenna systems, and transmission line products of the concern. Included are new developments in high power transmission lines, ground-to-air and telemetry antennas, 21-inch waveguide, microwave and two-way communication antennas, and the introduction of two new sizes of "He-

FEB. SALE! BEST BUYS!

- **STEPPER-RELAY (MFD. BY PRICE ELECTRIC CORP.)** TYPE #8507-1, 7 1/2 Ohms coil resistance. 3 Decks, 15 contacts (on last deck). Can be used for many stepper applications. Worth \$6.50 surplus. Our price only \$3.50. Unused in original manufacturer's cartons.
- **Western Electric Mercury Relay.** WE#D17-1584. SPDT, Mercury-pressure sealed. 4500 Ohm coil. Standard octal base. Best relay available for use in electronic keys, etc. SPECIAL \$4.95.
- **RUSSELL ELECTRIC 3/16 H.P. MOTOR.** 3450 RPM—1.8 Amps continuous duty. Operates on 115 Volts D.C. (Also will operate on 115 A.C.). Weighs 20 1/2 lbs. NEW, in original cartons. Very low price \$5.95 ea. In lots of 10 ONLY \$4.95 each.
- **G.E. STEP-DOWN TRANSFORMER.** Pri: 110 or 220 at 50/60 CPS. Sec: 20 1/2 Volts. Tapped down at 19 1/2 and 18 1/2 Volts. Will handle 1.52 Amps conservatively. Wgt: 5 lbs. Catalog #CG 301114. Size: 3 1/2" H x 3 1/2" W x 3 1/2" D. \$2.50.
- **FTR MINIATURE CHOKE.** Brand new! Hermetically Sealed, 2 Hys. at 130 Ma. 2 3/4" H x 1 1/2" W x 1" D. Stock No. 3CG315-127. Price 40¢.
- **CHOKE.** Approx. 6 Hy. at 500 Ma. (26 ohms D.C. Resistance). Stock No. 6-500 EL. \$3.95 each (2 for \$6.00).
- **WESTINGHOUSE CHOKE.** 10 Hy. at 200 Ma. 77 Ohms D.C. resistance. \$1.90.
- **12 VDC DYNAMOTORS.** Input: 12 VDC at 11 Amps. Output: 420 VDC at 250 Ma. intermittent duty (160 Ma. continuous duty). Also operates from 24 VDC at 5 1/2 Amps. input. Measures 7" x 3 1/2" Dia. NEW \$7.95.
- **FILAMENT TRANSFORMERS.** Pri: 115 or 230 V. Sec: 5 Volts at 10 Amps. Hi-Volt ins. Ideal for 872A's, etc., \$3.75.
- **Single Primary Type.** Pri: 115 VAC Tapped. Sec: 5 Volts at 10 A. (6300 Working Volts Insul.). Ideal for 872A's, etc. Cat. #F90132. \$3.00.
- **CARTER DUO-VOLT DYNAMOTOR.** Operates from 6 or 12 Volts D.C. input. Medium size units puts out 400 Volts D.C. at 375 Ma.—PRICE \$15.95. Large size units put out 620 Volts D.C. at 280 Ma.—PRICE \$19.95. All units are brand new genuine Carter Dynamotors.
- **GENERAL RADIO VARIAC.** Type 200-CUH —2 Amperes—115 or 230 VAC. 50 to 60 Cycles. Brand new in original sealed C.R. cartons. Less knob and dial—\$11.95.
- **National NC-60 Receiver**—Brand New. Factory sealed carton. \$59.95.
- **SIMPSON 0 TO 50 MICROAMMETER**—2 3/4" High x 3" Wide Mounted in Deluxe 6" x 3" x 2 1/4" Bakelite Instrument Case With 12 Position Rotary Switch—Stock #TM-30-1—Special \$4.95.
- **TUBE SPECIALS**—6C21 @ \$10.00 — 4X150A @ \$8.50—807W @ \$1.25.

WRITE FOR LATEST TUBE CATALOG FREE! Receiving, transmitting, special purpose tubes, diodes, transistors, etc. We have a large diversified stock at sensible prices. Export inquiries welcomed.

HOW TO ORDER: Send full remittance and save C.O.D. collection fee.—Include sufficient money for postage.—We refund unused amount.—If you desire shipment C.O.D. include 25% deposit.—Send cash by registered mail. No C.O.D.'s on tube cartons. All Prices F.O.B. N. Y. C. Specify How to Ship.

Open Monday to Saturday—Come in and Browse—We are near Prince St./BMT Station—Spring St./IRT Sta.

BARRY ELECTRONICS CORP.

512 Broadway, Dept. RN-2, N.Y. 12, N.Y.

Phone: WALKER 5-7000

Tes Bench PUZZLER: No. 5

By **BOB ELDRIDGE**

Time out for thinking may mean time saved in less point-by-point testing of individual components.

AS A REAL "DOG," this one was rather mild. With a little logic, it was cleared up without the loss of much time. Nevertheless, it was an interesting exercise in deduction from available facts. As such, it does make the grade as a legitimate puzzler.

The fault: no setting could be found for the sync gating control, shown in the accompanying schematic, that would hold good for all channels. Normally this control is set so that the picture is just stable on the strongest channel available. After such adjustment, stability should then be maintained on all other, weaker channels. All tubes were checked out, but no defects were uncovered in this direction.

Voltages around the 6CS6 sync separator measured just about as given on the schematic when a normally weak and slightly snowy channel was being received. The normal voltages, given by the manufacturer, are indicated on the schematic. As compared to them, actual readings were as follows: point 1, -10 volts; point 2, 41 volts; and point 3, 80 volts. With a stronger signal tuned in, readings became rather higher in amplitude, as follows: point 1, -18 volts; point 2, 44 volts; and point 3, 89 volts.

One input grid of this stage (point 1) is fed the composite video waveform from the video amplifier. Signal was

checked at this point with an oscilloscope, but there was no evidence of sync-pulse clipping here, whether a weak or strong signal was being received. However, on the two channels compared (one strong, one weak), amplitude of this signal varied over a ratio of about 4 to 1.

With the information obtained to this point, it was decided that the next move should be a check of the video amplifier, video output, and a.g.c. circuits. Accordingly the v.t.v.m. was again brought into play for voltage readings. The video amplifier plate, point 4, read 92 volts instead of the specified 100. Point 5 was right at about 200 volts. Point 6 was noticeably down to 118 volts (normal 125); point 7 was barely up (132 instead of 130 volts); and point 8 read a normal 240 volts.

No further tests were made before repair, except for a confirmation check of the suspected component. Not only was the bench man able to diagnose exactly which component had become defective, but he correctly surmised what had gone wrong with it and to what extent.

All you need for this one is straight logic; there are no hidden traps or disguised facts. If you're in a hurry for the answer or want to check it against your own, turn to page 166.

A fault in this circuit caused sync instability with signal-strength variations.

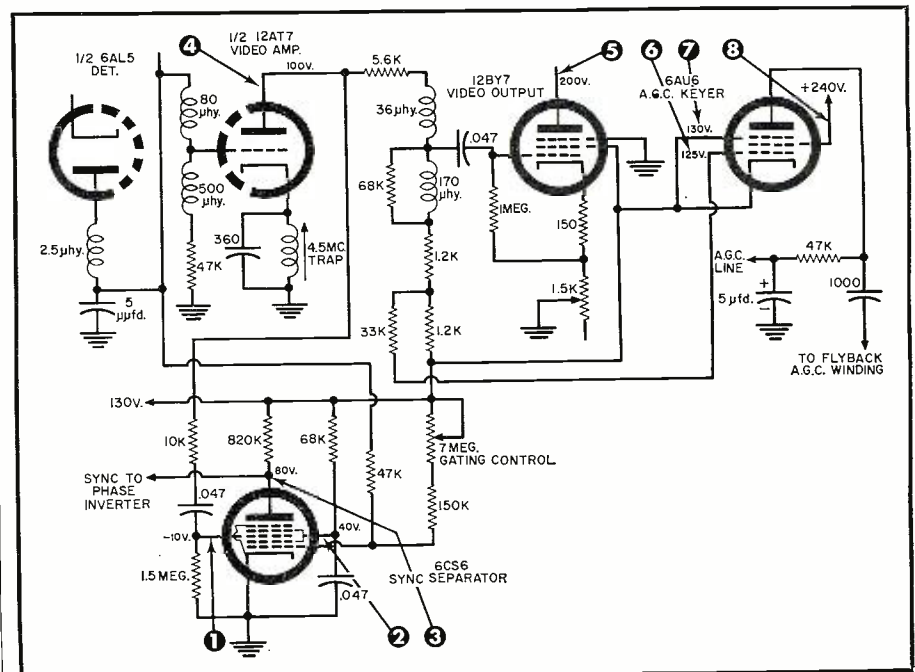

Webcor STEREO Tape Deck from OLSON!

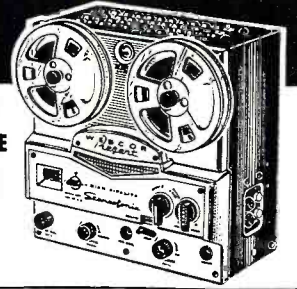

Reg. \$169.95
OLSON PRICE
\$127.45
 Stock No.
AM-137

Olson WHOLESALE CATALOGS



• RADIO • TV
 • TOOLS • HI-FI
 • APPLIANCES, ETC.

SAVE 1/2
UP TO 1/2

Nationally Known Brands...

- GE • RCA • MAGNAVOX
- NORELCO • UNIVERSITY
- JENSEN and many more!

Our \$1,000,000.00 inventory includes 2,500 Super Values in Hi-Fi's, Tools, Appliances, Speakers, Amplifiers, Antennas, Tubes, Etc.—made by manufacturers such as GE, RCA, Magnavox, Bogen, Garrard, University, Norelco, Jensen, Stewart-Warner, and many others.

HERE'S OUR OFFER

Send \$1.00 with the coupon at right and we will mail you the 8 Wholesale Catalog issues, one every 6 weeks. We will deduct the \$1.00 from your first order and still send you the remainder of the catalogs FREE! If you are not 100% satisfied, return the first catalog and we will send you your \$1.00 back.

FREE OF CHARGE!

Order merchandise from this page and we will send you all 8 catalogs (one every 6 weeks) FREE OF CHARGE!
 Catalog subscription offer good only in U. S. A. and possessions.

Records and plays any monaural tape. Also plays back stereo inline (stacked) tapes. Choice of three speeds: 1 1/2, 3 3/4 and 7 1/2 IPS. Plays in either vertical or horizontal position. Two motor controls; record-playback control and fast forward-fast rewind control. Built-in edit key, magic-eye record level indicator, and built-in 2 watt monitor amplifier with control. Numerical type tape counter. Dual built-in preamplifiers for stereo playback have cathode follower output. Gives constant speed and power at all speed settings. Response: 40 to 15,000 cps at 7 1/2 IPS. Size: 8" H x 13" D x 13 1/2" W. With instructions, rubber reel hubs, and interlock line cord. 110 volts 60 cps. Shpg. wt. 26 lbs.

Monarch STEREO Changer

\$21.95 3 for \$65.00
 Stock No. RP-165
 Plays both stereo and monaural discs manually or automatically. Rubber padded, weighted turntable rim driven by four pole induction motor. With turnover high crystal cartridge with dual sapphire stylus. Beige with brown trim. 12 5/8" x 10 3/4" x 11 1/2" v. 60 cps. Shpg. wt. 15 lbs.
 45 RPM Spindle. No. RP-7. \$2.37
 Mounting Base. No. CA-48. \$4.07

Automatic TIME SWITCH

*Handles Up to 30 Amps
\$5.99 3 for \$17.50
 Stock No. X-582
 For control of lights, signs, air conditioners, etc., where a daily on and off operation is required. Rugged synchronous clock type motor. Silver switch contact will handle up to 30 amps. Steel case with nasp. For 110-120 V.. 50-60 cps. Shpg. wt. 4 lbs.

4-Speed MOTOR & TURNTABLE

\$6.73 Reg. \$11.50
 Stock No. MO-6
 Genuine Alliance motor and turntable with 16 1/2", 33 1/3, 45 and 78 RPM speeds. Self starting, quiet rim drive, precision built, 45 RPM built-in retractable, adapter. 110 Volts A.C., 60 cps. Shpg. wt. 5 lbs.

Ronette PHONO ARM

\$2.99 Reg. \$11.50
 Stock No. M-92
 Fine quality Ronette phono arm with latest type high output crystal turnover cartridge with 1 and 3 mil sapphire tipped needles. Spring counter balanced arm. With mounting hardware and instructions. Shpg. wt. 1 lb.

Shield Mark VII STEREO AMPLIFIER

\$38.88 Stock No. AM-122
 Printed circuit, dual 7-watt amplifiers on single chassis. Frequency response 45 to 20,000 CPS ± 1 DB. Speaker output 8 ohms. Controls; tone controls for each channel; loudness control; and balance. Inputs for magnetic or crystal phono, tuner or tape. 3-AX7/ECC83, 2-6BQ5/EI-84, 1-6Z80. Size: 12" x 4" x 10 1/2". Brushed brass control panel with beige crackle finish cage. Shpg. wt. 13 lbs.

Golden Classic Speaker & Enclosure

\$4.88 3 for \$13.50
 Stock No. CA-121
 Ideal extension speaker for use with any radio phono, amplifier, TV, or as remote for most intercoms. Has built-in 4" P.M. speaker with finger-type volume control. Rated at 3 watts; voice coil; 3.2 ohms. Hand rubbed, high gloss finish in walnut with contrasting grille cloth. Can be set on desk or hung on wall with clips supplied. Size: 8" x 5 3/4" x 4 1/8". Shpg. wt. 3 lbs.

WELLER 8200K SOLDERING KIT

\$5.83 ★ U.L. APPROVED
 ★ DUAL HEAT GUN
 Stock No. TL-243
 Instant heat, built-in spot-high, "thermogermatic" control. Includes supply of solder, soldering brush, and soldering aid. Dual heat, 90 and 125 watts. For 110 volts, 60 cycle. Shpg. wt. 3 lbs.
 Extra tips for above. No. TL-244. Pkg. of 2, 25c

Shield HORN TWEETER

\$8.95 Stock No. S-307
 3 for \$26.50
 20 watt driver coupled to horn provides response from 1,000 cps to 17,000 cps. Use with any speaker. Finished in grey and gold enamel. May be mounted in console or on top of system. 8 ohms. Size: 2" x 4 3/4" x 5 11/32". Shpg. wt. 3 lbs.

Magnavox 12" Hi-Fi Speaker System

\$11.88 Reg. \$20.25
 Stock No. AS-404
 Per System 2 Systems—\$22.50
 Custom designed Magnavox system, consists of 12" woofer with special non-polarized capacitor attached to frame, and 2 matched 4" hard cone tweeters. 12" woofer has heavy cadmium plated frame, 1" voice coil with dust cover. 4" "Deep Throat" tweeters reinforce midrange and assure clean, crisp highs. Response 45 to 17,000 cps, with 15 watt power handling capacity. Ideal for stereophonic systems where two matched speaker systems are required. With instructions. Shpg. wt. 8 lbs.

SPECIAL ENCLOSURE FOR ABOVE

\$18.95 Blonde—CA-120
 Mahogany—CA-119
 Completely assembled, wood grain plastic covered, speaker board with holes cut out—ready to install. Size 23 7/8 x 13 1/2 x 19 1/4". Shpg. wt. 26 lbs.

OLSON Stores In:

- AKRON
73 E. Mill St.
- CHICAGO
4101 N. Milwaukee
- CHICAGO
123 N. Western
- CLEVELAND
2020 Euclid Ave.
- PITTSBURGH
5918 Penn Ave.
- MILWAUKEE
423 W. Michigan
- BUFFALO
711 Main St.

IT'S EASY TO ORDER FROM OLSON'S

How to order: Order directly from this ad. For convenience use this order blank. Fill in columns below with quantity desired, stock number, description, and price. You may send remittance with order (include enough for postage or parcel post shipment), or if you prefer send a \$2.00 deposit with your order and Olson will ship C.O.D. for the balance. Mail your order to: T-39 Forge St., Akron 8, Ohio.

MONEY BACK GUARANTEE: Everything you order from Olson is guaranteed as advertised. If you are not more than satisfied, you may return merchandise for cash refund.

Minimum Order \$5.00

Quan.	Stock Number	DESCRIPTION	Price Each	TOTAL

Here is my order for merchandise from this page. This entitles me to the 8 FREE Wholesale catalog issues.

Enclosed find \$1.00 for the 8 Wholesale catalog issues to be sent to me one every 6 weeks.

NAME _____ T-39 Total _____

ADDRESS _____ Add Postage _____

CITY _____ ZONE _____ STATE _____ TOTAL AMOUNT _____

Olson Radio Warehouse

T-39 FORGE ST.
 AKRON 8, OHIO

Advance POWER SUPPLY KIT BARGAIN!

Primary 115V, 60 Cy. Sec. 400-0-400 V. @ 200 Ma., 6.3 VCT @ 4 Amps, 5 VCT @ 3 Amp std. mounting plus 8 HY 200 MA chokes and **\$7.50** DC Power Supply Kit 24 VDC—2 amp output... \$3.95

BUYS . . . RELAYS . . . BUYS

11 VAC	SIGMA 41P 5VDC \$1.49
3 PDT Ceramic	24V VAC... 1.89
Leach #1177... \$ 3.25	110 VAC... 1.89
5 PST hvy dty	5,000-ohm plate
Dunco... 4.15	pull-in @ 2 Ma 2.25
12 PDT Dunco... 10.50	SIGMA 5F
6 VDC, P&B,	16,000-ohm plate
DPST	pull-in @ 1/2 Ma. 1A
12 VDC DPDT plus	& 1C contacts \$3.95
SPST	
10 amp contact 1.39	

LARGE STOCK AC, DC RELAYS

*****Solenoids*****

A-B #200 \$2.95 | 115V 60 cye cont. duty. (2 for \$5.50) | 18 Lb. pull... each \$5.50 (2 for \$10.00)
24V & 230V SORENG IN STOCK!

STEPPING RELAYS

Resettable type, 3 deck, 10 pos. 24 VDC... ea. \$8.95
5 deck, 25 pos, no reset ea. \$6.95
2 deck, 44 pos, no reset ea. \$6.95
5 deck, 23 pos, no reset ea. \$7.50

MCELROY TAPE PULLER

115V AC-DC... **\$8.95**

CHOKES FULLY CASED

6 hy, 100 Ma... \$1.09	Signal Corps Earphones
8 hy, 100 Ma... 1.49	Hi-Impedance Dual Headset, complete w/ headband & Cord. Used terrific Value \$1.79
8 hy, 200 Ma... 1.89	Per Set... 2 for \$3.25
10 hy, 150 Ma... 2.19	
22 hy, 100 Ma... 2.59	

*****Transformers*****

6.3 V FILAMENT	12V, 2 Amp... \$1.19
20 Amp... \$3.95	24 V 2 Amp... 1.29
15 Amp... 2.59	21/2 V Sec. 10 Amps. Ea. for pr. of 5 \$3.95
3 Amp... 1.89	866's... \$3.95
1 Amp... 1.29	

ISOLATION TRANSFORMER

115 V in, 115 V out. Conservatively rated 250 watts. W/cord, plug and receptacle. **\$6.50**
Adjustable for input regulation.

SCOOP! RG-8/U CO-AX CABLE

52-ohm impedance, 100-ft. length... \$6.75
RG-59A/U (72-ohm) with male and female connectors. 50-ft. coils... \$2.45 ea.

OIL CONDENSER BARGAINS

2 Mfd 600 VDC... .45	8 Mfd 1500 VDC \$2.95
4 Mfd 600 VDC... .75	10 Mfd 1500 VDC 3.75
8 Mfd 600 VDC... .90	16 Mfd 1500 VDC 2.95
10 Mfd 600 VDC 1.10	2 Mfd 2000 VDC 1.50
12 Mfd 600 VDC 1.35	3 Mfd 2000 VDC 2.75
20 Mfd 600 VDC 1.75	1 Mfd 3000 VDC 1.95
1 Mfd 1000 VDC .60	2 Mfd 4000 VDC 5.75
2 Mfd 1000 VDC .75	2 Mfd 5000 VDC 8.75
4 Mfd 1000 VDC 1.25	1 Mfd 6000 VDC 5.95
8 Mfd 1000 VDC 1.60	1 Mfd 7500 VDC 6.95
10 Mfd 1000 VDC 1.75	2 Mfd 10000 VDC 29.50
15 Mfd 1000 VDC 2.45	1 Mfd 12500 VDC 24.50
4 Mfd 1500 VDC 1.75	2 Mfd 12500 VDC 32.50

G. E. RELAY CONTROL

(Ideal for Model Controls, Etc.)
Contains a sigma midget 8,000 ohm, relay (trips at less than 2 MA), high impedance choke, bi-metal strip, neon pilot and many useful parts. The sensitive relay alone is worth much more than the total low Price of... **\$1.25** Each 10 for **\$9.95**

SPECIAL! PANEL METERS

1" METERS		3" METERS	
0-200 Micro... \$3.95	0-20 Microamps... \$5.45	0-100 Microamps... 5.45	0-200 Microamps... 5.45
0-1 Ma... 3.50	0-10 VAC... 4.45	0-150 VAC... 4.45	0-1 Ma... 4.45
2" METERS		0-5 Ma... 3.45	
0-1 Ma... \$3.25	0-100 Ma... 3.45	0-250 Ma... 3.45	0-200 VDC... 3.45
0-1.5 amps RF... 2.95	0-100 Ma... 3.45	0-5 amp, AC... 3.45	0-300 DC amps... 6.50
0-5 amps RF... 2.95	0-100 Ma... 3.45	0-300 DC amps... 6.50	0-15 KV DC, 3" w/shunt... 6.25
0-200 Micro, rub-ber mnt... 2.95	0-100 Ma... 3.45	0-15 KV DC, 3" w/shunt... 6.25	0-3 1/2 KV, 3" w/shunt... 6.25
0-30 Ma... 3.25	0-100 Ma... 3.45	0-3 1/2 KV, 3" w/shunt... 6.25	2" 75 Microamps Null Indicator... 5.75
0-300 VAC... 3.25	0-100 Ma... 3.45	0-300 DC amps... 6.50	
-10.0 to +6 DB (Weston) ... 4.50	0-100 Ma... 3.45	0-300 DC amps... 6.50	

115 V, 60 Cye. SELSYNS	RUNNING TIME METER	SELENIUM RECTIFIERS FULL VOLT BRIDGE
High torque. Useful as antenna indicators, etc.	0-9999.9 hrs., 110 V, 60 cye.	30-36 VAC input, 24-28 VDC output, 1/2 Amp... \$1.19
each \$5.95 (\$10.50 pr.)	\$12.45	150 Ma... \$1.29
		1 1/2 Amp... \$1.29
		110V... \$5.19

Special on . . . POWER SUPPLIES!

All wired—Ready to use.
PRI—115 V AC; SEC.—540-0-940 V @ 230 MA; 5.4 & 5 V @ 6 Amps CT; 12 V @ 5 Amps; 40 V @ 50 MA; 6.3 V CT @ 7 Amps.
12 Hy Choke @ 300 Ma
4 10 Mfd. 600 V Cap.
3 5U4's **\$21.95**

PRI—115 V AC; SEC.—540-0-940 V @ 230 MA; 2 1/2 V CT @ 10 Amps; 1—6.3 CT @ 4 Amps; 1—6.3 CT @ 4 Amps; 10 Hy choke @ 250 Ma.
2—6 Mfd. 1500 V Cap. **\$23.95**

*****GR-VARIACS*****

110/220 AC in 0-270 V AC 2 Amps. NEW. Fully Cased. W/ Knob, Dial, 6 Ft. Line Cord. Receptacle; And On/Off Switch. Original Ctns. **\$16.95**

Min. Order \$3.00—25% with order F.O.B. New York 10 DAY GUAR. PRICE OF MDSE. ONLY

Advance Electronics

8 West Broadway • New York 7, N. Y. • RECTOR 2-0270

SOLUTION TO BENCH PUZZLER NO. 5

(See page 164)

THE TIP-OFF on this defect was the grid-cathode bias on the a.g.c. tube. Normally this should be 5 volts (130 volts on the cathode and 125 on the grid). With 132 volts on the cathode and 118 on the grid, bias increased to 14 volts. Since this prevented the a.g.c. tube from keying properly, a.g.c. action was inadequate, although present to some extent. This accounted for the varying amplitude of video signal measured at point 1.

The bench man surmised that the resistor designated as the culprit in the accompanying partial schematic, nominally 1200 ohms, must have gone up "about three times as high as normal" to produce the voltage changes observed. In fact, it was found to be 3300 ohms when measured.

The 6CS6 requires that a reasonably constant level of signal be fed to its grid for proper operation. This is obviously a job for the a.g.c. system.

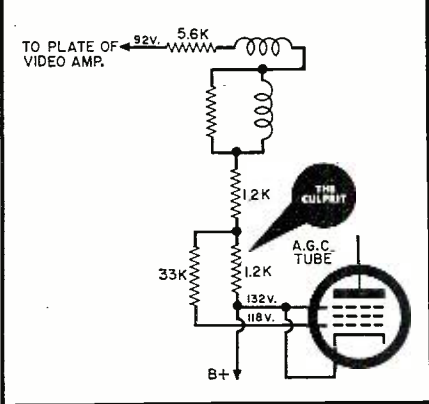

PHOTO CREDITS

Page	Credit
38 (Fig. 1), 40	Barnes Engineering Co.
38 (Fig. 3), 41	Official U.S.A.F. Photo
45 (Figs. 2 & 3A)	Walkirt Co.
46, 47	Heath Company
61 (top)	CBS-Hytron
61 (center), 124	Shure Brothers
61 (bottom)	Glaser Steers
62	Neshaminy Electronic Corp.
63	Janszen Laboratories, Inc.
65	CIBA Pharmaceutical Products Inc.
100, 101, 140	Phlico Corporation
120	Bell Telephone Laboratories
132, 133	Allied Radio Corporation
138	RCA

Answer to Puzzle appearing on page 137

M	U	L	T	I	P	L	I	E	R	R	E	E	D
A	D	I	X	L									E
R	E	A	D	I	N	G	P	E	A	K			C
K	D	N	L	O	T	G	P						A
E	R	D		D	O	T		P	R	O	D		
R	T	T	U	B	E	R	F						E
V	C	X	I	U	B								
S	H	U	N	T									P
E	S	G	N	T									O
A	C	A	L	I	G	N	A						
P	R	I	C	E									P
													O
N													E
V													
M	O	V	E	M	E	N	T						

IT'S QUALITY for STEREO! QUAL-KITS are EASIEST!

	Model STA-30 \$49.95	COMPLETE 30 Watt STEREO 2 CHANNEL AMPLIFIER with the smart, slim look in Hi-Fi, 2 preamps, 2 power amps. Controls all stereo/monaural sources (tapes, records, tuners). Separate ganged base and treble controls, balance control, mode switch, rumble filter. 6 duo inputs, tape output, etc.
	Model 2000 \$22.75	IDEAL SECOND AMPLIFIER for stereo—12 watt Williamson type
	Model 1000 \$31.85	MODEL 2000 12 WATT AMP and Preamp... \$28.50
	Model 1100 \$25.50	Radios Cpl./Tubes & Cabinet
	Model 1200 \$19.95	Model 250—Superhet, AC-DC. 16.45
		Model 350—2 band, BC & SW. 19.75

And they have the finest features and specs. Fully illustrated step-by-step 28-page manual makes assembly a snap! **WRITE FOR FREE CATALOG!** 10% Fed. tax included in all prices. Cover & case optional.

QUALITY-ELECTRONICS

319 Church St. Dept. T3, New York 13, N. Y.

TAPE RECORDERS

HI-FI COMPONENTS SLEEP LEARN KITS

Low cost, high quality recording tape, in boxes or cans.

UNUSUAL VALUES FREE 1959 Catalog

DRESSNER, 69-02 RA, 174 St., Flushing 65, N.Y.

MAIL ORDER HI-FI

You can now purchase all your Hi-Fi from one reliable source and be assured of perfect delivery. Carston makes delivery from NY stock on most Hi-Fi, Recorders and Tape within 24 hours. SEND US A LIST OF YOUR HI-FI REQUIREMENTS FOR OUR WHOLESALE QUOTATION and our FREE wholesale catalogue.

CARSTON STUDIOS

215-TD East 88 St. New York 28, N.Y.

For the tops in value and the best trade-in on High Fidelity equipment.

Check with Arrow!

ARROW ELECTRONICS INC.

DEPT. R

65 Cortlandt Street, New York 7, N. Y. • Dighy 9-4730
525 Joricho Turnpike, Mineola, N. Y. • Pioneer 6-8686

CRYSTAL CONTROLLED CONVERTERS

POLICE • FIRE • COMMERCIAL

For use with 12 V. Transistor type car radios—30-50 MC.

\$24.50

Can be self installed in seconds. Other models for 152-162 MC available. Also complete line of conventional powered converters, tuners and receivers.

A practical converter for emergency use with powered home or auto sets. Tuneable over 8 MC. 26-50 MC or **\$13.95**
108-174 MC... \$13.95

Also available crystal controlled up to 34 MC \$18.95.

WRITE FOR LITERATURE

KUHN ELECTRONICS

20 GLENWOOD CINCINNATI 17, OHIO

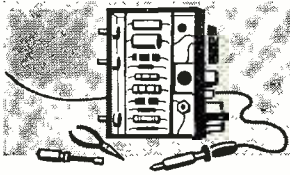

ELECTRONICS MARKET PLACE

RATE: 50¢ per word. Minimum 10 words. May 1959 Issue closes March 9th. Send order and remittance to: RADIO & TV NEWS, One Park Ave., N. Y. C. 16, N. Y.

RADIO ENGINEERING

ELECTRONICS! Associate degree—29 months. Technicians, field engineers, specialists in communications, missiles, computers, radar, automation. Start September, February. Valparaiso Technical Institute, Dept. N, Valparaiso, Indiana.

FOR SALE

RADIO & TV Tubes at manufacturers prices. Guaranteed—Send for free price list. Edison Electronic Tube Co., Menlo Park, N. J.

GOVERNMENT Sells—Surplus Electronics; Walkie-Talkies; Transceivers; Test Equipment; Oscilloscopes; Radar; Voltmeters; Misc.—Fraction of Army costs—Buy direct now from U. S. Government—"Depot List & Procedure" \$1.00—Brody, Box 8-RT, Sunnyside 4, New York.

TUBES—TV, Radio, Transmitting And Industrial Types At Sensibly Low Prices. New, Guaranteed, 1st Quality, Top Name Brands Only. Write For Free Catalog or Call WALKER 5-7000, Barry Electronics Corp., 512 Broadway, New York 12N, N. Y.

TELEVISION Sets \$11.95. Plus shipping. Jones TV, Sanatoga, Pa.

TELEVISION & Radio Tubes, Parts and Supplies Guaranteed. Hi-Quality Tube Co., Inc., 284 Lafayette St., Rahway, New Jersey.

GOVERNMENT Surplus Snooperscopes, parabolic reflectors, Receivers, Transmitters. Picture list 5¢. Meshna, 580 N. Lynn, Malden 48, Mass.

MILITARY communications receivers such as 388's, 389's, 390's, 51J's, both sold and serviced. Gizmos & Such, Still River, Massachusetts.

TRADE-IN TV \$6 up, Also Color. Write, Justis, Newport, Delaware.

DIAGRAMS for repairing radios \$1.00. Television \$2.00. Give make, model. Diagram Service, Box 672-RN, Hartford 1, Conn.

ELECTRONIC Projects—Organs, Timers, Counters, Etc., \$1. each. List Free—Parks, Box 1665A, Lake City, Seattle 55, Wash.

PROFITABLE! Make, Repair, Service Fluorescent Fixtures—Free Catalog. Shoplite, 650N Franklin, Nutley 10, New Jersey.

RADIO Control: Handie Talkie—Basic Transmitter/Receiver Chassis. New, Wired, with Tube \$7.65; Specials: 5" Mu. Metal Scope Shield \$2.25; Teletype Governor Motor 110 volts, 60 Cycle \$5.95; Push-Pull Solenoid 110 volts, 60 cycle or 24 volts DC \$2.45. Send for Free Catalog N: Gyro Electronics Company, 36 Walker Street, New York, N. Y.

\$50 TRANSISTOR Radio \$23.95, Soldering Gun \$8.95 C.O.D., Hypnotizer \$19.95. Transworld Export, Box 929, Indio, California.

LABORATORY Instruments, Surplus Electronics, Engineering, Farhills, Box 26X, Dayton 19, Ohio.

YOUR classified message placed right here will attract the attention of more than 250,000 electronics fans. You'll get fast results. For full details, write to Martin Lincoln, Radio & TV News, One Park Avenue, New York 16, New York.

YOUR tubetester modernized, checks latest series-string tubes accurately. Simple instructions. \$1.00. Adams Laboratory, 68-77 218 Street, Bayside 64, N. Y.

SAVE Money! Don't Buy until you get our price list! All types Radio & TV tubes at Mfrs. prices! 100% Guaranteed! 24-hour Service! Write United Radio Co., Newark, N. J.

BUY Surplus Jeeps, tractors, winches, pumps, tools, hydraulics, electronics, boating, typewriters, generators wholesale direct from government. List and procedure \$1.00. Aviation Surplus, Box 8-ZD, Thomasville, Penna.

SNOOPERSCOPES Naval Nancy U.S./C3. Excellent to New condition with cases \$39.95 others low as \$12.95. Clarence E. Perry, 2930 Longbeach Blvd., Longbeach, Calif.

WANTED

CASH Paid! Sell your surplus electronic tubes. Want unused, clean transmitting, special purpose, receiving, TV types, magnetrons, Klystrons, broadcast, etc. Also want military & commercial lab test and communications gear. We swap too, for tubes or choice equipment. Send specific details in first letter. For a fair deal write, wire or telephone. Barry, 512 Broadway, New York 12, N. Y. WALKER 5-7000.

CYLINDER and old disc phonographs. Edison, Conqueror, Idelia, and Oratorio models. Berliner Gramophones and Zono-o-phones, Columbia cylinder Graphophones, and coin-operated cylinder phonos. Want old catalogues and literature on early phonos prior to 1919. Will pay cash or trade late hi-fi components. Classified Box 50 % Radio & TV News, 1 Park Ave., N. Y. C. 16, N. Y.

LABORATORY Quality Equipment and Military Surplus Electronics bought, sold. Engineering Associates, 432 Patterson Road, Dayton 9, Ohio.

WANTED, ARN-14c, ARN-30, ARC-15, OMNI Sets, and components. CRT-3 Victory Girls, AS313B Loops, ARC-12, 51R2-3, 17L3-4, 18S2-3, R-388/URR, R-390/URR, BC-348, Testsets, "Top Dollar Paid." Bill Slep, W4FHV, Box 178, Ellenton, Florida.

WANTED: Good used V.U. Magnemite magnetic Recorder. Write—U. W. Maupin, 5439 Skiles, Kansas City 29, Mo.

WANTED: Special Purpose Vacuum Tubes: Klystrons, Magnetrons, Power Tubes, Lab Test Equipment: X, S, K bands, Signal Generator, Slotted Lines, Aircraft Communication Equipment. I pay top prices fast! Republic 5-0215. Bob Sanett, 2033 W. Venice Blvd., Los Angeles 6, California.

HIGH-FIDELITY

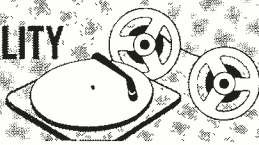

HI-FI Haven, New Jersey's Leading Sound Center. Write for information on unique mail order plan that offers professional advice and low prices. 28 Easton Ave., New Brunswick, New Jersey.

DISGUSTED with "HI" Hi-Fi Prices? Unusual Discounts On Your High Fidelity Requirements. Write: Key Electronics, 120 Liberty St., New York 6, N. Y. EVERgreen 4-6071.

UNUSUAL Values. Hi-Fi components, tapes and tape recorders. Free catalogue TV. Stereo Center, 51 W. 35 St.; N. Y. C. 1.

TAPE & RECORDERS

RECORDERS, Tape Decks, Stereo, Tapes, Accessories, Excellent Values, Catalogue. Efsco, 270S Concord, West Hempstead, N. Y.

RECORDERS, HiFi, Tapes, Free Wholesale Catalog. Carston, 215-R East 88 St., N. Y. C. 28.

AMPEX, Concertone, Crown, Ferragraph, Presto, Tandberg, Pentron, Bell, Sherwood, Rek-O-Kut, Dynakit, Others. Trades. Boynton Studio, 10RT Pennsylvania, Yonkers, N. Y.

TAPE Recorders, Hi-Fi Components, Sleep Learning Equipment, Tapes, Unusual Values. Free Catalog. Dressner, 69-02F, 174 St., Flushing 65, N.Y.

LEARN While Asleep with amazing new Electronics Educator endless tape recorder. Details free. Research Association, Box 24-S, Olympia, Wash.

LABELS for dual-track tape. New type. Positive identification both sides. Secures tape end. Removable. Reversible. No stickum. No rewind. One package with kit: \$1.25 postpaid. Write: Color-Coded Labels, Route 1, Madison, Wisc.

LP Records, Stereodiscs, Stereotapes, 20% Discount Catalog 30¢. SWRS, 1108 Winbern, Houston, Texas.

REPAIRS and SERVICING

ALL Makes High Fidelity Speakers Repaired. Amprite, 70 Vesey St., N. Y. 7, N. Y. BA 7-2580.

SCHEMATIC, Repair Instructions, HiFi's, T.V.'s, Radio's, Phonographs, Tape Recorders, 99¢. Send Make, Model Number. "Radio Coop," Box 5938, Kansas City 11, Missouri.

INSTRUCTION

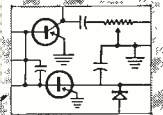

PHOTOGRAPHY For Pleasure or profit. Learn at home. Practical basic training. Long established school. Free booklet. American School of Photography, 835 Diversey Parkway, Dept. 2254, Chicago 14, Illinois.

ENGINEERING Degrees Earned through Home Study. Electronics, Electrical, Mechanical, Civil, Physics. When writing, specify course desired. Pacific International College of Arts and Sciences, primarily a correspondence school. Residence classes also carried. 5719-C Santa Monica Blvd., Hollywood 38, California.

USED Correspondence Courses and Books sold and rented. Money back guarantee. Catalog Free. (Courses Bought). Lee Mountain, Pisgah, Alabama.

COMPLETE Your High School at home in spare time with 62-year-old school. Texts furnished. No classes. Diploma. Information booklet free. American School, Dept. X336, Drexel at 58th, Chicago 37, Illinois.

HELP WANTED

MEN-Women Agents: sensational new money-makers—Beautifully hand-painted plastic personalized photo enlargements, compacts, rings, bracelets, lockets, etc. Simply take orders, pocket 40% commission—we deliver and collect. Sales outfit free. Novello, 3341 North Ave., Chicago 47.

AMERICAN Overseas Jobs. High Pay. Men, Women. Transportation Paid. Free information. Write: Transworld Information Service, Dept. MZ, 200 West 34th St., New York 1.

TECHNICIANS, Engineers are needed now in Florida. Direct information on companies employing, living conditions, business opportunities, etc. Latest 1959 Service Directory Guide. Only \$2.00. Satisfaction Guaranteed. Sampey & Company, 5411 Ira Street, Orlando, Fla.

WANT A Better Job? ? High Pay? ? Overseas—U.S.A. All Occupations. Free information. Employment Headquarters, 79 Wall Street, Dept. 3-E, New York 5.

FOREIGN Employment Information—\$1. Parks, Box 1665A, Lake City, Seattle 55, Wash.

MISCELLANEOUS

DECALS—Trademarks, Service, Sales, etc. Write Allied Decals, Inc., 8378 Hough, Cleveland, Ohio.

FRANCHISES available in selected areas to operate radio, television and electronics schools. Nominal investment, annual potential \$50,000 to \$200,000. Box 569, % Radio & TV News, One Park Avenue, New York 16, N. Y.

RADIO Parts Stores & Hi-Fi Salons! Someone "borrowing" your personal copy of Radio & TV News each month? You ought to be taking advantage of Radio & TV News' convenient re-sale plan. Sell copies in your store—perform a good service for your customers—with no risk involved. For details, write: Direct Sales Department, Radio & TV News, One Park Avenue, New York 16, New York.

SHOPPING GUIDE

Classified

A HANDY GUIDE TO PRODUCTS, NOT NECESSARILY ELECTRONIC, BUT OF WIDE GENERAL INTEREST.

BUSINESS OPPORTUNITIES

PARTNER, returning to college wishes to sell his share 1/2 of thriving TV Service business located in Sarasota, Florida. Price \$4,000. George R. King—1542 First St., Sarasota, Fla.

TV Picture Tube Rebuilding plant and training program still available for many territories. Investment \$8,000-\$11,000. Annual volume \$25,000 to \$100,000. Windsor P.O., 999 N. Main St., Glen Ellyn, Ill.

MANUFACTURERS' Representative—We are fully prepared through long experience to give your products effective sales and service representation in the Southeastern states. Inquiries invited. Ray C. Caudle, P.O. Box 5903, Birmingham 9, Alabama.

YOUR Own home-operated business! Take over your area as our Service Distributor keeping stores supplied. Nationally advertised 28-year-old line pays you 66 2/3% mark-up. Less than \$100 for merchandise, starts you. For samples, highly successful plan, write Novo, Inc., 1168-P Milwaukee, Chicago 22, Ill.

EARN Extra money selling advertising book matches. Free samples furnished. Matchcorp, Dept. MD-39, Chicago 32, Ill.

EARN Extra Cash! Prepare advertising postals. Langdons, Box 41107Z, Los Angeles 41, California.

\$30-\$60 WEEKLY Addressing Envelopes at Home. Instructions \$1 (refundable). Reiss, 210 Fifth Ave., Suite 1102-M, New York 10.

MAILMAN Brings Us \$150 Daily. Operate Home Mail Order Business. Write Publicity, Box 727ZE, Kalamazoo, Michigan.

MAKE \$25-\$50 Week, clipping newspaper items for publishers. Some clippings worth \$5.00 each. Particulars free. National, 81-DG, Knickerbocker Station, New York.

FREE-Lance Photographers register now. No obligation. For application write: Accredited Press, Inc. Lawrence 6, New York.

DETECTIVES—Experience unnecessary. Detective Particulars, Wagoner, 125-Z, West 86th, N. Y.

PHOTOGRAPHY—FILM, EQUIPMENT, SERVICES

5000 8mm.-16mm. Films, Equipment. Free catalogues. International Greenvale, New York.

MESTON'S the preferred 35mm color slides. Top quality, biggest library, best package. Exciting Preview Package four slides hermetically sealed in plastic plus 80 page catalog only \$1.00. Meston's Travels, Dept. RT, 3801 N. Piedras, El Paso, Texas.

FREE! Blackhawk's big sale catalog 8mm., 16mm. movies, 2"x2" color slides. Biggest selection anywhere! Projectors, cameras, supplies—big discounts! Get free, every month, 24-page newspaper size bargain list! Blackhawk Films, Davenport 25, Iowa.

ABSOLUTELY highest quality professional double weight enlargements at dealers' prices. 5x7, 32¢; 8x10, 39¢; 11x14, 85¢. No extra charge for cropping or dodging. New negative from your photo 60¢; minimum order \$1.00. 25% discount on Kodacolor processing. 20% discount on Developing By Kodak. Foto Portrait Co., 1172-R Ogden Ave., New York City 52.

COLOR Economy! Anscochrome, Ektachrome film developing, 80¢ (20 exp. 35 mm rolls mounted). Color prints from transparencies—2 1/2"x3 1/2" six for \$1.00, 3 1/2"x5 six for \$1.50, 5x7 each 75¢, 8x10—\$1.50. Lee-Jan-Lab., Box 382, LaGrange, Illinois.

AMATEURS And Professionals—Extra Cash from your photos. Become a Member of our World-Wide Photo Agency and enjoy innumerable benefits. Send your 8x10 Photos for Presentation to World Markets and Only \$1.00 for Membership number and informative letter. Limited Offer. Photo-World, 538 North Federal, Fort Lauderdale, Florida.

STAMPS & COINS

COIN Magazine 200 pages. Sample 40¢. Scrapbook, 7328 Milwaukee, Chicago 48.

77 DIFFERENT U.S., 100 Different China, 25 Different Czechoslovakia, all 60¢ approvals. Leonards, 11437 North Keeler, Chicago 51.

U.S. Stamps. Giant Bargain Catalog—15¢. Raymax 35-VZD Maidenlane, NYC 38.

UNITED Nations. Five Different 10¢. Approvals. Anderson, 1112 Harrison, San Francisco 3, Calif.

NEW! 1959 Bargain American Coin Catalogue! Revised Prices! Only 25¢. Write: Sullivan, 128 EB East Fourth St., St. Paul 1, Minnesota.

100 LARGE U.S. Commemorative—only 25¢ with approvals. Wm. Rice, 87 Washington Ave., Kingston 43, N.Y.

508 DIFFERENT Worldwide from Madagascar, Macao, Guinea, etc., cataloging over \$15.00 on 35¢. Approvals. Littleton Stamp Company, Littleton Q17, New Hampshire.

1000 DIFFERENT Worldwide Stamps \$1.25. Valued over \$20.00. Universal, Box 6, Kenosha 18, Wisconsin.

GIGANTIC Collection Free! Includes triangles, early United States, animals, commemoratives, British Colonies, high value pictorials, etc. Complete collection plus big illustrated magazine all free. Send 5¢ for postage. Gray Stamp Company, Dept. Z2, Toronto, Canada.

307 WORLDWIDE Different stamps only 35¢. Approvals. Niagastamp, St. Catharines 690, Ontario.

MISCELLANEOUS

FLYING Saucers Latest Reports, Articles. Subscribe for "The Saucerian" magazine. Six issues \$2.00. Saucers, Dept. 4, Box 2228, Clarksburg, West Va.

WHY not be the person you wish to be, realizing the fulfillment of your desires? Good things are attracted to you when you know and apply the rules. Read: Man, God's Helpmate \$1.25; Using the Magnetic Forces of Your Mind \$3.00 postpaid. I.P. Society, Dept. Z, P.O. Box 42187, Los Angeles 42, California. (In Calif. add 4% sales tax.)

The Law of Life Revealed and How to Apply it, \$1.00. The Open Way, Celina, Tennessee.

BARBELLS, Courses, Apparatus. Catalogue 10¢. Good Barbell Co., Dept. D, Siloam Springs, Arkansas.

OPTICAL Bargains—Request Free Giant "CJ". 96 pages—Astronomical telescopes, Microscopes, Lenses, Binoculars, Kits, Parts. Amazing war surplus bargains. Edmund Scientific Co., Barrington, New Jersey.

BINOCULAR specialists, all makes required. Authorized Bausch Lomb, Zeiss, Hensoldt, Bushnell dealer. Tele-Optics, 5514 Lawrence, Chicago.

ENGINES OHV V8's. All Popular Makes 1956, 1959. Ledbetter Enterprises, 1015 West 17th, Texarkana, Texas.

PRINTING Presses, Type, Supplies, List 4¢. Turnbaugh Service, Mechanicsburg, Pa.

"WINEMAKING; Beer, Ale Brewing." Illustrated. \$2.00. Many others. Eaton Books, Box 1242-TC, Santa Rosa, California.

YOUR classified message placed right here will attract the attention of more than 250,000 electronics fans. You'll get fast results. For full details, write to Martin Lincoln, Radio & TV News, One Park Avenue, New York 16, New York.

PHONOGRAPH Records cheap, postpaid. Catalogue. Paramount, Box 242-N, Williamsport, Penna.

INDEX OF Advertisers

MARCH 1959

While every precaution is taken to insure accuracy, we cannot guarantee against the possibility of an occasional change or omission in the preparation of this index.

ADVERTISER	PAGE NO.	ADVERTISER	PAGE NO.	ADVERTISER	PAGE NO.
Aero Products	126	Electro-Voice, Inc.	4th Cover	Picture Tube Outlet	155
Advance Electronics	166	Electronic Chemical Corp.	152	Pilot Radio Corporation	14
Airex Radio Corporation	96	Eric Resistor Corporation	96	Platt Electronics Corp.	140
Allied Radio Corp.	9, 106, 107, 108, 109	Everest Records	125	Progressive "Edu-Kits" Inc.	137
Appliance Servicemen's Purchasing Group	91	Fair Radio Sales	143	Quality Electronics	166
Arkay	127	Ferrodynamics Corporation	2nd Cover	RCA Institutes, Inc.	29
Arrow Electronics, Inc.	166	G & G Radio Supply Co.	153	R W Electronics, Inc.	163
Arrow Sales, Inc.	147	Garrard Sales Corp.	123	Rad-Tel Tube Co.	115
Ashe Radio Co., Walter	149	General Electric Company	30	Radio Corporation of America	12, 13, 21, 89, 111
Audio Devices, Inc.	95	Globe Electronics	104	Radio Shack Corp.	121
B & K Manufacturing Co.	75	Goodheart Co., R. E.	147	Reeves Soundcraft Corp.	141
Baltimore Technical Institute	136	Grantham School of Electronics	15	Rex Radio Supply Co.	134
Barry Electronics Corp.	164	Greentee Tool Co.	163	Rider Publisher, Inc., John F.	160
Bell Telephone Laboratories	28	Harvey Radio Co., Inc.	138	Rinehart & Co., Inc.	142, 145, 154
Bendix Radio	145	Heath Company	76, 77, 78, 79, 80, 81, 82, 83, 84, 85, 86, 87, 88	Sams & Co., Inc., Howard W.	23, 128
Blonder-Tongue Laboratories, Inc.	8	Henshaw Radio Supply	149	Sarkes Tarzian, Inc.	22
Brooks Radio & TV Corp.	144, 159	Hickok Electrical Instrument Co., The	120	Seco Manufacturing Co.	124
Burroughs Corporation	24	Hi-Mu Electronics Sales Co.	152	Seg Electronics	129
Burstein-Applebee Co.	129	IDM Corp.	98, 99	Sonotone Corp.	94
CBS-Hytron	34	Indiana Technical College	151	Sparks Radio Supply	104
C & H Sales Co.	136	JansZen Loudspeakers	92	Spaulding Products Company	110
Canadian Institute of Science & Technology Ltd.	134	Key Electronics Co.	149	Spencer-Kennedy Laboratories, Inc.	146
Candee Co., J. J.	154	Krylon	96	Sprayberry Academy of Radio-Television	31
Candler System Co.	155	Kuhn Electronics	166	Standard Line Electric Company	159
Capitol Radio Engineering Institute	19, 20, 135	Lafayette Radio	112, 113	Standard Surplus	105
Carston Studios	166	Lampkin Laboratories, Inc.	104	Stromberg-Carlson	93
Century Electronics Co., Inc.	102, 103	LeKtron	151	Supreme Publications	105
Champion DeArment Tool Company	158	McGraw-Hill Book Co.	155	"TAB"	148
Channel Master Corp.	26, 27	McNeil Electric & Equipment Co.	151	Terado Company	148
Charles Engineering, Inc.	146	Mallory & Co., Inc., P. R.	10, 11	Texas Crystals	136
Cleveland Institute of Radio Electronics	25	Micro Electron Tube Co.	139	Tri-State College	155
Columbia Electronics	155	Milwaukee School of Engineering	90	Triplet Electrical Instrument Company	3rd Cover
Columbia LP Record Club	7	Moss Electronic, Inc.	116, 117, 118, 119	University Loudspeakers, Inc.	32, 97
Communications Equip. Co.	148	NCB Laboratories	134	Valparaiso Technical Institute	149
Cotter, Herman E.	147	National Radio Institute	3	Video Electric Company	131
Coyne Electrical School	139, 146, 150	National Schools	17	Weller Electric Corp.	18
DeLo Radio	6	Neshaminy Electronic Corp.	92	Wen Products, Inc.	114
DeVry Technical Institute	5	Olson Radio Warehouse	165	World Radio Laboratories	161
Dressner	166	Paco Electronics Co., Inc.	16	Xcelite, Incorporated	154
Dynaco Inc.	122	Peak Electronics Company	162	Zalytron Tube Corp.	123
EICD	35, 36				

FASTEST

Now, in New Triplett Model 3414 you will recognize another answer to a long standing need—a **FASTER**, more versatile tube tester.

- * All switch settings can be made before the tube warms up; you are ready to test as soon as the filaments reach proper temperature.
- * Rejects burned-out tubes instantly without waiting for the filament to heat.
- * Complete flexibility for new tube setups; plus the non-obsolence factor.
- * A few simple switch settings give the complete and accurate story of tube capabilities.
- * Modified plate conductance circuit—for closer correlation to tube characteristics.

Neon Indicator shorts test—NEW, fast and accurate. Slightest inter-element shorts show while the cathodes are hot.

New variable leakage test from 0.3 megohms to over 3 megohms.

Checks all today's and tomorrow's tubes (including new series filament tubes). With BV adapter TV picture tubes can be tested in the set.



Two other Triplett testers—

Burton Browne Advertising



To the left for the ultimate in laboratory quality testing Model 3423 at \$199.50 Mutual Conductance Tube Tester.

For full information see your Triplett distributor or write

New Model 690-A Transistor Tester Leakage and Gain test for all low and medium power PNP and NPN type transistors—\$29.50 net.



TRIPLETT ELECTRICAL INSTRUMENT COMPANY • BLUFFTON, OHIO



the case of the stereo

HUMMMMINGBIRD

or MAGNETIC vs CERAMIC

You may have been reading many controversial advertisements as to the merits of various stereo cartridges... namely, the magnetic version vs. the ceramic version. Qualified claims are made by their manufacturers... and most are accurate. But how a specific cartridge *sounds* in your stereo system is really the criterion. Let's consider the real facts:

..... Audio Engineers agree that magnetic
IT'S A FACT! stereo cartridges are excellent, costly
... but burdened with *hum*. Tests prove that the new Electro-Voice Magneramic cartridge is completely hum-free. No motor or line hum can possibly be introduced to mar soft record passages, because the Magneramic is *non-inductive*.

..... The simpler the
IT'S AN ENGINEERING AXIOM! design of a precision product, the less chance there is of manufacturing defect. Magnetic stereo cartridges are far more complicated than the comparable Electro-Voice Magneramic stereo cartridge. With E-V, you are assured years of trouble-free, high fidelity stereo performance.

..... When the Electro-Voice corps of
IT'S POSITIVE! 60 engineers began intensive scientific stereo studies, they had the choice of either designing a magnetic or a ceramic cartridge. Knowing that two of the most vital factors for true audio reproduction were lack-of-hum and trouble-free performance, they took the positive approach and produced a stereo cartridge incorporating simple elements permitting positive, stable control for uniform output.

And so, with the advent of stereo, Electro-Voice introduced an entirely new concept in ceramic cartridges... a true high-fidelity series...

THE E-V MAGNERAMIC



which will consistently outperform the best magnetics and do away with the 'hummingbird' in your stereo system.

Choose the Magneramic... a new improved E-V stereo cartridge which plugs directly into magnetic inputs. See why it's the choice of so many FM stations for critical stereo broadcasts:

- NO HUM
- BEST CHANNEL SEPARATION
Over 25 db isolation between channels
- HIGHEST COMPLIANCE
Horizontal and vertical compliance equal to or surpasses the best magnetic cartridges
- WIDEST RANGE FREQUENCY RESPONSE
Far in excess of any monaural (monophonic) or stereo record
- FLATTEST RESPONSE TO WESTREX 1A VELOCITY CURVE
From 20 cps to beyond audibility
- HIGH 20 MILLIVOLTS OUTPUT
All the voltage you need... and then some
- PROVEN SUPERIOR
for conventional monophonic records as well as stereo records
- GUARANTEED OR YOUR MONEY BACK
We invite you to try an E-V Magneramic, with E-V's unqualified guarantee backed by over 30 years as a manufacturer.

Give the Magneramic a thorough listening test. If for any reason you aren't completely convinced of its superiority, your FRANCHISED Electro-Voice dealer is authorized to give you a full refund.

Step up to the excitement of stereo... step up to Electro-Voice Stereo... the industry's standard. Over a half-million in use, more than the total of all other stereo cartridges combined, attest to its acceptance as stereo's standard. Choose either the E-V Magneramic for magnetic inputs or the E-V Standard Stereo Cartridge for non-magnetic inputs.

21 MD with 0.7 Mil Diamond Stylus, net \$19.50; 26 MDST Turnunder with 0.7 Mil Diamond Stylus, and 3-Mil Sapphire Stylus for 78 R.P.M.'s, net \$22.50; 21 MS with 0.7 Mil Sapphire Stylus, net \$9.90; 26 MST Turnunder with 0.7 Mil Sapphire Stylus, and 3-Mil Sapphire Stylus for 78 R.P.M.'s, net \$12.90.

GOOD STEREO DEPENDS ON THESE VITAL FEATURES: FREQUENCY RESPONSE, 20-16,000 cps flat (Westrex 1A); ELEMENTS, 2 PZT Ceramic; OUTPUT VOLTS, 20 mv. Nominal; COMPLIANCE, 2 x 10⁻⁶ cm/dyne; WEIGHT, 3.4 Grams; TRACKING FORCE, 4-6 Grams; CHANNEL SEPARATION, 25 db at 1 KC; MOUNTING, EIA (RETMA) Standard 1/2" x 7/16" Center; STYLUS, .7 Mil (Diamond or Sapphire); OUTPUT TERMINALS, Standard .050 Connectors; IMPEDANCE OR LOAD, 22,000 ohm or higher magnetic input.

See your High Fidelity Specialist or write Dept. AD-2



Electro-Voice
INC., BUCHANAN, MICHIGAN

Over 1/4 Million in Use...
MORE THAN ALL OTHERS COMBINED