

150 Radio Hook-Ups

Prepared by the staff of

**RADIO
NEWS**

PRICE
25¢

THE E. I. CO.
NEW YORK CITY

150 RADIO HOOKUPS

BY THE STAFF OF



Published by
THE E. I. COMPANY
37 Vesey Street
New York City

Printed in the United States of America

Copyright by
THE E. I. COMPANY
1926



















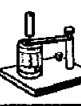



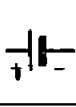



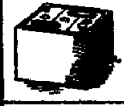













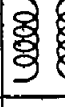
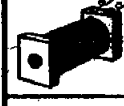

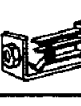





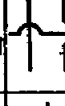

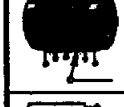
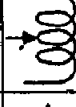





All rights reserved, including that of translation into foreign
languages, including the Scandinavian

Radio Symbols

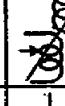
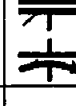
THE radio set owner always wants to know and learn more about his receiver—how it operates, what the various parts do and in what manner they function. Invariably, he seeks recourse to well-written and popular articles, describing these things in detail. In many cases, though the reader really understands the line of thought, he fails to

comprehend the wiring diagram, and looks on it as a meaningless maze. To alleviate or remedy this condition, we are presenting to our readers the very latest compilation of up-to-date radio symbols, covering the entire field of instruments and apparatus used in receiving circuits.

This page with its invaluable contents will be found most instructive and enlightening.

| | | | | | | | | |
|---|------------------------|---|---|-----------------------|---|---|-------------------------------|---|
|  | ANTENNA |  |  | VOLT-METER |  |  | SWITCH FILAMENT |  |
|  | LOOP ANTENNA |  |  | CRYSTAL DETECTOR |  |  | SWITCH S.P.S.T. |  |
|  | "A" BATTERY DRY CELL |  |  | GRID LEAK FIXED |  |  | SWITCH S.P.D.T. |  |
|  | "A" BATTERY STORAGE |  |  | GRID LEAK VARIABLE |  |  | SWITCH D.P.S.T. |  |
|  | "B" BATTERY |  |  | JACK SINGLE CIRCUIT |  |  | TRANSFORMER AUDIO FREQ. |  |
|  | BUZZER |  |  | JACK DOUBLE CIRCUIT |  |  | TRANSFORMER RADIO FREQ. |  |
|  | CHOKE COIL AUDIO FREQ. |  |  | JACK FILAMENT CONTROL |  |  | TRANSFORMER TUNED RADIO FREQ. |  |
|  | INDUCTANCE COIL FIXED |  |  | NO CONNECTION |  |  | VACUUM TUBE |  |
|  | INDUCTANCE COIL TAPPED |  |  | POTENTIOMETER |  |  | VARIOMETER |  |
|  | CONDENSER FIXED |  |  | RECEIVERS TELEPHONE |  |  | VARIO-COUPLER |  |
|  | CONDENSER VARIABLE |  |  | RHEOSTAT |  |  | LIGHTNING ARRESTER |  |
|  | CONNECTION |  |  | RESISTANCES |  |  | GROUND |  |

Circuit Analysis

THERE are so many circuits—good, extra good and nefarious ones—that a beginner is most apt to become bewildered and throw up his hands and exclaim, "I give up." Whether that startled you at the time you entered the radio game—a most entrancing hobby, to be sure—does not mean that you are to be classed with the well known "dumbbells" that infest the radio art and go about acclaiming their superior intellect—and inferiority complex! Rather, you are to be pitied. For since the beginning, there has been no fully compiled or completely classified list of all these circuits which are continually the bane of one's existence.

Perhaps there is a very good reason why such a list has not been compiled. Perhaps, it is the very fact that the progress of radio has been so rapid in the past few years, that it would have been an endless and unceasing task to consolidate all of them into a handy classification. However, the information which appears for the first time, in this article, will be found to be of real value to the experimenter and radio man. It will serve as an unerring guide and be instrumental in showing what has been done in the way of improving radio reception and will probably open many new channels which have remained dormant because these channels have been obscured by lack of sufficient realization of existing conditions. Therein lies the real value of this work.

There are but five avenues in which to classify all the existing receiving circuits.

Circuits can be, fundamentally, of the non-regenerative, regenerative, radio frequency, super-regenerative or super-heterodyne types. To date, there are no other classes in which circuits may be placed, but undoubtedly, although many leading engineers believe the contrary, it is probable that new classifications will be evolved. The following list should be copied and filed away, so as to be at hand whenever necessary. It is advisable to memorize it, since the information is well worth knowing and having at instant command.

With two fundamental circuits to start with, in the non-regenerative classification; and the choice of eleven different types of detectors; five fundamentals and two detectors in the regenerative classification; seven fundamentals with seven separate modifications of but one of them in use with three types of detectors in the radio frequency classification; three fundamentals in use with three types of detectors in the superregenerative classification and four fundamentals with the use of four different types of detectors in the super-heterodyne classification, it is indeed not surprising that many are at a loss which of so many to choose. Again, one should not lose sight of the fact that audio frequency amplification can be of the transformer, resistance and choke coil coupling types. Also, push-pull transformer coupling, push-pull resistance coupling and power amplification can be used. All this complicates matters more, but by careful analysis it is not only possible to designate the proper

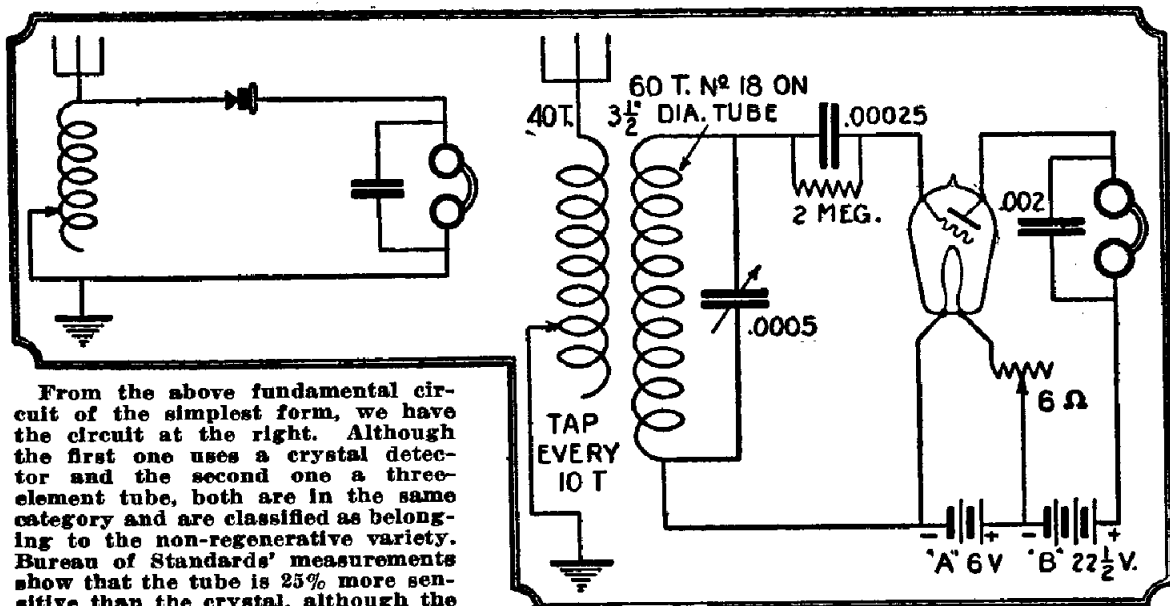

From the above fundamental circuit of the simplest form, we have the circuit at the right. Although the first one uses a crystal detector and the second one a three-element tube, both are in the same category and are classified as belonging to the non-regenerative variety. Bureau of Standards' measurements show that the tube is 25% more sensitive than the crystal, although the latter gives 50% more clarity.

classification of the circuit but with a little practice one can readily resolve it into its simplest fundamental form.

On these pages we will find a fundamental circuit and one of its best practical forms and the experimenter need but follow the given specifications so that he can build up the receiver.

It is taken for granted that the reader has sufficient knowledge of circuits to know the fundamental principles underlying their operation. If he has not, recourse should be had to some of the excellent books now on the market and obtainable at nominal cost.

With but a slight stretch of the imagination, one can readily perceive the almost infinite number of circuits possible to make; and although the three element tube is by far the most popular form of detector and amplifier, with the crystal detector as a far distant second, still the numerous circuit combinations that are possible could not be consummated and built up by the average experimenter in years.

Reflex circuits alone—there are hundreds of them—find great favor in the eyes of the experimenter. Then again the conductively, inductively and capacitively coupled antenna systems further increase the number of combinations.

1. NON-REGENERATIVE.

- A. Auto-coupled.
- B. Loosely-coupled.
- 1. Coherer.
- 2. Crystal (with and without battery).
- 3. Microphonic.
- 4. Electrolytic.
- 5. Magnetic.
- 6. Colloidal.
- 7. Tikker.
- 8. Heterodyne.
- 9. Two element tube.
- 10. Three element tube.
- 11. Sodian.

2. REGENERATIVE.

- A. Auto-coupled.
- 1. Inductive feed-back.
- 2. Capacitative feed-back.
- B. Loose-coupled.
- 1. Inductive feed-back.
- 2. Capacitative feed-back.
- C. Regenerative reflex.
- 1. Three element tube.
- 2. Four element tube.

3. RADIO FREQUENCY.

- A. UNTUNED.
- 1. Resistance coupled.
- 2. Impedance coupled.
- 3. Transformer coupled.
- B. TUNED.
- 1. Impedance coupled.
- 2. Transformer coupled.
- a. *Loosely coupled.*
Positive feed-back.
- b. *Closely coupled.*
Negative feed-back.
Losser.
Absorption circuit.
- c. *Neutralised.*
Hazeltine.
Rice.
Farrand.
- C. REFLEX.

- 1. Straight.
- 2. Inverse.
- 1. Two element tube.
- 2. Three element tube.
- 3. Four element tube.

4. SUPER-REGENERATIVE.

- A. Straight.
- A. Flewelling.
- C. Autoplex.
- 1. Two element tube.
- 2. Three element tube.
- 3. Four element tube.

5. SUPER-HETERODYNE.

- A. Straight.
- 1. Tropadyne.
- 2. Ultradyn.
- B. Second Harmonic.

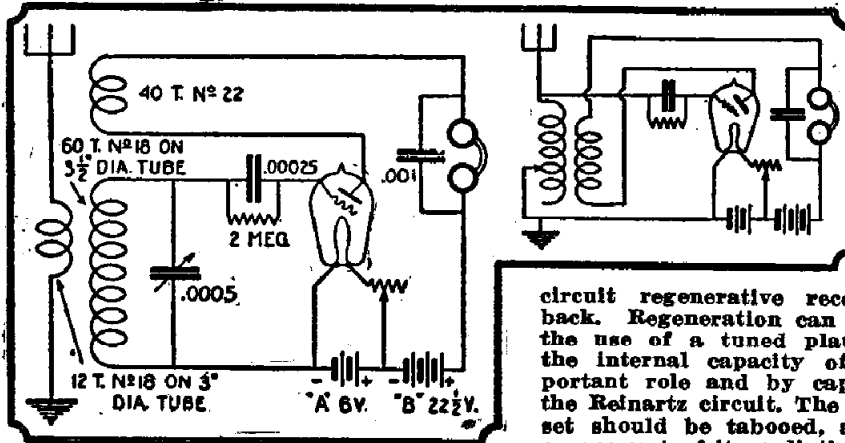

gives complete details for the construction of the set which is familiarly known as the old standby three-circuit regenerative.

With the discovery of the three-element tube came the regenerative detector. Regeneration increases the volume and sensitivity of a set in a very large degree. There is one drawback, however, that of radiation when the set starts to oscillate due to over-regeneration. The above diagram shows a three-

circuit regenerative receiver using tickler feed-back. Regeneration can also be obtained through the use of a tuned plate system, in which case the internal capacity of the tube plays an important role and by capacitatively feed-back as in the Rehnartz circuit. The single circuit regenerative set should be tabooed, as it is a persistent pest on account of its radiating qualities. The diagram

150 RADIO HOOKUPS

1. Electrolytic detector.
2. Two element tube.

3. Three element tube.
4. Four element tube.

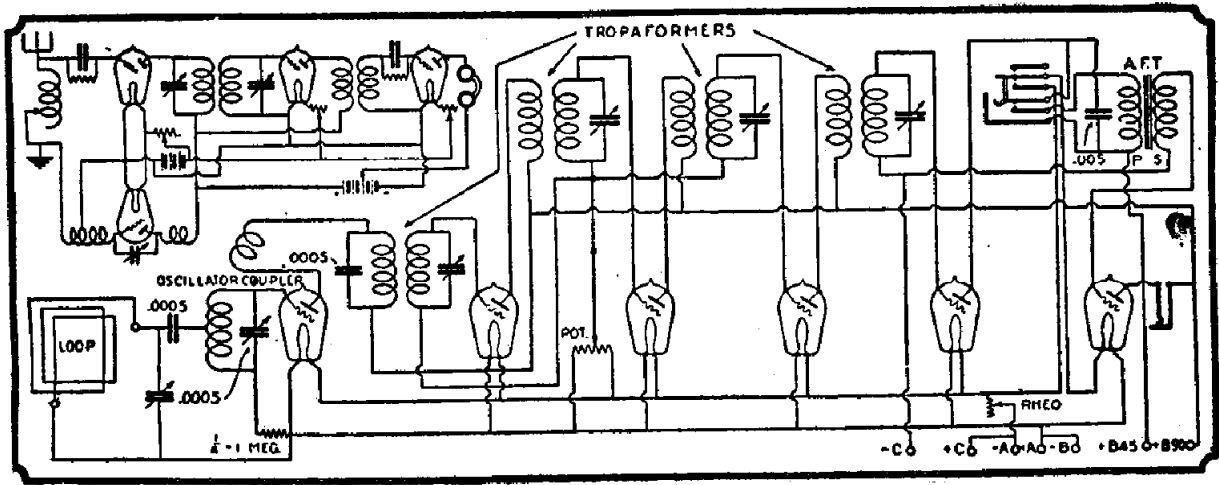

The super-heterodyne is a circuit which works on an entirely different principle from those described previously. It is safe to say that the super-heterodyne is one of the most selective sets and for this reason is used by many amateurs for short-wave (100 to 200 m) work. If reference is made to the fundamental circuit, it will be seen that the circuit is comprised of a first detector a heterodyne oscillator, one stage of intermediate frequency transformation, and a second detector. The success of the super-heterodyne lies in the design of the intermediate transformers which raise the wave-length of the incoming signals and thus allow more accurate tuning. The well-known Tropadyne adaptation is shown here. This circuit does not radiate, and, using a loop, gives very good results.

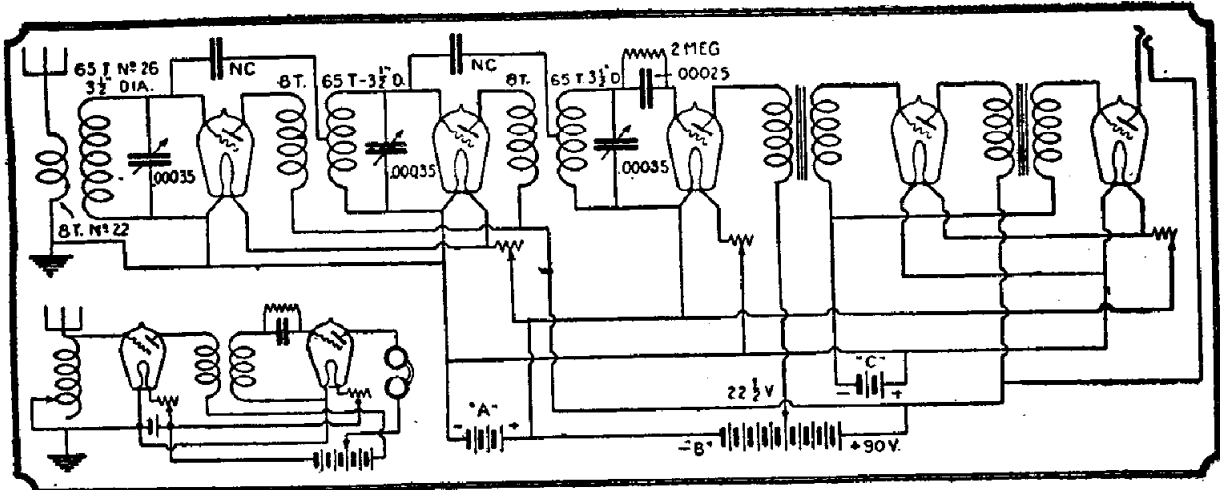

The field of the radio frequency amplifier circuit is by far the largest and the great number of "dynes," "plexes" and reflexes are the result of various combinations using radio frequency amplification. Note that the fundamental circuit is represented as one stage of tuned R.F., auto-coupled with untuned transformer coupling to a non-regenerative detector. The adaptation can be recognized as the neutrodyne circuit, which has given much satisfaction. In analyzing the neutrodyne, it is at once seen that it belongs to the radio frequency classification and employs tuned transformer coupling, is neutralized by the Hazeltine method and uses, in combination, a non-regenerative detector and two stages of transformer coupled audio frequency amplification.

A very interesting development is the super-regenerative receiver. The super-regenerative set works on an entirely different principle from that of its predecessor. The circuit is such as to allow a condition whereby oscillations of both an audio and radio frequency nature are set up. Due to the audio frequency component, the grid assumes a "negative resistance value" and passes an enormous amount of current, thus greatly intensifying an incoming signal. Of course, there is the problem of coping with the audio frequency "squeal," as it is called, but the circuit has been perfected to an extent where it is hardly noticeable. The well-known Autoplex receiver is shown as the adaptation of the fundamental. The circuit, which is simplicity itself, is capable of excellent results. Note absence of capacities.

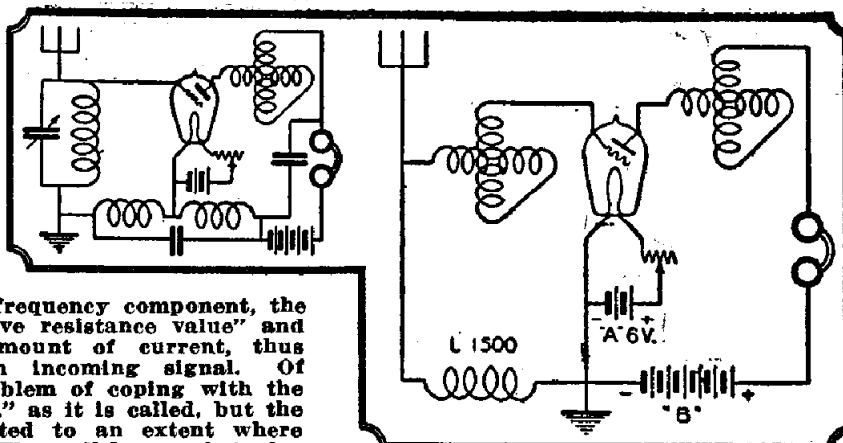

Crystal and Non-Regenerative Hook-Ups

Circuit No. 1. shows a crystal detector circuit using a two slide tuning coil as the tuning element. The antenna is connected to one of the sliders and the ground to the other so that the inductance between them may be varied. This arrangement permits the antenna circuit to be tuned and also the coupling between the primary and secondary circuits to be changed to increase the selectivity. The secondary circuit is composed of the section of the coil comprised between the top of the coil and the slider connected to the ground. The condenser C is a by-pass condenser of about .001 M.F. capacity. With the sliders as shown, the coupling tight.

Circuit No. 2 is that of a crystal receiving set using a vario-coupler or loose

when tuned by means of the variable condenser C. C1 is the by-pass condenser of .001 MF. capacity. To tune this circuit, couple coils tightly, set condenser C at zero and vary the primary for signal. Then vary C until signal is loudest.

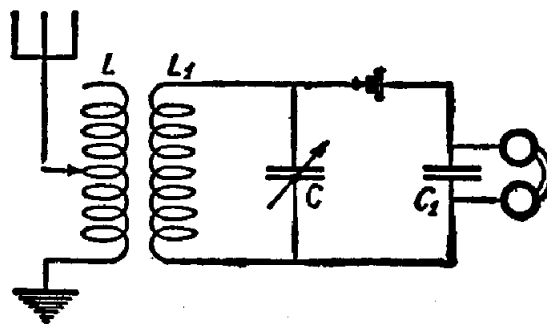

Circuit 2

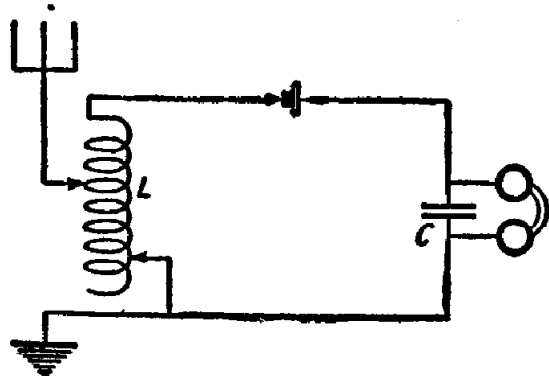

Circuit 1

coupler for tuning. The two circuits are separate and the secondary coil may turn or slide inside of the primary, which may be varied either by means of a sliding contact or switch and switch points connected to taps on coil L. The secondary L1 is fixed and has the proper number of turns to receive over the desired wave bands

Circuit No. 3 is similar to the circuit No. 2 except for the addition of the variable condenser in the antenna circuit. This condenser permits finer tuning and also allows wave-lengths shorter than the natural wave-length of the antenna to be received. The variable condenser C 2 shown between the primary coil and the ground permits extremely sharp tuning and has the effect of shortening the natural wave-length of the antenna exactly as if some wire were cut out of the antenna itself. With such a receiver there are four tuning controls, the primary tuning switch, the primary condenser, the coupling between coils L and L 1, and the secondary condenser C. The tuning of such a receiver is the same as that of the circuit No. 2 and the antenna variable condenser should be set at maximum while tuning. When the desired signal is tuned in the primary condenser is readjusted to obtain selectivity and finer tuning.

150 RADIO HOOKUPS

Needless to say, the crystal detector should be adjusted before tuning. This may be done with a buzzer or by listening on some local station which is easily tuned in.

Circuit No. 4 is the same as No. 3 with another additional improvement consisting in the tuning of the detector circuit by means of a switch or slider on the secondary coil. This arrangement provides an extra circuit for the detector and tele-

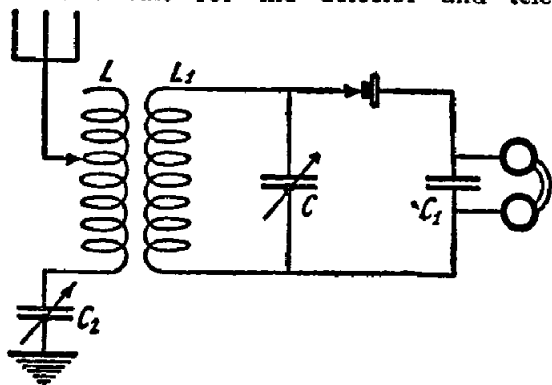

Circuit 3

phones which increases the signal strength and selectively. Since this control is not critical the tuning is the same as that of the circuit No. 3, the inductance of coil L 1 being adjusted after the desired signal is tuned in.

The two coils L and L 1 may be wound on tubing or spider web fashion, with taps every 10 or 15 turns to vary the amount of inductance in the circuit. The number of turns on each coil varies, of course, with the wave-length to be tuned in. If only the broadcast range is to be received, about

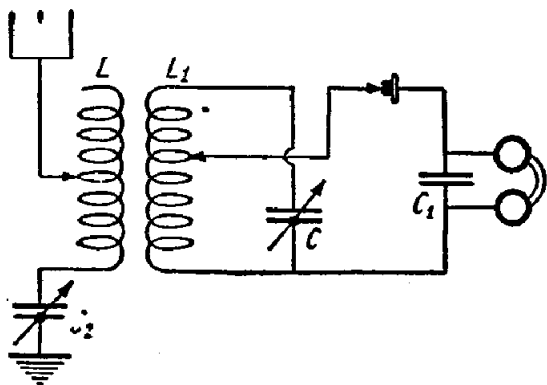

Circuit 4

50 or 60 turns of No. 20 D. C. C. wire should prove suitable. The coupling between the two coils should be variable so as to increase the selectivity of the receiving system whenever necessary. The two coils may be mounted on a rod so as to slide along the same axis, or they may be mounted on a hinge to vary the angle between them.

Circuit No. 5 is a simplification of the other circuits in that the number of controls is reduced without sacrificing much of the selectivity. In this arrangement coil L 1 composing, with the condenser, the secondary circuit, is tightly coupled directly over coil L 1. In order to tune the primary circuit a separate coil L 2 mounted at right angles or at a distance from L 1 and variable, is used to tune the primary or antenna circuit. In this arrangement there are only two controls, that is, the switch or slider on coil L 2 and the variable condenser C.

This circuit, on account of its simplicity, is recommended to the beginners who do not know how to tune the more complicated receivers. It may be constructed as follows: Coil L 1 should consist of 60 turns of No. 20 D.C.C. wire wound in a single layer on bakelite or hard rubber. Directly over this winding should be

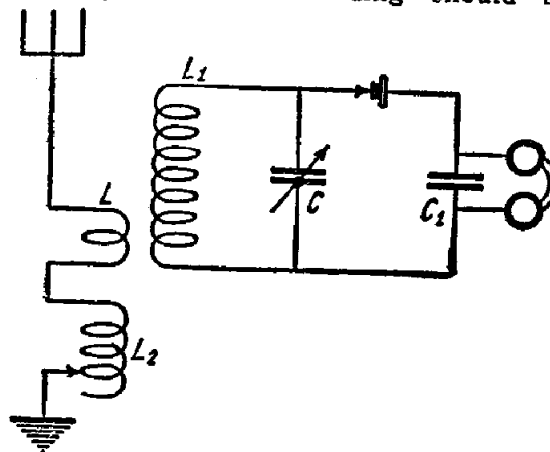

Circuit 5

wound 6 turns of the same wire composing coil L. Coil L 2 is similar to L 1 but with a tap every 5 turns. Use 3" diameter tubing.

Circuit No. 6. When it is desired to receive long and short wave-lengths, the use of a series parallel switch is useful to control the primary condenser in series or in parallel with the primary coil.

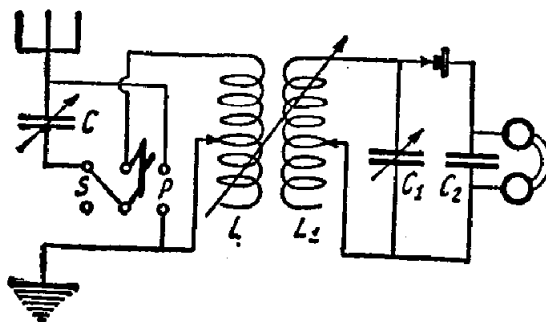

Circuit 6

The two variable condensers C and C 1 should be of the 43 plate type having a capacity of .001 mfd., preferably equipped with a vernier. The telephone condenser C 2 is an ordinary .001 mfd. fixed condenser. In this circuit the antenna variable condenser C is used in series to receive the short wave-lengths; in parallel with the primary coil to tune in the long ones.

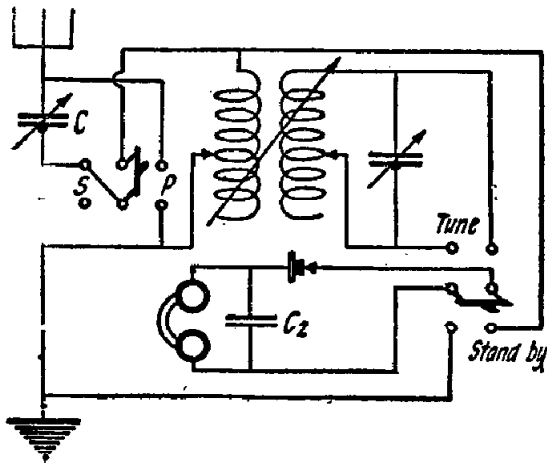

Circuit 7

Circuit No. 7 is similar to No. 6 but with an extra double pole double throw switch connecting the detector and telephones either across the primary or the secondary

For the reception of short wave-lengths the two coils may be composed of a standard variocoupler or loose coupler having about 60 turns 3 inches in diameter on each coil, or the equivalent.

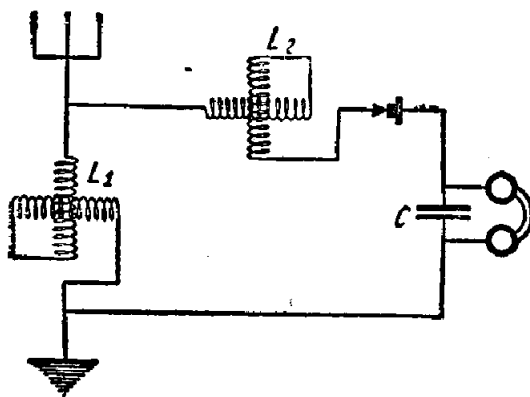

Circuit 8

For experimental purposes, or when great selectivity is not necessary. Circuit No. 8 may be employed. In this circuit two variometers are used for tuning instead of variable condensers or tapped coils. The first one, L 1, tunes the antenna circuit, and the other L 2, the secondary circuit.

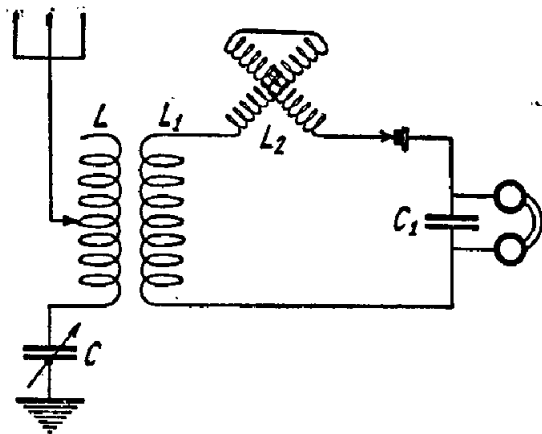

Circuit 9

Circuit No. 9 is similar to but will prove much more selective than No. 8. If interference is experienced, the secondary can be rotated so that it is at an angle to the primary and the set returned. In this way it will not be difficult to tune out most interfering stations. The variable condenser shown at C may have a capacity of .0005 or .001 mfd. The variometer L2 is a standard instrument and should be of good construction for best results. It will be

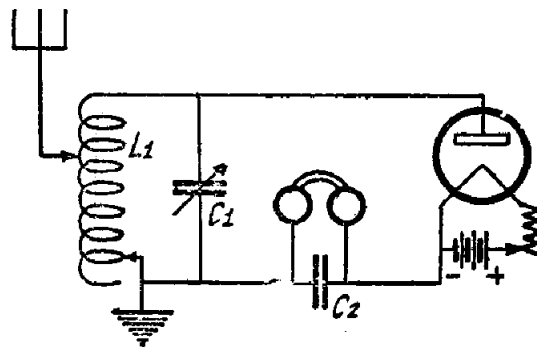

Circuit 10

Circuit No. 10 shows a single circuit receiver using a two electrode tube instead of a crystal. Although it is only a little more sensitive than a crystal receiver, it does not have to be adjusted and is always ready for operation. The inductance L1 may

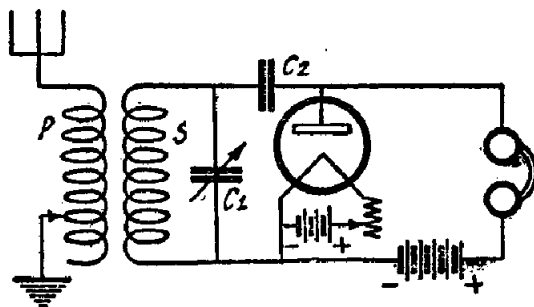

Circuit 11

consist of the primary of a standard variocoupler or it may be made by winding 60 turns of No. 22 S.C.C. wire on a 3½-inch tube. The winding should be tapped about every six turns and two switch points are connected to each tap. This will give an inductance that can be varied over the same winding by two switches. A two-slide tuning coil may also be employed as

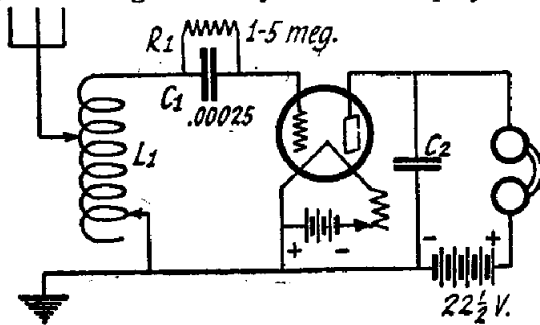

Circuit 12

the tuner, instead of the tapped inductance. The variable condenser C1 has a capacity of .0005 mfd. A condenser of this size usually consists of 23 plates. The by-pass condenser C2 is fixed and has a capacity of .001 mfd.

Circuit No. 11 also uses a two-element tube, but in this case a variocoupler is employed for the tuner. The primary of this variocoupler will consist of the same number of turns as the tuner in Circuit No. 10. Only one switch and one set of taps are used to vary the inductance. This primary may be tapped every six turns, which will give 10 switch points.

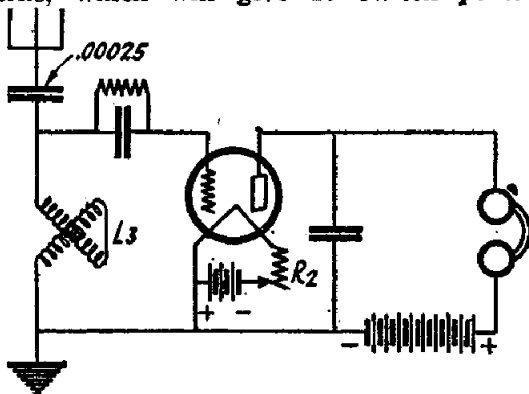

Circuit 13

The secondary of this coupler is made so that it will rotate inside of the primary and is wound with about 45 turns of No. 24 S.C.C. wire. The variable condenser C1 should be about .0005 mfd. and the fixed condenser, C2, is of the same capacity. A "B" battery of 22½ volts is used in this circuit and greater signal strength will be had with this arrangement than can be expected with Circuit No. 10. If

interference is experienced, the secondary may be turned so that it is at quite an angle to the primary and the set returned until the station again comes in strong.

Circuit No. 12 is the simplest of all circuits using a three-element tube and, as in the case of all preceding circuits, is non-regenerative. A fixed condenser of .00025 mfd. capacity is placed in the grid circuit between the grid of the tube and the tuner and is known as a grid condenser. A grid leak (R1) is shunted across the grid condenser and will usually be from one to five megohms in resistance. The usual by-pass condenser C2, is .001 mfd. and is connected across the phones and the "B" battery. A "B" battery is always used in a circuit employing a three-element tube. The voltage of this battery will depend upon the type of tube used. If a soft tube, such as a UV-200 is employed, the "B" battery will vary between 16 ½ and 22 ½ volts. With such a tube, when the rheostat—which in this case will have a resistance of

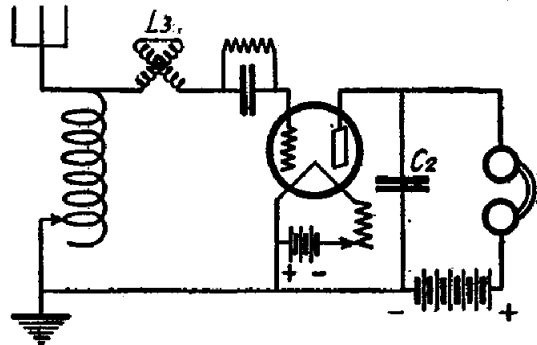

Circuit 14

six ohms—is turned up to a certain point, a slight hiss will be heard in the phones. For best results the tube should always be operated just under this hiss.

Circuit No. 13. This circuit is similar to No. 12, but employs a variometer L3, for tuning. The wave-length of the average variometer, when used in series with the antenna, is too high to respond to the lower broadcast wave-lengths and a fixed condenser of .00025 mfd. capacity should be placed in series with the antenna to reduce it. The grid condenser in this receiver is a .00025 mfd. one, which is standard for most circuits. The tuning is very simple, the variometer being varied until the station is picked up. The resistance of the rheostat R2 will depend upon the kind of tube used. The voltage of the "B" battery, will also depend upon the tube, but it will usually be not higher than 45 volts. A circuit such as this, which does not use regeneration, will have a receiving range of about 100 miles.

150 RADIO HOOKUPS

Circuit No. 14 is a circuit that will prove fairly selective. The antenna system is tuned by means of a tuning coil which may consist of 60 turns of No. 22 S.C.C. wire on a 3 ½ inch tube tapped every six turns. The secondary, or grid circuit is tuned by a standard variometer L3. The switch on the antenna coil is varied until the desired signal is picked up and then the fine tuning is done by means of the variometer. If a UV-200 tube is employed as the detector, it would be best

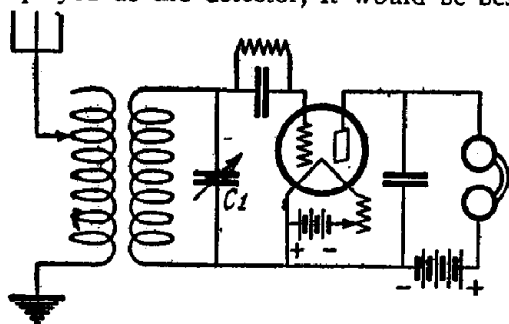

Circuit 15

to use a "B" battery that is tapped from 16 ½ to 22 ½ volts, so that different voltages may be tried to determine which gives best results. Care should be taken that the positive of the "B" battery is always connected to the plate through the phones. The by-pass condenser C2 is not always necessary and the receiver should be tried both with and without it, to determine which gives better results. This condenser will be of about .001 mfd. and is not critical.

Circuit No. 15. In this circuit a variocoupler is used in place of the tuning coil shown in Circuit No. 14. Also, the secondary circuit is tuned by means of a variable condenser of .0005 mfd. capacity, instead of the variometer. Much greater selectivity will be had in a two-circuit receiver of this kind, as it is possible to vary the coupling between the primary and the secondary coils of the variocoupler. When tuning, the primary switch lever is placed on the second or third tap and the variable condenser varied until a station is picked up. If no station is heard, the switch lever is changed to another tap and the condenser again varied. Sometimes certain taps on the primary will give better results than others for certain stations, but this can only be determined by experiment. As a rule, however, one certain tap on the primary of the variocoupler will bring in most stations in the broadcast wavelength range and it will not be necessary to change to another tap unless a great variation of wave-length is required. This circuit will

give very good results, although as it is not regenerative, stations further than 100 or 200 miles distant will not be picked up except under exceptional conditions.

Circuit No. 16. Here is a circuit that will prove far more sensitive than any of the others thus far described. In this receiver the Sodion tube is employed as the detector. A special form of loose coupler must be used with this tube, as very loose coupling is required for best operation. This tube does not have a grid, as is the case in a three-element tube, but instead it has a curved metal plate known as the collector. The circuit for this tube is similar to a standard vacuum tube circuit, but it requires a potentiometer of about 50 ohms (R2) in series with a fixed resistance of 150 ohms (R3) connected across the filament battery and rheostat as shown. The primary of the coupler may be tapped as usual, or it may consist of a fixed inductance with a variable condenser of .001 mfd. capacity in series. The secondary of the coupler is tuned by a variable condenser of .0005 mfd. capacity. This circuit is very sensitive, especially on weak signals, which makes it excellent for long distance reception. A receiver using this tube cannot oscillate, is non-regenerative, and will not interfere with other receiving sets.

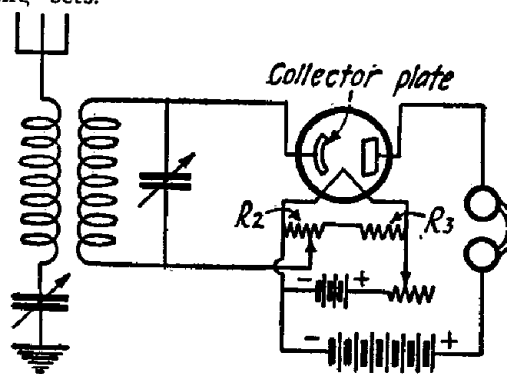

Circuit 16

Circuit No. 17. For the fan who lives in a district congested with many broadcast stations which are difficult to separate, the receiving circuit shown in Fig. 17 should prove of great interest. Nearly every fan who has built a set has given some thought to wave traps, and it is this principle which is used in this circuit.

The coils used in the receiver may be wound in basket-weave style or may be the single-layer inductances. In either case, however, they should be wound with No. 14 D.C.C. wire in order to reduce the resistance of the circuit as much as possible. The inductance L1 has 20 turns and is shunted by the variable condenser C1 which

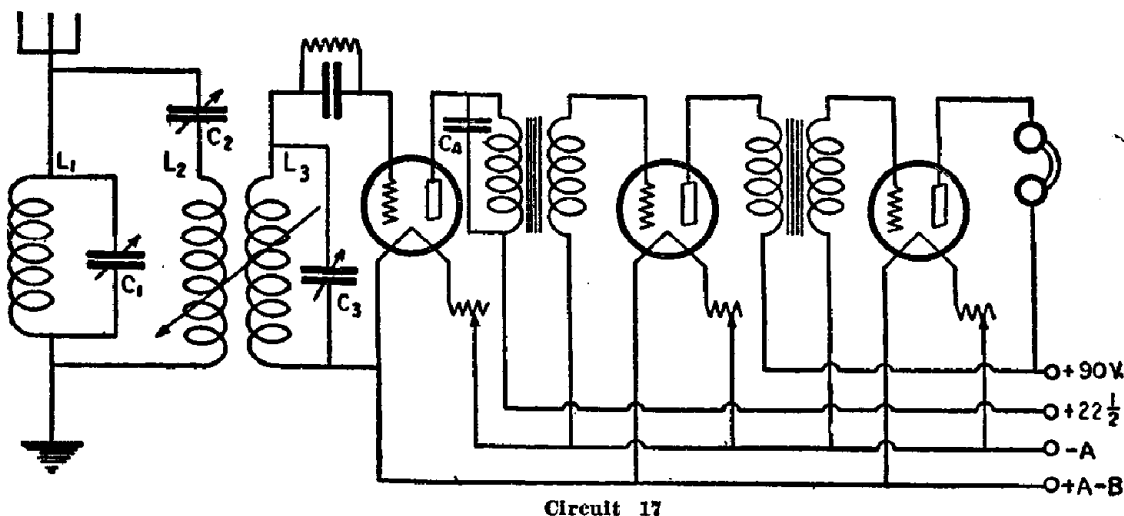

Circuit 17

has a capacity of .001 mf. The coils, L2 and L3, which are in inductive relationship to one another, have 50 and 15 turns, respectively. It should also be noticed that the inductance L1 should not be near the other two inductances, L2 and L3. The condenser C2 has a capacity of .0005 mfd.

Circuit No. 19 shows the simplest form of regenerative receiver using a standard three-element tube. This receiver is of the ultra-audion type, and regeneration is obtained and controlled by means of the rheostat R2 and the variable grid condenser C2. A fixed grid condenser of .00025 mfd. capacity may be used, but if a variable one of .0005 mfd. is employed, greater control over the regeneration may be had. The tuning coil in this circuit is a fixed inductance and may take the form of honeycomb or spider-web coil of 25 or 35 turns. This is shown as L1. The tuning is accomplished by means of a variable condenser C1, which is in series with the coil and ground and which has a capacity of .001 mfd.

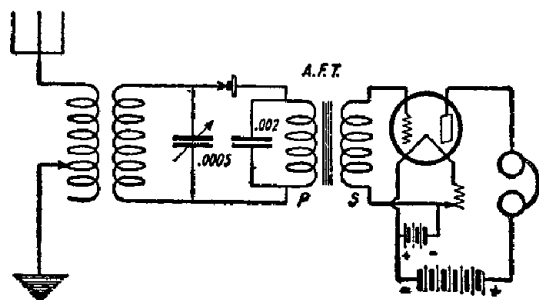

Circuit 18

When local stations only are desired, and pure reproduction is wanted, a crystal receiver in conjunction with one stage of audio frequency amplification will give excellent results. Such a circuit is shown in circuit No. 18.

Regenerative Hook-Ups

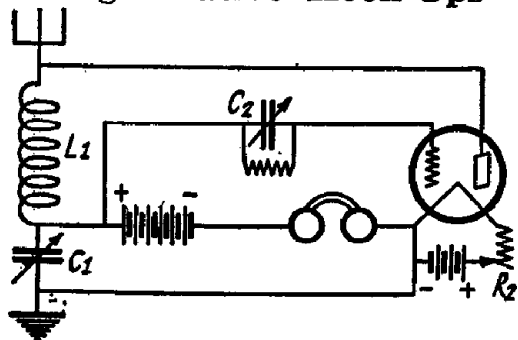

Circuit 19

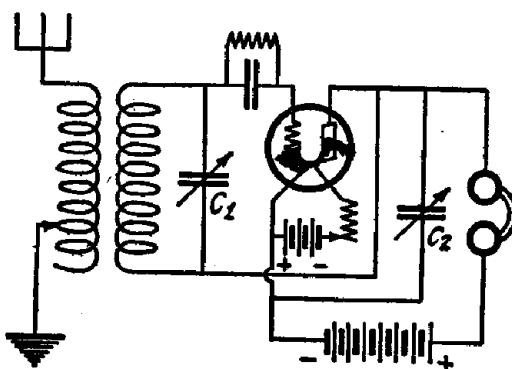

Circuit 20

Circuit No. 20 shows another form of ultra-audion receiver using a variocoupler in place of a single coil. Tuning is accomplished by means of the switch on the primary and the variable condenser C1 in shunt with the secondary. Regeneration in this case is controlled by means of the .0005 mfd. variable condenser shown as

C2. It will be seen that the phones and "B" battery in this receiver are removed from the oscillatory circuit and the lower terminal of the secondary, instead of being connected to the "A" battery is run directly to the plate of the tube. The grid condenser may be variable if desired, and will help to control regeneration, but this is not necessary for good operation. In tuning a receiver of this kind, the primary of the coupler is varied by means of the switch and the secondary circuit is tuned by means of the variable condenser C1. If the variable condenser C2 has all of its plates intermeshed, the tube will go into a state of oscillation which will distort signals and create interference in nearby receiving sets. The remedy for this is to furnish less capacity by moving the rotary plates of the condenser until the signals are clear and not distorted. If the signal is not very loud, more regeneration can be obtained by increasing the capacity of the condenser.

Circuit No. 21 is of the single crcut type

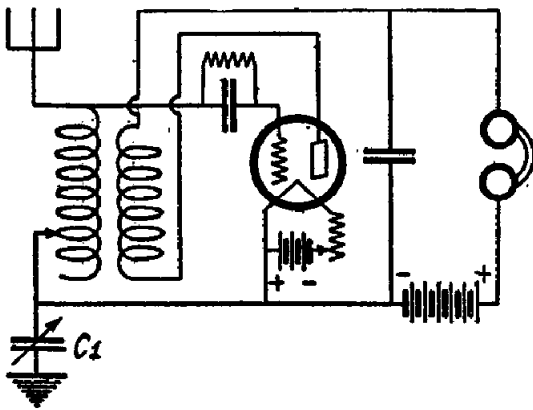

Circuit 21

and tuning is accomplished by means of the switch on the primary and the variable condenser C1 of .001 mfd. capacity in the ground circuit. Any wavelength may be reached to the limit of the tuner by varying the switch and tuning between the taps with the variable condenser. The secondary of the coupler is connected in the plate circuit of the tube in series with the phones and "B" battery and regeneration is obtained by varying the coupling between the two coils. When assembling this circuit, and the primary and secondary coils are parallel with each other the plate and the grid leads should always be connected to opposite ends of their respective coils. When these two coils are parallel, greatest coupling is had and the tube will be in a constant state of oscillation. When a station is tuned in, the secondary should be placed at such an angle to the primary that the signal is loudest without being distorted, which

will usually be just before the tube goes into oscillation. This oscillation point is indicated by a click in the phones and at this point a squeal will be heard and signals will become mushy and distorted. As stated before, *never operate a regenerative set with the tube in an oscillating condition.*

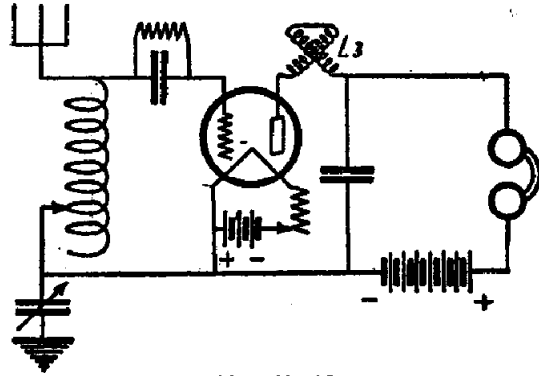

Circuit 22

In crcut No. 22 we have another regenerative receiver which uses the same tuning system as Circuit 19, but in this case regeneration is obtained by means of a variometer L3, in the plate circuit instead of the tickler coil. This variometer tunes the plate circuit to the same wave-length as that of the grid circuit and when these two circuits are exactly in tune, or in resonance, the tube will go into oscillation. When a station is tuned in by means of the switch and series condenser, the variometer is varied and as it approaches the resonance point, regeneration will take place and the signals will increase greatly in strength. It will be found easier if the grid and plate circuits are both tuned at

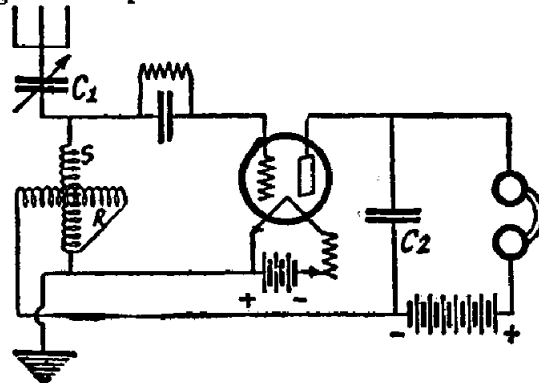

Circuit 23

the same time, as in this way, if any weak station is in the range of this receiver, it will then be picked up. This receiver, or, in fact, any receiver shown in these pages with the exception of diagrams 10, 11 and 16, can be used with any of the three element tubes on the market. Great care should always be taken that the right voltage is used for the filament, as other-

wise the tube might easily be burned out. This receiver is also of the single-circuit type and consequently will not give very sharp tuning, although it is capable of long distance reception if no interference is experienced.

Circuit No. 23. Here is shown a very simple single circuit regenerative receiver using a single variometer for tuning and regeneration. This variometer should invariably be of small size, having no more

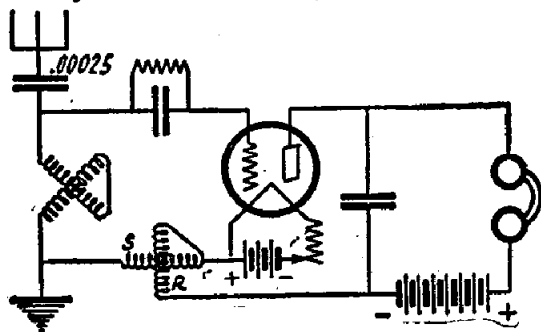

Circuit 24

than 40 or 45 turns on the stator, and the same number on the rotor. In this receiver the stator of the variometer acts as the tuner and is connected in the antenna circuit in series with a variable condenser C1, of .001 mfd. capacity. The ground is taken off at the intersection of the stator and rotor, as shown. The other end of the rotor is connected to the plate of the tube through the "B" battery and phones. A small variometer should be used because if one of standard size is employed in this circuit there will be too much wire on the stator to tune to the lower wave-

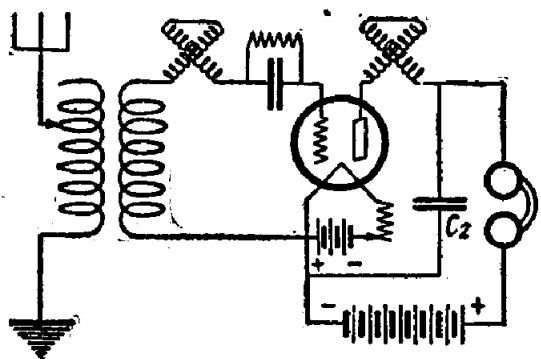

Circuit 25

lengths. The by-pass condenser shown at C2, may not be necessary and the receiver should be tried with and without it to determine which connection gives the better results.

Circuit No. 24 is a regenerative receiving set using two variometers, one of which is placed in the antenna circuit for tuning and the other in the grid-filament-plate circuit for regeneration. As will be seen, the

filament connection is made at the junction of the rotor and stator of the second variometer. The stator of this variometer is connected between the filament and the ground side of the tuning variometer. The rotor is connected between the filament and the plate of the tube in series with the phones and the "B" battery. This variometer should be of small size having no more than 40 or 45 turns on the stator and the same number of turns on the rotor. As this receiver will cause great interference under certain conditions, care should be taken that it is operated correctly.

Circuit No. 25 shows a receiver which will prove very selective, and for a one-tube receiver is very hard to excel. A standard variocoupler is used for tuning. A variometer is inserted in the grid, or secondary circuit which will give very close tuning. Another variometer of the same size is used in plate circuit for regeneration. A by-pass condenser C2, of .001 mfd. capacity usually will be found necessary in this circuit. Contrary to the general opinion, the tuning of this receiver is not difficult. The primary switch is set on a switch point usually the third

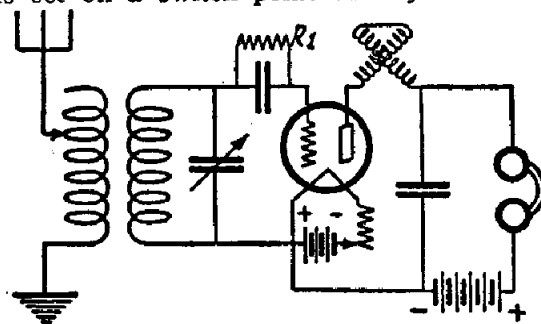

Circuit 26

or fourth, where broadcast stations will be received. Both variometers should be varied simultaneously, keeping just under the oscillation point. In this way, as the tuning of the secondary circuit is changed, the receiver is always at its most efficient point and weak stations can readily be heard.

Circuit No. 26 is the same circuit as No. 25 with the exception that a variable condenser is used to tune the secondary circuit instead of a variometer. By using this variable condenser the tuning will be slightly sharper and a wider band of wave-lengths will be covered. The grid leak R1 will have as resistance from one to five megohms depending upon the type of tube used. The tuning of this receiver is identical with that of diagram No. 25. If interference is experienced, the coupling between the rotor and stator coils may be

loosened and the set slightly returned. As the rotor is turned at a greater angle to the stator, sharper tuning will be had. If the angle is very great, the signal strength will be lessened, but this is sometimes advisable to eliminate heavy interference. Under good conditions a receiver of this type should have a receiving range of 800 to 1,200 miles, if conditions are very favorable.

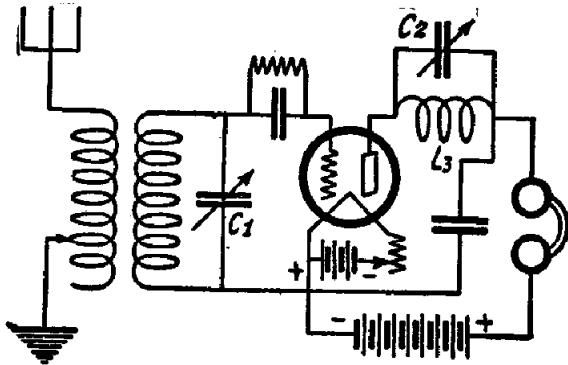

Circuit 27

Circuit No. 27 is also a three circuit regenerative receiver, but in this case instead of a variometer in the plate circuit for regeneration, a fixed inductance L_3 , shunted by a variable condenser C_2 , is used. This inductance should be approximately the same value as the secondary of the variocoupler. A honeycomb coil of 50 turns will give very good results in this position. The variable condenser C_2 , has a capacity of .0005 mfd. The condenser C_1 , also has a capacity of .0005 mfd, and is used to tune the secondary circuit. The tuning of this

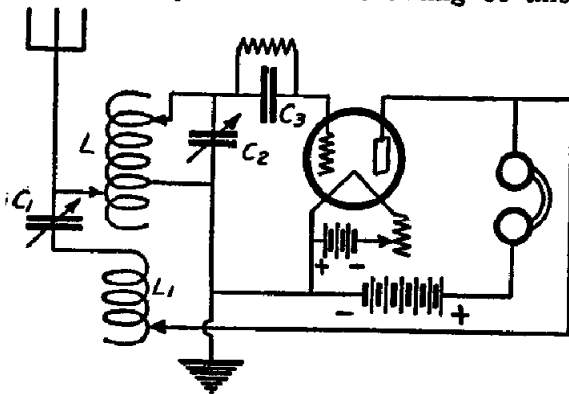

Circuit 28

receiver follows the same method as employed in diagrams 25 and 26, both condensers being varied at the same time. The variocoupler used in this circuit should be of good manufacture and should contain from 45 to 50 turns on the secondary. The primary is tapped at every 8 or 10 turns and is varied by means of a switch. It is not necessary that this primary be finely tuned. Try reversing the "A" battery leads

as one connection will work better with certain tubes.

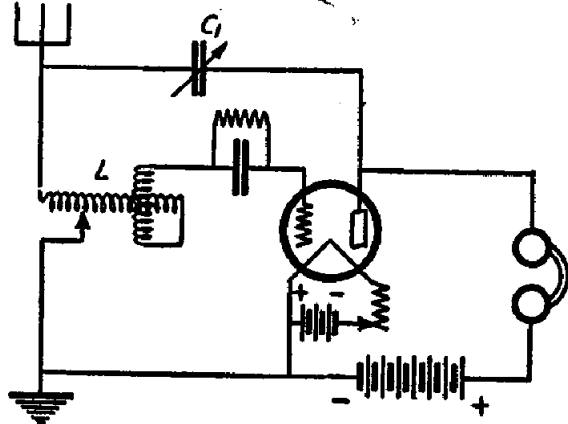

Circuit 29

In circuit No. 28 we have the well known Reinartz circuit. This receiver will give very selective tuning and is quite a favorite with the amateurs. This circuit was originally designed for C.W. reception, but it will also give very fine results on radiophone work. Coils L and L_1 are wound in spider-web fashion on the same form. These coils have been described many times in various radio publications and they may be procured from any radio supply dealer. L_1 in this circuit acts as a tickler coil, but regeneration is mostly obtained by capacity feed back through the variable condenser C_1 . This condenser has a capacity of .001 mfd. The variable condenser C_2 , with which most of the tuning is done, may have 17 or 23 plates. The grid condenser C_3 has a capacity of .00025 mfd, and should be of good make. The "B" battery voltage will depend upon the type of tube used.

In circuit No. 29 is shown what is known as the modified Reinartz receiver. At first glance this circuit appears to be new, but it is nothing more than an untuned primary circuit having capacity feed-back for regeneration. The instrument shown as L is a standard variocoupler of the old type,

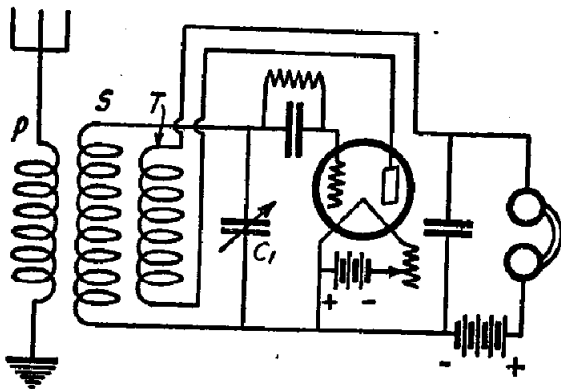

Circuit 30

where the secondary may be revolved through 180 degrees. The secondary winding is connected to the end of the primary winding as shown. The lower end of the primary winding should be tapped every turn for 10 turns and is controlled by a switch. By using more or less turns by means of this switch, great selectivity is obtained. The variable condenser C_1 has a capacity of .001 mfd. and is used to produce regeneration. When tuning this receiver the switch may be set on any point and the rotor of the variocoupler turned until a station is picked up. Greater volume is then obtained by increasing the capacity of the variable condenser C_1 . It is best practice to make both of these operations at the same time, as in this way the receiver can always be kept at the maximum point of regeneration and very weak signals picked up.

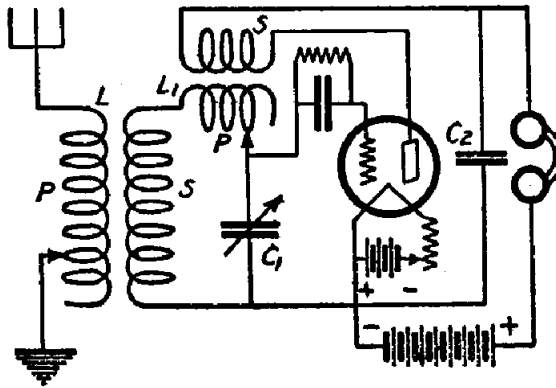

Circuit 31

In *Circuit No. 30* we have a simple regenerative receiver which combines selectivity with long distance reception. The tuner of this receiver consists of a rewind variocoupler. A coupler of the 180-degree type having a secondary winding of 35 to 40 turns is recommended. The primary winding should be removed and a new winding consisting of 42 turns of No. 20 S.C.C. wire wound on in its place. This winding will be the secondary of the instrument. The primary consists of 10 turns of No. 18 or No. 20 S.C.C. wire wound directly over the lower end of the primary and separated from it by two or three layers of cardboard or other insulating material. The variable condenser C_1 has a capacity of .0005 mfd. and should preferably be of a vernier type. A non-vernier condenser may be used, but in this case a vernier dial is recommended. When connecting the tickler coil, the plate of the tube should be connected to the lower terminal if, when the tickler is horizontal in respect to the secondary, the grid is connected to the top terminal of this

secondary coil. If these connections are correctly made, there will be no need to reverse the tickler connections afterward.

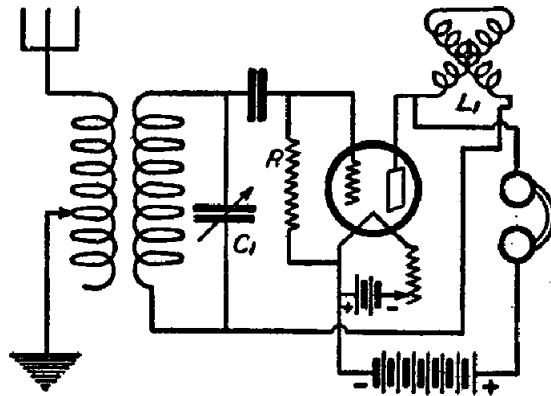

Circuit 32

Circuit No. 31 shows a circuit with which a fairly wide band of wave-lengths may be covered with efficiency. In this circuit two variocouplers are employed and are shown as L and L_1 . Regeneration is obtained by means of the secondary of the second variocoupler acting as a tickler in the plate circuit of the tube. To obtain regeneration, part of the winding of the primary of L_1 must always be used, and for this reason it is advisable that the variocoupler L have a secondary of about 30 turns. The variable condenser C_1 , with which the secondary tuning is accomplished, has a capacity of .0005 mfd. It will be found that for practically all broadcast stations only one or two taps in the primary of L_1 will be used. Experiment will

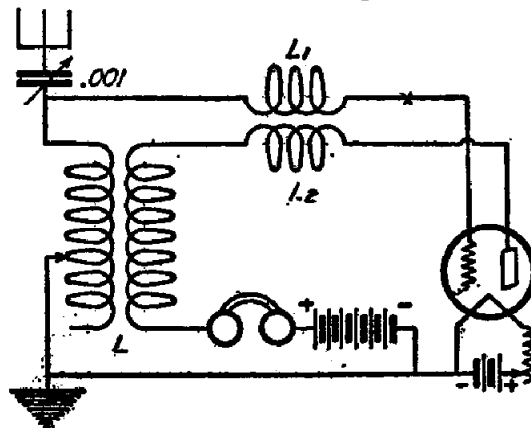

Circuit 33

determine which taps to use on the primary of L for certain stations. As the secondary of this first variocoupler can be varied in its inductive relation to the primary, very sharp and selective tuning will be had. If the primaries have sufficient turns, a wave-length of 3,000 meters may be reached. The by-pass condenser C_2 will have a capacity of .001 mfd.

Circuit No. 32 also shows a three circuit regenerative receiver, but in this case the phones and the "B" battery are removed from the oscillatory circuit. It will be noted that the grid return of the tube does not connect to the filament but goes to the plate through the plate variometer. In this circuit the grid leak R must be connected from the grid to the positive side of the

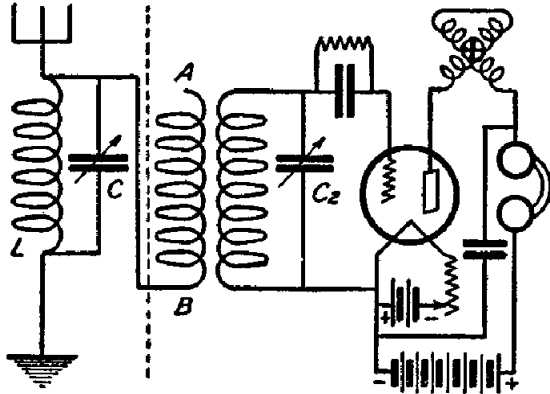

Circuit 34

"A" battery. The values of the various instruments in this circuit are the same as in preceding diagrams. The tuning of this circuit is no different than the other three circuit regenerative receivers shown, the variable condenser C1 and the plate variometer L1 phones and "B" battery are removed from the oscillatory circuits, no by-pass condenser will be found necessary. This circuit will be found extremely sensitive fairly easy to tune and under favorable conditions will bring in long distance stations.

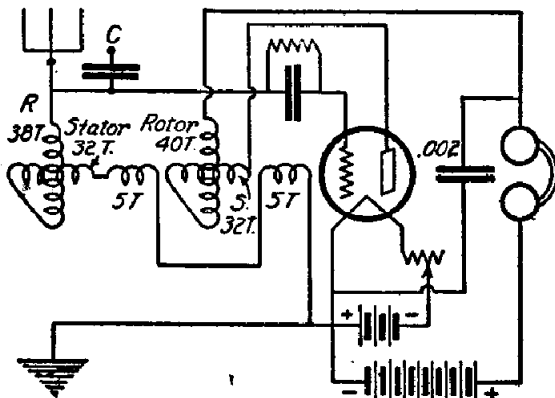

Circuit 35

Circuit No. 33 shows a simple regenerative receiver that is slightly different from the standard circuits. A standard variocoupler L is employed with a secondary winding consisting of not more than 40 turns. The primary should consist of about 80 turns tapped every 10 turns and is employed with a variable condenser of .001 mfd. in series with the antenna. The two

inductances, L1 and L2, are spider-web coils of about 20 turns each. These two coils are mounted stationary, in inductive relation to each other and about three inches apart. One coil goes to the grid of the tube and the other is connected to the plate in series with the secondary of the tuner, the phones and the "B" battery. The tuning is accomplished by means of the primary switch and the variable condenser. Regeneration is obtained by varying the inductive relation of the secondary to the primary. The leads on one of the spider-web coils should be reversed when the set is in operation, to determine which gives best results. As a rule no grid condenser is required in this circuit, but one may be tried in the position shown at X.

In Circuit No. 34 is shown a circuit that is very little known, but which will prove very effective in eliminating interference. As will be seen, any type of two or three circuit tuner may be used in conjunction with this system to good advantage. In

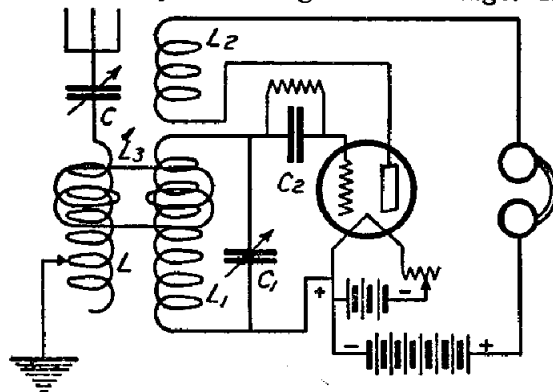

Circuit 36

this case it is shown with a standard three circuit regenerative receiver. The inductance L will consist of about 35 turns of wire wound on a three inch tube. The size of this coil is only approximate as it will vary in accordance with the size of the antenna employed. It might be advisable to wind 50 turns on a three-inch tube tapped every 10 turns so that the size of the coil may be varied for any size of antenna. The variable condenser C may be .0005 or .001 mfd. capacity. It will be noticed that only one connection is made from the coil L to the primary of the tuner. This connection should be tried at both A and B, as one connection will work very much better than the other. The inductance L should not be in inductive relation to the tuner of the receiver. When tuning this receiver it will be found necessary to vary the condenser C and the condenser C2 at the same time, as both must be in resonance.

In *Circuit No. 35* is shown a diagram which will prove very efficient being selective and sensitive and at the same time very compact. This type of receiver may readily be used as a portable set. It

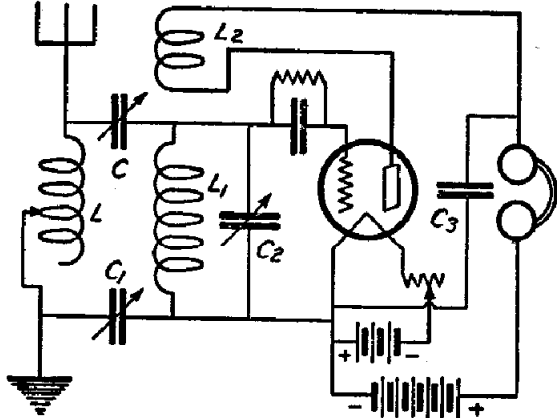

Circuit 37

really consists of two variometers, the stators of which are both wound upon the same form separated from each other $1\frac{3}{4}$ inches. The stator winding of the plate variometer is continued for five turns on each side of the stator winding of the plate variometer as shown. This gives a combination of tuned plate and tickler feed-back. The proper number of turns for both variometers is shown on the diagram. It will be advisable to place a fixed condenser (C) of .0005 mfd. in the antenna circuit and provide two binding posts so that the antenna may be

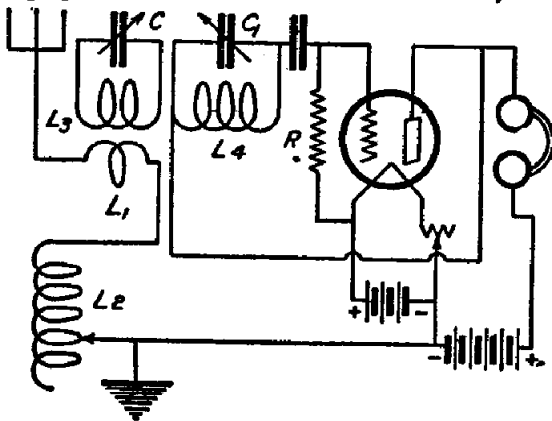

Circuit 38

connected directly to the variometer or through the condenser as desired.

In *Circuit No. 36* we have a receiver which will prove very selective, especially in a district where many broadcast stations are located. The condenser C may be of .00025 mfd. capacity, but may be left out if desired, as it is not absolutely necessary. L may be a coil of 80 turns tapped at every 10 turns, L1 and L2 are the primary and secondary of a vario-

coupler. In this case, the primary of the coupler should consist of about 35 turns of wire. L is not in inductive relation to L1 but is coupled thereto by means of a continuous loop of wire shown at L3. This loop should be wound three turns around each coil, as shown in the diagram. Most tuning will be done with the condenser C1, which in this case may be of .0005 mfd. The grid condenser C2 is of standard size (.00025 mfd.).

Circuit No. 37. In this diagram we have a circuit using capacity coupling. This coupling is accomplished by means of

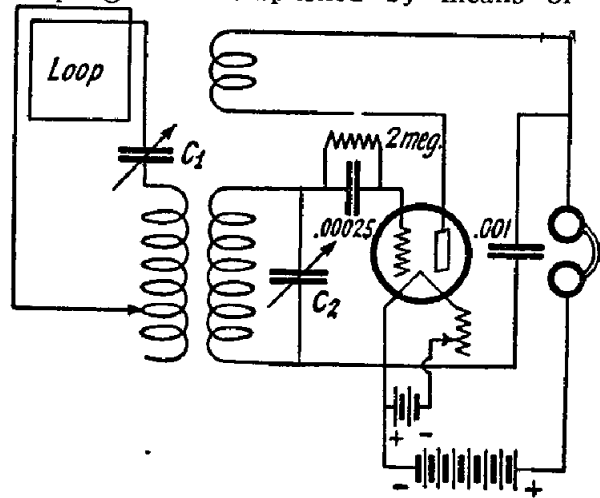

Circuit 39

condensers C and C1, which are of .0005 mfd. capacity. The main tuning inductance L is as usual, of about 80 turns, which may be tapped at every 10 or 12 turns. Coils L1 and L2 may be the primary and secondary of a standard variocoupler. It will not be necessary to use taps on the primary of this coupler, as a fixed number of turns (approximately 35) will be sufficient when tuned by the .0005 mfd. variable condenser C2. The coil L2 is inserted in the plate circuit of the detector for regeneration. The bypass condenser C3 is of .001 mfd.

Circuit No. 38 shows the well-known Cockaday circuit, which has proven very

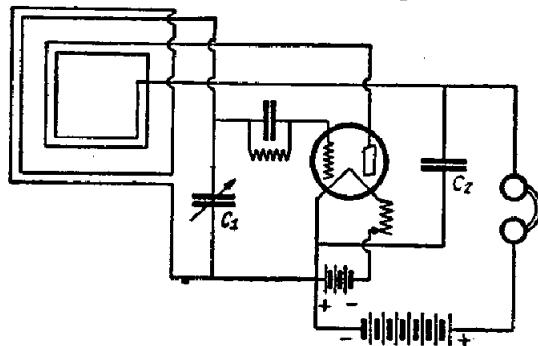

Circuit 40

popular. The antenna system is comprised of coils L1 and L2. L1 is a single turn of bus-bar wire around coil L3. L2 consists of 43 turns of No. 18 S.C.C. wire on a 3-inch tube. This coil is double bank wound and may be tapped every six turns. It is in non-inductive relation to the other coils. D3 consists of 34 turns of

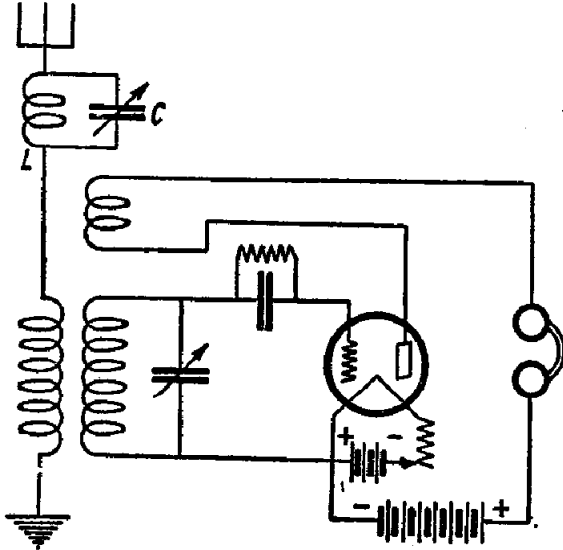

Circuit 41

No. 18 S.C.C. wire and is also wound on a 3-inch tube. L4 consists of 65 turns of the same size wire and is wound on the same tube, with L3, separated from it by about 1/8 inch. Variable condensers C and C1 have a capacity of approximately .0003 mfd. and are of the 17-plate variety.

Where an outside antenna is undesirable and only one tube is to be employed, it is sometimes possible to use a loop when quite near a broadcast station. The circuit for this arrangement is shown in circuit 39. The tuner and tickler may be of any standard form such as a variocoupler, honeycomb or spider-web coils. If a variocoupled is employed, it will be necessary to use 35 turns of the outside winding as the secondary. A separate primary winding may then be wound directly over the secondary and should consist of 25 turns tapped every five turns. The condenser C1 may be of .0005 or .001 mfd. capacity. The condenser C2 which tunes the secondary circuit should be .0005 mfd. capacity. The rotor of the coupler is, of course, used as the tickler.

In circuit No. 40 is shown another one-tube loop receiver. Two loops are used in this circuit, one as the tuner and the other for regeneration, in the plate circuit. The tuner is the larger loop consisting of 12 turns of wire on a 2-foot frame. As shown in the diagram, the

plate loop is placed in the center of the larger loop and is so arranged that it can be rotated similar to an ordinary tickler coil. The number of turns in this loop is not critical, being in the neighborhood of 15. If desired, this loop may be of the same size as the other and arranged so that the distance between it and the other one may be varied. Tuning is accomplished in this circuit by means of the condenser C1, which is of .0005 mfd. capacity. A by-pass condenser will usually be found necessary in this circuit and is shown as C2.

In circuit 41 is shown a standard regenerative receiver with the addition of a wave trap in the antenna circuit. This wave trap is composed of a fixed inductance L, shunted by a variable condenser C. The fixed inductance may be a honeycomb coil of 50 or 75 turns or, if desired, it may be constructed by winding 45 turns of No. 24 S.C.C. wire on a three-inch tube. The variable condenser is of the 23 plate variety and has a capacity of .0005 mfd. When it is desired to eliminate the interfering station the variable condenser should be adjusted until its signal strength is at a minimum or

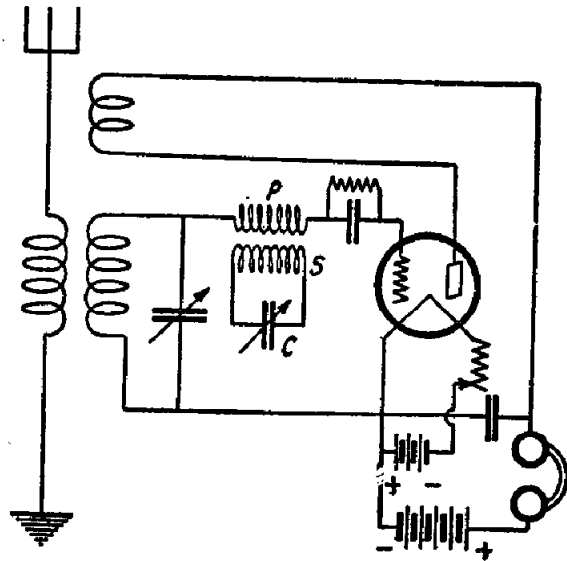

Circuit 42

until entirely wiped out.

Another type of wave trap which will prove extremely efficient and which can be incorporated directly in the receiver is shown in circuit No. 42. This wave trap consists of a primary and a secondary coil, the secondary being shunted by a variable condenser. The secondary consists of 45 turns of No. 22 S.C.C. wire wound on a tube three inches in diameter. The primary consists of 10 turns of the same size wound directly over the

secondary and separated from it by a single layer of cardboard. The variable condenser C is of .0005 mfd. capacity.

In circuit No. 43 is shown another method of eliminating interference. This consists of a variable inductance, L, in series with a variable condenser, C, connected from the antenna to the plate of the tube. In this case it will be necessary to employ a variable condenser, C1, in the antenna circuit. This condenser may be of .0005 or .001 mfd. capacity. The inductance, L, may consist of 50 turns of No. 22 S.C.C. wire wound on a tube three inches in diameter and tapped every 10 turns. The variable condenser may be of .0005 mfd. capacity. If desired, regeneration may be obtained by inserting a variometer of standard size in the plate

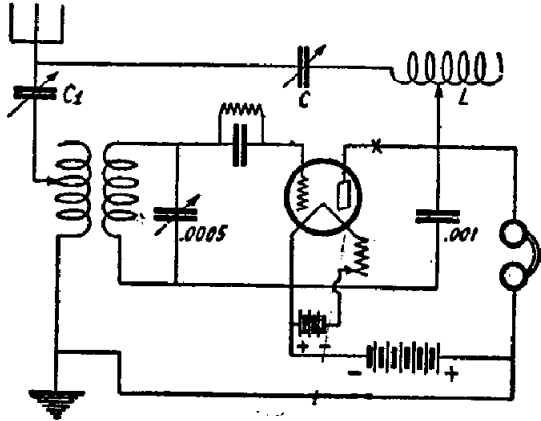

Circuit 43

circuit of the vacuum tube at the point marked X.

In circuit No. 44 we have a receiver which operates fairly well without a "B" battery. This receiver is of the single circuit type using a variocoupler for tuning. The condenser C1, may be either .0005 or .001 mfd. capacity. The second-

ary of the variocoupler is in the plate circuit of the detector tube for regeneration and should contain at least 80 turns of wire. As no "B" battery is used the phones are connected directly to the positive lead of the "A" battery. A variable grid leak of from one to five megohms

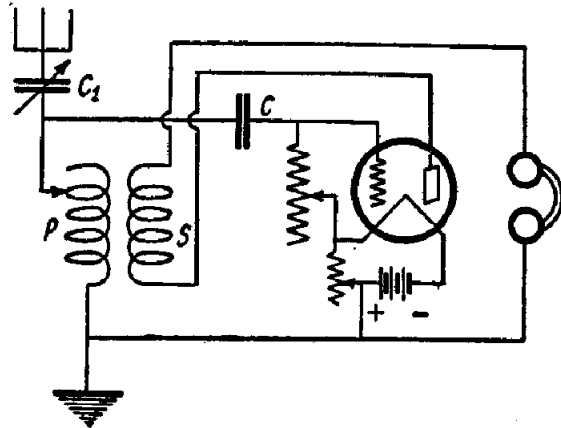

Circuit 44

resistance will be found advisable and should be connected directly from the grid to the positive terminal of the "A" battery. The grid condenser, C, may be of .00025 or .0005 mfd. capacity.

Where greater volume is desired, one stage of audio frequency amplification may be added to practically any detector circuit, and a diagram through which this is accomplished is shown in No. 45. It will be noticed that this one stage of audio frequency amplification is used in conjunction with a standard three-circuit regenerative receiver. An audio-frequency transformer must be employed as shown at T. The primary of this transformer is connected in the plate circuit of the detector tube in place of the phones. It is recommended that a transformer with a

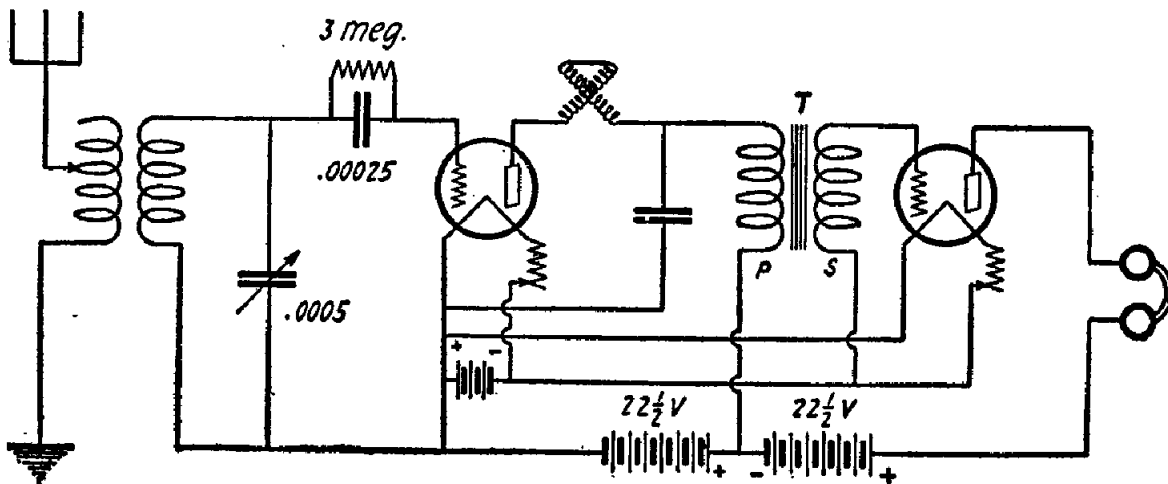

Circuit 45

150 RADIO HOOKUPS

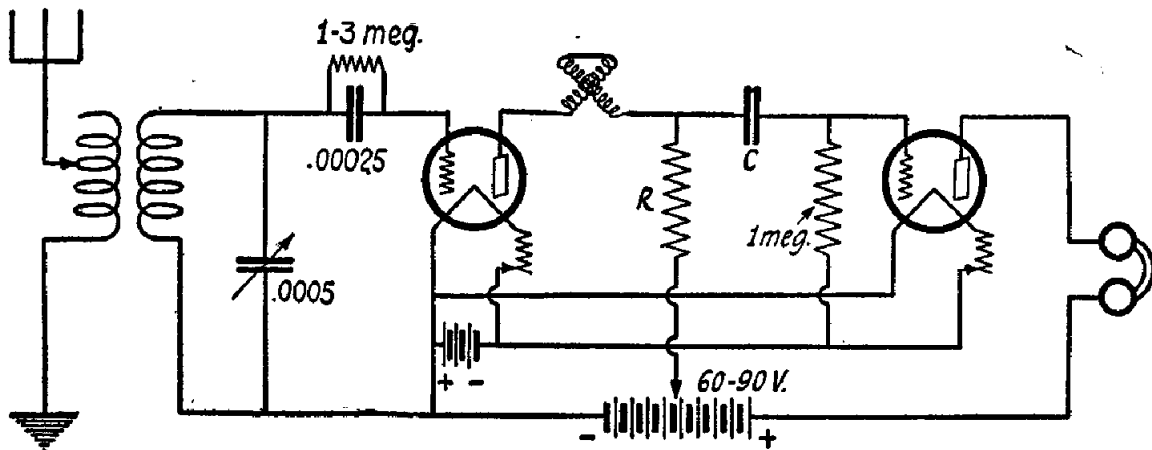

Circuit 46

ratio of not higher than 5 to 1 be employed as otherwise distortion is liable to occur. A hard or amplifying tube such as a UV-201A or a C-301A must be employed as the amplifier. For best results it would also be necessary to use a higher plate voltage on this tube. As a rule 45 volts will be sufficient for one stage of amplification and this is obtained by connecting two 22 1/4-volt "B" batteries in series.

It is almost impossible to obtain an audio-frequency transformer that will not distort to some extent and for this reason a resistance coupled amplifier is sometimes made use of. However, since a resistance coupled amplifier will only give about 2/3 the amplification delivered by a transformer, it is not generally used for one stage. A circuit using resistance coupling is given in *circuit No. 46*. It is shown in conjunction with a three circuit regenerative receiver, although any type of receiver may be employed. The

resistance shown at R should be of the non-inductive type and of a value of 50,000 ohms. It will usually be found necessary to use a higher "B" battery voltage with resistance coupling than with transformers. A grid condenser will also be required in the grid circuit of the amplifying tube as shown at C so that the "B" battery voltage will not be impressed upon the grid. The capacity of this condenser is not critical and may be from .006 to 1 mfd. As an amplifying tube must be operated with a negative potential upon the grid a grid leak of one megohm is connected from the grid of the tube to the negative of the "A" battery.

In *circuit No. 47* is shown another system of providing distortionless amplification. Instead of a resistance a choke coil is employed and is shown at X. If desired, this choke coil may be construct-

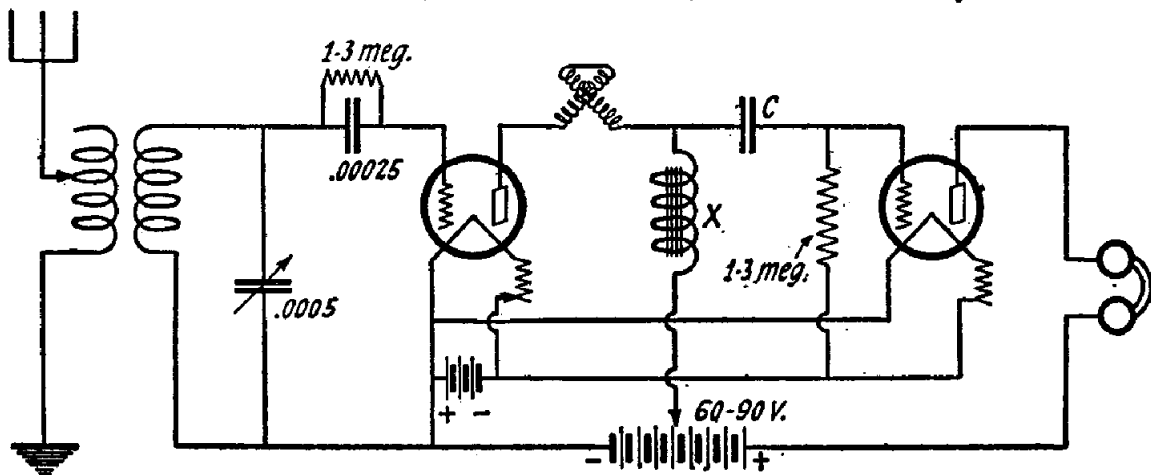

Circuit 47

ed by winding 5,460 turns of No. 34 S.S.C. wire in 14 layers on an iron wire core $3\frac{1}{2}$ inches long and $\frac{3}{8}$ inch in diameter. In winding it will prove best to separate every two or three layers of wire with a piece of waxed paper. If an old audio frequency transformer the primary of which is burned out happens to be laying about, the secondary will function very well as this choke coil. The grid condenser shown in this diagram at C should be of approximately .01 mfd. capacity. The grid leak connected from the grid to the negative filament should be from 1 to 3 megohms, best determined by experiment. A hard or amplifying tube must, of course, be used in this circuit and a "B" battery voltage from 60 to 90 is recommended. This type of amplification has been shown with a standard three circuit regenerative receiver, but it may be used with practically any circuit. Although it will not produce the same volume of sound as an amplifier using an audio-frequency transformer, it will, nevertheless, give sufficient volume to operate a loud speaker when fairly close to a broadcast station.

Choke coil coupled amplification has recently received another impetus for broadcast reception due to its faithful reproduction of voice and music and the usual lack of distortion found in a circuit employing it. It is quite possible to purchase choke coils especially designed for this purpose on the market today and in some cases a complete unit incorporating not only the choke coil but also the blocking condenser and the grid leak for the audio frequency amplifying tube may be had. Using this unit, the construction of an impedance or choke coupled amplifier is greatly simplified, as the only accessory necessary for connecting up an

additional stage of amplification is the amplifying tube and a socket.

It is sometimes undesirable to use a stage of audio frequency amplification when the ear phones are employed and some means must be used so that the phones may be plugged in on the detector alone and the amplifier disconnected from the circuit. In *circuit 48* is shown how this is accomplished by means of a double circuit jack. This type of jack has two outside and two inside springs which normally make contact with each other. However, when a phone plug is inserted the two outside springs disconnect from the two on the inside, thereby breaking this part of the circuit and allowing the current to flow through the phones instead of the primary of the audio-frequency transformer. A single circuit jack is connected in the plate circuit of the amplifying tube so that the phones may be connected at this point when desired. In this circuit the audio stage is shown in conjunction with the untuned primary receiver described in *No. 30*. It may be necessary to connect a by-pass condenser of .0005 mfd. or .001 mfd. capacity in the position shown at C1.

In *circuit No. 49* is shown regenerative circuit in conjunction with one stage of audio frequency amplification using filament control jacks. These jacks are very convenient, since with their use it is unnecessary to turn off the filament current to the tubes not in use. A little study of this circuit will show that when the phones are plugged into the first jack, the detector tube alone lights up and when the phones are plugged in the second jack, both tubes are lighted. When the set is not in use it is only necessary to remove the plug and the filament current is automatically cut off. An untuned pri-

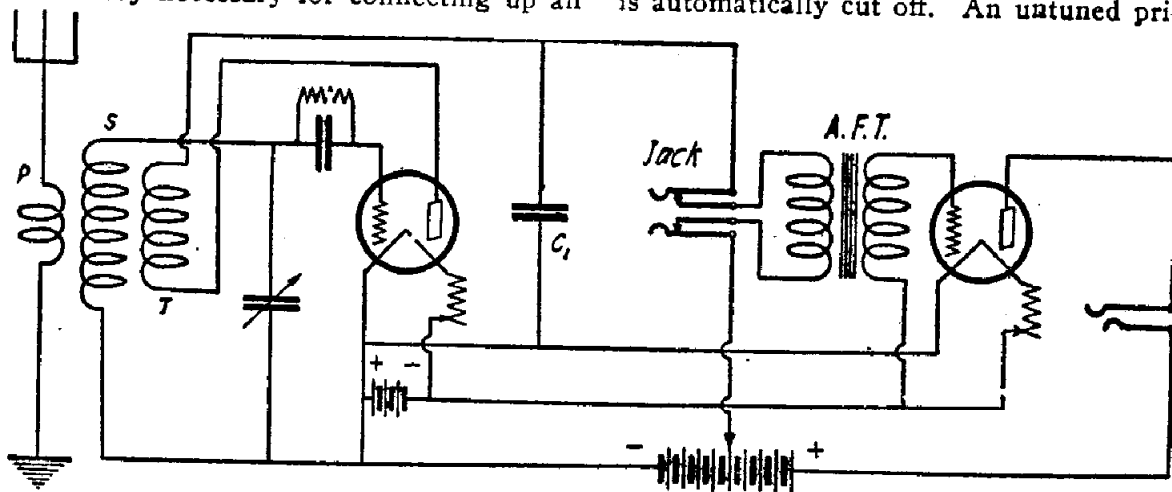

Circuit 48

150 RADIO HOOKUPS

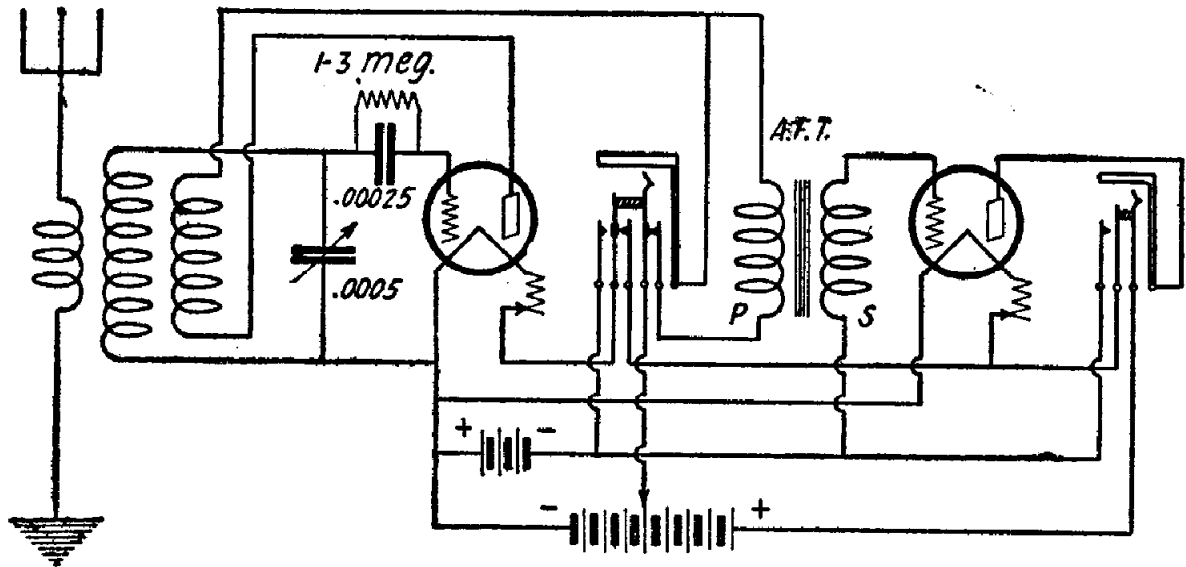

Circuit 49

mary coupler is shown as the tuner in this circuit, although any type of tuner may be employed. A condenser of .0005 mfd. capacity is shunted across the secondary for tuning. Any type of receiving tube may be employed providing the correct "A" battery voltage is used.

It sometimes happens that the primary of the audio frequency transformer burns out. In such cases the secondary may be used as a choke coil amplifier and when used in this connection will function extremely well. The volume obtained may not be as great as when a transformer is used, but the quality of reproduction will be excellent. A diagram showing a circuit employing such use of a transformer is given in *circuit No. 50*. A double circuit jack is also incorporated so that the detector alone may be used when desired. A grid condenser must, of course, be employed in the grid circuit of the amplifying tube and has a capacity

of .01 mfd. A grid leak of one megohm is connected from the grid of the tube directly to the negative of the "A" battery. In this circuit a variometer is shown as the tuner, and a .00025 mfd. condenser is placed in series with the antenna to lower the wave-length.

Circuit No. 51. Those experimenters who are familiar with the Reinartz circuit will notice in the accompanying diagram several changes, viz., the absence of the plate coil and the addition of a coil in the antenna circuit, which is for the purpose of detuning this circuit so that the effect on the tuning will be zero. Through this means the tuner can be calibrated before being connected to the antenna, and its calibration will remain constant, regardless of the size and type of antenna to which it may be connected. The great advantage of this detuning coil is the fact that it cuts receiver radiation to zero.

For the R.F. choke coil, wind on an ordinary size drinking glass about 2½ inches

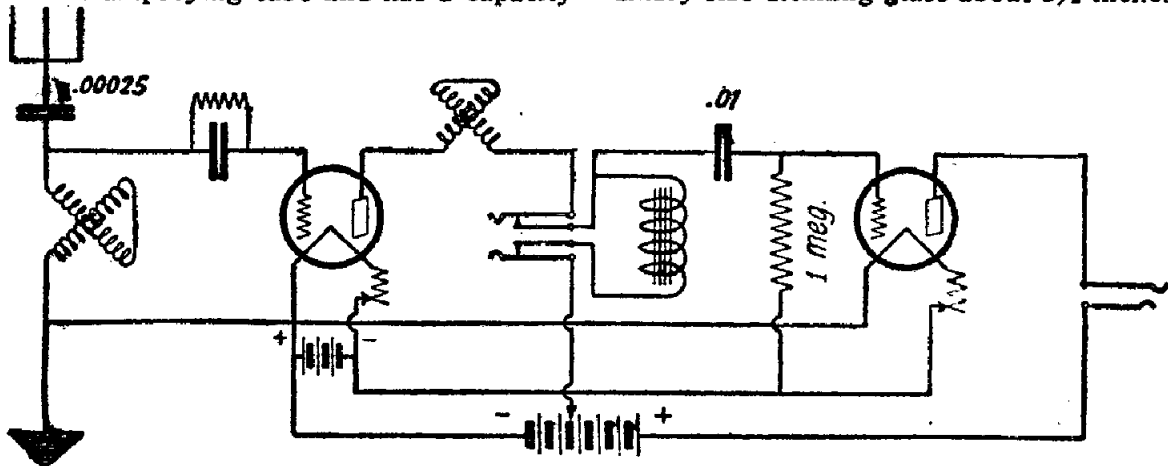

Circuit 50

150 RADIO HOOKUPS

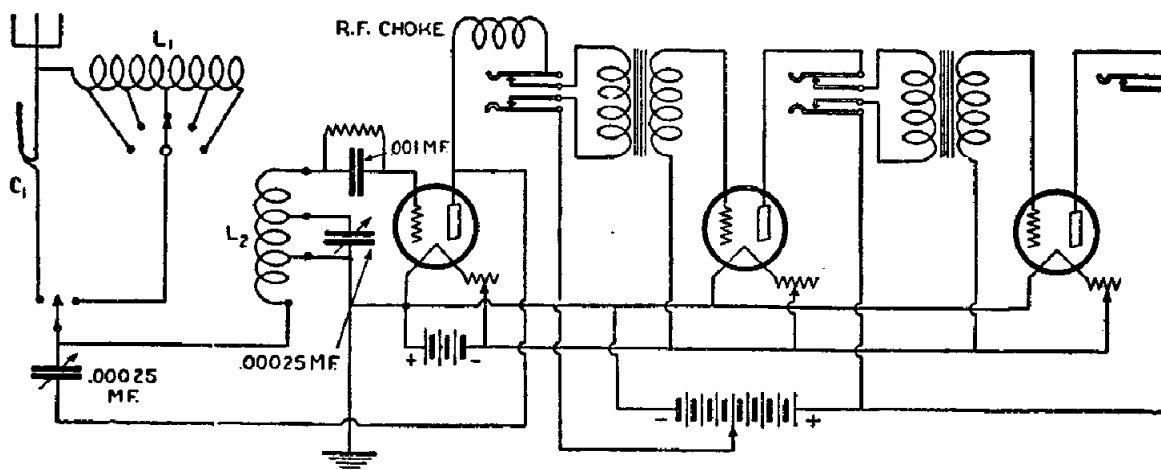

Circuit 51

in diameter, 75 turns of No. 24 D.C.C. wire in jumble fashion. Slip off the tumbler and wind a few turns of thread around the coil so that it will be self-supporting. The coil should be mounted as near the plate of the tube as is consistent with good wiring practice and should not be placed near any of the other coils.

Around the same drinking glass wind 50 turns of the same size wire, making a loop for tapping at every tenth turn. This coil L1 is mounted on the tuner panel near the antenna connection. Connect one end of a 2-foot length of lampcord to the switch-point and the other to the antenna, leaving the other ends open. See C1. Two pieces of magnet wire twisted together may be used if desired. If selectivity is too great, add to length of wire.

If the wave-length is to be 150 to 220 meters, the coil L2 is made as follows: On the same tumbler wind in jumble fashion, as before, 5 turns of No. 16 D.C.C. wire, making a 3-inch loop for tapping; then continue for 15 turns with another tap loop and then 5 more turns. Bind, as before, with thread. It will be noticed that there is a 4-to-1 turn ratio of antenna to ground and grid to ground. Maintain this ratio in any other coil that is made. Also notice that the tuning range is 150 to 220 meters, and that if a cipher is added to the 15 turns that are shunted by the condenser, you will have 150, and if a cipher is added to the total number of secondary turns, which is 20, you will have 200, meaning that the approximately range of any coil made with the turn ratio, as above, may be determined beforehand.

Circuit No. 52. For experimenters who wish a circuit that is very selective, the one in the accompanying diagram is recommended. The inductances, L1 and L2,

are wound of No. 22 D.C.C. wire on 3-inch tubing and each coil has 50 turns. These two coils should be mounted at right angles, and there should be at least 12 inches between centers. For extreme selectivity a separate unit might be built consisting of L1 and the .001 mf. condenser. These two coils are linked together by the coils indicated by the heavy line in the diagram. This connecting link is a rubber-covered wire, having as low a resistance as possible. There is one turn of this link coil around each inductance. If a separate unit is built, as mentioned above, it might be placed two feet away from the rest of the circuit. The variometer in the plate circuit of the tube is for regeneration.

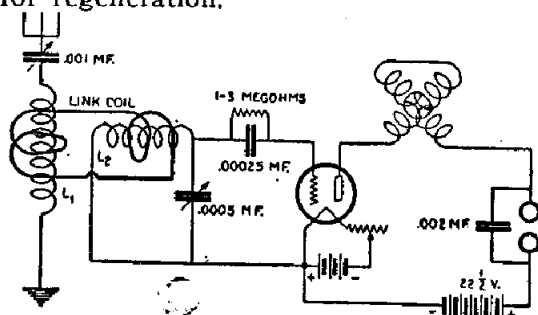

Circuit 52

The type of vacuum tube that may be used is a UV-201A or C-301A. The length of antenna should be about 125 feet, although this is not very important.

Circuit No. 53. One of the most interesting circuits for the experimenter is the hook-up shown in Fig. 53. It is an adaption of the famous Hartley oscillator circuit. The apparatus required for this circuit can be easily made by the average experimenter. The inductance L2 is wound on a bakelite or hard rubber tube 3½ inches in diameter and consists of 35 turns of No. 18 D.C.C. wire. Directly over this

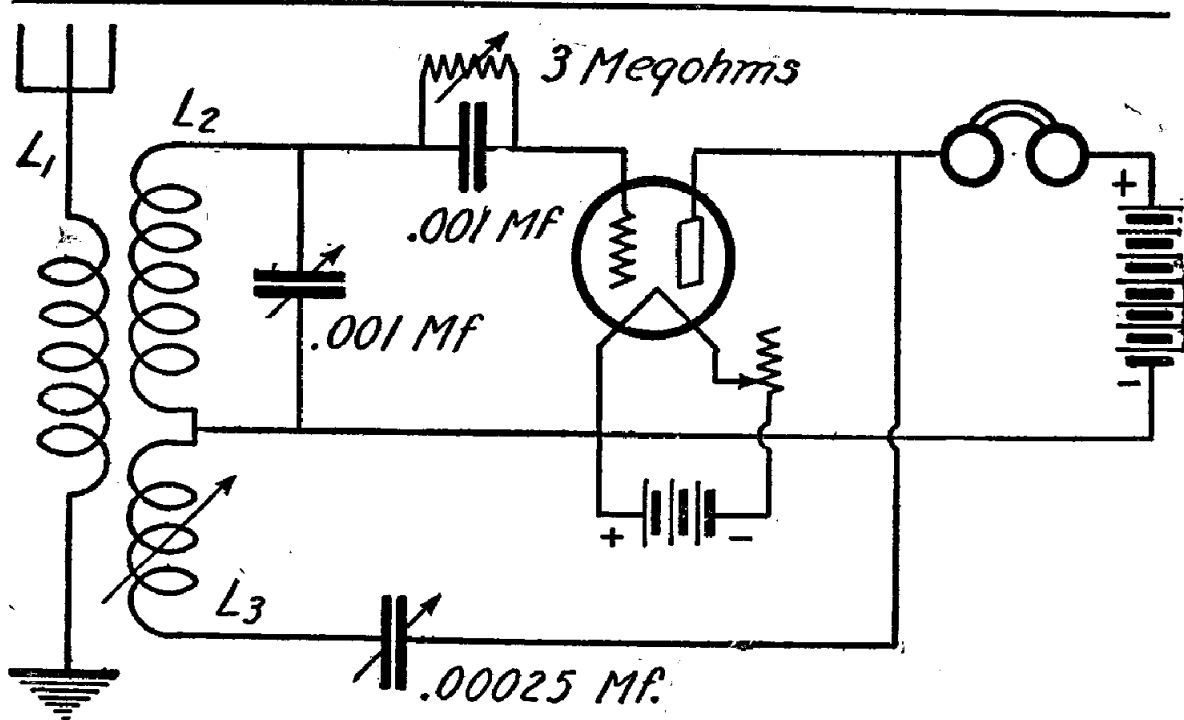

Circuit 53

winding is placed L_1 which is 10 turns of the same size wire. The movable part of the coil, L_3 is wound with 20 turns of No. 20 D.D.C. wire on a bakelite tube $2\frac{3}{4}$ inches in diameter. The tube on which are wound L_1 and L_2 is placed with its axis parallel to the panel. In the end opposite that which has the inductance L_1 on it, drill two holes diametrically opposite to take the bearings of the rotor, L_3 . These bearings are made of small machine screws. The rotor does not have to be controlled from the front of the panel, as it remains in the same position after once being set. The two variable condensers are placed at the left-hand side of the panel with the inductances directly in their rear. With this arrangement very short leads are the result.

The tuning of the set is extremely sharp, and as may be expected a vernier control must be used on the .001 mfd. condenser. The close approach to the point of oscillation is evidenced by the fact that the circuit does not "spill over" into oscillations suddenly as is the case with nearly all regenerators. As the regeneration control condenser is increased, the amplification increases continuously, gradually working into the condition for oscillation. The approach is so close that both the incoming signals and the regenerative whistle can be heard at the same time when the tuning is very close.

The adjustment of the movable part of the coil is made as follows: The set is tuned for the longest wave-length it is de-

sired to receive, with the movable coil at right angles to the main coil. This is the condition for least amplification or feed-the set just begins to oscillate. It need not be adjusted after this, and it will be found back. The movable coil is rotated until that the controlling may be done entirely by the .00025 mfd. condenser.

This circuit will function on any size antenna, but it is advised that the total length be limited to 120 feet. This includes the lead in. The different sizes of antenna are compensated by the tuning condenser; that is if the set has been calibrated and a different antenna is used then the readings will be different also.

When constructing this set, be sure that the rotor plates of the .001 mf. variable condenser used for tuning are connected to the filament circuit. It is sometimes advisable to connect this point, that is, the filament circuit, to the ground. Making the connections in this way reduces any body capacity effect that might otherwise be noticed when tuning.

Circuit No. 54. Here is shown a regenerative receiver in conjunction with two stages of audio frequency amplification. The tuner in this receiver is an untuned primary coupler and was described in circuit No. 30. Audio frequency transformers are used in the amplifier and should not have a ratio higher than 5:1. A double circuit jack is inserted after the first stage so that the phones may be plugged in at this point. When the loud speaker is used, it is plugged into the

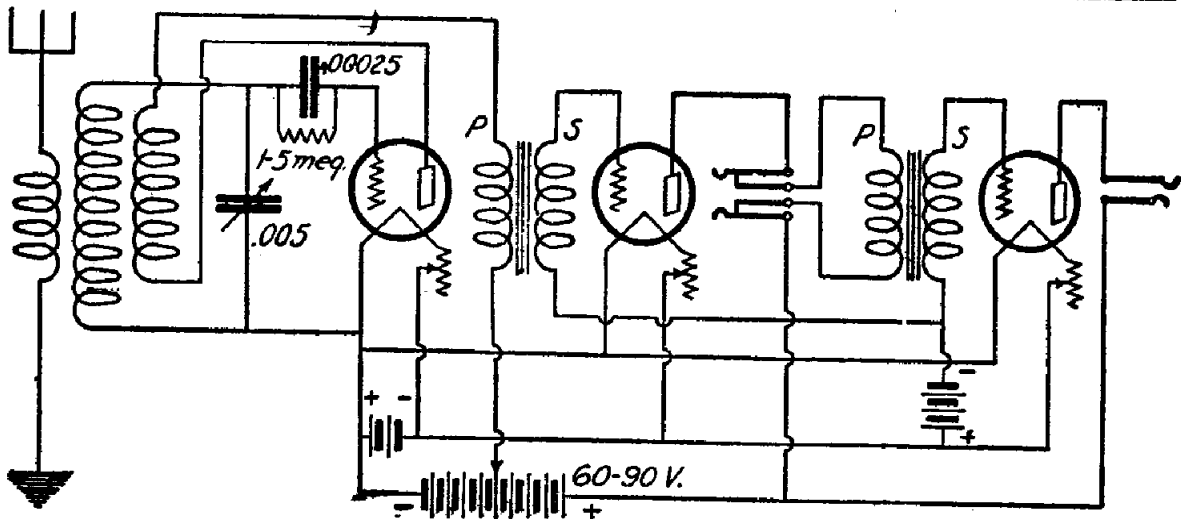

Circuit 54

single circuit jack after the last stage. If a good antenna is used with this receiver, fair volume will be obtained on the loud speaker on the first stage when local stations are received. The grid returns of the two amplifying tubes are connected together and run to the negative terminal of a "C" battery which will have a voltage of from three to nine volts, depending upon the voltage of the "B" battery. This "C" battery has its positive terminal connected to the negative of the "A" battery. A "C" battery is necessary when a high voltage is used on the plates, as it cuts down the current consumption and helps toward the elimination of distortion.

Circuit No. 55. The hook-up shown in the accompanying sketch is the well-known Reinartz circuit. The efficiency of

this circuit is due largely to the fact that all the inductances are brought together and concentrated in one small space. The coils forming the aerial-secondary and feed-back inductances may be wound on a 2½-inch tube with No. 22 D.D.C. wire. The feed-back coil may be spaced about ¼ inch from satisfactorily on a ground alone without any antenna whatsoever. It is also selective and easy to control, as there are but two adjustments. The selectivity of this set the other. If a spider-web coil is used the all around efficiency will be increased. The coils then are wound on a form that is 1¾ inches in diameter. The aerial-secondary coil is tapped at every turn for the first 10, the 12th turn is tapped and connected to ground and the movable contact of the potentiometer,

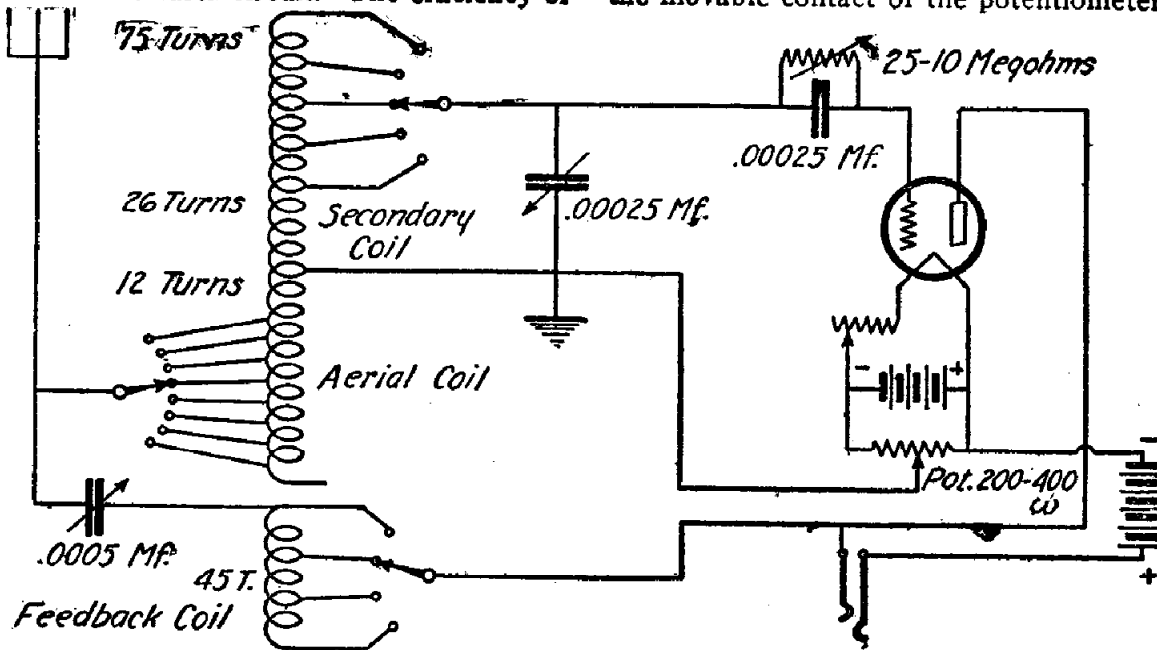

Circuit 55

and from the 26th to the 75th turn the coil is tapped every seven turns. The feedback coil of 45 turns is tapped at every 15th turn. The movable plates of the .0005 mfd. condenser should be connected to the antenna and those of the 11-plate condenser which should be of the vernier type, should be connected to the ground. The inductance should be mounted at least three inches back of the panel so that the leads from the inductance will extend directly to the switch points without crossing. The dry cell type of tube may be used, but the UV-201A type is recommended. With a potentiometer in the circuit, as illustrated, this set, if properly constructed, should be an excellent DX getter.

It is interesting to note that this circuit was designed primarily for C.W. reception, but it is one of the most selective broadcast receivers known today. The circuit shown in Fig. 55 has only one tube, but audio frequency amplification may be added very easily.

Circuit No. 56. The accompanying diagram shows a circuit that is extremely sensitive; so much so that it will operate very satisfactorily.

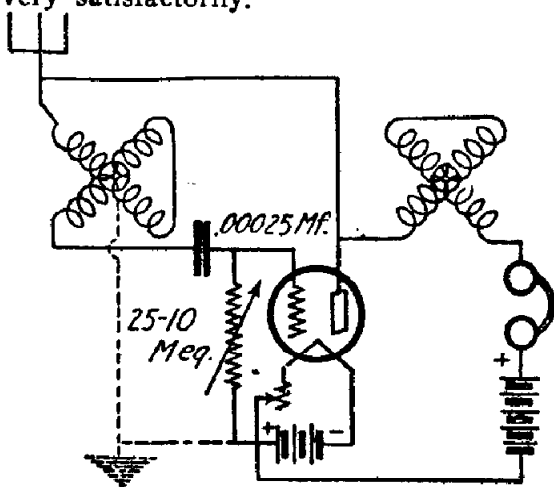

Circuit 56

The ground tap is taken from the center of one coil of the variometer. One end of this coil must go to the aerial binding post. When using a ground with no antenna, the ground is connected directly to the antenna binding post. Because of this, this set is especially adapted to being made into a portable outfit. A dry cell tube is recommended if this is to be a portable set, although better results will be found if a large tube is used.

It may not be amiss here to say a few words in regard to circuits that are adaptable to use in portable sets. Editors of radio question and answer departments

often receive inquiries asking whether or not this or that type of set can be used in a portable receiver. This question is one that can be answered by anyone knowing anything at all about radio if he will only stop to consider the situation from a few different angles. The first important one is whether or not batteries of large size can be carried. Then again, is more than one tube used? Is a loop to be employed or can a regular aerial and ground be used? It is upon these points that the construction of a portable set hinges and not on the actual circuit to be employed. Practically any circuit from a crystal detector to a Super-Heterodyne can be made into some type of portable receiving set. The only thing that is necessary for the constructor to do is exercise a little ingenuity in the placement and arrangement of parts. For instance, grid and plate inductances in multi-tube sets should not be in inductive relation to each other. They should be placed so that the windings run at right angles to each other or should be far enough apart so that there can be no interaction between them. Another good example of this work is the angle at which the coils in a Neutrodyne are placed. This arrangement also reduces the inductive effect found between parallel coils. Then again, audio frequency amplifying transformers should be accorded the same treatment. Place the cores at right angles and distortion and noise will be reduced. And so we can see that the answer to the question propounded above is that practically any circuit can be used in a portable receiver if the instruments used are small enough and if judgment is employed in arranging them.

Circuit No. 57. In the accompanying diagram is shown the fundamental circuit for the Hartley oscillator and a pick-up

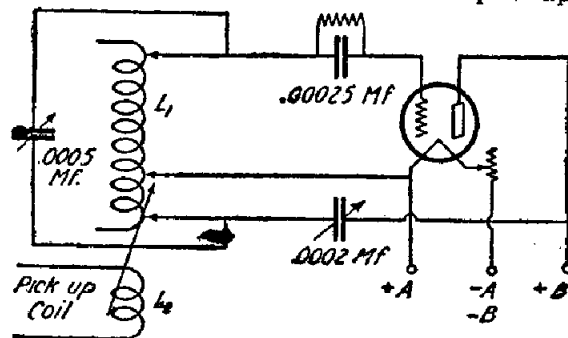

Circuit 57

coil for the Super-Heterodyne receiver. The inductance L1 is composed of 50 turns of No. 22 D.C.C. wire wound on a 3-inch tube. The pick-up coil, L2, has 10 turns of the same size wire wound on the same tube spaced about 1/2 inch from the first mentioned winding.

Reflex Hook - Ups

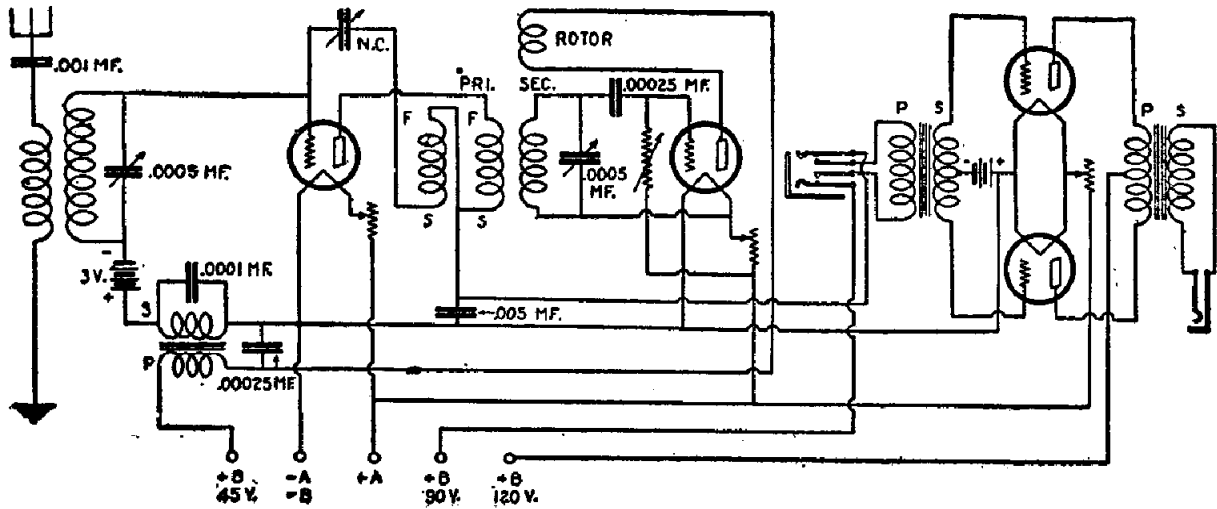

Circuit 58

Circuit No. 58. This type of reflex receiver is sensitive, selective and gives signals of excellent volume and clarity. The quality of reproduction depends greatly upon the inductive relations of the various coils, as will be seen by experimenting with the circuit.

The primary and secondary coils are wound on a 3-inch tube of bakelite or hard rubber. The primary has 10 turns and is wound over the secondary of 50 turns, No. 20 D.C.C. wire being used. There are two ways of making the four-coil unit. One is to wind the coils in cylindrical form and the other is to employ spider-web forms. S and F indicate the start and finish of a two-wire coil made by winding two wires, side by side, on the form at the same time, the wire being no larger than No. 26 D.C.C. It is also advisable for one wire to have colored insulation so that there will be no danger of confusing the windings. It has been found that the R.F. tube can be more easily neutralized if these two wires are twisted together before winding them on the form. Twenty turns of this twisted wire are wound on a spider-web form or on a 3-inch tube. This leaves four connecting ends, two at the start, S, and two at the finish, F. The S of one coil and the F of other coil are connected. On a second spider-web form placed about 1/2 inch from the first, are wound 45 turns of No. 22 D.C.C. wire. If the 3-inch tube is being used, the same number of turns may be wound on, starting 1/4 inch from the starting end of the 20-turn coil. At the finishing end of the 20-turn coil is placed the tickler, which has 22 turns of the same size wire. If spider-web forms

are used, the tickler may be about the same number of turns, placed on one of these forms and variably coupled to the secondary. It should be noticed that the antenna and secondary coils must not be in inductive relationship to the four coils just described.

A reflex circuit that is very simple to build and will prove quite selective is shown in *circuit No. 59*. This is known as the Harkness single tube reflex and uses a special tuner and radio frequency transformer. The secondary of the tuner

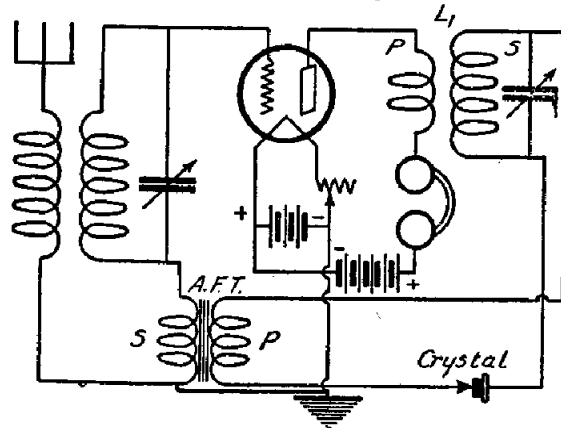

Circuit 59

er is constructed by winding 55 turns of No. 24 S.C.C. wire on a 3-inch tube. The primary is of 15 turns, wound directly over the secondary and separated from it by a piece of insulating paper. The secondary of this coupler is shunted by a variable condenser of 17 plates. The special radio frequency transformer shown as L1 is made in a similar fashion. The secondary is wound the same as the spe-

150 RADIO HOOKUPS

cial coupler but the primary consists of 20 turns of wire. The secondary of this transformer is also shunted by a 17-plate condenser. A fixed crystal detector is ordinarily used in this receiver, although any good crystal detector may be employed. This receiver operates very satisfactorily without the use of any by-pass condensers that are commonly needed in other reflex circuits.

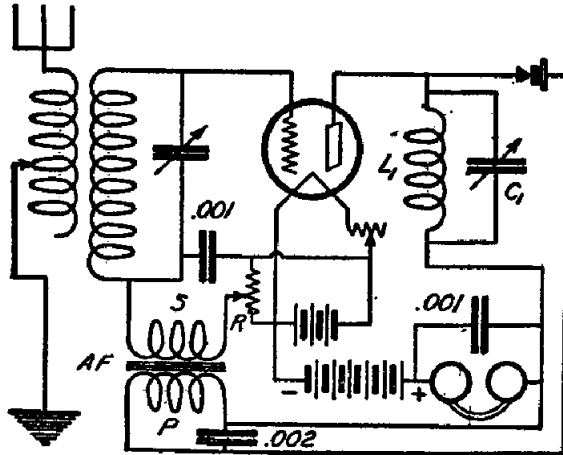

Circuit 60

Another reflex circuit is shown in *Circuit No. 60*. In this circuit, instead of a radio frequency transformer, a tuned impedance coil is employed. This coil is shown as L1 and may be made by winding 45 turns of No. 24 S.C.C. wire on a 3-inch tube. A variable condenser C1 of .0005 mfd. capacity is shunted across this impedance coil for tuning. Any type of tuner may be used, although in this case a standard variocoupler is shown, the secondary of which is tuned by a 23-plate potentiometer shown as R is employed to keep the tube in a stable operating condition. This type of reflex receiver will be found much more selective than that shown in diagram No. 61. The tuning condenser across the secondary of the coupler and the variable condenser across the tuned impedance coil must both be tuned to exactly the same wave-length before any station can be received. If the tube tends to oscillate, the potentiometer lever should be moved towards the positive side to correct this condition.

In *circuit No. 61* we have a simple one-tube reflex receiver. This receiver incorporates one stage of radio and one stage of audio frequency amplification. The same tube is used to amplify at radio frequency and after detection by the crystal shown as D, it again amplifies at

audio frequency. An ordinary variocoupler may be used for tuning and the secondary is shunted by a variable condenser of .0005 mfd. capacity. A potentiometer shown as R is used so that the tube may be kept from oscillating. This instrument should be of rather high resistance; in the neighborhood of 400 ohms. It will be noticed that fixed condensers are connected across the phones and the primary and secondary of the audio frequency transformers. These condensers are known as by-pass condensers and are employed to allow the radio frequency currents to pass the high resistance of the phones and the coils of the audio frequency transformers.

Circuit No. 62. So much has been said about the popularity, low cost, and faithful reproduction of the reflex circuit, that many people are beginning to realize its importance and are turning toward it. However, as there are so many reflex circuits, it is often confusing to the layman as to just what circuit he should use. The Rasla reflex circuit, as shown in the accompanying diagram, is one of the simplest and most efficient receivers of this type it is possible to build.

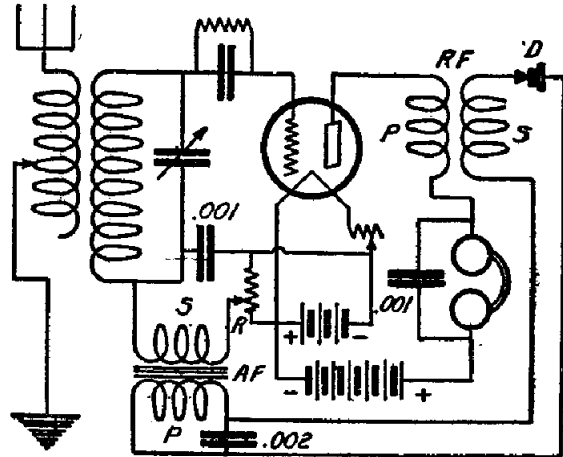

Circuit 61

By reference to the diagram, it will be noted that the antenna system is untuned, of a semi-aperiodic nature. The secondary is tuned by .00035 mfd. condenser of the low loss type, but as will be noted, only a part of the secondary coil is included in the grid circuit. A small balancing condenser tends to obviate the undesirable creation of oscillations, and also serves somewhat as a volume control. Analyzing the circuit we see that it consists of one stage of tuned radio frequency amplification, crystal detector, a reflexed stage of audio frequency and two stages

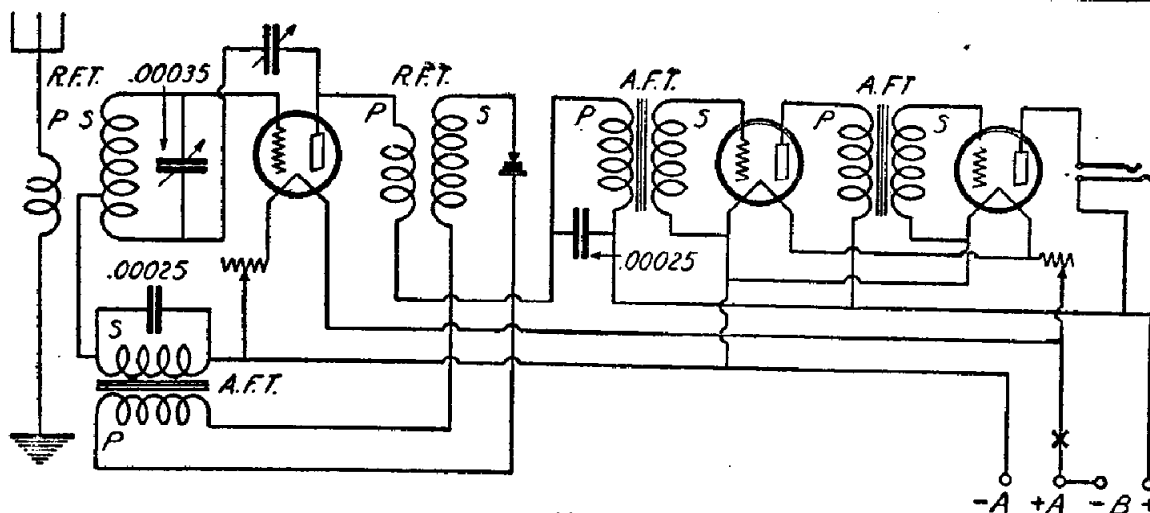

Circuit 62

of straight audio frequency amplification.

The radio frequency transformer is one that is designed so that its impedance matches that of the fixed detector, thus giving maximum transfer of energy and efficient coupling. A .00025 mfd. fixed condenser is shunted across the secondary of the audio transformer which is used for reflexing. A 30 ohm rheostat is necessary for the careful adjustment of the detector tube, while a 6 ohm rheostat will handle the audio frequency amplifier tubes very nicely.

Circuit No. 63. In the accompanying diagram is the Acme reflex circuit, which has three stages of radio frequency amplification, a crystal detector, and three stages

of audio frequency amplification. There are but four tubes used, however, which should be of the UV-201A type. The crystal should be a fixed detector. This is one of the simplest and most powerful reflex circuits that has ever been designed and if good apparatus is used in it, the results should be all that can be expected from four vacuum tubes and possibly even a little bit more. Use a good stable crystal detector as this is an important part of the set. A permanent one is to be desired, if simplicity is one of the points in view.

Circuit No. 64. The circuit of the Inverse Duplex receiver is so made that each tube performs its duty as a radio

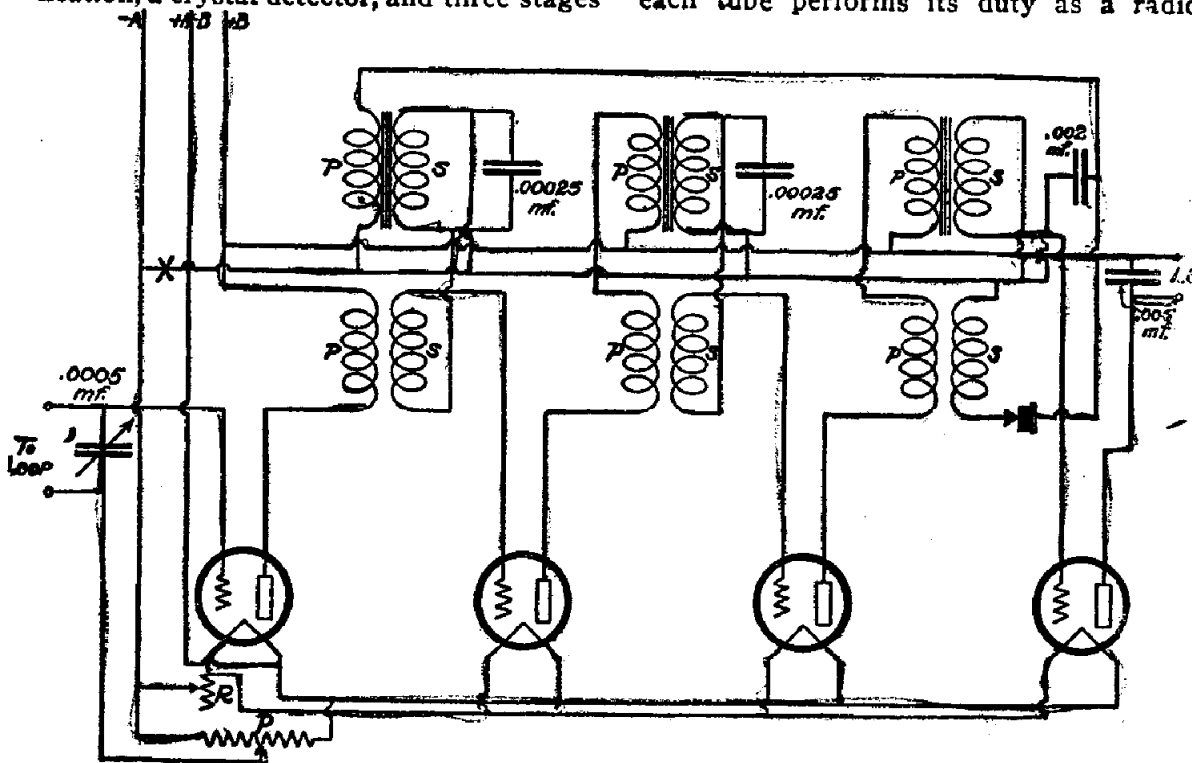

Circuit 63

150 RADIO HOOKUPS

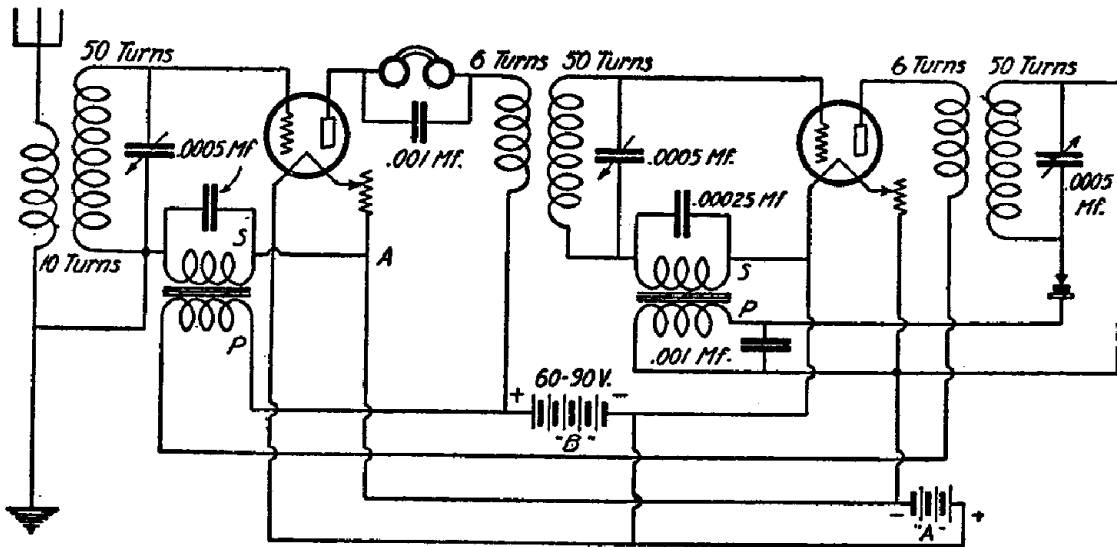

Circuit 64

frequency amplifier as well as an audio frequency amplifier. This circuit is so designed that all parts of it are balanced, which is not always the case in reflex circuits. This unbalancing of reflex circuits is one of the chief causes of trouble in this type of receiver. It is an excellent plan to thoroughly test the radio frequency stages of amplification before adding on the audio frequency stages. In the accompanying diagram the circuit is shown with a crystal detector instead of the electron tube that has formerly been used. This type of detector should give exceptionally clear signals and the difference in volume will be hardly noticeable.

The primary and secondary coils are wound on the same 3-inch bakelite or hard rubber tube and are wound with No. 24 D.C.C. wire. The secondary has 50 turns and the primary that is wound over the secondary separated only by the insulation

of the wire, has 10 turns. The radio frequency transformers are also wound on 3-inch tubes with the same size wire as that mentioned above. The secondary has 50 turns and directly over this is wound the primary of 6 turns. Instead of running the grid return wire of the first tube to the point marked A, it may be connected to the movable arm of a 400-ohm potentiometer, which should be connected across the filament battery in the usual manner. This is for getting the proper bias on the grid of the first tube.

In case the experimenter wishes to try an indoor antenna with this circuit instead of the outdoor antenna for which it is designed, the loop is connected directly across the first .0005 mfd. variable condenser. This will eliminate the aperiodic primary and the secondary coils of 10 and 50 turns respectively. Excellent reception has been accomplished on a loop antenna with this circuit, but the outdoor antenna

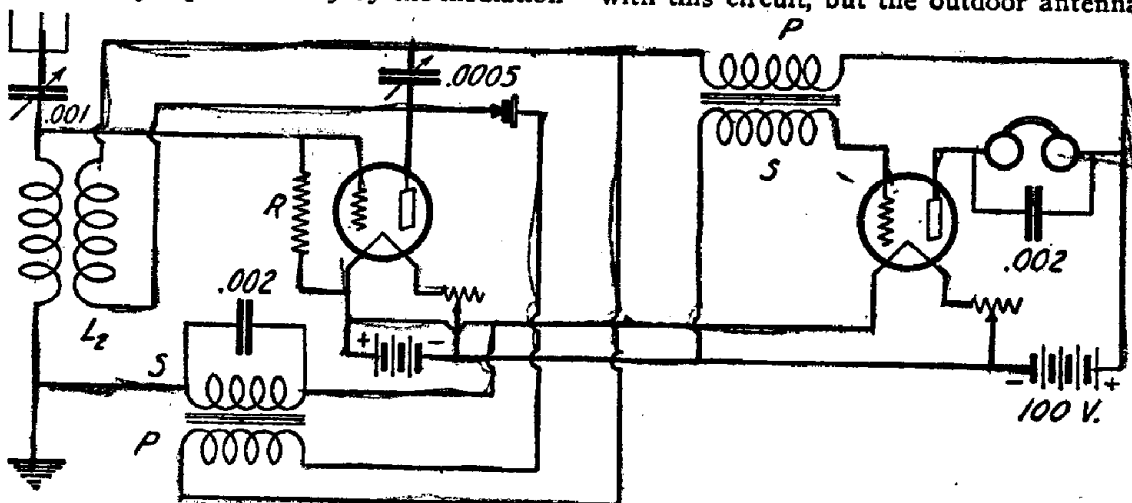

Circuit 65

is recommended for all around good reception.

The types of tubes that are best adapted for use in this receiver are the UV201-A and C301-A. Although the smaller tubes of the 199 type may be used, they will not give the volume that the larger ones will produce. The crystal should be of the fixed type in order that there is no trouble from adjusting it during reception.

Circuit No. 65. The S.T.-100 circuit is a stage of radio frequency amplification, crystal detector, and two stages of audio frequency amplification. The S.T.-100 is one of the easiest reflex circuits to build, there being nothing tricky about it. The usual precautions in wiring a set should be observed, as short leads from and to transformers, etc. The antenna inductance L1 should be a 35- or 50-turn honeycomb and the tickler coil should be a 75-turn honeycomb. The resistance between the grid of the first tube and the positive filament should be about 100,000 ohms. This is an essential part of the circuit and if unsatisfactory results are obtained with 100,000 ohms, lower values should be tried. The "B" battery of 100 volts may be shunted by a 1 mfd. condenser. Because there is but one stage of radio frequency amplification the S.T.-100 is not very effective on long distance signals. Its chief use seems to be in obtaining very loud signals within a 50-mile range. Also the reception on a loud speaker is much better than when phones are used. By applying 4.5 to 9 volts on the grids of both tubes, the quality of speech and amplification is materially improved.

Circuit No. 66. The Inverse-Duplex cir-

cuit shown in Fig. 66 is so arranged that each tube does the work of two. In many reflex circuits some tubes do more work than others and an unbalanced circuit results with correspondingly poor reception. The Inverse-Duplex is so designed that all parts of the circuit are balanced. Before the audio frequency stages of amplification are added, the radio frequency stages and detector should be tested. Also before connecting any condensers in the set, they should be tested for short circuit. If the first part of the circuit functions satisfactorily, the two audio frequency transformers may be added. This set is rather a difficult one in which to eliminate howls, but by reversing the leads to the transformers this trouble may be overcome. A loop antenna is the proper type to use. Wind 8 to 12 turns of No. 18 wire spaced 1/4 inch apart on the 18-inch frame. UV-201A tubes or those of similar type should be used, as the set is designed to operate with storage battery tubes.

The 400-ohm potentiometer that is connected across the filament battery is used in order to give the proper grid bias to the first tube. As in every receiver employing radio frequency amplification, the grid bias is an important factor in the stabilizing of the set, as it allows the tube to operate at the proper point on the grid voltage-plate current characteristic curve.

The one big feature of this particular reflex circuit is that the tubes are not in any case overloaded. This is the trouble with the usual reflex circuit but by the Inverse Duplex method, the tube that acts as the first stage of R. F. is the second

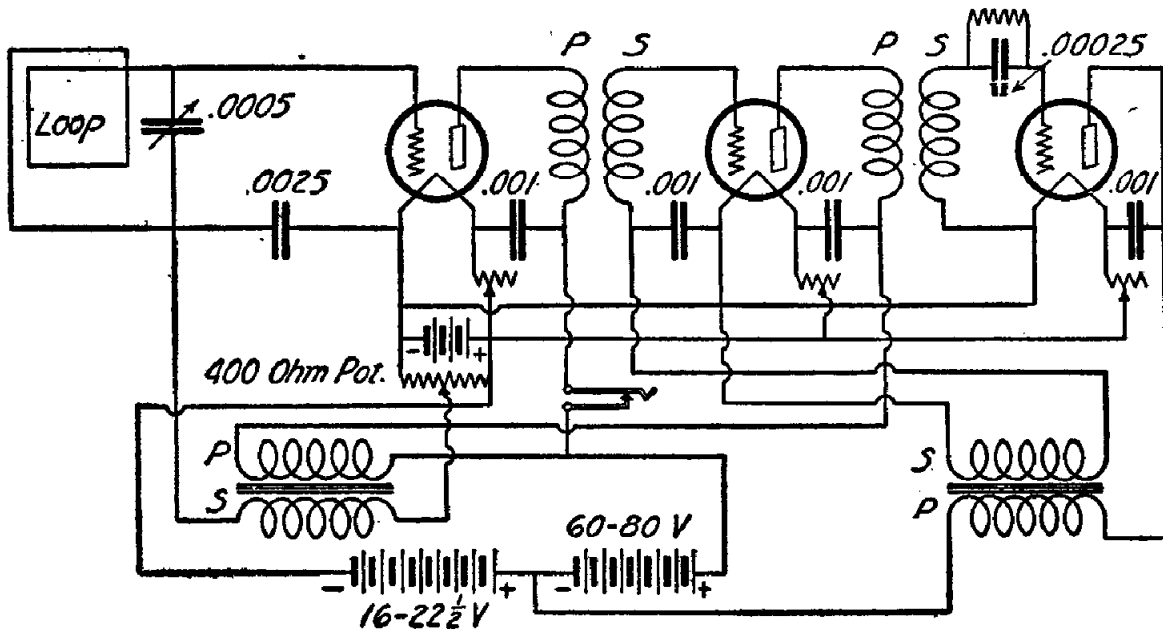

Circuit 66

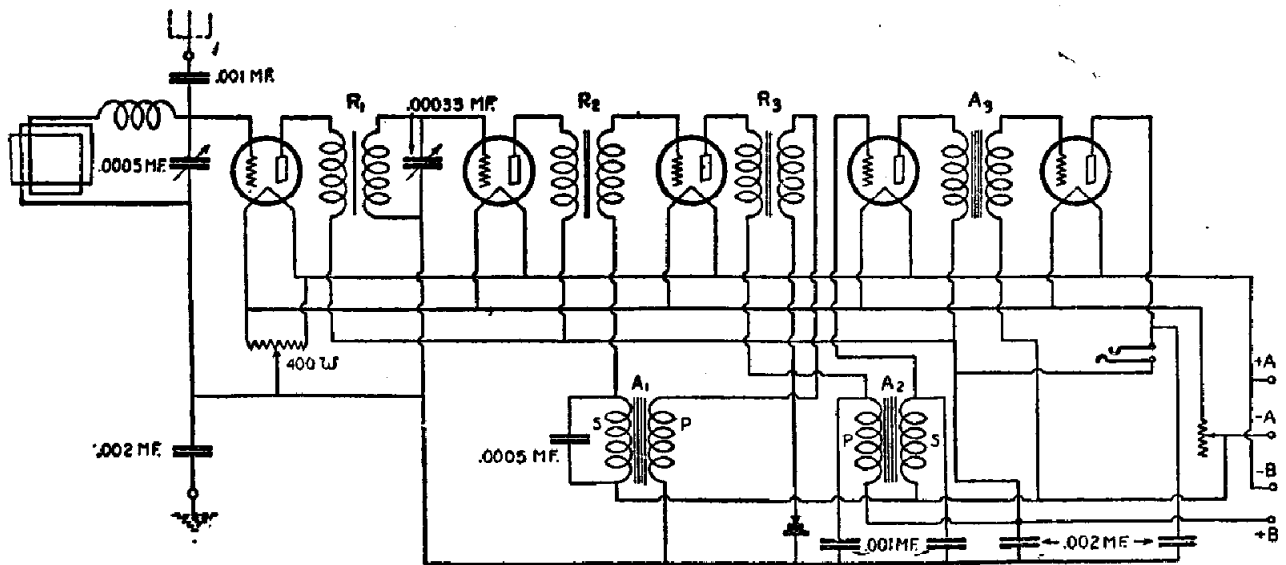

Circuit 67

A. F., while the second R. F. acts as the first A. F. Thus the loads are balanced.

If the set has a tendency to oscillate or howl, try reversing the leads of the transformers one pair at a time until the noise has stopped. The use of a "C" battery is good practice in this as in any circuit that has more than three tubes, because it not only reduces "B" battery consumption, but also greatly improves the quality of reception.

The loop antenna is of special design. It has 15 turns of No. 22 Litz. wire spaced $\frac{3}{8}$ inch apart wound in a spiral on sticks three feet long.

Use manufactured R.F. transformers and in the audio amplifier do not use transformers with a higher ratio than 5 to 1.

A good many reflex circuits are hard to get into correct operation as they are critical and erratic. This one particular set, however, might almost be classed as an exception to the rule inasmuch as possibly thousands of them have been built and practically all of them have worked perfectly without the least bit of trouble.

Circuit No. 67. This reflex receiver has a sensitivity determined by the utilization of three stages of radio frequency amplification, one of which is tuned in order to give a high degree of selectivity. This selectivity is increased by the use of a loop antenna.

The radio frequency transformers can be home-made if desired, and the specifications are given below, but it is recommended that a standard type of transformer is installed, as transformers are more or less difficult to construct. The first R. F. transformer, R1, has a primary

winding of 33 turns and the secondary has 105 turns, wound with No. 26 wire. The windings are of the "pie" type and the mean diameter is $1\frac{1}{4}$ inches. Two of the pie windings are in the primary and three in the secondary, and there is also a little iron used in the core. R2 has 75 turns on the primary and 400 turns in the secondary, wound with No. 34 wire, the mean diameter of the coils being about $\frac{3}{4}$ inches. R3 is also wound with No. 34 wire and has the same diameter. There are 225 turns on the primary and 330 turns on the secondary. Each of these transformers has a little more iron in the core than the preceding one. The audio frequency transformers A1 and A3 have a ratio of 4 to 1 and A2 has a ratio of 5 to 1. The panel may be about 15 inches long and the depth of the cabinet about 8 inches. There is a crystal employed for rectification instead of a tube, because of its many well-known advantages.

The three stages of audio frequency amplification are used to get enough volume; it is possible to use as many as three stages because of the staggered characteristics and the balancing and opposing of the stray fields of the transformer systems. In the commercial receiver there is a grounded metal panel used; the lowest connection line in the accompanying diagram represents this grounded panel.

Circuit No. 68. This is an English circuit that has found great favor among British radio fans. It differs from the ordinary form of reflex circuits in that the audio frequency amplifier has resistance coupling instead of transformer coupling. As a resistance has no natu-

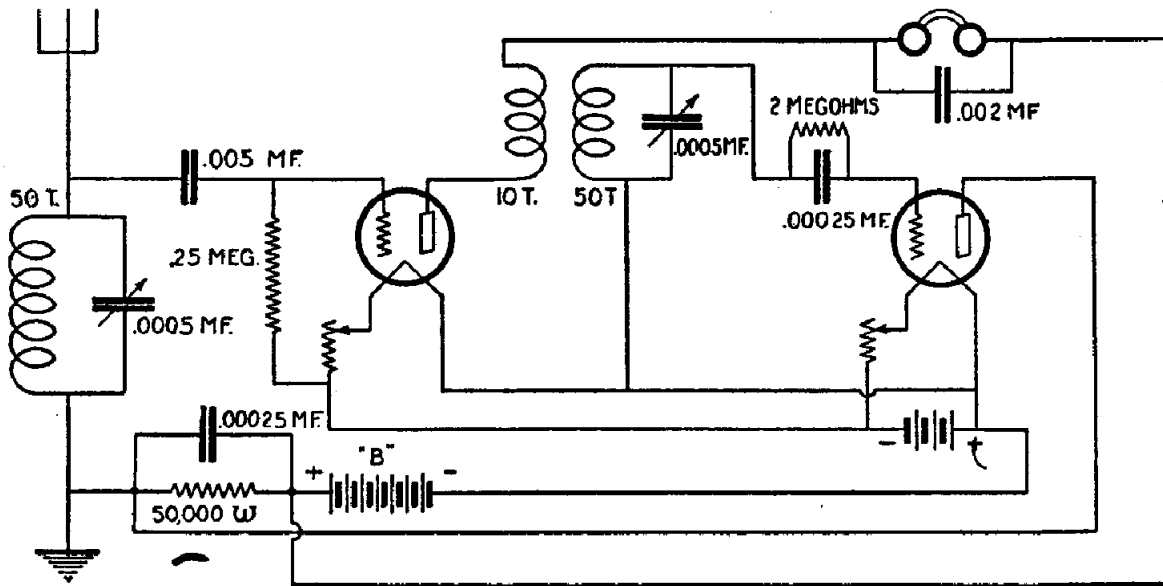

Circuit 68

ral period of vibration it will not cause the howling which is so common in transformer coupled reflex circuits. In Fig. 68 the first tube acts as both radio and audio frequency amplifier and the second tube is the detector. In the plate circuit of the detector is a resistance of 50,000 ohms, shunted by the condenser.

The grid condenser in the first tube circuit is used for blocking the plate voltage from the grid of the tube. The phones or loud speaker are connected in the plate circuit of the amplifier tube in series with the primary of the radio frequency transformer, which is preferably of the tuned type and should be so adjusted that the circuit will not oscillate at any setting of the condensers. A plate voltage in the neighborhood of 10 volts, depending, of course, upon the type of tubes employed, will be necessary for good reception.

Fig. 69 shows the standard reflex circuit. The current from the crystal is passed through a step-up transformer and amplified by the tube. The head-set is included in the plate circuit of the tube. A "C" battery and potentiometer are recommended in this circuit while experimenting, but may be dispensed with when the correct values are obtained. The action of this circuit is as follows: The radio frequency currents received by the antenna are amplified by the tube, detected by the crystal, and amplified by the same tube at audio frequency, giving the same results that would be obtained from a set using a one stage R.F. amplifier, detector, and one stage A.F. amplifier. Instead of using a tuned radio frequency transformer as shown in the diagram an un-tuned iron

core transformer may be used. There are various types on the market that will give good results. The amplification that this circuit gives depends largely upon the crystal detector and the values of the fixed condensers and other instruments.

Somewhat better results are claimed for the circuit, Fig. 70. In this hook-up the secondary of the audio amplifying transformer is connected to the grid side of the tuning circuit and not to the filament side.

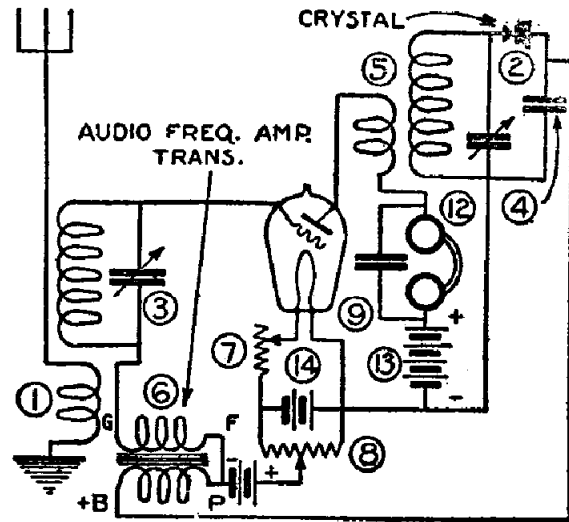

Circuit 69

Of course there are many other connections that may be tried, such as grounding the filament, connecting the crystal across the primary coil instead of the secondary coil, etc. When working properly a good single tube reflex circuit will give an amplification of over 3,000 times.

Circuit 71 is similar to circuit 69 except

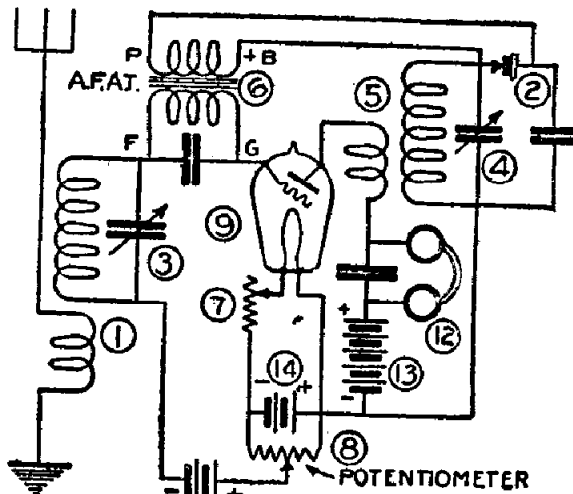

Circuit 70

that the transformer is omitted and the currents are amplified directly from the crystal. The fixed condensers shown are not marked; it is up to the experimenter to determine the correct values. The amplification will be less than that of circuit 10 as the transformer is omitted.

Slight improvements are embodied in the circuit shown in Fig. 72. In the first place the secondary of the amplifying transformer is connected to the center tap end of the coil connects to the grid and of the secondary of the tuning coil. One the other to a one-half megohm grid leak connected to the filament. This makes

a bridge circuit and no radio frequency currents will pass through the audio transformer and a by-pass condenser is unnecessary. This circuit is more stable than the others. The plate circuit also differs. Instead of the usual transformer, a single coil with a slider is used. This not only tunes the circuit but regulates the amount of energy taken by the crystal. The coil may be a single layer winding of No. 26 wire on a 2½-inch diameter tube. About 80 turns should be used.

In the above circuits we have given the approximate amplification possible. This is given as voltage amplification and not energy amplification. If the voltage amplification is given as 1,600, the energy amplification is the square root of this,

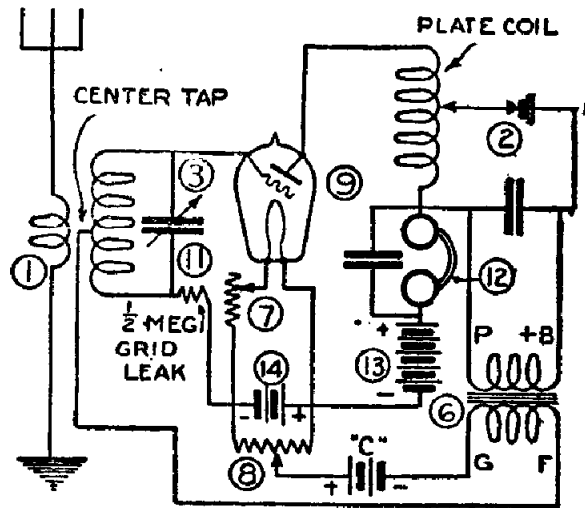

Circuit 72

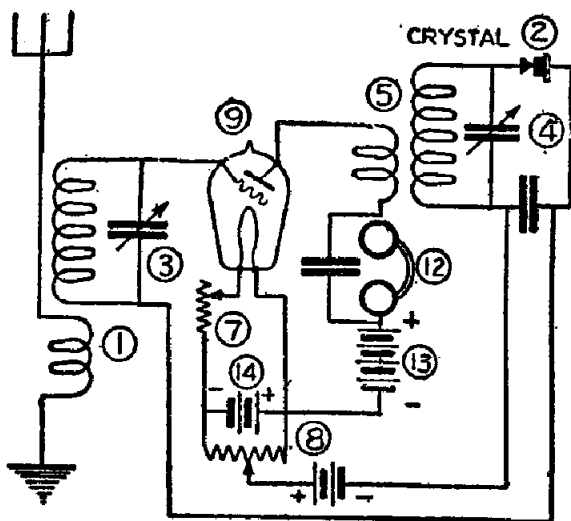

Circuit 71

or 40, and the sound will appear about 40 times as loud, and not 1,600 times.

In circuit 73 the radio frequency currents are impressed upon the grid and filament of the tube, repeated in the tuned plate circuit, and detected by the crystal detector; the rectified or audio frequency currents pass through the step-up transformer and are impressed upon the grid and filament of the same tube. They are amplified by the tube and repeated in the telephone headset. Thus the tube amplifies both radio and audio frequency currents simultaneously. To explain why we do not obtain the amplification that we are entitled to, we must consider the rectifying action of the tube as well as that of the crystal. On account of the rectifying action between the grid and filament of the tube, the incoming radio frequency currents build up a negative charge on the grid side of the fixed con-

denser (C) across the secondary of the audio transformer. This causes a reduction in plate current and the signal is heard in the headset with the crystal disconnected. With the crystal connected, the rectifying action of the crystal builds up a negative charge on one side of the condenser (C1) connected across the primary of the audio transformer. Thus for each group of incoming oscillations a negative charge is impressed across both the primary and the secondary windings of the audio transformer, setting up a current flow in both windings, which, from the nature of the circuit, must oppose each other, and unless the ratio of the transformer suits the constants of the other instruments, the transformer is useless. It is on this account that experimenters have obtained as good results with the crystal and transformer removed as with them connected. Now that we

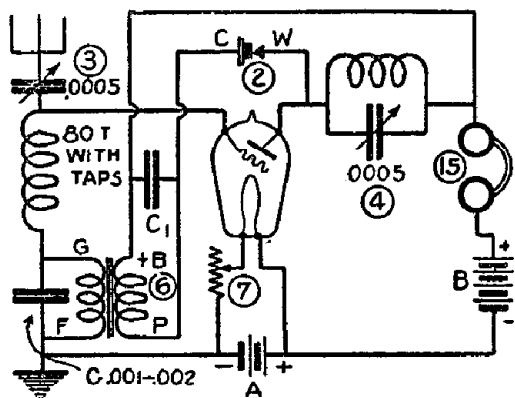

Circuit 73

know the trouble we will see how it can be avoided. It may be well to mention first that this circuit, Fig. 73, is one of the simplest and best reflex circuits in existence today. It has the disadvantage of picking up audio frequency noises from lighting circuits, the amount of disturbance, of course, depending upon the location of the set.

Fig. 74 shows a circuit in which the rectifying action of the tube has no effect on the action of the audio transformer. This is accomplished by connecting two fixed condensers in the grid lead (C1) and (C). Condenser (C) is of comparatively large capacity, .002 mfd., for it must pass both radio and audio frequency currents. Condenser (C1) is of small capacity, .00025 mfd., as it should by-pass the radio frequency currents only. The grid leak (R) is required. It should be of one-half to one megohm. With this circuit, the negative charges that accumulate on the grid must leak off through the

grid leak (R); they cannot leak off through the secondary of the transformer on account of the blocking condenser (C), and therefore cannot balance out the current in the primary of the transformer. Experimenters should obtain very good results from this circuit. The remainder of the circuit needs no special comment as it is standard; all of the circuits shown

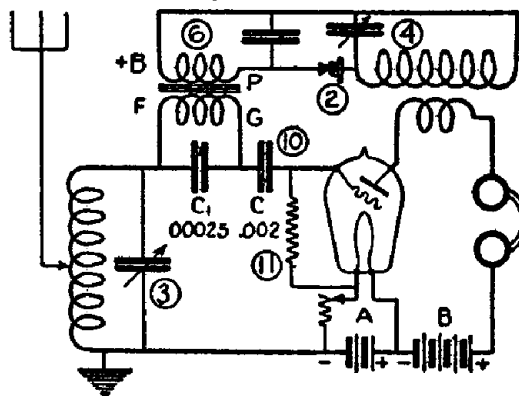

Circuit 74

in this issue and also last month's issue should be tried out with the double grid condenser.

A simplified reflex circuit with the added improvement of the extra grid condenser is shown in Fig. 75. All this circuit requires is a standard three circuit tuner. A crystal detector and audio transformer are connected across the tickler winding of the coil. The secondary is connected across the small grid condenser as shown. Note that the condensers have been reversed from the locations shown in Fig. 74, merely to show that there are two ways of obtaining the same result.

Peck's reflex circuits use no crystal detectors at all. The tube is used as a radio amplifier, detector, and audio frequency regeneration, with an audio frequency transformer for the feed-back coupler. Figs. 76 and 77 show two of these

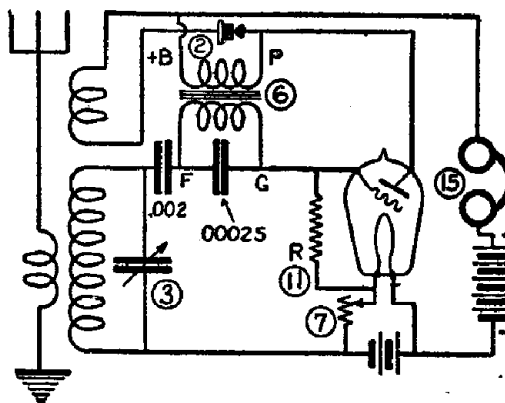

Circuit 75

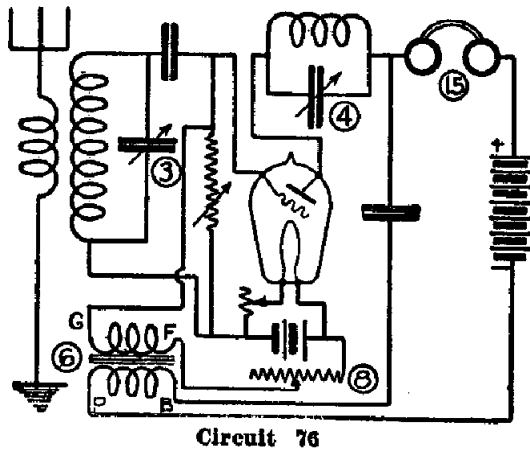

Circuit 76

circuits. Both are easily tried on the hook-up board, the only additional equipment required being a variable grid leak.

Of course, with an audio frequency feed-back connection, the circuit will howl at audio frequency unless the feed-back is controlled. This is accomplished by adjusting the grid leak. If the circuit doesn't work at first try reversing the transformer connections. A variable grid

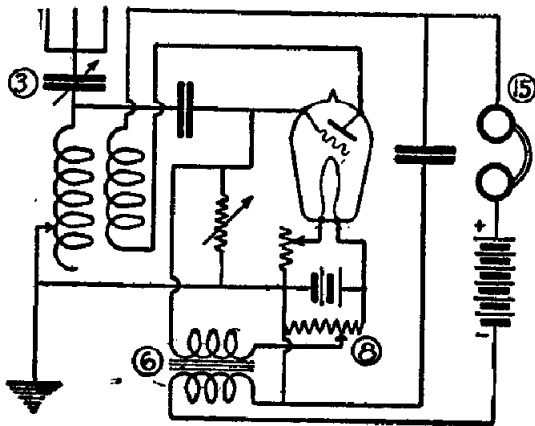

Circuit 77

leak should also be tried across the primary of the transformer. The hook-up shown at Fig. 76 has a tuned plate circuit for regeneration; in Fig. 77 a tickler feed back is employed. Honeycomb coils of about 60 and 100 turns each may be used in this circuit.

A simple reflex circuit that gives exceptional volume on local stations is

shown in Fig. 78. This hook-up is easily connected on the hook-up board and requires few clip and tip leads. A Rasco R. F. transformer is used and the oscillations are controlled by the potentiometer

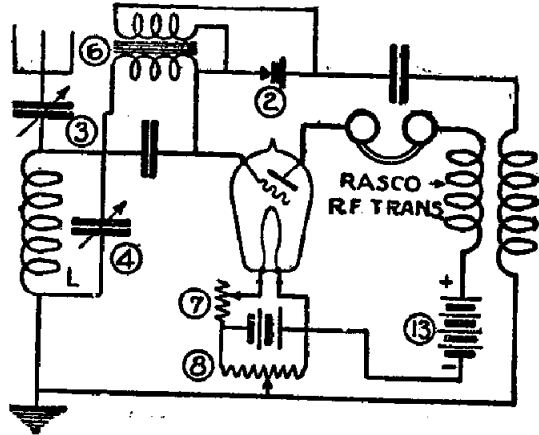

Circuit 78

The experimenter may try various sizes of fixed condensers across the secondary of the audio transformer and he may also try two grid condensers as shown in Fig. 74. When the proper combination has been found a very good one dial single tube receiving set can be made.

Many improvements are embodied in the loop receiver shown in Fig. 79. The tickler or feed back coil is mounted within the loop, and may consist of two turns mounted so that the coupling is variable. Thus we have regenerative amplification. Rectification is obtained by the crystal.

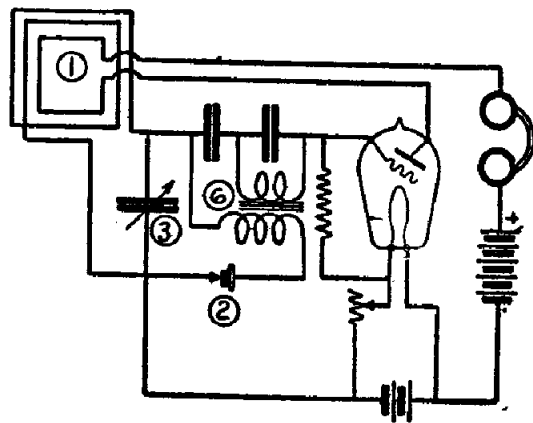

Circuit 79

Radio Frequency Hook-Ups

When reception over greater distance is desired with a crystal receiver, a stage of radio frequency amplification may be placed directly before the receiver without altering the wiring in any way, providing a variocoupler is used in the crystal receiver. A diagram of this circuit is shown in *circuit No. 80*. The radio frequency amplifier consists of an amplifying tube and a tuner. The tuner in this case is an ordinary variometer with a .00025 mfd. condenser in the antenna circuit. The plate of the radio frequency tube is connected directly to the antenna

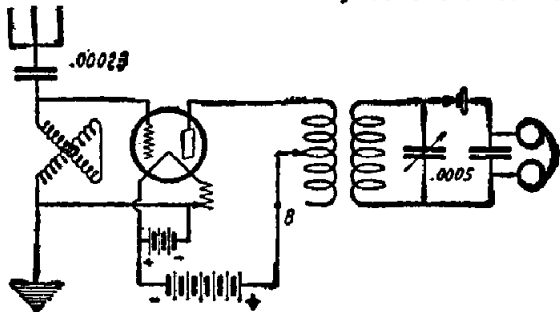

Circuit 80

binding post of the crystal set and the ground binding post is connected to the positive terminal of the "B" battery. No radio frequency transformer is employed, the variocoupler serving as a tuned radio frequency transformer.

In *circuit No. 81* is shown a 2-tube receiver consisting of detector and one stage of radio frequency amplification. In this circuit a radio frequency transformer is employed. The tuner consists of a standard variocoupler with the secondary tuned by a .0005 mfd. variable condenser. As regeneration is not had in this circuit the tuning will be rather broad unless the coupling between the primary and secondary

of the variocoupler is kept comparatively loose at all times. A potentiometer of 400 ohms is connected across the "A" battery leads and the grid return of the amplifier tube is connected to the movable arm. If the radio frequency tube oscillates, the potentiometer lever should be moved towards the positive side until the oscillation ceases. If this lever can be moved all the way to the negative side without the tube oscillation at any wave-length, the potentiometer may be omitted and the grid return connected directly to the negative "A" battery. A filament switch shown at B is employed so tubes may be switched on or off and so the potentiometer will be disconnected when the set is not in use.

In *circuit No. 82* is shown a radio frequency amplifier using the tuned impedance system of amplification. In this case the tuned impedance coil consists of a standard variometer connected in the plate circuit of the amplifying tube. A standard grid condenser of .00025 mfd., capacity is employed in the detector grid circuit, and the grid leak is connected from the grid directly to the positive lead of the "A" battery, as shown. In this circuit it is essential that a potentiometer be employed, as otherwise the radio frequency tube would be in a constant state of oscillation. This potentiometer should have a resistance of approximately 400 ohms. A filament switch is also connected in the negative "A" battery lead. The tuning of this receiver will be found fairly sharp. The secondary variable condenser of the tuner and the plate variometer must both be tuned to the same wavelength for any given station. It will be noticed that on the lower wave-lengths

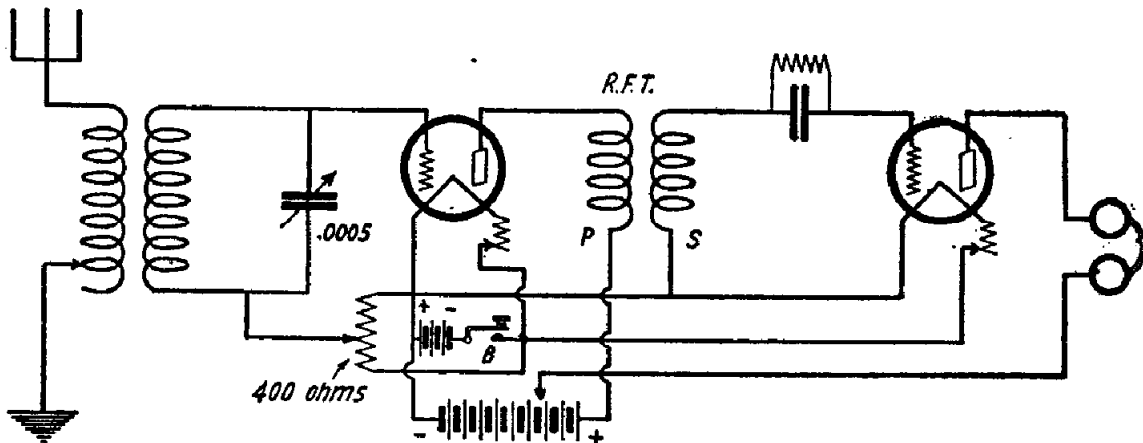

Circuit 81

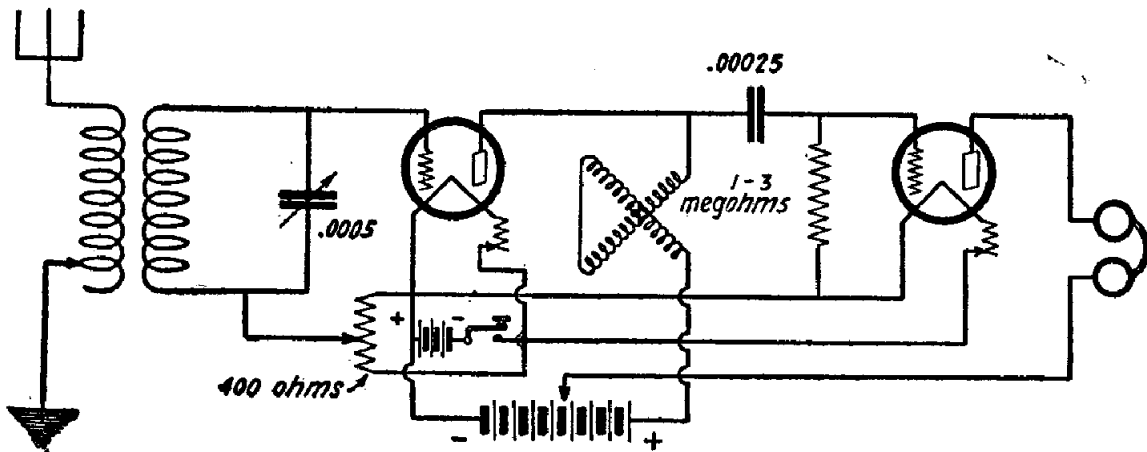

Circuit 82

the potentiometer lever must be moved closer to the positive side to keep the tube from oscillating.

Circuit No. 83 shows another type of tuned impedance radio frequency amplification. In this case, instead of the variometer, a coil of wire shunted by a variable condenser is employed in the plate circuit of the amplifier. This coil shown at 1, may consist of 40 turns of No. 22 S.C.C. wire wound on a tube 3½ inches in diameter. The variable condenser should have a capacity of .0005 mfd. This type of tuned impedance coupling will give slightly better results as regards sharpness of tuning than that described in diagram 82. The grid condenser has a capacity of .00025 mfd. and the grid leak has a resistance of one megohm. The potentiometer shown at R must be employed and should have a resistance of at least 400 ohms. A variocoupler is employed in this circuit, the secondary of which is shunted by a variable condenser of .0005 mfd. capacity. As a radio frequency tube in this type of circuit will oscillate very readily great care should be

taken that it is handled correctly so interference is not created in nearby receiving sets.

In circuit No. 84 is shown a radio frequency receiver which if correctly built and operated will give exceptional results. This receiver consists of one stage of tuned transformer coupled radio frequency amplification with regeneration in the detector circuit. The coils L, L1 and L2 are the primary, secondary and tickler of an untuned primary coupler. This untuned primary coupler was described in diagram 30 in this book. It will be noticed that this is circuit No. 30 with one stage of radio frequency amplification connected directly ahead of the detector. The tuner used in the antenna system consists of a primary and secondary which is identical with the primary and secondary of coils L and L1. The secondary of this tuner is shunted by a variable condenser of .0005 mfd. capacity. The untuned primary coupler secondary must also be tuned with a condenser of the same capacity. Both condensers must be tuned to the same wave-length to receive any station. As

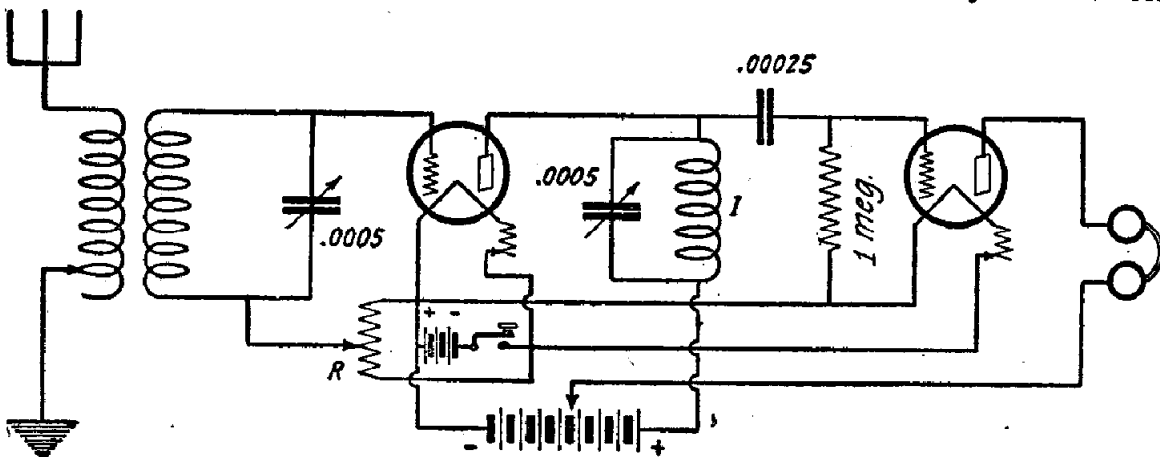

Circuit 83

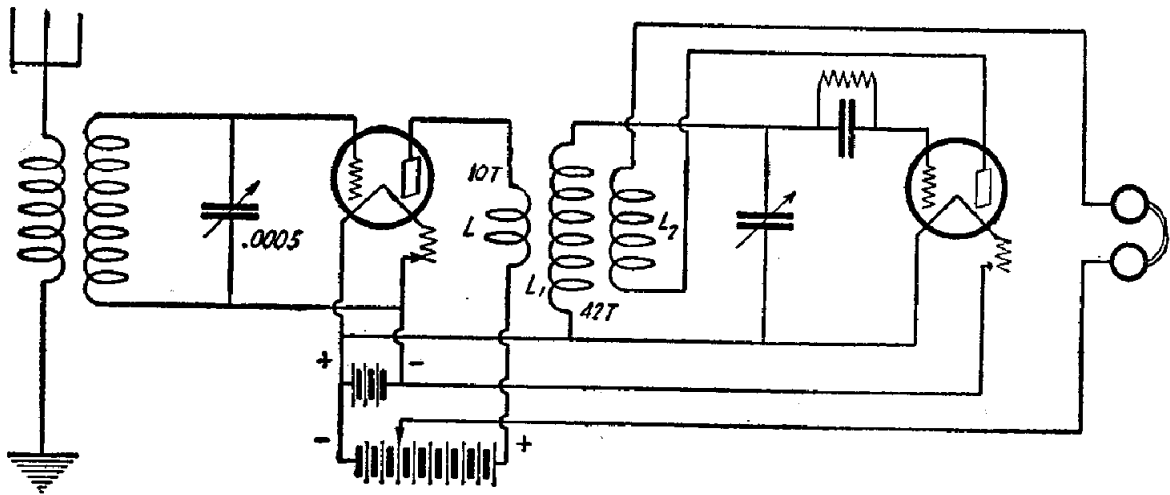

Circuit 84

the regeneration obtained in the detector circuit is equal to an extra stage of radio frequency amplification, this receiver will duplicate the results of most three-tube R.F. sets. No potentiometer is required in this receiver.

Circuit No. 85. Where long distance reception is desired, together with simplicity of tuning, the circuit shown here may be used. This consists of a tuner employing two stages of radio frequency amplification. As regeneration is not employed in this circuit, a coupler should be used which is capable of very loose coupling between the primary and secondary, otherwise the tuning will be broad. A variable condenser of .0005 mfd. capacity is employed across the secondary of the coupler for tuning. To avoid capacity effects, this condenser must be connected with the rotary plates to the filament. If a good make of radio frequency transformer is used, the tubes will oscillate

and consequently a potentiometer must be employed so that this oscillation can be controlled.

Circuit No. 86. Here we have a circuit combining one stage of radio frequency with regeneration in the detector circuit. As one stage of audio frequency is also used, a loud speaker may be employed on practically all stations received. The antenna tuner consists of an untuned primary coupler without the rotor. The radio frequency transformer is an ordinary untuned primary coupler, like that described in circuit No. 30. The primary of this coupler must be wound with large wire, of not more than 10 turns. The secondaries of both couplers are shunted by variable condensers of .0005 mfd. capacity for tuning. Both condensers must be varied at the same time, as both secondary circuits must be in resonance before any station can be picked up. No potentiometer is necessary in this receiver,

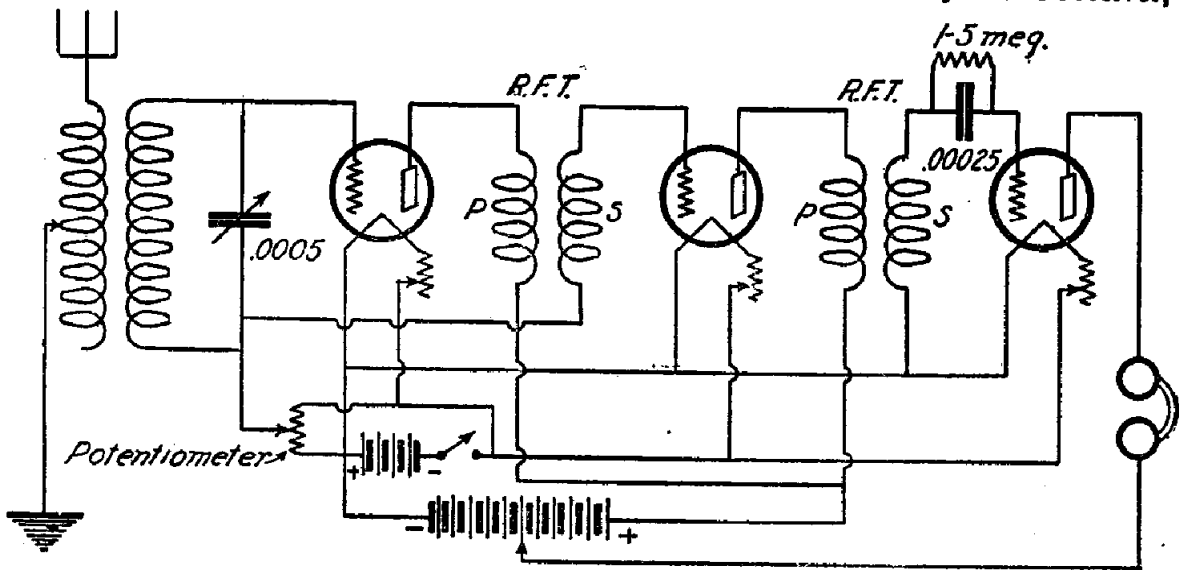

Circuit 85

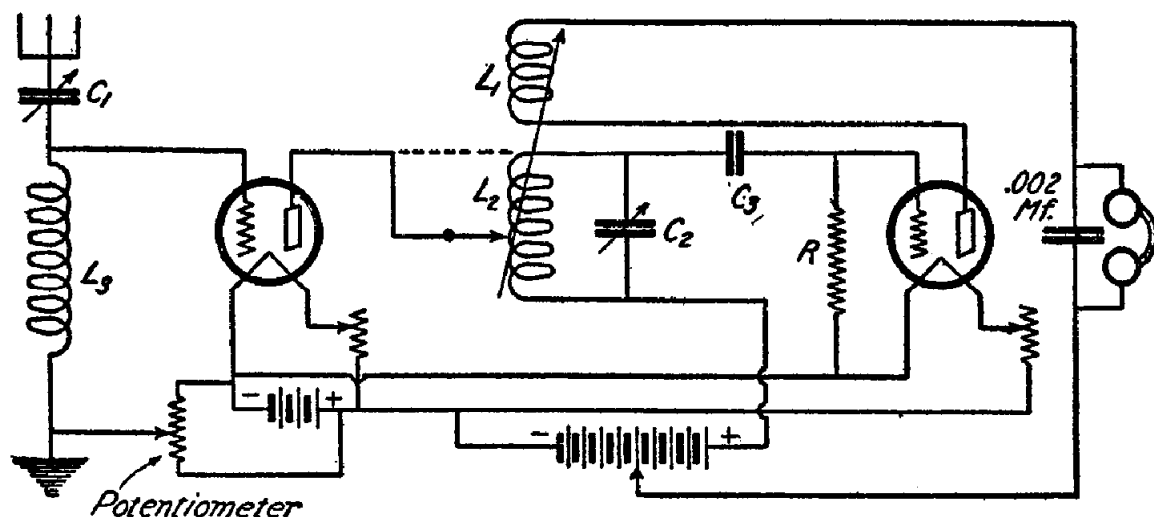

Circuit 88

honeycomb coils may be used instead of the variocoupler, in which case the lead from the plate of the first tube is connected as indicated by the dotted line in the diagram. The grid leak R of 1 megohm is connected between the grid and the negative filament binding post of the detector tube.

Circuit No. 89. This circuit is an excellent one for the reception of C.W. signals. The four inductances shown are honeycomb coils, their size depending on the wave-length band to be covered. The variable condensers C^1 and C^2 have a capacity of .0005 mfd. and C^3 is .001 mfd. The plate voltage on the oscillator tube is not critical and may be 45 volts. The first tube, called the modulator, is connected across the oscillating circuit of the oscillator tube. The space between the filament and the plate acts as a resistance, the value of which is varied by the incoming signals impressed upon the grid. No "B" battery is necessary for the mod-

ulator tube, as its plate is supplied by high frequency current from the oscillating circuit.

This circuit may also be employed for the reception of broadcast programs by the use of the proper size inductances. Coils L^1 and L^2 may be a variocoupler and inductances L^3 and L^4 may be 50 and 25 turns duo-lateral coils respectively. This rather unique circuit should prove of great interest.

Circuit No. 90. In this diagram is shown the Superdyne receiver, with two stages of audio frequency amplification. L^1 is four turns of No. 22 D. C. wire wound directly over the 42 turns of L^2 . These windings are on a tube four inches in diameter. L^3 is 36 turns of the same wire on a rotor, which is $3\frac{5}{8}$ inches in diameter. This rotor is inserted half way into one end of the four inch tube and is arranged with bearings for rotation. The plate inductance coil is 45 turns of the same wire, wound on a four-inch tube.

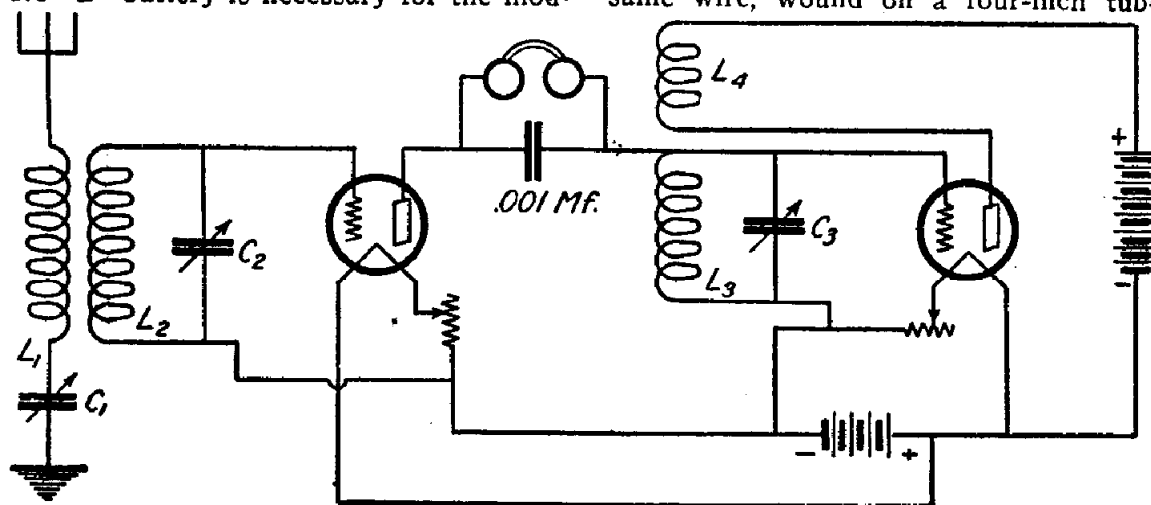

Circuit 89

150 RADIO HOOKUPS

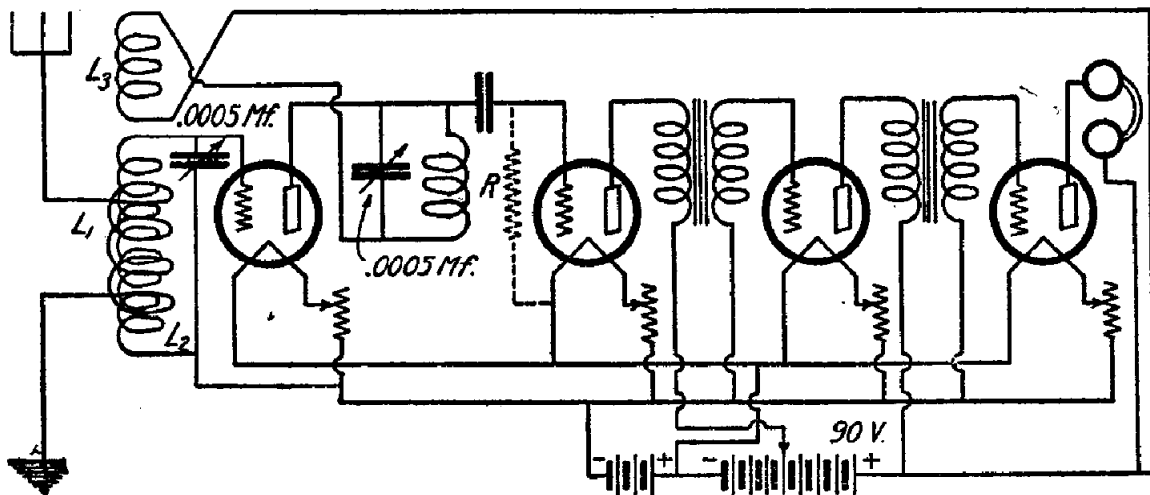

Circuit 90

The variable condensers, which should be of the vernier type, have a capacity of .0005 mfd. When constructing the set, it is important that the plate coil be at right angles to the coupler to prevent any inductive effects. This set will give excellent results also with a short indoor antenna connected to the grid side of L^2 , the negative side of the "A" battery being grounded. This eliminates L^1 , which is used for an outdoor antenna. A grid leak is sometimes necessary, depending upon the type of detector tube used and is placed in the position shown by the dotted resistance R.

Circuit No. 91. The Telefunne circuit is one which has stood the test of time and is famous for its extreme selectivity and the fact that it will not radiate. This set has a wave-length range of 200 to 550 meters and has the same dial settings at all times for a given station. The variocoupler is a 3-inch length of 3-inch tubing

for the stator and a $\frac{3}{4}$ -inch length of $2\frac{1}{8}$ -inch tubing for the tickler coil. The tickler L^4 has 28 turns of No. 26 S.S.C. wire and the stator L^3 has 39 turns of No. 24 S.S.C. wire. The inductance L^2 consists of four turns of No. 24 S.S.C. wire, wound directly over L^3 , but separated by a strip of varnished cambric cloth. A standard variocoupler may be used instead of L^3 and L^4 . For L^1 wind 68 turns of No. 26 S.S.C. wire, tapped at the fifteenth turn, on a 3-inch tube.

Circuit No. 92. For the fan who wishes a set that is stable and excellent for DX work, we can recommend the one shown in Fig. 92. It is an English circuit and built entirely of standard parts. The variometer in the antenna circuit and the variocoupler that is used as a radio frequency transformer should be of a high grade, for the proper functioning of the circuit is dependent upon their quality. The 400-ohm potentiometer is used to

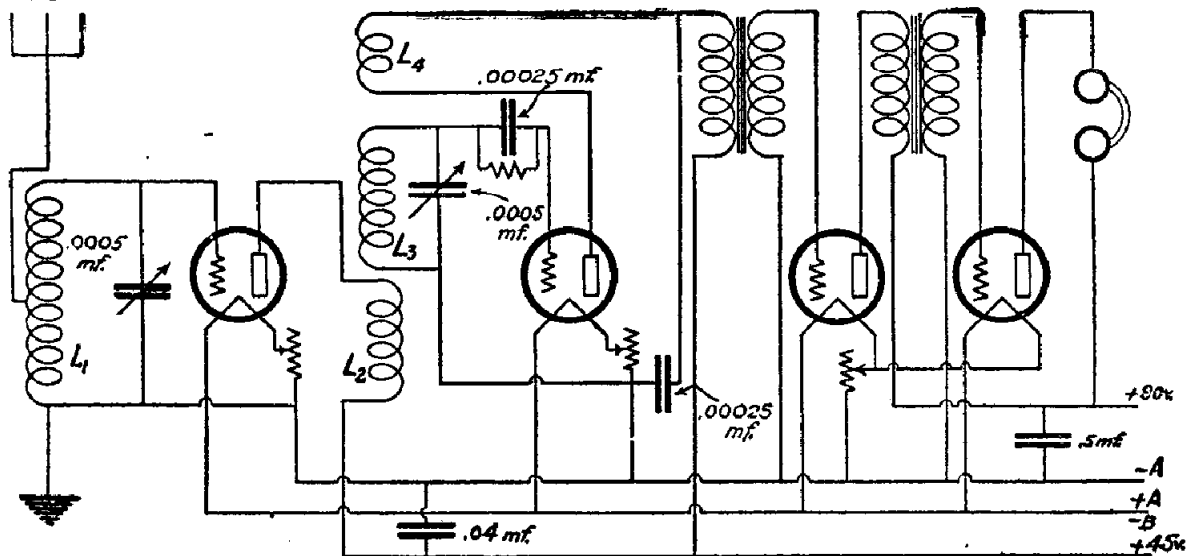

Circuit 91

150 RADIO HOOKUPS

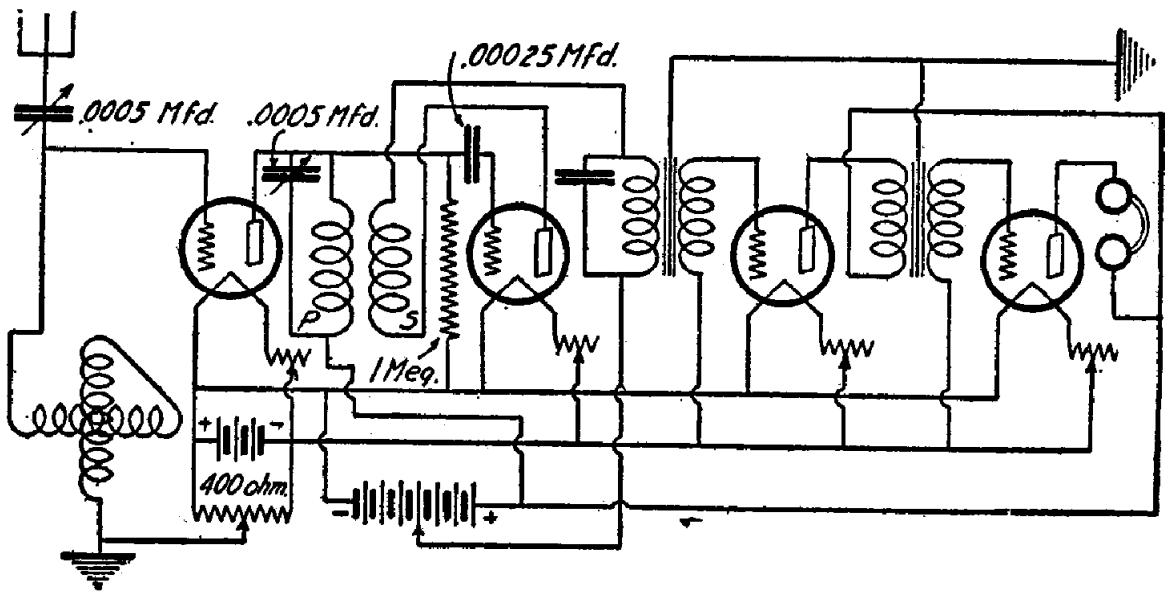

Circuit 92

place the correct grid bias on the radio frequency tube. The cores of the audio frequency transformers are shown connected to ground, but this is optional. Connect the stationary plates of the variable condenser in the antenna circuit to the antenna binding post and those of the variable condenser across the stator of the variocoupler to the plate binding post of the tube. UV-199 tubes will work very well in this set, but it is recommended that UV-201A tubes be used for the best results. The audio frequency transformers should have a ratio of 5 or $5\frac{1}{2}$ to 1. At least 90 volts "B" battery should be connected to the plates of all the tubes with the exception of the detector.

Circuit No. 93. To dwell at length upon the wonders of the Neutrodyne receiver would be rehearsing an oft told tale. However, no series of circuits would be complete without one. The hook-up shown in Fig. 93 is the standard one that was invented by Prof. Hazeltine, except that there has been added two stages of audio frequency amplification. A variometer

may be used for obtaining regeneration. This is placed in the lead from the plate terminal of the third tube to the primary of the next transformer. This will considerably improve the reception of weak signals and give a more uniform action over the entire range of broadcast wavelengths. Do not try to force loud signals by using too much "B" battery; $67\frac{1}{2}$ volts is usually sufficient and no more than 90 should ever be used. The condensers shunted across the secondaries of the "neutroformers" have 17 plates and by careful adjustments when placing the dials on them, stations can be tuned in at approximately the same readings for all three. UV-201A type of tubes will be best in the four amplifier stages and the UV-200 type should be used as a detector, although a 201A may be used.

Circuit No. 94. In Fig. 83 is shown an English circuit comprising three stages of radio frequency amplification and a detector. Z1 and Z2 are choke coils and are wound on a tube 2 inches in diameter, using 350 turns of No. 30 B. & S. gauge D.

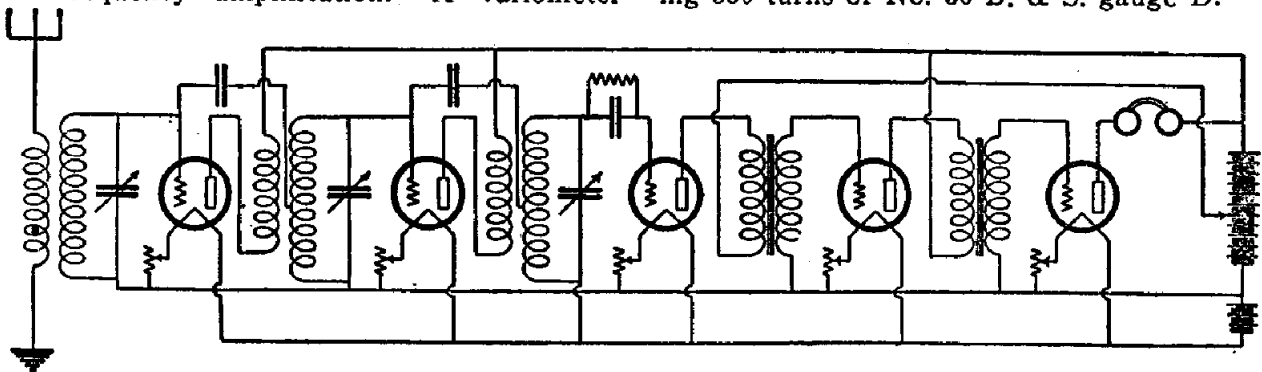

Circuit 93

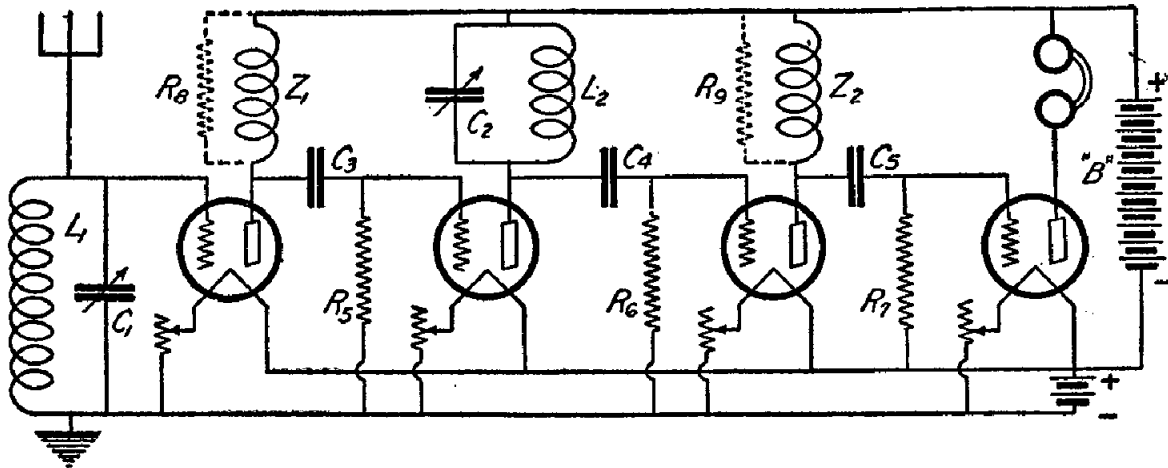

Circuit 94

C.C. wire, L1 and L2 are made of 54 turns of No. 20 B. & S. gauge D.C.C. wire wound on a 3-inch tube. The variability of .0005 mfd. The three condensers in the plate circuits of the tubes, C3 and C4, have a capacity of .0005 mfd. and C5, a capacity of .00025 mfd. The resistances, R5, R6 and R7, have a value of 70,000 ohms. There are shown two resistances, R8 and R9, of a resistance between 50,000 and 100,000 ohms, that may be used instead of the choke coils. UV-199 tubes may be used in this set, but UV-201A tubes will give better volume. In this circuit although three stages of radio frequency amplification are used, there is but one condenser to tune, controlling these three stages. With the other condenser in the grid circuit of the first tube, this makes the set as easy to tune as one with but one stage of radio frequency amplification and detector.

Circuit No. 95. For the fan who is looking for a set that brings in the stations consistently we can recommend the circuit shown in Fig. 95. It has two stages of transformer coupled radio frequency amplification, detector, and two stages

of audio frequency amplification. One of the greatest advantages of the set is that there are but two controls—the .0005 mfd. condenser shunted across the loop antenna and the potentiometer that adjusts the grid bias on the first two tubes. Any good make of radio frequency transformer may be used. However, proper precautions should be taken to prevent any inductive coupling between them. The condenser should be of the low loss type and a vernier adjustment is essential. UV-201A tubes are recommended for use in this circuit.

Above it was mentioned that any good make of radio frequency transformer would suffice in the plate circuits of the first two tubes; it should also be stated that the transformers should be built around laminated iron cores. When purchasing radio frequency transformers, the buyer should ascertain the wave-length band that the transformer is designed to cover. If the receiver is designed for broadcast reception the transformers should be designed to cover a wave-length band from 200 to 600 meters. The selection of the radio frequency transformers should be carefully made, as the receiver

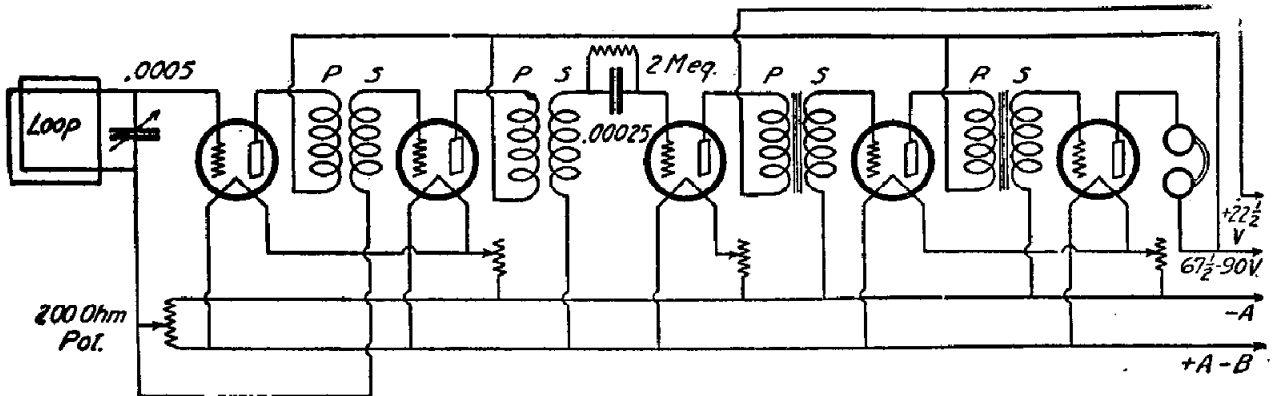

Circuit 95

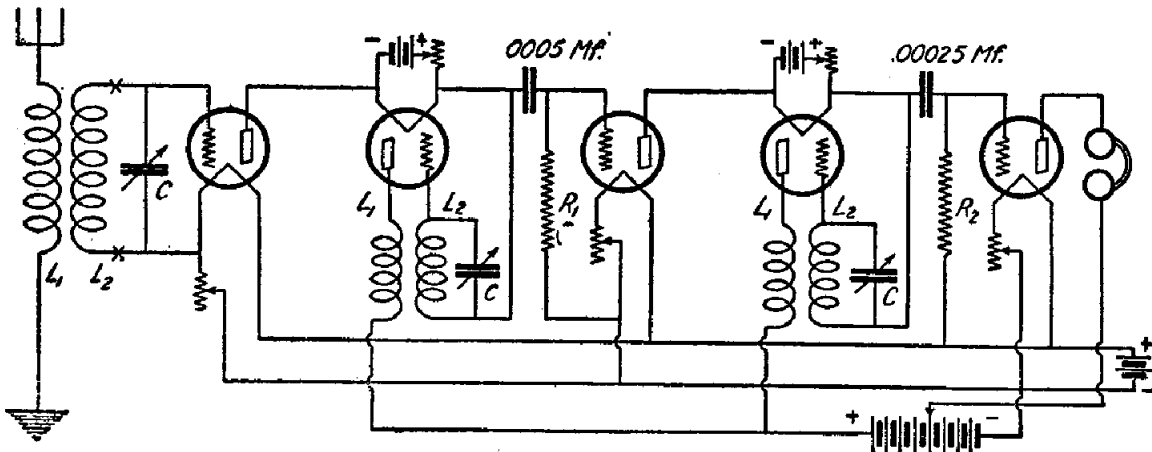

Circuit 96

will not function at maximum efficiency unless there are excellent transformers in the circuit.

Circuit No. 96. A new and ingenious system of resistance coupled radio frequency amplification is shown in the accompanying sketch. Not only are the vacuum tubes used as amplifiers, but they are also employed as resistances. The chief feature of the circuit is the minimization, if not the complete elimination of foreign noises and distortion. The inductances L_1 and L_2 are wound on a three-inch tube. The secondary of 60 turns is wound on the tube first, over which is placed a strip of varnished cambric for insulation. On this cambric is wound the primary of 15 turns. The condensers C have a value of .0003 mfd. The resistance R_1 is 1 megohm and R_2 is 2 megohms. The second and fourth tubes are of the WD-11 type because a separate filament battery must be used for each. The other three tubes should be of the UV-201A type for best results. If it is desired to use a loop antenna, the first coupler may be eliminated and the loop may be connected at the points marked X. As in

all resistance coupled amplifiers, the voltage of the "B" battery must be higher than in the ordinary tuned plate or other style circuits. The exact plate potential required will vary with the type of tube used. The high degree of amplification and clarity of signal obtained with this circuit is truly remarkable. The construction is well within the scope of the average experimenter.

Circuit No. 97. The secret of this set's success lies in the blocking tube used between the first and second regenerative circuits. Oscillations are controlled entirely by the two ticklers, there being no potentiometer, which adds greatly to the simplicity of control. The couplers are alike as to size and windings. They may be made with any 180-degree variocoupler form. First wind on the stationary form 40 turns of No. 24 D.S.C. wire. Directly over this winding, a strip of cambric should be placed, over which are wound seven turns of the same wire. The tickler coil should have 40 turns of the same size wire. These three windings should be wound in the same direction. The variable condensers C_1 are .0005 mfd. and

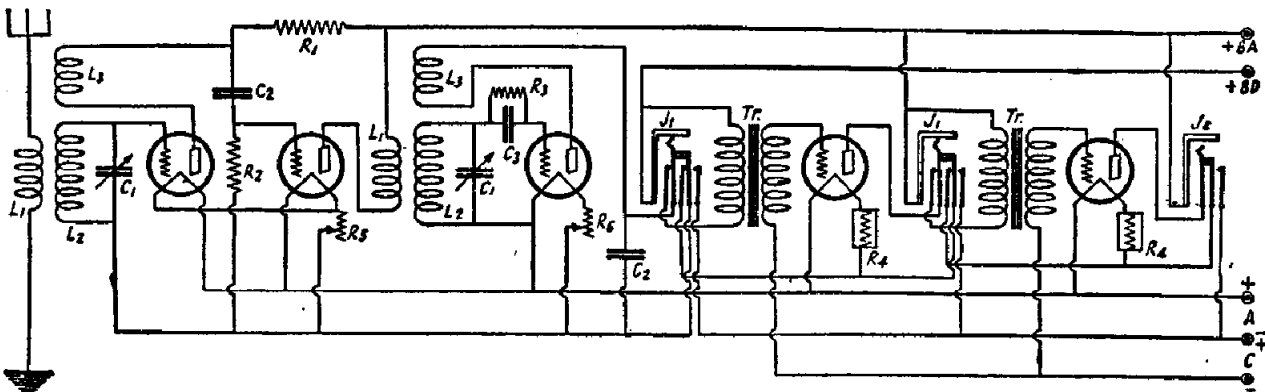

Circuit 97

150 RADIO HOOKUPS

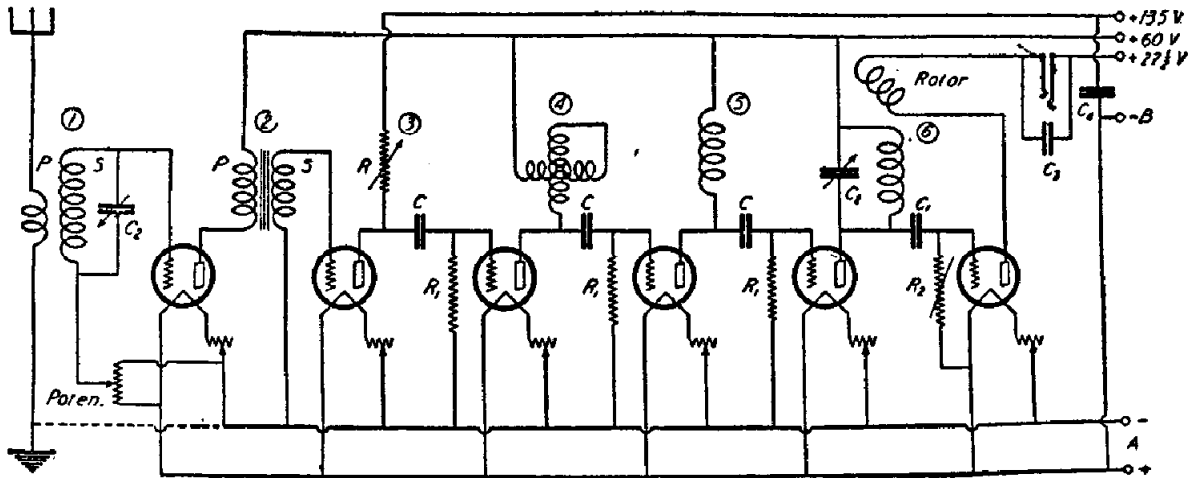

Circuit 98

C2 have a value of .0005 mfd., C3, the grid condenser, is .00025 mfd. R2 and R3 are resistances having a value of 2 megohms and the resistances R4 are amperites. Results may be obtained using either a loop or an outside antenna. If a loop antenna is used, the primary of the first variocoupler is eliminated from the circuit, the loop being connected in series with the secondary.

Circuit No. 98. The circuit numbered 98 is one to delight the heart of the experimenter. It requires six tubes, but every stage of amplification is coupled to the preceding one in a different manner. The experimenter may vary these coupling placements in any way he wishes.

The constants are as follows: One is a standard two-coil type of coupler with an untuned, fixed coupling, primary. Primary "P" may consist of about 10 turns of No. 24 D.C.C. wire wound at the end of secondary "S." This secondary consists of about 50 turns of the same size wire wound on a three-inch tube, but spaced about 1/4 inch from the primary.

Unit two is a standard radio frequency transformer. It will probably be best to use a high-grade iron core radio frequency transformer, as shown, rather than an air core type.

Unit three incorporates resistance coupling with a plate resistor "R," variable between 25,000 and 250,000 ohms. The working value of this resistance will be close to 100,000 ohms.

Unit four shows how a variometer is used for the tuned impedance type of coupling.

Unit five shows a choke coil type of coupling known as the "T. A. T." system. The natural period, or wave-length, of this coil is outside of the operating range of the set and functions mainly as an induc-

tive resistance. It comprises about 250 turns of No. 30 D.C.C. wire wound on a 2 1/2-inch tube.

Unit six employs tuned impedance, but instead of using a variometer, as in unit four, a coil is shown tuned by a variable condenser. This coil may consist of about 50 turns of No. 24 D.C.C. wire on a three inch tube.

Condensers "C" are blocking condensers used to prevent the plate current being applied to the grids of the tubes. They may be of about .0005 mfd. capacity. The detector condenser, C1, is of .00025 mfd. capacity. Variable condensers C2 are of .0005 mfd. capacity, C3 is about .001 mfd., C4 about .05 mfd.

Resistances R1 are one megohm grid leaks.

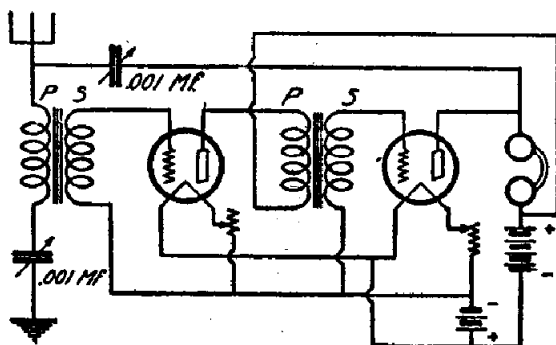

Circuit 99

The potentiometer has a resistance of 200 to 400 ohms.

Circuit No. 99. Very few experimenters are aware that audio frequency transformers may be used as shown in Fig. 99. This hook-up is one which will make the set operate on a wave-length in the neighborhood of 6,000 to 10,000 meters

and up. As may be seen in the diagram two variable condensers are employed, having a capacity of .001 mfd. (43 plates).

If the experimenter has several types of transformers on the bench, it would be an interesting thing to determine what sort of reception would result with several stages of this sort of amplification. There is no reason to believe that it would not be possible to pick up the long wave stations using a circuit of this type, because the longer the wave-length, i. e., the lower the frequency, the more efficiently will the set operate. If the input transformer of a pair of push-pull transformers is available, the tapped winding would be used to change the wave-length, as tapping in one, either part of or the whole winding would act as a different amount of inductance in the circuit. This transformer would of course be used in the antenna and ground circuit, as primary and secondary.

*Circuit No. 100. It is a safe bet that one out of every five receivers now on the

size wire being used for the primary. A .0005 mfd. variable condenser is shunted around the secondary and will be found to give excellent selectivity. The regenerative qualities of the three-circuit tuner will still more enhance the receptive ability of the receiver as a whole.

Whether two stages of transformer-coupled audio, three stages of resistance-coupled or one stage of push-pull amplification are used, the circuit will give unexcelled results when properly wired.

For the beginner who desires to build the tuner himself, the following information may be helpful. The primary consists of twelve turns of No. 12 D.C.C. wire on a tube three inches in diameter. The secondary can be wound on the same tube about one-half inch away and consists of 55 turns of No. 16 D.C.C. The tickler coil is wound with No. 22 D.C.C. on a smaller size diameter tube and contains 34 turns. It should be mounted in close inductive relation to the secondary and should be variable in coupling to it.

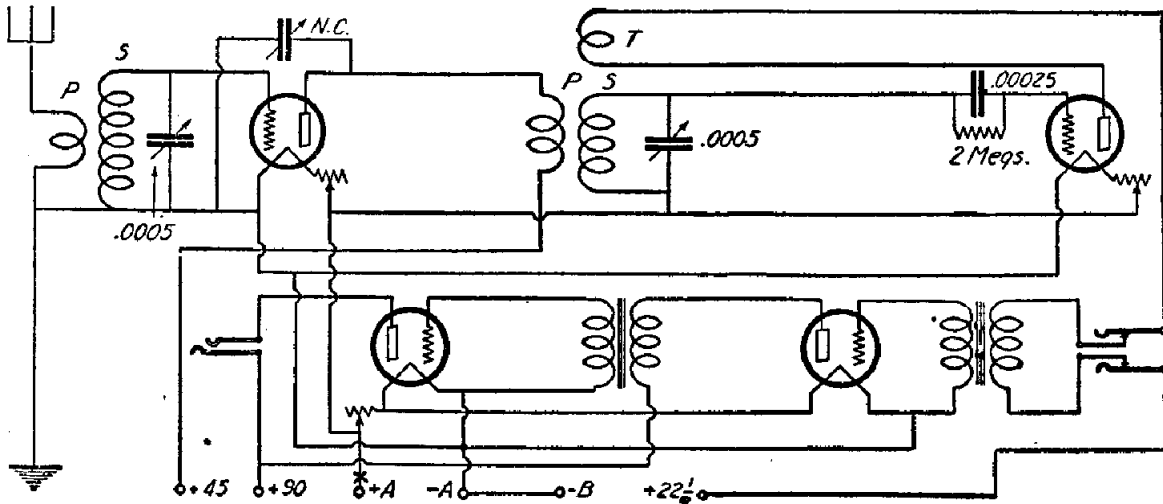

Circuit 100

market is a regenerative set employing 3 or more tubes. The owners of such a set experience interference which often cannot be eliminated readily and many of them resort to a wave trap as a remedy.

By the addition of one tube more, it becomes possible to increase greatly the range and selectivity of the set. The extra tube is used in the capacity of a radio frequency amplifier, which through the use of a small variable condenser known as a neutralizing condenser, affords protection against radiation and serves as an aid to distance-getting.

The antenna is connected to a six turn primary winding on a form 3 1/2 inches in diameter. This winding is placed in the center and above a secondary consisting of 60 turns of No. 22 D.C.C., the same

If it is desired, a standard three circuit coupler of the ordinary type available on the market today may be used for the tuning coil indicated by P, S and T in the diagram.

A word about the auxiliary equipment. The antenna should be a single wire about 100 feet long and well insulated. The ground connection should go to a cold water pipe and a good clamp employed which will insure a permanent connection.

The small neutralizing condenser will have to be adjusted occasionally and should have a value of 15 mfd. maximum capacity.

Circuit No. 101. The receiver that is shown in the accompanying diagram is one that is non-radiating if properly adjusted, and extremely selective. How-

150 RADIO HOOKUPS

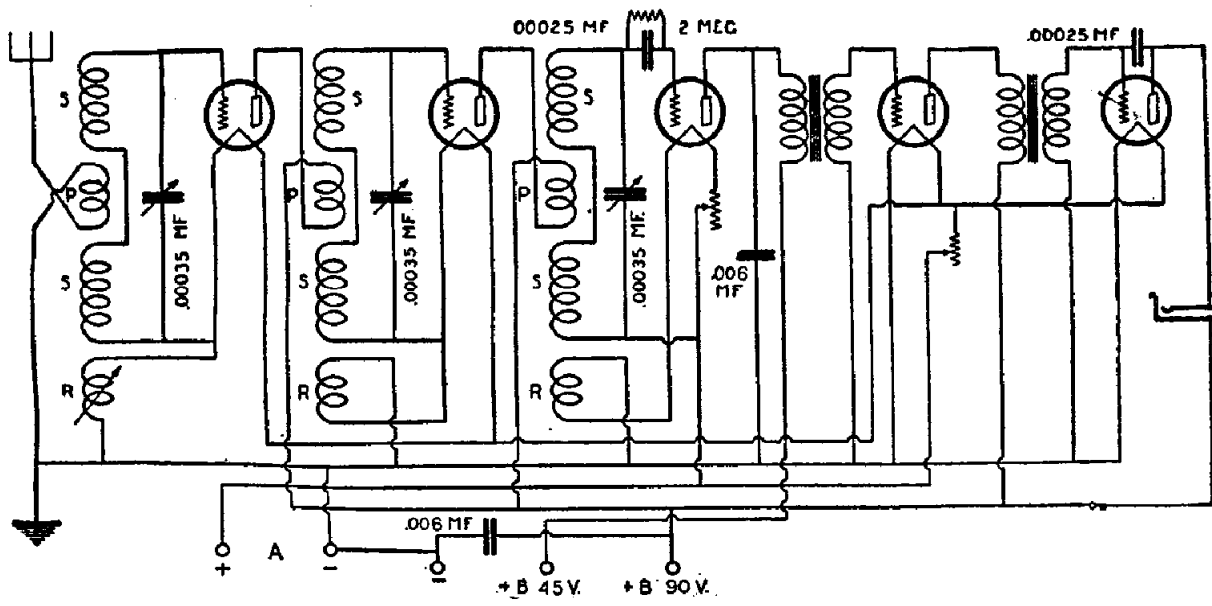

Circuit 101

ever, a word of precaution should be inserted here: if the set is improperly adjusted it becomes a powerful squealer.

Three bakelite or hard rubber tubes $2\frac{1}{2}$ inches in diameter and 6 inches in length are required. First there is wound on 45 turns of No. 22 D.C.C. wire and $\frac{1}{8}$ of an inch away from this winding is wound 6 turns of the same size wire, which is the primary coil. The secondary winding is then continued for another 45 turns, thus making two 45-turn coils in series on the same tube. Then the compensating winding of 6 turns is wound on, in the opposite direction from that of the other coils on same tube.

The above description applies to two of the transformers, the third being slightly different in that the compensating coil is wound on a small rotor which is placed at one end of the tube. This rotor is a piece of bakelite tubing 2 inches in diameter and one inch long, at one end of which is placed the 6-turn winding. Here it is unnecessary that the winding be in the opposite direction, as the coil itself may be rotated through 180 degrees and thus change its polarity. This last coil described is used in the grid circuit of the first tube, the other two transformers being used in the second and third tube circuits.

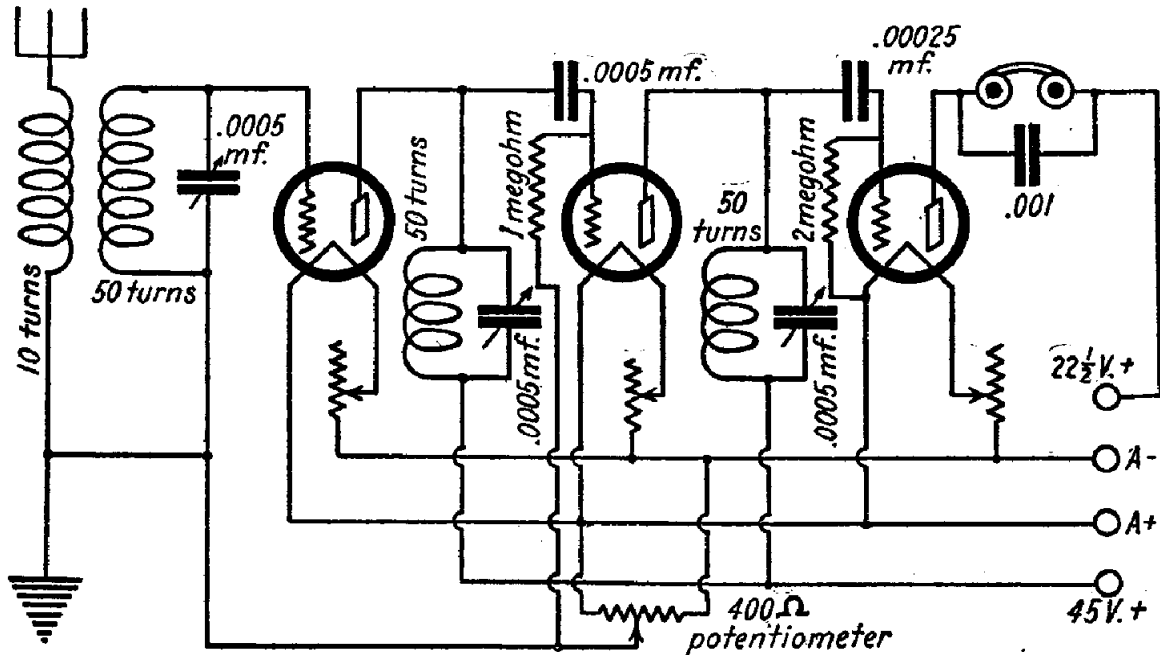

Circuit 102

150 RADIO HOOKUPS

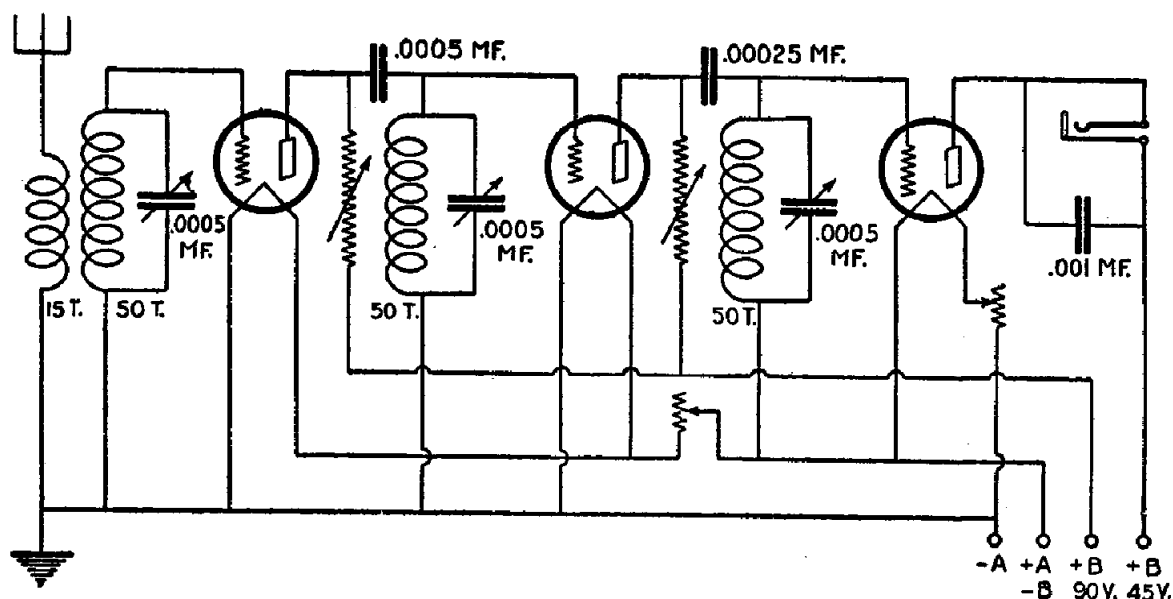

Circuit 103

There is not shown in the diagram any form of audio frequency amplification, but this is placed after the detector in the conventional manner. Type UV201-A or C301-A tubes should be employed.

The field of experimenting in radio is very large. One fundamental circuit can be used in many variations which will still further resolve themselves into others of more or less complexity. Thus, radio frequency amplification can take place in types of tuned and untuned circuits, both of which may be neutralized and may be effected by means of resistance, impedance and choke coupling, up to several stages of amplification.

The same applies to audio frequency amplification in the measure that several types of coupling may be employed; resistance, choke, transformer and push-pull. The detector tube can be regenerative, non-regenerative, superdynamized or heterodyned. These different methods are adaptable to other variable factors, so that the number of combinations possible becomes indeed great.

The general tendency in circuit design is the use of no more than three stages of radio frequency amplification, though most commercial receivers incorporate two steps. Again, two stages of transformer coupled audio frequency amplification are used to a greater extent than other types.

Experiment! There is a vast field for improvement in circuit design and, last but not least, record the results of your work. Such records may become of great value in the future.

Circuit No. 102. The three-tube circuit that is shown in Fig. 102 is not difficult

of construction and, if properly made, should give excellent results. The primary and secondary coils, which are wound on the same 3-inch bakelite or hard rubber tube, consists of No. 24 D.C.C. wire. The aperiodic primary has 10 turns and the secondary, over which the primary is wound, has 50 turns. The two coils in the plate circuits of the radio frequency amplifier tubes are 50 turns of No. 24 D.C.C. wire, wound on a 3-inch tube. The grid leak across the second tube is 1 megohm and that across the detector has a resistance of 2 megohms.

Circuit No. 103. Resistance coupled R. F. amplifiers at wave-lengths below 600 meters give rather mediocre results, but if a tuned circuit is used instead of the usual grid leaks, much better results are obtained. Such a circuit is shown in Fig. 103. The resistances should be variable so that they may be adjusted to prevent oscillation of the circuit at any wave-length.

The antenna and secondary coils are wound on a 3-inch bakelite or hard rubber tube. The secondary of 50 turns of No. 24 D.C.C. wire is first wound on the tube and over this is wound the 15 turns that form the primary. The two coils that are in the plate circuits of the radio frequency amplifier tubes are 50 turns of the same size wire wound also on 3-inch tubes. The blocking condensers of .0005 mfd. and .00025 mfd. in the plate circuits of the first two tubes should be tested before being installed, for, if they are shorted, the plate voltage will be introduced into the filament circuit, and the tubes blown out.

Super Regenerative Hook-Ups

Circuit No. 104 shows a super-regenerative receiver which, if correctly constructed and operated, will give remarkable results on all stations received. A loop is used for this type of receiver and is tuned by a variable condenser of .0005 mfd. capacity. Coil L is a honeycomb or duolateral coil of 1,500 turns and coil L1 is one of 1,250 turns. These coils are shunted by a fixed condenser C of .004 mfd. capacity. A standard variometer is inserted in the plate circuit, which will control the regeneration. A fixed condenser C1 is also shown connected across the phones, but it may sometimes be dispensed with, with no loss in efficiency. When receiving, there will always be in evidence a high pitched whistle known as the variation frequency. If this

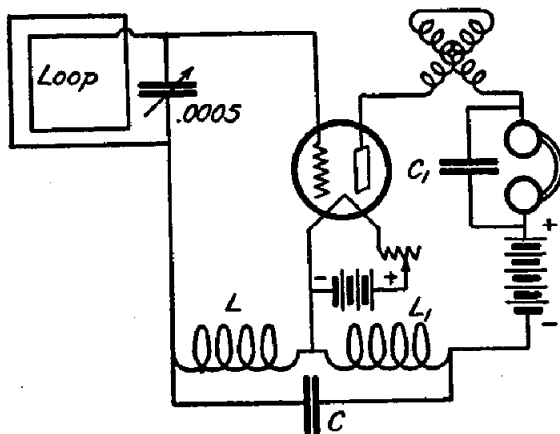

Circuit 104

whistle is too bothersome it may be reduced by decreasing the size of the condenser C.

Circuit No. 105 shows a simplified and improved super-regenerative circuit known as the Autoplex. In this circuit two variometers shown as L and L1 are employed to tune the grid and plate circuits. These variometers must be of good manufacture and should have a large value of inductance. Only one honeycomb coil of 1,250 turns shown at L2 is used in this receiver. This receiver will give every good results with an antenna or ground alone, connected to point A. If a ground is to be used with the antenna, it should be connected to point B. As a rule best results are obtained with an antenna of about 50 feet in length.

A unique form of super-regenerative receiver known as the Flewelling circuit is shown in circuit No. 106. This circuit does

not employ large sized honeycomb coils as do most "supers," but instead, uses three condensers of .006 mfd. capacity each. The inductances L and L1 may be the primary and secondary of an ordinary

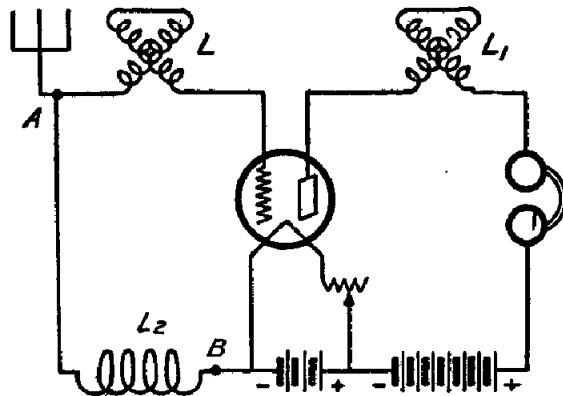

Circuit 105

variocoupler. It might prove of advantage to have the primary of this coupler tapped every 10 turns in the usual way. The secondary used as a tickler, however, must be wound with at least 100 turns of wire for the best results. Two grid leaks shown as R are employed and must be variable. The resistance of these leaks will vary from 1 to 10 megohms.

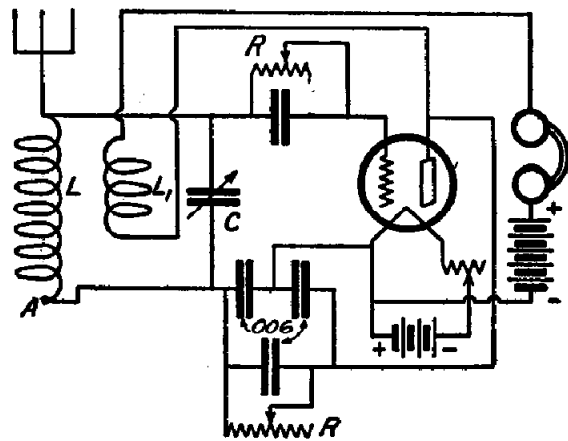

Circuit 106

The variable condenser C which is used for tuning, has a capacity of .0005 mfd. (23 plates). The "B" battery in this receiver must be fairly large and can be of any voltage from 90 to 150. A hard or amplifying tube must be used in this receiver if best results are to be obtained.

150 RADIO HOOKUPS

A ground is not shown in the diagram, as it is usually not necessary, but one may be tried at the point shown as A.

In *circuit No. 107* is shown a modified and greatly simplified Flewelling circuit. The same tuning system is used in this receiver as was shown in circuit No. 106. In any Flewelling receiver the tickler coil in the plate circuit must be wound with at least 100 or 120 turns of wire. Only

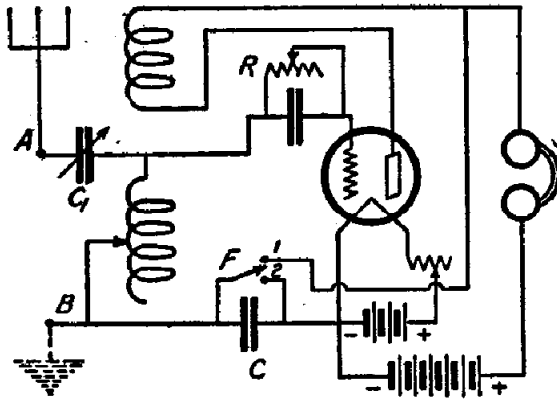

Circuit 107

one fixed condenser of .006 mfd. is used in this receiver. This condenser may be shorted by the switch F, so that the receiver can be used as an ordinary single circuit regenerative set. When used as a "super" the switch is thrown to point 1 and a ground is connected to point B, as shown by the dotted lines. The

variable condenser C1 may have 17 or 23 ed. The grid leak R is variable and has plates, but the smaller size is recommended a resistance of from 1 to 10 megohms. When this receiver is operating correctly as a super-regenerative set, local stations will be strong enough to operate a loud speaker.

Circuit No. 108. Although the Super Regenerative type of set is a more or less difficult one to master, when the experimenter does get it adjusted properly the results obtained are gratifying. In Fig. 108 is shown a two-tube "Super" that presents no great difficulties of construction. The inductance L1 consists of 16 turns and L2 of 40 turns of No. 26 D.C.C. wire, both coils being wound on the same 3½-inch tube, with ½ inch between windings. The inductances of 1,250 and 1,500 turns should be of the honeycomb coil type and should be in inductive relationship with each other. The loop should be about three feet square and have 10 turns which are spaced ¼ inch apart. To operate at maximum efficiency, a UV-201A type of tube should be used and at least 90 volts on the plate of the first tube, the oscillator and 45 volts on the plate of the second, which is the detector, although this latter figure may be varied, depending on the individual tube.

Another type of super regenerative circuit is shown in *circuit No. 109* and is known as the Bishop Ultra-regenerator. In this receiver two fixed condensers C1 and C2 of .002 mfd. capacity are employed. A fixed resistance of 12,000 ohms is shunted across these condensers. The

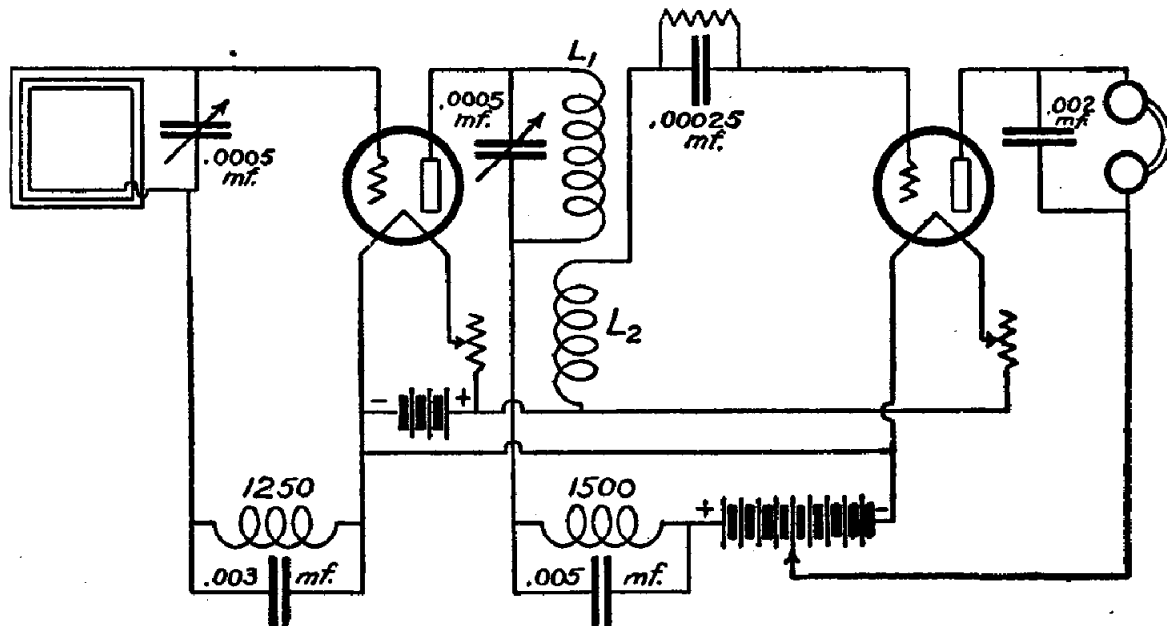

Circuit 108

tuning inductance L may consist of 80 turns of wire tapped every 10 turns and the tuning is done by means of the variable condenser C , which has a capacity of .0005 mfd. Regeneration is obtained by means of the tuned plate method and a variometer of standard size is employed for this purpose. A radio frequency choke coil, shown as $L1$ is also inserted in the plate circuit between the variometer and the phones and consists of a honeycomb or duo-lateral coil of 400 turns. A fixed grid leak is shown in the circuit, but it is always advisable to use a variable grid leak of from 1 to about 10 megohms.

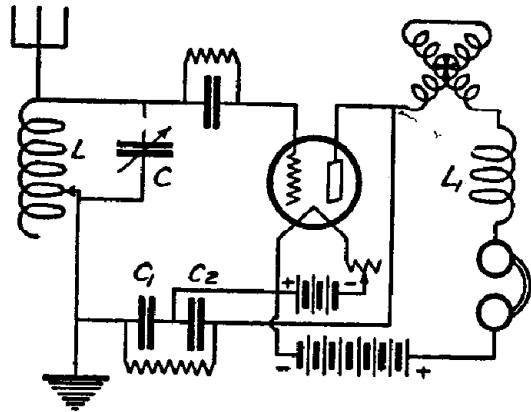

Circuit 109

Amplifier and Oscillator Hook-Ups

Circuit No. 110. In this diagram we have a circuit of a 2-stage audio frequency amplifier which may be added any standard one tube receiver. Audio frequency transformers are used and a ratio of not higher than five to one is advised. One single circuit and two double circuit jacks are employed, thus allowing either detector, first or second stage of audio frequency to be used. The output of the detector tube is connected directly to the two input binding posts on the amplifier. A fixed condenser C is shown shunted across the primary of the first transformer. This condenser is of low capacity, approximately .00025 mfd. and is employed to compensate for the capacity of the phone cords when the phones are removed from the detector circuit. If this condenser is of the right size there will be no need of retuning when the change is made from the detector to the first stage. The same "A" and "B" batteries

are employed for both detector and amplifier.

All that is necessary is to connect the positive and the negative filament binding posts of the detector to the respective terminals of the "A" battery and take a tap off at $22\frac{1}{2}$ or 45 volts on the "B" battery and connect it to the plus "B" battery post of the detector on the receiver. No wire need be connected to the minus "B" battery binding post on the receiver as the negative circuit of the "B" battery is completed to the "A" battery in the audio frequency amplifier.

The type of tube to be employed in this audio frequency amplifier circuit is a matter of preference. If WD-11, WD-12 or UV-199 tubes are used, employ a $1\frac{1}{2}$ volt "A" battery for the first two types and a $4\frac{1}{2}$ volt "A" battery and 25 to 30 ohm rheostats for the last mentioned type. "B" voltages from 45 to 60 can be safely utilized. If UV-201A or Western

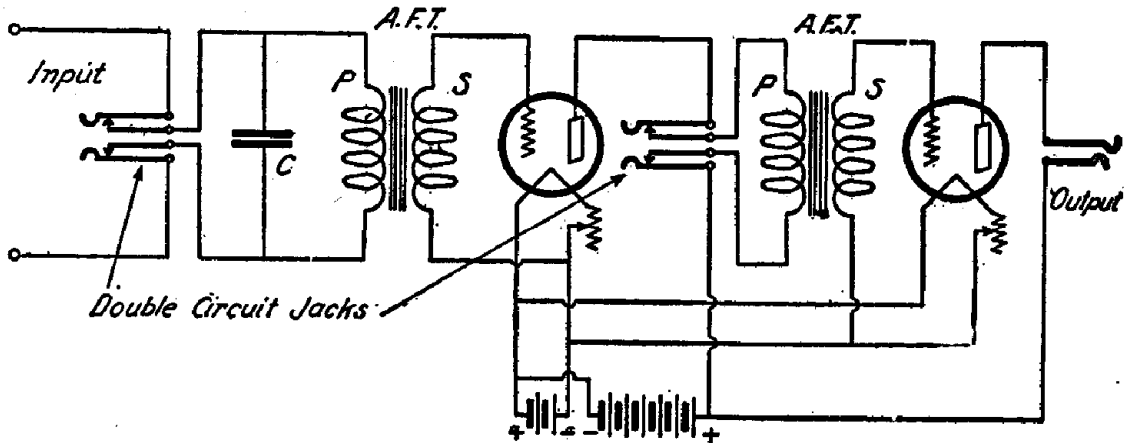

Circuit 110

150 RADIO HOOKUPS

Electric E tubes are used, a six volt "A" battery will be required, and 25 ohm rheostats if those of the first mentioned types of tubes are employed. "B" voltages from 45 to 100 may be used.

Circuit No. 111. Very few radio experimenters pay much attention to audio frequency amplification because the detecting part of the circuit seems to hold a much greater interest. However, the study of audio amplification is a most interesting one, the ultimate goal being volume without the sacrifice of purity of tone.

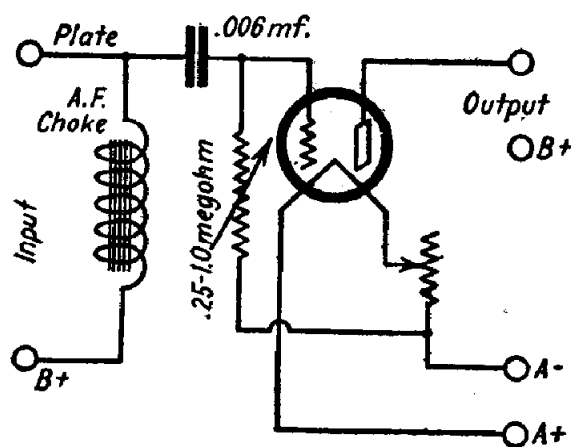

Circuit 111

Audio frequency transformers have many advantages, which need not be mentioned here as they are so well known. In Fig. 111 is shown a type of amplifier that may prove to be a most interesting study and, at the same time, quite inexpensive to construct. The only materials necessary are an audio frequency choke coil which may be the secondary of an audio frequency transformer, a fixed condenser having a capacity of .006 mfd. and a variable grid leak having a resistance

that may be varied from .25 to 1.0 megohm. The electron tube should be a 6V 201-A or C301-A, in order that the plate voltage necessary for the functioning of the stage of amplification may be applied with safety. The rheostat is placed in the negative lead of the filament and the grid return, i. e., the lead from the grid leak, is connected to the negative lead, but between the rheostat and the "A" battery. The plate voltage applied to the input side of the amplifier should be about 45 to 60 volts and that applied to the output should be between 60 and 90 volts.

Circuit No. 112. Where an audio frequency amplifier is desired, which will give very little distortion, three stages of resistance coupled amplification are recommended. Distortion is always present when audio frequency transformers are employed, and the circuit shown will be free from this trouble. As a resistance coupled amplifier does not give as much volume as one using transformers, three stages will be required instead of two. The resistances R should be approximately 50,000 to 70,000 ohms. Grid condensers C are employed in the grid circuits and should be of fairly high capacity, approximately 1/2 mfd. These condensers must be employed so that the plate voltage is not applied to the grid of the tubes. The resistances shown as R1 are ordinary grid leaks of approximately 1/2 megohm resistance. Best results will be obtained with a rather high "B" battery voltage and 120 to 150 volts are recommended.

It is necessary, no matter the type of tube employed, that a high "B" voltage be employed, as there is a considerable drop of potential across the resistances, thus making the effective plate voltage a good deal lower than the actual voltage of the "B" battery.

This circuit is shown to be used in con-

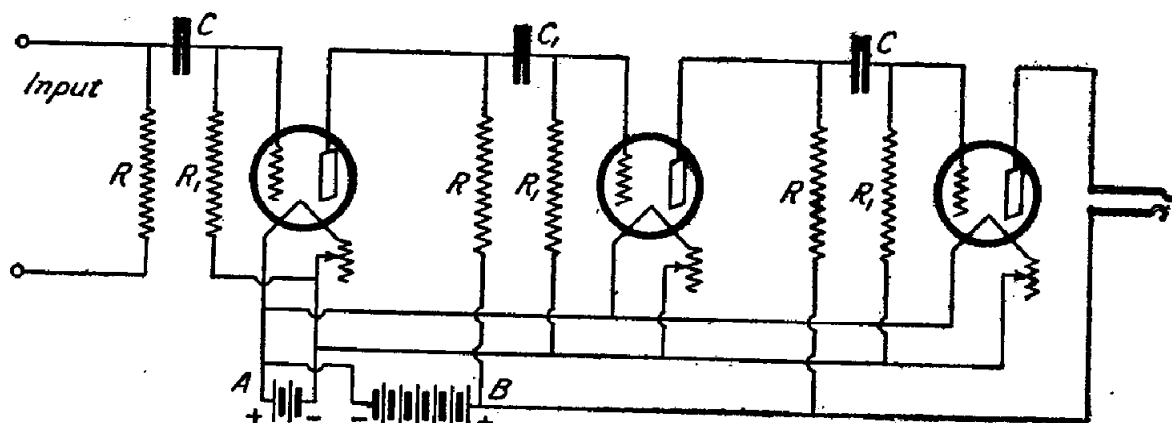

Circuit 112

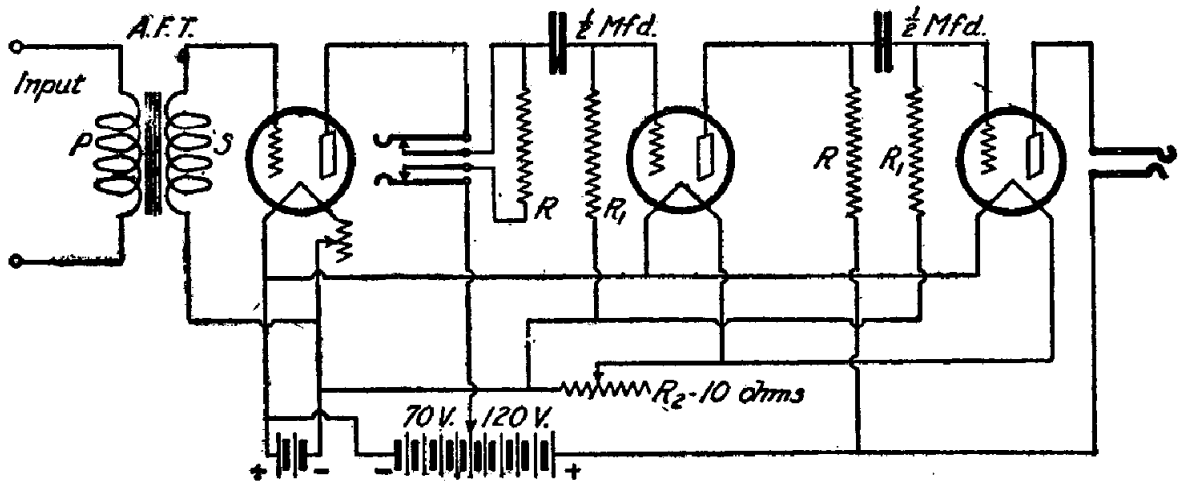

Circuit 113

junction with any standard receiving circuit and is arranged so that the "A" and "B" batteries are common to both. The return circuit to the filament of the first resistance-R is completed through the receiver in use.

Circuit No. 113. Here is a three stage audio frequency amplifier combining an audio frequency transformer and resistance coupled amplification. The audio frequency transformer is employed in the first stage and a double circuit jack is also used after the first amplifying tube so that the phones may be plugged in at this position. The grid condensers in the grid circuits of the last two tubes are of $\frac{1}{2}$ mfd. capacity and the resistances R are approximately 50,000 ohms. The grid leaks shown as R1 are of $\frac{1}{2}$ megohm resistance and are connected directly to the negative of the "A" battery. One rheostat of 10 ohms, shown as R2, is employed to light the filaments of the last two tubes. The same "B" battery voltage may be employed for all three stages, but it is

recommended that the last two tubes have a much higher voltage than the first. This amplifier may be employed with any standard one tube circuit and will give exceptionally good results.

Circuit No. 114. Here we have a two stage audio frequency amplifier using the push-pull method of amplification. In a circuit of this kind three tubes are employed for two stages of amplification. It employed for the last two tubes. The secondary of the first transformer has its two opposite terminals connected to the will be seen that special transformers all grids of the tubes and the primary of the last transformer has its two end terminals connected to the plates of the tubes.

Circuit No. 115. Another efficient form of oscillator other than the Hartley described before is the Colpitts circuit. In this circuit, the coupling between input and output is capacitive and can be varied by changing the value of the capacity C. In effecting this change, the oscillatory period of the circuit LC^2C^2 is

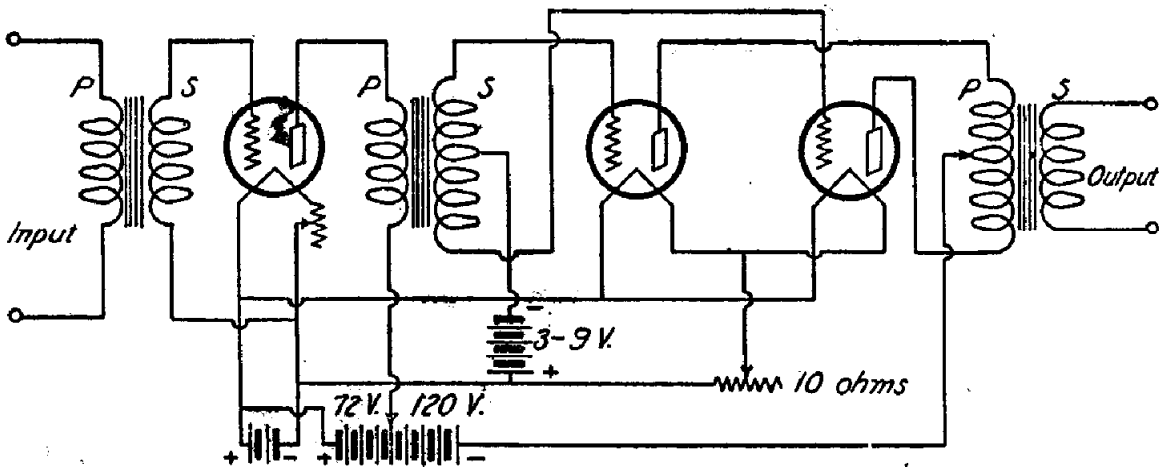

Circuit 114

changed, and it thus becomes necessary to change the capacity C^2 an amount necessary to obtain the desired period of oscillation.

It might be well to recall that in the case of the Hartley oscillator, the coupling between the input circuit (grid), and the output circuit (radio frequency), was obtained by conductive coupling. As noted above, the double adjustment is somewhat of a slight disadvantage when using the Colpitts oscillator in practice. The capacity C^2 has the high potential applied to it and in order not to affect the oscillatory circuit $LC^2C^2C^1$, a radio frequency choke coil must be interposed between the plate supply, as is shown. C^4 is a grid condenser while R is a grid leak. Due to the multiplicity of condensers it

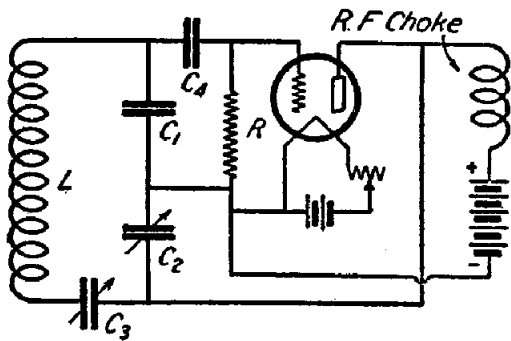

Circuit 115

is best to check the frequency with a standard wavemeter, because the matter of calculating the frequency would resolve itself into a rather difficult job.

Circuit No. 116. One of the simplest oscillators is that devised by Heising. The circuit has a number of desirable features, which are evident upon reference to the diagram. By changing the position of the clip A, it is possible to vary the coupling between input and output. This form of oscillator has found wide appreciation

and is being used by many amateurs and experimenters. Here again, as in the Colpitts oscillator, the capacity-grid leak resistance method of obtaining the required negative potential on the grid of the tube, is used.

There are different modifications of os-

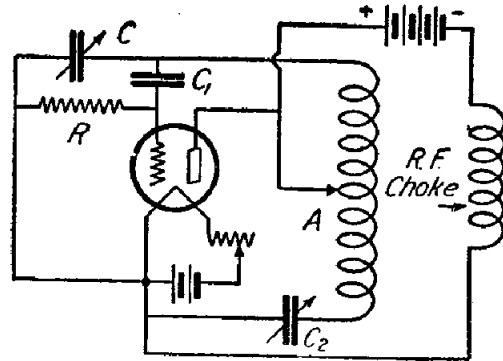

Circuit 116

illators, but all are adaptations of the circuits described.

Circuit No. 117. Another type of oscillatory circuit is shown in Fig. 117. Three honeycombed coils are employed to form the inductances, and the 23-plate condenser is connected across the grid coil for controlling oscillations. The same data for tubes that was indicated in the former oscillator applies to this circuit, too.

Both of these hook-ups are given in these columns because every Super-Heterodyne circuit has as its fundamental, some such circuit for changing the incoming frequency to the wave-length that the intermediate transformers are designed for, by heterodyning. Also the principle of oscillations and how they are produced in a circuit should be thoroughly understood by every experimenter.

Circuit No. 118. This circuit is a radio frequency feed-back amplifying unit that uses two tubes and is resistance coupled.

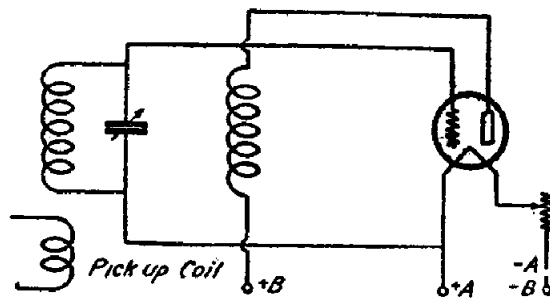

Circuit 117

150 RADIO HOOKUPS

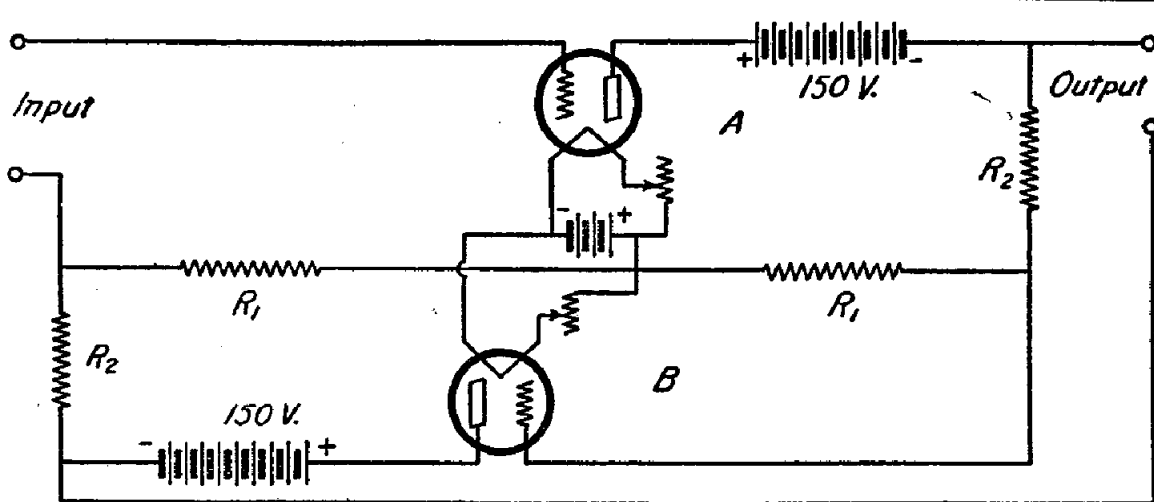

Circuit 118

Resistances R^1 are 10,000 ohms and R^2 are 50,000 ohms. The terminals marked "input" are connected to the tuning unit and those marked "output" go directly to the detector tube. The output from the tube A is fed into the tube B, which in turn is fed into the tube A again through the tuner. As this action is continuous, the resulting input to the detector tube is larger than with the usual type of resistance coupled R. F. amplifier.

It is best to use either the UV-201A type tube with this radio frequency amplifier, or the Western Electric "E" tubes, as with these it is possible to use high plate voltages. It is necessary to have separate "B" batteries having a voltage between 100 and 150 volts, as the voltage drop across the resistance is very high. The resistances R^1 and R^2 may be of the Lavite type.

Circuit No. 119. In this circuit are shown

two stages of audio frequency amplification, having filament control jacks. The use of these jacks will mean in the long run a saving to the builder, as only the filaments of the tubes that are being used are lit. This amplifying unit can be built as an integral part of a set, or can be built in a separate cabinet for the experimenter's work bench. If built as a separate unit, binding posts are used to connect it with the tuner. Four binding posts are needed for the "A" and "B" battery terminals and two for the input. A precaution to be observed is to place the transformers at right angles to each other to reduce, as far as possible, any losses that may occur.

Circuit No. 120. The audio frequency oscillator circuit, shown in the accompanying sketch, should recommend itself to the experimenter who is interested in making tests on loud speakers or any instrument

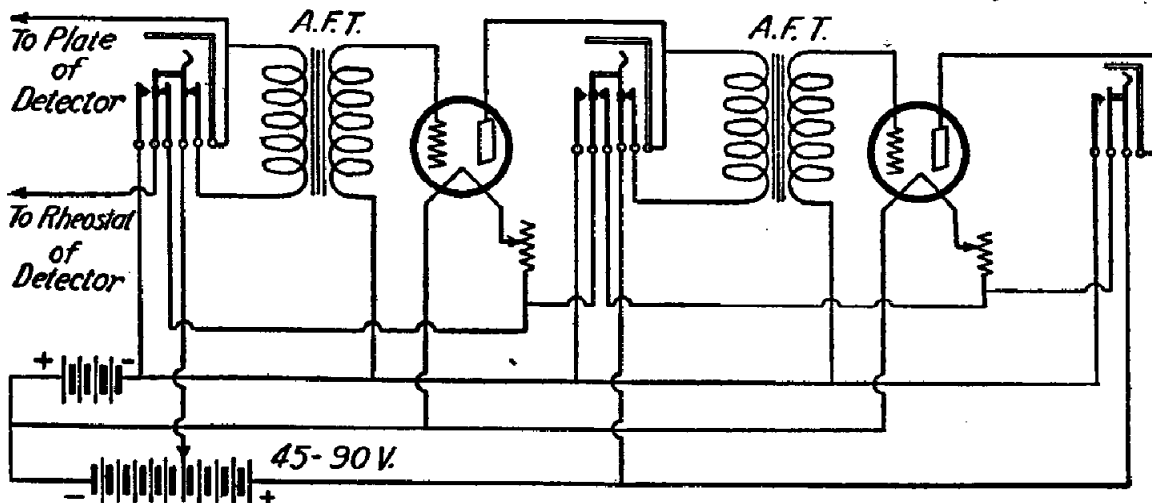

Circuit 119

150 RADIO HOOKUPS

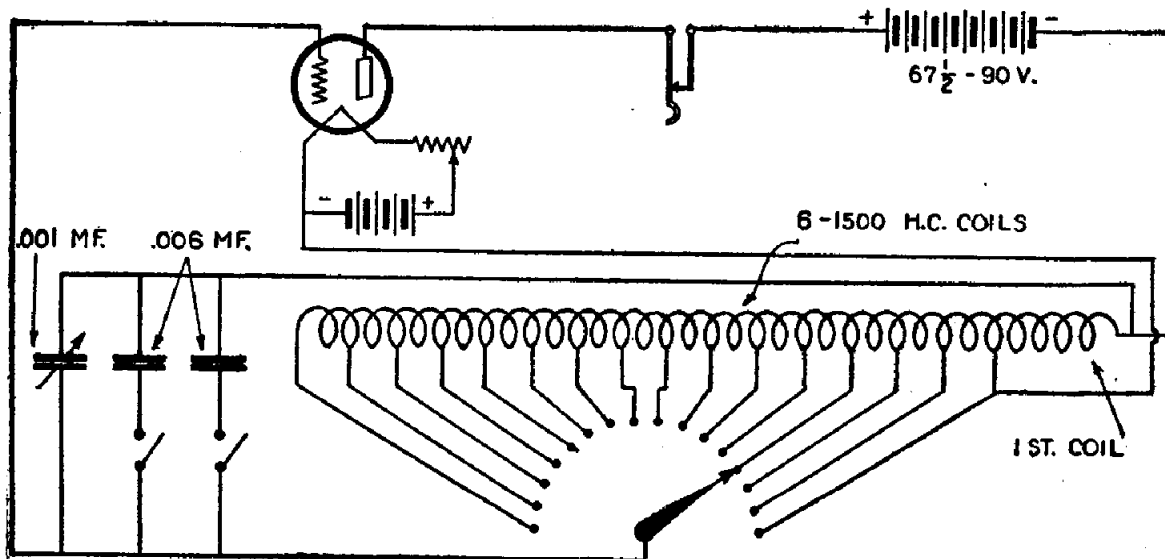

Circuit 120

that needs a source of audio frequency current. By employing sufficient inductance and capacity in the circuit and using a tap switch for varying the inductance, different tones may be obtained.

The inductance is made by connecting six 1500-turn honeycomb coils in series and bringing out to the switch-points twelve taps. These coils may be placed side by side and clamped in position by some suitable means. Care should be taken that the fields of the coils assist one another, i. e., that the winding is all in the same direction. If the outside end of one coil is connected to the inside end of the next, the circuit should operate correctly. It will be noted that the negative side of the "B" battery is connected to one of the end coils, which we will call the first coil. The filament of the tube is connected to the other lead of the first coil, where it is attached to the second coil.

It will perhaps be difficult to procure two condensers having a capacity of .06 mf., so if the experimenter will build up ten condensers of .006 mf. capacity each and connect them in parallel, he will have the equivalent of a .06 mf. condenser. The variable condenser shown will act as a vernier adjustment to the frequency.

Super-Heterodyne Circuits

Circuit No. 121. In the circuit shown in Fig. 121 there is incorporated a different system of producing beat notes than is employed in any other Super-Heterodyne receiver. Amperites instead of rheostats are used throughout. The 200 to 400-ohm potentiometer shown is used to give the proper grid bias to the intermediate frequency tubes. It is hardly necessary to say that the apparatus should be so placed that leads may be as short as possible.

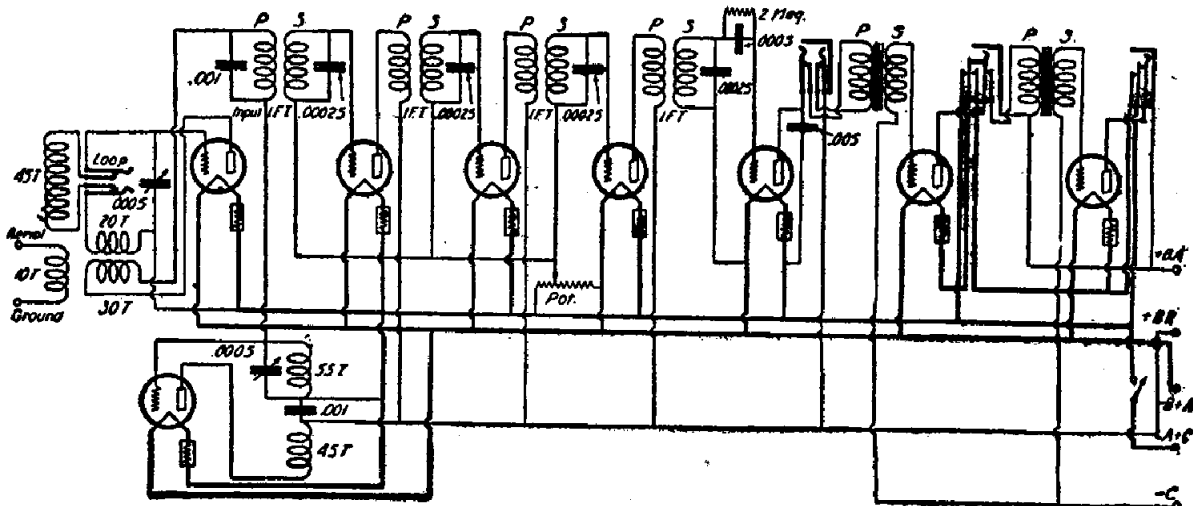

Circuit 121

150 RADIO HOOKUPS

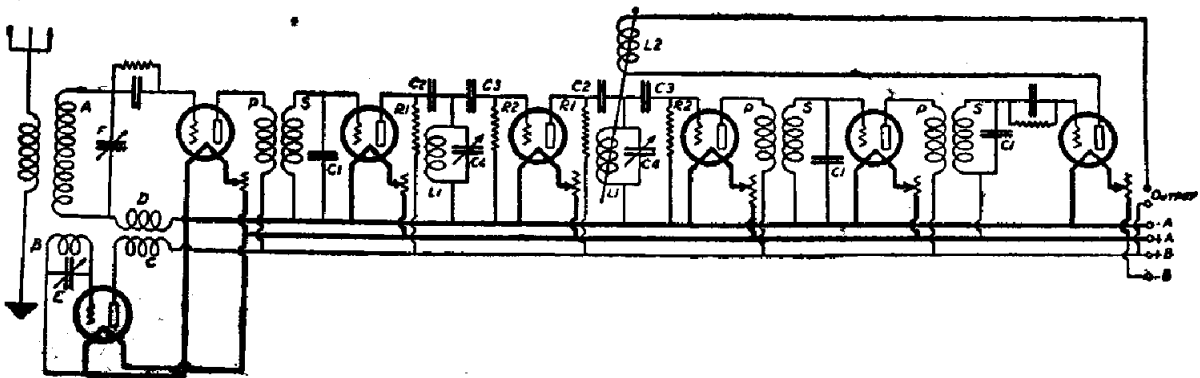

Circuit 122

Circuit No. 122. One of the complaints sometimes heard from users of super-heterodyne receivers is that the intermediate stages are wont to pass through to the second detector all the noises that are picked up as static, and the like. Through the process embodied in the receiver shown in Fig. 122, the majority of these unwelcome noises are eliminated. No deviation from standard super-heterodyne practice will be noticed in the circuit up to the plate circuit of the third tube. Instead of the intermediate frequency transformer here, there is a resistance, a tuned circuit and a grid leak.

The condensers C2 and C3 are of small capacity, .00025 mf. or less. Experience will show that the static and tube noises are of audio frequency and are usually loud in ratio to the signal intensity. Therefore, the size of C2 effectually prevents their passage into the grid of the next tube. The only possibility left to them is to take the alternative path through the resistance R¹ which is approximately 25,000 ohms. Here they are dissipated in the form of heat, leaving only the higher frequencies to pass on.

The detector and oscillator are of the

standard type. The tuning coil A may be made by winding 64 turns of No. 18 S.C.C. wire on a 3-inch tube. The condensers E and F have a capacity of .0005 mf. The pick-up coil D may be 10 turns of No. 18 wire wound at the end of the oscillator inductance tube, which is also 3 inches in diameter. The plate and grid coils, B and C, for the oscillator may consist of 40 turns for the former and 64 for the latter, separated about one-half an inch from each other on the tube. The resistances R2 have a value of about three megohms. L1 is a 400-turn honeycomb coil and C4 has a value of .001 mf. capacity. L2, the tickler coil for obtaining regeneration, has between 8 and 15 turns of No. 18 wire wound on a 3-inch tube. The definite number of turns cannot be given as they will vary in different sets.

In the hook-up no audio frequency is shown. Any type amplifier may be added at the output posts or incorporated in the set.

Circuit No. 123. The value of the Tropadyne need not be told to readers of Radio News, as the merits of the circuit have been told in the August and November, 1924, issues and in this book.

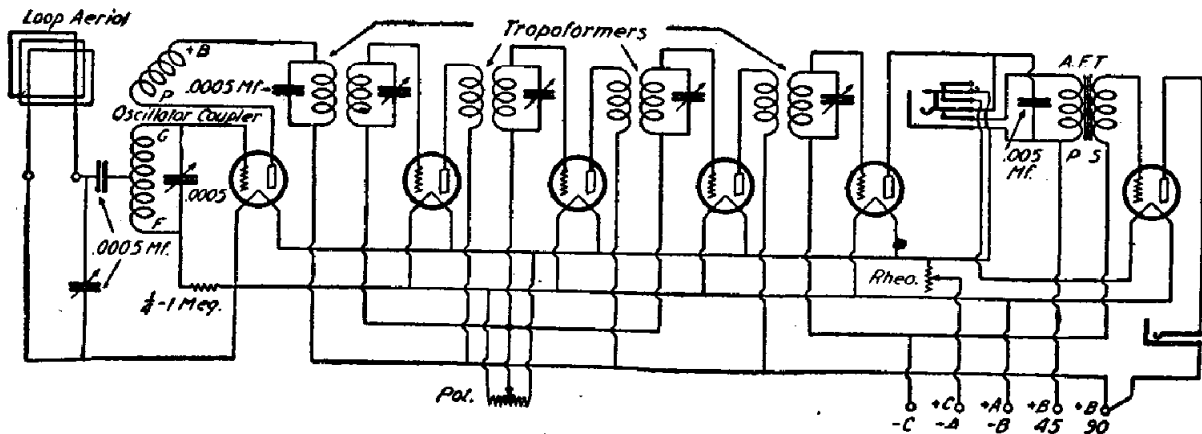

Circuit 123

150 RADIO HOOKUPS

In the first place there are but six tubes used, giving as much volume as the average set using more tubes. The selectivity of this set is excellent. Two lengths of three-inch tubing, one three inches and the other four inches long, are required to wind the coupler and the oscillator coils on. The primary and secondary coils are wound on the 3-inch tube and are designated as AG and GF, respectively. The primary coil AG consists of 8 turns of No. 24 S.S.C. wire and the secondary GF is 50 turns of the same wire, both coils being wound in the same direction. On the 3-inch tube that is 4 inches in length, wind on 12 turns of No. 20 S.S.C. wire and then wind on 55 turns of the same wire. On these two tubes the two windings are spaced $\frac{1}{2}$ inch apart. The two variable condensers have a capacity of .0005 mf., i. e., 23-plate condensers. The remaining apparatus has the values indicated in the diagram. The frequency changer tube, which is the first one at the left in the diagram, is placed in the layout of the apparatus between the two condensers. This is done in order to make the connections as short as possible to this tube and condensers. The size of the panel necessary for this receiver is one 7 by 30 inches, which size allows sufficient space for wiring.

Above are given the constants for a coil that is used as a coupler when an outside antenna is used. The coil is shown in the circuit diagram published on page 49 of this book, and is designated by the same letters. Although this cir-

cuit functions very satisfactorily on an outside antenna, it performs excellently on a loop antenna, and if this is used the coupler need not be constructed.

The connections of the Tropadyne are similar to the standard Super-Heterodyne except for the first tube. It will be noticed, however, that there are no grid condenser and grid leak in the circuit of the second detector. These two pieces of apparatus were eliminated because it was found that distortion was decreased to a minimum by operating the tube on the lower bend of the tube's characteristic curve. This is accomplished by connecting the grid return lead to the negative terminal of the "C" battery, which acts as a grid bias for the audio frequency amplifier tube. This applies a negative potential to the grid of the detector, and heretofore very little or no current is absorbed by the detector, and the selectivity of the intermediate amplifier is considerably improved. With a "C" battery of 9 volts and a plate voltage of 45, the selectivity is so great that powerful local stations otherwise broad in tuning are tuned in and out with the vernier alone. This battery does not decrease the volume and the quality of reproduction is remarkable. The data for the construction of the intermediate transformers will be found in this volume as referred to above. These transformers are tuned by variable condensers across the secondaries, so that each transformer is operating on the same wave-length.

Circuit No. 124. Many fans are anxious

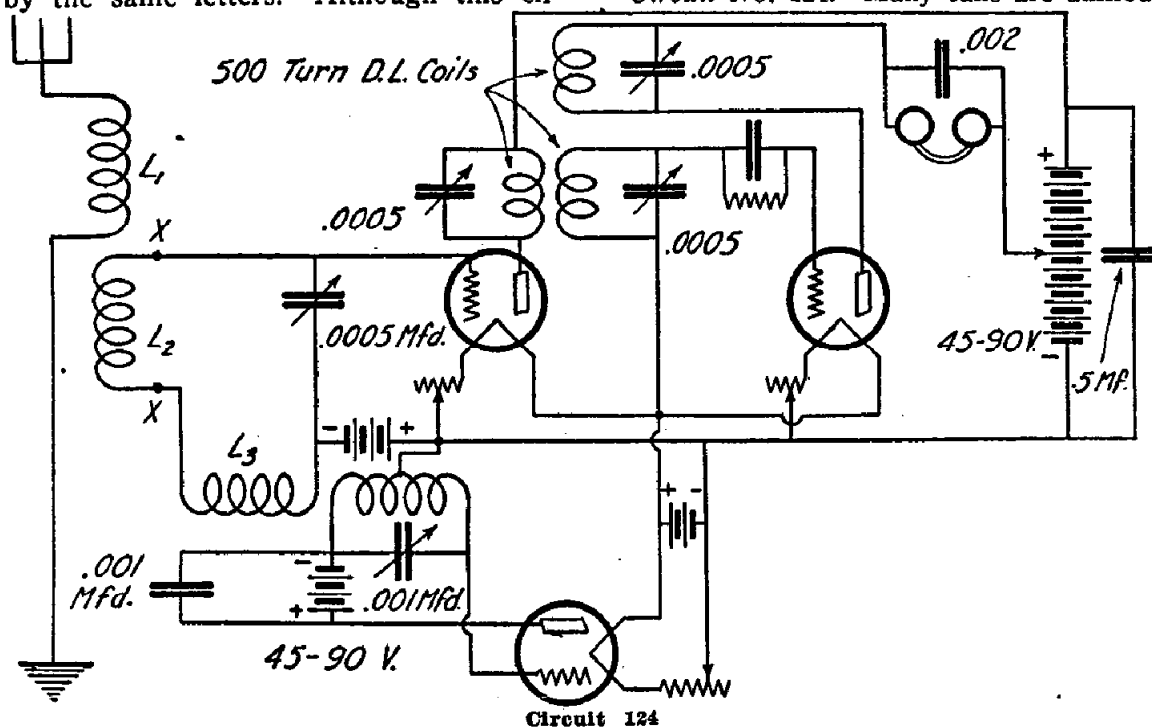

“THE RADIO CONSTRUCTOR”

Pattern No. 7

HOW TO MAKE

The Hazeltine Neutrodyne Receiver

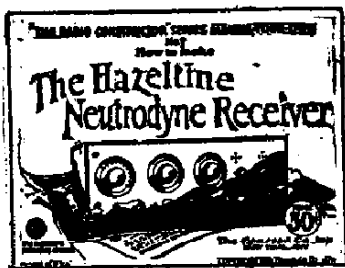

Complete detailed instructions for building a five-tube Neutrodyne receiving set can be obtained in the form of a pattern which makes the construction of the set as simple as a woman makes a garment from a dress pattern.

The contents of "The Radio Constructor" Set No. 7 Packet consists of a four-page pamphlet giving a list of parts required; full directions for drilling the panel; making the neutroformers and neutralizing condensers; and the adjustment and operation of the finished set. The packet also contains two blue prints, size 18x30 inches, giving the actual size panel layout, a perspective wiring diagram of the various parts on the panel and base, and details for building a suitable cabinet for the set.

All contained in a heavy manila envelope printed in two colors, size 9x12.

Price **50c.** *Prepaid*

THE CONSRAD COMPANY, Inc.

64 CHURCH STREET

NEW YORK CITY

"THE RADIO CONSTRUCTOR"

Pattern No. 14

HOW TO MAKE THE GENUINE STANDARD Super-Heterodyne



This Super-Heterodyne pattern is one of the largest things ever attempted in the way of blue prints with an instruction booklet.

It consists of two large blue prints, measuring $19\frac{1}{2} \times 44$ in. These blue prints are drawn full size so that the builder of this set has no difficulty whatsoever with extra measurements. With this pattern comes a complete 16-page booklet, size 8×12 in. It is the most complete booklet of its kind ever made up. It describes every detail of circuit, and shows how to proceed in the building of the set. It lists the necessary parts required and tells not only how to make and assemble them, but also how to operate the completed set.

Here is an opportunity for every radio receiving set constructor to build one of the largest and finest sets that have so far been developed in radio.

Price \$1⁰⁰ Prepaid

THE CONSRAD COMPANY, Inc.

64 CHURCH STREET

NEW YORK CITY

BUILD YOUR COCKADAY SET FROM A CONSRAD PATTERN

How To Make A Cockaday Receiver

Pattern No. 6



The Cockaday four-circuit tuner is one of the latest advancements in radio. Its main advantage lies in the fact that the set can be adjusted to the highest point of regeneration, and tuning accomplished over a wide band of wave-lengths without the necessity for readjustment the regeneration control. The set described in our packet was designed and built at our own shop. All dimensions, size of

wire, number of turns, etc., are given, leaving nothing to the imagination.

The Packet consists of a fully illustrated instruction Pamphlet, size $8\frac{1}{2} \times 11\frac{1}{2}$ inches and two large Blue Print Patterns, 18 x 28 inches—one of the Actual Size Panel Layout with directions for building a suitable cabinet, and one Perspective Wiring Diagram of the Set.

Contained in a Two-Color Printed Envelope, size 9x12 inches.

Price **50c.** Prepaid

How To Make A Five Tube Cockaday Receiver

With Push-Pull Amplification

Pattern No. 11

This pattern gives the complete assembly, wiring, adjusting and tuning details for the new Cockaday five-tube receiver with Push-Pull amplification. The set as described in our pamphlet of instructions is one of the best receivers for the reception of distant stations due to its remarkable selectivity. It is also noted for great volume, as the power amplifier of the Push-Pull type used in this set is, without question, a big improvement over other forms of audio frequency amplifiers.



Complete instructions in a four-page pamphlet. Size $8\frac{1}{2} \times 11$ inches. One large blue print Pattern showing a Perspective Wiring Diagram, and Full Size Panel Layout, both size 18x28 inches. Contained in a heavy two-colored printed envelope, size 9x12 inches.

Price **50c.** Prepaid

THE CONSRAD CO., Inc.

64 Church Street

N. Y. C.

SIMPLIFIED RADIO BOOKS!

*For Everyone Owning or Operating
a Radio Receiver*

IT IS not difficult to keep a Radio Receiver in perfect condition at all times. A simple elementary knowledge of the principles of Radio Receiving and a reference book for locating trouble will suffice anyone.

These books are written just for this purpose—to enable anyone in an easy way to know how to keep a Receiver in good condition and understand enough to build a set himself.

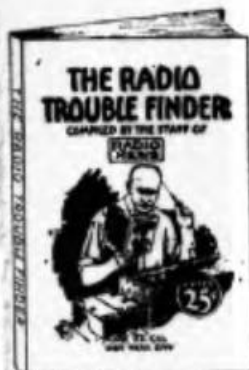

1001 RADIO QUESTIONS AND ANSWERS

The staff of "RADIO NEWS" has created a book in which appears the cream of every radio man's problems and the best method of coping with them. There is contained invaluable information on every phase of radio. Information on hundreds of simple and complex hook-ups is given in clear and concise language. Information on practically every type of receiving set, manufactured receivers, vacuum tubes, miscellaneous circuits, and in short just what the radio enthusiast needs as an *unerring guide and aid*.

Contains 116 Pages. Illustrated.
Size 9x12 in.

PRICE 50c

HISTORY AND CONSTRUCTION OF THE SUPER-HETERODYNE

Any man interested in Super-Heterodynes, their origin, development, and the various "Super-Het." circuits in use today will prize this big book. It is the finest array of data on this powerful system, ever assembled. Illustrations, circuits and data of all kinds are included, no Radio Fan should be without one.

Size 9x12 in. 100 Pages. Illustrated.

PRICE 50c

THE RADIO TROUBLE FINDER

This book explains the common and special faults of all the standard receivers of today; tells how to recognize instantly, by various sounds, where the trouble lies and also gives special simple tests by which you can determine what is wrong with your receiver. Then for each par-

ticular fault there is explained the proper procedure for correcting it.

Size 6x9 in. Illustrated.

PRICE 25c

500 RADIO WRINKLES

The 500 RADIO WRINKLES BOOK is a very comprehensive compilation of the best time and money saving hints that can be effected. Under fifteen separate and distinct headings, the entire field of radio apparatus and instruments has been covered in simple, understandable language. There are no ifs nor buts to complicate directions. The Beginner as well as the more advanced radio man will soon find that this book contains a veritable storehouse of practical, inexpensive hints toward improving his radio apparatus.

100 Pages. Illustrated. Size 9x12 in.

PRICE 50c

AMATEURS' HANDBOOK

The "RADIO NEWS" Amateurs' Handbook contains a wide, varied and carefully selected array of the finest and most helpful radio articles that have appeared in the pages of Radio's Greatest Magazine, "RADIO NEWS."

The cream of practical, up-to-the-minute, circuits and miscellaneous information and data is culled from "RADIO NEWS" and presented in compact form in this book. It embraces every phase of radio.

Size 9x12 in. 116 Pages.

PRICE 50c

Each of these books cover a different angle of Radio. Select the one or ones you desire and buy them today from the nearest Newsdealer or Radio store or use the coupon on this page.

ACT NOW!

**EXPERIMENTER PUB. CO.
INCORPORATED**

53 Park Place, New York, N. Y.

Experimenter Publishing Co., Inc.,
53 Park Place, New York, N. Y.

Gentlemen:
I enclose \$..... for one copy of 1001 RADIO QUESTIONS AND ANSWERS, SUPER-HETERODYNE BOOK, RADIO TROUBLE FINDER, 500 RADIO WRINKLES, AMATEURS' HANDBOOK.

Name.....

Address.....

City, State.....

(Check magazines desired and enclose full price.)

The biggest, finest Call Book—and more

50¢

Revised
every 3
months

New
Radio
inform-
ation
each
issue

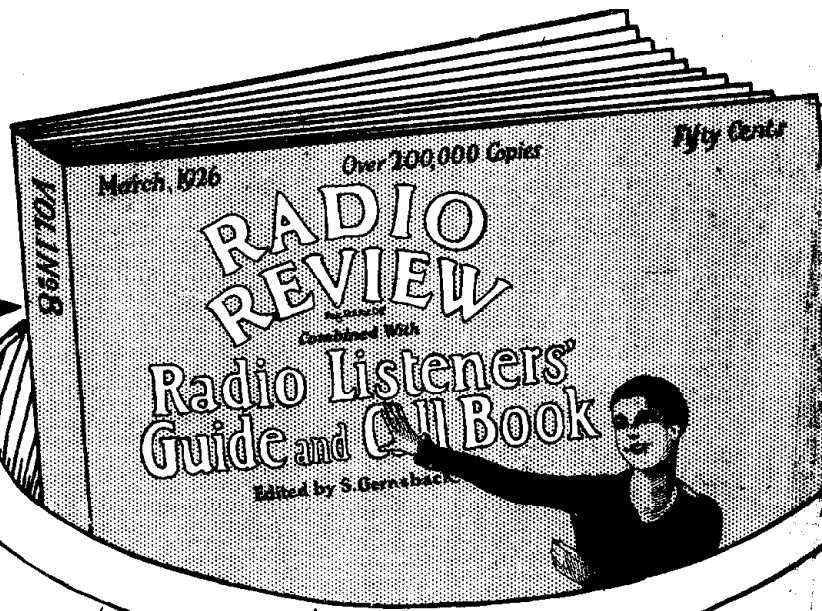

A Whole Barrellful of Useful, Valuable Information for Set Users

DON'T operate your Radio Set in the dark. Here's a big magazine that gives you the name, the call letters, the power, the wave length, etc., of every Broadcast Station in the United States—and the hours they operate too. It gives plenty of new hookup information, General Radio information and carries in every issue a supplement of S. Gernsback's Radio Encyclopedia.

It is divided into four parts, each complete, authentic and up-to-the-minute.

The first part contains the finest and most up-to-date list of Broadcast stations obtainable—listed by Call Letters, Wave Length and cities, together with the broadcast schedule of each station for every day of the week. The book also lists all Canadian and Foreign Broadcast stations.

The second part of the magazine is devoted to articles of

interest to the Radio Set Owner, giving him information on all subjects he ought to know, to better understand the operation of his Radio Set.

The third part contains a great number of constructional articles to delight the fancy of the hookup fan on many modern receivers.

The fourth part contains a new supplement of S. Gernsback's Radio Encyclopedia, profusely illustrated and complete in every respect.

In all a tremendously valuable book to have on hand by every user of a radio receiver. The *Call Book* for ready reference to stations received. The *constructional articles* for data on your new set. The *Encyclopedia* for an intimate and authentic knowledge of Radio and the *Listeners information* for first hand knowledge on how to care for your set and operate it properly.

This big magazine is sold everywhere by
60,000 newsdealers and radio dealers. Buy a
copy NOW.

SOLD ON ALL NEWSSTANDS

Published by THE CONSRAD CO., Inc., 64 Church St., New York, N. Y.