

RADIO WORLD

Trade Reg. U.S. Pat. Off.

Vol. 8. No. 4 ILLUSTRATED Every Week
155-186

VACUUM TUBE WONDERS EXPLAINED THE RX-1, A 4-TUBE QUALITY RECEIVER

THE THOROUGHbred



THE THOROUGHbred, shown above, at right, is a 1-tube DX set of extreme simplicity and economy. The home-made cabinet is only 5 1/2" square. Compare its size with that of the headphones the toy thoroughbred (at left) is wearing. See constructional article on page 3. (Hayden Photo.)

B-C-L

October 17, 1925

B-C-L

THE WEEKLY CATALOGUE

A Safe Guide for the Discerning Buyer

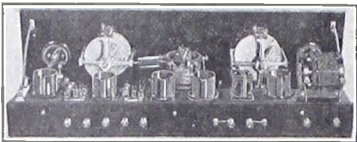

Complete kit of official parts for Radio World's 1926 Model Diamond of the Air, as prescribed by Herman Bernard. Drilled and engraved panel, Bruno coils and condensers, Bretwood leak, etc. **\$39.50**

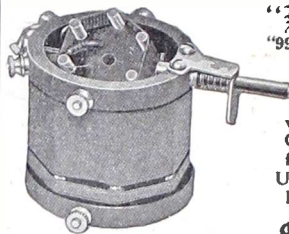

"Bruno"
"99" 3-circuit
tuner

wound on
Quartzite
for .0005.
Used in the
Diamond.

\$5.50



"Bruno"
"55"

Matched radio-frequency coil for use with the "99." Wound on Quartzite for tuning with a .0005 mfd. condenser.

Strictly low-loss and typifying highest efficiency **\$3.00**

The B-C-L Weekly Catalogue, published herewith, keeps the reader informed of the latest and best prices on standard products of proven efficiency.

Catalogues published weeks or months in advance of distribution cannot contain brand-new products and must necessarily reflect old market conditions.

COMPLETE KITS

Hayden's Thoroughbred (without cabinet).....	\$7.50
3-Tube Rasla Reflex.....	24.50
"Bruno 77" 3-Tube DX.....	19.50
Ambassador 3-Tube.....	17.50
Roberts' Kneekout.....	33.50
Browning-Drake.....	32.45
Bernard Audio Amplifier.....	10.50
Freshman KIT, coils and condensers.....	7.50

VARIABLE CONDENSERS

Bruno 3-section (three .00025 tuned by one motion).....	\$5.95
Hammarland, 43 pl. vernier.....	2.95
Manhattan low-loss, .0005 vern.....	2.75
U. S. Tool .00025, .00035, .0005, all vernier.....	7.75
Wade .0005, 58; .00025.....	3.75
Ameco Allocating SLF .00035.....	3.95
Ameco Allocating SLF .0005.....	3.95
Heath Radiant, vernier, all cap.....	1.95
King Cardwell, all cap.....	2.95
Sleeve Type Neutralizing Condenser.....	.25
Continental Midget.....	1.00

SOCKETS

5-Gang Shelf for Diamond.....	\$2.50
4-Gang Shelf.....	2.00
3-Gang Shelf.....	1.50
Panel Mount, Triple.....	.75c
Federal.....	.65c
Bell Standard Navy and 99.....	.45c
UX Adapters (Na-aid).....	.35c

AUDIO TRANSFORMERS

Thordarson Autotormer.....	\$4.25
Federal 65, 65A.....	3.75
Eria 3-to-1, 6-to-1.....	3.50
Thordarson 2-to-1.....	3.10
Thordarson 6-to-1.....	3.10
Thordarson 3-to-1.....	2.95
Jefferson Star 6-to-1.....	2.10
Jefferson Star 3-to-1.....	2.10
Rauland Lyric.....	6.95
General Radio (new types).....	3.95
Crescent 6-to-1, 3-to-1.....	2.50
Ame 4 1/4-to-1, A2.....	1.95
All-American 10-to-1.....	3.75
Amertran 5-to-1 and 3-to-1.....	3.85
DeForest 3-to-1.....	3.95

COILS

"Bruno 66" 3-circuit Tuner.....	\$2.25
"Bruno" Filter.....	2.25
Clartuner.....	3.50
Eria Balloon Circloid (toroid).....	3.65
Bruno Coils for Roberts' Kneekout.....	9.00
Yankee 3-circuit.....	1.65

FIXED CONDENSERS

Dubiller 2.0 mfd.....	\$1.45
Dubiller 1.0 mfd.....	1.00
Dubiller 0.25 mfd.....	.75c
Dubiller .006 mfd.....	.55c
General Instrument .001, .0005, .00025.....	.45c
Grid Condenser .00025, with clips.....	.50c
Grid Condenser .00025, with clips, and 2-meg. leak.....	.80c

SPEAKERS

Amplion Type.....	\$4.50
Crosley Musicone.....	13.50

RHEOSTATS

"Bruno" 6, 10, 20, 30 ohms.....	50c
Patent, all sizes.....	59c
Cutter-Hammer 6 ohm.....	45c
Ameco 6, 20 or 30 ohms.....	.69c
Klossner vernier, 6 ohm.....	.59c
Klossner plain, 6 ohm.....	.45c
Bradleystat.....	\$1.39
Fada 6 or 30 ohm.....	.39c
Frost 6 ohm.....	.40c
Federal 6 ohm.....	.59c

JACKS

Firth SC or DC.....	30c
Jones SC, 35c; DC.....	.45c
Federal SC, 40c; DC.....	.50c

FIXED CRYSTALS

Carborundum.....	\$1.50
Rasla.....	.95c

DIALS

Apex vernier.....	\$1.45
Marko hairline vernier.....	1.95
Venus 4" vernier.....	.95c
Kurz Kash Bakelite 4".....	.50c
Univernier.....	.95c
B. M. S. vernier.....	1.10
Pathe 2, 3, 4".....	.25c
Na-aid 4".....	.50c
Accuratone.....	2.75

TUBES

Venus Voltron 201A, 99 types.....	\$1.45
R. C. A. Tubes UV201A, UV199, WD12, UX120.....	2.25
DeForest DV2, DV3, DV3A, DV5.....	2.50

LEAKS

Bradleyleak.....	\$1.39
Fixed Leaks, all values.....	30c

BALLASTS

Vebv, 3/4 amp.....	50c
Amperite, for all tubes (specify your tubes).....	.95c

HARD RUBBER PANELS

7x10.....	.60c	7x18.....	\$1.00
7x12.....	.70c	7x21.....	1.25
7x14.....	.80c	7x24.....	1.50
7x26.....	\$1.65		
For 1926 Diamond, 7x24" drilled and engraved.....	2.65		
For Powertone, 7x18" drilled and engraved.....	2.50		
For 3-Tube Ambassador, drilled and engraved.....	1.45		

MISCELLANEOUS

Clarostat.....	\$1.95
Dubiller Duratran (fixed RF transformer).....	2.25
Crosley Pup.....	9.50
8-lead Battery Cable.....	45c
Prompto A Battery Switch.....	.22c
Columbia 3-Honeycomb Coil Mount, geared.....	95c
Short-wave RF Choke Coil.....	1.25
Amrad Variometer (new type).....	1.25
Freshman B Eliminator (AC).....	20.00
Freshman Rectifying AC Tube.....	2.50
Freshman B Eliminator (DC), needs no tube.....	17.50
Daven 3-stage Resistance Audio Amplifier Unit; factory made; Bakelite base.....	12.50
Centralab 500,000-ohm pot.....	1.65
Baseboard 6 1/2 x 7".....	25c
"Bruno" Brackets, per pair.....	1.00
Globe 45-volt B Battery.....	1.85
1" Bezels.....	10c
Pyrex Insulator.....	35c
Compensating Insulator.....	40c
100 ft. 7 Strand Aerial.....	1.00
50 ft. No. 14 Insul. Leadin.....	.50c
Ground Clamp.....	10c
Keystone Arrestor.....	1.10
"Bruno" Blinding Posts, dozen.....	40c
Patent Plugs.....	25c
Phone or Speaker Cords, tipped.....	45c
Engraving for Panels.....	15c
Powertone Socket Shell, Sockets, Resistor and Leak Mounts (unit).....	2.75
"Bruno" 14 pt. Tap Switch.....	49c
\$1.00 Hydrometer.....	45c
Busbar, round or square, 3 for Spaghetti, length.....	3c
Balkite Charger.....	12.50
3-amp. Westinghouse Noiseless; with bulb.....	14.50
0-50 Leader Voltmeter.....	65c
Eureka DPDT Panel Switch.....	50c

COMPLETE LINE OF GENERAL RADIO PARTS IN STOCK

Thordarson-Wade, Kit of official parts, including 3 Wade Condensers and 3 Thordarson Autotormers. Indorsed by Herman Bernard. **\$41.50**

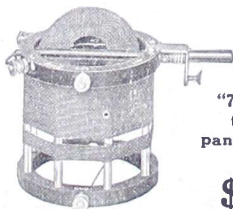

"Bruno"
"77" 3-circuit
tuner with
pancake tickler.
For .0005.
\$5.50

NO-LOSS General Instrument. Variable Condensers, Pyrex or Isolantite; all capacities **\$2.95**
Vernier, with Dial, \$1 Extra

BRETWOOD
Variable Grid Leak..... **\$1.50**

BETTS & BETTS
Collapsible Loop..... **\$2.25**

AEROVOX
Bypass Condensers
0.1 mfd..... **65c**
0.25 mfd..... **75c**
1.0 mfd..... **\$1.00**

For **SHORT WAVES**. Sidney E. Finkelstein's 2-tube, 25 to 110 meter Receiver Kit, including "Bruno" SW coil **\$12.95**

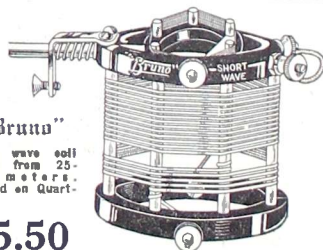

"Bruno"
short wave coil
tunes from 25-
110 meters.
Wound on Quartzite
\$5.50

Send for
"Bruno"
Circulars

B-C-L RADIO SERVICE CO.
223 Fulton Street Dept. W New York City

Expert
Technical
Q. & A. Service
FREE

RADIO WORLD

[Entered as second-class matter, March, 1922, at the post office at New York, N. Y., under the Act of March 3, 1879]

A Weekly Paper Published by Hennessy Radio Publications Corporation from Publication Office, 145 West 45th Street, New York, N. Y. Telephone: BRYant 0558, 0559

Vol. VII. No. 3. Whole No. 186.

October 17, 1925

15c per copy, \$6.00 a year

THE THOROUGHbred

By *Herbert E. Hayden*

Photographs by the Author



HERBERT E. HAYDEN

THE demand is ever great for a 1-tube set, but the constructor does not want to feel that he is missing any distant stations he should reasonably expect to receive, or that volume must be very low and selectivity poor just because the set has only one tube. Therefore, he incorporates regeneration in some form. Most often this has been a tickler coil, the inductive relationship of which to a secondary was varied to give the desired amount of feedback. But there is another method of providing and controlling regeneration that has not been discussed as much as it deserves, and that is to have a fixed tickler and to put a resistance across it that may be varied to give the necessary amount of regeneration. While feedback is of course related to frequency, and the extent of regeneration must depend on the wavelength of the received signal, it is nevertheless true that the resistance-controlled form of regeneration is not nearly so critical as that provided by the rotary coil. The approach to the regenerative state is very gradual indeed. This simplifies tuning and adds comfort to the many enjoyable features of this receiver.

Set Proves Excellent

The circuit used is the standard regenerative receiver, with the exception already noted, and it proved so excellent in its performance that it struck me as being a true thoroughbred. And that's just what it is. The toy dog (stuffed, of course) that adorns the front cover of this issue typifies at least the miniature size of the actual receiver, for he is a wee mite, and he—or she—also suggests the thoroughbred character of the set.

Only 5" Square!

The wooden box in which the set is contained is only $5\frac{1}{2}$ " square, and a good idea of its proportionate size may be had by comparing it with the size of the everyday telephone receivers that are weighting down the toy representation of the thoroughbred on the front cover. I do not mean the set when I speak of a toy, but merely the dog, for the set, while affording all the delights of a plaything, serves altogether too practical and utilitarian a purpose to be confused with the objects that are strewn shattered with such costly speed in a nursery!

The design of the set is along the same general lines, in point of size, as that of the Crosley pup, but the circuit is not just the same.

In the Thoroughbred the socket should be placed on top, fastened to the wooden cabinet, and holes bored so that the leads from the socket may thus be introduced into the set. The tuning dial will be on

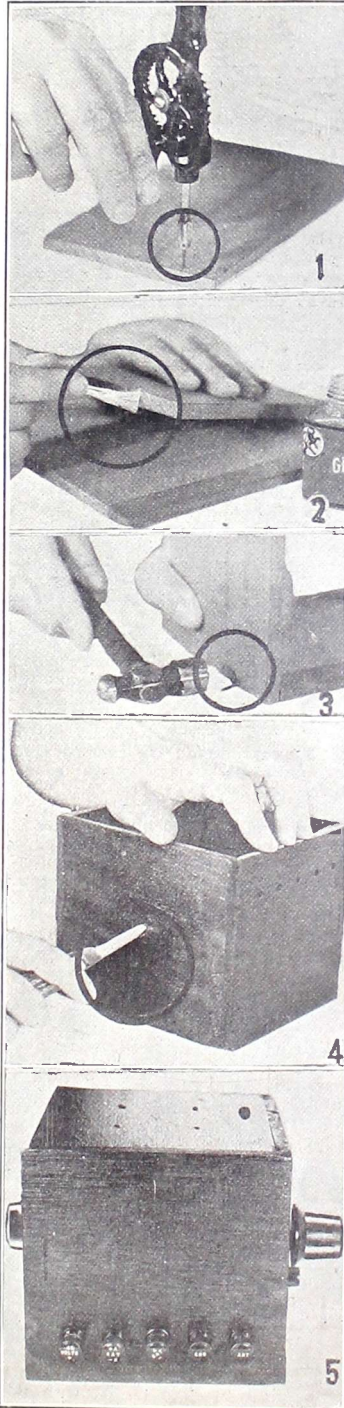

MAKING the cabinet for the set.

the front of the set, and as it is fastened to one plane of the cabinet no panel is necessary. The rheostat and two phone binding posts would be on the plane that constitutes the left side of the box, when one looks at the front of the set. The other binding posts are in the back. On the plane constituting the right-hand side of the box is the knob for the variable resistor.

Reason for Compactness

The extreme compactness results largely from use of the same parts that I employed in the tuning and regenerating sections of the circuit. The variable condenser is the Connecticut D10, while the coil and variable resistor are a commercial unit, the Clarotuner. As for the rest of the apparatus, there is very little, as will be confirmed when you read the list of parts. The set is very inexpensive and anybody who desires a set can scarcely complain that he has not the price to make one, as the Thoroughbred can be made at an expense about equal to that of a good hat—for a man. Of course a good hat for a woman is a different story.

The Socket

The socket should be of the 99 type, so that a tube requiring a $4\frac{1}{2}$ -volt A battery may be used. This type of tube is better than the 11 and 12 types, in that the amplification is greater and the volume stronger. Also, the sensitivity is at least as good. The tubes to use are the UV199, C299 or DV3A. The last-named tube is of De Forest manufacture and may be obtained in models suitable either for the 199 type base (DV3A) or standard base (DV3). Hence if you use a 199 socket and a DV tube, get the right model DV3. All these tubes are ready oscillators, and that is what you want.

The construction of the box and the receiver as a whole is shown in thirteen photographs, including the one on the front cover, ten others being published in this week's issue. In next week's RADIO WORLD I shall show two other photographs, one of which is very important, and also tell something about the manner in which to tune this set to get the utmost distance.

The photographs are numbered, and that identifies them quite sufficiently.

Making the Cabinet

The cabinet is made of five little boards, $\frac{1}{4}$ -inch thick. They are placed together so that the little box measures about $5\frac{1}{2}$ inches square. No bottom board has been provided, nor is one considered necessary.

Some persons split thin little boards through carelessness. Before you attempt to put the box together use a small drill and drill right through the edge of the boards (Fig. 1) so as to make the use of the boards an easy matter, and avoid splitting the wood. The various operations are shown photographically and include drilling, gluing (Fig. 2) and nailing (Fig. 3). The little board is placed on top, and thus this rather simple cabinet is completed.

The next operation is to stain the box some desirable color such as mahogany. Draw a very light line $2\frac{1}{2}$ " from the

Making the Cabinet for the Set

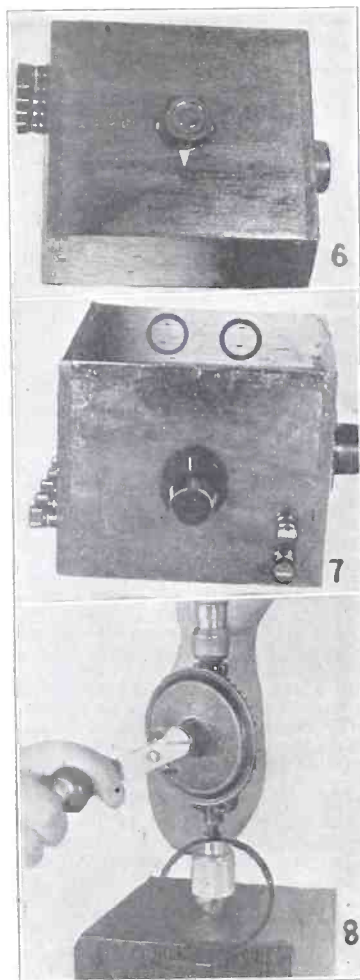

bottom of the box on three sides. Then locate the center of each side or plane and make a center dot. Do this on the three marked sides. The fourth side will be considered the rear and used for the row of binding posts. This will keep the wires away from the panel.

Mounting Parts

Next select any one of the three sides and drill or cut a hole about $\frac{3}{8}$ " through the center dot to make room for the one hole for mounting the D10 Triple Range Condenser (Fig. 4). This side will be considered the front. Now the same procedure is followed on the side to the left of the operator (condenser facing front) and the Clarotuner. Model TCH is installed in the same manner, as it also is a one hole mount. If you haven't a drill large enough to make a $\frac{3}{8}$ " hole or so, use a knife (Fig. 4).

Now on the right-hand side of the box drill a hole $\frac{3}{4}$ " for the rheostat shaft. Some rheostats require only this hole. Drill whatever mounting holes are necessary. Next place the two phone posts in position. They are mounted right alongside the Clarotuner $\frac{1}{2}$ " from the bottom and 1" back from the front panel.

The other posts are placed on a line $\frac{3}{4}$ " apart, one inch up from the bottom of the cabinet rear. They are as follows (Fig. 5), starting from left to right. 45 volts plus, A plus and B minus (both on the one post), A minus, ground and aerial. Now the 199 tube socket is mounted on

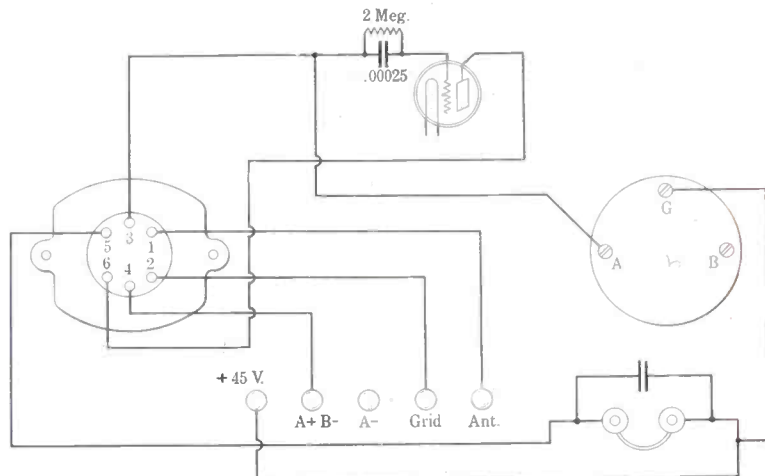

THE WIRING DIAGRAM of the Thoroughbred, shown in picture form. The connections to the Clarotuner and the Connecticut Condenser are shown. Note the open B connection on the condenser.

LIST OF PARTS

One wooden box, $5\frac{1}{2}$ " square.
 One 99 type socket.
 Seven binding posts.
 One 30-ohm rheostat.
 One Clarotuner, Model TCH.
 One Connecticut D10 condenser (with dial).
 One dial pointer.
 One .00025 grid condenser.
 One 2-megohm grid leak.
 Accessories: Two 22 $\frac{1}{2}$ -volt B batteries; aerial wire; ground clamp; one 4 $\frac{1}{2}$ -volt C battery (for use as the A battery); one pair phones; one UV199, C299 or DV3 tube; brads, nuts, screws, hardware; $\frac{1}{2}$ lb. bell wire.

the top of the little box and small holes drilled alongside the socket binding posts for connecting wires.

The D10 is a small compression type of variable condenser and follows the popular low-loss design of construction. In one piece of apparatus we have our choice of a .00025, a .0005 or a .001 condenser. The dial makes the full 360-degree turn, and consequently gives a better spacing than many 180-degree operated devices. The diagram shows just how to connect the condenser to get .0005 which is the value used in the Thoroughbred. It will be noticed that the busbar on the rear of the condenser has been removed altogether, as it is not necessary for use with .0005 requirements.

The wiring is to be done with ordinary bell wire, as this is just the thing to fit into the small space.

You will note in the electrical diagram that there is no rheostat placed. However, when building the set it should be put in the negative lead. By placing the rheostat in the negative lead we may obtain a negative bias on the tube.

If one is experimentally inclined he might try inserting a special C battery in the grid circuit instead of the convention grid leak and condenser. The results may be found to be better and maybe not. This of course depends upon the type of tube used and its inner characteristics. Another thing to note is the fixed grid leak. In the diagram it is stated that this leak has a resistance of 2 megohms. Some tubes work better with a 3 or 4-megohm resistance and still others worked well with a 1-megohm resistance. The majority of them worked O. K. with the 2-megohm resistance.

The grid condenser need not to be changed. The value is the same for all receiving tubes, be they hard or soft. By a soft tube is meant that when the tube is evacuated there is some gas left in the tube. In the hard tube all the gas is taken out except that which remains due to the inefficiency of the vacuum pump. It is a very difficult proposition to get a tube with a perfect vacuum.

Rheostat Wiring

The rheostat was left out for simplicity sake, that is, the wiring of the circuit can more easily be followed. The following is how the rheostat is wired up: The arm of the rheostat goes to the A+ post on the terminal strip. The post holding the resistance wire goes to the F+ post on the socket. The F+ post of the socket goes to the A+ B- post on the terminal strip.

The by-pass condenser, which is shunted across the phones is not an actual necessity.

(Concluded next week)

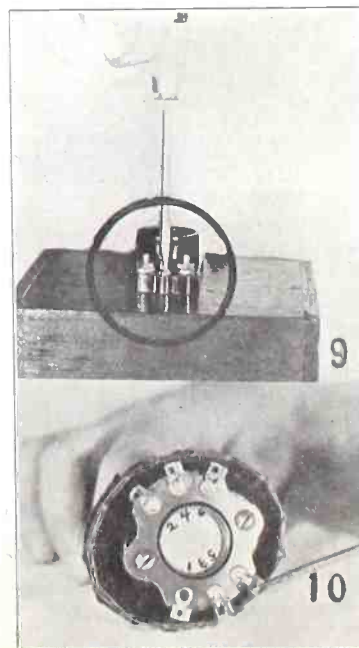

O'Rourke's Favorite SW Set

By Capt. P. V. O'Rourke

I HAVE BEEN working on short wave receivers for quite a time, and finally decided on what I consider the most practical receiver for such purposes. This is shown in an electrical diagram, Fig. 1. The Hartley method of obtaining oscillations from a 3-element tube was used. The method of obtaining these oscillations is by capacity feedback. The plate of the tube is coupled back to the grid by means of the condenser C₂. I tried the inductive method, that is, with a rotary tickler, in which the plate of the tube is coupled back to the grid by means of the coil. When using the inductive method of tuning I found that the tickler had to be so small that it had little or no effect, and the regeneration was poor. When there was regeneration present, (with larger tickler) it was uncontrollable. To compensate for this factor a condenser was used.



CAPT. PETER V. O'ROURKE

To make the coil is a very simple operation. If you do not care for looks, the operation takes ten minutes, and the coil is just as efficient, but not so good on looks. I used a quartzite form, although any type of low loss form may be used with equal success. The primary, L₁, is wound first. Six turns are made. The diameter of this form is 2½", and the height or length is 4". No. 18 bell or double cotton covered wire is used. Space the windings ⅛" if possible. This is not essential. Next the secondary is wound. There are 6 turns made and a tap is taken. Then 11 more turns are made. This will give us 17 turns on the secondary, L₂. When winding, pull the wire tight. I realize that it is very difficult to do so, but otherwise you will have a great many kinks in the wire. These kinks introduce resistance in the circuit, and if there is one thing that we want to avoid in high frequency it is resistance. The spacing between primary and secondary should be ¼".

If you will look at the photos you will note that I used a peculiar type of variable condensers. This type is known as the Helicon. To go from minimum to maximum capacity in the condenser you have to turn the dial five revolutions. On short waves this is great, as the more the separation the better. The capacities of these condensers are .00025 mfd. Note that the rotors are grounded, which prevents body

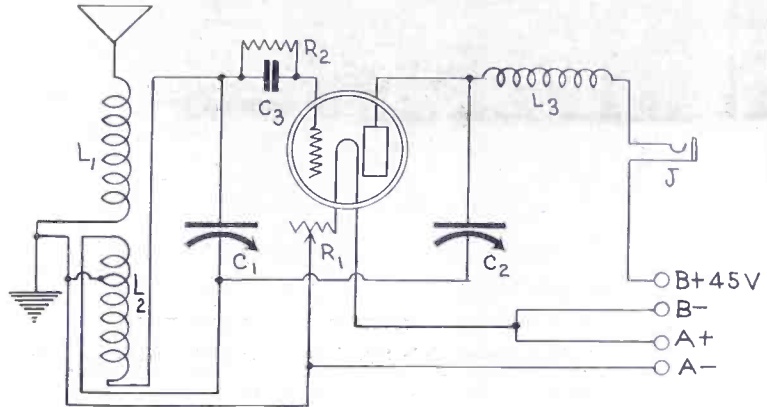

FIG. 1, the wiring diagram of the shortwave set, approximate range, 8 to 75 meters.

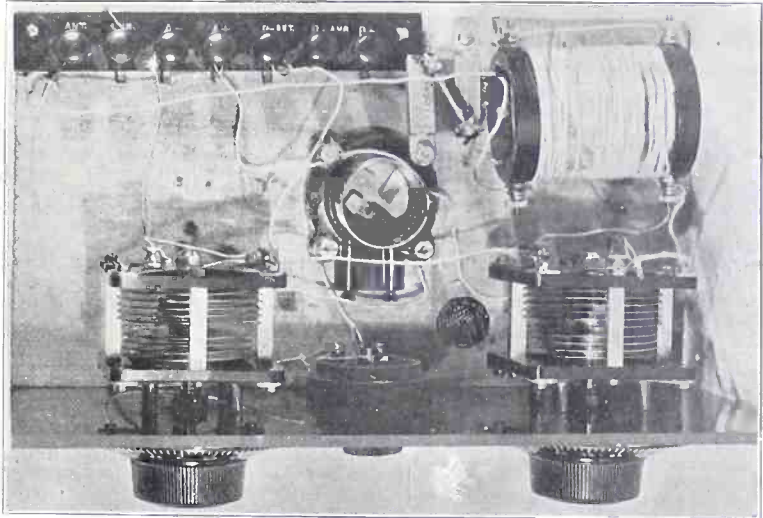

FIG. 2, showing how the parts of the shortwave set are laid out. Note the choke coil near the plate post of the socket. This is a top view.

capacity. Of course, any other type of .00025 mfd. variable condenser may be used in the set with equal success.

Drilling the Panel

The panel is 7x12". Two and three-quarters inch from the right-hand edge, and 3½" from the top and the bottom of the panel, lay the template of the condenser that you are using. The condenser that I

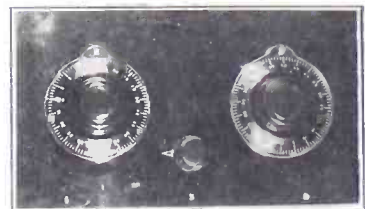

FIG. 3, showing the panel view.

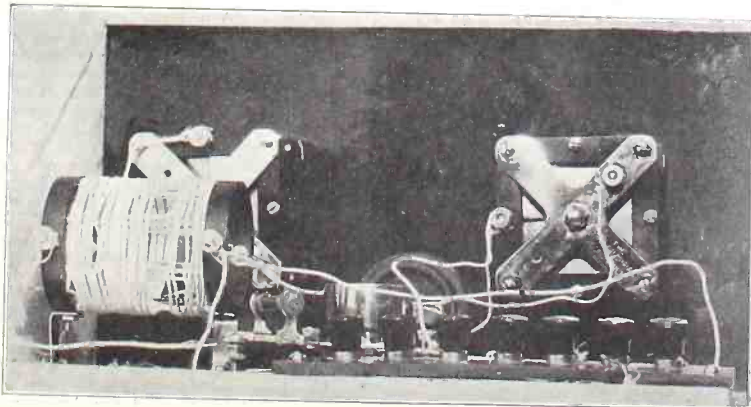

FIG. 4, showing how the back of the receiver looks.

used was 3" square. The dial was 3½". Six and one-half inches from this hole drill another hole for the other condenser, also .00025 mfd., lay the other template over the hole. The rheostat is placed in exactly the center, or 6" from both the right and the left-hand edge of the panel. It is 1½" from the bottom. The only other holes to drill beside the mounting holes of the condenser and the rheostat are the baseboard holes. There are three of them. The ones on the extreme ends are 2" from those ends. The center one is 6" from both the right and left-hand edges. They are ¼" from the bottom. The baseboard is 10" long and 6" wide.

The socket is placed directly in back of the rheostat, 2" being left for play. That is enough space left so that you could put

(Concluded on page 22)

Working the Thordarson-Wade

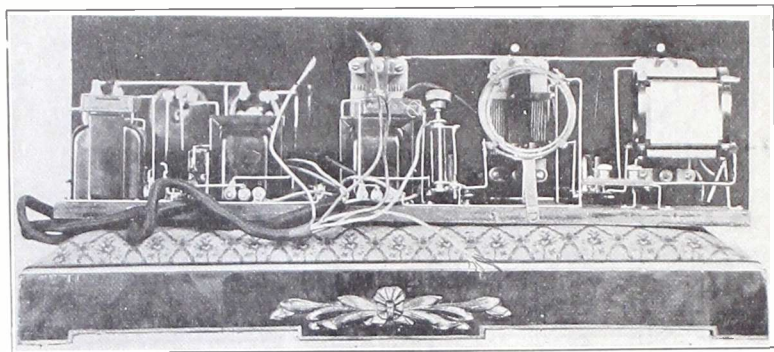

THE rear view of the Thordarson-Wade Set, showing the Bretwood Variable Grid Leak just to the right of the first Autoformer. The leak is not placed on the panel in this receiver because its setting may be left at the point of maximum general efficiency, once that is determined. DX hounds may desire occasionally to convert a whistling carrier wave into a program and may turn the knob slightly for that purpose.

By Herman Bernard

Associate, Institute of Radio Engineers

SOME sets anybody can tune, without previous experience, and get fine results. Other sets require some special knowledge. One of these is the Thordarson-Wade, described from a constructional viewpoint in the October 3 and 10 issues of RADIO WORLD. While even total ignorance will result in some measure of reception, and indeed of a sort that will satisfy quite a large percentage of persons, only a knowledge of the fundamental workings will enable one to achieve that rapturous goal—full, rich, thrilling tones, surpassed in quality by nothing that radio has to offer.

The sources of trouble, grouped in the order of their importance, are:

- (1) Choking effects.
- (2) Uncontrollable oscillations.
- (3) Tuning.

It is assumed that the wiring was done properly. All directions necessary for building the set were given in the constructional article, and if those are followed strictly, and the set will not work, or emits only a poor peep, then some part is defective, some coil short-circuited or other blemish present that should be located with earphone and a dry-cell.

The Choking Effect

The choking effect is a serious consideration, because it is quite likely to occur, and the builder of the set may wrongly assume that the marvelous quality that was promised was a case of over-enthusiasm. But the set has been in nightly operation for more than three weeks and it has stood up manfully under all sorts of tests, including the hunting of distant stations, and always with a deep-throated resonance that is charming to ear and soul.

A set may be choked due to overloading anywhere along the line, from the radio-frequency input to the final audio-output. A tube can handle just so much, no more, under given conditions, and when the voltage at the grid is too strong to permit the amplified plate response to keep pace, then there is trouble. Hence, in order of position in the circuit, let us take up the various sources of possible choking.

The RF tube has only one safe volume control, the rheostat, which should be used for properly keying up this audion for best action. If the filament is heated too low there will be either faint signals or over-oscillation, and the adjustment of this rheostat is therefore very important. It can not be considered as some-

thing independent, since unless the detector tube is also correctly heated, there will not be uniform efficiency as governed by the filament heating. In other words a compensating effect exists whereby the RF tube and the detector tube balance each other. If one is heated too much the other may have to be heated too much to gain any sort of passable reception, or if one is underheated the other may have to be either underheated or overheated. There is, however, in any set, only one point which represents maximum efficiency for any tube, although some slight variation may be necessary on account of some extremely different frequency when one passes on to another station.

Getting Started

A good way to start is to turn the RF rheostat a little less than half way up, provided it is a 20-ohm instrument, as prescribed. Then the detector rheostat setting is determined. Meanwhile it is assumed some local station is being heard, and perhaps trouble is being experienced, such as hissing. Now vary the detector rheostat. Some tubes will function best as detectors when they are lighted very low. Just barely turn on the rheostat and you will often get the best results. Determining the right position of the detector rheostat arm is important, since one is not to adjust this rheostat any more, unless a freshly charged A battery is being used, or one which is rather low, in which case corresponding adjustment is necessary so that the tube will be heated at the correct temperature, denied it by the battery condition unless the resistance is changed accordingly.

Beginning with the lowest possible heating of the detector tube, now adjust the RF rheostat to a lower temperature. If a local station is being received it is possible that the signal will get fainter and fainter, until finally it disappears. If the RF rheostat can be manipulated that way, and turned off completely, without causing over-oscillation in the set at any point, the detector tube may be assumed to be operating at the correct temperature. This is not a set where the RF rheostat is used as an oscillation control, or even to vary volume, as we have a variable condenser to take care of that as an RF function.

Naturally all tests like these will be made on local stations and if these are fairly loud they will be plainly audible no matter what may be the setting of the variable condenser C3 under the saturation point. Turn the condenser C3 to represent higher and higher capacity settings, and see whether oscillation is produced. Normally the oscillation point or

Dials Synchronize Almost Perfectly

The dial settings for the Thordarson-Wade Set, as made for laboratory purposes, with the parts specified in the constructional article published in the October 3 and 10 issues of RADIO WORLD, synchronize almost perfectly. This simplifies tuning very considerably, in that the memory need be relied on for only one number instead of two. The settings given are for the tuning condensers only, and take no account of the regeneration condenser, since the capacity therein necessary for proper feedback depends on a variety of considerations, e. g., grid leak setting, rheostat settings, plate voltage, potentiometer setting, etc. Dial 1 is the RF tuner, Dial 2 the detector input tuner.

Following is a list of some of the stations tuned in from New York City in less than half an hour:

Stations	Meters	Dial 1	Dial 2
WNYC	526	82	82
WEAF	492	77	77
WJZ	455	71	71
WOR	405	63	63
WHN	361	57	57
WCBD, Zion City	345	43	42½
WMCA	341	54	54
WGBS	316	50	50
WPG, Atlantic City	300	47	47
WAAM	263	41	41
WRNY	259	40	40
WGCP	252	39	39
WMCA (2d harmonic)	171	20	21½

climax should be registered at about 50 for the highest wavelength station you can receive. If it is 30 or 20 or even less, then pursue the following: First turn down the RF rheostat a little, then move up the condenser until the reading is about 50 or a little less. Second, if this fails, reduce the B battery voltage on the RF tube. Third, if this fails, too, reduce the plate voltage on the detector tube. Finally you will be able to get the oscillation point at about 50. A final expedient would be to make the tap on L4 nearer the end of the coil, but that should not be necessary.

Do Not Detune

We have considered every possible means afforded by the set itself for the elimination of choking effects or other forms of distortion on the radio-frequency side, except detuning and grid leak. It is bad practice to detune to avoid too much volume, because the ideal radio receiver should be responsive to exactly the desired frequency. If it is a selective set it must be a sharp tuner on a quality basis to pass the side bands that make rich tones and natural voice and music possible, and any detuning necessarily means the chopping off of side bands. One form of distortion—more volume than the tubes can handle—is simply replaced by another form—the cutting down of volume by adversely affecting the incoming wave. This is bad indeed. With only the best practice as our goal we shall decide on utter resonance as a prerequisite, and if the set can not handle the product of this resonance, we will shoot trouble until it does.

The other factor is the variable grid leak, in this case the Bretwood. This, it will be remembered, is mounted on the baseboard. It should be set so as to conform with best requirements and left that way, the only exceptions being in the event another tube is used for detector, or a distant station's carrier wave refuses to yield to actual reception. The slight

Picture Diagram for Trouble-Shooting In the Thordarson-Wade 5-Tube Set

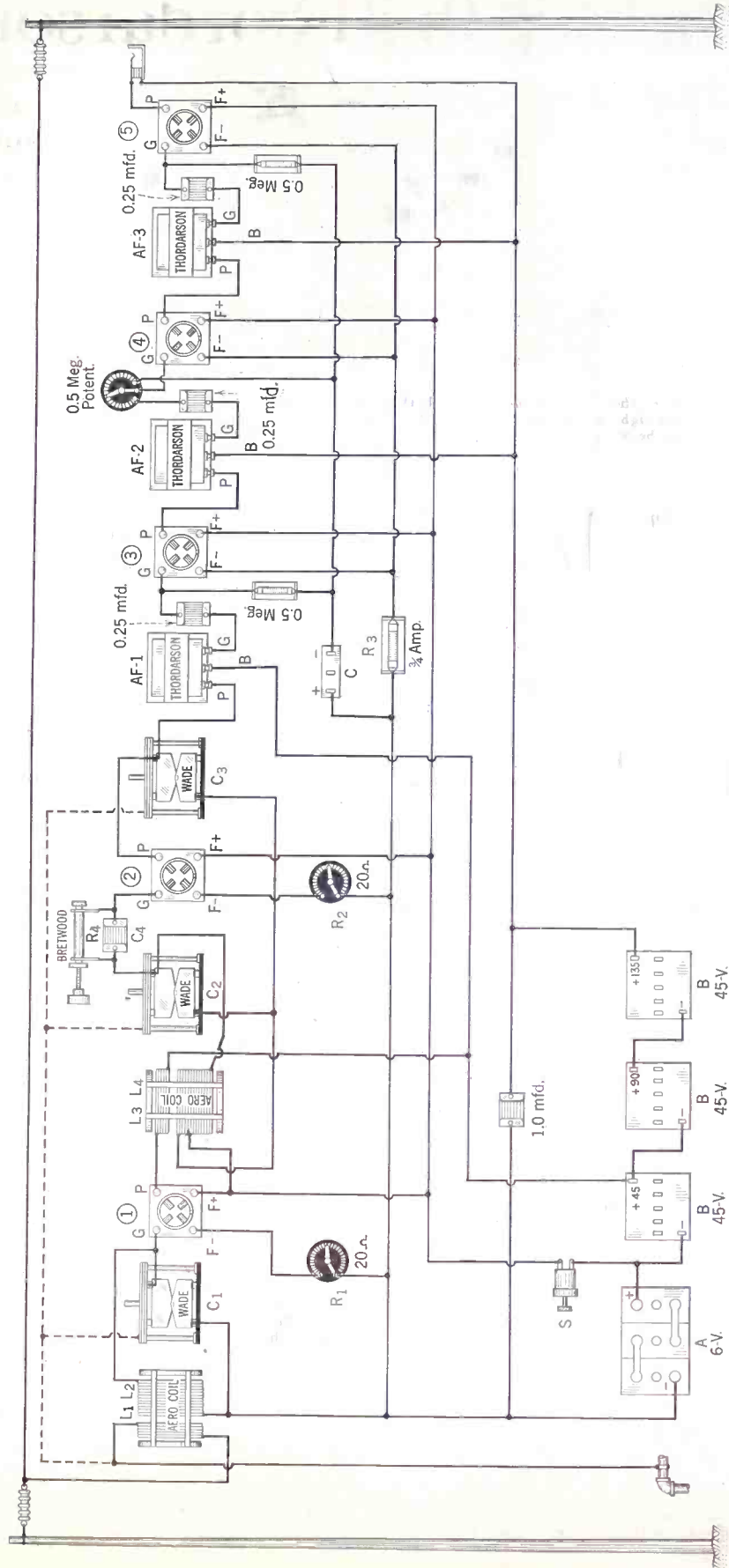

THE CONSTANTS referred to in the trouble-shooting article are identified in the above picture diagram of the wiring.

Working the Thordarson-Wade

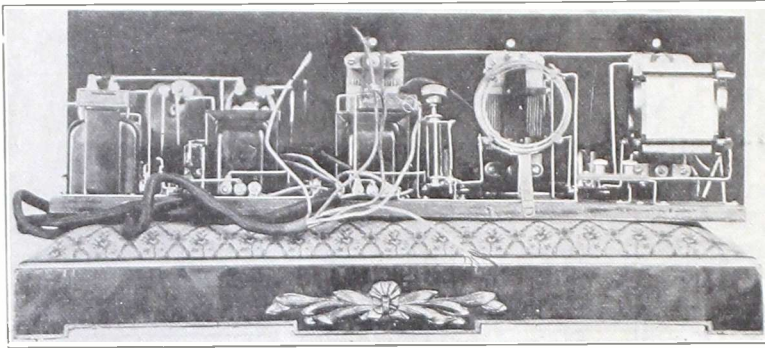

THE rear view of the Thordarson-Wade Set, showing the Bretwood Variable Grid Leak just to the right of the first Autoformer. The leak is not placed on the panel in this receiver because its setting may be left at the point of maximum general efficiency, once that is determined. DX hounds may desire occasionally to convert a whistling carrier wave into a program and may turn the knob slightly for that purpose.

By Herman Bernard

Associate, Institute of Radio Engineers

SOME sets anybody can tune, without previous experience, and get fine results. Other sets require some special knowledge. One of these is the Thordarson-Wade, described from a constructional viewpoint in the October 3 and 10 issues of RADIO WORLD. While even total ignorance will result in some measure of reception, and indeed of a sort that will satisfy quite a large percentage of persons, only a knowledge of the fundamental workings will enable one to achieve that rapturous goal—full, rich, thrilling tones, surpassed in quality by nothing that radio has to offer.

The sources of trouble, grouped in the order of their importance, are:

- (1) Choking effects.
- (2) Uncontrollable oscillations.
- (3) Tuning.

It is assumed that the wiring was done properly. All directions necessary for building the set were given in the constructional article, and if those are followed strictly, and the set will not work, or emits only a poor peep, then some part is defective, some coil short-circuited or other blemish present that should be located with earphone and a dry-cell.

The Choking Effect

The choking effect is a serious consideration, because it is quite likely to occur, and the builder of the set may wrongly assume that the marvelous quality that was promised was a case of over-enthusiasm. But the set has been in nightly operation for more than three weeks and it has stood up manfully under all sorts of tests, including the hunting of distant stations, and always with a deep-throated resonance that is charming to ear and soul.

A set may be choked due to overloading anywhere along the line, from the radio-frequency input to the final audio-output. A tube can handle just so much, no more, under given conditions, and when the voltage at the grid is too strong to permit the amplified plate response to keep pace, then there is trouble. Hence, in order of position in the circuit, let us take up the various sources of possible choking.

The RF tube has only one safe volume control, the rheostat, which should be used for properly keying up this audion for best action. If the filament is heated too low there will be either faint signals or over-oscillation, and the adjustment of this rheostat is therefore very important. It can not be considered as some-

thing independent, since unless the detector tube is also correctly heated, there will not be uniform efficiency as governed by the filament heating. In other words a compensating effect exists whereby the RF tube and the detector tube balance each other. If one is heated too much the other may have to be heated too much to gain any sort of passable reception, or if one is underheated the other may have to be either underheated or overheated. There is, however, in any set, only one point which represents maximum efficiency for any tube, although some slight variation may be necessary on account of some extremely different frequency when one passes on to another station.

Getting Started

A good way to start is to turn the RF rheostat a little less than half way up, provided it is a 20-ohm instrument, as prescribed. Then the detector rheostat setting is determined. Meanwhile it is assumed some local station is being heard, and perhaps trouble is being experienced, such as hissing. Now vary the detector rheostat. Some tubes will function best as detectors when they are lighted very low. Just barely turn on the rheostat and you will often get the best results. Determining the right position of the detector rheostat arm is important, since one is not to adjust this rheostat any more, unless a freshly charged A battery is being used, or one which is rather low, in which case corresponding adjustment is necessary so that the tube will be heated at the correct temperature, denied it by the battery condition unless the resistance is changed accordingly.

Beginning with the lowest possible heating of the detector tube, now adjust the RF rheostat to a lower temperature. If a local station is being received it is possible that the signal will get fainter and fainter, until finally it disappears. If the RF rheostat can be manipulated that way, and turned off completely, without causing over-oscillation in the set at any point, the detector tube may be assumed to be operating at the correct temperature. This is not a set where the RF rheostat is used as an oscillation control, or even to vary volume, as we have a variable condenser to take care of that as an RF function.

Naturally all tests like these will be made on local stations and if these are fairly loud they will be plainly audible no matter what may be the setting of the variable condenser C3 under the saturation point. Turn the condenser C3 to represent higher and higher capacity settings, and see whether oscillation is produced. Normally the oscillation point or

Dials Synchronize Almost Perfectly

The dial settings for the Thordarson-Wade Set, as made for laboratory purposes, with the parts specified in the constructional article published in the October 3 and 10 issues of RADIO WORLD, synchronize almost perfectly. This simplifies tuning very considerably, in that the memory need be relied on for only one number instead of two. The settings given are for the tuning condensers only, and take no account of the regeneration condenser, since the capacity therein necessary for proper feedback depends on a variety of considerations, e. g., grid leak setting, rheostat settings, plate voltage, potentiometer setting, etc. Dial 1 is the RF tuner, Dial 2 the detector input tuner.

Following is a list of some of the stations tuned in from New York City in less than half an hour:

Stations	Meters	Dial 1	Dial 2
WNYC	526	82	82
WEAF	492	77	77
WJZ	455	71	71
WOR	405	63	63
WHN	361	57	57
WCBD, Zion City	345	43	42½
WMCA	341	54	54
WGBS	316	50	50
WPG, Atlantic City	300	47	47
WAAM	263	41	41
WRNY	259	40	40
WGCP	252	39	39
WMCA (2d harmonic)	171	20	21½

climax should be registered at about 50 for the highest wavelength station you can receive. If it is 30 or 20 or even less, then pursue the following: First turn down the RF rheostat a little, then move up the condenser until the reading is about 50 or a little less. Second, if this fails, reduce the B battery voltage on the RF tube. Third, if this fails, too, reduce the plate voltage on the detector tube. Finally you will be able to get the oscillation point at about 50. A final expedient would be to make the tap on L4 nearer the end of the coil, but that should not be necessary.

Do Not Detune

We have considered every possible means afforded by the set itself for the elimination of choking effects or other forms of distortion on the radio-frequency side, except detuning and grid leak. It is bad practice to detune to avoid too much volume, because the ideal radio receiver should be responsive to exactly the desired frequency. If it is a selective set it must be a sharp tuner on a quality basis to pass the side bands that make rich tones and natural voice and music possible, and any detuning necessarily means the chopping off of side bands. One form of distortion—more volume than the tubes can handle—is simply replaced by another form—the cutting down of volume by adversely affecting the incoming wave. This is bad indeed. With only the best practice as our goal we shall decide on utter resonance as a prerequisite, and if the set can not handle the product of this resonance, we will shoot trouble until it does.

The other factor is the variable grid leak, in this case the Bretwood. This, it will be remembered, is mounted on the baseboard. It should be set so as to conform with best requirements and left that way, the only exceptions being in the event another tube is used for detector, or a distant station's carrier wave refuses to yield to actual reception. The slight

Picture Diagram for Trouble-Shooting In the Thordarson-Wade 5-Tube Set

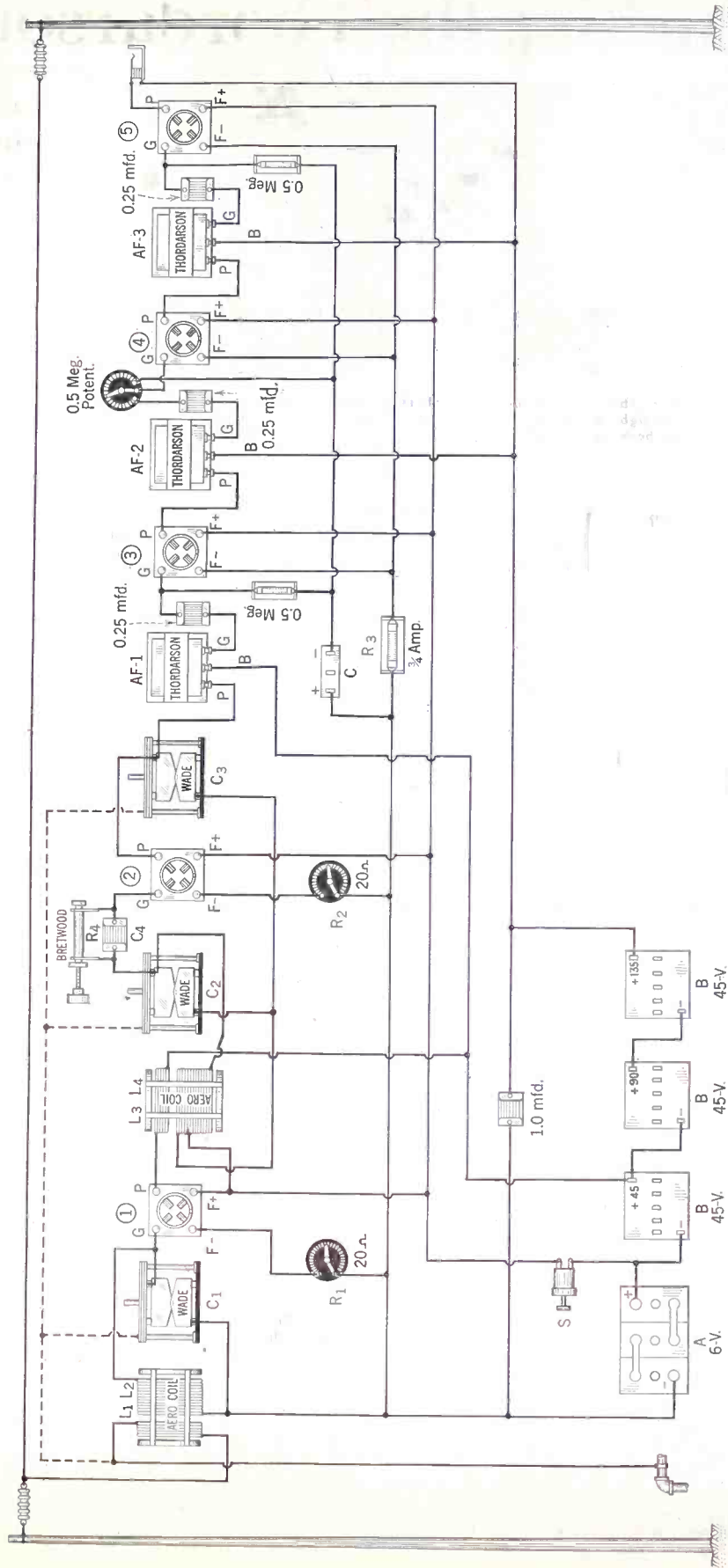

THE CONSTANTS referred to in the trouble-shooting article are identified in the above picture diagram of the wiring.

The Set that Startled Mother

variation of the leak setting for extremely distant reception will not affect the reception of locals, and the setting as it was when distance was being enjoyed may well be left "as is."

The leak functions so that when the plunger is all the way in the resistance is all the way out, that is, the minimum resistance is used, hence the leakage path from grid to filament is greatest. By unscrewing the resistance is increased, the leakage cut down. Assuming the leak plunger all the way in, about eight or ten turns in the only possible direction will give approximately the right setting for most tubes. But as tubes vary, one will start with this position, and if choking or oscillation exists, even after tests have been made as previously outlined, the leak knob will be turned outward (to the left).

All these tests are preliminary, that is, after we have taken up the audio pathology we may find that the RF and detector side that we thought were quite all right still need attention.

Analyzing the Audio

On the audio side the resistors are indeed important. The 0.5 meg. leak in the grid circuit of the first audio tube is about right for all conditions and no special attention need be paid to it, until all else has failed. The resistor in the grid circuit of the second audio tube is a variable one (a 500,000-ohm potentiometer), and its setting is rather critical, although once this is determined it need be changed only slightly, if at all, when exceptionally weak or strong stations are being received. Thus, one will find that some passable sort of reception is heard and yet that energetic volume that one has been led to expect is missing. Adjust the potentiometer so that a slight hiss is heard, then gently turn it back until this hiss is gone. The setting determines both the leakage from the grid and to some extent the bias thereon. Strangely enough, it has an effect upon oscillations in the radio side on the receiver, due no doubt to the common A and B batteries used. That is one reason for suggesting the inclusion of the 1.0 mfd. fixed bypass condenser—to keep this effect at a minimum. However, once you adjust the potentiometer, which is exclusively a volume or purity control and not to be confused with the more usual radio purpose to which a potentiometer is put, that adjustment will remain the same for all local stations and most distant ones, with the exceptions already



HERMAN BERNARD

volume is there, one must imagine, but a restricted passageway, as if a tightening effect upon one's throat, is blocking the sound. Vary the condenser C3 until you come near the saturation point, then slightly retune the two other condensers. You will need two hands to do this, one on the RF, the other on the detector dial. Perhaps you will just strike the solution—hear the enveloping volume, with the low notes reaching your ears with astounding fidelity of pitch, and the middle and high ones coming through in the same glorious fashion. It is amazing what a difference there is between getting the set working pretty well and just right.

The Grid Biasing Battery

If still your zealous efforts bring you only a little nearer to the goal you may rest comfortably assured that the grid biasing battery is not at the correct voltage. The formulaic considerations are not conclusive by any means. Disregard all data you ever read or heard on the subject of what is the correct bias for a given plate voltage. The test is to be made by ear. The bias that is figured out on paper has to do largely with economy, and we are concerned with quality. You will probably find that 3 volts negative bias will be about right, although you should try $4\frac{1}{2}$, and, up to 10 or 12, some intermediate voltages. The biasing effect of the potentiometer has something to do with this, as it is compensatory, hence experiment independently and do not be afraid to go against the accepted biasing ratings. If you find that an utter absence of bias improves reception, then by all means leave out the C battery, although it is unlikely that any improvement will be noted by its utter omission.

Radio-frequency Features.

The regeneration control is particularly handy, since the set may be operated as a

non-regenerative receiver for the reception of local stations, and only two dials used for tuning. This is done by tuning in a low wavelength station and getting the C3 setting that affords best volume and clarity. Then for the higher wavelengths the same setting may be used, unless the station is a notoriously weak one, at your point of reception, in which case C3 may be moved up two or three degrees. For locals it will not be necessary to vary the C3 settings more than 10 divisions of the dial, and, as suggested, perhaps no motion here will be needed. This is due to the condenser assuming merely a bypass purpose, since it is connected as would be a fixed bypass condenser, only with a small winding to boot (the few turns on L4 between tap and rotors).

The advantage of this form of regeneration control therefore is that you do not tune out the signal from a local station by any adjustment of C3, unless you introduce over-regeneration. I was assuming the omission of the regeneration feature.

As all forms of regeneration bring up the possibility of distortion arising from forced feedback—an extreme amount of returned energy being used to compel reception that the set is unable to render—you reduce this tendency by omitting the regenerative option where it is not needed. That means stations, say, up to 50 miles away.

Exact Tuning

Now, the tuning is easy, once you learn how, as is everything else. But here the learning will not take long. The resonance point must be achieved to the greatest degree of precision, otherwise the set will not prove itself the glorious monument to quality that it really is.

In tuning it may be found that for a given station you get pretty good reception when the dials at left read 60 and 62. Then you try retuning by slight variations, and suddenly a great burst of delightful volume comes through the speaker. You look at the dials. They read 61 and 61. You were off the resonant point.

Another possibility is that when not in exact resonance there will be better quality than when resonance is achieved. Usually in such a case resonance will be accompanied either by some slight distortion or by oscillations, great or small. Turn back the feedback condenser a little and you will bring about that luscious volume mentioned before. Indeed, the same condition has been reached in either case—resonance accompanied by correct feedback (if any).

With the receiver that was built for laboratory purposes and which I kidnapped into my home I had no trouble at all, after I had spent half an hour exploring its mysteries. The whole trick is to get the proper balance. Indeed, that is the problem all throughout radio, whether it be balance of inductance and capacity alone or that plus the important balance of resistance, which is so in this receiver.

My mother was not at home when I was playing around with the set. I got it working in splendid fashion, then turned it off to answer a telephone call. Before I was finished with the conversation my mother arrived home. I hung up the receiver a few moments later. My mother happened to be in another room. I pulled out the switch button. Goldy and Dusty were sporting themselves with their usually enjoyable foolishness at WEAF. My mother was startled.

"What's that?" she exclaimed, and a moment later knew the answer. And the set had really done what many sets are advertised as being capable of doing—startled one by the utter naturalness of its tone, so that for the moment it seemed a fact that the artists were in one's very home.

B Battery Eliminator Hookup

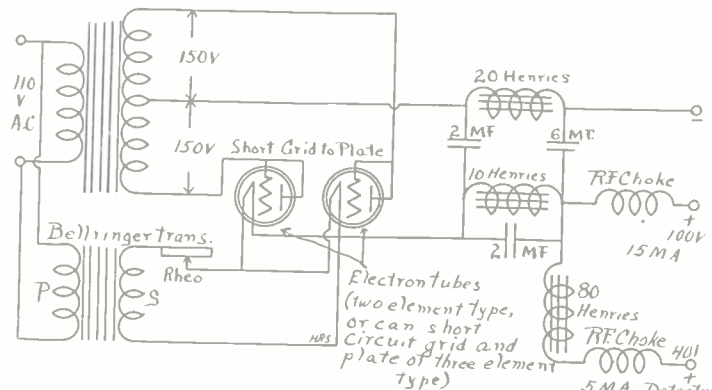

ONE of the most successful types of battery eliminators is shown above. Note that ordinary 201A type tubes are used for rectifying the A. C.

The Wonders of the Tube

By C. B. Jolliffe

Physicist, Bureau of Standards.

IT has been said that without the development of electron tubes the present system of radio broadcasting would never have been possible. Certainly the electron tube is the essential part of our radio telephone broadcasting system as it has developed. Every broadcast transmitting station uses several electron tubes to make available radio signals that may be picked up by receiving sets, the majority of which are likewise equipped with electron tubes.

The tubes used in the transmitting stations vary in size from 2½" long by ½" in diameter to tubes more than a foot long and 6" in diameter. The higher power stations are using tubes that must be continually cooled by water. These tubes are made almost entirely of metal and are capable of producing several kilowatts of radio-frequency power. The action of these large tubes does not differ from the action of smaller ones used in receiving sets. The difference is only a matter of size and power applied.

Functions of Tube

The electron tube is capable of performing two functions, amplification and detection of alternating current voltages. Its action as an amplifier makes possible a third function that is generation or production of alternating current. This function is used primarily in transmitting sets, although some receiving sets make use of it also. A disturbance is started in the circuit associated with the input of the tube, which is amplified by the tube, given to the output circuit which by virtue of some form of coupling gives it back to the input, and the cycle is repeated continuously. Because of this the disturbance is not allowed to do away but is sustained, the power being supplied from external sources, such as batteries. Since the electron current has no inertia effects, the action is instantaneous and alternating currents having frequencies from a fraction of a cycle a second to several million cycles per second can be generated by the same tube simply by altering the circuit arrangements which determine the frequency of the set.

The Transmission Work

In the broadcasting stations of this country the frequencies of the currents produced are from 550,000 to 1,500,000 cycles per second. The oscillator tubes generate this carrier frequency which is capable of radiating waves into space. Other tubes take the feeble alternating currents from the microphone which have frequencies from 20 to 10,000 cycles per second, and amplify them. However, these currents cannot radiate, so another set of tubes impresses these amplified voice currents on the radio-frequency generating tubes and modifies the radio-frequency current so that it carries into space not only the radio-frequency but also the lower frequency voice currents.

When the radio-frequency current is induced in the receiving antenna the audio frequency cannot be heard unless the radio frequency is partly destroyed. This is done by using the detecting property of the tube. The detector tube utilizing the second function of the tube, detection, takes the audio-frequency off the carrier wave and makes it audible. This audible signal may not give a strong enough signal, so it is introduced into a tube adjusted to amplify. Thus the signal is strengthened up to any degree desired.

RF Amplification

On the other hand, it is often desirable to amplify the radio-frequency signal before detection. This is also done by

Marconi's First



AT a recent wireless exhibition in Albert Hall, London, Guglielmo Marconi (above) made a grimace when he held the first transmitter he ever used. (International Newsreel)

means of the electron tube. All of these different uses are brought out by the correct arrangement of the circuit constants, such as the inductance, capacity, grid voltage, grid leak, etc. The different possible sizes and adjustments of the various circuit constants make up the many hundred different types of receiving sets. Up to very recently the development in electron tubes in this country for radio use has been to develop general purpose tubes so that any tube could be used for any purpose in most types of receiving sets with only small adjustments. The choice of a tube for a particular receiving set then is usually a matter of filament power consumption and power output of the set.

The New Tubes

Recently there have been some tubes put on the market designed for special purposes which are explained in the advertisements.

The use of the electron tube, however, is not limited to radio alone. Electron

tubes so arranged as to amplify telephone currents have been inserted in the long-distance telephone lines and have made it possible to extend the distance limit of the telephone, which was formerly about 1,000 miles, so that anyone in the United States can now talk to anyone else in the United States.

In the not too distant future even this limit will be removed, as it has been shown that it is possible to combine radio and wire telephony and before many years the telephone system of America will be interconnected with the systems of other continents.

Aid to the Partly Deaf

The amplifying property of the electron tube has also been used to aid those persons who have defective hearing. The sound waves that are strong enough to be heard by the normal person but not by the person with defective hearing are received on a microphone and transferred into electrical vibrations. These are amplified by means of one or more electron tubes and then transferred back to sound of much greater intensity than the original by means of a telephone receiver, thus serving the same purpose as raising the intensity of the original sound.

A similar use is public address systems where the normal voice of a speaker is made audible to many thousand people, that is, the sound of the voice is amplified many times by use of several electron tubes, and projected by means of loud speakers which are capable of being heard many hundred feet away. The use of the proper tubes and apparatus gives a faithful reproduction of the original voice.

Another entirely different use of the electron tube is in heating and melting of metals. The tube is used to generate alternating current of a high frequency as in radio. This current flowing in a coil surrounding the metal induces in it similar currents which because of the resistance of the metal, increase its temperature to the degree desired. This makes it possible to heat metals that are contained in a vacuum or in some particular gas and so control the conditions very accurately.

Electron tube amplifiers make it possible for a large assembly of doctors simultaneously to hear the heartbeats of a patient. Electron tubes have made it possible to send pictures by wire and radio, and just recently there was produced at a distance the image of moving objects sent by radio using electron tubes. Going still further afield the electron tube has been used to measure the rate and method of growth of a plant root, which illustrates how it has been adopted in other fields far different from radio.

Announcers Elect Board; Seek to Improve Radio

The Radio Announcers of America in New York city elected the following Board of Directors: Bob Emery, of WEEL, Boston; G. V. Willets, of WRNY, New York; George S. Cruger, of WOO, Philadelphia; Lambdin Kay, of WSB, Atlanta; Harold Hough, of WBAP, Fort Worth; John Daggett, of KMG, Los Angeles; Richard V. Haller, of KGW, Portland; Corley W. Kirby, of WWJ, Detroit; Charles Burke, of WHT, Chicago, and A. W. Ryan, of CNRO, Ottawa.

Membership in the Radio Announcers of America is limited to persons of good standing, citizens of the United States of America or the Dominion of Canada, who are either announcers or alternates of a listed broadcasting station, or those per-

sons or corporations owning or operating a listed radio broadcasting station within the United States or Canada and directors of these stations.

Members are to be elected by the board of governors, which also has control of the management of affairs and the property, funds and finances of the association. It is to make radio an even better form of entertainment that the Association of Radio Announcers of America has been formed. Its chief aim is to raise broadcasting and announcing to an even higher level by creating a central unit, through which literature may be distributed, and in general to act as a source of guidance and improvement to the radio announcers of America.

The Conversational Directions for Wiring the Set that Thrilled Jack

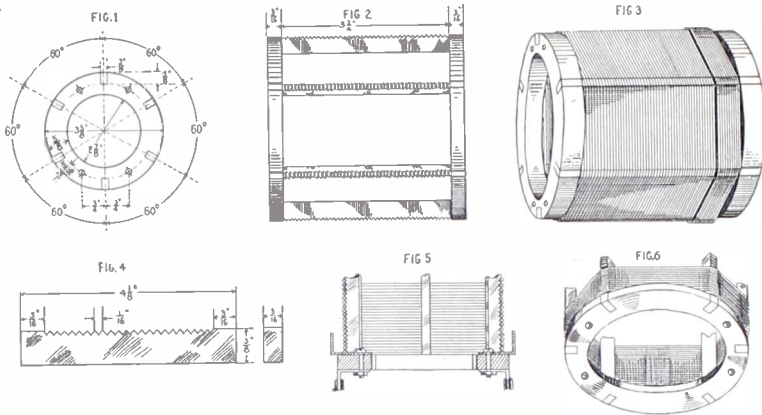

DIAGRAMS depicting the various stages in the making of the radio-frequency transformers.

(Part I of this article was published last week, Oct. 10 issue. Part II, the conclusion, follows.)

By Lewis Winner

Associate, Institute of Radio Engineers

"SAY, there is one mounting detail you left out," remonstrated Jack.

"What's that?"



LEWIS WINNER

"Where do you put the radio-frequency coils that have their secondaries tuned by the variable condensers?"

"Oh, yes. You recall that I told you to place angle irons at each end of the coils when I was describing how to make them. Well, the coil containing the windings, L5 (the primary) and L6 (the secondary), should have one of its angle irons taken off, mounted at right angles to the other coil, L3L4. Take any iron off and place it under one of the set screws in the horizontal line to the one that you left alone. This means that there will be two irons on one circumference, instead of one on the circumference and one at the extreme circumference of the same coil. This coil is mounted in front of socket 4. You will find that with some brackets, the space left between the shelf and the panel will not allow the placing of this coil. The only thing that could be done in that case is to mount the coil, between the sockets 3 and 4."

Fitting in the Coils

"How did you manage to fit your coil in?"

"I had to cut out a portion of that shelf. That is, I cut out slots, so that the circular ends of the form could fit in. However, that is nothing to worry about, as nine-tenths of the brackets allow plenty of space. The other coil, L3L4, is placed at right angles to L5L6. This means that the circumference of L3L4 faces the portion of L5L6 that has all its winding on, or the outer surface. This is placed $\frac{1}{2}$ " away from L5L6. If you will look in my set and also at the diagram you will see that the primary winding L3 is in back of socket 3. One angle iron will fall between the grid leak and condenser, C3 and R7, and socket 3.

The other iron will fall between sockets 3 and 4."

"Well, I guess that is all there is to the mounting portion. I think I will call it a night. What say?"

"Righto. When will I see you again? You know, I have yet to tell you how to wire the set up, and also various tips on making the set work just right."

"How about to-morrow night?"

"Suits me."

"Fine. Thanks very much, OM, for the dope you gave me. Gud nite."

"Au Revoir, until to-morrow night."

It was 12.30 A. M. when Jack arrived at home and his wife soon started to bombard him with questions as to why he came home so late, especially on a week day night. But when he told her the reason she subsided.

The Wiring

Jack arrived punctually. The wiring was then discussed by me:

"The first thing that will be attended to is the primary winding of the first radio-frequency transformer. The post marked P, or plate, goes to the binding post on the terminal strip marked antenna. The post marked B, which is also in the primary winding of the same transformer, goes to the binding post on the terminal strip, marked ground. This same connection goes to one of the terminals of the 1.0 mfd. fixed condenser, C7. Now for the secondary. The post marked grid goes to the grid post of the first radio-frequency amplifier socket, known as socket 1. The only remaining terminal (F) goes to the other terminal of C7, the 1.0 mfd. fixed condenser, and to the middle post of the potentiometer. This middle post is the arm, and slides over the resistance wire. This arm, by means of a nickel covered piece of copper, is attached to the binding post which makes the contact. Now the post which has the resistance attached to it goes to the arm of the first rheostat R1. This rheostat is on the extreme right hand side of the rheostat shelf. The resistance wire of this rheostat goes to the F— post of socket 1. The F+ post of this same socket goes to the only other terminal left on the potentiometer, which holds the resistance wire. This means that the resistance wire of the potentiometer is shunted across the filament terminals of the tube. The next transformer to be considered is the tuned radio-frequency one, or L3L4. The beginning of the winding of that portion of the transformer which has the least amount of turns, L3 (the primary)

goes to the plate post on this socket (1). The end of this same winding goes to the B+ 2 post on the terminal strip.

The Second Tube

"Now for the second tube. The beginning of the secondary winding L4 goes to the loop post on the terminal strip. The grid post of socket 2 goes to the grid post on the terminal strip. This means that the grid is not permanently connected to the beginning of the secondary unless a strip of wire (called a 'strap') is run from one post to the other. This method was used so that the loop could be used in the circuit. The ending of this same winding goes to the F post on the terminal strip. The loop post on the terminal strip goes to the rotary plates of the first variable condenser, C1, and also to the arm of the potentiometer. This is the same place that the F post on the untuned radio-frequency transformer went to. The grid post of this socket goes to the stator plates of the variable condenser C1. The rotary plates are, of course, those plates which are attached to the shaft, on which the dial goes, and which revolve, or turn around. Difficulty is encountered sometimes in finding the post where these plates go. It usually is in the center, where a pigtail connection is used (a pigtail connection is one in which two or more points are joined by means of a piece of wire, which is flexible; this is the only means of obtaining a direct connection. The other methods are either by friction or set screw), the post is near the bottom, or directly underneath the revolving pin. The stator plate connection may be made off any one of the three binding posts, if there be such, which hold the stator plates.

"The rheostat R2 is next attended to. The arm of this instrument goes to the arm of rheostat R1, which, as you know, goes to the resistance of the potentiometer. The resistance wire of this same rheostat goes to the F— post on socket 2. The F+ post of this same socket goes to the resistance wire of the potentiometer, which in turn goes to the F+ post on socket 1. The third radio-frequency transformer is now hooked up. The primary (L5) winding goes to the plate post on socket 2. This is the beginning of the winding. The ending of this same winding goes to B+ 2 post on the terminal strip. This is also connected to the ending of the primary winding of L3. The beginning of the secondary winding, L6, goes to one terminal of the resistance, R7), which is the grid leak, and to one terminal of the grid condenser, C3. It also goes to the stationary plates of the variable condenser, C2. The other terminals of the grid leak and condenser go to the grid post on socket 3. The ending of the winding, L6, goes to the variable plates of the variable condenser, C2, to the loop post on the terminal strip. This post, as I said before, goes to the arm of the potentiometer. Now, as you see, the endings of all the secondaries (which are the grid returns, as they come to the grid post of these respective tubes, 1, 2, and 3) all go to the arm of the potentiometer. The arm of the third rheostat, R3, goes to the arm of R2. The resistance wire of this rheostat, R3, goes to the F— post on socket 3. The F+ post goes to the F+ post of the other two sockets.

"We have now finished the first 3 tubes, and will now tackle the audio-frequency amplifiers. The wiring of this portion of the circuit is very simple. The plate post of the audio-frequency amplifying transformer AFT1 goes to the plate post of socket 3, and to one terminal of the fixed condenser C6. The B+ post of this trans-

The Best Aerial and Ground for Fine Volume and Distance Reception

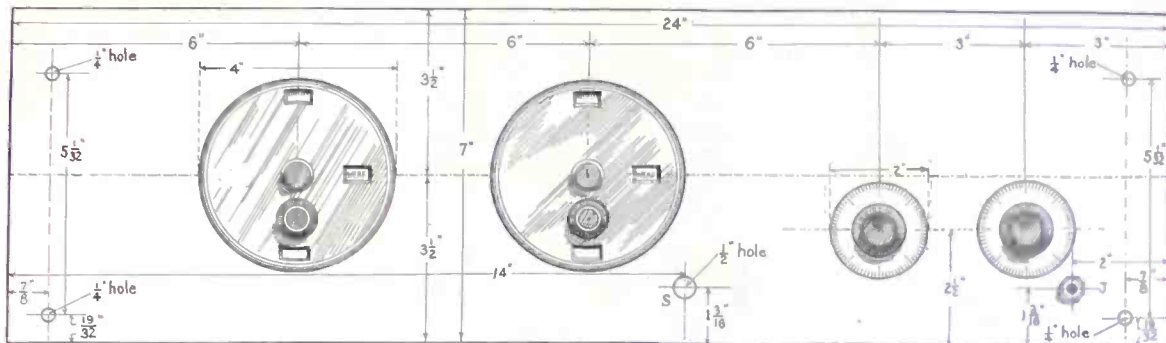

FIG. 7, how the panel looks.

LIST OF PARTS

- One untuned RFT (L1L2).
- Two tuned RFT (L3L4L5L6).
- Two .0005 mfd. SLF variable condensers (C1C2).
- Three low ratio AFT (AFT 1, L7, L8).
- Three 1.0 mfd. fixed condensers (C4C5C7).
- Four 10-ohm rheostats (R1R4R5R6)
- Two 20-ohm rheostats (R2R3).
- One 400-ohm potentiometer.
- One .001 mfd. fixed variable condenser (C6).
- Two .5 megohm resistances (R8R9).
- One switch (S).
- One .00025 mfd. grid condenser (C3).
- One 2 megohm grid leak (R7).
- One single circuit jack (J).
- Six sockets.
- One pair of brackets.
- One 7x24" panel.
- One 3x23" socket shelf.
- One 2 1/2 x 23" rheostat mounting shelf.
- One terminal strip.
- Two 4" dials.
- Accessories: Four plain binding posts, connecting wire, screws, nuts, A and B batteries, phones, loud speaker, etc.

6. The F+ post of socket goes to the F+ post of socket 5. All the F+ posts are now connected together. This main lead goes to the A+B- post on the terminal strip. The plate post of the last socket, 6, goes to the top terminal of the jack, J. The bottom terminal goes to the B+ 3 post on the terminal strip.

"I guess that finishes the wiring of the set."

"Yes."
"You did not tell me the different values of the various condensers, resistances, etc."

"Oh yes, I forgot. I told you that both variable condensers have a value of .0005 mfd. You said that you have a pair of .00035 mfd. Those are O. K. also. They may be of the straight-line frequency type. With this type the low wave stations are spread out, and tuning is much easier. The

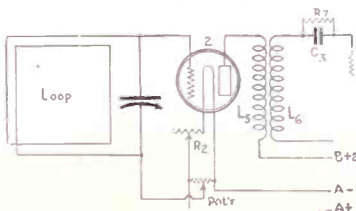

FIG. 8, how to connect the loop.

former goes to the B+ post 1, on the terminal strip and also to the left off terminal of the fixed condenser C6. The grid post of the transformer goes to the grid post on the socket 4. The F- post to the arm of the rheostat R4. This arm also goes to the arm of R3. The resistance wire goes to the F- post of the socket 4. The F+ post of this socket goes to the F+ post of socket 3. With the other two transformers, known as L7 and L8, a little bit of magic has to be transformed. Connect the B+ post to the F- post on both transformers. This means that there will be only two leads left out instead of the conventional 4. Therefore, the only terminals that are out are the P and the G posts."

"This is a little difficult to understand. Is there no place where I can gather some detailed information regarding this type of wiring up of transformers?"

"Why, yes. J. E. Anderson, in the Oct. 10 issue of RADIO WORLD, wrote a splendid article on this subject. I have a copy of this issue, which I will gladly lend you."

"Thanks."

Other Stages

"Well," I continued, "to go on with the wiring. The plate post of L7 goes to the plate post on socket 4. The grid post, which usually goes to the grid post on the socket of the next socket, goes to the B+ 3 post on the terminal strip. The plate post of socket 4 also goes to one terminal of the fixed condenser, C4. The other terminal of this fixed condenser goes to one terminal of the grid leak, R8, and to the grid post of socket 5. The other terminal of the leak goes to the - post of the C Battery. The arm of the rheostat R5 goes to the F- post of socket 5. The F+ post of the socket goes to the F+ post of socket 4. The plate post of L8 goes to the plate post of the socket 5. The grid post of L8 goes to the B+ 3 post on the terminal strip. This means that the grid posts of L7 and L8 are connected together and go to the B+ 3 post. The plate post of socket 5 goes to the fixed condenser C5. The other terminal of this fixed condenser goes to one terminal of the grid leak, R9. This same lead goes to the grid post of socket 6. The other terminal of this resistance goes to the C- post. This is the same place that one lead (grid return lead) of R8 went to. The arm of the last rheostat, R6, goes to the arm of R5. It also goes to the C+ post, and to the terminal of the switch. The other terminal of the switch goes to the A- post. You will note that when the switch is turned on, the arms of the rheostats are all in the A- minus lead. The resistance of the last rheostat goes to the F- post of socket

condenser C7 is a 1.0 mfd. fixed. The grid condenser C3 is of the .00025 mfd. type. The fixed condenser C6 has a value of .001 mfd. The fixed condensers C4 and C5 have a value of 1 mfd. The rheostats R2 and R3 are 20 ohm type. The others, R1, R4, R5 and R6 are all 10 ohm rheostats. The potentiometer is of the 400 ohm type. The resistances R8 and R9 have a value of .5 megohms. The tubes that I used were of the 201A type."

Successful Operation

"How about operation?" Jack asked.
"There is no doubt that after you have built the set, especially since you are a beginner, you are going to have trouble. After you completely wired the set, take a battery and phones. The battery should be of the 1 1/2 volt type. Connect one terminal of the battery to the phones. This will give you two leads. Starting from the first transformers, test for open circuits, placing one terminal to one end of the primary of, say, first RFT, and the other terminal to the other end of the primary, a click should be heard in the phones. However, if you place one terminal on the primary and one on the secondary and you still get a click, you have a short circuit, and the transformer should be taken out of the set. In other words, wherever there is a complete winding, a click should be heard in the phones, and wherever there is no continuous winding, such as the two separate windings (the primary and the secondary) a click should not be heard. Test the AFT, L7 and L8 for complete circuits.

"You will find that even though you think that you joined the F- and B posts together, the battery test will show you that there is no complete connection and the volume of the set will be low, which will completely puzzle you. When you test the fixed condensers, a slight click should be heard, after the phones and the battery have been left for a few seconds. This is due to the charge and the discharge of the condenser. If placed on and immediately taken off, no click will be present. Tests for shorts between leads that are close together. Very often you will think that the wires are not touching, but upon test, a pronounced click will be heard. Test the socket prongs. That is, place one terminal on the post and one terminal on the prong. Many times, there will be no connection between the prong or the post will be loose, which will cause a very disagreeable noise to be heard in the set. Lay the battery and the phones aside."

"Say, what size wires did you use for wiring up the set? It seems to me that
(Continued on page 24)

Regenerative Set Operation

The Canadian Department of Marine and Fisheries has published the following practical treatise on the operation of regenerative sets:

The principle of regeneration as used in radio receiving sets is that the part of the output of the detector vacuum tube feeds back into its own input and thus greatly increases the volume of the signal.

The electric waves reaching the receiving set from the transmitting station travel down the aerial wire through the primary coil in the set and so to earth down the ground wire. The weak electric current resulting from this influences the vacuum tube in such a way as to set it functioning.

The resulting output from the plate circuit of this tube is fed back in such a manner as to set up a "field" or influence in the part of the circuit connected to the input (the grid) of the tube. This "field" induces in the input circuit a current of electricity of the same frequency as that of the received electric waves. The energy, therefore, which comes down the antenna wire is automatically strengthened by an impulse from the output of the detector tube.

Causes Squeals

Unless controlled this action will continue until the saturation point or climax is reached, the tube being then said to be in a state of oscillation. When a receiving set is in oscillation it causes howling and squealing in your own and your neighbor's receiving sets. Regeneration should therefore never be allowed to proceed to this point, as it then constitutes a public nuisance.

On commercial receivers regeneration is not always described by this name and the dial which controls this feature of the equipment may be designated by any of the following terms: Regeneration, amplification, reaction, varind, tickler, sensitivity and feed-back.

Vices of Oscillation

When a radio receiving set, in a state of oscillation is being tuned to a broadcast station:

1. It causes whistles in radio receiving sets of all types which are tuned to the same station; this interference may be heard up to a distance of several miles.
2. It distorts the quality of your own music.
3. It uses more B battery power and, therefore, the life of the B battery is reduced.
4. It tends to reduce the life of the detector tube.

When a radio receiving set, in a state of oscillation, is exactly tuned to a broadcast station it is said to be in the state of zero beat. This distorts the broadcast reception and also interferes with neighboring receiving sets which are tuned to the same station.

In a word, regeneration carried to oscillation causes great annoyance to your neighbors, poor reception and expense to yourself, and has no advantages whatever.

The interfering whistle which you hear in your receiving set may originate in your own set, or it may be interference caused by your neighbor. In order to determine this point you may make the following test:

Leave the regeneration control in a fixed position, slowly rotate the tuning dial, and note particularly the change in sound of the whistle. If the whistle rises and lowers in pitch sympathetically with the movement of your tuning dial it indicates that your receiving set is in a state of oscillation and probably causing interference to other sets. On the other hand, if the whistle does not change in pitch corresponding to each movement of

Winners



CUPS were awarded to Billy Jones (left) and Ernest Hare, the Happiness Boys, at the recent Radio World's Fair in New York City, for their popularity.

your tuning dial, but simply varies in volume, the whistle is not caused by your receiving set, but is interference produced by some other oscillating receiving set in the neighborhood.

"Non-radiating" Radiators

Many so-called non-radiating receivers under certain conditions will radiate and thus causes interference. Make it your business to see that your set is not causing trouble.

If you are in doubt as to whether your set can cause interference, you can chuck up by making the following test, but be careful to do so at a time when only a few persons are listening in, so as not to cause annoyance:

Call a neighbor on the telephone and ask him to listen in on a particular station at a prearranged time, and then tune your own set to the same station. Turn up your detector tube filament to normal and put the regeneration control to its maximum; move your tuning dial five times slowly across the point corresponding to the tuning of that station, then telephone your neighbor and ask him if he heard the interference corresponding to these five movements of the dial on your receiving set. If he heard your interference, the probability is that hundreds of others also have been annoyed at times by radiation from your receiving set. You should

therefore learn how to operate without causing this interference.

How to Adjust a Set

If you will take the trouble to observe the rules which follow you will obtain greater satisfaction and enjoyment from your radio receiving set, and at the same time cause minimum annoyance to your neighbors.

(1) Practice on tuning powerful stations first, and do not try to pick up weak distant stations until you become expert.

(2) Use both hands, one hand for the regeneration control and the other hand for the tuning control.

(3) Keep the regeneration control always just below the point of oscillation. Your set is then in the most sensitive condition. This is the reason for using your two hands for tuning.

(4) If your set then accidentally breaks into oscillation, turn back the regeneration control at once.

(5) Do not try to find a station by the "whistle." If your set is tuned just below the whistling point, the signals will come in clear and your regeneration control can then be turned a little further to increase the volume.

(6) Do not force regeneration in an attempt to obtain loud speaker volume from a set not designed for the purpose.

(7) Do not force regeneration in an attempt to hear stations beyond the range of your set.

Freak DX Reception

The fact that you once heard a distant station on your receiving set is no indication that you can hear this station regularly, for occasionally a radio broadcast from a distant station is received with extra strength due to some freak condition. When you have tried to tune in a station in the correct manner for a minute or two and are not able to hear it, do not unduly increase your regeneration and persistently wiggle your dials, for in so doing you may be causing annoyance to some other broadcast listener who would otherwise be able to receive this distant station on a multitude-tube receiving set.

You can accordingly assist in eliminating these whistles by:

- (a) Learning to operate correctly yourself.
- (b) Not allowing children who are not old enough to understand the correct method of operation, to cause interference from your set.

STANDARD FREQUENCY SCHEDULE

The Bureau of Standards transmits, twice each month, continuous wave radio signals of definitely announced frequencies, from the standardization of frequency meters (wave meters), transmitters and receivers. The signals are transmitted from the bureau's station WWV, Washington, D. C., and from station 6XBM, Stanford University, California. The complete frequency transmission included a "general call," a "standard frequency signal" and "announcements."

The schedule of standard frequency signals from both stations is as follows:

	Oct. 20	Nov. 5	Nov. 20	Dec. 5	Dev. 19
10:00 to 10:08 p. m.	1500 (200)	3000 (100)	125 (2400)	300 (1000)	550 (545)
10:12 to 10:20 p. m.	1650 (182)	3300 (91)	133 (2254)	315 (952)	630 (476)
10:24 to 10:32 p. m.	1800 (167)	3600 (83)	143 (2097)	345 (869)	730 (411)
10:36 to 10:44 p. m.	2000 (150)	4000 (75)	155 (1934)	375 (800)	850 (353)
10:48 to 10:56 p. m.	2200 (136)	4400 (68)	166.5 (1800)	425 (705)	980 (356)
11:00 to 11:08 p. m.	2450 (122)	4900 (61)	205 (1463)	500 (600)	1130 (265)
11:12 to 11:20 p. m.	2700 (111)	5400 (55)	260 (1153)	600 (500)	1300 (231)
11:24 to 11:32 p. m.	3000 (100)	6000 (50)	315 (952)	666 (450)	1500 (200)

Eastern standard time for WWV, Washington, D. C. Pacific standard time for 6XBM, California.

In the above table the numbers represent the frequency in kilocycles and the numbers in parentheses the approximate wavelength in meters.

Radio University

A QUESTION and Answer Department
 conducted by **RADIO WORLD** for
 its Readers by its staff of Experts. Address
 Letters to The Radio University, **RADIO**
WORLD, 145 West 45th St., New York City.

WILL YOU please give me a picture diagram of a 1-dial 2-tube speaker set, and state the different constants of the coils.—Robert Barson, Des Moines, Ia.

Fig. 214 shows the picture diagram. The primary L1 has 10 turns wound on a form 3½" in diameter and 4" high. The secondary L2 has 43 turns wound on the same tubing, ¾" spacing being left between the two windings. The primary L3, of the second radio-frequency transformer is wound on a form 3½" in diameter and contains the same number of turns as L1. L4 is wound on the same tubing and contains the same number of turns as L2. C1 is a

No. 22 double cotton wire. The secondary consists of 45 turns of the same wire on the same tubing. There is no spacing between the windings. (2) The primary consists of 10 turns of No. 22 double cotton covered wire. The secondary consists of 45 turns of the same wire on the same tubing. No spacing between turns. (3) Yes. (4) Yes. (5) Yes. (6) Yes. (7) UV200.

I AM using a set of Haynes-Griffin intermediate transformers (new type), and in tuning the input enough to obtain selectivity, the volume is very weak. Is

present I am using this Diamond on a 3-wire outside aerial about 90 feet in all and would like to get it operating correctly on this before purchasing a loop.—L. W. Lougeay, 18 East "C" St., Belleville, Ill.

The first thing that you want to do is to change your antenna system. Make it a single wire aerial 90 feet in length. See that the prongs of all the sockets are touching the terminals of the respective tubes. Look at the tickler leads. There might be a broken lead present, which you cannot see, due to the covering over the wire. Test with a 1½-volt battery and phones connected in series. Reverse your tickler leads. Insert a new grid leak. See if the plates of the variable condensers do not touch at certain points during turning them.

I HAVE built the Diamond but have not fared well. I always hear a frying noise and the set is not very selective. The primary of the RF coil consists of 12 turns wound on a 3" tubing, while the secondary consists of 45 turns. The wire used was No. 22 SCC. The primary of the 3-circuit tuner consists of 15 turns,

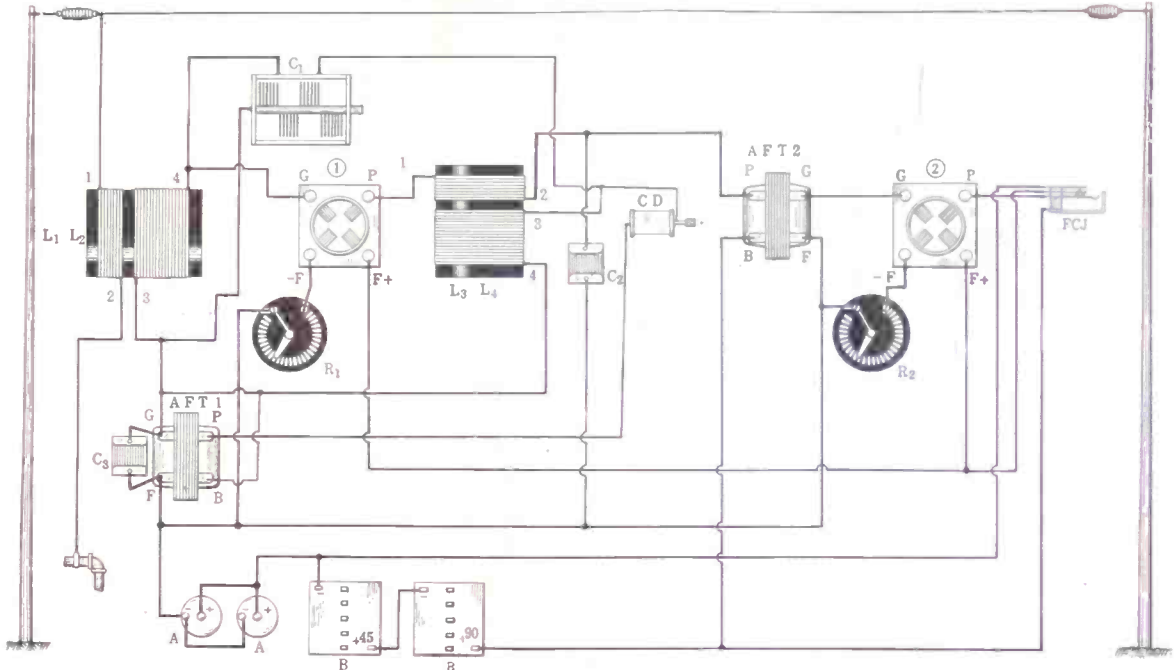

FIG. 214, showing the pictorial diagram requested by Robert Barson.

double condenser, each portion of the condenser having a maximum capacity of .0005 mfd. R1 and R2 are both 10-ohm rheostats. The tubes used of the 201A type. C2 is a .001 mfd. fixed condenser, while C3 is also a .001 mfd. fixed condenser.

I AM now about to build the 1926 Diamond and would ask if you would kindly furnish me with the following information: (1) I have a Bruno 77 3-circuit tuner which is 3½" in diameter out side of the glass rods. How many turns on the primary and how many on the secondary? (2) I also have a Bruno 55 RF Coil which is 3½" outside diameter. How many turns on primary and on secondary? (3) Can I use a Rauland Lyric transformer (R-500)? (4) Can I use two Hammerlund SLF .0005 mfd. condensers? (5) Can I use Federal 27-60 ohm rheostats instead of 20 ohm as recommended? (6) Can I use three units of Daven resistance coupled amplification? (7) As a detector tube, would you recommend RCA UV200 or Sodian D21?—H. A. Simonds, Carbondale, Pa.

it probable that the other transformers are not accurately matched to the same peak and could small variable condensers be shunted across these transformers remedy this?—C. F. McFall, 43 E. Chestnut St., Hazelton, Pa.

Yes, a Chelton or Continental Midget condenser will probably strengthen the signals up.

I HAVE built the 1925 Diamond but do not think that it is doing just what it should in the way of reception. I am using a Bremer-Tully Low-Loss 3-Circuit Tuner for all wavelengths, RFT and condensers with vernier dials. Am now using De Forrest DV-5-RF tube, De Forrest DV-2-Detector and Cunningham 301A as AF tubes. My set brings in St. Louis stations, about 18 miles distant with a great deal of volume but I can not get any DX to amount to anything. When I do get it it is not loud or clear. I can not hold it for more than a minute or two when it fades out. I get a continued rattling or sizzling on the speaker when any station is located and at times get a good bit of howling when tuning. At

while the secondary consists of 40 turns, and is wound on a form 3" in diameter. The tickler is wound on a form 2x1¼" and consists of 40 turns. This is all wound with Litz wire.—J. A. Bouchard, care T. D. Dubuc, 228 Rue St. Jean, Quebec, Can.

You will have to rewind your 3-circuit tuner. The primary should contain 10 turns, the secondary 45 turns and the tickler 35 turns. No. 22 DCC wire should be used. There must be a broken lead in the Litz wire.

I HAVE made the receiver described in the March 21 issue of RADIO WORLD by Capt. P. V. O'Rourke. I wound the coils as specified, which is for .0005 mfd. variable condensers, but I am using the .000375 mfd. variable condensers instead. The result is, the set is difficult to tune and spills over very easily. I would like to use the 15-plate (.000375 mfd.) condensers, so would you please give me the proper amount of turns to place on the form.—A. W. Hale, 149 N. Boulevard, Albany, N. Y.

The primary L1 consists of 14 turns. The secondary L2 consists of 50 turns.

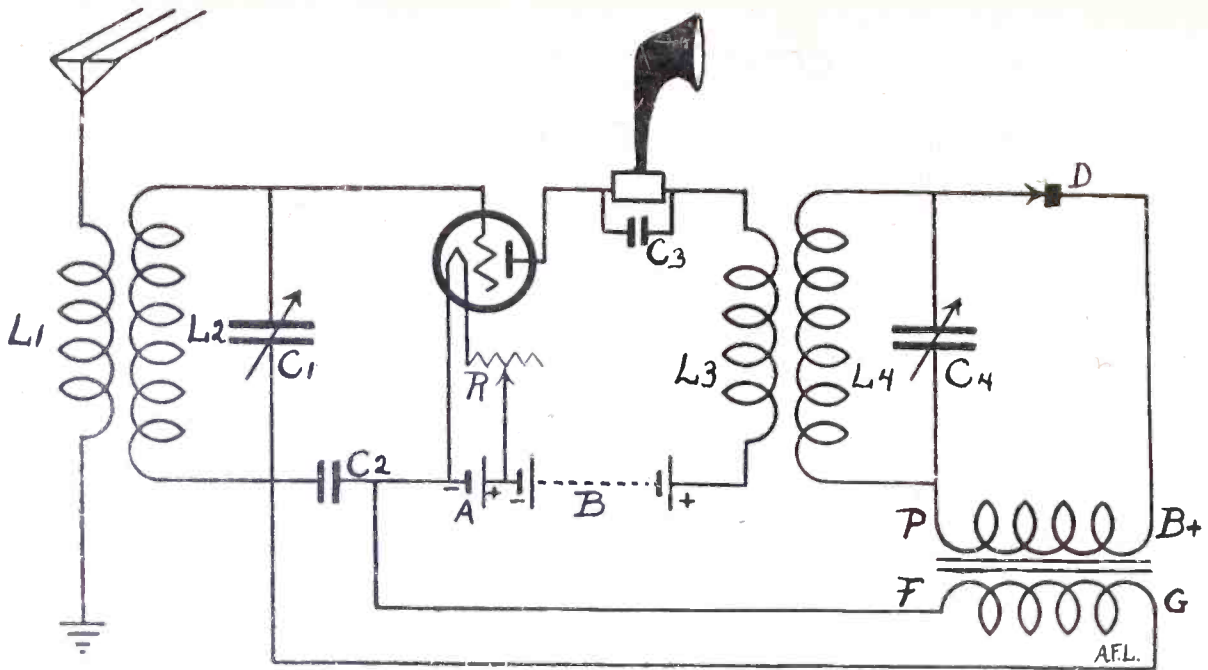

FIG. 215, showing the electrical diagram of the 1-tube loud-speaker set.

The tickler L3 consists of 40 turns. The primary L4 has the same number of turns as L1, while the secondary L5 consists of the same number of turns as L2.

IN REFERENCE to the reflex circuit, published in the Radio University in the August 29 issue of RADIO WORLD. (1) How will I wind the coils for the .00035 mfd. variable condensers? (2) Can I use a 6-ohm rheostat instead of the Amperites?—R. Rogers, N. Y. City.

(1) L1 consists of 15 turns, wound on a form 3" in diameter, 4" high, with No. 22 DCC wire. L2, the secondary, consists of 53 turns of the same wire. L3 has 15 turns, L4 has 53 turns and L5 the tickler is wound on form 2½" high. This contains 43 turns. L3, L4 is wound on a form 3½" diameter tubing. Use No. 22 DCC wire in winding this coil. (2) Yes.

I AM building the Diamond, 1926 model. I would like to use the WD11 as a detector and the WD12 as the amplifiers. (1) Would this work as well as the UV199? I would like to use dry cell tubes if possible.—Samuel Davis, 572 Minnesota St., St. Paul, Minn.

The UV199 type will give you a bit more volume than the WD tubes. The 201A type tubes may be used with dry cells. Connect four 1½-volt batteries in series.

I WOULD like to have some information regarding the 1-control Regenerative Set, as described by Percy Warren in the Sept. 26 issue of RADIO WORLD. (1) What is the capacity of C1? (2) What is the capacity of C2, C3 and C4? (3) Can R be a variable resistance?—John Walkow, 6447 St. Aubin Ave., Detroit, Mich.

(1) C1 is a .0005 mfd. variable condenser. (2) C2 is a .000025 mfd. condenser. If you cannot get a condenser with so small a capacity a midget variable will do. C3 is a .00025 mfd. grid condenser. C4 is a .001 mfd. fixed condenser. (3) Yes.

A DIAGRAM of a 1-Tube Loud-Speaker set using a crystal as a detector is requested.—T. Reson, Fort Worth, Tex.

Fig. 215 shows the electrical diagram of a 1-tube loud-speaker set. The primary, L1 consists of 10 turns wound on a form 3½" in diameter and 4" high. The secondary is wound on the same form. There

is ¼" left between the primary and the secondary windings. The secondary consists of 46 turns. The primary of the second RFT, L3 contains the same number of turns as the primary, L1. It is also wound on a form 3½" in diameter and 4" high. The secondary is wound on the same form leaving ¼" between the windings. The secondary consists of the same number of turns as L2. No. 22 double cotton covered wire is used in winding the coils. C1 and C4 are .0005 mfd. variable condensers. C2 is a .001 mfd. fixed condenser. The audio-frequency transformer used is of the high ratio type, about 6-to-1. C3 is a .001 mfd. fixed condenser used for by-pass action. The tube used is of the 201A type. The resistance of the rheostat is 10 ohms. The voltage supplied to the plate of the tube is 45 to 67½. D is the crystal detector, and is of the fixed type.

WILL YOU please give the diagram of a 2-tube voluminous receiver?—T. D. Utops, Chicago, Ill.

Fig. 216, shows the electrical wiring diagram of a 2-tube voluminous set. The radio frequency tube is of the regenerative type, while the detector is non-regenerative in action. L1, L2, L3 is a 3-circuit tuner. L3 may be variable or fixed. L4 is a 35 turn coil wound on a form 3½"

in diameter. C1 and C2 are both .0005 mfd. variable condensers. C3 is a .008 mfd. fixed condenser. Different values will have to be tried here, in order to obtain full success from this set. R3 is a variable grid leak. R1 and R2 are both 10-ohm rheostats. J is a single-circuit jack.

I GET WTAM at 45, and some stations below that, down to 5 where I get WBBM. Then I pick up WCX at 85 and between 45 and 85 I cannot bring anything in. Can you tell me how I can pull in the stations between 390 and 517 meters. (2) Would the straight-line frequency condenser be better than the rotor type condenser? (3) I am getting whistles when I tune in a station and then again they will come in without any fuss at all. What can I do to get rid of the whistles?—H. F. Douglas, 305 Lighthouse St., Erie, Pa.

(1) Your trouble lies in your antenna system. If you will look on the roof, you will find that your antenna wire is running parallel to another antenna. When the neighbor tunes in a station, you will not be able to hear that station. It happens that he is listening in to the stations between those wavelengths. By using an indoor antenna, your trouble will be cured.

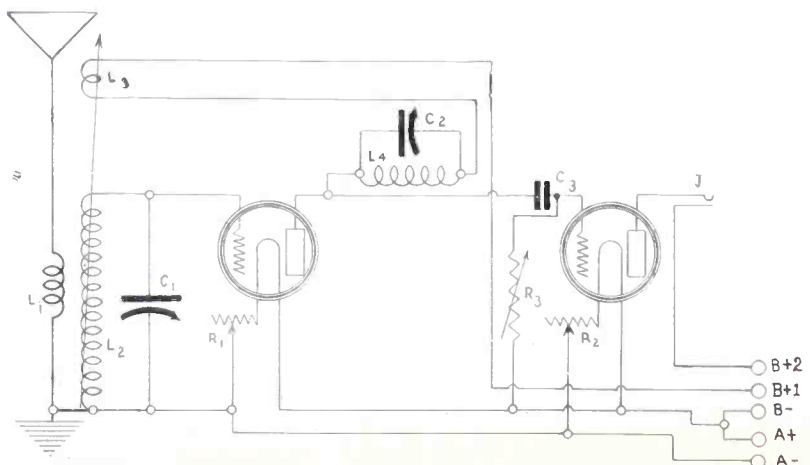

FIG. 216, showing the electrical diagram of a 2-tube volume set.

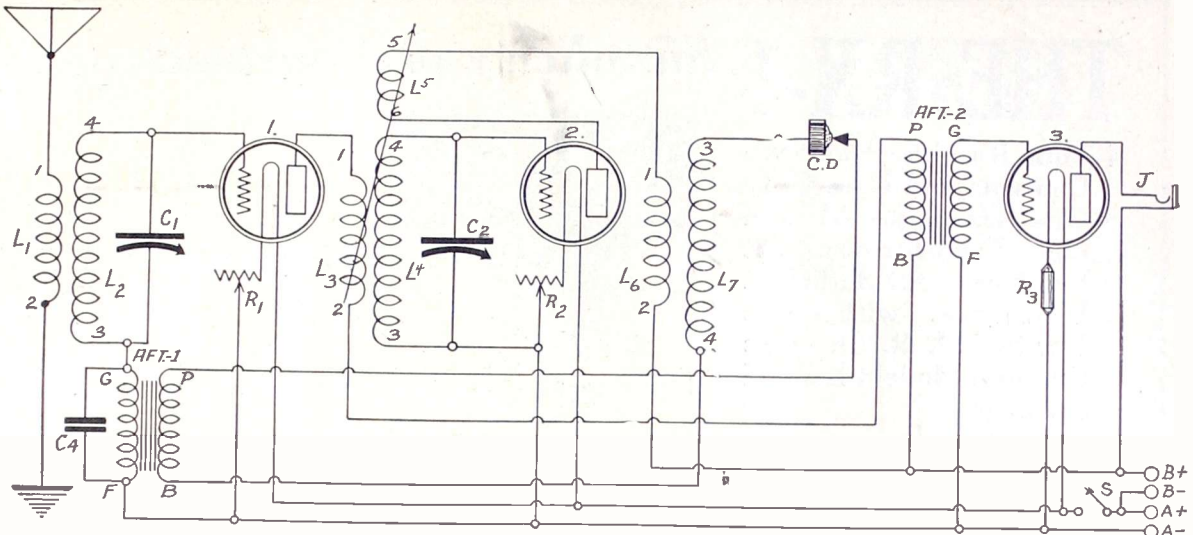

FIG. 217, showing the electrical diagram of a 3-tube reflex.

(2) Yes, but only for the low wave stations. (3) See your neighbor who no doubt owns a regenerative set.

WILL YOU kindly tell me where I can get information regarding the obtaining of parts for the 1926 Diamond?—John Goodridge, 226 South 9th St., Saganaw, Mich. Consult the advertising columns of RADIO WORLD.

A DIAGRAM of a 3-tube reflex receiver, in which the RF tube is regenerative, a crystal used as the detector, and one stage of transformer AF coupling.—R. Bemmins, Cleveland, O.

Fig. 217 shows the electrical diagram of such a receiver. L1, the primary is wound on a form 3 1/2" in diameter, and 4" high. There are 10 turns wound for L1. The secondary is wound on the same form, 1/4" space being left. There are 45 turns on the secondary. The primaries, L3 and L4 contain the same number of turns as L1, and is also wound on a form 3 1/2", 4" high. The secondaries are wound on the same forms with their primaries, and contain the same number of turns as the other secondary, L2. The tickler is wound on a form, 2 1/2" in diameter and 2" high. There are 35 turns wound. The wire used is No. 22 double cotton covered wire. C1 and C2 are both .0005 mfd. variable condensers. C4 is a .001 mfd. fixed condenser. The first audio-frequency transformer is of the high ratio type, while the second audio-frequency transformer is of the low ratio type. The 201A type tube is used. R1 and R2 are both 10 ohm rheostats. R3 is a ballast resistance the type used depending upon the tube used. The crystal used is of the fixed type. J is a single circuit jack. There are 67 1/2 volts placed on the plate of the tube.

I HAVE built the 2-tube Speaker set, described in the Sept. 19 issue of RADIO WORLD, but I don't obtain much volume. (2) Will you please let me know what value C2 and C3 fixed condensers are?—A. C. Williams, 509 Morris Ave., Providence, R. I.

(1) Reverse crystal leads. Reverse the secondary of AFT 1. Reverse your A battery. (2) C2 and C3 are a .001 mfd. fixed condensers.

I HAVE an Ambassador 3-circuit tuner. The wire on the tickler is torn to pieces. (1) What size wire and how many turns shall I use to rewind it? I do not wish to use Litz wire. (2) If I rewind the primary and the secondary how many turns shall I put on?—Al. Quitt, Box 58, Sanatarinin, Col.

(1) There should be 35 turns put on and No. 22 double cotton covered wire should

be used to wind the coil. (2) The primary contains 10 turns, and the secondary contains 45 turns. The wire used to wind it is No. 22 Double cotton covered.

I WOULD like to build the Diamond but find that I have two .001 mfd. variable condensers, instead of the usual .0005 mfd. variable condensers. Would you please give me the number of turns to wind on the primary, secondary and the tickler coils so that I can use these condensers?—Clement Aspegren, care KSAC, Manhattan, Kansas.

The primary is wound on a form, 3 1/2" in diameter and 4" high. It consists of 7 turns. The secondary is wound on the same form and 1/4" space is left between the primary and the secondary. The secondary contains 30 turns. The tickler is wound on a form 2 1/2" in diameter and 2" high. It consists of 20 turns. All the windings are made up of No. 22 double cotton covered wire.

PLEASE give me a couple of diagrams which will demonstrate how local oscillations can be obtained from a 3-element vacuum tube.—C. Thompson, Long Island City, L. I.

In Figs. 218 and 219 the principle that you desired is explained fully in diagrammatical form. The Fig. 217 diagram shows a circuit in which the natural frequency of the grid circuit equals the frequency by which the changes of current occur throughout the system. L1 is a 34-turn coil wound on a form 3 1/2" in diameter. L2 has 10 turns, and L3 has 35, both wound on the same tubing as L1. Use No. 22 DCC wire. C1 is a .005 mfd. variable condenser. C2 is a .00025 mfd. variable condenser. Fig. 218 (bottom) shows a more powerful method of obtaining os-

cillations from a tube. L1 has 37 turns, L2 has 36, both wound on a tubing 3 1/2" in diameter. Use No. 24 DCC wire... C1 is a .0005 mfd. variable condenser... C2 is a .001 mfd. condenser.

The vacuum tubes used in both cases were of the 201A type and 67 1/2 volts are supplied to the plate. The rheostats in both cases have a resistance of 10 ohms. A 6-volt battery supplies the voltage to light the filaments of the tube. You will note that in both cases the conventional grid leak and condenser is left out. This was only done for simplifying the matter of reading the diagram. The value of the grid leak is 2 megohms, while that of the condenser is .00025 mfd.

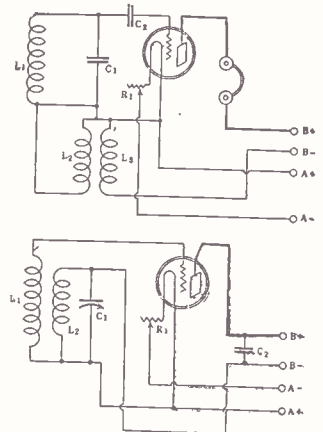

FIG. 218 (top) and 219 (bottom) showing how to obtain oscillations from a tube.

Join RADIO WORLD'S University Club

and we will enter your name on our subscription and University lists by special number. Put this number on the outside of the forwarding envelope (not the enclosed return envelope) and also put it in your queries and the questions will be answered the same days as received.

And Get Free Question and Answer Service for the Coming 52 Weeks.

RADIO WORLD, 145 West 45th Street, New York City.

Enclosed find \$6.00 for RADIO WORLD for one year (52 Nos.) and also consider this an application to join RADIO WORLD'S University Club, which gives me free information in your Radio University Department for the coming year, and a number indicating my membership.

Name

Street

City and State

THE RX-1 *Simplicity of Construction is Co*

4-Tube Receiver Has Two Controls and Uses Only One Resistance AF and One Transformer, Yet Produces All-Sufficient Volume, with Fine Purity—M. B. Sleeper's Original Model Changed Slightly

GETS DX EVEN IN STEEL BUILDING

Author Did Not Think the Theory Would Work Out in Practice, But Changed His Mind After He Tuned in the First Station.

By H. C. Hight

A 4-TUBE set of decided attractiveness, both in point of quality of received signals and in ease of tuning, is shown in Fig. 1. There is nothing new in its principle, which is perhaps fortunate, but it does deviate from common practice to this extent: (a) although only two A F stages are used, only one is transformer-coupled, the other being resistance-coupled; (b) the resistance stage is placed ahead of the transformer stage. The set accomplishes very remarkable results, in point of quality of reproduced speech and music. It is very simple in construction, there being one tuned RF stage and a tube detector in which there is no regeneration.

In the transformer-coupled stage, using a high-grade low ratio (preferably 3-to-1) transformer, the quality is superb.

It Works Out in Practice

Beyond doubt the majority of persons who have constructed various hookups, using one or two stages of radio-frequency and a regenerative or non-regenerative detector, and then two audio transformers or three resistance-coupled stages, will say that this is another one of those things

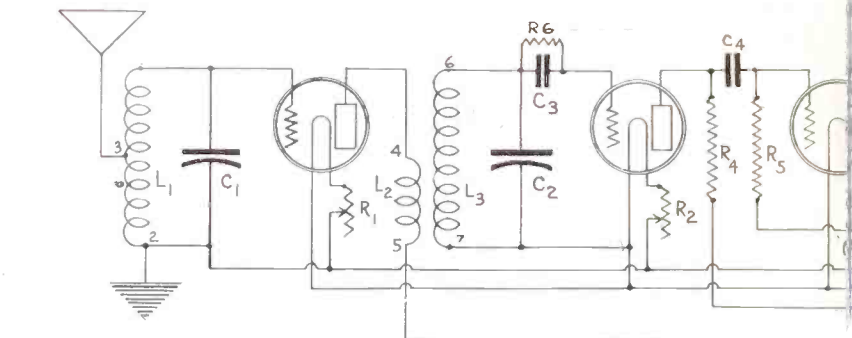

FIG. 1, the wiring diagram of the receiver. L1L2 is a continuous winding or autotransformer. The variable condensers, C1 and C2, are .0005 mfd. R1 controls volume and is not molested for locals. The audio transformer should be of low ratio. The C meg. resistor is in the detector plate circuit, the 1.0 meg. leak in the first audio

that looks pretty good on paper but is not much good in practice.

Well, that was my first opinion on reading an article by M. B. Sleeper on this set, which is called the RX-1. But it looked good enough to try out, anyway.

Now comes the interesting part of the story. When the set was completed, batteries and antenna and ground connected, and tubes inserted, I was inwardly a little dubious, but turned on the switch. And then—a wonderful thrill.

Just by accident both dials were almost exactly on WJZ's setting, and the instant the switch was turned on my home was flooded with the clearest and most faithful reproduction in music that I had ever heard. The music being played at that moment was by one of those wonderful orchestras that we so often hear from WJZ.

Every station around New York that was on the air was tuned in with great volume and with quality and clarity that were astonishing. No inter-station interference was experienced except that while on WAAM there was a very slight trace of WRNY during the few seconds of silence between WAAM's selections. But WRNY is only about three-quarters of a mile distant from where the set was operating and is separated by only about five meters from WAAM.

Works in Steel Building

The set is being used in a 24-story steel skyscraper in New York City and the only means of getting reception is from about forty feet of wire dangling from the end of a stick down the side of the building, and only two feet away from the wall.

Anyone who has tried to get distant stations in a steel building will realize what a handicap this condition is. The steel structure absorbs much of the radio waves

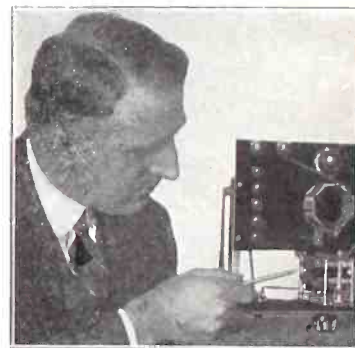

Fig. 2, the author, H. C. Hight, "points with pride" to an attractive part of the set.

that come near it, but even with this difficulty the set brought in WGY (low power) and KDKA with good volume and fine clarity. Also two Philadelphia stations and Providence were heard, but not so well as the others. From past experience with other powerful sets in this same place I know that the RX-1 will bring in all the DX that any reasonable fan will want, when a good outdoor aerial is used. And further, what he does get will be good. That is the main object in radio reception today.

Some Changes From the Original

The original hookup specifies a 199 tube for the radio-frequency stage, which is all right if you prefer to use it, and calls for a Sodian detector tube. All well and good, but try and get a Sodian. Yes, there are a few of them still in captivity, but it looks as if they will soon be unobtainable. And then what would you do? Let a perfectly good hookup like this go by the board for the want of a tube? Not by any means!

For some months I used Magnavox tubes very successfully, particularly as radio-frequency amplifiers and detectors, and found that neutralizing condensers could be entirely eliminated. As a detector the tube's sensitivity, stability of operation and clarity of tone make it the logical one to use in the RX-1, both as radio-frequency and detector tubes. Any good one-quarter ampere tube will give perfect satisfaction in the audio stages.

There is another change I made from the original specification. I used a 30-ohm rheostat for the radio-frequency and one for the detector tube, whereas the RF tube originally had a ballast resistor. The reason is that the detector rheostat can

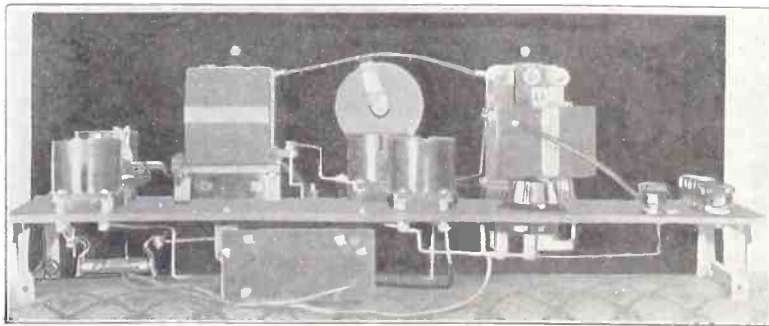

(Photos by Foto Topics.)

FIG. 4, rear view, showing relative position of the instruments.

Confirmed by Photographs of the Set

PARTS

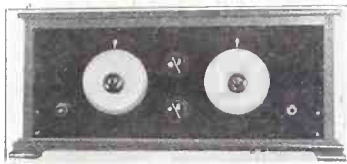
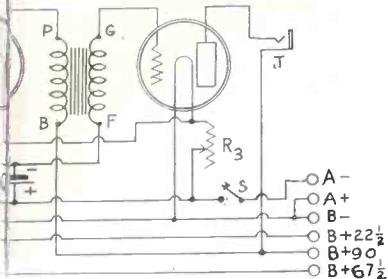

FIG. 3, the front panel view of the set.

although by removing bases from Benjamin sockets and turning screws upside down and through the panel, just as good a job is obtained.

The Coils for the Set

The coils are of the pickle-bottle type. The antenna coil has 58 turns of No. 22 DSC wire and should be 2 1/4 inches in diameter across flat sides. The aerial tap is taken off at the 15th turn. The RF coil has 70 turns of No. 22 DSC in a form 2 1/4 inches diameter. The primary L3 consists of 20 turns of No. 40 DSC wire, bunched as closely as possible and placed inside the secondary winding L4 on the filament end of secondary. It is not advisable to solder this small wire. Carefully connect the two ends to suitable binding posts, fastened to coil mounting, and make necessary connections from binding posts. The coils I used were the RX-1 type of Eastern pickle-bottle coils.

The variable condensers used were the sturdy and efficient Wade, which use a 360° dial with a 16-to-1 ratio vernier built in. Low-wave station separation with these condensers is much greater than that obtained by the conventional type of rotary straight-line frequency condenser using a 180° dial. Very wide tuning range is possible with this type of condenser. WBNY, New York's latest station, on 209 meters, comes in at 28, leaving considerable room below for stations of lower wavelengths (if ever that is needed). Incidentally, this station was received very clearly and with no undue tendency to oscillation, despite the low wavelength. WNYC, at 526 meters, came in at 88 and all intermediate stations were spaced liberally over the dial. The condensers are of .0005 mfd. capacity and are mounted on panel with single hole mounting with a spacing of 7 1/2 inches between centers of shafts. As coils are mounted immediately behind condensers and at right angles it also gives them 7 1/2 inches spacing from center to center, which is sufficient to prevent interstage coupling.

It will be found that the best results will be obtained by using 67 volts on the

- One antenna coupler.
- One RF transformer.
- Two 30-ohm rheostats.
- One 10 or 15-ohm rheostat.
- One .00025 mfd. grid condenser.
- One 2-meg. grid leak.
- Two .0005 mfd. variable condensers.
- Two 4" dials.
- Four sockets.
- One SC jack.
- One 0.1 meg. resistor.
- One 1.0 grid leak.
- One .006 mfd. condenser.
- One audio transformer.
- One A battery switch.

transformer. L3L4 is an interstage coupling slightly adjusted for DX reception, but voltage may be from 3 or 4 1/2. The 0.1 mfd circuit.

be just barely turned on and best results will be obtained both as to volume and sensitivity. The filament shows only a dull red glow. Set this rheostat at the best point and leave it alone. It is not at all critical.

RF Rheostat Important

The entire control of volume as well as the control of input to the detector is accomplished by a very limited movement of the radio-frequency tube's rheostat. For locals you will turn it down as low as possible and for DX or greater volume turn it up less than half way.

Turning up this rheostat too far will only result in throwing the tube into oscillation which will be evidenced by a very faint whine. But this is never necessary, as distance reception and volume can be obtained without ever bringing the tube to the over-oscillation point. The detector tube will not spill over under any condition. Turning detector rheostat too high will merely slightly weaken signal strength.

The rheostat for the audio tubes (10 or 15 ohms) should be mounted in a convenient place on sub-panel, set at the lowest point at which clarity and sufficient volume is obtained, and then forgotten.

Parts Discussed

A few remarks on parts may be helpful. A 7x18 Bakelite front panel is used with a 7x18 inch rubber sub-panel. Cut this sub-panel down to 17 1/4 inches in length, so that it will fit nicely in the cabinet. Sub-panel should be mounted on Benjamin brackets which are 2 inches high and give exactly the space necessary to mount a 3-to-1 Samson transformer horizontally. The transformer rests on the floor of the cabinet, supports its own weight and prevents any sagging of sub-panel. The transformer may be attached to the sub-panel by means of brass angles. This panel should be mounted on the brackets with its front edge 1 1/8 inches back of front panel. This will make the total depth of sub-panel 8 3/4 inches and will allow the set to fit easily in a cabinet 9 inches deep.

Suitable cut-outs should be made in panel to allow for the Wade variable condensers to be mounted vertically.

One 15-ohm DeJur and two 30-ohm Centralab rheostats were used. One of the latest type Daven resistor units with fixed condenser enclosed was employed in first audio stage. Insert the 0.1 meg. resistor between P. and B. plus and the 1.0 meg. resistor between G and F minus.

As all wiring is below sub-panel the sockets must be of the sub-panel wiring type. That type of Shaw socket is used.

plate of the radio-frequency tube, and although we always associate high plate voltages with resistance coupling, 22 1/2 volts is positively the proper voltage to use on the plate of the detector in this set. On the other stages 90 volts will give all the volume that anyone will need.

Easy to Operate

Operation is simplicity itself. Turn the dials to the proper setting, which will be found to be very sharp. An occasional touch to the radio-frequency rheostat for the control of volume or to get distant stations will result in reception that will be hard to duplicate. Any of the good speakers will give very excellent results, but a large cone type will work particularly well with this set.

It will be found that best results will be had by using a short aerial, either inside or outside. It can be from 50 to 75 feet long, or where loud DX is preferred to extreme selectivity as much as 100 feet or even a little more will be the favorite.

It is customary and also a very good idea to run a trouble-shooting article on a new hookup, but I feel very sure that if the parts specified or ones equally as good are used and the job properly and carefully done and battery connections and antenna and ground properly made, the greatest trouble would be to shut the thing off and go to bed.

Diagram Data

In Fig. 1 the terminal of L1 that goes to grid (actually the end of the winding) may be regarded as 1, while the beginning is 2 and the tap is 3. Also, 4 and 5 represent the terminals of the interstage coupler's primary, while 6 and 7 are the secondary terminals. The three rheostats are on the negative A battery leg. R4 is 0.1 meg. and R5 is 1.0 meg.

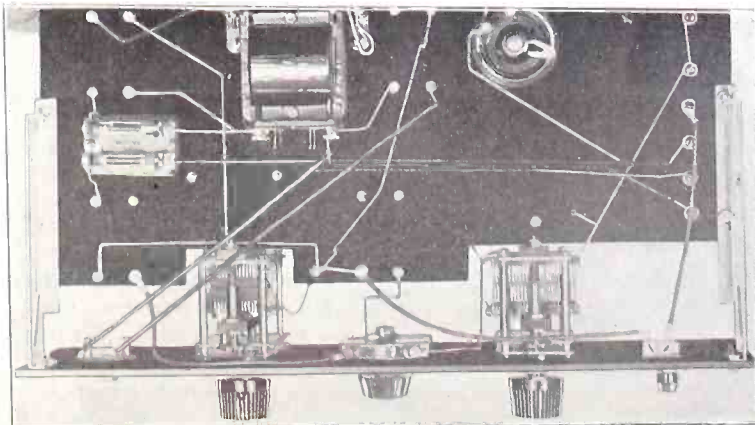

FIG. 5, the bottom view. The wiring is done beneath the sub-panel.

THE KEY TO THE AIR

KEY

Abbreviations: EST, Eastern Standard Time; CST, Central Standard Time; MST, Mountain Standard Time; PST, Pacific Standard Time;

How to tune in a desired distant station at just the right time—Choose your station from the list published herewith. See what time division the station is under (EST, CST, etc.); then consult the table below. Add to or subtract, as directed from the time as given on the PROGRAM. The result will be the same BY YOUR CLOCK that you should tune in, unless daylight saving time intervenes, as explained below.—The table:

If you are in	And want a station in	Subtract	Add
EST	CST	1 hr.	2 hrs.
EST	MST	2 hrs.	3 hrs.
EST	PST	3 hrs.	4 hrs.
CST	EST	1 hr.	2 hrs.
CST	MST	2 hrs.	3 hrs.
CST	PST	3 hrs.	4 hrs.
MST	EST	2 hrs.	3 hrs.
MST	MST	1 hr.	2 hrs.
MST	PST	1 hr.	2 hrs.
PST	EST	3 hrs.	4 hrs.
PST	CST	2 hrs.	3 hrs.
PST	DST	1 hr.	2 hrs.

FRIDAY, OCTOBER 16

WAAM, Newark, N. J., 263 (EST)—11 AM to 12; 7 PM to 10:30.
 WAHG, Richmond Hill, N. Y., 316 (EST)—12:30 to 1:05 PM; 7:30 to 11:05 PM.
 WAMD, Minneapolis, Minn., 243.8 (CST)—12 to 1 PM, 10 to 12.
 WBBM, Chicago, Ill., 226 (CST)—8 to 10 PM.
 WBRR, New York City, 22.6 (EST)—8 PM to 11.
 WBOQ, Richmond Hill, N. Y., 236 (EST)—7:30 PM to 11:30.
 WBZ, Springfield, Mass., 333.1 (EST)—6 PM to 11.
 WCCO, St. Paul and Minneapolis, Minn., 416.4 (CST)—9:30 AM to 12 M.; 1:30 to 4; 5:30 to 10.
 WCAE, Pittsburgh, Pa., 461.3 (EST)—12:30 to 1:30 PM, 4:30 to 5:30; 6:30 to 11.
 WDAF, Kansas City, Mo., 365.6 (CST)—3:30 to 7 PM; 8 to 10; 11:45 to 1 AM.
 WEAF, New York City, 492 (EST)—6:45 AM to 7:45; 11 to 12; 4 PM to 5; 6 to 12.
 WEAR, Cleveland, O., 390 (EST)—11:30 AM to 12:10 PM; 3:30 to 4:10; 8 to 11.
 WEOA, Ohio State University, 293.9 (EST)—8 PM to 10.
 WEEI, Boston, Mass., 476 (EST)—6:45 AM to 7:45; 2 PM to 3:15; 5:30 to 10.
 WEMC, Berrien Springs, Mich., 286 (CST)—9 PM to 11.
 WFAA, Dallas, Texas, 475.9 (CST)—10:30 AM to 11:30; 12:30 PM to 1; 2:30 to 6; 6:45 to 7; 8:30 to 9:30.
 WFB, New York City, 22.6 (EST)—2 PM to 6.
 WGBS, New York City, 316 (EST)—10 AM to 11; 1:30 PM to 4; 6 to 7:30.
 WGPC, New York City, 252 (EST)—2:30 PM to 5:15; 8 to 11.
 WGES, Chicago, Ill., 250 (CST)—7 to 9 PM; 11 to 1 AM.
 WGN, Chicago, Ill., 370 (CST)—9:31 AM to 3:30 PM; 5:30 to 11:30.
 WGR, Buffalo, N. Y., 319 (EST)—12 M to 12:45 PM; 7:30 to 11.
 WGW, Schenectady, N. Y., 379.5 (EST)—1 PM to 2; 5:30 to 10:30.
 WHAD, Milwaukee, Wis., 275 (CST)—11 AM to 12:15 PM; 4 to 5; 6 to 7:30; 8:30 to 10.
 WHAS, Louisville, Ky., 399.8 (CST)—4 PM to 5; 7:30 to 9.
 WHN, New York City, 360 (EST)—12:30 PM to 1; 2:15 to 5; 7 to 11; 12 to 12:30 AM.
 WHO, Des Moines, Iowa, 526 (EST)—7 PM to 9; 11 to 12; 12:30 to 1:30; 4:30 to 5:30; 6:30 to 9:30.
 WHT, Chicago, Ill., 400 (EST)—11 AM to 2 PM; 7 to 8:30; 8:45 to 10:05; 10:30 to 1 AM.
 WIP, Philadelphia, Pa., 508.2 (EST)—6:45 AM to 7:15; 10 to 11; 1 PM to 2; 3 to 5; 6 to 7.
 WJY, New York City, 405 (EST)—7:30 PM to 11:30.
 WJZ, New York City, 455 (EST)—10 AM to 11; 1 PM to 2; 4 to 6; 7 to 10:30.
 WLIT, Philadelphia, Pa., 395 (EST)—12:02 PM to 12:30; 2 to 5; 4:30 to 6; 7:30 to 1 AM.
 WLW, Cincinnati, O., 422.3 (EST)—10:45 AM to 12:15; 1:30 to 2:30.
 WMCA, New York City, 341 (EST)—11 AM to 12 M.; 6:30 PM to 12.
 WNYC, New York City, 526 (EST)—3:45 PM to 4:45; 6:20 to 11.
 WOAW, Omaha, Neb., 526 (CST)—12:30 PM to 1; 5:45 to 7:10; 9 to 11.
 WOC, Davenport, Iowa, 484 (CST)—12:57 PM to 8; 3 to 3:30; 5:45 to 12.
 WOR, Newark, N. J., 430.5 (EST)—6:45 AM to 7:45; 2:30 PM to 4; 6:15 to 7.
 WPAK, Fargo, N. D., 283 (CST)—7:30 PM to 9.
 WPG, Atlantic City, N. J., 299.8 (EST)—7 PM to 8:30; 10 to 12.
 WQJ, Chicago, Ill., 448 (CST)—11 AM to 12 M.; 3 PM to 4; 7 to 8; 10 to 2 AM.
 WRC, Washington, D. C., 469 (EST)—9 AM to 10; 12 PM to 1; 5 to 7.
 WRBO, Lansing, Michigan, 285.5 (EST)—10 PM to 11.
 WRNY, New York City, 258.5 (EST)—11:59 to 2 PM; 7:59 to 9:45.
 WSB, Atlanta, Ga., 423.3 (CST)—12 M to 1 PM; 2:30 to 3:30; 5 to 6; 8 to 9; 10:45 to 12.
 WSBF, St. Louis, Mo., 273 (CST)—12 M to 1 PM; 3 to 4; 7:30 to 10; 12 PM to 1 AM.

WWJ, Detroit, Mich., 352.7 (EST)—8 AM to 8:30; 9:30 to 10:30; 11:55 to 1:30; 3 to 4; 6 to 7; 8 to 10.
 KDKA, Pittsburgh, Pa., 309 (EST)—6 AM to 7; 9:45 to 12:20 PM; 1:30 to 3:20; 3:30 to 11.
 KPAA, State College of Wash., 348.6 (PST)—7:30 PM to 9.
 KFV, Brookings, S. D., 273 (MST)—8 PM to 9.
 KFI, Los Angeles, Cal., 467 (PST)—5 PM to 10.
 KFKX, Hastings, Neb., 288.3 (CST)—12:30 PM to 1:30; 9:30 to 12.
 KFNF, Shenandoah, Iowa, 266 (CST)—12:15 PM to 1:15; 3 to 4; 6:30 to 10.
 KFOA, Seattle, Wash., 455 (PST)—12:30 PM to 1:30; 4 to 5:15; 6 to 11.
 KGO, Oakland, Cal., 261.2 (PST)—11:10 AM to 1 PM; 1:30 to 3; 4 to 7.
 KGW, Portland, Oregon, 491.5 (PST)—11:30 AM to 1:30 PM; 5 to 10.
 KHJ, Los Angeles, Cal., 405.2 (PST)—7 AM to 7:15; 12 M to 3:30 PM; 5:30 to 11:30.
 KJR, Seattle, Wash., 484.4 (PST)—10:30 AM to 11:30 AM, 1 PM to 6:30; 8:30 to 11.
 KNX, Hollywood, Cal., 337 (PST)—11:30 AM to 12:30 PM; 1 to 2; 4 to 5; 6:30 to 12.
 KOA, Denver, Colo., 322.4 (MST)—11:45 AM to 12:30 PM; 3:30 to 4:15; 6 to 10.
 KOB, State College of New Mexico, 348.6 (MST)—11:55 AM to 12:30 PM; 7:30 to 8:30; 9:55 to 10:10.
 KOIL, Council Bluffs, Iowa, 278 (CST)—7:30 PM to 8:45; 11 to 12 M.
 KPO, San Francisco, Cal., 429 (PST)—7:30 AM to 8; 10:30 to 12 M, 1 PM to 2; 4:30 to 11.
 KSD, St. Louis, Mo., 545.1 (CST)—4 PM to 5.
 KTHS, Hot Springs, Ark., 374.8 (CST)—12:30 PM to 1; 8:20 to 10.
 KYW, Chicago, Ill., 536 (CSTDS)—6:30 AM to 7:30; 10:55 to 1 PM; 2:25 to 3:30; 6:02 to 7:20; 9 to 1:30 AM.
 CNRA, Moncton, Canada, 313 (EST)—8:30 PM to 10:30.
 CNRE, Edmonton, Canada, 516.9 (MST)—8:30 PM to 10:30.
 CNRS, Saskatoon, Canada, 400 (MST)—2:30 PM to 3.
 CNRT, Toronto, Canada, 357 (EST)—6:30 PM to 11.

SATURDAY, OCTOBER 17

WAAM, Newark, N. J., 263 (EST)—7 PM to 11.
 WAHG, Richmond Hill, N. Y., 316 (EST)—12:30 PM to 1:05, 12 to 2 AM.
 WAMD, Minneapolis, Minn., 243.8 (CST)—12 M to 1 PM; 10 to 12.
 WBBM, Chicago, Ill., 226 (EST)—8 PM to 1 AM.
 WBRR, New York City, 22.6 (EST)—8 PM to 9.
 WBOQ, Richmond Hill, N. Y., 236 (EST)—3:30 PM to 6:30.
 WBZ, Springfield, Mass., 333.1 (EST)—11 AM to 12:30 PM; 7 to 9.
 WCAE, Pittsburgh, Pa., 461.3 (EST)—10:45 AM to 12 M.; 3 PM to 4; 6:30 to 7:30.
 WCB, Zion, Ill., 344.6 (CST)—8 PM to 10.
 WCCO, St. Paul and Minneapolis, Minn., 416.4 (CST)—9:30 AM to 12:30 PM; 2:30 to 5; 6 to 10.
 WEAF, New York City, 492 (EST)—6:45 AM to 7:45; 4 PM to 5; 6 to 12.
 WEEI, Boston, Mass., 476 (EST)—6:45 AM to 7 AM.
 WEAR, Cleveland, O., 390 (EST)—11:30 AM to 12:10 PM; 3:30 to 4:10; 7 to 8.
 WEMC, Berrien Springs, Mich., 286 (CST)—11 AM to 12:30 PM; 8:15 to 11.
 WFAA, Dallas, Texas, 475.9 (CST)—12:30 PM to 1; 6 to 7; 8:30 to 9:30; 11 to 12:30 AM.
 WFBH, New York City, 22.6 (EST)—2 PM to 7:30; 11:30 to 12:30 AM.
 WGBS, New York City, 316 (EST)—10 AM to 11:1:30 PM to 3; 6 to 11.
 WGPC, New York City, 252 (EST)—2:30 PM to 5:15.
 WGES, Chicago, Ill., 250 (CST)—7 PM to 9; 11 to 1 AM.
 WGN, Chicago, Ill., 370 (CST)—9:31 AM to 2:30 PM; 3 to 5:57; 6 to 11:30.
 WGW, Schenectady, N. Y., 379.5 (EST)—7:30 PM to 10.
 WHAD, Milwaukee, Wis., 275 (CST)—11 AM to 12:30 PM; 4 to 5; 6 to 7:30.
 WHAR, Atlantic City, N. J., 275 (EST)—2 PM to 3; 7:30 to 9.
 WHAS, Louisville, Ky., 399.8 (CST)—4 PM to 5; 7:30 to 9.
 WHN, New York City, 360 (EST)—2:15 PM to 5; 7:30 to 10.
 WHO, Des Moines, Iowa, 526 (CST)—11 AM to 12:30 PM; 4 to 5:30; 7:30 to 8:30.
 WHT, Chicago, Ill., 400 (CST)—11 AM to 2 PM; 7 to 8:30; 10:30 to 1 AM.
 WIP, Philadelphia, Pa., 508.2 (EST)—7 AM to 8; 10:20 to 11; 1 PM to 2; 3 to 4; 6 to 11:30.
 WJY, New York City, 405 (EST)—2:30 PM to 5; 8 to 10:30.
 WJZ, New York City, 455 (EST)—9 AM to 12:30 PM; 2:30 to 4; 7 to 10.
 WKRC, Cincinnati, O., 326 (EST)—10 to 12 M.
 WLWC, Cincinnati, O., 422.3 (EST)—9:30 AM to 12:30 PM; 7:30 to 10.
 WMAR, Lockport, N. Y., 265.5 (EST)—10:25 AM to 12:30 PM.
 WMCA, New York City, 341 (EST)—3 to 5 PM; 6:30 to 2.
 WNYC, New York City, 526 (EST)—1 to 3 M; 7 to 11.
 WOAW, Omaha, Neb., 526 (CST)—10 AM to 1; 2:15 to 4; 9 to 11.
 WOC, Davenport, Iowa, 484 (CST)—12:57 PM to 8; 5:45 to 7:10; 9 to 12.
 WOP, Philadelphia, Pa., 508.2 (EST)—11 AM to 1 PM; 4:40 to 5; 10:55 to 11:02.
 WOR, Newark, N. J., 430.5 (EST)—6:45 AM to 7:45; 2:30 PM to 4; 6:15 to 7:30; 8 to 11.

SUNDAY, OCTOBER 18

WBBM, Chicago, Ill., 226 (CST)—4 PM to 6; 8 to 10.
 WBRR, New York City, 22.6 (EST)—10 AM to 12 M.; 9 PM to 11.
 WCCO, St. Paul and Minneapolis, Minn., 416 (CST)—11 AM to 12:30 PM; 4:10 to 5:10; 7:20 to 10.
 WDAF, Kansas City, Mo., 365.6 (CST)—4 PM to 5:30.
 WEAF, New York City, 492 (EST)—3 PM to 5; 5:20 to 10:15.
 WEAR, Cleveland, O., 390 (EST)—3:30 PM to 5; 7 to 8; 9 to 10.
 WFBH, New York City, 22.6 (EST)—5 PM to 7.
 WGBS, New York City, 316 (EST)—3:30 PM to 4:30; 8 to 10.
 WGP, New York City, 252 (EST)—8 PM to 11.
 WGES, Chicago, Ill., 250 (CST)—5 PM to 7; 10:30 to 12 M.
 WGN, Chicago, Ill., 370 (CST)—11 AM to 12:45 PM; 2:30 to 5; 9 to 10.
 WGR, Buffalo, N. Y., 319.5 (EST)—9:30 AM; 10 to 8 PM.
 WGW, Schenectady, N. Y., 379.5 (EST)—9:30 AM to 12:30 PM; 2:35 to 3:45; 6:30 to 10:30.
 WHAD, Milwaukee, Wis., 275 (CST)—3:15 PM to 4:15.
 WHAR, Atlantic City, N. J., 275 (EST)—2:30 PM to 3:45; 7:50 to 10; 11:15 to 12.
 WHN, New York City, 360 (EST)—1 PM to 1:30; 3 to 6; 10 to 12.
 WHT, Chicago, Ill., 238 (CST)—9:30 AM to 1:15 PM; 5 to 9.
 WIP, Philadelphia, Pa., 508.2 (EST)—10:45 AM to 12:30 PM; 4:15 to 5:30.
 WJZ, New York City, 455 (EST)—9 AM to 12:30 PM; 2:30 to 4; 7 to 11.
 WKRC, Cincinnati, O., 326 (EST)—6:45 PM to 11.
 WMCA, New York City, 341 (EST)—11 AM to 12:15 PM; 7 to 7:30.
 WNYC, New York City, 526 (EST)—9 PM to 11.
 WOCL, Jamestown, N. Y., 275.1 (EST)—9 PM to 11.
 WOO, Philadelphia, Pa., 508.2 (EST)—10:45 AM to 12:30 PM; 2:30 to 4.
 WPG, Atlantic City, N. J., 299.8 (EST)—3:15 PM to 5; 9 to 11.
 WQJ, Chicago, Ill., 448 (CST)—10:30 AM to 12:30 PM; 3 PM to 4; 8 to 10.
 WRBO, Lansing, Michigan, 285.5 (EST)—10 AM to 11.
 WRNY, New York City, 258.5 (EST)—3 PM to 5; 7:59 to 10.
 WSBF, St. Louis, Mo., 273 (CST)—9 to 11 PM.
 WWJ, Detroit, Mich., 352.7 (EST)—11 AM to 12:30 PM; 2 to 4; 6:20 to 9.
 KDKA, Pittsburgh, Pa., 309 (EST)—9:45 AM to 10:55; 11:55 to 12 M.; 2:30 PM to 5:30; 7 to 11.
 KFNF, Shenandoah, Iowa, 266 (CST)—10:45 AM to 12:30 PM; 2:30 to 4:30; 6:30 to 10.
 KOA, Denver, Colo., 322.4 (MST)—10:55 AM to 1 PM; 4 PM to 5:30; 7:45 to 10.
 KOIL, Council Bluffs, Iowa, 278 (CST)—11 AM to 12:30 PM; 7:30 to 9.
 KGW, Portland, Oregon, 491.5 (PST)—10:30 AM to 12:30 PM; 6 to 9.
 KHJ, Los Angeles, Cal., 405.2 (EST)—10 AM to 9:30 PM; 6 to 9.
 KJR, Seattle, Wash., 484.4 (PST)—11 AM to 12:30 PM; 3 to 4:30; 7:15 to 9.
 KTHS, Hot Springs, Ark., 374.8 (CST)—11 AM to 12:30 PM; 2:30 to 3:40; 8:40 to 11.

MONDAY, OCTOBER 19

WAAM, Newark, N. J., 263 (EST)—11 AM to 12 M; 7 PM to 11.
 WAHG, Richmond Hill, N. Y., 316 (ESTDS)—12:30 AM to 1:05 PM; 7:30 to 12.
 WAMB, Minneapolis, Minn., 243.8 (CST)—10 PM to 12.
 WBBM, Chicago, Ill., 226 (CST)—6 PM to 7.
 WBBR, New York City, 272.6 (ESTDS)—8 PM to 9.
 WBZ, Springfield, Mass., 333.1 (EST)—6 PM 11:30.
 WCAE, Pittsburgh, Pa., 461.3 (EST)—12:30 PM to 1:30; 4:30 to 5:30; 6:30 to 12.
 WCBD, Zion, Ill., 344.6 (CST)—8 PM to 10.
 WCCO, St. Paul and Minneapolis, Minn., 416 (CST)—9:30 AM to 12 M; 1:30 PM to 6:15.
 WDAF, Kansas City, Mo., 365.6 (CST)—3:30 PM to 7; 8 to 10; 11:45 to 1 AM.
 WEAF, New York City, 492 (EST)—6:45 AM to 7:45; 4 PM to 5; 6 to 11:30.
 WEAR, Cleveland, O., 300 (EST)—11:30 AM to 12:10 PM; 3:30 to 4:10; 7 to 8.
 WEEL, Boston, Mass., 476 (EST)—6:45 AM to 8; 3 PM to 4; 5:30 to 10.
 WEMC, Berrien Springs, Mich., 286 (CST)—8:15 PM to 11.
 WFAP, Dallas, Texas, 475.9 (EST)—10:30 AM to 11:30; 12:30 PM to 1; 2:30 to 6; 6:45 to 7; 8:30 to 9:30.
 WFBH, New York City, 272.6 (EST)—2 PM to 6:30.
 WGCP, New York City, 252 (EST)—2:30 PM 11; 1:30 to 3:10; 6 to 7:30.
 WGES, Chicago, Ill., 250 (CST)—5 PM to 8.
 WGPC, New York City, 252 (EST)—2:30 PM to 5:18; 8 to 10:45.
 WGN, Chicago, Ill., 370 (CST)—9:31 AM to 3:30 PM; 3:30 to 5:57.
 WGR, Buffalo, N. Y., 319 (EST)—12 M to 12:30 PM; 2:30 to 4:30; 7:30 to 11.
 WGY, Schenectady, N. Y., 379.5 (EST)—1 PM to 2; 5:30 to 8:30.
 WHAD, Milwaukee, Wis., 275 (CST)—11 AM to 12:15 PM; 4 to 5; 6 to 7:30; 8 to 10.
 WHAR, Atlantic City, N. J., 275 (EST)—2 PM to 3; 7:30 to 9.
 WHAS, Louisville, Ky., 399.8 (CST)—4 PM to 5; 7:30 to 9.
 WHN, New York City, 360 (EST)—2:15 PM to 5; 6:30 to 12.
 WHO, Des Moines, Iowa, 526 (CST)—12:15 PM to 1:30; 7:30 to 9; 11:15 to 12.
 WHI, Chicago, Ill., 400 (CST)—11 AM to 2 PM; 4 to 8:30; 10:30 to AM.
 WIP, Philadelphia, Pa., 508.2 (EST)—7 AM to 8; 1 PM to 2; 3 to 8.
 WJZ, New York City, 455 (EST)—10 AM to 11; 1 PM to 2; 4 to 5:30; 6 to 6:30; 7 to 11.
 WKRC, Cincinnati, O., 326 (EST)—8 PM to 10.
 WLIT, Philadelphia, Pa., 395 (EST)—12:02 PM to 1; 2 to 3; 4:40 to 6; 7:30 to 11:30.
 WLW, Cincinnati, O., 422.3 (EST)—10:45 AM to 12:15 PM; 1:30 to 2:30; 3 to 5; 6 to 10.
 WMAK, Lockport, N. Y., 265.5 (EST)—8 PM to 12.
 WMCA, New York City, 341 (EST)—11 AM to 12 M; 6:30 PM to 12.
 WNYC, New York City, 526 (EST)—3:15 PM to 4:15; 6:20 to 11.
 WOAW, Omaha, Neb., 526 (CST)—12:30 PM to 1:30; 5:45 to 10:30.
 WOC, Davenport, Iowa, 484 (CST)—12:57 PM to 3; 3:30; 5:45 to 6.
 WOO, Philadelphia, Pa., 508.2 (EST)—11 AM to 1 PM; 4:40 to 6; 7:30 to 11.
 WOR, Newark, N. J., 405 (EST)—6:45 AM to 7:45; 2:30 to 4; 6:15 to 11:30.
 WPAK, Fargo, N. D., 283 (CST)—7:30 PM to 9.
 WPG, Atlantic City, N. J., 299.8 (EST)—7 PM to 11.
 WOJ, Chicago, Ill., 488 (CST)—11 AM to 12 M; 3 PM to 4.
 WOC, Washington, D. C., 469 (EST)—9 AM to 10; 12 M to 2; 6:15 PM to 6:30.
 WREO, Lansing, Michigan, 285.5 (EST)—10 PM to 11.
 WRNY, New York City, 258.5 (EST)—11:59 AM to 2 PM; 7:30 to 11.
 WSB, Atlanta, Ga., 428.3 (CST)—12 M to 1 PM; 2:30 to 3:30; 5 to 6; 8 to 9; 10:45 to 12.
 WSBF, St. Louis, Mo., 273 (CST)—12 M to 1 PM; 3 to 4; 7:30 to 10:30; 12 to 1 AM.
 WWJ, Detroit, Mich., 352.7 (EST)—8 AM to 8:30; 9:30 to 10:30; 11:55 to 1:30 PM; 3 to 4; 6 to 10.
 KDKA, Pittsburgh, Pa., 309 (EST)—6 AM to 7; 9:45 to 12:15 PM; 2:30 to 3:20; 5:30 to 10.
 KWSC, State College of Wash., 348.6 (PST)—7:30 PM to 9.
 KFI, Los Angeles, Cal., 467 (PST)—5 PM to 11.
 KFKX, Hastings, Neb., 288.3 (CST)—12:30 PM to 1:30; 5:15 to 6:15; 9:30 to 12:30.
 KPNF, Shenandoah, Iowa, 266 (CST)—12:15 PM to 1:15; 3 to 4; 6:30 to 10.
 KFOA, Seattle, Wash., 455 (PST)—12:45 PM to 1:30; 4 to 5:15; 6 to 10.
 KGO, Oakland, Cal., 361.2 (PST)—9 AM to 10:30; 11:30 AM to 1 PM; 1:30 to 6; 6:45 to 7; 8 to 1 AM.
 KGW, Portland, Oregon, 491.5 (PST)—11:30 AM to 1:30; 5 to 8.
 KHJ, Los Angeles, Cal., 405.2 (PST)—7 AM to 7:15; 12 M to 1:30 PM; 5:30 to 10.
 KJR, Seattle, Wash., 384.4 (PST)—1 PM to 2:45; 6 to 6:30; 7 to 11.
 KNX, Hollywood, Cal., 337 (PST)—12 M to 1 PM; 4 to 5; 6:30 to 12.
 KOB, State College of New Mexico, 348.6 (MST)—11:55 AM to 12:30 PM; 7:30 to 8:30; 9:55 to 10:10.
 KOIL, Council Bluffs, Iowa, 278 (CST)—7:30 PM to 10.
 KPO, San Francisco, Cal., 428 (PST)—10:30 AM to 12 M; 1 PM to 2; 3:30 to 4:30 to 10.
 KSD, St. Louis, Mo., 545.1 (CST)—7:30 PM to 10.
 KTHS, Hot Springs, Ark., 374.8 (CST)—12:30 PM to 1; 8:30 to 10.

With
 Irving Hoffman
 at
WBNY

New York City, 209 Meters



JIMMY CLARK, SKETCHED PERFECTING IRVING BERLINS NEW MELODY "YOU FORGOT TO REMEMBER," WHICH HE BROADCAST



MISS FLORENCE CONANT, COLORATURA SOPRANO.



DR. BARUCH, MANAGER OF WBNY, IS A MEMBER OF THE GARTER.



GEORGE MORRIS, CHIEF ANNOUNCER OF WBNY.



HERMAN HELLER, MUSICAL DIRECTOR OF THIS STATION.



THOMAS MEIGHAN, POPULAR MOVIE STAR WAS THERE.



ALBERT WEISBERG, WHO HELPED MAKE UP THE INITIAL PROGRAM.

KYW, Chicago, Ill., 536 (CSTDS)—6:30 AM to 7:30; 10:55 to 1 PM; 2:15 to 3:30; 6:02 to 7.

TUESDAY, OCTOBER 20

WAAM, Newark, N. J., 263 (EST)—11 AM to 12 M; 7 PM to 11.
 WAHG, Richmond Hill, N. Y., 316 (EST)—12 PM to 1:05 AM.
 WAMB, Minneapolis, Minn., 243.8 (CST)—12 M to 1 PM; 10 to 12.
 WBBM, Chicago, Ill., 226 (CST)—8 PM to 12.
 WBBR, Richmond Hill, N. Y., 316 (EST)—3:30 PM to 6:30.

WBZ, Springfield, Mass., 333.1 (EST)—6 PM to 11.
 WCAE, Pittsburgh, Pa., 461.3 (EST)—12:30 PM to 1:30; 4:30 to 5:30; 6:30 to 11.
 WCCO, St. Paul and Minneapolis, Minn., 416.4 (CST)—9:30 AM to 12 M; 1:30 PM to 4; 5:30 to 10.
 WDAF, Kansas City, Mo., 365.6 (CST)—3:30 PM to 7; 11:45 to 1 AM.
 WEAF, New York City, 492 (EST)—6:45 AM to 7:45; 11 to 12 M; 4 PM to 5; 6 to 12.
 WEAR, Cleveland, O., 300 (EST)—11:30 AM to 12:10 PM; 7 to 10; 10 to 11.
 WEEL, Boston, Mass., 476 (EST)—6:45 AM to 8; 1 PM to 2; 6:30 to 10.
 WFAP, Dallas, Texas, 475.9 (CST)—10:30 AM to 11:30; 12:30 PM to 1; 2:30 to 6; 6:45 to 7; 8:30 to 9:30; 11 to 12.
 WFBH, New York City, 272.6 (EST)—2 PM to 6:30; 11:30 to 12:30 AM.
 WGBS, New York City, 316 (EST)—10 AM to 11; 1:30 PM to 3; 6 to 11:30.
 WGCP, New York City, 252 (EST)—2:30 PM to 5:15.
 WGES, Chicago, Ill., 250 (CST)—7 PM to 9; 11 to 1 AM.
 WGN, Chicago, Ill., 370 (CST)—9:31 AM to 3:30 PM; 5:30 to 11:30.
 WGR, Buffalo, N. Y., 319 (EST)—11 AM to 12:45 PM; 7:30 to 11.
 WGY, Schenectady, N. Y., 379.5 (EST)—11 PM to 2:30; 5:30 to 7:30; 9:15 to 11:30.
 WHAD, Milwaukee, Wis., 275 (CST)—11 AM to 12:15 PM; 4 to 5; 6 to 7:30.
 WHAS, Louisville, Ky., 399.8 (CST)—4 PM to 5; 7:30 to 9.
 WHAR, Atlantic City, N. J., 275 (EST)—2 PM to 3; 7:30 to 9; 11:15 to 12.
 WHN, New York City, 360 (EST)—12:30 PM to 1; 2:15 to 3:15; 4 to 5:30; 7:30 to 10:45; 11:30 to 12:30 AM.
 WHO, Des Moines, Iowa, 526 (CST)—12:15 PM to 1:30; 7:30 to 9; 11:30 to 12.
 WHI, Chicago, Ill., 400 (CST)—11 AM to 2 PM; 7 to 8:30; 10:30 to 1 AM.
 WIP, Philadelphia, Pa., 508.2 (EST)—7 AM to 8; 1 PM to 2; 3 to 4:30; 6 to 11.
 WJY, New York City, 405 (EST)—7:30 PM to 1:30.
 WJZ, New York City, 455 (EST)—10 AM to 11; 1 PM to 2; 4 to 6; 7 to 11.
 WKRC, Cincinnati, O., 326 (EST)—6 PM to 12, 12:30 PM; 2 to 3; 4:30 to 7.
 WLIT, Philadelphia, Pa., 395 (EST)—11 AM to 12:30 PM; 2 to 3; 4:30 to 7.
 WLW, Cincinnati, O., 422.3 (EST)—10:45 AM to 1 PM; 1:30 to 2:30; 3 to 5; 6 to 11.
 WMCA, New York City, 341 (EST)—11 AM to 12 M; 6:30 PM to 12.
 WNYC, New York City, 526 (EST)—3:45 PM to 5; 6:50 to 11.
 WOAW, Omaha, Neb., 526 (CST)—12:30 PM to 1:30; 5:45 to 11.
 WOC, Davenport, Iowa, 484 (CST)—12:57 PM to 2; 3 to 3:30; 5:45 to 10.
 WOO, Philadelphia, Pa., 508.2 (EST)—11 AM to 1 PM; 4:40 to 5; 10:55 to 11:02.
 WOR, Newark, N. J., 405 (EST)—6:45 AM to 7:45; 2:30 PM to 4; 6:15 to 7:30.
 WPG, Atlantic City, N. J., 299.8 (EST)—7 PM to 11.
 WOJ, Chicago, Ill., 488 (CST)—11 AM to 12 M; 3 PM to 4; 7 to 8; 10 to 12 M.
 WRC, Washington, D. C., 469 (EST)—9 AM to 10; 12 M to 2; 6:55 PM to 11.
 WREO, Lansing, Michigan, 285.5 (EST)—8:15 PM to 11.
 WRNY, New York City, 258.2 (EST)—11:59 AM to 2 PM; 4:30 to 5; 8 to 11.
 WSB, Atlanta, Ga., 428.3 (CST)—12 M to 1 PM; 2:30 to 3:30; 5 to 6; 8 to 9; 10:45 to 12.
 WSBF, St. Louis, Mo., 273 (CST)—12 M to 1 PM; 3 to 4; 8 to 10; 11:30 to 1 AM.
 WWJ, Detroit, Mich., 352.7 (EST)—8 AM to 8:30; 9:30 to 10:30; 11:55 to 1:30 PM; 3 to 4; 6 to 10.
 KDKA, Pittsburgh, Pa., 309 (EST)—9:45 PM to 12:15 PM; 2:30 to 3:20; 5:30 to 10.
 KFI, Los Angeles, Cal., 467 (PST)—5 PM to 11.
 KFKX, Hastings, Neb., 288.3 (CST)—12:30 PM to 1:30; 5:15 to 6:15; 9:30 to 12:30.
 KFMQ, Fayetteville, Ark., 299.8 (CST)—9 PM to 10.
 KFOA, Seattle, Wash., 455 (PST)—12:30 PM to 1:30; 4 to 5:15; 6 to 11.
 KGO, Oakland, Cal., 361.2 (PST)—11:30 AM to 1 PM; 1:30 to 3; 4 to 6:45; 8 to 1 AM.
 KGW, Portland, Oregon, 491.5 (PST)—11:30 AM to 1:30 PM; 5 to 11.
 KHJ, Los Angeles, Cal., 405.2 (PST)—7 AM to 7:15; 12 M to 1:30 PM; 5:30 to 11.
 KJR, Seattle, Wash., 384.4 (PST)—9 AM to 6:30 PM; 8:30 to 1 AM.
 KNX, Hollywood, Cal., 337 (PST)—9 AM to 10; 1 PM to 2; 4 to 5; 6:30 to 12.

WEDNESDAY, OCTOBER 21

WAAM, Newark, N. J., 263 (EST)—12:30 PM to 1:05; 7:30 to 11:05.
 WAHG, Richmond Hill, N. Y., 316 (EST)—12 M to 1:05 PM; 8 to 12.
 WAMB, Minneapolis, Minn., 243.8 (CST)—12 M to 1 PM; 10 to 12.
 WBBM, Chicago, Ill., 226 (CST)—8 PM to 10.
 WBBR, Springfield, Mass., 333.1 (EST)—6 PM to 11.
 WCAE, Pittsburgh, Pa., 461.3 (EST)—12:30 PM to 1:30; 4:30 to 5:30; 6:30 to 11.
 WCCO, St. Paul and Minneapolis, Minn., 416.4 (CST)—9:30 AM to 12 M; 1:30 to 4; 5:30 to 11.
 WDAF, Kansas City, Mo., 365.6 (CST)—3:30 PM to 7; 8 to 9:15; 11:45 to 1 AM.
 WEAF, New York City, 492 (EST)—6:45 AM to 7:45; 11 to 12 M; 4 PM to 5; 6 to 12.
 WEAO, Ohio State University, 293.9 (EST)—8 PM to 10.
 WEAR, Cleveland, O., 300 (EST)—11:30 AM to 12:10 PM; 3:30 to 4:10; 6:45 to 7:45.
 (Continued on page 26)

A Thought For the Week

No longer does father drop in a radio store and say: "Please give me a raz-dazz for my boy. He's building a set for his mother." Father sails in now, orders what he wants for his own set and will fight the man who says he isn't a hard-boiled, wise and resourceful radio fan.

RADIO WORLD



Radio World's Slogan: "A radio set for every home."

TELEPHONES: BRYANT 0558, 0559 PUBLISHED EVERY WEDNESDAY (Dated Saturdays of same week) FROM PUBLICATION OFFICE

HENNESSY RADIO PUBLICATIONS CORPORATION ROLAND BURKE HENNESSY, President M. H. HENNESSY, Vice-President FRED S. CLARK, Secretary and Manager 145 WEST 45th STREET, NEW YORK, N. Y. (Between Broadway and Sixth Ave.) European Representatives: The International News Co. Breams Bldgs., Chancery Lane, London, Eng. Paris, France Brentano's, 33 Avenue de l'Opera. Chicago Representatives: A. T. Sears & Son, Peoples Gas Cincinnati, H. A. Baunstein & Co., Provident Bank Bldg. San Francisco, Lloyd B. Chappell, 456 O'Farrell St.

EDITOR, Roland Burke Hennessy MANAGING EDITOR, Herman Bernard

SUBSCRIPTION RATES

Fifteen cents a copy, \$6.00 a year, \$3.00 for six months, \$1.50 for three months. Add \$1.00 a year extra for foreign postage. Canada, 50 cents. Recd by new subscribers of the first copy of RADIO WORLD mailed to them after sending in their order is automatic acknowledgment of their subscription order. Changes of address should be received at this office two weeks before date of publication. Always give old address also. State whether subscription is new or a renewal.

ADVERTISING RATES

Table with 3 columns: Ad Type, Dimensions, and Rate. Includes General Advertising, 1 Page 7 1/2 x 11, 482 lines \$300.00, 24 times consecutively or E. O. W. one year 15%, WEEKLY, dated each Saturday, published Wednesday.

CLASSIFIED ADVERTISEMENTS

Ten cents per word. Minimum, 10 words. Cash with order. Business Opportunities 50 cents a line; minimum, \$1.00.

Entered as second-class matter, March 28, 1922, at the Post Office at New York, N. Y., under the act of March 3, 1879.

OCTOBER 17, 1925

JOIN THE A. B. C.

A. B. C. stands for American Broadcast Club, an organization of fans banded together to promote the welfare of radio. There are no dues, no obligations. Address A. B. C. Editor, RADIO WORLD, 145 West 45th St., N. Y. City. The names and addresses of new members follow:

- J. W. Hoke, 1513 Penn Ave., New Castle, Pa. Wm. Norman Kearney, 2918 N. 16th St., Philadelphia, Pa. Joseph Monninghoff, Riegelsville, Pa. Harrison Waterman, 99 Franklin Ave., Ocean Grove, N. J. Albert Piekerting, West Midway, Mass. G. A. Long, 506 East 18th St., Crowley, La. Martin V. Eddy, 1314 Sigsbee St., Grand Rapids, Mich. Lazarus Harris, 258 E. Market St., Wilkes Barre, Penn. J. H. Sloan, 190 University Ave., Toronto, Ontario, Canada. S. Miller, 931 Willow Ave., Hoboken, N. J. George J. Patentaude, 23 Wall St., Southbridge, Mass. John B. Springs, Corner North and Beau St., Washington, Pa. Carlos Casanova, 7 Str. Vadi Slr., Mayaguez, P. R.

Warming Up to Radio

"THE STUDENT PRINCE" will be broadcast from WJZ, New York City, this month, the date not being fixed at the time this is being written.

The announcement is indeed important, as it represents the first instance of a notable producing firm accepting radio with open arms. The conventional attitude of the producers has been to regard radio as a rival and to fight it, as they futilely fought the movies only a few years ago.

J. J. and Lee Shubert, the producers of "The Student Prince," make this outstanding broadcasting venture extremely important because they select such a notably good work, rich in melody and stirring in character. The broadcasting, from the producers' viewpoint, is purely experimental, and on the box-office results alone will the radio policy of the Messrs. Shubert be determined.

Last Winter Vincent Lopez and his orchestra made a test, not quite the same in fact, but representing the same principle. Let us hope the Messrs. Shubert encounter the same great box-office success. The world is large enough for the stage and the microphone.

Let us trust that the Metropolitan Opera Company directors will manage to have some suitable operas broadcast.

Consulting the Public

IN an endeavor to have the public view represented very fully at the Fourth National Radio Conference on November 9 Secretary Hoover has decided to invite all the radio publications and newspapers publishing radio supplements to send a delegate to this important session. This is a wise move, as the airing of the views of all sides is one of the outstanding points of value of the conference. Eager although Secretary Hoover may be to determine what the public attitude is on given radio problems, he no doubt finds it extremely difficult to determine those elusive points. The radio editors are constantly in touch with their readers and thus are able to help out with valuable facts and opinions.

The main problem of the conference of course will concern finding a place for applicants for broadcasting licenses. Either the wavelengths must be re-assigned on some basis affording a greater number of channels, or some form of curtailment of hours enjoyed by existing stations must be established. Otherwise the stations that want to get a place on the air will not be accommodated. The proposal to reduce both the maximum and minimum of the broadcast belt will no doubt be discussed from many angles. This suggested solution, while it has possibilities, involves international agreements and it would be very slow in getting actually established. In the interests of speed it seems likely that some other plan would have to be followed. The manufacturers no doubt will oppose going down to lower waves, because of the effect on their business, which is based on the present wavelength scale. If shorter waves win out, then no doubt delay must ensue, because it would be unreasonable to foist this plan on the public and trade with costly suddenness.

No More Nonsense, Please!

JANUARY 24 will begin International Radio Week. It is hoped that fans the world over are preparing for this treat. The reception of signals from Europe and England will probably be more successful this year than last, due to transmission improvements. Probably short waves will be used in relaying, and then American stations will rebroadcast on their regular waves the programs that are thus imported duty-free. Possessors of short-wave sets will be able to pick up the signals direct, and this will be fun aplenty. Of course due announcement should be made of the relay wavelengths that will be used, so that fans may have the proper coils ready.

American and Canadian stations will be asked to remain silent so that programs from abroad may be picked up by the stations participating in the test. Last year there were some violations, the vice not being cured by the irresponsibility of the transgressor. The famous hoax of the operatic music sent out by some small Southwestern station, and the ugly humor of someone else pretending to be "St. Petersburg, Russia," will be remembered by many. This is closer to criminality than to humor and it is hoped that all will show good sense this year.

THE RADIO TRADE

Werrenrath Opens The Kent Series of Notable Concerts

REINALD WERRENRATH, American baritone, opened the Kent Sunday night musical series, at WEAf. In the Metropolitan district static was unfortunately plentiful. In eleven other cities the same program was broadcast and in nearly all of them static was absent.



REINALD WERRENRATH

Beginning with a group of favorite old concert songs, Mr. Werrenrath took up three songs of the sea, including Deems Taylor's "Captain Stratton's Fancy." His final group of ballads concluded with Charles Gilbert Spross's musical setting of Kipling's "Gunga Din," sung for the first time in America.

A. Atwater Kent, of Philadelphia, is financing the programs, which will be given every Sunday evening at 9:15 o'clock throughout the winter. To-morrow Mme. Louise Homer contralto, formerly of the Metropolitan Company, will be the principal attraction.

The list of other stars announced for future programs includes Mabel Garrison, soprano, formerly of the Metropolitan Company; Charles Hackett, American tenor, of the Chicago Opera Company; Anna Case, American soprano; Frieda Hempel, coloratura soprano, formerly of the Metropolitan Opera Company; Edward Johnson, tenor, Metropolitan Opera Company; Mme. Ernestine Schumann-Heink, contralto, formerly of the Metropolitan Opera Company.

Secretary of Labor Davis spoke from Washington before Mr. Werrenrath sang. His voice was carried by wire to the WEAf microphone. The line hum was very bad.

Secretary Davis said: "When I heard the announcement of these concerts a few days ago and looked over the magnificent list of artists. I wondered if any single force had ever possessed such powers of spreading good. Occasionally I have had the pleasure of hearing the finest singers, the most famous musicians, just as you have heard them. But in the past you and I sometimes found it hard or impossible to get to the concert halls or hear opera performed.

"The great artists necessarily appeared only in the larger cities, where large audiences were assured. The artists could be in only one place at a time, and that meant that only a limited number could hear them. But now science has wiped out distance. It has torn down the walls

of the concert hall and opera house. The whole world is now one open opera house. We are all one vast audience. And the music is brought to us as we sit at home."

Mr. Kent said a few words: "Ever since radio came into reality it has seemed to me that some day the greatest music would be brought to the greatest possible number of homes. It is a tremendous satisfaction to me to have played a part in bringing this about and I sincerely hope that there will be as much pleasure for you in hearing these concerts as there has been to me in arranging them."

NEW MAIL ORDER DEPARTMENT

The Rix Radio Supply House, 5505 Fourth Avenue, Brooklyn, N. Y., has added a mail order department for the benefit of their out-of-town customers. They will carry only standard parts, supplies and sets and will cheerfully refund on any unsatisfactory transaction. They make it a practice to fill orders the same day they are received.

GENUINE WESTERN ELECTRIC CONDENSERS

The American Sales Co., of 21 Warren Street, N. Y. C., have an exceptional bargain in 8 mfd. Filter Condensers manufactured by the Western Electric Co. These condensers are especially suitable for "B" Battery Eliminators.

Tested and Approved by RADIO WORLD Laboratories

Coming Events

- OCT. 18 to 18—National Radio Show, City Auditorium, Denver, Colo.
- OCT. 12 to 15—South Texas Radio Exposition, Post Dispatch (KPRC), Houston, Tex.
- OCT. 12 to 17—Boston Radio Show, Mechanics' Hall. Write to B. R. S., 209 Massachusetts Ave., Boston, Mass.
- OCT. 12 to 17—St. Louis Radio Show, Coliseum. Write Thomas P. Convey, manager, 737 Frisco Bldg., St. Louis, Mo.
- OCT. 12 to 17—Radio Show, Montreal, Can., Canadian Expos. Co.
- OCT. 17 to 24—Brooklyn Radio Show, 2d Regt. Armory. Write Jos. O'Malley, 1157 Atlantic Ave., Brooklyn, N. Y.
- OCT. 19 to 25—Second Annual Cincinnati Radio Exposition, Music Hall. Write to G. B. Bodenhof, care Cincinnati Enquirer.
- OCT. 28 to 31—First Annual Rochester Times-Union Radio Exposition, Convention Hall, Rochester, N. Y. Write Howard H. Smith, care Times-Union.
- NOV. 2 to 7—Radio Show, Toronto, Can., Canadian Expos. Co.
- NOV. 3 to 8—Radio Trade Association Exposition, Arena Gardens, Detroit. Write Robt. J. Kirchner, chairman.
- NOV. 7 to 14—Second Columbus Radio Show and Electrical Exposition. Write Lewis Hill, Dispatch, Columbus, O.
- NOV. 19 to 25—Milwaukee Radio Exp., Civic Auditorium. Write Sidney Neu, of J. Andrae & Sons, Milwaukee, Wis.
- NOV. 17 to 22—4th Annual Chicago Radio Exp., Coliseum. Write Herrmann & Kerr, Cort Theatre Bldg., Chicago, Ill.

HOW TO BUILD THE POWERTONE. I dial 5 tubes, described in RADIO WORLD, issues of Aug. 29 and Sept. 5 Powertone Trouble-shooting, Sept. 12. Send 45c for all three. Special diagrams and "blueprint in black" included among the many illustrations. RADIO WORLD, 145 West 45th St., N. Y. City.

"A" and "B" Battery Eliminator, by P. E. Edelman; How to Make a Wavemeter, by Lewis Winner; Official List of Broadcasting Stations; Resistance AF in RF Set That Gets DX on 2 Controls, by Capt. P. V. O'Rourke, etc., 15c a copy or start your subscription with that number. RADIO WORLD, 145 West 45th St., N. Y. City.

Literature Wanted

THE names of readers of RADIO WORLD who desire literature from radio jobbers and dealers are published in RADIO WORLD on request of the reader. The blank below may be used, or a post card or letter will do instead.

Trade Service Editor,
RADIO WORLD,
145 West 45th St., N. Y. City.
I desire to receive radio literature.

Name

City or town.....

State

Are you a dealer?.....

If not who is your dealer?

His Name

His Address

- A. H. Boemler, 4051 McPherson Ave., St. Louis Mo.
- John T. Huccon, Alexandria, La
- James H. Powers P. O. Box 223 Madison, N. C
- M. V. Eddy, 1114 Sigbee St., Grand Rapids Mich
- Harry O. Hamilton, Cudahy, Wis.
- Sanders (amp. Monroe, Ga
- M. Richmond Chicago, Ill
- George J. Patenaude 23 Wall St Southbridge Mass
- Dean Smith, Fort Chester, N. Y
- H. W. Story, Box 216 Santiago de Cuba Cuba
- Car wners Supply Co., 68 Winter St., Haverhill Mass (Dealer.)
- Joseph Xen 5138 Gerry St San Francisco Cal
- A. H. N. Lee 16 Chapman St., Greenfield Mass.
- A. J. Heamer, Marshalltown, Iowa (Dealer)
- A. M. Fields Hamilton, O
- D. W. Smiley, Plattsmouth, Neb (Dealer)
- Emmanuel M. Muhlenford 495 Claremont Park way Bronx, New York City
- Nelvin Evans, Moorfield W. Va
- E. F. Johnson 432 36th St Brooklyn N. Y
- J. H. Sloan, 81 Gates Ave Mount Ontario Canada
- Edward Smith, Farringham Va
- A. J. Friedman 1315 St John's Place Brooklyn N. Y.
- W. A. Hendrix, Bucatanua Miss
- J. C. Scheuffele Mary, N. D
- D. A. Ross, 108 Belmont Block Edmonton Canada
- Edward O. Broadbent, 5th Ave West Hamilton, Ontario, Canada
- George Fuchs, 311 S. Scott St., La
- James S. Drexler, c/o Westinghouse High School Pittsburgh, Pa
- Springdale Radio Sales Service Co., Springdale Ia (Dealer)
- Clyde C. Carpenter, 1015 Southern Boulevard N. Y. City.
- Philip H. Gimbel, 6601 Denison Ave., Cleveland Ohio.

Business Opportunities Radio and Electrical

10 cents a word. \$1.00 Minimum.

RADIO PARTS manufacturing concern; great opportunity for man; \$5,000; established customers of the entire United States and Canada, large profits; season starting. Box 100, RADIO WORLD.

RADIO

Wanted—Partner with \$5,000 to join me in taking over plant fully equipped manufacturing radio sets, transformers, A and B battery eliminator and other parts; opportunity lifetime for any one waiting get into radio. Box 200, RADIO WORLD.

RADIO DEPARTMENT

To Lease—In Department Store! Ample space and surroundings on second floor, present stock to be taken over at market prices; splendid opportunity for live-wire radio man. ADAMS, WERTHEIMER CO., Fordham Road and Concourse, New York City.

LET US BE YOUR FACTORY

Do not use your funds to buy machinery and equipment; we are thoroughly equipped in machines and have broadest experience in building dies and tools for economical production; will make your parts or build your complete device; make use of our facilities and experience. Interstate Mechanical Laboratories, 521 West 57th Street, New York City. Phone Columbus 5321.

A DYNAMIC SET, Enormous Power on J Tubes, by P. E. Edelman. An Anti-Radiation Toroid Set, by Capt. P. V. O'Rourke. Four Crystal Hook-ups, by Lewis Winner. Other features in RADIO WORLD dated July 25, 1925. 15c a copy, or start your subscription with that number. RADIO WORLD, 145 West 45th St., N. Y. City.

Attention Radio World Subscribers!

Subscribers will note that the end of their subscriptions is indicated on the labels on wrappers. If your wrapper shows the date later than the current issue, you are behind in your subscription. Please send payment for renewal. Thank you!
RADIO WORLD, 145 West 45th Street, New York City.

Wiring the Hartley SW Set

(Concluded from page 5)

your hand and screw the connections onto the rheostat. The coil is mounted on angle irons, on the right-hand side of the baseboard in the back. The outside circumference should come in line with the edge of the baseboard. The terminal strip is placed in the extreme left-hand corner of the baseboard. This will take up about 6" of the space of the board. The coil takes up 2½" in width of the board and 5½" in length of the board. One terminal of the grid leak and the condenser are mounted directly on the binding post of the socket. The drilling of the holes for the condenser and the rheostat automatically place these parts.

How to Wire the Set

The first thing to do is wire up the filament portion of the circuit. The arm of the rheostat goes to the A— post on the terminal strip. The wire or the resistance of this rheostat goes to the F— post on the socket. The F+ post of the socket goes to the A+ post on the terminal strip. The arm of the rheostat also goes to the tap. This same connection goes to the ground post on the terminal strip. Summarizing: ground to tap to rheostat arm to A— post. The beginning of the primary winding, L1, goes to the antenna post. The end of this same winding goes to the ground post. The ending of the secondary winding, L2, goes to the grid leak and the condenser R1, and C3. The other terminals of the grid leak and condenser go to the grid post



FIG. 5, closeup showing how the Spiral Condenser looks. The rotor plates enter the field of the stator one in spiral fashion. From maximum to minimum capacity is represented by 500 divisions of the dial. A counter tells the number of revolutions.

of the socket. The beginning of this winding goes to the rotary plates of C1 and C2. The stationary plates of variable condenser C1 go to the end of the secondary, which goes to one terminal of the grid leak and condenser. The stationary plates of the variable condenser C2 go to the plate post of the socket. This same connection also goes to one terminal of a radio-frequency choke coil. This coil is wound on a tubing 1½" in diameter. There are 300 turns of No. 36 enameled wire wound. The other terminal of this choke coil goes to one binding post or the top terminal of a single circuit jack. I would not advise the use of a jack as it adds capacity to the set. The other binding post goes to the B+ 45 volts post. The A+ post is connected to the B—.

Obtaining Signals

When wiring the set use only the heaviest type of wire and forget bus bar. No. 18

- ### LIST OF PARTS
- Two .00025 mfd. variable condensers, (C1 and C2).
 - One short-wave coil (L1, L2).
 - One radio-frequency choke coil (L3).
 - One grid leak, 2 megohms (R1).
 - One grid condenser, .00025 mfd. (C3).
 - One socket.
 - Two 3½" dials.
 - One terminal strip.
 - One 7 x 12" panel.
 - One 6 x 10" baseboard.
 - One rheostat, 20 ohms (R2).
 - One pound of No. 18 double cotton covered wire.
 - Accessories: Phones, antenna, ground wire, nuts and screws.

or 14 copper cotton or rubber covered wire is great. I used No. 18. Do not solder any connections, except the tap connection. Bring all the leads directly to their respective posts and screw them down tight. The grid leak is not critical.

There will be some difficulty encountered when tuning in with this set, as it may take a long time before you will hit a station. I fished around for a half hour before I hit one, but I soon lost it. This was due to the station changing its wavelength for testing purposes. The best time to listen in with this type of set is during the broadcasting period, as you will catch many station rebroadcasting their programs. A great deal of relay work is done on these high frequencies. However, you can easily tell if the set is working. As soon as the A and the B batteries are hooked up, and the filament of the tube lit up, listen for the regenerative click. If this click does not come in, add more turns to the RF choke. Use an extremely short antenna, about 85 foot, with lead-in and water pipe ground. According to theoretical calculations this set will receive from 8 to 75 meters with this type of antenna. If you desire to receive higher wavelengths, add on turns to the secondary. By adding on 5 more turns you will be able to hear as high as 110 meters. The number of turns on the primary does not change, until 175 meters are to be received.

REMOVAL NOTICE!
Radio World
has moved to more spacious offices at
No. 145 W. 45th St., near Broadway,
New York City.
Telephones: BRYant 0558, 0559

Antenna-Mat
A unique device placed under telephone receiver acts as a perfect aerial.
Does away with need of outside aerial, loop or tape.
Absolute satisfaction guaranteed or money back. Place a dollar in envelope and mail at our risk.
T. M. CAVEN COMPANY
2367 Crescent Avenue, Astoria, L. I., N. Y.
Tested and approved by Radio World

LESTRON
THE REAL 110 VOLT
TUBE
Works Without Batteries
FOR A. C. or D. C. NO REWIRING
LESTEIN CORPORATION
2 BROADWAY N. Y. CITY

Buzzer Modulation

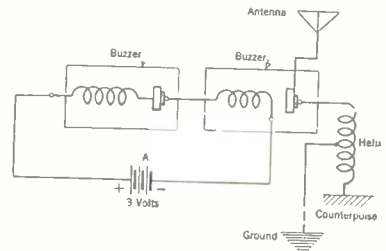

FILL OUT AND MAIL NOW

SUBSCRIPTION BLANK

RADIO WORLD

RADIO WORLD

1493 Broadway, New York City

Please send me RADIO WORLD formonths, for which
please find enclosed \$.....

SUBSCRIPTION RATES:

Single Copy.....\$.15
Three Months..... 1.50
Six Months..... 3.00
One Year, 52 Issues..... 6.00
Add \$1.00 a Year for Foreign Postage; 50c for Canadian Postage.

RADIO CATALOG
also **LOG**
FREE SAVE on all the latest standard radio merchandise!
No exceptions. Our 1926 Beautifully Illustrated Catalog.
JUST OFF THE PRESS!
Everything new in Radio AT SLASHED PRICES. Write for it today, before you buy anything. Delay means losing exceptional chance to participate in this great BARGAIN SALE. Rush your name and address at once and get also a
LOG BOOK FREE
ECONOMY RADIO SALES COMPANY
288 6th Ave., Dept. E, New York
Deal Direct and Save Real Money
(No Dealers)

Fourth Conference Called by Hoover for November 9

WASHINGTON.

Secretary Hoover will call the Fourth National Radio conference in session in Washington on November 9. The scope of the conference will differ in many respects from that of any previous sessions. Recog-

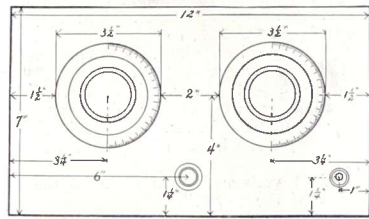

A FRONT panel view of a 2-dial 1-tube receiver. The dial in the center is for the rheostat, while the hole at the right hand edge is for the jack.

nizing that the radio public is the biggest factor in the present situation, Secretary Hoover will attempt to bring to the conference the views of fans throughout the country.

To accomplish this, every radio publication in the United States, including magazines and daily papers which conduct radio columns, will be invited to send a representative to the conference. It is believed that the representatives of the press will more nearly reflect the views of the radio public than any other group. In addition, the Secretary will invite every broadcasting station to send a representative.

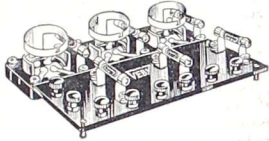

The New VEBY AMPLIFIER

A Resistance Coupled Amplifier that will truly fit within the cabinet of any commercial receiver. Just seven inches long and five inches deep. It is fully assembled and ready to attach. The price is.....\$12.00
VEBY Hi Mu Tubes A. F. 20 for R. C. Amplifiers\$3.00
VEBY Power Tubes A. F. 6 for the last stage\$4.50



47-51 MORRIS AVENUE. NEWARK, N. J.

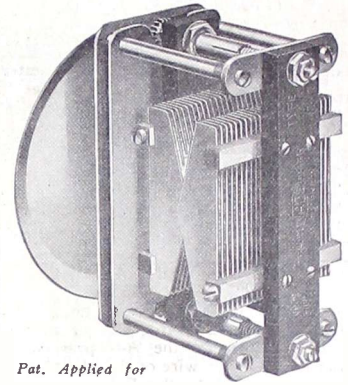

Pat. Applied for

WIDE Separation of Stations

Tuning is easy NOW! Special plate construction, exclusively a Wade feature, spreads all stations evenly over a 360 degree dial. Gives a wider separation of stations than ordinary rotor plate types of straight line frequency condensers using 180 degree dials.

Because of this wide separation of stations, the Wade condenser is specified in the R. X. 1 receiver and many critical circuits where sharp tuning is essential.

Wade condensers cover the entire broadcast band, even down below 200 meters.

All sizes, complete with 4-inch silvered 360 degree vernier dial, 32-1 ratio for:

Short Wave .000125 mfd.	\$7.50
.00025 mfd.	7.75
.0005 mfd.	8.00

At your dealers, otherwise send purchase price and you will be supplied postpaid.

Wade Radio Corporation
1819-C Broadway New York

POWERTONE

SET or KIT

This is the receiver that the whole family will enjoy tuning. Just one dial to turn. Volume aplenty, quality superb, range remarkable! Sold in cabinet on 10-day money-back guarantee **\$39.50**
With Bretwood Variable Grid Leak installed. \$40.50

The same genuine licensed parts as used in the factory set, but without cabinet. Easy to build. Drilled and engraved panel. Hookups included in the boxed kit..... **\$29.50**
With Bretwood Variable Grid Leak.....\$30.50

RADIO DIVISION, COLUMBIA PRINT

145 WEST 45th STREET

NEW YORK CITY

RADIO WORLD'S 2-For-Price-of-1 Subscription Offer For NEW RADIO WORLD Subscribers Ordering NOW

Radio World has made arrangements

- To offer a year's subscription FREE for any one of the following publications with one year's subscription for RADIO WORLD
- RADIO NEWS or -RADIO DEALER or
- POPULAR RADIO or -RADIO JOURNAL or
- RADIO BROADCAST or -RADIO (San Francisco) or
- SCIENCE AND INVENTION or -THE EXPERIMENTER or
- RADIO AGE

This is the way to get two publications

- for the price of one;
- Send \$6.00 today for RADIO WORLD
- for one year (regular price
- for 52 numbers)
- and select any one of the other
- nine publications for twelve months.
- Add \$1.00 a year extra for
- Canadian or Foreign Postage.
- Present RADIO WORLD subscribers
- can take advantage of this offer by
- extending subscriptions one year
- if they send renewals NOW.

RADIO WORLD'S SPECIAL TWO-FOR-PRICE-OF-ONE SUBSCRIPTION BLANK

RADIO WORLD, 145 West 45th St., N. Y. City.

Enclosed find \$6.00, for which send me RADIO WORLD for twelve months (52 numbers), beginning..... and also without additional cost, Radio News, or Popular Radio, or Radio Broadcast, or Science and Invention, or Radio Dealer, or Radio (San Francisco), or The Experimenter, or Radio Journal, or Radio Age (or \$10.00 for two yearly subscriptions).

Indicate if renewal. Offer Good Until October 25, 1925

Name
Street Address
City and State

Tuning Directions for the Set That Gave Jack a Good Time

(Continued from page 11)

you used very heavy stuff."
 "Yes, I used No. 14 rubber covered copper wire."
 "But you can't make a neat set with that type of wire."
 "Give me the efficiency."
 "I have some No. 14 stranded wire, which has a rubber, and then a cotton coating. How's that for wiring?"
 "Fine, if you have enough of it."
 "Did you solder all your connections?"
 "No, I soldered only those which were

absolutely necessary. Where the connections could be screwed down, I did so. Poor soldering causes resistance. You may not know how to solder, so I would advise you to leave the iron alone. Of course, you can learn, but until then, do as I said. I'm no expert either. However, if the soldering connections are done properly, there is nothing better, where soldering is absolutely needed, as in long filament leads, etc."

"What voltage do you place on the filaments of the tubes?"

"I use a 6-volt storage battery, which, with the rheostat in the circuit, delivers the proper amount of voltage, which is 5."

"Those B+ 1, 2 and 3—what are they for?"

"Well, the B+ 1 post goes to the plate post of the detector tube. There are 45 volts of B battery placed here. The B+ 2 post goes to the plates of the radio-frequency amplifiers. Here 67½ volts of B battery are used. The B+ 3 post goes to the plate of the 3 audio-amplifiers. Here 90 to 112½ volts of B battery are used."

Tuning

"How should the set be tuned, when the first attempt is made, that is, when you have just completed the set?"

"First insert the tubes. Connect the A battery. Pull the switch. See if the tubes light. Now get an old tube that has been lying around the house. The only essentiality of this tube is that it have a good filament. Insert this tube in the detector circuit. Place the detector B battery on. If the tube stays lit, the circuit is O. K. Of Course, there is very little reason why the tube should burn out, but it is always good to take precautions, as \$2.50 is not very easily found or desired to be thrown away. This applies in my case, and I think in yours. Now place the same tube in the various RF stages, and attach the RF B battery. Take the tube out and insert in the various AF sockets, applying the B battery. All right, we are all set. Now insert all the 6 tubes, attach the antenna and the ground, and plug in the loud speaker. Light all the tubes up. The rheostats that are on the shelf will have to be turned up one-half the way. The other two, which are on the shelf will have to be turned up just about one-quarter of the way. The arm of the potentiometer is turned so that it rests in the center of the resistance wire. This is left alone for the present. Now tune both the condensers. Condenser C2 will be 2 points ahead of condenser C1. The station will come in without any noise

WOUND WIRE AERIAL
 ABSOLUTELY "DIFFERENT"
 NOTHING BEATS AN OUTSIDE AERIAL
 MAKE those stations that you ALMOST GET—
 COME IN.
 Don't buy a NEW set, GET THE BEST out of YOURS.
 WRITE TODAY—Price \$5.00, Shipped C.O.D.
 YOUR AERIAL IS IMPORTANT, WHY NOT HAVE
 THE BEST?
 Your money back if it does not beat
 any aerial that you have ever used.
 THE WOUND WIRE AERIAL CO.
 REEDVILLE, VIRGINIA

Positively Greater Volume,
 Distance and Perfect Selectivity
 with
AERO COIL
 Low Loss Inductances
 AERO PRODUCTS, INC.
 1772 WILSON AVENUE, CHICAGO

LOUD SPEAKER RECEPTION
 from either coast on three tubes.
 Blueprint and instructions.....\$1.00
 Necessary low loss coil.....\$2.50
 Beautiful finished instrument.....\$35.00
S. A. TWITCHELL CO.
 1930 Western Avenue Minneapolis, Minn.

DEALERS BIG DISCOUNTS
 Radio's biggest season is here. Get our
 new catalog showing huge stocks of radio
 parts, sets, kits at lowest rock-bottom
 prices. Quick service. Wonderful special
 offer on best sets, tubes, batteries.
 Write for free copy.
 W.C. Braun Co., 31-49 S. Clinton St., Chicago, U.S.A.

HERCULES AERIAL MAST
 20 Ft. Mast \$10
 40 Ft. Mast \$25
 60 Ft. Mast \$45
 All steel construction, complete
 with guy wires and masthead
 pulley. We pay the freight.
 S. W. HULL & CO., Dept. E3
 2048 E. 79th St., Cleveland, O.
FREE Write for literature and Blueprint

Build the Powertone!

It is easy to tune—only one dial. It has wonderful tone and volume. It is marvelous for bringing in far-distant stations.



"It Has a Soul for Music."

Use the Official Kit or buy the Official set, both licensed under the Hogan Patents.

Official Boxed Kit, including drilled and engraved panel and hookup **\$29.50**

Licensed Set, made in our factory of same parts; installed in cabinet **\$39.50**

Inquiries Invited from the Trade.

BRUNO RADIO CORPORATION

Telephone: Cortlandt 4467
Dept. W. 223 Fulton St. N. Y. City

as you noted when tuning in the stations. Then by turning up the rheostat R2, the signal is brought in louder. Now turn the potentiometer to the right and to the left.

FREE BOOKLET FOR INVENTORS
 IF YOUR INVENTION is new and useful it is patentable. Send me your sketch. Z. H. POLACHEK, 70 Wall St., New York.
 Reg. Patent Attorney-Engineer

CROSLEY
 RADIO CATALOG FREE
 Describes fully the complete line of radio frequency sets, regenerative sets (licensed under Armstrong U. S. Patent No. 1,113,149) and parts.
 Write for Catalog Today.
THE CROSLEY RADIO CORPORATION
 POWEL CROSLEY, Jr., President
 7408 Sasafraas Street Cincinnati, Ohio

RADIO TUBES
 All Types, guaranteed.
\$1.50 each
ACME PRODUCTS CO.
 Dept. 105
 903 Broad St. Newark, N. J.

PANELS
 RADION and HARD RUBBER
 RETAIL ANY SIZE WHOLESALE
 PRICE LIST MAILED ON REQUEST
HARD RUBBER SHEETS—RODS—TUBING
 Special Hard Rubber Parts Made to Order.
 Send Sample or Sketch for Quotation.
NEW YORK HARD RUBBER TURNING CO.
 212 CENTRE ST. NEW YORK

The New and Better Diamond of the Air

 The Bernard Audio Amplifier
 DX, Selectivity, Volume and Quality
 —All Marvelously Combined in
 RADIO WORLD'S 1926 Model
DIAMOND OF THE AIR
 5 tubes, including Bernard AF hookup,
 Sept. 12, 19 and 26 issues of RADIO
 WORLD, including picture diagrams of
 wiring.
 Send 45c. for these three numbers or
 start your subscription with the Sept.
 12 issue. Send \$6 for yearly subscrip-
 tion and get these three issues FREE.
 Address Circulation Manager, RADIO
 WORLD, 145 W. 45th St., New York
 City.

HOOK-UPS!—A lot of them, some of which are sure to suit your purpose, appeared in RADIO WORLD dated Aug. 15. 15c a copy, or start your subscription with that number. RADIO WORLD, 145 West 45th St., N. Y. City.

Is It Worth While to Go a Distance to the Water Pipe?

There will be a certain point reached, when the set will start to squeal. At this point

THE RAMBLER SIX A REAL PORTABLE

Volume, Clarity, Portability, Durability and Beauty Unequaled

Lightest in weight. 21 pounds.

Smallest in size. 14x9½x9¾ inches

LIST PRICE.....\$80.00

If your dealer cannot make immediate delivery we will ship direct from factory same day your money order or check is received.

American Interstate Radio Service

183 Greenwich Street, New York City
Distributors. Jobbers, Dealers, write for special trade terms.

"Bruno" Magic Dial



Makes any semi-circular plate condenser tune like the straight-line frequency type. No gears, no backlash.

\$250

BRUNO RADIO CORPORATION
Dept. W103 221 Fulton St. New York City
Inquiries Solicited from the Trade

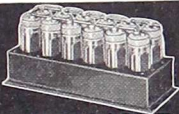

only **\$3.50**
C.O.D.

THE RABAT SENIOR
4200 MIL. AMPS. CAPACITY

THE most amazing offer ever made on wet "B" batteries. Rabats are used with any type radio set. They produce stronger, clearer tones. 12 cell 24 volt only \$2.50, 24 cell 48 volt \$7.00, fully charged ready to use.

Rabat Super "B" Charger Only \$3.00
Rabat Double Duty A & B Charger \$11.00

SEND NO MONEY but order today. After examination and approval pay expressman small c.o.d. charges. All prices f.o.b. factory. These gold medal Rabat Batteries are sold on an absolute money back guarantee. Over 100,000 satisfied users. THE RADIO RABAT CO. 1247 Orason, Cleveland, O.

\$4.75



POLLO

A loud speaker of surprising musical quality and volume. In the class with high priced speakers. Artistically designed. Swan neck type. Adjustable unit where volume and tone are at all times under perfect control. Send no money. Just pay the postman.

RIX RADIO
SUPPLY HOUSE, INC.

5505 4th Ave. Dept. 43 Brooklyn, N. Y.

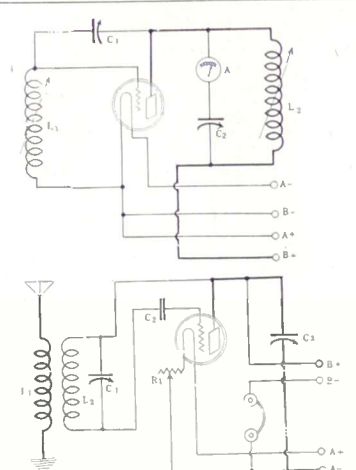

THESE two diagrams represent methods by which the plate may be coupled back to grid, thereby establishing regeneration.

let the potentiometer alone. By decreasing the rheostat, R2, this squeal will be killed." "How do you attach the loop?" "The loop can be left always attached to the set. You see where posts F, Loop, Loop, and G are? Well, when you want to use the loop, take the piece of wire that connects the G post to the Loop post and the F post to the Loop post off. Also turn off the first tube."

"And how do you use the antenna?" "Connect the loop post to the Grid post and the F post to the other Loop post. Light the first tube." "What is the B— attached to?" "That goes to the A+." "Do you have to reverse the A battery to get louder signals?" "It doesn't hurt to try it." "How long should my antenna be?" "The longest it should be, including the lead-in, is 110 feet."

"That is impossible. I live on the first floor of a 6-story apartment house, and the length of my aerial is about 200 feet."

"Place a .001 mfd. condenser in series with the aerial lead. You will get the required length of the antenna."

"What do you think is the best ground? I use the steam pipe, but the results are not so good, although the set itself is nothing to rave about."

"There is only one ground and the best connection to it is the cold water pipe or the damp earth itself if such is accessible."

"The water pipe is far away from my set. Won't that hinder reception any?"

"It will, but the results will be 100% better than with the steam pipe."

Takes the Mystery out of RADIO



JUST OUT
514 PAGES

Compiled by
HARRY F. DART,
E.E.

Formerly with the
Western Electric Co.,
and U. S. Army In-
structor of Radio.

Technically edited by
F. H. Doane

NO MORE need you turn from book to book, hoping to find what you want. It is all here, in 514 pages crammed full of every possible radio detail. Written in plain language, by engineers for laymen. More than 100,000 sold.

IT EXPLAINS: Electrical terms and circuits, antennas, batteries, generators and motors, electron (vacuum) tubes, many receiving hook-ups, radio and audio frequency amplification, broadcast and commercial transmitters and receivers, super-regeneration, codes, etc.

Send \$1 today and get this 514-page I. C. S. Radio Handbook—the biggest value in radio today.

International Correspondence Schools
Box 8, 92-E Scranton, Penna.
I enclose One Dollar. Please send me—post-paid—the 514-page I. C. S. Radio Handbook. It is understood that if I am not entirely satisfied I may return this book within five days and you will refund my money.
Name,
Address,
Check here and enclose \$1.50 if you wish the de luxe edition, bound in leather.

EVEREADY Radio Batteries

—they last longer



**CONDENSERS
VARIABLES
RHEOSTATS**

AMSCO PRODUCTS, Inc. New York City

Mailing Lists



Will help you increase sales Send for FREE catalog giving counts and prices on classified names of your best prospective customers—National, State, Local—Individuals, Professions, Business Firms

99% by return or 5c each

ROSS-Gould Co. 10th St. St. Louis

CRYSTAL SETS FOR USE TODAY, by Lewis Winner with diagrams in RADIO WORLD, dated July 25, 1925, 15c a copy, or start your subscription with that number. RADIO WORLD, 145 West 45th St., N. Y. City.

WESTERN ELECTRIC CO. FIXED CONDENSERS

8 MFD. 350 VOLT BREAKDOWN



These Condensers are JUST WHAT YOU WANT for your "B" BATTERY ELIMINATOR and your EXPERIMENTAL WORK. The Condensers are made of the Best Quality of paper and Tin Foil and each Condenser is sealed in a metal container to prevent injury while handling. They are compact, accurate and mounting brackets are conveniently located for placing anywhere in the circuit.

Don't Forget This Is a Western Electric Co. Product
EXTRA SPECIAL PRICE \$1.85 EACH

AMERICAN SALES CO., 21 WARREN ST., NEW YORK CITY

THE KEY TO THE AIR

(Continued from page 19)

WEEL, Boston, Mass., 476 (EST)—6:45 AM to 8; 3 PM to 4; 5:30 to 10.
 WEMC, Berrien Spring, Mich., 266 (CST)—8:15 PM to 11.
 WFAA, Dallas, Texas, 475.9 (CST)—10:30 AM to 11:30; 12:30 PM to 1

The KELLOGG SYMPHONY REPRODUCER

All that the music implies in beauty of tone, volume and appearance. Priced at \$25.00, and worth far more when the marvelous quality of the reception is compared with that of ordinary "loud speakers." Ask your dealer for a demonstration, or if your dealer does not carry it, write for folder H W.

KELLOGG SWITCHBOARD & SUPPLY CO.
 1066 W. Adams St. Chicago, Ill.

EVERY SET BUILDER NEEDS THIS



"Morsing Bus-Bar Union"

Makes for quick assembling. Repairs can be made by using Morsing Bus-Bar Union without taking set apart.

Assemble round or square Bus-Bar and solder three wires at a time. Order No. 1 for No. 14, No. 2 for 12 wire. Send 25 cents for enough for building one set, or ten dozen for \$1.00.

Newark Watch Case Material Co.
 15 Ward Street Newark, N. J.
 DISTRIBUTORS WANTED

WFBH, New York City, 270.6 (EST)—2 PM to 7:30; 12 M to 1 AM.
 WGCP, New York City, 252 (EST)—2:30 PM to 5:18; 8 to 10.
 WGES, Chicago, Ill., 250 (CST)—7 PM to 9; 11 to 1 AM.
 WGBS, New York City, 316 (EST)—10 AM to 11 PM; 1:30 to 4; 6 to 7.
 WGN, Chicago, Ill., 370 (CST)—9:31 AM to 3:30 PM; 5:30 to 11:30.
 WGR, Buffalo, N. Y., 319 (EST)—12 M to 12:45 PM; 2:30 to 4:30; 6:30 to 11.
 WGY, Schenectady, N. Y., 379.5 (CST)—5:30 PM to 7:30.
 WHAD, Milwaukee, Wis., 275 (CST)—11 AM to 12:15 PM; 4 to 5; 6 to 7:30; 8 to 10; 11:30 to 12:30 AM.
 WHAS, Louisville, Ky., 399.8 (CST)—4 PM to 5; 7:30 to 9.
 WHN, New York City, 368 (EST)—2:15 PM to 5:30; 7:30 to 11; 11:30 to 12:30 AM.
 WHO, Des Moines, Iowa, 526 (CST)—12:15 PM to 1:30; 6:30 to 12 M.
 WHT, Chicago, Ill., 400 (CST)—11 AM to 2 PM; 7 to 8:30; 10:30 to 1 AM.
 WIP, Philadelphia, Pa., 568 (EST)—7 AM to 8; 10:20 to 11; 1 PM to 2; 3 to 4; 6 to 8.
 WJZ, New York City, 455 (EST)—10 AM to 11; 1 PM to 2; 4 to 6; 6 to 11:30.
 WKRC, Cincinnati, Ohio, 326 (EST)—8 PM to 10.
 WLIT, Philadelphia, Pa., 395 (EST)—12:02 PM to 12:30; 2 to 3; 4:30 to 6; 7:30 to 9.
 WLW, Cincinnati, O., 422.3 (EST)—10:45 AM to 12:15 PM; 1:30 to 2:30; 3 to 5; 6 to 11.
 WMCA, New York City, 341 (EST)—10:45 AM to 12 M; 6:30 PM to 12.
 WNYC, New York City, 526 (EST)—6:30 PM to 11.
 WOC, Davenport, Iowa, 484 (CST)—12:57 PM to 2; 3 to 3:30; 4 to 7:05; 9 to 11.
 WOR, Newark, N. J., 405 (EST)—6:45 AM to 7:45; 2:30 PM to 4; 6:15 to 12 M.
 WPAK, Fargo, N. D., 283 (CST)—7:30 PM to 9.
 WOJ, Chicago, Ill., 448 (CST)—11 AM to 12 M; 3 PM to 7; 8 to 10; 10 to 2 AM.
 WRC, Washington, D. C., 469 (EST)—9 AM to 10; 12 M to 2; 6:25 PM to 7.
 WREQ, Lansing, Michigan, 285.5 (EST)—10 PM to 11.

WRNY, New York City, 258.5 (EST)—11:59 AM to 2 PM; 7:59 to 9:55.
 WSB, Atlanta, Ga., 428.3 (CST)—12 M to 1 PM; 2:30 to 3:30; 5 to 6; 10:45 to 12.
 WSBF, St. Louis, Mo., 273 (CST)—12 M to 1 PM; 3 to 4; 7:30 to 9.
 WWJ, Detroit, Mich., 352.7 (EST)—6 AM to 8:30; 9:30 to 10:30; 11:55 to 1:30 PM; 3 to 4; 6 to 7; 8 to 10.
 KDKA, Pittsburgh, Pa., 309 (EST)—6 AM to 7; 9:45 to 12:15 PM; 2:30 to 3:30; 5:30 to 11.
 KFAE, State College of Wash., 348.6 (PST)—7:30 PM to 9.
 KFI, Los Angeles, Cal., 467 (PST)—5 PM to 11.
 KFKX, Hastings, Neb., 288.3 (CST)—12:30 PM to 1:30; 5:15 to 6:15; 9:30 to 12:30 AM.
 KFMO, Fayetteville, Ark., 299.8 (CST)—7:30 PM to 9.
 KPNF, Shenandoah, Iowa, 266 (CST)—12:15 PM to 1:15; 3 to 4; 6:30 to 10.
 KPOA, Seattle, Wash., 455 (PST)—12:30 PM to 1:30; 4 to 5:15; 6 to 10.
 KGO, Oakland, Cal., 361.2 (PST)—11:30 AM to 1 PM; 1:30 to 2:30; 3 to 6:45.
 KGW, Portland, Oregon, 491.5 (PST)—11:30 AM to 1:30 PM; 5 to 10.
 KHJ, Los Angeles, Cal., 405.2 (PST)—7 AM to 7:15; 12 M to 1:30 PM; 5:30 to 12.
 KJR, Seattle, Wash., 484.4 (PST)—9 AM to 1 AM.
 KNX, Hollywood, Cal., 337 (PST)—1 PM to 2; 7 to 12.
 KOIL, Council Bluffs, Iowa, 278 (CST)—7:30 PM to 9; 11 to 12 M.
 KPO, San Francisco, Cal., 429 (PST)—7 AM to 7:45; 10 to 12 M; 1 PM to 2; 3:30 to 11.
 KSD, St. Louis, Mo., 541.1 (CST)—6 PM to 7.
 KTHS, Hot Springs, Ark., 374.8 (CST)—12:30 PM to 1; 8:30 to 10:30.
 KYW, Chicago, Ill., 536 (CST)—6:30 AM to 7:30; 10:30 to 1 PM; 2:15 to 4; 6:02 to 11:30.
 CNRA, Moncton, New Brunswick, Canada, 313 (EST)—9:30 PM to 11.
 CNRR, Regina, Saskatchewan, Canada—8 PM to 11.
 CNRO, Ottawa, Ontario, Canada, 435 (EST)—7 PM to 11.

THURSDAY, OCTOBER 22

WAAM, Newark, N. J., 263 (EST)—11 AM to 12 M; 7 PM to 11.
 WAHG, Richmond Hill N. Y., 316 (EST)—12:30 PM to 1:05.
 WAMB, Minneapolis, Minn., 243.8 (CST)—12 M to 1 PM; 10 to 12 M.
 WBBM, Chicago, Ill., 226 (CST)—8 PM to 10.
 WBOJ, Richmond Hill, N. Y., 236 (EST)—3:30 PM to 6:30.
 WBZ, Springfield, Mass., 333.1 (EST)—6 PM to 11:45.
 WCAE, Pittsburgh, Pa., 461.3 (CST)—12:30 PM to 1:30; 4:30 to 5:30; 6:30 to 11.
 WCBD, Zion, Ill., 344.6 (CST)—8 PM to 10.
 WCCO, St. Paul and Minneapolis, Minn., 416.4 (CST)—9:30 AM to 12 M; 1:30 PM to 4; 5:50 to 10.
 WEAF, New York City, 492 (EST)—6:45 AM to 7:45; 11 to 12 M; 4 PM to 5; 6 to 12.
 WEAR, Cleveland, O., 390 (EST)—10:30 AM to 12:10 PM; 3:30 to 4:15; 7 to 11.
 WEEL, Boston, Mass., 467 (EST)—6:45 AM to 7:45; 1 PM to 2; 2:30 to 10.
 WFAA, Dallas, Texas, 475.9 (CST)—10:30 AM to 11:30; 12:30 PM to 1; 2:30 to 6; 6:45 to 7; 8:30 to 9:30; 11 to 1 AM.
 WFBH, New York City, 272.6 (EST)—2 PM to 7:30.
 WGBS, New York City, 316 (EST)—10 AM to 11; 1:30 PM to 4; 6 to 10:30.
 WGCP, New York City, 316 (EST)—2:30 PM to 5:15.
 WGES, Chicago, Ill., 250 (CST)—5 PM to 8; 10:30 to 1 AM.
 WGN, Chicago, Ill., 370 (CST)—9:31 AM to 3:30 PM; 5:30 to 11:30.
 WHAD, Milwaukee, Wis., 275 (CST)—11 AM to 11:30; 6 PM to 7:15; 8:30 to 11.
 WGR, Buffalo, N. Y., 319 (EST)—12 M to 12:45 PM; 2 to 4; 7:30 to 11.
 WHAD, Milwaukee, Wis., 275 (CST)—11 AM to 12:15 PM; 4 to 5; 6 to 7:30; 8 to 10.
 WHAR, Atlantic City, N. J., 275 (EST)—2 PM to 3; 7:30 to 10.
 WHAS, Louisville, Ky., 399.6 (CST)—4 PM to 5; 7:30 to 9.
 WHN, New York City, 360 (EST)—2:15 PM to 5; 7:30 to 11; 11:30 to 12:30 AM.
 WHO, Des Moines, Iowa, 526 (CST)—7:30 PM to 9; 11 to 12.
 WHT, Chicago, Ill., 400 (CST)—11 AM to 2 PM; 7 to 8:30; 10:30 to 1 AM.
 WJY, New York City, 405 (EST)—7:30 PM to 11:30.
 WJZ, New York City, 455 (EST)—10 AM to 11.

As Easy to Tune in As to Listen in!

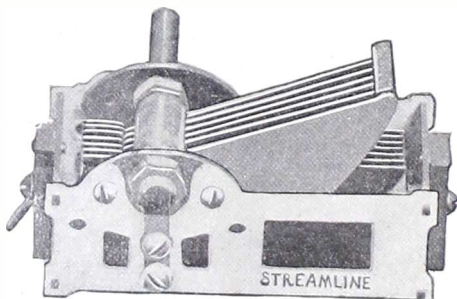

THAT is the condition happily brought about by the Streamline straight-line frequency condenser. Stations crowded on the lower waves by semicircular plate condensers are widely separated by this moderately-priced and marvelously efficient instrument. No more back-breaking

- .0005 (23 plates) **\$2.50**
- .00035 (17 plates) **\$2.25**
- .00025 (11 plates) **\$2.00**

ordeals tuning in stations! The coils used with your present semicircular plate condensers will cover the wavelength band, without change, when you install Streamline.



Inquiries Invited from the Trade

STREAMLINE RADIO CO., Dept. W2, 221 Fulton Street, N. Y. City
 Enclosed find \$..... for which send me by return mail Streamline SLF condensers, capacity

NAME

ADDRESS

CITY STATE

NEW IMPROVED

FRESHMAN MASTERPIECE

AT AUTHORIZED FRESHMAN DEALERS ONLY

THE KEY TO THE AIR

(Concluded from preceding page)

- 11; 1 PM to 2; 4 to 6; 7 to 12 M.
- WLIT, Philadelphia, Pa., 395 (EST)—12:02 PM to 12:30; 2 to 3; 4:30 to 5; 8:30 to 9.
- WLW, Cincinnati, O., 422.3 (EST)—10:40 AM to 12:15 PM; 1:30 to 5; 6 to 8; 10 to 11.
- WMAK, Lockport, N. Y., 265.5 (EST)—11 PM to 1 AM.
- WMCA, New York City, 341 (EST)—11 AM to 12 M; 6:30 PM to 12.
- WNYC, New York City, 526 (EST)—3:15 PM to 4:15; 6:30 to 11.
- WOWA, Omaha, Neb., 526 (CST)—12:30 PM to 1:30; 5:45 to 11.
- WOC, Davenport, Iowa, 484 (CST)—12:57 AM to 2 PM; 3 to 3:30; 4 to 7:10; 8 to 9.
- WOR, Newark, N. J., 405 (EST)—6:45 AM to 7:45; 2:30 PM to 4; 4:15 to 7.
- WPG, Atlantic City, N. J., 299.8 (EST)—7 PM to 11.
- WJL, Chicago, Ill., 448 (CST)—11 AM to 12 M; 3 PM to 4; 7 to 8; 10 to 12 AM.
- WRC, Washington, D. C., 469 (EST)—1 PM to 2; 4 to 6:30.
- WREO, Lansing, Michigan, 285.5 (EST)—8:15 PM to 9:45; 10 to 11.
- WRNY, New York City, 258.5 (EST)—11:59 AM to 2 PM; 7:59 to 10.
- WSB, Atlanta, Ga., 428.3 (CST)—12 M to 1 PM; 2:30 to 3:30; 5 to 6; 8 to 9; 10:45 to 12.
- WSBF, St. Louis, Mo., 273 (CST)—12 M to 1 PM; 3 to 4; 8 to 9.
- WWJ, Detroit, Mich., 352.7 (EST)—8 AM to 8:30; 9:30 to 10:30; 11:55 to 1:30; 3 to 4; 6 to 7; 8 to 9.
- KDKA, Pittsburgh, Pa., 309 (EST)—9:45 AM to 12:15 PM; 2:30 to 3:30; 5:30 to 10:15.
- KFAE, State College of Washington, 348.6 (PST)—7:30 PM to 9.
- KFI, Los Angeles, Cal., 467 (PST)—5 PM to 11.
- KFKX, Hastings, Neb., 288.3 (CST)—12:30 PM to 1:30; 5:15 to 6:15; 9:30 to 12:30.
- KFNF, Shenandoah, Iowa, 266 (CST)—12:15 to 1:15 PM; 3 to 4; 6:30 to 10.
- KGO, Oakland, Cal., 361.2 (PST)—11:30 AM to 1 PM; 1:30 to 3; 4 to 6:45; 7:15 to 10.
- KGW, Portland, Oregon, 491.5 (PST)—11:30 AM to 1:30 PM; 5 to 11.
- KHJ, Los Angeles, Cal., 405.2 (PST)—7 AM to 7:15; 12 M to 3:20; 5:30 to 11:30.

A REAL AUDIO AMPLIFIER



That does the work
Only \$7.00 Postpaid
Will positively increase the range and volume of any tube or crystal set three or four times. Inaudible signals built up to speaker volume. Complete as illustrated, including tube. Best parts and workmanship. Satisfaction absolutely guaranteed.

TRELLCOTT CO. 2118 Hate Avenue
Louisville, Ky.

New WGY Wire Taps Three Cities

Leading musical events of western and central New York State cities will be made available to the international audience of WGY as a result of wire-connecting Buffalo, Rochester, Syracuse and Utica to the transmitting equipment of the Schenectady station. WGY is already connected by wire to Albany, Poughkeepsie and New York and through WJZ and WRC. Leading musical events of Washington are conveyed to the General Electric Company's Eastern station.

AMBASSADOR

4-TUBE, \$25.95; 3-TUBE, \$17.95

With tubes, cabinet; 1-tube sets, \$2.95 up. Edzin Radio, 675 6th Ave. Chick. 10385. Open eves., Sundays.

ERLA Engineers design amazing new condenser

Spreads low wavelength stations without crowding those from 50° to 100°. Lightweight and compact in style.

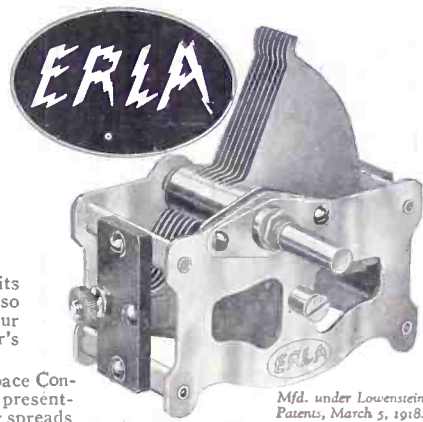

Mfd. under Lowenstein Patents, March 5, 1918.

RADIO science now offers you its newest condenser. Results are so amazing we ask you to test it in your own set. Get it at any Erla dealer's today.

This new invention—Erla *Equi Space Condenser—surpasses in results every present-day type. The straight line frequency spreads stations on the low wavelength proportions of the dial, but it also brings stations between 50° and 100° too close together. On the higher wavelengths are many high-powered stations that are extremely difficult to separate.

The Erla Equi Space makes allowance for this. It gives maximum spreads between stations over the entire range of the dial. Specially designed plates make this possible.

Now all stations, low frequency as well as high frequency, are spaced on the dial to insure the best results. Tuning is made far sharper. Sensitivity is greatly increased, reducing losses to an unprecedented minimum. Plates of special spring brass are scientifically spaced and give maximum conductivity. Scientific tests show a resistance far lower even than costly laboratory types.

Equi Space is small and compact, requiring little space. Very light but having extreme rigidity because of four riveted cross members.

Go to any radio store and see this amazing condenser today. It will make a striking difference in any set.

Send your name and address today and we will mail free, news of the latest radio discoveries and inventions.

*Trade Mark Registered

Made by

ELECTRICAL RESEARCH LABORATORIES

Chicago, U. S. A.

Special Erla Features

Minimum capacity only 10 m. m. f.

Ratio of maximum to minimum capacity 35 to 1.

Total resistance of only 3 ohms at 1000 cycles.

Four riveted cross-members supporting stator plates provide rigidity unapproached.

Single-hole mounting makes it easy and quick to attach.

Light weight plates of special spring brass appreciably reduce bulk and weight, and tremendously reduce tendency toward misalignment from rough usage.

FREE!

12-Cell — 24-Volt Storage 'B' Battery

Positively given free with each purchase of a WORLD "A" Storage Battery. You must send this ad with your order. WORLD Batteries are famous for their guaranteed quality and service. Backed by years of successful manufacture and thousands of satisfied users. Equipped with Solid Rubber Case, an insurance against acid and leakage. You save 50 per cent and get a

2-Year Guarantee

Bond in Writing — WORLD B. sell their friends. That's our best proof of performance. Send your order in today.

Solid Rubber Case Radio Batteries	
6-Volt, 100-Ampere-hours	\$11.25
6-Volt, 120-Ampere-hours	\$12.00
6-Volt, 140-Ampere-hours	\$13.00
Solid Rubber Case Auto Batteries	
6-Volt, 11-Plate	\$41.25
6-Volt, 13-Plate	\$45.00
6-Volt, 7-Plate	\$16.00

Send No Money — Just state battery you wish, day order is received, by Express C. O. D. subject to your examination on arrival. **FREE "B" Battery** included. **Extra Offer** — 5 per cent discount for cash in full with order. Buy new and get a guaranteed battery at 50 per cent saving to you.

WORLD BATTERY COMPANY
1219 So. Wabash Ave., CHICAGO, ILL.

World

STORAGE BATTERIES

WOKA — WCAF — WGN — WJS — KHJ — KGO — KFAE — WJZ — KOP

HOOK-UPS

A lot of them, some of which are sure to suit your purpose, appeared in RADIO WORLD dated August 15. 15c a copy, or start your subscription with that number.

RADIO WORLD, 145 West 45th St., N. Y. City.

A DYNAMIC SET. Enormous Power on 3 Tubes, by P. E. Edelman. An Anti-Radiation Toroid Set, by Capt. P. V. O'Rourke. Four Crystal Hook-ups, by Lewis Winner. Other features in RADIO WORLD dated July 25, 1925. 15c a copy, or start your subscription with that number. **RADIO WORLD**, 145 West 45th St., N. Y. City.

Dept. 18-A

Electrical Research Laboratories,
2500 Cottage Grove Ave., Chicago, Ill.

Tell me what's new in radio.

Name _____

Address _____

City _____

County _____ State _____

Class B Stations Now 114; Several Use Increased Power

WASHINGTON. The total number of class B broadcasting

Jones MULTI-PLUG THE STANDARD SET CONNECTOR

HOWARD B. JONES 618 S. CANAL STREET CHICAGO

GEM TUBE

A Guaranteed Radio Tube Within Reach of All

Every tube guaranteed. A tube for a dollar of \$2 value. A trial order will convince you as it has thousands of others. Send your orders at once.

Orders sent C.O.D. parcel post.

Type... 199A
Type... 199
Type... 200
Type... 201A
(with standard base) EACH
Dealers, Write for Discounts
GEM TUBE CO.

Dept. W, 200 B'way, N. Y. C.
220 So. State St., Chicago, Ill.
Lafayette Bldg., Detroit, Mich.



stations reached a new high mark with the transfer of WAFD, at port Huron, Michigan, from class A to B. This brings the class B total up to 114.

During the past month 21 stations were licensed while only nine were discontinued. This brings the grand total of stations up to 583, of which 466 are Class A, 2 Class B, and 1 Class C.

Several stations increased their power, taking advantage of the announcement of the Department of Commerce that increases in power could be made in more than 500-watt stages. Some of the power increases during the month follow:

- KFOA, Seattle, Wash., to 1,000 watts.
- KFMQ, Fayetteville, Ark., to 750 watts.
- KYW, Chicago, to 2,000 watts.
- WGY, Schenectady, to 3,500 watts.
- WHO, Des Moines, to 5,000 watts.
- WHT, Deerfield, to 2,000 watts.
- WTAM, Cleveland, to 3,500 watts.
- WTAS, Elgin, to 2,500 watts.

Nine stations discontinued follow:
WJBD—Ashland Broadcasting Committee, Ashland, Wis.

WABI—Bangor Hydro-Electric Co., Bangor, Maine.

WGBL—Elyria Radio Association, Elyria, Ohio.

KFLP—Everette M. Foster, Cedar Rapids, Iowa.

WSRF—Hardon Sales & Service, Broadlands, Ill.

WGBA—Jones Electric & Radio Mfg. Co., Baltimore, Md.

KUPR—Union Pacific Railroad Co., Omaha, Nebraska.

WSAV—C. W. Vick Radio Construction Co., Houston, Texas.

KFAF—Western Radio Corp., Denver, Colo.

New Stations

WASHINGTON.

Two Class A stations were licensed recently by the Department of Commerce, while one station was transferred from Class A to B. The new stations follow:

Call	Owner	Location	Kcs.	Meters	Watts
WJBG	Interstate Radio, Inc.	7 W. 4th St., Charlotte, N.C.	1340	224	10
WKBB	Sanders Bros., Joliet, Ill.		1400	214.2	100
WAFD	Albert B. Parfet Co., Port Huron, Michigan		1090	275	500

FREE two unusual RADIO CATALOGS



FOR "FANS"

OUR new 64-page Radio Catalog including all the best and latest Kits, Parts and Accessories for broadcast receiving sets. Lowest prices in the country.

FOR "HAMS"

NEW 32-page booklet of army and navy transmitting apparatus and miscellaneous specials for "hams" such as W. E. Choke Coils, Generators, Resistance Boxes, etc.

More than 1,000,000 fans and hams make our store their headquarters—get these books and find out why.

Write for either or both

509 South State Street



Dept. R. W. 6 Chicago Ill.

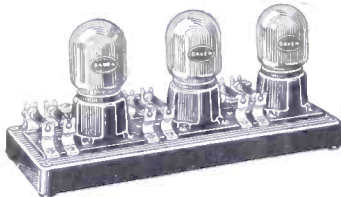

RE-BUILD Your Set

FOR pure tone quality change to, or add, three stages of Resistance Coupled Audio Amplification. Daven engineers have made it easy. Hook up a Daven Super-Amplifier—no labor of assembly—no distortion—perfect reception.

Daven precision-built unit with Bakelite base. Wonderful assembly. Compact, beautiful—\$15.00. Knock-down Kit \$9.00.

For more volume without distortion, use two Daven High Mu Tubes—\$4.00 each, and one Mu-6 (for last or output stage)—\$5.00.

Mail the coupon for complete information.

The Sine of Merit
DAVEN RADIO CORPORATION
Resistor Specialists
Reg. U. S. Pat. Off.

Newark

New Jersey



DAVEN RADIO CORPORATION L-10-25
158 Summit Street, Newark, N. J.

Please send me the following:
.....Resistor Manual, 80c is enclosed.
.....Complete Catalogue (free).

Name.....
Address.....

Get the Handbook of Resistance Coupled Amplification. At Daven's \$2.00. By mail 50c.

FOR DEALERS: Send your letterhead and we will have our nearest distributor communicate with you.

THE BIG LITTLE THINGS OF RADIO

Obsolete

Take the "GUESS" Out of Tube Control

with **AMPERITE** \$1.10 Everywhere

Amperite automatically controls tube current, eliminates hand rheostats, filament meters, guessing and all tube worry. Simplifies wiring, tuning and operation. Permits the use of any type of tube or any combination of tubes.

Tested and used by more than 50 set manufacturers and in every popular construction set

RADIALL COMPANY
Dept. RW-12 50 Franklin St., New York City

WRITE for FREE Hook-ups



AMPERITE
REG. U. S. PAT. OFF.

The "SELF-ADJUSTING" Rheostat

HOW TO BUILD THE POWERTONE, 1 dial, 5 tubes, described in RADIO WORLD, issues of Aug. 29 and Sept. 5. Powertone Trouble-shooting, Sept. 12. Send 45¢ for all three. Special diagrams and "blueprint in black" included among the many illustrations. RADIO WORLD, 145 West 45th St., N. Y. City.

HOOK-UPS

A lot of them, some of which are sure to suit your purpose, appeared in RADIO WORLD dated August 15. 15c a copy, or start your subscription with that number.

Oh boy

KESTER
Rosin Core
Radio SOLDER

Sure! is Safe and Simple

APPROVED BY RADIO ENGINEERS
A GENUINE SOLDER

CHICAGO SOLDER COMPANY
4242 Wightwood Ave., Chicago, U. S. A.

Originators and World's Largest Manufacturers of Self Fluxing Solder
YOUR DEALER CAN SUPPLY YOU

With
Irving Hoffman
at

KNX

Hollywood, Cal., 337 Meters



GALLISON PHELPS, TOWN CRIER OF NIGHT WATCH AT KNX.



E.J. ALBRIGHT, TOWN CRIER OF THE DAY WATCH.



CARRIE PRESTON RITTMESTER, PROGRAM MANAGER.



RAYMOND McFEETERS, CONCERT PIANIST AT KNX.



LILYAN MAY CHALLENGER, VOCALIST.



FORBES VAN WHY, IN CHARGE OF THE OPERATING ROOM.



JUNE PURSELL, VOCALIST AT STATION KNX, LOS ANGELES.

RADIO DE LUXE THE CLEARFIELD 6 TUBE

Encased in plate glass cabinet. Tuned Radio Frequency with Resistance Coupled Amplifier. \$115 (plus tax). True Tone Quality. List Price. . . . \$115

Write for Illustrated Booklet
Sherman Radio Mfg. Corporation
112-114 Trinity Place New York, N. Y.
Dealers write for our proposition.

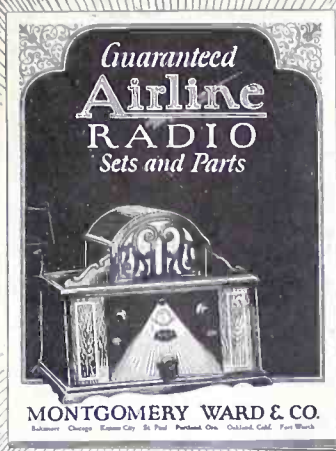

Ward's New Radio Catalogue Is Yours Free

Yours Free—the newest, most interesting book published on Radio. A book prepared by Radio experts—a complete Radio manual.
52 fully illustrated pages showing what is new in Radio and what has been approved by the best experts.
It shows sets from one tube to five tubes, the new one dial control, parts and supplies, batteries and cabinets. It gives a list of stations, a radio log for recording stations.

Headquarters for Radio

Ward's is today one of the greatest Radio stores in the world—selling

Write for your free copy of Ward's new Radio Catalogue
Address Dept. 42-R

ESTABLISHED 1872 Montgomery Ward & Co.

The Oldest Mail Order House is Today the Most Progressive
Baltimore Chicago Kansas City St. Paul Portland, Ore. Oakland, Calif. Ft. Worth

everything in Radio without the usual Radio Profits. And besides, we sell only the tested and approved equipment—selected and tested by our own experts, who are up to the minute in Radio. Thousands of customers write us of their delight and saving on Ward's Radio sets.
Our 53 year old Policy
For 53 years we have sold only quality merchandise under a Golden Rule Policy. You can rely absolutely upon the quality of everything shown in this Radio Catalogue.

DOUBLE-TOROID COILS



"Doubletoroids" can be mounted at any angle or spaced at any distance.

"Doubletoroids" make more selective sets possible, since they do not form miniature loop aerials.

"Doubletoroids" hold static and other disturbances to a minimum since no current from an external source can influence them.

Patented
March 31, 1925
Price \$2.75



Outstanding Features of the "Doubletoroids"
Both primary and secondary are true toroids.
The magnetic path is shortest.
It is the most compact.

Write for booklet in which Professor J. H. Morecroft gives his opinion of these coils.

It's Variable

The Nonoise Gridleak improves reception because it can be adjusted for every station. Fits standard brackets. Absolutely noiseless. At all dealers and in the better sets. Price, 85c.

NONOISE GRIDLEAK

RADIO FOUNDATION, INC.

25 WEST BROADWAY

NEW YORK

NEXT WEEK— An important discussion of fixed condensers, by J. E. ANDERSON, noted radio engineer.

Daylight Tests Called Feat in Navy's Short-Wave Work

WASHINGTON.

The outstanding accomplishment during the past month in the high-frequency field was

EASTERN PICKLE BOTTLE COILS RX1

are exclusively licensed by
M. B. Slinger for his new,
revolutionary, non-regenera-
tive four-tube RX-1 circuit
described in this issue. Per set,

\$6.00

Eastern Pickle Bottle Coils

are also designed for perfect performance in the following circuits:

SUPERDYNE (\$8.00 per set), BROWNING-
DRAKE (\$8.00 per set), ROBERTS (\$8.50 per
set), TUNED R. F. CIRCUITS (\$8.00 per call).

Certified by Hyman Bernard

At your dealers or direct, postpaid.

EASTERN COIL CORPORATION

22 WARREN ST.

NEW YORK

success attending daylight tests of the new transmitter at Bellevue, according to the Navy Department. Reliable night work on certain high frequencies is well established, while daylight communication has not been correspondingly reliable. These recent developments at the Naval Research Laboratory give reason to hope that long distance, low power, daylight communication may soon be possible. Here is the report of the Navy Department on the test:

"On September 9, Bellevue transmitted for



5 in 1 Connector

Use 1 to 5 headsets on any Radio Set with P and N Binding Posts. Ask your Dealer, or 25c. pair, postpaid.

JOBBERS, DEALERS
PRICES ON REQUEST

SNOW & COMPANY
Dept. W. 149 Church St., New York

CLAROTUNER



Specified For The
Famous Thoroughbred

RADIO World experts, Hayden and Bernard, specify the CLAROTUNER for the famous "Thoroughbred" circuit. More than that, they lay the success of this wonder circuit to the CLAROTUNER. There is no need of saying more.

CLAROTUNER mounts with only one hole. It incorporates the latest low loss design features. Ask your dealer about it! Model TCH \$4.50.

If distribution has not yet reached your dealer send your remittance direct to

American Mechanical Laboratories
Incorporated

285-7 N. SIXTH STREET, BROOKLYN, N. Y.

Ask about the
Clarostat, heart of
the Clarotuner.

test purposes on 11,700 kcs. (25.5 meters) for ten minutes at the beginning of each hour over a period of twenty-four hours. All naval radio stations and ships equipped with high-frequency receivers were requested to cover these schedules and forward results. The best results received to date are from the Trenton, which, at the time of the test, was in the vicinity of the Marquesas Islands. The Trenton reported copying continuously until completion of the test. The Ninth Naval District copied the test during the entire twenty-four hours. Reports from the Eleventh Naval District indicate that the signals were heard. An amateur in San Diego has reported that he copied these signals during the entire twenty-four hours. Tutuila reports good reception practically throughout the test. Reports from the Twelfth, Thirteenth and Fourteenth Naval Districts and Cordova do not indicate such good results."

Resistance Stage

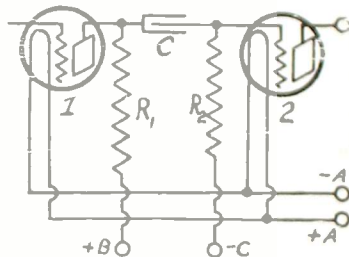

HOW to hookup a stage of resistance-coupled amplification. Taking for granted this is the first stage of such type of AF coupling, R1 has a resistance of .1 megohm, while R2 has a resistance of .1 megohm. The plate is connected either to a .05 megohm resistance if another stage is desired or to a terminal of the phones, the other terminal of the phones going to the B+ amplifier.

ULTRA-LOWLOSS CONDENSER

SPECIAL CUTLASS PLATES DISTRIBUTE THE STATIONS EVENLY OVER THE DIAL SIMPLIFIES TUNING CAPACITY 0005 MFD.

\$5.00

PHENIX RADIO CORP., 116-F East 25 St., N.Y.C.

RADIO WORLD'S QUICK-ACTION CLASSIFIED ADS.

10 CENTS A WORD. 10 WORDS MINIMUM.

LOOK! Standard Radio apparatus at 15% off list. This week's specials: Magnavox M4 Loud Speakers—\$20.00. New Valley "B" Eliminators, \$28.90. Send money order. J. P. Rose, 1019 Peoria Life Bldg., Peoria, Ill.

CONDENSERS 75c. Surplus stock, high grade vernier and plain variable condensers, all sizes While they last, 75c. Good three-mch dials. 15c Satisfaction guaranteed or money refunded. Order immediately, first come, first served. Radio Supply Company, Bluffton, Ohio.

COMPLETE LIST OF BROADCASTING STATIONS appeared in RADIO WORLD dated Oct. 3, 1925. 15c per copy, or start your subscription with that number. RADIO WORLD, 145 W. 45th St., N. Y. C.

HAVE YOU BEEN AWAY?

Have you missed any of the summer copies of RADIO WORLD?

We can supply you with any copies of RADIO WORLD published during the summer at our regular price of 15c per copy, or any seven copies for \$1.00, or start your subscription with any number.

MANUFACTURER OF NEW AND IMPROVED Station-finder and vernier tuning-dial wants live salesmen calling on radio trade. Excellent side line; good commission; exclusive territories. Westerland Corp., Dobbs Ferry, N. Y.

DINING AND SLEEPING CAR CONDUCTORS (White). Exp. unnecessary. We train you. Send for book of Rules and application. Supt. Railway Exchange, Sta. C, Los Angeles.

ATTENTION, RADIO DEALERS!—A five tube tuned R. F. long-distance set for \$16.85. Absolutely guaranteed by manufacturers. J. S. Radio Co., 86 E. 4th St., New York City.

BABY PORTABLE SET. How to make it. See RADIO WORLD dated May 16. 15c per copy, or start your subscription with that number. RADIO WORLD

HOW TO BUILD THE POWERTONE, 1 dial, 5 tubes, described in RADIO WORLD, issues of Aug. 29 and Sept. 5. Powertone Trouble-shooting, Sept. 12. Send 15c for all three. Special diagrams and "blueprint in black" included among the many illustrations. RADIO WORLD

PULLMAN CONDUCTORS, PORTERS. Men wishing such positions can easily qualify, information free. Supt., 123C, Railway Exchange, Kansas City.

SALESMEN!

MAKE \$100 WEEKLY IN SPARE TIME. Sell what the public wants—long distance radio receiving sets. Two sales weekly pay \$100 profit. No big investment, no canvassing. Sharpe of Colorado made \$955 in one month. Representatives wanted at once. This plan is sweeping the country—write today before your county is gone. Ozarka, Inc., 126 J. Austin Ave., Chicago, Ill.

CRYSTAL SETS FOR USE TODAY, by Lewis Winner, with diagrams, in RADIO WORLD, dated July 25, 1925. 15c a copy, or start your subscription with that number. RADIO WORLD, 145 West 45th St., N. Y. City.

A 1-CONTROL PORTABLE, by Capt. P. V. O'Rourke; A Baby Super-Heterodyne, only 4 Tubes, by J. E. Anderson; A More Powerful Diamond, Still only 4 Tubes, by Herman Bernard. Other features in RADIO WORLD, dated July 11, 1925. 15c a copy, or start your subscription with that number. RADIO WORLD

THE MONEY BACK STORE OF CORTLANDT ST.

CITY RADIO

79 CORTLANDT ST.
PHONE RECTOR 3338

Dept. RW, New York City, N. Y.

Immediate service on Mail Orders. Orders shipped same day received. Every purchase guaranteed by the oldest radio store in New York.

Thordarson-Wade Kit, \$42.50
Endorsed by Herman Bernard

Daven Super Amplifier Kits (new).....	\$11.45
Exide Sto. Bat., 100 amp., rubber case	12.95
Sterling 100 rubber case, 2-yr. guar.	10.25
Freshman Eliminators—D.C.,	\$17.50
Freshman Eliminators—A.C.,	20.00
Clarostat	1.70
Freshman Kit, Regular	\$17.50..... 8.95
Complete Bremer Tully Kit, including Drilled and Engraved Bakelite Panel	39.50
Amperites79
Eria Balloon Coils, set of three	8.95
Eria Kits, complete coils and con- densers	16.50
Amsco Cond., str. line fre., .0005	3.35
Morrison Units adj.	3.25
Sterling double reading meter, 0-8 and 0-120	2.75
Magnavox Horn M4	12.25
Federal Trans. 65 and 65A	3.15
Bremer-Tully Nameless Kit	16.95

Send name and address for our latest Radio Catalogue and radio map of the world.

The World Waited Long

for a Scientific Variable Grid Leak

and then along came—

THE BRETWOOD

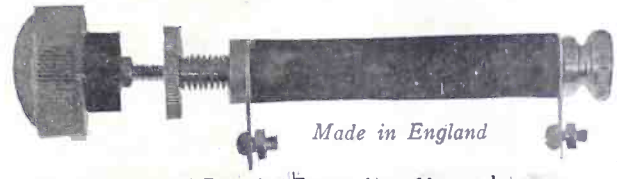

Made in England

Guaranteed Precision Range, 1/4 to 10 megohms.

"Fit for a King"

RADIO engineers had almost given up hope of finding a variable grid leak of permanent accuracy. And then along came the Bretwood.

They realized at once that the goal had been achieved. The Bretwood can be installed quickly on any set. Put the Bretwood in your receiver and note the improved tone, the greater volume, the increased distance range!

The Bretwood Variable Grid Leak is a non-inductive, single hole panel mount vernier instrument. It requires only 1/4" drill for clearance.

It is guaranteed to hold any given setting for three years without a variation of more than 1/10 of 1%!

The National Physical Laboratory—England's Bureau of Standards—found it to be foremost.



When the King Wanted a Grid Leak he Commanded Bretwood.

The Bretwood is officially prescribed for the 1926 Diamond of the Air and the Thordarson-Wade.

North American Bretwood Co.

145 West 45th Street New York City

Telephone: Bryant 0558

North American Bretwood Co., 145 W. 45th St., New York City:—Enclosed find \$1.50. Send one Bretwood Variable Grid Leak, prepaid, on 10-day money-back guarantee.

NameStreet

CityState

Members of the Trade, Write for Particulars.

REAL TONE FROM YOUR SET

Simply change over the audio end in 1 hour to the

resistance method of amplifying, using

MEGGIT RESISTORS

Send 10c (stamps) for booklet giving details in simple terms, with diagrams.

Cole Radio Mfg. Corp., Bloomfield, N. J.

Make Soldering a Pleasure

USE the Newest in Radio

Radio Soldering Fluid

Makes the Amateur a Professional. No scraping. Solders any metal. No corroding. Just apply Fluid with any solder.

25c per bottle; 30c mailed

Imperial Soldering Fluid Co.
81 Cortlandt Street New York

Get Your Coil Connections Right

When You Build

The Powertone

Construction of this 1-dial, 5-tube quality receiver fully described and illustrated, with "blue print in black" included, in Aug. 29 and Sept. 5 issues. Special discussion of how to connect the coil terminals. Trouble-shooting in this set, Sept. 12 issue. Send 45c. Get all three.

RADIO WORLD
145 West 45th St., N. Y. City

Here is the new
 Sleeper Serenader
 \$100!

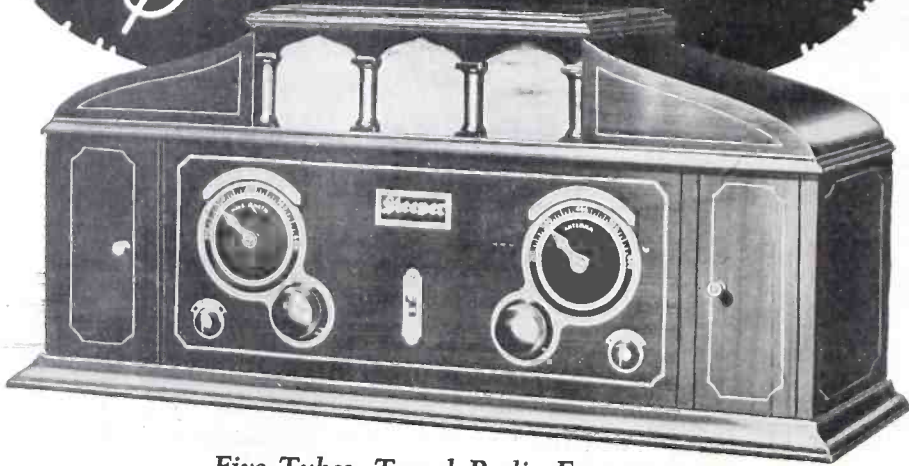

Five Tubes, Tuned Radio Frequency

RELY UPON EXPERIENCE TO PRODUCE QUALITY AT LOW COST

SLEEPER

REG. U. S. PAT. OFF.

RADIO RECEIVING SETS

—are better built of better materials to the most exacting specifications by an organization that has engaged exclusively in the manufacture of fine radio equipment since 1919.

Super
RADIO
Reception

Only experience and "pride of product" could have built such a set as the Serenader at so low a cost. For this is a new kind of radio set. Not until now has a receiver combined such tonal quality with such volume, selectivity and sensitivity. Your first twenty minutes with the Serenader will give you a wholly new conception of radio reception.

The Scout, \$75.00. The Monotrol, \$130.00.
 The Super-Symphonic, \$150.00.

TURN the switch and the softened glow of the concealed visored lights illuminate the tuning controls. Move the silver pointers to the designated wave length of your favorite station and you will hear it loud and clear, as distinctly and as naturally as though the artist were at your side—then, and only then, you will realize what Super Radio Reception means.

Other Sleeper models:



Serenader with console table, \$135.00

The table has a compartment for "A" battery and one for charger with switch for instantaneous change to charger. A better, more convenient radio installation at a remarkably low price.

If the Authorized Sleeper Dealer in your community has not yet received his quota, write us for descriptive literature and catalogue "W."

SLEEPER RADIO CORPORATION

438 WASHINGTON AVENUE,

LONG ISLAND CITY, NEW YORK