

DECEMBER, 1923

25 CENTS

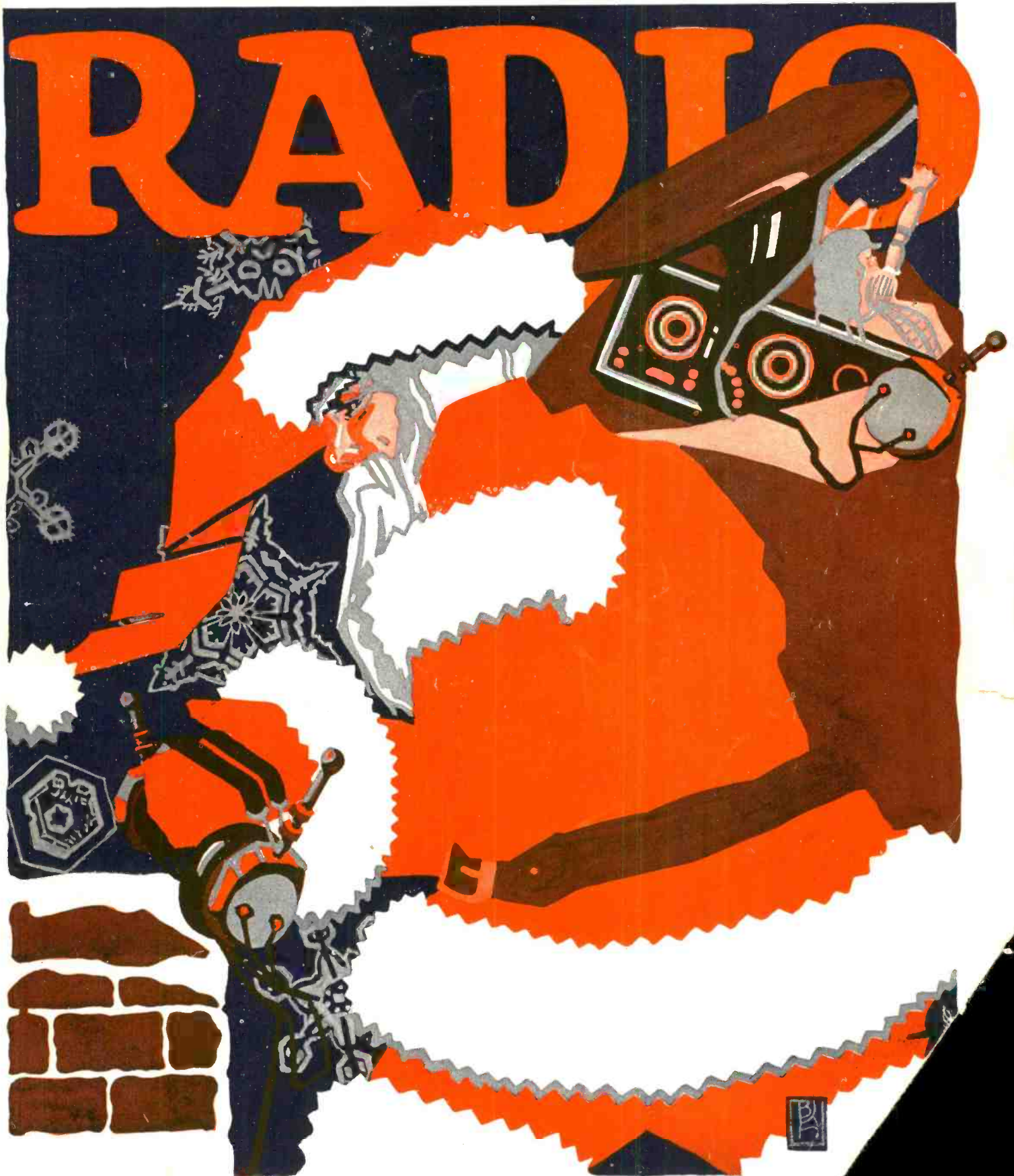

25 Leading Articles by 25 Leading Writers for



*Cunningham*

## RADIO TUBES

### *The Heart of your Receiving Set*

IN the case of all living things the heart is the most vital organ. Weaken, injure or destroy the heart and life is accordingly weakened, endangered or destroyed.

In a radio receiving set the tube is analogous to the heart. Remove it entirely and the set will cease to function. Use an inferior tube and the results will be inefficient and generally not pleasing to listen to.

In living things a perfect heart does not always insure a healthy body, but on the other hand it is indispensable. The same is true of the radio receiving set. It may be perfect in every detail but unless the best tubes are used the results will not be perfect.

Cunningham Radio Tubes were developed in the great Research

Laboratories of the General Electric Co., and are now being made in that company's modern and mammoth factories under the supervision of highly skilled engineers.

Better tubes are not attainable. There is a model specially adapted to every set, every circuit and every socket used today. Every radio dealer can supply you with Cunningham tubes. Buy them for replacements. Insist that they be included when purchasing a new set—and you will know that your receiving set has a perfect heart.

*The care and operation of each model of Receiving Tube is fully explained in our new 40-page "Radio Tube Data Book." Copies may be obtained by sending ten cents to our San Francisco office.*

Cunningham Radio Tubes	
6 Volts ¼ amp. Amplifier	\$6.50
3 Volts .06 amp. Battery Det. & C-11	6.50
Gas Con.	5.00
25 amp. Det. and	6.50
C-11	6.50

Home Office: 182 Second St.  
San Francisco, Calif.

154 West Lake Street  
Chicago, Illinois

30 Church Street  
New York City, N. Y.

*E. J. Cunningham Inc.*

#### PATENT NOTICE

Cunningham tubes are covered by patents dated 11-7-05, 1-15-07, 2-18-08, and others issued and pending. Licensed for amateur, experimental and entertainment use in radio communication. Any other use will be an infringement.



# The Outstanding Value in New Kennedy Radio Sets

The new Kennedy Radio Model V is everywhere acknowledged as the one outstanding value in the radio field today.

The receiving unit in Model V is a distinct advance in radio engineering. It is a special development of extensive research in the Kennedy Laboratories and was produced in response to an insistent, popular demand for more simplified apparatus. After initial settings are made, all tuning is controlled by a single dial. Yet, with this extreme simplicity of operation the selectivity of the earlier Kennedy models has been retained. The new unit responds to all broadcast wave-lengths and operates on any ordinary antenna.

The cabinet is of solid mahogany and follows a pleasing design that adapts itself to home surroundings. Equipment includes all tubes, dry batteries, Kennedy phones and plug—batteries are fully enclosed. Price, complete, \$125.00.

More elaborate Kennedy furniture models range from \$285.00 to \$825.00, completely equipped, including built-in loud speaker.

*See the new Kennedy furniture models at your dealer or write us for fully illustrated particulars.*

THE COLIN B. KENNEDY COMPANY

SAINT LOUIS

SAN FRANCISCO

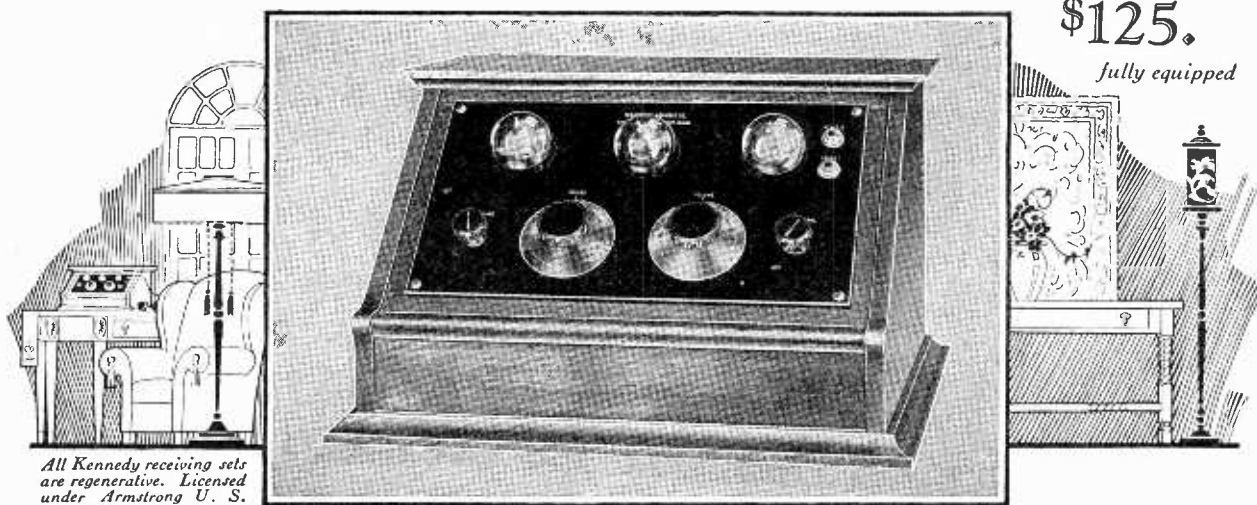

*All Kennedy receiving sets are regenerative. Licensed under Armstrong U. S. Patent No. 1,113,149.*

# K E N N E D Y

The Royalty  of Radio

Tell them that you saw it in RADIO

ADVERTISERS

# RADIO

Established 1917 as Pacific Radio News

Volume V

for DECEMBER, 1923

Number 12

## CONTENTS for DECEMBER, 1923

Radiatorial .....	9
Two-Way Radio Telephony with Airplanes, <i>By S. R. WINTERS</i> .....	10
The Outlaw Set of Paris, <i>By LLOYD JACQUET</i> .....	11
Electric Current Filters, <i>By DON LIPPINCOTT</i> .....	12
The Grimes Inverse Duplex, <i>By M. B. SLEEPER</i> .....	13
Handy Hints on Radio, <i>By D. B. MCGOWN</i> .....	14
Certain Inductance Considerations, <i>By SAMUEL G. MCMEEN</i> .....	15
Improvements to An Efficient Broadcast Receiver.....	16
<i>By H. T. GALLAHER</i>	
The "Ham Special" Receiver, <i>By BROOKE SAWYER</i> .....	17
Crystal Detector Notes, <i>By PAUL OARD</i> .....	18
Crystal Detectors and Their Adjustment, <i>By D. B. MCGOWN</i> .....	19
The Woman-Handler, <i>By VOLNEY G. MATHISON</i> .....	21
And It Came To Pass, <i>By S. P. WRIGHT</i> .....	22
Storage Battery Chargers, <i>By JESSE MARSTEN</i> .....	23
Unique Design for Short and Long Wave Receiver.....	25
<i>By HERMAN A. FISCHER</i>	
Some Further Adaptations of My Tuner, <i>By SIX ZEE JAY</i> .....	26
Increasing the Wavelength Range of Your Receiver,.....	27
<i>By EDWARD T. JONES</i>	
The Danger of Over-Insulation, <i>By A. REISNER</i> .....	28
Again That One-Tube Receiver, <i>By CARLOS S. MUNDT</i> .....	29
Selector Circuits To Eliminate Interference, <i>By GEORGE C. JONES</i> ...	30
Winding Inductance Coils, <i>By D. B. MCGOWN</i> .....	31
Power Losses in Transmitter Antenna Circuits.....	32
<i>By CHARLES K. FULGHUM</i>	
Whence Your Plate Voltage, <i>By FLORIAN J. FOX</i> .....	33
Some Principles of Detector Tube Operation,.....	35
<i>By MAURICE BUCHBINDER</i>	
A Simple Battery Switch, <i>By CHARLES F. FILSTEAD</i> .....	36
Queries and Replies, <i>By G. M. BEST</i> .....	37
News of the Radio Amateurs.....	39
Calls Heard .....	41
From the Radio Manufacturers.....	42

RADIO is Published Monthly by the Pacific Radio Publishing Co., Inc.,  
Pacific Building, San Francisco, Calif.

ARTHUR H. HALLORAN .....	Editor
LAWRENCE MOTT .....	Associate Editor
LOUIS TREVISIO .....	Art Editor
GERALD M. BEST .....	Technical Adviser
H. W. DICKOW .....	Advertising Manager

Branch Offices: 17 West 42nd St., New York City, Telephone Longacre 8248; 157 E. Ontario St., Chicago; 761 Spitzer Bldg., Toledo, Ohio; 52 Irving Street, Boston, Telephone Copley 5107-R; 1102 Republic Bldg., Kansas City, Mo.; Suite 511, 456 So. Spring St., Los Angeles, Cal., Telephone 12050; 2218 Third W., Seattle, Wash., Telephone Elliot 1903.

European Representatives: Compagnie Universelle De Representation wt de Commerce. Rue des Fortifications, 69, Anvers, Belgium.

Advertising Forms Close on the First of the Month Preceding Date of Issue.

Issued Monthly, 25c a copy. Subscription price \$2.50 per year in the U. S., \$3.00 per year elsewhere. Instructions for change of address should be sent to the publisher two weeks before the date they are to go into effect. Both old and new addresses must always be given.

Entered as second-class matter at the Post Office at San Francisco, Calif., under the Act of March 3, 1879.

Copyright 1923, by the Pacific Radio Publishing Co., Inc.

## COVER CONTEST AWARDS

After examining nearly 500 suggestions for front covers to be used during 1924, the judges selected twelve ideas as being acceptable and worthy of the first twelve prizes, and awarded 88 minor prizes to other contestants. The prizes have been sent to the winners, so that before this is in print the recipients will know of their good fortune. For the information of all we publish the names of the first twelve successful contestants as follows:

1. H. J. Wahl, Sacramento, Calif.
2. R. F. Browne, Hartford, Conn.
3. Mint Howell Jr., San Jose, Calif.
4. R. H. Deichen, Los Angeles, Calif.
5. Gilbert Mann, Providence, R. I.
6. Frederic C. Fornes Jr., Buffalo, N. Y.
7. Everett P. Gordon, Boston, Mass.
8. Wendell P. Munro, Marshalltown, Iowa.
9. Sarah M. Filstead, Los Angeles, Calif.
10. E. S. Sullivan, San Francisco, Calif.
11. Charles F. Filstead, Los Angeles, Calif.
12. H. J. Wahl, Sacramento, Calif.

The readers will have an opportunity to judge for themselves as the various covers appear during the year to come. This contest was so successful in demonstrating reader interest that the publishers have decided to start

### ANOTHER NEW CONTEST WITH \$50.00 IN CASH PRIZES

This contest will open December 1st and close December 31st. It is for the best account of what is the best advertisement in this issue and why. It is merely necessary for any reader to look over the advertising pages, decide what in his opinion is the best display advertisement and write out his reasons for so thinking.

The judges of the contest are D. Lyon, advertising agent, San Francisco; D. B. McGown, radio inspector sixth district, and H. W. Dickow, advertising manager of RADIO.

There will be 23 cash prizes, \$15.00 for the first, \$10.00 for the second, \$5.00 for the third, and \$1.00 each for the next 20. The announcement of the prize winners will be made in February RADIO.





*"The wise are free from perplexities."*

—Confucius  
*Perplexity never comes to the owner of a Grebe "13"  
 —he is a wise relay man.*

*Doctor Wu*



# The GREBE "13"

## A Real Receiver for Relay Men

### Four Points of Excellence

1. The perfect combination of Regeneration and Tuned Radio Frequency Amplification. This much-sought-for development gives you sharper tuning, greater distance, greater signal strength and less QRM.
2. Uses all kinds of Tubes. Special resistance units, instantly cut in or out by miniature "push-pull" switches, enable you to use any types of tubes in combination.
3. In the non-oscillating condition this Receiver builds spark signals to greater volume—in the oscillating condition all spark signals and practically all "mush" notes are suppressed.
4. The SECONDARY or Detector wavelength dial is calibrated direct in wavelengths. This most convenient arrangement enables you instantly to locate a station of known wavelength.



Licensed under Armstrong  
 U. S. Pat. No. 1,113, 149

**T**HIS is a short-wave development of the Grebe Broadcast Receiver, especially adapted to meet the requirements of long distance work on 80-300 meters. It affords sharper tuning, greater range, quieter operation.

Ask your dealer or write us.

**A. H. GREBE & CO., Inc.**

79 Van Wyck Blvd. . . Richmond Hill, N. Y.  
 Western Branch: 451 East 3rd Street, Los Angeles, Calif.



## The size you want— the insulation you need

**Y**OU don't need to wait while your panel is cut to order when you get ready to build your radio set. Just go to your dealer and ask for a Celoron Radio Panel. He will give you, without a moment's delay, the exact size you want. And—what is more important—you get the proper insulation for successful results in radio receiving.

Celoron is recognized by radio experts as the best material for insulation purposes. Its high dielectric strength makes it the ideal panel material.

### *Used by leading manufacturers*

Many of the leading manufacturers of radio equipment use Celoron in making their standard parts. It is approved by the U. S. Navy Department Bureau of Engineering and the U. S. Signal Corps.

Celoron Radio Panels come ready-cut in eight standard sizes, selected to meet the needs of the set-builder. Each panel is neatly wrapped in glassine paper to protect the handsome surface.

Celoron panels are readily worked with ordinary tools at home. They are easy to machine, saw, drill, and tap.

Ask a radio dealer for one of the following standard sizes:

1—6 x 7 x $\frac{1}{8}$	5—7 x 18 x $\frac{3}{16}$
2—7 x 9 x $\frac{1}{8}$	6—7 x 21 x $\frac{3}{16}$
3—7 x 12 x $\frac{1}{8}$	7—7 x 24 x $\frac{3}{16}$
4—7 x 14 x $\frac{3}{16}$	8—7 x 26 x $\frac{3}{16}$
	9—12 x 18 x $\frac{3}{16}$

We also furnish Celoron in full-sized sheets, and in tubes, and can cut panels in special sizes when desired. If your dealer hasn't yet stocked Celoron panels, ask him to order for you, or write direct to us, indicating by number the size you want.

### *Send for free booklet*

"Tuning in on a New World" is the title of a booklet we have prepared especially for the radio fan. It contains a list of the leading broadcasting stations in the United States and Canada, an explanation of symbols used in radio diagrams, and several popular radio hook-ups. This booklet will be sent without charge, on request.

*To radio dealers: Send for special dealer price list showing standard assortments*

## Diamond State Fibre Company

BRIDGEPORT (near Philadelphia) PENNSYLVANIA

BRANCH FACTORIES AND WAREHOUSES  
BOSTON CHICAGO SAN FRANCISCO

Offices in Principal Cities

In Canada: Diamond State Fibre Company of Canada, Limited, 245 Carlaw Ave., Toronto

# CONDENSITE CELORON STANDARD RADIO PANEL

# Your Kellogg Radio Christmas

Here is a way to get a wonderful receiver of Kellogg parts that most radio fans will tell you, are the most reliable, durable and efficient on the market. In several million families this year, each of us will be racking our brains to think of some Xmas present to please each member of the family.

Forget all this trouble and work, and plan a radio Christmas. Ask the boy or dad to make up a list of reliable parts for a simple set; then each one buy one part for someone in the family, and you will have a receiving set that will bring Christmas carols and the world to your fireside, if you have efficient Kellogg parts carefully put together.

Such assembling is an easy matter with Kellogg radio equipment. There are thousands of circuits, some very efficient, both as to distance and selectivity, that require only a condenser, coupler [or variometer], tube socket, fixed condenser, grid leak, tube, dials, and a few other inexpensive parts. You don't need to buy an expensive cabinet to have a good radio set.



If your dealer does not handle Kellogg, send us his address. We will send you our helpful and valuable radio hand book. Start today on your Christmas receiving set, and make every member of the household happy.



## KELLOGG SWITCHBOARD & SUPPLY COMPANY

CHICAGO, ILLINOIS



## MAGNAVOX Products

EVERY condition in the art of radio reproduction is most successfully met by Magnavox apparatus.

### Reproducers

- R2 with 18 inch horn . . . \$60.00  
 R3 with 14 inch horn . . . \$35.00  
 M1 with 14 inch horn; for dry battery sets . \$35.00

### Combination Sets

- A1-R consists of Magnavox Reproducer with 14 inch horn and 1-stage Amplifier . . . \$59.00  
 A2-R same with 2-stage Amplifier . . . \$85.00

### Power Amplifiers

- A1-One-stage . . \$27.50  
 AC-2-C-Two-stage 55.00  
 AC-3-C-Three-stage 75.00

Radio users will be sent new 32-page Magnavox Radio Catalogue on request.

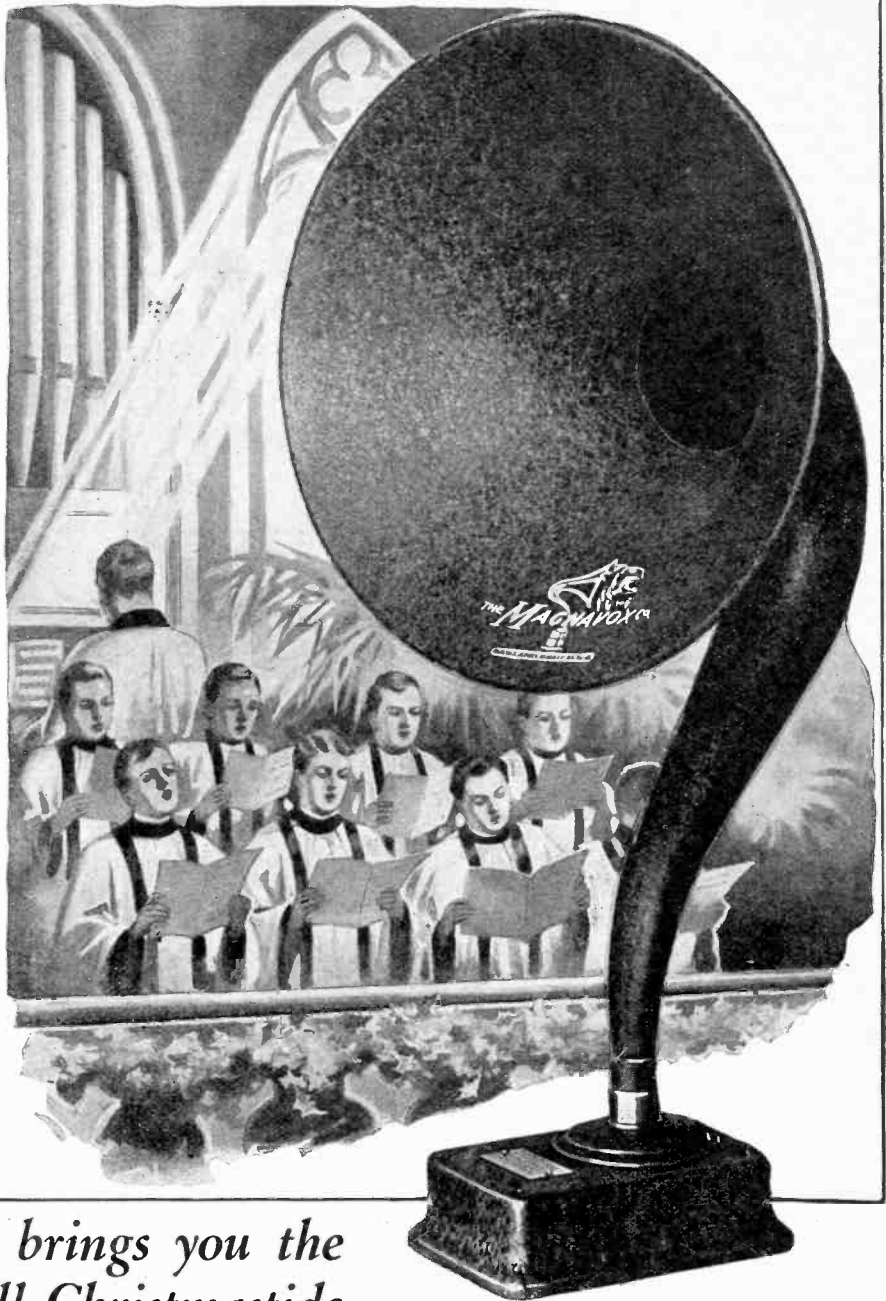

## Magnavox brings you the Voice of All Christmastide

THE Art of Radio Reproduction is enjoyed by every Magnavox owner. Despite the ever-increasing quality and variety of Broadcast Programs, many a receiving set gathers dust unlamented because of insufficient sensitivity or an unsatisfactory "loudspeaker."

Every Magnavox owner is a master of the art of radio reproduction—the results obtained by the use of Magnavox Reproducers and Power Amplifiers cannot be equalled with apparatus constructed in the ordinary way.

The special attention of dry battery receiving set owners is called to the new Magnavox Reproducer M1, illustrated above.

Magnavox Products can be had of good dealers everywhere.

THE MAGNAVOX COMPANY  
Oakland, Calif.

New York Office—370 Seventh Avenue  
Perkins Electric Limited—Canadian Distributors  
Toronto, Montreal, Winnipeg

# MAGNAVOX PRODUCTS

*There is a Magnavox for every receiving set*



The little button projects to warn, "I'm ON—don't forget me!" Saves both tubes and batteries.

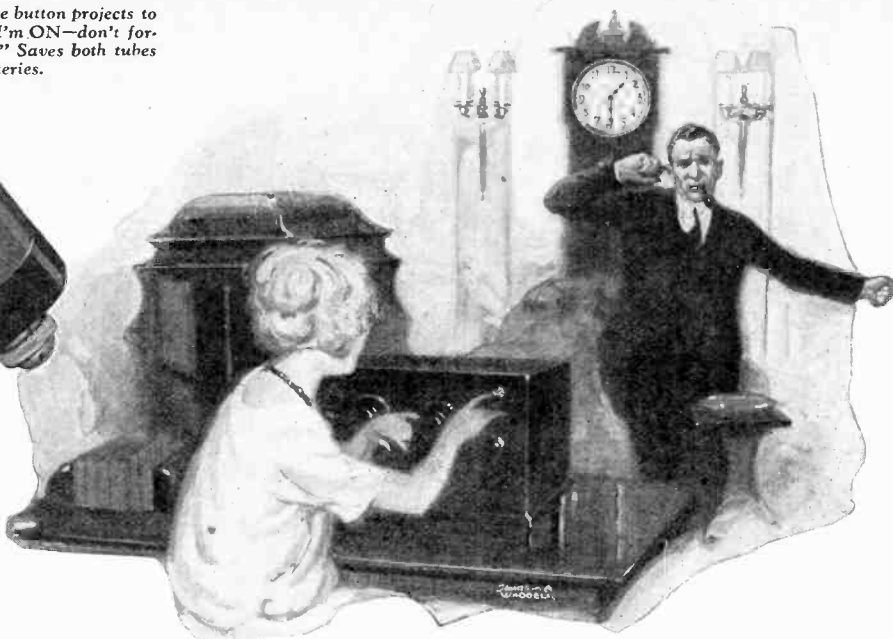

The C-H Radio Switch can be installed on any panel in only a few minutes. Just one 7-16 inch hole is required. Large, convenient binding posts with cupped washers make wiring easy.

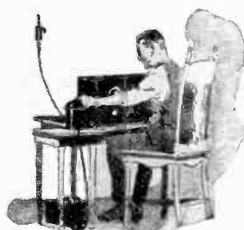

The heavy capacity of the C-H Radio Switch makes it suitable for a great number of radio control applications. Its perfect mechanism is the result of more than fifteen years' development by the famous C-H engineers, specialists in electrical control.

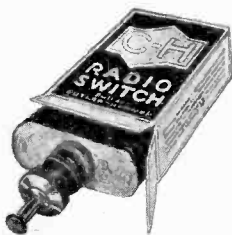

The Genuine Cutler-Hammer Radio Switch is sold only in the orange and blue carton, marked plainly with the C-H Trade mark. There is no substitute—even the Cutler-Hammer engineers could not build a switch to meet radio requirements and sell for less.

## If You Use the New Tubes You Certainly Need This C-H Switch

*There is No Filament Glare to Remind You When the Current is ON—The Little Nickeled Button Takes Its Place*

There is no easier, safer way to protect *any* tubes than by placing a C-H Radio Switch directly in the "A" battery circuit. Then you can always be certain, when you push in the sparkling nickel button, that the current is *completely off* throughout the set.

But with the new tubes, this little convenience becomes a necessity. There is no filament glare to remind you, and unless a C-H Radio Switch button projects to say, "I'm On, don't forget me," you may easily do so at the cost of tubes and batteries.

See your dealer today. Have him show you the Radio Switch in the orange and blue box—and look for the C-H trade mark. Then you can be sure that it has the famous C-H wiping knife-blade contact that cleans itself and holds a perfect connection so as not to introduce microphonic noises when used in the most delicate circuits. It only takes a few minutes to install on any panel and adds hours of pleasure. If your dealer is not yet stocked, send 60c plus 10c for packing and you will be supplied promptly.

**THE CUTLER-HAMMER MFG. CO.**

*Member Radio Section, Associated Manufacturers of Electrical Supplies*  
MILWAUKEE, WISCONSIN



# RADIO SWITCH

Tell them that you saw it in RADIO

# CLEAR~for the Crowd!

**M**MUSIC for the crowd as clear as one man gets it on the headphones! Sit back and listen. Tune in—shut your eyes—it's *real!* Every word clear—every musical note true—every instrument with its full rich tone. With a RADIOLA LOUDSPEAKER.

With the ordinary loudspeaker, there is something lost—and something added. The lost tones are the overtones and partials that give music or voice its richness, color, and personality. The added sounds are the independent vibrations of the horn itself—metallic—hard—and grating.

To erase these faults was the problem. Not to make another loudspeaker with the limitations of the old one—but to create a new one *without* those limitations. And we have it, in the RADIOLA LOUDSPEAKER.

### *First—we have greater tone range*

To get the deep tones of the organ—the full range of the piano—the highest notes of the violin—all with full color and richness.

### *Then—adjustable volume*

Volume enough for a large room, yet with means to soften the tone when a near station comes in too loud. On the RADIOLA LOUDSPEAKER you control the volume with a turn of the thumb.

### *And the horn*

This was a problem for acoustical experts. The mere shape of a horn can *make* it or ruin it. Each curve of the RADIOLA LOUDSPEAKER horn has been developed for pure tone reproduction. And it is made of a composition with no audible vibration of its own—amplifying without adding.

Radiola  
Loudspeaker  
Model U. Z.  
—1320

Price  
\$36.50



Radio Corporation of America

Sales Offices: Dept. 2059

223 Broadway, New York

10 So. La Salle St., Chicago, Ill.

433 California St., San Francisco, Cal.

# Radiola

REG. U. S. PAT. OFF.

## LOUDSPEAKER



This symbol  
of quality  
is your pro-  
tection



This symbol  
of quality  
is your pro-  
tection



December  
1923

# RADIO

Established 1917

Trademark Registered U. S. Patent Office

Volume 5  
No. 12

## Christmas Radiatorial

**R**ADIO is the latest and most effective agency for spreading the spirit of Christmas. By the spirit of Christmas is meant not the giving of gifts, not the cherished belief in Santa Claus, and not the feasting that characterizes the modern observance of the day, but the universal spirit of "peace on earth, good will toward men." Radio can and will create it.

To appreciate the true import of this spirit and how it may be made manifest it is merely necessary to realize that its antonym, strife on earth, ill will toward men, is primarily the result of mutual misunderstandings. Until men understand each other better, until they can take the other fellow's point of view, until they can sympathize with one another, strife and ill will are inevitable. Anything that removes the barriers of insularity promotes understanding and brings peace and good will.

Printing was the first great agency toward this end. It broadcast the power of the printed word and thereby brought about knowledge of what other men are thinking and doing. Then the invention of the steam and gas engines made it possible for man to visit other lands in person. But even the power of the printed word and the contacts of travel are limited as compared to the power of the spoken word as spread by radio.

The work of radio in spreading the real spirit of Christmas can be made as all-pervading as the electro-magnetic waves which carry the message through space. With the development of more powerful transmitting stations and their location throughout the globe it becomes possible to give the news and views of each section to all others and thus bring about the desired better understandings.

The progress toward this desired end, which has been painfully slow during past centuries, should be greatly accelerated with the advent of radio. There is still much Q R M to be overcome in the wiping out of jealousies and antagonisms. Men's minds, the delicate instruments that must receive the message, have not yet been tuned to the proper wave length. Nor are there yet enough men actuated by the spirit of service to humanity to announce the message.

Think of the beneficial effects of a chain of broadcasting stations encircling the globe and reaching all peoples thereof, if, in addition to music and entertainment, they should broadcast the gospel of peace and good will. Such a weapon in the hands of an international peace foundation could combat hatred instead of fostering it, could break down distrust and prejudices, and bring about a community of interest that would make war impossible. Here indeed is an opportunity for humanitarians and philanthropists.

These thoughts may seem idealistic. They certainly are ahead of the times. But now is none too soon to broadcast the seed that may eventually germinate and grow into a verdure of peace over all the earth. This is the vision toward which the eye of human progress is directed.

And so, with such meaning in mind, RADIO extends to all readers its sincere wish for a Merry Christmas.



# Radio Telephony With Airplanes

By S. R. Winters

A NOVEL departure was made recently in the use of radio telephony when four officers of the Field Artillery of the War Department operated a radio telephone outfit and adjusted fire from a battery of guns simultaneously from aircraft during a flight. This feat was accomplished following thirty minutes of instructions to these officers unskilled in the use of wireless telephone equipment.

The first attempt to employ a two-way radio-telephone outfit in conjunction with spot firing for the Field Artillery was for the Fourth Field Artillery at Gatun, Panama Canal Zone, which employed 2.95-inch mountain batteries. A mobile wireless outfit—type SCR-108, or radio tractor of the Signal Corps—was sent to Gatun. This wireless station on wheels was connected by conventional field telephone lines with battery commander's station direct. The results of the maneuvers were gratifying and officers of the Field Artillery of the War Department were commendatory of the achievements.

The so-called Coast Artillery reglages held during the firing season have been pronounced superior to any similar events in the Panama Canal Zone, both with respect to reliability and extension

of range of the two-way radio-telephone communication. The Air Service of the War Department, at the request of the Coast Artillery Defenses of Cristobal and Balboa, spotted the fire for the three Coast Artillery stations at Forts Amador, Sherman and Randolph. During the course of these maneuvers 49 flights were made for the purpose of negotiating radio-telephone communication and not a single failure was recorded.

The use of radio in the Panama Canal Zone is ordinarily associated with emergencies or where other forms of communication are interrupted. Yet, during the last twelve months the Air Service of the War Department negotiated 261 flights from France Field, Panama Canal Zone, for the purpose of carrying on radio communication. These ascensions embraced wireless test flights, voice-controlled formation flights, Coast Artillery reglages, Field Artillery reglages, tactical maneuvers and reconnaissance and coast patrol work. Thus the radio activities of the Air Service in the Panama Canal Zone averaged one flight a day, not including Saturdays and Sundays.

The regularity as well as the diversity of these flights in the interest of radio communication—a radio labora-

tory on the wing, if you please—have produced information of worth in both war and peace times. The value of radio-telephone communication in issuing and receiving instructions in the air has been unmistakably demonstrated. The results of the last tactical inspection by the Department Commander fortified any previous conclusions on this subject, when France Field was required to dispatch all of its aircraft and flying personnel to the Balboa Flying Field for inspection and maneuvers. The activities of the aircraft in proceeding to the different sectors and reporting positions and observations after arriving at these sectors established the significance of trustworthy wireless communication.

The experimental flights negotiated by the Air Service of the War Department in the interest of radio communication in the Panama Canal Zone have likewise disclosed certain information about radio apparatus. Notably, for the first time two DH4B airplanes, equipped with SCR-73 spark sets, were enabled to report their positions in the air by radio from Aguadulce to the France Field ground radio station, a distance of approximately 80 miles. This signalling was accomplished despite interference.

*Continued on page 50*



*Radio Tractor Used to Communicate With Flying Airplanes During Army Tests at Panama*

# The Outlaw Set of Paris

By Lloyd Jacquet

AFTER many months of mysterious transmissions, the "Mystery Set" of Paris has at last been located. And even now, it retains some of that enigmatic and puzzling atmosphere which envelops all mysteries. For fully a month, the mysterious transmitter, hidden somewhere in the big capital of France, baffled the efforts of the police, the military, and the amateurs, who all bent their energies toward its location. Yankee ingenuity, however, kept the radio field guessing, and it wasn't until a few weeks ago that the entire story of the "Zero Post" was revealed.

It could be said that the beginning of this remarkable set was in 1910, when R. Gouraud, a young amateur in New York City, began experimenting with radio. He went through the usual school of the amateur, and followed the progress of the science closely, until the beginning of the War, when he went to France in 1916 with the American Ambulance Corps. He was later transferred, upon our country's entry in the conflict, to the aviation section at Avord. After the war, he chose to stay in France, and, once settled, he plunged deeper than ever into his hobby.

Gouraud's first appearance into the limelight happened over a year ago, when he announced that he was using a rather unusual kind of radiating system with which to send out signals to the French amateurs. It was a four-wire prismatic cage, about 30 feet long, strung 40 ft. above the ground, and attached to a counterpoise. The distance between the counterpoise and the aerial was about 25 ft., and consisted of a four-wire arrangement. But, unlike other counterpoises, this one was not placed *under* the aerial but *on the same level with it*. Thus the effective height of the "ground" connection was also that of the aerial, and he had, theoretically at least, no ground to his set. Great success attended the use of this system.

These experiments in transmitting led the young American to further work, and he attempted further developments in the transmitting and receiving fields. In 1922, he developed a combination sending and receiving set which was very practical. It was so arranged that it required no switch to transfer over from sending to the receiving position. In other words, a conversation could be carried on exactly as with an ordinary

Cutting in boldly one night, as everyone was tuned in to listen to the Eiffel Tower, Gouraud opened up on his new set, and announced slowly in English that he was an American station testing. He talked, sang, and then announced that there would be further entertainment the next evening, and, with the usual "Bon soir mesdames et messieurs," closed up for the evening.

Transmitting without a license is, of

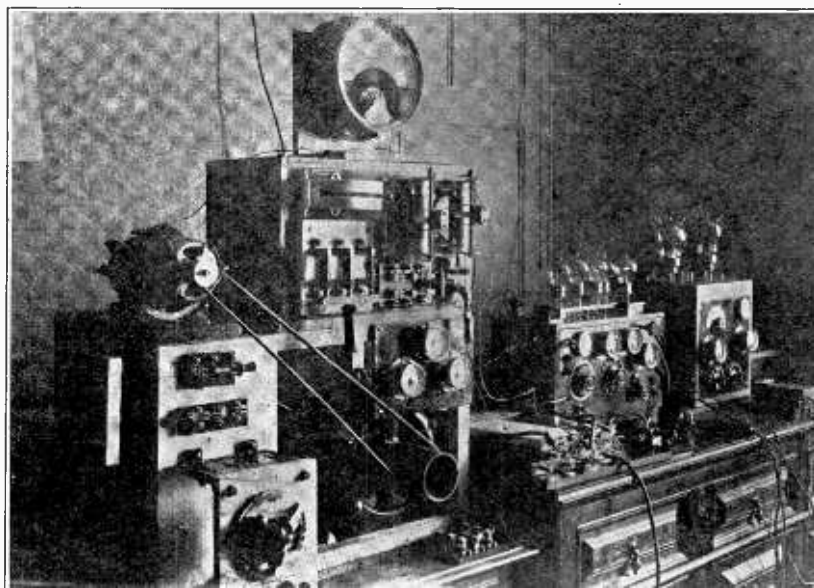

*The Parisian Mystery*

telephone,—each person equipped with such a set being able to talk back and forth without interruption. The first set was crude enough, compared to the many refinements which were developed later, and incorporated into the mystery set.

So, in a dark corner of the radio laboratory of the young experimenter was born the "Zero Post," which created such a storm last spring, and caused so much furor among radio fans and engineers as well. It was a transmitter of 800 watts input, and workable on wavelengths up to 1000 meters.

course, strictly prohibited in this country as it is in France, and Gouraud had no license. He had hit upon this idea, however, to see how far his set would carry.

The results came soon enough. The daily newspapers in Paris came forward with long stories of spy stations, others maintained it was a publicity stunt, and a third that it was an English station. Suffice it to say that the Paris ether was surcharged with excitement.

The young inventor continued his broadcasts for several days. Occasionally he would put on a record, and give his audience some jazz music, presumably of American origin. The newspapers began to publish regularly his "program," and to give out information as to the wavelength, hours of transmission, etc. Gouraud must have been chuckling to himself!

Soon, however, the military and the police took a hand in the matter, and automobiles equipped with direction finders began to scour the Paris streets and the suburbs. They located the set as far as the very block in which it was, but there the scent ended. They could not locate the mysterious "Zero Post."

The inventor himself came out with all of the details of the installation, and thus ended the career of one of the greatest radio mysteries that French radio fans ever beheld.

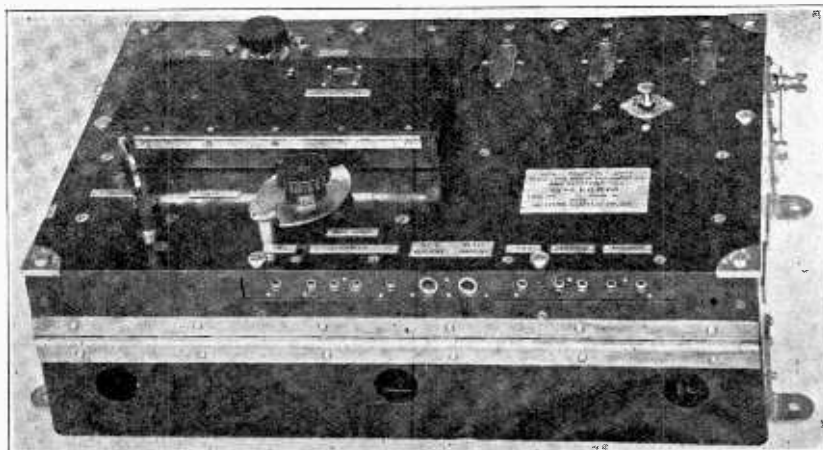

*Airplane Radio Transmitting and Receiving Set Which Reported Air Positions by Voice Modulation for 100 Miles Distance*



# Electric Current Filters

By Don Lippincott

*This article eliminates some of the mystery that has always been associated with filters for separating electric currents of different frequencies. It develops the theory and nomenclature of the subject and will be followed up by an article on practical filter design.*

THE theory of the electric current filter seems to be one subject on which there is no elementary literature. The reason is probably that, unlike most electrical apparatus, the filter grew from the top down, i.e., its theory was not deduced from its operation, but it was evolved in accordance with rigorous mathematical computations. Then, too, filters have been used almost wholly in telephone practice, and terminology quite unfamiliar not only to the amateur, but to many qualified engineers as well, has joined forces with the awe-inspiring mathematics to keep the casual reader at a distance.

There are three things that many amateurs would like to know about filters—what they do, how they do it and how they are made. We will touch upon these questions lightly and in order.

Suppose we have a line which carries current at many frequencies. We wish to deliver certain of these frequencies to a second line, at the same time excluding certain others. Between the two lines and connecting them we insert a filter. A filter is simply a combination of impedances, and, like any impedance, it offers opposition to the flow of current, and the amount of opposition it offers depends upon the frequency. Where the difference comes in is that the current of those frequencies which the filter is to exclude starts through the filter just as it would through any other impedance, but it is side-tracked, or short-circuited, on its way through, so that little if any of it ever reaches the second line. This disappearance of *current* as well as *voltage* is what is known as "attenuation," and cuts down the power passed through much faster than would any mere interposition of impedance.

The properties of filters that give them their especial value are: (1) Within certain frequency ranges (known as "pass-bands") power is transmitted without attenuation. (2) As the frequency changes, attenuation begins at certain definite "cut-off" points, and rises rapidly to high values, to fall off again as rapidly as the next cut-off point is approached. (3) Filters may be designed with as many pass-bands as required and the cut-off points may be established wherever required. (4) Adding a second filter section *multiplies* its effect. That is, if one section of a filter attenuates the power transmitted at a given frequency to one one-hundredth of its former value, a second sec-

tion will cut the total transmitted power to  $(1/100)^2$  or one ten-thousandth. This is in contrast to a blocking circuit, or wave trap, where the addition of a second section merely adds its effect, and where the transmitted power is not quite halved by the addition of a second section.

Perhaps the easiest way to comprehend the action of a filter is to consider its make-up with reference to one of its "stop-bands".

to pass and will attenuate high frequencies, but just where the dividing line comes depends on the capacity of the condensers and the inductance of the coils. The resistance of the load enters into the computation, so it is not possible to give exact data from the filter constants alone, but as a general indication we may say that .002 m.f. condensers and a 250-turn honeycomb coil would pass all audio-frequencies and attenuate all radio frequencies; 1 m.f.

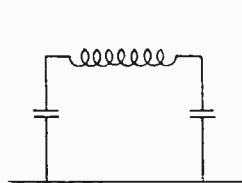

Fig. 1.  
Low-Pass Filter

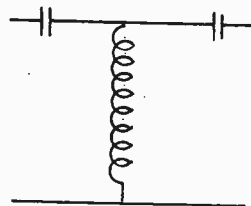

Fig. 2.  
High-Pass Filter, T Type

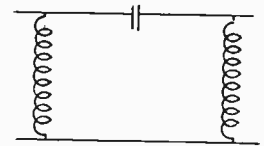

Fig. 3.  
High-Pass Filter,  $\pi$  Type

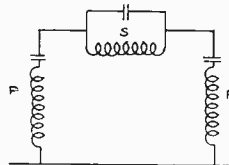

Fig. 4. High and Low-Pass Filter

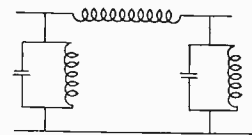

Fig. 5. Band Pass Filter

For any given frequency there is a circuit element which has infinite impedance. For zero frequency—direct current—this element is a condenser. For infinite frequency it is an inductance. For any intermediate frequency, it is an inductance and a condenser in parallel—"a parallel resonant circuit."

Corresponding with this element of infinite impedance is an "inverse circuit" which has zero impedance. This is an inductance for d.c., a condenser for infinite frequencies, and a series resonant circuit—condenser and inductance in series—for intermediate frequencies.

Now to build up our filter. We take a stop element, which is a parallel resonant circuit tuned to a frequency in the middle of our attenuating band, and place it in series with the line. Then across the line, at either end of the stop element, we place the inverse circuit which shorts out the frequency which has already been blocked.

The cut-off points are determined by the quantities chosen to make up the "stop" and "pass" elements. Thus Fig. 1 shows a "low pass" filter. This has an inductance coil as the series member and condensers as the shunt member. Such a filter will allow direct current

condenser and a 1-henry choke would cut off at about 225 cycles, all except the lowest audio frequencies; while 5 m.f. and a 5-henry choke would attenuate everything above 45 cycles.

By transposing the inductances and capacities we transpose the attenuating and pass-bands, so far as their general position is concerned, although the cut-off points will usually be somewhat changed. The low pass filter of Fig. 1 thus becomes a high-pass filter of the T-type if the elements are arranged as in Fig. 2. Fig. 3 gives another arrangement for a high-pass filter, known as the  $\pi$  type. As far as effect is concerned, these arrangements are equivalent.

Fig. 4 shows a high and low-pass filter. The series resonant circuits at *p,p*, serve to short the frequencies in the attenuating band, which are also blocked by the parallel resonant circuit at *s*. The mid point of the attenuating band is, of course, fixed by the resonant period of the component circuits. Small capacity and large inductance in the blocking circuit, *s*, combined with large capacities and small inductance in the pass circuits, *p*, will give a narrow attenuating band. If the relative magnitudes of the ele-

*Continued on page 80*

# The Grimes Inverse Duplex

By M. B. Sleeper

*This circuit has been successfully tried out by enough builders to give assurance that it is worth while. This first article, which is more or less descriptive, will be followed by a second giving details of construction, and by a third giving some interesting modifications.*

**D**URING the past year there have been dozens of circuits brought out by as many different people and given as many different names. Practically all of them can be reduced to the elements of the original regenerative or super-regenerative circuits. If tried out under proper conditions for making comparisons, they would probably show no advantages over those fundamental circuits, although it is quite possible that each one did give the best results of those used by the individual sponsors.

This might be taken as a sweeping condemnation of new circuits. It is not meant to be that. Every new set, if it does nothing more, at least helps to stimulate experimental work and to maintain activity. One of the best, if not *the* best, of these new circuits is the Inverse Duplex as invented and perfected by David Grimes.

This circuit has no end of possibilities, and is the most interesting thing you have seen for a long, long time. In addition, you will find that the ease with which the results to be described can be successfully reproduced makes the Inverse Duplex a new friend worth meeting.

Of the theory, it is sufficient to say that in the Inverse Duplex the same tubes are used for radio and audio-frequency amplification, as in the reflex, but the first radio-frequency amplifier is the last audio amplifier, and the last radio is the first audio amplifier. In other words, the small radio and the large audio amplification is carried by

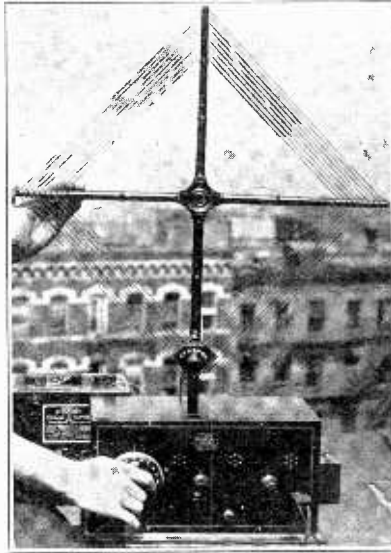

Fig. 1. Monotrol Set with Loop Aerial

the first tube, and the large radio and small audio amplification by the last tube. Consequently, with balanced loads on the tubes, each tube can be worked at full capacity without distortion.

This does not sound startling. However, there are other things accomplished, and in very new and surprising ways. Before we go into the details of home construction, let us go over one of the commercial applications of the circuit, for it helps greatly, in starting on a new trail, to know how someone else has succeeded on a similar one.

In Fig. 1 is shown the Sleeper Radio Monotrol, the first set put on the mar-

ket licensed for the Inverse Duplex circuit. The name gives away one of the secrets, for here is a highly selective set which requires only one control for tuning. There are other applications of the Inverse Duplex, however, which require more than one control, but we are not ready for those types yet.

On the front panel is the large tuning dial, at the left, the rheostat for the two amplifier tubes at the center, and the detector rheostat and phone jack at the right. Once the rheostats have been set, they are left alone, and the filaments turned on or off by the switch between the rheostat knobs. As for the loop—you are wrong. The switch on it does not vary the inductance for tuning. It does not change the wavelength. I call it the volume control. A little farther on, you'll find out just what it does.

More of a story is told in Fig. 2, the interior view. The Malone-Lemmon variable condenser, switch, Pacent jack, and Ermcostats are carried on the front panel, while there are mounted on the base panel three sockets, two audio-frequency transformers, an assortment of Dubilier Micadons, the terminal panel, and, underneath, held in place by their binding posts, two radio-frequency transformers.

You may think that the wiring diagram in Fig. 3 looks complicated, but you can see from the illustrations that, in practice, it can be worked out very simply. Just how simply it can be done in a home-made set you will see in the second article.

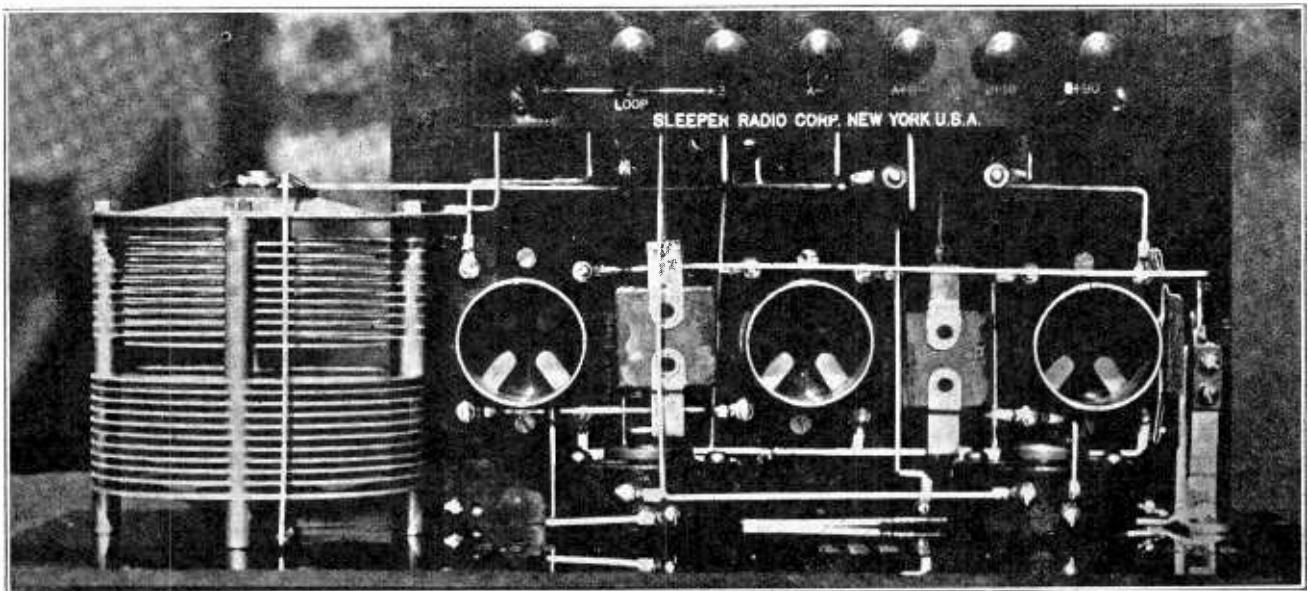

Fig. 2. Interior View of Monotrol





# Certain Inductance Considerations

By Samuel G. McMeen

*This article expresses in simple terms some facts ordinarily incomprehensible to the layman. It might well be called the arithmetic of tuning a radio receiving set. It includes tables whereby the inductance of coils ordinarily used by amateurs may be readily determined.*

TO know the wavelength of a signal it is necessary either to measure it or to calculate it. Neither is difficult, but measuring requires a wavemeter, and not every worker has that at hand. But it is possible to know the electrical dimensions of the parts of one's apparatus closely enough to make the calculation easy.

Whenever a transmitting or a receiving set is in tune for a certain wavelength, the product of the grid inductance and the capacity of the condenser across that inductance amounts to a certain quantity. That quantity is always the same for that wavelength, whether it be produced by a large inductance and a small capacity or the other way about. Indeed, there is an infinite number of pairs of inductances and capacities that will, when multiplied together, produce that quantity, and any one of these many pairs of values will satisfy the requirements. For practical reasons, however, the best pair is that in which the inductance is large and the capacity small. But the rule holds that the set will be in tune whenever the product equals the particular value belonging to the particular wavelength.

It is customary to designate inductance by the symbol *L* and capacity by the symbol *C*. Their product, therefore, is *LC*. Thus—for a wavelength of 200 meters *LC* is 0.0113; for 375 meters, 0.0396; for 400 meters, 0.0450; and for 600 meters, 0.1010. In all the foregoing values the inductance is expressed in microhenries and the capacity in microfarads. If, therefore, a coil has a known inductance in microhenries, that value divided into the *LC* value given for the wavelength, will give the capacity required for the wavelength under consideration.

The values of honeycomb and duolateral coils generally is given by the makers in tables and on the coils themselves. If these values are expressed in millihenries, multiply them by 1000 to convert them into microhenries, if that form is needed. With a supply of such coils at hand one could hit upon a combination for a variety of wavelengths. Take the case, for example, of 400 meters wavelength. The *LC* value is 0.0450; the inductance of a 50 turn honeycomb coil is 150 microhenries. This goes into the *LC* value 0.003 times, and is the capacity required in parallel with the coil to tune it for 400 meters. Such a capacity is given by setting a .001 condenser at 30 scale divisions on a 100 division scale, and

TABLES OF INDUCTANCES OF WINDINGS OF VARIOUS WIRES AND DIMENSIONS

FOR SINGLE LAYER WINDINGS OF No. 18 WIRE, SINGLE COTTON

Diameter of Tube in inches	Length of Winding, in inches					
	1	2	3	4	5	6
	Inductance of Winding in Microhenries.					
3	39	108	188	272	359	447
3½	48	132	238	346	460	573
4	60	173	309	453	604	764

FOR SINGLE LAYER WINDINGS OF No. 20 WIRE, SINGLE COTTON

Diameter of Tube in inches	Length of Winding, in inches					
	1	2	3	4	5	6
	Inductance of Winding, in Microhenries					
3	53	176	306	447	587	715
3½	79	224	395	579	748	962
4	96	276	491	729	968	1300

FOR SINGLE LAYER WINDINGS OF No. 22 WIRE, SINGLE COTTON

Diameter of Tube in inches	Length of Winding, in inches					
	1	2	3	4	5	6
	Inductance of Winding, in Microhenries					
3	93	243	445	650	856	1061
3½	120	334	597	875	1153	1434
4	163	445	789	1150	1512	1880

FOR SINGLE LAYER WINDINGS OF No. 24 WIRE, SINGLE COTTON

Diameter of Tube in inches	Length of Winding, in inches					
	1	2	3	4	5	6
	Inductance of Winding, in Microhenries					
3	125	352	603	875	1152	1430
3½	170	476	812	1180	1550	1920
4	223	616	1065	1541	2014	2514

FOR SINGLE LAYER WINDINGS OF No. 26 WIRE, SINGLE COTTON

Diameter of Tube in inches	Length of Winding, in inches					
	1	2	3	4	5	6
	Inductance of Winding, in Microhenries					
3	167	473	820	1230	1568	1950
3½	211	583	1012	1472	1930	2400
4	301	840	1450	2160	2780	3450

with that setting of that condenser the circuit is in tune for 400 meters. But the same result can be had with a 75 turn coil and a different setting of the condenser. The inductance of that coil is twice as much as that of the 50 turn coil, or 300 microhenries. Hence

the condenser setting will be half as much, or 15 divisions of a hundred-division scale. In all cases, while the condition of being in tune may be true in each instance, the best receiving or transmitting results will be attained by using the largest of the possible inductances and the smallest capacity required by the value of *LC*.

For the determination of *LC* for any other value than given for the preceding several wavelengths, one may follow this simple procedure: Square the wavelength and multiply that by the factor 2.81 and point off seven places; the result will be the value of *LC* for that particular wavelength. A little table can thus be made for future reference if desired.

In the examples given above a .001 condenser was assumed to be used. Any other size will do so long as the maximum capacity is at least equal to the required capacity of the particular case in hand, and if the scale has a hundred divisions and the total capacity is known the value per division is a simple mental process to determine. In many cases the whole process of determining the condenser setting when the inductance is known is a simple mental one, which fact we mention merely to counteract the widespread impression that anything involving figuring is injurious to the tissues of the brain.

In the case of honeycomb and duolateral coils, as we have said, the inductance is known from the start, and no calculation of that quantity is necessary. But the amateur experimenter often winds coils himself, and these are usually so different from the former in their diameter and length that their values are also very different. Therefore it is necessary for some one to do some calculating or measuring in the cases of such windings. Usually the windings for radio sets are single layer coils, and there is a formula fitting all such cases. This is it:

$$L = \frac{0.03948 a^2 n^2 k}{b}$$

in which *L* = the inductance desired,  
*a* = the radius of the tube of the winding,  
*n* = the number of turns,  
*b* = the length of the winding, and  
*k* = a constant to be taken from a table.

We do not insert the table here, as our purpose is merely to show the

nature of the elements of the formula. It will be noticed that the result in all cases varies as the square of the radius or diameter of the tube and as the square of the number of turns, and also inversely as the length of the winding. This means that the inductance runs up rapidly as the size of the tube increases, and similarly as the number of turns increases. Also, that if the turns of a winding are spaced wider apart than the mere diameter of the wire, the length-increase diminishes the inductance.

The first of the three facts just mentioned explains why the inductance of, say, a 4 in. coil is so much greater than that of a honeycomb coil of the same number of turns, and the second and third show why the use of fine wire, with many turns per lineal inch, tends toward compactness in receiving sets, because of the two effects of the square number of turns and the shorter length of the winding. If anyone cares for the table, as calculated by Nagoaka, it may be found in Circular 74 of the Bureau of Standards.

In the hope of making the formula useful to more workers than by merely citing it, we have calculated the inductance for certain commonly used sizes of wire and certain quasi-standard diameters of tubes, in lengths of winding that are widely used in amateur experimental work. The results probably cover in all three particulars the needs of all receiving sets and some of those for transmitting sets. From the formula alone it is awkward to determine all that one needs to know in advance of a trial on a winding, but with a plurality of values already calculated it is possible to select with some precision the course one should follow.

Each of the tables treats but one size of wire, and though that is calculated for single cotton covering, the facts are not greatly different for double cotton covered wire, and the desired wavelength can be found at a condenser setting close by that indicated for the other covering.

In addition to the desirability of knowing inductances for the assembling of receiving and transmitting sets, it is useful to be able to produce known values of inductance as coils for wavemeters. Such a known coil, associated with a variable condenser and a small flashlight lamp, will form a very useful device for learning the wavelength output of transmitting sets and the wavelength input of receiving sets. There is on the market a condenser that has its scale graduated in microfarads as well as in simple scale divisions as fractions of a half-circumference. Putting such a device in series with the small lamp and the coil of known inductance gives an instrument that will flash the lamp at the setting whereat the coil and capacity are in resonance with the energy received when the wavemeter-coil turns are near to and

parallel with those of an active part of an oscillating transmitting set.

The reading of the meter is done by observing the capacity at which the lamp lights, multiplying that by the inductance of the coil and then finding that value of *LC* in the table one has prepared from the facts given above. For example, suppose the capacity reading on the condenser to have been 226 micro-microfarads (.000226 microfarads). Suppose also that the inductance of the wavemeter coil is 50 microhenries. These quantities multiplied together give 0.0113 as the value of *LC*, and from the little portion of a table given above one sees that the wavelength is 200 meters.

Happily, on such a condenser one-half of the scale is left without graduation marks. Therefore the blank space can be utilized for another scale one can supply, this being graduated in wavelengths calculated in advance.

To know the wavelength of received waves one does not depend on the lighting of the lamp, for the received energy is far too feeble to do that. One listens to the received signals, puts the wavemeter coil near to and parallel with grid-coil turns of the set, then turns the wavemeter knob till the reception markedly diminishes in volume. The meter is then read and the wavelength found as before.

### SOME IMPROVEMENTS TO AN EFFICIENT BROADCAST RECEIVER

By H. T. GALLAHER

THE circuit described by 6ZJ in the March issue has been used as the basis of the circuit herein described. 6ZJ's circuit, while giving very good results, was found to have considerable body capacity in the variometer, rheostat, *B* battery and phones, and also to be somewhat noisy.

The circuit herein described is the result of some experimenting with the above hook-up. For selectivity and loudness of signals, it equals any factory built single-circuit receiver the writer has ever heard. This circuit works very well with either a WD-11 or a UV-200 tube, and is very stable and easily controlled.

The main changes are the placing of the tuning condenser in the aerial lead, the insertion of a small fixed condenser *a* and the grid return lead *b*. The circuit is shown in Fig. 1.

Moving the condenser from ground lead to the aerial did away with practically all body capacity and extraneous noises. The condenser is shielded. Coil *a* was also changed from a tubular coil to a double spiderweb. This cuts down panel space as well as adding to all-around efficiency.

The double spiderweb coil *c* was built as follows: Two spiderweb forms were cut from a piece of fibre 6x10x1/8 as shown in Fig. 2. Eleven slots were cut

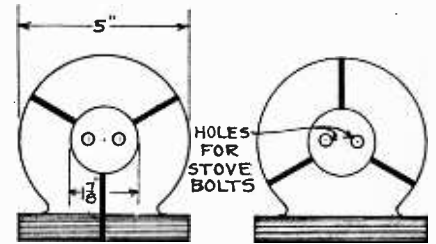

Fig. 2. Double Spiderweb Forms

in each, but the slots in one form were staggered half way between those of the other. Fig. 2 shows this with three slots only, for simplicity. Next a piece of 1 7/8-in. outside diameter tubing 3/4 in. long was glued between the two forms and two stove bolts inserted to hold forms together as shown in Fig. 3. The form is now ready for winding.

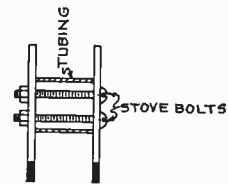

Fig. 3

Using No. 22 cotton covered, start in on one form, being careful that the rotation is the same as that on the variometer. Wind on one complete turn on form *a*, Fig. 3. Jump across to form *b* and wind on one complete turn. Jump back to *a* and put on one complete turn, then back to *b* again and so on, until you have wound on 80 turns total.

Continued on page 90

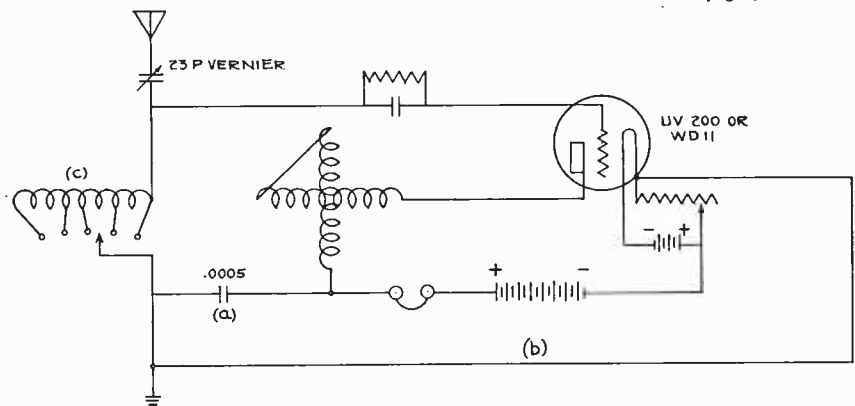

Fig. 1. Modified Circuit

# The "Ham Special" Receiver

By Brooke Sawyer

*Here is a straight-forward description of a Reinartz tuner with a range of 140 to 250 meters for amateur reception. Although directions are given for increasing the range to include the broadcast stations, it is intended primarily as an extremely selective set for amateur use, combining efficiency, ease of control and moderate price.*

FOR a long time I have held the conviction that the amateur transmitter is better than the amateur receiver. My reason for holding to this belief is that a wave once propagated into space keeps on going, its amplitude getting smaller and smaller, until it is not strong enough to affect the average detector tube. If we can boost up the small amount of energy received from a distant transmitter, or can conserve the energy received so that none of it is wasted, we are going to do better receiving. The amateur needs a receiver that is easily handled. In relay work he cannot be bothered with a multiplicity of controls. The receiver must be constructed for a low price and, above all, it must be selective and efficient.

What, then, shall we use? Radio frequency is probably a good answer, but there are no RF transformers on the market to my knowledge that are efficient on the band of 150 to 200 meters, and a super-heterodyne is too expensive. If we use tuned radio frequency our control is made too complex. Also it takes two stages of ordinary RF amplification to make up for a good regenerative circuit. We are now practically reduced to a good regenerative and we shall make our choice from that type.

For ease of control, selectivity, and moderate price, the justly famous and widely used Reinartz circuit appealed to me from the first. It may also be built for a very low cost. Since beginning to develop a good "Ham" receiver I have built eight sets of that type and have at last found one that I considered good enough to put in a mahogany cabinet, and I think that any amateur who handles any amount of traffic will find himself well repaid for the effort needed to build one.

Nothing remarkable is claimed in the design of this receiver. All that has been done is to guard against as much loss as possible so as to make use of every bit of received energy that we can. Although at this writing the season has barely commenced, I have heard every district except the first for some time past, and I have not burned the midnight Mazda to do it.

We will begin with the tuning inductance. This, with the tuning condenser, will give a range of 140-250 meters—just what we want and nothing wasted. The tube on which the inductance is wound is 4 in. in diameter and 5 in. long. The material is thin Bakelite, thin so as to reduce dielectric loss. The

wire is No. 18 D.C.C., space wound. The method of winding is as follows: If you have no lathe or other winding machine handy, put two short pieces of lath, about a foot long, in the jaws of a vise. Close to one end pass between the pieces of board the end of the No. 18, and near the other end No. 22 D.C.C. The No. 22 is for the spacing. You will need about 50 feet of each, but better have plenty of No. 18 so that you will have enough to do the wiring with when you assemble the set. The tension

within certain limits, the better the signal strength. Second, the change in wavelength per degree displacement is comparatively small, making a vernier adjustment unnecessary, although it is convenient. If a large condenser is used a vernier will certainly be necessary, as, due to the low damping of the circuit, it is extremely selective.

The grid condenser should be a good mica one of from .00025 to .0005 mfd. The radio-frequency choke shown in the phone lead is a Kellogg No. 503, 100 milli-henry iron cored. Although not shown in most receivers of this type designed for broadcast reception, it is necessary at higher frequencies as the capacity of the phone cord or primary of the first audio-frequency transformer is usually sufficient to short-circuit the radio-frequency feed-back to ground, causing failure of the set to oscillate. I use a universal Bradleystat to control the filament of the detector tube, connected up as for the UV-199 tube, but it works perfectly for any tube connected in this way and is very convenient when changing from one type of tube to another.

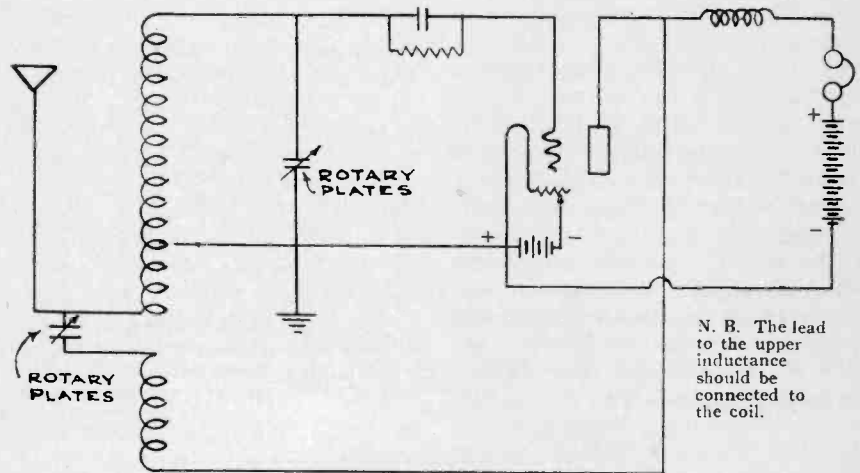

Hook-up for "Ham Special" Receiver

on the wire will be regulated by the pressure of the vise. Before you start winding study the location that the inductance is to have in the set, so that you will not have any unnecessarily long leads. In order to keep the radio-frequency paths short it is well to place the coil between the two condensers so that the condensers are at either side and not at either end of the inductance. The reason for this is obvious. Now begin the winding about half an inch from one end of the tube, keeping the tension on the wires as strong as possible so that you won't have to use any "dope" to hold the windings in place, and see that the No. 22 gets between each turn of No. 18. Wind on eight turns of No. 18 and then cut and anchor it. This is the feed-back winding. Commence again about 1/8 in. farther on and wind on 29 turns more in the same direction. Wind off the No. 22, and if you have anchored the No. 18 properly and kept the tension very tight, the winding should be perfectly firm. This is the hardest job in the whole set, the rest being easy.

The inductance is now complete and we will turn to the variable condensers. The grid tuning condenser has a maxi-

# Crystal Detector Notes

By Paul Oard

Here are some practical suggestions for the construction of a crystal detector. They include a test for sensitivity, a simple holder and a good circuit.

THE crystal detector has, in spite of much adverse criticism and some ridicule, held a place in the radio world from which it has not been shaken. The vacuum tube, at first threatening to displace it entirely, now bids fair to bring the crystal detector back into popularity with the development of the reflex circuit. The fact remains that for short distance reception, and where headphones are to be used in connection with such reception, the crystal detector is more efficient than the vacuum tube, if its efficiency is based upon an overall percentage, taking into consideration its compactness, lack of parts and therefore expense, and ease of adjustment.

Two things are essential in a crystal detector. First, the detector stand must be capable of swift and certain adjustment, permitting contact to be made readily over all of one surface of the crystal; second, the crystal must be sensitive.

newcomers in the radio field, there is a woeful lack of knowledge regarding the necessity for sensitive mineral. The writer has encountered many complaints from crystal set users, which trace to faulty mineral and nothing else. For every piece of sensitive galena, there are a dozen that are worthless. Pyrites as a rule has more average sensitivity, but is a little less sensitive generally than good galena.

Few of that newer generation of amateurs, the ones who purchase crystal sets in order to pick up broadcast programs, are familiar with that indispensable standby of the old timer, the buzzer test, which indicates infallibly whether or not the crystal is sensitive. A doorbell can be used in place of a buzzer, by bending back the clapper so that it does not strike the gong. Lacking the wherewithal to secure a buzzer, another old test may be resorted to, with which most

be purchased at stationery stores. This is made in the form of an endless coil spring mounted on a small clamp. This coil spring which is made like a ring, may be used to hold varying sizes of mineral, while the clamp may be drilled and bent to supply the mounting medium on the baseboard.

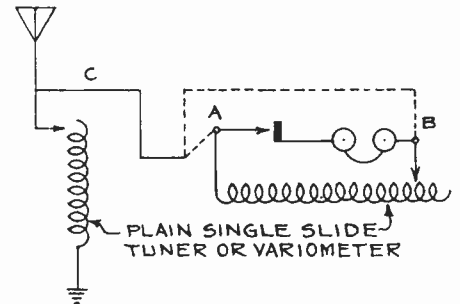

A New Crystal Circuit

The circuit presented here will be recognized as an adaptation of the so-called "unilateral" or open circuit type. It is not generally known nor used, but it is a circuit that affords comparative sharp tuning. On the face of it, it would not seem that the circuit would function, but the writer finds it quite effective. The connecting wire C must be tried on both connections A and B. As the circuit is unilateral, it will function on one of these connections only. This circuit will tune as sharply as the loose coupled type in general use. The two tuning coils have no inductive relation to each other, and may be placed as far apart as desired.

A small bit of cup or axle grease, or hard vaseline, placed on the mineral will serve to hold the catwhisker in place against jarring, and the adjustment will hold much better. The grease also prevents oxidation of the point of the catwhisker, which is important, a bright point serving to keep the detector in better working condition than one that oxidized or rusted.

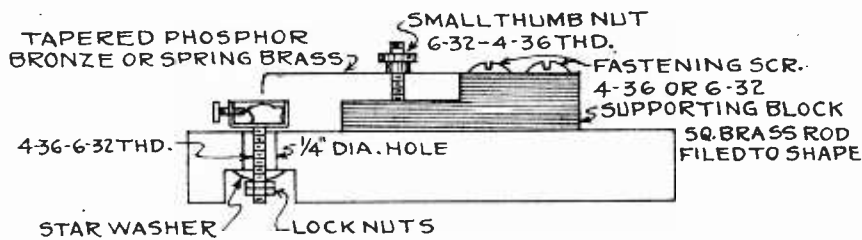

Detector Stand

Herewith is presented the sketch of a crystal detector stand that meets the first requirement fully, and which may be put together easily in the average radio workshop. The writer first saw this particular type used on the General Radio Company wavemeter. The adjustable feature, enabling contact to be made over the face of the mineral, lies in the cup itself. This cup is mounted over a hole  $\frac{1}{4}$  in. in diameter. The screw that holds the cup to the base should be a 6-32 or 4-36. A spring star washer, about  $\frac{3}{4}$  in. in diameter is slipped between the base of the detector and the locking nut, and pressure is applied with the locking nut just sufficient to hold the cup securely. The cup may now be turned freely and moved to any side at the same time, permitting the face of the mineral to be reached at all points. The cup should not be more than  $\frac{3}{4}$  in. in diameter, and the mineral not more than  $\frac{1}{2}$  in. square to facilitate quick adjustment.

As to sensitivity, either galena or iron pyrites are satisfactory and are probably the best minerals now available. At the present time, among the

of the old timers are familiar. After adjusting the mineral, turn on the electric light. As contact is made and broken, a minute spark occurs at the switch or socket contacts. If the mineral is sensitive at the point of contact, a click will be heard. With a little practice one may acquire the knack of turning the key of the socket in such a way as to make a succession of sparks. The hand should not touch the bare metal of the socket, as this oftentimes gives an inductive click that is deceiving.

Here are two little kinks that will help out in making up detector stands. One may purchase at any of the Woolworth stores, the so-called pierceless ear-rings. The part that clamps against the ear makes a dandy mineral holder, properly mounted. It will of course hold only small pieces of mineral, but if it is sensitive, this is no objection. Sometimes a raid on Sis's dressing table will yield the necessary material. The writer assumes no responsibility for consequences, however.

Another novel and thoroughly practical crystal holder may be found in a certain type of pencil holder that may



A Midsummer Night's Dream



# Crystal Detectors and Their Adjustment

By D. B. McGown

*That the oft-despised crystal has certain inherent advantages is the subject of this article. The author tells how these may be adapted for practical reception.*

HOW often you hear such a remark as "Oh, he hasn't much of a set—it's only a crystal outfit!", which savors slightly of an attitude of gentle "razz." How many of those who make such remarks realize that these same crystal outfits, or at least these same *type* outfits, have actually made radio history?

The crystal detector came into general use in 1908, the first being carborundum, which required a local battery for operation. Other battery crystal detectors were molybdenite, titanium dioxide, copper pyrite, iron pyrite, and the "perikon" detector, a combination of zinc oxide and copper pyrite crystals.

The other type, which still survives in use today, did not require a local battery, nor such a heavy contact. In this class we find several that were included in the former list, i.e. "perikon," and iron pyrites, and besides these silicon and galena.

In the hands of the average user, carborundum, galena, silicon, and iron pyrites were the best, in the order named, with the first two in a position where the actual constants of the particular crystals used determines their positions.

The battery type depend for their operation on their "unilateral conductivity," through certain directions in the crystal's formation, while the non-battery type depend on the "rectification" of the actual received energy. In other words, in the battery type, a direct current of small magnitude is passed through the crystal at all times; the received energy, which is delivered to the detector by the receiving set either aids or opposes the flow of this direct current, due to the fact that the crystal conducts current better in one direction than the other, which results in a sound in the head telephones. The rectifying type acts as a valve which passes one-half the cycle of an alternating current. Half of the cycle that is held back will be pulsating direct current, and if properly connected a condenser can be charged, and from this a pair of telephones operated. The actual received energy, therefore, operates the head-set, and the actual signal received varies according to the way the energy is emitted from the transmitting station. It may be in the form of groups of oscillations, like in a spark set, or it may be in the form of continuously variable continuous oscillations, such as we have in a telephone station, and it will be reproduced at the receiving end with absolute accuracy.

A crystal is very much less sensitive than a simple vacuum tube detector. It

is cheap, simple, not liable to damage, relatively easy to adjust, and self contained; it is ideal for a beginner, as it cannot be readily damaged and, if destroyed, can be cheaply replaced. It is not capable of remaining constantly in a sensitive condition; it is liable to oxidation and damage from dirt; and it broadens the tuning of the receiving apparatus.

Probably 90% of the present-day crystal sets are equipped with galena detectors. Usually, good galena has a rather "wavy" surface, which breaks, or shatters rather roughly. Galena which breaks in regular cubical crystal

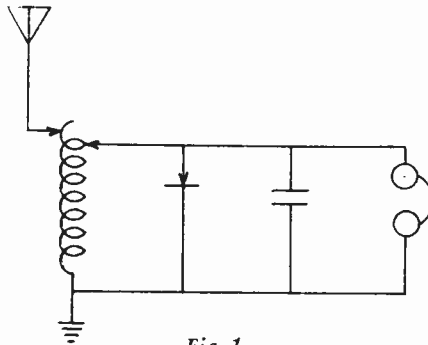

Fig. 1

form, is usually poor, and may have no sensitive spots on its surface. The so-called "steel" galena, which fractures with a crystallization resembling the grain of coarse steel is also good. It is entirely a matter of test to find out if a particular specimen is a good detector or not. Sometimes a very good-looking piece will be found worthless, but on the other hand a piece from one large lump, if sensitive, will usually show whether or not the whole lump will likewise prove sensitive. Galena from various parts of the country sometimes shows this in a marked degree. The writer has had specimens from certain mines, which all proved to be worthless, although of very nice wavy appearance, while specimens from the same mine, but from a different vein, showed up as very good, although casual appearance showed but little difference. Although certain specimens do possess spots that are sensitive, it is not an absolute test. Many times specimens will be found that are very good as far as numbers of sensitive surfaces go, that are very poor as far as actual sensitiveness on weak signals, while another specimen, that has relatively few "spots" will be unusually good on these said spots, and will bring in much louder signals from relatively distant stations.

Carborundum, in almost all cases, is sensitive only in the light-green, semi-

transparent crystals found at the base of the large crystal masses. It is absolutely essential that carborundum be tested carefully, before a sensitive specimen is found, and often the user despairs of finding a really good piece.

The mounting of crystals is important. Galena should be held solidly in a cup, clip, or similar device, and a very light contact allowed to rest on it. This usually takes the form of a light copper wire, which can be moved over the surface of the crystal. Carborundum, on the other hand, must be used with a rather heavy pressure. It is best to mount the crystal in a cup, with soft metal alloy, and to press down with a steel point, which is usually a phonograph

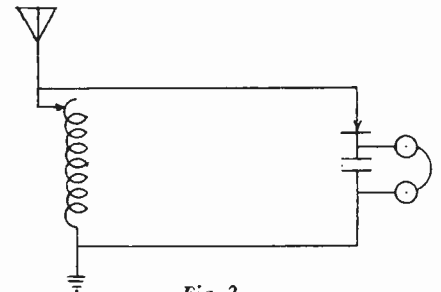

Fig. 2

needle, with considerable pressure, considering the size of the contact. This pressure may run up to as high as two or three pounds, and can best be applied with a spring, or screw.

Owing to the lightness of the contact, galena is more or less easy to get out of adjustment, and a pad of felt, rubber, or other soft material will help, if placed under the detector mounting. When transmitting, it is essential that a galena detector be disconnected, or short-circuited, as if left in circuit it will be burned so the sensitive spot is lost. It is better, by far, to open the circuit, either on one, or both poles of the detector, than to short it, as in the latter case a closed oscillatory circuit is set up, which may "knock" the point, anyway, while if disconnected, no bad results will be obtained on transmitting. No such precautions are needed with carborundum, as it will not be disturbed by vibration, so long as it is not jarred out of the contact position. It is proof against all damage from nearby transmitting stations, and even the strongest signals will not affect it in the least, although even moderate clicks of static might damage the point on a galena detector.

With all crystal detectors, the signal in the telephones depends on the current the crystal receives, rather than its potential. In a vacuum tube set, the signal depends entirely on the voltage, as it is

a trigger-effect device, but this does not hold in a crystal set. A single-circuit crystal set, as illustrated diagrammatically in Fig. 1, is the basic circuit of most of the sets of this type sold today, or the circuit shown in Fig. 2 may be used instead. Numerous other combinations are of about equal efficiency. In either case, we have an oscillatory circuit composed of the antenna, variable inductance, and ground. The crystal is connected directly across this, and all the energy received by the antenna is impressed on the crystal, even if it is of a very different frequency than the antenna is tuned to. Thus it is often impossible to do any tuning with such a circuit, although signals of considerable volume may be obtained. The addition of a second slider, as shown in Fig. 3,

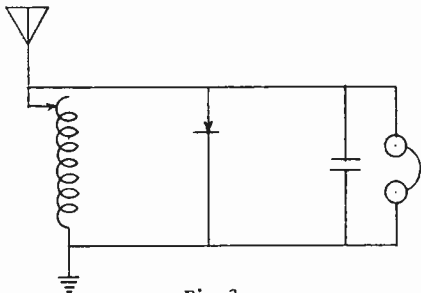

Fig. 3

will remove the detector from the antenna circuit, but as it forms a partial short-circuit across the turns connected between the ground and slider, it actually broadens the tuning, to an objectionable value; furthermore, as the resistance of the detector varies greatly, and is never the same, probably, even if adjusted to the same "point," it will cause detuning of the antenna circuit. In all cases the crystal is getting, however, a maximum of energy from the antenna circuit, which alone is enough to give broad tuning. Fig. 4 shows the connection for a loose-coupled crystal set, which is the best.

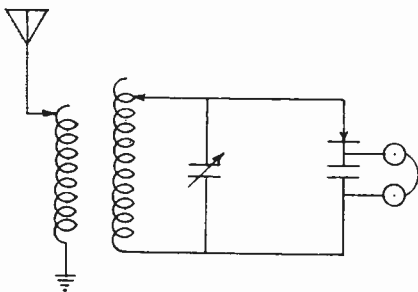

Fig. 4

The resistance of the crystal, when adjusted for reception, is quite high, probably 2000 to 10,000 ohms. This will roughly approximate its impedance, at ordinary spark or voice frequencies. Furthermore, the current delivered from a crystal is of very small magnitude. If we use low resistance telephones, we will have very little current flowing in them, and a weak response for two reasons: In the first place, because their impedance does not match the impedance of the crystal, so little current will flow,

and besides this, the actual effect on the diaphragm by the small current will not be very great, unless sufficient ampere turns are used. Telephones for crystal reception should be anywhere from 2000 to 3000 ohms, d.c. resistance, per pair.

The opinion exists that crystal reception is very limited, and that the usual range of crystal sets is about 15 to 25 miles. This is simply the range that is absolutely certain, with inexperienced listeners, and actually is a matter to be regretted. For many years crystals were used for commercial radio work, and many are the records that were established with them. The patience of the average operator using a crystal or "hunk of coal" as it was termed, was a matter that deserves much praise. When it is considered that more or less regular commercial communication was kept up over thousands of miles, with spark sets transmitting, and crystal sets receiving, usually connected as shown in Fig. 4, the more wonderful it is. Today someone thinks he has done well, when he hears a broadcasting station of 500 watts antenna input 250 miles away. He is only to be pitied in his ignorance. Take some of the old commercial and ship stations such as Manhattan Beach, Hatteras, Hillcrest (San Francisco), East San Pedro, and the like. In those days commercial work was handled, and messages sent and received that would make the distance(?) of the average crystal hound of today look sick.

In the days when crystals were used exclusively, it was not an uncommon thing for ships to handle business with Manhattan Beach (practically New York City) when the said ships were off Honduras! Similar, or better records were hung up on the Pacific Coast. Ship stations have been known to handle business with Hillcrest (KPH, San Francisco) when 2500 or 3000 miles west of Honolulu!! (4500 or 5000 miles from KPH). The said KPH station has even worked Japanese stations with spark transmitters of about 5 kw. input (probably not more than 2 kw. in the antenna), with crystal detectors at both ends! Traffic was handled with ships between San Francisco and Honolulu,

nightly, all the way both ways, from San Francisco to Honolulu. The claim that crystals are suited only for local or short distance work is certainly knocked flat by the above records, which are not exceeded greatly in these days of vacuum tube receivers.

The fact that these records were established by radio telegraph stations does not matter a great deal, as there was no chance to try any telephone tests—because there were no telephones going, but, if there had been, they would have been heard at great distances, as well, without doubt.

### AN EFFICIENT GROUNDLESS RECEIVER

By FREDERICK J. RUMFORD

**D**URING a series of interesting experiments recently carried out at Pelham, N. Y., by a staff of radio engineers from Columbia University while investigating "dead spots," they found that with a short antenna and with no ground they could obtain remarkable results in conjunction with the ordinary single-circuit regenerative receiver, using a variocoupler with tapt primary, of which the secondary functioned as a feed-back coil. In place of the usual type of aerial, they used a fishing reel upon which was wound about 50 ft. of bare wire, whose effective length could be varied with little or no trouble.

The table shows that the best results were obtained with no ground or counterpoise, and with the aerial anywhere from 38 to 50 ft. long, and a height of from 6 to 10 ft. from the ground.

Fig. 1 shows the hook-up from which a portable set suitable for the vacationist could be easily and inexpensively made up. It would be advisable to use one of the dry cell tubes.

TEST-RESULTS

AERIAL		Ground	Counterpoise	Tuning	Signals
Height	Length				
10 ft.	50 ft.	Pipe . . .	None . . .	Broad . . .	Faint
10 ft.	50 ft.	None . . .	Wire on ground . . .	Better . . .	Doubled
10 ft.	50 ft.	None . . .	2' below aerial . . .	Critical . . .	Louder
10 ft.	50 ft.	None . . .	None . . .	Average . . .	Same
10 ft.	38 ft.	None . . .	None . . .	Critical . . .	Same
10 ft.	37 ft.	None . . .	None . . .	Critical . . .	Less
6 ft.	50 ft.	None . . .	None . . .	Sharp . . .	Strong
2 ft.	50 ft.	None . . .	None . . .	Critical . . .	Less

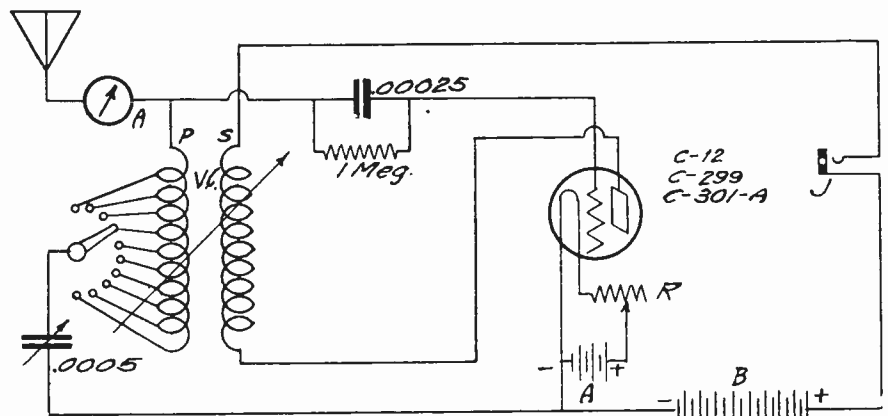

Fig. 1. Hook-up for Groundless Receiver



"Miss Minoiva Plum, sah!" sings out Whitewash.

## The Woman-Handler

By Volney G. Mathison

*Samuel Jones, the most famous character in radio fiction, again appears on the scene in a new role! Of course it is overdrawn, as is most humor. Even as the cartoonist emphasizes his subject's most prominent features, so also does the author bring out the foibles of the woman operator.*

"SAMUEL JONES!" exclaims old Kid Cunningham, as I stroll into the private office of his radio-factory hangout down on San Francisco's busy First Street. "Do you want a fine shore job?"

"Not specially," I replies, careless like, drapin' myself comfortable on the softest leather chair in th' joint an' haulin' out my old Durham sack. "I've just finished a pretty successful boot-leggin' trip from th' Orient, an' I've got a nice roll of th' Mercury-footed flapper-green in my sock. What are ya tryin' t' hang onto me?"

"Radio superintendent for the Tropical American Fruit Company," replies friend Cunningham. "You'll be in charge of the wireless operators on their fleet of twelve big steamships, and of their half-million-dollar private radio station at New Orleans. Salary hundred and twenty a week, a free ticket to New Orleans, and a thousand a year bonus if you make good. This job ought to be the zebra's stripes, as they say, for an old sea-dog brasspounder like you."

"Humph! It sounds like a wireless

correspondence-school ad," I observes, rollin' my smoke an' keepin' calm as a' old Cape Cod clamdigger on a Sunday afternoon. "Where's th' crack in th' glass?"

"There isn't any," declares brother Cunningham. "I've just sold the Tropical American a lot of latest type four-step-amplifier receiving instruments, and they happened to ask me if I could recommend them a good man for radio superintendent. There's just one unusual thing about this job—it seems that you have to fire their twenty-three present shipboard radio men and replace them with women wireless operators—"

"Huh!" I ejaculates, sittin' up with a jerk an' blowin' my cigaret half-way across th' office. "What in—by th' holy golden harps, I knew there was a fish in th' milk, some place!"

"But this is easy——" begins Cunningham.

"Yeh, it sounds like it!" I retorts. "Look here, you ain't goin' t' hang no such bracelet a' scorpions around my neck as that! I've camped in radio shacks on five oceans, an' had my tail

feathers shot away enough times t' be a wiser bird than I look! Me boss twenty-three radi — wimmen! Say, what in blazes d'ya think——

Just then th' office-boy opens th' door, an' in comes—a girl. Talk about th' peaches an' ice-cream—this sweet mamma has Harrison Fisher's golden-haired Cosmo covers knocked fer a row a' Swede Hildas! Did ya ever see a eighteen-year-old angel dolled out in a silk an' fur Parisian fashion-show, with Mack Sennet bathin-girl ankles, an' eyes that make you feel like you was drinkin' out a' old Ponty de Leon's fountain a' youth? Well—one look at her, an' I takes th' count like a chloroformed cat!

"Why, how do you do!" chirrup Cunningham, smilin' at th' angel a way he has no business to, him bein' married, with three kids.

"Mr. Jones, meet Miss Gloria Belleclair. This is the daughter of Colonel Gorgon Belleclair, the president of the Tropical American Fruit Company. Miss Belleclair, here is Samuel Jones,

*Continued on page 52*

"AND IT CAME TO PASS——"

Concerning the Coming of A  
Clearer Conception

By SEWELL PEASLEE WRIGHT

AND it came to pass that one who had been a member of the tribe of brass-pounders for many years, even for a decade, groaned exceedingly in spirit, and the burden of his lament was in this wise:

"Lo, the broadcast listener hath come into his own, and more than that; he wanteth all the air all the time, and he maketh hideous squallings with his set, and his brothers blameth it onto the amateur.

"He sitteth up and talketh wisely of radio when he knoweth naught about it; discriminating not between a microfarad and a kilowatt. He outnumbereth the code-pusher, and he turneth public sentiment in his own favor. He hindereth radio work, he maketh of himself a nuisance; truly he is a pest and an abomination, and I will have none of him!"

The Continental-catcher moaned in this wise, and his brothers joined with him, and the echoes were heard in the far corners of their country. And there arose great discussion, and much grey matter was consumed therein, but naught was accomplished, for the broadcast bug waxed strong, and his numbers multiplied and became legion, and his power accordingly.

And in some places the wail went up that the day of the key-cuddler was gone; that the sun had set thereon. There was mourning and weeping and wailing and gnashing of teeth, but the phone fiends multiplied exceedingly notwithstanding.

A year, even two of them, wound slowly onto the scroll of Time. And he who had been an amateur for ten years was then one of a dozen years' experience, for he had persevered, and kept on his pursuit of the great god Distance. C. W. bottles glowed where the mighty, roaring spark had once cast its flickering blue light, and its ozone had tickled the nostrils of those who came into its presence, but little else had changed.

In the heart of the relay radical there was much bitterness, for he had seen the broadcast listener wax fat and numerous. He had seen his hours of operation restricted, his time-honored rights and privileges filched and usurped by the new-comer. Unto himself he spake harsh words, in this wise:

"There is no good in this one who knoweth naught but the knack of twirling a dial. For whosoever comprehendeth not the art of the soldering iron and bus-bar wiring; who knoweth not the way of wire on a tube save that it looketh pretty in its nice green silk insulation, he is not worthy to don a headset, that which was once the proud badge of the ham."

And he shook his head sadly at that which had come to pass, for indeed it was grievous that the old-timer should be supplanted, ousted and villified by those who knew not the name of audiotron.

But one day late in the second year of the coming of the broadcast there came unto the bottle-burner one who introduced himself saying most modestly:

"It hath come to my ears that thou art an old-timer, and I am but a beginner. My new set worketh not, and I am come to ask that thou wilt look upon it, and explain unto me that which aileth it, that it may be remedied."

And he who had shot much trouble in twelve years was prevailed upon to go by the beseeching voice of the beginner, and accordingly they made their way unto the domicile of the latter.

"Here thou beholdeth the set," said the beginner shortly thereafter. "With my own hands I constructed it, which no doubt accounteth for its shortcomings, for I know but little about radio."

The old-timer stood for some moments without speaking, and in his face amazement was writ large, and with reason. For the set that he beheld was a fearful and wonderful thing of the very latest type, and it employed a circuit the complexness of which almost exceedeth human understanding. Yet lo, it was wired neatly, and the grouping of the units was intelligent and symmetrical.

"Meanest thou to say that thou hast constructed this set unaided?" queried the ancient ham, and the younger man nodded assent.

"Surely it is my own handiwork, unaided; thinkest thou that it is no good?" There was anxiety in his tone, which made the old switch-thrower grin right broadly.

"I see that I have made a grievous error; for I have deemed all broadcast listeners dubs and meddlers, and lo, you are building sets that are more compli-

cated by far than those I have myself. Thou hast worked intelligently, and thou has improved thy mind and thy knowledge of radio, and in time you may even aspire unto membership in the Ancient Order of Dot and Dash Dealers; is it not so?"

"Yea, of a verity; with several of my companions I am even now mastering Continental. But tell me, oh ye of great experience, what aileth this set of mine?"

And he who had shot much trouble went over the hook-up, and found no wrong therein. After half an hour he discovered that which was ailing, and he smiled largely.

"Thou has failed, oh beginner, in that thou hast neglected to fasten thy ground wire!" he chortled, and the young man turned a color like unto a boiled beet, so great was his shame.

But the old-timer extended his hand, and slapped the broadcast listener on the back most heartily.

"Be not downcast!" he advised. "Even those of us who were in the game when thou wert but a puling infant do things even more foolish."

The broadcast listener and the old-timer shook hands, and he who had five ex-calls to his credit departed shortly thereafter, and in his heart was a new understanding and a new respect for this listener to phone stuff, for lo, he had proven himself a fellow experimenter; a winder of coils and a wielder of the soldering iron. And the bitterness that was in his heart for these newcomers was washed away in a flood of understanding.

And it was very near unto Christmas, so that as he thought on these things he passed a great church, and in front thereof was a large bulletin board, and on it was writ large in green and red some words from the greatest of all Books. And the manner of these words was this:

"On Earth Peace, Good Will Toward Men."

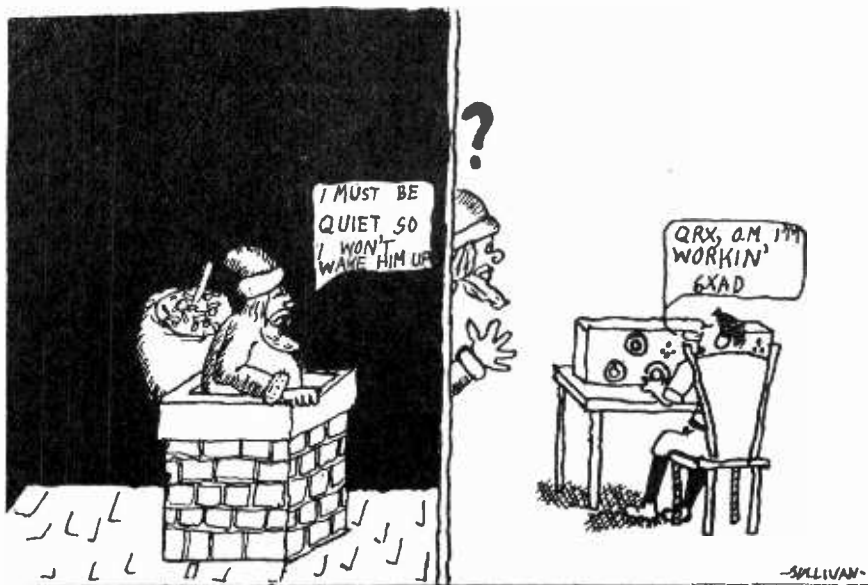



# Storage Battery Chargers

By Jesse Marsten

*Full details are here given as regards the method of operation of gas-filled tube rectifiers and vibrating contact rectifiers. A knowledge as to how these devices work is of interest to everyone concerned with the home-charging of storage batteries.*

THE problem of charging storage batteries is one of furnishing the run-down battery with direct current at a certain rate until its voltage is restored to its initial high value, generally 2 volts per cell. If the electric power supply is direct current it is simply necessary to supply this d.c. to the battery through a sufficiently high resistance to cut down the battery charging current to the value designated by the makers of the battery, as illustrated in detail in Fig. 1. How-

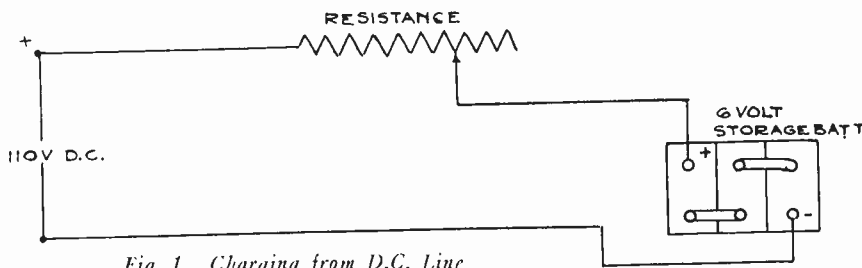

Fig. 1. Charging from D.C. Line

ever, if the electric power supply is alternating current the problem is entirely different. Alternating current cannot be used for charging storage batteries, for with each reversal of current through the battery there is a reversal of chemical reaction which prevents the battery from charging. The problem presents itself, therefore, of converting the existing a.c. into the necessary d.c. for charging the battery.

For this purpose various rectifiers have been developed, and the chief types fall into two classes: tube rectifiers or vibrating contact rectifiers. Each of these types is easy to handle, since the only operations involved are to connect the storage battery to marked posts on the rectifier and to attach a plug from the rectifier to the electric light socket.

### Gas-Filled Tube Rectifiers

The theory of the tube rectifier is somewhat similar to that of the vacuum tube. Suppose we have a gas-filled tube containing two electrodes, one a heated filament and the other a cold plate as in Fig. 2, with a resistance as shown. The filament is heated by some external means. If an alternating voltage is ap-

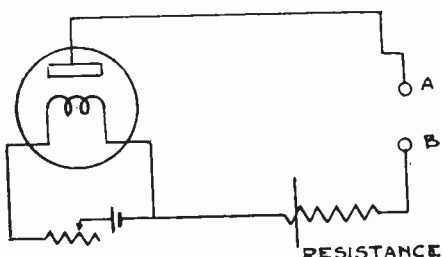

Fig. 2. Gas Filled Tube Rectifier

plied between the points A and B a direct pulsating current will flow through the resistance R. For only the positive half cycle of the a.c. wave of Fig. 3 is effective in causing current to flow between plate and filament of the tube. When the positive half cycle is applied to the plate, electrons from the heated filament are attracted to it, thus causing a current to flow, but when the negative half cycle is applied to the plate the electrons are repelled and no current

flows. The form of the current through the resistance R is therefore as shown in Fig. 4. If we now connect a battery in series with the resistance R as in Fig. 5 and apply the a.c. to the tube we will have this pulsating direct current flow-

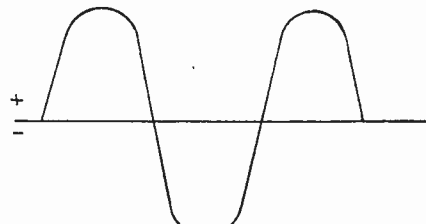

Fig. 3. A.C. Voltage Wave Applied to Rectifier

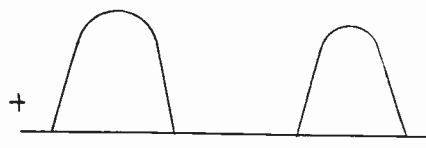

Fig. 4. Pulsating D.C. Flowing Through Rectifier

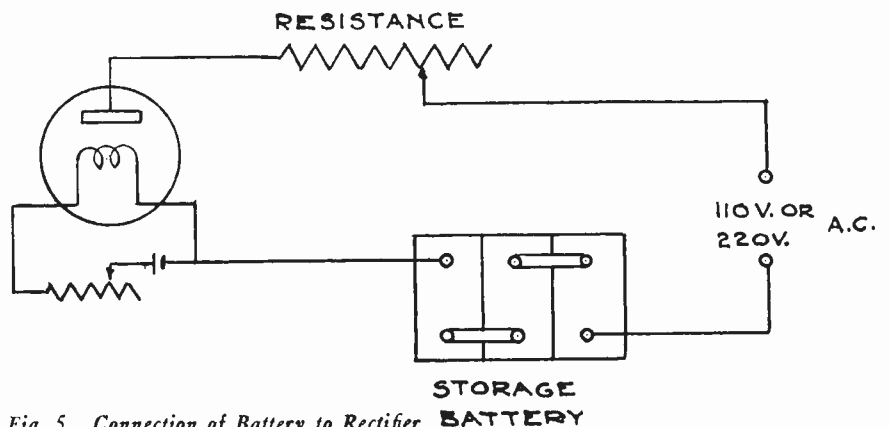

Fig. 5. Connection of Battery to Rectifier

ing through the battery and it will therefore be charged. The fact that the current through it is pulsating makes no difference, for the current is always in the same direction through the storage battery and hence the chemical reaction takes place in one direction, resulting in charging the battery.

It will be evident from the above that only one-half of the a.c. energy is used in charging the battery, the negative half of the voltage wave not being utilized. This does not necessarily mean that the efficiency of this method is low, because during the negative half of the wave no plate current flows and hence no energy is used other than the filament power, and this latter is made very low in commercial devices. Thus even with only one-half wave operation the efficiency may be high. However, it is possible to utilize both halves of the a.c. voltage wave for charging by the expedient of using two tubes in the manner shown in Fig. 6. During one-half of the wave the plate of one tube is positive and charging current flows through the battery, while during the other half of the wave the other tube is active, causing charging current to flow in the same direction as before through the battery. Thus both halves of the a.c. wave are utilized in charging the battery. This method is necessarily more expensive than half wave operation, and is really unnecessary for battery charging purposes.

To light the rectifier tube filament by means of a storage battery would be expensive and to charge the storage battery through a resistance which consumed energy would likewise be inefficient. This practice is not followed in commercial devices, as will be seen from an examination of a standard rectifier such as the Tungar or the Rectigon. Fig. 7 illustrates this type. It consists simply of a gas-filled tube, an auto-transformer,

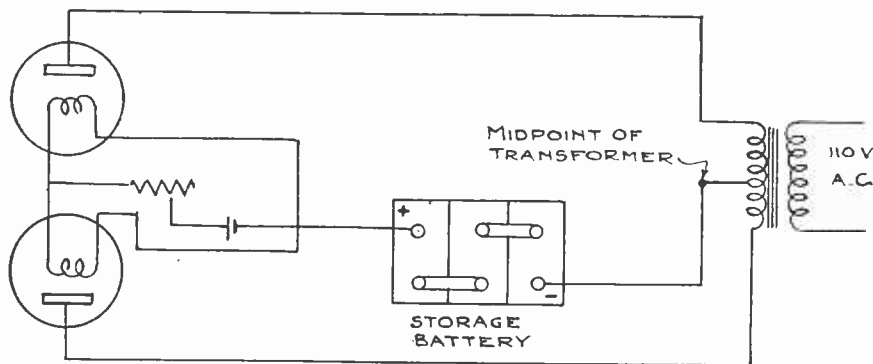

Fig. 6. Full Wave Rectification

and a fuse. Each of these parts is clearly visible in the housing which contains them all. The tube is a two-element gas-filled tube, containing a tungsten spiral filament and graphite anode. The tube is filled with argon gas which results in increasing the electron current from plate to filament to much higher values than would otherwise flow. In-



Fig. 7. Tungar Battery Charger

asmuch as the tube is operated on low plate voltage this is necessary as otherwise insufficient current would be obtained for charging the battery. The tubes will generally be found to have a dark gray-black deposit on the inside glass wall. This is due to some preparation which is used for purifying the argon gas. The auto-transformer is of conservative design whose function will be evident from an inspection of the wiring diagram of the Tungar charger, shown in Fig. 8. The a.c. voltage is applied between points *A* and *B* of the transformer. A small portion of the transformer winding, namely *CD*, is tapped off and connected directly to the filament terminals of the Tungar tube. This furnishes filament power in the most economical way and dispenses with

any outside source or accessories. Another portion of the transformer winding, namely *DE*, is tapped to supply the plate voltage to the tube. Thus the auto-transformer serves the purposes of cutting down the a.c. line voltage so that suitable filament and plate power may be applied. The battery is connected to points marked *Red* and *Black*. The fuse

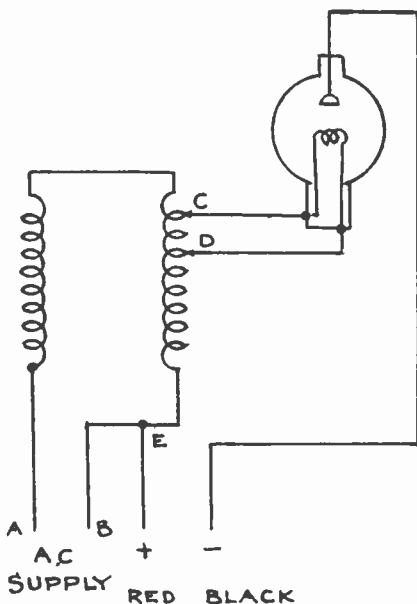

Fig. 8. Rectifier Connections

limits the charging current to the value for which it is designed, in the event this is exceeded it blows and opens the circuit.

It is thus seen that the charger need only be connected to the a.c. source of voltage and all necessary power is available. This is accomplished by means of a screw plug which may be attached to the lighting socket as shown in Fig. 7. Inasmuch as the line voltage varies in different localities precautions have been taken to adjust for this variation. Fig. 7 shows clearly three taps brought out from the transformer, marked 105, 115, and 125. The respective taps are to be used for line voltages corresponding to them.

These chargers come in various sizes designed by the charging current it will deliver, thus we have the 2-ampere size, 5-ampere size and so on. Obviously the type to use depends upon the size of the battery. Thus for a 20-ampere-

hour battery the 2-ampere size would be suitable, whereas an 80-ampere-hour battery could take the 5-ampere size charger. The lower the size of the charger the longer it will take to charge a given battery. The choice of a suitable charger therefore depends upon the size of the battery to be charged, how much it is used and how fast it is run down, how quickly it is desired to charge the battery. One point should be borne in mind, namely by charging your battery a couple of hours each day, irrespective of whether it is run down or not, a smaller size of charging outfit will do very well. It is not the best policy to wait until the battery is completely run down before charging. Another point to bear in mind is that it is not wise to exceed the maximum charging current for which the charger is rated, for it is harmful to the bulb. On the other hand, using too low a charging current results in unstable operation. In using such chargers it is always advisable to disconnect the receiving set from the battery when it is on charge, and to disconnect the charger from battery and line when the battery is in use. Never use the receiver or other radio set while battery is on charge. The reason for this is that some point of the radio set is always grounded, and generally one side of the a.c. power line also is grounded. It is possible that the polarity of the line ground may not jibe up with the radio ground, in which case harm is likely to come to the Tungar tube and possibly some part of the radio set.

#### Vibrating Contact Rectifiers

In the vibrating contact rectifier the charging current is supplied to the storage battery through two contacts. On the make the current flows through the battery and charges, and when the polarity of the charging current changes the contacts open and thus prevent current from flowing through the battery. To understand the theory of the operating of this type of charger consider first Fig.

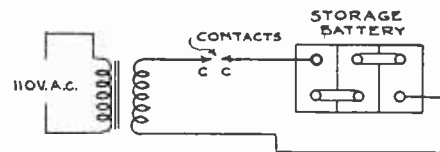

Fig. 9. Elementary Circuit for Vibrating Contact Charger

9, which shows the a.c. line voltage applied to a step-down transformer which reduces the line voltage to the value necessary to charge the storage battery. The a.c. voltage from the low side of the transformer is then fed into the storage battery to be charged through two contacts *CC* which make and break periodically. Suppose the charger is arranged so that the battery charges on the positive half of the wave. If the contacts make on the positive half cur-

Continued on page 84

# Unique Design for Short and Long Wave Receiver

By Herman A. Fischer, Associate Member I. R. E.

*The unique feature of this set is the method whereby a standard three-coil honeycomb hook-up may be adapted for experiments with a vario-coupler or other modifications. Its range covers the amateur, broadcast and commercial wavelengths.*

AFTER having constructed, used, torn apart and rebuilt many kinds of receiving sets, I decided that the next one I built would be a permanent fixture in my station. This, however, was not an easy matter to do, as the market was saturated with a large assortment of new circuits and designs. My main desire was to have a set with which I could experiment and change about a bit, but still have an outfit constructed in a cabinet which would present a

- 1 Plate variometer.
- 1 Rheostat.
- 1 Socket; combination preferred.
- 1 Mica grid Cond. with G. L. mounting.
- 2 Extension handles for H.C. Mount. (hard rubber or bakelite.)

This set was designed as a combination long and short wave tuner and is adaptable to the use of the amateur, broadcast listener or ex-commercial operator who enjoys copying a bit of 600 meter traffic or press on longer waves.

variometer, under which is the small push-pull canopy switch for cutting in or out the tickler (see Fig 3 S-2); rheostat control; tube windows; and six binding posts, two each for B battery, phones and A battery, respectively top to bottom.

Care must be taken when wiring the anti-capacity switch. Needing only a double-pole double-throw switch, and as the anti-capacity switch I used was a four-pole double-throw, I soldered the



Fig. 1. Front View of Completed Receiver



Fig. 2. Rear View of Completed Receiver

finished appearance. It could not be of the sectional panel idea, neither could it have a lot of stray wires reaching out in all directions. So, after careful consideration, the set which I will describe was decided upon and, after testing, I found that I had a set which was complete in every respect.

Figs. 1 and 2 are front and rear views, respectively, from which the

1, being in the latter class, know how they feel.

Referring to Fig. 4, front view, the parts from left to right are as follows: antenna and ground binding posts; primary condenser, under which is the anti-capacity switch for placing the primary condenser either in series or shunt; honeycomb mounting, above which are six binding posts, two each for primary, secondary and plate circuits as indicated in Fig. 3; secondary condenser; plate

two poles together on each side (see S-1 Fig. 3).

S-2 in Fig. 3 is a small single-pole, single-throw, push-pull, dash-board switch or, as in my case, a small push-pull canopy switch as used in electric fixtures. This switch opens the plate to the tickler coil for regeneration by the feed-back method on waves above 525 meters (determined by size of variometer) and closes circuit so that tuned plate regeneration is used on the lower waves, in which case the tickler coil should be removed from the plug. It will be noted that the plate variometer is in series with the tickler when S-2 is open. This will allow the plate to be tuned to a certain extent on the upper wavelengths.

The wavelengths which this set will cover depends on the size of the honeycomb coils used. However, the set is not limited to the use of honeycombs only, which is the reason for the six

*Continued on page 91*

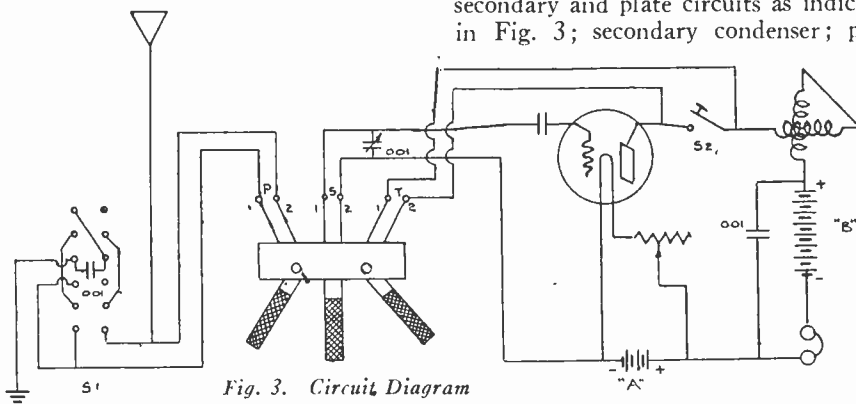

Fig. 3. Circuit Diagram

reader will get a fair idea of the construction. The circuit, Fig. 3, is of the conventional three-coil honeycomb, but with slight modification. Fig. 4 shows the layout of instruments on the panel. As every builder uses his own pet parts, no attempt has been made to give exact dimensions in the layout.

A list of parts required to complete the outfit is as follows:

- 1 Panel 7 in. x 24 in.
- 1 Cabinet 7 in. x 24 in. x 6 in. deep.
- 1 3-coil honeycomb mounting.
- 2 .001 MF vernier Var. Cond.
- 1 Anti-capacity switch.
- 3 4-in. Dials.
- 1 Rheostat dial.
- 14 Binding Posts.
- 5 lengths Bus Bar wire.

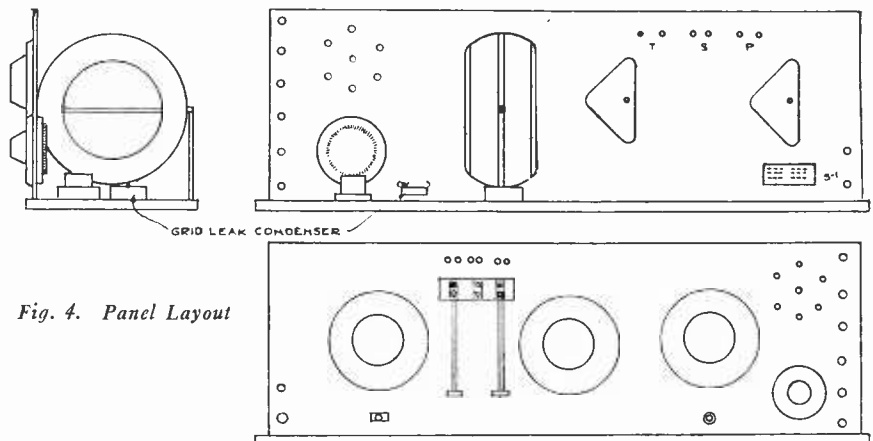

Fig. 4. Panel Layout

**SOME FURTHER ADAPTATIONS OF MY TUNER**

By SIX ZEE JAY

A TUNER having coupled plate and grid circuit features was described in March RADIO and also in a subsequent issue another adaptation was presented. However, this tuner is not subjected to these two uses alone but can be adapted to most any circuit using the vacuum valve and advantage can be taken of this "reflex" feature.

Some further uses are described herewith, the most prominent being its adaptation to radio-frequency amplification on short waves.

Figs. 1 and 2 illustrate circuit connections for a one-step radio-frequency amplifier. Fortunately, tuned coupling offers an efficient means for a one-step, in this case, and furthermore, as it gives greater amplification by two-fold over that obtainable with iron core transformers or others, it should be used.

I can offer no reason why the coupled grid-plate circuit should increase the efficient operation of the radio-frequency amplifier, other than that it does in practical use. I believe that better results would be had if this coupling could be varied. However, very good results are obtained with the tuner as it is.

The words, "Gibbons Circuit," will be used, for convenience, to designate the circuit that recently received pub-

Fig. 3. You will then find, to your delight, that fones come in good and strong and that the set will oscillate

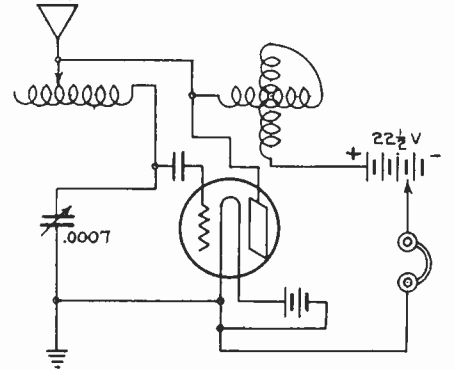

Fig. 3. Adaptation to Gibbons' Circuit

and regenerate freely over its entire wave-band, getting DX galore.

This tuner can be readily changed to the "tickler circuit," using the rotor of variometer as the tertiary feed-back coil with but a few minor changes in

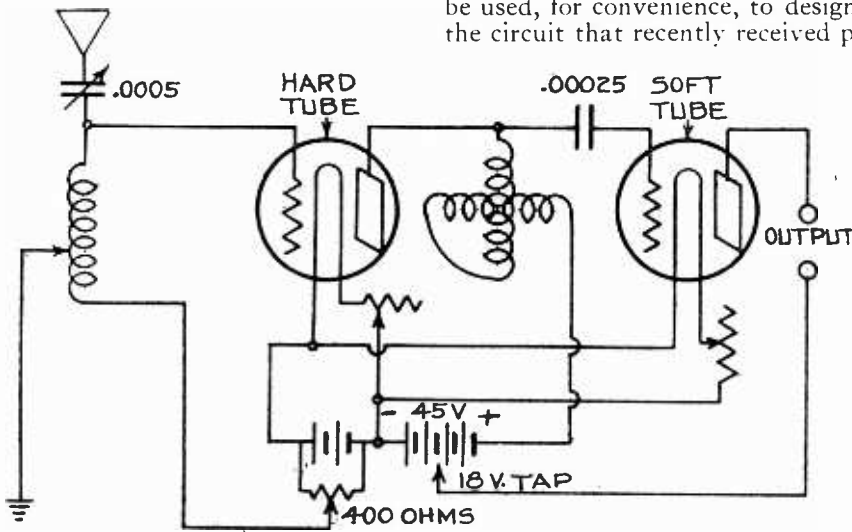

Fig. 1. Connection for a One-Step R. F. Amplifier

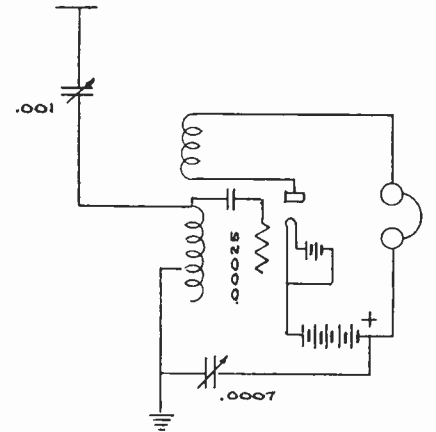

Fig. 4. Adaptation to Tickler Feed Back Circuit

connections. The circuit is shown in Fig. 4.

The "tickler" coil, in the single-tube "super," described by A. L. Groves in a recent number of QST, is here substituted with a variometer to obtain transfer of energy between grid and

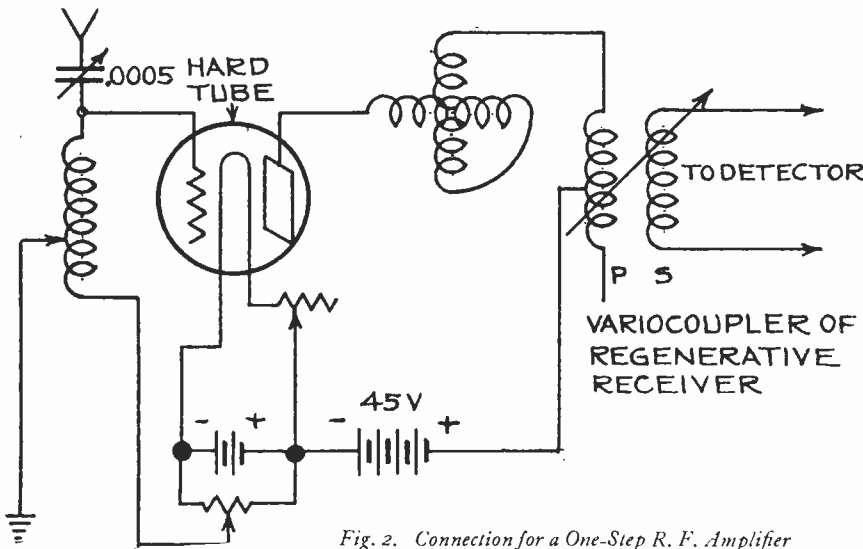

Fig. 2. Connection for a One-Step R. F. Amplifier

To construct the tuner, obtain a bakelite or fiber tube 3 1/2 ins. in diameter and wind on 80 turns of No. 22 D. C. C. copper wire, bringing out taps at every eighth turn. Using small brass angles, fasten the tube to the left side of a wooden variometer. If the inductance-variometer is to be used as a separate unit, then mount on an appropriate panel and cabinet. Otherwise incorporate it in the complete set contemplated.

licity among radio enthusiasts. There are several circuits similar to this one, but it seems as tho the "Gibbons Circuit" has facilities all of its own. However, modifications and improvements are always in order, so here goes:

Mr. Gibbons states that his circuit isn't much on the fones but does marvellous performances on 600 meters and is hard to make oscillate on 200. Here's the solution: use the inductance-variometer described and connect as per

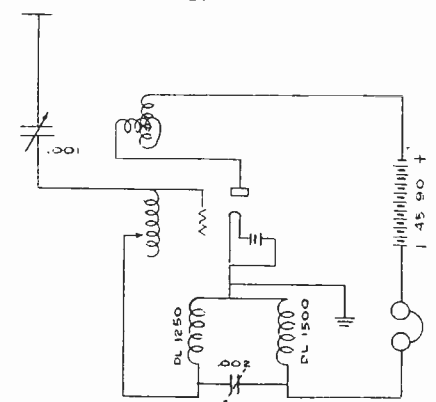

Fig. 5. Adaptation to Single-Tube "Super"

plate circuits. Just tuning the plate circuit alone, however, is not sufficient to obtain maximum results. Here is where my inductance - variometer comes into good use. Connections are shown in Fig. 5, and are self-explanatory.



# Increasing the Wavelength Range of Your Receiver

By Edward T. Jones, A. I. R. E.

*By means of these simple suggestions it is possible to change a set of limited range so as to get the higher wavelengths. The additional equipment costs less than a dollar and may be either mounted on the panel or inserted in the exterior antenna-ground lead.*

**B**EFORE Mr. Hoover came to the rescue of the broadcast listener, most of the radio apparatus was designed to receive over a range of from 170 to 700 meters, provided a fairly large antenna was employed at the receiving station. So many powerful broadcasting stations sprung up all over the country and were operating so closely together (insofar as their wavelengths were concerned) that the advisability of using a short antenna became evident and the information was spread by radio magazines to every nook and corner—and immediately antennas took on much smaller dimensions. This did help in eliminating considerable interference, but just about the time this work was completed, Mr. Hoover stepped in and assigned each station a wavelength that made it practically impossible for any of the larger stations to interfere with each other. Some of these stations were assigned wavelengths considerably longer than was the general practice.

This brought about another condition which to some extent caused confusion amongst the owners of radio receiving installations. It is the main purpose of this article to show how the wavelength range of the receiver (with the present antenna installation) can be increased to permit reception from such stations as Newark, Memphis, St. Louis and Omaha, who are employing wavelengths from 500 to 546 meters.

It matters not whether you are using a single or double circuit type of receiver—for the method described below is equally well suited for either type.

Here we are only concerned with the primary (antenna ground) portion of the receiver, for in the two-circuit receiver it is not generally necessary to make any changes in the secondary circuit, as it is not affected in the least by varying the length of the antenna itself. Two conditions may exist: The variable tuning condenser may be placed in series with the antenna, or the condenser may be in series with the ground, as shown in (a) and (b) of Fig. 1. Let us now consider the receiver in its present condition tuned to the longest wavelength possible; the variable condenser, whether in the antenna or ground circuit, is being employed at maximum capacity. In my particular case I found that I was just able to get Memphis with all the variable condenser in the circuit—denoting that I could not get above 500 meters to listen to those stations operating above that wavelength. Something had to be done. The con-

denser in my set is a 23-plate type having a capacity of .0005 mfd. Immediately an idea came to mind which worked so well that it prompted me to prepare this article for the benefit of those who are in the same "boat."

I took a fixed Dubilier condenser having a capacity of .0005 mfd. (equal to the maximum capacity of my 23-plate variable condenser) and devised a special circuit for cutting in these two condensers. The diagram of connections in Fig. 2 will show how this is accomplished. A double-pole, double-throw switch is so connected to the fixed and

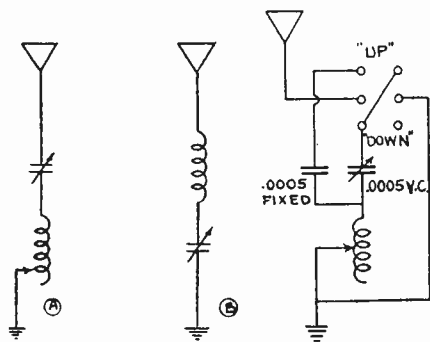

Fig. 1. Condenser Position in Primary Circuit

Fig. 2. Connection Diagram for D.P. D.T. Switch

variable condensers that, when the switch is thrown to position *up* the .0005 mfd. condenser is inserted in place of the 23-plate condenser and the maximum range of the receiver remains the same. Automatically the 23-plate variable condenser is "shunted" across the tuning inductance, and, by merely returning the dial to zero position (minimum capacity), tuning above 500 meters on my particular set begins. In other words, the 23-plate variable condenser is now functioning to tune the receiver above what was formerly the receiver's maximum capacity. By throwing the switch in the *down* position the receiver is returned to its normal operating condition.

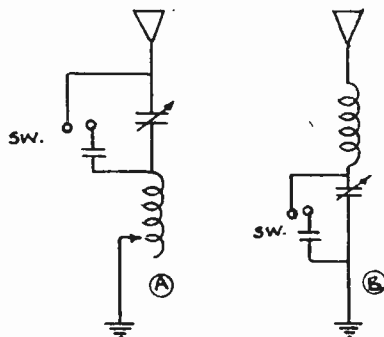

Fig. 3. Use of Shunt Condenser

If your receiver is equipped with a 43-plate condenser, the fixed condenser should have a capacity of .001 mfd. These fixed Dubilier condensers are readily obtained at any radio store, and list at 35 cents. The switch will cost about 50 cents. Another simple method of increasing the wavelength is shown in Fig. 3. There are two movements necessary to accomplish the desired results and it is not as simple as it appears. Personally, I much prefer the method first described. In Fig. 3 a fixed condenser having the same value as the maximum capacity of the variable condenser is shunted across the latter by

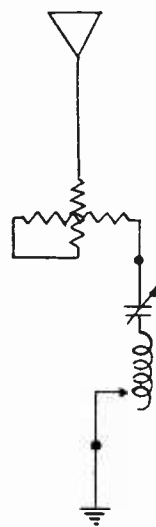

Fig. 4. Circuit with Variometer

closing the switch—*SW*. When the switch is closed the variable condenser dial must be returned to zero in order to begin tuning above the maximum of the receiver with only the variable condenser in the circuit.

Another method of increasing the wavelength of your present installation is to connect a variometer in the antenna circuit as shown in Fig. 4. This of course is not as simple as the first method described. It is necessary to thoroughly shield the variometer to prevent "body capacity" effect, and it is more expensive.

Never be afraid of leaving an Edison battery indefinitely, as long as it has solution in it, and as long as the case is well painted or greased. These batteries can be put away, at any time in any condition of charge or discharge, without damage. The only thing to watch is to see that the cases do not rust out, and this may be prevented by painting with P&B paint.

## THE DANGER OF OVER INSULATION

By A. REISNER

IN a previous article in August RADIO on the subject of insulation the writer called attention to the harmful effects which poor insulation may cause in radio sets. In this brief article it is intended to take up what, for lack of a better name, may be termed "over-insulation." The entire subject of insulation is too much ignored by radio fans who are always trying to get more and more out of their sets by making new coils, trying out new fangled circuits, etc. In this way they defeat their own purpose, for very frequently an improvement in insulation yields much improved results. In the previous article the writer showed how correct insulation means more output.

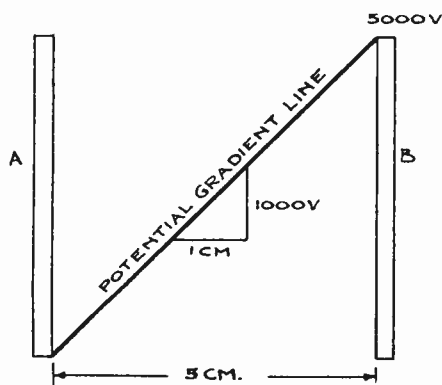

Fig. 1. Voltage Distribution Through Homogeneous Insulation

What is here called "over-insulation" is more concerned with the question of breakdowns due to high voltage. Wherever there is a high voltage there is always danger of arcing over between the points at which the voltage exists. Whether a breakdown in the insulation occurs depends upon the nature of the insulation and the distribution of voltage across it. Thus one form of insulation will withstand a greater voltage per centimeter thickness than another. By making the insulation thick enough almost any insulating material may be made to withstand any voltage.

In any insulation, however, what actually determines its power to withstand high voltages is the actual voltage distribution through it. In Fig. 1 we have assumed that a high voltage is applied between two terminals *A* and *B*, between which we have an insulating medium, let us say air. The discussion is valid for any type of insulating material. Let us also assume that the high voltage is 5,000 volts. The total voltage is then distributed uniformly through the insulation, that is across each centimeter of the insulation the same voltage is applied, this being equal to  $5000/d$ , where  $d$  is the thickness of the insulation. If the insulation is 5 cm. thick then the distribution of voltage, or field intensity will

be  $5000/5$ , or 1,000 volts per cm. If the insulation is  $\frac{1}{2}$  cm. thick then the electric field intensity is  $5,000/\frac{1}{2}$ , or 10,000 volts per cm. Each insulation material has a certain dielectric strength which may be given in volts per centimeter and if the voltage distribution through the insulator exceeds the dielectric strength a break down occurs. The insulation design is simply a matter of using enough thickness to decrease the voltage distribution below the dielectric strength so that no break down occurs. A safety factor should be allowed to take care of possible surge voltages and radio frequency. Thus the distribution of voltage may be made so that it is  $\frac{1}{3}$  of the dielectric strength so that the insulation will withstand three times the rated breakdown voltage of the insulation.

Where a homogeneous insulation is used the question of insulation is quite simple. The voltage distributes itself uniformly throughout the dielectric. But frequently inexperienced experimenters feel that they can improve the insulating qualities of a circuit by employing two dielectrics between the high potential points. To make this clear suppose that we have air insulation present between the two high potential points as in Fig. 2. What is frequently done by the inexpert, then, to improve the insulation between these points, is to insert in half the space a stronger dielectric than air, as for instance, glass or bakelite. The impression is that since glass or bakelite will withstand greater voltages than air a little glass or bakelite will improve the insulation qualities. This is what the writer calls "over-insulation," and as will now be shown, this method is entirely wrong and will result in worse insulation than if only the original air insulation were used alone.

To illustrate the problem simply suppose we have in Fig. 1 a voltage of 5000 volts distributed across 5 cm. of air space. Then the field intensity is  $5000/5$  or 1000 volts per centimeter of air insulation. Suppose now that we insert a slab of glass between the two electrodes *A* and *B*, as in Fig. 2, this slab being  $2\frac{1}{2}$  cm. thick. We now have half air insulation and half glass. Let us assume that the quality of the glass is such that its specific inductive capacity is 6. This means that for a given electrical charge the glass requires 1-6th the voltage that air requires, since voltage is inversely proportional to specific inductive capacity. Now in the case of Fig. 2 the capacity current flowing through the air dielectric is the same as that flowing through the glass dielectric, since they both comprise part of the same circuit. But since glass has a specific capacity 6 times greater than air only 1-6th the voltage is required to supply this capacity current through glass that is required to drive it through air. Consequently the total voltage of 5000

volts distributes itself in the following proportions: 6 parts across the air and 1 part across the glass, or, 1-7th of 5000 volts across glass, namely 714 volts, and the balance 4286 volts across the air. But there is now only  $2\frac{1}{2}$  cm. of air insulation, hence the electric field intensity across air is  $4286/2\frac{1}{2}$ , or 1712 volts per centimeter, or 712 volts more than when only air insulation was used.

The conclusion to be drawn from the above is that non-homogeneous insulation is worse than homogeneous insulation. The effect of inserting some additional insulation of greater dielectric strength than the original insulation present, is always to throw an increased burden on the weaker dielectric, more of the voltage being dis-

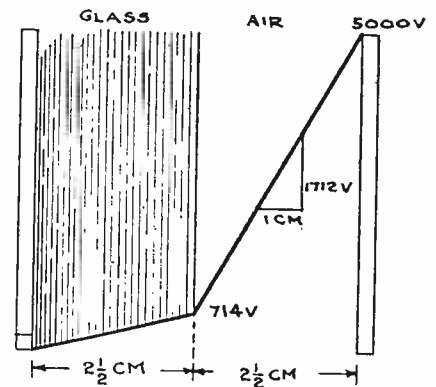

Fig. 2. Voltage Distribution Through Non-Homogeneous Insulation

tributed across the weaker insulation. Thus possibility of breakdown increases. This occurs whenever two different types of insulating material are used in series. No improvement of insulation results by thus "over-insulating" or adding some better insulating material. The weaker insulation suffers the more. Either change the entire insulation or not at all.

## ORCHESTRAS SOLD BY RADIO

J. E. Horn, president of the Consolidated Orchestras Booking Exchange, of New York City, has perfected a novel method of demonstrating concert and dance orchestras to clients via the radio. Heretofore a cafe, hotel or club in need of the services of an orchestra has insisted upon a demonstration of the musical organization, with the result that considerable expense has been involved. Now it has been arranged with radio stations all over the United States to demonstrate the various orchestras via broadcasting. Prospective clients may listen-in and thus determine whether or not the particular orchestra appeals to them, without the expense of traveling involved by either the orchestra or the client.

# Again That One-Tube Receiver

By Carlos S. Mundt

*This article describes the adaptation of a previously described set to honeycomb coils. Its construction and operation is simple and the results are remarkably good for one tube.*

IN February RADIO the writer presented an improved single-circuit receiver which possessed the advantages of increased selectivity and the reception of spark, C. W. and 'phone with equal facility. So many communications have been received regarding the adaptation of this receiver for honeycomb inductances, especially for 'phone work, that it was deemed advisable to present the matter anew.

Required apparatus: One .001 v.c.;

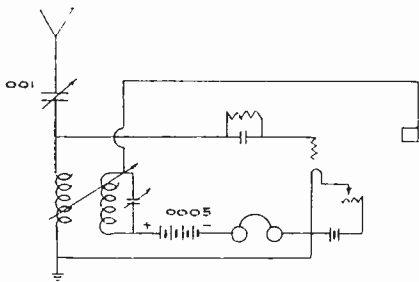

Fig. 1. Hook-up for One-Tube Receiver

one .0005 v.c.; one fixed R-G coil mounting; one movable R-G coil mounting; one 8x9x1/8 in. panel; necessary socket, tube, 'phones, batteries, grid condenser and leak, 'phone plug and jack.

Referring to Fig. 1, it will be seen that the .0005 variable condenser is here permanently shunted across the tickler (movable) coil. This constitutes a tuned

tickler and is the inherent advantage of this set, which is here designed especially for 'phone reception. Using this arrangement and a WD-11 tube, one experimenter in Princeton, N. J., was able to hear the conversation and music of two Los Angeles broadcasting stations. 2500 miles—one tube!!!

Fig. 2 shows the panel layout, which is indeed neat and compact. If desired, the binding post connections may be placed in the rear. For portability, a handle may be placed at the top of the cabinet and space provided in the interior to accommodate a dry cell or more, depending whether WD-11 or UV-199 or C-299 is used.

The inductances will vary with the antenna system, but it is a good plan to provide a goodly number in order to allow various combinations. One each of 25, 35, 50 and 75 turns would be advisable. Use the larger ones as tickler, and don't forget to reverse the tickler leads in case you do not get oscillations at the start.

An ingenious experimenter may wish to use this set with spiderweb inductances. These may be wound on fiber or heavy card forms, after which favorite methods of support for the mountings may be devised. One simple means is to slot one of the spiderweb arms so that it may fit an ordinary honeycomb mount

via the crosspiece and adjusting screw in exactly the same manner as the honeycomb coil itself.

For best operation of this set the rheostat had better be a vernier. It will be found that signals of amazing strength can be had with careful and precise control of the filament.

The coupling control will serve to separate a desired station from another on nearly the same wave, provided that the first is of equal or greater intensity than the second.

Don't expect to *slam* this set together and hear Greenland the first night. Patience, as has often been remarked, is indeed a virtue. Also it took at least several months to build Rome. A carefully planned and well built set will repay the time and energy put into it, and then some. What is more, you have to get the "feel" of any set. Go over to a neighbor and try running *his* set some evening. Chances are you'll not get a great deal out of it. So it is with any—you have to become accustomed to getting the knack of operating each individual set to its best advantage.

## A TUBE TESTER

By FREDERICK J. RUMFORD

There are many imitations of the UV-199 or C-299 dry cell vacuum tubes on the market. The writer has purchased what the dealer thought was a genuine UV-199. At time of purchase the dealer gave it the usual filament test. But later in experimental work this tube used considerably more than

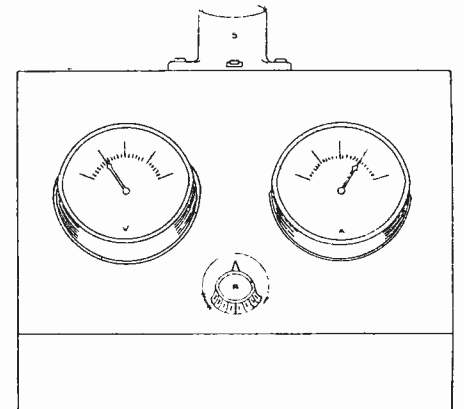

Fig. 1. Front View of Tube Tester

.06 amperes and also was very inefficient. These tubes are known as counterfeits and the writer has reason to believe that two thousand or more of these tubes are manufactured each day in several factories in New Jersey.

*Continued on page 30*

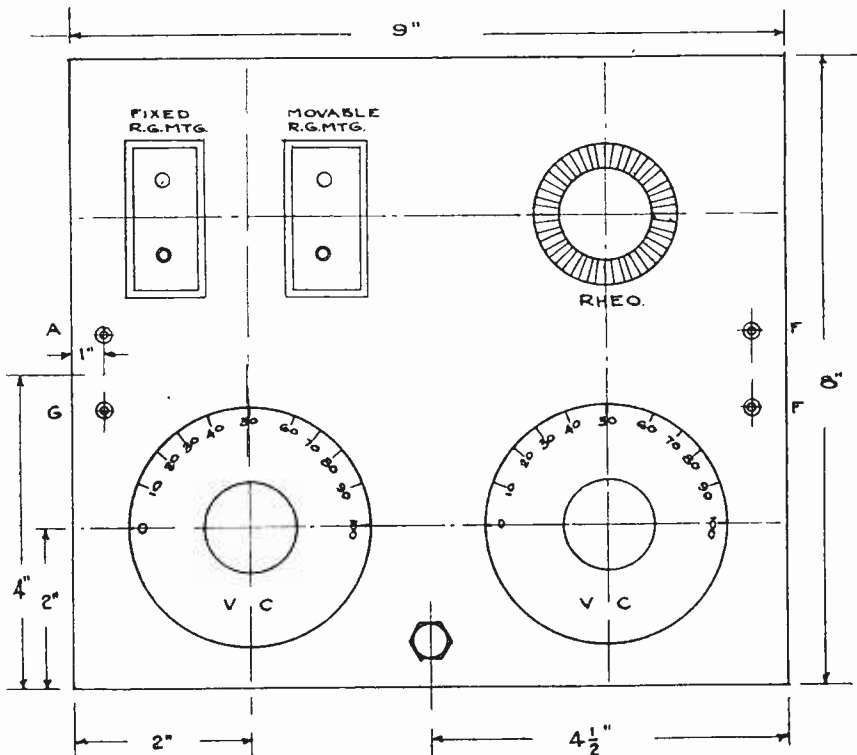

Fig. 2. Panel Layout

# Selector Circuits To Eliminate Interference

By George C. Jones

*While telling little that is new in wave filter design, this article gives the results of experiments by a practical man. His recommendations are so simple and so easily followed that they are worth trying.*

THE problem of eliminating interference is that of increasing the selectivity of a receiving set. After trying out and modifying every idea that came my way, I selected that shown in Fig. 1 as being the simplest. It consists merely of a 40-turn coil, a .00025 mfd. fixed condenser and a 43-plate variable condenser added to an ordinary single-circuit regenerative receiver. This "selector" can be assembled in a separate cabinet so that it may be attached to any set at will. It may also be used as a wavemeter, especially if equipped with a series-parallel switch.

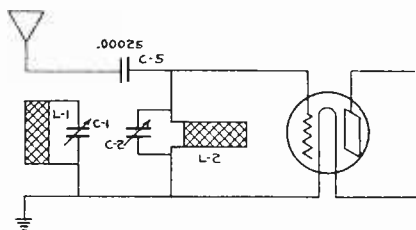

Fig. 1. Selector for Single-Circuit Set

While a honeycomb coil may be used, I have secured the best results with 40 turns of No. 14 wire bank-wound on a 3-in. coil with the regular honeycomb coil mounting. With an additional 25-turn and 60-turn coil it will be possible to cover a wave-range from 150 to 800 meters with a 100-ft. aerial.

The tuning inductance on a regular set need not be changed and it makes no difference how far the selector is placed from the set, as the selector coil must not be in inductive relation with the tuning-coil of the set. If the set has a series condenser in the antenna lead, the fixed condenser  $C_5$  can be omitted and the aerial lead of the selector connected to the regular  $A$  lead of the set, or—the  $C_5$  can be left in place and the condenser of the set changed to a parallel connection as in Fig. 1.

In using the selector, the switch  $S_1$  is placed at the open position and the set tuned in the usual way. The set is fairly selective this way, in fact much better than a plain single-circuit, as the condenser  $C_5$  acts somewhat as a loose coupling and signals a little off from the wave you are receiving are stopped to a certain extent and the set is not affected otherwise than by a slight lowering of the wavelength and a hardly perceptible decrease in signal strength.

Next throw  $S_1$  to the closed position and the signal will perhaps fade or entirely disappear, but do not try to retune, as the signal is merely going to ground through the selector and you cannot tune the set so that it will come

back. Now, by leaving the set tuned as it is and moving the  $C_1$  back and forth, a setting will be found where the signal comes back to the original strength, as the selector acts as a choke for that particular frequency and it cannot get through easily.

Reasoning that if it were so good on a single-circuit tuner it would be better if adapted to the primary of a two-circuit tuner, Fig. 2 was evolved and proved superior, although slightly more complicated. In this case the fixed condenser  $C_5$  was omitted as the series-primary condenser  $C_2$  serves in its place and also tunes the primary coil  $L_2$ .

In tuning, switch  $S_1$  is opened and the signal tuned in as usual with a double

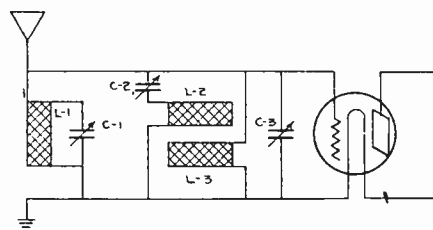

Fig. 2. Selector for Double-Circuit Set

circuit and then the selector is switched in and the interference eliminated.

In this hook-up the desired signal is allowed to pass freely through  $C_2$  and  $L_2$ , as when a coil and condenser are in series and tuned to resonance they furnish a free path to a certain frequency and act as an impedance to others. So here we have an ideal state of affairs,  $C_2$  and  $L_2$  let the desired signals pass through, thus inductively energizing coil  $L_3$  while  $C_1$  and  $L_1$  let the undesired ones through to ground and send the wanted ones around the detour to the set.

Now I should have stopped here, but as a two-blade switch-lever was lying on the bench along with a lot of unused

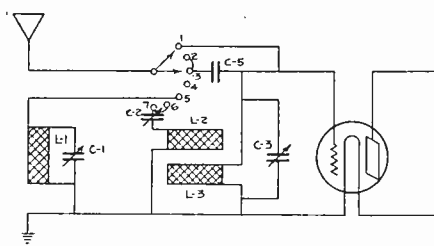

Fig. 3. Selector for Combination Set

tappet-points, I reached for a pencil and paper and in a short time had circuit Fig. 3, which is a handy combination of Nos. 1 and 2. By setting the switch lever  $S_2$  on two of the seven points and leaving one point unused between we have the following circuits:

- Points No. 1 & 2—Plain single-circuit.
- Points No. 2 & 4—Single-circuit with series condenser.
- Points No. 3 & 5—Single-circuit with "selector" attached.
- Points 4 & 6—Single-circuit with "one-wave" bypass.
- Points No. 5 & 7—Two-circuit with "selector" attached.
- Points No. 6 or 7—Plain two-circuit.

The writer was afraid to do any more on the thing, thinking it might start to broadcasting its own music, so it's all yours; see what you can do with it.

## A TUBE TESTER

*Continued from page 29*

As a protection to both the purchaser and the dealer, the herein described testing outfit will be found worth while. It may be built at a cost of from \$10.00 to \$15.00.

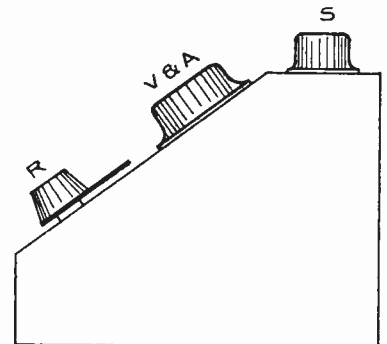

Fig. 2. End View

Fig. 1 shows the front view of the outfit. The panel is 7½ in. long by 6 in. wide, and ¼ in. thick. Fig. 2 shows an end view. Fig. 3 shows the internal

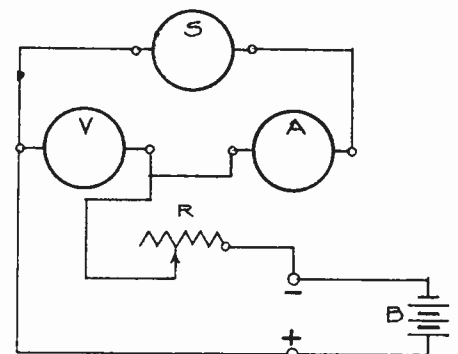

Fig. 3. Hook-up

and external hook-up,  $S$  being the tube socket,  $V$  a voltmeter (0-10),  $A$  a milliammeter (0-100),  $R$  a 30-ohm rheostat, and  $B$  three 6-in. dry cells.



# Winding Inductance Coils

By D. B. McGown

*After giving specific directions for winding a single-layer, cylindrical coil, the author discusses bank windings for various purposes. This constitutes the third article in a series on home radio shop practice.*

**S**PECIAL conditions frequently require specially wound coils. These may be wound with either bare or covered wire, the covering usually being either single or double cotton (S.C.C. or D.C.C.) or single or double silk (S.S.C. or D.S.C.). Besides these fabric insulating coverings "enamel" wire is often used, this "enamel" being the result of many coatings of cellulose acetate.

Coil winding may be either a "hand" or a lathe job, though it is extremely tedious without a lathe, or similar support. The first thing to be wound is the simplest, a single-layer cylindrical coil, for a loading coil, or variocoupler

ble, and a single turn is taken. This turn should come around and lay right next to the first turn, as shown in Fig. 1. If it does not, it should be unwound, and moved in such a way that it does lay where it is supposed to. At all times the operator should hold his hand at least 10 in. from the inductance coil; this will be found much better than if he is too close, as, after the correct "feel" of the winding is located, the wire will almost guide itself across the form, as the lathe is rotated, without paining or cramping the hand, as might result if the operative holds the wire too close to the form.

In ordinary electrical work the second layer is either wound directly over the first, or a sheet of thin paper, mica, or empire cloth is wound over the first winding, and the second layer wound on. In radio inductance coils this method would not be efficient, as the turns at the ends of the various coils would be at quite high potential differences, which reduces their effectiveness, as their distributed capacity would be raised greatly, and this would reduce the operating wavelength of the inductance coil. This is undesirable, and many forms of different windings have been developed to overcome this trouble. The most common are the bank-wound coils, and the more modern honeycomb type, of which there are several variations.

Bank winding is believed to be the most efficient. It consists of ordinary wire, or litz, wound in a series of nearly vertical layers, there being many layers, of but few turns each. Bank winding is usually counted as the number of total turns, "three-layer-banked," or the like. For example, 75 turns three-layer-banked would mean that there would be 25 layers, of vertically-wound wire, each layer being composed of three turns each. Two-layer-banked winding means two vertical turns of wire. It is not customary to wind more than a maximum of about 8 turns per vertical layer.

The reason for this peculiar type of winding is that it reduces the potential between turns as much as possible, which reduces the effective resistance to a low value. If a number of turns of considerable potential are close together, such as would be the case if ordinary long-length layer winding was used, the turns at opposite ends of the coil will be at quite a high potential, and therefore they will react more upon one-another, than if they were of low potential difference. The closer the various turns are together, the greater will be their effect on each other. In bank-wound inductances the greatest potential between turns would be equal to the number of turns in the single bank, i.e. in three-layer bank winding the greatest potential difference between any turns would be equal to but six times the difference between single turns, whereas in a 50-turn two-layer winding, the potential difference between adjacent turns at opposite ends of the coil would be 100 times the difference between two adjacent turns.

*Continued on page 46*

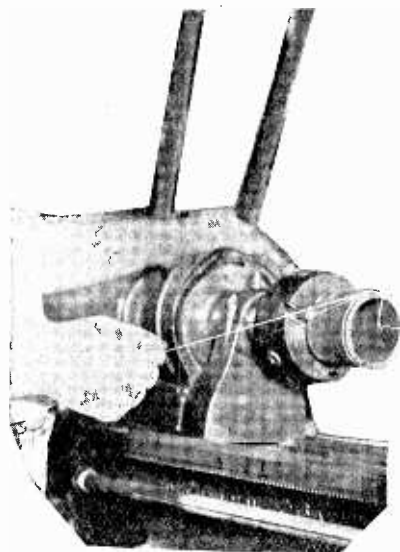

Fig. 1. How to Mount Tubing in Lathe

primary. Fig. 1 shows the mounting of the bakelite tubing (which is recommended in all cases) in a three-jawed lathe chuck. Two small holes are drilled near each end of the tube, with a small drill, the exact size of which depends on the size of the wire used. The illustration shows No. 22 D.C.C. wire and No. 43 drill holes. The external jaws of the lathe chuck were used, as this compresses the bakelite tube and tends to avoid cracking it. The wire is threaded through the two holes, as indicated, on the end farthest from the chuck. The wire spool is mounted on a small spindle, which permits the spool to turn easily, as the wire unwinds.

The operator grasps the wire firmly between the thumb and fingers, as shown, and turns the lathe over, with the other hand, by pulling the lathe belt (the driving power being shut off). Care is taken that the wire is held as near at right angles to the tube as possi-

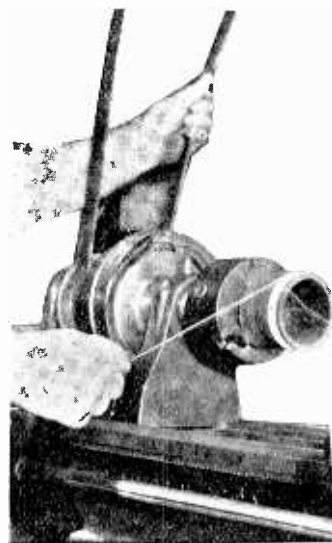

Fig. 2. Correct Position for Holding Wire

The correct position is shown in Fig. 2, where the operator's left hand is shown grasping the lathe belt and the wire being held in the right hand, which is held stationary, the wire being paid out from a spool behind the builder. The wire should not be held at exactly right angles to the winding form, but rather it should take a slight slant back against the windings, as is self-evident. It may be thought, at first, that it is easier to wind with the power applied to the lathe, and with the lathe running backwards, but if this is done, and anything goes wrong, and the wire slips off, or gets caught, the lathe will be so slow to stop that the wire may get tangled, or even break, before the lathe can be brought to rest. It is better, by far, to wind the coil more slowly, and get a better job.

The wire should be guided over the whole form, or over as much of it as is to be wound, and then the whole coil covered with some binder to hold the wire in place.

# Power Losses In Transmitter Antenna Circuits

By Charles K. Fulghum

*This discussion of the reasons for power losses in antenna circuits is suggestive of what can be done to minimize them and thereby increase the radiation. While intended for guidance in the construction of a transmitting aerial, many of the points are also applicable to receiving aeriels.*

THE power expended in an antenna circuit carrying high-frequency current may be considered as equivalent to the power dissipated by a resistance carrying the same current as flows in the antenna. This fictitious resistance, the effective resistance of an antenna, is not necessarily a measure of the effectiveness of an antenna as a radiator of electromagnetic waves, a value which is expressed in terms of radiation resistance, which is equal to that resistance which if inserted at an antinode of current in the antenna would dissipate the same power as that radiated by the antenna. It is apparent that these two values are not one and the same, and that the difference between the two must be accounted for as loss resistance, which must be kept as low as possible if the antenna is to expend efficiently the power supplied to it for the purpose of radio communication.

Loss resistance is due to power losses which occur in every antenna system, and frequently these losses are aggravated by poor antenna design, by the use of faulty materials in its construction, by objects in proximity to the antenna, and its location with respect to these objects. In general, the power losses in an antenna circuit are those due to dielectric absorption, leakage over insulators, corona, resistance in the antenna circuit, and eddy currents induced in neighboring conductors.

Dielectric absorption is caused by the presence of imperfect dielectrics, such as trees, houses, etc., in the vicinity of the antenna, and becomes especially pronounced if such objects are near the ends of the antenna where the potential gradient is the highest. Another large loss due to dielectric absorption often occurs at the lead-in insulator which usually consists of a comparatively large mass of imperfect dielectric. The loss occurring at this point can frequently be reduced by following the practice adopted by certain large power stations for bringing high-voltage lines into the building. A large pane of glass is mounted in the wall and the lead-in insulator, of small size and usually of porcelain, is mounted in the center of the pane. This construction too, will tend to reduce any loss which might occur due to leakage over the lead-in insulator.

Loss due to leakage over insulators can be kept at a minimum by using insulators of such material and design as to give the greatest insulation possible with a minimum amount of material, and by their correct placement

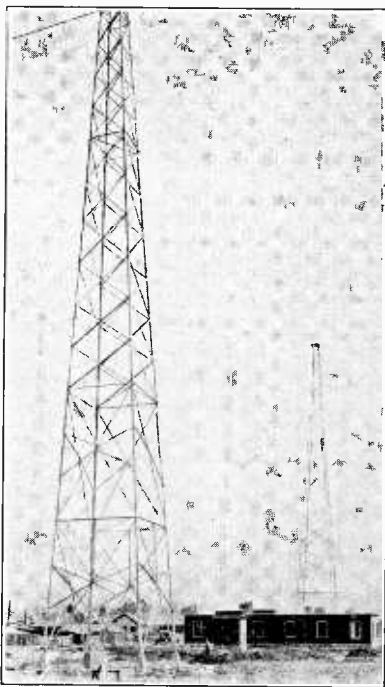

*Antennae towers, 150 ft. high, for the new General Electric Company broadcasting Station at Oakland, California*

in the circuit. Quartz is unquestionably the best material, giving a maximum of insulation and mechanical strength for a minimum of material, but the cost is so high that it is not in general use. Glazed porcelain is perhaps the best available material, while electrose, hard-rubber, unglazed porcelain, etc., are also used.

Since the potential gradient is usually highest at the ends of the antenna, the suspension insulators between the antenna and its supporting structures should be of the first quality. The insulation at this point usually consists of one very long insulator or a string of short insulators connected in series so as to reduce the capacity thru the string, placed between the antenna spreader and the supporting structure. A separate insulator between the end of each conductor in the antenna and the spreader is quite unnecessary and may increase losses due to leakage because of the decreased resistance resulting from the insulators connected in parallel. It is often the practice to fit the insulators used at the ends of the antenna with corona shields, since this causes the voltage gradient to be more evenly distributed over the insulator string, and prevents any possible flash-over from damaging the insulator.

Loss due to leakage in the antenna circuit will vary greatly from time to time, being especially great during

damp or rainy weather when, due to the film of water on the surface of the insulators, a large fraction of the power supplied to the antenna may leak away over the wet insulator surfaces. Often dust will collect on the surface of insulators, forming leakage paths of comparatively low resistance which may allow sufficient current to pass to result in a breakdown of the insulator. In general, such losses are unavoidable and the best that can be done to reduce them is to make the leakage paths over the insulators extremely long, and when practicable, to clean the dirty insulators from time to time.

Corona loss is due to a partial ionization of the air surrounding the conductors of an antenna, and takes place only at high voltages. Thus up to a certain limit of power input, the loss due to corona will be entirely negligible, but as the power is increased beyond the value, the loss due to corona will increase rapidly and may reach a value sufficiently great to materially affect the radiation. Usually, the possibility of loss due to corona is taken into consideration when an estimate of the effective dimensions of an antenna is being made, but when corona loss appears in an antenna circuit, the only effectual means of reducing it is by increasing the capacity of the antenna or decreasing the power supplied to it.

Eddy currents induced in nearby metallic structures may contribute to the losses occurring in an antenna circuit operating at short wavelengths. This loss is even more pronounced if there are nearby conductors which, due to their effective dimensions, have natural periods of oscillation within the range of frequencies at which the antenna is operated. Such circuits in resonance with the antenna may absorb a large amount of the power radiated from it. For this reason, the space about an antenna should be kept as free as possible from all metallic masses and such that have to be there should be grounded if possible, or as in the case of guy wires, broken up by means of insulators. Any conductor absorbing power from the antenna will reradiate a part of this power, and for this reason the detection of absorbing metallic structures by a wavemeter equipped with detector and phones is comparatively easy.

A certain resistance loss in any antenna system is unavoidable, due to the resistance of the conductors which compose the antenna, and the resistance of the ground. Resistance losses

*Continued on page 92*

# Whence Your Plate Voltage

By Florian J. Fox

*Herein is discussed the various sources of plate voltage for a C. W. transmitter. This article is the second of a series of which the "Vacuum Tube Oscillator" in the November number was the first and detailed directions for the construction of a high voltage transformer will be the next.*

THE problem of obtaining a reliable and inexpensive source of high voltage is one of the reasons why more of us do not build C. W. sets. Before describing in detail the most satisfactory method, rectified a.c. from the power lines, let us first consider the methods to be employed by those not fortunate enough to have electricity in the house.

Of these, the first is the electric battery, whether wet cell, dry cell or storage. The battery gives a *quality* of direct current second to no other source. Its inherently pure direct current is ideal for radiophone work. Its obvious drawback is the first cost and renewal expense. Wet cells are bulky and mussy; dry cells are expensive, though otherwise satisfactory.

The writer knows of one amateur who made 150 small cells from fruit jars and two small plates, a wooden separator, and elastic bands which held the units together. The cells were mounted on a special rack. Provision was made for charging in series—parallel and discharging in series. An electrolytic rectifier allowed him to charge the cells from the a.c. lighting supply. The plates were formed by charging and discharging the cells a number of times. The results were very satisfactory as far as we know. Were it not for the acid nuisance, the recharging, and the bulk, this method would be in more general use.

Another inexpensive source, for code work only, is an ordinary  $\frac{1}{4}$ -in. to  $\frac{1}{2}$ -in. spark coil. These sizes include the Ford coils. A large glass plate condenser may be connected across the secondary of the coil in order to reduce its potential low enough so that it may be applied to the tubes without danger of internal sparking and arc over. The condenser should be large enough to cut the spark length down to  $\frac{1}{16}$ -in. or less. The size can be easily found by trial. The capacity will be at least two or three times that used in the spark transmitter. There is no danger of getting it too large. Condensers with mica insulation will be found to be more compact. With such an outfit the writer has obtained 0.3 amperes radiation using two amplifier tubes as oscillators on a Hartley circuit. The set had a daylight range of at least 25 miles. One station in the East covered over 300 miles at night with a similar set, except that 5-watt transmitting tubes were used instead of receiving tubes. Storage batteries supply the filament current

question of polarity is quite important and is often overlooked by writers.

High voltage for the plates is sometimes produced in the windings of a large, specially-designed buzzer. The

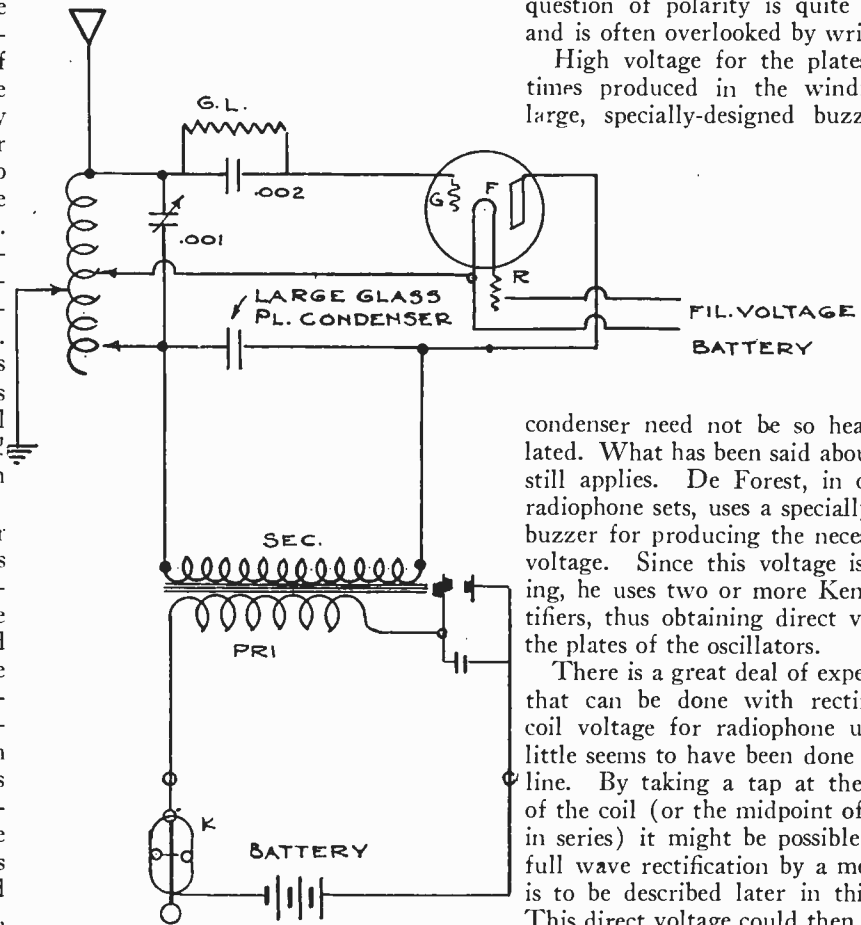

Fig. 1. Circuit Diagram for C. W. Transmitter with Spark Coil

See Fig. 1 for connection diagram. Vibrators are usually designed so that the "break" is faster than the "make." The result is that one end of the secondary will have a predominance of positive half cycles, and the other, a predominance of negative. The side having the predominance of positive should be connected to the plate side of the input to the oscillator. The next problem is to determine which side of the secondary has this predominance of positive. The writer used a charged electroscope. (See a book on electrostatics.)

Another method is to place a soft tube in the set and press the key. Observe the tube carefully, reverse the leads, and repeat. The connection which gives the "blue glow" or greatest "blue glow," is the correct one.

The last method is that of simple trial; try one connection and if the set does not function after a thorough test, try reversing the leads. This last method is the poorest, for the chances are that you will be trying to make the set oscillate on the wrong connection. This

condenser need not be so heavily insulated. What has been said about polarity still applies. De Forest, in one of his radiophone sets, uses a specially-designed buzzer for producing the necessary high voltage. Since this voltage is alternating, he uses two or more Kenetron rectifiers, thus obtaining direct voltage for the plates of the oscillators.

There is a great deal of experimenting that can be done with rectified spark coil voltage for radiophone use. Very little seems to have been done along this line. By taking a tap at the midpoint of the coil (or the midpoint of two coils in series) it might be possible to obtain full wave rectification by a method that is to be described later in this chapter. This direct voltage could then be filtered and used for radiophones. Any progress along these lines would undoubtedly be of great interest.

The motor-generator offers a fine source of plate voltage also. There are a few disadvantages. In the first place a good motor-generator set is quite expensive. Secondly, some are noisy and hence must be specially mounted, or enclosed, or placed in another part of the building. Some of them produce objectionable commutator ripples in the audible range of frequencies. Commutator ripples are due to slight changes in the voltage caused by commutation. These ripples may be quite objectionable when the transmitter is to be used as a radiophone. Special appliances, known as "filters" must be used to remove them. These will be described in a succeeding chapter. There are now on the market special high speed generators, having a great many commutator bars. The ripple in these generators is beyond audibility. A local radio engineer has found that some generators emit radio frequencies also. These may pass into the oscillator and show up in the antenna system as an additional carrier at some

definite wavelength. He found it necessary to connect a series of radio-frequency chokes in the high voltage leads to eliminate this false wave. This new and interesting fact might be well worth while remembering.

The last method that we shall take up is the use of rectified alternating current. A transformer is used to step up the voltage of the lighting supply to 350, 450 or 600 volts. This is then rectified and supplied to the transmitting tubes.

Kenetron tubes are in considerable use among amateurs and are used extensively in commercial and broadcasting stations. First cost and renewals, however, again prevent a great number of experimenters from using them.

An electrolytic rectifier will be found to be inexpensive and almost as satisfactory. It is very simple to construct, and once made it requires only an occasional renewal of solution. The author has used such a rectifier as described below for about three years. Procure 12 small jars having openings of at least 2-in. diameter. Next, procure enough sheet lead and sheet aluminum (1/16-in. to 1/8-in. thick) to make 12 plates, of each material. The plates are 1 1/2 in. x 3 in. and have connecting straps about 3 in. long. See Fig. 2 for dimensioned sketch.

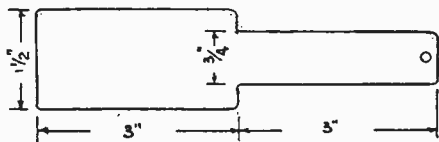

Fig. 2. Dimensions of Plates for Chemical Rectifier

Each jar contains one lead plate and one aluminum plate. The jars are arranged in two banks of six jars each. Each bank is connected in series. The two aluminum terminals (one from each bank) are connected together; this is the positive post. Each of the two remaining lead plates are connected to the high voltage transformer. The center of the transformer secondary is the negative terminal. See Fig. 3 for connections.

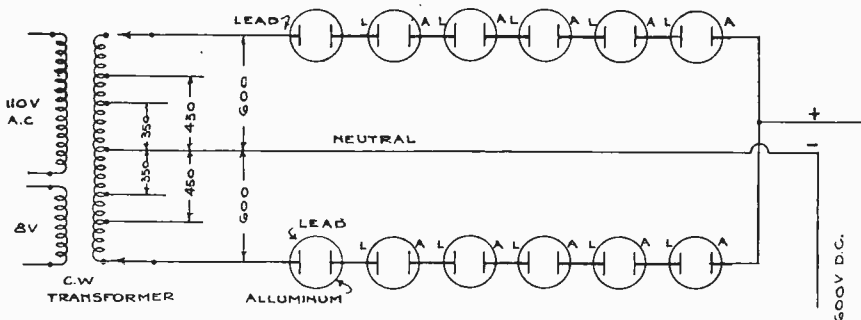

Fig. 3. Connections for Electrolytic Rectifier

The jars may be placed in a box or a rack of some kind. The tops of the plates (the connecting lugs) are bent over and bolted together, a lead plate being bolted to an aluminum one.

The electrolyte may be either sodium phosphate, potassium phosphate, or sodium borate (common borax). The

latter is what is used at the writer's station. Buy a package of "20 Mule Team Borax" and place a portion in a pitcher of warm water. Stir well for a few minutes and then let the liquid settle. Pour off the clear liquid and use it. Add more water to the sediment and repeat. Fill all the jars to within an inch of the top.

To form the plates, the rectifier simply has to be used for some time. Just connect it to the set and it will take care of itself. The lead plate becomes chocolate brown, and the aluminum plate white.

This white film on the aluminum plate has the property of permitting electrons to flow through it from the plate to the electrolyte, but not in the other direction. Since electrons flow in a direction opposite to that which electricity has been assumed to flow, we see that the aluminum plate is the positive one, and the lead plate the negative. For, after reaching the lead plate, the electrons will leave it, flow around the external circuit and return to the aluminum plate.

During any half cycle the voltage from one of the two high voltage secondaries will always be in a direction favorable for pushing a current through its bank of rectifiers. Thus we obtain full wave rectification.

Fig. 4 shows a method of obtaining full wave rectification, using only one transformer secondary. This may prove useful to some readers, but those who intend to make a transformer are strongly recommended to use the double secondary method, as it is much more reliable and satisfactory.

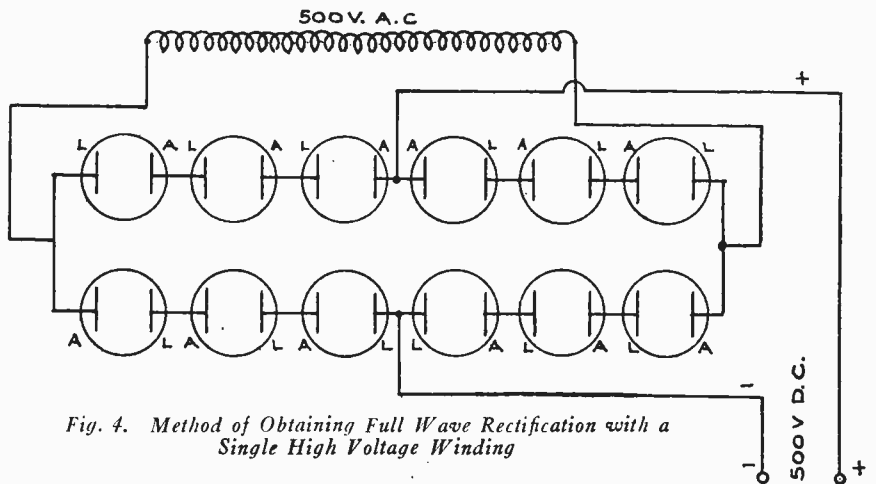

Fig. 4. Method of Obtaining Full Wave Rectification with a Single High Voltage Winding

### MILWAUKEE RADIO AMATEURS' CLUB

Milwaukee delegates reporting on the Second National American Radio Relay League Convention, held in Chicago, was the principal feature at the season's opening meeting of the Milwaukee Radio Amateurs' Club, Inc. Next was held the annual corporate meeting, at which seven directors and one vice-director were elected, who, in turn, appointed the society's five general officers and seven standing committee chairmen. The directors are C. N. Crapo, 9VD, the A.R.R.L.'s local District Superintendent; D. W. Gellerup, 9AOE; E. T. Howell, Sc.M., 9CVI; M. F. Szukalski, Jr., 9AAP; E. A. Cary, 9ATO; F. W. Catel, 9DTK; M. H. Doll, 9ALR; West Allis; and G. F. Metcalf, 9CKW, Wauwatosa. The officers are E. T. Howell, president; M. F. Szukalski, Jr., vice president; C. S. Polachek, secretary; E. W. Ruppenthal, 9AYA, treasurer; L. S. Hillegas-Baird, business manager; F. W. Catel, assistant treasurer; and the committee chairmen are: Legal, Attorney L. J. Topolinski, general counsel; publications, H. G. Fawcett; technical, D. W. Gellerup; membership, F. W. Catel; program, E. T. Howell; publicity, L. S. Hillegas-Baird; and traffic, C. N. Crapo. The committees are all in action. The technical one remains a leader, recently giving an interesting report entitled "C. W. Transmitter Circuits." Many lectures by well-known radio men are being arranged by the program committee. Two have already been given; they were "The New Tatelum Chemical Rectifier" by H. L. Olesen, 9CSR, Fansteel Products Co., North Chicago, and "Vacuum Tube Characteristics" by J. H. Miller, Electrical Engineer, Jewell Instrument Co., Chicago.

### BOOK REVIEWS

"Fundamentals of Radio" by James L. Thomas, 207 pages, 5x7 1/2, published by D. Van Nostrand Co., New York City. Price \$1.50.

This is a text book on the elementary theory of radio, suitable for either class room use or individual home study. Starting with a brief review of electrical principles in terms of electrons, it takes up successively the theory of the design and operation of the several parts that make up radio transmitting and receiving sets. In simple language it discusses the oscillating circuit, damped and undamped wave transmitters and receivers, vacuum tubes and radio measurements. It is especially good in its explanation of the how and why of transmitters and consequently is a good book for the amateur. The mathematical treatment does not extend beyond arithmetic.



# Some Principles of Detector Tube Operation

By Maurice Buchbinder

*The distinction is here drawn as to the different effect of a grid biasing battery and of a grid condenser and leak in the functioning of a detector tube. The manner of presentation is clearer than in most texts and is worthy of careful study.*

**D**ETECTOR and amplifier tubes are similar in construction and may under some conditions be interchanged. Thus, an amplifier tube can always be used for detecting, but a detector is generally a poor amplifier. The essential difference between the two lies in the much greater amount of residual gas left in the detector. This assists its operation as a rectifier of radio-frequency currents, but damages its amplifying qualities. The familiar bluish glow in a detector tube when too high a plate voltage is being used is due to ionization of the gas within the tube.

The detector consists of a plate, a grid and an incandescent filament shown

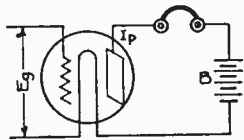

Fig. 1. Elements of Detector Tube

diagrammatically in Fig. 1. The *B* battery in the sketch is always driving a steady current from plate to filament. When, however, we apply a voltage  $E_g$  between the grid and the filament, as by an additional battery or potentiometer, then this current  $I_p$  is changed to another value. Thus if we vary the applied voltage, then, for each value of potential, there is a separate value of plate current. We may, therefore, plot a curve between plate current as ordinates and grid voltage as abscissas. We start with a voltage of zero and increase a few volts. Then we go back and increase in the opposite direction—that is, apply a negative voltage or reverse the

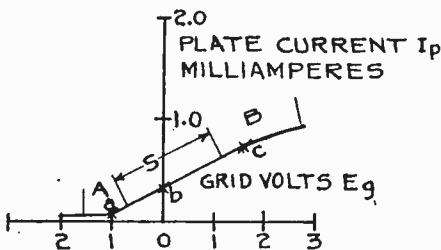

Fig. 2. Curve Showing Variation of Plate Current With Grid Voltage

leads to the grid. Fig. 2 is a typical curve obtained with a detector tube. It is seen that this curve has a straight portion *S*, and two curved parts, one before and the other after the straight portion.

There is, however, another curve which may be plotted, namely *grid voltage* against *grid current*. It must be

remembered that, perforated and small as the grid may be, it nevertheless attracts electrons to its meshes and consequently draws a definite current. That this phenomenon is not insignificant can be appreciated when we realize that the most important feature of detection, using a grid condenser, lies in this grid current, grid voltage characteristic of the detector tube. Fig. 3 illustrates grid voltage as abscissas plotted against grid

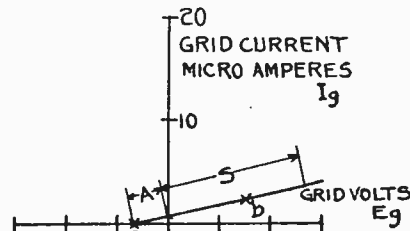

Fig. 3. Curve Showing Variation of Grid Current With Grid Voltage

current as ordinates in a typical detector tube. The striking features of this curve are a straight portion *S* and a curved portion *A*. If the grid voltage be made one or two volts negative the current in the grid falls to zero, since the grid repels all electrons from it.

Now, with both characteristic curves fixed in mind, we can pass to a consideration of the simple non-regenerative receiving circuit. There are two possibilities in the use of a detector. We can use a grid condenser with a leak or we can quite as well do without. There are commercial examples of good sets using either principle. But, if the beginner or home constructor is to know which method to employ he must know what conditions to satisfy in either case, and above all—the basic principles. The one easiest to understand is the one not using a grid condenser.

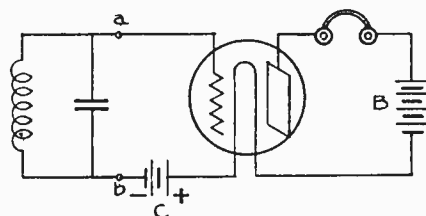

Fig. 4. Wiring Diagram of V. T. Detector Circuit With Grid Biasing Battery

Fig. 4 is the wiring diagram of a simple vacuum tube detector circuit. The effect of the radio-frequency tuning condenser and coil is to apply between points *a* and *b* a high-frequency voltage following closely the current in the

radiating antenna. Now this current is not directly audible, because, if it were to flow through the telephone, it would rise and fall so quickly (radio-frequency) that the phone diaphragms and the ears would not get time to respond. It must therefore be rectified—that is, the radio-frequency component is sifted out and only the audio component left to affect the telephone diaphragms and the ear. Referring back to Fig. 2, we see that if the grid voltage were maintained at point *b* normally, when no signals were arriving, then the effect of the signals will be to alternately raise and lower the grid voltage at a radio-frequency. But, since point *b* is at the center of the straight line portion of the curve *S*, any rise in grid voltage will raise the plate current and any fall will lower the plate current by an equal amount. Hence the current in the plate is an exact reproduction of the applied voltage and, being radio-frequency, it is not heard, and the vacuum tube will not function as a rectifier at all, or very poorly. Suppose, however, that we bias the grid as by an extra grid battery *C*, and make it negative, bringing it to point *a*. At that position any rise in grid voltage causes a rise in plate current, but a fall in grid voltage produces very little effect on the plate current because the latter already is nearly zero. Now, conditions are en-

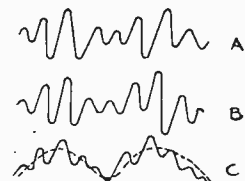

Fig. 5. Curves in Detector Circuit Using Grid Bias; *A*, Grid Voltage; *B*, Resultant Plate Current; *C*, Rectified Plate Current.

tirely different. The current in the plate circuit and telephone is no longer radio-frequency. It has been rectified and has thereby obtained a strong audio-frequency component which is audible. We can illustrate the above reasoning by three curves in Fig. 5. *A* is the grid voltage curve produced by a continuous note in the transmitter; *B* is the resultant plate current were we to operate at point *b*; *C* is the rectified plate current when we operate at point *a* through the use of some biasing device.

We shall now pass on to a study of the detector circuit which makes use of the grid condenser, Fig. 6. The effect, as before, of the radio-frequency tuning condenser and inductance is to apply be-

tween points *a* and *b* a high-frequency voltage following closely the radiated antenna current. This voltage is divided between *C*, the grid condenser,

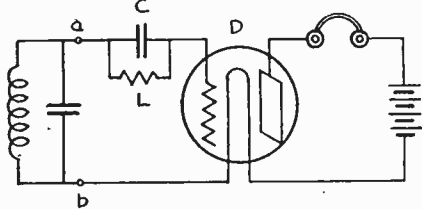

Fig. 6. Detector Circuit With Grid Condenser

and *D*, the space within the vacuum tube between grid and filament. Let us go back to Fig. 3, the grid current—grid voltage characteristic, in order to determine the action of this space *D*. If the grid were nominally at a point *b* in the center of the straight line portion *S*, then, for the same reasons as before, there will be no rectifying. That is, when the grid voltage increases, the grid current increases correspondingly, and when the grid voltage decreases, by the same amount the grid current will decrease by an identical amount. We can operate the tube at a point *a*, in the curved portion of the curve, however. In that case an increase in grid voltage will increase the grid current, but a decrease will produce no effect on grid current, since the latter is practically zero to start with. Therefore, operated about the point *a* by a suitable biasing device, the space *D* between grid and filament acts like a rectifier—permitting current to pass in only one direction. With this property clearly in our minds, we can return to the circuit of Fig. 6. We see that between *a* and *b* we have a rectifier in series with the grid condenser *C*. There can be only one effect, the charging up of the grid condenser in accordance with the audible fluctuations of the transmitted voice or music, this charge leaking off slowly through the grid leak *L*. The charge on the condenser is transmitted practically unchanged through the receiving inductance, which acts like a short circuit for audio-frequency currents. Hence the grid itself will fluctuate in voltage in accordance with the audio-frequency

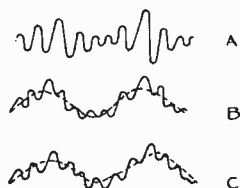

Fig. 7. Curves in Detector Circuit Using Grid Condenser

currents — not the received radio-frequency. The grid voltage then affects the plate current, and therefore the telephones. The above can be made clearer by considering a simple incoming wave such as would result from a sustained

note. Fig. 7 shows three curves: *A* is the radio-frequency voltage across the tuning condenser. *B* is the rectified audio-frequency current across the grid condenser and between grid and filament. *C* is the rectified plate and telephone current, containing very little radio-frequency.

It was stated that an amplifier tube may be used for detecting purposes provided we employ a grid condenser. This follows from the fact that the grid current—grid voltage characteristic of an amplifying tube is quite similar to that of the detector. The same cannot be said of the plate current—grid voltage curve. The latter is considerably steeper and straighter in the case of a high vacuum tube than in a gas tube.

### A SIMPLE BATTERY SWITCH

By CHARLES F. FILSTEAD

Without a switch to turn off both the *A* and *B* batteries on a receiving set, no matter how careful an operator is to turn his rheostats off when he finishes

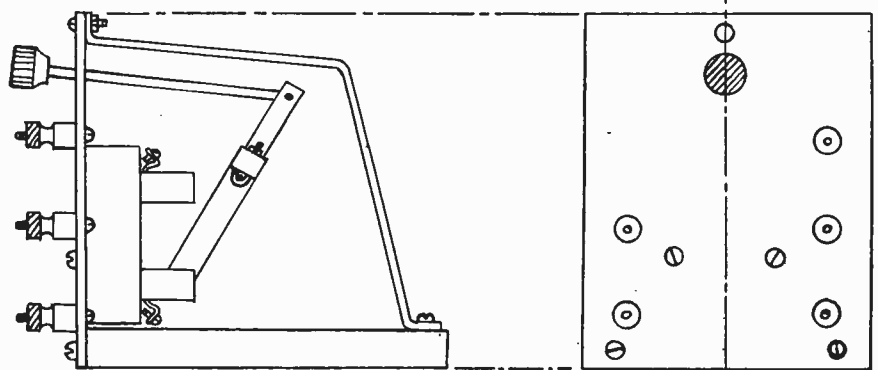

Panel Assembly for Switch

receiving, there is always the chance of his forgetting to do so, with the resulting strain on tubes and drain on batteries. When a switch is used there is not so much likelihood of his forgetting. Many amateurs do not care to spend the money necessary to install filament-control jacks or a special switch to turn off the filaments; and it is indeed a nuisance to have to turn down several rheostats every time the set is turned off.

A double-blade, single-throw knife switch will serve the purpose as well as will a panel-type, anti-capacity switch, and will be much cheaper; but, of course, it will not look nearly so well. A knife switch can be made an ornament to the set, and at the same time serve its purpose well, by mounting it on the back of a small bakelite panel and controlling it from the front by a lever. The panel need not be very large: four by five inches will do. The switch—base and all—is fastened to the back of the panel by two flat-head, nickel-plated machine screws, which are countersunk into the bakelite. An inch long

piece of  $\frac{1}{8}$  by  $\frac{1}{4}$ -in. brass rod is now bent into an L-shape, the upper part of the L being  $\frac{3}{4}$  in. long.

The knob should now be removed from the mounted switch, and the L-shaped piece of brass fastened in its place by threading the screw that formerly held the knob into a hole drilled in the

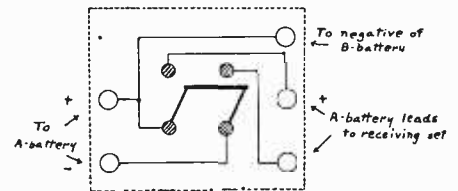

Diagram of Connections

shorter arm of the L-piece. The L-piece now takes the place of the knob. A small hole is drilled in the upper end of the long part of the L, and the end of a  $3\frac{1}{2}$ -in.-long piece of  $\frac{3}{16}$ -in. round brass rod is riveted to it. It should not be riveted so tightly but what it can turn freely at the joint. This rod sticks through a  $\frac{1}{4}$ -in. hole in the bakelite panel and has a small, hard-rubber knob,

which was taken from a battery threaded to it. The switch can be closed by pulling this knob out, and opened by pushing it in. With the switch open, both the *A* and *B* batteries are disconnected from the receiving set, and there is no danger of the set being left running.

If it is desired, the panel can be made higher and an *A*-battery potentiometer mounted above the switch and used to control the *B* battery. To finish the mounting, a piece of wood, 4 by 6 in., is fastened to the bottom of the panel by two screws to serve as a base. The panel is supported and made rigid by a rod of  $\frac{1}{8}$  by  $\frac{1}{4}$ -in. brass running from the top of the panel to the rear of the base. Two binding posts are mounted on the left of the panel for the leads from the *A* battery. There are three binding posts on the right of the panel: the upper one is for the negative lead from the *B* battery, and the two lower ones are the *A* battery leads to the set. The connections are given in the accompanying diagram.

# QUERIES & REPLIES

## ON C.W. PRACTICE

BY  
**Gerald M. Best**  
TECHNICAL ADVISOR



Questions submitted for answer in this department should be typewritten or in ink, written on one side of the paper. All answers of general interest will be published. Readers are invited to use this service without charge, except that 25c per question should be forwarded when personal answer by mail is wanted.

Please publish the circuit diagram for a one-stage amplifier using a UV-199 tube, to be added to the circuit described in August RADIO, under the title of "A Simplified Reinartz Tuner." I wish to use a WD-11 as a detector, so I presume a separate "A" battery will be necessary.  
—J. W. F., Oakland, Calif.

as the primary and secondary circuits are concerned, the only plausible reason for the whistle would be too much inductance in the plate variometer, and too close coupling between the plate and grid variometers. It may be that oscillating receiving sets in your neighborhood are the cause of your trouble, as such interference is always more pronounced during the quiet hour, on account of the large number of people listening for distant stations at that time. Better start an investigation of your immediate neighborhood, and find out who has the offending receiver.

Is it possible to apply the neutrodyne principle to the amplifiers in a master oscillator circuit to keep them from oscillating by themselves? Is it possible to drive a five-watt tube by means of a C-

ter oscillator circuit from a standpoint of efficiency and economy.

W. B., Whittier, Calif.

The amplifier tubes can be protected from self-oscillation by means of small radio-frequency chokes in the grid lead of each tube. A suitable choke would be 10 turns of No. 24 wire on a 3-inch tube, although you may be able to stop the oscillation with a smaller choke, which, of course, would be better. With a plate voltage of 120, a C-301-A tube would probably develop sufficient power output to successfully modulate a 5-watt tube. Four dry cells would operate the A tube for a number of hours, so that the difference in filament voltage between the C-301-A and the average 5-watt tube would not materially affect the cost of operation of the set.

The master oscillator circuit is one of the best circuits from the standpoint of stability. C. W. telegraph signals with this type of circuit are noted for their steadiness. More power can be developed per tube in this circuit, where the high-powered tubes are used as amplifiers, and the low-powered tubes as exciters. There are numerous adjustments, however, and more apparatus is required, so that the cost of the equipment would be greater than with a self-excited set. The cost of operation should be about the same as is the case with the other standard transmitters.

Kindly publish a circuit for one step of tuned radio-frequency amplification, to be used with a tuner of the well known single-circuit type.

—H. L. P., Groton, Mass.

This circuit, with the additions requested, is shown in Fig. 2. It may be that, with careful attention to the wiring of the radio-frequency stage, the potentiometer will not be necessary, and if the set does not have a tendency to oscillate, the grid of the amplifier

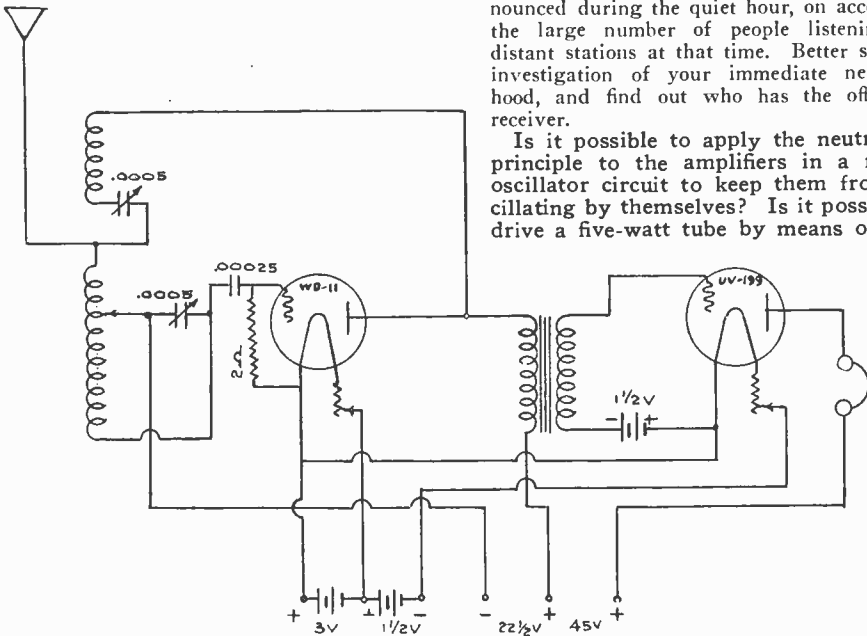

Fig. 1

The circuit you wish is shown in Fig. 1. It will not be necessary to have an additional filament battery, the two dry cells being arranged as shown in the diagram so as to provide two different voltages. It might be well to interchange the two dry cells occasionally, in order that the current drain will be equal, as the WD-11 consumes .25 amperes at 1.2 volts, and the UV-199 has a current consumption of .06 amperes at 3 volts, so that the dry cell supplying the WD-11 tube gets the most use.

Why are VT-1 vacuum tubes not accepted by the leading companies for repair? What is a galvanometer used for?  
—L. A., Vallejo, Calif.

VT-1 tubes are made with a patented oxide coated filament, the process of which is rather difficult for firms other than the manufacturer to duplicate. Repair companies usually accept only tubes having a plain, non-treated tungsten filament, such as is used with tubes now obsolete. A galvanometer is generally used for indicating conditions of resonance in wavemeter circuits, so far as its radio uses are concerned.

Please explain why it is so difficult for me in tuning long distance stations to get rid of the carrier wave whistle. Am using a regenerative circuit, with two variometers.—R. R. H., Oakland, Calif.

If you cannot tune out the whistle when you have the station tuned properly so far

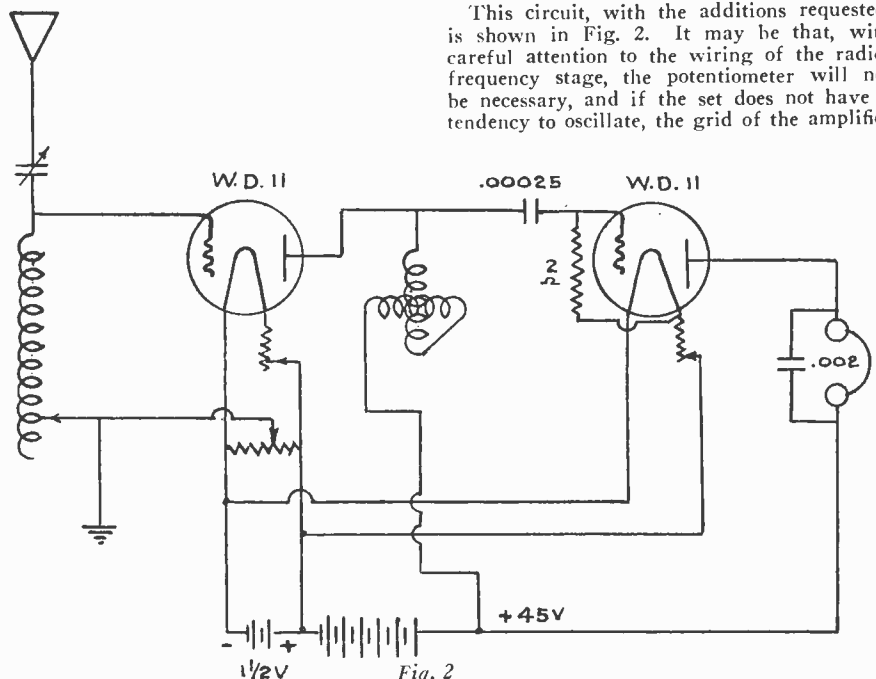

Fig. 2

301-A tube, or is the filament voltage of this tube so low as to make its use impractical? Give your opinion of the mas-

may be connected directly to the negative side of the filament.

Please publish a circuit of a 10-watt

C. W. telegraph set using a transformer and two kenetron rectifier tubes to supply the plate voltage. Also tell me how I can make a 1½ millihenry iron core choke coil, and a .01 M. F. condenser that will stand 750 volts. I intend to use the above for a filter.—C. W., Swayzee, Ind.

turns of No. 36 D.S. wire for the primary, and 130 turns of No. 38 S. S. wire for the secondary, the windings being placed on the spool in a hap-hazard manner rather than evenly, in order to cut down the distributed capacity. It is quite likely that you will have to wind several such transformers before you find one that is successful, so you had best provide yourself with several of the spools and sufficient wire to wind a few of the transformers,

is to be used as the input transformer of a push-pull amplifier, as described in September RADIO? What size fixed condensers are C-1, C2 and C-3 in the circuit shown in the September issue? Where can the above resistances be obtained or how can they be made?

—O. R., Chicago, Ill.

It would be desirable to use a transformer having a secondary impedance of at least 500,000 ohms, and perhaps one having a turn ratio of 5 to 1 would have the right characteristics for use in a push-pull amplifier. Only one transformer is necessary, and the resistances should be 250,000 ohms each, or ¼ megohm grid leaks, which are easily obtainable. It is desirable that these resistances be approximately equal, so that care should be used in selecting the resistances in order that each tube will receive approximately the same voltage. C-1 and C-2 are not necessary to the operation of a push-pull amplifier, and should not have been shown in the diagram. C-3 will aid in suppressing any tendency on the part of the amplifier to sing, and should be about 2 microfarads. As a matter of fact, the circuit shown on Page 34 of September RADIO is not a push-pull, or differentially connected amplifier at all, but simply an arrangement by which the two tubes are placed in parallel. Unless the two tubes work from the same input and output transformers, the desirable advantages of the differential circuit cannot be obtained, and as good results could be had by placing the grids and plates in parallel, working the tubes between ordinary inter-tube transformers. It is absolutely necessary that the tubes in a differential circuit should be connected to windings on the same transformer core, which is not possible where two separately insulated transformers are used. The resistance shunt method is the only practical and theoretically correct scheme to use in building a push-pull amplifier, where transformers having split windings cannot be obtained.

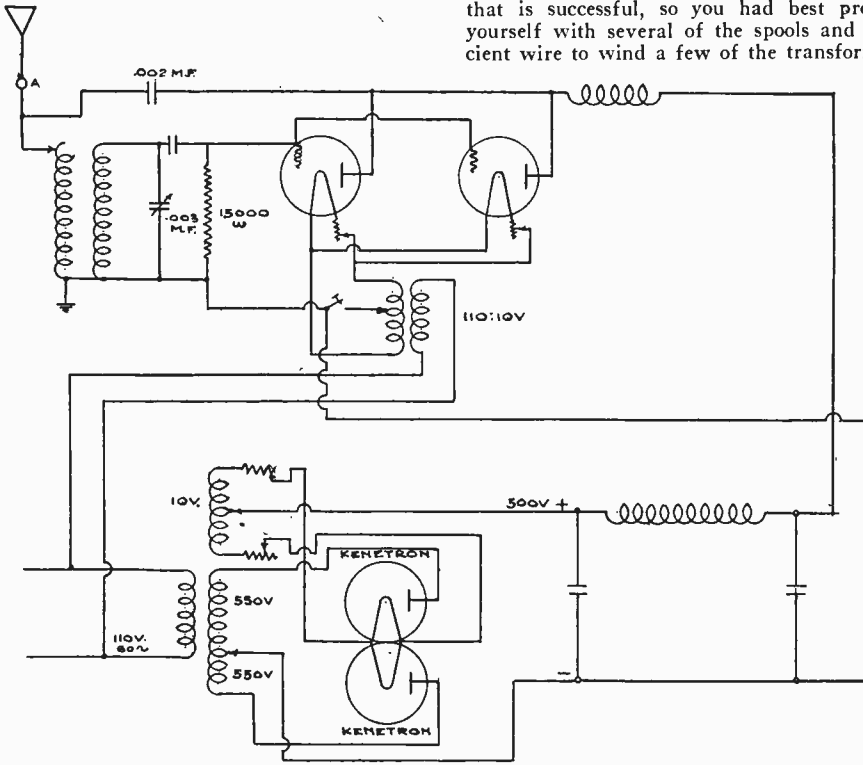

Fig. 3

The circuit is shown in schematic form in Fig. 3. A filter composed of a 1½ millihenry choke and a .01 M. F. condenser would not filter out the noise from a 750-volt Kenetron rectifier. What you need is a filter as shown in Fig. 3, on Page 35 of October RADIO. Such a filter will require 14 M. F. capacity, and 7.5 henrys for the inductance. If such a filter involves too much expense, wind 5000 turns of No. 26 S. C. C. wire on a rectangular core 1½ inches by 1½ inches cross section, and shunt a 2-microfarad condenser from each side of the choke to the other side of the line. The choke should be placed in the positive side of the d.c. line.

Please publish data for an untuned air core, radio-frequency transformer suitable for the present broadcast wavelengths. I am planning to use the transformer in the Grimes Inverse Duplex circuit.—B. L., Berkeley, Calif.

A good radio-frequency transformer may be made by cutting a ⅛-in. slot in a wooden spool form, so that the hub of the spool is ¾ in. in diameter and a winding depth of 1 in. is available. In this slot wind 105

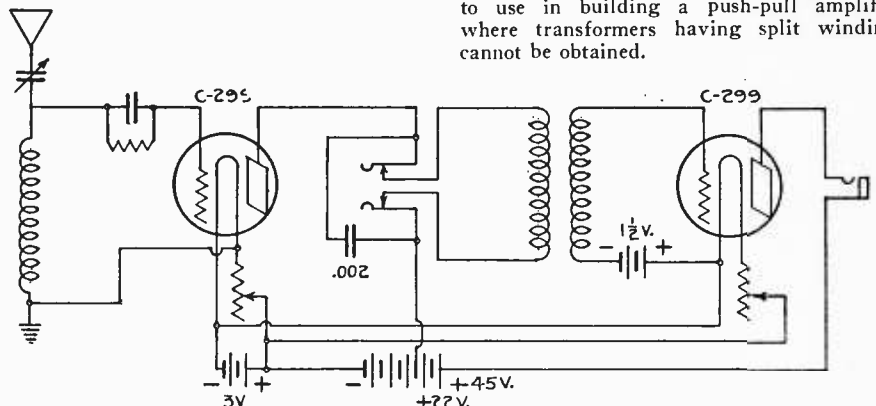

Fig. 4

in order that you can be sure to obtain a good one.

Please publish the circuit shown on Page 33 of August RADIO, with one stage of audio-frequency amplification added.—M. H. H., Blissfield, Mich.

The circuit requested is shown in Fig. 4.

What size resistances should be used on the secondary of a transformer which

Would like to have a circuit diagram of two stages of tuned radio-frequency amplification, and detector, using C-299 tubes.—A. W. C., Cupertino, Calif.

The diagram is shown in Fig. 5. Either variometers or tapped inductance coils may be used in the plate circuits, as indicated.

### NEWS OF THE AMATEUR OPERATORS

Call 9AWV has been issued to Geo. E. Zemba, (ex 9AWS), 406 Buchanan St. N. E., Minneapolis, Minn.; all cards answered.

8BNH is W. E. Slabaugh, Jr., 142 So. Union St., Akron, Ohio.

Call 3CHG has been assigned to Elmer Gabel, 412 Meredith St., Kennett Sq., Pa. He wants Q.S.L. on his 50-watt signals.

8KG, J. W. Kidd, Niles, Ohio, using 2 five-watt oscillators, 2 five-watt modulators and 2 one-watt speech amplifiers with 500 volts, 160-200 m. a. on plate of all tubes, claims full verification that he was heard in London, England, on voice on September 19th, at 5:15 G.M.T.

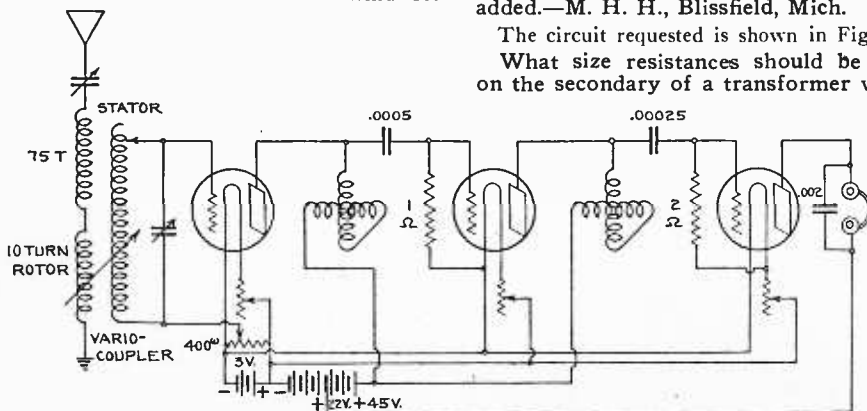

Fig. 5

# WITH THE AMATEUR OPERATORS

## CANADIAN 9BP AGAIN WORKS WNP

Jack Barnsley, operator at Can. 9BP, whose excellent work with WNP, the McMillan expedition ship now at Refuge Harbor, Greenland, was first reported in November RADIO, advises that from October 9th to 23rd he heard nothing from Donald Mix, operator on the *Bowdoin*, on account of bad radio

sent all on hand, together with news of the past two weeks.

Barnsley says: "It should not be many days or weeks now when stations in every district will be working WNP, as his signals were absolutely Q.S.A. the last time I worked him, and he is hearing all districts."

Barnsley is a Canadian amateur 28 years old who has been interested in radio since 1911. He had considerable commercial experience on coastal and deep-sea steamers from 1914 to 1917, when he joined the Royal Flying Corps, during which service he was stationed at Toronto. After the war he took

## SIXTH DISTRICT CONVENTION AMENDS THE PACIFIC PLAN

The fourth annual convention of radio amateurs in the Sixth District was held at San Francisco, October 13th, with representatives present from 18 clubs. D. B. McGown, radio inspector, acted as chairman of the meeting and explained the new regulations regarding amateur transmission.

The principal business transacted was the revision of the Pacific Plan to conform with the new law whereby amateurs are not allowed to transmit between 8:00 and 10:30 p.m. daily and during church services on Sunday. Any part of the old plan not in conformity with this ruling was declared void. The former provision that no station shall continuously transmit longer than 15 minutes was withdrawn and the plan was amended to read that both local and long distance relay work be allowed from 6:30 to 7:30 p.m.

During the meeting and ensuing dinner talks were made by A. H. Babcock, Pacific Coast A.R.R.L., director, who told of association activities in the West; E. W. Stone, who spoke about vacuum tubes; and D. B. McGown, who detailed some experiments on wavelengths of 50 to 150 meters. Local conditions were described by the delegates from various clubs. B. R. Cole was elected division manager for Northern California and M. E. McCreery of Los Angeles was requested to have an acceptable man elected for Southern California.

The following stations were selected as terminals for two-way trans-Australian tests: 6PL, 6ALK, 6KA, 6CMR, 6CGW, 6BVG, 6AWT, 6ARB, 6ZH, 6CHL, 6NX, 6AUU. Santa Barbara was named as the 1924 meeting place.

## NEWS OF AMATEUR OPERATORS

8BCF has been reassigned to Chas. R. Allison, 968 W. Wayne St., Lima, Ohio.

8CCI has been reassigned to James C. Lisk, 902 S. Elizabeth St., Lima, Ohio.

Y. W. P. Evans, Hon. Secretary of the Manchester Wireless Society, 2 Parkside Road, Princess Road, Manchester, England, is anxious to have direct communication from owners of American transmitting stations with reference to special tests with the 1000-watt station, 5MT, operated by members of the Society. This station will be on the air every week from the end of October to February, 1924.

Lester Picker, 6ZH, of San Ysidro, San Diego County, Calif., who has been confined to his bed for nearly two years as a result of an injury to his spine caused by a fall from an aerial, received further injuries to his spine and broke his right arm when he was thrown from an auto into which another machine was carelessly driven. He was being brought home from an amateur meeting at Los Angeles when the accident occurred. His many friends of the air are requested to drop him a card, as he is unable, temporarily, to operate his transmitting set.

Call 6ADM, formerly call of H. J. Bolton, 112 No. Dillon St., Los Angeles, has been reassigned to Floyd W. Barnes, at 438 Carrillo St., Santa Rosa, Calif. Would appreciate reports from anyone hearing my 10-watts d.c. C. W. All cards answered promptly.

Ashley C. Dixon, Jr., R.F.D. 3, Stevensville, Montana, advises that call 7IT was assigned to him on March 15, 1923. The government call book and others have listed this as the call of Roy Anderson, Ketchikan, Alaska.



Antenna System at Can. 9BP

conditions around Prince Rupert, B. C. During this two weeks' period of non-communication messages from all parts of the "States" piled up at 9BP.

But on October 22nd Barnsley was able to send all of them, Mix copying them without a hitch, including a long cipher message of over 60 words. On October 23rd Mix advised that he had heard 9BP regularly on schedule on detector alone, but had been unable to raise 9BP in reply.

On October 24th Barnsley gave Mix three messages and copied three, including press. On October 25th he received ten messages and

up radio for pleasure in connection with his regular work as agent for the Union Steamship Co. His present station has been in commission since the spring of 1922.

The transmitter uses two 50-watt tubes in full wave self-rectifying circuit with 1500 volts a.c. on the plates. It is a duplicate of old 6ZAC's transmitter which was described in May, 1922, RADIO, with the exception that it has been modified for the reversed feed-back circuit.

The antenna is an inverted L 6-wire cage 63 ft. high and 75 ft. top with 45 ft. cage lead-in. The 12-wire counterpoise is 85 ft. long and 10 ft. from the ground. No ground connection is used with the transmitter.

The receiver is a Paragon Type R A 10 three-circuit regenerative tuner with Paragon D A 2 two-step audio-frequency amplifier; Baldwin and Western Electric telephones.



Jack Barnsley, Can. 9BP

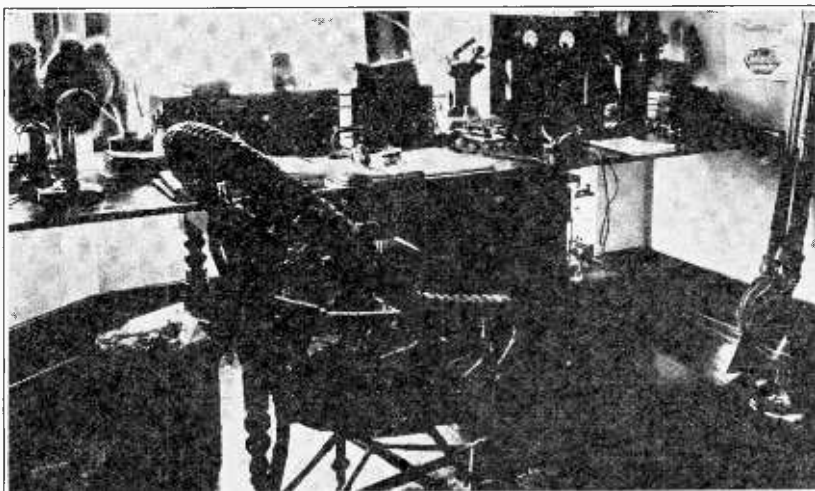

Interior View of Can. 9BP



## MOTT HEARS WNP AND AUSTRALIA AT ONE SITTING

On the night of October 24th, after test transmission to Maclurcan of Sydney, Australia, and White and Frank R. Rose of New Zealand, 6XAD-6ZW at Avalon, Calif., copied WNP and 5GM (or 3GM) of Australia.

WNP was first heard by Shumaker and was copied by him and Major Mott for nearly two hours. He was sending press and messages to Canadian 9BP. Among the messages copied by means of a Grebe CR-13 receiver were the following:

1:15 A.M.—9BP de WNP—music excellent and appreciate special service for myself—sig. Mix.

1:20 A.M.—To Boys of Robbins House—Milton Academy, Milton, Mass.: Thoroughly enjoying trip eleven degrees from north pole. Kindest regards to head master and all my friends at school. Sig. Don Mix.

Fm WNP to B. F. Webber, Webber Tavern, Wiscasset, Maine: Having fine time. Regards. Sig. Mix.

To ..... QRN spoiled address... msg received. Winter here with weather below zero and heavy snow. Sun up for few mins for last time today. All well. Sig. Macmillan.

At 2:21 A.M. Shumaker caught a very faint DCCW signal, on 240 meters. All that either he or Mott could decipher was: "6XAD fm 5GM (or it MAY have been 3GM?) Australia"; then something about "QSA" and "repeating it....."

The reports of October reception of 6XAD-6ZW follows:

1aqm, 1aug, 1bbw, 1bwj, 1cdo, 1pa, 2kf, 2clx, 2ceg, 2cwk (heard 6xad-6zw while still daylight as far as Chicago), 3abg, (3cbm), 3gc, 3mo, G. H. Long, New Bedford, Mass., 3apv, 3ey, 4io, (4ku), (4cl-Can.), 4jk, 5ek, 5anc, 5bx, (6abs-Honolulu), (7zu), (7wm), (7hw), P. Cunningham, Portland, Ore., 7oy, (8pl), 8avj, 8cae, 8ckv, 8cej, 8ceo, (8bcp),

(8fu), 8ago, 8tt, 8buj, 8lj, 8jj, 8bf, 8nq, (8xe), (8aig), 8ve, (8zc), 8xh, 8bbi, W. Boltz, Buffalo, N. Y., (9aic), 9eae, 9dkx, 9brk, 9agh, (9apf), (9miy), 9bab, 9ehy, 9cah, 9elq, (9cyy), 9bpy, 9rc, 9mm, 9ir, 9bbr, 9ehi, 9edh, 1cmp (qsa with 20 watts), 1ow, 1jv, (3bhm), (7jf), (8bke), 8bhe, (8zy), (8adg), (8bdv), (9awm).

in a triangular form (when we changed from 10 to 15 watts a couple of months ago, had to "squeeze" the third tube in between the other two). The power flops out of an old  $\frac{1}{2}$  kw. Thor, rewound to give about 750 volts with the magnetic shunt clear off, about 700 flat being used regularly. At first had the primary of the transformer tapped and

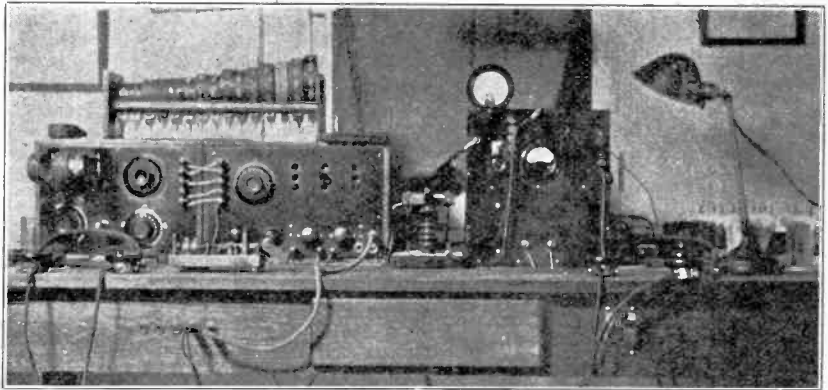

Radio Station 5ADB

## RADIO STATION 5ADB

Radio 5ADB, operated by E. R. McCracken and E. H. Funk at 2117 Grant St., El Paso, Texas, has frequently been reported among the "Calls Heard" and the operators have been asked whether they are operating a 250-watter, whereas actually they are using three 5-watt tubes!

The aerial is an ordinary 4-wire flat-top, 40 ft. high and 70 ft. long, wires spaced about  $2\frac{1}{2}$  ft. apart. The counterpoise runs under the aerial on the same masts, consisting of 8 wires, spaced 1 ft. apart. Lead-ins from aerial and counterpoise go directly to lightning switch, thence into the shack, which is a 20x12 cement concern.

"The transmitter consists of three five-watters, sitting on a shelf behind the panel,

used as an auto-transformer, to heat the filaments, thereby saving much winding on the part of us. But the transformer seemed to heat more than the filaments in that arrangement, even though we did put the thing in oil, so finally had to take a day off and wind a separate filament-heating transformer.

"Rectifier is contained in 20 of Mr. Kress' five-cent glasses, arranged in the bridge circuit, with a "QST" brute force filter tied on to it, and which results in an "almost" DC tone, according to reports. That is, when the rectifiers are doing their stuff. The ungracefully mounted meter is the filament voltmeter, which had to go somewhere, as we couldn't hang it up by a string.

"Forgot to say the circuit is the straight Hartley, which surely does work for us,

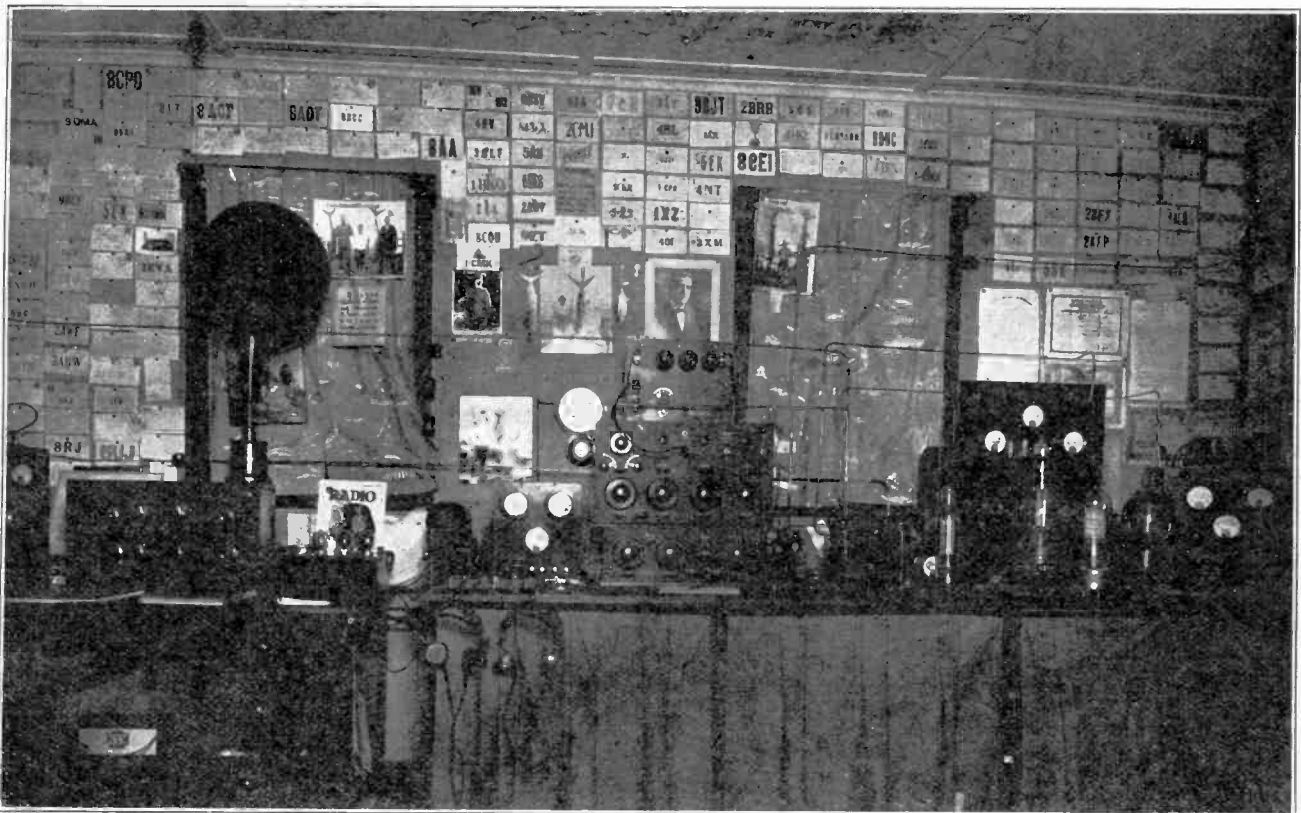

Latest Picture of 6XAD-6ZW

Left to Right: (1) 20-watt transmitter with four W. E. 5-watt tubes, radiation 2.3 amps. on 203 meters; (2) Grebe CR-7 with W. E. loud speaker; (3) 100-watt transmitter with 2 W. E. (or G. E.) tubes, radiation 6.1 amps. on 210 meters; (4) W. E. amplifiers, Grebe CR-6 and Grebe "13"; (5) Antenna switch and switch for changing power,

ground, counterpoise and antenna from one set to another; (6) 250 and 500-watt transmitter using either G. E. 250, Westinghouse 500 or British 500, radiation 10.12 amperes on 216 meters; (7) Special 250-watt W. E. transmitter used in work with WNP, Australia, and New Zealand, radiation 10 amps. on 218 meters.



# FROM THE RADIO MANUFACTURERS

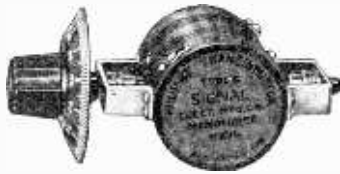
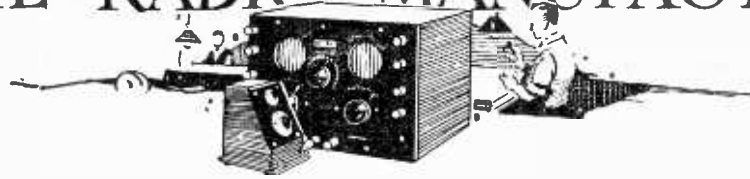

The "Transinductor" is a new type of variable transformer which gives selective tuning and high amplification by means of a one-dial control of the magnetic inductance, capacity and iron flux. It is equally well adapted for either radio or audio-frequency amplification with any make of tube.



The Como Duplex transformer is made with split coil for push-pull audio-frequency amplification; designed for use singly or with two or three stages of straight audio; gives great volume of sound without distortion.

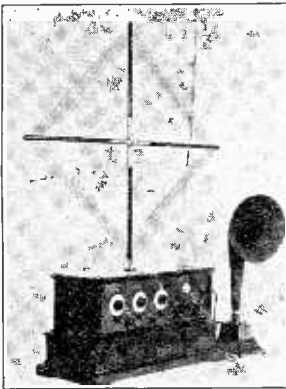

Murad MA-17 Receiver and Audio-phonograph, comprising r. f., detector, and a. f. in one cabinet with loop aerial, an ultra-sensitive receiver combining simplicity of operation with high selectivity; employs one dial for tuning and two dials for eliminating interference from nearby stations through special rejector circuits.

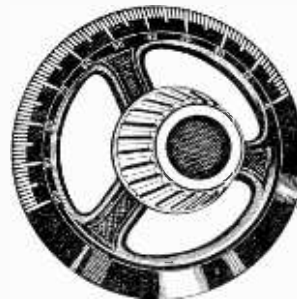

The Frost bakelite spider dial is designed to permit close tuning without vernier attachment; the beveled edge is of the conventional type, but the spider or yoke center and the fluted knob make it easy to grip; numbers and divisions are filled with white enamel, fitted with  $\frac{3}{16}$  or  $\frac{1}{4}$  in. brass bushing with set screw; made with  $2\frac{1}{2}$  or 3-in. dial.



The Shamrock variometer employs pig-tail connections from the rotor to the stator coil to eliminate noises and leakage; separate Fahnestock connections for rotor and stator leads permit use as a straight or split variometer; a floating stop allows full 360 degree turn of rotor within stator, thus giving maximum inductive efficiency; guaranteed to tune above 600 meters.

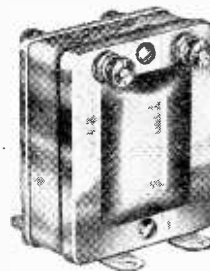

The National audio-frequency transformer is claimed to give great volume and fine tone quality, especially for low notes; shell type laminated silicon steel core assures minimum core loss and accurately wound coils give low distributed capacity; completely inclosed in metal case to eliminate stray fields; extra long binding posts plainly marked; made in  $3\frac{1}{2}$  to 1 and 6 to 1 ratios.

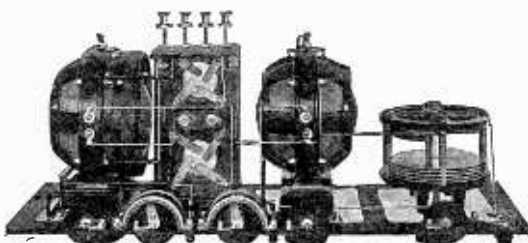

The Grebe "13" receiver is a short wave development, 80 to 300 meters, of the circuit employed in the "CR-12"; it employs two specially designed variometers with "split" windings and a stabilizer for control-

ling regeneration; sharp tuning is facilitated by a variable antenna series condenser. Other features include individual shields for each tuning element, tapered grip dials with tangent wheel verniers, and direct reading

reostat controls. It uses 1 stage tuned r. f. and detector; when oscillating all spark signals and "mush" are suppressed; when not oscillating it gives great volume to spark signals; detector dial is calibrated direct in wavelengths.



# SUPREME!!

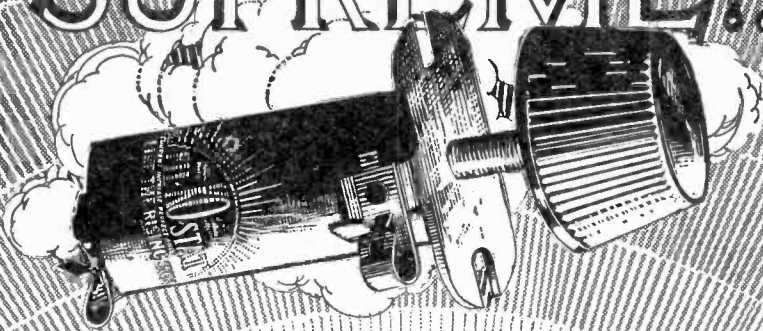

# FIL-KO-STAT

**S**UPREME because it was designed to be supreme! That's the secret of FIL-KO-STAT superiority. Built to permit *infinite* adjustment of electronic flow in the vacuum tube—whereas other devices were drafted into radio service because, before the FIL-KO-STAT, there was no real *filament* control.

Put a FIL-KO-STAT in your set to-day. The maker's guarantee *assures* your satisfaction—and FIL-KO-STAT satisfaction means noise shut out—distance brought in—stations you never heard before.

FIL-KO-STAT has no screws to tamper with—no adjustments to puzzle—no discs to break or chip—no wires. It is *not* a powdered carbon rheostat—FIL-KO-STAT resistance element is 70% metallic substance. Its full resistance is 30 Ohms—only *two* terminals and you use them for *all* tubes, including 5-watt transmitting tubes. Triple tested and adjusted in the laboratory to the ideal "off" position for any of them.

GUARANTEED BY THE MAKER



Recommended and Sold by Dealers in High Class Radio Supplies

## RADIO STORES CORPORATION

SOLE INTERNATIONAL DISTRIBUTORS

DEPT. R 12, 218-222 WEST 34TH STREET, NEW YORK  
CHICAGO MINNEAPOLIS KANSAS CITY LOS ANGELES

Price

**\$2**

In Canada 2 1/2

# FOR ALL TUBES

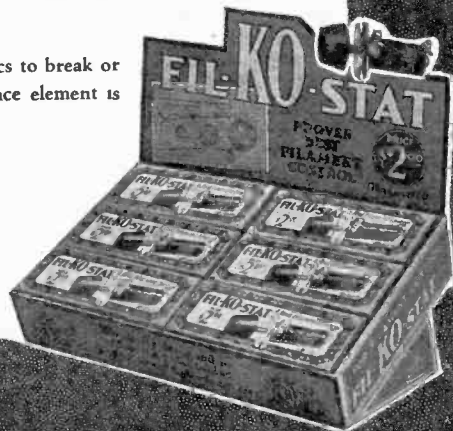

Tell them that you saw it in RADIO



**Charges Radio and Auto Batteries at Home  
Over Night - For a Nickel!**

For a friend who owns a radio set or automobile, what could be more appropriate than a gift which would eliminate the inconvenience and expense of taking his battery to a service station every time it requires recharging? The

**GOLD SEAL  
HOMCHARGER**  
*The World's Most Popular  
Battery Charger*

is such a gift, appropriately dressed up in a beautiful Christmas package, too. It charges any AUTO, RADIO or "B" storage battery in the simplest, quickest and most efficient manner possible. Connects to any lamp socket—operates silently—requires no watching. Fully automatic in operation—absolutely safe.

**HOMCHARGER'S TEN POINTS OF SUPERIORITY**

1. **Simple**—Only one moving and wearing part, replaceable after thousands of hours use for \$1.00. Will last a lifetime.
2. **Efficient**—Uses less than one-half the current of any bulb or liquid type rectifier. Will charge any radio or automobile battery for a nickel.
3. **Quick**—Its high charging rate of 7 amperes eliminates long waiting for battery to become charged. Will charge any "A" or "B" battery over night, or three times as fast as a 2-ampere machine.
4. **Clean**—No expensive bulbs to break or acids to spill or replace. No acid fumes. Charges without muss, fuss or bother.
5. **Dependable**—Tungsten contacts insure continuous operation—prevent sticking and stopping.
6. **Fool-Proof**—Can be operated by anyone. Attach to lamp socket and connect battery either way, it will always charge. High-grade ammeter eliminates guess work.
7. **Safe**—No danger of shock or fire. Tested and approved by Fire Insurance Underwriters everywhere. Gives tapering charge—will not overheat or injure battery.
8. **Beautiful**—Mahogany and Gold Finish.
9. **Unqualifiedly Guaranteed.**
10. **Popularly Priced**—Retail at \$18.50 complete (\$25.00 Canada). No extras to buy. Sold by all dealers.

**DEALERS! JOBBERS!**

GOLD SEAL HOMCHARGERS in their attractive Xmas packages are going to be "best sellers" to the holiday trade. Write for our elaborate merchandising plans and then prepare to get your share of this big "Homcharger Xmas business".

**Insist on the GOLD SEAL**

ACCEPT NO SUBSTITUTE. Like all good products, the HOMCHARGER has been widely imitated. No other charger is just as good. INSIST on seeing our registered trade-mark, the "GOLD SEAL," on nameplate and carton before purchasing.



**WESTERN DISTRIBUTOR:  
BERTRAM SMITH**

516 San Fernando Bldg., Los Angeles, Cal.  
Shipments to all points west of Rockies from Los Angeles stock

**The Automatic Electrical Devices Co., 117 West Third St., Cincinnati, O.**  
*Largest Manufacturers of Vibrating Rectifiers in the World*

**C. W. MANUAL** —Only a few left  
\$1.00 per copy  
"RADIO"  
Pacific Bldg.,  
San Francisco

**CALLS HEARD**

*Continued from page 41*

At 6CLZ, 2131 Grant St., Berkeley, California

C. W.—U. S.: 5thd, 5ama, 5be, 5ht, 5if, 5lr, 5ql, 5xa, 5za, 5zav, 6aa0, 6acg, 6adb, 6adm, 6adn, 6adt, 6adv, 6afg, 6afq, 6age, 6ahw, 6ajh, 6alo, 6aqd, 6aqw, 6asa, 6awq, 6bac, 6bah, 6bbh, 6bbq, 6bdw, 6beg, 6beh, 6beq, 6bfb, 6bge, 6bic, 6bjq, 6bks, 6bkx, 6blg, 6blr, 6blw, 6bmc, 6bmn, 6boq, 6bpz, 6bqc, 6bqe, 6bqk, 6bqr, 6bqs, 6bqw, 6bqy, 6bra, 6brf, 6bri, 6brk, 6brs, 6buo, 6bur, 6bve, 6bvg, 6bwe, 6cae, 6caw, 6chi, 6cbl, 6ceu, 6cfl, 6cfz, 6cga, 6cgc, 6cgd, 6cgg, 6cgl, 6cgv, 6chu, 6chv, 6chz, 6cia, 6cid, 6cjb, 6cju, 6ckv, 6ckh, 6cll, 6cmq, 6cmr, 6cng, 6cnh, 6cni, 6cod, 6eb, 6ec, 6ei, 6en, 6hv, 6iq, 6js, 6kj, 6od, 6om, 6pe, 6pi, 6pl, 6rm, 6ua, 6vd, 6xad, 6ya, 6zg, 6zh, 6zw, 7aa1, 7aau, 7aby, 7aci, 7acm, 7acx, 7adm, 7adp, 7adr, 7ads, 7afe, 7aft, 7age, 7aiy, 7aje, 7ajv, 7ak, 7akv, 7akz, 7bj, 7bz, 7dc, 7ez, 7gi, 7go, 7it, 7lh, 7ln, 7ly, 7no, 7nt, 7ob, 7oh, 7oy, 7px, 7qf, 7qj, 7qy, 7rn, 7rs, 7sn, 7sy, 7to, 7tq, 7tt, 7ve, 7vf, 7vn, 7wp, 7ws, 7xm, 7zi, 7zn, 7zo, 7zs, 7zu, 7zx, 8bwk, 8er, 8fu, 8vg, 8zz, 9aau, 9aim, 9amb, 9apf, 9avz, 9axx, 9bg, 9bik, 9bjk, 9bri, 9bun, 9bxq, 9bzi, 9caa, 9cbj, 9cfy, 9cvc, 9cwc, 9dgi, 9dkb, 9dxn, 9eky, 9mc, 9uh, 9vm, 9yaj, 9zg, 9zt, 9zv.

Daylite—C. W.: 6adm, 6adv, 6afg, 6ahw, 6bqc, 6bqr, 6brf, 6bri, 6bvg, 6cae, 6cga, 6cgd, 6cgw, 6chu, 6cid, 6ckh, 6pl, 6vd, 6zar, 7adr, 7lr, 9amb, 9apf.

Spark: 6avu (daylite).  
Fone: 6ahw (daylite).  
I. C. W.: 6xbj.

Canadian C. W.: 4cl, 5cn, 5ct, 5go. Anyone wishing further check pse qsl crd. AllStns hrd on Reinartz with 1 tube.

By 6AFT ex-5AIF, 7526½ Figueroa, Los Angeles

5aat, 5adb, 5aec, 5age, 5aj, 5akn, 5aky, 5ge, 5in, 5jf, 5lg, 5lr, 5mn, 5qq, 5uo, 5zav, 7adp, 7afe, 7agv, 7ame, 7bj, 7br, 7gp, 7j, 7nn, 7qf, 7qj, 7ql, 7sf, 7tk, 7yl, 7zd, 7zn, 8hv, 9aaw, 9aim, 9auu, 9axx, 9bjk, 9bvo, 9bzi, 9caa, 9ccz, 9cip, 9cvc, 9cvo, 9dek, 9eky, 9ve, 9zt. Can. 5cn.

By 7ER, 7AF, 7WA

Sat. nite, Oct. 6, 1923, after midnight P.S.T. on single wire, 50 ft. long, top of Mount Spokane, with Reinartz tuner and 1-stage A.F.:

5ek, 5agj, 5amh, 5pv, 5zav, 5akw, 6cod, 6nx, 6hp, 6aos, 6chl, 6awt, 6ts, 6bql, 6cfl, 6pl, 6bri, 6km, 6cbd, 6cgv, 6zar, 6aly, 6blg, 6kh, 7aw, 7adp, 7afe, 7aif, 7to, 7qy, 7ll, 7wp, 7dc, 7ez, 7lu, 7it, 7acp, 8pl, 8ajh, 9ebt, 9aim, 9dkb, 9aog, 9afw, 9caa, 9ehn, 9dkq, 9bg, 9bab, 9bjk, 9apf, 9bqy, 9aic, 9bez, 9vm, 9hav, 9dsw, 9yaj, 9cmi, 9eky, 9awv, 9zy, 9blg, 9bfi, 9ack, 9vz, 9eae, 9daw, 9dqe, 9can.

Can.: 4hf, 4cl, 5go, 5cn.

By 8??? ex. 6CIW, 228 W. 2nd Ave., Columbus, Ohio

1aff, 1aw, 1ere, 1gv, 1hx, 2bhn, 2cg, 2chu, 2cu, 2cvu, 3aa, 3ab, 3bu, 3hs, 3iw, 3pi, 3sp, 4eb, 4ga, 4gp, 4jk, 5ake qra?, 5hr, 9aau, 9aav, 9aaw, 9apz, 9ars, 9aua, 9bkj, 9cgo, 9ctr, 9cud, 9dct, 9eky, 9nn, 9qb.

C. W. Can.: 2bu 3th.

By 6GZ Charles Bruere Jr., 1430 Wright St., Los Angeles, Calif.

4gy, 4ku, 5adb, 5aj, 5akn, 5aky, 5de, 5ek, 5en, 5fc?, 5ga, 5ge, 5gw, 5jf, 5kg, 5lr, 5mn, 5pb, 5qq, 5uo, 5za, 5zav, 5zr, 6adm, 6adt, 6ag, 6aiv, 6aja, 6ajf, 6ame, 6anb, 6ani, 6ao, 6aoc, 6aof, 6aol, 6aou, 6aph, 6atz, 6aup, 6bbc, 6bcj, 6bcr, 6bds, 6bfb, 6bfi, 6bfu, 6bgy, 6bkd, 6bny, 6boh, 6bon, 6bos, 6bou, 6bov, 6bpf, 6bqb, 6bua, 6ccr, 6cec, 6cej, 6ceu, 6cfl, 6cgv, 6cgl, 6chp, 6ckv, 6cmi, 6cqi, 6dd, 6eh, 6fo, 6fy, 6hi, 6il, 6km, 6kw, 6la, 6lu, 6no, 6nx, 6oh, 6sz, 6tv, 6ua, 6vd, 6zah, 6zaj, 6zar, 6zh, 6zk, 7ak, 7cl, 7fl, 7gj, 7gw, 7ir, 7pf, 7qu, 7rc, 7se, 7sf, 7to, 7wp, 7ws, 7zd, 8bx?, 9aob, 9apf, 9aps, 9auw, 9avz, 9bjk, 9bun, 9bvo, 9bzi, 9ccs, 9ccz, 9cvc, 9dge, 9eky, 9zt.

Can.: 5am, 5ci.

By P.O. Box 1202, San Diego, California

3bw, 4ft, 5ql, 5qg, 5ado, 5sl, 5cn, 5kc, 5mn, 6ait, 6aup, 6aqd (spk), 6chu, 6bon, 6con, 6acg, 6iq, 6vd, 7adp, 7to, 7gh, 7fc, 8eyt, 8adk, 8sn, 8sf, 8vg, 9ahz, 9aom, 9apf, 9avn, 9doo, 9dmj, 9czu, 9dma, 9aim, 9caa, 9dms, 9axl, 9bxq, 9cvc, 9cde, 9bix, 9dzy, 9rc, 9zt, 9wz, 9lz.

By 6AAJ, 206 Ellsworth Ave., San Mateo, Calif.

3di, 4kv, 5be, 5ek, 5gn, 5hl, 5aao, 5akn, 5amh, 5zav, 6cc, 6cu, 6kj, 6pl, 6aao, 6ac, 6adn, 6agk, 6hlm, 6bur, 6cas, 6cgv, 6cni, 7ak, 7dc, 7gt, 7gv, 7ks, 7lh, 7ln, 7qj, 7ve, 7we, 7ws, 7zl, 7zo, 7zu, 7zx, 7abb, 7ads, 7afe, 7afo, 7age, 7akt, 8ab, 8at, 8er, 8je, 8jj, 8xe, 8zx, 8aje, 8amm, 8bda, 8bhn, 8cax, 8cpb, 8bg, 9eq, 9zg, 9zn, 9amb, 9any, 9ape, 9auu, 9bez, 9bzi, 9cbj, 9cns, 9cte, 9daw, 9dfh, 9djm, 9ebt.

Can.: 3ko, 4dq, 5ct, 5go, 5hg. All crds. ans. 5 watter hr.

*Continued on page 76*



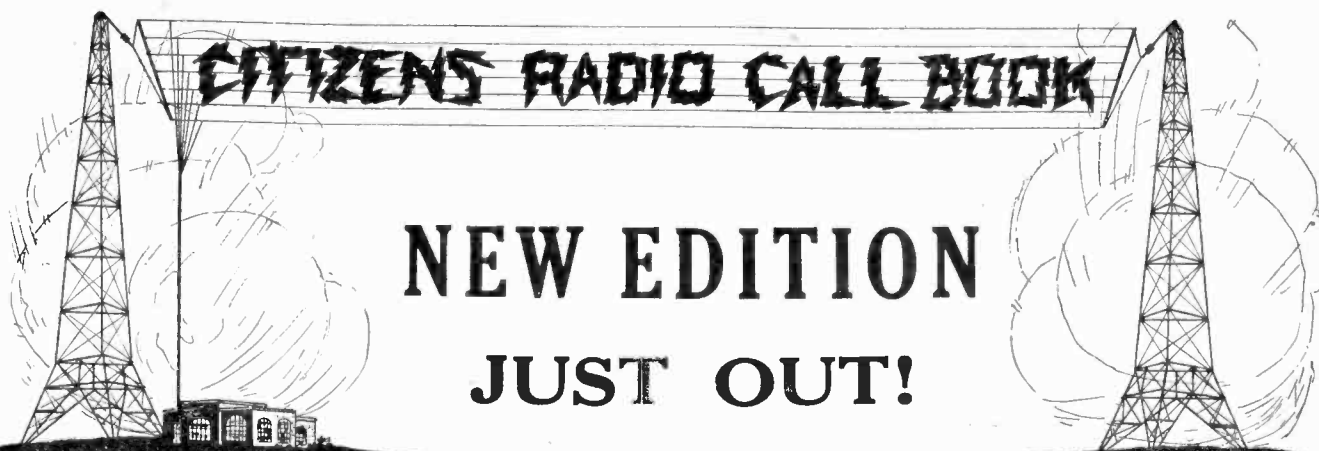

# NEW EDITION JUST OUT!

## What the Greatest of CALL BOOKS Contains:—

**200  
PAGES**

*of the most  
essential data,  
costing  
thousands  
of dollars  
to assemble,  
is yours  
for only  
50 CENTS*

**THIS** brand new issue of the Citizens Radio Call Book contains all the Broadcasting Stations with schedules, also wavelength, kilocycle and class of station (A-B-C), complete list of Foreign Broadcast Stations;

Extra large Broadcasting Map, showing location and call letters of all broadcasting stations.

Complete air line distance map—you can instantly see, in plain figures, distance you are from transmitting station.

Blank Map to mark your personal records on distant stations, also log sheet to mark all dial readings to preserve for future reference.

Contains new list of all American, Canadian, English, French, Australian and World's amateur stations, with call letters and location.

A.R.R.L. Divisional Map giving personnel of executive and operating officials.

Articles by Paul Godley, L. M. Cockaday, and others.

Graphic illustrations of Neutrodyne, Reflex, Four Circuit Tuner, etc., etc.

Full construction and operating data given on each circuit.

This is only half the story—USE the coupon.

*The demand for this great book will be unusually heavy. Order at once by using coupon and avoid delay. We guarantee return mail service if coupon is used.*

**JOBBERs and DEALERS  
write for discounts**



**“Worth  
\$5.00”** —is what  
many users say.

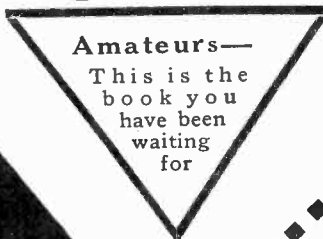

Amateurs—  
This is the  
book you  
have been  
waiting  
for

Please add 24 cents for postage west of Salt Lake; 25c to Canada or foreign countries; 17c east of Salt Lake.

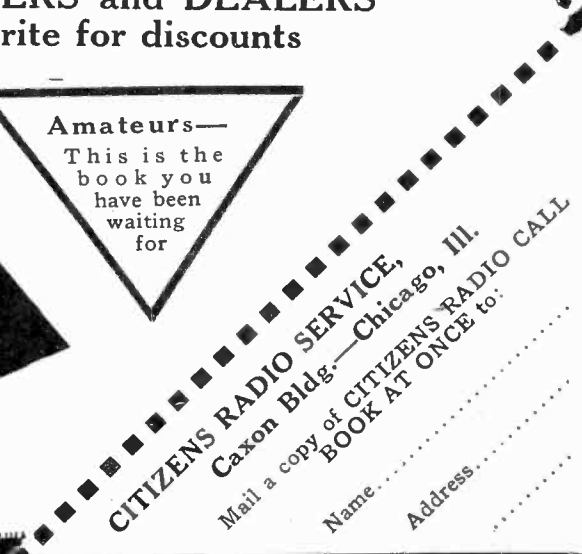
  
**CITIZENS RADIO SERVICE,**  
 Caxon Bldg.—Chicago, Ill.  
 Mail a copy of **CITIZENS RADIO CALL  
BOOK AT ONCE to:**  
 Name.....  
 Address.....



**"Tungar—for your Christmas cheer —makes a perfect radio year" and keeps the auto battery fit**

Few Christmas gifts are so universally useful throughout the year as Tungar—the simple little instrument that charges your radio or your auto storage battery from the electric light circuit.

Owners of the finest high power radio sets are depending upon the storage battery for clearest near and far reception, and depending upon Tungar to keep the battery fully charged at "concert pitch".

You attach Tungar wherever there is a lamp or a convenience outlet. Turn it on and leave it, any hour, day or night.

Operation cost low. No moving parts to get out of order.

For years motor car owners have used Tungar for charging their automobile batteries.

See it at any good electrical shop, or write for literature. Address Section Rd. 12.

Merchandise Department  
General Electric Company  
Bridgeport, Connecticut

Tungar Battery Charger. Operates on Alternating Current.

(Prices east of the Rockies)  
2 Ampere Outfits Complete—\$18.00

5 Ampere Complete—\$28.00  
Special attachment for charging 12 or 24 cell "B" Storage Battery—\$3.00

Special attachment for charging 2 or 4 volt "A" Storage Battery—\$1.25

Both attachments fit either Tungar



Charge 'em at Home, with

**Tungar**

**BATTERY CHARGER**

35A—105D

A GENERAL ELECTRIC PRODUCT

**WINDING INDUCTANCE COILS**

Continued from page 31

Bank-wound coils are wound on a short section of a right circular cone. They are built up in this shape from a cylindrical tube as follows: First two turns are wound on the form, side by side, just as if two turns of a single-layer coil were to be wound. Fig. 3 shows the two turns side by side, on the form. When the third turn is started, it is brought UP and wound between the first two just wound. The start of this third turn is shown in Fig. 3, and can

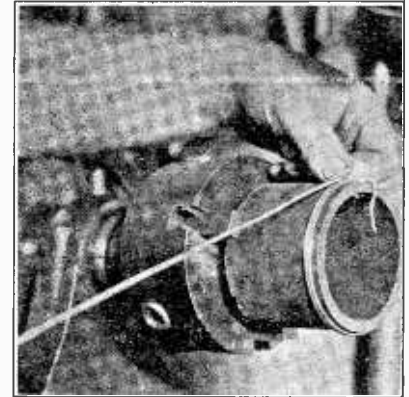

Fig. 3. Starting the Bank Winding

be seen right under the thumb of the operative; this turn is, of course, continued all around the coil, and finally it reaches the starting point again. This is indicated in Fig. 4, and at this point

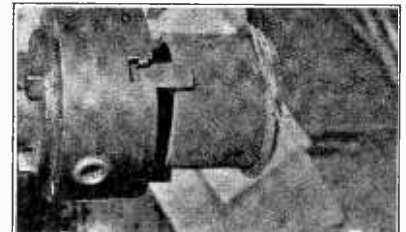

Fig. 4. Dropping Wire Down to Form

the wire drops DOWN again to the winding form, and successive turns are wound on the tops of each succeeding turn, except that every time the top of the pile is reached the winding drops down to the form, and the process is again repeated. This is shown diagrammatically in Fig. 5, where it can be seen

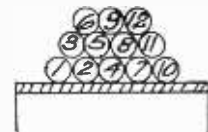

Fig. 5. Three-Banked Winding

that turns 1 and 2 are wound on the form direct, turn 3 is then wound on top of, and between these, and turn 4 is again down on the bottom of the pile. Turns 5 and 6 are again wound upwards, and, when turn 6 is completed, the winding drops down to the tube, again, and forms turn 7, when the process is repeated as many times as it is

Continued on page 48

**Loud Speaking Crystal Set At Last**

You can add a loud speaker to any crystal set by using the STEINMETZ Amplifier costing only \$8.50. Guaranteed to operate on any kind of crystal set regardless of what type it is, or we will refund your money. By using your crystal set with this amplifier music is brought in as clear as a bell and can be heard all over the room. Amplifier uses dry cell tube. Write for our complete catalog and also information on a highly efficient detector and two-stage amplifier at \$22.50.

STEINMETZ WIRELESS MFG. CO.  
Manufacturers and Engineers  
5705 Penn Ave. Pittsburgh, Pa.

**\* Xmas Special \***

**Federal Receiver**

Formerly \$25  
Sale Price \$12.95



A complete radio telephone receiving set, including tuner, detector, condensers, headset, aerial equipment and instructions for installing and operating.

Every set is fully tested and guaranteed

**Empire Radio Corporation**

271 West 125th St. New York City

Tell them that you saw it in RADIO

# TUSKA RADIO



## Tuska Popular No. 225

3-bulb Regenerative Receiving Set. Piano finish mahogany cabinet. Amplifier switch. Concealed binding posts. Armstrong circuit, licensed under Patent No. 1,113,149. Price \$75, without bulbs, batteries or loud speaker.

Ask for special circular No. 12-F, describing this set.

*Your  
entertainers  
are ready*



**S**INGERS, bands, orchestras, speakers, organists, humorists—an unlimited host of performers are yours to command when you own a Tuska Radio. A simple adjustment of dials, and you can choose between them. Dozens of programs are in the air. Your Tuska will bring in whichever entertainer pleases you best and shut out all others.

Tuska owners are not obliged to tinker incessantly and add devices to correct construction faults. Their pleasure is unmarred by troubles. Every Tuska set is finished with exacting care by painstaking New England workmen—the best that live. Then it is examined and tested on

distant signals by inspectors who are keenly critical. Both manufacturing and testing are under the personal direction of C. D. Tuska, a pioneer radio engineer.

For a dozen years before general radio broadcasting began, Tuska-made instruments were famous among radio experimenters for skillful design, superb workmanship and high efficiency. In the past two years the demand for Tuska Radio has grown enormously. Each set in this increased production of to-day is as perfectly built as the finest Tuska instrument ever made—and yet, the prices are remarkably moderate for high-grade radio receivers.

*Ask any first-class radio store to show you one of the models of Tuska Radio, priced \$35 upward.*

THE C. D. TUSKA CO., Hartford, Conn.

### Ogden, Utah, receives Troy, N. Y.

"In one evening, using Tuska 225 with one amplifier only, I received 19 stations, including San Francisco; Calgary, Alberta; and Troy, N. Y. Conditions were not abnormal, and the same stations were received again last night.

W. D. GARNER."



### Picks up Davenport the first time he tunes

"I never had my hands on a set until my Tuska came Saturday. First evening, I tuned in Pittsburgh, New York, Richmond, Ind., and Davenport, Iowa. It certainly was great.

WM. PARSONS, Salisbury, Conn."

# -JUST PLUG IT IN,

*IT FITS A STANDARD SOCKET*

*An Adapter for UV-199  
and C-299 Radiotrons  
which supplies the  
required resistance*

It is no longer necessary to use an extra resistance coil, in series with low resistance rheostats—and the substitution of a high resistance rheostat is a needless expense.

The change to UV-199 and C-299 tubes may be made by simply connecting to a filament battery of proper voltage and inserting this combination Resistance-Adapter.

### Construction Details

- |  |   |
|--|---|
| <p>(1) Contact at tube terminals is positive. Steel spring supplements tension of phosphor bronze contacts.</p> <p>(2) Design of spring and method of mounting contacts gives low distributed capacity.</p> <p>(3) First quality insulation, moulded in one piece, reduces leakage to a minimum.</p> | <p>(4) Resistance element (18 ohms) is counter-sunk in a deep groove, assuring thorough protection from mechanical injury.</p> <p>(5) Projecting knurled edge simplifies insertion and removal of Adapter.</p> <p>(6) Like all other Eise-mann Products, this unit will be found to be thoroughly efficient and high grade.</p> |
|--|---|

Ask Your Dealer For It.  
Price \$1.25



**EISEMANN MAGNETO CORPORATION**

William N. Shaw, President  
BROOKLYN, N. Y.

Detroit

Chicago

San Francisco

necessary to get the required number of turns on the whole winding.

There may be any number of vertical, or "banked" turns, which can be wound on the form, but actually and practically the advantages of banking gradually decrease as the height increases, as this more nearly approaches a layer winding again. Generally this should not be brought up to more than six or seven turns. The diagrams show a three-banked winding. Two-banked windings would be made up with but two vertical layers, that is, again referring to Fig. 5, turn 6 would be brought down to the form, in the place where turn 7 now is, and turn 7 would then take its place on top of turn 6, and thus the process would be repeated. If, on the other hand, a four-banked winding was wanted, turn 10 would be wound on between turns 6 and 9, and the start of the next bank (at the bottom) would be turn 11.

The simplest and easiest wire to bank wind is about No. 20 to No. 24 cotton-covered magnet wire. If the wire is smaller than this it usually becomes difficult to hold in place, while if larger it becomes tiresome, owing to the increased stiffness of the wire.

Sometime, during the process, it will be found necessary to put some binder on the winding, to hold it in place. The most handy substance is common collodion (nitro-cellulose dissolved in ether). This will be found to dry with great rapidity, and at the same time to be of reasonable strength mechanically, and of good dielectric value. Shellac may be used, but, if it is, the whole coil should be dried when completed in a moderately warm oven (not over 150 degrees F.) until all the extraneous solvent has been dried out, as considerable water is absorbed in shellac. A better way is to impregnate the whole coil (after winding it dry) in some good grade of baking varnish, and then baking. The coils may also be impregnated with bakelite, and the whole mass vulcanized. This will give a very solid and strong coil, but one which it is impossible to alter after winding, as the bakelite combines with the fabric insulation and forms a solid mass.

In winding coils, bakelite or formica tubing is to be preferred, if it can be obtained, as it is a very good insulator and possesses excellent mechanical properties. It is, unfortunately quite expensive, and sometimes difficult to obtain in the sizes needed. Common bituminized fibre conduit, such as is used for underground cable work, is a fair substitute, if it is turned down to a thin wall  $\frac{1}{8}$  in. in thickness. Cardboard, as purchased on the market, is not very good, as it absorbs moisture too easily. It may be boiled in paraffine, or a mixture of rosin and paraffine, and much better conditions obtained.

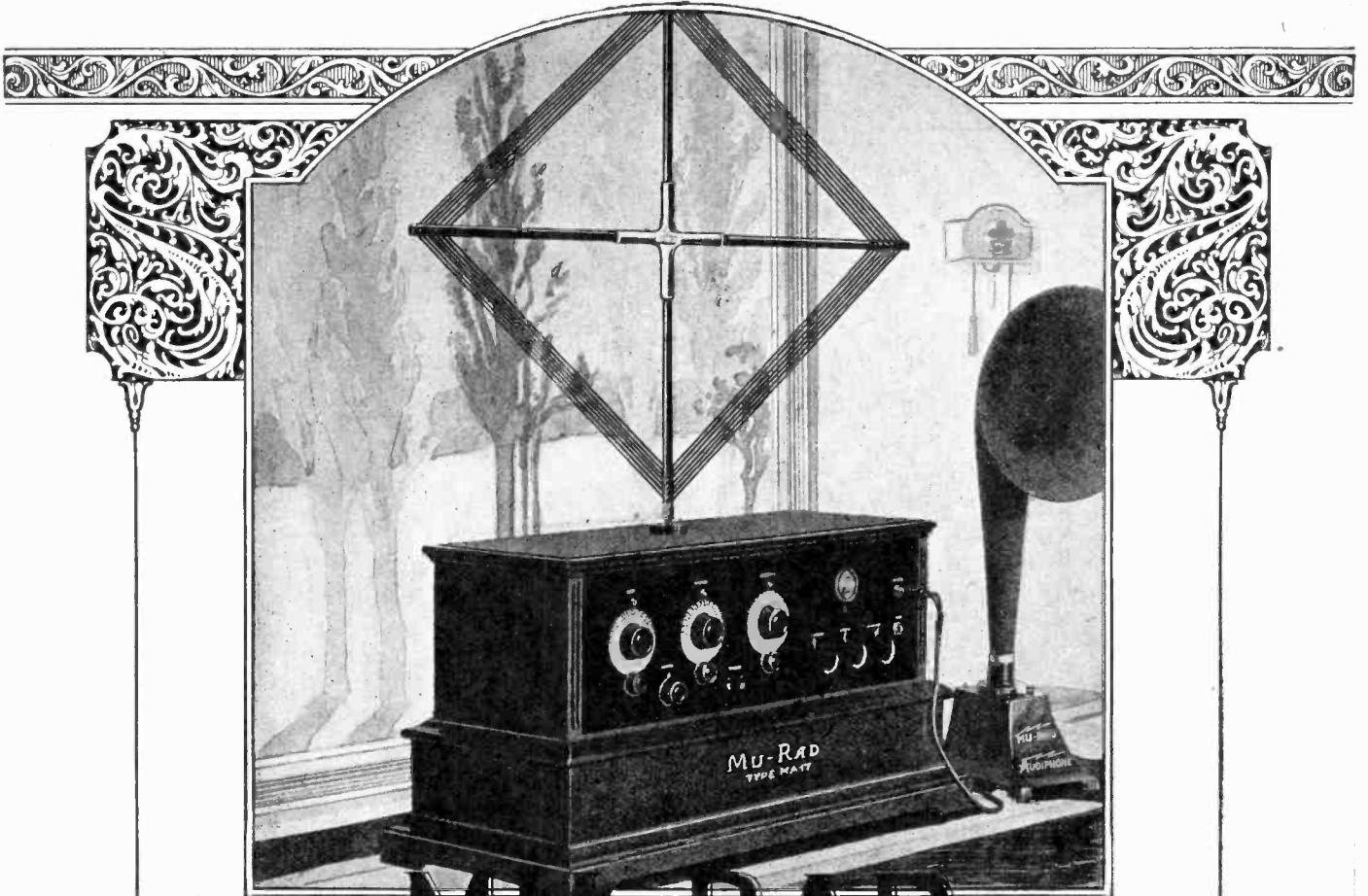

# MU-RAD RECEIVERS

## NEW MU-RAD RECEIVER MA-17

MU-RAD, in the vanguard of the radio art, once again blazing a new trail of progress. Years of scientific achievement anticipated in this *super set*, the MU-RAD MA-17. A new sensitivity, greater distance, fuller volume, with the absolute simplicity and substantial construction of the famous MU-RAD MA-13. Most recently discovered principles are embodied and developments of the future thoughtfully considered in the designing of the MU-RAD MA-17.

Three stages of radio and two of audio frequency amplification and detector. One tuning dial and two selecting dials, each independent of the other. Plug-in type r. f. transformers to care for changes of tube type or wave lengths. Panel-mounted volt-meter for quick reading of A and B batteries. Solid mahogany, Adam Brown hand-rubbed finish cabinet with loop fitted into top and compartment in base for "B" batteries. Guaranteed for 1000 miles reception using only a 2-foot loop.

WRITE FOR BOOKLET AND THE NAME OF THE NEAREST DEALER

**MU-RAD LABORATORIES, INC.**

806 FIFTH AVE ASBURY PARK, NEW JERSEY

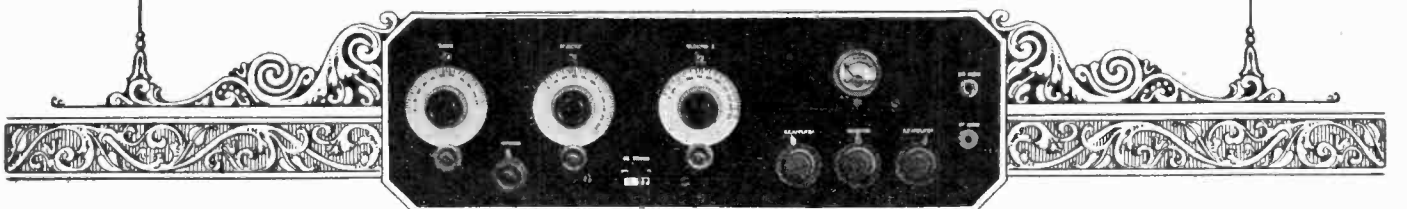

Tell them that you saw it in RADIO



# Tube Efficiency Is Trebled With Erla Synchronizing Transformers

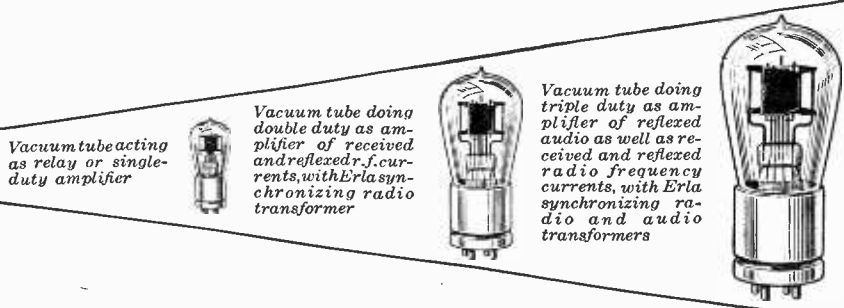

Vacuum tube acting as relay or single-duty amplifier

Vacuum tube doing double duty as amplifier of received and reflexed r. f. currents, with Erla synchronizing radio transformer

Vacuum tube doing triple duty as amplifier of reflexed audio as well as received and reflexed radio frequency currents, with Erla synchronizing radio and audio transformers

Responsible for the unduplicated efficiency of Erla reflex circuits is a basic Erla discovery of vital and far reaching importance.

Discordance and instability in reflex circuits, it has been ascertained, are due directly to failure of transformers properly to synchronize received and reflexed currents having the same phase characteristics, in their simultaneous passage through amplifying tubes.

Obviously, if the lag between such currents were as much as 180°, the net result of their opposing forces would be zero, resulting in an absolute canceling of signal strength. Any intermediate lag, on the other hand, results inevitably in the generation of amplified distortion.

Erla scientists solved this problem by designing radio and audio transformers of an entirely new and special type, positively assuring perfect synchronization of received and reflexed radio frequency, as well as rectified radio and reflexed audio frequency currents.

This achievement, enabling vacuum tubes successfully to do triple duty, as simultaneous amplifiers of radio frequency, reflexed radio frequency and reflexed audio frequency currents, marks one of the most important advancements of recent years.

For complete details, ask your dealer for Erla Bulletin No. 14, describing and illustrating perfected Erla one, two and three-tube reflex circuits. Or write us, giving your dealer's name.

**Electrical Research Laboratories**  
Dept. H 2515 Michigan Ave., Chicago

# ERLA



Perfect synchronization of received and reflexed r. f. currents make Erla radio transformers indispensable in reflex work. List, \$5



Rectified radio frequency and reflexed audio frequency currents are accurately synchronized by Erla audio transformers. List Price, \$5



Providing utmost sensitiveness with perfect stability, the Erla fixed crystal rectifier is uniquely adapted for reflex work. List, \$1

Jobbers—Unexampled sales opportunities are created by Erla leadership in research and manufacturing. Write for liberal terms and discounts

## TELEPHONY WITH AIRPLANES

*Continued from page 10*

Experiments in the course of maneuvers conducted by the Air Service have indicated that SCR-73 (meaning Signal Corps) spark sets are not comparable in effective ranges with those established by the SCR-68 radio-telephone outfits on Martin Bombers. The latter equipment have been successful in transmitting reports on positions in the air on two occasions by voice and buzzer modulation from Pearl Islands to France Field, 100 miles apart. The SCR-73 spark sets are installed on DH-4B airplanes, but their maximum communication range in the Panama Canal Zone has not been determined. The belief has been expressed, however, that their transmitting range from the air to France Field should approximate 150 miles. When installed on Martin Bombers this same type of Signal Corps spark set should have a transmission range of from 200 to 300 miles, according to one estimate.

Oddly enough, it would seem, radio apparatus installed in the Panama Canal Zone can only be kept in serviceable condition by constant usage. The corroding effect of the climate in the tropics is responsible for this unfortunate situation. For that reason, as well as the training and experience which is obtained by the personnel, frequent radio test flights are recommended in a report to the Washington office of the Air Service of the War Department. For instance, voice - controlled formation flights are recommended as weekly events, or at least twice a month, as a means of training the personnel in radio communication and aircraft tactics. Similarly, the diversity of radio communication which this last year surpassed all previous undertakings, might be repeated with frequency, such as tactical maneuvers, coast patrol, and field artillery spotting.

### Let Radio Experts Buy For You

Why hunt from store to store? Save time, trouble and money—a group of Radio Experts in New York will act as your personal representative, buy for you any standard make of radio equipment you want, from the smallest part to a complete set, either assembled or unassembled, and deliver it to you prepaid—all for less than if you did your own buying. Satisfaction guaranteed. Advice on all radio problems—free to our clients. Write for plan.

**PERSONAL SERVICE PURCHASING BUREAU**  
605 Fifth Ave., Desk 14, New York

### Ask your dealer for a Montrose Vernier Condenser

The condenser with genuine bakelite end pieces. Has positive contact between the vernier plate and main shaft. Will get the results where others fail.

Guaranteed to Give Entire Satisfaction

**MONTROSE MFG. CO.**  
1200 Bedford Ave., Brooklyn, N. Y.

## GERMAN HEADPHONES

### 6000 OHMS

Special Introductory Offer **\$8.50** Per Pair  
(Regular Price \$14.50)

WITH HEADBAND AND CORD

Made by Neufeldt & Kuhnke, Kiel, Germany

**C. H. RUBY** 4719 YGNACIO AVE. OAKLAND, CALIF.

### THE IDEAL HEADSET FOR DX RECEPTION!

Guaranteed to be superior to any Phone on the market or your money refunded without question.

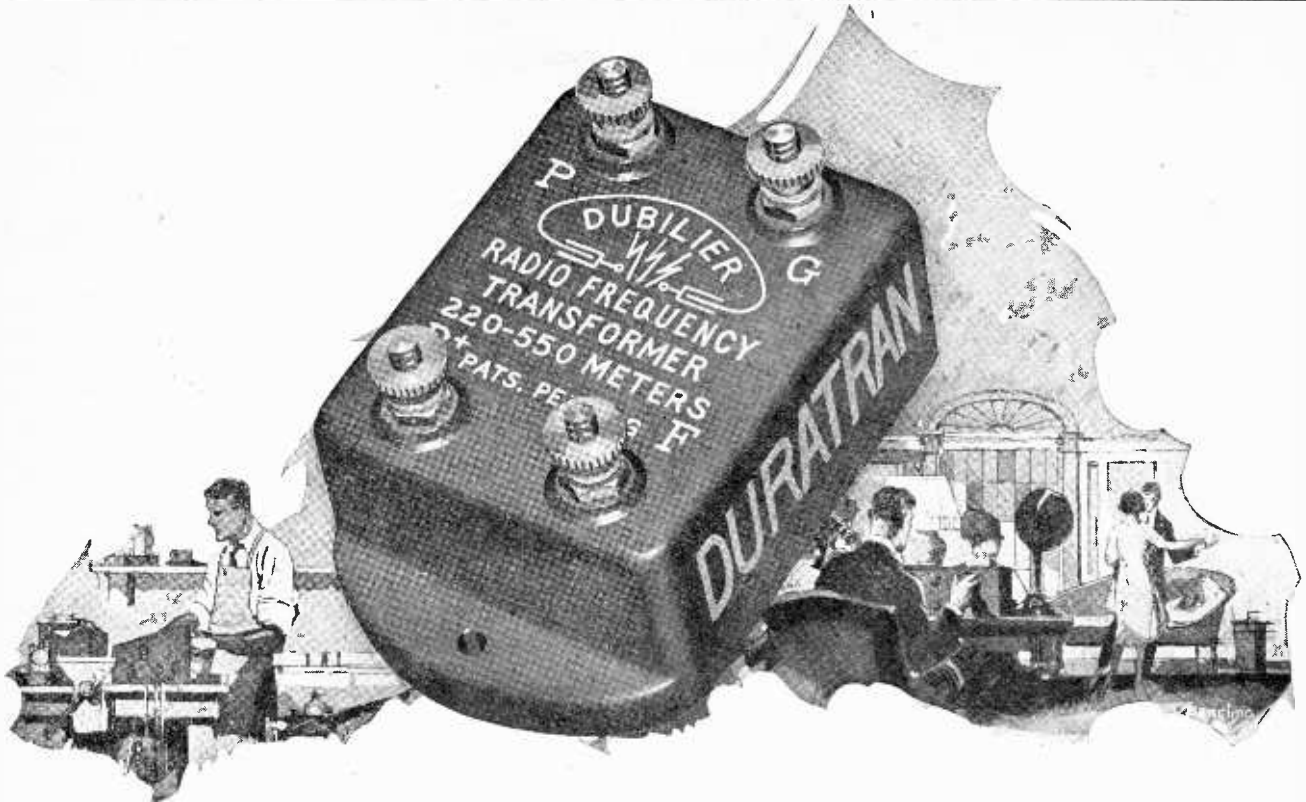

# The Dubilier Duratran *amplification on all wavelengths*

The Dubilier Duratran is the supreme radio-frequency transformer. It amplifies powerfully and uniformly *over all the wavelengths* now used by broadcasting stations.

*Price \$5.00—At all good dealers*

Write for free booklet on Duratran radio-frequency amplification

**DUBILIER CONDENSER AND RADIO CORP.**

48-50 West Fourth Street, New York

The Dubilier  
Ducon  
(Socket-plug)



Dubilier Micadon  
(Fixed Condenser)



Dubilier Variadon  
(Mica Variable  
Condenser)

# DUBILIER DEVICES

## THE WOMAN-HANDLER

Continued from page 21

the old-time deep-sea wireless operator I was telling you of, who is going to be your father's radio superintendent.

"Pleased t' meet'cha," I mumbles, dazed like.

"And I am ever so glad to know you, Mr. Jones!" exclaims th' angel, floatin' straight over to me an' donatin' me a smile that toboggans me forty times fu'ther into a trance than I already was.

"Do you know, I'm wonderfully interested in this idea of using girl operators on daddy's ships," she says, sittin' down alongside of me. "Indeed, the plan is all mine!"

"Is it?" I murmurs, half conscious like.

"Yes, you see, it's just going to be a little step toward bringing about the eventual recognition of woman's ability to wield her scepter in industry as well as in the kitchen; to take a dominant place in commerce instead of slaving her life away watering the rubber plant in the parlor; her right to drown as well as to vote! This is the age of the new woman, the super-woman, the woman who runs oil mines and coal wells,—and everything a man does! Isn't it wonderful!"

"Wonderful!" I mumbles, wonderin' if I have accidentally drunk a milk-can full a' hop.

"I'm so glad you feel about it as I do!" exclaims th' angel, wrapping another smile around me that gives me a sensation like I was walkin' on th' Milky Way. 'Tint glad, because I know that to choose and direct twenty-three women wireless operators for a fleet of ships will require one who thoroughly understands the feminine disposition, and who has a kindly sympathy for its little peculiarities—

"You'll find Mr. Jones a hundred-percenter on that score," old devil Cunningham assures th' angel, with a fiendish smirk I would have handed him a Dempsey fer, if I hadn't forgotten how to move. "Mr. Jones' experience with the fair sex has been, er—long and varied."

"Then I suppose it's all settled," replies the angel. "Papa says he wishes to see his new radio superintendent at his suite over in the Palace Hotel; so if you, Mr. Jones, will ride over with me in my limousine—"

THE trip with th' angel, from th' wireless trust's Woolworth tower over to th' Palace Hotel, in a rubber-tired boulevard Mauretania, seems like part of a corn-likker mirage; but when we arrives abeam th' lobby of this low-browed millionaire's lodging-house, I runs into somethin' that brings me out of my trance as sudden as th' drunken

## Another Radio Achievement

"For the Grid of Your Tube"-- Use

# GREWOL VARI-GRID

An exceedingly small enclosed vernier variable condenser, taking up but 1 1/4" on your panel and absolutely replacing all 11 and 23 plate condensers!

Two articles for less than the price of one. The Grewol Vari-Grid is especially adapted for use as a variable grid condenser, being equipped with a variable grid leak which can be removed if desired.

Every set needs at least one. You'll get a 100% improvement in distance and reception by using the Grewol Vari-Grid in your grid circuit. Try one in the aerial circuit too, and across the secondary. They work wherever ordinary condensers are used. And they have a vernier adjustment.

You've plenty of room for two on your present set. They take up so little room; only one hole to drill.

Write for folder

**RANDEL WIRELESS CO.**  
2 Central Ave., Newark, N. J.



At  
Your  
Dealer's  
or sent  
direct  
upon  
receipt  
of

\$2.25



**MOSS-SCHURY MFG. CO., Inc.**

Manufacturers of precision electrical devices. Radio division 2011-2015 Franklin St., Detroit U. S. A.

### Unequaled Clearness Thru a New Magnetic Principle of Construction

Lieut. Commander Raison, U. S. Navy, says: "I use your head-set in preference to others in experimental work."

Radio experts are enthusiastic boosters for this remarkable instrument.

DEALERS—Write today for discounts and descriptive folder.

# BROWNLIE CRYSTAL

FOR REFLEX OR CRYSTAL SETS



50¢

"Clear as a Bell"

Guaranteed Sensitive from Edge to Edge. Surpasses all synthetic substances and other crystal rectifiers. Withstands Heavy Plate Voltage.

Endorsed and Sold to the Leading Makers of Reflex and Crystal Sets.

Order From Your Dealer or Direct

**Roland Brownlie, Mfr.**

22-24 Saunders Street,  
MEDFORD, MASS.

Radio's Pioneer Crystal Maker

## Build Your Own HAZELTINE NEUTRODYNE with FREED-EISEMANN Licensed Essential Parts



Complete wiring diagram, instructions, etc. sent in special container with patented essential parts. Three NEUTROFORMER COILS

mounted on variable condensers, and DOUBLE NEUTRODON (as illustrated), sent for \$2.00. Ask your dealer to show you these parts, as well as complete assembled five-tube Neutrodyne Set in mahogany cabinet, Model NR-5, \$150.

Or send 25c for Neutrodyne Constructor which shows "How to Make the Neutrodyne"

**FREED-EISEMANN RADIO CORPORATION**

Tell them that you saw it in RADIO

ship's cook who woke up t' find th' crew's three-hundred-pound mascot black-bear cub standin' on his chest an' a bellerin' at him fer his breakfast. Fancy a sun-burned ol' southerner, about six foot two, wearin' a big, wide black hat, china-crockery blue eyes, an' a reddish race-track-gambler's mustache, which is droppin' around a bad-smellin' stogy—Colonel Gorgon Belleclair!

"Befo' we go any fu'thuh, there's one thing I'd have yo'all tuh understand, suh," he announces, haughty like, after he has run th' angel out a' th' lobby. "Fo' my part, I don't approve o' usin' women and gals on ouah ships fo' radio operatuh, a'tall, suh!"

"Neither do I!" I declares, fervent like. "If you ask me, it's a helluva idea—"

"Take care, suh!" breaks in th' colonel, his cold blue eyes strikin' fire. "It's my dawtuh's plan, an' when yo' criticize my dawtuh, yo' criticize me, suh!"

"Scuse me—suh!" I says, meek-like, wonderin' if th' old rebel is harborin' a big long-barreled six-shooter.

"What I was about tuh say, befo' you'all interrupted me," resumes th' colonel, "is that if yo' accept this position, yo' got tuh run it with a' iron hand, suh! Yo' got tuh make yore operatuh gals toe the mark! Ouah radio service in the Tropical American is pufect, and if yo' fail tuh keep it thataway, I reckon tuh hold you'all responsible, suh!" He glares at me, menacin' like.

"Well, I ain't no Napoleon, so I guess this is my chance t' back out—" I starts to say; but just then I discovers th' angel smilin' at me from a' opposite balcony. Now, as I was sayin', I ain't no Bonaparte, but when anybody tries t' bawl me out or make me take back-water in front of a woman, it makes me goatier'n a Durham bull with a red handkerchief pinned to his nose an' a hornet under his tail.

"Say, look here, Mr. Colonel Gorgon Belleclair!" I flares up, hard-boiled like. "I ain't scared of your darned old job! I'm a takin' it, an' by th' holy harps, I'll run it, too, or—or break twenty-three mineral-lavaed necks!"

**D**URIN' th' trip south from Frisco to New Orleans, I have no chance t' get to feelin' sorry fer myself, because old Colonel Belleclair has me ride in his own private Pullman, an' th' angel shines up t' me all th' way like strawberries an' lemon-cream pie.

Time we arrive in th' Crescent City, I'm feelin' pretty interested; but this is nothin' to next mornin', when th' colonel takes me around to th' twenty-story Tropical American building down on th' main cow-path an' introduces me to my private office. I grabs a slant at my J. Pierpont mahogany desk, an' thick



*Natural Re-PRODUCTION*

# Atlas AMPLITONE LOUD SPEAKER

FOR Christmas give the radio enthusiast his fondest expectation—a perfect radio re-PRODUCER, the *Atlas Loud Speaker*. Natural re-PRODUCTION, identical with the original in the broadcasting studio. The patented "double diaphragm" responds uniformly to the full range of sound intensities. Adjustable to each individual set and receiving conditions. The *Atlas Loud Speaker* is a gift to an entire home. Hear the *Atlas Loud Speaker* at your dealer's.

TRADE MARK

*Letters from Users Requested*

The remarkable re-PRODUCTIONS of *Atlas Loud Speakers* makes every owner enthusiastic. "Musical experts," writes a man in St. Paul, "have pronounced it the clearest reproduction they have ever heard." What results have you accomplished with your *Atlas Loud Speaker*? Write us about them—TODAY.

**WARNING! Be sure you get the genuine *Atlas Loud Speaker* with our red tag factory guarantee!!**

**List Price \$25**

**Write for Booklet "E"**  
Contains Helpful Information

Distributed in California by  
**LEO J. MEYBERG CO.**  
973 Mission Street  
San Francisco, California

Sole Canadian Distributors  
The Marconi Wireless Telegraph Company of Canada, Limited

MANUFACTURED BY  
**Multiple Electric Products Co. Inc.**  
ORANGE ST. RADIO DIVISION NEWARK, N. J.

## LEARN THE RADIO CODE

*in 3 hours or less by the CORYDON SNYDER CODE METHOD*

Copyrighted and Patent applied for

ONE PURCHASER SAYS:

"I did not have much faith in your advertisement and when I received your method I was still more doubtful. However, I went at it and in one hour I memorized the Code completely. You certainly have a great method and I wish you the greatest success." (Name upon request)

This home study course sent post paid upon receipt of 50c, stamps or coin.  
Or, send stamp for particulars, to

**Corydon Snyder, 1161 So. Ridgeland Av., Oak Park, Ill.**

Tell them that you saw it in RADIO



## SIGNALING

CONSIDER the vast difference between the methods of the savage and the marvellous broadcasting of today. This difference can be stated in one word—instruments.

Modern broadcasting employs delicate instruments to transform messages into electricity. Satisfactory reception requires equally fine apparatus to translate this current into the original music or spoken word.

Upon your loud speaker or head phones falls the task of transforming the electric current that flows through our set into sound. Poorly designed or carelessly constructed instruments cannot do this with satisfaction to you.

Holtzer-Cabot Phones and Loud Speakers are the perfected results of 25 years' specialization in the manufacture of sensitive electric apparatus.

Holtzer-Cabot Loud Speaker,	\$25 00
No. 2 Universal Head Phones,	9 50
No. 4 National Head Phones,	6 00

Write for booklets "What you should know about Radio Reception" and "A better Loud Speaker."

THE HOLTZER-CABOT ELECTRIC CO.

125 Amory Street, Boston, Mass.  
6161-65 South State Street, Chicago, Ill.  
Department C

*Holtzer-Cabot*  
BUSINESS ESTABLISHED 1875

HEAD-SETS

# RADIO INSTITUTE OF AMERICA

## TRAINING IN ALL COMMERCIAL BRANCHES OF RADIO

If you cannot attend the Radio Institute of America in person the same instruction can come to you through our recently inaugurated "HOME STUDY COURSE"—Investigate.



Detailed information free on request.

Conducted by

THE RADIO CORPORATION OF AMERICA

331 Call Bldg.  
98 Worth St.

Phone Douglas 3030  
Phone Franklin 1144

San Francisco, Calif.  
New York City

Tell them that you saw it in RADIO

leather chairs, a swell wide window overlookin' th' city an' th' river-piers below, where two big white Tropical American passenger liners are lyin', an' over close by, a pretty green park, in which is the two high steel towers an' th' fine concrete buildings of th' fruit company's powerful city wireless station—say, fancy a hard-fisted old key-puncher like me, who's been rollin' around on th' Pacific fer twelve years scoffin' boiled mule, bein' turned loose in a joint like this!

"Old King Tut was a piker alongside a' you, Samuel Jones!" I remarks to myself, as I sit down in my Kaiser Wilhelm chair an' use my desk-top fer a lookin'-glass t' part my hair in. "This is sure what I call th' hod-carrier's monacles! Ahem! Har-r-rumph! Bring on them lousy wimmen!"

I soon realizes, however, that bringin' 'em on is also part of my job. Where I'm going to find twenty-three females with first-class commercial radio operator licenses looks like a stumper. Leanin' back in my chair an' hoistin' my hoofs up onto my green desk-blotter, I rolls a smoke an' thinks it over a while.

"An ad in a wireless magazine would get 'em," I tells myself, "but I want quicker action. I guess a little display in th' radio sections a' some of th' New Orleans an' New York newspapers is my best bet. Now fer some ad-copy—I wonder if I rate a stenographer around this joint!"

Catchin' sight of a row of pearl buttons on my J. Pierpont, I pushes one of 'em, thinkin' to myself that I hope it don't work a fire-bell or bring a policeman. Pretty soon, I hears th' door open, an' a girl's voice says:

"Did you ring for me, sir?"

"Yeh, you bet!" I says, blowin' out a cloud of cigaret smoke an' gazin' off out of th' window, with a mien like I was th' sultan a' Turkey. "Ahem! Har-r— Woman, take some dictation!"

Hearin' a soft little laugh behind me, I wheels around like a shot, an' who does I see standin' in th' door, with a stenographer's scratch-paper gadget in her lovely hand, but—th' angel!

"Umph!" I gasps, so surprized that I tries to stand up with my feet on my desk, an' nearly break my neck. "Say, whadd're you doin' here!"

"Why, I'm your private secretary!" laughs th' angel, comin' over an' standin' in front of me, happy like.

"Well, I'll go to Hades!" I sputters, saggin' down in my chair.

"It'll be for only a little while!" exclaims th' angel, lookin' at me anxious like. "As soon as you've taught me enough radio to get a commercial license, I'm going to be a wireless operator, too, on one of daddy's big ships—a—don't you want me for your stenographer?"

Continued on page 56





# Sodion



## A New Era in Radio

THAT, in the fullest sense of the word, is what the SODION TUBE means to everybody who owns or expects to own a receiving set.

Based on an entirely new principle—utilizing the highly valuable and peculiar properties of the sodium ion

## The Sodion Tube

(Sodium-Ion)

is many times more sensitive and produces far stronger signals than any detector yet developed.

Due to the fact that it cannot be made to oscillate, it not only eliminates any semblance of whistles or beat-note howls in your own reception, *but does not interfere with the reception of others.*

At a meeting of the Institute of Radio Engineers where this tube was being demonstrated, a prominent Scientist and Radio Engineer, in contrasting this with the action of the ordinary detector, dubbed it.

### “THE GOLDEN RULE TUBE”

Stable and uniform in operation. Runs for hours without adjustment. Has no grid. No grid leak or grid condenser are required. Crystal tone reception. Unusually sensitive to weak signals. Operates on dry cells or storage battery.

*Bulletin A-100 describing this tube upon request*



**CONNECTICUT**  
MERIDEN

TELEPHONE  
& ELECTRIC

Radio Division

**COMPANY**  
CONNECTICUT



Tell them that you saw it in RADIO

# New York Coil Company's Radio Products

Are leaders everywhere in quality,  
ease of installing and utmost efficiency

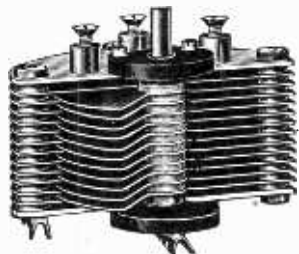

11 Plate... \$1.50  
23 Plate... 2.00  
43 Plate... 3.00  
3 Plate... 1.25



Supplementary Vernier  
Condenser—\$1.00

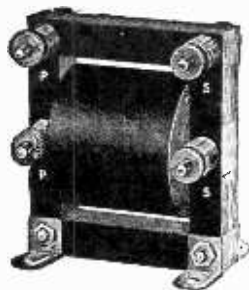

Amplifying  
distortionless  
Transformers,  
correct for any  
tubes.

Price \$4.00



Precision  
Variable Grid Leak  
Price \$1.50

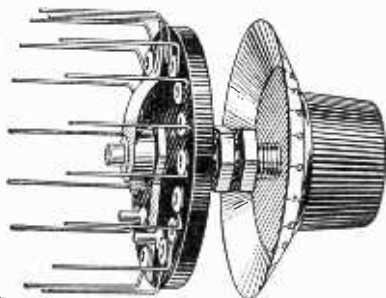

Inductance Tap Switch, but one hole  
to drill, furnished with 15 wire con-  
nections. No soldering. Price \$1.50

Our Variometers and Coup-  
plers are large, full size in-  
struments—correct for com-  
plete broadcast range. Mica Fixed Condensers—all

capacities.

## New York Coil Company

338 Pearl Street

New York City, N. Y.

Pacific Coast—MARSHANK SALES CO., 1240 S. Main St., Los Angeles, Calif.

## Marle Transformers

Audio and  
Radio  
Frequency

Superior  
Quality  
Reasonably  
Priced

Ask Your Dealer!

Manufactured by  
MARLE ENGINEERING CO.  
Orange, N. J.

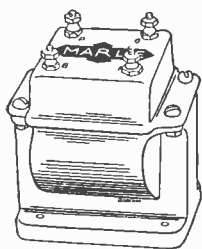

## BROADCAST PROGRAM

A weekly magazine devoted  
to Western Broadcasting.

5c per copy.  
26 issues for \$1.00.

BROADCAST PROGRAM

449 Pacific Bldg.  
San Francisco, Cal.

Continued from page 54

"Do I!" I busts out, sittin' up like old kid Antone bein' offered a ham-sandwich by Cleo. "Do I! Say, angel, you can be my stenographer fer life—

Realizin' that I am sayin' somethin' that might be took a couple a' different ways, I stops off short, an' begins feelin' hot under th' ears.

"Oh!" exclaims th' angel, blushin' like a sunset, an' lookin' down at th' carpet. "I—a—did you wish me to take some dictation, Mr. Jones?"

THE next day our copy is in th' newspapers, together with a bunch a' witty cracks in th' radio sections about th' impendin' feminization of th' Tropical American Fruit Company's steamships. Th' stuff is all good advertisin', an' within twenty-four hours it begins to work like a barrel full a' yeast an' hops.

Th' first one to appear on th' scene is a goofy-lookin' synthetic blonde with scraggly bobbed hair an' froggish eyes.

"I'd just love to be a radio operatress on one of your big ships!" she gushes. "I've watched them leave from the Canal-Street thing—dock, I mean, ever so many times; so I know all about them. It must be grand to wear those funny little black ear-muffs and listen all day long to the love messages flying through the ether—"

"Ahem!" I says. "Har-r—

"I'm sure I'd look perfectly splendid in a suit with gold bands and stars!" rushes on Miss Frog-Eyes, plasterin' a slushy smile onto me that makes me feel like a disgustin' long-haired poodle has licked me in th' face. "How romantic it will be to promenade at sunrise with the captain, and maybe— Indeed, I just love boats—oh, I'm fairly wild to stand up on that high deck thing and watch the big waves float by, and send O-S-O, when the ship starts to sink—

"Hey, woman, look here!" I barks out, bristly like. "I want t' ask you a question! Have you got a license?"

"License!" she repeats, kind of chilled like. "What's that—do you mean a marriage lic—o-o-o-h! Do I get a husband, too, if—

"No chance!" I snaps, "but you'll git lockjaw, if you don't rest your trap a little! Don't you know that before anybody can be a radio operator on a passenger liner, or on any other ship, they've got t' pass a stiff examination from Uncle Sam an' git a fancy bill-poster from him showin' they know th' difference between a push-button an' a poker-chip! If you haven't got a first-class, first-grade commercial radio operator's license—

"Oh, but I don't need that!" Miss Frog-Eyes sticks in. "I'm just too competent for anything—really! We have a swell radio at home we got for twelve

Continued on page 58

# New "Town and Country Set"

By Dr. Fulton Cutting and Mr. Bowden Washington

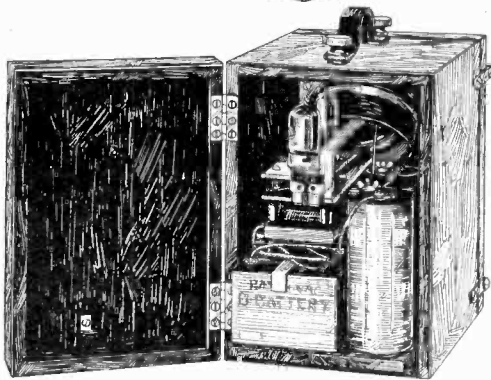
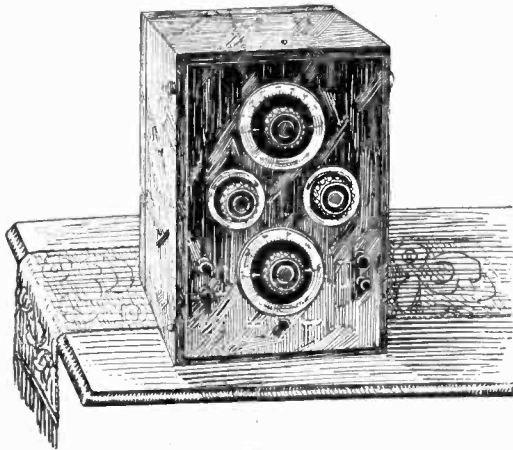

At last, a successful all-purpose receiver. Out of the years of experience of Dr. Cutting and Mr. Washington has come this "Town and Country" model—a portable that you can carry with you when and where you wish—yet the perfect set for your home.

In your home, without the carrying handle, "Town and Country" is a handsome 2-tube, *double circuit* cabinet set, highly selective, range up to 1200 miles, capable of operating a loud speaker for local or near-by stations.

*and then, at a turn  
of a switch—*

it becomes a 2-tube, *single circuit* portable set—ready to operate on any sort of *temporary antennae*—a wire around the top of your car—stretched along a tent top—or across the room in the home of a friend.

It's the complete all-purpose set—no compromise. Self contained—uses dry batteries—LARGE dry batteries that last. It's complete with Brandes Head-set—ready for antennae and ground wires when you get it—ready to give you "what's in the air." Price, \$97.50. See it at a C & W Dealer's—or write for literature.

Cutting & Washington Radio Corp.  
Minneapolis, Minn.

OPERATING STATION WLAC

For more than 10 years Dr. Fulton Cutting and Mr. Bowden Washington have been designing the highest type of professional radio equipment—U. S. and Foreign Naval Apparatus, Radio for the U. S. Merchant Marine, U. S. and foreign land stations. And now, they have turned their attention to *Radio for the Home*—you can own a genuine C & W Receiver—know the simplicity, ease of operation, sharp selectivity and clear reception that characterize the best professional equipment.

## Cutting and Washington

Standard of Excellence in Radio Since 1914

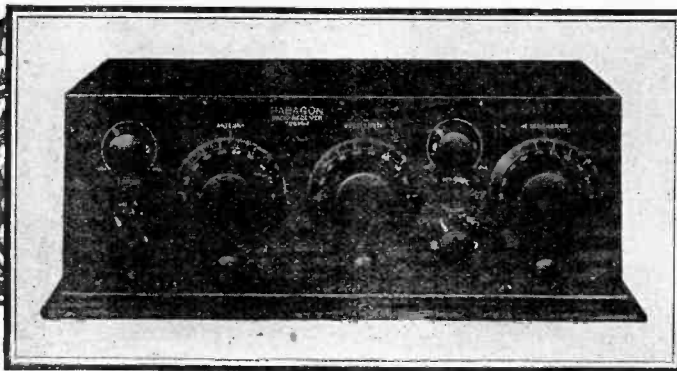

Type RB-2

Price \$135.00

## Announcing a New Paragon Receiver —the Ideal Family Christmas Gift

What could be a more wonderful Christmas gift than a radio receiving set that you *know* is the best that money can buy? Think of the pleasure it will bring to every member of the family, young and old. Think of the happiness it will mean to you every night of the year.

PARAGON Radio Receivers are famous as the three circuit pioneers which have proved their superiority by eight years of practical operation.

The newest PARAGON, pictured above, is the last word in sensitivity and selectivity. The superiority of this type over all other classes of receiving equipment has been thoroughly proved by the long list of distance records which it holds. Included in these records are the reception of the first transcontinental amateur message, the reception of the first trans-Atlantic message, and the unbroken communication which it has maintained with the McMillan Expedition frozen in above the Arctic Circle.

The operation of the new PARAGON receiver is so materially simplified that even in the hands of a novice it equals in every way the performance of the older type in the hands of an expert.

You need only switch on the tubes, set the calibrated dial and turn two other dials that automatically give you their proper position for the reception of any given broadcasting station.

In appearance it is an addition to any home. All cabinet work is of mahogany with a brown mahogany finish. All metal parts showing, inside as well as outside of the cabinet, are nickel plated. 98% of the wiring is invisible. The whole outfit is compact, neat, solidly built, and finely finished. It is the ideal Radio receiver and the ideal holiday gift.

*An illustrated Catalog of Paragon Radio Products  
is yours for the asking*

*Dealers: We believe in the proper distribution of Paragon Radio Products. Our Exclusive Distributors are particularly interested in territorially protected dealers, who will concentrate, solicit and serve the consumer in the sale of Paragon Radio Receivers. If interested, write us for details.*

ADAMS-MORGAN CO., 2 Alvin Avenue, Upper Montclair, N. J.

*Pacific Coast Sales Representative:*

*Paul Sutcliffe, Room 400, San Fernando Bldg., Los Angeles, Cal.*

# PARAGON

Reg. U. S. Pat. Off.

## RADIO PRODUCTS

*Continued from page 56*

Shux washing-powder coupons, and I learned on it. I know how to put in new glass pretties when the old ones go out, and I can turn the—the tuner battery or the tickly aerial thing—isn't it? I held the nails while papa fixed up the ground pole on our house, and I'm the only one in our family who can tell every jazz piece that comes out of the Maggie's-Voice—

By this time, I've punched three or four of th' pearl buttons on my J. Pierpont, which brings my office boy, a bud-din' Jack Johnson as black as a coal mine on a rainy midnight.

"Here, Whitewash!" I says to him. "Take this rattle-trap down an' set it on th' ash-can till its main-spring un-winds; then send it home!"

Th' kid drags out th' rusty peroxide lady Marconi, only to return with another female freak—a little skinny runt with a chalky white face, like a wax doll molded by a bolshevik toy-maker aimin' at sabotage.

"Humph! I s'pose you're another Jack Binns, ain't ya?" I slings at her, right off th' bat. "What funny little tickly things do you know how t' turn?"

"Not any!" she flares back at me, like a little spit-cat.

"No!" I says, surprised. "Haven't you got a' oatmeal coupon radio receiver?"

"I have not!" hisses Miss Spit-cat. "I make up the musical programs for the radio concerts broadcasted by Hamburger's Home Friend Furniture Company!"

"Oh, you don't say!" I observes, impressed like. "That's great, all right,—but if you haven't got a first-class, first-grade—"

"I have!" snarls Miss Spit-cat, stickin' under my nose a fresh, new operator's ticket with th' ink still wet on it.

For a second, I stares at it.

"Well, I'll go to Hades!" I splutters. "An' here I used t' think radio inspectors was honest men!"

"Leave your name an' address with my African door-pilot as you go out," I tells her. "Next!"

"Heah's Miss Rebecca Levy, sah!" announces Whitewash, leadin' in a waddling squashy pumpkin with a little King Tut sky-piece on her bean, an' a Palestine glister all over her.

"Kindly, mister, how much is the selery for lady wirelesses?" she asks, as she comes to anchor abeam my J. Pierpont.

"Hundred an' twenty-five for chiefs, and ninety for seconds," I replies, business-like. "Have you got a first-class, first—"

"I'm a chief!" announces Miss Levy. "Do I get my rooms and board from this job, or must I bring my own pretzels—"

"We'll feed ya!" I tells her. "Pork

*Continued on page 60*

Member  
Radio Section



Manufacturers  
of Electrical  
Supplies

# Make this a Radio Xmas

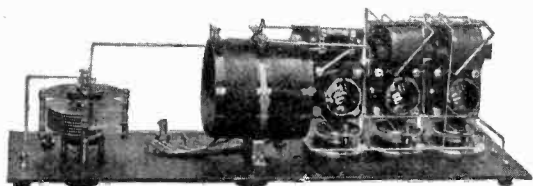

TYPE AD2 SHORT WAVE RECEIVER..... \$49.00  
150 to 630 Meters—Knock Down Form only

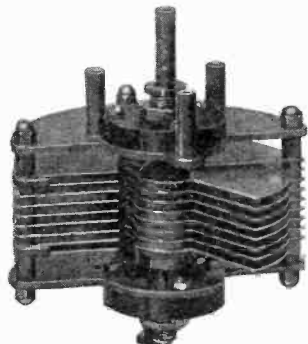

- Cat. No. 200 3 Plate (.00005) \$3.25
- Cat. No. 184 9 Plate (.000175) \$3.75
- Cat. No. 111 11 Plate (.00025) \$4.00
- Cat. No. 185 17 Plate (.00035) \$4.25
- Cat. No. 190 23 Plate (.0005) \$4.50
- Cat. No. 186 35 Plate (.001) \$5.00



No. 193  
Vernier  
Adjuster  
\$0.35

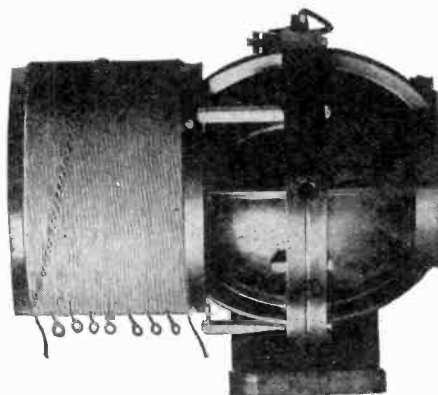

No. 165..... \$13.00  
Se-Ar-De Radiometer with  
B. W. Inductance

*Orders Placed Now Will Be Received  
in Ample Time for Your Holiday Trade*

**R. MITCHELL CO. :** 255 Atlantic Avenue  
Boston, Massachusetts

For 47 years Manufacturers of Scientific and other equipment  
Look for trade mark on every piece

Jobbers and Dealers write for discounts  
Cable Address—Searde-Boston

PACIFIC COAST OFFICE  
EXPORT OFFICE

709 Mission St.,  
44 Whitehall St.,

San Francisco, Cal.  
New York, N. Y.



**Turn the knob  
Select the station  
you want to hear  
on indoor antenna or loop**

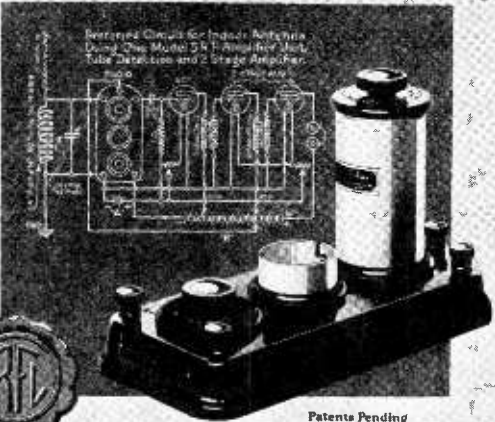

**Radio Frequency  
Amplifier Unit**  
with BALLANTINE  
**Variotransformer**  
*Fits Your Set*

Add one or more stages of R. F. amplification to your present set—be it home-built or manufactured. Complete, with socket, rheostat and variotransformer. \$15.00 at dealers, or postpaid.

*Limited edition of "Radio Frequency Amplification with the Ballantine Variotransformer" a 25-page booklet—mailed free on request.*

**BOONTON RUBBER MFG. CO.**

*Pioneers in making Radio parts of Bakelite*

424 FANNY ROAD

BOONTON, N. J., U. S. A.

**"EURACO PRODUCTS"**

(Guaranteed)

Compact — Interchangeable — Accurate  
Most Efficient



Price 40 cents per Unit  
Mfgs. of

**MICA CONDENSERS, GRID LEAKS,  
MOUNTINGS**

*Interesting Proposition for Dealers*

**European Radio Company**

1342 East 22nd Street Brooklyn, N. Y.

**"B" BATTERIES**

AN

**EVEREADY**

PRODUCT

43V. Batteries, tapped.....\$5.00  
22½V. Batteries, Navy Type..... 3.00  
22½V. Batteries, Commercial Type..... 2.00

Latter two types especially adapted to  
Cunningham and Radiotron Tubes.  
Postage Prepaid Anywhere in U. S.

**ETS-HOKIN & GALVIN**

Wireless Engineers

10 Mission Street

SAN FRANCISCO

*Continued from page 58*

sausages three times a day, an' fried ham on Sundays! Leave your license with th' boy as ya go out! Ahem! Har-r-rumph! Bring 'em on, Whitewash! Bring 'em on!"

"Miss Minoiva Plum, sah!" sings out Whitewash.

"How deeu yeeu deeu!" says a shrill female voice, like somebody draggin' a file across a rusty tomato can.

Turnin' around, I sees standin' in th' door, loaded down with valises, hat-boxes, an' a wire cage with a big green parrot in it, th' original skinny Old Maid, like what you see on th' little girls' playin'-cards. Under a lid that was out a' date on th' Ark, she's has a bunch a' false hair done up in curls an' bangs, while her horrific map would strike a Patagonian turtle with locomoter ataxia.

"He's single!" screams her parrot, lookin' hard at me.

"I'm pleased teeu meet yeeu!" she simpers, oglin' at me until I get a sensation like I'd put myself outside of a couple dozen newlywed's bakin'-powder biscuits. "Are yeeu the gentleman who is hiring girrls for the Tropical—"

"Yeh—girrls!" I breaks in. "I ain't runnin' no antic-shop, though!"

"I've brought my licenses," she says, settin' down her junk an' producin' a new ticket along with a sheaf of expired ones big enough to choke a snowshed. "I've been a radio fan ever since—"

since—  
"Ever since radio was invented," I remarks, lookin' over her bundle of faded, dusty waste-paper. "I guess you're there, all right. I'll tell you what I'll do. I'll give you an assignment right now as chief operator on the *Pastores*, the Tropical America's thirty-thousand-ton flagship. How's that?"

"He loves you!" shrieks her fool parrot, startin' to flop around in his cage, excited like.

"Oh, wonderful, reely!" titters Miss Minerva Plum, sweet as a squeaky wheelbarrow. "But—a—tee-hee, I'm just a young innocent girl and I—a—tee-hee—do I have a chaperone?"

For a second I stares at her.

"Chaperone!" I barks. "Well, I'll go to—say, woman, don't be so dumb! You need a chaperone like a oyster needs a' auto-strop! Take your trunk out a' here an' git aboard th' *Pastores*! I s'pose all th' passengers will jump overboard when they git a slant at ya, but that ain't my war-debt! I'm here t' hire wimmen brasspounders, an' by th' holy golden harps, I'm a hirin' 'em! Ahem—"

"Aw reservoir, sweet papa!" sings out th' parrot.

*Continued on page 62*

Tell them that you saw it in RADIO

# Radio Catalogue Free—

**Write us  
a post card—**

**Address Dept. 39-R**

and we will send you free this 52 page catalogue of radio sets and parts. It also contains explanation of radio terms, map and list of broadcasting stations and much radio information, including an explanation of successful hook-ups and circuits.

You will be amazed at the low prices Ward's quote. A complete tube set having a range of 500 miles and more, including tubes, head set, batteries, and antenna equipment, as low as \$23.50.

This catalogue contains everything for the expert and amateur. Complete sets and every improved part for building sets, all the most up-to-date devices—at the lowest possible prices.

## Headquarters for Radio

Montgomery Ward & Co. is headquarters for Radio, selling everything direct by mail without the usual "Radio-profits." Why pay higher prices? Ward quality is the best and the prices will often save you one-third. Everything sold under our Fifty Year Old Guarantee,—Your Money Back if You Are Not Satisfied. Write today for your copy of this complete 52-page Radio Book.

**Write to our house nearest you. Address Dept. 39-R**

**Chicago    Kansas City    St. Paul    Portland, Ore.    Ft. Worth**

# Montgomery Ward & Co.

**The Oldest Mail Order House is Today the Most Progressive**



This trademark

is  
on  
all



# RADION Panels

It absolutely guarantees you the lowest phase angle difference, the lowest dielectric constant, the highest resistivity, and supreme moisture, gas and acid repelling properties.

Eighteen stock sizes, all with the trademark.

These leading manufacturers  
of CONDENSERS adopted  
RADION ENDS

6x7	6x10 1/2	6x14
6x21	7x9	7x10
7x12	7x14	7x18
7x21	7x24	7x48
9x14	10x12	12x14
12x21	14x18	20x24



Amsco Products, Inc.  
Commercial Screw Machine Prod. Co.  
Elgin Tool Works, Inc.  
Freed Eiseman Radio Corp.  
General Radio Co.  
Heath Radio & Elec. Mfg. Co.

Jewett Mfg. Corp.  
S. S. Novelty Co.  
Pacnet Electric Co.  
Superior Instrument Co.  
Thompson Levering Co., Inc.  
Workrite Mfg. Co.

because RADION is the best possible insulation against current losses in high frequency reception.

**American Hard Rubber Co.**  
11 Mercer Street, New York

# RADION

*Panels - Dials - Knobs - Sockets - Insulators*

*Continued from page 60*

ABOUT a week later, one day durin' th' noon hour, I takes a stroll down among the flowers an' palms in th' pretty park where th' Tropical American's big wireless station is located. Driftin' along as unconcerned like as a London duke goin' t' tea, I runs smack onto my stenographer angel sittin' on a bench an' holdin' hands with a tall, good-lookin' young fellow, who I can see thinks a lot of her.

Feelin' like I have been slashed through with a meat-axe, I starts backin' off, glarin' green-eyed; but just then th' angel sees me, an' jumpin' up, she says:

"Oh, Mr. Jones, won't you meet my brother, Billy!"

"Er—pleased t' meet'cha," I says; feelin' relieved as th' Yiddish pawn-broker when he woke up after dreamin' somebody has stole a hatful a' diamonds off of him. "I never knew Gloria had a brother, before!"

"No, I—you see, I never mention him when daddy is near," says th' angel. "He's been disinherited for being engaged to marry the daughter of Major Graham Ramsey, a part owner of the Tropical American Fruit Company, and a deadly enemy of papa's."

"One's a rebel an' th' other a Yank, I s'pose," I observes.

"No, Major Ramsey is a southerner, too," replies the angel. "They've hated each other frightfully ever since they were boys, when they both wanted to marry a vampy French actress. They haven't spoken for thirty years, on account of her."

"Humph! An' then old John Bacon or some other dumbell had th' crust t' say that money is th' root a' evil!" I remarks, sardonic. "Which one won her?"

"Neither," answers th' angel. "She married a plumber, instead."

"And now she's got six kids, and's as fat and ugly as an old hippopotamus!" adds th' brother, glum like.

"Billy is sailing third mate on our big liner, *Pastores*," says Gloria. "But daddy doesn't know it. If he should find out—"

"These old dynamite-tempered colonels an' majors git my goat!" I says to Billy. "Why don'tcha go ahead an' marry th' jane, anyway?"

"Yes, why not, Billy!" exclaims Gloria.

"But how can I!" wails Billy. "She's a millionaire's daughter, while I'm only a penniless sailor who may get fired tomorrow! It wouldn't be right!"

"I wonder," I says, lookin' into th' angel's eyes, "I wonder what your old hell-raisin' pop would do if I—if we—" but she starts blushin' like a house afire, an' I didn't have th' nerve to say the rest.

Returnin' to th' Tropical American

*Continued on page 64*

# AMPLION

*The World's Standard Loud Speaker*

## You Never Tire of the Amplion

THE most striking thing about the Amplion is that its reproduction is never tiring. Its perfect rendition, absence of harshness gives you a thrill that is pleasing and refreshing.

No matter if it's voice or instrument, the charm is there. The message has lost nothing in its flight through space. It holds you and enthral you just as if you were listening to the original.

The Amplion is made in several sizes to suit all occasions and pocket books from \$18.00 for the Junior model to \$66.00 for the Concert type.

Ask your dealers to let you hear the Amplion. You owe it to yourself to hear the world's standard loud speaker before you buy.

Folder of styles and prices on request.

*Patentees:*  
*Alfred Graham & Company*

### Signal Electric Mfg. Co.

Sole U. S. Distributors Menominee, Mich.

BURNDIPT OF CANADA, Ltd.

*Canadian Distributors*  
172 KING STREET, W.,  
TORONTO

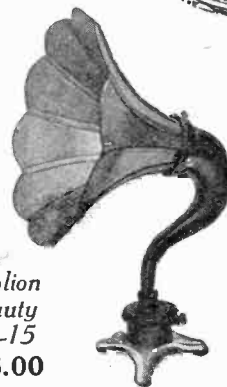

*Amplion  
Beauty  
AR-15  
\$46.00*

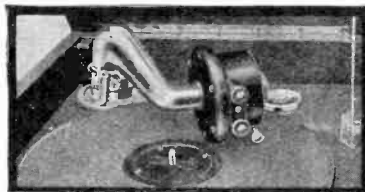

*Phonograph Unit  
AR-35—\$24.00*

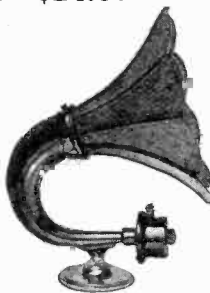

*Amplion  
Dragon  
AR-19  
\$40.00*



*Amplion Junior De Luxe  
AR-43  
\$26.00*

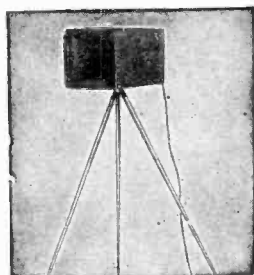

*Amplion Portable  
AR-61—\$50.00*



*Amplion  
Junior  
AR-39  
\$18.00*

*The Supremacy of the AMPLION is the Supremacy of Actual Performance*

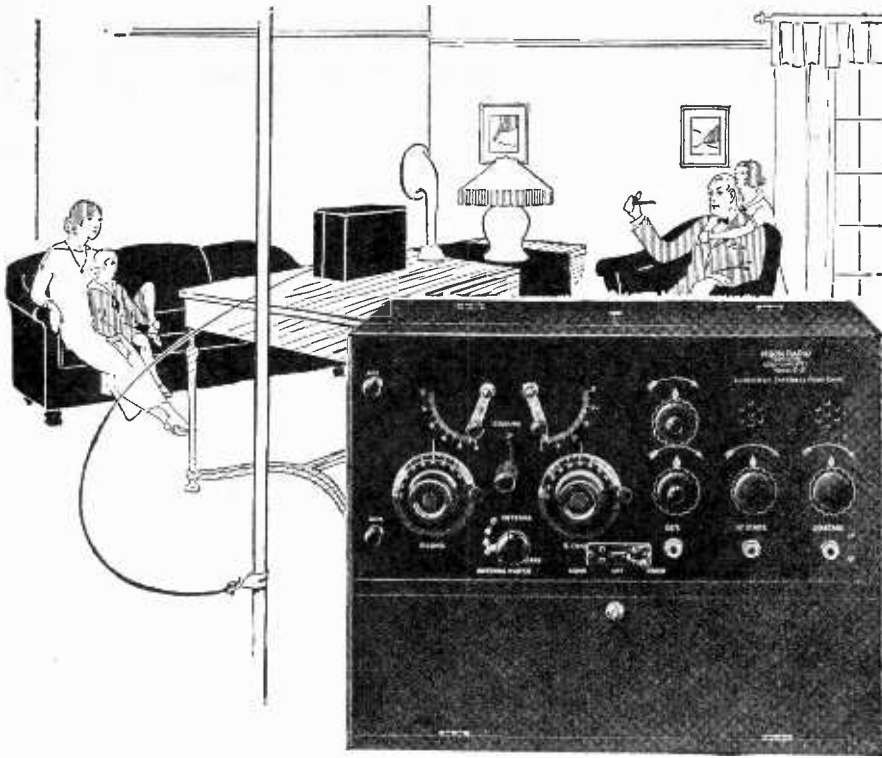

## —hook it to the waterpipe

Moon "Satterlee Antennaless" Radio will produce wonderful results simply connected to a waterpipe. No antenna, loop or indoor wire is necessary.

Stations within a conservative 1000 mile radius are regularly received with a non power loud speaker on this set.

It is the ideal set for use in apartments, automobiles, yachts or railroad trains where an antenna is not practical. Extremely sensitive, unusually selective, yet simple to operate.

*Clear Reception*

Dealers—ask about our franchise

Write today for our folder "California or Newark"

**MOON RADIO CORPORATION**  
501 Steinway Ave., Long Island City, N. Y.

In Canada, Continental Equipment Co., Ltd.  
New Birks Bldg., Montreal, Quebec

# MOON

Satterlee

## antennaless

# —RADIO—

Tell them that you saw it in RADIO

Continued from page 62

building, a few minutes later, I hears somethin' that sounds like a West Indies thunderstorm or th' battle a' Verdun goin' on in th' boss's private office.

"Colonel Gorgon Belleclair, this is an outrage!" somebody is a bellerin'. "As ownuh of twenty-five puhcent of the stock in this company, I protest, suh!"

"You'all can protest all yo' please, Major Graham Ramsey!" th' other fires back. "So long as I am president o' th' Tropical American Fruit Company, I shall operate it my own way, suh!"

Openin' th' door, cautious like, I sees Colonel Belleclair an' another portly, white-whiskered old southern gentleman standin' face to face, with a desk between 'em, their long droopin' mustaches bristlin' like two tom-cats' tails.

"I tell yo', I won't stand fo' it, suh!" roars Major Ramsey, gittin' purple around th' gills. "Do yo'all think yo' can make a monkey o' th' Tropical American Fruit Company thisaway, while I'm a stockholder! Yo' ought tuh be ashamed o' yoreself—look at this, suh!" Whippin' a newspaper out of his hip pocket, th' major spreads it out an' shoves it in Colonel Belleclair's face. Peekin' over th' colonel's shoulder, I sees, in big headlines:

**"TROPICAL AMERICAN INSTALLS SEA-GOING RADIO BEAUTIES!"**

Below this, horrific as life, is a great big picture of Miss Minerva Plum, hat-boxes, valises, parrot, an' all, standin' in th' door of th' radio shack on th' *Pastores*, a simperin' like a Tennessee rube at a leg-show!

"Well, I'll go to Hades!" I starts to mutter, but Major Ramsey don't give me no time.

"What do yo'all mean by it, suh!" he storms. "Are yo' aimin' tuh bankrupt the Tropical American? Do yo'all think weah going tuh git passengers tuh ride on ouah ships, when yo' got aboa'd that—that—" He chokes, an' points a shakin' finger at th' picture of Miss Plum.

"Heah! Heah! Stop hollerin' in my face, thataway!" flares up Colonel Belleclair. "I'll have yo' tuh understand, suh, that while the plan is my dawtuh's I take all—"

"Blast yore daughter!" bellers old Major Ramsey, gittin' black in th' face. "Yo' and yore entire family are a disgrace tuh this country, suh! I'm telling yo' right heah, suh, those children of ouahs shall nevu' marry while I draw breath! *Nevuh*, suh!"

"Indeed they shan't!" roars Colonel Belleclair. "I'm seeing tuh that, Major Graham Ramsey! Yo' get out o' this office, befo' I throw yo' out!"

Continued on page 66



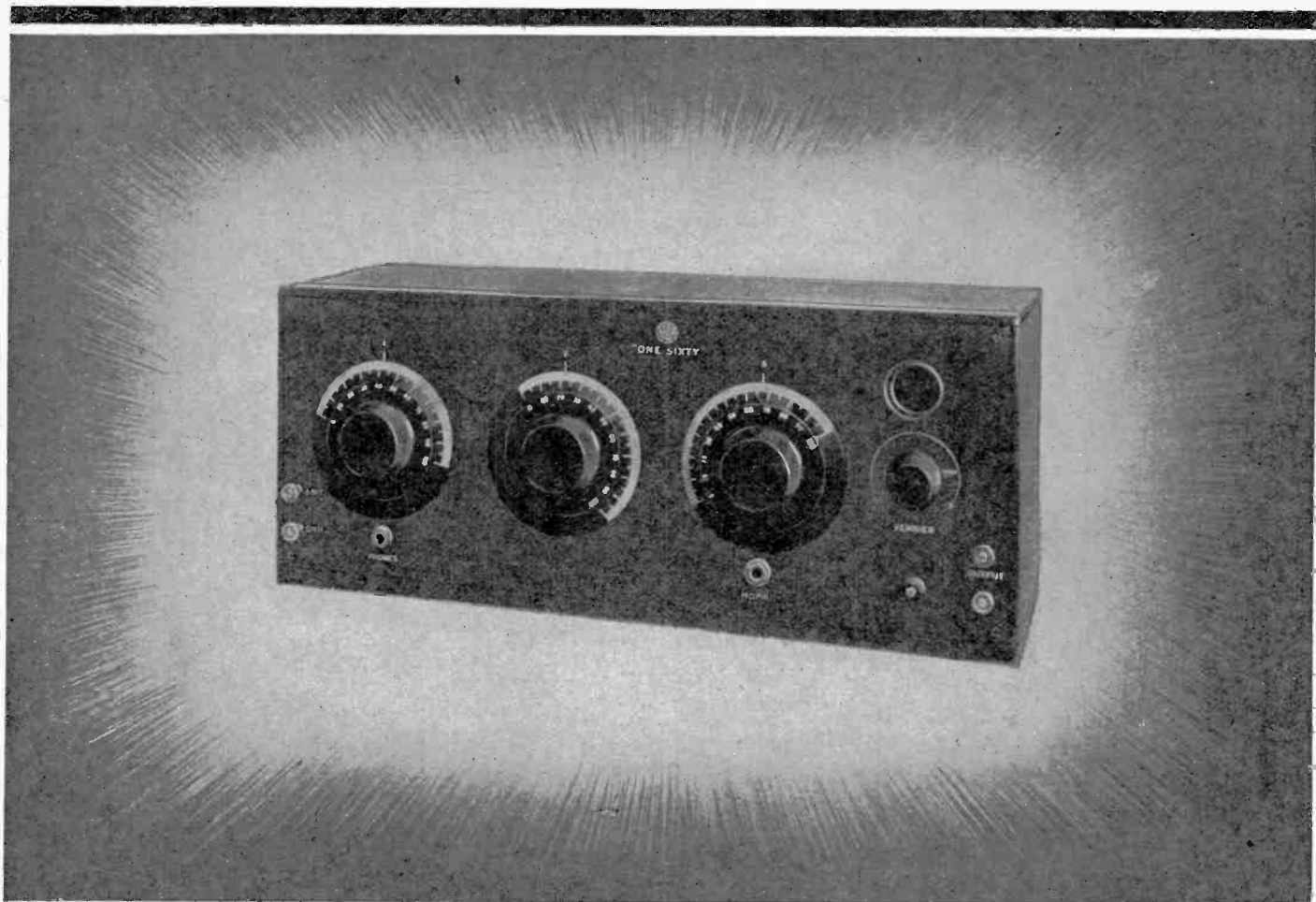

## “IF WE DON’T GET ’EM ON THE LOUD SPEAKER WE DON’T COUNT ’EM”

The FADA “One-Sixty” Neutrodyne receiver will consistently bring in stations one thousand to fifteen hundred miles distant on the loud speaker, and with pleasing purity and clarity of tone. The following is characteristic of what is repeatedly being done from New York City. Radio reception conditions on the Pacific coast being much better than in the East, even better results can be obtained.

Call Letters	City and State	Dial 1	Dial 2	Dial 3
WDAP	Chicago, Ill.	17	30	31
WJAX	Cleveland, Ohio	26	38	38
PWX	Havana, Cuba	28	42	41
WLAG	Minneapolis, Minn.	30	40	41
WHAS	Louisville, Ky.	31	40	41
WSB	Atlanta, Ga.	38	49	48
WJAZ	Chicago, Ill.	38	54	54
WOS	Jefferson City, Mo.	40	51	50
WCAP	Washington, D. C.	41	54	58
WBAP	Ft. Worth, Texas	51	61	60
WOC	Davenport, Iowa	56	67	66
WFAA	Dallas, Tex.	64	75	76
WOAW	Omaha, Neb.	65	77	77
KSD	St. Louis, Mo.	70	85	84

*Pacific Coast Representatives—Globe Commercial Company, 709 Mission Street, San Francisco, Calif.*

**F. A. D. ANDREA, INC.—1581-F JEROME AVE.—NEW YORK CITY**

*The* **FADA "ONE SIXTY"**  
 ~ WITH THE NEUTRODYNE CIRCUIT ~

## A Pleasant Surprise Awaits the User of the A C H Sharp Tuner Dials

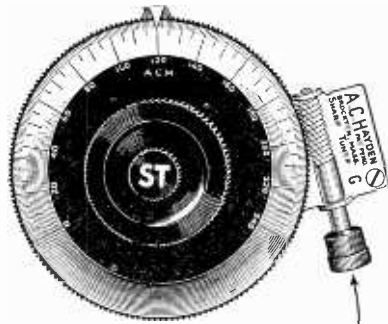

Why the A.C.H. is different

3 in. DIAL → A.C.H. → 156-T0-1  
4 in. DIAL → A.C.H. → 215-T0-1

Rough tuning or  
1,000th of an inch  
in either direction.

Can be installed  
and will  
improve any  
receiving set,  
making difficult  
tuning easy.

Price 3-inch size .....\$2.50  
Price 4-inch size .....\$5.00  
Regular fitting 5/16 shaft ¼  
and 3/16.....5c each extra

### Money Back Guarantee

The principle of the A C H Sharp Tuner has only been embodied on very expensive instruments where the most delicate adjustment is necessary, and then as a permanent part.

### Extra Advantage of the A C H

1. Can be attached or removed from any instrument.
2. Rough tuning same as any dial.
3. Movement so fine that the eye cannot detect but the ear can.
4. Automatically locks instrument so no jar can disturb it.
5. Dial grounded reducing the body capacity to a minimum.
6. Special dial 2 graduations where ordinarily one.

Mail Orders Sent Prepaid in U.S.A.

**A. C. HAYDEN RADIO & RESEARCH CO.**

Brockton, Mass., U. S. A.

Sold by Radio, Ltd., Montreal, Can.

Continued from page 64

"Just yo' try it, Colonel Gorgon Belleclair!" froths th' major, haulin' out a long black pistol an' brandishin' around, menacin' like. "You'a! get them—them—them petticoated horrors off o' ouah ships, or I'll have yore blood, suh! Good-day!" With this, Major Ramsey stomps out, slamin' th' door behind him with a bang like a locomotive driver switchin' a string of box-cars.

I skins off quiet like to my office, but in a minute Colonel Belleclair comes in an' stands opposite my desk.

"Nice day, Colonel," I remarks, kind of uneasy like.

"Gloria tells me that yo're teaching her radio suh," announces Colonel Belleclair, his mustache still bristlin'.

"Yes—suh—just a dot an' dash or so, once in a while," I replies, real cautious.

"I don't want it!" snaps Colonel Belleclair, glarin' at me. "I shan't allow my dawtuh tuh be a wireless gal on our ships, or on any ships! She—I tell yo', suh, Gloria is getting too much interested in this office tuh suit me. I shall put a stop tuh it, right now, suh! Yo' get yore self a nother stenographer!"

"Yezzir!" I says, pretty nervous an' shook up like.

Turnin' on his heel, th' colonel marches out, leavin' me sittin' there in front of my J. Pierpont feelin' like a caved-in subway tunnel. Finally, I notices that Whitewash is tuggin' at my coat sleeve.

"Yo' chief op'ratuh oveh in th' wi'less station done gone bughouse, sah!" he exclaims, rollin' his eyes around like a couple of eccentrics on a steam-engine. "He done telephone fo' you'all tuh come down thataway direckly, sah!"

Goin' down to the street an' crossin' over into the park, in which is th' Tropical American's big radio station, I observes that th' atmosphere is so lurid that even th' trees an' bushes seem to be wiltin' away. At th' door of the main building, I meets th' chief, glarin' an' foam'in' like a mad-dog.

"I quit!—I quit!" he hollers, tearin' out a fistful of his hair an' wavin' his arms around like a windmill. "I've seen some crummy radio gadgets in my time, but of all th' dumb, ignorant, numbed-skulled, unwashed, cov-fisted—come in here, you womanphile!—come in here an' less see you run this blasted joint yourself—grrrh!" He makes a grab at me, an' yanks me into th' receivin'-room.

Here I see message-blanks, log-sheets, an' carbon papers scattered around like a flock of forest leaves in a wind-storm; th' corner of th' receivin'-desk is chewed up with what looks like teeth marks; while alongside it, rigid as a rock, is settin' th' Tropical American's cargo superintendent, who is also general

Continued on page 68



## Radio Cabinets

29 different stock sizes, and shapes ranging—height from 6 in. to 8 in., and in width from 6 in. to 30 in.

Rich Mahogany Finished  
Highest grade Cabinet work

Made complete or knocked down. Write for illustrated folder and prices.

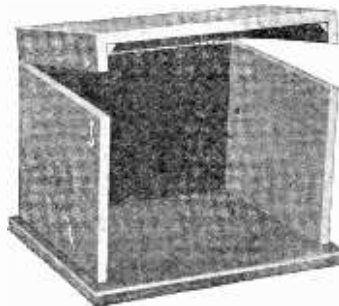

## Radio Table

This table is especially designed for radio. The compartment is 12 in. high with two doors opening full length. The table top is 20 in. wide x 36 in. long, and the height is 30 in. The legs are 1½ in. square brass capped with casters.

A durable piece of high class  
furniture \$22.00



"Signal" Radio  
Table Top  
20 x 36 in.  
Height 30 in.

**SIGNAL Electric**  
Mfg. Co.

Factory and General Offices  
1913 Broadway,  
Menominee, Michigan

Chicago      Boston      Pittsburgh      San Francisco      Minneapolis      Philadelphia  
Cleveland      St. Louis      Toronto      Montreal      New York      Los Angeles

You'll find our local address in your Telephone Directory



## Build Your New Radio Set Coto Compact and Portable

Many a time you will want to take it with you on hunting trip, auto tour or to give some sick person the wonderful enjoyment and encouragement of a bedside radio concert. Portability and compactness is the demand of the hour in radio. And Coto supplies that demand, always maintaining the splendid reliability for which the name Coto is known far and wide.

**Double the Fascination of Radio  
by Building Your Set Coto Dependable**

### Coto Compact Air Condenser with Vernier

Only  $2\frac{7}{8} \times 2\frac{7}{8}$  inches. Ruggedly built on rigid metal plate for years of super efficient service. Copper plates are all soldered firmly in place. Vernier is positive and delicate in action. Quality to compare with the best at moderate prices.

Type 3505—.0005 Mfd. \$5  
Type 3510—.001 Mfd. \$6

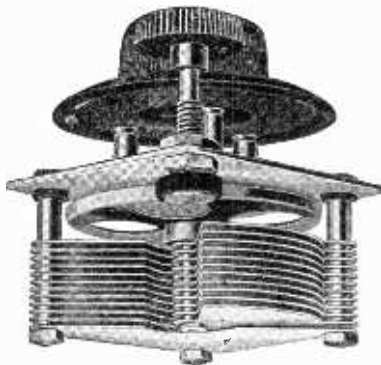

### JOBBER! DEALERS!

The backbone of your business is and always will be with the real radio enthusiast who Builds his Own Set. Coto advertising and Coto quality develop and hold this business. We want your selling co-operation.

**Coto-Coil Co.** 87 Willard Avenue.  
Providence, R. I.

**Pacific Coast Branch:**  
329 Union League Building, Los Angeles, Calif.

**Northwestern Branch:**  
George F. Darling, 705 Plymouth Building, Minneapolis, Minn.

**Southeastern Branch:**  
C. P. Atkinson, Atlanta Trust Co. Building, Atlanta, Ga.

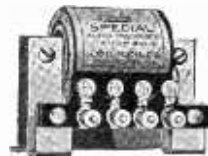

### Coto Special Audio Frequency Transformer

Turn ratio 3 to 1. Made to sell at a popular price but high grade in design and workmanship. Already selling by thousands. Type 4500. \$2.50.



### Coto Compact Audio Frequency Transformer

Compact and efficient. Handles large volume with uniform amplification and minimum distortion. Approved shell type. Ratio 5 to 1. Type 4000. \$5.00.



### Cotogrip Tube Socket

Has unique double positive grip of tube terminal posts. Best hard rubber insulation. Rugged and efficient. Type 7000. 85c.

### Coto Compact Moulded Variometer

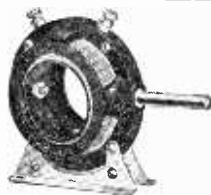

Size is only  $3\frac{1}{4} \times 1\frac{3}{4} \times 3\frac{3}{4}$  inches. Range 200 meters to 600 meters. Stator is honeycomb wound. Pigtail connections to rotor. Panel or base mounting. In highly polished brown bakelite. Type 8000. \$5.00.

### Coto Compact Moulded Vario- coupler

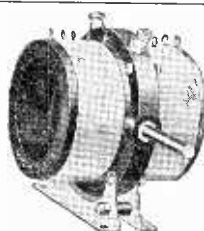

A companion piece of the Variometer. Size only  $3\frac{1}{4} \times 3 \times 3\frac{3}{4}$ . Range 200 to 600 meters. Panel or base mounting. Sells on sight. Type 9000. \$5.50.



### Coto Coils— The Original Honeycomb Wound Radio Inductances

Popular low priced favorites of the amateur and experimenter. Allow economical building of an all wave set. Quality maintained second to none. Sold mounted or unmounted.

## THREE THINGS TO REMEMBER WHEN YOU "BUILD YOUR OWN"

**T**HE success of that Radio Receiver you are going to build depends on just three things—the circuit, your care, and the parts you use.

Select your circuit—do a careful job—and use De Forest parts.

You protect yourself on the first two points—and the De Forest name protects you on the quality of the parts you use.

REMEMBER THAT DE FOREST INVENTED THE 3-ELECTRODE VACUUM TUBE that makes all present-day radio possible. So you will naturally want to use De Forest wet or dry cell audions. Remember that the De Forest experience in building radio parts goes back a quarter of a century—no wonder you can rely on them. Condensers, variometers, tube sockets, potentiometers, grid leaks, switches, honeycomb coils, and coil mountings—let them all be De Forest—and you will get the results!

Or, if you want a short cut to radio enjoyment and listening in on the broadcast of the Continent—if you want to forget the outdoor antenna—if you want ease of operation and brilliantly clear reception without interference—buy a De Forest Reflex Radiophone.

Either way, you rely on De Forest, the greatest name in radio.

**Radio Catalog Free** Send for De Forest new radio catalog with description and prices on sets (including Reflexes) audions or parts.



**DE FOREST RADIO TEL. & TEL. CO.**

Dept. R.4

Jersey City, N. J.

*If located west of Pennsylvania address*

**DE FOREST RADIO TEL. & TEL. CO.**

WESTERN SALES DIVISION

Dept. R4, 5680-12th Street, Detroit, Mich.



*Continued from page 66*

passenger agent, with a' expression on his perspirin' map about as lovin' as a Dusseldorf sausage-maker receivin' a dozen French army captains in full dress fer dinner.

"Do you realize we've got five ships out here in the Gulf of Mexico with those barnacle-toed females aboard, that we haven't been able to get a single message to or from, since the day they left New Aw'lins—" begins the G.P.A.

"Lissen t' this!" yells th' chief. "Lissen t' this baboon-fingered freak on th' General Belmont tryin' t' call our letters —W-H-T!"

He switches on his receiving apparatus an' from th' phones lyin' on th' desk comes a thin, squealy spark:

"W—W-X—sqawk! splutter! W-5-Q —dot-dot-dot, — splash! — bang! — screech!"

"Shut it off!" I snaps, stickin' my fingers in my ears.

"Shut it off, huh!" snarls th' chief. "That's what I been havin' t' listen to hour after hour—"

"We've been trying to raise the *Turrialba* for three days, with orders for her to go to Boca del Toro and load ninety thousand bunches of bananas cut by mistake and going to rot!" wails the cargo supe and G.P.A. "Just now, the chief received a message from her—"

"Yeh, here's what I got—an' all I've got or ever goin' t' git from th' *Turrialba*!" snarls th' chief, stickin' a message in my face. "It's from that little spit-fire dame you put on there, to her ma—read it!"

I reads it:

*"Dear Mother: Have met a wonderful Central American army general, and leaving this horrible old boat at Havana to marry him. Please send by extra rush express my best pink silk—"*

"And now the *Turrialba* is going to be tied up in Havana as tight as a shoe on a Spanish dancer's foot, for lack of a radio operator!" sobs th' cargo supe. "Those ninety thousand bunches of bananas at Boca del Toro—"

"Here's another from a Miss Rebecca Levy on th' Colonel Belleclair,— addressed to you!" busts in th' chief, shovin' a second telegram at me. I takes it an' reads:

*"This morning that sooty third-assistant engineer of this sickenly boat went in the clothes-room and hung his dirty pajamas next by my white muslin nightgown. I shall have him to apology at my knees, or—"*

"I never could make out th' rest of it!" snaps the chief. "But later she sent this one:

*'I have met the brute and he is mine. Rebecca.'*

"Those ninety thousand bunches of bananas—" blubbers th' cargo supe.

"An' now I hear you're sendin' our

*Continued on page 70*

## Critical Circuits

Require Good Mica Condensers



The FRESHMAN is so designed that constant equal pressure is exerted on the condenser plates over the entire area. They are the only condensers that do this and therefore the only condensers that avoid noises which are due to variable pressure on the plates.

Capacity	Each	Capacity	Each	Capacity	Each
.0001	\$.35	.0008	\$.40	.005	\$.75
.00015	.35	.001	.40	.006	.75
.00025	.35	.0015	.40	.007	1.00
.0002	.35	.002	.40	.008	1.00
.0003	.35	.0025	.50	.01	1.00
.00035	.35	.003	.60	.015	1.50
.0005	.35	.0035	.70	.02	2.00
.0006	.40	.004	.75	.025	2.50

At your dealers, otherwise send purchase price and you will be supplied postpaid.

Ask your dealer or write for our free diagrams of the Neutrodyne. Sensational New Kaufman Circuit No. 2, Flewelling and other circuits.

**Chas. Freshman Co. Inc.**  
Radio Condenser Products  
106 SEVENTH AVE., NEW YORK

A Super Vernier Rheostat

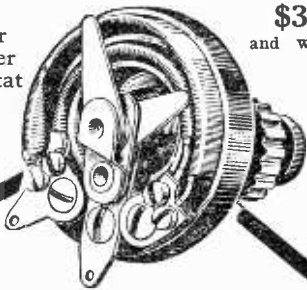

\$3.00 and worth it

100% EFFICIENCY FROM YOUR TUBES

Premier

## "MICROSTAT"

Trade Mark

There is no substitute for the Premier "Microstat"—no other instrument that gives such perfect control of the current delivered to the filament of radio tubes. New principle—two windings in parallel—one 6 ohm—other 40 ohm. Absolutely noiseless. Infinite control—handles any tube—Cap. 3 amp. Bakelite moulded—silver etched dial. Do not install a rheostat until you know all about the "Microstat." Our Bulletin No. 93 explains it in detail. Send for it. It's FREE.

**Premier Electric Company**  
3813 Ravenswood Ave. Chicago

Sales Offices:

817 West 3rd St., Los Angeles  
445 Stark St., Portland

Ask your Dealer for "MICROSTAT"

## RADIO PARTS

AT WHOLESALE PRICES  
SEND FOR PRICE LIST  
SYMPHER MFG. CO., Dept. R. TOLEDO, OHIO

## U.S. TOOL CONDENSERS



Precisely Lathed Shafts  
Insure Exact Alignment

THE bearings, where continued use first tests the quality of a condenser, in U. S. Tool Condensers are machined as carefully as the parts of the finest precision instruments. The main rotor shaft fits its bearings with just a micrometer determined space between to give smooth, frictionless turning, but without enough space to allow side or end play. Consequently wear is reduced to insignificance. Another reason why all U. S. Tool Condensers are so unconditionally guaranteed.

Write for booklet and name of your nearest dealer.

## U. S. Tool Co., Inc.

114 Mechanic St., Newark, N. J.

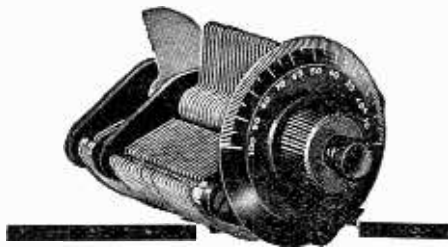

## RUSONITE

CRYSTAL RECTIFIER

(Patent Pending)  
THE PERFECT SYNTHETIC CRYSTAL DETECTOR SENSITIVE OVER ENTIRE SURFACE  
No hunting for "Spots." Loud and Clear. Endorsed by Thousands of Satisfied Users.

Sensitiveness Guaranteed Price Mounted 50c

14 K. Gold Supersensitive RUSONITE CATWHISKER, Price Permanent. Will not Oxidize. 25c

RUSONITE REFLEX CRYSTAL Manufactured Expressly for Reflex Circuits. Will Stand Up Under Heavy Plate Voltage Guaranteed Price Mounted \$1.00

Order from your dealer or direct from RUSONITE PRODUCTS CORP. 15 Park Row. New York, N. Y.

This is the Switch that does the trick; Turn it 'til you hear it click!



Today! get the new 1-9-2-4 model

## 4-Way Radio Switch Plug--

You can tune in through your head set and switch in the loud speaker simply by turning the dial, if you have a



The new 1924 model embodies many refinements—you will find it wonderfully convenient to use.

With the "4-Way", 2 head sets can be readily attached, or one head set and loud speaker. Both can be used at same time or either one alone.

\$1.50 At your dealer's

Four Way Co. DEPT. E

Springfield, Mass.



Jones "Fiddle Stick" Vernier 10c at your dealers From us postpaid 12c

The one Vernier that eliminates body capacity. Simply drill small hole beside dial and you can make adjustments never dreamt of before. Handy—convenient—and brings in stations unheard before. Catalog of Jones complete line of Radio accessories on request. Condenser cleaner 10c at your dealers or sample postpaid 12c.

HOWARD B. JONES 612 S. Canal St., Chicago, Ill.

## You Don't Need Tubes

to get out of town. If you want new stations on your crystal set WRITE ME TODAY. Mine works 400 to 1,000 miles without tubes or batteries! Thousands have bought my plans and now get results like mine. CHANGES OFTEN COST LESS THAN A DOLLAR. Send self-addressed envelope for further information. Leon Lambert, 524 South Volusia, Wichita, Kansas.



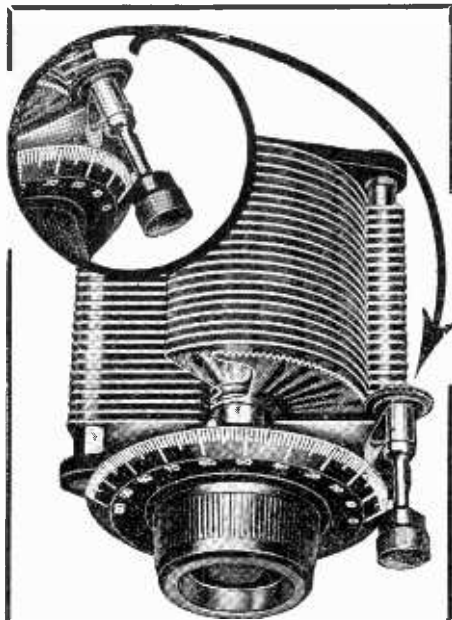

## HEATH'S Radiant Condensers

Heath Radiant Condensers will tune as perfectly years later as they do the day you install them. The plates, (which in other condensers buckle and get out of alignment) in Radiant Condensers are permanently FLAT by a patented process. They are pressed into absolute flatness and then tempered, so that they can never lose that flatness. Look for the Radiant trade-mark, impressed on every rotary plate of Heath's Radiant Condensers.

### Vernier, Geared Like a Watch

Adjusting knob geared to vernier plate so that an ordinary turn is reduced to micrometer fineness. Positive, accurate, durable. No play. Separate tension adjustment.

Write for Illustrated Booklet.

### LIST PRICES—VERNIER TYPE

- 13 Plate including 2 3/4" dial and knob ..... \$5.00
- 25 Plate including 2 3/4" dial and knob ..... \$5.50
- 45 Plate including 2 3/4" dial and knob ..... \$6.50

### Distributors for Southern California

**THE ELECTRIC CORPORATION**  
836 S. Los Angeles Street Los Angeles

**WESTERN RADIO INC.**  
637 S. Hope Street Los Angeles

### Distributor for Northern California

**ELECTRIC APPLIANCE CO.**  
807 Mission Street San Francisco

## HEATH RADIO & ELECTRIC MFG. CO.

208 First Street  
Newark, N. J., U. S. A.

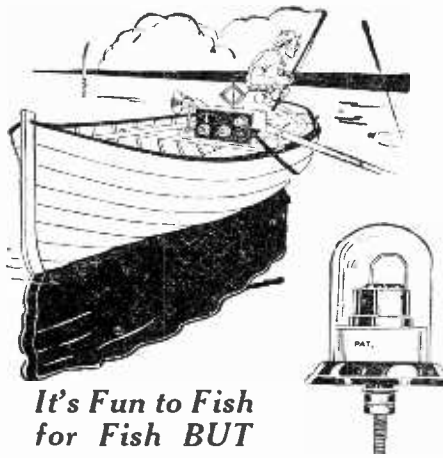

### It's Fun to Fish for Fish BUT

fishing for a spot on your detector is no pleasure at all  
**THE GREWOL**  
Fixed Detector  
is always set and ready for use. No adjusting or replacements. The most satisfactory, always sensitive, guaranteed detector. At your dealer's or direct upon receipt of \$2.00.  
Write for free booklet with new reflex hookups. **\$2.00**



**RANDEL WIRELESS COMPANY**  
2 Central Ave. Newark, N. J.

## YELLOW TIP MICROMETER ADJUSTING CRYSTAL DETECTOR



Any adjustment made in a moment—fixed instantly! Held indefinitely, until you wish to change, then—“A Twist of the Wrist—It's Set.”  
Ideal for reflex and other circuits. Write for folder and name of your nearest dealer. **\$2**

Dealers and Jobbers—Write for Attractive Proposition

### Wholesale Radio Equipment Company

Exclusive Factory Representatives  
34 William Street Newark, N. J.

## CARTER JACK SWITCH

To Open and Close CIRCUITS



Style No. 2, \$1.00

Made with 2, 3, 4 and 6 springs. Complete with “OFF and ON” name plate, Knob and Pointer. Prices: \$1.00 to \$1.60, according to style. Ask your Dealer!

Send for illustrated catalog and FREE interesting hook-ups for Jack Switches.



Coast Representative:  
**ATLANTIC & PACIFIC SALES CO.,**  
San Francisco, Calif.



## WOC TRESKO

Licensed under Armstrong U. S. Patent No. 1,113,149.

A Long Distance 1,000-mile, 600-meter Range Regenerative Tuner for \$10.00. Add Parcel Post on 6 lbs. New Circuit, Startling Results. Cheaper than Crystal Set. Uses any Aerial. Amplifiers to match set for your loud speakers. Circulars free. Full instructions.

**TRESKO**  
DAVENPORT, IOWA

Continued from page 68

flagship *Pastores* out at four o'clock this afternoon with another cock-eyed cross between a giraffe an' a Gila monster—

“By my soul, never!” yells th' G.P.A., jumpin' up like a bumb has gone off under him. “If the *Pastores* sails with that red-skirted gorillless aboard, it'll be over my dead body!”

“Well, you're droppin' your tears in th' wrong mud-puddle, both a' you!” I says, short like. “I don't own this here Tropical American Fruit Company! My runnin' orders is t' put wimmen brasspounders on these blasted ships, an' by th' holy harps, I'll put 'em on, if I have t' kick 'em up th' gang-plank with a pile-driver!”

Goin' back up to my office, I finds th' angel waitin' for me—in her hand a fresh, crinkly first-class radio operator's license.

“I just got it this afternoon!” she cries, all delighted. “Now, I'm going to be a wireless girl, too!”

“No—I—you can't!” I exclaims, moppin' my perspirin' beak with my handkerchief.

Th' angel stares at me, surprised.

“Why not? she wants to know, her pretty lips startin' to tremble. “Don't you think I'll make a good operator? You taught me—

“Yes, yes!” I breaks in, gettin' all fussed up. “You'd made a wonderful—anything; but your old war-horse of a pop—

“Don't mind him,” says Gloria. “He doesn't mean anything.”

“Th' heck he don't!” I busts out. “If I want t' meet a sudden death, all I've got to do is—

“I've studied so hard to get this license!” falters th' angel, two big tears quiverin' on her lovely lashes.

“But—

“Put me on the *Pastores*,” pleads Gloria. “Billy's third mate there, you know, and he'll take care of me.”

“You can't make the *Pastores*,” I says, relieved like. “She sails at four o'clock—one hour.”

“Oh—but I can make it!” exclaims Gloria, eager like. “My trunks are aboard, already!”

“Well, I'll go to Hades!” I gasps.

“Please!” Gloria begs.

“But th' old colonel—

“Please!” repeats the angel; then she comes right over close to me an' puts one of her ivory arms around my neck.

“Hey, stop that!” I splutters, stickin' my thumb into my inkstand an' upsettin' it. “Whadda'ya tryin' t'—

“Please,—Sammy!” she says again, snuggin' up a little closer.

“Hell!” I explodes. “Old Colonel Gorgon Belleclair never was up against nothin' like this!”

I writes out th' angel's assignment order for the *Pastores*, while she sits on

the arm of my chair an' watches me do it.

"You can give this to th' captain, when you go aboard," I says to her, kind of dubious. "Tell him t' throw that old dragon, Miss Minerva Plum, onto th' dock — bag, b a g g a g e, an' parrot!"

"Oh, you're wonderful!" cries the angel; then she leans over an' turns loose a kiss right on my astonished lips! In a second, she has vanished.

For about an hour, I sits there at my J. Pierpont, in a kind of dream, feelin' like I was floatin' in a mixture a' rainbows an' roses. Finally, the sound of three long, deep-toned steamer blasts rouses me; an' lookin' out of my office window at the city and the wide Mississippi below, I sees the *Pastores*, the thirty-thousand-ton flagship of the Tropical American, dropping down the channel toward the river mouth, smoke tinges hanging above her huge funnels, pretty a picture in the evening sunlight as ever you saw!

"Sink me fer a flat-footed dumbell if this ain't th' real bootleggers' jelly-beans!" I exclaims to myself, swellin' up like a barber's cat with a pound a' liver. "Keep a stiff upper lip, Samuel Jones, an' you'll own this doggone Tropical American Fruit Company!"

I goes back into my dreams again, while th' daylight fades an' the city lights up. Sittin' there, I fall asleep.

It is about eleven o'clock when I get woke up by a newsboy down in the street with a locomotive-whistle voice, who is yellin' "Wuxtry! Wuxtre-e-e!" like a new World War has broke out, or a sugar profiteer has been convicted. Feelin' too contented to care much which it is, I yawns an' starts to roll myself a smoke before goin' home, when suddenly I hear what sounds like th' beginnin' of a Guatemala earthquake, somewhere in th' buildin'. Directly, I realizes that it's a lot of people comin' full speed up th' stairs—then my office door flies open an' in busts Colonel Belleclair an' Major Graham Ramsey, both puffin' like a couple of Barney-Google Spark-Plugs, an' their long mustaches bristlin' out like th' quills of a porcupine gone mad from th' heat!

"Here's th' scoundrel-l-l! howls Major Ramsey.

"Yo' damned skunk, yo'!" bellers Colonel Belleclair.

"Whassamatter!" I exclaims, startin' up, feelin' sickish around th' gills.

"Mattuh!" raves Colonel Belleclair. "What do yo' mean by allowin' my dawtuh tuh sail on the *Pastores*!"

"She—I, well, your passenger agent was goin' t' commit suicide, if I didn't git that Miss Minerva Plum off a' there!" I says, kind of bluffly like, like a' empty barrel tryin' t' sound full. "Gloria'll be all right; th' third mate on th' *Pastores* is her brother, Billy—"

"Brothuh, my haid!" howls Major Ramsey. "Billy is my son! I kicked out that fool young whippuhsnappuh tuh keep him from marryin'—"

"Look heah, suh!" thunders Colonel Belleclair, holdin' up a newspaper that looks like it's just hot off th' press. Across th' top, in big black letters that look a foot high, I sees:

*"Disowned Daughter of Colonel Belleclair Marries Disinherited Son of Major Ramsey. Commander of Steamship 'Pastores' Performs Ceremony as Ship Passes Beyond Three-Mile Limit!"*

"You disowned her!" I splutters. "No! — no! — no!" roars Colonel Belleclair.

"She said so tuh get that—that cussed son o' mine tuh —" begins Major Ramsey.

"An' when he saw her sailing as wireless gal on the *Pastores*, I reckon he believed it!" foams Colonel Belleclair.

"Hot darn ye!" thunders Major Ramsey, haulin' out his big long six-shooter.

"I'll have yo' blood, suh!" bellers

## WALNART Variable Grid Resistance

Complete with  
Dial and Pointer **\$1.00**  
List

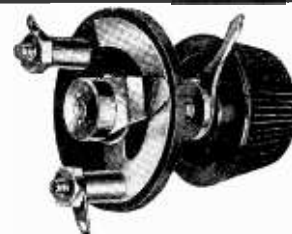

Clears up signals.

Gives longer life to batteries.

Simple to operate and install.

Will last indefinitely without deterioration or loss in efficiency.

Can be used with or without a fixed condenser.

The one Variable Grid Resistance that has given entire satisfaction.

Complete with knob and pointer, \$1

We also manufacture Variable condensers, plain and vernier, tube sockets, standard, and UV 199, vernier adjusters, inductance switches, etc., of highest quality. Ask to see them at your dealers.

**WALNART ELECTRIC MFG. CO.**

Dept. 203, 1249 W. Van Buren St.  
CHICAGO

Write for folder of complete line of Walnart Radio Parts

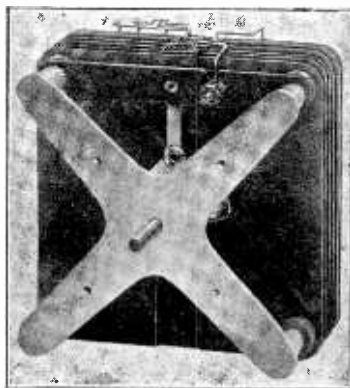

## VARIO-FORMERS

Used in the



circuit are guaranteed to give the greatest radio frequency amplification and selectivity.

### Telos Vario-formers

are the only practical devices for obtaining tuned radio frequency amplification in one unit. Type TC4 for wave length range of 180 to 610 meters.

Write for FREE booklet on  
Radio Frequency Amplifiers  
by Lester L. Jones  
Formerly Expert Radio Aid, U.S.N.

**DANZIGER-JONES, Inc.**  
25 W. Waverly Place New York City

Tell them that you saw it in RADIO

# It's the contact that counts

A CAREFUL examination will show that each contact in Na-ald sockets and adapters is of a wiping nature on a broad surface, and so designed that strong tension is permanent, no matter how often the bulbs may be removed or how much the connecting prongs in the tubes vary. Na-ald sockets are moulded of Bakelite, with uniform cross-section and cure, and other engineering features incorporated to avoid plate to grid losses and to insure that each tube develops its fullest efficiency.

The new Na-ald dials combine rare beauty of design with highest efficiency in use. These dials are moulded from genuine Condensite in such a way that absorption losses are reduced to a minimum. Knobs are so shaped that fingers do not conceal clear numerals and graduation on the bevel of Na-ald dials.

Na-ald Circuit Booklet packed with each Na-ald product

Write for "Why a Bakelite Socket?" and other descriptive literature

**Alden Manufacturing Company**

Manufacturers of sockets and dials for every radio requirement

Dept. H 52 Willow Street  
SPRINGFIELD, MASS.

Cable Address, Aldenco

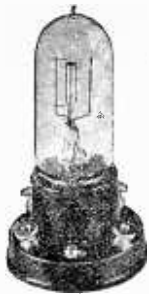

NA-ALD W. D. 11  
No. 411, Price 75c



No. 3023-4, 2-inch Dial  
Price 35c, 3 for \$1.00

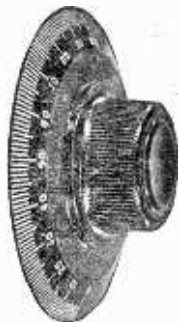

No. 3783-4  
1/2-in. Insert 1/4-in. Insert  
3/4-in. Dial Price 75c  
3-in. Dials, 35c, 3 for \$1.00



NA-ALD Special Socket  
No. 499  
Price 50c for U.V. 199 tubes



Small Space Socket, No. 401  
35c, 3 for \$1.00



De Luxe No. 400. Price 75c



Adapter No. 429 for U.V.  
199 Tubes. Price 75c

Colonel Belleclair, producin' another still wickeder lookin' Krupp.

About now, I realizes it's time to disoccupy some space. I makes a lightnin' streak fer th' door—an' collides fair into Miss Minerva Plum, her hair down around her chin, her hat hangin' on th' side of her bean, her parrot cage all bent up, her valises an' hat-boxes battered an' smashed. Altogether, I can see it must a' took about fourteen sailors to throw her on th' dock.

"You-u-u-u!" she screeches, droppin' her stuff on th' floor an' spreadin' out her claws.

"Kill him!" squawks her big green parrot, floppin' up an' down in his loped-side cage.

In a flash, I seems t' be wrapped up in a derailed Coney Island shoot-the chutes hit by a tornado; while my face feels like it's th' scene of a death-battle between a dozen wild-cats an' a chimpanzee. Collar, tie, an' clothes comes off'a me in ribbons an' shreds—then I get landed over th' bean with a water-cooler an' take th' count.

"Lowlife slumgullion!" I hears her parrot say, like it was a thousand miles out to sea. Through a kind of rollin' blue fog, I distinguishes policemen's stars an' ambulance mens' white uniforms; while off in th' dim background two old southern gentlemen seem to be shakin' hands.

If your Edison battery is getting so it will not hold its charge, try renewing the solution. Usually a complete renewal of the solution every two years will keep these batteries in good condition, provided they are worked according to their rating.

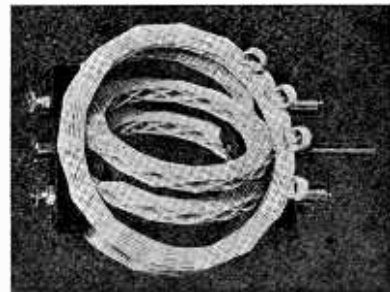

DIAMOND WEAVE VARIOCOUPLER

## an R-M-C product

Seven-eighths of windings are in mid-air, thus reducing dielectric losses to a minimum. Diamond weave construction reduces distributed capacity to a minimum. The R.M.C. Variocoupler has a wave range of 150 to 600 meters. The Variometer is the same size and general construction as the Variocoupler, and has a variance in inductance of 300 meters. Outside diameter of primary windings is 4 1/8"; of secondary, 3 1/4". Extreme length, 5 1/4". These R.M.C. products will greatly improve any circuit where a variocoupler or variometer can be used.

Variocoupler. . . . . \$4.25  
Variometer. . . . . \$4.25

Write for catalog of other diamond weave coils, and Radio Frequency Transformer

THE RADIO MANUFACTURING COMPANY  
of Springfield, Massachusetts

Dept. D 97 Dwight Street



The Improved **MIRACO**

Gets 'Em From Coast to Coast

Clearly and distinctly, too! For our users tell us that Cincinnati hears Frisco, Denver hears Schenectady, New York hears Havana; Scores of long distance records were made on these instruments last year, so with the many new refinements incorporated the result obtained now will be far better than ever.

### HIGHEST QUALITY AT LOWEST PRICE

This has always been the MIRACO key-note and the thousands of sets now in use are a fitting tribute to MIRACO'S excellent performance. Many new improvements, such as new sockets resting on shock absorbing pads—a refinement found only in the most expensive sets—rheostats with multiple resistance windings, making it possible to use either dry cell or storage battery tubes, and a new aluminum shield that prevents annoying body capacity effects, are embodied.

Cabinet is of solid mahogany—workmanship the finest—operation extremely simple yet always dependable.  
2 tube outfit shown above. . . \$29.50 1 tube outfit. . . . \$18.50  
4 tube outfit shown below. . . . . \$54.50

Write for our new bulletin today  
DEALERS—JOBBER: Write for our proposition quickly.  
AGENTS: There's still some territory open—write or wire.

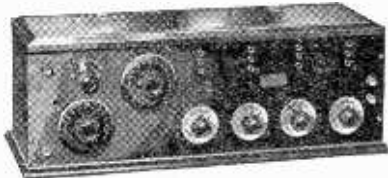

THE MIDWEST RADIO CO.  
814 Main Street—Cincinnati, Ohio

## A NEW DISCOVERY!

EXTREME SUPER-REGENERATION

is obtained without noises through

## FRESHMAN

Variable Resistance Leaks

by connecting between plate and Grid of the tube as disclosed by the sensational

### New Kaufman Circuit No. 2



Only the Knob Shows on the Panel

PANEL TYPE

Absolutely No Pencil Markings



BASE TYPE

Freshman Resistance Leaks are especially built for use as tuning instruments. Construction is such that they will withstand unusual usage. Freshman Leaks give an unbroken range of 180 degrees from 0 to 10 megohms. Absolutely guaranteed. Enables you to get stations you never heard before.

EITHER TYPE

Complete with either .00025 or .0005 mfd. \$1.00  
Mica Condenser. . . . . 75c  
Without Condenser. . . . . 75c

At your dealers—otherwise send purchase price and you will be supplied postpaid.

Ask your dealer or write direct for free diagram showing how you can convert your single tube circuit into the new sensational Kaufman Circuit No. 2.

**Chas. Freshman Co. Inc.**  
Radio Condenser Products

106 SEVENTH AVE., NEW YORK

Tell them that you saw it in RADIO

# The TOWN CRIER of TODAY



IN the quaint old villages and towns of long ago, when each community was a world unto itself, the Town Crier played an important part in the affairs of the day. With clanging bell and stentorian voice, he used to broadcast the news, perhaps weeks old, that occasionally drifted in from outside places.

Today news from all parts is immediately available right at your fireside. No matter how isolated your abode, Radio binds you to civilization. By a turn of the dial, the happenings, entertainments and amusements of the world are yours to command.

The Crosley Manufacturing Company has done much towards bringing this new wonder within the reach of all and has made Radio a living, tangible thing—something to use in daily life, in business or pleasure.

Popularly priced, these famous receivers give perfect performance. Unsolicited letters are received daily from owners telling of satisfaction and new distance records.

Everyday tests prove to us that Crosley instruments are the most simple and efficient Radio receivers ever offered to the public, regardless of cost.

*For Sale By Good Dealers Everywhere*

Write for complete catalog. This fully describes the Crosley line of Radio parts and receivers which range in price from a 2 tube set at \$30 to the new beautiful Model XL at \$140.



**CROSLEY**  
Better - Cost Less  
Radio Products

*The Broadcasting Station  
WLW is maintained by the  
Crosley Manufacturing Co.*

**CROSLEY**

Model X-J  
\$65

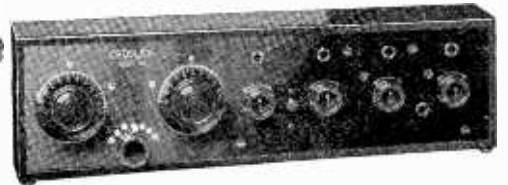

Crosley Model X-J \$65.

A 4-tube radio frequency set combining one stage of Tuned Radio Frequency Amplification, a Detector, and two stages of Audio Frequency Amplification. A jack to plug in on three tubes for head phones, the four tubes being otherwise connected to loud speaker, new Crosley Multistat, universal rheostats for all makes of tubes for dry cells or storage batteries, new condenser with molded plates, filament switch and other refinements add to its performance and beauty.

*Nowhere can a better receiver be purchased at any price*

Cost of necessary accessories from \$40.00 up.  
List prices on our equipment west of the Rockies 10% higher. In Canada add duty.

Mail This Coupon Today

Crosley Manufacturing Co.,  
1219 Alfred St., Cincinnati, O.

Gentlemen: Please mail me free of charge your complete catalog of Crosley instruments and parts together with booklet entitled "The Simplicity of Radio."

Name.....

Address.....

**CROSLEY MANUFACTURING CO.**

Powel Crosley, Jr., President

1219 Alfred Street

Cincinnati, Ohio

Tell them that you saw it in RADIO

# BAKELITE

REG. U.S. PAT. OFF.

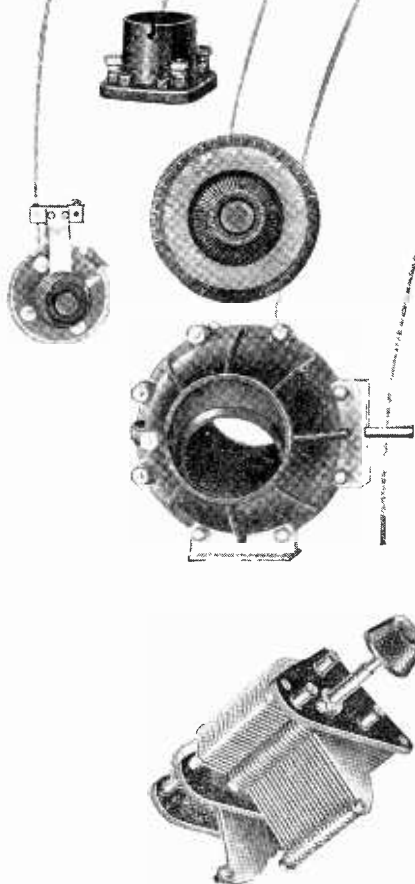
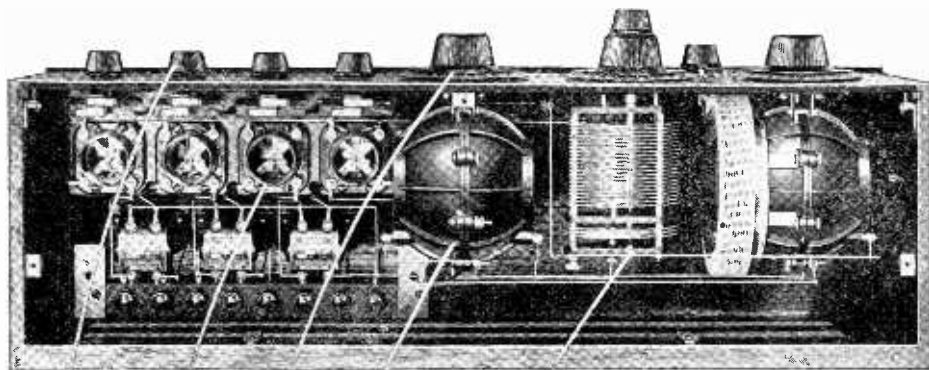

## Kellogg and BAKELITE

In the Jones' Symphony Set, manufactured exclusively by the Kellogg Switchboard and Supply Company, Bakelite insulation, in both molded and laminated forms, is used throughout.

Bakelite has been adopted as standard insulation by the leading Radio Manufacturers, because of the permanence of its dielectric and mechanical properties and its changeless color.

The careful manufacturer and designer of radio apparatus chooses Bakelite because of his confidence that wherever and whenever it is used in the future it will maintain the SAME resistivity which figured in his design calculations.

Because of its high temperature resistance and its non-absorbent properties, Bakelite performs equally well in all climates and under all atmospheric conditions.

Send us your name and address and we will mail you a copy of our Radio Booklet T.

### BAKELITE CORPORATION

Address the Divisions

General Bakelite Company, 247 Park Avenue, New York  
Condensite Company of America, Bloomfield, New Jersey  
Redmanol Chem. Prod. Co., 636 West 22nd Street, Chicago

### BAKELITE Condensite REDMANOL

are the registered  
Trade Marks for the  
Phenol Resin  
Products  
manufactured under  
patents owned by  
BAKELITE CORPORATION

## THE MATERIAL OF A THOUSAND USES

### HAM SPECIAL RECEIVER

Continued from page 17

Now, for the wiring and assembly. The set is wired entirely with No. 18 and "point-to-point" or "bee-line" wiring is used to make the leads as short as possible. You will notice in the diagram that the aerial is brought directly to the end of the tuning inductance so there are no "dead ends" to absorb energy. Although I have shown taps in the aerial-ground portion of the inductance they are not really necessary and the ground may be brought off the fourth turn without any disadvantage. I brought off six taps, tapping every turn from the aerial end, up to the seventh turn. I cannot see that this is of any great advantage, however. The rest of the wiring speaks for itself. Plan your set so that all leads will be as short as possible, especially those carrying any radio-frequency.

As to operation, this receiver is ideal for a one-armed paper hanger, but he will not have to be nearly as busy as he is supposed to be when at work. When everything is connected up light the tube to its normal brilliancy, set the grid tuning condenser about the middle of its scale and increase the feed-back condenser gradually until oscillations start; then reduce the filament current until oscillations stop and increase it until the tube just does oscillate. This is the point of maximum sensitivity. Now, if the set is properly constructed and wired, it should oscillate freely over the entire range. Once you bring in a station he is THERE. You don't have to risk losing him by trying to better his signals by fussing with a grid and plate variometer. When you've got him, you've got him and that's all there is to it. You will be surprised what little trouble the local "sync" rectifiers will cause you and you are not losing any sensitivity by reason of its selectivity.

If any broadcast fan has been so charmed as to wade this far there is a word of hope for him also. If he will wind on 50 turns in the grid tuning inductance and use a slightly larger condenser, such as a .00035 mfd., and tap the grid inductance into three equal portions, it will cover the whole broadcast range, but, because of the "dead ends," will not be quite as efficient as the "Ham Special." Using such a set in the heart of Los Angeles, I have been able to bring in KPO with excellent audibility with KFI, but not KHJ, going full blast. There are very few standard regenerative sets that can do this. At Redlands we had KSD in St. Louis on the Magnavox for half an hour one evening at the first of the summer.

No amplifier has been shown in the diagram, as most amateurs have a two-step in a separate cabinet. As one stage of audio-frequency will give all the

Continued on page 76





# Make Him Smile On Christmas Morn

Make him happy—give him a real gift that will be enjoyed by both young and old—give him an Ace Radio Set.

The Ace Type 3 C Consol-ette is a comparatively new addition to the Ace Family. It has beautiful solid mahogany, wax finished cabinet and greatly adds to the appearance of the finest home.

**An ACE  
Radio Set  
will do it!**

This set consists of a regenerative tuner, detector and two stages of amplification, with built-in loud speaker. The tuning circuit is licensed under the Armstrong U. S. Patent No. 1,113,149 and due to the particular method of winding Crosley coils it is exceptionally selective. Has sufficient room inside cabinet for dry batteries, making a complete self-contained long range receiving outfit. Has phone jack for tuning with head phones. Crosley multistat; filament switch; Crosley moulded condenser, beautifully engraved formica panel. Uses all kinds of tubes. Price \$125.00; with stand \$150.00. Prices do not include batteries or tubes.

Let an Ace Radio Set bring happiness to someone on Christmas morning.

*If your dealer cannot supply you, order direct mentioning his name.*

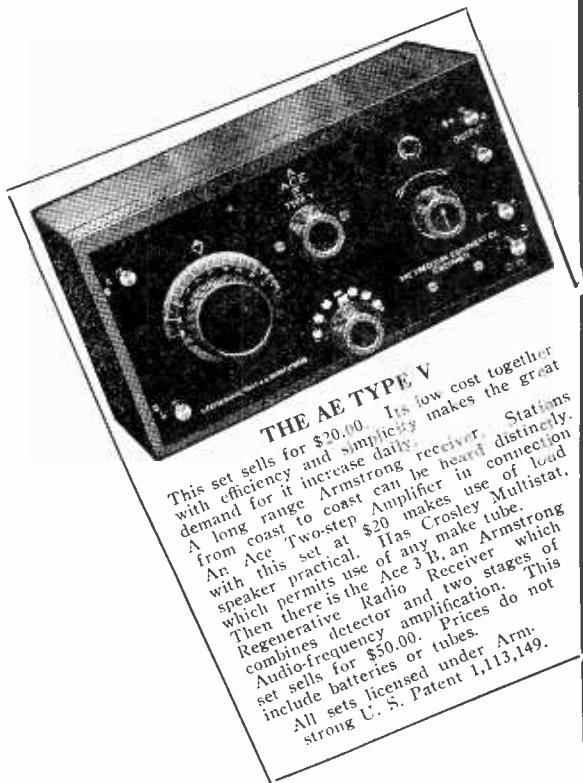

**THE AE TYPE V**  
This set sells for \$20.00. Its low cost together with efficiency and simplicity makes the great demand for it increase daily.  
A long coast to coast can be heard distinctly. An Ace Two-step Amplifier in connection with this set at \$20 makes use of lead speaker practical. Has Crosley Multistat, which permits use of any make tube. Then there is the Ace 3 B, an Armstrong Regenerative Radio Receiver which combines detector and two stages of audio-frequency amplification. This set sells for \$50.00. Prices do not include batteries or tubes.  
All sets licensed under Armstrong U. S. Patent 1,113,149.

**The Precision Equipment Company**  
1219 Vandalia Ave. Powel Crosley Jr., Pres. Cincinnati, Ohio

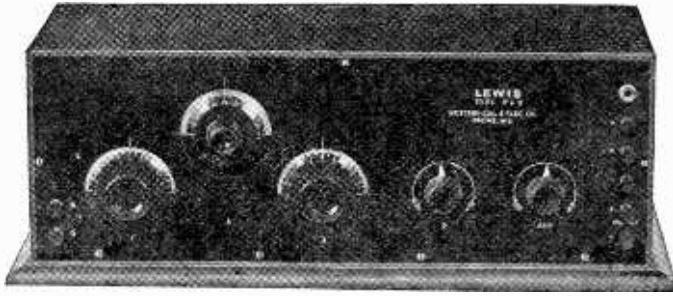

## The Most Practical Set for Low Wave Specialists

Are you having trouble getting short wave signals? The WC-5-SW shown above picks up signals on wave lengths from 90 to 380 meters sharp and clear. It is built by and for short wave specialists. The price is \$85.00.

# WC-5-SW

Built Especially for Transmitting Amateurs

The WC-5-SW is a 4-tube set. One stage of tuned Radio-Frequency amplification is employed ahead of the detector to make it super-sensitive. Two stages of audio-frequency are used to bring up the signal strength. Uses any type of tubes. Gives perfect control of audibility. Detector rectifies only. Uses antenna compensating condenser. Only two control adjustments. Pure negative biasing on all tubes, thus marked saving on "B" Battery current. Tuned Radio-Frequency sharpest known and most selective principle ever adopted. Plate potential non-critical. Mono-block tube socket. No grid plate leads on audio amplifiers. Audio amplification absolutely necessary when using low efficiency receiving antenna, i.e., underground or indoor. Mahogany cabinet, piano rub finish. Rabbed-in panel. Split lid cover.

*Write for complete description and illustrated folder on this practical set for low wave specialists. All transmitting amateurs will be interested in this literature.*

## OTT RADIO, Inc.

226 Main Street

La Crosse, Wis.

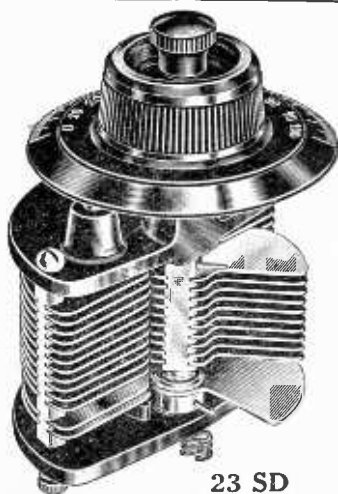

## THE DOUBLE KNOB SEXTON CONDENSER

Most compact vernier condenser built. Furnished with 3 inch black bakelite dial. Separate button for vernier control. Ball thrust bearing insures perfect action.

Balanced Models contain Half Capacity Switch

For name of Distributor write our Western Representative, F. L. Tomlinson, P. O. Box No. 2308, San Francisco, or

**THE HARTFORD INSTRUMENT CO., Inc.**

308 Pearl Street

Hartford, Conn.

23 SD

Continued from page 74

volume desirable, it could be built very conveniently into the tuner. The broadcast receiver mentioned above is of that type. Putting a negative bias on the grid of "A" type amplifier tubes is highly recommended. Be sure to connect the grid return as shown in the directions packed with the tubes.

This set is so sensitive that the advantage of the low one-wire aerial can be made use of fully. Using a single wire about 50 ft. long and 20 ft. high with a single rubber-covered buried counterpoise instead of a ground, 6TV can be heard all over the house and out on the street on a one-step. Atmospheric are practically nil with this type of receiving antenna.

If anyone has any pointers on the construction of the "Ham Special" or any criticisms of it I shall appreciate hearing from him very much. I have worked hard trying to develop a good amateur receiver and shall be glad to know of the efforts of others along this line.

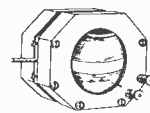

Double Silk Insulation. Metal Parts Nickel Plated. 200-650 Meters

**Just Out!**

**SMALLER!  
CHEAPER!  
BETTER!  
THE NEW**

**"CYMO"  
Variometer**

Introductory Price

**\$2.40**

Post Paid Anywhere in U. S.

Regular Price, \$3.50

Takes up less space in your Portable Set—less panel space—weighs less—perfect efficiency in all circuits—drilling guide for mounting—free booklet of reliable hook-ups with order. Tear out this "ad", put name and address on margin—send with P. O. money order or draft to

**RADIO DEVICES CO.**

693 Mission St.

San Francisco, Cal.

## The H. K. Switch

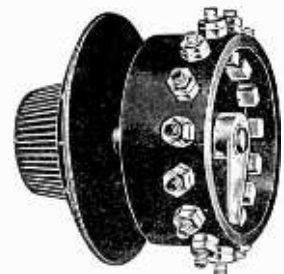

Pat. Pending

The H. K. Multipoint Switch does away with the difficulty of drilling holes in a panel for switch points, only takes a few minutes to mount. Assures good contact. Is neat in appearance. Contacts are arranged so wires can be attached with ease. 2½ in. Dial, calibrated to show contact in use.

**PRICE COMPLETE WITH DIAL \$2**

*Awarded Certificate of Merit 38 by Radio News Laboratories.*

Do not receive postage stamps. Be sure to send enough Extra money to cover postage.

Special prices to Dealers and Jobbers.

**KNOOP & PENCE CO.**  
PEOTONE, ILL.

# No delays in our Mail Order Department We Ship Within 4 Hours

The following stock of brand New and Latest equipment is offered for XMAS

FADA Neutrodyne .....\$120.00  
 FADA Neutrodyne Parts.....\$25.00  
 FADA Neutrodyne Books .....50¢

### MAGNAVOX EQUIPMENT

M1 (gold or black finish).....\$35.00  
 R3 (black finish).....\$35.00  
 1, 2 and 3-Stage Amplifiers.

### GREBE SETS

CR9 .....\$130.00 | CR8 ..... \$80.00  
 CR12 .....\$175.00 | CR13 .....\$95.00

### DUTHO "B" BATTERIES

25 volt, \$5.00 50 volt, \$9.00 100 volt, \$17.00  
 New Nov. Edition Citizens Radio Call Book.....50¢

### BURGESS BATTERIES

45 volt No. 2306.....\$5.50  
 22½ volt No. 4156.....\$1.75  
 22½ Small (Tapped), No. 5155.....\$2.75  
 22½ Large (Tapped), No. 2156.....\$3.00

### NEW TYPE HOMECHARGERS

Just Out.....\$18.50

### TUNGAR Rectifiers—

2 Amp.....\$18.50  
 5 Amp.....\$28.00

"BUG" Keys .....\$17.50

ESCO 500-volt Generator.....\$70.00

1000 volt .....\$135.00

## Do Your Xmas Buying Right Now!

THREE  
STORES

# WARNER BROS.

THREE  
STORES

350 Market Street

San Francisco

428 Market Street

Oakland—Twenty-second and Telegraph Avenue

## FROST-RADIO

*Ask Your Neighbor*

Two new items for your  
receiving set



EVERYONE who has used the new **FROST-RADIO** Metal Frame Vernier Rheostat is delighted with its smooth action, close regulation, and fine finish. A tremendous value at 75 cents.

### For UV-199 Tubes

The new **FROST-RADIO** genuine Bakelite UV-199 Adapter has knurled edge, phosphor bronze spring contacts, nickel plated prongs. Moulded in construction. Fits any standard socket. A quality product at a low price.

Your dealer now has complete stocks of these new items. Inspect and order them from him today.



**FROST-RADIO**  
No. 611 UV-199  
Adapter; 50c

## HERBERT H. FROST, Inc.

154 WEST LAKE STREET, CHICAGO, ILLINOIS.  
 30 Church St., New York 550 Gates Bldg., Kansas City, Mo.

# SPECIAL CHRISTMAS OFFER

The New Model

## Gottschalk

Loud Speaker, regularly selling for \$22, will be sold for

# \$17

until Dec. 25th if you order direct from manufacturer—saving you \$5.00 on the regular price.



5 DAY  
FREE  
TRIAL

We will ship C.O.D. for \$17.00 on 5 days' trial. Money refunded if not absolutely satisfactory.

Dealers: Write for trade prices

Gottschalk Electric & Mfg. Co.  
172 Fifth St. San Francisco, Cal.

**CALLS HEARD**

*Continued from page 44*

By 2BBX, Burton Synnett, 1287 Castle Hill Ave., Bronx, New York

On Reinartz tuner and 1 step. All over 500 miles.  
4en, 4eq (i.c.w.), 4ft, 4kw, 4qr, 5aby, 5agj, 5ama, 5ah, 5ek, 5ga, 5gm, 5jr, 5pv, 5qw, 5lc, 5lr, 5nj, 5nn, 5up, 5vy, 5xk, 5xv, 5za, 9aa, 9afi, 9alq, 9aly, 9amb, 9amu, 9ape, 9arh, 9ase, 9asv, 9awf, 9awg, 9axx, 9baf, 9bk, 9blg, 9bmx, 9bsh, 9bzi, 9cjc, 9ckw, 9clz, 9cno, 9col, 9cp, 9cte, 9cti, 9cvs, 9dce, 9dcr, 9dtt, 9dyy, 9dzj, 9edm, 9edo, 9eis, 9eky, 9ess, 9ih, 9mc, 9nu, 9rc, 9uz, 9vm, 9vz, 9zt, 9zy.

Can.: 1ar, 2bn, 3aa, 3ge, 3oh, 3rp, 9al.  
(WL, qsl crd to anyone writing me.) Using 10 watts here, ever hear me?

By 9BFI, Leon Mears, 4511 Colfax Ave. So., Minneapolis, Minn.

1arf, 1ask, (1bwj), 1cmp, 1bn, 1il, 1er, 2bab, 2bsc, 2bxw, 2crq, 2cg, 2gk, 2ry, 3brx, 3bva, 3cn, 3si, 3sg, 3ta, 3zo, 3ts, 4ai, 4cu, 4db, 4dx, 4dy, 4cg, 4ft, 4mb, 4my, 4aru, 5abt, (5aec), 5agj, 5aiu, 5akg, 5amh, 5amj, 5zas, 5zav, 6atz, 6awt, 6bcl, 6bcz, 6bdc, 6bqc, 6bvg, 6bwz, 6cfz, 6cgw, 6chl, 6ckh, 6dn, 6nn, 6rm, 6vv, 6zr, 7pv, (8ada),

8adk, 8agp, 8ala, 8ame, 8anb, 8apt, 8apy, 8arq, (8avd), (8azo), 8bhf, 8biz, 8bky, 8bux, 8bvr, 8bwz, 8bog, 8ced, (8cej), 8cer, 8enw, (8ctp), 8cyo, 8cvt, 8dae, (8dge), 8dge, 8bvz, 8dke, 8dkj, 8dkm, 8dsq, 8ab, (8al), 8bf, 8cr, 8do, 8ef, 8fi, 8hv, 8j, 8ig, 8px, 8rj, 8tr, 8so, 8vq, 8uf, 8wy, 8wa, 8zc, 8zv, 8zz. Will qsl to any of the above if they request.

At 9BTL, 1015 Thomas Ave. No., Minneapolis, Minn.

1aw, (1alj), 1bcg, 1bes, 1bdi, 1bmj, 1bwj, 1cbg, 1er, 1sn, (2agb), 2brb, 2cfb, 3aaq, 3acy, 3ajg, 3bva, (3bvl), 3ge, 3iw, 3su, (3tj), 3zo, (4af), 4cs, 4dx, 4fa, 4ft, 4gx, 4mb, 6alv, 6arb, 6awt, (6bgy), 6bhu, 6bm, 6bpz, 6bvg, 6bu, 6chl, 6pe, 6pl, 6rm, 6zah, 7agv, (7ajq), 7it, (7ly), 7wn, 7wp, 7wv, 7zd, 7zf.

By Canadian 5GO, 466 Pender St. E., Vancouver, B. C.

1bwj, 4ku, 5ht, (5lr), 5ql, 5qq, 5zav, (6fy), (6gx), (6oh), (6pe), (6tu), (6zk), (6age), (6ahu), (6ajf), (6alk), (6anb), (6aoo), (6arb), (6aty), (6bgy), (6bih), (6bpf), (6bpz), (6bql), (6brf), (6bua), (6buy), (6bug), (6buo), (6bvs), (6bwe), (6cfi), (6chl), (6cid), (6ckf), (7dc), (7fd), (7ge), (7go), (7je), (7lr), (7ly), (7nl),

(7qf), (7sz), (7to), (7wp), (7wx), (7adr), (7ael), (7ahz), (7akk), (7akv), 8gz, 8tt, 8vq, 8ada, (9ack), (9ban), (9dgv), (9dlf), (9dqe).  
Can.: 3ni, 4cl, 4dq, (4er), 4hf, 5ct, (9bp).  
Above hrd on det es 1 step audio w/out grnd  
—pse qsl my 20 watts.

By 6BUF, 4257 23rd St., San Francisco, Calif.

(6anb), 6aoi, 6apw, 6bic, 6bpz, 6brf, (6beg), 6buo, 6cbu, 6ceu, (6cfz), 6od, (6pl), 7aby, 7adp, 7it, 7ly, 7zf, 7zn, 7zu, 9amb, 9bjk, 9bun, 9caa, 9cvc. Anyone hearing my 5 watts C. W., pse ksl crd and qrk. All cards answered immediately.

By 6ZE, 6XBL

On peanut tube portable set described in January, 1923. RADIO, on a single-wire antenna 12 ft. high and 50 ft. long, near San Jose, Calif., morning of Oct. 7, 1923. (All Pacific Standard time.)

3:32 A.M.—5lr calling cq, qrz.  
3:33 A.M.—5zav signing off qrk fair.  
3:37 A.M.—9bez cqng very qrz.  
3:52 A.M.—Can. 4cl calling cq, long call—very qsa.  
3:53 A.M.—7age signing off, qrk good.

# Teleradio

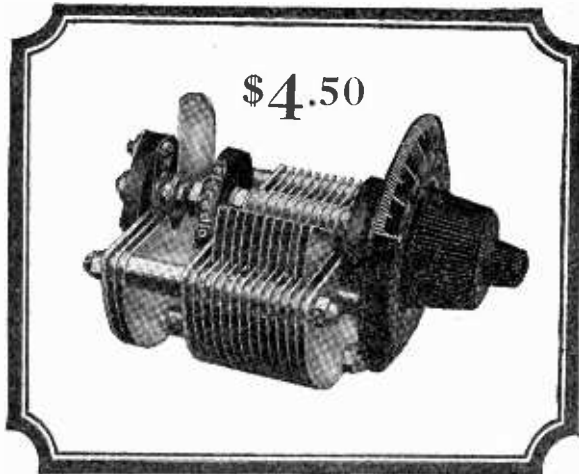

## Reliability in Your Condenser



### SUPER-SENSITIVE

Teleradio head phones accurately reproduce the faintest signals on either crystal or tube sets, and bring in voice or music with wonderful tonal quality. Equally successful for local or long distance work. Built on sound engineering principles and are so sturdy they will stand up under unusual usage.

2000 ohm. . . . . \$5.50  
2200 ohm. . . . . 6.00  
3000 ohm. . . . . 7.00

The principal factors that brand reliability in condensers are sturdiness and accuracy.

Teleradio Vernier Condensers are well worthy of these qualities. The plates are extra heavy polished hard aluminum that will not warp. Rigid construction throughout insures perfect plate alignment. Special locking feature prevents short circuiting of vernier, and provides permanent and perfect contact. Capacity is accurate and constant. All metal parts nickel plated. Built for base or panel mounting. Guaranteed electrically and mechanically perfect.

Truly, tuning is a pleasure with Teleradio Condensers.

**Teleradio Engineering Corp.**  
484-488 Broome St., New York City

VERNIER CONDENSERS, 23 plate \$4.50, 43 plate \$5.50. VARIABLE CONDENSERS, 3 plate \$2.00, 11 plate \$2.50, 23 plate \$3.00, 43 plate \$4.00. RHEOSTATS (6 and 30 ohm) \$1.00. LIGHTNING ARRESTER \$1.00.

## TELERADIO PRODUCTS



## The Ideal Gift For Your Radio Friend

Scarcely a gift you could think of will bring more genuine appreciation than the satisfaction obtained from an F-F Battery Charger.

It is shock-proof and fool-proof. It has been the one satisfactory charger for ten years past. It has no expensive parts to replace. Battery cannot discharge through it. And it utilizes both sides of the alternating current wave. (Efficiency.) The

### F-F BATTERY CHARGER

will charge a dead battery because it operates independently of battery. Copper to Carbon contactors that cannot BURN or STICK permit a desirably high charging rate.

Insist on the F-F for complete satisfaction.

Buy from your dealer. If he cannot supply you, write for literature or enclose remittance covering express or postal charges on 9 lbs.

IT'S FREE—Write for Bulletin No. 33  
**The France Mfg. Co.**  
10433 Berea Road  
Cleveland, Ohio

*Oldest Manufacturer of the First Successful Mechanical Charger.*

# “West of the Rockies”

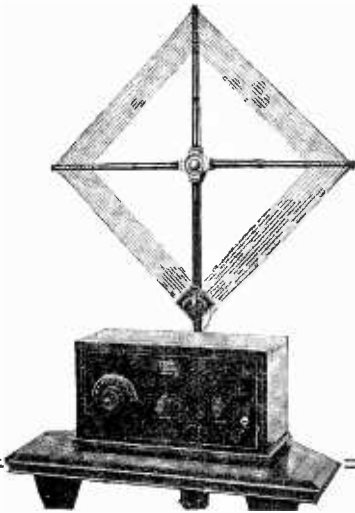

## SLEEPER MONOTROL

—would not be called “the most perfect radio set in America” if it had not demonstrated its superiority in all localities. It is as much superior West of the Rockies as upon the Eastern Coast. The Coast Coupler Company of Long Beach, Cal., for instance, writes that:

“Several of our customers report reception of stations in Frisco and Portland, Ore., on the loud speaker audible all over the room with the MONOTROL using the loop only. This is better than any other set is doing here.

“Two brothers who are violin makers have been over a year looking at and listening to radio sets. Both say that the MONOTROL is the only radio set they would want to own, because no other set has given them such perfect tonal quality.”

In Hollywood also, as introduced to the moving picture profession by Miss Marguerite Clark, the SLEEPER MONOTROL has become a favorite. Its beauty, its single simple tuning control, the clear sweet tonal quality of its reception without objectionable outside wires, are outstanding features of the MONOTROL that your dealer will be glad to demonstrate. Interesting booklet free upon request.

### Sleeper Radio Corporation

88 R. Park Place, New York, N. Y.

#### WEST COAST REPRESENTATIVES

A. S. Lindstrom,  
111 New Montgomery St.,  
San Francisco, Cal.

H. A. Killam, Electric Sales Corp.,  
312 McKay Bldg., 1144 Maple Ave.,  
Portland, Ore. Los Angeles, Cal.

George H. Maire,  
95 Connecticut St.,  
Seattle, Wash.

Alexander & Lavenson Elect. Suply Co.  
926 Howard St., San Francisco  
San Francisco Jobbers

# DX -- 10-POINT

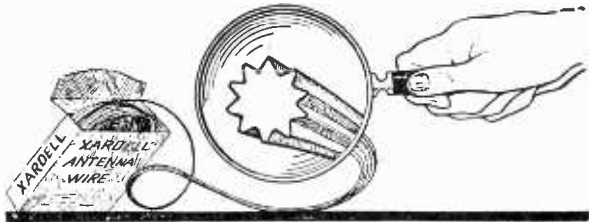

## ANTENNA WIRE

**\$2.00**  
PER  
HUNDRED  
FEET  
DEPT.-P-

Designed for long distance reception and is different and better than the usual make-shifts, being hard drawn from the finest copper, having a corrugated surface with ten collecting points on the circumference. This gives a greater collective surface to the high-frequency radio currents. The result is extremely sensitiveness and increase in range and clearness of any set from the simplest Crystal to the finest multiple tube receiver.

Use this antenna wire and enjoy the full possibilities of your set.

Sold in coils 100 feet, 200 feet and 500 feet. Order direct or from your nearest dealer.

**XARDELL CORP. UTICA, N.Y.**

## Introducing the “SR 25”

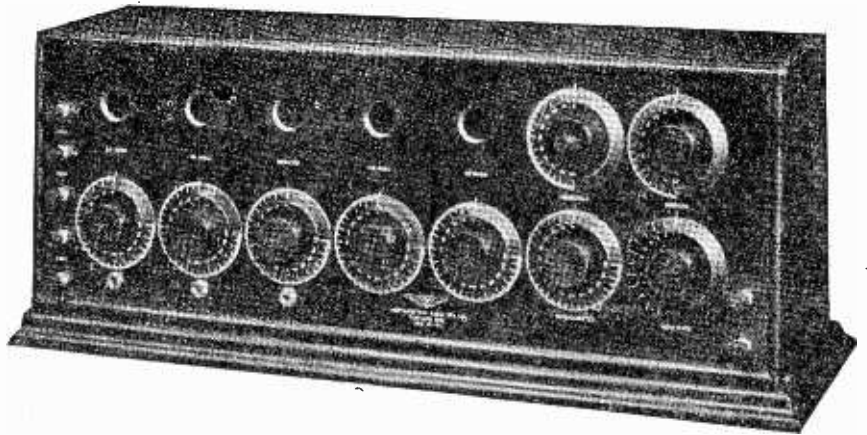

WE INVITE YOUR ENQUIRIES

### Hallock and Watson Radio Service

192 Park Street

“KGG”

Portland, Ore.

**WEIGHS ONLY 8 OZ.**

**The Scientific**

A 200,000\*\* COMPANY stands squarely back of the guarantee on every Scientific headset

**SEND NO MONEY!**

20,000 TURNS EQUIVALENT TO 3,000 OHMS

Order TODAY by Postcard and Pay Postman on arrival

**\$2.95** POST-PAID

**LOUD SPEAKER UNIT '1925**

**THE PHONE IT TOOK 15 SOLID YEARS TO DESIGN**

**We Guarantee** The Scientific Headset to be the greatest value on the market. Try it for five days. If not satisfactory send it back and your money will be refunded immediately. Circular on request. Dealers wanted.

**THE SCIENTIFIC ELECTRIC WORKS**  
98 Brookline Ave. Dept. E BOSTON, MASS.

## The Radio Dealer YEAR BOOK

1923-1924

—now out—

Complete classified Manufacturers' Lists. An encyclopedia of Radio Jobbers. A directory of Radio Trade Marks.

Complete in one volume. One Dollar per copy.

Issued by the publishers of The Radio Dealer, the Radio Trade's Monthly, and the Radio Dealer WEEKLY, for Manufacturers.

THE RADIO DEALER CO.

1133 Broadway, New York City.

Western Office  
512 Pacific Bldg. San Francisco, Calif.

Tell them that you saw it in RADIO



## CONCERNING BURGESS BATTERIES

The unique position of esteem and confidence occupied by Burgess Radio Batteries is a natural development of the conservative policy which has characterized the manufacture, advertising and sale of Burgess products.

Of interest, perhaps, to the thinking battery buyer is the fact that no Burgess product is advertised or sold until its merit has been proven, not only by our own rigid tests, but also those of the foremost radio engineers, manufacturers and experimenters in the country.

Through friendly criticism and suggestions, together with extensive research and engineering by the C. F. Burgess Laboratories the efficiency of Burgess Batteries has increased to a degree which we believe is not equalled elsewhere.

Ask Any Radio Engineer

### BURGESS BATTERY COMPANY

ENGINEERS - DRY BATTERIES - MANUFACTURERS  
FLASHLIGHT - RADIO - IGNITION - TELEPHONE  
GENERAL SALES OFFICE: HARRIS TRUST BLDG., CHICAGO  
LABORATORIES AND WORKS: MADISON, WISCONSIN

#### BRANCHES

NEW YORK BOSTON KANSAS CITY MINNEAPOLIS  
WASHINGTON PITTSBURGH ST. LOUIS NEW ORLEANS

#### IN CANADA

PLANTS: NIAGARA FALLS AND WINNIPEG  
BRANCHES: TORONTO MONTREAL ST. JOHN



## RATHBUN SINGLE-HOLE MOUNTING SUPERIOR CONDENSERS

Die-cast. Light, compact, highly efficient. Proven by 2 years' service. Plain and vernier combination types. Dealers, Jobbers, write!

Rathbun Mfg. Co.  
Jamestown, N. Y.

## ELECTRIC CURRENT FILTERS

Continued from page 12

ments are reversed, the attenuating band will be a wide one.

A band-pass filter is shown in Fig. 5. Here two blocking elements are used *in series*—a condenser for the low frequencies and an inductance for the high, and two pass elements *in parallel* give the short circuiting elements.

Fig. 5 also gives a hint of another way to design a filter, which is by a consideration of the pass-bands instead of the attenuating bands. Thus the two blocking elements in this figure taken together form a series resonant circuit, with the resonant point in the center of the pass band. Similarly the two shorting elements together form a blocking element for an intermediate frequency—

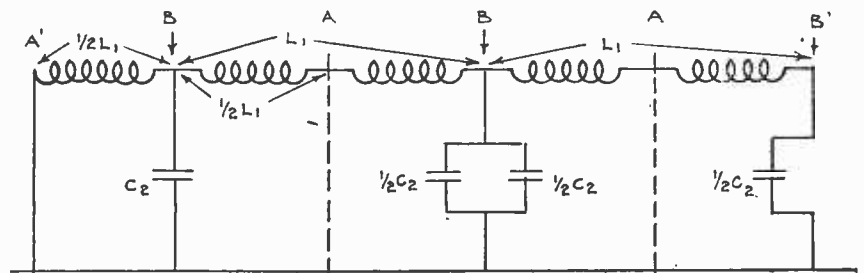

Fig. 6.  $2\frac{1}{2}$  Section Filter, T Type from Left to Right,  $\pi$  Type from Right to Left

again about the center of the pass band. The same thing is true of the other types shown. In some of the more complex types of filter the two methods of design may not lead to identical physical structures, but they will give identical characteristics.

It will be observed that, so far, resistance has been neglected. This is not because it has no effect, but because in a really efficient filter it must be reduced to a point where it is negligible. Its chief effects are to introduce attenuation into the pass bands, and to make the cut-off points less definite. It also serves to make the attenuation at the frequency of "infinite attenuation" something less than "infinite," but this effect is seldom noticeable.

It is evident that the types of filters shown by no means constitute the entire list of possible filters. Almost any combination of series and shunt impedances will act as a filter, and most such combinations are used for the purpose, in order to get desired combinations of cut-off, impedance and frequency of maximum attenuation. The forms shown, however, are the basic ones from which to derive the more complex types. No attempt will be made here to discuss these latter structures, but one such section will be used in connection with the low-pass filter given later.

Before going on to the subject of design, there are a few minor matters that should be cleared up, as to types of filter, definition of a "section," and choice of type for a particular use. Fig. 6 shows

a typical low-pass filter of  $2\frac{1}{2}$  sections. We may read from left to right and consider the sections as extending between the lines *aa* in which case we have a T type filter, or we may read from right to left and consider the sections as extending between the arrows *bb*, which gives a  $\pi$  type filter. The half sections of which the two types are formed are identical, the difference being only the order in which they are arranged. They are equally efficient and for many purposes there is no choice between them. If the source of current supply is of constant potential, however, a resonant series circuit directly across the line may well draw a destructive current, as it is practically a dead short across the line. The actual current of attenuating frequency will be less if the

series member is inserted before the shunt member, and hence the T type is preferable.

The T section filter is said to be terminated in mid-series; the  $\pi$  section in mid shunt. Accordingly the impedance of the end member of a T-type filter is only  $\frac{1}{2}$  of the impedance of the section as used in computation. The  $\pi$  type filter is terminated in mid shunt, and the admittance of the shunt member is  $\frac{1}{2}$  the admittance of the section (admittance is the reciprocal of impedance). This means that the impedance of each of these shunt members is double that of the section. Going back to Fig. 6, it will be seen that just as the inductance at *a* is formed by two coils like that at *a'* *in series*, so the condenser at *b* is really formed of two like that at *b'* *in parallel*. All this may be stated as follows: In a T filter the impedance is divided and half is placed on either side of the shunt member. In a  $\pi$  type, the admittance is divided and half is placed on either side of the series member.

Most authors on the subject of filters emphasize the importance of the resistance of the load. This is entirely justified from the telephone engineer's point of view, as he must balance the filter against the line in order to avoid reflections and "echoes" which not only disturb transmission but waste power and attenuate where no attenuation is wanted. A filter balanced against its output impedance is also desirable in that it avoids excessive current or poten-

Continued on page 82

Tell them that you saw it in RADIO



**The Saturn**  
**"Above the Ordinary"**  
**Radio Products**  
 Automatic Plug

Terminal tips inserted, or removed in a moment. Perfect electrical connection without taking apart or soldering. Your satisfaction with the *Saturn Automatic Plug* unreservedly guaranteed.

**\$1**

**Perfect Jack**  
 A difficult soldering job made easy by crow-foot offset and solder-flex compound on blades. Brass brackets, nickel-plated with rounded corners. Blades of spring German Silver. Solid silver contact points. Right in every detail.

**List Prices**

No. 1	Single Circuit, Open	50c
No. 2	" " closed	55c
No. 3	Double " "	70c
No. 4	Single Filament control	75c
No. 5	Double " "	80c

Write for Folder

**The SATURN Mfg. & Sales Co.**  
 48 Beekman St.  
 New York, N. Y.

# Enhance Your Set With "PIONEER"

**Beauty Is Only Skin Deep? —not always**

Might just as well build a good looking set as not.

Build your set with Pioneer Variometers and Variocouplers and you have a set whose instruments are not only the most efficient yet devised but, for sheer beauty have nothing to equal them.

Pioneer Variometers and Variocouplers are made of genuine Bakelite, moulded in our own factory. A rich deep mahogany finish—the wiring is covered with pure green silk. The hardware is heavily nicked. It will stand up. All contacts are positive—both instruments are made for either table or panel mounting.

Ask your dealer or write us.

**PIONEER RADIO CORPORATION**  
 107 Pioneer Ave., GALESBURG, ILL.  
 Sales Agents in All Large Cities

**LEARN RADIO**

Here's your opportunity. Radio needs you. Win success in this fascinating field. Trained men in demand at highest salaries. Learn at home, in your spare time.

**Be a Radio Expert**

I will train you, quickly and easily, to design, construct, install, operate, repair, maintain, and sell all forms of Radio apparatus. My new methods are the most successful in existence. Learn to earn **\$1,800 to \$10,000 a Year**

**FREE** Wonderful, home-construction tube receiving set, of latest design. Write for "Radio Facts" free. Engineer Mohaupt. American Electrical Association Dept. 812 4513 Ravenswood Ave., Chicago

**HIGHEST QUALITY SILVERTONE Lowest Price TUBES**

**O-T SILVERTONE DETECTOR AND AMPLIFIER**

Model...O-T9  
 Fil.Volt. 2 to 4  
 Fil.Amp. .06

ONE PRICE \$6.00 Everywhere

Send no money—Pay the postman. Money back, without question, if not exactly as represented.

Manufactured by DeForest Tel. & Tel. Co. Exclusively for the O. & T. Electric Corporation 1819 Broadway New York High class representatives wanted.

**\$650**

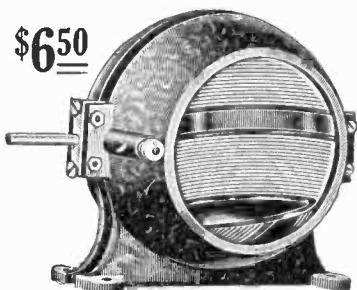

"Pioneer" Variometer

**\$700**

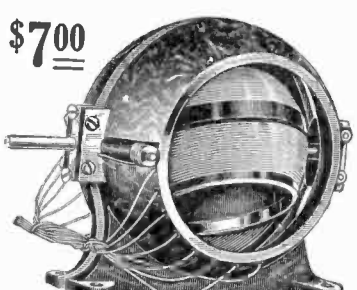

"Pioneer" Variocoupler

**GUARANTEED TUBE REPAIRS**

W.D.11	3.50
W.D.12	3.50
U.V.200	2.75
U.V.201	3.00
C.300	2.75
C.301	3.00
U.V.201A	3.50
C.301A	3.50
D.V.6A	3.50

All tubes positively guaranteed to be satisfactory. Special discounts to dealers. Tubes returned P.P., C.O.D.

**HARVARD RADIO LABORATORIES**  
 200-204 Old Colony Ave.  
 So. Boston, Mass.

**Loud Speaker \$1**

**Radio Adapter \$1**

Hear all broadcasting through phonograph. Make your own horn. Attach B-R Phonadapter to YOUR phonograph. All can hear. Entire family, neighbors, guests can hear operas, lectures, latest news, with this adapter. Stretches over receiver of any standard type head-set and attaches to tone-arm of ANY phonograph. Made of soft pure gum rubber. Quickly attached and removed. Thousands in use. Will not amplify or distort. For single receiver. For pair of receivers (more than twice the volume) \$1.50

Go to your dealer. If he cannot supply you send money order, check or currency at our risk. Prompt delivery—postpaid. Also send us name of favorite radio dealer.

**The Beckley Ralston Company**  
 1815 So. Michigan Ave., Chicago, Ill.

Tell them that you saw it in RADIO

Continued from page 80

tial rises due to resonance which might prove troublesome.

For the uses of the radio amateur, however, the exact cut-off point is seldom a matter of importance. A low-pass filter for his plate supply, or a high pass to cut induction hum out of his receiver, is all that he needs, and as long as the objectionable frequencies are cut out, the exact cut-off means very little and even fairly wide departure from the theoretically correct resistance will not result in dangerously high voltages. Therefore, in designing his filter, the amateur will estimate the resistance of his load, but if he misses it by 50% the effect upon the filtering will not be noticeable. Therefore, we will ignore the attenuating effect of reflections, and say that our cut-off points come where  $Z_1 = -4Z_2$ . Here  $Z_1$  is the total series impedance per section, and  $Z_2$  is the total shunt impedance per section. Do not use the half quantities at the end of a section in this formula. The minus sign indicates that if the series reactance is inductive the shunt reactance must be capacitive, and vice versa.

The impedance of a condenser is  $1/2 \pi f C$ , where  $\pi = 3.1416$ ,  $f =$  frequency in cycles and  $C =$  capacitance in farads. That of an inductance is  $2\pi f L$ , when  $L$  is the inductance in henries. In a low-pass filter the inductance  $L_1$  is the series member and the capacitance  $C_2$  the shunt. By substituting these values in the equation  $Z_1 = -4Z_2$  we obtain  $2\pi f L_1 = 4/2 \pi f C_2$ , whence  $f = 1/\pi \sqrt{C_2 L_1}$ , which is the cut-off point for the low-pass filter. Likewise, for the high-pass filter the capacitance  $C_1$  is the series element and the inductance  $L_2$  is the shunt element. Therefore  $1/2 \pi f C_1 = 4 (2\pi f L_2)$  and  $f = 1/4 \pi \sqrt{C_1 L_2}$ . The subscript 1 always indicates a series element and 2 a shunt element.

The type of filter used for eliminating commutator ripples or for "smoothing out" rectified a.c. is almost always of the simple low-pass type. The fundamental of rectified a.c. (60 cycles) has a frequency of  $2 \times 60$  or 120 cycles. Near to its cut-off point a low-pass filter attenuates very little, the attenuation rising toward infinity as the frequency increases. It might, therefore, seem more logical to use a high and low-pass filter, giving infinite attenuation at 120 cycles, and a very sharp rise of attenuation from cut-off. The reason for not doing this is that the wave form of a rectified sinusoidal current is not sinusoidal, but is made up of an infinite number of sinusoidal components. Moreover, although the lower frequencies of this series are the audible ones, it is the higher ones which are most undesirably effective in spreading out the transmission side bands and causing interference.



# The Trinity Loud Speaker

TYPE "A1"  
\$25.00  
21-in. Fiber Horn

The only device of its kind in the Radio field

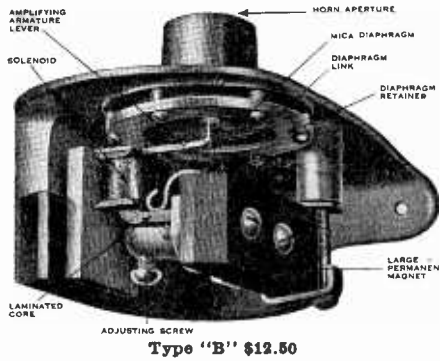

Study the illustration carefully and you will understand why it produces full, clear, natural tones with perfect reproduction of all vocal and instrumental music. May be used with phonograph. No storage battery required.

The Trinity Loud Speaker is an instrument that combines the best qualities of a phonograph reproducer in combination with electro magnetic principles best fitted for radio amplification. Absolutely perfect reproduction of all music and speech without distortion. The volume may be regulated from that required for a room in your home to a tremendous output that can be heard hundreds of feet out of doors by simply increasing "B" battery voltage. No storage batteries required. The instrument is of a heavy duty type and is guaranteed fully by the manufacturers.

Ask your dealer for demonstration—if he cannot we can.

## TRINITY RADIO CORP.

446 Tremont Street

BOSTON, MASS.

### RADIO RECEIVING TABLE for \$8.00—Delivered!



Hardwood,  
Hand-rubbed  
Mahogany  
Finish

Size—15 in. x 28 in. x 29 in. high.  
Legs—1 1/2 inches square.

Underneath table is a battery tray fastened with two buttons—can be detached instantly. Tray not visible except by looking underneath table. Size of tray—3 in. x 8 in. x 18 in. inside measurement.

#### PRICES

No. 60-R Radio Table complete.. \$8.00  
To east of Miss. river.....\$6.75  
All transportation charges PREPAID.  
Cash with order.

The above table is very low in price but high in quality. Rigid, strong, and will be an ornament in any home.

We manufacture Radio Furniture of all kinds—Desks, Tables and Cabinets

THE SOUTHERN TOY CO. Inc.  
Hickory, North Carolina

## PHONES That Satisfy

For tone volume, clarity, and sensitiveness these instruments will afford greatest satisfaction.



### Burns

Loud Speaker  
A single unit with convenient tone adjuster. Adaptable to phonograph or loud speaker horn. Requires no battery. PRICE \$10.00

#### HEAD SETS

These several styles of Head Sets have been designed to meet requirements of different types of receiving sets.



- Victor .....\$5.00
- Keystone ..... 5.00
- Swedish-American 2200 ohm.... 6.00
- Army & Navy 2500 ohm..... 8.00
- Army & Navy 3200 ohm.....10.00

Dealers' inquiries solicited

*American Electric*  
COMPANY  
Chicago, U. S. A.

**AMPERITE**  
AUTOMATIC FILAMENT CURRENT ADJUSTER  
FOR EVERY STANDARD TUBE  
ELIMINATES RHEOSTATS  
EXPELS ALL TUBE TROUBLES

FROM YOUR DEALER OR  
RADIALL COMPANY  
554 GRAND AVE., NEW HAVEN, CONN. \$1.10 WITH MOUNTING

"Hear it by Radio"  
Denver's Largest Exclusive Radio Wholesalers  
**PARAGON DISTRIBUTORS**  
THE ROCKY MOUNTAIN RADIO CORPORATION  
1512-1516 Broadway Denver, Colorado

Tell them that you saw it in RADIO

# An Engineering Achievement

## K & C NEW VARIABLE CONDENSER IS 100 PER CENT

THE day of the unstable variable condenser has passed. The Kilbourne and Clark Mfg. Co. hastened it and now have passed it. The new type K-C variable condenser is the answer. This condenser is the outcome of months of study of the faults of all variable condensers. It is the embodiment of all that is desirable. Objectionable, faulty features have been eliminated down to the most minute point.

The K-C variable condenser of the new type is mounted on two pure bakelite moulded end plates, this high grade non-hygroscopic insulating material preventing the leakage so common with cheap moulded substitutes. The shaft of the rotor plates revolves in bronze bushings that are moulded in. These bushings give a wear-proof permanent bearing that obviates enlarged shaft holes and resulting short circuits and explosive noises in the head phones. There are no sliding contacts. The rotor plates are correct connected with a lug by means of flexible Belden braid, affording a direct and positive contact.

The K-C vernier condenser comes with dial, correctly marked from 0 to 100, and a separate control knob for the vernier adjustment. The vernier is a two-plate extension on the condenser that has been designed to give the greatest breadth of movement in tuning in the faintest of signals.

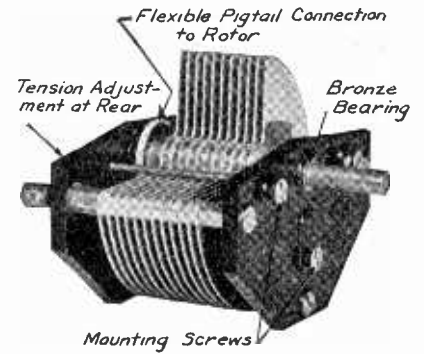

View Showing Typical Construction

## Kilbourne & Clark Mfg. Co.

Head Office & Works, Seattle

### BRANCH OFFICES

Portland, 305 Larrabee St. Phone 6156.  
 San Francisco, 591 Mission St. Phone Sutter 40.  
 Los Angeles, 1103 W. 10th St. Phone 581-002.  
 New York City, 80 Washington St.

A HIGH-GRADE COMPLETE LINE OF RADIO PARTS FOR EXCLUSIVE USERS

For 10 years we have built radio apparatus for ships, shore stations, U. S. Navy, amateur and experimental use.

Cat. No.	Capacity	No. of Plates	List Price
3	.00003 mfd.	3	\$2.50
7	.0001 mfd.	7	2.75
13	.0002 mfd.	13	3.25
17	.0003 mfd.	17	3.35
23	.0005 mfd.	23	3.50
31	.0007 mfd.	31	4.75
43	.001 mfd.	43	5.00
63	.0015 mfd.	63	7.75

For condenser with vernier adjustment add \$2.00 list to above prices.



Your Guarantee

## T-B-H PHONES



6-A  
3200 ohms

Junior  
2000 ohms

Ideal  
Christmas  
Gifts

T-B-H Headsets reproduce clearly and naturally.—Extremely sensitive. ALUMINUM CASES

Type 6-A 20500 Turns (3200 ohms).....\$7.00  
 Junior 16000 Turns (2000 ohms).....\$5.00

If your dealer does not carry them, order from our nearest distributor.  
 Dealers and Jobbers—Write for Discounts.

**The T-B-H Corp.**  
 Dansville, New York, U.S.A.  
 DISTRIBUTORS

The Eastern Specialty Co., Philadelphia, Pa.  
 Donaldson Radio Co., Kansas City, Mo.  
 Marie A. Alvarez, Havana, Cuba  
 V. R. & A. C. Johns, Auckland, New Zealand

## Amplification perfection

with an audio transformer  
means PURE TONE QUALITY  
with MAXIMUM VOLUME.

The *AMERTRAN*  
—REG. U.S. PAT. OFF.—



### AUDIO TRANSFORMER

is acknowledged by professional radio engineers to be the Standard of Excellence for audio amplification.

The reason for the popularity of the AmerTran among professional radio men is apparent in the Amplification Chart shown in our Circular No. 1005.

Price \$7  
 Ask your electrical dealer, or sent carriage charges collect. (Wt. 1 lb.)

Turn ratio 5:1. Amplification ratio, 30-40 times audibility in the flat part of the curve.

## American Transformer Company

Designers and builders of radio transformers for over 20 years.

174 Emmet St.,  
 Newark, N. J.

Pacific Coast Office  
 Rialto Bldg., San Francisco

Continued from page 86

is not attracted and contacts do not close. Thus charging the battery on the negative half wave is avoided. However, when the a.c. magnet is excited in the same direction as the d.c. magnet the total pull on the armature is increased and the armature attracted, thus closing the contacts. When the vibrating contacts are closed current flows through the armature contacts and battery and charges the latter. Thus only once during each cycle does the magnetizing force become great enough to attract the armature and close the contacts. The armature is designed so that its natural period of vibration is approximately the same as

the frequency of the a.c. Thus 60-cycle battery chargers have armatures which have natural periods of about 60 cycles per second. The tension of the armature may be adjusted by means of a thumb screw, in this way bringing the natural period of vibration of the armature exactly in tune with that of the a.c. supply, thus assuring that the armature vibrates in synchronism with the a.c. and operates the contacts but once each cycle.

If the battery terminals are reversed the charging current will still be in the right direction. For with reversal of battery terminals the d.c. magnet coil *A* will be energized in the opposite direc-

tion. In order for the armature to operate and close the contacts the a.c. coil will have to be energized in the opposite direction to assist the d.c. magnetization. When this occurs the charging current flows through the battery likewise in the opposite direction, which is the proper direction, since the battery terminals were reversed. Thus, irrespective of how the battery terminals are connected to the charger, the battery is charged in the right direction, i.e. the charger is "self-polarizing."

When a.c. power is not supplied to the charger, the battery, if connected to the charger, should not have a tendency to discharge through the transformer winding. This is automatically taken care of by the fact that since the a.c. magnet coil *B* is not excited there is not enough pull on the armature to close contacts, thus preventing discharge of battery. On the other hand, to conserve energy, it is desirable that when the battery is not connected the charger should not operate even though it is connected to the a.c. power supply. This is doubly taken care of as follows: First, since only the a.c. is effective in magnetizing the electro-magnet, insufficient power is available to attract the armature. Secondly, even if there were enough power to attract the armature, it would not vibrate, due to the fact that this attractive force would be exerted twice during each cycle of the a.c. But since the armature is designed to have a natural period one-half this frequency, it will not vibrate.

Like the gas-filled rectifier, this charger requires only two connections to be made: A screw plug fits into a lamp socket for obtaining a.c. charging current, and connections must be made to the battery terminals. The actual charging of batteries is therefore reduced to a very simple operation.

Although it may be a very spectacular experiment, don't try fusing copper wire across a lead storage battery, as it will quickly ruin it. On the other hand, if you have a sluggish Edison battery, this treatment is beneficial, and a short-circuit discharge once in a while is a good thing!

## Samson HW-A1 AUDIO FREQUENCY Transformer



THE SECRET OF

ITS SUCCESS

### Constructed with Helical windings

in both primary and secondary Coils (an exclusive feature), the Samson Transformer has proven its superiority under actual operating conditions. In a nutshell:

- a—The Effect of Distributed Capacity Reduced to a Minimum.
- b—Resistance Reduced to a Minimum.
- c—The Effect of Current Leakage Between Adjacent Wires. Reduced to a Minimum.
- d—Clearer Reception—No Howling.

**Note the Coil pictured above;** wires are in *layers* at right angles to the core. Write for detail story of the advantages of this *Exclusive Samson Patent*. Free Chart No. 24 of Tests will be included.

The next time at your dealers, examine Radio's newest achievement; ask about the

Ratio 6 to 1

Samson  
HW-A1  
AUDIO FREQUENCY  
Transformer

\$7 at Dealers

SALES OFFICES:

Boston, New York, Philadelphia, Pittsburgh, Atlanta, Chicago, Cleveland, Detroit, Indianapolis, St. Louis, Minneapolis, San Francisco, Los Angeles, Seattle, Portland, Montreal and Toronto.

SAMSON ELECTRIC COMPANY, CANTON, MASS.

The New Indestructible

### Metaelectric Soldering Iron

Operates with the simplicity, comfort, ease, and efficiency of a Pen on any electric circuit.

\$5.50

"worth it"

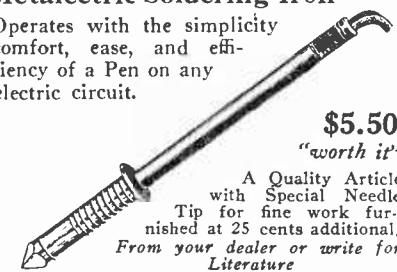

A Quality Article with Special Needle Tip for fine work furnished at 25 cents additional. From your dealer or write for Literature.  
POST ELECTRIC CO., Mfrs. (5th Div.)  
30 East 42nd St., New York City



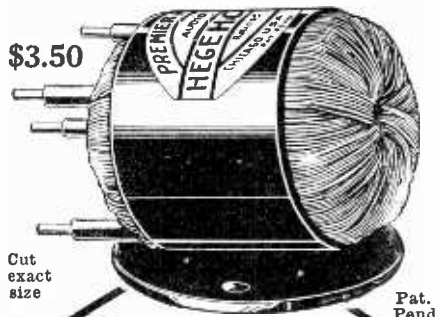

\$3.50

Cut exact size

Pat. Pend.

Hear Them ALL CLEARLY with Premier

**"HEGEHOG"**

Trade Mark Audio Transformer

Little but mighty—a wizard for volume and tone quality. Look at the cut. It shows the "HEGEHOG" one-half actual size. "Small," you say. Yes, but inside this "Little Wonder" you will find more efficiency, more reproduction volume, and less distortion than found in any other Transformer, regardless of size, price or design. The secret is in its patented construction. It is shielded 100% against foreign noises. Fully guaranteed. You'll want them in your next "hook-up," so get all the facts NOW. Our Free Bulletin No. 93 gives them fully. Send for it.

**Premier Electric Company**  
3813 Ravenswood Ave. Chicago

Sales Offices:  
817 West 3rd St., Los Angeles  
445 Stark St., Portland  
Ask your Dealer for "HEGEHOG"

**RHAMSTINE\***

Presents the New Victophone  
--for all Phonographs and Loud-Speaking Horns



**\$7.50 Postpaid**  
Complete with Cord

Relentless research in the field of loud-speaker units has resulted in Rhamstine\* achieving the ultimate in tone and volume. The New Victophone will exceed your expectations; you will appreciate its superiority upon comparison with other loud-speakers. Every part of this new Phonograph unit was designed and built to excel in efficiency and in beauty all other makes. It can be furnished to fit all phonographs—the Standard Type fits the Victrola, Columbia, Jewett or Sonora. Specify make of phonograph when ordering. List Price, Standard Type, \$7.50.

Order the New Victophone and test it before buying any other loud-speaker.

Manufactured by

**J. THOS. RHAMSTINE\***

500 E. Woodbridge, Detroit, Michigan  
★Maker of Radio and Electrical Products

**Acoustically Correct!**

The Trimm extra large Loud Speaker unit with its wonderful ADJUSTO instantly regulating loud speaker to signal strength insures greatest volume without flaws or distortion. At three prices:

**ACOUSTICOLA STANDARD MODEL \$22.50**

Standard Model with non-metallic horn, 21½" high; bell 10" diam.

**ACOUSTICOLA GRAND \$35.00**

With solid Cast Aluminum Horn; the world's finest loud speaker.



Acousticola Grand

**ACOUSTICOLA PHONOGRAPH ATTACHMENT \$10.00**

TRIMM HEADSETS

"PROFESSIONAL" model—3000 ohm \$7.65

"DEPENDABLE" model—2400 ohm \$5.00



Any Trimm product shipped and sold on approval and Guaranteed FOR LIFE. Write for descriptive folders. Mention your dealer's name.

**TRIMM RADIO MFG. CO.**

24-30 S. Clinton St.

DEPT. 58

Chicago, Ill.

**Just Out!**

*The New* **RADIO BATTERY EVEREADY "THREE"**

THREE CELLS ~ THREE TERMINALS ~ THREE PURPOSES

May be used—

As an "A" Battery for portable sets having UV-199 Tubes.

As a "B" Battery for obtaining additional "B" Battery voltage.

As a "C" Battery for furnishing negative potential to amplifying Tube Grids.



Eveready "Three" has three Fahnestock Spring Clip Connectors making it possible to secure 1½, 3 or 4½ volts from the battery.

Ask your dealer or write us for circular No. 1025 giving complete information on this NEW Three Purpose RADIO BATTERY. Order Eveready "Three" by catalog number 771.

Made by the largest dry battery manufacturers in the world—makers of the famous

Eveready Storage "A" Batteries for Storage Battery Tubes;  
Eveready Dry Cell Radio "A" Batteries for Dry Cell Tubes;  
Eveready "B" Batteries for all Vacuum Tubes.

NATIONAL CARBON COMPANY, Inc.

San Francisco, Calif.

Los Angeles, Calif.

RELIABLE

**EVEREADY**  
Radio Batteries

NOISELESS

—they last longer

Tell them that you saw it in RADIO

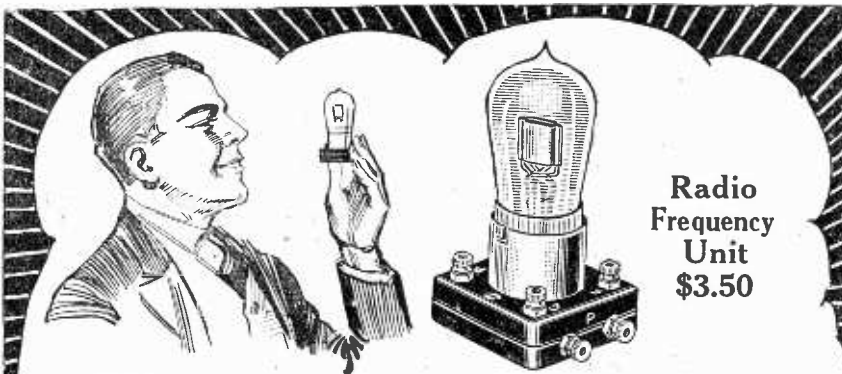

**Radio  
Frequency  
Unit  
\$3.50**

**Make Your Radio Tubes Give You  
Full Service!**



**Radio-Frequency  
Transformer  
\$2.50**

Just as several messages pass over the line at the same time in modern telegraphy, so in the modern Radio circuits two frequencies can be amplified by the same tube.

Our Engineers have perfected the United Radio Frequency Transformer. Its success in reflex circuits, when used with United Audio Frequency Transformer has been so pronounced as to be the outstanding advance in Radio this season.



**Audio-Frequency  
Amplifying  
Transformers  
\$4.50**

To get the best results from the circuit you use to build your set, you must use the parts stipulated in the circuit diagram.

Our reflex circuit is yours for the asking. Its long distance reception and strength of signals will both please and surprise you, but it must be built with United parts; we cannot recommend it otherwise.



**Condensers  
Vernier & Plain  
\$2.25 to \$6.50**

**UNITED RADIO PARTS**

**Special Transformer**

We are in a position to supply special Transformer, having split primary and secondary, adaptable for Push-Pull circuits. Price \$11 per pair.

**United Mfg. & Distributing Co.  
9705 Cottage Grove Avenue  
Chicago, Illinois**

*New York Office  
50 Church Street  
New York, N. Y.*

*San Francisco Office  
709 Mission S.  
San Francisco, Cal.*

**IMPROVEMENTS IN RECEIVER**

*Continued from page 16*

Leave taps every 10 turns, beginning with the 30th.

A good way to mount this coil is as follows: Slot a piece of board, as shown in Fig. 4. This should be long enough



*Fig. 4. Spiderweb Mounting*

so that one or both ends may be screwed to baseboard of your set. Next glue the shaded portion of the form (Fig. 2) into the slots—after gluing the forms into the slots, the stove bolts through the center may be removed. The distance that the double spiderweb should be mounted from the variometer is best determined by experiment.

A potentiometer across the *A* battery with the grid return *b* connected to the movable arm is some help in tuning, but the experience of the writer has been that it is more of a luxury than a necessity. Increasing the value of condenser *a* will increase regeneration to some extent.

This circuit has been built up using UV-200 for detector and 201's for 2-stage amplifier. The writer has taken it to several homes and compared it with other single and 3-circuit tuners. It compares very favorably with the best of them. The writer has also received several stations without interference from WOC, which is about three miles away.

The circuit is all that 6ZJ claimed for it and more. He is to be given credit for designing a real receiver and one that will fit the average pocketbook.

**A Socket of  
Exceptional Merit**

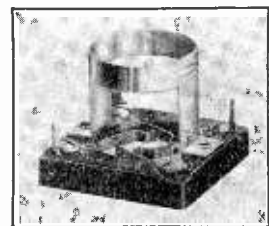

**SPECIFICATIONS**

1. Contact springs and terminals of one piece heavy phosphor bronze.
2. Convenient screw terminals of large dimensions.
3. Handy soldering terminals.
4. Skeleton sleeve allows for inspection of tube contacts without removal of socket.
5. Base, high grade moulded insulation 2 1/2 inches square.
6. All metal parts highly polished and heavy nickel plated.

*At your dealers or by mail  
on receipt of purchase price*

**Price Only 50c**  
**WEIN SALES CORP.**  
254 Park Ave. Brooklyn, New York

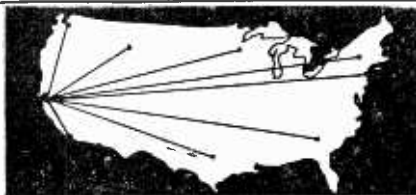

**ONE TUBE**

Broadcasting from Atlantic Coast and Cuba heard in California by users of the *Cross Country Circuit*. This range is due to simplicity of set as only one operating control is used in tuning. Any novice can build it easily and cheaply. Dry cell tubes may be used. Complete instructions, Blue Print panel layout, assembly photo, etc. postpaid for 25c. Stamps accepted.

**VESCO RADIO SHOP**  
BX R-117 OAKLAND, CAL.



**WILL SAVE YOU TIME, LABOR AND MONEY**

Ask your dealer for HORTON'S. Imitations will not operate.

List Price \$2.00

Attractive Discounts to Dealers and Jobbers

Write for FREE Literature

**HORTON-SNYDER MFG. CO.**

333-5 Washington St., Brooklyn, N. Y.

Tell them that you saw it in RADIO

The low-pass filter is increasingly effective as the frequency rises, and therefore a filter of this class which eliminates the fundamental passably well will block off the higher frequencies even better. It has been termed the "brute force" filter, but there are occasions where "brute force" is justifiable. Better than this, however, is to combine a section designed specifically to give maximum attenuation at 120 cycles with a low-pass section. In this way a high degree of attenuation may be obtained at all frequencies.

Some practical filter designs will be given in the second half of this paper to be published later.

## Cold Winter Nights

Won't find you on the roof fixing the aerial—removing snow and sleet, exposing yourself to sickness, if you use



### ANTENELLA

(No aerial or antenna needed.)

A light socket plug that eliminates all outside wiring, lightning arresters and other inconveniences. Merely plug Antenella in any light socket and you can enjoy the best in radio in any room in the house.

Now Only \$1.25

At your dealers—otherwise send purchase price and you will be supplied postpaid.

**Chas. Freshman Co. Inc.**  
Radio Condenser Products  
106 Seventh Ave., New York.

*Approved!*



### A FISCHER Product

Even the Experts Look No Further—They Know

This 180° Multi-Coupler is splendidly built, Bank-wound, with a wave length of 800 Meters, 5 Soldered Leads, Bankwound Stator on genuine Bakelite Tubing, Kiln Dried Rotor, Fahnestock Spring Clip Connections, Aluminum Mounting Base, Non-conductive Adhesive.

20 Diagrams \$4.50 Free with Each

For sale at your dealer's—otherwise send the \$4.50 directly to the manufacturer and you will be supplied postpaid.

**G. H. FISCHER & CO.**  
123 Liberty Street New York City

## The Original AUTOMATIC TELEPHONE PLUG!

### COMSCO BULL DOG GRIP PLUG

### Eliminates plug troubles

Saves you from short circuit and battery kicks. No more burned out phones or ruined transformers. No more broken finger nails.

Simple to operate  Bull Dog Grip Plug

**INSERT**  
By a single touch and the connecting tips of your phone cords accomplish automatically the most perfect electrical contact



FOR ONE PAIR PHONES \$1.00  
FOR TWO PAIR PHONES \$1.50



**RELEASE**  
by pressing the small knob and the tips will slide out easily without pulling the electrical contacts

For sale at your dealer. Otherwise send purchase price to us and you will be supplied

**GENERAL INSTRUMENT Co., 123 Liberty St., N.Y.C.**

Better Than Ever!

### The Improved *Sterling* PORTABLE RECTIFIER

Meets the Latest Requirements of Battery Charging

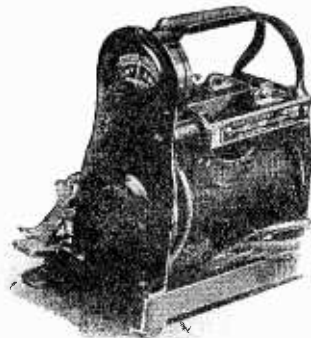

Recent developments in the radio field instigated new improvements in the design of the Sterling Rectifier. The 5 ampere maximum charging rate has been adopted and with it the number of contacts has been reduced to one, offering more simplicity and ease of adjustment. Special wear-resisting carbons of large cross section area prevent freezing and sticking. Quiet in operation. No consideration of polarity necessary in connecting to battery. Cannot overcharge battery because of tapering charge.

List Price \$17.00

Ask us about the new Sterling "B" Battery Charging Attachment. Just the thing you need for complete charging efficiency. Price \$5.00.

**The Sterling Manufacturing Company**  
281 Prospect Ave. Cleveland, Ohio  
**DETSCH AND COMPANY**  
Pacific Coast Dist. 555 Turk St. San Francisco, Calif.



## Prompt Shipments

A Radiola for every purpose and purse

IT'S early to talk of "shortages" and "slow deliveries," but business is bigger and better every day and all indications point to a demand this fall and winter far ahead of our manufacturers' ability to meet.

In this connection we remind you that our stock of both sets and parts—everything worth while in radio—and plenty of all—is complete, and your mail orders will be taken care of immediately.

We pay the postage—send your next order to us and be surprised at our quick action!

**COAST RADIO CO., INC.**  
El Monte California

# ELECTRAD PRODUCTS



## The NEW DIODE

A revelation for all reflex work. Replaces the crystal and overcomes all former difficulties of reflex circuits. Requires no adjustments for change of wave lengths. Gives you the clear reproductions of a crystal with the sturdiness and reliability of a tube. No "B" batteries required. Operates on less than 1/2 ampere from single dry cell. Easily adapted to Erla and all other circuits.

\$2

Socket 50c



## The NEW VARIOHM

The latest invention in variable grid leaks. Each movement gives a definite new resistance. Positively does the work where others fail. A gradual resistance over entire range of 1/4 to 10 megohms. Eliminates circuit noises, is moisture proof and non-microphonic. Ideal for use in Miloplex and other circuits. Guaranteed.

75c

## The LEAD-IN

Fits right under closed window. Can be bent into any shape to fit ledges. Covered with fire-proof insulating material which prevents grounding of circuits on wet window sills. Takes the place of ungainly porcelain tubes and holes in the window sash. Always presents a neat appearance.

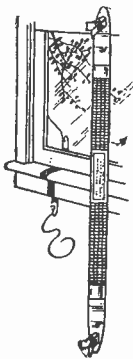

40c

All products at your dealers, otherwise send purchase price and you will be supplied postpaid.

Write for FREE Cockaday-Diode Reflex Circuit.

**ELECTRAD, Inc.**  
428-E Broadway  
New York

## STORAGE BATTERY CHARGERS

Continued from page 24

rent flows through the battery and charges it. The instant the current reverses to the negative half of the a.c. wave the contacts break and no current can flow through the battery. Thus we have a half wave rectifier.

This rectifier, however, must meet more complicated conditions. In the first place precautions must be taken that the battery will not discharge while charging. Suppose that the battery B has a voltage equal to OA, Fig. 10, at

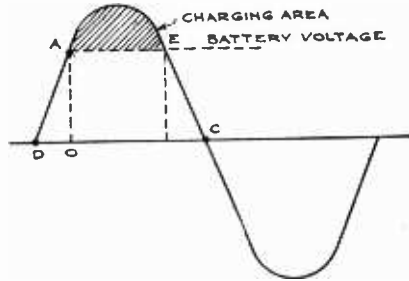

Fig. 10. Diagram of Charging Cycle

the commencement of charging. If the vibrating contacts close during the positive half cycle between DA and CE, the battery voltage will be greater than the charging voltage, hence the battery will discharge through the transformer, thus vitiating the effects of charging. Furthermore, if the contacts should close at any time during the negative half cycle the charging current from the transformer will flow in the opposite direction through the battery, which is equivalent to discharging the battery. It is therefore seen that the vibrating contacts must close and the charging current must flow through the battery for the small portion of the a.c. cycle represented by the shaded area in Fig. 10, at which times the charging voltage is equal to or greater than the battery terminal voltage. Since this occurs but once during each cycle the vibrating contacts must be timed to synchronize with the frequency of the charging a.c. If we deal with 25 cycle a.c. the contacts must

be timed to close 25 times each second, and so on. In order to obviate the possibility of the charging current flowing through the battery in the wrong direction and so help to discharge the battery, the rectifier must be "self-polarizing," that is, the charging current must flow through the battery in the right direction irrespective of how the battery terminals are connected to the rectifier.

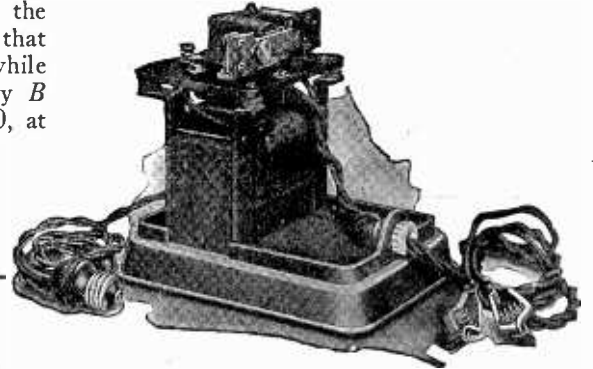

Fig. 11. Typical Vibrating Contact Rectifier

How these conditions are met in practice will best be seen from a consideration of a standard typical charger, a picture of which is seen in Fig. 11. The schematic connection diagram of this charger is shown in Fig. 12. The complete charging outfit consists essentially of the following parts:

- (a). A step-down transformer T for reducing the line voltage from 110 or 220 volts a.c. to the voltage necessary for charging the battery. This transformer is seen mounted directly on the base in Fig. 11. The transformer should be efficiently designed to reduce losses which go to increase cost of charging batteries. It should also be designed so that it will be capable of withstanding reasonable overload without undue heating.
- (b). An electro-magnet M, Fig. 12, seen in Fig. 11 mounted on top of the step-down transformer,

Continued on page 86

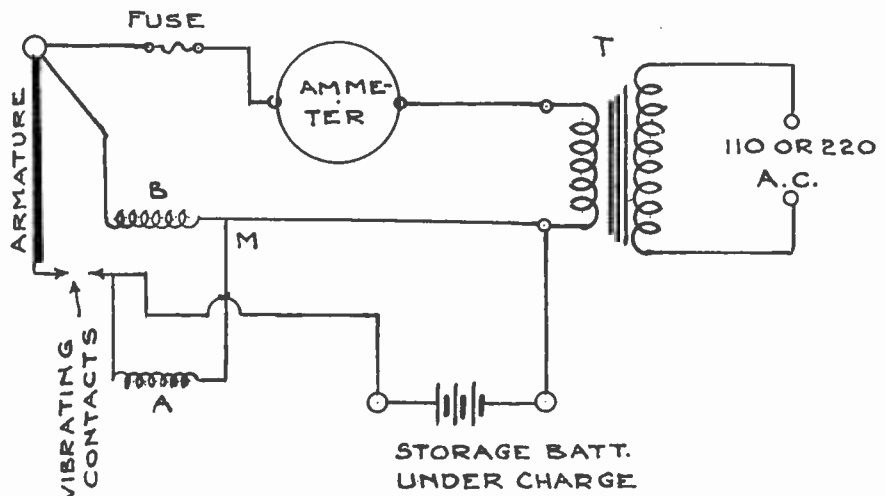
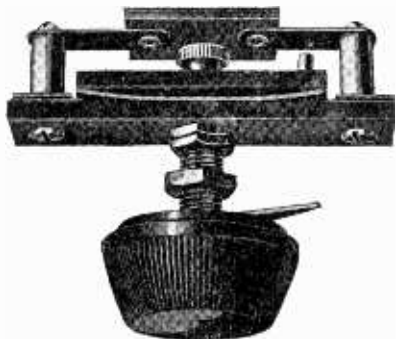

Fig. 12. Schematic Diagram of Vibrating Contact Charger

Tell them that you saw it in RADIO



**Get Those Far Away Stations**

RADIO EXPERTS state that the grid leak is the most important part of a radio set and that your success or failure is largely determined by this one element.

**Don't Experiment**

with the uncertain pencil mark types or condemn your set until you have tried a C R L Variable Grid Leak.

A turn of the knob increases or decreases the resistance, smoothly and without steps, by changing the area of contact between a spring and a high resistance impregnated strip.

Equip your set with a C R L Adjustable Grid Leak and enjoy the satisfaction that comes from knowing that you have perfect control over the most important element in your circuit.

Every instrument carefully tested and fully guaranteed.

- No. 106 (without condenser).....\$1.50
- No. 107 (with .00025 mica condenser) \$1.85

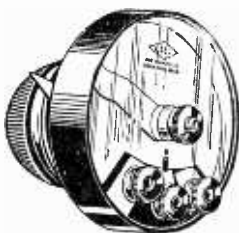

**CRL POTENTIOMETERS**  
— Non-Inductive —

has no fine wire,—there is absolutely no trouble due to loose turns; the volume is increased as there is no inductive choke coil action such as is always present in wire wound devices.

- No. 110 (400 ohms).....\$1.75
- No. 111 (2000 ohms)..... 2.00

**Central Radio Laboratories**  
309 16th St.,  
MILWAUKEE WISCONSIN

**NEW "REGAL" PRODUCTS for the 1923-1924 season**

- NEW "REGAL" AUDIO FREQUENCY TRANSFORMER.....\$4.50
- NEW "REGAL" DOUBLE ARM INDUCTANCE SWITCH..... 1.50
- NEW "REGAL" VERNIER RHEOSTAT, 30 Ohm..... 1.25
- NEW "REGAL" VARIO-COUPLER ..... 4.50

**Regal Inductance Switch**



15-point Inductance Switch all in one unit. Beware of cheap imitations. Ask for the Regal. Does away with all drilling of holes in panel. Complete with handsome knob and dial ..... \$1.50

**Regal Rheostat**

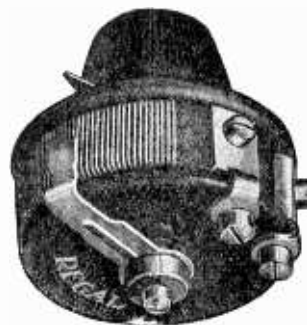

The Big Regal Line is now ready for the trade. If your dealer does not carry Regal products write us direct. Send for catalog No. 22

Exposed resistance wire for sharp sensitive tuning. A fine, dependable, quality instrument.  
6 Ohms .....\$1.00  
30 Ohms ..... 1.00  
30 Ohms Vernier ..... 1.25

**THE AMERICAN SPECIALTY CO., BRIDGEPORT, CONN.**

**Bristol One Stage Power Amplifier**

**No C Battery Required**



Ask your dealer or send for bulletin 3011-W.

Give your loud speaker a treat.

A unit that can be used as a third stage without howling. The usual objections against a third stage of audio-frequency amplification are entirely eliminated by the use of the new Patented circuit.

The Bristol One Stage Power Amplifier does not require separate "A" or "B" battery. It uses common tubes such as U.V. 201A, 216A and U.T.2.

A remarkable achievement—a third stage audio that works RIGHT—install one today and give that distant station a chance to come in like the locals.

**THE BRISTOL COMPANY**  
Waterbury, Conn.

BRANCH OFFICES:  
Boston New York Pittsburgh Philadelphia Detroit Chicago St. Louis San Francisco

**WD11 and WD12 REPAIRED**

ALSO OTHER TYPES OF TUBES for \$3.00

and guarantee them to work like new. We prepay parcel post back to you.

**QUICK SERVICE**

**THOMAS BROWN CO.**  
515 ORANGE ST. NEWARK, N. J.

**We Repair**

**RADIO TUBES**

- WD-11 .....\$3.50
- WD-12 ..... 3.50
- UV-200 ..... 2.75
- UV-201 ..... 3.00
- C-300 ..... 2.75
- C-301 ..... 3.00
- DV-6 ..... 3.00
- UV-199 .....\$3.50
- C-299 ..... 3.50
- UV-201A ..... 3.50
- C-301A ..... 3.50
- UV-202 ..... 4.00
- C-302 ..... 4.00
- DV-6A ..... 3.50

Mail orders solicited and promptly attended to.

**H. & H. RADIO CO.**

P. O. Box 22-M Clinton Hill Sta., Newark, N. J.



Dealer's Special Discount

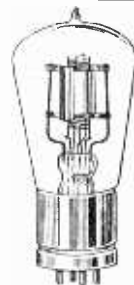

Agent's Special Discount

Tell them that you saw it in RADIO



Continued from page 84

has two windings, a d.c. winding *A*, and a.c. winding *B*. The storage battery to be charged furnishes the magnetizing current to the d.c. winding (which current is so small as to be a very small drain on the battery), while the a.c. magnet coil is excited by current from the step-down transformer.

(c). A vibrating armature which makes and breaks two contacts.

(d). An ammeter for registering the charging current, and a fuse for opening the circuit in case of too heavy overload.

The operation of this charger is as follows, referring to the schematic diagram of Fig. 12: The normal position of the armature when the charger is not operating is such that the contacts are open. The d.c. magnet coil *A* is energized by the storage battery to be charged, and when the a.c. power is not

supplied to charger this magnetizing force is insufficient to attract the armature, hence the contacts remain open. When the a.c. power is supplied to the charger the a.c. magnet coil *B* is excited from the transformer *T*. During one-half the a.c. cycle the coil *B* is magnetized in the same direction as coil, during the other half in the opposite direction. When it is magnetized in the opposite direction the pull on the armature is less than with d.c. alone, hence the armature

Continued on page 88

## An Easy Way to tune out Interference

The FERBEND "Wave Trap" Makes Every Night Silent Night

Get the station you want quickly. Listen in on the distant stations without annoying squawk-k-k-s or irritating whistles. Listen like this St. Louis user: "Heard Havana clearly with three St. Louis stations broadcasting. My receiver works like a new set. The 'Ferbend' is certainly a wonder."

### YOU Can Obtain These Remarkable Results

You can obtain results as satisfactory as this St. Louis user. If you don't, it doesn't cost you a penny, for the "Wave Trap" is sold with a positive guarantee that it will tune out your powerful local stations. Don't wait. Order now at our risk.

SEND NO MONEY. You need not send a penny. Pay Postman \$6.00 (plus postage). If you prefer, send \$6.00 with order and Wave Trap is mailed postpaid. Money-back guarantee either way. You see, you take no risk, so order TODAY.

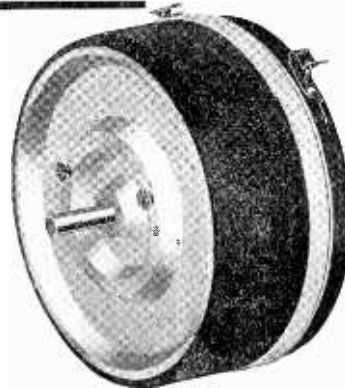

Ferbend Wave Trap ready for mounting, \$6.00.

Wave Trap mounted on formica panel in mahogany finished cabinet 6x5x6 at \$8.50 complete. Circular on request.

FERBEND ELECTRIC CO., 17 E. S. Water St., Chicago.

Send me a Ferbend Wave Trap. I will pay Postman \$6.00, plus postage. I understand you guarantee Wave Trap to tune out our local stations or refund money.

Name .....

Address .....

## HUNT'S UNIVERSAL HAIR-LINE RADIO TUNING DEVICE

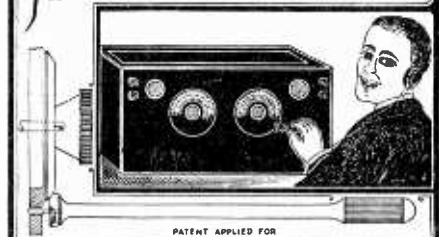

### Overcomes Body Capacity

Gives micrometric adjustment outside the field of inductivity.

Tested and approved by amateurs and experts. Enables you to tune distant stations easier and more clearly. Simple as A B C. Installed from outside, no dismantling of your set necessary. Audibility made more natural or less distorted by the fine adjustments obtained. One Hunt's Device handles all dials on set or several sets. Costs only one dollar on guarantee of money refunded if not satisfied. Ask your dealer or order direct from Hunt Co., 484 Shrine Bldg., Memphis, Tenn.

### A. R. R. L. Station

Always GLAD to Q. S. R.

Electric Specialty Co., Stamford, Conn.

Gentlemen:-

It has been sometime since I have written you, but want to let you know that the 500 Watt, 1000 volt Motor-Generator Set of your make, I bought one year ago, has given perfect service. Have gotten all districts - Mexico, Cuba and Canada with it. People marvel at the quality of modulation. All say I sound like a Broadcasting Station.

I work New York City often, also Oil City, Louisiana. All report that I sound like I am using battery for plate, instead of Generator.

Thought that I would let you know of the success of this outfit, as I believe in letting the manufacturer know of the fine points as well as the poor ones.

*Yours Very Truly  
J. E. Phillips  
Opn at 9HK.*

### Clinton, Iowa

728 Bluff Blvd.  
Sept. 29, 1923.

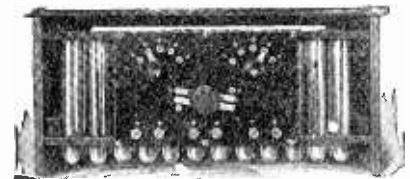

### 100 Volt Panel Type "Satisfaction increasing; customers want more."

That's the message that came across the continent with an order from an Oregon distributor. KICO Batteries always make good. Alkaline type, won't sulphate or buckle. Life unlimited. Not harmed by short-circuiting, overcharging, idleness. Panel switches give single cell variations. Recharge from any 110-volt A. C. line with small home rectifier. Charge lasts 3 to 6 months in detector plate circuit.

#### GUARANTEE

Your money back on any KICO Battery if not satisfied within 30 days. Write for full information on "A" and "B" Batteries.

Unmounted Rectifier \$1.00  
Mounted Rectifier... \$2.50

Cells	Volts	Price Plain	With Panels
16	22	\$ 5.50	.....
24	32	7.25	\$11.75
36	48	9.50	14.00
50	68	12.50	17.00
78	100	17.50	22.50
108	145	23.50	28.50

KIMLEY ELECTRIC COMPANY, Inc.  
2669 MAIN STREET BUFFALO, N. Y.

**KICO** Storage "B" Batteries --long service, low cost

**SHORT AND LONG WAVE RECEIVER**

*Continued from page 25*

binding posts over the honeycomb mounting. The leads from the honeycombs being flexible and having solder-lugs as terminals can be easily disconnected from the posts, (connections being made from the outside) and the set is ready for experimental purposes.

If the user desires to try a new variocoupler, he may do so by connecting the variocoupler primary posts to the primary posts on the set and the variocoupler secondary posts to the secondary posts on the set. Keeping S-2 closed, he will secure regeneration by tuning the plate variometer. His primary and secondary circuits are tuned by means of the primary and secondary condensers in the set.

Suppose he now wishes to experiment with the much-abused single circuit. Removing his variocoupler from the circuit, he connects a bus connection from primary post No. 1 to secondary post No. 1 and one from primary post No. 2 to secondary post No. 2. He then either has the choice of connecting his secondary honeycomb coil in the circuit or of using an external coil. Setting the secondary condenser at zero and tuning with the primary condenser in series, he has his standard single-circuit, using either tuned plate regeneration or feed-back.

These are only a couple of the combinations. Others will suggest themselves.

I am using an external three-coil spider-web mounting at present and get fine results. With a combination of spiderweb coils I can cover a wavelength range of from 175 to 1000 meters. I expect to go higher when I get my honeycombs.

Just a word as to the connections to avoid body-capacity effects. The movable plates of the primary condenser should be connected to the ground and the movable plates of the secondary condenser to the filament return as per Fig. 3. The stator of the plate variometer should be connected to the plate through S-2 and a grounded shield is placed across the panel in back of the secondary condenser and the plate variometer. No body-capacity is experienced with this arrangement even on C. W. signals of short wavelength.

The honeycomb mounting is mounted upside down with the knobs underneath. The knobs are removed and substituted by extensions which will bring the adjustment well below the coils so that the operator's hands do not touch the coils. All the instruments are mounted on the panel so that when removing the panel for inspection all connections are on the panel.

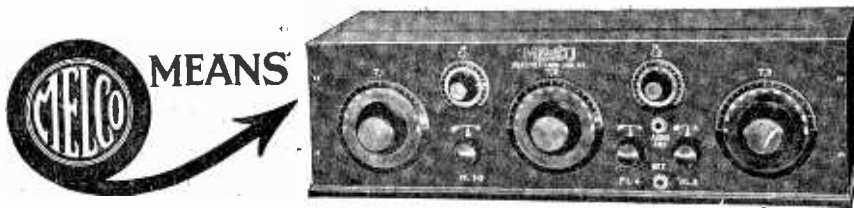

**REAL RADIO PERFORMANCE**  
*New Principle of Tuned Radio Frequency Gives Remarkable Results with the*  
**MELCO-SUPREME**

*The Radio-Frequency Amplifying Receiver that—*

**PRICE ONLY \$140**

Operates with merely a 10-FT. WIRE. Not even a ground necessary.  
 Offers exceptional CLARITY without the slightest loss of tone quality.  
 Assures unusual program SELECTIVITY through its single tuning adjustment.  
 Affords real LONG DISTANCE by covering all Broadcasting ranges from 180 to 610 Meters.

Complete knock-down parts for Melco-Supreme including drilled engraved Bakelite panel and solid mahogany cabinet.

**PRICE \$90**

The Acmedyne Circuit employed in the Melco-Supreme has been described in detail by Mr. Lawrence Cockaday in his article on "Tuned Radio-Frequency Amplification in Popular Radio" and recommended by leading Radio Publications and Newspapers in the United States and Canada.

We also manufacture a complete line of parts under the AMSCO Brand. Write for our literature illustrating and describing our entire line of quality apparatus.

**AMSCO PRODUCTS, Inc.**  
 Broome and Lafayette Streets Dept. R New York City

**Tubes Repaired**

We repair vacuum tubes and guarantee them to work like new. Money refunded if not satisfied.

WD11-WD12 .....	\$3.50	UV200-C300 .....	\$2.75
201A-301A .....	3.50	UV201-C301 .....	3.25
DeForest & AP'S .....	3.50	UV199 .....	3.50

No other tubes than above accepted

**THE ONLY LABORATORY IN THE WEST**  
 Broken Glass Shells replaced — No extra charge

**AL. D. BERGEZ CO.**

Dealers Write for Special Proposition  
 172 FIFTH STREET SAN FRANCISCO, California

**U. S. NAVY RADIO SETS**

*A REAL BARGAIN FOR THE CW MAN*

We have available for immediate delivery, Ten Navy Standard Radio Phone Transmitter-Receiver, Type CW 938A, made by the Western Electric Co. These sets are BRAND NEW, in their Original Cases with Original Seals intact. This equipment is identical with that used by the Navy on sub-chasers.

Each set is supplied with the following equipment, less tubes and batteries. Two VT 2 tubes are used for transmitting and six VT1 tubes for receiving.

Two Dynamotors on spring-mounted frames to supply 350 volts for transmitting and power amplifier tubes. To be driven with 32 volts DC. Type CW 927A.

- 1 switchboard for same with two-range voltmeter, fuses, switches and controls. Type CW 828.
- 1 B Battery container. Type 353A.
- 1 antenna grounding switch.
- 3 headsets 2200 ohms. Type CW 834.
- 1 box spare parts, cords, fuses, brushes, resistances, leaks, etc.
- 2 transmitters. Type 326W.
- 1 hand transmitter with control switch in handle. Type 326W.
- 1 power amplifier employing 3 tubes. Type CW 926B.
- 1 loud speaker. Type CW 929.
- 1 station for remote control.
- 1 remote control push switch.

The Transmitter is of 5-watt capacity employing the Heissing system of modulation. The Receiver has detector and two steps of amplification, which, with the power amplifier, gives five steps. The Receiver and Transmitter are in one case. The Power Amplifier is in a separate case. Let us again remind you that THE ENTIRE EQUIPMENT WAS BUILT TO NAVY SPECIFICATION BY THE WESTERN ELECTRIC CO. These sets are ideal for use with 32-volt farm lighting current. This is the chance of a lifetime. If you want one of these sets, send in your money. \$350.00 takes the complete outfit. Don't write—wire. Terms: \$100 with order, balance C.O.D. express or freight sight draft against bill of lading. Shipping weight 425 lbs. Displacement 27 cu. ft.

We have also available for immediate delivery a Navy standard 1 kw Spark Set ALSO NEW. Built to Navy specifications by Kilbourne & Clark. Complete with changeover switch, protective device and key. For immediate delivery, \$1,250.00.

Also an S.E. 143 Navy Standard Receiving Set, complete with detector box, \$165.00.

**HEINTZ & KOHLMOS, Inc. 219-223 Natoma St. San Francisco**

# Keep Yourself Up to the Minute on RADIO

The one best way to do it is with a Lefax Perpetual Radio Handbook. It grows with every new discovery about Radio. It cannot become old or out-of-date. It gives all known facts and the new ones as they are learned by the authors—Dr. J. H. Dellinger and L. E. Whittemore, Chiefs of the Radio Laboratory, U. S. Bureau of Standards, Washington, D. C.

The purchase of a Lefax Handbook makes you a registered owner. That entitles you to complete information on new Radio developments every month, without additional charge for the first twelve months. This information comes to you in printed, punched page form. You add the pages instantly, easily. Included in this fine work is a complete list of broadcasting stations and full information about every one. No radio book is or can be like

## LEFAX PERPETUAL RADIO HANDBOOK

It is pocket size, loose leaf, bound in flexible imitation Morocco leather—fine looking and long, long wearing. Type is clear and sharp. Illustrations are clean, finely made and easy to understand. Index tabs are made of linen—tough and strong—plainly marked.

Remember, you have in Lefax a practical Radio guide that will keep you up to the minute on Radio and all that goes with it. Lefax Perpetual Radio Handbook grows with Radio. You get new, useful, authentic information, free, every month. But you pay for your book only once. You don't have to write for new facts. They come to you automatically. Ask your Radio supply man, stationer or bookseller for Lefax Perpetual Radio Handbook.

LEFAX, INCORPORATED, *Publishers*  
9th Street, above Walnut  
Philadelphia, Pa.

## PhonoFlex SUPER RADIO PRODUCTS

A Complete Line Of Radio Parts And  
Equipment Of Quality

BE SURE IT'S PhonoFlex. SEND FOR OUR CATALOGUE.

Jobbers and Dealers solicited.

American Radio Phonolamp Corp.

220 W. 42nd St.

Room 2300

New York City

## POWER LOSSES

*Continued from page 32*

in the conductors in the antenna and lead-in are due to the ohmic resistance of these conductors and to the skin-effect which is manifest at high-frequencies. These losses can be somewhat reduced by using wires of large cross-sectional area, and so constructed that the surface area is very great. Poor connections occasionally contribute to resistance loss, while sharp turns and bends in the conductors of the antenna and lead-in have the effect of slightly increasing resistance losses, especially at high-frequencies.

Ground resistance can be reduced by using an extensive system of buried wires, well grounded in moist soil, for the ground system, or by using a counterpoise ground. Another arrangement which will reduce ground resistance and which, due to other causes usually increases radiation, is the multiple-tuned antenna. This system consists essentially of a number of tuned vertical antenna connected at the top to a horizontal inverted L or T type antenna. Each of the vertical antenna is connected independently to the ground, hence all the ground resistances are in multiple, reducing the total ground resistance to a value much lower than would be found in any other type of antenna operating at the same power and wavelength.

In general, power losses in an antenna circuit vary greatly with the frequency or wavelength at which the circuit is operated. Losses due to dielectric absorption, leakage, and corona, decrease as the frequency is increased and are therefore more important in antennae circuits operating at long wavelengths; while losses due to eddy currents and resistance increase as the frequency is increased and have their importance in short-wave circuits. Plotting a resistance curve of the combined losses occurring in an antenna circuit at different frequencies will indicate a frequency at which the combined losses are lowest. Combining this curve with a curve of the radiation resistance of the antenna circuit under observation will therefore indicate a wavelength at which the effective resistance of the antenna circuit is lowest. This wavelength is usually two or three times greater than the fundamental wavelength of the antenna and is, as a rule, the best wavelength at which to operate the antenna.

## FREE

*Complete Price List*  
AITKEN RADIO CO.  
504 Superior St., Toledo, O.

# ★ ★ RADIO ADS ★ ★

**A CLASSIFIED ADVERTISING SECTION READ BY BETTER BUYERS**

The rate per word is five cents, net. Remittance must accompany all advertisements. Include name and address when counting words.  
**ADS FOR THE JANUARY ISSUE MUST REACH US BY DECEMBER FIRST**

**C. W. and RADIO PHONISTS**—Our new converters will satisfy your need for a more efficient and durable direct current plate supply. No armatures to burn out. Output from seven hundred to two thousand volts at .4 amperes. Synchronous Motors, Transformers and other parts sold separate. Write immediately. Kimley Equipment Mfg. Co., 290 Winslow Ave., Buffalo, N. Y. (tc)

**ARC & SPARK SYSTEMS**  
 Send for Descriptive Circular 'RD.  
 Interesting and Instructive (to)  
 Pacific Radio School 433 Call Bldg., San Francisco

**BRANCH MANAGERS WANTED AT ONCE.**  
 WOULD YOU LIKE TO TAKE THE MANAGERS CHAIR AND DIRECT SALESMEN IN YOUR TERRITORY, EACH ONE OF THEM BRINGING YOU A GOOD PROFIT?

OUR NEW BUSINESS METHOD IS SO PROFITABLE THAT TERRITORY IS BEING ASSIGNED RAPIDLY. WE ARE GETTING SALESMEN ALL OVER THE COUNTRY AND MUST HAVE YOUNG MEN TO MANAGE THEM.  
**QUALIFICATIONS NECESSARY:**  
 WE PREFER YOUNG MEN:  
 MUST HAVE HAD SOME EXPERIENCE ASSEMBLING RADIO SETS, OR HAVE YOUNG MAN AS ASSOCIATE WHO HAS HAD SUCH EXPERIENCE;  
 MUST BE ABLE TO GIVE REFERENCE.  
 IF YOU THINK YOU MIGHT WANT THIS PLACE DON'T WAIT, WRITE AT ONCE, SOME ONE ELSE MAY BEAT YOU TO IT.

**NATIONAL RADIO SERVICE CO.,**  
 858 PACIFIC BLDG., SAN FRANCISCO, CAL.

**RADIO WORLD, THE GREAT NATIONAL WEEKLY**—published every seven days with all the latest news, developments and pictures of the radio field. 15c a copy. \$6.00 a year (52 numbers), \$3.00 six months, \$1.50 three months. Special to radio readers. Send \$1.00 and we will send you the next eight issues of RADIO WORLD. Pub. Office, 1493 Broadway, New York. (tc)

**WE CAN USE MORE SALESMEN.**  
 OUR NEW BUSINESS METHOD IS HELPING NEW RADIO SALESMEN TO MAKE QUICK SALES AND BIG PROFITS. WE FURNISH LIVE LEADS AND ASSIST YOU IN CLOSING SALES. EASY TERMS, LONG TIME TO PAY IS MAKING SALES EVERYWHERE. IF NO MANAGER APPOINTED IN YOUR TERRITORY, SEE OUR "MANAGER ADV." ABOVE.

**NATIONAL RADIO SERVICE CO.,**  
 858 PACIFIC BLDG., SAN FRANCISCO, CAL.

**Vacuum Tube Hospital**  
 We repair and guarantee them.  
 Agents, Dealers, and Customers Wanted.  
 George H. Porell Co., Inc.  
 West Somerville, Mass. (tc)

**RADIO MECHANIC WANTED.**  
 NATIONAL RADIO SERVICE ASSOCIATION WANTS RADIO MECHANIC IN EVERY TOWN TO ASSEMBLE A NEW SUPER-RADIO FREQUENCY RECEIVER AND TO GIVE SERVICE ON OTHER KINDS OF SETS. WELL ADVERTISED REGULAR INFORMATION FROM THE ENGINEERING DEPARTMENT IS VERY VALUABLE, BEST OF CHANCES TO GROW UP WITH THE RADIO INDUSTRY. BIG PERCENTAGE PROFIT.

**NATIONAL RADIO SERVICE CO.,**  
 858 PACIFIC BLDG., SAN FRANCISCO, CAL.

**C. W. AND RADIOPHONISTS.** One hundred Ohio and Wagner 110v., sixty cycle A. C. synchronous motors built in 1/4 H. P. frames with 1/2" shafts are yours for \$18.00 each F. O. B. Buffalo, N. Y. Original selling price \$28.50. We also have the parts to attach to these motors to make synchronous rectifiers which will handle 2000 volts. **KIMLEY ELECTRIC CO., Inc.,** 2665 Main St., Buffalo, N. Y.

A good pair of phones free. The new Navy Type \$3.00 Atlas adjustable diaphragm headsets will be sent free of charge to anybody sending us five subscriptions to "RADIO" for one year each. Send \$12.50 to cover full payment and the phones are yours. "RADIO," San Francisco.

**RADIO GENERATORS—500 Volt 100 Watt \$25.50** each. Battery Charger \$12.50—High Speed Motors. Motor-Generator Sets, all sizes. **MOTOR SPECIALTIES Co.,** Crafton, Penna. (tc)

**FREE**, one of the new Gottschalk \$22.50 Loud Speakers. Send us only eight subscriptions to "RADIO" for one year each and you will receive this loud speaker absolutely free of charge. A great quantity have already been awarded to our subscribers. Only a few are left. Send us eight subscriptions at \$2.50 per year each and the loud speaker will be shipped by parcel post, prepaid. "RADIO," Pacific Building, San Francisco, Cal.

**LEARN THE CODE.**—Free instruction course with only one subscription to "RADIO" for one year. \$2.00 is the full price. "RADIO," Pacific Building, San Francisco.

**"TELEFUNKEN" TRANSMITTING TUBES**  
 —Genuine Guaranteed 20-watt, \$15. 20-watt, \$12.50. Filament 2 Amps. Plate 800 volts. C.O.D. or money order. Edison elements 5c pair.—Arthur Beyer, 106 Morningside Drive, New York.

**\$7.50 A. C. Electric Co.,** moulded variocouplers free. Send us four subscriptions to "RADIO" for one year each and the variocoupler will be sent to you postpaid, free of charge. Full price for four subscriptions and the premium is only \$10.000. Only a few left. Act quick. "RADIO," Pacific Building, San Francisco, Cal.

**\$6.00 Lefax Radio Handbook** with one year free "RADIOFAX" monthly service. Get all of this great material for only two subscriptions to "RADIO" for one year each. Send us \$5.00 and get this big combination. Only a very small quantity of these books on hand. "RADIO," Pacific Building, San Francisco.

**FOR SALE:**—Honeycomb set with two step amplifier, including Edison A Battery, Baldwin phones and loudspeaker, and rectifier, \$100.00. Donald Relfe, 870-54th Street, Oakland, Cal.

**NO FOOLING**—Put the needle on the jumping spot and you have music. Write for literature on wonder Phonograph Attachment. Raymond Moore, North Fourth Ave., Tucson, Arizona.

**FOR SALE OR TRADE:**—One new 200 watt Acme C. W. Transformer. Will sell for \$15.00 postpaid. What have you to trade? Herbert Settle, 462 E. Burkhardt St., Moberly, Missouri.

**FOR SALE:**—DeFOREST REFLEX D7A, including tubes and loudspeaker with Dictograph phone unit. All for \$100.00. James M. Fox, Hotel Carlton, Berkeley, Cal.

**QSL CARDS. 200—\$1.25. 500—\$2.25. SEND FOR SAMPLES.** H. Olmsted, 1100 Virginia Ave., S. W., Washington, D. C. (Nov. and Dec.)

**SELL**—One tube DX Reflex \$30.00 complete. Oswald, 3219 West 82nd St., Cleveland, Ohio.

**LIGHTNING STRANGE BATTERY COMPOUND.** Charges discharged batteries instantly. Eliminates old method entirely. Gallon free to agents. Lightning Co., St. Paul, Minn.

**SALESMEN MAKE \$120 WEEKLY, FREE RADIO INSTRUMENT.** OZARKA is the longest distance receiver. Introduce it to your friends and secure your own free. No canvassing. 2 sales weekly nets you \$120. Sharpe of Colorado made \$955 one month. Our plan sweeping country. Write today giving name your county. **OZARKA INCORPORATED,** 814 Washington Blvd., Chicago, Ill.

**MAGNAVOX R3 or M1.** Latest nationally advertised reproducers. List \$35. Introductory \$25. The factory sealed carton is your guarantee. Radio Central, Dept. P., Abilene, Kansas.

**WANTED:**—High grade young men to travel extensively as Radio Salesmen for well known manufacturer of established mechanical and electrical lines. Must be capable of highest type of sales and service work in demonstrating and introducing line of patented radio equipment. Men preferred who have good electrical education in addition to fine practical knowledge of up-to-date radio apparatus. Character references required. Excellent opportunity for promotion as Sales and Service Engineers. Write stating experience, education, age and salary desired. Box "B"—Radio, Pacific Bldg., San Francisco.

Ohio and Wagner 60 cycle 110 v. synchronous motors \$18.00. Attachments to make synchronous rectifiers for C. W. transmission \$12.00. Acme plate transformers, King Chargers, "A" and "B" batteries and other supplies on hand. Prices reasonable. Write **KIMLEY ELECTRIC COMPANY, Inc.,** 2665 Main St. Buffalo, N. Y.

**CLEARANCE SALE.**—Not a cut price proposition but a genuine clearance sale of a large stock of good radio apparatus that must be disposed of to make room for new lines. The items listed herewith are but a few of the many clearance specials. Be sure to write us today for a complete list of other offerings.

- Type
- Acmefone Receiver with detector, two-step amplifiers and loudspeaker. Can be made regenerative at small cost. . . \$30.00
  - HRA Clapp-Eastham Detector-Amplifier. . . 10.00
  - No. 8 Federal Detector-Amplifier. . . 20.00
  - No. 9 Federal Two-Step Amplifier. . . 25.00
  - No. 20-AFico Detector. . . 8.00
  - No. 521 Kennedy Two-Step Amplifier. . . 40.00
  - No. 220 Kennedy Intermediate Receiver. . . 75.00
  - No. 525 Kennedy Two-Step Amplifier. . . 50.00
  - No. 330 Remler Detector Panel. . . 5.00
  - No. 331 Remler Amplifying Panel (without transformer). . . 3.50
  - No. 502 Remler Variometer Panel. . . 6.00
  - No. 505 Remler Variocoupler Panel. . . 8.00
  - CR-7 Grebe Long Wave Receiver (slightly used). . . 100.00
  - S-325 30 watt, 350 v. Ray-Di-Co Motor Generator. . . 30.00
  - 500 watt Transmitting Set. . . 400.00

These supplies are guaranteed to be in perfect condition. The excess stock is the cause for the sale. You buy these from the largest radio store in the West. Send your orders today to **THE RADIO STORE, 560 East Colorado St., Pasadena, Calif.**

- Vacuum Tubes Repaired and Guaranteed**
- W. D.-11-12. . . \$3.50
  - U. V.-201A. . . 3.50
  - U. V.-199. . . 3.50
  - U. V.-200-201. . . 2.75

**Arlington Research Laboratory**  
 27 Warren Street. New York, N. Y.  
 Tubes returned Parcel Post, C. O. D.

**Grebe Dials, 4" type, yes the real thing, \$1.50;** Baldwin Phones (C) Double \$10.50. Single \$5.25; DeForest Vernier Condensers .0015, \$12.00—.001, \$11.00; UV199-WD11-WD12-UV201A, \$5.95. King Amplitone Horns \$7.00; Pathe Moulded Variometer or Variocoupler \$3.75; Erla Reflex Transformers \$4.75. Samson Transformers \$6.50; Pathe Dials, similar to Grebe, 4", \$1.25—3", \$1.00—Rheostat Dial \$9.00; Thordarson Transformers 3-1, \$3.50; 6-1, \$4.15; Federal, 65, \$6.75; Acme Radio or Audio, \$4.25. Murdock Phones, 2000, \$3.75. 3000, \$4.25; All-Wave Couplers, \$6.50. Push-Pull Transformers, \$12.50 set; Fada Triple Sockets, \$2.75. Brandes Superiors, \$5.75. Everything Postpaid. Write for prices on anything in the radio line. **Hendrick Radio Equipment, 85 West 181 Street, New York City.**

**Pocket Edition: List Broadcasting Stations corrected TO DATE** with list Canadian Stations, 15c—Letters and Figures for Radio room on gummed paper set of letters and figures 10c. **Pacific Screw Co. dept. W. 645 N. E. 53rd St., Portland, Oregon.**

**RADIO BARGAINS:**—RCA Ariola Senior sets with WD11 tube and Brandes Phones \$49.75. DeForest D7A Reflex Set regular \$125.00 for \$100.00. We are overstocked on these two sets. Send for our catalog of Radio supplies. **Van Blaricom Co. 21 South Main Helena, Mont.**

**TUNED RF TRANSFORMER Type 3-A,** price \$1.25; mounted on 23-plate variable condenser Type 3-A-23 price \$4. Used with loop or outside aerial. With the purchase of 3 RF TRANSFORMERS a diagram is furnished of 3 tube TUNED RF RECEIVER having only 3 controls with one tube successfully reflected audio. Satisfaction assured. Order yours today and get those DX broadcasters. **RAY-DEE-ARTCRAFT INSTRUMENT CO., REDLANDS, CALIF.**

**RADIO ON CONSIGNMENT PLAN.**—Pay me when you sell—800 agents wanted. Make big money. Write. **Gilbert Swanson, Cambridge, Ills.**

**TELEGRAPHY—Morse and Wireless—**taught at home in half usual time and at trifling cost. Omnigraph Automatic Transmitter will send, on Sounder or Buzzer, unlimited messages, any speed, just as expert operator would. Adopted by U. S. Govt. and used by leading Universities, Colleges, Technical and Telegraph Schools, throughout U. S. Catalog free. **Omnigraph Mfg. Co., 16 J. Hudson St., New York.**

**FOR SALE.**—Storage Battery and UV200 Tube. **Charles Ormond, 1435 5th St., Alameda, Cal.**

**Thrill your best Friend  
this Christmas!** —make him a present of  
a distance-getting



**ALL-AMERICAN**

**Amplifying Transformer**  
(Audio or Radio Frequency)

Largest selling transformers in the world. More than a quarter million in service. Standard equipment on the better sets. They work with all circuits.

All better dealers sell "All-American"

**RAULAND MFG. CO.**  
200 N. Jefferson St. Chicago  
*Pioneers in the Industry*

"All-American"  
Bakelite Tube  
Socket—base  
or panel  
mounting  
75c

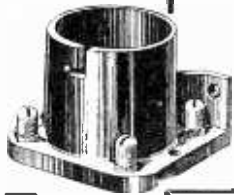

"All-American"  
Audio  
Frequency  
Transformer;  
three ratios.



**Free!** Book of tested hook-ups.  
Send 2c to cover postage.

**Telmaco Radio Guide Book**

**Describes the Best  
in Radio**

Our new 64-page Catalog No. TCR contains twenty of the most popular radio circuits printed in blue. These include the Hazeltine Neutrodyne, Grimes Inverted, Colpitts, Flewelling, Reinartz, Diode Electrad, Heterodyne, Super-Regenerative and many others. Each article used in circuit is attractively pictured instead of appearing in straight schematic form. Besides containing blue prints, the best in radio is also illustrated and described. Catalog sent postpaid for Ten Cents. Each circuit worth double. **Send for your copy today.**



20 Circuits  
in Blue in  
Catalog

**DEALERS!** Our New Dealers' Catalog and Price List describes nearly all the better Standard Radio Lines. You should have it. Mailed FREE to all bonafide dealers making request on their business stationery.

**TELMACO**  
*Quality Radio Exclusively*

Radio Division  
**TELEPHONE MAINTENANCE CO.**  
20 So. Wells St., Dept. A Chicago, Ill.

**COMO DUPLEX TRANSFORMERS**  
For Push-Pull Amplification



There is a combined filtering action which assures perfect results when ordinary amplification fails.

It can be added to your present amplifier, giving you power amplification on the weak signals that more of the ordinary amplification would kill.

Sold in matched pairs.  
Price \$12.50 per pair.

**COMO APPARATUS COMPANY**  
446 Tremont Street Boston, Mass.

A copy of "HOW TO MAKE A POWER AMPLIFIER" is yours for the asking.

Tell them that you saw it in RADIO

**STATEMENT OF THE OWNERSHIP, MANAGEMENT, CIRCULATION, ETC., REQUIRED BY THE ACT OF CONGRESS OF AUGUST 24, 1912,**  
Of "RADIO", published monthly at San Francisco, Cal., for Oct. 1, 1923.  
State of California,  
County of San Francisco—ss.

Before me, a Notary Public in and for the State and county aforesaid, personally appeared H. W. Dickow, who, having been duly sworn according to law, deposes and says that he is the Business Manager of "RADIO" and that the following is, to the best of his knowledge and belief, a true statement of the ownership, management (and if a daily paper, the circulation), etc., of the aforesaid publication, for the date shown in the above caption, required by the Act of August 24, 1912, embodied in section 443, Postal Laws and Regulations, printed on the reverse of this form. to wit:

1. That the names and addresses of the publisher, editor, managing editor, and business managers are:

Publisher, Pacific Radio Publishing Co., Inc., Pacific Bldg., San Francisco.  
Editor, A. H. Halloran, Pacific Bldg., San Francisco.

Managing Editor, none.  
Business Manager, H. W. Dickow, Pacific Bldg., San Francisco.

2. That the owner is: (If the publication is owned by an individual his name and address, or if owned by more than one individual the name and address of each, should be given below; if the publication is owned by a corporation the name of the corporation and the names and addresses of the stockholders owning or holding one per cent or more of the total amount of stock should be given.)  
Pacific Radio Publishing Co., Inc., Pacific Bldg., San Francisco.

A. H. Halloran, Pacific Bldg., San Francisco.  
H. W. Dickow, Pacific Bldg., San Francisco.  
H. L. Halloran, Berkeley, Cal.

3. That the known bondholders, mortgagees, and other security holders owning or holding 1 per cent or more of total amount of bonds, mortgages, or other securities are: (If there are none, so state.)  
None.

4. That the two paragraphs next above, giving the names of the owners, stockholders, and security holders, if any, contain not only the list of stockholders and security holders as they appear upon the books of the company but also, in cases where the stockholder or security holder appears upon the books of the company as trustee or in any other fiduciary relation, the name of the person or corporation for whom such trustee is acting, is given; also that the said two paragraphs contain statements embracing affiant's full knowledge and belief as to the circumstances and conditions under which stockholders and security holders who do not appear upon the books of the company as trustees, hold stock and securities in a capacity other than that of a bona fide owner; and this affiant has no reason to believe that any other person, association, or corporation has any interest direct or indirect in the said stock, bonds, or other securities than as so stated by him.

5. That the average number of copies of each issue of this publication sold or distributed, through the mails or otherwise, to paid subscribers during the six months preceding the date shown above is— (This information is required from daily publications only.)

H. W. DICKOW,  
Business Manager.

Sworn to and subscribed before me this first day of October, 1923.

(Seal) JOHN WISNOM.  
(My commission expires Aug. 14, 1925.)

**REFLEX**  
**D X**  
**CRYSTAL**

**Not Synthetic**

**\$1.00** We select only the very best for this work

The seconds—*better* than the usual store crystals we sell at six for \$1.00

**W. H. BRYANT**  
453 Washington St. BOSTON



# A Christmas Gift

**T**HIS is your chance to give yourself a practical gift. Send us one dollar in full payment for a subscription to "RADIO" for 5 months and we will send you a copy of the big, new 196 page, November 1923 issue of *Citizen's Radio Call Book* FREE!

### What the New Call Book Contains:

- Neutrodyne Diagrams—
- Flewelling Circuit—
- Reflex Circuits—
- Haynes DX Receiver—
- Grimes Inverted Reflex—
- The Reinartz Tuner—
- All U. S. Amateur Calls—
- Numerous Radio Maps—
- Definitions, Questions and Answers, Broadcast Maps, Distance Maps and Charts, Etc.

196 Pages of the most valuable radio material

**ALL FOR ONLY \$1.00**  
REGULAR PRICE \$1.75

**This Great Holiday Offer Expires on Dec. 24th**  
**ACT NOW AND SAVE 75 CENTS**

## Please Use This Xmas Coupon

**MAIL IT RIGHT NOW**



**"RADIO"**—Pacific Bldg., San Francisco, Calif.  
Here's my dollar. Send me a copy of the big, New November 1923 Edition of *Citizen's Radio Call Book* and a subscription to "RADIO" for 5 months.

Name.....

Address.....

City and State.....



Tell them that you saw it in RADIO



*Fine Lenses  
without close adjustment  
are worthless!*

## Why cripple your radio set with poor filament control?

EVERY seaman knows that a binocular cannot bring in distance clearly unless focused with extreme care. It is the last fractional turn of the adjusting screw, perhaps the width of a hair, that brings the distant object within the range of clear vision. The slightest turn, either way, makes a blurred, distorted image.

The same is true of radio sets. The finest detector tube cannot bring in distance clearly without ultra-fine filament control. The Universal Bradleystat performs this delicate operation with utmost precision. The gradual adjustment of the Bradleystat knob brings in distant stations without noise or distortion. Every fine radio set deserves a Bradleystat. Are you getting the best out of your set, today? Try a Universal Bradleystat.

**Bradleystat**  
REGISTERED U. S. PAT. OFF.  
PERFECT FILAMENT CONTROL

Retail Price, \$1.85  
In Canada, \$2.50  
Postage 10c



Perfect Control For ALL Tubes

If you want to extend the range of your radio set, improve reception and get louder signals, learn about Bradleystat by mailing the coupon below.

Allen-Bradley Co.,  
288 Greenfield Ave., Milwaukee, Wis.

I would like to know more about the Bradleystat and why it improves radio reception.

Name \_\_\_\_\_

Address \_\_\_\_\_



**Allen-Bradley Co.**  
Electric Controlling Apparatus  
288 Greenfield Ave. Milwaukee, Wis.



Manufacturers of graphite disc rheostats for over 20 years.

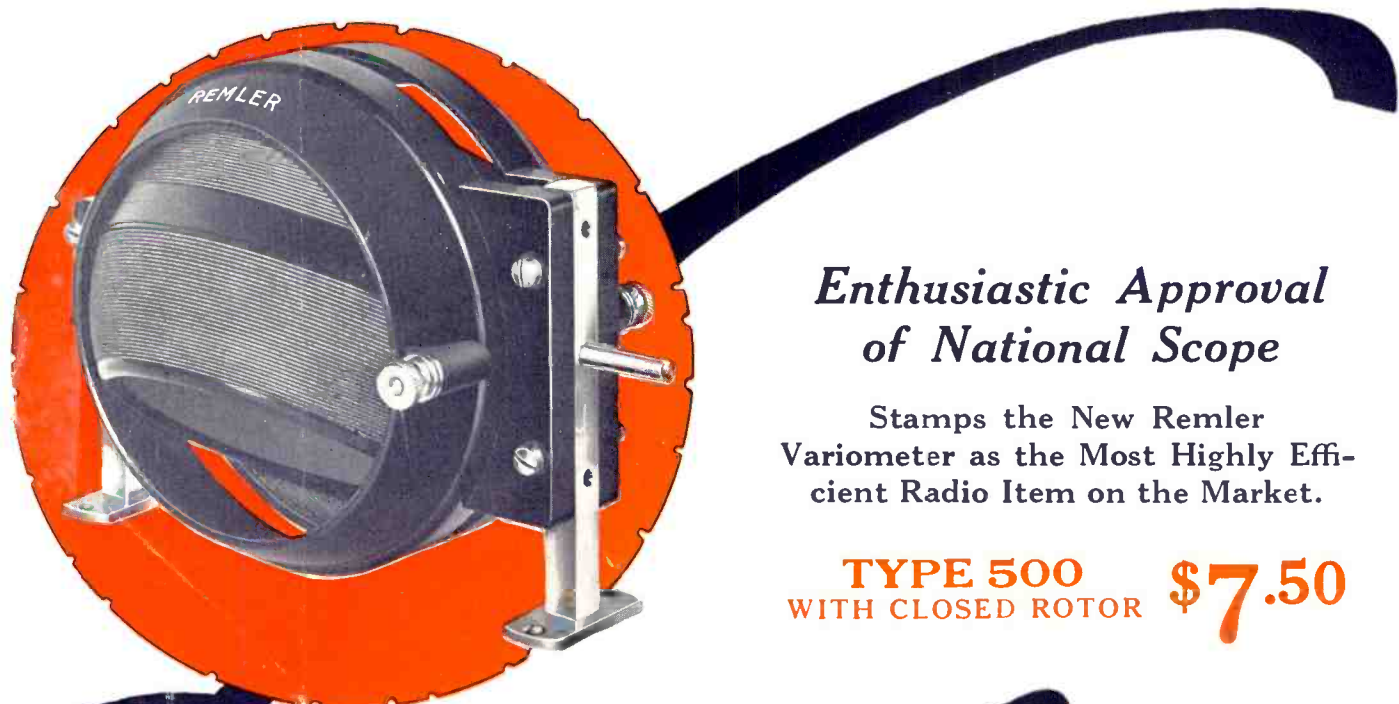

*Enthusiastic Approval  
of National Scope*

Stamps the New Remler  
Variometer as the Most Highly Effi-  
cient Radio Item on the Market.

**TYPE 500**     **\$7.50**  
WITH CLOSED ROTOR

# Remler VARIOMETER:

**WITH INTERNAL PIGTAIL CONNECTIONS**

*Wave Length Range 180 to 570 Meters Positively Guaranteed*

Seldom, if ever, has there been more genuine enthusiasm shown over any radio apparatus as has been demonstrated by everyone who has examined and placed in operation this new and improved Remler Variometer.

Its low minimum and high maximum wave length—the *greatest ever obtained in a variometer* and the wave length variation is exactly proportional to the reading of the dial scale. When used with any variocoupler it will cover the entire range of amateur and broadcast wave length. A wave length range of 180 to at least 570 meters is guaranteed when used with a *Remler* vario-coupler. Pigtailed connections are used between stator and rotor resulting in perfect contact and quiet operation. All metal parts are buffed and nicked; green silk wire is used on both stator and rotor. The general appearance and quality of the bakelite molding is the best obtainable, making it a leader in appearance as well as performance.

If your dealer cannot supply you, send the attached coupon direct to us with express or postal money order. Write for complete descriptive circular.

**Remler Radio Mfg. Co.,**  
182 Second Street, San Francisco, Calif.

Gentlemen:  
Please send me by return parcel post one new and Improved Remler Variometer Type 500 for which I enclose Seven dollars and fifty cents (\$7.50). If for any reason whatsoever I am not satisfied with this Variometer, I can return it to you express collect and you will refund my seven dollars and fifty cents in full.

Name.....  
Address.....

## Remler Radio Mfg. Co.

*Home Office:*

154 West Lake Street,     182 Second St.,     30 Church Street,  
Chicago                             SAN FRANCISCO                     New York City



# "Tune In" on a Real Job and Get the Pay of a Specialist

*This Free Book Will Show You  
How to Earn \$1,500 to \$10,000  
Yearly as a Radio Expert*



**T**HE man who would be a success in business today must be a specialist. The market is already crowded with clerks, stenographers, accountants and detail men of every description. And as the number of applicants increases, the pay and opportunities diminish. Not that these men are unnecessary, for their work is important and essential. But the competition has always been keen in general work of this kind and it is bound to increase in proportion to the number of good men available.

## Radio Needs Trained Men

There is perhaps no other field today where specialists are needed more than in Radio. Trained men are required in every branch of this fascinating, profitable profession. And the opportunities are great—almost without limit! Radio has swept across the face of the whole earth with a speed as surprising as it was sudden. Almost overnight it jumped into the front rank of the world's leading industries. Yet it is here to stay—and grow! For that reason Radio needs good men. It is ready to treat them right and pay them well. And for the men who "get in" NOW, the best is none too good.

### PICK OUT THE JOB YOU WANT WE WILL HELP YOU GET IT

This is a brief list of the positions in the Radio field today, and the salaries paid—

- Radio Mechanic, \$1,500 to \$4,000 a year.
- Radio Inspector, \$1,800 to \$1,500 a year.
- Radio Salesmen, \$2,000 to \$10,000 a year.
- Radio Engineer, \$3,500 a year and up.
- Radio Executives, up to \$15,000 a year.
- Radio Instructor, \$200 to \$500 a month.
- Radio Draftsmen, \$7 to \$15 a day.
- First Class Ship Operator, \$105 a month, all expenses paid.
- Second Class Ship Operator, \$95 a month, all expenses paid.
- Third Class Operator, \$85 a month, all expenses paid.
- Commercial Land Station Operator, \$150 a month and up.
- Broadcasting Station Operator, \$125 to \$250 a month.

## Get Into This Big Paying Profession

Consider for a moment the possibilities of Radio. The shores of every continent are dotted with transmitting and receiving stations. Practically every vessel is now equipped for communication with land and other ships. Hotels, railroad terminals, public buildings and Government stations are flashing their business messages 'cross cities, rivers, mountains and seas. At night, millions of men, women and children are "listening in" to music, speeches, news, important events and business reports, broadcast for their amusement and education. Factories, stores, banks, laboratories, business houses and newspaper offices are employing Radio experts in every branch of the profession. Yet the demand for good men is far greater than the supply. If YOU are sick of plugging along in the daily grind of monotonous office routine—held down by the thousands of men who are doing the same work as you—get out of the rut into this big paying profession.

## You Can Qualify at Home Easily and Quickly

On land and sea, the news of the world's progress is flowing under the skilled fingers of Certified "Radio-tricians"—men who are well-paid, honored and respected for their specialized knowledge and important work. A short course of training at home for the enjoyable work of Radio, will quickly enable you to be independent, to travel and see the world if you wish, or establish yourself in a permanent position in your own town. Radio will take you out of the rut of a bare existence, into the enviable standing of a specialist—with unlimited opportunities for honor, power, wealth and satisfaction. It will make you a doer of real things, a vital force in the world and an important factor in your own community. Start to train NOW for a Radio position while the profession is growing. You can start TODAY—in your spare hours at home. The National Radio Institute is training men, in their spare hours at home, for every important branch of the big Radio

**This  
FREE  
BOOK  
Will Tell  
You How**

industry. To any man who is eager to better his conditions and make a place for himself in this fascinating and profitable profession, we will gladly send a copy of this timely, helpful book—*absolutely free*. It is called "Your Opportunities in Radio" and it will open up a chain of opportunities that you will do well to carefully consider.

You assume no obligation whatever in sending for this interesting, helpful book. It is yours for the asking—FREE. For that reason you can hardly afford to miss it. Ask for a copy today and learn the tremendous opportunities that are open in Radio, how we are preparing men at home to take advantage of these opportunities, and how we aid them in securing the kind of positions that lead to independence and success, "Tune in" on a real job—mail the coupon for this Free Book today—and then "stand by" until it arrives by return mail. It will PAY you! National Radio Institute, Dept. IOM, Washington, D. C.

### This Will Bring It!

NATIONAL RADIO INSTITUTE,  
Dept. IOM, Washington, D. C.

Without any obligation on my part, please send me a FREE copy of your book, "Your Opportunities in Radio." Also tell me how your Free Employment Service will help me secure a position, and send me details of your special short-time offer.

Name .....

Street .....

City..... State.....