

MARCH, 1926

25 CENTS

RADIO

(Reg. U. S. Patent Off.)



Cunningham

RADIO TUBES

Since 1915—
Standard for all Sets



PROVEN DEPENDABLE

In millions of homes where Radio is Entertainment; in thousands of homes where Radio is a Hobby, and in thousands of laboratories where Radio is a serious matter for Research—Cunningham Radio Tubes have proven dependable.

The familiar Orange and Blue Carton is famous the world over as tube representative of quality in reception plus rugged endurance.

Since 1915 -- Standard for All Sets

Types C- & CX-

E. J. Cunningham Inc.

NEW YORK

CHICAGO

SAN FRANCISCO

Tower

REG. U.S. PAT. OFF.



Wherever There Are Ears to Hear —

There's a Tower Speaker or Headset to fit every taste, every pocketbook.

The Meistersinger Speakers, the Scientific Speaker and the famous Tower Phonograph Attachment are equipped with the wonderful new double diaphragm—the greatest single contribution to sound reproduction since Bell invented the telephone receiver. These Tower Units re-create ALL the instruments of the orchestra,—as well as choral singing and the spoken word—in their original, living vividness with full resonance, color and shading. Before you buy—Hear a Tower Speaker.

On Sale by Good Dealers From Coast to Coast

TOWER MFG. CORPORATION
BOSTON, MASS.

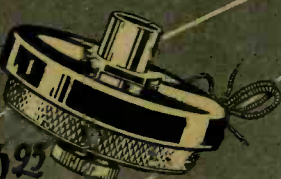

Phonograph Attachment



Scientific

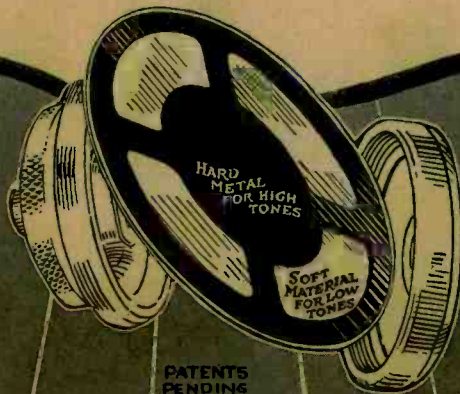

PATENTS PENDING

** Only Tower Products are equipped with this New Diaphragm*

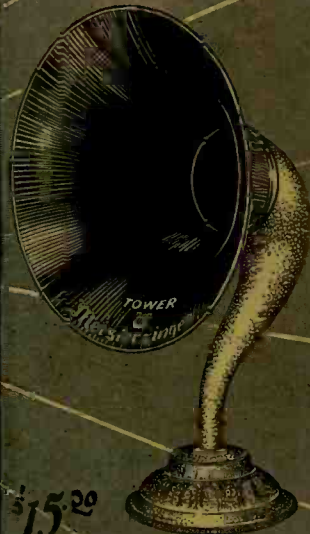

Meistersinger



Little Spitsfire

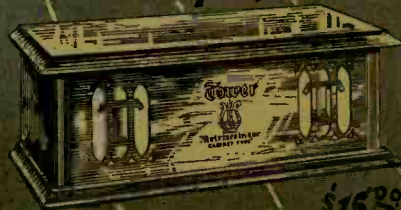

Meistersinger
CABINET MODEL

WORLD'S GREATEST SPEAKER VALUES

Tell them that you saw it in RADIO

RADIO

With Which is Incorporated "Radio Journal"

Established 1917

Published Monthly by the Pacific Radio Publishing Co.

ARTHUR H. HALLORAN

Editor

GERALD M. BEST

Technical Editor

H. W. DICKOW

Advertising Manager

Branch Offices:

New York City, 17 W. 42nd St.
Chicago, 307 N. Michigan Ave.
Boston, 52 Irving St.
Kansas City, Mo., Davies & Dil-
lon, 707 Land Bank Bldg.

Rates:

Issued Monthly, 25c a copy.
Subscription price \$2.50 per year
in the U. S., \$3.00 per year else-
where.

Correct Addresses:

Instructions for change of ad-
dress should be sent to the pub-
lisher two weeks before the date
they are to go into effect. Both
old and new addresses must al-
ways be given.

Advertising:

Advertising Forms Close on the
First of the Month Preceding
Date of Issue.

Member Radio Magazine Publishers' Association
Entered as second-class matter at Post Office at San Francisco, Calif.
Copyright 1926 by the Pacific Radio Publishing Co.

Address all communications to

Pacific Radio Publishing Company

Pacific Building, San Francisco, California

VOLUME VIII

MARCH, 1926

NUMBER 3

CONTENTS

	PAGE
COVER DESIGN, "THE BEDTIME STORY" <i>By Leav X Lansworth</i>	5
RADIOTORIAL COMMENT <i>By Arthur H. Halloran</i>	7
PAPER CONDENSERS <i>By Alexander Nyman</i>	8
REFINEMENTS IN THE MCAA ANTI-STATIC DEVICES <i>By Edward B. Patterson</i>	11
AN EFFICIENT THREE-TUBE SET <i>By E. M. Sargent</i>	14
A NEW FIVE-TUBE RECEIVER <i>By Edwin E. Turner</i>	15
GETTING ACROSS <i>By Earle Ennis</i>	19
A CHEAP "B" BATTERY ELIMINATOR <i>By Clinton Osborne</i>	21
DESIGN OF SMALL POWER TRANSFORMERS AND FILTER INDUCTANCES <i>By Jennings B. Dow</i>	23
AN INEXPENSIVE REFLEX RECEIVER <i>By Dr. Maurice Buchbinder</i>	27
LOW-LOSS COIL FORM	28
EUROPEAN RADIO NOTES <i>By H. de A. Donisthorpe</i>	28
A BABY RADIO TRANSMITTER <i>By W. H. Hoffman</i>	29
WHAT IS MEANT BY POWER FACTOR <i>By Arthur Hobart</i>	30
HANDY HINTS <i>By D. B. McGown</i>	31
CONSTRUCTION OF A SIMPLE CONE TYPE SPEAKER <i>By E. C. Nichols</i>	32
QUERIES AND REPLIES	33
USING THE RIGHT TRANSMITTING ANTENNA <i>By Frank C. Jones</i>	35
HARMONIC CALIBRATION <i>By C. H. Campbell</i>	36
A. R. R. L. BANQUET AT LOS ANGELES <i>By Wallace S. Wiggins</i>	36
THE 50-WATT TRANSMITTER AT 6XAO <i>By G. M. Best</i>	37
PARALLEL WIRE SHORT WAVE OSCILLATORS <i>By Frank C. Jones</i>	39
CALLS HEARD	44

Forecast of Contributions for April Issue

G. M. Best has built a new superheterodyne, including two stages of intermediate frequency amplification and using large tubes and a crystal detector. He gives complete directions for its construction and operation.

Don C. Wallace, in the course of his article on "Improving Short Wave Reception" gives some valuable suggestions on detecting and minimizing interference from power lines by shielding the receiver.

"The Wonderful Battymeter" is a humorous account of the experiences of a commercial operator in getting his license. The author is C. Sterling Gleason.

P. S. Lucas, who conducted "The Commercial Brasspounder" in *Radio Journal*, which has been incorporated with RADIO, will start a similar department in the next issue.

D. B. McGown describes the construction of a 15-watt tube transmitter using the new "X" 7½-watt tubes.

"Low Pass Filter Design" is the subject of the next in the series of articles by Lieut. Jennings B. Dow. He presents all the facts on filtering 60 cycle a. c. about as clearly and simply as they have ever been printed.

The next installment by E. M. Sargent describes the construction of an unusually efficient four-tube set.

In "The Radio Service Man's Bag of Tricks" E. E. Griffin illustrates and describes the construction and use of a repair kit for shooting all kinds of radio troubles.

Willis L. Nye outlines the fundamentals to be considered in designing and building a short wave receiver. The suggestions for eliminating difficulties are particularly practical. With the increasing interest in short-wave reception readers will welcome the news that G. M. Best is building a short wave receiver employing standard parts that may be assembled by the novice.

Harry R. Lubcke tells how to make a battery charger resistance unit that will carry 5 amperes without excessive heating.

The amateur operator should be especially interested in Don C. Wallace's article on "Improving 40 Meter Foreign Reception." A. Binneweg discusses "Short Wave Oscillator Adjustment and Operation."

Everett W. Thatcher submits the results of an extensive investigation of "Short Wave Reflection Phenomena" as conducted by Oberlin College.

G. F. Lampkin, in "Coil Dope," tells the effects of collodion, shellac, varnish and other dopes on the properties of several kinds of coils.

"Roll Your Own" by Frank F. Schindler, while labeled as fiction, speaks many a truth in jest.

Perhaps you, too, can cut your "B" battery costs in half. Just follow the chart. It gives you the secret of "B" battery economy.

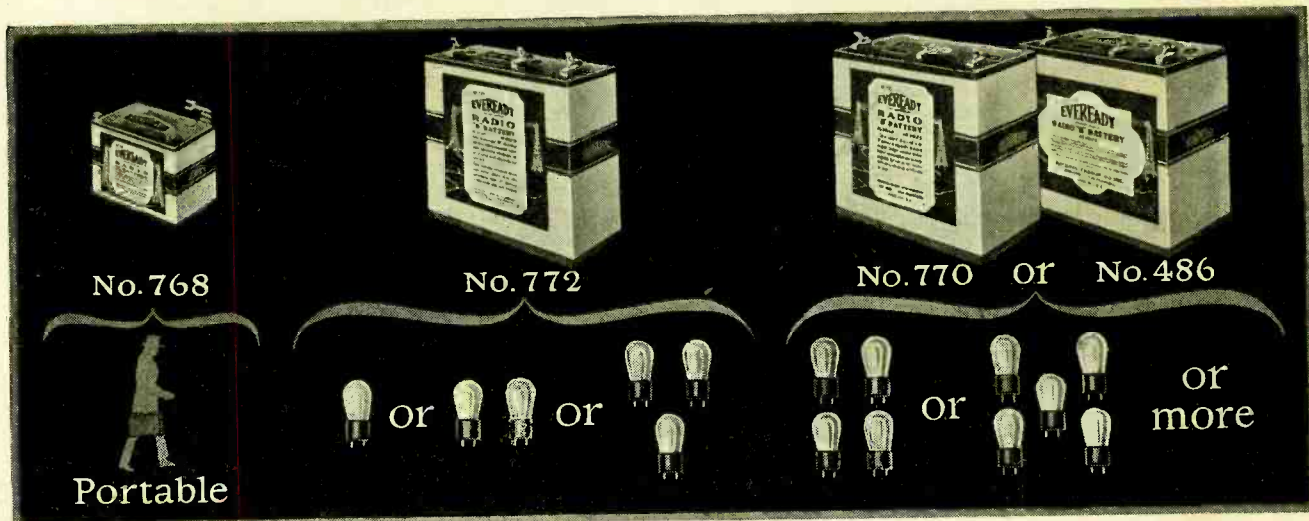

THOUSANDS of people have made the discovery that Eveready "B" Batteries, when used in the proper size and with a "C" battery*, are the most economical, reliable and satisfactory source of radio current.

On sets of one to three tubes, Eveready "B" Battery No. 772, used with a "C" battery, will last a year or longer, usually longer. On sets of four and five tubes either of the larger Heavy Duty Eveready Batteries No. 770 or No. 486, used with a "C" battery*, will last eight months or more.

These figures are based on the average use of receivers, which a country-wide survey has shown to be two hours daily throughout the year. If you listen longer, of course, your batteries will have a somewhat

*NOTE: In addition to the increased life which an Eveready "C" Battery gives to your "B" batteries, it will add a quality of reception unobtainable without it.

shorter life, and if you listen less, they will last just that much longer.

Here is the secret of "B" battery satisfaction and economy:

With sets of from 1 to 3 tubes, use Eveready No. 772.

With sets of 4 or more tubes, use either of the Heavy Duty Batteries, No. 770, or the even longer-lived Eveready Layerbilt No. 486.

Use a "C" battery on all but single tube sets.

Evereadys give you their remarkable service to the full when they are correctly matched in capacity to the demands made upon them by your receiver. It is wasteful to buy batteries that are too small. Follow the chart.

In addition to the batteries

EVEREADY
Radio Batteries
-they last longer

illustrated, which fit practically all of the receivers in use, we also make a number of other types for special purposes. There is an Eveready Radio Battery for every radio use. To learn more about the entire Eveready line, write for the booklet, "Choosing and Using the Right Radio Batteries," which we will be glad to send you on request. This booklet also tells about the proper battery equipment for use with the new power tubes. There is an Eveready dealer nearby.

Manufactured and guaranteed by
NATIONAL CARBON CO., INC.
New York San Francisco
Canadian National Carbon Co., Limited
Toronto, Ontario

Tuesday night means Eveready Hour
—9 P. M., Eastern Standard Time,
through the following stations:

WEAF—New York	WSAI—Cincinnati
WJAR—Providence	WEAR—Cleveland
WEEI—Boston	WWJ—Detroit
WTAG—Worcester	WGN—Chicago
WFL—Philadelphia	WOC—Davenport
WGR—Buffalo	WCCO—Minneapolis
WCAE—Pittsburgh	WCCO—St. Paul
	KSD—St. Louis
	KGO—San Francisco, 8 P. M. Pacific Coast Time

Tell them that you saw it in RADIO

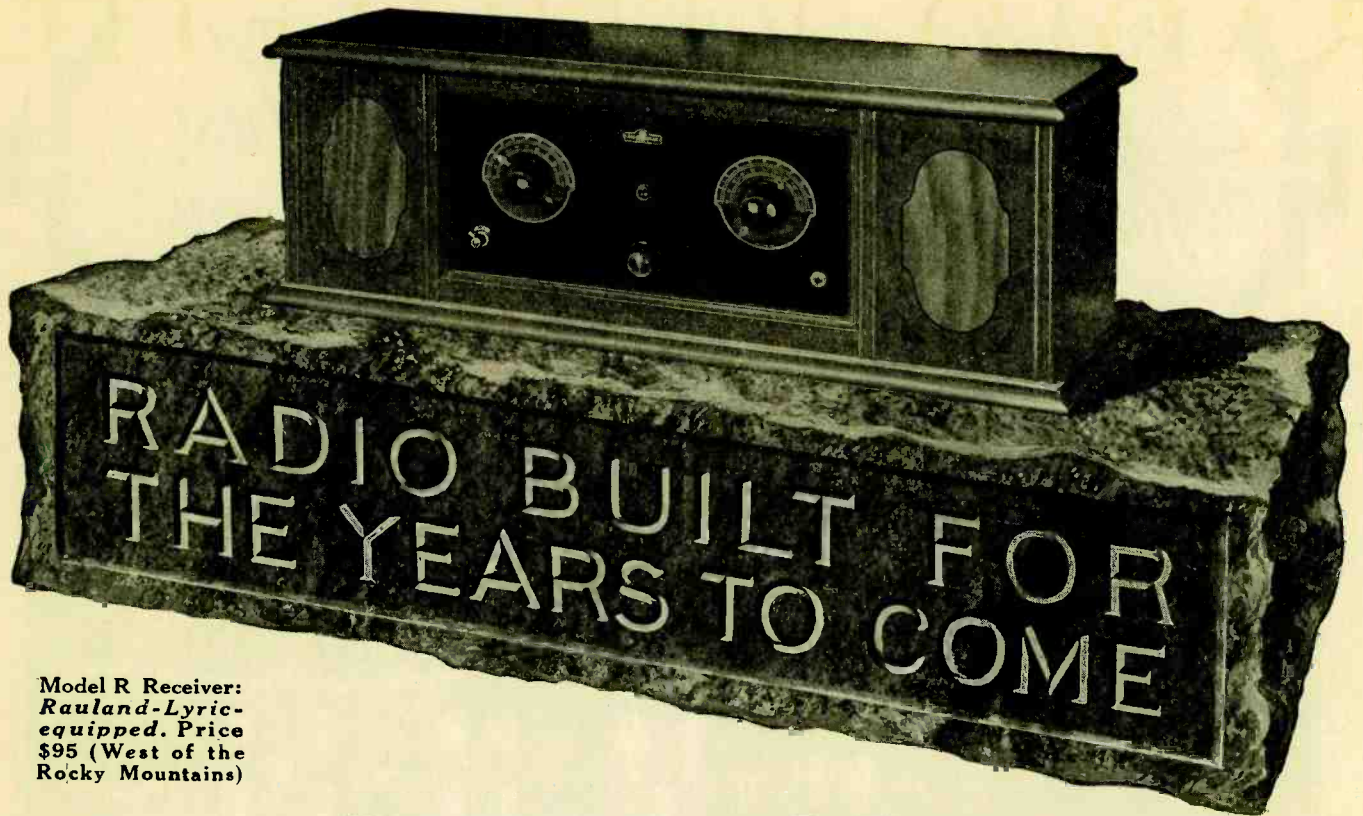

Model R Receiver:
Rauland-Lyric-
equipped. Price
\$95 (West of the
Rocky Mountains)

Beauty and Permanence

Listeners Marvel—

at the wealth of enjoyment awaiting but a touch of the fingers.

Women Are Delighted—

with the tasteful stateliness of the Model R cabinet, as much as with the neatness of its battery accommodations.

Engineers Voice Approval—

of the rigid spot-welded steel chassis, protecting from damage every part of a set that stands as a notable example of the *completely manufactured* rather than the merely *assembled* radio receiver.

Service Men Commend—

the thoroughness with which every part has been made proof against the interruption of its service, so far as human ingenuity can devise.

Dealers Are Enthusiastic—

over the excitement created everywhere by this unique receiver and the uniform satisfaction felt by its users.

Buy "Solid Value" in Your Radio

The leading wholesaler of radio apparatus in your community has probably been, for years, an ALL-AMERICAN Authorized Distributor. ALL-AMERICAN Guaranteed Radio Products are being shown everywhere by responsible and reliable dealers.

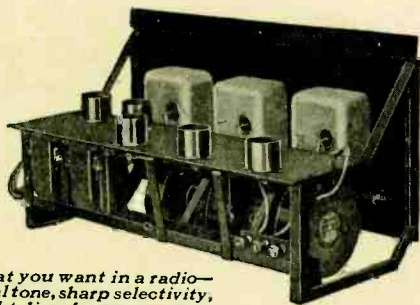

All that you want in a radio—
natural tone, sharp selectivity,
straight-line-frequency tuning
(360°) unaffected by posi-
tion of the fingers, extreme
sensitiveness, permanence.

ALL-AMERICAN RADIO CORPORATION, E. N. Rauland, Pres., 4209 Belmont Ave., Chicago, U. S. A.

RMA

OWNING AND OPERATING STATION WENR—266 METERS

ALL-AMERICAN

Pioneers in the Radio Industry

RADIO 'RITHMETIC

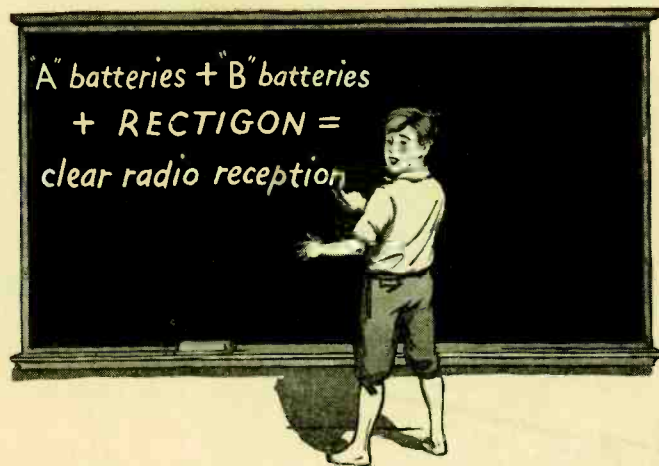

Multiply distance by adding a *RECTIGON*

A SIMPLE solution for so big a result! Want band music? Try KDKA. Jazz? Theatricals? Maybe you'll find it at WBZ, KYW or KFKX. What your local stations won't provide can be obtained easily from somewhere else.

How well you receive radio entertainment depends upon the condition of your batteries —and that's up to you. With a Westinghouse

Rectigon on the job both your "A" and "B" batteries can be kept fully alive to the greatest possibilities of your set.

And it's easy as can be. Just snap on the leads and turn on the current. There's no muss or fuss; no acids; no chemicals, and no noise. The Rectigon more than pays for itself within a short time.

WESTINGHOUSE ELECTRIC & MANUFACTURING COMPANY

SOUTH BEND, INDIANA

The Westinghouse Rectigon Battery Charger

No storage-battery
radio is complete
without a
RECTIGON.



© 1926,
W. E. & M. Co.

Westinghouse manufactures, also, a complete line of Micarta radio panels, Micarta tubes and instruments.

Tell them that you saw it in RADIO

December 28, 1925.

Acme Apparatus Co.,
Cambridge, Mass.

Gentlemen: -

I have one of your new cone type reproducers and I am very much pleased with it.

I have heard all the good makes of speakers before I bought this one but did not find one to suit me. Then I saw your ad in Radio News and having bought your brand of goods in the past I had confidence enough in your goods to buy this speaker without first hearing one and I am well satisfied. Every one says it's the best speaker they have heard. I am using it with a * * * * set and get coast to coast on this speaker.

Thank you.

Mrs. E. F. Hemmye
1814 Highland Avenue,
Burlington, Iowa.

Yours truly,



Thank You, Mrs. Hemmye

—confidence like yours built the Acme business



Acme "double free-edge cone" loud speaker. Round model, \$25.

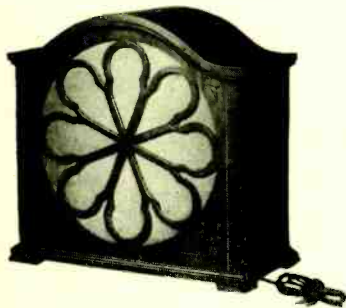

Acme "double free-edge cone" loud speaker. Cabinet model. Like the round model it puts back into the "shadow voice" the living, recognizable individualistic tones of the speaker or instrument. Price \$35.

FROM the time Acme made the first audio amplifying transformer offered the public, and through the years from then to 1926, we have always tried to make the best radio apparatus. We have had thousands of friendly letters, but never could there be a more whole hearted trust placed in a manufacturing firm than to buy its new product without trial simply because of the firm's reputation. Confidence like Mrs. Hemmye's warms our hearts as no other stimulant could.

We spent 5 years and made 256 experimental loud speakers before we perfected the new Acme "double free-edge cone." We feel our efforts are rewarded when old Acme friends write us letters like this. We hope you will like this new principle loud speaker as much as Mrs. Hemmye. Any Authorized Acme Dealer will be glad to give you a demonstration and explain its new principle to you. Acme Apparatus Co., Pioneer Radio and Transformer Engineers and Manufacturers, Dept. D13, Cambridge, Mass., U. S. A.

Pacific Coast Factory Representative
THE SPECTOR COMPANY
Rialto Building, San Francisco

ACME ~for amplification

RADIO

WITH WHICH IS INCORPORATED "RADIO JOURNAL"

VOLUME VIII

MARCH, 1926

No 3

Radiatorial Comment

THE failure of most listeners to hear European radio stations during this year's tests demonstrated that such attempts are still too far ahead of the times. Direct reception of such ultra-long distances has to contend against too many natural and unnatural phenomena to be generally successful until the radio art has been greatly improved.

Yet plans are already being made to repeat the tests next year. The promoters deem that the tremendous amount of free publicity given in the newspapers is worth more than the actual success of the trials. They seem to overlook the fact that the adverse reaction of such publicity on a disappointed public does radio more harm than good. Throughout America there were one thousand people who did not hear Europe for every one who did.

Furthermore, exaggerated claims as to the ability of certain kinds of sets to get Europe reflected against the advertising of more truthful manufacturers and indirectly brought discredit upon an industry which allowed such statements to pass unchallenged. Public confidence in radio has especially been undermined by claims published in parts of the country where there was little likelihood of European reception under the best of conditions.

Those who know the limitations of radio realize the unfavorable effect of raising expectations which are improbable of fulfillment. They recognize the fallacy of selling radio sets on the basis of their ability to get extremely long distance. Radio, whether in California or Kalamazoo, is best sold on the merits of local reception and any undue emphasis upon the possibilities of long distance reception today is detrimental to the best interests of the industry and of the public.

Nevertheless the public wants and is entitled to the benefits of international kinship which radio is capable of promoting. Every listener gets a thrill out of hearing programs which originate four or five thousand miles away. This natural human desire to roam can be satisfied in either of two simple, practical ways without interfering with the stay-at-homes.

Both methods involve the retransmission of European radio programs from some favorable location along the Atlantic seaboard. One method, by wire interconnection of a chain of stations across the continent, would allow every owner of a set whether a humble crystal or an elaborate multi-tube outfit, to enjoy this novel sensation without depriving others of their entertainment.

The other method, by radio retransmission from an Eastern to a Western station should satisfy the most ardent DX fan. These stations, if necessary, could be assigned temporary wavelengths which would not interfere with the wavelengths used by European stations. Persons unable to get

direct reception would then have a fair chance to hear the re-broadcasting.

Both of these suggestions are earnestly commended to the consideration of those who will have charge of next year's program. Unless some plan is adopted which gives greater consideration to the privileges of the majority the scheme will not be given the courteous co-operation which was accorded it this year.

But whatever the plan adopted, care should be exercised against emphasizing the idea that a new radio set will get Europe if the old one does not. Surely a radio becomes obsolete soon enough without speeding its path to the junk-pile by means of statements that will not stand the acid test of truth.

WJAZ is the first radio station to disregard the authority of the Department of Commerce in the assignment of wavelengths. When forced to divide time on the wavelength regularly assigned to them they used a channel already reserved for Canadian stations. Consequently the government has brought suit.

In the opinion of those in a position to know, the Government has a poor case and has little likelihood of winning its suit. There does not seem to be legal authority for the discriminatory power that is exercised by the Secretary of Commerce. No finger has yet written the law that would make WJAZ "pirates in the free air of America."

These statements are not intended to extenuate the conduct of WJAZ in appropriating what has already been given to another. They are not meant as criticism of Secretary Hoover in the exercise of a power from which he has repeatedly asked to be relieved. Undoubtedly he has given the best answer, as is now possible, to this perplexing problem. He has sincerely tried to avoid the position of a radio czar, but when the responsibility has been thrust upon him he has just as sincerely tried to exercise it in the interest of the listening public.

The fault lies not with the Secretary but with Congress in its failure to pass a radio law which defines his duties and authority. For at least three years such legislation has not been able to get through Congress. For four years the problems have been becoming more complex. And the only basis for decision has been the antiquated law of 1912.

Much as we respect the Department's decisions, we hope that they will be overruled in this case if thereby Congress is roused to action. The present lack of security is retarding radio development. So let there be no further delay in the enactment of a radio law that will put authority and responsibility in one and the same place, as does the White Bill.

Paper Condensers

The Several Features of Manufacture Affecting Their Mechanical and Electrical Properties

By Alexander Nyman

STATIC condensers made of impregnated paper and tinfoil have found a large application in the radio industry. Such a condenser has the peculiarity of giving a considerable capacity for a very low cost and in a small space. It has been therefore used wherever a large capacity is required, whether for direct, radio frequency or audio frequency current. It is evident that when radio frequency is passing through a paper condenser care must be taken that this condenser has low loss, that is, low power factor. The power factor is, however, of not such a great importance at audio frequencies.

The following electrical properties of paper condensers are of importance: The capacity of paper condensers should be, in general, accurate to within 10 or 15%, but in many cases of by-pass condensers an excess in capacity will only improve the operation. The accuracy of a paper condenser can be maintained in the manufacture by care, in adjusting the number of turns of paper and foil and, also, the pressure at which the condensers are compressed.

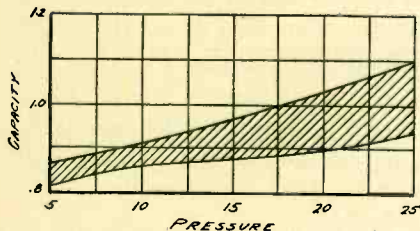

Fig. 1. Variation in Condenser Capacity at Different Pressures.

Fig. 1 shows a variation in capacity on a group of condensers when compressed at different pressures. It will be seen that at low pressure the variation of capacity is the least, although the actual value of capacity is not as high as it can be made by applying a higher pressure. It is necessary to strike at a compromise for an economic and accurate condenser.

The breakdown voltage of a condenser is determined mostly by the choice of material and of impregnation. In general, the operating voltage of a condenser should be very much lower than the breakdown voltage.

Fig. 2 gives the relation of breakdown voltage, test voltage and operating voltage on condensers with various amount of insulation. These curves apply, of course, only to a certain grade of ma-

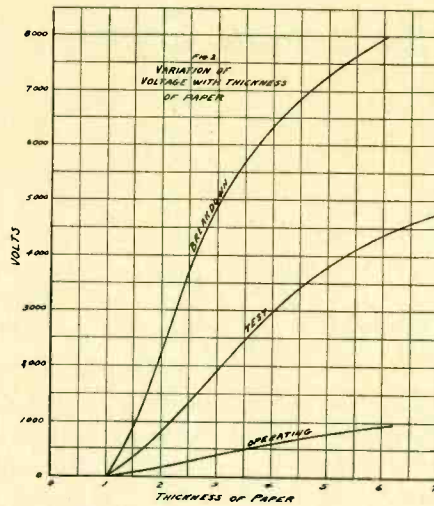

Fig. 2. Variation of Voltage with Thickness of Paper.

terial which has been found satisfactory and economical.

The object of specifying an operating voltage so far below the breakdown voltage is in order to insure a long life and to safeguard the condenser against sudden surges in voltage.

The life of a condenser is dependent on the voltage applied to it. For this reason, the flash test which is usually applied to a condenser should be considered only as a guide to the operating voltage. As a rule the operating voltage should be about 1/5 of the flash test voltage.

In the majority of radio circuits the leakage resistance of a condenser is of considerable importance. By leakage resistance is meant the resistance that permits a certain amount of direct current to flow through the condenser. With a proper design, choice of material and impregnation, this leakage resistance can be increased until the amount of leakage current is negligible. It is evident, that the larger is the capacity, the lower is the probable leakage resistance. On the other hand, when a condenser is designed for a higher voltage, more insulation must be used and for that reason the leakage resistance will be higher.

It has been found that the leakage resistance of a complete condenser varies with the pressure at which the condenser is clamped during impregnation. This becomes, therefore, an important factor in manufacturing a condenser.

The leakage resistance is further affected by the temperature of the condenser. Fig. 4 illustrates the variation of leakage resistance with temperature. Although the individual condensers may have varying leakage resistance, in general a well designed and built condenser will have the same proportional change in resistance for certain change in temperature. If, however, the condenser during manufacture has been permitted to absorb a certain amount of moisture, the leakage resistance is not only lowered

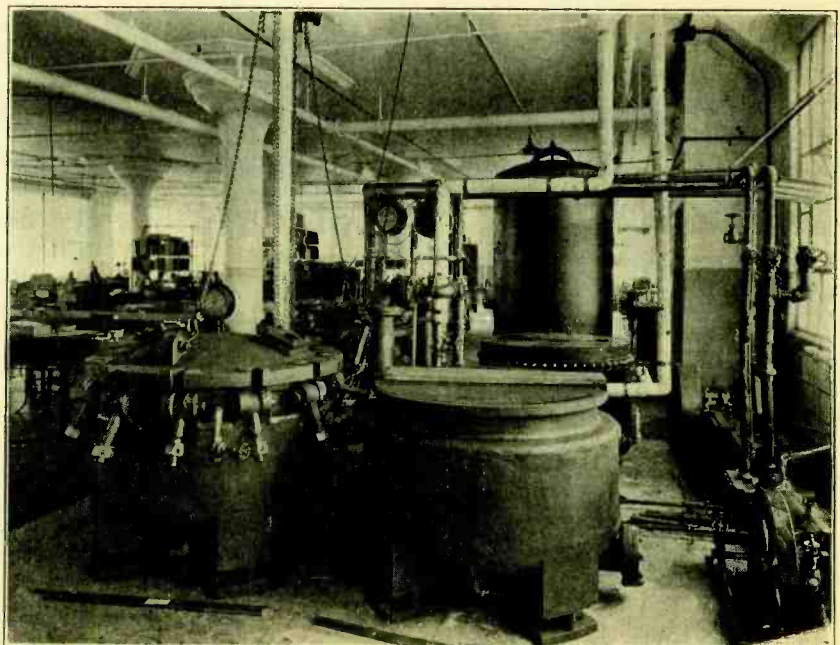

Drying and Impregnating Equipment.

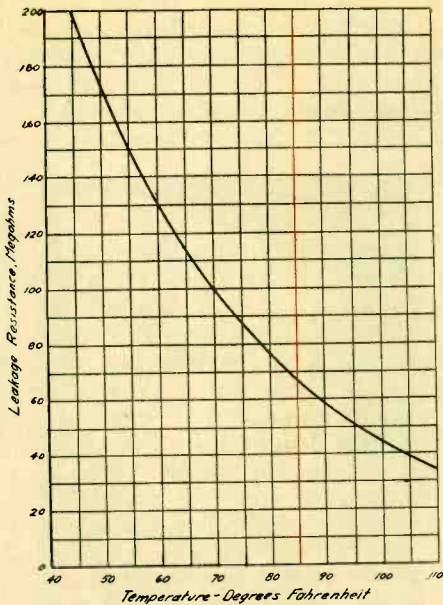

Fig. 4. Variation of Leakage Resistance with Temperature.

but its variation with the temperature may be entirely changed. A condenser with low leakage resistance is moreover susceptible to local heating in the body of the condenser and a consequent local reduction in insulation resistance. It will be readily seen that such an effect may be cumulative, that is, a higher temperature will lower the leakage resistance, admit more current with further heating and further lowering of leakage resistance. Such a condition would lead eventually to a complete breakdown of this condenser. From this point of view it becomes apparent how im-

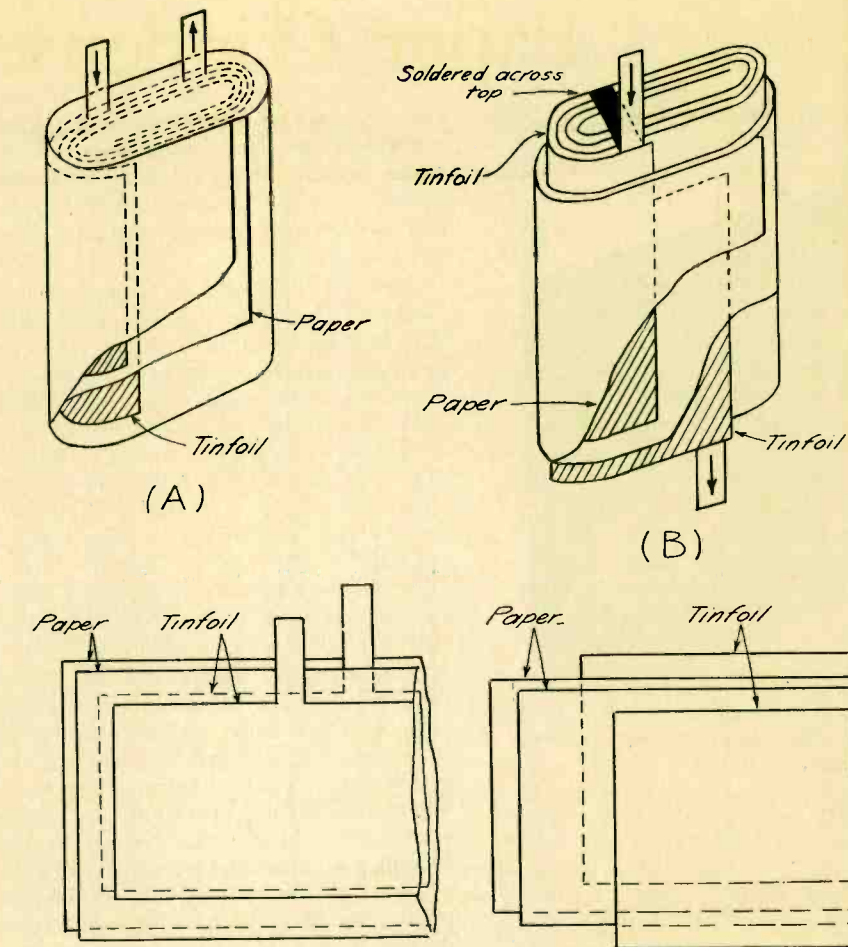

Fig. 5. Methods of Condenser Construction.

portant it is to keep the leakage resistance well above the safe limit.

The power factor of a condenser is defined by the ratio of energy lost to the

total energy supplied to the condenser. This factor becomes especially important in radio frequency operation. Thus if a condenser is used as a by-pass for radio frequency current and it happens to have a poor power factor, this condenser will be equivalent to a resistance and a condenser in series, and instead of allowing the radio frequency current to pass through freely, it will act as an impedance to this current.

In certain cases the inductance of the current path in a condenser becomes of importance. This is particularly true at radio frequency, where even a small inductance may constitute an objectionable feature. The design of the condenser should be such that under no circumstances should the current pass through a long and involved path. The longer the path for the current, the lower is the inductance.

Fig. 5 illustrates two ways in which paper condensers are commonly constructed. The figure marked *A* shows a type of construction where the current is admitted through a copper tab to one point of the condenser winding and removed at another point on the opposite tinfoil. It will be seen that a current after entering into the condenser must pass through either the full length of tinfoil or at least through half of that length. The construction marked *B* in



Testing a Condenser for Voltage Flash, Capacity and Leakage Resistance.

Fig. 5 has the tinfoil brought out at each end of the condenser. Therefore, instead of passing through the length of the winding, the current has to go only across the width of the tinfoil strip, a much shorter path. It is evident, and



Typical Paper Condenser Filled with Wax Which Withstands 160 Degrees Temperature Without Flowing

the results bear out the fact, that the power factor in the second case is considerably lower than in the first. This type of construction is therefore eminently suitable for radio frequency work.

It is necessary to protect a paper condenser by a metal container, as the material in itself is liable to damage. A paper condenser is sometimes inserted in a paper container but it is clear that a container of this nature would not pro-

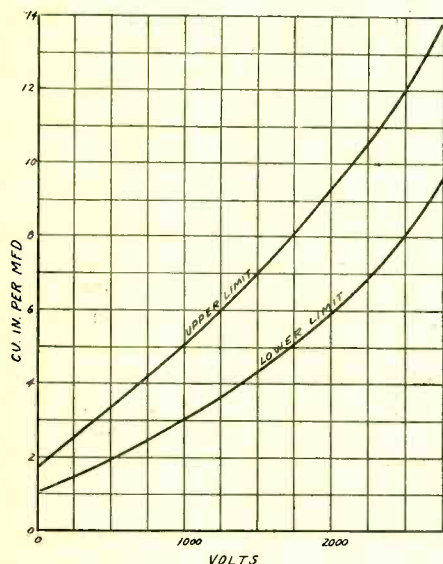

Fig. 6. Volume of Paper Condensers in Cubic Inches per Microfarad at Different Voltages.

tect the condenser from either a pressure at one side of the condenser or from the damage due to dropping or jamming the condenser against some metal part.

Moreover, the condenser must be protected from the presence of moisture which will gradually soak through the usual impregnating materials. It is for this reason that a metal container completely sealed with a special sealing com-

pound is the best protection for a paper condenser.

It is very important in cases where the condenser is mounted horizontally and subject to considerable heating in a warm climate or in a hot location, to choose a sealing compound which will withstand the temperature without softening.

The size of a paper condenser will depend to a considerable extent on the design and choice of materials. It will be found however, that for a good practical condenser and capacities varying from $\frac{1}{2}$ mfd. up, the volume of a paper condenser will conform to Fig. 6 which shows the upper and lower limits of cubic inches per microfarad at different test voltages. Since the space economy is greater with larger capacity the lower limit will be approached; the upper limit corresponds roughly to half microfarad capacity.

The materials used in making paper condensers should be chosen with great care, as even under ordinary working conditions this material is subject to especially heavy electrical strains, and during manufacturing operation the same material is subject to mechanical strain. During the manufacture of paper it is necessary to eliminate all the possibility of any metallic particles or other conducting pieces of matter from entering into the mixture. Very often the mixture is treated by passing it over magnets to extract pieces of iron. It is however more reliable and more satisfactory to so perfect the methods of manufacture of paper that such a removal is unnecessary. If there is a possibility of iron particles entering, there is nothing to prevent copper or other metals from entering as well, and a magnet would not remove them.

The tinfoil for paper condensers is usually very thin and of very smooth and even surface. It is inadmissible to have any jagged edges or roughness, as under the pressure during impregnation the paper may be damaged or even pierced by any irregularity of the surface.

The impregnating material, which is usually some type of wax, should be also carefully selected with a view to its chemical and electrical properties. In particular, this wax must be free from any traces of acid and other impurities. The wax is one of the constituent parts of the insulation of the paper condenser and should therefore be as carefully chosen and as carefully kept in a clean and dry condition as the paper.

The description of the process of manufacture and the properties of paper condensers is intended to convey an idea of the degree of engineering skill and manufacturing care which is necessary in producing this article. With all the precautions and safeguards taken, the condenser is impressed very often into a service for which it is not intended.

Sometimes several condensers are connected in series and d. c. is applied to this combination. Such an arrangement is entirely unsafe, since it is impossible to be positive that all of these condensers

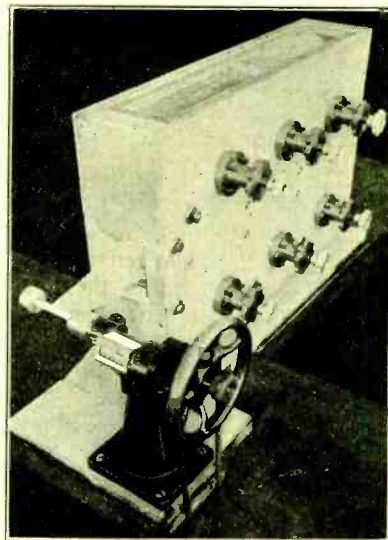

A Winding Machine for Making Paper Condensers.

have the same leakage resistance and it is after all this leakage resistance that determines the distribution of d. c. voltages on condensers. This can be explained as follows: With alternating current, the potential of any individual condenser of a series is determined by its capacity, because a current flows through the capacity of the condenser, and the drop of potential through any one capacity is proportional to that capacity, and the current flowing through it. However, on d. c., no current will flow through a perfect condenser after the condenser is charged. With the ordinary condenser and a certain amount of leakage, the current will continue to flow, but that current will be only due to the leakage resistance, and the voltage which will be finally established on the condenser will be proportional to this leakage resistance and the current which flows through it.

A condenser is often subjected to a combination of voltage strains, the peak values of which reach considerably in excess of the specified working voltage. Thus a filter condenser may carry a direct current and superimposed on it an alternating current of fairly high magnitude. Such a condition is especially severe as the continually applied alternating current may cause sufficient heating to make the condenser unsuitable for direct current. In such a case the only safe remedy is to have a condenser of ample enough voltage characteristic to withstand this service. In other cases a similar condenser may be subjected to quite high voltage stresses at intermittent intervals and withstand them satisfactorily. It is the continually applied voltage with intermittent surges that is most severe and should require the maximum discretion in the choice of the proper rating.

Refinements in the McCaa Anti-Static Devices

An Account of the Theory and Practical Use of This Recognized Method of Mitigating Static and Other Forms of Interference

By Edward B. Patterson, B. Sc.

THE anti-static devices invented by Dr. D. G. McCaa have aroused considerable interest in the radio world. As with most inventions, improvements and certain refinements have been made which add to the efficiency of the early original circuits. This article will treat on these refinements which have been made by Dr. McCaa.

Although the general name "anti-static" has been applied to his devices it must be remembered that they also act on strays caused by power leaks and other forms of interference in this general family of atmospheric disturbances. The devices are therefore useful in both winter and summer.

In order for the devices to work, static does not have to be on its good behavior and come from one direction only, such as Mexico or Russia. The anti-static action is, in fact, very pronounced even when an electrical disturbance is directly overhead.

It should be understood at the start that directional loops, very long aeri- als, etc., are not necessary for the operation of the McCaa circuits which may be placed ahead of practically any type of receiver. An ordinary aerial system with a good ground is employed, but a loop can be used if desired.

The above is not mentioned with the idea of praising the McCaa system. Whether it is a good one or not the reader may decide for himself after constructing one of the units to be described.

Before proceeding directly to the constructional details, a short explanation

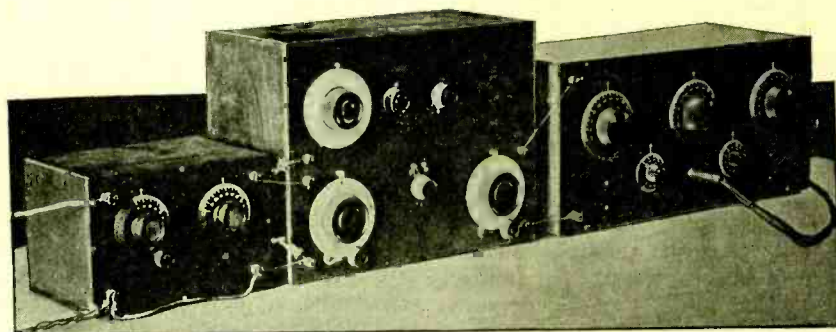

Fig. 4. McCaa Anti-Static Device with Receiver.

of the principles of the devices will be undertaken for those who, as yet, are unfamiliar with them.

What we call the value of inductance of a coil is determined by the number of effective lines of force produced. To clarify this statement we will refer to the ordinary variometer with its two windings in series. When the two windings are in such a position that their fields of force aid one another the inductance is at a high value. On the other hand, when the fields oppose or "buck," the inductance falls to a minimum.

The McCaa systems depend upon the fact that the inductance, or rather inductive reactance of a coil, may be made negligible by the bucking action of another coil whose magnetic lines of force tend to annul or neutralize the lines of force in the first coil. A coil having a high inductance draws less alternating current than one having a lower inductance.

To understand the latest anti-static

The coils, P_1 and P_2 , arranged on each side of the secondary coil, have their magnetic couplings so adjusted that there is no transfer of energy into the secondary by virtue of the primary fields bucking each other. Nothing is heard in the receiver.

At this time, however, the desired signal current is causing a certain magnetic field in coil A . This coil is chosen with a greater number of turns than P_2 and hence more of the current in the antenna goes through P_2 than through A . The coil A , therefore, has little effect on P_2 under normal conditions.

Let us assume one unit or line of magnetic force has been created in coil A due to the desired signal. The oscillator or driver D is then brought into action and by proper manipulation annuls or neutralizes the one unit in coil A .

This tends to reduce what we call the inductance of coil A . Now if the inductance of the coil falls to a minimum or negligible amount, one important action takes place. Coil A becomes a direct short circuit across P_2 because the current finds an easy path through coil A . Immediately the bucking action of P_2 on P_1 is removed and the signal is heard.

This shortcircuiting action on P_2 only takes place when the assumed one unit of magnetic force due to the signal in A is neutralized by the driver.

We can pass the desired signal into the secondary at any chosen intervals and for this reason the circuit just described is called the "Local Beat Frequency Driver System." At a certain interval the driver lines of force and the signal lines of force in A will be in phase and no signal will be heard in the receiver. But with advances of time, the driver and the signal will be 180 degrees out of phase and the signal will come through.

Adjustments of the driver will give any beat action desired and therefore the

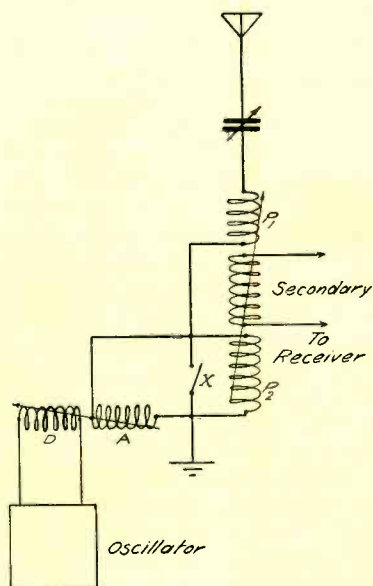
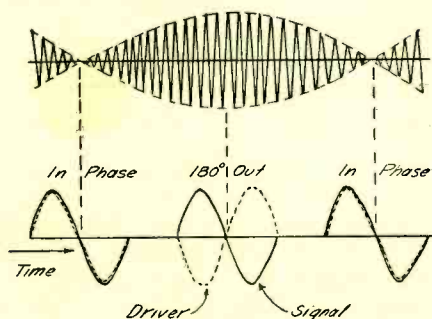

Fig. 1. Circuit Diagram of Local Beat Frequency Driver System.



system we must first analyze one of the early circuits shown in Fig. 1. The switch X is closed, short circuiting the coil P_2 which is chosen smaller than P_1 . The antenna is tuned to the desired signal frequency, as is likewise the secondary, and the signal passes through to the receiver. The switch X is opened, admitting P_2 into the antenna system.

system can be adapted for superheterodyne receivers.

So far we have been dealing only with the desired signal. When the device is needed, the static and strays will be of a greater intensity than the signal. Let us assume that static creates 20 units of force in coil *A* to the desired signal's 1 unit. The driver has been set to neutralize but 1 unit in coil *A*. Manifestly, the inductance of *A* does not fall for the static and *P*₂ is not shorted and hence the buckling action of *P*₂ on *P*₁ is still present for the static.

Yes, it is true that static of "almost" the same intensity as signal will pass into the secondary and will be heard. Static producing one unit of force in *A* will be allowed to pass through in the same manner as the signal of the same value.

For those who like analogies the explanation of the theoretical operation of all the McCaa anti-static devices shown in Fig. 2 may be helpful. We can picture static as a liquid contained in the large tank and the signal as in the small one.

If all of the static as represented by the tank were to pass into the receiver it would completely override the signal. But the anti-static device controls the static and strays so that the ratio of signal to static is 1 to 1. This ratio represents peak voltage only. Static impulses are irregular and highly damped as compared to signals and hence, although peak voltages of signal and static are the same, the energy content of the signal impulse is greater than static. The orifice for the static tank will be somewhat smaller than the signal orifice.

Perhaps the above statements will disappoint some who have been lead to believe there are magical circuits which will positively prohibit static. There is no need for such a feeling. The small amount of static which enters the McCaa system is not objectionable. In severe tests at the Radio Laboratories of

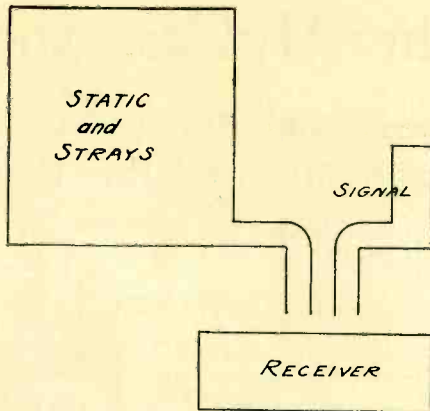

Fig. 2. Hydraulic Analogy of McCaa Anti-Static Device

Horace A. Beale, Jr. at Parkesburg, Pa., and at Dr. McCaa's home in Lancaster, Pa., disturbances from arc lights, electrical storms, etc., which without the devices would have made reception impossible, were passed into the background and were not objectionable.

In the system just described the control frequency is clean, that is, the device functions because of a local driver. In the next system to be explained, the signal frequency itself is the control. Further reading will make this point clear.

In Fig. 3 is shown the simple "Signal Frequency Synchronous Driver." The operation of this device is not difficult to understand.

The aerial circuit is tuned to the desired signal frequency, let us say, 1,000 kilocycles or 300 meters. The incoming signal energy is transferred to the 25 turn honeycomb coil, *S*. With the switch *X* closed, the variable condenser *C*_s is adjusted so that it brings its circuit to resonance. Then the coil *S*_M is tuned by the condenser *C*_M of the main receiver and the signal is heard.

The switch *X* is opened which brings *P*₂ into bucking action on *P*₁ (in the same manner as first described) and the

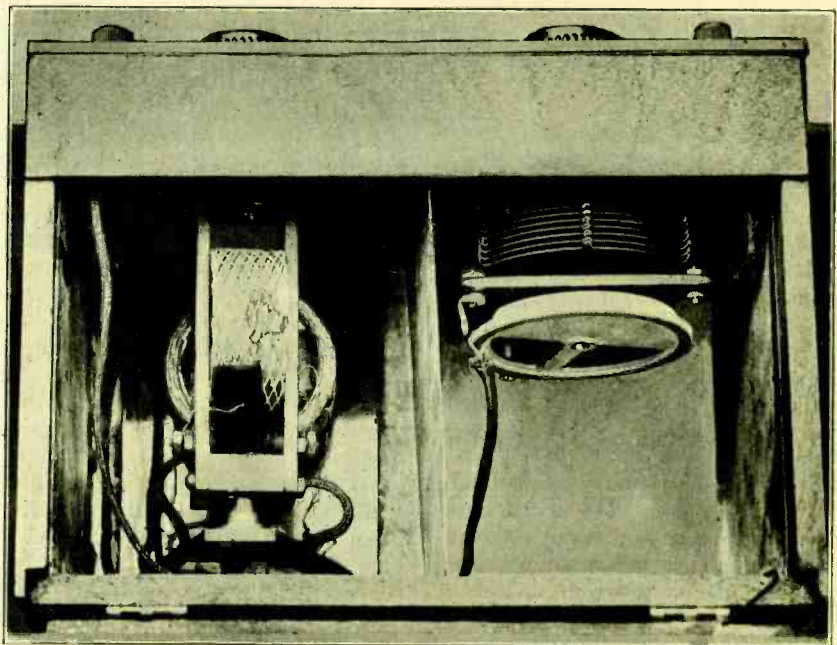

Fig. 5. Rear View of Antenna Coupler.

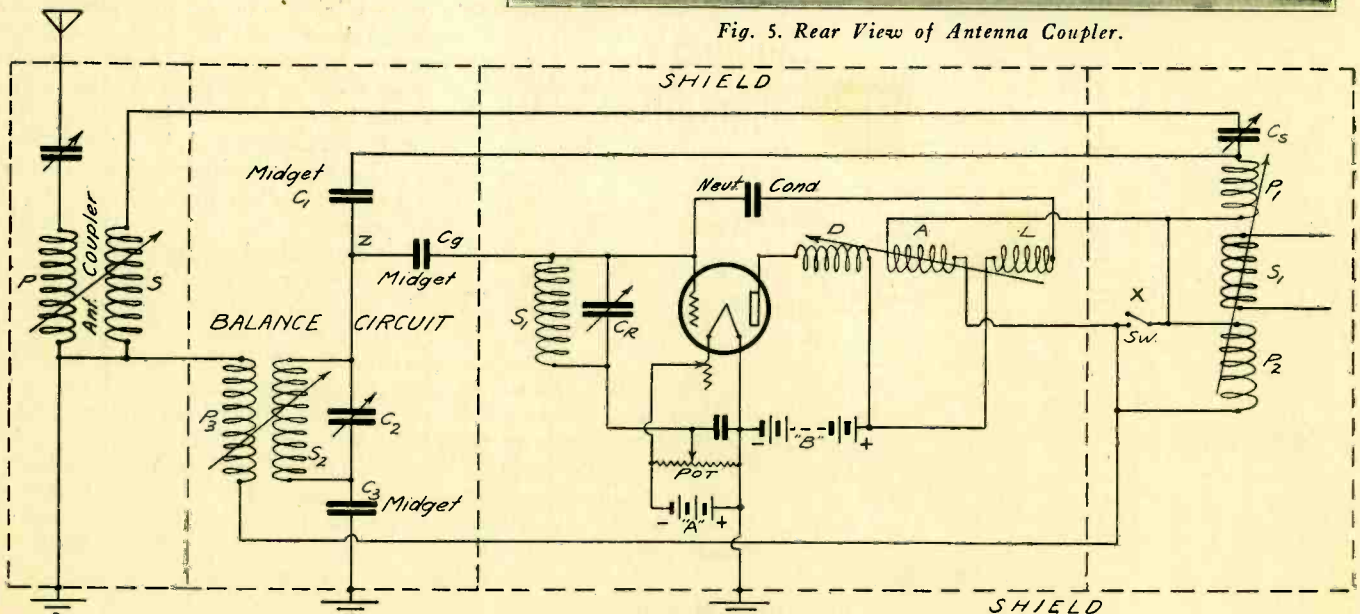

Fig. 3. Circuit Diagram of Signal Frequency Synchronous Driver System.

result is no signal or static heard in the main receiver. In addition to the bucking action when coil P_2 is admitted, its circuit is detuned because P_2 has a fairly high inductance as shown by the relative number of turns.

However, in spite of this detuning, a certain amount of current due to the signal will flow in the coil P_3 which in turn is transferred to circuit S_1C_r (tuned to 1,000 kilocycles) and on to the grid of the tube (called the repeater) which is now in operation. The signal impulses are amplified by the tube and appear at D . The coupling of D to A is arranged so that the number of magnetic units of force in A produced by the signal is neutralized. Upon having its inductance reduced to a negligible value, the coil A acts as a short circuit on P_2 and the desired signal passes into the main receiver. Of course, it can be seen the action is similar to that of the other system.

Coil L with its condenser is for the purpose of neutralizing the tube capacity and prevents undesired impulses in A from passing on to the grid circuit.

The circuit in Fig. 3 differs from the early circuit of this particular type in that the aerial does not go direct to P_1 from the connection marked "post," but is, instead, magnetically coupled to the tuned antenna. Placing the anti-static system in a closed secondary circuit coupled to the antenna has several distinct advantages. When the coils P_2 and A are inserted, the secondary is detuned with respect to the antenna and it responds to the static component in the antenna corresponding to its natural period. This is weaker than the resonant component, and therefore the static oscillation train in the secondary will be lower in amplitude.

It has been found that the static oscillation has a frequency corresponding to the natural period of the secondary and its decrement will correspond with the decrement of the closed secondary circuit. This decrement can be made low by using a large amount of inductance and a small capacity. Reference to the formula for determining decre-

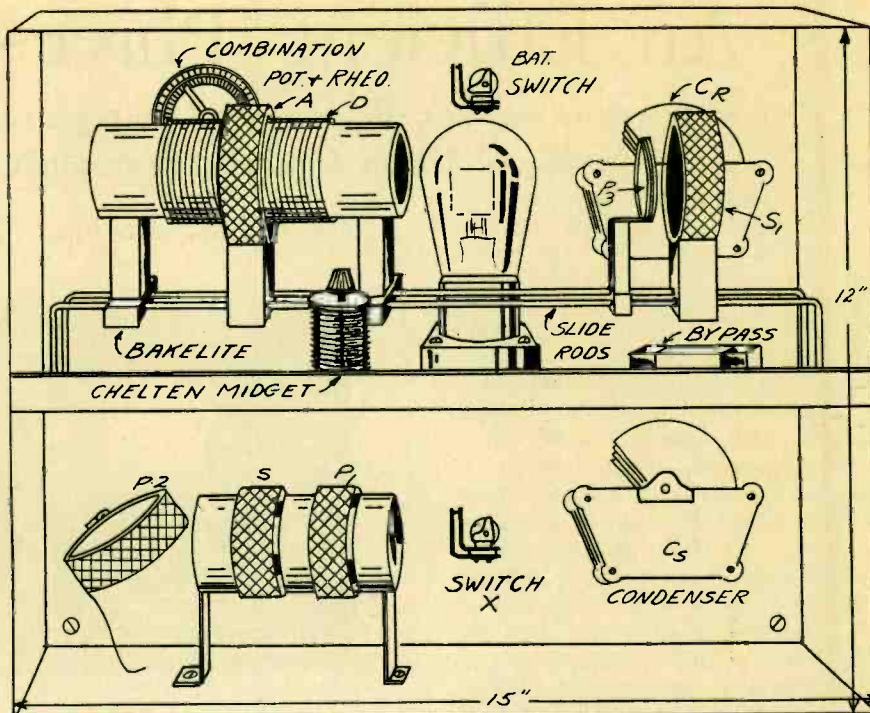

Fig. 6. Rear View of Anti-Static Instrument Assembly.

ment will indicate the importance of using a high value of inductance.

With the closed secondary C_s , P_1 , P_2 , etc., the resistance is lower than if it were connected directly to the average antenna and hence this also aids in keeping the decrement low.

Another point was brought out by Dr. McCaa in the explanation of his circuit. Grant that there is a static component at the desired signal frequency even when the antenna is detuned. This static component is representative of a transient momentary acting force, and by virtue of the new closed circuit is not effectually transferred to the input circuit of the repeating system as is the undamped signal oscillation.

In the operation of this circuit it is most desirable to use as high a value of P_2 and A as possible because this shifts the band of static components farther away from the signal frequency and causes a weak (if any) component to be present at signal frequency. How far detuning may be carried depends upon

the amplifying power of the repeater tube.

Construction

The general appearance of the apparatus used in the circuit just described is shown in the accompanying picture of the anti-static placed beside a radio frequency receiver. The small cabinet directly on the left contains the coils marked P and S in the schematic diagram and also the condenser in series with the aerial. In building this unit the experimenter may follow his own ideas, merely bearing in mind that the means must be provided whereby the coupling is made variable. The coil S may be placed on a shaft as shown and then fastened to a dial on the front panel.

The series condenser is shown shielded from the coils and the whole cabinet is lined with a copper shielding and connected to ground. The important fact to remember is that coil S should be shielded from strays because it feeds directly into the device.

(Continued on Page 59)

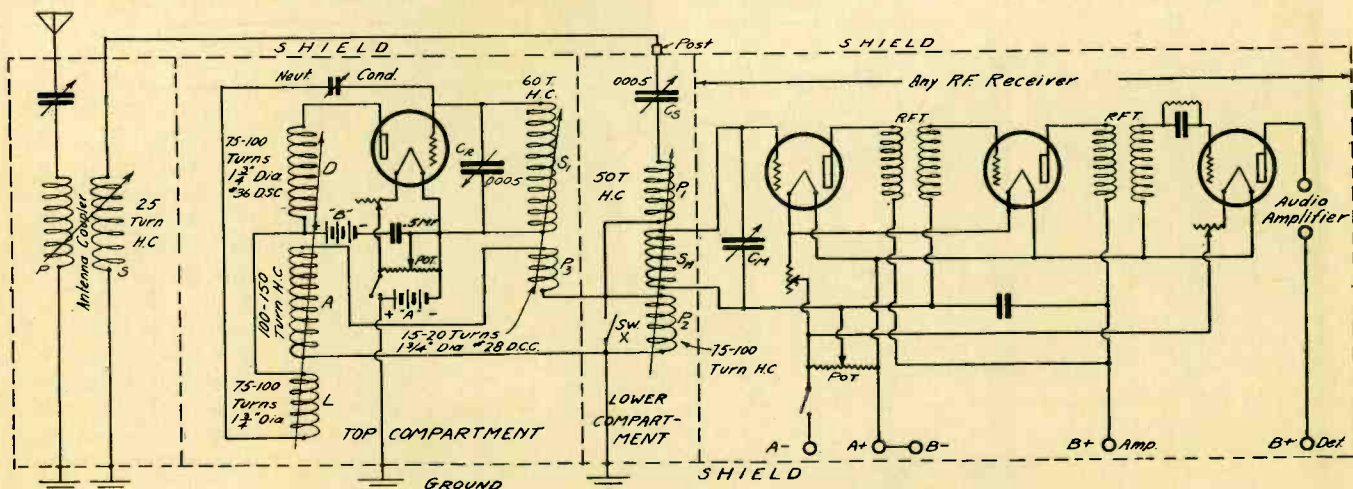

Fig. 8. Static Balance Circuit with Signal Frequency Synchronous Driver.

An Efficient Three-Tube Set

Consisting of One R. F. Stage Detector and One A. F. and
Based Upon Circuits Previously Described

By *E. M. Sargent*

BEFORE starting with the details of Circuit No. 3, the writer would like to answer one or two questions which have come up several times since this series was started. One question which has been asked repeatedly is regarding the use of a crystal detector. It seems that many radio fans are under the impression that in order to get good tone from a set it is essential to use a crystal detector and conversely, when a crystal detector is used, perfection of tone is bound to follow. This, the writer believes, is an erroneous idea.

It is true that, as a general thing, a crystal detector has a better tone than a tube detector, but this is not because of any inherent fault in the tube; rather, the trouble is usually with the operator of the set. It is natural with a tube set to try to work it at its maximum capacity so as to get all the distance and volume possible. If a local station is coming in clearly on the headphones, the owner of the set usually proceeds to see how loud he can get it and the resulting overload on the tube causes distortion. Overloading a crystal detector in a crystal set is impossible and hence the tone delivered is always good.

A simple experiment will convince any crystal set owner that his crystal set is not delivering to the earphones an exact replica of the music that is being radiocast. Tune the set to some station that is coming in fairly loud and then, without changing the tuning dials, lift up the cat whisker and set it down in several different places. Notice that the tone of the music has slightly different characteristics every time the cat whisker is moved to a new place. It is therefore clear that all of these different tones

cannot be correct and it is more than likely that not one of them are, which is another way of saying that even a crystal distorts.

When used in a reflex set, a crystal is much more likely to distort because of the heavy overload put on it by the radio frequency amplifiers ahead of it, and as a general rule better tone quality can be obtained with a tube detector. The

tone can be still further improved by eliminating the reflex and using each tube for but one purpose. That is one reason why this series of circuits contains no reflex sets.

Another question that has come up several times is regarding the substitution of parts which may already be in the work-shop of the set builder. The circuits of this series as described are

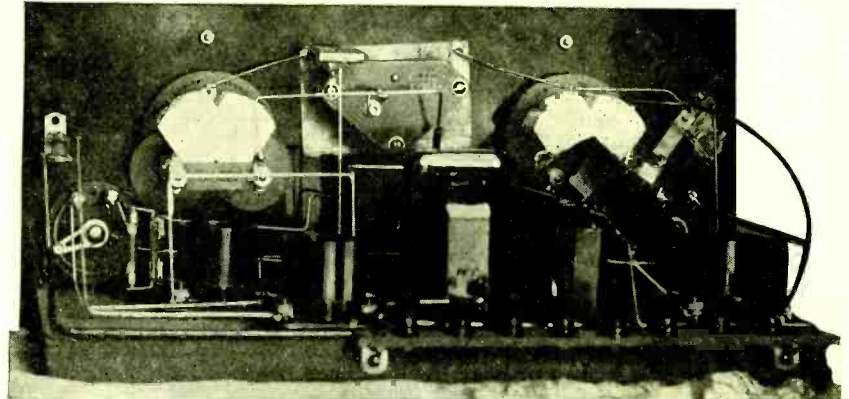

Rear View of Completed Three-Tube Set.

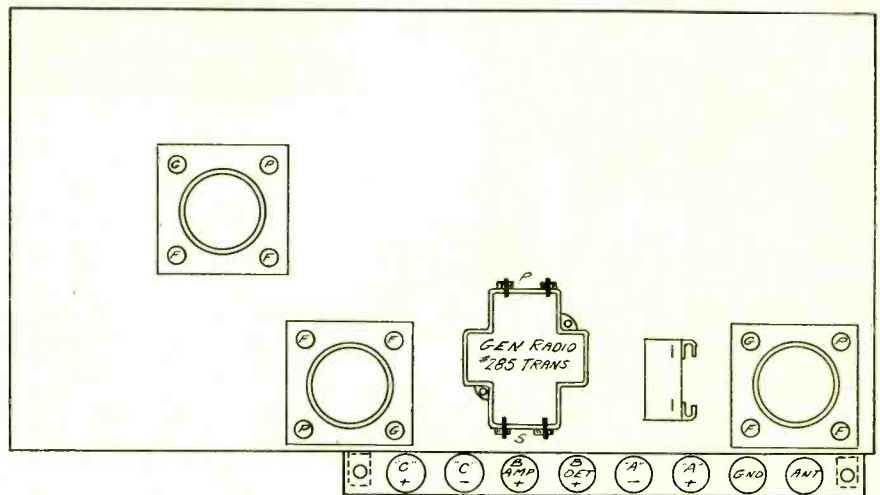

Fig. 2. Baseboard Layout for Three-tube Set.

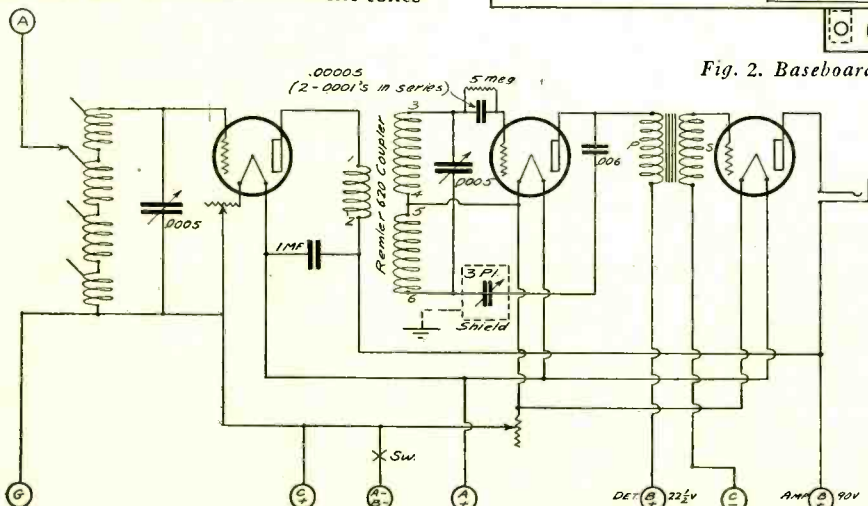

Fig. 1. Circuit Diagram for Efficient Three-tube Set.

made to operate most efficiently with a given set of parts which are specified with each circuit. This does not mean that in certain places other parts will not work just as well but it does mean that if the circuit is to be given a fair trial it should be made up exactly as described.

Now to Circuit No. 3. Fig. 1 shows the wiring diagram. The panel layout is exactly the same as in Circuit No. 2, which was described in February RADIO. The added parts for the three tube set are: one socket, one 1 mfd. condenser, and a tube. The input coil is used between the antenna and ground

(Continued on Page 50)

A New Five-Tube Receiver

Operative From the Light Socket and Employing Fieldless Inductances, Impedance Coupled Audio, and an Improved Current Supply Unit

By Edwin E. Turner

THE principal consideration in receiver design at the present time seems to be quality of reproduction. Selectivity is another attribute, nearly as important. Sensitivity, of course, is much to be desired. Finally if it is possible to operate the receiver from the light socket, so much the better. The receiver which forms the subject of this discussion succeeds admirably in the realization of the ideals which have been outlined. It employs fieldless inductances, impedance coupled audio and a current supply unit which possess certain advantages in point of ease of adjustment and constancy of operation.

The circuit used is by no means new. It consists of the time honored stage of tuned radio frequency, regenerative detector and three stages of impedance coupled audio. However it adapts itself readily to the use of toroids, which possess certain advantages in spite of their larger distributed capacity and higher radio frequency resistance. Solenoids of small diameter and correspondingly small external field may be substituted at the option of the builder with identical results. Capacitive control of regeneration is employed, in a manner which gives sensibly fixed regeneration over the entire wave band, with the added advantage of manual control when necessary to secure that last iota of amplification.

A tuned or untuned antenna circuit may be selected at will, giving respectively a three and a two control set. The energy ordinarily wasted in a resistance, to drop the power supply voltage to a value suitable for the filaments of the tubes, is used in the fields of an electrodynamic cone speaker of truly exceptional acoustical range, which will form the

LIST OF PARTS USED FOR RECEIVER	
3	Dials (Marco).
3	G. R. Type 247-F .0005 S. L. W. variable condensers.
2	G. R. Type 368 Micro-Condensers.
3	Thordarson Autoformers.
5	UX sockets.
3	Inductances (Erla, Thorola or Bremer-Tully toroids) or solenoids as specified.
1	Variable grid leak (Strand).
1	500,000 ohm modulator (Centralab).
1	Weston Type 506 meter, 5 volt scale.
1	Bradleyohm 100 to 1,000 ohms.
1	Choke as specified.
2	0.5 megohm grid leaks with mountings (Daven).
1	Inductance Switch, two contacts and two stops—G. R. 171-F.
1	Panel 7x24 in.
1	Binding Post Strip (as shown).
13	Binding Posts.
6	1 mfd. Condensers, Tobe-Deutschmann, Dubiller.
1	Filament Switch.
1	.00025 mfd. grid condenser.
1	Baseboard, 7x23x½ in.

Raytheon rectifier is shown in Fig. 3 for transformer voltages of 250 and 200 respectively on each side of the center tap. Since we wish to draw approximately 70 milliamperes it is evident that the higher voltage must be used. At a 70 mil drain the output is approximately 110 volts.

In Fig. 1 is shown the simplified diagram of the power supply unit output circuit, in order that we may more easily comprehend its operation. V_1 , the output voltage, is impressed directly across the filaments of the four 199 tubes in series, with a fixed resistance R_1 and a variable resistance R_2 in series. In the receiver used by the writer R_1 comprised the fields of a cone type speaker of the electrodynamic type wound to 1500 ohms

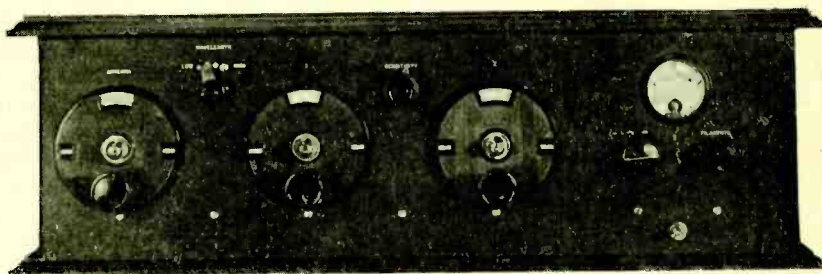

Front Panel View.

subject of a future article. The ordinary type of speaker may be used if desired. This will be apparent later. Not the least of this receiver's advantages is its compactness, made possible by the use of small solenoids.

The power supply unit uses the Raytheon rectifier but, with suitable changes to supply the additional filaments with current, the UX-213 or CX-313 may be used as described in the article on the "ABC Eliminator" in RADIO for December. The regulation curve of the

with No. 30 enameled wire. When the ordinary speaker is used R_1 may be a fixed resistance of 1500 ohms, such as a Federal No. 25 potentiometer. A variable resistance of 1000 to 10,000 ohms set at near minimum may be used if desired.

R_2 , which is the rheostat on the receiver panel, is variable from 100 to 1,000 ohms, and serves to adjust the filaments of the tubes to exactly the correct voltage. R_3 and R_4 serve to drop the voltage to the proper value for the amplifiers and detector respectively.

It will be noted that the B voltages for all of the tubes are secured directly from the high voltage tap, being dropped to the correct values by suitable resistances. In this way the adjustment of any one value is independent of any other, except in so far as the regulation of the supply voltage is affected by the larger or smaller current drain involved. This effect is much less marked with the connection shown, than when the various B battery voltages are obtained by tapping the series filament resistance at various points. In the latter case each adjustment is quite dependent upon the others.

The plate voltage used on the radio,

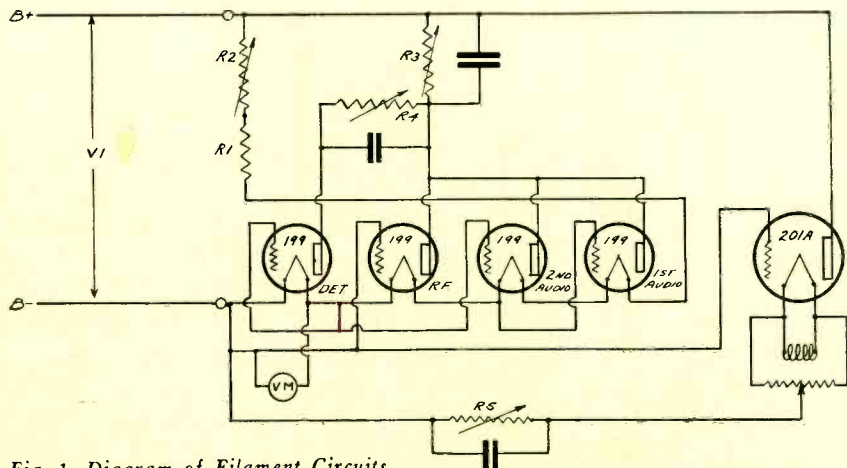
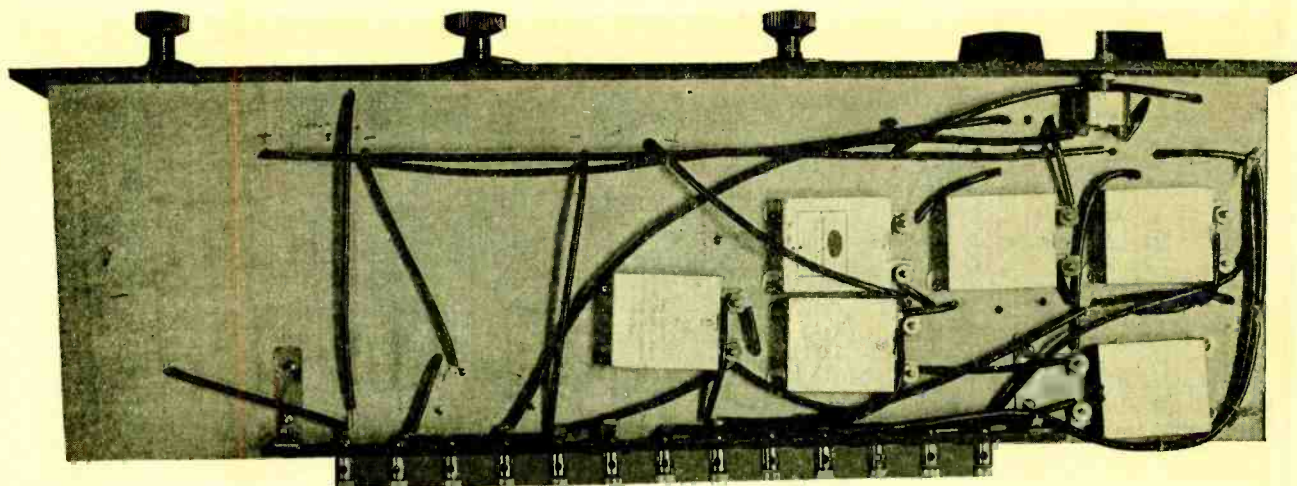

Fig. 1. Diagram of Filament Circuits.



View of Under Part of Shelf.

view) shows the three impedance coupling condensers, the three by-pass condensers, and the filament switch.

The circuit diagram is given in Fig. 2 for both the receiver proper and the power supply unit. The power unit needs no comment, except that a fixed resistance must be connected between the points X-X if the field of the speaker is not used. This should be approximately 1,500 ohms as above noted. The circuit diagram of the receiver itself shows the connections plainly. The stator and rotor plates of all condenser plates are so marked. These should be followed in order to eliminate body capacity effects.

The grid leak used on the detector should be variable from $\frac{1}{2}$ to 10 meg-ohms. Coil L_1 , if solenoids are used, should consist of 110 turns of No. 36 d. s. c. wire on a hard rubber tube $1\frac{1}{2}$ in. in diameter and $1\frac{1}{8}$ in. long.

Coil L_2 consists of two windings. The secondary is composed of 90 turns of No. 30 d. s. c. wire on a hard rubber tube $1\frac{1}{2}$ in. in diameter and $1\frac{1}{4}$ in. long. The primary, which consists of 10 turns

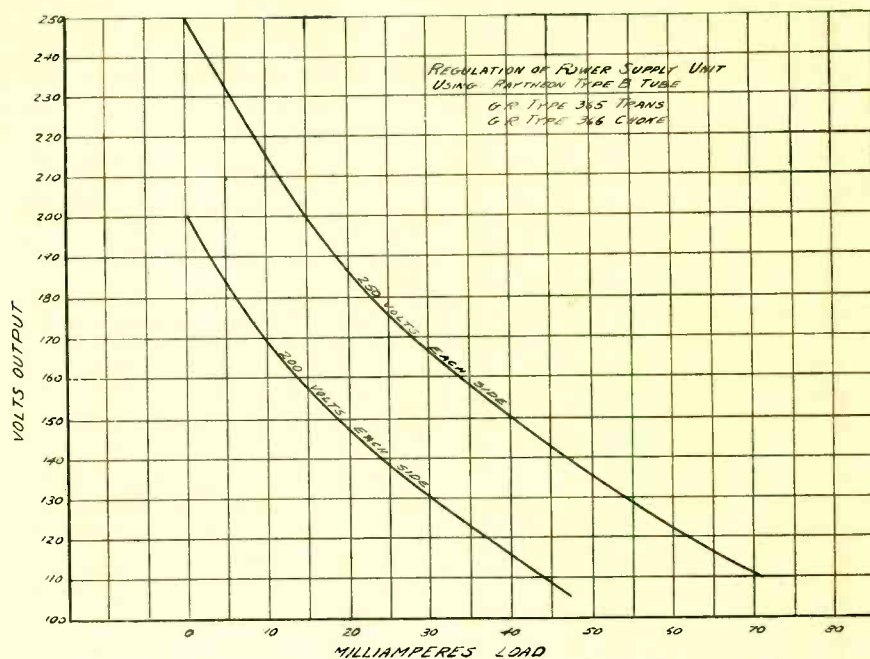
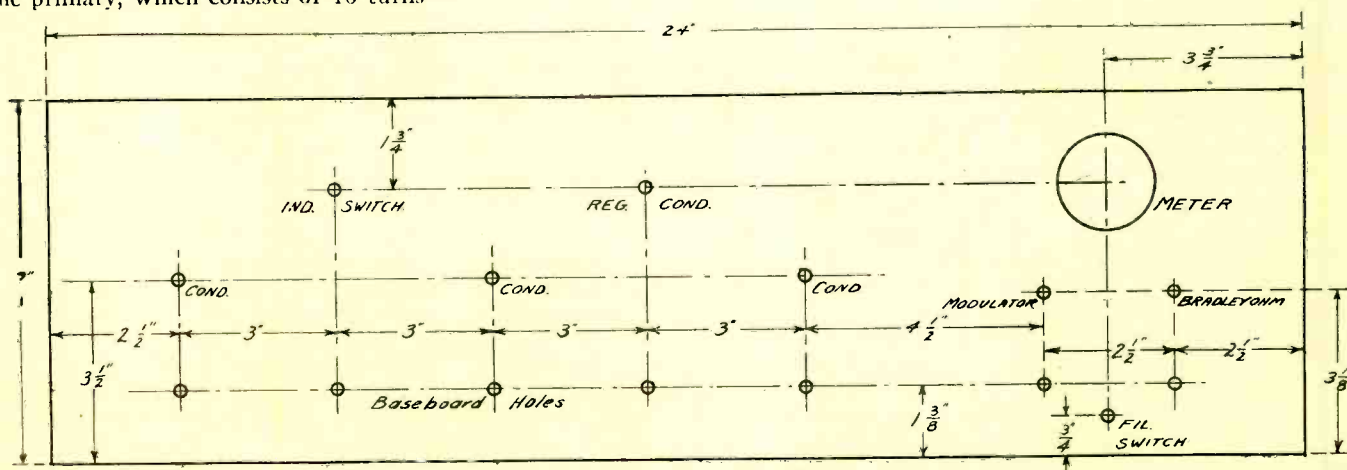

Fig. 3. Voltage-Current Curves of Raytheon Tube.



of the same wire should be wound immediately adjacent to the grounded end of the secondary.

The tuned impedance coil L_3 should consist of 90 turns of No. 30 d. s. c. wire on a hard rubber tube $1\frac{1}{2}$ in. in diameter and $1\frac{1}{4}$ in. long. This coil should be tapped 60 turns from the plate

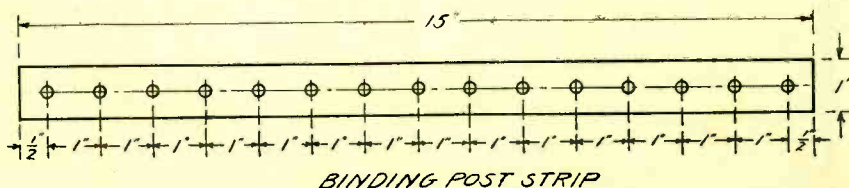
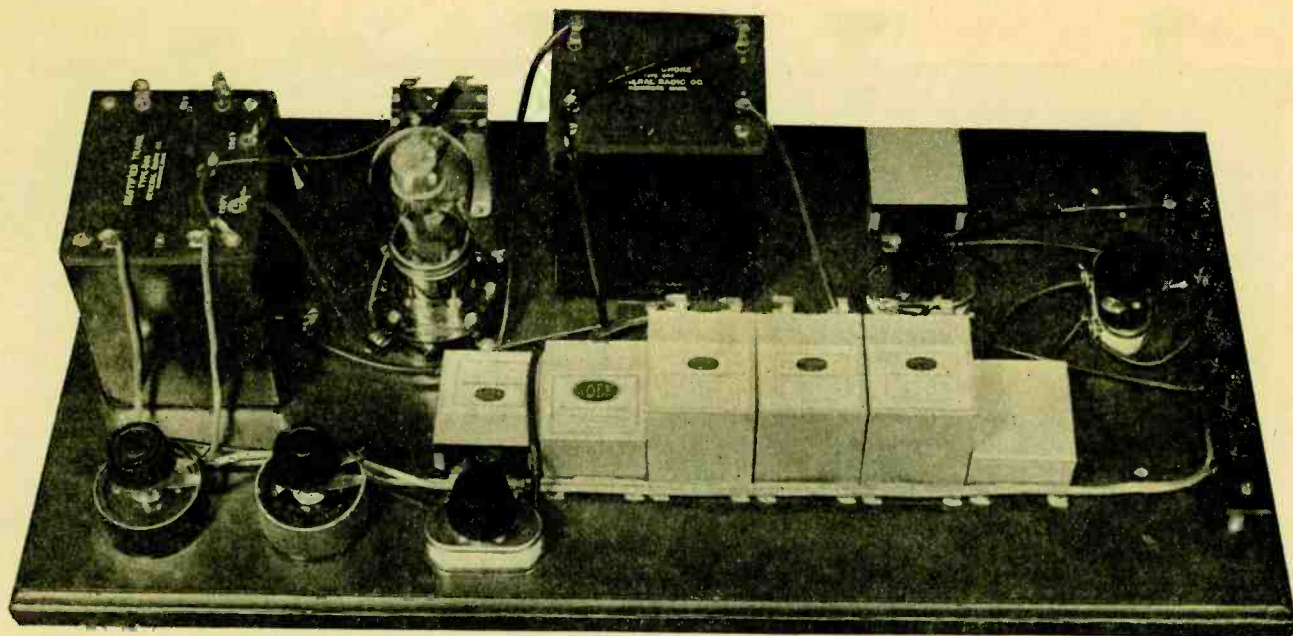

Fig. 4. Panel and Binding Post Strip Templates.



Arrangement of Power Unit for A. C. Supply.

end for the neutralizing condenser and 30 turns from the plate end for the plus *B* return.

The detector plate choke may well be made by winding 500 turns of No. 36 d. s. c. wire on an ordinary threadspool. If toroid inductances are used, two of the so-called antenna coupler types should be used for L_1 and L_3 . The tap for the neutralizing condenser and for the *B* positive return may be made by soldering to the turns of the toroid at points approximately one third and two thirds respectively around the circumference from the grid end. The regular tuned transformer type of toroid may be used for primary and secondary of L_2 .

The volume control used was the Centralab 500,000 ohm modulator which is connected in the grid circuit of the second audio tube. This serves also as the grid leak for this tube. It is very effective in eliminating whatever a. c. hum is present, since a point may be selected where the volume is entirely sufficient and the hum absolutely inaudible on the loudspeaker with the receiver unmodulated. The potentiometer on the power supply unit must be adjusted for minimum hum. The null point is quite distinct and easily found. When the receiver is operating properly no trace of hum whatever should be heard. If power noises are heard it is indicative of the fact that improper adjustments have been made. The setting of the detector grid leak is important in this respect. If the voltage applied to the plates of the radio and audio amplifiers is too high humming will result.

The cases of the impedance coils in the audio stages should be connected together and to the ground post of the receiver. The cases of the transformer, choke coil and all of the condensers in the power unit should be connected together and to the *B* negative lead (which is grounded through the receiver). The

variable resistance R_g in the circuit diagram determines the bias which is applied to the grid of the power tube. This should be adjusted on strong signals until the signals are clear and the tube does not block.

LIST OF PARTS USED FOR POWER SUPPLY UNIT	
700	1 General Radio Transformer, Type 365, 250 V Secondaries 7.5 volt filament winding.
500	1 G. R. Type 368 Choke.
750	1 G. R. Type 156 Socket.
150	1 G. R. Type 301 200-ohm potentiometer.
125	1 G. R. Type 301 30-ohm rheostat.
00	1 Raytheon Type B rectifier tube.
404	Bradleyohms 1 (100 to 1,000), 1 (20,000 to 200,000), 2 (1,000 to 10,000) ohms.
125	9 Filter Condensers—3 4-mfd., 1 2-mfd., 3 1-mfd. and 2 0.1-mfd.
507	Binding Posts and Binding Post strip.
101	Baseboard, 21x10 $\frac{3}{4}$ x $\frac{1}{2}$ in.

The power unit should be placed a few feet from the receiver and connected to it by flexible wires. The 7.5 volt a. c. wires should consist of a twisted pair of lamp cords and should be kept as far away from the other wires as possible. All of the other leads may be bunched together into one cable. Under no circumstances forget the proper resistance between the points *X-X*, because the tubes will be immediately burned out if you do.

The electrodynamic cone speaker with excitation furnished by the series filament circuit is strongly recommended. This type is capable of producing a great deal more volume than other types of cones and has a frequency characteristic equalled by none. The cone need not be large, six in. width is plenty, due to the large thrust as compared with diaphragm or reed types. The restoring force need only be that furnished by the rubber tape which supports the cone around the edge. An output transformer is required of course.

The operation of the receiver is simple. First it must be neutralized. This is done by causing the detector to oscillate

by advancing the regeneration control. A station is then tuned in at some point in the middle of the scale and the r. f. condenser turned slowly back and forth. If the pitch of the beat note changes, the receiver is not properly neutralized. When the proper setting of the neutralizing condenser has been selected it will be found that the intensity but not the pitch of the squeal will be changed by turning the r. f. grid condenser. The receiver may well be neutralized with the switch *SW* on the short side and the antenna tuning condenser set at half scale.

The switch *SW* makes for extreme flexibility in handling the receiver. When the switch is thrown to the low side, the antenna condenser is connected in series with the antenna tuning inductance L_1 and the primary *P*. This is an excellent arrangement for short waves. When thrown to the high side the switch connects the antenna condenser in shunt to the coil, the whole being in series with the primary. For the long wavelengths where the coupling is inadequate with the usual untuned primary this results in increased sensitivity. After one has learned to use the receiver, the combination of L_1 with the antenna condenser in shunt may be used as a closely coupled wavetrapp to eliminate any undesirable station close by. With the switch on the high side the receiver may be used as a two control set if desired. If used on a line where the regulation is at all good the receiver should give excellent satisfaction.

In making the receiver extra binding posts were provided, so that it would be a simple matter to change over to dry battery supply for the 199 tubes. Such a change has not been found necessary nor desirable. In country districts where the line voltage varies considerably from time to time, the advantages of this re-

(Continued on Page 48)

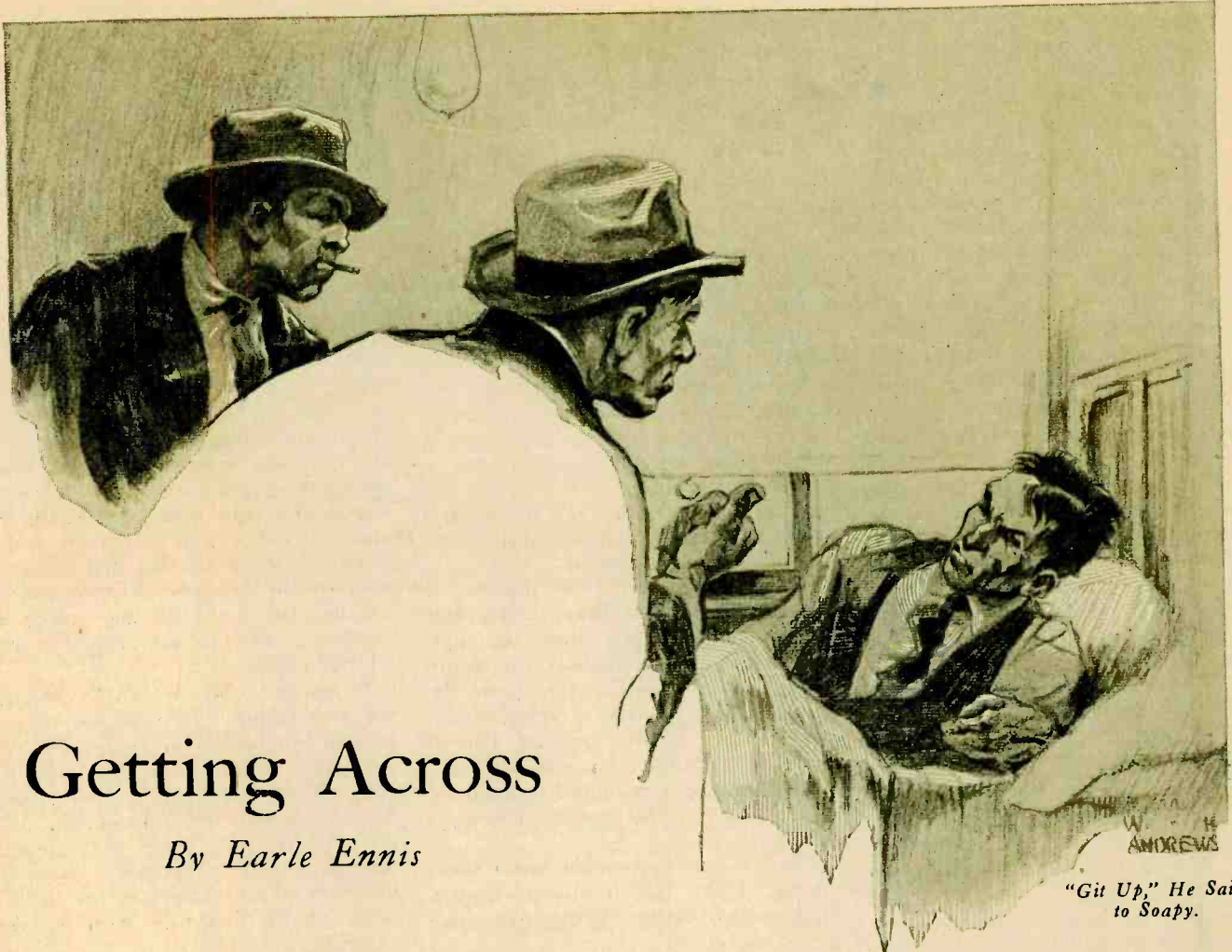

Getting Across

By Earle Ennis

"Git Up," He Said
to Soapy.

"SOAPY" McGEE was, by instinct, training and profession, a burglar. He called himself a "can worker," and boasted, not without reason, that there never was a "box" that, given enough time and the right conditions, he could not get into. But he had one pronounced fault, one that tripped cleverer men than Soapy, viz., he was a "snow-bird" or drug addict. Under the influence of its operation, he was quiet and dependable. Away from it, and he became as erratic as a landlady's temper.

It was his failing for "snow" which led Soapy to establish an affiliation with "Bumper" Hawkins and his gang of loft-workers, and thugs, who "specialized" in warehouse robberies and general banditry. For, by underground channels, it had come to Soapy's ears that Bumper and his crowd frequently turned in the Oriental freight, priceless cans of opium which were negotiable on the waterfront for any commodity from cocaine to whiskey.

In the parlance of the underworld, Soapy was "empty"—a slang expression for financial paralysis. Burglary had taken a sudden drop due to a newspaper campaign against police inactivity, and extra precautions were being taken against the night prowler. Soapy had deemed it wise to "lay low" until this vigilance was relaxed or until some new

and safer field opened for his activities. This had cut into his bankroll, so that when Bumper Hawkins suggested a form of co-partnership, Soapy, after a moment's hesitation, agreed.

"But get this," he said, his small eyes gleaming. "I ain't goin' in for no rough work. Get me? I know youse and the way youse works. You smack 'em over the head and that ain't my stuff. I'm a can worker, but I ain't no grave digger. If I work with youse, I work alone." It was somewhat paradoxical but Bumper got his meaning.

"Yeah—and you get this," he said, sticking out an aggressive chin. "I'm doin' you a favor lettin' you in on my pickin's. I got a good business, I have. None better downtown anywhere. I know what's what and who put it there. Savvey? I pick the jobs and you cracks the cans, but I'll be there just the same."

Soapy thought this over. Then he drew in his horns.

"All right," he said. "But no funny business. I ain't gonna dance on no rope because youse is too quick with a rod or a pipe."

"Aw say," growled Bumper, not a bit annoyed. "You ain't seen me work, fellah. I'm the smoothest thing in this city—bar none."

The way being paved for further negotiations, Bumper pulled out a bottle of bootleg and proffered a drink which

Soapy declined. Like all drug users he drank but little, contenting himself with the reactions from his own specialty.

Bumper Hawkins, it seemed, had a gang of about ten good, trusty yeggs from which he drew different squads for anything from murder to highway robbery, and picking pockets. They were a hard-working lot, according to Bumper, and took what came their way with philosophic equanimity.

"They's a good bunch of boys," he told Soapy, "even if I do say it m'self. None better. If a cop needs bumpin'—they bump. If it's payroll—bingo. They're there a million. I'd put 'em against anything, anywhere, anytime."

"Well," said Soapy with becoming modesty, "I'm pretty good m'self, so I'll be right at home."

Despite this brave announcement, Soapy was not at home. He was, as a matter of fact, entirely out of his element. He had an inborn fear of working with anyone else on a "job." Soapy belonged to that vast army of crooks who trusted nobody but themselves, because they knew their own reactions to certain events, but they were never sure of the reactions of a partner.

But he swallowed his scruples against working with Bumper and the gang, when the latter, like a born leader, sensed Soapy's greatest need, and handed him a package of his favorite drug. With

this whirling dizzily through his system, Soapy turned aside his natural caution and in its place permitted a vast expanse of optimism to take root.

Soapy's meeting with Bumper Hawkins had taken place in the latter's room on Columbus avenue—a narrow, dingy apartment up a dirty flight of stairs. Bumper did not live there. His residence was a mystery, even to his gang. But he used the place for an "office" and sometimes for a "hangout" when the police hunt grew too hot. The Italian that ran the place catered to Bumper's type of trade so that as things went, Bumper was fairly safe.

It was on Tuesday that Soapy established the alliance. Bumper had hinted at a "job" later in the week, but this worried Soapy not a whit. He was comfortable once again, for Bumper had loaned him money for food, and he had a fire going in the iron stove, and plenty of cheap fiction to read. He listened to the beat of rain on the tin roof and congratulated himself that he was "in soft" at last.

On Thursday afternoon Bumper and one of his henchmen, a hard-faced ex-convict who answered to the name of Pete, stamped up the stairs. Bumper locked the door.

"Git up," he said to Soapy, lounging comfortably on the bed. "We got business."

They drew up chairs to the unpainted table which were the only articles of furniture in the room besides the bed.

"Here's the dope," said Bumper. "Pete has piped a good lay out on Pacific avenue. There's a wealthy bozo who has a swell shanty—pichures, hooch, silver, and a wall-box. They're an old time family with a lot of plate and jack on the place. Pete's done some tailin' and he seen the old boy buyin' opera tickets. Savvey?"

Soapy nodded. He savvied.

"We figger on the crash about 9 p.," Bumper went on. "That gives us a couple of hours to work. There's only a maid and a butler in the joint. The chuffer will be downtown with the family. Me, you, Pete and Ed Handy will pop the nest. Ed will drive the car and watch for bulls. What say?"

Soapy nodded indifferently.

"And I open the can. Huh?"

"Yeah." Bumper spoke with finality. "We make the break and clean the shack while you open the box."

Soapy sat up suddenly.

"Nix!" he snapped. "I ain't gonna have youse guys fallin' all over the place when I'm workin'. M'nerves . . ."

Bumper interrupted suddenly. "Lissen rat," he said. "You been lap-pin' up my stuff, eatin my grub and layin' low in my hangout. For what, heh? Well then. You work with me, you take orders from me. Get it?"

He bulked over Soapy, a huge, vici-

ous figure. Soapy, never gifted with much courage, quailed.

"Oh, all right," he mumbled. "It ain't my idea . . . I bet youse guys pies the works . . ."

"We pies nothin'," snapped Bumper. "That's the way I always works, and it ain't failed yet. I know my stuff."

He lifted the mattress on the bed and pulled out a bottle of precious bootleg. There were a number of drinks after that during which essential details were discussed. An hour later, Bumper and Pete left the place. Soapy went back to his bed, and the cheap fiction. But the print failed to hold him. He kept turning over the coming burglary. It was his first job with a gang and he was uneasy about it.

"I was a damn fool . . . but a guy's gotta eat," he said, unconsciously paraphrasing a famous Senator.

It was 9 o'clock to the minute of Thursday night that Bumper Hawkins and his gang swooped down like night birds of prey on the residence of Henry Judson, retired capitalist, on upper Pacific avenue, in the city's exclusive residence district. The mansion loomed large and pretentious against its neighbors. As Bumper exclaimed to Pete, out of the corner of his mouth, it was "a wow."

There was a light on the lower floor, but the front curtains were drawn. Soapy nudged Bumper as they rode slowly past the place.

"I don't like that light," he growled.

"S all ri," Bumper retorted. "The butler lays around the library readin' 'til the folks get back. You leave him to me. We go in the back way. The girl's upstairs, in bed . . ."

The sudden crackle of a paper at his elbow drew his attention.

"What's that?" he demanded.

"Nothin' but a shot," mumbled Soapy, fumbling with a "shot" of his precious drug. Bumper grabbed it out of his hand.

"Gimme that," he said. "Think I'm gonna have you all hopped up? A hell of a lot of use you'll be . . ."

"Hey—cut that out," protested Soapy. "I gotta have a shot for m-noives."

"You'll git it afterward—not before," snapped Bumper. "You take it now, and you'll go to sleep. I know you hoppers."

"Say lookit here!" Soapy's eyes gleamed. "You can't . . ."

But Bumper cut him off with an automatic thrust into his ribs.

"One yeep out of you, and you're hamburg," he growled. "I'm runnin' this party. You take orders."

Soapy subsided. He could have wept with misery and disappointment, but he dared not question Bumper's automatic and his reputation for the quick use of it. He sank back, bitter and venomous. Bumper, with all his experience with the sordid emotions of the human soul,

would have been surprised at the depth of Soapy's hate in that moment.

The car with the four men in it circled the block and came to a halt at an alley which passed in the rear of the Judson home. Bumper, Pete and Soapy got out. The driver threw in the clutch and drove slowly around to the front. He halted his car not in front of the Judson place, but before the house adjoining, and came to a halt with the engine running. He seemed to be waiting for someone inside the house.

While Bumper and his gang were preparing to loot the palatial home of a man who, with his wife, sat unconscious of the impending raid, in a box at the opera, a mile away, a number of things were taking place elsewhere. For instance, in a radio station across the bay, some ten miles distant from the Judson home, a certain friction had developed between the dramatic director and the leading man of the company which was producing "Her Second Choice," a popular radio play.

"I am sorry, Mr. Wilford," the director was saying, "but you do not put enough emphasis into your scene with the man who has taken your wife from you. Your portrayal of the wronged husband is not forceful enough. You must understand that a microphone is an audible vehicle and not a visual one. Gestures do not carry over the air. You must get the idea over with the voice alone."

The star drew himself up stiffly.

"If I put any more emphasis into the scene, it will be necessary to shout," he said acidly.

"Well, at least that would get the idea over," snapped the director.

The star glared at him, and then a wicked light burned for an instant in his eyes,—a light born of a sudden resolve. This friction between them had come to an issue. So shouting would get the idea over, would it? He grinned sardonically to himself. Very well—he'd get it across.

This episode in the broadcasting station was not the only thing which was taking place coincidentally with the attempted robbery of the Judson home at 9 o'clock that evening. At exactly that hour, a steel-covered machine, with bulletproof windshields, and five heavily armed men, glided away from police headquarters with the casualness of a private car out for a breath of evening air. This was the official "shot-gun" squad, the most deadly, dangerous aggregation of co-ordinated elements in police circles. Every man in the car was utterly fearless, a dead shot, and armed with every known police weapon from shot guns to tear gas bombs. In every sense, the vehicle was a "death car" as deadly as an electric chair to the evil-doer.

"Say Dan," said the detective sergeant in charge, "let's mosey up along the resi-

(Continued on Page 54)

A Cheap "B" Battery Eliminator

A Unique Circuit Giving 250 Volts Without Step-up Transformer and Applicable to Either Tube or Colloid Rectifiers

By Clinton Osborne

MOST battery eliminators require a power transformer to step up the line voltage so that the rectifier tube or tubes may be properly operated. Such transformers are often expensive and are a deterrent to constructing a B eliminator when one would often be appreciated.

A scheme suggested by Dr. Van Der Bijl in his book on the "Thermionic Vacuum Tube" was tried out, using material easily picked up in any radio store, and an eliminator of surprising capabilities resulted. The circuit is shown in

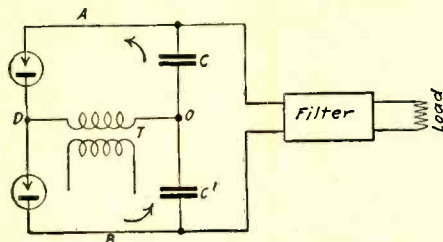

Fig. 1. Theoretical Diagram of Rectifier.

Fig. 1, and the theory of its operation can best be explained in Dr. Van Der Bijl's own words.

"When the transformer voltage is such that D is at a positive potential with respect to O, an electron current will flow in the direction of the arrow through the valve AD, thus charging the condenser C such that A is positive with respect to O. But during this half period no current will flow through DB. During the next half cycle, current flows only through DB, charging B negatively with respect to O. The potential difference between A and B (if the condensers did not discharge themselves) would therefore be twice the transformer voltage. What actually happens is that the one condenser discharges through the load while the other is being charged. Hence if the broken line in

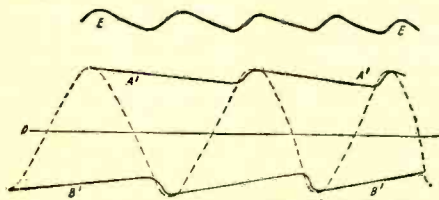
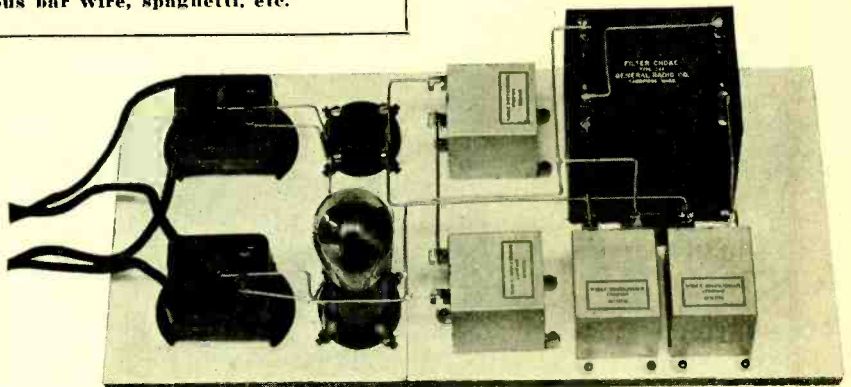

Fig. 2. Components of Rectified A. C.

Fig. 2 represents the potential of the point D with respect to O, the curves A^1A^1 and B^1B^1 will represent the potentials of A and B respectively with regard to O. The potential difference between A and B is therefore obtained by adding the curves A^1 and B^1 and is given by EE . Thus, although the condensers are charged only in alternate

- LIST OF PARTS**
- 2 UX-112 power tubes.
 - 2 UX type sockets.
 - 2.5-watt bell ringing transformers—Jefferson, Wayne, Dongan.
 - 2 2 to 4 mfd. fixed condensers for rectifier—Tobe Deutschmann, Dubilier.
 - 2 4 mfd. fixed condensers for filter system—Tobe Deutschmann, Dubilier.
 - 1 Filter choke—General Radio, Dongan, Jefferson, Thordarson.
 - Necessary Bradleyohms and 2 mfd. condensers according to battery taps required. See Fig. 3.
 - Binding posts, flexible lamp cord for a. c. connection, a. c. snap switch bus bar wire, spaghetti, etc.



Appearance of Completed "B" Eliminator.

half periods, the voltage fluctuation in the circuit leading to the filter is double the frequency of the impressed voltage, while the mean voltage on the filter is approximately twice the impressed voltage."

Actually, when the load is slight, it was found that the rectified d. c. voltage is considerably greater than twice the measured a. c. supply potential. This is due to the fact that a. c. voltmeters measure the root mean square of the

peak voltages whereas our vacuum tubes rectify the peak voltage.

Fig. 3 shows schematically the layout of the current supply set as finally arranged. It will be noted that separate transformers were used for lighting the filaments of the rectifier tubes. This is necessary, as were a single transformer used, one of the rectifiers would be shorted out. The transformer T shown in Fig. 1 was not used, the 110 volts being taken directly from the house supply.

As one side of the house supply is grounded, the ground wire on the radio set will either short out one of the rectifier tubes or one of the condensers C or C'. In order to avoid this, a .01 mfd. condenser was placed in series with the ground on the radio set. This should be done inside the cabinet so that no part of the ground lead will be standing at a potential of 110 volts to ground. If this is not done, blown lighting supply fuses will result.

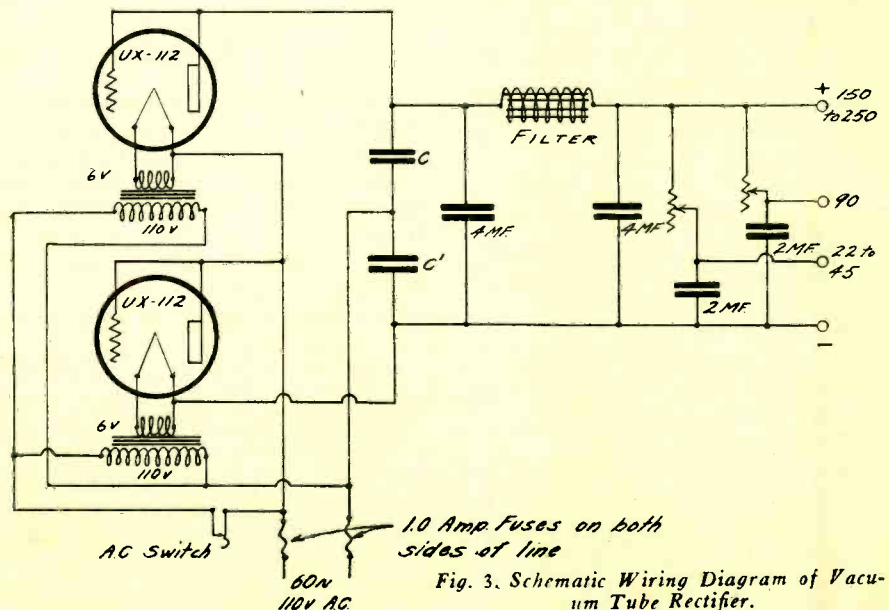

Fig. 3. Schematic Wiring Diagram of Vacuum Tube Rectifier.

The condensers C and C^1 are 2 mfd. for a small load, but should be increased to 4 mfd. or more if a load of much more than 15 milliamperes at 190 volts is required. In order to determine the adaptability of this B eliminator to various sets and tubes, a current-voltage curve was made with both 2 and 4 mfd. in C and C^1 , with UX-112 and Western Electric 216-A tubes as rectifiers. The latter tubes were used because it was through that the life of the UX-112 tube would be rather short when supplying 30 or more milliamperes to some of the larger sets.

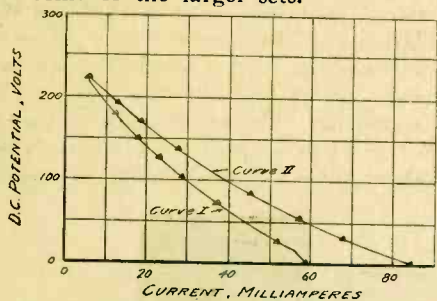

Fig. 4. Curve of Current Output, Using Western Electric 216-A Tubes.

In the current-voltage curves shown in Figs. 4 and 5, Curve I was made using 2 mfd. for C and C^1 and Curve II using 4 mfd. By increasing this capacity a somewhat higher voltage may be maintained for a given current output.

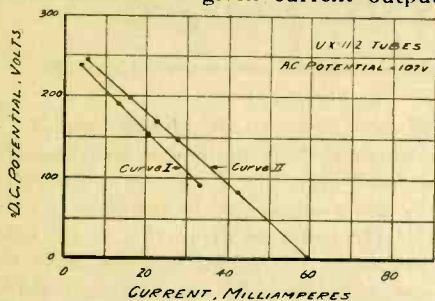

Fig. 5. Output Current, Using UX-112 Tubes.

The voltage increase is greater between 2 and 4 mfd. than between 4 and 6 mfd. and there is little to be gained by increasing beyond 6 mfd. It is also noticeable that the gain in voltage due to increased capacity is much greater as the load increases.

The construction of the eliminator from standard parts is simple. For furnishing B current for the average radio set, the new UX-112 power tube is well adapted, unless the current drain is to be excessive. The UX-213 rectifier tube cannot be used in this circuit, as the filaments are connected in parallel, inside the tube. For lighting the filaments of the two tubes, small, inexpensive bell ringing transformers may be used, and should have secondaries wound to 6 volts. The 2 or 4 mfd. condensers in the rectifier circuit should be capable of withstanding 500 volts, so that high grade by-pass condensers will do. The filter circuit may be identical with that described in past issues of RADIO, for either the ABC eliminator or the Raytheon B eliminator. The list of parts

from batteries, measure the plate current in each B plus lead with a milliammeter, with battery supply, and after the changeover to the B eliminator, measure the current drain again and adjust the Bradleyohms until the same current as had with the batteries is obtained.

The general appearance of the B eliminator is shown in the picture. Lay out the apparatus on a baseboard approximately 8x12 in. keeping the rectifier tubes, filament transformers and set shown is a good combination to use, for B supply lead when voltages lower than the UX-112 or UX-216-B tubes. Bradleyohms should be placed in the positive 150 are desired, as shown in Fig. 3. These resistances should be adjusted until the proper voltage is applied to the tubes, which may be determined best with a high resistance voltmeter. If one is not obtainable, and the set with which the eliminator is to be used is now operating of by-pass condensers in one group, and the filter at the other end of the board. If desired, the outfit can be mounted on a panel, so that the adjustments of the Bradleyohms may be more easily made. As the voltages in various parts of the circuit run as high as 250 volts, it would be preferable to wire the parts together with insulated lamp cord, but bus bar wire may be used if it is well insulated with spaghetti.

An alternative scheme is to use colloid rectifiers such as accompany small storage batteries, as shown in Fig. 6. This system makes a very cheap but less portable arrangement. The maximum volt-

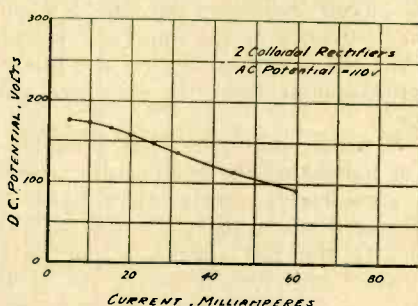

Fig. 7. Colloid Rectifier Current Output Curve.

age obtainable is considerably less than that of a tube rectifier, but the curve shown in Fig. 7 shows that 20 milliamperes are obtainable at 150 volts, which is ample for practically all radio sets. In using the colloid rectifiers, it was

found necessary to place an extremely heavy load on them before they would operate in a circuit with only a few milliamperes drain. To do this, a low resistance consisting of a 150 watt mazda lamp was placed around condenser C until the associated rectifier bubbled for several minutes. This short circuit was then removed and one placed similarly on C^1 . The economy of the colloid system is due to the fact that the sockets, tubes and filament transformers are all replaced by two electrolytic rectifiers, which may be made at home or purchased at a very reasonable price.

The two rectifiers may be made by obtaining two 1 quart fruit jars, and filling them with a solution made by dissolving as much common borax as possible in 2 quarts of distilled water. Be sure to use distilled water, as tap water contains impurities and the rectifier may not work. The negative electrodes should be made from lead strips, 1 x 6 in. being a convenient size, and the positive electrodes, of the same dimensions, should be made of pure aluminum, which may be obtained from supply houses catering to amateur transmission trade. (See the classified section of QST). Place the electrodes in the jars, allowing a separation of about 1 in., and form the plates by connecting the rectifier system to the power line and connecting the 150 watt lamp as previously explained. The forming process ordinarily takes only a few minutes, but leaving the rectifier on for a few hours will not injure it, and will insure properly formed electrodes. It is a good idea to cover the top of the solution with a small amount of lubricating oil, ordinary medium motor oil being sufficient for all purposes.

A series of recent tests of 24 different battery chargers show an average electrical efficiency (ratio of output to input) of 15 per cent for the vacuum tube type, 31 per cent for electrolytic rectifiers, and 33 per cent for the vibrator type. The general conclusion was that the vacuum tube type is the most desirable for short period charging, the electrolytic type the simplest and most efficient for trickle charging, and the vibrator type should be used only where the interference from the make and break contacts will not interfere with radio sets.

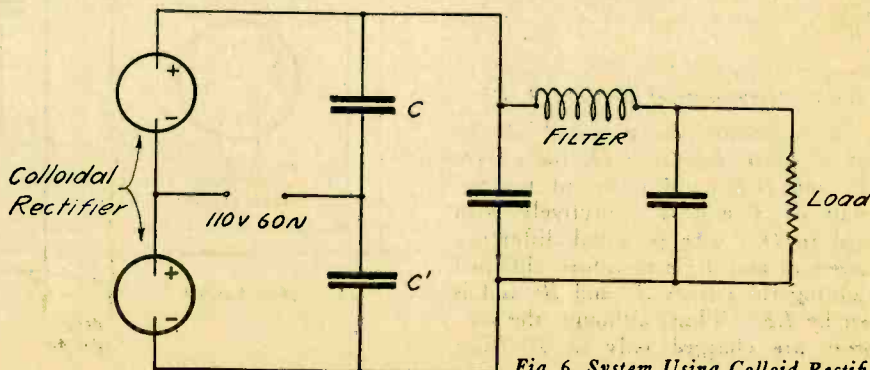

Fig. 6. System Using Colloid Rectifiers.

Design of Small Power Transformers and Filter Inductances

Specifications for Core and Coil Sizes for Battery Eliminators and Amateur Transmitters up to 3½ K. W. Output

By Jennings B. Dow

THE most effective means for securing the higher voltages necessary for the operation of certain types of *B* battery eliminators, of experimental equipment, and of amateur transmitters is a transformer which steps up 110 volt alternating current for plate supply and steps it down for filament supply. Likewise it is necessary to have choke coil inductances of specified characteristics for use in associated filter equipment. While such apparatus is available on the market a description of the method of design and construction should be of value to those interested in radio.

The important elements in transformer design are the selection of material for the core and the determination of the number of turns and the size of wire for the primary or secondary windings so as to deliver the required current and voltage. Eliminating any theoretical discussion and assuming that an ordinary grade of transformer core steel laminations is available, the problem may be solved by means of a few simple arithmetical formulas. The first part of this discussion is concerned with a transformer to supply both filament and plate current. The second part discusses choke coils.

For simplicity in treatment and construction it is assumed that the transformer core laminations are rectangular in shape with a small "window" cut out in

each. The cross-sectional area necessary depends upon the power in watts to be handled. This area can be determined from the curves in Fig. 1 which give the cross-sectional area in square inches required for a given output in watts at 25, 60 or 125 cycles.

These curves are based upon the use of an ordinary grade of transformer iron, such as No. 28 gauge silicon steel, having a loss not exceeding 1.3 watts per pound at 60 cycles. A poorer grade will require a larger core, about twice the area if "stovepipe iron" is used. A better grade will allow a slightly smaller core area. The curves are based upon a flux density *B* of 40,000 magnetic lines per square inch for 125 cycles, 50,000 for 60 cycles, and 75,000 per 25 cycles. These are the safe values commonly used.

A. H. Babcock has suggested that the total weight of iron to be used can be determined from the fact that for each 40 watts of output 1 lb. of iron is necessary. He also uses the rule that the length of the core in feet is equal to 0.3 weight times the area in inches (ft.=.3 lb.×A).

Determination of primary turns may be made from the following relation:

$$T_p = \frac{E_p \times 22,522.5}{fBA} \dots (1)$$

where T_p =number of turns in primary, E_p =primary voltage, f =frequency,

B =40 for 125 cycles, 50 for 60 cycles and 75 for 25 cycles, and A =area of core section in square inches.

Determination of the secondary turns is made from the formula:

$$T_s = \frac{E_s T_p}{E_p} \dots (2),$$

where T_s =number of turns in secondary, E_s =secondary voltage.

Determination of wire size depends upon an allowance of 1500 circular mils per ampere. Multiply the number of amperes to be carried by 1500 and find from Table I the size of wire nearest to this area in circular mils.

Determination of core and winding shape depends first upon the space necessary for the required number of turns of the wire size selected. This information is given in Table II for various wire sizes and insulations. Allowance will also have to be made for space occupied for insulation over the core, between the layers and between the windings.

A typical problem is the design of a transformer to meet the following specifications:

Primary Voltage E_p =110.

Frequency f =60.

Secondary Voltage for Plate Supply E_s =1000 and 1500 volts on each side of center tap.)

Secondary Voltage for Filament Supply E_s =12 volt (6 volts on each side of center tap.)

Filament current required=13 amperes.

Plate current required=150 milliamperes.

Output=600 watts.

Inspection of the 60 cycle curve of Fig. 1 shows that for 600 watts output a core section of 3.5 sq. in. is necessary. Substituting the given values in equation (1) the required primary turns

$$T_p = \frac{110 \times 22,522.5}{60 \times 50 \times 3.5} = 236.$$

For the 1000 volt secondary, from equation (2)

$$T_s = \frac{1000 \times 236}{110} = 2145$$

turns between the center tap of the high voltage winding and the No. 1 tap to obtain 1000 volts. Likewise for the 1500 volt secondary from equation (2)

$$T_s = \frac{1500 \times 236}{110} = 3218$$

turns between the same center tap and

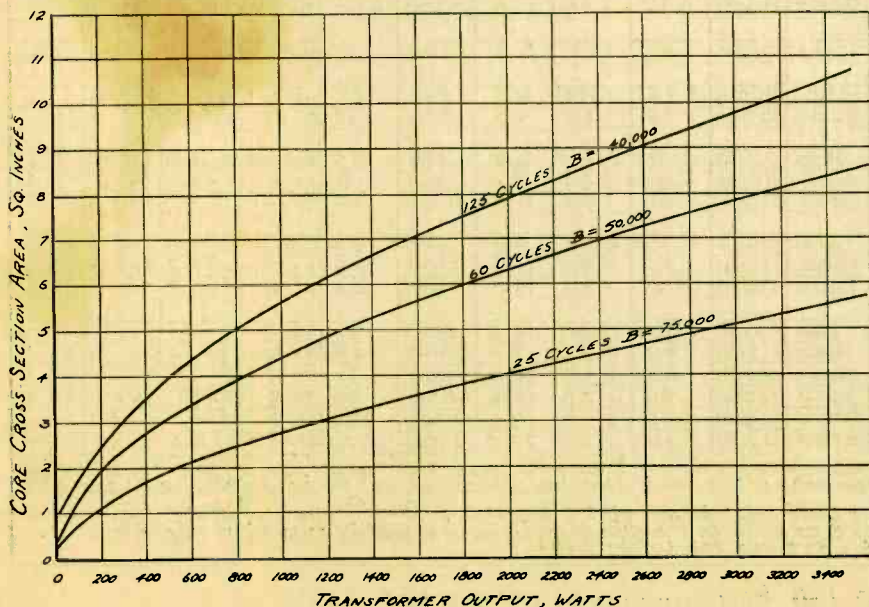

Fig. 1. Core Area Required for Given Output From Transformers.

DESIGN DATA FOR INDUCTANCE COILS WITH IRON CORES. *Weight of Steel taken as 480 ^{lbs}/_{cu. ft.} = 0.28 ^{pounds}/_{cubic inches}*

CORE SIZE Cross Section	INDUCTANCE	EQUIV GAP	# ACTUAL	GAP	NO TURNS	FLUX DENS.	WINDING FORM	MEAN TURN	FEET OF WIRE	RESISTANCE	WEIGHT OF COPPER	CORE DIMENSIONS	POUNDS				
	HENRYS	(G)	Decimals	Nearest Fraction	(N)	(B) Lines per inch	b c	inches	(D.C.)	LB	Long Piece Short Piece	STEEL					
1/2 x 1/2	0.5	.040"	.017"	1/64"	1600	6500	0.42"	0.28"	3.0	400	82.5	1.00z	1/2 x 1.6	1/2 x .50	0.30		
	1.0	.041	.019		2300	9000	0.50	0.33	3.2	615	127.0	1.5 "	1/2 x 1.7	1/2 x .55	0.31		
	5.0	.043	.023		5200	20000	0.75	0.50	3.8	1670	345.0	4.0 "	1/2 x 1.92	1/2 x .75	0.37		
	10.0	.046	.030	1/32"	7600	27000	0.90	0.60	4.2	2640	545.0	6.5 "	1/2 x 2.1	1/2 x .85	0.41		
	15.0	.048	.035		9500	32000	1.00	0.68	4.5	3510	725.0	8.5 "	1/2 x 2.2	1/2 x .85	0.43		
3/4 x 3/4	5.0	.043"	.023		3500	13000	0.62"	0.42"	4.5	1310	271	3.25oz	3/4 x 2.4	3/4 x .75	1.0		
	10.0	.046	.030		5000	18000	0.73	0.49	4.75	2000	411	5.0 "	3/4 x 2.5	3/4 x .75	1.0		
	15.0	.048	.035		6300	21000	0.82	0.55	5.0	2630	544	6.5 "	3/4 x 2.6	3/4 x .75	1.05		
	20.0	.052	.044	3/64"	7600	24000	0.91	0.60	5.2	3280	678	8.0 "	3/4 x 2.7	3/4 x .85	1.1		
	50.0	.070	.100	7/64"	14000	33000	1.25	0.83	6.0	7000	1445	1LB 1 "	3/4 x 3.0	3/4 x 1.0	1.25		
1 x 1	10.0	.046"	.030	1/32"	3800	14000	0.64"	0.43"	5.6	1760	364	4.25oz	1 x 3.0	1 x .75	2.1		
	15.0	.048	.035		4800	16000	0.69	0.49	5.8	2310	478	5.5 "	1 x 3.0	1 x .75	2.1		
	20.0	.052	.044	3/64"	5700	18000	0.78	0.52	5.9	2800	580	6.75 "	1 x 3.1	1 x .75	2.2		
	50.0	.070	.100	7/64"	11000	25000	1.10	0.75	6.7	6130	1270	15.0 "	1 x 3.5	1 x 1.0	2.5		
	100.0	.100	.250	1/4"	18000	29000	1.40	0.93	7.4	11000	2280	1LB 10 "	1 x 3.8	1 x 1.1	2.75		
2 x 2	100.0	.100"	.250	1/4"	8900	14000	0.97"	0.65"	10.4	7700	1590	1LB 3oz	2 x 5.5	2 x 1.0	14.5		
	1/2 x 1/2	0.5	.040"	.017	1/64"	1600	13000	0.55"	0.38"	3.4	450	46	2.20z	1/2 x 1.6	1/2 x 0.63	0.31	
		1.0	.041	.019		2300	18000	0.66	0.45	3.6	700	72	3.5 "	1/2 x 1.75	1/2 x 0.70	0.35	
		5.0	.043	.023		5200	39000	1.00	0.68	4.5	1950	200	9.5 "	1/2 x 2.10	1/2 x 0.95	0.43	
		3/4 x 3/4	1.0	.041"	.019		1500	12000	0.53"	0.37"	4.3	540	56	2.70z	3/4 x 2.10	3/4 x 0.63	0.87
5.0			.043	.023		3500	26000	0.83	0.56	5.0	1470	151	7.2 "	3/4 x 2.5	3/4 x 0.80	1.05	
10.0	.046		.030	1/32"	5000	35000	1.00	0.67	5.4	2250	230	11.0 "	3/4 x 2.6	3/4 x 0.95	1.12		
1 x 1	5.0		.043"	.023		2600	20000	0.71"	0.49"	5.8	1250	130	6.10z	1 x 2.8	1 x 0.75	2.0	
	10.0		.046	.030	1/32"	3800	27000	0.86	0.58	6.1	1940	200	9.5 "	1 x 3.0	1 x 0.85	2.2	
	15.0	.048	.035		4800	32000	0.96	0.65	6.4	2550	260	12.5 "	1 x 3.1	1 x 0.90	2.25		
	2 x 2	10.0	.046"	.030	1/32"	1900	13000	0.60"	0.42"	9.5	1500	160	7.5oz	2 x 4.66	2 x 0.60	11.5	
		15.0	.048	.035		2400	16000	0.68	0.46	9.7	1900	200	9.5 "	2 x 4.75	2 x 0.66	12.3	
20.0		.052	.044	3/64"	2900	18000	0.75	0.51	9.8	2400	250	11.5 "	2 x 4.85	2 x 0.75	12.5		
50.0		.070	.100	7/64"	5300	24000	1.00	0.70	10.5	4600	480	1LB 6.5 "	2 x 5.50	2 x 0.95	14.0		
100.0		.100	.250	1/4"	8900	28000	1.33	0.90	11.2	8300	860	2LB 8 "	2 x 5.90	2 x 1.15	16.0		
1/2 x 1/2	0.5	.040"	.017	1/64"	1600	32000	0.90"	0.60"	4.2	550	22.5	7oz	1/2 x 2	1/2 x .85	0.40		
	1.0	.082	.120	1/8"	3200	32000	1.30	0.85	5.1	1350	55	1LB 1 "	1/2 x 2.5	1/2 x 1.10	0.50		
	3/4 x 3/4	0.5	.040"	.017	1/64"	1000	21000	0.72"	0.46"	4.7	390	16	5oz	3/4 x 2.3	3/4 x 0.71	0.96	
		1.0	.041	.019		1500	30000	0.90	0.58	5.1	640	26	8 "	3/4 x 2.5	3/4 x 0.83	1.05	
		1 x 1	1.0	.041"	.019		1100	22000	0.75"	0.50"	5.8	530	22	6.5oz	1 x 2.9	1 x 0.75	2.10
5.0			.086	.170	1/64"	3700	35000	1.40	0.92	7.3	2260	92	1LB 12 "	1 x 3.6	1 x 1.20	2.7	
2 x 2			5.0	.043"	.023	1/4"	1300	23000	0.82"	0.53"	9.7	1050	43	13oz	2 x 4.9	2 x 0.80	12.7
	10.0		.050	.040	1/64"	2000	32000	1.05	0.68	10.5	1750	71	1LB 6 "	2 x 5.2	2 x 1.0	13.8	
	15.0		.096	.200	13/64"	3300	28000	1.35	0.86	11.1	3060	125	2 1/2 "	2 x 5.5	2 x 1.1	14.7	
	20.0	.104	.280	9/32"	4000	32000	1.43	0.95	11.5	3820	156	2 1/2 "	2 x 5.6	2 x 1.2	15.2		
	3 x 3	10.0	.046"	.030		1300	22000	0.81"	0.53"	14.0	1510	62	1LB 3oz	3 x 6.9	3 x 0.8	39	
15.0		.048	.035		1600	26000	0.90	0.60	14.2	1900	77	1 1/2 "	3 x 7.0	3 x 0.85	40		
20.0		.052	.044	3/64"	1900	30000	1.00	0.65	14.4	2300	93	1 1/2 "	3 x 7.1	3 x 0.9	41		
50.0		.140	.330	1/2"	5000	28000	1.60	1.10	15.9	6600	270	5 1/2 "	3 x 7.8	3 x 1.35	46		
100.0		.200	.600	19/32"	8400	34000	2.10	1.40	17.0	12000	485	9 1/2 "	3 x 8.3	3 x 1.65	50		
1/2 x 1/2	0.5	0.16"	.35	1/32"	3200	32000	1.80"	1.20"	6.4	1700	35	2LB 10oz	1/2 x 3	1/2 x 1.45	0.62		
	3/4 x 3/4	0.5	0.08"	.170	1/64"	1480	30000	1.25"	.83"	6.0	735	15	1LB 2oz	3/4 x 2.9	3/4 x 1.1	1.26	
		1.0	0.16	.35	1/32"	3000	30000	1.75	1.20	7.2	1800	37	2 1/2 "	3/4 x 3.5	3/4 x 1.5	1.6	
		1 x 1	0.5	0.04"	.02	1/64"	800	32000	0.90"	0.60"	6.2	410	8.5	0LB 10oz	1 x 3.0	1 x 0.85	2.2
			1.0	0.082	.17	1/64"	1600	31000	1.30	0.85	7.1	945	19	1 1/2 "	1 x 3.5	1 x 1.0	2.5
5.0			0.387	.75	3/4"	7800	32000	2.90	1.90	11.0	7000	143	10 1/4 "	1 x 5.2	1 x 2.2	2.2	
2 x 2	1.0		0.041"	.019		560	22000	0.75"	0.50"	9.8	460	9.4	0LB 12oz	2 x 4.9	2 x 0.75	12.7	
	5.0		0.086	.17	1/64"	1800	32000	1.35	0.90	11.3	1700	35	2 1/2 "	2 x 5.5	2 x 1.15	15.0	
	10.0	0.184	.40	13/32"	3800	33000	2.00	1.30	12.8	4100	83	6 1/2 "	2 x 6.2	2 x 1.5	17.3		
	3 x 3	5.0	0.043"	.023		860	30000	1.00"	0.60"	14.2	1000	21	1LB 10oz	3 x 7.1	3 x 0.85	40.0	
		10.0	0.092	.20	13/64"	1840	31500	1.40	0.92	15.3	2350	48	3 1/2 "	3 x 7.5	3 x 1.15	43.5	
15.0		0.130	.30	19/64"	2620	32000	1.65	1.10	16.0	3500	71	5 1/2 "	3 x 7.8	3 x 1.4	46.0		
20.0		0.175	.38	3/8"	3500	32000	1.90	1.25	16.6	4850	99	7 1/2 "	3 x 8.1	3 x 1.5	48.0		
50.0		0.432	.80	13/16"	8700	32000	3.00	2.00	19.2	14000	282	21 1/2 "	3 x 9.3	3 x 2.3	58.0		
100.0	0.900	1.50	1 1/2"	16700	31500	4.10	2.80	22.0	31000	620	41 1/2 "	3 x 10.5	3 x 3.1	68.0			

* The Actual Gap can only be an approximation owing to the many factors which may effect fringing of flux, permeability of core, etc. It must be adjusted by trial until the proper value of inductance is obtained or better yet, until the set up operates at the best point.
 † The values of (B); the flux density are those obtained with all D.C. & 60 A.C., or the effective B if all A.C. The maximum value in the latter case will be 1.41 x B as given. In the case of rectified A.C. applied to coil with no previous smoothing the maximum B may be 1.57 times the values given

Fig. 4. Design Data for Inductance Coils with Iron Cores.

the outside or No. 2 tap to obtain 1500 volts. Therefore make each secondary section 3218 turns and tap each at 2145 turns.

From equation (2) we can determine the number of turns required to give 13 volts for filament supply as $13 \times 236 / 110 = 28$. Following the original specifications the filament supply winding should be tapped at the mid-point or 14 turns.

To secure an output of 600 watts at an efficiency of 90 per cent the input must be $600 / .90 = 667$ watts. The primary current at 110 volts will then be $667 / 110 = 6$ amperes. Allowing 1500 circular mils per ampere this current will require $6 \times 1500 = 9000$ c. m., which from Table I, is amply met by No. 10 wire.

As the filament winding is to carry 13 amperes, the area should be $13 \times 1500 = 19,500$ circular mils, corresponding to No. 7 wire. But as this may be wound as a single exposed layer on the core sufficient heat radiating surface will be provided by No. 8 wire.

For a plate current of 150 milliamperes the high voltage secondary will

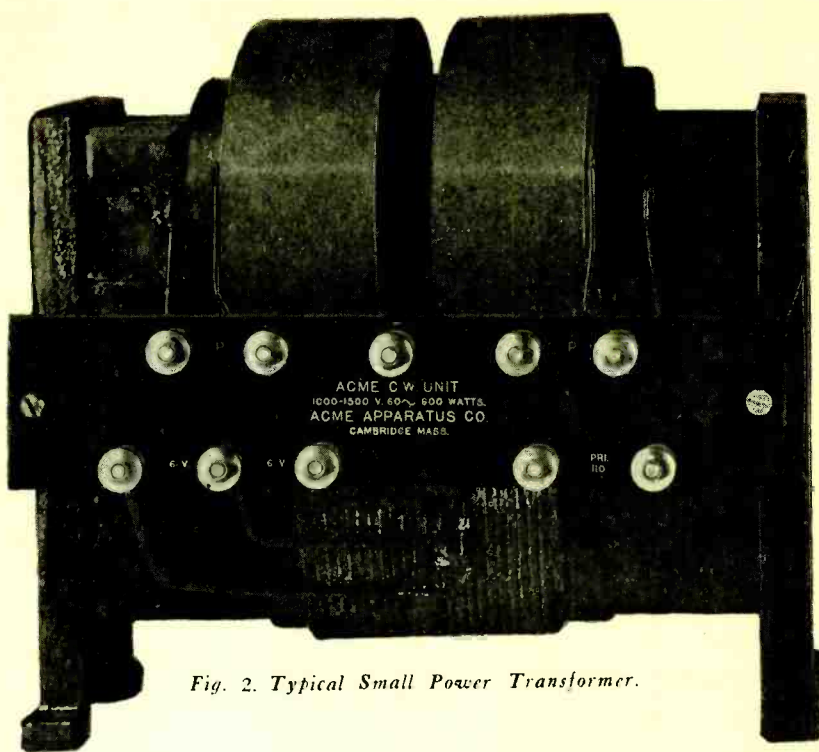

Fig. 2. Typical Small Power Transformer.

Table I: Copper Wire

Giving Measurements at 68° F. (20° C.) with Specific Gravity of 8.89 (Brown & Sharpe)

A. W. G.	Diameter	Area	Weight	Length	RESISTANCE	
B. & S. Gauge	Inches	Circular Mils	Pounds per 1000 Feet	Feet per Pound	Ohms per 1000 Feet	Ohms per Pound
0000	0.4600	211,600.	640.5	1.561	0.04901	.00007652
000	0.4096	167,800.	507.9	1.969	.06180	.0001217
00	0.3648	133,100.	402.8	2.483	.07793	.0001935
0	0.3249	105,500.	319.5	3.130	.09827	.0003076
1	0.2893	83,690.	253.3	3.948	.1239	.0004891
2	0.2576	66,370.	200.9	4.978	.1563	.0007778
3	0.2294	52,630.	159.3	6.276	.1970	.001237
4	0.2043	41,740.	126.4	7.911	.2485	.001966
5	0.1819	33,100.	100.2	9.980	.3133	.003121
6	0.1620	26,250.	79.46	12.58	.3951	.004972
7	0.1443	20,820.	63.02	15.87	.4982	.007905
8	0.1285	16,510.	49.98	20.01	.6282	.01257
9	0.1144	13,090.	39.63	25.23	.7921	.01999
10	0.1019	10,380.	31.43	31.82	.9989	.03178
11	0.09074	8,324.	24.92	40.13	1.260	.05053
12	0.08081	6,530.	19.77	50.58	1.588	.08035
13	0.07196	5,178.	15.68	63.77	2.003	.1278
14	0.06408	4,107.	12.43	80.45	2.525	.2032
15	0.05707	3,257.	9.858	101.4	3.184	.3230
16	0.05082	2,583.	7.818	127.9	4.016	.5136
17	0.04526	2,048.	6.200	161.3	5.064	.8167
18	0.04030	1,624.	4.917	203.4	6.385	1.299
19	0.03589	1,288.	3.899	256.5	8.051	2.065
20	0.03196	1,022.	3.092	323.4	10.15	3.283
21	0.02846	810.1	2.452	407.8	12.80	5.221
22	0.02535	642.4	1.945	514.1	16.14	8.301
23	0.02257	509.5	1.542	648.5	20.36	13.20
24	0.02010	404.0	1.223	817.7	25.67	20.99
25	0.01790	320.4	0.9699	1031.	32.37	33.37
26	0.01594	254.1	0.7692	1300.	40.81	53.06
27	0.01420	201.5	0.6100	1639.	51.47	84.37
28	0.01126	159.8	0.4837	2067.	64.90	134.2
29	0.01264	126.7	0.3836	2606.	81.83	213.3
30	0.01003	100.5	0.3042	3287.	103.2	329.2
31	0.008928	79.70	0.2413	4144.	130.1	539.3
32	0.007950	63.21	0.1913	5227.	164.1	857.6
33	0.007080	50.13	0.1517	6591.	206.9	1364.
34	0.006305	39.75	0.1203	8312.	260.9	2168.
35	0.005615	31.52	0.09542	10480.	329.0	3448.
36	0.005000	25.00	0.07568	13213.	414.8	5482.
37	0.004453	19.83	0.0601	16664.	523.1	8717.
38	0.003965	15.72	0.04759	21012.	659.6	13860.
39	0.003531	12.47	0.03774	26497.	831.8	22040.
40	0.003145	9.888	0.02990	33411.	1049.	35040.
(41)*	0.00275	7.5625	0.02289	43,700.	1370.	59,900.
(42)*	0.00250	6.2500	0.01892	52,800.	1660.	87,700.
(43)*	0.00225	5.0625	0.01532	65,300.	2050.	133,700.
(44)*	0.00200	4.0000	0.01211	82,600.	2600.	214,000.
(45)*	0.00175	3.0625	0.00927	107,900.	3390.	365,200.
(46)*	0.00150	2.2500	0.00681	146,800.	4610.	676,800.

*B. & S. Gauge numbers for the sizes smaller than No. 40 are often used, but are not yet fully recognized. It is best to specify these sizes by their diameters.

Table II: Turns Per Square Inch

B. & S.	Beld-enamel	Single Cotton	Double Cotton	Single Silk	Double Silk	Cot-enamel	Silk-enamel
8	57	53	48			52	
9	72	66	59			64	
10	90	84	76			80	
11	113	104	93			100	
12	141	129	114			124	
13	177	160	140			151	
14	221	198	171			187	
15	277	245	208			230	
16	348	312	260	351	327	289	326
17	437	383	316	437	405	358	408
18	548	472	378	548	503	438	505
19	681	581	455	682	619	532	622
20	852	712	545	848	761	644	769
21	1065	868	650	1055	935	780	946
22	1340	1128	865	1315	1150	1008	1175
23	1665	1370	1030	1620	1400	1220	1440
24	2100	1665	1215	2010	1705	1475	1775
25	2630	2020	1420	2470	2070	1790	2180
26	3320	2445	1690	3005	2510	2155	2680
27	4145	2925	1945	3680	3010	2590	3275
28	5250	3500	2250	4600	3620	3100	4030
29	6510	4120	2560	5530	4270	3660	4865
30	8175	4900	2930	6810	5100	4320	5890
31	10200	5770	3330	8260	6010	5120	7170
32	12650	6700	3720	9870	6990	5960	8560
33	16200	7780	4140	11850	8160	7020	10400
34	19950	9010	4595	14250	9480	8060	12200
35	25000	10300	5070	16800	10870	9200	14500
36	31700	11750	5550	19850	12430	10550	17300
37	39600	13250	6045	23300	14100	12000	20400
38	49100	14900	6510	27300	15960	13400	23600
39	62600	16600	6935	31700	17850	15150	27850
40	77600	18400	7450	36700	19900	16750	32000

require $0.15 \times 1500 = 225$ c. m. so that No. 26 wire will do the job.

Summarizing, the 110 volt winding will consist of 236 turns of No. 10 d. c. c. wire which, from Table II, occupies $236/76 = 3.1$ sq. in. The 12 volt filament wiring will consist of 28 turns of No. 8 d. c. c. wire which, from Table II, occupies $28/48 = .58$ sq. in. This should be wound as a single layer on the leg of the core opposite the high voltage and primary winding. The high voltage winding will consist of two sections each containing 3218 turns of No. 26 s. c. c. wire, which, from Table II, will require $3218/2445 = 1.32$ sq. in. of winding space for each section.

With the above information as a guide and allowing for insulation over the core and between the 110 volt and high voltage winding, as well as between every other layer of the coil, it will be found that a core having window dimensions of 2.75×6.75 in. will be satisfactory. The arrangement of the coils and manner of tapping illustrated in Fig. 2 may be followed to advantage.

Iron Core Inductances

THE problem of designing an inductance coil of given value for use in a filter or other circuit may be simplified by adopting as a standard the form of core and winding shown in

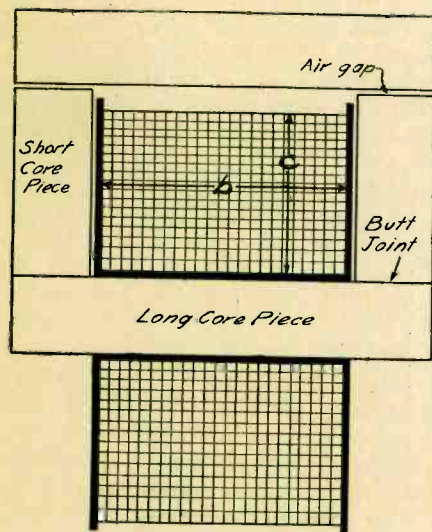

Note: Length of air gap given in table is total air gap.

Fig. 3. Simple Form of Core for Inductance Coil.

Fig. 3. The vital point is the size of the air gap, which must be taken as a compromise between a large one, which reduces the inductance and requires a large amount of wire, and a small one, which increases the harmonics and nullifies the purpose of a filter. Experiments have shown that with a silicon sheet steel core 10 in. in length an air gap 0.05 in. long consumes about 90 per cent of the ampere-turns, leaving 10 per cent

to magnetize the core. This is a good value which can best be approximated by a final adjustment of the air-gap before the choke is finished.

Silicon sheet steel having a thickness of 0.014 in. or less is the best material available for core laminations. The thinner the steel, the lower the losses. Losses are also reduced by painting all pieces with shellac or Japan lacquer. The corners should be made with butt joints instead of the usual interleaved system found in transformers. An air gap is needed in any case, and the losses are lower with butt joints. After the adjustment of the air gap, the core should be clamped firmly in place since the magnetic pull is considerable. After the proper length of air gap is determined, a paper or fibre pad may be placed in the air gap to insure permanence in its length.

Economy is gained by using wire with the thinnest insulation. As a comparison, a coil of No. 28 enameled wire 1.75 in. long and 2 in. outside diameter with a core 0.5 in. square gave the same inductance as a coil wound with No. 25 cotton covered wire 2.75 in. long and 4.0 in. in diameter with a core 1 in. square. Heavy flexible leads should be soldered to the ends of the coil and firmly taped down to prevent breaking off. For a minimum amount of winding, the core should be covered with a layer of tape and the winding run directly on that. For voltages above 500, extra insulation must be used but this should be no thicker than absolutely necessary. Accordingly, the very best insulating material should be used under the winding.

The dimensions given in Fig. 4, together with much of this accompanying information are taken from an article on Electric Filters by F. S. Dellenbaugh as published in QST. They cover all of the winding on one side of the core. The winding may be split into two coils, one on each long core piece, which takes less wire per turn but does not use the copper so effectively, due to the magnetic leakage between coils, and hence requires more turns. If the winding is not any deeper than the thickness of the core, it is probably not worth while to split the coil. If the winding is very deep, the coil should be split and about 10 per cent extra turns used on each of the two resulting coils. The wire sizes given in the table of Fig. 4 are conservative and 10 per cent larger currents can be carried continuously and 25 per cent greater currents may be carried for short periods of time. To promote cooling, coils should not be taped heavily over the outside.

Single layer inductances such as used in oscillating circuits should be of the open construction type illustrated in Fig. 5. A minimum of insulating material should be used. The conductor

should preferably consist of thin copper tubing or edgewise wound copper strip. A minimum of conductor material consistent with good conducting qualities and high frequency current carrying capacity should be used. The following sizes of conductor are appropriate for the tube ratings indicated.

No. of Tubes	Size of Tubes	1st Choice	2nd Choice
1	5 watt	0.040 by 0.25 E. W.	No. 10 Solid Cop. Wire
2	5 watt	0.040 by 0.25 E. W.	No. 10 Solid Cop. Wire
4	5 watt	0.060 by 0.25 E. W.	No. 8 Solid Cop. Wire
1	50 watt	0.060 by 0.50 E. W.	No. 6 Solid Cop. Wire
2	50 watt	0.060 by 0.50 E. W.	No. 6 Solid Cop. Wire
4	50 watt	0.060 by 0.75 E. W.	No. 4 Solid Cop. Wire
1	250 watt	0.060 by 0.75 E. W.	No. 4 Solid Cop. Wire
2	250 watt	0.060 by 0.75 E. W.	No. 4 Solid Cop. Wire
4	250 watt	0.25 O. D. Cop. Tub.	0.060 by 0.75 E. W.
1	5 K. W.	0.40 O. D. Cop. Tub.	
1	20 K. W.	0.75 O. D. Cop. Tub.	

E. W.—Edgewise Wound Copper Strip.

To assist the reader in the design and construction of inductances of the single

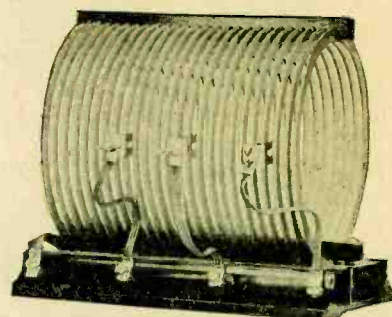

Fig. 5. Oscillating Circuit Inductance.

layer type, the following approximate relation is given.

$$L = \frac{0.155r^2n^2}{l}K$$

where, L —inductance in microhenries.

r —radius of coil measured from axis to center of conductor, in inches.

n —number of turns.

l —length of coil measured between centers of end turns, in inches.

K —a constant depending upon the ratio of $2r/l$

The following values of K are commonly used:

$2r/l$	0.10	0.25	0.50	0.75	1.0	1.5	2.0
K	0.96	0.90	0.82	0.75	0.69	0.60	0.53

The above formula is based upon the use of round wire. For practical purposes, its use may be extended to conductors of other ordinary shapes.

During the past month the radio operators of the Marine side of the British Marconi company have been on strike as a protest against a reduction in wages. The effect of this strike on the shipping world has been considerable and many vessels have gone to sea without their complement of operators. The government authorities have had to allow ships to sail without their telegraphist in order not to disorganize the shipping world. In view of the uncertainty caused by the strike the Marconi company have stopped the paying of their interim dividend.

An Inexpensive Reflex Receiver

Constructional and Operating Directions for Using Alternating Current Filament Supply

By Dr. Maurice Buchbinder

IF tone quality, distance, and volume are to be obtained from a radio receiver, which at the same time must be inexpensive, one of the best possible combinations of apparatus is a reflex receiver with alternating current filament supply. The set is simple to construct, largely because standard parts are used. Building is merely a process of assembling the different items.

By reference to the schematic wiring diagram in Fig. 1, it is noted that three identical r. f. units are used, each consisting of an r. f. coupler plus a variable condenser. Air condensers of capacity specified by the manufacturers of the coils should be used, and will generally be .0005 mfd. The list of parts describes the various pieces of apparatus marked on the diagram, the bell ringing transformer preferably being of the 10 watt variety, wound to 6 volts secondary.

The r. f. units are spaced in the usual way, evenly distributed over the panel and as widely apart as possible. The potentiometer and filament control rheostat as well as the jack and filament switch are also mounted conveniently on the panel to the right. The picture shows the top view of the completed set, and indicates the proper angulation of the coils.

On the panel from left to right are seen the first and second variable condensers, potentiometer, and to the extreme right the variable condenser next to the crystal detector. The arrangement of audio transformers on the baseboard is for convenience in wiring, but may have to be changed to suit the particular type of audio transformers used. The bell ringing transformer was ex-

- LIST OF PARTS USED**
- 3 .0005 mfd. variable condensers.
 - 3 r. f. couplers (Kellogg No. 602).
 - 3 Sockets for UX-201A tubes.
 - 1 30 ohm filament rheostat.
 - 2 .002 mfd. mica condensers.
 - 1 .0005 mfd. mica condenser.
 - 1 Adjustable reflex crystal.
 - 1 Filament switch.
 - 1 Jack.
 - 3 Dials.
 - 2 Audio frequency transformers.
 - 1 4½ volt "C" battery.
 - 1 Bell-ringing transformer.
 - 2 Neutralizing condensers.
 - 1 7x21x3/16 in. Formica panel.
 - 1 7x21x3/4 in. baseboard.

ternally situated in the experimental set, and connected to the filament circuit by means of flexible wire. The transformer may be located at the rear of the baseboard if room can be found for it.

ternally situated in the experimental set, and connected to the filament circuit by means of flexible wire. The transformer may be located at the rear of the baseboard if room can be found for it.

Theoretically, the circuit does not differ from the conventional reflex. Tube No. 1 acts as a r. f. and audio amplifier, Tube No. 2 is a r. f. amplifier and Tube No. 3 is an audio amplifier. The only peculiar feature of the circuit is the use of a. c. to heat the filaments, which are connected in parallel and controlled by a 30 ohm rheostat. Across the filaments is placed a 400 ohm potentiometer, the variable point being connected to the positive terminal of the C battery and

the negative pole of the C battery is the common return for all the grid circuits. Regarding the a. c. filament operation, we should certainly expect to hear a considerable hum due to the fluctuations in the filament current, and yet it is found quite possible to eliminate this sound by suitable balancing. The hum is not in any case due to the fluctuations in the filament heating, but entirely to variations in the normal grid voltage. Each filament heats up to a constant tempera-

ture whether a. c. or d. c. is flowing through it. The heating effect in any resistance is proportional to the square of the maximum current in the circuit, whether it is direct or of a simple harmonic alternating character. We must conclude therefore that the hum must be due only to some grid effect.

Thus, if the grid of a tube heated with a. c. be connected to either end of the filament, a considerable alternating plate current will result. If, however, the grid be connected to the central point of the filament, no alternating plate current is noticed, because the average grid voltage with respect to the entire filament length is constant under these conditions. We must not forget that the filament cannot be considered a point of single potential, but there is a definite voltage drop along its entire length. Let us refer to Fig. 2 for an explanation of what happens.

Fig. 2-a represents the manner in which a grid is normally connected in the amplifier circuit. The filament is lighted by a. c. as in Fig. 2b. The grid potential is varying with respect to the average filament potential, the maximum variation being 2 volts. In Fig. 2-c the maximum is similarly 2 volts. In Fig. 2-d the maximum average variation is zero; in other words, the grid voltage is fixed, in spite of the variation in filament current and voltage. In practice we cannot tap off a central point, such as C¹, on the filament, but we may ob-

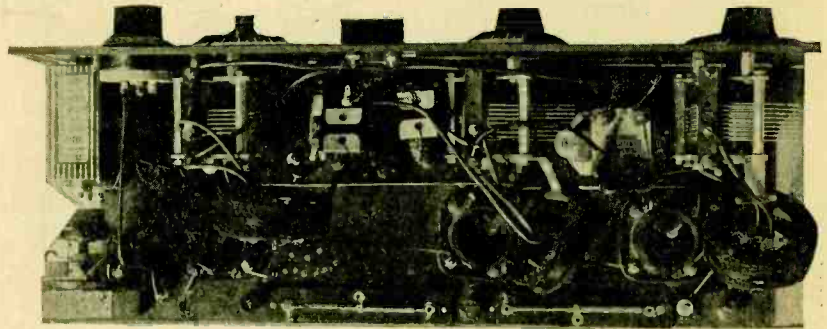

Top View of Completed Reflex Receiver.

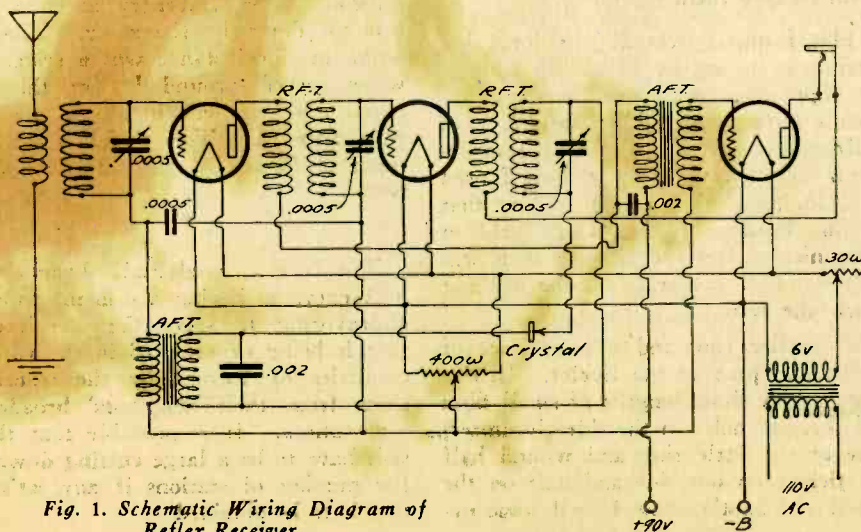

Fig. 1. Schematic Wiring Diagram of Reflex Receiver.

tain the same results by the use of a potentiometer which locates a point C^1 at the same potential as C . This is a Wheatstone Bridge arrangement. As the amplifier operates most efficiently with a negative grid bias, we must interpose a C battery between the potentiometer and the grid tap. Thus we reach an arrangement illustrated in Fig. 2-e.

If the emission of the filament is uneven throughout its length, we may not be able to secure a complete elimination of the hum. Thus we may balance for one tube and not the others with the same potentiometer adjustment. In that case we may neutralize the residual hum by making the common negative B bat-

LOW-LOSS COIL FORM

Here's a low-loss coil form that is easily adapted to any circuit of the regenerative or radio frequency types. Being one of those radio constructors whose enjoyment of radio tinkering would be nil if I merely assembled a lot of manufactured apparatus, I assume there are many others like me who may be interested.

This coil form essentially consists of two celluloid rings and celluloid "ribs" between them. I used 3 in. white celluloid harness rings, obtainable from a harness or saddlery shop. For ribs I used celluloid knitting needles about $\frac{3}{8}$ in. thick and 13 in. long. For a 3 in. ring,

ralin made for automobile curtain "windings" to make a small tube that fit inside the ring, using the cement to hold it there. But a piece of bakelite tubing should do just as well, since we are given to understand that "low loss" ticklers are not essential.

I am now using these forms for the "L. C." circuit as modified and described in a recent issue of RADIO. I'm hoping it will effectively supplant the "tickler" type of regenerative control, which is never smooth enough to be really satisfactory at all wavelengths.

Inasmuch as there are several sizes of harness rings on the market the use of inductance tables is necessary—unless you want to guess first, then cut and try. But with this coil form it is not so difficult to cut and try. You can take off a turn of wire and wind around a rib to hold it while you are "trying." Or you can daub a little of the Dupont where the wires touch the ribs without materially affecting the capacity of the coil; then the wire can be removed, a turn at a time, without loosening the rest of the winding.

Terminals can easily be screwed to the rings at convenient points, and mounting also is easy with these forms. Besides, they make a sightly looking job.

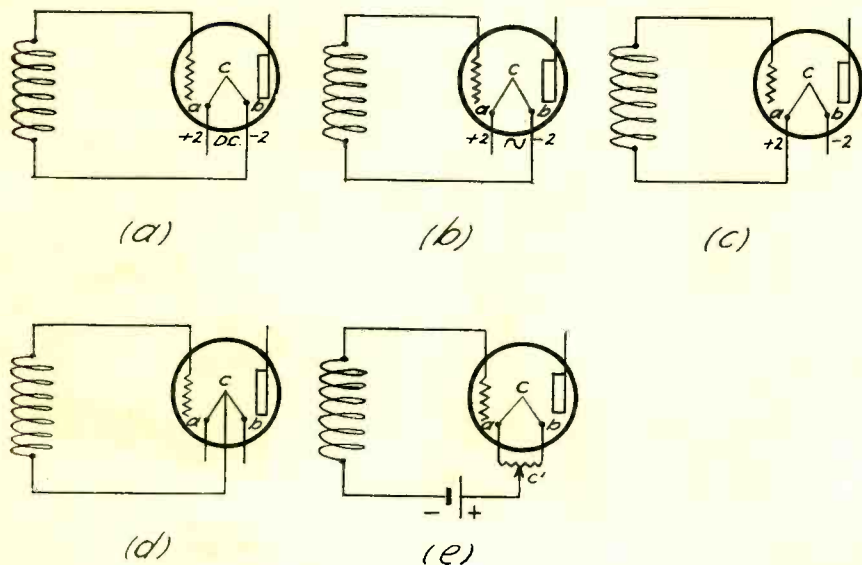

Fig. 2. Theory of A. C. Filament Operation.

tery return to either side of the filament instead of to the potentiometer. A trial before making permanent connections will tell if this procedure is necessary.

Be sure to select good audio transformers for the outfit. Good tone quality results only when the transformers will amplify the low as well as the high notes of the musical scale, and when associated with a good loud speaker. The selectivity of the set is excellent, and when connected to an average antenna, will bring in distant stations through powerful locals without difficulty.

Early in 1927 India will be in possession of two broadcasting stations, to be erected at Calcutta and Bombay. It is intended that these two stations shall each have a range of one thousand miles. The company that will be responsible for this enterprise will rely on the revenue from receiving licenses for its income, 80 per cent of the government license fee will be handed over for this purpose. It is interesting for Americans to note that almost all foreign countries provide a license fee to be paid by the listener, whereas no such charge is made in America. The many evasions in payment constitute a serious problem.

seven ribs make a staunch form—although it is easier to space an even number around the side circumference of the rings. That will make a form approximately $2\frac{5}{8}$ in. in diameter.

It is best, of course, to make holes in which the "ribs" will fit tightly; but Col. Dupont makes a "household cement" that sells for two-bits in collapsible tubes that is full of ether or acetone and it cements celluloid perfectly. (Also is is good for "spotting" turns of a coil to keep them tight.)

This form, if over $2\frac{1}{2}$ in. long, has a tendency to sag in the middle, due to the suppleness of the needles, and perhaps a fibre rod would be better. On a Browning Drake radio frequency-detector coil that was $3\frac{1}{2}$ in. long I used a $\frac{1}{2}$ in. piece of bakelite tubing that fit just inside the ribs, which held in place nicely after the Dupont stuff was used—and of course, the tube did not touch the wire.

A smaller ring and a long piece of needle can provide the tickler. In one case I stuck short lengths of small fibre rod through holes in the side circumference of the little ring and wound half the tickler on one side and half on the other. In another case I used some py-

EUROPEAN RADIO NOTES

From H. DE A. DONISTHORPE

The German station at Konigwusterhausen (LP.) has a new mast reputed to be the largest of its kind in the world. The mast which is in the form of a triangular lattice tower is 900 ft. high, tapering from a ground structure 70 yards wide to a top platform of 32 ft. across. A novel feature is the erection of a short wave transmitter on the top platform.

During the recent snow storms that have been experienced in Europe several of the well known high power broadcasting stations were put out of commission. The Daventry antenna was brought down by the snow. The antenna in this instance was a system of wires spaced around hoops; this antenna has been substituted by a single wire antenna. The Eiffel tower antenna in Paris also suffered in the same way.

The International Radiophone Union in Geneva is having a difficult time in endeavoring to solve the interference that is being experienced in the various countries of Europe by the transmissions from their neighbors' broadcasting stations. It is probable that there will have to be a large cutting down of the number of stations if any satisfaction is to be obtained.

A Baby Radio Transmitter

By *W. H. Hoffman*

A GREAT deal of interest has been manifested by amateurs and radiocast listeners in the development of low powered short wave radiotelegraph transmitters. The amateurs themselves have already done a great deal of experimenting along this line, and some fine records have resulted, as already described in RADIO. Many radiocast listeners of experimental trend of mind have desired to break into the amateur field, but hesitated to spend large sums of money for high powered tubes and associated apparatus.

The way is made easy as the result of experiments conducted by the C. F. Burgess Laboratories Radio Station 9EK-9XH at Madison, Wisc., and a baby radio transmitter using one dry cell tube of the 99 type has been developed to a remarkable degree of efficiency. Complete details of this transmitter are contained in a bulletin recently issued by The Burgess Company, and extracts are being reproduced here so that those interested in the construction of the set may have the details.

Around a UV-199 or C-299 tube, there are assembled in as compact a form as practicable, two receiving type variable condensers, two small inductance coils, and a small fixed condenser, as shown in Fig. 1. These form a radio

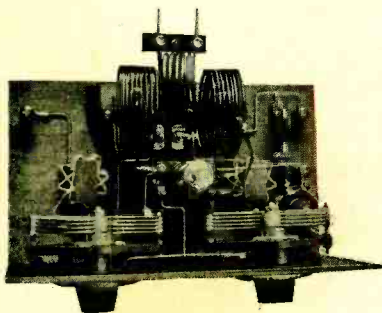

Fig. 1. Top View of Baby Transmitter.

frequency generating circuit to which *A* and *B* battery energy is fed from dry cells. Radio frequency choke coils in series with the *B* battery feed and with the grid leak resistor, prevent losses of the high frequency energy in these circuits. A third small inductance coil, placed between the other two, couples energy into the antenna circuit. Fig. 2 shows the rear view of the set, and indicates the position of the inductance coils and other apparatus.

The oscillating circuit is shown schematically in Fig. 3, it being a modification of the Colpitts oscillator. The efficiency and stability of the circuit are due to the fact that the two series inductances and capacities form a high frequency

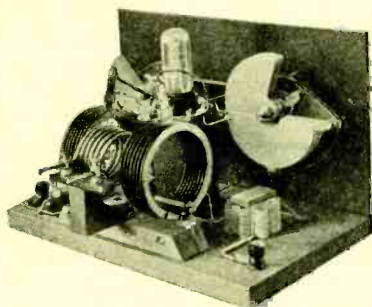

Fig. 2. Rear View, Showing Arrangement of Coils.

bridge circuit. The *B* battery circuit as well as the grid leak circuit are connected to points of little or no difference in radio frequency potential, thus reducing to a

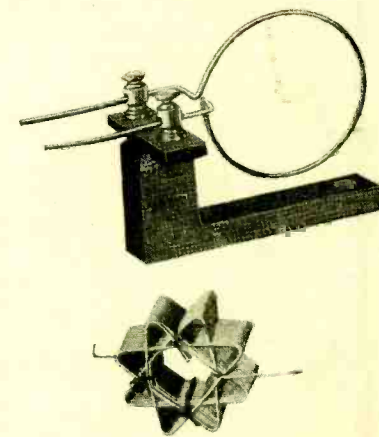
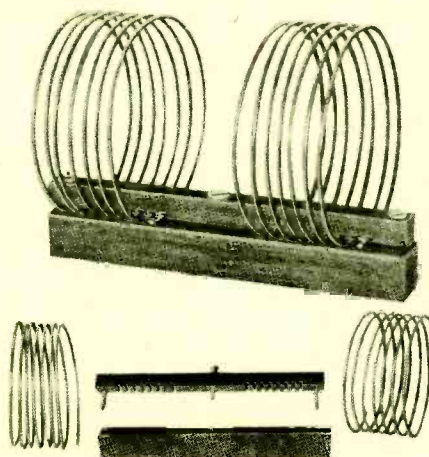

Fig. 4. Details of Coil Construction.

minimum radio frequency losses through them.

Constructional data for the various parts necessary to build the set, for the 40 meter band, are given in the following table, the reference letters being shown in the schematic wiring diagram of Fig. 3.

Details of the Coupling Coil, r. f. Choke coils and the Oscillator system are shown in Fig. 4, the oscillator coils being at the left, the antenna coil at the upper right and the r. f. choke at the

lower right of the picture. The experimental transmitter used edgewise wound copper strip, but No. 14 solid copper wire may be used, as it is more easily obtained. The supports of the various coils are made from dry hardwood. All wiring should be in heavy, solid copper wire, without spaghetti or other insulation.

The most important part of the transmitter is the antenna system. Several systems may be employed, including loop transmission, but one particularly satisfactory method is to use a small antenna having a natural frequency approximating that at which it is desired to transmit. For 7500 kilocycle (40 meter) transmission a single wire about 33 ft. long erected as nearly vertical as practical should prove effective. If a counterpoise is used instead of a ground, it should be of approximately the same dimensions as the antenna. A series antenna condenser of about .00025 mfd. may be connected between the counterpoise and the coupling coil. Another method is to use a larger antenna and tune it to exactly 3 or 5 times the wave-

(Continued on Page 46)

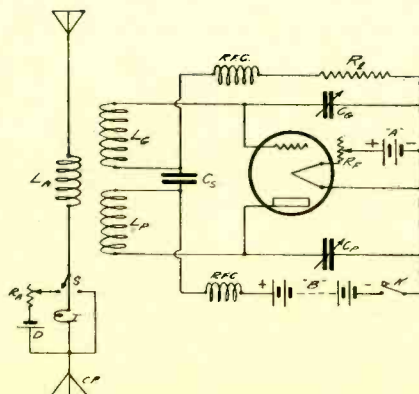

Fig. 3. Schematic Wiring Diagram.

What Is Meant by Power Factor

By Arthur Hobart

POWER Factor is a ratio or percentage by which the product of volts and amperes must be multiplied so as to find the actual power in watts delivered from an alternating current circuit containing either inductance or capacity or both. While this fact is understood by students of elementary electricity its specific application is sometimes confusing.

Thus what is meant when a condenser is said to have a power factor of 0.2 degrees? In general, the power factor of a condenser measures the ratio of the energy which is lost or consumed in the condenser to the total energy which is supplied to the condenser. But in order to understand the method of measuring a specific value some consideration must first be given to the elementary theory of alternating currents.

Whereas with direct current the average power in a circuit is numerically equal to the steady current in amperes multiplied by the steady potential in volts, $P=IE$, in an alternating current, where the current and voltage pass through a series of values from zero to maximum positive to zero to maximum negative to zero during each cycle, this equation is true only when the voltage reaches its maximum or zero values at the same time that the current reaches its corresponding values. They are then said to be in phase and the power factor is unity, a condition attained only when the circuit contains nothing but resistance or when the capacity and the inductance neutralize each other.

If alternating current is passed through a circuit containing inductance, the voltage attains its maximum value a small fraction of a second before the current reaches its maximum value and throughout the entire cycle attains a given value at similar time intervals before the current reaches its corresponding proportionate value.

This interval of time is called the "phase angle." For instance, with a 60 cycle current the elapsed time between

corresponding values is $1/60$ of a second. If this $1/60$ second time interval is represented on a circle like the face of a watch, as in Fig. 1, the $1/60$ second hand would make an angle of 90 degrees with its zero position after $1/240$ of a second had elapsed; an angle of 180 degrees after $1/120$ of a second had elapsed; an angle of 270 degrees after $1/80$ of a second had elapsed and an angle of 360 degrees after $1/60$ of a second had elapsed. This time angle is the so-called "phase angle." Its value depends upon the size of the inductance and upon the number of cycles per second. It becomes relatively great at the very high frequencies used in radio.

Likewise if a capacity, such as a variable condenser, be substituted for the inductance in the circuit, the voltage will attain its maximum value at a small fraction of a second after the current attains its maximum value. The voltage will lag behind the current throughout the completed cycle, the angle of lag, or phase angle, depending upon the value of the capacity and the frequency.

Thus we see that an inductance causes a positive phase angle and that a capacity causes a negative phase angle. If the circuit contains both inductance and capacity, the phase angle is equal to the difference between the two separate phase angles and is positive or negative accordingly as one or the other predominates. If they are equal, the phase angle is zero, the voltage and the current attain corresponding values at the same instant of time, and the circuit is said to be in resonance. In such case the power is equal to the product of the amperes and volts.

But in any other case this product must be multiplied by a factor whose value depends upon the phase angle. This factor is called the power factor or the fraction by which EI must be multiplied in order to obtain the true value of the power in the circuit. It may be easily calculated from a slight modification of the clock diagram already used.

Thus in Fig. 2, let zero time be represented by the line CO and assume a phase angle θ of $22\frac{1}{2}$ degrees, bounded by the lines CO and CA . If a perpendicular line be dropped from A to B , the ratio of CB to AC gives the de-

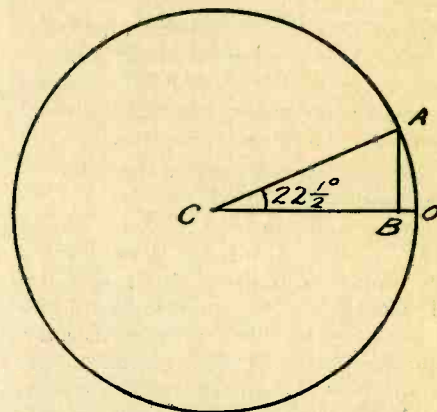

Fig. 2. Phase Angle of $22\frac{1}{2}$ Degrees.

sired fraction or power factor, which in this case is .9239.

In trigonometry this ratio is known as the cosine of the angle and may be found for any angle in a table of cosines. In this diagram CB represents the proportion of the total current AC which is in phase with the voltage and BA represents that which is out of phase. Obviously, CB becomes less as the phase angle increases to 90 degrees then becomes greater as it increases to 180 degrees then less to 270 degrees and then greater to 360 degrees. It can never be greater than unity, when the resistance constitutes the only opposition to the flow of current.

If there is no inductance or capacity in the circuit, or if they neutralize one another, the phase angle is zero and the ratio of CB to CA is unity. If an insulating material has a power factor of 2.1 degrees, the ratio of CB to CA for 2.1 degrees is 0.9991 which means that the apparent watts EI multiplied by .9991 gives the true watts that flow through a circuit in which this insulating material is placed, the difference being a power loss that appears as heat. This material, then, is better than would be one having a phase angle say of 5 degrees and a power factor of .9962.

With a table of trigonometric functions at hand, the phase angle can be calculated without measurement, if the frequency, the capacity, and the resistance are known. Merely find the angle whose tangent is equal to $1/6.28fCR$ then find the cosine, or power factor, corresponding to this angle.

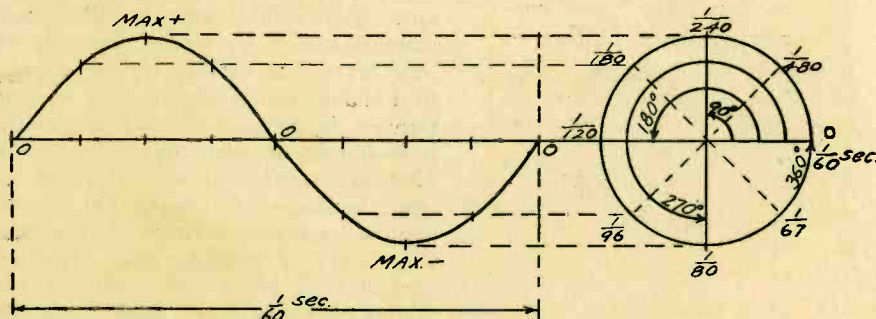

Fig. 1. Phase Angles of an Alternating Current.

Another instance of the use of power factor is in the rating of a variable condenser. An absolutely perfect condenser having no series resistance would have a phase angle of 90 degrees, but due to imperfect insulation between the plates, the normal condenser has a phase angle of less than 90 degrees. The poorer the insulation between the plates the greater is the departure from 90 degrees and the more power absorbed as heat.

The rating of a condenser is generally based upon the difference between the ideal 90 degrees and the actual phase angle. This phase difference for small angles is numerically equal to $6.28 fCR$ where f is the frequency, C the capacity and R the resistance between plates.

Obviously the less the resistance the greater the phase difference. Instead of designating the condenser's inefficiency in terms of phase difference the equivalent power factor is sometimes used, zero power factor indicating an ideal condenser or insulator. While the power factor of a transformer may be analyzed in the same manner, it is customary to consider its impedance relations. An ideal transformer consists of an inductance and a resistance in series which combine to make an impedance Z . The AC power delivered by a transformer coil is equal to the product of the voltage and actual current, but the actual current is equal to the voltage divided by the impedance, $I = \frac{E}{Z}$, whereas if there were no inductance, I would equal $\frac{E}{R}$. Consequently the ratio of resistance to impedance, the fraction $\frac{R}{Z}$, also gives the power factor.

When trying out different loud-speakers, don't connect up a half dozen, one after the other, and decide that so-and-so is the absolute "best." Be sure that all circuit and tube conditions are right before you start in, and that each speaker gets a fair chance. Some will be fine on moderate power, and fall down on great volume, and this through their inability to carry the load, while others will require more power to operate, but if properly supplied will prove better than those using more moderate amounts of energy.

When a receiving set is using considerable potential for the operation of a loud-speaker, do not forget that there may be a high enough voltage present to cause serious shock, and even possible death, if the live circuits are handled incautiously. A fine plan is to turn off the B battery before getting into the set, to make any changes or repairs.

Never use tinsel cord, such as is used for head telephones, for any filament circuits, as it may have a very high resistance, which will render the set almost, if not quite inoperative, due to potential drop.

HANDY HINTS

By D. B. McGOWN

Asphalt base "roofing paint" makes a good substitute for acid-proof paint for coating battery boxes, trays and other parts that are liable to acid corrosion. If too thick, it may be thinned with gasoline or turpentine.

An often overlooked place to bring in a lead-in is the chimney. While the smoke may dirty the wire, if it is stretched tightly, this should give no trouble.

To shut off a battery charge at a certain time, a wooden spool may be fitted to the "alarm" key of a common alarm clock, and the latter set for the time desired. When the alarm goes off, the spool will wind up a string, which will thus pull out a switch, and shut off the power. Similar means can be used, of course, to start such a device.

When dry cells start to get weak, never connect a fresh set without first removing the old ones. If you do thus connect them, the weak ones will run down the good ones, and no good object will be served.

In building a portable set, why on

earth load yourself down with many pounds of No. 6 dry batteries. Why not arrange to have one, or even two sets of flashlight batteries in the set, which can be replaced at any hardware store for a small sum, and for semi-permanent use connect in the large ones.

In taking care of storage B batteries an "eye dropper" such as can be obtained at any druggist's, will prove most handy in replacing evaporation with distilled water, etc., and will keep from spilling or otherwise losing electrolyte through over-filling.

When wiring up that new set, try out a color scheme, where one color means A battery leads, another B battery, etc., and while more trouble at first, it will surprise you how easy this gets to be after a while, and how easy to trace out "bugs" if any develop.

In a multi-tube set a couple of spare tubes, well tested and marked, may often save you an evening's regret, which would be eliminated if you had the spares on hand, and as you'd buy them anyway, in the long run, it pays better to keep them right where they can be used.

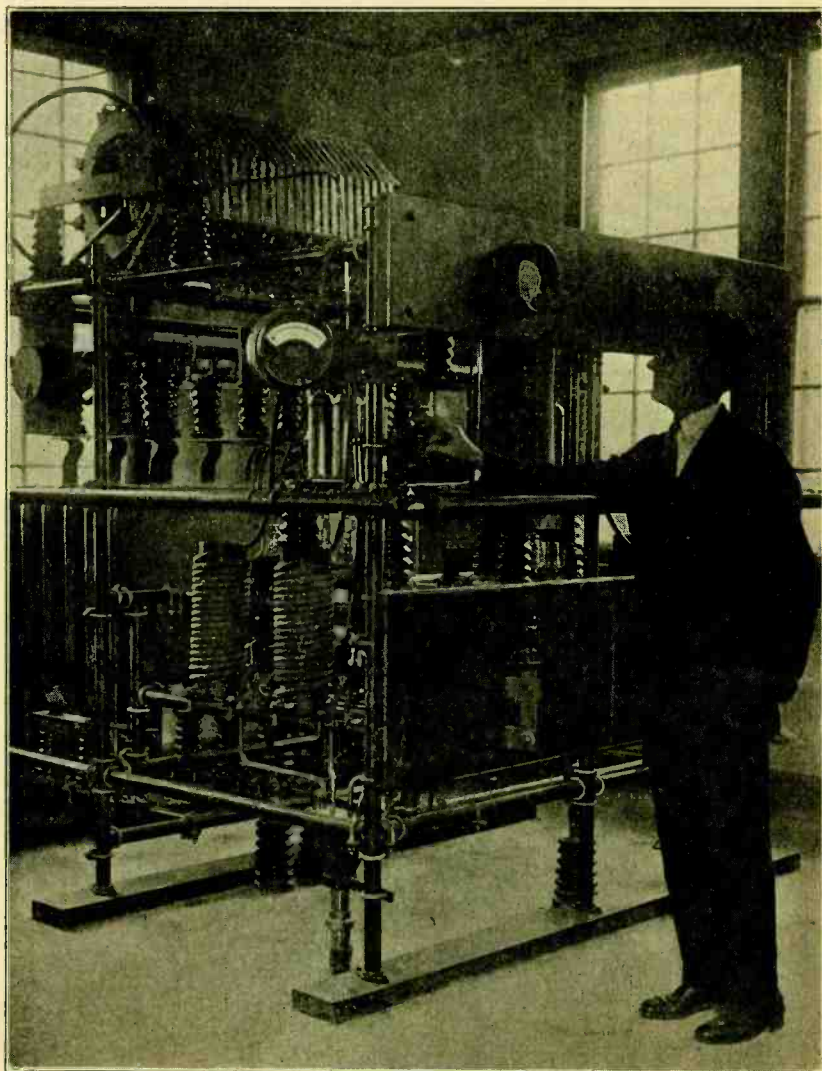

One of the Two 40-Kilowatt Transmitters at 2XAR, the Bound Brook, N. J. Station of the Radio Corporation of America.

Construction of a Simple Cone Type Speaker

By E. C. Nichols

With the advent of the smaller and more acute angle cone it is possible to successfully construct a cone speaker using an ordinary fone unit. Surprising results may be obtained from a simple set up. This can be readily demonstrated by the application of the prin-

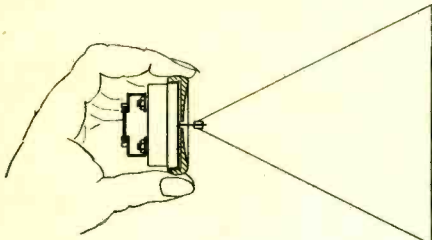

Fig. 1. Principle of Cone Type Speaker.

ciple shown in Fig. 1. A paper cone 6 in. in diameter and 6 in. high is made up from the development shown in Fig. 2. Into the small end of this cone an

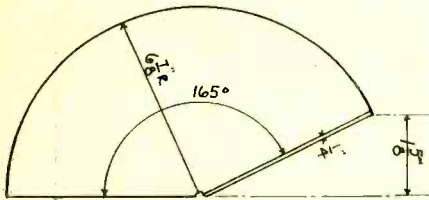

Fig. 2. Development of Paper Cone.

ordinary rubber eraser, such as is used on the end of a lead pencil, is securely glued. A common straight pin is soldered to the center of the diaphragm of a fone unit and the cone is supported on this pin by impaling the rubber tip on the pin. This simple arrangement

will bring out those desirable bass notes usually suppressed if not entirely lacking in the ordinary horn type speaker.

Much better results may be obtained from a more permanent set up as shown in Fig. 3. Here most of the requirements as stated by Dr. J. P. Minton in his article, *Hornless Types of Loud Speakers*, in January *RADIO* have been satisfied. The cone is small that it may be in keeping with the output of the fone unit, 6 in. in diameter by 6 in. high.

The material used for the cone should be determined somewhat by the power available from the audio amplifier. A cone of o-tag or light blotting paper is preferable where there is plenty of power, but, for the average audio amplifier a cone made of Watman's cold pressed water color paper will give the best results. The rougher the paper the better, as it adds to the stability of the cone without increasing the weight. A trial of cones made of different weights of paper will be wise in order to obtain the best results.

The rubber tip should be made as small as possible as it is important that all vibrating parts be light in weight. A firm rubber is preferable to a soft rubber. Care should be taken in glueing the tip into the cone. Too much glue will defeat the purpose of the rubber so use just enough to fasten it securely.

The large end of the cone is freely supported in a flexible ring of chamois skin or kid of 8 in. outside diameter by 5 in. inside diameter. The cone may

or may not be glued to this ring as one desires. If it is desired to try several cones the omission of the glue will simplify matters.

When soldering the pin to the diaphragm the diaphragm should be removed from the unit. Sometimes difficulty is encountered in removing the diaphragm because of the tightness of the rubber cap. This may be overcome by first carefully heating the cap after which it may be easily removed. A small pot of enamel is scraped off the center of the diaphragm and after tinning this spot and the head of the pin, solder them together, taking care to get the pin at right angles to the face of the diaphragm. All excess solder should be removed to keep down the weight of the moving parts.

A fone unit which rattles under ordinary conditions will not necessarily rattle after the cone is mounted on it for the inertia of the mounted cone changes the whole characteristic of the diaphragm. A unit with a chronic rattle may be corrected by inserting a shim washer of paper or copper, which is approximately .002 in. thick, between the diaphragm and the shell. Before doing this, however, a careful adjustment of the rubber tip on the pin may correct the trouble. An adjustment which gives maximum volume without causing the diaphragm to strike the magnets in the unit is most desirable and the supporting ring at the large end of the cone will have just enough restraining effect to maintain this balance. The unit should be shunted with a fixed condenser of from .001 to .005 mfd.

As an experiment this speaker has been operated successfully with three stages of resistance coupled amplification using 200 volts of *B* battery. The mounting for the parts described above may be made of wood, five ply being preferable but not absolutely necessary. A neat box with silk covered louvres may enclose the whole and make a most presentable and especially enjoyable loud speaker.

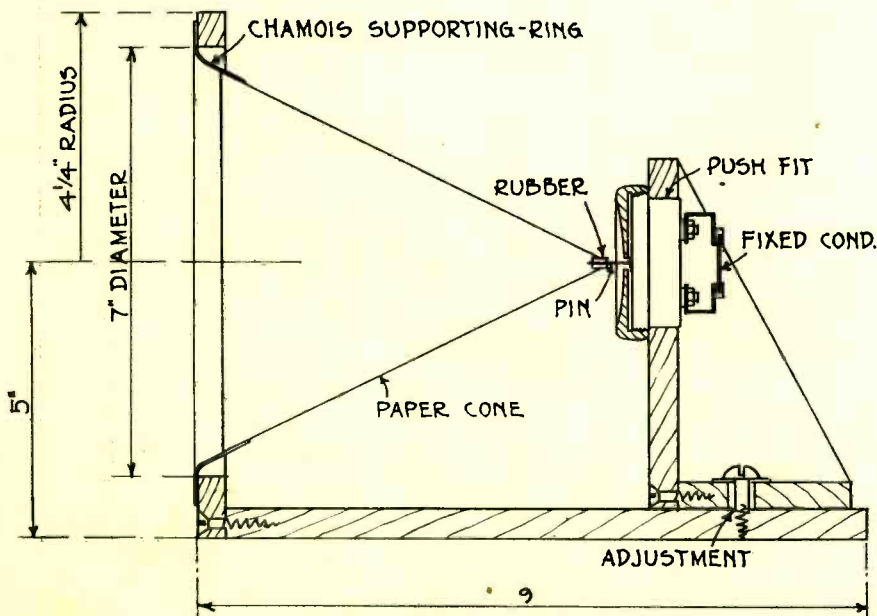

Fig. 3. Constructional Details.

Early in the New Year a radio telephone service will be inaugurated for the use of the passengers on express trains running over the Berlin to Hamburg line. The system has been worked out so that the passengers will be able to call up an exchange and to get in touch with any ordinary land line telephone subscriber.



QUERIES and REPLIES



Questions submitted for answer in this department should be typewritten or in ink, written on one side of the paper. All answers of general interest will be published. Readers are invited to use this service without charge, except that 25c per question should be forwarded when personal answer by mail is wanted.

Please publish an A. B. C. Battery Eliminator circuit for use with 110 volts d. c.—F. A. M., Escuinapa, Mexico.
The circuit for the A. B. C. Battery Elim-

November 1925 RADIO, but delivering three voltages, 120, 45 and 22½ volts.—R. R. W., Philadelphia, Pa.

The filter circuit, with the necessary vari-

added, and can the set be made into a one-tube super-regenerator?—W. H. H.—Auckland, N. Z.

The r. f. amplifier described by A. J. Haynes in November 1925 RADIO is the best combination to adopt. Connect the output of this amplifier to the antenna binding post on the present set, and use common A and B batteries, for all tubes. Connect the ground binding post on the set to the negative A battery. No circuit using the Super-Regenerator with the DX-Bringer-In was published, and so far as is known, the success of the experiments made by the author did not warrant publication of the data.

I have a 7 tube Silver Super which does not give satisfactory results on distance. Have taken it to several repair shops, and they say they can get Chicago on the set, but I am from Missouri. What can be done to enable me to receive distance?—W. H., San Francisco, Calif.

If your batteries and tubes have all been tested and found O. K., the trouble may be in your location, especially if the set has been tried out in other places and distant stations tuned in. As you do not state what kind of a loop antenna is used, it is difficult to diagnose any trouble in the r. f. end of the circuit. The Silver Super ordinarily is a very good distance-getter, and is selective as well.

Please publish a circuit for long wave C. W., using honeycomb coils.—W. E. G., Hollywood, Calif.

The circuit you wish was published in Fig. 3, Page 36 of December 1925 RADIO.

Kindly publish more details about the 10 watt transmitter shown in Fig. 2 of the Queries and Replies Department of January RADIO.—A. J. H., Edwardsville, Pa.

The inductance coils and other tuning apparatus may be similar to that used in the Baby Transmitter described elsewhere in this issue. The 3 millihenry choke may be a 250 turn honeycomb coil, or 250 turns of No. 24 D. C. C. on a 3 in. tube. The 6 henry choke may be purchased ready-made, or may be constructed by winding 2200 turns of No. 26 enameled wire on a core 1 x 2 in. of silicon steel. An air gap must be provided in the core, in order to obtain the

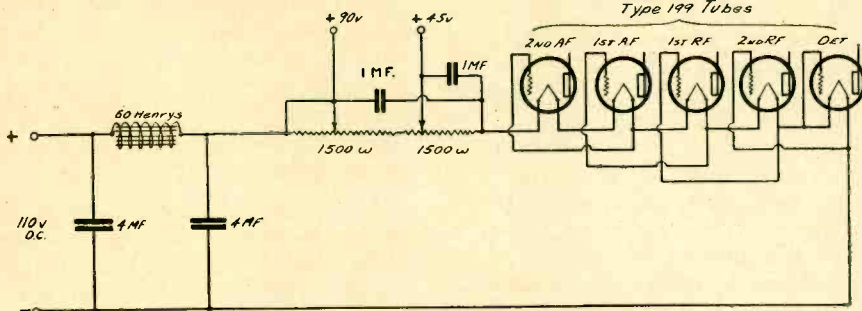

Fig. 1. ABC Battery Eliminator for 110 Volts D. C.

inator is shown in Fig. 1. A maximum voltage of 90 for the plate circuit is available, so that a power tube cannot be used without a booster battery. The filament circuit shown in the diagram is for a five tube tuned r. f. receiver of conventional pattern.

Am having trouble cutting out local interference, with my Browning-Drake receiver. How can I cut down on this trouble?—J. G., Los Angeles, Calif.

able resistors and fixed condensers is shown in Fig. 3. Two Bradleyohms, one of 25,000 to 100,000 ohms and the other from 10,000 to 25,000 ohms will be required, the former being used to supply the 22½ volt circuit, and the latter the 45 volt tap.

Have built the DX Bringer-In as described in May 1923 RADIO and have heard stations as far away as KGO. Could a stage of r. f. amplification be

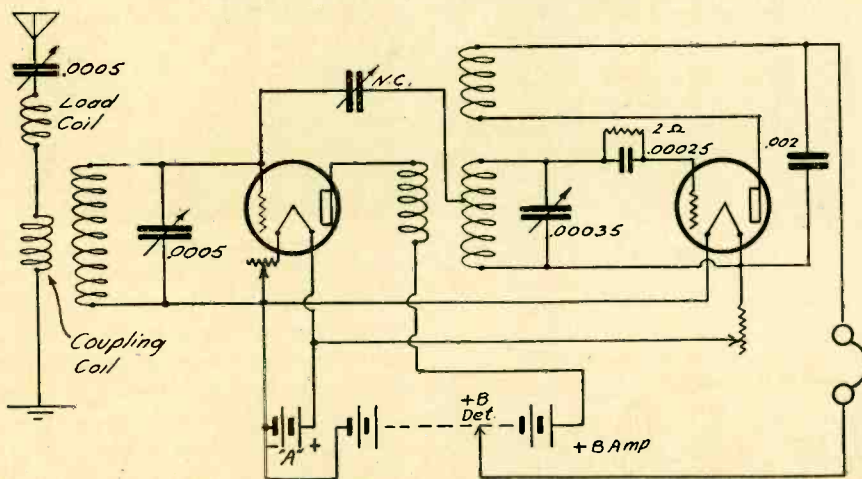

Fig. 2. Modified Browning-Drake Circuit.

Tuning the antenna circuit with the scheme shown in Fig. 2 is an excellent method of cutting out interference from powerful local stations. Shielding the back of the panel and the inside of the cabinet is another aid to interference prevention. The loading coil shown in Fig. 2 may be either a 75 turn honeycomb coil, or a General Radio No. 277-C inductance coil. The coupling coil should consist of 5 turns of No. 20 D. C. C. wire wound around the filament end of the secondary coil.

Please publish a circuit for the Raytheon tube similar to the one given in

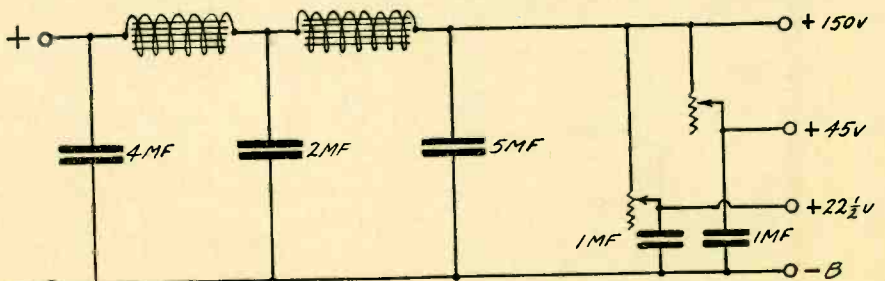

Fig. 3. Raytheon Filter Circuit, Arranged for Variable Voltage Supply.

proper inductance with direct current flowing through the winding. The modulation transformer will depend upon the type of microphone used, but for the circuit shown, may be of the conventional type such as is made by the General Radio Co. The 400 ohm potentiometer and 2 mfd. condenser may be of the type used in receiving apparatus, and the double pole double throw switch can be the Federal 1424-W anti-capacity key or switch of similar nature. The filament lighting transformer should be capable of supplying 5 amperes at 8 volts, assuming that four UX-210 five watt tubes are used. A rheostat in the primary of the transformer will aid in controlling the filament voltage.

I would like to build the Selective Crystal Set described by E. M. Sargent in December RADIO, but would like to

has a rotor wound with 30 turns of No. 32 d. s. c. wire. The circuit published herewith shows battery connections for a power tube in the last audio stage, which is desirable if a cone type loud speaker is to be used with the set.

I notice that various radio receiving circuits show fixed condensers across the primary of the first audio transformer, varying in size anywhere from .0005 mfd. to .006 mfd. What is the correct value? —S. H. J., Danbury, Conn.

A capacity of any kind across either the primary or secondary windings of a high grade audio transformer such as we can now buy is a detriment, no matter how you look at it. A shunt capacity of this kind tunes the transformer to a definite audio frequency well within the range of the voice or the

average musical instrument, and consequently, that transformer is bound to be more efficient at that particular frequency than at any other, and distortion results. Unfortunately, the condenser must be in the circuit, due to the fact that in the plate circuit of the detector tube, a path must be provided for the radio frequency currents which the detector tube amplifies to a certain extent, and as the audio frequency transformer primary does not provide a low resistance path for these high frequencies, another path of low impedance must be furnished, and this must take the form of a fixed condenser. The condenser should be as small as possible, and yet furnish the low resistance circuit, so that .002 mfd. should ordinarily be sufficient. If the transformer has a large amount of distributed capacity, this condenser may not need to be as large. In superheterodyne circuits, where the frequency entering the detector circuit is relatively low, being around 50,000 cycles, this condenser must be larger in order to by-pass the high frequency currents, but in any case should not exceed .003 mfd. Condensers of .006 mfd. will introduce very bad distortion and should never be used.

MODESTO RADIO CLUBHOUSE

The new home of the Modesto Radio Club, as illustrated herewith, is a handsome stucco structure about 20x40 ft., placed on a large lot, having ample space for growth. The house is well furnished as a living room and will be equipped with a complete transmitter, receiver and laboratory.

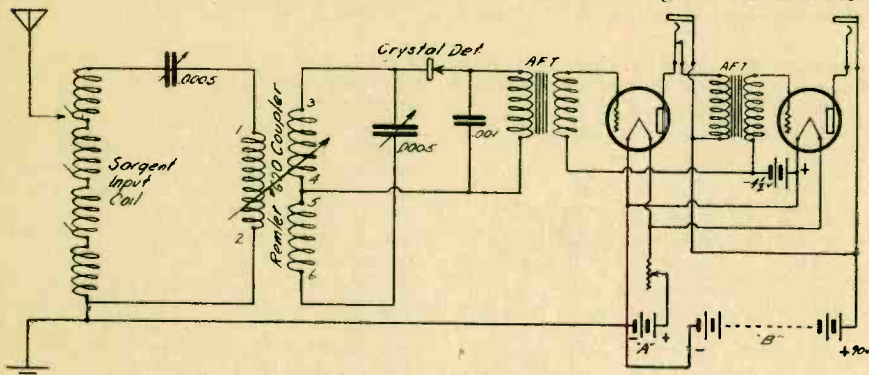

Fig. 4. Adding Two Audio Stages to Sargent Crystal Set.

add a two stage audio frequency amplifier. Would you kindly publish this circuit, telling me if the outfit would supply loud speaker volume on local stations.—J. E. S., Los Angeles, Calif.

The circuit you wish is shown in Fig. 4. This receiver should give excellent volume and quality from local stations, with the average loud speaker.

Please publish the circuit of the Silver 1926 Model Receiver, with a description of the coils and other details.—R. C. B., Elkhart, Ind., D. M., San Leandro, Calif.

The circuit of the Silver 1926 is shown in Fig. 5. The inductances used in this set vary in size, depending upon the wavelength range, but for 200 to 550 meters, the following dimensions are given: Using standard ribbed forms, 2 1/2 in. wide, and 4 in. long, the r. f. transformers consist of 18 turn primary and 84 turn secondary, wound with No. 26 d. s. c. wire. The primary is wound just over the lower end of the secondary, at the filament end. The antenna coil is similar to the r. f. transformer, except that it

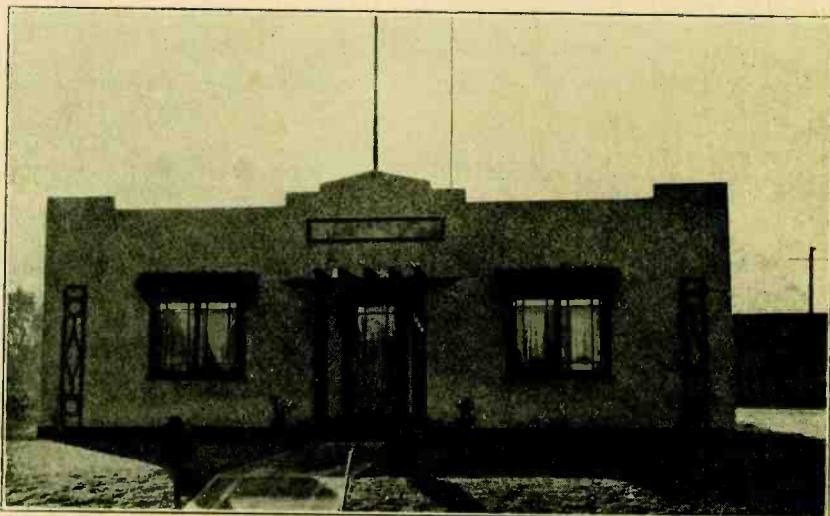

Radio Club House Opened January 16th at Modesto, Calif., With a Hamfest Attended by 150 Amateurs. The First \$700 of Its \$2,000 Cost Was Raised by Selling "Hot Dogs" at The County Fair.

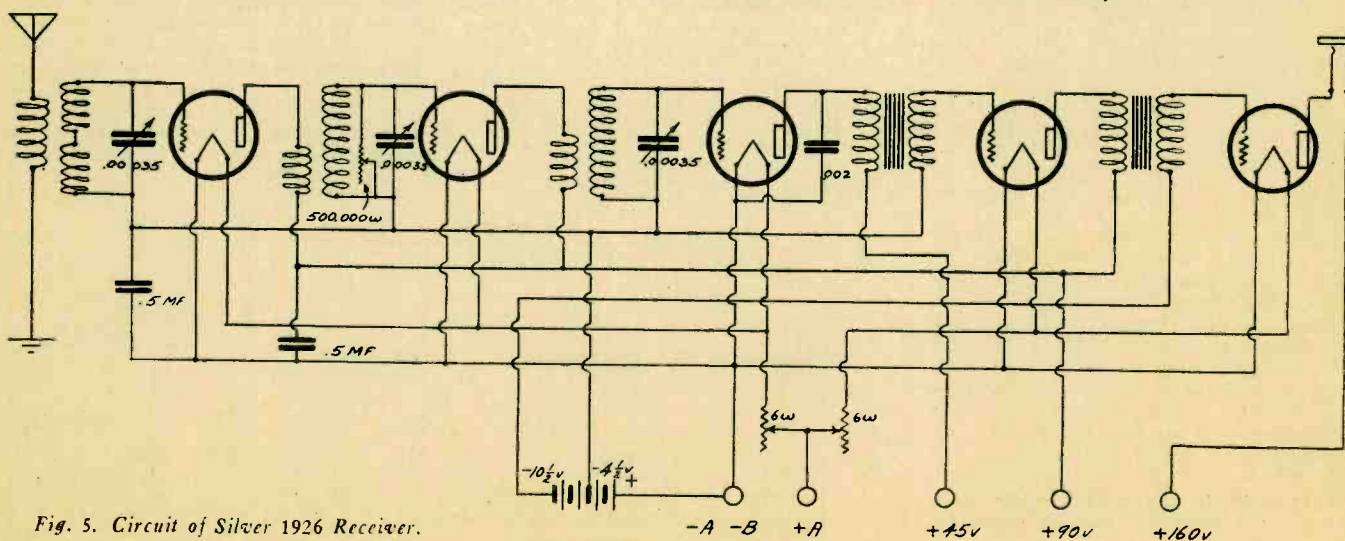

Fig. 5. Circuit of Silver 1926 Receiver.

With the Amateur Operators

USING THE RIGHT TRANSMITTING ANTENNA

By FRANK C. JONES, 6AJF

THE OBJECT of the following discussion is to present some of the advantages and disadvantages of various types of short-wave antennas. If proper care is used, any of them will work with any good oscillator system, but the main idea is to put up an antenna system which is best adapted to the neighborhood with respect to space and nearby objects.

Because one type of antenna works very efficiently and wonderful "dx" is obtained at one location is no reason why it should be used universally anymore than to use one type of counterpoise. Very often the counterpoise, in the usual sense of the word probably cuts down on the efficiency of the antenna system and should be eliminated especially on wavelengths below 100 meters. Again this will depend on the surrounding objects such as buildings and trees and the nearness of them to the proposed antenna system.

Perhaps the most common type used on the short waves is the semi-vertical aerial with some kind of a counterpoise spread out under it. The aerial generally consists of a small cage, a single wire or a combination of the two, which should be best. Using a fairly heavy single wire, with an expanding cage up near the top should be quite efficient since the center of capacity is quite high and corona losses should be a minimum even on considerable power input. A good star-shaped arrangement of wires beneath the aerial should, and does, work very efficiently as a counterpoise. One or two wires in the counterpoise will work quite well and so some such arrangement should be used in the majority of cases where the space for the aerial system is sufficiently great. Another factor generally overlooked is the immense amount of guy wire spreading out around the aerial of this type and supporting the mast (and absorbing considerable power generally as each insulator acts as a small condenser). About the only way to help this matter is to cut the guy wires up into short lengths of 5 or 10 ft. and use long insulators between the lengths.

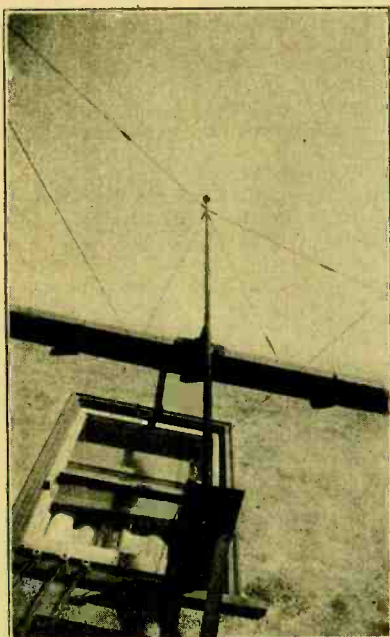

Brass Mast Aerial at 6AJF.

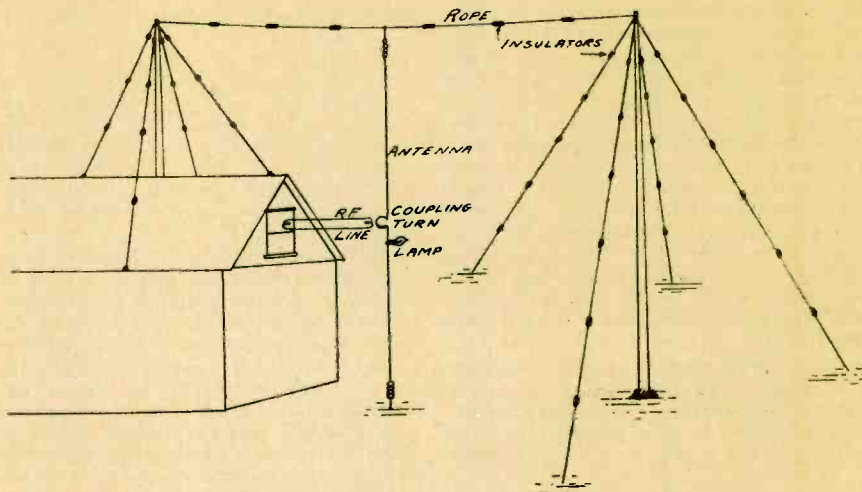

Fig. 1. Vertical Antenna, Using Transmission Line.

Very often the system will work better using a ground instead of the counterpoise, though the antenna current may be much less using the ground. The only way is to actually try it, making sure that a good ground is used by putting metal sheets down into damp ground. This increases the effective height of the antenna system and so compensates for the increased resistance and lower antenna current. When operating near the fundamental, the resistance is quite high anyway and adding a few ohms in a ground connection doesn't anywhere near overcome the increase of effective height. When the location is at sea level or near a large body of water, a ground will probably be more efficient five times out of six. In order to get away from the losses due to the mast and guy wires in the above type of antenna, a brass mast aerial with waxed ropes for guying was used successfully at 6AJF. The picture gives an idea of the construction of the mast aerial and of the counterpoise. Since a mast is needed it was decided to use the mast as the aerial and insulate the base of it with a large stand-off insulator. The base is at practically zero potential if the nodal point occurs near there, so one insulator is more than sufficient. As shown, the base was on a level with the lead-in window and a two-wire counterpoise in the shape of a V used on the same level. The guy ropes were boiled in a mixture of paraffin and beeswax until all of the moisture was boiled out. Glass insulators were used at short intervals in the ropes and they were attached about four feet from the top of the mast so as not to be too near the point of maximum voltage.

The mast itself was made up at a cost of about \$7.00 from three telescoping sections of thin brass tubing and a copper ball for the top to eliminate corona losses. The sections were telescoped about 18 inches and soldered with a blow torch. After the ball was soldered on, the total length was about 30 feet since the system was designed for 40 meters. The two counterpoise wires were somewhat over 20 ft. long, of enameled wire to eliminate corrosion and for the same reason the mast was lacquered. By knowing the length of the mast up to the guy ropes and the horizontal distance from the base of the mast to the points to which the guys were attached, the length of the guy ropes could be calculated from $L = \sqrt{v^2 + h^2}$ where L = guy rope length, v = vertical height and h = horizontal distance. This makes it possible to attach at least two or three of the guy ropes and so one person can raise the mast and

tie it into position (when the wind isn't blowing too hard.)

In the vertical aerial and vertical counterpoise system, the counterpoise is quite effective in radiating energy and so is probably more efficient than the previous systems mentioned using horizontal counterpoises. As ordinarily used, for twenty meters and less, a one or two-turn coupling coil is used at the center of a wire or cage and energy fed into the system by coupling the oscillator directly or through a radio frequency transmission line (energy coupling) or sometimes by capacitive coupling. Since this system is generally used on 20 meters or lower, it is possible that an inclined or even horizontal aerial would work fine and does according to reports. Most of the energy on such short waves reaches the distant stations by some phenomena of refraction and so starting the waves up at an angle, if such a thing is possible, should give more refracted or reflected energy at the receiving station. This type of aerial can be used advantageously by a person having the transmitter on the second or third floor of a building and where the vertical counterpoise wire would not be too close to buildings. The scheme is shown in Fig. 1 in this case using a r.f. transmission line for coupling and a small flashlight lamp for indicating resonance. About the easiest way of inserting the lamp is to use a regular porcelain flashlight-lamp socket connected in series with the aerial and shunted by two or three inches of wire in a partial turn.

The next type of antenna does not use an antenna or ground in the usual sense and can be used on all of the amateur bands from 80 on down to 5 meters making it very convenient for the experimenter. This system was used successfully for a year at 6AJF in

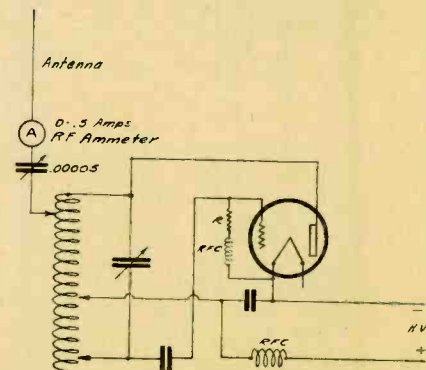

Fig. 2. Method of Coupling Oscillator to Antenna.

a rather poor location in which the usual systems were inefficient due to nearby buildings and trees. The antenna consisted of a long single wire of such length as to be some multiple of half-wavelengths of the wave to be used and is coupled to the oscillator through a very small variable condenser as shown in Fig. 2. The actual length of the single wire, if vertical, will be very near the wavelength used if measured in meters. A full wave is used as is advisable for the 40 meter band, but generally the wire will be shorter and has to be trimmed to get it on the wavelength desired. When operating on the other wave bands, the resonant wave will be approximately half or double and so forth. By designing it for a full wave on 40 meters, 80 meters will be a half wave which is the longest "fundamental" that can be used and 20 meters will be two waves.

Sometimes grounding the oscillator filament will increase the radiation though it seems to make little difference on the shorter waves. This was checked by inserting r.f. chokes in the filament leads as well as all high voltage

leads so as to eliminate all possible grounds in the set. The coupling condenser should be of very low loss construction such as two parallel plates separated about 1 in. and about 2 in. square with plate glass or hard rubber supports. It should be semi-variable as it determines the power input to the antenna. Resonance is obtained by the use of a small r.f. ammeter placed a few feet above the coupling condenser as it indicates a maximum whenever the oscillator is tuned to one of the half-waves of the antenna. The actual reading of this meter means nothing since it isn't located at one of the nodal points of the wire but it serves very well as a resonance indicator.

The above system can of course be used with any oscillator, the Hartley circuit being shown as it is quite simple and efficient. This antenna besides being very convenient for quick shifts to any of the amateur wave bands, can be put up in any neighborhood since it looks, ordinarily, very much like a BCL aerial. The one used for quite a long time at 6AJF was an inverted L type with about 60 feet of it nearly horizontal. Where there is no room for a counterpoise or where it is down between tall buildings and trees, it is advisable to use this type of antenna as it can generally be made to clear nearby objects easily and no counterpoise net work is used. For five meters, it is very efficient for both receiving and transmitting using a vertical wire almost exactly one or two waves in length. This system was used on three meters at 6XM on field tests with beam transmission.

The next system which can be used is shown in Fig. 3 and is convenient to feed the antenna out clear of the house. The free part is made a half wave in length and the parallel parts a quarter wave long. The two parallel wires, spaced from one to six inches, neutralize each other as far as radiation is concerned while the free end acts as a simple antenna with a half wave impressed. This system keeps the high voltage parts of the antenna system clear of the apparatus and building and from a few preliminary tests on short waves, seems to work quite efficiently. The main difficulty is in arranging the parallel wire part so as to keep down losses and still have a rigid construction to maintain a steady wave. Pyrex glass insulators were used to hold the two wires apart on an experimental 20 meter antenna which seemed to work quite well.

In conclusion it may be said that the most efficient antenna system is the type which is best suited for the surroundings in which it is to be used. No doubt some types are inherently a little better under ideal conditions but very few of us have those conditions so the best plan is to use a little good common sense when designing a transmitting antenna.

HARMONIC CALIBRATION

By C. H. CAMPBELL, 11V.

WHEN an accurate standard is available, the usual method of calibrating a wavemeter for shorter wavelengths is to make several smaller inductances for the meter and calibrate them by harmonics.

Several ways of doing this have been suggested but the writer believes that the method presented here is the least liable to an error of any of them.

First disconnect the antenna and counterpoise from the transmitter and reduce the plate voltage; then carefully tune the transmitter to the lowest wave to which the standard is calibrated. Adjust the receiving set to twice this wavelength and check with the wavemeter to make sure it is really twice the wave. If the transmitter has been tuned to 100 meters, it will be operating on the second harmonic of 200 meters. The oscillator emits many other harmonics and it is important to know which one the re-

ceiver is tuned to or the results will be inaccurate. Take a reading from the transmitter using the wavemeter with one of the new inductances, for the first point of calibration. Lower the wavelength of the transmitter two or three meters and follow the harmonic down by readjusting the receiver to a lower wave and measure its wavelength.

The transmitter is tuned to half this value so a reading is taken from the transmitter, using the new inductance, for the second point of the calibration curve. Do this all the way down to the lower limit of the coil—the more readings taken, the smaller the chance for an error. Plot the calibration curve on graph paper and then this can be used as a standard to calibrate another coil for a lower range.

Recently, the writer accurately calibrated a wavemeter from 100 down to 15 meters, using this method.

A. R. R. L. BANQUET AT LOS ANGELES

By WALLACE S. WIGGINS, 6CHZ

About sixty "hams" of the Southern Section, Pacific Division, attended a banquet and "hamfest" in Los Angeles, on January 7th. D. B. McGown, Radio Inspector, 6th District, and A. H. Babcock, Director, Pacific Division, were guests of honor.

L. Elden Smith, 6BUR, was unanimously elected as the new Section Manager. Elmer Burgman, 6CTO, was A. S. M., but has also resigned and is going into the hardware business. He was another good man, and we are sorry to see him go.

Mr. Babcock made an excellent speech, stating that the development of short wave transmission in Army and Navy activities, was due to the efforts of the members of the League. He announced that the "central" station at Hartford was to be built soon, and that it was to be the gift of Mr. Foster of Hawaii.

Mr. McGown thanked the gang for past cooperation with the Department of Commerce, and extended the offer of future cooperation. He also gave us some surprising data on new developments, such as an oscillating circuit of .2 millimeter wavelength and of operating conditions at some of the large short wave stations. He said that WIZ puts 22 kilowatts into the antenna! Sounds like the old spark days.

Several "stunts" provided entertainment for the evening. The first of these was put on by some of the local boys, and was in charge of J. H. Deeney, Jr., 6AFG, of Hollywood. It was a cracker-eating contest. The first to eat five crackers and whistle his call won the prize of animal crackers. This prize was carried off by Myron Hexter, 6CNL, after a close tie with "Pete" Kridler, 6CSS. Myron had the biggest mouth. The second offering for the evening was a Charleston exhibition by "Professor" Garland Swain, 6CQA, with "Wally" Wiggins, 6CHZ, at the piano. Both boys are members of the Whittier gang. "Swainy" struts a "mean toddle" and received a big hand. Following this, the entire Whittier delegation rendered a couple of vocal selections which were graciously endured by those present.

The Los Angeles bunch had a fine "stunt" with E. O. Knoch, 6BIJX, and Robt. Edgar, 6CVE and ex-Australian 5AP in charge. This was a code contest, and differed from most contests of this kind in that the contestant sent only the complicated (?) and difficult (?) call, CQ, three times. Owing to the fact that he luckily remembered to make the "attention" signal, "Wally" Wiggins, 6CHZ, was given the prize by the judges. Mr. Babcock, 6ZD; Mr. McGown, R. I.; and Mr. Smith, 6BUR, were the judges. The prize was a pair of dials,

(Continued on Page 52)

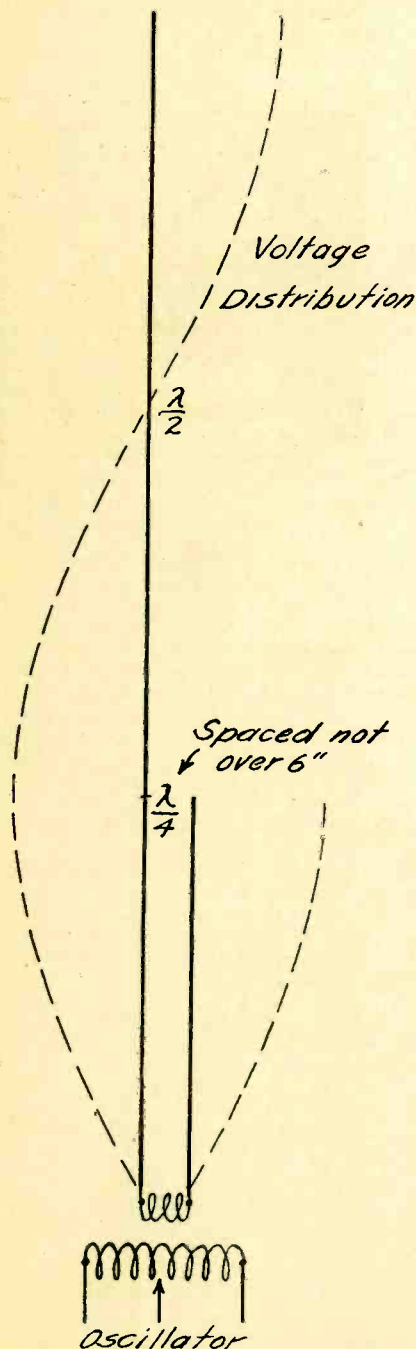

Fig. 3. Parallel Wire Antenna System Vertical Mast-Antenna.

THE 50-WATT TRANSMITTER AT 6 XAO

By G. M. BEST

IN order to provide apparatus for a series of short wave experiments in connection with RADIO's calibration laboratory, a 50 watt short wave transmitter was recently constructed and placed in satisfactory operation at 6XAO, at Piedmont, California. This transmitter is similar in design and theory to the equipment installed on the yacht Kaimiloa, KFUH, described by Ralph M. Heintz in November 1925 QST, and the new transmitter at 6XAD, described in September 1925 RADIO. It was built in the laboratory of Heintz & Kohlmoos, and employs the "oft discussed" tuned grid and plate circuit, with two W. E. 50 watt tubes operating on opposite halves of the 60 cycle plate supply. Believing that the constructional details of such a transmitter would be of general interest, a set of diagrams and pictures have been prepared, so that the transmitter may be duplicated by those who like its looks.

In Fig. 1 is shown a general view of the completed transmitter, installed and ready for operation. At the left, on the wall, is

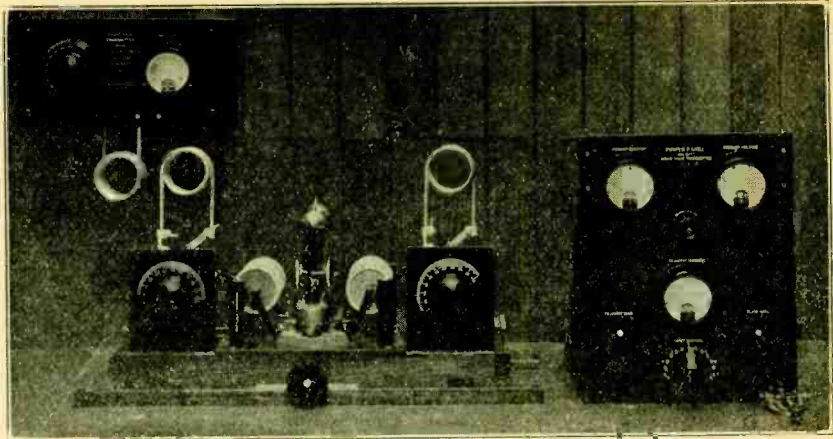

Fig. 1. Completed Transmitter.

rent is regulated by a primary rheostat, mounted at the upper center of the power panel. The plate voltage is supplied by a Westinghouse pole transformer having two 1100 volt secondaries. The plate voltage adjustment is obtained by shunting the primary

As the schematic diagram may be confusing, in understanding the theory of the oscillator circuit, Fig. 4 will show the circuit in simplified form. L_1 and L_2 are the plate and grid tuning coils, respectively, and C_1 and C_2 the variable tuning condensers.

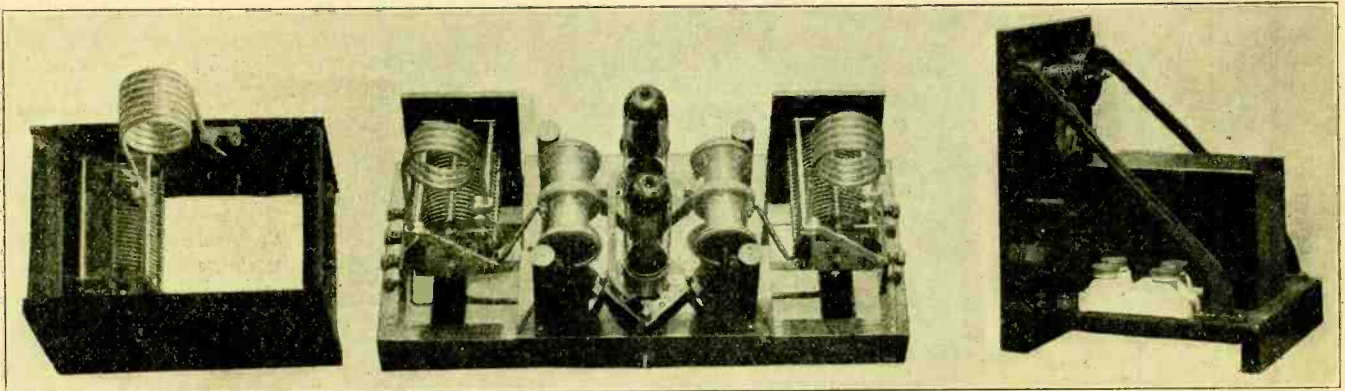

Fig. 2. Details of Transmitter, Showing Individual Panels.

the antenna panel, in the center is the transmitter proper, and at the right is the power panel. The antenna tuning equipment is fastened rigidly to the wall, and coupling between the antenna system and the oscillator circuit is obtained by mounting the oscillator on a wooden truck or bed, supported on tracks, and arranged so that it can be moved by a rack and pinion mechanism through a distance of 6 in. or more.

Fig. 2 shows the individual panels, and enables a clearer understanding of the construction of the oscillator. At the left of the oscillator panel is the plate inductance, tuning condenser, r. f. chokes and fixed condensers. In the center are the two 50 watt tubes, and at the right are the grid fixed condensers, r. f. chokes, and grid tuned circuit. Concealed beneath the tube shelf are two .002 mfd. by-pass condensers across the filament circuit. The power panel, a front view of which is shown in Fig. 1 and a side view in Fig. 2, contains the necessary meters for the power supply, filament and plate switches, filament rheostat, auto-transformer for varying the plate voltage, and a standard plug fuse block. The antenna panel contains a .00035 mfd. variable air condenser, inductance coil with mounting, and the antenna ammeter.

The schematic wiring diagram of the complete outfit is shown in Fig. 3. The apparatus contained within the dotted lines is mounted on the power panel, except the two .002 mfd. bypass condensers, which are part of the oscillator equipment. Filament voltage is supplied by a filament lighting transformer of standard size for 50 watt tubes, with 10 volt secondary. The filament cur-

with an auto transformer having a number of taps, and by which the voltage across the primary may be regulated from 50 to 125 volts, with 125 volt supply. An a. c. voltmeter and ammeter in the primary circuit permit the figuring of the input watts without the expense of a wattmeter.

C_3 and C_4 are the plate and grid feed condensers, and the inter-electrode capacities are represented by C_5 , C_6 and C_7 . With the inductive coupling fixed, L_1-C_1 is coupled as loosely to the grid circuit L_2-C_2 as possible, so that coupling condenser C_3 is only slightly greater than the plate-filament capacity of

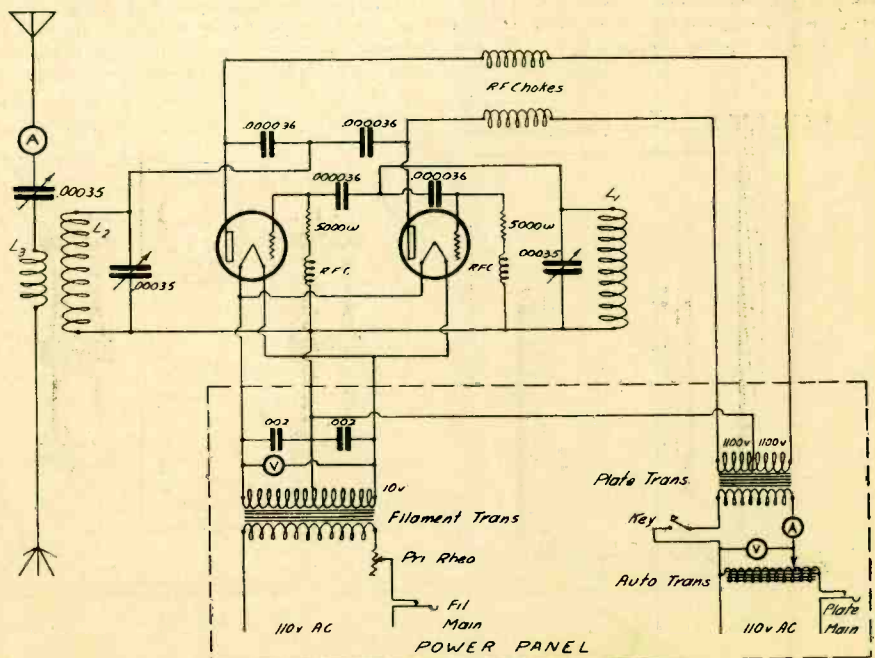

Fig. 3. Schematic Wiring Diagram.

the tube, or .000036 mfd. This condenser functions not only as a plate blocking condenser, but as a grid coupling condenser, for the grid circuit receives its energy from L_1-C_1 through three capacities in series C_2 , C_3 and C_4 . If C_3 and C_4 are small, the possible effect of L_2 on L_1 is slight and the effect of L_1-C_1 on L_2-C_2 is limited by the weak capacity coupling through C_2-C_3 and

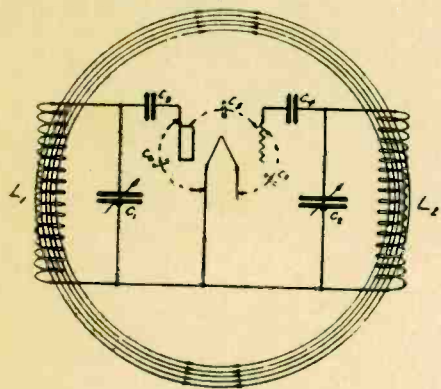

Fig. 4. Theory of Oscillatory Circuit.

- LIST OF PARTS**
- 3 .00035 mfd. air condensers—National.
 - 2 UC-1846 .000036-.000036 mfd. Fixed Condensers.
 - 4 R. F. chokes (See Text).
 - 2 Vacuum tube sockets—50 watt size.
 - 1 Thermocouple ammeter—0.2 amps.—Jewell, Weston.
 - 1 A. C. Voltmeter 0-150 v.—Jewell, Weston.
 - 1 A. C. Voltmeter 0-15 v.—Jewell, Weston.
 - 1 A. C. Ammeter 0-10 a.—Jewell, Weston.
 - 1 Filament control rheostat—Primary type.
 - 1 Auto transformer—Westinghouse Sign lighting type or Helntz & Kohlmoos.
 - 1 7 tap switch for auto-transformer.
 - 2 push button switches for primary power circuits.
 - 2 .002 mfd. mica condensers.
 - 2 5000 ohm Ward Leonard Resistors.
 - 1 Set inductance coils (See Text).
 - Paucels, Baseboards, per text.

will produce oscillations of marked steadiness, and is quite easy to tune.

A list of parts actually used in the set is given at the head of this column, and will serve as a guide in collecting the necessary

no panel template is shown here. The antenna condenser should be mounted to the left, and the radiation ammeter to the right, the latter ordinarily being of the 0-2 ampere size. The clips for mounting the inductances are of special construction, one being fastened to the back of the panel and the others to one of the support rods of the antenna condenser. All inductance coils are wound with 1/4 in. copper tubing heavily silver plated, and fitted on the ends with 3/8 in. solid copper tips. These tips fit into bushings which have a setscrew for tightening, so that a positive contact is assured. A sliding fitting on the condenser support rod enables inductances of different sizes to fit in the same position on the antenna panel.

The power panel is 12 x 15 x 1/2 in., of bakelite or formica, with baseboard 12 x 12 in. of 1/2 in. hardwood. Two metal brackets serve as support for the top of the panel. At the top of the panel are the primary ammeter and voltmeter, below is the filament rheostat, and filament voltmeter, and at the bottom are the filament and plate switches, and the tap switch connected to the auto-transformer. As will be seen in Fig. 2, the latter takes up most of the rooms on the baseboard, the wiring being con-

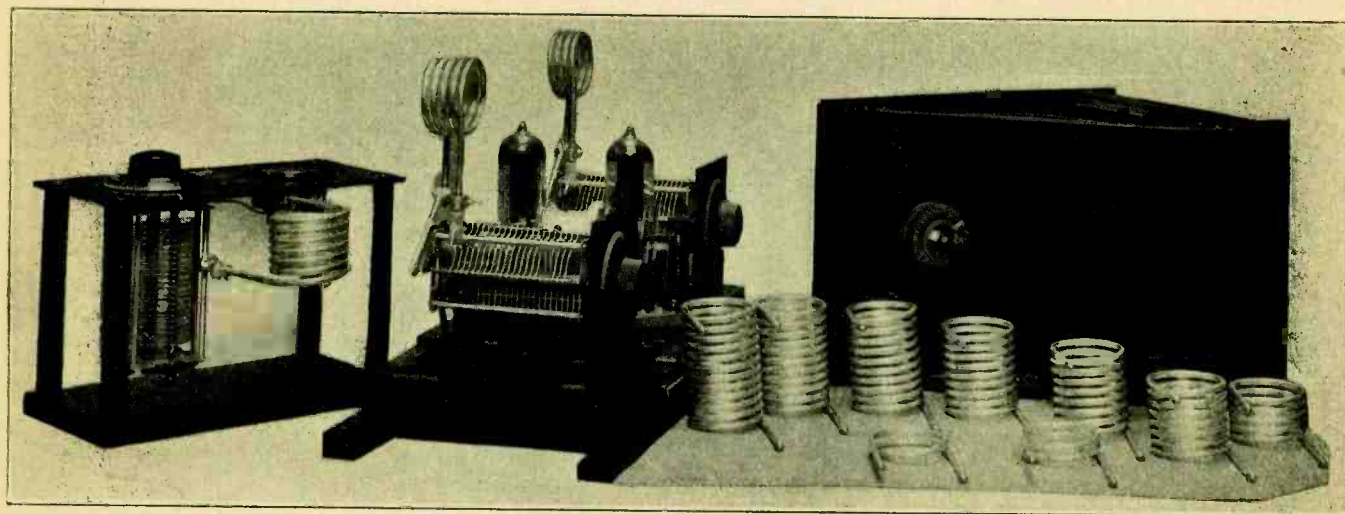

Fig. 5. Side View, Showing Set of Coils.

C_5 . The series capacities C_2 and C_3 are parasitic capacities in parallel with C_1 but are so small that should they be changed, the effect on the constancy of the L_1-C_1 frequency would be slight. The same is true of the two series capacities C_4 and C_7 and their effect on L_2-C_2 . Hence the transmitter

material. The antenna panel is made of bakelite or formica, and is 6 1/2 x 12 1/4 x 1/4 in. It is supported at the four corners by 1 in. round wooden rods, 8 in. long, fastened to a baseboard 6 1/2 x 12 1/2 x 1 in. of hardwood. As drilling instructions are given with the National transmitting condensers,

sealed underneath the baseboard for the sake of appearance.

The oscillator is mounted on a wooden truck, the details of which are given in Figs. 6 and 7. The frame is made of 1/2 in. hardwood, and is set on a track of the same material, so that the frame may be moved

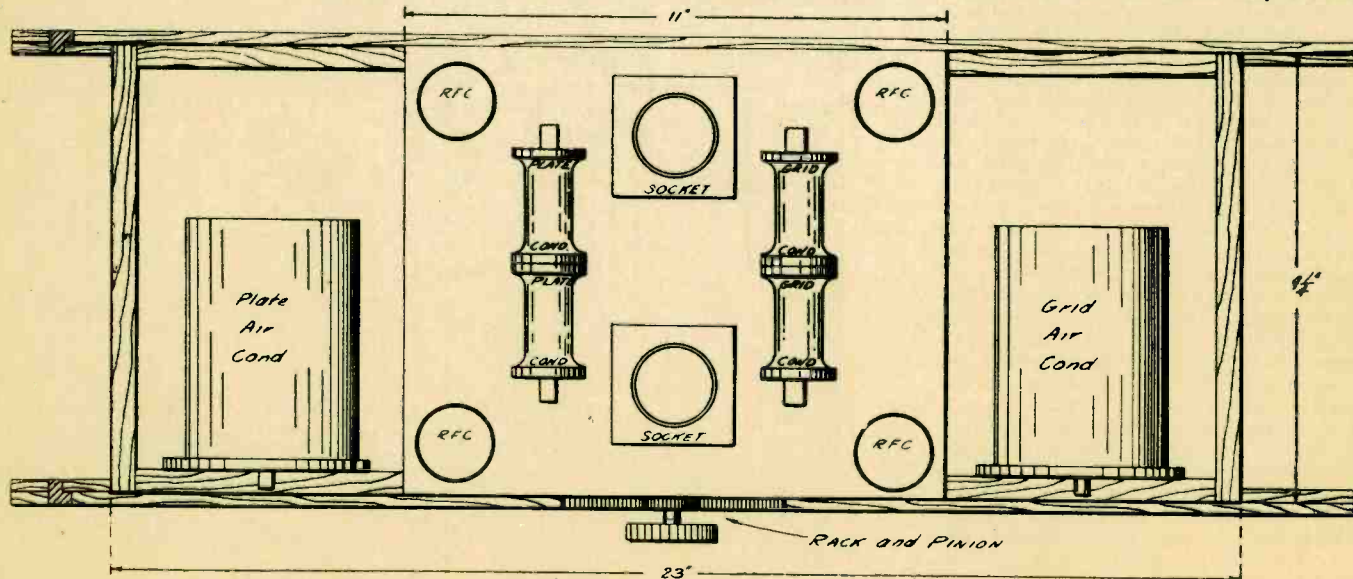

Fig. 6. Plan of Oscillator Frame.

back and forth over a range of 8 in. or more. by means of the rack and pinion, which may be purchased at practically any machinery supply house. The two variable condensers are mounted on individual panels 5 x 7 x 1/4 in., a 1 in. lap being made on the wooden framework so that the panels may be held vertical. The tube sockets,

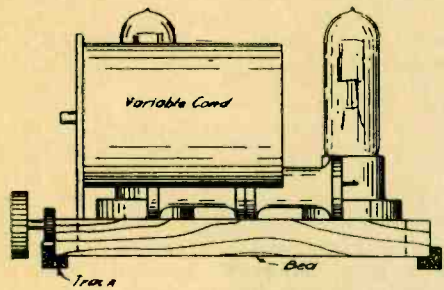

Fig. 7. End View of Oscillator.

fixed condensers, grid leaks and chokes are all mounted on a bakelite shelf 9 1/4 x 11 x 1/4 in. as shown in the diagram. The r. f. chokes are wound on 7/8 in. wooden rods 3 1/2 in. long and consist of 175 turns of No. 28 enameled wire. The fixed grid and plate condensers are UC-1846 transmitting condensers, each condenser consisting of a pair of .000036 mfd. condensers in series, with the mid-tap at the metal case. The condensers are supported by the copper strip leads to the tube socket terminals, the leads being heavy enough so as to be free from vibration. The chokes are mounted on the panel with woodscrews passed through from the under side. The inductance coils are all 2 3/4 in. diameter, of 1/4 in. copper tubing, with 4 in. stems. The stems are tipped with 3/8 in. copper sleeves made from 3/8 in. rod. A total of 12 inductances are required to cover all waves from 10 to 80 meters, the coils have the following number of turns: 1-12T, 1-11T, 1-10T, 1-9T, 1-8T, 1-6T, 2-5T, 1-4T, 1-3T, 2-2T.

Wiring of the filament circuit, plate supply and other low frequency circuits is done with No. 12 enameled wire. The high frequency leads are 1/4 in. copper tubing or heavy copper strip, depending upon the position of the apparatus. Where the leads support the apparatus, copper strip is used. Keying is accomplished in the primary circuit, on the line side of the auto-transformer. Contrary to the expressed opinion of many observers, this method of keying does not produce a wobbly note, or one having a pronounced chirp, nor does it emit key clicks.

The tuning of the transmitter is obtained by selecting inductance coils of the proper size for the wave band desired, mounting them in their places on the grid, plate and antenna panels, and adjusting the grid tuning condenser to about mid scale. The plate condenser is then moved slowly back and forth until the grid and plate circuits are in resonance, as will be attested by a rise in the primary current as indicated by the primary ammeter on the power panel. If the antenna resonant frequency is anywhere near the oscillator frequency, the antenna ammeter will show a deflection, and the antenna series condenser, together with the coupling between the oscillator and the antenna coil should be varied until maximum radiation is obtained. Having once obtained a setting for a particular wavelength and the nature of the adjustments ascertained, the adjusting of the set to other waves is simple, and can best be learned by actual experience.

With the particular transmitter shown, a long, single wire, vertical antenna was used, and operated on various harmonics instead of designing the antenna for a particular wave. This was found to be the best method since it was desired to transmit on any wave between 10 and 80 meters.

PARALLEL WIRE SHORT-WAVE OSCILLATORS

By FRANK C. JONES, 6AJF

EXPERIMENTS at 6XM and 6AJF on waves below five meters, using vacuum tube oscillators in more or less standard circuits, were conducted to find out the characteristics of such circuits on the very short waves.

An oscillator which worked quite nicely down to about 1.2 meters, using a standard five watt vacuum tube in the circuit shown

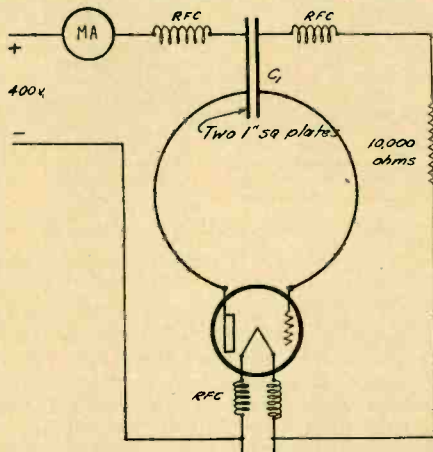

Fig. 1. Fundamental Oscillator Circuit.

in Fig. 1, was constructed. By using better designed radio frequency choke coils, probably a smaller condenser could have been used and the oscillator would have worked down to at least 1.0 meters. A hard rubber strip was used as a support for the condenser and the r. f. chokes and the inductance were simply the plate and grid leads from the five watt tube extended about 1/2 in. and soldered to the two plates of the condenser, as shown in the picture. The chokes in the filament leads consisted of a basket weave coil of about 20 turns. Later more efficient coils were developed using either space winding or basket weave and using less in number of turns. The method of testing the radio frequency chokes was to try different types in an oscillator plate circuit and to operate the oscillator at about the wavelength at which the coils were to be used, then by lowering the plate voltage the most efficient coil was found for each wavelength used. With the less efficient coils a higher plate voltage was required to main-

tain oscillations. It was found that a minimum in which the distributed capacity was by far the best, such as a basket weave or space winding with only dielectric in the core of the coil.

The oscillator circuit shown in Fig. 1 is a fundamental oscillator circuit which can be derived from any of the standard circuits such as the Hartley or Colpitts. The method gives the shortest leads of any possible in which a closed LC circuit is used and for maximum efficiency the grid and plate leads of the tube should come out more directly from the elements than is the case of the small sized transmitter tubes available on the market. These short wavelengths or high frequencies are detrimental to the life of the tubes due to dielectric strain in the glass stem within the tube, this acting as the dielectric of a condenser of which the leads are the plates of the condenser. The glass generally becomes hot enough to actually conduct and so forms a short-circuit between the leads in this stem.

The next idea worked out was to use a master oscillator system oscillating on 2 or 3 meters and using one of the harmonics such as the 3rd to energize the grid of the amplifier tube. Naturally, difficulties presented themselves in getting the harmonic desired and cutting out the fundamental or main wave and all of the other harmonics as well as to produce a strong harmonic. The first experiments were made using two five watt tubes and overloading the oscillator so that fairly strong harmonics would be generated. Various systems were worked on in order to filter out all but the desired frequency which in most of the experiments corresponded to a 3/4 meter or 75 centimeter wavelength. The parallel wire system as shown in the picture of the apparatus layout seemed to work about the best and would seem to offer a large field for experimentation.

Parallel wire systems have been in use for wavelength measurements but very little work has been done using them as oscillator circuits, and as resonant circuits to emphasize a certain desired frequency. Experiments were first carried on using two straight pieces of No. 14 bus wire connected to the grid and plate of a five watt tube, the base of which had been previously removed by heating over a gas flame. The prongs should be heated first and the solder flipped out, after which the base can be heated over a gas burner, rotating the tube and then when the sealing compound softens, the base slips off readily. The two wires were tied to small insulators so these wires

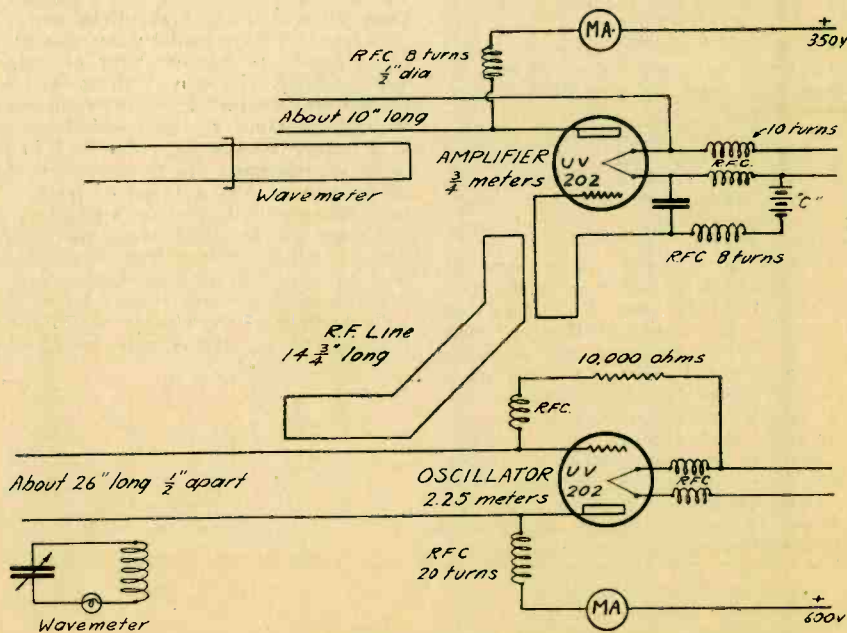
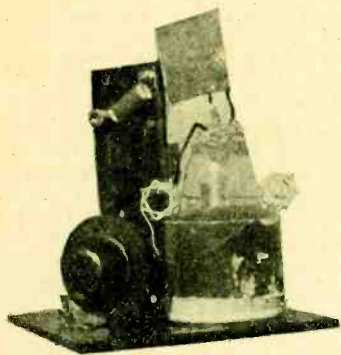

Fig. 2. Master Oscillator Circuit for 75 C. M. Work

formed a parallel wire system with about $\frac{1}{2}$ in. spacing, the length being varied by means of a pair of wire cutters. The oscillator circuit is shown in Fig. 2 and looks new but really isn't, it being nearly the same as that shown in Fig. 1 in effect. The inductance and capacitance of the two parallel wires gives the LC circuit and as such has proven to be a very efficient oscillator for wavelengths below five meters. The length of wire determines the wavelength of the oscillator, the spacing being varied merely to give a most efficient balance of inductance and capacitance. As the wires are brought closer together, the capacity increases but the inductance decreases, so very little effect is produced on the wavelength of the oscillator within limits.



Master Oscillator for $2\frac{1}{4}$ Meters.

Power can be taken from such an oscillator by using a radio frequency transmission line such as used in "Energy coupling" and running a few inches of the line along near the parallel wires of the oscillator. This r. f. line needs only the ends shorted so as to give the effect of a one turn coupling coil. Care must be taken in watching the line to see that it isn't some multiple of half wavelengths of the oscillator since then it would absorb considerable power itself, similar to a parallel wire measuring system. By making the line either a half or a full wave in actual length of the wavelength desired, that particular frequency will be emphasized. In one case the line was made about 37.5 centimeters long corresponding to a half wave (75 cm. sending set) and using the third harmonic of a 2.25 meter oscillator. This made the line six wavelengths long with regard to the main wave of the oscillator, 2.25 meters, but makes it a half wave for the third harmonic which would then be emphasized and fed into the amplifier tuned to 75 centimeters. In this way it was hoped that the 75 cm. wave would be the main or strongest wave fed into the amplifier which had the plate circuit tuned to approximately 75 cm. and more or less the same with grid circuit. Theoretically this should work fine and in actual practice it seemed to work quite well though on such short waves the tuning of the amplifier plate circuit became quite a good guessing contest.

Parallel wires were used to measure the wavelengths of the transmitter, using two parallel No. 14 wires about 26 in. long and spaced about $1\frac{1}{4}$ in. apart. One end was shorted and the oscillator or amplifier coupled to this end since the effect of a small coil of about $\frac{3}{4}$ turn is obtained. A sliding short-circuiting wire was used in locating the next "hump" or point of maximum current. In a parallel wire system the "waves" of voltage and current are in effect stationary because the waves reflected back from the open end are in phase with the impressed waves, the voltage and current differing by 90° . If the shorting link of wire is at the points of zero voltage, a large current can flow across it and still not destroy the effect of standing waves along the wires. However, if the shorting link is

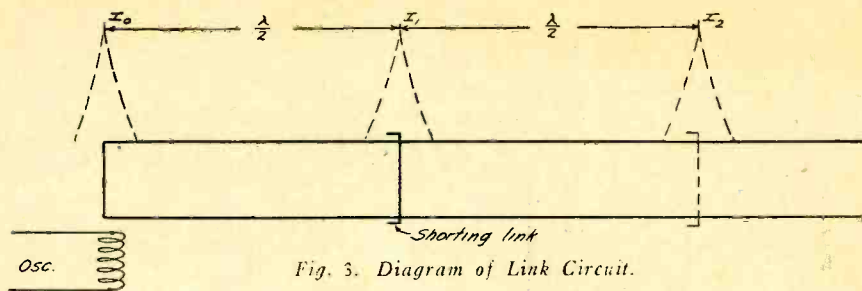

Fig. 3. Diagram of Link Circuit.



Arrangement of Parallel Wire Apparatus.

at any other place the effect is destroyed. In actual practice the resistance and inductance of this link is a finite value, though for longer waves the apparent effect on the accuracy of the measurements is very small. On such short waves, below one meter, the effect of spacing between wires, size of wires and the impedance of this shorting link of wire are quite important where accuracy is desired and some other means used such as the effects of waves in space between a radiating system and a reflector. Since only approximate wavelengths were desired, very rough measurements were made. Since the impedance of the shorting link must be very small even for rough measurements, it was impossible to use some current indicating device such as a flashlight lamp or a thermocouple. While a thermocouple could have been shunted across part of the shorting link of wire, still it would have to be a very small element in order to not affect the field between the wires. Anything besides air between the wires especially along where the voltage is high changes the capacitance between the wires and so the distance between maximum points of current. The method of making the measurements can be seen from Fig. 3, the sliding link being moved along the parallel wires by pushing with a stick of wood such as a ruler. The distance between I_0 and I_1 is a half wavelength of the transmitted wave, or for more accurate results the distance between I_1 and I_2 should be used. The closed end of the parallel wires was coupled quite closely to the oscillator or amplifier and the slide wire moved along until a deflection was obtained in the plate millimeter. A grid millimeter would indicate "resonance" more readily and was used in some later experiments. The wavemeter shown in the picture, has a range of from 1.5 up to 5.0 meters and is made of a small variable condenser, a flashlight lamp and a small turn of wire. A long extension handle is used to vary the condenser setting and the arrangement calibrated from a larger parallel wire system which made use of thermocouples and a sensitive galvanometer. This

wavemeter was very convenient for measuring the main wavelength of the oscillator and the other small parallel wire system for measuring the harmonics and the transmitted wave of the amplifier.

In actual operation the main oscillator was tuned to the desired wave of 2.25 meters using the regular wavemeter (range 1.5 to 5 meters) and then the r.f. line coupled to it and to the grid of the amplifier so that the third harmonic (75 cm.) would be fed to the amplifier. When the "parallel wire" wavemeter was brought up adjacent to the plate circuit of the amplifier and the shorting link moved along, the plate or grid meters in this amplifier change when resonance is obtained. When the parallel wire system is tuned to the same wave as the amplifier, considerable power will be absorbed which causes an increase of plate current in both tubes particularly the amplifier and so offers an easy method of determining the wavelength of the amplifier output.

The output of such a system can be fed into a reflector system by using a radio frequency transmission line and in time of war would make a very secret means of communication if a proper type of detector was used. The reflector could be a simple parabolic cylinder with the wires spaced a few inches apart and about 14 in. long. The aerial should be about the same overall length with a very small turn in the center, about 1 in. diameter, for coupling to the r. f. transmission line. The design of such a reflector is shown in Fig. 4 and has the aerial at the focus of the parabola. The focal length should be a quarter wavelength or $7\frac{3}{8}$ in., so as to obtain reflection. The phase of the oscillations in space will then be such as to reinforce the waves being sent out by the aerial in an outward direction. By placing the wires around the parabola as shown in Fig. 4, the phase of oscillations to the rear is such as to counteract the radiation from other reflector wires in a direction back of the reflector. Since each reflector wire is tuned to the transmitted wave, it

(Continued on Page 63)

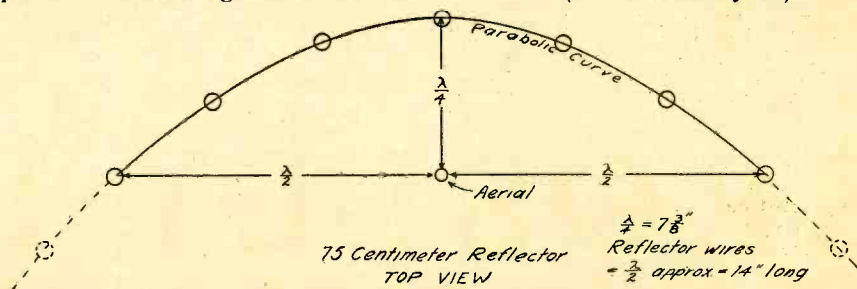

Fig. 4. Diagram of Reflector.

The Newest

Achievements of

POWEL CROSLEY JR.

INDUSTRIALIST—PIONEER RADIO BUILDER—MASTER OF MASS PRODUCTION

Four Entirely New 4- and 5-tube Radio Sets—Also the Crescendon

Never before has Crosley engineering and manufacturing genius been so brilliantly demonstrated as in this group of new Crosley sets.

Here, at prices so low as to be literally revolutionary, are three 5-tube sets and one 4-tube set—entirely new in principle, design, circuit, and appearance—entirely unique in the results they give on distant and local stations—entirely unprecedented in the values they now introduce.

On two of these sets is offered the Crescendon, a new and exclusive Crosley feature—an extra volume control by which average incoming signals can be built up or modified in a manner nothing short of amazing. Introduced on the new 4-29 and 5-38, the Crescendon principle makes its first appearance in the low price field, its use having hitherto been restricted to one set costing several times as much.

Particular emphasis is directed to the new Crosley RFL receiving sets that utilize an entirely new and patented circuit which provides true cascade amplification and closely approaches the theoretical maximum of efficiency per tube. Non-oscillating at any frequency and absolutely non-radiating, the RFL Crosleys are specifically recommended for use in congested areas and for satisfactory performance in the hands of inexperienced operators.

In addition to their truly marvelous selectivity, sensitivity, and purity of tone, these new Crosleys have been given a new order of beauty that cannot help but win the highest admiration.

We do more than urge you to go to the nearest Crosley dealer for a demonstration! We ask you to go prepared for the most startling revelation in radio ever announced in the entire history of the industry—and predict that your expectations will be more than satisfied!

Crosley manufactures radio receiving sets which are licensed under Armstrong U. S. Patent No. 1,113,149, or under patent applications of Radio Frequency Laboratories, Inc.

THE CROSLEY RADIO CORPORATION, CINCINNATI, OHIO

Owning and operating WLW, first remote control super-power broadcasting station in America



The Crosley 4-tube—4-29

in which the Crescendon is equivalent to one or more additional tubes of tuned radio frequency amplification **\$29**



The Crosley 5-tube—5-38

All the volume, selectivity, sensitivity and purity of tone available in the best 5-tube set—plus the Crescendon..... **\$38**



The Crosley 5-tube RFL-60

A set so marvelous in performance that its appearance on the market is bound to create a new standard of **\$60** comparison.....



The Crosley 5-tube RFL-75

For simplicity and speed in tuning, fidelity of tone, and decorative beauty—it stands unchallenged at **\$75** twice the price.....

West of the Rocky Mountains all prices as published are 10% higher

CROSLEY RADIO

BETTER • COSTS LESS

Tell them that you saw it in RADIO



The RADIO BROADCAST

UNIVERSAL

FOUR TUBE RECEIVER

Chosen from Circuits as BEST PRACTICE IN



GENERAL RADIO
Type 277-D Coupling Coil
Price, \$1.50

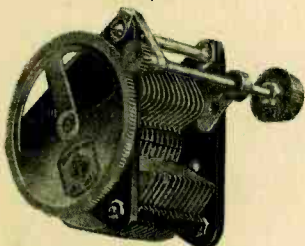

GENERAL RADIO
Type 247-H
Geared Variable Condenser
Price, \$5.00



GENERAL RADIO
Type 368
Micro-Condenser
Price, \$1.25



Panel View of UNIVERSAL

In selecting the Radio Broadcast "UNIVERSAL" our aim has been to single out one particular circuit which from a standpoint of performance, simplicity and economy of construction and operation would meet the most rigid requirements of amateur set-builders under all reasonable receiving conditions.

Every conceivable type of circuit worthy of consideration has been investigated. Comparisons were made under a wide variety of receiving conditions by competitive tryouts with other receivers of creditable performance.

We found that the Radio Broadcast UNIVERSAL out-rivaled the other circuits in all-around achievement.

Build
The

RADIO BROADCAST

UNIVERSAL

FOUR TUBE RECEIVER

Behind the Panels



More than 200

Representing the

RECEIVER DESIGN

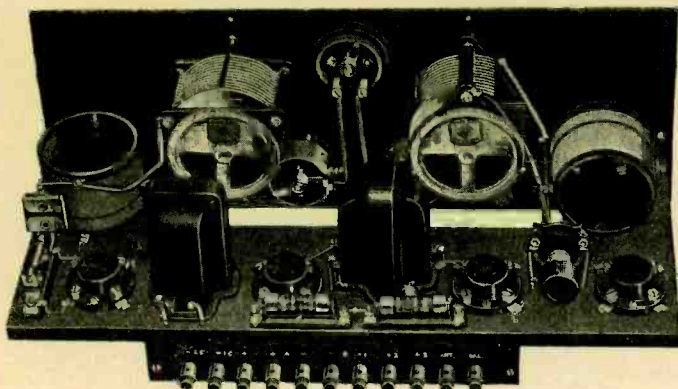

Inside View of UNIVERSAL

While the circuit itself is not new in principle its efficiency can not be doubted—the best proof of this being its performance.

To the set builder who expects real results from his set and wants advance assurance that he will get them we recommend the "UNIVERSAL" as the circuit to build.

We have prepared a booklet which contains all information necessary to the home construction of the UNIVERSAL. These booklets are available FREE to all set-builders who are looking for a reliable circuit built of reliable parts.

Ask your dealer or write for our booklet "Complete Construction Details for the Radio Broadcast Universal Four-Tube Receiver."

GENERAL RADIO CO.

Cambridge 39, Mass.

with

GENERAL RADIO

INSTRUMENTS

of Better Built Sets

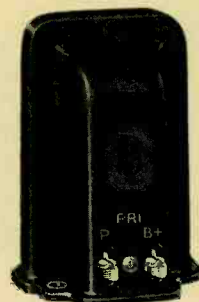

GENERAL RADIO
Type 285
Audio Transformer
Price, \$6.00

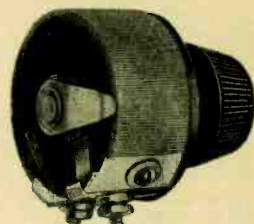

GENERAL RADIO
Type 301
Rheostat
Price, \$1.25



GENERAL RADIO
Type 349
UX Tube Socket
Price, 50c



With Tungar— an overnight charge for a dime!



It can't blow out Radiotrons if left hooked to set while charging.

Does not disturb radioreception in neighborhood.

It is complete—charges 2-4-6 volt "A" or 6-12 volt auto batteries, or 24-96 volt "B" batteries in series.

Especially adaptable to permanent installation in cabinet with switch control.

Five ampere size \$28.00
(East of Rockies)
Two ampere size \$18.00
60 cycles - 110 volts

Merchandise Department
General Electric Company
Bridgeport, Connecticut

Two clips for your battery and a plug for your house current—that's all. And the steady, quiet Tungar charges your batteries overnight.

Just about a dime's worth of current and two minutes of work. So simple!

It's the no-fuss, easy-to-use charger—for all batteries.

Tungar
REG. U.S. PAT. OFF.
BATTERY CHARGER

Tungar—a registered trademark—is found only on the genuine. Look for it on the name plate.

GENERAL ELECTRIC

The Largest Net Paid Circulation

of any radio magazine on the Pacific Coast is being enjoyed by

RADIOCAST WEEKLY

Send for a free sample copy

PACIFIC RADIO PUBLISHING CO.

Pacific Building - - - San Francisco, Calif.

CALLS HEARD



This Department is to be retained and enlarged in RADIO, its size depending upon the number of lists submitted by readers.

By Chas. Lang (CASE), 5102 Delaware Ave., Eagle Rock, Calif.

Alaska: 7de. Australia: 2ae, 2af, 2ax, 2cm, 2rj, 2lo, 2ul, 2yh, 2yg, 2yi, 3ad, 3bd, 3bq, 3ef, 3kb, 3xo, 4an, 5bg, 7jb, 8ab. Brazil: 1a, 1ab. Canada: 1ar, 4gt, 5ba. Chile: 2ld, 9tc. France: 8wag. Great Britain: 2lz, 2sz. Hawaiian Islands: 6aff, 6ajl, 6asr, 6buc, 6cmh, fx-1. Mexico: 1aa, 1b, 1k, 1x, 9a. Philippine Islands: 1cw, 1hr, 1es. Samoa: 6zac. Argentina: af-1, ae-5, cb-8, da-1, da-2, db-2, fb-5. New Zealand: 1af, 1ao, 1ax, 2ac, 2ae, 2ap, 2ax, 2bl, 2xa, 3ad, 3am, 4ac, 4ag, 4al, 4an, 4ar, 4as. Miscellaneous: h-9ad, s-2co, s-sqc, 8tok. Commercial: nrri, numm, npm, npo, nps, nqs, nq-1, nkf, nve, wiz, wir, kel, kol, hu37c. All cards answered. QRK?

By GALL-GCKW, New Zealand

z-2ac, z-4ag, z-1aa, z-4al, z-1ar, z-9ac. Australia: a-2bb, a-3xo, a-3bd, a-xo. Mexico: bx, m-1aa, m-9a. Canadian: c-3oh, c-3ni, c-2fo, c-3xi, c-2bv, c-9ac, c-3dh. Argentina: c-b8. Holland: h-oll. Netherlands: pb3, Spain: e-ar2, e-ar6. Also every state in U. S.: 1so, 1aac, 1xam, 2buy, 3ald.

By GCIX, 317 N. Friends Ave., Whittier, Calif.

Argentina: afl, ba1, (bg8), fb5, fc6, fh4. Australia: (2bb), 2cm, 2rj, 2tm, (2yi), 3ad, 3ak, (3hl), 3jp, 3kb, 3tm, (3yx), 4aj, 4an, 4qh, (5bg). Brazil: 1ab, (1ac), 1ae, 1af, 1ap, 1an, 1ar, 1ia, rgt. Canada: 3xi, 4gt, 5an, 5co. Chile: 2ld, 3il. England: 2kf, 2sz. France: fw. Guam: npn. Hawaii: (6buc), fxi, npm. Japan: 1pp. Miscellaneous: gdvb, ku, nosn, (wyd), wyl, (wva), sdk. Mexico: lb, (lg), lk. New Zealand: (lao), lax, (lfq), 2ac, 2ad, 2xa, 3ad, 3af, 4aa, 4ac, 4ag, 4ak, 4an, (4ar), 4as. Panama: 99x, nba. Samoa: 6zac, npu. South Africa: a3b.

By DAPY, 3337 Oak Park Ave., Berwyn, Ill.

1aa, 1aci, 1ak, 1aof, 1ask, 1awe, 1bbh, 1bsd, 1bz, 1cjr, 1ckp, 1cmg, 1coe, 1db, 1rm, (1ue), 1za, 2aev, 2afv, 2aj, 2akv, (2bm), 2cty, 2ez, (2oj), 3aal, 3apm, 3bnu, 2bwt, (3hu), 3qi, 3tr, 3vl, 4cm, 4it, 4iz, 4je, 4ll, 4lt, 4og, 4rm, (4rz), 4wu, 5aaq, 5abi, (5abz), 5ada, 5ade, 5ahr, 5alz, 5apl, (5apq), 5aqx, 5atx, 5avv, 5ft, 5hn, 5hp, 5pl, 5qh, 5qz, 5ul, 5vv, 5wk, 6akm, 6akt, 6ano, 6bjv, 6bis, 6bvq, 6cmx, 6cof, 6cers, 6erz, 6dag, 6dbl, 6hm, 6kg, 6lr, (6nw), 7afo, 7aib, 7cy, 7dd, 7eo, 7gv, 7jf, 7lu, (7mz), 7nl, 7no, 7oy, (7uq). Canadian: (c-3dh), c-3ni, c-3qs, c-4cc, c-4ea. Miscellaneous: fw, lpz, srd, wir, wiz, wqo. Navy Stations: nfv, nism, nkf, nle, noeg, nsg. England: g-6tm.

By U-2BUY

(5aaq), (5acl), (5agn), 5agp, 5ahp, (5ahr), (5ajj), 5akp, 5aky, (5ask), 5atx, 5auh, 5aut, (5ak), 5ew, 5hy, 5qk, 5rg, (5sd), 5sp, (5yb), 6aak, 6agn, 6arm, 6ann, 6ano, 6apk, 6apw, 6aqp, 6asd, 6ase, 6bas, 6bes, 6bde, 6bek, 6bgc, 6bhr, 6blt, (6bve), 6cae, 6cgw, 6cia, 6cig, 6cii, 6cin, 6cix, (6com), 6cqa, 6ctd, 6cuc, 6daa, 6dag, 6dah, 6daq, 6das, 6dax, 6dbe, 6bq, 6ct, (6fz), 6gg, 6hm, (6ih), 6ml, 6no, 6rw, 6sb, (6sl), (6ts), 6vc, (6vr), 6zq, 7ay, 7dd, 7df, 7ky, 7ho, 7rl, (9cbl), (9ded), (9oo), pse, qsl. England: (2bz), 2cc, 2kf, 2kw, 2nb, 2nm, 2qb, 2sz, 2xy, 5ma, 5qv, 5xy, 6iv, 6lj, 6nf, (6td), 6yu. France: 8bf, 8ca, 8jd, 8lx, 8pm, 8xp, 8yb, 8za, 8yr, 1tz. Holland: pb3. Belgium: 4yz, b2. Spain: ear6, ear9. Finland: 2co. Brazil: lav. Hawaii: 6buc, fxi. Italy: 1as, 1ay, 1bd, 1rm. Panama: 99x. Mexico: 9a. Canada: (1ak), 1dd, 1ei, 2be, 3fu, (3gq), 5hp, 8ar. Cuba: 2jt. Miscellaneous: sgc, (sdk), (ncc), wvy, o6na calling u2mu qra?, nq1, npb, nism, 65 watts input hv. Will appreciate reports on my sigs. 4 more states to go, Nevada, Wyoming, Idaho and N. Dakota; how abt it om, pse QRR 2buy! All crds ansd.

Send for this New Hookup

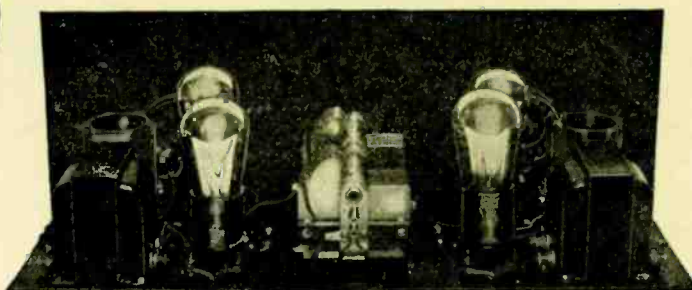

Four Tube Receiver

Here is the outstanding radio receiver development of the season, in which is combined the genius of two of the most successful and distinguished radio engineers, assisted by the engineering and laboratory staffs of seven prominent radio manufacturers. Here is a receiver for the home builder that will represent for several seasons to come a far greater value than any other design available. Send for the book. Read how to obtain the following

Startling New Features

SINGLE CONTROL—But one tuning or station selector control.

SELECTIVITY—In a residential district of New York City, within a few hundred yards of powerful stations, thirty-five stations were heard between 9 and 10 p. m. on the loud-speaker. KFI, in Los Angeles, was heard with ample volume to fill two rooms. Tests in Chicago brought in either coast with ample speaker volume, and indicated that a consistent range of 1,000 to 2,500 miles might be expected.

QUALITY—Two new-type Thordarson power amplifying transformers possessing a substantially flat frequency characteristic over the range of 40 to 6,000 cycles, give a quality of reproduction so perfect that comparison by the best trained human ear with other types of amplifiers will not reveal any superior type.

VOLUME—In all cases the volume will exceed that obtainable from other four-tube receivers, and in practically all cases equal or exceed that obtainable from standard five and six-tube receivers.

UNLIMITED WAVELENGTH RANGE—Through the use of interchangeable coils, the wave-length range is practically unlimited.

WIRING AND ASSEMBLY—All wiring is carried in a special harness. Since each wire is exactly the right length, and has a special color, it is impossible to go wrong in wiring. No soldering is needed unless preferred by the builder. Only a screwdriver and a pair of pliers necessary to assemble this set in less than two hours.

Over-all design, rugged and solid. Adapted to practically any standard cabinet, any standard tube, any battery or eliminator source of supply, outdoor antenna or loop. While the parts are the best that the leading laboratories of the country afford, the set can be built at an extremely low cost. Full description of the receiver will be published in the March issue of Popular Radio.

Get the hand book at your nearest Radio Dealer or clip the coupon and send with 25 cents TO-DAY. Address

The S-C Merchandising
Company
108 S. Wabash Ave.
Chicago



The S-C
Merchandising
Company
108 S. Wabash Avenue · Chicago

Gentlemen: Please find enclosed 25c. for which send me hand book of the new S-C Receiver.

No choicer group of radio products has ever been embodied in a single radio receiver. Not only are these manufacturers nationally known and accepted as the leaders in radio design and construction, but they have developed for the S-C receiver many new features which will create a new standard in reception throughout the radio world.

Represented Manufacturers:

Belden Mfg. Co.
S-C Wiring Harness

Central Radio Laboratories
Centralab Resistance

Polymet Mfg. Corporation
Fixed Condensers, Leak
and Leak Clips

Silver-Marshall, Inc.
Variable Condensers, Coil Sockets,
Coils, Tube Sockets, Vernier Dial,
Mounting Brackets

Thordarson Electric Mfg. Co.
Equiformer Audio
Transformers

Poster & Co.
Drilled and Processed Front Panel
and Drilled Sub-Panel

Yaxley Mfg. Co.
Rheostat, Jacks, Switch

NAME _____

ADDRESS _____

A BABY TRANSMITTER

(Continued from Page 29)

length of the transmitter. This has sometimes been termed transmitting on a harmonic, and has been used very effectively in connection with the "Baby Transmitter."

A coil antenna or loop may be used for transmitting over distances of at least a few miles. A single turn loop, three feet on a side, in series with a 3 plate variable condenser and a single turn, 3 in. diameter coupling coil will tune to the 40 meter band.

In operating the set, it is best to connect a switch somewhere in the lead to the *A* battery for cutting off the current to the tube filament. An equal number of turns are connected in each of the inductance coils and the two variable condensers should be adjusted to approximately equal settings. When the tube filament is lighted and the key is closed, the transmitter will oscillate persistently. The condenser settings are then varied until resonance with the antenna circuit is obtained.

Resonance with the antenna may be obtained in a number of ways. A thermogalvanometer such as is used in ordinary wavemeters may be inserted in series with the antenna and used as an antenna ammeter, the maximum deflection denoting resonance. A d. c. milliammeter having a scale of 0-50, connected in series with the *B* batteries will show resonance by rising sharply as the resonant point is passed over when tuning.

When no meters are available, a 2½ volt flashlight bulb may be connected in the antenna circuit, as shown in the

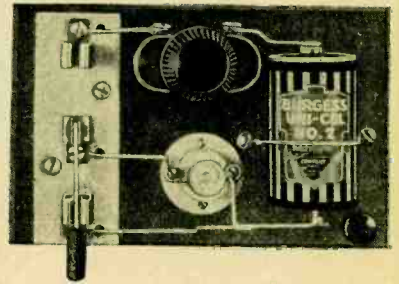

Fig. 5. Resonance Indicator.

schematic diagram, and in Fig. 5. To find resonance the switch is thrown to connect the battery to the lamp. The rheostat is adjusted until the lamp filament just begins to glow. When the transmitter is carefully tuned to resonance with the antenna circuit, the slight amount of additional energy will noticeably brighten the lamp filament.

To prevent unstable action that may occur between coupled tuned circuits, it is best to adjust the transmitter to a point slightly one side of the point where maximum radiation occurs. After the adjustments are completed by means of the lamp, the switch should be thrown to the side where the lamp is disconnected

(Continued on Page 48)

Direct Reading

Price

\$120

Liberal Discount

Accurate

A Sound Investment



New Method of Testing Tubes — Dynamometer

NOW you can SEE your tubes tested. Insist on TESTED TUBES — Dynamometer tested. No meaningless curves or calculations. Any clerk can test 3 tubes per minute on this wonderful instrument, which is direct reading and absolutely accurate. Measures amplification factor, plate impedance and mutual conductance of any type on the market.

Inquiries invited from Manufacturers, Distributors and Reliable Dealers

SUPERADIO

In addition to the Dynamometer, write for details of the Superadio 5-Tube Receiver with only two dials. Price, \$56. And the Superadio B Battery Eliminator. You'll be interested.

DEALERS: Good Territory Open. Write

DeWITT-LaFRANCE CO., Inc.

54 Washburn Ave., Cambridge, Massachusetts

Boston Representative:

Martin, Hartley & Dewitt Sales Co., 99 Bedford St.

Chicago Representative:

William A. Welty & Co., 36 So. State St.



APEX VERNIER DIALS

Are Best on Any Set

Ask Your Dealer or Write

APEX ELECTRIC MFG. CO.

1410 W. 59th Street, Chicago

ELECTRAD

Certified Radio Parts

RADIO AGENTS WANTED

5 Tube Demonstrator FREE!

Famous Air King line of 5-Tube T. R. F. Receivers. 3 models, retail for only \$49.50 to \$59.50. Solid walnut cabinets. Wonderful tone and power. Liberal discounts to user agents. Write today. 20TH CENTURY RADIO CO., 1012 Coca Cola Bldg., Kansas City, Mo.

The World's Greatest Radio Story



Ward's New Radio Catalogue is Now Ready

Are you interested in seeing what is new in Radio— what is best and what has been approved?

And do you wish to know the lowest prices on tested sets, prices made without the usual "Radio profits?"

This Catalogue is a Complete Guide to Radio

Ward's is headquarters for Radio, with probably the largest retail radio department in the whole world.

This new 52 page Radio Catalogue shows everything in parts, batteries, cabinets, contains a list of stations, a radio log for recording stations. It shows the best of the new sets. One tube sets that give amazing results.

ESTABLISHED 1872
Montgomery Ward & Co.

The Oldest Mail Order House is Today the Most Progressive
Baltimore Chicago Kansas City St. Paul Portland, Ore. Oakland, Calif. Ft. Worth

Five tube sets with a single dial to turn. Think of tuning in one station after another by turning a single dial!

Every price quoted means a big saving to you. Everything offered is tested by our own Radio Experts. In fact, the best experts compiled this Catalogue for you.

Write for this 52 Page Book. It is yours free.

Our 53 year old Policy

For 53 years we have sold only quality merchandise under a Golden Rule Policy. You can rely absolutely upon the quality of everything shown in this Radio Catalogue.

To Montgomery Ward & Co., Dept. 39-R

Baltimore Chicago Kansas City St. Paul
Portland, Ore. Oakland, Calif. Fort Worth

(Mail this coupon to our house nearest you.)

Please mail my free copy of Montgomery Ward's New Radio Catalogue.

Name.....

Local address.....

Post office.....

State.....

New! Tone and Volume Control



The new CENTRALAB MODULATOR PLUG gives any degree of tone volume from a whisper to maximum, by the simple turn of a knob. Great for smoothing out powerful local stations, and for lessening static interference. Centralab Modulator Plug can be attached in a moment. No tools necessary. It replaces your present phone plug.

Retails at \$2.50 at your dealer's, or direct from us

Central Radio Laboratories
Keefe Ave., Milwaukee, Wis.

Centralab

A BABY TRANSMITTER

(Continued from Page 46)

from the battery and shorted out, thus removing the resistance from the antenna circuit.

It is of interest in working this set to know how long the batteries will last. The filament current may be supplied by three 6 in. dry cells, or a 4½ volt tubular flashlight battery. With three 6 in. batteries about 700 service hours will be obtained. With flashlight batteries about 100 service hours are possible. The plate current from the B batteries varies with the number of tubes and the voltage applied. For a 5 lb. B battery of 22½ volt size, retailing at \$2.00, 4600 milliampere hours can be obtained, making possible many hundreds of hours life with the single tube transmitter.

In conclusion, a timely word to the beginner is appropriate. All radio transmitting stations must have a government license, and must be operated by a person holding a license. These licenses are issued by the Dept. of Commerce, and information about obtaining them may be had by writing to the Department at Washington, D. C. Amateur stations are allowed to transmit on a number of wave bands, one of which is from 37½ to 42.8 meters, using telegraph signals. Voice transmission on this band is not allowed except for those stations holding an experimental license and are operated by personnel holding commercial operators' certificates.

A NEW FIVE-TUBE RECEIVER

(Continued from Page 18)

ceiver may be better realized by using dry cells to light the filaments of the four small tubes. They should, of course be connected in parallel if this is done. The builder may make the necessary change in filament connections.

If the electrodynamic cone is used with the field coils in series with the filaments of the tubes care should be taken not to use a filament switch. The power unit as a whole should be turned off at the light socket, because if the filament circuit is opened the stored up energy in the fields will be released through the filaments and will burn them out. If a filament switch is used it should be connected in shunt to all the filaments of the small tubes in series. The tubes are then turned out by shortcircuiting them. This will occasion a slight increase in the load on the power unit, but it will not be serious. This connection is shown by the dotted lines.

If the small solenoids are used in place of the toroid inductances they should be placed six in. apart, on a line with the condensers and at right angles to each other.

Announcement is made that Myers tubes will hereafter be made in Cleveland, Ohio as well as in Canada.

CARTER

\$1.75 "DIALITE"

Complete With Lamp

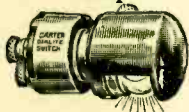

Half Size

Coast Distributors:
A. S. LINDSTROM & COMPANY
274 Brannan St.
San Francisco, Calif.

Illuminates dials and front of panels. Provided with extra terminal to be used as filament switch when desired. Complete with 6 Volt Lamp.

CURRENT CONSUMPTION NEGLIGIBLE

Ask your dealer to show you

In Canada: Carter Radio Co., Limited, Toronto



"IMP" Pilot Switch \$1.50

Complete with Lamp



Half Size

Branch Offices

Los Angeles
Portland
Seattle
Salt Lake City

Safe!

BRACH Vacuum Lightning Arrester

LATEST "COAST TO COAST" FULLY GUARANTEED

RADIO'S-10 DAYS FREE TRIAL
SAVE 1/3 TO 1/2

Users everywhere report Miraco Radios got programs coast to coast on loud speaker; outperform sets three times as costly. Many hear foreign countries. Radio's most amazing values in unconditionally guaranteed, factory-built long distance sets—let testimony of users convince you.

MIRACO RADIO GETS 'EM COAST TO COAST

Powerful New Multi-tube Miraco gets long distance on loud speaker. Set, ONLY \$27.35 retail



FREE! Literature on latest improved 1 to 5 tube models, new low prices, testimony of users and SPECIAL OFFER. Write:

MIDWEST RADIO CORP'N
Pioneer Builders of Sets
414 W. E. 8th St. Cincinnati, O.

AGENTS WANTED Write for discount.

LINK YOUR SUPER

to an OUTDOOR AERIAL!
INCREASE YOUR RANGE AND VOLUME!
IMPROVE THE SELECTIVITY!

Write today for full information

The Superadio Co. 136 LIBERTY ST.
NEW YORK CITY

ARE YOU A SUBSCRIBER?

Send for Trial Subscription

\$1.00 for Six Months

Tell them that you saw it in RADIO

HAMMARLUND Low-Loss COILS

A New Standard of Efficiency

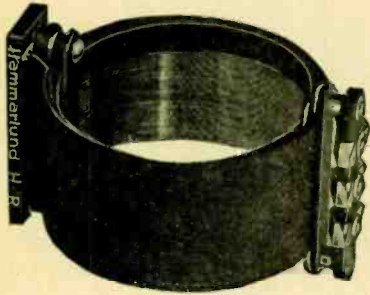

The
HAMMARLUND-ROBERTS
Unit

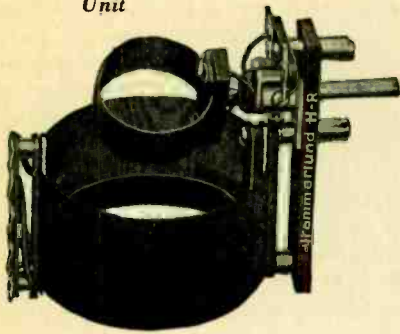

NEVER before were coils of such high efficiency available in commercial form.

By an ingenious process, Hammarlund engineers have devised a way to wind the famous solenoid coil with a definite space between turns, supported and anchored by a mere film of dielectric material. Thus, inductance is kept high, with low distributed capacity and absolutely no chance for short circuits.

They are regular equipment in the wonderful new Hammarlund-Roberts Receiver and the Eagle Neutrodyne. Various sizes and arrangements are available for other standard circuits.

Write for Descriptive Folder

Hammarlund Mfg. Co.
424-438 W. 33rd St., New York

Pacific Coast Representatives:
ATLANTIC & PACIFIC AGENCIES CORP.
383 Brannan St., San Francisco

For Better Radio
Hammarlund
PRECISION
PRODUCTS

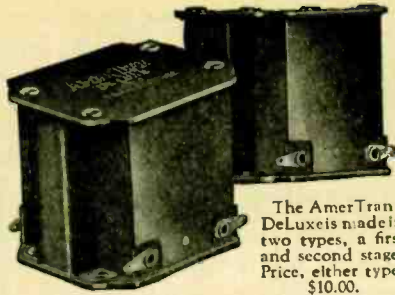

The AmerTran DeLuxeis made in two types, a first and second stage. Price, either type, \$10.00.

*A New Standard of Excellence
in Audio Amplification*

The realism of this new audio transformer is outstanding. Realism of this kind results from the uniform amplification of the fundamental tones of the lower register. The AmerTran DeLux makes possible the natural reproduction of not only the Overtones, but *all* of the transmitted *Fundamental* tones.

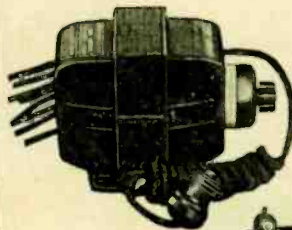

AmerTran Power Transformer type PF-45, Price \$15.00, type PF-52, Price \$18.00.

The AmerChoke type 854 is a choke coil or impedance of general utility. Price \$6.00.



A Good Audio Amplifier

Requires enough plate and grid bias voltage on its tubes to prevent them from being overloaded by the signal voltage.

The AmerTran PF-45 or PF-52 with the half wave high voltage rectifying tubes now available and suitable condensers and resistances—together with three AmerChokes Type 854 will furnish these proper voltages. This combination will give real *quality loudspeaker volume*. AmerTran Power Transformers also supply A. C. filament current for the last audio tube.



AmerTran Audio Transformers type AF6 (turn Ratio 5) and AF7 (turn ratio 3½) are the leaders in their class. Price, either type, \$5.00.

Write for booklet describing these and other AmerTran Products—with recommendations on their use. It's free on request. All prices are F. O. B. Newark, N. J.

AMERICAN TRANSFORMER CO.
178 Emmet Street, Newark, N. J.

"Transformer builders for over twenty-five years"
Sold Only at Authorized AmerTran Dealers.

Pacific Coast Office:

RIALTO BUILDING, SAN FRANCISCO, CALIF.

QUALITY **DONGAN** PRODUCTS

**A New and Finer Quality
of Reception**

**RAYTHEON TUBE
B-ELIMINATORS**

Using

DONGAN

**B-Power Units
Transformers**



509—Full Wave
\$7.00 List

Also—Transformers and Chokes for R. C. A. and Cunningham Tubes

Chokes



514—20 Henry
\$5.00 List

Raytheon Tubes
\$6.00 List

Thousands of fans who have built their own B - Eliminator, using Raytheon Tubes and Dongan Transformers and Chokes, have found an almost unbelievable improvement in reception. Smooth, uninterrupted plate supply perfects the quality of all signals and greatly clears up and gives added strength to DX work—the ideal equipment for the International Tests.

Dongan B-Power Units are essential parts to the construction of this remarkable new Eliminator. Complete instructions make it easy to build your own. Tubes and Dongan parts at most good dealers. For interesting details, write for information at once.

Manufacturers

For B-Eliminator and Receiving Set manufacturers, Dongan offers a complete line of B-Power Units, Audio Transformers, A. C. Tube Step-Down Transformers and Voltmeters. Information or engineering co-operation at your request.

Dongan Electric Manufacturing Co.
2981-3001 Franklin St., Detroit, Mich.

Pacific Coast Representatives:

San Francisco—
Industrial Sales Co., 171 Second Street

Los Angeles—
Sierra Electric Co., 443 So. San Pedro Street

Portland, Ore.—
C. E. Gay, 166 Lownsdale Street

Seattle, Wash.—
E. P. Denham, 2726 45th Avenue S. W.

TRANSFORMERS of MERIT for FIFTEEN YEARS

FROST-FONES Highly Sensitive to Weak Signals

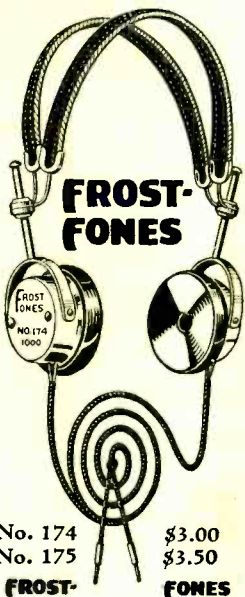

To get any real enjoyment out of DX work you must use a good pair of head fones, which are designed specifically to pick up weak signals. Due to our extreme care in winding coils, lapping shells, grinding magnets and testing and measuring **FROST-FONES** they are about twice as sensitive to weak signals as most other head fones. We could not be more particular about **FROST-FONE** quality if we built them to sell for ten dollars. Our huge production insures low prices and our rigid inspection guarantees high quality. Your dealer right in your neighborhood stocks **FROST-FONES**. Order from him today.

HERBERT H. FROST, Inc.
 314 West Superior Street Chicago, Illinois
 NEW YORK KANSAS CITY LOS ANGELES
 Export Office: 314 West Superior Street, Chicago

No. 174 \$3.00
 No. 175 \$3.50
FROST-FONES

AN EFFICIENT THREE-TUBE SET

(Continued from Page 14)

and the first radio frequency tube and the Remler oscillator coupler becomes the radio frequency transformer between the r. f. tube and the detector. The socket is added at the back of the baseboard and at the extreme left. The rheostat on the left hand side of the panel is shifted to control the r. f. tube only, the detector and audio tubes being handled by the right hand rheostat. A spring detector socket should be used to avoid howling and microphonic noises from the detector tube. Either a Benjamin or the new Eby spring socket is recommended in this place. The wiring is very simple and may be followed out from Fig. 1.

The results obtained from the three tube set will depend largely upon the patience used to master the tuning. There are many controls on the panel and it is necessary to operate each one intelligently to get the most sensitive results from the set. The operator should understand what each control is for. Any set that uses one stage of tuned radio frequency and a regenerative detector is very tricky and will do many strange and unusual things if not handled right. On the other hand, it is a very efficient combination when operated properly.

Tuned radio frequency amplifiers always have a strong tendency to oscillate and some means of oscillation control must be introduced to hold the set down. In a circuit like this where a few turns in series with the plate are closely coupled to the grid coil of the following tube, which is tuned by a condenser, the effect is the same as if the plate circuit itself were tuned. Loosening the coupling between the few plate turns and the following tuned grid coil lessens the reacting effect of the grid coil and hence lessens the tendency for oscillation in the first tube. This coupling can be loosened to such a degree that regeneration will take place but no oscillations will occur. This is the most efficient point at which to operate the radio frequency coupling.

Referring to Fig. 1, the rotor of the Remler coupler is in the plate circuit and the turns on the stationary coil are in the following grid circuit which is tuned to the same wavelength as the antenna. With the rotor tightly coupled to the stator, the tendency to oscillate is so strong with the rheostat turned up that the whole set will be locked tight. As this coupling is gradually loosened and the two tuning dials slightly readjusted to keep both circuits on the same wavelength, a point will be found where the oscillation will cease. This is the right setting for the coupler and once it is found it can be left practically unchanged. This setting should be de-

The Reason

THE TUBE WITH A SENSIBLE GUARANTEE

Quality! Performance Dependability

are the factors which made Supertron the foremost Independent Tube in America!!!

The Public buy and enjoy Supertrons because they are assured of satisfaction by a serial numbered guarantee on each tube for their protection—at their own price; the public demand price—two dollars.

All Types \$2.00
 Canada, \$2.75

Try Supertron and Be Glad.
 At Good Dealers.

Branch offices in principal cities
 throughout the United States

Supertron Mfg. Co.
 Hoboken, N. J.

SUPERTRON
 A SERIAL NUMBER GUARANTEE

Proved by Performance!

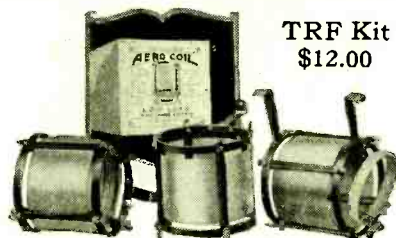

TRF Kit
 \$12.00

AERO COILS

This season—thousands more fans found the answer to complete radio satisfaction thru Aero Coils. Selectivity! Distance! Power! All these—to a degree not yet even approached by any other inductances. And simply because the Aero Coil is patented—both in principle and in construction. Any set—any circuit is greatly improved by substituting these wonder inductances for those you are now using. At your dealers.

Write for free Aero Booklet!

CT-80—Three Circuit Tuner.....	\$ 8.00
(Variable Primary)	
TRF-110—Radio Frequency Regenerative Kit.....	11.00
WT-40—Wave Trap Coil.....	4.00
OS-55—Oscillator.....	5.50
AX-45—Antenna Coupler.....	4.50
(Variable Primary)	

AERO PRODUCTS, Inc.
 217 N. Desplaines Street, CHICAGO

ZENITH RADIO

—LONG DISTANCE—
 Exclusive choice of MacMillan for his North Polar Expedition.
ZENITH RADIO CORPORATION
 310 South Michigan Avenue, Chicago, Illinois

10c RADIO LOG
 Books for Keeping Records.
 "RADIO," San Francisco

Laboratory Product

CRESCENT LAVITE RESISTANCES

For Distortionless Amplification



As transmitting Grid leaks, they are made in special sizes and are not afraid of power. Dissipate 10 watts. Four standard sizes, \$1.50 each. Special resistances, \$2.50 each.

CRESCENT RADIO SUPPLY COMPANY
 3 Liberty Street, Jamaica, N. Y.

terminated when the radio frequency rheostat is turned at least three quarters of the way on, and the 3 plate condenser set at zero. Although this coupling will vary slightly with the wavelength, the difference can easily be made up by changing the setting of the radio frequency rheostat.

This method of avoiding oscillation takes the place of neutralizing. It is a little better because a point can always be found where the oscillations will stop, while with a neutralizing system, the services of an expert are sometimes required to find the neutralizing point. The same thing is accomplished by both methods.

The three plate condenser supplies the regeneration for the detector tube and the operation of this condenser will be very much as previously described in connection with the two tube set.

Operation: Use two hands to operate the set. Remember that trying to get nine tube results on three tubes requires plenty of work on the part of the operator, and act accordingly. "Cross" the two dials slowly up and down the scale. This means to rotate one slowly from zero to maximum and keep continually but slowly crossing back and forth over the point of resonance (where they are on the same wave) with the other. The tuning will be very sharp on the right hand control and any except local stations will probably tune out in less than two degrees. The set is very selective—even more so than Circuit No. 2.

Under the most favorable conditions, the set has done two thousand miles on the loud speaker. To be exact, the set located in Oakland, Cal., has received WEBH, KYW, WHB and KDKA. How near these results can be duplicated depends on location, atmospheric conditions and the operator. Probably forty per cent depends on location and conditions and sixty per cent on the operator. And it is well to bear in mind that the above results are under the most favorable conditions—not average conditions.

From time to time a great deal has been said about the effect of location on radio reception. Do not take this lightly, as location means everything. The writer had this forcibly impressed upon him several months ago while carrying a self-contained portable receiving set around town in the back seat of an automobile. A start was made from KGO and the machine driven directly away from the station for about three miles along a street which had no street cars but which was crossed in several places by high power lines. There were points along the street where it was impossible to pick up the program and other points where it came in very strong. These dead spots would suddenly appear for no apparent reason and they were undoubtedly caused by reflection from power wires or other metallic objects in the vicinity. A lack of signals in one

CARDWELL CONDENSERS

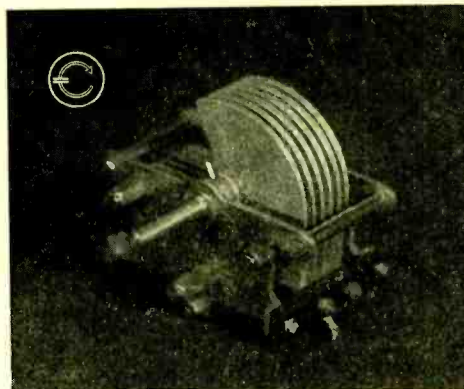

.0005 mfd.
\$5.00

.00035 mfd.
\$4.75

... a condenser you can depend on!
The New Type "E" Condenser, with tapering plates, answers the Straight Frequency Question. . . .
... holds calibration permanently, with full size rotor, and full size stator plates. . . .
... will mount entirely behind a four-inch dial, and extend less than three inches back of the panel. . . .
... is really low loss, and mechanically perfect. . . .
... is made in all standard sizes, at reasonable prices.

THE ALLEN D. CARDWELL MFG. CORPORATION

81 Prospect Street

Brooklyn, New York

Write for catalogue. If your dealer can't supply, order direct.

"THE STANDARD OF COMPARISON"

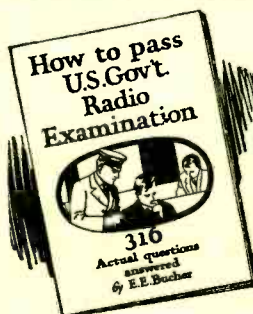

PASS the U. S. Government Commercial or Amateur Radio License examination! This book will help you do it! Send sixty cents in stamps or coin for your copy—postage prepaid to any point in the U. S., Canada or Mexico

For a Short Time Only **60c**

RADIO INSTITUTE OF AMERICA
322 Broadway, New York City

You Can Get Greater Reflex or Crystal Set Reception if you use the

BROWNLIE Vernier Detector

\$2.00 at Your Dealer or Direct
ROLAND BROWNLIE & CO.,
22 Saunders St. Medford, Mass.



AIR LINE MAP AND LOG

50c The best log and map we have ever seen. Very handy and simple.

"RADIO"
Pacific Bldg. San Francisco

Tell them that you saw it in RADIO

51

Convert your present receiver
into a light socket set with

FANSTEEL
Balkite
Radio Power Units

Ask your radio dealer

PACIFIC COAST DISTRIBUTORS—Seattle, A. S. Lindstrom Co., 95 Connecticut Street; San Francisco, A. S. Lindstrom Co., 274 Brannan Street; Los Angeles, A. S. Lindstrom Co., 324 N. San Pedro Street; Portland, A. S. Lindstrom Co., 146½ N. 10th Street; Salt Lake City, A. S. Lindstrom Co., 407 Dooly Building; Denver, Jack L. Hursch Co., 1641 Stout Street

Manufactured by FANSTEEL PRODUCTS COMPANY, Inc., North Chicago, Illinois

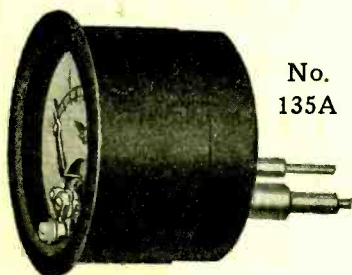

No. 135A

Send for

New No. 739 circular describing special voltmeters for Radiola, Victor and Brunswick sets.

Order from dealer

Jewell Electrical Instrument Company

1650 Walnut Street, Chicago

26 years making good instruments.

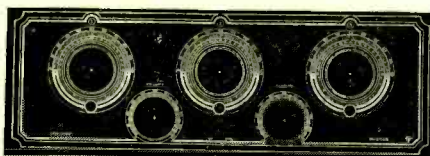

RADIO PANELS

Smooth, perfect edges, cut with patented non-metallic saws

Highest quality panels cut, drilled, and engraved, to order. Only finest bakelite used. 3/16" thick, 2 cents per square inch. 1/8" thick, 1½ cents per square inch. Letters engraved, 4 cents each; Arrows and Markers, 15 cents; Border-lines, 35 cents up; Dials, 50 cents up; edges bevelled, 35 cents up; Meter-holes cut, each, 50 cents. Send rough sketches for estimate.

8-hour service. We ship everywhere, mail orders solicited. Radio shops and set-builders write for discount-sheets.

Volney G. Mathison & Co.

660 Twelfth St.

Oakland, California

RADIOCAST WEEKLY

Forty-eight Pages of Programs, Photos, Humor, Musical Reviews, Schedules, Tables, Editorials, Etc.

5c Per Radiocast Weekly Copy 433 Pacific Bldg., SAN FRANCISCO

A SUBSCRIPTION TO "RADIO" INSURES REGULAR RECEIPT OF COPY

GETTING ACROSS

(Continued from Page 20)

dence district tonight. We might pick up some of those second story babies."

The driver nodded. The residence district in his mind meant upper Pacific avenue, where the homes of the rich abounded. Without hesitation, he nosed off the main highways and by devious but rapid turns and twists, swung rapidly toward the north, his powerful engine held under an instant control, ready for a desperate burst of speed if the occasion arose.

"It's a good night," said one of the party. "There'll be a moon up pretty soon."

There were no further words between them. The deadly machine faded away in the shadows, its destination merely a check mark on the headquarters blotter, indicating that it was "out somewhere" after the prowlers of the night.

The entrance to the Judson home was childishly simple for Bumper Hawkins. He glued a piece of glove to a window pane. Then he ran a glass cutter in a circle with a slight hiss. There was a sharp tap and the glass came away, fastened to the glove. Bumper ran his hand through the hole, turned the window catch and swung the window open. One by one the three men climbed cautiously inside.

They found themselves in a sun-porch, which gave entrance to a dining room. The door of this room was open and a light beyond told of the butler's late watch for the Judsons. Bumper signalled for complete silence. Then, with the stealth of a stalking cat he crept through the door in a crouching position, his feet making no sound on the soft carpet. After a bit he disappeared from view.

Listening intently, the others heard a sudden "splat" and a grunt. There was a sound of some one stirring around . . . Bumper came to the door and waved his hand. They went forward. The butler was lying on his face, gagged, tied and unconscious from a blow on the head.

"Never knew a thing," said Bumper boastfully. "He'll be out about an hour." Not for nothing he had earned his sobriquet of "Bumper." Pete jerked a thumb toward an alcove.

"The box is over here," he said.

He indicated a curtain. Soapy slid noiselessly across the room and examined the safe that it concealed. He grinned broadly.

"Soup?" asked Bumper casually.

Soapy shook his head with derision.

"Come along job," he sneered.

A "come-along" is a queer-looking instrument which operates much like an automobile jack in principle. It has a foot to anchor it to the floor and a turn screw by which enormous pressure or traction may be exerted. An ordinary safe is a piece of card-board when the device once starts pulling at the combina-

terminated when the radio frequency rheostat is turned at least three quarters of the way on, and the 3 plate condenser set at zero. Although this coupling will vary slightly with the wavelength, the difference can easily be made up by changing the setting of the radio frequency rheostat.

This method of avoiding oscillation takes the place of neutralizing. It is a little better because a point can always be found where the oscillations will stop, while with a neutralizing system, the services of an expert are sometimes required to find the neutralizing point. The same thing is accomplished by both methods.

The three plate condenser supplies the regeneration for the detector tube and the operation of this condenser will be very much as previously described in connection with the two tube set.

Operation: Use two hands to operate the set. Remember that trying to get nine tube results on three tubes requires plenty of work on the part of the operator, and act accordingly. "Cross" the two dials slowly up and down the scale. This means to rotate one slowly from zero to maximum and keep continually but slowly crossing back and forth over the point of resonance (where they are on the same wave) with the other. The tuning will be very sharp on the right hand control and any except local stations will probably tune out in less than two degrees. The set is very selective—even more so than Circuit No. 2.

Under the most favorable conditions, the set has done two thousand miles on the loud speaker. To be exact, the set located in Oakland, Cal., has received WEBH, KYW, WHB and KDKA. How near these results can be duplicated depends on location, atmospheric conditions and the operator. Probably forty per cent depends on location and conditions and sixty per cent on the operator. And it is well to bear in mind that the above results are under the most favorable conditions—not average conditions.

From time to time a great deal has been said about the effect of location on radio reception. Do not take this lightly, as location means everything. The writer had this forcibly impressed upon him several months ago while carrying a self-contained portable receiving set around town in the back seat of an automobile. A start was made from KGO and the machine driven directly away from the station for about three miles along a street which had no street cars but which was crossed in several places by high power lines. There were points along the street where it was impossible to pick up the program and other points where it came in very strong. These dead spots would suddenly appear for no apparent reason and they were undoubtedly caused by reflection from power wires or other metallic objects in the vicinity. A lack of signals in one

CARDWELL CONDENSERS

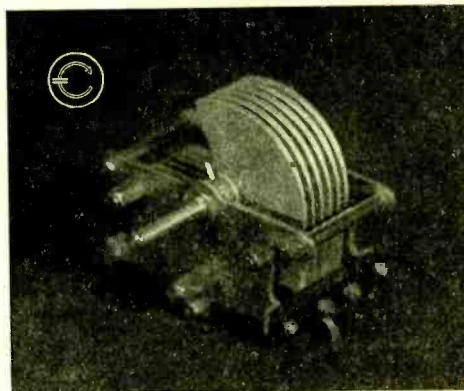

.0005 mfd.
\$5.00

.00035 mfd.
\$4.75

... a condenser you can depend on!
The New Type "E" Condenser, with tapering plates, answers the Straight Frequency Question. . . .

... holds calibration permanently, with full size rotor, and full size stator plates. . . .

... will mount entirely behind a four-inch dial, and extend less than three inches back of the panel. . . .

... is really low loss, and mechanically perfect. . . .

... is made in all standard sizes, at reasonable prices.

THE ALLEN D. CARDWELL MFG.
CORPORATION

81 Prospect Street

Brooklyn, New York

Write for catalogue. If your dealer can't supply, order direct.

"THE STANDARD OF COMPARISON"

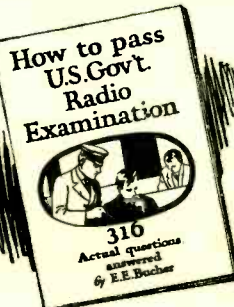

PASS the U. S. Government Commercial or Amateur Radio License examination! This book will help you do it! Send sixty cents in stamps or coin for your copy—postage prepaid to any point in the U. S., Canada or Mexico

For a Short Time Only **60c**

RADIO INSTITUTE OF AMERICA
322 Broadway, New York City

You Can Get Greater Reflex or Crystal Set Reception if you use the

BROWNLIE Vernier Detector

\$2.00 at Your Dealer or Direct
ROLAND BROWNLIE & CO.,
22 Saunders St. Medford, Mass.

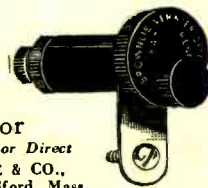

AIR LINE MAP AND LOG

50c The best log and map we have ever seen. Very handy and simple.

"RADIO"
Pacific Bldg. San Francisco

Tell them that you saw it in RADIO

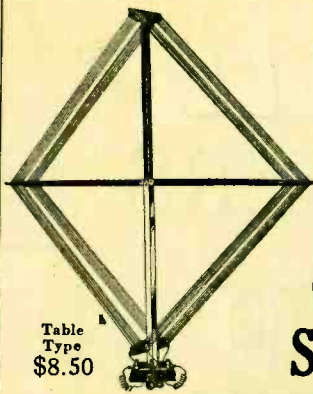
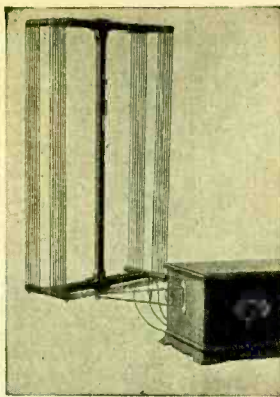

Table Type
\$8.50

Take Your Choice!
TWO GOOD SIGNAL LOOP AERIALS



Bracket Type, \$8.50

A bracket type that attaches right onto the end of your radio cabinet or a table type—you can't miss it on either one. When you buy a Signal Loop you're buying more than just good looks. You're buying an aerial backed by thirty years of experience in the manufacturing of electrical equipment.

Where quarters are close, remember the bracket type loop attaches right onto the end of your set and does away with that "extra piece of apparatus." It turns a complete 360° in the width of the standard cabinet.

Both aerials are beautifully constructed. The bracket type is of solid walnut. The table type is mahogany finished. All metal parts are heavily nickel plated. A third tap is provided for sets requiring it. Ask your favorite dealer to show you the Signal Loops—either type \$8.50. You will surely want one.

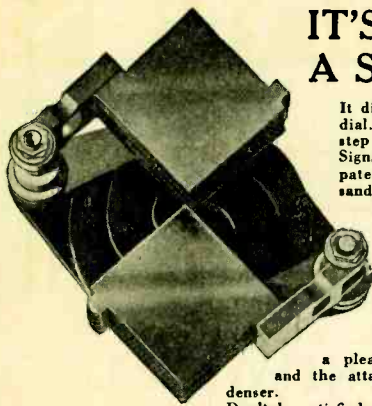

IT'S EASY TUNING WITH A SIGNAL SPIRAL CAM

It distributes the wave lengths evenly over the 360° of the dial. Stations come in clearly without interference. Just step in at your dealer's and ask him to show you the Signal Spiral Cam Condenser—the condenser with the patented cam control. Then you will appreciate why thousands of fans have selected this condenser for their sets above hundreds of other condensers on the market today.

The Signal Spiral Cam Condenser is built for perfect control of high frequency as well as low frequency wave lengths. Results are uniform at all points on the dial—the scientifically designed cam takes care of that. There is absolutely no back lash and a balanced condition of the plate assemblies permits a smooth, velvety action that makes tuning a pleasure. Design permits single or three-hole mounting and the attaching of air core transformer directly into the condenser.

Don't be satisfied with "just condensers." See the "Spiral Cam" before you buy. Three capacities, all one price—.00025, .00035 and .0005, \$4.00 and worth a lot more.

Jobbers and Dealers: If you are not fully acquainted with Signal Radio Products, we will be pleased to send you complete information. Write us at once for literature.

SIGNAL ELECTRIC MANUFACTURING CO.

Dept. 3-B, Menominee, Mich.

1216 Hearst Building
San Francisco

408 San Fernando Bldg.
Los Angeles

ARE YOU A SUBSCRIBER?
SEND FOR TRIAL SUBSCRIPTION
\$1.00 FOR SIX MONTHS

Filter Condensers
for "B" Supply Unit

All sizes—All specifications—Meet all requirements—Made in three voltage ranges. Full specifications and details at your dealer's or direct.
POTTER MANUFACTURING CO., North Chicago, Ill.

Potter
By-Pass and Filter
Condensers
(An American-Made Product)

Yours-free!



WRS 96-PAGE Radio Guide Book

Profusely illustrated and "chockful" of interest for the radio fans.

Trouble shooting chart. List of stations and Log Chart and hundreds of RADIO VALUES ON A

MONEY BACK GUARANTEE

Your satisfaction is insured. Service and quality guaranteed or money refunded. Fill all your radio needs here—complete stock—24-hour service.

FREE A postal brings your copy. Write for it TODAY. Mention "Pacific Radio."

Wholesale Radio Service Company
6 Church Street Dept. AR-12 New York City

place seemed to be made up by more somewhere else.

An electrical map of a city block would show your receiving set surrounded first by a maze of water, drain, vent and gas pipes, standing up like a forest around it. Electric and doorbell wiring would appear to be hanging like vines around these pipes. In the center of it all would be the furnace with large pipes almost a foot in diameter, radiating in several directions. If the house happened to be finished in stucco, a complete iron wire shield would surround this entire forest of pipes and wire, all of which act like antennae and absorb radio waves. Does this sound like an ideal place for a radio set? It is no wonder that loop sets work better on the top story of a house than in the basement. There are about twenty such electrical forests to the city block, besides the street power wires and phone wires. These wires, being visible, usually come in for all of the blame when a dead spot is encountered, although actually they form a very small portion of the total interference to the passage of radio waves. It is no wonder that extreme distance is not done very often in city locations and it is easily seen why moving from a steel frame apartment house to a ranch in the country is like putting five stages of radio frequency into your set.

However, that is getting away from the story. In the average city location, Circuit No. 3 should do from 500 to 1000 miles at this time of the year. If the set fails to get distance don't tear it apart and change the hookup without first taking it to the house of a friend who has been getting distance, and trying it there. Remember that the circuit has worked and done good distance and is not a trick circuit. If instructions are carefully followed the set and the results can be duplicated.

A. R. R. L. BANQUET

(Continued from Page 36)

"guaranteed not to oscillate." Don Brockway, 6PL, won the "booby" prize, a boob medal, after a determined effort to do so. We are sorry that 6PL will be silent for an indefinite period owing to college, as it was an excellent station. Possibly Don may find time at a future date, if he can ease up on the Y. L.'s. If he can Charleston half as well as his brother, W. W. Brockway, 6MG, he is all right. The latter concluded the entertainment with another Charleston, demonstrating the fact that he surely "knows his stuff." The boys liked it.

T. A. Graul, ex-8SF, was introduced to the gang. He was welcomed by the California representatives to the National Convention, who remembered him as an excellent code artist on a door key. He is a real "ham" and will soon become a "six." More power to him. He can get it from the Edison Co.

Dr. J. E. Waters, 6EC, of Santa Ana, made a good suggestion for handling local traffic. He suggested 80 meters for this work with a simple loading device to QSY. We are tired of hearing the old story about Australia being easier to QSO than a point twenty miles distant. Some of the old "ham spirit" is being lost this way too.

for the A. C. Set

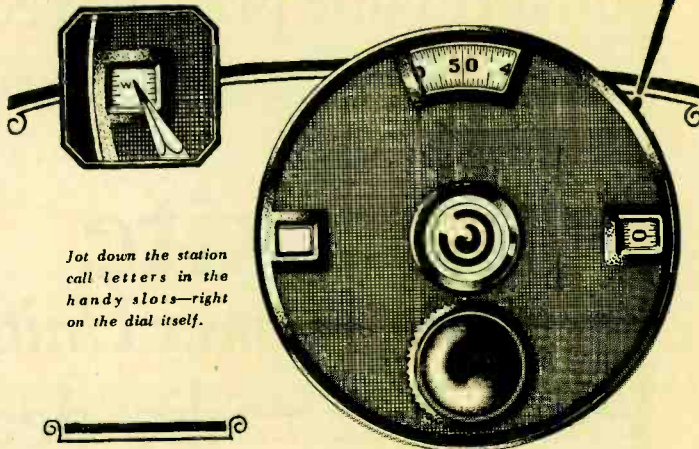

Dot down the station call letters in the handy slots—right on the dial itself.

THE light-socket receiver, described by E. E. Turner, in this issue, is one of this season's big developments. Naturally, it has MAR-CO dials as standard

equipment. For MAR-CO dials alone, provide the searching, responsive action needed today. Martin Copeland Co., Providence, R. I.

Hair-trigger response

**MAR-CO
DIALS**

Micrometer-like action



The 1926 model tuning control

THE GREATEST RADIO BOOK EVER PUBLISHED

CONTAINS

An up-to-date list of all the broadcasting stations in the world; giving wavelengths, power, schedules, kilocycles and slogans. A wonderful rotogravure section containing pictures of studio artists and announcers from all the leading stations. Complete construction data on how to build The Counterphase Six, The Browning-Drake Circuit with impedance coupled amplification, The Marcodyne Receiver, A New Five Tube Tuned Radio Frequency Receiver, A "Super" with a universal filament control system, A wonderful new eight tube "Super" that has no inherent harmonics, A short wave receiver, A new single control circuit, The Raytheon "B" eliminator and a five tube receiver using the McCullough AC tubes. All of these articles are wonderfully illustrated with pictures, panel and baseboard layouts, graphic and schematic diagrams; constructed and thoroughly tested in our laboratories. Maps, log sheets, and all the latest hookups.

Only FIFTY Cents

Dealers write for our guaranteed plan of sale

Amateurs:

We have just finished compiling a complete and up-to-date list of all the Amateur stations in the United States and thirty-five foreign countries. Also all commercial stations and high-power stations all over the world.

Sent postpaid for Seventy-five Cents

PUBLISHED BY

Citizens Radio Service Bureau

508 South Dearborn Street

Chicago, Illinois

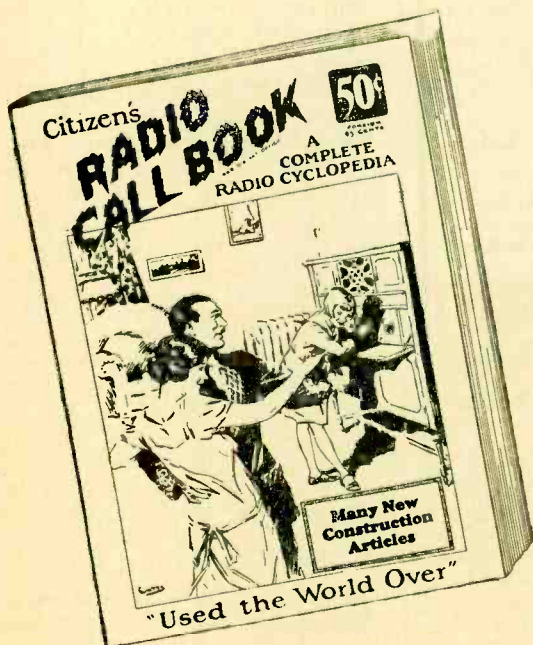

Convert your present receiver
into a light socket set with

FAN STEEL
Balkite
Radio Power Units

Ask your radio dealer

PACIFIC COAST DISTRIBUTORS—Seattle, A. S. Lindstrom Co., 95 Connecticut Street; San Francisco, A. S. Lindstrom Co., 274 Brannan Street; Los Angeles, A. S. Lindstrom Co., 324 N. San Pedro Street; Portland, A. S. Lindstrom Co., 146 1/2 N. 10th Street; Salt Lake City, A. S. Lindstrom Co., 407 Dooly Building; Denver, Jack L. Hursch Co., 1641 Stout Street

Manufactured by FANSTEEL PRODUCTS COMPANY, Inc., North Chicago, Illinois

GETTING ACROSS

(Continued from Page 20)

dence district tonight. We might pick up some of those second story babies."

The driver nodded. The residence district in his mind meant upper Pacific avenue, where the homes of the rich abounded. Without hesitation, he nosed off the main highways and by devious but rapid turns and twists, swung rapidly toward the north, his powerful engine held under an instant control, ready for a desperate burst of speed if the occasion arose.

"It's a good night," said one of the party. "There'll be a moon up pretty soon."

There were no further words between them. The deadly machine faded away in the shadows, its destination merely a check mark on the headquarters blotter, indicating that it was "out somewhere" after the prowlers of the night.

The entrance to the Judson home was childishly simple for Bumper Hawkins. He glued a piece of glove to a window pane. Then he ran a glass cutter in a circle with a slight hiss. There was a sharp tap and the glass came away, fastened to the glove. Bumper ran his hand through the hole, turned the window catch and swung the window open. One by one the three men climbed cautiously inside.

They found themselves in a sun-porch, which gave entrance to a dining room. The door of this room was open and a light beyond told of the butler's late watch for the Judsons. Bumper signalled for complete silence. Then, with the stealth of a stalking cat he crept through the door in a crouching position, his feet making no sound on the soft carpet. After a bit he disappeared from view.

Listening intently, the others heard a sudden "splat" and a grunt. There was a sound of some one stirring around . . . Bumper came to the door and waved his hand. They went forward. The butler was lying on his face, gagged, tied and unconscious from a blow on the head.

"Never knew a thing," said Bumper boastfully. "He'll be out about an hour." Not for nothing he had earned his sobriquet of "Bumper." Pete jerked a thumb toward an alcove.

"The box is over here," he said.

He indicated a curtain. Soapy slid noiselessly across the room and examined the safe that it concealed. He grinned broadly.

"Soup?" asked Bumper casually.

Soapy shook his head with derision.

"Come along job," he sneered.

A "come-along" is a queer-looking instrument which operates much like an automobile jack in principle. It has a foot to anchor it to the floor and a turn screw by which enormous pressure or traction may be exerted. An ordinary safe is a piece of card-board when the device once starts pulling at the combina-

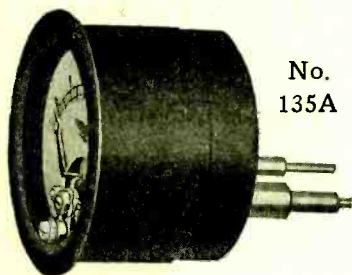

No. 135A

Send for

New No. 739 circular describing special voltmeters for Radiola, Victor and Brunswick sets.

Order from dealer

Jewell Electrical Instrument Company

1650 Walnut Street, Chicago

26 years making good instruments.

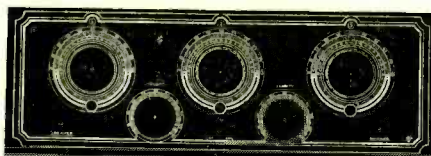

RADIO PANELS

Smooth, perfect edges, cut with patented non-metallic saws

Highest quality panels cut, drilled, and engraved, to order. Only finest bakelite used. 3/16" thick, 2 cents per square inch. 1/8" thick, 1 1/2 cents per square inch. Letters engraved, 4 cents each; Arrows and Markers, 15 cents; Border-lines, 35 cents up; Dials, 50 cents up; edges bevelled, 35 cents up; Meter-holes cut, each, 50 cents. Send rough sketches for estimate.

8-hour service. We ship everywhere, mail orders solicited. Radio shops and set-builders write for discount-sheets.

Volney G. Mathison & Co.

660 Twelfth St.

Oakland, California

RADIOCAST WEEKLY

Forty-eight Pages of Programs, Photos, Humor, Musical Reviews, Schedules, Tables, Editorials, Etc.

5c Per Radiocast Weekly Copy 433 Pacific Bldg.,

SAN FRANCISCO

A SUBSCRIPTION TO "RADIO"

INSURES REGULAR RECEIPT OF COPY

tion, and the inner mechanism can no more resist its force than a liner can resist the pull of a sway-backed tug.

With rapid, professional motions, Soapy opened his grip, took out a "come-along" and set to work. Bumper and Pete went about the business of sorting the silverware, estimating its value and probable pawnable quality, leaving Soapy to his own devices.

Outside, in front of the Judson home, Ed, the driver of the bandit car had not been idle. In his dual job of chauffeur and lookout, he had to show considerable alertness. He left his engine running and crossing the lawn, hid himself in the shadows of the Judson garden. Hardly had he done so when a big, black machine slipped quietly past, its engine hum barely audible. There was no reason why Ed should have paid any attention to it, except that it was going a bit slower than the other cars on the street.

The instinct of the lawbreaker, always acute, whispered an ominous warning to some inner sense. He watched it closely, crouching back in the shadows. His actions would have been entirely different had he heard the remarks of the men in the "death car" as it crept along.

"Get that, Charlie?" said a detective suddenly.

"No, What was it?"

"Empty car . . . Engine running!"

"The hell. Dan—double back!"

This to the driver.

The police machine turned the corner, casually, negligently. Abruptly the driver stepped on the gas, and with incredible speed it circled the entire block, so that when it returned to the street on which the Judson home was situated, once again, it was pointed in the opposite direction. Slowing down to normal speed, it cruised easily past the residence where the gang were at work. The shot-gun squad, hidden in the shadow of the top, gave keen-eyed scrutiny to the house and its environs.

"You're right, Bill," said the sergeant. "Something funny there. I can feel it."

The driver understood. He continued another block and turned to the right, coming back on the next street to the intersecting street which debouched nearest to the Judson home. Near the corner, he pulled in to the curb, killed his engine and snapped off the lights. The detectives picked up their shotguns from the floor. One man threw his right leg over the door on the right hand side, hooked his left toe under a steel stirrup on the floor, and waited, astride of the door. On the opposite side of the car, a left-handed marksman, duplicated his motion, his gun across his knees.

The police trap was ready—ready for the bandit car with the running engine, at the curb near the Judson house—ready, but out of sight around the corner.

when

you have done everything
to your set and yet you
don't get *Results* - try

AEROVOX

FIXED CONDENSERS

Tested and approved by M. I. T., Yale, Radio News, Popular Radio and Popular Science. Used by over 200 of America's leading set manufacturers. Made in all capacities. Also manufacturers of Grid Leaks, Resistors, Resistofomers and Rheostats.

Branch Offices:
Chicago, Ill.,
53 W. Jackson Blvd.
Cincinnati, Ohio,
304 Palace Theatre Bldg.
Boston, Mass.,
104 Portland Street
Los Angeles, Calif.,
324 No. San Pedro St.

Accuracy *plus* Quality
Results

AEROVOX WIRELESS CORPORATION

489-491-493 Broome Street, New York City

A NEW WESTON Contribution for BETTER RADIO RESULTS

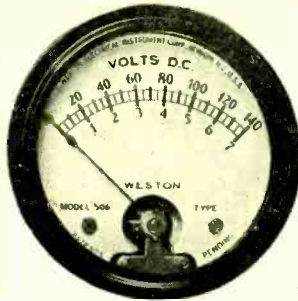

WESTON
506 Voltmeter
and Universal
Bi-Polar Switch

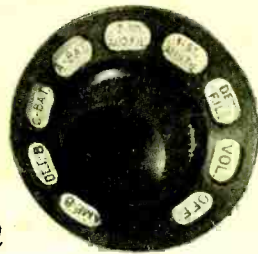

THIS voltmeter and switch on the panel of your set—regardless of make—will give you a complete electrical check—just by a turn of the switch! It insures use of tubes at proper filament voltages, and prolongs their life, extends battery use and gives you an entirely new standard of radio operation. This unique combination of Weston Double Range Voltmeter (140/7 volts) and Multi-Point Switch is recognized as a great contribution to the art of Radio. Such is the fame of Weston Radio Instruments that the best dealers in your community will be eager to show you the Model 506 and Multi-Point Switch; or for further technical information write us at once for the new circular "N" describing it.

Weston Electrical Instrument Corporation

156 Weston Avenue

Newark, N. J.

Pacific Coast Representatives:

Western Electric Company, Seattle, Wash.; J. H. Southard, San Francisco, Calif.; A. A. Barbera, Los Angeles, Calif.; Repair Service Laboratory, 682 Mission St. San Francisco, Cal.

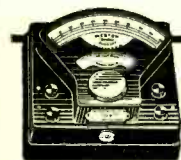

STANDARD THE WORLD OVER

WESTON

Pioneers since 1888

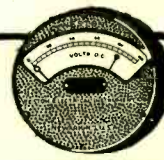

RADIO from Factory to YOU

Get our list price on Parts also
Knocked Down 1 and 3 Tube Sets
Compare List Price with others then
Deduct 20 to 50 per Cent Your Price
A. C. HAYDEN CO., Brockton, Mass.

Tell them that you saw it in RADIO

55

-it's in the TUBE

YOUR receiving set can be no better than its tubes. CECO Tubes give maximum results in clarity of tone, rich volume and long life.

Our charted tests (results confirmed by laboratories of national reputation), PROVE CECO TUBES SUPERIORITY—as detectors, as amplifiers.

Buy CECO Tubes whether your set takes one tube or eight.

Now ready! CECO Tubes with new type long PRONG BASES. Also, power amplifier tubes, E (Dry Cell Type), F (Storage Battery), for last stage of Audio Frequency. Ask your radio dealer.

C. E. MFG. CO., Inc.
702 Eddy St., Providence, R. I.

CECO TUBES

	"A"	"B"	"C"
Filament Volts	5.0	3.0	3.0
Filament Current	0.25	.06	.06
Plate Voltage	20 to 120	20 to 80	20 to 80



Hoyt Radio Rotary Meter

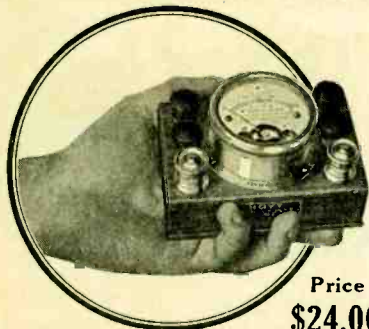

Price
\$24.00

This unique meter will do all testing necessary on Radio receiving sets, tubes, batteries and battery eliminators. It furnishes the experimenter and Radio dealer with a single instrument with 5 different ranges, reading from as low as 1/4 milampere or 1.8 volt to 7.5 milampere or 150 volts. Operation is simple and accident-proof.

BURTON-ROGERS CO.
26 Brighton Ave. Boston, Mass.

London--New York San Francisco

via the new 1926

Super Hetro Radio

Any radio engineer will tell you that a Super Hetro Receiver is the most powerful, most selective and greatest distance getter of all. We offer a 5-tube Super Hetro giving the results and volume of 8 tubes in a beautiful cabinet size 10 by 31 by 11 for the remarkable and most reasonable price of \$45.00 net. Unequaled in construction and appearance. Sold on a free 10-day trial, with a coast to coast reception guarantee. Large circular on request.

**Mercury Electric
Corporation Bldg.**
2030 GRAND AVE.
NEW YORK CITY, N. Y.

The Largest Net Paid Circulation

of any radio magazine on the Pacific Coast is being enjoyed by

RADIOCAST WEEKLY

Send for a free sample copy

PACIFIC RADIO PUBLISHING CO.

Pacific Building - - - San Francisco, Calif.

But Ed had not been asleep all this time. The second trip of the police car past the Judson home had warned him with finality that his machine was under suspicion. He guessed the identity of the big black machine.

"The dicks!" he whispered.

As the car disappeared from sight he ran to the small box on the side of the house where the electric lights fed into the place. It was the main service switch and had been agreed upon as a signalling device for the gang inside.

"Yank the lights if the cops come," Bumper had ordered.

Ed fumbled into the box and found the switch handle. With a quick motion he pulled it and plunged the house in darkness. There was a startled oath inside the dwelling from Bumper Hawkins as the lights went out. Soapy's nerves jangling horribly, crouched against the safe with sudden terror.

"Get out quick," snapped Bumper. "It's the cops."

But such is the trick of Fate that no matter how man figures his cards, the plays fall not to his calculation. It so happened that directly across the room, in a duplicate alcove from the one that housed the safe, was an expensive radio set—one on which Henry Judson had spent considerable time and money. It was more modern than most sets, in that it operated wholly from the electric light circuit. The salesman, when he sold the set to Judson, had emphasized this fact, and Judson had craftily raised an objection.

"On winter nights when the power is off, what will run the radio set?" he had asked.

The salesman, being an individual of resource, paused only a moment in his answer.

"Oh, that's easy," he said. "We'll have an automatic tripper arranged so that when the lights go off, the set will switch itself over to a storage battery."

"That would be satisfactory," said Judson and wrote out a check.

And so it had been done—that very thing. Thus it happened, that when Ed, the driver of the bandit car, jerked the light switch of the house, the radio set was on the circuit. Someone had left it on, perhaps the butler, perhaps Henry Judson himself. Who knows? However it was, when the house went suddenly dark, Soapy McGee heard the click of the automatic tripper behind him as the set shifted over to the storage batteries in its base. To Soapy, with his nerves ajangle it sounded like the click of a gun.

Bumper Hawkins heard it also, but his ears fooled him. To Bumper it sounded like the click of a door. The butler had been over there somewhere. He hurled himself forward suddenly, stumbled, and fell into the radio set, clawing at the thing, whirling one of the

(Continued on Page 58)



DON'T WAIT!
Pep Up That Set Now With
X-L VARIO DENSERS

Install them in your receiver and hear them speak for themselves

SPECIFIED BY
GERALD M. BEST

Endorsed and Used by the Foremost
Radio Engineers

SPECIAL FOR MODIFIED 45,000 CYCLE SUPERHETERODYNE
CAP. RANGE .00002 to .0001 M. F., \$1.50
MODEL N—Capacity range 1.8 to 20 micro-microfarads for balance in Roberts two tube, Browning-Drake, McMurdo Silver's Knockout, Neutrodyne and tuned radio frequency circuits. Price, \$1.00.
MODEL C—Two capacity ranges, .00016 to .00055 and .0003 to .001 Microfarads, for the Cockaday circuit, filter and intermediate frequency tuning in superheterodyne and positive grid bias in all sets. Price, \$1.50.

X-L RADIO LABORATORIES
2426 Lincoln Avenue CHICAGO

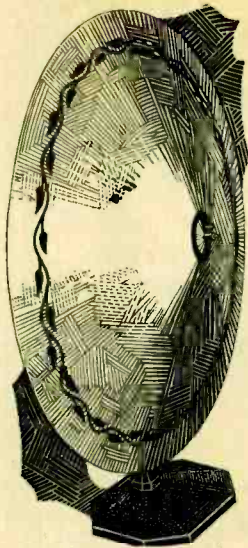

Make Your Own Cone Loud Speaker and Save \$25⁰⁰

(All Parts Supplied)

Why pay \$35 or more for a cone loud speaker when you can easily assemble a splendid super-sensitive one at home with the complete parts we send you—and save \$25?

We include a special complete cone unit, blue print, and simplified directions for assembling. You can easily set up this wonderful speaker in a few interesting hours. Large size, stands eighteen inches high, complete in every detail. Not only unmatched for beauty, but reproduces the finest sound of music or voice with faultless accuracy. Yet the cost is amazingly low—only \$10—for the most approved form of speaker known. You make this big saving because we save the cost of assembling and packing and you save all jobbers' and dealers' profits.

Send No Money

Simply send name and address and the complete outfit will be sent you by return mail. When postman brings package, deposit with him only \$10.00 in full payment. If you aren't more than delighted—if you're not absolutely convinced that you have a cone speaker equally as fine as any \$35 cone sold—simply return the parts within ten days and your money will be instantly refunded. Never before has a better radio bargain been offered. You would pay at least \$35 for a cone speaker of equal quality anywhere. Act at once. Write NOW!

SCIENTIFIC RADIO LABORATORIES 254 West 34th Street, Dept. 63
New York City

NEW S-M PARTS

Low Loss Inductances

All-bakelite, low loss, interchangeable coils for 50-500 meters. May be used as oscillators, antenna adapters and R. F. Transformers in standard circuits. Each 3 1/4" long with winding diameter of 2".



Price All Types 50-600 meters Each \$2.50
Sockets for any size coils Each \$1.00

S-M 210 and 211 Transformers



Designed so that maximum amplification will be obtained at 60 kilocycles. Both types in bakelite housings, hermetically sealed. No. 210 is iron-core type while No. 211 is of the air-core type, and is supplied with measured tuning condenser. Each transformer is furnished with individual laboratory curve chart. Price, Both Types.....Each \$6.00

S-M Type 316 Low Loss Condenser

Double bearing type, supplied with permanent finish brass plates. Stator section placed rigidly in U-shaped, die-cast frame carrying two adjustable cone rotor bearings. Special feature permits ganging any number of condensers one behind another for single control dial. Provided for single or double hole panel mounting and two-hole base mounting. Price...\$5.75

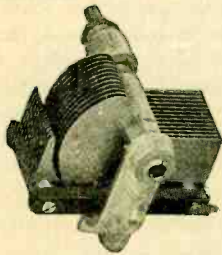

Universal Vernier Dial

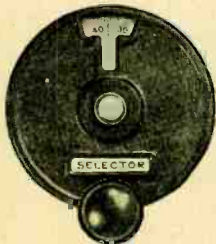

Composed of black bakelite dial housing enclosing reversible, celluloid-finished indicator plate marked off to half-degree divisions. Ratio: 14.5 to 1. Absolutely without backlash due to automatic friction take-up. Fits any condenser—left or right—half or full turn movement. Price\$2.50

See S-M Products at your Dealer's or send for Circulars

Silver-Marshall, Inc.
106 S. Wabash Ave., Chicago.

"A Better Condenser"



The TOBE DEUTSCHMANN High-Voltage Bi-Pass Condenser in its silvered, shielded metal case is designed for all usual by-pass work in radio receiving sets, and for construction of "B" eliminators of the Raytheon and other types.

0.10 Mfd.....\$0.60	0.5 Mfd.....\$0.75
0.25 Mfd.....\$0.70	1.0 Mfd.....\$0.90
	2.0 Mfd.....\$1.75

We announce a new TOBE High-Voltage Filter Condenser for strictly filter uses, for power amplifiers and other high-tension work up to 750 volts. Each of these is individually tested and stamped with date of test. Accuracy is guaranteed to within 5% of rating. Put up in heavy metal cases and recommended for precision work. Prices are the same as our former list on filter-condensers.

The new TOBE "B" BLOCK is out for "B" eliminator construction, with one 8 Mfd., two 2 Mfd., and two 1 Mfd. condensers in one case. Saves \$2.50 over cost of separate units,—saves space,—saves wiring. Send for free eliminator diagrams

TOBE DEUTSCHMANN COMPANY
CORNHILL, BOSTON, MASS.

THE BIG OBSTACLE to Sending removed —



Price
\$17
More than simply a key

MARTIN VIBROPLEX SENDING MACHINE WORKS THE EASY WAY—JUST PRESS THE LEVER—the machine does the rest.

Over 100,000 Radio and Telegraph Operators consider VIBROPLEX a first necessity, and use it daily. An expert's speed, clarity and precision result to beginner and master operator alike from the use of VIBROPLEX—signals that are easy to read.

The illustrated model (\$17) can be used directly in the majority of DX circuits; furnished with extra heavy contact points (\$25) for direct use in any circuit (without relay).

Send check, or money order for either model, or pay postman.

VIBROPLEX CO., Inc.

796 FULTON STREET BROOKLYN, N. Y.

Machine for Winding Honeycomb Coils

With this machine anyone can wind their own low-loss coils to suit their particular requirements. It will wind honeycomb type coils any width from one-half inch to one inch and the inside diameter of the coil can be arranged to suit by using various sizes of wooden spools on the winding spindle. It has a recorder with an adjustable pointer for counting the number of turns. Each machine is neatly finished in black enamel and packed in an individual carton. Price \$6.00

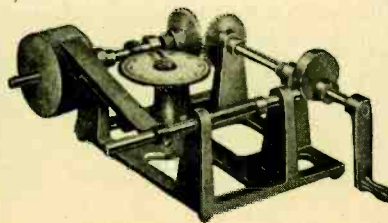

MORRIS REGISTER COMPANY

Succeeding Morris Cash and Credit Register Company
Factory: 29th and Broadway, Council Bluffs, Iowa.

TEAR OUT

Radio Institute of America
322 Broadway, New York City

Please send me full information about your Home Study Course of radio instruction.

I am interested in the complete course, including code instruction, which qualifies for the U. S. Gov't Commercial or Amateur Radio License.

I am interested in the technical course for radio dealers, jobbers and salesmen.

Name

Address

A Shortage of Trained Radio Men!

We can't supply trained radio operators to the shipping companies fast enough! Atlantic, Pacific—Gulf and Lakes—our graduates are sought everywhere.

You can't get better radio training than that offered by Radio Institute of America. Courses planned and supervised by RCA secure you your 1st Class Commercial Radio Operator's License. And an immediate position awaits every graduate.

Moreover you can study at home in spare time.

The coupon will bring you complete information.

RADIO INSTITUTE OF AMERICA

Formerly Marconi Institute
Established in 1909

322 Broadway, New York City



AMPLION

**Product of
38 Years'
Experience**

For Better Radio Reproduction

"I have listened to many loud speakers, but never to any music which can compare with that reproduced by the Amplion. The sound is clear, sweet and well modulated. It brings in clearly instruments in bands and orchestras that were lost in other speakers. Through my Amplion I enjoy my radio to a degree I had never thought possible."

You will be as appreciative as this gentleman, once you hear your set through an Amplion. Creation of the originators and oldest makers of loud speaking devices—Alfred Graham & Co., London, England—The Amplion leads in popularity throughout the world.

Enjoy an Amplion demonstration at your dealer's. Six models, including phonograph units, equipped with cords and panel plugs, \$12 up. Write for the "Amplion Pedigree."

**THE AMPLION CORPORATION
OF AMERICA**

Suite O, 280 Madison Ave., New York City

Chicago Branch: 27-29 N. Morgan St.

Burndep of Canada, Ltd., Toronto

(Continued from Page 56)

dials so that the set co-ordinated suddenly with the station across the bay, just as the company, broadcasting "Her Second Choice," came to the tense scene between the wronged husband and the false friend.

Wilford, the star, had no previous knowledge of Soapy McGee or Soapy's pals. He was not concerned with the robbery of the Judson home, or the cruising of the police "death car." He was concerned only with a director who had aroused his wrath by an unjust criticism of his acting. His wicked resolve to

put emphasis into his part came to a head. And so . . .

"You dirty dog—put up your hands and take what's coming to you!" he roared with stentorian force.

The words burst into the library of the Judson home with the concussion of a field piece. With a squeak of pure animal terror Soapy McGee whipped out his automatic and began firing toward the sound. Bumper Hawkins, struggling to regain his balance, got the bullet in his back. He went down, coughing, clutching at his own weapon. Presently he began firing toward Soapy, the flashes of the two weapons lighting the room intermittently with a dim death glare.

Ed, at the first shot had run back to his car, and jumped to the seat. A moment later, Peter came running from the rear, hatless, and breathing heavily.

"Let's get out of here," snapped Ed, nervously, as the muffled detonations of the two automatics came to their ears.

"Step on her," ordered Pete, and the machine raced away from the curb, gathering speed. As it shot across the street intersection, the police machine, with two men astride of its doors, roared up alongside.

"Pull up there!" commanded the sergeant. "This is the police machine."

"Go to hell!" shouted Pete, and emptied his gun at the nearest face—that of the driver—trying to shoot him out of the seat. The bullet spatted harmlessly on the bullet-proof glass, making a tiny frosted spot.

Ed, the driver, opened his throttle and began to draw away from the heavier police car. As he did so, the police chauffeur, as coolly and deliberately as a billiard player, swung the black death-trap into the rear-wheel of the bandit machine, crushing the whole vehicle diagonally against a telephone pole, with a sickening smash. Ed was conscious, only for a moment of the action, of a dull wonder, and then the contents of a sawed-off shotgun fired at a distance of about eight feet, bored through the car and into his back . . .

Pete heard Ed's death-scream. He twisted in his seat to stare at him, in time to get the second barrel . . .

Back in the Judson house, while a terrified maid screamed on the upper floor, Soapy McGee clawed desperately at the face of a safe he was destined never to open, and sank slowly to the floor, the world going black around him, and his head toward the dead body of Bumper Hawkins . . .

"I knowed I should've . . . woiked alone . . ." he gasped—and died.

And across the bay, in the broadcasting station, a director with blazing eyes, fronted a star whose pique had led him to break all canons of good acting to put an idea across. "You've raised hell!" he said. He never knew how true his words really were. . . .

McCAA ANTI-STATIC DEVICES

(Continued from Page 13)

The middle cabinet in Fig. 4 contains the instruments represented in the middle of the schematic diagram (top and lower compartments). In order to indicate more clearly the arrangement of the apparatus, a line drawing has been made of the rear of this cabinet. Each of the parts is marked the same as in the circuit diagram and the values of inductance and capacity are given.

The dimensions of the cabinet are 15 by 12 by 7 in. deep. The cabinet must be shielded and the two compartments also shielded from each other. The shield is grounded. Care should be taken with this part of the construction because otherwise static impulses will enter and destroy the anti-static action of the outfit. Copper lining, well bonded, is satisfactory.

The lid for this cabinet may be placed either at the back or else at the top of the top compartment and at the back of the lower compartment. The lids should be provided with flanges of copper.

The coils *D* and *L* are wound on the same tube, $1\frac{3}{4}$ in. in diameter. There is a space of $\frac{1}{4}$ to $\frac{1}{8}$ in. between *D* and *L* which are wound in the same direction. The tube is placed inside of coil *A* so that the space containing no wire comes in the center of the honeycomb coil *A*.

In the accompanying picture of the complete outfit, a neutrodyne receiver is shown on the right. The anti-static device may be placed ahead of practically any type of receiver. Although the receiver may ordinarily tune broadly the device makes the set very selective. Dr. McCaa says the anti-static device will operate with a regenerative receiver, but its action will not be so satisfactory, because the feedback amplifies the incoming signal oscillation in the antenna circuit and thereby presents less favorable action.

It should be noted that the main receiver should be shielded as the anti-static device would be of little avail if the static and stray discharges could affect the receiver itself after being weeded out by the device.

The battery leads may be run in a shielded cable, the outside of which is grounded. The *B* batteries for the middle cabinet may be placed directly inside the top compartment in the spare space. Of course, if the large type of *B* batteries are employed this is not possible.

The number of turns of the honeycomb coil, *S_M*, will depend upon the capacity of the variable condenser in the main receiver and hence should be chosen accordingly.

Operation

After the complete set has been assembled and connected to a good grounding system, the outfit is ready for opera-

Let the Pure Tones Through

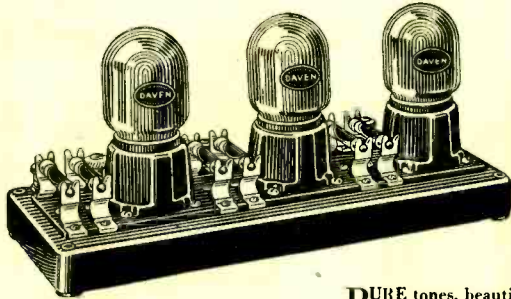

The Daven Super-Amplifier used with any set or circuit carries through the full, clear tones of the broadcasting station programs. If you prefer to assemble the Amplifier, obtain the Daven 3-stage Kit, which includes all parts except sockets.

Make Your Old Set A 1926 Model!

PURE tones, beautifully clear and full, go out from the broadcasting station. They reach your detector still pure and clear. But what then?

From the detector your amplifying apparatus operates. Distortion arises unless you take advantage of a method of amplifying that far-sighted manufacturers and thousands of set builders are now adopting—Resistance Coupled Amplification. Resistance Coupling is not new, but *Resistance Coupling with real volume amplification is new*. It is the most approved method of letting pure tones through.

The Daven Super-Amplifier costs little. It is easily and conveniently installed in any set made. Buy it complete to save hook-up labor. For those preferring to assemble, the Daven 3-stage Kit gives all the necessary parts except sockets. You will join hundreds of others who have written to thank us for the improvement Daven has given.

Write us today for The Resistor Manual, an authoritative book on Resistance Coupled Amplification, 25c at good dealers, 30c by mail.



The new Daven Special Coupling Condenser Type "A", for Resistance Coupled Amplification, sold separately and also included in all Daven Amplifiers. Kits and Resistor-Couplers. For greater volume and better quality.



The new Daven High MU Tube Type MU-20, used with the Daven Super-Amplifier, gives 50% more volume—6 volt, $\frac{1}{2}$ ampere. A Daven Power Tube Type MU-6 in the last or output stage helps any set regardless of the method of amplification—6 volt, $\frac{1}{2}$ ampere.



THE RESISTOR MANUAL is the handbook of Resistance Coupled Amplification. At your dealer's 25c. By mail postpaid 30c.

DAVEN PRODUCTS ARE SOLD ONLY BY GOOD DEALERS

The Sine of Merit
DAVEN RADIO CORPORATION
Resistor Specialists

Newark

Reg. U. S. Pat. Off.

New Jersey

CLIP THIS COUPON

DAVEN RADIO CORPORATION
131 Summit Street, Newark, New Jersey
Please send me the following on Resistance Coupled Amplification:
Check One
 Resistor Manual. 30c is enclosed.
 Complete Catalog (free).

Name

Address

For Dealers: Send your letterhead and we will have our nearest distributor communicate with you.

THE BIG LITTLE THINGS OF RADIO

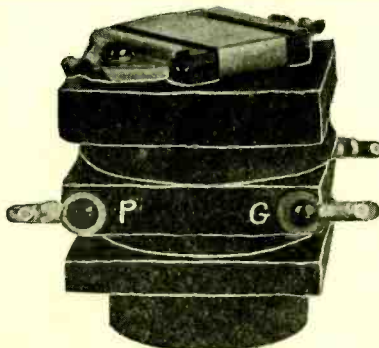

Filter Transformers

Northern Electric Type Filter Coils, adjusted to any specified frequency between 25 and 60 kilocycles, complete with calibrated condenser

ONLY \$5.00

ARMY SALES COMPANY

1650 JACKSON STREET
SAN FRANCISCO, CALIFORNIA

Throw away that inefficient, unknown quantity in your set and replace it with a filter which won't distort.

Can You Read Pictures?

?

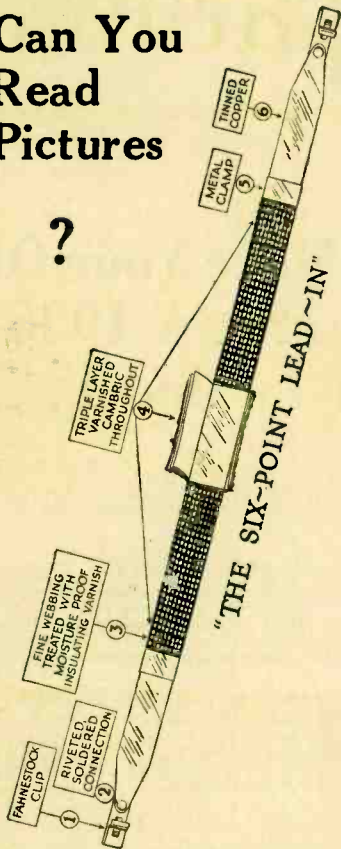

Then these pictures will tell you why you should refuse anything but an Electrad Certified Lead-In.

Saves your window or door frames. Fits under locked windows. Bends to any desired shape. Imitations do that too, but they stop there. Notice what else you get in the Electrad: 3000 volt insulation, 10 inches long, water-proofed and protected entire length. Riveted and soldered Fahnestock slips.

Sold at all good radio stores and counters. Price 40c. Ask for it by name. For safety's sake refuse imitations.

For Clearer Purer Reception Do this---

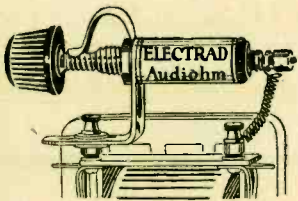

Place an Electrad Audiohm across the secondary of your audio transformer. Then you will enjoy your radio. Kills distortion, eliminates squeals and howls. Fits all audio transformers. Easy to attach. For sale at all good radio stores and counters, \$1.50.

ELECTRAD, INC.

428 Broadway, New York

Makers of Certified Radio Essentials and Accessories: Grid Leaks, Fixed Condensers, By-Pass Condensers, Variouhms, Resistances, Rheostats and Potentiometers, Jacks, Switches, etc. Write for Catalog.

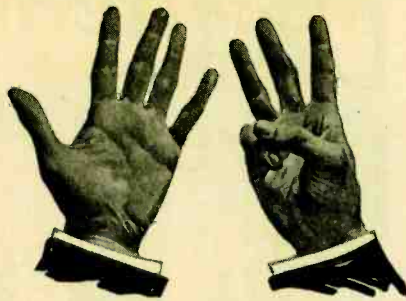

8 OUT OF 10 of America's Radio Receivers are Factory Equipped with Eby

It is not guesswork that has made EBY Binding Posts standard equipment on 80% of the radio receivers made in America. Nor is it price.

EBY is the almost unanimous choice of the radio manufacturers because of their own tests—the most exacting science can devise.

Your dealer has all of the 27 different markings and will gladly show you their points of superiority.



27 different markings
List price 15c

AND NOW ANOTHER EBY LEADER



EBY QUALITY SOCKET

This new socket insures a positive wiping contact at all times. Its ingenious design allows the tube to "float" when in service, thereby reducing microphonic noises and protecting the tube against damage. And it also permits interchangeability and other features of the new UX and CX tubes.

List Price 60c

If your dealer can't accommodate you, write direct to us

H. H. Eby Mfg. Company

4710 STENTON AVE.
PHILADELPHIA, PENNSYLVANIA

tion. First of all the bucking action of the P_1 and P_2 coils on the secondary of the main receiver is determined in the following manner. The repeater tube is not lighted and the switch X is closed. Tune in a station. This is accomplished by tuning the aerial circuit. (The primary or P coil inductance of the antenna coupler will depend for its size on the aerial system and the series variable condenser. Try a 50 or 75 turn coil with a .0005 mfd. variable).

After the coupler primary has been tuned, vary the capacity of C_s and bring the volume to maximum by varying the coupling between P and S . The main receiver must also be tuned and if a potentiometer is used as shown in the circuit of Fig. 3, adjust it well under the oscillating point.

The switch X is opened and if the coils are properly connected, the desired signal will not be heard. Be sure this is possible before proceeding further. The coupling of P_1 to S_M will be closer than P_2 to S_M because P_2 is larger than P_1 . It is very important to note whether static and other noises have been bucked out. If noises are heard, examine the main receiver and its shielding, etc. Naturally, it is folly to build an anti-static unit for use with a "static factory" in the receiver itself. If you wish to work with anti-static units take the trouble to employ a good receiver.

With the switch X still open and no signal or static coming through, light the filament of the repeater tube. Vary the capacity of C_r , tuning the grid circuit of the repeater so that it is set for the frequency of the desired station. Adjust the potentiometer of the repeater until the desired signal is heard in the main receiver. If the signal is not of normal strength, increase the coupling of P_3 to S_1 . The coils are placed approximately as shown in the line drawing of the anti-static apparatus.

The repeater tube must be neutralized with the midget condenser. To determine the neutralized point move P_3 away from S_1 and then vary the neutralizing condenser until no signal is heard. This indicates there will be no feedback of energy induced in D from A over to the grid of the tube.

If the dials of the main receiver have not been logged it will be found helpful to tune in stations by the carrier-wave whistle. The potentiometer of the repeater is advanced until the whistle is heard and the tuning can then be readily accomplished.

Try the anti-static device for several stations and if it does not seem to be giving maximum results, it is likely that coil P_2 and coil A should be changed to some higher value of inductance as shown in Fig. 3. This shifts the band of static components farther away from the signal frequency.

Static Balance Circuit

The foregoing explanation should be

MYERS TUBES



Get Out of the Fog

Myers Tubes make an instantaneous improvement in the clarity, volume, distance and quality of reception from any Radio Set.

The Tube is the Voice of the Circuit

MYERS Tubes are real Radio Tubes—not modified incandescent lamps. They are made by pioneer Radio Tube designers, for Radio purposes exclusively. Compact, precisely correct, free from dead spaces and clumsy dimensions. Finest performance, finest appearance.

Special internal geometry gives highest mutual conductance and largest factor of amplification, resulting in maximum performance when used in either transformer, impedance or resistance coupled circuits.

Unbreakable in normal use. Double-end electrode supports. Absolutely non-microphonic. Perfectly uniform. No matching necessary.

Marvelous Clarity

Internationally preferred by amateurs and experts. Made with standard four prong base, or double-end, in types Myers 01A, Myers 01X, Myers 99, Myers 99X.

List price, any type \$2.50.

Fully protected by patents pending and issued in the United States and Foreign Countries.

At Your Dealers

Myers Radio Tube Corporation
Cleveland, Ohio



You Get Perfect Tone Quality With MURDOCK Headphones.

WM. J. MURDOCK CO.

211 South San Pedro St., Los Angeles;
509 Mission St., San Francisco; 406 Occidental St., Seattle, Wash.

MURDOCK RADIO

ARE YOU A SUBSCRIBER?
SEND FOR TRIAL SUBSCRIPTION
\$1.00 FOR SIX MONTHS

ARE YOU THE MAN ?

to be the first in your town to sell and demonstrate **POWEROLA**, the famous 5 tube **NO-BATTERY ELECTRIC LIGHT SOCKET RADIO RECEIVER** (not an attachment), universal for D.C. or A.C. (110-115 v. 40-60 cycles), now sold and demonstrated thru **THE NEW YORK EDISON CO.**, public utility companies and radio, electric and music dealers everywhere. Absolutely dependable, fully guaranteed, powerful, practical, perfect in performance. Tested and endorsed by Popular Radio, Radio Broadcast, Radio News, and all leading Authorities and Engineers of your local electric light company.

Are You the Man Who Sees Opportunities Ahead for Real Money Making?

Write for literature, terms and prices at once

You Too Can Make Powerola

Send \$1.00 for wiring diagrams showing how to rewire any old or new parts. Battery Sets, or Radio Circuits (1 to 8 Tubes) and power apparatus used, to operate satisfactorily from A.C. or D.C. Get in at once on wonderful and exclusive business. Thousands of homes are waiting for you now.

Powerola Radio Corp.
1845 Broadway Dept. R N. Y. City

Jo-day
-in every
good set!



A turn of the Tuning Dial—that's all!

And presto! The AMPERITE self-adjusting rheostat control does the rest. Tones so clear, voices so distinct, volume so good, you simply are amazed. Tubes deliver as never before when under the seemingly magical influence of AMPERITE individual control. No guessing. Less wiring. Permits of any type or combination of tubes. Specified in all popular construction sets. Price, \$1.10.

There is an AMPERITE for every tube

Write for free hook-ups

Radiall Company

Dept. R.-3, 50 Franklin St., N. Y. City

AMPERITE
REG. U.S. PAT. OFF.
The "SELF-ADJUSTING" Rheostat

VEBY HIGH-MU TUBES

Will give your resistance-coupled amplifier greater volume of better quality than is possible with any other tube.

A. F. 20 High-Mu\$3.50
A. F. 6 Power Tube.....\$4.50

VEBY RADIO CO.

"Quality Resistors"

47-51 Morris Ave. Newark, N. J.

coupler box, which will give a neat arrangement.

In conclusion it should be said the McCaa anti-static circuits here presented will give satisfactory results if attention is paid to careful construction and operation. Although the devices will find the greatest use in summer, nevertheless many fans living in localities where atmospheric disturbances produced by machinery abound will find it valuable all year long.

NEWS OF THE AMATEUR OPERATORS

6BMM has been re-issued to Wm. A. Lang, 133 East Avenue 44, Los Angeles, Calif., who formerly operated 2ATI. He will soon be on the air again.

6BJX, E. O. Knock, 2823 East 6th St., Los Angeles, Calif., was heard in England while he was working PI-1HR on 40 meters. He has maintained continuous schedule with the Philippines since Oct. 9th.

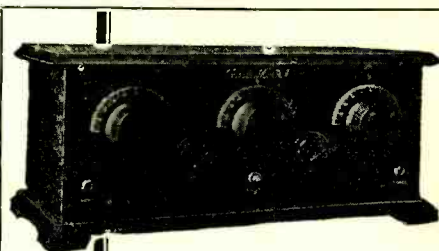

In
7x18"
Cabinet

It's
a
5-Tube

Gold Medal
Tuned
Radio Frequency
Receiver

Was \$60
without accessories

NOW \$25

without accessories

Agents write for proposition

Satisfaction Guaranteed

Delivered free anywhere
in the United States

Gold Medal Radio

1048 Longwood Avenue
New York City

Tell them that you saw it in RADIO

SHORT WAVE OSCILLATORS

(Continued from Page 40)

acts as an aerial and reflector and so radiates energy and the main idea of such a reflector is to get the wires placed so that re-enforcement occurs in the desired direction and counteraction in other directions. The further the sides of the parabolic cylinder are extended, the sharper the beam, and when so extended, the spacing between the wires can be made greater, a half wavelength seeming to give less radiation to the rear in actual tests on three meters. The correct locations of the reflector wires can be computed easily using the formula of a parabola, $y^2 = 4px$ where $p = \lambda/4$ or a quarter wavelength, and using rectangular coordinates.

A more desirable reflector for such short wavelengths would be more on the plan of a searchlight with the antenna as concentrated as possible so as to have it near the focal point of the reflector. Any metal bowl which was about 2.5 feet across and about 7.5 inches deep could be used with pretty good results. Perhaps the most efficient aerial would be a tiny loop aerial fed by the r. f. transmission line. The main idea would be to have it very much like a searchlight so that the beam could be readily sent in any desired direction. Such an arrangement would look something like a small electric heater which has a cylindrical or parabolic reflector.

In order to receive such a beam using present day vacuum tubes, the best scheme would be to use a wire some multiple of half wavelengths long and attached at its lower end to a grid condenser and grid of the tube. Such a wire will be tuned approximately to the transmitted wave, that is, it will have a definite period with respect to that wave. In order to obtain detector action, a small grid condenser and a grid leak to filament should be used. Since such a system would not be very sensitive (similar to a non-regenerative receiver), and regeneration cannot be used readily, the best thing to do would be to use the super-heterodyne principle. An oscillator could be set up on some higher wavelength and one of its harmonics used to heterodyne the incoming signal to some lower frequency and a radio or intermediate frequency amplifier used. This principle should be used on higher wavelengths such as on the five meter band where a wire say one wavelength long or two should be connected to the grid of this tube and the incoming frequency heterodyned down to a lower frequency and into an amplifier.

Some interesting things were noticed about this type of transmitter, one being that enough power could be drawn from the parallel wire oscillator with a one turn coupling coil to burn out a flashlight lamp even when the power input to the five watt tube was much less than normal rating. Another thing was that some of the harmonics of this oscillator when it was overloaded were strong enough to be quite noticeable with the parallel wire wavemeter. In one case, operating the oscillator on about 2.1 meters, the harmonic on 30 centimeters was so strong that the oscillator would cease working when the parallel wire wavemeter was tuned to 30 centimeters. This was the seventh harmonic and could have been used on the amplifier and by having the amplifier circuits tuned to a 30 centimeter wavelength, this wave could have been transmitted.

AIR LINE MAP AND LOG

50c The best log and map we have ever seen. Very handy and simple.

"RADIO"

Pacific Bldg. San Francisco

Headquarters for

C-10 and C-7 Parts
Golden-Leutz Plios
Pliodynes and Super Pliodynes
General Radio Apparatus
E. I. S. Apparatus
Dubilier Condensers
Weston Meters
Formica Panels
Premier Jacks
Cunningham Tubes
General Electric Tungars
Mahogany Cabinets
Special Engraving
Special Condensers, Coils,
Shielding, etc.

No General Catalog
Issued

Write for quotation on any Radio
Apparatus or material required

NORDEN-HAUCK, Inc.
ENGINEERS
1617 CHESTNUT STREET
PHILADELPHIA, PA.

NEW PROFITS For Radio Dealers



The B & R 5 Battery Charger will charge 5 Radio "A" batteries at once. Built for 110 volts, no power line needed. Plug it in on any lamp socket and set it to work. It pays for itself in two to three months.

Price, \$60, with bulb
Send for our Charger booklet

BURTON & ROGERS MFG. CO.
755 Boylston St., Boston, Mass.

ARE YOU A SUBSCRIBER?
SEND FOR TRIAL SUBSCRIPTION
\$1.00 FOR SIX MONTHS

RADIOADS

A Classified Advertising Section
Read by Better Buyers.

The rate per word is eight cents net.
Remittance must accompany all advertisements. Include name and address when counting words.

Ads for the March Issue Must Reach
Us by February Fifth

AGENTS! Make \$60.00 weekly. Distribute quality food and toilet preparations among friends and neighbors. No money or experience necessary. Free automobile. Desk BF3, Health Products Co., Cincinnati, O.

AGENTS—STEADY INCOME. Large manufacturer of soaps, perfumes, toilet articles and pure food products, etc., wishes representatives in each locality. Manufacturer direct to consumer. Big profits. Honest goods. Whole or spare time. Cash or credit. Send at once for particulars. American Products Co., 5793 American Bldg., Cincinnati, Ohio.

LARGE SIZE connected Edison Elements, 4c a pair. Dealers, write for prices. See-Jay Battery Co., 915 Brook Ave., New York City.

DO YOU GET TIRED of buying "B" batteries? A lifetime Edison will solve your troubles. Good, live, large size elements connected with pure nickel wire, electrically welded, .07c pair. All parts for sale. Sample cell and dope sheet, 10c. Paul Mills, Woodburn, Oregon.

WANTED—More readers of "RADIO" to advertise their used equipment in these columns. RADIOADS bring quick and profitable sales. Turn your excess apparatus into profit. Some of our readers want just what you have to offer. Try the RADIOADS. You, too, will then be convinced that they PAY. Mail your copy now for the next issue.

KEEP station records in THE RADIO LOG BOOK, a handy pamphlet for recording stations heard, dial settings and other data. The price is only 10 cents per copy. For sale by Pacific Radio Pub. Co., Pacific Building, San Francisco.

MAKE \$100 WEEKLY in spare time. Sell what the public wants—long distance radio receiving sets. Two sales weekly pays \$100 profit. No big investment, no canvassing. Sharpe of Colorado made \$955 in one month. Representatives wanted at once. This plan is sweeping the country. Write today before your county is gone. OZARKA, INC., 126-E Austin Avenue, Chicago.

THE NEW square plate Ensign Variable Condensers. JUST OUT! Brass plates. Efficient on low waves. Get one of these condensers without cost in return for your subscription to "RADIO" for only two years. Five dollars brings you the condenser and the magazine. Send your check now. There are only a few of these condensers in our stock. "RADIO," Pacific Building, San Francisco.

FUNNY RADIO STORIES. Twelve of 'em in the "RADIOBUSTER," Volney C. Mathison's humorous thriller. 112 pages in bound form. Mathison knows how to write. You will enjoy his stories. Send \$1.00 today for a copy of the "RADIOBUSTER," or get it free with your subscription to "RADIO" for one year (\$2.50). Pacific Radio Publishing Co., Pacific Building, San Francisco.

YOUR RADIO QUESTIONS ANSWERED FREE.—Gerald M. Best, technical editor of "RADIO," will answer ten radio questions for you if you subscribe to "RADIO" for only one year at \$2.50. Get this wonderful technical service, together with a good, practical radio magazine. "RADIO," Pacific Bldg., San Francisco.

RADIOCAST WEEKLY

Sixty-four Pages of Programs,
Photos, Humor, Musical Reviews,
Schedules, Tables, Editorials, Etc.

5c Per Radiocast Weekly
Copy 433 Pacific Bldg.,

SAN FRANCISCO

Tell them that you saw it in RADIO

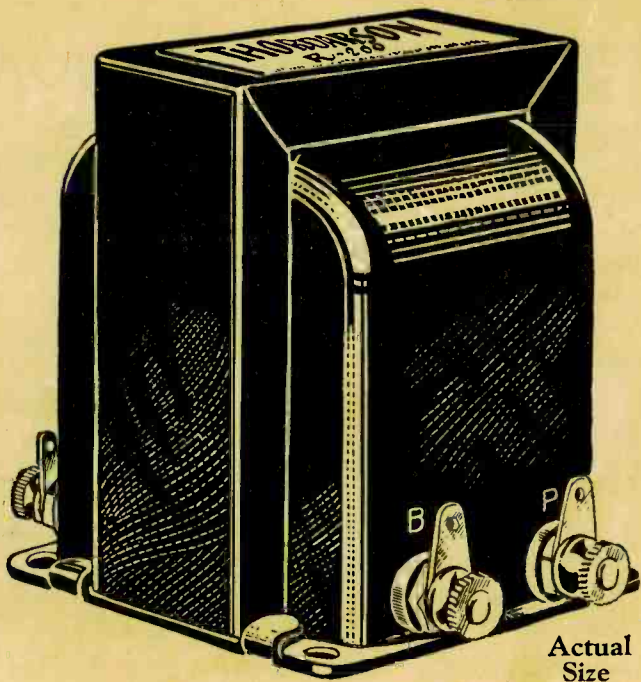

Actual Size

Here is the New
THORDARSON
R-200

used in the
Silver-Cockaday
 Single Control
 Receiver

described in Popular Radio, March

Price \$8 each

A Big New Audio Frequency Transformer—Guaranteed by Thordarson

THIS big new Thordarson R-200 contains a super-size layer-wound square coil. The much larger magnetic circuit, so provided, minimizes core losses (a leading cause of distortion in powerful receivers). If your present transformers distort voices and instruments when you desire full volume, if they blur the low notes, if they are lacking in genuine musical quality, replace them with a pair of these big new Thordarson R-200's. Ideally adapted for all two-stage amplifiers.

If dealer is not yet supplied, order from us. Write for fully descriptive literature.

Other Thordarson Transformers

Autoformers (All Frequency Amplifiers), \$5 each. Regular Super Audio Frequency Transformers in either sub-panel or top mounting type: 2-1, \$5; 3½-1, \$4; 6-1, \$4.50. Power Amplifying Transformers, \$13 the pair. Interstage Power Ampli-

fyng Transformers, \$8. For Raytheon B-eliminators: R-195 Transformer, \$7; R-196 Choke, \$5. All Thordarson products are unconditionally guaranteed. Shipped direct upon receipt of price, if dealer cannot supply.

THORDARSON ELECTRIC MANUFACTURING CO.
Transformer specialists since 1895
WORLD'S OLDEST AND LARGEST EXCLUSIVE TRANSFORMER MAKERS
Chicago, U.S.A.

ZENITH
KENNEDY
 WI
Radiodyne
 CL
Planstiehl
Howard
Thermodyne
OZARKA
Deresnadyne
ADLER-ROYAL
MURDOCK
MU-RAD
Valleytone
LEICH
Silver-Marshall
GLOBE
Monark
Newport
BUCKINGHAM
NUNN-LANDON
KUSTOMBILT and
many others
 use Thordarson
 Super-Amplifying
 Transformers

Nationals Win Experts' Approval

For several years we have supplied the leading radio experts with NATIONAL apparatus. As they progressed in their development of the science and art of radio, we have met their expanding needs. They have become our steadfast friends.

NATIONAL radio products are the standard of quality. Comparisons only serve to emphasize the recognized leadership of radio apparatus bearing the NATIONAL name.

Home set-builders are safe in following the example of experts in choosing NATIONAL radio products.

National Transmitting Apparatus Used by Gerald M. Best, Technical Editor of Radio

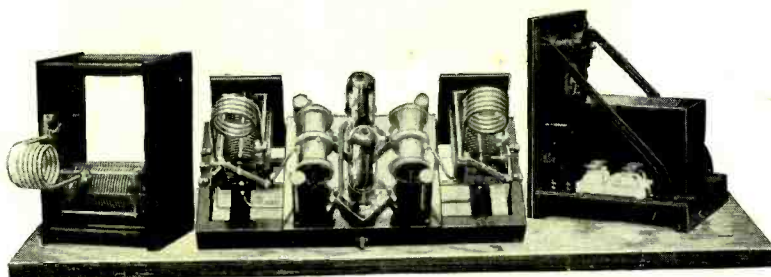

The illustration shows Mr. Best's short wave transmitter, using NATIONAL Type DXT transmitting condensers. These condensers are designed for continuous operation at 1500 volts—400 meters.

FOR THE HOME SET-BUILDER

These NATIONAL Radio Products Give the Utmost Satisfaction

NATIONAL Tuning Units Embodying the Genuine BROWNING-DRAKE TRANSFORMER

BD1-A
Patents pending

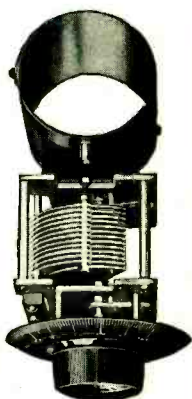

NATIONAL Tuning Unit BD1-A, comprising the BROWNING-DRAKE Inductance Coil and NATIONAL Condenser.

Price \$9.25

Also the
National
Equimeter
(Straight Line Wave
Length)
CONDENSERS

and the

National
Velvet Vernier
DIALS

NATIONAL Tuning Units are standard — their efficiency proved.

Send for Bulletin 105R

BD2-A
Patents pending

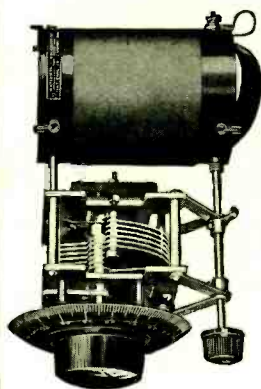

NATIONAL Tuning Unit BD2-A, comprising genuine BROWNING-DRAKE Transformer and NATIONAL condenser.

Price \$12.75

The New NATIONAL IMPEDAFORMER



An impedance coupled audio system that does away with transformers. Includes choke coil, grid condenser and grid leak built into a single unit so that its connections are the same as an ordinary transformer. Prices: Type A (choke coil only) \$4; Type B (complete) \$5.50.

Send for Bulletin 103R.

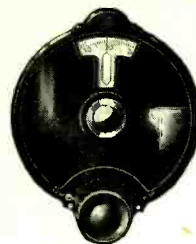

Price \$2.50

Send for Bulletin 109R

Type B, Variable Velvet Vernier Dials

With this new NATIONAL Type B Dial, any ratio you desire, from a minimum of 6 to 1 to maximum of 20 to 1, is instantly obtained by shifting a small lever. It's marvelous how it separates stations. Has the same velvety smoothness, the same freedom from back lash as the National's popular Type A Dial. Easily mounted on the 1/4-inch shaft of any standard variable condenser.

*Get the Genuine. Insist upon NATIONAL COMPANY'S RADIO Products.
Your dealer appreciates your patronage and will gladly get them for you.*

NATIONAL COMPANY, Inc.
110 Brookline St. W. A. READY, PRESIDENT Cambridge, Mass.

130,000 times better

One of the great steps forward in the development of the Radiotron was the evolution of the X-L filament.

When you tune in to clear reception, do you know that a stream of electrons leaping from a glowing filament is the current which, translated into sound, you hear as a symphony, a jazz orchestra, a clever story?

The more electrons thrown off at a given temperature, the longer the tube lasts, and the longer the batteries last. The X-L filament in Radiotrons UV-199 and UV-201-A throws off, at operating temperature, 130,000 times as many electrons as an ordinary tungsten filament. In one sense, therefore, the X-L filament is 130,000 times better!

And this filament means stability, too—and silent operation. And it keeps its efficiency practically to the end of its life.

Watch for the RCA mark on every tube you buy, and know that you have the latest, most perfected tube, as well as the most accurately made.

Radiotron UV-201-A

is the standard tube for storage battery sets. UX-201-A is exactly like it, but has a new base.

Radiotron UV-199

is the standard tube for dry battery sets. UX-199 is exactly like it, but has a new base.

RADIO CORPORATION OF AMERICA
New York Chicago San Francisco

RCA Radiotron

MADE BY THE MAKERS OF RADIOLAS

Printed by the Leighton Press, San Francisco, Calif.