

25c [30c
in Canada]

JUNE, 1934

\$3.00
PER YEAR
BY SUBSCRIPTION

RADIO

ESTABLISHED 1917

SHORT-WAVE AND EXPERIMENTAL

- IN THIS ISSUE -

New 50-Watt RK-20 Pentode Oscillator
New Data on Grid Modulation Systems
New HK-357 Gammatron Tube Data
New and More Efficient Push-Push Doubler



Admiral Byrd's Expedition
Tunes-in on American
Broadcasts with a
McMurdo-Silver Mas-
terpiece Receiver.

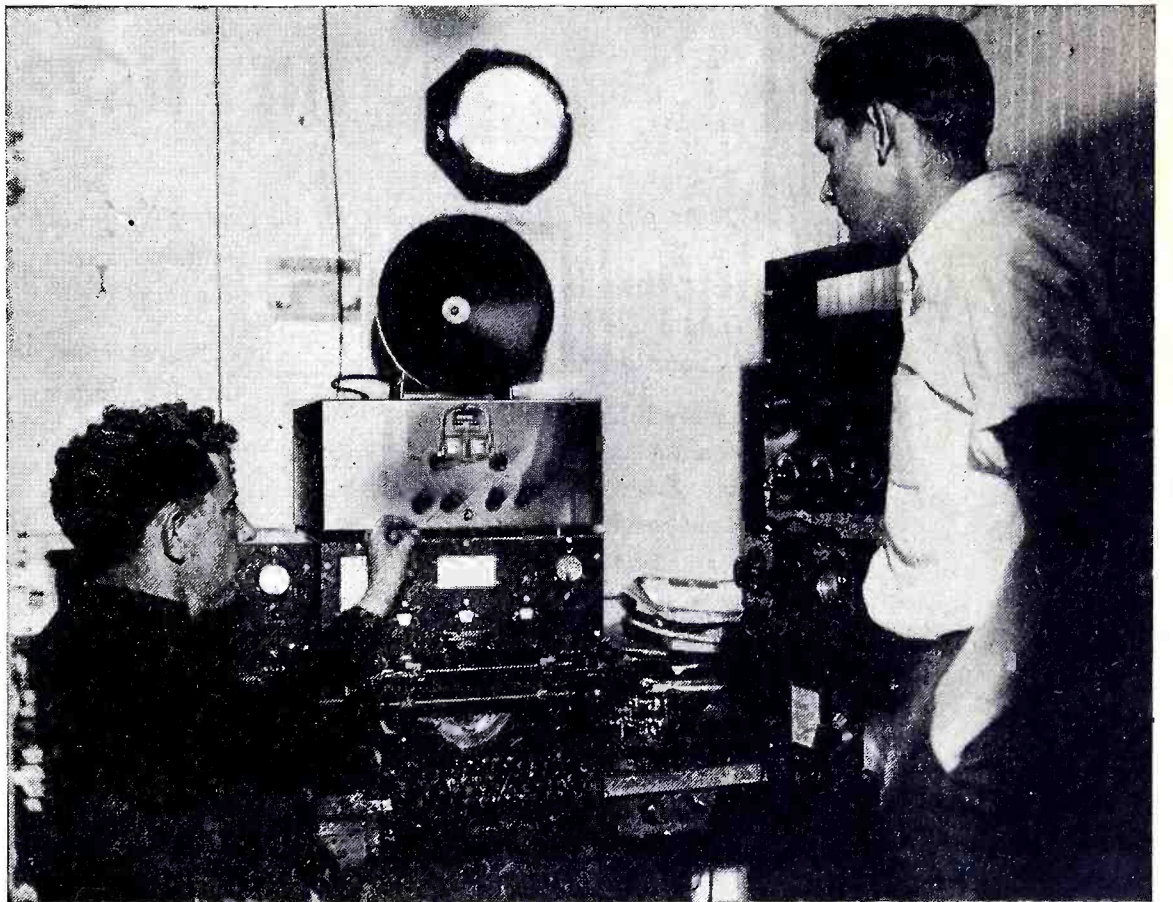

FEATURE ARTICLES By . . .

Clayton F. Bane - - Warner Hobdy - - Norris Hawkins - - George B. Hart
I. A. Mitchell - Frank C. Jones - Don C. Wallace - Col. Clair Foster

RADIOTELEPHONE DEPARTMENT - - HAM HINTS - - TUBE TECHNIQUE
AMPLIFIER DATA - - D-X NEWS - - "SCRATCH!"



It looked like just another radio job to Jim when he was invited to join up for the hop, but he admits he got a few thrills he never expected before he was through!

With a crew of two Australians—Capt. Charles E. Kingsford-Smith, commander, and Capt. Charles T. P. Ulm—and two Americans—Harry W. Lyon, navigator, and James W. Warner, radio operator—the Southern Cross took off from Oakland, Cal. on May 31, 1928 and landed at Brisbane, Australia on June 9. In three hops, it spanned 6638 miles of water! Hitting those pin point "way stations" in mid ocean was in itself no mean feat of navigation!

Jim Warner, radio operator on the epochal flight of the Southern Cross from California to Australia, says...

"I HAVE NEVER FOUND A BETTER RADIO TUBE THAN TUNG-SOL... THEY HAVE ENDURANCE!"

Sixteen years a radio operator in the U. S. Navy, Jim Warner literally jumped at the chance to "pound the brass" on the now famous flight of the Southern Cross from Oakland, California to Brisbane, Australia.

Just how much his nimble fingers and super-sensitive ears contributed to the final successful outcome of that defiant nine-day dash over 6600 miles of ocean, who can tell? But that he knows as much as any man alive about radio performance under gruelling conditions, nobody can doubt!

Jim wasn't paid to say any kind words about Tung-Sol tubes. He speaks from 18 years of

experience—and what he says about **Tung-Sol endurance**, you can prove to yourself in your own radio.

The stamina, the ability to stand up that men like Jim Warner are glad to praise, is built right into every Tung-Sol tube that leaves our plant—an inevitable result of precision methods that in many respects are unique in the industry.

Next time you need radio tubes, equip with Tung-Sols. Compare their performance and their lasting power with any tube you've ever used, and you'll find out why radio fans from coast to coast call Tung-Sol the "Long-Life Tubel"

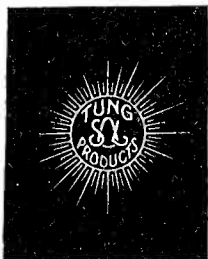
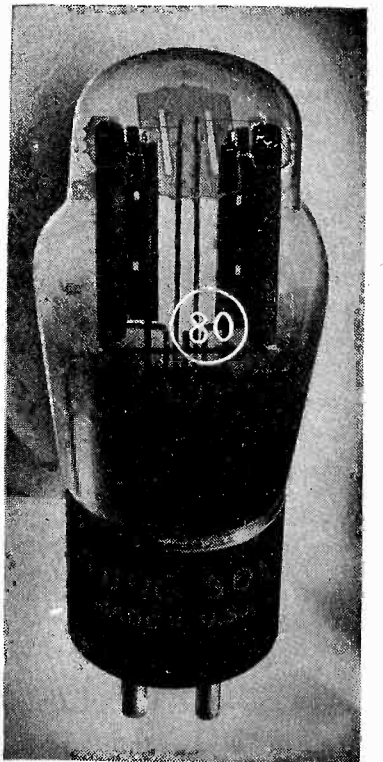

TUNG-SOL
LONG LIFE RADIO TUBES

TUNG-SOL RADIO TUBES INC., NEWARK, N. J.

Atlanta

Boston

Charlotte

Cleveland

Chicago

Dallas

Detroit

Kansas City

Los Angeles

New York

St. Paul

PACIFIC COAST DIVISION, 1816 SO. FLOWER ST., LOS ANGELES, CALIF.

PACIFIC COAST WHOLESALE AGENTS

DISTRIBUTORS, INC.
1816 So. Flower St.
Los Angeles, Calif.

MOTOR HDWE. & EQUIP. CO
1133 Columbia St.,
San Diego, Calif.

KAEMPER-BARRETT CORP., LTD.
1118 Mission St.,
San Francisco, Calif.

PORTLAND RADIO SUPPLY CO.
1300 W. Burnside,
Portland, Ore.

SEATTLE RADIO SUPPLY INC.
2319 2nd Ave.,
Seattle, Wash.

BROWN-JOHNSTON CO.
118 N. Lincoln,
Spokane, Wash.

BRANCH OFFICES:
 New York City,
 253 W. 128th St.
 Tel. MOument 2-2812
 Boston,
 J. H. Condon,
 6 Marlboro St.
 Chicago,
 C. W. Nelson,
 3618 North Bernard St.
 Los Angeles, Calif.
 1455 Glenville Drive.
 Tel. CRestview 4017

RADIO

ESTABLISHED 1917

Reg. U. S. Pat. Off.

A NATIONAL MAGAZINE - PUBLISHED MONTHLY

Publication Offices—Pacific Building, San Francisco, California

Clayton F. Bane, Editor

H. W. Dickow, Business Manager. Norris Hawkins, Associate Editor.
 D. B. McGown, Technical Editor. Frank C. Jones, Ultra-Short-Wave-Engineering Editor.
 Clair Foster, Amateur Activity Editor. George B. Hart, Contributing Editor.

25c per copy, \$3.00 per year by subscription in the U.S. \$4.00 elsewhere. Send subscriptions to the San Francisco office. Entered as second class matter at the Post Office at San Francisco, California, under the Act of March 3rd, 1879.

Vol. 16

JUNE, 1934

No. 6

RADIOTORIAL COMMENT

A "Practical Change" in Our Communications Regulations Is Made. Madrid Treaty Ratified. Oriental Third Party Traffic Unlawful.

★ ★ ★ ★

THE Madrid Treaty has been ratified by the United States Senate. Ratification of the treaty makes useless any further campaign against it. The next step is the proverbial life-long campaign to persuade some of the foreign nations to make treaty reservations in order that U. S. amateurs may, some day, again handle third-party traffic with certain foreign countries. But none of us will live to see that day.

This magazine waged a campaign of constructive criticism of the individuals whose acquiescence facilitated ratification of the treaty. You were told that ratification of the treaty would have no practical effect on your communications regulations . . . that when the treaty is ratified you won't know the difference. A tremendous amount of strife, ill-will, untruth and gross misrepresentation was injected into an otherwise-peaceful fraternity of radio amateurs. Those who handled third-party traffic with the Orient were loud in their condemnation of the treaty; those who regard amateur radio as child's-play and those who profit at the expense of the amateur were equally loud in their approval of the treaty with its damaging third-party message clause . . . **THE ONLY CLAUSE WHICH THIS MAGAZINE OBJECTED TO.**

Before the treaty was ratified, radio amateurs handled third-party messages with the Orient. The treaty forbids amateurs to handle such traffic. So we ask . . . "Was there a Practical Change in Our Communications Regulations?" Any five-year-old child can answer that question.

You were told that when the treaty is ratified you won't know the difference. Amateur station on the West Coast . . . manned by red-blooded public-spirited citizens who invested thousands of dollars in the finest kind of de luxe amateur equipment (the kind you need to maintain a consistent schedule with the Orient) can no longer enjoy the thrill of a nightly Oriental traffic schedule. The traffic hooks are empty. If you still don't believe the amateurs on the coast "know the difference", if you still believe the treaty had no effect on their communications regulations, send a message destined for the Orient to any one of these amateurs and let them tell you

why it won't get through. "'Twas written into the treaty—'third-party traffic is forbidden,'" they will tell you.

Hereafter you can waltz down to the telegraph or cable office and pay for your traffic if you want it to land in the Orient . . . precisely in conformity with the wishes of those who were so anxious to have the treaty ratified. The days of radio-hitch-hiking for some poor unfortunate in the Orient, who once used amateur to get a word of cheer to some loved one in this country, are but a memory.

The Congressional Record of the "Legislative Day" of April 26 reports verbatim the remarks of several senators who were addressing the subject of the ratification of the treaty. They declared that many amateurs had protested to them against the new amateur restrictions, but since the organization they believed was speaking for the amateurs did not oppose the treaty, they had come to the conclusion that it should be ratified. It is quite apparent that if the amateurs had not lost six to eight months while the truth was unknown to them we would have stood a very good chance of convincing the senators of the injustice of the new clause.

Little did these senators know that only a portion of the licensed amateur fraternity is allied with the organization which is supposed to represent them. At a recent tri-section meeting in Oakland, California, more than 400 amateurs were in attendance. By actual count, 97 of the 400 were members of the amateur's association.

It was not the great body of thinking amateurs that wanted the treaty ratified. The spokesman of the association which represents a part of the licensed radio amateur fraternity saw no reason why the treaty should not be ratified. The commercial interests fought hard to have it ratified. And it was ratified.

So that a repetition of the debacle in radio amateur ranks shall not occur again, it seems that some officials of the amateur's league who wroked so hard to convince the amateurs that ratification of the treaty would have no effect on their communications regulations are now equally aggressive in their plans to persuade some foreign nations to permit amateurs to again handle third-party traffic. Last month they helped boot us off the Oriental traffic chain and now they ask certain foreign governments to permit ama-

teurs to again handle third-party messages. Funny world, isn't it?

Meanwhile, the trans-Pacific Traffic Association, noted for its roster of intelligent amateur radio operators who once performed a great humanitarian service . . . who helped prove that amateur radio is operated in the interest, convenience and necessity of the public, has a plaster on its door, "GONE FISHING".

•••

The Board Meets

AT a recent meeting of the Board of Directors of the ARRL it was ruled that hereafter only licensed radio amateur members of the League shall be eligible to vote. The decision has met with favorable response and is a big step in the right direction. It was further ruled that approval be given the use of "N" prefixes by those naval reserve amateurs who operate in the non-amateur frequencies as part of the NCR. This magazine has long objected to the cluttering of the amateur frequencies by the "N" operators on drill nights. The latest ARRL ruling is timely and welcomed because it will relieve congestion in the 80 meter band. Hereafter the "N" drills will take place outside the regular amateur channel. The request of the Southern California amateurs for a separate division with its own director was denied because of the belief that, if granted, other divisions would ask for similar privileges.

The board approved a plan of ARRL cooperation with the National Broadcasting Company in its proposed series of thirteen weekly broadcasts to glorify the achievements of the radio amateur—invite the bcl to write to ARRL for a booklet on amateur radio—try to get him started as an amateur, and thus greatly increase the future number of licensed radio amateurs. More equipment can be sold and more money made by those who like the color of the amateur's money

Rule 371 Modified

"Amateur stations shall not be used for broadcasting any form of entertainment, nor for the simultaneous retransmission by automatic means of programs or signals emanating from any class of station other than amateur."

The foregoing supersedes any previous instructions that may be in conflict therewith.—(Signed) Herbert L. Pettey, Secretary, Federal Radio Commission.

COL. FOSTER'S COMMENT

WGHM

100,000 New Amateurs Wanted

THERE is afoot a plan to create a big new market for the sale of amateur apparatus. The NBC plans to put on a series of broadcasts beginning in June and dramatize for the public the achievements of the amateurs for the purpose of getting the general public interested in amateur radio. The ARRL is to be associated with the project, to have all inquiries directed to ARRL headquarters and to have the ARRL prepare and distribute a booklet in response.

When this ambitious project was put up to ARRL the manufacturer was advised by ARRL headquarters to "direct any literature on the subject exclusively to the 5 meter band." The suggestion "was entirely acceptable", says Mr. K. B. Warner in his letter of April 14 to the ARRL directors in which he outlines the plan in detail. He then proceeds with his task of selling the project to the Board. The letter is too long to reprint. We shall quote only the parts that illustrate the ARRL headquarters' wish to ally itself with the project. If anyone wants the whole letter he may secure it from his ARRL director.

Says Mr. Warner:

"NBC is looking for material. We can supply it. The Broadcasts would be unsponsored and non-commercial, and in themselves would provide a highly desirable form of publicity for the splendid achievements of the amateurs. The programs would conclude with the statement that the listener, too, may engage in this interesting work by becoming a radio amateur, and for further information he would send 10 cents or 25 cents to ARRL for a booklet. We would then have a booklet available somewhat resembling our 'How to Become' booklet, explaining amateur radio by describing only low price five meter STABILIZED voice equipment, and explaining that the lower frequency amateur bands are too congested to be interesting, and in every way seeking to direct new interest exclusively to the five meter band. We can prepare such a booklet."

"If the Board of Directors decides that ARRL will not associate itself with the idea in any manner, we feel reasonably certain that it will go ahead nonetheless under some other auspices. There are plenty of groups that would like to sponsor such a program and it is worth examining whether ARRL can afford to let the project be sponsored by any other amateur group or some other radio publisher."

"The only way out we have so far been able to visualize is to have a prepared booklet ready, with a remittance demanded that not only holds down the volume of those actually interested but provides the money to pay for the booklet and mailing it."

"We would not expect that more than one per cent of those receiving the booklet would ever carry the ideas to fruition, particularly considering that knowledge of the code is still a requirement for licenses. On such a basis

the scheme would offer no danger to amateur radio even if all the newcomers eventually moved to our lower frequencies. Rather, we would have achieved a modest and quite desirable growth and by our participation we would have averted what might easily be a serious menace under other auspices."

Referring to 5 meters Warner says, "Such a band is capable of accommodating an immense number of stations all over the country. Whereas our normal bands are congested to the place where we must give serious thought to any projects that promise materially greater occupancy."

"There exists in this country today a large number of people who are fascinated by the possibilities of amateur voice communication but to whom the present requirement of learning the code is an insurmountable obstacle. Many of these people would make amateurs of a very high type. Many of them are men of means, able to lay out the money for good equipment, technically minded and able to master the intricacies of the technique but uninterested in telegraphy and incapable of learning the code just to get licenses. We have had no place for them. Quite properly, we have never been able to stomach the thought of permitting a phone licensee the right to roam through our bands without knowledge of continental code. But thereby we have deprived ourselves of the presence in amateur radio of plenty of men capable of becoming amateurs of the highest type except with respect to telegraphing. I wonder whether the five meter band doesn't present an opportunity to do something very interesting and valuable in this connection, something that would come close to solving several dilemmas of the day and open up an interesting prospect for the future."

"It is virtually heresy in ARRL circles to propose or even to discuss the license to engage in amateur telephony without knowledge of the code. But might it not be an excellent idea to provide such a privilege IF IT WERE RESTRICTED TO THE FREQUENCIES ABOVE 28,000 KC? Would it not seem to offer a great many interesting advantages? I have thought about this quite a good deal and I would like to set down the following thoughts about such a project:

(1) It would enable us to take into amateur radio an excellent new type of amateur. His presence would give our hobby added strength of which we can not now take advantage, because we can not now let him into amateur radio with the right to operate on all our bands.

(2) It would provide an adequate population for the 5 meter band and enable us to hold it against the endeavors of the television people eventually to take it away from us.

(3) There is growing pressure from people interested only in telephony, from manufacturers interested in selling them apparatus, and from some sections of the radio press, to secure the right to engage in amateur radio telephony only without knowledge of the code. Some day this effort unquestionably will succeed. All the tactical advantages in this problem will lie with ARRL sponsorship. It would be better for ARRL to sponsor the move than to have the privilege ultimately wrested by other groups against our opposition.

(4) If ARRL sponsors the idea, it can be con-

finied to high frequencies, overcoming the inherent danger to our lower-frequency telegraphy that lies in any such new type license. For instance, one would have no fear of the congestion of amateur bands as a result of the broadcast programs mentioned earlier in this letter if the licensees were permitted five meter phone operation under a new type of license that did not require code knowledge but which forbade their operation on any lower frequency bands.

(5) Immensely interesting operating possibilities occur in the five meter band as soon as we have adequate population. Many of us old time telegraphing amateurs will get a kick out of such possibilities. We sometimes wonder if we're not getting a bit blasé, now that we've conquered all the DX possibilities. Here would be real relaying all over again. Can you imagine the thrill that would come from participating in the first Transcon Relay on five meters, and in the ultimate possibilities of five meter automatic relaying over long distances, via repeater stations. But we can not get anywhere with such possibilities unless we have a very large five meter phone population.

(6) Such a license might permit 5 meter mobile operation on boats, for which there has been considerable demand both from amateurs and boat owners. It would divert this demand from other bands.

(7) Finally, no other band has enough spare room to permit us to encourage the general new growth which otherwise is highly desirable as adding to the strength and health of amateur radio as an institution.

"May I not suggest that this general subject is worthy of your consideration?"

NOW I'll tell you my thoughts. Viewing it merely as a business proposal the letter makes the project and its objective quite clear. And it makes emphatically clear that Warner wants the ARRL to tie up with it. But his sales talk to the directors is so obviously eager that it advances some decidedly faulty premises, it strains its reasoning far past the breaking point, it makes some bad contradictions, and it makes some wholly unwarranted predictions as to the effect on the amateurs if his designs were carried out.

The letter is the most outrageous proposal I have ever seen from the pen of a man who insists that he is working for the interests of the amateurs—a most barefaced proposal to put up to the directors of an organization that flaunts the slogan, "Of, by and for the amateur", however mendacious that slogan may be. The letter shows clearly either that Warner is quite willing to sacrifice the amateurs for the money the scheme promises the ARRL or else that he is under strong compulsion from the commercial members of the ARRL. Either or both.

The letter shows either that the commercial people believe the amateurs of the United States are all sapheads or else that the non-amateur people because they comprise the greater part of the membership of the ARRL have the right to dictate the actions of the officers of that organization. Either or both. As for the first, the commercials are wrong; as for the second, they are right. The majority of the owners of a corporation—the ARRL or any other corporation—have the right to dictate the policies and actions of their officers. One of the pet sayings of the ARRL headquarters is, "The majority rules." The majority owners of the ARRL are not the amateur members.

(Continued on page 35)

The Banehawk Super-Heterodyne

By CLAYTON F. BANE and NORRIS HAWKINS

PART VI

Adjusting the IF Amplifier. Power Supply Details

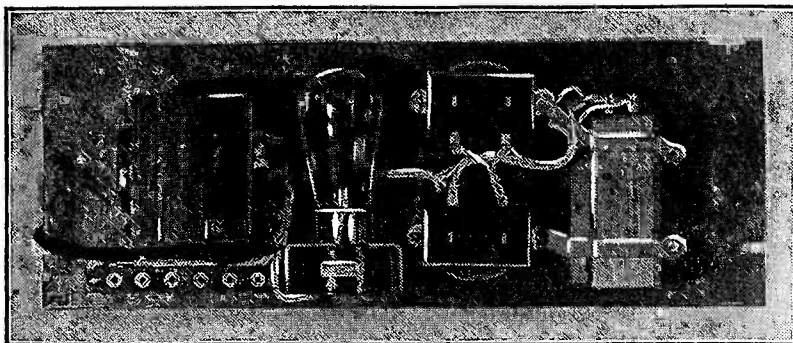

The Complete Power Supply on a Relay-Rack Panel

NOW for the preliminary adjustment of the IF amplifier. It is a lamentable fact that with most of the cheaper IF transformers the frequency marked on the can is not always correct. In an IF amplifier without crystal filter this fact is of no particular significance, since it makes small difference whether the IF frequency happens to be 450 or 470 KC, as might be the case with some brands of transformers supposed to be 465 KC. When using a crystal filter it makes all the difference in the world. Since it is a very difficult matter to take wire off the coils to increase the frequency, or to add additional trimmer capacity to decrease the frequency, it is best to go about the matter in a round-about way. Get the IF working and lined-up, then determine the frequency accurately by means of a calibrated oscillator. Knowing the exact IF frequency it then becomes a simple matter to have the crystal ground to that exact frequency. In the case of IF transformers with guaranteed accuracy it is generally considered good practice to set up an oscillator with the crystal in its grid circuit in the conventional manner and tune the IF stages to this frequency—ON THE NOSE! The quartz filter has an extremely sharp resonance response and unless all stages are in exact alignment with this frequency, failure is inevitable.

Another peculiar source of grief in IF amplifiers is one which causes violent oscillation . . . having the IF coils too far apart on the dowel. We want all the spacing possible, for reasons of selectivity, up to the critical point. When the coils are coupled comparatively close together they couple resistance into one another (lower the Q), which resistance has the effect of damping-out the oscillation. It must be remembered that an IF stage is in effect a tuned-grid-tuned-plate circuit, and will oscillate at the slightest provocation.

The selectivity of an amplifier can be increased by adjustment of the IF transformers and can also be improved somewhat by the addition of one or two IF transformers for a sort of a band-pass effect. This addition of another tuned circuit or circuits has proved to be of value in smoothing-out various small humps which occur on either side of resonance. It is entirely possible to over-couple the tuned circuits, thus causing some very troublesome phenomena. Too-close coupling can result in splitting the resonance curve, i.e., a dip at resonance and a peak on either side. Both of these humps are lower in amplitude than the original resonance curve.

Aside from the two controls for the crystal stage, we have also added two other switches on the panel. One of these switches is connected in the positive lead to the BFO to turn this oscillator off for phone reception, and the other switch is across the audio volume control to cut-out the sock in the phones while

transmitting. This switch merely passes all the IF input to the audio to ground, and still leaves an echo in the phones which serves to acquaint the operator with his sending.

All of the variable resistances come out to the front of the panel and the air-tuned transformers are tuned by means of holes in the panel. These holes are in exact alignment with the slotted shaft of the trimmers.

enough to amply support the rather-heavy parts. The transformers are made by United Transformer Co., and have provisions for this type of mounting. The rather unusual side-panel socket is the new Johnson and is ideally suited to this purpose. The transformer used has two sets of 2.5 volt filament windings thus allowing a separate winding for the front-end and IF-audio units. In order to avoid running power leads all over the set, it is well to provide a separate bleeder across the power supply to keep the peaks down, to protect the filter condensers, and to provide a drop for the IF screen and oscillator voltages.

With the chokes and filter used (total 30 mikes and two 30 henry chokes), absolutely no trouble has been experienced from hum. In stubborn cases, a mica condenser of approximately .01 from each of the rectifier plates to ground should affect a complete cure. There is no point in using an 83 rectifier; an input choke would have to be used and

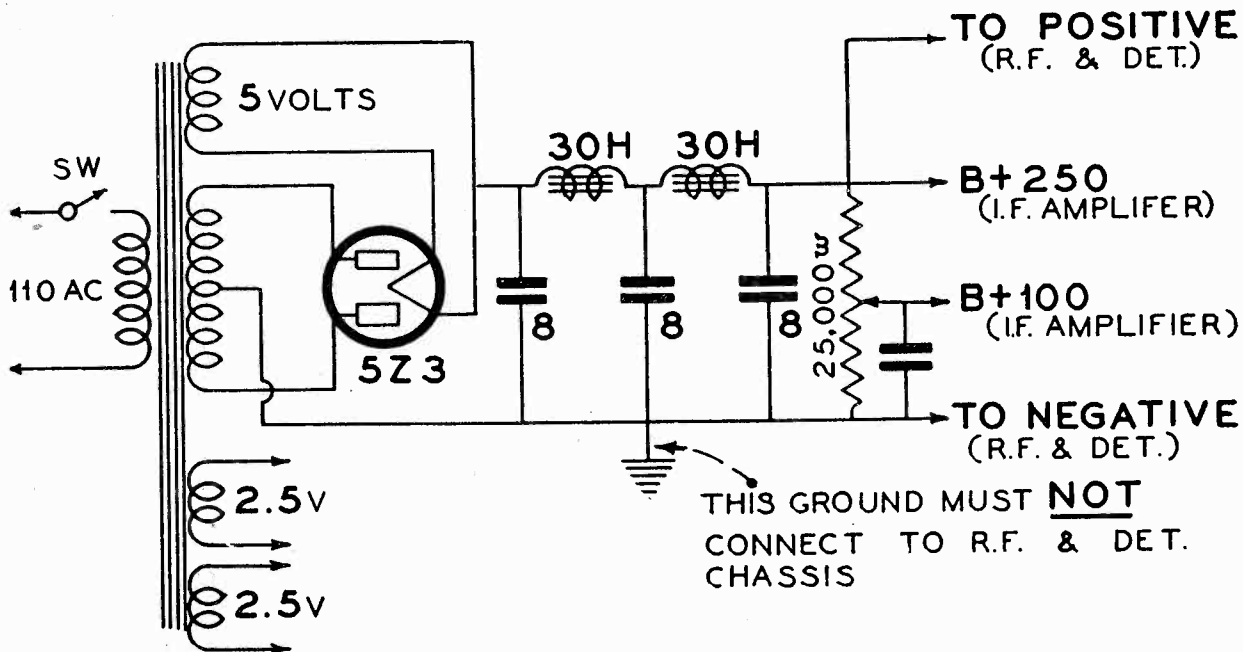

POWER SUPPLY FOR BANEHAWK SUPER

The Power Supply

THE power supply units, transformer, two chokes, rectifier tube, socket and filter condensers, are supported from the front panel without recourse to a sub-panel. This is entirely feasible providing the panel itself is made of heavy material. Our panel is No. 12 gauge iron, cheap and strong

the 83 has the further disadvantage that it sometimes introduces a stubborn, tunable hum. The 5Z3, while having slightly higher voltage drop, has neither of these disadvantages and is an inexpensive, efficient rectifier.

The power supply occupies the top position on the rack, the IF unit is below it, and

(Continued on page 31)

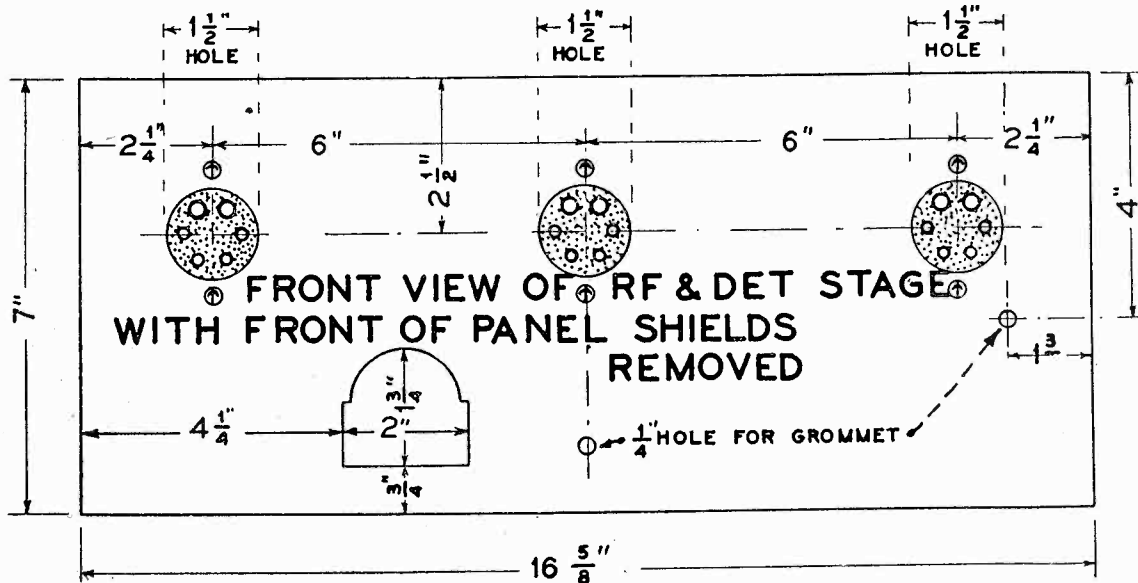

PANEL DRILLING DETAILS, RF PORTION

A New High-Power Pentode

The Raytheon RK20

By CLAYTON F. BANE

IT IS not the policy of "RADIO" to sugar-coat some new tube, just because it is new. When a new tube arrives and our laboratory tests show it to have merit, we believe in presenting the results of our findings without delay. The RK20 has a great deal more to commend it than the mere fact that it is new. We were able to obtain the manufacturer's output rating, watt for watt! With a start like that, can we be blamed for waxing enthusiastic?

We have been impatiently waiting for some manufacturer to give us a good, medium or high power pentode, but heretofore no one has seen fit to produce such a tube larger than the 59. While the 59 certainly has its uses, it still falls short of being ideal, even in its power class. The screening is far from perfect, making it almost impossible to use the tube as an unneutralized buffer. The fact that the screening is none too good has been the cause of cracked crystals, incurred while using the 59 in Tri-Tet and similar electron-coupled, crystal oscillator circuits. While this is probably due to carelessness and inexperience with the newer circuits, the fact remains that it is highly desirable that a tube for use in such circuits be perfectly screened in order to prevent excessive feedback when both the plate and cathode circuits are tuned to the same frequency.

The RK20 has such screening! Since it does not have a cathode, it is necessary to either use RF chokes in the filament leads or else thread the filament leads through the cathode coil. This particular phase is treated elsewhere in this article and will not be taken up here.

Frankly speaking, when the RK20 was first installed for preliminary test we were not certain that it would do all the data sheets claimed for it. Our doubts were dispelled as the tests progressed.

The tube was first installed in a conventional crystal oscillator circuit to determine the effectiveness of the screening and various other important characteristics. Being cautious, we started with 600 volts, although the sheet said 1200 volts was the allowable maximum. With everything set, the plate voltage was applied but the circuit would not oscillate in spite of the fact that everything was gone over carefully. Shock number one was experienced! The tube was so well screened that there was not enough feedback to give the crystal sufficient stress to start it oscillating! A very small capacity was added from grid to plate and oscillation was made possible. The radio-frequency grid current in the grid circuit of the crystal stage was measured and found to be extremely low, 10 mills. The output was found to be approximately 12 watts. The plate voltage at this output was about 600 volts and the screen voltage approximately 100 volts. The curves in Fig. 1 show how the power output increased as the plate voltage was increased. The other curve shows the increase of output with input.

As the plate voltage is increased, the RF grid voltage naturally increases proportionately. However, this current at no time was greater than 50 mills, even with 1100 volts on the plate. It was found that this RF grid current could be further decreased by lowering the external capacity added from grid to plate. Since this capacity was originally of a very low value, it was discovered that the plate current rose quite rapidly as the capacity

was decreased below a certain optimum value. This value, in most cases, will not exceed 2 to 4 micro-mikes. The reason for the rise in plate current is obvious; the situation being that insufficient feedback is obtained through such a small capacity to properly excite the crystal, and allow it to apply its control voltage on the grid. We are merely pointing out

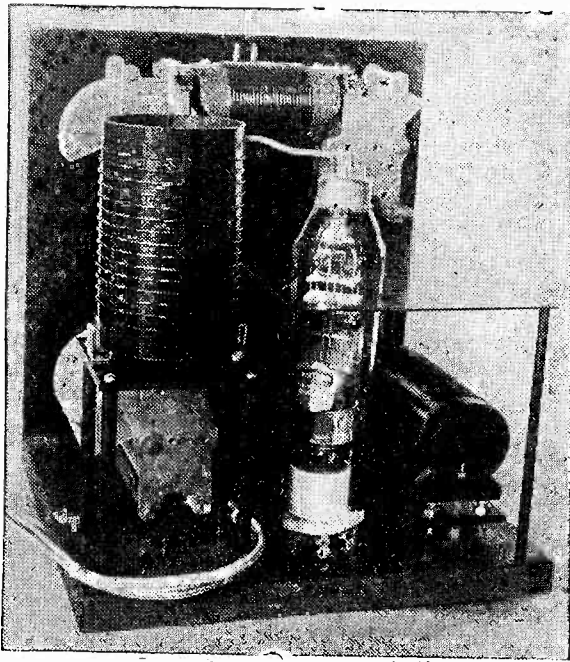

A Complete One-Tube Transmitter, Crystal Control, Using the New RK20 High-Power Pentode.

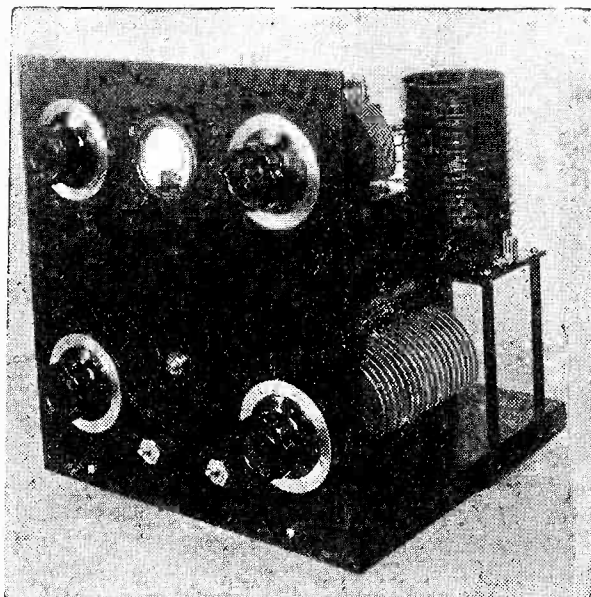

Front View of the RK20 Transmitter, designed and Built for "RADIO" by Chas. L. Watson of Western Wireless.

these facts to those who desire to operate this fine tube as a conventional crystal oscillator. Unless the grid circuit is inside the tank coil (figuratively speaking), it will not be possible to obtain oscillation without some external feedback. A pair of round electrodes, approximately the size of pennies, mounted on a threaded shaft, would make a suitable coupling condenser. For use in Tri-Tet oscillators, no such precautions are necessary, and it is possible to operate both plate and cathode circuits on the same frequency without excessive RF stress across the crystal.

Radiotelephone Operation

FOR those interested in radiophone operation, this new tube offers many interesting possibilities. The RAYTHEON folks tell us that the RK20, operated either

as an electron-coupled or crystal oscillator, can be modulated on the suppressor grid without frequency distortion. In this respect it operates like two tubes in one envelope with the screen acting as the plate of the triode driver and the power being drawn from the plate. Less than one-half watt of audio is required to fully modulate the tube. Good?

Obviously a tube having such excellent power output capabilities and such good screening is ideal as an amplifier. In this case neutralization is unnecessary, providing a little care is taken in the design so as not to place grid and plate circuits in too-close proximity.

In our preliminary experiments with this tube as an amplifier we were to compare it with an 865. The transmitter stage in which the RK20 was to be installed had an 865 as a buffer amplifier, which was excited by a 59, straight crystal oscillator, using an 80 meter crystal and 400 volts on the plate. This same stage was described in the last issue in TRANSMITTING TECHS.

Power Measurements

POWER measurements on the '65 showed that it was capable of an output of 15 watts with 550 volts on the plate and 150 volts on the screen. The efficiency was computed to be approximately 70%. In this, and subsequent measurements with the RK20, a number of lamps of different wattage ratings were used. Since the brilliance of lamps is difficult to determine by eye, a photo cell with a microammeter was used to check the results. The lamp was first installed in a regular 110 volt circuit and the brilliance, or amount of illumination was checked by means of the photo cell. This checking was done in a dark room, so that the cell would not register any light other than that coming from the lamp under test. It was then a simple matter to couple the lamp to the amplifier stage and compare the readings. This method offers a fairly accurate method of measuring output, providing the cell indicator is calibrated. Obviously, results are in error unless the exact calibrating conditions are simulated in the transmitter check.

RATHEON RK 20
POWER OUTPUT CURVE

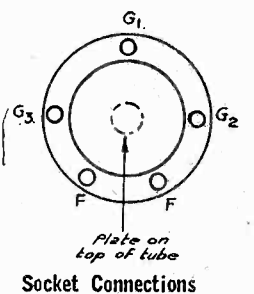
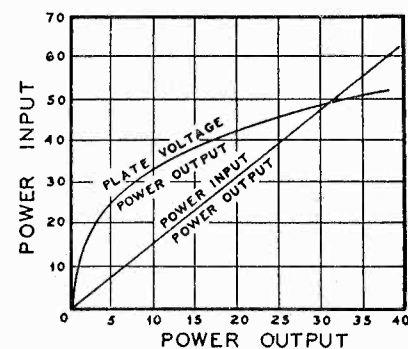

Substitution of the RK20 for the 865 gave slightly less output with the same plate voltage, but slightly-lower screen voltage. As the screen voltage was increased to about 150 volts the output rose to the same as the 65. The output increased greatly with higher plate voltage until a final measurement was made, showing an output of nearly 50 watts with 1200 volts on the plate and 300 volts on the screen. Since this was the maximum value allowed by the manufacturer we did not deem it good practice to continue the tests with

higher plate voltages. At 1200 volts, not the slightest sign of plate or screen heating was detected; an eye having been kept on both during all tests for color indication. Self-oscillation or regeneration was apparently totally lacking, although the tube was merely wired in the 865 position without any particular attention to the length of leads.

Excitation

IN ALL the amplifier tests the tube was biased to a point slightly below cutoff and with the available excitation from the crystal stage being somewhat limited, it is perhaps significant that efficiencies of about 70% were obtained without trouble.

This tube is easy to excite, and at normal loads and plate voltages the manufacturers claim that one watt from the driver is sufficient excitation for proper output.

The photographs shows a small, compact transmitter using the RK20 as an electron-coupled, crystal oscillator. Its circuit does not differ widely from a number of lower-power crystal oscillators. One exception is the winding of the two filament leads into a cathode coil. This is necessary when using any filamentary type of tube as an electron coupled oscillator. It is very difficult to make good RF chokes that will effectively offer sufficient impedance to RF and at the same time be capable of passing several amperes. We hesitate to think of the distributed capacity and physical dimensions of such a choke. This cathode coil is wound on a threaded bakelite tube, although it is entirely possible to accomplish the same purpose by inter-winding the wires on an ungrooved form.

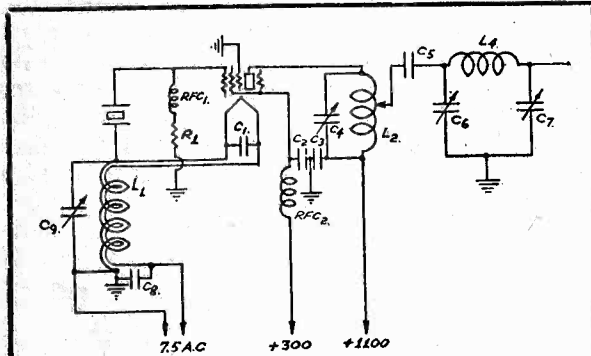

FIG. 1

RK20 Transmitter Legend

- C1, C5—.002
- C2, C3, C8—.006
- C4, C9—.00015 Cardwell
- C6, C7—.0005
- L1—Two wires, interwound, each 30 turns of No. 16 enameled, on 2-in. diameter bakelite tubing. (Space wires 8 turns to inch)
- L2—14 turns No. 10 wire on 3-in. diameter bakelite form (4 turns per inch).
- L4—25 turns No. 14 wire on 2-in. diameter bakelite tubing, 12 turns per inch.
- RFC1, RFC2—Hammarlund 5-pie receiving type RF Chokes
- R1—15,000 to 20,000 ohms

The popular, low-pass filter is used to couple the transmitter to various antennas with maximum efficiency. Since in our own case a single wire feed antenna was to be used, only one inductance in the filter was necessary. Where a two-wire feeder, such as the Zepp, is to be used it will be necessary to add another inductance in addition to feeding the plate voltage through the center-tap of the plate tank instead of at the end, as is now done. Either way apparently works very efficiently.

This 50 watt transmitter is capable of working on 80, 40 and 20 meter bands, using either an 80 meter crystal and doubling and quadrupling to the higher frequency bands, or a 40 meter crystal for that band and 20 meters.

RK-20 Characteristics

GENERAL DATA

Number of Electrodes.....	5
Filament Voltage.....	7.5 Volts
Filament Current.....	3.0 Amperes
Average characteristics determined at	
Eb = 1250 V.	Ec = -13 V.
Ed = 300 V.	Ee = 0 V.
Ef = 7.5 V. AC	
Plate Current.....	28 MA
Amplification Factor.....	1,500
Plate Resistance.....	500,000 Ohms
Grid-Plate Transconductance.....	3,000 Micromhos
Approx. Direct Interelectrode Capacitance	
Plate to Control Grid.....	.006 uuf.
Input (Control grid to filament and screen).....	11.0 uuf.
Output (Plate to filament, screen and suppressor grid).....	10.0 uuf.
Length.....	8 3/4" Max.
Diameter.....	2 1/8" Max.
Base (Isolantite).....	Med. 5 prong
RF Power Amplifier—Class B or Suppressor Grid	

Modulated Amplifier or Oscillator

Max. Operating Plate Voltage.....	1,250 Volts
Max. Operating Screen Voltage.....	300 Volts
Max. Unmod. Plate Current.....	65 MA
Max. Plate Dissipation.....	35 Watts
Max. Screen Dissipation.....	10 Watts
Max. RF Grid Current.....	5 Amperes
Typical Operation:	
Eb = 1250 V.	Ed = 300 V.
Ee = -28.5 V.	Ef = 7.5 V. AC
Ec = -75 V.	

Carrier Output.....	16.5 Watts
Peak Power Output.....	66 Watts
Suppressor Cur. (0 to +45 v.).....	.25 to 4 MA
Suppressor Voltage—peak swing.....	100 V. to +45 V.
Control Grid Current, DC.....	5 MA
Peak Audio Volt. for 100% mod.....	72.5 V.

Oscillator and RF Power Amplifier—Class C

Max. Operating Plate Voltage.....	1250 Volts
Max. DC Plate Current.....	65 MA
Max. DC Grid Current.....	10 MA
Max. Plate Dissipation.....	35 Watts
Max. Screen Dissipation.....	10 Watts
Max. RF Grid Current.....	5 Amperes
Typical Operation:	
Eb = 1250 V.	Ec = -75
Ee = 0	Ef = 7.5 V. AC
Ed = 300 V.	

Output.....	50 Watts
-------------	----------

OPERATING NOTES

In operation either as an oscillator or RF amplifier the circuit must be adjusted for the lowest DC grid current possible with sufficient excitation to provide the rated output. Usually a value between 5 MA and 10 MA will be found to give maximum power output with highest screen grid efficiency. The screen grid should not be operated at higher temperature than is shown by a dull red color. For long tube life and for maximum operating efficiency, both the control and screen grid DC currents should be checked continuously.

Shielding of the grid input tuning system from the plate tuning apparatus is desirable and will provide improved stability. If a shield is applied to the RK20, it should enclose the base end and extend up only to the lower internal shield. The tube shield should clear the glass bulb by at least 1/8 of an inch.

RK-20 Adjustments

ASINGLE millimeter in the plate circuit will enable the operator to make all of the necessary adjustments. A word of caution is in order. In starting-up such a transmitter for the first time, it is generally advisable to first use low plate voltage until the operator has the assurance that everything is as it should be. This caution is particularly applicable to electron-coupled circuits where a misadjustment of the cathode coil will certainly not do the crystal any good. When all adjustments are made, raise the plate voltage and get a very pleasant surprise.

Ever since the adoption of crystal control by the amateurs the crystal tube has been the weak link. The 47, one of the first low-power pentodes, set the precedent for a larger tube, but months passed and such a tube was still not presented. The advent of the RK20 fills a long-felt need, and with its coming we see the long-desired possibility of a two-tube transmitter with an output of between 400 and 500 watts.

In the next issue we will show how to modulate the RK20 as a one-tube transmitter.

Answering Some Questions On the Banehawk Super

THE hundreds of letters received on the Banehawk receiver have given us an excellent cross-section of the problems which have puzzled many. Quite naturally, a receiver of radical design is a very difficult thing to show in a photograph and still give all the details. We are very much afraid that our photos did not show as many things as we had intended. We promised some time ago that as soon as we were assured that there was sufficient interest in the receiver we would show mechanical dimensions in detail. A complete pamphlet of the Banehawk is now being printed.

The following are the answers to the most generally asked questions:

Question:

How can a two-gang condenser, such as the Hammarlund with common rotors, be used in place of the insulated shaft condenser shown in the original drawings?

Answer:

This condenser can be very easily used by simply moving the blocking condenser originally isolating the coil-condenser from ground, to a point in between the coil and the tuning condenser. While this has the effect of lowering the capacity of the detector tuning condenser, it is not at all detrimental because the trimmer condenser can bring its capacity up to any desired point. The main reason for using an insulated rotor condenser was simply one of convenience in wiring. The common rotor worked out very fine in a subsequent receiver.

Question:

What was meant by saying that the grid resistor on the oscillator "— goes across the tank circuit?"

Answer:

We are very much afraid that this is one of those cases where "ham-expression" gets one into difficulties. The resistor does not go across the tank circuit, but rather from the grid side of the grid condenser to ground.

Question:

What is the trimmer in series with the oscillator tuning condenser?

Answer:

This is not a trimmer; it is the band-spread condenser. Decreasing the capacity of this series condenser has the effect of lowering the capacity of the oscillator tuning condenser, which in turn allows a greater arc of rotation for a given amount of band width. In operation, this condenser should not be rotated vigorously. It is quite critical but its use enables the band to be set for any desired spread on the dial.

Question:

How is the antenna coupled to the RF coil?

Answer:

Nearly any type of coupling can be employed to the RF stage. In one case we used the standard National coils (NOT band spread). What is ordinarily the plate coil was used as the antenna pick-up coil. When this coil is not tuned, a great deal of the coupling will be capacitive, due to the closeness of the windings. In this case, a series condenser must be inserted in the antenna lead, otherwise so much resistance will be coupled into the grid coil as to make the RF regeneration a problematical thing. Usually it is necessary to add two or three turns to the tickler windings on the National coils, in addition to moving the tickler winding closer to the grid coil. The cathode winding (tickler), should have the winding wound in the same direction as the grid coil, with the cathode going to the end nearest to the ground end of the grid coil.

More On the Push-Push Doubler

By WARNER HOBODY, W6MV

FREQUENCY doubling is one of the weakest spots in modern crystal controlled transmitters. The conventional doublers usually depend on distortion in the amplifying characteristics of the tube itself to generate the harmonic frequency. The output of a distortion doubler is limited by the low plate efficiency and the low power amplification. Fairly satisfactory results may be obtained by the use of plate doubling if the following suggestions are followed: (1) The plate voltage should be as high as the tube

current impulses in the plate tank as there are cycles in the input circuit or, in other words, the frequency of the plate tank is twice that of the grid circuit.

There are two main disadvantages to push-push doubling. First, the plate to ground tube capacities are in parallel across the plate tank and it is hard to obtain a low C plate tank on 10 or 5 meters unless two of the newer low C, high-frequency tubes such as the 354, 800 or 825 are used. Secondly, the push-push doubler shows a distressing tendency to

ment circuit to one tube, and change the plate coil. The grid to plate capacity of the tube with its filament cold effectively neutralizes the other tube, provided the wiring of the grid circuit is symmetrical and further provided that the tubes are of the same manufacture. As a matter of fact, no difficulties have been encountered when using several different makes of tubes (both 46's or 210's) but certain makes of tubes may cause trouble in this respect.

It will be seen that neutralization, when not doubling, is accomplished through the

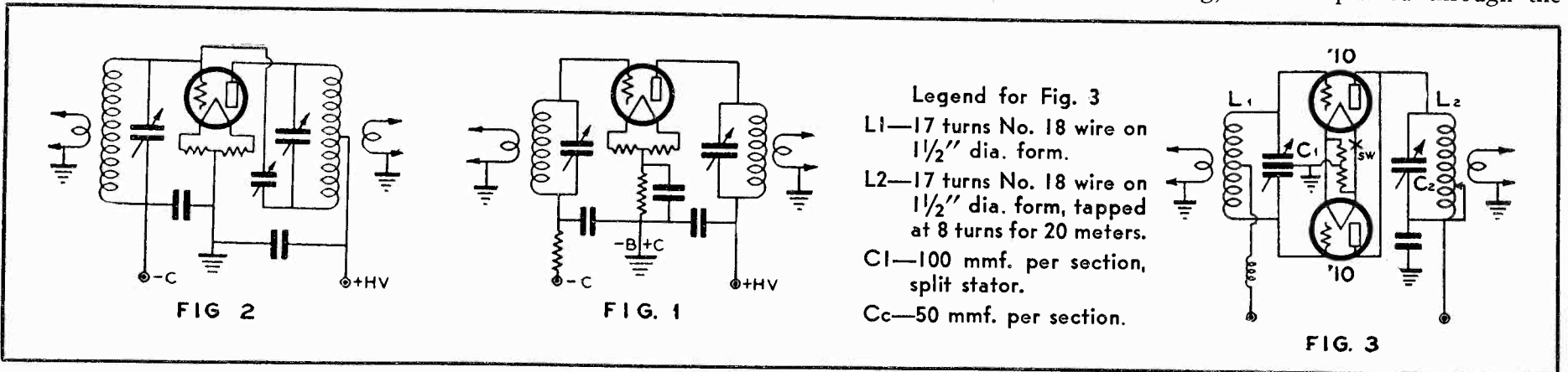

insulation and gas content will allow. (2) The bias should be from three-and-one-half to seven times cutoff, and should be adjustable because the exact bias depends on the harmonic desired and the type of tube used as the doubler. (3) The excitation voltage should be as great as possible without materially exceeding the bias voltage. (4) The grid DC current should never exceed a very small value, approximately five milliamperes. This precludes the possibility of simultaneous grid and plate distortion doubling, which is to be avoided because grid distortion tends to neutralize the effect of plate distortion, the combination reducing the harmonic output. The plate tank should be extremely low C and the coupling to the load should be rather tight.

The output of the doubler is materially increased by the use of regeneration, which may be obtained through an impedance in the cathode circuit common to both grid and plate circuits as shown in Fig. 1, or by the addition of a feedback condenser resembling the ordinary neutralizing condenser, of a straight amplifier, see Fig. 2. This prevents oscillation at the fundamental frequency and makes the stage highly regenerative at the harmonic frequency.

The plate doubler, while widely used, has numerous disadvantages. In the first place, plate efficiency is sacrificed due to the fact that the grid cannot be driven very far positive. At the same time little power amplification is realized because the tube is biased far beyond class B (cut-off).

The newer push-push doubler* (Fig. 3) avoids practically all of the disadvantages common to distortion doublers. The bias, excitation, plate efficiency and power output are comparable to straight amplifier operation. Instead of depending on distortion to produce the harmonic frequency in the tank circuit, we now have each tube operating as a straight amplifier on alternate half cycles of the excitation frequency. Because the plates are tied together, the plate current impulses delivered to the tank are in the same direction, and because the grids are in push-pull each tube is being excited on alternate half cycles. Thus there are twice as many

oscillate by itself unless the following precautions are taken:

The present wide use of link coupling between stages has made push-push doublers practical, because the push-pull grid tank adds little or no complication from a constructional standpoint. However, a split-stator grid condenser, with the rotor grounded, is essential

ables a change from one hand to another without bother of reneutralizing. It is found that practically no loss occurs if the plate tank is designed for operation at the grid circuit frequency, and half of the plate turns are shorted out for doubling. A low resistance shorting link should be used to minimize losses in the link. Avoid the use of

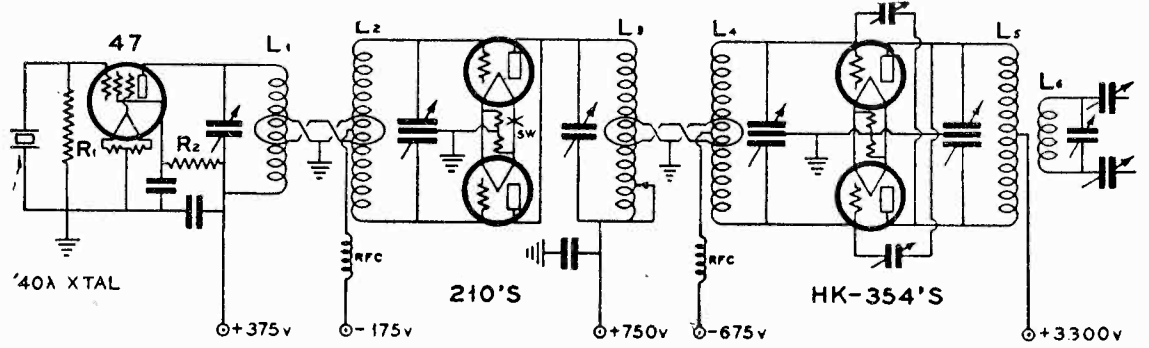

- FIG. 4**
 R1—10,000 ohms. R2—30,000 ohms.
 L1—17 turns No. 18 wire on 1 1/2" dia. form.
 L2—Same as L1 but center-tapped.
 L3—15 turns No. 14 wire on 1 1/2" dia. form, tapped at 8 turns.
 L4—22 turns No. 14 wire on 1 1/2" dia. form, center-tapped for 40 meters. For 20 meters L4 has 12 turns, center-tapped, No. 14 wire on 1 1/2" dia. form.
 L5—40 meters—20 turns 1/4" copper tubing, 6" dia. For 20 meters use 10 turn coil.
 L6—Depends on feeder length.

if self oscillation is to be eliminated because the reactance of the grid circuit must be capacitive rather than inductive, to the harmonic frequency. It follows that the bias voltage must be fed through an RF choke to the center of the grid tank in order to keep the RF grid return through the split-stator grid condenser. This effectively prevents the stage from oscillating as a TNT oscillator, which is the case when the center of the grid coil is bypassed to ground.

Where parasitics occur (as in any push-pull stage) the addition of a 50 ohm non-inductive resistor in each grid lead, at the socket, will effectively stop them.

When it is desired to operate the push-push stage as buffer amplifier without doubling, it is only necessary to open the fila-

use of a split grid tank, rather than through the more familiar split plate tank. This ensteel clips. A flexible way to accomplish this consists in establishing the point at which the tap will be located for doubling and then soldering a permanent connection at that point, which is brought to a husky knife switch.

(Continued on page 24)

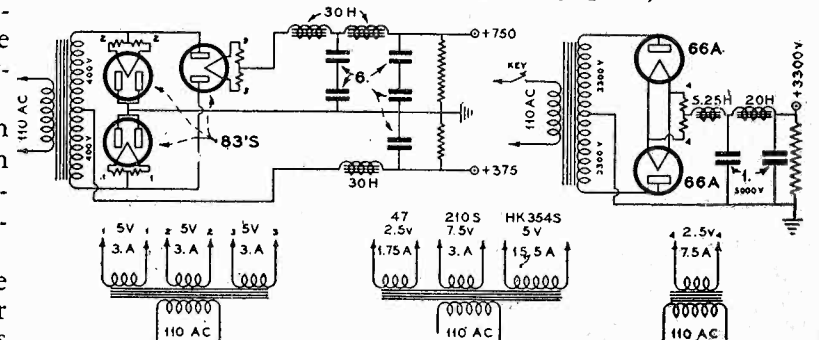

FIG. 5

* See article "Double or Nothing" by W6WB, "RADIO", December 1933.

5-Meter Antenna Systems

By FRANK C. JONES

THE subject of five meter antennas has always been of interest because the results obtained with these miniature systems sometimes can be useful in the design of lower frequency antennas. More and more interest will be shown in 5 meter antenna design as this band becomes more popular for amateur use and as television progresses.

In the transmission and reception of 5 meter signals the direct, or ground wave is used. At longer wavelengths a skywave is utilized and thus great distances are possible by means of reflections from the Heaviside layer. The five meter signals usually seem to penetrate this layer with little reflection back to earth and therefore it is necessary to depend upon the direct wave. The earth is a good reflector for short waves and it is necessary for the transmitting and receiving stations to be within visual range of each other. A hill on the earth's curvature is enough of a "mirror" or reflector to literally bend or push the five meter signals upward to a much greater extent than at longer wavelengths. For this reason a airplane can go from 100 to 200 miles away from a transmitter and still receive five meter signals if it can climb to a high enough altitude.

The point to be emphasized in the preceding paragraph is that as much height should be used as possible at both the transmitter and receiving antennas. Since the direct wave is used, an antenna should be used which has a low angle of radiation both for transmission and reception. Vertical polarization has been proven to be much more effective than horizontal polarization and thus vertical antennas are indicated if they are of the simple half-wave type.

Half-wave antennas have been used very successfully because their radiation pattern is a figure 8 with the greatest radiation parallel to the earth. In this case the wave is transmitted at a low angle with respect to the earth, since it acts as a reflector tending to bend the wave front up away from the ground. There is less tendency for upward bend with vertical polarization, otherwise a half-wave horizontal antenna would be just as effective. Of course, the horizontal antenna would have to have its axis perpendicular to the receiving station in order to get maximum effect from the figure 8 radiation pattern, and it would have to be at least a wavelength above ground. Our 20 and 40 meter antennas are usually less than a half-wavelength above ground, therefore the earth acts as an antenna reflector wire and shoots the wave upward at what is termed "high angle radiation."

For transmission an effective antenna is a half-wave vertical wire using a two wire matched impedance line. This line can be a pair of No. 18 wires spaced 2 or 3 inches, fanned out in a Y at the antenna end in order to be terminated properly. Each wire can be connected about 13 to 14 inches each side of center of the antenna, and at the transmitter end, terminated across a parallel tuned circuit which is coupled to the oscillator or amplifier tank circuit. This type of line can be spaced with dowel rod and string spacers, or transposition blocks could probably be used.

In some locations a directional antenna can be used for both transmitting and receiving with a gain of several D.B. units. The simplest form uses parasitic reflectors or directors or combinations of the two. Reflector wires are longer than the antenna and are placed a quarter-wave behind the antenna and a half-

wave way if used on the sides of the antenna. Director wires are different in that they are always placed in a straight line in front of the antenna at spacings of $\frac{3}{8}$ wavelength from it and each succeeding director. The beam can be made very sharp if enough director wires are used, and back or side radiation can be minimized by the use of reflector wires which also increase the intensity in the desired direction. These spacings are $6\frac{1}{2}$

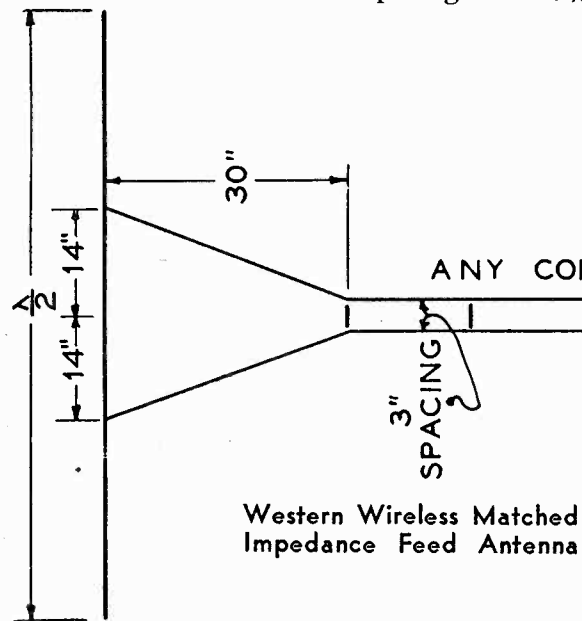

feet for director wires, for an average 5 meter antenna resonant at the middle of the amateur band, $4\frac{1}{2}$ feet back and $8\frac{1}{2}$ feet at each side of reflector wires. The following chart gives the proper lengths for these antenna, allowing for end effects:

Wave-length	Freq. MC	Antenna Length	Director Length	Reflector Length
5.36	60	8' 4"	7' 7"	7' 7"
5.17	58	8' 1"	7' 4"	8' 4"
5.0	56	7' 9"	7' 1"	8' 1"
10.65	28.2	16' 8"	15' 2"	17' 1"

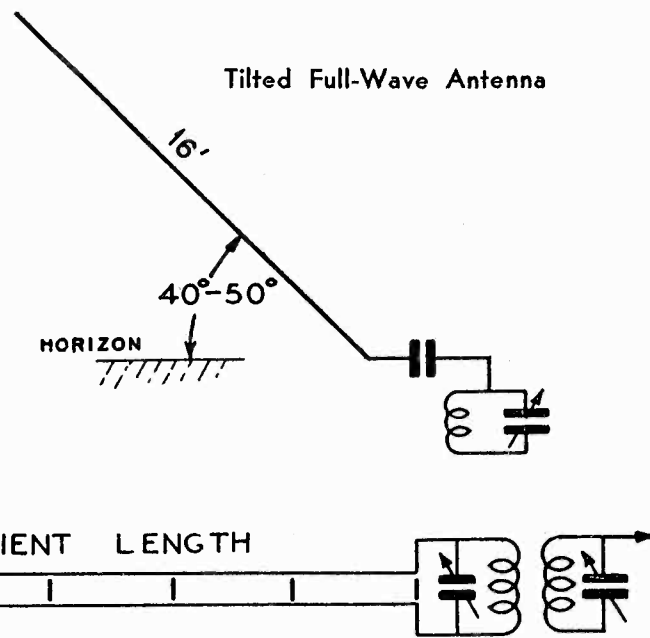
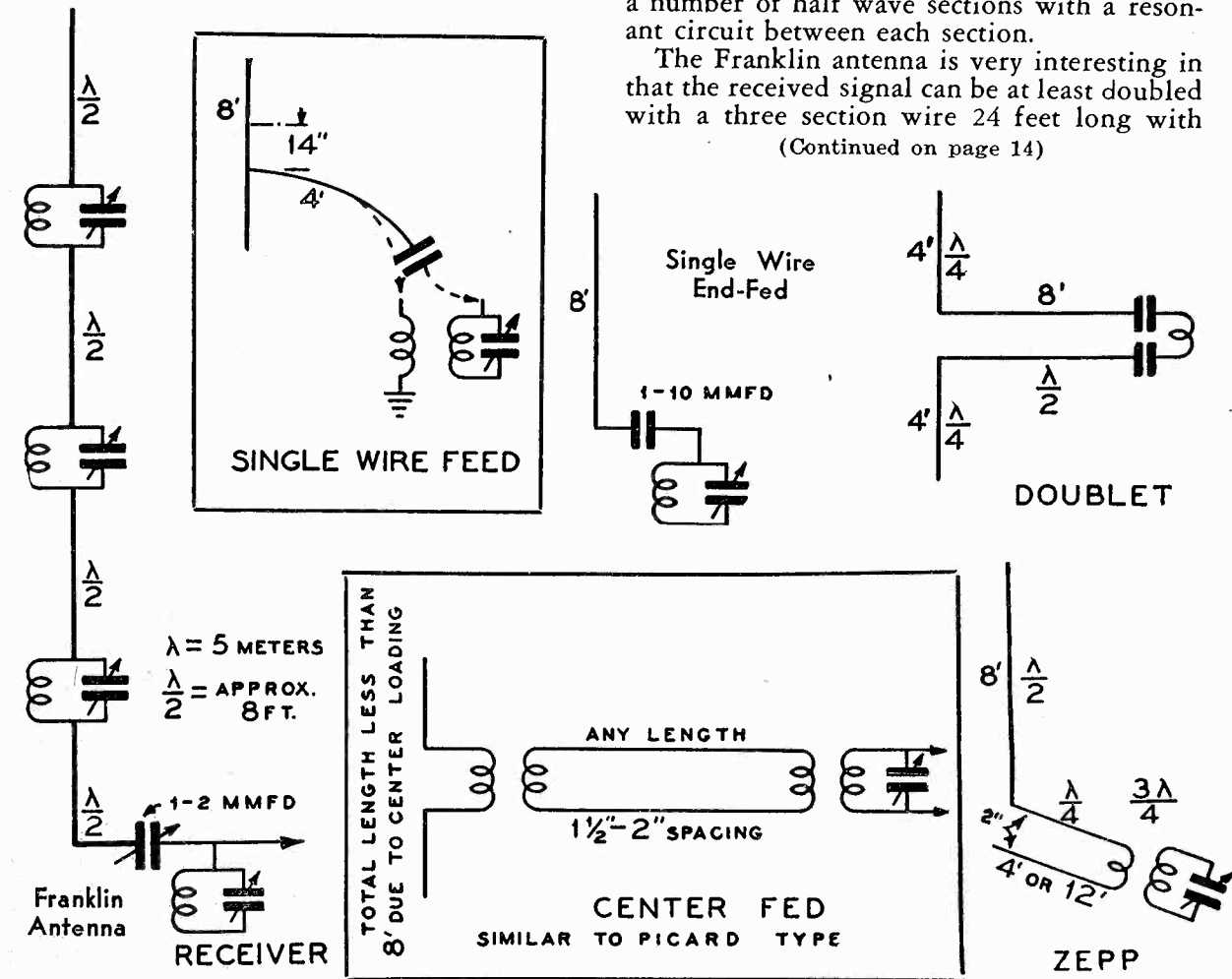

A SURPRISINGLY good receiving antenna consists of an eight foot wire with its lower end coupled through a very small capacity to the grid circuit of the receiver. This type works well in any type of building not constructed with too much steel and "chicken wire", such as used in stucco coated exteriors. Moving this antenna a few feet in a room will often increase the signal several fold due to reflective or directive effects of nearby objects, such as house wiring. If most of this antenna wire can be vertical, or nearly so, very good results are usually obtained.

A good transmitting antenna always makes a good receiving antenna, but for purposes of two-way phone operation, or for a person interested in receiving only, other forms of antennas are useful, such as the one described above. Another more effective five meter antenna is the Franklin type which consists of a number of half wave sections with a resonant circuit between each section.

The Franklin antenna is very interesting in that the received signal can be at least doubled with a three section wire 24 feet long with

(Continued on page 14)

Class B-Prime Grid Modulation

Higher Efficiency and Better Quality Characterize This Entirely New Amplifier

By J. N. A. HAWKINS, W6AAR-W6AAL-W6XZ

THERE comes a time in every amateur's life when he feels the urge to experiment with radiotelephony and thus engage in a rag chew in his native tongue, rather than in the foreign language of symbols known as the Continental Code. Some amateurs are able to resist this urge but the vast majority of them succumb sooner or later. When the CW man starts thinking about phone he wastes little time exploring the sacred mysteries of class B modulators, because in the first place, he owns but little audio equipment, and secondly, he does not want to go out and buy the necessary tubes, transformers and additional power supply because he is not at all sure that he will want to stay on phone once he gets one. Thus it usually happens that some form of grid modulation is attempted, due to the simplicity of the circuit diagram.

Fundamentals of Grid Modulation

GRID modulation is characterized by the fact that very little audio power is necessary to modulate the grid bias of an RF amplifier. However, the complexity of adjustment has prevented about 99% of those attempting it from obtaining satisfactory results. Usually terrific distortion and overmodulation followed most attempts to obtain the combination of 100% modulation capability and high plate efficiency.

Let us briefly consider the fundamentals of modulation. When audio modulation is used the radio-frequency carrier has two sidebands which carry the transmitted intelligence. Mathematics shows that one-third of the power in a completely modulated signal is contained in the two sidebands, while the other two-thirds consists of the carrier. Thus the problem which faces the builder of a phone transmitter is to increase the power output of the transmitter, during modulation, up to a maximum of 50% for complete modulation. This additional power must be released in exact accordance with the variations in sound pressure which the operator's voice impresses on the microphone.

Plate modulation of a class C amplifier takes this additional power in the form of AC and adds it to the normal DC plate input to the modulated amplifier, which is operated under such conditions that its power output varies directly with the plate input. This AC power is supplied by the audio output of the modulator tubes and therefore we arrive at the conclusion that the power output of the modulators must be equal to one-half of the DC watts input to the class C modulated amplifier. Thus the real function of the modulator tube, or tubes, in a plate modulated phone, is to release power from the power supply for use in the modulated amplifier, so that its power output may be increased during modulation.

To date, no one has succeeded in making a grid modulated amplifier release its own additional plate input from the power supply. This problem has attracted the attention of engineers and scientists all over the world for about 25 years, and despite statements to the contrary, no one yet has successfully made an RF amplifier which can modulate itself.

Where, then, does the power come from that increases the carrier output when the grid-modulated amplifier is modulated? Let us digress here and consider the fundamental

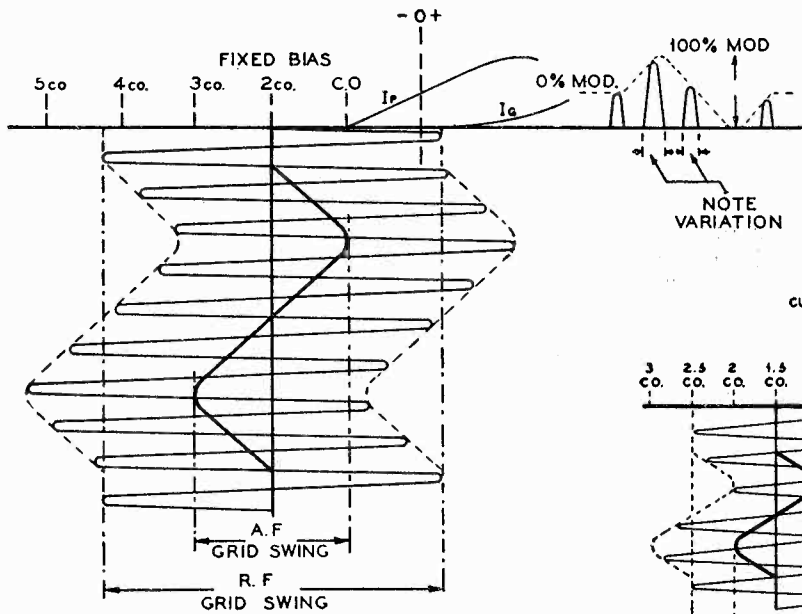

Fig. 1
Jones System of Grid Modulation

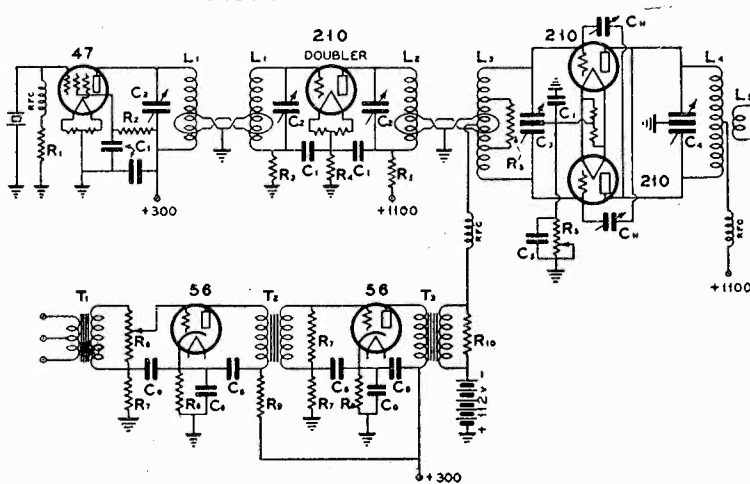

FIG. 2

nature of a vacuum tube amplifier. It might be defined as a device which converts DC (plate power) into AC (RF output) power. This conversion process is never 100% efficient and the difference between the plate input and the power output is dissipated from the plate of the tube in the form of heat. The efficiency of a vacuum tube amplifier depends on a number of things and varies widely for different types of amplifiers. If a given amplifier is, for example, 25% efficient under a given set of conditions, it will have a certain power output. Now, without changing the DC plate input to the amplifier, let us change some of its operating conditions so that it becomes 50% efficient. If we now measure the power output we will find that when we doubled the plate efficiency, keeping the plate input constant, the power output is one-and-one-half times what it was before. Thus if we can find some way to cause the plate efficiency to double, we can obtain the 50% increase in output that we need for complete modulation. Under certain conditions the grid bias voltage affords this means of varying the plate efficiency of the amplifier.

Therefore ALL GRID MODULATION SYSTEMS, WHETHER THEY USE THE CONTROL-GRID, SCREEN-GRID OR SUPPRESSOR-GRID FOR THE AUDIO CONTROL, OPERATE WITH CONSTANT PLATE INPUT AND VARIABLE EFFICIENCY. Some may dispute this statement but rather than argue mathematics in this article, I will

Fig. 3 (Below)
Western Electric
Grid Modulation

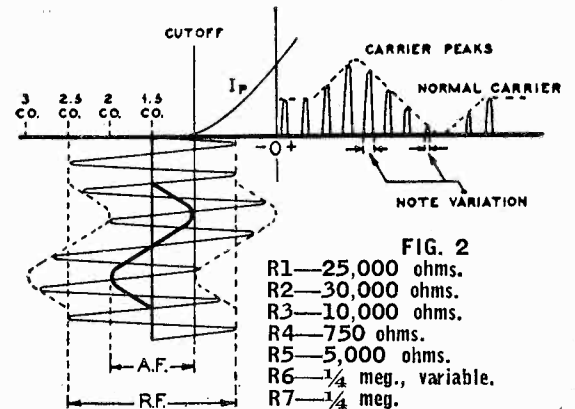

FIG. 2
R1—25,000 ohms.
R2—30,000 ohms.
R3—10,000 ohms.
R4—750 ohms.
R5—5,000 ohms.
R6—1/4 meg., variable.
R7—1/4 meg.
R8—2,500 ohms.
R9—10,000 ohms.
R10—10,000 ohms.
C1—.006 mfd.
C2—.00001 mfd. variable.
C3—.000014 mfd. split stator.
C4—100 mmf. split stator.
Cn—Neutralizing Condensers, 25 mmf. variable.
C5—2 mfd., 600 v. non-inductive.
C6—1 mfd., 400 volt.
T1—Mike to Grid Transformer.
T2—Interstage Transformer.
T3—2:1 Step Down Transformer.

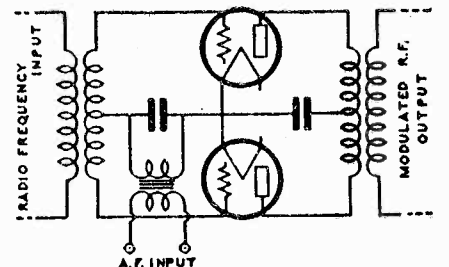

Fig. 4—Fundamental Circuit of Grid Modulation

simply announce that I will donate a brand new HK354 Gammatron to the man who can demonstrate a grid-modulated amplifier, capable of symmetrical and linear 100% modulation, whose plate efficiency remains constant when modulated. I don't say it can't be done; I only say it hasn't been done. I hope I lose the Gammatron because it would be well worth it.

The Class B Prime Circuit

LET us examine the drawbacks of the two best-known grid modulation systems and see wherein lies the advantages of the class B Prime circuit.

The first system is the so-called "Western Electric" method. (See Proceedings IRE for Feb. 1933, p. 212) also (See Figs. 3 and 4). The 100 watt amplifier operates with a bias of 1.5 times cut-off. The RF excitation is adjusted so that the unmodulated excitation peaks reach about halfway between zero bias and cut-off bias. The audio signal applied to the fixed bias swings the RF peaks up to zero bias and down to cut-off. Thus the grid excursions resemble closely those of a class A amplifier and the grid is never driven positive. The maximum plate efficiency occurs when the audio signal swings the RF excitation peaks up to the zero bias point on

the characteristic. This efficiency is approximately 45%, so the unmodulated plate efficiency is one-half this value, or 22.5%. Individual transmitters vary slightly, depending on operating frequency, but this value is about average for all of the type 12A transmitters. This plate efficiency of 22% (carrier only) means that about 450 watts of constant plate input is necessary in order to get a 100 watt carrier. This system holds little interest for the amateur, because 350 watts of plate dissipation costs too much for only 100 watts of output. While under exceptional conditions it might be possible for an amateur to use this system and obtain a higher value of plate efficiency, it must be remembered that the WE-270A tube was designed particularly for this type of modulation and operates at 3000 volts on the plate. It would take a materially higher plate voltage to get higher plate efficiency, and even then the increase would be very small. Several amateurs who tried this system were unable to get even 22% efficiency, when using conventional tubes.

The other system of grid modulation differs but little from the one described above, but is able to get materially higher plate efficiencies. This system has been called the Jones System, although I am under the impression that Mr. Frank Jones lays no claim to its development. It was described in "RADIO" for February 1934. It is characterized by the fact that the grid is driven considerably positive; in fact the unmodulated excitation peaks are slightly on the positive side of zero bias (See Fig. 1). The fixed bias is from 1.5 to 2 times cut-off and the plate input stays nearly constant. Under modulation, the fixed bias is varied by an amount equal to the difference between cut-off bias and the total fixed bias. The maximum plate efficiency occurs when the excitation peaks are most positive, and as the bias has been shifted by the audio signal to the cut-off point at this instant, the condition is that of a class B linear amplifier. As the maximum theoretical plate efficiency of a class B amplifier is 79.3% the unmodulated plate efficiency would be something less than one-half of this value. In practice, 66% plate efficiency is seldom realized (as in most class B audio amplifiers) and thus the unmodulated plate efficiency of the Jones system is usually under 33%. By reducing the percentage modulation capability, or by overmodulating, the plate efficiency of this system may be materially increased. However, I am assuming that 100% modulation capability is wanted, together with freedom from carrier shift and overmodulation.

The main drawback to the two systems described above lies in the fact that it is impossible to achieve linear modulation when only fixed bias is used, and this bias exceeds the cut-off value. Both systems show appreciable amplitude distortion as the percentage of modulation is increased, although in the Western Electric system the design of the tube minimizes this effect so that it is not evident to the ear up to about 90% modulation (see Fig. 5). In the Jones system this distortion is much more pronounced due to the higher bias and wider grid excursions. Distortion due to the non-linear grid current curve can be largely eliminated by using a husky coupling transformer with the proper impedance ratio to feed the audio signal into the grid circuit.

The reason for the amplitude, or harmonic distortion, in the above systems lies in the fact that the average value of the plate current is not proportional to the peak value of the plate current, during modulation. This is evident from a study of the plate current impulses shown in Fig. 1. As the grid swings more positive (during modulation), plate current flows during a longer time interval, and as the grid goes more negative, plate current flows for a shorter time interval than when the bias is unmodulated. For distortionless modulation it is essential that the interval during which plate current flows shall remain constant, regardless of the percentage of modulation. This condition is fulfilled only when the fixed bias is exactly equal to the cut-off value. However, while fixed cut-off bias is entirely workable for a class B linear amplifier, which is amplifying a wave which was modulated in some preceding stage, it can not be used in a grid modulated amplifier because the operating bias must always ex-

ceed cut-off by an amount equal or greater than one-half the audio signal voltage, in order to keep the negative halves of the RF excitation cycles from crossing the cut-off point during modulation.

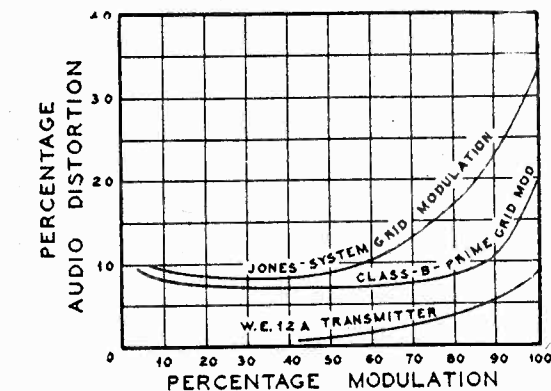

FIG. 5—Comparison of Harmonic Distortion of Various Grid Modulation Systems

ceed cut-off by an amount equal or greater than one-half the audio signal voltage, in order to keep the negative halves of the RF excitation cycles from crossing the cut-off point during modulation.

The Answer To the Problem

THE answer to the problem is CLASS B PRIME amplification. In class B Prime (see Fig. 2) the fixed bias is equal to cut-off bias. This bias should usually be supplied from batteries. The rest of the bias is obtained from a cathode bias resistor connected in the conventional manner. The extra bias supplied by the voltage drop through this resistor is proportional to the plate current and therefore to the grid voltage. When the ratio of grid voltage to this excess bias voltage is a constant, a condition arises where the plate current impulses all flow for the same time interval, regardless of their peak amplitude.

In the "Western Electric" and Jones systems the distortion increases almost directly as the ratio of fixed bias to cut-off bias. This limits any attempt to increase the plate efficiencies by using higher values of bias and driving voltage. However, in Class B Prime the total bias may be as high as desired in the search for a higher plate efficiency and the absolute value of the total bias, and therefore the driving voltage is dictated by the usual class C amplifier considerations. A limiting factor in class B Prime is the voltage drop across the cathode resistor which represents a growing waste of perfectly good plate volts, as the bias is increased. There is no objection to driving the grid of the class B Prime amplifier to positive saturation, although extremely high values of grid current will cause some slight distortion because the grid current flows through the cathode resistor. Therefore the plate voltage should be as high as the tube insulation and gas content will allow, so that positive saturation will be as close to the zero bias line as possible.

The best tubes to use as Class B Prime amplifiers are those of medium mu, such as the 210, 211, 800, RK18, 242A, 852 and HK354. The high mu tubes, such as the 841, 203A, 830B, 46 and the screen-grid tubes have an advantage in that a smaller cathode resistor can be used because less bias is necessary to reach any given number of times cut-off. However, the high plate impedance of these tubes makes their use undesirable because it is hard to get a linear dynamic characteristic.

The low mu tubes, such as the 245, 2A3, 845 or HK255 have the most linear characteristic, but the cathode bias resistor must

be so large in order to get enough bias for efficient operation that a terrific waste of plate voltage results. However, if there are no limitations to the plate voltage available, the low mu tubes will possibly give better results than the medium mu tubes. Perhaps the best single index of merit is the mutual conductance, although this factor of merit is measured under such widely varying conditions that direct comparisons should be made with caution, except for tubes of the same general type.

Class B Prime Circuit

THE circuit of a simple low-power transmitter is shown in Fig. 2. This transmitter uses two 210's running at 40 watts input. The carrier output is about 16.5 watts, which is not bad considering that materially less than one watt of audio power is necessary to completely modulate it. The input and output could be increased about 25% without exceeding the dissipation limit of 15 watts per tube. The plate efficiency at 100% modulation is 82%, indicating 41% as the unmodulated plate efficiency. Remember that the plates of a grid modulated amplifier cool off during modulation because the plate loss is greatest when unmodulated. The fixed battery bias is 112 volts and the additional cathode bias is 185 volts. The plate current is 44 milliamperes and the 5000 ohm variable cathode resistor is adjusted to about 4200 ohms. The final adjustment of this variable resistor is made for minimum variation in plate current, when modulated. The 5,000 ohm resistor tapped across the grid tank stabilizes the load on the buffer stage, which varies somewhat during modulation. The turns ratio on the audio coupling transformer is not critical and will depend on the grid current, which in turn depends on the antenna coupling and excitation. However, a 2:1 step down will be about right in most cases.

Here are some general suggestions for placing a class B Prime amplifier in operation. When comparatively low plate voltages are used and the output is not limited by the plate loss, the antenna coupling should be rather tight; in this case we are interested in maximum output rather than maximum plate efficiency. However, when the plate voltage is high it will be found that the plate dissipation limits the input, and thus the output. In this case the antenna coupling should be rather loose.

Start by applying cut-off bias to the grid by means of batteries. (Cut-off equals plate voltage divided by amplification factor). This value of bias will have to be readjusted later to allow for the reduction in plate voltage due to the drop in the cathode resistor, but it can be approximated by guessing at the additional bias that would be necessary for the same stage when operated as a high efficiency class C amplifier. The conditions of total bias and excitation for class B Prime amplifiers are almost identical to class C operation.

Place the stabilizing resistor across roughly half of the turns in the grid tank and then couple-up the excitation as far as possible without exceeding the safe ratings of the RF driver tube. Then remove the stabilizing resistor momentarily. The plate current to the driver should drop about 50% when this is done. If the drop is more than 50% the load resistor was tapped across too many turns on the grid coil, so try again. If the drop in plate current is less than about 50%, try tapping the resistor across more turns. The actual number of turns depends on the particular driver tube and the grid impedance of the final amplifier, and will vary widely in different transmitters. Now replace the resistor and neutralize the stage in the conventional manner. After neutralization, reduce the coupling to minimum.

For the medium-mu tubes the additional
(Continued on page 31)

A Brief History of Directive Radio Transmission

By JOSEPH DOCKENDORF

WITH the increase in interest and experiments on the 28 megacycle band and the ultra-high frequency bands of 5 meters and 77 centimeters by radio amateurs, it is felt that a brief history and bibliography of past work on these bands, particularly with reference to their use for directional transmission and reception in beam form, would be of more than passing interest to readers in general and amateurs in particular. The historical end of radio has not attracted writers and many valuable and interesting achievements have been successfully accomplished in the past, some not yet fully utilized by modern engineers. So let us look into the past as recorded in writings of many different engineers in half a dozen countries.

In 1887 Hertz used circular resonators about one foot in diameter and discovered the reflection and beam formation of electromagnetic waves. This is found in his book "Electric Waves" on page 175, published in the German in 1893 and translated into English in 1909. The greatest advance in beam transmission of signals was achieved by Marconi, who in 1896 spanned a distance of over two miles by their means. An increasingly greater distance was covered when the wavelength was increased, but this resulted in the necessity for proportionately larger reflectors with physical dimensions out of the question. The need for transmission to ships at sea with the wider beam area needed to insure contact with a given vessel, resulted in further research on beams being set aside and the "free broadcast" of energy began with the use of larger antennae and greater ranges. It is interesting to speculate on what the present state of radio would have been had beams been commercialized and wavelengths of 2 to 10 meters been in use; these waves with their low angle of propagation and greater skip distance might have retarded the development of radio and the billion dollar industry as we know it today might never have come into being. It was thought at this time that an increase in wavelength would bring about an increase in distance. Later, wavelengths of 10,000 meters were used for communication purposes over a distance of 1,000 miles. I have in my files a copy of an application from an amateur in Austin, Texas, January, 1916, wherein he stated that he was using a wavelength of 200 meters and had applied to the Radio Inspector for permission to use a wavelength of 450 meters in order to have a greater communication range. Amateurs as a whole in 1916 failed to realize that wavelengths of 125 meters had been used between 1902 and 1909 by British concerns, attaining a range of over a thousand miles with a power of 100 watts; this with a coherer and tape receiver.

From 1902 to 1907 a German engineer, Braun, had the field of beams to himself, his papers on the subject occurring in *Phys. Zeit.* in 1903, volume 4, page 363, entitled "Research On a Method of Directive Wireless"; 1906 in *Electrician* Vol. 57, page 222, "On Directed Wireless Telegraphy"; and in 1907 *Jahrb.d.Draht.*, volume 1, "Directive Wireless Telegraphy." In 1907 Prof. Pickard, Lee De Forst and L. H. Walter took up the correspondence on the subject. 1907 in radio history means the exposition of the principles of the Bellini Tosi directive methods and goniometer, the system being described in "Electrical Engineering", volume 2, page 771, and "Electrical World", volume 50, page 1203, by E. Bellini and A. Tosi. This system is used today with very few changes by the Aeronautics Branch of the Department of Commerce in their radio beacon transmitters for air navigational aids. A system of feeding different phase currents to an antenna array was discussed in 1906; this method of directional

transmission and reception should come into greater use during the next ten years as more engineers use and become familiar with the characteristics. It presupposes a fundamental knowledge of advanced alternating currents and vector analysis, hence is out of the realm of the majority of radio amateurs. It is used today on some transatlantic and transpacific circuits.

Between 1916 and 1921 it is interesting to note that all experiments which were conducted on a wavelength of 5 meters showed that radio waves acted in a similar manner to light waves and that all manner of "tricks" could be performed and relied upon over distances where the operators at the two stations were in visible communication, i.e., could see the other station; this occurred up to distances of 25 miles. At this early date Marconi and his English colleagues noticed that in the reflection of light into a beam a highly polished reflector was necessary, and in the reflection of sound a rough surfaced reflector could obtain good results; radio waves on the order of 5 meters seem to follow the same principle as to reflectors as did sound; hence, this discovery permitted doing away with metallic reflectors which had always been clumsy to handle and the substituting of wires forming the necessary general shape.

In 1921 telephone signals were carried out over a distance of 97 miles on a wavelength of 15 meters, and 700 watt input to a vacuum tube. The first 100 meter transmission of which I can find any record occurred in 1921 between Suffolk and Holland and between Suffolk, England, and Norway; this was without the use of beams but by the "general broadcast" from a free antenna. Later this was changed to a half-wave system and parabolic reflectors used. Note that on 100 meters the first amateur communication across the Atlantic occurred on November 27, 1923, so it appears that the amateurs were very quick to learn, particularly the French amateur Dely. In April, 1924, telegraph signals were transmitted from England to Australia and one month later telephone signals were sent. In 1923 the RCA used an auxiliary transmitter on a wavelength of 100 meters for communication between Tuckerton and South America. Finally the Corporation went down to 15 meters and achieved much better results. The practice in England and on the Continent at that time was to utilize beam transmissions, but either from lackadaisical reasons or disdain the American experimenters still used free transmission and as a result did not attain the high point of commercial efficiency which characterized the European work. Therefore, the Tuckerton-South American circuit suffered badly from fading, echo, and unreliability. The British government as early as 1924 carried out duplex operation between the British Isles and British colonies at a speed of 100, and more words per minute by means of beam transmission.

All this time there was another technological field opening up—Aeronautics. The first flier was also the first member of the Caterpillar Club, one Veranzio, who, with an improvised umbrella, successfully jumped from a tower in Venice in 1617. The first balloon negotiated the English Channel with Blanchard, a professional balloonist, and Dr. Jeffries, an American, in 1785. The Wright Brothers made the first heavier-than-air flight on Dec. 17, 1903, in America. In 1912 M. Dieckmann in *Janrb.d.Draht.*, volume 6, pages 51 and 70, contributed articles "Wireless Telegraphic Orientation and Meteorological Information

from Airships" and "Airships and Wireless Telegraphy." Previous to this date other engineers, notably British and German, had discussed and carried out experiments with vessels at sea with a view toward development of a procedure to facilitate the location of a ship in foggy and inclement weather. The attenuation factors were discussed and discovery made as to the effect of ship's hull, smokestack, rigging, and the relative advantages of locating the direction finder equipment ashore or on board ship. An error of only 5 to 10 per cent in bearing was considered good, whereas today, even under adverse conditions, vessels can attain an accuracy of better than 2 per cent.

After 1920 the United States engineers, particularly the Bureau of Standards and Naval Research Laboratory, did very good research work. C. J. Robinson in "Radio Review", in 1919 discussed the factors affecting efficiency in flight, and in 1920 brought out the effect of magneto, plane static and rigging in reception during flight. In 1922 F. A. Kolster and F. W. Dunmore in *Scientific Paper* No. 428 discussed the radio direction finder quite thoroughly. In 1922 L. E. Whittemore in "Radio Broadcasting" described methods of using the direction finder in the location of illegal broadcasting stations. At this period other engineers made good use of the Bellini-Tosi system, popularly known as the B-T system. Under the Air Navigation Act of 1926 the Congress took air mail development away from the Post Office Department and made it a function of the Department of Commerce. Thereafter plans were rushed for the installation of 2 KW aural radio beacons with reliable service area of at least 200 miles in diameter. In 1932 the loop system of aerial was done away with and one-half-wave vertical towers were installed, overcoming what was known as the "night effect". This night effect was dealt with by G. M. Wright and S. B. Smith in "Radio Review", volume 2, page 394, in an article entitled "The Heart Shaped Diagram and Its Behavior Under Night Effect Conditions." This was in 1921. In 1927 A. Blondel treated on a method of a rotating radio beacon with 12 to 32 courses, instead of the customary present four or less courses, made possible by means of feeding directional antennae with polyphase currents at correct intervals and with a due regard for proper spacing of antenna and reflector. His system is not in use at present due to present stage of aviation development but it will eventually come into greater use when plane speed increases and there are a greater number of planes and routes to be served. It can be said in all fairness and without reflection to any other engineer, that Blondel had the best ideas and suggestions of any experimenter in the past two decades. He seems to have the peculiar gift that his mind could pass through mere details of an experiment or theory and settle upon the essential factor which he would proceed to discuss and set forth in simple and lucid language, utilizing his wide knowledge of the other sciences to clarify and expound, and finally forecast the future uses of a practical application of his theory. He should be ranked second only to Marconi in this and other fields of radio.

The German and English engineers should be placed first in the field of beam transmission, with the Americans second, since from 1900 to 1920 the English dominated the technical contributions to this field, as judged from the writings of those years. Because of the fact that Marconi did so much work under contract to the British Post Office he should be classed with the English. He regularly makes new contributions, however, and

(Continued on page 32)

Directive Antennas

By DON C. WALLACE, W6AM

AMATEUR radio offers the experimenter many an alibi; some agree on one thing, others on another. What works good in your location may not work at all in mine. When I "maintain" that something should be done in a certain way, you maintain that I am "all wet". Conversely, I feel the same about you, when you advance a theory of which I do not approve. So it goes. Were it not for this wide difference of opinion there would be no amateur radio. If we all used the same kind of antennas, receivers and transmitters there would be nothing left for us to talk about. If we were certain of a "best method", nothing else would be left to "discover". It would be the end of this fascinating sport.

I was in San Francisco recently for a chat with the folks who publish "RADIO". As usual, we talked about nothing but antennas. One of the magazine folks told me of the thrill he received from his first QSO with a station in South Africa.

I soon learned that the antenna sloped in the direction of South Africa. Sloped antennas are directional, of which I will tell more later. I was then asked, "What is the correct length for Zepp feeders?"

For best results, a 40-meter Zepp antenna can have a radiator 133 feet long, regardless of frequency used in the 40-meter band, and the feeders should be either 33 feet, 90 feet or 160 feet long.

With this system, no feeder tuning condensers are required. If, on the other hand, series-tuning of the feeders is wanted, the feeders should be five feet longer than the figures above show. The usual .0005 mfd. variable condensers are suitable for series-tuning.

To find out exactly how long the antennas should be, you can conduct a few simple experiments, as follows: (1) Pull the antenna into position but with the feed line disconnected from it. (In other words, the wires going into the feeder will terminate). (2) Reduce the power of the transmitter to a few watts, otherwise your antenna meter will burn out. (3) Tune-up the feeders. (4) Lower the antenna, attach the antenna to the feeders, and return to the station.

If a change in tuning is necessary in order to bring the transmitter into resonance, the antenna is either too long or too short. You can readily tell if the antenna is too long by the action of the series condenser in the feed lines; the capacity would have to be reduced to maintain resonance if the antenna is too long, or capacity must be increased if the antenna is too short. Regardless of the length of the feed line (33, 90 or 160 feet), the same method can be used. It applies equally well in tuning-up beam antennas, enabling you to make sure that the antenna proper starts at the point where the feed line actually terminates.

These details are relatively unimportant, as many have found. Instead of going to all this trouble you can be assured in advance that a 133-foot antenna will give excellent results.

The Zepp, with its 133-foot radiator, and feeders 33 feet, 90 feet or 160 feet long (any of these feeder lengths is equally satisfactory), is DIRECTIONAL on 40 meters . . . DIRECTIONAL FROM BOTH ENDS, if horizontal; MORE DIRECTIONAL FROM THE LOW END, if sloped. In other words, if the low-end of the antenna points toward South Africa, that is the direction in which you will get best transmission.

If, on the other hand, you have a Zepp antenna with a radiator only 66 feet long, it

is directional at RIGHT ANGLES to the direction in which the antenna runs, if the radiator is horizontal. But if the radiator is sloped, the directional effect is again in the direction of the slope.

Therefore, the 133-foot radiator for a 40-meter Zepp is far more effective for directional transmission than one with a 66-foot radiator.

I propounded these theories at various times, and was once told to have myself boxed

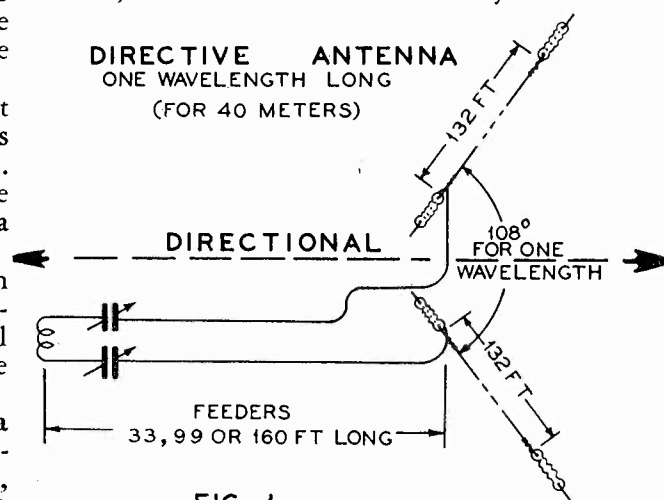

FIG. 1

The directive effect of this antenna increases as the "beam" is tilted toward the direction in which transmission is desired. If the "beam" is horizontal, directive effect will be equal from both ends of the antenna.

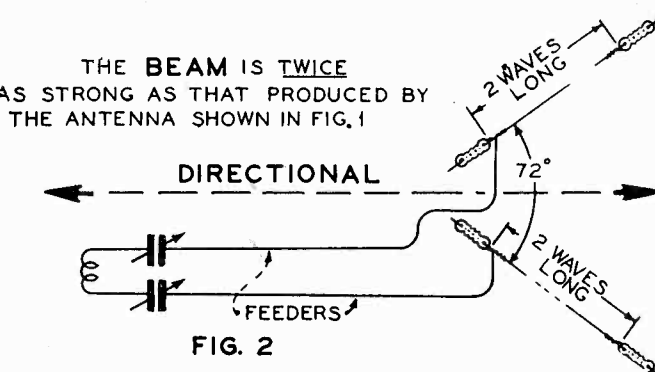

FIG. 2

The "beam" of this directive antenna is twice as strong as that from the beam in Fig. 1, because the beam is only half as wide when a 2-wavelength antenna is used.

and shipped to the Bureau of Standards to be calibrated. So the argument continues in full swing. Kruse maintains that the feeder length of a Zepp makes no difference at all . . . that the feeders are only parts of the antenna system, folded up. Others advise you to look at a chart and measure your radiator and feeder lines to a gnat's eyebrow.

My hobby is antenna-tinkering. This reason for this is my good fortune in being situated in a wide-open location where I can erect new antennas 'til the cows come home, without having to take down the old antennas. Thus I have been able to make direct comparisons, under actual operating conditions. The wide-open spaces have permitted me to erect the new directive antennas which give a 20-KW signal with 1 KW input in the direction to which the beam points. But let me first get this Zepp problem off my mind.

The best 40-meter Zepp I have ever used is one with a radiator 133 feet long. The feeders can be either 33 feet, 90 feet, or 160 feet long, if connected directly to the antenna coupling coil, or the feeders should be 5 feet longer if series-tuning of the feeders is to be

desired. A 40-meter Zepp radiator, 133 feet long, if, of course, full-wave. Extensive experiments with Zepp feeders conducted at my location have proved this contention. So I stand pat. You can argue the point, and try for a free prize which the editor will award for the best articles telling how other Zepp feeder lengths produce superior results.

If the radiator and feeders are not of the length prescribed, you merely "shock-excite" the system, instead of actually TUNING it. Thus the antenna is not given all it will take. Try it. I have ten antennas now in use at W6AM, and by the throw of switches I can change from one to another. The 40-meter Zepp with its 133 foot radiator and 33 foot feeders (using no feeder tuning condensers) has given the best results of any Zepp I have used. It is sloped in a southerly direction. Therefore, my best signals are transmitted south from that antenna.

The spacing of the feeders for a Zepp is not critical. The usual 6-inch Johnson feeder spacers are most generally used. Some commercial companies use two-foot feeder spacers for a 600-meter Zepp. I haven't been able to detect any difference between two-inch or two-foot separation.

A few words about vertical antennas. These antennas radiate "equally poor" in all directions, because they are non-directional. It is about the worst kind of an antenna I have used. It does not compare with a horizontal or sloped antenna of equal height.

How high should an antenna be from the ground? I have had exceptionally fine results with a Zepp that is 30 feet high at the high end and only three feet off the ground at the low end, with no surrounding obstructions. Some beam antennas now in use at my station are only 20 feet off the ground. I use No. 14 hard-drawn enameled copper wire for most of my antennas.

It is, of course, advisable to have the antenna as high as possible. You will perhaps recall the flight of the airplane "SOUTHERN CROSS", whose signals were heard around the world, day and night. The plane was flying at a very high altitude.

Airplane operators report that signal strength increases with altitude. However, there are certain spots where the reflected energy from the earth gives the effect of more signal strength in certain directions. These spots would obviously occur at different points along the wavelength used. For example, at a height of exactly one-half wavelength the signals would be stronger than if the antenna is a shade higher or lower than one-half wavelength. But if the antenna is raised to three-quarters wavelength high (or higher still—to one wavelength), better results will be secured because more energy will be radiated. Apparent exceptions to this rule are based on directional effects obtained from the reflection from earth, but if true directive antennas are used we can be assured that the antenna itself is responsible for these effects.

If you want to get more out of your Zepp, rebuild it . . . make the radiator 133 feet long, run it over vacant lots, if possible, make the feeders either 33 feet, 90 feet or 130 feet long, or 5 feet longer if you are going to use series tuning for the feeders.

Directive Antennas

DON'T let the old bugaboo of "tight quarters" worry you. You can erect a mighty fine directive antenna even in places where space is somewhat at a premium.

(Continued on page 30)



Refinements in the 354 Gammatron

THE makers of the 354 Gammatron report that by means of a minor change in the filament structure the grid characteristic is now exceptionally linear. This straight characteristic is of distinct advantage when the tube is used as an audio amplifier, particularly in class B. It also reduces distortion when used as a grid modulated RF amplifier.

Incidentally, comparatively few phone men realize that it is possible to obtain 500 watts of high quality audio power from a pair of 354's operating class B at 2000 volts, without materially exceeding the conservatively rated plate dissipation of 100 watts per tube.

The mutual conductance of the 354 at 1000 volts and zero bias is now 10,000 micro-mhos. This shows that while the 354 can be used with the highest plate voltages permissible on ANY air cooled tube, its mutual conductance at only 1000 volts is higher than that of any of the common 100 watt tubes, indicating that it is the easiest to excite to a given output and efficiency.

That Neutralizing Tap

IN NEUTRALIZING a single-ended RF amplifier there is only one PROPER location for the tap which is by-passed to ground, thus establishing a voltage node at this point. This location is at the CENTER of the tank coil and can either be the grid or plate coil, depending on whether Rice or Hazeltine neutralization is used. Many operators have found that they can get fairly satisfactory neutralization (at least the amplifier doesn't show the usual signs of self oscillation) with the tap located somewhere off center. They then compensate for the unbalanced RF voltage across the whole coil by increasing or decreasing the neutralizing capacity. Even though a voltage balance can be obtained, the neutralizing and exciting voltages are not exactly 180 degrees out of phase, i.e., over a part of the cycle there is a tendency to oscillate. This can roughen the note and sometimes cause the emission of parasites, although it also helps the power output through regeneration. While this condition might be allowable for CW use it is absolutely out as far as phone is concerned, if true linear modulation is desired. Even for CW use, it is better practice to keep everything perfectly neutralized. What good does it do to raise your output, through regeneration, from R6 to R8 if you allow an R4 backwave to be radiated? In these enlightened times there is no excuse for the radiation of any backwave whatsoever. If your set-up is such that all attempts to neutralize the backwave fail, then it is time to start keying the crystal.

Doublet Antennas and Transposed Feeders

THE whole point to a doublet antenna with canceling feeders is that the antenna can be removed from sources of man-made noise. A doublet is just a waste of time if the antenna itself is close to a power line or some other source of RF interference. The first step is to get the doublet in the clear, at least fifty feet away from all AC wiring or power poles. If it is impossible to get your doublet in the clear, you cannot realize all of this antenna's advantages. Don't be afraid of long feeders. If you use the proper matching system between the feeders and the antenna and use low loss feeders, the line can be a quarter of a mile long without appreciable loss in signal strength. A doublet does not work well on even harmonics of its fundamental frequency. This gives improved harmonic suppression when transmitting but, necessitates a separate antenna for each band.

Single Signal Reception Without a Crystal

THE selectivity of a crystal is due to its high Q. If we could find an IF transformer whose Q at 440 KC approached that of a crystal we could forget about the crystal and its attendant troubles. W6UE and others have utilized the old "Double-super" idea first shown by Silver some years ago. They use two intermediate frequencies, one near 500 KC to reduce image interference and one near 50 KC to provide real selectivity and gain. They use two high frequency oscillators and two heterodyne detectors in addition to the usual audio, or second detector. One of the high frequency oscillators is variable in the usual manner and the other is fixed. The fixed oscillator works on a frequency separated from the first intermediate frequency by the frequency of the second IF amplifier. This system is FB, PROVIDED the harmonics of the second oscillator are prevented from getting in the first detector, where they appear as R9 unmodulated carriers. Sargent minimizes this trouble in his 9-33 all wave super by using exceptionally good shielding around his fixed oscillator (a 2A7) and a separate heater winding for this tube. His two IF frequencies are 465 and 175 KC.

Ham Hints

— By JAYENAY —

Good and Bad Excitation Taps

WHEN driving a tube with a low grid impedance (such as a 46, 841 or 830B) by means of a tube with a high plate impedance (such as a 47, 2A5, 46 or 865) it is necessary to match the low impedance load to the high impedance driver by means of a transformer (Link coupling) or an autotransformer. Of course, Link coupling is the simple way out, but many hams with rack-mounted transmitters built before the days of link coupling find that they have no room for the additional grid coils and condensers, but must stay with capacity coupling for the time being. Theoretically, they can match a low grid impedance to a high plate impedance by tapping down on the plate tank of the driver in order to get autotransformer action (see Fig. 1). However, they often find that the driven stage refuses to neutralize when this is done and it insists on oscillating merrily until the plate

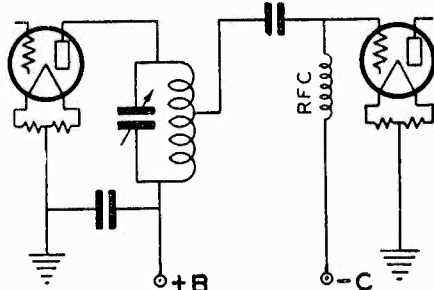

FIG. 1 WRONG WAY

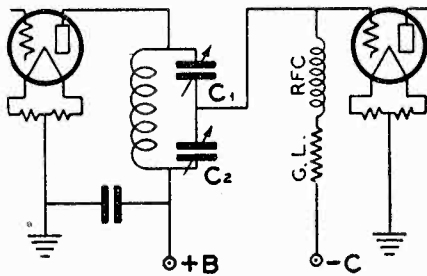

FIG. 2 RIGHT WAY

tap is put back to the plate end of the driver tank. The amount of inductance between the excitation tap and ground often acts as an untuned grid coil, and the driven stage then acts as a TNT oscillator. However, note Fig. 2. There we have the same autotransformer action as in Fig. 1, but instead of an inductance between the excitation tap and ground we have a capacity, and self-oscillation thus is impossible. The two condensers also provide a finer adjustment of the impedances so that we can easily experiment around with the two condensers until we get optimum step-down. For the benefit of those "critics" who still think in terms of excitation voltage, I freely admit that tapping down on the plate tank reduces the excitation VOLTAGE available on the grid of the driven stage, BUT all efficient class B and C amplifiers are excited with POWER, not voltage, and impedance matching is necessary for best results. All grid chokes have losses. Use only the best; also see that the grid choke does not resonate with C2, or fireworks will result.

The 2B6 As a Class B Driver

THIS strange and wonderful nightmare is the latest edition of the Triple-Twin tube which came out a couple of years ago. It consists of two direct coupled triodes in one envelope and has all of the good features of the better pentodes with none of the terrible distortion that is often present in the output of a pentode. It makes a fine driver for all of the low-powered class B combinations and has enough gain to work out of a single button carbon mike. Incidentally, it looks FB for a crystal oscillator and buffer combined. It might be that EFFICIENT doubler we have been searching for. Let's try it and see what happens.

Backwave With Primary Keying

MANY who use primary keying are surprised to find that their final amplifier draws five or ten mills of plate current when the key is up. It is hard to understand how there can be any plate voltage on the final amplifier when the primary of the power transformer is open. It is usually found that the capacity of the twisted pair often used to bring the keying leads up to the key or relay is sufficient to pass considerable AC power through the primary of the plate transformer, even though the circuit is apparently open.

Link Coupling Again

ONE tremendous advantage of link coupling often overlooked by the average Ham is the improvement in impedance-match that results from its use. Let us suppose, for a moment, that we have an 865 driving a 203A amplifier. The 865 has a very high plate impedance; in other words, it likes to deliver a lot of volts but few milliamperes of RF current. On the other hand, the 203A has a low impedance grid circuit. It doesn't require many volts to swing its grid, but due to the high grid current, many milliamperes of excitation current are necessary. Thus impedance-capacity coupling is most unsatisfactory between these two tubes. The big advantage of link coupling lies in the fact that the many volts and few milliamperes of RF power in the plate circuit of the 865 are transformed into more milliamperes and fewer volts at the grid of the 203A. This, in short, demonstrates the necessity of impedance matching, whether it be in a transmitter or in the audio channel of a receiver.

Of course, any form of inductive coupling would give this transformation of impedances, but link coupling is the most practical form of inductive coupling.

If you must use Impedance-Capacity coupling, it pays to use high mu tubes to drive low mu tubes, and vice versa. It follows that a pentode oscillator is not particularly suited to drive a 46 buffer or doubler, with capacity coupling, due to the low impedance grid circuit of the latter.

Give Your 866's a Break

FAR too many mercury vapor rectifiers go west through pure negligence. Keep the filament voltage right on the nose at its rated value, or kiss the tube farewell. It is not generally realized that the filament temperature has a tremendous effect on the liability of hot cathode vapor rectifier to break down. 5% is, in my opinion, far too much variation to allow if the tube is being run to capacity. This is true of all mercury vapor tubes, including the 83, 82, 872 and 871.

5-Meter Antenna Systems

(Continued from page 9)

two tuned circuits cut in at 8 ft. intervals. These tuned circuits can be 6 turns of No. 10 or 12 wire on 5/8 inch diameter with a little spacing between turns and tuned by a three or four plate midget tuning condenser. These coils can be soldered directly across the condenser terminals and the eight foot antenna sections also soldered on these connections. These circuits are easily tuned to five meters by previous adjustment when the coil and condenser are coupled like a wavemeter to a transmitter or receiver circuit. With an outside antenna, these tuned trap circuits should be protected against moisture. Any number of sections can be used in order to increase the effective height above ground.

The purpose of these tuned circuits is to prevent phase reversal of standing waves of voltage and current in an antenna of several half wavelengths. These "phasing coils" reverse the phase without themselves radiating to any extent; the desired effect of a number of antennas all radiating in phase is obtained.

A full-wave antenna, 16 feet long, without a phasing coil and condenser trap circuit has a radiation pattern like a shamrock, or four leaf clover, without much energy going out at right angles to the antenna. This radiation pattern should have a maximum in a direction parallel to the earth for five meter transmission or reception, so a 16 foot antenna can be used if it is tilted at an angle of 40 or 50 degrees toward or away from the desired directions. It should be more effective if tilted towards the desired direction since its upper "loop" would be used parallel to the earth, and because the upper loop would be useful, the effective height would be greater.

Any form of antenna can be used for five meter work, even a wire several hundred feet long, but best results are obtained if the antenna is designed only for five meter use. The vertical half-wave antennas mounted up on roof tops with two wire matched RF feeders, or the simple Franklin antennas are by far the best for non-directional transmission and reception.

800 Watts of Carrier With Low-Cost Tubes

By LINEAR

MODERN practice of long-known facts have given the amateur an entering wedge into the field of high power. The large and costly tube of the past has gone into the discard, since amateurs have found that power inputs up to the maximum limit of 1000 watts are readily obtainable with certain of the so-called "100 watt" variety. Enlarging on this idea of modern design we are describing a high-quality phone transmitter built and operated by William Eitel and Jack McCullough, signing W6UF-W6CHE.

Modern design means exibility. A modern transmitter must be able to operate in all the common bands with equal efficiency and output. The number of adjustments to obtain this flexibility must be reduced to a minimum and must not be "cranky".

Modern design means stability. Stability can only be obtained with plenty of shielding and isolation of circuits so that interaction between different components shall be at a minimum. Of course, isolation of the oscillator from the final amplifier is all-important.

Modern design means efficiency. Only by obtaining high efficiencies from the equipment on hand can one hope to get anything but mediocre results. By using simple straightforward ideas it is possible to obtain three or four times the power output formerly considered maximum, without impairing tube life or reducing necessary safety factors.

Modern design also dictates simplicity. Fortunately simplicity fits in very well with the other ideals, and for this reason it is possible to build a high-quality, high-powered transmitter at minimum cost.

These four ideals, Flexibility, Stability, Efficiency and Simplicity, play mighty important parts in the design of W6UF-W6CHE.

The oscillator is controlled by a 160 meter crystal. The choice of this frequency for the crystal may seem strange when it is realized that the transmitter is operated on 20 meters most of the time. However, for several reasons this choice is logical. (1) It allows all-band operation with a minimum number of crystals. (2) Large, thick crystals give greater output and are less fussy. (3) The oscillator frequency is usually far enough removed from that of the amplifier (except on the 160 meter band) so that several neutralizing adjustments are avoided and keying chirps are entirely eliminated.

The oscillator and doubler are connected in the familiar "Tri-tet" circuit using 160 meter crystals for all frequencies. The unsatisfactory performance of receiving tubes when overloaded warranted the addition of a neutralized 210 buffer stage to excite the 354 buffer-driver stage instead of using high plate voltages on the 59's.

When the 354 was replaced with the 357 Pentode, the higher power gain of the latter tube made the use of the 210 stage unnecessary, so it was eliminated. However, as the 357 was not generally available at this writing it was deemed advisable to show the 210 stage in the circuit. The pentode stage is shown in Fig. 1. All the neutralized stages use split-stator tank condensers, making it unnecessary to reneutralize when changing bands. It was intended to use link coupling between the 210 buffer and the 354 buffer-driver, but the latter stage proved so easy to drive that capacitive coupling was used.

The final amplifier was designed to run at about 80% plate efficiency with a pair of 354's in push-pull. Although there is no voltage limitation on the 354's it was decided that 2000 volts on the plates would be most desirable, since the cost of high voltage tank condensers is quite a factor, especially when modulation is involved. Another factor which helped keep the plate voltage down was the filter condensers. While, theoretically, the cost of a power supply filter is proportional to the power output, and not the voltage output, in practice most amateurs find that high current chokes are cheaper than high voltage filter condensers. 2000 volts also fits in nicely with the 7500 volt inverse peak rating of the more common mercury vapor rectifiers, making the use of a bridge circuit unnecessary. Therefore the final amplifier draws 500 mills at 2000 volts.

The keying circuit and bias circuit for the final amplifier deserve special mention. The keying relay shorts out the coupling link between the driver stage and the final amplifier.

This unique, though highly effective method completely eliminates clicks and thumps when using CW. The relay is normally CLOSED when the key is up. As the final amplifier uses grid-leak bias for reasons of economy and flexibility, it was necessary to provide a means of preventing excessive plate current with the key up. This was done with a second relay which was actuated by the rectified grid current through the grid leak and which cuts-in 1500 ohms of cathode bias whenever the excitation fails.

He is a hardy optimist who fails to recognize the protection provided by this simple device. Without excitation the final draws about 60 milliamperes. This maintains a load on the power supply, with consequent longer life for the filter condensers in the power supply.

The plate tank of the final amplifier uses rather low C, in line with present practice, in order to realize high plate efficiency, and the split-stator

and seems to kick the second and third harmonics around until they are totally lost in the shuffle. The speech amplifier is entirely conventional

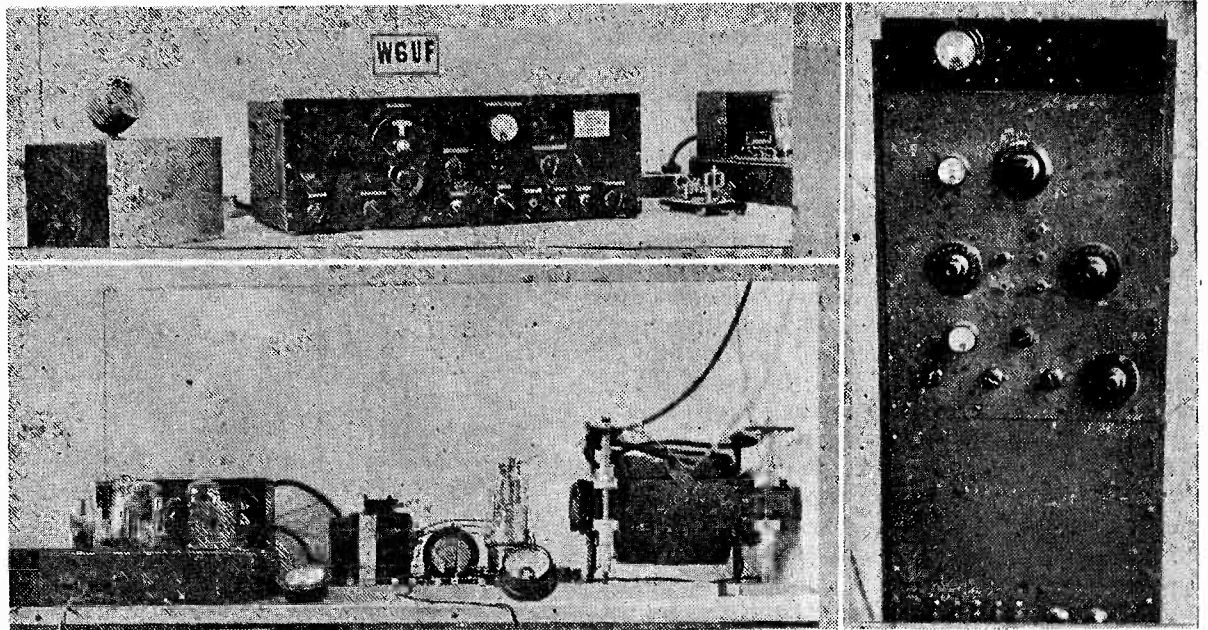

Upper illustration—Receiver and Condenser Microphone. Lower—Speech Amplifier and Modulators. Right—RF Portion of Transmitter

condensers eliminate all difficulty in neutralizing and protects the blocking condensers.

Although a high load impedance is used in the plate circuit of the final amplifier, little driving power is necessary to drive the stage to the full kilowatt input. Thus the 354 driver stage "loafs

and provides plenty of gain for the condenser mike. Effective AF and RF shielding is absolutely necessary to prevent feedback. The high degree

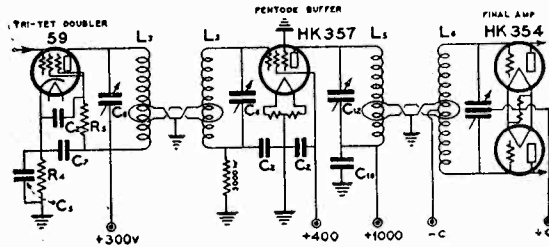

FIG. 1—Alternate Buffer using HK-357 Pentode

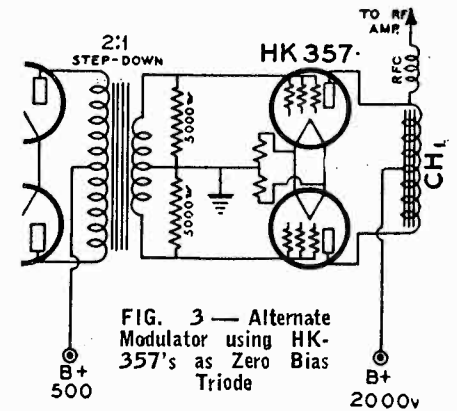
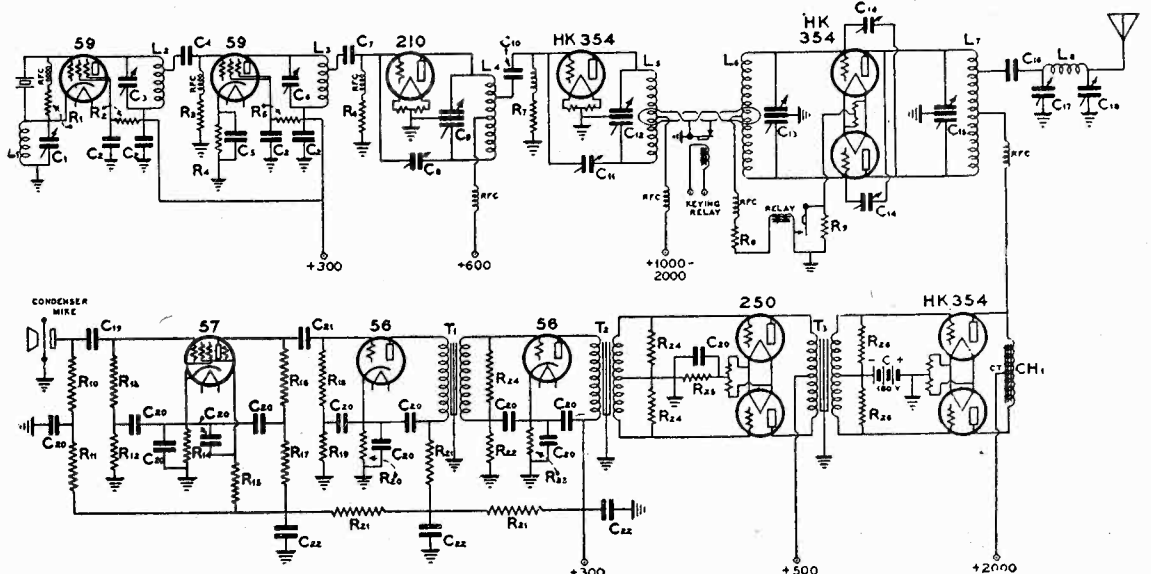

FIG. 3—Alternate Modulator using HK-357's as Zero Bias Triode

along" with from 100 to 150 watts input, depending on frequency.

The antenna consists of a single wire about 230 feet long and is fed at one end through the Collins version of the familiar pi network which effectively matches the antenna impedance to the tank tap. This network performs equally well on all bands

of isolation and by-passing may be considered a luxury by some but it is felt that the operator of a 1 KW phone owes it to the rest of the gang to use the highest possible audio quality in order to make (Continued on page 29)



THE MOST ECONOMICAL 1,000 WATT RADIOTELEPHONE

- C1—140 mmf. Hammarlund Condenser.
- C2—.01 mfd. C3—50 mmf. Hammarlund.
- C4—.00025. C5—.0001. C6—50 mmf. Hammarlund.
- C7—.00025. C8—22 mmf. Neutralizing.
- C9—100 mmf. split stator. C10—.00025.
- C11—15 mmf. neutralizing. C12—100 mmf. split stator.
- C13—100 mmf. split stator. C14—15 mmf. neutralizing.
- C15—100 mmf. split stator. C16—.001.
- C17—250 mmf. C18—250 mmf. C19—.001.
- C20—1 mfd. C21—.01 mfd. C22—8mfd.
- R1, R2, R3, R5, R17, R19—50,000 ohms.
- R4—1000 ohms. R6, R7—15,000 ohms.
- R8—25,000 ohms. R9—1500 ohms.
- R10—10 megohms. R11—5 megohms.
- R12—1/2 megohm. R13—1/4 megohm.
- R14—750 ohms. R15—1/2 megohm.
- R16—1/4 megohm. R18—1/4 megohm.
- R20—2500 ohms. R21—20,000 ohms.
- R22—1/4 megohm. R23—2500 ohms.
- R24—1 megohm. R25—750 ohms.
- R26—10,000 ohms.
- T1—Triode Plate to Grid.
- T2—Push-Pull Input. T3—Class B Input, 1:1 for 354's; 2:1 for 357's.
- Ch—Class B Output Choke, 92 henries.

Plate Supply Circuits and Ratings

By I. A. MITCHELL, Chief Engineer, United States Transformer Corp.

Tube Ratings

A KNOWLEDGE of rectifier circuits is essential to the modern amateur. With a full understanding of the various circuits which he can use for his plate supply rectifiers, economy can often be effected in both tubes and associated components. Inasmuch as practically all amateur transmitter plate supplies use mercury vapor rectifier tubes, the data compiled below will concern this type of tube only. Tubes of this type are rated on the basis of peak inverse voltage (the maximum voltage permissible in a direction opposite to the normal rectified current flow), and peak plate current. As the peak plate current with hot cathode mercury vapor tubes is affected only to a very small extent, by the internal drop of the tube, and as this drop is generally small in comparison to the rectified voltage, it can be neglected in theoretical discussion. On the basis of sine wave input the peak inverse voltage can generally be taken as 1.4 x the RMS AC voltage from the transformer.

Effects of Filter

The peak plate current is a little more difficult to determine and is affected very considerably by the form of filter into which the rectifier operates. The scope of this article being limited, the details of filter design will not be covered. However, as the filter circuit does affect the peak plate current of the rectifier tubes, it is necessary that we have some means of classifying fundamental filter circuits. There are three types of filter circuits used by the amateur; the common choke input filter circuit in which the rectifier tube is followed by a reactor, the condenser input filter circuit in which the rectifier tube is followed by a capacitor and the saturated reactor filter circuit which is really a compromise between the above.

Condenser Input

Where a filter circuit is used having condenser input, the peak plate current per tube in a full wave circuit may rise to values as great as four times the DC load current depending on the value of input capacitance. This naturally results in poor tube economy. In the case of 866 tubes for example, the peak plate current of .6 amperes might be reached when the DC obtained is only .15 amp. A second factor which limits the use of condenser input filters for amateur work is the poor regulation obtained in such circuits.

Choke Input

Where a filter circuit is used having choke input, the peak plate current per tube in a full wave circuit will generally run about 50% greater than the DC. If a saturated reactor is used, this peak current will be increased as the load current is increased to as high as 2½ times the DC.

With the knowledge of the peak inverse voltage and peak plate current of rectifier tubes, it is apparent that the proper tube or tubes and associated components can be readily determined for any plate supply output. These values for the tubes generally used by the amateur are enumerated below:

Tube Type	Peak Inverse Volts	Peak Plate Cur.
82	1,400 volts	.40 A.
83	1,400 volts	.80 A.
66	7,500 volts	.6 A.
66A	10,000 volts	.60 A.
72	7,500 volts	2.5 A.
72A	10,000 volts	2.5 A.
869	20,000 volts	5 A.

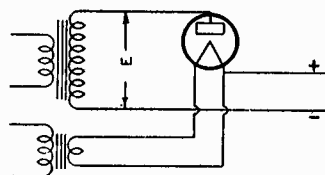

SINGLE PHASE HALF WAVE
FIG. 1

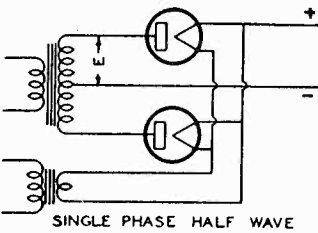

SINGLE PHASE HALF WAVE
FIG. 2

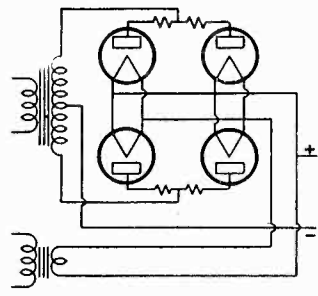

FULL WAVE PARALLEL TUBES
FIG. 3

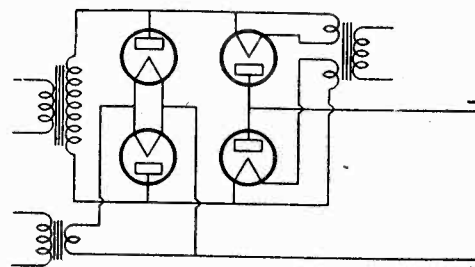

BRIDGE CIRCUIT
FIG. 4

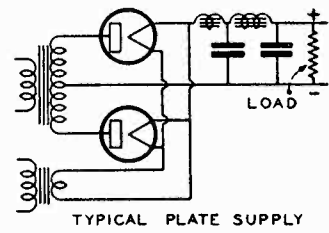

TYPICAL PLATE SUPPLY
FIG. 5

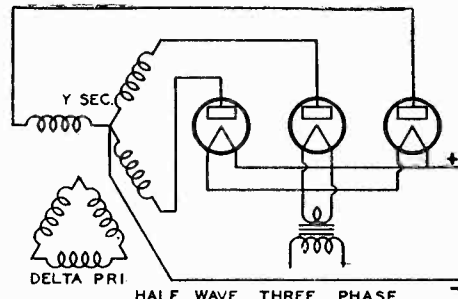

HALF WAVE THREE PHASE
FIG. 6

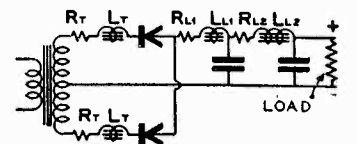

SIMPLIFIED FORM FIG. 7
FIG. 8

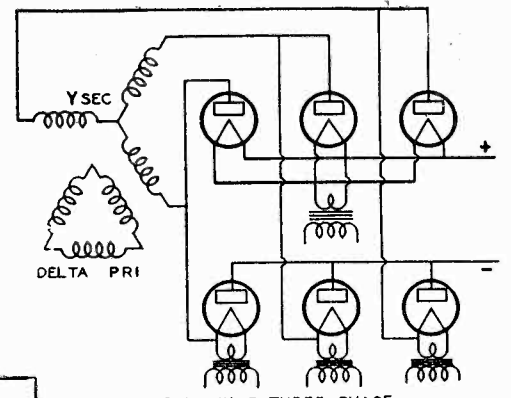

FULL WAVE THREE PHASE
FIG. 9

Standard Rectifier Circuits

Figs. 1 to 6 illustrate typical rectifier circuits applicable to amateur use. The single phase half wave circuit of Fig. 1 is not very popular due to the fact that the ripple is of greater magnitude and being of lower frequency than other systems is more difficult to filter. With choke input, the DC voltage will be approximately .45 that of the RMS voltage E. Fig. 2 illustrates the full wave single phase circuit which is most commonly used and with which every amateur is familiar. Fig. 3 is identical in nature with Fig. 2, except that four tubes (more if desired) are used to obtain higher current output. The resistors shown in the plates of these tubes are highly essential. Otherwise, one tube will generally take most of the load with the natural result that the tube life is greatly decreased. It has been the writer's experience that if a drop of about six volts is obtained across these resistors, stability will be obtained. Fig. 4 illustrates a bridge circuit. While this circuit involves four tubes, it has the great advantage that high DC voltages can be obtained without expensive (high peak inverse voltage) tubes and with low voltage transformers. In many cases where full wave rectification has been used it is desired to increase the DC voltage, it is possible to use the entire secondary output of the plate transformer, and with rectifier tubes in bridge connection, twice the DC voltage will be obtainable. Of course, this halves the current output due to the transformer current carrying limitations. Figs. 5 and 6 are similar in nature to Fig. 2, except that they are applied to three phase circuits. In the circuit of Fig. 5, each tube carries current for one-third of a cycle. The circuit of Fig. 6 is very commonly used for high power transmitters where three phase power supply is available, due to the high DC voltage which is obtainable. This circuit has the added advantage in that the ripple frequency is high, be-

ing six times the supply frequency, allowing easy filtering.

Analyzing these rectifier circuits, we obtain the values indicated below as the maximum operating and output values for any of the tubes described above:

Fig. No.	Transf. volts E	DC output volts at input to filter	Dc output current
1	.7 x peak inv. voltage	.45 x E	1.33 x peak plate current
2	.35 x peak inv. voltage	.9 x E	.66 x peak plate current
3	.35 x peak inv. voltage	.9 x E	1.32 x peak plate current
4	.7 x peak inv. voltage	.9 x E	.66 x peak plate current
5	.43 x peak inv. voltage	1.12 x E	.83 x peak plate current
6	.43 x peak inv. voltage	2.25 x E	1.0 x peak plate current

As an example, if we apply these figures to the 866 tube, we find that in a full wave circuit, (Fig. 2), the maximum transformer voltage E each side of center-tap is .35 x 7500 or 2650 volts. This gives us a DC voltage at the input to filter of 2650 x .9 or 2400 volts. The maximum DC output is .66 times the peak plate current of .6 amperes, or 400 MA. Naturally, voltages and currents lower than these values can be used. Where a saturated input reactor is used, the allowable DC is reduced. However, as these saturated reactors are normally used in conjunction with a class B amplifier load, the high DC and peak plate currents are normally of short duration reducing the tube life by an amount which is not excessive.

Predetermining DC Voltage

Actually, in practice, the DC voltage in which we are interested is that out of the filter. If we examine our complete circuit closely (Fig. 7), we find that it can be reduced to the simpler form of Fig. 8. Here we have the ratio of transformation such that E volts are induced in the transformer secondary. From the theoretical DC output which is .9 x E, we must subtract all the voltage

(Continued on page 23)

A Simple Beat-Frequency Oscillator

By BERNARD EPHRAM, E. E.

A SIMPLE beat-frequency oscillator that would not be elaborate nor technical in design is made possible by the composite arrangement herewith. This oscillator is remarkably stable, practically free from frequency drift, and is capable of holding its calibration over long periods of time. Part of this circuit has been modified from the ultra-short wave receiving system designed by H. E. Holman, of the Heinrich Hertz Institute, Berlin (1).

The circuit employs only one tube, type 2A7, functioning as two radio frequency oscillators electronically coupled to each other and to the output. The oscillatory circuits O-1 and O-2 oscillate at frequencies near 500 kilocycles. By careful design the constants of each circuit can be adjusted so that a difference frequency of one or two cycles may be obtained without synchronization.

The generated frequency is appreciably stable, and any changes in electrode voltages similarly affects adjacent electrodes in the tube envelope in a like manner. To reduce the frequency drift to a minimum due to ambient room temperatures it is best to place the oscillator coils and condensers in a small balsa-wood box. A change in the plate voltage of approximately 20 per cent will produce a scarcely discernible change in frequency as checked by a crystal controlled frequency standard. Heating of the plate after the oscillator is placed into service has no apparent effect upon the stability of frequency, this is because the cathode of the tube is indirectly heated and being at a constant high temperature quickly radiates its heat to the adjacent tube elements, this tends to maintain an even temperature within the tube after a few moments current has been supplied to the filamentary heater.

The use of large capacity and small coils in the oscillatory circuits minimizes radio frequency resistance, reduces the amplitude of the harmonics (chiefly second, if any) and assures good wave form. The fundamental oscillations have also a low amplitude which is essential to the performance of a beat frequency oscillator.

Referring to the figure it will be noted that the oscillators are resistance stabilized (2) by variable non-inductive feed-back resistances R-1 in series with blocking-condensers C. It is these feed-back resistances that control the stability of each oscillatory circuit. By resistance stabilization the generated frequency has an almost pure sinusoidal wave form; this resistance also limits the amplitude of the oscillations to the straight line part of the tube characteristic so that practically no harmonics are generated.

The switch "s" is used to open the grid circuit of the oscillator O-1 to stop oscillations through the associated circuit and tube elements. When this switch is open, the remaining oscillatory circuit O-2 may be used as a conventional electron-coupled oscillator and radio frequency currents can be taken off through condenser C-3 at terminal U-1.

If it is necessary to use a modulated radio frequency wave for testing receivers and other apparatus, the output can be modulated

by connecting the plate of an external tube to P-2 whose grid is being controlled by audio frequency voltages supplied by either a low-frequency oscillator or an electrical translating device. Another method by which it is possible to modulate the output can be accomplished by simply connecting any audio frequency source having a sufficient voltage across the output terminals P-3 and P-4 of the audio frequency transformer T. The percentage modulation obtained by this method will not be very high but may be satisfactory for some tests. Note here that transformer T is used as a two-way device; that is, audio frequency currents are induced from the primary into the secondary (output) when the switch "sw" is closed, as then

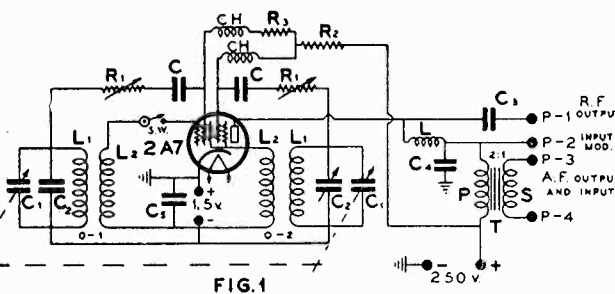

FIG. 1

COMPLEMENT OF PARTS

C equals .002 ufd
C1 equals 50 uufd
C2 equals .001 ufd
C3 equals .0005 ufd
C4 equals .001 ufd
C5 equals .01 ufd
R1 equals 0-100,000 ohms
R2 equals 40,000 ohms
R3 equals 10,000 ohms
Transformer ratio 2:1
L equals 100 mil. hy.
L1 equals 100 u.hy.
L2 equals 100 u. hy.
Ch equals 20 mil. hy.

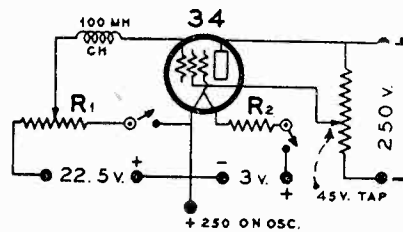

FIG. 2

Constants—R1 = 50,000 ohms 1 Watt R2 = 15 ohms, Ch = RF Choke.

When using constant current supply disconnect all wires leading to the ground in oscillator and connect to minus (-) post of power limiting device.

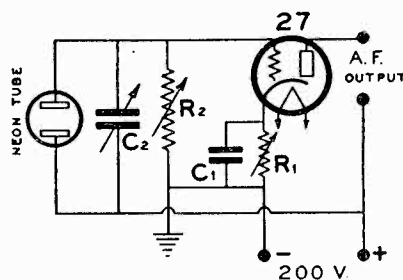

FIG. 3

NEON TUBE AUDIO FREQUENCY OSCILLATOR

R1 = 0-100,000 ohms. C1 = 1 mfd.
R2 = 0-10,000 ohms. C2 = .001 mfd.

the oscillator is functioning in the beat-frequency combination; however, when switch "sw" is opened, audio frequency currents impressed across the secondary (now input) are induced into the primary and so modulate the radio frequency currents produced by the oscillatory circuit O-2 which is electronically coupled to the output terminal P-1.

In the accompanying schematic diagram the primary winding of each oscillatory cir-

cuit is shunted by a .001 ufd. and 50 uufd. tuning condenser. The 50 uufd. condensers are coupled together, varied simultaneously and rotated in opposite directions. If the rotation is 270 degrees, a large dial will allow the reading of frequency to within 4 cycles without the use of a vernier or magnifier providing that the highest beat note is not greater than 10 kilocycles. Only one of the .001 ufd. condensers is variable and its capacity may be changed when the circuit O-2 is being employed as an electron-coupled oscillator. One of the 50 uufd. variable capacities in shunt with the .001 ufd. variable condenser may be used as a vernier for obtaining fine adjustments; however, since both 50 uufd. condensers are on the same control, varying these capacities with the switch "sw" open only varies the capacity of the condenser associated with the closed circuit O-2. The .001 ufd. variable condenser is set at maximum capacity when the switch "sw" is closed, tuning for beat-frequencies being accomplished by the dual 50 uufd. tuning condensers.

If it is desired to limit the power supply to the 2A7 a super-control pentode type '34 may be used as a power limiter, this will insure a constant current output for values of plate potential from 40 to several hundred volts.

By limiting the power supplied to the oscillator at some predetermined level the amplitude of the generated oscillations will be balanced when this level is reached or approximated, hence, by using a power limiting device on this or any type of oscillator it is possible to keep the oscillator generating oscillations without harmonics on the straight line portion of the plate current characteristic. The schematic diagram in figure 2 shows the wiring diagram for a type 34 pentode for use with the oscillator above described.

An auxiliary audio frequency oscillator for modulating the radio frequency output when the switch "sw" is open may be quickly assembled by using a commercial type of neon lamp with the resistor either shorted or taken out of the base and connected to a type '27 tube as shown in figure 3. This oscillator will cover the complete audio frequency range from about 30 to 10,000 cycles provided the neon tube has been operated across a DC or AC power supply at twice its rated voltage for at least twenty-four hours before the resistor has been taken out of the socket base. This "seasoning" operation is very important if the oscillator is expected to be stable in service. The frequency of this device may be changed by varying the .001 ufd. variable tuning condenser after the resistor R-1 has been properly adjusted which can only be done by trial operation.

A few of the uses for which the beat-frequency oscillator has proven invaluable are:

- (1) Bridge measurements of all kind.
- (2) Measurements in electrical communication apparatus.
- (3) Studies of response curves of loudspeakers and transformers.
- (4) Characteristic analysis of filters, cables and dielectrics.
- (5) Radio frequency signal generator for testing and lining-up receivers.

The foregoing are only a few examples for the possible uses of this simple and modest one-tube beat-frequency oscillator.

(1) HOLMAN, H. E.: Hochfr. El. Ak. 42: 89-99. 1933.

(2) TERMAN, F. E.: Resistance Stabilized Oscillators, ELECTRONICS, July, 1933.

Condenser Microphones

By C. R. HAAS

CONDENSER Mike! How many hams have turned a cold shoulder on these words? I venture to say that 50 per cent of them have, because in a ham's mind he associates all sorts of grief with those words. The first is the cost of the preamplifier; second, the impression that condenser mikes have to be operated from a DC supply; third, poor quality from one that you may construct, and fourth, the one thing all of us dread—RF feedback in one form or another.

We may make the statement that condenser mikes properly designed and properly operated (remember we say properly) are no more, if as much, trouble to operate than a double-button carbon mike. A great many of you will not agree with this last statement, but let us analyze these four points, one by one.

First is the cost of the preamplifier. You will find that on constructing a preamplifier with good parts the cost will tally about the same as an amplifier for a double-button mike, and the quality from a condenser mike in the end will be much more desirable.

In your mind you are saying to yourself: "But what about the gain in DB from a condenser head?" All of us know that a condenser head operating with one stage of amplification will bring the gain up to about nothing flat.

You will find that the gain from an all AC operated amplifier (such as is shown in these columns by W6BHO) is more than enough for the average station.

This brings us to the second major problem. The idea that condenser amplifiers have to be operated from an all DC source—this is not so! W6BHO has devised a very good circuit using a 2A6 and a 56 and is absolutely all AC operated. Now you say to yourself: "But how about the hum?" Well, there isn't a trace; hard to believe, but it is true.

The third item to be mastered is quality. How am I to get good quality from a condenser head which I may construct? All of us know that a properly designed head and amplifier, properly operated, will produce speech as good as any ham could ever desire, in mind.

The fourth item and the one that would seem most bothersome with a condenser mike, is our everlasting enemy, RF feedback in any form. You would be surprised to know that after installing an all AC preamplifier, all traces of RF feedback disappears from this

W6BHO's Condenser Mike Pre-Amplifier

All AC leads in shielded cable tied to ground. Tube shelf of copper or metal for inter-shield. Make all grid leads as short as possible. Use good grade of resistors and mica coupling resistors. Power supply must be well filtered. Four-wire shielded cable is used for power leads. As B— is below ground potential, do not ground at that point. Adjust sliders on the 25 watt 1000 ohm Electrad resistor for proper bias voltages, 1.3 v. for 2A6 and 13 v. for 56. Use high resistance voltmeter.

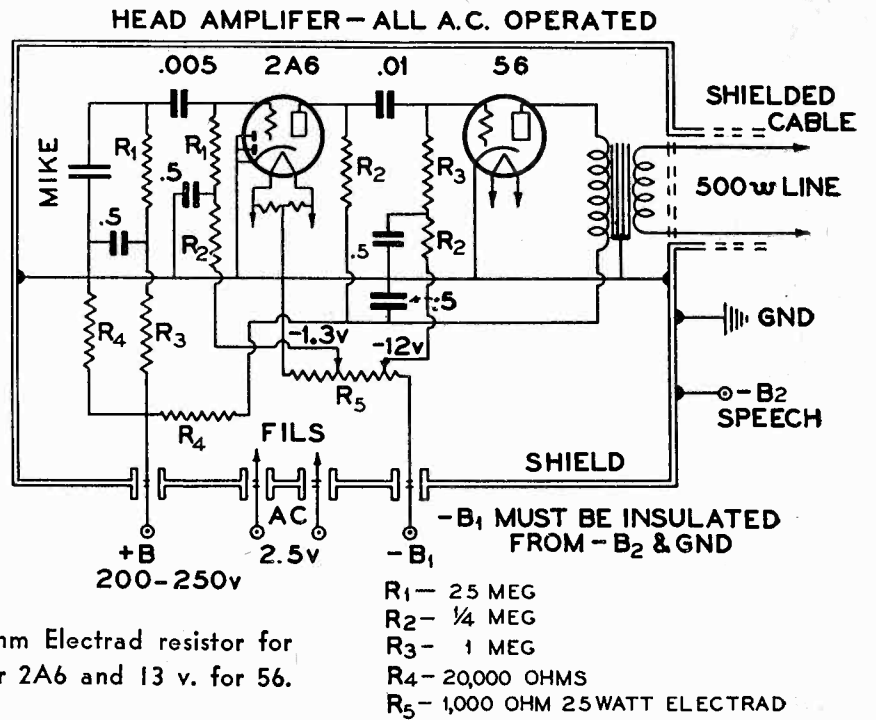

station as well as from several other that are in mind.

The writer made a statement at the beginning of this article on poor quality. Let us take in consideration a few facts. You cannot build a condenser head out of spare change, cheese cloth and mud, and expect it to work as well as a properly designed microphone.

Perhaps the first and worst mistake is that you may use any odd dimension at hand for the active part of the diaphragm. The diaphragm has a certain diameter and if the frequency response is to be anywhere near what it should be, this diameter must be strictly adhered to. If the diaphragm is too small in diameter, the frequency response will be shifted up to the high end of the voice spectrum. If the diaphragm is too large the frequency will be shifted the other way. Too small a diaphragm will tend to cut off the lows and if too large it will cut the highs, roughly speaking.

Now comes the importance of the material to use for the diaphragm. It is true that more than one kind of material can be used. But there is always a best kind. Some lads use the lead or tin foil that comes with certain kinds of cigarettes; some have a friend in the

garage business and borrow some shim brass for a diaphragm—any old kind they get is supposed to work. It is true that these materials will work, but it is also true that the frequency response and quality will not always be what is desired.

If lead, or tin foil, or shim brass is used in the head, and stretched beyond its resonant point, it still stretches up to a certain point. This stretching may continue for days, so the frequency response will also take days in assuming a different band of frequencies and no doubt this band will be some band that is not desired. In other words, a poor response.

Our Dural diaphragm is not the best by any means, but it is considered the best to our knowledge for practical purposes. Dural will stretch, but not to a very great extent, and Dural is a great deal lighter than the other metals, thickness remaining the same. Dural can be stretched a great deal tighter than the other metals (thickness remaining the same).

How tight should the diaphragm be stretched? The proper degree of stretching should be well above the natural frequency of the diaphragm itself, otherwise resonant peaks will show up which will spoil the natural frequency response of the head.

Next comes the question of what kind of metal to use for the head. A certain well-known company uses steel and a Dural stretching ring which is in contact with the Dural diaphragm. You may say, "Sure, that is easy to see, they do this because it is cheaper". But this is not the case. The real reason is the fact that steel has a lower co-efficient of expansion than brass and, therefore, would tend to retain its frequency response in all temperatures. The Dural stretching ring that is in contact with the Dural diaphragm has the same co-efficient as the diaphragm itself, and consequently this tends to help keep the frequency response curve from changing with variations in temperature.

Of course, all of these points are very fine and were dictated to us by our good friend Mr. Hoyle. For the average ham use, the kind of metal for your mike head really does not matter, and in your case may be disregarded, providing you do not make it from cast aluminum, which may be too light and pass out spurious frequencies when they are not wanted.

The most interesting part of the condenser

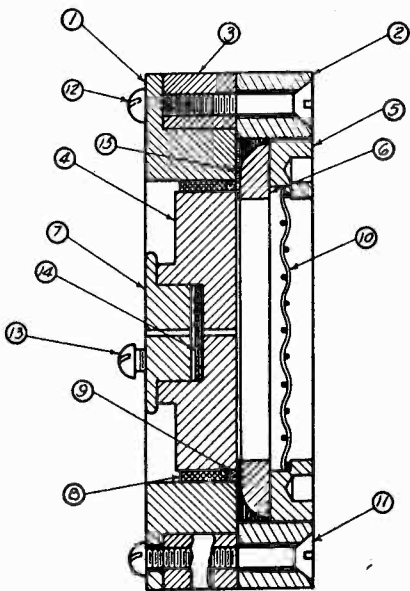

CONDENSER HEAD PARTS

1—Back plug. 2—Front half of shell. 3—Rear half of shell. 4—Back plug proper. 5—Tightening ring. 6—Stretching ring. 7—Plug to compensating chamber. 8—Insulation. 9—Sealing compound. 10—Screen. 11—Screws clamping diaphragm. 12—Screws holding rear plug. 13—Rear connection (to grid). 14—Compensating diaphragm. 15—Dural spacer .001 in. thickness.

Condenser Microphones

head, next to the diaphragm, is the back plug. There are several different methods used in the construction of the back plug. All strive for the same goal; an even and broad frequency response. First of all, the back plug must be vented, i.e., the air pressure on the back of the diaphragm must be equal to the outside air pressure. If this provision were not made each time you spoke into the mike, the quality reproduced would be somewhat like yelling into a cave that had no opening at the far end. This vent is a very small hole which provides the means for equal air pressure on both sides of the diaphragm. How can this be done without letting dust get into the head? This is provided for by means of the compensating diaphragm which is made of silk and which will compensate for all air pressures, at the same time keeping out all dust (the condenser head's worst and only enemy). The back plug in addition to the above must provide some sort of an air cushion for the diaphragm, otherwise the effect would be the same as letting the sound wave hit a solid steel wall, a sound which has no mellowness or color, so to speak. This provision is provided for by cutting small grooves in the back plug, these grooves acting as small air chambers which act against the diaphragm with a cushioning effect.

Now comes the importance of spacing. How far shall I space the back plug from diaphragm? The closer the back plug is to the diaphragm the more sensitive the head will be. Of course, there is a certain limit; too close spacing may cause the 200V to jump from the back plug to the diaphragm, thus ruining it. The spacing should not be over .022 inch. If wider spacing is used, the quality will begin to sound "boomy."

Of great importance is insulation. A condenser head connects to the grid of a high-gain tube, and any faulty insulation used in the head will show up as noise in the output. Some use bakelite, some a patented material, and others use mica. Bear in mind that you cannot use "any old mica" laying around the shack. The mica must be of the very best grade obtainable and must be water clear. However, for ordinary use a good grade of bakelite (first thoroughly dried in an oven) will do nicely. After the bakelite (or other type of insulation you choose to use) is machined, it must be sealed with bees-wax to exclude all moisture.

Now you are ready to assemble your condenser head. First of all it would be wise to "blow out" all parts with compressed air. Tie the parts on a wire and immerse in carbon-tetrachloride. Remove and blow with compressed air again. Do not wipe parts with a cloth; this is one of the worst things you can do. All of the parts should be assembled under a glass case of some sort, being very careful to keep out all particles of dirt. After the head is once in operation and is as quiet as it should be, you will have no reason to take it apart and "look it over".

The writer has been asked, "What is the secret in operating a condenser mike?" There is no secret; the answer is—first handle the head as you would a \$65 watch. Second, do not climb into the head and yell, and do not blow on the front of the diaphragm. The air pressure from your voice may be strong enough to cause the diaphragm to touch the back plate. If it does, put in a new diaphragm. Do not use over 200V on the head; you merely invite trouble. Do not expose the head to any undue moisture. Keep your fingers off the diaphragm. If the head becomes dirty, remove the back plug and blow the dirt off. Last but not least—if the head works O.K., LEAVE IT ALONE.

Heintz & Kaufman 357 Pentode

IT HAS been rumored in amateur circles for the last two years that H & K had a transmitting pentode on the fire. Here is some of the tentative preliminary data which has just been released.

As appearance goes, the tube outwardly resembles the 354. The plate and filament are identical. The three grids are all rigidly supported from a support in the base and the internal insulation is just as high as in the 354. There is no plate voltage limitation, as long as the heat dissipation is not excessive, but it should not be implied that it is necessary to use a high plate voltage in order to obtain good results. On the con-

on the screen, and the suppressor tied to the filament center tap, the RF output is 150 watts. When used as a tri-tet oscillator the second harmonic output is in excess of 75 watts. When used as a crystal oscillator the grid leak resistance is 50,000 ohms. It begins to look as if the two-stage 1 KW transmitter was here at last.

The screening is practically perfect because the capacity from plate to control grid is less than .007 MICRO-MICRO FARADS, or .00000007 ufd. Thus neutralization is unnecessary even at 60 megacycles.

The suppressor grid was designed for linear con-

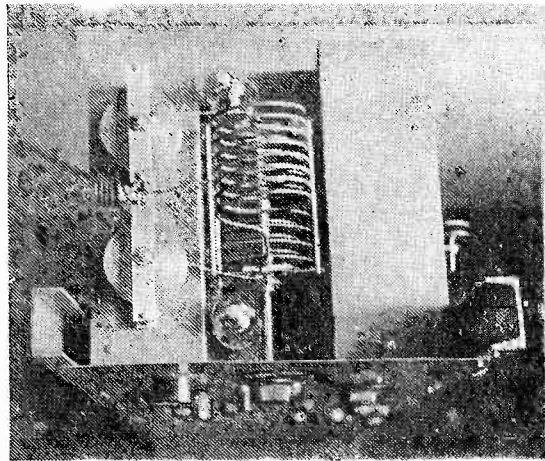

The Final Amplifier of W6UF uses two HK-354 Gammatrons which are driven by the new HK-357 Pentode

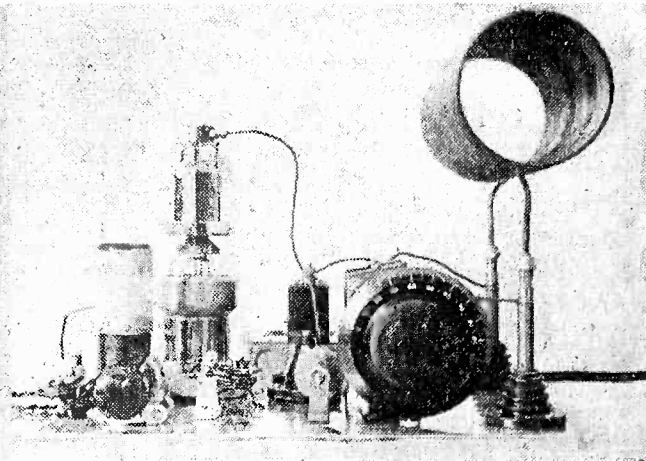

The HK-357 Transmitting Pentode as a complete one-tube Transmitter, using 2000 volts on the plate

trary, all the Heintz & Kaufman tubes were designed to operate on high voltages, but at the same time to give high output and efficiency at plate voltages as low as 600 volts.

This new 357 is also a remarkably good class B audio tube. A pair in class B operated at 2000 volts and zero bias have an audio output in excess of 500 watts into a 16,000 ohm load resistance (plate to plate), and only require a pair of 250's as audio drivers. When used in class B all three grids are tied together and act as the control grid.

As a crystal oscillator in the conventional pentode circuit, with 2000 volts on the plate and 300 volts

control of output, so that it can be used as a control element for phone use, in which case a 65 watt carrier can be completely and linearly modulated.

CHARACTERISTICS OF HK357 PENTODE

Plate Voltage	600V	1000V	1500V	2000V
Grid Bias	0	0	0	0
Screen Voltage	450V	450V	450	450
Suppressor Voltage	0	0	0	0
Plate Current	105	130	160	180
Screen Current	3MA	3MA	2.5MA	2MA
Bias for Plate				
—Current Cut-Off	-75V	-85V	-100V	-115V

Why the Bleeder Resistor?

WHY THE BLEEDER RESISTOR?

IN HIGH voltage power supply systems which use thermo-ionic or mercury-vapor rectifier tubes, and which are commonly used for radio transmitter and power amplifier plate supplies, it is customary to connect a load resistor, usually called a "Bleeder", across the filter output. This is necessary to keep the output voltage down to normal when the load is removed, as in keying a transmitter, or for any other reason. The bleeder supplies a small load which prevents the voltage from rising to excessive values. This admittedly wastes a certain amount of power, but the resultant safety prevents blowing out filter condensers and other equipment.

In any rectifier system of this type, the voltage across the transformer secondary is given as the

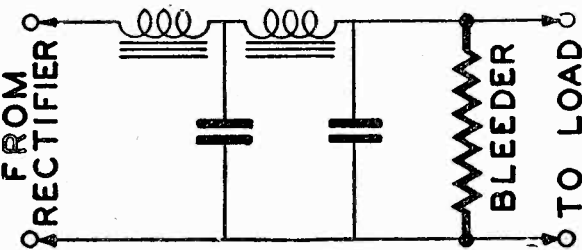

"Root Mean Square", or effective value. That is, if the secondary voltage is 2000 volts with a mid-tap, there will be 1000 volts average, or effective value across each side of the secondary. When this gets through the rectifier and filter system, the actual voltage delivered to the load will probably be about 700 to 900 volts, depending on various factors in the filter, which are of no interest in this discussion.

On the other hand, if each half of the secondary is rated at 1000 volts "R.M.S." the maximum, or peak voltage due to the peaks reached in the alternating current wave, will actually be the square root of two, or 1.41 times the effective value; in other words, about 1410 volts (or 2820 volts across the entire secondary).

This excess voltage is applied to all rectifier tubes. When a rectifier system feeds into a con-

denser filter system, which has no load, the condensers are fed continually with the high voltage pulses from the rectifier, and almost immediately build up to the maximum voltage. In the case of 1000 volt transformer and rectifier system mentioned above, this voltage would rise to about 1400 volts, which might very easily damage filter condensers rated at 1000 volts, if such condensers are used in the filter system.

In keying loads, such as are used with telegraph systems, this condition would occur every time the key is opened. When the key is again closed there would be a sudden rush of current which would give a very objectionable "chirp" to the signals. In telephone systems, especially those using class B modulators, there would be considerable chance of objectionable distortion produced, due to the poor voltage regulation of the power supply system.

The actual value of the bleeder resistor is not very critical. It should be high enough not to draw too much current, and at the same time it should not be of such high value that the voltage "soars" badly when the load is removed. In general, a load of about 15 to 25 milliamperes will be found to be about right. The Ward-Leonard table below gives the values for satisfactory bleeder resistors for almost any amateur transmitter power supply. The resistors used should have a generous heat rating; it is safer to select larger than smaller resistors, because the resistors must radiate all the energy they receive from the power supply in the form of heat. Small receiving type resistors are not satisfactory, and resistors of the "25 watt" size are about the smallest that should be used. The resistors should be mounted so the air may circulate freely around them, and they should be mounted as far away as possible from transformers, condensers, and other equipment, or the latter may be damaged by the heat given off from the blades.

Output voltage	Number of units (in series)	Resistance (ohms)	Current M.A.
500	1	25,000	20
1000	2	50,000	20
1500	3	75,000	20
2000	4	100,000	20
2500	5	125,000	20
3000	6	150,000	20

-RADIOTELEPHONY-

By "LINEAR"

50-Watt "Junk-Box Special" Grid-Modulated Phone

IN RESPONSE to many inquiries I present a grid-modulated 50 watt phone, whose overall cost compares favorably with that of an equivalent plate-modulated transmitter.

Grid modulation has been the subject of much controversy and after studying all of the present-day systems I came to the conclusion that the "Jones system", wherein some grid current flows in the unmodulated condition, offers most possibilities. This is the same system that was used in W6BCX's transmitter, shown last month.

ALL of the grid modulation systems investigated showed some inherent sources of distortion, but the Jones system compares favorably with the AVERAGE amateur plate modulated phone, although the best plate modulated phones are somewhat more linear than this system of grid modulation.

Despite the apparent simplicity of the circuit of a grid modulated phone, numerous difficulties lie in the path of truly good results. This is largely due to the tremendous amount of misinformation which has been passed around concerning the merits and demerits of this type of modulation.

The fundamental thing to keep in mind is that **GRID MODULATION IS EFFICIENCY MODULATION, AND THE DC PLATE INPUT SHOULD REMAIN CONSTANT UNDER MODULATION.** Any variation in the plate milliammeter indicates non-linear distortion and is to be avoided. As a matter of fact, it is impossible to avoid some variation, until someone figures out a way to keep the time interval, through which the plate current impulses flow, constant under modulation.

As I said before, grid modulation is efficiency modulation, and the amplifier is most efficient when completely modulated. The theoretical maximum possible efficiency, at this point, is 78.3%, but with practical circuits the maximum efficiency rarely exceeds 66%. As the distortion increases the bias and excitation are increased and it was decided keep the maximum plate efficiency down to about 50%, and thus avoid all the distortion possible. Remember that this figure of 50% refers to the completely modulated condition, so that the unmodulated plate efficiency is one-half of this value, or about 25%. This sounds too low to be useful, but think of the savings in modulator tubes, transformers and power supply, and you will understand why grid modulation has its points.

Now for the transmitter itself. The oscillator and buffer stages are conventional and their adjustment follows standard practice. The two 211E's are used in parallel in the final amplifier, rather than in push-pull, for the sake of simplicity in construction and neutralization. The small RF chokes built into the WE211E's effectively prevent parasitics. The other reason for using the tubes in parallel is that a much higher ratio of load impedance to plate impedance is possible. This effectively doubles the mutual conductance of the amplifier, over that of a single tube, and a high mutual conductance is essential for successful grid modulation.

The excitation to the modulated amplifier must be adjustable from zero up, and the coupling links afford a handy means of varying this coupling. The C bias **MUST** be supplied from batteries until such time as a low resistance bias source is available at a reasonable price. With 167 volts of bias on the grids of the 211E's and no plate voltage, neutralize in the conventional manner. The load tap marked L.T. should be disconnected from the plate tank L5 during the neutralizing and tuning process. After the stage is neutralized by means of C8, apply the plate voltage and tune C9 to resonance. The plate current will be quite low because the amplifier is unloaded. Now cut the power off and place the load tap L.T. about halfway between the center-tap of L5 and the neutralizing end of the coil. Now crank-up the grid excitation and adjust C10 to about one-half maximum capacity. Turn on the RF portion of the transmitter and tune C11 to resonance as indicated by minimum plate current at M1. Resistor R3 should be out of the circuit completely during

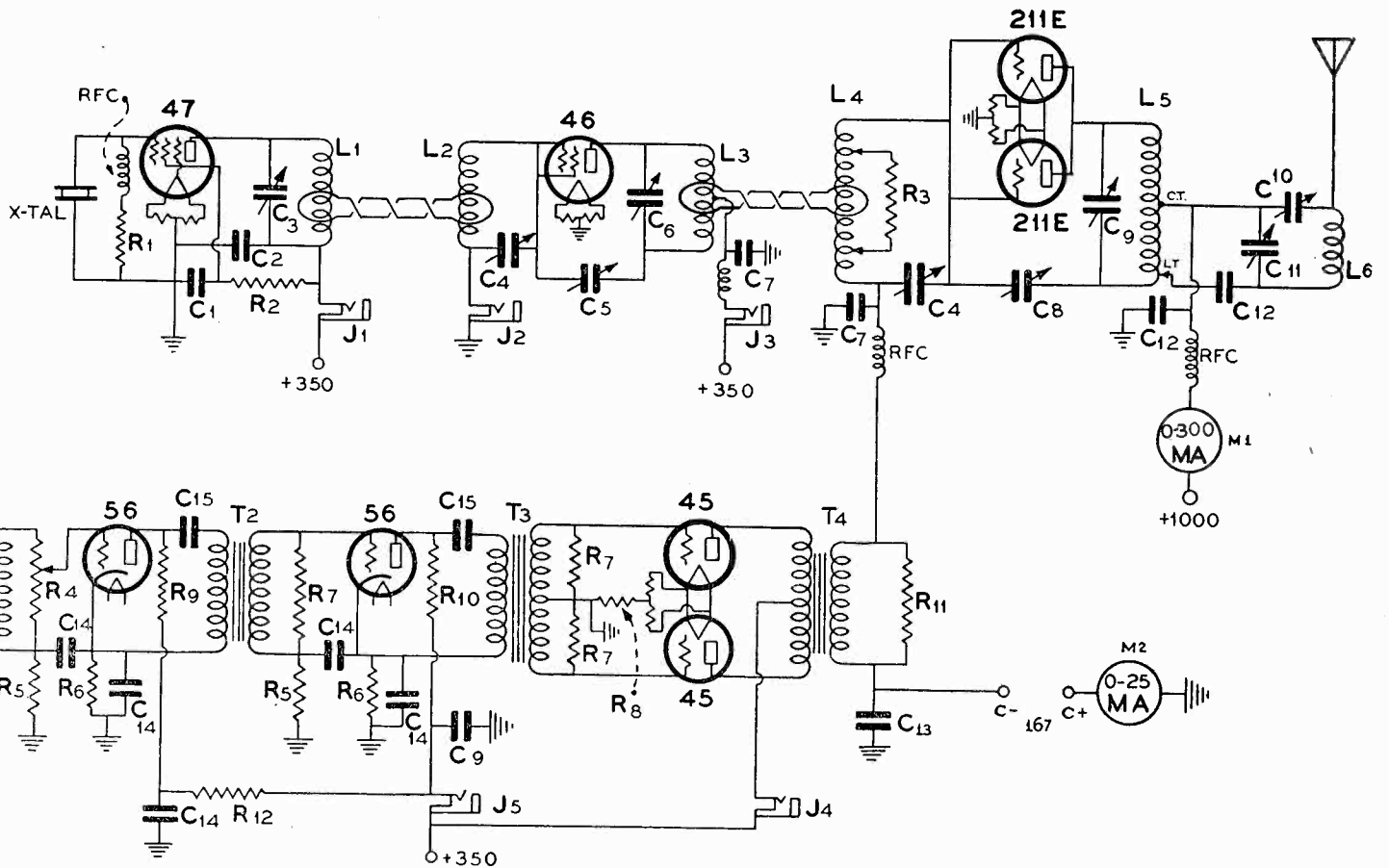

211, 211E or 242A Tubes Can Be Used In the Final Stage Without Change In Circuit Constants

LIST OF PARTS

- R1—15,000 to 50,000 ohms.
- R2—50,000 ohms.
- R3—20,000 ohms, 25 watts non-inductive.
- R4—200,000 ohm potentiometer.
- R5—.1 meg.
- R6—2500 ohms.
- R7—200,000 ohms.
- R8—1000 ohms.
- R9—30,000 ohms.
- R9—30,000 ohms.
- R10—20,000 ohms.
- R11—3,000 ohms.
- R12—20,000 ohms.
- C1—.01 ufd.
- C2—.006 ufd.
- C3—100 ufd. variable.
- C4—100 ufd. variable.
- C5—50 ufd. variable.
- C6—100 ufd. variable.
- C7—.001 ufd.
- C8—100 ufd. variable.
- C9—150 ufd. variable.
- C10—350 ufd. variable.
- C11—350 ufd. variable.
- C12—.006 ufd.
- C13—2 ufd.
- C14—1 ufd.
- C15—.25 ufd.
- T1—Mike to grid transformer.
- T2—Triode plate to grid transformer.
- T3—Triode plate to PP grids.
- T4—Class B input transformer, 2 to 1 or 3 to 1 step-down.
- L1, L2, L3, L4 and L5 are all low C 160 meter tanks.
- L6 is a medium high C tank for 160 meters. See previous coil tables for details. Every builder will use different coil diameters.

this tuning process. Vary C10 and restore resonance with C11 until the final amplifier draws 300 mills. It may be necessary to place a shunt across M1 to prevent the pointer or the meter itself from damage during this portion of the adjustment process. Now apply R3 across about half of the turns of L4. Gradually increase the number of turns across which R3 is tapped until the plate current shown at M1 declines to 200 MA. After each adjustment of R3 it will be necessary to retune C4 and C6 to resonance as indicated by maximum mills at M2. If the plate current at M1 refuses to get down to 200 mills, even when R3 is tapped across the whole grid coil, then C10

should be opened up a bit to reduce the antenna coupling, afterwards restoring resonance by means of C11.

When the plate current is brought down to 200 milliamperes, the grid current at M2 should be between 8 and 12 milliamperes. If the grid current is higher than 12 MA, then the antenna coupling is too loose and must be increased by increasing C10 and restoring C11. This will bring up the plate current, so it must be cut down by reducing the RF excitation on the grids of the 211E's. R3 provides a rough adjustment, but a fine adjustment is provided by the coupling link between L3 and L4. If the grid current is below 8 MA, then the reverse is necessary. In other words, less antenna coupling and more RF excitation is necessary. Again use R3 for the rough adjustment of the excitation, and the coupling link for the fine adjustment. C9 **MUST NOT BE TOUCHED AFTER THE LOAD TAP L.T. IS TAPPED ON TO THE PLATE TANK.** If it becomes necessary to adjust C9, first remove the load tap from the tank.

At this time the plate current should be 200 MA and the grid current about 10 MA; everything should be running cool and the note should be absolutely pure DC. Apply the audio signal and let us see what happens. It is assumed that all the bugs have been removed from the audio channel and music from a Broadcast signal is then introduced into T1, causing satisfactory sounds to be emitted from a speaker or phones tapped across part of R11.

Speaking into the mike will cause the plate current to rise slightly, about 5 or 10%. Anything more than this indicates excessive distortion. At the same time the grid current should nearly double, or go to about 20 MA. Remember, I am talking about voice peaks, not average values. If an antenna ammeter is in the antenna lead, it should just barely move under voice modulation. If the needle on the antenna ammeter moves more than about 5% on voice modulation, then you are probably hitting it too hard and are overmodulating. The old 22% rule applies only to sustained tones which are pure sine waves.

The main job of R3 is to stabilize the load on the buffer stage and R11 serves the same purpose for the modulators. The audio amplifier provides sufficient gain to work out of a broadcast quality double button carbon mike, but a pre-amplifier will be necessary if a ribbon or condenser mike is used.

It is very easy to overmodulate this transmitter (as with all grid modulated phones) so a modulation monitor consisting of a power detector and a 0-5 plate milliammeter is a handy gadget to have around. The plate current of the power detector should remain absolutely constant under (Continued on page 29)

REVIEW / D of FACTORY RECEIVERS

THE SKYRIDER

The Circuit

THE autodyne (originally called regenerative) circuit is well known to all pioneer radio fans. In its rudiments this circuit still remains the foundation of practically all professional radio circuit arrangements in good short wave receivers. The amateurs know this well. Though largely dormant recently in commercial receivers, because of the difficulty of control, methods and equipment for its efficient application are now afforded. The good qualities of the circuit have been retained and the modern simplicity of control and operation added in the design of the SKYRIDER.

With the employment of the new super-control tubes, advanced coil design and modern refinements, the SKYRIDER takes its bow as a really efficient short wave home entertainment receiver.

Briefly, the circuit is composed of a pre-selector RF stage employing the new 6D6 super-control screen grid tube; autodyne detector stage incorporating another of this same super-control tube; first audio stage using a 6C6; a power audio amplifier stage which drives the integral electro-dynamic speaker using a type '42 output pentode; full wave rectification with a type '80 rectifier.

Sensitivity

IT ATTAINS a high order of usable sensitivity in operation, comparable with that of the most expensive receivers of today. This sensitivity is more than adequate for daylight reception of foreign broadcast stations, even in relatively poor locations and without elaborate antenna system. Faint signals from stations up to 10,000 miles and more distant are effectively amplified into loud speaker reproduction, day or night, so long as the signal is slightly above your local noise level. Further than that no radio receiver can go.

Selectivity

THE autodyne stage is preceded by a stage of tuned radio frequency amplification, a system well known to provide the highest possible discrimination against unwanted signals. Tuning of its directly associated circuits is markedly sharpened by the use of the autodyne principle in the circuit. Still further increases in selectivity of the tuned circuits results from new departure in coil design and perfected mechanical control. The SKYRIDER is thus capable of separating adjoining stations cleanly and without hint of overlap, even in the most congested channels. Foreign stations, too, may be separated reliably, on their basis of spread.

Fidelity

THE tone quality of any receiver depends upon the perfect inter-action of all complements of the receiver design—the RF amplification, coupling stages, the audio system and the speaker. This demands a high order of engineering precision in design, equipment and construction—all of which are provided in the SKYRIDER. Because of efficiency of its circuits, there is accomplished a distortion-free delivery to the speaker, which though compact in size has sufficient capacity to handle the receiver output and to provide ample volume to fill the average home. Both high and low registers of voice and music are reproduced with faithfulness and color.

The New Tubes

PERHAPS no device in common use today represents the ingenuity and skill as do the new super-control radio tubes. The necessity for large numbers of tubes and complicated control is eliminated.

In the SKYRIDER only five of these tubes are used: one type 6C6, two type 6D6, one type '42 and one '80 rectifier. Modern, multi-element super-control tubes, operating efficiently in the autodyne circuit. High sensitivity plus smooth, easy control is attained by the use of these 6-volt heater tubes, selected because of their low electrostatic hum and inherent noise level.

The Sky rider Dial

IT IS the exclusive creation of the Hallicrafters' laboratory.

It will be observed in the illustration that all bands covered are clearly and directly marked on its face showing exactly where given frequency ranges fall and the types of broadcast service therein available, such as: Police, Phones, Planes, Amateurs, etc.

The moving Pointer takes the form of a rectangular transparent strip of celluloid with guide line and pencil point holes so that the dial can be permanently and accurately logged. Once a given station, like EAQ, Madrid, for instance, is located, merely imprint a dot through the pointer hole on the face of the dial. The next time you tune for EAQ, simply turn the dial to that dot and presto, there is the station!

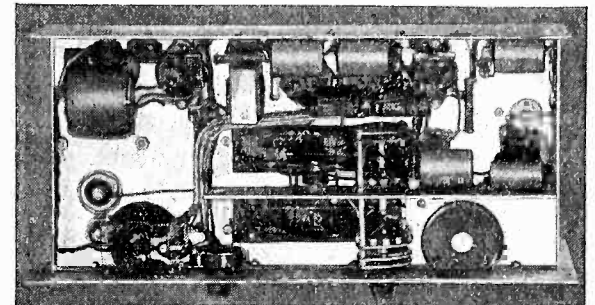
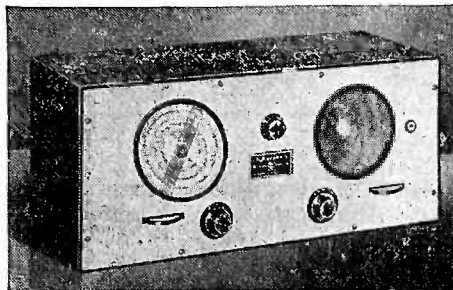

A "CLOSE-UP" OF THE SKYRIDER

At the left on the panel front is the Micro-Vernier, self-calibrating Tuning Control with thumb-action horizontal knob—18 to 1 vernier action. Pencil-point holes make accurate dial logging easy and simple.

The top center knob operates the improved, modified Band-Spread action over the entire tuning range.

The round knob at the left (below the dial) controls the 4-position Band-Selector Switch.

The right lower round knob actuates the Variable Sensitivity Control.

The left hand is placed at the left end of the cabinet with the thumb naturally covering the horizontal control knob. On an 18-1 vernier gear, the setting is very easy and precise.

Band Switching

THE lower left round knob controls the Band-Selector Switch. By this method, employing a wiping, self-clearing contact, the multiple switch in combination with advanced coils gives excellent results.

The entire range of all short wave bands is covered from 12 to 200 meters, 23,000 to 1,500 kilocycles or 23 to 1.5 megacycles. All station lists are now given in both meters and megacycles making the location of each station on the dial an easy procedure.

There are four plainly marked positions of this control to cover the bands as follows:

- 12 to 29 meters or 25 to 10.35 megacycles
- 27 to 50 meters or 11.1 to 6.00 megacycles
- 48 to 100 meters or 6.25 to 3.00 megacycles
- 97 to 200 meters or 3.1 to 1.5 megacycles

Advanced Coil Design

IT IS an established fact that radio frequency solenoids (which together with the variable condenser form the tuned circuits of the set) have an optimum ratio of length-to-diameter for highest efficiency in the receiving circuit. The most efficient coil has a length equal to its diameter, resulting in what may be termed "square" proportions.

It is quite evident that conventional plug-in coils depart markedly from the best shape, especially where only a few turns of wire are used as is the case in the higher frequency bands. By carefully varying the winding pitch and diameter of the coils, the tuned circuits of the SKYRIDER are kept at peak efficiency on all wave bands.

Each coil form contains several windings of copper wire whose size has been chosen in each case to give the lowest possible radio-frequency resistance. In contrast to the usual commercial practice, coupled coils are interwound to give the exact degree of mutual coupling necessary for best tube performance.

Chassis

THE chassis of the receiver has been designed around the two sets of coils which constitute the RF interstage coupling system and particular attention has been paid to every factor which influences the performance of these tuned circuits. The chassis has been cut out to maintain the maximum separation between coils and masses of metal which might otherwise introduce performance-impairing losses. The four antenna-grid circuit coils for the four wave bands are toward the front of

The right hand horizontal knob is the Audio Gain (Volume) Control.

The Phone Jack beside the speaker permits plugging of headphones for after-hours operation for the rabid DX fan.

Entirely AC operated—105-120 volts, 50-60 cycles. Built-in electro-dynamic speaker with black bezel and wire mesh grille.

Completely self-contained in crackle finished metal shielding cabinet; front panel is Eurado (an alloy containing silver) lacquered bright metal. Size, overall 17x7½x7½ inches. Weight, packed 24 lbs.

The placement of adjacent coils is worthy of note, for by allowing sufficient separation and arranging the axes of the individual coils so that they are mutually at right angles, stray coupling and interaction between "dead" coils and the selected coil is reduced to the absolute minimum. The mutual inductance between coils on the same axis is only one one-millionth of a henry—so little as to be negligible. Translated into terms of performance, this means the virtual elimination of "spotty" tuning over parts of the dial.

•••

New Catalogs

Readers are invited to write for copies of the following new catalogs which have just reached us for review:

Spring and Summer 1935 Edition Catalog of Allied Radio Corp., Dept. J., 833 W. Jackson Boulevard, Chicago, Ill. This new Allied catalog contains almost 100 pages of all the new sets, parts, tubes, test equipment, tools, etc. It is one of the largest catalogs ever released by Allied.

Exact Duplicate Replacement Transformer Catalog issued by Standard Transformer Corp., 850 Blackhawk Street, Chicago, Ill. Pocket size, 100 pages. Lists correct size, style and type number of Stancor Replacement Transformers for all receivers made by all manufacturers. New data is also found in this catalog relating to amateur radiotelephone equipment, broadcast and sound application. An interesting table of tubes to use with various types of radiotelephone equipment for amateur use is included in the new catalog.

New RCA "World-Wide" Antenna System

THE RCA World-Wide Antenna system has been developed after considerable research. It provides, primarily, an efficient means of collecting the shorter-wave signals on a "double doubler" or Duo Dipole Antenna. It then transfers the signal energy with negligible loss over a special, balanced transmission line to a newly developed matching transformer for the short-wave or all-wave radio receiving set. The transmission line has been carefully designed to match the double doubler antenna to the special receiver matching transformer.

Due to the design of the transmission line and the matching transformer little or no extraneous noise interference is picked up on the transmission line lead-in. This feature has obvious advantages, as it is a well-known fact that noise interference is more serious on the short-wave frequencies than on the standard broadcast frequencies.

Four Engineering Features

The features of the new RCA World-Wide Antenna System are summed up as follows:

1. An efficient double doubler antenna system specially designed for short-wave reception.

2. A balanced transmission line of proper length for best matching to the doubler antenna system and the Receiver Matching Transformer.

3. A specially developed Receiver Matching Transformer designed to eliminate noise picked up on the transmission line and to match the transmission line to most short-wave and all-wave sets on the market.

4. Provision for improvement of broadcast reception when using the double doubler as the collector for signal energy.

Double Doubler Antenna System

BY studying Fig. 1 it will be seen that, in reality, there are installed between the two supporting poles two distinct doublers—one doubler having 29 feet for each half section, and the other, 16½ feet for each half section. The purpose for this arrangement is to approach an ideal antenna system for all the short-wave broadcast bands. Theoretically it would be best to have a doubler designed and installed for each band, namely, one each for the 16, 19, 25, 31 and 49 meter bands. This would mean five doublers, and each one should be sufficiently separated from its neighbor to prevent disturbance of the reception. Obviously this would be quite an

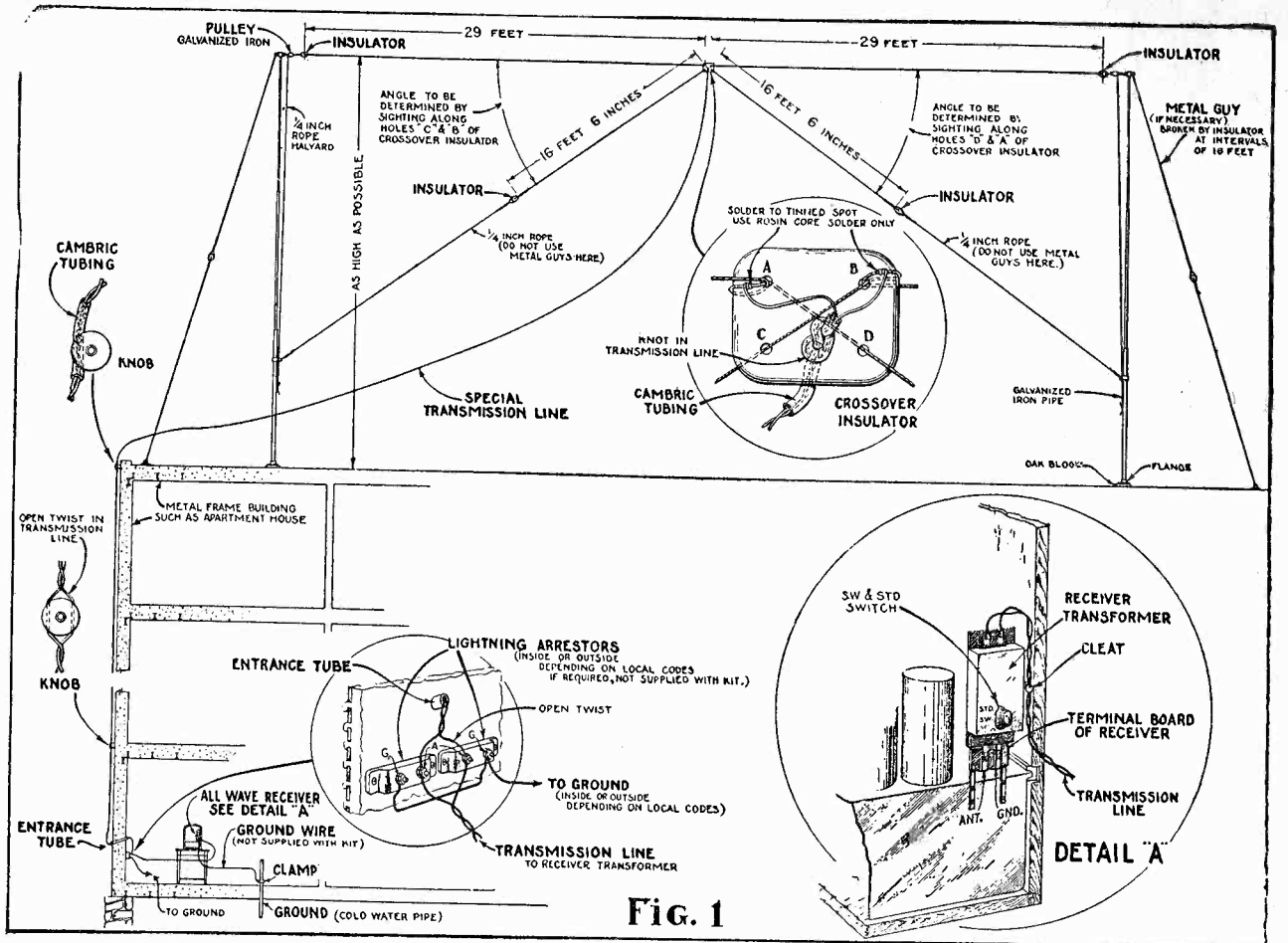
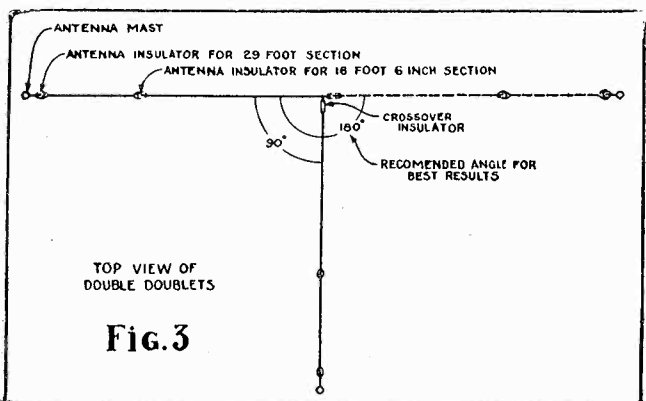
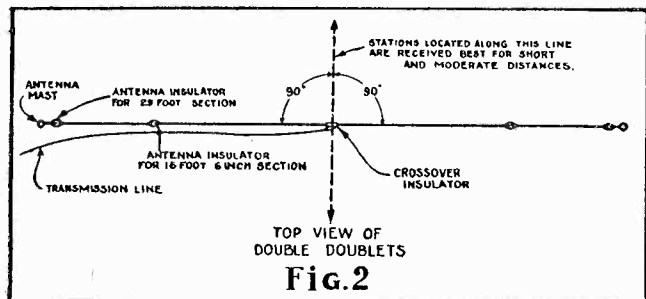

installation problem and economically prohibitive. Therefore the arrangement shown in Fig. 1 is the best approach to the ideal, as the 29-foot sections tend to tune or match the system toward the lower end (in frequency) of the short-wave broadcast band, namely, toward 49 meters, and the 16½-foot sections tend to tune or match the system toward the higher end (in frequency) of the short-wave broadcast band, namely, toward 16 meters. The connection of both doublers, or the "double doubler", to the transmission line, tends to give a smooth match throughout the short-wave broadcast band.

Determination of the proper lengths for each doubler made from the two continuous antenna wires, each 46½ feet long (6-in. allowed for each antenna strain insulator tie), is readily made by observing the tinned spot on the wire. Connection of the transmission line should be made to this spot by rosin core soldering as indicated by the detail of Fig. 1. Note that the long and short antenna wires, which are connected together, are located on opposite sides of the center transmission line connection.

When installing the antenna wires proper (two lengths of 46½ feet stranded wire), there should be kept in mind the following important considerations:

- Height above earth ground.
- Clearance from wires, buildings, highways, trolley lines, etc.
- Direction of span.

The statement that a radio receiver is as good as its antenna holds more truly for short-wave or all-wave receivers than broadcast receivers.

Height Important

(a) Height above earth ground is a most important consideration with the antenna construction of Fig. 1. Height above ground should be considered as the distance from the 29-foot horizontal sections to ground, the latter to be considered as earth ground if the span is on top of a frame dwelling with no grounded metal roof, or from a building to a

nearby pole, tree, or another building. If the span is installed on top of a steel framework building, or any building with a grounded roof, the earth ground is usually considered at the roof.

For good results a minimum of 30 feet above ground is recommended. The signal strength received varies with the height above ground.

Clearance From Wires, Etc.

(b-1) Clearance from wires and buildings is necessary so as to prevent these objects from casting radio shadows on the antenna system with consequent reduction in signal strength pick-up.

(b-2) Clearance or distance from wires, buildings containing electrical machinery, highways, trolley lines, etc., is very important in order to reduce the noise interference pick-up on the antenna itself. Since the lead-in system employs the balanced transmission line, practically eliminating noise pick-up on the lead-in, the obvious advantages of the use of the kit are readily seen. The antennas may be erected as far away as 500-foot-run of transmission line from the receiver if necessary. This is further explained under the section describing the transmission line.

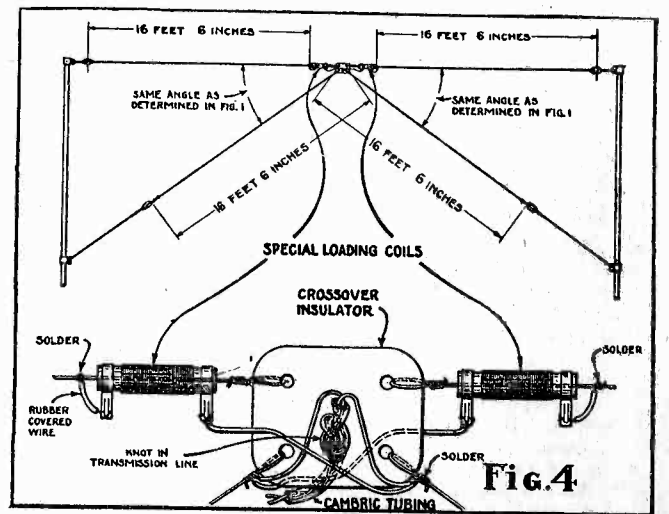

Direction Important

(c) The direction of the span for best results is that direction having the double doublet antenna placed broadside to the direction from which it is desired to receive. This direction of the span for best results is shown in Fig. 2.

If the antenna installation is to be located near a much-traveled highway, electric railway, etc., some reduction in interference received on the doublet antenna itself can be brought about by having the doublet span point in the direction of the interference.

Theoretically, the doublet should be stretched out fully—each half making an angle of 180 degrees with the other, as shown in Figs. 2 and 3, for most efficient reception. If this angle is reduced, due to constructional difficulties to 90 degrees, as shown in Fig. 3, signal strength will be decreased about 30% from the signal received from the doublet in its full 180-degree span.

The special antenna cross-over insulator of high-grade porcelain, supplied, has been

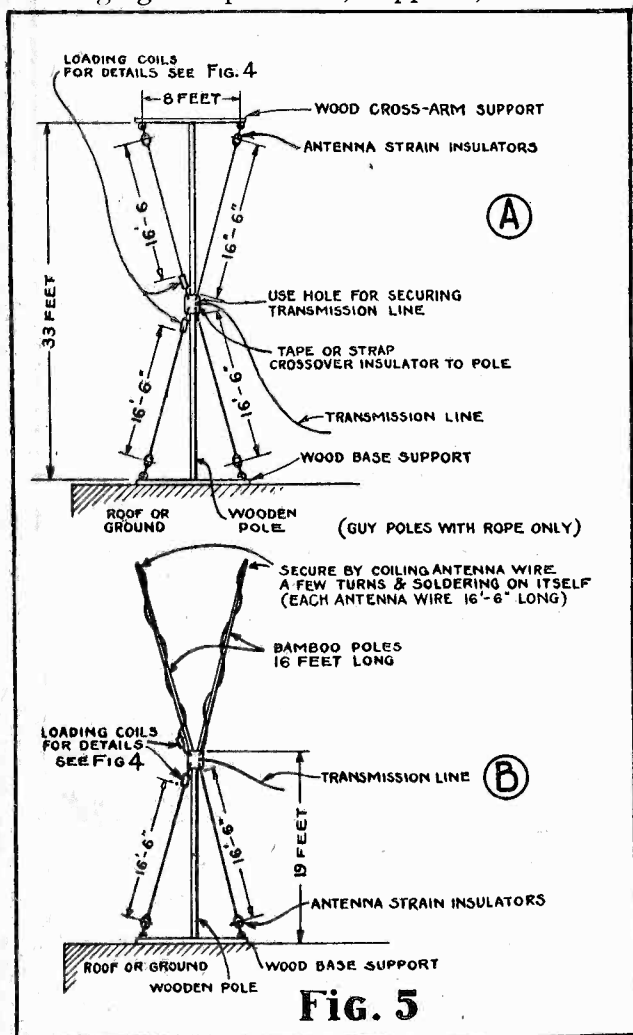

Fig. 5

designed to separate the doublet antenna and provide support for the transmission line, as illustrated in detail in Fig. 1.

Four antenna strain insulators of high-grade porcelain are supplied for efficiently insulating the ends of the doublets as shown in Fig. 1.

When connected to the transformer (and transformer connected to receiver) the transmission line is balanced to ground and eliminates or reduces to a minimum noise interference pick-up on the lead-in system.

Use Total Length

The total length supplied must always be used regardless if the doublet antenna system is only, for example, 60 feet of line run from the receiver location. The balance of 50 feet may be coiled up in a coil of convenient diameter, such as one foot, at the receiver end.

The connection of the conductors to the receiver transformer is immaterial so long as the ends do not short.

For distances greater than 110 feet, additional length of line must be added in multiples up to two (2) times, or up to 220 feet. After this distance additional lengths can be added up to 500 feet and can be cut anywhere convenient for connection to receiver.

Examples:

Line Run from Doublet In Feet	Line Length Used In Feet	Number of Lengths of 110 Feet	Length to be Coiled In Feet
95	110	1	15
150	220	2	70
210	220	2	10
300	300	3	No coil necessary. Cut off unused portion if desired.
500	500	5	

Increases Signal-to-Noise Ratio

Due to a most efficient match of the double doublet to the receiver for the shorter waves (3.5 [3500 KC] to 20 megacycles), there would be an unavoidable loss introduced for the frequencies assigned to broadcasting, police calls, etc., namely, 550 to 3500 KC. A Standard Broadcast (STD) Short Wave (SW) switch is therefore provided on the receiver transformer for improving the reception of the stations operating on the frequencies between 550 and 3500 KC. Strong local stations can, of course, in most cases, still be received with the switch in the short-wave receiving position.

Eleven Questions On the RCA Antenna System

Q. 1. How high should the horizontal portion (29-foot sections) of the double doublet be installed above ground?

A. Good results are obtained when the horizontal portion is 30 feet above ground. On top of steel-frame buildings ground is usually considered as being the roof.

Q. 2. How does signal strength vary with height of the doublet (29-foot sections) for the short-wave bands?

A. The signal strength received increases with the height above ground.

Q. 3. Is the doublet antenna directional?

A. Yes, theoretically it receives best from stations located along the perpendicular and in the same plane to the horizontal span (29-foot sections) of the doublet. See Fig. 2.

Q. 4. Is a vertical doublet better in performance than a horizontal doublet?

A. Yes and no. There is no directional effect with the vertical doublet, but, on the other hand, the horizontal doublet usually has a better signal to noise ratio. An advantage perhaps is that in some locations a vertical doublet of the type shown in Fig. 5 may be easier to install.

Q. 5. How does the special short-wave, all-weather cable compare with lead-in systems using transposition blocks?

A. (a) The losses over the normal lengths of lead-in of the special cable are negligible compared to the type using transposition blocks.

(b) Due to the construction of the special cable, installation of the lead-in is extremely simplified, less objectionable in appearance and less costly.

Q. 6. If the special cable lead-in length must be increased over 110 feet, how should it be done?

A. The lead-in length should only be increased by multiples up to two times 110 feet. In other words, the next best match would be 220 feet. After 220 feet, the length of line is not critical.

Q. 7. Should the alignment of the RCA Victor Model 140 be checked after connecting the All-Wave Kit?

A. Yes. It will usually be found that "A", "B" and "C" Band antenna adjustments are O.K. However, usually "D" Band antenna (transformer on top of chassis) will need re-trimming.

Q. 8. When installing special receiver transformer at set, what must always be kept in mind?

A. The important thing is to have the ground lead from the transformer to the receiver absolutely as short as possible.

Q. 9. What improvement is noticed when the kit is used on receivers using converters for short-wave reception?

A. Due to now having a tuned circuit (receiver transformer) ahead of the converter, it is found to be helpful in reducing the effect of troublesome cross-modulation from interfering code, local airport or amateur stations. The additional tuned circuit also tends to improve strength of signals received.

Q. 10. How can the total length of the doublet; namely, approximately 58 feet (two 29-foot sections), be decreased?

A. By installing loading coils—an accessory to the Kit (RCA Stock No. 6958)—as shown in Fig. 4. These permit a shortening of the over-all length to approximately 33 feet (two 16½-foot sections).

Q. 11. Is the doublet efficient when the horizontal angle between both sides (29-foot sections, or 16½-foot sections) is decreased from 180 degrees?

A. The efficiency of the doublet is decreased as the angle is decreased, due to less RF voltage being generated in sections of doublet as angle is decreased from 180 degrees... For 90 degrees this may cause as much as 30 per cent decrease in signal strength. See Fig. 3.

Plate Supply Circuits and Ratings

(Continued from page 16)

drops, which include the drop across R_t (the transformer resistance), across L_t (the transformer leakage reactance), across V (the tube drop), across RL_1 and RL_2 (the choke resistances). If the transformer regulation is

known, a value of E can be obtained which already incorporates the transformer losses. The DC output is then $(.9 \times E)$ minus 15 (the normal voltage drop across a mercury vapor tube), minus $ID_c \times (RL_1 \text{ plus } RL_2)$. This gives us a definite means of predetermining our DC output voltage from a rectifier using a choke input filter.

FIG. 9

DC volt.	DC MA	Rect. Tube	Plate Volts each side	Transformer Amps. Type No.	Filament Volts	Trans. Amp. Type No.	L1 Hys.	Type No.	L2 Hys.	Type No.	C1	C2	C3
400	200	83	515	.2	PA-110	5 3	PA-26	5-25	PA-103	10	PA-102	4	1 4
500	200	83	625	.2				5-25	PA-103	10	PA-102	4	1 4
600	250	66	750	.25	PA-111			6-30	PA-105	12	PA-104	2	1 2
730	250	66	900	.25				6-30	PA-105	12	PA-104	2	1 2
1050	200	66	1250	.2	PA-116			6-30	PA-105	12	PA-104	2	1 2
1190	200	66	1400	.2				6-30	PA-105	12	PA-104	2	1 2
1050	400	66	1250	.4	PA-112	2½	10	PA-34	5-25	PA-109	10	PA-108	2 1 2
1190	400	66	1400	.4				5-25	PA-109	10	PA-108	2 1 2	
1370	400	66	1600	.4	PA-113			5-25	PA-109	10	PA-108	2 1 2	
1720	400	66	2000	.4				5-25	PA-109	10	PA-108	2 1 2	
2160	500	66	2500	.5	PA-114			5-25	PA-109	10	PA-108	2 1 2	
2620	500	66	3000	.5				5-25	PA-109	10	PA-108	2 1 2	

Typical Plate Supplies

Inasmuch as the amateur is primarily interested in single phase, full wave, rectifier circuits, a number of popular types have been put in tabulated form in Fig. 9. The plate transformers shown all have two secondary voltages available each side of center, and the corresponding values of final DC voltage and available DC are shown with full detail on the filter circuit. The filter circuits are such that excellent regulation is obtained, making them useful for class B circuits. The first reactor is of the saturated type, and the second reactor is tapped to form a trap resonant circuit. The ripple output from the rectifiers shown varies from .1 to .2%, depending on the value of DC current. Type numbers are shown for both transformer and chokes, as the regulation obtained with components of different manufacture will often vary considerably.

Using the above information, anyone should be able to design a standard rectifier and predetermine its actual operation.

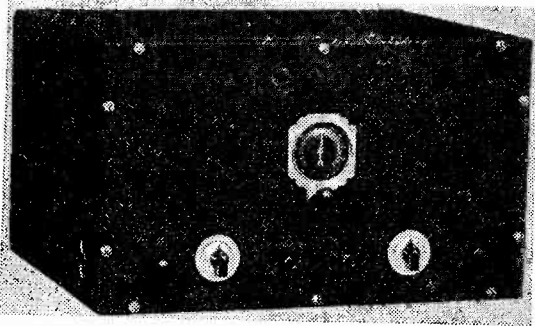

BARRETT DX-8 RECEIVER

Crystal Filter — Plus Tuned Radio Frequency Amplification

THE BARRETT DX-8 Amateur Superheterodyne receiver is the ONLY crystal-filter "super" in its price class that incorporates a stage of TUNED RADIO FREQUENCY Amplification ahead of the first Detector. The engineering design of this stage of pre-selector tuned RF is so carefully worked out that the overall gain of the DX-8 on frequencies higher than 7 megacycles is far superior to that of any other amateur receiver. When the signals are just beginning to fade out due to old man "skip" or are way "down-in-the-mud" of noise level, this extra gain and selectivity will still enable you to pull them through, while amateurs with other receivers will have to sit back and eye your exceptional DX records with envy. Needless to say, image interference is also entirely eliminated with such pre-selection ahead of the first detector, and any tendency to block-up on strong local signals is simply unheard of.

Amateur Net Prices \$72.50

Less Tubes, but including 3 sets of coils and 525 KC Mounted Crystal.

TERMS: 50% cash with order, balance C.O.D. Dealer's inquiries invited. Telegraphic orders received collect.

EXTRA ACCESSORIES:

Extra sets of coils, 10, 20, 40, 80, or 160 meter bands, set of three coils.....	NET \$3.00
(Note: three sets of coils furnished with receiver; specify bands desired)	
Broadcast band coils, set of three.....	3.50
Complete set of 2 matched RCA licensed tubes...	7.50

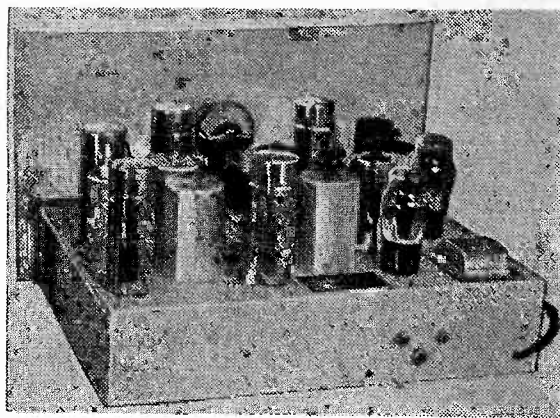

W9JNB, Rock Island, Ill., says:

My DX-8 receiver arrived OK, and in most excellent condition. Heard plenty of DX the first day of operation, and I am certainly very satisfied with its performance. I would recommend it to all my friends as the finest amateur receiver I have seen or operated.

Signed: Robert J. Sinnet, W9JNB
Radio Station WHBF
Rock Island, Illinois.

W9AZZ, Davenport, Iowa, says:

Your DX-8 receiver sure works FB. I hear plenty of DX, and the ZL's and VK's especially come in here with a bang, which is very good for the Middle West. The exceptional stability of your receiver in this climate, which is extremely variable, is a very valuable asset to its fine performance.

Signed: Earl N. Schoor, W9AZZ
Davenport, Iowa; Operator
Police Radio Station KGPN

10 EXCLUSIVE FEATURES

1. "Single-signal" quartz crystal filter circuit.
2. Stage of pre-selector tuned radio frequency amplification.
3. Full band-spread operation on any band of frequencies.
4. NEW Airplane type of dial; positive action, easily read.
5. 8 tubes; all newest type tubes; actually equivalent of 10 tubes.
6. Plug-in coils, wound on genuine BARRETT "MICALITE" Coil Forms; extremely low-pwr factor, no dirty switch contacts to become noisy, or large losses from long wiring leads.
7. Complete in one cabinet; NOTHING ELSE TO BUY.
8. Electrically welded steel cabinet and chassis; copper plated and baked enameled; strong and perfectly shielded.
9. Highly efficient operating range from 1500 KC to as high as 30 megacycles; works exceptionally efficient on amateur 10 meter band.
10. Operation for either Phone or C.W.; high quality audio system.

GUARANTEE: All BARRETT DX-8 Receivers are unconditionally guaranteed to be free from defects either in workmanship or materials for one year. If not fully satisfied with receiver for any reason, your money will be refunded if returned to factory within ten days.

THE BARRETT MFG. CO., 1382 16th Avenue, San Francisco, California

for YOUR antenna

Type "Q"
Transmitting
Antenna
System

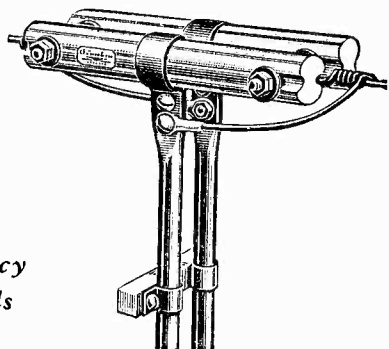

Better Efficiency
Louder Signals

No. 31
Transposition
Insulator

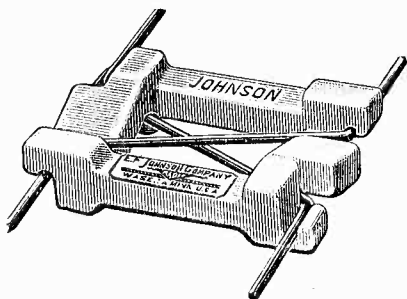

The JOHNSON line also includes "stand-offs," antenna insulators, airplane insulators, feeder spreaders, tube sockets, plugs and jacks, transmitting condensers, inductors, clips and handwheels, 5-meter antennas, doublet receiving antennas and doublet couplers. For all frequencies and all powers.

E. F. Johnson Company

Manufacturers of Radio Transmitting
Equipment

Waseca, Minnesota, U. S. A.

More on the Push-Push Doubler

(Continued from page 8)

Now for some actual results. Using a 40 meter crystal oscillator (47) link coupled to push-push 210's exciting an 852 on twenty meters, 45 milliamperes of grid current on the 852 are obtained when using a 15,000 ohm grid leak. This gives approximately 675 volts of grid bias on the 852, which operated efficiently at 3300 volts and 190 milliamperes as plate input. The two 210's operated at 750 volts and had 120 watts of plate input. The high plate efficiency of the push-push stage is demonstrated by the fact that when doubling with 120 watts input, no signs of color could be seen in the plates of the 210's. The same push-push doubler was used to drive push-pull HK354's to a kilowatt input without plate color on either stage. It was found that the doubler stage had practically the same output, efficiency and power amplification as an ordinary neutralized amplifier using two 210's in push-pull at 750 volts.

It is believed that this arrangement of a three-stage crystal controlled transmitter, consisting of inexpensive driver tubes and power supplies, and developing a usable output of over 800 watts with everything running cold, represents real progress toward simplicity and economy.

Fig. 4 shows the circuit diagram using push-pull HK354's in the final amplifier. Fig. 5 shows the complete power supply for the transmitter.

Note that the power supply for the first two stages uses an inexpensive plate transformer with 400 volts each side of the center tap. The use of three 83's in the bridge circuit provides 800 volts for the two 210's. This same power supply will be used to operate the modulation equipment necessary to grid modulate the final amplifier.

FORMS CLOSE
ON THE 10th
OF MONTH

RATES 10¢ PER
WORD PAYABLE
IN ADVANCE

**CLASSIFIED
RADIOADS**

NOTICE! Those who wish to advertise in these RADIOADS columns and who do not desire to divulge their names and addresses can use BOX NUMBERS, and all inquiries will be mailed, unopened, to the advertisers.

QSL CARDS. 75 cents, up. Samples. W2AOT, 554 Liberty Ave., Brooklyn, N. Y.

PRECISION cut and ground temperature calibrated crystals. Prompt service. 20% C.O.D. deposit. 160-80 meter 1/2 KC, \$2.75. 60-40 meter 1KC, \$3.50. Within 10 KC \$1.00 off. W9PRF, 418 South El Paso St., Colorado Springs, Colorado.

QSL's by W9DGH. 75c per 100. 1816 - 5th Ave. N., Minneapolis, Minnesota.

5-METER RADIOTELEPHONY. Great new book by Frank C. Jones, designer of San Francisco Bay Bridge 5-meter equipment. Dealers, distributors and sales agents wanted everywhere. Ready for distribution in 30 days. Shows many heretofore unpublished circuits for single-tube 5-meter transmitters, receivers and transceivers. The book will sell for 25c per copy. Send quarter in coin now for advanced copy. Publishers of "RADIO", Pacific Bldg., San Francisco, California.

SIX "X"-CUT 40 METER CRYSTALS. \$1.50 each. W9DGH.

RAYTHEON RK20 TRANSMITTERS. We can supply the entire transmitter (or individual parts) for the new RK20 transmitter described in this issue. Prices on request. Western Wireless, Ltd., 95 Minna St., San Francisco, California.

Montana reports KDKA 1800 miles, our crystal set. Blueprint 7 DX'ers, 25c. Modern Radio Labs. 151-F Liberty St., San Francisco, California.

QUARTZ CRYSTALS. 160 and 80 meters. 1 inch square, "X" cut. Unconditional guarantee, \$2.75. Specify Frequency. Immediate Delivery. Plug-in holders, \$1.50. W2AMA, 532 East 172nd St., New York, N. Y.

Edited by W. E. McNatt, Jr., W6FEW

YOUR contribution will be appreciated. Send your items to your Field Editor or to this department, c/o W. E. McNatt, Jr., W6FEW, Covina, California.

NEW ENGLAND NOTES FROM W1DP

The TWIN CITY RADIO CLUB of New Haven has moved from its old quarters to the corner of Washington and Howard avenues. They have a transmitter, W1GB, on 80 (c.c.). W1AMQ was recently elected president.

The U.S.N.R. has again expanded and now includes W1EFW. Bill Wood, W1GEL, found active duty in N.Y.C.

Mr. F. B. McLaren, prominent tube engineer, gave a lecture on a new vacuum tube to the Yale Student Branch of the A.I.E.E. which was widely attended by the local gang.

Will the YL over in Shelton please explain W1-AMQ's absence from the air?

And who is the hopeful U.S.N.R. recruit who took his physical exam and who couldn't see the large "A" half way across the room?

The latest New England convention came off with a record attendance for these parts.

Going for fone in a big way is the latest diversion of the Springfield gang . . . half of them are on 160 meters and the others are on 56 MC.

W1HCH says, "W1HBV are getting the plans together for a new radio shack and plan to have an xtal MOPA with three stages."

W1QW is on 5 meters for the first time and he likes to gab, as any of the five meter gang will tell you. He also handles the Naval Reserve for his district. "He knows his onions" is the war cry of the hams who know W1CJW, who is hoeing the potent weed on a farm in Fall River. The Naval Reserve at Hampton Beach is anchored safely in the hands of W1FPX.

Replacing Bob Wilson, who is graduating and going to G.E., W5EDJ is the new secretary at the Yale Radio Club, W1YU. (Since our correspondent seems to be quite modest, we'll tell you that he is the new President of the Yale gang and is also Chief Operator of their station—W1YU . . . Editor).

Having obtained their license, the radio club at Wallingford are putting a low power outfit on the air which will probably sprout a 50 watter soon.

W2APV OF BRONX (WHERE THE CHEERS COME FROM) REPORTS:

After twisting and untwisting so many feeders, W2GVT is looking like a pretzel, hi.

Yer corrspondent hes gone too, too divoon ever since he took on a YF as 2nd op.

W2FPT wails, "If they'd only answer me!" Hi, you'll get that foreigner yet, OM.

An NBCish fone is the pride of W2QZ, who is on 20 meters.

Training himself to again cop the speed championship of the 2nd district is W2GKB's avocation nowadays . . . he uses a tape.

A TPTG 50 watter lights W2SM's cigarettes and emperills his schnoz, heheheheh.

The Aussies are gonna be on the jump, no foolin', for W2EXM is reopening at Rockaway Point.

W2FZ is STILL working on that super super transmitter!

W2GQB is—oh, well—just another one of "them" things—a YL.

THIRD DISTRICT ACTIVITY AS REPORTED BY W3CCF-SI

This call stealing stuff is getting to be a serious problem. (Yet, brother!) Just how prevalent it is, I never realized until last week (about a month ago) when I was told that some kid was using my call on 3.9 fone. At various times I tore myself away from 40 meter DX long enough to listen on 3.9 . . . FINALLY, somewhere near the fone band, a self excited fone with a very nervous carrier was heard calling CQ and signing my call. Tearing my hair and wishing for a cat to kick, I managed to control my temper enough to look over the band for a call and see how my ghost was getting out—sure enough, and shades of the OLD MAN, away down, just out of the wrong end of the CW band, was a very MURDERLATED fone calling me, the bootlegger rather, and WHATINELL DO YOU THINK THAT YOUNG SQUIRT DID? HE SIGNED MY PORTABLE CALL. A few blankety blanks and a couple of GOSH DERNS!

What's a fellow going to do? Any suggestions will be appreciated. These kids (maybe not all kids at that) don't use much power, but a dozen or so low-power, well murderlated-wobulated sigs can cause a lot of trouble in a town. . .

Just read an article about some low power DX and happened to remember an incident which occurred at the station of Josh Swartz, W3WX, in 1931 . . . Josh was operating his portable, W3BIT, using 45 volts on a pair of 201-As and was contacting an 8 or 9, occasionally, on 14 MC. Finally, after hearing a G on the air, he screwed up enough courage to call him . . . lo and behold—the seemingly "impossible" happened, the G ANSWERED HIM WITH A QSA5 R7 report. After a 15-minute chat, power was reduced to one-half worn out "B" battery giving 20 volts and a plate current of 3

mils. A PERFECT HALF HOUR QSO was carried on—Pennsylvania to Great Britain, 3500 miles on SIX HUNDREDTHS 0.06 WATTS. Figure it out—58,000 miles-per-watt! Now W3WX has a kilowatt input. OKAY, MARS!

Alas, alack and Alaska! Charlie Steiger, W3JX, who has been a CW man since he started radio, about 20 years ago, is now being heard on 3.9 MC fone with a FB class B job.

W3AXT in Lancaster, Pa., has installed two new transmitters built by your scrivener's pard, Tom Hall W3ZJ. The 3.9 fone uses an 849 in the output stage and the 14 MC rig has two 852's on the tail end. Both are modulated by class B 203As. Seems as though Sam is getting ready for some really serious fone work.

Oh, oh! Another old timer is getting the urge to return to the air, Louie Wentz, ex-3BRL, he of the mighty spark (By the way, uncover your heads when I mention spark) just bought a Comet-Pro and threatens to get hisself a transmitter in the near future. Boy, OH BOY! I can still hear the sing of that spark . . . wonder if we could have the FRC give us permission to use spark for just one night?! . . . I can't figure it out, but all the phone men in this vicinity are working CW and all the supposed dyed-in-the-wool CW men are working fone . . . Oh, me—just another one of those eleven year cycles, I guess.

My hat is off to Spengler, W3UR. He's the only one I know who can connect up a seven prong socket without referring to a drawing.

W4BSJ, we are happy to announce, will tell you the low-down on the boys around Madison, Fla., in the next issue. The gang had a hamfest down "thar" on June 2nd and 3rd . . . we may have some interesting dope on it for you.

W5BMI, "EF", OFFERS:

W5NW, probably better known as "Soupy" Groves, is now a politician. He is running for ARRL directorship in the West Gulf Division . . . his YL-op sister helps considerably, too. And it is rumored that he is also out for Mayor of Neches, Texas, which is a bustling city of some 25 souls (sounds like a ghost city).—Best of luck, OM.

The man who made "Soupy" what he is today is Felix Johnson, W5LS, who is furthering the cause of the big politician by stumping for him. Evidently, Felix is gonna do the osculatory work, or sump'n.

Old-red-suspender-Bill, W5AUL, has been strangely missing lately from the 80 meter band. According to "Silent Keys" of QST, Abiline is not exactly the most healthy place to live in.

Explain your absence, Slim. Did the drill tower rid you of the lead?

THIS 'N THAT WITH W6FEW

Dunno whether or not you've heard about the last L. A. Section brawl, but sure was a dinger . . . bet Budlong thinks he's Bae Ruth now . . . he went "to bat" so often . . . speaking of bats . . . look in ADJ's belfry sometime . . . W6EQJ's baby has arrived . . . a boy . . . and no see-gars . . . Krohn, the Mail (male?) man is another proud father . . . he should be . . . he says the baby doesn't look like him . . . W6EBJ is rumored to be highly expectant father . . . how about some stogies, Sid? . . . W6EBK arrived home with a nice rig . . . from CCC . . . he's quite the boy on 40 and 80 now . . . glad to see you home, Johnny . . . whatta change . . . W6FDM says "Alaska"—"Alaska to come up sometime" . . . fergit it . . . W6JOE is looking for another "final" since his 800 went . . . the way of 'em all . . . the L. A. Section boys are well organized with the Federation going strong . . . the Chicago gang . . . and the Washington gang . . . have similar organizations . . . patterned after the California gang's . . . Arizona came in the Federation last month . . . now our organization is known, I think, as Federation of Radio Clubs, Southwest, etc. . . . the lower half of the Pacific Division petition as follows:

A PETITION

"We, the undersigned, being bona fide members of the Los Angeles Section of the American Radio Relay League, do hereby petition and request that the honorable Board of Directors of the American Radio Relay League, in the Executive Session at West Hartford, Conn., do immediately re-allocate and re-apportion the Pacific Division, namely, to wit: That the Arizona, San Diego and Los Angeles Sections be consolidated into a separate division to be known as "South-West Division", American Radio Relay League. We believe that such action is in the best interest of furthering the cause of amateur radio, positively necessary for the elimination of friction and the creation of harmony."

ROUNDING UP THE ARIZONA GANG . . . W6JRK

How do boys! Let's visit the shack of our dear friend W6AND, who can't even remember the year when he got his call. He has a nice rig on 20 mtr fone . . . which is also 40 meter phone! He likes to fiddle around with his little 100 watter on 40 CW . . . Ahhh! Look at the new antenna. He says it took him a week to get enough help to put it up, but it's up and he's off.

Now we run over to the Armory and see little Bobbie La Rue at the wheel . . . nice mans!

Here we go to 160. A CQ is signed by Bob, W6JFO, who is "on" as usual. Thence to 80 where, after a short time, we hear the neighbor's chickens in the speaker . . . oops, no it isn't, it's JFO on 80 . . . such a harmonic, right in the CW band (Boy! these words are gonna cost me plenty).

Listening on 40 we hear a 60 cycle hum; what can this mean? Suddenly the hum stops and a nice slow first pounds out "W6HUZ" with a nice xtal sig . . . he's using the key now—the "hum" was his bug!

"WHERE YOUR SHIP COMES IN" WITH W7CQI

W7QI, Seattle, is going strong again with his K6 and KA skeds. These skeds have been inactive for so long and Seattle and the Northwest are sure glad to have a reliable trans-Pacific sked again.

A real Old Timer of the "Good Old Daze" of sparks and whirring, buzzing gaps is W7EHO (formerly W7AAF of Tacoma) is back on the air at Aberdeen, Wash., with a brand new call. Glad to see you back, OT.

ADJUSTOHM

I to 100,000 OHMS

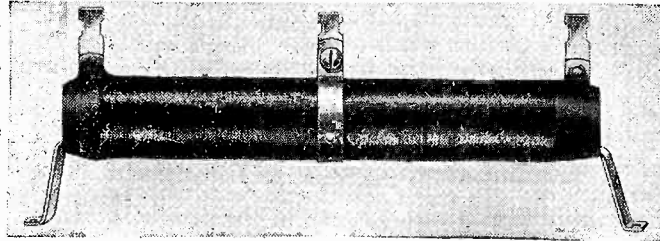

THE ADJUSTABLE RESISTOR

Therefore may be used as a Bleeder, Voltage Divider, Grid Bias, Blocked Grid Keying, Grid Leak, or Voltage Dropper. Loosening the screw on the band permits adjustment of the resistance. Potentiometer connections can be obtained by using end terminals and band connections. Send for FREE descriptive booklet 507.

WARD LEONARD ELECTRIC COMPANY
41 South Street, Mount Vernon, N. Y.

Please send me free copy of booklet 507.

Name _____
Street _____
City and State _____
Call Signal _____

Universal Power Cutter

for superior recordings—also needles, discs, recorders, blank records, microphones, stands, transformers, etc.



New catalog, just off the press, illustrates and describes over a hundred items of interest to everyone in radio.

Get a copy at your nearest jobber, or write on your letterhead for a free copy direct to

Universal Microphone Co., Ltd.
INGLEWOOD CALIFORNIA

Globe Giraffes

W3ZJ - W3SI - W3CCF

International High-Score Station of Tom Hall and Charlie Meyers

Tom Hall, W3ZJ and Charlie Meyers,
W3SI, W3CCF

3747 Derry Street, Harrisburg, Pa.

THE first acquaintance with the mysteries of ham radio was made by Tom Hall, W3ZJ, back in the days before the World War in the little town of Ridgway, Pennsylvania, nestled way up in the heart of the Alleghenies. Spurred on by the association with one of Pennsy's first stations using the call BO (the initials of the owner) the fundamentals of operation and construction were learned. Later, the World War and as we remember, down came the cages or what have you.

The next eight years were taken by service in the U. S. Navy and college. Then the old yearning once more came to the fore and the entrance into radio business and with it ham associations, transmitters and loss of sleep.

Radiotelephony has been used a great deal in the last few years under the calls of W3AKX, W3BEP, W3DX, W3ZJ and power ranged from 5 watts to 1 KW. On 85 and 75 meter fone all states have been worked several times and ZJ was the first east coast 85 meter fone to work Italy and Honolulu.

On 20 and 40 meters all continents have been worked on both frequencies in addition to all continents worked on 20 fone. In the 1934 International contest W3ZJ contacted 242 foreign stations in 49 countries besides Japan and Greenland contacts, which were unsatisfactory and could not be counted in the score of 34,496 points. With the present 20 and 40 meter rig as rebuilt and used for the International test over 90 countries have been worked during late 1933 and so far in 1934.

Charlie Myers cut his radio teeth on a spark coil and galena detector before the World War under the call JM and then 3TM. After the war a half KW spark made its appearance, soon to be replaced by a CW rig using a 202. The call 3CCF was assigned in 1921 and was one of the first to be heard in the unexplored waves around 100 meters. Both sides of the first U. S. A.-Europe contact between 8AB and 1MO on November 27, 1933, were heard by 3CCF but the little 202 in spite of the 1000 volts of straight AC couldn't bridge the gap to France. Ever since the first European QSO in 1924, DX has been a steady diet. Several profitable experience-getting years were spent with A. T. & T. and then four years in college where 3BHY splattered signals into the far corners of the world. In 1931, W3CCF's junk was moved into Harrisburg to combine with W3ZJ in a partnership station with three 1000 watt transmitters working 20 and 40 CW and 80 fone. In the International Goodwill Tests of 1932 W3CCF was the world's leading DX station, being heard in more countries and receiving more reports than any other station competing. During these tests, one transmission was copied in all six continents at the same time. The station holds a WAC and is waiting for one confirmation to arrive before making application for WAC on fone.

At the present time the call W3CCF is practically laid on the shelf as it is assigned to the owner's residence and the call W3SI is the new half of the W3ZJ partnership. The reason for the change

of calls is that W3SI figures that he will need 35,000 points to win the 1935 International Competition and the time gained in sending SI rather than CCF is a big factor. Hi.

At W3ZJ-W3SI two transmitters are in use at present. The first, which was the one used in the 34 tests, is built for accessibility and ease of making changes when some experimental work is in order. The RF portion of the rig is lo-

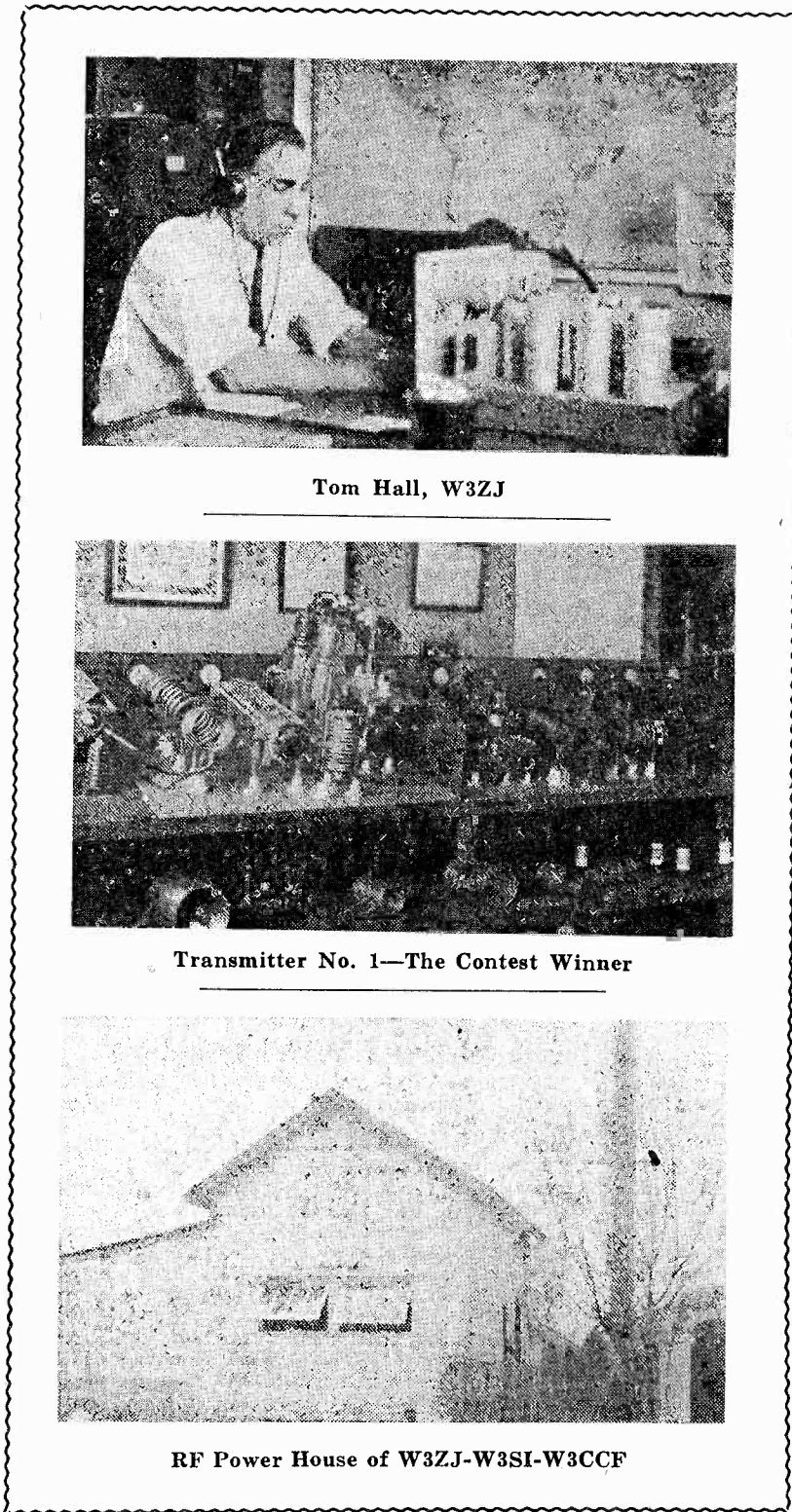

Tom Hall, W3ZJ

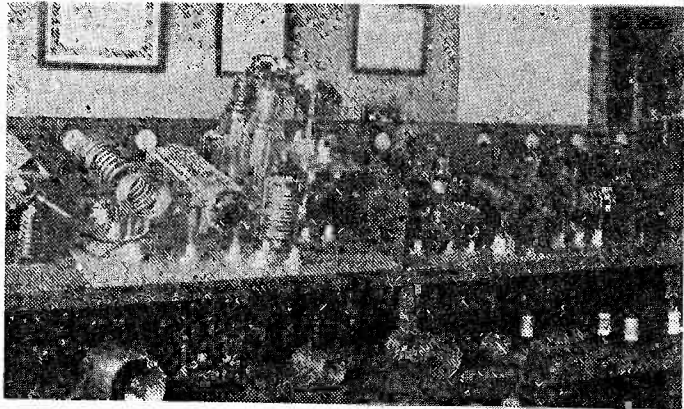

Transmitter No. 1—The Contest Winner

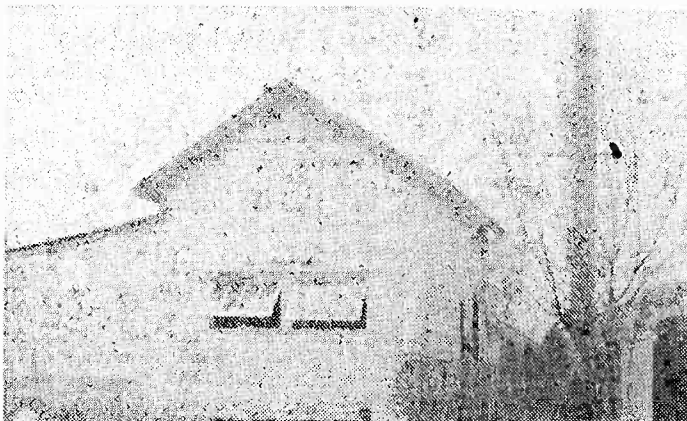

RF Power House of W3ZJ-W3SI-W3CCF

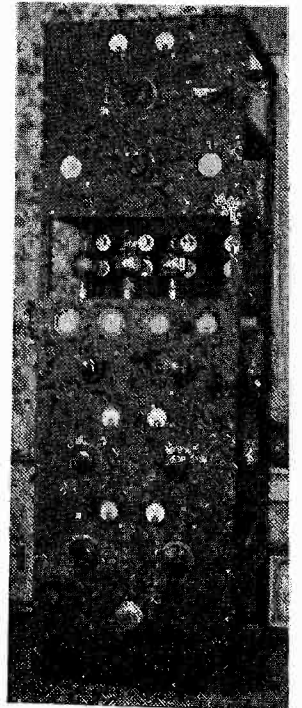

Transmitter and Power Supply No. 2

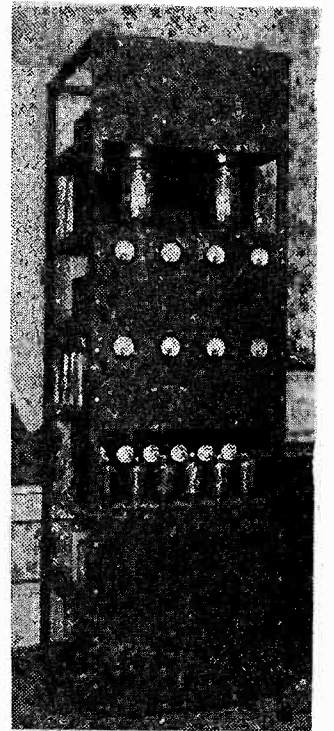

Charlie Meyers, W3SI-W3CCF

cated on the top of a large steel frame of Telefunken design. Bias batteries, spare coils, etc., are held by a middle shelf and the power supplies are located in the bottom. The six stages of the transmitter are fitted with plug-in coils to permit rapid band change and link coupling is used between all stages. The tube layout is as follows: 47 crystal oscillator, 46 doubler, parallel 46 buffer, 203A buffer, 852 buffer and push-pull 204A's in the final. An 80 meter crystal is used for 40 operation and a 40 crystal for 20 operation. Partial shielding is used between stages. Plate voltages are furnished by five power supplies, the one for the final using a 5 KW American transformer, 872 rectifiers and a conventional filter.

The ease and speed of band change was illustrated many times in recent tests when a new country, or later in the contest a new station, was heard on the "other band" and a change was made in time to permit answering the CQ.

The second transmitter is built in two racks, one containing the power supplies and modulators and the other the six RF stages. As in the first rig, link coupling is used throughout and the tube layout consists of a 47 crystal oscillator, 210 doubler,

210 buffer, 841 buffer, 852 buffer and four 852's push-pull, parallel in the final. For CW operation two 852's are sometimes used running at a kilowatt input. For fone operation the 852 buffer is modulated by a pair of 849's and the four 852's are operated class B at 1000 watts input. The main power supply uses a bridge rectifier and furnishes 4000 volts.

Many types of antennas have been tried but the one in use at present is an ordinary 40 meter half wave Zepp supported by two 80 foot wooden poles. The antenna runs north and south and is entirely in the open, the station being located on the outskirts of Harrisburg. A receiving antenna is stretched from the shack to the top of one of the poles. More DX can be heard on this receiving antenna than on any other tried, although the noise of automobiles passing is objectionable.

Two practically identical home-made receivers are in use. They are superheterodynes constructed of Hammarlund parts and are similar to the Pro except for the addition of a pre RF stage.

At present several new transmitters are under construction. See facing page for countries worked table.

I. R. F. NEWS (Formerly I.T.K.)

The Amateur's Legion of Honor

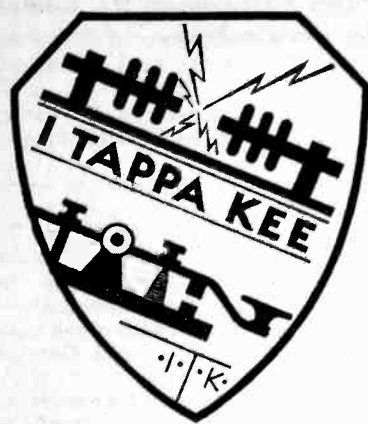

This department is edited by the President of the International Radio Fraternity, J. Richard Meloan (Jo) radio W6CGM-W6ZZGB, KERN.

All communications concerning the International Radio Fraternity, as well as inquiries from any amateur as to the Requirements for Membership, should be addressed to I.R.F.

Headquarters, either to the Secretary-Treasurer, Kenneth M. Isbell, W6AMR-W6BOQ, 5143 So. 6th Ave., Los Angeles, or to the President, J. R. Meloan, W6CGM-W6ZZGM, 1911 Forest St., Bakersfield, California.

What Are IRF Benefits?

IN REPLY to thousands of letters inquiring about the International Radio Fraternity perhaps the following outline will serve as a brief answer: Purpose:

1. To preserve and carry on the noble traditions and the fine spirit of the radio operating fraternity.
2. To band together amateur radio operators of similar interests and ideals into a world-wide fraternity sponsoring real fellowship and friendliness.
3. To give each man full expression of his ideas and to collectively by organization represent these ideas for the advancement of amateur radio.
4. To mobilize the courageous, upstanding, experienced and skilled amateurs—the kind who dare think for themselves, in the cause of a New Deal for the amateur and the subsequent betterment of amateur radio conditions and the radio art.

IRF Features:

1. Direct Vote of each member on all questions coming to the attention of the fraternity. Full and equal representation at all times on all matters by the individual. Consequent democratic rule of the fraternity by its members.
2. No Salaried Officers at present and no salaries shall be paid until such time as the business of the fraternity shall so demand and at no time will these salaries be fabulous but entirely within reason and decided by a vote of ALL the members.
3. Local Chapters, an integral active part of the whole organization NOT a loose affiliation.
4. Skilled amateurs of wide experience only are admitted to this fraternity. They also must come well-recommended and be known for their good conduct and influential standing in their respective communities.
5. Purely Amateur Membership. Every applicant must be a licensed amateur with at least three years active experience and a code speed of 20 wpm.
6. A Clean, Honest Fraternity. Its record is unblemished and shall continue to be so. IRF is unique in that it does NOT racketeer or commercialize amateur radio. Its financial status, record of vote and operations are entirely open to inspection of its members. We have nothing to conceal.
7. Lowest Possible Dues. These are a dollar per year. In return the member receives material and benefits which cost that amount. (Bulletins, cer-

IRF Station W3GS

Owned and operated by Jack Wagenseller, popular fraternity brother at Upper Darby, Pa., using three transmitters on the 5-20-40-80 meter bands, one of the East's most active traffic stations that has for the past seven years hung up an excellent record. Jack is age 25, enjoys music and is engaged in the occupation of manager of the amateur department of the M. and H. Company at Philadelphia.

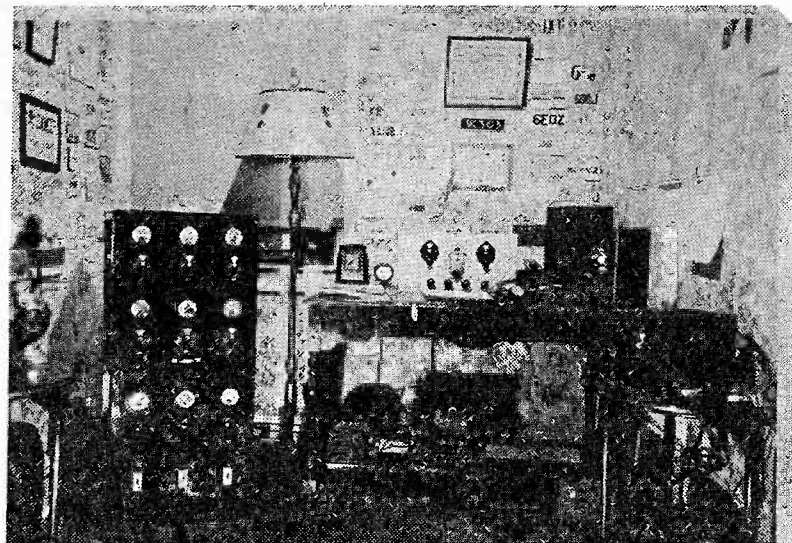

tificates, informative material, etc.) Also many privileges as well as support of IRF operation.

8. An Amateur Organization. NOT a commercial magazine publishing business. It is dictated to by no magazine. It is purely an amateur fraternity and is NOT commercializing amateur radio. Dues are set at exact cost. We do not sell subscriptions to radio magazines or have any financial interests whatsoever in these. (Confidential news reaches every member each month in "The Lightning Jerker", official news bulletin which benefit is included in the member's dues).

9. An Efficient Traffic Network insuring speedy, reliable and accurate dispatch of radio messages over established trunk lines manned by the world's finest amateur radio operators thus recognizing the amateur's chief claim to public service.

10. Military Cooperation. Full cooperation with the U. S. Naval Reserve and Army Amateur Radio System in realization of their vital importance to the Government and the public at large. The majority of the IRF membership are leaders in these two military units.

Finally a QSO with an IRF man is a 100% QSO.

The existence of the International Radio Fraternity (formerly I Tappa Kee) is fully justified by the above points and fills a DEFINITE NEED in amateur radio. Its plan and ideals were originated and put into action seven years ago. Today the merit of these ideas is being proven by their advocacy by amateur leaders everywhere.

Various reformers are likewise attempting to rebuild and reorganize other amateur organizations along these lines. IRF's high standards of radio operating has been apparently imitated and copied by several such as the "A1 Operators Club" recently organized. Imitation is the sincerest form of flattery.

Traffic Department

W6AOA, Frank Cuevas of Bakersfield, Calif., widely known traffic man of excellent record, has been appointed Acting Chief of Communications to fill in the unexpired term of the previous Chief and is already producing splendid results. Traffic routes are being successfully lined up over the United States and Canada and old ones strengthened.

New Official Dispatching Stations are being appointed to transmit the weekly and special dispatches originated at IRF Headquarters to keep members in close touch with every development. IRF stations able to broadcast these dispatches should write or radio W6AOA for appointment.

Also those wishing to work on Official traffic circuits do likewise. A number of fraternity men have reported getting special 3645 KC xtals this past month for operation on this IRF official frequency. Several new transcontinental trunks have just gone into operation and insure rapid relaying of messages from coast to coast in the minimum of time. These trans-cons usually work on the doubling freq. of 7290 KC. A message handled on an IRF trunk line reaches its destination station within 48 hours from origination regardless of whether it must go half way around the world or on a short hop.

More good fone stations are wanted for Official Dispatchers on the fone spectrum. IRF Headquarters will be glad to hear from first class fone stations anywhere in the world and consider them for IRF membership and appointment. This fraternity gives full recognition to the skilled fone man and accords him many benefits as well as representation of his problems.

Detailed news of IRF station activities will for the most part be found in the Official News Bulletin "The Lightning Jerker" sent all members, also when possible in Bill McNatts "One's To Nine's" Department in this magazine.

Sorority News

THIS is the first international organization to sponsor a sorority for YL and XYL operators. Upon investigation some time ago we found that many very capable feminine amateur radio operators existed who were eligible to this fraternity. This was not a little surprising inasmuch as the common superstition had existed that yls were all in the ten-word-per-minute class instead we discovered that there were sufficient YL-XYL operators on the air who could meet the unusually high operating standards of this fraternity that a real sorority was possible.

So far the "opposite sex operators" contacted have given the sorority idea enthusiastic reception. It seems that they have long wanted to become more closely associated with their sister operators of the ether and band themselves together into their own organization. The superiority of the males and discrimination against the females on the air is henceforth OUT as far as they are concerned. They will now take unified action to show that they can pound brass as good as any man.

While IRF has not been able to give as much time to this sorority as it deserved, some fine plans are now under way with a nucleus of very fine YL-XYL ops as the moving spirit thereof. They will undoubtedly elect their own officers and become a valuable auxiliary of the Fraternity and probably bear the name of Iota Rho Sigma (meaning International Radio Sorority) I.R.S., have their own special certificates, sorority pins, etc.

While we at first naturally avoided this feminine contingent, being a fraternity (brotherhood), we soon became forced with the necessity of creating a sorority unit. Many IRF brothers were demanding that the fine operating of several prominent YL-XYLs be fully recognized. So we accepted and gladly welcomed into IRF the following of which we are most proud: W6EK, Flora Card of Pomona, Calif. (foto and station description in previous issue of "RADIO"); W7AHJ-BT6, Esther Brunk, at Riverside, Calif., especially well known in the AARS as a DNCS; W7NH, Nellie Hart (who doesn't know Nellie?). If you've been on the air at all you have heard of this popular young lady; W9LW, Lucia Mida of Chicago (see foto and station description in May issue of "RADIO"), her record speaks for her and loudly, too; and last and likewise important May Rose Sparks, VE5KS of Armstrong, B. C., a code speed champion in Canada and incidentally she rates the Degree of Sparks in IRF.

These constitute the unusually good foundation on which the sorority of IRF shall rise. Headquarters will welcome correspondence from other eligible YL or XYL amateur operators anywhere in the world who wish to join this sorority.

COUNTRIES CONTACTED BY TOM HALL W3ZJ AND CHARLIE MYERS W3SI, W3CCF

1 Abyssinia	27 Costa Rica	53 Iraq	79 Porto Rica
2 Afghanistan	28 Cuba	54 Irish Free State	80 Portugal
3 Albania	29 Czechoslovakia	55 Italy	81 Roumania
4 Alaska	30 Denmark	56 Jamaica	82 Saar
5 Algeria	31 Dominicana	57 Japan	83 Siberia
6 Andorra	32 Dutch East Indies	58 Jugoslavia	84 South Africa
7 Angola	33 Dutch Guiana	59 Kenya	85 South Rhodesia
8 Argentina	34 Ecuador	60 Luxembourg	86 South Pole
9 Australia	35 Egypt	61 Madeira	87 Spain
10 Austria	36 Ellice Islands	62 Malay States	88 Sweden
11 Azores	37 Estonia	63 Martinique	89 Switzerland
12 Barbados	38 France	64 Mexico	90 Syria
13 Bahamas	39 French Guiana	65 Morocco	91 Tahiti
14 Belgium	40 French Indo China	66 Mozambique	92 Tanganyika
15 Belgian Congo	41 Fiji Islands	67 Netherlands	93 Trinidad
16 Bermuda	42 Finland	68 Newfoundland	94 Tunis
17 Bolivia	43 Germany	69 New Zealand	95 U. S. A.
18 Brazil	44 Greenland	70 Nicaragua	96 Uruguay
19 British Guiana	45 Great Britain	71 Nigeria	97 Russia
20 British Honduras	46 Guatemala	72 North Ireland	98 Venezuela
21 Canada	47 Guam	73 Norway	99 Virgin Islands
22 Canary Islands	48 Hawaii	74 North Pole	100 Scotland
23 Canal Zone	49 Haiti	75 Panama	101 Danzig
24 Ceylon	50 Honduras	76 Paraguay	102 Labrador
25 Chile	51 Hungary	77 Peru	103 Lithuania
26 Columbian Rep.	52 Iceland	78 Poland	

D-X News

By W6WB

★ ★ ★ ★

Official Country Bureau

Here Are the Plans For a New Bureau—
Your Comment Is Solicited

Purpose:

(a) To act in the capacity of an Official Bureau for the classification of DX countries which may be considered as legitimate.

(b) To appoint a group of representative and competent amateurs in at least three sections of the United States (East, Central and West), to act as a committee, the purpose of which is as follows:

(1) To act as an official body to consider the legitimacy of any countries that are not acceptable by common acclaim.

(2) To pass the results of their findings to the Official Secretaries, Charles Perrine and Herbert Becker, who will in turn advise those who inquire as to the action taken by the committee.

Duties of the Secretary:

(1) To fulfill the duties stated above.

(2) To act in the capacity of Corresponding Secretary to answer such correspondence as may arise in conjunction with the above.

(3) To affix the Official Seal of approval of the Official Committee.

(4) To issue such certificates or other credentials as may be issued for this purpose.

Committee Selection:

A group of representative men will be selected by "RADIO" to form the nucleus of the committee. These names to be published in "RADIO" for the approval of all concerned. These men will be selected from widely different parts of the country so as to avoid the possibility of local discrimination. These men will then be asked to submit a list of the countries of the world, according to continents, to the Official Secretary. The secretary will take these lists and put all the countries which are in unanimous accord in one list, and a separate list will show other countries not in agreement or unlisted by some of the committee. The list of countries in dispute will then be re-submitted to the committee for further consideration. Each member will be requested to submit in writing the reasons for selection or rejection of said country or countries. The secretary will then compile this data as a basis for an "Official Country" list. Under no considerations can a country be recognized as official unless two-thirds of the committee members are in agreement as to its legitimacy.

After the original list has been made up it will be printed in "RADIO" for a period of two months for the approval of interested parties. No change from the rulings of the Official Committee will be considered unless disapproval is expressed by at least fifty (50) parties. This disapproval must be expressed in writing to the secretary.

It is anticipated that many lists of countries will be submitted for official approval and that such lists will contain names of countries that have not been considered in the original list accepted by the committee. These additional countries will be listed and mailed to all committee members who will then pass judgment at their earliest convenience.

All committee members are requested to send their findings to the secretary at the earliest possible moment; in this way avoiding a delay of approval of someone's country list.

"RADIO" and the Official Secretary hope, by this method, to remove all argument as to the legitimacy of any particular DX country or countries appearing in any stations-worked list. By unprejudiced selection of committee members from all parts of the U. S., it is expected that complete approval of all concerned will be forthcoming.

CENTENARY CELEBRATIONS

By VK3ML

Manager, Centenary Contest Committee
Announcing the Melbourne Centenary
International DX Contest:

When? During the four week-ends in October, 1934.

For whom? A contest for both transmitting and receiving stations.

With whom? The whole world! VK works the world.

Thus, in brief, the Victorian Division of the WIA announces the first Australian International DX Contest. The test is being staged to give publicity to and celebrate Melbourne's Centenary, which commences in October this year.

This will be the first time in history that any division or even the F.H.Q. of the W.I.A. has staged such a magnificent undertaking. We have all been the "guests" of the W's and G's often enough and have thoroughly enjoyed their tests. Now it's our turn to offer one in return. We are inviting the whole world to come and contact as many VK's as they can. Our stations will only be asked to work as many DX stations as possible. That's easy enough? To each station contacted, a serial number is handed, and one is received in exchange. Together with this, a signal strength report will complete the QSO.

The scoring will be one point for each 1000 miles of QSO. Thus, the test is a combination of BERU and ARRL ideas, but we are going one better in several points.

To add to the fun of the Test, the VK's will multiply their total by the number of countries worked and those outside VK, by the number of VK districts contacted. What scores are possible with about 100 countries to work! Don't forget that the QRP merchant will get his "kick" out of the contest, because the world will be listening for even the squeakiest signal! It's a chance for everybody. If WAC's and WBE's are not won by the dozen; then don't blame us!

The S.W.L. will have his share of the fun, too. The contest provides for a separate test for receiving stations in all parts of the world, and they are eligible for awards also. The full details are given in the rules below.

Awards? Certainly. For the winning VK we hope to offer a brand new 852. The second and third prizes will probably be a 50 watt and a thermo couple meter, respectively. These have not been chosen to-date, but we want to get the "dope" on the test out early, so that it will give you time to chat the world up about it.

The success of the contest depends on the number of VK's entering. Thus, a few words about the test should be an essential part of all QSO's for the next six months. Tell everybody about it—tell the J's, the G's, and, in fact, every ham you work.

Besides the sumptuous awards listed here, the winning station in each division will be awarded one of the attractive Centenary contest certificates. For the SWL we have to offer a handsome cup as first prize and certificates as in the case of the transmitting contest. There will be plenty of awards left for the rest of the world! Special certificates, that can be proudly hung up for the next 100 years, will be offered to all countries.

Again, we are making the contest attractive to all by awarding, through the courtesy of the Editors of Amateur Radio, another prize for the world's best station description, which is to accompany each entry. More about that later, too.

The most important item to be explained now is the serial number business. It's the same as that used in the W contest, but in case any ham is not familiar with that test and its operations we are rehashing the details.

Each competing station allots himself three figures, anything between 111 and 999. He retains these throughout the contest. He must exchange a six figure serial number each QSO; so for the first contact he adds three naughts, making his number, say, 367,000. This is given to the station worked and one is received in exchange. Now, the second three figures from here on are taken from the first three of the serial number last received, and are added onto the station's own three figured number. For example, VK5FM has assigned himself 281 and has passed 281,000 onto his first DX QSO. He received from that station 457, 878 in exchange. His next number will now be 281,457 and so on throughout the test, adding the first three figures received to his own three after each contact. Stations at both ends do this and is proof of a QSO. Both the "in" and "out" serial numbers are entered in the log.

Naturally, distant stations will be most sought after to get those few extra points for each 1000

miles, but what a system can be worked out! ZL'ers all day and DX all night! There is nothing strenuous about this test because fatigue is spread over four week-ends!

"Amateur Radio" will be publishing further details each month, so look for them.

Melbourne Centenary International DX Contest
Rules and Conditions

1. There shall be two contests: (a) Transmitting; (b) Receiving.

2. The Wireless Institute of Australia Centenary Contest Committee's ruling will be binding in case of any dispute.

3. The nature of the Contest requires the world to work Australia.

4. The contest is to be held from 0001 G.M.T., Saturday, October 6, till Sunday, October 7, 1934, at 2359 G.M.T., and will be continued over the four week-ends in October at the times stated above on each occasion. The dates of the other week-ends are: October 13-14, October 20-21, and October 27-28, 1934.

5. The contest is open to all licensed transmitting amateurs and receiving stations in any part of the world. Unlicensed ship and expedition stations are not permitted to enter the contest. Financial members of the W.I.A. and its affiliated societies only will be eligible for an award in V.K.

6. Only one licensed operator is permitted to operate any one station under the owners call-sign. Should two or more operators operate any particular station, each will be considered a competitor and must enter under his own call-sign and submit, in his log, the contacts established by him. This debars persons from entering who have not a ham license.

7. Each entry must be signed by each competitor as a declaration of the above statement.

8. Each participant will assign himself a serial number of three figures as detailed in the contest description. When two or more operators work the one station each of them will allot himself a separate number.

9. All amateur frequency bands may be used.

10. Only one contact with a specific station on each of the bands during each week-end will be permitted.

11. Contacts may be repeated on each of the succeeding week-ends with the same stations in accordance with Rule 10.

12. Each contact must be accompanied with an exchange of serial numbers and signal strength reports using the T QSA and R systems.

13. Scoring: One point will be scored by each contacting station for every 1000 miles between the Capital Cities of the States of the competing stations, measured by a Great Circle Line. The points claimed are to be entered on the entry form.

14. Australian stations will multiply their total score by the number of countries worked and the stations outside VK, by the number of Australian Districts contacted, there being 8 all told, viz., VK2, 3, 4, 5, 6, 7, 8 and 9.

15. No prior entry need be made for this contest but each contestant is to submit a log at the conclusion of the test showing: Date, Time (G.M.T.), band, station worked, in and out signal strength reports, in and out serial numbers, distance between stations, and the points claimed for each QSO.

16. Entries from VK stations must reach the Wireless Institute of Australia (Victorian Division), Kelvin Hall, Collins Place, Melbourne, Victoria, no later than 1st December, 1934. Foreign entries will be received up till 31st January, 1935.

17. The awards for all winning competitors will consist of a special attractive Melbourne Centenary Contest Certificate. The station returning the highest total in any country will be entitled to an award, with the addition of similar special awards for the winners of each District of U. S. A. and Canada, and each of the British Isles. There will be no World Winner in this contest.

18. A special prize will be given to the grand winner in Australia, probably consisting of an 852 tube as the first prize. The contestant in each VK division who returns the highest total for his district will also be awarded a Centenary Certificate. The official organ of the W.I.A. "Amateur Radio" will award a special trophy for the outstanding station description accompanying logs.

19. Foreign stations should call CQ VK "CENT", and Australian stations CQ DX "CENT".

Receiving Contest

1. The rules for the receiving contest are the same as for the transmitting contest, but is open to members of any recognized Short Wave listeners Society in the world. No transmitting station is allowed to compete in the receiving contest.

2. Only one operator is permitted to operate any one receiver.

3. The dates, scoring of points, and logging of stations once on each band per week-end are subject to the same rules for the transmitting contest.

4. To count for points, the call-sign of the station being called, and the strength and tone of the calling station together with the serial number and signal strength report sent by the calling station, must be entered in the log.

5. The above items must be filled in before points can be claimed, that is, it is not sufficient to log a station calling CQ or TEST. Verification of
(Continued on page 34)



McMURDO-SILVER

5B SUPER... Choice of those who know

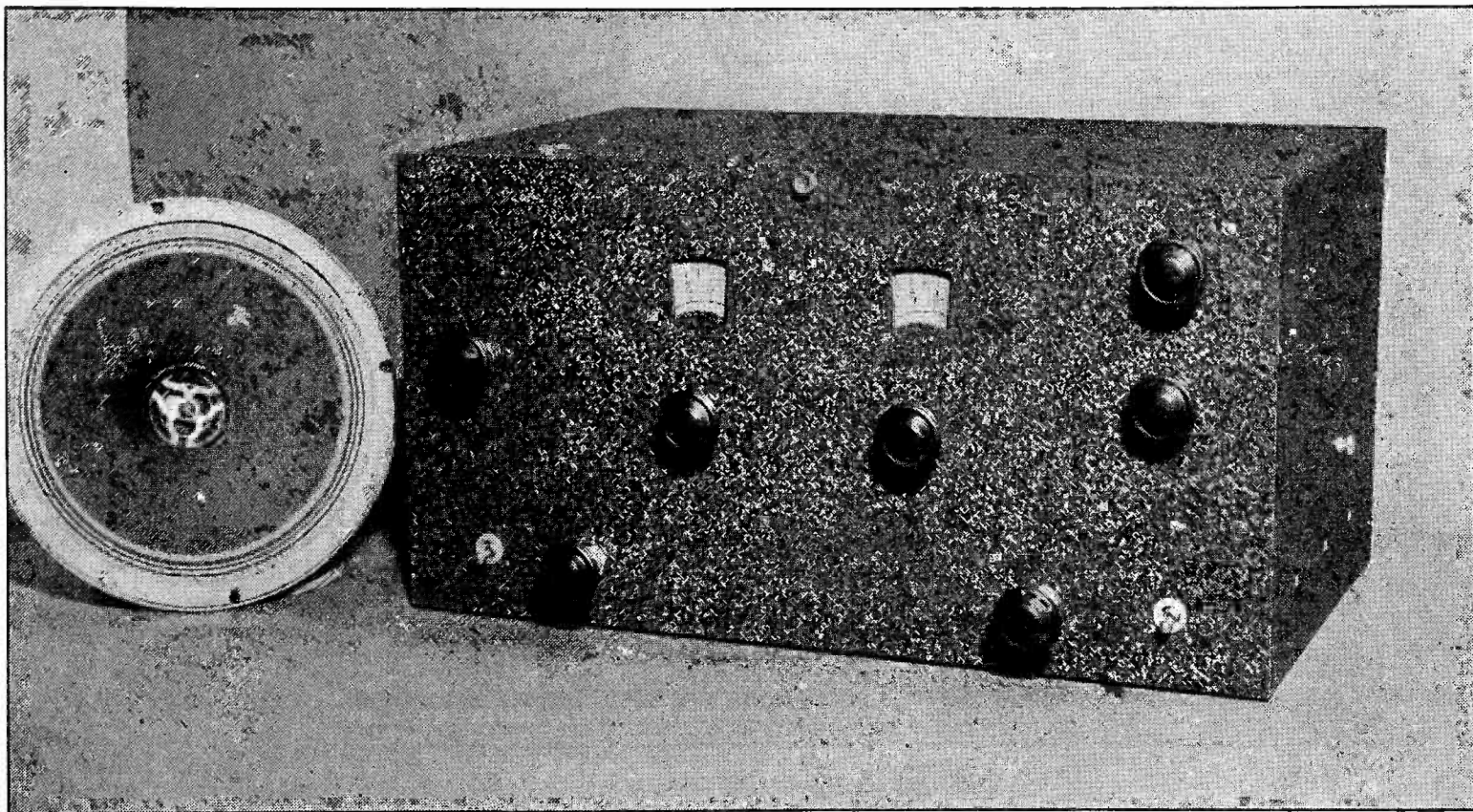

Compare Its Specifications Before You Buy—

Circuit—Eight-tube superheterodyne.

Tubes—'58 tuned RF, 2A7 1st detector—E.C. oscillator, two '58 tuned IF's, '58 audio beat oscillator, '56 second detector, '59 output, 5Z3 rectifier.

Range—1550 to 30,000 KC—five amateur bands on 1 dial.

Tuning—One main illuminated vernier tuning dial, smooth and easy, directly calibrated in megacycles. Band spread tuning *anywhere* in range—amateur, broadcast, commercial. 100 degree band spread 20 and 40 meters—200 degree spread 80 and 160 meters.

Wave Length Change—Same, positive, 6-gang wave change switch approved by Admiral Byrd and used in his four MASTERPIECE IIs.

IF Amplifier—Dual air tuned, Litz wire . . . 465 KC.

Beat Oscillator—Electron coupled '58. Beat note pitch adjustable from front panel.

Sensitivity—Better than one microvolt absolute.

Selectivity—Circuit designed, built and adjusted for crystal resonator, without crystal band width 21 KC 10,000 times down. With crystal, absolute single signal (50 cycles wide).

Power Output—3 watts undistorted. Supplied complete with Jensen dynamic speaker, and head phone jack on front panel.

Shielding—100% perfect, all parts individually shielded. Overall cabinet shield easily removable with 6 thumb nuts.

Price \$59.70

net to amateurs with eight guaranteed and tested Raytheon tubes. Each set complete with selectivity control, crystal switch, phasing condenser and crystal socket—ready for insertion of crystal. Add to above price \$9 net for Bliley crystal with holder, and complete crystal alignment—complete price, ready to go single signal with crystal, \$68.70.

SEND 3c stamp for new complete catalog describing above items, E. C. Frequency Meters, New Airplane Dials, Relay Racks, RF Chokes, Audio, Power and Filter Transformers, and a host of new and interesting amateur and commercial apparatus.

McMURDO-SILVER, INC.

3362 NORTH PAULINA STREET

CHICAGO, ILLINOIS

50-Watt "Junk-Box Special" Grid-Modulated Phone

(Continued from page 20)

modulation. Small variations indicate carrier shift, or unsymmetrical modulation, and large variations indicate overmodulation, either of which will cause unnecessary QRM.

A few words about the 211E. Its characteristics are about half way between the 210 and 211 types. Its plate dissipation is 65 watts and its amplification factor is 12. It has an oxide filament and is inclined to turn very blue at the least provocation. It has the virtue of cheapness and is rather easy to excite. The RF chokes in the grid and plate leads were intended to prevent the use of this tube at any but audio frequencies, but they offer little hindrance at frequencies below 2000 KC.

800 Watts of Carrier

(Continued from page 15)

the interference (heterodyne) radius of his transmitter nearly identical with the working radius. By the same token, his receiver should be better than the average so that he can work practically everyone who hears him.

The modulators are driven by a pair of 250's in push-pull, operating class A prime, through a 1:1 input transformer. The bias of 180 volts is supplied by batteries. The 354 modulators are rather easy on batteries because they draw quite a bit less grid current than 203A's or 849's when delivering 500 watts of audio power. The 354 modulators gave no trouble, but were replaced with 357's operating with all three grids tied together, in order to get away from batteries. By operating the 357 pentodes in this manner they become high mu triodes and require no bias on their grids. With the 357's in the circuit the input transformer from the 250's was changed to one with a 2:1 step-down ratio; the 357's at zero bias reflect back a much lower grid impedance than do the 354's. Little difference in output, efficiency or quality could be detected between the 354's and the 357's. The plate circuit of the modulators is coupled to the class C stage through a center-tapped choke with the lead to the RF stage tied directly to one plate. This method of coupling is superior to that which uses an output transformer as the leakage reactance which often reaches high values in conventional class B output transformers is kept to an absolute minimum through the use of the choke as shown. The final amplifier draws 500 mills at 2000 volts and represents a load of 4000 ohms. Thus the modulators work into a load impedance of

16,000 ohms from plate to plate. The load impedance is not critical when using 354's or 357's in class B; anything between 12,000 ohms and 24,000 ohms makes little difference in the driving power required. For those "idealists" who insist in matching their class B modulators to the last ohm, it is timely to state that the United Transformer Corp. will have available an output choke with a variety of taps which will allow almost any combination of impedances to be matched. The choke used by W6UF-W6CHE consists of 5,000 turns of No. 20 wire wound on a silicon core 2 3/4-in. x 2 3/4-in. The air-gap is 1/8 of an inch and 20,000 volt insulation is used. The inductance with no DC flowing is 92.5 henries.

The power supplies are conventional and need no special mention. The 2000 volt supply has extremely good voltage regulation with the normal current variation from about 600 mills unmodulated to 900 mills with 100% modulation.

One of the most prominent pieces of equipment in the station is the vacuum tube voltmeter which enables an exact determination to be made of percentage modulation, carrier shift and overmodulation. Sportsmanship demands that the transmitter be perfectly adjusted and operated; the use of 1 KW involves quite a responsibility to the rest of the amateur fraternity.

The New Metallic Tape Microphone

THE Metallic Tape Microphone is a new development of the highly efficient velocity or ribbon type and represents the latest engineering in a high quality Broadcast Microphone. It was developed primarily for studio recording and other applications requiring the very highest type of reproduction and full reliance may be placed in this instrument to reproduce with perfect fidelity all types of programs.

The Metallic Tape Microphone has an exceptionally strong magnetic field so engineered that full use is made of the entire strength of four large horseshoe magnets.

The case is unusually heavy and is made of cast aluminum accurately machined to close limits. The case houses the pick-up unit and the out-put transformer and acts as a perfect shield as well as a heavy, practically unbreakable case.

The sensitivity is unusual for this type of microphone due to the very high flux obtained by the four horseshoe magnets which are arranged in a perfectly symmetrical position.

Certain advantages are inherent in this type of microphone, it has none of the hiss of the carbon microphone, has no critical adjustments, is not subject to variation in humidity or temperature.

The Metallic Tape Microphone is substantially free from resonant peaks and has a low impedance which permits its use at a considerable distance from the pre-amplifier. It has marked directional characteristics enjoyed by no other type of microphone.

The Metallic Tape Microphone has a very fine frequency response covering efficiently all frequencies from 30 to 10,000 cycles with a practically flat curve.

MANUFACTURED BY

E. A. SCHLUETER

3382 62nd AVE.

OAKLAND, CALIF.

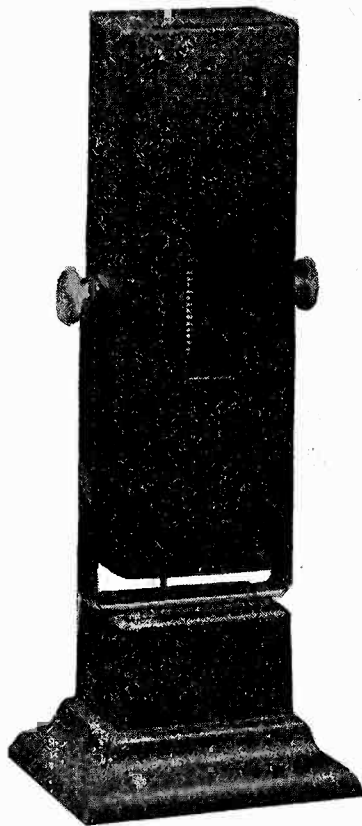

TYPE D 2

Directive Antennas

By DON C. WALLACE

(Continued from page 13)

It is astounding to note the improvement in signal strength ("R" reports) which you will get when you use a directive antenna, with the "beam" pointed in the direction in which you desire to transmit. Because this antenna is highly directional in one direction only, as shown in the diagrams, it behooves the amateur to build two or more such antennas so that transmission in various directions can be made. Obviously, such a system calls for ample wide-open space. The directive antenna shown is now in use at W6AM and has enabled me to get R/9 reports from stations which formerly gave me R/4.

The directive antenna, like any antenna, gives equally good results for reception as for transmission. If it is sloped, the directive effect is stronger in the direction of the slope. If the angle of separation is not as shown in the diagram, the directive effect will be greatly minimized. Being a powerful radiator in the line of direction of transmission, it is an equally poor radiator in other directions; it is only about 5% as effective in directions other than the one in which the beam is pointed.

What to Invent—By "Jayenay"

I WISH someone would invent a class C audio amplifier whose output wave shapes would resemble the input wave shapes. A single 852 could then modulate a 1000 watt phone. If that is too much trouble, then invent a class A, voltage driven, audio amplifier that is 80% efficient. If you are still too lazy to do that for me then show me how to "compress" all the audio frequencies into a single tone, say 1000 cycles; and then "decompress" the tone at the receiver so that the original audio frequencies are again present to operate the loud speaker. Simple, my dear Watson!



C. Q.

D. E.

And now, STANCOR Transformers for AMATEUR BROADCAST

You "hams" are the most particular buyers in this whole radio business, you know what you want and the maker of equipment that doesn't meet with your ideas of what it should be is sure enough on the spot.

That's the biggest reason why you're going to go for STANCOR Transformers for Amateur Broadcast—because they're your kind of material.

You know, STANCOR Transformers for replacement . . . for renewing the performance of receiving sets had established a reputation for making the best of that type of transformer available to the service man . . . for being responsible for more of the worthwhile developments in

that business than any other single manufacturer in the business.

So, when "hams" all over the country, doing service work and using STANCOR Replacement Transformers, asked so often for STANCOR Transformers for their stations, STANCOR had an unusual field in which to experiment and from which to add to the experience of its own highly specialized engineers.

And now, STANCOR Transformers for Amateur Broadcast are ready for you, after more than a year of developing, rejecting, rebuilding and redesigning . . . complete sets of transformers for the beginner and for the advanced amateur who is adding more or changing to 'phone transmission . . . a STANCOR Transformer for whatever tube may be desired to use.

Send for the new 1934 STANCOR catalog illustrating and listing twenty pages of STANCOR Transformers designed and built for your special and particular use.

**Standard Transformer
Corporation**

860 Blackhawk St., Chicago, Ill.

WIRES and CABLES

FOR EVERY RADIO NEED

Whether you are building a "Super" or servicing a customer's set, you can always depend on Consolidated Radio products to fulfill your every requirement perfectly.

Send today for circular containing valuable wire data and listing of Consolidated products. Address

**CONSOLIDATED
WIRE AND
ASSOCIATED
CORPORATIONS**

Peoria & Harrison Sts., Chicago, Ill.

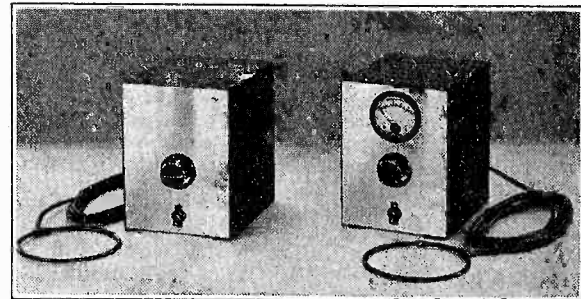

MIXER—MONITOR

The real way to listen to your transmitter. Not a frequency checker, but a listening monitor with a he-man output. For c.w., or for phone, and a good code oscillator besides.

Ask your dealer, or write direct

G. F. LAMPKIN LABORATORIES
146 W. McMillan St. Cincinnati, Ohio

USE THIS COUPON TODAY

Send me at once your new 1934 STANCOR catalog of Transformers for Amateur Broadcast.

NAME.....

ADDRESS.....

CITY..... STATE.....

CALL LETTERS.....

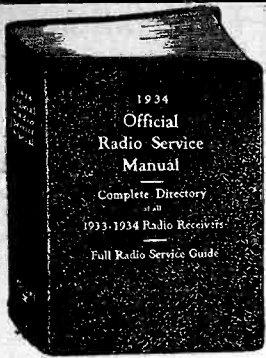

FREE

1934 Official Short Wave Radio Manual
1934 Official Radio Service Manual



FREE WITH ARCO TUBE PURCHASES, you may select a 1934 OFFICIAL SHORT WAVE RADIO MANUAL which sells for \$2.50 with your order amounting to \$8. If you prefer you can get FREE, the 1934 OFFICIAL RADIO SERVICE MANUAL which sells for \$3.50 with orders amounting to \$10.00 or both manuals for orders of \$17.00.

THIS OFFER IS SUBJECT TO WITHDRAWAL WITHOUT NOTICE

Complete Stock Ready for Immediate Shipment
Order from this page—Remit 20% with order, balance C. O. D. All prices are F.O.B. FACTORY, Newark. Shipments go forward express or parcel post. No order for less than \$3.00 accepted.

Type No.	Fil. Voltage	Your Cost	Type No.	Fil. Voltage	Your Cost
00A	5.0	.40	82	2.5	.85
01A	5.0	.30	83	5.0	.85
1	6.3	.85	84	6.3	.85
10	7.5	1.10	85	6.3	.60
12A	5.0	.40	89	6.3	.60
20	3.3	.40	X199	3.3	.40
22	3.3	.85	V199	3.3	.40
24A	2.5	.40	2A3	2.5	1.10
26	1.5	.30	2A5	2.5	.85
27	2.5	.30	2A6	2.5	.85
30	2.0	.60	2A7	2.5	1.10
31	2.0	.60	2B6	2.5	1.10
32	2.0	.60	2B7	2.5	1.10
33	2.0	.85	5Z3	5.0	.85
34	2.0	.85	6A4	6.3	1.10
35	2.5	.60	6A7	6.3	1.10
36	6.3	.60	6B7	6.3	1.10
37	6.3	.60	6C6	6.3	.85
38	6.3	.60	6C7	6.3	.85
39	6.3	.60	6D6	6.3	.85
40	5.0	.40	6D7	6.3	.85
41	6.3	.60	6E7	6.3	.85
42	6.3	.60	6F7	6.3	.85
43	25.0	.85	6Y5	6.3	.85
44	6.3	.60	6Z3	6.3	.85
45	2.5	.40	6Z4	6.3	.85
46	2.5	.60	6Z5	6.3	.85
47	2.5	.60	12A5	6.3	.85
48	30.0	1.10	12Z5	6.3	.85
49	2.0	.85	25Z5	25.0	.85
50	7.5	1.10	12Z3	12.6	.85
51	2.5	.60	182B	5.0	.85
53	2.5	.85	183	5.0	.85
55	2.5	.60	401	3.0	1.50
56	2.5	.60	403	3.0	2.00
57	2.5	.60	484	3.0	.85
58	2.5	.60	485	3.0	.85
59	2.5	.60	586	7.5	2.10
71A	5.0	.30	686	3.0	.85
75	6.3	.85	866	2.5	2.75
77	6.3	.85	PZH	2.5	.85
78	6.3	.85	WD11	1.1	.60
79	6.3	1.10	WD12	1.1	.60
80	5.0	.40	216B	7.5	.85
81	7.5	1.10	213	5.0	.60

RECTIFIER AND CHARGER BULBS

125 Mil. rectifier tube B.H. (Raytheon type)	\$1.25
6-10 Amp. trickle charger Bulb (Tungar type)	2.00
2 Amp. charger Bulb (Tungar type)	2.00
5 and 6 Amp. charger Bulb (Tungar type)	3.75
15 Amp. charger Bulb (Tungar type)	7.50
UX-280M—5.0 Full Wave Mercury Vapor Rectifier	1.10
VX-281M—7.5 Half Wave Mercury Vapor Rectifier	1.90
UX-871—2.5 Half Wave Mercury Vapor Rectifier	1.10
UX-872—7500 Volts Half Wave Merc. Vap. Rec.	11.00

TELEVISION TUBES and PHOTO ELECTRIC CELLS

Photo Cell (Potassium), 2 1/2" Length Overall	\$1.75
Photo Cell (Potassium), 3 1/2" Length Overall	2.10
Photo Cell (Caesium Type), 4 1/2" Length Overall	7.90
Photo Cell (Caesium Type), 3" Length Overall	5.90
Photo Cell (Caesium Type), Same as UX-868	4.90
Television Tube (Neon Reflectron), 1" Sq. Cathode	2.85
Television Tube (Neon), 1" Sq. Cathode	2.85
Television Tube (Neon), 1 1/2" Sq. Cathode	3.85

Specifications and quotations on TRANSMITTER TUBES, CRATER TUBES, GLOW LAMPS, HIGH VACUUM TYPE CATHODE RAY TUBES, suitable for television and standard oscillographic uses, SUBMITTED ON REQUEST.

ARCO TUBE COMPANY

232 Central Ave.

Newark, N. J.

The Banehawk Superheterodyne

(Continued from page 5)

the high-frequency portion is at the very bottom where the controls are accessible for tuning. Contrary to a fallacious belief by many, the rack is not a full length one, but is a 36-inch table rack, made by Western Wireless. The controls for tuning are about three inches above the level of the table. To one using a rack receiver for the first time the idea may seem awkward, but it is convenient and flexible means for tuning a complicated receiver.

We cannot close this series without mentioning something about the little McMurdo-Silver amplifier used in all of the preliminary experiments. This unit has worked beautifully and is heartily recommended to the man who does not care to build his own. It has a great many of the desirable features mentioned in this article and it has as much gain as any similar but more complicated unit we have ever used.

Class B-Prime Grid Modulation

(Continued from page 11)

bias supplied by the cathode resistor will generally be about twice the fixed bias. This is based on the assumption that three times cut-off will be about the right bias for average plate loads, efficiencies and excitations. However, this amount will vary with the individual transmitter and roughly the resistance of the cathode bias resistor will vary inversely with the mutual conductance of the tube, for a given interval of plate current flow in the amplifier plate circuit. The bias resistor should have about 25% more resistance than that calculated from the plate current in order to allow for leeway in the final adjustment. The probable plate current can roughly be estimated by multiplying the plate dissipation of the stage in watts by 1.66 (40% eff.) and then dividing by the total plate volts, less twice cut-off bias.

Couple the antenna rather tightly to the amplifier and increase the coupling from the driver until the plate current equals the estimated value calculated above, or until the plate shows color, which will probably occur first. Loosen the antenna coupling a bit and again increase the excitation. Continue this until the plates just start to show color at the previously estimated plate current. It is preferable to have the antenna coupling as loose as possible, consistent with proper plate current and output. The linearity of the amplifier increases as the load increases.

When the plates just start to show color at the estimated plate current, correct the fixed bias for true cut-off, and then vary the cathode resistor until modulation causes the least possible change in plate current. This latter adjustment may slightly change the actual value of the plate current and a slight readjustment of the excitation may be necessary. When properly adjusted, the unmodulated plate efficiency should be higher than 38%, given a reasonably high plate supply voltage, and can be as high as 45% with ideal, but entirely practical circuits. With 100% modulation, with a PURE tone, the antenna current should rise the well-known 22%, and up to 90% modulation the plate current should not vary by more than 2%. However, under voice modulation the antenna current will vary less than 5%.

Users of ALL types of grid modulation should be warned that it is very easy to have non-symmetrical modulation (carrier shift) if the RF excitation is too high or too low. This condition will be indicated by variation in the plate milliammeter during modulation, and makes a transmitter particularly suscept-

(Continued on page 32)

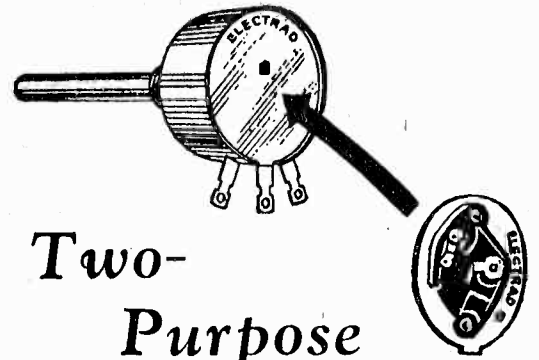

Two-Purpose VOLUME CONTROLS

A STANDARD volume control, or combined with power-switch. Just snap out the plain end cover and snap in the switch assembly. All done in a moment without disconnecting wiring. A great time and labor saver in replacement work. Only five types in the service kit will fit 799 standard receiver models. Long ALUMINUM shafts easily cut to desired length.

FREE Vest-Pocket Volume Control Guide

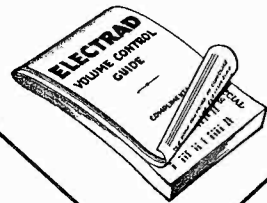

Write Dept. PR-6

For Complete New Catalog



SANGAMO Accurate Condensers

These condensers are ideal for shortwave equipment. Tested at 2500 and 5000 volts for use in small radio transmitters. For maximum efficiency use these low loss units.

Write for catalog sheet

SANGAMO ELECTRIC CO.
SPRINGFIELD, ILLINOIS



HERE THEY ARE!

Really Portable Transceivers With Battery Space in Same Case

This feature will be appreciated by anyone doing serious 5 meter work in the field.

SOLD AT PRICES YOU WOULD LIKE TO PAY—BUT NOT BUILT DOWN TO THOSE PRICES.

NATICO transceivers can be supplied in three models, all of which have the same outward appearance.

Type TR-1 Battery Model **\$10.95**

(less tubes and batteries)
This NATICO 5 meter transceiver is strictly portable allowing two way communication even when being carried. This is accomplished by the fact that the two dry cells and 90 to 135 volt B battery are self contained in the one case. TUBES REQUIRED: One 30 and One 33.

Type TR-2; Mobile Model **\$11.95**

(less tubes, batteries or eliminator)
Specially designed for automobile use or wherever a 6 volt battery is available. The case has sufficient space to hold the 135 to 180 volts of B battery or a 6 volt B Eliminator which eliminates the necessity of all B batteries. TUBES REQUIRED: One 76 and One 41.

Type TR-3: AC Model **\$16.95**

(including power supply, less tubes)
Here you have a portable A.C. transceiver which includes power supply in the same case (size only 6 1/2" x 7 3/4" x 12 7/8"). It can be operated anywhere that 110 volt A.C. is available. TUBES REQUIRED: One 76, One 41 and One 80.

ACCESSORIES

Matched tube kits for—

TR-1	\$1.95
TR-2	1.75
TR-3	2.15
6 VOLT B ELIMINATOR FOR TR-2.....	\$11.50

NATICO'S EXCLUSIVE DISTRIBUTORS

GROSS RADIO, INC.

51 VESEY STREET, DEPT. PR, NEW YORK CITY, N. Y.

CONCOURSE CONDENSERS

USED BY RADIO MEN WHO KNOW SUPERIOR PRODUCTS

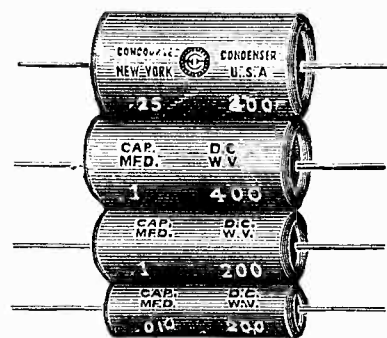

The "Peewee" Wax Paper Tubular Condensers recently announced by us, so superior in construction, the smallest on the market.

NOW ANOTHER NEW ACHIEVEMENT

600 Volt Peak Dry Electrolytics in the Smallest Possible Dimensions.

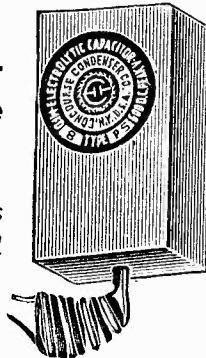

With the usual Concourse Super Quality these new Midget Condensers and our extensive line of low voltage units for AC-DC Receivers are ideal for replacements in any standard sets or in new models.

A TIMELY SUGGESTION

Use Our Spark Suppressor Condensers, Built to withstand the High Temperature and Vibration of Any Automobile. Ruggedly Constructed.

Write for Our New Free Catalog

CONCOURSE CONDENSER CO. 387-411 Wales Ave., New York

MICROMETER FREQUOMETER

The latest in amateur frequency meters—it has a micrometer for a dial.

Amateurs over the country say "I can set and read frequencies 'on the nose' as never before."

The MFM is all a.c. operated, comes complete, ready to use, and is engineered to have a stability and permanence on a par with the precision of the micrometer.

—Technical data on request—

G. F. LAMPKIN LABORATORIES
146 W. McMillan St. Cincinnati, Ohio

SMITH-PRECISION CRYSTALS

Full-sized, specially ground X cut crystals; powerful, accurately calibrated, single-frequency oscillators. Unconditionally guaranteed.

3500-4000 kc/s—Close to Frequency,	\$2.35
7000-7500 kc/s—Close to Frequency,	\$3.95
3500-4000 kc/s—To Exact Frequency,	\$2.90
465-525 kc/s—S.S. Filters X Cut...	\$2.60

Postpaid by airmail.

Commercial Frequencies at Attractive Prices.

W. W. SMITH W6BCX

Pioneer Manufacturer of
Fine-Quality Piezo Plates

215 West Cook Santa Maria, Calif.

Class B-Prime Grid Modulation

(Continued from page 31)

ible to overmodulation. The variation in the plate milliammeter is almost directly proportional to the percentage of distortion. A vacuum tube voltmeter is a handy instrument for reading percentage modulation and costs but little.

On the whole, grid modulation of a Class B Prime amplifier can be highly satisfactory if care is taken to see that it is properly adjusted.

Does grid modulation cost more or less than plate modulation, for a given carrier output? Let us take a 300 watt carrier as an example. With plate modulation, 400 watts and more of plate input (75% eff.) is required. At any rate, it means that 100 watts of dissipation must be available. The modulators for such a 400 watt input would probably consist of a pair of 50 watters in class B. Another 200 watts of dissipation. Total 300 watts of tubes, plus a class B output transformer and an 800 watt power supply with the usual class B regulation. I am assuming that the class B drivers would act for both sides by becoming the modulators for the grid modulated stage.

To get 300 watts of carrier with grid modulation at 40% plate efficiency requires 1.5 times 300 watts, or 450 watts of available plate dissipation in the tubes. This is 150 watts more plate dissipation than was required by the plate modulated stage, but no class B equipment with its many sources of grief is needed, and the power supply need deliver only 750 watts constant input. Thus regulation is unimportant. Grid modulation has a great advantage over plate modulation for simplicity of equipment and all of the equipment can be used when the operator changes over to CW. Of course, if you want to get all the carrier you can for 1 KW input, that is another story. But how many do? Plate modulation was given all of the "breaks" in the above comparison in order to choose one of the most economical tube combinations possible with plate modulation.

Directive Transmission

(Continued from page 12)

should someday in the future give the public a description of his selective use of beams over short distances, providing secrecy to communications. Aeronautical engineers have caused American radio engineers to develop beams to a point where we exceed the Europeans. This is probably due to the greater terrain, and wider selection of apparatus. In future articles attempts will be made to discuss some of the simpler but practical methods of beam transmission applicable alike to commercial usage and to amateurs. Some of the titles of books and magazines were abbreviated, so there follows an explanation of these abbreviations with full names:

Phys. Rev.—Physical Review (U.S.)

Phys. Zeit.—Physikalische Heitschrift Zeitschrift

(German).

Jahrb.d.Draht.—Jahrbuch Zeitschrift fur Drahtlose Telegraphie und telephonie Sowie des Gesamtgebietes der Hochfrequenztechnik. (German).

Peaked Audio Amplifiers

THE widespread use of SS supers represents a development much to be encouraged. Due to the fact that a fixed beat oscillator is used, all signals that are received on the crystal "peak", are heard at the same audio frequency. As long as this is the case, why not use the old peaked audio amplifier to further improve overall selectivity?

Progress

Ed Wynn claims that the Radio will never replace the horse.

SHALLCROSS WHEATSTONE BRIDGE

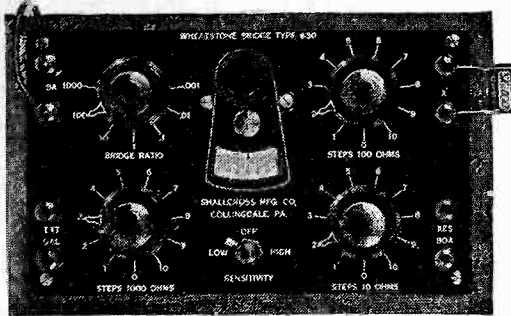

Built around a highly sensitive galvanometer and Shallcross Resistors. Range .01 ohms to 11.1 Megohms.

Send for Bulletin 630-B describing this instrument
SHALLCROSS MFG. CO.
COLLINGDALE, PENNA.

LEARN CODE AT HOME

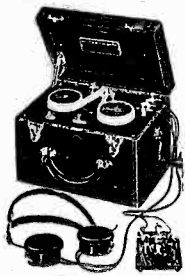

Easy—Efficient—Quick

The Instructograph is the ideal method to correctly master the code. Complete outfit can be rented for as low as \$2.00 per month, and can be applied on purchase price if desired.

Get started now and become a full fledged Ham. Write for interesting circular.

INSTRUCTOGRAPH CO.
914 Lakeside Place, Chicago, Ill.



Write today for instructive bulletin.

4503 Ravenswood Ave.
Chicago, Ill.

Low Range FUSES

INSTRUMENT LITTELFUSES
1/100, 1/50, 1/25, 1/8, 1/4, 3/8, 1/2, 3/4, 1, and 2 amps, positively protect meters, radios, amplifiers, etc. Also made in 1000, 5000, and 10,000 volt ranges for broadcast equipment, etc. \$100 Protection Guarantee. There is a distributor near you.
LITTELFUSE LABORATORIES

LATEST IN "B" POWER

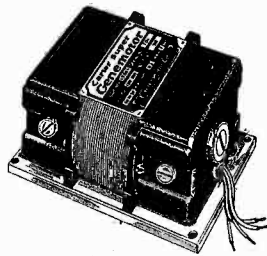

Smallest unit on the market. 2 3/8" wide, 4" high by 5" long. This complete Genemotor furnishes up to 200 volts D.C. Operates from 6 volt storage battery. Ideal for Auto, Airplane or Battery Radios, and Portable Amplifiers.

Write for details and prices on this and other types.

CARTER MOTOR CO.

365 W. Superior St.

Chicago, Ill.

QSL's

We make every effort not to see how cheaply QSLs can be made, but to make the finest available funds for the work permit. At your request, you will receive a few samples—ideas of others—and prices. See what improvements you can make upon them, and let us create your ideal!

CHAS. E. SPITZ
BOX 1804 (W6FZQ) PHOENIX, ARIZ.

For better and longer service, better filtration with no current leakage,

**Use G-H PAPER WOUND
ELECTROLYTIC REPLACEMENT
CONDENSERS**

GIRARD-HOPKINS, Oakland, Calif.

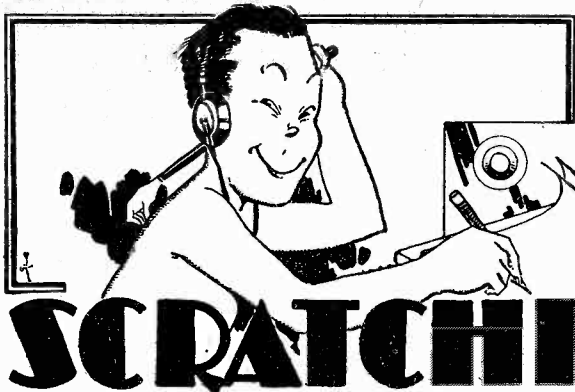

Oscokme, Japan.
April 23rd, 1934.

Respectful Ed.
Dear Editor:

I must hasten with report to you from first great hamfest which amateurs here in Japan have successfully put forth. Such hamfeeds are troublesome thing for one man to conduct, as all other sixty-seven committee members do nothing but sit on something and yap instructions as how chairman of hamfest shall conduct such great affair. Which result in one man doing all of laborious work and all other members then roastpan him for cold cow meat which are usually cooked two months before hamfest take place. I have been seeking source of information leaks to kitchen cooks who get tipoff on dates for such hamfests, and always make prepare for serving most terrible food to great gatherings of amateurs with iron hearts and wooden stomachs. On bill of fair for our hamfest we are served with such luscious foods as chicken-a-la-can, cold slaw mixed with ohm slaw, tomatoe soop which taste like red led, hamburger stake which is so thin it look like it wear tights, and sundry other knick-knacks and I scream Sundays.

Forewarned warning have been furnished me as chairman for hamfest that far better I should make arrangements with good independent caterer to supply food for stomach and thought instead of asking big hotel tiecoon to use own poor judgment in arranging bill of fair. With consequence I make hoof to nearby preofessional catering establishment on front of which are large glassy window with sign which read "Constance Snell... Caterer To The Elite". But when I walk into such establishment I whiff peculiar odor coming from kitchen in which Chinese cook burn large stick of insense. I walk into kitchen and ask of him, "Do I smell Chinese Insense?" And he say back to me... "NO, YOU SMEL PUNK".

Proprietor of establishment then come in to greet me with outstretched palm and offer to escort me to place where food is cooked. I do not stay long, and when I remove myself from establishment, I tell proprietor he should make change of name on sign on window and instead of have on sign such words as Constance Snell, he should be more honest with peepul and make it read Constant Smell.*

I then solicit aid from advertising expert who know much about exaggerated phrases to put on mailing circulars to make sure of great and profitable attendance. He say to me to put on top of circular that all great executiffs of amateur organizations make personal appearance in own flesh at hamfest and that all opponents of such will also make attendance, and great amateur rally shall commence which conclude with march on Tokio to dethrone powerful commical radio zear and replace him with big shot radio amateur who will run communication department with free wide open channels for amateurs to use on any frequency which make self help to, cafeteria style.

Results from mailing such circular to all amateurs bring terrific response and meeting hall for hamfest are filled with overflowing like packed sardine can. Honorabull chairman of hamfest get up and announce he are ready for any question. First question come from man who hang from ceiling and ask, "How is the weather in Hartford?" To wit come reply from chairman,—"Windy and Warner". Next come hand raising from man who say he wish to take stump and make speech, but he forget bring stump with him, so will make speech next time. Continuous progress are being made and vital issue immediately come up for question. Proposal are read for making invitation for grand roundup of hundred thousand people to come into 5 meter band where they can make study of amateur radio and soon become promoted to 40 and 80 meter bands and keep other amateurs company because 40 and 80 meter bands are so dead at present time. Such proposal bring forth reading of report by great amateur spokesman who say his organization have no intention of permitting hundred thousand 5 meter newcoming people to use anything but 5 meter bands but he do not say what are going to stop such cavalcade from quickly learning radio ham code and make stampede for other amateur bands. Scratchi get up and make suggestion that present amateur bands should better be made from rubber, so can stretch
(Continued on page 34)

* Editor's Note: This is an actual from-life incident which took place in San Francisco more than 15 years ago. Constant Snell, The Caterer, is still doing business at the same old stand.

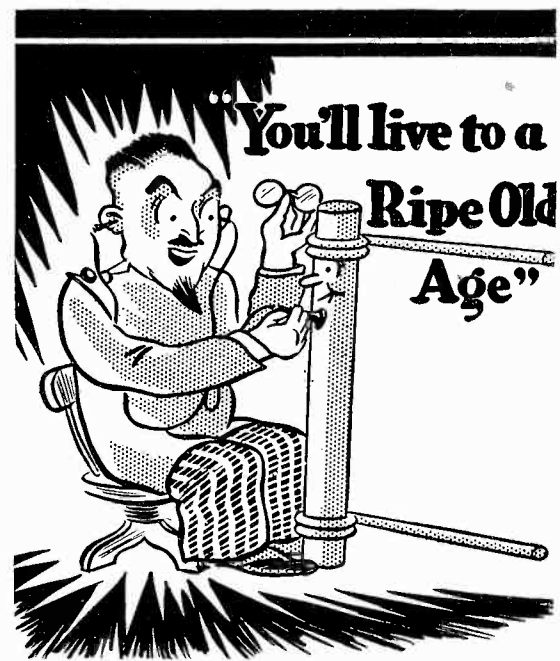

Nothin' wrong with this boy. If you ask us he's a tough hombre... he ought to be... for he was Baptized with Fire at 2700 degrees and he's vibration proof, heat proof and moisture proof.

On that next replacement job try a **CENTRALAB FIXED RESISTOR** and note the difference.

Good business too... for the customer won't be coming back with a squawk.

At your jobber...

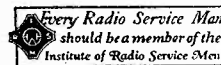

Centralab RESISTORS

CENTRAL RADIO LABORATORIES
MILWAUKEE

McCorkle Crystal Oven

Dependable Control to less than 1/2° C. **\$8.75** plus transp.

Write for details

McCORKLE CONTROLS, INC.
6TH & BANCROFT WAY BERKELEY, CALIF.

Sockets

The socket in your set is one of the least expensive parts that you buy—

Therefore, you should insist upon sockets that have a reputation for lasting satisfaction.

OAK Sockets are now used by the great majority of leading set manufacturers.

4, 5, 6 and 7 Prongs.

Write for descriptive sheets and prices, or see your jobber.



OAK MFG. CO.
711 West Lake St., Chicago, Ill.

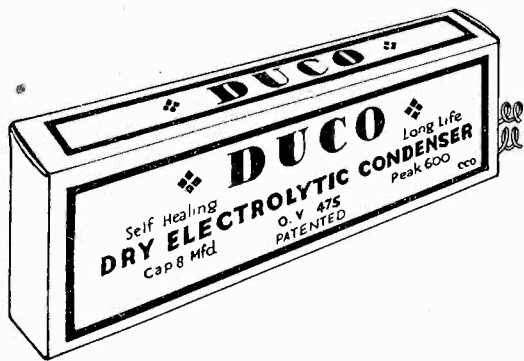

DUCO

"Best by Test"

All DUCO Condensers fully guaranteed for one year.

IN NO OTHER CONDENSERS DO YOU FIND THESE FEATURES:

1. Duco condensers are positively self-healing, even up to 3000 volts.
2. Better and longer life than the wet electrolytic condensers.
3. Smaller in size than any other make on the market.
4. For economy in costs it has no equal.
5. DUCO condensers in use over six years showing long shelf and use life.
6. All condensers are rated very conservatively.
7. Growing faster than any other make.
8. Used by best service men in the world.
9. Adopted by finest engineers of set manufacturers.
10. Guaranteed for one year.

DUCO CONDENSERS are fully protected by patents and patent applications all over the world. The response since we introduced our new condenser has been remarkable.

You, too, will be surprised at its performance.

Send for Free Catalog
Sales and Jobber Territory Open

Mfgd. by

**DUMONT
ELECTRIC CO.**

453R Broome Street

New York City, N. Y., U. S. A.

TUNING CONTROLS

FOR RADIO SET MANUFACTURERS

New Airplane Type
in Ten Styles

More Than 50 Kinds Shown in Our Catalogs
Also Escutcheons, Cabinets, Name Plates and Other
Specialties

Write for Catalog

**REMOTE CONTROLS
FOR AUTO RADIOS**

EXPORT ORDERS RECEIVE SPECIAL ATTENTION
Cable Address—CROWNAME CHICAGO

Jobbers and Dealers Find Our Line Profitable

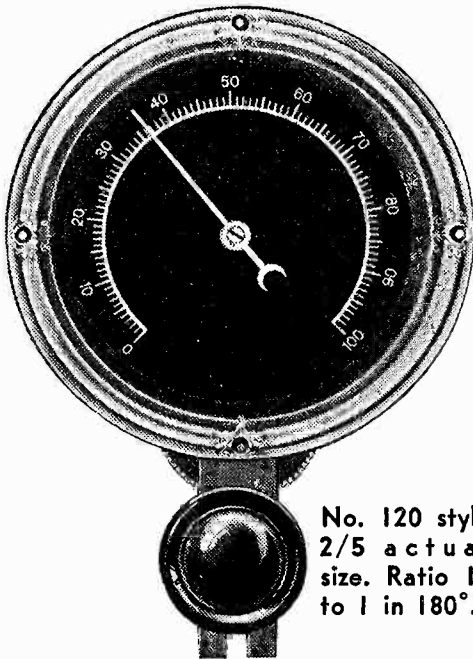

CROWE NAME PLATE & MFG. CO.

1755 GRACE STREET

Established 35 Years

CHICAGO, ILL., U. S. A.

Pacific Coast Representative, W. BERT KNIGHT, INC.

TRIMM PHONES



designed to meet your specific requirements.

If the product you are designing or marketing requires a headphone, make sure it is one that will give the utmost in performance and service.

TRIMM PHONES represent the highest in quality and efficiency because they are made for your individual need. We have a phone for every purpose. Our engineers will be glad to assist you.

TRIMM RADIO MFG. CO.
1528 Armitage Ave. Chicago, U. S. A.

QUALITY

at a Price You Can Afford to Pay!

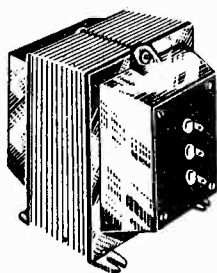

**FRANKLIN
Transformers**

Very conservative ratings on Transformers and Chokes for every Amateur Station.

"MOST SOCK PER DOLLAR"

Write for Catalogs

FRANKLIN TRANSFORMER MFG. CO.
607-609 22 Ave. N.E., Minneapolis, Minn.

DX News

(Continued from page 28)

reception must be made in accordance with the conditions in Rules 4 above,

6. VK receiving stations cannot include VK transmitting calls in their logs, only foreign. Foreign stations will enter-up VK station heard only.

7. The awards in the transmitting and receiving contests will be similar. The winning VK receiving station will be awarded a cup, providing he is a member of the W.I.A. or its affiliated societies.

8. Receiving logs are to be similar to the transmitting logs.

"RADIO",
San Francisco.
Gentlemen:

We have read in "RADIO" the discussion concerning what can really be counted a dx country and the discussion about the number of countries certain stations have contacted. We enclose our list of countries contacted and would like to have it published in "RADIO" in order to get some discussion started. (Editor's Note—See Globe Girdler page in this issue.)

We claim to have worked more countries than any other W station. Our list of 103 countries we believe to be made up of actual dx countries. We have not counted islands which are really part of a country already counted; Tasmania for instance is not counted because Australia has been counted.

W3ZJ-W3SI is the combined station of Tom Hall who is also licensed as W3DX and Charlie Myers also licensed as W3CCF.

W3CCF was the world's leading station in the 1932 International Good Will Tests.

W3ZJ with 34,000 points is certain to be the world's highest scoring station in the 1934 Relay Competition.

Both operators have been awarded WAC certificates and claim to be the only W station to have contacted all continents on fone. No WAC on fone has been secured yet as each operator lacks one confirmation.

Well, anyway, you will find the list enclosed. So wishing you lots of luck and success.

73

(Signed) Charlie Myers, W3SI.
Tom Hall, W3ZJ.

Scratchi

(Continued from page 33)

far apart before more people become invited into present amateur inferno.

Matter come to abrupt close when chairman announce free raffle drawing of many thousand yen worth of amateur prizes.

First prize are mammoth big transformer which amateur from stix are luck winner of, and which cost him twice as much to ship home as can buy transformer for in store in own town.

Second prize are hundred foot antenna pole which chairman hand to growing boy who work for growing concern, and then tell him to have pole wrapped up and carry home with him.

Third prize are assortment of grid leak drip pans and fourth prize are pair of large switches for connect in series with antenna lead and pull switches out when desire to make receiving set more free from interference.

Chairman then announce sudden cessation of raffle drawing because all rest of prizes have mysteriously make disappearance. Investigation committee are organized to inspect all, amateur stations in nation to see where missing parts have found new home, or if such parts were stolen by slick hamfest visitor who then sell them back again to unsuspecting owners of store which donate the prizes.

I am making rounds of all amateur stations and stores, Mr. Editor, to look for stolen parts. I take advice from great writer who say keep your nose to the ground, but I soon get snoot full and hoping you are doing the same, I am,

Your successful hamfest promoter,
Scratchi.

A Hum Hint by "Jayenay"

THERE are about 66,729 possible sources of unwanted hum in a ham phone, but one of the more common ones is often overlooked. **GROUND THE MIKE.** When I say ground the mike, I don't mean to attach a ground to one side of the mike battery which is fifteen feet away under the table; put a special, and short connection from the mike frame to a separate ground. A good test for an ungrounded mike is to touch the frame with your tongue. Yes, I though so! you got bit, didn't you? Any trace of RF at this point means that there is probably some hum being picked up as well, so try this before scattering various and sundry parts over the shack trying to locate that last bit of hum.

100,000 New Amateurs Wanted

(Continued from page 4)

All of Warner's talk about "making amateurs of a very high type" out of people to whom "learning the code is an insurmountable obstacle" is the veriest cant. By it he indicates his own measure of the mentality of the ARRL directors.

Warner is afraid, so he says, that if the ARRL does not join in the RCAR project for making "amateurs" out of the general public some other amateur group or radio publisher will sponsor it.

"RADIO"—if Warner means us—will not father any commercial corporation's project to use the amateurs for building up a market by flooding any of the amateur bands with "amateurs of the highest type" to whom "learning of the code is an insurmountable obstacle." "RADIO" is a "business", but it is not that kind of a business. It is not in the shady business of massaging the amateur's head with one hand while pulling his leg with the other.

The RCAR, too, is a business. Its present project is a legitimate business plan for selling its goods, and it is justified in using every legitimate means for promoting its business. It is 'good business' on its part to use the amateurs or any other group to further its business plans. But amateur radio is not a business. And any man who claims to speak for it who proposes swarming amateur territory with business-manufactured "amateurs" is deserving of our indignant distrust.

There is no reason why the RCAR should not expect the support of the ARRL. There is no reason why the ARRL should not give it. But in Heaven's name let the partnership be open and above board! Let the ARRL and the RCAR join hands in this money-making venture, as suggested by Warner. Let them together make money out of their partnership. Let them make a host of new radio enthusiasts, since that is what Warner wants. And let the big end of the combination—the commercial people—provide space on the air for this new type of codeless "amateur" by transferring to him some of their own frequencies for which they have no practical use, instead of adopting Warner's suggestion that the amateurs provide the space by surrendering one of our own bands!

But let us not call "amateurs" these purchasers of ARRL booklets on "five meter stabilized voice equipment" to whom a code learned by twelve-year-old children is an insurmountable obstacle. Let us not call their activities amateur radio. If it needs a name, call it Citizen Radio. And if the ARRL wants to fill its membership with this class of enthusiasts let it call itself the Citizens Radio Relay League. The ARRL ownership is already too polyglot to stand the partnership relations of still another class that is non-amateur.

Asserting that there is growing pressure for the right to engage in amateur radiotelephony without knowledge of the code Warner says, "Some day this effort unquestionably will succeed." This sounds strangely like my own words that have been quoted several times in the press, "Some day the public will learn that it, without any technical training, can use fone sets to talk with one another over the air; and when that time comes the public will rise up and say, 'This is our air and we are going to use it for our own purposes—not permit it to be monopolized by a few commercial corporations for their private profit!'"

I think that time will come. But it will come normally—if it comes at all—and not through any scheme promoted by a combination of licensed amateurs and the very people who have forced the amateurs into their present meagre bands. Not by a combination of the ARRL and the commercials to high-pressure the public into radio by kidding the peo-

24 YEARS OF LEADERSHIP!

THE prestige of Hammarlund Condensers was firmly established in 1910, when radio as we know it today was but a dream.

And the basic refinements which then made Hammarlund Condensers the choice of radio pioneers now make them still the unchallenged preference of today's leaders, who really know what good condensers should be.

They have changed in design, of course, according to the needs of the times. But the one thing which remains as fixed as Gibraltar is their *quality*.

Whether your condenser requirements are for receiving or transmitting, balancing, trimming, equalizing, padding or what not, remember there is a Hammarlund model to fit your exact needs—moderately priced and backed by a name and resources which guarantee your complete satisfaction.

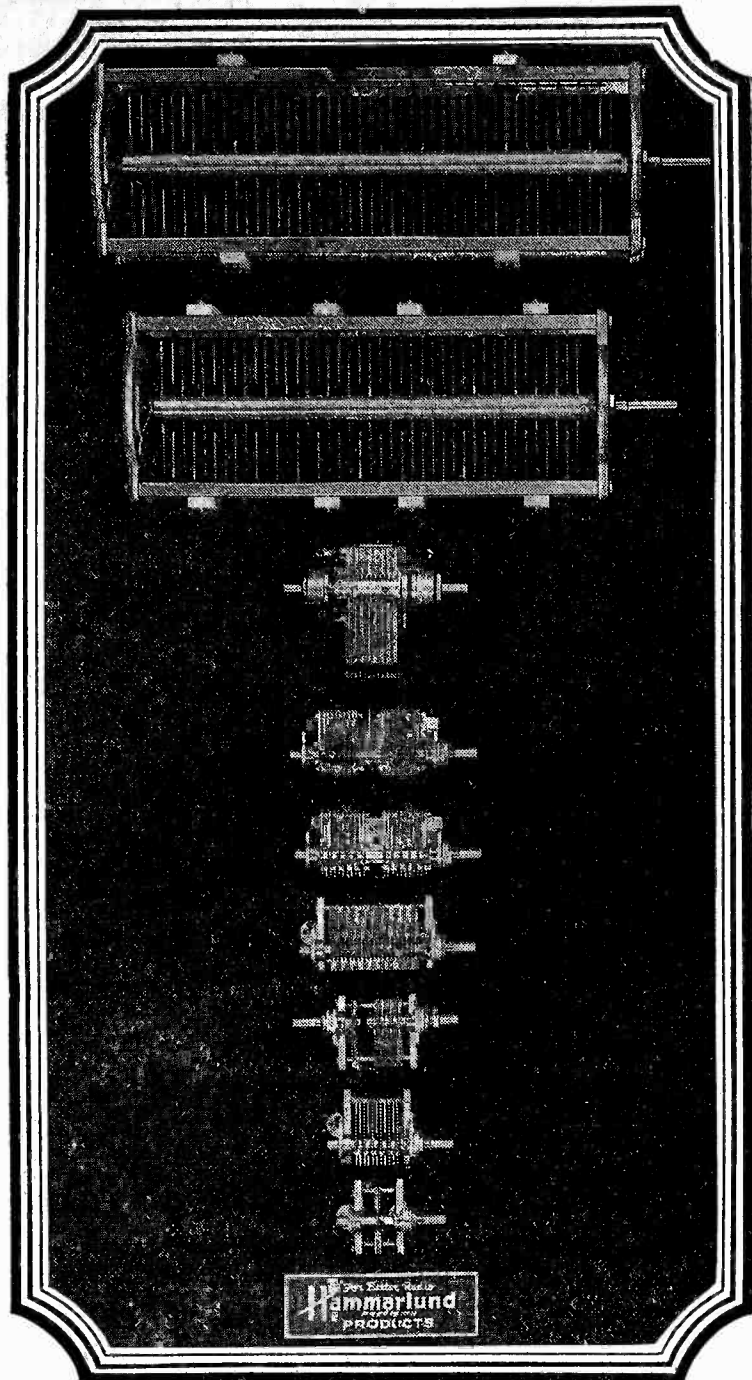

The above illustration shows only a few of the many Hammarlund Stock Model Condensers for all purposes and in all ratings, described in the new "34" catalog.

Write Dept. PR-6
For FREE Copy

HAMMARLUND MANUFACTURING CO.

424-438 West 33rd Street - - - - New York, N. Y.

ple into believing they are being invited into an exclusive fraternity of real amateurs.

Even though the project is built around the motive of exploiting the amateurs for the purpose of digging more money out of the public on the sham pretext of fraternalism, even though it would lower the whole standard of amateur radio, let us at any rate accord to K. W. Warner the sole distinction of having advanced a wholly new conception of amateur radio.

I wish this story might end here. It is not a pleasant job to set down the conclusion. Grown men will already have got the real significance of the Warner letter but some of the younger amateurs may have missed it. The letter is a complete expose of the community of thought and interest of the ARRL headquarters and the commercial radio corporations. For years, in spite of all the headquarters' denials and alibis, many of us have

been certain that this community of interest existed. It remained for this letter to complete the disclosure in black and white.

It is these commercial corporations that have systematically deprived the amateurs of their rightful share of the air. With the protection of amateur rights in the hands of a man who could write such a letter is there any amateur who wasn't born yesterday who can now believe that those rights were vigorously, exclusively, intelligently and courageously guarded!

Clair Foster, W6HM.

Key Clicks

AFTER all key click filters fail take the one that just about does the job and put a pair of .5 mfd. condensers across the line and ground the CT of them. This will work, and how. It has worked for me and I told several locals and they all say that they can't keep the OW with the BCL set from drowning out the DX. —Submitted by Ralph E. Nichols, W1CNU.

Greater Power with GRAPHITE ANODES

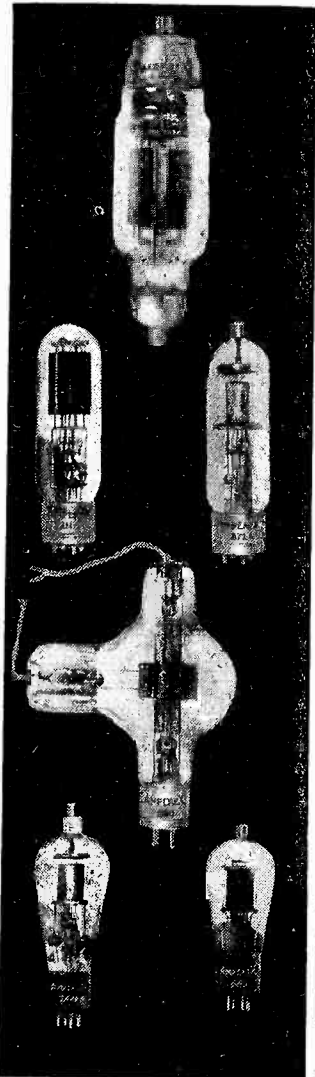

The Cooler Operation of Amperex Power Tubes—because of the greater surface and black body radiation of the Graphite Anodes results in longer life and greater power output.

800	—	\$ 10.00	List Price
203A	—	15.00	List Price
211	—	12.50	List Price
210	—	3.00	List Price
830	—	8.75	List Price
845	—	17.50	List Price
852	—	22.50	List Price
860	—	35.00	List Price
866A	—	5.00	List Price
872	—	15.00	List Price
872A	—	17.50	List Price
204A	—	95.00	List Price
849	—	160.00	List Price

Dealers write for complete catalog and discounts

AMPEREX ELECTRONIC PRODUCTS, INC.

79 Washington St., Brooklyn, N. Y.

AMPEREX
Power Tubes •

CONDENSER HEAD

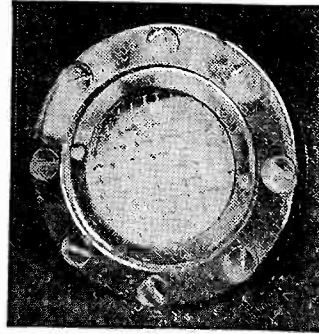

Turned from brass
Stretched Dural diaphragm
Compensating diaphragm
Weight 1½ Lbs.
3" in diameter
One and one-eighth thick
Nickel plated
Frequency response 30 to 8000 CPS

PRICE
\$6.00
POSTAGE PREPAID

UNCONDITIONALLY GUARANTEED

CONDENSER MOUNTING

All cast aluminum
Stands 13¼ inches overall.
The tubing 4" in dia. 9" long

FINISHES:

All Crackle
Tube only crackle, the rest buffed
All buffed, (add \$1.00 extra)

PRICE **\$5.25**
POSTAGE PREPAID

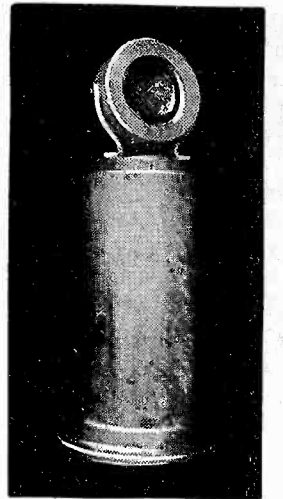

Blue print of an all AC hook-up head amp. with each order

C. H. HAAS

3939 Tracy Street, Los Angeles

W6EAH

A SHORT WAVE KIT THAT REALLY IS

New THE UNIVERSAL MASCOT

Here is a one-tube Short Wave receiver to astonish and thrill you! A thing of beauty. Nothing unsightly. Everything hidden away in a beautiful bakelite cabinet. But beauty is not its only claim to fame, for it incorporates a simplified circuit, easy to wire, high efficiency, ease of tuning and amazing performance. Brings in police calls, airplane calls, ships at sea, etc.

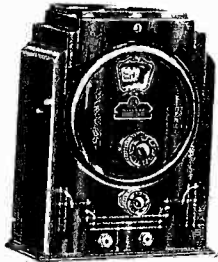

Uses type 30 tube.
Complete kit of parts, including cabinet and four 6-prong, 3 winding coils covering wave lengths from 16-38, 35-75, 73-137, 135-200.
LIST PRICE... **\$9.95**

WE ARE SHORT WAVE HEADQUARTERS

ICA quality S.W. parts are the standard of quality. Recommended by engineers, set builders, etc., in all leading magazines. Our products include: converters, condensers, chokes, crystal holders, plug in coils, S.W. and all-wave antenna systems, etc., etc. Guard yourself against substitution! All ICA products come packed in original boxes . . . never in bulk.

NOW—Is the Time to Order

from your jobber or favorite Mail Order House at 40% off. If he cannot supply you with the Mascot or ICA parts . . . write direct!

INSULINE CORP. OF AMERICA
23-25 PARK PLACE, NEW YORK, N.Y.

Dept. _____
Send me one complete kit of parts for the Mascot one-tube S. W. Receiver. Send me name of nearest ICA jobber who can supply me.

Name _____
Address _____
City _____ State _____

2 Outstanding

CONDENSER TYPE

MICROPHONES

(MODEL S-2)

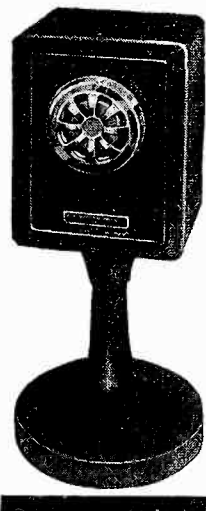

A salient development in condenser microphones. Ideal for use with the new wide range P.A. equipment. Response substantially flat up to 9000 cycles. High sensitivity—output approximately -20 D.B. in normal use. Milled bronze removable head; case 6" high x 4½" wide x 4½" deep of cast aluminum, crackle lacquer finish. Two stages of amplification. A remarkably fine condenser microphone with 25 ft. shielded cord and tubes included at new 1934 low price.

(MODEL L-2)

Made for broadcast recording and for those who require a condenser microphone of the highest quality. Precision built like the finest instrument. Housing eliminates sound reflection. Two stages of amplification. Range 40 to 10,000 cycles. 7" wide, 7⅝" high, 5⅛" deep. This unit is of unusual sturdy construction with performance plus qualities. Cord and tubes included. Get facts on these two microphones—free catalog lists our complete line of condenser and carbon type microphones you should know about.

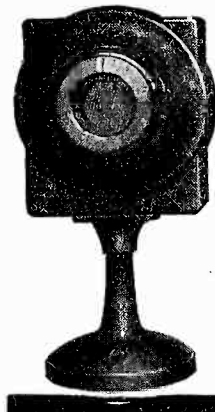

SEND POST CARD TODAY FOR

free catalog

SOUND ENGINEERING CORP.
416 N. LEAVITT ST.
CHICAGO, ILL.

NEW

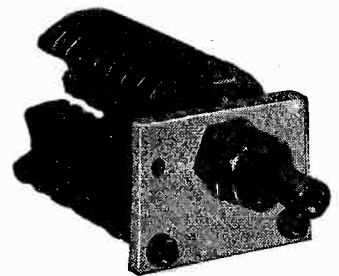

The CARDWELL "TRIM-AIR"

Receiving and Transmitting

A high quality, isolantite-insulated Midget condenser. Has many applications and several novel features such as rotor lock, detachable rotor extension leaving a screw driver slot for adjustment, provision for either single hole or behind-the-panel mounting, etc.

Send for literature describing these and other receiving and transmitting condensers comprising the famous CARDWELL line.

THE ALLEN D. CARDWELL MFG. CORP'N.

87 Prospect Street, Brooklyn, N. Y.

NOW *the* SKY-RIDER Presents Continuous Band-Spread

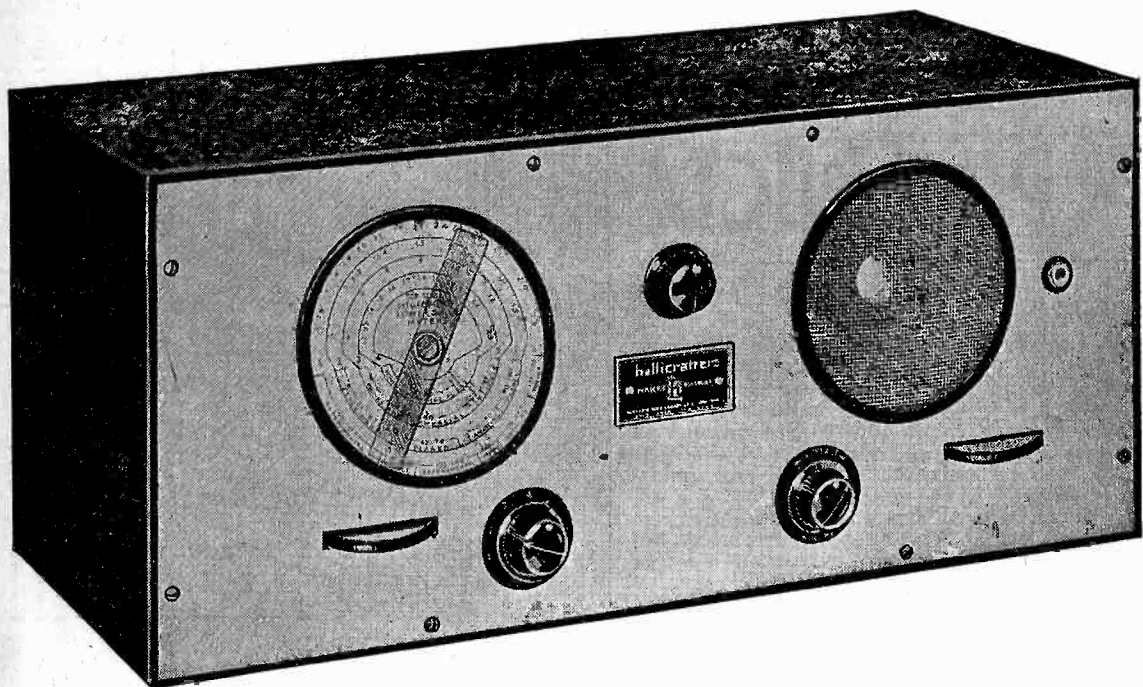

America's most successful short-wave receiver now steps farther ahead with **continuous band-spread**.

At last you can have, at extremely moderate price, a receiver that easily separates every channel, all without the use of plug-in coils or special band-spreading contrivances.

The new SKY-RIDER is the answer to your problems of better reception, regardless of whether you are interested in amateur' phone, c.w., or just listening to foreign or domestic phones. Every station channel is easily separated on its broad dial.

A Super-Performing Short-Wave Receiver

Entirely A. C. operated.

Built-in dynamic speaker.

Entire unit, including power pack, housed in crackle finished metal shielding cabinet. Panel of lacquered bright metal.

Micro-vernier tuning control with thumb action, horizontal knob. 18 to 1 reduction accomplished with anti-backlash worm drive.

Short-wave tuning range from 200 to 12 meters is divided into four bands, each accurately calibrated on the airplane type tuning dial.

Frequency indicating pointer on tuning dial has pencil point holes to accurately log stations right on the dial.

No plug-in coils. Wave-change switch of new design eliminates plug-in coil losses and inconvenience.

Improved band-spread action over entire tuning range provides complete separation of all phone and telegraph signals.

Dual gain controls provide separate adjustment of R.F. sensitivity and audio amplification, assuring positive control of signal to noise ratio. This is an outstanding advancement developed expressly for the SKY-RIDER.

Plug-in jack provided on front panel to allow operation of receiver with headphones, thus not disturbing other occupants of the same room.

Has switch on front panel to allow instant disconnection of plate voltage while transmitting.

Input provides for use of standard aerial and also secures the utmost advantage of "doublet" antenna systems.

Furnished complete with all equipment necessary for immediate operation over entire short-wave frequency band. No coils, speaker, or other accessories to buy.

Write your jobber, or the factory for low net price.

WRITE FOR FREE BOOKLET!

HALLICRAFTERS, Inc.,

Dept. R, 417 N. State St., Chicago, Ill.

Please send immediately free copy of the HALLICRAFTERS SKY-RIDER booklet.

Name

Address

Hallicrafters, Inc.

417 N. State Street

Chicago, Ill.

Radio Dealers and Jobbers who desire to advertise in these columns are invited to write for rates.

RADIO BUYERS' GUIDE

A Monthly Listing of Reliable Radio Dealers and Jobbers who solicit the patronage of our readers. Buy from your nearest Dealer or Distributor. He is dependable and reliable.

CHICAGO, ILLINOIS

Chicago Radio Apparatus Company, Inc.

415 South Dearborn Street
Harrison 2276

Dependable Radio Equipment
Established 1921

Bulletins on request—we specialize in short wave transmitting and receiving apparatus.
Catalog Ten cents.

CHICAGO, ILLINOIS

MID-WEST RADIO MART

520 South State Street
CHICAGO

Write for Special Catalog—Free

CHICAGO, ILLINOIS

Newark Electric Company

226 W. Madison St.
Chicago

All Kinds of Equipment for
Service Men - Amateurs - Experimenters
Write for free catalog

OAKLAND, CALIFORNIA RADIO SUPPLY CO.

2085 BROADWAY.

New 2-Tube Sargent DX-Ranger Kit,
\$12.50 complete.

New Sargent 9-33 Superheterodyne,
\$69.50, net, less tubes.

Sargent Short-Wave Sets and Kits.
Write for Circulars.

ST. PAUL, MINNESOTA

LEW BONN COMPANY

2484 University Avenue

Rex L. Munger, W9LIP, Sales Engineer

Radio Wholesaler

Complete Stock

Twice as Big as Before
IS

THE SECOND EDITION of KRUSE'S RADIOPHONE GUIDE

● and is just as full of operating and constructional information that isn't found elsewhere.

● And furthermore . . . there's a complete set of

Batcher's 'Radiographs'

the simplest problem-solvers we ever saw.

● At your dealers or Postpaid for 50c
(Canada 75c)

ROBERT S. KRUSE, Guilford, Connecticut

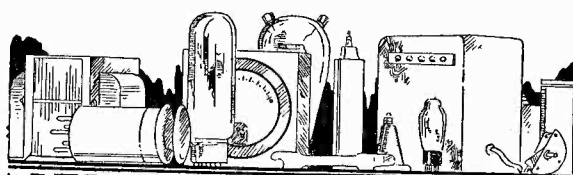

NEW PRODUCTS

McCorkle Crystal Oven

On first thought it might appear that the sensitivity of a crystal oven would depend upon the heat insulation and the sensitiveness of the thermostat. There are, however, a number of other factors that must be taken into consideration and there is a certain definite relation between heat input, heat losses, insulation, over-run and under-run temperatures. A proper co-ordination of these factors will result in a straight line temperature curve, just as on an engine the peripheral fly-wheel speed will remain constant even though power is produced with a series of impulses.

With the McCorkle Oven a rapid and positive air circulation is obtained by jacketing the tubular resistor in such a manner as to provide a rapid intake of air at the bottom and a discharge through the top.

Due to the efficient insulation of the oven the temperature rise is much more rapid than the temperature fall. To prevent over-run of temperatures, a thermostat is located in such a position as to be in the direct warm-air stream from the heater. By this arrangement the thermostat anticipates the actual heat demand within the oven proper and breaks the operating circuit just before the oven reaches the desired temperature. This arrangement, with the extremely low specific heat of the element (total weight less than one ounce), minimizes over-run temperatures.

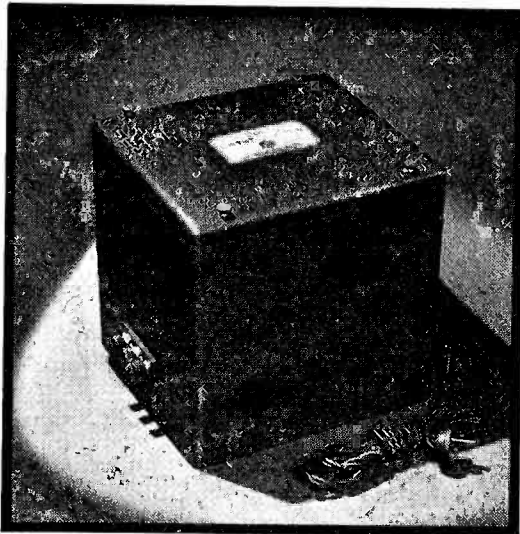

The thermostat employed in the McCorkle Oven has had a wide application for a number of years in heat and cold control devices and has proven to be extremely sensitive and dependable. On this thermostat one contact is carried by the adjusting worm, or screw, the other contact being mounted on a phosphor-bronze spring to flex freely, both above and below the point of "make" and "break". This construction eliminates the possibility of distortion of the thermo-blade and insures a permanent constant setting.

The ELEKATHERMAX HEATING ELEMENT is manufactured under the Gyrus patents. This resistor is non-inductive and operates on a wire temperature of approximately 100° C. The life of this element is guaranteed indefinitely when used on rated voltage. Its tubular form and circulating shell insures a rapid movement or circulation of air within the oven.

HEAT INSULATION: The entire oven and clamp-on top is lined with one inch of high-grade insulating material. In addition, the inner surface is treated to utilize the principle of heat reflection.

Contact points are of a special heat-treated alloy which has proven to have unusual resistance to oxidizing, pitting, or sticking.

Net price to amateurs, \$8.75. Manufactured by McCorkle Controls, Inc., 6th and Bancroft Way, Berkeley, California.

CHICAGO, ILLINOIS

Chicago Radio Apparatus Company, Inc.

415 South Dearborn Street
Harrison 2276

Dependable Radio Equipment
Established 1921

Bulletins on request—we specialize in short wave transmitting and receiving apparatus.
Catalog Ten cents.

PITTSBURGH, PENNSYLVANIA

CAMERADIO COMPANY

603 Grant Street

Tri-State "Ham" Headquarters
Standard Apparatus Standard Discounts

FRESNO, CALIFORNIA

PORTS MANUFACTURING CO.

3265 E. Belmont Ave. Radio W6AVV
National FB7-SW3 and Parts; Hammarlund,
Cardwell, Bliley Crystals; Johnson Insulators.
Complete Stock --- Write for the Dope
Established 1914 Leading Ham Supply Store

SAN FRANCISCO, CALIFORNIA



1452 Market Street.

"The House of a Million Radio Parts"

Hammarlund and National sets and parts.
RCA-DeForest Amateur Transmitting Tubes.

Collins Transmitters.

Arcturus Receiving Tubes.

Trimm Phones, all types.

Johnson Antenna Feeders, Insulators,
Transposition Blocks.

SEATTLE, WASHINGTON



LARGEST PARTS SUPPLY DEPOT
IN THE NORTHWEST

Four of Our Employees Are Licensed
Amateurs

DISTRIBUTORS

DUBILIER-WARD LEONARD
CARDWELL-RCA TRANSMITTING TUBES
WESTINGHOUSE METERS

KANSAS CITY, MISSOURI

Burstein-Applebee Company

1012-14 McGee Street

"Specialists" in supplies for the Amateur and
Serviceman



sets amazing new acceptance record among housewives

Orders for Crosley Shelvador and Tri-Shelvador Refrigerators are pouring in. The big Crosley factories are being taxed to capacity. Housewives all over the country are demanding the exclusive features and the exceptional value that only Crosley can give.

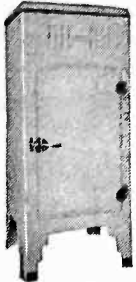

Model EA-43
4.3 cu. ft. NET capacity,
9.15 sq. ft. shelf area,
2 ice trays—42 cubes—
one double depth tray.
\$117.00



Model EA-55
5.5 cu. ft. NET capacity,
11.6 sq. ft. shelf area,
3 ice trays—63 cubes—
one double depth tray.
\$145.00

Provides about 50% more "usable" storage capacity

Shelvador provides a definite place for many items that are "space robbers" in ordinary refrigerators. Example: an orange occupies exactly the shelf space an orange should—not the shelf space of a milk bottle.

Streamline Beauty

The *Streamline Beauty* of Shelvador and Tri-Shelvador models does justice to the modern woman's sense of beauty. The pleasing design fits in with modern kitchen arrangement.

Compare These Features

There is the famous Shelvador, ventilated front, automatically illuminated interior, no-stop defrosting control (defrosts while refrigerator is operating), chromium plated stamped brass hardware of modern design, thorough insulation throughout (including door), round cornered porcelain interior, white lacquer exterior with black trimming, ample tray capacity for quick freezing of ice cubes.

All models have automatically illuminated interior

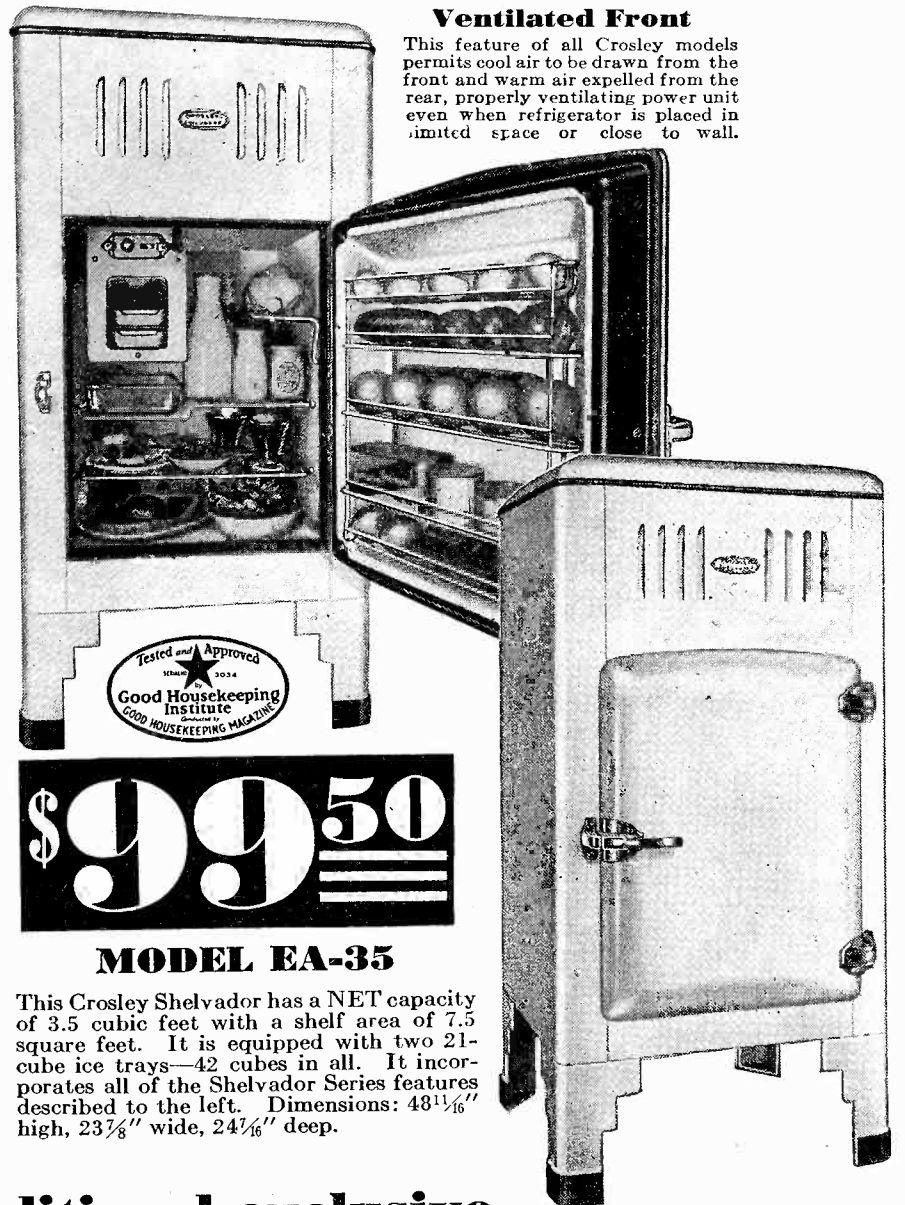

Ventilated Front

This feature of all Crosley models permits cool air to be drawn from the front and warm air expelled from the rear, properly ventilating power unit even when refrigerator is placed in limited space or close to wall.

\$99.50

MODEL EA-35

This Crosley Shelvador has a NET capacity of 3.5 cubic feet with a shelf area of 7.5 square feet. It is equipped with two 21-cube ice trays—42 cubes in all. It incorporates all of the Shelvador Series features described to the left. Dimensions: 48 $\frac{1}{16}$ " high, 23 $\frac{7}{8}$ " wide, 24 $\frac{1}{16}$ " deep.



brings additional exclusive features that offer the utmost in electric refrigeration value

The Crosley Tri-Shelvador Series incorporates all the features of the Crosley Shelvador. It has *additional* features that make it the outstanding achievement in electric refrigeration.

- 1. THE SHELVATRAY . . .** Can be placed in a horizontal position instantly. Place articles on it and carry them, Shelvatray and all, to table, range or cabinet. An exclusive Crosley feature. (Patent pending.)
- 2. THE SHELVABASKET . . .** Swings with the door. Not refrigerated. Handy for greens, carrots, cabbages and the like. Exclusive. (Patent pending.)
- 3. THE STORABIN . . .** A place for potatoes, onions and other bulky items. Not refrigerated. Exclusive with Tri-Shelvador. (Patent pending.)

Self-closing porcelain door to freezing chamber is a feature of all Tri-Shelvador models. Model E-55 (left) has 5.5 cu. ft. NET capacity, 11.6 sq. ft. shelf area, 3 ice trays—63 ice cubes—one double depth tray. The Crosley Shelvador and Tri-Shelvador models represent the latest in refrigeration design, convenience and performance. Ask your Crosley distributor for a demonstration. *All models available in full porcelain at slight extra cost.*

Montana, Wyoming, Colorado, New Mexico and west, prices slightly higher.



Model E-43
4.3 cu. ft. NET capacity,
9.15 sq. ft. shelf area,
2 ice trays—42 cubes—
one double depth tray.
\$135.00

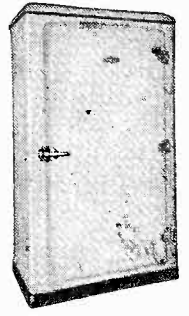

Model E-70
7 cu. ft. NET capacity,
14.9 sq. ft. shelf area,
4 ice trays—84 cubes—
one double depth tray.
\$185.00

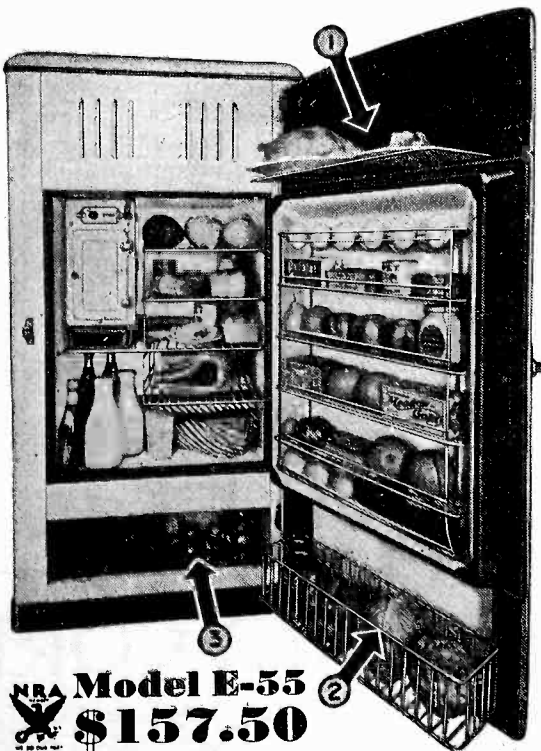

Model E-55
\$157.50

The Crosley Radio Corporation - Cincinnati
(Pioneer Manufacturers of Radio Receiving Sets)
POWEL CROSLEY, Jr., President Home of "the Nation's Station"—WLW

ALL PRICES INCLUDE DELIVERY..INSTALLATION..ONE YEAR FREE SERVICE



UTC class B audio and power components are available for every type of transmitter. Thorough research, expert engineering design and exacting laboratory checkups are responsible for the enviable reputation of UTC products.



204A-849 Output Transformer

THE output transformer illustrated, designed either for 204A's or 849's in class B, has a linear response from 30 to 12,000 cycles. The unit is oil immersed and shielded in a heavy gauge high permeability casting. All leads are terminated in high tension ceramic bushings. The transformer is insulated for 20,000 volts and will handle 1000 watts audio power.

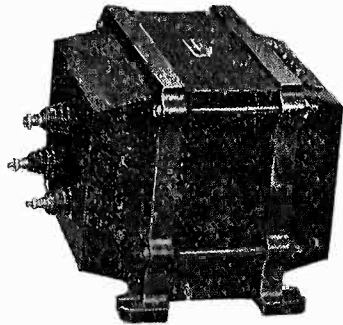

UTS shielded type heavy duty plate transformer

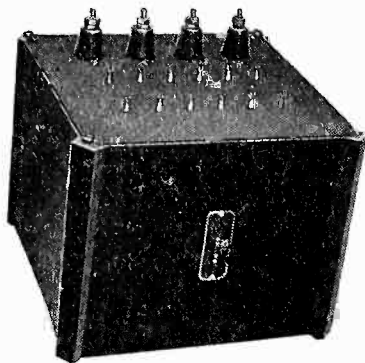

LS type shielded 203A output transformer for Broadcast use.

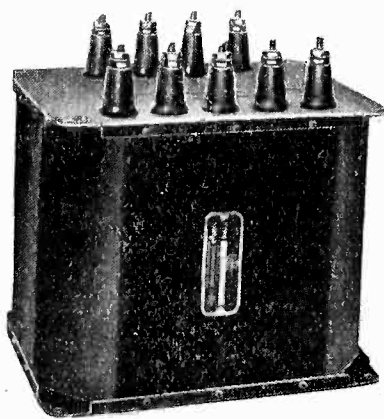

PA type 830B shielded output transformer for phone transmitter use.

UTC Audio Output Units for the New H-K Gammatrons Are Now Available

CLASS B INPUT SWINGING CHOKES					
Type	Swinging Action	Current Range	DC Resistance	List price	Net to Dealer-ham
PA-101	5 to 25 henrys	15 to 150 MA	115	\$5.00	\$3.00
PA-103	5 to 25 henrys	20 to 200 MA	110	8.00	4.80
PA-105	6 to 30 henrys	25 to 250 MA	90	12.00	7.20

TRAP RESONANT SMOOTHING CHOKES					
Type	Inductance	DC Output	DC Resistance	List price	Net to Dealer-ham
100	8 henrys	150 MA	115	\$5.00	\$3.00
102	10 henrys	200 MA	110	8.00	4.80
104	12 henrys	250 MA	90	12.00	7.20

FILAMENT AND PLATE TRANSFORMERS				
Type	Purpose		List price	Net to Dealer-ham
PA-34	Filament transformer—2½ V.C.T. 10 amps for two 866's—5000 volt insulation.		\$7.50	\$4.50
PA-111	Plate transformer—750 or 900 volts each side of center at 200 MA— for class B 800's.		15.00	9.00
PA-112	Plate transformer—1250 or 1400 volts each side of center at 400 MA. For class B 203's and 830B's.		35.00	21.00
PA-106	Filament transformer—2½ V.C.T. at 10 amps. 10,000 V. insulation. 2-10 V.C.T. 3.5 amp. windings for 203A's.		15.00	9.00
PA-102	Filament transformer—7½ V.C.T. at 6.5 amps for 2-800's, RK-18's, 825's, 210's. 5000 V. insulation.		11.00	6.60
PA-115	C bias plate transformer for 203's, 830B's, or 800's using one or two 82 rectifiers.		10.00	6.00
PA-116	Plate transformer—1250 or 1400 volts each side of center at 200 MA for class B 800's.		25.00	15.00

The new 1000-B Bulletin is ready

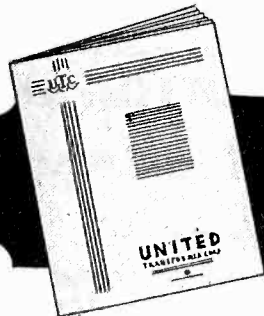

Send for your FREE Copy Today

16 PAGES OF VALUABLE DATA COVERING NEWLY DESIGNED AND TESTED HIGH FIDELITY AND WIDE RANGE AMPLIFIER CIRCUITS

Exclusive Pacific Coast Distributors Carrying a Complete Stock of UTC Products

UPPER CALIFORNIA
 Offenbach Electric Co. 1452 Market St., San Francisco
 E. C. Wenger Company 1020 Oak St., Oakland
 Wholesale Radio & Electric Supply 271 Ninth St., San Francisco
 SEATTLE, WASH.—Seattle Radio Supply Inc. 2319 Second Ave.

UNITED TRANSFORMER CORP.

Export Division, 15 Laight St., New York, N. Y.

264-266 CANAL STREET

NEW YORK, N. Y.

LOWER CALIFORNIA
 Pacific Radio Exchange Inc. 729 S. Main St., Los Angeles
 Radio Supply Co. 912-14 S. Broadway, Los Angeles
 Coast Electric Co. 744 G St., San Diego
 Prest & Dean Radio Co. 400 American Avenue, Long Beach