

$$E = I \times R$$

$$R = \frac{E}{I}$$

$$I = \frac{E}{R}$$

CONDENSERS IN SERIES

$$C_{TOTAL} = \frac{C_1 \times C_2}{C_1 + C_2}$$

RESISTANCES IN PARALLEL

$$R_{TOTAL} = \frac{R_1 \times R_2}{R_1 + R_2}$$

# RADIO

ESTABLISHED 1917

## SHORT-WAVE AND EXPERIMENTAL

BOTTOM VIEWS OF SOCKETS

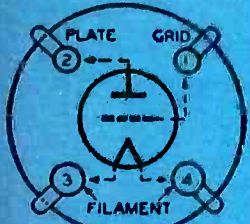

4-PRONG SOCKET  
0-201-A, 45, 210, 30, 31, ETC.

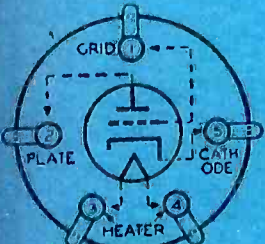

5-PRONG SOCKET  
56-46-47-76-27-37

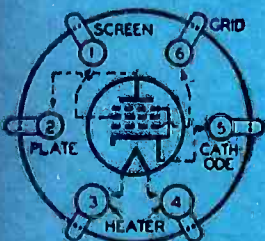

6-PRONG SOCKET  
2A5-41-42-43

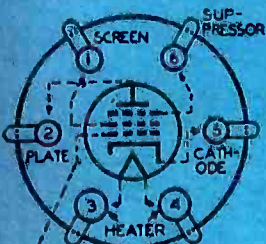

GRID-METAL TOP CAP  
6-PRONG SOCKET  
57-58-606-606-77-78

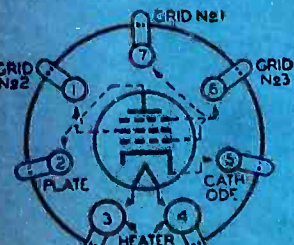

7-PRONG SOCKET 59

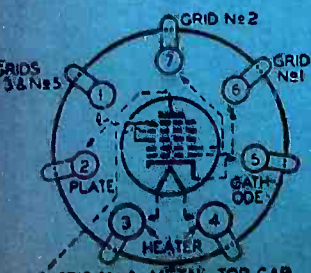

GRID No. 4-METAL TOP CAP  
7-PRONG SOCKET  
2A7-6A7

- IN THIS ISSUE -

### A New Frequency-Doubling System

### Crystal Filter Theory and Operation

### High-Power C.W. Transmitter Design

### A Cigar-Box 160 Meter Phone

### The New EIMAC Transmitting Tube



Continuously variable link coupling from an 852 stage to a P.P.P. Linear Amplifier. The illustration shows the method used by W6AWT, described elsewhere in this issue.

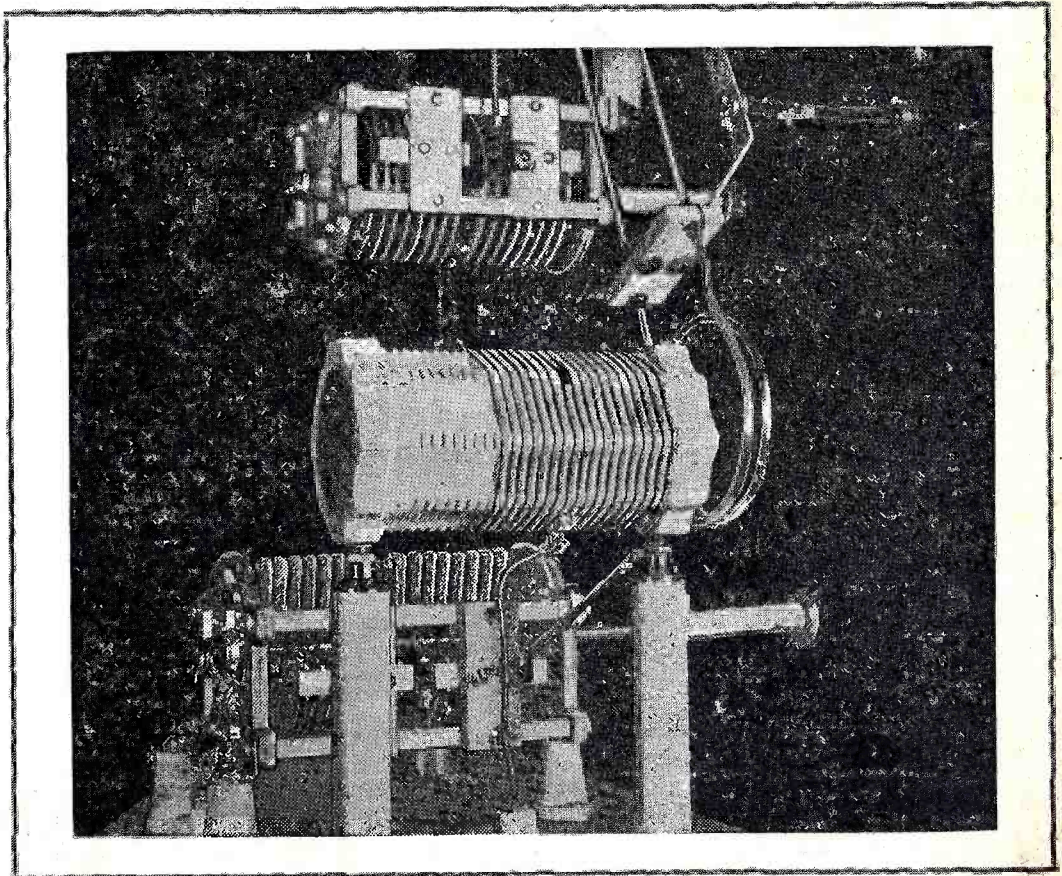

FEATURE ARTICLES BY . . .

CLAYTON F. BANE  
CHAS. PERRINE, JR.

CHAS. L. WATSON  
FRANK LESTER

J. N. A. HAWKINS  
BERNARD EPHRAIM

# BROADCASTERS GO *Sylvania*

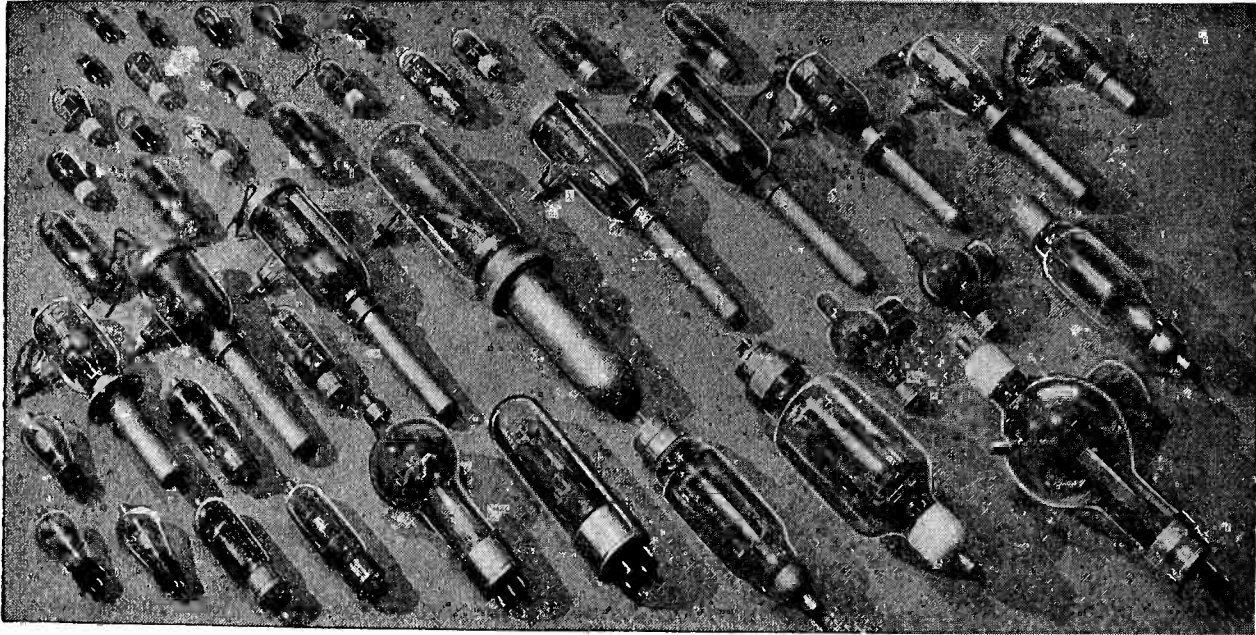

## SYLVANIA HAS THE ONLY COMPLETE LINE OF GRAPHITE ANODE TRANSMITTING TUBES

Broadcast engineers are becoming more and more SYLVANIA minded because they recognize the notably improved transmitting tubes which this company has developed and introduced. The progressive SYLVANIA achievements came after a long period during which no appreciable progress was made in power tube engineering. Leading scientists have proclaimed that the SYLVANIA Graphite Anode development marks the first fundamental improvement in transmitting tube design since the advent of broadcasting.

*More than half of the broadcasting stations in the country are either partially or entirely SYLVANIA equipped.*

Engineers in steadily increasing numbers are specifying SYLVANIA. This is true not only in the broadcast field but in all other fields of radio communication and for industrial applications where dependable heavy duty service is demanded.

The SYLVANIA line spans the entire range of popular air-cooled and water-cooled types.

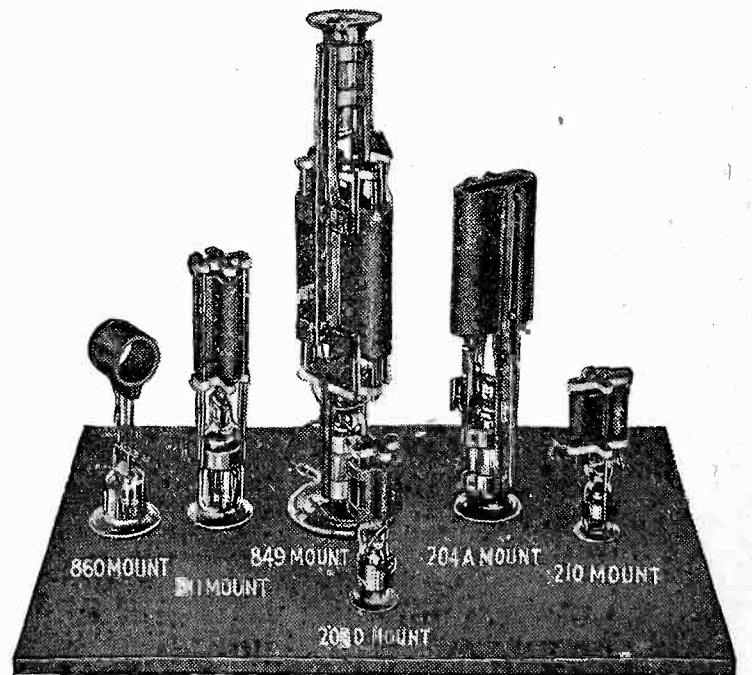
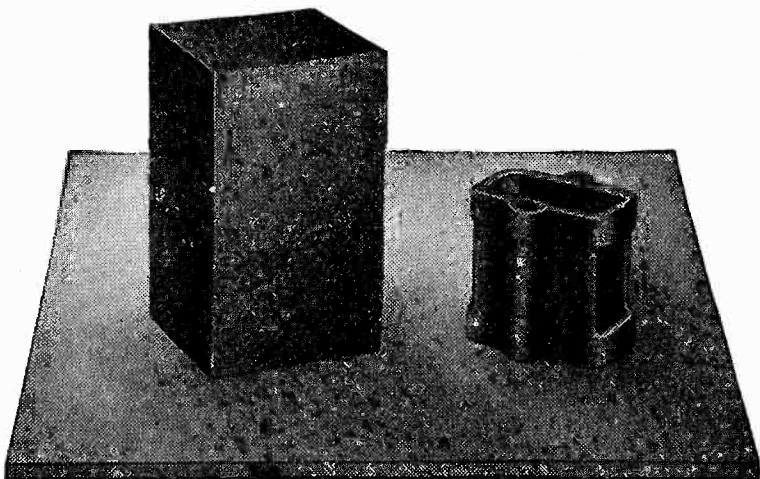

## HYGRADE SYLVANIA CORPORATION

ELECTRONICS DEPARTMENT  
CLIFTON, N. J.

Factories: SALEM, MASS.

EMPORIUM, PA.

ST. MARYS, PA.

CLIFTON, N. J.

# If It's a "HAMMARLUND" You KNOW It's Good

**O**N THE question of mere *price*, Hammarlund occasionally loses a sale. But no one can afford to undersell Hammarlund **QUALITY!**

Nothing can ever be *too* good in radio. The problem, then, becomes one of selecting the best equipment you can buy for the price you can afford to pay.

If your need is for *dependable* Condensers, Chokes, I. F. Transformers, Coils, Coil Forms, Shields, Sockets, or a complete receiver or transmitter for which you will never have to apologize, we suggest that you consult the Hammarlund Catalog. And we are confident you will find the prices as low as for any similar products of equal quality. *Mail the Coupon NOW!*

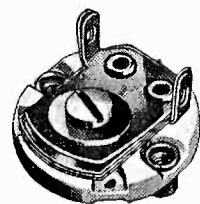
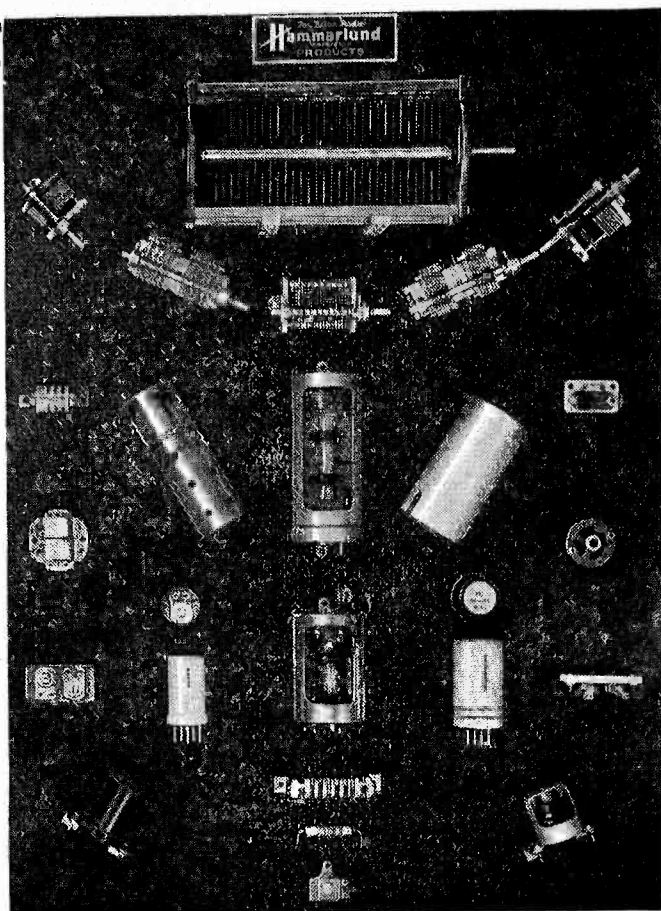

"IBT" MIDGET  
TRIMMER CONDENSER

New types of compact Hammarlund Condensers now available for trimming, padding, and transformer-tuning.

Some mount inside Coil Forms or Shields.

They are accurately rated, constant and reliable under the most severe conditions.

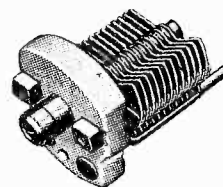

"APC" AIR  
PADDING CONDENSER

## LOW-LOSS, HIGH-EFFICIENCY COIL FORMS and COILS

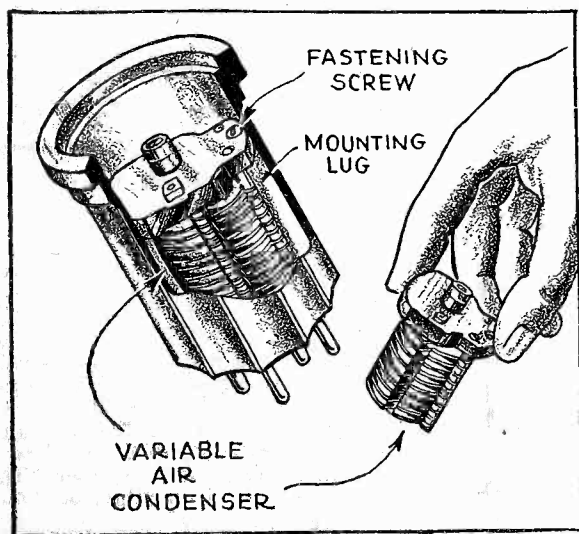

Recent development of the remarkable "XP-53" low-loss dielectric now makes it possible to offer highly efficient S-W Coils and Coil Forms at the lowest prices in Hammarlund history.



HAMMARLUND MANUFACTURING CO.,  
424-432 W. 33rd St., New York

.....Check here *and attach 10c* for 16-page Hammarlund 1935 Short-Wave Manual, illustrating and describing most popular S-W circuits of past year, with schematic and picture diagrams and parts lists.

.....Check here for **FREE** information on XP-53 Coil Forms and Coils.

.....Check here for **FREE** General Catalog.

Name.....

Address.....

PR-11

# The NEW 5C PROFESSIONAL SINGLE SIGNAL SUPERHETERODYNE



## SEE WHAT W9USA SAYS ABOUT ITS PRECISION

"After four months' continuous daily operation at World's Fair Station W9USA and public demonstrations daily at Hall of Science Theatre, very glad report most uniformly satisfactory results four of your 5B receivers. ...Congratulations excellent design."  
F. J. Hinds, Chairman, World's Fair Radio Amateur Council.

## TYPE 10D 100 WATT PROFESSIONAL PHONE-C.W. TRANSMITTER

The type 10D transmitter is the amateur's dream come true. It provides 100 to 120 watts of crystal controlled r.f. power on the 10, 20, 40, 80 and 160 meter amateur bands modulated 100% with high fidelity broadcast station modulation, all at a cost below what you can build it for!

It employs one RK20 screen grid r.f. pentode as a crystal controlled Tritet (electron coupled) oscillator. Modulation is affected by suppressor grid voltage variation, which is obtained from a simple three stage audio modulator. But read its specifications, look at its price, and get on the air with 100 watts peak (35 watt phone carrier) of broadcast station voice quality cheaper than you can build a 100 watt telegraph transmitter!

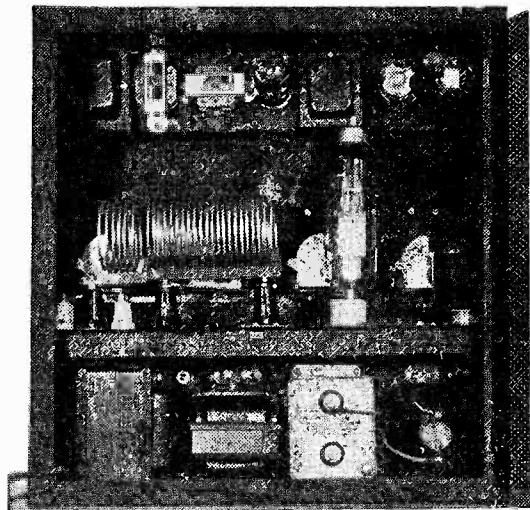
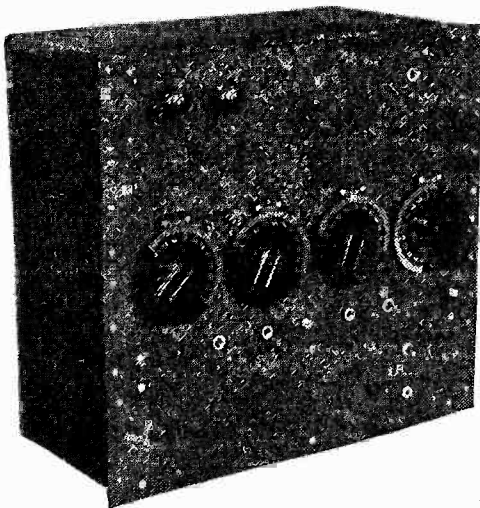

The 5C is the 1934 improved model of the now famous 5B—choice of W9USA of the World's Fair and amateurs the world over in preference to all available competition.

The first outstanding feature of the new 5C is the accurately calibrated large airplane "watch" dial, having one pointer for the three-gang main tuning condenser, and a second pointer on a 0-100 division scale for the three-gang band spread condenser—available by simply pulling out the tuning knob!

The 5C has a new high-gain tuned r.f. stage on all bands for image selectivity, and manual or automatic volume control at the turn of a switch, plus all the features that have made the 5B famous, including air tuned i.f. amplifier.

That it is far in advance of all other competitive receivers is proven conclusively by the roster of its users—from W9USA to Col. Foster W6HM.

## TECHNICAL FEATURES

**Sensitivity:** Every 5C receiver shipped from the laboratory is guaranteed to have a sensitivity of 1 microvolt absolute or better.

**Selectivity:** Each 5C will have selectivity curve 26 kc. wide 10,000 times down without crystals, or 50 cycles wide with crystal.

**Fidelity:** The overall antenna to speaker fidelity of the 5C without crystal is uniform to 6 decibels from 30 to 4000 cycles—or absolutely uniform over the entire fundamental musical range at the loud speaker output. Yet by means of the crystal control knob, 50 cycles selectivity can be had at will.

**Power Output:** The undistorted power output of the 5C is three watts.

**Volume Control:** The 5C is equipped with audio volume control for use when the A.V.C. is switched in, and with manual i.f. sensitivity control for use when A.V.C. is switched out for high speed telegraph reception. By the turn of a knob the sensitivity can be raised to the maximum and very weak distant stations may be brought in easily—or lowered for locals.

**Circuit:** All wave superheterodyne employing a '58 r.f. amplifier, 2A7 high efficiency first detector and electron coupled oscillator, two '58 i.f. amplifier stages, '55 diode second detector, diode A.V.C. and triode first audio stage, '58 audio beat oscillator for C.W. code reception, 2A5 in Class A power output stage, and one '80 rectifier.

**Wave Length Range:** 13 to 200 meters, or 1500 to 23,000 kc. in three low C bands.

**Dial:** One illuminated dial accurately calibrated (error not over 1%) in megacycles (thousands of kilocycles) for the three short wave bands. Tuning ratio is nine to one.

**Band Spread Tuning:** All stations can be tuned on the main dial, or will be found well spread out and easy to tune on the band spread dial, which, located on the main large airplane "watch" dial, is brought into use by simply pulling out the tuning knob, which then operates the band spread pointer and three-gang band spread condenser. Band spread approximately 100 degrees for 80 and 160 meter, 50 degrees for 20 and 40 meter amateur bands approximately, and available

anywhere in range of receiver by pulling out tuning knob.

**Wave Length Change:** One knob, with colored indicators matching dial scale colors. Knob actuates positive three position, six-gang selector switch having positive non-wearing, silver plated contacts.

**I.F. Amplification:** Two stages of dual air tuned 465 kc. amplification using a total of five "Litz" wound tuned circuits and two '58 super control tubes.

**Shielding:** All r.f. and i.f. circuits completely shielded from external pickup. Two antenna binding posts only "hot" points exposed. Heavy cabinet provided with hinged top for easy access.

**Loud Speaker:** Specially designed and matched Jensen dynamic unit in cabinet 7" square and 3 1/2" deep.

**Tropical Climate Provision:** All transformers, coils and condensers specially sealed against moisture, particularly for tropical climates. All filter condensers, power transformers, chokes and resistors greatly oversize to avoid possibility of breakdown in places remote from replacement part sources.

**Finish:** Crystalline black on all parts except tube and r.f. shields, which are polished aluminum.

**Dimensions:** 17" long over all, 10 3/4" deep and 8 3/4" high.

**Antenna:** Separate r.f. primaries for each band and allow use of doublets or Marconi antennae at will.

**Crystal:** When ordered, the 5C can be supplied with special Bliley quartz crystal resonator in Bliley holder, and with i.f. amplifier properly aligned to exact crystal frequency. Type 5C communication receiver, as above, complete with eight tested Raytheon tubes, Jensen speaker and cabinets, ready to operate, list price \$124.50. Net price to amateurs \$74.20. Order it direct or from your dealer.

Add to above for Bliley 465 kc. crystal in Bliley holder and specific receiver alignment for individual crystal supplied, list price \$15.00. Net price to licensed amateurs \$9.00.

Order it from your dealer or direct and join the P.W.A.C. Club (Phone Worked All Countries).

## SPECIFICATIONS

**R.F. Output:** 100 to 120 watts on fundamental crystal frequency. 60 watts on crystal second harmonic.  
**Frequency Range:** 10, 20, 40, 80 or 160 meter amateur bands. One pair of two plug-in coils covers each band.  
**Tubes Needed:** 1—RK20 Oscillator, 1—RK19 Rectifier, 1—2A5 Power Amplifier, 1—53 Voltage Amplifier (2 stages), 1—80 Rectifier.

**Modulation:** Linear suppressor grid modulation variable from zero to over 100% at will. Harmonic distortion less than 5% at 100% modulation.

**Audio Frequency Range:** Modulation curve flat to 4db. from 40 to 8000 cycles. Variable tone control provided for high audio frequency attenuation as desired.

**A.C. Modulation Hum:** Negligible.

**Phone-Telegraph Section:** Two position toggle switch and r.f. unit selects phone or C.W. telegraph operation at will.

**Antenna Tuning:** Two 365 mmf. condensers provided for series antenna tuning, or parallel antenna tuning by shift of two connecting links.

**Meters:** None provided except on special order

(mounted on r.f. unit panel). One 0-150 ma. millimeter and, if desired, one 0-2 antenna thermoameter are all required to check operation.

**Controls:** Oscillator plate, r.f. plate and two antenna tuning dials. Phone-Telegraph, send-receive, modulator on-off and power on-off switches. Screen and plate current measuring jacks. Key jack.

**Size:** Total height of all three 19" x 7 1/8" aluminum relay rack panels, 19 1/4". Supplied complete in dust cover shielding cabinet of perforated steel with hinged rear door. May be operated on table, or mounted in relay rack.

**Power Required:** 350 watts at 105 to 125 volts, 50 to 60 cycle A.C.

**Accessories Needed:** One Bliley crystal and holder (specify frequency), one crystal microphone, and tubes as listed above.

Price net to Amateurs, \$119.70.

Five Raytheon tubes \$25.23 net.

Coils, per set of two (one set included, specify if for 20, 40, 80 or 160 meter band) \$3.60.

Send 3c stamp for new complete catalog describing above items, E.C. Frequency Meters, New Airplane Dials, Relay Racks, R.F. Chokes, Audio, Power and Filter Transformers, and a host of new and interesting amateur and commercial apparatus.

# McMURDO SILVER, INC.

3362 NORTH PAULINA STREET, CHICAGO, U. S. A.

BRANCH OFFICES:  
New York City,  
253 W. 128th St.  
Tel. MOument 2-2812  
Boston,  
J. H. Condon,  
6 Marlboro St.  
Chicago,  
C. W. Nelson,  
3618 North Bernard St.  
Los Angeles, Calif.  
1455 Glenville Drive.  
Tel. CRestview 4017

# RADIO

ESTABLISHED 1917

Reg. U. S. Pat. Off.

A NATIONAL MAGAZINE - PUBLISHED MONTHLY

Publication Offices—Pacific Building, San Francisco, California

Clayton F. Bane, Editor  
D. B. McGown, Technical Editor. Frank C. Jones, Ultra-Short-Wave-Engineering Editor.  
Clair Foster, Amateur Activity Editor. George B. Hart, Contributing Editor.  
H. W. Dickow, Business Manager.

25c per copy, \$3.00 per year by subscription in the U. S. \$4.00 elsewhere. Send subscriptions to the San Francisco office. Entered as second class matter at the Post Office at San Francisco, California, under the Act of March 3rd, 1879.

Vol. 16

NOVEMBER, 1934

No. 11

## RADIOTORIAL COMMENT

### An Opportunity to Elect a Good Director

**B**ETWEEN November 1 and December 20, members of the amateurs' league will elect Directors to guide their destinies during 1935-1936. The future of amateur radio is in the hands of the amateurs themselves. Today, more than at any other previous time in amateur radio history, a new deal is demanded by the amateur. How to get it? By the election of capable men who understand the problems of the amateur, men who have the courage and the ability to help get for the amateur what he needs.

Amateurs in and around Chicago will nominate Fred J. Hinds to the Directorship of the Central Division. Mr. Hinds is the man who successfully conducted the business of the World's Fair Radio Amateur Council as its general manager. He is a businessman, and a businesslike amateur. His call is W9APY. He does not believe in a one-man amateur administration. The amateurs of the Central Division desire to make themselves heard. There is no better way to do this than to elect him to the Central Division Directorship.

He is honest, fearless and untiring in safeguarding the interests of his fellow amateurs. He knows that something is radically wrong with amateur radio and he knows how to correct the evil. If elected, he will be one of the progressive Directors on the Board. His opinions coincide with those of Culver and Jabs. Those who follow amateur politics know what Culver and Jabs have already accomplished. A half-dozen more men of the Culver-Jabs-Hinds makeup are needed to pull amateur radio out of the rut into which it has fallen. The opportunity to elect such men presents itself at the coming election.

When the members of Culver's division and of Jabs' division asked that certain investigations be made, it did not take these men long to get action, even though they were opposed by others on the board. Some of the constructive measures which these men proposed fell by the wayside because the proverbial stone wall was there again.

There is only one way in which this stone wall can be shattered. A majority of the members of the board must be of the progressive type. They must not be "yes men." They must be men who cannot be persuaded to change their opinions once they face the board assembled. If the members of a division instruct the Director to bring about certain reforms it is the solemn duty of the

Director to make it his business to see that the wishes of the majority of the members of his division are respected. A Director who fails to vote as the members of his division instruct him to vote is guilty of foul play.

This is no time to talk about "loyalty to your leader." Amateur radio has no leader, else it would not be where it is today. The amateurs are still looking for a leader. He can be chosen from the ranks of a new Board of Directors. The Director who gives the best account of his stewardship wouldn't be a bad man to select as a leader. At no previous time in the history of amateur radio has the amateur given more serious thought to the election of Directors. Elect a few more men of the Culver and Jabs stock, elect Fred J. Hinds, and watch the picture change.



### Something for the Progressive Director to Act Upon

**A** REQUEST has been made that K. B. Warner disclose the statistics showing the actual number of licensed U. S. amateurs who are members of the league. There are many who want to know the percentage of licensed-vs-non-licensed U. S. amateur membership of the organization. Why are the amateurs still refused this information? The membership of the league is said to number about 20,000. The Call Book shows that more than 40,000 amateur licenses have been issued. Soon this number will reach 50,000. The Amateur Radio Protective Association now makes a formal demand that Warner release this information. If the findings show that the league is composed of more non-amateurs than licensed U. S. amateurs, something is going to be done about it. The Amateur Radio Protective Association sends a request to this magazine that forthcoming amateur conventions take action on this matter, instruct directors to get the information without further delay so that all amateurs will know whether they are represented by a wholly-amateur organization or by an organization composed largely of non-licensed amateurs and others. We must face the next International Convention with a clean slate. When we tell the Convention that the radio amateur is represented by a 100% amateur organization we must tell the truth. There are too many schemers who are gunning for the amateur frequencies. They boast that the amateur is not organized and that it is an easy matter to pull the wool over his eyes.



### James Millen Speaks

**S**AYS James Millen of National Company, Malden, Mass., on page 61 of a contemporary amateur publication . . .

"—Many important improvements are due to their investigations, and they have won the thorough respect of the commercial organizations. Realizing their value, we endeavor to try out every new scheme as it is presented, and we have a well equipped laboratory for that purpose. Unfortunately, the last two or three published schemes we have seen have been unsound and poorly engineered. This would be none of our business except that they were plans for "improving" FB-7 receivers, and rather than have some receivers spoiled, we are using this space to tell the amateur to steer clear of them. We promise to let you know if we run across any good suggestions."

An article was published in a recent issue of "RADIO" entitled, "Getting More Out of the FBXA." Possibly, this is one of the articles to which Mr. Millen so vigorously objects. Obviously, the manufacturer of a receiver releases it with self-assumed pride and assurance that it is "the last word," and that no "improvements" are possible.

One of our readers, a radio engineer (without a title) of ability and foresight, purchased an FBXA receiver. He found that by adding regeneration to the detector circuit the receiver gave markedly-better performance. So "improved" was the reception that he asked us to tell our readers how to get more out of the FBXA.

Thereupon the wrath of Mr. James Millen was aroused. He doesn't like the publisher of

(Continued on page 34)

# Practical Considerations in the Design of Quartz Crystal Filters

PART I  
By CLAYTON F. BANE

THE subject of quartz crystal filters is confusing to many users, due to a lack of understanding of the technical nature of the device.

The use of a quartz crystal as a resonator is not new. Dr. Robinson, a British Scientist, applied the idea of a practical quartz crystal as a resonator to a radio receiver. His receiver, however, was designed for broadcast use and was named the "Stenode". The Stenode receiver did not attain wide popularity because the selectivity was so great that most of the higher-frequency components of the modulated carrier were "lopped off".

A quartz crystal, cut on certain axes and ground with the faces parallel, has the property of oscillation, and the same plate has another unique property . . . that of a resonator.

In order to better illustrate the function of resonator, take the crystal from its place in the circuit and replace it with its electrical equivalent in inductance and capacity. A crystal of 451.5 KC has an equivalent inductance of 3.5 henries and a capacity of less than one-tenth micro-microfarad! The effective "Q" of such a circuit is well over 1000. Realizing that the "Q" of a circuit is the property which governs the shape of the resonance curve, it is found that such a circuit would have a very narrow shoulder, sharply-peaked resonance curve. It would be impossible to obtain such a resonance curve from any combination of inductance and capacity; the quartz crystal alone possesses these unique properties.

Again likening the quartz resonator to an equivalent circuit, the crystal has all of the properties of a series-resonant circuit. Series-resonant circuits offer a very low impedance to the resonant frequency (that frequency where the inductive reactance and the capacitive reactance are equal), while at the same time presenting very high impedance to

sides; it has sloping sides. The slope of the sides, or the "steepness", is dependent, among other things, upon the "Q" of the circuit. With a circuit having a resonance curve with gradual sloping sides, an interfering signal may be only ten points down in strength from the desired signal at the output of the receiver. In contrast, a circuit such as a quartz filter with extremely steep sides can cause the interfering signal to be down from the wanted signal ten thousand times. These figures are merely illustrative of the effect of the extreme discrimination or selectivity of such circuits as compared with the ordinary tuned-parallel-resonant circuits used in an IF amplifier.

Fig. 1 is the crystal filter used in the Hammarlund Comet-Pro receiver. It incorporates several good features and improvements. The mixer stage is fed through the primary of an ordinary IF transformer, but in lieu of the conventional tuned secondary loosely coupled to the primary a smaller, untuned winding closely coupled to the primary is used instead. The impedance of an ordinary tuned circuit can be estimated to be approximately 100,000 ohms. Maximum transfer of energy results when input and output impedances are equal. If an ordinary tuned secondary works into the crystal, the impedance of the crystal would approximate 100,000 ohms. Using Terman's "Radio Engineering" as a reference, it is found that a 451.5 KC crystal actually has a resistance of only 9,036 ohms.

Again from Terman, the formula for the resistance of an X-cut crystal is given with fair approximation as follows:  $R = 130,000 \frac{t}{lw}$ , where R = resistance, t = thickness of the crystal, l = length of crystal and w = width

3.16 to 1. All this can be better illustrated by a typical example of a matching transformer to work into a crystal of 9,000 ohms from a primary of 100,000 ohms. Assume that an IF transformer of 451 KC has a winding of 250 turns. Although this is an arbitrary value, it is fairly correct for most transformers. 250 divided by 3.16 equals 79.1 turns, which is the correct value for the low-impedance coil. This lower-impedance winding must be center-tapped. Thus it is necessary to use 79 turns on each side of center; both windings are wound in the same direc-

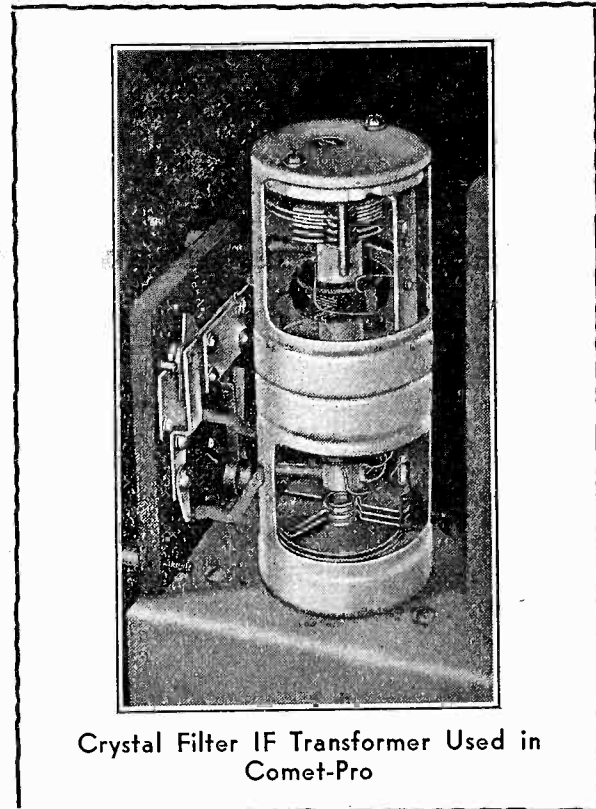

Crystal Filter IF Transformer Used in Comet-Pro

tion with the inside leads of one winding and the outside lead of the other tied together. These windings should be wound directly over the primary and should be wound with No. 32 DSC wire, although litz wire is preferable if it can be obtained. When the impedance is stepped-down to match the crystal, the voltage is accordingly stepped-down, so that on the output winding there will be 79 turns, wound in the same manner, which affords the necessary step-up voltage ratio.

The opposite half of the input winding is for the purpose of supplying a voltage equal and opposite, which is applied through the phasing condenser across the crystal. This condenser is used for neutralizing the capacity of the crystal holder, which is effectively in parallel with the crystal. Parallel resonance has the opposite effect of the crystal resonance, i.e., it offers a high impedance to the resonant frequency and low impedance to all other frequencies, the effect somewhat cancellative on the incoming signal. By adjusting the phasing condenser an undesirable signal near the wanted signal can be attenuated to a considerable extent. The explanation is simple; the crystal works in the usual manner to pass the wanted signal, while at the same time its parallel rejectivity effect is shifted over to the unwanted signal. The coupling condenser from the junction of the crystal and the phasing condenser should be made adjustable with a maximum capacity of 50 mmf. Proper setting of this condenser can best be determined by experiment.

The selectivity of the type of filter de-

(Continued on page 16)

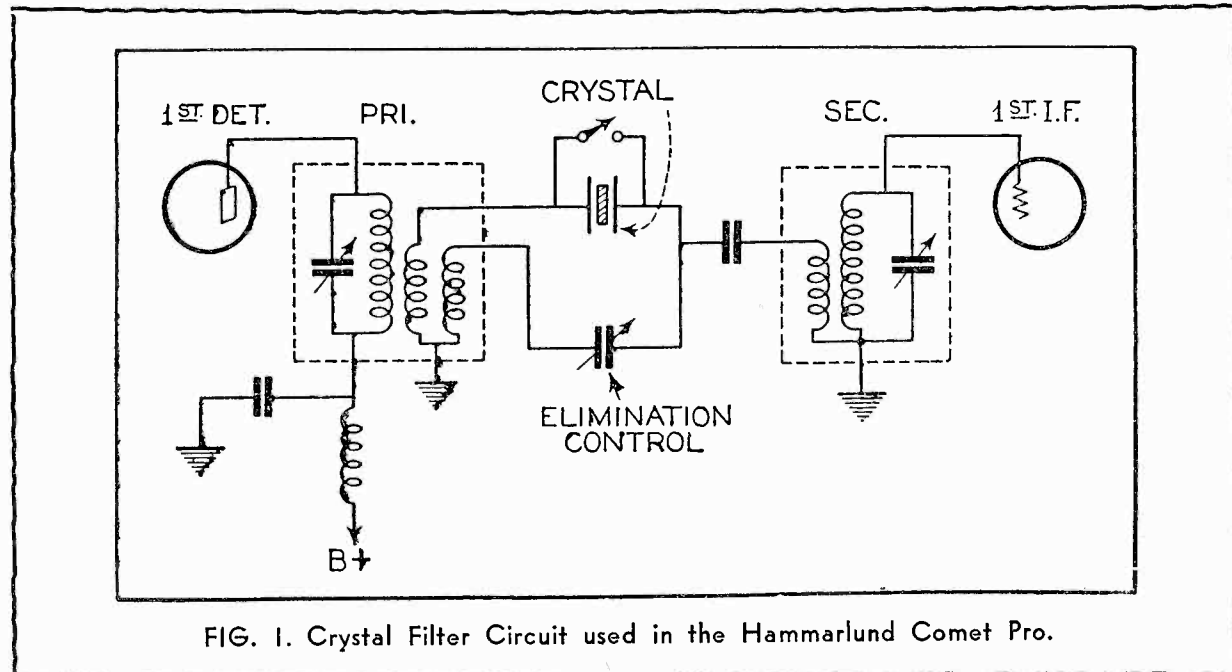

FIG. 1. Crystal Filter Circuit used in the Hammarlund Comet Pro.

all other frequencies. Impedance is that property of a circuit which offers opposition to the flow of an alternating current. More properly, the impedance of a circuit is the sum of the reactances and the resistance. Taking the first definition into consideration, it can be seen that a series-resonant circuit will pass the resonant frequency (in this case the signal to which the receiver is tuned), and reject other adjacent signals. The resonance curve does not have straight up and down

of crystal. Thus it can be seen that the resistance of all crystals is not the same; it varies according to the physical dimensions of the crystal. All dimensions are in centimeters when the above formula is used.

In order to obtain the proper impedance match it is necessary to transform the 100,000 ohms impedance of the primary down to the 9,000 ohms of the crystal, an impedance step-down ratio of roughly 10 to 1. The turns-ratio would be the square root of 10, or

# Cathode-Ray Curve Tracing Data For Aligning Tuned Circuits

"VISUALS" or curve-tracing devices for showing the resonance curves of the intermediate or radio-frequency stages of broadcast receivers have been in use for some time. Some manufacturers have installed enough "Visuals" to align their entire production. Others have installed one or more for aligning part of the production and for checking the work of aligners equipped with meter indicators.

The "Visual" is particularly useful where coupling is such that a double-peaked resonance curve is obtained, since the depth of the valley between the peaks is difficult to determine unless a plot of the curve can be examined. Such a plot is, of course, constantly before the "Visual" aligner so that the effect of coupling or tuning adjustments can be observed during the adjusting process. However, the cost of these curve-tracing devices has in many instances made their use impracticable and has made it necessary to resort to slower methods of checking the design and production of the intermediates. In contrast to high-priced apparatus employing the string galvanometer, cathode-ray apparatus is comparatively inexpensive and will give better results.

Some of the advantages of a cathode-ray "Visual" over the string-galvanometer type are:

1. The trace is more brilliant and does not require an awkward hood for observations in daylight.
2. Overload does not damage the apparatus but merely causes the beam to deflect off the screen.
3. The apparatus can be made portable.
4. The cost of the apparatus is low.

A resonance curve tracer employing the type 906 cathode-ray tube has been set up and operated in the laboratory of the RCA Radiotron Co. This device is designed to cover a range of intermediate frequencies of 100 KC to 500 KC and has an amplifier-detector section which is practically flat over the entire range. Since it is believed that a "Visual" of this type will be of distinct value to many laboratories as well as to manufacturers and service men who desire to improve their testing facilities, a detailed description of the instrument is given in this article. Fig. 1 is the schematic circuit diagram while Fig. 2 shows the functional layout and a suggested arrangement for a portable resonance curve tracer. It should be borne in mind that the principles and methods involved in this application can be applied to obtain the curves of any form of tuned circuit and that the frequency range is not limited to the 100-500 KC of the apparatus illustrated.

A resonance curve is a plot of the voltage output of a tuned stage for a given frequency band. To obtain this curve, it is necessary to have a voltage source, which in this instance is the oscillator  $T_2$  of Fig. 1, and to have a source of variable frequency covering a range which extends above and below the resonant frequency. The frequency variation to sweep across the frequency range of the tuned circuit can be accomplished manually by hand manipulation of a condenser or it can be speeded up to thirty times a second as is done in this case by means of an 1800 RPM motor. The fluctuating output voltage of the stage is then amplified, rectified, and again amplified, and finally applied to one set of

the deflecting plates of a cathode-ray tube. The other set of deflecting plates is supplied with the sweep-frequency voltage.

The frequency sweep is produced by a motor of about 1/20 h.p. or more, driving a rotating condenser  $C_2$  of maximum capacitance of 0.00035  $\mu\text{f}$ . A range switch  $S_2$  connects different values of capacitance  $C_3, C_4, C_5$ , etc., in series with  $C_2$  to adjust the sweep for

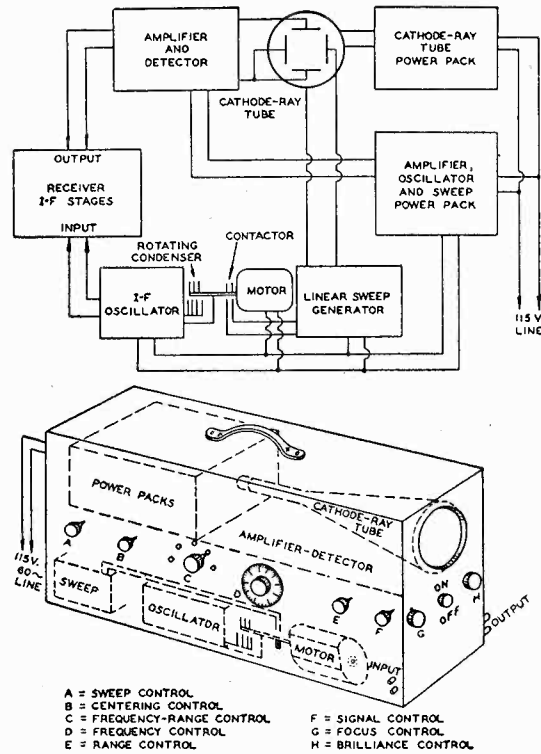

FIG. 2

different frequency ranges. The oscillator is tuned by adjusting  $C_1$ .

A contractor on the motor shaft controls the linear-sweep voltage by periodically short-circuiting condenser  $C_7$ . Condenser  $C_7$  charges linearly with time during the half revolution that condenser  $C_2$  sweeps the frequency. During the remaining half revolution, condenser  $C_7$  is short-circuited and  $C_2$  returns to the initial position.

The rheostat  $P_3$  in the cathode circuit of Tube  $T_1$  controls the rate of charge of condenser  $C_7$ . When  $P_3$  is properly adjusted, the contactor on the motor causes the voltage of condenser  $C_7$  to return to zero somewhat before the condenser becomes fully charged. When  $P_3$  is adjusted for too slow a charging rate, the sweep, as viewed on the screen of the cathode-ray tube, returns to zero before the full width of the screen has been traversed. On the other hand, if  $P_3$  is adjusted so that the charging rate is too high, the sweep terminates with the condenser fully charged before the contactor has returned it to zero. Considerable distortion of the resonance curve traced on the screen results from this latter adjustment due to non-linearity at the end of the sweep.

The proper adjustment of  $P_3$  causes a full sweep across the screen without any bright spot occurring at the end of the sweep. The appearance of a bright spot is due to the beam remaining in one position for a greater length of time than in other positions. A bright spot should appear at the beginning of the sweep since the beam remains there for one-half of the cycle. At the end of the sweep, no spot should appear when  $P_3$  is properly adjusted.

The centering of the pattern on the screen is accomplished by adjusting the knob of potentiometer  $P_4$ .

The frequency-range switch  $S_2$  and the tuning condenser  $C_1$  should be adjusted so that the resonance characteristic appears in the center of the sweep on the screen. As condenser  $C_1$  is varied, the resonance characteristic is shifted along the sweep axis. The best value of  $C_1$  is that which centers the resonance curve on the sweep range.

The input to the grid of the IF stage to be tested is connected to the contact terminal of potentiometer  $P_5$ . The test signal can be adjusted by means of  $P_5$  to give a suitable height of resonance curve. The range switch  $S_3$  reduces the signal when an overall test of two or more IF stages is made.

(Continued on page 19)

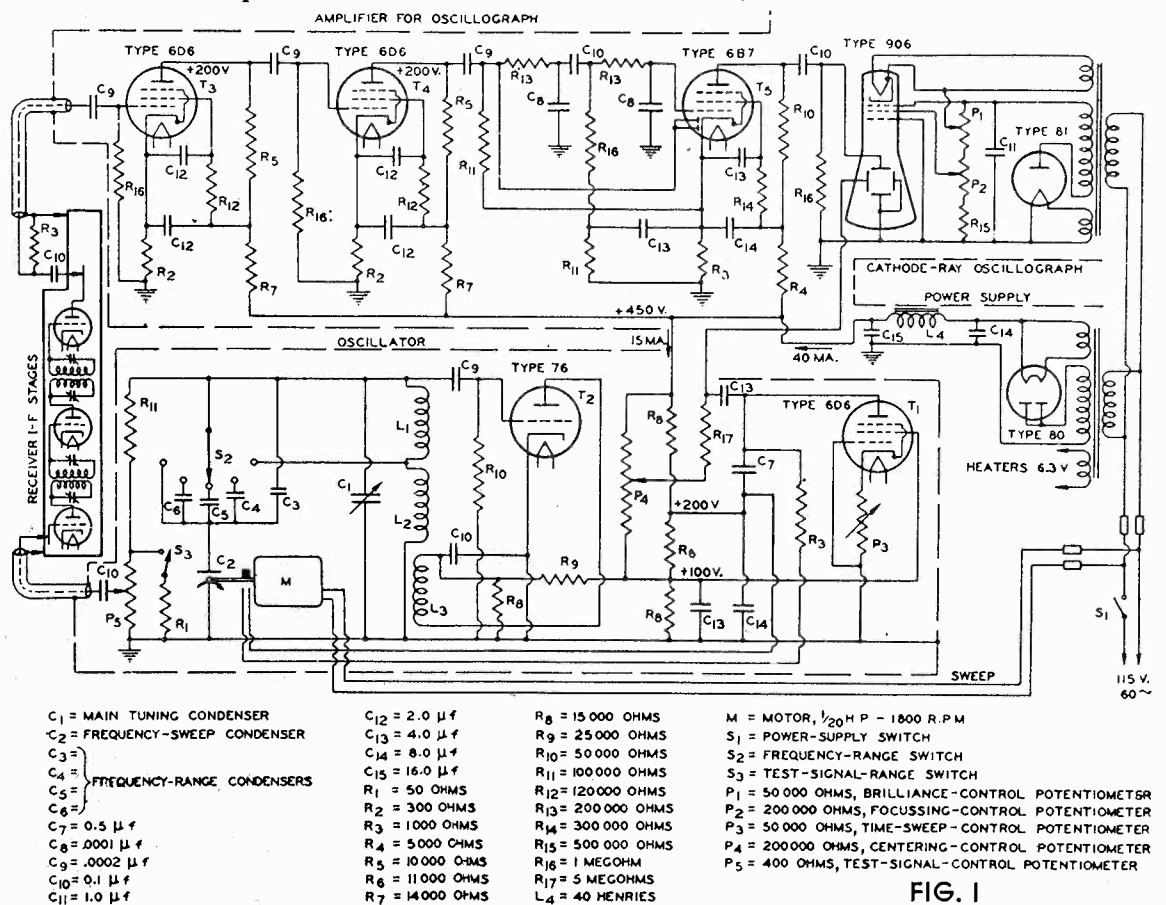

FIG. 1

\*Copyright, 1934, by RCA Radiotron Co., Inc.

# The Conservative Kilowatt

## A Complete Description of W6AWT, One of the Nation's Finest Stations

**T**HIS is a description of the new 1KW transmitter used by W6AWT on 20 80 meter phone and 20 and 40 meter CW. It is far from just another transmitter. The broadcast quality of the mechanical workmanship and audio channel is outstanding. Every component is designed for a large safety factor, as witnessed by the use of four 852s in push-pull-parallel in the final, driven in turn by another 852.

Instead of using five to seven stages of small tubes running at dangerously-high plate voltages and temperatures, each with a power gain of possibly only three or four-to-one, this transmitter uses only three stages on 80 and 40 meters between the crystal plate and the final amplifier. These three stages use tubes that are large enough to give a large power gain as well as enough power output to give a reserve of excitation power for the final amplifier. The 2A5 crystal oscillator operates gently at 275 volts on the plate in order to obtain maximum frequency stability and freedom from drift. The crystal stage is link coupled to the 830 buffer stage and an 841 doubler is employed between the 2A5 and the 830 when operating on 20 meter phone. The 830 is link coupled to the 852 driver stage. The 830 has enough output to drive the single 852 to 800 watts of cool input with only 2500 volts, although the driver 52 usually runs with only 250 watts input. This indicated excess of excitation is mainly for the purpose of providing perfect phone operation where high grid excitation is necessary to insure filling-up the modulation envelope at high percentages of modulation, which eliminates "carrier shift."

The final amplifier is perfectly symmetrical with respect to ground, thus making it easy to neutralize. Aluminum chassis and split-stator condensers are used throughout. Each component of the transmitter is grounded at only one point, on each chassis; the ground of each chassis is, in turn connected to the main ground bus.

The neutralizing condensers are protected against DC flashover by the use of 6000 volt blocking condensers in series with the neutralizing condensers. Thus a momentary RF arc-over will not carry DC along with it to short-out the plate power supply through the bias supply.

The parasitic-preventing grid chokes, shown in each of the four grid leads of the final tubes, consist of 10 turns of No. 12 enameled wire  $\frac{3}{8}$  inch in diameter. These chokes effectively prevent any tendency for each half of the final amplifier to oscillate as a push-pull ultra-high frequency oscillator, as well as preventing inductive feedback from plate to grid, which would seriously affect the neutralization of the stage.

The load stabilizing resistor connected across the grid circuit of the final amplifier (marked R in the diagram) is used to stabilize the load on the modulated driver stage when the final amplifier is used as a linear amplifier. The load on the driver stage varies quite widely during modulation because the final draws no grid current during part of each audio frequency cycle, and at other portions of the audio cycle the grid current goes up to quite high values. This change of load effects the driver voltage output and distortion would be introduced unless the resistor R is used to provide a steady drain of power from the driver.

The final amplifier is operated in three

different ways for linear amplification. (1) As a conventional linear amplifier, with fixed bias supplied from a separate bias pack equal to cut-off. The driver stage is then modulated 100 per cent by means of two

845s operating in class A prime. (2) The final amplifier is sometimes operated as a modulation-gaining linear amplifier. This type of linear amplifier operates with bias equal to one-and-one-half times cut-off. The driver stage is then modulated 50 per cent by the 845 modulators operating true class A. Although the excitation supplied to the grids of the final linear amplifier is modulated only 50 per cent, the RF output of the final amplifier is modulated 100 per cent because there is a gain of 50 per cent in the percentage of modulation in the final amplifier. This represents a tremendous economy of audio power required to modulate the driver stage because 50 per cent modulation requires only one-fourth of the audio power necessary to effect 100 per cent modulation. The higher bias and excitation on the final amplifier also allows it to operate more efficiently than true class B linear operation.

The third system consists of class B prime linear amplification, where the fixed, separate bias equals cut-off and a cathode bias resistor is used to provide additional bias so that the total bias is approximately three times cut-off. This high bias allows the stage to operate at practically 40 per cent plate efficiency (unmodulated), which swings-up to 80 per cent efficiency on audio peaks.

The most important single adjustment for successful operation of a linear amplifier is the control of excitation. The excitation to the final amplifier is controlled at two points. The rough control is the resistor R, and the fine control consists of a variable coupling link in the transmission line between the driver and the final. This control is varied by a dial on the front panel. It represents a distinct improvement over the use of conventional variable condensers when capacitive coupling is used between the driver stage and the linear. The variable coupling condensers were very troublesome in that each variation of the excitation called for re-tuning of both stages. The low impedance of the link circuit eliminates this difficulty and the coupling can be varied between wide limits without effecting the tuning of any stage.

The operation of the linear amplifier is checked with an oscilloscope. W6AWT is employed by Television Laboratories, Ltd., where the modern high vacuum cathode ray oscilloscope and the cold cathode electron multiplier were born.

The audio channel begins with a condenser mike with two stages of battery-operated 864s in the head amplifier. A 200 ohm line carries the amplified mike output to the main voltage amplifier, which consists of two stages of transformer coupled 56s, the second stage being push-pull. This feeds the push-pull 2A3s which drive the class A prime 845s. The 845s are the modulators and can deliver a clean 200 watts of power when called upon to do so. However, the 845s are usually operated at about the 100 watt point in order to minimize harmonic distortion.

For CW, the transmitter is keyed in the coupling link through which the 830 buffer stage is driven, thus preventing clicks in nearby BCL receivers. No clicks are heard in a BCL receiver installed within 10 feet of the transmitter. The use of fixed bias on all stages following the keying circuit prevents anything from "taking off" when the key is up. Cathode bias is used for the 830 tube

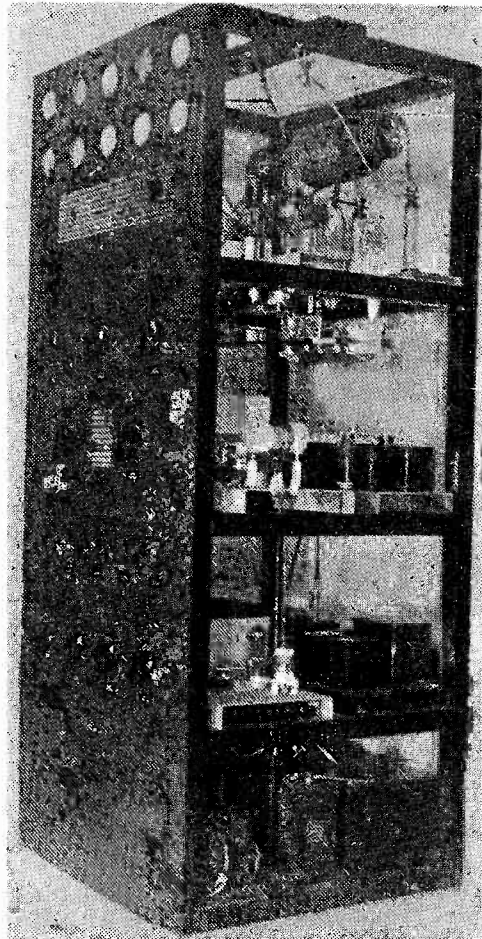

1 K.W. Transmitter and Power Supply

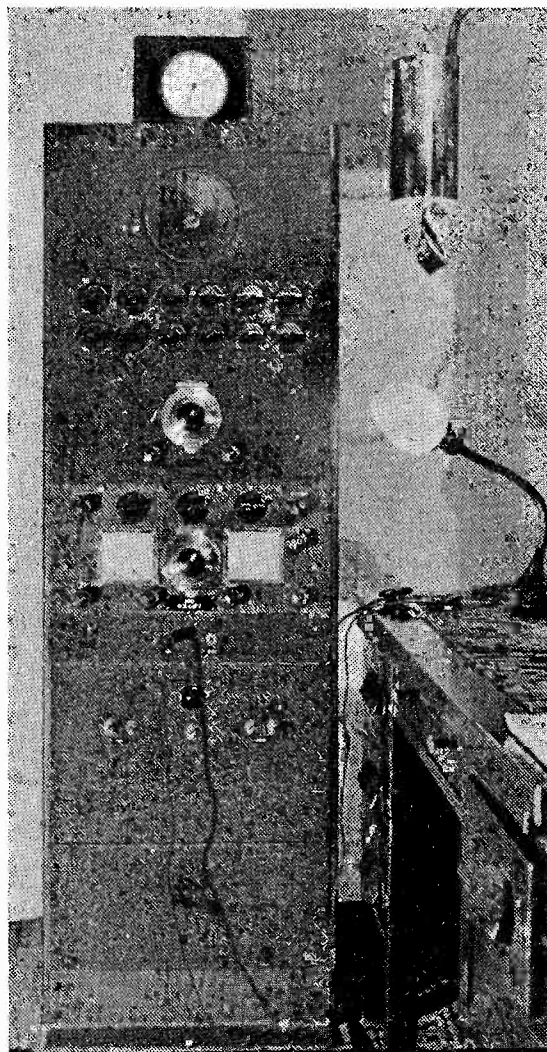

Receiver Rack with home-built AGSX type Receiver.



and the value of the resistor is such as to keep the plate current of the 830 stage approximately constant, whether the key is up or down. The load drawn by the plate supply of the 830 therefore remains constant.

The high voltage plate supply delivers between 2500 and 2800 volts of DC, depending on whether phone or CW is used.

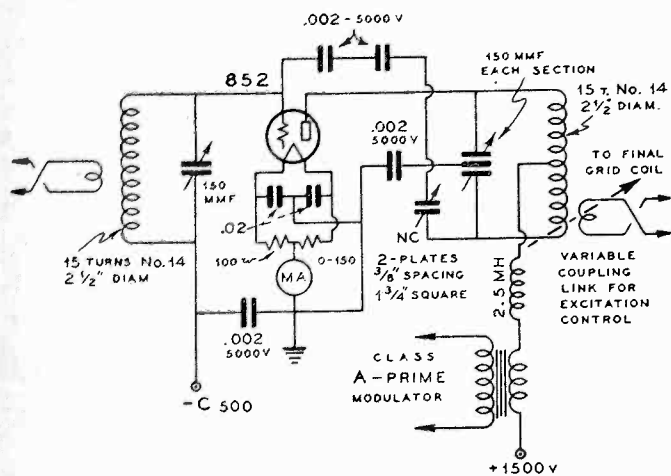

852 Driver for Final

The hash filter in the high voltage legs from the power transformer keeps the mercury vapor hash developed by the 72s from getting back into the receiver or speech channel through the 110 volt line. This also prevents the rectifier buzz from finding its way into BCL receivers via the power line. The exceptionally large amount of filter in the plate supply is used to eliminate the last vestige of carrier noise on phone. The total drain from the AC line is only 1675 watts when operating with 800 watts output and 1KW input to the final. This includes all filaments and bias supplies, as well as the various high voltage supplies.

All of the meters in the transmitter are protected by means of RF chokes in series, and by mica condensers shunted across the

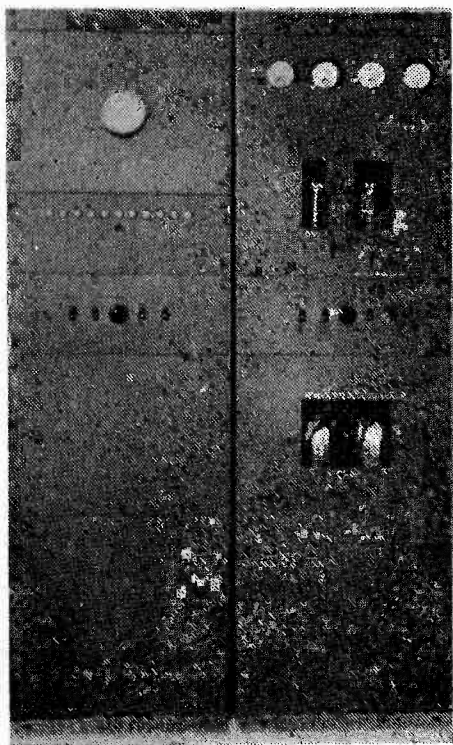

Modulator and Cathode-Ray Oscilloscope

meters. Fuses are provided in the main line and circuit breaking relays automatically cut off the high voltage, should the bias fail. There is an overload breaker which also protects the transmitter if anything arcs-over. A twenty-four-hour test with the key down and a full 800 watts output into the dummy antenna showed that all components were operating at normal values. The transmitter is loosely coupled to the antenna feeders and a very sharp signal is emitted with conse-

quent freedom from interference with other amateur transmissions. A properly designed and operated high power transmitter can therefore be more free from interference than transmitters of lesser power not properly operated.

The antenna is a 66 foot, 40 meter Zepp, supported between two lattice-work towers

European contacts on 20 meters on October 21, one with G2OA in Britain, another with PAØCE in Holland, and the reports from both stations were QSA 5, R6.

The receiver is unique in that it looks like a factory-made AGSX. It was home-built by W6AWT, from the chassis to the gear-drive tuning condenser catacomb. Each

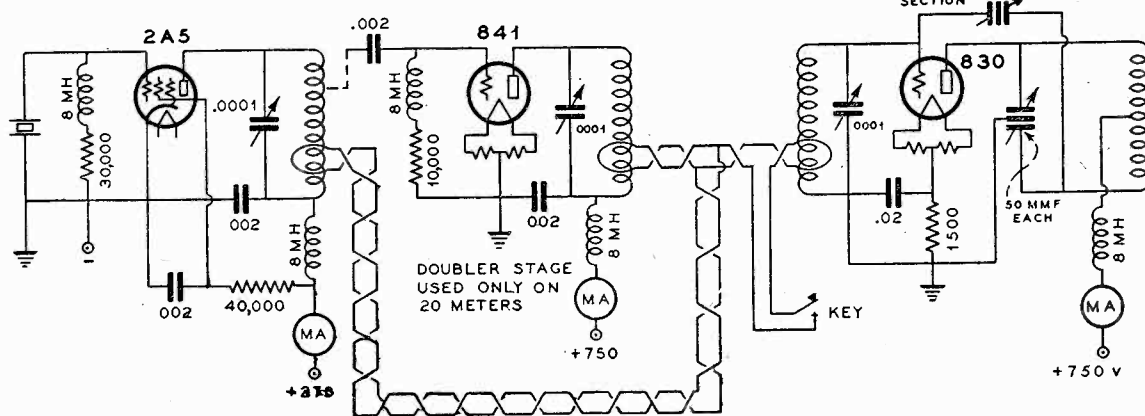

2A5 OSCILLATOR - 20 METER DOUBLER & 830 BUFFER

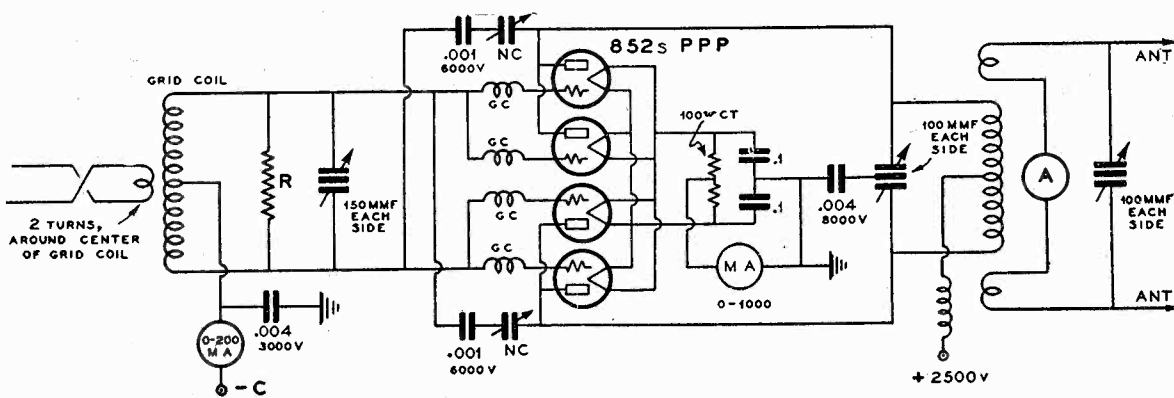

MERCURY VAPOR HASH FILTER & POWER SUPPLY FOR FINAL & PRECEDING STAGE

each 60 feet above ground level. The feeders are 60 feet long, parallel-tuned on 20 and 40 meters, series-tuned on 80. A vertical antenna consisting of a 66 foot length of 4-inch copper drain pipe will soon be installed.

Although the tank coil in the final amplifier shown in the illustration is wound with 3/8-inch copper tubing, recent tests with 20 meter coils have proved that equal, or better results can be obtained when using 6 turns No. 12 enameled wire, wound on a 2 1/2-inch diameter isolantite form. With 1KW input to the final amplifier, this 20 meter coil, wound with small wire, gave better results than when the 3/8-inch or 1/4-inch copper tubing coils were used. This increase in power output is perhaps due to the fact that there is a smaller amount of metal in the field of the coil, a reduction in loss from "short-circuited turn effect" and because the field of a small coil is more concentrated.

As proof of the effectiveness of the small-wire tank coil, station W6AWT made two

component is interchangeable with standard factory replacement parts.

In designing the receiver it was found that wire-wound resistors gave a higher signal to-noise ratio.

Above the home-built AGSX-type receiver is mounted an SW3 T. R. F. receiver, rebuilt so that its selectivity is increased for use in congested areas. The SW3 is used principally for standby purposes. The loud speaker is of the permanent-magnet type and above the speaker is mounted an electric clock. The remaining panels on the rack are used for mounting the plug-in coils and power supply units.

The station first took the air in 1920 with C. W. when spark was still the order of the day. The transmitter here illustrated has been in operation for less than two months and already 33 countries have been worked, with a minimum report of R5 on 20 and 40 meters.

W6AWT's C. W. frequencies are 7001, 7005, 7150, 7299, 14002, 14010. Phone frequencies are 3900 and 14150.

# The "Les-Tet" Exciter in a Medium-Power Radiophone

By FRANK LESTER \*  
(W2AMJ)

ALMOST every amateur who has used a transmitter sprawled out on a bread-board has wanted a rack-and-panel outfit, something of which he could be proud and show to his friends without apologies. Until recently, however, rack-and-panel construction has been a little beyond the financial reach of most amateurs. The owner of a rig of this kind was regarded as a most fortunate fellow indeed!

Having gone through every phase of the amateur game from crystal detectors to crystal oscillators, the writer decided to tackle the design of an inexpensive rack transmitter when he was placed in charge of the amateur division of a large Eastern radio firm. The tentative specifications laid out for the job were as follows: (1) full metal rack and panel construction of commercial quality; (2) 100-watt CW output, this being a good average power; (3) crystal control, with easy wave shifting; (4) utmost stability; (5) optional modulation equipment for phone at minimum expense; (6) completely self-contained; (7) plenty of meters to tell what's going on in the circuits; (8) adaptability to different types of antennas.

After several months of work, the transmitter as pictured herewith fully meets all of the original requirements. A few years ago this amount of money would just about get an amateur started on a rack and panel outfit, the meters and a couple of condensers alone costing half that much! As the transmitter has been built up of a number of independent but inter-connecting units, which represent some interesting ideas in both electrical design and mechanical construction, a complete description of it will undoubtedly interest both new and old amateurs.

First, for a general idea of the outfit's physical size and layout. The whole job stands 6 feet high off the ground, and measures  $19\frac{3}{4}$  inches wide and  $16\frac{3}{4}$  inches deep at the base. The rack is of sturdy one-inch structural iron, the panels of  $\frac{1}{8}$ -inch steel. All surfaces are finished in black crackle, which is impervious to finger marks, moisture and all the other abuses to which a radio transmitter is subjected. There are five units of uniform width, from top to bottom as follows: Universal antenna coupling unit, push-pull power amplifier, "Les-tet" exciting unit, modulator and power supply. A blank panel closing-in the bottom is supplied for any use the owner cares to put it to.

The "Les-tet" exciter unit is shown diagrammatically in Fig. 1. The exciter uses a single 2B6 tube in a circuit developed by Mr. Lester and found to possess highly desirable characteristics. The 2B6, which has not received the recognition it deserves, consists of two triodes in one envelope, with the cathode of the first and smaller "tube" connected internally to the grid of the larger "tube". This construction permits the use of the 2B6 as a marvelous crystal oscillator and buffer amplifier (or doubler) combination. The crystal is connected directly across grid G1 and cathode K1 of the first tube unit. The plate tank circuit, consisting of plug-in coil L1 and condenser C1, is connected above ground—between the cathode and ground, as shown. L1 is tapped about one-third the way up from the bottom, this section providing neutralizing voltage (through C3) for the amplifier section of the 2B6 when the

latter is used as a straight amplifier on the crystal's fundamental frequency.

Since neutralization is unnecessary when the second 2B6 section operates as a frequency doubler and the neutralizing condenser C3 becomes undesirable, the coil L2 is wound on a five-prong form, and C3 can be removed from the circuit merely by cutting the link to the fifth pin. For instance, suppose an 80-meter crystal is used. For 80-meter operation the second 2B6 section acts as a straight buffer and must be neutralized, and therefore C3 is left in the circuit with the stock coil unchanged. For 40-meter operation with the same crystal, a 40-meter coil is used for L2, with the link removed to remove C3. The correct adjustment of the latter for 80-meter neutralization is thus left undisturbed and there is none of the usual mess of returning the exciter unit when shifting from one band to another.

Variable excitation of the amplifier section of V1 is made possible by R3, which merely controls the grid bias. R2 is a fixed limiting resistor to prevent the tube from losing all its bias if R1 is accidentally turned all the way out. This is a simple and effective control and works beautifully.

Both L1 and L2 are wound on receiving forms and can be pushed in and pulled out of their sockets in a jiffy.

The arrangement of the parts of the exciter is simplicity itself. The 2B6 is mounted in the center of the chassis, with the crystal L1 and C1 at its right, C3 directly behind it, and L2, C2 and R3 to its left. Individual milliammeters are used for the oscillator and amplifier units of the 2B6.

The two little stand-off insulators on the left connect directly to a corresponding pair on the power amplifier, just above.

It might be mentioned in passing that this oscillator-amplifier unit by itself is an excellent low power transmitter, with an output of 7 to 10 watts. The single tube constitutes a full M.O.P.A., and the signals on the air have that steady-as-a-rock, piercing note characteristic of a well-built crystal controlled job. Many amateurs are buying this unit as a starter, and intend to build up the whole outfit piece by piece. Incidentally, all the units of this transmitter, including the rack itself, are available separately.

The power amplifier, link coupled to the buffer amplifier, uses two of the new Raytheon RK-20 power pentodes in push-pull. These tubes require no neutralization and lend themselves beautifully to economical, simple suppressor-grid modulation for phone. The grid coil L3 is wound on a small plug-in form, like L1 and L2, while the plate tank L4 is a heavy inductor wound on an accurately threaded bakelite form. The tuning condensers C7 and C8 are of the split-stator type. The screen, suppressor and filament circuits are all adequately filtered by suitable condensers and RF chokes.

A two-position switch allows quick changing from CW to phone. For telegraph operation the suppressors are returned directly to filament, and for phone are run to the secondary of the modulating transformer in the modulator unit.

Meters are provided for reading grid, screen and plate current. These are permanently in the circuit and require no juggling of plugs or other loose connectors.

The tubular envelopes of the RK-20s, with

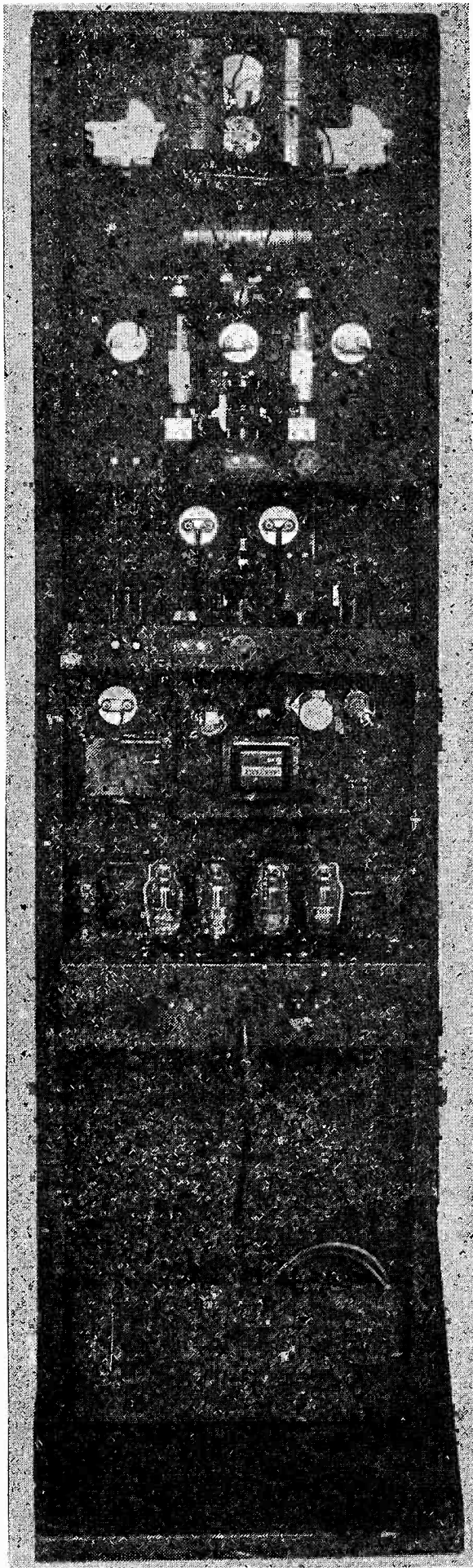

Rear view of the new Lafayette 100-watt transmitter. Top to bottom: universal antenna coupling unit, power amplifier, exciter-buffer, modulator, power supply. The connecting cables between the various units were removed when the picture was taken, because they passed in front of some of the important parts on the chassis.

\* Engineer, Wholesale Radio Service Co., Inc.

the plate connections at the top, permit a perfectly balanced and symmetrical layout of parts, following the actual electrical circuit almost exactly.

The antenna coupling unit makes use of the Collins universal impedance matching idea, and allows the use of double-wire feeders with half-wave Hertz antennas. An additional coupling coil, permitting the use of single wire feed systems, is available as a separate accessory. This is truly a universal coupling device, yet is very easy to adjust. The coils L5 and L6 are fixed in place, being arranged with clips for variation of their inductance as different antenna systems require. A 0-2½-ampere meter is required.

This coupling system has another advantage in that it suppresses harmonics very successfully, something that ordinary coupling arrangements do not do at all.

The modulator unit, mounted on the rack directly below the exciter, is a self-contained three-stage resistance-capacity coupled amplifier, with its own power pack. The crystal microphone (which is recommended for its quality and simplicity) is connected across the grid circuit of V4, a 57, operating as a voltage amplifier. This works into V5, a 2B6, operating with the two triode sections in cascade. The grid potentiometer R9 is the gain control. The power pack is of unusual construction, using an 80 rectifier. To use phone instead of CW, the operator merely shifts the switch on the power amplifier panel and snaps on the modulator power switch, after, of course, he has tuned the transmitter to one of the phone channels.

The bottom-most unit is the heavy-duty power supply, using four type 83 rectifier tubes in a bridge circuit to give 1250 volts at 250 ma. and 550 volts at 250 ma. Two separate filament transformers are used; one for the 83 filaments and the other for the 2B6 in the exciter and the RK-20s in the power amplifier. The regulation is very good and the ripple voltage is exceptionally low. The filter condensers are of the paper type—not electrolytics—and are operated below their normal ratings.

Separate switches are used for the filament and plate circuits. S1 is turned on first, lighting all filaments except those of the modulator unit's tubes. After 15 or 20 seconds S2 may be turned on.

Note that the 2.5 volt secondary that feeds the 2B6 exciter tube has two pilot lights across it. The first lights up when S1 is

closed, but the other remains dark until S2 is closed. S2 is a double pole, single throw switch. This simple stunt was devised because the plate transformer T8 supplies high voltage only and has no low voltage windings suitable for for pilot light operation.

At the bottom of the rack is a compartment for holding grid bias batteries.

Power connections between the various units are made by convenient plugs and cables. One unit can (Continued on page 21)

### OSCILLATOR-BUFFER AMPLIFIER

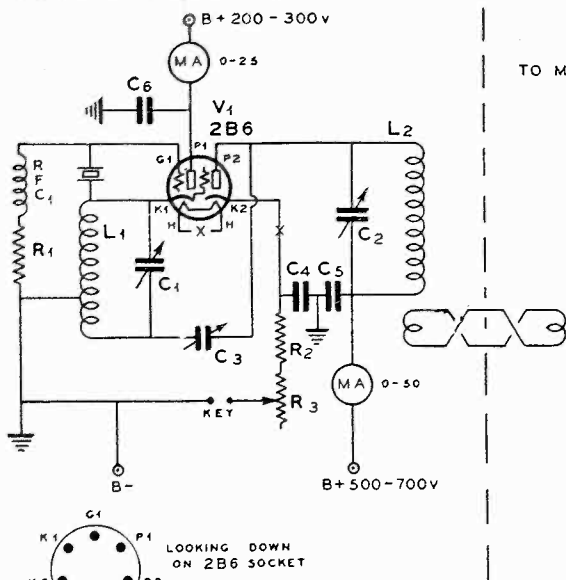

LAFAYETTE "LES-TET"

FIG. 1

### POWER AMPLIFIER

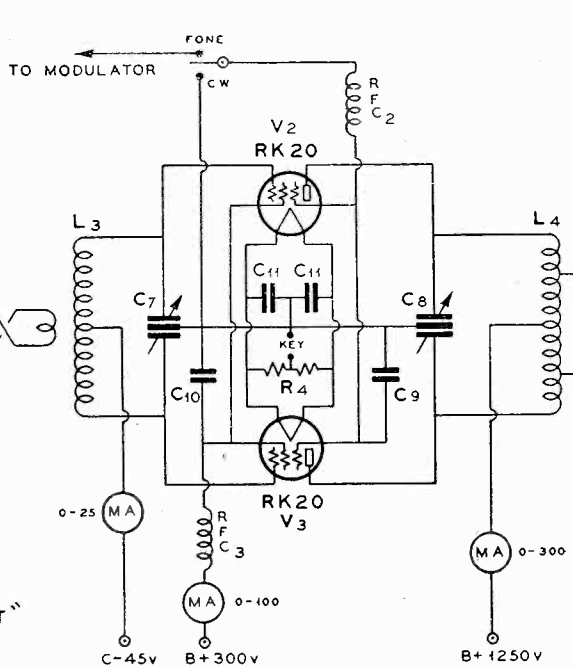
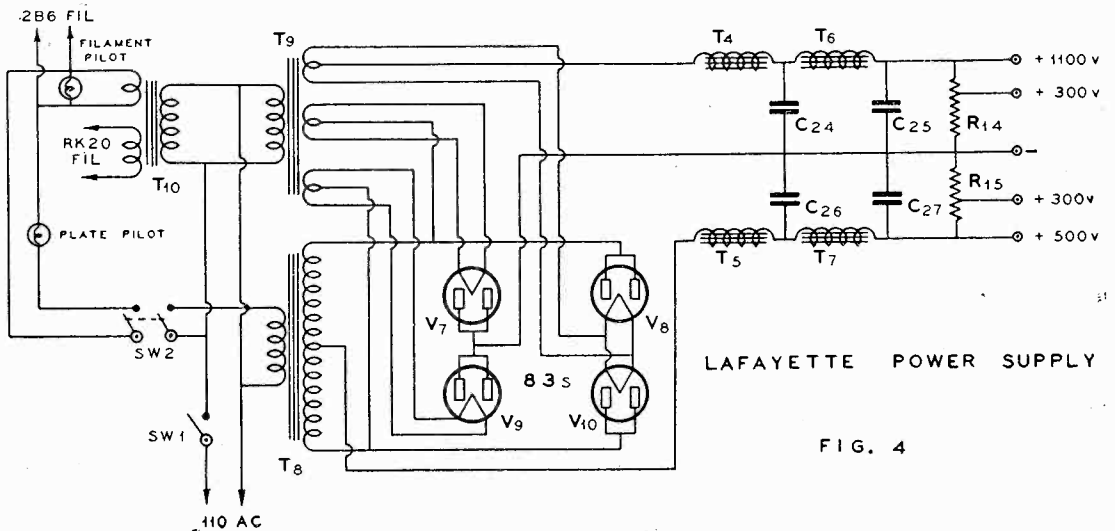
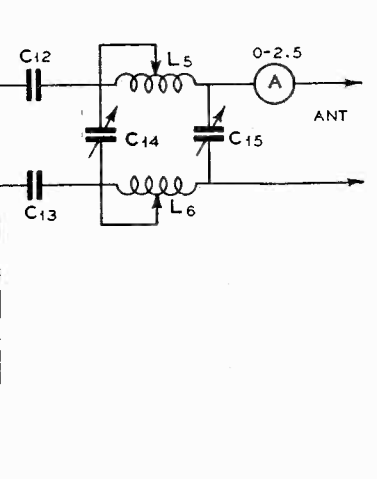

FIG. 2

### ANTENNA COUPLING



LAFAYETTE POWER SUPPLY

FIG. 4

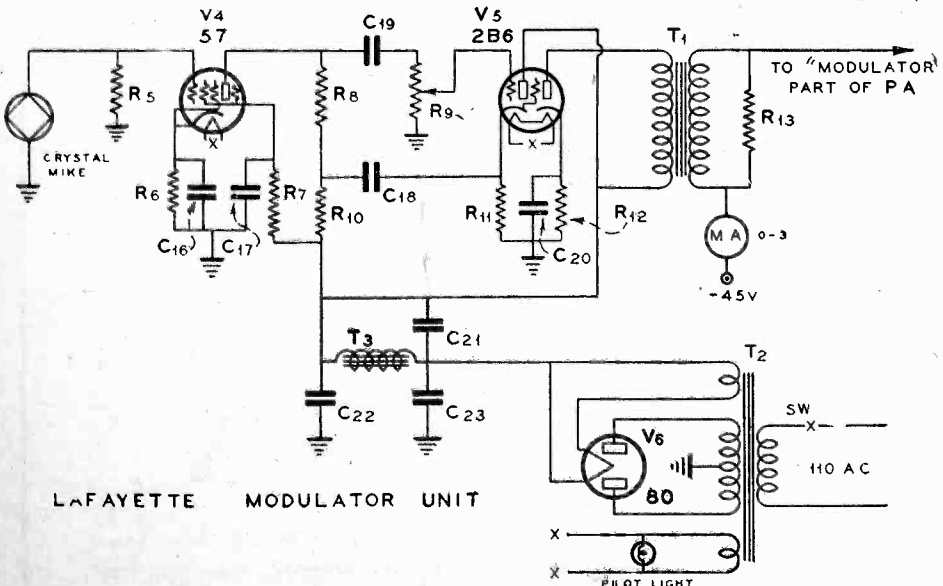

LAFAYETTE MODULATOR UNIT

FIG. 3

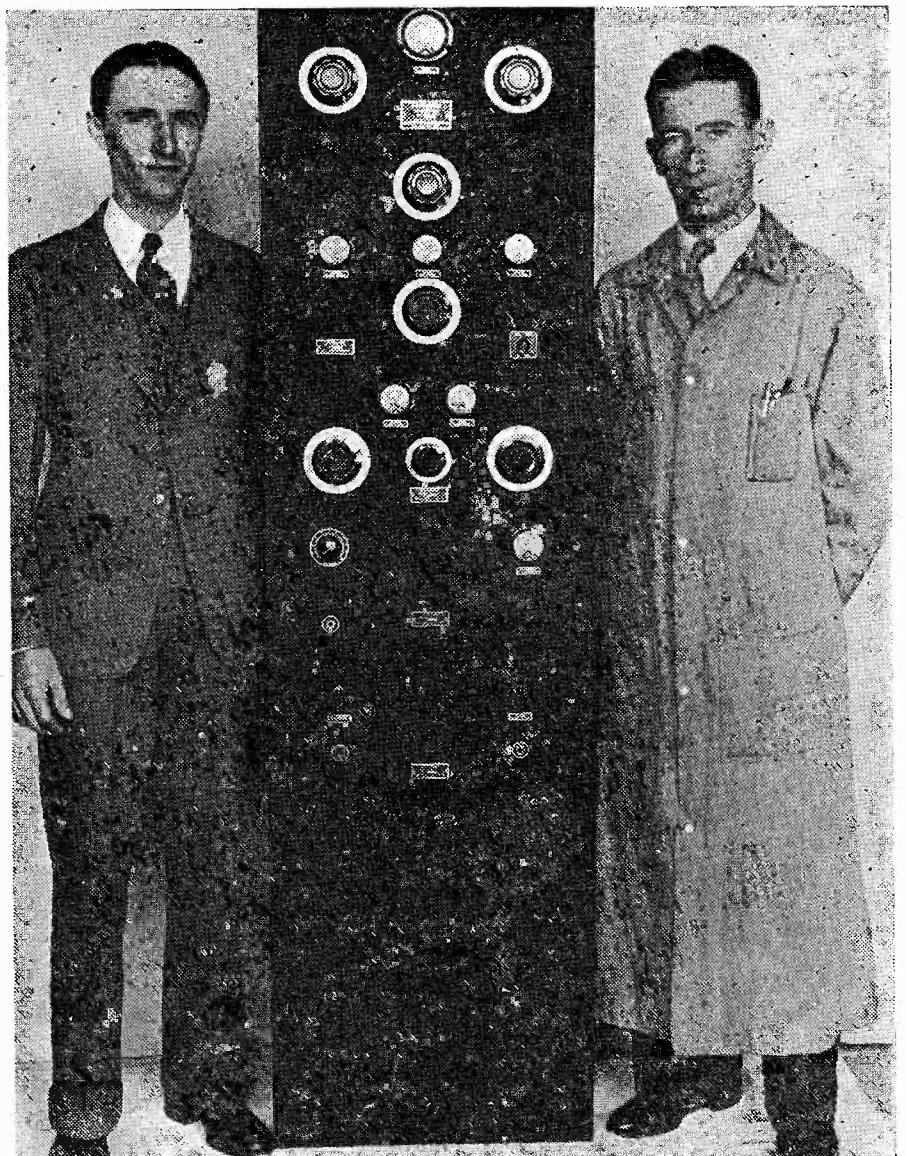

The author (left) with Roy Neusch, W2CF, designers of the new Lafayette 100-watt transmitter.

# AMATEUR NEWS



Harriett Ellsworth, W6HEG

BY INTRODUCING her as W6HEG you may slightly raise your eyebrows, but by telling you that her old call was 7SI, many old-timers recall fond memories and dreams. You think of the gal who could make raw AC sound better than the prettiest of crystals. She is Mrs. Harriet Ellsworth Gilbert, YF etc. of Ed Gilbert, W6GAT.

Almost eleven years ago, as a youngster of fifteen living in Boise, Idaho, she began the study of the Continental code. After listening in on a Federal receiver, CQs and code signals became readable. Being feminine, the inability to talk back was more than annoying. The R. I. came to town and after a frightful morning under his watchful eye she emerged with the second blue ticket issued to a YL in the 7th district.

Immediately aid was enlisted from among neighboring hams and a transmitter was built from the ground up. Her OM skeptically raised two forty-foot masts from which proudly swung a five-wire cage aerial . . . that's what they were called in those days . . . with a seven-wire counterpoise beneath. The call of 7SI was assigned and thereafter the world became 7SI-conscious. It aroused so much curiosity that her photo was published in a radio magazine in October, 1924. She is the YL who made one CQ last all night long.

She broke hearts for a year and a half, then at the U of U in Salt Lake City she began anew under the call of 6BNV so that she could talk to the home folks and to the boy friend attending the U of Idaho who used 7JF's (W6FFP) station. But there are some things you can't do by radio, so . . . while visiting in Los Angeles at a radio club meeting there was a grand scramble and 6AIC was named the winner. 7SI was soon changed to Mrs. 6AIC. Radio became a side issue and finally simmered down to the BCL variety. A junior op arrived with background noise that drove the loudest signal out. 6AIC was again smitten by his former flame and he became W6GAT.

W6GAT's first transmitter used the original five-watter of both 7SI and 6AIC. This brought back old radio memories, so Mrs. W6GAT took a new exam and was assigned

the call W6HEG. They are often on the air together and they have had many pleasant contacts with old timers, from ZS2A to LU8BAS.

W6GAT's brute strength enables him to take the key away from Harriet when he is at home, but when he is away she is back at the old game of thump-thumping some poor guy's heart.

Using HEG's own words, "As a concluding confession I will say there has never been any sport or amusement which has given me more pleasure than amateur radio. I wish I could make more wives see what they are missing by not becoming a licensed YF." And we echo, "We, too."

## FRESNO CONVENTION PLANS COMPLETED

ALL is in readiness for the 1934 Pacific Division Convention which will be staged in Fresno, California, November 10 and 11. The number of advanced reservations is most gratifying and is an indication that the attendance will be another record-breaker. General Chairman Jacks, his co-workers Kirkpatrick, Shaw, Wolf, Fast, Clarke, Davis, DeJarnett and Ports, have everything in readiness for the Coast's big day. The ladies' entertainment committee, consisting of Miss Opal Larson, Mrs. Hazel Ports and Marian B. Jack, announces that the LYs, YFs and OWs will have something to regret if they do not join their hubbies and boy friends on the trek to Fresno.

In addition to the speakers whose names were mentioned in the last issue of this magazine, the conventioners will be addressed by the tube engineers from the new Eitel-McCullough organization and by Clayton F. Bane of "RADIO." The 5-meter contest will be staged on Sunday, November 11, not on Saturday as was previously announced. However, the 3/4-meter contest will take place on Saturday, as originally planned. A 30-page program will be issued and a large collection of prizes is already on hand.

Much interest in the convention has been stimulated by a series of 75-meter broadcasts which have been heard up and down the Coast.



K. B. Warner, Leader of the Amateurs

The Open Forum will be a history-maker in that a number of vital resolutions are to be presented and many timely subjects will be discussed.

The Hotel Fresno is the official headquarters and accommodations can be secured at very reasonable rates. You are advised to communicate with Mr. Howard A. Fast, W6BUZ, 1820 Broadway, Fresno, California, for reservations.

## New Spot for W6CUH

At the stroke of midnight on December 1th, Chas. Perrine, Jr. (W6CUH) and Herbert Becker (W6QD) will stand on the front porch of their Manhattan Beach QRM factory and with a tear in each eye, and a firm grip of the hand, they will bid each other Adios. The age-old QD-CUH combine comes to the parting of the ways. W6CUH is moving into a residence of his own, also located at Manhattan Beach, and he will have his new station on the air before the close of the year. W6QD will remain "as is."

## CONVENTION COMMITTEE

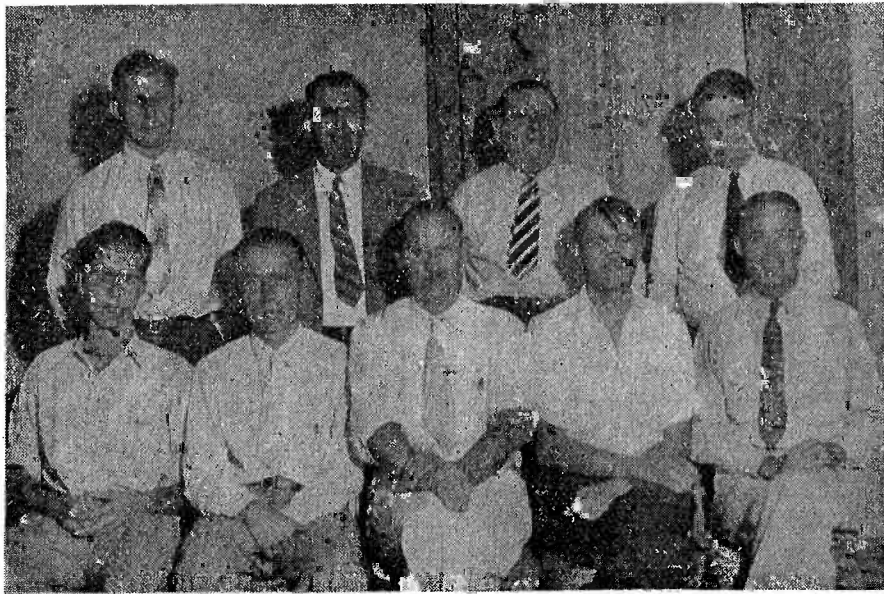

Left to right. Top row: W6DWE Claude Kirkpatrick, B. J. DeJarnatt; W6BWK Wm. Shaw, W6AVV Mason Ports. Bottom row: W6ENA Stewart Purcell, W6BUZ Howard Fast, W6FPW R. A. Jack, W6CRF Vernon Edgar, W6TO Phil Davis.

# REVIEW of Factory Receivers

## Review of the New Jacobs' Transceiver

By FRANK JACOBS

THE push-pull oscillator, class B modulator transceivers herein described have a power output of from 10 to 50 times that of the conventional transceiver employing type 30 and 33 tubes. The use of highly efficient tubes and circuits makes possible an output comparable to that of a medium-powered transmitter. The transceiver chassis and cases are made of crackle-finished steel, are 10 by 7 by 5 inches, and weigh from 7½ to 9½ pounds, depending on type. The front panel and chassis are a welded unit which fits into the hinged top cabinet. Special models with speaker grill and battery or generator compartment follow the same chassis design.

Twin triodes are the foundation of the Jacobs transceivers. Their use makes possible short leads so important at ultra-high frequencies, and simplifies the problem of realizing high output power. These tubes are available in three styles, the 19 for 2-volt operation, the 53 for 2.5-volt, and the 79 and 6A6 for 6 volts. The 19, 53 and 6A6 are peculiarly adaptable to 5-meter oscillators, having all plate and grid leads in the base. The 79 has one grid terminal in the cap, making symmetrical push-pull connections awkward.

The Jacobs transceivers use twin triodes as oscillators and twin triodes as class B modulators; which with a class A driver, make the equivalent of a five-tube transceiver, although employing only three tubes. The oscillator tube and unity coupled ⅜-inch copper inductance are mounted above the chassis on a bakelite platform. Plate and grid leads are brought directly to the socket prongs, making all RF components symmetrical and keeping them out of the field of other circuits.

The audio frequency circuits are confined to the region below the chassis subpanel. No wiring other than the plate, grid and filament leads to the oscillator circuit come above the base.

When the send-receive knob is thrown to the receive position the RF panel assembly becomes a push-pull super-regenerative de-

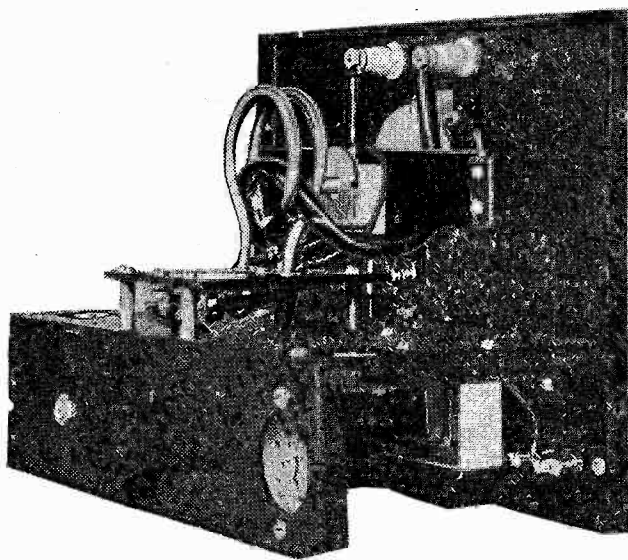

Interior view of Jacobs Transceiver, showing Unity-Coupling Coil.

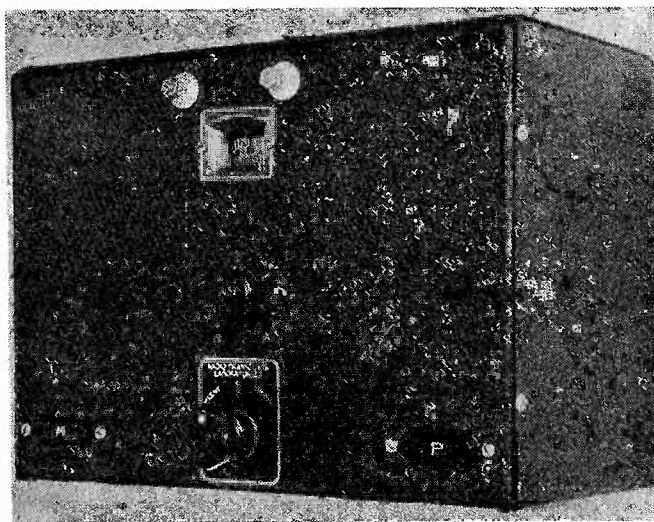

The Jacobs Transceiver in metal cabinet.

tor feeding into a special primary winding on the microphone transformer. After being amplified by the driver and class B amplifier tubes, sufficient energy is developed to operate a loudspeaker. The 19-A transceiver delivers 2.1 watts U.O.P. to a speaker, greater power than that of many broadcast receivers; and the 53 (or 6A6) gives a maximum undistorted power of 10 watts.

Throwing the knob to "Transmit" changes the RF assembly into a high-powered oscillator circuit and connects the microphone to its transformer.

The 19-A transceiver may be used either as a portable or as a mobile station. Filament voltages of 2 or 6 volts from No. 6 dry cells may be employed. When four No. 6 dry cells are employed the current draw is only 0.25 amperes; three 19s being employed with filaments in series. Battery life is approximately 130 hours. A rheostat to compensate for the deterioration of dry cells is incorporated. Access is had by means of a slotted shaft in the rear of the cabinet; out of the way of playful hands. At a plate voltage of 135 the transceiver consumes 20 m.a. on reception and 50 m.a. on transmission. On extreme modulation peaks 75 m.a. is drawn. Either an automobile B-eliminator or B batteries may be used.

The Type 53-A is made for mobile or AC operation. In the former role the filaments are wired for connection to a 6-volt storage battery, while in the latter the filaments are heated from a 2.5-volt source.

Models similar to those described but having a separate transmitter and receiver in the same cabinet, permit duplex operation or relaying of signals. These units have transmitters similar to the above and separate low current receivers with non-radiating super-regenerative oscillators. The annoying radiating "squeal" is eliminated by the use of an untuned RF stage.

Selected oscillator tubes are supplied by the manufacturer when desired, because it has been found that all tubes of the same type are not good high-frequency oscillators.

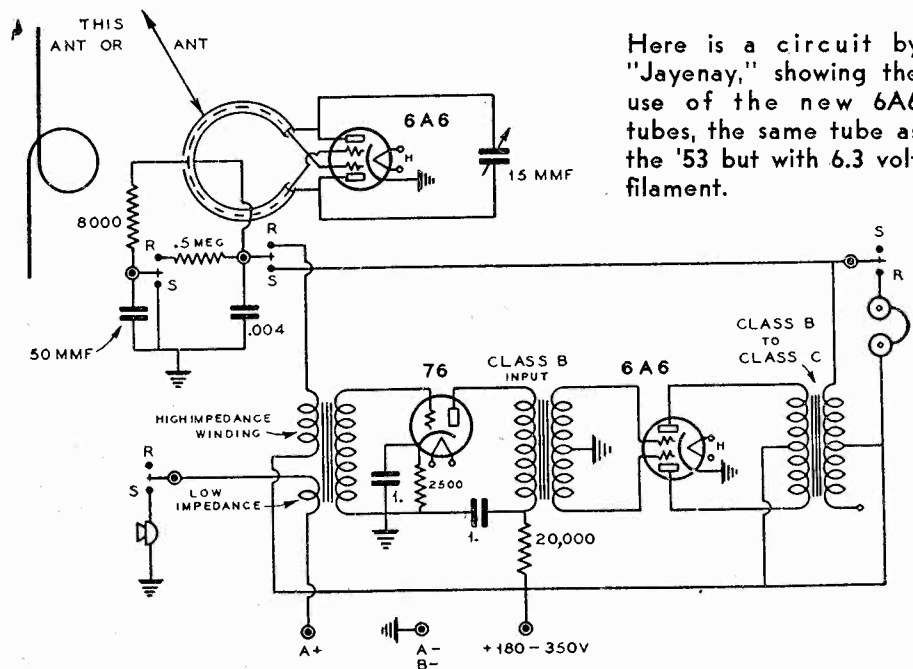
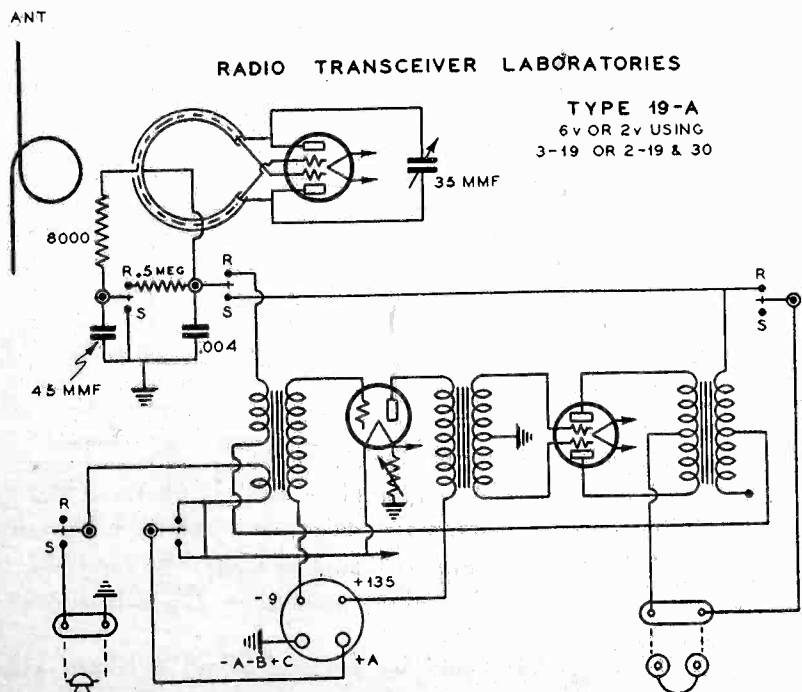

# A Cigar-Box 10 Watt 160-Meter Phone

By HAROLD D. SIMPSON  
W6JQV

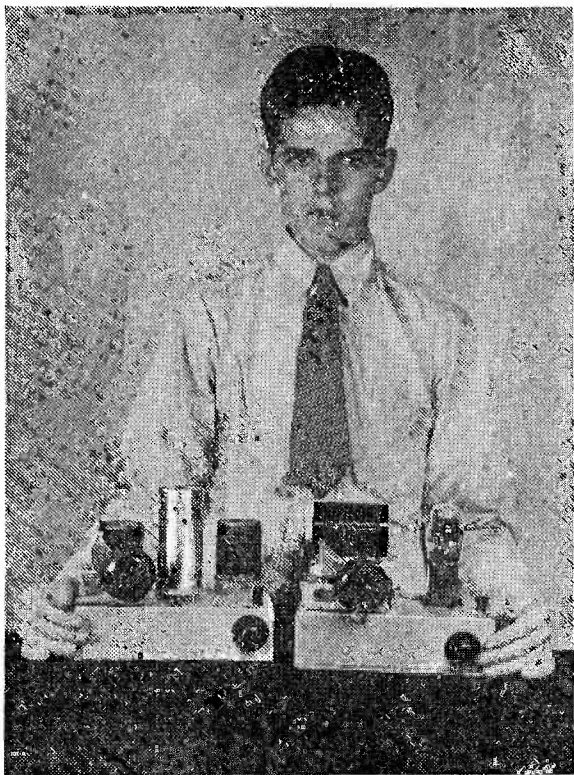

Harold D. Simpson, W6JQV, and his Cigar-Box Phone

**A**FTER your father has smoked or given away his last Christmas cigars, you can use the empty cigar boxes and build a compact, inexpensive 10-watt 160 meter phone, the cost of which will not exceed fifteen dollars, including the power supply units.

Such a phone has been in successful operation at W6JQV, W6GKJ and W6JNN. The first contact was with a station 50 miles away, an R8 report in the daytime was received.

The transmitter itself consists of a '24A electron-coupled oscillator with the grid and plate circuits both on 160 meters, capacitively-coupled to a neutralized '45 class C modulated amplifier, which is inductively coupled to a Marconi antenna. The '45 amplifier stage is modulated by another '45 used as a class A modulator by means of the simple and effective double-choke system. The '45 modulator is driven by a '56 amplifier tube with transformer coupling. This provides sufficient gain to work out a single-button microphone. Practically all of the parts were taken from an old broadcast receiver. All leads are short and direct. Socket holes for wafer sockets can be cut out with a pen-knife. The tank coils are wound on common impregnated paper forms, which have little loss at 160 meters. The transmitter is conventional and straightforward and the only precaution necessary is in the connection of the filament windings. Because the '45 modulator uses automatic cathode bias, its filament is not grounded, as is the filament of the '45 class C amplifier tube. Thus two separate 2½ volt filament windings must be used, one for the audio portion, another for the R. F. portion of the transmitter.

The .01 MFD. condenser shunted across the single-button microphone reduces the carbon hiss and adds to the intelligibility of speech. The only critical component in the entire transmitter is the .0001 MFD. coupling condenser between the plate of the '24A oscillator tube and the grid of the '45 R. F. amplifier tube. If the capacity is too large the oscillator will be unstable, if too small the '45 will not receive sufficient excitation.

For best oscillator stability the plate tank condenser of the '24A oscillator should be

very slightly detuned from resonance. The amount of detuning necessary will not be more than 2 degrees on a conventional 180-degree dial. The oscillator grid coil is fairly-high C, while the oscillator and amplifier plate tanks should operate with as

was very much in evidence when a type '46 tube was used as the modulated amplifier. The '45 modulator can be replaced with a 250 tube without changing the bias resistor, or a 2A5 can be used, with the bias reduced to about 500 ohms. If a 2A5 is used as modulator, the screen voltage should not exceed 250 volts, and the voltage should be reduced below 200 volts if the plate voltage is higher than 250 volts.

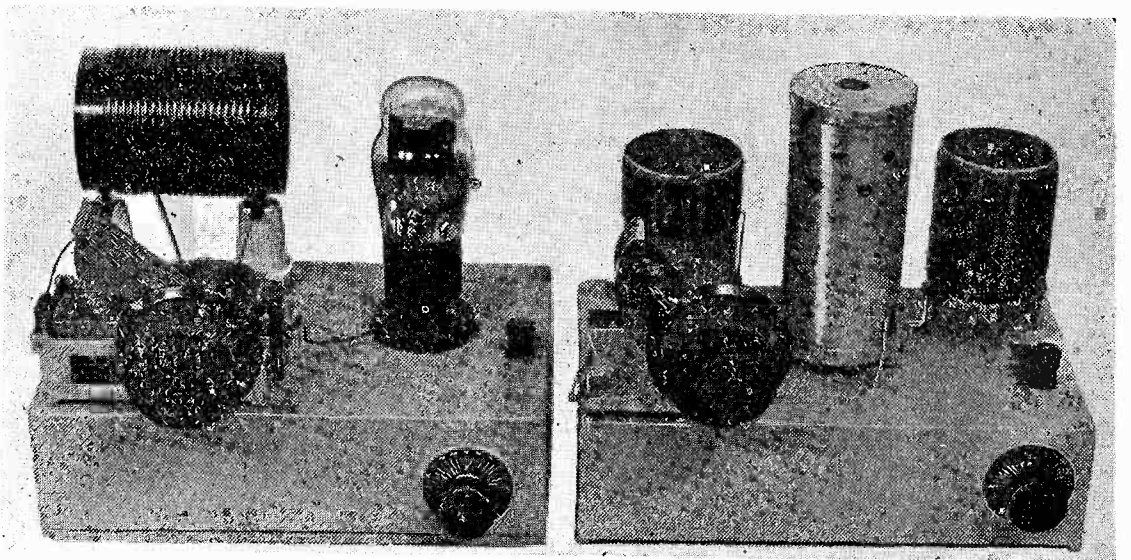

Electron-Coupled Oscillator and '45 Amplifier Stage, each mounted on a cigar box. The by-pass condensers, resistors, neutralizing condenser and RF chokes are mounted under the lids of the cigar boxes.

low C as possible in order to get maximum excitation and efficiency. Frequency of output is determined by the tapped tank in the grid circuit of the '24A tube, and thus the grid coil and condenser should be rigidly constructed and solidly-mounted in order to prevent frequency wobulation. The use of a '45 in the modulated amplifier not only requires less excitation from the oscillator for a given output but also eliminates practically all of the frequency modulation which

The first step in tuning-up the transmitter and putting it on the air is to find the middle of the 160 meter band while listening on a receiver. Then apply plate voltage to the oscillator and tune the grid coil until the oscillator output beats with the receiver, which is indicated by a pure, sharp whistle in the headphones. Then tune the plate condenser for minimum plate current as indicated by a milliammeter in series with the

(Continued on Page 17)

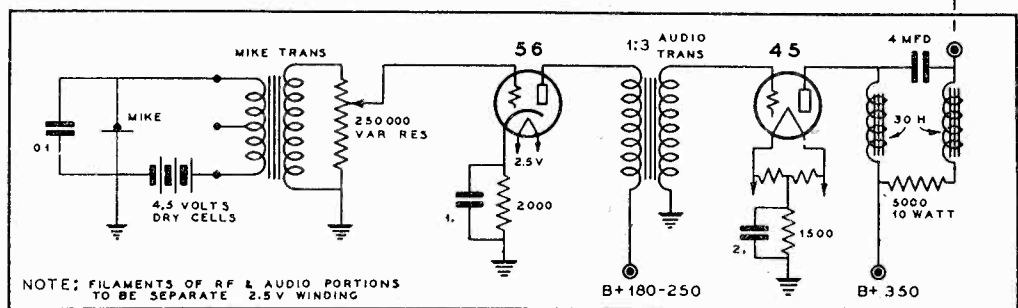
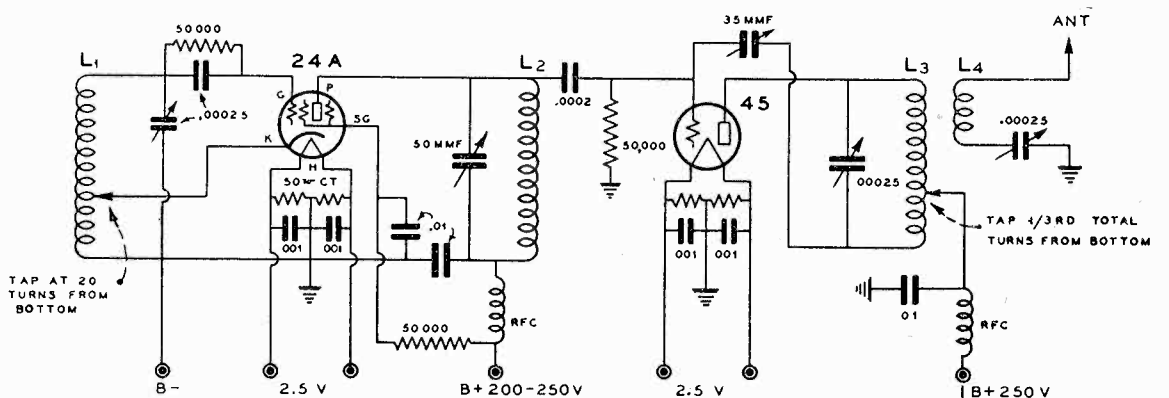

Circuit Diagram of Cigar-Box Phone.

## COIL WINDING DATA FOR 106-METER OPERATION

L1 (Grid Coil for Oscillator): 25 turns No. 18 enameled wire, close wound on a 2-inch diameter form, with the cathode tap taken at the eighth turn from bottom or grounded end of coil.  
L2 (Plate Coil for Oscillator): 60 turns No. 18 enameled wire, close wound on 3-inch diameter form.

L3 (Amplifier Plate Coil): 25 turns No. 18 DCC wire, close wound, on 3-inch diameter form.

L4 (Antenna Coupling Coil): 25 turns No. 18 DCC wire, close wound, on 2½-inch diameter form.

L4 should be coupled about 2 inches away from L3.

# Improved Amplifier Design for High Power

By CHAS. PERRINE, JR.,  
W6CUH\*

THIS is the story of an amplifier that was worked out to fit the requirements of the HK354. However, the new design has several features of its own which result in performance well in advance of present-day practice. A glance at the photograph will convince the reader just how far convention has been left behind in laying out the parts. The whole assembly is literally up in the air, and if the photo is examined closely the whole circuit can be seen as if drawn out on paper. Actually, the circuit diagram layout was taken as a model for the new design. It still has much of the appearance of the rack-and-panel affairs, and is even more efficient than a "breadboard" layout. The cost is lower than rack-and-panel because a wood rack is used, baked crackle finished for commercial appearance.

Of chief importance is the ease of exciting the 354—200 watts excitation was sufficient for 90 per cent efficiency at 1KW with only 3000 volts as compared with older type tubes requiring twice as much driving power. The 354 accomplishes this because of its high mutual conductance, which means that even at 1000 volts it will deliver high output with small excitation. At 4500 volts it performs perfectly, and its insulation allows still higher plate voltages with safety. Second to such features is the extreme stability and freedom from feedback of the new design. It neutralizes 100 per cent and was on the air with 1KW input just 15 minutes after first lighting the filaments and coupling the link to the 200 watt buffer in the initial tuning-up.

The complete circuit of the amplifier is shown in Fig. 1. Low-C and fairly-high plate voltage are combined to give good efficiency. The grid tank is link coupled to the driver and tuned by a split-stator condenser so as to eliminate the grid blocking condenser. Both the center tap of the plate tank condenser and rotor of the tank condenser are by-passed to the filaments. Bias is furnished by the 20,000 ohm gridleak. Referring to the photograph, the grid tank and link input are at the bottom of the rack. Next is the grid tank condenser mounted on the underside of the tube shelf, the top of which also carries the two-gang neutralizing condenser seen between the tubes. Just below the top of the rack is the plate tank condenser, and well in the clear above everything is the final tank coil. Keeping the output tank well above the other parts in the set, and remote from all objects, is a very definite advantage of this design over regular breadboard construction. Thus the input and output circuits of the amplifier are widely separated, leaving little possibility of feedback. However, some question may be raised as to the length of the leads, but some thought will show that long leads merely add inductance because the tuned circuits are already Low-C. They do not introduce feedback because all circuits are well spaced. A metal rack must not be used because it forms a closed loop, tightly coupled to the leads forming the final tank circuit.

The construction of the rack is evident from the photos. Three-fourths-inch dry pine was used. The base is 12 inches by 19 inches, while the rack is 36 inches high, 19 inches wide and 6 inches deep. The shelf for the tubes is 14 inches above the base. The entire assembly was given a baked crackle finish after all holes were cut. The resulting effect is a very business-like appearance of a metal rack.

\*Amateur Equipment Engineer, Audio Products Co., Los Angeles, California.

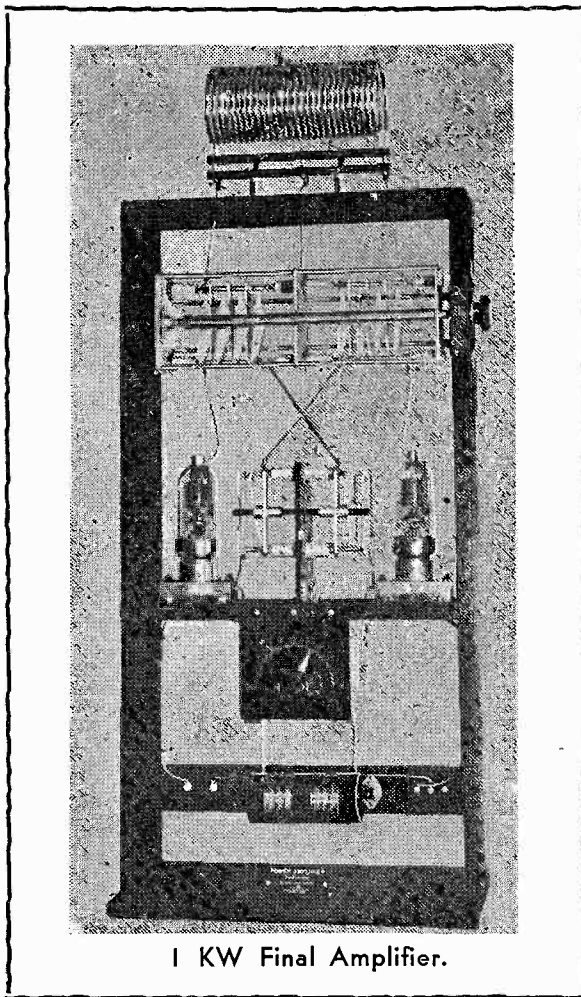

1 KW Final Amplifier.

The grid tank is wound on threaded bakelite tubing. It is of the plug-in type. Five GR plugs are used. The two outer plugs are used for the grid connections because they carry the highest RF voltage. The next two are for the feedline which goes to the one-turn link, wound around the center of the tank. This one turn is made of rubber covered wire, and is left permanently in the center of the coil. The center plug carries the coil centertap that feeds the bias. On the wooden strip that carries the base for the

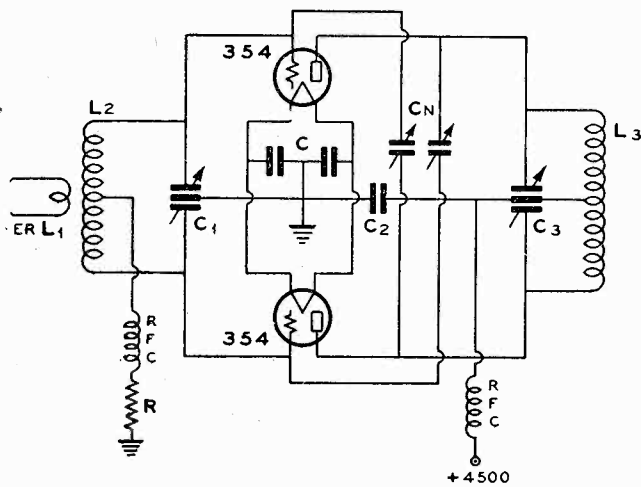

FIG. 1

FIG. 1. CIRCUIT AND CONSTANTS

R—20,000 ohms, 200 wats. C—.005, receiving type. C1—Split-Stator, 40 MMF, 4000 volts each section. C2—.002, 7000 volt mica. C3—Split-Stator, 35 MMF, 15,000 volts per section. CN—10 MMF, 15,000 volts. L1—2 turns for any band, No. 14 wire around center of L2. L2—No. 16 wire on 2 1/2-inch threaded tubing, spaced diameter of wire, 30 turns for 3.5 MC, 18 turns for 7 MC, 10 turns for 14 MC. L3—1/4-inch tubing, 4 inches diameter, 10 inches long, 26 turns for 7 MC, 12 turns for 14 MC. L3—(For 80 meters) 1 3/8-inch tubing, 6 inches diameter, 12 inches long, 30 turns for 3.5 MC.

grid coil the terminals for power leads are mounted, as can be seen from the rear view of the rack. The two feeder leads are brought in on the two stand-off insulators mounted at the center of the strip.

The neutralizing condensers are especially adaptable for high power work, and were incorporated into a single unit by ganging the rotors to simplify adjustment. Care should be taken in mounting these condensers between the tubes so that none of the metal parts of the condensers come near the tube envelopes. The corona from the edge of a neutralizing condenser plate will go right through the glass of a tube! The condenser is supported from two bakelite strips, set into the rack supports which simultaneously insulate the rotor and make for rigidity. The output coil is wound with cadmium plated copper tubing. The plating is cheap and adds greatly to the appearance without affecting the electrical properties of the coil. The tank is plug-in by means of heavy plugs and jacks mounted on hard rubber strips. Even though the RF voltages developed are high, the 5-inch spacing between plugs prevents losses. The leads from the condenser to the coil pass through 2-inch holes cut in the wooden crosspiece at the top of the rack. Ordinary wire is sufficient for these leads because the tank current is very small when Low-C is used.

The wiring is very simple, due to the open nature of the amplifier. All RF circuits are wired with tinned No. 10 wire. Small size ignition cable is used for filament and plate voltage wiring. Bakelite cleats support the power wiring on the sides of the rack. Round braid is used for the flexible leads to the plate connections on the tubes.

Although the adjustment of this amplifier is simplicity itself, some pointers on securing maximum performance will not be amiss. A single-turn link is used around the driver tank (a 242A with 250 watts input) connected to the grid link on the final by ordinary twisted lamp cord. All coupling adjustments are made with the link around the driver tank, moving it toward the plate end of the tank serves to increase coupling. After the link coils are coupled, the grid tuning condenser is adjusted for maximum grid current. The driver end of the link is then juggled until still further increases in grid current are secured, meanwhile retuning the driver plate tank and the final grid circuit if necessary. In the case of the amplifier herein described, the grid current through the 20,000 ohm resistor was 70 MA.

Adjust the neutralizing condensers simultaneously until tuning the plate tank condenser to resonance causes no change in grid current. Of course, be careful to retune the grid condensers to resonance each time the neutralizing condensers are changed. The point of correct neutralization is very broad.

Apply reduced plate voltage to the final and tune the tank condenser for plate current dip with the antenna feeder (single wire fed Hertz) clipped on the coil. The feeder will usually be clipped about 3 turns to one side of center. If one tube seems to run warm after applying full voltage, the output tank is slightly unbalanced. This can be easily corrected by slightly stretching that half of the tank coil connected to the tube which is running cool, and re-tuning slightly to take care of the change in inductance. By this means it will be possible to perfectly match the load on the two tubes. At 4500 volts the tubes behave as if a mere 100 watts is handled. Even at 3000 volts they show no color under keying with 1KW.

# Amplifiers? - - - Phooey!

**G**OSH, I was a hard guy to convert to crystal! I went on the air in '26 with a Hartley oscillator (built up mostly of borrowed equipment), and the little rig worked like a charm. The broadcast set was minus one 201A when W6DHQ was on the air, but a Hawaiian and an Alaskan on forty meters succumbed to my persistency, so I firmly believed that nothing was worth a continental hoot but a Hartley. RAC note? Sure, but it got out fine. In fact, I smeared all over those poor saps using DC. Frequency drift. Sure, all over the place—but that was the other guy's worry, not mine. QSL cards? You couldn't even find the light switch on the wall. The only drawback to this new-found pleasure of mine was the fact that a few kill-joys would keep getting in my hair with "Why don't you put in a crystal?" or "Crystal control would surely fix up that note," and a lot of nonsense like that. With

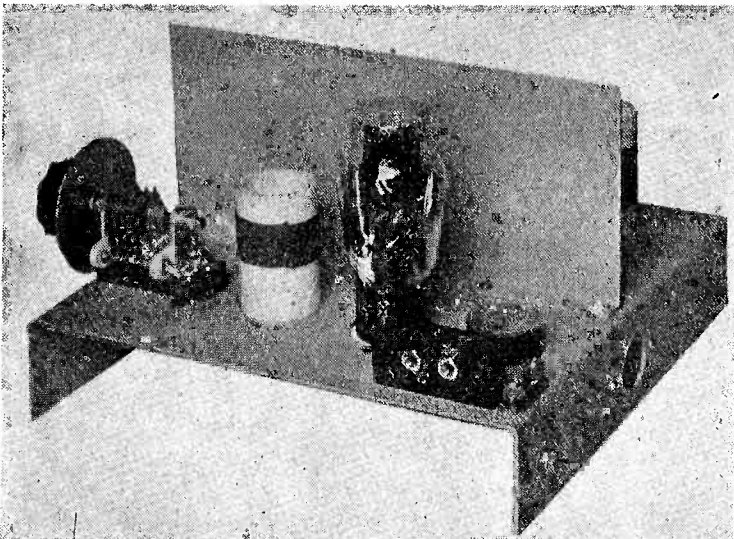

A One-Tube Xtal Transmitter to which an amplifier stage can be added at any future time.

fiendish glee I would smile patronizingly, mutter a "Yeah, I guess it would," turn up the filament voltage another notch, and let out another ten-times-ten CQ. About that stage of the game I thought a "lid" was a cover on a manhole.

The old Hartley, grown to a 210 with 600 volts now, still punched ether holes until December, 1932. Then came the dawn. Important things that make history always happen suddenly, like that. W6DVD, during a QSO, happened to mention casually to me that W6DWE down in Clovis was doing big things with only a crystal oscillator. Only a crystal oscillator? Hmm! (I forgot to mention that I'm just a little lazy.) That business of an amplifier had always worried me, since the budget at our house was flatter than a bride's first cake. A letter was immediately dispatched to DWE, whereupon I received a fine friendly letter, circuit and all.

If I couldn't do any more than patronize home industry as far as QSOs were concerned, at least they were going to hear a sweet signal. That was my decision. Imagine anyone using a Hartley with RAC! I couldn't imagine it.

For a whole evening the wire cutters snapped and the solder flew. Being born under the sign Taurus, I had to do things artistically. Morning came (it always comes) and the sun shone through the window on one tired ham operator pounding his ear in sheer exhaustion. On the dining room table was a swell-looking crystal oscillator in a rack and panel that would have done credit to a couple of kilowatts. Prominently exposed, above the middle shelf was a brand

## An Article for the Beginner By GENE CLARK, W6DQH

new '47 and a 3640 KC crystal in a commercial holder.

That evening I wired up a 400-volt plate supply, hooked it on, and gave the key a poosh. A quick turn of the plate condenser tuned the thing, and the flashlight globe in series with a turn of wire, lying alongside the coil, flashed brightly for an instant and then went the way of all globes. Maybe there's something to this crystal oscillator business! The antenna and counterpoise were next coupled on, and reports of R6 to R8 were received during the next few months from Canada, Alaska, Mexico and twenty-eight states, including New York, New Jersey, West Virginia, Kentucky, Illinois and Ohio, and a regular sked was kept with W9DGS in North Dakota. R8 and R9 reports were the usual thing up and down the Pacific Coast, and all tone reports were "crystal DC" and "crystal PDC." (I didn't have a filter choke, by the way.) Also, the little rig proved to be the berries for reliable Army Amateur work.

Brothers—and I'm speaking to the newcomers in the game—if you've been shying from crystal control because of the cost, forget it and put a simple crystal oscillator on the air. But get a good crystal. Skimp anywhere but on the crystal. You must have a rock that will put out, as any good crystal will, and one that will be active enough to key properly. The one I have follows the bug with all the weights off.

Here's the circuit. Nothing unusual about it at all.

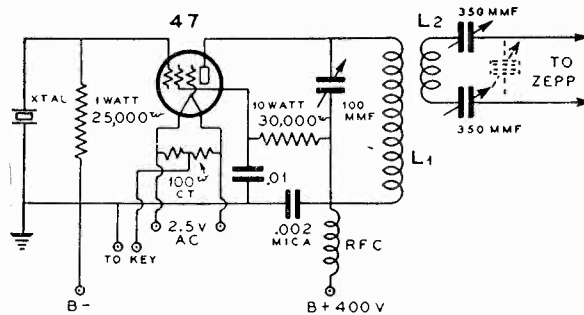

Circuit Diagram of the One-Tube Transmitter

Just remember to make your coil of such a size that the circuit will tune to your crystal frequency with the condenser practically all the way out. Low C, high L—that's the secret of getting power out of the thing. You can put as high as 600 volts on the plate of the '47 with no danger to the crystal, but unless you have a pretty hard '47 the tube might throw in the sponge at that voltage—but don't worry about the crystal.

With all the dope published about crystal oscillator circuits I see no need to dwell any longer on technical details, as the purpose of this missive is to show you that an ordinary crystal oscillator, with a little intelligent handling, is really a complete and efficient transmitter with plenty of that thing we call suds.

I can hear you saying, "Aw, I'll bet you had a good location." Well, if an apartment house with a busy elevator, and street cars running by the door, is a good location, then I had one.

The antenna used when this rig first worked across the continent was an antenna-counterpoise arrangement, each wire being 64¼ feet long, series tuned. Later I tripled the length of one of them, with improved results. This gave me 257 feet of antenna. I believe that if I had five dollars to spend

on the improvement of my transmitter today, one dollar would be spent on the transmitter itself, and four dollars on the antenna.

Are you using a selfish-cited oscillator now? Do you honestly want to improve your signal on the air and forget that worry of being off-frequency, but get a headache when thinking about those multi-stage crystal sets? Do you still want to work break-in? Then put a simple crystal-controlled oscillator on the air. It's surprising what it'll do. I might even say it's amazing. I think I will. It's amazing!

## Quartz Filters

(Continued from page 6)

scribed is so great that, when first used, one is apt to tune over some signals without hearing them. It may seem that the volume drops appreciably when the filter is switched in, because the background noise disappears entirely, but when the signals are tuned-in on the exact peak, they seemingly come right up out of nowhere.

A crystal filter should be followed with at least two stages of IF amplification and possibly an additional tuned circuit to give a proper degree of selectivity. Peculiarly enough, additional selectivity is a very necessary requirement, because practically all crystals have an additional peak on either side of resonance. These peaks are governed somewhat by the physical dimensions of the particular crystal in use, but in general all crystals have two peaks and some have even more. In order to minimize the effect of these spurious peaks, the selectivity of the tuned circuits following the filter must be adequate. In general, the more tuned circuits, the better, although each tuned circuit adds a small amount of loss.

It has been found that an air-gap holder is necessary for proper operation of a resonator because the removal of the top plate from actual contact with the crystal allows a greater freedom of vibration with attendant increases in efficiency. The gap is not critical, however, and can be about the thickness of a sheet of paper.

In lining-up the IF amplifier for use with a crystal filter, it is almost necessary to use the crystal itself as an oscillator. This is not difficult to do, although some resonators make poor oscillators. The crystal is hooked-up as a conventional crystal oscillator in a transmitter, with the exception that a small air gap is used and the usual grid leak and choke combination is eliminated entirely. Use a winding from an IF transformer for the plate inductance with the trimmer attached. For lining-up purposes, a type 30 tube can be used for the oscillator, with 2 volts AC on the filament. The AC is desirable to modulate the signal and to simplify the adjusting process. Plate voltage (180 volts) is secured from a tap on the voltage divider of the bias supply used for the transmitter. A 0-25MA meter in the plate circuit is a good indicator for oscillation. The plate current will dip as the trimmer condenser tunes the inductance to the resonant frequency of the crystal. A piece of insulated wire is brought near the inductance and the far end of the wire hooked over the grid input to the first IF. Tuning the IF to exact resonance with the crystal then becomes a simple matter.

Good shielding is important in the IF amplifier. All signals from the front end must pass through the crystal itself and they must not leak through to the grid of the first or second IF because of poor shielding. As a simple test, remove the crystal from

(Continued on page 36)



# A Cigar Box 10-Watt 160-Meter Phone

(Continued from Page 14)

B-plus lead of the oscillator. Tuning the plate condenser varies the frequency of the grid circuit, so the grid condenser must be slightly returned in order to bring back the audible beat note in the receiver.

The plate voltage is then cut off from the '45 R. F. amplifier stage and a small neon glow lamp is held at the end of the plate tank. The plate condenser is then tuned for maximum glow in the neon lamp. Then vary the neutralizing condenser, meanwhile rocking the plate tank condenser back and forth

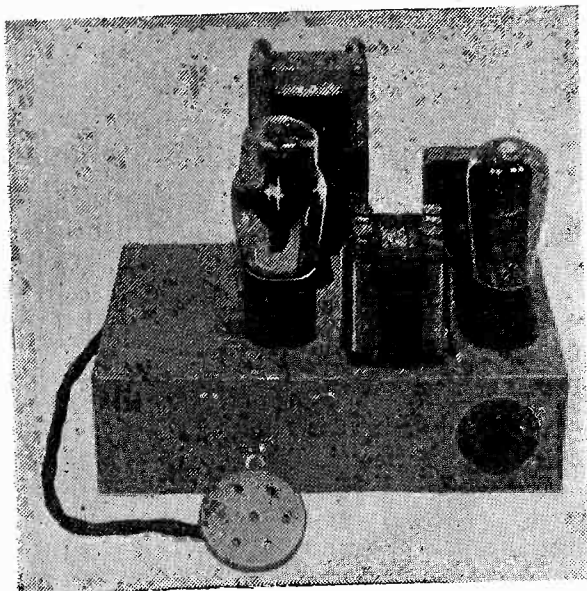

Even the power supply and modulator components are mounted on a cigar box, as shown above.

across the point of resonance until the glow in the neon lamp goes out, at which point the stage is neutralized.

Then apply plate voltage to the '45 R. F. tube and tune for minimum plate current, as indicated by the milliammeter in the B-plus load. The antenna coupling should be varied, meanwhile retuning the plate tank condenser after each variation of antenna coupling, until the '45 R. F. amplifier stage draws 30 milliamperes plate current.

The operation of the speech amplifier can be checked by means of a milliammeter in the B-plus lead to the speech tubes. The plate current to every stage in this transmitter should remain constant during modulation; any variation is an indication of distortion. After the speech amplifier has been checked you are ready to call "CQ."

Upward modulation is indicated by the neon bulb method. When tied to the antenna lead the neon bulb gets brighter when the microphone is spoken into. Thus you can literally "see your voice."

## CALLS HEARD

### Calls Worked from W7BB

CT1AA, CT1GU, D4BAR, D4BDR, D4BUF, D4UAN, D4HL, EA1BC, EA4AO, EA4BG, EA5BE, EAR185, EI8B, F8EO, F8EX, F8PZ, F8YOR, G2BB, G2BY, G2NH, G6HP, G6LK, I1ER, LY1B, LY2JB, OE6AT, CH3NA, OH3NP, OK1PK, OK2DD, ON4AU, PAXF, SPIAR, SP3PV, SM7RV, ST2D, OZ1K, PJ6XM, U1KP, U1NM, U3AN, UN1DB, UN7DD, ZC1E, ZC6AN, ZE1FJ, SU1EG, ZD2A ZS2A, ZS2F, ZT5R, ZU1E, ZU1R, RMAU, RMAZ.  
E. R. STEVENS, 915, 13th North.

### By W8DVS, Ambridge, Pa.

Heard and Worked Sept. 9 to Sept. 18 on 14MC. CX1AM, CX1BU, (CX1FB), (EA8AH), (EZ4SAC), EZ4SAX, FM4AA, FM8BG, FM8CR, FM8DA, HB9J, HB9AO, HB9AQ, I2IY, (I1UL), I1XX, LU3E, LU6AP, LU6DJK, LU8DJ, LY1J, (OE1ER), OE1FH, (OE3FL), OH3NP, OH5NR, OH5NB, OH7NJ, ON4CSL, OZ8D (PK1XB),

PY1FF, PY2BX, PY2QB, PY3CF, (SU1JC), SU1SG, SU1SJ, (SU2NP), (TC1XX), U1BC, U1BL, U1CR, (U3CV), U3VB, (U6AQ), (VQ4CRL), VQ4CRP, VQ8A, (XQ2L), X0HNP, XU3FU, (XZN2B), (XZN2C), YU7VV, YM42O, (YM4RL), 2C6FF, (ZE1JB).

Calls in parenthesis were called but not worked. G's and other more common European and closer DX omitted.

VQ8A is new prefix for Ascension Islands, South Atlantic.

XU3FU is Russian ship last reported on QSO at Wrangell Island, Northern Siberia.

### Calls Heard at WICNU

Stamford, Conn.  
Sept. 15 to Oct. 15  
HEARD ON CW  
14 MC.

CT1AZ, D4BAU, D4BBN, D4BCC, D4BDR, D4CAF, EA3BV, EA3EG, EA3EI, EA4AV, EA5BD, EI6F, EI8B, F3AD, F8BF, F8BS, F8DT, F8EB, F8EF, F8EJ, F8EO, F8FC, F8JI, F8PQ, F8RJ, F8TQ, F8XU, FM4AA, FM8DA, G2BM, G2DC, G2GB, G2GK, G2HF, G2IN, G2KB, G2KY, G2KZ, G2MV, G2NM, G2OI, G2RF, G2RQ, G2ZF, G5BD, G5DK, G5HC, G5KU, G5ND, G5NI, G5QA, G5RL, G5SR, G5VN, G5WP, G5XB, G5XQ, G5YH, G5YR, G6AG, G6BS, G6BT, G6CJ, G6DH, G6DL, G6HB, G6HP, G6QX, G6RH, G6RS, G6VP, HAF3H, HB9AQ, EZ4SAX, I1ID, I1MD,

K5AA, K5AE, K5AF, K5AY, HJ3AJH, HJ5ABG, NY1AB, NY2AB, OE1FH, OK2DD, ON4ABC, ON4AS, ON4CSL, ON4DX, ON4HBP, ON4ID, ON4JB, ON4MY, ON4RX, PY1AW, PY1IF, SU1SG, TI2RC, TI2RU, TI2TAO, PAOAZ, PAOCE, PAOGG, PAOLL, PAOPA, PAOXF, PAOZK, VO8HK, VO8Y, VP2AT, VP2BX, VP4AA, VP5AA, VP5AB, CP5GM, VP5JB, VP5IS, VP5PZ, V1UU, YU7VV, VQ4CRP, X1CM, X4J, VQ8A, HJAW, XZN2B, WV2RE.

### HEARD ON FONE

14 MC.

EA4AV, G5BJ, G5ML, HI7G, HI6X, ON4BZ (also CW), X1A, X1M.

### HEARD ON CW

MC.

CE2BX, CT1AO, CT1ED, D4BDR, D4BUF, D4CPJ, EA1AE, EA3CY, EA3EG, EA4AO, EA4AV, EA5BA, EA5BC, EA5BS, EA8AH, F8WK, FM8BG, G6CL, G6RV, HB9AQ, HB9B, HC1JW, K5AG, K6KVX, LU1EP, LU6AX, NY1AA, NY2AB, OK1CB, OK2FF, OZ8D, PAOXG, U3EN, VK2VQ, VK3MR, VK7KV, X1AG, X1AM, X1B, X1BA, X1BC, X1BY, X1CC, X1CT, X1CY, X1N, X1W, VO8Y, VP4AA, VP5IS, VP5MK, ZL1CD, ZL1GX, ZL1HY, ZL2BV, ZL2CJ, ZL2CP, ZL2FN, ZL2FP, ZL2JQ, ZL2LB, ZL2NW, ZL3AE, ZL3AX, ZL3CC, ZL3GM, ZL4AI, WV2RE, XOH2FJ.

Conditions good on 14 MC during the morning from 7 till 10 for Europeans. ON4CSL is sure giving VQ4CRP a run for being the most consistent African here.

# Additional Coil Winding Data for Link-Coupled Stages

Coil Winding Chart for 1 1/2-in. and 2 1/2-in. Dia. Coil Forms, Such as Standard Hammarlund 1 1/2-in. Isolantite Plug-in Forms and Bud Radio 2 1/2-in. Ribbed Transmitting Coil Forms. Single Section Variable Condensers Used for Tuning.

BAND	1 1/2" Dia. Coil Form	Size of Tuning Condenser	BAND	2 1/2" dia. Coil Form	Size of Tuning Condenser	REMARKS
160	Not Satisfactory	Not Satisfactory	160	46 Turns No. 16 DCC. Close wound	100 MMF. or larger	The winding data shown here is for coils that are tuned with single-section variable condensers. See Chart below for coil winding data when split-stator variable condensers are used.
80	35 Turns No. 22 DCC. Close wound	100 MMF.	80	23 Turns No. 16 DCC. Spaced one dia.	100 MMF.	
40	19 to 21 Turns No. 16 DCC. Spaced one dia.	100 MMF.	40	16 Turns No. 16 DCC. Spaced one dia.	25-35 MMF.	
20	11 to 13 Turns No. 16 DCC. Spaced one dia.	25-35 MMF.	20	8 to 10 Turns No. 16 DCC. Spaced one dia.	25-35 MMF.	
10	5 to 6 Turns No. 16 DCC. Spaced one dia.	25-35 MMF.	10	5 Turns No. 16 DCC. Spaced one dia.	25-35 MMF.	

Coil Winding Chart for 1 1/2-in. and 2 1/2-in. Dia. Coil Forms. Split-Stator Variable Condenser Used for Tuning.

BAND	1 1/2" Dia. Coil Form	Size of Tuning Condenser	BAND	2 1/2" dia. Coil Form	Size of Tuning Condenser	REMARKS
160	Not Satisfactory	Not Satisfactory	160	59 Turns No. 16 Enameled Close wound. Tap at center.	250 MMF. Each Section (smaller condenser can be used).	The standard Hammarlund 35 MMF. Each section split-stator double-spaced midget variable condensers are satisfactory. The Cardwell Trim-Air 100 MMF. midgets can also be used by merely removing alternate plates from rotor and stator sections and ganging two of these condensers together. The capacity will then be 25 MMF. per section and the coil data shown here will also be satisfactory for this capacity.
80	Not Satisfactory	Not Satisfactory	80	55 to 57 Turns No. 16 DCC. Close wound. Tap at center.	35 MMF. Each Section	
40	35 Turns No. 16 DCC. Close wound. Tap at center.	35 MMF. Each Section	40	29 Turns No. 14 Enameled Space wound. To cover 3 inches.	35 MMF. Each Section	
20	19 Turns No. 16 DCC. Spaced one dia. Tap at center.	35 MMF. Each Section	20	15 Turns No. 14 Enameled Spaced one dia. Tap at center.	35 MMF. Each Section	
10	9 to 11 Turns No. 16 DCC. Spaced one dia. Tap at center.	35 MMF. Each Section	10	6 to 8 Turns No. 14 Enameled Spaced one dia. Tap at center.	35 MMF. Each Section	

NOTE:—For use with split-stator condensers, a 40-meter coil can be wound on a standard 1 1/2-in. diameter Isolantite Plug-in Coil Form, using No. 16 DCC wire, close wound, but the entire winding space of the coil must be utilized. These forms will not hold more than 35 turns of No. 16 DCC wire.

Although the above charts were computed from coils used in actual practice, with the condenser sizes as shown, it is usually necessary to either add turns to the coil or remove turns from it. The many considerations which enter into transmitter construction make it impossible to publish charts which are 100 per cent accurate.

However, the data given here will be found correct in most cases. If the circuit does not tune to resonance with the coil and condenser sizes shown above, merely add or remove a turn or two of wire at a time until resonance is found. The information given in these tables will save the constructor much time and trouble.

# A Fool-Proof Doubling System

By E. HAYES\* and K. KEELEY\*

THE "hybrid" doubler circuit (two tubes, with push-pull grids and parallel plates, sometimes called "push-push") is fast becoming a popular circuit in amateur ranks, in spite of its tendency to misbehave.

A number of amateurs have found that when using multiple grid tubes (47s, 46s, 865s, etc.) as doublers in this circuit everything acts as one hopes for, but on employing 10s, 03As or any of the common larger tubes the circuit persistently oscillates and usually after considerable grief the standard single tube doubler is resorted to with the resulting need for an extra stage. It is the purpose of this article to present an improvement in the "hybrid" circuit which completely removes all tendency toward erratic behavior.

Figure 1 is the circuit which is without this improvement and the one usually tried. Using 46s or 47s it works nicely giving an output comparable to that of a similar push-pull amplifier on the fundamental frequency.

When triodes are substituted for the 47s, however, the fun begins. The triodes oscillate frantically at any frequency except the desired doubled frequency.

W6MV† has pointed out that "if the grid circuit is made capacitive (Fig. 2) rather than inductive," the tendency toward oscillations will be lessened but in our own experience, the circuit of Fig. 2 while an improvement over Fig. 1 is not all that could be desired and the setup still tries to oscillate at undesired frequencies.

The next step, therefore, is to see if these oscillations can not be completely stopped. The circuit of Fig. 3 seems to be the answer. As soon as this circuit was used with a pair of 10s all tendency toward oscillation disappeared and the tuning was as smooth as that of a well-built non-doubling amplifier.

Figure 4 shows an arrangement using a d.p.d.t. switch and two coils which permits QSY from fundamental frequency to twice fundamental frequency with 3 simple operations.

1. Throw switch S to proper position (1 for fundamental and 2 for twice fundamental).

2. Place proper coil in tank circuit.

3. Tune tank circuit.

These operations require only about 60 seconds. The possible output is about the same for both frequencies.

The circuits should be neutralized while connected as a regular push-pull amplifier

the plate current is found. The final now is ready for operation with a load.

If the push-pull final stage is normally operated with considerable grid current flowing, the bias should be increased, or a resistor placed in the grid return circuit, to increase the bias and reduce the grid current. The push-pull doubler will then operate

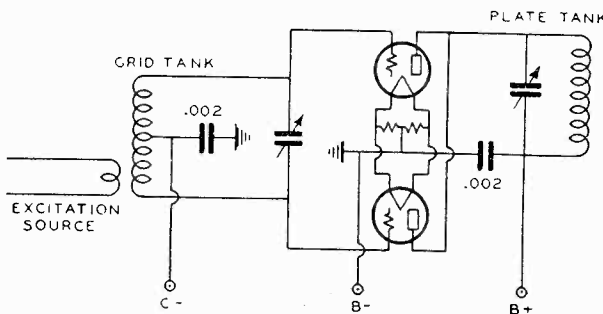

FIG. 1

much more efficiently. A number of amateurs have used their final stage as a doubler and have operated with plate efficiencies of 50 to 60 per cent and higher. This system can be used to quadruple with efficiencies in the same range. If there is an absorption type frequency meter handy, it might be wise to check the frequency of the final and see that it is doubling and not quadrupling. This type of amplifier quadruples as efficiently as the usual doubler doubles, and in at least one case, the final was tuned to 10 meters with the operator wondering why the transmitter wasn't getting out on 20.

This doubler, like most doublers, is a class C amplifier, and maximum efficiency calls for high L, high plate voltage, and high bias. It operates best when the bias is ad-

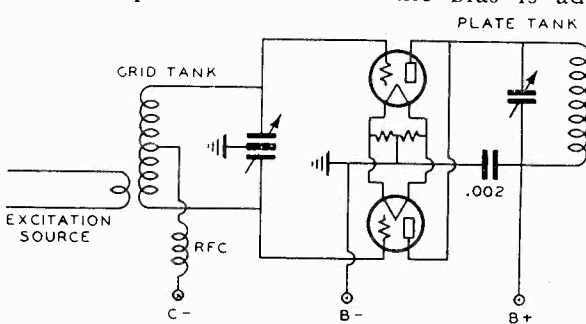

FIG. 2

justed high enough so that the grid current is less than is desirable in the usual class C amplifier.

It is well to point out that while link

power, and it is quite easy to radiate considerable power at twice the frequency to which the final tank is tuned. This "hybrid" amplifier is no exception. If any trouble is encountered, a wave trap tuned to the undesired harmonic and placed in the antenna feeder or feeders, will eliminate, or materially reduce this radiation. If the Collins Universal coupling is used, needless to say, no wave trap is necessary.

Now let us examine the features of Fig. 3 and see just why it is apparently so fool proof. Unwanted oscillations can be caused in three major ways.

1. Impulses on the plate being fed to the grid circuit through plate-to-grid capacity.

2. Impulses on the grid being fed to the plate circuit through the plate-to-grid capacity.

3. Unwanted RF voltages appearing in the grid return circuit through faulty return and cathode or filament circuits.

Figure 5 is an exact duplicate of the RF portion of Fig. 3. Through inspection it can be seen that all of the plate circuit (the darker portion) is coupled with exact capacitive symmetry to the grid circuit. Thus it would be impossible for any plate impulses to feed into the grid circuit and cause oscillations on the approximate grid-tank frequency; for any impulse fed into the top end of the grid coil by the plate circuit is equally fed into the bottom end and so the two cancel. Thus oscillations caused by method 1 are eliminated. This holds true for either the circuit of Figure 2 or 3.

Now let us examine figure 6 which is also an exact duplicate of the RF portion of Fig. 3 (and also the exact circuit of Fig. 5). By simple inspection it can be seen that the grid circuit (the darker portion) is exactly symmetrically coupled to the plate circuit providing  $C_1 = C_2$  and  $C_4 = C_3$ .

Thus by setting neutralizing condensers  $C_2$  and  $C_3$  equal to plate-to-grid capacity,  $C_1$  and  $C_4$ , the possibility of oscillations by method 2 is eliminated. This does not hold for Fig. 2 since the necessary neutralizing condensers are absent.

The prevention or regeneration or degeneration caused by RF getting into the filament or grid return is not so easily explained since the source of the cause is not readily detected. A few rules may be made, however, which if followed will bring results.

If possible, avoid by-passing or grounding the center of either tank circuit coil. Use a split-stator condenser and ground or by-pass

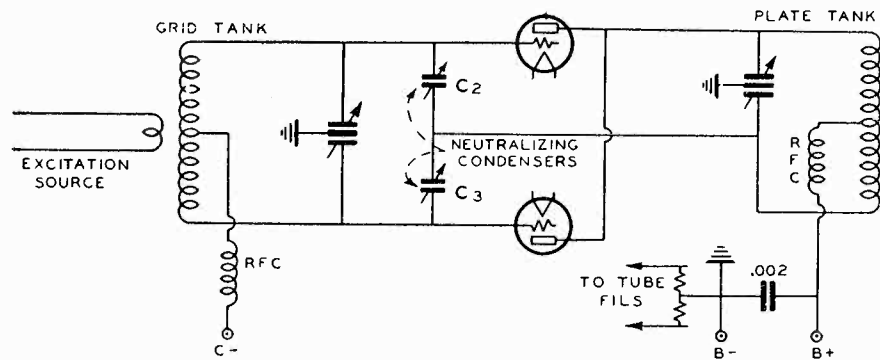

FIG. 3

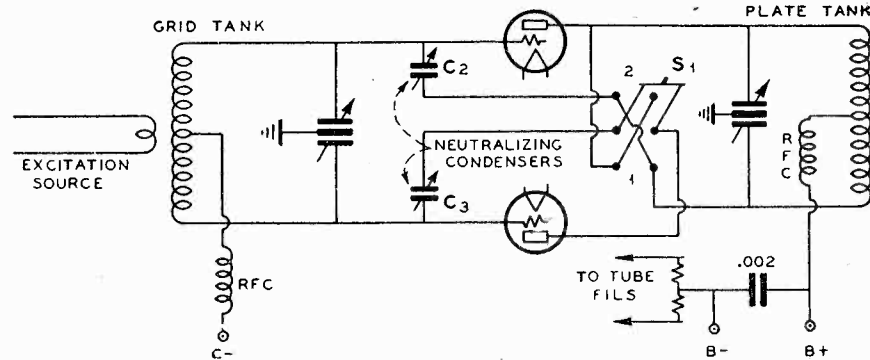

FIG. 4

after which no changes are necessary. Then to increase frequency by a factor two, change the tank coil of the final to one that will tune to twice the frequency of the grid circuit, and with no load coupled to the final, apply a reduced plate voltage and vary the tank condenser until a pronounced dip in

\*W6BC El Monte, Calif. Pertinent remarks gratefully received by E. Hayes, 302 Mohawk Ave., Scotia, N. Y., or K. Keely (KREG), 518 S. Van Ness, Santa Ana, Calif.

† Warner Hobby, W6MV, RADIO, June, 1934, pp 8: "More on the Push-Push Doubler."

coupling is shown in all the diagrams, it is not at all necessary to use link coupling for this type of doubler any more than link coupling is necessary for push-pull amplifiers. Link coupling simply aids very materially in increasing the excitation available at the grids, and the more excitation available, with suitable bias, the greater the efficiency of the final, whether a straight amplifier or a doubler amplifier.

Any single-ended amplifier, operated at high efficiencies, is rich in second harmonic

the rotor side. Connections to the center of the tank coil may be made by using a reliable choke with the opposite end by-passed. Tank circuits with both the center of the coil and condenser by-passed or grounded are bad. The fact that such an arrangement constitutes two tuned circuits very tightly coupled and gives a queer tuning characteristic is sufficient reason in itself. Also any slight lack of symmetry will tend to shift one of the proper grounded points and perhaps cause excess RF current in the filament return.

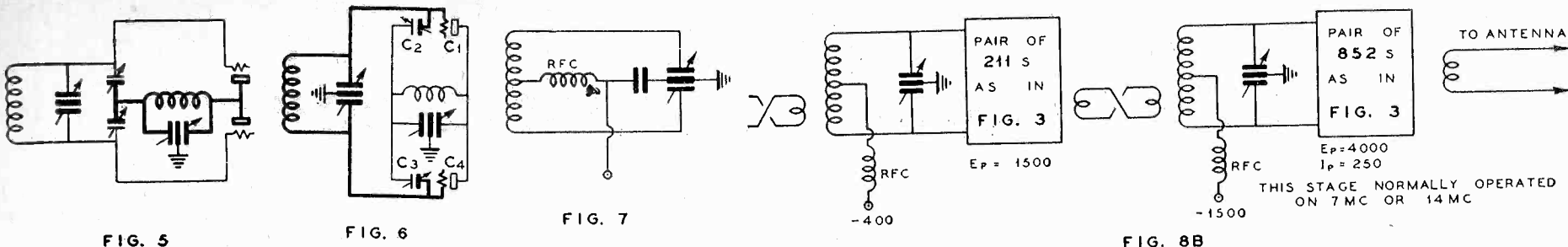

FIG. 5

FIG. 6

FIG. 7

FIG. 8B

Observation on Figures 2 and 3 will show that through the tube capacities the tank circuits have a certain amount of capacity of which the center point (the filaments) is grounded. Thus, also grounding the center of the coil might produce undesired results. This is the reason for constructing tank circuits with only the center of the capacity by-passed or connected to ground RF potential. Figure 7 shows the type of tank circuit recommended for all cases where a double-ended coil is used.

Care should be shown in placing filament and grid return leads, keeping them out of strong fields. It is also advisable to connect the grid return as close as possible to the filaments themselves. This prevents any RF voltages in the cathode lead from being impressed on the grid, such as happens when using a cathode resistor for bias.

The new pentode transmitting tubes with this type of doubling offer unlimited flexibility in bands and ease of QSY. One layout consists of an RK 20, electron coupled xtal oscillator and a 150-watt pentode as the final. With an 80-meter xtal, 800 watts output is

obtainable in 3 bands, and 400 watts in a fourth. A transmitter of this sort is about the ultimate in simplification; no neutralizing is necessary, and QSY from band to band with the use of plug-in coils is accomplished in 15-30 seconds.

To dispel any doubt from the minds of the dubious as to whether the push-push doubler works, it can be said that the transmitter in Fig. 3 has been used at W6BC for 18 months, and has proven entirely satisfactory

in every way. Using 210s as doublers, 60 watts of power is obtainable on 7 MC, while the 211 stages, doubling, can be made to furnish 500 watts of power with 700 watts input. As most of the operating at W6BC is done on 7 and 14 MC, the normal arrangement is that shown in Fig. 8. It has been no task at all to have 1 kw. input to the '52s and 850 watts output on 7MC, and 30 seconds later, have the same input and output on 14 MC.

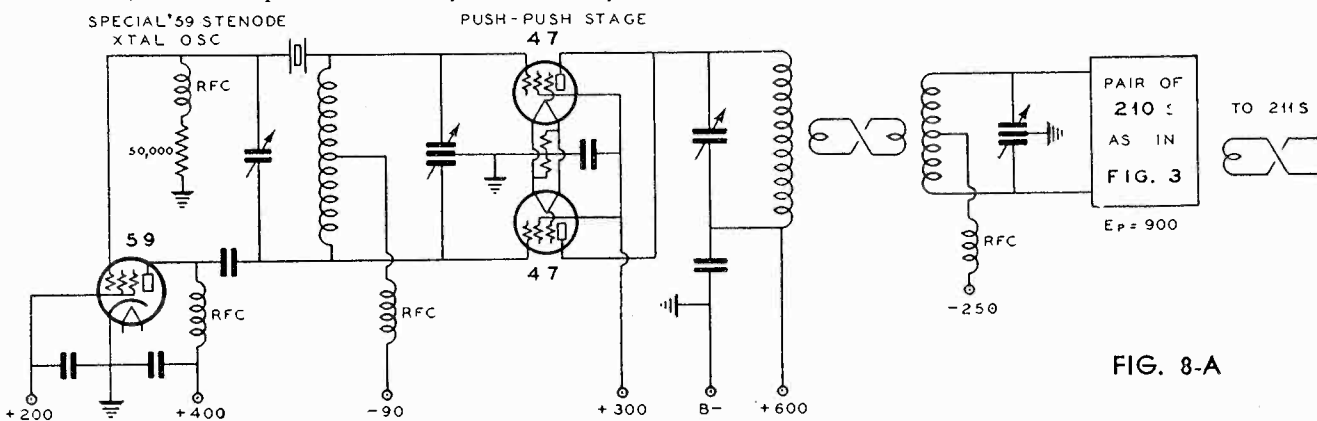

FIG. 8-A

## Cathode-Ray Curve Tracing Data

(Continued from Page 7)

When intermediates are to be aligned, the output voltage from the plate of the tube following the IF stage is connected through a blocking condenser in series with a low resistance of approximately 1000 ohms to the amplifier circuit as shown in Fig. 2. When the tube following the IF stage is a diode detector, the resistance can be eliminated. In this case, the input lead is connected to the high-potential end of the diode load resistance. Sufficient IF voltage is generally across the by-pass condenser of the diode load resistor to give a deflection on the cathode-ray tube. Since the diode load is by-passed, there is no capacity effect from the connecting leads and the resonance adjustment does not change with their removal. The resonance curve obtained on the screen of the cathode-ray tube represents audio frequency and, hence, appears not as a modulation envelope, but as a single-line curve above the zero axis.

The constants of the oscillator circuit will depend somewhat upon the arrangement of the wiring, distributed capacitance, etc. In order to realize the full operating range of frequencies from 100 KC to 500 KC, it is important to have tuning condensers with low minimum capacitances, and to keep wiring capacitances at a minimum. The exact values for the constants of the oscillator circuit are best determined by actual test after the apparatus is in operation. Suggested values for these constants are as follows:

- $C_1 = 150$  uuf maximum
- $C_2 = 350$  uuf " (ball-bearing type)
- $C_3 = 0.00005$  uf "
- $C_4 = 0.00005$  uf "
- $C_5 = 0.0001$  uf "
- $C_6 = 0.00035$  uf "
- $L_1 = 2.0$  millihenries
- $L_2 = 2.0$  "
- $L_3 = 5.0$  "

The inductances are closely coupled.

Desirable characteristics for the oscillator are uniform voltage output especially throughout the sweep range, and frequency

change proportional to the angular rotation of the frequency-sweep condenser  $C_2$ . This condenser should preferably be one of the straight-line-frequency type, although an ordinary semi-circular plate condenser is easier to balance mechanically in order to avoid vibration. The latter, however, is satisfactory for the usual alignment purposes; that is, with it no distortion of the resonance curve is noticeable to the eye, although it could not be depended upon for precise measurements.

Care should be taken to select a variable condenser that is rugged in construction and revolves on ball bearings. Contact with the rotor can be made by means of a brush or other smooth-riding pressure contact on the condenser shaft. The short-circuiting contactor is a standard automotive ignition breaker. It is operated by a cam on the motor shaft. A bakelite drum having a metal insert in its periphery can be used as a shorting device, if it is desired.

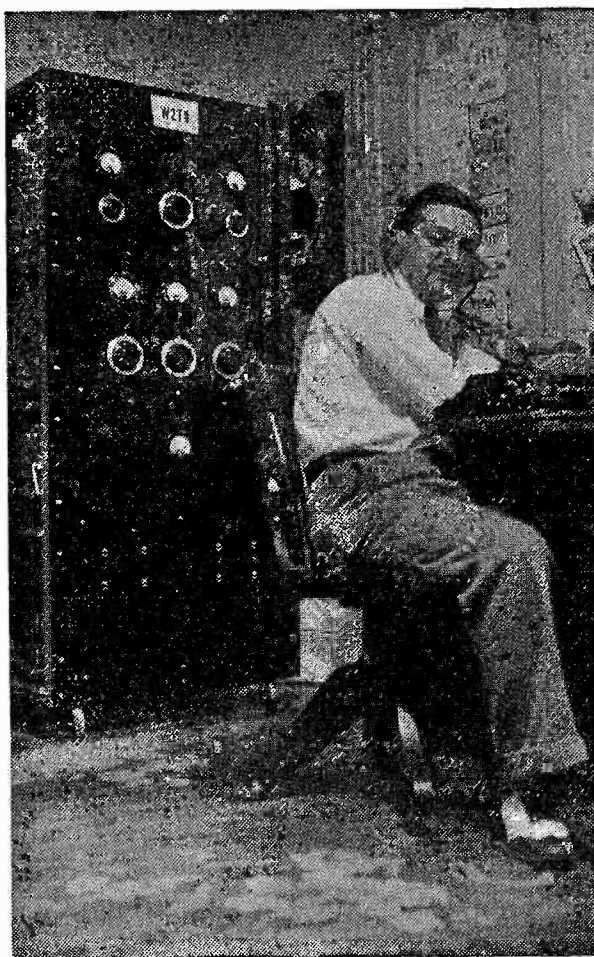

### I. R. F. Station W2TO

OWNED and operated by Brother Fred L. Ulrich, who seems to have grown up with radio; the ham game has been his hobby for the past 15 years, while for the past 12 years commercial work has been providing the bread and butter.

During the period immediately after the war-ban was lifted he received his license (amateur). Shortly afterwards, in 1922, he joined forces with Uncle Sam's Navy, later graduating from the Naval Radio School at Great Lakes, Ill. During the six years of his service, he pounded brass at NAJ, NPW, NAE and NBS; rattled a key down in a submarine, up in a bombing plane, and swung a loop at a compass station. (What versatility!) His spare time during the six years of service was filled with non-routine duties such as stringing a new antenna between the 450-foot masts at NAJ during a raging blizzard; changing the armature of a radio generator down in the engine room of a "tub" while in tropical waters—"I remember the temperature exactly," writes Fred, "it was 149 degrees . . . no use mentioning the sweating and swearing that was attached to the job." And, to top that, he went to the rescue in answer to ELEVEN distress calls!

Since his honorable discharge from the service he has pounded brass and kept fire in the old beacon on the Fire Island Lightship, and has rattled the key on one of the great white ships of the United Fruit Company. For the past five years he has been busy keeping the antenna meters of WNYC registering current.

During what leisure time Fred now experiences, he keeps W2TO busy on 14 MC. All the operating is done from the swivel chair, which is being held down by the OM himself.

# High Fidelity Amplification

## High Fidelity Requirements

THE past few years have effected a great increase in the overall fidelity of audio amplification systems. This is well exemplified by the Western Electric binaural equipment demonstrated a few months ago. The effectiveness of this equipment was not due solely to the binaural effect, but primarily to the ideal fidelity of the audio system. While most people who listened to this equipment were pleasantly amazed, few realized that reproduction of similar nature can be obtained commercially and is not solely a laboratory possibility. While this binaural equipment incorporates an actual frequency range of 35 to 16,000 cycles, for normal high fidelity it has been found that a frequency range of 60 to 8000 cycles is suitable. The harmonic content should not exceed 5 per cent and the volume range of reproduction must be approximately 70 DB. In addition to this, it is also necessary that the volume level be sufficiently great to deliver satisfactory sound at the maximum transmission distance required. This article covers only the audio amplifier requirements for high fidelity and does not treat of accessory requirements such as pickups and reproducing devices.

## Factors Controlling Fidelity

If we examine the above design requirements in sequence, the corresponding controlling factors can readily be determined. Frequency discrimination in audio amplification is almost entirely controlled by the audio transformers used. Many years of research in this field have resulted in the development of transformers having extremely wide frequency range. Commercial produc-

By I. A. MITCHELL\*

With a volume range of 70 db. it is necessary that the noise level be at least 70 db. below maximum output. Modern quality resistors and condensers have practically a negligible noise level, narrowing noise difficulties almost entirely to AC hum.

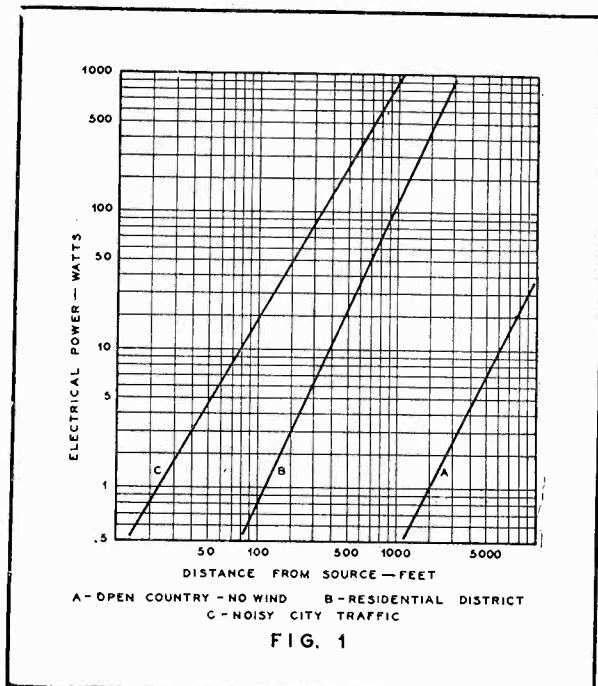

## Power Output Requirements

Power output requirements are unfortunately greatly dependent upon external noise level conditions. As the human ear has a

This is particularly true in the public address field. For satisfactory operation under the worst normal conditions, an amplifier must therefore have comparatively high power output. To cover a distance of 300 feet under noisy conditions, as per Fig. 1, or 100 feet where heavy street traffic is encountered, 100 watts of electrical audio power would be required.

Figure 2 illustrates the complete circuit diagram of a high fidelity audio amplifier suitable for raising the input level of a crystal, condenser, dynamic or carbon microphone to an output level of 100 watts at 5 per cent distortion. This amplifier employs standard tubes and A prime amplification in the output section. It is extremely economical both in original cost and operation. The overall gain of this amplifier system is approximately 120 db.

## Amplifier Design Details

It is desirable in high gain amplification equipment to isolate the low and high level stages. In addition to the reduction of increased hum and feedback tendencies this allows the control of gain and mixing at a level higher than that of the original source. The reduction in noise level is generally considerable. The low level amplifier is commercially termed a voltage or pre-amplifier. The pre-amplifier illustrated in Fig. 2 was described in detail in the March issue of "RADIO."

The main amplifier is unique in the fact that a full 100 watts is obtained from the conservative and comparatively inexpensive 845 tube.

Due to its excellent fidelity and low har-

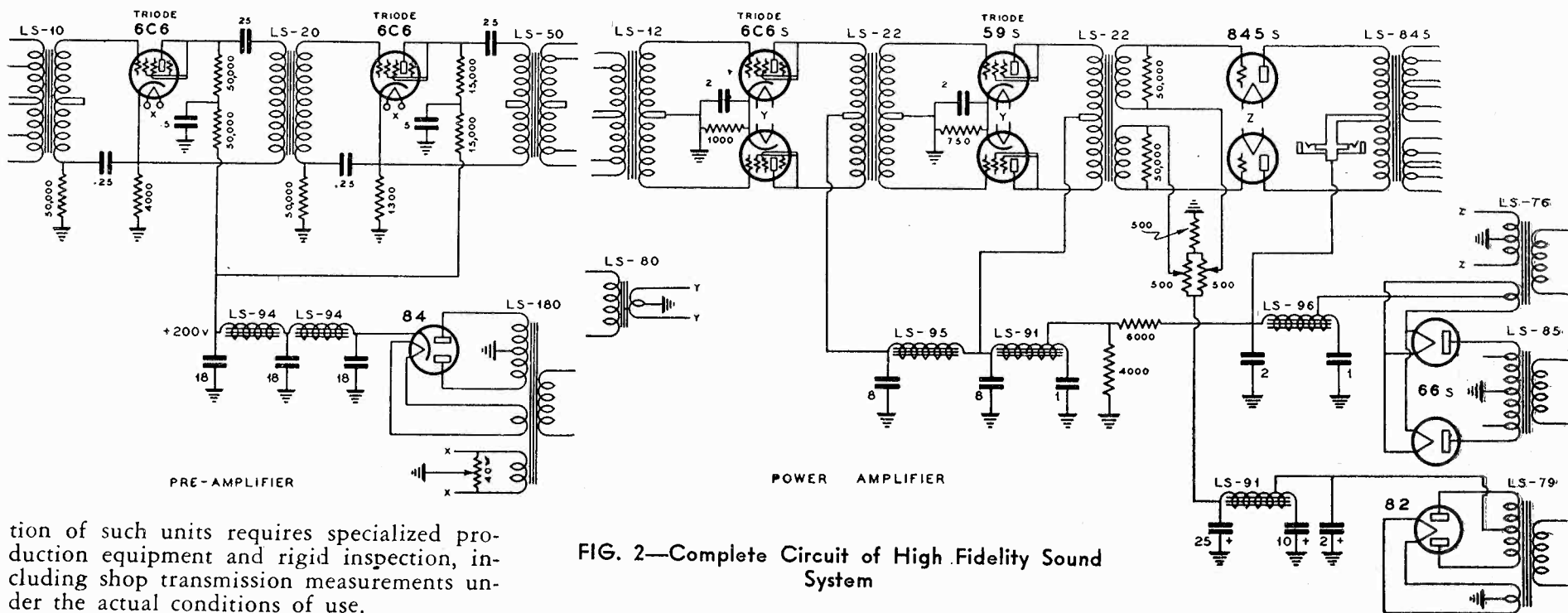

FIG. 2—Complete Circuit of High Fidelity Sound System

tion of such units requires specialized production equipment and rigid inspection, including shop transmission measurements under the actual conditions of use.

Harmonic content is primarily a function of the tubes used and their operation. When properly used, a vacuum tube is practically a linear device (at the point of linearity deviation harmonics are introduced). Consequently, it is essential that the power output be normally kept below the point of maximum allowable deviation. This in turn, to meet our high fidelity requirements, makes necessary the use of proper vacuum tubes, correctly operated, so that not over 5 per cent harmonic distortion is effected at the highest power output normally required. In addition to this, care must be taken in the design of audio transformers, particularly those operating at high level, so that the transformer will operate over an essentially linear portion of the core material magnetization curve.

logarithmic sensitivity, it is apparent that a sound level readily heard in a quiet town would not be sufficiently great to cover the same area in a noisy city. Fig. 1 illustrates the amount of amplifier power output required to cover various distances as compared to the surrounding noise level using a cluster of modern dynamic speakers. It is seen from these curves that a sound source will cover in an average residential district more than 2 1/2 times the distance it would cover in city traffic. Compared to very quiet areas, such as open country with no traffic, the difference is even more apparent. Power which is satisfactory over a mile distance under such conditions would barely be suitable for half an average city block. In many cases, amplifiers have to be constructed for use at various locations at different times.

monic content the 845 tube has been very popular in both theatre and public address work, where a power output of 30 to 50 watts was required. However, few people realize that properly used in push pull connection a pair of these tubes can deliver 100 watts with only 5 per cent distortion operating with only 1250 volts on the plate and 225 to 260 volts bias. While some attempts were made in the past to increase the power output from 845 tubes, the tubes were invariably operated above the manufacturers' plate voltage rating of 1250 volts, so that tube life was appreciably shortened.

The above method of overbiased operation of the 845 tubes is normally termed AB or Class A prime. Its efficiency depends upon the fact that while high 2nd harmonic is developed, the push pull connection tends to

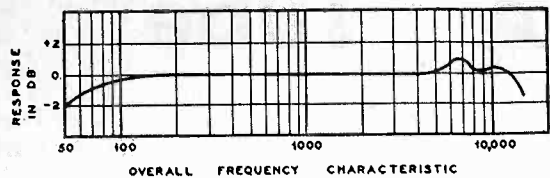

FIG. 3

balance out this distortion. It is desirable that the tubes be well balanced and provision for this balancing is afforded in the circuit of Fig. 2. Incidentally, it is interesting to note that RCA is using these tubes in the audio output section of their new high fidelity low power transmitters.

### Circuit Details

The unusual simplicity of this circuit is apparent. Push-pull transformer coupled stages are used throughout. The push-pull connection tends to balance out plate hum and also eliminates the necessity for parallel feeding the audio transformers. The 59 tubes have sufficient power to drive the 845s to maximum output with a negligible introduction of distortion from themselves. The loading resistors in shunt with the 845 input transformer secondary tend to stabilize the load reflected to the 59 tubes (triode connected). A separate power supply is used to provide bias for the output tubes and the two 500-ohm potentiometers shown are adjustable so that the plate currents can be perfectly balanced.

The filter circuits for both plate and bias supply of the main amplifier used tuned filters having extremely high efficiency. The output transformer shown has ideal universal impedances for public address use, namely, 1.2, 2.5, 5, 7.5, 10, 15, 20, 30, 50, 125, 200, 250, 333 and 500 ohms. If we summarize the actual important factors in this amplifier, they may be noted as follows:

- High gain—120 db. suitable for all PA applications.
- Low distortion—less than 5 per cent at ALL levels below normal maximum output
- True class A prime operation in output stage
- High power output—100 watts
- Plate supply having good regulation
- Low hum level
- Unusual simplicity of construction
- Inexpensive tubes, and economical operation

### Uses of Sound Equipment

New uses of sound reinforcement and sound projection are being discovered daily. In addition to public address systems, we now have such audio applications as the reproduction of clock chimes and carillons over large areas, the aiding of docking of vessels, announcing and call systems, inter-vessel communications, advertising from airplanes, dirigibles, boats and motor trucks, and the numerous other uses which we encounter daily in modern cities. The value of amplification equipment designed for such purposes generally depends not on the acoustical output, but on the undistorted acoustical output. This is particularly important at the present moment, when the public is being educated to high fidelity.

Flat line amplifiers are essential for the reproduction of sound effects from the new wide range sound film recordings and the long playing, vertically cut, hill and dale records, which are coming into wide use.

The amplifier system described will faithfully transmit all frequencies from 40 to 10,000 cycles as illustrated in Fig. 3, at levels from the barely audible pianissimo effects to the resounding orchestral clashes of ten million times greater power, without any underlying noise or hum. As such, it is ideal for any sound amplifier application having high fidelity requirements.

\* Chief Engineer, United Transformer Corp.

## The "Les-Tet" Exciter

(Continued from page 11)

be pulled out of the rack for inspection, revision, etc., without disturbing any of the others in the slightest. The flexibility of the whole arrangement will greatly appeal to the amateur accustomed to the confusion and hay-wire aspect of bread-board layouts.

As far as actual operation is concerned, this new Lafayette transmitter leaves little to be desired. With as much as 120 watts of power available for CW, and 30 to 40 watts on phone, DX is merely a matter of the band selected, the location and the operator's skill. The transmitter itself certainly does its stuff!

### Parts List—Oscillator & Amplifier

C1—100 mf.; C2—100 mmf.; C3—25 mmf.; C4—.01 mf.; C5—.005 mf.; C6—.005 mf.; C7—130 mmf. each section (split sections); C8—70 mmf. each section (split sections); C9—.002 mf.; C10—.002 mf.; C11—.002 mf.; C12—.001 mf.; C13—.001 mf.; C14—480 mmf.; C15—220 mmf.; L1—Oscillator inductor ("plate" coil); L2—Amplifier inductor (plate tank); L3—Power amplifier grid inductor; L4—Power amplifier plate tank; L5, L6—Antenna impedance matching inductors; R1—100,000 ohms; R2—1000 ohms; R3—5000 ohms; R4—75 ohms, center tapped; RF1, RF2, RF3—2.5 millihenry r.f. chokes.

### Parts List—Modulator Unit

C16—5 mf.; C17—.5 mf.; C18—.5 mf.; C19—.1 mf.; C20—25 mf.; C21—.1 mf.; C22—8 mf.; C23—4 mf.; R5—5 megohms; R6—5000 ohms; R7—2 megohms; R8—250,000 ohms; R9—1 megohm potentiometer; R10—100,000 ohms; R11—10,000 ohms; R12—750 ohms; R13—10,000 ohms; T1—Modulation transformer; T2—Power supply transformer; T3—30 henry filter choke.

### Parts List—Power Supply

C24—2 mf.; C25—4 mf.; C26—4 mf.; C27—4 mf.; R14—50,000 ohms; R15—25,000 ohms; T4—Swinging chokes; T6—Filter chokes; T8—High voltage transformer; T9—Rectifier filament transformer; T10-2B6—RK20 filament transformer.

# The New PATTERSON PR-12

The Patterson radio plant in Los Angeles is a scene of great activity these days. Advance inquiries regarding the new PR-12 have been greater than ever before from amateurs, dealers and jobbers, some of them even coming to us in the hope of securing the information a little in advance of somebody else.

Our readers will be glad to know that the plans which so interested them were not considered up to the high Patterson standards and on August 7th all models submitted by the Engineering staff were debilerately scrapped. That department has been reorganized and E. R. Patterson himself is now actively in charge as Chief Engineer. This has made it necessary to defer delivery of the PR-12 models for a month.

The PR-12 is a super-PR-10 and is said to be as much superior to the PR-10 as that receiver was to its predecessors. The range is from 550 meters down to 8 meters instead of the usual 15. Sensitivity, selectivity, and tonal quality have been improved to a marked degree. Crystal filter is optional. The receiver is expected to set another mark in the amateur world.

Thousands of dollars have been invested in new dies. Parts are now being punched and stamped and the first shipments are scheduled to go forth to jobbers about November 1st.

If the reception accorded PR-10 nationally is a fair criterion, PR-12 will soon be a standard amateur receiver throughout the country.

## ADVANCES IN THE TECHNIC OF QUARTZ PIEZO-ELECTRIC CRYSTALLOGRAPHY

By ALBERT F. HOEFLICH

FOR several years the art of quartz crystal production has evidently been at a standstill, but recently, through the work of the Bell Laboratories and independent experimenters, a number of important advances have been made.

Bell physicists, by application of the mathematical theory of the elasticity to piezo-electric theory, have produced crystal cuts with new characteristics. Among these are the AC cut plate, a very sturdy plate, because of freedom from side-tones; the AT cut plate, having practically a zero temperature co-efficient of frequency against temperature, and a new filter bar having but a single peak of resonance and a much higher Q than former crystals of this type.

For some reason the Bell people have never used the X-cut plate, possibly because of patent restrictions. For high-frequency work the writer has found this plate unsurpassed. For maximum "activity" X-cut plates of frequencies higher than 2500 KC appear to have characteristics as good as those of the AC cut plate, although they may have a somewhat greater tendency to fracture under abnormal operating conditions.

The writer has been experimenting with the X-Prime cut for the last two years with excellent results. This cut, a modified form of the X-cut plate, is especially suitable for crystals ground between frequencies of 5,000 to 15,000 KC's, producing 7,000 KC's band crystals of excellent strength, which give equal output compared with 3,500 KC band plates with very little more brush discharge than the lower frequency plate. In fact, some of these crystals have operated over periods of a year with so little electrode corrosion that it has been unnecessary to re-polish the electrodes during this time. Plate voltages of over 400 were used.

Another type of plate used by the writer is the "Harmonic Plate." This plate has the ability to oscillate at full output on the first, third, fifth or seventh, etc., harmonics of its fundamental frequency. It is useful for ultra-high frequency because the finished plate can have a thickness of several times that necessary if fundamental operation were used. This type of plate is not yet in production.

### Calls Heard—7-14 MC Bands

Heard at W1HQ, Milford, Conn., U. S. A.

CM1ML, 2JM, 2MA, 2WW, 2OP, 2FA, 2MG, CN8YBQ, CT1EV, 1CB, 1BY, 2AW, 3AB, 3AD, CX2AM, D4BDR, 4CAF, D4BAR, 4BBN, 4BNN, 4BBK, 4BIU, 4BAO, EA1AU, 1AY, EA1AZ, 1AM, 1BC, 2AD, 3AN, 4AH, 5BC, 5BE, BJ, 8AF, EI8B, EI2D, EZ4SAX, F3AD, F3MTA, F8DT, 8EB, 8KJ, 8TQ, 8PZ, F8ZF, 8JJ, 8LD, 8EO, 8EF, 8WB, FM8CR, G2KI, 2DL, G2LA, 2MA, 2ZQ, 2OA, 2BM, 2NH, 2DC, 5ZG, 5UF, 5VQ, G5LV, 5BD, 5LH, 5LA, 5WY, 5NF, 5RX, GI5QX, 5MZ, 6YW, HAF3D, 4H, 8D, HB9G, 9J, 9Y, HC1LC, 2JM, HJ1AK, HI8X, I1TKM, 1UL, 1ID, 1KI, K6DWQ, 6COG, 6BFI, 6BAZ, 6JJP, LA1G, 1H, 3G, 3R, 3Y, LU1EP, 1CH, 1JH, 2FA, 2FC, 3FA, LU3AO, 4DQ, 6DJK, 7AZ, 7BH, 8DR, 9AX, 9BV, NY1AA, NY2AB, NY1AB, K5AA, 5AE, 5AE, 5AZ, OA4AA, 4B, 4J, 4Z, OH1NJ, 3NH, 3NP, OK1SU, AW, 1BC, 2MA, 2RM, 3ID, ON4AU, ON4ACE, 4FE, 4FE, 4JB, 4BZ, 4CSL, OZ1D, 3J, 5J, PA0XOK, PA0VA, LR, XF, FX, AP, LL, XG, DC, QQ, KK, RP, ZZ, PF, PA0CE, IM, CH, QF, PZ1FE, PX1AA, PY1AA, 1AW, 1DW, 1CR, PY1AH, 2BX, 2BW, 2BU, 2BN, 2BK, 2BD, 2CB, 2CD, 2BQ, 2QB, PY3AN, 9AM, PYP2Z, SU1EC, 1MM, 1SG, 6HL, SM6WL, 6UA, 7SG, SP1DE, 1DC, 1BC, TI2FG, 2WD, 2TAO, VK20C, 2DR, 2PX, 3JQ, VK3WL, VQ4CRJ, VR2VW, VP4AA, 4JR, 4TC, 4TB, 5PZ, 6MR, 7NB, VP2GP, X1AA, 1AG, AM, 1N, 1Q, 1H, 1BY, 1CM, 2T, 3H, 3X, 9DU, YI7LY, YM4ZO, ZD2A, 2C, ZE1JB, 1JJ, ZL2KI, ZL2SP, ZS1H, ZS4M, ZS2A, ZT1H.

# Analyzing the New EIMAC Tube

THE last three years has witnessed the development of over 100 new and different types of receiving tubes, all of which can be divided into about five classifications, including the dual-purpose tubes. The small transmitting tubes for low power operation closely resemble overgrown receiving tubes.

Transmitting tubes of more than 50 watts plate dissipation have been improved but slightly since 1928, when the 852 type was developed. The 203A and 211 types are practically the same as when they were first developed ten or twelve years ago. Admittedly some improvements have been made, particularly in regard to new plate materials, but the old "fifty watters" are still low-voltage, high C tubes. They lack efficiency when used at high-frequencies.

What features should a modern high-frequency transmitting tube possess?

(1) It should be "Hard". In other words, its vacuum should be as high as science knows how to make it. A "hard" tube has two distinct advantages. High plate voltages can be applied without fear of ionization or of destroying the active filament coating by positive ion bombardment. If no gas is present, no positive gas ions will be present to wipe the thorium off of the filament. (2) There is no doubt that the thoriated tungsten filament is by far the best all-around element. It is a very efficient emitter of electrons, it is just as rugged as a pure tungsten filament and it requires much less heating power, per unit of emission, than straight tungsten. The active thorium, which constitutes the actual source of the electronic emission, remains on the filament, where it belongs, instead of leaving the filament and sputtering on to the grid structure—a common fault of oxide coated filaments. Most transmitting tubes using oxide coated filaments suffer from primary emission from the control grid whenever the control grid is heated, even though they are more efficient emitters of electrons.

In order to realize the advantages of thoriated coated tungsten filaments, the filament must operate in a vacuum of about  $10^{-8}$  MM of mercury, or very near the standard X-ray vacuum. The presence of gas molecules in the tube tends to "poison" the thoriated tungsten filament and reduce its usable peak emission. This high degree of vacuum must not only be obtained, it must be maintained during the life of the tube. Thus the plate and grid materials must be chosen so that they can be made almost entirely gas-free, even at overload temperatures. This practically necessitates the use of either tungsten or tantalum for the plate and grid material, because neither carbon nor molybdenum can be "cleaned-up" to the extent of tungsten or tantalum. It is almost impossible to fabricate tungsten into suitable form and tantalum is therefore rapidly coming to the fore as the nearly-ideal plate and grid material. Its only drawback is its high cost. In order to maintain a very high degree of vacuum, the ideal tube would use no "Getter" to aid the exhausting process. A "Getter" consists of a small amount of a compound such as magnesium, ignited at the completion of the exhaust process, and which absorbs as products of combustion most of the occluded gas remaining in the tube. A "Getter" does not eliminate the residual gas, it merely moves it over to one spot in the tube which usually remains cool as long as the tube is not momentarily overloaded. However, what amateur does not, at some time during his career, accidentally overload his tubes by running them materially above their rated plate dis-

sipation? At such a time, the "Getter" is almost certain to give off some of the gas previously absorbed. If the plate or grid also gives off some gas during the overload, part of it will be absorbed when the tube again cools off, but most of the gas usually remains. The "Getter" can reabsorb only part of the gas it gave off when heated, so that only a few of the present-day tubes maintain a very high degree of vacuum once they have been overloaded. The tube does not have to ionize and turn blue in order to have an excess of gas. Ionization is only a secondary disadvantage due to the presence of gas. The principal disadvantage is that even a small quantity of gas very materially reduces the usable filament emission. This in itself is undesirable, because it reduces the amount of power output that can be obtained. What

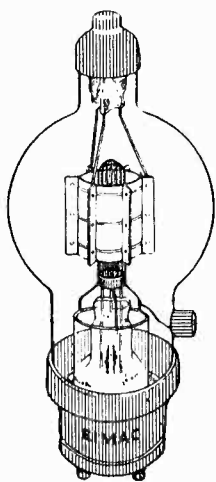

**EIMAC 150T**  
**General Purpose Triode**

EIMAC 150T is a medium mu, three element vacuum tube designed for use as an oscillator or amplifier at audio and radio frequencies up to 75 megacycles. The plate lead is brought out of the top of the glass envelope and the grid lead comes out the side, which reduces interelectrode capacities and increases the interelectrode insulation. The relatively low plate resistance coupled with the amplification factor of approximately 13, ensures a high mutual conductance, which reduces the amount of grid driving power necessary to obtain maximum power output with high plate efficiency.

is far more important is the fact that it increases the plate resistance and thus reduces the mutual conductance and makes the tube very hard to excite.

Many amateurs use tubes that are slightly gassy; not enough, perhaps, to turn blue at the applied plate voltage, but nevertheless gassy enough so that they are two or three times as hard to excite as a new tube of the same type. Thus the ideal tube would have no "Getter" and the grid and plate material would be tantalum. The tube should remain on the pump long enough to enable practically all of the gas to get out. From three to five hours is required for hard pumping. During the closing moments of the exhaust, the plate dissipation should be run up to ten times rated plate dissipation in order to make sure that the tube elements are infinitely hotter than they would ever be in practice, even during the momentary overloads which sooner or later occur.

In order to obtain maximum heat dissipation without excessive glass heating it is important that the glass envelope be of a good grade of hard glass, and that it be free from discoloration. It is evident that discoloration of the glass impairs its ability to radiate heat. This provides another potent reason for using tantalum as an element material. Tantalum is the only plate material

that can be heated to over 2000 degrees centigrade without ejecting impurities that collect on the glass.

The ideal tube must have very high DC and RF insulation between the various elements in order to allow low C operation at high frequencies and at high plate voltages. This means that the plate lead and the grid lead must be brought out of the glass seals at widely-separated points. Many of the newer tubes are built with this high interelectrode insulation between the seals, but the retention of the internal supporting insulator still represents a common source of breakdown and arc-over, especially at frequencies above 10,000 KC. In the ideal tube the elements would be supported from the glass envelope.

The proven advantages of high L and low C in a tank circuit makes low interelectrode capacities necessary for high-frequency operation. Therefore the ideal tube should have cylindrical tube elements, designed for a minimum plate-to-grid capacity and plate-to-filament capacity. Another advantage of cylindrical elements is that the plate will heat more evenly and the electron emission from the filament is better distributed.

In most high-frequency tubes in which cylindrical elements are used, some measure of their ability to amplify power is sacrificed. In other words, they become hard to drive to high plate efficiency and power output. This is usually caused by the fact that cylindrical elements make it difficult for the designer to obtain a sufficiently low plate resistance. Because the plate load impedance must be from five to ten times the internal dynamic plate resistance it is obvious that the load resistance must be increased if the plate resistance of the tube is increased. When the plate load impedance is increased, the plate voltage must be raised in proportion in order to obtain the same power output. Cylindrical element tubes not only permit the use of higher plate voltages than the flat plate types, they also require it. Most of the low C, high-frequency tubes require more than 1000 volts on the plate. They also require almost as much grid driving power as they give in plate power output, a condition which is very undesirable. The ideal tube would have a low enough plate resistance to compare favorably with the flat plate tubes at 1000 volts plate voltage, even better as the plate voltage is increased to 3000 volts. The plate resistance should be low enough so that very high plate efficiencies can be obtained at 2000 volts, which efficiencies are only obtainable with conventional low C tubes with plate voltages of 4000 to 5000 volts.

The plate resistance of a triode can be made quite low if a low amplification factor is also accepted. The combination of high amplification factor and a low plate resistance is what is desired. The term "mutual conductance" compares the combination of these two factors, so that the real index of power gain, or amount of grid excitation required for a given plate efficiency and power output, is mutual conductance. While a comparison of mutual conductances between two tubes is only partially accurate, insofar as actual tube performance is concerned, it is the best "yardstick" we have. The higher the mutual conductance, the easier it is to drive a tube to maximum power output.

As a matter of convenience, an amplification factor of about 12 gives the best all-around results for a general-purpose tube. Transmitting tubes are general-purpose tubes. They should be fairly stable as self-excited oscillators on five or ten meters and they

should have a respectable audio power output in both class A and class B.

An ideal tube would have a low voltage, large diameter, husky filament, one that is rather oversized in comparison to the plate dissipation of the tube. Transmitting tubes are no longer power dissipators, they are power converters. Ten years or so ago, when most of the present-day transmitting tubes were designed, 50 per cent plate efficiency was about all that an oscillator or class C amplifier was expected to have. Thus the tubes were designed to have only enough filament to allow a plate input equal to about twice the plate dissipation. Now that 80 per cent plate efficiencies are becoming more common, it is necessary to provide enough filament emission to enable the tube to draw four or more times as many watts in plate input as it must dissipate in the form of heat. Thus the modern tube delivers about four-fifths of its plate input in the form of useful radio-frequency energy and it is only called upon to dissipate about one-fifth of the plate input.

It is interesting to relate that this manuscript, up to this point, was sent to this magazine over a year ago by a well-known amateur and engineer. It was not deemed wise to publish it at that time because no "ideal" amateur tube was then available. However, the tube has arrived at last. It is the EIMAC 150-T, manufactured by Eitel-McCullough, Inc., a new firm composed of Mr. W. W. Eitel, W6UF of ten-meter fame, and Mr. J. A. McCullough, W6CHE whose high-power phone is well known among those on the 4 and 14 MC phone bands. The new tube is a low C, high mutual conductance, all voltage triode and has a conservative plate dissipation of 150 watts. It uses 50 watts of filament heating power into its thoriated tungsten filament, which gives more usable filament emission than any other tube anywhere near its size. It is designed for operation in all of the amateur bands and preliminary tests show that it is one of the easiest tubes to excite. Next month a transmitter will be shown which uses an astoundingly small amount of grid excitation in order to obtain 800 watts of output with 1000 watts of plate input. This high efficiency is realized not at 5000 volts on the plate, but at only 2500 volts. At 1000 volts plate voltage it

was found that the new tube is not only useful, but is actually easier to excite than practically all of the flat-plate tubes which were particularly designed to be easy to excite at 1000 volts plate voltage. It is hard to realize that a tube can be equally useful at both low and high plate voltages. Nevertheless, the EIMAC 150-T demonstrated quite clearly that a respectable output can be obtained even with only 600 volts on the plate, yet showed no signs of strain at 5000 volts on the plate. It was also found that little increase in output or efficiency was obtained by using plate voltages higher than 3000 volts. For class B audio use, it is possible to obtain 750 watts of high quality power at 3000 volts, and 500 watts is easily obtained at 2500 volts. The plate and grid are made of tantalum and, due to its use, the tube will not become "gassy". The X-ray vacuum allows the large diameter thoriated tungsten filament to operate at maximum emission efficiency and minimizes damage from momentary overloads. Due to the exceptionally high vacuum, a minimum life of 1500 to 2500 hours can be expected.

The Nonex bulb is quite clear and is designed for maximum mechanical strength. The plate lead is brought out at the top of the envelope, and the grid lead is brought out at the side. Thus the possibility of breakdown is greatly minimized. No internal insulators of any sort are used because the plate is supported entirely from a rigid tripod stem at the top of the envelope.

The tube uses the new "Ghost" grid which permits maximum control over the electron stream between the filament and the plate, without appreciably raising the plate resistance through the effect known as "electronic shading", caused by the fact that the projected diameter of the grid wires represents a portion of the plate area which can never receive electrons from the filament. The projected diameter of the grid wires in the EIMAC 150-T is considerably smaller than any of the conventional tubes which use a control grid with an equal controlling effect on the plate current, and thus there is less electronic shadowing effect to reduce the mutual conductance.

The EIMAC 150-T uses the well-known double-V filament instead of the more-common spiral filament which is used in prac-

tically all of the conventional tubes with cylindrical elements. This type of filament is very efficient and rugged and is rigidly supported by a pair of small, but husky springs mounted at the top of a tungsten supporting rod.

The tube has a fifty-watt base of a special type, designed to strengthen the lower portion of the glass envelope, where mechanical failure often occurs.

## ★ ★ ★ A COMPROMISE CRYSTAL FILTER

SINCE the original advent of the crystal filter receiver many versions have made their appearance, some with decided advantages and others with improvements and unique ideas in another way. It is almost impossible to embody every possible refinement into a receiver, due to the space limitations, not to mention the cost. The average receiver should also be capable of being portable. W6GEA presents his own idea of a complete receiver for all frequencies, especially the amateur bands. The assembly is complete and ready for the final tests. It consists of two R. F. stages, the first with optional regeneration for the gain which is needed in the higher frequencies, first detector, high frequency oscillator, crystal filter unit, three stages intermediate frequency amplification, second detector, beat frequency oscillator for C. W. reception, one audio frequency stage and automatic volume control.

The next issue will bring you the complete chassis details, showing the adequate shielding and component parts for this receiver. The circuit is a standard "hook-up" with no trick ideas which may or may not work.

Read about this new amateur receiver, designed by Stewart Ayres in December "Radio."

## ● ● ● CALLS HEARD W3OP Allentown, Pa.

All On 7 MC.

Sept. 1 to Oct. 15, 1934

CT1GG, CT1OI, CT1KZ, CT14D, CT1AO, CT1ZZ, D4BJ1, D4BIU, D4BUI, D41OG, D4BJU, D4BBN, D4BKU, EA5BG, EA5BA, EA4B, EA5BM, EA3EG, EA8AE, EA5BS, EA2BH, EA5BE, EA7BU, EA1AN, EI6F, EI5F, EI8B, EZ4SAX, F3AI, F3EQ, F8XF, F8YZ, F8VI, F8QW, F8NE, F8JJ, F81X, F8XC, FM8PW, FM8GBA, FM8CR, FM4AA, G6VF, G2D1, G5MP, G5P1, G5BJ, G2ZJ, G6NF, G6UF, G6NJ, G5CU, G5QU, G2VQ, G6VA, G5FU, G5P1, G2UY, G2KZ, G2KB, G6WY, G5HC, G6OY, G5UF, G51I, G6HB, G6DH, G2DB, G2TV, G2VZ, G21Z, G6RS, G6RQ, G5YV, G5BD, HB9AQ, I1KA, I1U1, I1XX, K61BB, K61EP, K6IAE, K6DV, K6BAZ, K6IBW, K6JUY, ON4HBP, ON4GU, PA0PO, PA01K, PA0DK, PA0XG, PA0CE, PA0HG, PA0ZJ, PA0RP, PA0PN, PA0AB, PA0FF, SP1BD, XZN2C, CN8MO, Z14GG, Z12NT, Z13HG, Z12CY, Z11DV, Z13HK, Z12FZ, Z14FZ, Z12BZ, Z121N, Z12BN, Z13BJ, Z11GX, Z12KD, Z12FQ, VK3JK, VK5GO, VK2AP, VK2ZU, VK3KX, VK5WH, VK2FM, VK5FM, VK3HT, VK2EO, VK2AZ, VK4RY, VK3CW, VK2XZ, VK2IC, VK5RT, VK5XU, VK5MZ, VK2KA, VK7RC, VK2CY, VK2ZW, VK2GM, VK7CK, VK2XV, VK3GP, VK2YM, VK2YA, VK5HG.

The Receiver is a home-made detector and 1 audio stage.

**Calls Heard at New Mills, N. B.,**

**Canada, August 10-August 20, 14 MC**

SU1MO, SU1EC, SU1CH, VQ4CRP, ZS5X, FM8BG, FM4AA, EZ4SAX, ZC6FE, I1XX, LY1J, KN3, W1OXDA (fone ex CW), OE3FL, SM7YG, SM7YE, YM4ZO, F3DN, D4BARJ, D4BHH, D4BAR, HAF3D, D4BKK, D4BGT, HB9AQ, HB9AX, EI6F, OK1AS, D4CAF, YN1AA, CT2BK, VP4CF, VP5PZ, VP2CD, HP1A, PY2CD, LU6ER, LU1EP, K5AA, NY1AB, NY2AB.

**Calls Heard at W6DOB-W6AET**

W2TP, W2NJ, W3BWD, W4AJY, W6EHM, W6DCV, W6DKT, W6WB, W6CAL, W6EUP, W6ZH, W6BXV, W6PT, W6AXV, W6CLH, W6FA, W7AVV, W8CRA (14 and 28 MC), W8IO, W9FG, W9NY, W9DIJ, W9CYT, W9FFQ, W9EQG, W9GFZ, W9IH, NY1AB (?), WAZ, KKZ and Long Beach police on approximately 8 1/2 meters.

Tentative Characteristics of the  
EIMAC 150T

Filament voltage.....	5	volts	
Filament current.....	10	amperes	
Rated plate dissipation.....	150	watts	
Amplification factor (average).....	13		
Normal maximum plate current.....	200	milliamperes	
Peak filament emission.....	6.1	amperes	
Mutual conductance.....	5800	7300	12300
Plate voltage.....	1000	2000	3000
Plate resistance.....	2750	1900	1250
Normal power output (class C 75% eff.).....	150	300	400

### Operating Conditions

#### Class C Radio Frequency Power Amplifier (CW Telegraphy)

Plate voltage.....	1000	2000	3000
Plate current.....	200	200	200
Grid current (DC).....	25	25	25
Grid bias voltage (Twice "cut-off").....	-158	-325	-530
Power output (75% eff.).....	150	300	450
Grid driving power (approximate).....	7.5	15	22.5

#### Class C Radio Frequency Power Amplifier (Telephony)

Plate voltage.....	1000	2000	3000
Plate current.....	200	200	200
Grid current (DC).....	35	35	35
Grid bias voltage (2.2 times "cut-off").....	-174	-360	-580
Normal carrier output (75% eff.).....	150	300	450
Peak power output (100% modulation).....	600	1200	1800
Grid driving power (approximate).....	12.5	25	37.5

#### Class B Audio Frequency Power Amplifier or Modulator

Plate voltage.....	1000	2000	3000
Grid bias voltage.....	-75	-165	-265
Static plate current (per tube).....	12	12	10
Max. signal plate current (per tube).....	200	200	200
Load resistance (plate-to-plate).....	6000	12000	20000
Nominal power output (two tubes).....	250	500	750

#### Class B Linear Radio Frequency Power Amplifier (Telephony)

Plate voltage.....	1000	2000	3000
Grid bias voltage.....	-79	-170	-275
Normal plate efficiency (unmodulated).....	30%	33 1/2%	33 1/2%
Nominal power output (carrier).....	60	75	75
Peak power output (100% modulation).....	240	300	300
Plate dissipation.....	140	150	150

# Headquarters for Efficiency

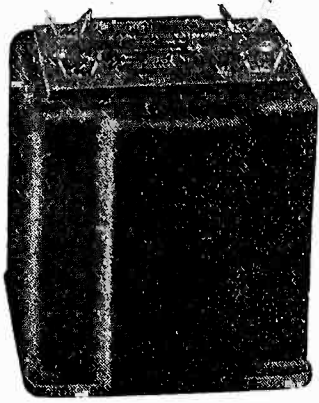

## RESONANT CHOKE

Designed by W6CUH for his RESONANT FILTER that provides "adequate filter" at far LESS cost than the regular brute force type. See article in October RADIO on this money saving idea. Choke tapped for 1 or 2mfd series condenser. Heavy construction for powers up to 1KW; handles any voltage from 1000 to 5000. Complete instructions and guarantee included. Shipping Weight 8 lbs. Net Price, \$6.00

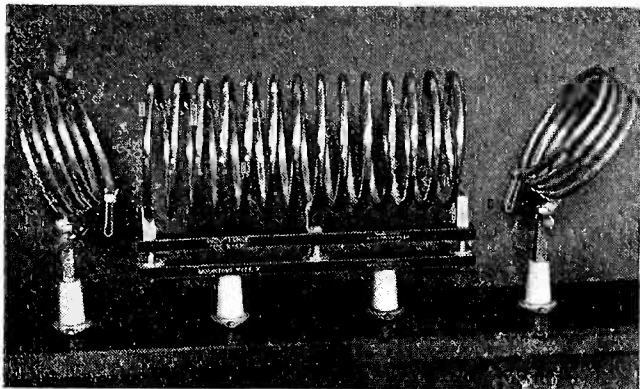

**TANK COILS** A real Low-C plug-in job for the High Power Man. Cadmium plated copper tubing. Especially designed for use with our WS type Split-Stator Condensers on 14, 7, and 3.5mc. Coil shown is 14mc. for single 852. Net Prices and shipping wghts.: Coil (any band) \$7.50, 2 lbs. Base, \$2.50, 1 lb. Antenna coil, \$5.00, 2 lbs.

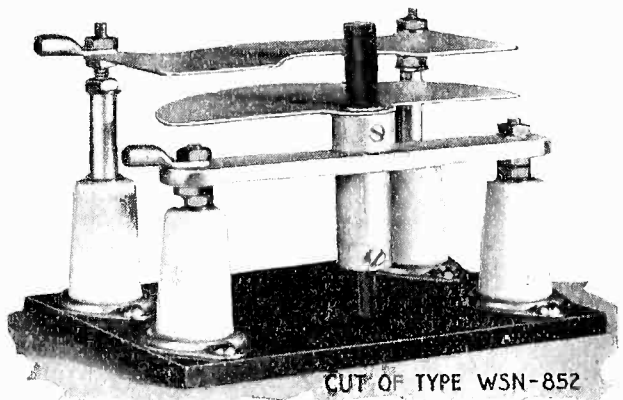

CUT OF TYPE WSN-852

## NEUTRALIZING CONDENSER

WSN852 shown has 10mmf maximum capacity for 852s and 354s. WSN204 is for higher capacity tubes, having 30mmf. Bakelite shaft slotted for screwdriver adjustment or front panel control. Shipping wghts. 1½ lbs. Net Prices: WSN852, \$3.33. WSN204, \$5.00.

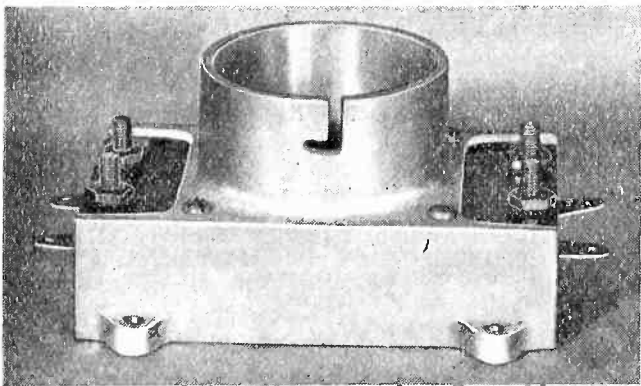

## 50-WATT SOCKET

Heavy cast aluminum shell. Compact design. MYCALEX insulation and heavy phosphor-bronze contact springs. Shipping weight 1½ lbs. Net Price, \$3.00.

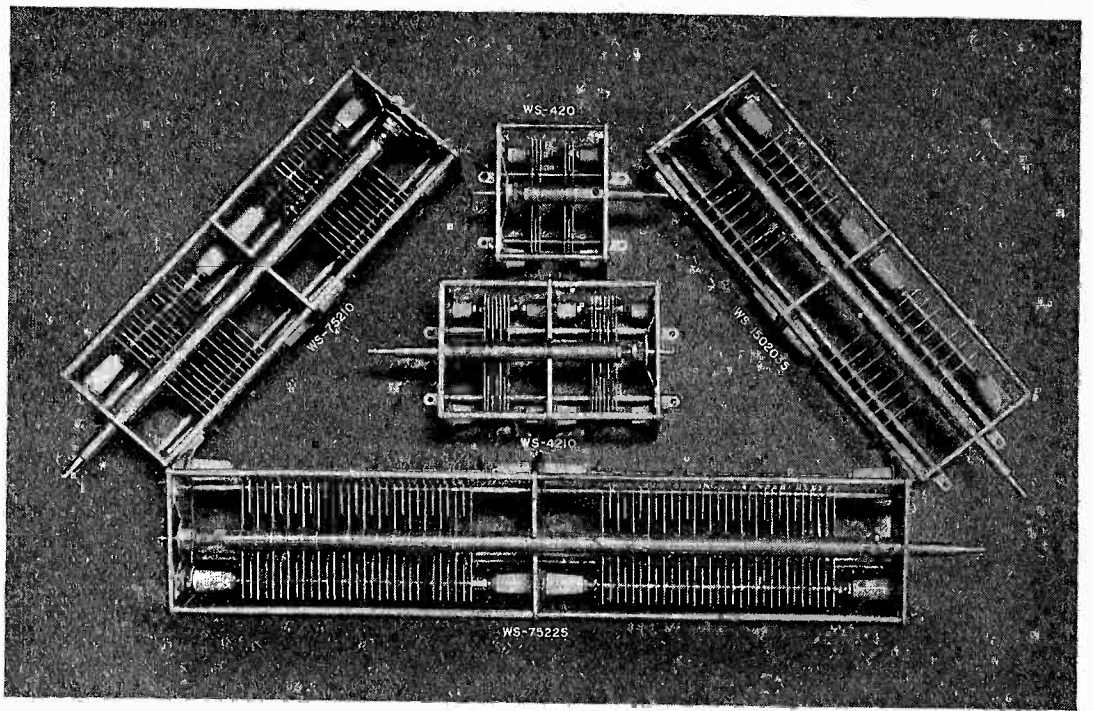

## SPLIT STATOR CONDENSERS

Type	Max. Cap.	Voltage Rating	Spacing Bet. Adj. Sta. Plates	Length	Suitable for Tubes	Ship. Wgt.	Net Price
WS-4204	2-.00004	4000	¼"	5¾"	800, 825, 203A, 50T.	4 lbs.	\$8.00
WS-4210	2-.0001	4000	¼"	11¼"		6 lbs.	10.00
WS-75210	2-.0001	7500	½"	16½"	852, 860, 204A, 150T.	8½ lbs.	13.33
WS-75225	2-.00025	7500	½"	26½"		12 lbs.	16.67
WS-1502035	2-.000035	15000	1"	16½"	852, 150T.	8½ lbs.	15.00

Also 15 Single Section Models 4000 to 15000 volt. Special sizes and capacities to order.

Commercial Type High Voltage Transmitting Condensers. Heavy dural plates with machine rounded edges. End plates are also heavy dural. Cadmium plated steel tie rods. Spacers accurately machined brass, cadmium plated. Panel space required is small, only 5½"x5½". Types WS4204 and WS1502035 are special Low-C models for Modern High Efficiency circuits. The WS1502035 is the ONLY condenser within reach of the ham capable of handling 852s, 150Ts, and 354s at Full Power—ask W4CBY, W6CXW, and W1EER.

## ENGINEERING SERVICE and Technical Advice

Our new Amateur Radio Department has been formed expressly to work on amateur problems. Chas. D. Perrine, Jr., W6CUH, is in charge and will welcome the opportunity to help you with your problems. The Department is working on new developments and has already contributed the revolutionary new Resonant Filter to amateur radio. Next month comes something entirely new in crystal control—"1-kw with two stages using ordinary crystals". Our aim is to solve your high power problems.

The high power amplifier shown on the right is an example of the advanced engineering and construction available from us at moderate cost. We design and build transmitters and special equipment of all kinds, including high quality speech input equipment for broadcast and sound picture installations. Let us quote on your requirements, and assure you of a real commercial job. We have been manufacturing quality radio and electrical apparatus since 1907.

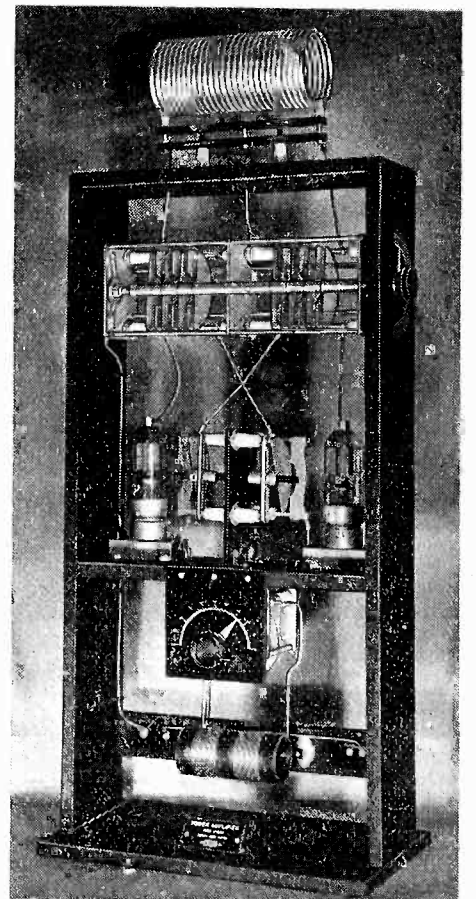

1000 WATT High Efficiency Amplifier for either 14, 7, or 3.5mc. Requires only 100 watts excitation, 3000 volts plate. Net Price with set of coils for one band, \$100.00 less tubes

### ORDER DIRECT FROM THIS PAGE

Our new policy is to sell DIRECT TO YOU only. You then receive our lowest prices because intermediate handling charges are eliminated. We can also give you better service and technical advice through direct contact. Tell us your problems when ordering. Write for bulletin R-104, just off the press, fully describing our line of transmitting equipment shown on this page. Terms: cash with order, or 50% with order, balance C.O.D. Goods sent express collect unless otherwise ordered, in which case transportation charges must be included. Any overpayment promptly refunded.

## AUDIO PRODUCTS COMPANY

4189 W. 2nd St.  
Los Angeles, Cal.

A. J. EDGCOMB  
Since 1907

Formerly  
"The Wireless Shop"



# Grid-Bias for the Transmitter

By JAYENAY

**P**RACTICALLY all radio-frequency power amplifiers are operated under conditions such that plate current flows in the form of short, peaked impulses which last for less than one-half of the alternating current cycle. This means that plate current is "Cut-off" during most of the RF cycle and this condition is highly desirable for high efficiency and high power output from small tubes. In order to keep the plate current at zero during most of the RF cycle it is necessary that the control grid of the amplifier tube be kept quite negative with respect to the filament by means of a DC voltage which is termed "negative bias." The AC excitation voltage, which usually comes from the plate circuit of the preceding amplifier stage, periodically overcomes this bias voltage and even makes the grid slightly positive with respect to the filament and therefore causes a short impulse of plate current to flow.

If no grid bias were used, the tube would draw plate current all of the time. This would result in very inefficient operation because the plate would never have an opportunity to cool off.

## Cut-Off Bias

Cut-off bias is that value of negative bias which is just sufficient to reduce the plate voltage to zero. Then, by means of batteries, apply different values of negative bias to the control grid of the tube. If a reading is taken on the plate milliammeter with varying values of negative grid bias on the control grid, it will be found that the plate current decreases as the negative bias is increased. At one point it will be found that the plate current is reduced to zero, and any further increase in negative grid bias has no effect on the plate current which remains at zero. Thus the lowest value of negative grid bias which reduces the plate current to zero is termed "cut-off bias." If the negative bias remains fixed for a moment at the cut-off point, and if the plate voltage is then increased, it will be found that the tube will again draw plate current. With the plate voltage remaining fixed at its newer and higher value, it is found that more negative bias than was used before must be applied to the control grid to again cut off the flow of plate current. Thus the conclusion is reached that there is some definite relationship between the plate voltage and the amount of grid bias necessary to cut-off the plate current. Cut-off bias, therefore, depends on the plate voltage and must be made higher as the plate voltage is increased.

It is not necessary to experiment with bias batteries and different plate voltages in order to determine cut-off bias for a given set of conditions. It can be calculated quite closely simply by dividing the voltage applied to the plate by the amplification factor of that tube, which may be obtained from any table of tube characteristics. Thus for a 210 tube operating with a plate voltage of 600 volts, cut-off bias is determined by dividing 600 by 8.5 (average amplification factor or  $\mu$  of a 210), which is approximately 76 volts. When estimating cut-off bias in this manner it is usually desirable to add from 5 per cent to 10 per cent more bias than that calculated because of the variable  $\mu$  tendency which is characteristic of all control grids as the cut-off point is approached

## Effect of Bias on Efficiency and Output

The amount of negative grid bias has a very definite effect on plate efficiency and power output. If the plate voltage and RF excitation voltage remain fixed, and if the bias voltage is increased beyond the cut-off point in a radio-frequency power amplifier, the power output and input decline, although

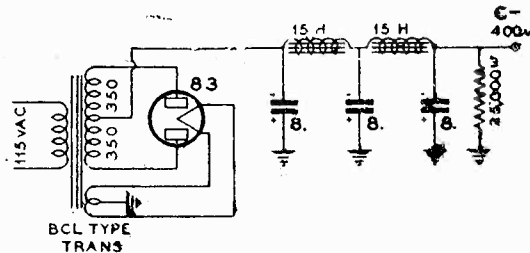

Here is shown a Bias Pack which uses a medium-to-high resistance bleeder. Voltage regulation is usually unimportant in biasing a class C amplifier and thus only enough bleeder is used to protect the filter condensers.

the plate efficiency rises. It is therefore necessary to make a compromise between power output and plate efficiency. The smallest amount of bias that allows the plate of the amplifier tube to run cool should be used beyond the cut-off point. This results in the maximum power output for a given tube,

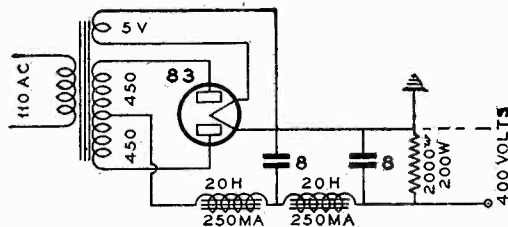

In the Bias Pack shown above, a low-resistance bleeder is used to provide a heavy, continuous current drain in order to stabilize the voltage output. A Bias Pack of this type is suitable for class B audio or class B Prime Linear Amplifier operation.

plate voltage, and RF excitation voltage. If it is desired to increase the power output it will be necessary to increase the plate voltage, loosen the antenna coupling, and in many cases increase the radio-frequency excitation voltage. When this is done the bias must be readjusted to the lowest value that allows the plate to remain cool, as previously mentioned. The actual value of this bias, as measured in number of times cut-off bias, will vary from about 1.25 times cut-off in a low-efficiency, high-gain buffer stage to about 4 times cut-off bias in an extremely high efficiency low-gain amplifier, operating with very high plate voltage and RF excitation. The bias voltage and the grid driving power are closely related and the higher the bias the more grid driving power is necessary to reach a given power output. For tubes of generally-similar characteristics, the one with the highest zero bias mutual conductance (see tube tables) requires the least amount of bias and grid driving power for maximum power output and plate efficiency. As an example of the effect of mutual conductance on the required bias voltage (and therefore the amount of excitation power necessary) it is found that under a given set of conditions a type 852 must be biased to 3.5 times cut-off and excited with 106 watts of grid driving power in order to obtain 400 watts of radio-frequency power output at 80 per

cent plate efficiency. On the other hand, a type 150-T, which has a considerably higher mutual conductance when used under the same conditions in the same amplifier stage, requires a bias of only 2.1 times cut-off and only 29 watts of grid driving power is necessary to obtain the same 400-watt output at the same plate efficiency (80 per cent).

When a radio-frequency power amplifier is plate modulated, the negative grid bias must be equal to or greater than twice cut-off. This is necessary in order that the peak power output can increase as the square of the plate voltage, which is essential for linear modulation.

## Sources of Bias

In general, bias may be supplied from two distinct sources: (1) from within the amplifier circuit itself, due to a voltage drop across either a grid-leak resistor or a cathode bias resistor. (2) From a source external to the amplifier circuit itself, such as batteries or a special rectified AC bias supply pack.

## Grid-Leak Bias

Whenever the control grid of an amplifier tube becomes positive with respect to the filament (as it does in all radio-frequency power amplifiers), the positive charge on this grid attracts some of the electrons emitted from the filament. These electrons flow back to the filament through the external DC grid return and therefore cause a current flow in that circuit. If a resistance is placed in series with the grid return, there will be a voltage drop across that resistor due to the current flowing through it; the end closest to the grid will be negative with respect to the end closest to the filament, thus necessarily causing the grid itself to become negative with respect to the filament. The voltage drop across this grid-leak resistor consists of a varying DC voltage superimposed on a constant value of DC voltage, which DC voltage is proportional to the effective value of the grid current impulses. The AC component is of no concern because it is by-passed by means of a condenser directly back to the filament, and thus by measuring the DC grid current with a DC milliammeter in series with the grid leak, the grid bias can be easily calculated by Ohm's law by multiplying the grid current by the ohmic resistance of the grid leak.

Grid-leak bias is quite flexible and more or less automatically adjusts itself with any variation in RF excitation. The value of grid lead resistor is not particularly critical because the DC grid current usually decreases as the grid-leak resistance increases, thereby keeping the product of the two more or less constant for a given amount of RF excitation. Thus the value of the grid-leak resistance can vary from one-half to four times the optimum value, a ratio of four to one, without materially affecting the negative DC bias voltage actually applied to the grid of the amplifier tube.

Grid-leak bias has certain disadvantages and because the bias voltage is proportional to the RF excitation it cannot be used in grid modulated or linear amplifiers, whose bias must be supplied from a source of good voltage regulation so that the bias voltage is independent of grid current. When grid-leak bias is used alone, it is evident that the bias disappears when the excitation fails, thus allowing dangerously-high values of plate current to flow, with consequent damage to the tube. Therefore it is desirable to augment grid-leak bias with either cathode bias or a separate bias supply in order to keep the plate current within safe limits whenever

(Continued on page 30)

# Decibels—Technique and Practical Application

## Voltage Amplifiers

WHEN plans are being drafted contemplating the design of power amplifiers it is essential that the following data be determined: First, the input and output signal levels to be used; second, the size of the power tubes that would adequately deliver an undistorted output; and third, the input signal voltage that must be applied to the amplifier to deliver the desired output. This last requirement is the most important in the design of voltage amplifiers as it is the ratio of the input signal voltage to the output signal voltage that governs the amount of amplification.

The voltage step-up in a transformer-coupled amplifier depends chiefly upon the mu of tubes and the turns ratio of the inter-stage coupling transformers. The step-up value in any amplifier is calculated by multiplying the step-up factor of each voltage amplifying or step-up device. Thus for example, if an amplifier were designed having an input transformer with a ratio of 3:1 coupled to a tube having a mu of 7, the voltage step-up would be approximately 3 times 7 or 21. It is seldom that the total product will be exactly the figure derived because it is not quite possible to obtain the full mu of the tube.

From the voltage gain in an amplifier it is possible to calculate the input and output signal levels and at the same time be able to determine at what level the input signal must be in order to obtain the desired output. By converting voltage ratios into decibels, power levels can be determined. Hence, to find the gain in decibels when the input and output voltages are known, the following expression is used:

$$(\text{gain}) \text{ Ndb} = 20 \text{ Log} \frac{E_1}{E_2} \quad (7)$$

Where  $E_1$ , is the output voltage; and  $E_2$ , the input voltage.

The next problem employs the above equation. Note that the logarithm is multiplied by 20 instead of by 10 as in previous examples.

**ILLUSTRATION:** A certain one-stage amplifier consisted of the following parts: 1 input transformer, ratio 2:1; and 1 output tube having a mu of 95. Determine the gain in decibels with an input voltage of 1 volt.

**SOLUTION:** By Equation (7)

$$2 \times 95 = 190 \text{ voltage gain}$$

$$\text{therefore, } \frac{E_1}{E_2} = \frac{190}{1} = 190$$

$$\text{Log } 190 = 2.278$$

$$20 \times 2.278 = 45.56 \text{ Decibel Gain}$$

In the above illustration it was shown how a voltage ratio may be converted into a decibel value; now below, is the reverse of this process. Here the conversion of decibels to voltage ratios are shown. The following demonstrates the processes of conversion is taken from the expression

$$E(\text{gain}) = \text{antilog} \frac{\text{Ndb}}{20} \quad (8)$$

Where E is the voltage gain (power ratio); Ndb, the decibels; and 20, the divisor.

**ILLUSTRATION:** In the preceding example the amplifier was found to have an overall gain of 45.56 decibels. What voltage ratio does this value represent?

**SOLUTION:** By Equation (8)

$$\frac{\text{Ndb}}{20} = \frac{45.56}{20} = 2.278$$

$$\text{Antilog } 2.278 = 190 \text{ Voltage ratio (gain)}$$

By BEMARD EPHRAIM, E. E.  
PART II

## Input Voltages

In designing power amplifiers it is paramount to have EXACT knowledge of the magnitude of the input signal voltage necessary to drive the output power tubes to maximum undistorted output. Without this information it would largely be a matter of guesswork in determining whether or not the power stages were being worked overloaded or underloaded.

Good design dictates that to obtain the maximum undistorted output signal, the input signal cannot be greater than the rated input signal voltage to the amplifying device. This means that if the input signal voltage is less than the maximum input rating, the output decreases; and conversely, if greater, it increases. Thus, if the signal voltage is allowed to be carried beyond the safe carrying capacity of the tubes, distortion will inevitably be introduced. It is, therefore, imperative that the input voltage be of the optimum value without causing the power tubes to verload.

To determine the input voltage take the PEAK VOLTAGE necessary to drive the grid of the output tube to maximum and divide this figure by the total overall gain PRECEDING THE LAST STAGE.

**ILLUSTRATION:** A two-stage amplifier was planned to be assembled of the following parts: 1 input transformer, ratio 3:1; 1 output tube type '45, grid volts 50, watts 1.6; and 1 output transformer, ratio 1:1. What must be the input voltage necessary to drive the '45 tube to maximum undistorted output?

**SOLUTION:**

$$\text{Gain preceding last stage} = 5 \times 5 \times 3 = 75$$

$$\text{thus, } \frac{50 \text{ (grid volts)}}{75 \text{ (gain)}} = .66 \text{ Volts Input}$$

## Signal Levels

In actual practice it is often necessary to change from one input device to another, such as from a phonograph pickup to a microphone, or to other devices having lower output levels than the input level of the amplifier. On such occasions the input signal level changes due to the different output levels of the input devices. If an amplifier has not been designed to compensate for these differences there will be a loss in the amount of useful energy delivered to the output of the final amplifier stages. On the other hand, if an amplifier could accommodate lower input levels, the use of higher ones would increase the load on the amplifier beyond the point of maximum undistorted output. This excess load would cause distortion unless some suitable control or attenuating network was employed to hold the input signal level to a point where overloading could not possibly occur. The devices used for this regulation are called "gain controls." It would not be necessary to govern the gain on an installation where the maximum output was always desired or where the input signal level remained substantially at some one level. However, in many instances, some type of gain control must be used because the input signal varies appreciably over certain limits.

How much the input signal varies can be best explained by a simple illustration, thus: If normal or nominal button current be supplied to a common microphone, the output signal will vary with the acoustic pressure on the diaphragm. Hence, if a person speaks

loud and close to a microphone the output level will rise, and conversely, if a person should speak in lower tones, or move away from the microphone the signal level will drop. In both instances the gain control is utilized to compensate for the differences in the output power as the speaker either stepped up to, or moved away from, the microphone. The subject of the "gain control" will be treated in detail in another paper soon to appear in 'RADIO.' Here, it has only been the intention to show how the gain control may be used to regulate the input signal voltage without reference to the mechanics or design of the control as a unit.

## Microphone Levels

Practically all acousto-electric apparatus energizing amplifiers have output levels rated in decibels. The output signal levels of these devices vary considerably from each other as may be noted from the table below:

	Decibels	Aver.
Phonograph pickup .....	0 to -30	-15
Carbon microphones.....	-30 to -60	-45
Piezo-elec. microphones..	-70 to -80	-45
Dynamic microphones ...	-75 to -95	-85
Condenser microphones..	-95 to -100	-97
Velocity microphones.....	-100 to -110	-105

In general, the lower the output signal level, the higher will be the acoustic response over the entire audio-spectrum. On the other hand, the higher the input signal level, the lower will be the overall fidelity.

The output levels of microphones and phonograph pickups have the same power values ascribed to them as those derived from calculating power output levels of amplifiers. Therefore, the same equations employed in connection with power ratios are similarly applied when converting output signal levels to power values.

## Computing Specifications

In computing the technical specifications for various types of amplifiers, the following illustrations will, no doubt, be satisfactory for all practical purposes. The technique, being self-explanatory, need not warrant further discussion.

**ILLUSTRATION:** The design specifications of a certain two-stage amplifier called for the following parts: 1 input transformer, ratio 3:1; 1 input tube, mu 30; 1 inter-stage transformer, ratio 2:1; 1 output tube, type 2A3, watts 3.5, mu 4.2, grid volts 45; and 1 output transformer, ratio 1:1. Assuming an input voltage of unity (1 volt) to the amplifier, determine the following in the order numerically listed:

- (1) Voltage Amplification
- (2) Overall Gain in db
- (3) Output Signal Level in db
- (4) Input Signal Level in db
- (5) Input Signal Level in Watts
- (6) Input Signal Voltage

**SOLUTION:** (1) Voltage Amplification

The voltage step-up of the parts complement computed in the order as they appear in the above specifications will be  $3 \times 30 \times 2 \times 4.2 \times 1 = 756$  Volt. Amplification.

**SOLUTION:** (2) Overall Gain in db  
By Equation (7)

$$(\text{gain}) \text{ Ndb} = 20 \text{ Log} \frac{E_1}{E_2}$$

$$\frac{E_1}{E_2} = \frac{756}{1} = 756$$

$$\text{Log } 756 = 2.878$$

$$20 \times 2.878 = 57.56 \text{ db Overall Gain}$$

**SOLUTION:** (3) Output Signal Level in db  
This signal level is found by converting the output in watts to decibels, hence,

By Equation (2)

$$\text{Ndb} = 10 \text{ Log } \frac{P_1}{P_2}$$

$$\frac{P_1}{P_2} = \frac{3.5}{.006} = 583$$

$$\text{Log } 583 = 2.765$$

$10 \times 2.765 = 27.65$  db Output Signal Level

**SOLUTION: (4) Input Signal Level in db**  
The maximum input signal level in decibels is determined by algebraically adding the output signal level in db to the overall gain in db. The former being prefixed by a PLUS and the latter by a MINUS sign. Thus,  
-57.00 overall gain  
+27.65 output level

-29.35 db Input Signal Level  
(read as -29.3 and disregard the last figure)  
**SOLUTION: (5) Input Signal Level in Watts**  
By Equation (6)

$$P = .006 \text{ antilog } \frac{\text{Ndb}}{10}$$

$$\frac{\text{Ndb}}{10} = \frac{-29.3}{10} = -3.01$$

$$\text{Antilog } -3.01 = .00102$$

$$.006 \times .00102 = .00000612 \text{ or}$$

.0061 mw input level  
**SOLUTION: (6) Input Signal Voltage**  
Gain preceding last stage =  
 $3 \times 30 \times 2 = 180$  gain  
45  
and  $\frac{180}{45} = .25$  Volt Input Signal  
180

### Push-Pull Amplifiers

In the preceding design the maximum undistorted output obtained was only 3.5 watts. This output may be adequate for some applications, while for others, twice as much power may be required. To double the output of the previous amplifier it is only necessary to push-pull the last amplifying stage and replace the inter-stage and output transformers with push-pull types. (Note: the 2A3 tube in a push-pull arrangement has a rating of 10 to 15 watts; in this case, it is assumed that the voltages have been adjusted so that the output is only doubled).

To determine the voltage step-up (voltage ratio) of a push-pull amplifier take the ratio of one half of the secondary winding of the push-pull transformer and multiply it by the mu of one of the output tubes in the push-pull stage; the product, when doubled, will be the voltage amplification or step-up.

**ILLUSTRATION:** Using the first stage of the amplifier described in the previous section as an exciter, it is desired to push-pull the last stage of the same amplifier in order to boost the output from 3.5 to 7 watts. In changing the design the following parts were used: 1 inter-stage push-pull transformer, ratio 2:1, per section; 2 output tubes, types 2A3, mu 4.2, watts 3.5, grid volts 45; and 1 output push-pull transformer, ratio 1:1 per section. In this new combination how much voltage amplification is obtained?

**SOLUTION:** From the specifications given, the voltage amplification will be  $3 \times 30 \times 16.8 \times 1 = 1512$  Volt. Amplification  
Where  $3 \times 30$  equal the step-up voltage of the first stage; 16.8, step-up for the push-pull stage; and 1, the ratio of the output transformer.

To determine the balance of the technical data proceed EXACTLY as illustrated under preceding solutions 2, 3, 4, 5, and 6. For convenience the outline has been arranged and listed below so that comparisons can be readily made between the 3.5 and 7 watt combinations.

	3.5 Watt	7 Watt
Volt. amp.....	756.	1512.
Overall gain in db	57.56	63.58

Output signal level in db.....	27.65	30.64
Input signal level in db.....	-29.35	-32.94
Input signal level in watts....	.0061mw.	.0006mw.
Input signal voltage .....	.25	.25

When comparing the relative merits of both amplifiers observe closely that the difference between the output signal levels of the 3.5 and 7 watt combinations are only 2.89 db. Note also that doubling the power did not double the output signal level. In general, doubling the power adds about only 3 db.

Acoustically, that is from the loudspeaker standpoint, it takes approximately one decibel to note an appreciable change in the volume of sound. This is because the intensity of sound as heard by the ear varies logarithmically with the acoustic power. For practical purposes it is only necessary to remember, that if two sounds differ in physical intensity by less than one decibel they usually sound alike. If they are much more than one decibel apart one sounds slightly louder than the other. This quantitative data is also applicable to amplifiers in that the output signal levels must differ by at least 1.5 db in order to note any change in volume. In the 7 watt amplifier, the output level has been increased by only 2.89 decibels at the expense of doubling the power. This small increase sometimes does not warrant using a push-pull combination, but, where high-quality amplification is required and where harmonic distortion must be kept at minimum a push-pull amplifier is almost universally employed.

Another interesting point of comparison is that of the input signal levels. Here, note particularly, that the difference between the input signal levels are 3.59 db. This difference means that the amplifier using the push-pull combination will deliver maximum output at a signal level of 3.59 db LOWER than that of the 3.5 watt lay-out. (Do not confuse this rating with voltage). In general, increasing the power output level of an amplifier DECREASES the input signal level and not as is the usual conception, that increasing the power output necessitates an increase in signal input in order to drive the power output stages to maximum.

### Pre-amplifiers

Pre-amplifiers are employed to raise low input signal levels up to some required input level of another intermediate or succeeding amplifier. For example: If an amplifier was designed to operate at an input level of minus 30db, and instead, a considerably

lower input level was used, a pre-amplifier would then have to be designed to bring the low input signal up to the rated input signal level of -30db to obtain the full undistorted output from the power tubes in the main amplifier. The amount of gain necessary to raise a low input signal level up to another level may be determined by the following equation:

$$E(\text{gain}) = \text{antilog } \frac{\text{Ndb}_1 - \text{Ndb}_2}{20} \quad (9)$$

Where E is the voltage step-up or gain; Ndb<sub>1</sub>, the input signal level of the pre-amplifier or new low input signal level; Ndb<sub>2</sub>, the input signal level to the intermediate amplifier; and 20, the divisor.

To apply the equation the following example is given:

**ILLUSTRATION:** In the preceding discussion the 7 watt push-pull amplifier was found to have an input signal level of -32.8db. Now, if this amplifier is excited by an input signal level of -60db how much voltage amplification will be necessary to raise the gain up to -32db so that the push-pull amplifier will work at full output?

**SOLUTION:** By Equation (9)

$$\frac{\text{Ndb}_1 - \text{Ndb}_2}{20} = \frac{60 - 32.9}{20} = 1.355$$

$$\text{Antilog } 1.355 = 22.6 \text{ Voltage Gain}$$

From the above example it can be seen that a voltage step-up of 22.6 is required as additional amplification to raise the signal level of minus 60db up to minus 32.9db in order to drive the power tubes in the last stage to full output. This additional gain can be obtained by designing a pre-amplifier having an input transformer with a ratio of 2.5:1 coupled to a tube having a mu of 9.1.

Below are tabulated comparative figures showing the difference between the 7 watt push-pull combination with and without the pre-amplifier.

	Pre-amplifier	
Volt. amplification....	410,005	1512.
Overall gain in db....	90.80	63.58
Output signal level		
in db .....	30.70	30.70
Input signal level		
in db .....	-60.10	-32.94
Input signal level		
in watts (micro)....	.0006	.0006mw.
Input signal voltage..	.001+	.25

In summarizing all the preceding illustrations it has NOT been the intention that the design of the amplifiers be considered as ideal combinations to follow. However, the various examples have been only selected as a means of clarifying the requirements of this exposition.

(Continued on Page 32)

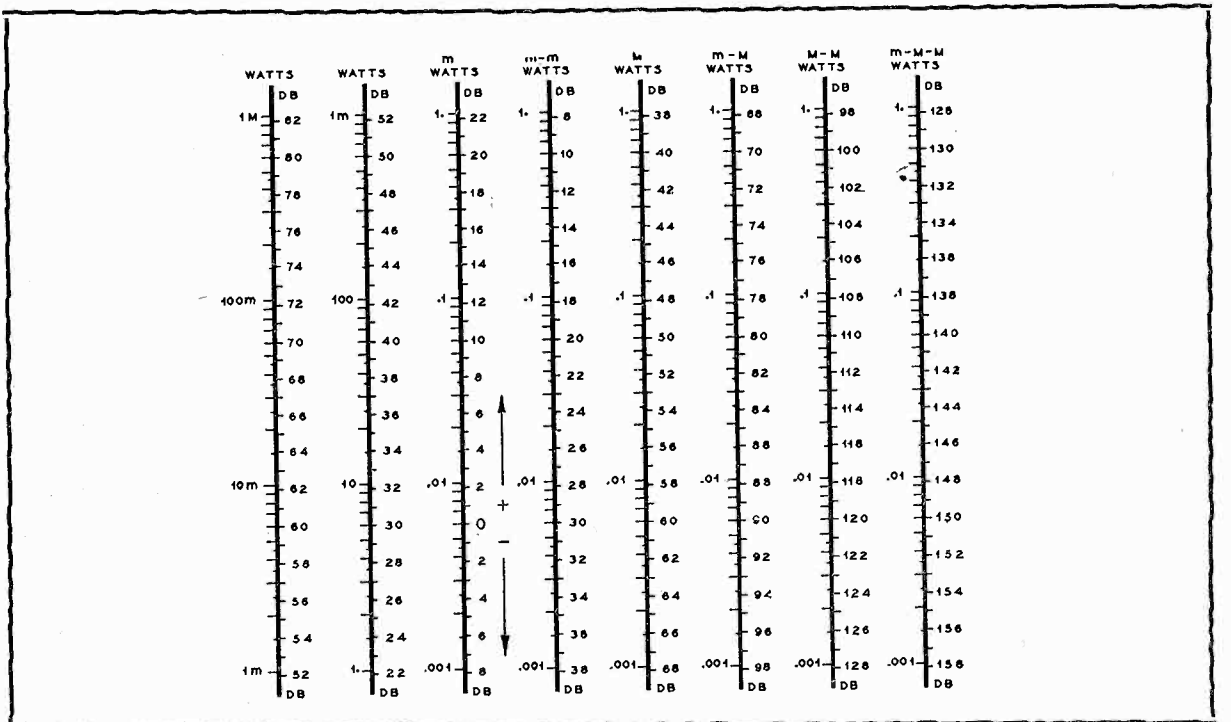

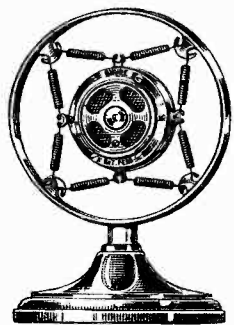

# Two-Button Microphone Circuits

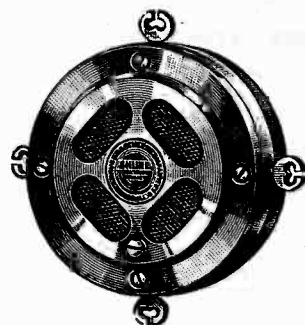

## Hum Reducing Input Circuit

**H**UM problems immediately arise when an input transformer is added to a high gain amplifier which has integral AC power supply. Usually, despite all attempts to orient the input transformer for minimum induction, stray fields from the power transformers and filter chokes introduce high hum voltages in the input transformer secondary. For any given conditions of stray field, the hum in the amplifier output increases in direct proportion to the amplifier gain and the number of turns on the input transformer secondary. The difficulties become very pronounced, for instance, in portable sound-on-film amplifiers where the overall gain is frequently more than 100 db.

Fig. 1-A shows the usual arrangement of

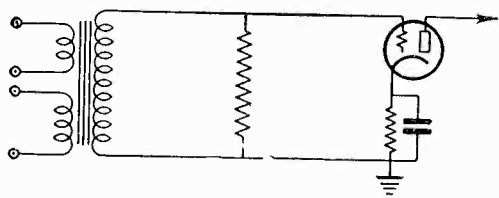

FIG. 1A

the input transformer in the grid circuit of the first stage; the hum level is, of course, relatively high. Now, in high gain sound-on-film amplifiers, a rather low voltage is sufficient for full amplifier output. Fig 1-B is a

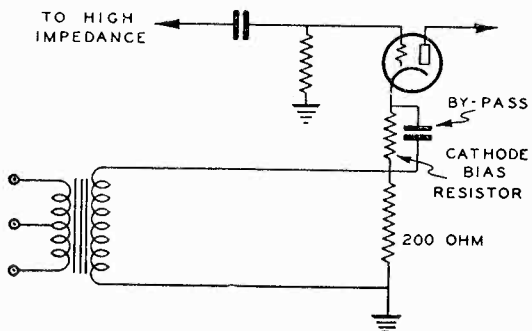

FIG. 1B

circuit which takes advantage of this fact. The transformer may be a 200-to-200 ohm unit, a mixing transformer for instance, with the secondary connected into the cathode circuit and terminated with a 200-ohm re-

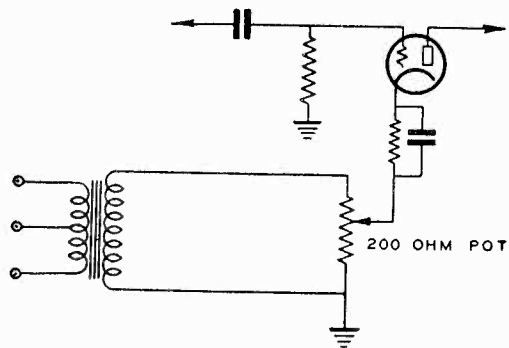

FIG. 1C

sistance. Since there are relatively few turns on such transformers (compared with the usual input transformer secondary) the induced hum voltage will be correspondingly

©1934 Shure Brothers Company, Chicago. All rights reserved.

low. Impedances are, of course, perfectly matched. Since the DC resistance of the transformer secondary will be about 20 ohms or less, the bias voltage will be practically unaffected. One additional advantage of the circuit is that no connections to the high-impedance grid circuit are required, thus avoiding "capacity" hum which might arise in running grid-circuit connectors to switches. To switch off the low impedance source, simply short circuit the terminating resistor as shown.

If volume control of the low-impedance source is required, the arrangement of Fig. 1-C is suitable. The 200-ohm resistor is replaced by a 200-ohm potentiometer connected as shown.

Both of these circuits will be found especially suitable for adding low-impedance input to existing high-gain AC operated amplifiers, especially in portable and theatre sound picture equipment.

## Rectified AC Supply for Carbon Microphones

It is especially desirable to eliminate batteries in portable sound equipment to reduce the weight of the equipment. Sound systems which are operated by non-technical personnel are logically made fully AC-operated to minimize service failures due to run-down batteries.

The button current for carbon microphone can be obtained easily from the amplifier power supply system. Several precautions, however, should be observed to prevent momentary application of excessive voltage to the microphone. Fig 2-A shows the basic

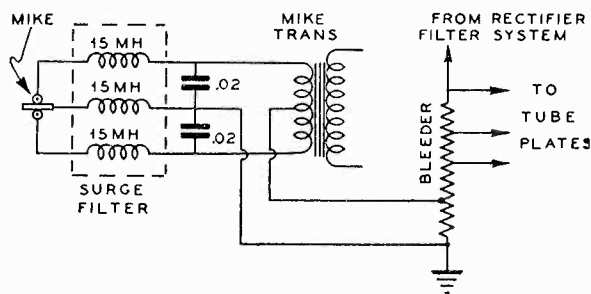

FIG. 2A

circuit for obtaining the button current from the bleeder system of the amplifier. Usually about 10 to 25 m.a. (5 to 10 m.a. per button) will be required, which approaches the total current flowing in the bleeder, hence the microphone circuit must be tapped across a resistance which is high compared with the effective resistance of the microphone load so that practically all of the bleeder current will flow through the microphone. Thus the portion of the bleeder system shunted by the microphone circuit is practically short-circuited when the microphone is connected, and this will upset the voltages supplied to the various tubes unless the bleeder is re-designed. A disadvantage of the elementary circuit of Fig 2-A is the momentary high voltage which is applied to the microphone if it is plugged into the bleeder system with the amplifier turned on; this is likely to cause cohering and burning of the diaphragm.

Fig. 2-B shows a potentiometer for current control inserted in series with the existing bleeder system, a method which overcomes

many of the above difficulties. The arm of the potentiometer should always be turned back to minimum current before the power supply is shut off, which can be automatically accomplished using the familiar potentiometer switch combination employed in radio receivers. The potentiometer resistance may be approximately 1000 ohms with a current rating somewhat greater than the normal current in the lower part of the

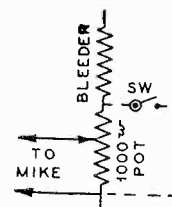

FIG. 2B

bleeder system. The switch is, of course, wired in series with the power transformer primary. The microphone should be connected to the amplifier with the potentiometer in the "Off" position, gradually advancing the control until the proper current is obtained. Remember that the maximum current for the microphone circuit will be slightly less than the available bleeder current.

The resistance of the potentiometer will be practically short-circuited when the microphone is in use. If the amplifier is intended for use without the microphone, it may be advisable to cut the potentiometer out of circuit to prevent voltage changes. A single pole switch, as shown dotted in Fig. 2-B, will accomplish this result very simply.

## Surge Filter for Two-Button Microphones

Carbon microphones tend to "pack" if the circuit is opened while normal button current is flowing. This is caused by the high transient voltage induced in the microphone transformer primary winding when the circuit is opened. As a preventive measure, the current should always be reduced to a minimum by turning down the rheostat or potentiometer before disconnecting the microphone or switching off the battery.

A simple filter section, which is essentially a low pass network, will act as a shock-absorber for transients, and the arrangement of Fig 2-A has been found to afford rather complete protection against "surge packing." The chokes have an inductance of approximately 1.5 millihenries each, and may consist of universal air-core windings, or approximately 100 turns of about No. 28 magnet wire, random wound on a stack of transformer "I" laminations. "I" laminations taken from a small loudspeaker output transformer are quite suitable. The condensers have a capacity of .02 mfd. each. Low voltage paper condensers are satisfactory.

The surge filter accomplishes another useful result when used with radio-telephone transmitters where the antenna and speech input equipment are close together, for if the system is thoroughly shielded throughout, the surge filter will effectively prevent RF feedback through the speech-input equipment. Completely shielded cables should be used for microphone connections.

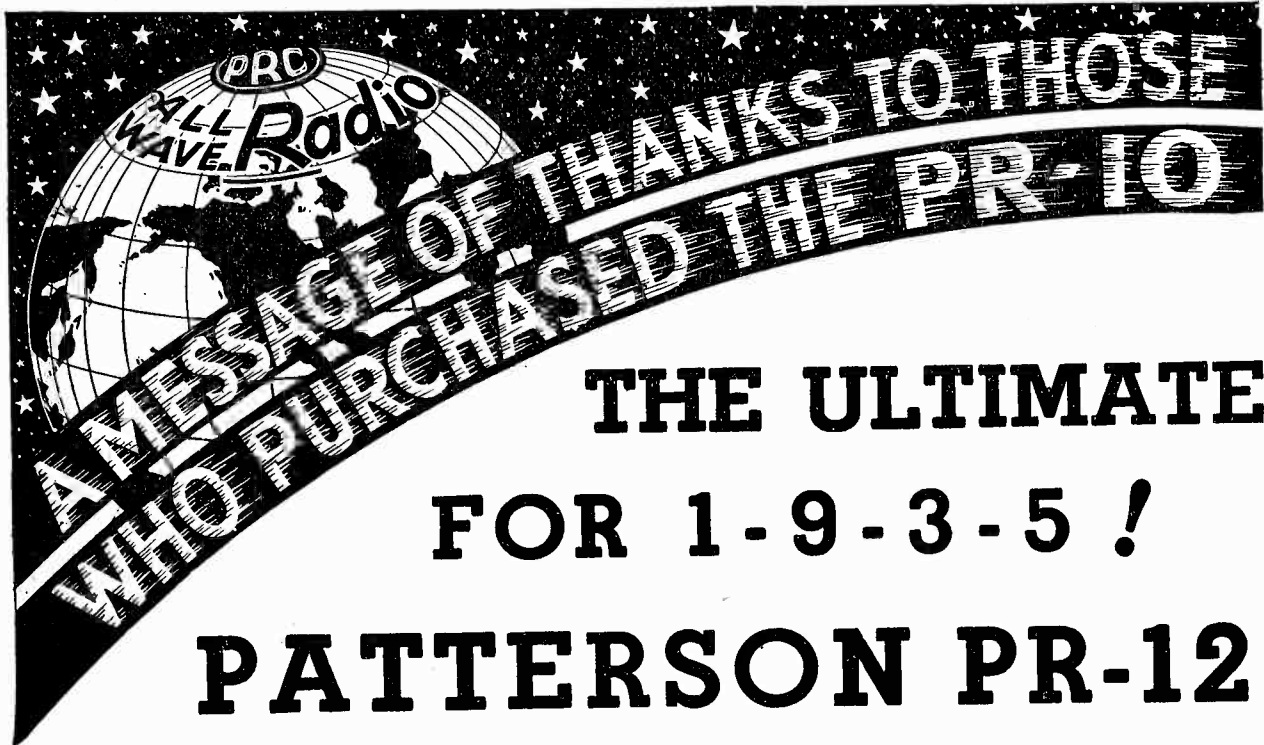

**THE ULTIMATE  
FOR 1-9-3-5!  
PATTERSON PR-12**

+

A word of personal thanks to the thousands who purchased our superb PR-10, the wonder set of all waves for 1934. . . . Here's good news for those who have not thrilled to Patterson super-performance: "It takes a Patterson to beat a Patterson!" is a common saying in the industry today. And here's the proof: PR-12, personally designed and engineered by E. R. Patterson, will be ready November 1st! The one set that out-performs PR-10. Frankly, we have been told it should carry a "1937" label, so far ahead of all competition is it today! . . . It will do more than you expect—on all bands! . . . Literature ready now. Write today. Arrange with your jobber to see PR-12 at once. List prices: Console, with crystal: \$179.50; metal case, with crystal: \$149.50; metal case, without crystal: \$139.50. Our jobbers extend customary amateur discount of 40%. Buy PR-12 with confidence! You'll be repaid.

+

**PATTERSON RADIO COMPANY**

1320 South Los Angeles St., Los Angeles, California, U. S. A.

# 'HAMS' Here is the OHMITE Amateur

H  
A  
N  
D  
B  
O  
O  
K

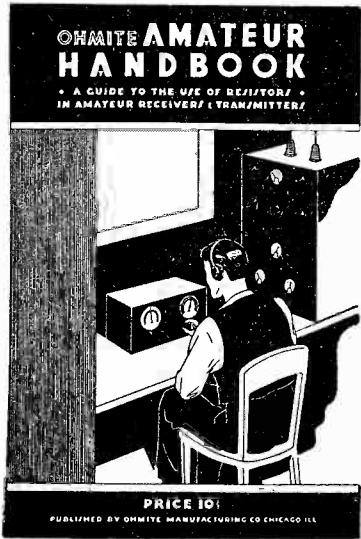

Here is the Handbook you have always wanted . . . sixteen pages of resistor and rheostat data needed by every amateur . . . how to select bleeder resistors, voltage dividers, filament rheostats, plate supply systems, etc. Ingenious tables and charts eliminate formulas and calculations and save 90% of the work. The Handbook also contains data on a new AC-DC Frequency Meter Monitor, a Class-B Modulator, wattage and resistance charts, Ohm's Law Charts, new MULTIVOLT tapped resistors, power rheostats, etc.

Price 10c

Use the coupon below or see your parts dealer for the biggest dime's worth you ever received.

**OHMITE**  
MANUFACTURING COMPANY  
629 N. Albany Ave., Chicago, Ill.  
Enclosed find 10c for my copy of the OHMITE AMATEUR HANDBOOK.

NAME \_\_\_\_\_  
ADDRESS \_\_\_\_\_  
CITY \_\_\_\_\_ STATE \_\_\_\_\_

## QUALITY

at a Price You Can Afford to Pay!

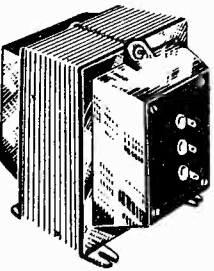

## FRANKLIN Transformers

Very conservative ratings on Transformers and Chokes for every Amateur Station.

"MOST SOCK PER DOLLAR"

Write for Catalogs

FRANKLIN TRANSFORMER MFG. CO.  
607-609 22 Ave. N.E., Minneapolis, Minn.

## LITTELFUSES

Instrument Littlefuses, for meters, 1/200 amp. up.  
Hi-Volt Littlefuses for transmitters, etc. 1000, 5000 and 10,000 volt ranges, 1/16 amp. up.  
Neon Voltage Fuses & Indicators (Tattellites) 100, 250, 500, 1,000 & 2,000 volt ratings.  
Aircraft Fuses, Auto Fuses, Fuse Mountings, etc.  
Get new Catalog No. 6

LITTELFUSE LABS., 4503 Ravenswood Ave., Chicago, Ill.

## Grid Bias

(Continued from Page 25)

the excitation fails. The amount of bias supplied in addition to the grid-leak bias should usually approximate cut-off bias so that the plate current will drop to zero if the crystal stage stops oscillating, or if something becomes detuned in any of the other stages.

### Cathode Bias

This form of bias utilizes the voltage drop across a resistor in the B-minus lead from the high voltage power supply, caused by the flow of plate current through this resistance. Because the B-minus lead of most high-voltage power supplies is directly grounded, the bias resistor must be placed in the negative side of the DC plate circuit of the tube itself. The negative side of the DC plate circuit of a vacuum tube amplifier is between the filament center-tap and ground, and a resistor placed between these two points will have the total plate current flowing through it. It will therefore have a voltage drop across the resistor which is equal to the product of the plate current in amperes, times the resistance in ohms. The grounded end of this cathode bias is more negative than the filament end by the amount of voltage drop across the resistor. Therefore, if the DC grid return is brought to the ground end of this resistor, the grid of the amplifier will be negative with respect to the filament.

Cathode bias is probably the safest bias supply known, because the negative bias voltage is a function of the plate current and is largely independent of the RF grid excitation. The plate current, therefore, can never reach a dangerously-high value if the excitation fails. This type of bias is generally unsuitable for class B linear amplifiers, although the use of cathode bias is essential in the newer Hakwins Class B-Prime linear or grid-modulated amplifiers.

This type of bias can be used in a plate-modulated class C amplifier provided a large audio by-pass condenser is connected across the bias resistor in addition to the usual mica radio-frequency by-pass condenser. The principal disadvantage of cathode bias is that the bias voltage must be subtracted from the total power supply voltage in order to obtain the net plate voltage across the amplifier tube. In a high efficiency amplifier stage using a low mu tube and biased to perhaps 3 times cut-off, it may require a 1600-volt power supply to actually realize 1000 volts on the plate of the amplifier tube, because 600 volts is deducted for negative bias.

Cathode bias is sometimes called automatic bias because variations in plate current automatically change the bias to compensate for these variations.

### Separate Bias Supplies

Negative grid bias may be supplied from any source of voltage external to the amplifier circuit itself, such as dry batteries or B eliminators. B batteries rarely fail without giving considerable warning to the operator and they represent one of the safest sources of negative bias. However, these batteries wear out rather rapidly due to the charging effect of the DC grid current which causes the voltage as well as the internal resistance of the batteries to rise. After a few months of use, the batteries often become noisy, especially when used for phone work. When charged-up they bulge and leak. It is not unusual to find a 45-volt battery which measures at 60 volts after only a month or two of service in the grid circuit of a class C amplifier. This would be of no particular disadvantage if the 60 volts remains constant, but it usually wavers and fluctuates and often has an adverse effect on the note of the signal.

(Continued on Page 33)

## NEW GIANT Plug-In Coil Form

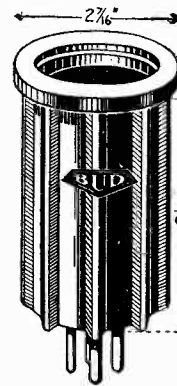

An ideal form for Transmitter Inductances and long wave receiver inductances and numerous other uses. Made of special low loss bakelite. Bakelite body of coil form is 2 1/4" in diameter and 3 1/2" long. Winding space 3 1/4".

Standard base to fit either 4, 5 or 6 prong sockets. Eight ribs extending 1/4" insure low loss air core windings. Top of form has moulded grip ridge.

No. 734—4 Prong—\$.75

No. 735—5 Prong—\$.80

No. 736—6 Prong—\$.85



Your Favorite Jobber Stocks BUD RADIO Parts  
Write for New 1935 Catalog

List prices shown in this advertisement are subject to 40% discount when purchase is made from an authorized BUD jobber. If your jobber cannot supply BUD parts, send your order direct to us together with your jobber's name and we will make shipment direct.

**BUD RADIO, INC.**

1937 E. 55th St.

Cleveland, Ohio

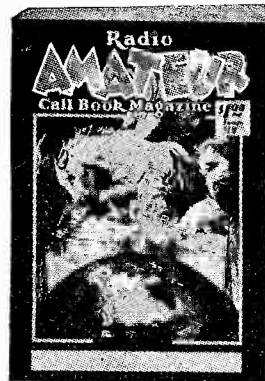

## NEW EDITION Now Ready

The only Radio Call Book published that lists all of the radio amateurs throughout the entire world.

Also a complete list of high frequency commercial stations, International abbreviations and amateur prefixes, "Q, R, & T," systems for reporting signals, New US radio inspection districts, high frequency press, time and weather schedules, and high frequency commercial stations listed by frequencies.

Every ham should have one. Always up-to-date. Single copies \$1.10. Annual subscription \$3.65.

RADIO AMATEUR CALL BOOK, INC.,  
600 SOUTH DEARBORN ST. CHICAGO, ILL

## ANKER-CRUISER

3-TUBE A.C.-D.C. SET

WORLD-WIDE  
RECEPTION

KIT  
**\$10.45**  
NET

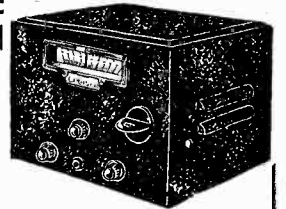

### OUTSTANDING FEATURES

Electron coupled feedback, 3 tubes, 6C6, 43, and 25Z5, humfree built-in 110 AC-DC power supply, front panel plug-in coils, front panel phone plug, automatic speaker cutoff, hinged cover black crackled metal cabinet, 13 to 200 meters—Complete Kit of Parts, including 4 front plug-in coils, hardware, diagram, instructions, etcetera. List, \$17.41; net \$10.45. Wiring and testing, list \$3.40; net \$2.05. Broadcast coil, list, \$.99; net, \$.59. Kit of Arcturus Tubes, list, \$3.95; net, \$2.37. Ankerlite phone, list, \$1.75; net, \$1.05. Order from this page. Free Anker Catalog on Request.

**ANKER LABS**

20 W. 22nd St. Dept. R-11 New York City

\$1 brings you the next four issues  
of "RADIO"—Subscribe NOW.

# I. R. F. NEWS

(Formerly I.T.K.)

The Amateur's Legion of Honor

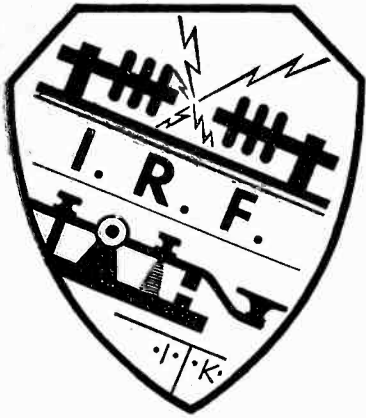

This department is edited by the President of the International Radio Fraternity, J. Richard Meloan (Jo) radio W6CGM-W6ZZGB, KERN.

All communications concerning the International Radio Fraternity, as well as inquiries from any amateur as to the Requirements for Membership, should be addressed to I.R.F.

Headquarters, International Radio Fraternity, 715 S. Hope St., Los Angeles, Calif.

## Third Honor Degree Awarded . . . "CQ Urgent"

IT WAS January the tenth, in the dead of winter, in the Far North. It had been an unprecedented cold winter with temperatures ranging to as far below zero as 76 degrees in some locations.

On the Alaska Peninsula a blizzard had been raging for several days. Caught in this blizzard was an Eskimo boy, Valentine Supsock, 16 years of age. He had risen long before daylight while his other Eskimo friends and his Uncle Frank Spoon were still sleeping. He was anxious to make his trap line that day to see if he had been successful.

It was while on this lonely "mush," made on foot, that the storm arose, and Valentine lost his way. He tried to keep on walking, realizing the danger of stopping to rest. That day passed. The night passed, and his companions and friends became alarmed for his safety. The second day they started in search for him.

Finally, Frank, and Nick Metigorok, Frank's brother-in-law, found Valentine lying on the ground. Thinking he had been frozen to death, they returned to the cabin for help. When they returned to the spot, Valentine was gone. He had become so exhausted from walking day and night that he finally stopped for a short nap. It was during this nap that he was discovered by his uncle. When he awakened he found that his feet were frozen, and he had to drag himself to his cabin, where he was finally found by the searching party.

Instead of packing his feet in snow, as should have been done, he was put to bed in a warm room. Next day a note was sent to Mrs. Hanson, a nurse, asking her to come and treat Valentine's feet. As soon as they were uncovered Mr. Hanson said to his wife, "That boy will have to go to the hospital and maybe have those feet amputated, or else he will die. How do you want him sent; by dog-team or by plane?"

It is a long, hard "mush" of some 300 miles, requiring a week's time to reach the hospital by dog-team.

"Send him by plane," said Frank Spoon, Valentine's uncle.

Hanson, K7BOE, looked at his watch and said, "I have a schedule with Cape Prince of Wales in 20 minutes. I'll see what I can do."

Hurrying to his station, he was soon on the air and called Wales, the station on schedule being K7CZM. No answer! Then, "CQ URGENT CQ URGENT CQ URGENT DE K7BOE . . ." Immediately after the call the steady, familiar note of K7ACZ came back, "Is there anything I can do for you?"

"Yes," said Hanson, "If you can relay a message to the Naval Communications Radio Station there at Dutch Harbor, ordering a plane from anchorage, do so at once. An Eskimo boy here has frozen his feet and must go to the hospital at once."

"O.K. I am at your service," replied K7ACZ, "I will pay for the message; it'll cost about \$2.90."

In a few minutes the message was phoned to N. C. Radio Station at Dutch Harbor, and was on its way to Anchorage Airplane Base, 400 miles down and 800 miles back over our heads to Anchorage.

The next morning a message was received from K7EGL, at Lake Iliamna, from McGee Airways: "SENDING A PLANE TO KANAKANAK WHERE PILOT WILL PROCEED TO PILOT POINT AND PICK UP ESKIMO WITH FROZEN FEET."

The plane came. A dog-team sped over the lakes and tundra and soon Valentine was in the air. Word was frequently received from the doctor at the hospital regarding Valentine's condition. Messages were received through commercial; relayed by amateur radio. Most of Valentine's feet were saved; this summer he was back, fishing on the beach with the aid of crutches.

Dr. Bergdorf, who cared for Valentine, said,  
(Continued on Page 32)



# TOP O' THE WAVE OF SUCCESS!

FROM the Arctics to the Tropics — East to West — in forty countries — on airplanes, naval craft, automobiles and police cars — in long-distance amateur sets and rich-toned home radios — in the initial equipment of 60% of the country's licensed radio-set manufacturers . . . millions of Raytheon 4-pillar Tubes are used.

Sheer quality is the outstanding reason why Raytheons are so widely chosen. More than 95 minute pieces of wire, metal and chemicals are processed with microscopic accuracy into the assemblage of Raytheon 4-pillar Tubes — giving to them an unrivaled uniformity of characteristics. 4-pillar element support gives Raytheons a matchless sturdiness that defies jolts and vibration and makes them a decided favorite, particularly where dependability and long life are demanded.

Twenty thousand dealers sell Raytheons, the only radio tubes with a distinctive and exclusive feature: 4-pillar construction.

**ANNOUNCEMENT** — The RK-20, for the amateur, has now been added to the illustrious Raytheon line . . . a filament type RF power pentode designed for use as a crystal controlled oscillator or suppressor grid modulated oscillator or RF amplifier. Try it and *note the difference.*

RAYTHEON PRODUCTION CORPORATION

# RAYTHEON

TRADE-MARK

## 4-PILLAR RADIO TUBES

30 East 42nd Street, New York City  
445 Lake Shore Drive . . . Chicago

55 Chapel Street . . . Newton, Mass.  
555 Howard Street, San Francisco

# RME-9D SINGLE SIGNAL SUPER

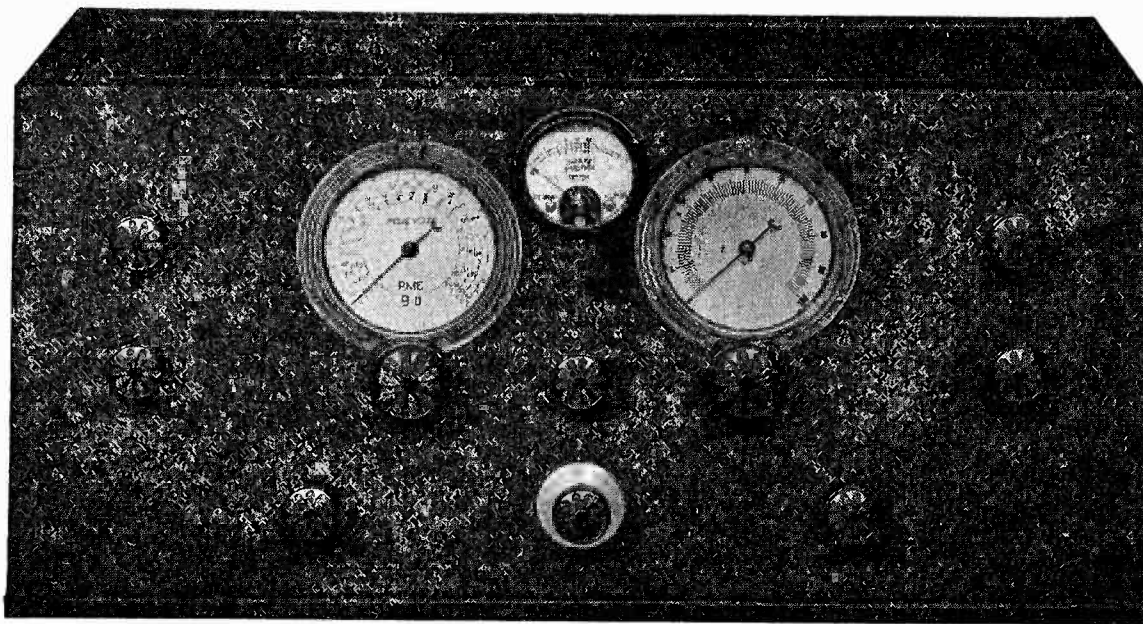

CONTINUOUS BAND SPREAD FROM 13 TO 540 METERS

No plug-in coils used. All controls located on the front of panel. A precision instrument built with the idea in mind that the best is never too good for particular amateurs. Mention a desir-

able feature and you will find it incorporated in the RME-9D. It does the job better than you have ever heard it done before. (For details see July issue of "RADIO," page 27). 10c in stamps will bring a complete descriptive folder.

## RADIO MFG. ENGINEERS

313-315 BRADLEY AVENUE

PEORIA, ILLINOIS

# TUNING CONTROLS

FOR RADIO SET MANUFACTURERS

**New Airplane Type**  
in Ten Styles

Write for our new catalog No. 55. Just off the press. Chuck full of the latest tuning controls, escutcheons, cabinets, name plates and other specialties. Twice the size of the last issue. Well worth sending for, plenty of valuable information.

REMOTE CONTROLS  
FOR AUTO RADIOS

EXPORT ORDERS RECEIVE SPECIAL ATTENTION  
Cable Address—CROWNAME CHICAGO

Jobbers and Dealers Find Our Line Profitable

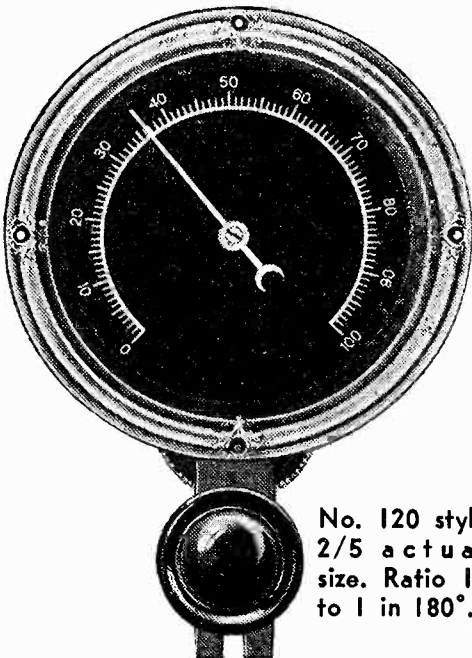

No. 120 style  
2/5 actual  
size. Ratio 12  
to 1 in 180°.

**CROWE NAME PLATE & MFG. CO.**

1755 GRACE STREET

Established 35 Years

CHICAGO, ILL., U. S. A.

Pacific Coast Representative, W. BERT KNIGHT, INC.

## POWERPLATE

Prices to specified frequency (Amateur Bands)

X cut, AT cut or Ac cut.....\$3.00 ea.

Y cut .....\$2.00 ea.

Commercial Crystals a Specialty

Piezo Electric Crystals for Transmitters,  
Receivers and Frequency Standards

**ALBERT F. HOEFLICH**

626 Sixteenth Ave.

San Francisco, Calif.

FRANK C. J. N. A.  
**JONES & HAWKINS**

Consulting Engineers

Special High Frequency and Ultra High  
Frequency Equipment Designed and  
Developed for Amateur, Military and  
Commercial Communications.

2850 - 19th Ave.

San Francisco, Calif.

## I. R. F. News (Continued from page 31)

"Hanson sent that boy just in time. If you hadn't sent him, he would have died."

The International Radio Fraternity recognizes the work of men having Hanson's caliber. Therefore, we present the HONOR DEGREE of I. R. F. to Samuel C. Hanson, K7BOE, an instructor with the Indian Field Service, United States Department of the Interior. His work is highly commended.

Hanson, in a letter to I.R.F. headquarters, says, "I am proud of my I.R.F. certificate. It is the prettiest thing on my shack wall, and we want to thank Louie Huber for introducing us to this fraternity. I only want to prove a worthy member (Ed. Note—He has done that!) and do my part to advance the organization and the principles for which it stands. I think a great deal of credit is due to those who have begun this organization and fostered it through these years in such a self-sacrificing spirit."

We mustn't overlook K7ACZ and G7EGL, who cooperated to a splendid extent with K7BOE, whose likeness and shack appear on this page.

## Ten Meter Contest Results

W1BZC, William C. Ellsworth, our Eastern representative, topped all comers on the 28 MC contest held July, August and September. Bill made many contacts, using phone, ICW and CW. The best "heard" DX was KKZ, Bolinas, Calif., heard Sept. 11. Several very fine contacts were made, covering 1500 miles or better. One DX contact was that made with W4AJY, Birmingham, Ala., on July 5; another was a QSO with W9FVI. Many QSOs were had with several Illinois, Wisconsin and Indiana stations. Quoting Bro. Ellsworth's report, "W9HUV reported me as his first QSO in three weeks. W9NY reported me as his first QSO since previous one of July 17. Band was dead during September up to closing date of contest, Sept. 15"—with the exception of hearing KKZ.

We suppose that, in light of next summer, being due around June, 1935, you would like to have the dope on the 28MC station equipment which was used by W1BZC; well, here 'tis: The receiver lineup is a simple one, and facts concerning its operation are valuable . . . one stage of TRF, oscillating detector and a pentode audio stage. Super-regeneration was controlled as to frequency of quenching, and amplitude was found to assist in CW reception, which fact contradicts customary practice. The antennae used for reception were many and of various designs, among which was a horizontal loop. The transmitter lineup: 210 Master Oscillator exciting another 210 as an amplifier, straight through on 28 MC, with an input, to the final, 500 volts at 60 mills, or 30 watts. For CW and phone a class B modulator was pressed into service and used a '46 driving a pair of '48s. The antenna used for transmitting was a vertical full-wave fed by Zepp type feeders.

## Decibels

(Continued from page 27)

To employ the decibel technique to other applications simply substitute other values for those given in the accompanying illustrations.

### Decibel Conversion Table

The conversion table shown in Fig. 2 is a direct reading logarithmic scale from which conversion of power to decibels, or inversions of decibels to power, may be read without computation.

The reference level of ZERO decibels is shown at .006 watt, however, by interpolation of the zero, other arbitrary power levels may be compared.

It is of interest to note that the scale covers powers up to 1 million watts (82db) and down to such infinitesimal powers as 1 millimicro-microwatt (-158.0db). This extremely low-level is used as an arbitrary noise level in the manufacture of precision attenuators and volume controls.

The scale is particularly useful where time cannot be taken for computation of the values shown in the table. The scale can also be used to check or verify solutions to problems involving decibels or power values.

NOTE: In reading the scale the small m stands for thousands, the large M for millions. The use of the large and small m's are now being adopted by many radio manufacturers and engineers.

MILLION WATT DECIBEL  
CONVERSION TABLE

Legend

m = Thousand or milli.

M = Million r micro.



WORLD-WIDE RECEPTION

# ANKER

ALL-WAVE SUPERHETERODYNE  
"DREADNAUGHT"

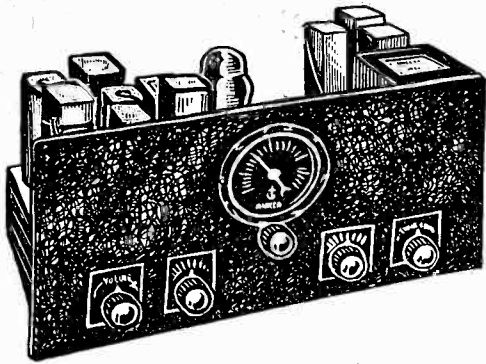

## QUICK FACTS

- Continuous band spread.
- Standard parts used throughout.
- Easily lined up. I.F.'s prealigned.
- 7 tube all wave super-het circuit.
- Built in Beat oscillator.
- Power supply also built in.
- 9½ to 550 meter range.
- Hi-ratio airplane dial tuning.
- Tone and static control.
- Hi signal to noise ratio.
- Front panel phone jack, automatic speaker cutout.

Foundation Kit consisting of drilled "Dreadnaught" chassis, black crackled panel, coil shield, and complete directions including schematic and pictorial diagrams. Net price

**\$1.95**

The remaining material can be bought as desired.

Complete Kit, including all necessary parts, 4 pairs of plug in inductances 9.5 to 200 meters, hardware, diagrams, etc., etc. List \$49.85

**\$29.91**  
NET

Less tubes and speaker

### ACCESSORIES

Wiring and tuning, list \$11.25. Net \$6.75.  
2 pair of broadcast coils, 200 to 550 meters, list \$2.60. Net \$1.56.

Anker high fidelity dynamic speaker in cabinet to match receiver. List \$8.25. Net \$4.95.

Kit of genuine Arcturus tubes for "Dreadnaught," list \$7.15. Net \$4.29.

Black crackled metal cabinet with hinged cover, ventilating louvres, etc., list \$5.25. Net \$3.15.

If rack panel is desired instead of regular panel, additional list \$2.00. Net \$1.20.

Order Direct from This Page—Free Catalogue of Anker Products on Request

## ANKER LABS

20 W. 22nd St., Dept. R-11, New York City

## Latest In "B" Power

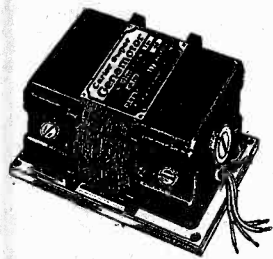

Smallest unit on the market. 2 7/8" wide. 4" high by 5" long. This complete Genemotor furnishes up to 200 volts D.C. Operates from 6 volt storage battery. Ideal for Auto, Airplane or Battery Radios, and Portable Amplifiers.

Write for details and prices on this and other types.

## CARTER MOTOR CO.

365 W. Superior St. Chicago, Ill.

Immediate delivery . . .

## McMURDO SILVER—5-C SUPER MASTERPIECE III . . . W. W. 9

Send 3c for new Silver catalog

W6LJY or YE NEW RADIO SHOPPE  
VAN NUYS, CALIF.

FORMS CLOSE ON THE 10th OF MONTH

RATES 10¢ PER WORD PAYABLE IN ADVANCE

### CLASSIFIED RADIODADS

CRYSTALS—80 or 160 Meter Bands, X or Y Cut, 1 inch square, Accuracy .002%, \$1.50. W8CHJ, 9255 Herkimer St., Detroit, Michigan.

WANT Service Equipment, Rider's Manuals, Etc. Trade Transmitting Parts. W6QW, Leslie Rosenblatt, Box 207, Livermore, California.

TRANSFORMERS—250 mill 600-800 each side, \$6.75. 400 mill 1000-2000-3000 each side, \$21.50. Frank Greben, W9CES, 2012 S. Peoria St., Chicago, Ill.

NEED CASH . . . sacrifice 500 watt crystal transmitter complete, including 3 power packs . . . \$300.00. Real quality. Details and photo on request. Act quickly . . . this won't last long! C. L. Barker, Henning, Minn.

WE BUY LINCOLN HEAD PENNIES. Will pay up to \$2.00 each if over ten years old. Indian Head Pennies worth up to \$51.00 each. Send 10c for BUYING CATALOG. CONTINENTAL COIN CO., INCORPORATED, PN-111 W. Jackson, Chicago.

## Grid Bias

(Continued from page 30)

Another form of separate bias supply consists of some form of rectifier and filter system whose positive terminal is grounded and whose negative terminal connects to the DC grid return of the amplifier stage. This bias supply often consists of an ancient B eliminator and is quite satisfactory if certain precautions are observed. If a B eliminator is used to bias a high-power class C stage, some form of relay should be used and controlled by the bias supply so that the plate voltage to the class C amplifier is cut off if the bias supply fails. Most of the older B eliminators and many of the newer types have very poor voltage regulation and trouble is often encountered with interaction when the same eliminator is used to bias two or more separate amplifier stages. Poor voltage regulation merely means high internal resistance in the B eliminator. Any variation in grid current in any one of the amplifier stages will vary the voltage drop across this internal resistance and thereby effect the bias supplied to the other stages of the transmitter. If a B eliminator, or a rectified AC bias supply is used to supply bias to a class B or class B-prime linear or grid modulated amplifier or to a class B audio amplifier, it is absolutely essential that the DC bias voltage remains constant and independent of the DC grid current. This means that the bias supply must have extremely good voltage regulation. Low resistance transformers and filters, as well as a mercury vapor rectifier tube and a low resistance, high current bleeder should be used to minimize variation in output bias voltage with the changes in grid current which normally occur in these types of amplifiers. If it is desired to adjust the DC voltage output from a bias pack of this type the operator must not tap down on the voltage divider or use a series resistance in either the primary or secondary of the transformer which feeds to bias rectifier. The best method is to either tap the primary of the transformer or an audio transformer can be used across the 110-volt line to vary the voltage supplied to the bias transformer without effecting the voltage regulation.

More than one of the above bias supplies can be used in series to bias a class C amplifier. In fact, it is highly recommended that a grid leak be used to augment the cut-off value of bias which is best supplied by either cathode bias resistor, batteries or a separate bias pack.

A grid-leak common to more than one class C stage should be avoided, due to tre-

New

## ELECTRAD

### VOLUME CONTROL

THE most sensational radio engineering development of recent times. *Marvelously improves control of radio volume.*

More uniform distribution of current, greater ruggedness, less wear and smoother operation than ever before attained.

## Guaranteed QUIET

Write Dept. PR-11 for Descriptive Circular and the New 1935 Resistor Catalog

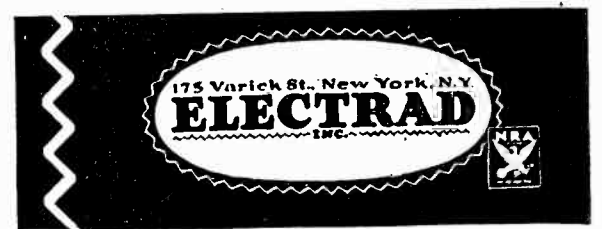

## RADIO ENGINEERING









RCA Institutes offers an extensive course of high standard embracing all phases of Radio. Practical training with modern equipment at New York and Chicago schools. Also specialized courses and Home Study Courses under convenient "No obligation" plan. Illustrated catalog on request.

RCA INSTITUTES, INC., Dept. RA-34  
75 Varick St., New York 1154 Merchandise Mart, Chicago  
Recognized Standard in Radio Instruction Since 1909

mendous interaction caused by the two different grid currents in the respective stages.

To compute the wattage rating of the resistor, either as a grid leak or to give cathode bias, multiply the square of the current in amperes flowing through the resistor by the resistance in ohms.

# IN STOCK

- NATIONAL   
 at Allied Radio  
 Hammarlund   
 at Allied Radio  
 BILEY   
 at Allied Radio  
 THORDARSON   
 at Allied Radio  
 RCA de Forest   
 at Allied Radio  
 JOHNSON 

and all other standard Amateur lines. Whatever your wants, we can supply them quicker and better at ALLIED, at consistently lower prices. The thing to do O. M. is to write today for the new 1935 ALLIED Catalog which is yours for the asking.

## Allied Radio

833 W. Jackson Blvd., Chicago, Dept. J

Please send me your Free 1935 Catalog with the Radio Amateur Listing.

Name .....

Address .....

City .....

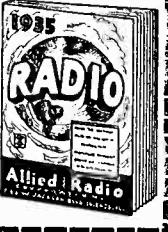

## Radiatorial Comment

(Continued from Page 5)

this magazine, he doesn't like this magazine. Rest assured that the changes suggested for the FBXA work wonders, else they would not have been published in these pages. Correspondence on file will disclose that the article was published for the purpose of bringing greater satisfaction and pleasure to the users of the FBXA . . . not at all for the purpose of attempting to make it appear that the receiver was not correctly engineered.

Take your choice . . . the word of the manufacturer who believes it may hurt his future business were it too widely known that his receiver could be "improved" upon, or the word of an unbiased editorial-writer-engineer, who made the changes, found them most satisfactory, and in true amateur spirit passed the word along to his fellow amateurs so that they, too, can get more enjoyment out of a similar receiver. Is there any receiver that cannot be improved upon?

Mr. Millen has not given us the reason why our suggested improvements will spoil the FBXA. We have asked for this information. Until it is forthcoming, we will continue to twiddle the regeneration knob of the FBXA, as per our published improvement, and hear signals we never heard before.

Mr. Millen's advice to readers of a contemporary magazine, urging them to "steer clear" of plans for improving the FB-7 receiver, was published as paid advertising matter. He could have sent an article to RADIO, telling why he believes our "scheme" will spoil his receiver, and we would have published this information without cost. Then our readers could have made their own decision. Why not call a spade a shovel?

# HARVEY TRANSCEIVERS

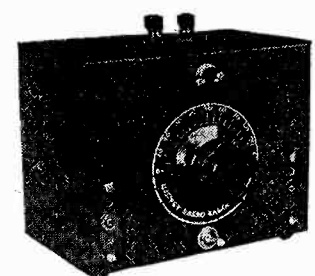

Proper design and peak performance have made these units the choice of Amateurs the world over. Enjoy the best.

2-volt model . . . \$18.75    6-volt model . . . \$17.95  
 Tubes--24 and 33    3.09    Tubes--37 and 41    1.17

## QUALITY APPARATUS

- TYPE M0-45 TRANSMITTER—A stable 5 tube unit for 5-10 meter phone work with an RF output of 10 watts—Class B modulated and adaptable for either portable or fixed use. Wired and tested with tubes. . . . \$29.50
- TYPE PS-45 POWER SUPPLY for above with 83 tube . . . . . \$26.50
- TYPE HF-3 RECEIVER—A 3 tube non-radiating unit covering a range of 5-10 meters. Price with one set of coils . . . . . \$23.50
- HARVEY TRITET—A universal exciter unit for five band operation, complete with tubes and coils for one band, \$52.00.
- RK-20 AMPLIFIER—A companion unit delivering 100 watts of RF output complete with two tubes and coils for one band. . . . . \$69.50

Write for descriptive Bulletin

## Harvey Radio Laboratories

12 Boylston St.                      Brookline, Mass.

## RADIO CLUBS

Special Group Subscription Rates are offered if 5 or more members subscribe at one time. Write for rates. "RADIO," Pacific Bldg., San Francisco, Calif.

## Behind the POLYMET Trade Mark

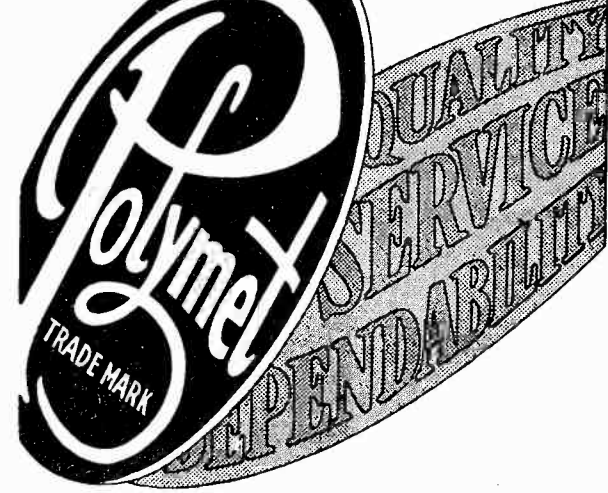

This midget size mica condenser is extremely popular where space limitation is a factor—Polymet fabricates seven different types of mica condensers from .000005 mfd to .03 mfd capacities.

### Hi-Frequency Condensers

These condensers are designed to eliminate the common faults of ordinary condensers such as poor power factor and inductance. Because of their low loss characteristics Polymet's new Hi-frequency line is particularly recommended for use in short wave receivers.

# POLYMET PRODUCTS

Are recognized by many of the leading manufacturers in both the radio and electrical industries for that HIGH QUALITY so essential to dependability. THEIR ENGINEERS DO NOT GUESS—THEY KNOW. The successful service man, experimenter, or amateur does not guess, he knows that the use of POLYMET products in his work is his GUARANTEE OF SATISFACTION.

## Polymet Condensers

- ELECTROLYTIC—Wet and Dry Types
- PAPER—Tubular and all can types
- MICA—All Types, Midget Sides with lugs & leads
- TRANSMITTING OIL CONDENSERS
- CONDENSER for all PURPOSES

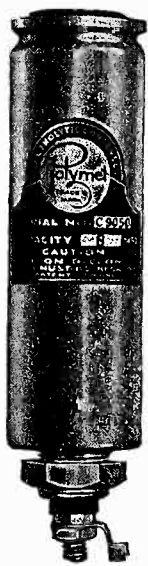

**POLYMET STANDARD WET ELECTROLYTIC**  
 This type wet electrolytic condenser type is most popularly used throughout the entire world because of its established reputation for quality and durability.



**PETITE CONDENSER**  
 A new POLYMET Tubular paper condenser in greatl; increasing demand by radio manufacturers. Its compactness and low cost effect many economies in radio.



**POLYMET DRY ELECTROLYTIC CONDENSERS**  
 Exceptionally popular in the leading AC-DC receiving sets. Furnished in many combination dual and triple units. Supplied in either cardboard or metal containers.

We Also Manufacture TRANSFORMERS and WIRE WOUND RESISTORS

## Polymet Manufacturing Corporation

831 E. 134th ST.                      NEW YORK, N. Y., U. S. A.

Write for New 1934 Catalog



Osockme, Japan, September 23, 1934  
 Hon. Editor of RADIO,  
 Dear Sir,  
 Dear Ed:

I am sorry I miss you on rush trip to New York radio show and return. I wait in your office for many long hours but it were first of month and I soon learn why you are out. Many customers come into your hideout, all with same purposes in mind. Each have many bills for which wish make collection and bouncer in your office tell same story to each. Might think it would be cheaper for you to pay your bills than pay big salary to seven foot bouncer who give me alibi and say he are hired to keep vast army of question asking hams from interfering with your duties of publishing grate radio magazine.

I wait impatiently all day long for you, Hon. Editor, as I have with me plans for get-me-rich-quick schemes which would have made many fortunes for you. I learn of many schemes while I am in big New York City town and I are full to overflowing with varieties and kinds of such.

When first I make entry into great New York city, I proceed to make visit to male order house from which I have purchase sundry radio parts of bad and poorer kind for year past. Male Order house have big sign on front door which say store closed for one week pending coming of big annual fire sale. I stick nose into back door and ask when fire are going to be started and clerk tell me that such conflagration will become ignited no later than six p.m. o'clock on day before sale. I ask him if my friend who are owner of store are in and he say no he have already make leave for Istanbul and have make settlement in advance with fire insurance company.

It make appearance to Scratchi that new male order parts house must be found from which can buy supplies. Scratchi hire taxi cab and tell driver to take me to next nearest radio wholesale house. I make ride in blind folded taxi for two and half some hours and driver give me bill for sixteen dollars and seventeen cents. I think next closest wholesale radio house must be far removed from original taking off place but when I walk back up on sidewalk again and look around I see I are only right across street from where I started from. That were one of rich-getting schemes which I wish converse with you in person while I wait for you in office. Next time I make go to New York I shall take rickshaw with me from home, as such would be cheaper than hiring taxi for quick coverage of big city.

I spend last day enjoying sights in city and make visit to Grant Stoom, Sing Sing, Isolation Hospital, Immigration office and also make call on Coroner. I have especially hilarious time.

It are evident to Scratchi that further hours of leisure must first be spent before doors of radio show are thrown open and away that night, so best thing for Scratchi to do are to listen to QRM from street peddlers who sell everything from second hand coffins to desert row boats. Before much time have make pass, Scratch become into purchased possession of raffle ticket which salesmen say are for raffling away of Brooklyn Bridge. I are most lucky at hamfests as I have always make win capitol prize and mayhap good fortune come to me again and I may win Brooklyn bridge. Ticket seller tell me to look for winning number in each Saturday issue of Saturday Evening Post magazine, which are now issued regularly on Tuesdays of each week, instead of on Wednesdays, as was former custom before publication date was changed from Fridays.

It now come time for stampede to radio show and Scratchi present free ticket for entrance admission. I find it become necessary for me to pay 57 cents tax with free ticket and interview with show manager bring information to me that seven cents of such tax are for new nesting place for blue eagles and other fifty cents are used to defray cost of ticket printing.

I find many things in radio show except radio things. One man in booth grab me by collar and try to sell me stock certificate in new company which will make manufacture of frozen vacuum. I tell him I are not interested in such process. He ask me wherefrom I come from and I tell him I are Scratchi from the land of the rising sun. Ah ha, he say, then you live in Hoboken.

I soon find that your magazine also have booth in show, Hon. Editor. So I put on my hat for disguise and make chat with person who are in your booth. He inform me with great esteem that

(Continued on Page 36)

# FREE The BIGGEST Latest, Most Complete 1935 RADIO CATALOG



This amazing new 1935 Radio Catalog is the last word . . . the greatest Bargain Book of Radio ever published by us or any other company. Over 50,000 items have been assembled in this great 192 page book to make it the outstanding book of the Radio Industry.

Contains our matchless SPECIALIZED SHORT WAVE DEPARTMENT which in itself is a complete catalog listing everything the Ham, Brasspounder and Experimenter will ever need. Sets, Kits, Transceivers, Pre-Selectors, Converters, as well as other Short Wave parts and accessories. Practically every nationally known manufacturer is listed here. The complete list reads like a Who's Who in Radio . . . and everything is at LOWEST WHOLESALE PRICES!

## NATIONAL DISTRIBUTORS

For all nationally known Radio Equipment at lowest wholesale prices. If you want S.W. Transmitting apparatus see us first. Here are a few of the lines we carry in stock at all times: Cardwell, Hammarlund, United Transformer, Allen-Bradley, Weston, Triplet, Leichner Transmitting Condensers, Cornell-Dubilier, Sangamo, Pyrex, Signal, etc., etc. We also can supply all products manufactured by the NATIONAL CO. at a discount of 40%.

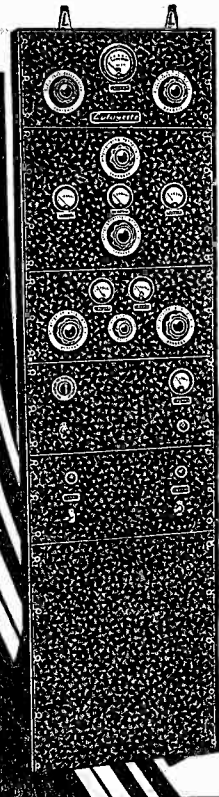

## Lafayette 100 Watt Transmitter Has All Latest Features—Entirely Self-Contained

This modern 100 watt C.W. and 30-40 watt Phone Transmitter will amaze you . . . Not only is its initial cost low, but for its rated output it is the most economical transmitter ever offered the amateur.

It incorporates all the latest features such as the following: 1. Suppressor-grid modulation that provides 100% modulation with a minimum of modulating equipment. 2. Crystal frequency control—the new "Les-tet" harmonic oscillator, which with a single 2B6 tube provides a stable crystal oscillator and is a very efficient doubler or a neutralizer buffer stage, having more than sufficient output to excite the 100 watt Class C Pentode Amplifier. 3. An Universal antenna matching unit that permits successful operation on practically any type antenna.

Everything is self contained. Just connect a key, a crystal microphone and antenna. Plug into any 110 V. 60 cycle outlet and operate! Complete control through use of meters permanently connected in circuit.

Comes complete with 1 set of coils (choice of 80, 40, or 20 M. bands) . . . **\$175**

Kit of tubes: 2-RK20's, 2-2B6's, 1-57, 5-83's . . . **\$35.44**

Wholesale Radio Service Co.  
 100 Sixth Ave., Dept. P-114  
 New York, N. Y.

Send me your FREE 1935 Catalog No. 56.  
 Send me order  information  described in attached letter.

Name . . . . .  
 Address . . . . .  
 City . . . . . State . . . . .

# WHOLESALE RADIO SERVICE CO. INC.

**NEW YORK ATLANTA**  
 100 Sixth Avenue 430 W. Peachtree St. N.W.  
 Local Branch 219 Central Ave., Newark, New Jersey.

## WATCH FOR IMPORTANT ANNOUNCEMENT In DECEMBER Issue

Concerning New  
**SHORT-WAVE APPARATUS**  
 ALAN RADIO CORP.

83 Cortlandt St. New York City  
 WESTERN BRANCH  
 1028 So. Olive St. Los Angeles, Calif.

## THE BEST IS NONE TOO GOOD



The Trimm Featherweight is not a common head-phone. It is a scientifically developed and precision built product. We specialize in solving unusual applications. Let our engineers know your headphone problems. We have a model to meet each need.

**TRIMM RADIO MFG. CO.**  
 1528 ARMITAGE AVE. CHICAGO, ILL.



It's a natural . . . this new RADIOHM with or without complicated testing apparatus . . . is still the best.

As smooth as a baby's skin . . . and as efficient as twenty years of laboratory work can make it.

No wonder the majority of service men use CENTRALLAB'S exclusively . . . and a mere handful give you practically every resistance combination you will ever need.



The new patented RADIOHM

**CENTRAL RADIO LABORATORIES**  
Milwaukee, Wis.

Every Radio Service Man should be a member of the Institute of Radio Service Men

# Centrallab

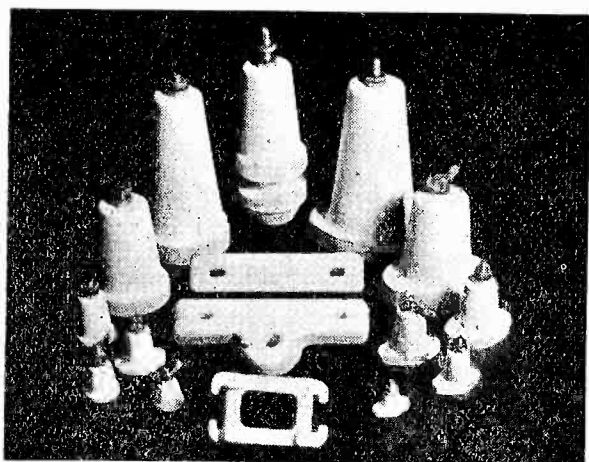

New

## BIRNBACH STANDOFFS

Most Complete Line

**BIRNBACH** announces the most complete line of white and brown, highly-glazed porcelain Standoff Insulators. 28 different models (including 56 new numbers) from 5/8" to 4 1/2" high. Standard and "Feed-Thru" models, wingnut, plain or jack types. Nickel-plated brass hardware. Cork mounting washers. Compact—Rugged—Safe!

Write Dept. PR-11 for Data Sheets

**BIRNBACH RADIO CO., Inc.**  
145 Hudson Street New York

## Quartz Crystals

(Continued from page 16)

the holder, re-assemble it and replace it in the filter unit as if though the crystal were inside. Put the switch on "Crystal" position and adjust the phasing condenser until the signals disappear entirely, or nearly so; the more effective the shielding, the lower the signal strength will be. The phasing condenser is merely used to balance-out the signal voltage across the capacity created by the plates of the holder. Exact neutralization is practically impossible, so that in making this test the final results are merely comparative.

In the next article, single-signal reception and further practical design and construction data will be given.

## Scratchi

(Continued from page 35)

your circulation have more than doubled in last two years. I am happy to hear this, Hon. Ed., as I recall letter which I receive from you two years ago which say you have no circulation at all. I am therefore happy that you have make it double now. I hope it are four times that much in another one more year or such.

After walking around radio show till closing time I find it are necessary for me to call express wagon to take to my hotel all such millions of catalogs and bargain sheets which every salesman in every booth shove into my pockets, down my back, under my hat, in my shoes and wrap around my neck. One salesman get so excited when he talk to me he poke his finger in my eye. He make quick apology but I tell him such are not necessary as I are still in possession of one more eye. When I get to hotel and remove myself from tons of catalogs, I find I also have in my pocket two tickets for speeding, one summons for divorce suit, one second hand cigar, two instruction sheets which show how to make money by suing the Radio Trust, three more such sheets which show how to lose money by doing same thing, one set of secret instructions that give information on how to win with Warner, with p.s. note at bottom which say please remit, your subscription has expired, one three year free trial offer of new filterless power supply made by Hutchinson-Wagner Not Incorporated, and one ticket which entitle me to free admission to Central Park.

I think, Hon. Ed., I have come into possession of valuable literature and I are sending such for you in great hopes you can take some months time off and read them all.

I will bring this letter to a close with the finish, Hon. Ed., and I will look for an answer from you in usual manners which are none at all.

Your Inimical Reader,  
Scratchi.

## WUNDERLICH Announces

A New Line of High-Frequency and Ultra-High Frequency Transmitters

DESIGNED BY

FRANK C. J. N. A.

## JONES and HAWKINS

15 Watt Carrier Class A Plate Modulated Phone, Crystal Controlled and High Fidelity Speech Amplifier. Price, less tubes and microphone. . . . \$75.00

150 Watt Carrier Class B-Prime Grid Modulated Phone. 400 watts on C.W. crystal controlled, push-push doubler and two Eimac 150-T tubes in final. Link coupled throughout, price, less tubes and microphone. . . . \$500.00

5-Meter Transmitter and Non-Radiating Receiver, combined (not a transceiver). Output 5 watts, uses 71A, 41, 6D6, 76 type tubes in metal cabinet, 7x7x7 inches. Price, less tubes . . . . . \$27.50

Catalog Sheets on Request  
Special Equipment to Your Order

**WUNDERLICH RADIO COMPANY**  
156 W. San Fernando St., SAN JOSE, CALIF.

Power and Portability  
Twin-Triode  
P.P. Oscillator  
Class B Modulator

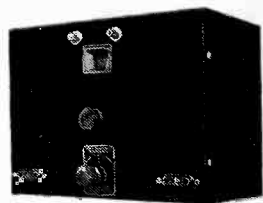

## 56 M. C. TRANSCEIVERS

Designed by FRANK JACOBS, W2BSL  
Experimental chassis described in June QST

Type 19-A—Battery or Genemotor operated, 2v. or 6v. fil. Uses 3-19's or 2-198.30. . . . \$22.50

Type 53-A—Genemotor or A-C operated. 2.5 or 6.3 v. fil. Uses 3-53's. . . . \$26.50

Type 53-AC—Same as 53-A but includes complete AC power supply and loudspeaker grill . . . . . \$37.50

Type T-R-19 — SEPARATE TRANSMITTER RECEIVER in same case. R.F. receiving stage to prevent radiation, duplex operation, loudspeaker grill . . . . . \$32.50

Type T-R-53—Same as T-R-19 but using 3-53's . . . . . \$36.50

Write for Descriptive Literature

**Radio Transceiver Laboratories**  
8427 - 105th Street Richmond Hill, N. Y.

## "SIGNAL HOP"

Beyond Your Fondest Hopes With PEAK Pre-Selector and Pre-Amplifier

The last word in Pre-Amplification! Two tuned stages of hi-gain 58 type tubes. Hundreds of tests prove that signals of R3 to R5 audibility are consistently boosted to R9 and R9+. Besides tremendous signal gain. PEAK gives increased sensitivity; absolute rejection of image or repeat spots; reduction of background noise; increased selectivity!

Operates with any S.W. or All-Wave set. Comes complete with 3 sets of built-in coils (none to plug in) covering all frequencies with overlap from 14-200 M. Other features include airplane type dial, smooth regeneration, automatic change-over switch, self-contained filament supply, etc. For 110-120 V. 50-60 Cycles, A.C. 25-60 cycles \$1.50 extra.

ATTENTION Hams and S.W. Fans! Order or get all the facts TODAY! List price \$33, less 40%; your price \$19.80 complete, less tubes. Order through your Dealer or M.O. House.

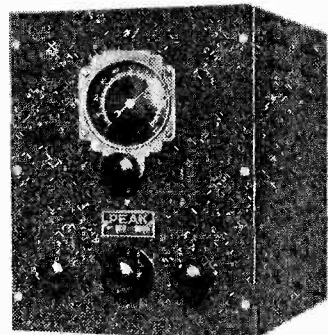

EASTERN RADIO SPECIALTY CO.

Mfrs. of Peak Products

113 E. 168th St. Dept. R22 New York, N.Y.

## NEW RADIO CATALOG

Just off the Press! Hundreds of latest developments in Short Wave and 5-Meter parts and accessories. Everything for the Serviceman, Ham, Amateur and Experimenter. Sensational new line of S.W. Receiver Kits from 1 to 5 tubes. RCA-Hazeltine licensee. Send 10c coin or stamps to partially defray cost of handling and mailing. Get your copy at once.

**INSULINE CORP. OF AMERICA**  
23-25 Park Place Dept. T-114 New York, N. Y.

\$1 brings you the next four issues of "RADIO"—Subscribe NOW.

# THE TUBE YOU ASKED FOR IS HERE AT LAST! EIMAC 150-T

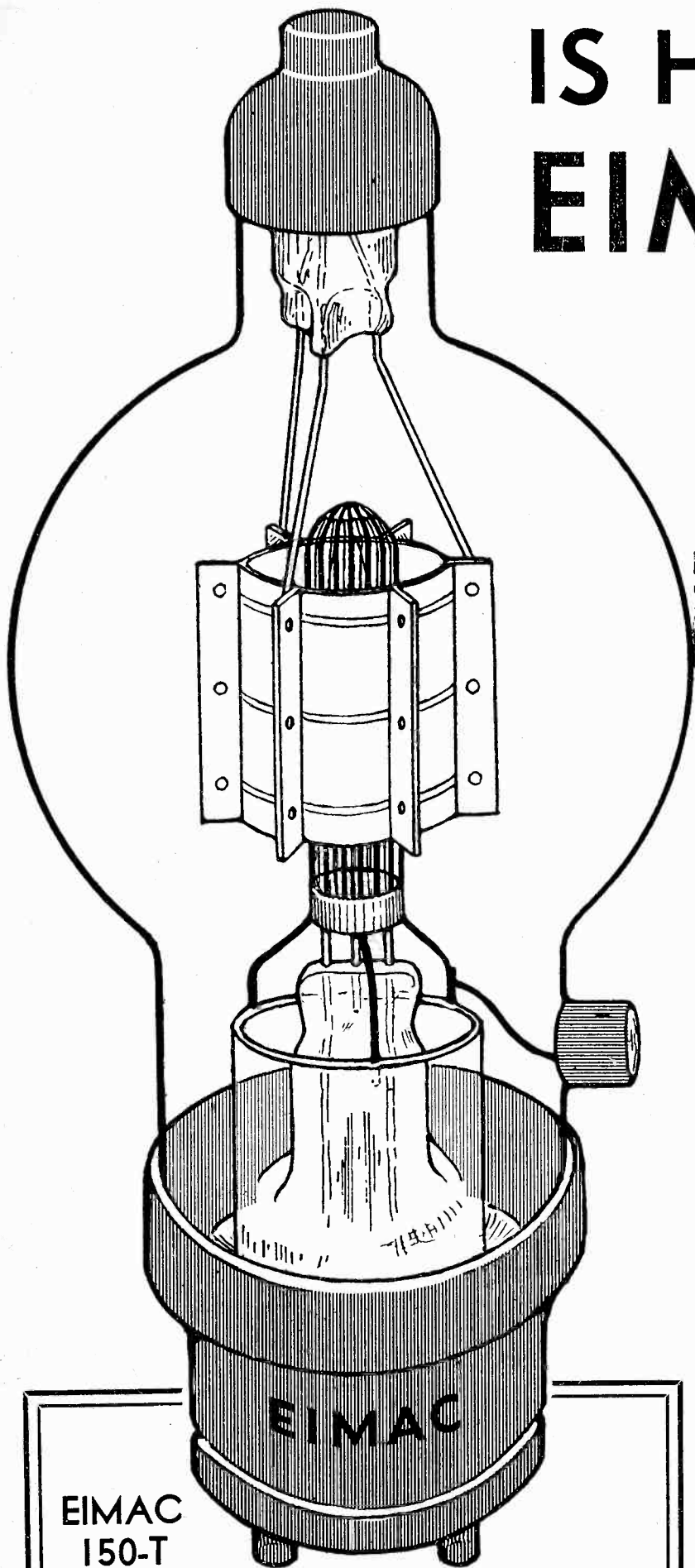

In Every Important Feature It Is

## Unsurpassed

The Culmination of Six Years' Experience in Designing and Building Transmitting Tubes for Military, Commercial and Amateur Use.

**H**ERE is a tube that solves the problems of the amateur, in that it is useful at 5-meters, as well as at audio frequencies, 100 cycles to 75,000,000 cycles. A pair of EIMAC 150-T tubes will give 750 watts of audio power with 3000 volts on the plates.

A single EIMAC 150-T, operated as a R. F. Class C Amplifier (75% eff.) will give 150 watts at 1000 volts; 300 watts at 2000 volts; 450 watts at 3000 volts, without exceeding the normal conservative ratings. However, high voltage is NOT essential for satisfactory operation, because the high mutual conductance allows the tube to operate with the maximum of power output and plate efficiency with only 1000 volts on the plate, whereas other tubes of somewhat similar characteristics require at least 2000 to 3000 volts for maximum efficiency. Thus this is the IDEAL tube for BOTH the low-power and the high-power man. It is the only tube the low-power man can buy, yet still utilize effectively when higher power is used. Your first cost is, therefore, your LAST tube cost.

### ★ PERFORMANCE

Maximum Power amplification is desired by all. The best index of power amplification is the constant, - - mutual conductance. The EIMAC 150-T has a greater mutual conductance than any known Low-C tube and is higher than all of the High-C tubes, with but one exception. 60% less excitation required.

### ★ RUGGEDNESS

In order to withstand the momentary overloads always associated with amateur operation, the Eimac 150-T maintains its high degree of vacuum even when the tube elements are red hot. This high degree of vacuum is made possible only because TANTALUM is used for grid and plate material, and because no "Getter" is used.

More POWER per dollar! Fewer dollars per hour of useful life! The result of six years' experience exclusively building transmitting tubes for ship, mobile, portable and amateur use. Unconditionally guaranteed to be gas-free, and against mechanical defects for two years.

EIMAC  
150-T

### CHARACTERISTICS

Fil. Voltage 5 V.; Fil. Current 10 A.; Rated Plate Dissipation 150 W.; Amp. Factor 13; Max. Plate Current 200 MA.

Plate Voltage	1,000	2,000	3,000
Plate Resistance	2,750	1,900	1,250
Mutual Conductance	5,800	7,300	12,300
Normal Power Output (75% eff.)	150W.	300W.	450W.

PRICE \$24.50. Sold Only by Reputable Dealers

"COMPARE AND REFLECT"

**Eitel-McCullough, Inc.**  
SAN BRUNO, CALIFORNIA, U. S. A.

DEALERS and JOBBERS are invited to write for territory. A Protective franchise and other interesting details sent on request.

Radio Dealers and Jobbers who desire to advertise in these columns are invited to write for rates.

# RADIO BUYERS' GUIDE

A Monthly Listing of Reliable Radio Dealers and Jobbers who solicit the patronage of our readers. Buy from your nearest Dealer or Distributor. He is dependable and reliable.

## CHICAGO, ILLINOIS

### Chicago Radio Apparatus Company, Inc.

415 South Dearborn Street  
Harrison 2276

Dependable Radio Equipment  
Established 1921

Bulletins on request—we specialize in short wave transmitting and receiving apparatus.  
Catalog Ten cents.

## CHICAGO, ILLINOIS

### MID-WEST RADIO MART

520 South State Street  
CHICAGO

Write for Special Catalog—Free

## CHICAGO, ILLINOIS

### Newark Electric Company

226 W. Madison St.  
Chicago

All Kinds of Equipment for  
Service Men - Amateurs - Experimenters  
Write for free catalog

## OAKLAND, CALIFORNIA RADIO SUPPLY CO.

2085 BROADWAY.

New Low Prices on Sargent Supers and Regenerative Kit Sets with Tuned R.F. Get the latest price lists and data.

Sargent Short-Wave Sets and Kits.  
Write for Circulars.

## ST. PAUL, MINNESOTA

### LEW BONN COMPANY

2484 University Avenue

Rex L. Munger, W9LIP, Sales Engineer

Radio Wholesaler

Complete Stock

## ST. LOUIS, MO.

### HAMS' TRADING POST

Want to buy? We have it to sell. Want to sell? We will buy for cash. Want to trade? We will trade. References—any midwest ham.

WALTER ASHE RADIO CO.

121 North Eleventh

## LOS ANGELES, CALIFORNIA

### RADIO SUPPLY CO.

912 SO. BROADWAY

The Amateurs'  
HEADQUARTERS of the WEST

All Nationally Advertised Parts for Receiving and Transmitting carried in stock at all times.

9 Licensed Amateurs on Our Staff

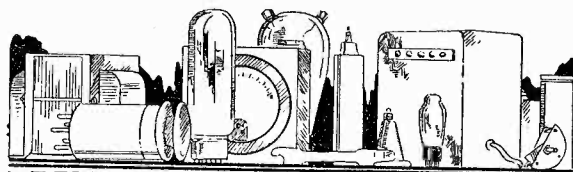

## NEW PRODUCTS

New Midget Air Tuned Padding Condenser Developed By Hammarlund

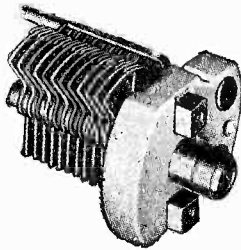

IN THE laboratories of the Hammarlund Manufacturing Company, 424 West 33rd street, New York City, a true midget, space saving, Isolantite based, air padding and tuning condenser, particularly useful in Marine, Aircraft and Police work, has just been evolved. The largest of the type, 100 mmf., measures only 1 3/8-in. by 1 1/8-in. by 1/2-in. Except for its minute size, it resembles the larger of the air condensers electrically, mechanically, and optically. Brass stator rotor and stator plates of .015 inch thickness, spaced the same distance are employed. A phosphor bronze spring plate affords perfect rigidity. Every other metal part is pure brass for highest conductivity and lowest loss. Being of this air type construction, it provides absolute maintenance of constant capacity under any conditions of vibration, temperature, and humidity. It is ideal for short wave or ultra short wave work, or for tuning IF transformers, trimming RF coils, and gang condensers, antenna tuning, fixed tuning of RF coils, or plug-in coils, and for padding purposes in general. The approximate capacity per air gap is 4 mmf.

## Littlefuse "Tattelites"

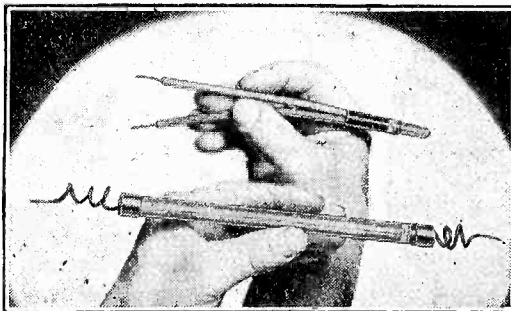

Littlefuse announces its latest addition to a specialized fuse family—"Tattelites." ("They Tell the Tale.")

Tattelites are a line of neon discharge tubes having breakdown potentials of 100, 250, 500, 1000, and 2000 volts. They are really "voltage" fuses protecting equipment against excessive voltages, whereas regular fuses protect against excessive currents. They operate by shunting out the overload.

The uses of this line are legion. They prevent insulation breakdowns; protect voltmeters, ammeters, transformers, condensers, and gaseous rectifiers against voltage surges; make good radio lightning arresters, and leak-off static charges from machinery; test for blown fuses, defective resistors, and condensers; indicate radio frequency, resonance peaks, high tension lines; and are used in making saw-tooth oscillators, trigger circuits, bleeders for D.C. power supplies, and stroboscope effects.

## Jobbers!

5-Meter Radio Is Growing!

Our new 5-meter Radiotelephony Book by Frank C. Jones is a Big Seller.

Order from "RADIO," Pacific Bldg., San Francisco  
25c RETAIL

## CHICAGO, ILLINOIS

### Chicago Radio Apparatus Company, Inc.

415 South Dearborn Street  
Harrison 2276

Dependable Radio Equipment  
Established 1921

Bulletins on request—we specialize in short wave transmitting and receiving apparatus.  
Catalog Ten cents.

## PITTSBURGH, PENNSYLVANIA

### CAMERADIO COMPANY

603 Grant Street

Tri-State "Ham" Headquarters  
Standard Apparatus Standard Discounts

## FRESNO, CALIFORNIA

### PORTS MANUFACTURING CO.

3265 E. Belmont Ave. Radio W6AVV  
National FB7-SW3 and Parts; Hammarlund, Cardwell, Bliley Crystals; Johnson Insulators.  
Distributors RAC-De Forest Transmitting Tubes  
Established 1914 Leading Ham Supply Store

## SAN FRANCISCO, CALIFORNIA



1452 Market Street.

"The House of a Million Radio Parts"

Hammarlund and National sets and parts.  
Sylvanite Amateur Transmitting Tubes  
Collins Transmitters.  
Arcturus Receiving Tubes.  
Trimm Phones, all types.  
Johnson Antenna Feeders, Insulators,  
Transposition Blocks.

## SEATTLE, WASHINGTON



LARGEST PARTS SUPPLY DEPOT  
IN THE NORTHWEST

Four of Our Employees Are Licensed

W7BRS Amateurs W7CR  
W7AVC W7WE

CORNELL DUBILIER, BLILEY, PATTERSON  
SETS, COLLINS, WARD, LEONARD,  
UNITED TRANS.

## VANCOUVER, B. C.

Palmer Radio Supply Company  
524 WEST PENDER STREET

B. C.'s Original "Ham" Supply House  
Everything for the Amateur and Service Man  
Write for Catalogue

# 3 Fast-Moving Leaders of the 1935 CROSLLEY Line

CROSLLEY invites comparison. The exquisite beauty of the cabinets, marvelous performance, wide range of prices make the Crosley line, when compared set for set, stand head and shoulders above competition. There is a model for every requirement and a price to suit any income. A. C.-D. C. and STANDARD BROADCAST models range in price from only \$19.99 to \$33.00, complete with tubes. DUAL RANGE models for all American broadcasts, including police, aviation and amateur reception are priced from \$29.95 to \$47.50 in both table and console models,

complete with tubes. Models for AMERICAN and FOREIGN reception, in table and console models are priced as low as \$39.95 and up to \$79.50, complete with tubes. An ALL-WAVE chassis is incorporated in a table model at the low price of \$79.50 and in a gorgeous console at only \$99.50, complete with tubes. Battery sets priced from \$19.99 to \$49.95, complete less batteries. Crosley continues its amazing success with this exceptionally complete line. No dealer can afford NOT to handle Crosley. Get in touch with your Crosley distributor immediately.

## The FIVER



5 Tubes \$19<sup>99</sup>  
COMPLETE

### SUPERHETERODYNE

A history-making receiver, improved and perfected, and a greater value than ever. Superheterodyne, full floating, moving coil electro-dynamic speaker, beautiful cabinet, one dual purpose tube making it the equivalent of a 6-tube set. It covers the entire band of American broadcasting and top police band. Excellent tone. Highly sensitive. Priced remarkably low.

## The SIXTY-ONE AMERICAN and FOREIGN



6 Tubes \$39<sup>95</sup>  
AMERICAN & FOREIGN  
COMPLETE  
SUPERHETERODYNE

Another smashing leader—a 6-tube American and Foreign receiver at only \$39.95—the most startling radio announcement of the year. Covers standard band from 540 to 1750 Kc., short wave band from 5700 to 15,500 Kc. Gorgeous cabinet, illuminated airplane type dial—30 to 1 high ratio drive, continuous tone control, automatic volume control, three gang tuning condenser, full floating moving coil electro-dynamic speaker. Two dual purpose tubes provide 8-tube efficiency.

## The DUALFIVER DeLuxe DUAL RANGE

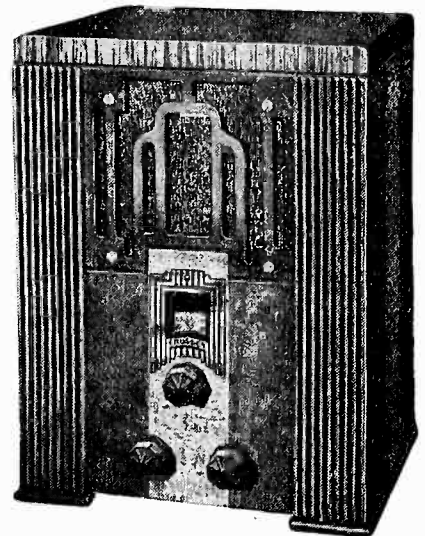

5 Tubes \$29<sup>95</sup>  
DUAL RANGE  
COMPLETE

### SUPERHETERODYNE

A 5-tube receiver having the performance of a 7-tube. Three gang condenser, automatic volume control (steady volume on distant stations), new and beautiful cabinet. A startling value in a long range, sensitive, beautifully toned receiver. Dual range for American broadcasts—all police calls, aviation and amateur reception.

Montana, Wyoming, Colorado, New Mexico and west, prices slightly higher.

## THE CROSLLEY RADIO CORPORATION

Home of "the Nation's Station"—WLW—500,000 watts—most powerful in the world—70 on your dial  
POWEL CROSLLEY, Jr., President

CINCINNATI

WHATEVER HAPPENS... YOU'RE THERE WITH A CROSLLEY  
**CROSLLEY RADIO**



# The UTC Engineering Laboratories

have developed  
**NEW**

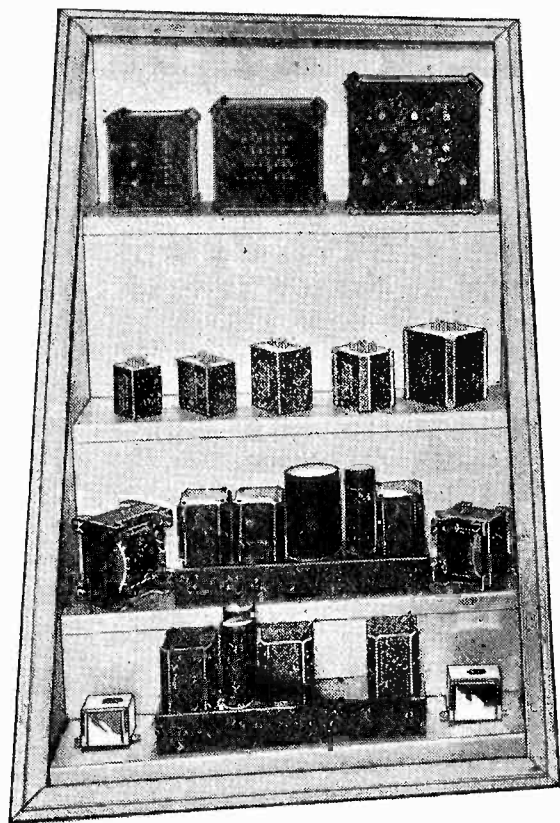

UTC linear standard and hiperm alloy portable series.

Niklshield audio and universal plate supply components.

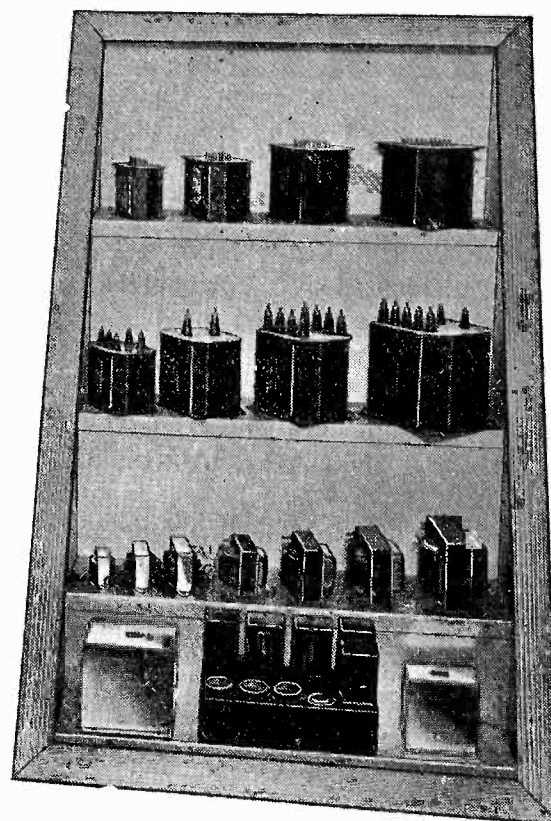

UTC public address, transmitting, and manufacturer's type audio and power components.

- Television transformers, linear from 30 to 200,000 cycles.
- Hi Q audio reactors
- Audio equalizers and filters
- Automatic voltage regulators
- Saturable control reactors
- High potential and high current test sets
- Oscillation transformers

## HIGH FIDELLITY HIGH POWER CLASS B AUDIO TRANSFORMERS

## UTC LINEAR STANDARD AND PUBLIC ADDRESS KITS

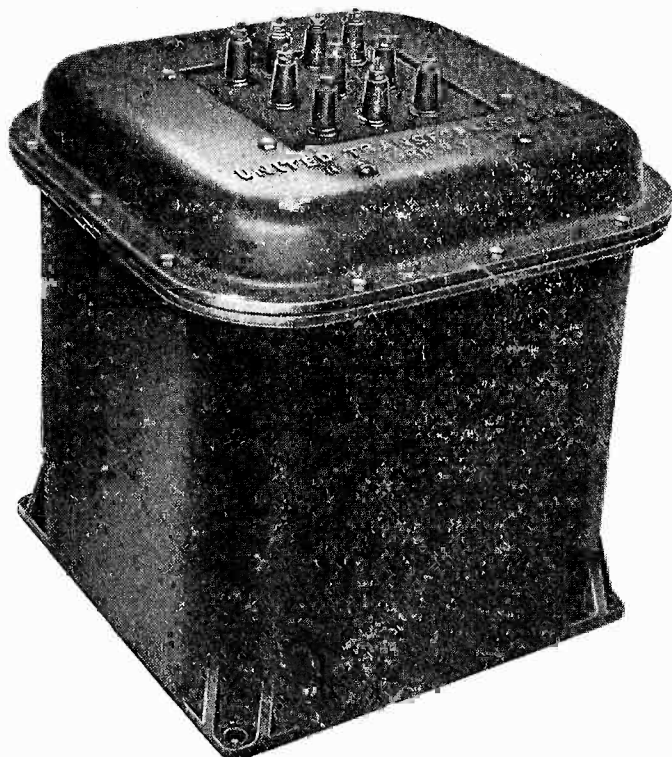

The output transformer illustrated, designed either for 204A's or 849's in Class B, has a linear response from 30 to 12,000 cycles. The unit is oil immersed and shielded in a heavy gauge high permeability casting. All leads are terminated in high tension ceramic bushings. The transformer is insulated for 20,000 volts and will handle 1,000 watts audio power.

UTC engineers take pleasure in announcing a new linear series of high power A prime and class B audio transformers for use with 800, 242A, 211, 845, 284A, 203A, HK-354, 212D, HK-255, 270A, 204A, 851 tubes.

Standard designs are now available on these units having a frequency response of  $\pm 2$  Db. from 30 to 12,000 cycles.

UTC linear standard and public address amplifier kits are available with completely drilled chassis carefully engineered for maximum results.

Write for the new U-1000C Manual. 24 pages devoted to basic amplifier circuits, including fundamental charts on attenuation network data, decibel charts, reactance charts, rectifier constants and class B circuit constants.

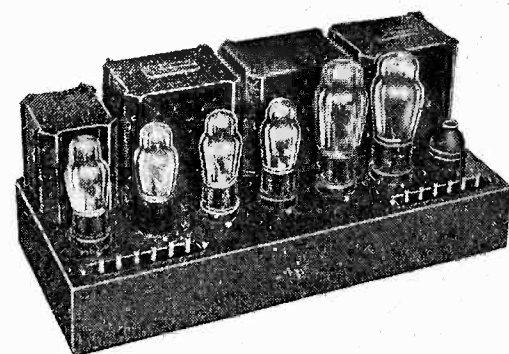
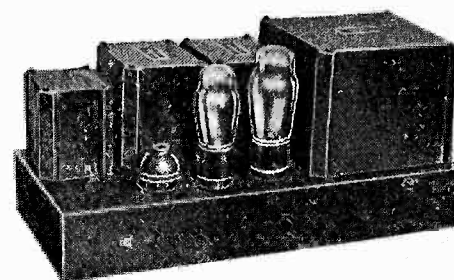

Amplifier illustrated incorporates three push-pull audio stages; gain: 80 Db.; linear from 30 to 15,000 cycles. Tubes used: 4 - 56's, 2 - 2A3's, 1 - 5Z3, 1 - 45. Fixed C bias for output stage.

# UNITED TRANSFORMER CORP.

264-266 CANAL STREET

Export Division, 15 Laight St., New York, N. Y.

NEW YORK, N. Y.

Exclusive UTC distributors carrying a complete stock of UTC products.

Goldhamer's, Inc. 610 Huron Road, Cleveland, Ohio  
 Wholesale Radio Service Co., Inc. 100 Sixth Ave., New York, N. Y.  
 Wholesale Radio Service Co., Inc. 219 Central Ave., Newark, N. J.  
 Wholesale Radio Service, Inc. 430 W. Peachtree St. N. W., Atlanta, Ga.  
 Sun Radio 227 Fulton Street, New York, N. Y.  
 William Gram 1444 Sheridan St., Lansing, Mich.  
 Mohawk Electric Co. 1335 State St., Schenectady, N. Y.  
 Walter Ashe 1100 Pine St., St. Louis, Mo.  
 Radio Shack 46 Brattle St., Boston, Mass.  
 Nutter & Cross 990 Milk St., Boston, Mass.  
 Radio Service Lab. of N. H. 1008 Elm St., Manchester, New Hampshire  
 Hatry & Young 203 Ann St., Hartford, Conn.

W. H. Edwards & Co. 32 Bway, Providence, R. I.  
 SEATTLE, WASH.—Seattle Radio Supply Inc. 2319 Second Ave.  
 Portland Radio Supply Co. 1300 W. Burnside, Portland, Ore.  
 Spokane Radio Co., Inc. 611 First Ave., Spokane, Wash.

### LOWER CALIFORNIA

Pacific Radio Exchange Inc. 729 S. Main St., Los Angeles  
 Radio Supply Co. 912-14 S. Broadway, Los Angeles  
 Coast Electric Co. 744 G. St., San Diego  
 Prest & Dean Radio Co. 400 American Avenue, Long Beach  
 Radio Television Supply Co. 1701 S. Grand Ave., Los Angeles, Calif.  
 Radio Specialties Co. 1816 West 8th St., Los Angeles, Calif.