

RADIO

ESTABLISHED 1917

A-235

**SPECIAL
YEARBOOK NUMBER**

The Worldwide Authority on
Amateur and Shortwave Radio

★
Annual Year-Book Number

JANUARY 1936 NUMBER 138

50c IN U.S.A. AND CANADA

—2s 9d in United Kingdom

2s 6d in Australia

TAYLOR TUBES ARE CUSTOM BUILT

to bring **YOU**

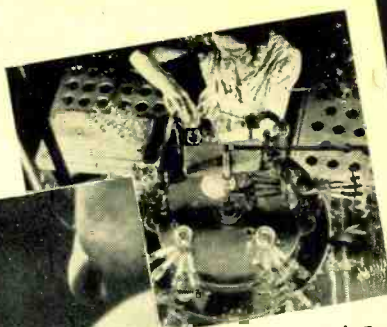

The difficult job of shaping the envelopes of 866J's and other small tubes requires the same expert individual care as exercised in larger tube building.

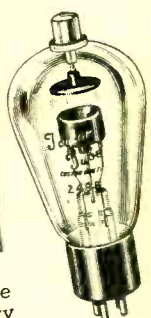

One of the world's finest glass-blowers is pictured here as he shapes the envelope of a T-200. Careful **CUSTOM BUILT** manufacture of every TAYLOR Tube makes them your favorites.

Photographs courtesy RADIO NEWS

MORE WATTS PER DOLLAR

The words "CUSTOM BUILT" which are printed on each TAYLOR TUBES carton, guarantee YOU better all around tube performance. Longer hours of efficient operating service can only come as a result of *individualized* and *skillful* "CUSTOM BUILT" tube manufacture. Every Taylor Tube, from the smallest to the largest, is individually built. The slogan, "MORE WATTS PER DOLLAR," is more than a boast — it is the true performance standard by which all Amateur Transmitting Tubes are gauged. Yes, with TAYLOR TUBES it's "How Many" AND "How Good."
NEW 1939 TAYLOR TUBES MANUAL AND CATALOG NOW READY

TAYLOR TUBES, INC., 2341 Wabansia Ave., CHICAGO, ILLINOIS

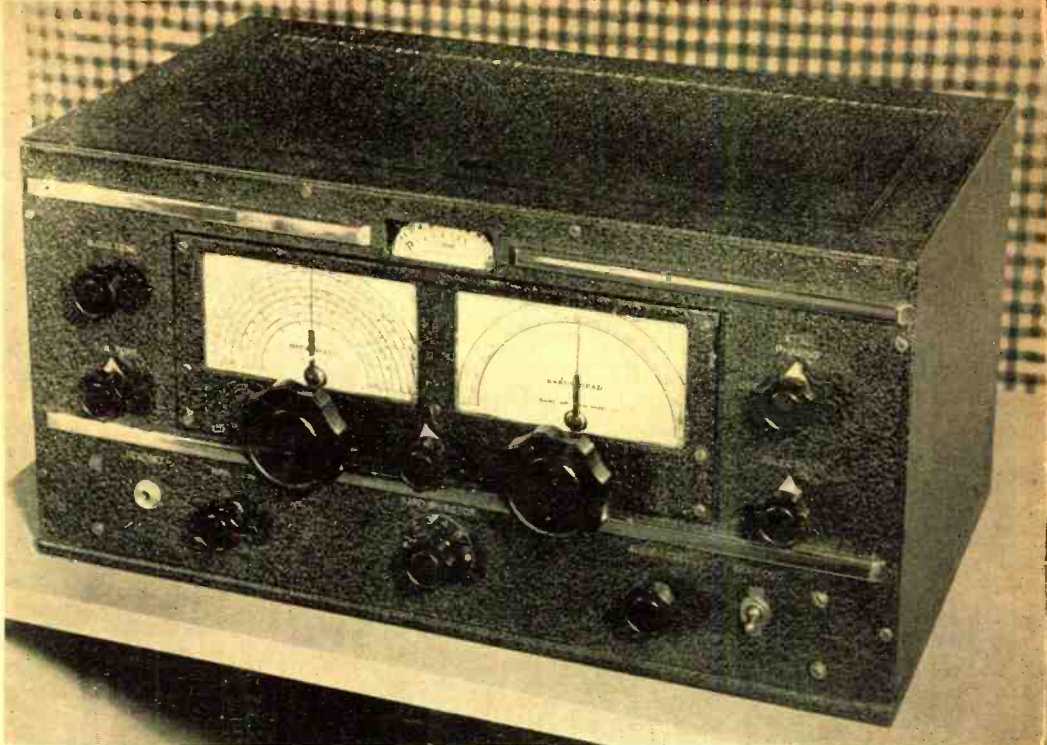

THE NEW RME-70

Equipped with green dial scales, green illuminated R meter scale; variable phasing crystal filter circuit of the latest type; a truly effective, fully automatic, noise suppressor; head phone jack; variable audio beat oscillator; manual—automatic volume control;—this instrument incorporates positively everything that could be desired by an operator. The noise suppressor may be cut in and out of the circuit from the front of the panel through the stand-by and volume control knob.

The cabinet size is 19" x 10½" x 9" high.

Tube line up:—1-6K7G R.F. Amplifier; 6J7G First detector; 6K7G Oscillator; 2-6K7G I.F. Amplifiers; 6H6 Second detector; 6K7 1st A.F. Amplifier; 6F6G Output tube; 6A6 noise suppressor; 6K7G Beat Oscillator; 80 rectifier.

The RME-70 is available in cabinet model only, either gray or black crinkle finish. Like the RME-69 it is outstanding in its performance and the price is right. Pay your dealer a visit and give this communication super the once-over.

RADIO MFG. ENGINEERS, Inc.
111 HARRISON ST. PEORIA, ILL.

Correspondence

Direct all correspondence, manuscripts, and orders to the home office at Los Angeles except Calls Heard and Raddioddities, Strays, etc., which should be sent to New York. Regarding advertising, see notice of right. Unusable, unsolicited manuscripts will be destroyed unless accompanied by a stamped, addressed return envelope.

Rates

SUBSCRIPTION RATES: Two years, \$4.00, or \$2.50 yearly in U. S. A. (add 3% tax in California), Canada*, Newfoundland*, Cuba*, and Mexico*. To Pan-American countries and Spain, \$0.50* per year additional. Elsewhere (except New Zealand), \$1.00* per year additional. To all places using British currency: two years, £1 5s.* or 14s.6d.* yearly. New Zealand only: 18s.6d. yearly, local currency, from Te Aro Book Dept, Ltd., 64 Courtenay Place, Wellington. Special issues are included only with subscriptions of one-half year or longer. Refunds on cancelled subscriptions will be made at the difference between the rate paid and the rate earned.

THREE YEAR SUBSCRIPTIONS at the rate of \$5.00, net, in advance, are accepted from the U. S. A. and Canada* only. Such subscriptions must be sent direct to our home office, not through agents.

SINGLE COPY PRICES: Prices are for regular issues; prices for special issues may vary but are usually those shown in parenthesis. At newsdealers, book stores, and radio parts dealers, 30c (50c) per copy in U. S. A. and Canada, 1s.8d. (2s.9d.) in United Kingdom, 2s. (3s.4d.) in Australia and New Zealand. By mail, postpaid, from home office: 30c (50c) in U. S. A., Canada*, Newfoundland*, Cuba*, and Mexico*; 35c* (55c)* in other Pan-American countries and Spain. Elsewhere, 40c* (65c)* or 1s.8d.* (2s.9d.)*.

BACK ISSUES, when available, 5c extra net. Back issues will not be included in subscriptions.

***REMITTANCES** must be payable at par in continental U. S. A. except as follows: Canadian bank, postal, and express orders and postal notes accepted; add 10c exchange to Canadian bank checks. British postal orders and cheques payable at par in London are acceptable at rates quoted in sterling. From elsewhere, remit by bank draft (preferred) or international money order.

The Editors of "Radio"

EDITOR

W. W. Smith, W6BCX

ASSOCIATE EDITORS

Ray L. Dawley, W6DHG

Frank C. Jones, W6AJF

B. A. Ontiveros, W6FFF

K. V. R. Lansingh, W6QX

E. H. Conklin, W9FM

CHICAGO

CONTRIBUTING EDITORS

Herbert Becker, W6QD

R. P. Turner, W1AY

EDITORIAL AND TECHNICAL ASSISTANTS

Faust R. Gonsett, W6VR

Jack Rothman, W6KFQ

Kennard D. Moore, W6PDB

Business Staff

Los Angeles

K. V. R. Lansingh, Publisher

E. M. Johnson, Advertising Manager

G. Jasaitis, Circulation Manager

A. McMullen, Editorial Secretary

New York

V. R. Lansingh, Eastern General Manager

M. M. Lloyd } Managing Editors

R. P. Turner } Managing Editors

J. B. Carter, Asst. Advertising Manager

Chicago

C. W. Nelson, Asst. Advertising Manager

Advertising

Advertising inquiries may be directed to our nearest office. For fastest service, prepare advertising copy in duplicate; send original copy and cuts (fully mounted and marked) to New York; send duplicate copy, proofs of cuts, and space order to the advertising manager at Los Angeles. Failure to send both will delay submission of proofs. Our printers (near New York) will not set type until the home office telegraphs its approval.

Miscellaneous Notices

IF YOU MOVE notify us in advance. We cannot replace copies sent to your old address. See "Changes of Address" notice elsewhere in this issue.

Radio is published ten times yearly (including enlarged special annual number) about the middle of the month preceding its date; August and September issues are omitted.

PUBLISHED BY RADIO, Ltd., Technical Publishers, 7460 Beverly Blvd., Los Angeles, California, U.S.A.

COPYRIGHT, 1938, by Radio, Ltd. All rights reserved. Reproduction without written permission is prohibited; permission is usually granted amateur radio papers on request.

TITLE REGISTERED at United States Patent Office.

PRINTED IN U.S.A. by Hughes Printing Company, East Stroudsburg, Pennsylvania.

RESPONSIBILITY will not be accepted for subscriptions placed with unauthorized agents. Prospective subscribers are urged to inspect carefully the credentials of anyone soliciting their business. Agents are never authorized to vary the rates quoted on this page.

BRANCH OFFICES transact a cash business with customers who call in person; mail orders and orders on open account should be sent only to Los Angeles.

Principal Foreign Agents

Europe: N. E. Read, 24, Church St., Oswestry, Shropshire, England. Australia: "The Bulletin", Box 2521BB, Sydney; McGills, 183 Elizabeth St., Melbourne; Swain & Co., Pitt St., Sydney. New Zealand: Te Aro Book Depot, Ltd., 64 Courtenay Place, Wellington. South America: F. Stark, Caixa 2786, Sao Paulo; "Revista Telegrafica", Peru 165, Buenos Aires; Editorial Pan America, Peru 677, Buenos Aires. South Africa: South African Radio Publications, 40 Trust Buildings, Fox Street, Johannesburg.

The Worldwide Technical Authority of Amateur, Shortwave, and Experimental Radio

RADIO, January, 1939, no. 235. Published monthly except August and September by Radio, Ltd., 7460 Beverly Blvd., Los Angeles, Calif. Entered as second-class matter Feb. 6, 1936, at the postoffice at Los Angeles, Calif., under the Act of March 3, 1879. Additional entry at East Stroudsburg, Pa. Registered for transmission by post as a newspaper at the G.P.O., Wellington, New Zealand.

"Radio" for Christmas

AN IDEAL GIFT

RADIO's annual Christmas gift rates will be in effect from November 15th to January 15th. To radio amateurs with a "fellow ham" to remember, to radio employees with a radio-minded employer who must not be forgotten, and to radio manufacturers and distributors who want to remind a favored customer repeatedly through the year of their appreciation of his business, a RADIO subscription is an ideal (and effortless) solution of that puzzling Christmas shopping problem.

ONE SUBSCRIPTION (one year)	\$2.50
TWO SUBSCRIPTIONS, each	2.35
THREE or more SUBSCRIPTIONS, each	2.25
SIX or more SUBSCRIPTIONS, each	2.00
TWELVE or more SUBSCRIPTIONS, each	1.75

Subscriptions at \$2.00 or less must be **cash with order**.

These rates apply for the U.S.A., Canada, Newfoundland, Cuba, and Mexico. To other independent American countries and Spain, add 50c per subscription. Elsewhere, add \$1.00 per subscription.

YOU MAY ENTER OR RENEW YOUR OWN SUBSCRIPTION AT THESE RATES

Rates for more than one subscription, as listed above, apply only on gift orders entered and paid for at one time by one individual or company. Unless otherwise requested, the subscriptions will be commenced with the January issue, which will be delivered as near Christmas as possible, together with an attractive card announcing the gift and the sender's greetings; those who are at present subscribers will automatically have subscriptions extended unless otherwise requested.



SX-17 SUPER SKYRIDER

With complete coverage from 5 meters to the top of the broadcast band, fractional microvolt sensitivity on all amateur bands, variable selectivity that ranges from broad high fidelity to better than 1 kc with crystal filter in circuit, 2 stages of Pre-Selection and a built-in Automatic Noise Limiter for cleaner reception on the higher frequencies, the SX-17 provides the amateur with a quality and versatility of performance that is difficult to surpass.

All this at its moderate cost, explains the world-wide preference of the amateur radio fraternity for the SX-17. Your Hallicrafters dealer will gladly show you the SX-17, or complete description will be sent you on request.

the hallicrafters inc.

2609 Indiana Avenue, Chicago, U. S. A. Cable Address: HALLICRAFT, Chicago

WORLD'S LARGEST BUILDERS OF AMATEUR COMMUNICATIONS EQUIPMENT



From the
PRIVATE LIFE
of
RADIO

As the spirit moves, we present in this column from time to time a bit of gossip about RADIO, its affiliated publications, and those who produce and distribute them.

—“From the private life of RADIO”.

Paper. Comments on paper from our readers are of interest. Yes, RADIO does use a better grade of paper than most publications in its field. The body of RADIO is at present printed on a sheet known as Production Gloss, the same paper as is used by *Life*. Why? Well, RADIO wants to get the most out of its larger illustrations, without extensive retouching, which no matter how well done always lends an air of artificiality to half tones. The cover is printed on M-C Folding Enamel, a special grade of enamel coated paper designed to withstand more handling than can ordinarily be stood by coated papers. Nearly a carload of paper will be used in this January issue.

We wonder why readers ordinarily consider “slick” papers to be of high quality and those of rough surface to be of poorer quality. This comment has been brought out by remarks regarding the current, 2nd edition of the *RADIO Antenna Handbook* which some believe to have been printed on poor paper. As a matter of fact it is printed on a more expensive paper than is RADIO, a paper similar to that used by such high class magazines as the *Reader's Digest* and known as “eggshell”; the same paper is also used in our own *Radio Digest*. It is characterized by good printing qualities (except for halftones), good opacity, and light weight. A light-weight paper was chosen to keep down mailing costs, which must be figured in the cost to the reader, and are not infrequently a considerable item, especially when the book in question weighs over eight ounces.

Dress Up Your Station

“W. A. Z.” MAP

Size 34" x 28"



A MAP OF THE WORLD FOR ONLY 25c!

Size: 34" x 28"

Heavy white paper

This is an enlarged reproduction of the W.A.Z. map which appears in the DX Department of this issue of “RADIO”. List of countries within each zone is also included.

The W.A.Z. plan is the best “yard-stick” yet developed for the measurement of DX achievement.

TWENTY FIVE CENTS

postpaid, anywhere. Canadian postal notes (25c) accepted. Five international postal reply coupons accepted as 25c.

RADIO, LTD.

7460 Beverly Blvd.

Los Angeles

CRYSTAL FILTER

ELECTRIC BAND SPREAD

R.F. ON ALL BANDS
CERAMIC COIL FORMS



Model 438
Only
\$49.95
less crystal

4 BANDS—8 TUBES
BUILT-IN SPEAKER

HOWARD DOES IT AGAIN!

With the advent of the world famous 430 many have asked for a larger receiver—here it is.

Model 438 embodies professional features never before associated with equipment in this price class . . . real "DX" with R-9 reception: Ceramic Coil Forms . . . R. F. Stage on all Bands . . . Separate Coils for each Band . . . Xtal Filter . . . Complete Coverage 540 KC—

43 mc . . . Electric Band Spread with vernier control . . . 2-stage Iron Core I. F. . . . Accurately Calibrated Slide Rule Dial . . . 8 Tubes . . . Provisions for a 6-volt Power Supply . . . Band in use Indicator . . . B. F. O. with Pitch Control . . . 2 Watts Power Output . . . Built-in 6" Dynamic Speaker . . . Head Phone Jack . . . Doublet or Marconi Antennae Connections . . . Provision for External Speaker . . . Provisions for Howard tube type 'R' Meter.

Models to Suit the Individual Tastes of the Most Exacting Amateur and Professional

Model 450A—12 Tubes—6 Bands—Frequency Coverage .54 to 65 MC . . . Ceramic Coil Forms . . . Dual I. F. Channels . . . Two S. L. F. Ceramic Insulated Tuning Condensers . . . 47 inches of electric bandsread . . . crystal filter . . . Calibrated 'R' Meter . . . Accurately calibrated direct reading dial . . . Price, with Tubes, less Speaker, less crystal. . . . \$87.50 Net

Model 430—6 Tubes—4 Bands—Frequency Coverage .54 to 40 MC . . . Ceramic Coil forms . . . B. F. O. with pitch control . . . Iron Core I. F. transformers . . . Electric band spread . . . Built-in Dynamic Speaker . . . Headphone jack . . . Accurate direct reading straight line dial . . . Price, Complete with tubes and speaker. . . . \$29.95 Net

Model 440—9 Tubes—5 Bands—Continuous coverage .54 MC to 40 MC . . . Ceramic Coil forms, S. L. F. Ceramic Insulated Tuning Condensers, Electric Bandsread, R. F. on all bands, Iron Core I. F. transformers . . . Electric band spread. Calibrated 'R' Meter, Crystal Filter . . . Price with tubes less Speaker, less Crystal \$66.50

HOWARD RADIO COMPANY
1731-35 West Belmont Ave., Chicago, Ill.
Please send me more information on
Model 438 _____ Model 430 _____
Model 450-A _____ Model 440 _____
CABLE ADDRESS: "Howardco" R

Name _____
Address _____
City _____ State _____

America's Oldest Radio Manufacturer

The publishers assume no responsibility for statements made herein by contributors and correspondents, nor does publication indicate approval thereof.

Table of Contents

Frontispiece: KNX Low-Power Stages - - - - - 10

ARTICLES

C. W. Super for the DX Man— <i>Leigh Norton, W6CEM</i> - - - - -	11
An Improved U.H.F. Receiver— <i>Groie Reber, W9GFZ, and E. H. Conklin</i>	17
A 56-Mc. Transmitter Exciter— <i>Jack Rothman, W6KFO</i>	23
Inexpensive Dx— <i>Emile Milles</i> - - - - -	26
Communications Receivers for 1939 - - - - -	29
More on the Three-Element Rotary— <i>E. H. Conklin</i>	35
A T20 100-Watt Phone— <i>Frank C. Jones, W6AJF</i> - - - - -	38
The G-OK, An Ideal Tube— <i>C. B. Stafford, W9KWP</i> - - - - -	43
Modern Speech Amplifier Design— <i>Douglas Fortune, W9UVC</i>	46
How Many Turns?— <i>Lewis F. Franklin, W6LTA</i> - - - - -	50
A Ten-Meter Auto-Radio Converter— <i>F. R. Gonsett, W6VVR</i>	52
Another Angle on Switching Crystals - - - - -	56
A 400-Watt Diathermy - - - - -	59
A Kilowatt on the New 810's - - - - -	62
Radio with the Airlines— <i>John Durkovic</i> - - - - -	64
An Inexpensive 25-Watt Modulator— <i>Ray L. Dawley, W6DHG</i>	72
—On the Care and Feeding of 807's— <i>W. W. Smith, W6BCX</i> - - - - -	75
Two Watts—On the Hoof— <i>Jay C. Boyd, W6PRM</i> - - - - -	77
A Great-Circle Globe— <i>Harry L. Woodley, W6LSK</i> - - - - -	81
A Novel Beam Antenna Indicator— <i>Donald G. Reed, W6LCL</i>	83
Memorizing the Color Code— <i>C. D. Morrison</i> - - - - -	84
Swing It!— <i>Eric T. Ledin, W6MUF</i> - - - - -	85
Revised Amateur Regulations - - - - -	87
Using the Reactance-Frequency Chart— <i>R. D. Pickett, W9BHF/6</i> - - - - -	90
200 Crystal Watts on 56 Mc - - - - -	97
Ionospheric Soundings for Amateurs— <i>Albert W. Friend, W8DSJ-W8KIU</i>	99
New Amateur Regulations - - - - -	105
A Simple Direction Finder - - - - -	107
The 28-Mc. Band in Great Britain— <i>Nelly Corry, G2YL</i> - - - - -	132

MISCELLANEOUS FEATURES

Pictorial Section:		Amateur Interest in U. S. Equatorial	
Photographs from Overseas		Islands - - - - -	89
Readers - - - - -	112, 113	Contributions to RADIO - - - - -	94
U. S. Territorial Hams - - - - -	114	Gone, Alas, But Not Forgotten—	
Y. L. Section - - - - -	115	<i>Russell G. Benedict, W6GNZ</i> - - - - -	109
F. C. C. Men - - - - -	119	WAZ Honor Roll - - - - -	124
Right at Home - - - - -	122	British Field Day - - - - -	133
From the Private Life of RADIO - - - - -	7	WAZ Map of the World - - - - -	134, 135
Hams Across the Sea - - - - -	33	Countries of the World and Prefixes - - - - -	136
FB, O. M.! - - - - -	57	The Marketplace - - - - -	192
Danger—High Voltage - - - - -	82	Advertising Index - - - - -	192
Radio in the Andes - - - - -	86	Buyer's Guide - - - - -	193, 194
Index to RADIO for 1938 - - - - -		187	

DEPARTMENTS

Dx - - - - -	125	New Books - - - - -	156, 158
56 Mc - - - - -	139	Calls Heard - - - - -	158
Yarn of the Month - - - - -	143	Postscripts and Announcements - - - - -	160
What's New in Radio - - - - -	150, 152	Open Forum - - - - -	162
Scratchi - - - - -	154		

**THE WORLDWIDE TECHNICAL AUTHORITY OF
AMATEUR, SHORTWAVE, AND EXPERIMENTAL RADIO**

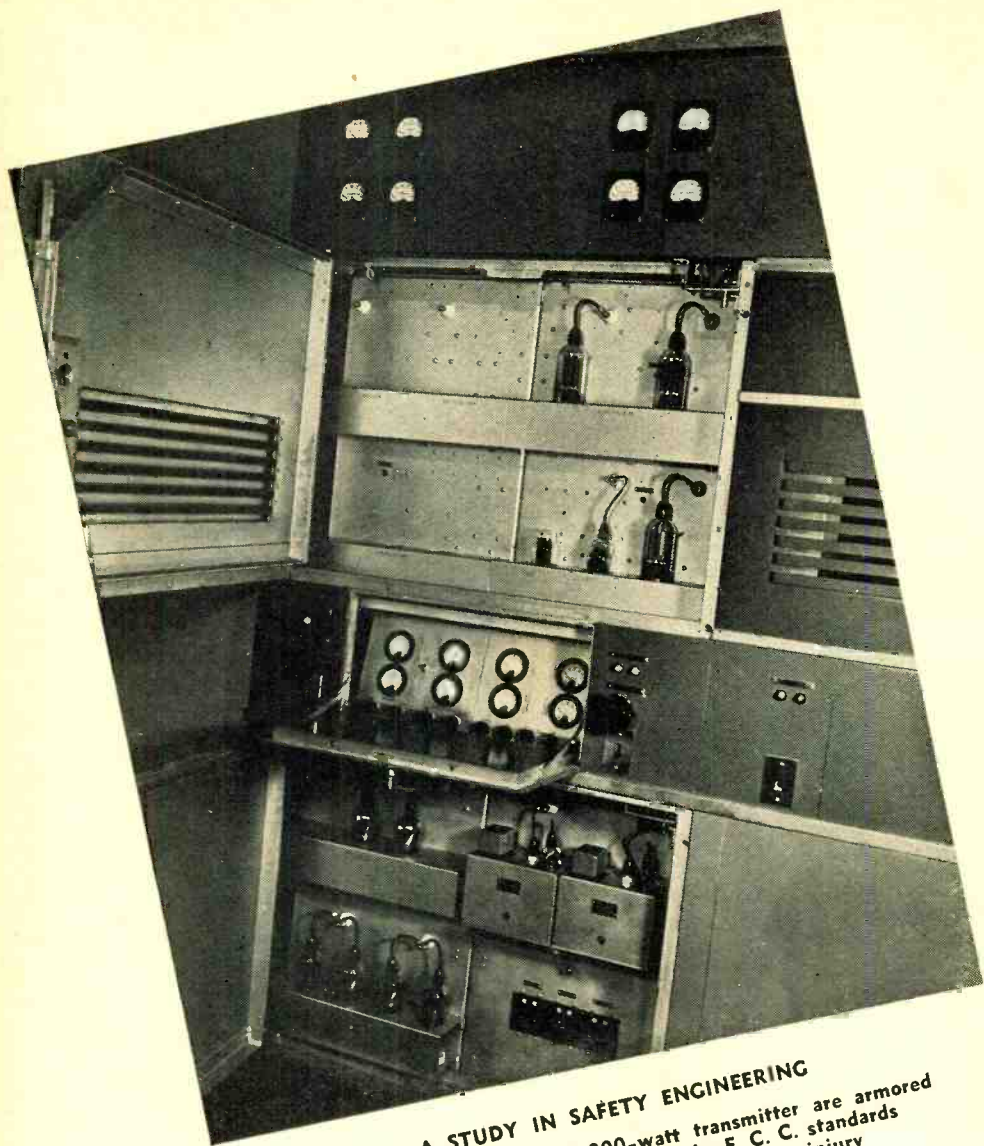

A STUDY IN SAFETY ENGINEERING
These stages of KNX's 50,000-watt transmitter are armored and insulated, in accordance with the F. C. C. standards of good engineering practice, to prevent injury to operators and increase electrical efficiency.

C. W. Super for the

DX MAN

Here is a receiver designed solely for the c.w. operator interested in dx. It lacks many of the "frills" of commercially manufactured receivers but stresses selectivity and sensitivity.

By LEIGH NORTON,* W6CEM

Modern high quality communication receivers follow more or less conventional design. Generally, there is a preselector consisting of one or two stages of r.f. amplification, separate mixer and oscillator, two stages of intermediate frequency amplification, diode detector and a.v.c. rectifier and, usually, an audio amplifier with sufficient output to supply a good sized theater.

Different manufacturers use different combinations of these features, and the amateur desiring a receiver for some specific purpose must submit to certain compromises if he is to buy a commercially manufactured product. One having the particular features he desires is usually quite a pretentious affair, oftentimes embodying many features he does not necessarily need or desire. The receiver to be described was designed to fulfill just one purpose; it is a highly sensitive and highly selective c.w. receiver. Naturally it performs well on phone signals, but it will not supply forty-eleven watts of audio, nor has it a.v.c. or a tuning indicator.

Coil switching schemes are necessarily somewhat inefficient at 28 Mc.; so it was decided to employ plug-in coils in this receiver and take no chance of that weak AC4 getting lost somewhere in a coil and switch assembly. A glance at the 10-meter coils in most commercial receivers will show the reason for the loss in sensitivity and poor image rejection at that frequency. It was decided, therefore, that in this receiver the 10-meter coil would be a *coil*—not a microscopic affair made neces-

sary by the high capacities existent in coil switching assemblies.

A.v.c. is of practically no use in a receiver used primarily for c.w. reception; so it was discarded at the outset. Along with a.v.c. went the insensitive and broad diode detector. A noise silencer of the peak-limiting type was employed and, in connection with the crystal filter, it supplies essentially noise-free operation except for the most severe noises of the "power leak" type. The only type of silencer applicable to a receiver of this type that is really effective on the "power leak" type of noise is one using the instantaneous a.v.c. method. To be effective, this type of filter must be placed ahead of the crystal filter, where selectivity is at a minimum. Consequently, any strong signal, even though it be removed from the point to which the receiver is tuned by several hundred kilocycles, will render the receiver inoperative by blocking out the i.f. amplifier. Thus, this type of silencer eventually proves to be a detriment rather than an advantage.

New Tubes Used

Two new tubes provide a noticeable increase in sensitivity as compared with older types. One of these is the 6K8, which is employed in the mixer stage with injection into its "oscillator" grid. Another little known type is the 6U7G, which is used in the r.f. stage. This is the octal-based version of our old friend, the 6D6. It has considerably lower input and output capacitances than the 6K7-6J7 types and permits a noticeable lowering of the shunting capacities across the input and output circuits. The 6K8 likewise has

* Technical Assistant, RADIO.

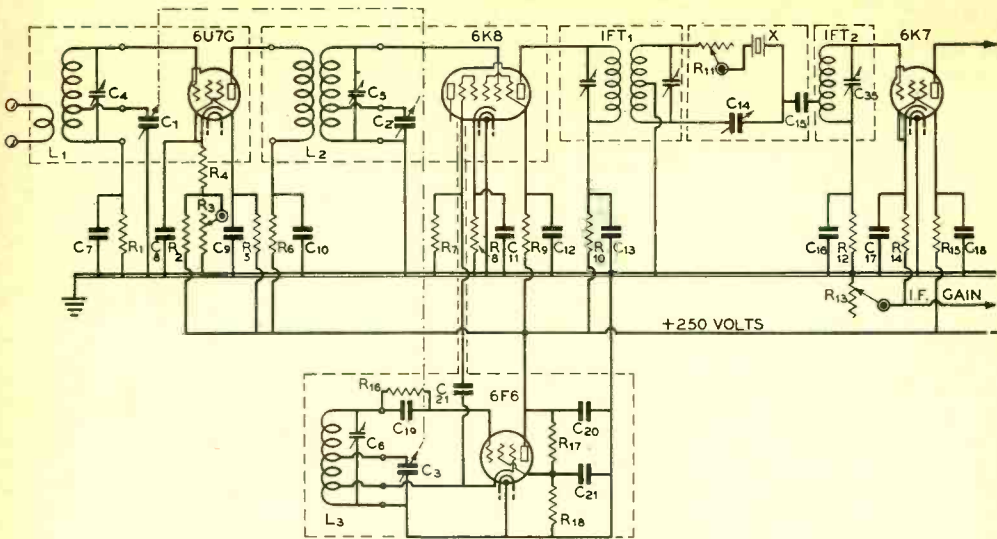

R.F. end of the c.w. super.

- | | | | |
|--|---|---|--|
| C₁, C₂, C₃ —35- μ fd. midget | C₁₉ —100- μ fd. mica | C₃₀, C₃₁ —10- μ fd. 25-volt electrolytic | R₉ —25,000-ohm potentiometer |
| C₄, C₅, C₆ —See coil table | C₂₀, C₂₁, C₂₂, C₂₃, C₂₄, C₂₅ | C₃₂ —250- μ fd. (in b.f.o. transformer shield) | R₁ —350 ohms, 1/2 watt |
| C₇, C₈, C₉, C₁₀, C₁₁, C₁₂ | C₂₆ —0.5- μ fd. 400-volt tubular | C₃₃ —75- μ fd. midget | R₂ —100,000 ohms, 1/2 watt |
| C₁₃ —0.5- μ fd. 400-volt tubular | C₂₇ —10- μ fd. 25 - volt electrolytic | C₃₄ —0.5- μ fd. 400 - volt tubular | R₃ —2000 ohms, 1/2 watt |
| C₁₄ —20- μ fd. midget | C₂₈ —0.01- μ fd. 400-volt tubular | R₄ —100,000 ohms, 1/2 watt | R₄ —500 ohms, 1/2 watt |
| C₁₆ —50- μ fd. mica | C₂₉ —0.5- μ fd. 400 - volt tubular | R₅ —100,000 ohms, 1 watt | R₅ —100,000 ohms, 1/2 watt |
| C₁₈, C₁₇, C₁₅ —0.5- μ fd. 400-volt tubular | | | |

an extremely low input capacitance. In passing, it might be mentioned that the amateur building his own receiver has an infinite advantage over his brother purchasing a manufactured product in that he need have no qualms about changing to newer tubes and circuits as they are developed. This applies especially to tubes, since octal basing has made all types interchangeable. There is something formidable about dismembering a manufactured receiver to try new circuits that causes most amateurs to think twice before making changes.

The high-frequency oscillator is a 6F6, chosen for its high output capabilities, thus allowing stable operation at the power level required for receiver oscillator use.

The plug-in coil system used has the advantage of allowing the grid connections to the tubes to be made from the logical place, the top of the coil. This also allows the coils to be mounted in sub-panel mounting sockets, thus providing short plate-to-coupling-coil leads between the detector and r.f. stages. The coils are wound as near the top of the forms

as the winding length permits and, since the coils become shorter in length on the higher frequencies, no ill effects from having the coils too close to the chassis have been observed.

On the two higher frequency bands the oscillator coil has a somewhat higher C/L ratio than the r.f. and mixer coils. This is most evident on the 28-Mc. coils, where the oscillator coil has half the inductance of the r.f. and mixer coils. The coils are wound in this manner to allow high stability in the oscillator and, at the same time, high sensitivity in the r.f. and mixer stages.

Bandspread

Bandspread is taken care of by using 35- μ fd. midget tuning condensers tapped across enough of the coils to give nearly full dial bandspread on each band. This system allows the use of ganged single-control tuning with the high-C oscillator and low-C detector tanks mentioned above. The tapped coil method should not be carried too far, however, such as using broadcast-type condensers

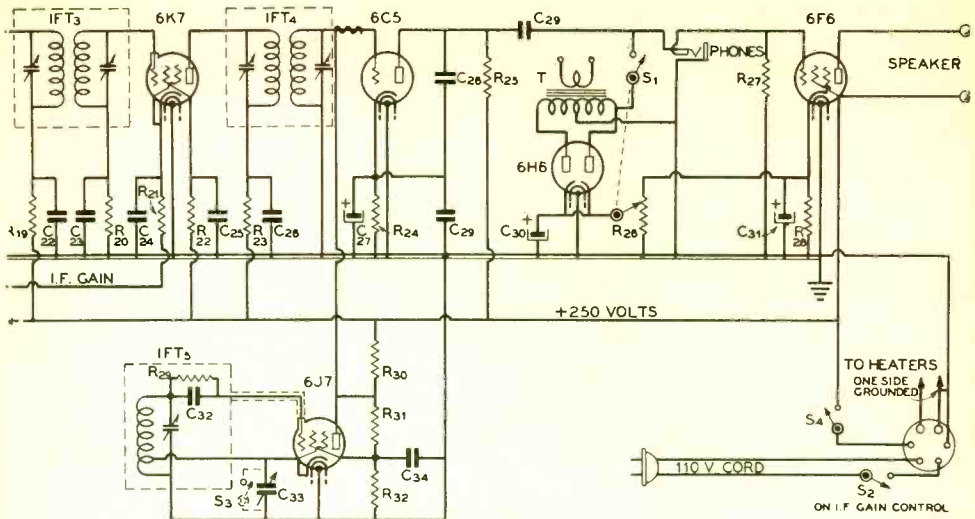

Circuit of the i.f. and audio channels.

R ₁₀ —2000 ohms, 1/2 watt	R ₁₇ —40,000 ohms, 1 watt	R ₂₀ —10,000-ohm potentiometer	IFT ₅ —2.5-mh. r.f. choke tapped between first and second pies. See text.
R ₁₁ —25,000-ohm potentiometer	R ₁₈ —50,000 ohms, 1 watt	R ₂₁ —150,000 ohms, 1/2 watt	IFT ₃ , IFT ₄ —465-kc. interstage i.f. transformers
R ₁₂ —100,000 ohms, 1/2 watt	R ₁₉ —2000 ohms, 1/2 watt	R ₂₂ —500 ohms, 10 watt	IFT ₁ —Beat-frequency oscillator transformer
R ₁₃ —15,000-ohm potentiometer	R ₂₀ —350 ohms, 1/2 watt	R ₂₃ —50,000 ohms, 1/2 watt (in b.f.o. transformer shield)	IFT ₂ —465-kc. i.f. transformer with center-tapped secondary
R ₁₄ —350 ohms, 1/2 watt	R ₂₁ —100,000 ohms, 1/2 watt	R ₂₄ —100,000 ohms, 1/2 watt	T—Small p.p. pentode-to-voice coil transformer
R ₁₅ —100,000 ohms, 1/2 watt	R ₂₂ —2000 ohms, 1/2 watt	R ₂₅ —20,000 ohms, 1/2 watt	
R ₁₆ —50,000 ohms, 1/2 watt	R ₂₃ —20,000 ohms, 1/2 watt	R ₂₆ —100,000 ohms, 1/2 watt	

tapped across a very small portion of the coils, as this type of operation is liable to lead to cross modulation and spurious signal troubles in the event that high-powered amateur or commercial stations are located nearby. As used in this receiver, however, the system has proven entirely satisfactory. This is principally due to the fact that the tuning condensers are relatively small (35 $\mu\text{fd.}$) and are therefore tapped across a comparatively large part of the coils in the r.f. and detector stages.

It was found that on the 7- and 14-Mc. bands mica trimmers would be satisfactory for the r.f. and detector stage coils, inasmuch as the slight capacity changes caused by temperature variations made no practical difference in the operation of the receiver. This was due largely to the use of the 6K8 as a mixer tube. Absolutely no interlocking effect takes place between the oscillator and mixer; consequently,

slight capacity changes in the detector trimmer do not cause the receiver to drift. The mica padding condensers used are mounted on the upper rim of the XP53 coil forms and are held in place by a 6-32 screw in a hole tapped through the coil rim. Mounting the trimmers in this manner removes them from the heavy field in the center of the coil and thus raises the Q of the coils somewhat. The oscillator coils, of course, have air-dielectric padding condensers mounted in them. The latter coils need not have the highest possible Q, but must be highly stable and drift-free.

On the ten-meter range, air padders are employed throughout in the interest of higher sensitivity. The 10-meter coils are quite different from the lower frequency ones in that the coils are wound *inside* the coil forms, rather than around them. The grid coils are wound of no. 14 wire and are self-supporting. They hang from the padding condenser ter-

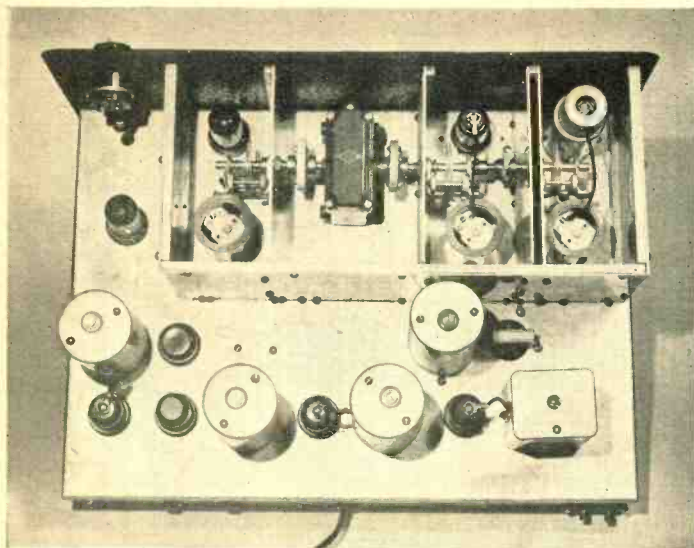

Top view of the receiver. Against the panel, from left to right, may be seen the 6U7G r.f., the 6K8 mixer and the 6F6 oscillator stages. The coils shown are those for 28 Mc. Across the rear of the chassis, from right to left, are the crystal output circuit, two 6K7 i.f. stages, 6C5 second detector and 6J7 beat oscillator. The crystal input transformer is directly in front of the first 6K7.

minals as shown on page 16. The primary windings are made of ordinary solid hookup wire and are installed in the forms before the grid windings are inserted. The primary coils are held in place by the simple expedient of soldering them into the base pins. As the oscillator coil on this band has relatively few turns, it was not found necessary to support it from within the form to prevent vibration. A coil of any greater size would probably have to be mechanically supported to keep it from vibrating and causing unstable operation.

The Crystal Filter

The crystal filter represents something new in the way of single-control, constantly variable selectivity. An ordinary 25,000-ohm variable resistor placed in series with the crystal provides any degree of selectivity from absolute "single-signal" out to "high-fidelity" phone. The resistor simply introduces enough resistance in series with the crystal to broaden its resonance peak out to any degree desired. A center-tapped input transformer provides out-of-phase voltage for the phasing condenser, which is a 20- μ fd. midget. The crystal filter shield can be seen in the bottom view of the chassis. The two controls are brought out through the shield and to the front panel through two pieces of wood dowel. The input transformer and the crystal itself are both mounted above the chassis in such a manner that their bottom connections fall inside the shield can below the chassis. An ordinary four-section 2.5-mh. r.f. choke is used as an output autotransformer. It is mounted in the

shield can at the left rear of the chassis and is tuned by a 75- μ fd. air-dielectric padding condenser which is also in the shield can. The tap on the choke is made between the first and second pies from the ground end.

The operation of this crystal filter has been a revelation. The selectivity control is normally set for a medium degree of selectivity and an interfering signal may then be eliminated by simply advancing the selectivity to any degree needed. Phone interference may be removed by running the selectivity up to a point where just enough of the desired signal's side bands are left to allow intelligibility.

The I. F. Amplifier

The i.f. amplifier uses 2 6K7's and follows conventional design practice with the exception of separate filtering of each plate, grid and screen circuit. This filtering contributes greatly to the receiver's overall stability and freedom from regeneration. A 6C5 is used as power detector, since the signal level at the output of the i.f. amplifier is sufficient to swing this type of detector to full output. In fact, a small speaker may be used on the output of the second detector. A single 6F6 audio stage supplies larger quantities of audio when it is desired to amaze visiting b.c.l.'s with a demonstration of ham dx.

Mechanical Details

The mechanical construction is clearly visible in the photographs. The ventilated cabinet has a hinged lid which allows coils to be changed easily. The r.f. and detector stages are on the left side of the chassis, while the

In this bottom view the crystal filter shield can be seen at the left center. The various by-pass condensers and resistors are arranged around the tubes with which they operate.

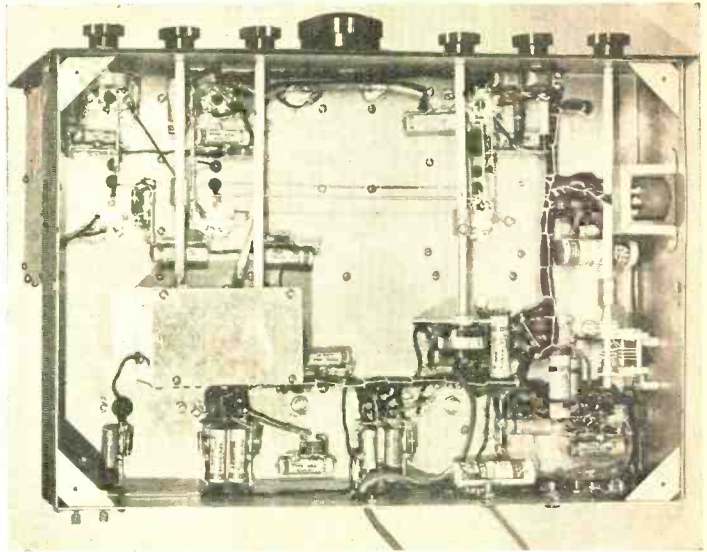

Coil Chart For C.W. Super

Coil	7 Mc.	14 Mc.	28 Mc.
L ₁ primary	5	5	5
L ₁ secondary	17½	8¾	10½
L ₁ tuning tap	8	3⅞	3¼
C ₄	80 μμfd.	80 μμfd.	25 μμfd.
L ₂ primary	10	10	5
L ₂ secondary	17½	8¾	10½
L ₂ tuning tap	8	3⅞	3¼
C ₅	80 μμfd.	80 μμfd.	25 μμfd.
L ₃	17½	7½	5¾
L ₃ cathode tap	2	2	1
L ₃ tuning tap	8	3⅞	2¾
C ₆	75 μμfd.	50 μμfd.	50 μμfd.

Turns to taps are counted from the ground end of coils. On the 28-Mc. coils, all trimmer condensers are air dielectric. On the 7- and 14-Mc. coils, condensers C₄ and C₅ are mica-dielectric trimmers, while condensers C₆ are air dielectric.

7-Mc. grid coils are 1½ inches in diameter and wound to occupy 1¾ inches.

14-Mc. grid coils are 1½ inches in diameter and wound to occupy 1½ inches.

28-Mc. r.f. and detector grid coils are ⅝ inch in diameter and 1 inch long.

28-Mc. oscillator coil is ⅝ inch in diameter and 9/16 inch long.

Primaries on the 7- and 14-Mc. coils are wound at the cold end of the grid coils and separated from them by approximately 3/16 inch.

7- and 14-Mc. coils are wound with no. 20 enameled.

Primaries on the 28-Mc. coils are wound inside the grid coils.

oscillator is mounted on the right side. These stages are separately shielded by the use of copious quantities of 1/16-inch aluminum and ¼-inch square brass rod. Each shield box measures 3 x 5½ x 6 inches. Double shielding is used between the r.f. and detector stages inasmuch as they are necessarily quite close together. In the interest of short leads and maximum 10-meter performance, these shield boxes were made somewhat smaller than ordinary design practice would indicate.

The i.f. amplifier, second detector and beat-frequency oscillator are arranged along the rear of the chassis. Directly behind the mixer section of the "front end" shielding is located the crystal filter input transformer. The leads to this transformer all terminate inside the small shield can under the chassis. The mixer plate lead runs through a copper tubing shield into this shield can. The output from the crystal filter is carried through a short lead into the bottom of the shield can containing the crystal output circuit.

The i.f. amplifier follows along the rear of the chassis to the right. At the extreme right end of the chassis are located the 6J7 beat-frequency oscillator tube and, in front of the tube, the b.f.o. transformer. The 6H6 noise limiter is located between the shield wall and the 6C5 detector. A 75-μμfd. midget condenser under the b.f.o. transformer is connected from the cathode of the 6J7 to ground and allows the beat note to be varied from the front panel. The beat oscillator is turned off by the use of a bent rotor plate on this condenser; it shorts the cathode to ground at full

capacity. This bent plate is shown at S_2 in the diagram.

The 6F6 audio stage is located midway between the b.f.o. transformer and the front panel. There are six controls along the front of the receiver below the chassis base. These are, from left to right, r.f. gain, crystal selectivity, crystal phasing, i.f. gain, "B" switch, and b.f.o. trimmer. Above the b.f.o. trimmer are the headphone jack and the noise limiter bias control. The bias control has a switch attached which disconnects the limiter when it is not needed. A switch on the i.f. gain control turns on the plate power supply. A separate transformer is used for the filament supply, thus allowing the filaments to be left running at all times. Letting the filaments run in this way does not shorten the tube life to any great extent and has the advantage of maintaining a nearly constant temperature in the oscillator shield can. If the filaments are turned off for several hours, about thirty minutes are required for the receiver to reach a stable operating temperature again.

Two shielded leads may be seen under the chassis. One of these is the mixer plate lead, while the other is the coupling lead from the mixer to the oscillator. Because of the arrangement of the parts in the mixer stage, the lead from the tube plate to the crystal filter input was necessarily quite long. It was therefore shielded by a piece of $\frac{1}{4}$ -inch copper tubing which is soldered to the chassis. The 6K8 is such a vigorous oscillator that it was found necessary to shield the lead to its "oscillator" grid to keep it from oscillating at the i.f. frequency. Another piece of $\frac{1}{4}$ -inch tubing serves as a shield here. The .05- μ fd. coupling condenser used between the oscillator and mixer is also helpful in reducing the tendency of the mixer to oscillate. It serves the

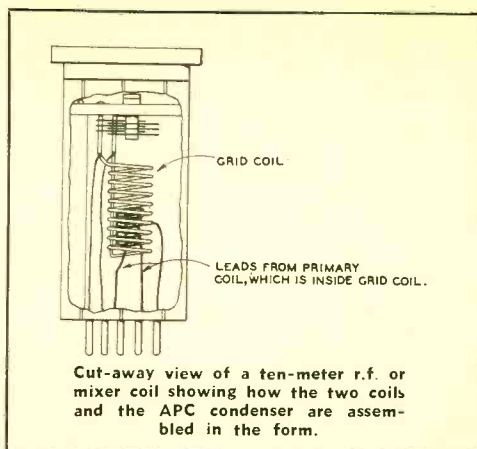

dual purpose of coupling the mixer and oscillator and by-passing the mixer "oscillator" grid to ground at the intermediate frequency.

Two short pieces of hookup wire (about $1\frac{1}{2}$ inches each) are twisted together to form the b.f.o.-to-detector coupling condenser. The coupling is adjusted by twisting enough of the wires together so that a "solid" beat is obtained on a moderately strong signal. Too much coupling will cause excessive hiss on extremely weak signals, while insufficient coupling will not allow a beat to be developed when receiving strong signals.

All the power connections terminate at a 6-prong socket at the rear of the chassis. Two of the wires in the cable leading from this socket carry the 110-volt primary voltage for the plate transformer primary. The other four wires carry the filament and plate supply voltage, of course. A power supply delivering 250 volts at 100 ma. and 6.3 volts at 4 amperes is used.

Here and There . . .

W1EGR and W5DZP both are named *Aubrey McKinney*.

Several months ago, A. F. Davis, R. E. Colvin and J. A. Houser, all Vermont hams, set up portable radio equipment powered by an old automobile engine at Shelburne Pass, Vt. 109 U. S. and Canadian stations were contacted in 26 hours to demonstrate how the city of Rutland might be kept in communication with the rest of the country in the event of a major disaster.

W1KEE is named *Radio* (hang that E —we thought we had something this time!)

When Howard Hughes landed at Floyd Bennett Field after doing an air-minded Jules Verne, resourceful New York at last found a use of acoustic feedback. With the wailing of police sirens, clanging of fire bells, screaming of whistles and the other things that constitute a Gotham welcome, the airport gang blended in the howls of the huge public address systems induced to feed back for the occasion.

An Improved U. H. F. RECEIVER

By
GROTE REBER,* W9GFZ
and
E. H. CONKLIN**

In RADIO for January, 1938,¹ we pointed out that high gain on very high frequencies can be obtained from r.f. stages using concentric lines as tuned circuits. The signal-to-noise ratio is much improved with this arrangement. Two receivers using plungers to tune the lines were discussed, and a number of suggestions were made for applying these lines to 2½- and 5-meter receivers, regardless of the type of detection used after the r.f. stages. A new receiver with lines of fixed length has been constructed and will be described here.

The original problem was to build a receiver for use on 155 Mc. (just below two meters which would be sensitive enough to get down to the noise level). The first job used push-pull RCA 956 acorn tubes and two-wire lines as couplers, but the length of power supply leads between stages was appreciable in terms of the wavelength, causing regeneration difficulties. The layout was abandoned. The second attempt used ordinary coils and u.h.f. trimmers, built into a hexagonal webbed shield. A stage gain of five was obtained, but this was not sufficient for the purpose.

Back to Concentric Lines

The third arrangement returned to concen-

* 212 West Seminary Ave., Wheaton, Ill.

** Associate Editor, RADIO.

¹ "High Frequency Receivers—Improving Their Performance," Reber and Conklin, RADIO, January, 1938, p. 112.

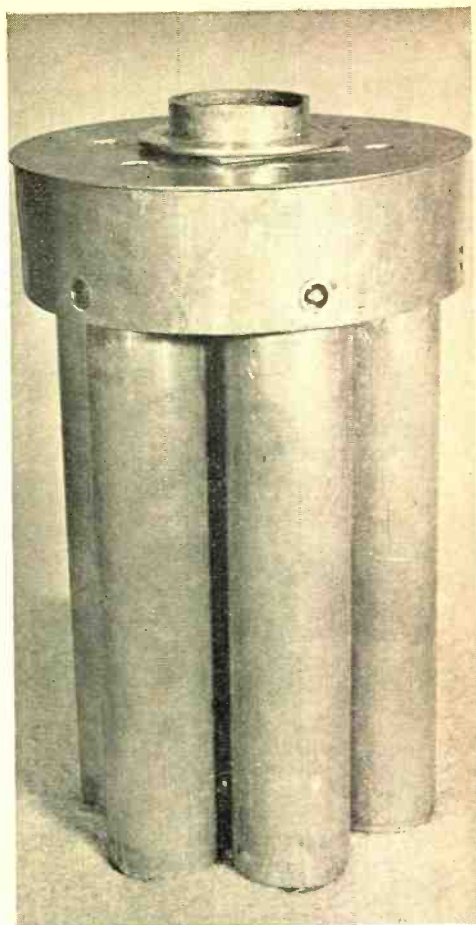

Figure 1. Multi-stage 155-Mc. receiver using RCA 956 acorn tubes in r.f. stages and 955 diode-connected in detector circuit. Note small test antenna extending from one stage.

tric lines as tuned circuits, adjusted at the tube end with small variables similar to neutralizing condensers. This gives a stage gain of twelve at 250 volts on the plates. The gain was measured at first by inserting a three-inch piece of wire through a hole in the shield, hooking it on the inner conductor of the resonant line. The comparative output of a diode detector was measured when the small antenna was moved from one stage to another. This had the disadvantage of body capacity variations and standing wave effects. The results were checked by feeding a signal into each stage, successively, through a small concentric line terminated in a light bulb which radiated enough energy into the shielded cavity for measurement purposes.

Gain vs. Noise

With an RCA 955, diode connected, as a

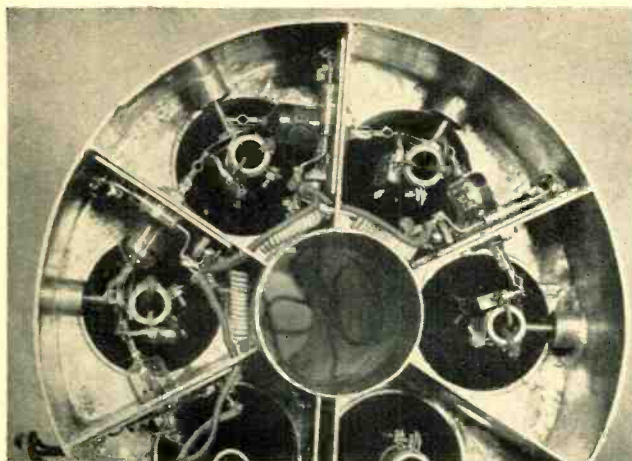
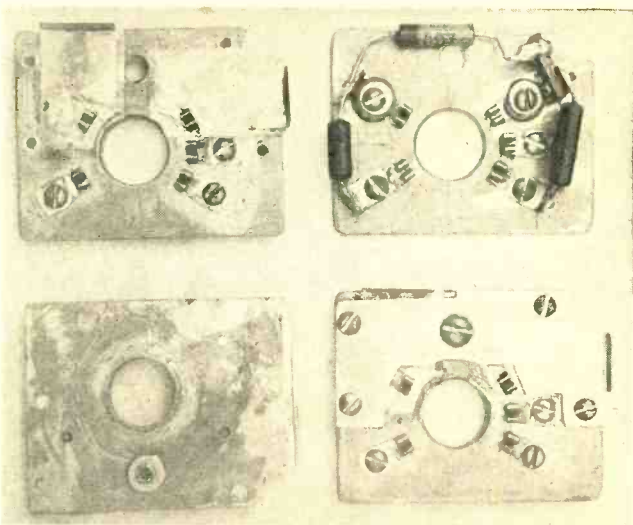

Figure 2. Under the cover of the 155-Mc. receiver, showing acorn tubes, tuning condensers, and the tops of the concentric-line couplers.

Figure 3. Socket construction. In upper right is the old form with insufficient by-pass capacity in the mounting clips. In lower right is newer design with larger by-pass capacity. The upper left-hand socket has its upper plate removed to show thin brass strip to which clips are soldered, and the insulating mica. In lower left, the bottom view shows, but the projecting circular tube shield is barely visible.



detector, plus some audio gain, there was no evidence of circuit noise in only one r.f. stage. When three stages were used, it was possible to demonstrate the amount of gain and the source of set noise by observing variations in the volume of this noise without a signal. The third stage increased the noise about 12 to 1 when everything was lined up but with no antenna. Tuning the first circuit through resonance caused the noise to change about 4 to 1, indicating that the set noise results from thermal agitation in the first tuned circuit rather than from the "shot effect" in the first tube. Removing the tube is necessary in order to reduce the noise to what it should be without this stage. This test demonstrated that an efficient tuned circuit in an r.f. stage

is necessary in order to obtain an improvement in signal-to-noise ratio at high frequencies; otherwise the r.f. tube may add as much noise as signal. Because the noise in the first tuned circuit predominates in the output, it appears that little more can be done to improve the r.f. end of this receiver.

Construction of the Receiver

This unit is pictured in figure 1. It retains the hexagonal shape of the original Dunmore receiver. It is designed to be operated at the focus of an outside parabolic antenna in all kinds of weather. Figure 2 shows the internal construction before the antenna coupling was inserted in the far end (bottom) of the center tube.

Each concentric line is only 1/16 wavelength, due partly to the loading effects of the acorn tubes with associated wiring, and to the desire to tune the circuits by adjusting a condenser rather than by sliding a shorting plunger inside of the lines. The outer conductor of each line is 9 1/2 inches long with an inside diameter of 1 7/8 inches; the inner conductor is 1 1/4 inches longer to give some room at the top to connect the acorn tubes and tuning condenser, and is 1/2 inch in outside diameter. A somewhat smaller inner conductor, down to 1/10 of the diameter of the outer one, presumably will not reduce the effectiveness of the unit.

Before the lines were assembled, the inner pipe of the first coupler was drilled and tapped for a 6-32 machine screw, one-third of the way up from the shorted end, for the antenna tap. A 1/4-inch hole through the outer conductor was also provided, through which a short piece of 1/4-inch glass tubing was inserted to insulate the antenna connection.

The bottom ends of the lines were closed with a copper plate, drilled so that plate and bias voltage leads could be brought down the inside of the inner conductor. These and other joints in the metal chassis were brazed or soldered at an automobile shop.

Sockets

Sockets of commercial manufacture can be used if two precautions are taken. First, additional by-pass condensers of extremely low reactance will be necessary if the sockets do not contain built-in mica by-passes of sufficient capacity. Second, the short grid end of the tubes will have to be shielded if stable

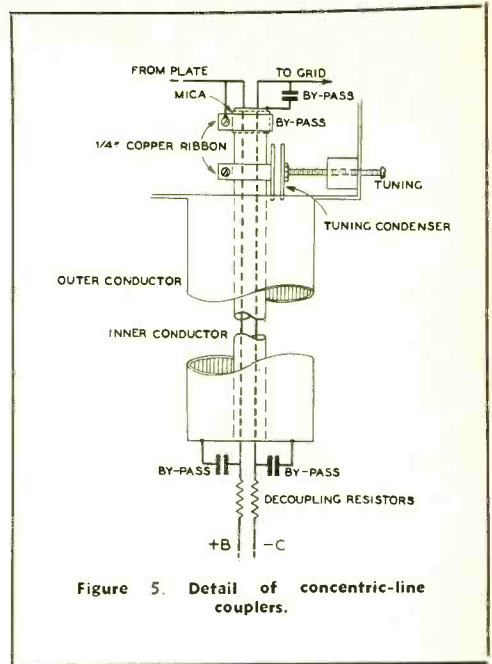

Figure 5. Detail of concentric-line couplers.

operation at high gain is to be attained. Copper tubing 1/4 inch long and 9/16 inch inside diameter was used in our homemade sockets.

The first sockets we constructed were built on a base of 1/16-inch copper plate measuring 1 3/4 by 2 1/4 inches. Mica was placed between the base and the screen and ungrounded heater mounting clips, supplied with the tubes. Washers and spaghetti insulation were necessary to make by-pass condensers out of the mounting clips. With care, sockets could be built without shorting the clips to the base plate. However, the by-pass capacity was not sufficient, and an additional condenser was required in each case.

A new design was found to be more simple and practical. The two clips to be insulated from the base were soldered to thin brass sheets 5/8 inch wide and 1 1/4 inches long. The base plate was covered with some sheets of mica on top of which the clips with their copper plates were placed. Next, another sheet of mica was put on over each of these plates and a large plate was fastened over the whole thing with a number of machine screws. The top plate had to be cut out for the various mounting clips. This design gave a much larger by-pass capacity, eliminating the need for the two extra by-pass condensers and the separate 75,000-ohm screen dropping resistors which also served as decoupling resistors. If all of the metal plates were polished to take

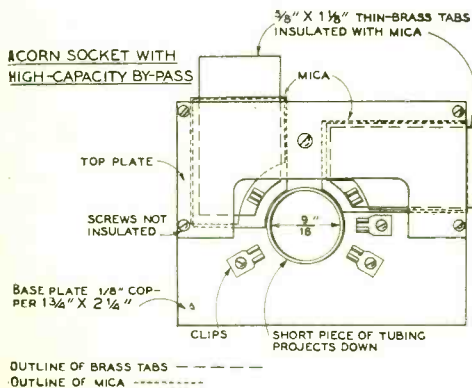

Figure 4. Schematic of acorn socket with high-capacity by-pass.

off burrs which might puncture the mica, no shorts developed. It was also possible to slide the insulated clips around, before the upper plate was screwed down, to adjust their position to fit the tube accurately.

Caution

The acorn tubes will take a lot of punishment, but it is well to be careful when putting them in sockets. In fact, we recommend trying out any new socket, grid or plate clip with a defunct tube. If the socket clips are not lined up properly, or if the clips are too tight, the glass chips away from the seal and air leaks into the tube.

By-passing

The construction of a 1.93-meter receiver with high r.f. gain certainly taught a few lessons in by-passing. At first we planned to use cathode bias, but it was next to impossible to by-pass the bias resistor when the earlier type of socket was used. A number of different types of condensers were tried, with best results from the very small molded type, having a capacity of only 50 $\mu\mu\text{fd}$. Apparently, the inductance in the average fixed condenser increases the reactance substantially. Silvered

mica condensers were not available for test at the time.

The effectiveness of by-passing was tested by touching a part, supposed to be at ground potential, with a screw driver when the receiver was in operation without an antenna, and with a test oscillator running. If the signal volume remained unchanged, it was assumed that the part was properly grounded for r.f.

The most important jobs of by-passing are at the screens and heaters. These are by-passed in the sockets but additional attention proved to be necessary in the first sockets used. The screen connected to a 75,000-ohm dropping resistor, the far end of which was again by-passed with 50 $\mu\mu\text{fd}$. Following this, a choke was inserted, consisting of twelve turns of no. 22 rubber covered wire closely wound on a 3/32-inch diameter. With the improved sockets, it was possible to eliminate the extra condenser, retaining only the chokes, making it practical to connect all the screens together and feed them with the proper voltage. Without the screen chokes, only two stages could be stabilized; it is relatively easy to make one or two stages operate but the difficulties compound with many stages and high gain.

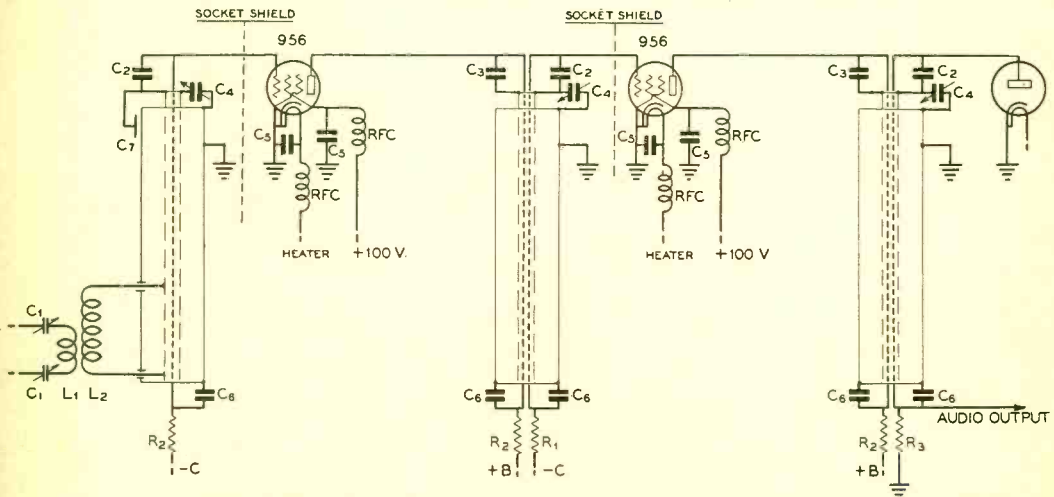

Figure 6. Schematic wiring diagram of receiver.

- C₁—Antenna trimmers
- C₂—0.0005- μfd . mica by-pass
- C₃—Built-in by-pass
- C₄—Tuning condensers; see text

- C₅—Socket by-pass condenser
- C₆—0.0025- μfd . mica by-pass
- C₇—Padder capacity to trim for antenna
- R₁—100,000-ohm de-

- coupling resistor
- R₂—6000-ohm decoupling resistor
- R₃—200,000-ohm diode-load resistor
- RFC—Small chokes; see text

- L₁—4 turns, 1/2" diameter
- L₂—8 turns, 5/8" diameter
- Diode detector—RCA-955 diode connected

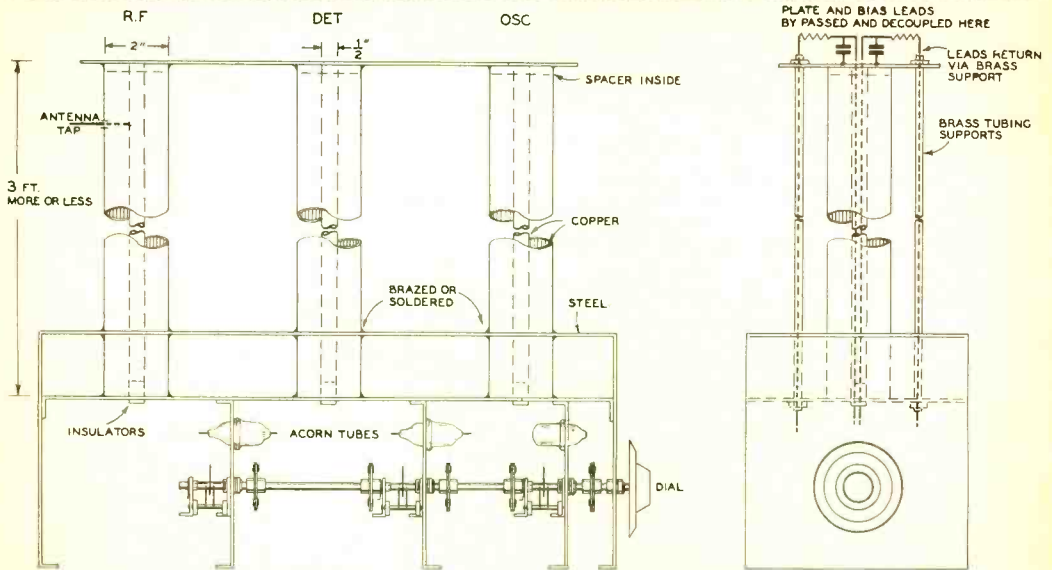

Figure 7. Working drawing of the concentric-line receiver

One side of the heater is connected to the cathode at the socket, the other being bypassed at the socket clip and fed through a choke consisting of fourteen turns of no. 18 d.c.c. wire wound on a $3/32$ -inch diameter, about $3/4$ inch long.

The remaining by-pass condensers require less care. Ordinary dual condensers are used at the closed end of the lines in order to ground the plate and bias leads as they emerge from the inner conductors. Decoupling resistors were used in series with these leads in order to isolate the stages.

We may have needlessly complicated the arrangement at the top of the inner conductors by mounting by-pass condensers here. Removing them later apparently made no difference but they did no harm, and in fact provided a means of anchoring the plate and bias supply leads rather than hanging them on the grid and plate clips on the tubes. The grid lead, carrying the bias voltage, is bypassed with a standard $50\text{-}\mu\text{mfd.}$ condenser. The plate lead is by-passed to the $1/4$ -inch-wide copper ribbon wrapped around the inner conductor, separated from it by $1\frac{1}{4}$ turns of five one-thousandths inch mica. Figure 5 shows the top of the concentric lines in detail.

Tuning Condensers

The fixed plate of the tuning condensers ($7/8$ inch round) was soldered to a piece of

the $1/4$ -inch copper ribbon twenty one-thousandths thick. This was wrapped around the inner pipe and fastened with a short 2-56 machine screw.

A $1/2$ -inch piece of $1/2$ -inch round brass rod, drilled and tapped for a 6-32 machine screw, was soldered to the side wall of the chassis opposite the center of the fixed plate. This much length is necessary to support the movable plate because the machine screw will wobble in a short thread. A 6-32 nut selected for having its threads square with the end was soldered to the center of the round movable condenser plate into which the bolt passing through the chassis wall and threaded rod is screwed. If the threads are not tight, solder can be put on them. Screw driver tuning with these condensers was satisfactory for our purposes but in a multi-stage receiver at 56 Mc., where continuous tuning over the band may be necessary, miniature variable condensers may be preferred. The necessary maximum capacity depends upon the length of the concentric lines in terms of wavelength. In the case of the first coupler, which does not have a tube's plate circuit hung on it, the condenser must be a few $\mu\text{mfd.}$ larger. If resonance does not occur at a convenient point on the tuning condenser, a copper strip can be fastened to the inner conductor of the line, placed so as to add a little additional capacity to the shield.

Copper tubing concentric line makes perhaps the best transmission line to the antenna,

being shielded from noise pickup. It is easily coupled into the receiver by hooking the inner conductor of the transmission line onto the inner conductor of the first tuned circuit at as low a point as gives satisfactory coupling.

However, most amateurs use a balanced two-wire line. On this receiver, the two-wire line is terminated in two small postage-stamp 3-30- μ fd. trimming condensers, one in series with each wire, and in a coil of four turns of no. 14 antenna wire wound on a $\frac{1}{2}$ -inch diameter, with the turns spaced one half of the wire diameter. This coil is loosely coupled to an eight-turn coil similarly wound but on a $\frac{5}{8}$ -inch diameter. One end of this secondary is grounded, though in our receiver it is run into the antenna coupler and connected to the base of the inner pipe, while the other end is connected to the inner conductor of the first tuning unit through the hole provided for that purpose, located $\frac{1}{3}$ of the way up from the shorted end of the tuner. Very likely, the tap can be $\frac{1}{4}$ or $\frac{1}{5}$ of the way up, inasmuch as less impedance in the secondary coil will then be required to match the tuner impedance at the tap point. So far, we have not noticed any excessive unbalance in the antenna resulting from this balanced-to-unbalanced antenna coupler, and no attempt has been made to split either coil into two units, or to use a Faraday screen.

Wiring

There is but little wiring to do in r.f. stages of this type, as will be seen in the circuit diagram, figure 6, and the photograph of the inside of the receiver, figure 2. The job is mainly one of construction. After the few connections are made, the acorn tubes can be placed in their sockets and the voltage and current to each element checked. We found that a bias of $-4\frac{1}{2}$ volts is necessary for operation close to the published characteristics. The readings are as follows:

Plate voltage250	volts
Plate current 6	ma.
Screen voltage100	volts
Screen current 1.8	ma.
Grid bias -4.5	volts
Heater voltage 6.3	volts
Tune gain, 155 Mc.	.. 12	

Adjustment

The initial adjustment can be made using the last stage as a detector by increasing its bias or inserting a grid leak and condenser. The output of a local test oscillator (modu-

lated) can be picked up on a few inches of wire protruding from the shielding, and clipped to the inner tubing of the last concentric line coupler. The tuning capacity on this coupler can be adjusted for resonance. At 155 Mc., with the condensers already described, resonance occurs with the plates separated about $\frac{1}{8}$ inch. Practically the whole peak is in a third of a turn on the 6-32 machine screw, indicating a plate movement of about $\frac{1}{100}$ inch. When the small test antenna is removed to the stage ahead, the coupler must be retuned slightly. The output is considerably higher when the second coupler is brought into resonance.

Antenna Adjustment

When the antenna is matched to the first tuned circuit of the receiver, the effective impedance of the first circuit is halved. Accordingly, to determine the proper antenna coupling, we first tuned the antenna series condensers, and then adjusted the coupling until the *set* noise (with no appreciable outside noise) dropped to one half its original value. With this amount of coupling, the first circuit still tunes about as sharply as before. With excessive coupling there is no point of resonance at all and the gain of the first stage falls off, because the antenna impedance then effectively short-circuits the grid of the first tube.

Detection

For the measurement job we had in mind, a diode detector plus audio amplification was decided upon. However, superregeneration, ordinary triode or pentode detectors, or a converter arrangement can be used. With a given number of acorn tubes available for a superheterodyne, there is some question as to the choice on 56 Mc. between using one more r.f. stage and a 6L7 or a 6K8 converter, or using an acorn tube as the mixer. The oscillator tank can be a coil and condenser arrangement, or one of the concentric lines can be used here too. The superheterodyne circuit has an advantage in signal-to-noise ratio in that a narrow-band i.f. amplifier will further reduce the noise in the output, just as a properly operated crystal reduces the noise in the ordinary communications receiver.

Five-Meter Design

At 56 Mc., many of the precautions taken at 155 Mc. may be unnecessary, such as placing the tubes in a circular layout, r.f. choke

[Continued on Page 177]

A Simple 56-Mc.

TRANSMITTER-EXCITER

By JACK ROTHMAN,* W6KFQ

Stable 56-Mc. signals are no longer a matter of courtesy; the new regulations make them mandatory. This simple 56-Mc. crystal-controlled exciter or transmitter has no critical or "trick" circuits and delivers 20 watts output. If desired the final stage can be modulated for phone.

Now that the much discussed and often prophesied "high stability" regulation has been applied to the five-meter band, some simple crystal-controlled u.h.f. rigs are in order. While the new regulations which went into effect on December 1 do not specifically call for crystal control, they are so worded as to make crystal practically a requirement for operation on the ultra highs. The regulations simply extend the frequency range of the present rules 381 and 382, which are so worded as to outlaw unstable, frequency-modulated and broad signals. The effect of these two rules has been to make crystal control practically

* Laboratorian, RADIO.

universal on the 28-Mc. and lower frequency bands and we may now look forward to seeing all the beneficial operating and technical practices which have been developed on the lower frequency bands applied to 56 Mc.

We may also hope to see a new type of 56-Mc. station—one whose operator is anxious to consolidate the recent ultra-high frequency developments and push forward toward that day when we shall have a complete understanding of the vagaries of this as yet undeveloped portion of the radio spectrum.

The transmitter-exciter to be described was designed with the intention of seeing just what could be done toward simplifying the 56-Mc.

This compact 56-Mc. crystal-controlled unit delivers 15 to 20 watts. A 42 oscillator on 7 Mc. drives a 6L6G quadrupler, which in turn drives a T21 doubler on 56 Mc.

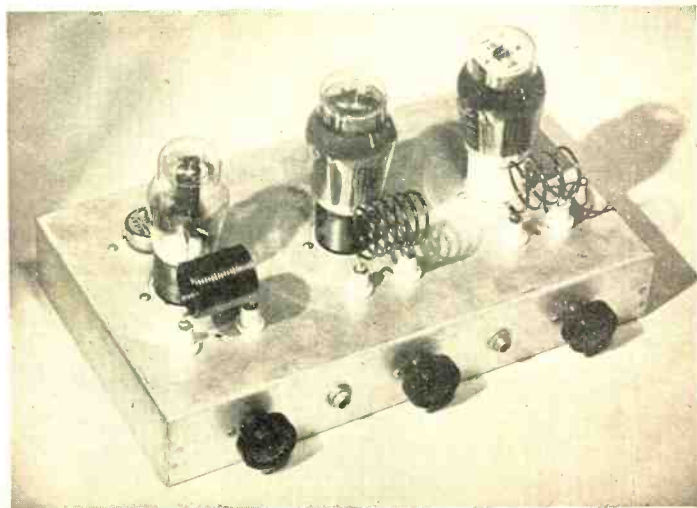

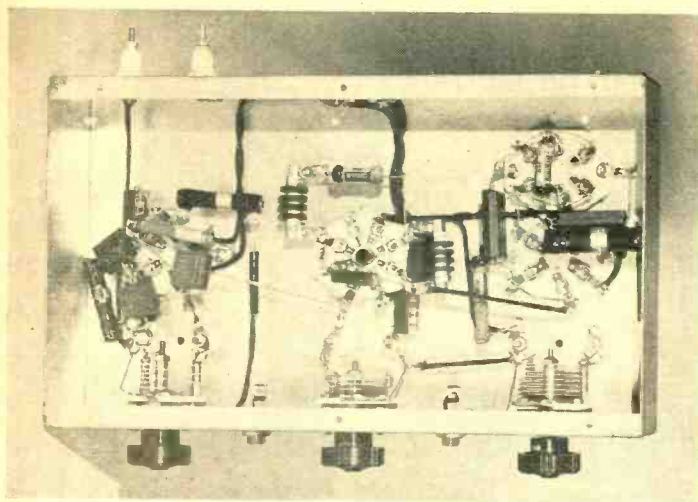

Underneath the chassis of the 56-Mc. r.f. unit. Note how relatively few components are used for the three stages.

crystal-control problem. It uses conventional circuits and low cost parts. With but three stages and a 7-Mc. crystal, it supplies 20 husky watts of crystal controlled, 56-Mc. r.f. For high quality phone operation the output stage may be modulated by the low cost, 25-watt modulator described elsewhere in this issue, or keyed for c.w. As an exciter it has sufficient output to drive a high power 56-Mc. final stage.

Experience has shown that equal if not better results can usually be obtained from a simple pentode crystal oscillator with its plate circuit operating on the crystal fundamental followed by an efficient quadrupler that can be realized through the use of a crystal oscillator which doubles in its plate circuit followed by a doubler. A 42 pentode oscillator is therefore used in this unit. It is an uncontested fact that a straight pentode oscillator running with low screen voltage such as this operates with considerably lower crystal current than does any other type of oscillator. The oscillator, when operated in this manner with 550 volts on the plate (some of which is lost in the cathode resistor, R_2) is ideally suited to drive the high-efficiency 6L6G quadrupler which follows.

The Quadrupler

A 6L6G with the two grids tied together, and thus operated as a μ triode, serves as an efficient quadrupler. The 6L6G is capacity coupled to the plate of the oscillator through C_3 , a 100- μ fd. mica condenser. This stage is biased by a 30,000-ohm $\frac{1}{2}$ -watt carbon resistor in the grid return. The combination of an r.f. choke and small mica condenser in the cathode circuit permits the stage to quadruple

with an efficiency approaching that of the average doubler. All of the ground return connections are brought to a single ground point on the isolantite tube socket. With the grids of the 6L6G tied together, the amplification factor is high enough so that the plate current drops to a safe value when the excitation is removed. The cathode biasing method used on the other two stages was therefore omitted on this stage and the full 550 volts applied between plate and cathode. When tuned to resonance, the plate current to the 6L6G is approximately 40 milliamperes.

The T21 Power Doubler

The ten-meter output from the quadrupler stage is fed directly from the 6L6G plate to the T21 grid through a .001- μ fd. mica coupling condenser. This would seem to be a rather large coupling condenser between these tubes, especially at this high frequency. Several values of coupling condensers were tried, however, and, while the capacity was not found to be especially critical, .001 μ fd. gave optimum results.

A T21 is employed as a doubler to 56 Mc. The T21 is a glorified version of the familiar 6L6G. It has a six-pin isolantite base which makes it admirably suited to operation at ultra-high frequencies. Bias on this stage is obtained from two sources. Grid leak bias is provided by a 150,000-ohm resistor, R_4 , in the grid return circuit. No r.f. choke is needed as the carbon resistor is as effective as most chokes at this frequency. The tube is also biased by the use of a cathode resistor, R_5 . The cathode is by-passed to ground by a .002- μ fd. mica condenser. A closed-circuit jack in the cathode circuit is provided for reading the

total cathode current to the T21. This jack may also be used for keying the unit in the output stage.

A series resistor supplying the screen voltage allows simultaneous plate and screen modulation of the T21. The screen, instead of being by-passed directly to ground, is by-passed back to the positive end of the plate tank coil. As the positive end of the coil is by-passed to ground by C_{11} , the net result of this method of connection is that the screen is by-passed to ground by two condensers (C_{10} and C_{11}) in series. The screen is grounded in this round-about manner to obviate a condition which is peculiar to plate-and-screen modulated tetrodes. This condition takes the form of a dropping off of modulation at high audio frequencies and is due to the fact that the screen by-pass condenser, when connected directly from screen to ground, not only grounds the screen for r.f. but by-passes the higher audio frequencies to ground.

Since the screen circuit of a beam tetrode is a rather high impedance circuit, the reactance of even a small condenser from screen to ground can be enough less than the screen impedance to cause a considerable loss of the higher audio frequencies. In some cases this effect can be so great as to cause downward modulation at high audio frequencies on a stage which modulates upward at low frequencies.

Coil Data

All coils are 1 inch in diameter and 1½ inches long. The oscillator coil has 20 turns of no. 16 enameled wire. The coils in the quadrupler and output stages are both wound with no. 14 enameled wire, the former having 6 turns while the latter has 4 turns.

Mechanical Details

There is little to be said concerning the mechanical details of the transmitter-exciter. The chassis measures 12 x 7 x 2 inches. As can be seen from the photographs, the tubes are evenly spaced along the center of the chassis. Each plate coil is directly in front of the tube with which it operates. The tank condensers are mounted on the front lip of the chassis directly below their respective coils. Small feed-through insulators are used to support the coils and at the same time to provide connections to the condensers. The coils are soldered directly to the rods through the insulators.

Inasmuch as each tuned circuit is on a different frequency, placing the coils in line along the front of the chassis does not have any adverse effect on the operation of the unit.

Underneath the chassis, parts are placed

[Continued on Page 178]

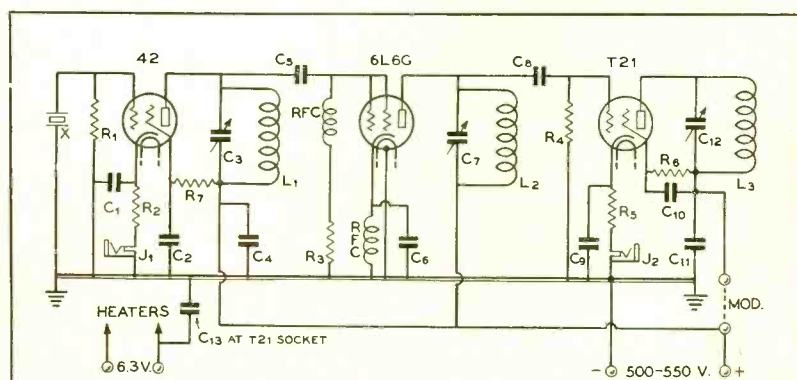

General wiring diagram of the 56-mc. r.f. unit.

- | | | |
|---------------------------------|---|---------------------------------|
| C_1, C_2 —.01- μ fd. mica | C_5 —.001- μ fd. mica | R_2 —400 ohms, 10 watt |
| C_3 —50- μ fd. midget | C_6 —.002- μ fd. mica | R_3 —25,000 ohms, ½ watt |
| C_4 —.005- μ fd. mica | C_{10}, C_{11} —.001- μ fd. mica | R_4 —150,000 ohms, 1 watt |
| C_7 —100- μ fd. mica | C_{12} —15- μ fd. midget,
doubled spaced | R_5 —600 ohms, 10 watt |
| C_8 —50- μ fd. mica | C_{13} —.001- μ fd. mica | R_6 —30,000 ohms, 10 watt |
| C_9 —15- μ fd. midget | R_1 —25,000 ohms, ½ watt | R_7 —100,000 ohms, 1 watt |
| | | RFC —2.5-mh. r.f. chokes |
| | | J_1, J_2 —Closed-circuit jack |



Inexpensive

DX

By EMILE MILLES*

This amateur station was constructed with not just one eye but both eyes on the pocketbook. The receiver illustrated in this photo was built for \$15 by resorting to old b.c.l. chassis (1929 vintage, 50c each) for many of the components. It is an a.c.-d.c. super-heterodyne and works surprisingly well.

A regenerative detector and one stage of audio cannot be beaten for sensitivity, and if you are a thousand miles from the nearest ham, a two tuber can deliver a surprising number of distant stations. Foreigners make their WAC with flea power transmitters and blooper receivers.

The American amateur must have something different, a receiver which will reject strong local signals close to the frequency to which he is listening. Because of conditions we must almost of necessity have a super-heterodyne.

Building such a receiver can be extremely expensive, if one judges by some of the super, super, de luxe models described in current periodicals.

One of the local amateurs, a student, wanted to get on the air. By considerable conniving he raised a grand total of \$30.00, which had to cover receiver, transmitter and accessories. But after a glance at a few catalogs, our hero was quite dejected.

After a long session of head scratching we arrived at a \$15.00 receiver and a \$15.00 transmitter. Since the receiver is the subject of this article, we'll save the transmitter for some other time.

A glance at the schematic will show the receiver to be an a.c.-d.c.-powered affair. This system was chosen for many reasons. The voltage regulation of such a supply is quite good. An a.c.-d.c.-powered signal generator used by the writer is remarkably stable. This is of real importance in a receiver to be used on ten meters, since the oscillator stability is a weakness of the usual receiver at this frequency.

The High Frequency Oscillator

After months of experimenting we found the electron coupled oscillator to be a source of a.c. hum at the high frequencies because of varying amounts of leakage between the cathode and heater. A change to the tickler circuit for the oscillator made it possible to get rid of seventy-five per cent of the hum in several experimental models.

The injection voltage is taken from the tickler rather than from a tap on the grid coil, to eliminate the last trace of pulling between the oscillator and the regenerative first detector. There is no variation in the signal except a normal attenuation (no change in pitch) when the detector is detuned from the signal.

All by-passes must be from the socket pins to a common ground. The by-passes from the bandspread condenser rotor should be suspended from the rotor contact direct to the common ground point to eliminate tuning noises. The band-set condenser is not critical, and the contact made by mounting on the metal panel has no disadvantages.

Mixer

We tried the new combination detector-oscillator tubes 6K3 and 6J8G. The 6L7-6J5 combination offered better frequency stability and a perfectly smooth control of regeneration.

The 6L7 uses a tickler coil for regeneration for the reasons previously described. We have definitely proved to our satisfaction that a well-designed regenerative first detector, loose-

* 1650 West 36th St., Los Angeles, Calif.

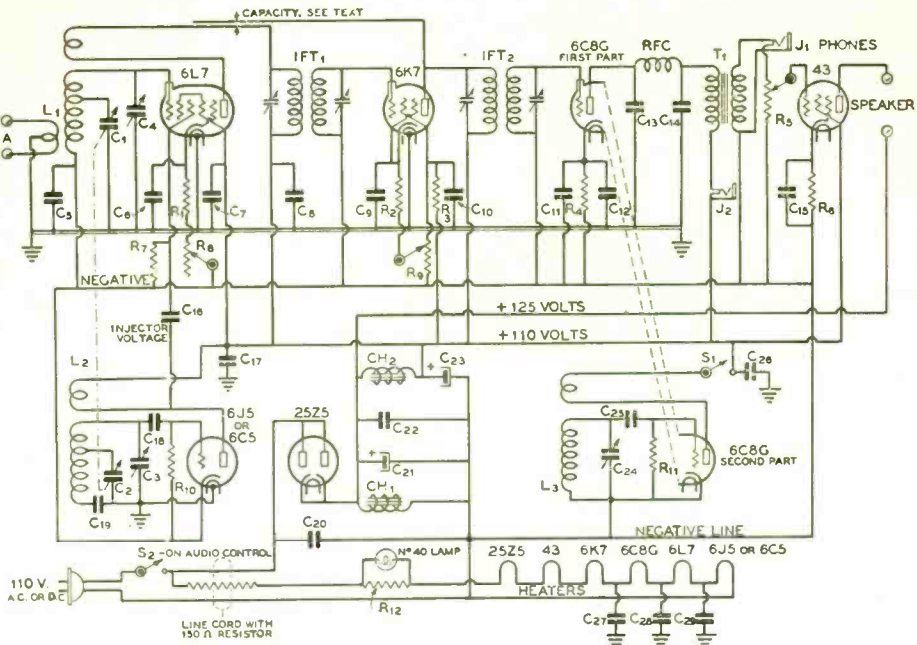

Wiring diagram of the inexpensive a.c.-d.c. superhet.

- C₁, C₂—15- μ fd. midget variable
- C₃, C₄—140- μ fd. midget variable
- C₅, C₆, C₇—.01- μ fd. tubular
- C₈, C₉, C₁₀—.05- μ fd. tubular
- C₁₁—10- μ fd. 25 v. electrolytic
- C₁₂—.05- μ fd. tubular
- C₁₃, C₁₄—.00025- μ fd. mica
- C₁₅—10- μ fd. 25 v. electrolytic
- C₁₆—.0001- μ fd. mica

- C₁₇—0.01- μ fd. tubular
- C₁₈—0.0001- μ fd. mica
- C₁₉—0.01- μ fd. tubular
- C₂₀—0.05- μ fd. tubular
- C₂₁—20- μ fd. 150 v. electrolytic
- C₂₂—0.05- μ fd. tubular
- C₂₃—20- μ fd. 200 v. electrolytic
- C₂₄—B.f.o. trimmer
- C₂₅—0.0001- μ fd. mica
- C₂₆—0.05- μ fd. tubular
- C₂₇, C₂₈, C₂₉—0.05- μ fd. tubular
- R₁, R₂—300 ohms, 1 watt

- R₃—5000 ohms, 1 watt
- R₄—50,000 ohms, 1 watt
- R₅—1-meg. tapered pot
- R₆—500 ohms, 2 watts
- R₇—50,000 ohms, 1 watt
- R₈—1000 ohms, 1 watt
- R₉—25,000-ohm pot
- R₁₀—50,000 ohms, 1 watt carbon
- R₁₁—50,000 ohms, 1 watt carbon
- R₁₂—40 ohms, 10 watts
- L₁, L₂, L₃—See coil table

- IFT₁, IFT₂—B.c.i. coils (see text)
- RFC—20-mh. r.f. choke
- J₁—Phone jack
- J₂—Meter jack
- T₁—Interstage a.f. trans from old b.c.i. set
- CH₁—2500- or 3000-ohm speaker field if dynamic speaker is used
- CH₂—20-hy. 30-ma. choke

ly coupled to the antenna, will be more sensitive and more selective than the average stage of r.f. feeding into a nonregenerative detector at ten meters.

The sockets for the 6L7 and 6J5 should be of the thin, bakelite wafer type, of ceramic material, or of one of the new transparent thermoplastics. A popular molded socket caused a loss of several R's in one set. We afterwards found that the d.c. resistance between adjacent contacts averaged about 30 megohms. Some "bakelite"!!

I. F. Amplifier

The i.f. transformers are b.c.i. coils taken from a t.r.f. radio chassis, vintage of 1929,

purchased for fifty cents. The dial, choke, some by-passes, audio transformers and lots of small parts were obtained from this same source.

Trimmers were mounted in the coils to peak the i.f.'s at about 1560 kc. As indicated in the diagram, the i.f. stage is made regenerative by a piece of wire soldered to the plate of the 6K7 tube about four inches long, and placed in a position near the 6L7 plate so that the 6K7 just barely oscillates with the cathode resistor at full gain. When accurately peaked the gain is almost as high as the usual 456-kc. amplifier. Regeneration is utilized only to increase selectivity. This control is smooth, if the by-passing has been well done.

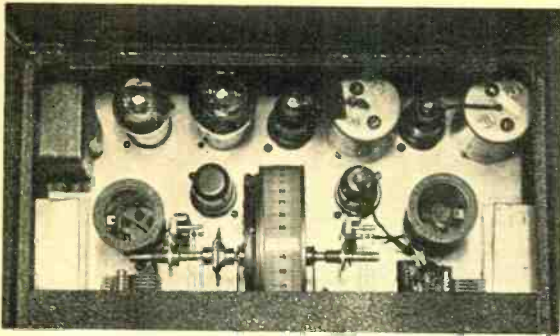

Looking down into the a.c.-d.c. superhet cabinet, showing layout of parts.

Second Detector

The bias detector proved itself to be more effective at this frequency than leak detection. The change from leak to bias detection resulted in improved selectivity.

The extra jack on the panel makes alignment easy. Because of the many high-fidelity broadcast stations and police stations near 1550 kc., care should be taken to choose an intermediate frequency which is in the clear.

The beat oscillator coil is a midget b.c.l. coil placed under the chassis, and is tuned by a trimmer. No coupling arrangement was found necessary, since the capacity in the wiring and tube gave a good solid beat note.

The audio transformer is also under the chassis deck. Resistance coupling would give better fidelity for music with a slight loss in gain. Incidentally, the chassis deck is just a sheet of auto body steel mounted to the panel with angles.

All wires carrying a.c. must be kept close down on the chassis deck and away from r.f. and i.f. leads and components, and also audio wiring. The by-passes to the filaments are necessary to eliminate the last trace of a.c. hum and instability. The filament sequence shown is the arrangement least productive of hum.

Insulated couplings between the dial and the bandspread condensers were found to be a necessity to eliminate the noises and erratic tuning caused by the variable ground loop through the dial bearing.

COIL TABLE

Band	Detector		Oscillator	
	grid	plate	grid	plate
10	no. 20 3 1/2 turns	no. 28 3 turns	no. 20 3 turns	no. 28 3 turns
20	no. 20 7 1/2 turns	no. 28 5 turns	no. 20 6 1/2 turns	no. 28 5 turns
40	no. 20 17 turns	no. 28 8 turns	no. 20 14 turns	no. 28 8 turns
80	no. 20 36 turns	no. 28 12 turns	no. 20 30 turns	no. 28 12 turns
160	no. 28 70 turns	no. 28 20 turns	no. 28 58 turns	no. 28 20 turns

1 1/2" dia. forms, 6 prongs. Coil windings have spacing adjusted for best tracking. Ticklers close wound at bottom of grid coil (ground end).

The general assembly of the receiver is relatively simple, but superlative performance requires careful attention to small details.

Considerable ingenuity must be used to meet the \$15.00 figure. The tubes, variable condensers, and cabinet cost just over \$9.00, leaving \$6.00 for the balance of the parts. Some of the older tuned radio frequency re-

[Continued on Page 177]

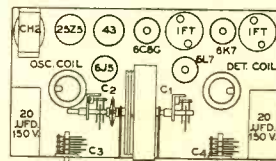
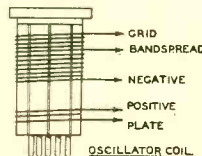
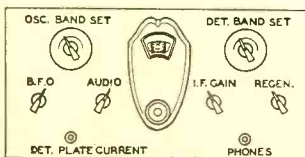

Showing chassis and front panel layout. Oscillator coil connections are shown in the pictorial sketch of the coil.

COMMUNICATIONS RECEIVERS

• for 1939

In accordance with the custom previously followed in the yearbook numbers of RADIO, we are running descriptions of several of the more popular communications receivers especially suited for amateur use. The particular models described are typical for the models offered for 1939, and are listed in alphabetical order.

HALLICRAFTERS MODEL SX17

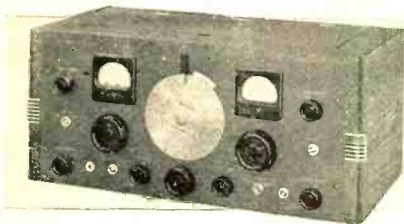

One of the most popular receivers of the comprehensive Hallicrafters line is the Special Super Skyrider SX17. This model was first built on special order, but it proved so popular that it was incorporated into the standard line.

Essentially, the SX17 is an improved model of the reliable SX16. It incorporates two stages of preselection as compared to the single stage in the SX16, and has a Dickert-type noise silencer to improve further the u.h.f. operation of the set. A total of 12 tubes is used in the newer receiver.

The receiver covers a range of 545 kc. to 62 Mc. in six frequency bands. All bands are directly calibrated and are tuned without the aid of charts or tables. A chrome plated pointer, operated by the bandswitch, moves up and down the dial to indicate which coils are in use. Through the use of variable-selectivity iron-core i.f. transformers and a crystal filter, a wide range of operating selectivity is obtained. The bandwidth can be varied, with 100 times resonant input, over a range of 30 to 1; the width is continuously variable from less than one kc. with the crystal at maximum selectivity to approximately 25.5 kc. with the control in the most broad position.

The bandspread system employed in the SX17 is unique in design and very smooth in

operation. The bandspread condenser is an integral part of the specially built tuning condenser, thus eliminating many of the losses in additional wiring and additional insulation on the second condenser. Over 1000° of bandspread on an unusual spiral dial give approximately 2 kc. per division on 14 Mc. and about 25 kc. for a complete rotation of the control knob. Large controls and an inertia tuning mechanism make the receiver quite smooth and easy to operate.

THE HALLICRAFTERS SKY CHAMPION



The Hallicrafters Sky Champion, S-20, is an 8-tube, a.c. operated, communications receiver employing one stage of preselection and having a built-in speaker. It covers the range from 545 kc. to 44 Mc. in four wavebands: 545 to 1800 kc., 1700 to 5800 kc., 5.8 to 18 Mc., and 17 to 44 Mc.

The receiver incorporates a large number of the design features commonly found only in the more expensive types of receivers. The bandspread system employs a separate tuning dial with an inertia tuning mechanism. Individual coils, not tapped ones for the h.f. bands, are employed on all bands. A pair of terminals are brought out for use with an R meter in case it is desired later to add this feature.

HOWARD MODEL 440

The Howard Model 440 is a 9-tube band-switching super covering a range of from 540 kc. to 40 Mc. in five bands.

In the Model 440, as in other Howard receivers, the r.f., mixer, and oscillator coils are wound on ceramic forms and trimmed by air-dielectric condensers. This type of construction allows accurate logging of stations since the inductance of the coils is not influenced by age or temperature.

There are, besides the usual second detector, beat oscillator, audio, and R meter amplifier stages, a stage of r.f. using a 6K7, a 6K8G combined oscillator and mixer, and two 6K7 i.f. stages. The audio output stage uses a single 6V6G, which provides 4½ watts of output. An 80 tube is used in the self-contained power supply.

A separate dial, coupled to a separate condenser, is provided for bandspread tuning. As with the Model 450-A, the amount of bandspread may be doubled, if desired, by removing one plate from each rotor of the three-gang bandspread condenser.

HOWARD MODEL 450-A

The Howard Model 450-A is a 12-tube receiver designed primarily for use on the short-wave bands. It covers a frequency range of from 540 kc. to 65 Mc. in six bands which may be selected at will by means of a switch.

This receiver is unique in that it overcomes the i.f. amplifier frequency problem which has been troubling receiver manufacturers since the 28- and 56-Mc. bands became popular. Two separate intermediate channels are provided; one at 465 kc., and the other at 1560 kc. The 1560 kc. i.f. gives the high signal-image ratio needed on the 28- and 56-Mc. bands, while the 465 kc. i.f. is provided with a crystal filter to allow a high degree of selectivity on the 14-Mc. and lower frequency



The Howard 440

ranges. Two switches on the front panel accomplish the frequency change by shifting the frequency of both the i.f. amplifier and the beat oscillator.

The receiver's complement of 12 tubes is apportioned as follows: 6K7, r.f. amplifier; 6L7, mixer; 6J5G, oscillator; two 6K7's, i.f. amplifiers; 6Q7G, second detector, a.v.c. and first audio; 6J7G, beat oscillator; 6J5G, phase inverter; 6J7G vacuum tube voltmeter (for R meter); two 6V6G's, push-pull audio; and 80 rectifier.

Aside from the i.f. amplifier switches previously mentioned and the main and bandspread tuning controls, controls on the front panel are provided for band change, audio gain, r.f. gain, tone, crystal phasing, selectivity, a.v.c. switch, send-receive switch, R-meter zero adjustment, beat oscillator pitch, and beat oscillator switch and injection control. A headphone jack is also on the front panel.

Bandspread is both electrical and mechanical. A separate three-gang bandspread condenser is connected to a dial which has a large pointer covering a 1000-division semicircular scale and a small "second hand" interpolation pointer reading on a 100-division circular scale.

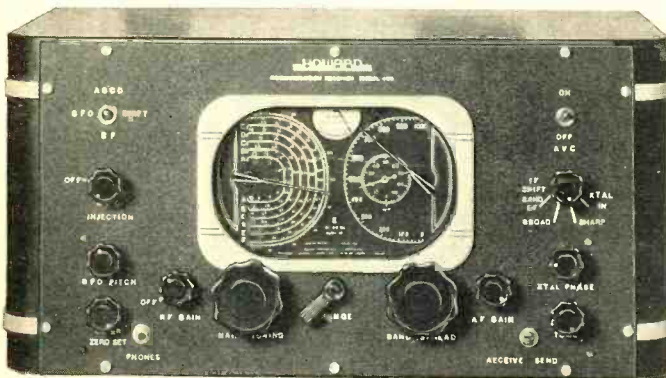

The Howard Model
450-A

THE RCA ACR-111



The ACR-111 is a single-signal super-heterodyne with two stages of r.f. ahead of the first detector on all frequency bands. A total of 16 tubes is employed throughout the receiver in the following electrical positions: the two r.f. stages, 6K7's; first detector, 6J7; high-frequency oscillator, 6J7; the two intermediate frequency stages, 6K7's; second detector, 6H6; a.v.c. rectifier and amplifier, 6R7; noise silencer, 6J7; the two audio amplifier stages, 6C5's; beat oscillator, 6J7 tuning and signal strength indicator, 6F5; push-pull output stage, 6F6's; and power supply rectifier, 5Z3. All tubes are of the metal type except the 6E5 tuning tube and the 5Z3 rectifier.

The receiver covers the range from 540 kc. to 32 Mc. in five wavebands. A constant-percentage electrical bandspread system is employed on all frequency ranges except the one covering the broadcast band, 540 to 1600 kc. The main-tuning and bandspread-tuning capacitors are arranged in a series-parallel circuit which avoids high minimum and maximum capacity effects. Greater uniformity of tuning throughout each bandspread range is thus obtained.

A balanced-link circuit is used to couple the first-detector plate to the first i.f. amplifier grid circuit. A 460-kc. crystal is connected in one arm of the link circuit and a phasing capacitor, which is front-panel controlled, is connected in the other. The impedances of the coils in this link circuit are designed so that the crystal-selectivity characteristic is not impractically sharp.

The i.f. amplifier is a two-stage transformer-coupled circuit in which the windings on all three transformers are resonated by molded mica capacitors. The transformers are peaked by means of adjustable magnetite cores. This arrangement gives unusual freedom from frequency shift of the i.f. amplifier due to atmospheric changes.

An unusual feature of the receiver, aside from its excellent electrical and mechanical layout, is the fact that two different types of

noise silencing are continually available. The noise limiter circuit consists of the second diode of the 6H6 second detector and an associated circuit to control automatically the bias on the detector. This silencer is particularly effective on excessive signal strengths or bursts of static.

The other circuit, the noise suppressor, consists of a 6J7 whose plate circuit effectively shunts the input circuit of the audio driver stage, and a means of making the shunting plate impedance very high for desired signals and very low for undesired noise impulses. The noise suppressor is particularly effective in reducing the interfering noises caused by dial telephones, automobile ignition, and similar recurrent staccato types of interference.

RME-70

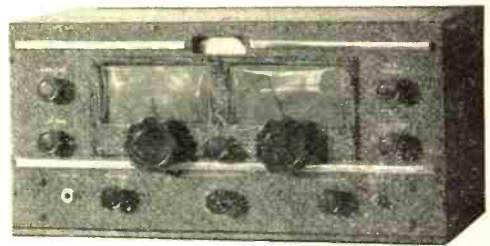

The Radio Manufacturing Engineers RME-70 is a new receiver designed along the lines of the now famous RME-69. Although it is somewhat lower in cost than the '69 it has a number of new features.

The signal-strength indicating meter is larger than the previous type and is illuminated; an efficient noise silencing system is incorporated at no extra cost; the break-in relay circuit is standard; crystal filter is standard; and the audio characteristics have been improved.

The new receiver is similar in external appearance to the RME-69 except that horizontal chromed bars have been added above and below the two tuning dials. The other RME accessory units, the DB-20 preselector and the 510X frequency expander may be had in the same style cabinets as the '70. The receiver comes standard with its complement of 11 tubes and with an 8-inch dynamic speaker mounted in a separate cabinet.

One outstanding fact concerning the RME-70 is the fact that it is a one-model one-type set; no variations upon its design or control arrangements are possible as in the RME-69. It was necessary to make the receiver a fixed

type with no optional alterations to produce it for the comparatively low price which it now carries.

RME 510X FREQUENCY EXPANDER

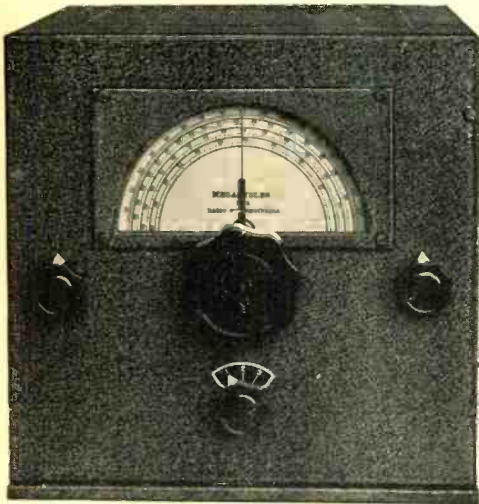

The RME 510X Frequency Expander is essentially a well-designed u.h.f. converter designed to extend the operating range of any good communications superheterodyne. It covers from 27.8 to 70 Mc. in three wavebands. The unit incorporates a self-contained power supply and has antenna provisions for either long single-wire antennas or doublet input.

The converter itself employs four tubes: a 6K7 r.f. preselector stage, a 6L7 converter, a 6C5 high-frequency oscillator, and an 80 as power supply rectifier. The 6L7 mixer operates into a tuned transformer with a low-impedance secondary winding. The characteristic impedance of this secondary winding, and hence of the link which carries the energy from the expander to the input of the main receiver, is 300 ohms. This is a value particularly suited to match the input impedance of the RME-69 receiver, although it will very closely match the input on the majority of the high-quality superheterodynes now on the market.

The sensitivity of the expander on its operating frequency will be of the same order as that of the receiver into which it is operating. When working into an RME-69 the sensitivity is approximately 1 microvolt over the operating range. The selectivity, of course, will be the same as that of the receiver. Image frequency ratios are quite high considering the high operating frequency: 750 to 1 at 60 Mc., 2750 to 1 at 45 Mc., and 10,000 to 1 at 39 Mc.

The dial is fully calibrated and gives good bandspread over all the tuning ranges.

SARGENT STREAMLINER '39



The Sargent Streamliner '39 is a 5-tube communication-type receiver covering 540 to 32,000 kc. in four bands. A large illuminated dial and high-ratio dial drive allow adequate bandspread.

Tube lineup is 6K8, mixer and oscillator; 6F7, combined i.f. amplifier and beat oscillator; 75, second detector, a.v.c., and first audio; 42, audio output stage; and 80, rectifier. A self-contained speaker is connected in the output of the 42 stage. A jack on the panel allows connecting the phones in series with the speaker for headphone reception.

Panel controls are (besides the tuning control) mixer trimmer, audio gain, bandswitch, and beat oscillator and a.v.c. switches. The mixer trimmer allows correcting the tracking of the first stage to correspond with the antenna in use.

SARGENT MODEL 51



The Sargent Model 51 is a 10-tube communications-type receiver which is available in two models covering two different frequency ranges. One model covers a frequency range of from 31,000 to 520 kc. in five overlapping bands, while the other covers from 31,000 to 80 kc. in seven bands.

[Continued on Page 186]

Hams

Across

the Sea



Dear OM's:

Radio Technical Section,
Saladeng, Bangkok, Siam

I beg to thank you for your letter, QSL card and the nice QSO's which we have made recently. This is the letter that you asked for. Please excuse the delay.

As I am not a journalist, and perhaps a bad writer, it is a bit difficult for me to give you the history of amateur radio in Siam. But I will do my best and tell you all I can.

Siam radio is still in its primitive state, especially amateur radio. Almost ten years ago, Siam boasted two amateur radio stations: HS1HH, operated at Radic Section of

Post & Telegraph Dept.; and HS1BK, operated at the Royal Siamese Naval Radio Station, Bangkok. A few years later HS1HH and HS1BK left the air, and Siam was no-QSL-card land for radio amateurs.

The Radio Section was then reorganized and became the Radio Technical Section with headquarters at Saladeng, southeast corner of Bangkok, where all commercial radio transmitters are installed. The only 3-kw. Telefunken quench spark transmitter which we had here had been replaced by a new Telefunken valve transmitter. Several powerful short-wave transmitters for overseas traffic have been installed as well as many small transmitters for inland service, and two broadcasting transmitters.

TO: **W6QD** U.S.A.



Siam again on bands

At last amateur radio again took root. In 1936, I was given permission to work as an amateur. On May 23, 1936, Siam again was heard on the ham bands, with HS1PJ running 400 watts input, crystal controlled. The receiver was an ACR136.

During 1936, HS1PJ was on the air frequently. I was very interested in amateur radio and had lots of time to spend enjoying it. Results were not astounding, though I have worked all continents on 14 Mc. c.w. Perhaps the trouble was that its frequency was in the midst of the W phone band, and we were always QRM'ed by phone stations.

With HS1PJ on c.w. I worked just 3 W6 stations in the year 1936, and none of the other W zones. I also worked four LU and two PY stations. Most of the stations worked by HS1BJ were in Europe, Africa, Australia and Asia.

On November 11, 1936, I built HS1RJ for going after dx. This new rig was MOPA,

210 into a 203A. Results from this rig were excellent. I have worked W8, W9, W2, W7, W4 with f.b. reports. That was the first QSO ever made between Siam and the eastern coast of the U. S. A.

Goes on Phone

I then planned to go on phone. So the old HS1BJ rig was reconstructed with a PA using a single 203A as final with a grid leak modulator using a 56 added. The normal output power on phone was about 25 watts.

Instead of using an expensive microphone, I used an old single-button carbon mike with a simple 57-2A5 resistance coupled speech amplifier.

I spent almost three weeks in reconstructing the HS1BJ transmitter for the DJDC contest in 1937 in which I luckily won the first prize for Asia.

Since March 25, 1937, until now I have worked six continents on 14 Mc. phone and c.w., 80 countries and 700 stations; 260 stations of which are U. S. amateur stations! Many of them were worked twice or more, and 22 of them, mostly W6 stations, were raised on phone.

DX Conditions

The dx conditions for Siam—U. S. Pacific coast QSO's seem to get better and better. In 1936, W stations were quite rare, and conditions were not better until December. In 1937 W stations were coming in here quite well all the year round. It was quite easy to get in touch with W6 and W7 stations every evening from 9 p.m. local time (6 a.m. p.s.t) until midnight (9 a.m. p.s.t). The best season for east coast stations was during October to February from 6 to 12 a.m. e.s.t.

The Siamese Radio Law prohibits the installation and operation of privately owned radio transmitters, so HS1BJ of the Radio Technical Section, P & T Dept., is the only HS station on the air in the amateur bands. I try my best to keep the station on the air as frequently as possible. I have a second operator so that the rest of the world may have a better chance to work an HS station.

The shack of HS1BJ is in a rice field just 100 yards from the powerful commercial and broadcasting stations. Right behind the shack stand tall masts for a directional beam antenna to Europe. The main roads are about 200 yards from the shack. Besides the QRM from the passing cars I frequently have QRM

from various kinds of insects, especially in rice crop season. Many of them along with several house lizards were electrocuted in my rig!

Most of the W6 and W7 stations are heard here very f.b., 569 up to 599 with the usual clear tone, unlike the signals from the east coast, which are usually blurred and unsteady in intensity. The best dx time for Pacific coast now is around 9 to 12 p.m. local time or 6 to 9 a.m. p.s.t.; and the best dx time for the east coast is around 5 to 8 p.m. (5 to 8 a.m. e.s.t.), and sometimes later. I worked W1TW as late as 2 a.m., or 2 p.m. e.s.t., one morning.

As the location of my shack is very bad for dx reception because of the high noise level and interference, I worked real dx with great difficulty. I often heard KA, VS6 working with W6 phone stations frequently when it was impossible to locate those W6 stations on my receiver.

I now work on 14 Mc. only. I have tried dx on 7 Mc., but I heard very few stations on this band and the QRN was always very strong. I have also listened in on the 28-Mc. band at different times and on different days, but the band was practically silent. The only 28-Mc. signals I used to hear came from Bombay, India. This is the only cause that discourages me from attempting 28-Mc. dx tests. The 14-Mc. band is always full and it is easy to raise dx stations.

Perhaps you may like to know some more about myself. I am a Siamese, 28 years old, educated in a government high school in Bangkok. I have been a radio operator since 1928, and I am now assistant to the chief of the government transmitting station at Saladeng and operating engineer of the experimental short-wave broadcasting station HS8PJ, which broadcasts every Monday and Thursday from 8 to 10 p.m. local time (5 to 7 a.m. p.s.t.) on 19.02 Mc. or 9.5 Mc. respectively. Unlike the other oriental countries, there is not a single foreigner employed in the Radio Technical Section of the P & T Dept. of Siam, and all of us were educated in Siam.

By the time you receive this letter I will be away from Bangkok, as I am going south to an island called "Puket" to install a radio-telephone transmitter for commercial phone contact with Bangkok. I will be away for one month.

I hope that we shall meet again some time on the air.

73,

Sangiem Powtongsook, HS1BJ

MORE *on the* 3-ELEMENT ROTARY

By E. H. CONKLIN*

The newest in rotary beam antennas, the three-element close-spaced array, is giving such astounding results that it is rapidly becoming the most popular rotary array. Judging by the performance obtained with this antenna, this popularity is well deserved. Introduced in RADIO in November, the system is covered in further detail.

In November RADIO, Gioga and Dawley discussed a number of installations of three-element rotary antennas for 14 and 28 Mc.** With additional adjustment data and patterns available on units independently developed, and considering the prominence that this array appears to deserve, a sequel to the original article is entirely in order.

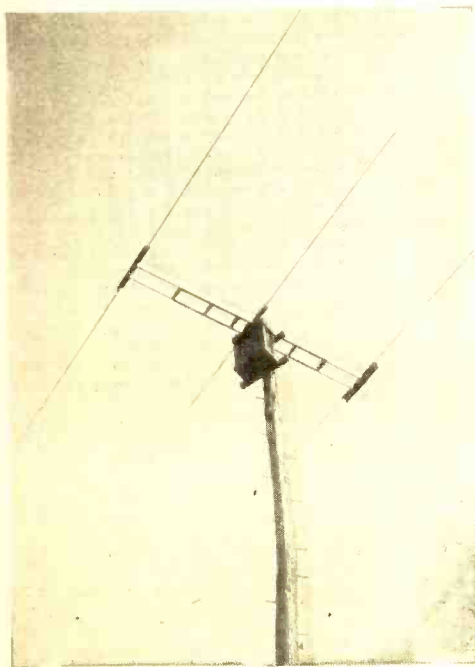

Figure 1. The three-element rotary beam installed by Dr. Dodds, W9ELK, Crawfordsville, Indiana.

Perhaps the statement that the rotary antenna problem has definitely been solved will appear to be overdone; but after recent listening tests on the three-element type, we were convinced that the long-sought antenna which would really allow the operator to choose his districts had at last been found.

Of course, a simple reflector system is good for perhaps 2 db gain, and a close-spaced job can get some 4 db gain¹—enough to make it less expensive to spend money on the antenna than to increase power from 400 watts to a kilowatt. However, most rotary systems have *not* done remarkably well when used on receivers, where gain is usually considered to be less important than interference elimination. But we were hardly prepared for something like a 1000-to-1 power ratio between desired and undesired directions, and the remarkable improvement that this beam produces while using it for receiving.

Listening Test Results

Late last winter we sat down to do a bit of listening on the new installation of W8LFE with the antenna pointed east of south, and immediately noticed that the 14-Mc. phone band was unusually clear of interference. Stations in South America, the West Indies, and W4's were coming through—all with remarkable freedom from QRM, pushing the meter up to R9. On several signals we turned the beam with the motor con-

* Associate Editor, RADIO.

** "The Three-Element Rotary," Gioga and Dawley, RADIO, Nov., 1938, p. 13.

¹ "New Design Data on the Flat-Top Beam," Kraus, RADIO, June, 1938, p. 15.

trol and heard them go down to R4 as indicated on the meter, only about one R point above the noise level. This low level persisted throughout nearly three-quarters of the rotation, then the signals recovered to R9. When the direction was west of south, mostly Mexicans and W5's were heard. When it was a little north of west, W6's and a few W7's came through.

It is true that a few VE1's were audible with good signal strength when the beam was pointed west, but still the western stations predominated with only one bad heterodyne encountered in an evening of listening. Whenever a good signal from the back or side was heard, we rotated the beam to it, heard the signal come up five R points, and the W6's drop down the same amount. An entirely different district predominated among the received phones.

This arrangement was a far greater improvement over the old two-element job² than the latter was over a simple doublet. It really made all the difference between complete satisfaction and just a few db gain. The discrimination of 30 db (5 R points) means that there is really 60 db (10 R points) change in the ratio of the desired signal to the undesired signal when the beam is turned from one to the other. That is, one goes up 5 R's and the other goes down 5 R's—a difference of ten compared with an ordinary nondirectional receiving antenna. A few back-end signals had a peculiar quivering tone to their carriers, possibly indicating changing

² "Let's Whip the Twenty-Meter Rotary," Conklin, RADIO, February, 1938, p. 56.

phase effects between several high-angle signal paths.

But enough of that. Let's get down to something practical.

The Initial Adjustment

Three horizontal elements on a crossbeam were set up in a large field. The spacing was one-tenth wavelength between elements. Using a doublet located some three wavelengths away, fed with a portable transmitter, the array was tuned. At first, the center element, which was to serve as the antenna, was tuned to resonance with the help of a thermogalvanometer in series with it. There was sufficient pickup from the driven doublet several wavelengths away to do this tuning. Next, the short director, placed between the antenna and the radiating doublet and spaced one-tenth wavelength from the antenna, was adjusted. With the hacksaw method of tuning, all is not lost if the director is made too short. It can be opened in the center and the ends connected with a piece of wire to increase the overall length.

Next, the director was opened in the center and the reflector was tuned. The director was again placed in operation and the antenna was retuned slightly.

The reflector and director tuning interlock somewhat, but not as much as one would expect. A second adjustment with both in position, after they have been tuned separately, will quickly give the best back-to-front ratio. Experience with perhaps a dozen close-spaced arrays suggests that standard dimensions with standard tubing results in reasonably accurate tuning even at different locations. Tables of

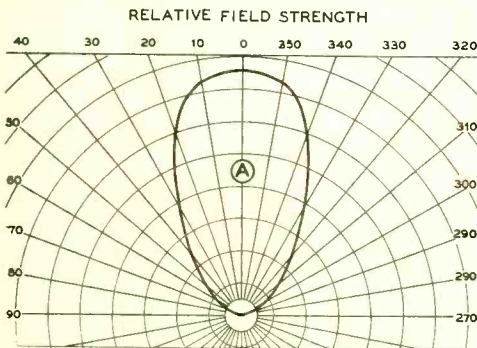
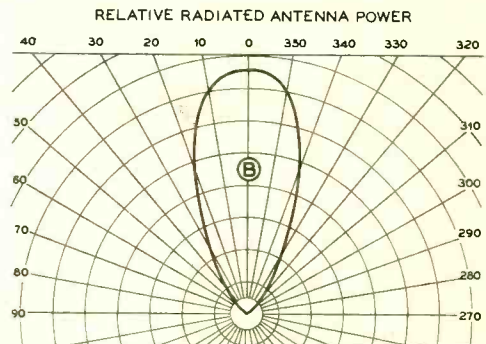

Figure 2. (A) shows measured relative field strength obtained by rotating the array and measuring the radiated energy in another doublet some distance from the rotary.



(B) gives a more accurate indication of the directivity of the array; in this chart the field-strength readings have been squared to give relative radiated power.



Figure 3. The three-element beam being assembled on the ground, as pointed out by Dr. Dodds, W9ELK.

dimensions have been given in the November, 1938, RADIO article.

When the adjusted antenna was rotated, driven with a short, balanced transmission line, a thermogalvanometer in the distant doublet went through a complete change. At the best direction, the power was adjusted for a full-scale deflection of 115 ma. At the sides and back, there was no indication of meter needle movement when the transmitter was keyed. The pattern given by these measurements appears in figure 2. It appears that the field strength varied over a 30 db range, equal to about a 1000-to-1 power ratio. A receiver connected to the antenna operated just as we have described, showing considerable directivity. While a two-element system has a poor front-to-back ratio where angles somewhat above the horizontal are being received, this is not true of the three-element array which, from all indications so far, operates just as well on actual signals, arriving above the horizontal, as indicated by the horizontal experimental pattern. As well as could be determined without more accurate power-measuring equipment, the front power gain over a simple doublet closely approached 10 db.

Later, a complete motor drive of standard

manufacture, together with a direction indicator, was obtained and installed at W8LFE. The antenna was mounted on a stub tower ten feet above a flat tin roof which is about fourteen feet square. Using as elements different tubes than those used in the first test, the array was similarly adjusted and connected to a short piece of twisted line. This was matched with Q-bars to a spaced line running down to the antenna change-over relay in the radio room.

A check during adjustment again indicated something like 10 db forward gain and 30 db front-to-side or front-to-back ratio. Another test was made with a station across town, where a receiver with an R meter was available. This meter is calibrated in R points of 6 db each, and also in db. During rotation, the maximum was 48 db and the minimum 18 db, a difference of 30 db, as indicated by the previous work. The complete readings are as follows:

plus	180°	18 db (R3—noise level)
	135	24
	90	24
	45	42
	0	48 (R8)
minus	45	42
	90	36
	135	27
	180	18

DX Results

Very few equipment changes have been made at W8LFE during the last three years. Many South American phones were worked a while back, but where formerly one out of two calls had been successful it became one out of twelve or twenty, and the rig just wasn't holding its own. The first day's operation with the new antenna started to make up for lost time. Practically every dx call on the first few mornings was successful. A test with an Australian revealed that at such a long distance, where very low angle radiation is more likely to be important, there was a perceptible change in signal strength upon a deviation of only 10 degrees, and one R point difference at 25 degrees, although the signal did not drop out completely until the beam was 45 degrees off. This has since been verified about a dozen times. A W7 said that the signals were good, on the nose, but too far down in the QRM at 30 degrees off. Ordinarily, the useful beam is at least 20 or 25 degrees on either side of the nose, although much beyond that signals drop off more sharply.

[Continued on Page 165]

A T-20 100-WATT PHONE

If you are interested in an inexpensive 100-watt phone that will cover from 10 to 160 meters and has all the latest features, this T-20 rig warrants your consideration. It has refinements ordinarily found only on more expensive phone transmitters, and gives surprising results for the money invested.

By FRANK C. JONES, * W6AJF

The 100-watt phone transmitter illustrated here has several interesting circuit combinations. The audio system has an adjustable automatic volume control in order to allow an average high level of modulation without overmodulation on peaks. Inverse feedback in the class-B driver stage provides an efficient and simple class-B driver having more gain than the usual push-pull 45 tube driver. The audio a.v.c. supplies a negative control voltage to the suppressor grid of the 6C6 pentode speech amplifier. Excessive audio input voltage to the TZ20 modulator tubes automatically reduces the gain of the 6C6 amplifier stage.

The r.f. circuits are relatively few for a transmitter designed for 160- to 10-meter operation. An untuned Pierce crystal oscillator is used for 160-, 75- and 20-meter operation. On 10 meters the 6C5 tube is changed over to a "sure-fire" regenerative oscillator with a 10-meter tuned coil in the plate circuit. This 10-meter coil has no effect when operating in the other bands and can be left in the circuit when the 6C5 is used as a Pierce oscillator on the lower frequencies.

The change from one type of oscillator to the other is obtained by an s.p.d.t. toggle switch mounted near the crystal socket. This switch connects a .0001- μ fd. mica condenser from grid to ground for the regular Pierce oscillator circuit or from plate and grid return circuits to ground for the other oscillator circuit on 10 meters. A good active 40-meter crystal or a 10-meter crystal should be used for 10-meter operation. This .0001- μ fd. condenser value depends upon the mechanical

layout of parts and may be as high as .00025 μ fd. in some cases. It should be large enough to prevent self-excited oscillation on 10 meters and small enough to work as a Pierce

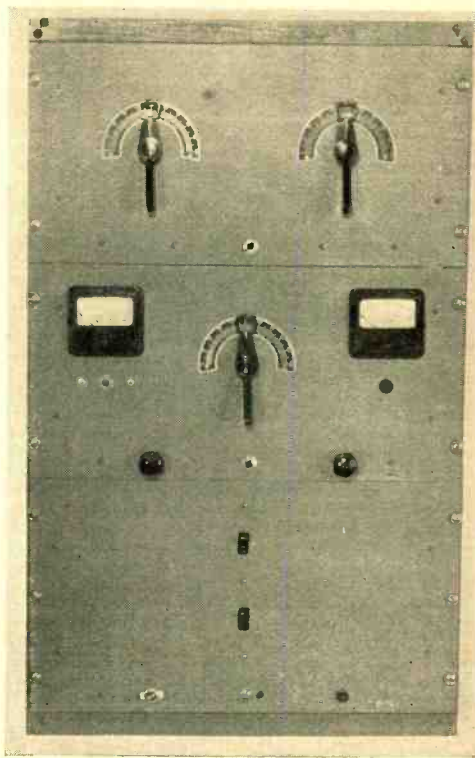

Figure 1. Front view of the 100-watt T20 phone.

* Engineering Editor, RADIO.

T20 100-WATT PHONE COIL DATA.

Coil Band	807 Plate	Final Grid	Final Plate
160	86 turns no. 26 d.c.c. close-wound 1½" dia.	Same as 807 with center tap in each case.	36 turns no. 14 4" long, 4" dia. c.t.
75	36 turns no. 22 d.c.c. 1½" long 1½" dia.	"	30 turns no. 14 3½" long, 2¾" dia. c.t.
20	10 turns no. 16 enam. 1¾" long, 1½" dia.	"	10 turns no. 14 4" long, 2¾" dia. c.t.
10	4 turns no. 16 enam. 1" long, 1½" dia.	"	6 turns no. 14 4" long, 2" dia. c.t.

oscillator on the lower frequency bands. It may be possible to connect a 50- or 100- μ fd.

fixed condenser between the crystal return circuit (to top of r.f. choke) and ground for most effective operation on all bands with a .0001- μ fd. (100- μ fd.) condenser at the switch position. The Pierce oscillator is not suitable for 10- and 20-meter crystals since these are third harmonic crystals and the 807 stage would have to work on the sixth harmonic.

The 807 should have a small parasitic suppressor in the form of a 10- or 20-ohm wire-wound resistor connected in series with the plate lead. The plate circuit is connected to a low impedance tap on the output transformer in order to apply a small audio voltage to this stage. This insures plenty of grid drive to the final amplifier on all bands from a rather low-powered driver stage. The audio voltage aids on peaks to drive the T20 grid circuit without any apparent distortion.

This idea was adapted from an article by Hawkins appearing some time ago in RADIO. The class-B stage works into about 12,000-ohms load through a 2-to-1 step-down ratio of impedances in the output transformer. The 807 stage connects across about 1000 ohms of the 6000-ohm secondary and part of the audio voltage reaches the 807 stage through the 4000-ohm plate voltage dropping resistor. It is not necessary to by-pass this resistor for audio frequencies since about two-thirds of the a.f. voltage across the 1000-ohm winding is effective on the 807 tube. An RK25 was tried in place of the 807 but tended to overheat when frequency doubling in this stage.

The set was built into a small relay rack 26" x 18½" using 3/16" x 1" angle iron. Three front panels are each 8" x 18" and are finished in grey wrinkle paint. Three 10" x



Figure 2. Back view of the T20 10-160-meter phone. The final amplifier is on the top deck, the excite- and speech stages on the second deck, and the two power supplies on the bottom deck.

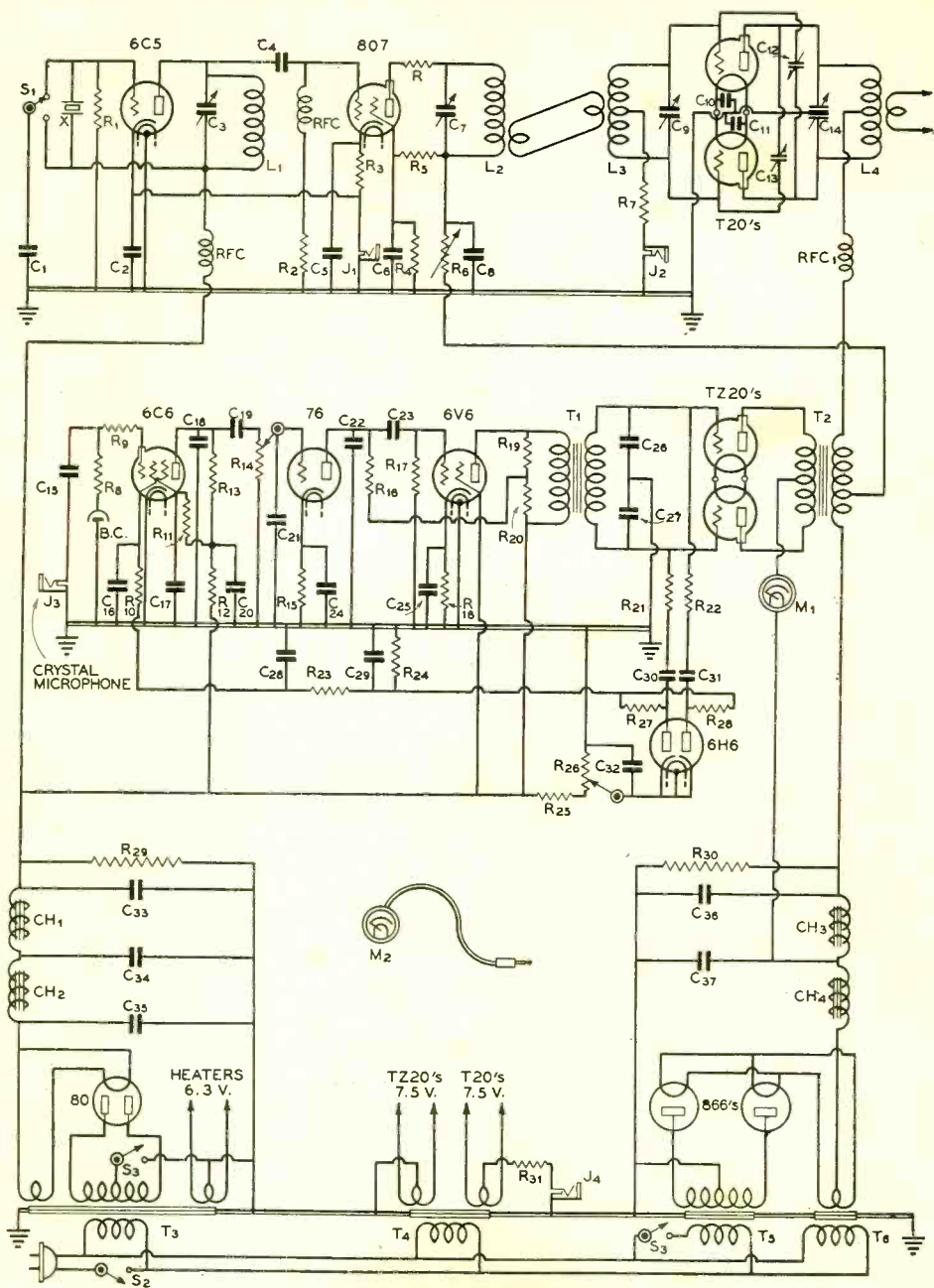

Figure 3. Schematic diagram of the complete transmitter.

- C₁—0001- μ fd. mica
- C₂—01- μ fd. tubular
- C₃—3-30- μ fd. mica trimmer
- C₄—50- μ fd. mica
- C₅—01- μ fd. tubular

- C₆—006- μ fd. mica
- C₇—50- μ fd. midget variable
- C₈—006- μ fd. mica
- C₉—50- μ fd. midget variable

- C₁₀, C₁₁—01- μ fd. tubular
- C₁₂, C₁₃—4- μ fd double-spaced midgets
- C₁₄—165 μ fd. per section, .084" air

- gap
- C₁₅—01 μ fd. tubular
- C₁₆, C₁₇—0.1- μ fd. tubular
- C₁₈—0001- μ fd. mica
- C₁₉—01- μ fd. tubular

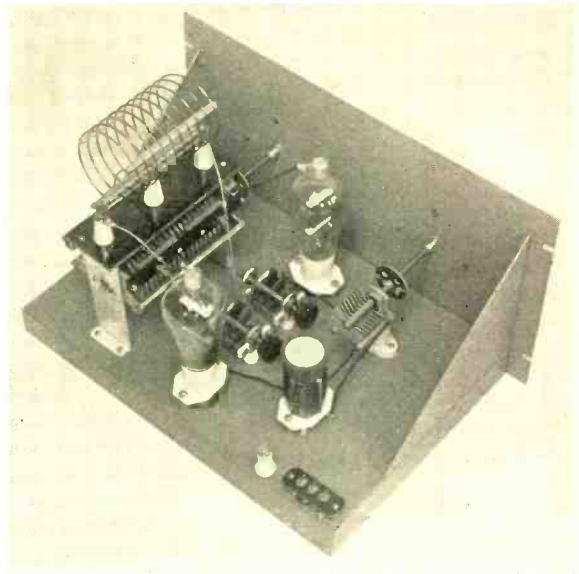

Figure 4. Push-pull T20 final amplifier. Efficiency is excellent from 10 to 160 meters.

1½" x 16" chassis were made from galvanized sheet iron and sprayed with the same paint. The galvanized iron allows soldering for common ground connections underneath the chassis.

In order to conserve space, the modulator, r.f. exciter and speech amplifiers were all mounted on the middle deck. This leads to

some r.f. feedback on the higher frequencies and some small mica condensers had to be connected as shown in the speech amplifier circuit diagram. Sometimes a ½-μfd. condenser from each heater lead to ground in the speech amplifier will aid in removing troublesome r.f. feedback.

The arrangements of parts is shown in the

Figure 3. Constants (continued)

C ₁₅₇ —0.5-μfd. tubular	R ₅ —50,000 ohms, 2 watts	R ₁₈ —400 ohms, 10 watts	RFC ₁ —2.5 mh. 250 ma.
C ₂₁ —0.001-μfd. mica	R ₁₅ —4000-ohm 50-watt resistor with slider	R ₁₆ —50,000 ohms, 1 watt carbon	T ₁ —Class-B input, about 2:1 pri. to ½ sec.
C ₂₂ —0.01-μfd. tubular	R ₇ —1500 ohms, 10 watts	R ₂₅₇ —5000 ohms, ½ watt carbon	T ₂ —Variable ratio 60-watt modulation transformer
C ₂₄ —0.5-μfd. tubular	R ₈ —1 meg., ½ watt carbon	R ₂₁ , R ₂₂ —250,000 ohms, ½ watt carbon	T ₃ —325 v. each side c.t. at 65 ma., 5 v. at 3 amp., and 6.3 v. at 3 amp.
C ₂₅ —10-μfd. 25-v. electrolytic	R ₁₅ —25,000 ohms, ½ watt carbon	R ₂₃ —250,000 ohms, 1 watt carbon	T ₄ —Two 7.5 v. 3 amp. windings
C ₂₆ , C ₂₇ —0.001-μfd. mica	R ₁₀ —250,000 ohms, ½ watt carbon	R ₂₄ , R ₂₅ —100,000 ohms, 1 watt carbon	T ₅ —1000 v. each side c.t. at 300 ma.
C ₂₈ , C ₂₉ —0.1-μfd. tubular	R ₁₁ —2 meg., ½ watt carbon	R ₂₆ —50,000-ohm pot.	T ₆ —2.5 v. at 10 amp. h.v. insulation
C ₃₀ , C ₃₁ —0.1-μfd. tubular	R ₁₂ —50,000 ohms, ½ watt carbon	R ₂₇ , R ₂₈ —100,000 ohms, ½ watt carbon	CH ₁ , CH ₂ —30 hy., 75 ma.
C ₃₂ —1-μfd. tubular	R ₁₃ —250,000 ohms, 1 watt carbon	R ₂₁ —25,000 ohms, 10 watts	CH ₃ —20 hy., 250 ma.
C ₃₃ , C ₃₄ , C ₃₅ —8-μfd. electrolytics	R ₁₄ —1-meg. tapered pot.	R ₂₂ —25,000 ohms, 10 watts	CH ₄ —5-25 hy. sw. choke, 300 ma.
C ₃₆ , C ₃₇ —4-μfd. 1000-v. oil filled compact type	R ₁₅ —2500 ohms, 1 watt carbon	R ₂₃ —25,000 ohms, 10 watts	M ₁ —0-150 ma. d.c.
R ₁ , R ₂ —50,000 ohms, 1 watt carbon	R ₁₆ —100,000 ohms, 1 watt carbon	R ₃₁ —200 ohms, 10 watts	M ₂ —(Plug-in meter) 0-200 ma. d.c.
R ₃ —500 ohms, 10 watts	R ₁₇ —500,000 ohms, ½ watt carbon	J ₁ , J ₂ , J ₃ , J ₄ —Closed-circuit jacks	
R ₄ —10,000 ohms, 10 watts		RFC—2.5 mh. 125 ma.	

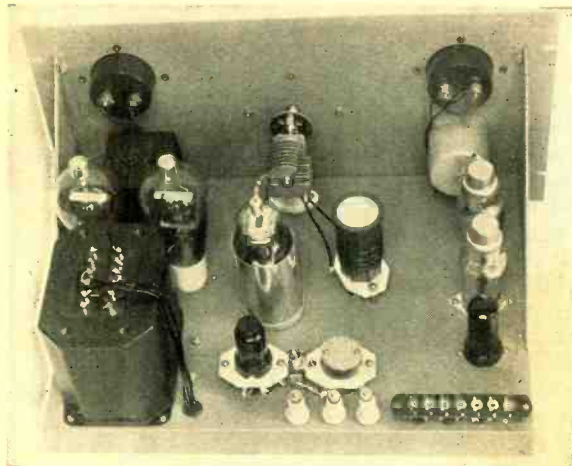
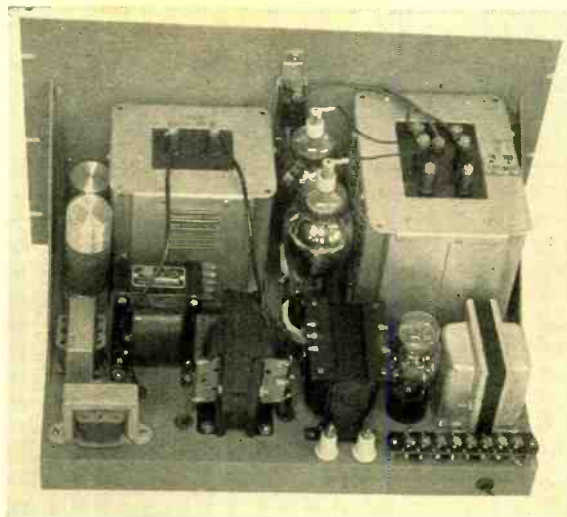

Figure 5. Modulator, r.f. exciter, and speech amplifier are lined up left to right on this deck.

Figure 6. On the bottom deck are the 800-volt and 250-volt power supplies which feed the entire transmitter.



photographs. The 10-meter oscillator coil is self-supporting and is mounted underneath the oscillator tube socket. The associated trimmer condenser can be adjusted once and for all and left at that setting.

Typical current readings are: 140 to 175 ma. in the final T20 cathode jack for any band; 35 to 50 ma. of grid current; 70 to 90 ma. in the exciter jack; 30 ma. zero signal class-B current; and 50 to 60 ma. peaks on speech. Keying for c.w. can be accomplished in either the exciter or final amplifier cathode jack. A protective 200-ohm resistor supplies some fixed bias to the T20 tubes when there is no r.f. excitation. Two power supplies furnish voltage for all stages in the trans-

mitter. One should be able to supply about 250 volts at 65 ma. and the other 800 volts with good regulation and a rating of 300 ma.

The audio a.v.c. circuit is coupled to the TZ20 grid circuits through $\frac{1}{4}$ -megohm resistors and .01- μ fd. blocking condensers. The correct value of resistors depends upon the particular class-B stage and varies from 50,000 to 250,000 ohms. Lower values provide more voltage across the 6H6 diode plates with greater control back to the 6C6 through the RC filter circuit. The point at which the automatic control takes place is adjusted by the bias on the 6H6 cathode. This positive

[Continued on Page 165]

THE G-OK

• An Ideal Tube

By C. B. STAFFORD,* W9KWP

This is the story of the G-OK, a tube which probably will never exist, but one of which tube designers have been dreaming for years. It is a tube whose plate current-grid voltage curve is a straight line. It has distinct cut-off and saturation points. It is stolen from that Utopia where all CQ's and QSL's are answered, tubes never blow up, and there is never any interference. If you are a doubter, glance at the curve of figure 1.

"But why," you will ask, "is such a tube desirable?"

The G-OK has characteristics which make it an admirable standard for comparison and explanation. For class-A or class-B work, one could not ask for more, unless it be that the tube manufacturers produce a G-OK. Let us proceed with our discussion of the uses of this idealized tube.

Suppose that a certain system requires an amplifier whose plate current waveform is the

same as the waveform of the impressed grid voltage. Assume that we don't care how much continuous plate current flows. A rapid thumbing of our radio texts shows this to be a class-A amplifier. Suppose that we bias the grid with a battery, or other source of constant voltage, so that any impressed a.c. voltage swings the grid voltage above or below a value of $k/2$. The maximum value of the impressed voltage must be held also to $k/2$, this value having been chosen because it biases the tube to the center of the operating portion of the curve. This permits a maximum value of grid voltage to be applied. If, for instance, a value of $k/4$ had been chosen for the bias voltage, the maximum permissible grid excitation voltage would have been $k/4$, and the maximum plate current variation would have been $q/4$ instead of $q/2$ as in figure 1. Figure 2 shows the result of impressing an exciting voltage in excess of $k/4$ on a G-OK biased to a value of $k/4$. Note how far from the impressed voltage

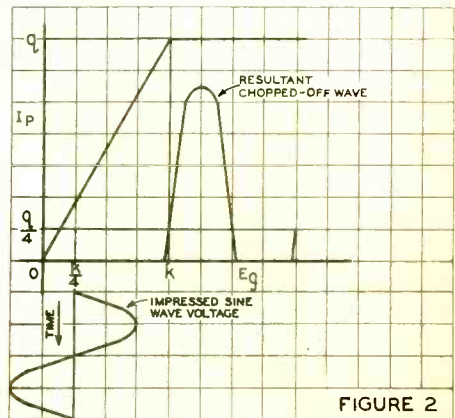
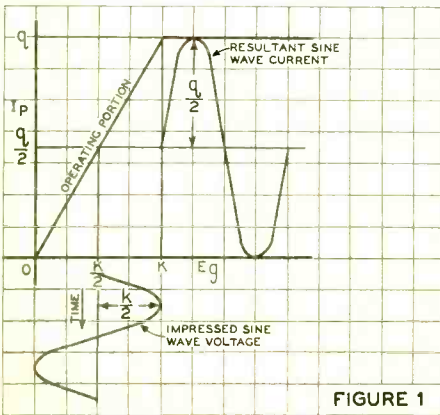

* 323 Wisconsin Ave., Oak Park, Illinois

wave form is the resulting wave form under these conditions. This illustrates why it is necessary to bias class-A amplifiers to the center of the the straight line portion of the

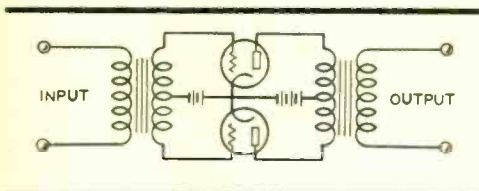

Figure 3.

curve. If this is not done the exciting voltage must be cut, with a resulting decrease in power output.

Suppose now that we want more power than can be obtained with a single G-OK. There are two readily apparent possibilities. The first is to connect two tubes in parallel.

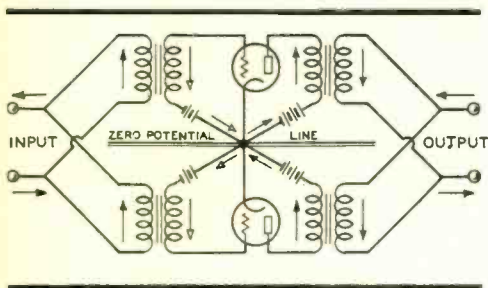

Figure 4.

If this is done, we must leave the grid bias at a value of $k/2$, and the plate current will have a maximum value of variation of q , rather than of $q/2$ with a single tube.

Another possibility is to connect the tubes in push-pull, as shown in figure 3. If the bias is left at $k/2$, this circuit may be broken into two single-tube class-A amplifiers as shown in figure 4. When current flows into the input transformer in the direction shown by the arrows, voltages will rise or fall on the grids as indicated. The decrease in grid voltage on the top amplifier will cause an increase in its plate current, which will in turn induce a voltage in the secondary of its output transformer in the direction shown. Similarly, the increase in grid voltage of the bottom amplifier will cause a decrease in its plate current, which will induce a voltage in its output transformer's secondary which is in phase with the top amplifier's output. Because of the strict linearity of the G-OK's characteristic curve, these two voltages will

be equal in magnitude and will add in the output.

It can be seen by looking at figure 4 that the alternating current components of the grid and plate circuits are opposite in direction and equal in magnitude. If the two circuits are combined as in figure 3, it is apparent that the alternating current flowing from right to left in the bottom grid circuit will just cancel that flowing from left to right in the top grid circuit. This results in zero alternating current in the cathode-to-exciting transformer circuit. The same is true of the plate supply circuit. This is a very useful phenomenon, frequently employed in high-frequency work to keep radio frequencies out of the power supplies and biasing systems. This is one of the reasons for the popularity of the push-pull transmitter circuits.

Let us now remove the bias from the grids of the G-OK's of figure 4 (apply zero bias). The output from each tube will now be alternate half cycles of sine waves. This is shown for one tube in solid lines in figure 5. As shown in April RADIO¹, this would result in high harmonic distortion. Suppose now that we add to this the wave form of the other tube (dotted lines in figure 5). When current flows in one tube, it doesn't flow in the other. This results in a perfect sine wave output of maximum value q . This is the same maximum value obtainable with the parallel connection. Of equal importance is the fact that plate current only flows through

¹ Stafford, "The Why of Harmonics," RADIO, April, 1938, p. 32.

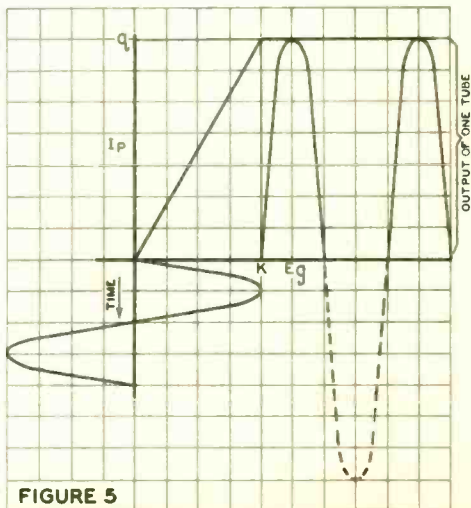

FIGURE 5

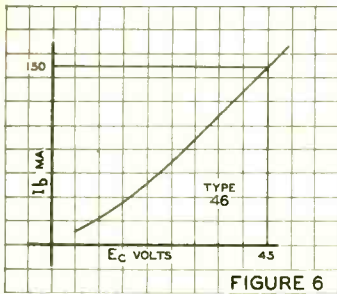

FIGURE 6

either tube one half of the time. The tubes are working only half as hard as they were in the parallel connection. This naturally results in higher efficiencies. This is of no importance for many applications, but for high-power transmitters, where the power bill represents an appreciable portion of the operating cost, and in portable work, where the power available is limited, this is quite useful. This, as you have already foreseen, is a class-B amplifier. The alternating current output of such an amplifier is directly proportional to the alternating grid voltage. Because it is a linear amplifier, it may be used to amplify modulated r.f. signals as well as audio frequencies. This latter application is used chiefly in transmitting circuits.

Although the manufacturers have not yet produced a G-OK, they have come reasonably close to one. Figure 6 shows the plate current-grid voltage curve of a type 46 tube. This tube found extensive use a few years ago

as a class-B audio amplifier, and many hams used them as modulators and as linear r.f. amplifiers.

If a single G-OK is used as a class-B amplifier with zero bias, the output will contain a number of harmonics. It can be shown by Fourier's Series that there will be no odd harmonics from this type of tube (neglecting those generated in the output transformer). In practice, due to the difference between the best obtainable characteristics and those of the G-OK, there will usually be some odd harmonics present. The G-OK will produce a large number of even harmonics. The top half of figure 7 shows the half waves which represent the output of a G-OK, and the chief components of the sinusoidal waves necessary to make up the half waves (see April RADIO). These consist of a fundamental and a second harmonic. The bottom half of figure 7 is the mirror image of the top half, displaced one half cycle or 180°. These two halves represent the output from the top and bottom halves of figure 4. It can easily be seen that if these two sets of component waves (fundamental and second) be added together, that the output wave will be a single sine wave composed of the two fundamentals present in each half of the figure, and that the second harmonics will cancel out. This is true of all of the even harmonics. This even harmonic cancellation is true of any balanced push-pull circuit, and further ac-

[Continued on Page 166]

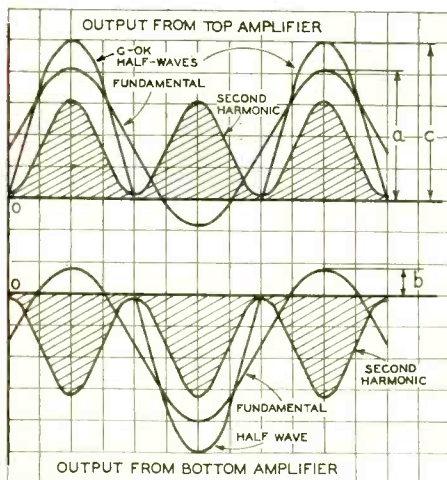

Figure 7.

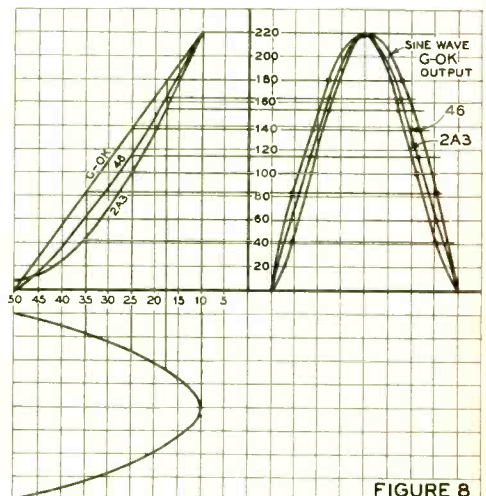

FIGURE 8



Front view of the completed amplifier. The crystal microphone plug connects to the shielded input just to the right of the gain control; automatic modulation control voltage connects to the rear of the chassis.

Modern Speech Amplifier Design

By DOUGLAS FORTUNE, W9UVC

One of the most important units of the phone transmitter is undoubtedly the speech amplifier and driver. Since the very nature of a phone transmitter requires the intelligent transmission of speech, it is the purpose of the speech amplifier to amplify the weak output of the microphone to such a point that sufficient driving power is developed for the class-B modulator stage. This should be done in such a way that the reproduction is natural and free from extraneous noises such as tube hiss and hum. At the present time there is a great deal of "splattering" in the amateur bands. A desirable feature in a truly modern speech amplifier would be some means of automatic modulation control, which, if properly designed, would also eliminate the distortion introduced by an overdriven driver or class-B modulator.

* Thordarson Electric Mfg. Co., 500 W. Huron St., Chicago, Ill.

With these considerations in mind the following speech amplifier was designed. In view of the present trend toward high- μ low-drive class-B tubes, the low-plate-resistance 2A3's were chosen for drivers, since they will deliver sufficient driving power for almost any class-B modulator. The 2A3's require no driving power whatever, but merely a peak grid-to-grid voltage of 120 volts. A single 6C5 operating into a step-up interstage transformer will provide this amount of voltage well below the grid current point of the 6C5. Since both the speech amplifier and the power supply are mounted on the same chassis, this input transformer is of the hum-bucking type to minimize hum pickup. A single 6L7 and a 6F5 provide the necessary voltage gain from the crystal microphone.

Although for most driver applications the 2A3's operate with such a plate-to-plate load that operation is strictly class A (that is, with-

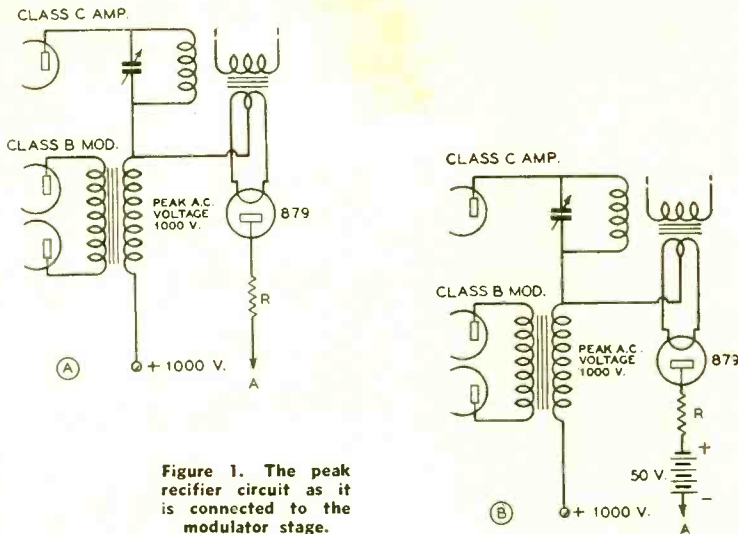

Figure 1. The peak rectifier circuit as it is connected to the modulator stage.

out plate current fluctuation)¹ the average plate current may vary in some instances; for this reason fixed bias was used. Although the 83 and the 82 would provide somewhat better regulation than the 5Z3 and the 80, these latter types were chosen to eliminate "hash" pickup by the receiver during stand-by periods.

Description of the Circuit

Because of the perfect shielding and compact size of metal tubes, these were used in the pre-amplifier stages. In order to eliminate the effect of cathode-to-heater leakage in the first stage, the cathode was operated at ground potential and a bias cell placed in the grid return. In some instances, depending upon the position of the speech amplifier and the length of microphone cable, it was found necessary to place an r.f. choke in the grid circuit of the 6F5. The addition of the small .0001- μ fd. mica condenser C_1 further tends to reduce r.f. pickup. When operated with a crystal microphone, C_1 in no way alters the frequency response of the amplifier since a crystal microphone is a condenser device and the net result is a slight lowering of the microphone output on all frequencies. The plate circuit of the 6F5 is resistance coupled to the grid of the 6L7 modulation control tube.

Although the automatic modulation control circuit has already been described,² a brief de-

scription of its operation may be in order. Figure 1A gives the various voltages for a class-C stage operating at 1000 volts. The peak a.c. voltage developed across the secondary of the modulation transformer is 1000 volts, and the actual voltage on the class-C stage for 100 per cent modulation varies from zero to 2000 volts. Should overmodulation occur, the rectifier will rectify the negative peaks and a voltage will appear across R. This voltage may be used to control the gain of one of the tubes in the speech amplifier. The objection to this circuit lies in the fact that overmodulation must take place before the controlling voltage is developed.

If a battery is inserted in the circuit, as shown in figure 1B, the rectifier will be brought into action before the plate voltage of the class-C stage reaches zero, that is, before overmodulation takes place. The ratio of the battery voltage to the class-C plate voltage determines the percentage of modulation at which the controlling voltage will start to be developed across R. In other words, if the battery voltage is 50 volts and the class-C plate voltage is 1000 volts, the rectifier will be brought into action at 95 per cent modulation. In the circuit diagram of the speech amplifier, figure 2, the equivalent of the battery voltage is developed across R_3 , which is variable, so that it may be used with any class-C modulated stage.

The resistor R_{14} is also variable, so that when R_3 has been set, R_{14} may be adjusted so that

¹ QST, September, 1937.

² RADIO, March, 1938.

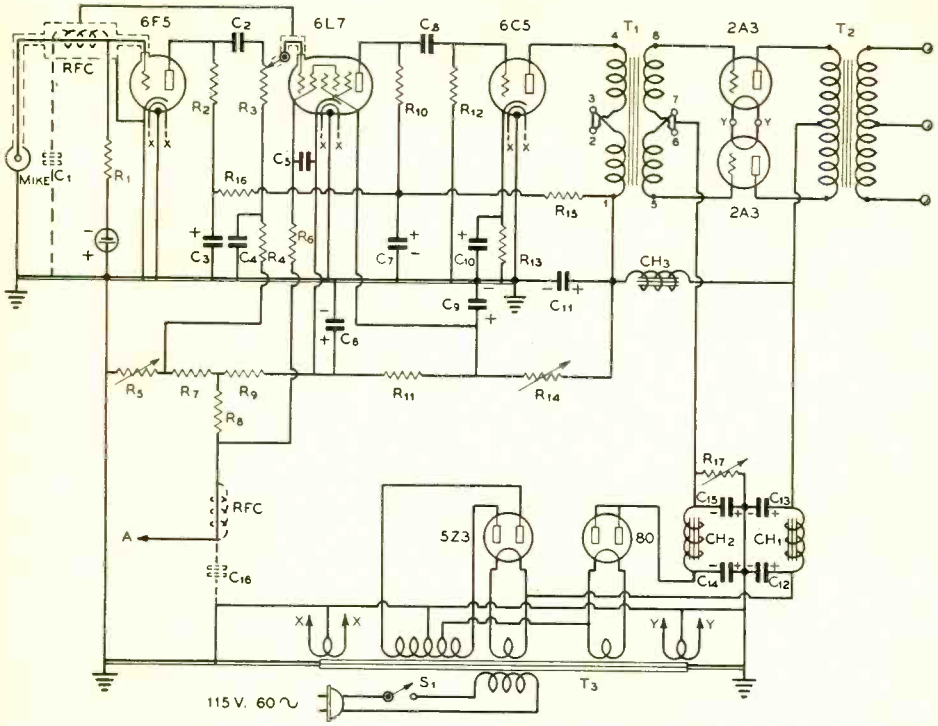

Figure 2. Schematic diagram of modern speech amplifier.

- | | | | |
|--|---|---|--|
| C ₁ —100- μ f. 500-volt mica | electrolytic | R ₅ —500,000 ohms, 1 watt | 1 watt |
| C ₂ —0.1- μ f. 400-volt tubular | C ₁₃ , C ₇ —Dual 8- μ f. 450-volt electrolytic | R ₇ —350 ohms, 10 watts | R ₁₇ —2500 ohms, 25-watt semi-variable |
| C ₃ —8- μ f. 450-volt electrolytic | C ₁₂ , C ₁₁ —Dual 8- μ f. 450-volt electrolytic | R ₈ —500,000 ohms, 1 watt | T ₁ —Triode plate-to-push-pull-grid transformer |
| C ₄ —0.5- μ f. 200-volt tubular | C ₁₄ , C ₁₅ —8- μ f. 200-volt electrolytic | R ₉ —150 ohms, 10 watts | T ₂ —Class-B input or driver-to-line transformer |
| C ₅ —0.5- μ f. 400-volt tubular | C ₁₀ —100- μ f. 500-volt mica | R ₁₀ —100,000 ohms, 1 watt | T ₃ —660 volts c.t., 160 ma.; 6.3 v., 2 a.; 5 v., 3 a.; 5 v., 2 a.; bias tap at 77 v. |
| C ₆ —8- μ f. 450-volt electrolytic | R ₁ —5 megohms, 1/2-watt | R ₁₁ —4000 ohms, 10 watts | CH ₁ —8-hy., 150-ma. filter choke |
| C ₇ , C ₁₁ —Dual 8- μ f. 450-volt electrolytic | R ₂ —250,000 ohms, 1 watt | R ₁₂ —250,000 ohms, 1 watt | CH ₂ —7-hy., 120-ma. filter choke |
| C ₈ —0.1- μ f. 400-volt tubular | R ₃ —500,000-ohm potentiometer | R ₁₃ —500 ohms, 1 watt | CH ₃ —40-hy., 15-ma. choke |
| C ₉ —8- μ f. 450-volt electrolytic | R ₄ —500,000 ohms, 1 watt | R ₁₄ —12,000 ohms, 25-watt semi-variable | |
| C ₁₀ —10- μ f. 25-volt | R ₆ —10,000 ohms, 25-watt semi-variable | R ₁₅ , R ₁₈ —20,000 ohms, | |

the correct bias is obtained for the 6L7. The volume control, R₃, is operated above ground by the potential developed across R₅, and the physical construction of R₃ should be such that the control arm is not grounded to the shell; nor should one end of the control be grounded to the shell, as is frequently done. The filter combination C₄ and R₄ prevents any ripple

which may be developed across R₅ from reaching the grid of the 6L7. The control grid of the 6L7 is operated at a negative potential of 10 volts with respect to the cathode. After R₅ has once been set, R₁₄ should be adjusted to give this value of voltage from the grid return to the cathode of the 6L7. Since both R₅ and R₁₄ are in a series circuit, the

setting of one affects the setting of the other. It may be necessary to readjust the two several times before the correct value of voltage appears across R_6 with the correct value of 10 volts on the 6L7.

The values of C_3 , R_4 and R_5 are very important, for they determine the time constant of the compressor circuit. The actual time for the injector grid to assume control depends upon the value of voltage applied between point A and ground. The condenser C_3 is charged through a 0.5-megohm resistor and discharged through a 1.0-megohm resistor, thus changing the time for control and the time for release. In addition, C_3 and R_4 should provide enough filtering to eliminate the modulating effect of the signal impressed on the injector grid. The filter section, consisting of C_3 and the r.f. choke, is necessary if lead A is unusually long, as is the case if the amplifier is placed on the operating table a considerable distance from the inverse rectifier so that there is a possibility of r.f. pickup.

The 6L7 is resistance coupled to the 6C5, which in turn is transformer coupled to the grids of the 2A3's. The output transformer T_2 may be a driver transformer in the event that the amplifier is mounted in a relay rack or an output transformer with a 500-ohm winding if the speech amplifier is placed a considerable distance from the class-B modulator.

Bias is taken from a tap on the high voltage secondary and connected to the filament of the 80 rectifier rather than to the plates, so that the ground connection for the bias rectifier is positive. The d.c. bias voltage is developed across R_{17} , which should be adjusted for the correct value of 60 volts. The plates of the

2A3 stage require only the filtering action of CH_1 since they are operated at a comparatively high level and any ripple tends to be cancelled by the push-pull action. The choke CH_2 provides additional filtering for the 6C5 stage and the resistor network from which the bias and plate supplies for the 6L7 are obtained.

Adjusting the Control Circuit

If the class-C stage is operated at 1000 volts, the voltage across R_3 should be adjusted for 5 per cent of this value, or 50 volts. For the modulation control circuit to work effectively, it is necessary that the modulator be capable of supplying the amount of voltage necessary to obtain at least 95 per cent modulation. In most average installations overmodulation is not usually possible because of the fact that poor line regulation reduces the effective plate voltage on the modulators. The manufacturer's class-B plate-to-plate load is based on the assumption of perfect plate regulation. As a result, the minimum plate voltage on the modulators at peak output is extremely low, and a few volts' reduction from poor line regulation or low line voltage will reduce the minimum plate voltage to such a point that 100 per cent modulation is impossible.

In a properly operating automatic modulation control circuit, the class-B modulator plate current on speech should not increase much above half the average value of sine-wave plate current as specified by the tube manufacturer. If the average current increases much beyond this value, either the automatic modulation control is not operating or the value of plate-to-plate load on the modulators is too low. When it is inconvenient to increase the plate voltage on the modulators, higher peak power may be obtained by decreasing the plate-to-plate load.³ For correct operation with the automatic modulation control, the gain control should be advanced slightly beyond the correct point for normal operation so that on loud signals the rectifier circuit will be brought into operation.

Driver-to-Line Transformer Considerations

In using an amplifier with 500-ohm output as a driver, there is frequently some misunderstanding regarding the correct ratio of the line to grid transformer.⁴ For this condition the 500-ohm value of the output winding should be disregarded and considered merely as a connecting link between the primary of the output transformer and the secondary of the

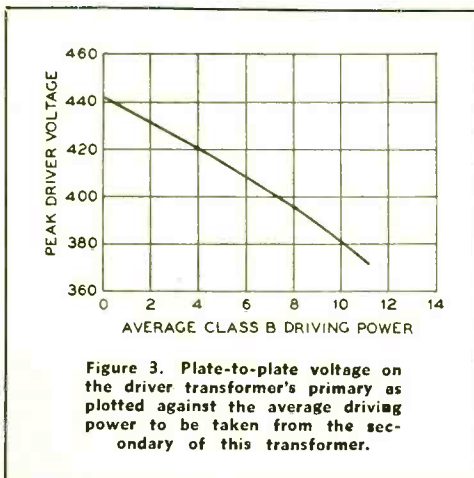

³ RADIO, April, 1938.

⁴ Communications, January, 1938, page 20.

actual driver transformer. Let us assume that the correct driver ratio for a given application is 3.2 to 1, total primary to half the secondary; and let us assume that for this application a speech amplifier with a 500-ohm output winding is used in conjunction with the line-to-grid transformer. The same ratio of 3.2 to 1, total primary to half the secondary, must be maintained from the primary of the output transformer to the secondary of the line-to-grid transformer. If the transformer on the amplifier has a plate-to-plate load of 3000 ohms to a 500-ohm load, the ratio of the output trans-

former is $\sqrt{\frac{3000}{500}}$ or 2.45 to 1. The correct ratio of the line-to-grid transformer to give an overall ratio of 3.2 to 1 should be $\frac{2.45}{3.2}$ or 1 to .765.

Figure 3 is a curve showing the voltage developed across the primary of the driver transformer for different values of average driving power. This curve shows the peak amount of signal voltage developed across the primary; and in computing the correct driver transformer ratio, it is necessary to know only the average driving power of the class-B tube and the peak grid voltage. In the case of the RCA 805 tube, for instance, the average driving power is 6 watts, and the peak grid voltage is 117.5 volts. For an average driving power of 6 watts it may be seen from the curve that the peak voltage across the primary is 408 volts. The correct ratio of the driver trans-

former is thus $\frac{408}{117.5}$ or 3.48 to 1, total primary to half the secondary.

It should be noted that the class-B driving power is given as average power, or the power averaged over the entire cycle. In the case of class-B tubes which operate with a considerable amount of bias, the value of average power is low in comparison to the value of peak power. Peak power is really the important consideration in driver design, since this peak amount of power must be delivered by the driver regardless of the actual value of average power. It is unfortunate that most tube manufacturers list the average value of driving power instead of the peak value from which the driver stage should be calculated. However, with the present trend toward the high- μ low-drive type modulator tube, the peak driving power is only approximately twice the average value since the grid impedance is practically linear over the entire audio cycle.

Mechanical Layout

The speech amplifier chassis itself was so designed that it is entirely universal from a mechanical viewpoint in that it may be placed in the regular relay rack with a relay rack panel, or mounted on the operating table with a 500-ohm line. The required panel height is 10½", and this size will fit any of the standard cabinets on the market. If this type of mounting is not desired, a regular metal screen cover and bottom plate may be used, such as is done in regular amplifier design.

How Many Turns?

By LEWIS F. FRANKLIN,* W6LTA

How many times have you been bothered by the bugaboo of winding a coil to a certain exact inductance only to find that your inductance calculator has been misplaced or that the fellow who borrowed it three months ago has not returned it? Rather than resort to cut-and-try methods, which are rather unsuitable when an exact value of in-

ductance is required, a simplification of one of the conventional inductance formulas was figured out.

The original formula is:

$$L = \frac{0.2 \cdot A^2 \cdot N^2}{3A + 9B + 10C}$$

Where:

L = Inductance in microhenries,

*North Fork, California.

- A = Inside diameter of coil in inches,
- B = Length of winding in inches,
- C = Radial depth of coil in inches (this value may be omitted for single-layer coils).
- N = Total number of turns.

If you have ever used this formula you probably had a coil form of a given diameter but did not know the number of turns to use or the length that the finished winding would occupy. The presence of these two unknowns complicated the solution of the equation. To get rid of B, the length of winding in inches, or at least express it differently, proceed as follows: Decide upon the size of wire that is to be used, taking into consideration the band of operation and the current that the wire will be called upon to handle, and decide upon the number of turns per inch that will be used. A wire table will give the correct value. Then express B in terms of N, as:

$$\frac{B \text{ (length of winding)} = \text{total number of turns in coil, } N}{\text{number of turns per linear inch } K} \text{ or } B = \frac{N}{K}$$

As a practical example let us say that we need a coil of 240 microhenries in inductance and wound on a coil form one inch in diameter. As the coil is to be used in a 160-meter receiver, we decide to use no. 32 enamel, close wound. The wire table says that this wire will wind 120 turns to the linear inch, (K).

- Thus: A = 1 inch
- N N
- B = $\frac{N}{K} = \frac{N}{120}$
- L = 240 microhenries
- N = unknown

$$\text{Then: } 240 = \frac{0.2 A^2 N^2}{3A + 9B} = \frac{0.2 N^2}{3 + \frac{9N}{120}}$$

$$240 = \frac{0.2 N^2}{\frac{360 + 9N}{120}} = \frac{24N^2}{360 + 9N}$$

Now, clearing of fractions:
 $86,400 + 2160N = 24N^2$

Or, in quadratic form:
 $24N^2 - 2160N - 86,400 = 0$

Dividing through by 24:
 $N^2 - 90N - 3600 = 0$

Factoring:

$$(N - 120)(N + 30) = 0$$

$$N - 120 = 0$$

$$N + 30 = 0$$

Taking the positive root:
 N = 120 turns

As another practical example let us say that we want a 6-microhenry plate coil for a high-power 20-meter final amplifier. We decide to wind the coil of 1/4-inch copper tubing and to space wind it 2 turns to the inch, hence K = 2. The coil will be wound 3 inches in diameter.

- Again tabulating our knowns:
- A = 3 inches
- N N
- B = $\frac{N}{K} = \frac{N}{2}$
- L = 6 microhenries
- N = unknown

$$\text{Then: } 6 = \frac{0.2 A^2 N^2}{3A + 9B} = \frac{0.2 \cdot 9 \cdot N^2}{9N + \frac{9N}{2}}$$

$$6 = \frac{1.8N^2}{18 + 9N} = \frac{3.6N^2}{18 + 9N}$$

$$108 + 54N = 3.6N^2$$

Dividing through by 3.6 and rearranging:
 $N^2 - 15N - 30 = 0$

Factoring:

$$(N - 16.78)(N + 1.78) = 0$$

Taking the positive root:
 N = 16.78 turns or, for practical purposes,
 N = 17 turns.

Then, since we had decided that the coil was to be wound 2 turns to the inch, we see that the coil length will be 8.5 inches.

The formula has been checked by experimentation for representative frequencies from 550 kc. throughout the amateur bands to 90 Mc. and the accuracy of computation is greater than the accuracy with which one can wind a coil by ordinary methods.

Ten-Meter AUTO-RADIO CONVERTER

By F. R. CONSETT,* W6VR

After considerable experimental work with mobile ten-meter equipment, the author concluded that there is a definite need for a GOOD u.h.f. superheterodyne for use in an automobile. The compact converter unit described can be used in conjunction with your regular auto receiver to make such a u.h.f. superhet.

The need for a good automobile receiver capable of receiving ten-meter signals has been felt for some time. There have been many complete receivers covering 28 Mc. presented to the amateur fraternity, especially since the recent increase in 28-Mc. activity. As a whole these receivers have been rather unsuited to automobile use due to their large size, their unhandy shape, and the large number of tubes used, the latter requiring a prohibitive amount of plate and filament power.

Since a majority of amateurs already have an auto receiver of at least fair sensitivity installed in their cars, it was decided that a small converter to go ahead of the b.c.l. set would make an ideal combination.

After the construction of several preliminary units, it was decided to leave off the conventional r.f. stage in the interest of compactness and low drain. The gain of the unit with the antenna feeding directly into the 6J8G mixer tube was high enough that the addition of a tuned r.f. stage was found unnecessary.

There have been several converters built with as many as two or three r.f. stages ahead of the first detector, but when an attempt is made to install a receiver of this type in an automobile, it is liable to occupy most of the front seat and to require a floorboard of wire to hook up the device. So, to make a unit that would be small enough to mount in a glove compartment, below the dash board, or on the steering column, it was decided to trim off all the nonessentials, leaving a one-tube combination oscillator-mixer that could be operated from the power supply of the auto set. If our present station receiver does not cover the 28-Mc. band, this converter can be used

ahead of it to make a very simple and inexpensive conversion of the receiver for ten meters. Since the drain of the unit is so small, it could be operated from the receiver's power supply, both for filament and plate, unless the power supply is already overloaded.

Images

From the standpoint of images, an r.f. stage ahead of the mixer would be helpful. But, since there are very few commercial stations in the vicinity of the 28-Mc. band, the problem of images is not serious. The ten-meter band covers 2000 kc.; hence, if we tune the b.c.l. set to some frequency just above 1500 kc., there will be no images within the band, as the images will be removed from the true signal by 3000 kc., or twice the i.f.

If the oscillator is tuned to the high-frequency side of the band, there is some possibility of image interference from the police stations operating in the range from 30,100 kc. to 33,000 kc. If serious interference is experienced, the oscillator may be moved to the low-frequency side of the signal. If there are no u.h.f. broadcast stations just below the 28-Mc. band in your vicinity, all will be well. Actually, in the installations that have been made, images have caused no trouble at all; ignition interference from *other* automobiles has been the greatest source of grief.

The Oscillator Section

The oscillator is a conventional tuned-grid, tickler plate type. By using this combination for the oscillator, the condenser C_1 is conveniently operated at ground potential, and this condenser may be combined with C_2 into a split-stator arrangement. The two oscillator coils (grid and tickler) are mounted upon an isolantite pillar standoff insulator and ce-

* Laboratorian, RADIO.

mented into place with low-loss coil dope. This makes rigid, vibration-free assembly. The two coils are wound in the same direction, spaced the diameter of the wire between turns, and the coils themselves are separated $\frac{1}{4}$ inch. Also, it will be noticed that the oscillator coil is mounted vertically to eliminate any coupling between this circuit and the horizontally-mounted antenna-circuit coil.

The ganged condenser was originally a 25- μfd . per section split-stator affair. However, the capacities of both sections have been reduced to obtain proper bandsread and correct C for tracking. All the rotor plates are left intact for mechanical reasons. All but two of the stator plates in the oscillator section (rear) are removed, and all but one of the plates in the detector section (front) are taken out. Thus we have the equivalent of a five-plate condenser for the oscillator and of a three-plate condenser for the detector.

Tracking

In order to make the oscillator and detector track over the entire band, it is necessary to place padding condensers across the oscillator and detector tuned circuits. A 25- μfd . midget air padder condenser is used across the oscillator tank where the padding capacity must be extremely stable with respect to vibration and changes in temperature. Changing the setting will naturally change the position of the band on the dial. The detector circuit is trimmed by means of a 3-30- μfd . midget mica trimmer. Be sure to mount the padding condensers so that the adjusting screw will be at ground potential. This will allow the set to be trimmed with a metal screwdriver.

The layout shown in the photograph is perhaps the simplest and most practical of the arrangements which will allow the use of the short leads required for efficient 28-Mc. operation. The split-stator tuning condenser is mounted above the subpanel by means of a pair of $\frac{1}{2}$ -inch bushings so that it will clear the back of the dial. The panel itself is made from a piece of 20-gauge terneplate and measures $4\frac{1}{2}$ inches wide by 5 inches high. The chassis is made from the same material and is $4\frac{1}{2}$ inches wide, 5 inches deep, and turned down 1 inch at front and rear. The chassis view shows quite well the positioning of the various components.

Power Supply

The auto radio in the car will supply the necessary plate and filament power. It is necessary to run only three wires (preferably shielded throughout their length to reduce ignition pickup) from the auto radio to the converter. One wire is used as ground, one for plate voltage and the other for the hot filament lead. As shown on the diagram and as actually employed on the converter, there are separate switches for the antenna circuits and for filament on-off. S_1 acts as the antenna switch and S_2 the filament control; no switch is required in the plate supply lead. If desired, a three-pole double-throw switch may be substituted for the two separate ones shown. This would make the changeover from ten-meter reception to b.c.l. reception more rapid.

The plate voltage in the average auto receiver is from 200 to 260 volts; this will be

Top view of the converter removed from its shield can. The grid coil for the mixer section of the 6J8C is mounted horizontally above the tuning condenser. The oscillator coil is mounted vertically on a standoff insulator just behind the tube.

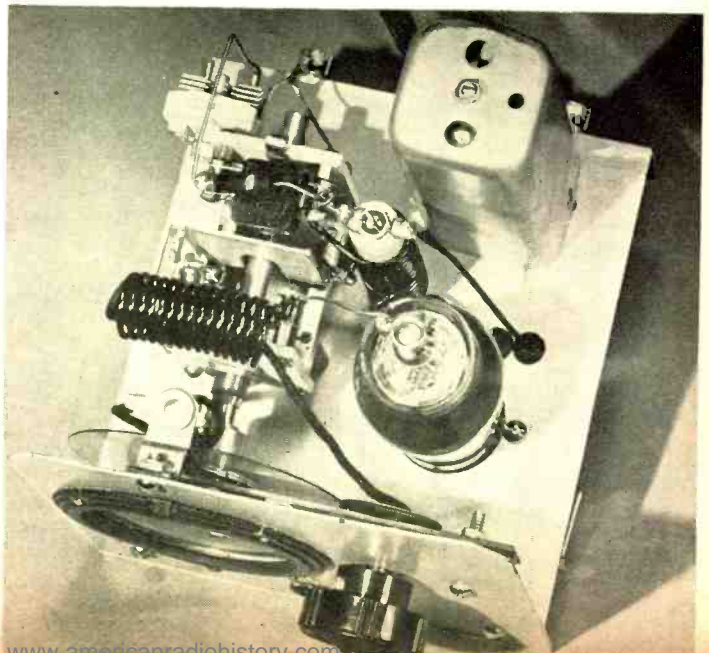

General wiring diagram for the 6J8G converter.

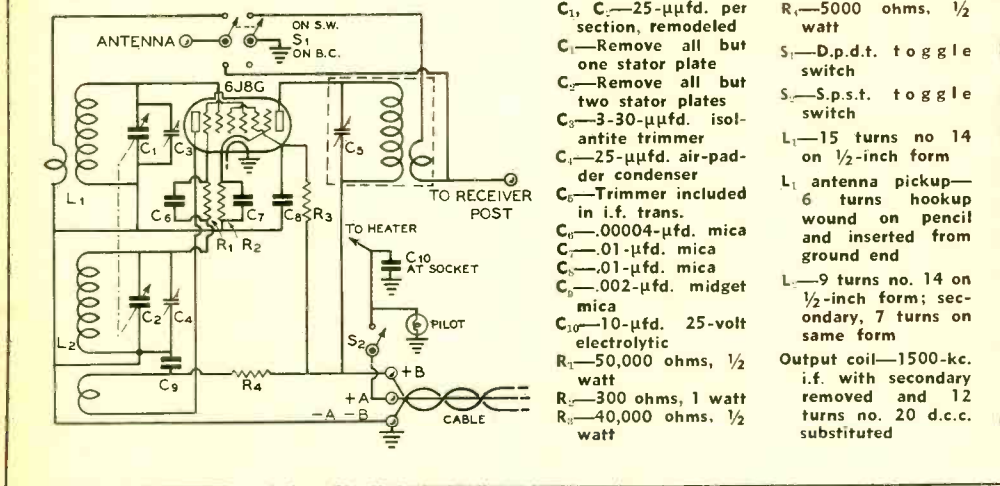

- C₁, C₂**—25- μ fd. per section, remodeled
C₁—Remove all but one stator plate
C₂—Remove all but two stator plates
C₃—3-30- μ fd. isolantite trimmer
C₄—25- μ fd. air-padder condenser
C₅—Trimmer included in i.f. trans.
C₆—.00004- μ fd. mica
C₇—.01- μ fd. mica
C₈—.01- μ fd. mica
C₉—.002- μ fd. midget mica
C₁₀—10- μ fd. 25-volt electrolytic
R₁—50,000 ohms, 1/2 watt
R₂—300 ohms, 1 watt
R₃—40,000 ohms, 1/2 watt
R₄—5000 ohms, 1/2 watt
S₁—D.p.d.t. toggle switch
S₂—S.p.s.t. toggle switch
L₁—15 turns no. 14 on 1/2-inch form
L₂—9 turns no. 14 on 1/2-inch form; secondary, 7 turns on same form
L₁ antenna pickup—6 turns hookup wound on pencil and inserted from ground end
L₂—9 turns no. 14 on 1/2-inch form; secondary, 7 turns on same form
Output coil—1500-kc. i.f. with secondary removed and 12 turns no. 20 d.c.c. substituted

ample to operate the converter quite satisfactorily. It will more than likely be necessary to by-pass the high-voltage lead at the converter to help eliminate ignition noise. The hot side of the filament line is also by-passed by condenser C₁₀ in the diagram.

Antenna Switching

S₁ as shown in the diagram and used in this model of the converter, is a double-pole double-throw toggle switch, used to throw the antenna from the converter to the auto set and to connect the output of the converter to the input of the set when 10-meter reception is desired. The center connection of one side of the switch goes to the antenna and the two outside connections on this side go to the converter and to the b.c.l. set. The other side of the switch connects or disconnects the lead from the converter to the antenna post of the auto set.

With the switch in one position, the antenna is connected to the input of the converter, and the converter's output goes to the input of the b.c.l. set. With the switch in the other position, the antenna is connected to the input of the auto set and the output link from the converter is disconnected. It is instantly possible to switch from ten-meter reception on the first position to the b.c. band on the second. If a separate filament switch for the converter is used as shown, it will be necessary to open this switch when converter operation is not desired; the dial lamp will give an indication of whether or not the converter has been left running.

Converter-to-Receiver Coupling

In order to couple the output of the converter efficiently to the input of the auto receiver, it has been found best to use a low-impedance link between the two. Direct capacity coupling was attempted in a preliminary model but was unsatisfactory. The input circuits of the majority of auto receivers are designed to work from a comparatively low-impedance source. This is due to the large capacity to ground of the average auto antenna. The low-impedance line between the two seems to match the impedances quite satisfactorily.

The coupling transformer originally was an inexpensive 1500-kc. air-core diode output i.f. transformer. There are, of course, two coils in the transformer as it comes. Remove the secondary with a pair of diagonals and replace it by 12 to 15 turns of no. 20 d.c.c. wound near the primary. This winding serves as the coupling to the link and will be found to match almost any auto radio input. If there is not enough signal transfer to the auto set's input, it may be necessary to experiment with a larger number of coupling turns. The second trimmer that was in the coil may be removed as it will no longer be required.

Antenna Connections

The antenna connections to the converter are placed at the rear of the chassis and are of the standard variety as used on all auto sets. A short lead of shielded wire with appropriate connectors at each end can be made to connect the output of the converter to the antenna

input of the auto set. The antenna best suited for use with the converter is a standard quarter-wave fishpole with a concentric line from it to the unit. The outer conductor of the concentric line should be grounded at several points. The fishpole also makes an excellent receiving antenna when operating into the b.c.l. set. Running-board antennas are not satisfactory for ten-meter reception. Several of the fellows using vertical antennas for car reception have placed a piece of wire, 12 to 15 inches long and mounted horizontally, at the top of the fishpole, claiming that local reception is considerably improved. If the converter is to be used with a car transmitter, the antenna lead should be run to the antenna relay and thence to the converter.

Tuning the Converter

When the unit has been completed and is ready for testing, connect it to the auto set and throw the switches to the proper position. Turn the gain up on the auto set, tune it just above 1500 kc., and adjust the trimmer on the 1500-kc. output coil in the converter to maximum hiss level. After peaking up the output circuit, set the trimmer condenser on the oscillator to slightly less than maximum capacity and peak up the detector condenser to maximum signal or ignition noise. Then tune the main dial to find the band and readjust the oscillator condenser to make it come within the dial. After the band has been set, go over all adjustments once again to make sure that all circuits are at peak. The volume control on the auto set will serve both for ten-meter reception and standard b.c.

Mounting

With the unit completed, a means of mounting must be considered. The author made a small metal box and placed the converter under the dash board on the left side of the steering wheel. When placed in this position, it is quite easy to tune the unit while driving. An alternate mounting method is to make a metal bracket and clamp the unit to the steering column. Still another method is to mount the unit in the glove compartment, but if your car has only one (on the right) it will be difficult to tune while driving. On cars that have two compartments, the converter may be mounted in the left-hand one, where it will be easy to tune while under way.

Auto Receivers

Since the auto receiver is used as power supply, audio, i.f. system and speaker, quite a saving is made, since the only additional piece of equipment required is the converter itself.

The author uses a five-tube Philco having one stage of r.f. The r.f. stage helps in reducing low-i.f. images in addition to boosting the output of the converter before the energy reaches the mixer in the auto set. In case the auto radio in use does not have an r.f. stage, it will be advisable, to add a single stage of 1500-kc. amplification to the output of the converter. A 6K7 connected in the conventional manner with a 1500-kc. interstage transformer between it and the mixer, with the output transformer previously described connected to the 6K7 plate circuit, would not add a great deal of bulk to the unit.

Ignition Noise

Ignition noise will be found to be the largest bugaboo of a converter-receiver of this type. However, interference from your own car can be virtually eliminated, and the noise from other cars can be greatly attenuated. First, place carbon-type suppressors on all spark plugs in addition to the one normally used on the distributor. Wire-wound suppressors were tried at first and were found to be unsatisfactory. Be very sure to shield everything quite carefully; ground all cables and the steering column where they come from the engine compartment through the firewall. The usual shielding and bonding precautions as done on making an auto radio installation will serve, but they must be carried out somewhat more carefully and to a greater degree.

Many types of noise silencing arrangements for the output of the auto set were tried. Some worked after a fashion; others did no noticeable good. But there was one arrangement that worked very satisfactorily in every case where it was tried. This was the simplest, and least expensive expedient of placing a neon bulb across the primary winding of the output transformer of the auto set. The base of the neon tube (a 1-watt bulb in this case) is heated with a soldering iron, the leads are unsoldered, and the metal shell is removed. The series resistor is removed and the two leads of the bulb are connected across the primary of the output transformer with a switch in series with one of them to remove the bulb from the circuit when b.c. reception is desired. It is as simple as all that—and the system really works surprisingly well *when the a.f. gain control is adjusted to the proper level.*

The unit may also be operated on the 56-Mc. band if desired, but images will more than likely be bothersome under certain conditions. However, the trend has been more toward ten meters for mobile work due to the ease with

[Continued on Page 170]



Figure 1. Just point the knob at the crystal you want to go to work.

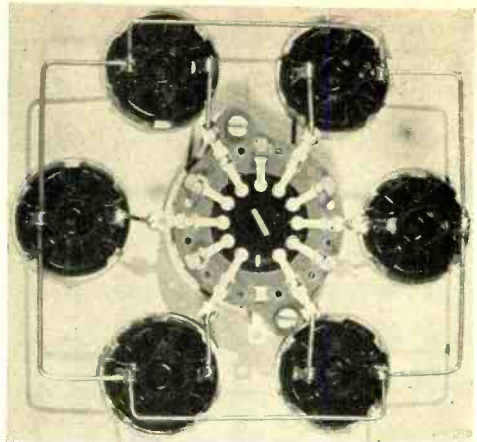

Figure 2. The arrangement permits very short leads from the switch points to the crystal sockets.

Another Angle on SWITCHING CRYSTALS

The advantages of having the crystal socket on the front panel (assuming that your exciter has a front panel) are such that there seems to be no justifiable reason for putting it behind the front panel on the chassis, where it is neither readily visible nor easily accessible. This is especially true when variable gap crystals are used, as the control on the crystal holder is certainly as important as the control on any other variable component in the exciter.

By mounting several crystal sockets around a selector switch as shown in the accompanying illustrations, several other worthwhile advantages are realized: It is not necessary to plug crystals in and out of a socket when changing frequency. One need but throw the selector switch so that the pointer is aimed at the crystal that is wanted.

Crystal switching arrangements which have the selector on the front panel and the crystal sockets behind the panel have the disadvantage that one has to keep his wits about him to be sure as to just which crystal is operative. With the crystals on the front panel in the arrangement illustrated, one just can't go wrong.

The selector switch should preferably be of the single-pole type having six positions, with the switch points spaced equally around 360 degrees. If this particular type of switch is not available, a standard 11-position switch will suffice. By skipping every other contact point, the six remaining points will be equally spaced around the circle. This is the type of switch used in the model shown. The only disadvantage of the 11-position switch is that there will be a "position" between crystals. However, one need only exercise care to point the knob on the selector switch directly at one of the crystal holders, and to make sure it isn't aimed midway between two.

By removing the mounting flange from flange-type sockets and mounting them by means of the spring retainer ring it is possible to cluster the sockets about the switch in a circle just large enough to leave clearance for the crystal holders. This reduces the space required on the panel for the crystals and permits very short leads from the switch points to the crystal socket pins.

The old gag of using a six-prong socket and wiring it so that it is impossible to insert the crystal "wrong" will not work with this

type of socket, as the jaws on the two heater pin holes were designed for filament pins and will not make contact with the crystal holder prongs, which are somewhat smaller. Therefore five-prong sockets are used, and to make sure no time will be wasted in attempting to insert a crystal holder improperly the control grid and two heater prong jaws are removed by pushing them out through the top of the socket with the aid of long nosed pliers.

These particular sockets require a 1 3/16" diameter hole for mounting by means of the retainer spring. If holes of this exact diameter are drilled, the sockets will be held quite firmly in place. If the holes are only slightly larger than this, the sockets will not be held firmly and will tend to "slop around." So don't try to use a standard size 1 1/4-inch hole saw or punch; if you don't have access to a 1 3/16" punch (rare, but they exist) use an adjustable circle cutter and take care in setting it.

Spacing the holes evenly around a circle is easy if you will remember that the radius of a circle makes a 60-degree chord, or one-

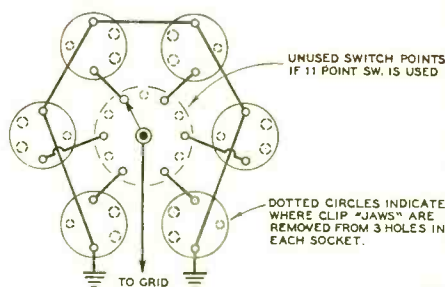

Figure 3. Showing connections to switch points.

sixth of a circle. Just scribe a circle of the desired size and "walk" the compasses or dividers around the circumference of this circle. In other words, the distance between centers of the crystal sockets is equal to the distance from the center of the switch to the center of a crystal socket.

The crystal oscillator tube should be placed reasonably close to the selector switch to permit a short grid lead, especially if 40- and 20-meter crystals are to be used.

Q B, O. M.!



Typical 1939 dx hound having an f.b. rag chew. "GE OM UR RST 559 HR—FB OM ES PSD MEET U—WX HR FB—NIL HR SO TTS DPE ON TT—TNX FER QSO—73 ES PSE PSE QSL" (Photo courtesy W2KBA)

He told me I was a-comin' in there RST 579X, and so was the weather down there in Bummingham, Alabam'. Nothing new down there so he said, old man, so now it's your turn, old man! So I said I'll turn in, if that's all you have down there, old man. So I said f.b. again, old man, and hope to see you real soon again, old man, and 73, old man, and dit ditditdit dit, old man. So we signed off, we two old men did, and the ages of the two of us added together wouldn't even make one-half one old man, but we call each other old man because every crack op., every punk, and every feller in short pants, long pants, three-cornered pants or no pants at all calls himself old man in this here ham game of ours.

We do the same thing all over again, in the same old way—telling the same old story to the same kind of hams, and we whittle away our time with RST this'n that, etc., when we wouldn't have to say RST at all

because that's taken for granted by every ham on the air. So why not just the figures "579"?

We are all supposed to have pure d.c., so the "X" at the tail end of the report doesn't interest us at all. Take out all the "old man" sayings from the report—forget the weather, and the devil with how much input you've got, because all we want to do is hear you anyway—and the entire ham message interchange between two hams would consume less than a minute flat, thus giving another 500,000 new hams a chance to get on the air by making room for them to send in. We are keeping a half million would-be amateurs out of ham radio simply because we take up too much time on reports, old man, and such. Isn't that true?

I like ham radio, old man, because it makes me feel old even before I am supposed to be old by the calendar. Gives me a sort of high-falootin' opinion of myself, you know, old man. We get together, we old men do, and we live the past all over again—we go back years, and years, and years—'way back, right deep into 1935, and we sure are old timers, wot? We talk about the things we did 'way back in 1935, three long years ago, and we laugh and laugh and laugh when a fellow old man who wears a size six hat chirps in and tells us it sure is great stuff, old man, to be a ham!

The point I'm trying to put over, old man, is the cold, cruel fact that this here ham business has really turned into a ritual or procedure, and the old-time fellowship of those years 'way back in 1935 has turned into a dreary RST, o.m., 73 and how's the WX down there, old man? There was a time when we used to chew the rag in the U.S.A., and chew the cloth in Australia, as the Auzzies say down there. Over in India where Mahatma Ghandi has the last remaining rag, and nothing to chew on, they have few hams, simply because of the dire shortage of rags.

But it's great to get together with a ham who will really chew the rag, swap yarns, and pound his key so hard when he sends "Hi" that you can almost hear the horse-laugh right over the air.

Why, it wasn't so many years ago when we played checkers by ham radio, just like the old-line telegraph ops. used to play, same as the station agents did when there was no traffic to move. And we had a lot of real fun playing checkers over the wire. Then, on the air, playing checkers beats all the millions of RST reports combined, because anybody can give you an RST, but not everybody can beat you at checkers.

The good fellowship must be brought back to ham radio. There's less of it now than

at any previous time. Where are those 50 w.p.m. rag-chewers we used to hear on the 80-meter band, blasting away with a line of gas that really had ear appeal? Something's happened of late. You don't hear them any more. They must have gone down on 20, and sunk there, because now it's dx, more dx, and less of the things that could make ham radio what it used to be.

I recently bought myself a fast-sending bug. The thing could send much faster than I. It always gave me a couple of extra dots, without charging me for them, and it was so full of life that I had to screw it to the table with heavy machine bolts. After a few days, I had to use only the dash lever of the bug because nobody could read me when I used both handles. I then wrote to the manufacturer and showed him how much money he could save by making bugs that had a dash lever only.

The thought had struck me that a fast operator on the air would get a lot of answers to his CQ. 'Tain't so. I got no comebacks at all. One hundred out of every hundred hams just whizzed past my signal on their receiver dials and thought I was a V-wheel image from a commercial station somewhere. Ham radio has changed. It's "QSL, please, old man, your signals RST."

So I'm having myself treated to an ultra-luxe tape-sending machine—a thing that sends for me automatically whenever some ham answers my CQ. The tape is the same for everybody, no matter who he is, or where he is. It simply sez: "Hiya, old man, thanks for the call, old man, you're QSA-4 here, R5, old man, WX here is the same as usual, old man, nil hr, old man, thanks for the f.b. QSO, old man. Hope to see you again some time, old man, 73, old man, and CUL.

That's the way to lick ham radio, old man. Then it won't get you, like it got me.

Strays

Sparks has long been the shipboard nickname for radio ops. W1KMV comes by it legitimately, however; his last name is Sparks.

Fones is W3HMN's name.

W4FMM is named *Lloyd George*.

W6PXN's name is *Current*.

W8ILL is named *WILL*.

A 400-Watt

DIATHERMY

- Foolproof
- Modern

While a few have harshly criticized us for publishing constructional data on diathermy machines, most amateurs realize that doctors are going to buy these "QRM contraptions" anyhow and that amateurs might as well cash in on the opportunity to make a few dollars by building them to order. In fact, the machines that have been described in this magazine create much less interference than the majority of commercially-built jobs, offered by manufacturers more interested in the margin of profit than in the amount of interference created by their product.

The diathermy machine illustrated in the accompanying photos is a de luxe model, having all worth-while refinements and capable of delivering more than sufficient power for all purposes to which such machines are put. Every known safety device has been incorporated in the machine in order to make it as fool proof as possible. All components have a large safety factor, thus reducing the chance for failure of any part even when the machine is used continuously for long periods of time.

Push-pull HF-200's are used in an Armstrong circuit having an untuned grid coil, commonly called a "TNT" circuit. The wavelength utilized is the same as that used by most of the modern machines, approximately 7 meters. Many of these machines are advertised as 5- or 6-meter machines, but most of them actually work on 7 or 8 meters.

A double deck steel cabinet, which is mounted on swivel-type rubber-tired wheels, houses the complete unit, as shown in figure 1. A narrow meter panel is placed above the r.f. panel, as may be seen in the illustration. The power supply is mounted at the bottom because of its weight.

By means of a tuned output circuit, adjustable from the front panel, fine adjustment of



Figure 1. De Luxe 400-watt diathermy machine incorporating many safety features and worthwhile refinements. Two HF-200's are used in a push-pull Armstrong circuit.

the output is obtained. To conserve the tubes when but little output is required, a "Lo-Hi" switch is incorporated. On the "high" position, approximately 2000 volts is applied to the tubes. On the "low" position, the 110-volt primary leads to the plate transformer are switched to the 220-volt taps on the transformer, cutting the plate voltage in half. Additional grid leak is cut into the circuit when the switch is thrown to the low position, further reducing the output slightly. This switch is used for coarse adjustment of the output, the tuning control for fine adjustment. This switch is actually three standard type toggle switches, ganged together by means of a holder made for the purpose. Three small toggle switches are used in a similar arrangement for the line switch, paralleled to provide sufficient current carrying capacity.

Not only is the output circuit tuned, but it is provided with adjustable coupling. This permits the coupling to be loosened until at no time the tuning of the pads throws the unit out of oscillation. The coupling is then left permanently in this position. The condenser C_3 of figure 3, which tunes the output circuit, is the only control on the front panel other than the switches. It is driven by means of a flexible shaft.

When the machine is first put in operation, the plate tank condenser C_5 is tuned to res-

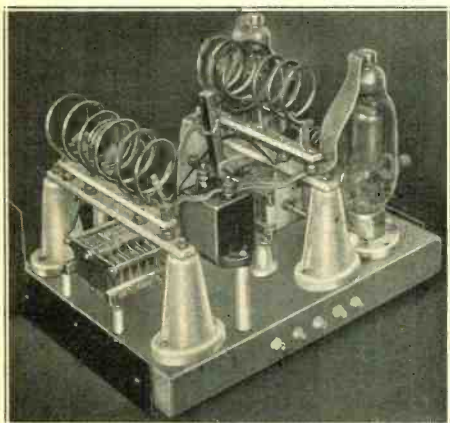

Figure 2. R.f. section of the de luxe diathermy. The grid coil is behind the tubes, the plate tank with its fixed-tune variable condenser directly in front of them, and the output coupler to the left. The condenser directly below the coupling coil to the left is driven from the front panel by means of a flexible shaft.

onance from the back of the cabinet. It is then left permanently in this position. When this condenser has been properly adjusted it will be possible to load the oscillator quite heavily without its going out of oscillation.

The applicator pads are a standard item, available from most medical supply houses. The output circuit utilized allows for satisfactory operation with most standard cord lengths regardless of where the pads are placed on the patient. Hence in ordering the

pads, it is not necessary to specify any particular length and pad cords, so long as the pads and cords are designed for use with 5- to 15-meter machines. The blocking condensers C_7 are merely a safety precaution.

The output circuit used also permits the use of any of the special applicators so long as they were designed for use with 5- to 8-meter machines.

To protect the tubes, meter and plate transformer in case the oscillator should go out of resonance due to excessive loading, an overload relay is incorporated. In order to trip properly when the machine is used on "Low" and goes out of oscillation, a 250-ma. relay is used. As the machine will sometimes draw more than this amount of current under normal conditions when used at full plate voltage, the relay is shunted by a suitable resistor to increase its capacity when the machine is run at full power. This is automatically done by the "Lo-Hi" switch.

A door switch, time delay relay, and time switch are incorporated to make the machine fool proof. The door switch shuts off the power supply when the cabinet door is opened. The time delay relay permits the 866's to reach operating temperature before allowing plate voltage to be applied, leaving nothing to chance. The time switch, directly below the tuning control, is similar to that used on electric stoves, and allows the doctor to preset the machine for any length treatment up to 30 minutes.

Two meters are provided, a plate milliammeter and an r.f. ammeter, the latter indi-

Figure 3. R. F. unit of the de luxe diathermy.

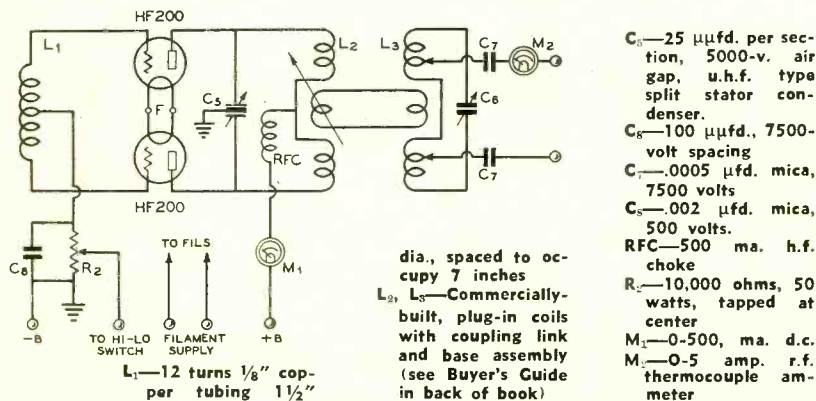

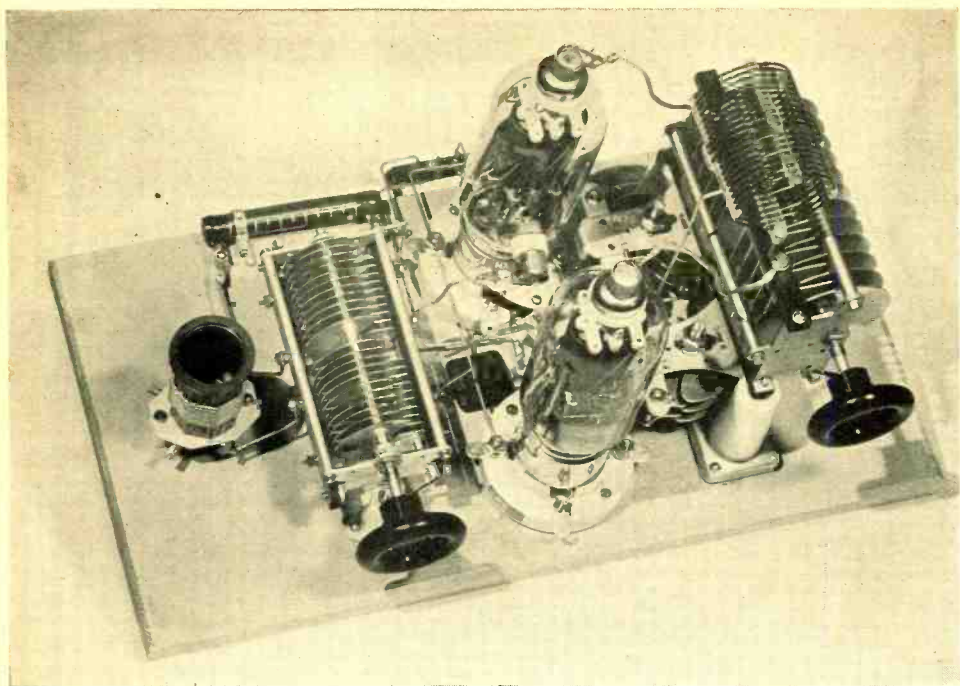

A KILOWATT *on the* NEW 810'S

A new RCA transmitting tube designed to operate with the maximum legal input at comparatively low plate voltages and at all frequencies up to 30 Mc. has recently been made available to the amateur. The tube is a high- μ triode and is designed with very short internal leads and low internal lead inductance to permit compact circuit layout for high-frequency installations. The high transconductance (perveance) of the new tube is the feature that allows it to operate at high plate efficiency with low driving power and with comparatively low plate voltage.

Forty-five watts of filament power in an M-type filament provides a reserve of emission for all normal types of operation. In addition, the filament is shielded at each end to conserve input power and to eliminate bulb darkening due to electron bombardment.

With a plate dissipation rating of 125 watts, two 810's supply an output of 750 watts for unmodulated c.w. operation, with 1000 watts input. The maximum plate voltage for this class of operation is 2000 volts and the plate current 250 milliamperes per tube. For plate-

modulated phone work, the maximum allowable plate voltage is 1600 volts and the plate current rating is 210 milliamperes per tube. This latter method of operation allows an input of 670 watts, which represents a hefty phone signal.

Nominal grid current rating is 40 milliamperes for c.w. and 50 milliamperes for phone, while the corresponding bias requirements are 160 volts and 200 volts, respectively. Twelve watts of driving power per tube is required for c.w. operation. As plate-modulated amplifiers the tubes must have 17 watts of driving power apiece.

Grid Modulation

In grid-modulated service, an output of 60 watts per tube may be obtained with 2000 plate volts and but 4 watts of driving power. At this output the plate current is 90 milliamperes and the bias voltage 140 volts. Bias must be from a fixed source, such as batteries or a well regulated power supply. Grid current for grid-modulated service should be 2 milliamperes per tube. Sixty watts of grid-

Wiring diagram of the 810 c.w. amplifier

- C₁—100- μ fd. per section
- C₂—50- μ fd. per section
- C₃, C₄—0.005- μ fd. mica
- NC—3-9 μ fd.
- R—4000 ohms, 50 watts
- L₁—16 turns 1½ inches in diameter and 1½ inches long
- L₂—14 turns 2 inches in diameter and 3 inches long
- L₃—3-to-5 turns over center of L₂; depends upon antenna used

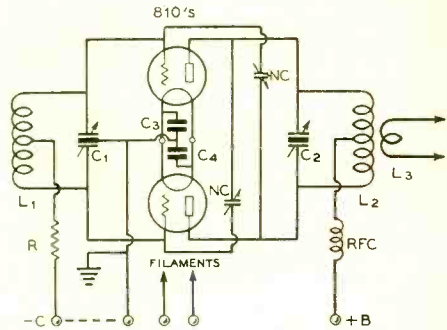

modulated output per tube may also be obtained with 1500 volts by increasing the plate current to 110 milliamperes. The driving power must also be increased slightly, 5 watts being required.

Physical Characteristics

The 810 has both the grid and plate leads brought out through the bulb; the plate lead being at the top and the grid lead at the side, of course. This method of construction allows an extremely compact stage to be built with a minimum of lead length.

The amplifier illustrated in the photograph is presented as an example of typical bread-board construction for a 1-kw. c.w. stage. While, with the coils shown in the photograph, it is intended only for 14-Mc. operation, with appropriate coils and an exciter such as the "4-25," it makes a compact 4-band final stage.

A 8½ x 17-inch wooden baseboard mounts all parts without undue crowding. The plate condenser, a 50 μ fd. per section unit, is supported above the baseboard on standoff insulators. Atop the condenser, supported from its

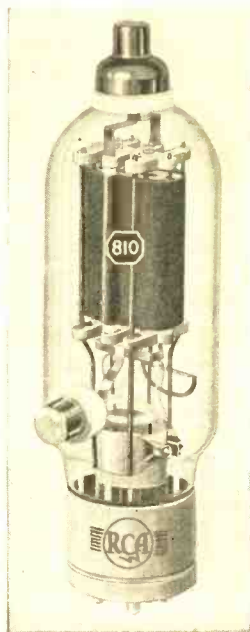

stator terminals, is mounted the plate coil. The coil has a link around its center which serves as an antenna-coupling coil. Two neutralizing condensers of the single-bearing type are mounted on the lower stator terminals of the plate condenser. The stators of the neutralizing condensers are cross connected to the grids of the 810's. Slots in the rotor shafts of the neutralizing condensers allow neutralizing adjustments to be made with a flat fibre rod. It should not be necessary to change the setting of the neutralizing condensers when changing bands.

Flexible leads are run from the two stators of the 100- μ fd.-per-section grid condenser to the grids of the tubes. The tubes are mounted with their grid terminals toward each other. The rotor of the grid condenser is grounded to provide circuit balance.

The filament by-pass condensers, only one of which is visible in the photograph, are supported from the wiring and are between the tubes.

A small fibre terminal strip mounted on the rear edge of the base provides connections for the filament voltage, external bias (if any), and negative high voltage. The positive high voltage terminal is a small standoff insulator directly behind the plate condenser. Voltage is fed from this terminal, through an r.f. choke under the plate condenser, to the center of the plate coil.

Operating conditions for the 810 are as follows:

**R. F. Power Amplifier and Oscillator
Class-C Telegraphy**

D.c. plate voltage (max.)	2000 volts
D.c. grid voltage (max.)	—500 volts
D.c. plate current (max.)	250 milliamperes
D.c. grid current (max.)	70 milliamperes
Plate input (max.)	500 watts
Plate dissipation (max.)	125 watts

[Continued on Page 174]



Figure 1. The operating position of a typical UAL ground station.

While relatively new, aviation and radio are two of the foremost industries we have today. Though much has been written about each, little seems to have been said about aviation radio. From the few articles published upon this subject, the impression left with the reader seems in most cases rather vague; the articles have been rather limited to one point or one phase of the whole subject.

For the benefit of the coming aeronautical radio operator, as well as for any other interested persons, we submit a picture of aviation radio as practiced by one of the major airlines.

Let us begin at the ground radio station and then work our way through the other phases of the industry. United Airlines had 36 ground radio stations at the last census. They are located approximately 200 miles apart along the courses that their planes fly. All of the stations are standard as to equipment and method of operation. They are maintained in good operating condition by a crew of servicemen, who travel from station to station all the time, making periodic inspections and necessary repairs. These men are based at strategic points along the line, so that a rush call in an emergency will have a serviceman at the point of trouble within several hours. To complete the picture let it be added that in between the UAL stations are located the stations maintained by the Department of Commerce. These aids to aviation, whose sole duty is to aid any and all airmen flying that course by broadcasting weather, winds aloft and any other information useful to a pilot, have been very well covered in previous articles.

A Typical Ground Station

For a view of the typical ground radio station, let us take a look at figure 1. This is a picture of the usual operating position, in which we see:

RADIO

with the airlines

By JOHN DURKOVIC *

(1) The operating desk, with a typewriter well in which is located a typewriter of special design. It has a split carriage for the use of two columns of constant-feed forms. One column consists of duplicates, the other, triplicates. This is to facilitate more rapid handling of message traffic to the various interested departments on the field. The keyboard is similar to the one in use at the

* 1208 Cosgriff Ct., Cheyenne, Wyoming.

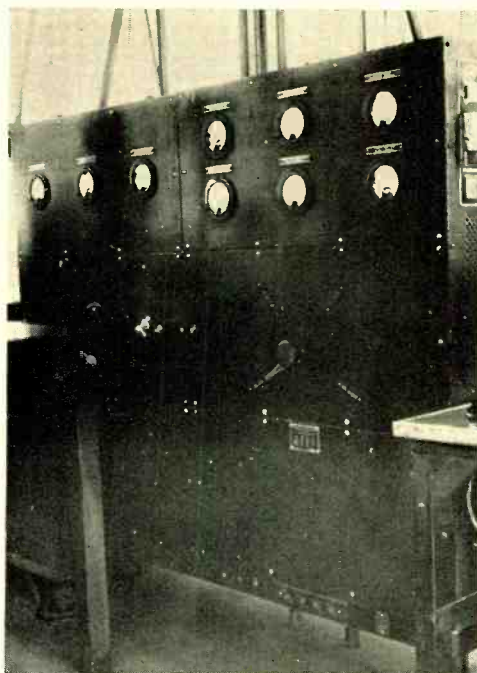

Figure 2. The four-frequency 400-watt ground-station transmitter.

Department of Commerce stations in that it contains weather code symbols especially adapted to this type of work. On the desk are also to be seen telephones for rapid communication with the various field departments as well as for city connections.

(2) In the lower right we see the teletype. In plain words, this is nothing more or less than an electric typewriter, remotely operated. On this instrument, hourly weather reports are received. These reports are received from weather observing stations, maintained by the Department of Commerce and covering the U.S.A., parts of Canada and Mexico as well as both oceans. To save time and space all information is coded and typed on a tape which is then rolled up at the other end and kept for reference. The "page" teletype records all information on a page of paper, instead of the tape.

(3) The clock is an electric-wind pendulum clock, with a sweep second hand. Master stations broadcast a time signal every hour, on the hour, and the clock is set by remote button, located to the right of the typewriter and seen as a white spot on the desk, directly under the microphone.

(4) The pipes to the left and above the

typewriter are a system of air tubes, used for rapid delivery of messages and similar to those seen in the local department store.

(5) The "shack" is located on top of a hangar or building, if possible, to insure best visibility.

Now that we have covered all the accessories, let us look into the actual radio equipment. Coming back to the desk, we can start with the microphone. This is a single-button, "press-to-talk" mike which feeds a three-stage "constant-level" amplifier, the output of which is coupled to the modulator through a three-stage audio amplifier. The task of the constant-level amplifier, as its name implies, is to keep the input to the main audio amplifier at a constant predetermined level, regardless of the input to the microphone.

The modulator consists of three W.E. 261-A tubes in parallel. The modulated amplifier is a W.E. 254-B, and it is coupled to a final W.E. 251-A linear stage.

The r.f. end of the transmitter starts with a W.E. 205-D, AT-cut crystal oscillator. This is followed by a second 205-D used as a doubler and buffer, coupled to the modulated amplifier mentioned above. The final stage, the linear, is capacitively coupled to a half-wave Hertz antenna with a single-wire transmission line. The transmitter will deliver a 400-watt carrier on any one of four frequencies with instant selection. The change-over switch is located on the front of the panel. All circuits are pretuned and four crystals are always standing by ready for instant use. When the operator desires to change frequency, a flip of the change-over switches, one on the transmitter and one on the receiver, accomplishes the purpose. The whole operation requires about two seconds. The switches mentioned may be seen in the pictures showing the front views of transmitter and receiver installations.

Receivers

For reception, usually two receivers per station are employed. These are single-signal, crystal-controlled superhets designed by UAL and built by Western Electric. Since all traffic is handled on only one frequency at one time, the receivers are fix-tuned in that only four controls are available on the outside of the panel. These are: volume control, sensitivity control, day and night frequency-shift switch and the off-on switch.

The transmitting antennas, by a change-over relay, are used for receiving. These antennas, being cut to the proper length and tuned to the operating frequency, make for best receiving efficiency. To avoid overloading and possibly damaging tubes during transmission,

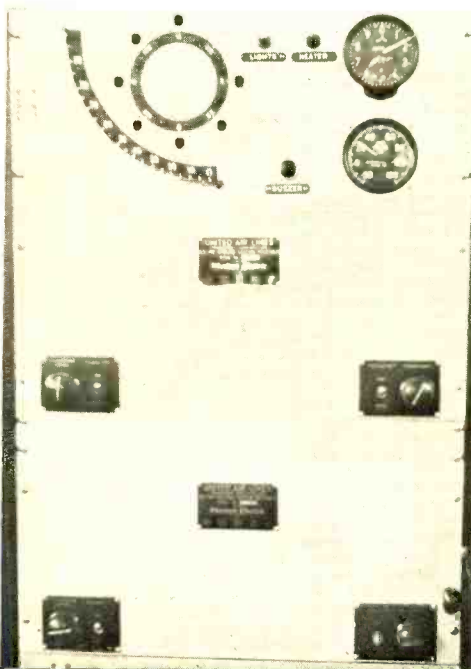

Figure 3. Section of receiving rack showing two day and night channel receivers and the weather panel.

a relay breaks the B plus circuit on the receiver every time the mike key is pressed.

Eight tubes are employed in each receiver, as follows: 6D6 day-frequency r.f. amplifier; 6A7 day-frequency detector-oscillator, AT crystal controlled; 6D6 night-frequency r.f. amplifier; 6A7 night-frequency detector-oscillator, AT crystal controlled; 6D6 first i.f.; 6D6 second i.f.; 6B7 second detector, a.v.c. and first a.f.; and 38 second a.f.

The output of each receiver is fed to a pair of jacks for earphones. The choice of the earphones rests with the operator on duty.

Now for an additional word on the frequency situation: after quite a bit of experimenting with frequencies most adaptable to aviation use, it was found that reception was best when using a higher frequency during daylight and a lower frequency during the hours of darkness. For this reason, "day" frequencies ranging from 5000 to 6000 kc., and "night" frequencies ranging from 3000 to 3500 kc. are assigned to aviation use.

On UAL the system is divided into four frequency divisions, each being assigned different day and night frequencies. This is done

to keep interference at a minimum. The frequency divisions were formed as follows: (1) Eastern Division, extending from Newark, N. J., to Chicago, Ill.; (2) Central Division, extending from Chicago, Ill., to Salt Lake City, Utah; (3) Mountain Division, formed by the triangle from Salt Lake City to Seattle, Wash., down to Oakland, Calif., and back to Salt Lake; and (4) Pacific Division, extending from Oakland, Calif., to San Diego, Calif.

Each division is assigned a day and a night frequency. In addition, the ground stations located close to the edge of their respective divisions are equipped with the two frequencies of the adjoining division, making the entire system pliable and interlocking. This has proved many times to be a great time saver, as intra-division relay work is decreased by stations being able to work into an adjoining division direct. This is where those change-over switches come into the picture. The transmitter change-over switch has already been described. In the receivers, frequency change is obtained with a toggle switch operating a relay which throws in a separate r.f.-detector-oscillator circuit, along with a crystal for that frequency.

Maintained and paid for by the airlines in the interests of safe air transportation is an organization known as Aeronautical Radio, Inc. This organization obtained the above mentioned frequencies from the F.C.C. and assigned them to the various airlines in the country. Orderly regulation by this organization has brought the use of these frequencies as well as the development of aviation radio to the high standard we enjoy today. Aeronautical Radio, Inc., is the legal representative of the airlines in all matters pertaining to aviation radio.

Let us now come back for a look at the rest of the equipment on the relay rack. Referring to figure 4 and starting from the top right and going down, we have: (a) the systems panel, containing switches, lights, jacks and plugs for control of all equipment in station; (b) weather panel, containing a wind-indicating instrument, barometer and thermometer. The wind instrument indicates the wind direction with the aid of lights, and its velocity with a column of liquid on a graduated scale. The lights operate on a commutator principle in connection with a wind vane; the liquid operates on a pressure principle. At the time the picture was taken, the wind was from the NE and 15 miles per hour. (c) superhedy receiver, on company frequencies, as already described; (d) same as (c), with fill-in panel in between; (e) constant level amplifier; (f) 12-volt, mercury-

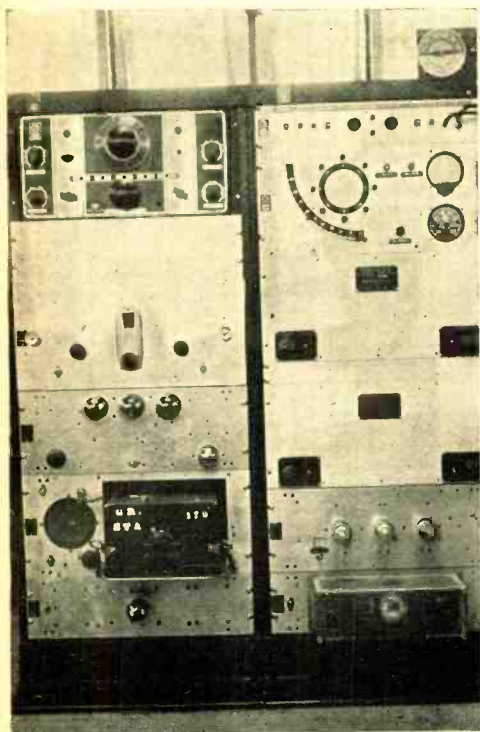

Figure 4. The complete receiving installation of a ground station.



Figure 5. An experimental installation of a static-reducing loop receiving antenna at the Cheyenne ground station.

vapor rectifier to supply all relay and microphone current.

In the rack to the left, we have: (a) a conventional superhet used in monitoring Department of Commerce frequencies for copying weather information; (b) a t.r.f. receiver used as a stand-by on 3105 kc., the aviation emergency frequency; (c) an audio amplifier, used as a p.a. system on the field, employing three 46 tubes with an 82 rectifier; (d) (black box seen next below) a long-wave W.E. 9D superhet used for monitoring the local Department of Commerce station. It is a complete installation, in that the panel contains the necessary loudspeaker, switches, volume controls, etc.; (e) an 82 rectifier power pack (bottom panel) furnishing the d.c. power for the receiver.

Figure 5 shows an experimental installation of an anti-static loop antenna. It is similar to the loop antenna used for the same purpose aboard aircraft, except that it was built larger for ground station use. Although still in the experimental stage it does very creditable work in that it reduces certain kinds of static quite appreciably. It is a rotatable affair, remotely controlled from the operator's position by crank. The dial located at upper right corner of right-hand relay rack in figure 4 indicates the direction in which the loop is pointed.

Figure 5 also shows an outside view of the

typical UAL ground radio station. It is the glass-enclosed tower seen in the background.

If the reader has tarried with us this far, it is felt he might be interested in knowing about the type of operator necessary for this type of station.

Airline Operators

To be eligible for a position as airline radio operator, a man must possess a radiotelephone second class license, or better. He must be able to type at least 50 w.p.m., touch system. He must be thoroughly versed in a knowledge of weather terms, codes, symbols and conditions. He is, at times, called upon for spot weather information, whereby he gives the pilot a report on the weather as he sees it right now.

He can and does have assistance in this respect, but the ability to do the above in a pinch, and alone, is very valuable. A good knowledge of radio theory as well as radio trouble shooting are also well worth knowing.

Level headedness, calmness under all conditions, clear diction, pleasing "air personality" are assets and all can be acquired with a little practice. A newly employed operator is put through a regular training period, but it would help no end if a man interested in entering this profession would obtain copies of the Department of Commerce weather

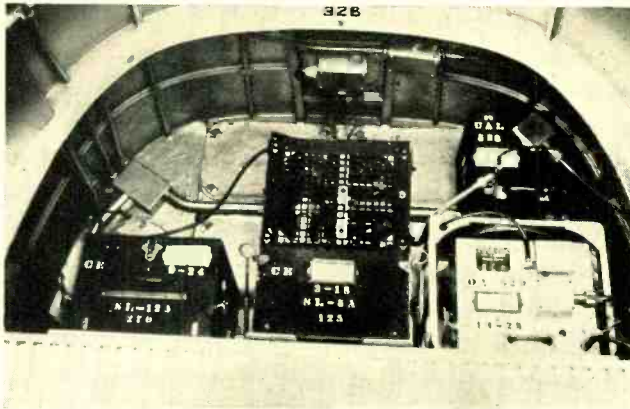

Figure 6. The complete radio installation inside a Boeing transport ship.

codes, symbols, etc. (Circular N, Washington, D.C.), getting a good basic knowledge of weather.

Incidentally, a second-class phone license is required of every man working on any and all parts of aviation radio. The aircraft radio serviceman as well as the radio mechanic fall in this category. Their job is lightened, however, by the fact that they are not required to be as well versed in weather, but they must again have a thorough knowledge of the plane equipment and wiring.

Another point worthy of mention is that any transportation business is usually a 24-hour-a-day proposition. Aviation is basically a transportation enterprise and, therefore, aviation radio comes under this heading. For this reason, an operator must be able and willing to work all hours of the day and night. This is not as bad as it sounds. Regular working schedules are arranged whereby each operator gets his share of working the various tricks of watch.

At the present time a radio operator can look for promotion to chief operator at a station; division chief operator; assistant dispatcher; or dispatcher. It is felt the future holds possibilities in this regard, but we hesitate even to attempt forecasting them. One fact is certain; aviation has not yet approached full maturity. Expansion of aviation radio, with a corresponding increase of responsible positions, depends entirely upon the growth of aviation, the limits of which at this time are unpredictable.

Aircraft Equipment

Let us now take a look at some of the plane equipment. To begin with, it is required that the pilot have, in addition to his

pilot license, at least a third-class radiotelephone license. This entitles him to operate the plane's radio equipment under the F.C.C. regulations.

At the present time, all primary power in the planes is obtained from 12-volt, 60-ampere-hour, lead-acid batteries. Each battery weighs 68 pounds, of which the Boeing type ship carries one and the Douglas Mainliner carries two connected in parallel. A 50-ampere engine-driven generator, whose output is adjustable by a control box, keeps the state of charge at a safe level. In addition, after approximately 10 hours' use, the batteries are routed through the battery shop for a thorough inspection and are serviced as and when necessary.

Transmitter power supply is obtained from a 12-volt dynamotor which furnishes 1050 volts at 500 ma. on the high voltage end. This is the plate supply for the transmitter tubes. Filament supply is taken directly from the battery.

A smaller 12-volt dynamotor, delivering approximately 250 volts at 80 ma., furnishes the plate supply for the receivers. The aircraft transmitter uses an AT-cut-crystal-controlled 205D oscillator, a 205D buffer doubler, three 261A tubes in parallel as modulators, and a 261A final amplifier. The ship transmitter measures about 10" x 13" x 14" and weighs approximately 25 pounds. It is rated at 50 watts output, high-level 100% modulated.

Plane Receivers

At present, each plane carries three receivers: one short wave for receiving UAL: ground stations, as well as other UAL ships;

one long wave for reception of Department of Commerce "beam" stations; and one auxiliary receiver capable of reception on both of these frequency ranges. The purpose of the auxiliary receiver is to permit reception of signals even during a complete failure of the regular equipment.

Under ordinary conditions, this set gets its primary power from the ship's batteries. High voltage is obtained with aid of a vibrator, just as is done in the present-day auto radio. In an emergency, by merely throwing a switch in the cockpit the set is powered by a 15-volt dry-cell battery, which will operate the auxiliary receiver for about three hours and which is entirely independent and separate from the rest of the plane's power supplies.

Both the long-wave and short-wave receivers mentioned are superhets. The s.w. is fix-tuned to the two company frequencies of the division in which the plane is flying. A rapid, manual frequency shift enables pilots to change to either day or night frequency while in flight. This receiver is also AT-cut-crystal controlled.

The long-wave receiver has a range from 200 to 400 kc. An illuminated, calibrated dial enables the pilot to tune to the various Department of Commerce "beam" stations as his flight progresses along the course. He has a list of the frequencies of each station on his course; so it becomes a simple matter to tune them in as he needs them. The pilot uses the beam primarily to guide him along his course; at the same time these stations keep him informed of the latest weather conditions ahead of as well as behind him.

Plane Antennas

Each plane carries four antennas. One transmitting antenna, located "topside," is the longest of them all, approximately 62 feet. It is mounted from nose to tail, above and parallel to the fuselage or cabin. It is loaded and tuned at the nose end, where it connects to the transmitter through a lead-in insulator.

The s.w. receiver uses the same antenna as the transmitter in connection with an antenna relay which breaks the connection to the receiver whenever the mike key is pressed for transmission.

The other three antennas are used on the long-wave and the auxiliary receivers. All three are supported from the under surface of the plane. Two of them are the conventional "V" type antennas, made of stranded phosphor bronze to eliminate failure from corrosion.

The third antenna is a rather new one. It is the anti-static loop antenna, located on the fore part of the belly just under the nose

and on the longitudinal axis of the plane. It measures approximately 10 inches inside diameter and consists of 6 turns of rubber-covered Litz wire in a formed micarta composition tubing, the whole being sprayed with a coating of cadmium, except for a spot about one-half inch wide on the center of the lower arc. The ends of the wire are connected on to a jack, for connection to receiver, the other grounded to one side of the supporting bracket.

The loop can be used as a homing device or radio compass. It is rotatable by remote control from the cockpit and an illuminated dial, calibrated in degrees, directly indicates position of the loop. As is well known, this type of antenna has nodes of signal strength depending upon its position in relation to the station to which the receiver is tuned. Utilizing this principle, the pilot is able to locate himself and to determine his position when he is flying above an overcast sky or fog.

One more point in regard to the plane equipment: because the motors do make some noise up there in the cockpit, an interphone system has been arranged, using the a.f. amplifier in the s.w. receiver whereby any member of the crew may talk to another. The

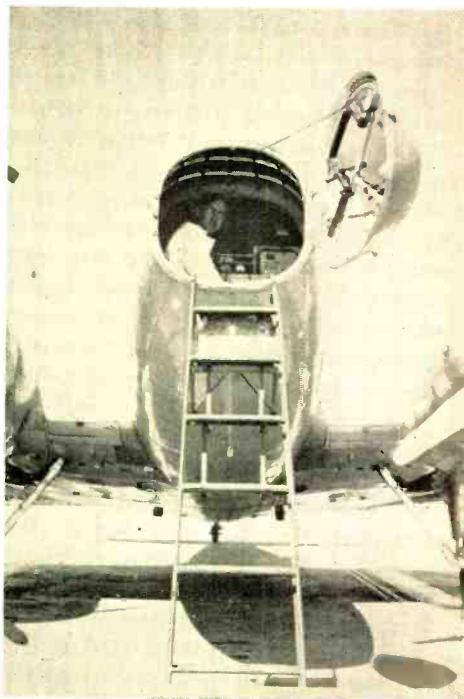

Figure 7. The location of the radio equipment as shown in figure 6 aboard the Boeing ship

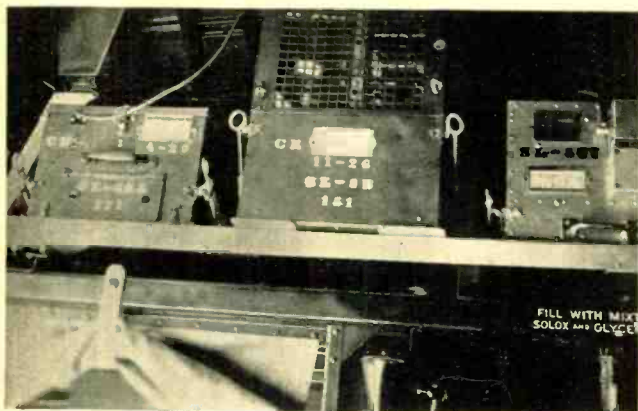

Figure 8. The radio installation inside the Douglas Mainliner.

Figure 9. The main transmitting antenna installation carried by the Douglas.



pilot and copilot use the same earphones that they wear all the time they are in the cockpit. The stewardess uses a handset. Pressing the mike button cuts in the necessary circuits for the interphone. Of course, the transmitter switch must be turned off during the use of the interphone, or everything said would be transmitted. (And don't think that hasn't happened.)

Preliminary Inspections

The above just about finishes a description of the equipment used. To make the picture a bit more complete, let us get aboard one of the "trips" about to leave Chicago. Suppose we are privileged characters and get to ride in the cockpit with the pilot, where we can watch and observe all the equipment so far described. As a preliminary outline, the following procedures are executed before and after a trip is dispatched.

The ground crew inspect and service the ship. Theirs is the job of checking and doing everything necessary for the safe operation of that plane, as well as putting aboard all the

necessary materials and supplies needed for the comfort of passengers aboard.

The stewardess, a registered nurse, checks all the passenger supplies, adjusts the seats, pillows, blankets, serves the passengers, checks their tickets and generally oversees their well being. The "Airline Hostess" would be an apt name to describe her duties.

The pilot is responsible for the safe conduct of that trip, the equipment and his passengers. The copilot is his assistant. In the cockpit, these two run up the motors, check them with the aid of instruments, and go through a regular routine of inspection and preparation for flight.

Either the pilot or copilot calls the company ground station for their ground check. This check consists of testing the radio equipment on both day and night frequencies. All information is given on the frequency opposite to the one in use on the rest of the radio circuit. This is done to avoid interference with the regular business of the circuit. The information given consists of advising the pilot of the ground wind on the field so he can plan the direction of take-off, the correct time, a

corrected barometric pressure and any other information pertinent to that particular trip or time.

After the ground check, the pilot or copilot calls the airport control tower, in this case WGEH, the Chicago control tower. From this point he receives the latest information on field conditions, field traffic, clearance and any other information of a local nature. The trip stays tuned to the tower frequency of 278 kc. until at least five minutes out. In this way, the pilot is kept advised of the position of any other planes in the vicinity of the Chicago airport. After the five-minute period is up, the pilot changes to the frequency in use on the UAL circuit and once again checks in with the ground station on that frequency, in this way checking his radio in the air. The use of the radio after this check depends a great deal upon the weather conditions, other planes in the air on the course of the trip, etc. A standard procedure is followed by all trips in reporting their position when over certain predetermined check points. Coming west out of Chicago, these check points would be: Sheridan, Sterling, Davenport, Des Moines, Adair, Omaha, etc. As can be noticed, these are towns along the course in Illinois, Iowa and Nebraska.

The Take-Off

Well, there go the pilot and copilot, getting aboard, so let us tag along. We are in the cockpit now, getting settled in our seats. A glance into the cabin shows the stewardess busily engaged in checking over the supplies aboard, inspecting all seats, the magazine rack, food rack and other miscellaneous items.

The pilot is calling the ground station; so let's listen in:

"Johnson in United trip 3, plane 65, checking with Chicago on day frequency."

"Chicago to Johnson, United trip 3, OK on day, go to night."

"Johnson OK. . . . how is it on night?"

"Chicago to United 3 OK on night, wind is E ENE10, Kollsman 3008; the correct time is 902p; United Airlines proceeds only with safety."

"Johnson, United 3, OK thanks."

That completes the check with the company ground station. Both pilots now are making a check on the motors. They are "running them up" and watching the instruments on the dash in front of them. They check the manifold pressures, watch the tachometers, oil pressure and temperatures, gas gauges and various other instruments necessary for a complete check on the motors. Everything is in perfect order. The pilot waves the wheel chocks away, and we taxi from the hangar



Figure 10. Looking forward toward the cockpit. The radio controls are the three knobs slightly below the center of the picture.

up to the administration building. He parks the plane at the gate indicated for this trip, sets his brakes and continues some minor adjustments on the equipment.

Now the copilot is picking up his mike; let's listen again:

"Jackson in United 3, on the apron, checking with WGEH; go ahead."

"WGEH to United 3, coming in OK, American Airlines due in from east at 906 p.m.; field clear after he lands; no other reported traffic. It will be OK to take off; wind is ENE 10 to 15 m.p.h."

"Jackson United 3; OK thanks."

During the check with the control tower, the passengers have been escorted to the plane and put aboard in their respective seats. The wheels are cleared, the passenger agent and the crew chief wave the pilot "all clear," the motors let out a roar, and we slowly taxi away from the "ad" building. Our copilot checks in with the control tower and obtains final clearance. The field and the air in the vicinity is all clear for our take-off.

We taxi out to the end of the runway; the pilot makes a final run-up of the motors, scans all the instruments once more and goes through a 3-minute procedure making everything shipshape. We are now lined up on the runway; the pilot gets a green light from the tower and we are off. In just a few minutes we are soaring high above the city.

[Continued on Page 168]



A companion unit to the Smith "4-25" exciter described in the December, 1938, issue or to the 56-Mc. exciter shown in this issue.

An Inexpensive 25-WATT MODULATOR

By RAY L. DAWLEY,* W6DHG

As a companion unit to either the "4-25" or the 56-Mc. exciter shown in this issue, this modulator unit is presented. Both the exciter units will run at a plate and screen input to the final stage of about 50 watts. This modulator will deliver a power output of about 25 watts with voice frequency input, ample to modulate fully the input to either of these exciters, or, for that matter, any other low-powered transmitter with 40 to 60 watts input to the modulated stage.

The amplifier would also be very well suited to use as a grid modulator for a high-powered final amplifier. More than sufficient output is available to modulate a kilowatt-input grid-modulated stage. For this use it would be advisable to place a load resistor equal to the rated impedance across the secondary winding of the modulation transformer. This will tend to stabilize the output and to reduce harmonic distortion on modulation peaks.

The amplifier could be used as a driver for a high-level class-B stage, but it would not be particularly suited to this use. The pentode 42's in the output are quite satisfactory when the load upon them is comparatively constant, but with the large variations in load imposed by the grids of a class-B stage the distortion

is greater than when using triodes in the same position. However, if about 10 db of degenerative feedback were used from one of the grids of the class-B stage to the grid of the 42 driver, the plate impedance of the 42's would be lowered to a value that would make them more satisfactory as drivers.

Tube Lineup

The first stage of the amplifier, a pentode connected 6J7, is designed to operate from a crystal or other high-impedance microphone. The input plug, at the extreme right of the front drop of the chassis, is of a shielded type allowing a firm screw-on connection to the grounded side of the microphone cable. To eliminate any possible trouble from hum pickup due to heater-cathode leakage in the first stage, the cathode of this tube is grounded and bias for the 6J7 is obtained from a single bias cell.

The plate circuit of the 6J7 is resistance-capacity coupled to the gain control, R_s , and thence to the grid of the second amplifier stage, the 6C5. The condenser C_s , from the plate of the 6J7 to ground, was found effective in eliminating any tendency toward high-frequency oscillation or toward feedback due to r.f. pickup from a high-frequency trans-

* Technical Editor, RADIO.

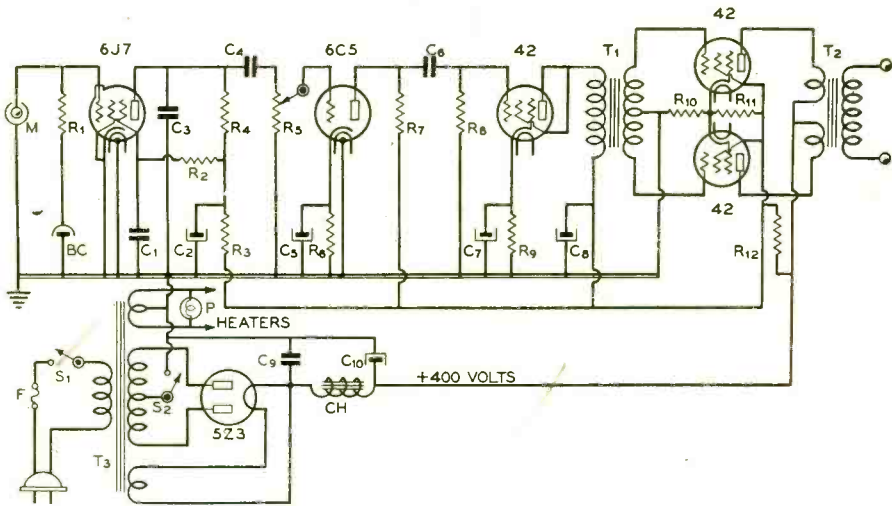

Wiring diagram of the 25-watt modulator.

- | | | | |
|---|---|--|---|
| C ₁ —12- μ fd. 450-volt electrolytic | C ₈ —12- μ fd. 450-volt electrolytic | R ₆ —2500 ohms, 1 watt | T ₁ —1.7/1 pri.-to- $\frac{1}{2}$ sec. driver trans. |
| C ₂ —0.001- μ fd. mica | C ₉ —4- μ fd. 600-volt paper | R ₇ —50,000 ohms, 1 watt | T ₂ —Multi-match output transformer |
| C ₃ —0.05- μ fd. 400-volt tubular | C ₁₀ —8- μ fd. 450-volt electrolytic | R ₈ —200,000 ohms, 1 watt | T ₃ —880 c.t., 125 ma.; 6.3 v., 3.3 a.; 5 v., 3 a. |
| C ₄ —10- μ fd. 25-volt electrolytic | R ₁ —1 megohm, $\frac{1}{2}$ watt | R ₉ —750 ohms, 10 watts | CH—9.5-hy. 110-ma. choke |
| C ₅ —0.1- μ fd. 400-volt tubular | R ₂ —1 megohm, 1 watt | R ₁₀ —250 ohms, 10 watts | P—Pilot lamp |
| C ₆ —10- μ fd. 25-volt electrolytic | R ₃ —50,000 ohms, 1 watt | R ₁₁ —10,000 ohms, 10 watts | F—2-ampere fuse |
| | R ₄ —250,000 ohms, 1 watt | R ₁₂ —2000 ohms, 10 watts | BC—Bias cell |
| | R ₅ —250,000-ohm potentiometer | | M—Shielded microphone connector |

mitter. Condenser C₂ serves to filter further the voltage from the power supply and to eliminate any tendency toward low-frequency oscillation or "motorboating" due to a common impedance between the high-level stages and the 6J7.

The 6C5 is operated in a perfectly conventional resistance coupled stage to give a voltage gain of about 14 between the 6J7 and the grid of the 42 driver.

The Driver and Output Stages

42's were chosen for use in both the driver and output stages for two reasons. First, they are inexpensive, considering their power capabilities; second, due to their ample insulation and large heater power they are able to give long service under a moderate overload.

The 42 driver is triode connected, since triode connection of this tube gives a worthwhile decrease in the overall distortion of the amplifier.

The driver transformer between the 42 and the output tubes is one allowing a choice of the transformation ratios between primary and half secondary. The highest of the three ratios, 1.7/1, was found to give the best overall results and the transformer was left connected in this manner.

The 42's in the final stage are pentode connected, for greater power output, and are operated with semi-stabilized cathode bias. R₁₁, the bleeder resistor for the power supply, is connected between the screens of the 42's and their cathodes, thus causing the bleeder current to flow through the cathode resistor. Under this condition of operation the cathode-to-ground voltage remains at a more constant value, allowing more output to be obtained from the tubes. The plates on the 42's are run at 425 volts and the screens are run at approximately 275 volts. With these values of plate, screen, and grid voltage, the 42's will give an output of about 25 watts at the secondary of the output transformer.

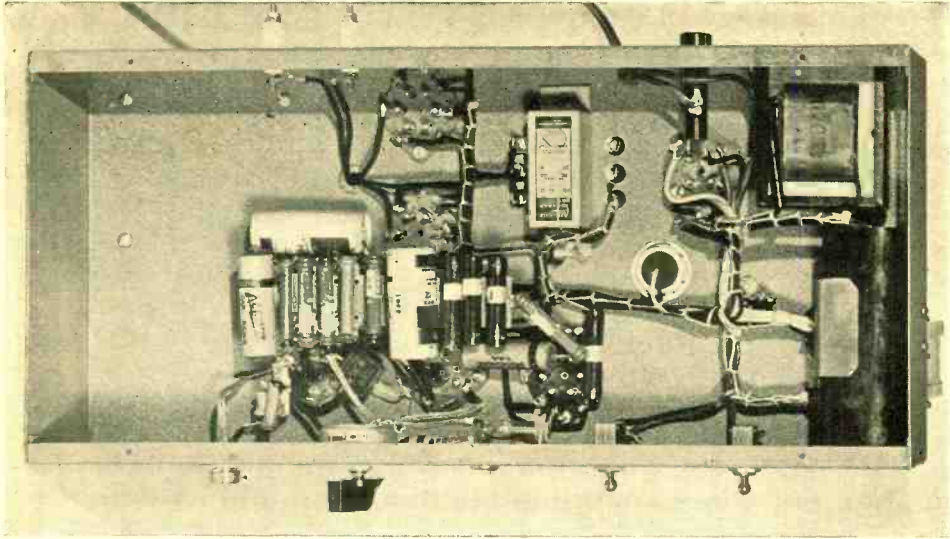

Underchassis view of the modulator. All resistors and some of the condensers are mounted upon or connected to the resistor mounting plate in the center of the chassis.

Power Supply

The power transformer used is rated at 880 volts c.t. at 125 ma. To obtain the desired 425 volts for the output stage, it was found necessary to use condenser input to the filter system. Consequently, a 5Z3 was used as rectifier in place of the more common 83. Since the load on the power supply does not vary appreciably, the stability of output voltage was found to be ample even though condenser input was being used.

Since the peak voltages impressed on the first filter condenser are quite large with condenser input, it was deemed desirable to employ an oil-impregnated paper condenser as the first filter. One of the comparatively inexpensive paper-cased condensers with wire leads was employed. A conventional metal-can electrolytic was used as the second filter condenser. Condensers C_2 and C_3 are the new compact tubular type, 12- μ fd., 450-volt electrolytics; these two condensers serve to filter further the output of the power supply in addition to their normal function as decoupling condensers.

If the modulator is to be incorporated with the station's regular operating equipment, switches S_1 and S_2 can be ganged with the other switches of the rig. If not, they will serve as the filament and standby switches, respectively. The fuse, F, is an added precaution to protect the power transformer should any of the condensers short out. A

2-ampere fuse of the small, automotive cartridge type will suffice for all normal service.

Operation

The use of the multi-match output transformer greatly simplifies placing the amplifier in operation. By the use of this transformer it is possible to operate the 42's into the correct value of load impedance when widely differing values of load are placed upon the secondary. The tubes should operate into approximately 12,000 ohms plate-to-plate with the specified values of screen and plate voltage. By consulting the chart given with the transformer, it will be possible to determine the correct taps to use when working into widely different values of secondary load.

There is one set of values given which is particularly well suited for use with the two exciter-transmitters previously mentioned. The output stages of both units normally operate at about 550 plate volts and a combined plate and screen current of about 90 ma. This gives a load value of about 6000 ohms. There is one set of tap connections which gives a 12,000-ohm plate-to-plate load on the primary with a 5460-ohm load upon the secondary. This set of connections should be used when modulating either of the above mentioned exciter-transmitters or any other amplifier of similar plate current and plate voltage operating requirements.

[Continued on Page 167]

—On the Care and Feeding of 807's

The 807 beam tetrode has found many applications in amateur transmitters because of its tremendous power gain, its high efficiency as a doubler, and because it need not be neutralized. However, certain problems are encountered with this tube which are not experienced with triodes. Several of these are covered in this article.

By W. W. SMITH,* W6BCX

Many amateurs have incorporated 807's in their exciters or transmitters and experienced no trouble in getting them to work properly. "I just hooked it up like the diagram and she perked right off." But just as often she doesn't perk right off; the stage is found to be full of parasitics and exhibits a strong desire to oscillate without benefit of external excitation. This in spite of the fact that the constants given in the diagram were followed religiously.

It is not the fault of the 807. On the contrary, it indicates that the tube has such a high power gain that special precautions are necessary unless the constructor is lucky enough to hit the right combination of values and parts layout by pure accident. More on instability later.

Plate-Screen Modulation

Another common complaint regarding 807's is actually a result of improved characteristics over the pentodes such as the 802. It is a result of the lower screen current and consequent high d.c. impedance of the screen circuit. Figure "A" illustrates the usual arrangement of components when a tetrode or pentode is to be plate-screen modulated for phone. The d.c. screen impedance of the 807 is so high that if more than about .002 μ f.d. is used at C₁ the impedance of the condenser to the higher audio frequencies will be lower than that offered by the screen circuit.

This would not be serious if the regulation of the modulating voltage on the screen were good, but the effect of the series dropping resistor R₁ is to make the screen voltage dependent to a large extent upon the impedance of the screen circuit. Thus the audio voltage impressed upon the screen by a given modu-

lating voltage applied to the B plus lead is dependent upon the audio frequency. If C₁ is large enough, the percentage modulation of the voltage applied to the screen will be negligible at the higher audio frequencies even though the plate voltage is being modulated 100 per cent. This effect will be more apparent with a high value of R₁ but will be noticeable with values as low as 10,000 ohms.

The circuit shown at "B" has none of these disadvantages, and possesses several other incidental advantages over the circuit of "A." If the condensers C₁ and C₂ are correctly proportioned, the percentage modulation applied to the screen will be practically independent of frequency (a.f.) This will hold true even with comparatively large values of C₁ and C₂ so long as they are proportioned correctly. We no longer have a modulated stage that modulates upward when "booed at" and downward when "hissed at."

Getting the correct ratio of C₁ to C₂ is made simple by the fact that a high degree of accuracy is not required, and by the fact that the correct screen voltage for a high level modulated 807 stage (normally operated) is approximately half the plate voltage. This means that the correct value of screen resistor for common values of plate voltage (around 500 volts) is one whose resistance is approximately equal to the d.c. impedance of the screen circuit, which usually figures around 25,000 ohms. Thus, with a 25,000-ohm screen resistor we need but make sure the two condensers are of the same capacity (and hence the same reactance to a given audio frequency), and the screen modulation won't know the condensers are in the circuit.

It will be noticed that the plate return is by-passed for r.f. by the two condensers in series. Thus, to determine the optimum capacities for the condensers proceed as follows: Decide upon the lowest band upon which you

* Editor, RADIO.

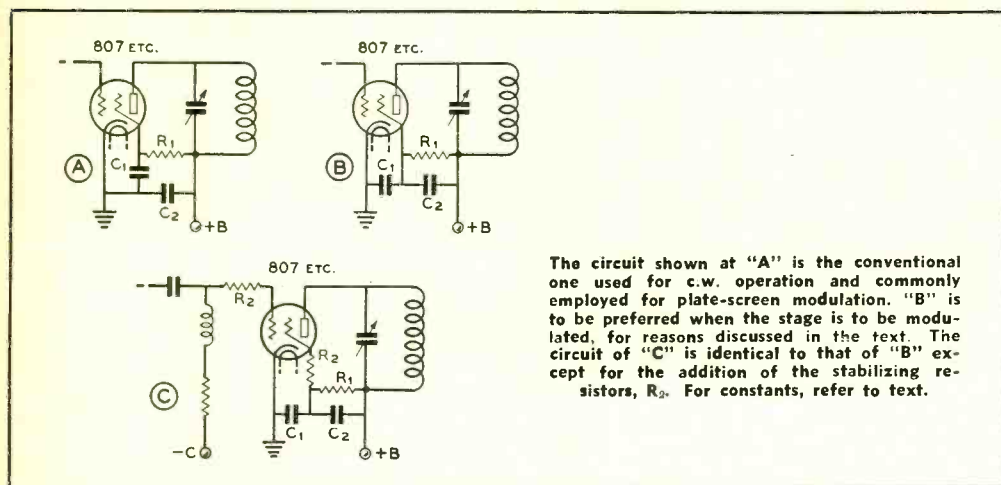

The circuit shown at "A" is the conventional one used for c.w. operation and commonly employed for plate-screen modulation. "B" is to be preferred when the stage is to be modulated, for reasons discussed in the text. The circuit of "C" is identical to that of "B" except for the addition of the stabilizing resistors, R_2 . For constants, refer to text.

expect to operate the stage. The amount of capacity required for by-passing the plate return effectively depends upon the frequency (r.f.) of operation. For 160 meters, .006 $\mu\text{fd.}$ is advisable, for 80 meters at least .003 $\mu\text{fd.}$ should be used, and so on. However, because C_1 and C_2 are in series, each should be twice the capacity decided upon as the lowest permissible by-passing capacity for the plate return. Thus if you intend to use your 807 stage only on 80 meters and shorter wavelengths, C_1 and C_2 should be at least .006 $\mu\text{fd.}$, as the effective series capacity will be halved, or .003 $\mu\text{fd.}$

In figure "B" condenser C_2 will have to be larger in capacity than C_2 in figure "A", but offsetting this is the fact that it need not be of as high a voltage rating, as the voltage impressed across it will be approximately half that impressed across C_2 in figure "A."

Stabilizing Resistors

Now to go into greater detail regarding the parasitics and self-oscillation mentioned at the beginning of the article. An 807 stage can be arranged with input and output circuits supposedly shielded, short r.f. leads, and all other details according to best design practice, and still it may exhibit instability. If so it indicates stray feedback or u.h.f. resonance of the r.f. leads. The feedback is usually a result of coupling in the return circuits, due to common impedances. Feedback that wouldn't even cause a triode to exhibit interest will cause an 807 to self-oscillate vigorously. One effective cure is to keep rearranging the physical layout until the bugs are gone. But this isn't always practical, and besides it takes up considerable time.

A simple method of taming the wildest of 807's and making them docile as lambs has been suggested by W6BHO and is illustrated at "C." With the resistors R_2 in the circuit the 807 stage loses its ferocity and will eat right out of the exciting stage's hand. The resistors R_2 are 50-ohm $\frac{1}{2}$ -watt carbon resistors, and have an advantage over parasitic chokes in that they require no "cut and try" and not only suppress parasitics but also effectively eliminate instability at the operating frequency. A resistor in one lead will not do the trick; resistors in both control grid and screen grid leads are required.

The grid current will be reduced slightly with the resistors in the circuit, especially at the higher frequencies. However, the additional excitation required is of no consequence because it is still less than a watt anyhow. Who cares if the tube requires a half-watt instead of a quarter-watt excitation? The excitation required in any case is so low that the biggest problem is excessive excitation rather than lack of excitation. It is very easy to overexcite an 807 when working "straight through." When doubling, more excitation can be used advantageously, especially if a high value of grid leak is used for bias. In fact if you are doubling in your 807 you can pour a whole 2 watts on the 807 grid. The output and efficiency are nearly as great, however, with the same value of excitation found optimum for "straight through" operation.

Beatrice Fairfax asks if radio is the modern Lorelei. She scores radio recluses, classing their stuff with golf, poker, and "the other woman."

TWO WATTS

... on the Hoof

By
JAY C. BOYD*
W6PRM

●

Front view of the little transmitter all ready for business. The microphone connector and main operating switch are located on the left side.

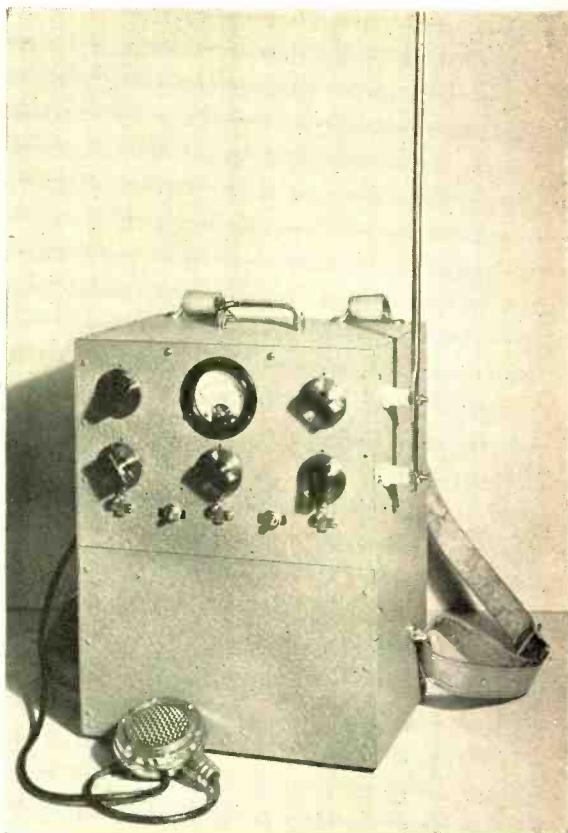

Here is a two-watt, portable-mobile transmitter designed for relay broadcast service on 40.6 Mc. It is entirely self-contained so that it may be carried on the back of some unfortunate announcer, much in the same manner as momma injun carried her little papoose.

Using batteries for power, it is independent of either power lines or telephone cables, and may be operated some distance beyond the range of either. It is particularly suitable for broadcasting outdoor sports events or for taking to the scene of unusual happenings. By increasing the number of coil turns slightly, it can be used on the 28-Mc amateur band.

Since this little rig must feed a full-grown broadcast station, it was necessary that it deliver a high-quality signal. The ancient and dishonorable self-excited, more or less modulated, oscillator was out of the question. Modulation had to approach "broadcast quality" and frequency control required either a crystal or a stable master oscillator.

The latter was chosen for several reasons, but the circuit was so designed that change-over to crystal control could be made merely

by replacing the oscillator grid coil with a crystal of suitable frequency.

This m.o.p.a. differs somewhat from the usual in that a doubler stage is provided between the oscillator and modulated amplifier. This adds much to the frequency stability. It also prevents any frequency modulation of the oscillator and eliminates frequency shifting which might be caused by antenna tuning or whipping.

The R. F. Section

As will be seen from the diagram, a type 19 tube serves as a t.n.t. oscillator, operating on 20.3 megacycles, and a doubler which drives the type 33 final amplifier at twice this frequency. This excites the quarter-wave fish-pole antenna on 40.6 megacycles.

Although the circuit appears quite straightforward, let it be known that a great deal of experimenting was necessary to get a tube and circuit combination that would really work as it should. Some of the values are rather critical, too, for satisfactory operation. You see, the tube manufacturers don't let on that these tubes will operate at radio frequencies; so it is necessary for the experimenter to find

* 2119 Longwood Ave., Los Angeles, Calif.

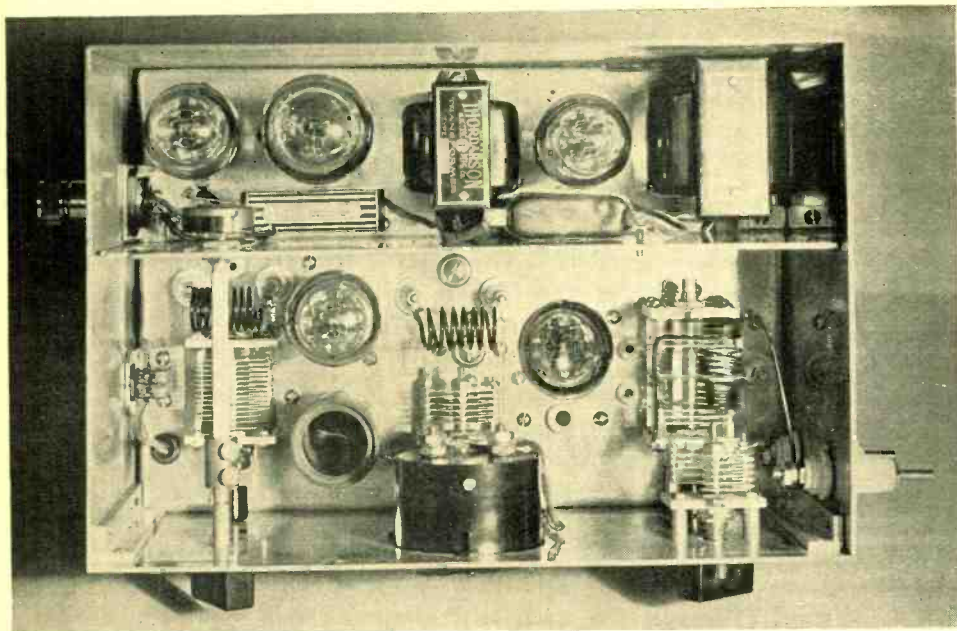

Looking down on the r.f. and modulator chassis. The shield proved quite effective in keeping r.f. from getting tangled up with the audio.

out their optimum operating characteristics for himself.

Straight capacity coupling to the final amplifier is used because it is simple and worked as well as link coupling, which was first tried. A type 19 tube was first tried in the final but sufficient excitation for linear, 100 per cent modulation could not be obtained.

Of the several two-volt pentodes available, the type 33 was chosen because of its greater filament power. Its grid is only partially shielded by its screen; so neutralization is necessary. An isolantite-mica trimming condenser serves nicely, and requires little space. This is suspended from a couple of small cone-type insulators which are mounted below the chassis in an inverted position. Adjustment is made by removing the adjusting screw and bending the movable plate in or out as necessary for complete neutralization.

Final grid and plate currents may be read from the single meter, having a 10-ma. movement. External shunts of one-fourth the meter resistance are required. These are made by winding a few inches of small resistance wire (from an old rheostat) around carbon resistors which serve as miniature coil forms and simplify the mounting problem.

Both plate and screen of the final amplifier were modulated in order to secure good linear-

ity. It is usually preferable to by-pass the screen dropping resistor, but due to the comparatively low value used, excellent linearity was obtained without it. The screen by-pass condenser should not be larger than specified, though, or the high-frequency audio response will be attenuated too much.

The final amplifier is operated at 150 to 180 volts and 25 to 30 ma., depending on the condition of the B batteries. This gives an input of 4 or 5 watts. With a screen current of six or eight ma., this represents a load impedance of about 4800 ohms.

Speech Amplifier and Modulator

In order to obtain good fidelity, liberally-designed class-B transformers were selected. In fact, the modulation transformer is labeled for a 6A6. Those designed for 19's usually have too low a secondary impedance and might have made the little rig sound like an aircraft transmitter. The latter would do for amateur work, but better quality is desirable for broadcast pickup.

Taking the screen dissipation into consideration showed that about three watts of audio power would be required for 100 per cent modulation. This is about fifty per cent more than a 19 will produce, if operated according to manufacturer's data. A measured 3.15

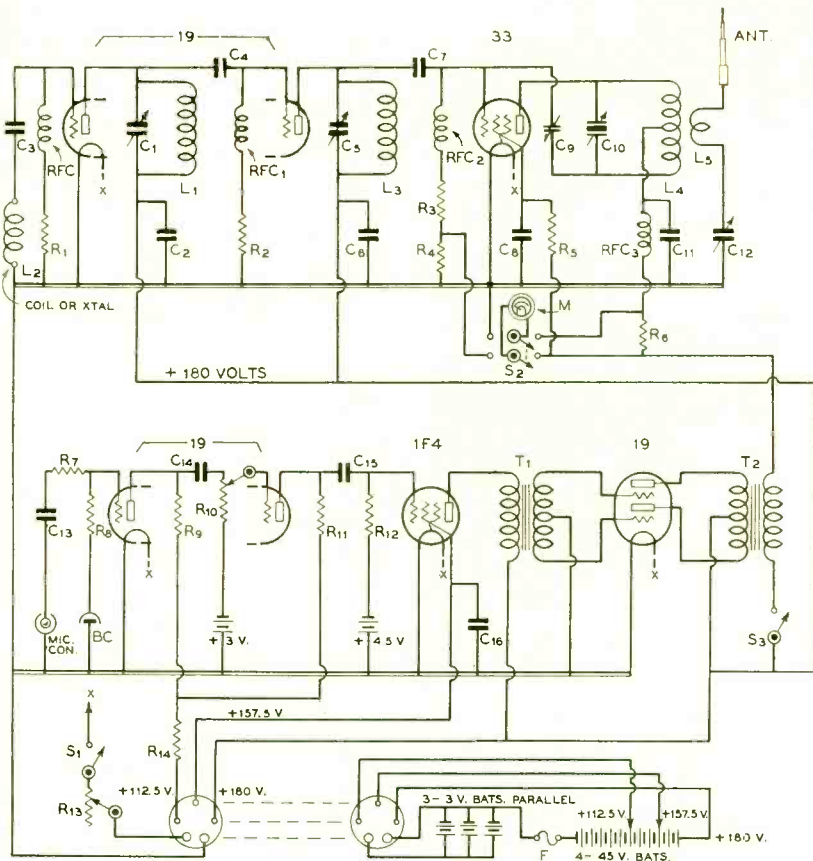

Schematic of the two-watt, portable-mobile transmitter.

- C₁—140- μ fd. midget variable
- C₂—0.006- μ fd. mica
- C₃, C₄—0.0001- μ fd. mica
- C₅—35- μ fd. midget variable
- C₆—0.006- μ fd. mica
- C₇—0.0001- μ fd. mica
- C₈—0.006- μ fd. mica
- C₉—3-30- μ fd. trimmer
- C₁₀—25- μ fd. per section split-stator midget
- C₁₁—0.006- μ fd. mica
- C₁₂—35- μ fd. midget variable
- C₁₃—0.5- μ fd. 400-volt tubular
- C₁₄, C₁₅—0.1- μ fd. 400-volt tubular

- C₁₆—0.5- μ fd. 400-volt tubular
- R₁—1000 ohms, 1 watt
- R₂—50,000 ohms, 1 watt
- R₃—15,000 ohms, 1 watt
- R₄—0.8-ohm shunt, see text
- R₅—5000 ohms, 1 watt
- R₆—0.8-ohm shunt, see text
- R₇—1 megohm, 1/2 watt
- R₈—5 megohms, 1/2 watt
- R₉—200,000 ohms, 1/2 watt
- R₁₀—500,000-ohm potentiometer

- R₁₁—200,000 ohms, 1/2 watt
- R₁₂—500,000 ohms, 1/2 watt
- R₁₃—6-ohm rheostat
- R₁₄—100,000 ohms, 1/2 watt
- RFC_{1,2,3}—2 1/2-mh. r.f. chokes
- F—1/2-ampere midget fuse
- T₁—Class-B driver transformer for 6A6 or 19 tube
- T₂—Class-B output transformer for 6A6 or 19 to 4500-ohm load
- L₁—10 turns of no. 14 enameled wire
- L₂—7 1/2 turns of no. 18 enameled wire

- L₃—6 turns of no. 14 enameled wire
 - L₄—9 turns of no. 14 enameled wire
 - L₅—2 turns of no. 14 enameled wire
- Note—L₁, L₃, and L₄ are all wound on a 9/16-inch form and stretched to 1-inch length. These tune to 7 1/2 meters. Their size should be increased about 50 per cent for ten meters or decreased about one third for five-meter operation.

watts was produced, however, by applying 180 volts to the plates and more grid excitation than usual. The waveform showed no appreciable distortion at this power but began to flatten and kink if driven beyond this value. Listening to the modulator while driving a 12-inch speaker showed excellent fidelity, both with voice and music. The waveform and frequency response were checked on a cathode-ray oscilloscope with the speech amplifier driven by an audio oscillator of variable frequency.

Type 19 modulators are often driven by type 30 drivers, but the latter tube will not furnish enough power to drive the modulator to more than about one-and-a-half watts. A 1F4 was selected because of its comparatively high class-A output and low excitation voltage. While pentode drivers are not generally desirable, no distortion could be observed under the conditions at which the driver is operated. This is because it is called upon to furnish only about half the power of which it is capable.

The preamplifier was somewhat of a problem and headache. Specifications called for operation from a diaphragm-type crystal microphone, and the proper amount of gain is none too easily obtained with the tubes and plate voltage available. A 1B4 worked well when talking close to the mike but this might not always be permissible.

Another 19, operating as a resistance-coupled cascade amplifier, gave plenty of gain but required careful handling to prevent self-oscillation. Separate bias batteries were used on all stages. Dissimilar bias is used on the preamplifier sections for the simple reason that it worked better that way. There was some trouble with feedback from the high-level stages operating from the same B's. The most effective means of decoupling was the using of a different voltage tap for the preamplifier, with the addition of the plate decoupling resistor shown. With the values given, the gain may be run wide open so long as the modulator is working into its proper load. The gain was much greater than obtained with the 1B4 originally used.

The Power Plant

Four blocks of Burgess no. 5308 B batteries are used to supply the plate current, and when these are placed horizontally so their terminals will be more accessible, they fit as though they were "poured in." Three blocks of F2BP, 3-volt A batteries lie flat on top of the B's, with enough room left at the side for a connecting plug and socket. All C batteries are located right in the audio section.

Total B battery drain is 90 ma., kicking up over 100 ma. with modulation. A set of batteries may last only three or four hours, but this is ample for the service intended. If anyone should duplicate this little transmitter for amateur use, they are advised to use larger batteries so the operating costs won't strain the pocketbook.

A 6-ohm rheostat, accessible by a screw-driver slot in the rear of the cabinet, is used for keeping the filaments at 2 volts. All A and B voltages may be measured by removing the cover.

Cabinet Construction

The compact transmitter is housed in an aluminum cabinet. Its width of 10 $\frac{5}{8}$ inches was determined by the four blocks of B batteries. The height is 13 $\frac{1}{4}$ inches and depth 7 $\frac{1}{2}$ inches. The weight is about 30 pounds, or about ten pounds lighter than regulation army packs.

The shoulder straps are detachable, since the transmitter may not always be carried as a pack. These must be carefully placed so the pack will not be uncomfortable.

It will be noted that the chassis is only slightly narrower than the panels and that these latter are placed inside the cabinet. This requires some very careful fitting but conserves space. The angle pieces are riveted to the panels, the panels being removed by taking out the screws on the sides of the cabinet.

A shield is shown between the r.f. and audio sections. There is another below the chassis, as well as a partition between the chassis and battery compartments. This avoids trouble from r.f. feedback.

Antenna System

An eight-foot telescoping automobile antenna is mounted on ceramic insulators. It operates as a Marconi with the cabinet as ground. A series condenser is used to facilitate tuning, although this might be done by telescoping the antenna. About 75 inches seems to be the correct length for 40.6 Mc., although it is not at all critical.

Testing was confined mostly to a dummy antenna and oscilloscope, with a nearby receiver as monitor. Modulation was linear up to 100 per cent and quality quite gratifying. The output was two or two-and-a-half watts, depending on battery voltage.

On one occasion the little rig was hooked onto a ten-meter antenna and tuned within that band. The coupling was rather makeshift, and the amplifier drew only about half-

[Continued on Page 171]

A
Great-Circle

GLOBE

By

HARRY L. WOODLEY*

W6LSK



A great circle map of some kind is almost a necessity around the shack of any dx-minded ham. For, although there has been considerable conjecture on the matter, it is generally agreed that radio signals of frequencies lower than 15 megacycles follow great circle paths between transmitting and receiving stations. Unfortunately, however, the great circle maps available in this country through the usual channels are centered on Washington, D. C., Topeka, or San Francisco. These maps are practically useless to a great number of amateurs who live some distance from these three cities.

Fortunately, with the aid of a ten-cent-store globe, any amateur can have a great circle globe of infinitely greater utility than a great circle map which is centered on a city several hundred miles from his home.

Rebuilding the Globe

The actual construction of the great circle globe is extremely simple. First, procure a globe similar to the one shown in the photograph. It should be about six inches in diameter and of the type having a small loose metal disc at the north pole which is intended

to be used for time correction between various localities. The mounting ring should have enough spring to allow removing the globe and remounting it on its new "poles." The one illustrated sold for twenty-five cents at a ten-cent store.

First, remove the globe from its mounting and bore a hole through your home town. This hole should be the same size as the holes originally punched in the globe at the north and south poles. Now bore another hole at your antipode. This hole will be at a point on the globe directly opposite your home town, of course. The antipode may easily be located by counting the degrees of latitude from the home town to the nearest pole and then counting off the same number of degrees from the *other pole* and on the opposite side of the globe. The opposite longitude may be traced right across either pole.

The Direction Indicator

The direction indicator may next be made from the time correction disc. The original marks on the disc are obliterated by dipping the disc in white paint. After the paint has

* 302 E. Pierce, Phoenix, Arizona.

dried, the four cardinal points of the compass should be marked on the disc with india ink. Any number of divisions may be marked in between these four points. Fifteen-degree divisions will be satisfactory for most purposes, however.

These divisions may be marked to read in any way the constructor desires. They may read east and west deviation from north, reading around 180 degrees in each direction at the south mark. Alternatively, they may be marked to read deviation from both north and south, thus reading up to 90 degrees in each direction at the east and west marks. The actual method of marking is of little importance, however, and depends entirely on individual preference.

The disc should be mounted directly over the hole at the home town and oriented so that its north line points directly toward the north pole. This direction can be determined accurately by stretching a string from the home town and the north pole and aligning the north line with the string. The disc may be held in place with a couple of escutcheon pins.

Using the Globe

The globe should now be reassembled on its mounting and is ready for use. By sighting down on the globe in the plane parallel with the mounting ring, the great circle path between the home town and any other point on the earth's surface may be determined. At the same time, the deviation from north (or south, if the direction indicator is so marked) may be read by sighting down on the indicating disc.

A word of caution is probably in order in connection with the direction indicator. When aligned as explained above, it gives the deviation in degrees from *true* north or south. This deviation is not the same as that indicated by an ordinary magnetic compass, which points to the magnetic pole. The magnetic pole is some distance from the true north pole and may be as much as 20 degrees east or west of the true pole, as viewed from various parts of the country. Any surveyor can give the amount of declination for any particular locality. This figure should be taken into consideration when figuring the direction of dx stations or lining up directive antennas.

DANGER — High Voltage

Most doctors show less respect for germs and more disregard for common sense rules of health than the layman. Likewise amateurs, who should know enough about the effects of high voltage to treat it with great respect, are notoriously careless in this regard. Possibly familiarity breeds contempt.

Most amateurs balk at incorporating in their apparatus numerous and elaborate safety devices considered as standard equipment on commercial radio transmitting apparatus. Rather than take space to describe safety devices which few amateurs would ever use, we are going to reprint a few timely warnings that first appeared in the 1938 edition of the RADIO HANDBOOK.

The high voltage power supplies even in a low-power transmitter are potentially lethal. They are also potential fire hazards. Pages could be written on "don't's" and precautionary measures, but the important thing is to *use your head*; don't fool with any part of your transmitter or power supply unless you

know exactly what you are doing and have your mind on what you are doing.

Not only should your transmitter installation be so arranged to minimize the danger of accidental shock for your own safety, but also because "haywire" installations that do not pass the underwriters' rules will invalidate your fire insurance. You have no claim against the insurance company if they can prove that the installation did not meet underwriters' specifications.

Some of the most important things to remember in regard to the high voltage danger are the following:

Do not rely upon bleeders to discharge your filter condensers; short the condenser with an insulated-handle screwdriver before handling any of the associated circuits. Bleeders occasionally blow out, and good filter condensers hold a charge a long time.

Beware of "zero adjuster" devices on meters placed in positive high-voltage leads. Also be

[Continued on Page 167]

A Novel Beam Antenna

DIRECTION INDICATOR

This indicator gives you a real picture of where the signals from your rotatable "signal squirter" are going, and just what the coverage of your beam is for any position of the antenna.



By DONALD G. REED, * W6LCL

While the great circle indicator globe described on page 81 of this issue is just what the doctor ordered when it comes to orienting fixed arrays with great accuracy, a modification of this gadget is more useful for giving continuous indication of the coverage of a rotary array as it is swung around the compass. Such a device is shown in the accompanying illustrations, which are largely self-explanatory as regards operation.

Construction

First, determine how broad the "nose" of your beam is in degrees. This can be done by noting how far the array can be rotated before there is a noticeable change in signal strength. This information will be required later.

Next, procure a small, inexpensive geographical reference globe, the type obtainable from most 5 & 10 cent stores. As hair line accuracy is not required, the cheap, pressed metal type will serve nicely. These are usually constructed in two halves, snapped together at the equator.

Locate your exact position on the globe, and then, by checking the latitude and longitude, determine the antipode. Drill two small holes

through the metal shell at these points, and using a stiff wire as a shaft, rotate the globe on its new axis. Mark an imaginary "equator" on the shell with a pencil as the globe is spun on its new axis.

Separate the two halves of the shell at the regular equator. Only moderate pressure should be required to spring the halves apart. With a pair of good tin snips, carefully cut along the artificial equator. When each hemisphere has been cut in this manner, solder the pieces together where they were originally pressed together at the true equator. You now have two "oblique" hemispheres, with your location the center of one and your antipode the center of the other.

In the photographs these are assembled on a display board. In actual practice they are mounted on a vertical piece of Masonite or plywood fastened to the back of the operating table near the antenna "steering wheel." Small blocks of wood, whittled to suitable shape, are glued to the mounting board, and the hemispheres are fastened to the blocks by means of small tacks or wood screws. The holes poked in the metal shell are then enlarged just enough to take a quarter-inch shaft. Corresponding quarter-inch holes are drilled in the mounting board to allow the shafts to protrude behind the board as in the illustration

* 2454 Lyric Ave., Los Angeles, Calif.

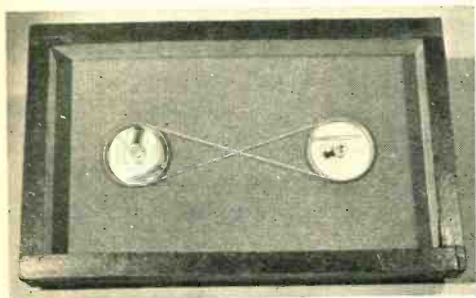

The indicator drive shafts are ganged with 1 to 1 ratio and the belt is crossed over to allow rotation in proper relation.

of the back of the assembly. The shafts are threaded or drilled and tapped on one end to allow the rotating indicators to be attached.

If the holes in the mounting board are not reinforced they will wear in time. Better bearings can be had by using the quarter-inch "panel bearings" offered by several manufacturers. Or, ordinary jacks can be used by bending the contact spring away from the shaft. A quarter-inch shaft will just fit snugly.

Indicators

The indicators are made from no. 14 or no. 12 wire, bent so as to include an arc equal to the coverage of the beam. The indicators illustrated are for a fairly sharp, unidirectional three-element array. A bidirectional array would require double indicators, which would look like a "butterfly," extending in opposite directions from the axis of rotation.

At first it might seem odd that the beam converges again at the antipode, and is broadest at approximately 6200 miles. Many amateurs seem to think the beam continues to get broader as it approaches the antipodes, but this is not so. Except for a very slight amount of bending, which varies with conditions and is seldom over 5 degrees at most, the "edges" of the beam follow a great circle path just as much as does the "nose" of the beam. And as all great circle paths from any point on the earth cross at the antipode, the beam consequently converges at the antipode, and would be extremely narrow at points near the antipode were it not for the slight bending previously mentioned. No allowance is made on the indicators for this slight spreading of the beam due to bending, as it is rather indeterminate and subject to conditions.

Two pulleys, of the type used to drive vernier tuning dial indicators and available as re-

MEMORIZING THE COLOR CODE

By C. O. MORRISON*

Adoption by the Radio Manufacturers Association of a standard color code for the marking of resistor and small condenser values is a boon to the serviceman and amateur. Too often, however, the use of a chart is necessary to decipher the value of a resistor. Upon discovering that the main portion of the color code was built around the same color sequence as the spectrum or rainbow, the writer has found it easy to memorize the code.

The code is built on the use of a different color for each numeral, from zero to nine inclusive. Since black is absence of color, it stands for zero. Brown is one; you will just have to remember that. Now come the colors of the rainbow in order. "But I don't know the colors of the rainbow," you may protest. Here's the trick. Meet Roy G. Biv. The letters of this fellow's name stand for the following colors and numerals: (2) red, (3) orange, (4) yellow, (5) green, (6) blue (includes I for indigo), (7) violet. Now since white is the opposite of black, we will let it stand for the other end of the series, or for 9, gray is almost white; so we shall let it stand for 8. The ten numerals of our decimal system are now represented by colors.

In use, a resistor is painted with one body color, an end (or both ends) is then painted with another color, and a third is used in a dot or stripe near the center of the resistor. The body color represents the first integer of the ohms value, the end color the second integer, and the dot or stripe color the number of ciphers following. Thus a red body, green end, and yellow dot means a 2 and a 5 followed by four zeros, or 250,000 ohms. If a resistor seems to have no dot it must be interpreted as having the same color dot as the body color.

Fixed condensers are sometimes marked with a series of three colored dots in line. The first dot gives the first integer, the second is the second integer, and the third is the number of ciphers. The resulting figure is the capacity in μfd . A series of orange, black and brown dots mean 300 μfd . or .0003 μfd .

Just grab a few resistors from the junk box and work out the system a few times to fix it in your mind and you'll never have to worry about misplaced color code charts.

[Continued on page 172]

* Lincoln High School, Lincoln, Nebr.

Swing It!

An Easy Way to Memorize the Code

By ERIC T. LEDIN,* W6MUF

Served on a platter in the license manuals is all the technical information necessary for that ham ticket, but in spite of stiffening exams, the bugbear of many a would-be is still that 13 words per. Very little help other than a code chart is offered, and to sit down and memorize dots and dashes, especially if the gray matter has slightly congealed with the years, is no waltz—that is, unless you can manage to make a swing session out of it.

Back in 1922 when the recently defunct Literary Digest was doing the marching, a radio column was a regular feature. Not the southern exposures of the Bopwell sisters but actual technical articles. From these dignified pages came my first crystal set—a marvel of paper clips and an ice cream carton, and from the same source—may it rest in peace—came an idea on learning the code that started my ham career.

That the unknown author of the above article had something on the ball is evidenced by the fact that after sixteen years, the details of that scheme are clear in my mind even though the actual mechanics are forgotten. I found it possible to reproduce the word groups so that some of them, because of memory tricks, are no doubt the originals.

Code and Rhythm

The idea of applying rhythm to code memorizing is by no means new. In March, 1936, R. H. Lampkin Jr. wrote an excellent article for RADIO on this very subject and even approached this idea quite closely in his grouping of words which contained the various letters of the alphabet. His application of musical notation to the actual code characters and spacings is especially well drawn and should be studied if at all possible.

The present opus is not intended as an improvement or a re-hash but as an adjunct to the above mentioned article. Once the code is actually memorized, the application of

rhythm is invaluable if progress is to be made, but that initial hump of getting the symbols to stick in your mind is still there, and the method stumbled upon so long ago is still the simplest encountered by the author.

Remember iambic pentameter and metric feet? Did you ever perspire at a blackboard scanning a line of Wordsworth's and translating the beats into symbols very much akin to the Morse code? It didn't take long before you could take a line of poetry and reduce it to a series of dots and dashes. The same can easily be done with words or word groups.

Take the word li-no-le-um. The accent naturally falls on the second syllable, and scanning the word would produce a distinct beat of the form (.—.), whereas the word un-der-stand has a different accentuation, obviously (.—).

Word Groups

Not necessarily confining ourselves to single words, the phrase Hilly Billy produces four short beats which would appear as (...). Those familiar with the code will already see the connection. What we have arrived at is three distinct letters of the code alphabet, namely L, U and H. To facilitate the association, each word or word group commences with the letter which it symbolizes and a study of the following list will make the idea even clearer.

—	Around
—...	Bakery Bun
—.—.	Crowded Cloister
—..	Dangerous
—	Egg
...—.	Fifi Foolish
—.—.	Good Gracious
....	Hilly Billy
..	Izzy
—.—.—	Jerome K. Jones
—.—	Kokomo
—.—.	Linoleum
—	May Day
—.	Neighbor

* Sausalito, Calif.

-----	Ozone Blows
-----	Polite People
-----	Quite Queer Indeed
-----	Reported
-----	Sissy Sid
-----	Tea
-----	Understand
-----	Visible Ray
-----	Without Words
-----	Hoax Silly Jokes
-----	Yes and You Too
-----	Zero Weather

At first glance this idea may appear confusing and then possibly will come an impatience with the scheme of memorizing an entire set of disconnected words in addition to the symbols. After reading through the chart just

once, however, several of the words will stick and you will find yourself unconsciously drumming a "dah dit dit dah" in tune with "Hoax Silly Jokes."

The one fault of this system is that memorizing is in this instance easier than forgetting—and complete disassociation of the word groups is necessary once they are learned, so that it will be possible to force the "Crowded Cloister" into the background and think of that distinctive beat only in terms of "C."

The inconvenience of learning irrelevant material that must be laboriously forgotten is overshadowed by the pleasure of grasping the code in a matter of an hour or so, and once it is possible for you to start "dahing" and "ditting" a page of type, progress will be rapid enough to carry its own encouragement.

Radio In the Andes

The Andean Anthropological Expedition is a nonprofit organization incorporated for the advancement of science. The expedition is sponsored by the Arizona Anthropological Association and the University of Arizona, and has the endorsement of twelve other universities, nineteen governmental agencies and eleven museums, besides many of the leading scientists of the country.

Two radio transmitters will be taken on the expedition, a 15-watt portable job powered by a hand generator, and a 100-watt transmitter for operation at the base. The latter will be powered by a gasoline-driven generator. Other transmitters will be added as the need for them arises when the expedition is in the field and a better idea as to the requirements is obtained from actual experience.

The expedition is accredited by the United States Department of State, Washington, D. C., through the Honorable Cordell Hull, Secretary of State. Through the cooperation of Dr. L. S. Rowe, Director General of the Pan-American Union and the Ambassadors of Ecuador and Peru, permits to enter and conduct research in these countries have been granted by the Ministers of Foreign Affairs of these two republics, and such diplomatic aid as lies within their jurisdiction has been offered the expedition.

Under the directorship of Dr. Robert E. Solosth, the expedition will conduct its investigations on the eastern slopes of the Andes mountains on the headwaters of the Amazon River in Ecuador and Peru.

The branches of science to be represented on the personnel are general anthropology; and, as the need for specialization in the separate divisions arises, physical anthropology, cial anthropology, ethnology, archaeology, dermatoglyphology and philology; general medicine and its allied sciences among which are tropical medicine, endocrinology, surgery, ophthalmology, refraction, dentistry and biologic and organic chemistry, with studies in botany and ethno-botany.

Special research in tropical medicine will be carried on by members of the staff who are particularly interested in this field of research.

The first base headquarters in Ecuador will be established at an altitude of 3500 feet, where living conditions are ideal, pure water abundant and climate healthful. Here permanent headquarters will be constructed to house the expedition personnel, the equipment and supplies and the permanently installed laboratories of each branch of science. At this base an aviation landing field will be

[Continued on Page 171]

REVISED AMATEUR REGULATIONS

The Federal Communications Commission at a regular meeting October 4 revised its regulations governing amateur radio stations and operators, the revisions to become effective December 1, 1938.

The changed regulations recognize the increasing importance of operation by the amateurs in emergencies affecting domestic communication facilities. The new rules provide for the use of specified frequencies in handling emergency communications and require all amateur stations in the affected area not engaged in relief work to discontinue operation on these frequencies during the emergency period.

Sec. 152.54. *Operation in Emergencies.* "In the event of widespread emergency conditions affecting domestic communication facilities, the Commission may confer with representatives of the amateur service and others and, if deemed advisable, will declare that a state of general communications emergency exists, designating the licensing area and areas concerned (in general not exceeding 1,000 miles from center of the affected area), whereupon it shall be incumbent upon each amateur station in such area or areas to observe the following restriction for the duration of such emergency:

"a. No transmission except those relating to relief work or other emergency service such as amateur nets can afford, shall be made within the 1715-2000¹ kilocycle or 3500-4000 kilocycle amateur bands. Incidental calling, testing, or working, including casual conversation or remarks not pertinent or necessary to constructive handling of the general situation shall be prohibited.

"b. The frequencies 1975-2000, 3500-3525, and 3975-4000 kilocycles shall be reserved for emergency calling channels, for initial calls from isolated stations or first calls concerning very important emergency relief matters or arrangements. All stations having occasion to use such channels shall, as quickly as possible, shift to other frequencies for carrying on their communications.

"c. A five-minute listening period for the first five minutes of each hour shall be ob-

served for initial calls of major importance, both in the designated emergency calling channels and throughout the 1715-2000¹ and 3500-4000 kilocycle bands. Only stations isolated or engaged in handling official traffic of the highest priority may continue with transmissions in these listening periods, which must be accurately observed. No replies to calls or resumption of routine traffic shall be made in the five-minute listening period.

"d. The Commission may designate certain amateur stations to assist in promulgation of its emergency announcement, and for policing the 1715-2000¹ and 3500-4000 kilocycle bands and warning non-complying stations noted operating therein. The operators of these observing stations shall report fully the identity of any stations failing, after due notice, to comply with any section of this regulation. Such designated stations will act in an advisory capacity when able to provide information on emergency circuits. Their policing authority is limited to the transmission of information from responsible official sources, and full reports of non-compliance which may serve as a basis for investigation and action under Section 502 of the Communications Act. Policing authority extends only to 1715-2000¹ and 3500-4000 kilocycle bands. Individual policing transmissions shall refer to this Section by number, shall specify the date of the Commission's declaration, the area and nature of the emergency, all briefly and concisely. Policing-observer stations shall not enter into discussions beyond essentials with the stations notified, or other stations.

"e. These special conditions imposed under this Section will cease to apply only after the Commission shall have declared such emergency to be terminated."

The new rules specify higher technical standards for the operation of amateur stations to reduce possibility of interference to other services as well as improving the amateur serv-

¹ Subject to change to "1750 to 2050" kilocycles in accordance with the "Inter-American Arrangement Covering Radiocommunication," Havana, 1937.

ice. Under the revised rules the amateur station is not permitted to transmit music although the transmission of single audio-frequency tones is permitted for testing.

Sec. 152.16. *Broadcasting Prohibited.* "An amateur station shall not be used for broadcasting any form of entertainment, nor for the simultaneous retransmission by automatic means of programs or signals emanating from any class of station other than amateur."

Sec. 152.17. *Radiotelephone Tests.* "The transmission of music by an amateur station is forbidden. However, single audio-frequency tones may be transmitted by radiotelephony for test purposes of short duration in connection with the development of experimental radiotelephone equipment."

An amateur station causing general interference, or violating certain rules may be silenced for specified hours, which may be increased in the event that corrective measures are not immediately applied.

Sec. 152.42. *Requirements for Prevention of Interference.* "Spurious radiations from an amateur transmitter operating on a frequency below 60,000 kilocycles shall be reduced or eliminated in accordance with good engineering practice and shall not be of sufficient intensity to cause interference on receiving sets of modern design which are tuned outside the frequency band of emission normally required for the type of emission employed. In the case of A-3 emission, the transmitter shall not be modulated in excess of its modulation capability to the extent that interfering spurious radiations occur, and in no case shall the emitted carrier be amplitude-modulated in excess of 100 per cent. Means shall be employed to insure that the transmitter is not modulated in excess of its modulation capability. A spurious radiation is any radiation from a transmitter which is outside the frequency band of emission normal for the type of transmission employed, including any component whose frequency is an integral multiple or submultiple of the carrier frequency (harmonics and subharmonics), spurious modulation products, key clicks, and other transient effects, and parasitic oscillations. The frequency of emission shall be as constant as the state of the art permits."

Sec. 152.43. *Modulation of Carrier Wave.* "Except for brief tests or adjustments, an amateur radiotelephone station shall not emit a carrier wave unless modulated for the purpose of communication."

Sec. 153.44. *Frequency Measurement and Regular Check.* "The licensee of an amateur

station shall provide for measurement of the transmitter frequency and establish procedure for checking it regularly. The measurement of transmitter frequency shall be made by means independent of the frequency control of the transmitter and shall be of sufficient accuracy to assure operation within the frequency band used."

Sec. 152.51. *Quiet Hours.* "In the event that the operation of an amateur station causes general interference to the reception of broadcast programs with receivers of modern design, such amateur station shall not operate during the hours from 8 o'clock p.m. to 10:30 p.m., local time, and on Sunday for the additional period from 10:30 a.m. until 1 p.m., local time, upon such frequency or frequencies as cause such interference."

Sec. 152.52. *Second Notice of Same Violation.* "In every case where an amateur station licensee is cited a second time within a year for the same violation under Section 152.25, 152.27, 152.28, 152.30, 152.31, 152.41, or 152.42, the Commission will direct that the station remain silent from 6 p.m. to 10:30 p.m. local time, until written notice has been received authorizing full-time operation. The licensee shall arrange for tests at other hours with at least two amateur stations within fifteen days of the date of notice, such tests to be made for the specific purpose of aiding the licensee in determining whether the emissions of his station are in accordance with the Commission's Regulations. The licensee shall report under oath to the Commission at the conclusion of the tests as to the observations reported by amateur licensees in relation to the reported violation. Such reports shall include a statement as to the corrective measures taken to insure compliance with the Regulations."

Sec. 152.53. *Third Notice of Same Violation.* "In every case where an amateur station licensee is cited the third time within a year for the same violation as indicated in Section 152.52, the Commission will direct that the station remain silent from 8 a.m. to 12 midnight, local time, except for the purpose of transmitting a prearranged test to be observed by a monitoring station of the Commission to be designated in each particular case. Upon completion of the test the station shall again remain silent during these hours until authorized by the Commission to resume full-time operation. The Commission will consider the results of the tests and the licensee's past record in determining the advisability of suspending the operator license and/or revoking the station license."

The holder of class-C privileges may be called upon to appear for class-B examination and any class-C holder who moves within 125 miles of an established examining point will automatically be required to appear for the examination within four months.

Sec. 151.19. *Additional Examination for Holders of Class-C Privileges.* "The Commission may require a licensee holding class-C privileges to appear at an examining point for a class-B examination. If such licensee fails to appear for examination when directed to do so, or fails to pass the supervisory examination, the license held will be cancelled and the holder thereof will not be issued another license for the class-C privileges.

"Whenever the holder of class-C amateur operator privileges changes his actual residence or station location to a point where he would not be eligible for class-C privileges in the first instance, or whenever a new examining point is established in a region from which applicants were previously eligible for class-C privileges, such holders of class-C privileges shall within four months thereafter appear at an examining point and be examined for class-C privileges. The license will be cancelled if such licensee fails to appear, or fails to pass the examination."

Any amateur or applicant failing an examination may be re-examined after two months instead of the previous requirement of three months.

Sec. 151.23. *Eligibility for Re-examination.* "An applicant who fails examination for amateur privileges may not take another examination for such privileges within two months, except that this rule shall not apply to an examination for class B following one for class C."

An amateur station may not be operated on the special frequencies granted to holders of class-A privileges unless the station licensee himself holds class-A operator privileges.

Sec. 152.29. *Additional Bands for Telephony.* An amateur station may use radiotelephony, type A-3 emission, in the following additional bands of frequencies; *provided* the station is licensed to a person who holds an amateur operator's license endorsed for class-A privileges, and actually is operated by an amateur operator holding class-A privileges:

3900 to 4000 kilocycles
14,150 to 14,250 kilocycles.

AMATEUR INTEREST IN U. S. EQUATORIAL ISLANDS

As a result of the story by Kenneth Lum King in the November issue of RADIO, considerable interest and curiosity have been evidenced by amateurs regarding the activities of the United States Government in the American Equatorial Islands. The following information supplied by the Division of Territories and Island Possessions of the United States Department of the Interior will help to clarify the occupation of the American Equatorial Islands in connection with the development of Pacific aviation.

In March, 1935, the Bureau of Air Commerce placed colonists on Jarvis, Baker, and Howland Islands for the purpose of making meteorological studies and perpetuating the claims of the United States to these islands. By Executive Order of May 13, 1936, the President placed the three islands for administrative purposes under the Division of Territories and Island Possessions, United States Department of the Interior, and Richard B. Black, Field Representative, was sent to Honolulu to organize the permanent occupation of the islands and to lead quarterly cruises with the cooperation of the United States Coast Guard for the purpose of landing supplies, water, and changes of personnel on the three islands.

An emergency landplane landing field was prepared early in 1937 on Howland Island with the cooperation of the U. S. Department of Commerce, and Amelia Earhart Putnam and her navigator, Frederick Noonan, were to have been the first to use it. It was a well-known fact that on the morning of July 2, 1937, Miss Earhart and Mr. Noonan met with disaster somewhere in the vicinity of Howland Island, which they were unable to pick up at the end of their longest over-water hop from Lae, New Guinea. The "Itasca" was standing by near the island and complied with every radio schedule prescribed by Miss Earhart.

Late in February, 1938, orders were received to place colonists and permanent stations on the islands of Canton and Enderbury in the Phoenix Group. This group had been claimed by Great Britain and there were three British colonists on Canton Island. On March 6 and 7 Enderbury and Canton Islands, respectively, were occupied by American parties and the American flag was raised. On August 10, 1938, the Secretary of State announced a joint agreement between the United States and Great Britain for the commercial use of Canton and Enderbury Islands.

Using the

REACTANCE-FREQUENCY CHART

By R. D. PICKETT, * W9BFH/6

Perhaps one of the most useful and least used charts available to the "amateur engineer" is the reactance-frequency form shown herewith. It is most useful in designing new equipment, particularly audio frequency apparatus; it is little used probably because of the small amount of publicity it has been given.

The purpose of this article is to show some of the many useful applications to which the chart may be put with a saving of much time and scratch paper.

Always a good method of demonstration, examples are certainly not out of place here.

Let us therefore suppose that an amplifier is to be built using a 6J7 pentode first stage followed by two 6C5's in cascade which in turn feed push-

pull 6L6's. The transformers to be used, say, have uniform frequency response from 100 to 4000 cycles;¹ hence, the resistance-coupled portion of the circuit should at least equal this response. The circuit of such an amplifier is shown in figure 1.

The values of resistors shown in the plate and grid circuits are more or less standard for the tubes used. If it is desired to increase the high frequency response so that it will be uniform to 20,000 cycles in the resistance-coupled portion, it will be necessary to decrease the value of R_3 to 100,000 ohms. R_1 will also have to be changed to 450 ohms. The plate filter resistor values, it will be noted, are about 20% of the values of

¹ This frequency range, incidentally, is one which will give sufficient "roundness" and realism to voice for even the most critical ear.

* 1153 North Vista St., Hollywood, Calif.

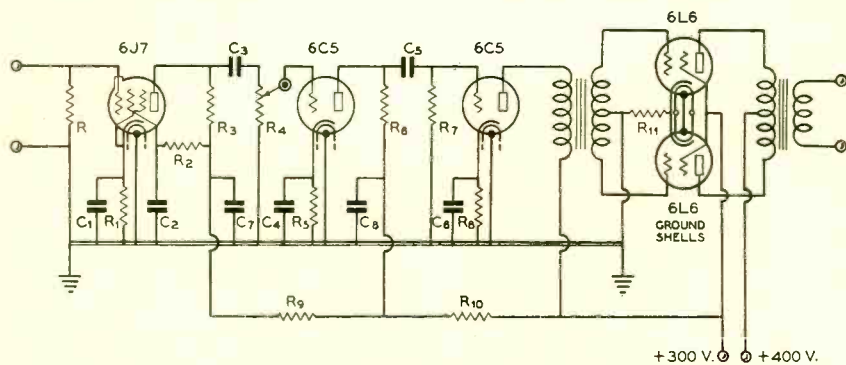
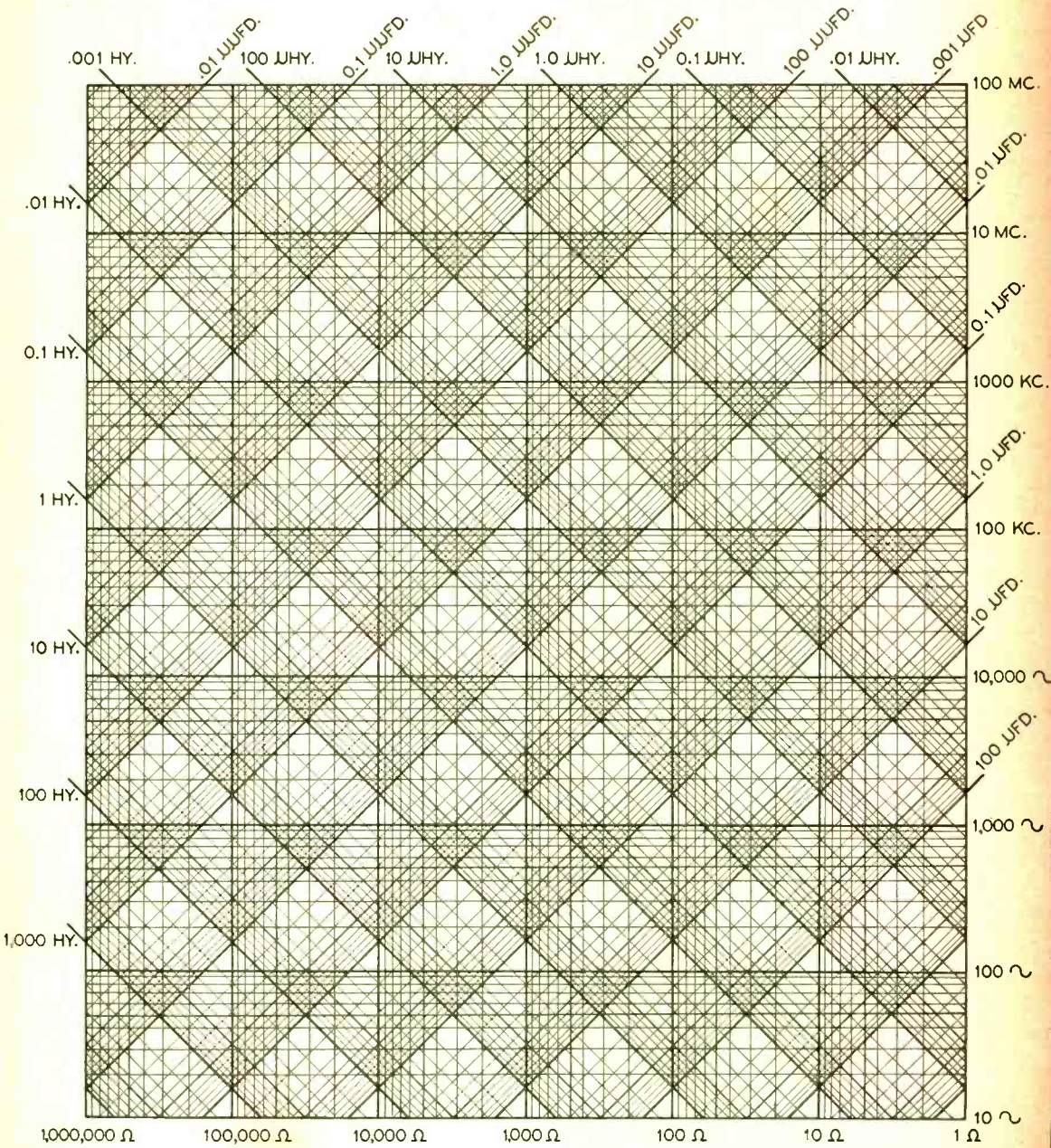

Figure 1. Amplifier design to show use of the chart.

R —1-megohm grid leak or input transformer	R_3 —250,000 ohms, 1 watt	R_6 —100,000 ohms, 1 watt	R_9 —50,000 ohms, 1 watt
R_1 —1200 ohms, 1 watt	R_4 —500,000-ohm potentiometer	R_7 —250,000 ohms, 1 watt	R_{10} —20,000 ohms, 1 watt
R_2 —1 megohm, 1 watt	R_5 —5000 ohms, 1 watt	R_8 —1000 ohms, 1 watt	R_{11} —200 ohms, 10 watts
			C_1, C_9 —See text



REACTANCE-FREQUENCY CHART

Full directions for the use of this chart to simplify design procedure are given in the accompanying article.

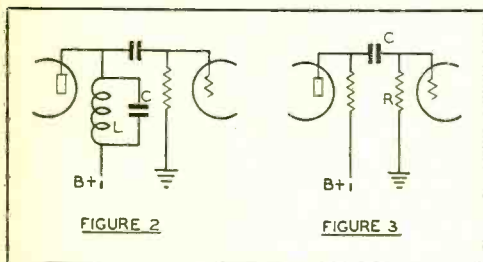

corresponding plate resistors. This relation has been chosen to give the best balance between economy in condenser cost and sufficiently good filtering action to prevent motorboating. The bias resistors are of the proper value for the plate resistors used.

Now, how large must the various condensers be in order to secure adequate bass-frequency signal transfer, by-passing action and absence of degeneration at 100 cycles?

The coupling condenser must be considered as a reactance in series with the grid leak resistor, and therefore its reactance at the lowest frequency to be passed must be very low compared with the grid resistor. A good ratio to choose is one-to-ten. The reactance of the condenser between the 6J7 and the first 6C5 should then be at least as low as 10% of 500,000 or 50,000 ohms at 100 cycles. And here is where our chart saves much time. Entering the chart vertically along the line marked 100 cycles to the horizontal line corresponding to 50,000 ohms, we find that this condenser should be at least .03 μ fd. Using the same procedure, the second coupling condenser, C_5 , is found to be .07 μ fd.

The by-pass condenser for the screen grid of the 6J7 should have a reactance that is very small compared with the screen dropping resistor, so that any signal that may be on the screen will be effectively blocked out of the power supply. The same method of calculation applies; i.e., C_3 should have a reactance of not over 100,000 ohms at 100 cycles, or from the chart, .02 μ fd. or larger. Similarly, the by-pass condensers in the filter networks should have reactances no greater than 5000 and 2000 ohms for C_7 and C_8 , respectively. These values of reactance are found to match 0.3- and 0.8- μ fd. condensers at 100 cycles.

Cathode By-Pass Condensers

To prevent degeneration in the cath-

ode bias circuits, the by-pass condensers must have a very low reactance compared with the resistors concerned. The same 10% rule is still a good one, so the condensers should have reactances of 120, 500 and 100 ohms for C_1 , C_4 and C_6 , respectively. These reactances, from the chart, are provided by 15-, 3- and 20- μ fd. condensers at 100 cycles.

Another use of the chart is in determining appropriate values of capacity and inductance in simple tuned filters, such as shown in figure 2. This particular application will probably be of principal interest to the c.w. man, although tuned filters have some definitely useful applications in a speech amplifier, in overcoming shortcomings of the rest of the equipment. Suppose, however, that we wish to peak the audio amplifier of a receiver to 1000 cycles for c.w. reception. In a plate circuit the reactance of the tuned circuit for this application should be somewhat lower than the impedance normally used in that circuit, so that the peak produced will be more pronounced.² A value of 5000 to 10,000 ohms in the plate of a low- μ triode such as a 6C5 or 56, or 50,000 to 100,000 ohms in a pentode plate, should be satisfactory. To find suitable values for this filter we enter the chart on any convenient value of reactance, say 7000 ohms, to the desired frequency, 1000 cycles in this case, and find that the 1-henry and .025- μ fd. diagonal lines intersect at this point. Since these are easily obtainable values of inductance and capacity, they may be used in our filter. One such filter was recently built by the author with a 250-mh. r.f. choke and a 0.1- μ fd. condenser and was very successfully used in the plate circuit of a 76. Although the gain was sacrificed somewhat due to the low resonance reactance of the circuit, it shows the versatility that may be obtained with parts on hand.

Yet another use of the chart lies in determining the value of coupling condenser to use for a desired bass cutoff. Suppose we have a circuit such as figure 3. We want to drop the bass 10 db at, say, 100 cycles. Since 10 db represents a voltage ratio of 3.15 to 1, 3.15 times as much voltage must appear across C and R as appears across R alone. Hence the

² It should be noted in passing that no actual peak is produced; that is, the gain of the amplifier is not increased at any frequency, but is attenuated at all but the resonant frequency of the filter.

reactance of C at 100 cycles must be 3.15 times the resistance of R , minus R . Or, if R is 250,000 ohms, the reactance of C at 100 cycles must be $3.15 \times 250,000 - 250,000 = 537,500$ ohms. From the chart we find the proper condenser is .003 μfd .

Tone Control Design

Now let's consider the case of the lowly tone control—a simple but very popular means of destroying the excellent quality put out by most of the broadcast stations. At any rate, suppose we wish to drop 5000 cycles a maximum of 15 db by the circuit of figure 4. Since the 7000-ohm primary of the output transformer, being properly loaded by the speaker, acts as an almost pure resistance, we can neglect its inductance. Fifteen db represents a voltage or current ratio of 5.62, so 5.62 times as much current must flow through C at 5000 cycles as through the transformer primary, with the tone control resistor R shorted out. Therefore, the reactance of C must be $7000/5.62 =$ about 1250 ohms at 5000 cycles. From the chart we find the proper condenser to be about .025 μfd .

Bass "Booping"

But there should be a better sort of tone control. Let's see what can be done about it. The desired result is a superabundance of bass, but this should not be accomplished by sacrificing the high frequency response except in very special cases. So figure 5 ought to do the trick provided the values of C and L aren't out of reason. A quick look at our chart shows that a 10-henry choke with a 0.5- μfd . condenser will resonate at 70 cycles—about the lowest frequency that can be used in the usual run of receiver—with a reactance of about 4500 ohms, which is about right for a single output pentode plate. So by putting a variable resistor of 50,000 ohms or so in series with the tuned circuit we have a variable tone control which effectively accentuates the bass, but leaves the high frequency response flat. A fixed resistor in series with the condenser C may be desirable to broaden the resonance peak a bit, although its value can best be determined by experiment.

An example of the improvement possible in existing equipment, as mentioned before, can be shown in certain types of crystal pickups which have an

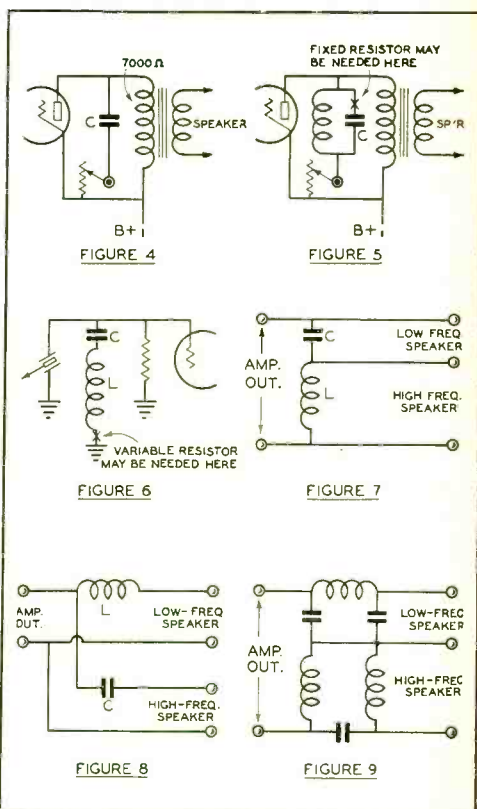

objectionable peak at or near 3500 cycles. Figure 6 shows the cure for this. As the load resistance on such a pickup is usually in the neighborhood of 500,000 ohms, the resonance reactance of the tuned circuit should be near this value. At 3500 cycles we find the values of C and L to be 100 μfd . and 25 henries. Because this filter is in a low-level, high-impedance circuit, adequate shielding of the components must be had.

Speaker Filter Systems

Another time saving application is found in calculating the values of C and L in multiple speaker filter systems. The simplest of these filters are shown in figures 7 and 8. While more elaborate systems using several coils and condensers will give theoretically better results, in most practical applications the improvement does not justify the additional cost. One such complex filter is shown in figure 9 for what it may be worth. It will be noted that figure 8 is a variation of figure 7 with two speakers

[Continued on Page 174]

CONTRIBUTIONS

to "Radio"

As a guide for prospective contributors we have compiled the following suggestions and information relative to writing and taking pictures for RADIO. Although it will not greatly affect the scale of payment, following the "style sheet" we have adopted and the suggestions relative to preparation of manuscript will increase the possibility of your manuscript's being accepted.—*The Editors.*

Contributions to our editorial pages are always welcome. They may pertain to any subject connected with amateur, short wave or experimental radio, or to radiomen.

PAYMENT

Payment is made, usually upon publication, for acceptable material of a technical and constructional nature. This policy has been adopted because we appreciate the fact that the author frequently goes to considerable trouble to correlate the data and prepare the manuscript.

We do not at present make payment for material of other than technical or constructional nature, though we appreciate the opportunity of examining it, and the privilege of publishing such as may be found suitable.

Manuscripts should *always* be directed to the home office, never to branch offices.

WHAT TO WRITE ON

We do not suggest subjects on which to write. Write on the subject or subjects which you know best and on which you have the most complete data. In general try to avoid mere "rewrites" of material to be found in standard texts; when such material is needed it can be readily prepared by our staff.

Outlines of proposed articles are always welcome. While we do not suggest subjects to authors, we will be glad upon receipt of a detailed outline to express our opinion as to whether or not the material upon which it is proposed to write should be satisfactory for publication. However, because of changing conditions and the fact that outlines do not always end up in the type of article expected, we cannot commit ourselves definitely until we have had time to examine the final manuscript.

"LEADS" APPRECIATED

If you have no article material which you believe would be of interest, perhaps you know someone who has. Such "leads" will be sincerely appreciated by us. If you do not care to send us the name and address of the man with such material, won't you suggest to him that he get in touch with us, or at least that he write us for a reprint of this article?

MAKE IT COMPLETE

Make your story complete; include all the details; give us a complete list of the parts, including both the electrical constants *and* the trade description (both trade name and type number) of manufactured parts which were used. Never mind the number of words. If it is necessary to cut the article, let us do the cutting. Portions which we believe unnecessary can be very readily cut out. On the other hand, if additional information is needed it means that both you and we must undertake more correspondence. And perhaps the unit described will have been disassembled and the information not available. It's much easier to do a complete job the first time.

DIAGRAMS AND PHOTOGRAPHS

Include plenty of diagrams and photographs. Diagrams may be sketched in pencil. They need not be fancy, as they will be redrawn by our draftsman. Simply make sure that they are clear and complete.

"A good picture is worth ten thousand words," says an old proverb. In radio you can make it fifteen thousand words and be nearer the truth. Let us have good photographs by all means—several of them.

Good sharp photographs, suitable for magazine reproduction *can* be taken by the layman

with very ordinary cameras. In fact, by following a few simple rules it is not even very hard to do.

PREPARING THE MANUSCRIPT

Please use your own style. It is not necessary to be extremely dignified. On the other hand, please do not be too colloquial in style.

There follow a few "rules" which will aid us in handling your manuscript. Compliance with them, insofar as it does not cause you undue labor, will be appreciated.

Please type your manuscript and double space it; leave a margin of at least one inch on all sides. Keep a carbon copy for yourself. Underline words which are to be emphasized; do not write them in capitals. Use good, but not "fancy," English and standard punctuation. It will save some labor on the part of our managing editor if you follow these abbreviations which have been adopted by us as "standard" for our editorial pages:

v.a., amps., hy., μ fd., $\mu\mu$ fd., a.c., d.c., r.a.c., a.v.c., q.a.v.c., r.f., i.f., a.f., b.f.o., kc., Mc., w.a.c., w.a.z., QRM, QRX, QRA, dx, px, wx, a.m., p.m., e.s.t., c.s.t., P.s.t., G.m.t., db, A.R.R.L., I.R.E., F.C.C., RCA. Others will be apparent by analogy. Do not capitalize abbreviations which would not be capitalized if written out in full.

PROMPT DECISION AND PAYMENT

We do not hold manuscripts indefinitely against possible future use. Although we cannot commit ourselves to accept or reject articles within any definite length of time, we endeavor to do so as promptly as the exigencies of other work permit. We cannot hold ourselves responsible for unsolicited manuscripts, but they will be handled with care. Rejected manuscripts will be returned only if accompanied by a stamped, addressed envelope. International reply coupons are accepted from foreign countries.

Ordinarily, payment is made for articles upon publication but when publication is indefinitely postponed for some reason, payment is made as soon as the material has been definitely accepted and set in type.

SCALE OF PAYMENT

The scale of payment varies from time to time according to the funds available. No definite figures can be given in advance. Authors who wish to protect themselves may specify a minimum price—in fact, they are urged to do so. Frankly, payment is not always commensurate with the "true worth" of such material and the value of the author's "knowing how." We hope, however, that authors will at least feel repaid for their

efforts in correlating the data and putting it in usable form.

Authors should understand that the value of the material to us and consequently the price to be paid is determined not only by the technical validity of their information and the manner of presentation, but also by many factors beyond their control, and some beyond ours. Among these are: the imminence of or recent appearance of similar material in RADIO or similar publications; the percentage of readers likely to be interested in the material at hand and their ability to understand it; the necessity of confirmatory work in our laboratory; the length after editing; and many other factors which need not be enumerated here.

Because of the limited time available we cannot in general enter into extended correspondence regarding material submitted or material which it is proposed to submit, but we will endeavor when practicable to reply to short, to-the-point questions which are accompanied by the usual stamped, addressed envelope.

INCIDENTAL PHOTOGRAPHS

RADIO pays for acceptable photographs of an odd, unusual, or otherwise interesting nature having some bearing on amateur, short-wave, or experimental radio. Rate of payment ranges from \$1.50 minimum for "passable" photos to \$5.00 for photographs of sufficient merit to warrant use on the front cover of the magazine.

We do not pay for unsolicited photographs of amateur stations or operators except under unusual circumstances, as when the operator or station has recently figured prominently in flood or other disaster relief work.

TAKING APPARATUS PHOTOS

It is surprising what excellent apparatus photographs a \$6 camera can take, but it is much more surprising to see what *bad* ones a \$60—or \$600—camera can make.

Both portrait photographers and "snapshotters" usually produce bad apparatus photographs, requiring a lot of retouching before a really good halftone "cut" for the magazine can be made from them.

COMMON MISTAKES

Portrait men like "soft" pictures with one-sided lighting. They tend to work with large lens openings, short exposures, and "soft" papers. Unfortunately, this is precisely the opposite of the right way to photograph apparatus. A good apparatus photo is so sharp and clear that you can "cut your finger on the edge of the metal panel." This does *not*

mean a "whitewash and soot" picture, but it does call for long exposure with a *small* lens opening and with even lighting.

"Snapshotters" not only make these errors but also think a *big* picture is necessary and turn up with either a picture taken with the camera so near that part of the apparatus is missed, or a big, gawky, fuzzy enlargement made at the corner drugstore.

THE RIGHT WAY

Aperture

Use the *smallest* stop (opening) you have. f128 is ideal but since most small cameras will not go down that far, do the best you can.

Lighting

Outdoors: Hang 1 or 2 layers of bedsheet, paper or blanket *above* the apparatus. Behind it, hang a patternless *gray* (not white) cloth, such as a cheap blanket, and wiggle it if possible to keep wrinkles from showing. *Please* make the background bigger than the object—lots bigger. Apparatus never looks just right with part of a Buick or the neighbor's pup peeping in at one corner. A plain concrete wall will serve as an emergency background. Other walls are terrible. So is a batch of bushes.

Indoors: Wait until night. Use a 40-watt room light to get things set up. Keep it behind the camera and the film will never know it. When everything is organized open the shutter and leave it open. Start and stop the exposure by turning on and off one (better two) "photoflood" lamps in tin or aluminum pans placed a bit back of the camera and to each side, or else very carefully screened if forward of the camera. Have at least one of the photofloods loose so you can wave it around to "wash out" shadows that you see during the exposure. Note that we said *photoflood*, not photoflash. The latter are not worth a hoot for apparatus.

Glare

Bakelite and metal panels are the very devil for causing white glares, which are actually blurry reflections of the lamps. Take 30 minutes to get set up. Try to locate things so that no glares can be seen when sighting over the camera. Sometimes a sheet of tracing cloth in front of the lamp helps; sometimes it helps to pat the glaring panel or tube envelope with a lump of putty, taking care not to "blob" it.

Time

Apparatus is very patient. Set the camera up solidly and *take time* to make the picture.

Indoors: With 2 photofloods make 4 pictures of each setup, with times of 1.5, 10, and 20 *minutes* respectively. One of these is sure to be right. *Minutes*, not seconds.

Outdoors: Work between 10 a.m. and 4 p.m., shade as described, and make 3 pictures. The 1st gets the time given in the table following; the 2d gets twice as much; the 3d gets 4 times as much. One will be right.

Aperture	Cloudy Day	Bright Sky
f128 (ideal)	32 seconds	16 seconds
f64	16 "	8 "
f16	8 "	4 "

Note that on a cloudy day your longest exposure will be from 32 to 128 seconds, depending on the opening. In cameras having no markings, use smallest stop available—if any choice—and assume it is f16.

Development

Tell the drugstore to develop and print *all* of your negatives. If this isn't done your best negatives will be thrown out as being "too hard," since they do not ordinarily deal with the making of halftone "cuts," which always soften a photo. If you do your own developing use the regular Eastman "time and temperature" process and develop fully.

Size

Better a good small picture, taken from the proper distance, than an oversized affair of 3d grade. Please don't worry about filling up the film. Naturally we prefer to have prints from 4" x 5" or larger films since there is then a chance to retouch—but a *good* 2¼" x 3¼" may not need retouching.

Antenna Photos

No good antenna photo was ever taken. Therefore, ignore the wires and get a picture of the poles. Use a "ray filter." To the back of the finished print paste a sheet of "onion skin" paper and fold it down over the photo. Then with a fine pencil sketch the antenna on this paper as carefully as you possibly can, not forgetting to show insulators in proper shape and size. Plenty of notes on an attached paper will help the retoucher to paint in the antenna.

Inside the Shack

The radio shack is always crowded and not properly lighted. It's hard to get the clutter out of the background, but we would rather have all the junk in creation showing than a streaky white background. White paper or sheets are *bad*. Use a gray blanket if possible

[Continued on Page 172]

200 Crystal Watts

ON 56 MC.

Although a surprising amount of 56-Mc. dx has been accomplished by operators using low-powered transmitters, there is a large group of u.h.f. experimenters who believe that much more consistent work will be possible when higher-powered 56-Mc. transmitters are more widely used. As a starter toward simple, medium-powered 56-Mc. amplifiers, the final stage shown in the photographs is presented.

The simultaneous development of two different pieces of equipment brought about the construction of this amplifier. The first of these was the 20-watt 56-Mc. exciter shown elsewhere in this issue. Second, Heintz and Kaufman released the type 24 Gammatron. With the exciter on one hand, figuratively speaking, and a pair of the new little tubes in the other, the temptation to use the exciter to drive a push-pull 24 amplifier was irresistible.

The results obtained far exceeded our fondest expectations. The whole transmitter acts like a 40-meter rig. It is hard to believe that the final stage is actually delivering 200 watts on 56 Mc., so smooth and "low frequencyish," to coin a phrase, is its operation.

The operation of push-pull amplifiers should be sufficiently well understood that it need not be discussed in connection with this one. A conventional, resistor-biased circuit is used with circuit balance provided by a grounded-rotor grid condenser. Plate voltage is fed to the center of the plate coil through a u.h.f. choke. Since the circuit is balanced by grounding the rotor of the grid condenser, it is possible to let the rotor of the plate condenser "float," thus increasing the allowable plate voltage for a given condenser spacing. No filament by-pass condensers are used, as they were found to be unnecessary. Mechanically, the amplifier differs somewhat from the usual push-pull stage and the mechanical layout will therefore be discussed in greater detail.

Construction Details

An 11 x 7 x 2-inch chassis allows ample room for all the components except the filament transformer, which is mounted externally. The filament transformer was left off the chassis because the smallest 6.3-volt, 6-ampere transformer available completely overshadowed the tubes which it supplied.

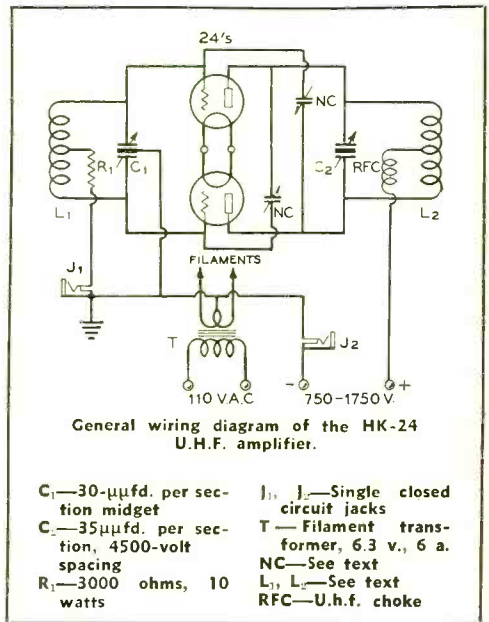

The plate condenser is one designed for use with diathermy oscillators. The stator terminals are arranged so as to allow an extremely compact neutralizing condenser assembly. This condenser is mounted on its side with the stator terminals toward the tubes. Two angle brackets and small standoff insulators serve to hold the condenser above the chassis. Mounting the condenser in this manner permits short plate leads to the upper stator terminals. The plate coil, which is 6 turns of no. 14 wire 1 1/4 inches in diameter is spaced so as to mount directly on these upper terminals.

Two small discs of aluminum, 1 inch in diameter and 1/16 inch thick, are used for the

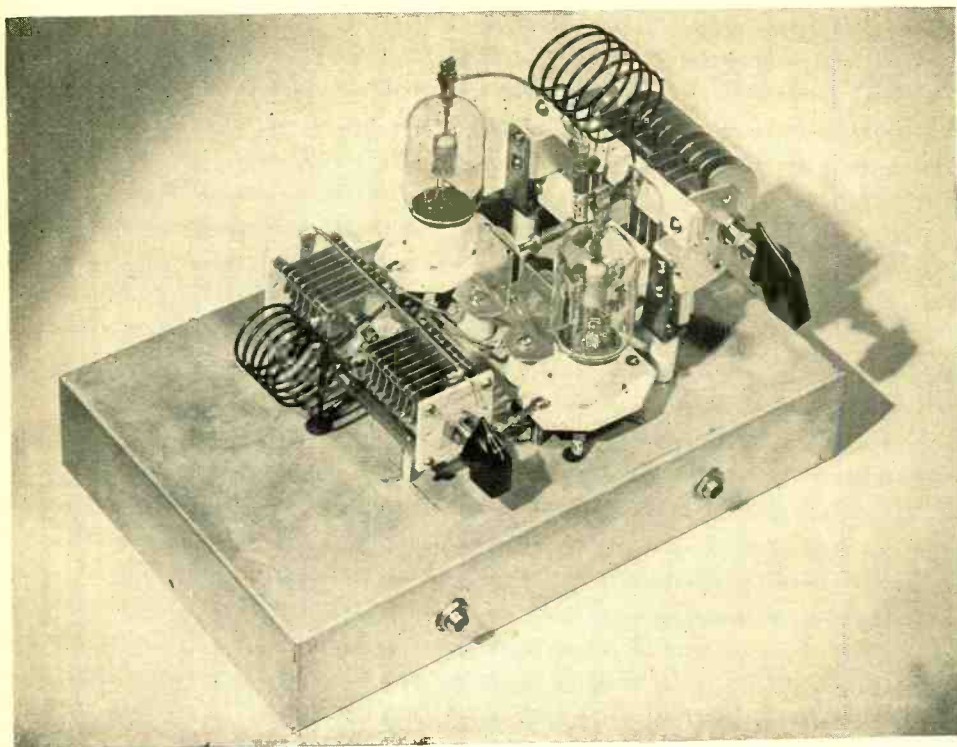

Extreme simplicity characterizes the amplifier. The neutralizing condensers may be seen between the tubes. All components, with the exception of the grid resistor, are above the chassis.

movable plates of the neutralizing condensers. Each of these plates has a flat-headed 6-32 screw through its center. The screws are held in place by nuts on the back of the discs. The heads are filed smooth with the surface of the discs. The edges of the discs are rounded with a fine-tooth file to prevent corona losses.

Two pieces of hollow rod, threaded with a 6-32 tap are mounted on the lower stator terminals of the plate condenser. The screws through the discs are screwed into these rods and neutralizing adjustments are made by running the screws in or out of the threaded rods, thus changing the spacing between the circular plates and the stationary plates, which are simply small rectangular pieces of aluminum mounted on standoff insulators.

A dual condenser, C_1 , having a capacity of $35 \mu\text{fd.}$ per section, is used across the grid coil, which is 6 turns of no. 14 enameled wire $1\frac{1}{8}$ inches in diameter and $1\frac{1}{8}$ inches long. This condenser tunes with its plates about one-third meshed. Both ends of the condenser

rotor are grounded for the sake of symmetry.

The u.h.f. choke in the positive lead is soldered directly to the center of the plate coil, which has 6 turns, $1\frac{1}{2}$ inches in diameter and $1\frac{1}{2}$ inches long. The amplifier should not be operated for any length of time with the load removed, as the heavy r.f. field within the plate coil will heat and melt the soldered connection at its center. With the tank circuit loaded however, no trouble of this kind has been experienced.

Operation

The following physical data and characteristics are given for the the convenience of those who are not yet familiar with the type 24:

Plate	Cylindrical tantalum
Grid	Vertical bar tantalum
Maximum length ..	$4\frac{3}{8}$ inches, including base pins

[Continued on Page 174]

IONOSPHERIC SOUNDINGS

● *for Amateurs*

By ALBERT WILEY FRIEND,*
W8DSJ-W8KIU

Amateurs have readily adapted themselves to most branches of communications and electronics, but one of the most important from the standpoint of radio communication has been neglected. It is the study of the ionosphere, the radio wave refracting regions in the atmosphere. Isolated communications laboratories have undertaken extensive studies of the subject, and very valuable work has been done in many instances. The major requirement now appears to be the availability of a large number of simultaneous measurements taken at well scattered points over the earth. These data would permit correlation with transmission conditions now already observed by many amateurs. Practical results, too are possible, including the determination of radio conditions even to the point of predicting possible 56-Mc. communication over long distances.

Review of Ionosphere Studies

Before discussing how the amateur may help to solve the problems of radio wave propagation, a brief review of past investigations should be quite helpful. Amateurs are not new to this field; in fact, Marconi might well be considered the first amateur. On December 12, 1901, after others had decided that "wireless" signals could not possibly travel around the spherical earth, he exhibited the true amateur spirit by disregarding all criticisms and transmitted signals across the Atlantic ocean. There had to be an explanation, so immediately Kennelly and Heaviside independently postulated a reflecting region of ionized gas at a height of perhaps 60 miles (about 100 kilometers) above the earth.

* Assistant Professor, West Virginia University, Morgantown, W. Va.

Again, no one believed that short waves were of any use for long distance communication, so they were given to the amateurs. By using Marconi's method of "doing it anyhow," they talked around the earth with only a few watts power. These accomplishments fired all ranks of men with great enthusiasm. Investigation was not to be denied.

In 1925, Appleton, in England, using a frequency sweep method, was able to prove the existence of the 100-kilometer reflecting region by observing the beat note between the direct and the reflected signals.¹ Not long afterward, Breit and Tuve, in the United States, devised a much superior method of measurement.² They sent out pulses (short dots) of signal; and by the use of an oscillograph at the receiving station, the direct and the reflected (echo) signals could be photographed. By knowing the sweep velocity on the oscillograph screen, and assuming the waves to travel always with the velocity of light in vacuum, it was quite easy to calculate a virtual height of reflection. This was called a *virtual* height since the calculated value was not the true height, but an apparent value derived from the assumption that the waves traveled throughout their entire path at a velocity of 300,000 kilometers per second and that they were reflected back from a sharp boundary. Although it is true that this was not the usual case, the virtual height has remained as a valuable index for the determination of the mode of wave transmissions. It definitely indicated how the reflection appeared to take place. There are other indices of performance, but

¹ E. V. Appleton and M. A. F. Barnett, *Nature*, Vol. 115, p. 333, March 7, 1925.

² G. Breit and M. A. Tuve, *Nature*, Vol. 116, p. 357, Sept. 5, 1925.

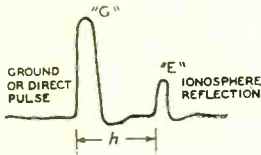

Figure 1. Drawing of ionosphere pulse pattern as seen on the cathode-ray tube screen showing the direct (or ground-wave) pulse and the E-region pulse.

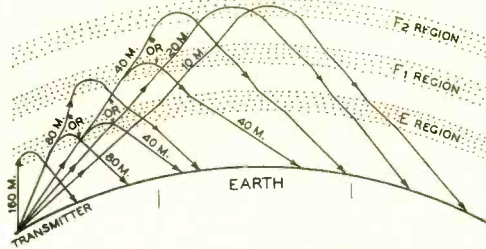

Figure 2. Approximate chart showing which amateur frequencies may be returned from the various ionosphere regions under different conditions. The layer boundaries are not sharply defined as shown, but rather diffuse from one layer into another with some ionization in between.

they should be considered in the order of their discovery. Figure 1 shows the cathode ray pulse pattern; the *G* pulse is the direct or ground wave, and the *E* pulse is the echo from the E region.

Later investigation by means of pulse reflections has shown the existence of the first discovered E region just above 100 kilometers, and the F regions from about 220 to 400 kilometers. Particularly in daytime, the F regions split into the less important F_1 , and the higher, more important F_2 layers. It has also been shown that the action of the earth's magnetic field produces magneto-ionic splitting of the F reflections—the reflected waves are elliptically polarized, due to the action of the magnetic field on the moving ions, and the parts of the waves having different polarizations are propagated differently. This produces two distinct penetration frequencies for each of the F regions. The component penetrating at the lower frequency is called the ordinary (f_{FO}), and the other is called the extraordinary ray (f_{FX}). This phenomenon may be noted on the frequency sweep chart of figure 3, which will be commented upon in detail later. It is really only a record of the distances between the humps of figure 1 as the transmitter frequency is increased.

It has been found that as the frequency is increased, a value for each reflecting region (and component thereof) is found at which the frequency has become too high for marked reflection to take place. This is called the *critical* or penetration frequency. A definite degree of ionization is necessary to prevent penetration of the waves of any given frequency to higher altitudes.

It is this quantity along with the virtual heights of reflections which determine the skip distances of short-wave signals. Figure 2 shows a sketch of approximate wave paths through the atmosphere. It serves to give some idea of how the signals of the different

amateur bands may be propagated at some particular time.

Figure 3 is a drawing of the virtual heights plotted against frequency. It will be noted that as the critical frequencies are approached (by increasing the transmitter frequency), the virtual heights seem to increase. This phenomenon is due to the increasing time delay of the signal in the ionized region. All critical frequency values are listed for the measuring condition of vertical incidence of the signals upon the ionosphere; that is, waves returned by reflection from directly overhead. Of course, when the critical frequency for vertical incidence has been exceeded, it is still possible to have the waves refracted back toward the earth at some lower, more glancing, angle such as that shown in figure 2.

Wave Propagation Charts

At the National Bureau of Standards, a very convenient chart has been developed for use with an assumed skip distance and a known virtual height to find the secant of the angle of incidence of a wave with respect to an ionospheric region.³ ("Secant" is a term used in trigonometry to describe the ratio, in a right triangle, obtained by dividing the hypotenuse by the length of the side adjacent to one of the acute angles—Ed.) This value is of use in computing the highest frequency which can be transmitted over a given path by ionospheric refraction when the critical penetration frequency for waves of vertical incidence is known. The angle of incidence between the waves and the ionized layer is the angle formed between the line of approach of the waves toward the layer and the vertical

³Newbern Smith, "Skip Distance Calculation," *QST*, Vol. 21, no. 5, p. 47.

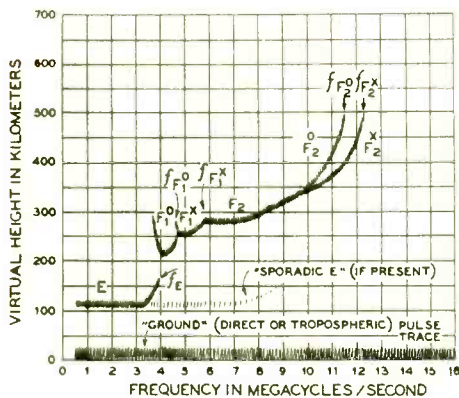

Figure 3. Frequency sweep chart showing typical penetration frequencies.

line drawn downward from the point of maximum height of the signal as it passes through the refracting region.

The angle may be more clearly visualized by reference to figure 4, where it is indicated by the letter ϕ (Phi). The importance of this angle lies in its connection with the penetration frequency. If f_F , the vertical penetration frequency for the F region is, for instance, 5 megacycles and the angle ϕ is of such a value that its secant is equal to 4.0 for a known distance and virtual reflection height, we know that a frequency of 4 times 5 or 20 megacycles will be transmitted over that path in one hop. The angle A of figure 4 is the angle of radiation of the waves above the horizontal.

A more complete chart has been devised for the same purpose as the Bureau of Standards chart. The chief advantage of this new arrangement, shown in figure 5, lies in its ease of use in finding the minimum skip distance when the operating frequency, the critical penetration frequency, and the layer height are known. The minimum angle of radiation above the horizon, which gives the maximum distance for one hop, can be assumed. As an example, the following conditions are assumed:

Operating frequency	30 Mc.
Critical penetration frequency	10 Mc.
Height of reflection	250 km.

Since it is known that secant ϕ can be obtained by dividing the operating frequency by the critical penetration frequency, secant ϕ equals 30/10 or 3.0. Following along the line for a height of 250 km. on figure 5, the intersection with the 3.0 secant curve is reached. Dropping down the vertical line from this point, the minimum skip distance

is indicated along the lower margin of the chart. This shows a distance of 1750 km. which is the minimum skip distance for the assumed conditions of transmission.

By referring to figure 6, the necessary angle of radiation above the horizon may be found at the intersection of the lines for a 250-km. layer height and a distance of 1750 km. This gives 12 degrees. This angle will very seldom be less than perhaps 5 degrees, and a minimum of $3\frac{1}{2}$ degrees is a common assumption. The chart of figure 5 is cut off at zero degrees, indicating horizontal radiation, while the broken line indicates the $3\frac{1}{2}$ -degree assumed minimum.

From the above example it should be apparent that figures 5 and 6 will serve as connecting links between ionosphere data and actual transmitting conditions. It is possible to measure the overhead conditions and find out what frequencies should be appropriate for certain communications or what skip distances can be expected for certain frequencies. Since the overhead conditions will not always prevail at other points on the earth, it will be necessary to allow for differences of time. For instance, if we wish to contact the Pacific coast from the Atlantic coast of North America at 2:00 p.m. eastern time, we must keep in mind that the time difference is three hours and that, if only a single skip is to be considered, the reflection must take place half way between. In order to approximate this condition, our local readings must be taken one-half of three hours, or $1\frac{1}{2}$ hours earlier

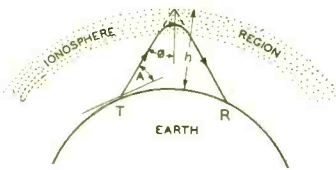

Figure 4. Sketch of a ray path through an ionosphere region showing the angles ϕ and A . A is the angle of radiation above the horizon and ϕ is the angle of incidence of the waves with the ionosphere. h is the virtual height of the ionosphere region.

at 12:30 p.m., e.s.t. The overhead ionosphere conditions should then be about the same as they will be at mid-continent at our scheduled time, 2:00 p.m., e.s.t.

It is also possible, by checking the skip distance with a receiver, to approximate certain ionosphere data, such as the penetration frequency, without the use of any other equipment. By means of the chart, then, conditions for other frequencies can be worked out.

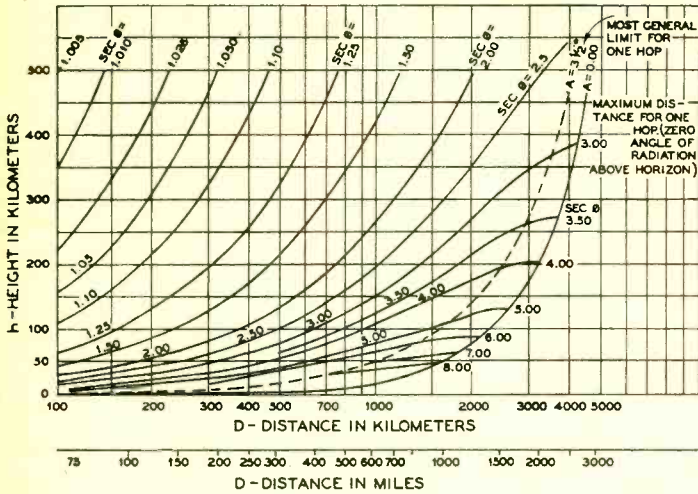

Figure 5. Skip distance chart utilizing secant ϕ from the formula:
 f = secant ϕ
 f (critical)
 The dashed line gives the chart limit when $A = \phi$.

Present Status of Ionosphere Knowledge

Since the entire subject of the ionosphere and some of its relations to transmission conditions have been considered in a general way, a complete outline of the entire ionosphere will be given. Below the ionosphere and directly adjacent to the earth lies the troposphere, the part of the earth's atmosphere in which most weather phenomena take place. In this region is produced the bending back to earth of ultra-high-frequency signals which causes the medium distance transmission (probably about 50 to 250 miles).⁴ They have been called C-region reflections. These phenomena are not yet well defined, but it has been clearly demonstrated that weather conditions are related to most of these variations of transmission conditions.

Higher up, in the stratosphere and above, are regions which may be truly called the ionosphere, because the presence of electrified particles (ions and electrons) has been definitely indicated. The lowest of these is the D region, extending at some times from perhaps 15 kilometers (9 miles) height to perhaps 80 kilometers (50 miles). The observed reflections are not at all stable. They may appear

at almost any height at any time. Their reflecting powers are generally fairly low, but they may reach extremely high values on certain occasions. The D-region absorption of signal energy is apparently quite a large factor and seems to account for much of the poor daytime transmission on the medium frequencies. We may characterize the entire action of the D region as sporadic in nature in so far as reflecting power is concerned.

Next in height is the E region at about 110 to 130 kilometers (65-80 miles) height. This is the region which accounts for a large part of the 160- and 80-meter and some other transmissions, notably the very short skip on high frequencies and the 400- to 1200-mile skip on five meters. This latter phenomenon probably is due to what has been termed sporadic-E reflection.⁵ The same conditions may hold true in the D region at times, but this has not been definitely connected with u.h.f. transmission, although it has been shown to cause changes in the transmission of broadcast waves.

Above the E region lies the F region which accounts for nearly all short-wave transmission. Generally during the winter and at night there is only a single F region at a height of about 230 to 300 kilometers (145 to 185 miles), but during the summer day this region generally splits into the F₁ at about 210 kilometers and the F₂ at about 350 to 400 kilometers. These regions both seem to consist

⁴ Ross A. Hull, *QST*, June, 1935.
 R. C. Colwell and A. W. Friend, *Nature*, Vol. 137, p. 782, May 9, 1936.
 Ross A. Hull, *QST*, May and July, 1937.
 A. W. Friend and R. C. Colwell, *Proc. I.R.E.*, Vol. 25, p. 1531, Dec., 1937.
 C. R. Englund, A. B. Crawford and W. W. Mumford, Program U.R.S.I. and I.R.E., Wash, D. C., April 29, 1938.

⁵ "56 Megacycles," *RADIO*, July, 1937, p. 24; *RADIO*, October, 1937, p. 87.
 "Characteristics of the Ionosphere at Washington, D. C., January to May, 1937," *Proc. I.R.E.*, September, 1937, p. 1182.

largely of free electrons. On account of the mobility of the electrons and the scarcity of air-molecule collisions in this highly rarefied atmosphere, magneto-ionic splitting is quite in evidence in both F_1 and F_2 layers. The refracted waves from these regions are thus elliptically polarized, and there are two penetration frequencies, one for the ordinary ray, f_{ro} , and another for the extraordinary, f_{rx} , about 800 kc. apart.

For the E and F regions the daytime critical penetration frequencies generally lie in the regions between 2 to 4 Mc. and 5 to 10 Mc. respectively. The next question in the application of this material to amateur conditions is how can the amateur measure this critical penetration value when he is limited to the use of specific bands of frequencies for transmission. It is true that this is a limiting factor, but by the use of fixed-frequency transmission in the 14-, 7- and 4-Mc. bands, a satisfactory index may be found. For instance, a measuring station operating on 7 Mc. can be used to check for reflection from directly overhead (vertical incidence). If F reflections are noted starting in the morning and ending late in the afternoon or evening, practice and comparison with Bureau of Standards' monthly reports as listed in the *Proceedings* of the Institute of Radio Engineers will enable the experimenter to estimate the critical penetration frequency curve for the rest of the day when the two points are known from the readings. The general appearance of such a curve is shown in figure 7. The points

marked X on the curve indicate the times when critical penetration conditions would be noted on the 7-Mc. frequency.

If the reflection could not be observed at vertical incidence within the limits of the amateur band, the help of other transmitting or receiving stations at distances of from one to two hundred kilometers could possibly be enlisted so as to obtain the final answer by means of the chart of figure 5 from readings taken at other than vertical incidence.

The most important use for ionosphere information by amateurs at the present moment lies in its application to the five-meter long-skip problem. It seems that there are small areas of high ionization in the E region, or lower, which appear suddenly. If a large number of amateurs could operate ionosphere sounding equipment for only a half minute or so each hour during operating periods, there would be a possibility of ascertaining most of the occasions of extra high ionization at all points where amateurs are located. Frequencies for these measurements at vertical incidence should be either 4.0 or 7.0 Mc. At the beginning of any strong E reflection (or D reflection) when the normal E critical frequency had fallen below 4.0 Mc. (as it normally remains), all observers could broadcast the occurrence. Stations several hundred miles on all sides of the strong ionization center should then be able to communicate across that zone by virtue of the available reflecting power for 5- or 10-meter waves.

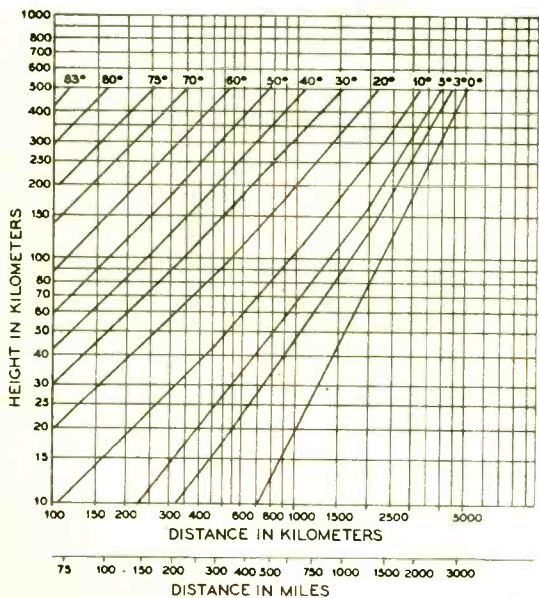
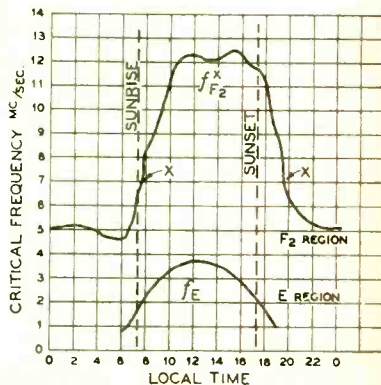

Figure 6. (Left) Angle of radiation, A, chart for a single transmission as shown in figure 4.

Figure 7. (Below) Variation of E and F_2 critical frequency during a single day.



Basic Equipment for Ionosphere Sounding

It has been shown what may be done by means of ionospheric investigation. All that remains is to find out how it may be done.

The necessary equipment for making ionospheric soundings consists of a transmitter hav-

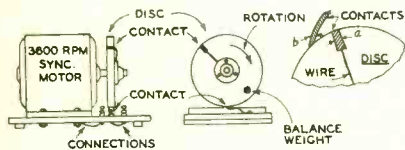

Figure 8. Diagram of mechanical-commutator type pulse generator.

ing a special short pulse keying attachment, a short-wave receiver having poor selectivity and moderate gain and a cathode-ray oscilloscope. If possible the transmitter should be from $\frac{1}{4}$ to 5 miles from the receiving station, but this is not at all necessary.

The requirements for the transmitter are that it shall emit carrier pulses (dots) of time duration between fifty and two hundred micro-seconds (50 times 10^{-6} seconds to 200 times 10^{-6} seconds) each, and that these pulses shall be emitted at a rate between ten and two hundred per second in synchronism with the power-line frequency or some other standard of time or frequency connected to both the transmitter and the receiver. Generally 15, 30 or 60 pulses per second are used when the power-line frequency is 60 cycles per second.

Crystal control of the transmitter is desirable if it is remotely controlled at a distance of two or more miles from the receiver, but when this is not the case, there will be fewer complications if a self-excited keyed oscillator is used.

Methods of pulsing (keying) the transmitter make quite an interesting study in themselves without even considering the various other phases of the problem.⁶ One of the simplest devices for this purpose is a mechanical arrangement somewhat similar to a motor commutator. A disc of wear-resistant insulating material is mounted upon the shaft of an 1800- or 3600-r.p.m. synchronous motor and provided with a single wedge slot on the periphery. This slot is then filled tightly with metal by hammering in a wedge from the side (figure 8). The slot should be only very slightly narrower at the outer edge than at the

edge toward the shaft. It is quite easy to calculate the approximate length of pulse given by this device if the speed of the motor, the diameter of the disc and the widths of both contacts are known. The formula is:

$$t = \frac{60(a + b)}{\pi D(\text{r.p.m.})}$$

where:

- t = time of contact in seconds
- a = width of contact face on disc
- b = width of spring contact face
- $\pi = 3.14$
- D = diameter of disc (a, b and D all in same units)

For instance, if it is desired to make $t =$ one hundred microseconds (100 times 10^{-6} sec.), the speed may be 3600 r.p.m., $D = 5$ inches and $b = 0.04$ inches. Solving for a (the width of contact on the disc) gives $a = \frac{1}{60}(\text{r.p.m.}) \frac{t}{\pi D} - b = \frac{1}{60} \times 3600 \times 100 \times 10^{-6} \times 3.14 \times 5 - 0.04 = 0.0542$ inches. The disc may be made of $\frac{1}{2}$ -inch thickness hard fibre sheet with a flanged shaft mounting bolted to the center before turning the edge true. The turning operation may be performed in any small machine shop. It has been found that a piece of clock-spring steel or hacksaw blade makes an excellent stationary contact, while a slug of hard copper performs very well as the moving contact. In service, this combination has operated continuously (24 hours every day) for over two weeks without any attention. It is necessary to test the output of this contactor by means of a cathode-ray oscillograph while adjusting the spring tension and bearing in order to overcome bouncing and uneven contacting. The best mode of operation will be found to be in a grid bias keying arrangement so as to limit the contact current to a very few milliamperes; a push-pull t.n.t. or Hartley transmitter of conventional constants using tubes which are capable of a *peak* output of at least one or two hundred watts is quite satisfactory. The antenna should be very tightly coupled to the tank circuit and should have a maximum of radiation in the vertical direction. The other special requirement is that the grids be biased to such an extent with the contacts open that oscillation shall cease almost instantly. Closing the contacts should drop the bias to normal. To eliminate radio interference from the contactor, a keying tube circuit may be desirable since any filter except a small radio frequency choke coil causes undesirable pulse broadening.

⁶R. C. Colwell, A. W. Friend and N. I. Hall
Rev. Sci. Inst., Vol. 7, p. 420, Nov., 1936

[Continued on Page 176]

NEW AMATEUR REGULATIONS

The following excerpts from the Federal Communications Commission's rules include all that deal solely with the amateur service and certain others that apply generally. These were effective December 1, 1938.

DEFINITIONS

Sec. 150.01 Amateur service. The term "amateur service" means a radio service carried on by amateur stations.

Sec. 150.02 Amateur station. The term "amateur station" means a station used by an "amateur," that is, a duly authorized person interested in radio technique solely with a personal aim and without pecuniary interest. It embraces all radio transmitting apparatus at a particular location used for amateur service and operated under a single instrument of authorization.

Sec. 150.03 Amateur portable station. The term "amateur portable station" means an amateur station that is portable in fact, that is so constructed that it may conveniently be moved about from place to place for communication, and that is in fact so moved from time to time, but which is not operated while in motion.

Sec. 150.04 Amateur portable-mobile station. The term "amateur portable-mobile station" means an amateur station that is portable in fact, that is so constructed that it may conveniently be transferred to or from a mobile unit or from one such unit to another, and that is in fact so transferred from time to time and is ordinarily used while such mobile unit is in motion.

Sec. 150.05 Amateur radio communication. The term "amateur radio communication" means radio communication between amateur stations solely with a personal aim and without pecuniary interest.

Sec. 150.06 Amateur operator. The term "amateur operator" means a person holding a valid license issued by the Federal Communications Commission authorizing him to operate licensed amateur stations.

AMATEUR OPERATORS

LICENSES; PRIVILEGES

Sec. 151.01 Eligibility for license. The following are eligible to apply for amateur operator license and privileges:

Class A—A United States citizen who has within five years of receipt of application held license as an amateur operator for a year or who in lieu thereof qualified under Section 151.20.

Class B—Any United States citizen.

Class C—A United States citizen whose actual residence, address, and station, are more than 125 miles airline from the nearest point where examination is given at least quarterly for Class B; or is shown by physician's certificate to be unable to appear for examination due to protracted disability; or is shown by certificate of the commanding officer to be in a camp of the Civilian Conservation Corps or in the regular military or naval service of the United States at a military post or naval station and unable to appear for Class B examination.

Sec. 151.02 Classification of operating privileges. Amateur operating privileges are as follows:

Class A—All amateur privileges.

Class B—Same as Class A except specially limited as in Section 152.28.

Class C—Same as Class B.

Sec. 151.03 Scope of operator authority. Amateur operators' licenses are valid only for the operation of licensed amateur stations; **provided, however,** any person holding a valid radio operator's license of any class may operate stations in the experimental service licensed for, and operating on, frequencies above 300,000 kilocycles.

Sec. 151.04 Posting of license. The original operator's license shall be posted in a conspicuous place in the room occupied by such operator while on duty or kept in his personal possession and available for inspection at all times while the operator is on duty, except when such license has been filed with application for modification or renewal, or has been mutilated, lost, or destroyed, and application has been made for a duplicate.

Sec. 151.05 Duplicate license. Any licensee applying for a duplicate license to replace an original which has been lost, mutilated, or de-

stroyed, shall submit to the Commission such mutilated license or affidavit attesting to the facts regarding the manner in which the original was lost or destroyed. If the original is later found, it or the duplicate shall be returned to the Commission.

Sec. 151.06 Renewal of amateur operator license. An amateur operator license may be renewed upon proper application and a showing that within three months of receipt of the application by the Commission the licensee has lawfully operated an amateur station licensed by the Commission, and, that he has communicated by radio with at least three other such amateur stations. Failure to meet the requirements of this

section will make it necessary for the applicant to again qualify by examination.

Sec. 151.07 Who may operate an amateur station. An amateur station may be operated only by a person holding a valid amateur operator's license, and then only to the extent provided for by the class of privileges for which the operator's license is endorsed. When an amateur station uses radiotelephony (type A-3 emission) the licensee may permit any person to transmit by voice, provided a duly licensed amateur operator maintains control over the emissions by turning the carrier on and off when required and signs the station off after the transmission has been completed.

EXAMINATIONS

Sec. 151.15 When required. Examination is required for a new license as an amateur operator or for change of class of privileges.

Sec. 151.16 Elements of examination. The examination for amateur operator privileges will comprise the following elements:

1. Code test—ability to send and receive, in plain language, messages in the International Morse Code at a speed of not less than thirteen words per minute, counting five characters to the word, each numeral or punctuation mark counting as two characters.
2. Amateur radio operation and apparatus, both telephone and telegraph.
3. Provisions of treaty, statute and regulations affecting amateurs.
4. Advanced amateur radiotelephony.

Sec. 151.17 Elements required for various privileges. Examinations for Class A privileges will include all four examination elements as specified in Section 151.16.

Examinations for Class B and C privileges will include elements 1, 2, and 3 as set forth in Section 151.16.

Sec. 151.18 Manner of conducting examination. Examinations for Class A and Class B privileges will be conducted by an authorized Commission employee or representative at points specified by the Commission.

Examinations for Class C privileges will be given by volunteer examiner(s), whom the Commission may designate or permit the applicant to select; in the latter event the examiner giving the code test shall be a holder of an amateur license with Class A or B privileges, or have held within five years a license as a professional radiotelegraph operator or have within that time been employed as a radiotelegraph operator in the service of the United States; and the examiner for the written test, if not the same individual, shall be a person of legal age.

Sec. 151.19 Additional examination for holders of Class C privileges. The Commission may require a licensee holding Class C privileges to

appear at an examining point for a Class B examination. If such licensee fails to appear for examination when directed to do so, or fails to pass the supervisory examination, the license held will be canceled and the holder thereof will not be issued another license for the Class C privileges.

Whenever the holder of Class C amateur operator privileges changes his actual residence or station location to a point where he would not be eligible to apply for Class C privileges in the first instance, or whenever a new examining point is established in a region from which applicants were previously eligible for Class C privileges, such holders of Class C privileges shall within four months thereafter appear at an examining point and be examined for Class B privileges. The license will be canceled if such licensee fails to appear, or fails to pass the examination.

Sec. 151.20 Examination abridgment. An applicant for Class A privileges, who holds a license with Class B privileges, will be required to pass only the added examination element No. 4 (see Section 151.16).

A holder of Class C privileges will not be accorded an abridged examination for either Class B or Class A privileges.

An applicant who has held a license for the class of privileges specified below, within five years prior to receipt of application, will be credited with examination elements as follows:

Class of license or privileges	Credits
Commercial extra first	Elements 1, 2 & 4
Radiotelegraph 1st, 2nd, or 3rd	Elements 1 & 2
Radiotelephone 1st or 2nd	Elements 2 & 4
Class A	Elements 2 & 4

No examination credit is given on account of license of Radiotelephone 3rd Class, nor for other class of license or privileges not above listed.

Sec. 151.21 Examination procedure. Applicants shall write examinations in longhand,—code tests and diagrams in ink or pencil, written tests in ink—except that applicants unable to do so because of physical disability may typewrite or dic-

[Continued on Page 164]

A Simple

DIRECTION FINDER

Most amateurs are somewhat awed by the "direction finders" used by boats and aircraft as aids to navigation. Actually these are nothing but our old friend, the loop antenna. Such a device has many uses around an amateur station.

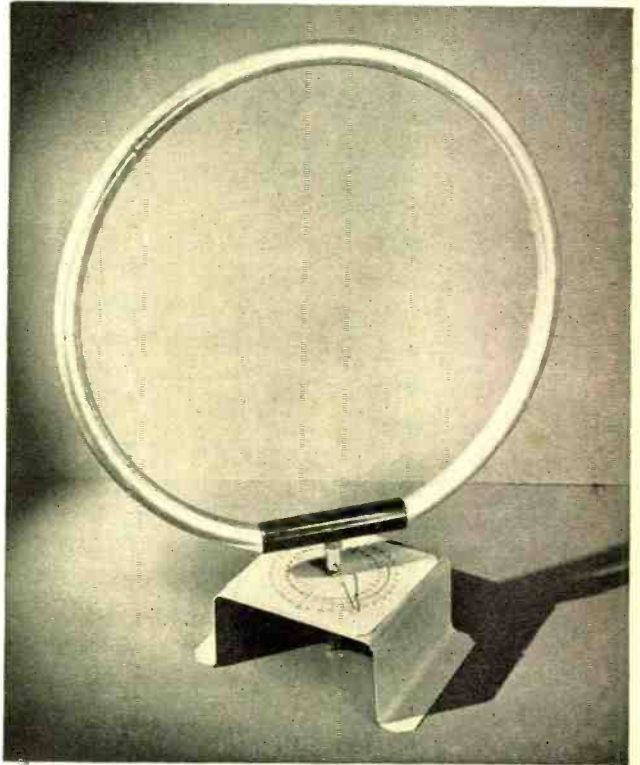

The simple loop antenna, once so popular for use with broadcast receivers, still has many uses as a direction finder. When properly constructed, it will give a highly accurate indication, because while the two "noses" are quite broad, the two nulls are very sharp.

A loop suitable for direction finding purposes is easy and inexpensive to construct, and will come in very handy around an amateur station for locating bootleggers, tracking down the source of power line and similar interference, and for orienting fixed beam antenna arrays. The latter application will be discussed in detail later in the article.

If a high degree of accuracy is desired, the loop must be constructed with care. A home-made direction finding loop capable of giving

highly accurate direction indications is shown in the accompanying illustration. Six turns of rubber covered wire are threaded through a circular aluminum pipe 20 inches in diameter. The shield cover itself is not a closed loop; if it were, there would be little signal pick-up. The aluminum pipe shield makes a neat, finished looking assembly.

The aluminum shield pipe is of 1-inch inside diameter stock, which was bent into a perfect circle by a local pipe bending company for 75c. It is best to have some concern having proper facilities do the bending for you; if you attempt the job yourself it will most likely be a rather sad looking mess before you are through.

A piece of bakelite tubing, of such diameter

that it will fit snugly over the aluminum shield pipe, joins the gap in the pipe and holds the assembly together as shown in the illustration.

Six turns of no. 18 stranded, rubber insulated wire are threaded through the shield with the assistance of a stiff, wire "snake." The center turn (3rd) is tapped and connected to one terminal (frame, or outside) of the three-conductor phone plug, which turns in a jack which acts as a bearing. The two ends of the loop are connected to the remaining terminals of the plug.

The bakelite mounting sleeve should be slipped over one end of the aluminum pipe and the turns threaded through both sleeve and pipe, because otherwise it would not be possible to put the sleeve in place after the pipe is threaded.

A pointer attached to the loop rotates around a large 360-degree scale, which is fixed permanently to the mounting base. Inside this scale is a smaller scale which is movable. It is calibrated in degrees like the larger one. These two scales, one stationary and the other adjustable, together with a compass will permit one to make all the calculations necessary for direction finding, whether on a mobile unit such as a boat, or at a fixed location. If desired a sight may be fastened to the bottom part of the loop itself, as it will come in handy for certain uses of the loop.

The scales can be purchased from most any drafting supply house, but will be found rather expensive. Suitable scales can be drawn on heavy paper with drafting instruments if cost is a consideration.

The receiver used in conjunction with the loop should have balanced (doublet) antenna input. A twisted cord (no longer than necessary) is run from the antenna terminals to the two outside loop terminals. A separate wire is run from the ground terminal on the loop (center tap) to an external ground and to the receiver chassis. The receiver should have high sensitivity if it is desired to check with distant stations, as the pickup capabilities of any small loop of this type are none too good. The loop will work satisfactorily over the broadcast band and up into the 160 meter amateur band. Pick up and accuracy on the higher frequency amateur bands will be rather poor, however.

The loop can be made smaller if necessary, such as might be desirable for certain types of mobile work. A 12-inch loop will have considerably less pickup than the 20-inch one illustrated, but it will be sufficient for many purposes.

Orienting Beam Antennas

A simple and accurate method of orienting fixed antenna arrays with a high degree of accuracy is as follows. On a large globe, stretch a piece of thread from your location to the place on the globe you want your array aimed. Somewhere along this line, or the line formed by projecting the line formed by the thread on through your location in the opposite direction, you will probably find a city having a high power broadcast station that can be heard on your b.c. receiver when using the loop. The station need not be exactly on the line formed by the thread, because you can allow for a few degrees deviation when erecting the array. Tune in the station on the loop, get the direction accurately, and orient your array accordingly.



The F. C. C. has released proposed regulations to cover the "mystery control" gadgets that have poured into the market recently. These devices are miniature transmitters used for dozens of purposes ranging from the operation of phonograph turntables through radio sets to the opening of garage doors. An informal hearing with the Radio Manufacturers Association has been called. The Commission desires that the total field at any point a dis-

$$\lambda$$
 tance of $\frac{\lambda}{2\pi}$ from the apparatus shall not

exceed 15 microvolts per meter. Otherwise, a license will be required for operation.

An emergency drill was staged at broadcast station WGAR to cover "the explosion of a freighter on Lake Erie." The entire engineering and program staff was mobilized quickly and was surprised upon arriving at the scene of the reported catastrophe to be assured by Coast Guardsmen that no boat had blown up. Mr. John F. Patt, station manager, who had ordered the drill, revealed later that several inadequacies were proved by the drill and that these are now being remedied.

It certainly served to keep the station staff on tip toe in case of a later real emergency, and it appears that hams might stage a similar stunt (without any broadcast notice, of course) to determine how rapidly and efficiently they can move if they have to.

GONE, ALAS!

But not Forgotten

By RUSSELL G. BENEDICT, W6GNZ

Bob Lee dropped in the other night and, after mention of this and that and why didn't that guy in Martinique answer cards, he remarks—

"Saw your pal Eddie downtown."

"Not *my* pal," says I. "He's just something I'd rather forget. Did he say why he QRT'd so suddenly?"

"No, only that he sold out," says Bob. "I'll bet the F.C.C. had something to do with it, though. That guy sure was a menace. Well, he lives out in the sticks now; so we won't have to worry about him if he gets on the air again. But what did he do to make you dislike him so thoroughly?"

"Everything!" says I. "He was always on the air, always in my hair. Just let me tell you—

"Back in '32 I was building 'short-wave' sets, practicing code, and reading up for the exam. Old Frenchy was working dx out at the beach. Then, dx meant mostly J's, AC8's, and such on 40. A few of the better stations worked ZS2A, XU1U or AU1KAU. Twenty went dead promptly at 5 p.m. every day. Good phones were getting used to 75 and bum ones made the night hideous on 160. We had electrolytic filters, 47's, SW3's, class-B audio, and the Loftin-White, but S.S. Supers, 58's, 5 meters, and simple, efficient tuned r.f. receivers were only on their way. The only standoffs you could buy were those brown beehives; 210's cost \$4.50 and up; only an aristocrat owned an 852.

"That spring I moved out on North Cypress Street, and one night while listening to W3XAL on 49 meters, a horrible noise came on. It sounded like that XE on 20 does, only this insult to my eardrums couldn't be tuned out. I thought it was a flashover on a power line until it CQ'D.

"The next day I located an antenna three backyards away and at the end of the feeders a transmitter—if you could call that conglomeration of misbegotten junk a transmitter. Alongside this outrage to amateur radio sat Edward.

"He was more than a little suspicious of me at first. When I said I was studying for a license, he warmed up a little and offered

to teach me both code and theory. I soon found out that his theory was as erratic as his code; so I stuck to copying commercials and reading the book.

"Finally I passed the exam. While waiting for my call, Frenchy and I built my first rig—an up-to-the-minute affair: 47 crystal, 47 doubler, 210, and 211E final. That was the '11E that flashed over its top insulator later on. Meanwhile I worked a few guys from Edward's shack—a difficult thing to do because his receiver was a detector and three step, and signals always tuned themselves out the minute you let go of the tiller and reached for a pencil. Also, his key worked like a tire pump. You just couldn't get your elbow on the table.

"His rig was one of those t.n.t. things, push-pull 210's, one good and one gassy. The push was lots better than the pull. Frenchy and I spent an evening trying to get a good note out of the contraption. We began by winding the grid coil around a dowel, instead of around the grid leak, where he had it. There was a monitor—the signal in it sounded like someone scratching on a carbon mike. Edward said the signal got better farther away. It must have; once he got T4 from San Francisco.

"We worked on that thing for hours. Everything was wrong: unsoldered connections, the plate coil vibrating, coupling miles too tight, not enough C. We attacked the power supply. Edward said it had 24 mikes of filter. It did all right—three 8-mike electrolytics in series. The half-meg. resistors were in series with them too, instead of across them!

"There were two transformers in series in the power supply. One put out 800 volts, the other about 300. The choke was a midget affair, good for about 25 mills. One '81 was just along for the ride. About that time, our remarks began to rub Edward's pelt the wrong way so we had to give up. We left him happy in his ignorance. He got a new 10 and an '81, and the note was passable r.a.c., though it still wiped out the band at my place.

"I got my heap going on 40, sharing time with Edward, and worked dozens of W's. Of course, with crystal and my 120-watt

QRO I worked four or five to his one. He made up for that by working one W four or five times as long. For a while all was merry as a wedding bell. Then he started letting his rig run during my time on the air, holding the key down and attempting to tune that mess. I retaliated, and the war was on. He broke up my QSO's on 40, I shifted to 80, where he couldn't QRM me much. My 40-meter harmonic was deadly to his O-V-3 at that short range, though. He thought I was still on 40 and was working through his QRM.

"All this time he was having trouble with b.c.l.'s. So was I, but my trouble was key clicks. His was a raspy noise in every b.c.l. set in the neighborhood. He generously blamed the whole thing on me and I had trouble with the Commission, but my log cleared me. Then Edward put his foot in it. He hung a fifty-watt light in the center of his antenna and spent three evenings, two of them mine, with his head out the window watching the bulb and tuning the feeder. I started over to his place to remonstrate and found two wild-looking b.c.l.'s ahead of me. They really lowered the boom on him, mentioning axes, antenna poles, fists, and Edward's nose. That beacon light in the center of his antenna had been a tip-off to them all, of course. He should have been smart enough to shut down during Amos 'n Andy, as I always did. Instead, he had to install seven wave traps, free of charge, on as many b.c.l. sets.

"Then dx got good; so I moved back to 40, and 20 in the afternoons. Edward heard me working VK, ZL, and such on 40, and South Americans on 20. That nearly broke his heart. Someone sold him a t.r.f. receiver, and then he could hear the loudest VK's himself. He even managed to work one or two. That was too much for him; he called off the time-sharing scheme entirely and I guess he planned to chase me off the air entirely. Every evening from seven 'til eleven that nightmare of a signal tore up the band. For a while I stuck it out, hoping the b.c.l.'s would hang him on his own pole. Unfortunately, they let him live. For a while I thought of hanging him myself, but finally figured out a way to outfox him.

"I borrowed a 160-meter rock and put a 47-210 c.w. rig on that band. His nutmeg grater didn't bother me at all up there, but my little gem fed him some choice key clicks on 40. A spy of mine reported that Edward was tearing his hair and fighting those mysterious clicks. He couldn't find any signal on the 40-meter band to fit 'em. Another stunt was to scratch the feeder of my single wire fed

antenna along the tank coil of the 40-meter rig, with the power turned off, of course. Try it; it puts out a high grade of static. I also started keying my 40-meter rig with no antenna and working all sorts of marvelous imaginary dx through his best QRM. My secret agent told Edward that I had rebuilt my receiver and QRM couldn't bother me any more.

"That did the business. Eddie left the air and paid Frenchy to build him a crystal rig: 47, 46, 10, 203A. Frenchy furnished a rock that hit about 7205, leaving the low end clear for me. After a couple of weeks, he wrote Frenchy that he couldn't raise any dx from 7205. Then Frenchy sold him a crystal on 7003, right in a nest of California kilowatts.

"Edward's mad genius for getting things wrong was best shown by the affair of the grid meters. I used some cheap meters in the grid returns of my rig. Not to be outdone, Edward got some of the same meters to read his grid current. One night he took his life in his hands and dropped over to complain that his meters kept burning out. Well, I found the meters right in the hot grid leads. No wonder they kept burning out!

"Being on good terms with Edward at the moment, I gave him some 3-amp. fuses for the power supply primaries, explaining that they would protect his tubes in case of short circuits. He put one in the *center tap* of his 203A stage, saying a 3-amp. fuse should protect the tube, as the filament was rated at 3.25 amps!

"For a while Edward went scientific. He invested in a large map of the U.S.A. and marked it off with circles showing his skip distance as compiled from his signal reports. Occasionally some ignorant guy right on a null circle would give him R8, thus disrupting the whole experiment and causing Edward to lose a few nights of sleep.

"That summer of '33 I moved about half a mile straight away from him, to that swell spot I had on top of the hill. Edward didn't bother me much there, and after a while he was heard no more. Then I went off the air myself for nearly a year.

"Early in '35 I fired up again. There was Edward. This time R9 plus on 20-meter phone, with blurps, bloop, squelches and parasitics all through and out of the band. He had taken one of those "Big Money in Radio" courses, passed the class-A exam, paid Harry Smith to build him a phone rig, bought a super, and automatically became one of the First Citizens of Hamdom. He joined a phone

[Continued on Page 181]

- Rotatable Two-Element Beam . . . at W3CHO.

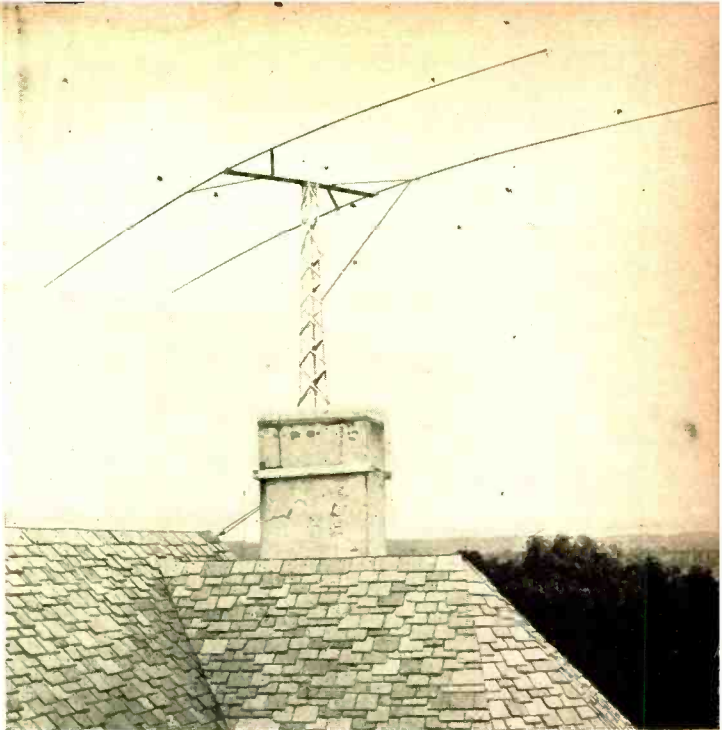

PICTORIAL

- **From Overseas Readers**
- **U. S. Territorial Hams**
- **Y. L. Section**
- **F. C. C. Men**
- **Right At Home**

PHOTOGRAPHS.....

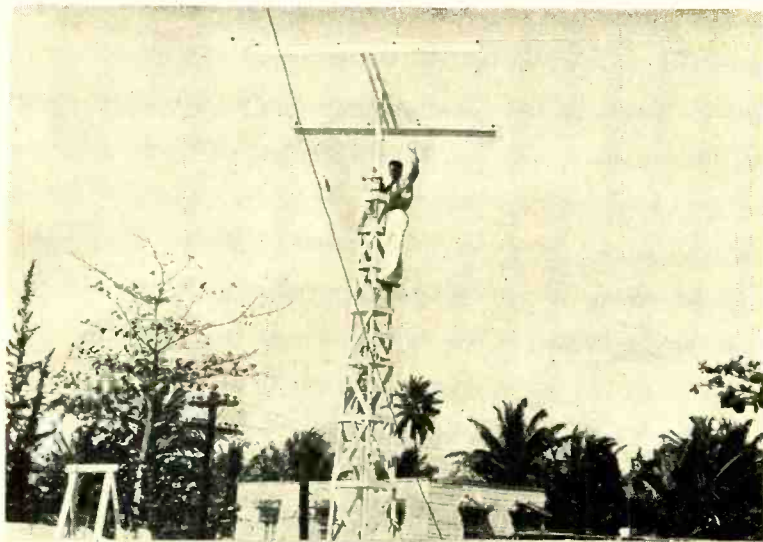

• From San Juan, Puerto Rico—K4EJF. The upper photo shows the OM, Alfonso Sanchez (Al, during his QSO's on 14-Mc. phone), on the 28-foot tower that supports his 14- and 28-Mc. flat-top beam. The tower is mounted upon the roof of the shack making the antenna proper about 48 feet above ground. A stub switching arrangement is used to switch the shorting bar electrically to either 14- or 28-Mc. position. The radiating sections of the rotatable beam are each 15 feet long and are made from galvanized iron, formed by the local tinshop.

The junior op is busily checking the band for Al in the lower photo. The junction box at the base of the map on the wall carries the leads from the position indicator on the beam itself to a series of 30 dial lamps that illuminate the map in the actual direction that the beam is pointing. A 16-pair telephone cable brings the leads from the rotary switch below the beam into the shack and to the indicator lights behind the map. Altogether rather a neat and well-designed installation.

.... From Our Overseas Readers



● G5BY is a call familiar to amateurs everywhere. Hilton L. O'Heffernan has won more honors in amateur radio in 13 years than most hams could garner in a lifetime. Incidentally, he has even more trophies for his prowess in another hobby, table tennis.

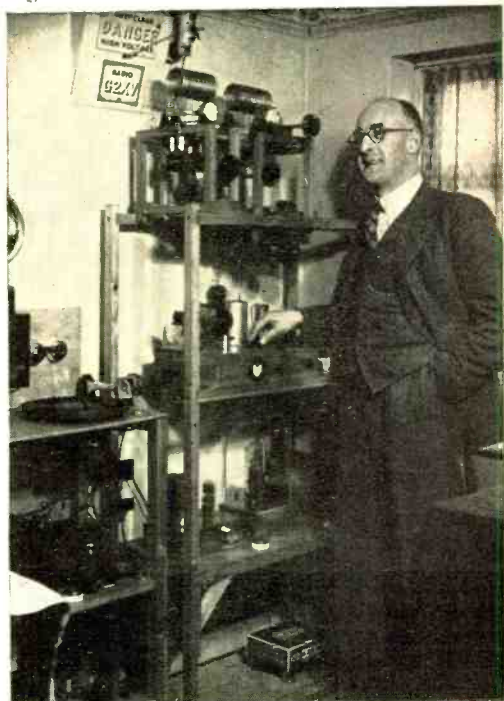

● From Great Britain, British amateur radio station G2XV of G. A. Jeapes, Cambridge, England, is the exact location.

U. S. Territorial Hams

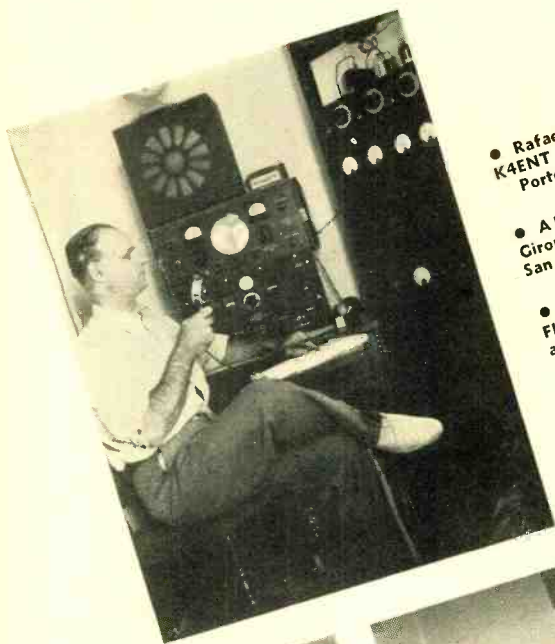

● Rafael J. Acosta of K4ENT in San Juan, Porto Rico (left).

● Alfonso Sanchez Girona, K4EJF, also of San Juan (lower left).

● The layout at John Fletchers' K7CTP in Unalaska, Alaska (right).

● K4ENT, C. T. Ackerman of W2DFM in Ridgewood, N. J., and Santos G. Ramierz, K4FAB, of Santurce, Porto Rico, (lower right).

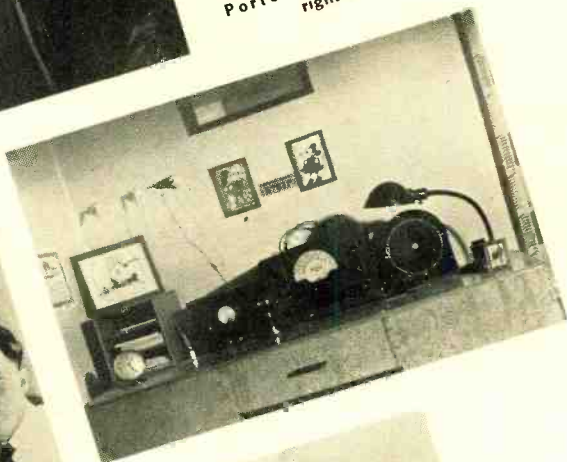

*The
Prettier Side*



- Carrie Jones, W9ILH . . . (top) . . . has had ticket since 1932.
- Opal Sisk, W9CMV . . . (center left) . . . on 80- and 40-meter c.w.
- Carol Ann Keating, WSWWP . . . (center right) . . . on 80- and 40-meter c.w.
- Letha Allendorf, W9OLD, WLUK . . . (bottom) . . . active APR-eaguer . . . brother and sister hams too [W5CZC (ex-W9IGW) and W9SRH].



● Flora L. Hoover, W6EK . . . (top) . . . on the air since 1931. She and husband W6ZG/ex-K6DEY on 80-meter band.



● D. June Brown, W9RBP . . . (center left) . . . now Mrs. H. J. Hengels, the o.m. being W9RTY . . . only feminine graduate from RCA Institutes in Chicago . . . took marine operating course.

● Eve Sanford, W4DAI . . . (bottom) . . . both she and her husband, W4DHM, on the air consistently . . . W4DAI usually 40-meter c.w. . . . has her w.a.c. and w.a.s. certificates.

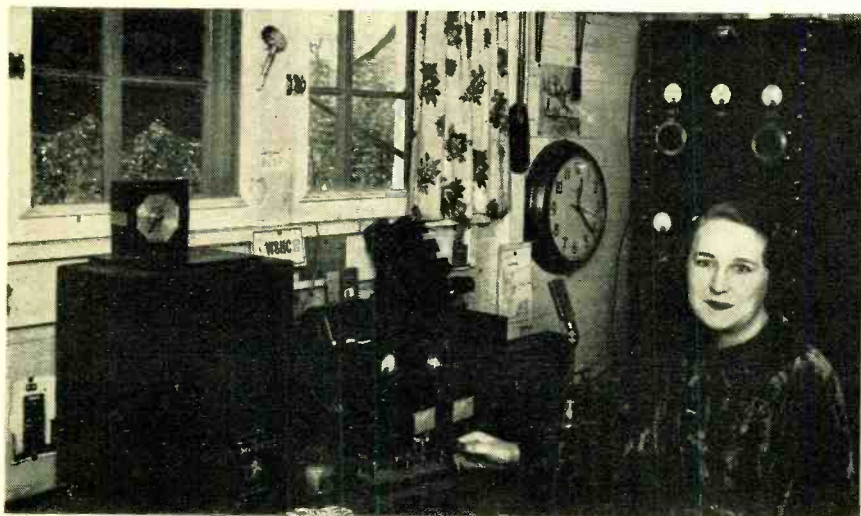



● Margaret H. Bornemann, W5ZV . . . (top)
 . . . formerly W2ZV . . . her soft drawing
 voice is give away to the fact that her home
 is in New Orleans.

● Mrs. V. E. Nolan, VK4LO . . . (center right)
 . . . interested in radio since 1922 . . . was sec-
 ond operator to VK4JU for many years until she
 obtained her own ticket in 1931 . . . particu-
 larly keen on c.w.

● Lecna Watkins, W8OSY . . . (bottom left)
 . . . studies electrical engineering, plays the
 violin, in addition to "hamming."

● P. E. "Beth" Rosenberg W8NCJ . . . (bot-
 tom right) . . . operates on 20-, 40- and 80-
 meter c.w.



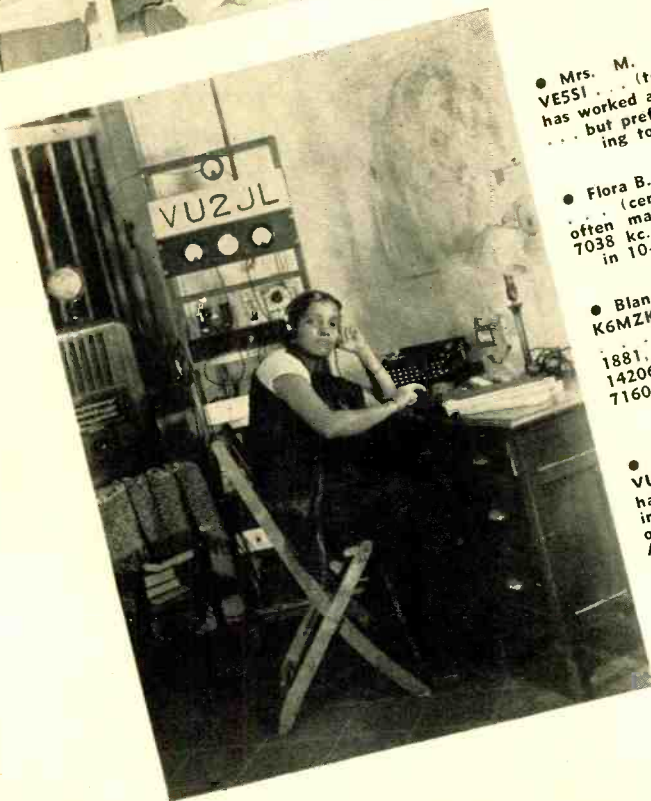

● Mrs. M. A. Barber, VESSI . . . (top left) . . . has worked all continents . . . but prefers ragchewing to dxing.

● Flora B. Young, K6PIO (center left) . . . often may be heard on 7038 kc. . . . interested in 10-meter phone.

● Blanche H. Oliveira, K6MZX . . . (center right) "Emzy Kay" on 1881, 1915, 3586, 3931, 14206 kc. phone; 7163, 7160, 7171, 14342 kc. c.w.

● Mrs. Indumati Dharap, VU2JL . . . (bottom) . . . has the distinction of being the first licensed y.l. operator in VU. Quite an American-looking station with the exception of the microphone and the man-sized key.

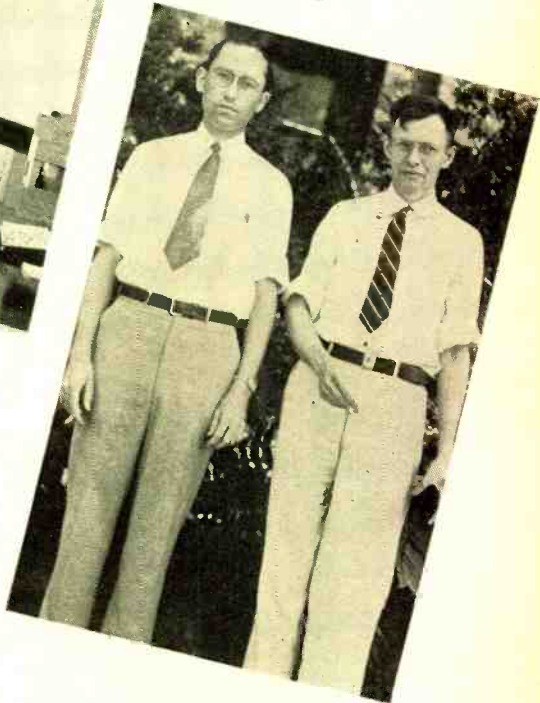

F. C. C. Men...

Benjamin Wolf (top), probably knows more about the ins and outs of the central monitoring station at Grand Island than any other person in the country. He has managed this traffic policeman of the ether since 1929, when construction of the station was underway and he came from inspection duties in San Francisco to supervise. Wolf probably knows, too, as much about radio inspecting as any man could, for he started out in this work back in 1913.

● Four F. C. C. inspection districts have been under the supervision of C. W. Loeber (bottom left) since 1930 when he left his work as a vacuum tube engineer with RCA Communications to become a government official. Now in the 16th district, he was formerly stationed in Chicago, Kansas City and Detroit. Loeber is an active amateur but prefers not to give us his call as "I regard myself as only another ham when on the air." His "ex" calls are W9ATW and W8QEZ.

● Amateur radio operators and electrical engineers both, these gentlemen (bottom right) watch over Great Lakes Monitoring station. Inspector in Charge—Irrving L. Weston—stands on the left in the picture. He has been in the game since 1923 with the calls W1BHB, W1ZX and W8IW. Now he is W9YJI in private life and W9YHL for the Great Lakes Naval Reserve unit. His partner is Inspector Irl D. Ball . . . present call W9BW, formerly of W8ARI and W8BWR. His experience dates back to pre-war 8CX.



● Somehow, in spite of all his exposure to radio, William J. McDonnell (above), 17th F. C. C. district inspector, escaped being an amateur radio operator. McDonnell has been in the radio business since the days when spark and tube transmitters with crystal detectors were first used aboard airplanes and captive balloons. He was then a radio operator and technician for Uncle Sam's air service. He did similar work for the army air service radio stations, after which he joined up with the Department of Commerce in his present post of radio inspector.



● L. C. Herndon of W7FEK (left), 14th F. C. C. district inspector, is one of the real pioneers of amateur radio—he's been interested in it for 27 years. In 1917, being a member of the NCR, he was called to active duty in the navy and his amateur station, 3SZ, was installed in the commandant's office in Norfolk, Va. Before assuming work with the governmental inspection service in 1921, W7FEK served as an inspector for the Independent Wireless Telegraph Company.



● "The ninth district may not have the most hams," writes Inspector-in-Charge Louis L. McCabe, "but they're the best in the U. S. A." That seems to be the way all of the R.I.'s feel about their districts. Inspector McCabe has been down Galveston way for the past six years . . . went there in 1932 and they liked him so much that he's been there ever since. While not on the air at the present time, he has been a ham and signed the call W5AWI during the days that the fifth call area was his home.



• Bernard Linden, W6XBL, W6ZC (above), R. I. of the 11th F. C. C. district, started tinkering with radio 'way back . . . 1904, to be exact. By 1909 he had started an experimental research and manufacturing plant, acquired a 5 kw. transmitter with the call HP. While a member of the Bay Counties Wireless association (believed to be the second organization of its kind in the U. S.), he used the call SAF. He has been with the F. C. C. and its predecessor organizations since 1917.



• Like Inspector Herndon, Emery H. Lee of W2LK and inspector of the 19th F. C. C. district, pioneered in amateur radio. Inspector Lee operated back in 1910 with the call "LEE". In 1911, he became "RY", changed next year to 7FW and in 1922 took over W2LK. He has been continuously in government radio service since 1921. Before that, his electrical engineering studies had led him into the related fields of commercial radio operating, and radio laboratory work.



Taken in Washington, D. C., in the summer of '37. Reading, left to right, back row: Louis E. Kearney, 3rd district; George Sterling, assistant chief, field section; W. D. Terrell, chief, field section, now retired; J. H. McKinney, then in 7th district, now in 21st district; Kenneth C. Clark, 13th district. Front row: Edward Bennett, 5th district; Charles A. Ellert, 4th district; Charles C. Kolster, 1st district; Arthur Batcheller, 2nd district; Theodore G. Deiler, 8th district.

Right at Home



● (Top) Two dentists exchange dx notes on a Sunday morning—Dr. Leo C. Haughwout, W6FTU, and Dr. J. Lynn Ironmonger, W6MLC.

● (Center) Gil Williams of W1APA, one of the de luxe dx'ers on the East coast.

● (Bottom) Carl Madsen of W1ZB . . . known by his writings on technical radio, his dx activities, and his radio engineering associations.

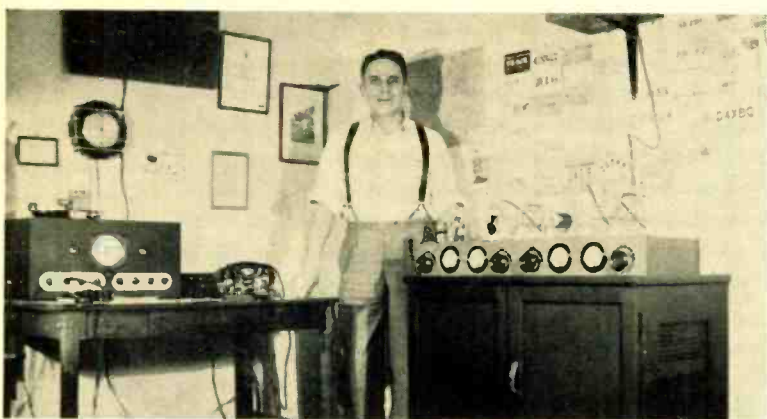

● The idea of working a lot of dx while the x.y.l. takes in a movie is a good one, but not when there is a brand new jr. op., reflects W9EKX.



DEPARTMENTS

- **Dx**
- **56 Megacycles**
- **Yarn of the Month**
- **What's New in Radio**
- **Scratchi**
- **New Books**
- **Open Forum**
- **Postscripts and Announcements**

RADIO

"WAZ" HONOR ROLL

C.W. AND PHONE

	Zones	Coun-tries						
ON4AU	40	148	G5BD	37	110	VK2AS	34	94
G2ZQ	40	143	W1AQT	37	107	W6EPZ	34	93
W3EVT	40	126	W8EUY	37	105	W8HGA	34	93
W8CRA	39	151	W9PTC	37	103	W6HJT	34	92
W6CXW	39	150	VE2EE	37	102	W5ASG	34	91
G6WY	39	150	G6GH	37	102	W8OUK	34	84
W6GRL	39	141	W2IYO	37	102	W8JSU	34	83
W8BTI	39	141	W6FKZ	37	101	VK2TF	34	81
W6ADP	39	140	W6ITH	37	100	W6MJR	34	81
W6BAX	39	140	W8KPB	37	100	ON4SS	34	80
W6CUH	39	140	W9AJA	37	99	VK2TI	34	75
W4CBY	39	138	W3AYS	37	98	W4ELQ	34	74
W8OSL	39	133	W3EXB	37	98	W8JK	34	74
W2GWE	39	129	W6ITH	37	98	W6LHN	34	71
W6KRI	39	129	W1BGC	37	97	VK2EG	34	70
W7BB	39	123	ZL2CI	37	97	VE5MZ	34	69
W6HX	39	123	W3AYS	37	97	VK2VN	34	63
G5BJ	39	120	W6VB	37	97	W9QOE	34	56
W2CYS	39	117	W6JBO	37	97	K6JPD	34	
G2LB	39	115	ON4T	37	96	W2FAR	34	
W6FZL	39	112	W7BYW	37	93	W3EGO	34	
ON4FE	39	110	W5CUJ	37	93	W8CNZ	34	
W6FZY	39	109	W1GDY	37	92	W8ACY	33	94
W3EVW	39	104	VK2AE	37	90	W1RY	33	92
XE1BT	39	90	W6GCB	37	81	W2BMX	33	90
K6AKP	39	67	W9UBB	37	77	W6KUT	33	90
G6VP	39		G6N J	37		W6CEM	33	88
W3ANH	39		W2BSR	37		W3RT	33	86
W4DHZ	39		W2DTB	37		W1APU	33	85
W2BHW	38	149	W4AH	37		W6LEE	33	85
W1BUX	38	145	VK3EO	36	112	W8QDU	33	85
W2GTZ	38	138	W2BJ	36	111	W9LQ	33	84
W8BKP	38	138	W9AFN	36	105	W2WC	33	83
W6KIP	38	137	W6BAM	36	103	W6NAE	33	83
W2GTZ	38	136	W3GHD	36	102	VE4LX	33	82
W6DOB	38	131	ON4EY	36	101	W6CVW	33	81
W2HHF	38	130	W1AQT	36	100	W6LCF	33	78
W1ZB	38	129	J2JJ	36	100	W6MVQ	33	77
W5BB	38	129	W8LZK	36	99	W7AVL	33	71
W5VV	38	129	W4IO	36	98	W2FAW	33	67
W2HHF	38	127	G2QT	36	98	OK2HX	33	66
W3EMM	38	124	W4DMB	36	97	VK2RA	33	65
W6QD	38	124	ON4VU	36	96	W6KQK	33	63
W4CYU	38	123	ZL1HY	36	95	K6CGK	33	62
W3EDP	38	121	G2IO	36	94	ON4TA	33	
W8LEC	38	121	G6YR	36	94	W5AXF	33	
W8DFH	38	119	W7AYO	36	94	W6LDJ	33	
W9PST	38	119	W6KWA	36	92	W8LDR	33	
W2AAL	38	118	W9KA	36	92	W9LBB	33	
W8DWW	38	118	W9PK	36	92	VK2VQ	32	99
W2GVZ	38	117	W5ENE	36	91	W6DIO	32	90
W1CC	38	116	W9CWW	36	91	W1APA	32	90
W3DDM	38	116	W8JAH	36	89	W3KT	32	85
W9UQT	38	116	W8MTY	36	86	G6WB	32	84
W3GAU	38	115	VK2NS	36	84	W1APU	32	83
W5KC	38	115	G2UX	36	83	W9FLH	32	80
W6AM	38	115	W6TI	36	77	ON4NC	32	79
W3EVW	38	114	W6GCX	36	76	W9PGS	32	78
W8HWE	38	112	W7DSZ	36	73	W6NLZ	32	76
W2BXA	38	111	W2GXH	36	71	W1AB	32	76
W6GRX	38	111	G6CL	36		W3CIC	32	75
LY1J	38	110	U1AD	36		W6AX	32	74
W6HZT	38	110	W2OA	36		W3GAP	32	70
W2GT	38	108	J2KG	36		W6KZL	32	67
W8KWI	38	108	W9ARL	36		W6LPR	32	67
W8QWF	38	108	W8AQT	35	110	W9DEI	32	66
W8AU	38	106	W8OXO	35	107	ZU1T	32	65
W8BOX	38	106	W6GHU	35	103	W6KRM	32	62
W9ADN	38	106	W8DOD	35	102	W6OAG	32	56
W9KG	38	106	W3TR	35	101	W8BTK	32	
W8LYQ	38	106	W8CJJ	35	98	W8HYC	32	
W2GN	38	104	W9RCQ	35	97	W4MR	31	92
LU7AZ	38	103	OK1AW	35	96	W6DRE	31	86
W9PST	38	103	W9EF	35	94	W6GNZ	31	85
W9ALV	38	102	ON4FQ	35	92	W8FJN	31	85
VE4RO	38	95	W3GEE	35	92	W2AOG	31	83
W8QXT	38	92	W6AQJ	35	92	W9LW	31	82
W8GBF	38	87	W6MHH	35	91	W2FLG	31	80
W9VDQ	38	79	W9RBI	35	91	W6KEV	31	80
G5YH	38		LU3DH	35	89	W2HVM	31	78
G6RB	38		W8AAT	35	87	G16TK	31	76
W4AJX	38		G6QX	35	80	SM6VX	31	76
W9TJ	38		W9GNU	35	77	W2GFF	31	75
W8KKG	37	127	W2AIW	35		W6NNR	31	74
W7AMX	37	122	W2IOP	35		G5VU	31	73
W6GAL	37	121	W3BBB	35		W5PJ	31	71
W8ZY	37	114	W6MCG	35		W9YEG	31	69
W6LYM	37	111	W6NHC	35		W6POZ	31	66
			SU1WM	34	109	VK2VA	31	62
			W3EPV	34	106	W6OFC	31	62
			W6HEW	34	103	W6IES	31	57
			W8BSF	34	100	W6CLA	31	51
						I1TKM	31	
						VK2QL	31	
						W3DCG	31	
						W6HXU	31	
						W6NLZ	31	
						W9YGC	31	
						VE2GA	30	84
						W4DCZ	30	80
						W3CDG	30	78
						W3UVA	30	76
						W3GHB	30	73
						W3GMS	30	72
						W2GFF	30	71
						W8MFB	30	71
						W4DTR	30	68
						W8MPD	30	66
						W9VKF	30	66
						W6OEG	30	61
						W9VLD	30	58
						W8PHD	30	57
						W8DPY	30	53
						VE5ZM	30	52
						W3EMA	30	
						W8DED	30	
						W8MAH	30	
						W9IWE	30	
						PHONE		
						W2AZ	37	89
						KA1ME	35	79
						W2IYO	34	88
						W6ITH	34	87
						W6OCH	34	85
						W3FJV	34	71
						W3FAM	33	68
						W6NNR	32	73
						W6CQI	32	70
						W9NLP	32	70
						W4CYU	31	88
						W6MLG	31	72
						W6LLQ	31	68
						W9TIZ	31	62
						F8KI	31	53
						W6AM	31	
						W4AH	31	
						W2IXY	30	85
						W2AOG	30	77
						W9JI	30	75
						VE1CR	30	68
						W7BVO	30	64
						W4DSY	30	
						G6BW	29	70
						W3EMM	29	76
						W6EJC	29	64
						W6OI	29	62
						W9YGC	29	
						W2IKV	28	77
						VE2EE	28	62
						W7BVO	28	61
						F8VC	28	58
						W9BVC	28	58
						W3LE	28	51
						W6IKQ	28	45
						W8LAC	27	72
						W8FTU	27	60
						W8RL	27	58
						G8MX	27	56
						W9ARA	27	53
						W6NLS	27	52
						W9ZTO	27	50
						W6GCT	27	49
						W9BBU	27	45
						W2HUQ	27	
						W5DBD	27	
						G5ZJ	26	77
						W2IVU	26	65
						W5DNV	26	60
						W8QXT	26	55
						VK4JP	26	32
						W6GAL	26	45
						W7EKA	26	45
						W9RBI	25	54
						W8JK	25	47
						W7AMQ	25	40
						W6LYM	25	39
						W6MXD	25	38
						W6LEE	25	34
						VK2ABG	25	
						W3SI	25	
						YV5AK	24	59
						W4TS	24	52
						W1BLO	24	50
						W6LPR	24	45

DX

AND OVERSEAS NEWS

Herb. Becker, W6QD

Send all contributions to Radio, attention DX Editor, 7460 Beverly Blvd., Los Angeles.

It's getting that time of year when holiday spirit is in the air, along with a different kind of dx. Winter dx is always fascinating because it brings out a lot of stuff not heard from for months. Even 40 meters is showing up well, although the main trouble is there are not enough dx men on 40 meters consistently to make it worth while. Anyway you might give it a whirl during January and see if a few new ones can be picked up. We would be very anxious to hear of your 40-meter results.

The "1939 Marathon"

Just a few words on the "Marathon." December RADIO contained complete details, but I'll run over the high points. Beginning January 1, 1939, and continuing until December 31, 1939, everyone starts from scratch to work as many zones and countries as possible in one year's time. The present "WAZ" Honor Roll will be continued, representing the "all time" totals. A new list will be run from month to month showing the standings of the highest 50 for combined c.w. and phone (as in the WAZ Honor Roll) and 25 for phone only. This list will be called the "1939 Marathon." The first results will be published in the April issue which will be off the press about the middle of March. This means we will need your first results not later than February 10. This will give you about a month and a half to accumulate zones and countries. Remember, in reporting please send in a list as you have done when reporting for the first time in the Honor Roll. Also, be sure to



Frank Lucas, W8CRA, one of the foremost dx men of the country, poses with his new jr. op.

keep your "Honor Roll" and "Marathon" totals separate when sending them in.

W9YNK seems to have a new gag—quoting from him sezze, "Been a fooling around with my variable xtal and when the QRM gets heavy, I just take my xtal (which is a cheap Y cut) and rub the darn thing in face powder (Mennen's is best) and that's the way I QSY—very cheap." Don't say I didn't warn you. From W2BXA we find he has cracked down on KA1AP after trailing after him for nine years. BXA also hooked F18AC, PK3EM, PJ1BV, PK6XX, ZC6NX, VS6AG and LZ7AN. My, my of all things . . . who do you think was bustin' forth the other night. Did you ever hear of W7BB, the one and only Ed Stevens? Well, he was back on the air after an absence of many moons. Ed is getting cranked up again now and I think we will hear him on at least for a few minutes every six months.

W8OSL has done himself a little good lately and picked off CR6AI and VS2AL . . . makes him 133 countries now. W2GVZ went up one by working G6IA on about 14,100 kc. Incidentally, G6IA is on the Isle of Man and is on c.w. around 2200 G.m.t. every day. The hurricane played heqq with W1AB's antennas and masts, but he's back on the air with his 100TH's going full blast. Horace pounced on zones 24

WAZ HONOR ROLL (Continued)

W2IUV	24	41	XE1BT	22
W6MVK	24	36	G6DT	21
W6MVQ	24	32	W6NEP	21
VE5OT	24		W8KWI	21
W2HCE	23	62	G3DO	21
W1HKK	23	60	W1JCX	21
W5ASG	23	46	W5BB	21
W6GRX	23	43	W6FZL	21
W9ORL	23	38	W9VYD	21
W7ALZ	23	27	W6HX	21
W7ESK	23		W7BJS	21
G3DO	22	52	W6OJK	20
W8QDU	22	48	W3AKX	20
W8DBC	22	46	W6IWS	20
W1KPK	22	40	K6KMB	20
W6FKK	22	26	W1COJ	20
W6NCW	22	23	W4BMR	20
W7AO	22			



J2KG is a well-known call both on phone and c.w. The transmitter ends up with a pair of 35T's.

and 28 with XU8NR, VS6AO, PK3EM and VS2AL.

Ah . . . here's W9PST with some very nice ones, and no fooling: ZD4AB, ZB1R, VQ2HC, CR7AF, and VQ3HJP. All this gives him 119 countries. W3EVW nabbed VS6AO for no. 113, and I might mention Roger has been doing a lot of good dx during the past few months, regardless of conditions.

Now for a few W6's . . . W6KUT worked VK2PL for another zone, and other new ones for Ed include HS1BJ, PJ1BV, VS2AL and VR4AD . . . Oh yes, and a mess of phonies. W6BAM found out from G5LI that he expects to be on the air in Barbados quite soon. No, the call isn't known yet. BAM also says W5ERZ will be on in Colombia with HK2FK . . . 14 Mc. and 28 Mc. phone and c.w. For country no. 103 BAM logged VP2AB. W6NLZ has been fussing around with his rock-crusher and just recently managed to send out a little code. It apparently was all right because VQ2GW came back and another time SU1WM answered, making John two brand new zones. We could throw in LA2X and ES1E for good measure. W6QAP heard H13N on 20 phone, but he himself was on c.w. . . . so what? Well, he just goes and borrows a modulator for the evening and works H13N. The next night Bud found his key in time to land ES5C.

W8CRA has been pretty busy lately, but strange as it may seem . . . he has not been too busy to do some fancy brasspounding. Frank's newest stuff includes the following (the frequencies will be found in the main list): XU8DI, XU8MR, VS2AL, VU2FZ, MX3A, J8CG, EP5SO, VP8AD, XZ2KR, VQ2HC, VU2FO, XU6W, XU6ST, PK1TT, KA8ZX, KA8ED, J5CS, VQ8AT, VP2LC, XU7CH, VU2ED, XU4XA, YS2LR, J6DU, U8IB, XU8VC, J9CA, FN1C and 7 VK9's with not a card from one. I can't go on without telling you that J9CA was

Frank's 151st country. Another bit of info squeezed out of him was that FB8AB is going to take trips to St. Paul Island and Amsterdam Island every other two weeks for three years, from Reunion Island. His headquarters will be in care of FR8VX on Reunion. W8CRA is using a new beam; I believe it is a lazy H. "Racehorse" Haas, W8HWE, forgot the nags long enough to give him a lift in tuning it up. I hear 8HWE is practically set to bust up a little ether, but to date we don't know if it's phone or c.w.

W7DL is active again and is adding a new one now and then. VQ8AI, VU2LK, VU2FX, VQ2HC, SU1WM, ZB1X, TF3C and CR7AD didn't do him a bit of harm. W7DL is still using the same old 150T's and from his 39 zones and 106 countries I would say they are doing OK. W8JAH worked EL2R but from indications of his being NG he went out and got ZD2H for that zone no. 35. W2IYO found himself working a station CR6AI who gives his QRA as: J. J. Chaves, Box 62, Mossamedes, Angola. Others by 2IYO are FI8AC, VS6AG, VS6AO, VU2EU, PK6XX, KA1AP, ZD2H, ZD4AB, I7AA, VQ2GW, CN1AA, KA1DL, CR7AG, CR7AD, FB8AB, OQ5AQ, OQ5AV, YS2LR, G8MF, G8DO, YV2CU VP3AA. W1AQT gets FI8AC for a new zone. New countries are ZD4AB, XU8DI, VQ2MI, YS2LR and CN1AA. Bob is still running 275 watts into a pair of RK51's.

Out here on the west coast the main question seems to be: "Do you need a personal introduction to work UK8IA?" On the other hand,



A. Te Riet, PK1RI, at his transmitter in Batavia-Centrum, Western Java.

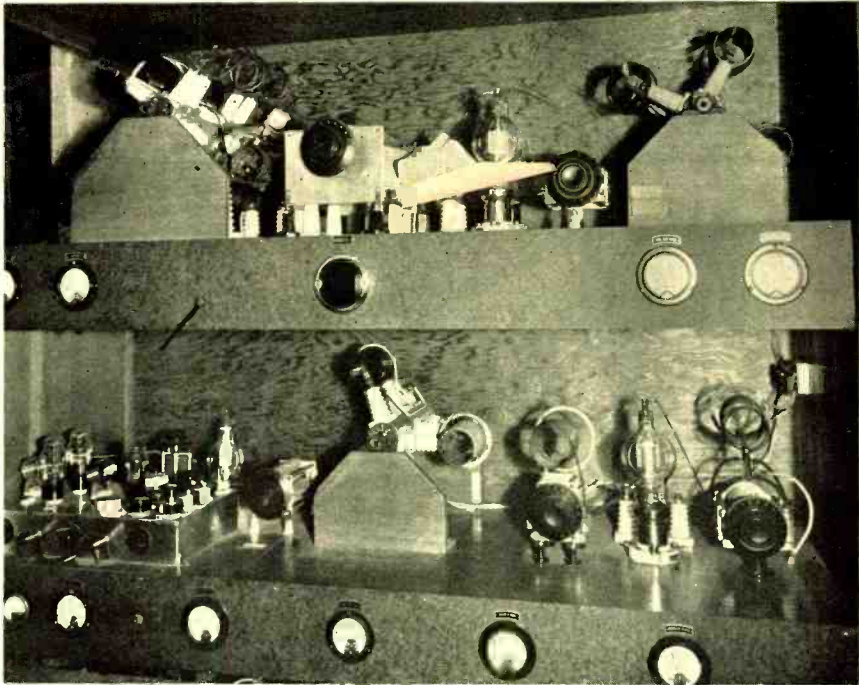

For the benefit of the many amateurs who have expressed an interest in the turret coil switching arrangement which permits W6GRL to float from band to band with the greatest of ease, we show this picture of his transmitter.

W6DOB worked him four mornings in a row, then decided to forget it for fear some cluck might cut a guy wire for "hogging" UK8IA too much. After plowing through the mail bag each month it is interesting to see which dx stations are "most reported." This month it looks as if ZD4AB is taking his share of the limelight, while VQ3HJP and YS2LR are batting it out every night too. Of course there are plenty of old reliables that are always coming through, and these I'm not considering.

Tom, W5BB, never gives up. Last month we mentioned he had all 38 zones confirmed, and now he pops up with the news that that isn't all . . . he has worked 21 zones on phone and they are all confirmed. Whatta guy!! Tom says his little bit of brag includes such things as VQ3HJP, K6HCO, ZM1AA, VP8AD, VQ2PL, VS3OL and ZD2H. W8DOD has been trying to work zone 37 for a long time and then one afternoon he must have gazed into the crystal ball because he knocked off both CR7AF and CR7AG. That's what I call grabbing 'em, and this is no pun even if Elmer's last name is Grabb. Others worthy of note are VQ8AI, YS2LR, UX1CR and G8MF. Now W2GFF is happy again . . . he had worked a station signing XTF5Q which didn't sound too good for

zone 40 so it wasn't counted . . . but now Dick has got this zone back by drawing a bead on TF3C. This makes 31 and 77. The rig is still the 211 with 200 watts and a couple of 8JK antennas.

This is as good as any place to tell you that when you work Enderbury Island, Canton Island or any island in the American Phoenix group it will count as the same country as Howland and Baker Islands. Of course, if you want to get another country out of the Phoenix group, there is VR2FR, who is on once in a while.

W6MCG is located on top of the Hollywood hills and has one of the best locations for dx around this neck of the woods. During the past 16 months he has tried all sorts of antennas and they have included V beams 477 feet long, double extended zepps, Q's, and 8JK's. Johnny has made 570 contacts with 358 stations in 32 European countries and has found the 8JK to be as good if not better than any other antenna tried. Some of his most recent (and, incidentally, he has never used more than 200 watts input) are SV1RX, CR7BC, CR7AF, OY3X, LX1AS, VQ3HJP, FI8AC, K6DSF, VK9VG, TF3C, VQ8AI, VR4AD, SU1SG and SU1WM.

W1BGC has added three zones to make 37 and the countries stand at 97. The new ones are



Frank Robb, G16TK, having some fun working the boys with his portable rig. G15UW is speaking over his shoulder. The transmitter uses a single 6L6 on 3.5, 7 and 14 Mc.

L7AA, ZD4AB, PK1MF. W8GBF is a new one with us and says that at times it seems it is all his kilowatt will do to get through the terrific QRM. All who agree signify by the usual sign.

G5BD has a new brick shack, also has built a new transmitter. Art is back on the air after quite an absence and is all steamed up about grabbing some of the dx he has missed. The antenna for 14 Mc. is a NW by SE doublet, but not too good for W stations. For 10, 40 and 80 meters he uses a zepp. Art says one of the most outstanding things he has noticed after his two-year layoff is the absence of Pacific stations coming through around 1500 G.m.t. He wonders if we have noticed the same thing . . . and the answer is "yes." G5BD, if you remember, was running quite a consistent stretch of QSO's with W6GRX, numbering 180 on 10, 20 and 40. Art has 37 zones and 110 countries . . . shhh!! including AC4YN.

W8OUK is another to work ZD4AB and now has 34 and 84. "Red" has been able to do more than that, too, and just as an indication of what his 200 watts is doing . . . ZD2H, CR7AG, OQ5AV, HR7WC, PJ1BV, VQ4CRI and ZP1P. He says after many sacrifices he managed to save "two bits" and bought a zone map. "Red" is studying engineering at Carnegie Tech and is not as active as he would like to be. I noticed his letter had a flock of 20's and 10's written on it like "doodles," and it finally dawned on me: Carnegie upset Pittsburgh 20 to 10.

W2JXH claims to have the world's worst location. He says, "My apartment is on the first floor of a 15-story building. How I ever get out is a puzzle to me as I have to use a vertical antenna. The antenna goes up from my window sill to the tenth floor, and this window opens into a court twenty feet square. The building, which is of steel construction, closes in the court on three

sides, and yet I work 'em in all directions." W2JXH says that YS2LR requests the cards be sent to W5FNX; and other good contacts for Harry are CP1AA, ZD4AB, J8CA, XU8RL, ZD2H, EL2A, TF5B, CX2AJ, VO6D . . . making 36 zones and 71 countries.

W2GTZ is still able to pick out new ones; this time they are PK6XX, VK4HN and TG9BA. Looks like a little phone work going on in there, Reeve. 38 and 138 for him now. K4KD can't seem to get over the 26 zones he has had for some time. He manages to get a few new countries like PJ1BV, G8MF, VQ8AS, U9ML. "Ma" says K4FHR is looking for dx nowadays and hooked a station in Estonia that he (K4KD) had been chasing for a year. K4FCV is a proud poppa of a brand new y.l., and not only this, but made WAC in the first two months on the air. Congrats on both.

Another DX Man Falls

W6ADP, known for his ability to sit patiently in front of his receiver twiddling dials, will not be sitting so patiently for some time to come, nor will he be twiddling any dials. The reason is simple: last July Glenn pulled a "sneaker" and after both of them said, "I do," they proceeded to keep it a secret. Anyway he and the x.y.l. have moved to Redding, which is located in the northern central part of the state. Well, W6ADP ended up with 39 zones and 140 countries. Congratulations, Glenn.

From the Phone Men

You may not know it, but W4CYU has 31 zones and 88 countries to his credit on phone. W6NLS adds a new zone in working SU1GP, and along with this one John hooked LA1Y and CT1KH for new countries. NLS uses 10 phone only.

W7BVO was just beginning to think he had hit a dead streak for nabbing new stuff when up pops VQ2HC. After Rollie had finished logging this one, SPIQE gave him a call. To top it off VQ4KTB came sailing through during the lunch hour, and Rollie didn't mind cutting his lunch down to one sandwich in order to grab this new one. After this spree he found he had 30 zones and 64 countries. To our happy phone family we add W2AOG with 30 and 77. Fred has been on since 1919 and has never used more than 250 watts. W6OI has been having a good time and his new countries are FB8AB, VQ4KTB, CN5NW, VP3AA, TG9BA, HR2A, VS7GJ and HB9DE. Dave now has 29 and 62.

Here is something that really stands out: W2AZ has just worked his 37th zone on phone . . . ZD2H was it. Frank has 89 countries, and these figures put him at the top of the phone list. G3DO kept skeds with W7BVO, W7EKA

and W6OI between 2000 and 2130 G.m.t., which strikes him as a most unusual time for west coast stations to come through. I can say, too, that the above fellows think the same way about it. This was on 14 Mc. of course. G3DO got VQ2HC for his 22nd zone and for new countries he has VQ2HC, VP6MR, OH2OI, SV1KE, and CN1AF. W3LE tells us that he has a letter from SV1KE and says that there are some fellows using his call. Apparently they listen in and if Bill isn't on the air they come on and use his call. There is only one way that you can tell if you work the real SV1KE and that is—Bill always QSL's. W3LE is still running around 200 watts to a pair of T20's. His antenna is the two-section 8JK and, as Lou puts it, "It's the berries." Lou has 28 zones and 51 countries. W6MVK has upped his to 24 and 36 by getting such dx as VU2LL, VR6AY, PK6XX, PA0UN, XZ2EZ, F8AI, YV1AG, YN1OP, K6BAZ, VS6AG, TI2HC, ZI2QL, PY2AC, CX2AK. MVK gives the QRA of VQ2MI as Box 235 N'Kana tu, Northern Rhodesia. The QRA of VQ8AI is Raoul Thomas, Thompson Road, Vacoas, Mauritius.

W7EKA has a new 3-element close-spaced beam for 10 meters and has been doing his share of picking 'em up. Cast your eyes on ZL4AF, VP6YB, HK3CO, CN8AV, TG9AA, K4EIL and TI3AV. CN8AV says he is anxious for contacts in Oregon, Montana and Wyoming.

As long as we're talking about W6's, we may as well finish up with them. W6OJK of Tucson, Arizona, adds his bit to the story of CN8AV. It appears that CN8AV is on the air around 10 to 11:30 a.m. p.s.t. looking for W6 and W7 contacts. His frequency is the same as G6BW, and G6BW is on 28,188 kc. CN8AV has an HF-100 in the final, and says he is a "leftenant" in the 64th Artillery Regiment in Meknes. As for W6OJK, he has 20 zones and 37 countries worked with his 100TH with around 300 watts input.

More from K7FST

In a letter from Charles De Remer, K7FST, he gives some interesting information. Charles says he is practically sitting on the pole and his location at present is Kotzebue, Alaska. The spot is all level and about six feet above high tide. He has put up three sticks and strung a V beam on them—275 feet per leg. It is headed for Chicago, the idea being that it should cover all of the states very well. It is interesting to note his reaction to the first batch of dx he has worked. On his first CQ he got W7GEJ and after that chat W6OCH nabbed him. After the first evening on the air he felt satisfied and hit the hay with a big smile on his face.

Now then, for those who haven't heard much about K7FST, I might say that every now and then Charles expects to go over to East Cape,

which is on the eastern tip of Siberia—and in zone 19. It will be a chance to get a card from a station in that zone. Well anyway, the next night he was on the air it seemed that all stations he worked were in Europe such as OE7EJ, ON4AS, OK1SV, OZ7CC, ES5C, F3AD, EI9L, GM6MD, G8AB, G8OH, HA7O, HB9CE, D4AFF, SM5RH, LA2W. Charles says he is on every night from 7:30 p.m. to 10:30 p.m. p.s.t. and the frequencies he is using are 14,208 kc. and 14,160 kc. Oh yes, he is using phone, but I'm sure we can arrange to get him to use a little c.w. now and then. We'll hear more from K7FST later.

Another point I wish to bring up is the fact that a few months back I mentioned about K7FST working from Wrangel Island, which is in zone 19. Right away a few fellows sent in K7FST as their zone 19 contact. Checking further into it, we noticed that there is a Wrangel, Alaska, as well as Wrangel Island. I believe one or two of the boys also discovered their cards were from the Alaskan location. K7FST plainly marked "zone 19" on all cards confirming contacts while at Wrangel Island. So if any of you are figuring on using this station as your zone 19 contact, better check into it.

Latest dx at W8ACY is VP5BR, VP2AT, J2KG, J2OV, LZ7AN. W2BHW is still finding time to pound brass, his latest being YA5XX, FU8AA, CR6AI and EA8AV. Lindy says CR6AI is usually around 14,150 but once in a while he jumps to 14,060 and tunes from the LF end of the band. W3AYS says not much going but wonders why things always happen to him—like finding LX1AG a BL. Many more want to know the same thing, including yours truly.

"Fat" Benning, W4CBY, is again very active for some unknown reason, and has jumped his countries to 138 with 39 zones. Fat's newest are VQ2PL, VQ2MI, ZD4AB, CN1AA, ZD2H, CR7BT, OQ5AV, VQ3HJP, YS2LR and PJ1BV . . . also a flock of Asians including XU4XA. Just a word about XU4XA. A great many of you have reported working him, and he gives each a little bit of information as to his whereabouts. From what I put together, it seems as though XU4XA is not in zone 23 but in zone 24. He said at one time he was up the Yangste River about 1500 miles, and told another that because of disruption of the postal facilities there would be quite a delay in the cards.

W1APA adds KA1FG, XU8NR, J8CG and CE3AJ, which make 32 and 90. Gil says there were about 200 in attendance at the first dx roundup in the East, which was held at Bridgeport. D4BIU, ZL2JQ, W2BHW, W2GTZ, W2IXY, W1BUX, W1TW, W1JPE, W2UK are just a few who were there. W2UK won the 150T . . . and on the level, too. While we are speaking of dx

roundups, can't leave out the one held in connection with the convention just staged in Los Angeles. Each year W6BYB donates a silver cup to the winner of the phone section and the c.w. section of the dx contest.

This year W6CXW was presented with the trophy for the c.w. section, and W6GRL received one for the phone section.

W2HHF grinds out UK8IA, NY1AC, VQ3HJP, VQ8AI, PK6XX, G6IR, YV2CU, U5KN, F18AC, VS2AE, ZD4AB, CR6AI, VQ2FJ, making 38 and 130. W5ASG comes through with ZD2H and VQ3HJP. There's that guy again. ASG now has 34 and 91, while on phone he is up to 23 and 46. W8OSL hooks VS2AL and CR6AI—now 133. W8KKG in Romney, W. Va., says he agrees with 8OXO about W. Va., being somewhere, but isn't too sure about Fairmont, which is OXO's QTH. I'm glad they are acquainted—or maybe I should duck anyway. Well, 8KKG has only worked some ordinary stuff, as he puts it, OY4C, TA1AA, F18AC, UK8IA, VR4AD, PJ1BV, VQ3HJP, ZD4AB, XU8NR and VU2FX—37 zones and 127 countries. W8GBF also is doing something—in fact, two new zones in F18AC and XU8NR, together with other nice dx such as CR7AF, VQ2MI, PK1MF, TF3C, EL2A, CP1AA, KA1FG.

Say, these fellows F18AC and CR6AI are really popping to the front—here's W2GVZ getting F18AC for his 38th zone, and CR6AI. W3EVW says ZS4U wants the W's to look for him on 14,300 kc.—so there's a job for some of your "guys." W8BTI is another to haul in CR6AI and VS2AL—now 141 countries. W5KC has no regard for his poor electric service meter—imagine dragging down five new zones. Those that make him 28 are VU2CX, F18AC, VQ2PL, CR7BT, and YI2BA. W3TR lands F18AC for 35th zone and W3EVW gets ZD4AB but finds LX1AW apparently NG so still has 114 countries.

G6WY has worked his 150th country—SV6SP in Canea, Crete, on 7120 kc.; he is genuine and QSL's. "Ham's" 149th was PJ1BV. G6WY adds that he worked W3BES and W8BTY on 3.5 Mc. W6BAX is knocking 'em off, and while working VP8AD he was told that VP8AG is on Georgia Island but doesn't get out except to LU and ZL, etc. It is a dead spot and only a few hundred miles can be covered. Best for BAX have been LX1AS, OY3X, K6HCO, U6WB, VU2AN and VQ5KLB . . . and, too, there was ZD4AB. This has helped in piling up 39 zones and 140 countries. W4ERD says that YI2BA still gives his QRA the same as in the Call Book and wants all W's to QSL—and he will do his part.

VE2EE now has 37 and 102, while on phone it is 28 and 62. Stan's newest additions are ZB1U, VS2LR, XU4XA, F18AC, VQ3HJP, and TG9BA. He is another of the merry throng who wishes the

owners of EC oscillators would park them at least 5 kc. off of the dx station, because it would give a fellow a chance to see to whom he came back—instead of listening to a lot of fellows still giving a long call.

The other morning overhead VS2AG telling someone that VS3OL was receiving a lot of cards, but as yet they haven't been able to locate VS3OL. After investigating all the cards and with the help of directional antennas they have come to the conclusion that VS3OL is coming from some point around New Orleans, or southern U.S.A. The cards seem to be addressed to Cecil Barrister, Cerabanga, Malaya. If anyone has anything further to offer, we would surely like to hear from you. In the meantime any of you who plan to use VS3OL as a zone or new country contact—better wait.

Tommy Cunningham, VO6D, is back from Labrador and is located in North Bay, Ontario, Canada. He will soon be on the air again with a VE3 call. Says he misses the good ol' spot up there where sigs were swell to copy. Tommy also says that there are three active stations in VO6 at present; VO6B on 20 phone uses 25 watts, VO6W has a self-excited 210 with 15 watts, and then there is another station with 200 watts who is the former VE2KD, but can't remember his call.

BERS 195 has broken his HAC record of 6 minutes, and now it is 3 minutes. Eric has heard 163 countries and 39 zones. He received a note from Fred Harry, YJ1RV in the New Hebrides, saying that there wasn't such a place as French New Hebrides or British New Hebrides—it is just plain New Hebrides and belongs to Britain. It is very strange, though, as Eric has cards from both YJ1RV and FUSAA. Just what the core is no one seems to know, but both calls appear to be official. Eric is still looking for a station in zone 2.

W6ITH had an unusual contact the other night when he hooked up with W6NWK/mobile, who is on the freighter "City of Delhart" and was between New Zealand and Pitcairn. He operates on 28-Mc. phone and on these frequencies: 28,672, 28,964, 29,660. As you no doubt know, 28-Mc. operation is legal on an American ship any place except when it is actually in foreign waters. ZS6A also told Reg that CR6AB is on phone in Angola, has several frequencies which are not available at this time. Last month a note of ITH'S was misinterpreted I guess . . . and we had in print that KA4LH would soon be on the air as he was building a new rig, etc. It should have been that KA4LH is building a new rig and will use 1000 watts compared to the 200 watts previously used. He has been on the air over a year and has a rhombic in the jungles pointed on California. Reg is another one of the boys to hook VQ4KTB on 20 phone . . . This helped make a

total of 37 zones and 100 countries, while on phone the figures are 34 and 87.

W21XY goes up a couple of countries and one zone by grabbing ZS3F and VQ4KTB. She now has 30 and 85, and says conditions have been rather poor lately on 20 meters. Another report from W7EKA gives him a nice brand new zone in SV1KE, who said Al was the first W7 worked by an SV phone. Other fine phone contacts for Al are ZS3F, XZ2DY, HB9DE . . . All this gives him 26 and 45. W9TIZ has been at work too, and if you don't think so just take a peek at these

four new zones for him: K7AOC, J2MI, KA1FH and PK6XX. Now has 31 and 62. W9RBI also got K7AOC for his 25th zone, and a few new countries: ZS3F, LZ11D, G16TK, HP1A. Ross says he is rebuilding for the winter downstairs. How far down, Ross?

W3FJU sends in an imposing list containing 34 zones and 71 countries all done on 20 phone. He is using a pair of T125's and has been chasing dx since last February. Don says that Y12BA told him he would be on phone shortly, and at present is on i.c.w. and c.w. in the American phone band. Some of 3FJU'S best are 11MS, HA8N, VQ4KTB, U3BX, VU2CQ, PK6XX, FB8AH, VR6AY, SU1CH, CN1AF, ZL2BE, ZL2JQ and J2MI.

FREQUENCY LIST

C.W.			
AC4YN	14,106	VQ2PL	14,420
CN1AA	14,420	VQ2MI	14,320
CN8AV	14,090	VQ3HJP	14,410
CP1AA	14,410	VQ8AF	14,290
CR6AI	14,145	VQ8AS	14,140
CR7AF	14,275	VS2AL	14,420
CR7AG	14,300	VS4JS	14,050
CR7AK	14,320	VS7RA	14,005
CR7BT	14,088	VS7RF	14,340
FI8AC	14,410	VU2AN	14,090
FT4AN	14,125	VU2EO	14,090
FU8AA	14,410	VU2EU	14,320
G61A	14,110	VU2ED	14,065
HR7WC	14,430	VU2FX	14,340
HR1JR	14,010	VU2LK	14,008
I1IT	27,980	XZ2DY	14,090
J3FP	14,095	XZ2KR	14,235
J9CA	14,280	XU4XA	14,280
J2KG	14,420		14,370
J8CA	14,345	XU6MK	14,120
J8CG	14,415		14,410
K6HCO	14,340	XU8BN	14,020
OQ5AV	14,035	ZU9MK	14,115
OX7ZL	14,025	XU6LN	14,110
PJ1BV	14,450	XU8NR	14,330
PJ3CO	14,412	XU8RL	14,280
PZ1AB	14,470	YI2BA	14,210
TF3C	14,425	YS2LR	14,410
TF5G	14,425	ZB1P	14,370
ST6KR	14,423	ZB1U	14,318
SV6SP	7,120	ZD2H	14,300
U81B	14,325	ZD4AB	14,412
UK81A	14,440		14,325
	14,350	ZM1AA	14,415
UX1CR	14,405		
VK9BW	14,040	CN5NW	14,060
	14,300	HB9DE	14,050
VK9VG	14,090	HR2A	14,280
	14,340	HP1A	14,300
VP2AB	14,400	TG9BA	14,030
VP2AD	14,400	VP3AA	14,120
VP5BR	14,130	VS7GJ	14,070
VP8AD	14,280	VQ4KTB	14,030
		ZS3F	14,080

A Word About Zones

There are some who believe the two zone lists contained in the "WAZ" Honor Roll are divided as to the c.w. list and phone list. This is definitely not true. There is no "c.w. only" list. When the Honor Roll was originated a list was started to see how many zones could be contacted, whether they be on c.w. or phone. In other words, the Honor Roll (excluding the "phone only" list) represents all the zones and countries one can work on any band, either on c.w. or phone. There are hams who use c.w. only, there are those who use phone only, and then there are many who use both c.w. and phone. The phone list is for phone only . . . that is, you must call and raise them on phone, but the station worked may be on either c.w. or phone. For the sake of simplicity you might consider the main portion of the Honor Roll as the grand total of all your achievements.

W9AM writes that in December he is sailing on the S. S. California for a four months' voyage to the Antarctic Ocean. He will be on 10 phone and c.w. with about 20 watts of power, so if you hear W9AM/mobile you will have an idea where he is. Guess they're going after whale oil. J2KG says that he QSL's 100% and yet the cards he receives in return are few. J2KG has worked 36 zones and 87 countries.

Well, gang, this just about winds up another year and you should be making a few resolutions. I understand a resolution will be adopted by quite a bunch not to rebuild their rigs more than five or six times during 1939, and they might include W8OSL, W5BB, W3EVT, W2GVZ, W6NNR, W7AYO, W1APA, W4CBY, W6ITH, W8AU, W7AMX, W6CD and dozens of others. W8CRA is going to leave his new antenna up for five years before changing it. By the way, it might be of interest to know that W6CD is in for real business now . . . they have purchased 16 acres on the mud flats on the San Francisco bay, just north of Berkeley. It was formerly a duck hunting

club. Only trouble is dragging the poles around in the slushy mud before putting them up . . . every once in a while they just about lose one of their ops (W6JO) in the mud. He is just a little over half pint in size. At present they are using V beams. Just received word that W6OCH has received confirmation from AC4AN for their QSO while AC4AN was in zone 23. If you recall a month or two ago VS6AN was on a mining trip in zone 23 and put his rig in the American phone band. OCH was so surprised to hook him he hasn't quite recovered. Wonder what's happened to W9KG, 9ARL and 9CWW? Also W1ZB, W8DWV, W8KPB? I'm going to have to shut this mill off here, otherwise you will be reading this in February. Keep up the good work, don't make resolutions you won't keep, and keep your EC or "band scooter" at least 5 kc. from the station you're calling (I'm sticking my neck out) until after you have raised him. I know I'm going to have a big year . . . just think, there will be twice as many 9's in "1939" as there were in 1938. Hope that's not too deep for you.

28-Mc. Band IN GREAT BRITAIN

By NELLY CORRY, G2YL

The general impression among regular "Ten-meter Addicts" seems to be that conditions in October were not so good as those of October, 1937. Certainly more dx was heard than ever before in the history of the band, and at times QRM was terrific, especially among the phones, but on the whole QRK's were lower, and QSB more prevalent than a year ago. G6DH reports that his graph of the highest frequency heard daily is keeping well below that of 1937, and it seems quite possible that we have already passed the peak of 28-Mc. conditions in the present solar cycle. The impression a casual listener on the band gets is that it is "all W phones," but BRS 3179 proved that there is plenty of activity all over the world by logging 90 different dx stations during the month, exclusive of North America and Europe.

Altogether stations were heard from 65 countries, and all continents were audible on October 2, 9, 15, 16, 18, 19, 22, 23, 24, 29 and 30. G6DH was w.a.c. on the 9th and 23rd, and G2DH worked all continents except Africa on the 9th. Oceanic signals came through daily from October 13 to 24 and on five other days, and included 23 Australians in VK2, 3, 4, 5 and 6. Stations in ZL2 were

heard by G6DH and G6YL, and ZL1CC and KA1AP by BRS 3179. On October 6, 1830 to 1930 G.m.t., several K6 phones were audible at good strength, viz., K6MVV worked by G2PL, K6MVX worked by G6DH, and K6BAZ was heard by BRS 3179. PK1VY was heard on seven days after the middle of the month, and was worked on phone by G6DH on October 16.

Stations in Asia, heard on 19 or more days, included VU2AN, who had 10 QSO's with G6DH during the month, and VU2DR, 2ED, 2EU, 2FS, 2FV and 2FZ. G6DH made first contact with Burma when he worked XZ2EX, and later XZ2DX, on phone on October 20, and XZ2DY was also heard active. Other interesting signals were HS1BJ, heard by BRS 3179; J2CD, heard by 2DQS; VS6AF, worked by G5ZT and G6KS; and VS6AG, heard by G6QZ. About 40 stations in Africa, the majority of whom used phone, were heard on at least 24 days, from CN, CR7, FA, FB, SU VQ2, VQ3, ZE, ZS1, 2, 4, 5 and 6. CR7AG was reported active for the first time by G6YL.

North Americans were audible on every day in the month except October 1, 7, 17 and 27. G6LI worked all W districts on phone on October 4, and G6KS completed his w.b.e. by QSO's with VE5, and worked all W districts except the 5th on c.w. on October 18. W mobile stations logged by BRS 3179 were W9BHP, a new ship station, and W3CQB, aircraft over New York.

Signals from Central America and the West Indies were also heard nearly every day, and included 24 stations in CM, FM, HH, HI, HR, K4, K5, TG, TI, VP6 and VP9. HI7G was the most consistent signal from this part of the world, and was heard on at least 22 days. As in North and Central America, phones predominated in the south and included two dozen or more stations in CE, CX, HC, HK, LU, PY, VP3 and YV.

Signals from eastern Europe were often up to S8, and on a few days skip was short enough to enable D's, F's, HB's, etc., to get through at good strength. Pre-skip signals from GM, GW, EL, ON and PA were also audible in England on many occasions, stations about 100 to 200 miles away sometimes being heard up to S6. The Hiss was heard on October 11, 14 and 17 for short periods.

W9TMP tells us that a K6, operating portable in Los Angeles, had three W9's and a W6 straining to get a message into Westwood, a suburb of Los Angeles. Reminds us of the newcomer to Manhattan who grabbed a taxi to go to a hotel across the street from Grand Central Station and was shown the town.

British Field Day

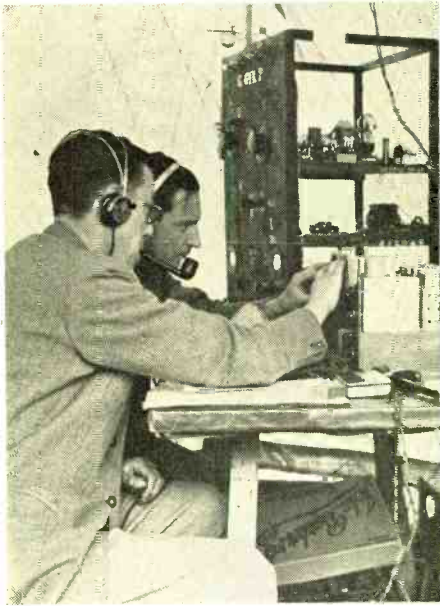

● The R.S.G.B. National field day brings out portable stations all over England, Ireland, Scotland, and Wales. Pictured here are some of the boys with gear they took out into the country.

● Portable G6CJP is to the left, with G5CV at the key and G6CJ tuning the receiver.

● Portable G6PRP is shown below. Sitting, left to right, are G6PRP, G3QY, and G6CO.



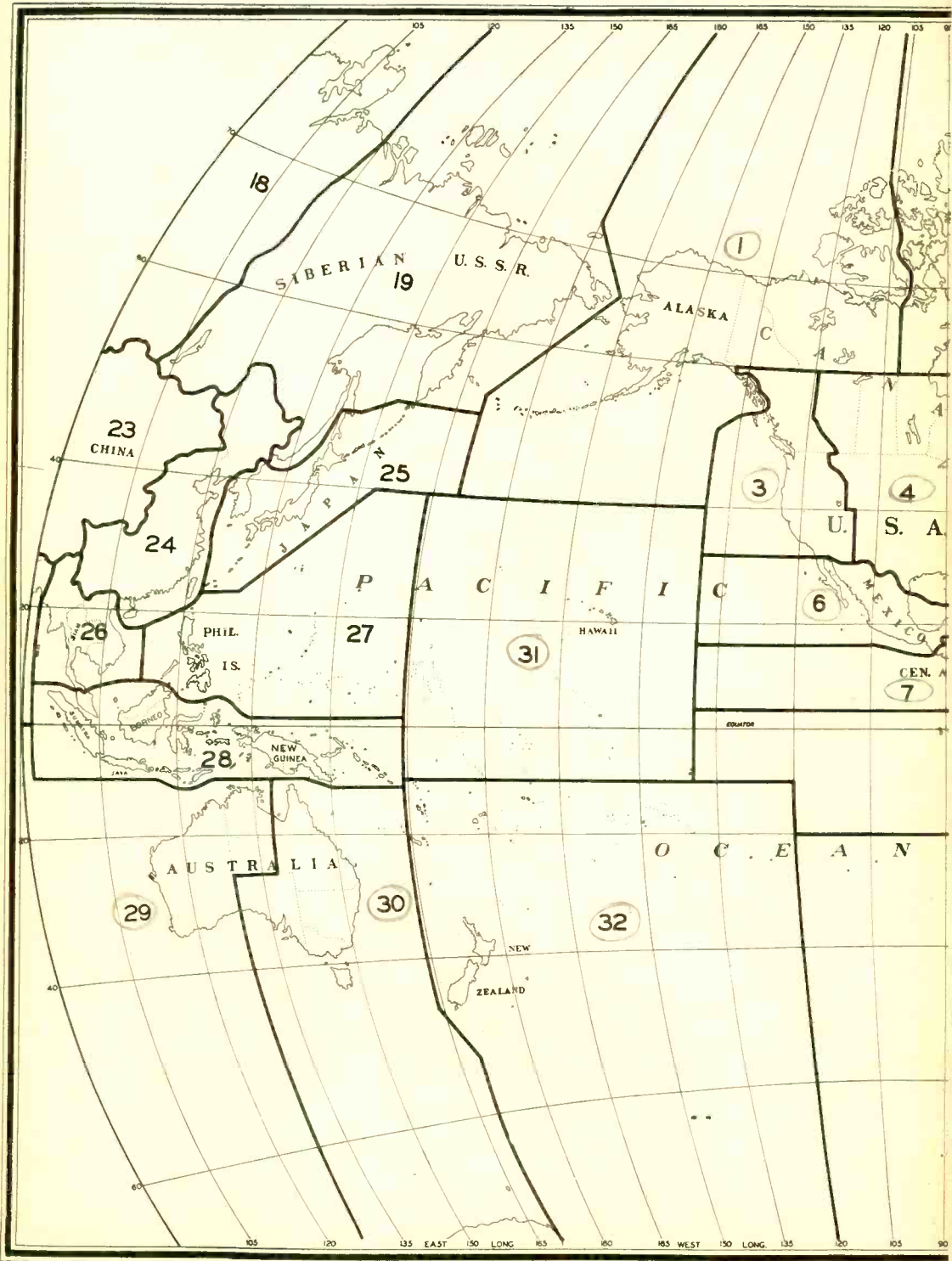

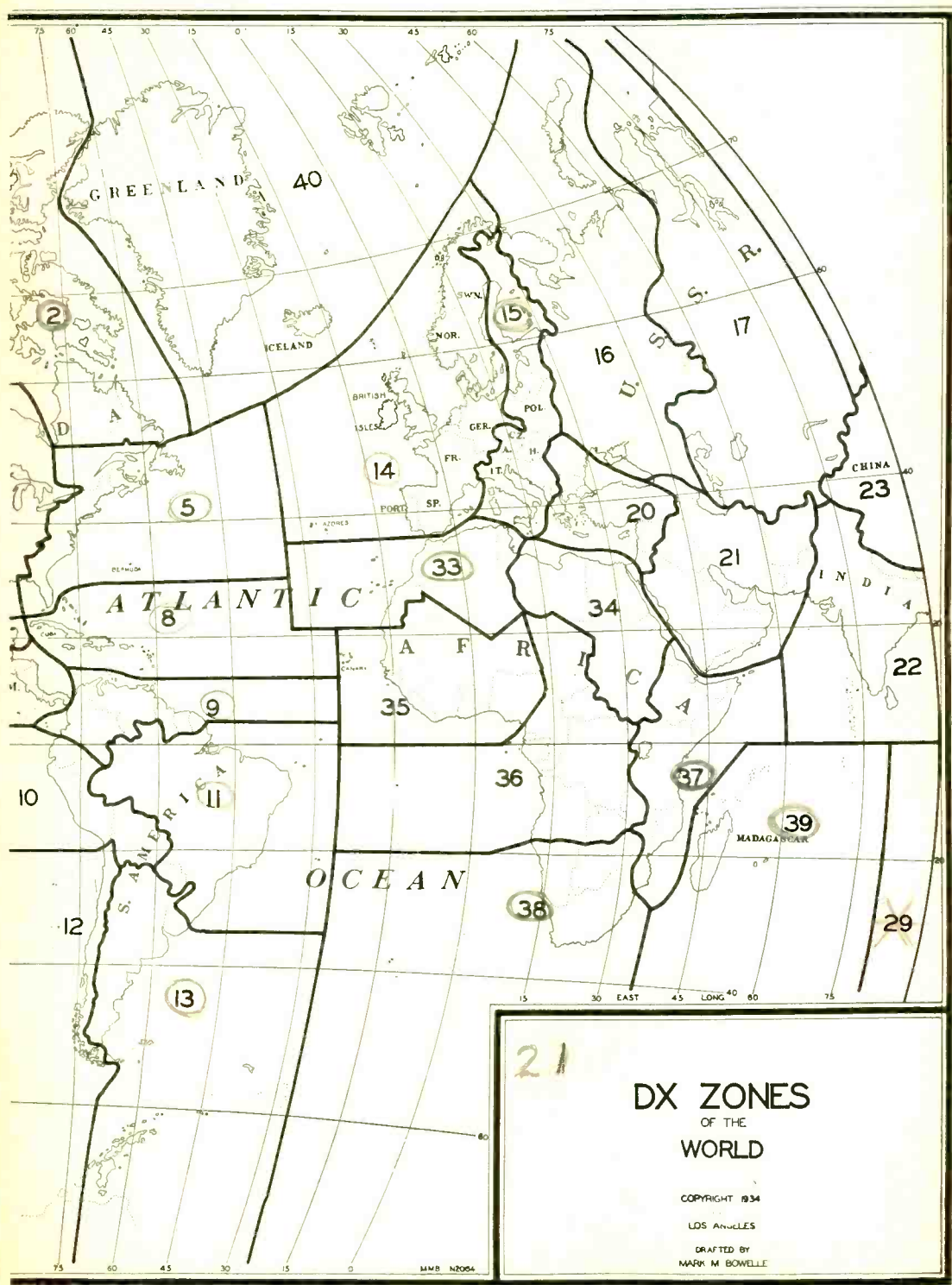

56 MC

By E. H. CONKLIN*

An easy W6 contact next summer for the ninth, fifth and eighth districts may be Clyde Criswell of Phoenix, Arizona, who now has the call W6QLZ. He has had a lot of experience receiving 42-45-Mc. television and 56-Mc. amateur signals during the last few years. He reported east coast television (F₂ layer transmission) on September 11 and 12, coming back on September 28, 29, 30 and October 1 and 2 after the mid-September ionosphere storms. This is a month earlier than in 1937. Both London and Paris television were heard from October 28 through November 4, and on the latter date all channels up to 46 Mc. were heard. Armstrong's frequency modulated transmitter on 42.8 had been coming in often, with peak signals from October 19 to 28.

Criswell says that London leaves the audio carrier on after the program, sometimes with a 500-cycle note. The television band has peaked up during the first week in November for three years.

Inter-band Relationship

There has been much comment on the connection between conditions on several amateur bands. We figured out the theoretical skip necessary at one frequency for a signal twice that frequency to be returned to earth. For the winter F₂ layer, which normally peaks up somewhat after noon at the point of reflection, we assumed a layer height of 250 km. as an average figure and find that a skip of 485 miles is required for the next band to become useful, which would occur at the maximum one-hop distance close to 1900 miles. A 485-mile skip on 14 Mc. should indicate that 28 Mc. is beginning to open at a distance of some 1900 miles in the same

* Associate Editor, RADIO. 512 N. Main St., Wheaton, Ill.

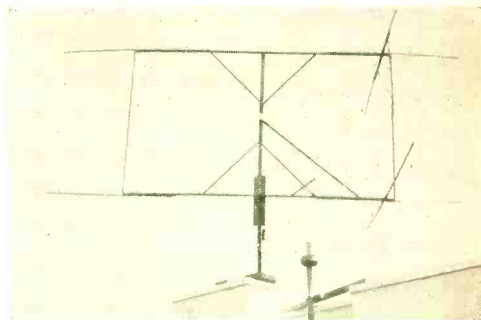

The highly effective rotary Yagi array used at W8CIR. Three directors (in line) and three reflectors (parabolic) are used.

direction; if 28 Mc. is open at 485 miles, then 56 Mc. should open (in the winter).

For the summer sporadic E layer, we assumed a normal layer height of 110 km. and the resulting figure is 320 miles. This means that the ionization at times last June 5 was probably strong enough to return 2½-meter signals to the earth 1200 miles away! In the case of the sporadic E layer, however, there may not be a large enough cloud of electrons to reflect to the same receiving point both the short-skip lower frequency signal which bounces off the layer only 160 miles away, and the long higher-frequency signal which must be reflected 600 miles away to come down at the maximum 1200 mile E layer single-hop distance. With the summer skip, therefore, ten-meter signals which cannot be heard closer than 700 miles, let us say, may not prove that the five-meter band is *not* open, because the layer may not extend close enough to bring in more nearby ten-meter signals. In any event, the next lower frequency band should always bring in signals from the same distance and direction.

England-Ireland Contact

Several months ago we mentioned a cross-band G-I contact on July 2. The *T & R Bulletin* mentions a two-way between G5MQ and a station signing IIRA. G5MQ and GW2NF also heard IITKM. The lack of regularly operating five meter stations on the continent made the active British stations content themselves with listening to harmonics, which indicate an open but empty band.

G5BY Active Again

Hilton L. O'Heffernan, well known in DX and 56-Mc. circles, writes as follows:

"Just a line to let you know that I hope to be on regularly on 56,208 all through the

winter, keeping the Saturday-Sunday transmission times.

"As you may know, I was out of radio all last winter, being desperately ill for three months with typhoid fever and then, a month after that was over, I had an operation for appendicitis! Have been away by the sea all the summer so missed any chance of doing anything on 56.

"Since being back, I have built a new superhet using acorns—especially for 56 Mc.—and have put up two rotatable beams—one, a six-element Yagi with three reflectors, radiator, and two directors; and a two-section, four-element W8JK which is normally horizontal but can be used vertically if required. The W8JK seems very good and gives a good 60-mile range on genuine ground wave. I still have, of course, the rhombic antenna, and hope that one of these three will do the trick.

"Interest on 56 Mc. in this country seems very limited. Here, only 10 miles from London and with a receiving radius of, say, 50 miles, there are never more than twelve stations on the band together during the whole of Sunday!"

56-Mc. Field Day

The October 17 field day, previously mentioned in this column, was again successful. Messages were relayed from VE3ADO in Toronto, Ontario, to Kyser Ridge, Maryland. VE3ADO was heard in Erie, Pa., and several times heard W8CIR near Pittsburgh, 230 miles away, who had an R7 signal. He wants to know if results like this can be expected at this time of the year (they had an hour QSO on the morning of August 7). Of course, this low atmosphere bending or long ground wave dx is not as seasonal as the 400-1200 mile sporadic E layer type, though it does appear that winter produces weaker signals, on the average, than summer. More field days with organized relays may open up some very good dx, and should be encouraged. We suggest, particularly, east-west attempts from Boston and New York through Chicago—signals have covered every part of the path on "ground wave" work, so an organized attempt may succeed. How about a Washington's Birthday relay on February 22 with two attempts, 11 a.m. and 9 p.m. eastern time? The route could be warmed up at the same times on January 1.

Last May 11, W8CIR in Aliquippa, Pa., and W8PK in East Bloomfield, N. Y., surprised themselves with a 210-mile contact over rugged country without prearrangement. CIR worked W8NOR in N. Tonawanda, N. Y., on July 15, also 210 miles. He says that 100-

200 mile dx was quite consistent during August.

VE3OJ and VE3XZ of Hamilton, Ontario, did some good portable work last season from a point five miles south of Hamilton. Using only 15 watts they worked VE3ADO in Toronto, W8RV in Buffalo, and W8QCJ in Lockport. The best dx was W8AGU in Penfield, N. Y., about 130 miles.

A few months back, W5EHM in Dallas found that his signals quite regularly bridged the 170 miles to W5ZS in Louisiana, and to W5ZZF. W9CLH often has been heard or worked from points in Illinois, Wisconsin and Michigan within 200 miles. W8KG says that with a stabilized transmitter and superhet receiver, a station in Akron can make contacts with Pittsburgh, Cleveland and Youngstown regularly.



The mast at W8IPD is easily lowered. A block and tackle system into the attic makes it possible to lower the mast and make antenna adjustments with little loss of time.

Last July, W8QDU in Detroit found it more interesting to make almost nightly contacts with Akron and even as far as W8CIR outside of Pittsburgh. His tier array (four W8JK's, one above another) blew down so W8QDU hasn't reported recent dx of this sort.

From Maine to Virginia, long hops of this kind have been more frequent, but work this year indicated that development of antennas and equipment is bringing about good dx work in almost every type of country all the way west.

Fluttering Signals

Occasionally, someone mentions hearing signals with a 30-cycle hum or flutter. In a morning schedule on August 12, W8NOR in N. Tonawanda, N. Y., heard W8NBV in Erie, Pa., 95 miles away, with what appeared to be a bad 30-cycle hum. NBV heard nothing, however, and gave up. Shortly after, NOR got a call from W1GUY in Ludlow, Mass. (290 miles?), who was badly distorted, with a hum on his carrier sounding like a self-excited oscillator. He came back giving NOR an R9 report, said he had crystal control with no hum, but NOR sounded the same. As the QSO progressed, the frequency went down to 20 cycles and the signals from R8 to R4. Shortly after, the flutter dropped to 15 cycles, then stopped, leaving a clear R9 signal for a few seconds which passed out completely and the band became quite dead.

Matching a Flat-top Beam

W5ALK says that he has an efficient feed method for his flat-top beams. He uses a two-inch spaced line, branched so as to feed both elements 180 degrees out-of-phase by twisting one branch a half turn. He then places the whole beam, with two elements eight feet three inches long spaced two feet, on top of a step ladder, shunts a six-volt pilot light across one or two inches at the center of one element, and slides the feeder connections along on each side of the center until the lamp is bright and standing waves on the line are eliminated. On 56 Mc., the matching points turned out to be seven inches from the center. The antenna is then raised into position. He claims that this method is not as critical as to change in frequency as a stub. On ten meters, the same system is used.

Antennas at W8CIR

Ed Doherr, W8CIR, is one of those fellows who has put up a haywire beam that worked fine, took it down to make it pretty, then found that it had lost its charm. When in an afternoon and an evening he threw together a rotatable Yagi for 56 Mc., only 20 feet above the ground, after talking about one for a year at least, it worked so well that he hesitates to dress it up. It has 3 directors and 3 reflectors.

The array is rotated by reaching out the window and turning the vertical pole seen in the picture. This has a one-foot wooden cartwheel at its top which is belted with copper wire to the two-foot cartwheel at the base of the mast, just visible in the picture. The antenna is fed with a spaced line fastened at one point to the mast.

Inasmuch as W8CIR has worked eight districts and lots of dx with this array, a discussion of its effectiveness in comparison with a Q-fed dipole mounted 80 feet high, will be of interest. Low power stabilized stations in Akron, 75 miles away, often can just be heard on the high dipole but will come up as high as R7 or R8 on the Yagi. Occasionally on short-haul dx to Buffalo or Erie, to the north, there is little difference between the high dipole and the low Yagi. To the east or west, it is not critically sharp within 15 degrees either side of the proper direction, but to the south into Florida, 10 degrees either way will practically lose the station.

Only on one occasion when checking with Pat, W5EHM, was the dipole as loud as the beam. This happened as the band opened on July 24 when the Yagi was R7 and the Q R7-9 with fast fading. Later, W5EHM said that the beam was back up to R9 plus. On rotating the beam on W5EHM, the receiver R-meter went from R3 off the back to R6 at the sides and R14 or so on the nose. When the band has been wide open, W8CIR has been called by stations off the sides or back of the beam but in every case rotating the antenna to the desired direction increased the signal many times.

A more simple structure would result if a single horizontal wood cross is used to support rods or tubing as radiators passing through holes in the wood frame, thus supporting the dipoles at their centers. No insulation is required. The elements can be adjusted with some kind of a sliding or screw extension. Proper adjustment with the actual spacing, insulation, and element diameter, will be necessary for the maximum performance. Feed is simplified by using a fixed antenna with the reflectors and directors pivoted on it. Balance in the feed system will improve the directivity on receiving. For further comments on these points, see the three-element beam stories in November, 1938, and this issue of RADIO.

Stabilized Equipment

Under the new regulations, a lot of rebuilding is in order. We note that there have been a lot of transmitter construction articles during the past few years that should be helpful whether a new doubler and final or a complete rig is contemplated. It is probably just as easy, for the less mechanically inclined, to use crystal control as to build a concentric line controlled m.o.p.a. such as that of W6DNS, described in RADIO several months ago.

Without frequency modulation on the signal, any previous advantage in using super-

regenerative or resistance coupled i.f. receivers now appears gone. A good receiver will have its noise output determined largely by the thermal agitation in the first tuned circuit, not by the shot effect in one of the tubes. In such a receiver, the noise is relative to the band width, which is large in either the super-regenerative or R-C i.f. receivers, and smaller in a sharp superheterodyne. The latter gives promise of being the ultimate in five-meter design, provided a high gain r.f. amplifier is used in front to overcome the poor conversion gain.

Getting high output with low noise, in r.f. stages, is covered in the concentric-line receiver article elsewhere in this issue. We highly recommend perhaps two stages of concentric line coupled r.f. stages, preferably with acorn tubes but not necessarily so, followed by the usual mixer stage using a 956, 1852, 1231 or 6J8G. In this setup, the signal to noise ratio is determined by the antenna pickup and the gain of the first stage, provided that the r.f. amplifier output is sufficient to override the converter inefficiency, and the noise is further reduced in sharp i.f. stages.

Bootleggers

Under the new stabilization regulations, bootleggers will very likely be run down quickly, especially those not crystal controlled. Some may move to 2½ meters, of course, but the QRM problem from these fellows is likely to be almost nil during 1939.

Potpourri

In case you don't know, *potpourri* is a word taken from French roots, meaning a collection of things, such as a vegetable stew. If you don't like it, just wait for the potful we have concocted for the next issue—if you send in some dope!

Those who did some two-way five-meter work on unmodulated c.w. over a distance of 200 miles or more during 1938 should send their scores to the R.S.G.B. The rules of this contest appeared in January, 1938, RADIO.

Additions to the dx roll of honor for districts and states worked, published in October RADIO, follows:

	Districts	States
W3HJO	7	
W2MO	6	20
W1JRY	5	
W3HJT	5	
W8EQG	5	10

W2MO says that he has worked 1834 *different* dx stations—and most of them were *not* on summer skip beyond 400 miles; five meters

must be a popular band in the east! (We have a midwestern viewpoint).

W4AUU in Macon, Georgia, used a four-half-wave lazy-H antenna (horizontal polarization) and a colinear type for summer dx work. He wants more of the Atlanta fellows to get on the 56-Mc. band.

The closing date for five-meter data is the 13th of the month, or about 37 days before delivery of each issue. We shall need fresh reports, observations, short items, equipment ideas and so on; so send them to the author of this column at 512 N. Main Street, Wheaton, Illinois. We were flooded with reports last summer and finally had to publish only a summary of them due to space limitations while the news was fresh.

W9XA Ham Broadcasts

Everett Dillard, W9BKO, has one of the experimental licenses recently issued by the F.C.C. to operate on 26,450 kc. and around 43 Mc. The transmitter is on the lower frequency now, using the call W9XA. The 100 watts is to be raised to a kilowatt immediately.

Although commercial programs are run, he wishes to make the station available for amateur radio and is now broadcasting the "Heart of America Club" meetings (Kansas City). As much as two or three hours a day are available for ham talks, possibly more on Sundays, including ultra-high frequency data, announcement of band opening into Kansas City, etc. Reports and information from anywhere will be used if a listening audience can be obtained.

The ground wave range appears to be 200 miles. During the winter, daytime reception beyond about 1000 miles will probably be consistent. In the summer, somewhat erratic reception from 300 to 1200 miles is expected, with occasional multiple hops to greater distances.

Frequencies

A collection of crystal-controlled frequencies, largely supplied by W1BRL of the "Horse traders," follows:

W2CUZ 56.008 Mc.	W9GGA 56.080	W1KUY 56.720
W9NY 56.012	W4BBP 56.080	W1JFK 56.8
W9HGW 56.016	W1BRL 56.096	W2LAH 56.8
W8QDU 56.016	W8CIR 56.130	W5AJC 56.8
W8JLQ 56.020	W1KNM 56.160	W9ANA 56.936
W4EDD 56.020	W1EKT 56.184	W3GQS 56.952
W2KXH 56.024	W9FEN 56.216	W1IJ 56.960
W1AVV 56.036	W5BY 56.208	W1DTE 56.962
W3AIR 56.036	W2ISY 56.4	W2FCB 56.996
W1HXP 56.040	W4FLH 56.5	W3DYE 57.012
W2IGH 56.042	W2IYX 56.600	W2IGH 57.024
W8QDU 56.060	W1FMM 56.624	W8QDU 57.030
W1HDF 56.072	W1EYM 56.68	W2BCC 57.044

[Continued on Page 175]

YARN *of the* MONTH

Oil is Well

April 3, 1938

Hello Some More, Bill:

It certainly is peaceful here on the farm. I never would have gone into radio if I had known what a rat race it would be. But that's all past now, and I shall stick to my amateur radio and my cultivating and let commercial radio go hang.



Peace on the farm

After I finished the harrowing job of harrowing yesterday afternoon, my kid brother and I took a dip in the creek. It was refreshing after a hard day's work. While we were standing in the deep pool, just at the bend, we could feel the fish

nibbling at our intruding ankles. You'll have to drop in later in the season, and we'll try our luck at arousing their curiosity with a few flies. My brother hasn't been successful in his efforts to rid the woods of game, although he has cleaned the general store of its stock of .22 ammunition, and that should provide further entertainment.

I have received several letters from my old boss, but he can't get me back into radio. Listening to sopranos, cheesy advertising, advice to the lovelorn, and half-witted "comedians" for almost a year has made me appreciate the simple farm life. But farming also has its worries. It is getting to be a problem to decide whether to plant and hope that prices go up, or not to plant and hope that the government will continue to pay you for it. Between the installment men and the politicians, a farmer has to be a financial wizard these days.

Let me know what you think of my plans for your trip out here.

73,

Cy

April 9, 1938

Dear Bill:

Darn it all! Every time I get peacefully settled, something happens. And as usual, it is radio. Why can't I keep my fingers out of it? My girl has never forgiven me for giving her the run-around the night of the high school prom to keep a sked with an Aussy. And that last two weeks of college is yet a vivid nightmare. Just as I was breathing with relief, to the tune of successful ham-fest and open-house demonstration, I realized that I had two weeks in which to graduate. Stated simply, I did about four years of school work in those last two weeks.

Well, I might as well get down to business and tell you the story from scratch. I was out on the tractor on the south 40, when I heard my brother call me. (Did I tell you that we put a 5-meter rig on board so that Mother could call us for lunch?) I gave him an answer and asked what he wanted. He replied that a man had just driven up in a swell car and asked for me. I asked him if there was anything about radio in the deal, and he said that the fellows was from some oil company. Thinking that maybe someone thought that there was oil on the old homestead, I dropped the harrow, opened up the tractor and headed her for the barn with her usual deafening roar and speed of 12 miles per. I dove through the pail of water under the pump and rubbed against the towel on my way around the house.

Mom, Pop, Billy and a man who introduced himself as Mr. Wilson of the Sunny Skies Oil Company were on the front porch. Mr. Wilson said that he and my boss had gone to college together and that they had just had a long talk. Knowing what the boss thought of my farm idea, I immediately became suspicious. With the boss, if it isn't radio, it just isn't. Sure enough, it was all tied up with radio, and it looks as if I also am.

Yes, Bill, yours truly has his fingers in

CY STAFFORD, W9KWP

things again. The Sunny Skies Oil Company has a radio station down in the Central American fields. They had a little trouble with the last operator. He got out of neutralization and broke into oscillation with the local lassies too frequently, and some of the home town boys got a little jealous. Wilson said that the boss had told him what a celibate I was and thought that I was just the man for the job. In fact, the two of them were so sure of this that they had bought my tickets for the next ship south and had given the other operator his final papers.

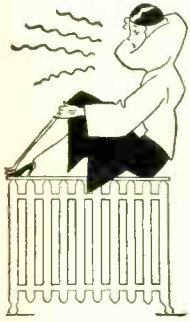

Carlotta made them shudder.

Mr. Wilson said this was "for his own good." He says he can't understand the other operator, as the station has a secretary who is supposed to be a pip. He says that returning operators "just shudder as if a cold wave had struck them" when asked about Carlotta.

Mom didn't think much of all this, but I couldn't pass up a trip like that with all expenses paid. The wages are fair, and there is some sort of a bonus for every month that the station has a 100% record of reports. After the schedules I've kept with ham equipment, that should be simple with a powerful commercial job. I'm leaving on the fifteenth of the month, so I shall drop in on you between now and then. They are paying me my travelling expenses plus \$200 for "good measure."

Since I haven't seen my Spanish book for three years, I think I shall burn a little midnight oil and see if I can't get back in condition. Maybe a few QSO's with the boys down under might help. It shouldn't be hard to study tonight, because I am so excited I know that I won't be able to sleep. I'll never give up radio again. This farming business is the most boring mess I was ever in.

Bonus Notches, or something,

Cy

(Letter found in Cy's wastebasket at the hotel.)

April 16, 1938

Listen Dope:

The next time I take time to stop off on an important business trip to say good-bye, you can tell that lousy girl of yours to go visit her grandmother or something. And that goes double for her rotten-spoiled kid sister.

It wasn't so bad to be told that our parting party was going to be as dry as a prospector crossing Death Valley in August, but when she stamped her foot and left the room every time I mentioned old times and some of the college brawls, it was too much. Then when we went to that Fireman's Dance and she picked up the kid sister, I almost burst.

While we were "dancing" Jane looked at me with that adolescent smirk of hers and said that I danced "too, too divinely," and that I hadn't stepped on her toes once. I told her that if she would get them on the floor where they belonged, and stop riding around on my pedal extremities, that I would see what I could do. She replied that I was "such a man," and "so cute," and that I must "be nervous about my trip into the wilds."

Now listen, pal, I'm not mad at you. But for the love of Mike, use some judgment next time. Did you have to get her little sister? And why couldn't we have gotten something to eat at a drugstore, instead of letting the little sister make that bread pudding that she learned how to concoct in home ec class? The stuff looked like the chewed end of a detective's nickel cigar, and didn't taste much better. And I'd advise you to throw that homemade root beer of yours down the drain, except that I have too much love for the poor fishies in the river. You had better stick to making home brew. . . .

(Letter actually sent to Bill the same night.)

April 16, 1938

Dear Willy:

I am very tired and shall just drop you a line or two. I really had a wonderful time last night, but I have been missing so much sleep studying my Spanish that I am afraid that I didn't reflect your charming girl's ability as a hostess. And that little sister of hers, Jane, is perfectly adorable. Mmm, boy! I'll have to investigate that when I get back up north. It isn't often that one finds a girl so young with such a well-developed personality. And can she cook!

Thanks again, Bill, and regards to Wilma and Jane.

73,
Cy



Our parting party was as dry as a prospector crossing Death Valley in August.

April 21, 1938

Oh Boy, Bill:

Is this the life! I've been on board for three days, and as far as I'm concerned, I could stay on for three years. We are stopping frequently for mail and to discharge cargo. The Captain says that he will pick up fruit on the northern trip.

What a small world this is. The second day I was on board I heard some code drifting out of a little room under the bridge and decided to pay Sparks a visit. When I got to talking to him, I found that he is one of the fellows from the radio club at college. We talked so long and furiously that he missed his px. But since we docked about that time I went ashore, picked up a few points from the local telegraph operator and we made up the Captain's press report from that.

And speaking of news, prick up your ears to this. Her name is Maria. She's a blonde, not platinum, not peroxide, but beautifully natural. Oh, yes. I met her on the dock when the boat pulled out. She lives on her father's plantation and is going south to visit a very dear friend. She had her hands full of luggage, and I offered my services. She was quite tickled and thought it was awfully nice of me to help her. I didn't think much of her at the time.

The first night on board we talked on the aft deck until after midnight. It was then that I really noticed her. That hair is gorgeous, fine and golden yellow and silky. It is very lovely to touch. And her eyes are not soft, woozy and dreamy, but smart and sparkling. Maria is interested in the work I am about to do and helps me with my Spanish.

I had better stop if I expect to get this finished before we leave. Don't worry about Maria, for she is just a pal. And I haven't forgotten about my future secretary Carlotta.

Oh, oh! There's Maria calling me.

73,
Cy

April 26, 1938

Dear Father Bill:

I suppose I might as well confess and get it out of my system, because Sparks is sure to spread the story around anyhow.

Maria certainly was sweet while she lasted. She helped me with my Spanish and other things every night. She said she made the trip frequently and knew all of the interesting places to visit in our various ports of call. She was gorgeous, she was divine, she was an

angel—until yesterday morning. Then she began to be slightly aloof. By the time we landed at San Baloney at noon, she knew me just well enough to ask me to help her with her bags.

When we got ashore, her "friend" met us. He came running up to us and said, "Maria, my darling. How are you?" And without waiting for an answer, he bestowed a decidedly nonpaternal kiss on her pretty little mouth. Then he turned to me and said, "And who is the young man my wife picked up this trip?" What a fish I turned out to be. I apparently have a lot of company, though.

San Baloney is the seacoast town nearest the station. It is typical of this part of the world. The territory upon which the station is located lies on the border between two small republics (run by dictators, as is usual these days). The road leading in is in the Northern Republic first, and then in the Southern Republic. The latter has control of the fields at present. The two countries fight over the fields continually, as the resulting taxes will pay all of the government expenses for either country.

I know now why the company gave me the \$200 for "good measure." The first person to meet me upon entering the town was the local customs official. He is also Chancellor of the Exchequer in his spare time. He looked over my passport and charged me fifty cents for the privilege. Then there was another tax for road upkeep in San Baloney. A tax followed for every suit I had, and another one for each hanky, each pair of shorts, and every sock. My revolver evoked cries of joy, for the tax per firearm is \$5. The ammunition was also taxed. A few technical books I had were taxed at so much per page. Pencils were assessed by the inch. The typewriter hit a new high at \$10.

But this year's biggest financial thrill for the Republic came when he looked over the radio equipment I brought down for ham operation. First he was puzzled. Then he was as happy as a child with a new toy. Finally he became as serious as a judge, about to deliver a death sentence. He thumbed through half a dozen manuals of "Tax and Instruction." But he could nowhere find the tax on radios. He finally multiplied the number of tubes by the number of knobs and charged me a dollar per unit in the answer. Fortunately for me, he didn't look inside the receiver and I got by on \$25.

After he had added up the total I paid him my bill and started to walk out. He said that that wasn't all and asked me to show him how much I had left. I had about

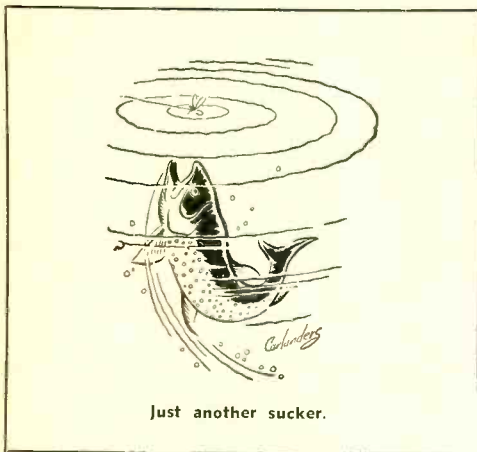

Just another sucker.

\$85 by then and he charged me a "cash possession" tax of ten cents on the dollar. After financing the government for its next year I felt entitled to a little service. So I asked him how to get into the oil fields. He replied that there was a motorbus which drove into the interior once a week. When asked how soon it would leave and from what spot, he said that it stopped in front of the hotel and would leave "soon." Having missed buses before, I grabbed my things and stumbled out of the office. It was supper time by then and I was wondering how to get some food. I parked my paraphernalia in front of the hotel and went inside and got a mess of frijoles con carne.

About sundown the owner of the hotel came out and tried to explain something to me, but I didn't understand either his English or his Spanish. He seemed to be trying to tell me that I could have a room in the hotel very reasonable, and I tried to tell him that I wasn't staying all night but was waiting for the bus. He shrugged his shoulders and went in.

At eight o'clock the next morning, while I was alternately looking up and down the road and cursing the bus, the Chancellor walked past and expressed great surprise at seeing me up so early. When I explained the situation, he said something about Americans always being in a hurry and explained that the bus wasn't due until ten o'clock the next morning. The bus is operated by the hotel and had been parked in back of it all of the time I was waiting for it to come down the road.

I'm tired of writing, so I shall mail this now. It won't be picked up by the boat for another two weeks, so you will probably re-

ceive my next couple of letters at the same time.

Another sucker,
Cy

May 2, 1938

Sweet William:

Is this place a washout! Why in the world didn't I stay on the farm?

After I finally got out of San Baloney I thought my troubles were over. But they were just starting. The "bus" turned out to be a hybrid model T. I recognized the parts of at least four different manufacturers on it. As a fellow passenger, I had a native with a pet rooster. The latter perched on me. I was told that I was greatly honored by his affection, as he is one of the best fighters in this section.

The hotel manager, who drove, kept his foot on the clutch pedal for most of the trip. Every time we hit a rock sufficiently large to slow us down, the driver would be shifted forward in his seat and his foot would jam the clutch into low, retarding our speed. Then he would pull the hand throttle all the way down and we would start off again, throwing him back from the pedal, putting us into high gear and almost throwing us off of the back. This form of square-wave oscillation kept up for the entire fifty miles, with only one break in its continuity. That was the time he missed the clutch pedal, hit the reverse instead and backed up forty feet off the road, eventually stopping when we hit a large boulder and stalled the engine.

After what seemed like ages, we crossed the border into the Southern Republic. Their customs official reduced my bank roll to \$45.50, by methods similar to those used by the Chancellor.

At about sundown the driver got down from his high seat, walked around to the front of the bus and lit the kerosene lanterns. He said that we would soon be there. About an hour later, while passing a small hut, someone hailed us. The bus stopped and the driver got out. He talked to a man for a few minutes and then told us that that was as far as we were going for that day. His friend who had hailed us had just passed a birthday and was intent on having a little help in celebrating. The driver was in no mood to pass up such a splendid opportunity, so we were all invited. After a few drinks of the stuff the driver's amigo was passing out I decided to quit. Good ol' corn liquor is tough stuff, but this was nothing short of distillate of dynamite. The rest of the crowd

seemed to be enjoying themselves without my help so I stole off to the tick which had been allotted me for the night. The next morning I tried to arouse the driver, but he was either dead or drunk and I didn't particularly care which. A little investigation proved that the station wasn't more than a half mile down the road, so I left instructions for the driver to bring my things when he came to and hiked off down the road.

My visions of the station were soon shattered. It is a three-room shack, one for the equipment, one for the secretary and one for me. The nearest oil well is 25 miles, which is also the nearest American. I walked up to the dump, recognizing it as a radio station only by its sky-wire, which is terrible. A gray-haired, short, chunky and barefoot woman walked out and said, "I am Carlotta." My heart fell into my boots. No wonder the other operators just shuddered when she was mentioned. They were lost for words, and so am I, as it is really that awful. I introduced myself and we proceeded to inspect the station.

As for Carlotta, she is more housekeeper than secretary. She can neither type nor take dictation. She knows just enough to write a little English. She never speaks unless spoken to, and then only as briefly as possible. But the worst part about Carlotta is her husband Carlos. Carlos just sits. When he feels particularly energetic, he takes a deep breath—and spits. He is even lazier than I would like to be.

It is no longer hard to understand the reasons for the company offering a bonus for the months during which the service is 100%. A flat 202 or a good spark coil would be up-to-date additions to this transmitter. There is a loading coil fastened to the antenna mast, and it is inhabited by a family of birds. Carlotta says it never rains more than a few minutes at a time, so the coil is left out in the open. There is no indication on the transmitter of its frequency, so I just left the adjustments the way they were. The receiver is one of the early marine jobs with a separate box for every stage. The stuff is strung out all around the room.

A messenger is sent in from the various wells every day with a report of the day's operation. These must be analyzed, and the important material sent on in by radio. The reports themselves are mailed north every week.

After much circuit tracing I found the switches which control the transmitter and the receiver. I was duly surprised to hear Panama on the receiver and even more surprised when I called them and got an answer.

The operator there says that he will give me about a month to get disgusted and quit. The transmitter went off the air five times during my five-minute QSO. Panama says that if I can get a ham rig on that the restrictions between the two republics are sufficiently lax not to cause any stir.

I've been here a week, Bill, and haven't missed a report yet. But I don't know how long I will be able to hold out. I should be able to get my ham rig on the air in a day or two. I don't know what has happened to the bus which picks up the mail. It hasn't been in since the morning I came.

With scorpions in my hair,

Cy

P.S. I'm sending this in to San Baloney by Donkey Express.

May 15, 1938

Dear Bill:

I don't know whether or not you will ever get this letter. I finally bribed Carlos into taking it to San Baloney for me, but I am afraid that he may not make it. To put it mildly, I am in hot water again.

It all started about a week ago. At that time I started sending my reports in on a ham band, as it was much more reliable. In the middle of a ham QSO one night I heard someone calling me. His call sounded like a phony, but I answered his modulated note anyhow and asked him what he wanted. The operator replied that I was interfering with government communications and that I should get off the air immediately. Thinking it was some kid back in the States trying to be smart, I told him just where he could go. He replied by ordering me out of the country! I asked who he was and he said he was the Minister of Propaganda, Communication and Motorcycle Travel for the Southern Republic. The oil fields are technically between the two countries, but just now the Southern one has control. I just shut down and hoped that he wouldn't hear me again. I listened to him for several hours, and it was obvious that he was directing some sort of a military campaign.

Just as I turned off the receiver the messenger who took your last letter into San Baloney rushed into the room. He was scared stiff, and it was fifteen minutes before we could calm him down so that Carlotta could tell me what he was trying to say.

The reason the bus hasn't been in is simple. The two republics have declared war and are apparently going to settle forever the question of who gets to tax the oil fields. I con-

templated calling the Marines, but then I realized that the Southern Army would hear me and possibly eliminate me if I called on the ham band, and the company's long-wave job was out of the picture (rats finally ate all of the wax off the condensers).

I decided that if I was going to be in no man's land I might as well get press reports on the subject, so I turned on the rig and listened to the directions being issued to the Southern forces. After a while I went to bed.

The next day the military radio was quiet. That is, it was quiet until I started to send my report to Panama and then it broke out in full fury. I became angrier than before and unloaded my mind. Judging from the signal strength, the "enemy" couldn't be very close. But that is where I was wrong. About half an hour later a motorcycle roared into camp (on all one cylinder) and I was placed under arrest. I accepted it gracefully and thanked the minister for his trouble. He allowed me an hour to pack my things before taking me away.

I told Carlotta that she would have to get said Minister of Propaganda out of the way for a while so that I would be able to get my report through. Panama told me not to get scared as the war was a monthly occurrence.

When the Minister and Carlotta got back, Carlos roused himself from his lethargy and spit clear across the sidewalk. Carlotta was laughing at the Minister and he looked as if a ghost had scared him. I'd give ten bucks to know what happened.

The Minister took me into camp and I looked over his equipment. It was sold by an outfit in the States and only covered the ham bands. The Minister hadn't yet mastered the intricacies of tuning, and it was only through the grace of the lack of filtering on his dynamotor that he was able to carry on communications. The signal was about twice as broad as the band. I was assigned to a tent and told not to try to escape.

Since I am not under guard, I have been walking back to the station every night and sending out my reports. I haven't given up hope of that bonus yet. This makes me sleepy during the day and the Minister likes this. He thinks it is my natural condition and thus isn't careful about what I overhear.

By copying the Minister's key-clicks I have found the entire plan of action. It is simply this. The first branch of the Army is to attack the Northern troops at dawn. The second branch is to take San Baloney and work up the coast from there. The Minister's troops are to fire the wells! There is ap-

parently no reason for this, but it appeals to the Minister's sense of beauty or something. If they get to the wells and start them on fire, the company can just go out of business. We haven't the men or equipment to fight one fire, much less all of the wells.

I shall not tell you more but will write later. I have a lot of things to do if I am going to save the wells, and I must get back to my tent before dawn.

Your corpse-to-be,
Cy

May 25, 1938

Well Willy:

All is again quiet in this sector. The birds are swooping around their nest in the loading coil, and it looks as if a blessed event has just hatched. Carlotta is cleaning the house and Margarita is typing up the day's reports. That explains my use of longhand on this letter.

I suppose it would be mean not to tell you what happened, so I shall drift over the details.

When Carlos left your last letter in San Baloney he told the officials there what I was planning to do. I sent another messenger out at the same time to get in touch with Don Jose, Northern General, and a third messenger to the oil wells to warn our men there. I figured that if the Southern Army was going to put us out of business, we might as well play ball with the Northern Army and hope for a better fate. After this I went back to my tent.

The Minister woke me at daybreak and said that he had work for me to do. As General in Chief of the Armies, he said he would have to leave. He wanted me to stay there and operate the station. He said that he would send messengers to me with instructions at regular intervals. The three armies were equipped with receivers and apparently I was to be dispatcher. The messages, of course, were to be in Spanish. I said that since he had been such a nice host that I couldn't refuse him. He seemed overjoyed and as a token of his friendship produced a bottle of choice wine. After splitting this between us, he climbed aboard his motorcycle and followed the trail his army had taken earlier in the morning.

As soon as he was gone, I ran to the station and got Carlotta. By the time the first

[Continued on Page 179]



Margarita, not Carlotta.

What's New

IN RADIO

AMATEUR TRANSMITTER



The Hallicrafters' Model HT-1 transmitter, recently placed on the market, combines the design skill of a staff of engineers who are themselves amateurs. Although of the table type, it is completely self-contained and provides 3-band, crystal-controlled operation with a carrier power of 100 watts on c.w. and 50 watts on phone. A band-change switch provides complete, instant changeover. Other external panel controls are: modulator gain control, and filament, plate, phone-c.w., stand-by and meter switches.

All tuning controls are inside the cabinet, which is of all-metal construction. The r.f. tube line-up is: 6A6, 6A6, RK-47. The audio end provides 50 watts output from a D-104 microphone and consists of a 6J7, 6J5 and four 6L6's in push-pull parallel, class AB. Rectifiers are two 5Z3's, 80 and 866. The final plate and grid circuits are metered and a third meter is switched to measure either exciter cathode or modulator current. Normally supplied for 10-20-40 meter operation, the HT-1 is also available to cover any three bands between 10 and 160 meters.

NEW VELOCITY MICROPHONE WITH ACOUSTIC COMPENSATION

The acoustic compensator has worked out so successfully on higher priced models that it is now also being supplied as standard equipment on the lower priced Amperite models such as the RSHK and RBSK, at no extra cost.

The acoustic compensator makes the microphone immediately adjustable to close or dis-

tance pickup. By merely pushing the compensator up the pitch is raised. By lowering the compensator the pitch is lowered. Variations in room conditions are easily compensated for with the acoustic compensator.

Not to be confused with a tone control, the acoustic compensator is a mechanical shutter that gradually closes the back of the microphone. An air cushion is formed behind the ribbon which changes its operation from velocity to pressure. In other words, it really changes the velocity to a dynamic microphone having a very light diaphragm without peaks.

ALL-BAND TRANSMITTER KIT

Designed to meet the demand for an economical, portable, self-contained transmitter, the Stancor 20-P embodies many excellent features.

The unit is a complete phone and c.w. transmitter, including power supply, all contained in a cabinet 19" x 13" x 8 $\frac{3}{4}$ " overall.

Crystal controlled, this transmitter will operate on any frequency from 1.6 to 60 Mc. Frequency change is readily accomplished by two plug-in coils.

Meter switching for all important circuits and oscillator keying to permit break-in operation are incorporated. All controls are located on the front panel to assure easy operation.

Punched chassis and front panel are available from Stancor. Transformers and other components are all stock items, readily obtained at any distributor.



25 watt output at one meter!

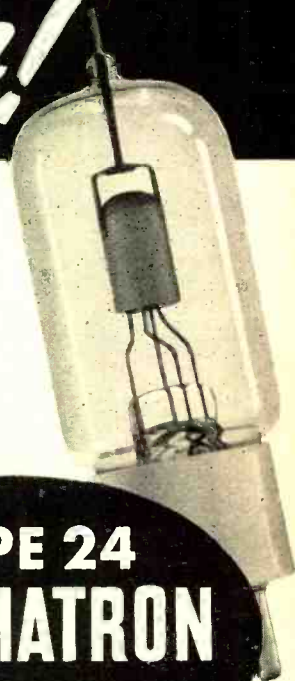
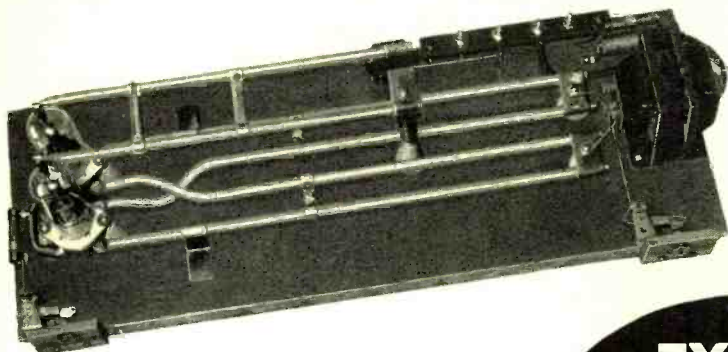

Shown above is a one-meter parallel rod oscillator which is capable of delivering more than 25 watts of radio frequency power to its load. Constructional information on this transmitter will be forwarded on request.

**TYPE 24
GAMMATRON
\$350**

HOW IT WORKS

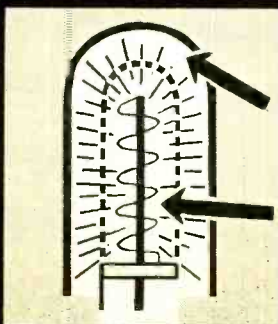

The phenomenal power output of the Type 24 Gammatron at ultra high frequencies is due to its scientific design.

The use of a long, capped Tantalum plate prevents the escape of stray electrons from the ends of the plate structure which greatly reduces the efficiency in ordinary U. H. F. tubes.

The use of a tantalum grid permits very close spacing to the filament, thus providing a very short time of electron flight and resultant high efficiency at very short wave lengths. Write for the U. H. F. data on the Type 24 Gammatron.

HEINTZ AND KAUFMAN
SOUTH SAN FRANCISCO LTD CALIFORNIA U. S. A.

The unit is easy to construct. Full instructions come with the chassis and front panel. Descriptive literature may be obtained by writing the manufacturers, Standard Transformer Corp., 1500 North Halsted St., Chicago, Illinois.

rent. The full 270° main capacity dial spreads calibration for accurate readings. The scale is linear and covers but one decade per range.

Everything concerning a condenser can be determined with this most useful instrument. A handy reference table mounted inside the removable cover provides the essential data once the general operation has been mastered.

CONDENSER AND RESISTOR BRIDGE



A more thorough means of testing all types of condensers under actual working conditions is now provided in the new condenser and resistance bridge recently made available by the Aerovox Corporation. In simple, handy, portable form, this instrument, well within reach of the serious radio worker, measures capacity from 100 $\mu\text{fd.}$ (.0001 $\mu\text{fd.}$) to 100 $\mu\text{fd.}$ and power factor from 0 to 50%. It tests for shorts and leakage. It measures resistance values from 10 ohms to 1 megohm in 5 ranges. It measures insulation resistance between 350 megohms to infinity at 500 volts and down to 10 megohms at lower voltage. It provides a vacuum-tube voltmeter, as well as a choice of voltmeter, millivoltmeter and milliammeter for external uses, as well as a continuously variable power supply of 15 to 600 volts for internal and external uses.

For testing electrolytic condensers especially, the instrument provides polarized voltage. The applied voltage at any moment can be read on the precision meter, likewise the leakage cur-

CODE PRACTICE RECORDS

A quick, highly practical and inexpensive method of learning the code has been introduced by the Ralston Record Company of Philadelphia, Penna. The course consists of a set of three double-sided ten-inch records together with an instruction book.

The inclusion of a complete and easily understandable code course together with practice transmissions on three double-sided records was made possible by use of a Poinsettia recording machine which records 160 lines per inch with exceptional clarity. The playing time of each Ralston record is approximately seven minutes as compared to less than three minutes for the average old-style recording.

Actual "pounding" for the master records was done by G. W. Mossbarger, expert Radio Telegrapher and Instructor, using a 713-A General Radio Beat Frequency Oscillator. When reproduced on any phonograph with a medium tone needle at 78 r.p.m., a standard frequency of 1000 cycles, plus or minus 5 cycles, is attained.

Selection of other frequency standards can be attained by the student when desired, merely by running the phonograph at different speeds.

Each record is divided into separate parts or lessons, with automatic feed lines and individual stop lines so that any lesson may easily be selected for study.

Pickups . . .

WTAR at Norfolk, Va., was granted special temporary authority to use amateur station W3NO as a relay broadcast station to transmit a Navy Day program from Hampton Roads.

IMITATED • COPIED • BUT NEVER DUPLICATED

SINCE 1910

THE ANSWER IS IN THE RECORD



STANDARD OF QUALITY FOR AMATEUR X'MTRS

"Finished work shows no trace of work." Only in its extra long-life and surviving economy does the modern C-D capacitor reveal the 28 years of precision engineering behind it. New Catalog 161 now available.

Features of Types 4 & 9

1. Low power-factor; high Q; long life.
2. High factor of safety—affords high voltage breakdown.
3. Low loss; high insulation resistance—reduces losses at all frequencies.
4. Practically constant capacity over wide range of temperature.

Features of Type 86

1. Patented series mica stack; Eliminates corona or losses.
2. Special low loss filter; Reduces stray losses.
3. Short heavy brass stud terminals; Low resistance connection.
4. Black glazed porcelain dehydrated case; Low R.F. losses.

Features of Type TJ-U

1. Hi-purity aluminum foil; Results in lower r.f. resistance; light weight construction.
2. Hi-purity multi-laminated Kraft tissue; Affords high voltage break down; minimum leakage.
3. Dykanol (chlorinated diphenol) impregnated and filled; Non-inflammable and non-explosive; long life; small size.
4. Hermetically sealed; Not affected by moisture; time or temperature.

Features of Type TL-A

1. Sturdy aluminum container; Extremely small size—convenient shape for simplified installation.
2. Dykanol impregnated and filled; Fire proof; Extra hi-dielectric strength.
3. Hermetically sealed.

MICA - PAPER - DYKANOL

CORNELL-DUBILIER
ELECTRIC CORPORATION
 South Plainfield, New Jersey
 Cable Address: CORDU

WET & DRY ELECTROLYTIC

PRODUCTS OF THE WORLD'S LARGEST MANUFACTURER OF CAPACITORS!



Seattle, Warsh., U. S. A.

Dear Hon. Ed. Sir:

I supposing you are make wonderment why Scratchi not rite to you for long since ago. Reason are, Hon. Ed. that Scratchi are been in United Shakes for last several month and are so busy making sight see that do getting somewhats delinkwent on correspondence. You see, Scratchi are born in U. S. A. when little boy, and are went to Osockme with Hon. uncle when I still inhabit a three cornered pants.

On account of Scratchi are not mad at anybody, are not wanting to make fight. So before trouble was get too hot, Scratchi are make tracks for grate country of which are really a citizen, which are fine place for piece loving sole like Scratchi are always been except time when brother Hamafisti are blow three of Scratchi's pet crystal and refusing to pay for same.

If you are not make too much laugh at Scratchi, will confess what have been doing to keeping so busy. You see, Hon. Ed., first thing Scratchi do when arrive in this country are make realization of long dreem to visit knight clubs which from Scratchi heer broadcasts of swing music across the Specific Ocean, as I are belong to *Osockme Jitterbug Society and Association for Appreciation of Swing Music*, and are know to fellow member as "Swing Ding Scratchi."

Well, Scratchi are rite down front with rest of alligator and get so absorb in hot stuffs music that are not notice everybody's are go back to tables to leave floor empty except Scratchi. When orchestra are swing out wide on "Dizzy Doodle," Scratchi are send into such ekstacy that feets get out of nootralization, and Scratchi are do solo Soozy Q and

Triple Truck rite around floor. Scratchi are not find out till afterwards that when make such sugar foots around the floor everybody's think he part of floor show, and are get biggest hand that anybody's are ever get in history of club except time that a smarty gentleman are set match to fan dancer's cellofane fans and everybody's are think it part of the ack.

Manager come out and nab Scratchi, who are expect to get eject out of place on ears, and exclame that Scratchi are probably have highest Q of any feets flicker who are been in his floor show, and wanting to know if Scratchi would be interest in contrack for 26 weak at \$150 purr weak plus 1 per cents of reseeps.

Well, Hon. Ed., "Sugarfeets Scratchi" and his ack are pack them in the place every night, and when contrack are just up, Scratchi are quite a nasty egg, which are want to invest in bizness connect with amchoor radio.

Scratchi have grate idea for receiver kit which can be purchase and construct in unit at a time. Then, when finish can change part of receiver when new circuit come out, making unnecesarily to tear up hole receiver. For instance, Hon Ed., the special noise redoosing antenna are call the *Scratchi Signal Sniffer*. This feed into little box containing preslector which are label *Scratchi Signal Sifter*. This are feed into first defective oscillator unit in box which are call the *Scratchi Signal Shifter*. Next unit are call *Scratchi Signal Lifter*, which are of course the intermediate freakancy amplifier. Then, if are wanting same, can purchasing *Scratchi Signal Philtre*, which are crystal unit. And if desire, *Scratchi Noise Wilter*, which are also connect to intermediate freakancy amplifier.

Scratchi are want the opinion of your tecknicel staff, Hon. Ed., before go aheading with grate bizness venchoor. Pleeze rite to Scratchi rite away, on account of because have deal on with honorable gentleman to let me buy some special stock in Wiley Katt Oil Industries, Ink. as special flavor to me. What you think Hon. Ed., what are your honest opinion on what are best way to invest monies please?

Respectively yours,

Hashafisti Scratchi

Scratchi's Back!

THE "4-25" EXCITER

4 BANDS
25 WATTS
(Output)

5 Seconds to
Change Bands

No Plug-In
Coils

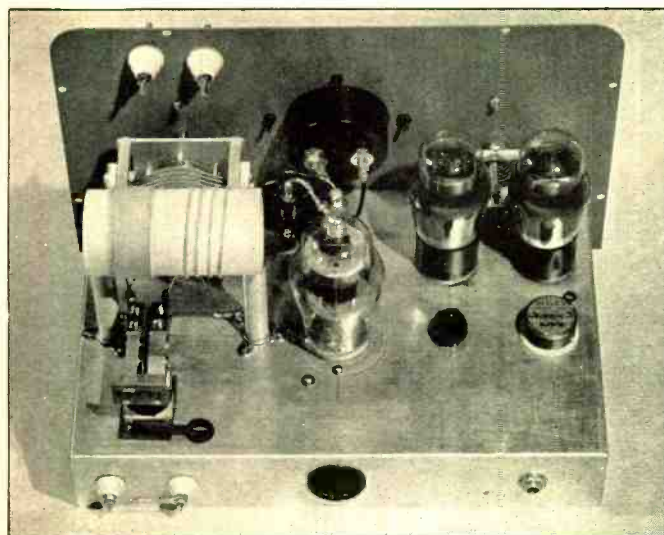
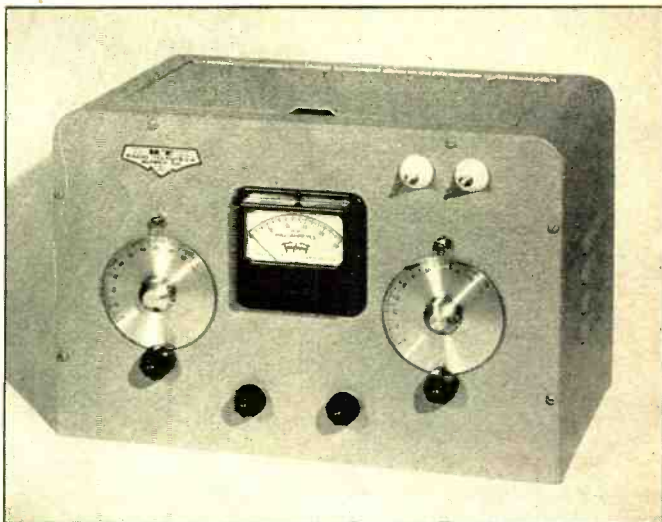

In the years of Kit construction by "Radio-Tel", the "4-25" is the most outstanding 25 watt exciter yet conceived.

Mr. W. W. Smith, W6BCX, Editor of "Radio", fully describes the "4-25" in December "Radio". Mr. Smith also originated the "Bi-Push", which is still tops for 40 watts of output, and the 15 watt "Dynapush".

The "4-25" is foolproof, has no tricky adjustments, and may be keyed or modulated.

Descriptive Bulletins Available

Baby Bi-Push Exciter (25 watts) Bulletin No. 14
Bi-Push Exciter (40 watts) Bulletin No. 15
10-20 Final Bulletin No. 16
RT-25, RT-50 Modulator-Amplifier, Bulletin No. 17
"4-25" Exciter (25 watts) Bulletin No. 18
Dynapush Exciter (15 watts) Bulletin No. 19

Our "4-25" Kit includes Milliammeter, Streamlined Cabinet, Tubes, and relay for bandswitching, as pictured.

"4-25" Exciter . . . RF portion KIT \$29.50
Wired and Tested 38.00
(If desired less meter and cabinet, deduct \$7.00)
Power Supply KIT \$16.00
Wired and Tested 20.00

Prices F.O.B. Los Angeles

W6QD - W6LFC - W6JWQ - W6NOF - W6NYU - W6CCX - W6DUX - W6FMK - W6HUM - W6EAS

RADIO-TELEVISION SUPPLY CO.

"WHERE HAM SPIRIT PREVAILS"

1701 So. Grand Ave.

Los Angeles, Calif.

NEW BOOKS

and trade literature

The RADIO HANDBOOK, Fifth (1939) Edition, by the Editors of RADIO. 592 pages, profusely illustrated, comprehensively indexed. Published by Radio, Ltd., 7460 Beverly Blvd., Los Angeles, Calif. Price postpaid, \$1.50 in continental U.S.A. Elsewhere, \$1.65.

The fifth edition of the RADIO HANDBOOK is not just the previous edition brought up to date; it is an enlarged and thoroughly revised reference manual on equipment, construction, theory, and operation of high-frequency and ultra-high-frequency radio. The new edition is characterized by the same completeness, originality, and accuracy that has resulted in previous editions of this work being recognized as the foremost and most authoritative text and reference work on the subjects which it embraces.

Radio amateurs in particular will find the wealth of information in its 592 pages to be invaluable in their work. The chapters on construction are alone worth the price of the book; the apparatus described contains the very latest in improvements and new ideas, and most of it appears for the first time in this book. All of the equipment and circuits described have first been tried in the laboratory by qualified technicians to prove their worth under actual operating conditions.

The enlarged chapter on test instruments and measuring equipment will be found especially timely in view of the new F.C.C. regulations which have just gone into effect.

As in past editions, the theoretical treatment and more useful formulas are supplemented by time-saving tables and charts which make laborious calculations unnecessary.

The data on and the practical application of the many new tubes brought out in the past year and the inclusion of several new antenna systems which give startling results would in themselves justify the purchase of the new edition even though one might have a copy of the previous edition on hand.

While the book contains data of interest to the most advanced engineer, the novice studying for his amateur license will find the book of great assistance in obtaining his "ticket." The book starts right at the beginning, with a discussion of

elementary electricity, but advances rapidly by virtue of the fact that no superfluous subjects or data extraneous to the subject at hand are given space.

A list of the chapter headings in themselves give the best story as to what subjects are treated. They are, in order: Fundamental Theory, Vacuum Tubes, Decibels and Logarithms, Antennas, In the Workshop, Learning the Code, Receiver Theory, Receiver Construction, Receiver Tube Characteristics, Transmitting Tubes, Transmitter Theory, Exciter Construction, C. W. Transmitter Construction, Radiotelephony Theory, Radiophone Transmitter Construction, U.H.F. Communication, Power Supplies, Test Equipment, Radiotherapy, Radio Laws, Appendix, Buyer's Guide, Index.

ELECTROLYTIC CAPACITORS, by Paul McKnight Deeley. Published by Cornell-Dubilier Electric Corporation, South Plainfield, New Jersey. 5 $\frac{3}{4}$ " by 7 $\frac{3}{4}$ ", 276 pages, price \$3.00 in U.S.A.

Until this time, there has not been an authoritative source on the general subject of electrolytic condensers. There have been infrequent articles of limited scope on certain of the phases of electrolytic condenser design and manufacture, but no comprehensive written work has been available on the subject. To remedy this situation, the author has prepared this book in the hope of making available, to the radio and electrical engineering fraternity, a fairly complete source of technical information on the theory, construction, characteristics and application of electrolytic capacitors of all types.

The entire subject is aptly and completely covered, from the fundamental theory involved, through the sources and types of materials used, to the manufacturing and final testing of the completed units. All types of electrolytic capacitors are covered: the wet type, low- and high-voltage dry types, and the alternating-current type are discussed in detail. The formation of the anodic films, the types and chemical composition of electrolytes, and the methods of winding, impregnating and ageing are covered in detail. Altogether, a well presented work on a subject of increasing importance to the radio industry is offered in this book.

Eeny . . .

- 1—Fundamental Theory
- 2—Vacuum Tube Theory and Practice
- 3—Decibels and Logarithms
- 4—Antennas
- 5—In the Workshop

- 6—Learning the Code
- 7—Radio Receiver Theory
- 8—Radio Receiver Construction
- 9—Receiver Tube Characteristics
- 10—Transmitting Tubes

Meeny . . .

- 11—Transmitter Theory
- 12—Exciter Construction
- 13—C. W. Transmitter Construction
- 14—Radiotelephony Theory
- 15—Radiotelephony Construction

Miney . . .

- 16—U.H.F. Communication
- 17—Power Supplies
- 18—Test Equipment
- 19—Radio Therapy
- 20—Radio Laws
- Appendix, Buyer's Guide, Index, etc.

Mo!

. . . Choose any *one* of these chapters, and you'll find it the most complete, practical, up-to-date material on that particular subject published. *All* of them are in

The "Radio" Handbook

FIFTH EDITION

Hot off the press with new receivers, new transmitters . . . antennas . . . charts . . . tables. More data than ever before . . . 20 long chapters; over 575 pages.

ONE DOLLAR, FIFTY CENTS

in continental U. S. A.

Elsewhere, \$1.65 or 7s. (Canadian postal notes and British postal orders accepted.)

RADIO
LITERATURE

Technical Publishers

7460 Beverly Boulevard, Los Angeles

The Capitol Radio Engineering Institute has released a 48-page catalog describing their complete courses in radio engineering. The catalog is profusely illustrated with photographs of the school's officers, faculty, laboratory equipment and buildings.

An unusually complete description of both the home-study and residence courses is given. Two double-page charts showing the sequence in which the various subjects that go to make up the regular and post-graduate courses are presented. Several pages are devoted to a complete detailed listing of the subjects covered in the home-study courses.

A copy of the catalog may be obtained directly from the Capitol Radio Engineering Institute, Washington, D. C.

THE RADIO AMATEUR'S HANDBOOK, Sixteenth (1939) Edition, by the Headquarters Staff of the American Radio Relay League. Published by the American Radio Relay League, West Hartford, Conn. 560 pages, including 6-page topical index and 104-page catalog section of amateur radio equipment. Price, paper bound, \$1.00 in continental U.S.A., \$1.25 elsewhere; buckram bound, \$2.50.

The 1939 edition of the RADIO AMATEUR'S HANDBOOK contains over 300,000 words, as well as some 815 illustrations, 50 charts and tables, and 87 practical equations and formulas. Increased space provided by the addition of several pages of text and a somewhat more compact format has been devoted to new material.

The thorough revision of the material in terms of latest amateur practice has been carried to the extent of actually designing, building and testing more than thirty pieces of new equipment. The equipment described represents good amateur practice, rather than striking or novel innovations of unproved merit, and is based on time-tried circuits and layouts of established worth.

The introductory chapter on fundamentals has been completely rewritten, and represents a fresh approach to this most important phase of the manual. The vacuum tube tables have been considerably expanded, with comprehensive data on the characteristics of approximately 400 types; tables for control and regulator tubes as cathode-ray tubes have been added.

The important chapters on receivers, transmitters and radiotelephony contain the bulk of the new equipment. The presentation demonstrates the fruits of an intensive analysis of the requirements of the modern amateur and a painstaking logical effort to fulfill these requirements. A greatly revised treatment of antenna systems, with considerably wider scope and much new material, completes a wholly up-to-date consideration of the basic requirements of the amateur station.

New constructional material is presented in the

chapters on power supplies, emergency and portable equipment, and instruments and measurements, as well. Other chapters have likewise been freshened and brought into step with the times.

The 1939 edition of the HANDBOOK is dedicated to the late Ross A. Hull, for ten years editor of the volume, who was accidentally electrocuted during the preparatory work on the present edition.

Calls Heard

Numeral suffix indicates "R" strength. Send Calls Heard to Calls Heard Editor, c/o RADIO, 7460 Beverly Blvd., Los Angeles, Calif.

*Alec G. Binnie, ZL-129,
Seddon Ave., Waihi, Auckland Province,
New Zealand
(February, 1938)
(4 Mc. phone)*

W6CAH.

(14 Mc. phone)

W—1JFG; 2CQL; 2DHI; 2GUX; 2HS; 2IXY; 2JIE; 3ARR; 3CIG; 3FAM; 4AH; 4BQZ; 4KR; 4MD; 5AA; 5DQ; 6AFP; 6AM; 6AVU; 6CQS; 6DID; 6DRL; 6DVW; 6GIL; 6IDV; 6ISH; 6ITH; 6JID; 6LFD; 6LFE; 6NCW; 6OGM; 6OXQ; 6QD; 6QSY; 6TT; 6WTX; 6YU; 7FKW; 7II; 8BDO; 8BJB; 8JDE; 8JOE; 8MJP; 9BG; 9CMF; 9GLL; 9KGL; 9KIP; 9LLX; 9MGT; 9NLP; 9QJG; 9OLY; 9ORL; 9QJK; 9WE; 9YGC. CE1AH; CE1AI; CE1AO; CE2AR; CE2BR; CE3AA; CN8AV; CN8MU; CO2LY; CX2AK; CX3BL; F3GR; F8DC; F8KI; F8LX; F8XN; F8XT; F18AC; G2PU; G5OV; G5RV; G5ZG; G6LK; G6LL; HB9CL; HC1FG; HC1JB; H15X; H17G; J2MI; J2NF. K—6BHL; BJJ; BNR; 6CMB; 6FAZ; HGAS; 6GNW; 6KGA; 6KIG; 6KPF; 6LK; 6MDV; 6MVA; 6MXM; 6NZQ; 6OQE; 6PCF. KA—1AF; 1AP; 1BH; 1ER; 1HS; 1MH; 1YL; 1ZL; 2OV. LU—1DA; 1DJ; 1HI; 1QA; 2BG; 3EJ; 5AL; 9BV; 9LQ. OA4A; OA4AO; PA00MQ; PK1JG; PK1PK; PK3VD; PY1AE; PY3BP; PY4BL; SU1SG; T12FG; VP3THE; XE1LK; XU8JM; XU8RB; XU8RU; XZ2DY; YV1AP.

(28 Mc. phone)

W—3HCC; 4DOF; 4EEV; 5AXQ; 5DER; 5FDE; 6AGJ; 6CWJ; 6GUU; 6KD; 6MDM; 6MRM; 6NGA; 6NTX; 6PBD.

Short Circuits

HAM is the name of a French village. OMSK is in Siberia.

KITE is a broadcast station in Kansas City.

Many foreigners out to work all States are licking some of o.m.'s right here in the States.

Europe is not considered a continent by some geographic experts.

RADIO's printer, located on *Crystal St.*, has a teletype number 73.

The RADIO Antenna Handbook

1. FUNDAMENTALS Characteristics and Considerations

Frequency, Kilocycles	L , 467.4	C , 95.4
2500	137' 10"	129' 10"
3000	115' 6"	107' 6"
3500	100' 0"	93' 0"
4000	88' 0"	81' 0"
700	66' 9"	62' 9"
1000	48' 10"	45' 10"
1500	32' 0"	30' 0"
2000	24' 0"	22' 6"

3. FEEDING THE ANTENNA

Shared-Stub Tuning Procedure
 The antenna requires a shared stub to match number of quarter waves of the antenna to voltage (or current) ratio of the antenna to reduce to as follows:
 which carries the radiator (or one of the half-wave sections if harmonically operated)

4. TRANSMISSION LINES and Feed Systems

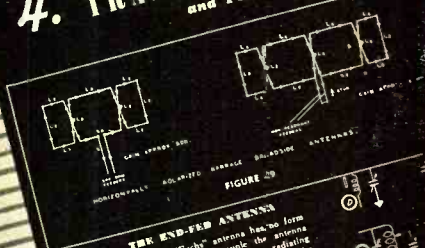

2. CHOOSING AN ANTENNA

THE SMITH BEAM-TO-BEAM
 Four dipoles can be formed into the shape of a square as in figure 28 A to produce a broadside radiator that has characteristics similar to the "Yagi" if started collinear and six spaced for slightly less directivity and radiation resistance. An identical square array can be supported at right angle from the same pole to give complete coverage, such as the resistance of the stub-squared version results in considerably higher voltage at the antenna.

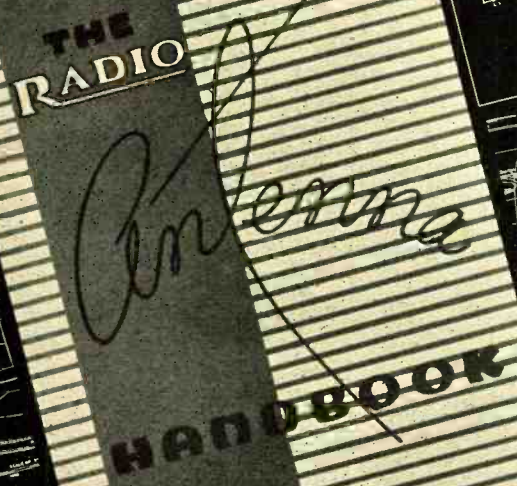

5. HARMONIC OPERATION

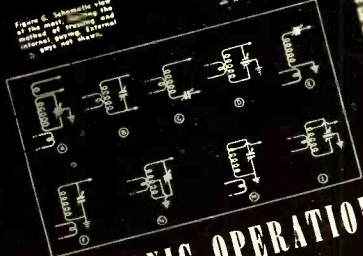

6. COUPLING TO THE TRANSMITTER



11. SUPPORTING THE ANTENNA

7. DIRECTIVE PROPERTIES OF ANTENNAS

Directional Arrays
 A high frequency doublet or directional array is usually mounted a high and in the array as possible for obvious reasons. Power

8. DIRECTABLE ARRAYS

ROTATING THE FLAT-TOP BEAM
 A single-section flat-top beam (described in preceding chapter) makes a compact and

9. U.H.F. ANTENNAS

Saving "Waterpipes"
 It is not necessary to take down a mast when the waterpipes are used. There is an easier method that is just as effective if the pole or mast is erected right at the top.

10. RECEIVING ANTENNAS

Two eyes should not be used to stand stilling around, an ultimately most laws its tip on them. This should be used only in a wild area and only in position, the mast should always be wrapped around the mast or

SEVENTY-FIVE CENTS in U.S.A. Elsewhere, 85c or 3s. 6d. Canadian Postal Notes and British Postal Orders Acceptable.

RADIO LIMITED Technical Publishers

7460 Beverly Boulevard, Los Angeles

POSTSCRIPTS...

and Announcements

Merry Christmas

RADIO takes this opportunity to wish its readers a very *Merry Christmas* and a happy and prosperous *New Year*.

We thank you for your loyalty and support, which make it possible for us to continue to bring you the latest and most outstanding developments in all phases of the radio field.

Boston-Chicago 56-Mc. Relay

For several years we have heard proposals for a Chicago to New York 56 Mc. relay, but generally such attempts were frustrated by a lack of knowledge of capable stations at various points along the route. While preparing a short discussion of the successful October 17th field day for the 56 Mc. column, we became convinced that organization will accomplish many things. If messages could be passed from VE3ADO in Toronto, Canada, to Maryland and return, a good share of the Chicago-Boston distance might also be spanned by a string of five meter stations with known consistent ranges. Having received a quantity of reports from stations active in long-distance work last summer, we laid out tentative routes and sent a number of letters to stations that might be interested.

Looking from the west (Chicago) end, the first link that bothered us was across either Michigan or Indiana. However, W8CVQ in Kalamazoo and W8QDU in Detroit have guaranteed to take a message from Chicago or Elgin and to put it into Cleveland or Akron either by themselves or with one additional relay between them. With very consistent work being done from Cleveland and Akron into Buffalo and Pittsburgh, the next link which promised difficulty was across New York or Pennsylvania, with a possible alternate route down to Hagerstown, Maryland, and somehow to Leesburg, Virginia, from which there should be little trouble through Washington, Baltimore, Philadelphia, New Jersey, New York City, and on into Boston.

The tentative route from Chicago east across New York state seems to be clear as far as Syracuse, although in some cases additional relays

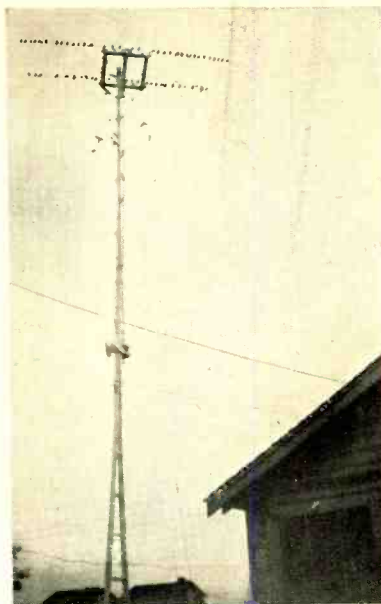

W8QYI constructed the close-spaced beam described in June RADIO and reports excellent results. However, he has trouble with birds using the elements for a perch, and after futile attempts at trying to discourage them has about decided to add a bird bath and let them really enjoy themselves. The only complaint the birds have to make is an objection to the "hot foot" they receive every time W8QYI turns on the rig. He says he can get an excellent idea of the voltage distribution on the elements by observing how far the birds jump.

may be necessary, or some of the stations eliminated. It looks like this:

W9CLH—Elgin, Illinois
W8CVQ—Kalamazoo, Michigan
W8QDU-NKJ—Detroit, Michigan
W8VO-BDG-LHU—Akron, Ohio
W8GGA-KOL—Cleveland, Ohio
W8TT—Painsville, Ohio
W8QKI—Ashtabula, Ohio
W8GU—Erie, Penna.
W8RV-NOR—Buffalo, New York
W8GBK—Sherman, New York
W8AGU—Penfield (Rochester), New York
W8PK—E. Bloomfield, New York
W8DSU—Auburn, New York
????—Syracuse, New York

At that point we seem to stop. Some Mohawk Valley stations have been reported heard on 56 Mc., which if active might succeed from that point east, as follows:

W8ENV—Syracuse
W8CGW—Oneida
W8NSL—Cazenovia
W8GQ-LMT—Utica
W8OQG—Richmondville

[Continued on Page 180]

By
the
"Editors
of
Radio"



Radio's OUTSTANDING LIBRARY

RADIO the world's foremost practical and constructional shortwave, amateur radio magazine, the foundation of the reputation and prestige of "THE EDITORS OF 'RADIO'," known the world over as the outstanding group in radio not affiliated with a definite commercial interest. Intensely practical; profusely illustrated with large photographs on coated paper. Ten issues yearly including double-size annual number. Yearly \$2.50 or TWO YEARS FOR \$4.00.*

"RADIO" HANDBOOK a \$5.00 book for \$1.50! Almost 600 pages; complete, authoritative, practical, large illustrations; thoroughly revised annually. Both a text and a reference book. Elementary theory, workshop practice, instruments, laws and operating, plus more new, up-to-the-minute yet tried-in-practice constructional data than in any other book at any price—from beginners' receivers to elaborate 1 kw. radiophones. PER COPY \$1.50.*

RADIO DIGEST the ONLY publication covering ALL phases of radio (except business and entertainment), reprints, digests, condenses the outstanding material from the entire radio press including many foreign papers and commercial "house organs" not generally available. Also includes "thumb nail sketches" of all important material in most worthwhile contemporary publications. R. D. is the only way to keep up with the whole, vastly interesting radio field (outside your own "pet" phase) without spending many hours and dollars reading the several dozen radio papers. Published bimonthly. TWO YEARS FOR \$2.50.*

Other Books by "The Editors of 'RADIO'":

- "RADIO" ANTENNA HANDBOOK, over 100 pages on antennas and nothing else; facts, curves, diagrams, tables, charts; no calculations necessary. Intensely practical. The only book of its kind; contains much more antenna data than in any "general" handbook. . . . Per copy, \$0.75*
- "RADIO" TELEPHONY HANDBOOK, over 100 pages devoted exclusively to radiotelephony; more comprehensive on this subject than any "general" handbook; a dozen radiophone transmitters are shown from 10 to 1000 watts. Over 100 illustrations. Clear, concise, intelligible. . . . Per copy, \$0.75*
- "RADIO" NOISE REDUCTION HANDBOOK tells how to stop

- or greatly reduce all radio "noise" except static. Noise reduction is equivalent to signal increase. Only book of its kind. . . . Per copy, \$0.35*
- "RADIO" AMATEUR NEWCOMER'S HANDBOOK, written especially for the beginner; simple theory; simple transmitters and receivers. How to learn the code; how to get started; radio laws and regulations. . . . Per copy, \$0.35*
- "RADIO" ULTRA HIGH FREQUENCY HANDBOOK, devoted exclusively to the simple yet distinctly different equipment and practice of communication at 12 meters and down, including microwaves. . . . Per copy, \$0.50*

*Above prices are for continental U.S.A. only; for rates elsewhere see individual advertisements in "RADIO" or send stamp for catalog.

RADIO LIMITED *Technical Publishers* 7460 Beverly Boulevard, Los Angeles

The Open Forum

Chair-Warmers

Los Angeles, Calif.

Sirs:

I am wondering if you know of any blind or crippled shut-ins who want to get started in ham radio and who could use some gear that I have lying around.

I have the following, all in good working condition, which I would like to give to some chair-warmer whose purse won't allow expenditures for ham gear.

1 power pack complete, output 350 v., 150 ma.

8 or 10 receiving tubes in good shape

pair of 866's, good condition

high-frequency buzzer

miscellaneous antenna material

2-tube regenerative short-wave receiver complete with coils, tubes, phones and a.c. power pack

miscellaneous audio transformers and similar odd parts

I would prefer to give this to someone who is American born and who is unable to purchase the stuff required to get started in the game. If the party should be located in Los Angeles or vicinity, I would be glad to set up the receiver and put up an antenna, etc.

If you can think of anyone who is worthy, please drop me a line with his name and address, and I'll do the rest.

M. A. O'BRADOVICK, EX W7TG
5567 Carlin Street

Modulated Oscillators

Norwood, Ohio

Sirs:

I have read the ideas and gripes of other hams in your magazine, and I have agreed with some and disagreed with others. Now I want to see how many other hams will kick about the same thing I am going to. It's about these South American phones.

You hear a weak CQ from a dx station, and just as he is about to sign his call—Grr!! Squeal!—Yes, you are right; it is a modulated oscillator. These oscillators also make a specialty of covering up a dx station just after you have taken a stand-by. The crystal-controlled ones sound fine (except one CO2 who doesn't know what a gain control is for; he

probably hangs his hat on it, if he owns one) but I don't see how any 20-meter phone would have the patience to follow one of the modulated oscillators all over the band. If the self-excited boys would go crystal control, they would be answered more often by other phones, and it would be a great help in clearing up the 20-meter c.w. band (lower portion).

I would like to hear the comments of other hams on this subject.

ROBERT WATSON, W8PBF
Shelby, Montana

Superhet Trouble

Sirs:

I wonder if most hams are aware that we are facing the possibility of losing our 160-meter band someday, due to the great number of small cheap superheterodyne receivers being turned out by manufacturers and dumped on the market for ignorant people to buy.

It happens that I live in a community where there is a great number of these receivers, and the frequency of our local broadcast station is such that when these receivers are tuned to this station the harmonics from the oscillator in these receivers fall right in our 160- and 80-meter bands. During certain times of the day, our low-frequency bands are completely covered from harmonics from broadcast receivers; hence, it is useless to try to operate on these bands at times. I have taken one of these receivers and actually transmitted over a distance of two miles by simply putting a key in the plate lead to the oscillator.

Another thing, when operating on the 160-meter band, our signal mixes with the oscillator harmonic, thus causing interference on the broadcast band. Of course, the amateur is the goat.

I say these receivers are unlawful, just as much so as the old single circuit regenerative receiver. If steps are not taken to curb the sale of this type of receiver, they will in time become so numerous and complaints so regular that the F.C.C. might take action and deprive us of the use of our low-frequency bands.

I have been operating phone for the last month on 160 meters, and most of the complaints have come from b.c.l.'s with this type of radio. It is hard to convince them that the

[Continued on Page 180]

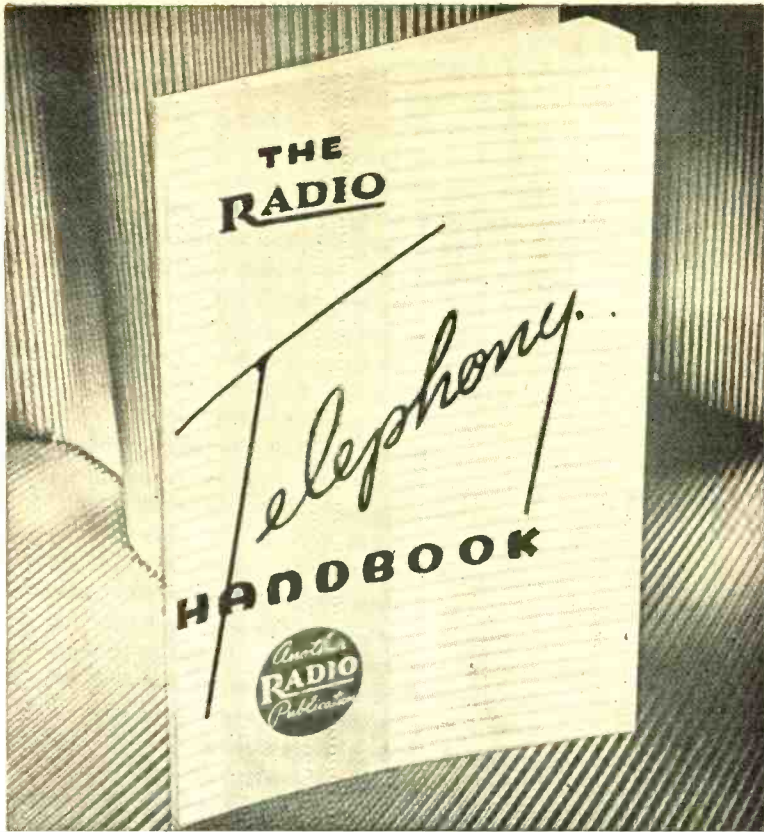

THE "RADIO" TELEPHONY HANDBOOK

Note: Copies of the first printing are entitled "Amateur Radiotelephony"; the text is the same.

This book has been written expressly for the "phone man" and the amateur interested in getting on phone. This clear yet concise work devotes itself particularly to the intricacies and technicalities peculiar to this field.

A dozen complete transmitters are described from the tiny, ten-watt size up to one kilowatt. Each has been laboratory built and tested, and tested on the air.

It is more comprehensive than the radio-telephony data to be found in any "general" handbook.

All systems of modulation are covered, also class BC amplifiers, inverse-feedback systems, modulation measuring equipment, and the like. Over 100 illustrations show how to construct and adjust all items described. 52 typical questions for the special-privilege Class-A license examination are answered in detail.

The best single investment you can make in your phone transmitter is the purchase of this book at

SEVENTY-FIVE CENTS

in continental U. S. A. Elsewhere, 85c or 3s. 6d.

RADIO
LIMITED

Technical Publishers

7460 Beverly Boulevard, Los Angeles

New Amateur Regulations

[Continued from Page 106]

tate their examinations and, if unable to draw required diagrams, may make instead a detailed description essentially equivalent. The examiner shall certify the nature of the applicant's disability and, if the examination is dictated, the name and address of the person(s) taking and transcribing the applicant's dictation.

Sec. 151.22. **Grading.** Code tests are graded as passed or failed, separately for sending and re-

ceiving tests. A code test is failed unless free of omission or other error for a continuous period of at least one minute at required speed. Failure to pass the required code test will terminate the examination. (See Sec. 151.23.)

A passing grade of 75 per cent is required separately for Class B and Class A written examinations.

Sec. 151.23. **Eligibility for reexamination.** An applicant who fails examination for amateur privileges may not take another examination for such privileges within two months, except that this rule shall not apply to an examination for Class B following one for Class C.

AMATEUR RADIO STATIONS

LICENSES

Sec. 152.01. **Eligibility for amateur station license.** License for an amateur station will be issued only to a licensed amateur operator who has made a satisfactory showing of control of proper transmitting apparatus and control of the premises upon which such apparatus is to be located; provided, however, that in the case of an amateur station of the military or Naval Reserve of the United States located in approved public quarters and established for training purposes, but not operated by the United States Government, a station license may be issued to a person in charge of such a station although not a licensed amateur operator.

Sec. 152.02 **Eligibility of corporations or organizations to hold license.** An amateur station license will not be issued to a school, company, corporation, association, or other organization; nor for their use; provided, however, that in the case of a bona fide amateur radio society a station license may be issued in accordance with Section 152.01 to a licensed amateur operator as trustee for such society.

Sec. 152.03 **Location of station.** An amateur radio station, and the control point thereof when remote control is authorized, shall not be located on premises controlled by an alien.

Sec. 152.04 **License period.** License for an amateur station will normally be for a period of three years from the date of issuance of a new, renewed, or modified license.

Sec. 152.05 **Authorized operation.** An amateur station license authorizes the operation of all transmitting apparatus used by the licensee at the location specified in the station license and in addition the operation of portable and portable mobile stations at other locations under the same instrument of authorization.

Sec. 152.06 **Renewal of amateur station license.** An amateur station license may be renewed upon proper application and a showing that, within three months of receipt of the application by the Commission, the licensee thereof has lawfully operated such station in communication by radio with at least three other amateur stations licensed by the Commission, except that in the case of an application for renewal of station license issued for an amateur society or reserve group, the required operation may be by any licensed amateur operator. Upon failure to comply with the above requirements, a successor license will not be granted until two months after expiration of the old license.

Sec. 152.07 **Posting of station license.** The original of each station license or a facsimile thereof shall be posted by the licensee in a conspicuous place in the room in which the transmitter is located or kept in the personal possession of the operator on duty, except when such license has been filed with application for modification or renewal, or has been mutilated, lost, or destroyed, and application has been made for a duplicate.

CALL SIGNALS

Sec. 152.08 **Assignment of call letters.** Amateur station calls will be assigned in regular order and special requests will not be considered except that a call may be reassigned to the latest holder, or if not under license during the past five years to any previous holder or to an amateur organization in memoriam to a deceased member and former holder, and particular calls may be temporarily assigned to stations connected with events of general public interest.

Sec. 152.09 **Call signals for member of U.S. N.R.** In the case of an amateur licensee whose station is licensed to a regularly commissioned or enlisted member of the United States Naval Reserve, the Commandant of the naval district in which such station is located may authorize in

his discretion the use of the call-letter prefix N in lieu of the prefix W or K, assigned in the license issued by the Commission, provided that such N prefix shall be used only when operating in the frequency bands 1715-2000¹ kilocycles, 3500-4000 kilocycles, 56,000-60,000 kilocycles, and 400,000-401,000 kilocycles in accordance with instructions to be issued by the Navy Department.

Sec. 152.10 **Transmission of call signals.** An operator of an amateur station shall transmit its assigned call at the end of each transmission and at least once every ten minutes during trans-

[Continued on Page 182]

¹ Subject to change to "1750 to 2050" kilocycles in accordance with the "Inter-American Arrangement Covering Radiocommunication", Havana, 1937.

More on the Three-Element Rotary

[Continued from Page 37]

Receiving Hints

One note of caution is in order. For receiving, the lowest pickup from undesired directions occurs with the transmission line balanced, and the coupling to the receiver purely inductive. If there is a feeder unbalanced or capacity coupling, the whole system, in a measure, operates as a Marconi antenna and some of the front-to-back ratio is lost. No special precautions were taken at W8LFE, but in the average installation it would be well to short the transmission line at the antenna to see if practically all signals disappear—as they should. A balancing coil, a ground in the center of the primary in the receiver, or a Faraday shield within or outside of the receiver, may all be suitable remedies, depending on the situation.

Constructional Suggestions

This array is quite practical to construct. It requires a crossbeam of only 15 feet for 20-meter operation, and hanging somewhat shortened half-wave elements from the center and ends of the pivoted crossbeam. We understand that some hams have used or-

dinary or telescoped copper, brass or dur-alumin tubing successfully, but all of our experience has been with plated, tapered steel tubes which really stand out very nearly straight in 17-foot sections, when securely anchored at the crossbeam.

Suitable feed systems and their adjustments have been discussed in the November RADIO article.

We sincerely feel that all two-element arrays should come down and be changed over for three-element operation; the great improvement in operation more than justifies the expense and labor of making the change.

A T20 100-Watt Phone

[Continued from Page 42]

bias from a 50,000-ohm potentiometer acts as a delay voltage and prevents the 6H6 from rectifying a.f. voltage below the point of over-modulation. The proper setting of this potentiometer can be easily determined by means of an oscilloscope or carrier-shift meter connected to the modulated r.f. output. The automatic action should take place soon enough to prevent any overmodulation or carrier shift. This setting will be the same



Play Safe!

Improper adjustments or incorrect operating conditions can bring about off-frequency radiation in any type of transmitter. The new F.C.C. regulation which requires every amateur station to incorporate an independent means for measurement of the transmitter frequency now places full responsibility squarely on each operator. Play safe—use a standard frequency oscillator in conjunction with your station receiver. You then will have a reliable monitor at low cost.

Where high precision is essential, the type SOC100 low-drift 100kc. Standard Frequency Crystal Unit priced at \$15.50 should be used. The SOC100X, X-cut, mounted 100kc. bar offers economical accuracy at \$9.50. When operation is well within the band limits, a flexible inexpensive frequency standard can be constructed with the type SMC100 Dual-Frequency Crystal Unit (100kc. and 1000kc.) priced at only \$7.75.

Ask your Bliley distributor for a copy of Bulletin A-6, which describes these and other Bliley Crystal Units.

BLILEY SF CRYSTAL UNITS

A NEW TREND

Ganged neutralizers for single control neutralization of push-pull amplifiers.

Long in use by commercial designers, ganged neutralizing capacitors are becoming more and more widely used by progressive amateur designers. Essentially conventional in natural layout, the push pull triode class "C" amplifier lends itself most fittingly to further simplicity achieved by use of Cardwell ganged neutralizing condensers. Medium power amplifiers in particular are readily adapted to their use. We introduce two new units, the ES-7-SDI (illustrated) and the ET-15-ADI, both of which are dual neutralizers requested by progressive amateur and commercial designers.

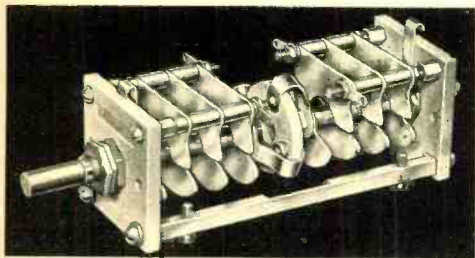

NEW Type ES-7-SDI—Dual Neutralizer

For push-pull T-40's, HY-40, HY-57, RK-18's etc.
 Maximum Capacity—each section 7 mmfd.
 Minimum Capacity—each section 4 mmfd.
 Airgap—.140". Peak V.—5000 V. at 7 M.C.
 Plates—.040" thick, buffed and polished aluminum.
 Size—4 1/2" x 1 1/2" x 1 1/2"
 Insulation—Isolanite end plates with Alsmag 196 insulated coupling between rotor sections.

List Price—\$4.50

Type ES-4-SDI—Dual Neutralizer,

similar to ES-7-SDI except maximum capacity per section is 4 mmfd. and minimum 1.5 mmfd. For push pull amplifiers using tubes such as 316-A, U11-35, 800, RK-30, 834, RK-32, 304-A and U11-50.

List Price—\$4.10

NEW Type ET-15-ADI—Dual Neutralizer

For push pull RK-59, 841, 10, 801, T-20, 809, RK-11, RK-12, 825, 756, 830, 316-A.
 Maximum Capacity—each section—15 mmfd.
 Minimum Capacity—each section—1.5 mmfd.
 Airgap—.070". Peak Voltage—2500.
 Plates—.020" thick aluminum—unbuffed.
 Size—3 1/2" x 1 1/2" x 1 1/2"
 Insulation—Isolanite end plates, with Alsmag 196 insulated coupling between rotor sections.

List Price—\$3.50

Type ET-30-ADI—A dual neutralizing unit,

similar to ET-15-ADI except for push pull tubes with grid to plate capacities higher than the capacity range of the ET-15-ADI. If plate modulation is used, plate voltages in excess of 600 V. should not be used.
 Maximum Capacity per section is 30 mmfd.
 Minimum Capacity per section is 4 mmfd.

List Price—\$4.10

Type NA-12-NDI—Dual Neutralizer,

similar in construction to the well known NP-35-ND H.F. dual except with greater plate spacing and lower capacity, with 10,000 V. LO-FLEX couplings between rotor sections. For neutralizing push pull amplifiers using such tubes as RK-31, 841-A, 835, 838, 261-A, RK-57 and 805.
 Maximum Capacity each section—12 mmfd.
 Minimum Capacity—each section—6 mmfd.
 Airgap—.218". Peak Voltage—6500 volts (conservative)
 Plates—.040" thick buffed and polished aluminum.
 Size—2 1/2" wide x 2 11/16" high x 5 25/32" long.
 Insulation—Isolanite and General Electric Mvcalex.

List Price—\$15.00

**THE ALLEN D. CARDWELL
 MANUFACTURING CORPORATION
 35 PROSPECT STREET, BROOKLYN, NEW YORK**

RADIO

for all bands of operation providing the T20 amplifier is loaded up to the same plate current on each band. The plate current is the difference between cathode and grid current readings in the T20 stage.

See Buyer's Guide, page 193 for parts and manufacturers.

The G-OK

[Continued from Page 45]

counts for their popularity. This second method of attack, namely of showing that odd harmonics are not generated and that even harmonics cancel out, checks our initial graphical analysis (by adding successive alternate half waves) that two G-OK's in push-pull do not generate harmonics.

In figure 8 are shown the characteristic curves of the G-OK, the 46 and the 2A3. They have been drawn to different scales so that the maximum and minimum plate current points approximately coincide. It can readily be seen that the curvature of the 46's characteristic curve is less than that of the 2A3's and greater than that of the G-OK's. In other words, the 46 more nearly approaches the ideal class-B tube than does the 2A3. This is reasonable, as the connections used to obtain this curve were those recommended for class-B service and the 46 was designed for this purpose.

By applying a sine wave to these three tubes, three different wave forms will result. The wave form from the G-OK will be sinusoidal, or the same as that impressed. That from the 46 will be almost a sinusoidal wave, and the one from the 2A3 will vary even more from the desired sinusoidal wave. In general, the greater the variation from a sine wave, the larger will be the number and amplitude of harmonics generated. It then becomes obvious that the distortion from a 2A3 in class B will be much greater than that from a 46, which was designed for this class of amplification. For a low order of distortion, a tube's characteristics should approach that of the G-OK. There are other factors which enter into the design of a class-B tube. Among these are the ability to operate at zero fixed bias and the ability of the grid to handle power without excessive heating. The straight line portion of most tubes used in class-B service will pass through the origin (plate current and grid voltage equal to zero) when extrapolated (extended in the same direction). This is seen to be ap-

proximately true, for example, with the 46's curve shown in figure 6.

When one compares the approximate linearity of many of the present day tubes with the snaky characteristic of their predecessors, the G-OK seems almost possible.

Danger—High Voltage
[Continued from Page 82]

careful of dial set screws if the rotor shaft of the condenser is "hot." Both of these situations represent poor practice to begin with.

Don't touch any transmitter components without first turning off all switches. If you do insist on making coupling adjustments, etc., with your transmitter on (very bad practice), *keep one hand behind you.*

Do not work on the high-voltage circuits or make adjustments where it is necessary to reach inside the transmitter *unless someone else is present.* Ninety per cent of the deaths of amateurs due to electrocution could have been prevented if someone had been present to kill the high voltage or remove the victim and to call the doctor and administer first aid before he arrived.

High-voltage gear should be so fixed that small children cannot manipulate the switches or come in contact with any of the wires or components. Either keep the radio room or gear under lock and key or else provide an "interlock" system whereby all primary circuits are broken when the transmitter cabinet is opened.

Familiarize yourself with the latest approved methods of first aid treatment for electrical shock. It may enable you to save a life some time.

Don't attempt to hurry *too much* if a companion comes in contact with high voltage and cannot extricate himself. Act quickly but do not act without deliberation or you may be in as bad a fix as the person you are trying to help. Do not touch the victim with your bare hands *if things are wet.* Otherwise, it is safe to grab him by a loose fold of clothing to pull him free, first making sure that you are well insulated from anything grounded. Turning off the voltage is simpler, when pos-

sible. However, do not waste precious moments dashing around trying to discover how to open the circuit. If you do not already know, try to remove the victim if it can be done safely.

A main primary switch at the entrance to the radio room, killing all primary circuits, will reduce the fire hazard and help your peace of mind, provided you make it an iron-clad rule always to throw the switch when leaving the room.

Beware of strange equipment. It may contain unconventional wiring or circuits. Do not take for granted that it is wired the way you would do it.

Inexpensive 25-Watt Modulator
[Continued from Page 74]

Newer Tubes

At the time of this writing, one of the new 6SJ7 tubes was not available for test, but this new tube type is very well suited for use in the first stage of high-gain speech amplifiers. The fact that the control grid of the 6SJ7 is brought out to a base pin allows the use of a very short lead from the microphone jack to the control grid and eliminates the necessity of the comparatively long shielded lead from the jack to the top of the tube.

The 6SJ7 could be substituted directly for the 6J7 with no change in the values of the component parts. It would only be necessary to make the appropriate pin connection changes.

See Buyer's Guide, page 194 for list of parts used in this article and manufacturer's type numbers.

See THE LATEST RADIO DEVELOPMENTS IN
ALLIED'S 1939 CATALOG

READY NOW—SEND FOR IT!

Amateurs!—Radio Builders!—send for the new 130 page ALLIED Catalog! It includes Everything in Radio in Radio's Biggest Book—latest Ham receivers: National NC-510 and NC-44; Hallicrafters "Dual Diversity" and "5-10", Sargent "Streamliner", Howard 430, 440, 450, etc.; newest transmitters: National, Hallicrafters, Utah, and G.T.C. "Pee-Wee"—\$2 new 1939 KNIGHT Radios—4-16 tubes—for AC, AC-DC, 32 Volt, Battery, and Auto operation. Dozens of Build-Your-Own Kits, with more than 100 diagrams and projects! Also books, tools, etc.

ALLIED RADIO CORP.
 Dept. 14-A-9
 833 W. Jackson Blvd., Chicago, Ill.

Send me your 1939 Catalog—Free.

Name

Address

Free!
SEND COUPON



110-VOLTS AC
 Anytime, Anywhere! With
KATOLIGHT PLANTS

Have special plant for operating radio receivers and transmitters. Close voltage regulation. Full 350 watts AC and 100 watts at 6 volts. Filtered and shielded.
 Amateur's price—JRA3, 350 watt \$66.00
 Amateur's price—JR55, 550 watt 97.50
 Other sizes up to 10,000 watts. Both gasoline and Diesel.
KATOLIGHT, Mankato, Minn., U. S. A.

Radio With the Airlines
 [Continued from Page 71]

We are about 3 minutes out of Chicago when the control tower calls and advises that a private ship has just reported 15 miles west at an altitude of 5000 feet. This information enables us to watch for this ship and sure enough, there he is, a little red ship, going by on our left. We are now at 5500 feet, so we pass a little above him. As can readily be seen, in bad weather, when a pilot is flying entirely by instruments and cannot see a thing beyond his wing tips, this type of information is invaluable.

We are now about 20 miles west of Chicago; so we change to the UAL circuit frequency and call our Chicago station for an air check. The ground station acknowledges our call with an "all OK" and we are on our way.

The trip continues smoothly along the course, with a radio report approximately every 25 minutes over the previously mentioned check points. When reporting over a check point, the pilot gives his time over, his altitude, sky and weather conditions, tempera-

ture and condition of air (i.e., smooth, rough or otherwise). This is a standard procedure for all trips and furnishes last minute information on all conditions along the course to all pilots about to take off for the same region.

There is the copilot reaching for his mike; let's listen again:

"Jackson in United trip 3, over Davenport at 1025; 8000; few high scattered clouds estimated 12,000; temperature 50; smooth, all OK."

"Moline to United 3; OK on report." (Moline is the location of the ground station).

Reports over Sheridan and Sterling are made in the same manner.

We make one more report over Des Moines, similar to the one over Davenport. The operator at Des Moines gives us the Omaha winds aloft, prepared by the Department of Commerce for every 1000 feet above the surface. The pilot decides to stay at 8000, because the wind at other altitudes is not much different in direction and velocity from that at 8000.

Before we are aware of it, the pilot has started a long, gliding descent for a landing at Omaha. The only sign of this action that is noticeable is a slight difference in the sound of the motors, as the pilot has slowed them down a trifle. When about 5 minutes from Omaha, the pilot calls the ground station at Omaha and asks for the ground wind. The operator at Omaha gives the pilot all the necessary information for a safe landing, consisting of the ground wind direction and velocity, the station Kollsman, a caution to be sure to lower his wheels, and field conditions. With this information available, the pilot can maneuver for a direct landing where otherwise he might be forced to circle the field several times.

The radio procedure just followed on the Chicago-Omaha leg of our trip is standard and is followed throughout the balance of our trip by each and every pilot. The trip continues in the same fashion, until it reaches its terminus, in this case Oakland, Calif. Of course, we change pilots along the way, as the complete trip takes about 11 hours.

Other Plane Equipment

Now a few words on the rest of the equipment. The microphones are single-button units, built very ruggedly, as they have to withstand some rough usage in the form of

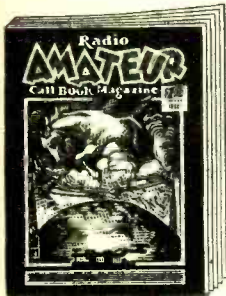

Buy a Fresh Copy Today of the RADIO AMATEUR CALL BOOK

The CALLBOOK is the only publication that lists all licensed radio amateurs in the United States and over a hundred and twenty-five different foreign countries.

Each issue also contains a world map showing amateur prefixes, press, time and weather schedules, amateur prefixes listed alphabetically and by countries and a world time conversion chart.

Complete . . . Accurate . . . Up-to-Date

Issued Quarterly

MARCH . . . JUNE . . . SEPTEMBER and DECEMBER

Annual subscription \$4.00

Single copies \$1.25

Buy your copy now from your radio jobber or direct from:

RADIO AMATEUR CALL BOOK, Inc.

606 S. Dearborn St. Chicago, Ill., U. S. A.

of us RADIO

EVERYTHING IN RADIO!

Our immense stock of radio sets, parts and supplies enables you to purchase your entire needs on one order. You'll find all your Nationally Known Favorites in this book which is FREE for the asking. Practically every order shipped same day received. WRITE FOR CATALOG.

BURSTEIN-APPLEBEE CO.
 1012-14 McGee St. • Kansas City, Mo.

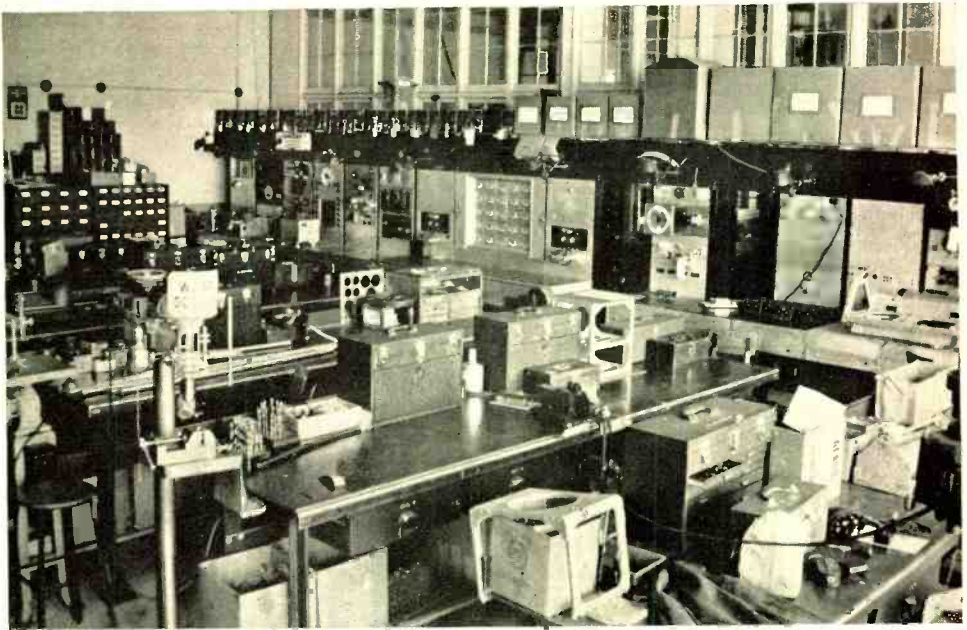

Figure 11. The radio equipment overhaul shop at Cheyenne, Wyoming.

vibration and rather severe handling. One type is entirely enclosed in a metal housing; the other has a bakelite cap with a metal back. The mike and earphones are connected to one plug, for connection to one jack, for ease of connection as well as simplicity.

All wiring inside the planes, besides being shielded, is run in duralumin conduit, with all cross connections being made inside dural junction boxes. All connections are made and kept tight with the aid of lockwashers.

Figure 6 shows the radio installation aboard a Boeing type ship. From left to right we have: the company s.w. receiver, the transmitter, the "beam" or l.w. receiver, and above the l.w. receiver, the auxiliary receiver.

Figure 7 shows the position of figure 6 in relation to rest of the plane. The mechanic is not part of the installation; he sneaked into the picture when we were not looking.

Figure 8 shows the radio installation aboard a Douglas Mainliner. All radio equipment is standard and interchangeable between the Boeing and Douglas type ships.

Figure 10 is a view of the cockpit. The radio controls can be identified by the three knobs in the center of the picture. The loop antenna rotating device and dial can be seen in upper center, with the radio switches just to the left and right. The other switches and instruments are also somewhat necessary for flying operations.

The motors and plane are overhauled after every 500 hours flying time. This work is

done at the repair base at Cheyenne, Wyoming, the largest and best equipped airplane overhaul base in the world. After a trip through these shops, the plane comes out as good as new.

During this overhaul, the radio equipment is also removed from the ship and thoroughly inspected and checked in a well equipped radio shop. This shop is shown in figure 11. The equipment is repaired or overhauled as found necessary; all wiring is inspected; in fact, the complete plane radio is inspected, cleaned up, rechecked and reinstalled. After

NOTICE!

to Customers in British Countries

Due to the present variations in dollar-sterling exchange,

*all sterling prices
are temporarily withdrawn*

Please remit in dollars only for RADIO, The "RADIO" HANDBOOK, and other publications by the Editors of RADIO.

Sterling prices will again be quoted as soon as stabilization of exchange makes this possible.

RADIO, LTD.

ANOTHER KIT FROM

RADIO SUPPLY

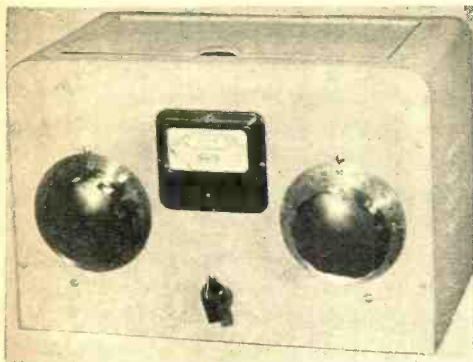

"XT3"

THE SENSATIONAL

SMITH EXCITER

IN KIT FORM

- Replaces the Bi-Push
- 4-Bands in 4 Seconds
- No Trick Circuits
- Equal Output All Bands
- No Neutralizing
- 35 Watts Output
- Can Be Modulated

SEE DECEMBER ISSUE OF "RADIO" FOR COMPLETE STORY.

"XT3" KIT	\$24.07
Includes Box and Punched Chassis	
Tubes XT3	\$5.30
Wired and Tested	\$8.50
Total	\$37.87
"XP2"	\$21.60
600 Volt Power Supply, well Filtered for "XT3"	
Dust Cover	\$1.50
Wired and Tested	\$5.00
	\$28.10

Write for Circular

RADIO SUPPLY

950 S. Broadway

LOS ANGELES

CALIFORNIA

RADIO

the ship is overhauled, it is test flown by the test pilot, who puts all parts of the plane (including the radio equipment) through a rigorous and complete test procedure. If the ship passes these rigid tests satisfactorily, it is then put back into service on the line.

The author wishes to thank Mr. J. S. Anderson and Mr. Gordon March for their able advice and their assistance in assembling the pictorial data herewith presented.

A 400-Watt Diathermy

[Continued from Page 61]

the exposed leads to the pads. Interference can be reduced still further by the use of a "screened" treatment room. The metal screening should be thoroughly bonded and grounded.

When the diathermy machine described in this article is first installed, checks should be made to determine if the machine is interfering with u.h.f. police services in the vicinity of 8 meters. If such proves to be the case, the frequency can be shifted slightly by adjustment of C_5 .

The correct application of radio therapy depends upon the ailment and should, therefore, be under the supervision of a skilled physician. Self-treatment or treatment of friends by means of a home-built diathermy machine should never be attempted unless the operator is thoroughly familiar with this branch of physio-therapy. Careless use of radio therapy has caused serious damage.

For list of parts used in the diathermy and manufacturers' type numbers, see Buyer's Guide, page 194.

10-M. Auto Converter

[Continued from Page 55]

which dx may be worked with low-power transmitters and due to the fact that there are plenty of local ragchewers on the air in the evening after the band has closed for dx.

As an added suggestion to those whose car batteries and generators will be unable to keep up with the auto equipment, especially if a transmitter is also installed, it is an excellent idea to install a small trickle charger under the hood of the car. Then, when the car is put up for the night, the a.c. plug may be placed into the garage outlet and the battery will be on charge until leaving the next morning. Dead battery troubles may be avoided by this simple and inexpensive means. See Buyer's Guide, Page 194, for parts list.

Radio In the Andes

[Continued from Page 86]

made and radio equipment of sufficient power will be installed to maintain constant contact with the United States and our various field parties.

This headquarters will be located in the tribal territory of the Jivaro Indians. From this base, field parties will make excursions into the interior establishing friendly contact with the natives and conducting their first investigations.

When the area about base headquarters has been covered, two other permanent outposts will be constructed with a landing field and radio at each, so that all the posts will be in constant contact by radio and airplane, as well as by mule pack train.

It is well known among informed South American explorers that on the eastern slopes of the Andes there are some hundred thousand square miles of territory not known to explorers or ever covered by accredited scientists. Much of the route of the expedition lies in this area.

A complete pictorial record, both still and motion picture, will be made of the expedition. It is planned to take several thousand feet of film of the tribal life and ceremonials of all types, of each tribe contacted. Latitude and longitude of important villages and the borders of their tribal territory, showing the area inhabited by each tribe, will be recorded.

The headquarters will be prepared to accommodate visiting scientists and students who have been recommended by a university or museum and who have been accepted by the expedition officials. This headquarters will be in the nature of a community and will accommodate 100 to 300 people and will have laboratory facilities for 25 to 50 scientists and their helpers. Servants and labor will be available to produce staple crops so as to make the headquarters self-supporting.

**HEADSET HEADQUARTERS
EARNED ITS
LEADERSHIP**



CANNON-BALL PHONES
Satisfying folks over 20 years, will please you.

because its product always leads as a satisfaction-maker. For clear, private reception use a Cannon-Ball Headset. Folder R-1 illustrates complete line. Write

C. F. CANNON COMPANY
SPRINGWATER, N. Y.

When the present project has been completed, it is the intention of the expedition officials to maintain the posts as permanent headquarters for the use of future expeditions or scientists desiring to work in this territory. Universities and museums cooperating with the expedition will then have access to these established housing and laboratory facilities in South America from which to conduct future scientific investigations.

Two Watts on the Hoof

[Continued from Page 80]

normal plate current. With about one watt in the antenna we contacted a hard-to-work station six miles away, on the other side of a range of high hills. It reported R6, while the 500-watt (input) rig was R8, according to the R-meter. So don't think a watt or two won't go places if you give it a chance!

See Buyer's Guide, Page 194, for parts list.

●
R. F. Ham and Marconi Brothers are located in New York City.

THE BEST  **FOR LESS**

**MASTER
TRANSMITTING CONDENSERS**

New advances in the design of Bud Master Transmitting Condensers increase the efficiency of any circuit operating at radio frequencies.

A complete series of capacities in single and dual units is available for any circuit, plus a special series for ultra high frequencies.

"Seeing is believing"—examine them at your jobber's. Send 10c for Big Log Book No. R19.

BUD RADIO, INC.
CLEVELAND, OHIO., U. S. A.

Novel Beam Antenna Indicator

[Continued from Page 84]

placement parts for several b.c.l. sets, are fastened to the two shafts on the back of the mounting board as shown in the illustration of the rear of the unit. These pulleys should be of the same diameter; in fact, it is best to purchase two of the same type to make sure they are of identical diameter.

The pulleys are ganged together by means of dial cable or small but strong fish line. Tension springs, connected as in vernier dial assemblies, are advisable to maintain sufficient tension on the line that there is no slipping and consequent loss of tracking. However, if the unit is to be used with an array having continuous rotation, it will not be possible to use these springs.

In the latter event it will be necessary to rig the cord up with considerable tension and then tighten it from time to time as tension is lost. Wax or belt dressing will reduce the tendency for slipping when springs are not used. Be sure to cross the line, or the indicators will not rotate in proper relation. An extra hitch around each pulley is a good idea.

If desired, straight pointer indicators can be substituted for the fan-shaped indicators illustrated. This will give you the "nose" of the beam rather than the coverage. Or an extra wire, bisecting the angle made by the fans, may be soldered to the fan type indicators. This will give exact orientation of the "nose" as well as the total coverage of the beam.

An extra pulley must be attached to one of the two shafts to act as drive pulley. The diameter of this should be such that the indicators follow the direction of the array (exact 1:1 ratio). Gear drive may be substituted if preferred.

Contributions to "Radio"

[Continued from Page 96]

and move during exposure if you can. In a pinch use gray or brown paper, but don't join sheets with paste or mucilage. Use rubber (tire) cement and let dry for 15 minutes, then handle gently. Getting enough distance is a harder job. It has been done by working through a window; in one case even by working around a corner with the aid of a high-grade plate glass mirror from a dresser in the "company" bedroom, doubling the exposure to make up for absorption and praying the family wouldn't get back before it was over.

"Deep" Apparatus

When the thing to be shown measures more than a few inches fore and aft, it is extremely important to *keep the camera away* as far as possible. For instance, in taking a tableful of equipment we find that the table is 30 inches wide front to back. We try to get the camera at least 9 feet away (let the picture size take care of itself) and focus on a bit of printed paper set 1/3 of the way back. If the

Here's Big News, fellows . . .

IMMEDIATE DELIVERY ON THE NEW

1939 Hammarlund HQ-120

12 TUBE COMMUNICATION RECEIVER

NET PRICE COMPLETE \$117.00

As we have been in the ham game since 1912, we understand your problems and guarantee you complete satisfaction. You will find our terms the lowest and our service the best. We have a special payment plan for parts and tubes on orders totalling \$25.00 or more net.

Receiver	Cash Price	Down Pay't and 12 Monthly Pay'ts
Hammarlund HQ-120 Complete	117.00	9.55
Hammarlund HQ-120X	129.00	10.55
National NC-44	49.50	4.04
RME-70 Complete	138.60	11.30
Super Skyrider 5-16	99.00	8.08
New NC 101X Complete	129.00	10.52
Skyrider 5-10 Complete	69.50	5.67
New NC100XA Complete	142.50	11.70

Also all other makes and models on similar terms.

Special low terms on Temco, RCA, Hallicrafters, and Harvey transmitters; also all transmitter kits.

DELAWARE RADIO SALES Co.

WILLARD S. WILSON, W3DQ, Pres.

405 Delaware Avenue

WILMINGTON DELAWARE

Prompt Delivery on Foreign Orders

**A BINDER
FOR YOUR COPIES OF
"RADIO"**

- . . . takes them from dusty corners
- . . . protects valuable references
- . . . places one year's developments in radio at your finger tips

AND ALSO HOLDS THAT BIG, NEW
RADIO HANDBOOK

Now only \$1.00, express collect in U.S.A.
Radio, Ltd., 7460 Beverly Blvd.,
Los Angeles California

RADIO

camera (as usual) has to be focussed by a little scale on the camera we measure 9 feet from the table, put the lens there, and set for 10 feet—and *don't* forget to stop away down.

Mailing

When mailing photographs, care should be taken to guard against their being bent. Do not put too much reliance upon a "Do not fold" note on the envelope. The safest way is to use heavy cardboard backing for all photographs too large to fit in a regular $6\frac{3}{4}$ envelope.

Paper clips can leave permanent marks and scars on the face of a photo. If you must use a paper clip, turn the photo over so that the clip does not come in contact with the face of the print.

Do not send negatives except when we request them. They are required only when it is desired to enlarge a photograph to facilitate retouching. We will write you for the negatives if we need them.

SUMMARY

Even lighting.

Very small stop, never larger than f16 or US 16, and better f32 or 64—128 if possible.

Very long exposure, 4 to 30 seconds by outdoor daylight; 1 to 29 minutes indoors (by photoflood lighting).

And, of course, keep a "log" so it will turn out better next time.

A script writer named *Chain* works for a national broadcasting chain.

The *Doctors' Telephone Service* of New York proposes a one-kilowatt special emergency station on 31180 kc. as an adjunct to its present service.

Changes of Address

To become effective with
The Next Issue

must be RECEIVED at Los Angeles
by the 10th of this month

Address labels are shipped to our mailers on that date. Remember: under U. S. postal laws, magazines sent to an old address are junked unless forwarding postage has been left in advance with the postmaster; unlike letters and cards, magazines are not forwarded either free or collect (except to addresses in the same city).

RADIO

**Circulation
Department**



Do yourself a good turn . . . and let that good old scout "Old Man Centralab" help you with his ADASHAFT kit . . . housed in a swell metal box, hinged, contains ten Midget Radiohms, five types of attachable shafts, etc.

This kit will enable you to do some mighty fine "deeds" for more than 400 different makes of receivers . . . actually thousands of different models. See your jobber.



Included in the ADASHAFT KIT

are the following: 10 Adashaft controls, 5 Midget Switch covers, 6 4-inch Adashafts, 1 10-inch Adashaft, 2 3-inch Auto type Adashafts, 1 6-inch Auto Type Adashaft, 2 slotted Insacups, 2 square hole Insacups, 1 300-ohm Bias Resistor, 5 Ground Straps, 10 "C" Washers, 5 Switch Insulators, and 10 Terminal Insulators . . . 1 Instruction form 648.

Centralab

Division of Globe Union, Inc.
MILWAUKEE, WIS

British Centralab, Ltd.
Canterbury Rd., Kilburn
London N.W.6, England

French Centralab Co.
118 Avenue Ledru-Rollin
Paris XI, France

A Kilowatt on the New 810's
[Continued from Page 63]

TYPICAL OPERATION

D.c. plate voltage	1500	2000	volts
D.c. grid voltage	—120	—160	volts
Peak r.f. grid voltage	280	330	volts
D.c. plate current	250	250	milliamperes
D.c. grid current	40	40	milliamperes
Driving power (approx.)	10	12	watts
Power output (approx.)	275	375	watts

Grid-Modulated R. F. Power Amplifier

D.c. plate voltage (max.)	2000	volts
D.c. grid voltage (max.)	500	volts
D.c. plate current (max.)	185	milliamperes
Plate input (max.)	185	watts
Plate dissipation (max.)	125	watts

TYPICAL OPERATION

D.c. plate voltage	1500	2000	volts
D.c. grid voltage	—140	—140	volts
Peak r.f. grid voltage	175	160	volts
Peak audio grid voltage	85	85	volts
D.c. plate current	110	92	milliamperes
D.c. grid current (approx.)	2	4	milliamperes

Driving power (approx.)	5	4	watts
Power output (approx.)	60	60	watts

Interelectrode Capacities

The interelectrode capacities of the 810 are: grid-plate, 4.8 $\mu\text{fd.}$; grid-filament, 8.7 $\mu\text{fd.}$; plate-filament, 12 $\mu\text{fd.}$

See Buyer's Guide, page 194, for parts list.

Reactance-Frequency Chart

[Continued from Page 93]

operated in parallel rather than in series. However, C and L are the same in either case.

For our example let's assume that the amplifier output impedance is 10 ohms and the desired crossover frequency is 200 cycles. Entering the chart horizontally on the 10-ohm line to the vertical 200-cycle line, we find that the .008-henry and 80- $\mu\text{fd.}$ lines intersect at this point. And these are the values to use for this particular condition. However, since 80- $\mu\text{fd.}$ condensers might be a bit difficult to obtain, let's see what would happen if we used a 500-ohm output from the amplifier and, of course, corresponding inputs to the speakers. Entering on the 500-ohm line of the chart to the 200-cycle line, we find that 1.5 henry and 1.5 $\mu\text{fd.}$ will do the trick at this impedance.

With these few examples as a starter many other uses of this chart will undoubtedly present themselves. Of course, the above problems might have been solved from the relations $X_L = 2\pi fL$ and $X_C = \frac{1}{2\pi fC}$, but we prefer to do them the easy and more rapid way.

200 Crystal Watts

[Continued from Page 98]

Maximum diameter	.1¼ inches
Plate dissipation	... 25 watts
Filament voltage	... 6.3 volts
Filament current	... 3 amperes
Grid-Plate capacity	... 1.7 $\mu\text{fd.}$
Amplification factor	.25
Plate voltage, unmodulated 1500 volts
Plate current 75 milliamperes
Grid current 30 milliamperes
Normal class-C bias	—120 volts

By slightly exceeding the plate voltage rating and operating the two tubes at 1750 volts, an output of slightly over 200 watts is ob-



**“Another Man”
is waiting for
Your Job!**

E. H. Rietsche Pres. CREI **CREI training insures your future**

• The Radio industry is crammed with “pretty good” men . . . that's why your boss can afford to be “chooney” in selecting men for better jobs. He knows that there is always **another man waiting for your job . . .** but, **DO YOU?** Right now is the time to insure your future in Radio. You must be **technically trained to hold and improve** your present position.

Good Men Have the Good Jobs

Modern improvements demand men with advanced technical training who can step into the new jobs that are constantly being created. There's always room at the top for men who can produce. Our story is vital to your future and the success of every Radioman—**send for it today.**

TEAR OUT COUPON AND MAIL FOR FREE BOOK

FREE

Please send me your new illustrated book, “A Tested Plan for a Future in Radio”.

Name

Address

City



Capitol Radio Engineering Institute
 Dept. RO-1, 3224 16th St., N.W., Washington, D. C.

RADIO

tained from the amplifier at the normal plate current of 150 ma. for the two tubes. For modulated operation, the plate voltage should be lowered to 1250 volts, however. Two jacks, J₁ and J₂, are provided for reading the grid and plate current. A one-turn link is used between the amplifier and the exciter and the grid current is adjusted to 50 milliamperes under load by varying the coupling.

With the load removed, the plate current to the two tubes is 40 milliamperes on resonance at 1750 volts. This dip, which is about what is usually expected from a 7- or 14-Mc. stage, indicates the high efficiency of the amplifier.

For list of parts used in this transmitter and manufacturers' type numbers, see Buyer's Guide, page 194.

56 Mc.

[Continued from Page 142]

W2IBP 57.072	W4EUU 57.376
W2HCB 57.200	W1KTF 57.384
W3AIR 57.200	W9YCZ 57.384
W1JLK 57.2	W1IXP 57.4
W2GAH 57.22	W1HDF 57.424
W9ZCD 57.224	W1KNM 57.464
W1CUD 57.240	W9ARN 57.465
W3CMZ 57.240	W9ZHT 57.465
W1FLQ 57.280	W2JCR 57.496
W2KLV 57.310	W1JQL 57.5
W1KPC 57.324	W1KGE 57.54

SOLAR
gives you **MORE** for your money



SOLAREX
Oil Impregnated
TRANSMITTING
CAPACITORS

Catalog upon request

SOLAR MFG. CORP.
599-601 BROADWAY, NEW YORK

Transmitter Band
Switching Made Easy

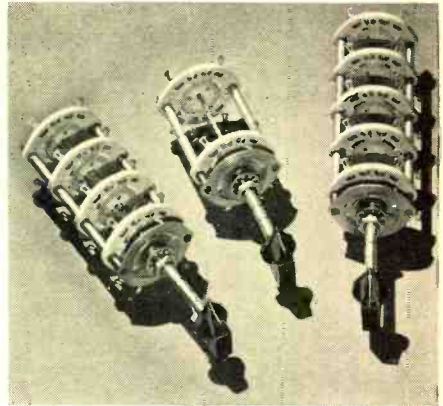

with **MALLORY-YAXLEY**
“**HamBand**” Switches

Convenient terminal arrangements, wide spacing of current carrying parts, heavy silver-plating on contacts, and low-loss magnesium silicate ceramic insulation especially designed for high frequency application... make band switching a reality for every amateur... and almost as easy as changing bands on a modern communications receiver. Mallory-Yaxley 160C HamBand Switches are rated for use in transmitter plate circuits using up to 1000 Volts DC with power up to 100 watts inclusive. Your Mallory-Yaxley distributor can give you complete information.

P. R. MALLORY & CO., Inc.
INDIANAPOLIS INDIANA
Cable Address — PELMALLO

Use **P.R. MALLORY & CO. INC.**
MALLORY
APPROVED RADIO
PRECISION PRODUCTS

Use **YAXLEY**
APPROVED RADIO
PRECISION PRODUCTS

W1LIC 57.548
 W2GPO 57.565
 W9VHG 57.6
 W2KPB 57.7
 W2HGB 57.8
 W5AJG 57.8
 W1LIC 57.904
 W4EDD 57.983
 W2JCY 58.000
 W1CUY 58.180
 W1LFN 58.216
 W3EZM 58.32
 W2EEL 58.4
 W1JNA 58.5

W1KPN 58.5
 W1KQK 58.57
 W2IYX 58.608
 W1JFF 58.656
 W2KPX 58.863
 W1FHN 58.904
 W3HOH 59.080
 W1CUY 59.240
 W2HHN 59.360
 W1DEI 59.68
 W1CAL 59.8
 W1KEE 59.908
 W1JFA 59.99

Ionosphere Soundings

[Continued from Page 104]

The mechanical pulser may be connected for blocked grid keying in a final amplifier stage if crystal control is used. In any case, all r.f.-tuned circuits which carry the pulse signal should have very low Q so as not to distort the pulses. The technique is similar to that used in television equipment except that the requirements are not so rigorous in case heights above 50 km. are being measured.

If special precautions are taken, the receiving equipment may even use the same antenna as the transmitter, but it is generally wise to separate the two systems as far as possible in the first attempt at ionosphere sounding. It is better if two amateurs separated by two to five miles can arrange to cooperate in making the first tests in order to make the technique as foolproof as possible. One should operate the pulse transmitter while the other receives the signals and makes the measurements.

The receiver must have no time constants comparable to the short time intervals being measured, and ordinary audio-frequency amplifiers must not be used. In any case *there must be no a.f. choke coil* connected in the circuit. A well aligned superheterodyne receiver serves the purpose quite well if the output is taken from the headphone jack across a 50,000-ohm (or less) resistor. The leads from the receiver should be connected directly across the vertical deflection plates of any oscilloscope through a pair of 0.1 to 0.001 μ f. blocking condensers.

The regular horizontal linear sweep circuit of the oscilloscope may be used, if it is available, for the horizontal sweep. Synchronization should be obtained externally from the 60-cycle line so as to position the received ground-wave pulse near the start of the sweep. This allows plenty of room for the ionospheric reflection pulses to appear later as the sweep progresses. Arrangements should be made to switch from the pulse to a calibrating wave of perhaps 600 to 3000 cycles per second for purposes of calibrating the time intervals between the received pulses. The timing wave

TRIMM

Commercial Headsets for

discriminating amateurs. Ultra-sensitive, lightweight, yet ruggedly constructed. The phone for your rig!

Write Dept. R-11 for folder

TRIMM RADIO MFG. CO. 1770 W. Berneau Ave.
Chicago, Ill.



THE law requires that every amateur station shall regularly check and measure transmitter frequency. Frequency measuring apparatus is required to be external to transmitter frequency control. For precise frequency measurement a stable and dependable frequency meter/monitor is indicated.

GUTHMAN is proud to offer the precision frequency meter and amplified monitor illustrated above, and parts for its construction.

This instrument provides features heretofore available only in precision laboratory equipment. Designed for precise measurement, it offers 73/4", 324 degree dial accurately calibrated for 5 to 160 meter bands, zero adjuster for use with 22 precision calibration frequencies regularly available, A.C. or D.C. operation, voltage and temperature stabilization of electron coupled oscillator, and monitor amplifier.

It is styled to "dress up" any station, priced extraordinarily low, designed for precision work. See your jobber, or write for full details on this and an outstanding line of quality r.f. and i.f. transformers, fixed and variable condensers and other parts.

EDWIN I. Guthman & CO., INC.
 402 S. PEORIA ST. • CHICAGO, U. S. A.

SUBSCRIBE NOW

and

SAVE MONEY

(See Page 5 for Details)

RADIO

must be synchronous with the 60-cycle power so as to provide a stationary pattern on the screen. This may easily be provided by the use of a multivibrator device or a small synchronous motor-generator set which may be constructed by any amateur.

Inexpensive DX

[Continued from Page 28]

ceivers will furnish good dials, high gain coils for the i.f. channel, a.f. transformer, resistors, etc. A magnetic speaker can be used for economy, but with considerable loss of quality.

This receiver compares very favorably with more expensive commercial jobs, and will outperform most of them on ten meters.

A center tapped choke and 6H6 tube or a copper oxide rectifier can be used to suppress auto ignition QRM, if the location is particularly bad. Because of the cost limitation in this receiver, we could not include a noise suppressor.

The author will answer any inquiries when accompanied by a self-addressed, stamped envelope.

Improved U.H.F. Receiver

[Continued from page 22]

coils in the heater circuit, and by-passes at the top of the inner conductor of the concentric lines. A knowledge of requirements at much higher frequencies, however, should prove helpful in getting maximum results from a specific receiver.

One suggested layout for a five-meter pre-selector or converter is shown in figure 7, in which straight-line construction will permit ganging the condensers. This style puts the shorted ends of the lines at the top, the tubes and tuning unit at the bottom. For added mechanical strength, brass tubes can run on either side of the copper tubes, through which the plate and bias leads can be brought back down. The chassis itself can be made of steel, the copper lines passing through the top and terminating on a shelf, with the lines soldered or brazed at both places for mechanical strength.

The optimum length for the couplers appears to be around 70 per cent of a quarter wavelength.² Short lines will mean some sacrifice in gain, no doubt, but lines only two feet long will be comparable in length to those in the 155-Mc. receiver, suggesting that quite

² "Resonant Lines as Circuit Elements," RADIO, March, 1938, p. 57; *Proc. I.R.E.*, December, 1937.

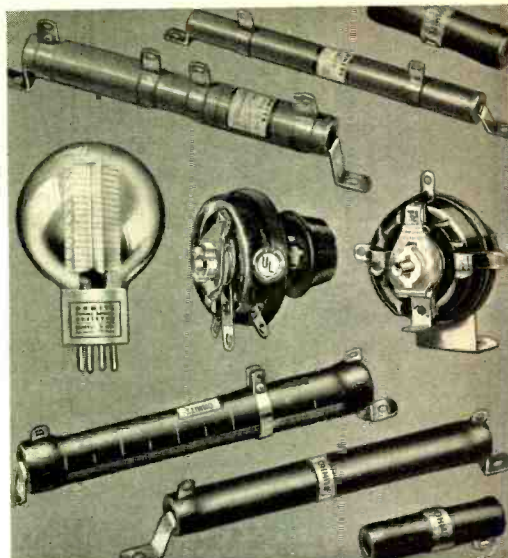

From Power Line to Antenna

OHMITE

parts improve your Rig!

DUMMY ANTENNA—New Ohmite Vacuum-Type. Used to easily, accurately measure actual transmitter output for tuning up to peak efficiency, and many other purposes.

RHEOSTATS—Time-proved Ohmite all-porcelain vitreous enameled Rheostats keep power tube filaments at exact rated value for best efficiency—Increase tube life.

BAND SWITCH—Provides instant, easy change from one frequency to another with really low-loss efficiency. For all transmitter stages.

BROWN DEVICES—Popular, dependable, economical Resistors for voltage dropping, bias units, bleeders, etc., 10 and 20 watt sizes.

DIVIDOHMS—Handy vitreous-enameled Adjustable Resistors for quick, accurate change of resistance value or replacement. 10 to 200 watts.

FIXED RESISTORS—Ohmite vitreous enameled Resistors used by eminent designers and manufacturers of amateur and commercial transmitters and receivers.

R. F. PLATE CHOKES—High frequency solenoid chokes designed to avoid either fundamental or harmonic resonance in the amateur bands.

POWER LINE CHOKES—Keep R. F. currents from going out over the power line—lessen interference with BCL receivers.

Available From Your Jobber. Write today for Free Catalog 17 and Dummy Antenna Bulletin 111.

OHMITE MANUFACTURING COMPANY

4837 West Flournoy Street ★ Chicago, U. S. A.

OHMITE

RHEOSTATS RESISTORS TAP SWITCHES

RELAYS

by Guardian

NEW R-100 RF

FOR BAND SWITCHING and HIGH VOLTAGE KEYING

		Net
Keying Relay	K-100	3.30
Break-in Relay	B-100	4.50
Overload Relays		
250 ma.	L-250	4.50
500 ma.	L-500	4.50
150-500 ma. adjustable	X-100	7.20
Time Delay Relay	T-100	9.00

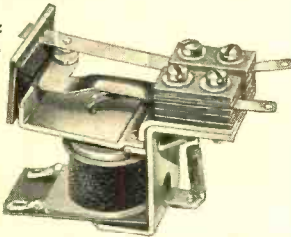

R-100 is used in sound transmitter tuning circuits to 1 KW and 14 megacycles, on all circuits to .5 KW, for shorting coil turns, adding condensers, switching crystals, etc. May also be used in conjunction with high voltage keying rigs.

R-100 contacts are single pole, single throw, normally open. Coil wound for 110 volts. Very low capacity between contacts, and contacts and ground. Self insulated. Easily mounted on panel, requiring but two holes. Solder lug type terminals, tinned phosphor bronze contact springs, insulated by Triple-X bakelite.

R-100-C identical with R-100, but has single pole, double throw contacts. \$1.50 Net

R-100-B normally closed contacts \$1.80 Net

R-100-G \$2.70 Net

GUARDIAN ELECTRIC

1623 W. WALNUT STREET, CHICAGO, ILLINOIS



ARE YOU PREPARED FOR THE NEW REGULATIONS—IF NOT *Meet Trutest*

- . . . the guaranteed accurate, top-quality mounted crystal that costs you less than the crystal alone used to cost. This TRUTEST unit comprises a low-drift AT cut xtal, accurate to .03% of calibrated frequency, mounted in newly designed, high efficiency type holder. Satisfaction guaranteed on a full rebate or exchange basis.
- Stock No. Frequency Your Cost Each
- K13514 7000 to 7300 kilocycles **\$3.45**
- K13513 3500 to 4000 kilocycles **2.95**
- K13512 1700 to 2000 kilocycles **2.95**
- Any above supplied to exact integral frequency add **1.00**

FREE CATALOG. Here's the new radio catalog that's out to save you real money! Everything you need in radio, here in one great book, and everything unconditionally guaranteed. Send for your FREE copy. Mail the coupon.

WHOLESALE RADIO SERVICE CO. INC.
 NEW YORK, N. Y. • CHICAGO, ILL. • ATLANTA, GA.
 100 SIXTH AVENUE 901 W. JACKSON BLVD. 205 PEACHTREE STREET
 BOSTON, MASS. • BRONX, N. Y. • NEWARK, N. J. • JAMAICA, L. I.

WHOLESALE RADIO SERVICE CO., INC.
 Dept. 6A9 • 100 Sixth Ave., New York, N. Y.
 Rush FREE 1939 RADIO Catalog No. 73

NAME.....
 STREET.....
 CITY..... STATE.....



PASTE COUPON ON PENNY POSTCARD

RADIO

a bit of gain can be obtained without building something that looks like a pipe organ. We have not tested other sizes and shapes of lines, although somewhat less gain should be expected if a small diameter conductor is used, and the line coiled up in the receiver. Square cross section pipe, webbed boxes, and folds to reduce overall length have been used in transmitters; these presumably might be applied to receiver construction as well.

For parts list and manufacturers' type numbers, see Buyer's Guide, page 193.

56-Mc. Transmitter-Exciter

[Continued from Page 25]

where convenience dictates. The T21 stage has all its ground return connections made to the feed-through insulator which is at the cold end of the plate tank. While this does not enhance the appearance of the unit, it aids in eliminating coupling in the various ground return circuits.

Two feed-through insulators at the rear of the chassis are provided for the connections from the modulator. If the unit is used as an exciter or c.w. transmitter, these terminals are simply shorted together.

Power is brought to the unit through a 4-wire cable which plugs into the fiber socket on the rear lip of the chassis. A power supply delivering 550 volts at 200 milliamperes is used. A filament transformer supplying 6.3 volts at 2.5 amperes is also required.

No antenna coupling circuit has been provided as the type of coupling circuit will depend upon the antenna used. Any of the usual capacitive, inductive or link-coupling circuits will be suitable, however. When used as an exciter, the unit should be link coupled to the next stage.

Tuning Up

There is only one point that need be brought up in connection with tuning the unit. It is possible to tune the quadrupler stage to the third, instead of the fourth, harmonic of the crystal and thus to have the output stage operating on the sixth, instead of the eighth, harmonic of the crystal frequency. The output frequency may be checked by the usual absorption-type wavemeter or, if no precalibrated wavemeter is available, a five-meter antenna, consisting of an 8-foot piece of hook-up wire with a one-turn loop at the center, may be coupled to the T21 plate coil. The antenna will not draw power from the T21 stage unless it is actually operating on 56 Mc.

The cathode current drawn by the tubes is as follows: 42 crystal oscillator, 40 milliam-

peres; 6L6G quadrupler, 40 milliamperes; T21, 55 milliamperes (unloaded). With the meter plugged in the cathode circuit of the T21 the total plate, screen and grid current is shown. This gives a false indication as to the plate current "dip" of the stage, which is to about 15 milliamperes lower than the cathode current would indicate.

For optimum performance, the T21 stage should be loaded to approximately 90 milliamperes. At this input, the output is approximately 20 watts and the efficiency slightly over 40 per cent.

For parts list and manufacturers' type numbers, see Buyer's Guide, page 193.

Yarn of The Month

[Continued from Page 148]

messenger got back, we were back at the camp and Carlotta was hidden in my tent. The messenger gave me the scrawled messages, saluted and left. Carlotta came out and read the message to me. It merely said that victory was assured, which was obviously just encouragement and not fact, so I sent it out.

After a while the messages began to be of more importance. When I was sure that the Minister was far enough away, Carlotta and I ran our own war. I told the troops at San Baloney to circle the town and cut off "reinforcements." As the town is surrounded by swamps, these troops got hopelessly scattered, and the men at San Baloney were easily able to capture them. By this time my messenger to Don Jose had returned with instructions to send the attacking troops into an ambush which he had prepared. I gave the first branch of the Southern Army the proper instructions and also told them that the North had surrendered and they were merely going up there to collect prisoners. I told them to turn off their receiver as there was no point in wasting the batteries after the victory. Then I told the Minister that he might as well fold up and go home. Realizing that he could only be defeated with the odds I had raised against him, he apparently took my advice for his army just vanished into the bushes.

The next morning Don Jose got into camp. He said that he had heard of me through his daughter, Maria! He promised his unflinching protection to the company and its wells. He practically bubbled over with gratitude. As a parting shot, he asked me to do him just one more favor. Feeling charitably inclined, I said I would do anything reasonable. And that explains Margarita.

Margarita took a business course in the States. She wanted a job, not with pay, but

for the experience. She is a dead ringer for her older sister Maria, only she is prettier and brunette. She is going to make a good secretary from all angles.

Oh, yes. I almost forgot. The company radioed me that I am now head of the Department of Diplomatic Relations, with an appropriate increase in salary. I also made my bonus for the month, plus a little gift of \$300 for exceptional service.



Well, Margarita is calling me to look over the reports and says she is tired of sitting in that stiff-backed chair. She learns rapidly.

73,
Cy

The letter *a* is the abbreviation of *amateur*.

My Creed . . .

TO give you specialized personal service of genuine value that is not available from other jobbers.

TO sell all equipment on 6% terms financed by myself so you can buy with less cost and more convenience.

TO take your equipment in trade at a fair value.

TO allow you to try any receiver for ten days without obligation and to cooperate with you in every way I can to see that you are entirely satisfied.

Compare Bob Henry's 6% Terms with Others

Model and Receiver	Cash Price	Down Payment	12 Monthly Payments
RME-70 complete . . .	\$138.60	\$27.72	\$9.79
Deluxe S-17	125.50	25.10	8.86
NC101X complete . . .	129.00	25.80	9.11
NC100A complete . . .	120.00	24.00	8.48
NC81X and NC80X . . .	99.00	19.80	6.99
Breting 49	99.00	19.80	6.99
Sky Champion	49.50	9.90	3.49

Also HQ-120, Super Pro, HRO, Breting 9, Howards, Sargents, others.

Similar 6% terms on National, Hallicrafter, Temco, Harvey, RME, RCA transmitters and Thordarson, National, UTC. Utah kits.

All orders and inquiries attended to by Bob Henry, W9ARA; active amateur for fourteen years; graduate E.E. from M.I.T.; owner of Henry Radio Shop selling amateur supplies for ten years. Your inquiries invited.

Henry Radio Shop

211 North Main Street Butler, Missouri

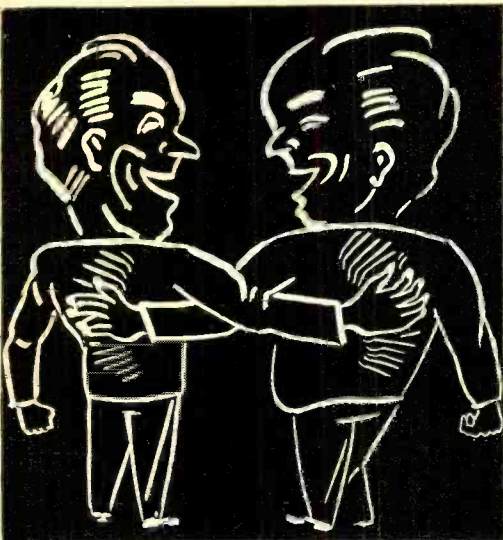

**You scratch their backs . . .
. . . and they'll scratch yours**

When you subscribed to "Radio" or bought this copy from your favorite dealer, did you realize that you received a gift of at least the amount you paid?

No "ham" magazine can be produced and distributed for much less than twice its "circulation revenue." Regrettable—but true. The additional value is a gift to you from our advertisers.

They've scratched your back. Isn't it fair that you scratch theirs by showing preference for their products when suited to the job at hand?

P.S. The same goes for the big "RADIO Handbook," too.

**IT'S THE AUTHORITY . . .
Take "Radio" Every Issue**

RADIO, Ltd., Technical Publishers
7460 Beverly Blvd.
Los Angeles, California

Send **RADIO** for

- one year, \$2.50 in U.S.A. and Canada*; for
- two years, \$4.00 } foreign rates* see page 4.
- five issues, \$1.00 for new subscribers in U.S.A. and Canada* only.

Also include

- "RADIO HANDBOOK" (\$1.50 in continental U.S.A.; elsewhere* \$1.65 or 7s.)
- "RADIO" ANTENNA HANDBOOK (75c in continental U.S.A.; elsewhere*, 85c or 3s. 6d.)
- "RADIO DIGEST", 2 years (\$2.50 in U.S.A., Canada*, Pan American countries*, elsewhere*, \$3.00 or 12s. 6d.)

Name Call

Address

City

* Remittances must be payable at par in continental U.S.A. Add 10c to Canadian checks. Canadian postal notes accepted. Code: 235

- ????—Johnstown
- W8JHW—Waterford
- W8RJM—Ballston Lake
- W8EID—Greenwich
- W1GUY—Springfield, Mass.

If the relay via New York does stop at Syracuse, it is still a good long way? We have found a string of stations in Pennsylvania which might provide a means of getting across the central part of that state to Allentown and then to Philadelphia or to New Jersey, but the hills may prove too difficult for success on this route.

The last possibility appears to be south from Pittsburgh, along the route covered by the October 17th relay, or via Washington, Pa.; Morgantown, West Va.; Keyser, West Va.; Hagerstown, Maryland. If the gap from there to Leesburg, Va., can be bridged, a message might go smoothly up from Washington.

The "field days" for these relay attempts are New Year's day, January 1 and Washington's birthday, February 22, at 11 a.m. and 9 p.m. eastern time. If messages cannot make the whole distance, they can be held for better conditions to help over difficult hops. A number of messages will be started—not only from the extremes of the circuit but from several intermediate points to "grease up" the system. It is also suggested that relaying stations originate messages to go backward along the network advising of the progress made. Reports of stations heard and worked, and message progress, should be mailed to E. H. Conklin, Associate Editor of RADIO, 512 N. Main Street, Wheaton, Illinois, so that improved arrangements can be made for later attempts.

Several have called our attention to the possibility of using c.w. when conditions are too poor for modulated signals to get through. Don't overlook the beat oscillator when trying for a little extra dx on five meters.

The Open Forum

[Continued from Page 162]

receiver itself is at fault. And again the Ham is the goat.

Another offender is the small a.c.-d.c. t.r.f. set which has no shielding on the coils. There is one in my locality, and though it is a half block away it is my best phone monitor, and the owner has caused me endless trouble. Though I observe quiet hours, it seems that some people will stay up and listen just to get a chance to squawk.

Our only solution is for the F.C.C. to stop the manufacture of this type of receiver. It

only takes the addition of a preselector stage ahead of the mixer tube to overcome a *very large* percentage of this trouble. In fact, an untuned r.f. stage helps to a great extent and would add but little to the cost of this type of set.

This problem well warrants the attention of all amateurs, and steps should be taken before it is too late. Perhaps if enough publicity is given to this grievance, the manufacturers might take the hint and do something about it of their own accord.

Z. M. POLING, W7CVQ

Gone, Alas

[Continued from Page 110]

net, handled dozens of messages, made skeds with an expedition he couldn't hear, rounded up relatives and friends of Eastern hams so that Mama could talk to little Susie, and set out to work all states on phone. He spilled bum Spanish to the South Americans and got bum English back. He enjoyed every minute of it—except having to listen part of the time. It all goes to prove that our best amateurs are made, not born.

"Harry had done a fair job of building the rig, even if he did use a 45 as a doubler, but no power on earth could teach Edward to tune it. There were more violent noises out of that rig than can be found in any Hollywood film library. The biggest and best of his parasitics would sort of mark time, as it were, out of the band on top of GMR until some good dx showed up, and then promptly move over on top of the dx and stay there until some better dx CQ'd. Several parasitics patrolled through the band itself, ready to pounce on anything you might want to work. Strong men wept, and weak men took to drink when that signal came on. Oh, how it stank!

"B.c.l.'s besieged Edward until he dared not show his face. The other local phones fought him on the air, and kicked to the Commission. Edward's telephone would commence ringing the minute he got on the air. He finally had it taken out.

"I called on him once during this time and got in, despite his suspicions, by offering to originate some traffic. Edward was proud of his station, and I was properly impressed. The thing I remember best, other than the antics of the class-C plate current, was a little box on the table, and a neat sign. It read, 'Amateurs are not allowed to accept money for messages. Contributions found in this box

will be used to improve our equipment.' Certainly a worthy cause!

"Edward's ham career reached its grand climax a few days later. There was a big shindig and parade downtown, and for two solid hours he rebroadcast a local broadcast station's account of the event, following their station calls with his own.

"That was about the last of Edward. Suddenly, his poles came down, the junk was sold, the house dark and silent. I, for one, heaved a sigh of relief, and worked some PA's and ZS's to take the taste out of my

Now—a high-powered—



NEW
The Library now comprises a revised selection of books culled from latest McGraw-Hill publications in the radio field.

Radio Engineering Library

—especially selected by radio specialists of McGraw-Hill publications

—to give most complete, dependable coverage of facts needed by all whose fields are grounded on radio fundamentals

—available at a special price and terms.

These books cover circuit phenomena, tube theory, networks, measurements, and other subjects—give specialized treatments of all fields of practical design and application. They are books of recognized position in the literature—books you will refer to and be referred to often. If you are practical designer, researcher or engineer in any field based on radio, you want these books for the help they give in hundreds of problems throughout the whole field of radio engineering.

5 volumes, 3064 pages, 2000 illustrations

1. Glasgow's **PRINCIPLES OF RADIO ENGINEERING**
2. Terman's **MEASUREMENTS IN RADIO ENGINEERING**
3. Chaffee's **THEORY OF THERMIONIC VACUUM TUBES**
4. Hund's **PHENOMENA IN HIGH FREQUENCY SYSTEMS**
5. Henney's **RADIO ENGINEERING HANDBOOK**

10 days' examination. Special price. Monthly payments. \$25.00 worth of books cost you only \$23.50 under this offer. Add these standard works to your library now; pay small monthly installments, while you use the books.

SEND THIS ON-APPROVAL COUPON

McGraw-Hill Book Co., Inc.,
330 W. 42nd St., N. Y. C.

Send me Radio Engineering Library, 5 vols., for 10 days' examination on approval. In 10 days I will send \$2.50, plus few cents postage, and \$3.00 monthly till \$23.50 is paid, or return books post-paid. (We pay postage on orders accompanied by remittance of first installment.)

Name

Address

City and State

Position

Company R-1-39

(Books sent on approval in U. S. and Canada only.)

mouth. I even changed my mind about entering a monastery.

"Three years have gone by, and when I think of him now, it all seems rather like a bad dream. So, the next time you see Edward, don't come around here and say, 'I saw your pal Edward today'."

New Amateur Regulations

[Continued from Page 164]

mission of more than ten minutes' duration: provided, however, that transmission of less than one minute duration from stations employing break-in operation need be identified only once every ten minutes of operation and at the termination of the correspondence. In addition, an operator of an amateur portable or portable-mobile radiotelegraph station shall transmit immediately after the call of the station the fraction-bar character (DN) followed by the number of the amateur call area in which the portable or portable-mobile amateur station is then operating, as for example:

Example 1. Portable or portable-mobile amateur station operating in the third amateur call area calls a fixed amateur station: W1ABC W1ABC W1ABC DE W2DEF DN3 W2DEF DN3 W2DEF DN3 AR.

Example 2. Fixed amateur station answers the portable or portable-mobile amateur station: W2DEF W2DEF W2DEF DE W1ABC W1ABC W1ABC K.

Example 3. Portable or portable-mobile amateur station calls a portable or portable-mobile amateur station: W3GHI W3GHI W3GHI DE W4JKL DN4 W4JKL DN4 W4JKL DN4 AR.

It telephony is used, the call sign of the station shall be followed by an announcement of the amateur call area in which the portable or portable-mobile station is operating.

Sec. 152.11 **Requirements for portable and portable-mobile operation.** A licensee of an amateur station may operate portable amateur stations (Section 150.03) in accordance with the provisions of Sections 152.09, 152.10, 152.12 and 152.45. Such licensee may operate portable and portable-mobile amateur stations without regard to Section 152.12, but in compliance with Sections 152.09, 152.10, and 152.45, when such operation takes place on authorized amateur frequencies above 28,000 kilocycles.

Sec. 152.12 **Special provisions for portable stations.** Advance notice in writing shall be given by the licensee to the inspector in charge of the district in which such portable station is to be operated. Such notices shall be given prior to any operation contemplated, and shall state the station call, name of licensee, the date of proposed operation, and the locations as specifically as possible. An amateur station operating under this Section shall not be operated during

2nd Printing



To our many customers, whose copies of the "RADIO" Noise Reduction Handbook have not yet been received: copies of the second printing are now available and in the mails.

To those of you who have not yet ordered: get your copy of this popular handbook now. Tells you how to eliminate or greatly reduce practically every form of radio noise except natural static. It's an indispensable "worry eliminator"!

35c in U.S.A. 40c or 1s. 8d. elsewhere. British postal orders accepted.

RADIO
LIMITED
Technical Publishers
7460 Beverly Boulevard, Los Angeles

RADIO

any period exceeding one month without giving further notice to the inspector in charge of the radio-inspection district in which the station will be operated, nor more than four consecutive periods of one month at the same location. This Section does not apply to the operation of portable or portable-mobile amateur stations on frequencies above 28,000 kilocycles. (See Section 152.11.)

Sec. 152.13 Special provisions for non-portable stations. The provisions for portable stations shall not be applied to any non-portable station except that:

a. An amateur station that has been moved from one permanent location to another permanent location may be operated at the latter location in accordance with the provisions governing portable stations for a period not exceeding sixty days, but in no event beyond the expiration date of the license, provided an application for modification of license to change the permanent location has been made to the Commission.

b. The licensee of an amateur station who is temporarily residing at a location other than the licensed location for a period not exceeding four months may for such period operate his amateur station at his temporary address in accordance with the provisions governing portable stations.

Sec. 152.14. Points of communication. An amateur station shall communicate only with other amateur stations, except that in emergencies or for testing purposes it may be used also for communication with commercial or Government radio stations. In addition, amateur stations may communicate with any mobile radio station which is licensed by the Commission to communicate with amateur stations, and with stations of expeditions which may also be authorized to communicate with amateur stations. They may also make transmissions to points equipped only with receiving apparatus for the measurement of emissions, observation of transmission phenomena, radio control of remote objects, and similar purely experimental purposes.

Sec. 152.15 No remuneration for use of station. An amateur station shall not be used to transmit or receive messages for hire, nor for communication for material compensation, direct or indirect, paid or promised.

Sec. 152.16 Broadcasting prohibited. An amateur station shall not be used for broadcasting any form of entertainment, nor for the simultaneous retransmission by automatic means of programs or signals emanating from any class of station other than amateur.

Sec. 152.17 Radiotelephone tests. The transmission of music by an amateur station is forbidden. However, single audio-frequency tones may be transmitted by radiotelephony for test purposes of short duration in connection with the development of experimental radiotelephone equipment.

ALLOCATION OF FREQUENCIES

Sec. 152.25 Frequencies for exclusive use of amateur stations. The following bands of frequencies are allocated exclusively for use by amateur stations:

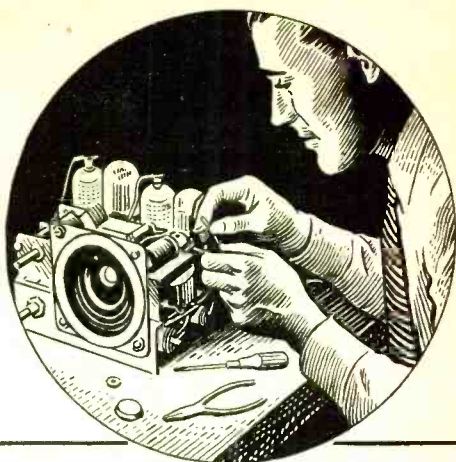

RADIO

MANY OPPORTUNITIES STILL AHEAD

• Radio has hit its full stride! The future, with Television, presents great opportunities — for the trained man! The International Correspondence Schools Radio Course, prepared by experts in practice as well as theory, is constantly revised to meet new developments. This Course can make you a trained man — prepare you for promotion and a trained man's salary! Send for free booklet.

INTERNATIONAL CORRESPONDENCE SCHOOLS

Box 8418, Scranton, Penna.

Explain fully about your course in the subject marked X:

- RADIO
- EXPERIMENTAL TELEVISION
- SOUND TECHNICIANS
- AVIATION SECTION OF RADIO OPERATING

Name _____ Age _____

Address _____

1715 to 2000 kc. ²	28000 to 30000 kc.
3500 to 4000 kc.	56000 to 60000 kc.
7000 to 7300 kc.	112000 to 118000 kc. ²
14000 to 14400 kc.	224000 to 230000 kc. ²
	400000 to 401000 kc.

Sec. 152.26 **Use of frequencies above 300000 kilocycles.** The licensee of an amateur station may, subject to change upon further order, operate amateur stations, with any type of emission authorized for amateur stations, on any frequency above 300000 kilocycles without separate licenses therefor.

Sec. 152.27 **Frequency bands for telephony.** The following bands of frequencies are allocated for use by amateur stations using radiotelephony, type A-3 emission:

1800 to 2000 kc.	112000 to 118000 kc. ²
28500 to 30000 kc.	224000 to 230000 kc. ²
56000 to 60000 kc.	400000 to 401000 kc.

Sec. 152.28 **Additional bands for telephony.** An amateur station may use radiotelephony, type A-3 emission, in the following additional bands of frequencies; **provided** the station is licensed to a person who holds an amateur operator's license endorsed for Class A privileges, and actually is operated by an amateur operator holding Class A privileges:

3900 to 4000 kc.	14150 to 14250 kc.
------------------	--------------------

Sec. 152.29 **Television and frequency modulation transmission.** The following bands of frequencies are allocated for use by amateur stations for television and radiotelephone frequency-modulation transmission:

112000 to 118000 kilocycles ²
224000 to 230000 kilocycles ²
400000 to 401000 kilocycles

Sec. 152.30 **Facsimile transmission.** The fol-

lowing bands of frequencies are allocated for use by amateur stations for facsimile transmission:

1715 to 2000 kc. ¹	112000 to 118000 kc. ²
56000 to 60000 kc.	224000 to 230000 kc. ²
	400000 to 401000 kc.

Sec. 152.31 **Individual frequency not specified.** Transmissions by an amateur station may be on any frequency within the bands above assigned. Sideband frequencies resulting from keying or modulating a transmitter shall be confined within the frequency band used.

Sec. 152.32 **Types of emission.** All bands of frequencies allocated to the amateur service may be used for radiotelegraphy, type A-1 emission. Type A-2 emission may be used in the following bands of frequencies only:

56000 to 60000 kilocycles
112000 to 118000 kilocycles ²
224000 to 230000 kilocycles ²
400000 to 401000 kilocycles

EQUIPMENT AND OPERATION

Sec. 152.40 **Maximum power input.** The licensee of an amateur station is authorized to use a maximum power input of 1 kilowatt to the plate circuit of the final amplifier stage of an oscillator-amplifier transmitter or to the plate circuit of an oscillator transmitter. An amateur transmitter operating with a power input exceeding nine-hundred watts to the plate circuit shall provide means for accurately measuring the plate power input to the vacuum tube, or tubes, supplying power to the antenna.

Sec. 152.41. **Power supply to transmitter.** The licensee of an amateur station using frequencies below 60000 kilocycles shall use adequately filtered direct-current plate power supply for the transmitting equipment to minimize frequency modulation and to prevent the emission of broad signals.

Sec. 152.42. **Requirements for prevention of interference.** Spurious radiations from an amateur transmitter operating on a frequency below 60000 kilocycles shall be reduced or eliminated in accordance with good engineering practice and shall not be of sufficient intensity to cause interference on receiving sets of modern design which are tuned outside the frequency band of emission normally required for the type of emission employed. In the case of A-3 emission, the transmitter shall not be modulated in excess of its modulation capability to the extent that interfering spurious radiations occur, and in no case shall the emitted carrier be amplitude-modulated in excess of 100 per cent. Means shall be employed to insure that the transmitter is not modulated in excess of its modulation capability. A spurious radiation is any radiation from a transmitter which is outside the frequency band of emission normal for the type of transmission employed, including any component whose frequency is an integral multiple or submultiple of the carrier frequency (harmonics and subharmonics), spurious modulation products, key clicks, and other transient effects, and parasitic oscillations. The frequency of emission shall be as constant as the state of the art permits.

DX with a "W.A.Z." MAP

The simplest and quickest way to tell which and how many zones you work during the dx marathon is to have one of RADIO'S W.A.Z. maps near your rig. A list of countries is included.

The W.A.Z. plan is the best "yard-stick" yet developed for the measurement of DX achievement.

TWENTY FIVE CENTS

postpaid, anywhere. Canadian postal notes (25c) accepted. Five international postal reply coupons accepted as 25c.

RADIO, LTD.

7460 BEVERLY BLVD., LOS ANGELES

Sec. 152.43 Modulation of carrier wave. Except for brief tests or adjustments, an amateur radio-telephone station shall not emit a carrier wave unless modulated for the purpose of communication.

Sec. 152.44 Frequency measurements and regular check. The licensee of an amateur station shall provide for measurement of the transmitter frequency and establish procedure for checking it regularly. The measurement of the transmitter frequency shall be made by means independent of the frequency control of the transmitter and shall be of sufficient accuracy to assure operation within the frequency band used.

Sec. 152.45 Logs. Each licensee of an amateur station shall keep an accurate log of station operation, including the following data:

a. The date and time of each transmission. (The date need only be entered once for each day's operation. The expression "time of each transmission" means the time of making a call and need not be repeated during the sequence of communication which immediately follows: however, an entry shall be made in the log when "signing off" so as to show the period during which communication was carried on.)

b. The signature of the person manipulating the transmitting key of a radiotelegraph transmitter or the signature of the person operating a transmitter of any other type (type A-3 to A-4 emission) with statement as to type of emission, and the signature of any other person who transmits by voice over a radiotelephone transmitter (type A-3 emission). (The signature need only be entered once in the log provided the log contains a statement to the effect that all transmissions were made by the person named except where otherwise stated. The signature of any other person who operates the station shall be entered in the proper space for his transmissions.)

c. Call letters of the station called. (This entry need not be repeated for calls made to the same station during any sequence of communication, provided the time of "signing off" is given.)

d. The input power to the oscillator, or to the final amplifier stage where an oscillator-amplifier transmitter is employed. (This need be entered only once, provided the input power is not changed.)

e. The frequency band used. (This information need be entered only once in the log for all transmissions until there is a change in frequency to another amateur band.)

f. The location of a portable or portable-mobile station at the time of each transmission. (This need be entered only once provided the location of the station is not changed. However, suitable entry shall be made in the log upon changing location, showing the type of vehicle or mobile unit in which the station is operated and the approximate geographical location of the station at the time of operation.)

g. The message traffic handled. (If record communications are handled in regular message form, a copy of each message sent and received shall be entered in the log or retained on file for at least one year.)

The log shall be preserved for a period of at least one year following the last date of entry. The copies of record communications and station

log, as required under this section, shall be available for inspection upon request by an authorized Government representative.

SPECIAL CONDITIONS

Sec. 152.50 Additional conditions to be observed by licensee. An amateur station license is granted subject to the conditions imposed in Sections 152.51 to 152.54 inclusive, in addition to any others that may be imposed during the term of the license. Any licensee receiving due notice requiring the station licensee to observe such conditions shall immediately act in conformity therewith.

Sec. 152.51 Quiet hours. In the event that the operation of an amateur station causes general interference to the reception of broadcast programs with receivers of modern design, such amateur station shall not operate during the hours from 8 o'clock p.m. to 10:30 p.m., local time, and on Sunday for the additional period from 10:30 a.m. until 1 p.m., local time, upon such frequency or frequencies as cause such interference.

Sec 152.52 Second notice of same violation. In every case where an amateur station licensee is cited a second time within a year for the same violation under Section 152.25, 152.27, 152.28, 152.30, 152.31, 152.41, or 152.42, the Commission will direct that the station remain silent from 6 p.m. to 10:30 p.m., local time, until written notice has been received authorizing full-time operation. The licensee shall arrange for tests at other hours with at least two amateur stations within fifteen days of the date of notice, such tests to be made for the specific purpose of aiding the licensee in determining whether the emissions of his station are in accordance with the Commission's Regulations. The licensee shall report under oath to the Commission at the conclusion of the tests as to the observations reported by amateur licensees in relation to the reported vio-

Say, OM,

**ARE YOU INTERESTED IN A
TRAVELING SALESMAN?**

How about some of those parts over there on the shelf that are too good to throw away, but really aren't of any use to you now that you bought all that new stuff? If you could afford it, wouldn't you like to hire someone to sell or trade them off for you?

We didn't start out to tell you a story, but we guarantee to put you in a good humor if you try RADIO'S marketplace . . . and as for affording it! Well, just take a look at those low rates. They're at the top of page number.

lation. Such reports shall include a statement as to the corrective measures taken to insure compliance with the Regulations.

Sec. 152.53 Third notice of same violation. In every case where an amateur station licensee is cited the third time within a year for the same violation as indicated in Section 152.52, the Commission will direct that the station remain silent from 8 a.m. to 12 midnight, local time, except for the purpose of transmitting a prearranged test to be observed by a monitoring station of the Commission to be designated in each particular case. Upon completion of the test the station shall again remain silent during these hours until authorized by the Commission to resume full-time operation. The Commission will consider the results of the tests and the licensee's past record in determining the advisability of suspending the operator license and/or revoking the station license.

Sec. 152.54 Operation in emergencies. In the event of widespread emergency conditions affecting domestic communication facilities, the Commission may confer with representatives of the amateur service and others and, if deemed advisable, will declare that a state of general communications emergency exists, designating the licensing area or areas concerned (in general not exceeding 1,000 miles from center of the affected area), whereupon it shall be incumbent upon each amateur station in such area or areas to observe the following restrictions for the duration of such emergency:

a. No transmissions except those relating to relief work or other emergency service such as amateur nets can afford, shall be made within the 1715-2000¹ kilocycle or 3500-4000 kilocycle amateur bands. Incidental calling, testing, or working, including casual conversation or remarks not pertinent or necessary to constructive handling of the general situation shall be prohibited.

b. The frequencies 1975-2000, 3500-3525, and 3975-4000 kilocycles shall be reserved for emergency calling channels, for initial calls from isolated stations or first calls concerning very important emergency relief matters or arrangements. All stations having occasion to use such channels shall, as quickly as possible, shift to other frequencies for carrying on their communications.

c. A five-minute listening period for the first five minutes of each hour shall be observed for initial calls of major importance, both in the designated emergency calling channels and throughout the 1715-2000¹ and 3500-4000 kilocycle bands. Only stations isolated or engaged in handling official traffic of the highest priority may continue with transmissions in these listening periods, which must be accurately observed. No replies to calls or resumption of routine traffic shall be made in the five-minute listening period.

d. The Commission may designate certain amateur stations to assist in promulgation of its emergency announcement, and for policing the 1715-2000¹ and 3500-4000 kilocycle bands and warning non-complying stations noted operating therein. The operators of these observing stations shall report fully the identity of any stations

failing, after due notice, to comply with any section of this regulation. Such designated stations will act in an advisory capacity when able to provide information on emergency circuits. Their policing authority is limited to the transmission of information from responsible official sources, and full reports of non-compliance which may serve as a basis for investigation and action under Section 502 of the Communications Act. Policing authority extends only to 1715-2000¹ and 3500-4000 kilocycle bands. Individual policing transmissions shall refer to this Section by number, shall specify the date of the Commission's declaration, the area and nature of the emergency, all briefly and concisely. Policing-observer stations shall not enter into discussions beyond essentials with the stations notified, or other stations.

e. These special conditions imposed under this Section will cease to apply only after the Commission shall have declared such emergency to be terminated.

² The Commission reserves the right to change or cancel these frequencies without advance notice or hearing.

Receivers For 1939

[Continued from Page 32]

The ten tubes are used as follows: one stage of r.f. mixer; separate oscillator; two stages of i.f.; diode detector; beat oscillator; audio driver; push-pull output; tuning indicator; and rectifier. Undistorted audio output is five watts.

One unique feature of the receiver is the use of a regenerative input stage on all bands except broadcast. A 6F7 is used in the r.f. stage with the pentode section as the r.f. amplifier and the triode section as a separate regenerator with its output in parallel with the r.f. amplifier section. This allows the pentode section to be used as a conventional r.f. stage, with optional regeneration added by the triode section when needed.

The dial used is a full-vision type with the knob numbered around its circumference for bandsread readings. A self-contained speaker and tuning eye indicator are included.

●
Electric Rays swim in water.

R. C. Coile signs his name with schematic symbols.

Be Thrifty — Save a Dollar
Radio", 1 yr., \$2.50 "Radio", 2 yrs. \$4.00

U.S.A., Canada, Spain, Newfoundland, and all
independent American countries.

Index to "Radio"

FOR THE YEAR 1938, ISSUES 225 TO 234

A. R. R. L.

(See also *Editorials*)

Maxim Memorial Inaugurated . . . Nov., 62
National Convention Notes . . . Oct., 14

Antennas, Feeders, and Masts

(See also *Ultra High Frequencies*)

After the Halyard Breaks—*Perrine* Jan., 134
Angle of Radiation vs. Angle of Reception . . . Jan., 52
Beer Coaster Insulators . . . Jan., 176, Feb., 24
Barrage Antenna—*Dawley* . . . July, 12
Beam-rotating System—*Lauth* . . . June, 19
Beam Without Insulators . . . Apr., 23
Bi-Square Array—*Smith* . . . Apr., 36
Compact Unidirectional Array—*Roberts* . . . Jan., 19
Constant-Resistance Lamp Loads . . . Jan., 126
Design of Close-Spaced Arrays—*Smith* . . . June, 38
Directing Stuff at Things—*Herbiveaux* . . . Apr., 30
Direction Indicator for Rotaries—*Waller* . . . Oct., 16, Nov., 62
Effect of Average Ground—*Conklin* . . . Mar., 36
Effective Turnbuckle Lock . . . Jan., 122
Fading—What Can Be Done About It? . . . Jan., 48
Field Strength Meter—*Dawley* . . . Apr., 17
Flat-Top Beam Correction (Correction to Dec. article by Kraus) . . . Jan., 145
Flat-Top Design Data—*Kraus* . . . June, 15
Four-Wire Matching Transformer—*Norton* . . . Nov., 49
Kites as Antenna Supports—*Hansen* . . . Nov., 37
Lead-in Problem—*Ticehurst* . . . Mar., 51
Let's Whip the 20-Meter Rotary—*Conklin* . . . Feb., 56
Matching Stub Switching—*Wiloughby* . . . Feb., 23
Measuring the Vertical Angle of Signal Arrival . . . Jan., 41
Model C Antennas—*Stavrou* . . . Jan., 87
147-Ft. Steel Mast—*Sampson* . . . Feb., 30
Optional End-Fire Directivity with Flat-Top Beam—*Sprole* and *Kraus* . . . Jan., 85, Mar., 64
Push-Button Beam—*W8NUN* . . . Mar., 41
Putting the "B" in Beam—*Pinkerton* . . . Jan., 119
Rotatable Mast—*Roberts* . . . Apr., 28
Simple Tubular Antenna—*Nalley* . . . Dec., 42
Simplified Flat-Top Rotary—*Donkin* and *Richards* . . . Jan., 91
Something for Nothing . . . June, 49

Story of a Vertical—*McNatt* and *Steiner* . . . Jan., 38
Switching from Series to Parallel . . . Jan., 90
Theory of Antenna Operation—*Conklin* . . . Jan., 103
Three-Element Rotary—*Gioga* and *Dawley* . . . Nov., 13
Vacuum-Type Dummy Antenna . . . Nov., 73
Vertical Antenna—*Donkin* . . . Mar., 50
Vertical Antenna Feed . . . Jan., 40, Feb., 71
Worm Turns Cold—*Conklin* . . . Feb., 28
Why Some Beams Don't Work—*Conklin* . . . Jan., 121

Book Reviews and Catalogs

Aerovox Corp. Catalog . . . Dec., 68
Allied Radio Catalog . . . Apr., 65
Allied Radio Catalog . . . Oct., 66
Bliley Catalog . . . June, 78
Cinaudagraph Corp. Catalog . . . Jan., 146
Cornell-Dubilier Catalog . . . Dec., 68
Electrolytic Capacitors—*Cornell-Dubilier* . . . July, 67
Hammarlund Catalog . . . Jan., 146
Hammarlund Manual . . . June, 95
How to Build Radio Receivers—*Meissner* . . . Dec., 68
How to Pass License Exams—*Drew* . . . June, 74
Mallory Dry-Disc Catalog . . . Oct., 66
Mallory Encyclopedia . . . June, 79
Meissner Catalog . . . Oct., 66
Newton Inst. of Applied Science Catalog . . . Dec., 68
Ohmite Catalog . . . July, 67
Question and Answers Handbook—*Allied* . . . Feb., 76
Radio Operators Manual—*General Electric* . . . Apr., 65
RCA Parts Catalog . . . Oct., 66
RCA Tube Charts . . . July, 67
Service Guide—*Stancor* . . . July, 67
Servicing Booklet . . . June, 74
Transmitting Tube Manual—*RCA* . . . Apr., 65
United Transformer Corp. Catalog . . . Dec., 68
When You Can Measure—*General Electric* . . . June, 74
Wholesale Radio Camera Catalog . . . July, 67
Wholesale Radio Catalog . . . June, 74
Wholesale Radio Catalog . . . Oct., 66

Calls Heard

Calls Heard, Jan., 144; Feb., 74; Mar., 70; Apr., 66; June, 72; Oct., 58; Nov., 61; Dec., 61

Conventions and Hamfests

Boston Hamfest Oct., 63
 Burlington, Iowa May, 66
 Charleston, W. Va. Apr., 64
 Cranbrook, B. C. June, 65
 Fargo, N. D. May, 66
 Fox River Valley, Ill. June, 65
 Grand Rapids, Mich. June, 95
 Indiana June, 65
 Jenny Lake, Wyo. May, 66
 Massachusetts State Convention Oct., 63, 64
 Milwaukee, Wisc. May, 66
 National Convention Mar., 64
 National Convention Apr., 64
 National Convention June, 65
 National Convention Notes Oct., 14
 Newark, N. J. Apr. 65
 Oregon Mar., 49
 Pacific and S. W. Division Conven-
 tion Nov., 95
 Spencer, Iowa June, 65
 Wichita, Kans. May, 66
 Wichita Falls, Tex. Apr. 64
 Wisconsin June, 65

Contests

56-Mc. R.S.G.B. Contest Jan., 148
 International 56-Mc. Dx Tests Oct., 64
 1938 QSL Contest Jan., 165
 QSL Card Contest Jan., 145
 QSL Card Contest Results July, 18

DX

DX Dept.—*W6QD* . . . Jan., 137; Feb., 64;
 Mar., 67; Apr., 15; May, 60; June, 61;
 July, 62; Oct., 54; Nov., 57; Dec., 57
 DX Cycles in 1938—*Perrine* Jan., 60
 Great Circle Maps—*General Electric* Nov., 62
 Long Range DX Prediction—*Conklin* July, 24

Editorials

Private Life of RADIO July, 5; Oct., 5;
 Nov., 9; Dec., 6

Emergency and Relief Work

Emergency Communication—*F.C.C.* . June, 23
 Emergency Primary Power—*Robbins* Nov., 35
 High Wind and Water in the East—
Turner Dec., 27
 Los Angeles Flood Apr., 9

Expeditions

Expedition—1938 Style—*Conklin* . . . June, 34
 Hughes Flight—*Turner* Oct., 11
 VP3THE, Terry-Holden Expedition
 —*Hungerford* Dec., 17

Federal Communications Commission

Educational B.C. Stations Apr., 29
 Emergency Communication June, 23
 Frequency Allocation Chart Dec., 62
 Getting Ready for the New Regula-
 tions—*Turner* Dec., 36
 Intercommunication System QRM . . Oct., 15
 Keeping up with the F.C.C. Jan., 82

Fiction

An evening with a Ham—*Eric Adams* Oct., 72
 Chaos in the Telephone Exchange—
Murphy Jan., 147
 Haywire and How—*Jessup* Feb., 68
 Little Ham, What Now?—*MacAllister* July, 70
 Monthly Frequency Check—*Brooks* . Nov., 70
 One Man's Story—*Hecht* Jan., 37
 Reminiscing Dec., 70
 Scanning 1948 Mar., 65
 Sunday in the Life of a Ham—
Sillman June, 68
 Yarnette—*W8PMD* July, 6
 Yearn of the Weak—*Stafford* May, 72
 White Slippers, Red Heels Behind—
Huber Apr., 62

Five Meters

(See *Ultra High Frequencies*)

Hams Across the Sea

Mid-Pacific—*K6BAZ* Nov., 18
 Pitcairn Island Oct., 63
 Story of EL2A—*Gould* Jan., 116
 VS3AE Jan., 125
 XE1G-XE1GE June, 26

Hints

A.C. Operated Relays—*Fox* Jan., 73
 Beer Coaster Insulators . . . Jan., 176, Feb., 24
 Chassis Construction Hints—*Stafford* Jan., 61

Chromium Polish—*Marks* Feb., 34
 Hot Zero Adjusters—*W6MEP* Jan., 164
 Liquid Soldering Flux—*Marks* Feb., 34
 Pencil QSY—*W6CUH* Jan., 164
 Relay Coil—*W5EPW* Mar., 49

Radio Aids to Air Navigation—*Ells* , Dec., 44
 RCA Television Courses Nov., 62
 Relaxation Oscillator—*Friend* Oct., 19
 Stamp Collecting Jan., 124
 Stamp Collecting Apr., 64
 Ten Years Ago Apr., 31, May, 49
 The Why of Harmonics—*Stafford* Apr., 32, May, 66
 210 Lament—*W6OFD* June, 96

Keying

Keying with Grid-Controlled Rectifiers Feb., 25
 QRQ?—*Weed* Dec., 53

New Apparatus

Antenna Kit—*Premax* Nov., 73
 Dual Ultra-Midget Capacitors—*Solar* Dec., 72
 Foundation Units—*Hammarlund* Oct., 68
 Hallicrafters Sky Champion May, 57
 Isolation Transformers—*Thordarson* Dec., 72
 Low-Loss Bandswitches—*Mallory* Oct., 68
 Portable Transmitter—*General Transformer Corp.* Oct., 69
 Time Indicator Card Oct., 68
 TQ Transmitting Capacitors—*Cornell-Dubilier* Dec., 72

Meters and Measurements

Applications for the 'Scope July, 37
 B. C. Type Modulation Indicator—*H. G. Jones* Oct., 41
 Beat-Frequency Audio Oscillator—*Anderson* June, 52
 Constant-Resistance Lamp Load Jan., 126
 C-R Oscilloscope for \$1.37—*Conklin* June, 45
 C-R Modulation Indicator—*Folkerts* May, 42
 Determining Transmitter Output—*Cromwell* May, 29
 Disc-Type Frequency Meter—*Forest* June, 30
 Field Strength Meter—*Dawley* Apr., 17
 Improved Volume Indicator—*Dawley* Feb., 12
 1000 Cycles Apr., 46
 Oscilloscope—*Boyd* Apr., 52
 'Scope of Unusual Mechanical Design Dec., 51
 Tracking Down the Decibel—*Burgess* Dec., 48
 Utilizing WWV Transmissions Jan., 65
 Vacuum-Type Dummy Antenna Nov., 73
 V-T Voltmeter—*Root* Feb., 31

Obituary

Ross A. Hull Nov., 12

Open Forum

After the SK—*W1GGH* Dec., 75
 Class A—*W1BGJ* June, 88
 Code Exam—*W6KTY* June, 76
 Continuous QSO—*VE5II* Mar., 5
 East vs. West—*W4DHZ* May, 65
 Examination OK—*Lewis* May, 65
 Examinations—*W2FSN* Mar., 8
 Flea-Bitten Topic—*Hilbun* Dec., 94
 Infernal Dit-Dabs—*W8PMJ* July, 6
 Learning the Code—*G6WY* Mar., 10
 Little Aubrey—*Allbright* Dec., 74
 Long QSO's—*VE5HA* May, 65
 Mass Production of Lids—*W3CM* June, 6
 Proper Bands—*Wallace* Feb., 73
 QSL's—*W6FTT* Jan., 174
 QSZ—*VK3BG* Oct., 65
 Repeating Calls—*F8SI* Feb., 73
 Reserve DX Band—*W2DA* Jan., 9
 Restrictions—*Fichtborn* Feb., 23
 Return Postage for QSL's—*Stephens* Mar., 5
 Schoolboy Mummery—*Poland* Jan., 12
 Separate Exams—*Croft* June, 76
 S.w.I. Problem—*W3QP* Jan., 174

Miscellaneous

A Ham's Album—*K7RT* Mar., 16
 After the SK (QSL)—*Ledin* May, 20
 Callbook Clipping—25c! Feb., 98
 Call on Auto Plates Oct., 63
 Card Indexing System—*Curran* Apr., 43
 Determination of Skip Distance—*Conklin* Apr., 24
 Dial Remote Control—*Grening* Oct., 24
 Electronic Relay Mar., 34
 Greek Letters Jan., 145
 Lecture Course on W1XAL Oct., 63, Dec., 62
 List Call at P. O. July, 66
 Long Range DX Prediction—*Conklin* July, 24
 Maxim Memorial Inaugurated Nov., 62
 Not Entirely a Man's Game Jan., 44
 Paley Award July, 66
 Phoney Picked Up June, 65

S.w.I. Speaks—*Gaughan* Nov., 69
 Taxes—*Tangen* Oct., 65
 30 Mc.—*W5TW* Apr., 8
 29,672 Kc.—*W5TW* Jan., 168
 Virginia Speaks Up—*W3EVT* Dec., 94
 Weird, Ghastly Signals—*Frobring* Nov., 69
 Young Squirt—*W9OHM* Oct., 65

Name Your Grid Current—*Johnson* .. Dec. 41
 Reduction of B.C.L. QRM—*Ewing* . Mar., 19
 Simple 160-Meter Phone—*Jones* .. Jan., 130
 Something for Nothing June, 49
 Speech Modulator—*Dawley* May, 13, Dec., 62
 Strictly 160 Meters—*Smith* Mar., 13
 Tracking Down the Decibel—*Bur-*
gess Dec., 48
 Voice-Operated Break-in—*Williams* Dec., 40
 Zero-Bias Modulators June, 21

Postscripts

Jan., 145; Feb., 71; Mar., 64; Apr., 64; May,
 66; June, 65; July, 66; Oct., 63; Nov., 62;
 Dec., 62

Question Box

Jan., 146; Feb., 70; Mar., 70; Apr., 65; July,
 67; Dec., 61

Radioddities

Radioddities are scattered throughout all is-
 sues.

Radiotelephony

(See also *Transmitting, U.H.F. and Meters*
and Measurements)

Automatic Modulation Control—
Waller Mar., 21
 Bandswitching Phone and C.W.
 RK20's—*Young* Feb., 59
 B.C. Type Modulation Indicator—
H. G. Jones Oct., 41
 Better Phone Quality—*Hawkins* July, 35
 Bridging and Speech Amplifier—
Adams Mar., 52
 Economical Phone and C. W. Trans-
 mitter—*Jones* Feb., 40
 Fifty-Watter in Parade Dress—*Boyd* Jan., 75
 5 to 160 Meter Phone—*Jones* Nov., 23
 Improved Volume Indicator—*Dawley* Feb., 12
 Inverse Feedback—*Bell* Oct., 47
 Mighty Mite—*Griggs* July, 19
 Mighty Mite De Luxe—*Griggs* Dec., 39
 Modern Self-Contained Kw. Phone—
Jones Jan., 25
 Modulating Beam Tetrodes Feb., 27
 Modulation-Transformer Design —
Root May, 34, July, 66
 More Speech Power from Class-B
 Modulators—*Fortune* Apr., 49

Receiving

(See also *U. H. F.*)

Acorn Five-Meter Superhet—*Ely* July, 42
 Acorn Pentode R.F. Stages Nov., 54
 All-Wave Tuner—*Adams* July, 27
 De Luxe Superhet—*Adams* Jan., 67
 Determination of Skip Distance—
Conklin Apr., 24
 Diversity Receiver—*Adams* May, 21
 Fading—What Can Be Done About
 It? Jan., 48
 56-Mc. Super Gainer—*Jones* May, 44
 Five Bands—Individually Tuned—
Leach Feb., 35
 Five and Ten Meter Converter—
Dawley Dec., 22
 Ham Band Superhet—*Adams* Feb., 50
 Hamset Receiver—*Birdwell* Apr., 40
 Improved 10-Meter Receiver—*Adams* Nov., 29
 Improving High-Frequency Receivers
 —*Reber* and *Conklin* Jan., 112, Mar., 57
 Measuring the Vertical Angle of
 Signal Arrival Jan., 41
 Midget Portable—*Broderson* June, 24
 Neon-Bulb Voltage Regulators—*Berg* Dec., 52
 Noise Damping and A.V.C. May, 33
 Portable Receiver—*Bolmarcich* July, 15
 Razor-Sharp Phone Selectivity Feb., 46
 Resonant Lines as Circuit Elements .. Mar., 57
 Review of 1938 Receivers Jan., 99
 Sharper I.F. Amplifiers Jan., 66
 Shifting to 1851 R.F. Tubes Nov., 53, Dec., 62
 Simple Super—*Wilcox* Apr., 56
 Simplified Single Signal—*Burnett* .. Jan., 123
 Single Control Bandsread—*Starr* .. Nov., 45
 Snug as a Bug Mar., 18
 Superregeneration—*Frink* Mar., 44, Apr., 19
 28-Mc. Converter—*Franke* May, 47
 222 Receiver—*Jones* June, 11

Ten Meters

(See *U. H. F.*)

Transmitting

(See also *Keying, Radiotelephony, Tubes* and *U. H. F.*)

Band Hopper July, 9
 Bandswitching Kilowatt—*Chow* Dec., 31
 Beginner's Transmitter June, 42
 Chokes in the Minus Lead Jan., 126
 Compact Crystal Control on the
 Ultra-High Frequencies—*Gonssett* Jan., 50
 Constant-Resistance Lamp Load Jan., 126
 Determination of Skip Distance—
 Conklin Apr., 24
 Dial Remote Control—*Grening* Oct., 24
 Dynapush Exciter—*Smith* Feb., 19
 Emergency Primary Power—*Robbins* Nov., 35
 Fixed-Capacity Final—*Perrine* Feb., 9
 Flexal Exciter—*Norton* May, 51 June, 65
 Flexal Exciter Comments—*Norton* Nov., 43
 Foolproof 10-Meter Rig—*Baumann* May, 31
 The "4-25" Exciter—*Smith* Dec., 11
 400-Watt HK-54 Amplifier—*Gonssett* Feb., 17
 Grid-Controlled Rectifiers Feb., 25
 Hot Zero Adjusters—*W6MEP* Jan., 164
 Improved Conversion Exciter—*Wea-*
 gant Feb., 14
 Inductive Tuning—*McCullough* Oct., 23
 Kilowatt Amplifier—*Gonssett* May, 55
 Low-Cost Medium Power Transmitter—
 Bullock and *Chambers* Dec., 34
 Midget Portable—*Broderson* Apr., 59
 Multiband Exciter with Switching—
 Raguse Jan., 32
 Multiple Crystal Holders—*Kaeliel* Nov., 45
 Name Your Grid Current—*Johnson* Dec., 41
 Neon-Bulb Voltage Regulators—
 Berg Dec., 52
 Newcomer's Special—*Rotbman* Oct., 38
 Obtaining Flexibility — *Christen-*
 sen Mar., 27, June, 65
 100-Watt Bandswitching Exciter—
 Hunter Oct., 30
 Pencil QSY—*W6CUH* Jan., 164
 Pierce Oscillator Mar., 64
 Push-Pull 809's—*Ontiveros* Feb., 48
 Push-to-Talk Relay—*Edgar* June, 27
 Remote Control Systems Jan., 125
 Remote Frequency Control—*Jones* Oct., 36
 Review of 1938 Transmitters Jan., 92
 Silencing Units—*Rauer* Mar., 18
 Solenoid Relay Construction—*Johns* June, 50
 Streamlined—*Frimerman* July, 52
 Sure-Fire Crystal Oscillator—*Jones* Apr., 47
 10-Meter Mobile Unit—*Gonssett* July, 32
 Trouble Shooting in R.F. Stages—
 Conklin July, 57
 Tuning Condenser Flashover—*Jones* Mar., 82
 U.H.F. Beam Oscillator—*W3HJO* Nov., 47
 Unit-Construction Final May, 58

Vacuum Condensers May, 50
 Which Tuning Condenser?—*Jones* Mar., 59

Tubes

813 Beam Tetrode Nov., 72
 832 Push-Pull Tetrode Oct., 70
 Grid Controlled Rectifiers Feb., 25
 902 'Scope July, 78
 1851 Pentode June, 78
 1852 Pentode, 1853 Pentode Oct., 69
 RCA 809 Jan., 127
 RCA 814 Jan., 128
 Gammatron 54 Jan., 129
 RCA 884 Jan., 129
 RCA 6SJ7, 6SK7, 6SF5, 6SQ7 Dec., 72
 RCA VR105-30, VR150-30 Dec., 72
 Kinescope 1800, 1801 Jan., 129
 6J8G Mixer Mar., 20

Ultra High Frequencies

(see also *Radiotelephony, Transmitting, Tubes*)

Acorn Five-Meter Superhet—*Ely* July, 26
 Acorn Pentode Sockets Nov., 54
 Beam Oscillator—*W3HJO* Nov., 47
 Beam Without Insulators Apr., 23
 Compact Crystal Control—*Gonssett* Jan., 50
 56 Mc.—*Conklin* Jan., 148; Feb., 72; Mar.,
 66; Apr., 66; May, 68; June, 66; July,
 68; Oct., 59; Nov., 64; Dec., 64
 56-Mc. DX Rampant—*Conklin* July, 46
 56-Mc. Super Gainer—*Jones* May, 44
 Five-Meter DX Explanation—*Conk-*
 lin Nov., 40
 5 to 160 Meter Phone—*Jones* Nov., 23
 Improved 10-Meter Receiver —
 Adams Nov., 29
 International 56-Mc. DX Tests Oct., 64
 90-Cm. Transceiver—*Romain* June, 35, Oct., 63
 Improving High-Frequency Receivers
 —*Reber* and *Conklin* Jan., 112, Mar., 57
 Measuring the Vertical Angle of Sig-
 nal Arrival Jan., 41
 Milk-Truck Mobile—*Peck* Jan., 24
 Mobile Installation—*Gonssett* Oct., 50
 Navy Test Transmissions July, 34
 Portable Receiver—*Bolmarcich* July, 15
 Resonant Lines as Circuit Elements Mar., 57
 R.S.G.B. Contest Jan., 148
 Super-regeneration—*Frink* Mar., 44, Apr., 19
 10-Meter Mobile Unit—*Gonssett* July, 33
 What's Happening to Ten? June, 29
 W9UAQ Beacon Apr., 35

The Marketplace

(a) Commercial rate 10c per word, cash with order; minimum, \$1.00. Capitals: 13c per word. For consecutive advertising, 15% discount for 3d, 4th, and 5th insertions; 25% thereafter. Break in continuity restores full rate. Copy may be changed as often as desired.

(b) Non-commercial rate: 5c per word, cash with order; minimum, 50c. Available only to licensed amateurs not trading for profit; our judgment as to character of advertisement must be accepted as final.

(c) Closing date (for classified forms only): 25th of month; e.g., forms for March issue, published in February, close January 25th.

(d) No display permitted except capitals.

(e) Used, reclaimed, defective, surplus, and like material must be so described.

(f) Ads not relating to radio or radiomen are acceptable but will be grouped separately.

(g) No commissions nor further discounts allowed. No proofs, free copies, nor reprints sent.

(h) Send all Marketplace ads direct to Los Angeles accompanied by remittance in full payable to the order of Radio, Ltd.

GLASS feeder spreaders. Perfect insulation. 2 to 6 inch, 4c. W9NER, Washington, Missouri.

SWAP Clough-Brengle signal generator, SW-3, Teleplex or Readrite analyzer for ham superhet. W7FQG. Coulee City, Washington.

WANTED: Good super. SX16 or similar. Pay cash. W6HEZ. CHASSIS. Any size or finish. Let us punch the holes. R. H. Lynch, 970 Camulos, Los Angeles, Calif.

MANUFACTURER'S Sale: Neutralizing Condensers. Latest Design, 2" \$0.60, 3" \$1.10. ALUMINUM Panels, plain or drilled to specifications. Chassis, Racks, Cabinets, made to order. Antenna Systems, Transmitters, Receivers. Ensell Radio Laboratory, Warren, Ohio. (Established 1924).

QSL's—HIGHEST QUALITY—LOWEST PRICES. RADIO HEAD-QUARTERS, FT. WAYNE, INDIANA.

LISTEN for High Frequency Broadcast Station, W9XA, 26,450 Kilocycles, Kansas City, Mo.

QSL's, SWL's: one color, 45c; two colors, 60c hundred, postpaid. Samples. W1FTM. 268 Piedmont, Waterbury, Conn.

QSL's—SWL's—Original, outstandingly DIFFERENT! FRITZ's—455 Mason—Joliet, Illinois.

BEST place on earth to buy Ham stuff. All popular lines stocked. W9KJF, Indianapolis, Indiana.

METERS repaired, redesigned, swapped, W9GIN, 2812 Indiana, Kansas City, Missouri.

COMPLETE high-power phone station for sale. \$50.00 down, \$25.00 a month. W6CIF.

FOR Sale: SX9 Super Skyriders, \$45.00. 300-watt input c.w. Xmitter \$85.00; can be grid modulated for 75-watts phone. H. E. Harrison, 1512 West 68th St., Los Angeles.

FOR Sale: Kw. amplifier with p.p. 100TH's, also pair of 807's. All tubes in good condition. Cash. W6MSM, Acampo, California.

RME 69 DB-20, iron core i.f. crystal. Want motorcycle. W6IVI.

YOUR sigs rcvd hr., phones CQ's, etc., on guaranteed phonograph records, special 35c. Brown's Radio Laboratory, Dolgeville, New York.

CRYSTALS AIRMAILED: 160—80AT—40X, \$1.95. 40 Lodrift \$2.75. Mounting, \$1.00. 80AT in Vari-gap, \$4.50. State desired frequency. Air wound coils, all types. COD's accepted. C-W Mfg. Co., 1170 Esperanza. Angelus 7310.

REAL bargains in uncased PRECISION TRANSFORMERS. 3000 volts center-tapped at 250 mils—\$6.00. 5000 volts center-tapped at 250 mils—\$9.00. Michigan Electrical Laboratory, Muskegon, Mich.

FLASH—Brand new RCA ACR-III receivers, factory sealed cartons —\$99.50 cash. No trades. W3DQ.

TRADE—Used oscilloscope, receiver, and quality transmitter parts, some new, for late model hunting rifle, shotgun, or good kodak. W7DSQ, Box 137, St. Ignatius, Montana.

SELL: at \$14.00, slightly used Taylor 814 or trade for new Eimac 100TH; 807—\$2.50; Taylor 825—\$3.00; RK 23—\$3.00; UV 211—\$2.50; National TCN 25 μ fd. high-power neutralizer —\$2.00; Hammarlund .0001 transmitting condenser—\$2.00; new Inca J-10—\$1.25; used Inca J-11—\$1.00; used Inca J-31—\$2.00; two 2- μ fd. Acme Parvot 1000 V condensers—\$0.75 ea.; Inca I-23—\$2.00; desk mike stand—\$1.00; Inca D-10 choke—\$1.00. Trade everything for two new Eimac 100 TH's. W6GMC

Advertising Index

Allied Radio Corp.	167
Bliley Electric Co.	165
Bud Radio, Inc.	171
Burstein-Applebee Co.	168
Cannon Co., C. F.	171
Capitol Radio Engineering Institute	174
Cardwell Mfg. Corp., Allen D.	166
Centralab	173
Cornell-Dubilier Electric Corp.	153
Delaware Radio Sales Co.	172
Eitel-McCullough, Inc.	149
Guardian Electric	178
Guthman & Co., Inc. Edwin I.	176
Hallicrafters, Inc., The	6
Heintz & Kaufman, Ltd.	151
Henry Radio Shop	179
Howard Radio Co.	8
International Correspondence Schools	183
Katolight	167
Mallory, P. R. & Co.	175

McGraw-Hill Book Co.	181
Ohmite Manufacturing Co.	177
Radio Amateur Call Book	168
RADIO <i>Antenna Handbook</i>	159
RADIO Binder	172
RADIO for Christmas	5
RADIO <i>Handbook</i>	157
RADIO <i>Noise Reduction Handbook</i>	182
RADIO's Outstanding Library	161
RADIO <i>Telephony Handbook</i>	163
RADIO WAZ Map	7, 184
Radio Manufacturing Engineers	3
Radio Supply Co.	170
Radio-Television Supply Co.	155
RCA Mfg. Co., Inc.	Cover 4
Solar Mfg. Corp.	175
Taylor Tubes, Inc.	Cover 2
Thordarson Electric Mfg. Co.	Cover 3
Trimm Radio Mfg. Co.	176
Wholesale Radio Service Co., Inc.	178
Wilson, Willard S.	172

Buyer's Guide

Where to Buy It

PARTS REQUIRED FOR BUILDING EQUIPMENT SHOWN IN THIS ISSUE

The parts listed are the components of the models built by the author or by "Radio's" Laboratory staff. Other parts of equal merit and equivalent electrical characteristics usually may be substituted without materially affecting the performance of the unit.

THE C. W. SUPER

Page 11

C₁, C₂, C₃—Hammarlund MC-35-S
C₄, C₅, C₆—Hammarlund APC and EC-80
C₇ to C₁₃ inclusive—Aerovox 484
C₁₄—Hammarlund MC-20-S
C₁₅, C₁₆—Aerovox 1467
C₁₆, C₁₇, C₁₈—Aerovox 484
C₂₀ to C₂₆ inclusive—Aerovox 484
C₂₇, C₃₀, C₃₁—Aerovox PR25
C₃₂—Aerovox 484
C₃₃, C₃₄—Aerovox 484
C₃₅—Hammarlund MC-75-S
C₃₆—Hammarlund APC-75
IFT₁—Hammarlund ATT-465-CT
IFT₂, IFT₄—Hammarlund ATT-465
IFT₃—Hammarlund ATO-465
Coil forms—Hammarlund SWF-5

IMPROVED U.H.F. RECEIVER

Page 17

C₂, C₆—Solar type MT
R₁, R₂, R₃—IRC type BT-1/2

56-MC. TRANSMITTER-EXCITER

Page 23

C₁, C₂—Solar MP-4119
C₃—Cardwell ZR-50-AS
C₄—Solar MW-1239
C₅—Solar MW-1216
C₆—Solar MW-1210
C₇—Cardwell ZR-15-AS
C₈, C₁₀, C₁₁, C₁₃—Solar MW-1227
C₉—Solar MW-1233
C₁₂—Cardwell ZT-15-AS
R₁, R₃, R₄, R₇—Centralab carbon
R₂, R₅, R₆—Ohmite Brown Devil
RFC—Bud 920
Isolantite sockets—Hammarlund S-6 and S-8
Wafer socket—Bud 113
Crystal—Bliley B-5
Tubes—RCA-42, RCA-6L6G, Taylor T21

INEXPENSIVE DX

Page 26

Cabinet—Bud type 1190
Coil forms—Bud type 310
CH₂—UTC type R-16
C₂₁, C₂₃—Cornell-Dubilier type BR
C₁, C₇—Bud type 328
C₃, C₄—Bud type 396
Knobs—Bud type 579 and 581
Line Cord with Resistor—Ohmite "Cordohm"
Tubes—RCA
Remaining components from old b.c.l. set

ILLINOIS—Chicago

CHICAGO RADIO APPARATUS CO., Inc.

Established 1921

415 SOUTH DEARBORN STREET
(Near Van Buren Street)

ALL SUPPLIES FOR THE SHORT WAVE
FAN AND RADIO AMATEUR. QUOTA-
TIONS FREELY GIVEN ON ANY KIT
OR LAYOUT

Short Wave Receivers Taken in Trade
Get our low prices

T-20 100-WATT PHONE

Page 38

Midget mica condensers—Cornell-Dubilier type
Tubular condensers—Cornell-Dubilier type DT
C₇, C₉—Hammarlund SM-50-X
C₁₃—Bud type 567
C₁₁—Cardwell type XP-165-KD
X—Bliley LD2 or B5
C₃₃, C₃₄, C₃₅—Solar type Z-208
C₂₆, C₂₇—Solar type X-104
CH₁, CH₂—Stancor C-1002
CH₃—Stancor C-1412
CH₄—UTC type S-34
T₁—UTC type PA-53-AX
T₂—UTC type VM-2
T₃—Stancor type P-948
T₄—Thordarson type T-54F66
T₅—UTC type S-46
T₆—UTC type S-57
Carbon resistors—Centralab
Wire-wound resistors—Ohmite Brown Devil
Coil forms—Bud type 126
Jacks—Yaxley type 702
Microphone—Astatic type D2
T20's, TZ20's, and 866's—Taylor
All other tubes—RCA

Buyer's Guide

Continued

MODERN SPEECH AMPLIFIER DESIGN

Page 46

- Tubular condensers—Aerovox 284 and 484
Mica condensers—Aerovox 1467
C₃, C₆, C₇—Aerovox P450
C₇, C₁₁ and C₁₂, C₁₃—Aerovox GC5
C₁₀—Aerovox PR25
C₁₄, C₁₅—Aerovox PBS200
T₁—Thordarson T-15A74
T₂—Thordarson T-15S90 or T-67S54 for 500-ohm output; T-15D76, 77, 78, 79 or T-19D01, 02, 03, 04 for driver transformer
T₃—Thordarson T-15R05 or T-87R85
CH₂—Thordarson T-75C49
CH₃—Thordarson T-74C30
CH₁—Thordarson T-15C54 or T-74C29

10-M. AUTO-RADIO CONVERTER

Page 52

- C₁, C₂—Cardwell ER-25-AD rebuilt
C₃—Hammarlund MEX
C₄—Hammarlund APC-25
By-pass condensers—Solar type MW
Resistors—Centralab carbon

SWITCHING CRYSTALS

Page 56

- Switch—Mallory-Yaxley type 1311-L or Centralab "A" or "H" Switchkit.
Knob—Yaxley type 336
Sockets—Amphenol
Crystals—Bliley type LD-2, B-5, and VF-1

400-WATT DIATHERMY

Page 59

- L₂, L₃—Barker and Williamson type 10HDVL with base
C₅—Cardwell type JD-28-ND
C₆—Cardwell type XC-100-XS
C₇—Cornell-Dubilier type 35-C-86
C₈—Cornell-Dubilier type 9-6D2
T₁—U.T.C. type PA-34
T₂—U.T.C. type PA-114
T₃—U.T.C. type PA-126
T₄—U.T.C. type FT-2
RFC—Hammarlund CH-500

A KILOWATT ON 810's

Page 62

- C₁—Cardwell MT-100-GD
C₂—Cardwell XC-50-KD
C₃, C₇—Aerovox 1450
NC—Bud 1519
RFC—Bud 568
R₁—Ohmite 0577
Grid coil form—Bud 594
Tubes RCA-810's

25-WATT MODULATOR

Page 72

- Tubular condensers—Aerovox 484
C₂, C₅—Aerovox PRS450 12 μ fd.
C₃—Aerovox 1467 mica
C₆, C₇—Aerovox PB-10-10 25 volt
C₈—Aerovox 600-LU 4 μ fd.
C₁₀—Aerovox GL-475 8 μ fd.
Carbon resistors—Centralab 1 watt
Wirewound resistors—Ohmite Brown Devil
R₅—Mallory-Yaxley M control
T₁—Thordarson T81D42
T₂—Thordarson T11M74
T₃—Thordarson T74R28
CH—Thordarson T57C53
Bias Cell—Mallory-Yaxley

TWO WATTS ON THE HOOF

Page 77

- C₁—Cardwell Trim-Air ZU-140-AS
C₅, C₁₂—Cardwell Trim-Air ZR-35-AS
C₁₀—Cardwell ER-25-AD
Neutralizing condenser—Hammarlund 3-30 MEX.
Mica condensers—Cornell-Dubilier type W
Tubular condensers—Cornell-Dubilier type DT
R₁₀—Centralab midget Radiohm. N103
R₁₃—Yaxley M6R rheostat
T₁—Thordarson T-54D63 driver transformer for 19 tube
T₂—Thordarson T-67M59 class-B modulation transformer designed for 6A6 in order to obtain 4500-ohm secondary impedance.

200 CRYSTAL WATTS

Page 97

- C₁—Cardwell ET-30-ADI
C₂—Cardwell NP-35-ND
R₁—Ohmite Brown Devil
J₁, J₂—Yaxley 702
RFC—Ohmite Z-1
T—Thordarson T-19F98
Sockets—Hammarlund S-4
Tubes—Heintz and Kaufman type 24's
Bar Knobs—Bud type 579 and 581



ATTENTION ALL HAM'S

THORDARSON QUALITY AT PRICES YOU WILL APPRECIATE

THE "19" SERIES

- * PLATE TRANSFORMERS
- * CHOKES
- * MODULATION TRANSFORMERS
- * FILAMENT TRANSFORMERS
- * DRIVER TRANSFORMERS

"19" SERIES PLATE SUPPLY TRANSFORMERS

Primary 115 Volts, 50-60 Cycles

Transformers rated in D.C. volts from two section filter. Electrostatic shield between primary and secondary.

Type No.	Sec. A.C. Load Volts	D.C. Volts	D.C. M.A.	Your Cost
T-19P55	600-0-600 550-0-550	500* 400	250	\$ 4.50
T-19P56	900-0-900 800-0-800	750 600	225	4.80
T-19P57	1075-0-1075 907-0-907	1000** 900	125 150	6.00
T-19P58	1200-0-1200 900-0-900	1000** 750	200 150	7.80
T-19P59	1560-0-1560 1250-0-1250	1250 1000	300	9.60
T-19P60	1875-0-1875 1560-0-1560	1500 1250	300	11.10
T-19P51	2125-0-2125 1875-0-1875	1750 1500	300	12.00
T-19P62	2420-0-2420 2125-0-2125	2000 1750	300	12.90
T-19P63	1560-0-1560 1265-0-1265	1250 1000	500	13.80
T-19P64	1875-0-1875 1560-0-1560	1500 1250	500	17.70
T-19P65	3000-0-3000 2420-0-2420	2500 2000	300	17.70
T-19P66	2125-0-2125 1875-0-1875	1750 1500	500	22.50
T-19P67	2450-0-2450 2125-0-2125	2000 1750	500	25.50
T-19P68	3000-0-3000 2450-0-2450	2500 2000	500	30.00

* This transformer has a bias tap at 30V. ** These transformers designed for double rectifiers and will deliver both secondary ratings simultaneously.

"19" SERIES SWINGING AND FILTER CHOKES

Inductance listed is that actually measured at rated current.

SWINGING CHOKES

Type No.	Cap. D.C. M.A.	Inductance Henries	D.C. Res. Ohms	Volts Insulation	Your Cost
T-19C35	200	5-20	130	3000	\$2.85
T-19C36	300	5-20	105	3000	3.90
T-19C37	400	5-20	90	4000	5.40
T-19C38	500	5-20	75	4000	6.90

SMOOTHING CHOKES

T-19C42	200	12	130	3000	2.85
T-19C43	300	12	105	3000	3.90
T-19C44	400	12	90	4000	5.40
T-19C45	500	12	75	4000	6.90

THORDARSON QUALITY FOR THE "HAM" IN THE POPULAR-PRICE FIELD! COMPARE!

Shown on the left is catalog information on the plate transformers and chokes in this new series of transformers. Complete information on the full series in Catalog No. 400-C, from your parts distributor or write factory for *Free* copy.

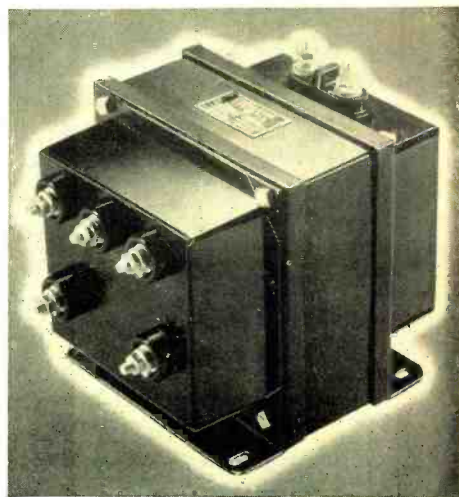

"19" Series Plate Transformer
Mounting Style 2 K
Fully Shielded - Air Cooled

THORDARSON ELECTRIC MFG. CO.

500 W. HURON ST., CHICAGO, ILL.

Demand "Power by Thordarson"

RCA Introduces

New WHITE SCREEN

TELEVISION TUBES

906-P4—WHITE SCREEN... \$15.00

Introducing the new RCA-906-P4, a 3-inch television Kinescope. Similar to the present RCA-906 Cathode-Ray Tube, this new tube features a white fluorescent screen—and an unusually low cost! In addition to its low initial cost, this new tube provides low circuit cost because of its low voltage operation. Has conductive coating which minimizes deflecting-plate loading and prevents drifting of the pattern with changes in bias.

1802-P4—WHITE SCREEN... \$27.50

Introducing the 1802-P4, a 5-inch television Kinescope having electrostatic deflection and white screen. This tube provides excellent quality television pictures. *The deflection sensitivity is such that the beam may be deflected across the entire screen with no more voltage than is required for full deflection on 3-inch tube.* Separate terminals are provided in the new Magnal 11-pin base for each deflecting plate.

1802-P1—GREEN SCREEN... \$24.75

Introducing the 1802-P1, a new 5-inch oscillograph tube which is similar to the 1802-P4 except for its green screen. In oscillographic application the 1802-P1 represents extremely high quality because it is capable of providing excellent television pictures. For television purposes the 1802-P1 operates well with an anode potential of only 1200 volts.

RCA presents the Magic Key every Sunday, 2 to 3 P.M., E.S.T., on the NBC Blue Network

RCA Radio Tubes—first in metal, foremost in glass, finest in performance



for

TELEVISION

RCA Mfg. Co., Inc., Camden, N. J. A Service of the Radio Corporation of America