

RADIO

APRIL, 1944

Design • Production • Operation

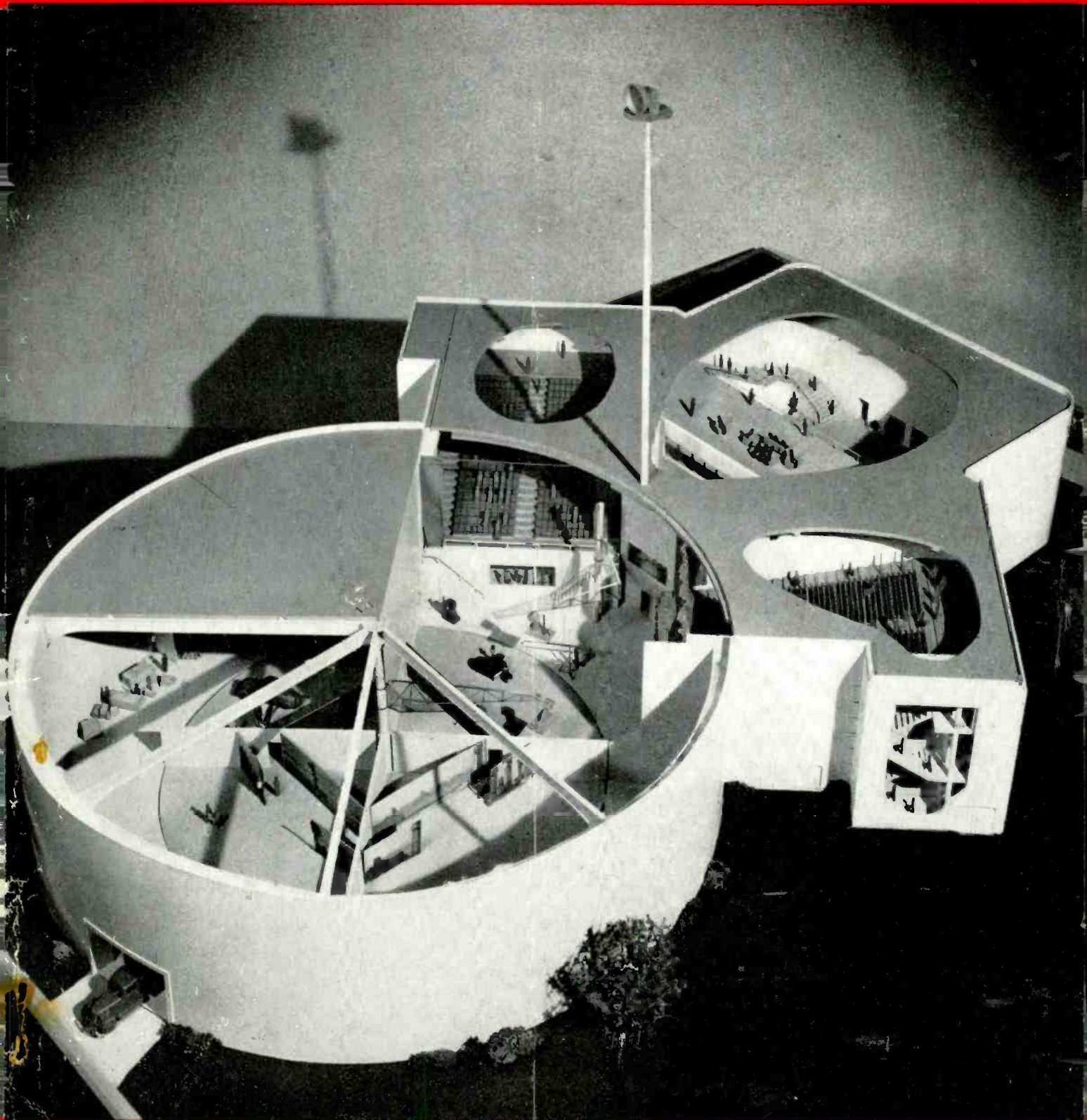

The Journal for Radio-Electronic Engineers



on the
threshold of a
new Era!

This is an "Electronics" war! Radio and electronics are writing a most vital chapter in the history of modern warfare. Many of the new developments in electronic tubes are military secrets, but in the postwar period the whole world will benefit by the tremendous strides in the engineering achievements and manufacturing methods born of military needs.

Yes, the foundation is being laid *today* for the glorious peacetime era of electronic achievement that will begin on that *tomorrow* when victory is assured. Then, as now, Raytheon will supply electronic tubes with the "Plus-Extra" performance qualities that have built the Raytheon reputation over the years.

When the Peace is won, Raytheon, due to its unique wartime experience, will be better qualified than ever before to supply manufacturers of postwar radios and of industrial electronic equipment with electronic tubes for the most exacting applications.

Raytheon Production Corporation

Newton, Massachusetts • Los Angeles • New York • Chicago • Atlanta



All Four Raytheon Divisions Have Been Awarded Army-Navy "E" Plus Stars

RAYTHEON

High Fidelity
RADIO & ELECTRONIC TUBES



DEVOTED TO RESEARCH AND THE MANUFACTURE OF TUBES FOR THE NEW ERA OF ELECTRONICS

TOP COVER . . . *for Attack at Dawn!*

As dawn comes, lean, snarling pursuit planes roar through a lightening sky to become protective patrol above ground operations. It is "top cover" to shield the men below from air-assault, or to blast in low, screaming dives enemy installations that are blocking the advance.

The ever present, Hallicrafters-built SCR-299 Mobile Radio Communications Trucks are often the means of directing the "top cover." Operating under any conditions, these Giants of Military Radio, whether calling for "top cover" or directing the fire of artillery, "get the message through."

BUY MORE BONDS!



hallicrafters RADIO

THE HALLCRAFTERS COMPANY, MANUFACTURERS OF
RADIO AND ELECTRONIC EQUIPMENT, CHICAGO 16, U.S.A.



NEW LETTER CONTEST for SERVICEMEN!

ELEVEN 1st PRIZE WINNERS IN 5 MONTHS IN CONTEST No. 1!

Yes, sir, guys, the hundreds of letters received were so swell that *double* first prize winners had to be awarded each of the first four months and there were *triple* first prize winners the fifth and last month . . .

SO—HERE WE GO AGAIN!

Get in on this NEW letter contest—write and tell us your *first hand* experiences with *all* types of Radio Communications equipment built by Hallicrafters including the famous SCR-299!

RULES FOR THE CONTEST

Hallicrafters will give \$100.00 for the best letter received during each of the five months of April, May, June, July and August. (Deadline: Your letter must be received by midnight, the last day of each month.)

For every serious letter received Hallicrafters will send \$1.00 so even if you do not win a big prize your time will not be in vain.

Your letter will become the property of Hallicrafters and they will have the right to reproduce it in a Hallicrafters advertisement. Write as many letters as you wish. V-mail letters will do.

Military regulations prohibit the publication of winners' names and photos at present . . . monthly winners will be notified immediately upon judging.

BUY MORE BONDS!



hallicrafters RADIO

THE HALLICRAFTERS CO. MANUFACTURERS OF RADIO AND ELECTRONIC EQUIPMENT, CHICAGO 16, U. S. A.

Another Leader in Radio Manufacturing

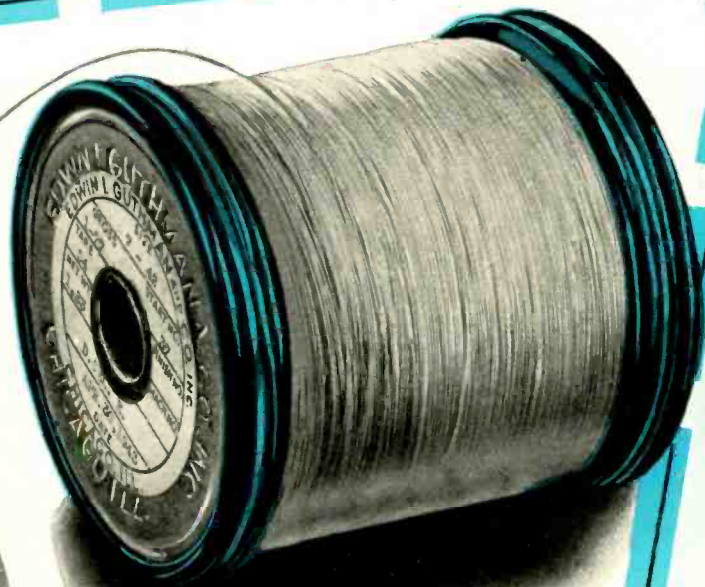

GUTHMAN *Super Q Wire*

★ The large and complete Guthman "Super Q Wire"

Manufacturing Department serves the leading manufacturers of radio equipment with standard types of Litzendraht and textile served wire for RF use.

★ Guthman's own, specially designed equipment for manufacturing insulating material is adjustable to give uniform quality, and to meet individual design requirements. ★ Our experience helps us in maintaining a high standard of perfection, and qualifies our analysis of design problems and difficult requirements within a minimum element of time. Tests are made in our own proving grounds. ★ Guthman products are no higher priced than others of comparable quality.

The usual Guthman dependability for service is available even in today's critical production situation. ★ Though producing for war contracts, we can accept additional orders in our Super Q Insulated Wire Department. All of our work is engineered to meet U.S. Government Army and Navy, R.M.A. and N.E.M.A. Standards.



EDWIN I. GUTHMAN & CO. INC.

15 SOUTH THROOP STREET CHICAGO

PRECISION MANUFACTURERS AND ENGINEERS OF RADIO AND ELECTRICAL EQUIPMENT

RADIO

★ APRIL, 1944

5



GLASS . . .

FOR LOW LOSS INSULATION!

● When glass is used as the fibrous component in Formica laminated plastic sheets, tubes and rods the material becomes a low loss insulator comparable to ceramics, and capable of replacing ceramics for many uses. At the same time it retains typical Formica characteristics, of machinability and adaptation to rapid production processes.

Compared to ceramic insulators this glass base Formica—Grade MF 66—has high mechanical strength and resistance to impact and vibration. It is as good as other grades of Formica in that regard.

Formica glass base MF 66 is being used for antenna base insulators on airplanes and ground installations.

Other glass base grades: FF 10—Heat resistant—for such applications as motor slot wedges.

FF 41—arc resistant—for ignition parts and switch parts. It does not support combustion.

All of these grades are immune to fungus growth—a quality that is important in the tropics.

"The Formica Story" is a moving picture showing the qualities of Formica, how it is made, how it is used. Available on loan.



THE FORMICA INSULATION COMPANY
4670 SPRING GROVE AVENUE CINCINNATI 32, OHIO

RADIO

Published by RADIO MAGAZINES, INC.

John H. Potts Editor
Sanford R. Cowan Publisher

APRIL 1944

Vol. 28, No. 4

CONTENTS

COVER

Working model of a television studio designed for postwar broadcasting. This model was exhibited at a press luncheon in New York City which was sponsored by the General Electric Company. (See page 46)

ARTICLES

Reactive Phase in Wave Guides— <i>V. J. Young</i>	21
Notes on Oscillator Crystals— <i>Joseph Anlage</i>	25
Revised List of Army-Navy Preferred Tubes	29
Vibration Insulation with Structural Rubber— <i>J. W. Devorss, Jr.</i>	30
Radio Design Worksheet: No. 24—Polyphase Communications Circuits	36
R-F Transmission Lines— <i>A. C. Matthews</i>	37
Radio Bibliography: 15—Household Receivers, Part 3— <i>F. X. Rettenmeyer</i>	44
Postwar Television Studio Design	46

MISCELLANEOUS

Transients	8
TECHNICANA	
New Volume Expander	10
Balanced D-C Amplifier	10
Measuring UHF Impedance	14
Frequency Synthesizer	16
Disc Recordings	19
Crystal-Controlled Clock	19
Measuring Distance by Radio	56
Electronic Power Maintenance	57
New Products	40
This Month	42
New ASA Standards	56
Advertising Index	58

Executive & Editorial Offices

342 MADISON AVENUE
NEW YORK 17, N. Y.

Telephone MUrray Hill 2-1346

John H. Potts *President*
Sanford R. Cowan *Sec'y-Treas.*
Charles H. Farrell *Adv. Manager*
Ruth Rosen *Adv. Production*
Sylvia Bornkoff *Circl. Manager*

PACIFIC COAST REPRESENTATIVE

Lloyd B. Chappell,
427 West 5th St., Los Angeles, Cal.

GREAT BRITAIN REPRESENTATIVE

Radio Society of Great Britain,
New Ruskin House, Little Russell St.,
London, W.C. 1, England

RADIO Magazine (title registered U. S. Pat. Off.) is published monthly at 34 N. Crystal Street, East Stroudsburg, Pa., by Radio Magazines, Inc. Executive and Editorial Offices at 342 Madison Avenue, New York 17, N. Y. Subscription rates—United States and Possessions, \$3.00 for 1 year, \$5.00 for 2 years; elsewhere \$4.00 per year. Single copies 35c. Printed in U.S.A. All rights reserved, entire contents Copyright 1944 by Radio Magazines, Inc. Entered as Second Class Matter October 31, 1942, at the Post Office at East Stroudsburg, Pa., under the Act of March 3, 1879.

RADIO

* APRIL, 1944

7

Transients

ENGINEER-EXECUTIVES

★ Many of the newer companies which have sprung into existence during the war have adopted a policy of offering executive positions with high-sounding titles to engineers having little or no experience in directing the work of others. Too often this doesn't work out as expected. While the engineer can bring to his job a sympathetic understanding of the problems involved in the projects he has to supervise, he is quite likely to become enslaved by technical details which should be delegated to others. As an engineer, he is trained to concern himself with even the most minute details; as an executive, his principal aim must be to get things done, and quickly.

Thus the engineer who assumes the duties of an executive finds that he must adopt an entirely different approach to his job than that to which he has been accustomed. There are no equivalent circuits for human beings, and the human equations with which he has to deal are often more difficult to manipulate than those of the mathematical variety. The process of adapting himself to executive work is bound to cause him to subordinate those problems which are more the concern of the engineer than of the executive, and the degree to which he is successful in accomplishing this determines whether he remains an engineer or becomes a good executive. More often than not, he ends up as an engineer who is not as good as he used to be and as an executive who is not as good as he would like to be.

CALLING ALL CARS

★ With all the efforts which have been made toward secrecy in crime detection, it seems strange that nothing appears to have been done about making police radio transmissions confidential. Under the present systems, anyone who has a receiver which will tune to the assigned frequency of the transmitting station can pick up police instructions just as promptly as the officers to whom they are directed. Granted that present police radio systems have done a swell job in aiding in apprehending criminals, the fact remains that a criminal with a simple, portable receiver can be forewarned and make his getaway before the police arrive.

Perhaps some manufacturers are already at work on this problem. In any event, it would seem that there should be a ready market for a simple system of secret transmission.

POSTWAR AIRCRAFT RADIO

★ According to the *New York Journal of Commerce* aviation executives are agreed that family planes will be produced in quantity to sell for approximately two thousand dollars. It is estimated by the Administrator of Civil Aeronautics that approximately 500,000 civil airplanes, most of them privately owned, will be in use during the postwar decade. It is further stated that the radio compass will probably be standard factory equipment.

The private owner's radio equipment, it is pointed out, will undoubtedly be a receiver operating on VHF, with a direction-finding attachment. In quantity production, it is stated that at least one company is prepared to produce the receiver alone for less than \$30. A transmitter, for communication with airport towers and CAA communication stations, should not cost more than \$50 on a mass production basis. A complete aircraft radio installation is estimated to cost about \$150 in quantity production.

While this is quite a sizeable market in its own right, there is also the possibility of a very large export trade in similar equipment. It would seem that those manufacturers who have done worthwhile development work in the aircraft radio field can look forward to a reasonably broad and profitable market after the war.

TELEVISION IN EDUCATION

★ A point frequently raised in comparing television programs with the more usual radio variety is that the former require concentration while many of the latter do not. And, because the average radio listener has become accustomed to using his radio as a background for other occupations, many feel that this is one important limitation to the widespread sale of television receivers.

But it is equally true that sound movies also require concentration, both visual and aural, for full enjoyment. They get it. This has proved of value for educational purposes as well as for amusement. The field for television receivers in education, particularly in those wide areas where competent teachers are scarce, seems large. Because television in itself is new and interesting, it has greater potential possibilities as an instructional medium than sound movies. And a good television receiver should cost much less than a sound-movie outfit.



Wilcox Radio Equipment Serves Braniff Airways

The major airlines of the nation depend on Wilcox equipment for reliable radio communications. In addition, Wilcox installations today are serving military operations in practically all parts of the world.

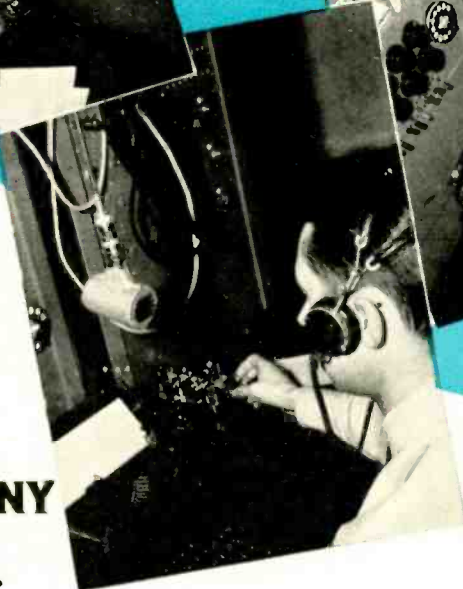
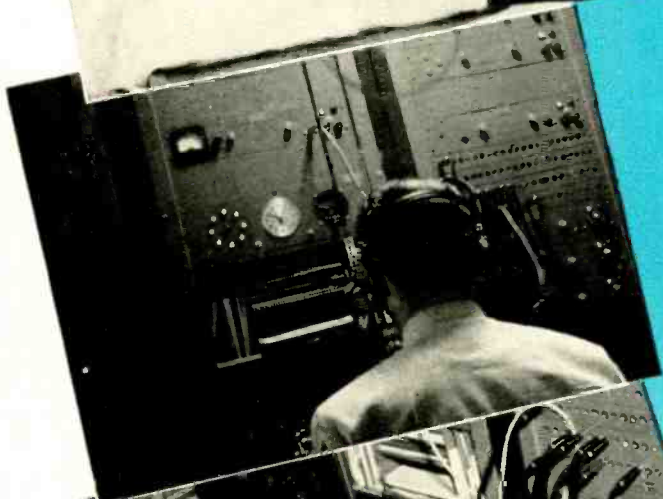

WILCOX ELECTRIC COMPANY

Manufacturers of Radio Equipment

Fourteenth & Chestnut ☆ Kansas City, Mo.

*Photographs, courtesy
Braniff Airways.*

RADIO

★ APRIL, 1944

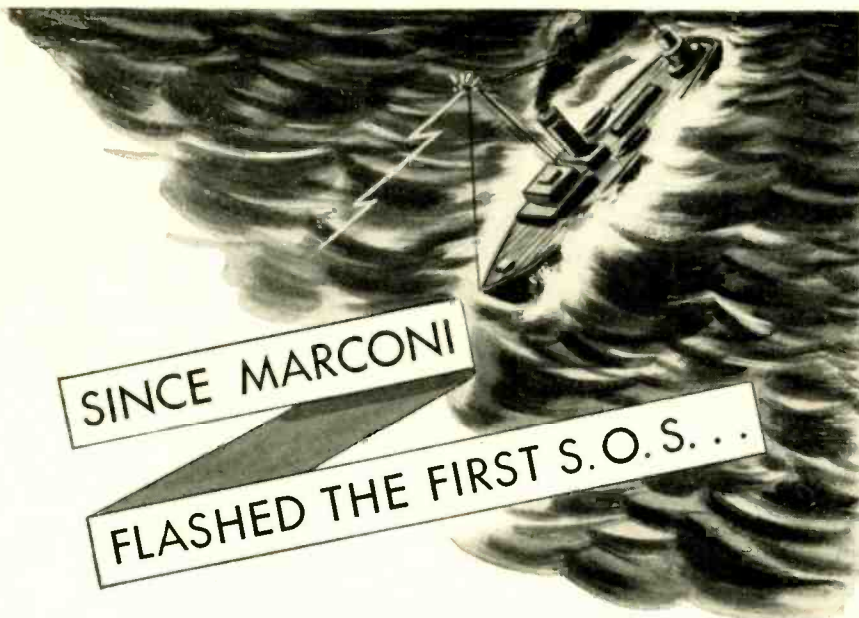

Since that historic day in 1899 when an electric impulse was transmitted from the Marconi apparatus aboard an English lightship, miracles have been performed in, and with radio communication. Contemporary with that development and—indispensable to it—was the power regulating component—the transformer.

In recent development Stancor Transformers have played a noteworthy role, and this experience multiplied a hundred-fold by the intimate association with wartime electronic units, will be a rich source of appeal when industry asks for improved safety and control.

STANCOR Transformers

STANDARD TRANSFORMER CORPORATION
1500 NORTH HALSTED STREET - CHICAGO

Manufacturers of quality transformers, reactors, power packs and allied products for the electronic industries.



SEND FOR
NEW
COMPLETE
CATALOG

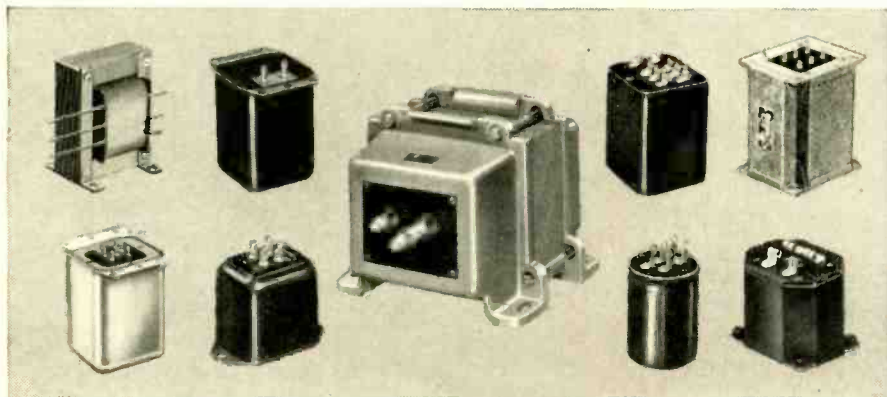

NEW VOLUME EXPANDER

★ A new circuit for volume expansion, employing a cathode follower, is described in an article by M. O. Felix in the March, 1944, issue of *Wireless World*. As shown in Fig. 1, the 6H6 diode rectifier controls a 6K7, which is triode-connected. With this arrangement, the degree of expansion obtainable is 18 db.

Advantages claimed for this circuit are:

1). Higher input voltages may be handled (20 volts or more) without distortion, thus simplifying the hum-pickup problem encountered in previous types requiring very small input voltages.

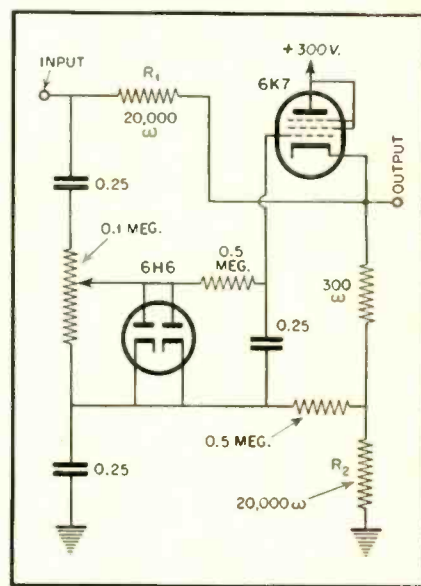

Figure 1

2). No separate amplifier is required before the rectifier.

3). The use of the cathode-follower circuit provides a low output impedance, so that a shielded lead may be run for some distance, if required, without introducing appreciable attenuation.

4). The expander may be cut out of the circuit completely in several ways; for example, by inserting a large cathode-bias resistor.

Delayed expansion may be secured by applying a fixed bias to the rectifier.

BALANCED D-C AMPLIFIER

★ The fine points of adjusting a balanced d-c amplifier so that the galvanometer deflection is not affected by small changes in filament current is discussed in the article "Behavior of a

[Continued on page 12]



Detective work to Foil Corrosion

In Automatic Electric's chemical laboratory, before any materials are accepted for use in relays, they are carefully tested for the presence of sulphur, bromine, chlorine, or other elements that might cause corrosion, affect insulation or give rise to other troubles

IN THE selection of materials and finishes for use in Automatic Electric relays, performance and durability are given first consideration. The aim of the designers is to produce an apparatus that will resist all corrosive influences throughout long years of tough service—even when this means foregoing the bright, shiny appearance which is so attractive at first. Every factor in the design of Automatic Electric relays is given similar attention—resulting in a unique fund of design data and experience. This background is the reason why Automatic Electric relays serve so dependably under tough conditions.

You can make this experience work for you—by calling in the Automatic Electric field engineer. His job is to help you select the apparatus that will best meet your need. Call him in next time you are faced with an electrical control problem. Write for Catalog 4071.

AUTOMATIC ELECTRIC SALES CORPORATION
1033 West Van Buren Street • Chicago 7, Ill.

In Canada: Automatic Electric
(Canada) Limited, Toronto

Relays
AND OTHER CONTROL DEVICES
by **AUTOMATIC ELECTRIC**

PARTS AND ASSEMBLIES FOR EVERY ELECTRICAL CONTROL NEED

RADIO

* APRIL, 1944

11

BLILEY CRYSTALS

RIDE WITH THE SCR-299

Built by **hallicrafters**

ONE of the outstanding achievements in wartime radio transmitter design is the SCR-299. Serving equally well as a mobile or stationary radio station, this now famous equipment is doing a real job on our battle fronts.

This war is run by radio. The vital importance of maintaining reliable communications necessitates the selection of quartz crystal units that are accurate and dependable. Bliley Crystals are engineered for service they are used in all branches of military communications and are, of course, supplied for the SCR-299



BACK THE ATTACK WITH WAR BONDS

BLILEY ELECTRIC CO., ERIE, PA.

TECHNICANA

[Continued from page 10]

Balanced DC Amplifier," by Roy C. Spencer and LeRoy Schulz in the January, 1943, issue of the *Review of Scientific Instruments*.

The circuit under consideration is shown in Fig. 2. It is generally known that by suitable adjustment of the different resistors, a condition can be obtained where the curve of deflection versus filament current passes through a minimum. The circuit is then said to be balanced. The authors of the article

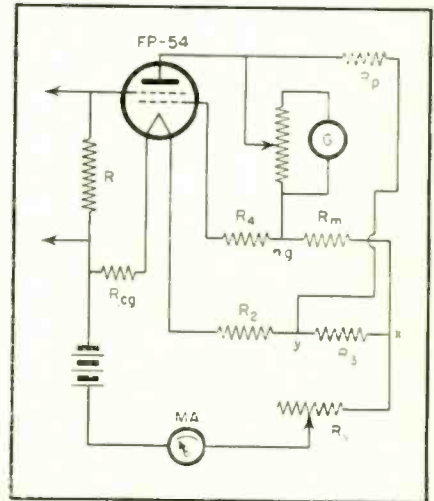

Figure 2

found that this condition of balance is varied with the deflection (or current through R), as shown in Fig. 3A. Here the minimum obtained at different amounts of deflection occur at different filament currents. In other words,

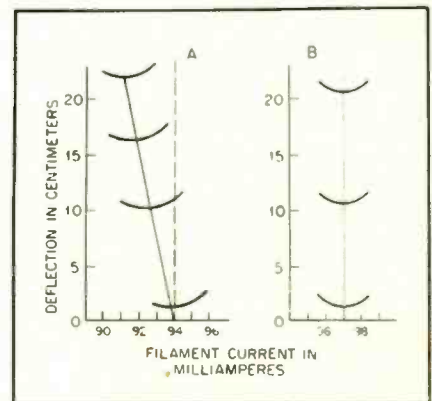

Figure 3

when the circuit is balanced at zero deflection it is not balanced for deflections which are far different from zero. Thus errors can occur. The minima in Fig. 3A are in a sloping straight line. A more perfect condition of balance can be had by a readjustment of the resistors so that all the minima occur at the same filament current, as in Fig. 3B. The current is now bal-

[Continued on page 14]

Talk About PRODUCTION Without DIES!

4,000 Parts Per Day with DI-ACRO Bender

Here is an example of "DIE-LESS DUPLICATING" typical of a great variety of formed parts readily made with DI-ACRO Precision Machines,—Benders, Brakes, Shears. Picture below shows an acute right angle bend and photograph above shows the finished part formed to die precision. Women



"Enclosed pictures in our plant prove the DI-ACRO Bender will do a real production job. We are making 4,000 completed parts per day which is competitive to most Power Presses." (Name on request)

operating DI-ACRO units maintain a high out-put on production work.

Send for CATALOG showing DI-ACRO Precision Machines and many examples of parts made with "DIE-LESS DUPLICATING."



O'NEIL-IRWIN MFG. CO.

346 EIGHTH AVENUE SOUTH • MINNEAPOLIS 15, MINNESOTA

Connecticut Telephone and Electric Division,

M E R I D E N



C O N N E C T I C U T



Today: Field telephones, military switchboards, electronic devices, aircraft ignition systems—produced to Army-Navy "E" standards by a group of men and women putting an average of 15% of their incomes into war bonds and proud of one of the lowest percentages of absenteeism in the nation.



Tomorrow: Civilian communications equipment, industrial control instruments, hospital communicating and signalling equipment, and precision electrical products—produced by men and women who are demonstrating their ability to get things done and done right—earning the right to be remembered.

© 1944 Great American Industries, Inc., Meriden, Conn.

RADIO

★ APRIL, 1944

13

There Are Two Sides

TO EVERY STORY

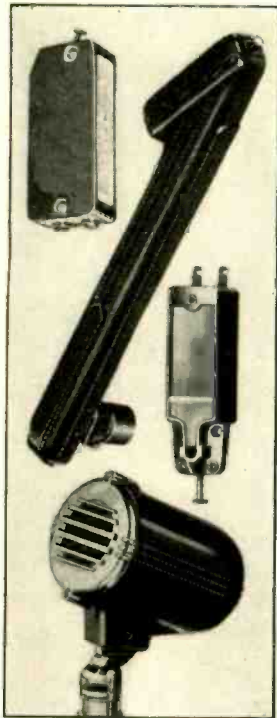

On the one side, Astatic continues to manufacture Microphones, Pickups, Cartridges and Recording Heads for various branches of the military service and accredited industrial or public address uses.

On the other side, Astatic is using its extensive facilities to manufacture Coaxial Cable Connectors for wartime radio communications and radar equipment.

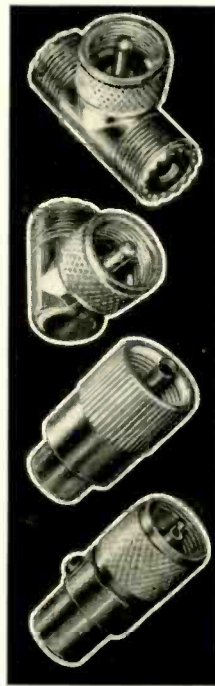

ASTATIC

IN CANADA:
CANADIAN ASTATIC, LTD.
TORONTO, ONTARIO

THE ASTATIC CORPORATION
YOUNGSTOWN, OHIO

TECHNICANA

[Continued from page 12]

anced, regardless of the amount of deflection. The values given for the conditions of Figs. 3A and 3B are:

	R3	R4	Rn	Rp	R2	Rcg
Fig. 3A	1.9	10,000	2,000	4500	37	37
Fig. 3B	2.0	5,000	2,000	6600	37	41
	(all values in ohms)					

On plotting the curve of filament current versus deflection, it was further found that there was more than one minimum and maximum. By adjustment of the resistors these can be made to shift about, and so a minimum and maximum can be made to form a point of deflection which results in a broad plateau, so that the filament current can now be varied over a greater range without changing the galvanometer deflection.

The difference in emission of different tubes appeared to be the cause of their variation in behavior. Tubes having identical emission for a given filament current behaved practically the same. Some tubes with very low emission could be improved by flashing them at 6-8 volts for one minute; the emission then increases. A low emission results in a shorter range of filament current over which it can be balanced.

The article also contains a suggested order of steps for balancing the circuit of Fig. 2.

MEASURING UHF IMPEDANCE

★ Impedance at ultra-high frequencies can be measured on a Lecher wire system if the wires are terminated in the unknown impedance and various current or voltage measurements are made along the line. An improvement in this method is described by Gordon Williams in the *Proceedings of the Physical Society* for January, 1944, Vol. 6, Part I, No. 313, in an article, "A New Method for the Measurement of Impedance at Ultra-High Frequencies using a System of Lecher Wires."

One of the difficulties in the measurement described was that the oscillator power must not vary while taking readings. Errors due to this cause can be eliminated if the ratio between two currents is read rather than the absolute values. Such a method was introduced by Flint and Williams; they used the unknown impedance in series with a current meter as the terminating impedance and a movable bridge which consisted only of a current meter. In this method, the impedance of the meter in series with the unknown impedance must be known and a special experiment must be performed to find it. In his paper, Williams proposes that two movable bridges be used, each consisting of simply a meter while the

[Continued on page 16]

X-RAYED!

TO INSURE PERFECT JOINT

Note elimination of junction boxes in right angle bends, designed and engineered by Andrew to meet exacting requirements of this special application.

Inner conductor is bent, not spliced. Outer conductor is mitered and silver soldered. X-ray insures no silver solder penetration into cable, eliminating danger of short circuit. Sealing and pressurizing transmission lines before plating prevents possible corrosion.

For your problems in radio antenna equipment, consult Andrew. The Andrew Co. is a pioneer in the manufacture and engineering of coaxial cables and accessories. Free catalog on request. Write today.

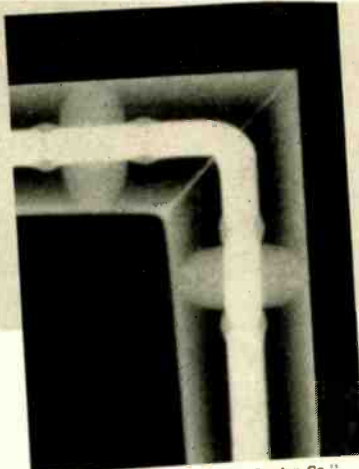

"Photo by G. A. Russ, Claud S. Gordon Co."

X-ray illustrates Andrew right angle coaxial cable assembly, part of a Fan Marker Beacon Transmitter made for CAA by Farnsworth Television and Radio Corporation. Pilots' lives depend on the 100% reliability of this equipment. Andrew is proud of the use of its coaxial cable in this installation.

ANDREW CO.

363 EAST 75TH ST.,
CHICAGO 19, ILLINOIS

COAXIAL CABLES



Inductors - to specifications

From the small 100 watt tube socket types to the large 100KW types using copper tubing, Johnson inductors are designed to rigid specifications. They are more than coils. Into each of Johnson's inductors go more than 20 years of "know how"—familiarity with materials—skill in mechanical design—knowledge of circuits—and experience in electrical design for greatest efficiency in the particular application. Tapped inductors, fixed and variable coupling coils, variable inductors, and clips are all features Johnson can furnish. Copper tubing, wire, edgewise wound copper strip, or flat copper strip are available. Insulation materials used are steatite, Mycalex, Bakelite, and porcelain. Write for suggestions on YOUR inductor problem. Quotations furnished on the basis of either mechanical specifications or performance specifications.

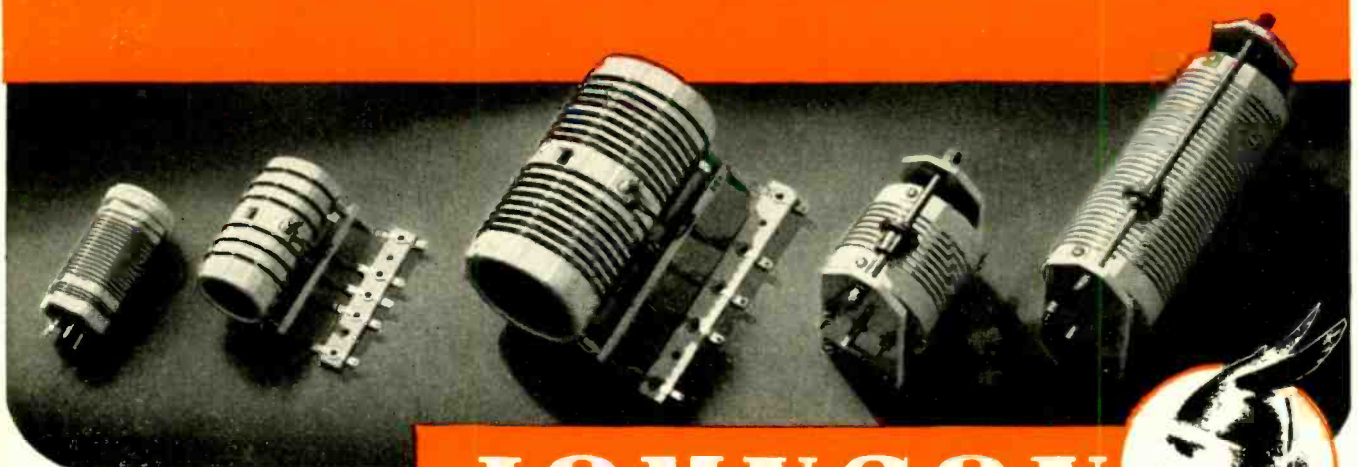

Write for New
JOHNSON CATALOG
968K

JOHNSON

a famous name in Radio



E. F. JOHNSON COMPANY • WASECA • MINNESOTA

RADIO

★ APRIL, 1944

15

Products of
"MERIT"
 means
 Fine Radio Parts

... PARTS manufactured exactly to the most precise specifications.

Long manufacturers of component radio parts, MERIT entered the war program as a complete, co-ordinated manufacturing unit of skilled radio engineers, experienced precision workmen and skilled operators with the most modern equipment.

MERIT quickly established its ability to understand difficult requirements, quote intelligently and produce in quantity to the most exacting specifications.

Transformers—Coils—Reactors—Electrical Windings of All Types for the Radio and Radar Trade and other Electronic Applications.



MERIT COIL & TRANSFORMER CORP.
 311 North Desplaines St. CHICAGO 6, ILL.

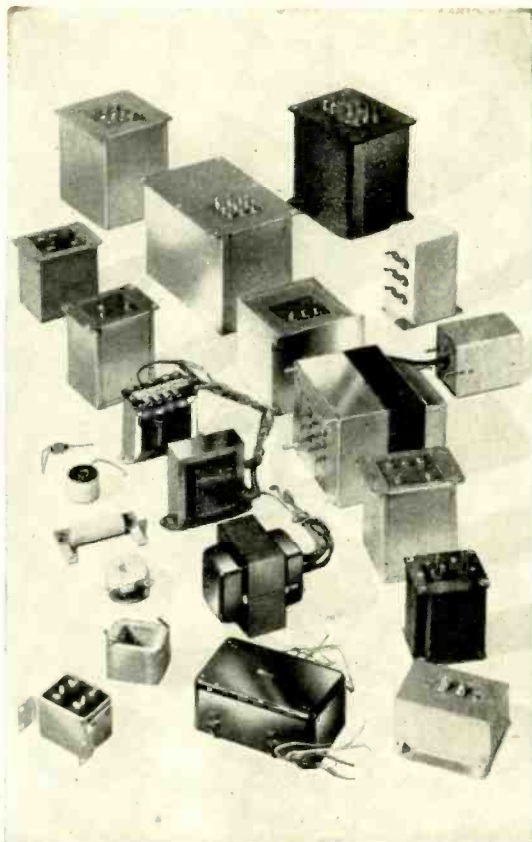

TECHNICANA

[Continued from page 14]

unknown impedance alone is used to terminate the line. In order to simplify the calculations, the two bridges, Z_1 and Z_2 in Fig. 4, should be moved "in tandem" being always separated by the distance S_1 which can be determined

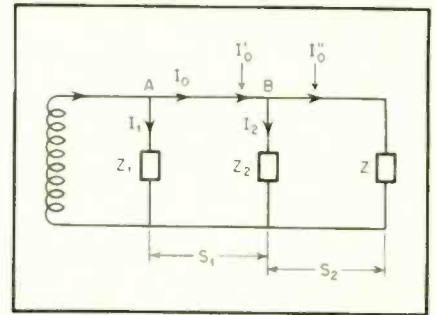

Figure 4

experimentally for each case. The unknown impedance can be calculated from the ratio of the currents I_1 and I_2 as the two bridges are moved about on the wire system. The impedances of the two movable bridges need not be known.

The article further contains a mathematical proof of this method.

THE FREQUENCY SYNTHESIZER

★ Frequency measurements can be made by comparing the signal of unknown frequency with harmonics of a standard frequency signal. This system has its disadvantages, for in order to have sufficient accuracy, successive harmonics must be spaced closely which

PEAK EFFICIENCY... LONGER LIFE
 for Electronic Tube Equipment

Eliminate tube generated heat and you get peak efficiency from electronic equipment... and longer tube life too! This is being proved by leading manufacturers of electronic equipment today thanks to the efficiency of PILOT BLOWERS. Available in five standard sizes with output ranging from 49 to 106 C.F.M. also with custom-built F.H.P. Motors with output from 15 to 120 C.F.M.
 Write for Bulletin 507

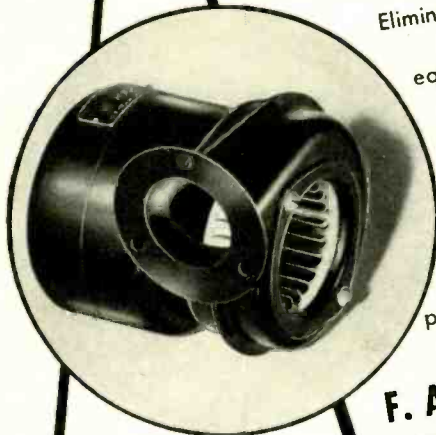

F. A. SMITH MFG. CO., INC.
 701 Davis St., Rochester 5, N. Y.

FRACTIONAL H. P. MOTORS **Pilot** CENTRIFUGAL BLOWERS

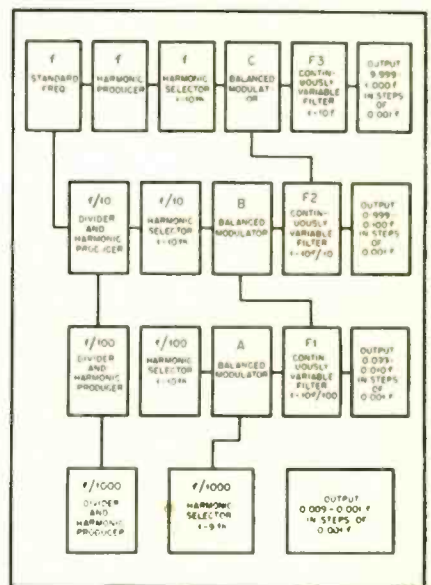

Figure 5

in turn means that a high order of harmonic must be used. It then becomes difficult to establish the order of any individual harmonic.

A new method of frequency measurement is described in an article "The Frequency Synthesizer" by H. J. Fin-

[Continued on page 19]



History of Communications Number Four of a Series

SMOKE SIGNAL COMMUNICATIONS

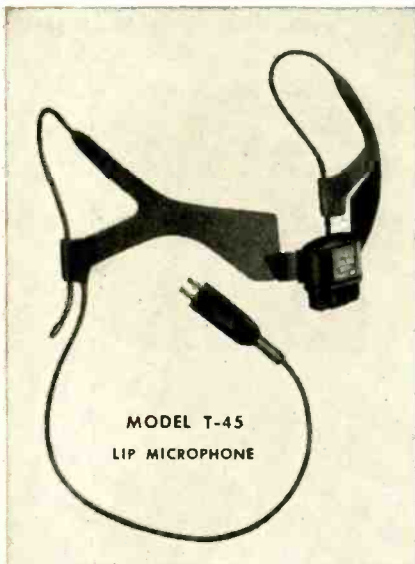

While the puffs of our early American smoke Signals were not as complicated as the Morse Code, this type of communication was a speedy and effective means of communication at that time and could be seen for scores of miles on a clear day. Used for transmitting their battle messages, smoke signals in the days of the early American meant a progressive means of communication.

Restricted by climatic conditions this type of communication was limited in its use. Universal microphones in the part they play in modern electronic voice communication must withstand the climates of the Arctic and the Tropics all in a day's work. Built to accomplish a specific job, Universal Microphones are "getting the message through" on every Allied front.

Model T-45, illustrated at left, is the new Lip Microphone being manufactured by Universal for the U. S. Army Signal Corps. Shortly, these microphones will be available to priority users through local Radio Jobbers.

UNIVERSAL MICROPHONE COMPANY
INGLEWOOD, CALIFORNIA



FOREIGN DIVISION: 301 CLAY STREET, SAN FRANCISCO 11, CALIFORNIA .. CANADIAN DIVISION: 560 KING STREET WEST, TORONTO 1, ONTARIO, CANADA

RADIO

★ APRIL, 1944

17

wherever a tube is used...

for example — INDUCTION HEATING

Electronic heaters with inductor coils connected to terminals of Oscillator Type Tubes, are used for brazing, soldering, hardening, and banding of small diameter parts, thin sections and low resistance materials.

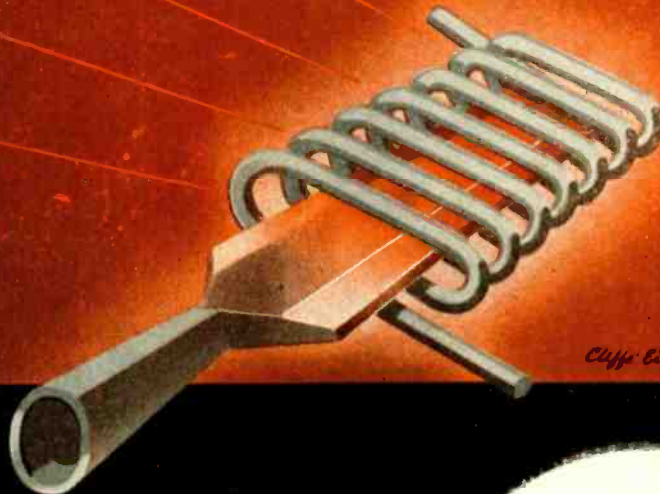
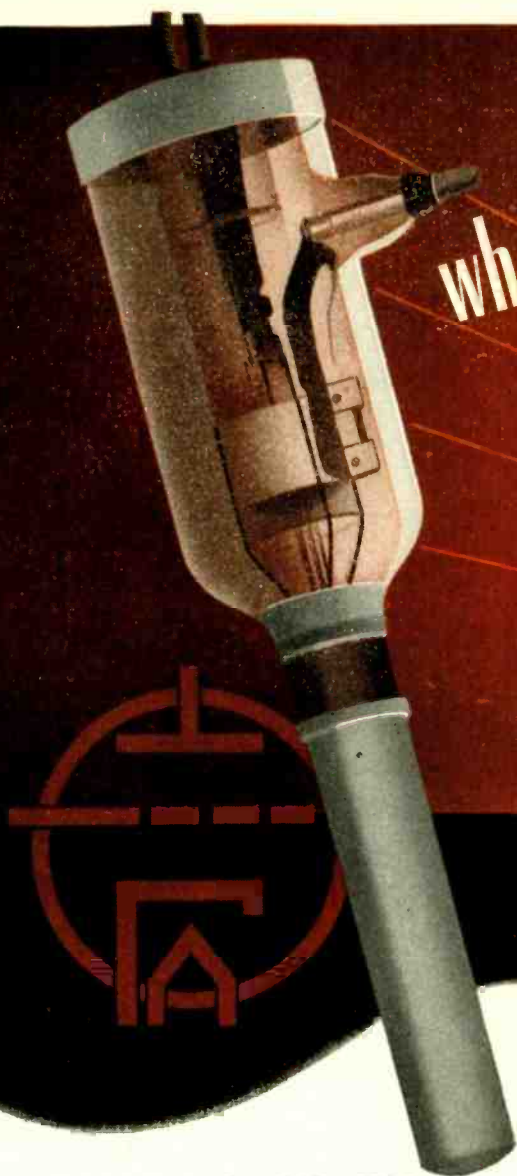

THERE'S A JOB FOR

Relays BY GUARDIAN

Induction heating costs less, is more dependable and easier by the electronic method. Safer, too, even with inexperienced hands, when protected from improper operation by quality relays such as the Guardian Series 90 Interlock Relay and the Series L-500 Overload Relay.

Series 90 Interlock Relay locks mechanically from an electrical impulse and unlatches or resets from another such impulse. Combinations up to DPDT available with $12\frac{1}{2}$ amp. contacts rated at 110 v., 60 cycles, non-inductive load. Coil resistances up to 10,000 ohms. For AC or DC operation.

Series L-500 Overload Relay, manual reset, protects DC circuits against abnormal current surges where current conditions are constant. Contacts can take severe overloads undamaged, cannot be reset during overload. Rated for 1500 watts on 110 v., 60 cycle, non-inductive AC.

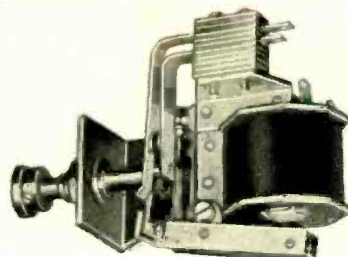

Series L-500—Overload Relay
Ask for Bulletin R-5

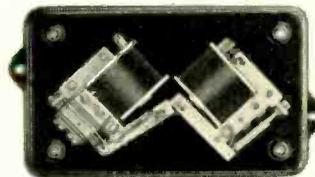

Series 90—Interlock Relay
Ask for Bulletin 21

Consult Guardian wherever a tube is used—however—Relays by Guardian are NOT limited to tube applications but may be used wherever automatic control is desired for making, breaking, or changing the characteristics of electrical circuits.

GUARDIAN  **ELECTRIC**
1605-D W. WALNUT STREET CHICAGO 12, ILLINOIS
A COMPLETE LINE OF RELAYS SERVING AMERICAN WAR INDUSTRY

TECHNICANA

[Continued from page 16]

den in the *Journal of the Institution of Electrical Engineers*, Part III, for December, 1943. The frequency synthesizer is an instrument for the generation of any harmonic of any subharmonic of a standard frequency signal. By addition and subtraction of these harmonics it is possible to generate any frequency with a pure output. Or, in other words, the frequency synthesizer is a standard signal generator which is variable in steps, and in which the required frequency can be set by means of several decade switches in the same manner as these are used in a resistance box. The smallest step can of course be 1 kc or 10 kc or any amount desired.

The principle of the frequency synthesizer is illustrated in Fig. 5. The signal of a standard frequency oscillator (1000 kc for purposes of illustration), is fed to several frequency dividers in cascade; the order of frequency division in each case is 10. Thus we obtain sources of 1, 10, 100 and 1000 kc. Each of these signals is fed to a harmonic generator and the appropriate harmonic (up to the ninth) of each can be selected by tuned circuits which are switched. The sum of the four chosen harmonics is obtained by successive heterodyning in the balanced modulators *A*, *B* and *C*. Each modulator is followed by a filter which rejects the undesired sum or difference frequency as the case may be. Thus any four digit frequency from 1 kc to 9999 kc can be dialed.

In order to filter out the undesired sum or difference frequency it is necessary that this undesired frequency be sufficiently far removed from the desired frequency. Therefore it is not expedient to use the sum frequency in all cases, but to employ a special technique which is best shown by an example. Let it be required to generate 81 kc. One might select the 8th harmonic of 10 kc and add this to the fundamental of 1 kc, in which case it is necessary to separate the sum and the difference, 81 kc and 79 kc, a difficult thing to do. It is thus better practice to take the 9th harmonic of 10 kc and subtract the ninth harmonic of 1 kc, giving sum and difference frequencies of 99 kc and 81 kc which can be separated much easier. This technique gives rise to a special problem of switching which is also described in the article. The end result is an instrument with direct reading decade switches.

DISC RECORDINGS

In England, there has been considerable discussion among those interested in sound recording as to improvements needed in disc records for

domestic record reproduction. In *Wireless World*, January, 1944, Donald W. Aldous, Technical Secretary of the British Sound Recording Association, surveys suggested improvements in disc recording and discusses possible alternative systems.

Among the suggested improvements and modifications are the following:

- 1). Vertical or hill-and-dale cut.
- 2). Constant amplitude recording.
- 3). Constant groove-speed recording.
- 4). Variable groove-pitch recording.
- 5). Pressings in a "scratch-free" plastic.
- 6). Standardization of groove size, shape and pitch.
- 7). Markings on record labels to indicate frequency characteristic used.
- 8). The coefficient of compression, so that the correct volume expansion coefficient may be used in reproduction.
- 9). The use of an f-m pickup.

It is pointed out that the constant-groove speed method was employed in the "Longanote" record, marketed by Filmaphone Flexible Records, Ltd., in England in the early 1930's and was revived in this country in 1940.

Regarding sound-on-film as an alternative, the difficulties mentioned are the need for a less costly film base than cellulose acetate, the computation of optical components capable of the necessary standard of definition, the need for perfecting mechanical devices for the recording, printing and reproduction of the film, and, finally, the complicated patent situation regarding the use of certain devices and methods.

CRYSTAL-CONTROLLED CLOCK

★ In the March, 1944, issue of the *Bell Laboratories Record* is a description of the crystal-controlled clock developed by Bell Laboratories as a standard of

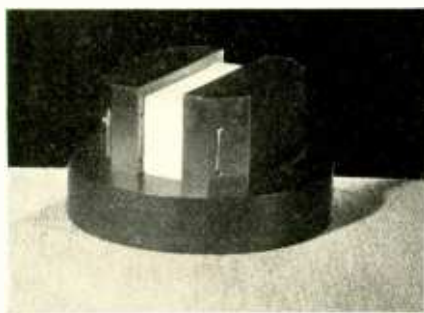

frequency. Originally devised by W. A. Marrison, using the crystal and mounting shown, this clock proved to be a highly accurate timepiece, and when put in operation in 1927 its daily deviation was less than one part in one million. By 1929 this deviation had been reduced to one part in ten million and now its accuracy is better than one part in a hundred million and its design has been considerably simplified.

[Continued on page 56]

Ultra-High-Frequency

Transmitting

Capacitors



● Engineered and especially recommended for use in ultra-high-frequency FM radio transmitters. Readily adaptable for use as fixed tuning capacitors, by-pass, blocking, coupling, neutralizing, and antenna-series capacitors.

AEROVOX TYPE 1860

Losses extremely low due to highly refined sulphur dielectric. Corona losses avoided by unique construction design, grounded case, and single high-tension mica-insulated terminal.

10,000 test volts eff. .0001
.000025, and .00005 mfd.; 5000
volts. .00005 mfd.

Catalog lists maximum current in amperes at operating frequencies from 1000 KC to 75 MC max., for this and the 1865 type.

Type 1865 (not illustrated) differs in use of cast-aluminum case and steatite insulation supporting terminal.

● Ask Our Jobber...

Ask about these and other types of capacitors for your requirements. Ask for latest catalog—or write us direct.



Capacitors

INDIVIDUALLY TESTED

AEROVOX CORP., NEW BEDFORD, MASS., U. S. A.

In Canada: AEROVOX CANADA LTD., HAMILTON, ONT.

Export: 13 E. 40 ST., NEW YORK 16, N. Y. Cable: 'ARLAB'

Famous Signatures

Michel Angelo Rembrandt

Morganstouff Whistler

Leonardo da Vinci Rubens

Vincent Van Gogh A. VANDYCK

Raphael P. Cezanne

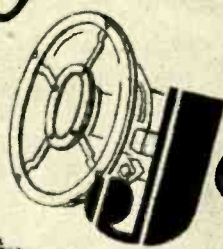

Jensen

Manufacturers and Designers of Fine Acoustic Equipment

JENSEN RADIO MANUFACTURING COMPANY, 6601 S. LARAMIE AVE., CHICAGO 38, U. S. A.

Reactive Phase in WAVE GUIDES

V. J. YOUNG

Engineer, Sperry Gyroscope Company

★ In calculating the transfer of electrical energy in ordinary wired circuits, we are usually concerned with one or more of three basic circuit elements; inductance, capacitance, or resistance. At audio and low radio frequencies, nearly everyone has a pretty good idea of how these look and knows something about how they act, both as lumped elements in a circuit and as a distributed effect along a line. On the other hand, when we deal with microwaves and use either a wave guide or coaxial line so that it is difficult or impossible to measure currents and voltages, we may have to think hard to know how even to define the terms to say nothing of making efficient use of them.

Why fundamental ideas of phase relations at low frequencies must be modified when dealing with microwaves in wave guides and coaxial lines

Fig. 1B shows the same sort of argument for an inductance. Here the voltage depends upon the rate of change of the current. This rate of change is greatest when the current first starts to flow and still has a lot of increasing to do. Thus, with an inductance, the voltage leads the current because its maximum comes first and it approaches zero when the current has built up to its final steady value.

With resistance there is neither leading nor lagging; when the switch is closed both voltage and current instantaneously attain their final values.

In Fig. 1D is shown how this leading or lagging appears when alternating current is used instead of a battery and a switch. The facts are that a.c. is just an automatic method of switching the battery with a little polarity reversing thrown in for good measure.

Current and Voltage

Fig. 1 illustrates the way in which current and voltage appear in and across circuit elements as a function of time. If the element is a capacity, then current must first flow and the charge be carried to the capacitor before a voltage can appear there. Thus, with a capacity, the current leads the voltage. In Fig. 1A the case is shown for a d-c source connected through a switch to a capacitor. At the instant just before the switch is closed, both i and v are of course zero. Thus, when we plot current and voltage against time, both are zero until the switch is closed. However, immediately the circuit is completed, a current begins to flow and as time passes this current becomes smaller until, when the condenser is completely charged, it is zero. The voltage across the condenser, on the other hand, cannot appear until a current has carried a charge to the condenser and cannot reach its full value until the condenser is completely charged.

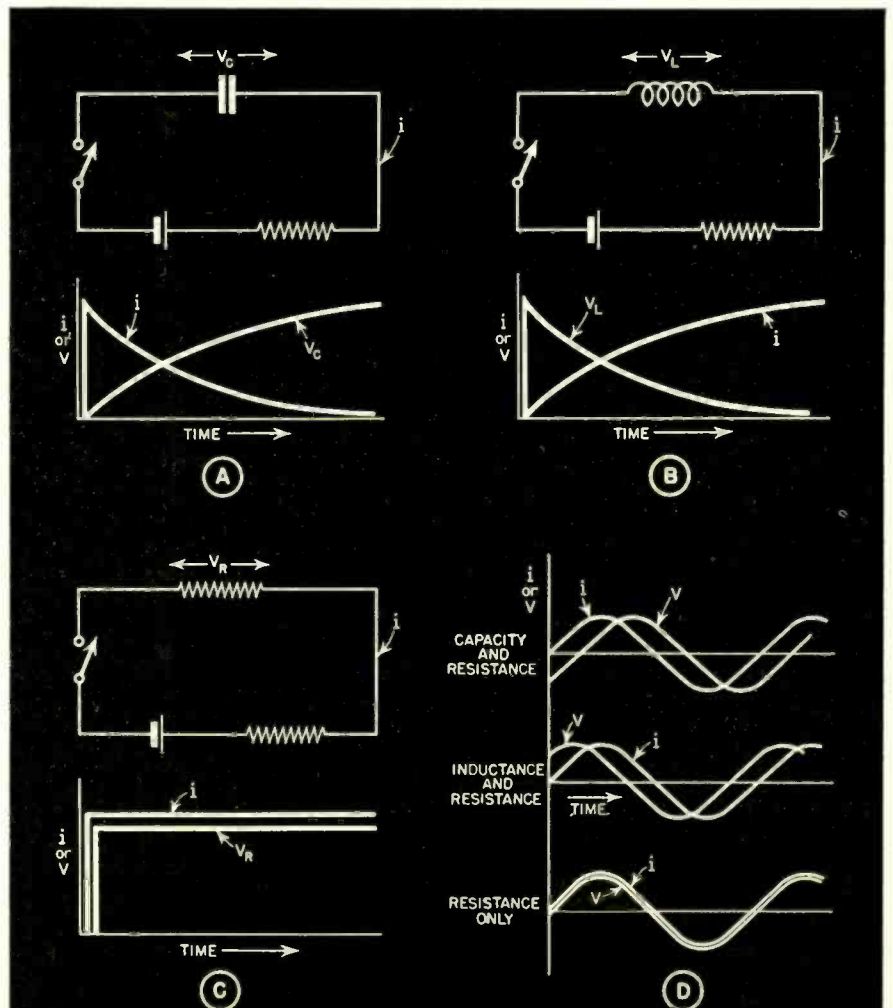

Fig. 1. Phase difference between current and voltage for inductance, capacitance and resistance.

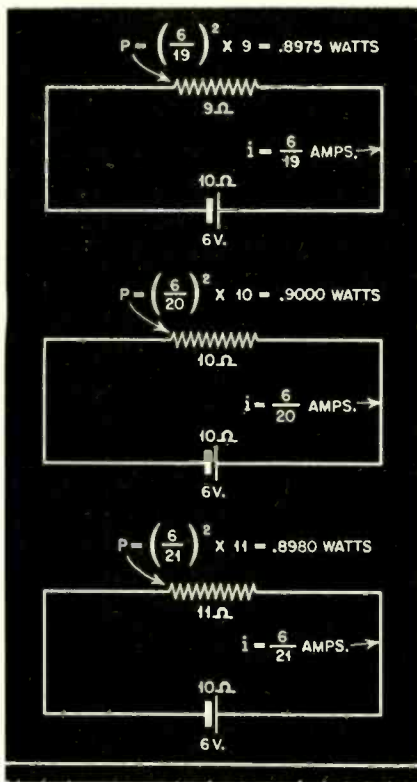

Fig. 2. Illustration of impedance matching to obtain maximum energy transfer from source to load

The values of inductance and capacitance, expressed as coefficients of inductance or capacitance and usually given in henrys or farads, are of less concern to us in microwave transmission along wave guides and coaxial lines

than are the more direct quantities of inductive or capacitive reactance. The usefulness of farads and henrys in wired circuits depends upon the fact that over reasonable frequency ranges these quantities are independent of frequency. A given coil may be said to have an inductance of 500 mh whether a frequency of 100 or 200 cycles is used. The coefficient of inductance is really an electrical description of the mechanical arrangement of the coil. With wave guide propagation, however, the frequency is more or less fixed by the shape and size of the wave guide and the transmission mode being used. Over the fairly small percentage-wise range of frequencies allowed in normal designs, impedance is as good a measure of the inductive or capacitive property of a wave guide circuit as we require and much more directly useable.

Impedance Matching

Impedance or reactance, moreover, does serve the same function in microwave transmission as in low-frequency work. Namely, it is useful as a criterion for matching one line into another. In Fig. 2 is drawn a 6-volt battery whose internal resistive impedance is 10 ohms. It is shown connected successively to load resistances of 9, 10 and 11 ohms. The simplest use of Ohm's law gives the current that will flow in each case and i^2r tells the power delivered to the load. A maximum power transfer from the battery

to the load is obtained when the impedance of the load is just equal to that of the source. The same is true of microwave impedance; if power is to flow from one wave guide device into another, then a maximum transfer will occur when the impedances of the two are equal. Just as in ordinary alternating current matching, this equality of impedance implies correctness of phase as well as magnitude. It is this matter of phase which particularly concerns us here.

In order to see how inductance in the ordinary sense can be interpreted for microwave measurements where we measure electric and magnetic fields rather than currents and voltages, which are much more difficult for wave guides or coaxial lines, we will first examine cases with which we can be sure of what to expect with low frequencies and try to visualize the electro-magnetic fields. Fig. 3 illustrates this. In Fig. 3A is shown a length of coaxial line shorted at the far end. From the viewpoint of ordinary circuit theory this represents just a closed loop and should thus be expected to be inductive. In Fig. 3B is shown another length of line, but this time with an open circuit at the far end. This should be expected to be capacitive.

In each of the coaxial lines of Fig. 3, curves are drawn to represent the strength and sense of the electric or magnetic field. Assuming that the line is of small enough diameter to insure operation in the fundamental mode, those curves which are drawn with the center wire as the abscissa show by their amplitude the strength of the electric field between the inner and outer conductor or the strength of the magnetic field around the center wire. Each curve represents the situation at some particular time so, if we imagine an infinite number of these curves drawn in, we have a representation of the fields for every instant during a cycle. In each of the coaxial lines shown in Fig. 3 one of the curves of the family is drawn as a solid line while the rest are broken. By focusing our attention on the solid curve, it is quite easy to see the similarity of field phase shift to that of ordinary currents and voltages. Specific impedance in a wave guide or coaxial line may be defined as E/H , where E is the electric field and H the magnetic field. The phase angle between E and H indicates whether the reactive component of that impedance is inductive or capacitive.

In Fig. 3A, at a given instant the electric field is 90° further from the source than is the magnetic field. This corresponds to the usual statement that, with inductance, the voltage leads the current by 90° . In Fig. 3B it is the

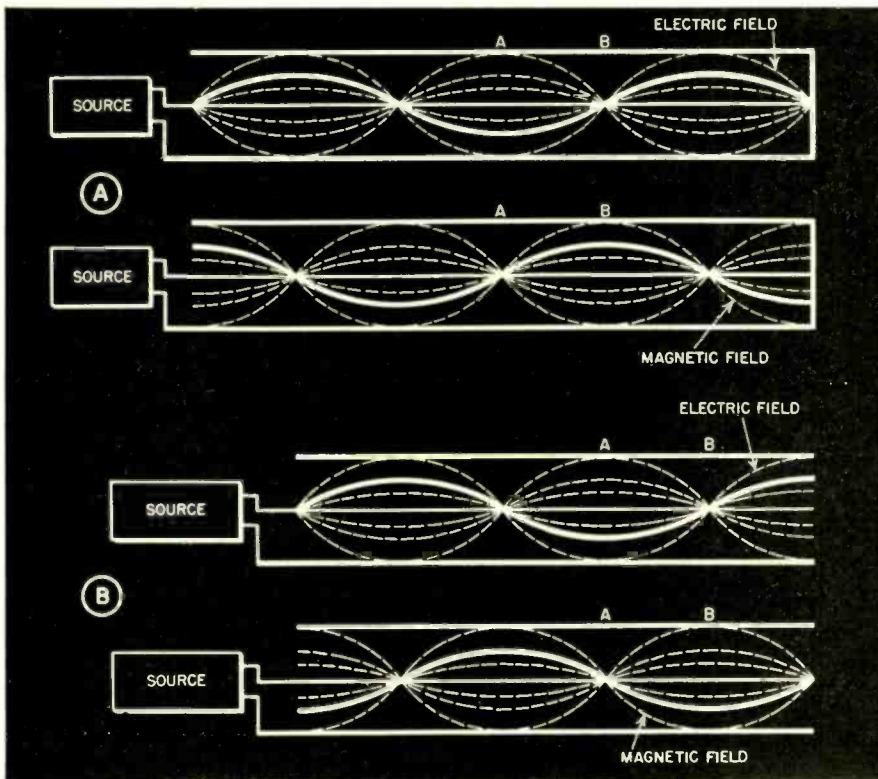

Fig. 3. Inductive and capacitive effects of short-circuited and open-ended coaxial lines, both tuned to produce standing waves with the source at an approximate node

magnetic field which is furthest from the source, corresponding to a capacitive advance of current phase over voltage. Indeed, these correspondences come as no surprise since any expression we can ever write down for magnetic fields other than those of permanent magnets invariably depends upon current, and the electric field is itself measured as volts per cm.

Standing Wave Characteristics

Actually, the correspondence is somewhat less clearly shown by *Fig. 3* than has been intimated above. With current and voltage, an inductive phase shift means that at a given point across the inductive loop, the maximum voltage is followed by a maximum current at a length of time later equal to a quarter of a cycle. With the coaxial line cases shown in *Fig. 3*, we are dealing with standing waves and a maximum electric field is never found at a point where a maximum magnetic field may be observed. The answer to this lies in the discussion of how standing waves are generated by traveling waves proceeding in opposite directions¹ and is really no different whether current and voltage or electric and magnetic fields are considered. The important thing is to see that a measurable change in wave guide or coaxial line propagation does exist, depending upon inductive or capacitive properties of that line and the source and load connected to it.

As a matter of fact, if access is had only to a central section of a uniform line and no specifications of the load or source are given, it is impossible by ordinary measurements to distinguish between pure capacity and pure inductance. Normally, the only measurement made on a wave guide or coaxial line is that of standing wave ratio. This is usually accomplished by a scheme similar to that shown in *Fig. 4*. Effectively, the apparatus measures the average value of the electric field and, by moving the probe carriage along the wave guide, it allows this measurement to be made as a function of distance along the guide. The standing wave ratio, usually abbreviated as swr, is then defined as the ratio of the largest to the smallest measurement of the average electric field that may be found in moving the carriage along the guide through a distance of one wavelength. Thus with a short-circuited or open-circuited conductor such as that shown in *Fig. 3*, where no net energy is transmitted, the swr is infinite. The probe would give a finite reading at a point such as *A* and a zero reading at *B*. At the opposite extreme

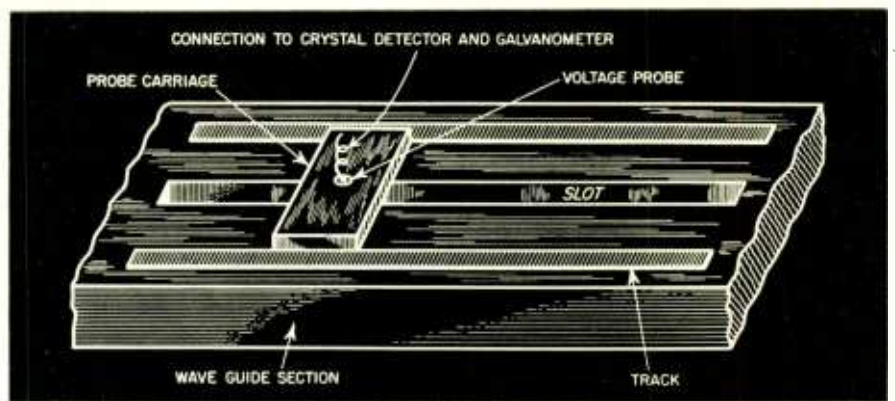

Fig. 4. Schematic diagram of apparatus for measuring standing wave ratio

where inductive and capacitive effects are entirely tuned out and no reflected wave exists, the electric field is shown as a function of time by curves such as those in *Fig. 5*. At any two points such as *C* and *D*, there is no distinction between the average values of the electric field.

SWR Characteristics

Thus swr is by itself a figure of merit of the transmission efficiency of a wave guide or coaxial line. Unity swr indicates perfect transmission; infinite swr shows complete reflection of the energy from a short circuit or open circuit; any intermediate value tells us that some energy is being transmitted and some reflected. It is when these intermediate values are obtained that the concepts of inductance and capacitance are helpful. Since in practice unity swr is usually impossible to obtain, some capacitive or inductive effect is almost always present. When it is desired to substitute one wave guide device for another in an array where unity swr cannot be obtained, it is necessary for a proper match and hence, for the same or a better swr in the whole system, the new component must not only be capable of a low swr itself, but also have the same inductive or capacitive property as the piece to be replaced.

Fig. 6 shows a simple case in which a discontinuity of some sort in a piece of line is such as to give a swr greater than unity. Both in *Fig. 6A* and in *Fig. 6B* a swr of about 1.5 is illustrated, but while that in *Fig. 6A* is capacitive, that in *Fig. 6B* is inductive.

The energy flowing from left to right up to the junction is shown as two parts, one of which travels on past the junction into a line with unity swr, and the other part of which is reflected to form the standing wave as shown. It is clear in this particular case that a measurement with swr apparatus can easily distinguish between the two. If the maximums ahead of the junction come nearer to distances of an odd number of half wavelengths from the junction, the reactance is inductive; if they come nearer to an integral number of whole wavelengths, the reactance is capacitive.

Wave Guide Constrictions

As an example of how a wave guide section may be made inductive or capacitive, *Fig. 7* shows constrictions in a rectangular guide that are appropriate. A wave guide of this sort is very often operated in a mode such as to cause the electric field to occur across the small dimension and the magnetic field along the larger one. If this mode is maintained and if the diaphragm-like constrictions are very thin as compared to a wavelength, then a partial closing of the guide which completely shorts circuits part of the electric field will appear as an inductive reactance in the guide; a constriction in the other direction will appear as a capacitive reactance; and a combination of the two may be so proportioned as to match the impedance of the guide and cause no reflection at all.

It is easy partially to understand the inductive case from the discussion of

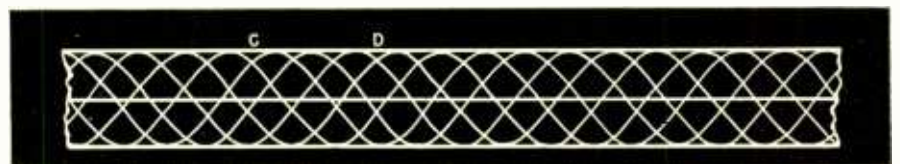

Fig. 5. Electric field in a coaxial line with unity standing wave ratio

¹ Mismatching in Coaxial Lines, RADIO, April, 1943.

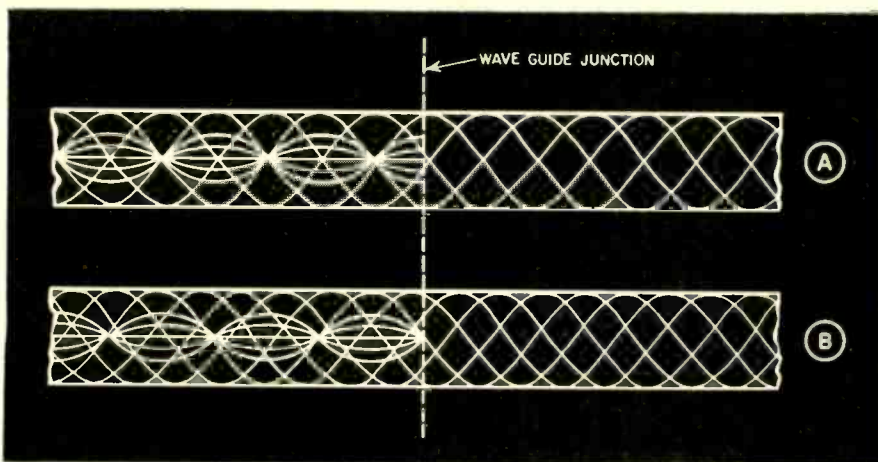

Fig. 6. Inductive and capacitive wave-guide junctions, each having an swr of 1.5

Fig. 3 alone. Just as in that sketch a short circuit of a coaxial line was seen to compare with inductance in the ordinary sense and the effect on the field distribution thus created, so here the electric field is short circuited in part and any standing wave in the electric field caused by reflection must have a node at the constriction as characterizes inductance. Moreover, a capacitive constriction does not represent a short circuit of the electric field, but only raises its intensity by causing the same voltage on the walls of the guide to be distributed over a smaller air gap so that the number of volts per cm is higher. In a sense, however, such a constriction may be said to be a short circuit of the magnetic field in the same way that an open line is a magnetic short or at least a null. No current can flow near the open ends of the open-circuited line of Fig. 3 simply because there is no place for it to go, and thus a magnetic node in the standing wave is assured. In the wave guide constriction case, the electric field is

concentrated at the gap, and only there can dielectric currents flow to maintain the magnetic field. Another way of saying it is that with the capacitive constriction, eddy currents flow in the constriction and keep part of the traveling magnetic field wave zero so capacitive reflections characterized by a node there in the magnetic field are obtained.

Need for Empirical Data

Actually, all this is only an explanation in part and may even be a dangerous one if it is not understood to be only a way of showing wave guide results in terms of quantities which are more or less familiar. The complete story of wave guide propagation and the design of terminations, joints, bends, etc. is a difficult one; so difficult in fact that current practices are still best classed as an art rather than as a science. When direct and complete calculations can be made, they are invariably based upon Maxwell's field equations and give results directly in terms

of the E and H field. The whole idea of reactance and impedance is then only an unnecessary step on the way to the solution. More often, however, the mathematical calculations must be tempered with empirical data, and impedance quantities serve to present the facts to the engineer in a manner analogous to the problems which arise in transmission line theory.

For example, the equivalent impedance of a piece of very regular rectangular wave guide may be calculated for the mode we have discussed to be equal to

$$Z = K \frac{E b}{H a}$$

where K is a constant independent of the dimensions of the guide, E and H are the maximum values of the field as obtained at the center of the guide and b and a are, respectively, the shorter and longer dimensions of the guide. Calculations also show that the ratio E/H may be expected to be represented by

$$\frac{E}{H} = \sqrt{\frac{\mu}{\epsilon}} \frac{1}{\sqrt{1 - (\lambda_0/2a)^2}}$$

where μ and ϵ are the permeability and dielectric constant of the medium, and λ_0 is the free space wavelength of the frequency being transmitted. From these two equations it is clear that we should be able to obtain a perfect match between two sizes of rectangular guide by selecting proper values of b and a to give the same Z . Experimentally, this is verified within certain limits, as we also might well expect it to be from our considerations of matching diaphragms. Electrically, the insertion of a rectangular matching diaphragm like that one shown in Fig. 7, is the same as inserting a very short length of smaller guide.

Practical Limitations

If this criterion for matching different size rectangular guides is examined more closely, however, it will be seen that it must not be followed blindly. It follows from the equations, for example, that if a becomes only very slightly greater than a half wavelength, b becomes very small. This means that in theory a very thin wave guide can be constructed with any desired impedance. With such a guide, however, the necessary fields become very great and dissipative losses due to corona and the resistance of the walls may make its use prohibitive.

Also, at wave guide junctions, the possibility of coupling to other modes of propagation must not be overlooked. In the straight sections of a wave guide

[Continued on page 55]

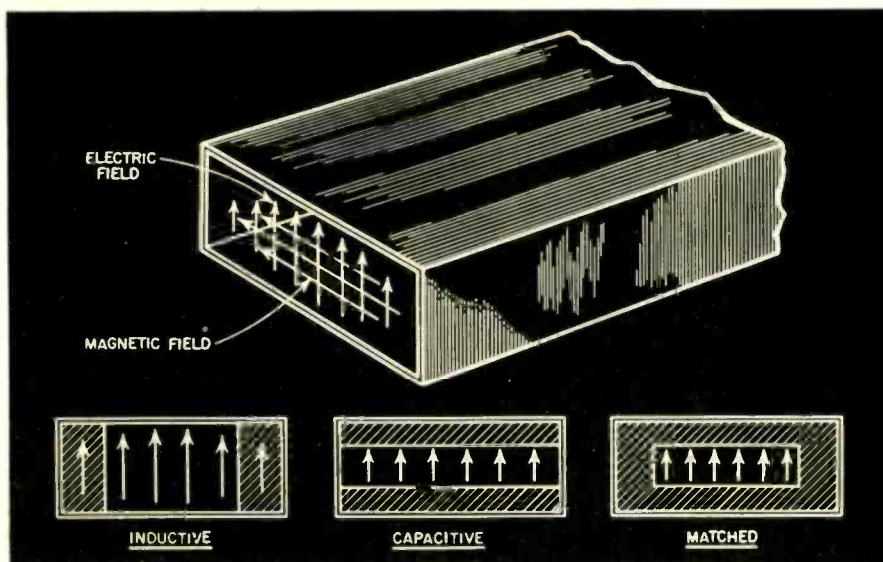

Fig. 7. Reactive constriction in a wave guide

NOTES ON OSCILLATOR CRYSTALS

JOSEPH ANLAGE

Engineer, North American Philips Co., Inc.

Crystal characteristics, design data and methods of securing improved performance at high frequencies from crystal-controlled oscillators

★ It is sometimes thought that frequency control with a quartz plate is possible only at one selected frequency, that frequency being its calibrated value. Actually, a number of other possible modes of frequency control are available from the same quartz oscillator plate. This is especially true of the so-called low-drift type of crystal unit. While the remote modes of motion are not usually excited for use in the control of frequency, it is hoped that the proposed methods and applications to be described here will be of use in extending the range of frequencies as well as the usefulness of the average crystal oscillator plate.

Types of Crystal Cuts

Crystal cuts having designations peculiar to their respective manufacturers may be summarized as follows: AT, BT, CT, DT, AC, V1, V2, C, E, X, Y, Z.—Tourmaline, X—Circular. These

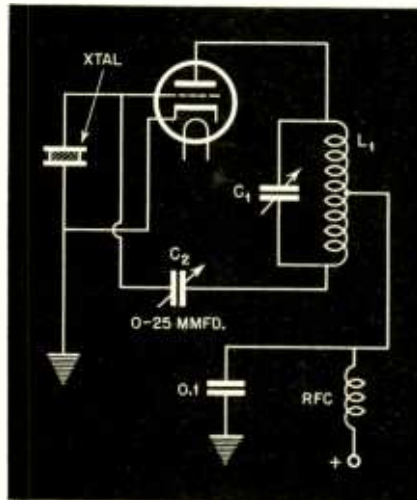

Fig. 2. Low-frequency crystal-controlled oscillator circuit

present any unusual difficulties. A circuit such as is shown in Fig. 1 will almost always excite any of the crystal cuts mentioned previously and is especially good at high frequencies. The circuit of Fig. 2 is particularly adaptable to low-frequency oscillators. Feedback is controlled by adjustment of C2.

The tri-tet oscillator circuit shown in Fig. 3 is familiar to most engineers and technicians. With careful adjustment of the inductance and capacitance arrangements it is possible to gang the tuning controls and thus adjust the frequency more conveniently. An inductive reactance must be presented to the crystal element to have a smooth starting of oscillation and control of the circuit when its resonant frequency is approached. The design data tabulated in Table 1 will

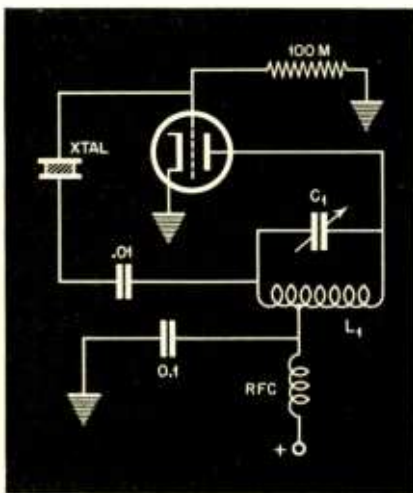

Fig. 1. Sensitive high-frequency crystal-controlled oscillator circuit

are, at present, the most widely distributed types of oscillator crystal units, although they are only representative and are by no means a complete listing of all usable types that may be manufactured. These identifying letters and numbers do not necessarily indicate that the cuts are different in each case; actually, a few are very similar in orientation.

When properly tuned in a circuit adapted for the purpose, practically all these types will have one or more rather low frequencies of vibration, depending upon the various sizes and dimensions of the crystal. Factors which influence the efficiency of these low-frequency modes of motion are, for the main part, holder mounting arrangements and the quality of the ground crystal.

Circuit arrangements are also most important, but in general these do not

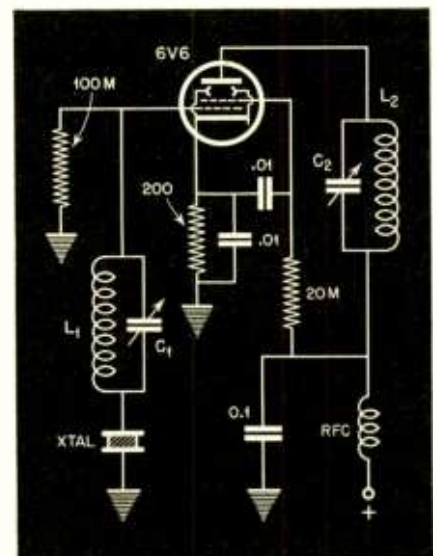

Fig. 3. High-frequency crystal-controlled oscillator circuit

TABLE 1

Cut	Thickness Mode (K)	Low Freq. (K)	Harmonic (N x K)
AT	65.3	120	65.3
BT	100.4	82	100.4
CT	66.5	122	66.5
DT	101	83	101
AC	65	120	65
V1	67	121	67
V2	98	81	98
C	65	120	65
E	92	85	92
X	113	130	113
Y	77.5	113	77.5
Z—Tourmaline	146	172	146
X—Circular Quartz	113	150	113

Frequency in kc = $K/\text{thickness in inches}$.
 $N = \text{odd harmonic multiple}$.

K is a numerical constant used in the calculation of frequency of a crystal. It is a function of the elastic constants present in the crystal unit and varies with the orientation and mode of vibration of the crystal plate.

provide a fairly close approximation of the frequency response for various types of cuts.

The temperature coefficients of the thickness-mode oscillator plates are perhaps familiar to many users, at least of the more popular cuts such as X and Y types. A convenient calculation may be used to readily determine the temperature coefficient of any quartz plate over a temperature range of known intervals. Substituting in the following

$$\text{Average T.C./mc/}^\circ\text{C.} \cong \frac{\text{change in freq. in cycles}}{(\text{change in temp. } ^\circ\text{C})(\text{freq. mc})}$$

For crystals vibrated in the contour or face-shear mode, the temperature coefficient is easily changed by adjustment of the length and width dimensions of the plate as well as the orientation angle. Normally, for use at frequencies controlled by the thickness dimension, the temperature coefficient is fixed by the manner in which it was originally oriented from the rough quartz crystal. For quartz oscillator plates approximately .020 inch or more in thickness, when carefully adjusted

by grinding, the two dimensions of length and width will also affect somewhat the temperature coefficient. The axial relationship and various modes of operation are shown in Figs. 4 to 7, inclusive.

It may be interesting to point out the variations in temperature coefficient introduced by electrode pressure. By reducing the pressure on a given crystal or rearranging the electrode positions the average temperature coefficient may easily be changed to a greater or lesser degree. This is especially noticeable with relatively thin thickness-mode oscillator crystals.

Power Capabilities

Excitation of quartz oscillator plates in the various modes of motion affects the ability of the crystal to handle successfully a worthwhile amount of impressed voltage and current. As may be expected, the frequency involved bears an important relationship to the power capabilities of a particular type of quartz plate. The orientation, physical dimensions and mounting arrangements are very important items. Shown below are the approximate current

limits of an average low-drift crystal at various frequencies with an impressed radio-frequency voltage of 75 volts, rms.

Approximate Frequency	R-F Current Max. Ma.
200 kc	5
500 kc	15
2,000 kc	50
5,000 kc	90
10,000 kc	130
20,000 kc	175

It is normally good practice to run the oscillator circuit at low values of current and voltage in order to prevent a temperature rise in the crystal and a resulting change in its frequency. While this is not serious in the low-drift type of unit, it does result in the possibility of change of activity that may reduce the expected amount of output. Perhaps the urge to step up the oscillator output will produce re-

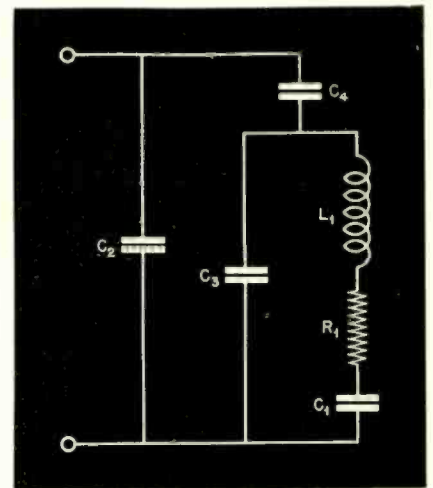
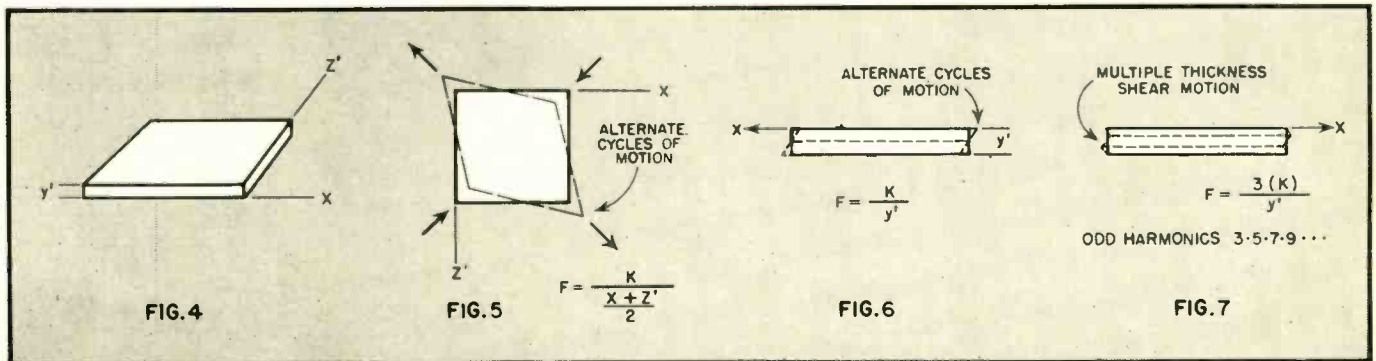

Fig. 8. Equivalent circuit of crystal and holder

sults far in excess of the recommended limits mentioned; if so, the particular quartz plate used is probably not well manufactured and not the best specimen of a high-Q crystal.

Modes of interference that couple to the main desired control frequency will in large part limit the rate of power



Quartz oscillator plate, showing axial relationship for a rotated orientation; face shear, thickness shear, and harmonic thickness shear modes of crystal

capability of a crystal plate. In such cases, fractures are easily produced with slight overloads. X- and Y-cut units are especially bad in this respect. The AT and AC types are excellent for their good electromechanical activity in conjunction with relative freedom from interfering modes of coupling which cause conflict in the power transfer.

Crystal cleanliness is important. If not sufficiently free from foreign matter, its potential activity response will be damped out to some degree. As normally manufactured and mounted, crystals produced in years past have, over a period of time, seemed to diminish in activity with an accompanying frequency rise. Perhaps many of these units were taken apart and cleaned. If so, they probably exhibited new life but with a decided frequency rise. Unfortunately, this was unintentional at

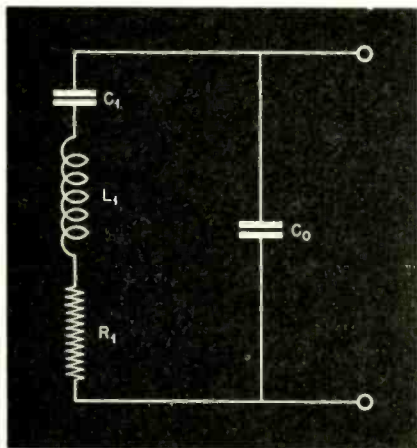

Fig. 10. Equivalent circuit of plated type of crystal unit

the time of manufacture but it went unsuspected for the most part and the cause was not very well understood. The explanation lies in the fact that liberated quartz particles collected on the surfaces of the ground quartz crystal for a few days or weeks after the final frequency adjustment was made. The grade of abrasive used in this adjustment produced a proportional sub-surface disturbance that did not, at once result in a stable condition. This trouble is, of course, most noticeable in thickness-mode oscillator plates of medium, high and ultra-high-frequency types, this latter type including the harmonic-mode oscillator plates such as the C and E cuts.

Harmonic Operation

Plates designed for fundamental thickness shear-mode operation can be used in many cases at the odd harmonic mechanical multiples of the fundamental frequency. These odd mechani-

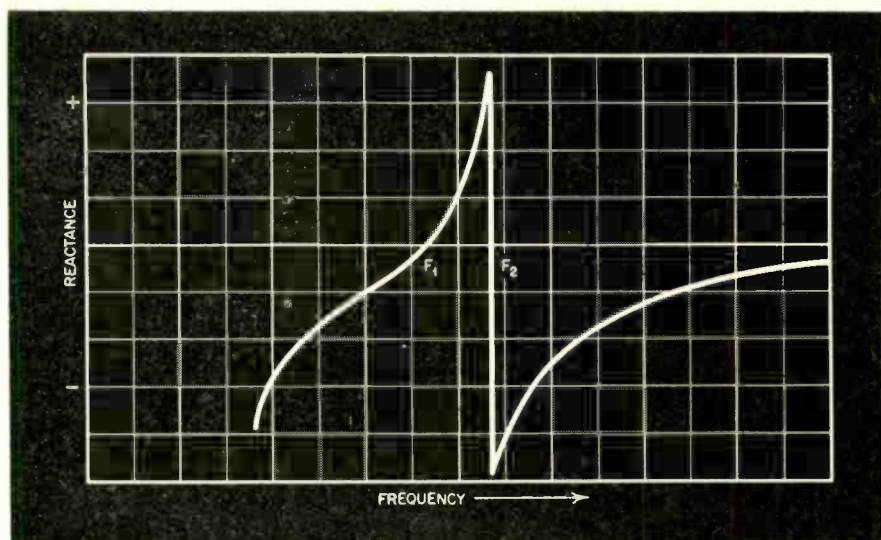

Fig. 9. Typical reactance curve of crystal oscillator plate

cal harmonics are not always multiples of the fundamental frequency to the exact cycle because of circuit conditions as well as holder mounting and grinding technique, although for practical purposes the circuit may be adjusted to produce the precise multiple of the base frequency.

For excitation of the odd-order mechanical harmonic frequencies of a thickness-mode oscillator crystal, the crystal shunt capacity should be kept to a minimum. In the equivalent circuit schematic of a mounted quartz crystal, the holder capacity is represented by C_2 of Fig. 8 and is the principal cause of high shunt capacity, excluding the circuit of the oscillator into which it may work. Electrodes with large air gaps in pressure-type mounted crystal units are inefficient at

the harmonic frequencies because of low electromechanical coupling to the surfaces of the quartz plate. Electrodes in physical contact with both surfaces are apt to produce weighted damping that will not permit excitation of these harmonic modes. In any arrangement for using a high mechanical harmonic of the quartz plate it may be assumed that a contact to an area representing one-half the total surface of the particular crystal will be most important and useful at the center.

Operation At Higher Frequencies

To obtain results at these higher frequencies the crystal must contain a rather carefully adjusted surface symmetry. Resonance conditions due to supersonic air columns in the air

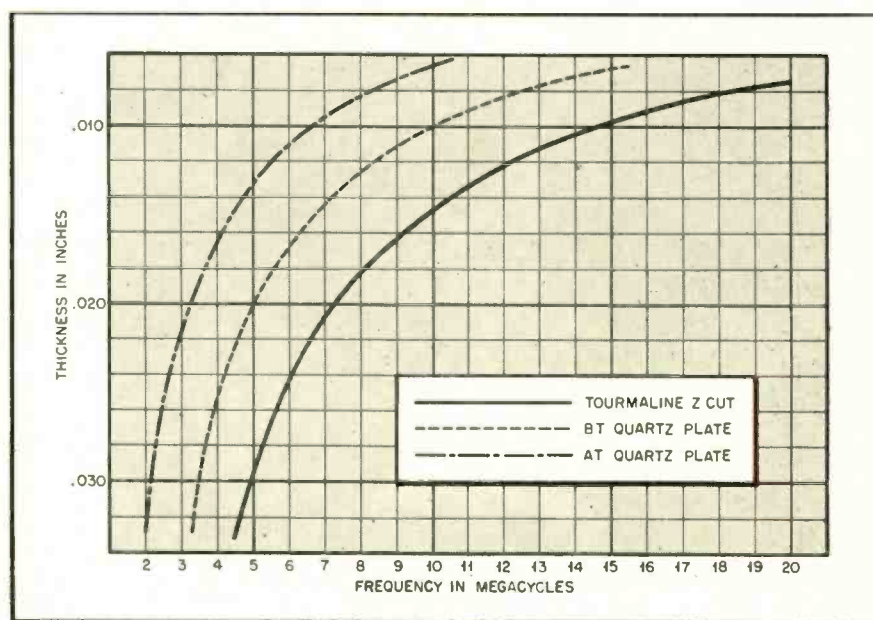

Fig. 11. Frequency-thickness curves of tourmaline (Z cut) and quartz plates

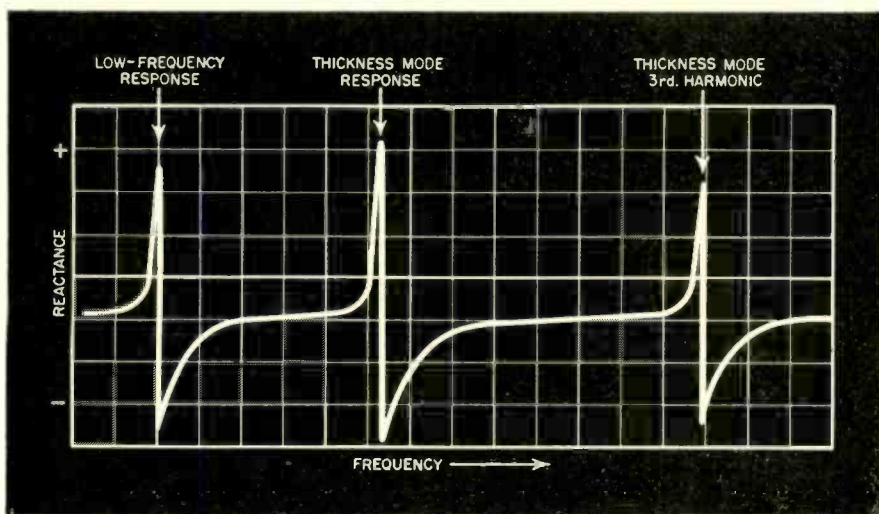

Fig. 12. Reactance vs. frequency response curves

gap may prevent maximum activity at critical air gaps of one-half wavelength and its multiples. If this trouble occurs, a change in adjustment of the air gap will help. However, this adjustment applies only to the temperature at which it is made; the trouble may reappear when the crystal temperature is changed.

A typical reactance curve is illustrated in Fig. 9, where $F1$ is the frequency of series resonance and $F2$ is the frequency of series resonance of

an average crystal oscillator plate. The available inductive region between $F1$ and $F2$ is a measure of the ability of the crystal to oscillate satisfactorily. It can be seen from the formula

$$F2 = \frac{1}{2\pi \sqrt{L C_1 C_0 / (C_1 + C_0)}}$$

that $F2$ will be close to $F1$ if C_0 is large with respect to $C1$. In most circuits C_0 of Fig. 10 is of the order of 10 $\mu\mu\text{f}$ or larger, with a resultant reduction in the inductive band-width.

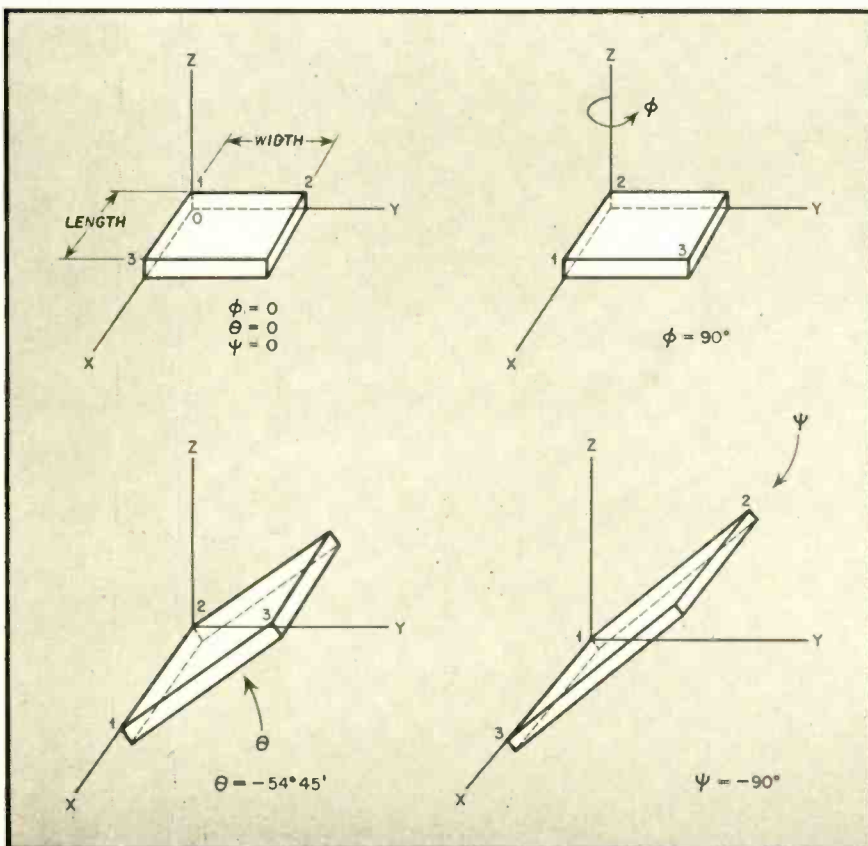

Fig. 13. Orientation for AT-cut crystal (IRE nomenclature). For all orientations viewing from 1 to 0 and 2 to 1 counter-clockwise is positive

To successfully excite odd mechanical harmonics of the average thickness-mode type, above 7 times the fundamental, a reduction in $C2$ of Fig. 8 and oscillator input capacity must be effected. If this can be carried to a redesigned holder of very low loss and physical shunt capacity, the possibility of exciting the 9th and 11th harmonics directly will be possible. A bridge-type oscillator circuit of a regenerative type will provide a means of realizing fundamental output from a single oscillator stage at approximately 100 mc with conventional crystal units. A compact oscillator circuit using the acorn type 955 tube will provide a satisfactory exciter at high harmonic frequencies when used in the circuit of Fig. 1.

Metal-plated Crystals

Metal-plated crystal units are being given serious consideration for use in all types of circuit applications. Metal or other conductive coatings may be applied to the crystal surfaces by a variety of methods such as sputtering, evaporation, chemical solution, metal pastes, and electroplating.

The effect of the conducting film on a crystal will vary with the mode of vibration used. When the thickness mode of motion is used, the film of metal coating acts as a loading factor that changes the resonant frequency of the crystal being measured. The coating should bear a uniform thickness over both major plane surfaces of the crystal and have a point-to-point resistance of preferably less than 10 ohms d.c. for a given plated surface.

The natural resonant frequency of the crystal is reduced in direct proportion to the thickness of the deposited film over a substantial percentage of its resonant frequency. Frequency adjustment to closely specified limits may be readily attained through application of greater or lesser amounts of coating, as the case may be, for a particular frequency desired. Frequency-thickness ratios can be used as a means for computing the film thicknesses for certain amounts of frequency change, depending upon the type of thickness-mode oscillator being plated.

The equivalent circuit as shown in Fig. 10 is representative of the plated type of crystal unit. It can be seen that the series capacitance normally present in the loose electrode mounted type of holder is not encountered with the adhered metal-film type of conducting electrode. Metal-coated crystals have advantages chiefly in the saving in space and weight over other types of metal electrodes. An increased electromechanical coupling is realized as well as added frequency stability, in portable and close-frequency-toler-

[Continued on page 55]

Revised List Of

Army-Navy Preferred Tubes

Effective Feb. 15, 1944

★ The accompanying Army-Navy Preferred List of Radio Electron Tubes sets up a group of unclassified general purpose tubes selected jointly by the Signal Corps and the Bureau of Ships. The purpose of this list is to effect an eventual reduction in the variety of tubes used in Service Equipment.

It is mandatory that all unclassified tubes to be used in all future designs of new equipments under the jurisdiction of the Signal Corps Laboratories or the Radio Division of the Bureau of Ships be chosen from this list. Exceptions to this rule are hereinafter noted.

The term "new equipments," as mentioned in Paragraph 2 above, is taken to include:

a. Equipments basically new in electrical design, with no similar prototypes.

b. Equipments having a similar prototype but completely redesigned as to electrical characteristics.

c. New test equipment for operational field use.

The term "new equipments," as mentioned in Paragraph 2 above, does not include:

a. Equipments either basically new or redesigned, that are likely to be manufactured in very small quantity, such as laboratory measuring instruments.

b. Equipments that are solely mechanical redesigns of existing prototypes.

c. Equipments that are reorders without change of existing models.

d. Equipments in the design stage before the effective date of adoption of this Preferred List.

The foregoing statements in Paragraphs 3 and 4 above are explanatory in nature and are not intended to be all-inclusive.

In the event that it is believed that a tube other than one of those included in this Preferred List should be used in the design of new equipments for either the Signal Corps or Navy, specific approval of the Service concerned

must be obtained. Such approval, when Signal Corps equipment is concerned, is to be requested from the Signal Corps Laboratory concerned with such equipment; the said Laboratory will then make known its recommendations in the matter to the Signal Corps Standards Agency where the final decision will be made and returned to the laboratory for transmittal to the party requesting the exception. When Navy equipment is concerned, the request for exception shall be addressed to the Radio Division, Bureau of Ships, Code 930-A, Navy Department.

The publication of this list is in no way intended to hamper or restrict development work in the field of radio electron tube or radio electron tube applications.

This list takes effect immediately.
Office of the Chief Signal Officer,
Headquarters, Army Service Forces,
War Department.

Chief of the Bureau of Ships,
Navy Department.

RECEIVING

FILAMENT VOLTAGE	DIODES	DIODE TRIODES	TRIODES	TWIN TRIODES	PENTODES		CONVERTERS	POWER OUTPUT	INDICATORS	RECTIFIERS	MISCELLANEOUS
					REMOTE	SHARP					
1.4	1A3	1LM4	1LE3	3A5 3B7/1291	1T4	1L4 1LM5 1S5	1LC6 1R5	3A4 306/1299 3S4			CRYSTALS
5.0										5U4G 5Y3GT	1N21B 1N23 1N27
6.3	6AL5 6H6* 559 9006	6AQ6 6SQ7* 6SR7*	2C22 2C26 6C4 6J4 6J5* 7E5/1201 9002	6J6 6SL7GT 6SN7GT	6SG7* 6SK7* 9003	6AC7* 6AG5 6AG7* 6AK5 6SH7* 6SJ7* 7W7 9001	6SA7*	686G 6L6GA 6N7GT/G 6V6GT/G 6Y6G	6E5	6X5GT/G 1005	PHOTOTUBES 918 927
12.6	12H6*	12SQ7* 12SR7*	12J6GT	12SL7GT 12SN7GT	12SG7* 12SK7*	12SH7* 12SJ7*	12SA7*	12A6*	1629		VOLTAGE REGULATORS 0B3/VR-90 0C3/VR-105 0D3/VR-150
25 and above								25L6GT/G 28D7	991	25Z6GT/G	

TRANSMITTING

TRIODES	TETRODES	TWIN TETRODES	PENTODES	RECTIFIERS			CLIPPER TUBES	GAS SWITCHING	CATHODE RAY
				VACUUM	GAS	GRID CONTROL			
2C26	801A	5021	2E22	2X2	4B25	3C23	73	1B32/532A	2AP1
2C44	809	715B	803	3B24	83	3C31/C1B	719A	471A	3BP1
6C21	811	807	837	5R4GY	866A/866	C5B		532	3DP1
15E	826	813		371B	872A/872	884			3FP7
VT127A	833A	814		705A		2050			5CP1
327B	838	1625		836					5CP7
434A	1626			1616					5FP7
446A	8005			8016					5JP1
527	8014A			8020					7BP7
530	8025								12DP7 12GP7

*Where direct interchangeability is assured "GT" and "L" counterparts of the preferred metal tubes may be used. Miniature tubes (which are in italics) shall be used only when essential to Service requirements.

Vibration

J. W. DEVORSS, JR.

Mechanical Goods Division,
U. S. Rubber Company

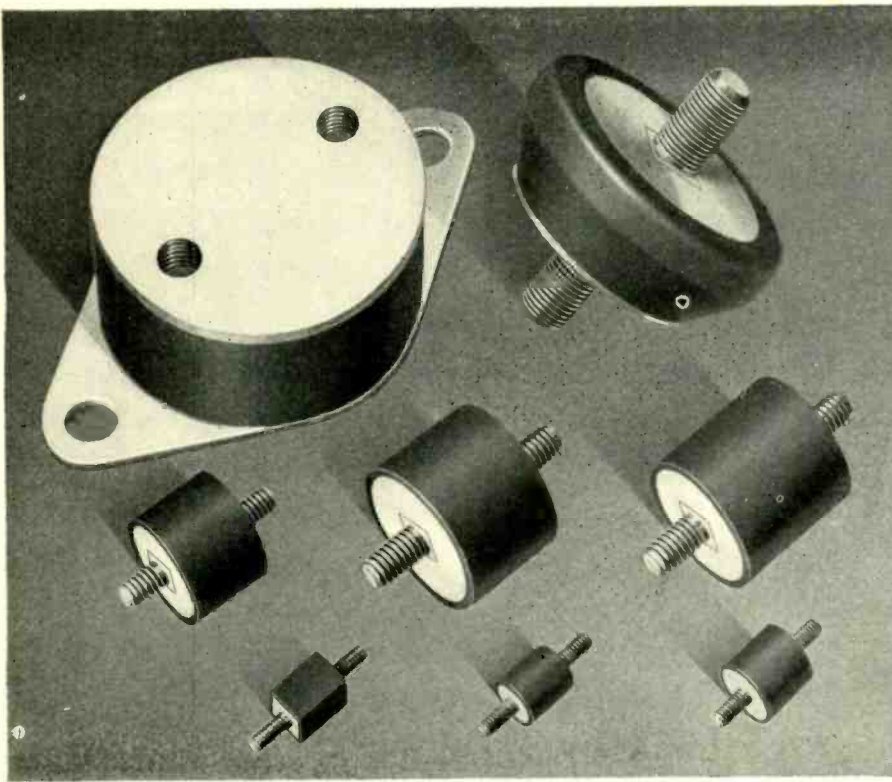

Fig. 8. Cylindrical type rubber mountings

Mechanical Fundamentals

In order to apply rubber to vibration insulation, the mechanical fundamentals must be known. Vibration transferred from a mechanism can be reduced by (1) supporting the entire mechanism on resilient mountings of the proper flexibility and proper design, (2) rigidly securing the mechanism to a heavy foundation, or (3) the use of counter-vibrators. The resilient suspension of a machine is generally the most practical and economical method and, therefore, is the method most extensively used.

The fundamentals of resilient suspension are readily demonstrated with a chain of rubber bands and a weight. Consider the weight suspended from one end of the chain of rubber bands,

★ The subject of this paper is the application of structural rubber (load supporting rubber used as a mechanical building material) to the insulation of objectionable mechanical vibration. This is a highly specialized field of rubber technology and represents a very small section of the rubber industry. Of the several thousand compounds, only a limited number are

considered as standard for use as structural materials; data on the structural qualities of these are quite complete.

The principal uses of structural rubber are to reduce the transmission of (1) vibration, (2) impact shock, and (3) noise. Of these, its use to reduce the transmission of vibration is the most widespread.

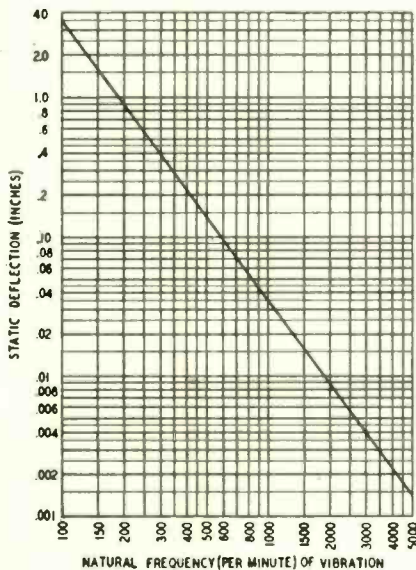

Fig. 1. Relationship between static deflection and natural frequency of spring system

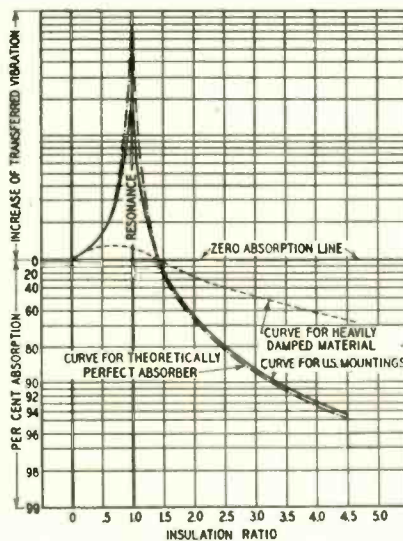

Fig. 2. Chart showing the efficiency of rubber mountings for vibration insulation

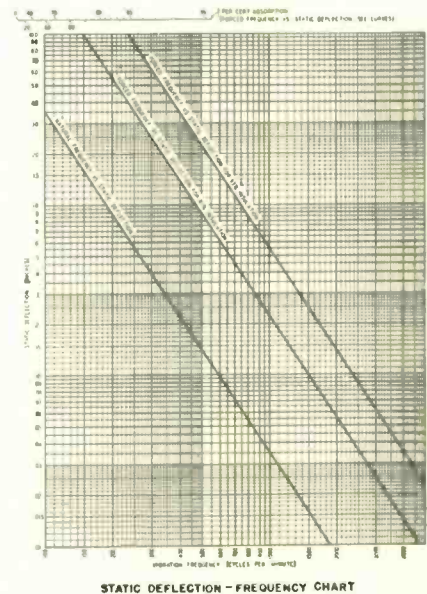

Fig. 3. Relationship between static deflection and per cent insulation

Insulation With Structural Rubber

Fundamental principles of vibration insulation and their application to radio equipment design, with practical examples of proper vibration-insulation technique

the other end held in the hand. Now, if the hand is moved rapidly up and down, it will be noticed that the weight stands practically still. In other words, the vibration is not transmitted through the rubber bands. Now, if the chain is shortened and the experiment repeated, the weight moves with an appreciable amplitude. It can also be shown that if the hand is moved more slowly, more vibration will be transferred to the weight.

A resiliently suspended mechanism acts just like the weight suspended from the rubber bands. The rubber bands are a type of spring.

When a weight is suspended on a spring, the spring elongates. This is called the *static deflection* and is generally measured in inches. The spring rate (sometimes called spring coefficient) of a spring is defined as the number of pounds required to deflect the spring one inch statically: a spring rate of ten pounds means that a ten-pound load placed on the spring will deflect it statically one inch.

If the weight on a spring is pulled downward and suddenly released, it will oscillate up and down. The number of oscillations per minute is called the *natural frequency* of the spring system. The natural frequency is a function of the static deflection, which in turn is determined by the stiffness of the spring and the weight of the sprung load. With given conditions, therefore, the natural frequency is fixed and cannot be changed. A well-known example of this fact is the tuning fork.

Fig. 1 shows that where the static deflection is small the natural frequency is high. Where the static deflection is large the natural frequency is low. The natural frequency of a mounting suspension can be found

from this chart if the static deflection of the mountings is known.

Forced Vibration

Ordinarily a mechanism is forced (by electricity or other power) to operate, and if it vibrates, its vibration is known as *forced vibration*. Some small part of the mechanism may be forced to move rapidly up and down. This reciprocating action usually forces the entire mechanism to vibrate in a smaller amplitude but at the same frequency and in the same direction as the reciprocating small part. Usually



Fig. 10. Non-adhesion type mounting

the frequency of this reciprocating movement is known or can be determined easily. If one cycle of movement takes place for every revolution of the shaft, then the frequency per minute is the same as the r.p.m. of the shaft. If there are *two* equally-spaced reciprocating movements for each shaft revolution, then the forced frequency per minute is *twice* the shaft r.p.m., and so on.

If a mechanism is supported on resilient mountings which are arranged so that the natural frequency is considerably lower than the forced frequency of vibration, then a considerable portion of the vibration of the mechanism will be isolated by the mountings.

A measure of the effectiveness of a resilient mounting installation is given by the *insulation ratio*, i. e., the quotient of forced frequency by natural frequency. Fig. 2 shows the actual effectiveness of rubber mountings.

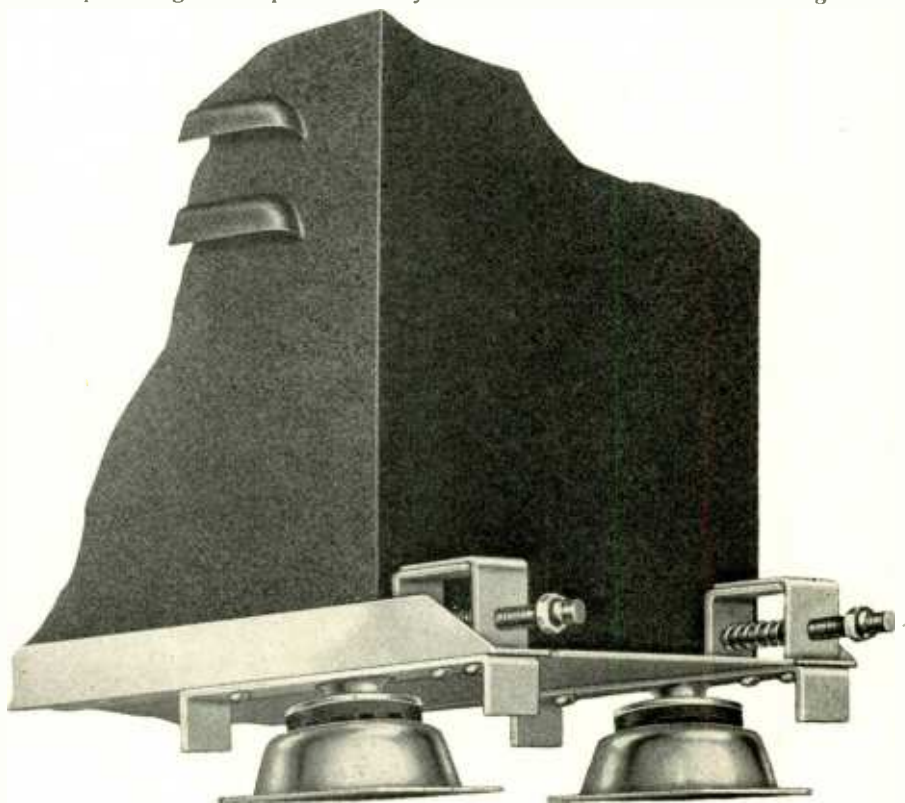

Fig. 11. Installation of non-adhesion type mounting 5150-C to insulate vibration from aircraft radio

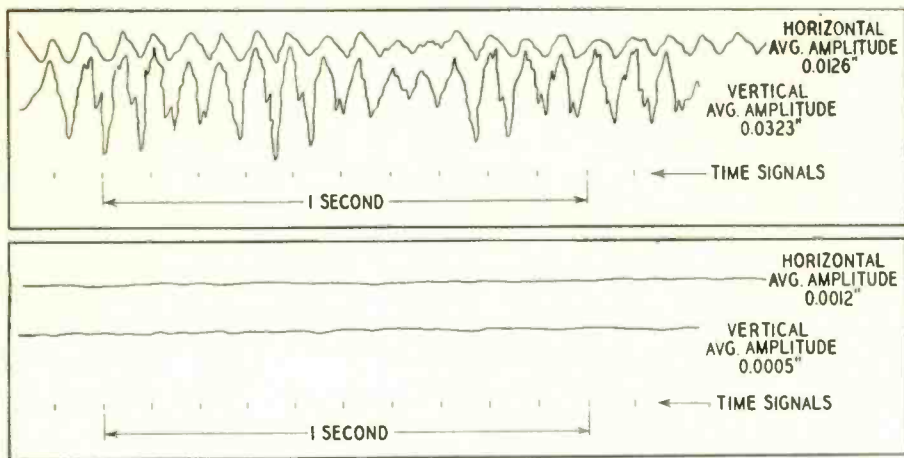

Fig. 4. Photographic record of actual results accomplished in vibration insulation using rubber mountings. Upper record shows vibration amplitude without rubber mountings

Forced Frequency vs. Natural Frequency	Insulation Ratio	% of Vibration Insulated by Mountings
Where forced frequency is 4 times natural frequency	4	93 (Excellent)
Where forced frequency is 3 times natural frequency	3	87.5 (Very good)
Where forced frequency is 2.5 times natural frequency	2.5	81 (Good)
Where forced frequency is 2 times natural frequency	2	66.6 (Fair)
Where forced frequency is 1.5 times natural frequency	1.5	20 (Very poor)
Where forced frequency is 1.4 times natural frequency	1.4	None

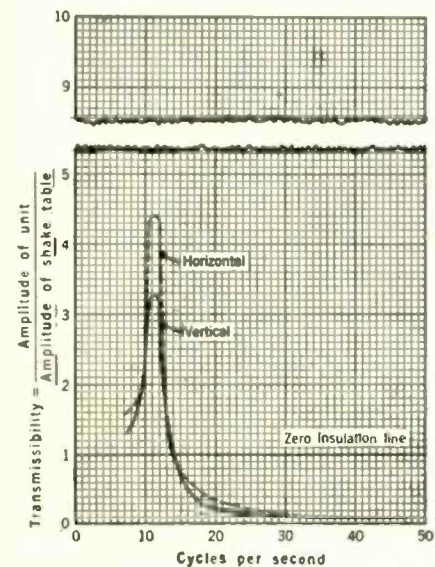

Fig. 5. Transmissibility curve with resilient supports in horizontal plane at center of gravity

When forced frequency equals natural frequency, the result is worse than if no mountings were used. This condition is known as resonance. Satisfactory results are usually obtained when the ratio of forced to natural frequency is 2.5 or slightly greater.

The graph in Fig. 3 relates static deflections and absorption percentages, as well as static deflections and frequencies.

Test Results

A photographic record of a vibration existing in a structure is shown in

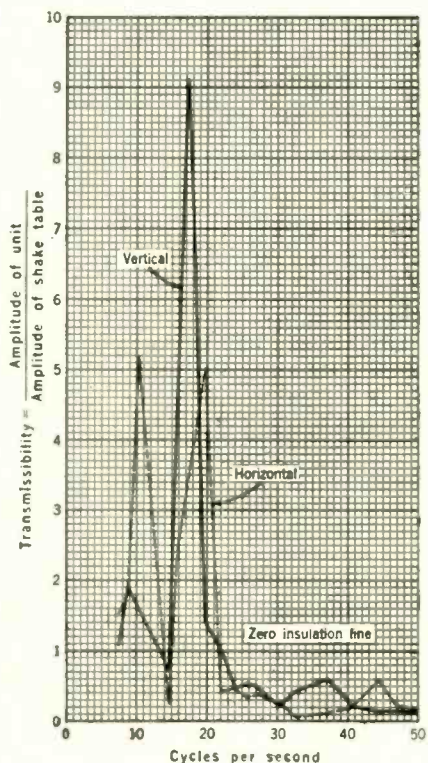

Fig. 6. Transmissibility curve with resilient supports in a horizontal plane approximately six inches below center of gravity

Fig. 4. The equipment when bolted rigidly to the floor vibrated as shown in the top records, which indicate the horizontal and vertical vibration. After the proper installation of mountings underneath the equipment, the vibration from the structure to the equipment was reduced as shown in the lower group of records, which indicate the reduction in amplitude of movement. The actual reduction of vibration transmission was in the neighborhood of 64 to 1. The record also indicates that vibration very seldom, if ever, occurs linearly. The vibration in the stationary parts of reciprocating and rotating machines is generally in a plane at right angles to the crank shaft. Depending upon the structure, the plane may occur tilted at some angle to the horizontal, hence components of the vibration exist along all three principal axes. In order to absorb vibration of this type properly, it is necessary that the direction of vibration be considered and that the spring rate of the resilient supports be properly calculated along all three principal axes. In addition to the translatory motion along the three principal axes, consideration must be given to the rocking modes which exist when the plane of the resilient mountings is below the center of gravity of the supported unit. These rotational modes

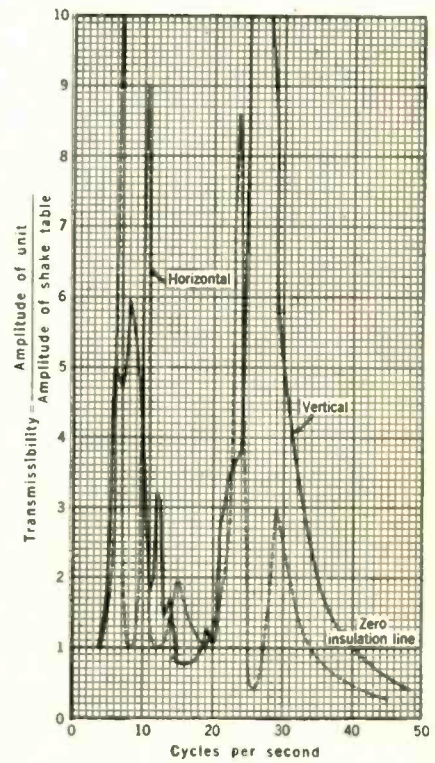

Fig. 7. Transmissibility curve with resilient supports located in the same position as Fig. 6 but with a considerably stiffer horizontal spring rate

are extremely important as they extend the range of frequencies at which resonance occurs. An indication of their effect is illustrated in Figs. 5 and 6 which are the results of tests on a vibration table. The mountings in each case are exactly the same, having equal spring rates in all directions as demonstrated by Fig. 5. The results shown in Fig. 5 are obtained with the mountings located in a horizontal plane at the center of gravity. Those in Fig. 6 are obtained with the mount-

ings in a horizontal plane approximately six inches below the center of gravity. It can be seen that a marked improvement in insulation is obtained with the center-of-gravity support.

If the same unit tested for Figs. 5 and 6 is resiliently supported on mountings which are relatively stiffer in a horizontal direction, the rocking modes extend over a wider range than that shown in Fig. 6 as indicated by the curves shown on Fig. 7. This curve demonstrates the necessity of taking

the spring rate in all directions into consideration when a choice of mounting is being made.

Types of Mountings

Structural rubber is generally adhered to steel to facilitate its application as a mounting for mechanisms. Fig. 8 shows the simplest type of mounting consisting of a column of rubber with steel studs adhered to each end. This type of mounting can be used to absorb relatively low impressed

Fig. 13. Nomograph for determining deflections of rubber adhered between parallel metal plates and stressed in compression

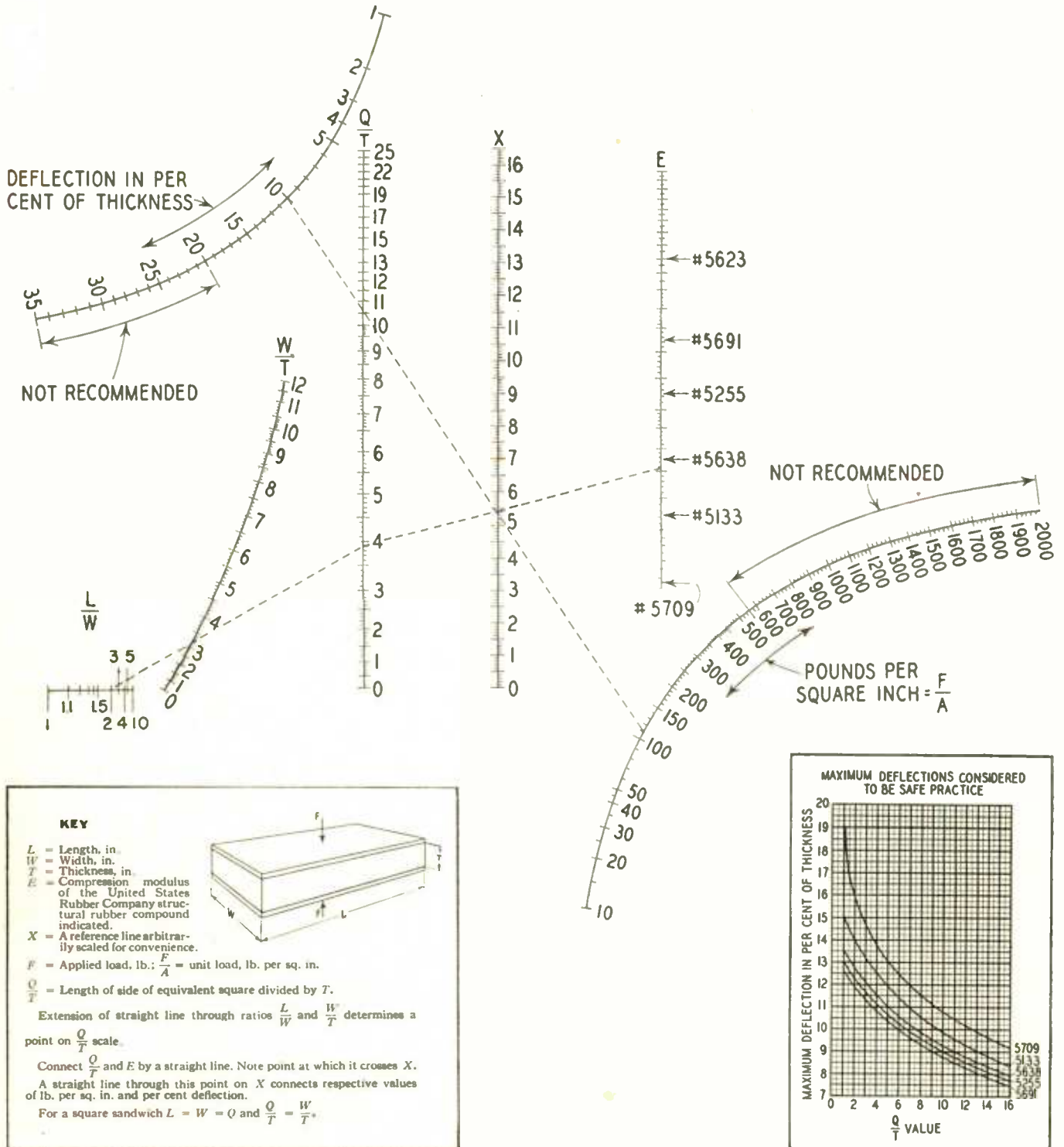

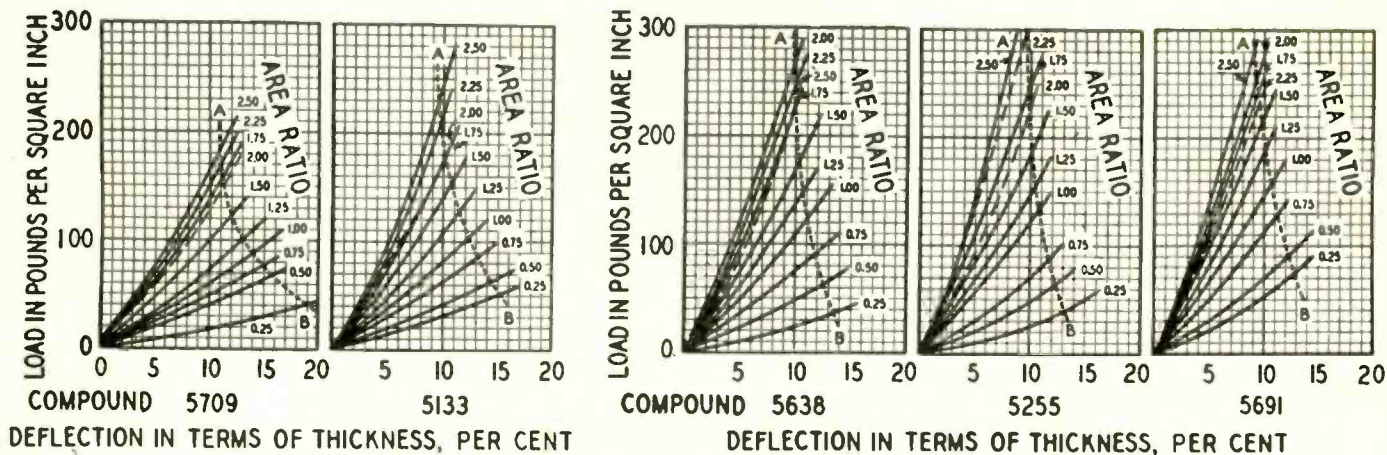

Fig. 12. Load deflection characteristics for five structural rubber compounds not adhered to metal

frequencies in three directions. Its application to insulate the base of a voltage regulator from vibration is shown in Fig. 9.

The mounting shown in Fig. 10, however, is designed so that it does not require rubber-to-metal adhesion. The rubber is held in place mechanically and is so shaped that the spring rates are approximately equal in all directions. This type of mounting is used extensively in aircraft where forced frequencies are relatively high and amplitudes of vibration are not excessive. The metal washers on either side of the rubber section limit the excursion and provide a safety feature. It is considered good engineering practice to incorporate a safety device with resilient supports so that if the springing means should be burned or other-

wise accidentally destroyed, the equipment would not be released. An application is illustrated in Fig. 11.

In order to design mountings employing structural rubber, it is necessary to have complete data on the physical characteristics of the material. One of the most important characteristics of the rubber is its incompressibility; rubber is less compressible than water.

Rubber can be used in compression, in shear, in flexure, in torsion, and in tension. It is primarily used in shear and in compression. By compression is meant subjecting the rubber to a load which tends to squeeze it. The deflection of rubber in compression for different slabs which are not dimensionally proportional can be related by a ratio called the *area ratio*. This ratio

is determined by dividing the load-bearing area of the slab by what is termed the bulge area, the unrestricted area of the slab which is free to bulge. As an example, a slab one inch thick and four inches square would have a load-bearing area of sixteen square inches and a bulge area of sixteen square inches. The area ratio determined as above would be one. A slab one inch thick and two inches square would have a load-bearing area of four square inches and a bulge area of eight square inches. The area ratio is 0.5. Referring to the curves shown in Fig. 12, we can see that the deflections of these two slabs with different area ratios, although subjected to the same load in pounds per square inch, are different. It is possible to determine the load deflection characteristics of

Fig. 15. Physical properties of six structural rubbers

U. S. STRUCTURAL RUBBER NUMBER	5709	5133	5638	5255	5691	5623
Shear modulus, lb. per sq. in.	50	70	95	140	195	...
*Logarithmic decrement of amplitude (Referred to base 10)	.041	.055	.14	.23	.35	.47
*Successive amplitude ratio	.91	.88	.72	.59	.45	.34
Per cent energy loss due to hysteresis, per cycle of vibration	17	22	47	65	80	89
Specific heat	.47	.43	.40	.38	.35	.33
Thermal conductivity in B.T.U., per sq. ft. per hour for a temp. gradient of 1° F. per in. thickness	0.97	1.04	1.08	1.15	1.26	1.33
Velocity of sound in rubber rods, feet per sec.	115	165	210	345	750	...

*The logarithmic decrement given here represents the negative of the power to which 10 must be raised in order to obtain the ratio of any two consecutive amplitudes (on the same side of zero deflection) as unexcited vibration dies out. For instance, if the logarithmic decrement is 0.2, the ratio of one amplitude to the preceding one is,

$$10^{-0.2} = \frac{1}{10^{0.2}} = \frac{1}{1.585} = 0.631 = \text{Successive Amplitude Ratio}$$

(Ordinarily logarithmic decrement is referred to Napierian log base *e* and if such values are required, they would be 2.30 times the values given here.)

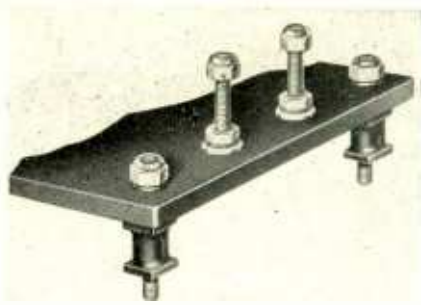

Fig. 9. Voltage regulator base resiliently supported on cylindrical type mountings

any rubber slab, which is not adhered to metal plates, from Fig. 12, provided the area ratio of the slab is calculated as above. It should be noted that in the higher area ratios, the positions of the curves are not consistent. The data are given exactly as determined experimentally from tests on hundreds of samples. It is believed that a certain slippage exists between the pressure faces of the slabs, accounting for the irregularity. Actually rubber used structurally is generally adhered to metal to facilitate its application. When rubber is used in this manner, slippage does not occur between the pressure faces. A nomograph, as shown in Fig. 13, has been designed to facilitate the determination of deflection characteristics of rubber in this condition. The nomograph can also be used for designs which are not rectangular in shape by determining the equivalent rectangular shape for whatever design is under consideration.

Rubber in Shear

The use of rubber in shear is illustrated by the shear "sandwich" in Fig. 14. By sandwich it is meant that the rubber is bonded between two steel plates, or as shown in the illustration, two layers of rubber are bonded between three steel plates; here the load is applied to the center plate, and the two outside plates are held by a suitable support. The shear modulus of various rubber compounds can be determined as can be done for steel. The shear moduli of structural rubbers, however, run between 50 and 200 pounds per square inch. The shear moduli of six structural rubber compounds are shown in Fig. 15, along with other physical characteristics. Of particular interest are the figures on velocity of sound in rubber rods, the logarithmic decrement, and energy loss due to hysteresis.

At the present time synthetic rubbers must be substituted for the natural product in many applications, and their physical properties relating to structural characteristics in compounds are

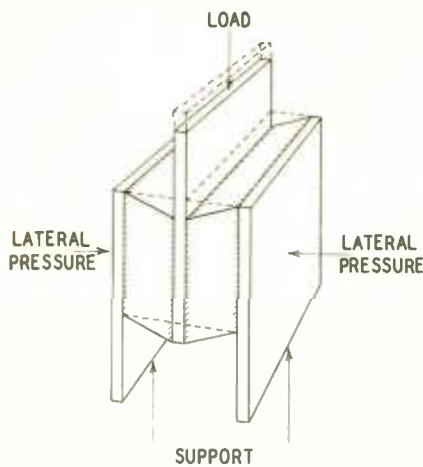

Fig. 14. Simple shear sandwich

being explored intensively. The properties of each basic type of synthetic rubber vary widely from one hardness to another and in varying degree from those of natural rubber. Preliminary tests of compounds indicate that the dynamic fatigue life of buna-S is comparatively short when compared with rubber, neoprene and butyl. The increase in modulus of butyl at lowered temperatures is marked and increases rapidly with increasing compound hardness. The drift under load and hysteresis of the synthetics vary considerably. It is extremely important to know all of the service conditions and to have data on the structural characteristics available when deciding which type of synthetic rubber will be best suited to a specific installation. It should also be kept in mind that the chemistry of synthetic rubber formulation is extremely active at present and improvement in the structural characteristics is to be expected.

We have discussed primarily the static properties of rubber. It should be mentioned that the natural frequency of a rubber spring system does not always follow the calculations made from the static deflection. Fig. 16 shows the factor by which the calculated natural frequency should be multiplied in order to obtain the actual

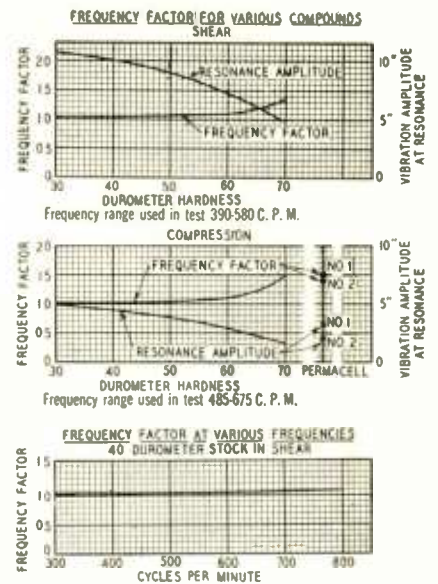

Fig. 16. Charts used for determination of factors by which calculated resonance frequency must be multiplied to determine actual resonance frequency

dynamic frequency. In most calculations, however, this refinement can be neglected, particularly when dealing with the softer rubbers in general applications.

Knowing the physical characteristics necessary for structural design, it is possible to devise special and unusual applications of structural rubber for many purposes. It is often necessary to maintain the stability of a mechanism when resiliently supported. Hints as to how this stability can be obtained are given diagrammatically in Fig. 17.

The use of structural rubber in shear and in compression has been described above. It should be noted that it is undesirable to stress rubber in tension and also that its use in flexure is limited. Its use in torsion, of course, is related to the data given for shear.

It is generally advisable, when special applications are to be made, to consult some authoritative source to obtain their experience as related to the individual problem.

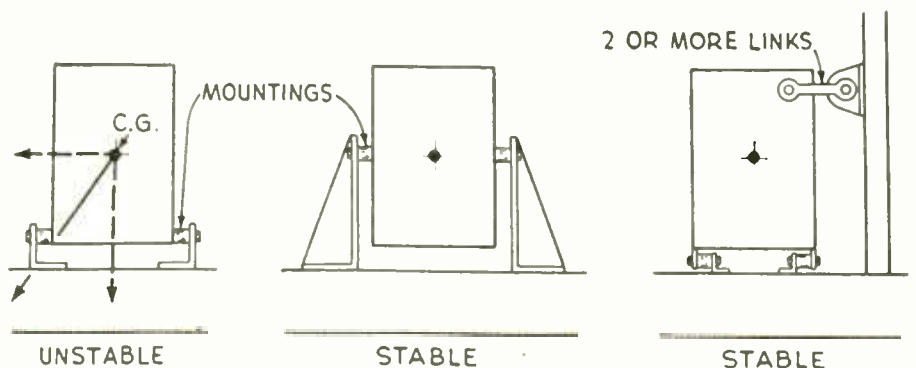

Fig. 17. Means of obtaining stability on a resiliently supported unit

POLYPHASE COMMUNICATION CIRCUITS

In RADIO Design Worksheet No. 21,* it was shown that a single-phase sine wave can be split into two waves in phase quadrature by means of resistive and reactive networks. This two-phase system can be applied to the input of a push-pull amplifier and then converted in the amplifier output to a three-phase system by means of a Scott-connected output transformer. Other than isolating the phase-splitting circuits and amplifying the two-phase signal, the amplifier serves no useful purpose. Theoretically, the Scott transformer could be connected directly to the phase-splitting circuits. Practically, this would require some additional connection. This system is reproduced in Fig. 1.

From Fig. 1, we have

$$M = \frac{a}{2} \sin \omega t + \frac{a}{2} \sin \omega t = a \sin \omega t$$

$$K = \frac{a}{2} \sin \omega t + \frac{a}{2} \sin \left(\omega t + \frac{\pi}{2} \right) =$$

$$\sqrt{\frac{a^2}{4} + \frac{3a^2}{4}} \sin \left(\omega t + \frac{\pi}{3} \right)$$

$$L = -\frac{a}{2} \sin \omega t + \frac{a}{2} \sin \left(\omega t + \frac{\pi}{2} \right) =$$

$$-\sqrt{\frac{a^2}{4} + \frac{3a^2}{4}} \sin \left(\omega t + \frac{2\pi}{3} \right)$$

This is shown vectorially in Fig. 2. These are the equations for the Scott-connected output circuit.

Now consider a push-pull amplifier with Y-connected input and output transformers, as shown in Fig. 3.

Let:

$$\begin{aligned} e_1 &= e \sin \omega t \\ e_2 &= e \sin \left(\omega t - \frac{2\pi}{3} \right) \\ e_3 &= e \sin \left(\omega t + \frac{2\pi}{3} \right) \end{aligned}$$

Then

$$\begin{aligned} i_1 &= Ae \sin \omega t \\ i_2 &= Ae \sin \left(\omega t - \frac{2\pi}{3} \right) \\ i_3 &= i_1 + i_2 = Ae \left[\sin \omega t + \sin \left(\omega t - \frac{2\pi}{3} \right) \right] \\ &= \sqrt{A^2 e^2 + A^2 e^2} \sin \left(\omega t + \frac{2\pi}{3} \right) \\ &= Ae \sin \left(\omega t + \frac{2\pi}{3} \right) \end{aligned}$$

where A is proportional to the amplification of the system.

We shall likewise have three voltages of equal magnitude and having a phase relationship of $\frac{2\pi}{3}$ radians. This indicates that the push-pull amplifier will amplify a three-phase signal satisfactorily. This is shown vectorially in Fig. 4.

If desired, the three output secondaries may be connected in delta provided the transformer ratios are equal, as indicated in Fig. 5. If, however, the three output secondaries are to be Y-connected, the transformer ratios can no longer be equal. Rather, the conditions of Figs. 1 and 2 must obtain.

C. R. Nelson

* RADIO, January, 1944.

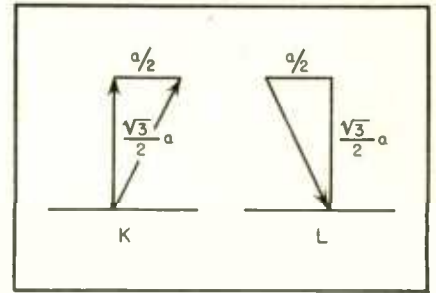

Figure 2

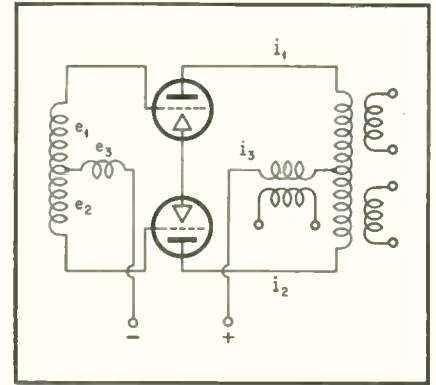

Figure 3

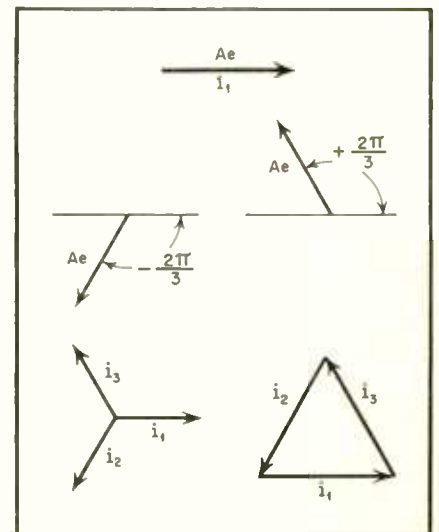

Figure 4

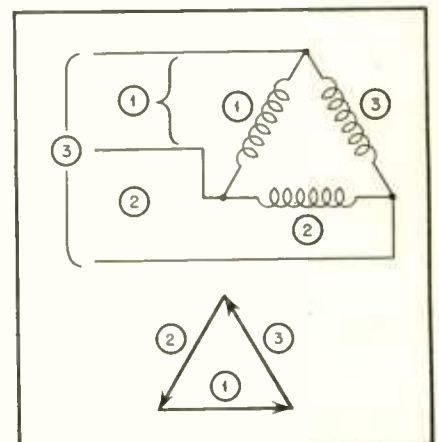

Figure 5

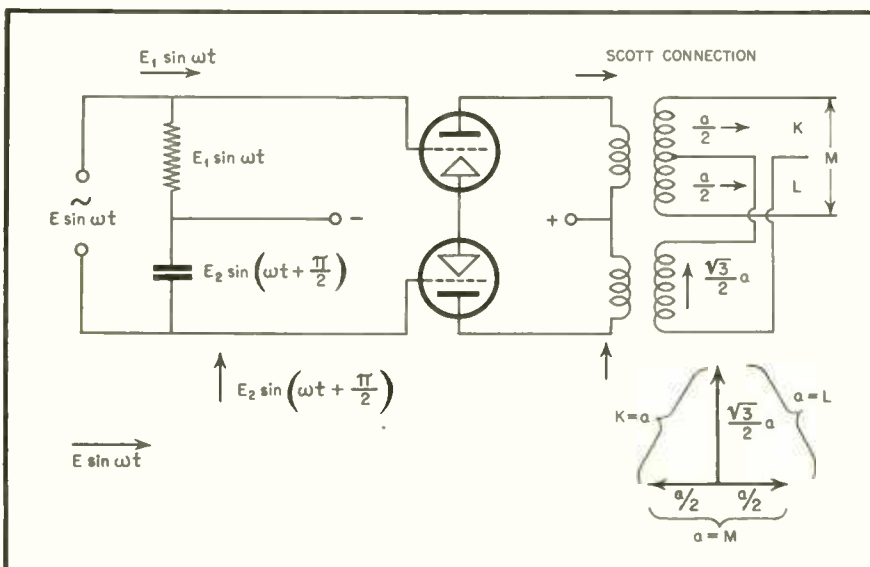

Figure 1

R-F TRANSMISSION LINES

A. C. MATTHEWS

An analysis of the characteristics of various types of coaxial cables, with design data and practical notes on their selection and application

★ The use of coaxial or concentric transmission lines in place of the open-wire type has increased tremendously in the last few years. There are several good reasons for the gradual trend away from the open-wire type line. For instance, the impedance of the open-type line was normally too high to "match" directly into the center of a half wave antenna or array. It was difficult to maintain a proper balance to ground even though the line was transposed at regular intervals. The radiation was excessive unless the line was properly designed, installed and maintained. Last, but not least, the installation was difficult to make and it required a fairly open space for good results.

Coaxial Lines

All these faults have been corrected to a large extent in the coaxial type of line. Since the electric field lies entirely between the two conductors and the outer conductor completely shields the inner one, no radiation can take place. The outer shield may be grounded, thus eliminating danger to personnel due to shock. The shielding also permits the line to be installed in almost any location, as unbalance due to nearby objects, and pickup of spurious electric or magnetic fields from other electrical circuits are no longer problems. Furthermore, the impedance of a coaxial line can readily be made to "match" an antenna.

This article will be devoted to the non-resonant type of line. As its name implies, this type of line does not have pronounced standing waves due to resonant conditions when properly terminated in a resistive load equal to the surge impedance of the line. This is true whether the line is but a few feet or several hundred feet in length.

Under conditions of proper termination the voltage and current are practically in phase with each other and the power is comparatively uniform, except for a gradual decrease due to losses at the end of the line is ap-

proached. This is usually expressed as db (decibel) loss per unit length.

In the design of a transmission-line system, the first consideration in the selection of a line should be (assuming, of course, that the correct line impedance is available) the voltage breakdown or power-handling capacity. Having satisfied this requirement, the next step should be the determination of the amount of attenuation allowable. It is often the case that, in order to satisfy the attenuation requirement, it is necessary to choose a line which will be several times larger than one considered only from a voltage-breakdown standpoint.

Power ratings supplied by manufacturers ordinarily have been given an adequate safety factor; however, there are several factors which must be considered in some applications. The termination of the line must be reasonably good, the location with respect to moisture condensation, and the type of modulation to be employed if used for transmitting purposes. It is good policy to calculate the maximum voltage requirements, with modulation, and allow a safety factor of at least two times for unusual conditions of tuning or matching. A terminated line behaves normally only when the load or termination is reasonably correct. If

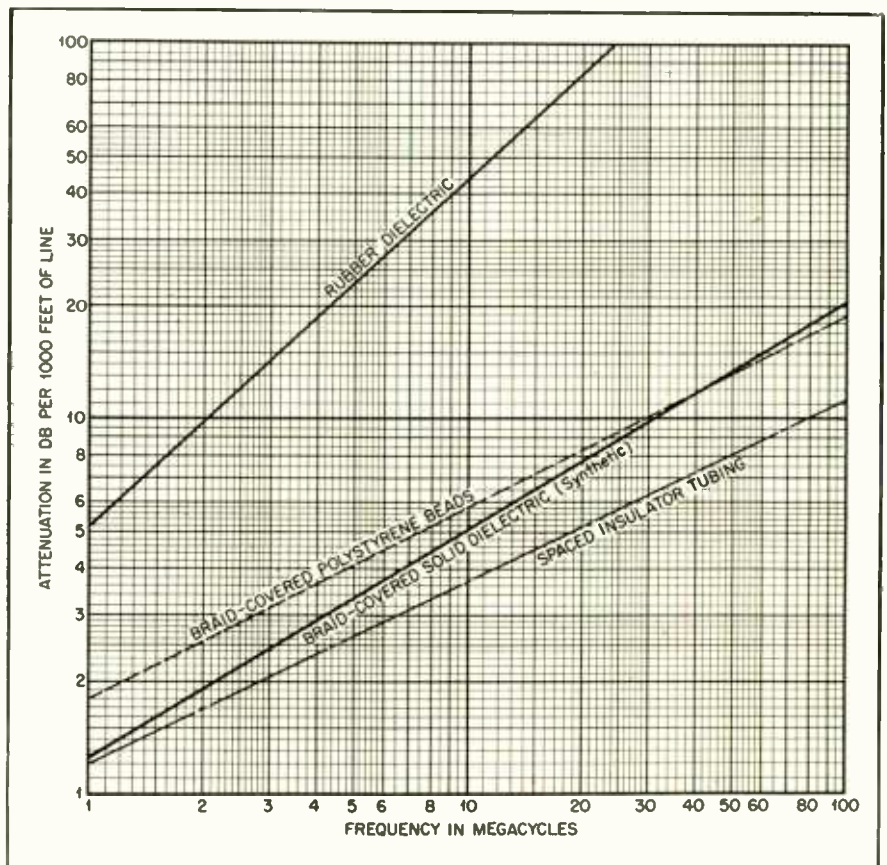

Fig. 1. Attenuation of typical coaxial cables

TABLE 1

Manufacturer and Type No.	O.D.	(Imp.) Z	mmf/ft	Loss db/1000' @ 1 mc	Dielectric	Remarks	
Doolittle & Falknor	C-1	3/8	70	19.8	0.94	Air or gas	Spaced insulators-soft copper tubing.
	C-6	5/8	73	14.8	0.55	"	"
	C-4	7/8	66	16.0	0.33	"	Spaced insulators-hard copper tubing.
Victor J. Andrew Co.	83	3/8	72	16.1	0.98	"	Spaced insulators-soft copper tubing.
	23	5/8	65	17.9	0.46	"	"
	33	7/8	66	15.9	0.33	"	Spaced insulators-hard copper tubing.
Amphenol	72-12	3/8	72	20.0	1.7	Polystyrene	Interlocking beads-braided copper shield.
	72-12C	.407	78	...	1.3	"	Interlocking beads-soft copper tubing.
21-B-460-7/21 XV	.460	72	21.0	..	Polyethylene	Solid dielectric-braided copper shield.	

Some typical commercially available r-f transmission lines. These represent only a few of the available types. Data compiled from manufacturers' literature

the load varies considerably the voltage-breakdown point may be approached and the attenuation will be increased. Moderate mismatches are tolerable, especially if the operating voltage is not excessive.

The total loss is attributable to the sum of the resistance loss along the line and the dielectric loss between the inner and outer conductors. As can be seen from Fig. 1, these losses vary with frequency and the physical construction of the line. The resistance loss, which is largely due to "skin effect," increases in direct proportion to the square root of the frequency. Since the design of a coaxial cable is such that a large conductor surface is available, the losses due to resistive effects can be made practically negligible by selecting a suitable diameter outer conductor. Table 1 gives typical loss figures for commercially available cable. To determine the loss of a specific length of cable at a given frequency it is only necessary to multiply the loss in db by the square root of the desired operating frequency in megacycles and then by the fraction of 1000 feet employed. For example, suppose a cable had a loss of 0.98 db per 1000' at 1 mc, and it was desired to use 225 feet of the cable at a frequency of 100 mc. The loss would be $0.98 \times \sqrt{225} \times 0.1 = 1.47$ db.

Coaxial lines are available in two types; those having a solid dielectric, and those in which the major portion of the dielectric is air or gas.

Solid Dielectric Cable

The core material of the solid dielectric type usually consists of rubber,

polyethylene or a mixture of polyisobutylene and other materials. Polyisobutylene is particularly desirable because of its low loss (approximately the same as polystyrene), flexibility at extremely low temperatures, toughness and otherwise excellent mechanical stability. The material is applied tightly around an inner conductor of solid or stranded copper wire in such a manner as to be substantially free from voids. Any voids in the insulation are likely spots for moisture to condense, thus causing increased losses and lowering of the breakdown point of the cable. They are also objectionable because of the likelihood of the outer conductor shorting to the inner conductor when the cable is bent at that point. A void will also produce a

discontinuity in the impedance of the line and can seriously affect its performance at ultra-high frequencies. Stranded conductors are generally employed because of their greater flexibility, except at ultra-high frequencies, where solid inner conductors are preferred because of their lower losses.

The outer conductor is composed of one or two braids of either tinned or plain copper wire. To complete the cable a protective covering of synthetic resin or waxed cotton braid is used which should be impervious to moisture effects due to weather conditions, since any deterioration of the outer cover is likely to be accompanied by greater absorption of moisture. This would affect the leakage resistance and effective capacity of the cable which, in turn, would change the impedance and attenuation.

These cables are now being used extensively as transmission lines for high and ultra-high-frequency applications because of their flexibility and the ease with which an installation can be made. Suitable jackets or coverings have been developed which withstand severe handling under adverse conditions of temperature and humidity. While the attenuation of the solid dielectric cable is somewhat higher than those employing air or gas as the dielectric, the flexibility of the former makes its use desirable in many instances. Where flexibility is absolutely essential and the cable attenuation is higher than desired a larger diameter cable should be specified, which will thereby reduce the attenuation to a desired value.

Air Dielectric Cable

Cables with air or gas as the major portion of the dielectric usually employ soft copper tubing for both the inner and outer conductors. As shown

[Continued on page 46]

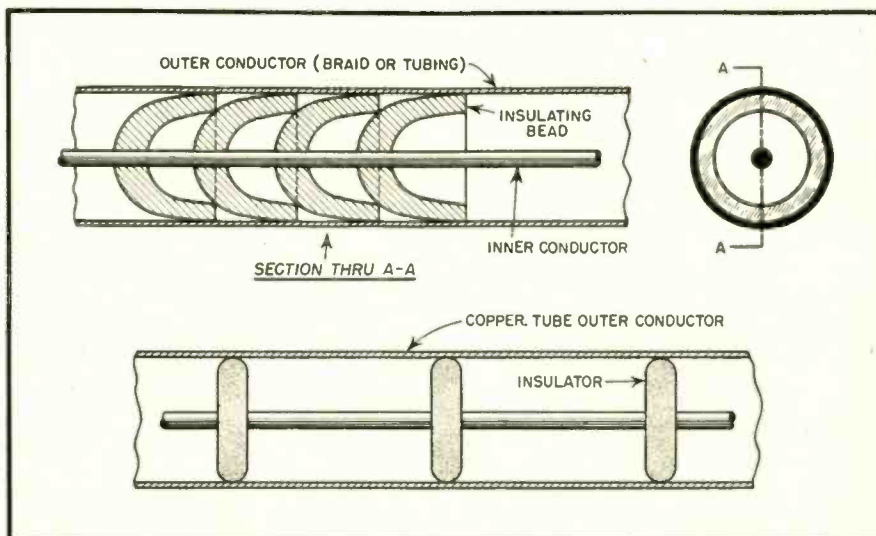

Fig. 2. Beaded type (above) and (below) spaced type coaxial lines

in Fig. 2, the inner conductor is supported coaxially within the outer conductor at regular intervals by small insulators of ceramic or other non-hygroscopic low-loss material. The beaded type construction has the advantage of maintaining the inner conductor more nearly in the center of the line, where it is necessary to make a bend due to the nature of the installation. It is obvious, however, that a "beaded" line will have greater dielectric loss than the spaced insulator type, so this factor must be considered.

Where it is necessary to install a transmission line out of doors, it is advisable to pressurize the line with dry air or nitrogen gas. This prevents moisture from leaking into the line, or forming by condensation due to "breathing" caused by changes in temperature. Where it is possible to install the line below the surface of the ground, temperature changes are not so great; however, for trouble-free operation pressurizing is advised. A pressure of ten pounds is usually sufficient for most purposes.

Nitrogen gas is ideal for this purpose, since it is chemically inert and has a dielectric strength slightly higher than air. It is important, however, to specify "oil-pumped nitrogen" gas for this purpose as the "water-pumped" variety is not suitable, since its moisture content is too high.

Another means of pressurizing transmission lines is by the use of dehydrated air. While dehydrated air does not increase the voltage-breakdown point, it nevertheless is as satisfactory in all other respects. Furthermore, its economy and simplicity of installation appeals to most designers. Silica gel is used as the desiccant. This can be renewed when it becomes saturated, by heating it in an open pan in an oven at a temperature of 300 to 350 degrees F. A cobalt indicator is often supplied with the silica-gel unit to indicate when the unit needs replacing. The indicator should be blue when it is installed and will turn pink or white as it becomes saturated. The amount of desiccant required depends upon the length of line to be pressurized, the temperature, and the humidity under which it must work.

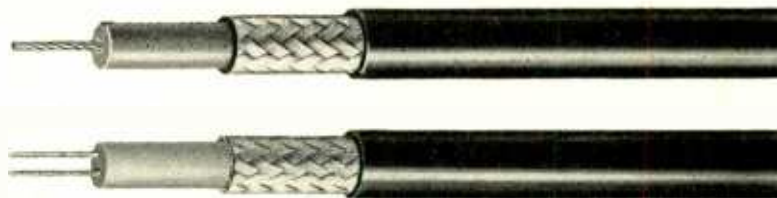

Flexible r-f transmission lines. (Courtesy of American Phenolic Corp.)

Design Problems

One of the most difficult problems in the design of a pressurized system is to provide a low-loss leak-proof terminal at the ends of the line. A satisfactory solution to the problem has been found by employing a technique of metal-to-glass sealing similar to that used in vacuum-tube construction. Glass, although not as good an insulator at high radio frequencies as some of the ceramics, can be used for this purpose if precautions are taken to keep as much of the material out of the strong electric field as possible, consistent with good mechanical strength. A special alloy metal which has the same coefficient of thermal expansion as the annealed glass must obviously be used.

A good seal, unfortunately, is not the only requirement for an end terminal. The electrical design must also have low shunt capacitance, high leakage resistance and a minimum of line discontinuity. These characteristics are particularly important at frequencies above 100 megacycles. At these frequencies the reactance of the end terminal, due to excess capacitance, is often so low that a large portion of the power is lost before the load is reached. Any irregularity in the impedance of the connecting terminal should be avoided since this will result in undesirable reflections and consequent power loss. For the same reason junction boxes and gas input fittings must be designed to minimize this effect. It is actually possible, where considerable power is involved, to observe "hot spots" on a line due to improper design.

In addition to these factors, it is necessary to make allowance for expansion of the line due to changes in temperature between seasons, and day and night. Expansion is not particu-

larly troublesome with a solid-dielectric or soft copper-tubing cable; however, with hard copper tubing the expansion must be considered. As pointed out previously, if the line is buried underground temperature variations will be minimized and in many cases no other precautions will be necessary. In some applications where it is not prac-

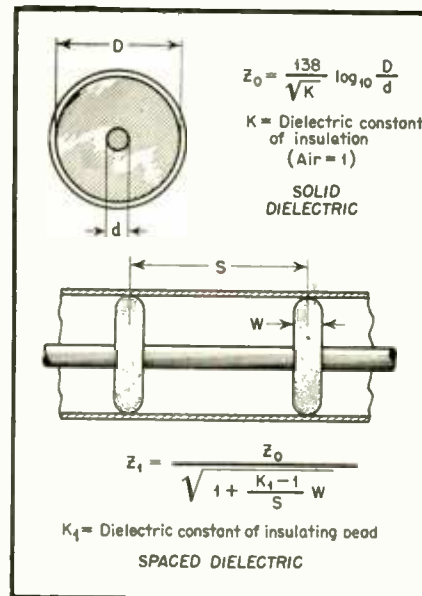

Fig. 3. Coaxial transmission cable design equations. Attenuation is a minimum when D/d equals 3.6

ticable, due to local conditions, to permit the line to be buried, the expansion will have to be accommodated by installing the line so that only one point (usually the center) is securely fastened, thereby allowing the ends to slide freely with any expansion. In installations, with long lines it will be found that the inner conductor does not elongate the same amount as the outer conductor and it becomes necessary to provide an expansion connection for the inner conductor. These and other expansion fittings are available commercially.

Impedance

The characteristic or surge impedance of a coaxial transmission line depends upon the physical dimensions of the conductors and the dielectric between them. Fig. 3 shows cross-sectional views of a line together with design equations. Note that "D" is the inside diameter of the outer conductor, [Continued on page 48]

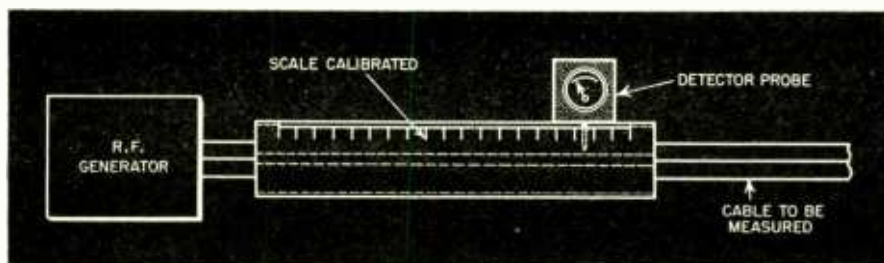

Fig. 4. Slotted line section set up for measuring velocity constant of line

New Products

NEW BOBBIN-TYPE RESISTORS

One of the latest developments in the application of Sprague Koolohm ceramic-insulated wire construction to the solution of resistor problems is the new Koolohm Bobbin-Type Resistor. Instrument resistor stability, to an extent hitherto unobtainable, is assured for these resistors by an exclusive Sprague current and temperature aging process.

Standard resistance tolerance for Koolohm Bobbin-Type Resistors is plus or minus 5% for full wattage rating, although closer tolerances, as low as plus or minus ½%, can be provided at lower wattage ratings. Maximum power rating is 2.5 watts and maximum resistance 250,000 ohms in a section ⅝" wide and having a diameter of 13/16". The maximum recommended operating temperature (ambient plus rise) is 150° C.

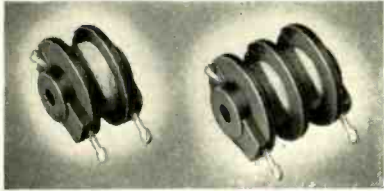

These Bobbin-Type Resistors are wound with the well-known flexible ceramic-insulated Koolohm resistance wire on molded high-temperature plastic forms, fitted with lug terminals molded integrally into the forms. Units are varnish-impregnated to provide additional protection against tropical humidity conditions.

Koolohm Bobbin-Type Resistors are recommended for use as meter multipliers, as resistance standards in control instruments, as resistance elements of RC oscillators, as power resistors of medium wattage ratings in values to ½ megohm, and where a high degree of stability is required.

Data sheet will gladly be sent on request to the Sprague Specialties Company, Resistor Division, North Adams, Mass.

NEW INTERVAL TIMER

Accuracy stated to be hitherto impossible to attain, has been achieved in a new interval counter developed in direct reading instrument by the Potter Instrument Company, 136-56 Roosevelt Avenue, Flushing, N. Y. It is called a Counter Chronograph Interval Timer.

Using electronic counters in the timer, with a 100 kc crystal-controlled oscillator to generate the initial counting rate, an electronic switch or "gate" is first actuated by a pulse from the initiation of the time interval. The 100 kc frequency is divided by four decades down to an output of 0.1 second.

The pulse generated by the termination of the time interval turns the electronic gate off, leaving a count on the panel indi-



cators. The resulting count is the number of cycles of the 100 kc source that have elapsed in that time interval. So accurate is this reading that it gives fractions of a second of plus 0 and minus 1 cycle of the 100 kc source or 0.00001 second for any reading. The full capacity reading of the panel is 0.09999 second. In addition, the counter can "run over" this reading if desired.

The electronic counter decades are unique in that only four tubes are used for counting and indicating a scale of ten. The answers are indicated for each decade on four neon lamps designated 1-2-4-8. Combinations of these lamps indicate 0 to 9.

The instrument operates from a line voltage of 100-125 v 60 cycles a.c. The tube complement is 27 tubes. Plug-in construction of the units is used throughout. The Counter Chronograph Interval Timer's dimensions are 15" x 10" x 10" and the weight is approximately 30 pounds.

NEW SILVER MICAS

A capacity range of 6 to 2000 μf measured at 1 megacycle is now available in Silver Mica Capacitors manufactured by Centralab. Several new types with many terminal arrangements have also been added to the 830 and 831 types first manufactured.

The basic construction of the Silver Mica Capacitor is stacked mica discs individually silvered and vacuum impregnated in transil oil after assembly. They are especially useful for high-frequency applications.

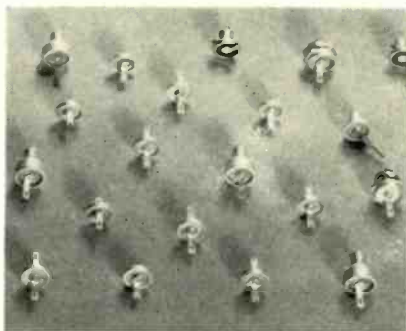

Power factor of all types is .08% for resonant circuit application, .12% for bypass or blocking use. Leakage resistance

is 10,000 megohms. The light right angle terminal can be ordered straight or bent as desired.

Literature on all new types of Silver Mica Capacitors is in the preparatory stage and will be completed sometime in May.

NEW PILOT LIGHT

Known as the Gothard Series #1110 Pilot Light, this new unit is available in several variations. Primarily for ungrounded panels, all variations of this new light are equipped with two solder terminals.

This new light is also available as a shutter-type light, for such applications that require variable intensities to satisfy varying conditions. 90° turn of the shutter provides gradation from bright light, through intermediate glows to a dim glow, or total blackout. They can also be furnished with polarized lens. All models mount in an 11/16" hole and have ½" jewels.

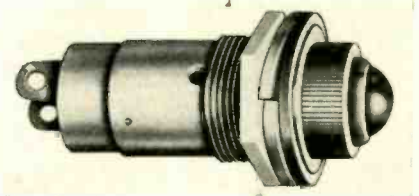

Lamps are removed from front of panel. This new series of pilot lights is manufactured by the Gothard Manufacturing Company of Springfield, Illinois.

NEW M-SCOPE INSTRUMENT

This instrument consists of two specially designed radio units; a transmitter and receiver. In operation, the transmitter sends out a continuous signal. When there is no metal interposed between the two units, a definite volume of sound is heard in the earphones of the receiver, and a meter mounted on the receiver gives a definite reading. If a metal object lies between the two units, the sound heard in the earphones will be louder and meter reading higher.

It locates the position of buried pipe lines, or metallic conductors, pipe bends, dead ends, valves, covered manholes, drip boxes, cast-iron bells, insulated joints, stubs or services, the center of a buried pipe or metallic conductor, the depth of a pipe line or metallic conductor, unknown metallic hazards in path of excavators and traces the course of an underground line without contact with the line itself. It eliminates exploratory excavations and prevents accidents damage to other unknown lines in the way of trench or ditch diggers.

The worthwhile addition to the M-Scope Pipe Finder is the M-Scope Water Leak Detector. The instrument will exactly

New Products



detect leaks in water and oil lines which are under pressure. Accurate readings can be taken with the 4½ inch visual indicator and headphones. By means of a 10-stage frequency selector control, the best leak response can be determined and interference filtered out.

Further data may be obtained by writing the Fisher Research Laboratory, 1961-63-65 University Ave., Palo Alto, Calif.

NEW CABLE CLAMP

A new waterproof cable clamp, especially adapted to aircraft installations, has been announced by Oxford-Tartak Radio Corporation, 3911 S. Michigan Ave., Chicago 15, Ill.



This is a compression type of clamp with all parts mounted or ringed on the cable axis to provide faster assembly time. All components are locked by a simple push-together and turning motion. It can be made in any size and shape to adapt to all types of jobs.

FRACTIONAL H. P. MOTORS

Bantam Fractional H. P. Motors are built to special order for installations requiring maximum power per ounce of weight, such as cooling fans and blowers, vacuum pumps, remote control of radio and instruments, band switching and other airplane applications.



SM-2 Motors are completely enclosed with aluminum ends, ball bearings and stainless steel shafts. They run at speeds from 2000 to 20,000 r.p.m. on alternating or direct current or both. They are re-

versible with high starting torque and low current draw. Can be wound for voltages from 6 to 230. Are corrosion-proof to pass the 200-hour, 20% salt-spray tests.

Windings are of high grade magnet wire, impregnated with best varnish; mica insulated commutator; laminated field and armature cores.

Flange, clamp, base or integral mountings are furnished for operating in any required mounting position. Bantam Motors are engineered and built to users' precise specifications by Small Motors, Inc., 1308-22 Elston Ave., Chicago 22, Ill.

AN-3101 CONNECTOR

Newest Cannon electrical connector in the Army-Navy Specifications line is the type known as AN 3101, according to the proposed AN-W-C-591a specifications. Although in general appearance this new type looks like a plug, it has been designated as a "receptacle" inasmuch as it has a male coupling thread similar to Type AN 3100 and AN 3102.



AN 3101 is a mating cord connector for AN 3106 and AN 3108. Since it has no mounting facilities such as the flange on Types AN 3100 and AN 3102, it may be used in place of an AN 3100 or AN 3102 when regular mounting is not necessary. Also adaptable for use with an extension cord.

All standard Cannon parts are used in conjunction with a special barrel. Shell material is aluminum alloy, with sand blast and clear lacquer finish. Thread lubricant on threads.

Available are sizes 8s to 16s, and 12 to 36 (incl.). All tooled Cannon insert arrangements are adaptable and interchangeable in Cannon Type AN 3101.

Copies of AN 3101 Bulletin will be sent at no cost upon request to Cannon Electric Development Company, 3209 Humboldt Street, Los Angeles 31, California.

NEW AIRCRAFT-TYPE MOTOR

Another new design of Aircraft type Direct Current series motor of larger capacity has been added to the line of Aircraft motors now being produced by the Alliance Mfg. Company, Alliance, Ohio.

Primarily designed for use in air-borne equipment, the unit operates continuous duty on 13 volt d.c. source at 7.4 amperes, delivering a full 1/12 h.p. at 7,500 r.p.m. It measures overall less than ¼" diameter

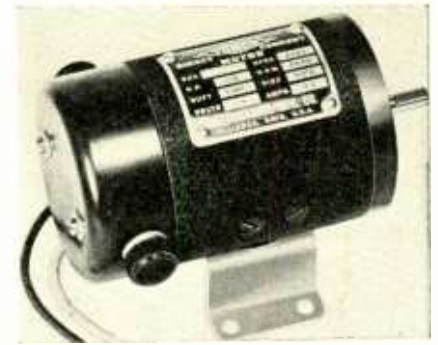

shaft extension, 4 5/16" in length by 2¾" diameter and weighs but 3½ lbs. Low temperature rise permits operation under high ambient temperatures.

Descriptive literature and further information may be obtained upon request from the Alliance Mfg. Company, Lake Park Boulevard, Alliance, Ohio.

RADIO DEMONSTRATOR UNIT

Industrial executives and school principals will be interested in a new panel-type demonstrator unit designed to simplify instruction in the theory and radio circuit design, operation and servicing for workers' training programs and school curricula.

A complete 5-tube superheterodyne broadcast receiver, it is assembled on a 30 by 36-inch imprinted panel and mounted in a reinforced hardwood frame 3 inches deep. It may be set up on a table or blackboard, two removable mounting feet providing the proper support. It may also be placed on a wall for vertical observation.

The unit actually operates, with surprisingly good results obtained through a small speaker mounted on the baffle board. Tubes are of the high voltage filament type and the circuit is wired for 110-volt a.c.-d.c. operation. All parts except the loop are mounted in plain view adjacent to their schematic positions on the panel which is printed in four colors.

Available now to all industrial units, schools and other institutions conducting educational programs. Developed and man-

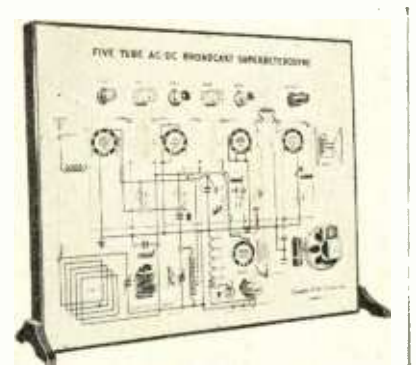

ufactured by the Lafayette Radio Corporation, 901 West Jackson Boulevard, Chicago 7, it contains well over 200 individual pieces.

[Continued on page 57]

This Month

WESTINGHOUSE NAMES STIEFEL

The appointment of *Ira B. Stiefel* as assistant to the vice-president in charge of Industrial Relations for the Westinghouse Electric and Manufacturing Company was announced recently.

Mr. Stiefel has been Manager of Industrial Relations at the Company's East Pittsburgh Works since 1937. His new headquarters will be in downtown Pittsburgh.

Since joining Westinghouse in 1912 as a member of the Company's Graduate Student Course, he has been successively assistant superintendent of Coils and Insulation, assistant superintendent of the Motor Division, superintendent of Mill and Foundry, and Manager of Feeder Division No. 1.

RCA APPOINTS BROWN

Charles B. Brown has been appointed Advertising Director of the RCA Victor Division of the Radio Corporation of America, it has been announced.

Mr. Brown, who has relinquished his position as Director of Advertising, Promotion and Research of the National Broadcasting Company, will have responsibilities as co-ordinator of advertising for the various RCA Victor products and of the three advertising agencies which serve RCA Victor. These agencies are the J. Walter Thompson Company which handles RCA's "What's New?" radio program, as well as the advertising for Victor and Bluebird records, and for the International Division; Ruthrauff & Ryan Inc., for radio, phonograph and television instruments; and Kenyon & Eckhardt, Inc. for RCA tubes, special radio apparatus and industrial electronic and radio apparatus.

NBC APPOINTS HEATH

Horton H. Heath, who has been Director of Advertising and Publicity for the Radio Corporation of America, has accepted a position with the National Broadcasting Company, it has been announced by *Niles Trammell*, President.

Mr. Heath was appointed Assistant to *Frank E. Mullen*, Vice President and General Manager of the National Broadcasting Company, and under his direction will supervise institutional advertising and promotion.

RCA APPOINTS DUNLAP

Orrin E. Dunlap, Jr., Manager of the RCA Department of Information, has been appointed Director of Advertising and Publicity for RCA, it has been announced by *David Sarnoff*, President of the Radio Corporation of America.

Mr. Dunlap succeeds *Horton H. Heath*, who has accepted a position with the National Broadcasting Company as Assistant to the Vice President and General Manager.

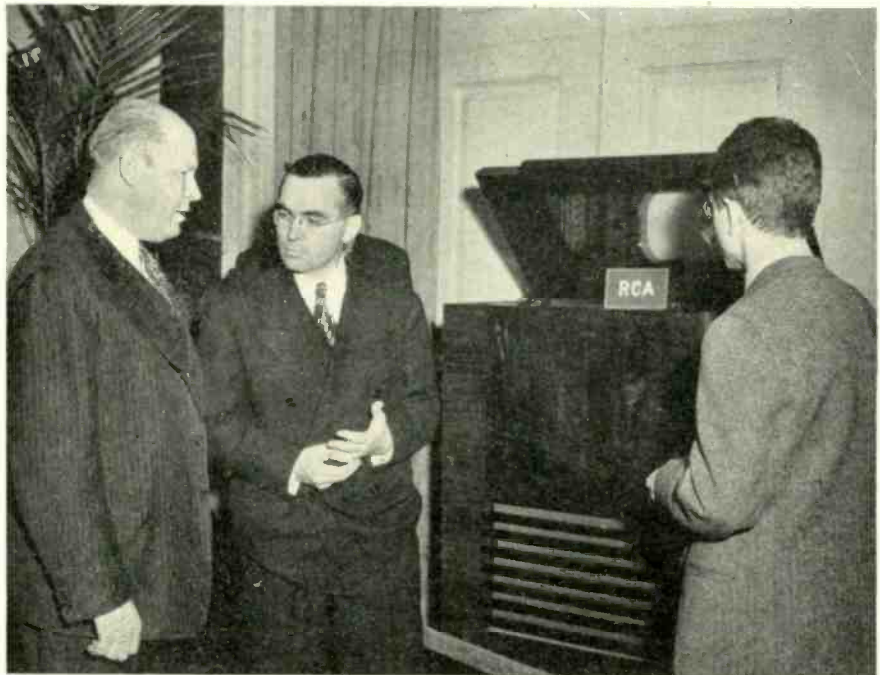

Allen P. DuMont (left), President of DuMont Laboratories, shown discussing new techniques in commercial television with *Thomas F. Joyce*, Vice President of RCA-Victor Division, Radio Corp. of America. Mr. Joyce declared that television will be important to the prosperity of America if launched on a large scale postwar.

CARDWELL APPOINTS FABEL

Elected by the Directors of the Allen D. Cardwell Mfg. Corp., Brooklyn, N. Y., to fill the newly-created office of Vice-President in Charge of Sales, *Joseph K. Fabel* has resigned the post of Assistant District Manager, New York Section of the Army-Navy Electronics Production



Agency. Mr. Fabel began serving in the expediting division of the U. S. Army Signal Corps in February of 1942, before Army and Navy electronics expediting activities were integrated through the creation of the ANEPA agency.

HOFFMAN JOINS MACHLETT

Machlett Laboratories, Inc., announces the appointment of *Henry J. Hoffman* as Sales Manager of the Power Tube Division, as well as Administrative Assistant to *Miles Pennybacker*, Vice President.

FORMICA RECEPTION

Representatives of the laminated plastics industry and of the press and radio were guests of the Formica Insulation Company, Cincinnati, for the premiere showing of "The Formica Story," chronicle of the laminated plastics industry. The picture



J. Roger White (left), Vice President and Sales Manager, *D. J. O'Connor, Sr.*, President, and *George Clark*, Vice President and Chief Engineer, of the Formica Insulation Company

was shown at a reception-premiere in the Starlight Roof Garden of the Hotel Waldorf-Astoria in New York City.

This Month

KRIVOBOK JOINS I. N. C.

Dr. V. N. Krivobok, recognized authority on stainless steel and former Professor of Metallurgy at the Carnegie Institute of Technology for many years, has become associated with the Development and Research Division of The International Nickel Company at New York, Robert C. Stanley, President, announces.

FRANKLIN NAMES ANDERSON

Franklin Transformer Company, Minneapolis, has announced the appointment of *R. L. Anderson* as chief engineer. He now is in charge of new developments in Army and Navy equipment, including welders, transformers, crystals and certain still-secret products for the military and lend-lease.

SYLVANIA THREE-BAGGER

Army-Navy E Awards were made to three of the plants of Sylvania Electric Products, Inc., on March 1. The three-ply ceremony marked one of the rare occasions on which a single corporation received a multiple award in one day.

The plants which have earned E awards are the Loring Avenue and Boston Street plants, in Salem, Mass., and the Danvers, Mass., plant.

HILLIARD NOW BENDIX G.M.

The appointment of *W. P. Hilliard* as general manager of the Radio Division of Bendix Aviation Corporation, at Baltimore, Md., and Red Bank, N. J., has been announced by *Ernest R. Breech*, president of the corporation.

Mr. Hilliard, who has been director of sales and engineering of the Radio Division since its inception in 1936, succeeds *Hugh Benet*, who will assume for the corporation other responsibilities of a special assignment nature.

DR. JOLLIFFE WRITES INDUSTRY REVIEW

A review of the radio industry in 1943 has been prepared for the American Year Book by *Dr. C. B. Jolliffe*, chief engineer of the RCA Victor Division of Radio Corporation of America, Camden, N. J. Principal subjects discussed by Dr. Jolliffe include domestic broadcasting, international broadcasting, radio servicing, police and aviation radio, and electronics.

LITTELFUSE APPOINTS FOOTE

The appointment of *William A. Foote* to be Sales Coordinator of Littelfuse Incorporated, El Monte, California, and Chicago, Illinois, brings a man of exceptional qualifications to the Littelfuse staff.

Mr. Foote's business career includes the presidency and general sales management of the Wingfoote Petroleum Company—affiliation with the Standard Oil Company of New York as Marketing Counsel—national directorship of sales of the Deoxolin Chemical Corporation. He was born in Homer, N. Y., and is 42 years old.

UNIVERSAL NOTES

Robert Ramsey, inside plant follow-up man at the Inglewood, Cal., twin plants



Standing, left to right: *Lew Howard*, Peerless Electrical Products Co.; *E. Danielson*, Remler Co., Ltd.; *Leslie Howell*, Gilfillan Bros., Inc.; *James L. Fouch*, Universal Microphone Company; *Clayton Bane*, Technical Radio Co.; *E. P. Gertsch*, Air Associates, Inc.

Seated, left to right: *Herb Becker*, Eitel-McCullough, Inc.; *H. L. Hoffman*, Hoffman Radio Corporation; *Jack Kaufman*, Heintz and Kaufman, Ltd.; *Howard Thomas*, Packard-Bell Co.

of the Universal Microphone Co., has been promoted to manager of outside production. He succeeds *Neville Robinson*, who designed to take a lengthy rest in the desert. Ramsey joined the force earlier this year after being discharged from the army with Alaskan service.

Spring housecleaning at the Inglewood, Cal., plants of the Universal Microphone Co. include removal of camouflage paint and nets and re-painting of all buildings; return of outside signs; and neon displays on rooftops.

Dr. Ralph L. Power, Los Angeles radio counsellor, is supervising editing of *Micro Topics*, bi-weekly house organ of the Universal Microphone Co., Inglewood, Cal. Magazine is now into its second year.

NEW CALLITE BULLETIN

Callite Tungsten Corporation have released a new technical bulletin on their Calliflex Bi-Metal, which is described as a reliable economical material for use as a temperature responsive element, in automatic control.

"Calliflex" Thermostatic Bi-Metal is available in five types according to temperature requirements. These are low, medium, special medium, high, and rust-resisting types.

Bulletin No. 155 on Calliflex gives technical data on the deflection and power of the various types in strip and coil, also data on thicknesses, sizes, etc., of value to the product designer and engineer. Copies may be had on request to Callite Tungsten Corporation, 540 Thirty-ninth Street, Union City, N. J.

NEW UTAH APPOINTEES

Recently *Mr. Fred R. Tuerk*, President of the Utah Radio Products Company, announced that *W. A. Ellmore*, Vice President in Charge of Engineering, assumes the additional duties of heading the Sales Department due to the resignation of *Oden F. Jester*, Vice President in Charge of Sales, who has accepted a position as Vice President of Meissner Manufacturing Company. Mr. Ellmore will assume his new duties as of April 1st, 1944.

Well known in the Radio Industry, Mr. Ellmore has been with the Utah Radio Products Company for fifteen years.

Mr. Tuerk also announced that *Chester L. Walker*, formerly Chief Engineer, has been promoted to Sales Manager in Charge of Manufacturing and Equipment Division. *Robert M. Karet* continues as Sales Manager of the Wholesale and



W. A. ELLMORE

Sound Division and *Frank E. Ellithorpe* continues as Sales Manager of the Carter Division.

Mr. Tuerk also said that *Marion S. Danisch* will become Chief Engineer. Danisch is well known in Radio Engineering circles, and has been identified with the Industry for sixteen years. His experience includes a number of years as Chief Engineer of Ucoa Radio Sociedad Anonima, South American affiliate of the Utah Radio Products Company.

Gordon S. Carbonneau, who has been Production Engineer of the Utah Radio Products Company for many years, has been appointed to new duties as Engineer in Charge of the Quality Control Division.

RADIO BIBLIOGRAPHY

F. X. RETTENMEYER

RCA Victor Division
Radio Corporation of America

15—HOUSEHOLD RECEIVERS, PART 3

- A Self-tuning Radio Set, *Lit. Digest*, Vol. 95, Dec. 31, 1927, page 45.
- Selling the Quality Market; "Radio Architect" did \$100,000 business in three years in a town of 9,000 by specializing in built-to-order cabinets and high grade sets, *Radio Retailing*, Vol. 5, Feb. 1927, page 43.
- Set Locates Metal in Ground, *Radio World*, Vol. 10, Feb. 12, 1927, page 17.
- A Set That Records What It Receives, *Pop. Radio*, Vol. 11, Jan. 1927, page 40.
- Seven-Tube Single Control Receiver, *Radio Retailing*, Vol. 6, July 1927, page 96.
- A "Shielded" Crystal Receiver, *Pop. Radio*, Vol. 11, April 1928, page 362.
- Notes on the Shielded Dual-control Receiver—M. Silver—*Radio Broadcast*, Vol. 10, Feb. 1927, page 386.
- Six-Tube Receiver, *Radio Retailing*, Vol. 5, April 1927, page 68.
- Empire Broadcast Reception—H. F. Smith—*Wireless World*, Vol. 20, June 29, 1927, page 806.
- Wireless World Regional Receiver—H. F. Smith—*Wireless World*, Vol. 21, Aug. 17, 1927, page 196.
- Notes on Radio Receiver Measurements—T. A. Smith & G. Rodwin—*Proceedings IRE*, Vol. 15, May 1927, page 387.
- Some of the New Factory Built Models, *Radio*, Vol. 9, July 1927, page 39.
- The Gomex Super-reflex Receiver—A. Van A. Sommers—*Radio News*, Vol. 9, Sept. 1927, page 230.
- Alternative Programme Quality Receiver—A. L. M. Sowerby—*Wireless World*, Vol. 21, Dec. 28, 1927, page 832.
- Golden Opportunities of Custom Set Builders—E. Sowers—*Radio News*, Vol. 9, Dec. 1927, page 594.
- Specifications of Factory-Built Receivers Exhibited at R.M.A. Show, *Radio*, Vol. 9, July 1927, page 34.
- A Transatlantic Radiotelephone Receiver—G. Spelvin—*Radio News*, Vol. 8, April 1927, page 1224.
- To Build Radio Equipped Modern Homes, *Radio Retailing*, Vol. 5, Jan. 1927, page 71.
- Preservation of Quality in a Well-designed Set—T. Turkey—*Radio World*, Vol. 11, Sept. 10, 1927, page 10.
- Two Amplifier Combinations in Ten-Tube Set, *Radio News*, Nov. 1927, page 468.
- Types of New Sets Planned for 1927-28, *Radio Retailing*, Vol. 5, June 1927, page 97.
- Tuned-Anode Single-Valve Receiver—N. P. Vincer-Minter—*Wireless World*, Vol. 21, Oct. 12, 1927, page 504.
- Supers et M.F. (Superheterodynes and i.f. amplifiers. The faults of i.f. amplifiers)—J. Vivie—*QST Francais*, Vol. 8, Dec. 1927, page 10.
- Reduction of Interference in Broadcast Reception—A. N. Goldsmith—*Proceedings IRE*, Oct. 1926, page 575.
- Combined Electromagnetic and Electrostatic Coupling and Some Uses of the Combination—E. H. Loftin & S. Y. White—*Proceedings IRE*, Oct. 1926, page 605.
- On the Origin of the Superheterodyne Method—W. L. Schottky—*Proceedings IRE*, Oct. 1926, page 695.
- Maintaining a Constant Reading on an Ammeter in the Filament Battery Circuit of a Thermionic Triode—E. H. W. Banner—*Proceedings IRE*, June 1926, page 235.
- Portable Receiving Sets for Measuring Field Strengths at Broadcasting Frequencies—A. G. Jensen—*Proceedings IRE*, June 1926, page 333.
- Sources of "A," "B" and "C" Power for Radio Receivers—W. E. Holland—*Proceedings IRE*, June 1926, page 345.
- Servicing of Broadcast Receivers—L. Manley & W. E. Garity—*Proceedings IRE*, Aug. 1926, page 541.
- Tendencies in Modern Receiver Design—J. G. Aceves—*Radio Broadcast*, Vol. 9, July 1926, page 248.
- Constructing the Shielded Hammarlund-Roberts Receiver—V. T. Baird—*Radio News*, Vol. 8, Dec. 1926, page 652.
- A Batteryless Receiver—J. Bernslev—*Radio News*, Vol. 8, Aug. 1926, page 130.
- Duo-Wave-Range Receiver—J. Bernslev—*Radio News*, Vol. 8, July 1926, page 40.
- Un Récepteur d'Ondes Courtes Étudié pour la Gamme 11-280 Metres (A short-wave receiver for the range between 11 and 280 meters)—L. Berthet—*Radio Électricité*, Vol. 7, May 10, 1926, page 178.
- Un Récepteur Neutrodyne Étudié pour la Gamme de 200 à 3000 Metres—L. Berthet—*Radio Électricité*, Vol. 7, March 10, 1926, page 90.
- A Complete Socket Power Receiver—G. M. Best—*Radio*, Vol. 8, Aug. 1926, page 17.
- The Equamatic Tuned R.F. Receiver—G. M. Best—*Radio*, Vol. 8, Oct. 1926, page 29.
- The Counterphase Power Six—G. M. Best—*Radio*, Vol. 8, Dec. 1926, page 35.
- Short-wave Receiver at 6XAO—G. M. Best—*Radio*, Vol. 8, May 1926, page 3.
- Oliver Lodge Invents "N" Set—A. C. Blackall—*Radio Digest*, Vol. 17, April 17, 1926, page 3.
- The Antennaless Receiver—L. B. Blan—*Radio World*, Vol. 10, Nov. 27, 1926, page 3.
- The Making of a Single-Control Receiver—A. S. Blatterman—*QST*, Vol. 10, April 1926, page 17.
- How to Build the "Equamatic" Five-Tube Receiver—Z. Bouck—*Radio Broadcast*, Vol. 9, Oct. 1926, page 479.
- A Single-Tube Receiver that Won't Radiate—Z. Bouck—*Radio Broadcast*, Vol. 10, Dec. 1926, page 169.
- Superheterodyne Radio Receivers—A. E. Bowyer-Lowe—*Sci. Abs.*, Section B, Vol. 29, May 25, 1926, page 256.
- Short-wave Receiver Using Interchangeable Coils—F. A. Boyce—*Wireless World*, Vol. 18, March 10, 1926, page 379.
- Additional Notes on the R. B. "Lab" Receiver—J. B. Brennan—*Radio Broadcast*, Vol. 10, Dec. 1926, page 178.
- Constructing the R. B. "Lab" Receiver—J. B. Brennan—*Radio Broadcast*, Vol. 10, Nov. 1926, page 35.
- The "Radio Broadcast" Local Receiver—J. B. Brennan—*Radio Broadcast*, Vol. 9, May 1926, page 42.
- A Simple 4-Tube Set—W. Brill—*Radio World*, Vol. 9, March 27, 1926, page 11.
- An Inexpensive Reflex Receiver—M. Buchbinder—*Radio*, March 1926, page 27.
- An Automatic Receiver Controlled by Connecting and Disconnecting the Loudspeaker—A. P. Castellain—*Wireless World*, Vol. 18, June 9, 1926, page 756.
- The 1-Hour 3-Tube Set—C. Charlton—*Radio World*, Vol. 9, March 27, 1926.
- A High Quality "Local" Receiver—K. Clough—*Radio Broadcast*, Vol. 9, Aug. 1926, page 305.
- An Economical 4-Tube Set—E. T. Collins—*Radio World*, Vol. 9, March 27, 1926, page 3.
- A Colpitts One Valve Receiver, *Pop. Wireless*, Vol. 9, July 3, 1926, page 637.
- How to Test Radio Receivers—H. Diamond—*Radio*, Feb. 1926, page 22.
- An All-wave Duplex Receiver Covering All Wavelengths from 20 to 20,000 Meters by Means of Three Units—M. Doran—*Radio*, Vol. 7, July 1926, page 27.
- The Power Booster Set—M. C. Drew—*Radio World*, Vol. 9, April 17, 1926, page 5.
- Autumn Styles in Radio—O. E. Dunlap—*Sci. Amer.*, Vol. 82, Nov. 1926, page 340.
- Problems in Broadcast Receiver Design—P. P. Eckersley—*Exp. Wireless*, Vol. 3, Aug. 1926, page 499.
- A Short-wave Superheterodyne Receiver—G. I. Eltz—*Radio Broadcast*, Vol. 10, Nov. 1926, page 54.
- Everyman's Receiver—L. Fenway—*Radio News*, Vol. 7, June 1926, page 1656, and July 1926, page 44.
- A Stabilized TRF Receiver—R. Ferris—*Radio World*, Vol. 9, April 10, 1926, page 4.

(Continued on page 46)



Echophone Model EC-1

(Illustrated) a compact communications receiver with every necessary feature for good reception. Covers from 550 kc. to 30 mc. on three bands. Electrical bandspread on all bands. Six tubes. Self-contained speaker. 115-125 volts AC or DC.



Echophone Radio Co., 540 N. Michigan Ave., Chicago 11, Illinois

Hard Circuits Made Easy—G. E. Field—*Pop. Wireless*, Vol. 8, Feb. 13, 1926, page 1347.

An Autobalanced Receiver—C. J. Fitch—*Radio News*, Vol. 8, Nov. 1926, page 497.

A "Five-in-Two" Receiver—C. J. Fitch—*Radio News*, Vol. 8, Oct. 1926, page 362.

Four Receivers, *Radio Broadcast*, Vol. 8, Feb. 1926, page 450.

How to Build a Grimes Inverse Duplex—F. J. Fox—*Radio Broadcast*, Vol. 8, Feb. 1926, page 439.

Le Reglage de la Réaction dans un Récepteur à Cadre—E. Fromy—*L'Onde Électrique*, Vol. 5, Feb. 1926, page 89.

Sets Classified for Selectivity—A. N. Goldsmith—*Radio World*, Vol. 10, Nov. 13, 1926, page 12.

Complications of Crystal Reception—W. H. F. Griffiths—*Wireless World*, Vol. 18, Feb. 17, 1926, page 245.

Further Notes on the Loading Effects of Crystals—W. H. F. Griffiths—*Wireless World*, Vol. 18, March 3, 1926, page 334.

How to Build the New Orthophase Radio Receiver—R. J. Griffith—*Pop. Radio*, Vol. 9, Feb. 1926, page 142.

Shielding Radio Receivers Gains Favor—H. Green—*Radio News*, Vol. 7, April 1926, page 1442.

An H.F. & Detector Receiver, *Pop. Wireless*, Vol. 8, Feb. 6, 1926, page 1287.

An Automatic Double-Range Receiver—S. Harris—*Radio News*, Vol. 7, March 1926, page 1287.

The "Excelsior" Receiver. (In the receiver described in this article, there has been incorporated the balanced-bridge system of radio-frequency amplification and a new type of audio-frequency amplifier.)—S. Harris—*Radio News*, Vol. 8, Oct. 1926, page 360.

Short-wave Receiving Sets—L. W. Hatry—*QST*, Vol. 10, July 1926, page 20.

[To Be Continued]

POSTWAR TELEVISION STUDIO DESIGN

★ A working model of television studios designed for the postwar broadcasting of regular commercial network programs with large studio audiences was recently exhibited by engineers of The Austin Company at the Waldorf-Astoria Hotel in New York City. (See cover photo).

The model was "unveiled" at a press luncheon where Dr. Walter R. G. Baker, vice president of General Electric Company and other G-E officials discussed "Television Postwar" and announced the company's plans for the new industry.

Austin engineers have developed a basic new building design for the studios, with a turntable stage and unique layout which make it possible to accommodate rapid changes of scene and audience without duplication of costly television equipment.

Separate audience seating areas, each accommodating several hundred people, are provided on either side of a single broadcasting control room and overlook one quadrant of the revolving stage from which all productions are to be broadcast. Sound-resistant curtains across the front of each seating area make it possible to use the two sides alternately for alternate programs, or jointly when desired. When the curtain is drawn on one section, at the end of a program, spectators can leave it and a new audience can assemble there for a later program without disturbing the next succeeding broadcast which is viewed meanwhile from the other audience section.

The design was adopted following a study of facilities and experience at G-E's television station, WRGB,

Schenectady, and in the light of Austin's experience in the design and construction of facilities for communications and entertainment industries.

The studios have been planned along modern, functional lines with a welded rigid frame steel structure which supports several cantilevered television cameras, as well as the circular roof in the stage area. With one of these cameras mounted on the pivotal column in the center of the revolving stage and the others on the sides, it is possible to cover every part of the stage, at any distance and from every angle. The same cameras can be directed toward the audience for visual broadcasts of audience participation.

Similar flexibility is provided in the system of high level studio illumination, which uses water-cooled mercury vapor lamps operated by remote controls.

Lighting, noise and atmospheric conditions are subject to complete control in all parts of the building, which utilizes special insulated wall and roof construction developed by Austin engineers for the efficient, economical air-conditioning of large windowless, control conditioned industrial plants.

Spacious backstage areas around the revolving stage are available for construction of sets, storage of sponsors' exhibits or other equipment. Stage receiving doors are large enough to handle small aircraft and room-size displays.

Offices, camera rooms, dressing rooms, sponsors' observation rooms, and other auxiliary facilities are provided on the first floor, below the audience seating areas and the control

room. A lofty lobby and exhibition hall extends across the entrance facade.

The design was developed by J. K. Gannett of New York, vice president and director of engineering of The Austin Company, in collaboration with Robert Smith, Jr., architect, and Brown W. Saveland, electrical engineer, of the company's research staff. Austin has designed and built some of the motion picture industry's largest sound stages and studios, NBC's big Hollywood broadcasting studios, Technicolor laboratories here and abroad, as well as commercial and naval transmitting and listening stations from coast to coast.

Facilities shown in the Austin model will only be required in the larger cities where the more ambitious network programs originate, according to Mr. Gannett. He explained that secondary stations suited for local or network television broadcasting on a smaller scale are being projected along equally modern, functional lines.

★

REEVES APPOINTS SPEED

Hazard E. Reeves, Executive Vice-President, Reeves Sound Laboratories, announces the appointment of *William C. Speed*, Vice-President in Charge of Manufacturing.

Mr. Speed, who has, since the organization of the Company, been identified with crystal production, is a Director of the Company as well. He is also Vice-President of Audio Manufacturing Corp., of Stamford, Conn., and New York, N. Y.

Prior to his present work, Mr. Speed was associated with the Vitaphone Corp., Paramount Studios, Paris, France.

W.P.B. Encourages Industrial Sound Installations In Feb. 28th Announcement



RACON
endorses new
policy 100%

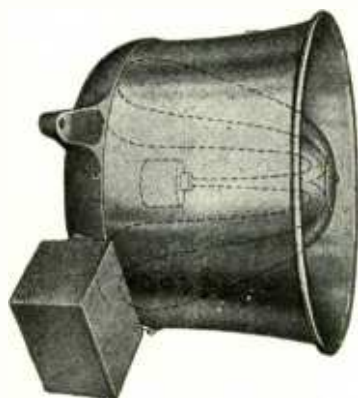

Here is the RACON MARINE HORN Speaker used on many bombers and navy vessels. Approved by the U. S. Coast Guard, formerly the Bur. of Marine Inspection, Dept. of Commerce. Several sizes available, Stormproofed, of the reentrant type, suitable for indoor or outdoor use—may be used as both speaker and microphone.



RE-ENTRANT TRUMPET; available in 3½', 4½' and 6' sizes. Compact. Delivers highly concentrated sound with great efficiency over long distances.

Public address sound equipment for industrial plants engaged in war work contribute to speeding up production. Music relieves fatigue and stimulates workers. Paging systems quickly locate personnel and reduce use of jammed telephone lines. So, WPB will now accept applications for industrial sound installations when submitted on WPB Form 617.

Most of the best industrial p.a. installations in use are RACON speaker equipped. They are the finest speakers made and there is a type for every conceivable application. Our catalog is available without charge.

For Marine p.a. installations, too, RACON leads. Approved by the U. S. Coast Guard, RACON speakers are used aboard Army and Navy vessels. Only RACON can supply, when needed, patented Weatherproof, Stormproof Acoustic Material which is impervious to any weather condition and prevents resonant effects.

RACON ELECTRIC CO., 52 E. 19th St., N. Y.

RACON

RADIO

★ APRIL, 1944

R-F TRANSMISSION LINES

[Continued from page 39]

and "d" the outside diameter of the inner conductor. "D" and "d" dimensions may be in centimeters or inches so long as both are of the same units, since we are both interested in the ratio between the two. "K" is the dielectric constant of the insulating material between the conductors. Where spaced beads are used it is necessary to determine the percent space occupied by the beads in order to obtain a more accurate impedance calculation. As shown in the equations, the surge impedance

is proportional to the reciprocal of the square root of "K." Where the dielectric material is other than air, this results in a lower impedance line.

Standing Waves

Theoretically, with an infinitely long line a signal applied to the start would never reach the far end, but would gradually decrease in amplitude, due to losses. This being the case, the signal would never be reflected, so no standing waves would be present. Suppose this line had a finite length and was terminated in a resistive load equal to the surge impedance; under these conditions, the load would absorb all of the

power, and likewise there would be no reflections regardless of the length of the line. However, if the load was not resistive but reactive, reflections would occur, and the combination of the transmitted and the reflected signals would produce a standing wave.

The standing-wave-ratio may be defined as the ratio of minimum voltage along the line (neglecting normal attenuation loss) and is an indication of load mismatch. As an example, suppose the minimum and maximum voltage along the line to be 5 and 10 volts respectively. This is a ratio of 1 to 2; therefore, the load impedance is either $\frac{1}{2}$ or 2 times that of the line. If the load is appreciably reactive this gives only a rough approximation.

Velocity of Transmission

It is well known that the speed of radio waves in free space is 300 million meters per second. However, when radio waves are transmitted through a transmission line the speed is reduced by a factor of $1/\sqrt{K}$, where "K" represents the dielectric constant of the cable. Obviously then, the distance of one wavelength of cable is somewhat less than that in free space, since a wavelength is equal to the velocity of transmission divided by frequency. It should be noted that the velocity of transmission does not remain constant over a large frequency range, due to the fact that the dielectric constant of the insulation varies somewhat with frequency.

A commonly used method of checking the velocity is by means of a slotted line section as shown in Fig. 4. Having set up the equipment as shown, the probe in the slotted section is adjusted to the first point of minimum voltage, starting from the cable end. This point is accurately determined and recorded. Now a small piece is cut from the end of the cable and the probe readjusted to the minimum voltage point. The velocity constant of the line is indicated by the ratio of change in probe distance to the length of cable which has been cut off. For example, if the probe is shifted 3 inches for the minimum voltage points when 4 inches is cut from the cable, the velocity constant is 0.75 or 75% and one wavelength of cable would, therefore, be equal to three-quarters of a wavelength in actual distance.

Specifications

The writing of specifications for r-f transmission cables should include the following:

1. *Outline drawing* showing the general construction with dimensions where important.
2. *Conductors*—physical dimensions, material, solid or stranded.

[Continued on page 50]

Ingenious New Technical Methods

Presented in the hope that they will prove interesting and useful to you.



Center Scope Brings Optical Precision to Machine Shop Operations

The Center Scope is an optical centering and locating tool that can be easily and quickly used on any machine to center work reference lines to a spindle axis. It permits accuracy to a degree never before obtainable, as the optical beam or line of sight is absolutely inflexible and cannot be distorted.

The Center Scope's easy accuracy eliminates many human errors, as the operator can see just what the cutting tool will do before it is actually fed into the work. It increases production, improves efficiency and prevents spoilage. There is no pressure on the work piece nor is it subject to wear or changes in temperature—for the Center Scope never touches the layout.

The Center Scope enables the operator to easily and quickly locate edges to a spindle axis, set-up faster and compensate for run-out. It saves vital hours in checking, inspecting and measuring when mechanical methods and tools are impossible to use. Its 45 x magnification allows operator to see ".001" and requires no technical knowledge or training to operate.

While there is nothing particularly new or ingenious about Wrigley's Spearmint gum, it is proving useful to millions of people in many new ways. Workers in war plants everywhere have found it helps keep them alert and relieves nervous tension and dry mouth while they are on the job.

You can get complete information from the Center Scope Instrument Company, 351 S. LaBrea Ave., Los Angeles, Calif., or Kearney & Trecker Products Corporation, Milwaukee, Wis.

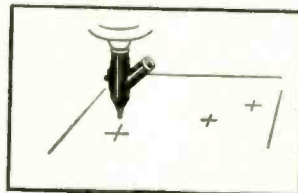

ON A VERTICAL MILL—locating and centering height gauge or size block layouts. Permits jig borer accuracy on more machines.

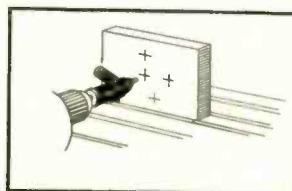

ON A HORIZONTAL MILL—the ability to center a layout, edge block or rotary table plug while spindle is running. Permits quick and easy set-up for high precision work.

Y-109

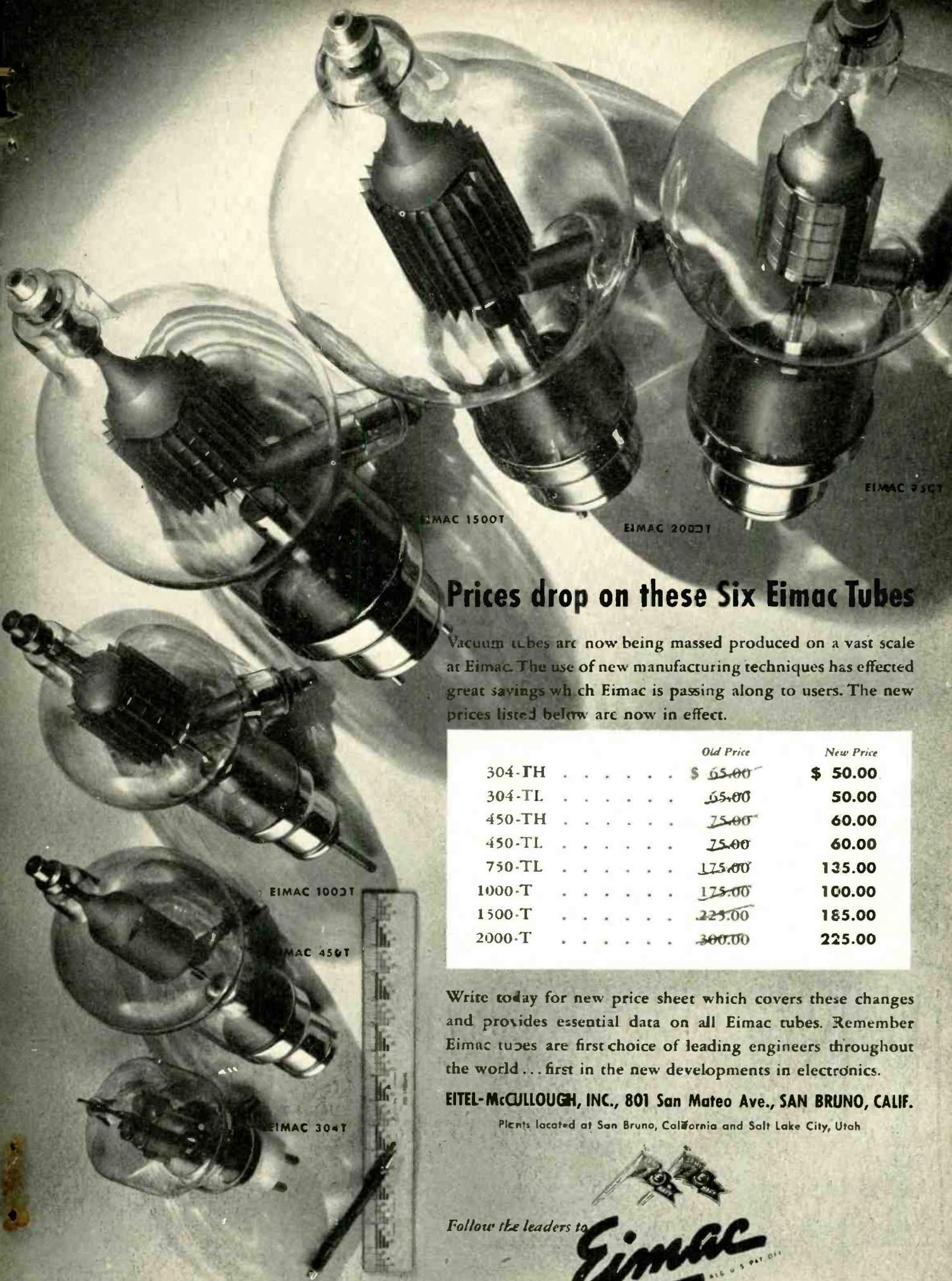

Prices drop on these Six Eimac Tubes

Vacuum tubes are now being massed produced on a vast scale at Eimac. The use of new manufacturing techniques has effected great savings which Eimac is passing along to users. The new prices listed below are now in effect.

	Old Price	New Price
304-TH	\$ 65.00	\$ 50.00
304-TL	65.00	50.00
450-TH	75.00	60.00
450-TL	75.00	60.00
750-TL	175.00	135.00
1000-T	175.00	100.00
1500-T	225.00	185.00
2000-T	300.00	225.00

Write today for new price sheet which covers these changes and provides essential data on all Eimac tubes. Remember Eimac tubes are first choice of leading engineers throughout the world... first in the new developments in electronics.

EITEL-McCULLOUGH, INC., 801 San Mateo Ave., SAN BRUNO, CALIF.
 Plants located at San Bruno, California and Salt Lake City, Utah

Follow the leaders to

Eimac
 TUBES

Export Agents: FRAZAR & HANSEN

KEN-RAD

ELECTRON TUBES

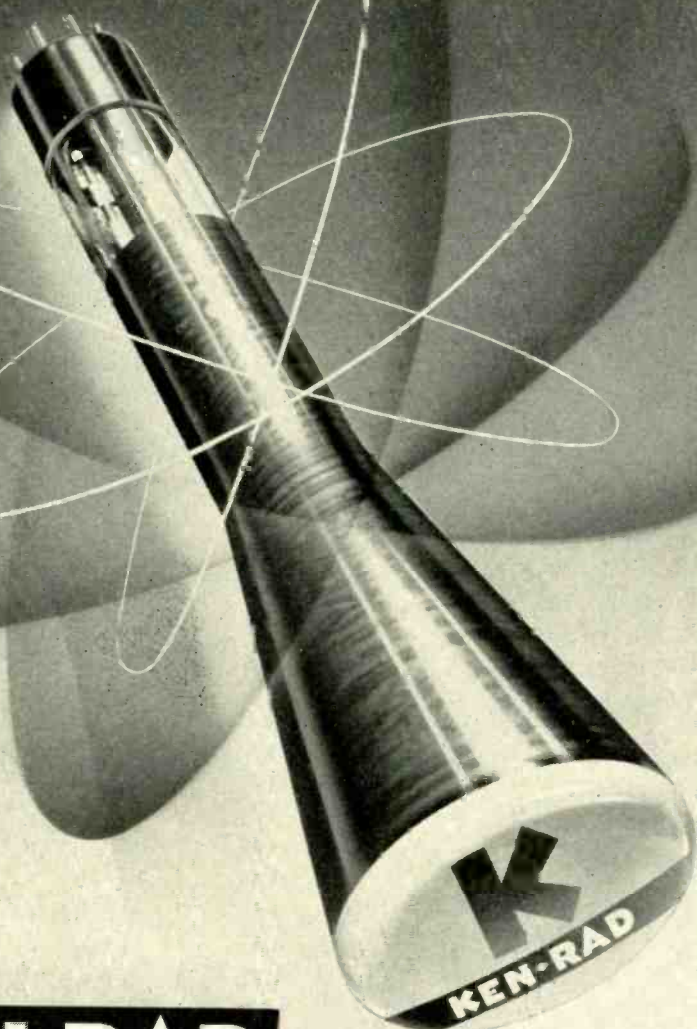

KEN-RAD

EXECUTIVE OFFICES

OWENSBORO · KENTUCKY

EXPORTS 15 MOORE STREET NEW YORK

TRANSMITTING
TUBES

CATHODE RAY
TUBES

SPECIAL
PURPOSE TUBES

RECEIVING
TUBES

INCANDESCENT
LAMPS

FLUORESCENT
LAMPS

WANTED—ENGINEER—TECHNICIANS

Radio, Electrical and Mechanical Design Engineers, Draftsmen and Technicians for war and post-war design work.

Engineering degree, or, actual design experience in Communication Radio, Broadcast Receivers, Television and other Electronic Fields is required.

Write giving full details, education, experience, draft status and salary desired. Essential workers need release statement and U.S.E.S. consent. All inquiries confidential.

Chief Engineer, Electrical Research Laboratories, Inc.

2020 Ridge Avenue: Evanston, Illinois

ERLA-SENTINEL RADIO

R-F TRANSMISSION LINES

[Continued from page 48]

3. *Dielectric*—Material—solid, beads or spaced sections.

4. *Capacitance*—Measured between 1000 cycles and 1 megacycle in micro-micro-farads per foot.

5. *Impedance*—Measured at 1000 cycles or calculated from velocity of cable and capacity measurement.

6. *Attenuation*—Measured at a specified frequency in db/foot.

7. *Rated Operating Voltage*—Measured under specified conditions of temperature, humidity and load termination. Cable should withstand twice operating voltage for one minute at a specified frequency.

8. *Corona*—Cable should be checked for corona at 60 cycles with a specified voltage for one minute.

9. *Insulation Resistance*—Measured at 25°C should exceed a specified resistance after one minute with at least 200 volts applied.

10. *Pliability*—Cable dielectric or covering (when used) should show no signs of cracking or loss of flexibility at -40°C. The inner conductor in a solid dielectric type of cable should not be displaced more than 15% due to bending at either high or low specified temperatures.

11. *Immersion*—Cable should be capable of withstanding immersion for a specified number of hours in tap water at room temperature without affecting any specified characteristic more than plus or minus 10%.

These items are not intended to be the last word in specifications since the intended application may be such that some points do not apply. The list is given simply as a guide and should be taken as such.

For additional data on the theory and design of transmission lines reference should be made to the following:

Radio Engineers' Handbook, Terman, McGraw-Hill Book Company.

Reference Data for Radio Engineers, Federal Tel. & Radio Corp.

U.H.F. Techniques, Brainerd, D. Van Nostrand Co.

High-Frequency Alternating Currents, McIlwain & Brainerd, John Wiley and Sons.

Communication Engineering, Everitt, McGraw Hill Book Co.

★

DUMONT APPOINTS CUFF

The Allen B. DuMont Laboratories have appointed *Samuel H. Cuff* as General Sales Promotion Manager for Television. Mr. Cuff will direct DuMont sales promotion on Radio Television Receiving Sets, Television Transmitter Equipment, and DuMont-owned Television Station Time Sales.



TESTING TOMORROW'S RADIO TUBES

• Early in the war, Sylvania engineers stepped up experiment to perfect more rugged and more sensitive radio tubes for vital military communications.

Engineers added to a great array of precision checking instruments. They designed and built special new instruments to detect variations in radio tube characteristics never charted before.

This intensive research program has developed improved radio tubes. Many are now military secrets. But they promise to make postwar radio reception a revelation of clarity and fidelity.

After the war, as in the past, it will pay you to sell Sylvania.

Quality That Serves the War Shall Serve the Peace

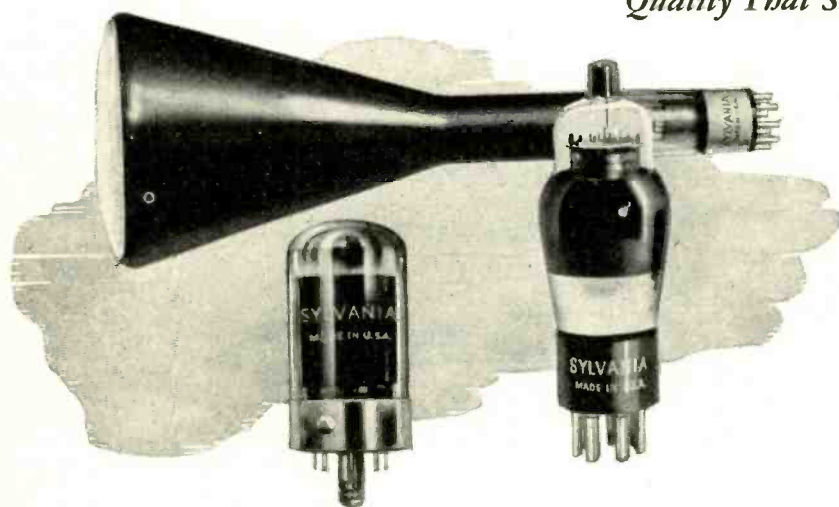

RADIO DIVISION EMPORIUM, PENNSYLVANIA

SYLVANIA

ELECTRIC PRODUCTS INC.

RADIO TUBES, CATHODE RAY TUBES, ELECTRONIC DEVICES, INCANDESCENT LAMPS, FLUORESCENT LAMPS, FIXTURES AND ACCESSORIES

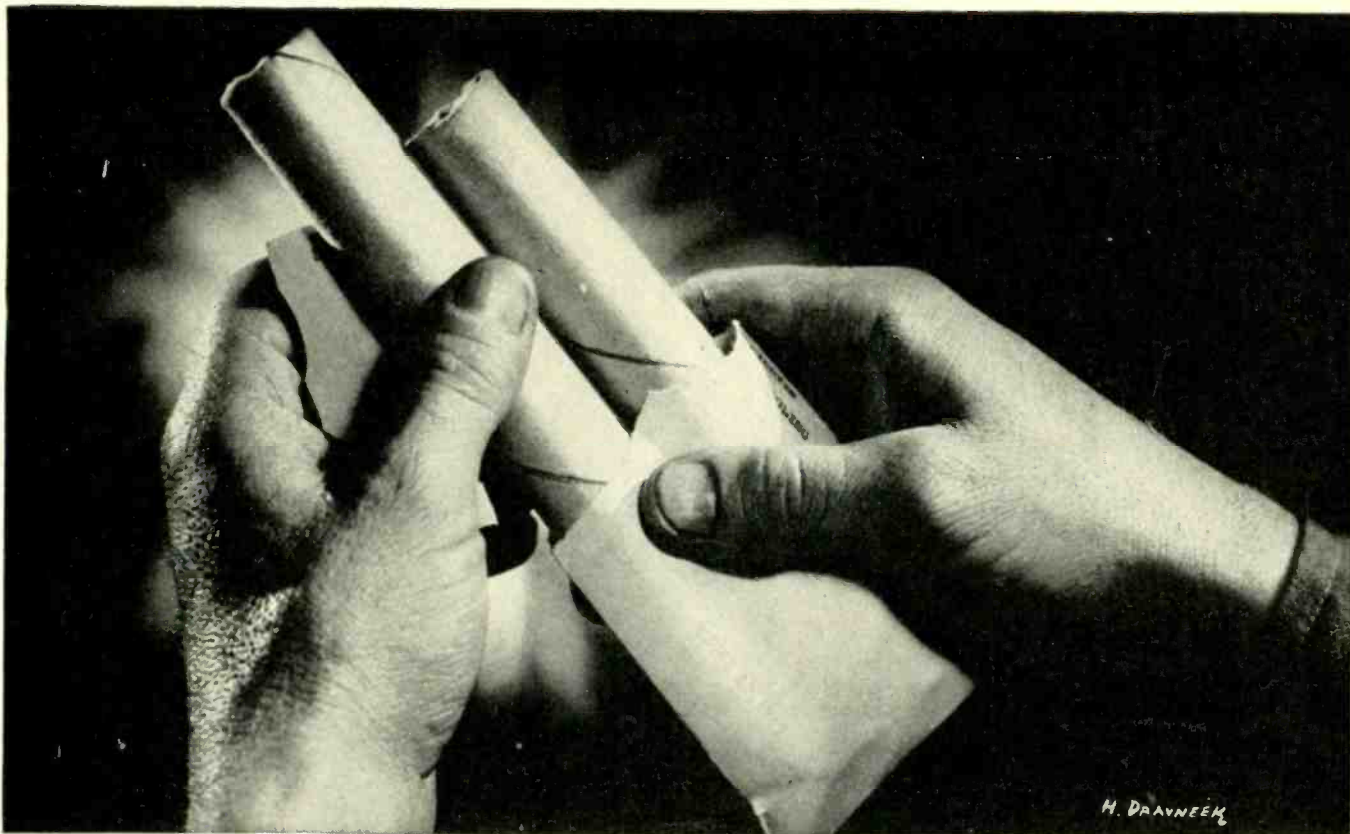

Mister—you're getting paid in DYNAMITE!

LET'S NOT KID OURSELVES about this. Our pay envelope today *is* dynamite.

If we handle it *wrong*, it can blow up in our face . . . lengthen the war . . . and maybe wreck *our* chances of having happiness and security *after* the war.

The wrong way to handle it . . . and why
The wrong way is for us to be good-time Charlies. To wink at prices that look too steep . . . telling ourselves we can afford to splurge.

We *can't* afford to—whether we're business men, farmers, or workers. And here's why:

Splurging will boost prices. First on one thing, then all along the line.

Then, wages will have to go up to meet higher prices. And higher wages will push prices up some more . . . faster and faster, like a runaway snowball.

The reason this can happen is that there is more money in pay envelopes today than there are things to buy with it. This year, we Americans will have *45 billion* dollars more income than there are goods and services to buy at present prices. *45 billion dollars extra money!*

That's the dynamite!

The right way to handle it . . . and why
Our Government is doing a lot of things to

keep the cost of living from snow-balling. Rationing helps. Price ceilings help. Wage-and-rent stabilization helps. Higher taxes help. They're *controls* on those dangerous excess dollars.

But the real control is in our hands. Yours. Mine.

It won't be fun. It will mean sacrifice and penny-pinching. But it's the only way we can win this war . . . pay for it . . . and keep America a going nation afterwards.

And, after all, the sacrifice of tightening our belts and doing without is a small sacrifice compared with giving your life or your blood in battle!

Here's what You must do

Buy only what you absolutely need. And this means absolutely. If you're tempted, think what a front-line soldier finds he can get along without.

Don't ask higher prices—for your own labor, your own services, or goods you sell.

Resist pressure to force **YOUR** prices up.

Buy rationed goods only by exchanging stamps. Shun the Black Market as you would the plague.

Don't pay a cent above ceiling prices.

Take a grin-and-bear-it attitude on taxes. They must get heavier. But remember, these taxes help pay for Victory.

Pay off your debts. Don't make new ones. Getting yourself in the clear helps keep your Country in the clear.

Start a savings account. Buy and keep up adequate life insurance. This puts your dollars where they'll do you good.

Buy more War Bonds. Not just a "percent" that lets you feel patriotic, but enough so it *really* pinches your pocket-book.

If we do these things, we and our Government won't have to fight a post-war battle against collapsing prices and paralyzed business. It's *our* pay envelope. It's up to *us*.

KEEP PRICES DOWN!

Use it up • Wear it out

Make it do • Or do without

This advertisement, prepared by the War Advertising Council, is contributed by this Magazine in co-operation with the Magazine Publishers of America.

RADIO

GROUP SUBSCRIPTIONS SAVE YOU UP TO 50%!

TEAR OUT—MAIL TO RADIO

RADIO MAGAZINES, INC.

342 Madison Ave., New York 17, N. Y.

Kindly enter the following subscriptions. Remittance is attached. (1 to 6 subscriptions may be ordered on this form).

- | | |
|---------------------------------------------------------------|--------|
| <input type="checkbox"/> One 1-year subscription | \$3.00 |
| <input type="checkbox"/> Two 1-year subscriptions | \$5.00 |
| <input type="checkbox"/> Three 1-year subscriptions | \$6.00 |
| <input type="checkbox"/> Four 1-year subscriptions | \$7.00 |
| <input type="checkbox"/> Five 1-year subscriptions | \$8.00 |

Groups of 6 or more subscriptions in the U.S.A. will be accepted at the rate of \$1.50 each. For Canadian groups add \$.50 to each subscription ordered.

PLEASE PRINT

Name

Address

Position Company

Name

Address

Position Company

Name

Address

Position Company

Name

Address

Position Company

Name

Address

Position Company

Name

Address

Position Company

NOTE: If you do not wish to tear out this order blank, print or type a list giving each subscriber's name, address, employer's name and their respective positions. Mail it in today!



You and your co-workers can now save up to half the regular cost of a RADIO subscription by using the Group Plan. The more men in a Group the more each saves, up to 50%. Present subscriptions may be **RENEWED** or **EXTENDED** as part of a group.

The combination of exclusive, fine and timely articles plus this low-rate subscription offer makes RADIO a must-have publication. So fellows, form a Group today and send it to—

RADIO MAGAZINES, INC.

342 MADISON AVENUE NEW YORK 17, N. Y.

What happens when your hat comes down?



SOMEDAY, a group of grim-faced men will walk stiffly into a room, sit down at a table, sign a piece of paper—and the War will be over.

That'll be quite a day. It doesn't take much imagination to picture the way the hats will be tossed into the air all over America on *that* day.

But what about the day after?

What happens when the tumult and the shouting have died, and all of us turn back to the job of actually making this country the wonderful place we've dreamed it would be?

What happens to you "after the War?"

No man knows just what's going to happen then. But we know one thing that must *not* happen:

We must *not* have a postwar America fumbling to restore an out-of-gear economy, staggering under a burden of idle factories and idle men, wracked with internal dissension and stricken with poverty and want.

We must *not* have breadlines and vacant farms and jobless, tired men in Army overcoats tramping city streets.

That is why we must buy War Bonds—now.

For every time you buy a Bond, you not only help finance the War. You help to build up a vast reserve of postwar buying power. Buying power that can mean millions of postwar jobs making billions of dollars' worth of postwar goods and a healthy, prosperous, strong America in which there'll be a richer, happier living for every one of us.

To protect your Country, your family, and your job *after* the War—*buy War Bonds now!*

Let's all **KEEP BACKING THE ATTACK!**

*The Treasury Department acknowledges with appreciation
the publication of this message by*

RADIO

NOTES ON

OSCILLATOR CRYSTALS

[Continued from page 28]

ance equipment. For contour types of vibrations the amount of metal coating is relatively unimportant, for this mode of motion is usually low in frequency and is not affected to the extent experienced with a thickness-mode oscillator.

Tourmaline Crystals

High-frequency crystal control has been attempted numerous times through the use of tourmaline crystals in place of quartz. It is generally more difficult to obtain large and completely clear specimens of tourmaline as compared to quartz, and their softer and more fragile structure is less durable. Because it may be successfully ground to thinner dimensions, tourmaline does provide a material for excellent high-frequency oscillator crystals, having a better thickness-versus-frequency ratio for frequencies where quartz becomes too thin and fragile. This is indicated in Fig. 11. The electromechanical activity of tourmaline Z-cut crystals is quite good and compares with the more active quartz cuts in this respect.

Serious temperature coefficient and discontinuity effects are the main disadvantages met with in the use of tourmaline crystals. The frequency deviation with temperature rise is approximately —45 cycles per mc per degree Centigrade for this type of cut. When used in conjunction with a temperature-compensated holder the stability realized makes the use of these plates practicable under carefully controlled conditions of frequency tolerance. A reasonable amount of activity may be found that will provide excellent frequency control on the odd harmonic multiples of its base frequency. This is especially significant because of the advantage of the high frequency-to-thickness ratios normally possible with tourmaline plates. For example, a ten-thousandths thick tourmaline plate will vibrate at about 45 megacycles when excited on the 3rd harmonic with the oscillator tank circuit tuned to 45 megacycles, using the circuit shown in Fig. 1.

These results are obtained with a simple triode or pentode oscillator as illustrated. With more care in crystal design as well as circuit layout the 5th and 7th harmonics may be excited as well, giving in the above-mentioned case 75 and 105 megacycles directly at the oscillator tube tank circuit. While power outputs may not be great

at these higher harmonics it is usually sufficient to excite any of the low-power, low-drive, beam-power pentode tubes used as radio-frequency exciter units.

Reactance-versus-frequency curves showing the response for most thickness-mode crystal oscillators are illustrated in Fig. 12. The orientation for AT-cut crystals, following I.R.E. nomenclature, is shown in Fig. 13.

★

REACTIVE PHASE IN WAVE GUIDES

[Continued from page 24]

these unwanted modes will usually be attenuated out in a few inches, but a dissipative loss of power may well be associated with that attenuation.

The propagation of electromagnetic waves in hollow pipe is no more a simple subject than many other fields of electrical engineering. The concepts of impedance and reactance cannot be used alone; they express only certain properties of the line in a form which is convenient. The final answer always depends upon the distribution in time and space of the electric and magnetic fields.

★

MICROSCOPE CAPACITOR

This .01-mfd. 40,000 VDC capacitor was built for a special application of the electron microscope. Other features of this capacitor are its capability of continuous operation at 80° C. and of withstanding total submersion and heavy surges.

The case is welded steel measuring $4\frac{1}{8}$ " x $5\frac{3}{4}$ " x 7" high with a stand-off insulator $8\frac{1}{2}$ " high. This insulator is the well known



Westinghouse Solder Seal type, soldered directly to the case, thus eliminating the possibility of oil leakage or the entrance of moisture.

Manufactured by Industrial Specialty Company, 1725 West North Avenue, Chicago 22, Illinois.

*Purchasing Agents!
Engineers!*

JUST OUT!



**NEW
1944
EDITION
FREE!**

800 Page
Buying Guide

RADIO PARTS

**RADIO TUBES
and INDUSTRIAL
ELECTRONIC EQUIPMENT**

— IN A HURRY
FROM OUR LARGE STOCK!

★ ★ ★
SEND FOR FREE CATALOG!

New 1944 Edition—Just Out!

Write today on your company letterhead for this massive 800 page, bound volume containing everything in radio and electronic equipment.

Address Box D.A.

— Telephone BARclay 7-1840 —

**SUN RADIO
& ELECTRONICS CO.**
212 Fulton Street, New York 7, N. Y.

... Here's How You Can Qualify for a BETTER RADIO JOB!

... CREI technical training is preparing others for good-paying radio jobs — WHY NOT YOU?

Are you finding yourself in a routine job—a job that any other man can handle just as well as you? Today, radio JOBS are many—but radio CAREERS are few! Now is the opportune time for you to equip yourself with the necessary technical training to qualify for an important engineering position with a sound future.

NOW when industry needs men, is the time for you to investigate radio career training. Your radio experience backed by modern CREI technical training will equip you to share in the good-paying jobs that await trained men... and to make good in the important positions that lead to security and happiness!

Write for Details

About CREI Home Study Courses

If you are a professional or amateur radioman and want to make more money—let us prove to you we have something you need to qualify for the BETTER career-job opportunities that can be yours. To help us intelligently answer your inquiry—PLEASE STATE BRIEFLY YOUR EDUCATION, RADIO EXPERIENCE AND PRESENT POSITION.

Free Booklet Sent

**CAPITOL RADIO
ENGINEERING INSTITUTE**

Dopt. RA-4, 3224-16th St., N.W., Washington 10, D.C.

NEW ASA STANDARDS



Serving

UNCLE SAM

WITH
THE
NEW

DUMONT

VICTORY MODEL
TE

SUPERCAPS

Dumont Electrolytic tubulars for the duration have the following special features...and are guaranteed to give the same high quality performance for which all Dumont Electrolytic Tubulars have a reputation.

SELF HEALING
LONG LIFE
ECONOMICAL
VARNISHED TUBES
DOUBLE SEALED
SMALL SIZE
FULLY GUARANTEED
Patent Pending

BUY
WAR
BONDS

DUMONT
ELECTRICO.

MFR'S OF
CAPACITORS FOR EVERY REQUIREMENT

34 HUBERT STREET
NEW YORK, N. Y.

★ **Porcelain Radio Insulators:** — A new standard for Porcelain Radio Insulators, just approved by the American Standards Association, is now available to industry and the armed forces. This standard completes a series of American War Standards covering the broad field of ceramic insulation for communication and electronic purposes.

This standard follows the pattern of the preceding specifications covering insulators made of steatite, glass-bonded mica, and glass. Definite requirements for dimensional tolerances and finishes have been included, as in earlier standards. Also, there is an appendix on design criteria recommended by leading manufacturers in each field. This appendix is intended to help design engineers not only in the radio manufacturing industry but also in the insulation industry itself.

All four insulator standards outline tests designed to determine the ability of the completed insulators to stand up in service under any of the conditions encountered by the various branches of our armed services, and supply data on the basic electrical characteristics of these components.

These new standards have been adopted for procurement purposes by the Radio Division, Navy Department, Bureau of Ships, and by the Signal Corps of the U. S. Army. It is anticipated that they will be used in the design of new equipment and, where practicable, in existing equipment and for replacement purposes.

★ **Temperature-Compensating Capacitors:** —A standard for Fixed Ceramic-Dielectric Capacitors of temperature-compensating types has been recently completed by the American Standards Association. Ceramic-dielectric capacitors may be designed to have either a positive, zero, or negative coefficient of capacitance with temperature. They are used mostly with the negative coefficient to compensate for the temperature changes in other capacitors and inductors.

This standard covers classification of capacitors, material, workmanship, general and detailed requirements, methods of sampling, inspection and tests. The provisions of the standard are written in a form that can be used directly for procurement purposes and it has been adopted by the Radio Division, Bureau of Ships, Navy Department and the Signal Corps of the U. S.

Army. It is hoped that designers of equipment will utilize this standard as extensively as possible in order that maximum production may be had with a minimum waste of time and material.

★ **Quartz Crystal Standard.** A standard for quartz crystal used for frequency control in aircraft radio equipment has just been approved by the American Standards Association. These crystals are required to hold the frequency within a fiftieth of one per cent over a wide range of temperature.

This standard, for the first time, coordinates British, Canadian, and American practice in the manufacture of aircraft crystal units. The standard was prepared through the joint efforts of industry and the armed forces at the request of the War Production Board to facilitate the production of these widely used crystal units. It has already been adopted by the Signal Corps Standard Agency, and the Bureau of Ships. In addition to covering the performance requirements and test methods that come up to the high quality of crystal unit required by the armed forces, it serves as a guide in the design of new equipment.

★ TECHNICANA

[Continued from page 19]

MEASURING DISTANCE BY RADIO

★ The January, 1944, issue of the *Journal of the Franklin Institute* contains the first part of an article on "Historical Notes on the Determination of Distance by Timed Radio Waves" by C. D. Tuska. This, the first part of the article discusses the first efforts made to determine the height of the ionosphere.

After Marconi's successful attempt at bridging the Atlantic in 1901 one began to speculate how the radio waves came to follow the curvature of the earth. Soon, the theory of the reflecting layer was proposed independently by Kennelly in the U.S.A. and by Heaviside in England. Kennelly derived a value of 55 miles for the virtual height of the reflecting layer. Since then various attempts were made to verify this theory and to measure the height of this layer. In this abstract we shall not repeat all the attempts mentioned in the original article but shall illustrate the main lines of attack.

One of the first measurements of the virtual height of the reflecting layer

were made by Appleton and Barnett in England in December, 1924. In this experiment the frequency of a transmitter was uniformly varied over a small range. At the receiver, the direct and indirect rays caused interference resulting in maxima and minima of the signal strength as the frequency was varied. The number of these maxima and minima in a given frequency range determines the difference in length of the two paths. The result of this experiment gave the height as 80 km or 50 miles.

Breit and Tuve appear to have been the first to make such an experiment in the United States. Their method consisted in transmitting short pulses of 1/1000th of a second while, at the receiver, these were fed to an oscilloscope. Any reflection should be seen as a small secondary pulse and the distance between them on the screen of the oscilloscope was a measure of the time delay, hence, the length of the path. They eventually obtained results and found several different values for the virtual height of the reflecting layer, the lowest one being 55 miles.

Smith-Rose and Barfield determined the angle of the downcoming wave by measuring the ratio between the electric and magnetic field.

Heising used a frequency-modulated transmitter in 1925, the frequency was uniformly varied while short pulses of 1/16th second were sent out. The direct and indirectly received wave, having left the transmitter at different times had a different frequency and formed a beat. The frequency of the beat was a measure of the distance.

Still another method (proposed by Löwy in 1923) consisted in switching the transmitter and receiver on and off rapidly by an electronic switch. The transmitter was off when the receiver was on and vice versa. At a definite rate of switching the output from the receiver is maximum; this rate of switching is a measure of the distance.

ELECTRONIC POWER MAINTENANCE

Special installation and maintenance requirements for electronic heat-processing equipment were outlined by S. Walden Shaw, RCA field engineer, at the March meeting of the Electrical Maintenance Engineers Association of Philadelphia. Members of the Power Maintenance Association of South Jersey met jointly with the Philadelphia group for the occasion.

While installation of RCA electronic power generators is relatively simple, Shaw said, the high voltages and high frequencies employed must be taken into account in selecting equipment for and installing coupling circuits and applicator assemblies.

One factor is that high-frequency currents travel only on the surface of a con-

ductor, he pointed out. Coupling circuits, therefore, must be made from tubing or pipe with a relatively large surface area. The surface of a pipe 2½ inches in diameter might be required, for example, to carry high-frequency currents of an amperage which, at low frequency, could be carried by a ¼-inch solid conductor.

Another consideration is the avoidance of points or sharp edges in the design of electrodes, in order to minimize the tendency of high voltages (often from 10 to 20 thousand volts) to form an arc from the edge of one electrode to the other. To avoid such short-circuiting of the material which has been placed between the electrodes for heating, voltages must be limited by the thickness of the load assembly.

Once installation is completed, Shaw said, the most serious responsibility of the plant maintenance man is to see that dust accumulations are prevented by periodic cleaning of all parts of the set-up, and to check meter readings for any substantial deviation from standard.

Dust containing either metallic particles or moisture may cause arcing if permitted to accumulate, he explained, while off-standard readings appearing on any of the meters on the generator may indicate the need for suspending operation of the equipment until adjustments are made.

The excitation, filament voltage, and high-frequency output power control settings are normally determined at the time of installation, he said, and there is little occasion to employ others except when setting up for an entirely different work load. Efficient operation, he pointed out, demands that the best control settings be determined for each new load.

The services of RCA field engineers for supervising installation, assistance in working out applications, and periodic technical inspections are provided for in contracts covering purchase of RCA equipment.

★

New Products

[Continued from page 41]

NEW BATTERY CONNECTOR

A new development in quick-disconnect battery connectors particularly adapted to G-1 standard batteries conforming to AN-



W-B-141 specifications has been recently designed and manufactured by Cannon Electric Development Company.

Based on the screw jack principle found in many Cannon connectors, this new fit-



Customers—not in ones or twos, but in hundreds. If not in person, then they're represented by letter or telephone. And they're in early every day . . . before breakfast, so it seems . . . with requests for urgent radio and electronic components and equipment. Some are needed for the Armed Forces . . . others for industry and dealers . . . still others for laboratory projects, and schools. We're doing our best to fill orders and speed deliveries. We're doing our best to help you cut through red tape and solve vexing technical problems. And our best, as you must know, is just about the best there is.

For Non-Critical Consumer Applications

Lafayette Radio Corp. carries a supply of all standard radio replacement parts in addition to a wide variety of useful parts and equipment!

FREE! THE BOOK OF THE YEAR!
Catalog of Radio Components
and Equipment



Lafayette Radio Corp.'s latest contribution to war-time America. A catalog that should be in the hands of all war agencies. Send for your FREE copy. MAIL COUPON TODAY!

LAFAYETTE RADIO CORP.
 901 W. JACKSON BLVD., CHICAGO 7, ILL., Dept. F
 Please send me a FREE copy of the new Lafayette Radio Corporation Catalog No. 94.
 NAME
 ADDRESS
 CITY STATE

901 W. Jackson Blvd. 265 Peachtree Street
 CHICAGO 7, ILLINOIS ATLANTA 3, GEORGIA

ting speeds removal of batteries and banishes shorting and fire hazards. The large handwheel which turns a gear and disengages the battery is notched and easily operated by a gloved hand in sub-zero temperatures. The pin contacts in the receptacle are so enclosed by its shell that the contacts cannot touch any outside metal surfaces during removal and hence will not short. The two pin contacts are leaded copper for 12-24 volt rating, 600 amperes continuous duty.

Further information and data may be obtained from the Cannon Electric Development Company, 3209 Humboldt Street, Los Angeles 31, California.

G-E METER DATA

The first series of a new kind of parts publication, prepared by the General Electric Company, has recently been released. They cover the 2½-inch d-c and r-f ammeters and voltmeters of the new internal-pivot design for both radio and aircraft.

TUBE SUBSTITUTION BOOKLET

A comprehensive Tube Substitution Directory, the most complete list of its kind ever offered, designed to help radio



RADIO AND ELECTRONIC DEVICES

BURSTEIN-APPLEBEE CO.
1012-14 McGee St. Kansas City, Mo.

DRAFTSMEN

with 3 to 5 years' experience
Offered excellent opportunity with one of America's foremost electronic laboratories. Some electronic experience required. Essential workers need release.

HAZELTINE ELECTRONICS CORP.
58-25 Little Neck Pkwy, Little Neck, L.I.

Free transportation from Little Neck station. Northern Boulevard & Jericho Turnpike.

Post-War Radio Engineer WANTED NOW

To the radio engineer who is thoroughly familiar with broadcast receiver designs, production and detailing; and who can take a set through from scratch whether it be a midget or a console, we offer a superb post-war position open now with a live-wire, progressive Midwest plant. Salary commensurate with ability and previous experience, but we will not hesitate to start at \$6000. Write in full detail describing former work and background, enclosing a small picture (which will not be returned) if possible. All replies held in strictest confidence. Our employees know of this advertisement. Box 1124, RADIO MAGAZINE.

dealers and service men use available tubes in place of hard-to-get types in servicing civilian radio receivers, has just been published by the Radio Corporation of America, through its Commercial Engineering Section in Harrison, N. J.

More than 2,000 substitutions are suggested by RCA in this 16-page guide.

Outstanding features of the directory include:

A listing, in numerical-alphabetical order of 304 RCA Receiving Tube types—and in most cases one or more substitution types which can be used as replacements;

Notations, with clear and detailed explanations, of the space limitations and the wiring, filament-circuit or heater-circuit, and socket changes involved in making the substitutions;

Sample calculations of series and shunt resistors in heater strings;

Suggested substitutions cross-indexed and keyed to cathode voltages and functional groupings tabulated in the "Classified Chart of Receiving Tubes," which is also included.

Copies of the directory, which cost ten cents, are available through RCA distributors or directly through the RCA Commercial Engineering Section, 596 South Fifth Street, Harrison, N. J.

SPECIAL POTENTIOMETERS

Precision potentiometers which can operate for 2,500,000 revolutions at 360° continuous rotation in both directions, for 24 hours a day are among the types brought forth by the DeJur-Amsco Corporation of Shelton, Conn., in its 1944

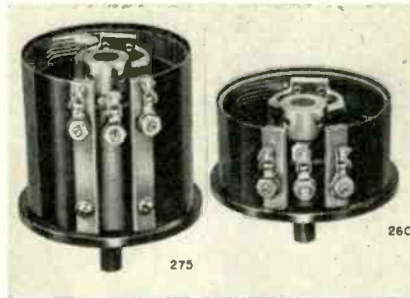

Rotating Potentiometers

listing of units designed for a variety of electronic and industrial techniques.

Among the ten-odd models included in its bulletin are Types 260, 275, 261, 260T, and 291. Outstanding feature of this group is the fact that extremely close tolerances are used, which require winding equipment built especially for DeJur.

Types 261, 281, 291, 276, 292, and 296 have top wipers which are provided for the highest types of accuracy and for the closest tolerances. Designed as Low Operating Temperature Types, as defined by the American Standards Association, and for the most difficult types of service, all of the models are well able to maintain the pace of daily continuous operation. On inspection after completing the 2,500,000 revolutions, they appear to need no adjustments.

ADVERTISING INDEX

Aerovox Corporation	19
Andrew Co., Victor J.	14
Astatic Corporation, The	14
Automatic Electric Sales Corp.	11
Bliley Electric Co.	12
Burstein-Applebee Co.	58
Capitol Radio Eng. Institute ..	55
Connecticut Tel. & Elec. Div. .	13
Dumont Electric Co.	56
Echophone Radio Co.	45
Eitel-McCullough, Inc.	49
Formica Insulation Co., The ..	6
Guardian Electric Mfg. Co. ...	18
Guthman & Co., Inc., Edwin I.	5
Hallicrafters Co., The	3, 4
Hazeltine Electronics Corp. ...	58
Help Wanted Engineer	58
Hytron Corporation	Cover 3
Jensen Radio Mfg. Co.	20
Johnson Co., E. F.	15
Ken-Rad Tube & Lamp Corp. .	50
Lafayette Radio Corp.	57
Merit Coil & Transformer Corp.	16
O'Neil-Irwin Mfg. Co.	12
Racon Electric Co.	46
Raytheon Production Corp. Cover	2
Red Cross	52
Sentinel Radio Corp.	50
Smith Mfg. Co., F. A.	16
Standard Transformer Corp. ...	10
Sun Radio Co.	55
Sylvania Electric Prods. Co. ...	51
Universal Microphone Co.	17
U. S. Treasury Department ...	54
Westinghouse Elec. & Mfg. Co.	Cover 4
Wilcox Electric Company, Inc.	9
Wrigley Jr. Co., Wm.	48



"I understand, Colonel, that you're interested in performance!"



There is a time and place for everything.

Oscar's single-minded enthusiasm might have been better timed. On the other hand, his point is well taken.

In manufacturing electronic tubes, performance is the ultimate goal. To assure uniform reliability, Hytron tubes are painstakingly produced to standard factory test specifications tighter than customer tolerances. Then for the final ver-

dict on actual performance, we turn to you who design, build, and operate the intricate electronic tools of war.

Those using Hytron tubes such as the 1616, OC3/VR-105, and OD3/VR-150, will not be surprised to discover that these tubes have earned the reputation of being the best in the industry.

You owe it to yourself to become familiar with these and other popular Hytron tubes, many of which appear on the Army-Navy Preferred List.



OLDEST EXCLUSIVE MANUFACTURER OF RADIO RECEIVING TUBES

HYTRON
CORPORATION ELECTRONIC AND RADIO TUBES
SALEM AND NEWBURYPORT, MASS.



**BUY
ANOTHER
WAR BOND**

4 NEW *Fact-Ful* GUIDES FOR DESIGNERS OF COMMUNICATIONS EQUIPMENT

D-C CAPACITORS—Lists and describes a complete range of capacitors for d-c applications from 400 to 250,000 volts. Booklet 3300.

PRESTITE INSULATOR GUIDE—Blueprints of SOLDER-SEALED bushing assemblies, terminal boards and many other items available for communications equipment. Booklet 3244.

Hipersil Cores—Lists sizes and applications of new 2-piece, thin-lamination cores for High-Frequency equipment. Booklet 3221-A.

WESTINGHOUSE DYNAMOTORS—A full description and listing of dynamotors available for aviation and communications equipment. Booklet 3242.

Callout Boxes:
 - HIGH VOLTAGE D-C CAPACITORS ...
 - SOLDER-SEAL CERAMIC INSULATORS FOR HIGH-FREQUENCY APPLICATIONS ...
 - FASTER HF COIL ASSEMBLIES ...
 - STEPPED-UP D-C VOLTAGES ...

SEND FOR THESE NEW BOOKLETS TODAY!

Whether it's a problem of stepping up d-c power ... reducing core assembly time ... locating the right high-frequency insulators or high-voltage d-c capacitors in a hurry, you'll find the answer in these new Westinghouse publications. Complete listings of sizes, weights and dimensions, together with application guides make these booklets an invaluable aid in designing and ordering.

These are only four examples of the help that Westinghouse can offer in the design and manufacture of communications equipment.

Other helpful publications are available on

- Micarta insulating parts and materials
- Thermostats
- Instruments
- Rectox rectifiers
- Relays
- Contactors

Whatever your problem, Westinghouse Communications Equipment and Communications Specialists can help you find a quick solution. Call on Westinghouse for help. Ask for the booklets you want from your Westinghouse representative, or write Westinghouse Electric & Mfg. Co., East Pittsburgh, Pa., Dept. 7-N.

J-94613



Westinghouse
PLANTS IN 25 CITIES ... OFFICES EVERYWHERE

Communications Products