

Recording engineer producer

\$2.50
FEBRUARY 1980
VOLUME 11 — NUMBER 1

INCLUDING: CONCERT SOUND REINFORCEMENT

Neumann
0364
E

MICROPHONES
NEUMANN — page 82
LINE LEVEL U-47 — page 94
MICROPHONE NON-LINEARITY — page 102
SM-81 — page 108

RELATING RECORDING SCIENCE • TO RECORDING ART • TO RECORDING EQUIPMENT

THE TOTAL ENVIRONMENT CONCEPT

A top-notch acoustic designer:
One who is devoted to his craft,
one of the best. A top-notch
architect, a specialist in recording
studio construction. A top-notch
interior designer—a Hollywood set
designer—one whose imagination
is unbounded.



We have these de-
signers on our new staff.
Guided by your desires
and tastes, they will
create a combination of
color, texture and sound
that is perfectly suited to your
needs. You'll be recording in a
total environment. Totally original.

Totally yours.



*Sketches for
Discos de Centro America*

LATEST PROJECTS

SOUNDSATIONS (one studio), San Diego

DAVID GATES (one studio), Los Angeles

DISCOS DE CENTRO AMERICA (studio and disc-
mastering), Guatemala City

MUSIC ANNEX (one studio), San Francisco

THE CUTTING HEAD (disc-mastering), Los Angeles

EVERYTHING AUDIO

16055 Ventura Boulevard, Suite 1001 • Encino, California 91436 • (213) 995-4175

European Representative: Nick Franks, Amek Systems and Controls, Ltd., Islington Mill, James St. Salford M3 5HW, England • (061) 834 6747

Australian Representative: Con Psorakis, Audio Controls, 22 Finnis Street, North Adelaide, S.A. 5006 • (08) 267 4529

Central American Representative: John Moore, Audio Express, P.O. Box 89 F, Guatemala City, Guatemala • (011) 502-2-316319

INTRODUCING

... an automated recording console system without equal in the industry. Comparable computer-equipped consoles begin at \$150,000 — and still lack the total productive capability of the Amek system.

The M-2000 A console has four band parametric equalization; ten VCA groups; six auxiliary outputs; one mic and two line inputs per module, with balanced differential amps; stereo solo in place with or without echo; variable hi and lo pass filters; master selection for mic/line, monitor buss/monitor tape, mute/solo group — more useful features than anything in its class. Stock frame size is 36 / 24.

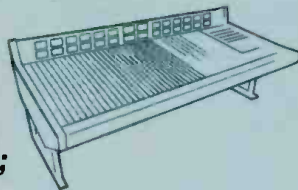

AMEK M-2000 A **\$60,000.***

AUTO-PAK is Amek's computer editing and mass storage system utilizing the SMPTE time code. It is the only console computer that can vocalize all commands when entered and all information as it appears on-screen. The master keyboard selectively lights the correct keys for each function group. The computer

also performs as a tape locate and motion control unit. Auto-Pak's storage has three times the capacity with none of the problems inherent in floppy disks. Memory consists of 4k pages of high-speed Random Access memory (RAM) and is used only when required by fader action. Mixes can be edited and stored on tape or in RAM.

AUTO-PAK **\$25,000.**

Console is also compatible with Allison 65K Programmer

*Subject to adjustment for dollar value fluctuations at time of sale.

**EVERYTHING
AUDIO**

Brian Cornfield
16055 Ventura Boulevard, Suite 1001
Encino, California 91436
Call (213) 995-4175

MARTIN AUDIO

Courtney Spencer or Bruce Martin
423 West 55th Street
New York, New York 10019
Call (212) 541-5900

AMEK SYSTEMS AND CONTROLS, LTD.
Islington Mill, James St. Salford M3 5HW, England



THE NEVE 8108

The most advanced audio console ever!

The 8108 Range.

Just introduced to the world at the AES Exhibition in Los Angeles in May 1979, this thoroughly new console range received much praise for the quantum leap in sound recording technology it represents. Building on their computer/digital experience earned through the successful NECAM Computer Mixing System, Neve engineers have developed the technically superior 8108 range. The console is in production and early deliveries are now being made to several West Coast top name studios. The 8108 Range is available in 56/48, 48/32 or 32/24. Join the Neve world of excellence. Please call or write for our beautiful 8108 brochure.

Memorized Track Assignment.

All track (bus) assignment is performed at the Central Assignment Panel, allowing up to 56 inputs to be switched to any (or all) of up to 48 tracks. Digitally controlled FET switches provide super reliable routing steered by a powerful micro-processor. Solid state memories can store complete track assignments for up to four different recording sessions, available for recall on moments notice. Days, weeks, months or even years later, input to track switching from memory for a 56/48 console is accomplished in about 2 seconds.

Instant Interrogation.

With the increased number of inputs and tracks being used in studios today, making it difficult to quickly realize track assignment during operation, Neve devised a unique Assignment Interrogation System which enables the engineer to instantly realize assignment, either *from* an input or *to* a track. "Finger close" buttons are mounted below the faders in a recessed area. Assignment indication is cleverly provided both below the faders and on the Central Assignment Panel, simultaneously readying this panel for reassignment of inputs and tracks.

Simultaneous VU/PPM.

The 8108 Range features operator selected mode of metering. Dual column high resolution bargraph meters can provide VU only, PPM only, or VU/PPM simultaneously. Additional bargraph meters may indicate reverberation send or return. Conventional VU meters available on mixdown output.

NECAM or VCA Grouping.

The 8108 Range gives you the widest choice in fader systems. VCA Grouping is standard. NECAM Computer Assisted Mixing may be added to bring the ultimate touch to the 8108 console. Manual faders may also be fitted.

Serviceability.

No other console provides the serviceability and reliability like the 8108 Range consoles. Computer-wiring is used virtually throughout, with solid state switching cards replacing hundreds of mechanical switches. Channel strips are easily removed, in turn with readily removable subassemblies. It is the finest and most advanced console system ever introduced. Please call or write. The Neve 8108 Range is in your future!



Rupert Neve Incorporated · Berkshire Industrial Park, Bethel, Connecticut 06801 Tel (203) 744-6230 Telex 969638
Rupert Neve Incorporated · Suite 609, 6255 Sunset Blvd., Hollywood, California 90028 Tel (213) 465-4822
Rupert Neve of Canada, Ltd. · 2721 Rena Road, Malton, Ontario L4T 3K1, Canada Tel (416) 677-6611 Telex 983502
Neve Electronics International, Ltd. · Cambridge House, Melbourn, Royston, Hertfordshire, SG8 6AU England Tel (0763) 60776
Rupert Neve GmbH · 6100 Darmstadt Bismarckstrasse 114, West Germany Tel. (06151) 81764



RECORDING engineer/producer

— the magazine to exclusively serve the Recording Studio market ... all those whose work involves the recording of commercially marketable sound.

— the magazine produced to relate ... Recording ART to Recording SCIENCE to Recording EQUIPMENT.



Editor/Publisher **MARTIN GALLAY**
 Managing Editor **TOM LUBIN**
 Consulting Editors **PETER BUTT**
 PATRICK MALONEY
 MARTIN POLON
 Operations Manager .. **D. KEITH LARKIN**
 Business Manager **V.L. GAFFNEY**
 Advertising Services and
 Circulation Manager ... **PATTY COLLINS**



"RECORDING Engineer/Producer"
 (USPS) 768-840)

is published six times a year by GALLAY COMMUNICATIONS, INC., 1850 N. Whitley Avenue, Hollywood, California 90028, and is sent to qualified recipients in the United States. One year (six issues) subscriptions for other than qualified individuals and companies may be purchased at the following rates:

United States (surface mail) \$10.00
 United States (air mail) ... \$17.00
 All Other Countries \$19.00

Foreign subscriptions payable in U.S. funds only by bank check or money order.



RECORDING Engineer/Producer is not responsible for any claim made by any person based on the publication by RECORDING Engineer/Producer of material submitted for publication.

Material appearing in RECORDING Engineer/Producer may not be reproduced without written permission of the publisher.



Controlled Circulation Postage
 paid at
 Los Angeles, California

Postmaster: Send form 3579 for
 address correction to:

RECORDING Engineer/Producer
 P.O. Box 2449
 Hollywood, California 90028
 (213) 467-1111

February 1980
 Volume 11 — Number 1

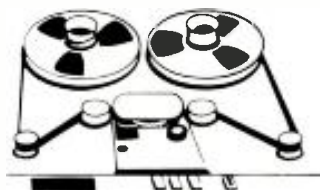

—CONTENTS—

- page 24 · interview: Producer/Arranger **BOB ESTY** by Tom Lubin
 (Larry Emerine on the engineering aspects of working with Bob Esty · page 26)
- page 42 · concert sound reinforcement: **Practical Solutions to Concert Grounding Problems** by Ed Simeone and Robert Carr
- page 60 · studio acoustics: **Low Frequency Absorption ... Helmholtz Resonators for Studio Use** by F. Alton Everest
- page 74 · film sound: **The New Multi-Channel Sound, Optical Release Formats ... The Dolby System** by Robert Peterson ... **The Kintek System** by John Mosely
- microphones -
- page 82 · **NEUMANN the History of Tube Condenser Microphones** by Winn Schwartau and David Smith
 (Engineering the Capacitive Microphone Capsule · page 84)
- page 94 · **Line Level Output from the Classic U-47** by David Coe and Tom Lubin
- page 102 · **Sources of Non-Linearities in Microphones** by John Meyer
- page 108 · **an in-use product review ... The Shure SM-81 ... a new design concept in electrets** by Rich Warren
- cover -
- Photography by Art Rex. Three rarely seen vintage microphones from the collection of Indigo Ranch Studios' Richard Kaplan. Left is the Schoeps CM-S1/U; center the Sony C-220-A, and on the right is the Beyer M-130.
- departments -
- View: What the Audio/Video Fusion can mean to the Recording Studio Industry** by Steven Barnett ... page 10
- Studio Update** ... page 19
- Soundman's Guide to Venues** by Patrick Maloney ... page 56
- New Products** ... 113
- Classified** ... page 124
- Late News** ... page 129

THIS ISSUE OF R-e/p IS SPONSORED BY THE FOLLOWING LIST OF ADVERTISERS

AKG	51	Meyer Sound Labs	114
A&R Record Manufacturing Co.	102	MICMIX Audio Products	29
Abadon/Sun, Inc.	125	Midas Audio	7
Allen & Heath	85	Mike Shop	44
Dan Alexander	127	Rupert Neve, Inc.	4-5, 26
Allison Reseach	53	Nexus, Inc.	76
Ampex Corporation	8-9	Omnircraft, Inc.	119
Ashly Audio, Inc.	115	Orange County Electronics	111
Audicon Marketing Group	109	Orban Associates, Inc.	37
Audi-Ence, Inc.	101	Otari Corporation	32-33
Audio & Design Recording	93	PML	105
Audio Engineering Associates	126	Peavey Electronics	57
Audio Industries	55	Pro-Audio/Seattle	106
Audio-Kinetics	49, 89	Professional Recording & Sound	129
Audio-Technica, US	21	Programming Technologies	79
Audiotechniques, Inc.	113	Polyline Corporation	124
Auditronics	40-41	Quad-Eight Electronics	87
BGW Systems, Inc.	59	Quintek Distribution	49, 89
BTX Corporation	121	RTS Systems	108
Beyer Dynamics	103	Roland Corporation, U.S.	104
Rudi Breuer	46	Saki Magnetics	72
Cadac Audio	12-13	SESCOM	124
Countryman Associates	73	Shure Brothers, Inc.	bk cvr
dbx, Incorporated	61	Sony	75
DeltaLab Research	107	Soundcraft	42
EMT - Franz	91	Sound Workshop	10-11, 47, 71
Electro-Media Systems	130	Spectra Sonics	45
Electro-Voice, Inc.	63	Stanton Magnetics	48
Eventide Clockworks	81	Stephens Electronics	80
Everything Audio	2-3, 120, 123	Studer/ReVox America	99
Express Sound	68	TTM	83
Flanner & Hafsoos	70	Tangent Systems, Inc.	31
Gotham Audio Corporation	83, 91	TEAC/Tascam	39
The Hardy Company	77	Telex Communications	95
Harrison Systems	131	3M Companies	18
Inovonics, Inc.	116	Trident Audio	34
K-Disc Mastering	78	UREI	97
LT Sound	125	Vision-Sound Pro Audio	14, 17
Lexicon, Inc.	113	Westlake Audio	66-67
MCI	23	Whirlwind Music, Inc.	126
MXR Pro Products	65	White Instruments	128
Magnetic Reference Labs	122	Windt Audio Engineering	127
Mattel Toys	126	Yamaha International	25

MIDAS the professionals' choice

Russell Pope, concert sound engineer for Supertramp, with their 36 into 8/2 MIDAS Live Sound Console on the 1979 'Breakfast Over America' World Tour. Critically acclaimed for their excellent sound in live concerts all over the world, Supertramp have used MIDAS since the beginning. Why MIDAS? Because MIDAS experience and design philosophy provide highest quality signal processing in a compact and rugged modular frame built to withstand years of use. Russell Pope and Supertramp are professionals. MIDAS is the professionals' choice.



MIDAS AUDIO SYSTEMS LTD. 10000 SOUTH SA. 50. NORTHFIELD STREET TORONTO ONTARIO M2H 3G4 CANADA
MIDAS CANADA 10000 SOUTH SA. 50. NORTHFIELD STREET TORONTO ONTARIO M2H 3G4 CANADA

Introducing a present



Once you go through a recording session with the new ATR-124 24-channel recorder by Ampex, you'll want to go through another. Because with each new session you'll discover something new you can do. Things that you can only do with a recorder that's full of features of the future.

ATR-124 gives you the unheard of:

Time on your hands.

Which means you can use that time to give clients more of what they're paying for—your creative skills. With the ATR-124 microprocessor-based control system, you can pre-program what you want to do ahead of time so you won't waste studio time setting things up. When their time starts, you're ready to record by touching a single recall button.

ATR-124 also lets you duplicate a technique you may have used earlier in the session without

having to rethink what you did. Just touch the memory button and it'll all come back to you. ATR-124 lets you rehearse what you've got in mind, without recording it, to make sure what you've got in mind is right. Tape can be manipulated faster which means you'll get the sound you want sooner. And the chance to try something "a little different." All because of the speed and accuracy that ATR-124 puts at your fingertips.

ATR-124 doesn't take away your creativity, it adds to it.

The less time spent setting up, correcting, and redoing, the more time spent creating. And when you add features that help you create to the ones that help you save time, you've got one very potent piece of audio machinery. Take the control panel for instance. It's like nothing you've ever seen. Pushpads linked to a microprocessor give you a new level of creative flexibility. Program a setup, then change it. Then change it back, all with a single fingertip.

A repeatable, variable speed oscillator for pitch correction and special effects is built in. In addition

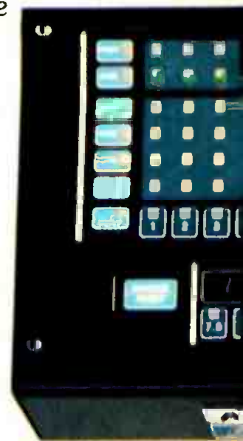

From the future: ATR-124.

to the standard output, there is an optional auxiliary output with each channel that enhances flexibility. So don't think that ATR-124 is going to

Memory, and Record Mode diagnostics. The point is this: If you like the ATR-100, you're going to love working with the ATR-124.

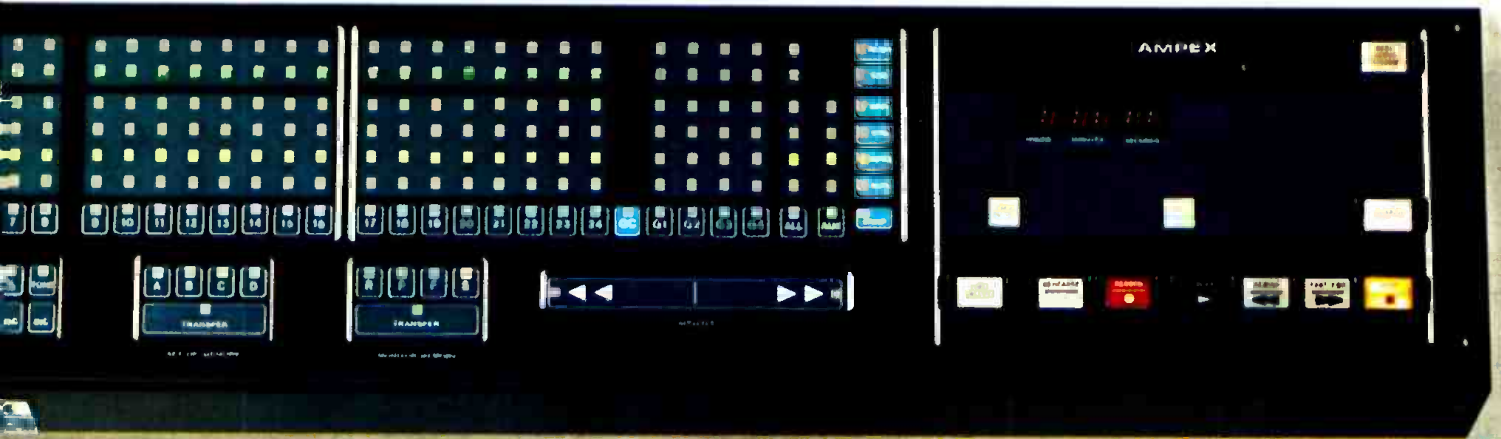

ATR-124's Control Panel. Speed and accuracy at your fingertips.

replace anything that you do. On the contrary, it's going to improve the skills you have, if not help you develop some new ones.

ATR-124 picks up where ATR-100 leaves off.

It's only natural that the people who brought you the ATR-100 should be the ones to bring you something better. ATR-124 offers you 24 channels instead of 4. You also get many new and exclusive features. The kind that have set Ampex apart from the crowd for the last 30 years. Features like balanced, transformerless inputs and outputs; a patented flux gate record head; 16" reel capability; input and output signal bus for setup alignment; membrane switch setup panel; fingertip-operated shuttle speed control; and microprocessor-based synthesized Varispeed -50% to +200% in .1% steps or in 1/4 tone steps. ATR-124 also features microprocessor-based control of Channel Grouping, multiple 24-channel Setup Memory, Programmable Monitoring, Stay Alive

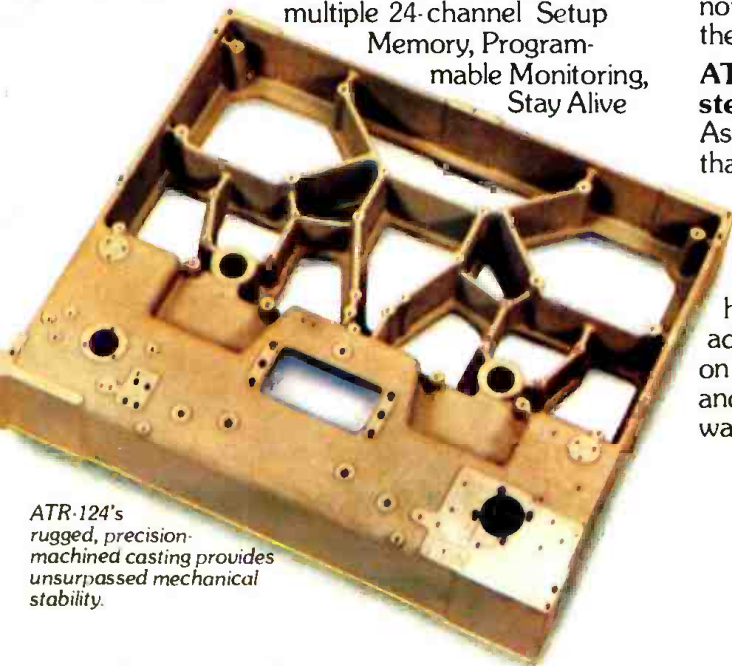

ATR-124's rugged, precision-machined casting provides unsurpassed mechanical stability.

ATR-124 options.

As impressive as the ATR-124 itself.

With the addition of a built-in Multi-Point Search-To-Cue (MPSTC), you can rehearse edits and control five tape-time actuated events and be compatible with SMPTE time code. Separately controlled auxiliary output amplifiers with each channel provide simultaneous monitoring of normal and sync playback as well as all other monitoring modes. A roll-around remote control unit can also be added to the ATR-124 which contains all control features normally found on the main unit.

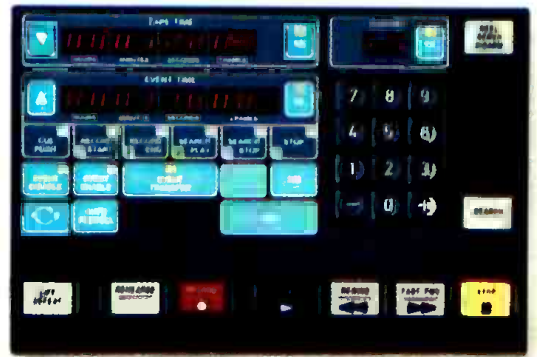

ATR-124's Multi-Point Search-To-Cue (MPSTC). Provides 100 cue locations.

ATR-124. Your next step is to experience it firsthand.

As you scan the points we've covered, remember that you're scanning just a small portion of ATR-124's story. We haven't even begun to discuss the accessibility of key components for easy servicing and minimal downtime, or the features we've built in to give you greatly improved tape handling. To find out more, write to us at the address shown below. We'll send you a brochure on ATR-124, our latest audio effort. Better yet, call us and we'll set up a demonstration. It's really the only way to listen to the future.

ATR-124. Pure 24-Channel Gold From Ampex.

AMPEX

Listen to the future

Ampex Corporation, Audio-Video Systems Division,
401 Broadway, Redwood City, California 94063 415/367-2011

for additional information circle no. 2

www.americanradiohistory.com

views letters news

— VIEW —
EXPLORING
what the
AUDIO/VIDEO FUSION
can mean to the
RECORDING STUDIO INDUSTRY
by
Steven Barnett

"When I got involved with music ten or fifteen years ago," recalls recording artist/producer Todd Rundgren, "it was because it was the most vital art form happening. The people I knew were constantly buying records, listening to and absorbing what they heard. They tried to respond to the recording artist and emulate what they learned from the record.

"To a certain degree, that phenomenon is still prevalent, but the heroes of nowadays are . . . people that appear on television. Everybody nowadays is more influenced by television than by records."

In keeping pace with his own observations on the changing media, Rundgren has recently completed RCA's first video disk and is one of the first recording artists to become involved with the audio/video fusion, audio recording artists turning their music into images — video music.

It is a phenomenon long heralded by the

entertainment industry, and for just as long, its actual arrival has been put off. Now, as we enter the eighties, it appears that we are indeed at the beginning of a home video revolution.

The Present

By the end of the decade, nearly half of the television homes in the United States will be hooked up to some form of cable system which, in addition to carrying standard network fare, and along with satellite hook-ups, will offer a substantial number of new channels to the viewing public.

It is predicted that these new channels will drift toward specialty offerings, vertical programming similar to their counterparts on the radio dial.



Jay Levy — Lorimar

Atlanta broadcasting and sport tycoon Ted Turner has already announced the formation of an all-news television station to be broadcast via satellite to cable subscribers around the country.

Of more interest to recording artists are plans described by Jay Levy, formerly an A&R man with RSO Records

and currently general manager of Lorimar's new record division, and a vice president of the company's film division

"Depending on whose estimates you listen to," says Bill Seal, of Aberdeen Video, "there are between one and two million home video recorders out there right now. That's not very many, but predictions are that within the next five years, they will be selling at a rate of five million per year."

Although Seal acknowledges that home video machines in mass use "is not an overnight thing," the figures are important to him, as Aberdeen is one of several video companies currently involved with the production of video music.

Perhaps the most long awaited arrival of this video age is the video disk. Video disk players from RCA, JVC, and Sony are in the development and testing stages, and the test marketing of the Magnavox Magnavision™ model has proved quite promising, with retailers initially having trouble keeping the player and the disks in stock. There are



Bill Seal - Aberdeen

The Sound Workshop Series 1600 recording console.

As technology advances at an ever increasing rate, it has become easier to design and build recording equipment that yields "professional" specifications. But specifications alone do not define a product. As we conceived the Series 1600, we saw the need for a "true" professional console that would be at home in major multi-track installations, yet offer the cost effectiveness that other manufacturers promise.

The Sound Workshop Series 1600 employs a modular design philosophy, allowing numerous initial configurations, and the ability to add features and function as need dictates and cash flow allows.

The Series 1600 is available with our standard transformer coupled mic-pre or our new transformerless design which features the TRANS-AMPLZ* amplifier module.

Two equalizers are offered: the standard 3-Band 12-Frequency;

and the optional full parametric which offers complete control of frequency, boost/cut, and "Q" on

each band. Both EQ sections are completely stable, offer ± 15 dB range, and include an 18 dB/octave switchable low-cut filter as well as LED status indication for EQ IN and LOW-CUT IN.

The standard level indicator is an LED column which can be ordered with or later retro-fitted with Peak reading capabilities. Our new High Resolution Meter Module offers the convenience of

LED metering with even greater resolution than standard meters. All of our LED indicators feature

fully adjustable intensity to compensate for ambient light conditions, and accept our Spectrum Analyzer which adds Real-Time Analyzation to the Series 1600. Standard Vu Meters are available on special order.

Our VCA Grouping Package permits assignment of each Input channel to up to 3 Input Sub-

groups allowing from two inputs to the entire console to be controlled by one fader, even if each channel is assigned to a separate output.

The gymnastics necessary to cope with today's complex mixes are handled by ARMS Automation, leaving the engineer and producer to return to their art: music and creativity. ARMS is a true computer based system featuring INDEPENDENT MUTE WRITE (if you are considering other automation systems, don't buy one that can't write mutes independently!!!), Auto-nulling,

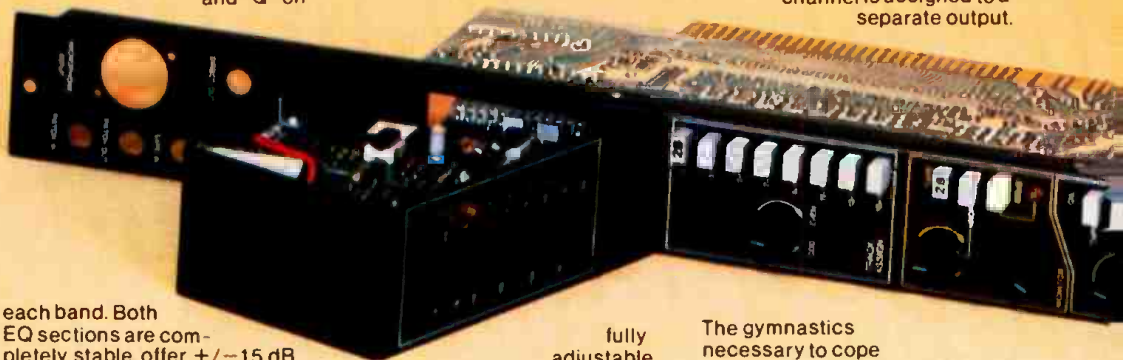

*Registered trademark of the Valley People, Inc. Nashville, Tennessee.

currently 203 titles in the MCA disk catalog, with 160 in release.

"We were in Atlanta with the only video disk system in the world," explains senior marketing vice president Kenny Ingram, "and there were sales to people from all over. It was a very abnormal situation."

As the marketing progressed, MCA, the sole supplier of the software, and Magnavox were able to make sure that both the player and disks were in the stores, and things settled into a more normal pattern.



Kenny Ingram
Magnavox

"People now come in responding to advertising," says Ingram. "They buy the product, and we're as happy as a clam."

The machine uses the laser optical system developed by Philips, and is now available in Dallas and Seattle, as well as Atlanta. The product retails for \$775 per unit.

"The range of the albums is \$5.95 to \$24.95. The later the movie, the more blockbuster in nature, the more expensive the album.

"MCA hasn't gotten to (marketing video music) yet, but you can be sure that they're going to."

Plans for distribution of the Magnavox player and disks are continuing at a fast pace. "We're not every place in the U.S. now, but by the first quarter of 1981, we plan to have 100% coverage of the United States."

The method of distribution of the video product itself, be it tape, disk, or cable, is still subject to quantum leaps in technology as the electronics become more and more advanced.

The Future

"Eventually," predicts Rundgren, "it will be centrally operated. You won't have to own your own reproducer . . . your television, music, telephone, everything will be tied together. You will have your own computer in your house.

"Someday all recordings could just be placed in a giant bank, and you could just load it out."

So within the artistic and technological latitudes of video, we find a rather safe constant.

"Whether it is video disk or video tape," offers Seal, "it makes no difference to us,

because it all starts with video tape anyway."

How, then, will the recording artist and the recording studio fit into the changing face of television.

Aside from the home video market still developing, there are currently alternate fields of video promotion materials, usually underwritten by labels or management, and the video demo for bands seeking exposure to labels and clubs. Each of these will be examined in detail in future segments.

"Anybody who has an interest in video," suggests Rundgren, "should begin by re-educating themselves about the techniques that are available. It is much more sophisticated, and complicated, and expensive than sound recording."

In its most basic form, video tape recording requires lights, a camera, a video monitor, a video tape recorder, and some sort of audio mixer and microphones.

If more than one camera is being used with only one tape machine, additional monitors and a switcher are required to make the cuts back and forth from camera to camera.

Often in multiple camera shoots, each camera will feed its own tape machine in "isolation." The several tapes are then edited together in post-production. In taping with this method consideration must be given to the cost of the additional tape machines and the post-production equipment.

In Rundgren's last quote, perhaps the word *expensive* should have been underlined. As in audio recording, in video there are varying levels of quality, ranging from home movie style equipment to the finest in broadcast quality gear.

— continued overleaf . . .



A new philosophy of console design.

computer controlled Entry and Exit modes, programmable muting, in-place-solo and more ARMS will accept our soon to be released Super-Group option which allows an UNLIMITED number of programmable input subgroups.

Almost all of the options available for the Series 1600 can be retrofitted with no additional expense over the cost if factory installed. Write for additional details. We're choosy about who sells the Series 1600, so if you need assistance in finding the right dealer, call Emil Handke, here at Sound Workshop (516-582-6210).



The Series 1600 also features Penny & Giles faders; fully balanced inputs, transformers coupled track outputs, independent Studio and Control Room sections, 4 send busses with input-sourcing and output assignment; and our unique modular, balanced TT Patch Bay.

BRINGING THE TECHNOLOGY WITHIN EVERYONE'S REACH.
Sound Workshop

Sound Workshop Professional Audio Products, Inc.
1324 Motor Parkway, Hauppauge, New York 11787 (516) 582-6210

what the
AUDIO/VIDEO FUSION
can mean to the
RECORDING STUDIO INDUSTRY
(continued)

For the sake of this discussion, let us focus on the latter for a moment: equipment that meets the industry-set standards for quality and that does provide finer video recording.

According to Emory Cohen, vice president of Compact Video Systems, in Los Angeles, cameras of this type "cost between \$70,000 and \$120,000 apiece, excluding lenses, which will run between \$15,000 and \$30,000 each."



Emory Cohen



Tony Zetland

"High quality recording machines run between \$30,000 and \$40,000," according to Ethan Bush, general manager of sound services at Compact.

In the accompanying box, we have listed the equipment to be found: 1) in a broadcast quality mobile video truck, 2) in a system acceptable to most cable stations, and 3) for a package suitable for doing demo tapes for bands. These prices are only approximate and

- \$25,000 -

Demo Package

- 2 Cameras with color capability
- 3 3/4-inch U-Matic video cassette recorders
- A post-production switcher
- Lighting
- 3 Monitors

This package, appropriate for doing demos of bands and local social events, can be put together for around \$25,000, excluding vehicle and audio mixing panel.

vary from manufacturer to manufacturer, but they are listed only to give one a point of departure for thinking about getting involved in video.

The expense of video is something that will be constantly referred to in this piece as it progresses in discussion of the various markets, but keep in mind that the same technological advances that have given us an electronic calculator for \$15 will bring down the cost of the video medium eventually.

Investment in this field becomes an even more serious consideration for the audio recording studios when one considers the financial demands of the coming digital technology. It is a difficult choice to make.

There are also still serious questions about sales.

Is video music cost effective with theatrical motion pictures released on disk or tape; will audio music re-recording survive?

"When faced with a choice between a theatrical motion picture, say 'The Godfather,' and the new Cheap Trick video disk," an

- \$250,000 -

Cablecast Package

- 4 Semi-pro cameras and camera control
- 2 Portable 3/4-inch U-Matic video cassette recorders
- 2 Permanent 3/4-inch U-Matics installed with an editing console
- 6 Monitors
- An 8 channel portable audio mixer
- Microphones
- Cables and accessories
- Basic lighting equipment
- Standard RV van

This package is acceptable for most cable television stations with regard to picture quality, and would cost approximately \$250,000. With a good deal of time base correction and image enhancement, tapes from this system may be played over the air on local stations, depending upon the attitudes of station management. As it cannot be considered high quality broadcast equipment, and since it can be considered too sophisticated for small demo work, this kit can be called a "starter" for those interested in exploring video at a level higher than demos, but who do not have the money for the state-of-the-art. Questions of specific market for this equipment must be explored in depth before investment.

anonymous industry observer suggests, "and both are roughly the same price, the consumer at large will probably chose 'The Godfather.'"

His point is well taken. Theatrical and television product have other avenues of

A partial list of studios that use
CADAC Consoles continuously backed-up
by CADAC AUDIO...

- Denmark - Danish Royal Theatre, Copenhagen (2 consoles)
- France - Damiens Studio, Paris Vogue (P. I. P.), Paris (2 consoles)
- Hong Kong - R. T. V., Hong Kong
- Spain - R. C. A., Madrid
- Estudios Gema, Barcelona (2 consoles)
- Sweden - Swedish Broadcasting, Stockholm
- Germany - Union Studios, Munich (3 consoles)
- Bavaria Musik Studios, Munich
- Sonopress, Gutersloh (8 consoles)
- Italy - R. C. A. S. p. a., Rome (3 consoles)
- Cinevox Record S. p. a., Rome (2 consoles)
- Stonecastle Studios, Como (2 consoles)
- T. V. R. Voxson, Rome (2 consoles)
- Belgium - Morgan, Brussels
- Holland - Dureco, WEESP
- Austria - Gerhard Heinz Tonstudio, Vienna
- United Kingdom - Scorpio Sound, London
- Morgan, London (3 consoles)
- Pye, London
- Sain Recordaiu CYF, Caernarfon
- Lansdowne Recording Studios Ltd., London (2 consoles)
- South Africa - Video Sound Pty. Ltd., Johannesburg

cadac

Years of experience building consoles known worldwide for their high quality standard, superior reliability and human engineering.

**cadac
audio**

Presenting a series of in line consoles featuring a high degree of flexibility, optional DC sub-grouping plus CARE® automation. Available in custom configurations with up to 48 tracks for use in music recording, mixing, theater and broadcasting.

Exclusively represented in the USA by:

IRV JOEL & ASSOCIATES, INC.
528 River Road, Teaneck, NJ 07666
Telephone: 201/692-0010
On the west coast contact:
Dick Burden at 213/340-4590



CADAC AUDIO
C.A. Audio Systems Ltd, 141 Lower Luton Road
Harpندن, Herts AL5 5EQ England
Telephone: 44-5827-64351 Telex: 826323

- \$1,000,000 -

**Broadcast Quality Package
("On Line") For Location Use**

- 4 Cameras with camera control
- 4 one-inch Helical 'C' format VTRs*
- Switcher
- Effects Generator
- 10 Video monitors in the trailer
- 2 Portable video monitors
- A 24 x 8 mixing panel
- Audio monitors
- Microphones
- Visual processing equipment
- Truck tractor
- Truck trailer
- Power generator
- Connecting panels
- Cables and accessories

This typical professional package could not be assembled for less than \$1 million, and many such packages, particularly in a studio situation, could run into the tens of millions of dollars. This does not include lighting or post-production facilities.

**In video recording machines, the heads spin to give the same effect as increased tape speed. In a Helical C-format machine, one head is utilized with the tape wrapped around it at an omega angle. An older design, the quad two-inch unit uses four heads spinning in proper alignment while the tape passes by all four perpendicular to the heads. Audio in C-format can be recorded in stereo.*

release to help absorb the costs of production. Consequently they can afford much higher production values. The recording artists will now be entering the market place having to compete with such product on an equal basis. The public will decide which is the better buy.

"Ultimately," counters Rundgren, "existing catalogs will be exhausted and all the possible movies that have been made over the past fifty years will be available, and then people will want new programming."

"Movies are fine home entertainment," says Levy, "and will work in the initial phases in video disk. But I think that there's going to be a point where there will be such a demand, hopefully, for the product that new product will have to be created."

Seal said that the two were different products, not unlike family cars and sports cars, while Ingram added, "I see it as a whole new avenue for exploitation on the part of the recording artist. They have a chance now to heighten the interest in their product."



Kip Walton

Another producer of video music is Kip Walton of "In Session." He sees it as two different audiences. "I think if there's a music buyer out there he will buy music people. I don't think that the conflict really exists."

One of the chief concerns of the consumer is the cost of the product. Production

values will affect this.

"If the production values are such that the price of video music is equal to the price of a theatrical motion picture on disk," suggests Martin Polon, associate editor of Video Magazine, "then sales potential will be different than in a situation where video music is priced only ten dollars over conventional audio records and less than the films."

Another industry critic suggests that in a time of sagging record sales, the labels are not willing to make the investment required for first rate production values in video music when the product may only become a specialty item like the audiophile disk.

Technological advances will affect this, however.

"I think that it will come down," says Levy. "Using the things that Rundgren has done as an example, he said that they would be much cheaper to do today, because some of the techniques that he did have now been made much easier by new technology."

"Video is the total electronic medium, and we've seen it in every area of video . . . in color cameras . . . we've seen it in every area of technology. Costs are going to go down."

"One factor," says Polon, "that could swing the public to video music would be the presence of stereo

TV equipment in the home. If the system, tape or disk, is designed to provide stereo playback



Martin Polon



**cadac
audio**

proven technical excellence meticulously handcrafted

Picture shows Chicago Recording Studio B 36/32 F Series In Line Console and CADAC Power House Monitor Systems.

for additional information circle no. 4

what the
AUDIO/VIDEO FUSION
can mean to the
RECORDING STUDIO INDUSTRY
(continued)

with the picture, it will enhance the market for video music."

Hardware And Formats

The question of hardware is also a concern, for with two different video tape formats, Beta and VHS, and two different disk retrieval methods, stylus and optical, the public may find it confusing as to which to select.

Should these problems of home hardware and production costs be eventually resolved, there are several different avenues in the creative aspects of video music that need to be explored.

The possibility of boredom with the video material is a major concern. Rundgren has said that people could always turn off the picture and just listen, but video burn-out can also be affected by artistic choices. However, these will affect the production costs and eventually the retail price.

As in audio music, there are different interpretations of what video music should do.

Kip Walton is the producer and director of the "In Session" series, which aired first on ABC, and now via subscription television. He has worked with such artists as Janis Ian, Ella Fitzgerald, and Aretha Franklin.

His programs, ranging in length from 60 to 90 minutes, are usually set in a recording studio, the artist's environment, and consist of performance by the artist with the medium of

television remaining as transparent as possible.

"I really enjoy having absolutely pure, good music on TV," he says. "Usually it's over-sweetened and over-produced and over-edited, and I personally am not into that.

"You are so dazzled by the effects that you really lose who the artist is and what the music is.

"I think that's what the home music market is about. Presenting pure, uncluttered entertainment. That's the stuff you can watch over and over again. When it gets real over-produced, it gets tedious to see it more than one time.

Making the medium transparent is not always easy or inexpensive.

Budgets on Walton's productions, depending on the length and the artists involved, have ranged from \$100,000 to \$300,000.

"We'd come into the studio the day before," explains Walton, "and get the lighting in, and then we were on a one day taping schedule. The folks would come in about eight in the morning and get out at about ten at night."

Walton directed the shows in which audio was taken from the recording studio's board and put directly on a monaural track on the video tape.

"Whoever was attached to the studio did the mix," says Walton. "They are record people and care more about the music."

Lighting for the shoots was handled by Imero Fiorentino Associates lighting designer Bill Klages. He describes the problems in lighting a recording studio as "no different than lighting anything outside the studio."

He included problems such as "the requirements for power, the means of suspension of the lights, and the placement of them in positions not always ideal.

"Time is short," he explains, "and the place is only available to you for a certain period of time. A great number of compromises have to be made and still one must give a relatively sophisticated product."

Although studios may have large power supplies, Klages had to supplant his lighting with an auxiliary generator capable of putting out 150 kilowatts. AC cables also had to be routed so as to avoid interference with their audio counterparts.

Suspension of lights is a particular problem in an acoustically designed recording studio.

"At RCA, for example, we had to remove part of the ceiling tiles and use the beams underneath to make sure that nothing would fall down. We also had portable scaffolding and lighting instruments on the floor hidden behind musical instruments, and so forth.

"The intent is to make it look like we didn't stage anything and it just happened; but, of course, there is no such thing."

Available light can be used for an "unfinished, documentary effect," but this style of shooting could cause the viewer to become aware of the medium and be distracted from the artists.

"Yes, you will get a picture," says Klages, "but the close-ups won't look very good, and it will have nothing. It will look like a lot of evenly diffused light coming straight down."

Klages used roughly fifty lighting instruments on the "In Session" shoots, but, as he said, "It's not important how many

VISION-SOUND
BRINGS TO NY.

Harrison music and film production consoles with DCI Distributed Control Intelligence. Each module's computer software allows easy user programmable changes rather than irreversible hardware modifications. Greater flexibility than ever before!

A new degree of accuracy. Pioneering exclusives that represent a fresh approach to recording systems. BRYSTON AMPLIFIERS THE NEOTEK RECORDING CONSOLE ACD/JOHN MEYER MONITOR SYSTEMS

instruments to a lighting designer, it's how much you get out of each one."

For a small video set-up, Klages estimates that it would take between \$20,000 to \$30,000 for a good, portable lighting starter package.

In a concert situation, the lights are usually designed for the benefit of the audience in attendance. Hence, says Klages, "when you're taping a concert the lights must be altered to get an acceptable video picture.

"Intensity is a problem," he says, "and the camera can only see a certain number of things, so if you start to mix too many colors, it comes out white or yellow or some funny look.

"The eye can see a great deal more than the camera. Generally, the end result is only fair unless you start all over again and make it specifically for television. The two do not really mix."

In a concert situation with Teddy Pendergrass, Walton used a separate audio truck and ran a 16-track tape machine in sync with his video recorders.

"Cameras in concerts are stuck in pre-subscribed positions," he adds, "where in the studio, you can move around more."

Walton does very little post-production on his shows. All he does, aside from titles and such, is cut the material down to the right length.

"We would bring it down to an hour-and-a-half, but there was no interior editing within pieces."

Walton usually uses four to five cameras and leases his portable video gear from Compact Video Systems most of the time, and does much of his editing there on computer controlled equipment of their own design. His

production values called for very high quality video equipment of a price range found in the first package listed.

Additional expense included leasing of the audio studio, musicians' fees, the lighting crew, and his video personnel.

Visual Poetry

Another area of video music usually calling for higher grade equipment are concept video pieces, which are interpretive in nature. This is the area in which Todd Rundgren is moving and where Jay Levy feels that video music belongs.

"I guess the best analogy for me is poetry," he says. "I think that video disks in the music area in order to be really successful have to parallel what poetry does as compared to narrative prose.

"Poetry enables the reader, or in the video disk case, the viewer, to participate in an experience which is programmed by the author, but at the same time the reader brings his own past experience and feelings to that video or poetic piece and thus creates something new for him, and also to create something new for him every time the video disk is viewed.

"As with 'Lucy In The Sky With Diamonds,' I dare say that there are hardly any two listeners who conjure up the same images and the same feelings upon hearing that song."

Rundgren's demo for RCA included a visual interpretation of "The Plants As Realized by Tomita," by Holst.

"I had a variety of other things that I had showed them," he says, "but that was the one that they responded to. They were looking for

someone to put together a demonstration disk to show people that the real potential of video disk is in what appears on the disk and not in the hardware.

A new syndicated rock show, "Hollywood Heartbeat," will begin airing this spring, and will be showing many video presentations of this type along with straight performance numbers of mostly New Wave bands.

New Wave artists are becoming more and more aware of the potential of video and this work reflects that interest.

A piece in particular by a European band, The Bugles, demonstrates a great deal of the capabilities that video carries for interpreting songs in a visual fashion beyond the band simply performing.



Larry Smith



Richard Mann

Executive producer Larry Smith and producer Richard Mann are both very excited about the nature of this new video music.

Video presentations of this sort are expensive to do and rely on a great deal of complex and expensive equipment. Also, to

— continued on page 127 . . .

A complete service/maintenance facility 15 minutes from Manhattan studios. Service for the needs of the owner/builder with assistance in financing, site selection and installation. The finest names in microphones, peripheral and signal processing hardware to allow the professional to furnish his studio with equipment of uncompromising quality

Support and service for those sincerely interested in raising the standard of the art of recording to new levels; the creative experience more accurately retained

Concern. Concern for the evolution of the recording profession.

Freddie started backup singing in his New Jersey junior high school. He earned a Bachelor of Music Degree from Howard University, and taught in Washington, D.C., while moonlighting as a producer. In 1969, his first Motown production, "I Want You Back" by the Jackson Five, went platinum. Since then, he has collected close to 30 gold or platinum records. Freddie now owns his own studio in L.A. and has recently produced disco hits for Yvonne Elliman, Tavares, David Naughton, Gloria Gaynor, and Peaches and Herb.

ON CREATIVE EXPRESSION

"I'm thinking charts. I'm thinking commercial. And I'm thinking hit, as opposed to creative expression. Because that's usually what I'm hired for. I mean, I hear the standard rap that I would get from a company person or a manager is that 'this group, live, is a knockout. I mean, they're killers. All they need is that hit record. When they get that hit record, man, you're gonna see the baddest group that ever existed in the history of recorded music.' So they want the charts. And that's why I approach it like that."

ON HEARING

"I only go by the ears, and I do hear very well. Musically and technically. I hear stuff all over the place. The guitar player—if he accidentally hits an open A string while he's fingering a chord, we could have thirty pieces on tape and I'll hear that and solo it out and bust him—say, 'Hey, could you keep that string quiet?' He says, 'You mean you actually heard that?' So my ears are really my fortune. That's where everything lies. Right in my ears."

ON RHYTHM SESSIONS

"I do my basic rundown on the rhythm date. The guys are really cookin' and the groove is there and everything. I come in and take a listen to what kinds of sounds I have. But if that sound is not there, then I don't record until the sound is right. There may be some other producers who would just go with the flow. 'If it's groovin', hey, you know, we'll save it in the mix.' But I've attempted to save things in the mix. It doesn't happen. It has to be on tape."

ON TAPE

"I do not know much about the characteristics, physically, of what tape is made of. I'm not too much into that—the chemistry involved. However, after spending six years at Motown—they had many, many rules and regulations. Now, one was that we always use Scotch Tape. When I ventured off into the world of independent producing, out of habit, and not wanting to change a good thing, I went right back to the same tape, which was 250. And I was then approached by other engineers telling me that if you switched, you could increase your performances here—you know, the bottom end, so forth and so on. And I did stray away and I did try cutting other projects on different types of tape. And the bottom line is that I came back to Scotch. I can't say that I noticed the difference of, you know, 3 dB and the low end with Scotch, and the other only gave me a dB-and-a-half. I can't say that. I only go with my ears, which tell me that my home is with Scotch Tape."

SCOTCH 250

WHEN YOU LISTEN FOR A LIVING.



FREDDIE PERREN ON TAPE.

SCOTCH® is a registered trademark of 3M

3M

for additional information circle no. 6

www.americanradiohistory.com

STUDIO UPDATE



Pacific West

Northwest:

■ **PACIFIC WEST RECORDERS** (Seattle, Washington) has opened their new 24-track studio in Redmond, a suburb of Seattle. The facility features an MCI JH-114 24-track recorder, an MCI JH-428B console expanded to 26 x 26, and an entire new physical plant. The new studio design and construction was by owner **JOHN FRECHETTE**. The facility now offers a 19' x 22' symmetrical control room, a 24' x 38' x 12' trapped studio with a string area and a totally glass-enclosed, specially trapped drum room. Frechette is currently building a duplicate of this studio in Hollywood, California. MCI JH-50 automation has been ordered and will be installed in Pacific West by mid-April. **TIM ROCK** is the studio manager.

Northern California:

■ At **HEIDER RECORDING** (San Francisco) **THE GREG KIHN BAND** has completed their latest album for **BERSERKLEY RECORDS** with **MATTHEW KAUFMAN** producing and **JEFFREY NORMAN** engineering. **TOM JOHNSTON** is doing vocal overdubs for an upcoming "TV Soundstage" segment, and **SAMMY HAGAR** is beginning his own LP for **CAPITOL RECORDS** with initial tracking by **TOM SCHOLZ**, followed by **GEOFF WORKMAN**. 245 Hyde Street, San Francisco, CA 94102. (415) 771-5780

■ **HOUSTON RECORDING** (Cucamonga, California) provided its remote truck for recording six live radio shows from the Sahara Hotel, in Las Vegas. Artists included **JACK JONES**, **RICH LITTLE**, and **PETE BARBUTTI**. Engineering was handled by **RICH HOUSTON** with assistance from **PAUL WESTERHOFF** and **MARK BARBUTTI**. 9340 Foothill, #32, Cucamonga, CA 91730. (714) 987-0379.

■ **VILLA RECORDERS** (Modesto, California) recently installed a UREI Time Aligned™ Monitoring System along with 26 channels of Dolby noise reduction, four more channels of parametric EQ, Scamp noise gates, and sweep EQ. Currently in the studio is the recently re-formed group, **HUMBLE PIE**, working on an album set for release in early 1980. 3013 Shoemaker Avenue, Modesto, CA 95351. (209) 521-1494.

■ **THE AUTOMATT RECORDING STUDIOS** (San Francisco) took part in a series of recording studio tours which were open to the public during January. Proceeds from the tours were to the benefit of the San Francisco chapter of the Academy of Recording Arts and Sciences. Activity at the studio has also included **JOURNEY** mixing their new LP for **COLUMBIA RECORDS** with **KEVIN ELLSON** and **JEFFREY WORKMAN** co-producing and co-engineering; **CON-FUNK-SHUN** doing overdubs with **SKIP SCARBOROUGH** producing and **LESLIE ANN JONES** engineering, and **THE TAZMANIAN DEVILS** mixing their debut album for **WARNER BROTHERS** with **ERIK JACOBSEN** producing and **MARK NEEDHAM** at the board. 827 Folsom Street, San Francisco, CA 94107. (415) 777-2930.

■ **HEAVENLY RECORDING STUDIOS** (Sacramento, California) has had **TAVARES** musical director **QUINN HARRIS** in producing **TONY ZAZZETTI'S** new project with **LARRY LAUZON** engineering, and is doing overdubs on **JILL HOLLIER'S** debut album with **STEVEN C. SOMERS** producing and **MARTIN ASHLEY** and **Lauson** at the board. Recent equipment additions include a UREI LA-2A limiter and Quad-Eight Companders. 1020 35th Avenue, Sacramento, CA 95822. (916) 428-5888.

■ **STUDIO "C"** (Stockton, California) is drawing up plans for their new 24-track facility, and they have taken delivery of an Intertec Data Superbrain Computer, which will store session information and can be programmed for automation when the new studio is opened. Studio "C" also announces the formation of **C-DUCTIONS, A PRODUCTION COMPANY**, to serve the San Joaquin Valley. **SCOTT MEADE**, writer, arranger/producer; **RALPH STOVER**, writer/producer; and **DREW PALMER**, engineer/producer are the core of the company's staff. 2220 Broadridge Way, Stockton, CA 95209. (209) 477-5130.

■ **RANCHO RIVERA RECORDING** (San Francisco) announces the appointment of **GARY MANKIN** to the post of studio manager of the facility where **YVES GAUTSCHI** and **ERNEST EAST** are currently cutting tracks for Pepper People Productions. 1124 Rivera Street, San Francisco, CA 94116. (415) 661-6977.

Southern California:

■ **SANTA BARBARA SOUND RECORDING** (Santa Barbara, California) is making use of their new Studer A-80 24-track recorder in sessions with **ARISTA** recording artists **BREAKWATER**. **DON MURRAY**, who brought **LEE RITENOUR** to Santa Barbara Sound earlier in the year, is engineering the sessions. Also at the studio, mixing has been completed with **JIM MESSINA** for Don Kirshner's Rock Concert, and Ritenour's digital recording, done in part at Santa Barbara, is soon to be released in Japan. 33 West Haley Street, Santa Barbara, CA 93101. (805) 963-4425.

■ **GROUP IV RECORDING** (Hollywood, California) in a departure from normal recording activity, provided its control room as a double of the L.A. International Airport control tower for the taping of a segment from the upcoming CBS **BOB NEWHART SPECIAL**. In this scene from the multi-location program, Newhart plays an air traffic controller, and was directed by **GREG GARRISON**, who is also executive producer of the special. 1541 N. Wilcox, Hollywood, CA 90028. (213) 466-6444.

■ **CAPITOL STUDIOS** (Hollywood, California) has had its staff recording maintenance engineers build and install two new consoles for its masters and tape transfer rooms, according to **JOHN HARKIN**, one of the six engineers involved. The board in the mastering facility, Recording Room 2, began with a new high voltage Op-Amp, custom built by **DEANE JENSEN**, of Jensen Transformers, and a stripped new chassis. Using Neve equalizers and compressors the staff designed

have you?

- increased track capacity — gone to 24, 16, 8 •
- added key people • won awards •
- moved or expanded • added important equipment •

these are some of the interesting news items that can be announced in the next available issue. Write:

R-e/p STUDIO UPDATE

P.O. BOX 2449 • HOLLYWOOD, CA 90028

STUDIO UPDATE

Southern California (continued)

and built graphic EQ line amps. The team constructed the console without the use of transformers. The tape transfer room console for Edit Room 3 began with a Sphere frame and equalizers and utilized amps and wiring by Harkin and company. No transformers were used in this board either, and a completely scratch board is being designed and built for Edit Room 5 by the Capitol team. 1750 N. Vine Street, Hollywood, CA 90028. (213) 462-6252.

■ **SCOTT/SUNSTROM RECORDING STUDIOS** (Los Angeles) are located in the old ABC Records building on Beverly Boulevard, and utilized a Jack Edwards designed studio with an Augsperger monitoring system. Other equipment includes a custom built Demedio 36 x 24 board, a 3M-79 24-track machine, an Ampex 1200 24-track recorder, 2- and 4-track machines, Eventide Flangers, Phasers, and Harmonizers, and additional monitors by JBL and Auratone. 8255 Beverly Boulevard, Los Angeles, CA 90048. (213) 658-5990.

■ At **MONTEREY RECORDING STUDIOS** (Glendale, California) **AMBROSIA** recently finished cutting two tracks for their new **WARNER BROTHERS LP** with **MIKE VERDIOCT** engineering, while newly appointed studio manager **RICHARD TILLES** completed mixing the new **BELL & JAMES** single for **A&M RECORDS**. **BROTHERS BY CHOICE** were also in the studio with **BARNETT WILLIAMS** producing and Tilles engineering. In another staff change, **MARVIN HALL** was named chief engineer of the facility. 230 S. Orange Street, Glendale, CA 91204. (213) 240-9046.

■ At **INTERNATIONAL AUTOMATED MEDIA** (Irvine, California) **THE BEACH BOYS** are mixing their latest single with **STREVE DESPER** and **SCOTT SPAIN** engineering, while **BROOKLYN DREAMS** prepared material for their fourth **CASABLANCA** release, and **DENNY CORRELL** tracks his second solo album with **SKIP KONTE** producing and **WILLIE HARLAN** engineering. In the mastering room, **THE VENTURES** are mixing a greatest hits package for European release with **RICK DONALDSON** at the controls. 17422 Murphy Avenue, Irvine, CA 92714. (714) 751-2015.

■ **RUDY RECORDS** (Hollywood, California) is recording **DAVID CROSBY'S** latest solo album with **STANLEY JOHNSTON** engineering. Johnston was the associate producer of the "No Nukes" album, which was assembled and mixed at Rudy. 1522 Crossroads of the World, Hollywood, CA 90028. (213) 467-6000.

■ **MAMA JO'S RECORDING STUDIOS** (North Hollywood, California) is in full operation after several months of remodeling and expansion. **AMBROSIA** is putting finishing touches on their upcoming **WARNER BROTHERS LP** produced by **FREDDIE PIRO**, **BILL PFORDRESHER**, and the group itself, while producer **BILL MAXWELL** is working on basic tracks with gospel artist **KEITH GREEN** and engineer **BOBBY COTTON**. 8321 Lankershim Boulevard, North Hollywood, CA 91605.

■ **CANTRAX RECORDS** (Long Beach, California) has moved to a larger location to better serve its clientele. Equipment in the new studio is by Studer, ReVox, and Tascam, and Cantrax also offers complete remote facilities. **RICHARD CANNOTA** is chief engineer. 1720 Park Avenue, Long Beach, CA 90815.

■ **ELDORADO RECORDING STUDIOS** (Hollywood, California) is recording a joint project with **BRIAN ENO** and **DAVID BYRNE** of **TALKING HEADS**, while at night in the studio is television star **MACKENZIE PHILLIPS** laying tracks for her upcoming **New Wave** debut LP. Eldorado is also doing audio work for the syndicated rock show, "Hollywood Heartbeat." To help handle the extra work, studio manager **NADYA BELL** has enlisted the talents of engineer **GEORGE SLOAN**. 1717 N. Vine Street, Hollywood, CA 90028. (213) 467-6151.

■ **ARTISAN SOUND RECORDERS** (Hollywood, California) now contains two fully equipped mixdown rooms, with studio "C" featuring an automated MCI console for 48-track work, and studio "B" offering a 32-channel operation. New TAD speaker elements have been installed in the Sierra/Hidley monitors, which have been converted to bi-amp systems, and Lexicon digital units have been installed as well. Mastering projects handled by the team of **JO HANSCH** and **GREGORY FULGINITI** have included the new **ROADMASTER LP** for **PHONOGRAM/MERCURY**, produced by **FLO AND EDDIE** and **JOHN STRONACH**, and the upcoming **JOURNEY** album for **CBS** produced by **KEVIN ELSON** and **GEOFF WORKMAN**. 1690 N. Wilcox, Hollywood, CA 90028. (213) 843-8099.

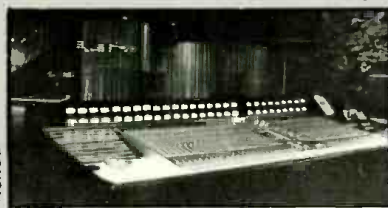

Kendun

■ **KENDUN RECORDERS** (Burbank, California) has installed a new computerized Solid State Logic console in its Studio 1 facility. Other renovations include the installation of Lexicon digital units as well as new TAD drivers placed in the Sierra/Hidley monitoring system with its conversion to bi-amp. Recording at the studios have been **THE BROTHERS JOHNSON** with **QUINCY JONES** producing and **BRUCE SWEDEN** and **RALPH OSBORN** at the console, while **HEART** is preparing a **Greatest Hits LP** in Mastering Room III, with **MIKE FLICKER** supervising and **JOHN GOLDEN** at the console. **BRUCE BOTNICK** operated the digital equipment to transfer material from all the group's past albums. Also using the mastering facilities are **SYLVESTER** and **TWO TONS OF FUN**, with **HARVEY FUQUA** supervising the **FANTASY RECORDS** project with **JIM SINETOS** engineering. 619 S. Glenwood Place, Burbank, CA 91506. (213) 843-8096.

■ **RUSK SOUND STUDIOS** (Hollywood, California) finds **DANCIN' MACHINE** laying down their new **CASABLANCA LP** with **JUERGEN KOPPERS** producing and engineering, and thirteen-year-old **ATLANTIC** artist **STACY LATTISAW** is in for sweetening sessions with **NARADA MICHAEL WALDEN** producing and Koppers behind the panel. 1556 N. LaBrea Avenue, Hollywood, CA 90028. (213) 462-6477.

■ **THE PASHA MUSIC HOUSE** (Hollywood, California) has **JESSE COLIN YOUNG** in studio co-producing his own album with **JEFF LABES** for **ELEKTRA/ASYLUM** with **LEWIS MARK** engineering. New Pasha signing, **THE WOLVES**, is finishing up four sides producing themselves with **LARRY BROWN** and **DREW BENNETT** behind the board, and **SPENCER PROFFER** is producing **O'KELSEY & THE PULSE** for **POLYDOR INTERNATIONAL**, with Brown again engineering. 5615 Melrose Avenue, Hollywood, CA 90038. (213) 466-3507.

Mountain:

■ **MOUNTAIN EARS RECORDING** (Boulder, Colorado) has producer **JIM MASON** working on an upcoming LP with **THE FLYERS** for **FEYLINE/CBS RECORDS** with **JOHN ALDRIDGE** and **NEAL PENDERGRAFT** engineering. Also, in the studio is **JOCK BARTLEY** of **FIREBALL**, producing a commercial to promote solar energy for the Department of Energy. P. O. Box 2240, Boulder, CO 80306. (303) 444-3277.

■ **SANBORN PRODUCTIONS** (Boulder, Colorado) has completed several engagements of late with its 24-track remote truck including two nights with **PAUL BUTTERFIELD** and **RICK DANKO** at Boulder's Blue Note nightclub, with tracks for an upcoming live album engineered by **MARK HARMON**, and two performances by the 16-piece jazz band, **VIC CIONITTI AND FRIENDS** at Colorado Women's College with **BOB BURNAM** at the controls. 1280 28th Street, Suite 10, Boulder, CO 80303. (303) 443-2372.

Model 537 The Extra Quiet EQUALIZER with EQUALITY (of course!)

UREI
QUALITY
OF COURSE

The Model 537 Graphic Equalizer is our new Extra Quiet EQUALIZER with EQUALITY (of course!). Signal to noise is better than 110 dB at maximum output (greater than 20 db over its predecessor 527-A) thanks to newest active circuitry and components. The 537 provides 12 dB of boost or cut at each of its 27 frequencies which are centered at ISO $\frac{1}{3}$ -octave increments from 40 Hz to 16 kHz. Input capability of +20 dBm and output of +24 dBm with excellent noise figure, gives it exceptional dynamic range. The 537's 27 filters are active, minimum phase L-C networks that combine for minimum ripple and phase shift when used in combination. Adjustable front panel control gives up to 20 dB gain. Completely self-contained with a regulated power supply.

Why don't you EQUietly slip out and see the 537 at your UREI dealer today!

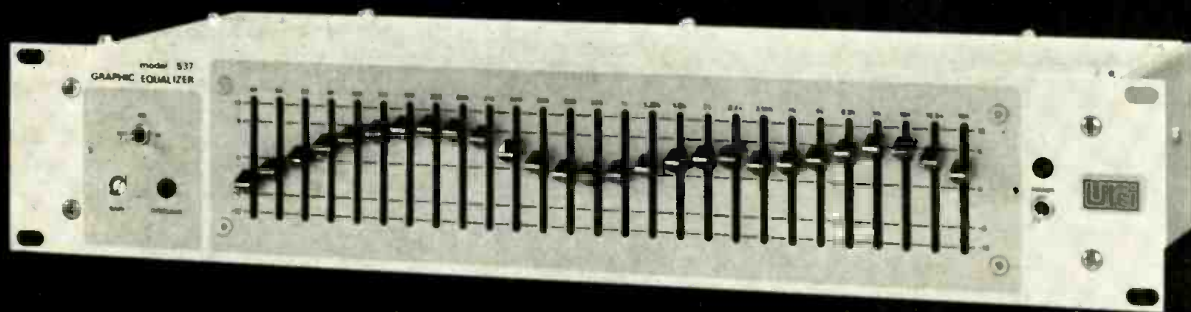

UREI

8460 San Fernando Road, Sun Valley, California 91352 (213) 767-1000

Worldwide: Gotham Export Corporation, New York; Canada: E. S. Gould Marketing, Montreal

STUDIO UPDATE

Southeast:

■ **CRITERIA RECORDING STUDIOS** (Miami, Florida) broke ground this past December for a new wing to their facility. The 7,500 square foot addition will include a studio, two disk-cutting rooms, and three separate living room/lounges for visiting recording artists. Portions of the new building will be operational in six months, but the new studio, designed with a 25-foot ceiling, will take almost a year to complete. Criteria's own engineers and producers will take an active role in acoustical design, according to studio founder and president, **MACK EMERMAN**. Artists working of late at Criteria have included **ANDY GIBB**, **HARRY CHAPIN**, and **MC GUINN, CLARK & HILLMAN**. 1755 N.E. 149th Street, Miami, FL 33181. (305) 947-5611.



Criteria

■ **TRIAD RECORDING STUDIOS** (Fort Lauderdale, Florida) was one of the studios used by **NEIL YOUNG** to record his "Rust Never Sleeps" LP, which won Best Album of the Year in both *Rolling Stone Magazine's Critics Poll* and *Reader's Poll* for 1979. In Triad of late has been **JEFF SANTIAGO** producing **HOT ASH** with **VINCENT OLIVERI** engineering. 5075 Northeast 13th Avenue, Fort Lauderdale, FL 33334. (305) 771-1431 or 945-4821.

■ **KEYS SOUND RECORDERS** (Islamorada, Florida) formerly Mainspring Music, of New York, has re-opened in its new Florida location. P. O. Box 275, Islamorada, FL 33036.

■ At **APOGEE RECORDING STUDIOS** (Atlanta, Georgia) **KURT KINZEL** is in doing work on **THE OUTLAWS'** live project, **HAMILTON BOHANNON** is producing **LIZ LANDS** for **POLYDOR** with **TOM RACE** engineering. **MIKE GREENE** and **SKIP LANE** are finishing mixdown of the new **LARRY G. HUDSON** album set for release this month. 125 Simpson Street, North West Atlanta, GA 30313. (404) 522-8460.

■ **dgp STUDIOS** (North Miami, Florida) is continuing with construction of their second studio at their North Miami facility. The 16-track room will be airtight and will "float" on its own foundation, as in its predecessor's design. dgp is owned by **DAVE GRAVELINE'S** Graveline Enterprises, Incorporated. 1975 North East 149th Street, North Miami, FL 33181. (305) 940-6999.

■ **STRAWBERRY JAMM SOUND COMPANY** (West Columbia, South Carolina) has just completed recording a New Wave R&B LP with **MIDNIGHT BLUE**. **BOB CURLEE** engineered the album which was mastered by **JIM LLOYD** at Masterfonics. Also in the studio is the **ROB CROSBY GROUP** working on their second album at Strawberry Jamm. 3964 Apian Way, West Columbia, SC 29169. (803) 356-4540.



Bee Jay

■ **BEE JAY RECORDING STUDIOS** (Orlando, Florida) recently upgraded its "B" studio to 24-track capability. The installation, supervised by Valley Audio, of Nashville, features an MCI 24-track recorder, a 26-input Auditronics 501 console, and UREI 811 Time Aligned™ monitors. Both Dolby and dbx noise reduction are offered along with an Eventide Harmonizer, an ADR Scamp Rack, and Lexicon Prime Time. Mikes are by Neumann, Beyer, RCA, Sennheiser, and others. The announcement was made by **ERIC SCHABACKER**, president of Bee Jay, and **JIM KATT**, vice president of the studios. 5000 Eggleston Avenue, Orlando, FL 32810.

South Central:

■ **GOODNIGHT AUDIO** (Dallas) recently had **B. B. KING** in cutting the audio track for a new Coca-Cola television commercial. Resident engineer **TOM "GORDO" GONDOLF** was on the board for the session. Also in Goodnight is local songwriter **GARY NICHOLSON** working on tracks for his latest composition, "Juke Box Argument," which was recorded for the upcoming **JOHN TRAVOLTA** film, "Urban Cowboy." 11260 Goodnight Lane, Dallas, TX 75229. (214) 241-5182.

■ **BULL RUN STUDIOS** (Ashland, Tennessee) is the new "resort" recording complex owned by Sanborn Productions, of Boulder, Colorado. Two 800 foot studios are situated in a 7,500 square foot house which is located on 28 acres of secluded riverfront property. The facility features guest cabins, a pool, water skiing, and a hot tub, and is 25 miles from Nashville's Music Row. Route 1, Ashland, TN.

■ **RIVER CITY RECORDERS** (Baton Rouge, Louisiana) has opened a new studio featuring a 24-track MCI recorder and a Harrison 2824 mixing console with an Allison 65K Programmer. Other equipment includes MCI 2-track recorders, signal processing by UREI, Eventide, and Lexicon, and mikes from Neumann, AKG, Shure, and Electro-Voice. Monitors include JBL, Big Red's, MDM-4s, and Auratone Cubes. Chief engineer and studio manager is **HAL ELLIS**, with **RONNIE DOBBS** as senior staff engineer. River City is a division of **ROYAL SHIELD, INC.** 1251 North Acadian Thruway West, Baton Rouge, LA 70802. (504) 383-8671.

■ **BUFFALO SOUND STUDIOS** (Fort Worth, Texas) has begun its second year of operation with the addition of an MCI 538C computer-assisted mixdown console. The 32-input board is bridged with MCI Plasma Light Meters displaying both peak and VU modes, and spectrum analysis. Control Room "A" now also includes 24-tracks of Dolby for the MCI recorder, Kepexes, Gain Brains, Dynafanger, UREI 539 1/3-octave room equalizers, and custom modified Super Red monitors. Also newly completed is a 3,000 cubic foot live echo chamber to complement the EMT 140 TS and MICMIX Series C. Owner **JIM HODGES** also announces the addition of **LARRY WALLACE**, formerly of Autumn Studios, Dallas, to the Buffalo engineering staff. 910 Currie Street, Fort Worth, Texas 76107. (817) 335-7233.

have you?

- increased track capacity — gone 24, 16, 8 •
- added key people • won awards •
- moved or expanded • added important equipment •

these are some of the interesting news items that can be announced in the next available issue. Write:

R-e/p STUDIO UPDATE

P.O. BOX 2449 • HOLLYWOOD, CA 90028

MCI's AutoLock

Doubles Recording Versatility

Lock two MCI recorder/reproducers together for maximum track capacity. Separate them to serve two studios.

MCI's new JH-45 AutoLock is a microprocessor based synchronizer/autolocator providing features you can't imagine, but MCI's engineers could:

- 10 memories
- programmable user bits
- MCI AutoLocator and shuttle functions
- programmable record punch in/out
- uses SMPTE, EBU, video drop frame code
- high speed reader for chase function, odd and even field and vertical serration, user programmable for video use
- displays master or slave position and offset in real time



4007 N.E. 6th Avenue • Fort Lauderdale, Florida 33334 • Phone (305) 566-2853

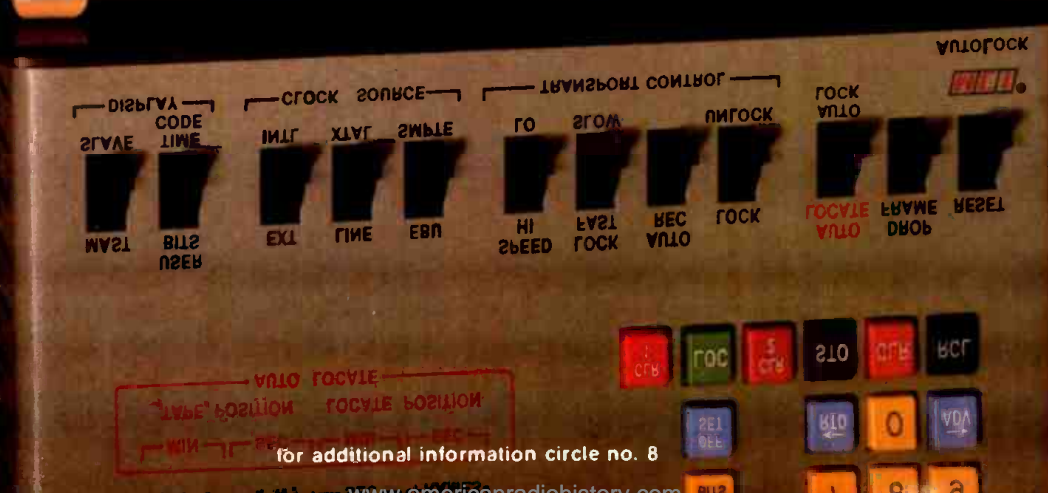
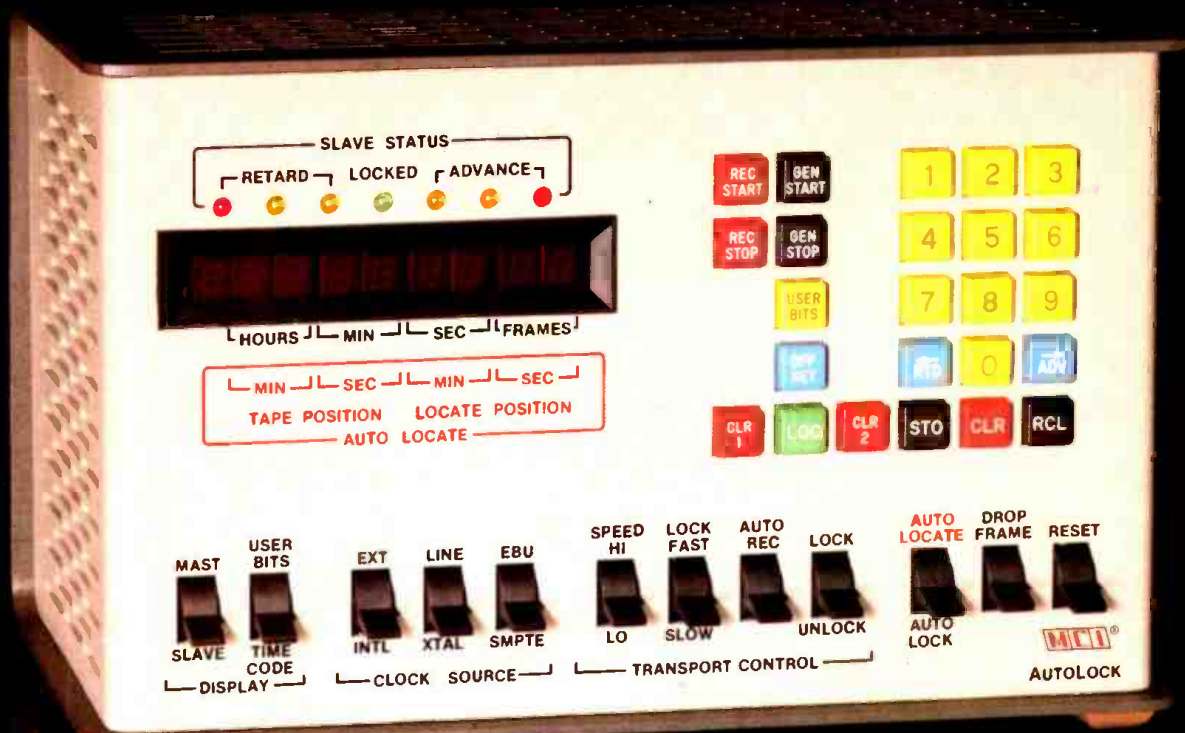

“ . . . mixing is an extension of arranging . . . ”



arranger • producer • song writer
BOB ESTY

R-e/p (Tom Lubin): Primarily your background is that of a song writer . . .

Bob Esty: I was originally in arranger/conductor. I had written music, but not with the idea of writing pop songs until about 1976. I found a writing and singing partner named Michele Aller. We put together an Ashford & Simpson type thing and performed it at *The Troubador* in '77. A lot of people came to see us. Michele and I tried to write with another songwriter friend of mine, but it turned out to be very awkward because his writing background was much more musical theater. He put a lot of emphasis on the song as a craft, which we appreciated, but the direction had nothing to do with what we were trying to present. We were more interested in being a high energy R&B-based act. Michele said, "Well, if he can write, we can write." So we wrote a few songs and presented acts. We didn't know anybody in the record business. We invited anyone we could contact. Barry Crost, who is now a movie producer, at the time was the personal manager to Cat Stevens and Dusty Springfield, invited Dusty to the presentation at the *Troub* in '77. Barry was interested in managing us as an act. Kenny Loggins came to it because he knew someone in the band. Out of that performance we got a lot of interest. We sent out a mailing to everybody . . . a poster, etc. We sent out about 300 of them to every name in any record company that we could find, knowing, of course, that a great majority of them would throw them out.

We called up the record companies and asked who was head of A&R, who was the vice president, the president; whether or not they had a publishing company, and who was head of that. Michele was signed to Motown Records for awhile until 1973. She was one of the first white artists to be signed to Mo-West. So Michele knew some people through that and, as it turned out, the legal department were friends of her family. She knew the producer of Rock Concert, so we got a list from them. Bonnie Burns brought a lot of people. We contacted Richard Perry's office and he sent Carol Pinkess to see us, and they gave us studio time to do a demo of our material.

Out of this whole thing we got a song on a Dusty Springfield album for United Artists called, "It Begins Again." I went in and arranged it; the producer was Roy Thomas

Baker. Because of that I also arranged another song on the album. At that same time I did "Last Dance," which happened through Paul Jabara who I knew from New York. I had co-written a song with Paul for his first album, called "Shut Out." Donna Summer sang a part in it; that's how I met her.

When it came time to do "Last Dance" (which Paul had talked her into doing), Neil Bogart said he wanted it recorded. He had heard a piano/voice demo we had done with her and had liked it. Arranging the piece was interesting since I had never really done a serious disco arrangement. (In 1976 I did a sort of pseudo-disco thing with Paul called "Yankee Doodle Dandy.") After listening to "Last Dance" Georgio Morodor and Pete Belotte, her producers, asked me to go to Germany to arrange Donna's "Once Upon A Time" album. I knew a little German, but I didn't know anybody there. I learned a lot through observation; it was a great opportunity. Until then I hadn't ever thought of producing, it was never in my mind.

R-e/p (Tom Lubin): Were you interested in performing?

Bob Esty: Performing and writing. I wasn't sure what a producer did. Being in Germany with them, well, I still wasn't sure what producers did. They were good as a team because Pete really controlled musically what went on, and Georgio wrote the songs, and Donna did the lyrics with Pete. It was done backwards from the way I thought it was done. I thought you had a song and you recorded it. They would have a sketch of a song without knowing what it was about. The whole album was done that way. No one knew what the songs would be so I had to put them in order based on their musical content. I knew the whole concept was Cinderella, but that was it. Pete was there most of the time. Georgio was seldom there, he would come in when Donna did the vocals and when the basics were cut. It was a 24-hour grind for three weeks to get the double LP done.

While I was there Georgio asked me if I would like to co-produce Roberta Kelly, who was an artist on Casablanca living in Munich. I said, "okay." It turned out to be less of a co-production than I had planned. Georgio didn't come to any of the sessions . . . I did the whole album. It was all supposed to be gospel.

Georgio had asked me once if I knew the song, "Oh! Happy Day" . . . then asked if I wanted to do gospel disco. I said, "Sure, why not!" Roberta, who was raised a Roman Catholic, had very little previous exposure to gospel or how to sing it. But she pulled it off great.

Once the vocals were done I came Los Angeles and put on choir and strings. The tape was sent back to Munich to be mixed by Georgio with Jeurgen Kopper, who was his engineer.

In the meantime, because of "Last Dance," Neil Bogart wanted to sign me to Casablanca as an artist, and wasn't sure how. I said I wanted to be signed with my writing partner. We signed as an act, though he had no idea what it was. My first full production was for D. C. LaRue with "Thank God It's Friday." We did a couple of cuts for the film, then I did his album called "Confessions." I learned very quickly that every act has its own peculiarities. They either write songs or they don't. Each has its own unusual way of doing it. In D. C. LaRue's case, he is not primarily a singer, he's a concept person. He comes up with a concept for an album and then writes songs to fit the concept. It's like a fantasy thing. His music was a very hard core, avant-garde disco. He has a cult following and everything, which I wasn't even aware of until I started working with him.

I got involved with two other projects that had problems, took a long time, and ended up going nowhere.

As a result I became quite concerned after spending so much time trying to create things for people just for the experience. I wanted to do something that made some sense. So Neil Bogart said he wanted me to produce Cher. My first reaction was laughter. I liked some of the things she sang. I figured she'd be difficult, but I really didn't know what to think. I met her and was still unsure. I found her delightful, but we didn't exactly hit it off by any means.

I got together with Neil Bogart and Michele . . . who had been on the back burner as an artist along with me. I had brought her in on one of the previous projects but it didn't really work out. The artist felt we were ganging up on him.

For Cher we wrote this song called "Take Me Home" because Neil said he wanted to have a "Last Dance" type song that expressed a strong female point of view . . . disco. We wrote her something about a girl in a club who takes the initiative about wanting to go home.

How serious are you about a power amp?



We build our Professional Series power amplifiers as if our reputation were at stake. Because it is. And so is yours, when you select an amplifier. That's why you should consider Yamaha power amps. They come through for both of us. Because we both designed them. Comments and suggestions from professionals like yourself were incorporated into the final design. As a result, Yamaha power amps excel in the areas that can make or break a power amp — performance, reliability, and flexibility. Take the P-2200 for instance.

Performance. The very conservatively rated specs tell the story. The P-2200 produces 200 watts continuous power per channel, from 20Hz to 20kHz, with less than 0.05% THD, both channels driven into 8 ohms. I.M. and THD are typically less than 0.01% @ 150W for powerfully clean sound.

Peak-reading meters accurately display a full five decades (50dB) of output level for accurate monitoring of program dynamics, transient power demands, and headroom. Frequency response is 20Hz to 20kHz, +0dB/−0.5dB, ensuring transparent highs. The high damping factor of over 300 (8 ohms, 20Hz to 1kHz) provides tighter low-frequency driver excursion and efficient power transfer.

Reliability. Large toroidal power transformers, multiple protection circuits, heavy front panels, serviceable printed circuits, massive heat sinks, and fully vented chassis are some of the reasons Yamaha power amps have a proven reputation for reliability.

Flexibility. Detented, log-linear input attenuators, marked in 22 calibrated dB steps, allow you precise, repeatable setups, accurate input sensitivity adjustments, and simultaneous adjustment of the level of two channels or programs on separate amplifiers. The P-2200 has one male and one female XLR connector plus two parallel phone jacks for each channel for convenient chaining to another amp and



adaptor-free connection to any mixer. A polarity switch satisfies DIN/JIS or USA wiring practice. The P-2200 is readily suited for monaural operation as well as 70-volt commercial applications.

The P-2201 is identical to the P-2200 except it does not have the peak-reading meters. The P-2100 and the P-2050 differ primarily in rated power output and size. Each model offers the maximum in performance, flexibility, reliability and value for the dollar in its category.

We have a technical brochure covering all four models. Write Yamaha, P.O. Box 6600, Buena Park, CA 90622. Or better yet, visit your dealer for a demonstration of the Yamaha power amps that take their job as seriously as you take yours.

Because you're serious.



NECAM!

The incomparable Neve Computer Assisted Mixing system.
The only automation system instinctively simple to use, yet performs
more functions, more reliably than any other automation system!
RPM Sound Studios of New York City is another quality conscious studio
joining the Neve world of excellence. Please call or write.
NECAM is in your future!



Model 8068/NECAM
36 in / 32 track console
at RPM Sound Studios
12 East 12th Street
New York, N.Y.

 **Neve**

for additional information call 1-800-441-2222

www.americanradiohistory.com

“... in the case of Georgio Moroder and Donna Summer ...
the combination just happens ... and that combination just happens to be right ...
that's why a lot of producers are famous ... that doesn't
mean that producer can work with anyone ...”

LARRY EMERINE on the engineering aspects of working with Bob Esty

R-e/p (Tom Lubin): Tell me about your basic session set-up.

Larry Emerine: It's always different and it depends on the song.

What we do is run the whole song down with the band. We might spend two or three hours working it out. Making sure there are no mistakes in the arrangement, seeing how it feels, setting the tempo. If it's a disco record we might want pure separation between the instruments.

Lately we have been cutting the basic with a click track and then re-cutting the drums with the drummer hearing what he and the others have just done. So he has the feel of them all playing with him, but he's really overdubbing the drums to the track. Once that's done the drummer listens in the control room while the rest of the band re-does their parts. This maintains the feeling of people playing with each other. After you've done it a few times it doesn't feel strange. The drummers like it a lot because it gives them a chance to punch in if they screw up. On a seven or a nine or a twelve minute cut there's a lot of drumming, and it's easy to screw up. They flub a kick drum part; they get tired; it's very hard to do.

R-e/p (Tom Lubin): How many instruments comprise a basic date.

Larry Emerine: Again it depends on the tune, but usually it's drums, bass, one guitar, and a keyboard. We try to establish a tune as simply as possible. If you want to spend time working on the arrangement, how the song works, the chorus, the break here or there, and all that, the more players in the room the more problems you can have.

R-e/p (Tom Lubin): Do you have a typical mike set-up for basics?

Larry Emerine: There are a lot of engineers that always use certain microphones on certain instruments. I don't do that. It depends on the song. It depends on how I want the song to sound. Whether I'm going to use room mikes, or no room at all on any of the instruments. I might use one of five or six kick drum mikes; or, two or three in combination. One limited kick drum mike and one not limited. It's all contingent on what we want.

I always know what we're going to record, and what kind of a tune it is. So before we cut it I'll decide what kind of a sound I want it to be, but that doesn't mean I'll lock into that for good. We cut a lot of different records so the sound has to reflect the record. I know engineers that have a particular sound, and it may be a great sound, but always the same. I've been told people can hear one of my records, but I try to make each record with a different sound.

R-e/p (Tom Lubin): You manage Studio 55 (Hollywood, California) as well as engineer?

Larry Emerine: Yes.

R-e/p (Tom Lubin): Do you use an assistant?

Larry Emerine: Yes, I always use Stephen Marcussen. He and I have worked together over three years now.

R-e/p (Tom Lubin): What's Studio 55 like acoustically?

Larry Emerine: The big room is 40 by 50 feet, and has a 30-foot ceiling. It's a tall, open, live room. It's unlike most of the studios in town. It's been a recording studio since the early twenties. "White Christmas" was cut in there. It was Decca Records' in 30s and 40s. Before we bought it, it had five owners in five years, and then we got involved. We built a new control room, but left the studio essentially the way it was, with slat lined walls. It is relatively live, and that's part of the sound. It's got a two-inch thick wood floor.

R-e/p: Who re-did the control room?

LE: It was a combination of Jack Edwards, Howard Steele, and myself. The design, the wood treatment, and the way it looks was my influence. The acoustic properties, the speakers' focus, and where the soffit and traps would be, were designed between Howard and Jack.

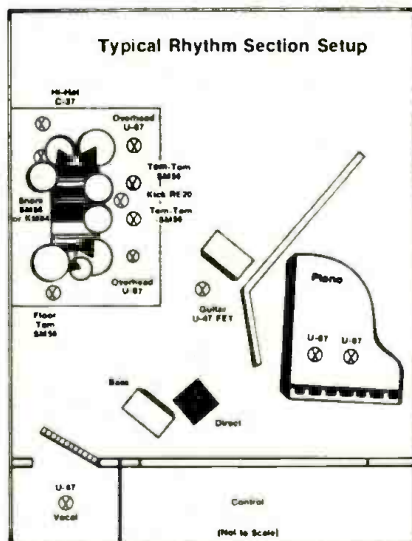

We did three cuts and Ron Dante did six. Then it was decided that the stuff that Ron did was not in the right direction, and would we write more songs based around "Take Me Home." Anyway, that was what Neil wanted so we went in and finished the side, re-cut "Happy Was The Day We Met," which Ron had previously cut. On the second side she wanted to make her musical statement since she hated disco, she just hated it. The second side was definitely different. We did ballads, and so on. It contained two of Ron's productions. My experience with Cher is that she is a singer with a unique voice so strong and deep for a girl. We had to be careful how we used it because it's a performance voice. During the vocals I was giving her some coaching.

R-e/p: Which means you had to be quite a diplomat.

BE: Yes, she took it well, I must say. She was so frustrated; and is easily intimidated by other singers. She's used to going in and doing a couple of passes at a vocal and whatever comes out ... comes out and that's it. She certainly didn't want to have someone like me suggesting how she sing it. She enjoyed how it turned out, and it was successful, but she never thought she could perform it because she had worked so hard on the vocals. She's very self conscious performing this type of music ... she likes rock 'n' roll. In reality her voice is more suited to rock 'n' roll. On the second album, "Prisoner," we wanted to explore those things and make it an album that told what she was like so the songs were written by myself, Michele, and Michael Brooks that explored her attitudes and problems about being a media star. But the thrust of the package got into an area I didn't want it to be.

R-e/p: The package doesn't match the album?

BE: Yeah, I know. It has nothing to do with the album. There was a big fight, and it's one of the reasons we are not doing anything else together.

R-e/p: How did "The Main Event" and working with Streisand come about?

BE: I always thought there would come a time when I would work with Barbra Streisand. The Streisand thing was again through Paul Jabara. I told him that I didn't want to work with him anymore. We had done a number of projects together and it had become too painful an experience. We knew each other too well. But Paul persisted. He had joined Primus Artists Publishing, which was a part of the now defunct First Artist Productions, a company started by Streisand, Dustin Hoffman, Sidney Portier, and Steve McQueen. Paul had a life-long dream to work with Streisand. He had actually written a musical called "Rachael Lillie Rosenbloom," about a girl living across the street from Barbra Streisand. RSO produced it on Broadway but it was a big flop.

The song for "Main Event" I thought was okay, but it was difficult for me to translate it into what they wanted to hear. The whole middle "Fight" part had to be written in to justify it as a disco tune. Barbra was not crazy

LARRY EMERINE

The room has two sets of large monitors, JBLs and Big Red 604Es with Mastering Lab crossovers, but no one I know uses the JBLs. I love the 604Es. I wouldn't consider making a record on anything else. I've tried making records on other speakers, but I'll stay with the Big Reds. Their design is pretty interesting. The 604E is essentially a 1930 speaker, the frame and casting are from the 30s. Doug Sax, at The Mastering Lab, and his brother took the speakers and built the Mastering Lab crossover. It smoothed out that honk that they have with the old Altec crossovers. They later added the 15" extra woofer, which is a Utah woofer driver with a special cone. It's the standard as far as I'm concerned and it's what I like to hear when I go to another studio. No other speaker punches like it does.

It's true that they have a bit of honk, but among the people who use them, the attitude is if you can get your tape to sound good on them it will sound good anywhere. That's certainly not the case with a lot of other speakers. Especially custom speakers where what you hear is determined by how they've been tuned. You don't tune these speakers . . . you put them in your room and tune your room to them. 604Es have a little mid-range hump. When I master I add a little mid-range. Since they do honk, I have a tendency to not push the mid-range in a mix. But the drum-bass relationship will be correct, the high hat will be right.

R-e/p: Tell me about the boards you use.

LE: Each studio is different. The board we cut tracks on is a transformerless Quantum console. Quantum doesn't really build big boards and I don't think they really want to build big boards; but they built us one. It's manual and very straight ahead. The other studio is a mixing suite with a small overdub studio. It has an almost transformerless Neve Necam. We modified it by taking out most of the transformers. There is one left in the phase reversal circuit. We pulled it and compared the sound with and without and couldn't hear any difference, so we decided to leave it in because it requires quite a bit of work to design around it. Because Neve uses transformers to step up the signal current, we had to build amplifiers to replace each transformer to get the correct amount of signal boost. The board sounds 100 per cent better.

The Neve continues to sound like a Neve. It has a punchy bottom now that the transformers are gone. I'm not in love with the mid-range and top EQ, but it's usable and workable. It seems that there are always trade-offs. No one makes an automated console that sounds incredible. The board we have in "A," the Quantum, sounds incredible.

The Quantum has a very straight ahead signal path. When you plug a good condenser microphone into that board what comes out of the speakers will blow you away.

On the other hand, you have to learn the Neve and work with it to get results. You just don't put it up and mix flat and get a great anything. It's not like that. But it's real usable. And if you spend some time with it you'll get anything you want. And the automation is great, there's no doubt about it.

The servo faders really do work — especially for the stuff that we do. I could see that if I were cutting simple rock and roll I probably wouldn't even use it. There would no need for it. Since I get off on mixing, I would just mix it. But when you start doing twelve minute disco records like the Streisand "Main Event Fight" song, it becomes a very complex process. It took twelve hours to mix it. I think the Necam is the easiest one to use of the automation systems. It has 38 inputs and 16 output busses.

The Quantum board is a 32-input board with 8 auxiliary inputs and is constantly being updated. When our guys find an amplifier with a quicker slew rate, or a better distortion figure, or this or that, they will improve it.

R-e/p: What machines do you use?

LE: Ampex 1200 24-track, and I record and master at 30 ips with Dolby.

R-e/p: What's your low frequency EQ?

LE: 100 Hz.

R-e/p: What type of tape?

LE: Agfa 468.

R-e/p: What's your favorite limiter?

LE: Teletronix LA-2A. Next would be an LA-3A. From time-to-time I'll use a Gain Brain.

R-e/p: Have you made any comparison between the new LA-2A and the vintage version?

LE: Yes, I bought some of each and I hear no difference at all. For limiting complex, sophisticated, transient signals I can't find anything that I like better. When you put something into it, the signal comes out musically intact. All the transients are still there, the three dimensionality, and depth are still there. I can't say that about an LA-4A or a 1176, or a dbx, or any other limiter that I know of.

R-e/p: Do you use outboard EQ?

LE: Seldom. I use board EQ.

— continued overleaf . . .

arranger producer song writer

BOB ESTY

continued

about the song, but Jon Peters liked it and wanted her to do a contemporary song that had something to do with current musical tastes, but it was up to her to decide.

Initially she wasn't sure how to sing it. We really worked on it, figuring out exactly how her phrasing should be to make it applicable to what it was. It ended up just Barbra, myself, and my engineer-co-producer, Larry Emerine, who manages Studio 55. Larry is an excellent engineer and has been co-producing with me since "Main Event." He's more than an engineer. He has very good ideas about music. I hope that we can work with Barbra again in the future. This recording was a bit different for her. She's used to going in with the whole orchestra there and singing it. We had a great time.

R-e/p: How much did you know about studios before getting into it?

BE: Very little.

" . . . the German string and brass players? . . . the musicianship was very high quality, but they had difficulty with what I call soulful playing . . . they were so precise that it was a problem making it sound spontaneous . . . "

R-e/p: What was your background?

BE: I went to a conservatory, Peabody, in Baltimore. I didn't like it. That was right after high school. I went there to see if I wanted to do serious classical music, which was how I was trained. I was in the Bach Society as a singer. I had to sight read vocal parts. I played church organ and piano, and took opera singing lessons. I was in opera productions and into the whole classical thing. At the same time I was doing shows — Broadway type shows. I wrote a musical for off-Broadway. I couldn't decide whether I wanted to do classical music or have a college education. I went to Franklin & Marshall College, in Pennsylvania, which is a very old school and very conservative. I was the person on campus that was into everything musical or dramatic I could find.

R-e/p: Did you get your degree?

BE: No, I went for four years and never got around to it. I kept dropping courses. I'd start with four and end up with three. By that time I had begun doing industrial shows, which are big convention shows. I worked with Armstrong Cork Company as an independent director. I hired their shows together. They would have a twenty minute speech by the president of sales, and then there would be a production number, about fifteen musical numbers per show. We had an orchestra, lighting . . . it was like doing a Broadway show. I traveled with it for about two or three years. I moved to New York in the meantime, and continued to travel all around the country staying at the best hotels . . . very Carte Blanche.

R-e/p: It certainly was not like being on the road with a band.

BE: Not at all. I learned more about orchestrating and arranging, which I didn't

Incredible...

the "Acoustic Chamber Synthesizer"™



the XL-305
by

Master Room™

- Totally new design approach
- The sound of a live acoustic chamber
- Natural sound, even on percussion
- Self-contained rack mount unit
- Full two-channel stereo

The Master Room XL-305 is a totally new design approach in reverberation technology. For the first time, the qualities and properties of a live acoustic chamber are available in a rack mount unit at an affordable price. There is a natural sound on percussion, as well as voices and all other musical instruments. This quality has not been obtainable from other compact reverberation devices. The XL-305 exhibits no unwanted side effects; it's as natural as a live chamber itself.

To hear this new advancement in reverberation, see your professional audio dealer and ask for a demonstration of this exciting new unit. Hear the XL-305 "Acoustic Chamber Synthesizer" for yourself, and you too will agree... It's INCREDIBLE.

MICMIX Audio Products, Inc.

2995 Ladybird Lane

Dallas, Texas 75220

(214) 352-3811

for additional information circle no. 11

www.americanradiohistory.com

LARRY EMERINE

R-e/p: Very much of it?
LE: I use what I need.

R-e/p: Are you apt to use more EQ or change the microphone?
LE: I suppose I'm more likely to change the microphone, but I'm not afraid to use EQ. There are engineers who won't use EQ, and I think that's ridiculous. But if I find myself putting in too much EQ I'll change the mike; but I almost always use some EQ.

R-e/p: Do you use a standard string set-up?
LE: I always have the same set-up depending on how many strings there are. I use twelve Neumann U67s. Usually one microphone for two violins. I'll also use them on the viola and cellos. It depends on how many mikes I have. I'll sometimes use Telefunken 251s or Neumann M49s on bass fiddles, and a pair of Sony C-500s overhead to be blended in.

R-e/p: What about a brass date?
LE: It depends again on the song.

R-e/p: Do you use ribbons?
LE: No, not much. When I did Manhattan Transfer I did because I was going for a stylized sound. On brass I'll use a U67. If I had to pick a mike that I would use on everything it would be that mike. I think that it had great phase coherence and enough top and bottom. But I use quite a number of different mikes. For instance, I almost always use dynamic mikes on tom toms. I use Shure SM56. I've tried a lot of other mikes on toms, but I can't get what I want so I use 56s on tom and sometimes on snare. I like to have total control of the levels on the toms, so close miking with the SM56 is ideal because they have a fairly narrow pattern.

Sometimes on the snare I'll put a Neumann KM84 or KM88 on the top of the snare; sometimes a Sony C-500. It depends on the drummer. I don't want to stick a C-500 or KM88 in there with some drummer that might bang the microphone — especially the C-500 — which is a great mike. It's large, and if they bang it — that's it, because it's not made anymore.

R-e/p: The percussion is very transparent.
LE: A Neumann U67.

R-e/p: What about acoustic guitar?
LE: It depends on the guitar. If I want a brighter sound I'll use the Telefunken 251 or Neumann tube U47. I also like the M49, but I prefer the 251 to get that extra sparkle. It's really a great microphone. You wouldn't be able to use the 251 all the time since its pattern is so broad and bright, and it can cloud the whole track.

I also like the new Neumann microphone, the U89. It's got that top, a real nice pattern selection, and it sounds natural. I used it for all the percussion on Streisand, and it was wonderful on classical harp. It's the first new mike I've heard that I really think is great.

R-e/p: What's your feeling on general board signal flow and design?
LE: Less is better. When you look inside of some of these boards and see a million chips you have to conclude that the signal can't pass through all that and still sound good. At least I don't think so.

R-e/p: How long have you been working with Bob?
LE: Since the summer of 1977, about 2½ years. "Main Event" was our first co-production. We've now done a number of albums together — the relationship works well.

R-e/p: You've been doing film and video at Studio 55 . . .
LE: Bob and I did the whole "Roller Boogie" project there. The film had no pre-recorded material. They had done it backwards, as you know. We just transferred the whole film to video with SMPTE and scored it. And although the film did not have the

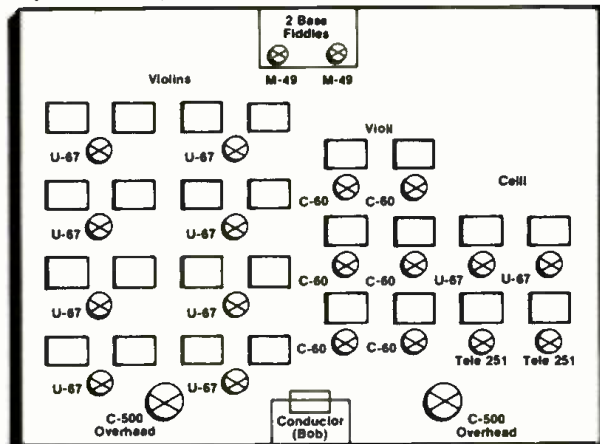

Typical String Section Setup

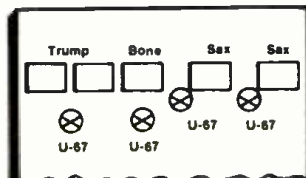

Woodwind and Brass Setup

... producing? . . .
"It's very important to have prior experience in the studio before actually producing . . . a lot of decisions are based on technical parameters . . . shortcuts can be achieved through technical knowledge . . ."

know how to do technically. They should have courses like that in colleges that tell you how to relate to the actual world. They can teach you music theory and musicology . . . but they don't tell you anything that is actually usable, unless you are going to be a professor of music. Through all of this I got friendly with the Bette Midler, and Barry Manilow, and got involved in doing an act for Sally Kellerman, which was a real experience, and it introduced me to Hollywood. I moved out here to do that and TV variety. I did the Smothers Brothers Show — the last one they did.

R-e/p: Arranging?
BE: Yes, musical coordinator between the acts and the musical director, Marty Paitch. I got to work with Linda Rondstadt, Chris and Rita, Arlo Guthrie, and quite a variety of people. Somewhere in there is when Michele and I started working together.

R-e/p: What was your reaction to the European disco recording scene?
BE: I thought the Munich machine was made up of German players that lived in Munich but, in fact, they're mostly English. Two of them do live in Munich. The drummer, Keith Forsey, and the other musicians are from London. They are flown to Munich and put up in this hotel. We would do one side a day on Donna's album. I felt like an outsider since even Donna wasn't there. She didn't come in until it was almost done. Till then she had heard none of it.

Working with the German string and brass players was more difficult than cutting tracks because my German is borderline. Here I was, this American Hippie, and they didn't know quite what to think at first. The musicianship was very high quality but they had a little difficulty with what I call soulful playing. Not the English guys, but the string and horn sections and some of the background singers. They were so precise that it was a problem trying to make it sound spontaneous.

R-e/p: What qualifies someone to produce?
BE: I think it's very important to have prior experience in the studio before you actually produce. There are a lot of decisions that are based on technical parameters. A lot of shortcuts can be achieved through technical knowledge. You want to be aware of a wide range of possibilities. What I became most conscious of was the big difference between artists. In the case of Georgio Moroder and Donna Summer, the combination just happens to be right, and that is why a lot of producers are famous. That doesn't mean that producer can work with anyone. There are so many variables. I was unaware of this. So many different ways to approach it. I think a would-be producer should try to work with a producer as an assistant. But it's also very hard if a producer puts himself in a "to be observed" position, sometimes it's distracting. My sessions are closed unless I know the people.

The Volks Console



3216 by Tangent

In its short (3 year) existence, the Volks-Console has found its way into the hearts, studios and homes of engineers, producers, and musicians around the world; out-selling its competition 3 to 1. The 3216 combines ease of operation, flexibility and the best specs in the industry, and is at home in recording studios, production, S.R., and other applications. **With features like these, its no wonder why.**

Automation

Tangent Automation uses the exclusive Faderaide automatic Fader nulling system, and the Allison 65K programmer. Faderaide frees you to concentrate on the mix, not Fader level sets. This feature cannot be found on any other Allison based system.

VCA Grouping

For those not needing full automation, nine voltage controlled subgroups are available. All VCA consoles may be expanded to full automation at anytime.

Multiple Solo Systems

In addition to the prefade listen (PFL) solo, a stereo positional, and subgroup solo are provided as standard features.

Semi Parametric EQ

One of the most musical EQ's available is a standard Tangent feature, not an expensive option as with other systems. The three band sweepable EQ covers the audio band from 20 to 20khz.

Transformerless Circuitry

Transformerless Balancing keeps your original sound pure with incredible transient response. Noise is within 3 dB of the theoretical limit.

Transformerless Balancing is suddenly a big deal among the other console manufacturers. It should be. Tangent's been doing it for years.

16 Submasters

Tangent's 16 submaster busses plus "Direct" allow tremendous flexibility for 16 or 24-track work.

FET Switching

Electronic FET switching silently rearranges the signal flow for maximum convenience and minimum repatching.

Lots of Extras

Penny & Giles faders, multiple Echo and Cue send, Phase Reverse, Tape Return Gain, and many other features on each channel give full professional control and reliability.

Tangent Does It ... Again!

Tangent Systems, Inc.

tangent 
Musical Engineering
2810 S. 24th St. / (602) 267-0653
Phoenix, Arizona 85034

for additional information circle no. 12

www.americanradiohistory.com

the New Workhouse



MTR-90: The Machine You Helped Design.

After extensive consultation with you, the people who depend on professional audio machinery for their livelihood, we found that a new generation of two-inch master recorder was required to meet your demands. You wanted better tape handling, increased performance, greater creative flexibility; you needed adaptation to multi-machine interlock, compact design, better serviceability and the number one priority—greater reliability. You felt that contemporary technology could be incorporated into an affordable machine. We felt the same way.

Here is the result of a collective vision—our engineering and your current and future needs—THE OTARI MTR-90.

The OTARI Optimal Tape Guidance System

Research has proven that impeccable tape handling can be achieved by a servo-controlled, symmetrical, and uniformly distributed constant tension tape path utilizing a wide diameter (60 mm) pinch-rollerless capstan. This elegantly simple method of controlling tape movement eliminates the problems of stretch and wear, which are generic to many conventionally designed 2" pinch-roller type transports. With the MTR-90 the only tape drive contact is on the tougher tape backing, thus allowing for the first time, virtually unlimited safe passes with your valuable 2" master tape.

The OTARI Unitized Transport

The integrity of the entire tape machine is dependent on the long-term stability of the top plate, its supporting frame and the integration of its head assembly. OTARI engineers felt it essential

to mate a super-rugged, precision top plate directly to a unitized, welded steel chassis to make it strong enough to withstand the most rigorous studio or remote work.

Electronics

By engineering single card circuitry, OTARI has refined "state-of-the-art" electronics by reducing the complexity and expense of multiple card assemblies. Active mixing of audio and bias in the record circuitry and proper utilization of high slew rate integrated op-amps and discrete components at critical stages are your best assurance of aural success.

The modular approach of the MTR-90's digitally controlled transport logic achieves a higher level of reliability along with the "real world" considerations for rapid diagnosis and serviceability.

The Man/Machine Interface

Included with every MTR-90 is the CB-104 Remote Session Controller. Offering total flexibility while pro-

viding immediate understanding on your first session, the CB-104 accomplishes mode selection faster than any other remote available. There's "positive feel" switching—important under session pressure; flexible standby mode monitoring, master switching, single control simulated punch in/out and more.

The optional CB-107 Memory Locator, which physically mates with the CB-104 Session Controller maximizes your efficiency and creativity with your clients' time. It features ten keyboard assignable memories, shuttle function, and independent, built-in stopwatch.

Factory support through a large domestic parts inventory, thorough documentation and communicative personnel versed in all aspects of studio equipment, are integral parts of the MTR-90's presentation to the professional. A network of the finest and most experienced audio dealerships is the final link in your assurance of OTARI's comprehensive approach to the professional recording community.

The OTARI machine has become *The New Workhorse*. And now, the advanced MTR-90: *The New Workhorse* for two-inch, multi-track 16/24 channel audio production.

Contact your nearest dealer for a demo and detailed color brochure. Get your ears on the tape machine you helped design!

CALIFORNIA Express Sound Costa Mesa Sound Genesis San Francisco Westlake Audio Los Angeles	TENNESSEE Valley Audio Nashville
TEXAS Westbrook Audio Dallas	
NEW YORK Martin Audio New York	

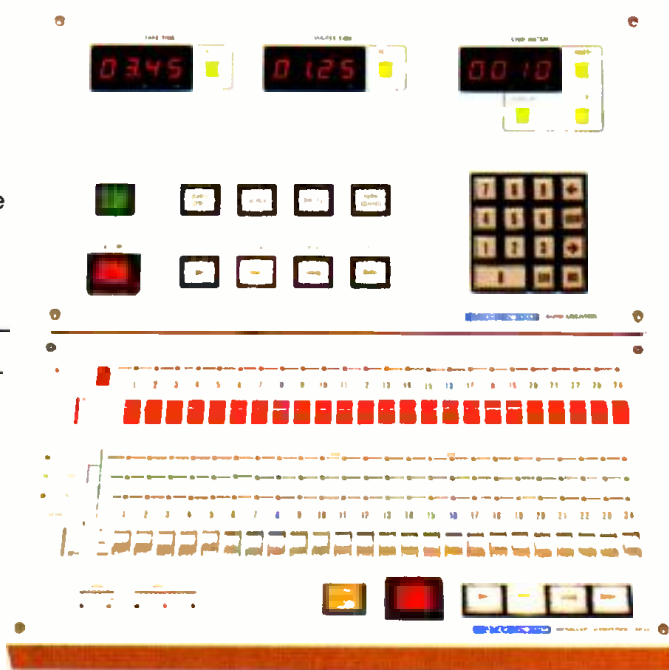

The CB-107 Memory Locator and the CB-104 Remote Session Controller.

The New Workhorse



Otari Corporation, 1559 Industrial Road, San Carlos, CA 94070, (415) 592-8311
In Canada: BSR (Canada, Ltd.), P.O. 7003 Sta. B. Rexdale, Ontario M9V 4B3

The sound you've been waiting for

TRIDENT TSM SERIES

shown here at Penny Lane Studios, NYC.

Features include:

- standard 60 and 72 channel remix capability
- 4-band parametric EQ with switchable Q
- 2-band parametric filters
- modular plug-in PC patch bay
- 6 aux send with stereo cue
- solo-mute-auto mute
- independent AFL/PFL monitor override
- monitor EQ-solo-muting-cue and echo...

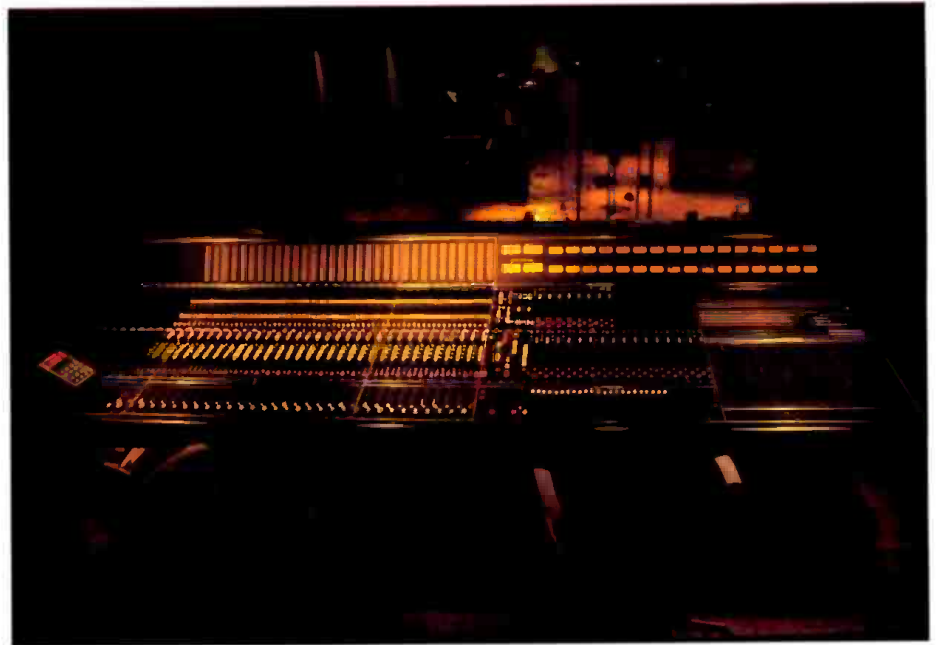

Automated 32-24 Series 80 console at Lucas/McFall Warehouse recording studios, NYC.

+++ NEW HIDLEY 'STUDIO B' AT

SOUNDMIXERS NYC WITH

FULLY AUTOMATED 40-32 TSM

RECORDING CONSOLE RECENTLY INSTALLED

BY EMPIRICAL AUDIO +++

... • complete automation facilities: programmable mute, solo, 9-subgroups. Allison/Trident Fadex.

Audio installation by **Empirical Audio**

3A Todd Place, Ossining, NY 10562
Telephone 914-762-3089

the U.S. East coast importer and distributor for Trident Audio Developments, U.K.

Empirical Audio also offer:

- Technology for the '80s: Allison Research Automation systems, VCA's, FADEX Advanced Music Systems, Audio Kinetics Intelligent Locators and QLOCK Synchronisers, 3M multitrack machines.
- Full engineering staffs for comprehensive audio systems design and construction, and service.
- PORTA-SHOP: N.Y.'s first portable maintenance facility.
- Computerized used equipment brokerage.

plus the complete range of Trident consoles...

TSM SERIES 80 FLEXIMIX

LARRY EMERINE

SMPTÉ code, when the tape and film were rolled together it all fit. The video machine was the master and the audio machine ran as the slave. It was no problem because we didn't have to roll a projector or hassle with any of that. There were video monitors in both the control room and studio so everybody had a view of the film. It's expensive, but it works.

I think what you're seeing is music-for-film people wanting to work in recording studios for their film work because they're trying to get around the film union trip, and the inflexible thinking that goes on in large studio film sound departments.

I would also say that many people who are doing films are un-hip to sound and what can be done. The music is always secondary, and every nickle they save is money in their pockets, and that's just the way it is. They don't want to know you want to record 24-track, and that you'll then have to mix it down. They want it scored right now, straight to 3 or 6 stripe magnetic film, and they want to be done with it. They just don't look at it as we do.

R-e/p: You've recently started your own mastering facility.

LE: Yes . . . Precision Lacquer. I built a mastering facility out of frustration. According to Allen Zentz, a close friend of mine, my tapes have more top than most. Possibly because our transformerless boards allow really punchy transients to get on tape, or perhaps because I Aphex.

I could always hear in mastering the separation loss at 10 kHz and 15 kHz. It just folds inward. The more demanding the program, the more it folds in. That's what I refer to as the metallic sound we all hear when we cut. The music picks up a metallic edge. It doesn't sound like the magnetic tape any longer. I was convinced that this did not have to be the case. So a friend of mine went down to Criteria, in Florida, and cut something on their Ortofon cutting set-up.

We cut a Streisand album there, and sure enough the disk we cut blew away everything that we had previously done here in Los Angeles. It was open, it was transient. The high hat was dead right where it belonged. It was unbelievable. When I heard that I decided to build a mastering facility. No one here had an Ortofon, nor seemed interested in putting one in.



Emerine and assistant Marcussen

R-e/p: How do you like the Cybersonics lathe?

LE: It works. We cut "Roller Boogie" on that lathe and the new Cher album, "Prisoner." We're the first to have one, so I'm sure we'll have the same kind of minor problems that we had with the first Neve Necam, but there have never been any major problems. The Cybersonics does everything they say it does. We have it sitting on a ridged platform that is secured to a 15" concrete wall. This building was ideal. It was once the Technicolor film processing complex. It was built in the '20s, and the walls were constructed to withstand chemical explosions. All the buildings in the complex are independent of each other. The pilings go down 36 feet to bed rock. The lathe sits on a pallet bolted to the wall.

R-e/p: Have you had any problems with the Ortofon?

LE: None, but the Ortofon design is completely different. You get much better separation from it than the Neumann. But it is true that it is more susceptible to blowing up. You probably can

lunch one of these heads before you would a Neumann, it's not as well protected. But that's the trade-off; I think all that protection is audible. It's also harder to change the stylus. It takes a lot more time, and you have to use a microscope and play with tweezers. The net result is less mastering product for a given amount of time, but this is a quality operation. I really don't care if I make a nickel off it. It's here because I was that upset with mastering in Los Angeles.

I plan to run it like we do at Studio 55, which is kept busy with just a few select clients. Richard Perry, primary owner of 55 is a principal client; and Howard Steel, Bob and I; and Bill Schnee work there, so we can't really take many other bookings. I want Precision to operate the same.

R-e/p: How long have you been associated with Studio 55?

LE: I worked for Richard Perry for two years before Studio 55 happened. I spent two years in the studio with Richard and his engineer, Bill Schnee. I was seconding, and changing mikes. It was never official, but I sort of helped Bill. I lived through the Carly Simon albums, and the Ringo Starr albums, and helped mix them. And I watched . . . I saw what was going on.

I was very frustrated because I was essentially a go-for. I pushed for a studio, and went out and found what was to become "55." And it all worked. □ □ □

*. . . elaborate arrangements? . . .
"a lot of unnecessary work when
musicians are used to working off
one another . . . with simple
charts they have more chance
of expressing themselves . . .
the other extreme, you don't ask
them to create the tune . . ."*

R-e/p: With the music that you are producing, do you produce it pretty much complete before you get to the vocal? Have you got all your backgrounds and overdub elements clearly defined?

BE: No. We do it mostly as an evolving thing. I know what the arrangement is.

R-e/p: As a producer doing the arrangement how elaborate do you write the basic chart?

BE: Just a rhythm chart with chord changes, and specific indications, maybe a chorded in version and a bass line that should be used. I have occasionally written out everything. "Last Dance" was that way, which is okay if you have to. But it's a lot of unnecessary work on my part when I'm using musicians that are used to going in and performing as a unit. Secondly, the whole idea is to work off of one another. You can't do that if you have specified every single lick. With a simple chart the musicians have more of a chance to express themselves without asking them to make the tune. That's the other extreme. You don't ask the musicians to create the tune . . . that's a rip-off.

R-e/p: So you give them enough direction to proceed, but you don't get in their way.

BE: I'll usually play with them during the rehearsal. If I hear the guitar player doing a specific riff that I think is the right direction for the tune, I'll say, "that's it!" If the bass player alters the bass line and it's better, then we go with that. I oftentimes will put a rough vocal on right after the basics are cut.

R-e/p: Is that a hedge against over-production?

BE: Yes, it is, because everything is created around what that is. It's very difficult to do an overdub without a vocal. Background vocals are usually last. The backgrounds are used like horns and strings.

R-e/p: Do you write them like you would brass or strings?

BE: I've done that. But unless there is a time factor it's not the best way, but it depends on who's singing them. Michele, Ron Green, and myself did them for "Roller Boogie." Sometimes it's nice to bring in other people. The Alessi Brothers and I did "The Main Event" background vocals. That was fun.

R-e/p: When you do background vocals what's your procedure for recording?

BE: Generally by that time everything is on. In some cases we don't listen to much else in the cans beside the rhythm section and lead vocal. In the control room they hear everything.

R-e/p: Do all the background singers stand around a single microphone?

BE: No, actually a lot of times we will do it on three separate microphones, and if we have

— continued overleaf . . .

February 1980 □ R-e/p 35

"disco . . . confused a great many who were buying and selling it at the record companies . . . the companies understood rock n' roll . . . they found out disco was not a listening thing . . . it required participation . . . few rock n' roll people enjoy dancing . . . too many jumped on the disco bandwagon . . . there was too much crap released under the guise of disco . . ."

the room we'll put them on separate tracks at least once. Then if there is any note or balance problem we can fix it. Michele and I can blend well, but it's harder if we have another voice going on. We almost always double track them.

R-e/p: Will you work, for instance, with the backgrounds you've already got on tape in one ear and the one you're working on in the other ear?

BE: Yes, but that depends. If it's a unison thing it's better to have it left and right. Other times it's better to have it in the middle because you worry less about each individual track. Often we'll get a background vocal part down, then double it and then overdub the double to improve on the original overdub, and erase the one that is least desirable. In those cases it's better to have all the tracks in the middle. Once you know the part and you're not making it up as you go, it becomes stronger with each double until it sounds just as you want it.

R-e/p: The work you did with the Brooklyn Dreams must have fit in well with their style since they, too, are so background oriented.

BE: Yes. I probably would have preferred having Joe Bean singing lead mostly. But they all wanted to have their own thing, which was understandable, so we did it that way. We tried to pick which of the songs were best for each of them, but it would have been much easier in terms of getting a sound to use one lead.

I find if it's a group that sings together all the time, such as the Brooklyn Dreams, they will prefer to sing around one microphone and blend themselves. If one of them is too loud they just back up, and that works great.

But in the case of Michele and I, we don't sing together enough nor work with a third person on a regular basis. Sometimes she and I will do two parts and then I do a third part and mix it all together. If we have the tracks sometimes I'll do all the parts.

R-e/p: You've also moved into film.

BE: I told Neil Bogart that I wanted to do a soundtrack. One of the reasons I signed with Casablanca was because they did do film.

R-e/p: "Roller Boogie" is not a Casablanca movie.

BE: No, but he said there was this movie that was being done called "Roller Boogie." The reason I took it was that I thought it would be a good way to do an album where you had to do musical numbers which were integrated to the film. Ordinarily, a film score album is a compilation of source material that the filmmaker has found. An example of this would be, "Thank God It's Friday." Some things were done for the film, but they were all done independently of the film production company. It was left to the film people to integrate the music into the script. I wanted to create a soundtrack that would seem to fit the film's ambience.

The problem that we had with "Roller Boogie" was that the film was shot incorrectly, technically speaking.

R-e/p: How's that?

BE: Well, if you're going to do a musical number on film you either have to have the musical number first, which they didn't have as they had filmed the entire movie before the score was written. Or, you need a click track rhythm that is in constant sync, which again they did not have. What they did is take currently popular records, record them on cassettes, and play them over a PA (i.e., "Bad Girls," "Hot Stuff"). What we had to do was write songs in the tempo of the records that they used. Since some of the records they had used had not been recorded with a click track, we had to manipulate our tempos to match. When I do a dance number I almost always use a click track for purposes of editing and keeping the tempo steady.

R-e/p: A digital metronome?

BE: Yes. I use it for most recordings.

R-e/p: The drummer works with the click in his earphones.

BE: Yes. A lot of drummers prefer it. Unless you're doing a band that plays together all the time, or a song that requires certain stretches where you can't use a click track.

R-e/p: Do you use a Rhythm Ace or a metronome?

BE: Both. The Rhythm Ace is good for some drummers, but I find that it sometimes imposes a rhythm pattern on what you're doing. I like a simple click track metronome. It's also what the film people use. When they have a musical cue they describe it, for instance, as a 12 point 0 (12.0) click.

I did the movie because I wanted to know technically what was involved in the scoring of a movie. And, although I had done "Main Event" and "Thank God It's Friday," my involvement in them had been peripheral.

For "Roller Boogie" we hired Craig Safin to score the film in terms of adapting the source music because I had never scored a film. I felt I shouldn't put myself in the position of doing a double job, plus producing the album and being the artist.

We recorded the whole score at Studio 55 because it was going to be both a record and a movie. The film was transferred to videotape, which worked fine most of the time. The video and multitrack were locked together with a SMPTE code. The SMPTE was for our video, but the film people didn't care about that. All they needed was a 60 cycle pulse so they could get everything going at the same time.



Unfortunately, because they didn't film everything at 60 pulses, we had no real tape-to-film reference. We had to hope that our click track was going to fit through the rougher areas. We had gotten it pretty close against our SMPTE video, but weren't sure if it would work against the film.

We did two mixes. One for the movie, and another for the record. The movie mix was whatever the length of the cue was. We found at times it was better to give them two-track stereo and a CSG mono combine of the two stereo tracks, while at other times it was better to give them the vocals and musical tracks separately.

I got involved with the mixing of the actual film which is real unusual, since they don't like to have the guy who does the music there while they mix. We had problems with it because there was an ideological split between the producer, director, myself, and the executive producer over the relationship of the music to the other elements in the film. Fortunately for me the executive producer and I agreed, and he was the one that said, "This is the way it's going to be!"

I had stayed away from the mixing for the first couple of days because I didn't think it was my position to be there. And, essentially, it wasn't. But when I went in I couldn't believe it. They were sublimating the music to sounds of the skates hitting the floor, and superfluous dialogue — things that meant nothing. But to the director, who had never done a musical, the dialogue was the most important thing. You had to hear the dialogue above everything else.

Since we had been working against the video, we had just assumed that when the music was put into the visuals you wouldn't hear the sea gulls and such. But they had the sea gulls, the rustle of clothes, zippers, buckles . . . and it was all unnecessary.

R-e/p: What do you think about the future of disco and dance music? You've done a great deal of that music though your background is rock 'n' roll and classical.

BE: Right. I don't know . . . I always loved to dance. I liked all the Motown songs and the Philadelphia material. I used to go to discos, except then I didn't know they were discos. That was until five years ago when they then became "discos." They had always used the term "disco," but most of the time they were juke box systems. Then the DJs came along.

What I find interesting is how few rock 'n' roll people enjoy dancing, or the process of it. It's not true of R&B, but it is for many of the people in rock. When disco came along the artists became secondary to the beat, and the production — which was fine for me, but it scared a lot of people who were performing the music. It also confused a great many who were buying and selling it at the record companies. As a result, the word "disco" has become a bad word, and now they're referring to it as "dance music." What is happening is the companies are trying to integrate more types of music into a category that was limited under the disco heading. When disco came along the companies understood rock, but not disco.

FOR CONSTANT Q: THE 622

Equalizer and notch filters? With a Constant Q parametric you get both in one.

The Orban 622, unlike most parametric equalizers, is a Constant Q design, providing almost infinite cut instead of the reciprocal's 12 to 20dB. This means the 622 can be used as a notch filter, providing greater flexibility to the professional while reducing equipment requirements. Long experience has shown the narrow cut and broader boost curves of Constant Q to be more musically useful, while the bandwidth control still allows de-equalization of recorded material to exactly cancel a previous boost.

Remember—reciprocal may be more common, and perhaps cheaper, but Constant Q is more useful for the demanding professional. Rugged construction, stability, reliability and responsive product support all make the Orban 622 the professional's choice in Constant Q parametrics.

For Orban equalizers and other fine professional audio products, see your local dealer, or contact Orban for the location of the dealer nearest you.

orban

Orban Associates Inc., 645 Bryant Street, San Francisco, CA 94107 (415) 957-1067

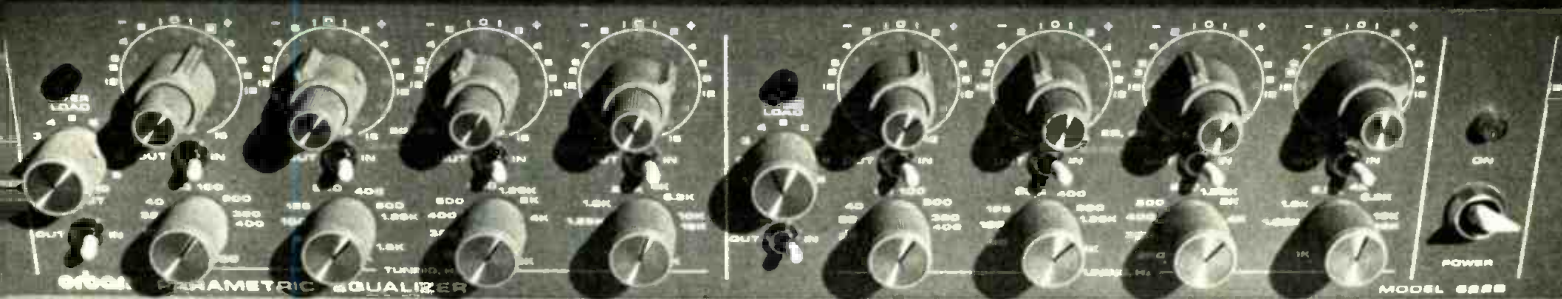

Ask your Orban dealer for a copy of our free booklet: "How to Choose Equalizers for Professional Recording Applications."

for additional information circle no. 15

February 1980 □ R-e/p 37



“ . . . to be a producer is very hard . . . it is such an undefined role . . . every producer does what he does a different way . . . which makes it hard to learn how to be one . . . ”

Disco started selling big and they scrambled. Unfortunately, a lot of the wrong people got involved and people who were into it, like the DJs, resented many of the people who jumped on the disco wagon.

Also, the latecomers found out that disco was not a listening thing, it required participation. What bothers me is the unnecessary backlash to the word, “disco.” There was just too much crap released under the guise of disco.

The unfortunate side of disco's decline is the diminished possibility of the concept disco artist doing video. Someone like D. C. LaRue would surely come up with some very interesting approaches to a visual musical fusion, away from the current trends in movie musicals. The common practice in Hollywood has been to take something like “Grease” and just re-film what occurred on stage rather than utilizing all the advantages and techniques which are available visually. It would have been interesting to see someone like Buzby Berkeley do video. He created pictures-to-music that could never have been done live.

Video representations of acts have generally had similar problems. Videotaping a performance is fine, but a song like “Pop Music” set to video was made into a visual presentation of the music. A marvelous advantage of the disco beat is that you can do anything visual on top of it. It's very open musically, and can be one of the most theatrical, or visually stimulating forms of music. So is New Wave — I thought the video of “Pop Music,” most David Bowie, Devo, etc., are also very creative.

R-e/p: You've worked in many studios both as artist and/or producer. Have you put any thought into the feel of the studio environment?

BE: I think that's real important. I have to feel comfortable and at home. I think it's important for a musician to come in and feel welcome. I have been in a lot of studio situations where I went in and felt that the facility was blown out of proportion in the extravagance of it all. The Perrier, Poland water syndrome. I don't particularly care for studios that have walls of volcanic rock. I don't care for these large facilities that have studios that are all essentially the same. I feel these studios are very impersonal, like a Marriot Motor Lodge.

The studio should have something to say about the personalities of the people involved in the studio. I think colors are very important. I don't like the over-decorated look, or garish studios. I think those sort of rooms are intimidating to the artist. Such studios have obviously spent a great deal of money on the decor, but I think it's inhibiting. I think it should be functional first and after that it should be comfortable. The colors should work well together. It should reflect the character of the people who own it and not look like a hundred other studios. It should have a total look to it.

I like Studio 55 because it is very low key. It was built by Richard Perry, so they don't really need to do any advertising, which is very nice because you don't feel the pressure that if a Fleetwood Mac calls up you're going to be cancelled. They're not out to get the “names” to generate more business.

Another thing that bothers me are studios that will end up charging you for everything they do and are very accountant oriented. I would rather have a higher flat rate with everything included. That way I don't get a bill with all this gear itemized at \$5.00 an hour here, and \$10.00 an hour there. I think charging a flat rate makes everyone less uptight, from the guy who's writing the Work Order to me, who's authorizing the payment.

A similar problem is dealing with the Musician's Union and the standard three hour Union session. If you have musicians and you're booked 3:00 p.m. to 6:00 p.m., and you have to work 'till 6:30 p.m. to accomplish what you're trying to do, I don't feel as though I should have to constantly look at the clock.

Basically, I guess, it's keeping the recording process from being influenced by a factory or assembly line mentality. That was one advantage of working in Munich. They don't hire musicians by the hour, they are hired by the song. When the string players came in to do three songs that's what they did. If it took them 6 hours instead of 3 they didn't get paid any more . . . within reason, of course.

R-e/p: Like if the charts weren't together.

BE: Right. And it was all negotiable. It's quite different there. I think the Union is important here, but at the same time you have to realize that they are in the business of making rules. That's their justification for existence. As a result there has been quite a lot of over-justification, and overkill.

R-e/p: What about the non-musical aspects of producing?

BE: I would like to assume that I could do what I'm supposed to do in the studio and all the other people at the record companies would do what they are supposed to do, but sometimes they don't. That's the part of producing that I don't like. The yelling and screaming on the phone about air play, or promotion, or with ad people that you think are doing the wrong things.

R-e/p: You use muting quite extensively in your mixing.

BE: Yes . . . we use an automated Neve Necam. I plan the muting, and by the time we get to mixing I have a pretty good idea of what's going on. I'll make decisions as I go as to what I'm going to do. This was one of the things that I learned from watching Georgio. To me the mixing is an extension of the arranging. It's so infinite what you can do in a mix. I've seen a two-minute song extended to eight minutes using mutes, and outboard equipment, and all

sorts of things.

Mixing is as valid a time as any to finally put together what you have. I find it is like editing a film. You have all these different elements on different tracks and you can put them together any way you want. Sometimes the unusual placement of a scene may make all the difference in the world. I'll edit and intercut, because I think a record should be a total thing and not just a collection of songs. I think it's an art form. I like doing music that has a point of view, or message. Music that can expand whoever is doing it into revealing something about themselves, exploring musically what is unique about them.

R-e/p: How involved have you gotten in the engineering?

BE: Well, quite a bit. Not in terms of microphone placement or selection, or anything like that. But when we get to the mix I'm involved. I don't profess to be a mixer, so I don't do it; but I take a great deal of interest in it.

When I work with an engineer I wait until he says that he's ready for comment. Because as far as I'm concerned the situation is much like working with an arranger. When I hire Jerry Hay to do horn arrangements for me. I tell him what I kind of want, and then he comes in and we work on it as it's played. When I'm working with Larry Emerine or whoever is mixing, I'm not going to be in there with comments every step of the way because that's what he's supposed to know. When he says he's ready then I listen and decide on musical relationships. Sometimes I don't get what I really want because of time. I would really like to know how to mix, but I don't have the time to really learn how to do it right, but I like to sneak in there and play with it.

The role of the producer is so flexible. You might be responsible for every single thing you hear from beginning to end, or you might be a producer in the sense that you hire everyone and let them do it.

There are a few producers who are more into the social aspects of the music business. They go to all the openings, and company parties, and they are great PR people. And I guess that's an element of producing, or part of it.

For instance, I'm an independent producer under contract to a label, so I have a certain obligation to them. But if they don't have someone on their roster that I want to work with I can do other projects. To be a true independent producer is very hard since it is such an undefined role. Every producer does what he does a different way, which makes it hard to learn how to be one. You find you're always influenced by who you've been around or what music you're doing. I approach it as a total musical picture. Because of my arranging background I want to work on each element.

□ □ □



EASY DECISION.

When you want to expand to 16-track and money is a real consideration, you have two choices: our new 85-16 or a used machine.

The 85-16 gives you sixteen tracks on one-inch tape with integral dbx**. S/N performance is better than 87dB (WTD, with dbx). Electronics-induced distortion is less than 0.1%—even at 25dB above normal operating level. And you have 28dB of system headroom.

We're using a newly designed transport for greater speed accuracy and long-term dependability. There's servo control throughout. And an internal micro-processor for the transport controls.

With a used machine, you may get 2-inch compatibility. But no warranty, a heavy refurbishing bill, out-dated technology and no

investment tax credit.

So why buy someone else's headache? Check into the new 85-16 for results you can bank on day in and day out. It's a decision you can live with.

*Retail prices are determined by individual TEAC TASCAM SERIES Dealers
**dbx is a trademark of dbx, Inc



TASCAM SERIES

TEAC Professional Products Group

©1979 TEAC Corporation of America, 7733 Telegraph Road, Montebello, CA 90640

Before you buy any automation console, test drive Auditronics 532 Memphis Machine...

Exclusive western distributor
Westlake Audio
(213) 655-0303

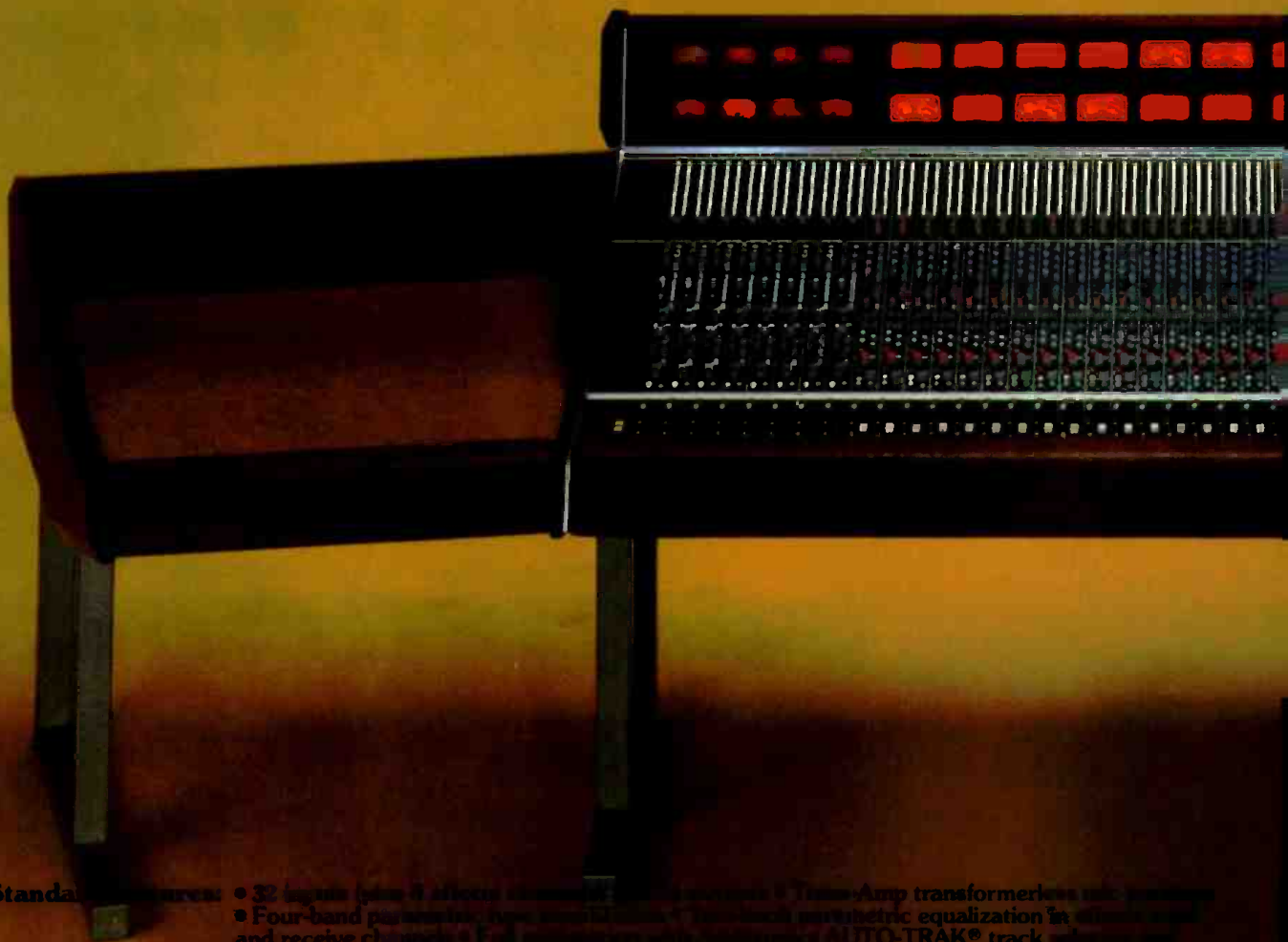

Standard features: • 32 inputs (plus 4 stereo channels) • 16 outputs • Trans-Amp transformerless tube preamps
• Four-band parametric-type equalizers • Two-band parametric equalization in stereo send
and receive channels • Full automation with automatic AUTO-TRAK® track selection and
Allison programming

... it's the best you can buy for under 100 grand

Exclusive eastern distributor
Valley Audio
(615) 383-4732



A receiver of 200 watts power, especially on all channels
with the best stereo effect. A receiver with the best high
fidelity sound and great value.



auditronics inc.

3750 Old Gerweil Road, Memphis, TN 38118
(901) 362-1350

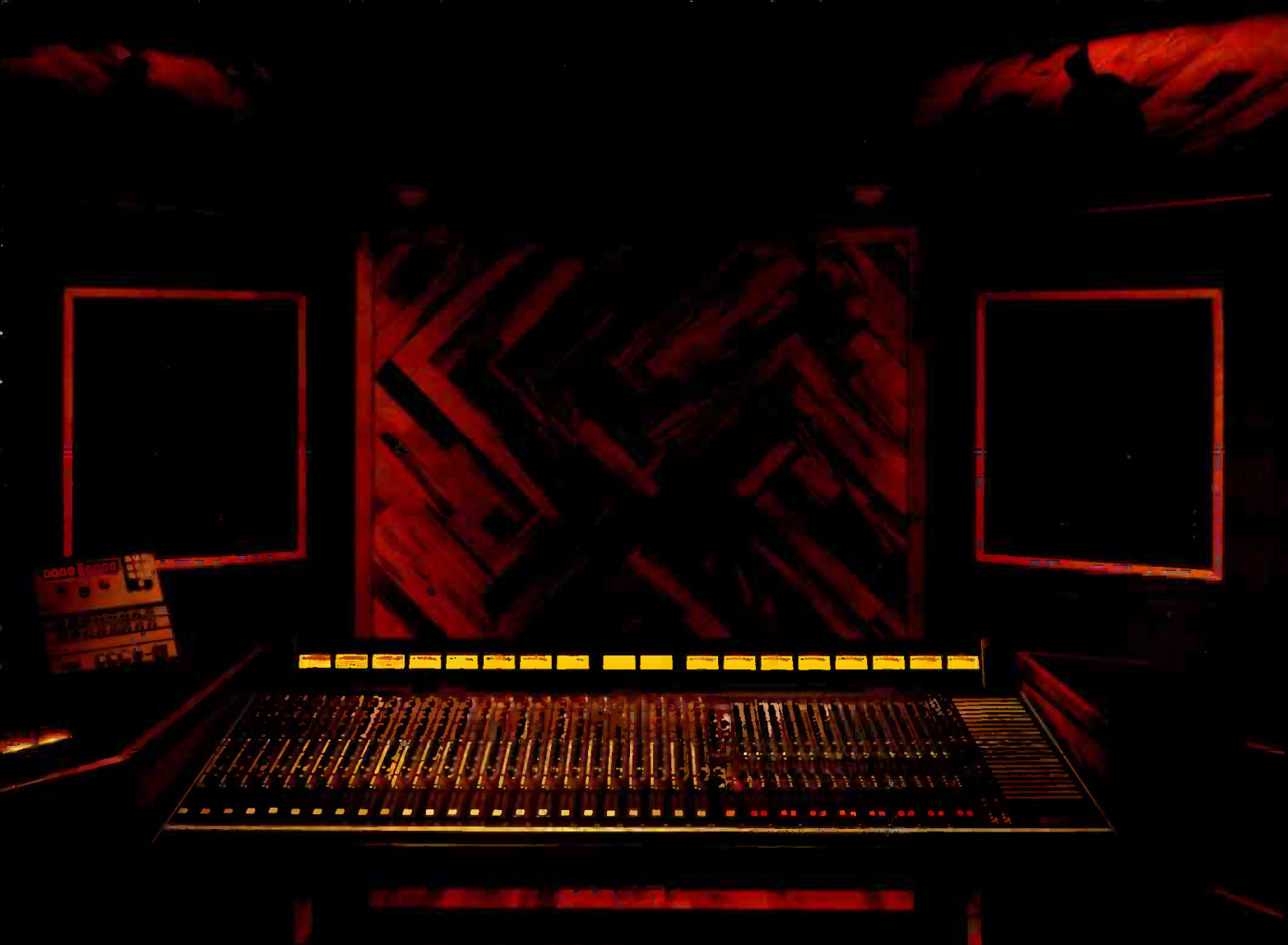

Soundcraft 1624

Manufacturing:
Soundcraft Electronics Ltd
5-8 Great Sutton Street
London ECTV 0BX
England
Telephone: (01) 251 3631
Telex: 21198

US Distribution:
Soundcraft Inc
PO Box 2023
Kalamazoo
Michigan 49003
Telephone: (616) 382 6300
Telex: 22-4408

West Coast:
Westlake Audio
6311 Wilshire Boulevard
Los Angeles
California 90048
Telephone: (213) 655 0303
Telex: 698645

Canadian Representation:
McKeen Productions Ltd
PO Box 4054 Station E
Ottawa
Ontario K1S 5B1
Telephone: (613) 236 7242
Telex: 053-3381



for additional information circle no. 17



www.americanradiohistory.com

Brandon Wade's Crosstown Recording, Kalamazoo, Michigan.

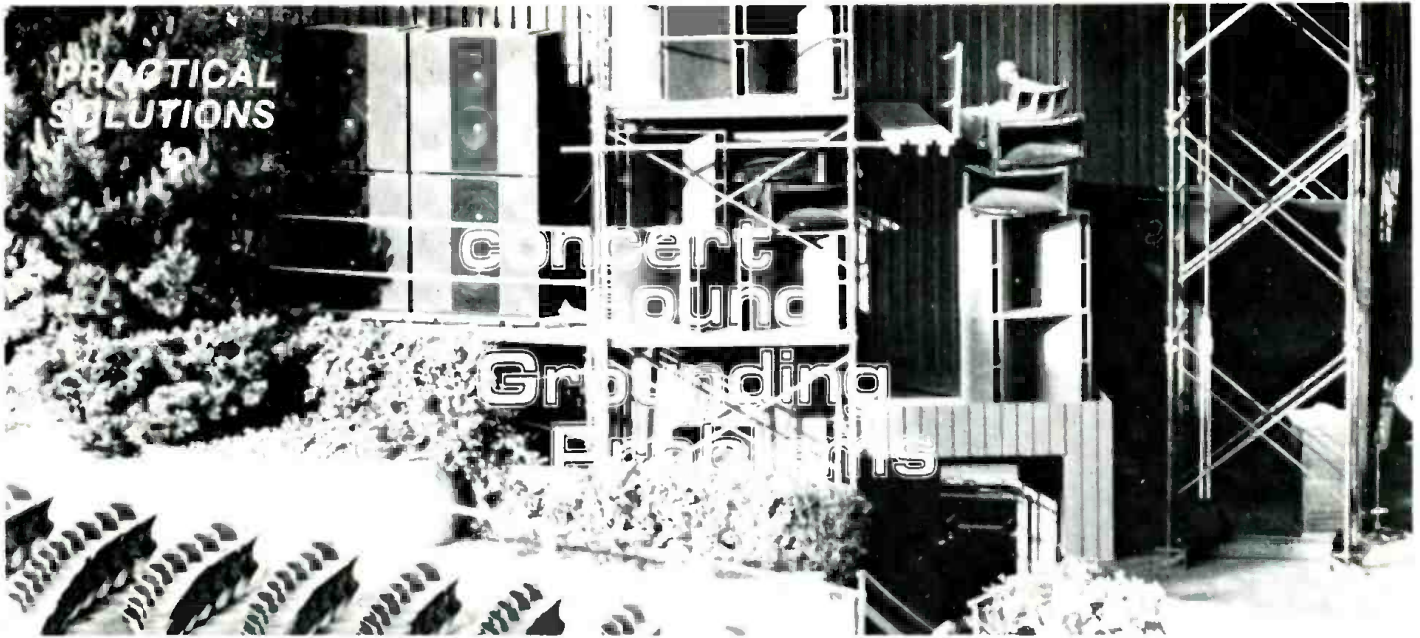

Ed Simeone & Robert Carr

Live concert work is one of the most demanding fields in professional audio. After traveling several hundred miles through the dead of night, the audio technician on entering an unfamiliar acoustical and electrical environment must construct within a limited amount of time a quality sound reinforcement.

The changes in acoustical parameters from show to show become easily recognizable whether the concert is scheduled indoors or out, and to the trained eyes and ears of the professional, the sound characteristics of a large arena are obvious even before the PA is turned on.

Electrical influences which can be neither seen nor heard are also different with each venue. Invisible fields from transformers, radio stations, old, unshielded lighting equipment, or a myriad of other unforeseen demons may play a part in the quality of any sound installation. These elements are not as obvious and they are much harder to detect and analyze quickly.

All major sound companies carry complete power distribution systems to insure a smooth running performance, but often this is still not the final answer.

A concert system is actually comprised of four individual subsystems:

- 1) the house mixer and outboard effects,
- 2) the onstage monitor system,
- 3) the power amplifiers and speakers, and

4) the band's instruments and amplifiers. The presence of a mobile recording truck would constitute a fifth subsystem.

All of these subsystems must be referenced to one common ground point which is generally within the main distribution box carried by the sound company.

The most common source of power found in larger halls across the U.S. is called "three phase Y power." This is comprised of three "hot" lines, a neutral line that is usually joined to earth at the facility's main distribution point, and the earth itself. Each "hot" line is 120 degrees out of phase with the other two, and referencing any one "hot" line to neutral yields 120 volts. If a connection is made between any two "hots," only 208 volts is available. The fact that the "hots" are 120 degrees out of phase results in some cancellation, and therefore, a

lower voltage than if the two lines were 180 degrees out of phase which would yield a strictly additive voltage total of 240 volts.

The neutral carries the return current of all three "hot" lines and the wire gauge of all the lines is the same. If the three "hots" had the same phase, the resultant total amplitude of the power returning through the neutral to the source would require a larger gauge wire. Since each "hot" is 120 degrees out of phase with the other two, the current takes its turn through the neutral 120 degrees behind or ahead of the other two "hots," thus allowing the gauge of the neutral to remain equal to that of each "hot."

It is standard procedure to distribute the subsystems as evenly as possible among the three power lines (Figure 1). In a large coliseum

— continued overleaf

FIGURE 1
HOUSE POWER HOOKUP

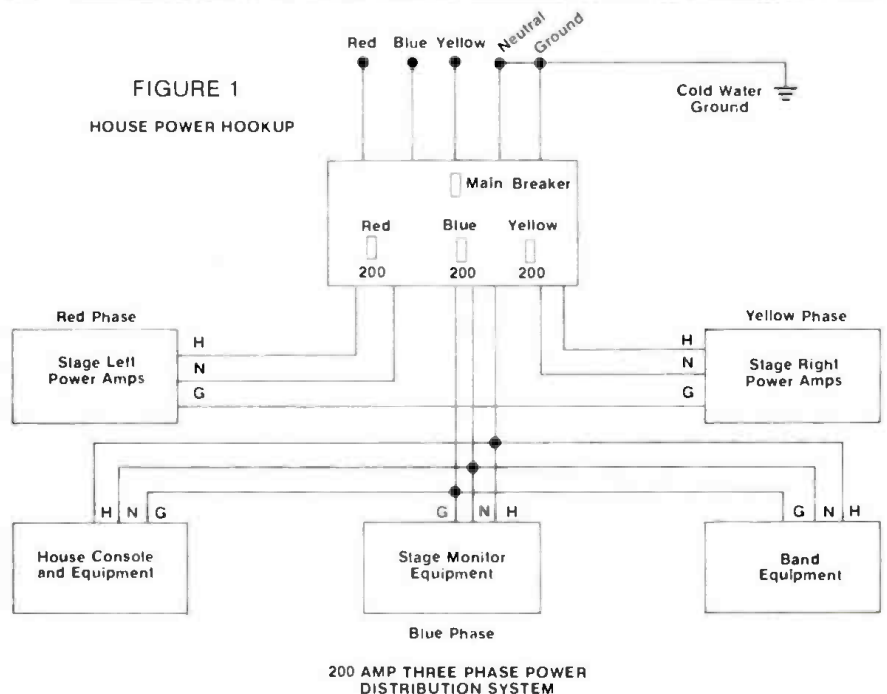

- the authors -

Ed Simeone is a free-lance engineer with twelve years experience in pro sound reinforcement. He has toured with major acts, including Journey and ELO.

Presently based in West Los Angeles, Ed runs a console rental business specializing in Midas consoles.

Robert Carr is a free-lance writer who has been published from time-to-time in Contemporary Keyboard, American Song Festival Cassette Gazette, and the Music Connection.

Carr has a Bachelor's Degree in Physics, and during his career has worked five years as a staff musician at East Coast Music Production Company (Evolution Productions).

GROUNDING PROBLEMS

Ed Simeone & Robert Carr

or outdoor system (30 kw or more), the power amps on stage right and stage left are each run on separate phases, leaving the third phase available for the band's gear, the monitor and house equipment. In systems requiring less power, the power amps may be run from a single phase, and the band equipment from one of the remaining two sources.

AC Integrity

It's imperative to be 100% sure of the integrity of the power in a facility. This is especially true of the older halls in England and Europe where the problem of PA hum or noise may be the result of poor connections between the building power entry point and the point where the distribution ground wires are attached. The solution to this particular problem often requires a bit of diplomacy as most house electricians insist there is nothing wrong with the power. "It's been fine for the last 30 years," is not an unusual attitude.

Bill Hough, former chief engineer for Tasco, in England, relates that while in an older theater in England, a usually well-behaved PA was plagued by intermittent hums and buzzes which were finally traced to the building's power lines. The power entered near the main entrance and traveled the length of the hall on ancient looking cables complete with in-line splices. After much persuading, the engineer convinced the house electrician to accompany him through the basement crawl space to

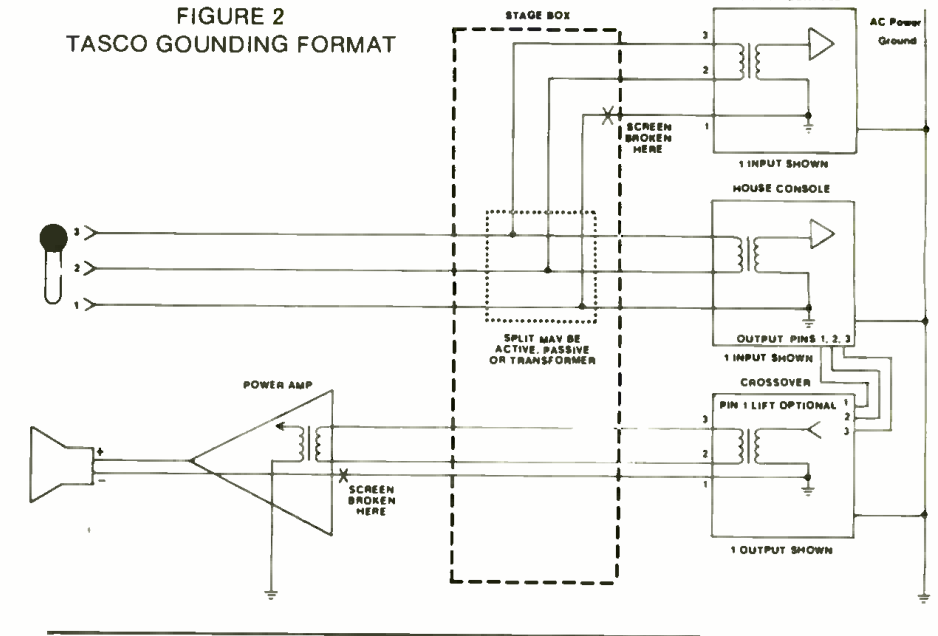

tighten every joint, thus reducing their resistance. All the problems disappeared immediately.

The Single Path To Ground

One of the basic rules for audio systems is, "thou shalt have one and only one path to ground," and it's of paramount importance to make sure that this ground is secure and reliable. Steve Neal, at FM Productions in San

Francisco, is confident that the "best is fire ground, meaning the large diameter metal pipe that feeds fire hoses and sprinkler systems. It leaves the building quickly and is most likely the closest route to ground. Avoid hot water pipes, steam pipes, and mechanical grounds, and you should be prepared to make your own neutral to ground connection." Be careful not to impair access to any valves or anything that needs access in case there is a fire or broken water main.

For a large sound system, 00 cable, also known as welder's cable, is a good heavy wire to use. Scrape the paint off the pipe and put a copper ground strap around it. The wire attaches to the strap via a clamp that looks like a large hose clamp for an automobile. A screw goes perpendicular to the clamp it's connecting, and digs straight into the clamp and pipe, thus insuring a good contact.

There are several basic methods used by the major sound reinforcement companies to achieve the single-path-to-ground rule.¹ Tasco, for example, prefers to ground each piece of equipment through the third prong of their AC plugs while breaking the audio ground between the different subsystems. This is an AC power grounded system (Figure 2).

Tycobrahe's method is based on signal grounding. They lift all but one of the AC grounds and connect one signal ground from each of the subsystems to this single AC grounded system, which in this case is the console. Both methods are quiet, but with the latter, if there is a fire or fault in one of the power amps, the 22 gauge screen wire running about 300 feet long would have to carry the full current load necessary to trip the circuit breaker. Needless to say, running 15 amps down a little piece of wire ages your multi-cable very quickly. Tycobrahe circumvents this problem by installing a high-speed, indicating circuit breaker at the AC grounds of the house and monitor consoles. If a serious problem does arise, a little button pops out on the front of the console alerting the engineer to a fault in the system.

The FM Approach

FM Productions uses its own method which is a hybrid with both power ground and signal

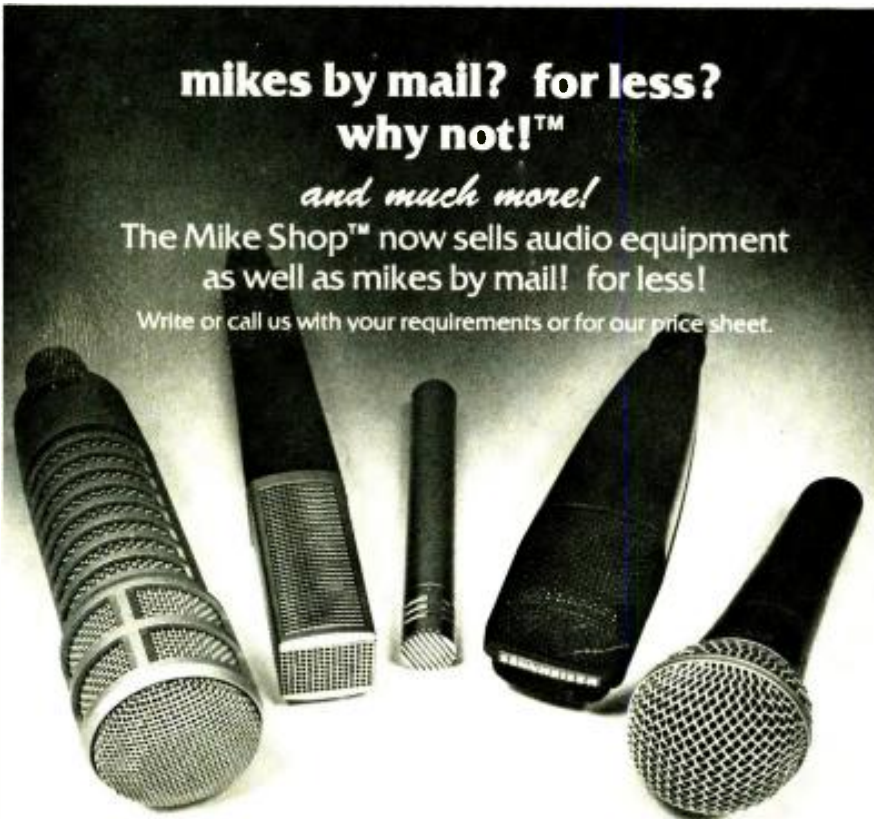

The Mike Shop™

PO Box 366T, Elmont, NY 11003 (516) 437-7925

A Division of Omnisound Ltd.

for additional information circle no. 18

The Amplifier Everyone is Talking About!



- in DISCO
- in BROADCAST
- in RECORDING STUDIOS
- in SOUND REINFORCEMENT

From Mexico City to Stockholm, the SPECTRA SONICS Model 701 Power Amplifier is causing not only a stir, but a wild explosion! Typical of professional listener comments are:

- "I didn't believe such power could be so clean!"
- "Are you sure it's turned on? I can't hear any noise."
- "I produced that record, but I've never really heard it until now!"
- "I didn't think it was possible for 'X' brand speakers to perform like that!"

If you have been to places such as: the GRAMMY DISCO PARTY, SPECTRA SOUND STUDIOS, or the CONCORD PAVILION (all tops in their field) you already know why such comments are being generated. However, most comments about the SPECTRA SONICS Model 701 Power Amplifier are unbelievable . . . until you've heard it!

For the very best in power amplification, see your SPECTRA SONICS professional audio dealer today, or contact:

SPECTRA SONICS

LEADER IN ADVANCED TECHNOLOGY



3750 Airport Road ■ Ogden, Utah 84403 ■ (801) 392-7531

WANTED!!!

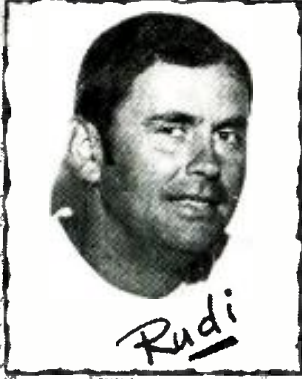

For the very best Studio Construction and Design available . . .

He is also known for doing work all over North America, giving firm estimates, exacting dates of completion and . . .
NO BULL !!!

He pleads guilty of constructing the following studios :

- Century 21, Winnipeg, Canada, new studio
- Sound Interchange, Toronto, Canada, new studio
- Superscope, San Fernando, California, new studio
- Chicago Recording Company, Chicago, Illinois, Studios 1, 2 and 3
- Bill Szymczyk's Bayshore Recording Studios, Inc., Coconut Grove, Florida, new studio
- The Shade Tree, Playboy Club, Lake Geneva, Wisconsin, new studio
- Group Four, Hollywood, Calif.
- KBK Earth City Studios, St. Louis, Missouri
- Village Recorders, Los Angeles, new studio
- Record Plant, Los Angeles, new studio
- Ronnie Milsap, Nashville, Tennessee, new studio
- Captain & Tennille, Los Angeles, two new studios

Call for information and details
RUDOLF A. BREUER

805 / 273-3792

Lic. No. 238315

GROUNDING PROBLEMS

Ed Simeone & Robert Carr

ground. They have taken the theoretical grounding procedures and applied them in the strictest sense by designating one solitary point at the base of the monitor mixer as ground for all the subsystems (Figure 3).

The monitor mixer is made the heart of the tree with a branch going to the stage left and stage right power amps, a branch to the house mixer, and a short branch to the rest of the monitor system. The third pin AC grounds are lifted at the power amps; the signal shield grounds are lifted between the amps and the console, and finally, a ten guage copper wire is run from each branch to the base of the monitor console. The ground for the stage monitor desk is also lifted leaving the point at its base — the fundamental ground reference point — as the only point tied to AC ground.

This approach places both the band's equipment and the microphone splitter box physically close to the fundamental ground reference point. It should be noted that the mike splitter network is the most sensitive part of the entire PA. Any unwanted noise at that junction will be raised 80 or 90 dB along with the rest of the amplified audio signal that is sent out to the speakers. Its physical closeness to the ground point minimizes the chances of any hum or noise reaching the amplifiers.

The ground for the house console and all its effects come through the mike lines, which in a large sound system could number up to 50 lines. That means that 50 pieces of 22 gauge wire are grounding the house mixer.

Some people would object to this method as being a lot of extra work, but FM feels it is the most consistent and effective course of action from venue to venue. Steve Neal made direct A-B comparisons of systems that use AC grounded power amps and floating signal inputs to those that lift the power amp AC ground while grounding the inputs to the monitor mixer ground point. He found that it was quieter to have the ground points together. Fundamentally, both are connected the same way, it's just a matter of one being further from the ground by the distance of the long AC runs.

"Yes, it does set up an apparent ground loop, but all the lines terminate very close to one another. Even though there are a lot of conductors, we have no problems."

The obvious advantage of the FM system that has all the grounds terminated close together, is the reduced possibility of induced currents in the line from non-uniform magnetic fields throughout an arena. This greatly reduces one of the prime causes of PA hum.

Induced Fields

Each magnetic field, regardless of the source, will probably induce some current into the lines that could cause hum. As long as there is one good path to ground and the PA is set up

FIGURE 3

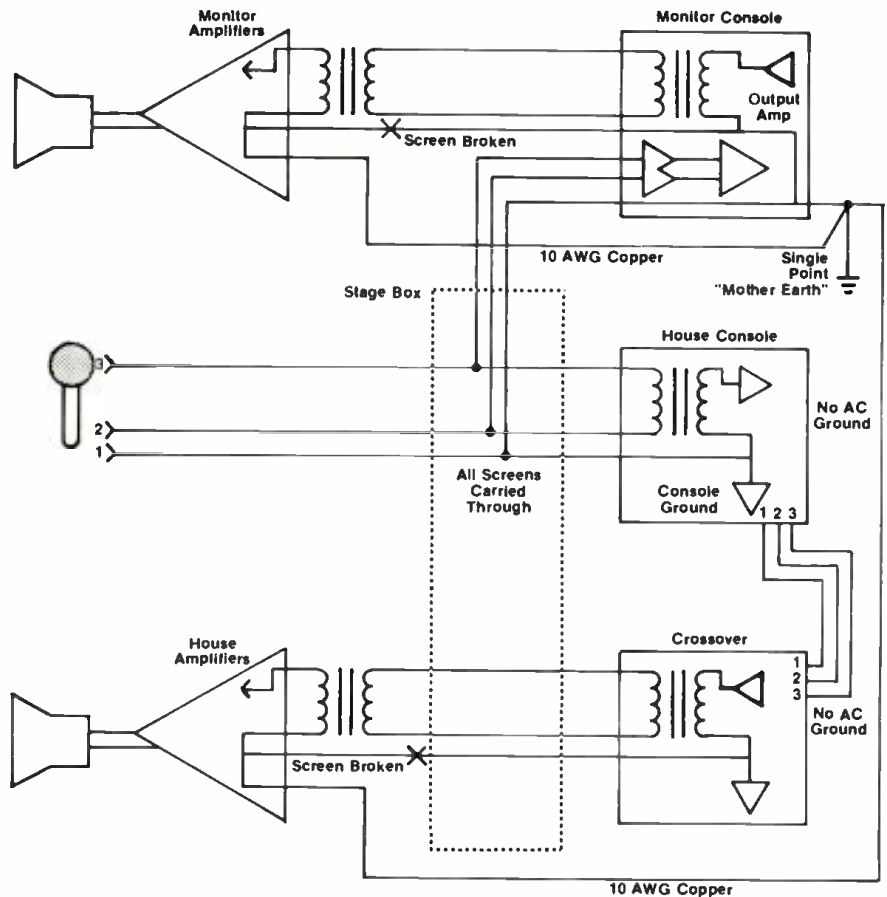

FM PRODUCTIONS GROUNDING FORMAT

for additional information circle no. 20

The Sound Workshop Series 30 Recording Console.

In the tradition of the highly acclaimed 1600. . .
Sonic excellence, flexibility, reliability, and a wide range of available options in
an abbreviated format designed for the expanding studio operation.

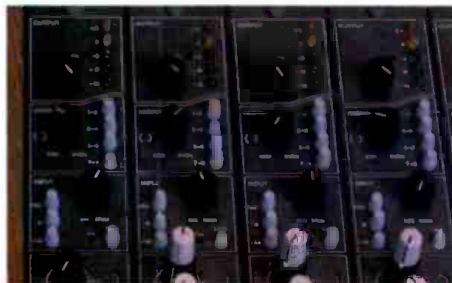
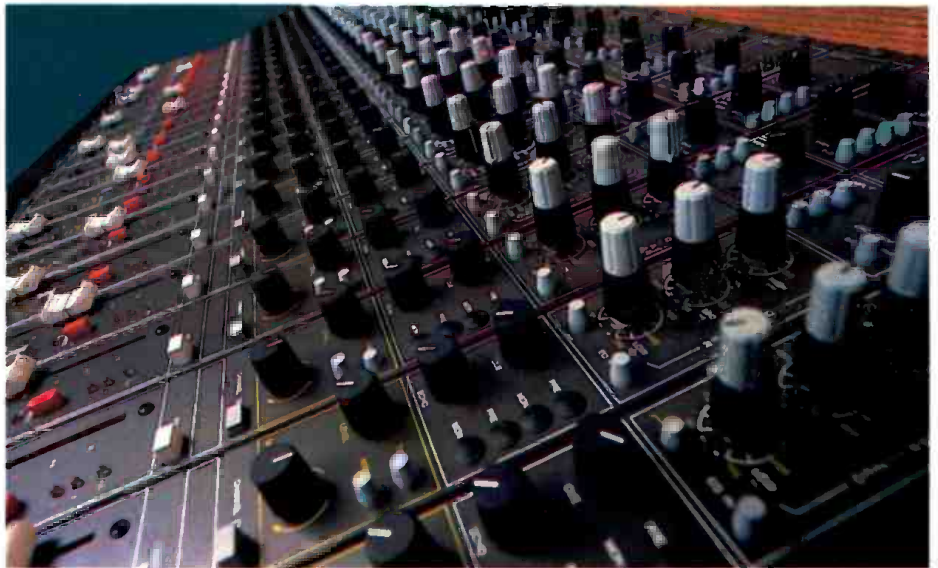

BRINGING THE TECHNOLOGY WITHIN EVERYONE'S REACH.
CH. Sound Workshop

Sound Workshop Professional Audio Products, Inc.
1324 Motor Parkway, Hauppauge, New York 11787
(516) 582-6210 Telex 649230

for additional information circle no. 21

February 1980 □ Re/p 47



Separating the mother from the master

Stanton-The Professional in the Recording Industry

Application – The Metal Mother – Stanton Plays it Back

Once the recording studio has delivered the lacquer disc to the plating plant it is sprayed with liquid silver making it electroconductive, and then electroplated with nickel which is separated from the lacquer. The nickel is now a negative image called a master and has, instead of a groove, a ridge that comes to a point. The master is treated and nickel plated again and upon separation forms a mother, a positive metal record. Engineers rely on the Stanton 881S cartridge in playback evaluation of the mother.

Stanton's 881S Professional Calibration Standard Cartridge is a sophisticated, low mass, phono pickup that features the patented Stereohedron® stylus tip for truest fidelity and gentlest possible treatment of the record groove.

From disc cutting to disco to home entertainment your choice should be the choice of the Professionals... Stanton cartridges.



© 1979 STANTON MAGNETICS

For further information contact: Stanton Magnetics, Inc., Terminal Drive, Plainview, N.Y. 11803



R-e/p 48 □ February 1980

GROUNDING PROBLEMS

Ed Simeone & Robert Carr

in a fully balanced mode, the induced current will either be cancelled or flow out of the system all together, and the hum will be substantially reduced if not completely removed.

For example: If any two pieces of equipment are in the same rack or next to each other, the chances are pretty good that they will be equally affected by any external fields in that area. On the other hand, if two pieces of equipment are separated by, say, 300 feet, the chances of them being in substantially different magnetic environments is greatly increased.

When the Electric Light Orchestra is on tour, they carry huge transformers that step-up the voltage for their lasers. These transformers can produce massive magnetic lines of force, which in turn induce substantial current to flow into the PA lines as well as other equipment in their vicinity.

The choice of the lowest practical source and termination impedances will also help reduce noise. When a given current is induced into a high impedance line, more voltage and noise are produced than if an identical field or current were induced into a low impedance line. The lower the impedance of the line, the less significant are the effects of the induced current.

It should be noted that an induced current doesn't necessarily have to come from an outside source. A magnetic field can be set up by the transformer in any of the units that are a part of the PA. Leaky capacitors can also generate a current through the chassis.

Mechanical Ground

There is another type of ground that should be considered at this point, and could probably be described best as "mechanical ground."

Most of the rack mounted equipment that is available today is either painted or anodized. Both coatings are excellent insulators. Care should be taken to remove the coating where the unit meets the rack. An alternative would be to use at least one star washer that would pierce the coating when the unit is mounted. Proper mechanical grounding is becoming less and less a problem as more manufacturers are providing signal ground and chassis ground posts on the back of their units.

All anodized equipment should be tested with an ohm meter to determine whether or not the unit offers any resistance between its chassis and the rack it is mounted in. It's not uncommon to read up to 15 ohms across a

chassis even though it has many screws bolting it together. On one occasion the hum in a system was removed by placing a jumper cable from a screw on the front panel to the chassis ground on the back of the unit.

Almost all manufacturers now separate the audio ground from the chassis ground. The two grounds are connected together at one point in the unit which is generally the neutral point of the power supply. Even though that point is connected to the ground prong on the AC cord and all the units are plugged into the same AC box, the variable grounds could be lifted at the AC box. The amplifiers (or whatever) should be grounded together mechanically through their chassis and the rack as well as through the signal cords. If each piece in a rack has a firm mechanical ground to the other units, any induced current will flow through the chassis to ground as opposed to through the signal wires, thus hum will not be generated.

A varistor should be included for transient suppression across the AC access point of every unit. A varistor exhibits a low impedance at high frequencies and effectively shunts noise spikes to ground. Three large varistors — one for each phase — can be placed within the main power distribution box, and any spikes entering the system are killed at that point. As an alternative, smaller varistors can be installed in the individual rack units, usually as close to the protected unit as possible. This is not exactly a grounding problem and solution, but it is useful information on suppressing transient noise spikes.

The Band's Equipment

The musical instruments and amplifiers are one area over which a sound technician has little or no technical control. The grounding of this equipment — almost exclusively unbalanced — is necessary for the safety of the musicians.

In most guitar amps, the polarity switch throws a capacitor from the AC chassis to ground to one side of the AC line (Figure 4). The problem arises when the lowest hum position connects the chassis of the amplifier to the "hot" side of the AC line. The strings of an electric guitar are joined to the amplifier through the shield of the guitar cord. If the capacitor shorts while the switch is connected to the "hot" side, the ground lug on the AC plug could save the performer from a severe shock. This is a deadly situation if the chassis ground does not go to earth via a low resistance path.

However, if the AC ground is lifted the 120 volts will travel down the guitar cord shield to the guitarist who would complete the circuit when he touched a grounded microphone housing. In England, or Europe, 240 volts

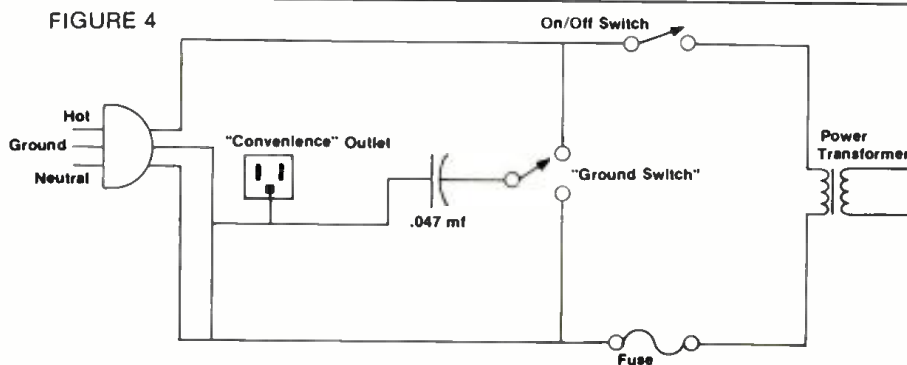

TYPICAL GUITAR AMPLIFIER AC INPUT

Now, from Advanced Music Systems



Finest Digital Delay Available with Pitch Change and Reverberation

The DMX 15-80 is internationally recognized as the finest quality digital delay line made. Up to 4 seconds of delay is possible without loss of signal quality. Responsive keypad control is used for entry, storage and recall from the unit's 9 memory locations. Because of its microprocessor design, the unit easily adapts to allow extra effects—those now available, and those yet to come. This versatility assures compatibility with future signal processing developments.

The pitch-change option makes use of an advanced 16 bit microprocessor to perform intelligent splicing and minimize glitching, which is so evident in other harmonizers.

There is also a reverberation option which provides 9 programs of reverb. VCO, Regeneration and Lock-in add to the unit's flexibility and



enhance its special effects capability. The 18 kHz bandwidth remains constant throughout the range of delay in this truly transparent processor. Typical distortion is 0.025 percent at 1 kHz. Signal/noise ratio: Better than 90 dB. Dynamic range: Better than 90 dB.

New Stereo Digital Delay

Now there's a two channel digital delay line engineered to the same high standard as the widely-respected DMX 15-80. The 15-80S is microprocessor-controlled for precise delay settings and instant and accurate recall. Maximum delay time is two full seconds on each channel at 18 kHz bandwidth. Delays are programmed with a resolution of one millisecond, and may be simultaneously entered into both channels to ensure phase coincidence. Regeneration controls are provided on both channels, and switches allow inputs to be paralleled and/or outputs to be mixed for special effects.

Advanced AMS digital technology gives the unit its truly transparent sound quality—18 kHz bandwidth, typical distortion of 0.025 percent at 1 kHz, signal/noise ratio: Better than 90 dB.

Two independent channels of delay—the equivalent of two DDL's—but at a far lower cost. Arrange for a demonstration today.



The Original Phaser/Flanger from AMS

...is now available in America. The DM 2-20 accurately simulates tape phasing in real time. Unlike most units of this kind the DM 2-20 uses two independent delay lines to allow true "over the top" phase simulation, which can be either manually or automatically swept.

Features include stereo output for that solid spatial sound and a ramp generator section to simulate the mechanical characteristics of tone cabinets. True cyclic pitch shifting is achieved with

visible speed indication. Single or cross modulation is available on the delay lines, and chorus character may be modified by use of manual phase control.

A tapped, infinitely variable delay may be selected for automatic double tracking effects—slight pitch changing is also possible for enhanced realism. The unit can also be operated in a phase cancellation mode to allow a further range of effects.

Bandwidth	20 Hz to 15 kHz
Signal noise ratio	72 dB
Max Phasing Frequency	Infinity, made possible by the use of multiple delay paths.
Phasing range	8 octaves within the audio bandwidth; continuous sweep no range switching.
Modulation section	Frequency range 0.05-20 Hz sinusoidal. Depth infinitely variable on one or both channels.
Delay time	Infinitely variable up to 60 ms, tapped or half delay.
Remote control	All functions are internally voltage controlled and are available externally as options.



*The Most Advanced Signal Processors
—Engineered to exacting aerospace standards—*

*For a demonstration or further information,
contact Ian or Carole at*

QUINTEK DISTRIBUTION, INC.

4721 Laurel Canyon Blvd., Suite 209, North Hollywood, CA 91607
Telex: 194781 • Phone (213) 980-5717

for additional information circle no. 23

February 1980 □ Re/p 49

GROUNDING PROBLEMS

Ed Simeone & Robert Carr

would be present and could result in cardiac arrest and death.

The audio technician, in most cases, has no control over the band's equipment and usually has little time to check it out. The second or third act may be new to the concert tour scene, and not have good road gear. If they're booked with the headliner only one or two nights the sound crew will not have the time to figure out the best grounding approach for that particular equipment. Even for the main act, with known instruments and amplifiers, a certain degree of unpredictability exists. The fact that something worked one night doesn't mean it will do so the next. That's why band sound checks are so important. If they arrive late while the audience is screaming for the show to begin, the sound crew will have to rely on their instinctive preparation without a practical rehearsal.

Minimal Precautions

There are a number of precautions that can be taken to safeguard the performers.

Look first at the AC plugs. If they are connected together in an irresponsible manner it's a sure sign of trouble (i.e., if all the amp and instrument AC plugs are connected with the use of ground lifters). The ground lifters should be removed and the amp and instrument lines distributed evenly over as few grounded AC sources as possible. Roadies will sometimes use ground lifters in an attempt to cut down the hum through an amplifier. In many cases this will make no major difference in the amount of noise if the sound company is supplying the power to the band. Even if they are not, it's better that the amp should hum a little rather than the artist be shocked, or worse, electrocuted.

The tragic death of Leslie Harvey in England, the lead guitarist for Stone the Crows, is a sad reminder of the importance of testing grounding techniques. A coroner's investigation proved that a short in the ground system of the ungrounded PA put a full 240 volt potential with a minimum of 10 amps on the shield of the mike cord. This would have blown the main fuses of the PA if it had been properly grounded. Unfortunately, it was the mike, artist, and guitar cord, that completed the circuit.

Regardless of the pressure to get the show started, always take the time to measure the voltage and resistance between pin 1 of the PA system (unplug the microphone and plug into pin 1) and the ground on the guitar amp which is connected through the shield on the guitar cord. If there is a reading of more than 5 volts, a problem is sure to exist somewhere. Take the time and correct it.

If a volt test is not possible, at least take the sleeve of the guitar cord and touch it to the microphone to determine whether or not any electrical hazard exists.

The resistance should be no more than 4 ohms and definitely less than 6 on a 250 foot piece of 22 gauge wire. Ideally, the results will be no voltage or resistance.

In the event that the sound company is lucky enough to do an entire tour with the same headliner and support acts, all of the band's gear should be subjected to a pre-tour checkup. Replace any AC plug that has a

missing ground lug, and verify that any metal piece that may come in contact with a band member is grounded to that lug. This is especially true with guitar and bass amps, although with the proliferation of wireless setups, the risk of shock is becoming less of a problem.

Directs

The majority of band equipment is, of course, unbalanced. This fact requires special attention when several units are hooked together or when an unbalanced unit drives a balanced input without the benefit of an additional isolating transformer.

Whenever possible, the use of DI (direct inject) or direct boxes would be the first choice for running an instrument's signal to the PA (Figure 5). Passive DIs, have excellent grounding isolation through the transformer and provide a pin 1 ground lift switch, but the use of non-loading active FET direct boxes on low level instruments is becoming more common (Figure 6). If the DI is to be phantom powered, check that it maintains true ground lift isolation. The ones manufactured by Carl Countryman have this feature.

The basic passive DI is a buffering transformer. The guitar amp signal enters the DI where the "hot" is tied to the "top" of the transformer, and the ground is tied to the "bottom." The ground is lifted and the unbalanced signal goes out to the house as a balanced line. Ground lift switches are often

included on the output side of the transformer.

If a DI box is unavailable, and a long, low impedance line must be driven from an unbalanced unit, make an adaptor that ties pin 3 of a pro XLR connector to the tip ("hot" output) of the unbalanced phone jack (Figure 7). Then tie the sleeves to pin 2. Pin 1 should be left open. At the point where the line enters the balanced input, tie pin 2 to pin 1. This makes pin 3 — hot; pin 2 — ground; and pin 1 — the screen. According to Steve Neal, this arrangement "gives a little better shielding property to an unbalanced line by grounding the screen only at the input."

Units such as a Roland Space Echo and some pedal effects with no AC third prong are grounded through their signal leads. The more professional pedals — i.e., MXR Delay Pedal — are being manufactured with the third prong AC ground post as a standard feature.

If a bass player insists that his wah-wah, for example, go through the PA, the following setup seems to be very effective. A DI should be used with its signal ground to the PA lifted. The preamp's ground should also be lifted. The power amp is the only electronics that's grounded, because in this case, it's the device that consumes the most power. Suppose the power amp is a BGW 750 with a 15 amp circuit breaker, and it suffers a major fault, 15 amps would have to flow before the circuit breaker would trip. An Alembic or Furman preamp may draw only .5 amps, and it's grounded to the power amp through the signal line as is

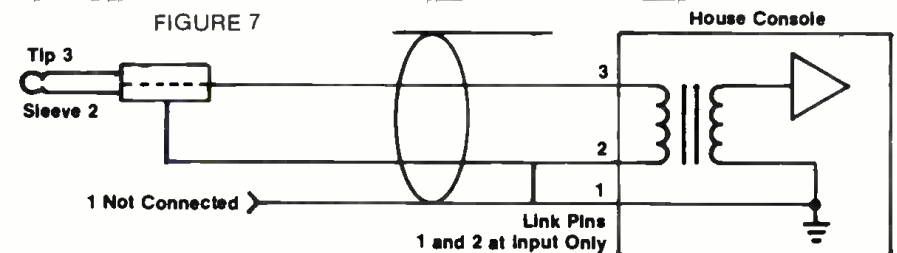
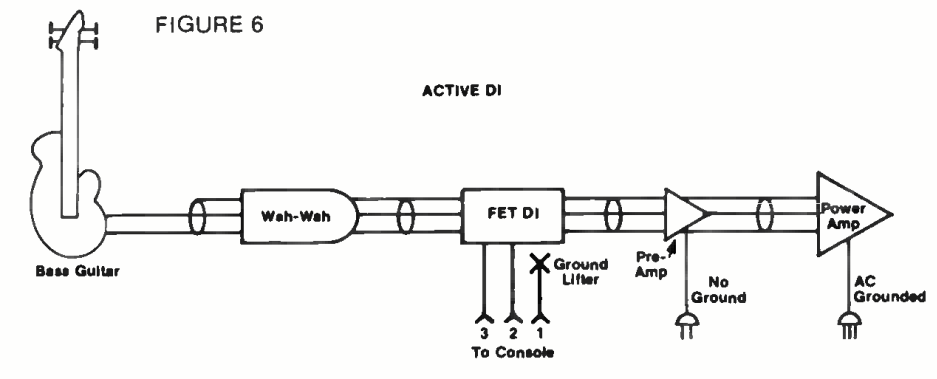
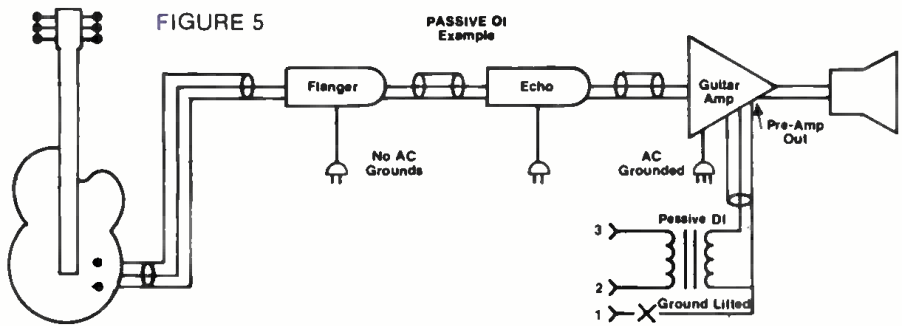

When an unbalanced unit drives a balanced input without the benefit of an additional buffering transformer (DI Box).

AKG[®]

ACOUSTICS

BX-5 Reverberation Unit

...featuring the world-renowned TTL system
in a portable, rack-mountable design



Trouble-free, travel-proofed, flexible and compact—the BX-5 is also free from acoustic feedback when placed close to loudspeakers. Its professional performance and features far surpass any other reverb available in this price range.

AKG BX-Systems—in use in over 60% of recording studios world-wide

Exclusive Torsional Transmission Line—for incomparable sound “openness”

Flutter-free Performance—uncolored “natural” reverberation

Built-in Reverb/Dry Signal Mixing—controls blend of reverb and original sound

Built-in Equalization—bass contour and mid-range “parametric” controls to style the character of the reverb

PHILIPS AUDIO VIDEO SYSTEMS CORP.
A NORTH AMERICAN PHILIPS COMPANY
91 McKee Drive, Mahwah, N.J. 07430 • (201) 529-3800



...the mark of professional quality

in microphones, headphones, phonocartridges, reverb units.

© AKG Akustische und Kino-Geräte GmbH, Austria

GROUNDING PROBLEMS

Ed Simeone & Robert Carr

everything else in the chain. The signal leads will be able to easily handle the low current required to trip the small device's fuse in case of failure. All current would flow toward the power amp and out its AC ground.

There is an increasing number of artists that are using rack-mounted, outboard equipment for effects in live concert situations. Several of these units are being manufactured with ground lift switches on the back panel, thus eliminating the need for AC ground lifters.

For another example, the ELO keyboard setup (Figure 8) offers an easy and effective method for grounding pianos, synths, and so on. All the keyboards are AC grounded except for the clavinet which is phantom powered. The power supply for the Midas mixer is also AC grounded. All the shields are lifted.

The Recording Truck Feed

The mobile recording truck, although not present at all concerts, is a common enough addition to sound reinforcement that a discussion of the unique situations its presence introduces should be included. Jack Crymes, chief engineer of the Record Plant's mobile operations, shared his expertise in this area.

The Record Plant has two separate power systems in the truck — one for the air conditioning and one for the electronics. Both systems are run by individual 10 kva stepdown transformers with primary taps at 180, 190, 200, 210, 220, 230, 240, and 250 volts. All the taps are switch selectable and an ammeter is installed on the primary side. Each transformer has a split phase secondary with two 110 volt windings (Figure 9).

Since this is a single phase system, they pull no current through the neutral which is often well saturated with SCR dimmer noise. By eliminating the neutral and including a Faraday shield in the custom wound transformer, the audio system AC power is kept relatively clean. The neutral wire appears on the hookups in the building, but is deleted at the truck; they use only the ground and the two "hots." One end of this electrical ground is tied to the frame of the truck and the other end is tied to a cold water ground. This connection is sufficient to guard against any life endangering short conditions.

The internal grounding is isolated from the body of the truck. All the electronics are joined together through the third prong of their AC plugs at the main AC box which never touches the truck frame. All outboard equipment audio shields are connected at both the inputs and outputs to the patchbay in their API console. This means each piece of equipment is grounded three times — input, output, and AC. It's obvious that apparent ground loops are being created, but in such a small area and with such low resistances between the units due to the number of shields, it's very unlikely that any one piece of equipment will ever be in a substantially different ground plane than any other piece. The common mode rejection of professional gear "is usually pretty good," because it is mostly high level (+4 dBv) balanced lines. Jack reiterated the illusive nature of ground loops that exist but just don't show up. "I've placed portable equipment in the same rack as a console power supply and still had ground problems."

FIGURE 8

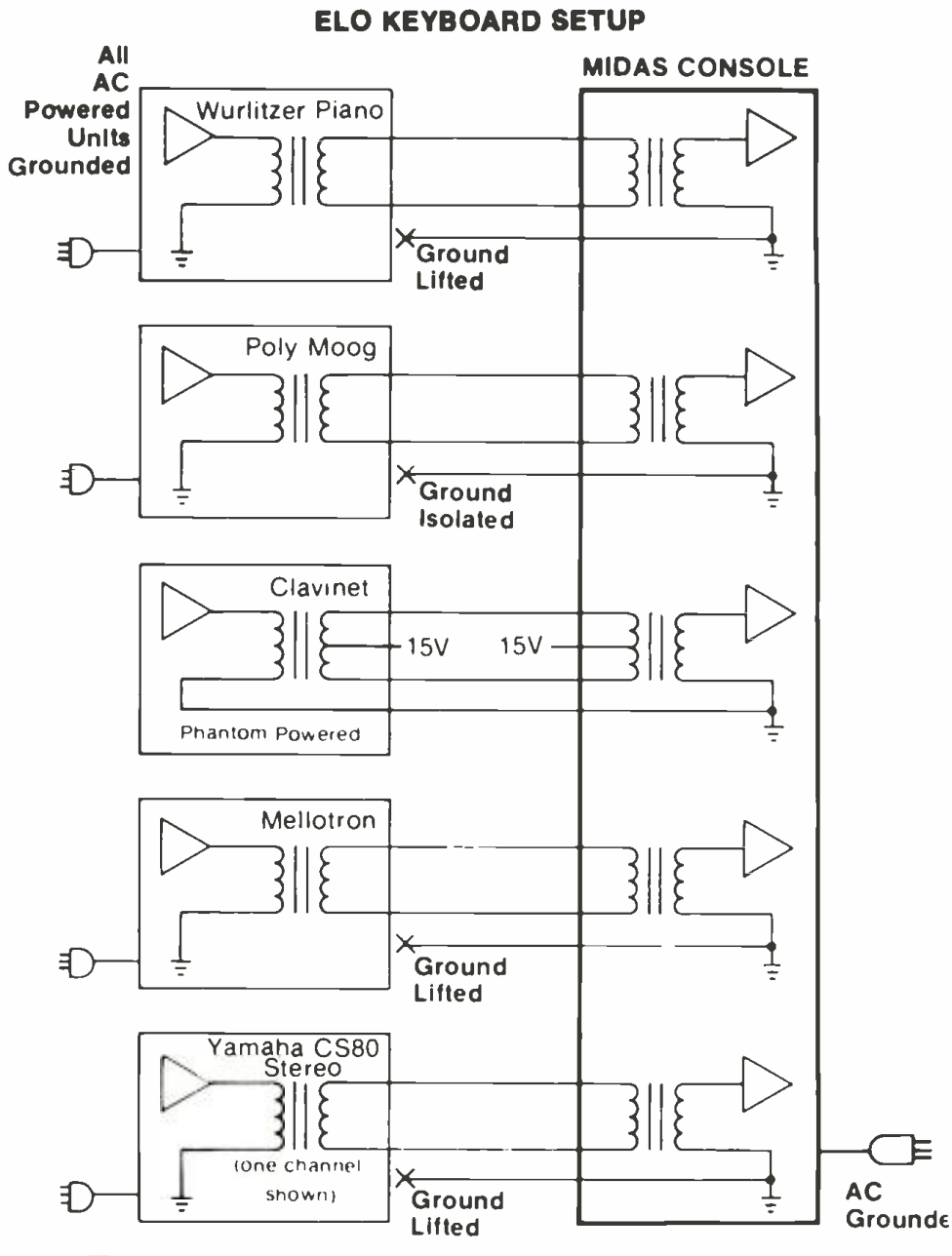
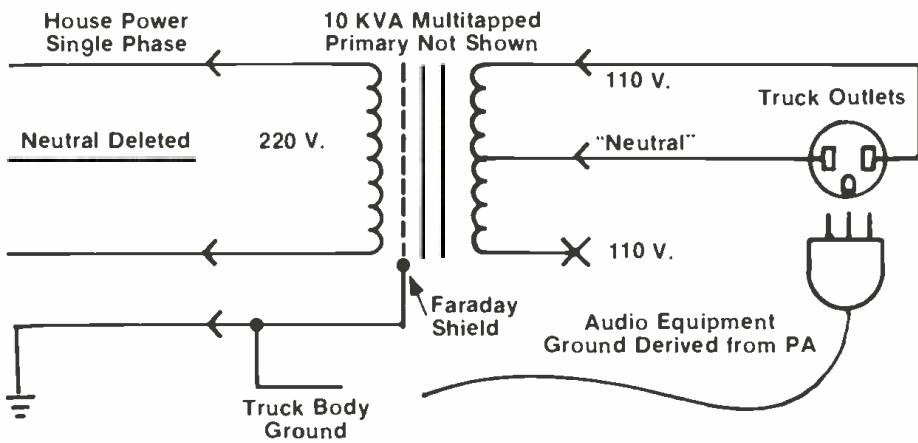

FIGURE 9

RECORD PLANT MOBILE PRIMARY POWER HOOKUP



OUR ANSWER TO THE ECONOMY CRUNCH...

FADEX™

So you want an automated console, but you can't see yourself committing upwards of \$100,000 to get one. Especially in today's tight money situation! Why not buy the **BEST AUTOMATED CONSOLE** on the market, *out of cash flow*? FADEX, plus your present board, gives you the chance to do just that. There's little doubt that FADEX is the best automation system. ...Best programming method, best VCA's, best sound. Can your console match it? If not, what are you waiting for? Want proof? Just give us a call, and we'll provide you with the names of owners of the **BEST AUTOMATED CONSOLES**. They'll tell it like it is!

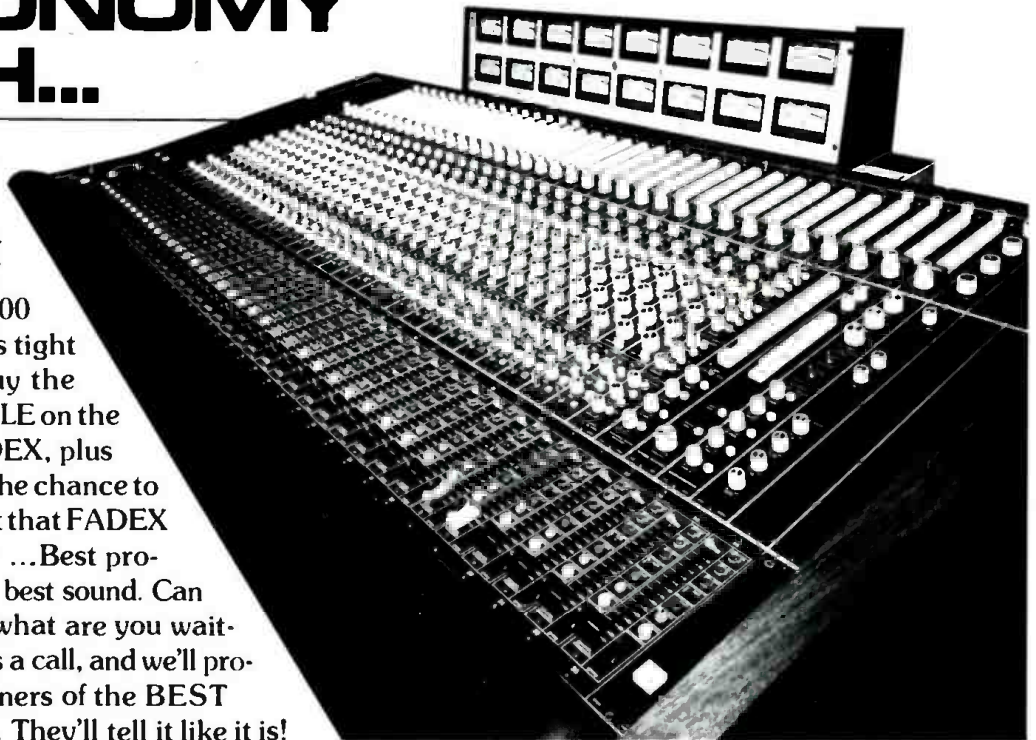



allison research

lin .25 .65 1.6

log 1 4

release .04 10

.2 2

0 2 4 6 8 10 12 14 16 18 20 40 60

release (sec)

attac (ms)

range (dB)

ratio (x)

atten.

in out +10

key mode +20 -40

thresh (dB)

kepex II®

THE SOUND OF THE EIGHTIES

KEPEX II

The original KEPEX made a lot of exciting music, out of some pretty lack-luster tracks. KEPEX II continues this enviable tradition, in style! ...New controls, new parameters, new VCA, new sound...GREAT SOUND.

If you thought you had done everything that could be done with a KEPEX, wait 'til you get your hands on a KEPEX II. But, don't wait long!



allison research, inc.
 2817 Erica Pl., P.O. Box 40288 · Nashville, TN 37204
 (615) 385-1760 · (615) 255-4766

GROUNDING PROBLEMS

Ed Simeone & Robert Curry

RF Fields

The most severe problems tend to manifest themselves in strong RF fields, such as near an FM or television transmitter. Jack continued, "You're dealing with wavelengths so short that there is really no way to ground equipment properly. If the grounded lead is more than several inches long, it is an appreciable part of the wavelength. I've had problems with TV sync buzz where the solution was as simple as straightening out a mike cable as it looped from the stand into the mike."

A method that does offer some relief from RF interference entails regularly grounding the screen of each interconnect at one end and then bypass it at the other end through a .001 mf or 0.01 mf capacitor. This will improve the ground isolation at audio frequencies while shunting to ground induced RF that is floating in the screen.

The Record Plant often ties the truck's electronics' ground to the PA system with a

heavy gauge cable while leaving all the grounds in the stage box floating, but this technique doesn't always work. The shielding within the splitter box is not always ideal because of its great distance from the main ground plane of the recording truck console.

"The theoretically perfect ground system simply doesn't always work, so occasionally we use a switch that ties pin 1 of the direct-out to pin 1 of the PA split-out."

Jack starts with all the switches off, and then makes adjustments as they are needed to get the quietest wiring situation.

Crymes uses Dean Jensen microphone splitting transformers which employ a separate Faraday shield for each winding, a system he and Dean developed several years ago (Figure 10). There is usually a voltage potential between the PA system and the mobile recording truck that is composed of high frequency spikes from SCR dimmers. Transformers that reject this type of spike require substantial common mode rejection. The dual Faraday shields substantially reduce the capacitive coupling between the two windings.

If the transformer has a Faraday shield on only one of the windings the capacitive

coupling present will induce "garbage" into the second winding. As a result of this problem came the idea of shielding both windings independently and connecting each Faraday shield to the ground of the two respective systems. Capacitive currents will flow only through the ground wires while the windings are left totally shielded.

Many variables can upset a system. For instance, if a ground switch is accidentally "on" for the DI that is connected to one of the instruments, the whole ground system may be affected by a stage AC outlet that is improperly grounded or has a noisy ground. There might be a 1/2-volt of "crappy" AC on the ground wire passing through the direct box and down the multipair cable on its way to a good ground, or as much as 2 amps flowing in the main cable radiating into who knows how many channels.

If all else fails, Jack will run two one-to-one transformers with Faraday shields in series with the audio feed. "It is a real dirty way to do it, but when time is of the essence, all the rules go out the window."

The toughest decision Crymes ever had to make in a live recording situation was whether or not to record a show when the entire stage was hot-to-ground, probably as a result of some leakage through a capacitor. The only solution was to make the truck hot-to-ground. All the amps, the mike stands, the whole PA system as well as the recording truck had roughly 90 volts on them. Luckily it wasn't the "hot" side of the AC line and the current was very low.

Jack explained, "If the PA has 90 volts on it, is it safer to put grounded mikes on stage or mikes at the same potential? I chose the latter. If we tried to ground everything, it created a horrendous buzz. What we're trying to do is tie the entire system together at the optimum ground point so no current can flow through any signal lines, screens, or ground paths. Many times what we do is, at best, a compromise."

Video Link

On the occasions that a TV truck is on the scene, Jack recommends never connecting any grounds to their vehicle, because there is almost always a potential present. Most video trucks draw 100 to 200 amps per leg and never use a power transformer. When feeding them, Crymes always buffers with a 600 ohm/600 ohm transformer and never connects the ground. Any problem in the video truck could throw the entire audio system, PA, monitors, and recording truck, into total chaos.

Theoretically, if everything is grounded properly, there should be no hum. Sometimes this is not the case, and the only alternative is to start breaking rules one at a time until the noise goes away. Generally, the closer two pieces of equipment are to one another, the more rules you can break. The most important consideration is to develop a basic grounding scheme at the beginning of a building program. If you follow the fundamental rules of grounding and power distribution, you should be able to turn it all on and enjoy both a quiet and safe system. □ □ □

1 - Additional information on grounding in the June 1978 issue of *R-e/p*, Vol. 9, No. 3. Ken Fause, *Audio Shielding, Grounding, and Safety*. Page 54.

The authors wish to thank the engineers named above as well as Dirk Schubert, of Jim Gamble Associates, for assistance in assembling this article.

FIGURE 10 MICROPHONE SPLITTING TECHNIQUES

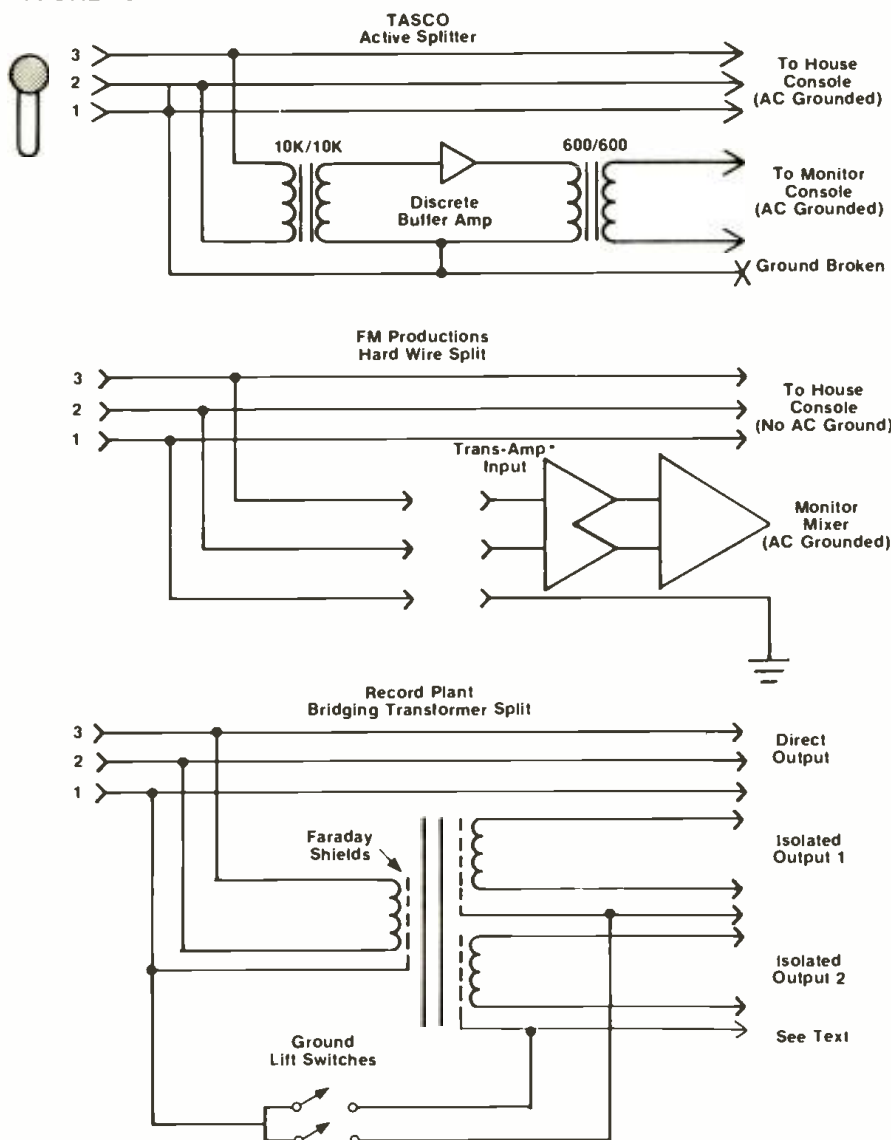

the
MAGIC
PAIR
at
Pasha Music House



Pasha's
MCI JH-536
console and
twin JH-16 24s
synchronized by
the JH-45
Autolocator

"Our **MCI** equipment has been outstanding — up to any challenge we have given it — and great support from Audio Industries! We love 'em!"

Larry Brown

Spencer Proffer

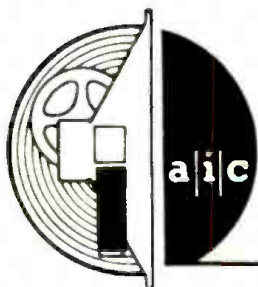

The people and the products —
We have them both.

audio industries corporation

1419 N. LA BREA AVE. • HOLLYWOOD, CALIFORNIA 90028 • (213) 851-4111 • TELEX 67-7363

for additional information circle no. 26

www.americanradiohistory.com

... the **SOUNDMAN'S GUIDE TO VENUES** is a new series being compiled by R-e/p's sound reinforcement consulting editor, **Pat Maloney**, whose full time profession is as an internationally recognized sound reinforcement engineer/mixer. The new series is the result of a questionnaire Pat developed to be sent to performance venues in anticipation of beginning a tour. The information returned by the venue is considered vital to planning the tour. At the end of each year R-e/p will offer an updated collection of these reports. — editor

SOUND MAN'S GUIDE TO VENUES

(#3 in the series)

MADISON SQUARE GARDEN
4 Penn Plaza
New York, NY 10001
(212) 563-8000

Facility

Totally enclosed Coliseum. Open weekdays 8 a.m. to 5 p.m. No closing time restrictions. Portable level stage is normally located at one end of oval-shaped arena floor.

Total seating: 19,500 on four circular levels, including 1,000 seats on arena floor.

Side fill stage monitors usually block about 2,000 seats and are placed on wing extensions off the sides of the stage. These wings are 8' wide with both height and depth variable. Recommended: Hang speakers here! Two house baskets (8' x 16') are permanently hung offstage left and right just in front of lip of stage. Bottom of basket must be 28' above arena floor in order to clear sight lines. Ceiling height at this point is about 70'. Inform Garden officials if you intend to use their hanging system.

Dimensions

Width of stage — 60'.

Depth of stage — 40'.

No orchestra pit.

4' High barricade located 7' in front of stage. Seating starts 3' from barricade.

Acoustics

One of the better sounding venues of this type. Nothing you wouldn't expect from an indoor coliseum. All seats are padded vinyl.

Reverb time Rt60 at 200 Hz = 4.25 sec.; at 500 Hz = 3.7 sec.; at 2,000 Hz = 3.35 sec. Full bandwidth = 4.4 sec.

Loading

The arena floor is 5 floors above street level. Loading door is 12' high x 20' wide and is located at 10 Pennsylvania Plaza — a small street just west of 7th Avenue and off 33rd Street.

Two semi's can back up to door at same time. All equipment is either loaded into elevators or taken to the 5th floor via house vehicles. Small trucks (under 12' high) can drive up ramp to 5th floor before unloading.

Important: Add a minimum of 2 hours to normal load-in time due to above considerations and strict union regulations regarding equipment handling. All equipment going onstage is handled by the IATSE. Everything destined for offstage use is handled by the IBEW. Packing equipment trucks to take advantage of this situation when unloading will save time and grief. Largest door into arena measures 10' high by 20' wide.

Truck and semi parking is available at nearby public parking lot.

Set Up

Area reserved for mixing console is 8' x 10' with an 8' table, located over Gate 1 in the center of house, off stage left. This area is 10' above the arena floor and about 80' from the stage. 150' of cable required to reach center stage via fire marshal approved routing.

Sound System

- house speakers -

Center cluster located over center of arena consists of 20 JBL 2350 horns with 2440 drivers and 10 JBL 2220 15" woofers in custom cabinets.

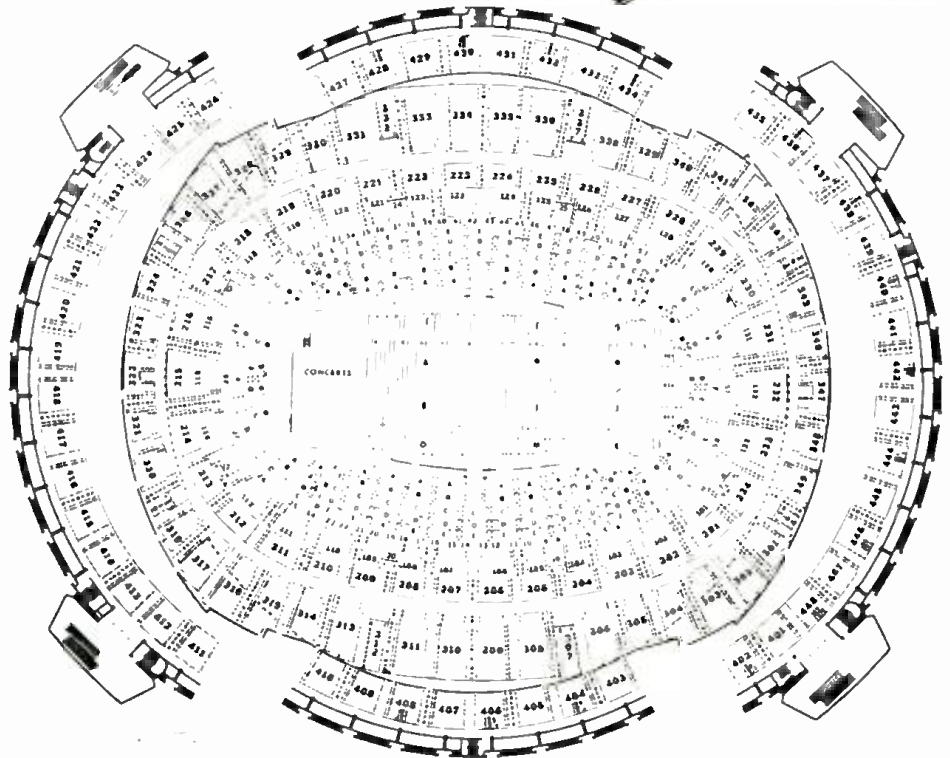

Rear cluster located above and behind stage and consists of 21 JBL 2350 horns with 2440 drivers and 10 JBL 15" woofers in custom cabinets.

This system was designed to produce a 93 dBA average level for sports and rodeo type production shows — not loud music. The rear cluster has been used for rear fill on music shows, however. It incorporates a time delay and separate level controls for each speaker.

- house amplifiers -

Altec 9440 amps are used for both high and low frequency drivers in this bi-amped system. 6,000 watts total. Third octave equalizers and peak limiters complete the system.

- monitor speakers -

4 Altec 1231 slant monitors. A house engineer is required to operate the house monitor system.

- house console -

Custom built using Automated Processes components. 30 in x 6 sub x 6 out with high, mid, and low EQ on each input. Accepts 600 ohm balanced line level input utilizing a 3-pin male XLR connector.

- monitor console -

Usually monitors are mixed from house console operated by house engineer. A separate monitor console (Longevin 24 x 2) can be provided at the stage, however. This console has overall EQ on the outputs only.

- microphones and stands -

Mostly Shure SM-57s with some E-V 15s. Various Atlas stands. Fairchild reverb unit. Reel-to-reel and cassette machines are built into house console.

Electrical

Any electric equipment brought in must be up to New York City electric code. Twico connectors are not allowed — must be Cam-loc. There must be a switch before every division of power. Main breaker box is about 25' from stage

and requires bare wire connections. House can provide as many 20 amp AC boxes as are needed. There is a grounded AC outlet at the console area.

Personnel

This is a strict union house. Separate loading crew must be called to bring equipment to end of truck. Divide equipment into two separate piles depending on whether they are destined for stage or offstage use.

Building Superintendent: Richard Donopria, 563-8150.

Assistant Superintendent: Bruce DeForest, 563-8151.

Chief Electrician: Norman Leonard, 563-8178.
Piano Tuner: Sam Berd (contact hall).

Traveling Soundman Reaction:

"House hanging system works very well and is hung in a good location. The house is a little boomy, but is easily compensated for. Front fill speakers necessary to cover the first 40' or so of arena floor. Requires a bit more monitor and side fill level than a proscenium stage. Table at mix position faces into center of house at a right angle to stage. Find out about all union regulations before arriving." **Mike Neal and Dennis Minnick, McCune Sound, San Francisco and Anaheim, California.**

"Requires a large PA to cover adequately due, in part, to the large volume of air that must be overcome. Similar to an outdoor gig in SPL requirements. Hang PA here and use front fill speakers onstage for the first few rows. Be careful of blocking too many seats with side fill monitors. Side fills can be hung to allow greater visibility. Don't be surprised if hanging clusters seem to move up and down due to excited audience vibrating arena floor!" **Bill Ferguson, Audio Engineer, New York City.**

Peavey equalizers have been designed using the latest computer assisted design techniques and precision components to offer the musician, sound man, and home audiophile flawless performance without extravagant cost or compromises in quality.

The Stereo Graphic features two independent ten-band sections with 15 dB cut or boost at ten center frequencies. Filters are provided for each channel with continuously variable 12 dB high and low cut or boost.

The EQ-27 features 27 bands at one-third octave centers throughout the audio range and is fully compatible with the most professional real time analyzers.

Each system's input circuitry can be matched to a wide range of signal levels thanks to special gain/attenuator level controls. Balanced and unbalanced outputs are equipped on each unit with protection for any accidental overvoltage or short circuit situation that may occur.

Because of a high level transformer balanced output circuitry, the Stereo Graphic and EQ-27 have the capability of providing greater than +16 dBm into 600 ohms making them excellent as high quality line amplifiers.

The Peavey Stereo Graphic and EQ-27 are technically two of the finest equalizers available today. Exceptional performance and compatibility with a wide range of signal and impedance levels make these units an unmatched professional value.

PEAVEY STEREO GRAPHIC & EQ-27 price/performance no other graphics can equal.



Complete specifications and descriptions of the Stereo Graphic and EQ-27 are available upon request

by writing our Literature and Promotional Department, Peavey Electronics; 711 A Street; Meridian, Miss. 39301.



February 1980 □ Re/p 57

for additional information circle no. 27

SOUND MAN'S GUIDE TO VENUES

(#4 in the series)

HAMMERSMITH ODEON
 Queen Caroline Street
 London W6, England
 Telephone: 01-741 3749

Directions from Closest Airport

From Heathrow Airport take the A4 to M4 to A30. Venue is visible from the A30 off the right side of the road — about 10 miles from the airport.

Facility

Old movie theater with full stage. Built in 1932. Open weekdays, 8 a.m. to 10 p.m. Shows must be over at 12 midnight. Permanent level proscenium stage. Orchestra pit can be raised using scaffolding, and stands 6" higher than stage with a short ramp down to stage level. Three stage ramps can be extended over pit.

Total seating: 3,500; standing room for 500. Single balcony against back wall.

Nine moveable pipes above stage are available to hang mikes or monitor speakers. Speaker platforms are stage level and located in front of the fire curtain. They are 12' wide x 8' deep and block sight lines for about 12 seats, total. No additional platforms or risers are available from the house.

House has facilities to hang speakers in front of fire curtain off stage left and right.

Dimensions

Width of stage and pit — 63'.

Depth of stage — 27½'.

Depth of pit — 12'.

Stage floor height above audience floor — 4'. 4' Barrier in front of pit.

Distance from stage to balcony — 80'.

Distance from pit to first row of seating — 3'.

Usable height from stage to proscenium arch — 35'.

Usable height from stage to grid — 53'.

Acoustics

Good sounding hall with short reverb time, fixed acoustics, and padded seats. Reverb time, Rt60 not available.

Loading

Loading door is located in backyard which is accessible from Fulham Palace Road. Best entrance is next to Duke of Cornwall Pub. Stage is a few steps down from loading door (12' high x 8' wide). Parking available for 6 cars and one large truck.

Set Up

Console area is on a 2' riser in the aisle at the back of the hall behind seating block 15. This location is under the balcony and is about 6' deep x 15' wide. An alternate mix position is at the front edge of the balcony in seating block 9. This alternate location takes up seats and blocks sightlines, so contact promoter well in advance. One-hundred meter cable is recommended to reach center stage via fire marshall approved routing.

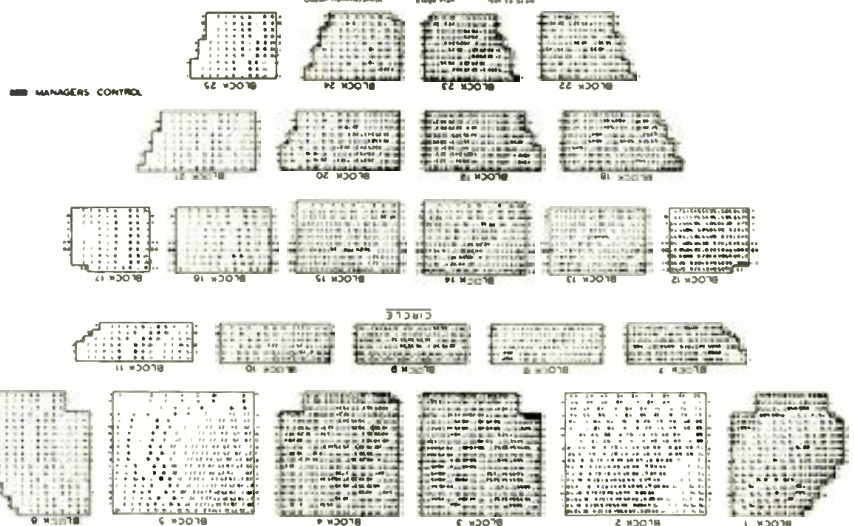
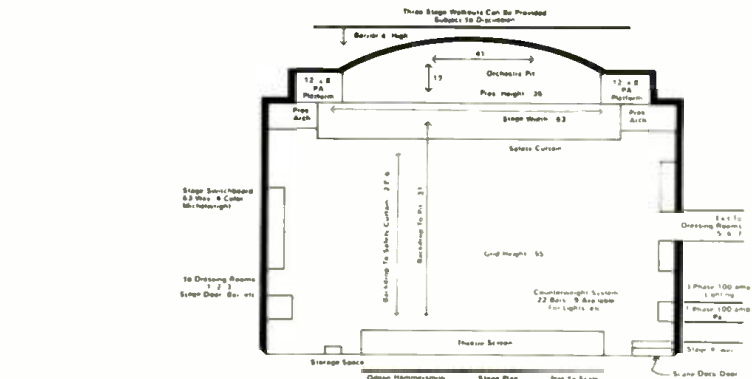

Sound System

Intended for lectures and small acoustic groups only. A single Westrex 125-watt mono amplifier drives two small column loudspeakers on the sides of the proscenium arch. Two multicell horns and one 15" bass speaker are located above the stage for balcony fill. Two more columns are positioned at the sides of the balcony. There is no stage monitor system. The house owns 6 Shure dynamic microphones and 6 mike stands. A 6-in x 1-out Westrex mixer with tone controls on each input completes the system.

Electrical

Service into building is 240 volt, 3 phase, 200 amp per phase. There is no additional 100 amp single phase circuit reserved for sound use only. Main breaker box is backstage right and requires lug connectors or bare wire.

There are two grounded 240 volt 13 amp circuits at console area under balcony.

There are 6 · 240 volt, 13 amp circuits available on stage. NOTE: 240 V to 120 V transformers should be brought over to power American-made equipment. Transformers can also be rented locally. Call venue for details. All equipment must be able to run at 50 cycles.

Personnel

Union house, non-departmentalized. Contact hall to arrange for "humpers" to load and unload trucks. They will move equipment

around on stage as well.

Building manager: Phillip Levers.

Stage Manager: Richard Burr.

Chief Electrician: Wi Phillips.

Piano Tuner: Bill Crago (contact through hall).

House piano is a Steinway Concert Grand.

Traveling Soundman Reaction

"An easy place to do a show with good equipment access. Fairly dry acoustics with just a little slapback onto the stage. It's bass-light under the balcony and bass-heavy in the balcony due to standing waves. Sound can be very good here if the level is kept within the limits of the hall; i.e., not extremely loud. If it's too loud the hall tends to "load up" and get boomy and muddy as do many similar cinema-type venues." **Chris Michie, Audio Engineer and Instructor, San Francisco and London.**

"A very good sounding hall that can handle a loud PA quite well. Smooth reverb, short decay time. The mix position under the balcony is theoretically not ideal, but in fact is as good as anywhere else in this venue. There are good hanging points in front of the stage for either center or side clusters. These clusters can't be heard from the mix position under the balcony, however, so speakers should also be placed at stage level. Easy load in and out. Very professional stagehands. Good draught Guinness at pub next door!" **Mick Williams, T.F.A. ElectroSound, London.**

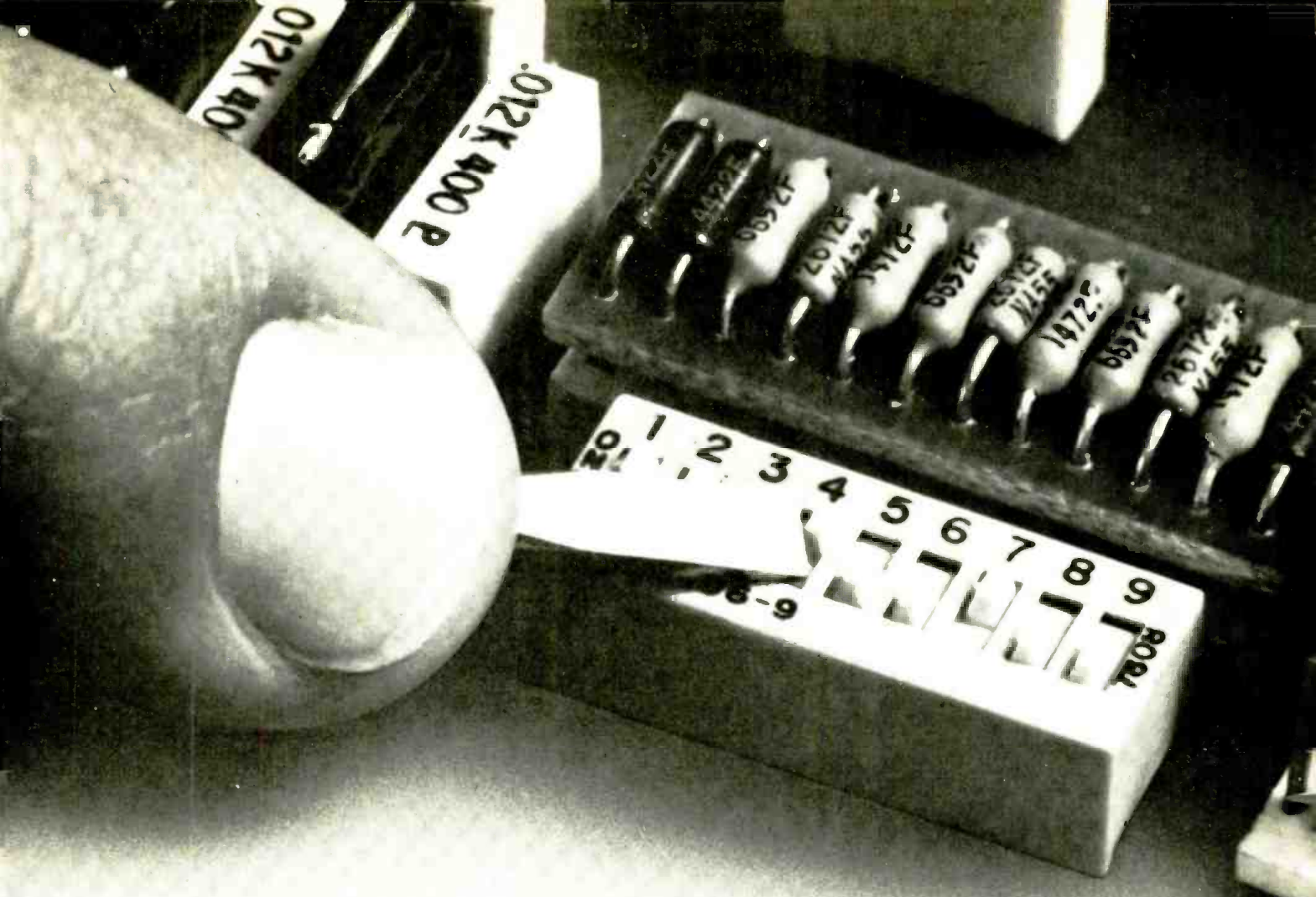

Pots are the Pits

The Model 10 and the Model 20, the potless professional crossovers from BGW. They're the first crossovers to feature Switchset™. With Switchset™, you can now select eight different 18 dB/octave crossover points... plus eight sub-sonic filter frequencies! Switchset™ provides repeatable precision via internal DIP switches... repeatability you can't get with inferior potentiometers.

Both models feature: separate signal and chassis grounding; level controls on all outputs; professional XLR-type connectors; low impedance long-line capability; and rear panel provisions for balanced inputs and outputs through plug-in transformers on the

Introducing the BGW Crossovers with Exclusive Switchset.™

Model 10. The Model 20 has electronically balanced differential inputs and bridged outputs as well as provisions for plug-in input transformers. Each crossover takes up only one rack-unit (1¾") of space in its steel, RFI immune case.



The Model 20 is a truly universal electronic crossover. By presetting the programming links it can be a stereo 2-way, stereo 2-way with mono subwoofer, mono 3-way, or mono 4-way crossover. Frequencies can overlap for special applications.

As a pro, you know that pots can be the pits. Check-out the superior design of the BGW crossovers. Write for full technical details or contact your local BGW pro dealer.

The new Model 10 and Model 20 crossovers with exclusive Switchset™ join the incomparable BGW amplifier line-up. We're The Power That Pros Depend On.



Depend On Us.

BGW Systems, Inc., 13130 S. Yukon Ave., Hawthorne, CA 90250 (213) 973-8090 In Canada: Omnimedia Corp., 9653 Cote de Liesse, Dorval, Quebec H9P 1A3

for additional information circle no. 28

HELMHOLTZ RESONATORS

(The low frequency sound absorber)
of great flexibility

For Studio Use

by F. Alton Everest

or
Coke bottles, slits, slats, slots,
and holes in studio decor

The absorption of sound at the lower audible frequencies may be achieved by (a) porous absorbers or (b) by resonant absorbers. Glass fiber is a common form of a porous absorber in which the sound energy is dissipated as heat in the tiny spaces between the fibers. The absorption of commercial forms of glass fiber and other fibrous absorbers at low audio frequencies, however, is quite poor. To absorb well the thickness of the porous material must be comparable to the wavelength of the sound. At 100 Hz the wavelength is 11.3 feet and using any porous absorber approaching this thickness would be somewhat impractical.

So, we turn to the resonant type to obtain good absorption at low frequencies. One way to utilize the principle of resonance for bass absorption is to use panels. For example, plywood sheets supported at the edges act as diaphragms, absorbing sound by fiber friction as they are caused to vibrate by sound in the room. Other forms of panel resonance, very commonly built into the studio, are gypsum board surfaces, glass plates, and subfloor sheeting. These vary considerably in their absorption efficiency. Being part of the studio structure they are easily overlooked but they must be considered in calculations if any reasonable accuracy is to be realized.

Helmholtz Resonators

The Helmholtz type of resonator is widely used to achieve adequate absorption at lower audio frequencies. There is nothing particularly mysterious about them, in fact they pop up in various forms in everyday life. Blowing across the opening of any bottle or jug produces a tone at its natural frequency of resonance. The air in the cavity is springy and the mass of the air in the neck of the jug reacts with this springiness to form an oscillating system, much as a weight on a spring, vibrating at its natural period. Change the volume of the air cavity, the length or diameter of the neck and you change the frequency of resonance.

Such a Helmholtz resonator has some very interesting characteristics. For instance, sound is absorbed at the frequency of resonance and at nearby frequencies. The width of this absorption band depends upon the friction of the system. A glass jug offers little friction to

the vibrating air and would have a very narrow absorption band. Adding a bit of gauze across the mouth of the jug or stuffing a wisp of cotton into the neck, the amplitude of the vibration is reduced and the width of the absorption band is increased.

The sound impinging on a Helmholtz resonator which is not absorbed is re-radiated. As the sound is re-radiated from the resonator opening it tends to be radiated in all directions. This means that unabsorbed energy is diffused and diffusion of sound is a very desirable thing in a studio.

Bottles and jugs are not appropriate forms of Helmholtz resonators to apply the resonance principle in studios. An interesting experiment conducted many years ago at Riverbank Acoustical Laboratories bears this out.* To demonstrate the effectiveness of a continuously swept narrow band technique of measuring sound absorption coefficients the idea was conceived to measure the absorption of Coca-Cola bottles. A tight array of 1,152 empty 10-ounce bottles was arranged in a standard 8 x 9 foot space on the concrete floor of the reverberation chamber. It was determined that a single, well-isolated bottle has an absorption of 5.9 sabins at its resonance frequency of 185 Hz, but with a bandwidth (between -3 dB points) of only 0.67 Hz! Absorption of 5.9 sabins is an astounding amount of absorption for a Coke bottle! This is about what a person, normally clothed, would absorb at 1,000 Hz, or what 5.9 square feet of glass fiber (2" thick, 3 lb/cu. ft. density) would absorb at midband. The sharpness of this absorption characteristic is even more amazing. This

would correspond to a Q of $185/0.67 = 276!$ As interesting as these data are, they tell us that leaving an empty Coke bottle in the studio will not devastate the acoustics of the room, but it might have a tiny effect at 185 Hz.

Well, if bottles are not a suitable form of Helmholtz resonators for a studio, what is? In Figure 1 we have conveniently idealized a square bottle with a tubular neck on it. Of course, this bottle alone would produce its characteristic tone if one were to blow across the opening. Stacking these bottles does not detract from the resonator action, but rather enhances it. It is a small step to a box of length L, width W, and depth H which has a lid of thickness equal to the length of necks of the bottles. In this lid are drilled holes having the same diameter as the holes in the neck. It is just a bit harder to realize that partitions between each segment may be removed without greatly affecting the Helmholtz action. In this way a Helmholtz resonator of the perforated face type can be related to funny shaped bottles giving us something of a physical picture of how perforated face resonators perform.

In a similar way Figure 2 illustrates another funny bottle with an elongated slit neck. These, too, can be stacked, even in multiple rows and we see that it is but a short step to a slot-type resonator. Here also we can dispense with separating walls in the air cavity without destroying the resonator action. A word of caution is in order. Subdividing the air space can improve the action of perforated or slit resonators but only because this reduces spurious, unwanted modes of vibration being set up within the air cavity.

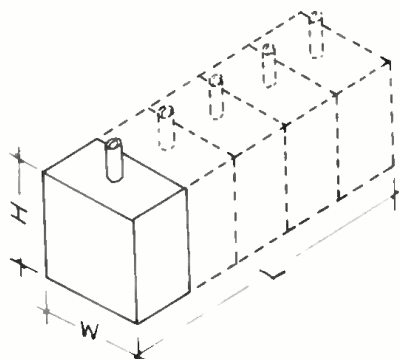

Figure 1: Development of a perforated face Helmholtz resonator from a single rectangular bottle resonator.

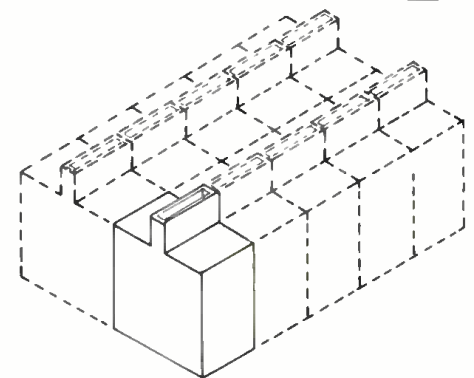

Figure 2: Development of a slot type Helmholtz resonator from a single rectangular bottle resonator.

THE 'OVER EASY' COMPRESSOR/LIMITER.

YOU'LL SWEAR IT ISN'T THERE.

Until now the recording engineer had to settle for a compressor/limiter that was somehow... limiting. Most compressor/limiters utilize a threshold above which compression kicks in, suddenly and audibly. The engineer has to use this device quite sparingly to preserve the "naturalness" of the music he's recording.

The dbx Model 165 is a compressor/limiter that is nothing short of revolutionary. "Over Easy"[™] compression allows the signal level to pass through the threshold and gradually adds the desired amount of gain change over the range of several dB. The result is compression that doesn't sound "compressed." Engineers who have used it have checked to make sure it was really connected.

The 165 incorporates other exclusive dbx design features such as true RMS level detection and feed forward gain control. A separate input is provided to the level detector. Because attack can be completed before the signal arrives at the gain control stage, this input allows the creation of special effects.

The 165 is the most flexible compressor/limiter in the dbx line. It is strappable for true stereo operation. (A master/slave switch is located conveniently on the front panel). It has manual attack and release rate controls that can be switched on for special effects. Despite all its features, it occupies only 3½" of rack space.

In the hands of a good engineer, dbx's new 165 is more than the most natural-sounding compressor/limiter you can buy; it is an integral part of the creative recording process. dbx, Incorporated, 71 Chapel Street, Newton, MA 02195, 617-964-3210.

dbx

Making Good Sound Better

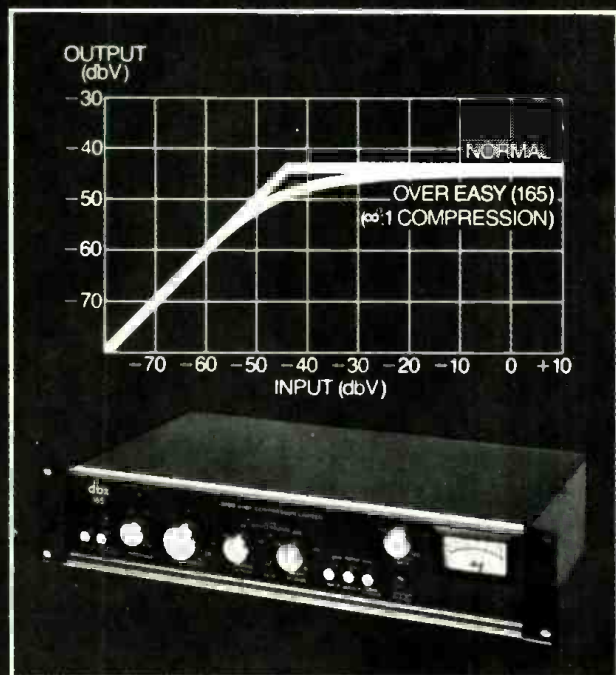

dbx is a registered trademark of dbx[®], Inc.

for additional information circle no. 36

February 1980 □ R1/p

www.americanradiohistory.com

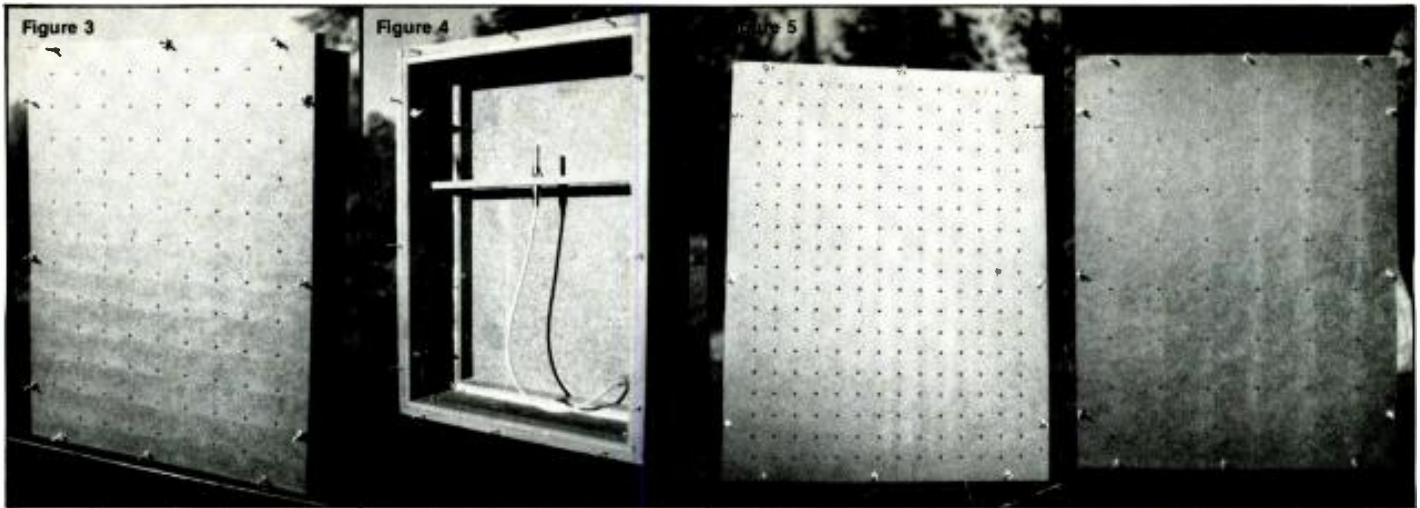

Fig. 3: Experimental Helmholtz resonator with means for changing the type of cover which was used for program of measurements. Fig. 4: Arrangement for outdoor measurement of sound pressure inside a Helmholtz resonator as a function of frequency. The B&K Type 4165 calibrated 1/2" condenser microphone is held in place by a crossbar arrangement. Fig. 5: Helmholtz perforated type resonator with a cover having 1.05% of its effective area in holes. Fig. 6: Helmholtz perforated type resonator with a cover having 0.18% of its effective area in holes. Fig. 8: (below) Arrangement of loudspeaker and experimental Helmholtz resonator with a slat type cover. Located on the slopes of the La Puente Hills overlooking the L.A. basin, bothersome reflections are minimized.

Experiments

It was decided to make some measurements on various forms of Helmholtz resonators applicable to acoustical treatment of studios. Rather than construct many boxes, a fixed box with changeable faces was selected. An old loudspeaker cabinet of 5/8" particle board and 23" x 30" inside dimensions was cut down to a depth of 7-7/8". That depth was carefully chosen to coincide with the 200 mm depth used by Mankovsky¹ because measured absorption coefficients for boxes of this depth and several different facings are included in his book.

The wing nut arrangement for changing faces is shown in Figure 3. The back was also secured with wood screws to facilitate removal and support for the calibrated 1/2" condenser microphone of the Bruel & Kjaer 2215 sound level meter installed as in Figure 4. Tightness between the changeable faces and the box was assured by a strip of sponge rubber. Potential cracks and a few actual holes were sealed with the application of a non-hardening sealant commonly used around bathtubs and in shower stalls. A small sheet of sponge rubber was tightly wrapped around the microphone cable and wedged into the hole in the back from which the cable emerges.

Three perforated faces were intentionally dimensioned to approximate those use by Mankovsky as shown in Table 1. These three covers were drilled, 1.05% (Perf-A, Figure 5), 0.42% (Perf-B, Figure 3), and 0.18% (Perf-C, Figure 6) perforation. Our Perf-B and Perf-C covers come reasonably close to those of Mankovsky, but Perf-A fell victim to illegible handwriting. The hole spacing should have been 1-3/8". Admittedly, a new panel should have been made but this was discouraged by the fact that even at 1-5/8" spacing there are 285 holes in the panel!

The perforation percentage is readily calculated on a single element of the repeated pattern. In Figure 7 the perforation percentage is simply the area of one hole (four quarter holes) divided by the area between the holes multiplied by 100. Warning: If you dive into the literature on

this subject be alert to confusion between the "perforation percentage" and "perforation fraction." If the fraction of hole area to panel area is not multiplied by 100, it is not properly labeled as percentage.

In addition to the perforated covers, a single slat type cover was fitted to the box (Figure 8).

Experimental Method

The experimental method employed was a very simple one suggested by Goyer and reported by Beranek.² If an anechoic chamber or reverberation chamber is not available, the sound pressure inside a Helmholtz resonator can be compared to that outside the resonator to determine the frequency to which the resonator is tuned.

A schematic diagram of instrumentation is shown in Figure 9. The physical layout, shown in Figure 10, is located outdoors in the special hillside "anechoic" facility overlooking the Los Angeles basin. It is a very rough estimate that reflection from the Bank of America building, a mile or so away, would be down about 120 dB. Would that were true of reflections from the nearby Jacaranda tree! By keeping the level up around 110 - 120 dB, environmental noise effects were minimized even on low frequency octave bands. For sounds of this level ear protectors as well as sympathetic neighbors are definitely recommended (Figure 10).

The method used involves comparing the sound pressure within the resonator to that

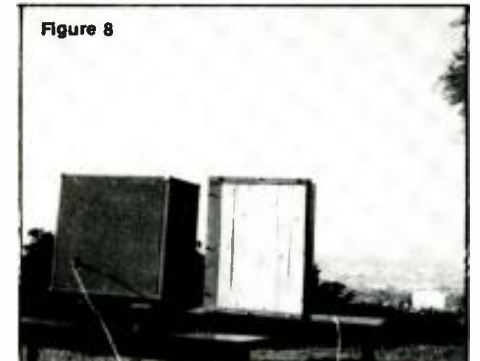
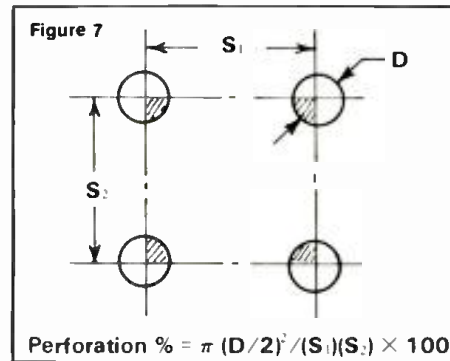
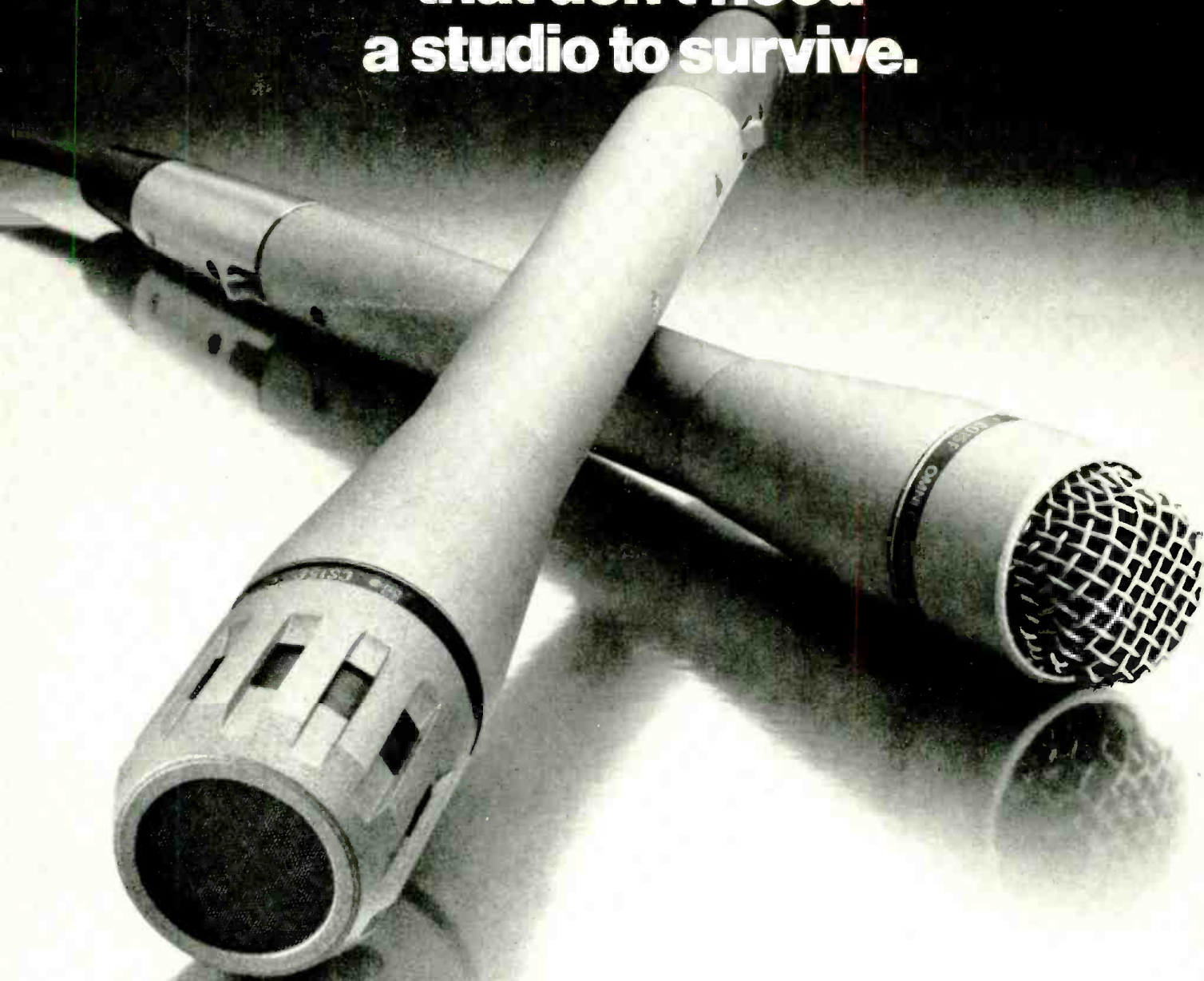

Table 1 RESONATOR SPECIFICATIONS				
	Resonator Type			Slat
	Perf-A	Perf-B	Perf-C	
Mankovsky¹				
Cover thickness	4 mm	4 mm	4 mm	
Hole diameter	5 mm	5 mm	5 mm	
Hole spacing	35 mm	65 mm	100 mm	
Depth, air space	200 mm	200 mm	200 mm	
Perforation %	1.60%	0.46%	0.196%	
Calculated f ₀	169 Hz	91 Hz	59 Hz	
Ours				
Cover thickness	3/16"	3/16"	3/16"	Slat thickness 3/4"
Hole diameter	3/16"	3/16"	3/16"	Slot width 1/16"
Hole spacing	1-5/8"	2-9/16"	3-15/16"	Slat width 3-9/16"
Depth, air space	7-7/8"	7-7/8"	7-7/8"	Air space 7-7/8"
Perforation %	1.05%	0.42%	0.18%	
Calculated f ₀	126 Hz	80 Hz	52 Hz	107 Hz

Studio quality microphones that don't need a studio to survive.



The CS15P condenser cardioid microphone is equally at home in a recording environment or broadcast studio. When hand-held it puts sex appeal in a voice with its bass-boosting proximity effect. With shaped high-frequency response and its ability to handle high sound pressure levels (140 dB with 1% THD at 1kHz), the CS15P is ideal for close-up vocal or solo instrument miking applications.

When boom mounted, the CS15P has better gain-before-feedback and a better signal-to-noise ratio than most shotguns. It's phantom powered and it's rugged.

The CO15P condenser omni extends frequency response to the very limits of audibility, 20 to 20,000 Hz. Unlike other "omni's," the CO15P maintains its omnidirectional polar pattern at the very highest frequencies. Perfect for the distant miking of an entire orchestra as well as up close on individual instruments. And like the CS15P, it's phantom powered and it's rugged.

The Electro-Voice warranty
Electro-Voice backs up these two microphones with the only unconditional warranty in the business: for two years we will replace or repair your CS15P or CO15P microphone, when returned to Electro-Voice for service, at no charge — no matter what caused the damage!

for additional information circle no. 37

We can do this because we build these microphones to meet our standards for performance, ruggedness and durability. We accept nothing less, and if you're a professional, buying a professional quality microphone, you shouldn't either.

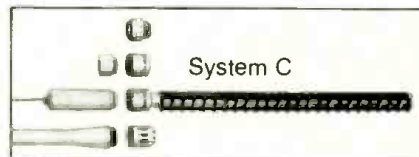

EV **Electro-Voice**[®]
a **gulton** company

600 Cecil Street, Buchanan, Michigan 49107

February 1980 □ Re/p 63

Figure 9

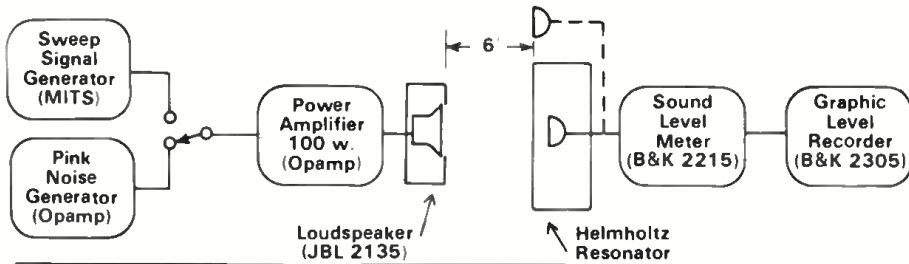

Figure 10

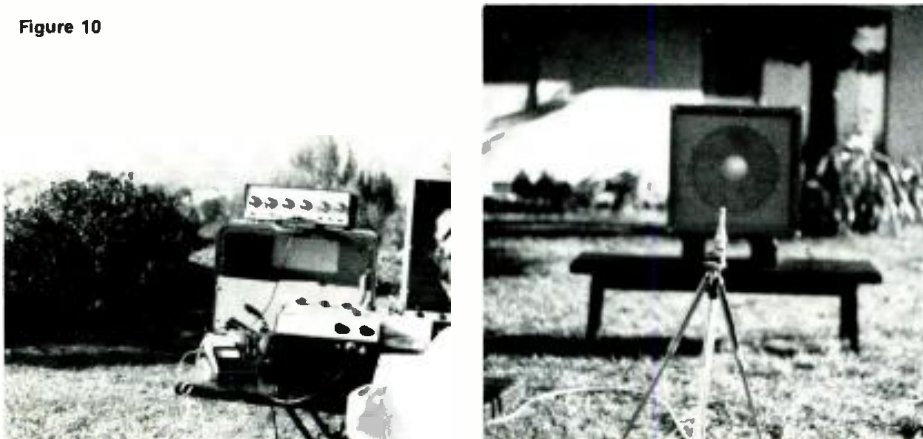

Fig. 9: Schematic diagram of measuring system. Fig. 10: Instrument arrangement of the outdoor "anechoic" facility. Ear protectors are required because of the 110-120 dB levels used to minimize the effects of environmental noise. Fig. 11: To compare the sound pressure within the Helmholtz resonator to that outside, the resonator is moved to one side and the measuring microphone placed where the face of the resonator was located.

outside the resonator as the frequency is varied in a standard way. Ideally, a dual channel measuring system would enable recording of both inside and outside pressures simultaneously. The procedure used was to make an outside pressure run (Figure 11) at the beginning and end of a series of measurements inside the box for various types of cover and glass fiber damping. To obtain the outside pressure the resonator was moved to one side and the measuring microphone placed exactly where the face of the resonator had been. Obviously, the very presence of the resonator itself as well as reflections from the ground and surrounding objects affect the outside pressure somewhat. However, every effort was made to make all

measurement runs under conditions as nearly identical as possible so that comparisons between the different resonator facings could be made with reasonable confidence. In other words, the procedure is not ideal but suitable for comparative measurements on a low budget.

Sine Sweep Tests

Figure 12 shows tracings from graphic level recorder tapes of sine sweep tests. At some frequencies the sound pressure inside the resonator (solid line) is above the sound pressure prevailing at the outside face of the resonator (broken line). This is what we would expect near resonance. At other frequencies the inside pressure falls

below the outside pressure. At frequencies well removed from the resonance peak it is logical to expect the box to shield the microphone inside. The sine sweep, in a way, reveals too much information in the form of up and down fluctuations resulting from complex spurious resonances of box panels and modal effects within the box. However, with no glass fiber in the box (Figure 12), a general progression of peaks from lower to higher frequencies as perforation percentage is increased can be noted. Not shown are sine sweep records taken with glass fiber in the box which are very difficult to interpret.

Similar sine sweep results for the slat facing are shown in Figure 13. Pressing the glass fiber against the back of the slat facing reduces the resonance effect, although the same glass fiber at the rear of the box has relatively little effect other than shifting the peak to a somewhat lower frequency as expected.

One-Third Octave Sweeps

A magnetic recording was made of the output of a General Radio Type 1382 random noise generator fed through a General Radio Type 1564 sound analyzer as it swept a 1/3 octave band. The playback of this recording was then used to drive the power amplifier and loudspeaker in the same manner as the swept sine signal.

The 1/3 octave sweep recordings of Figure 14 are considerably less erratic than the sine sweeps of Figures 12 and 13 as would be expected from the averaging effect of the wider band. Measurements using 1/3 octave bands of noise make sense in that, over much of the audible spectrum, the human ear analyzes sounds in critical bands roughly approximated by 1/3 octaves. However, in the 50 - 250 Hz region in which Helmholtz resonators are of greatest practical value, the critical bands of the ear are about 100 Hz wide which is better approximated by an octave bandwidth.

The recordings of Figures 14(A), (B), and (C), show nice resonance peaks of 10 or 12 dB. One mystery is the lack of agreement of peak frequency between the 1/3 octave

— continued on page 69 . . .

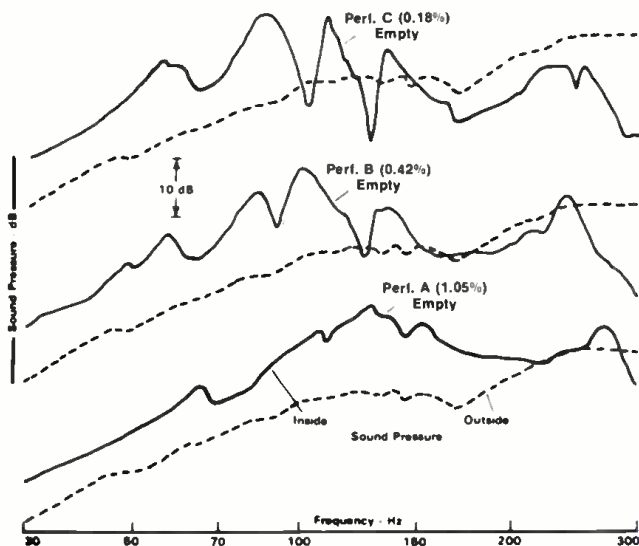

Figure 12: Sine sweep comparison of sound pressure inside Helmholtz resonator (solid line) with the corresponding sound pressure at the face of the resonator (broken line). Results for three perforation percentages are shown. No glass fiber in the resonators.

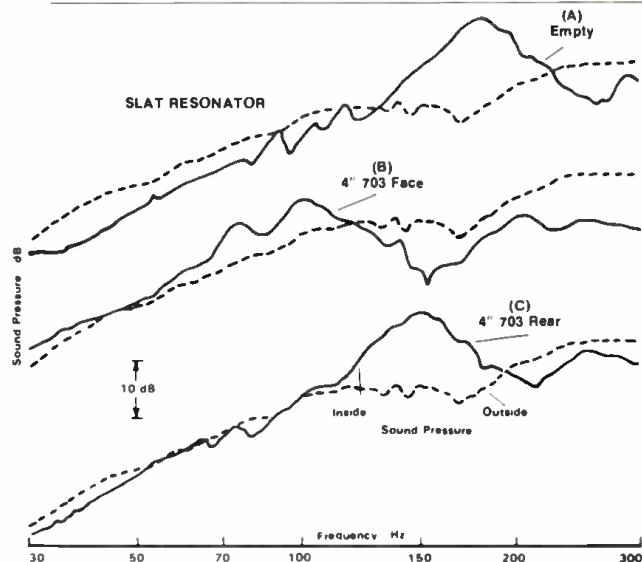

Figure 13: Sine sweep comparison of sound pressure inside a slat type Helmholtz resonator: (A) no glass fiber inside. (B) 4" of Type 703 Fiberglass against the face, and (C) 4" of Type 703 Fiberglass against the rear of the box.

New realms of expression from MXR.

The Pitch Transposer is MXR's newest addition to our professional line. It is one of our most innovative products, and possibly the most revolutionary signal processor in the music industry today. It is a unique, high-quality unit which provides a cost effective and flexible package for today's creative artists.

The Pitch Transposer extends your musical boundaries by creating live instrumental and vocal harmonies. It has 4 presets which allow the artist to predetermine the intervals to be processed. Transposed intervals can be preset anywhere from an octave below to an octave above the original pitch. The chosen interval is activated by means of touch controls or a rugged footswitch. LED indicators display which of the four presets has been selected.

A mix control is provided, enabling the unit to be used in one input of a mixing console, or with musical instrument amplifiers. A regeneration control provides for the recirculation of processed signals, creating more and more notes, depending upon the selected interval. This results in multitudes of voices or instrumental chords. An entire new range of sound effects and musical textures, unattainable with any other type of signal processor, is suddenly at your fingertips.

With many other pitch transposition devices a splicing noise, or glitch, is present. The MXR Pitch Transposer

renders these often offensive noises into a subtle vibrato which blends with the music, and is, in some cases, virtually inaudible. The result is a processed signal which is musical and usable.

We have been able to maintain a high level of sonic integrity in this most versatile signal processor. The frequency response of the processed signal is beyond 10 kHz, with a dynamic range exceeding 80 dB.

A micro computer based display option allows the user to read the created harmonic interval in terms of a pitch ratio, or as a musical interval (in half steps). This unique feature allows the pitch to be expressed in a language meaningful to both musicians and engineers.

We designed our Pitch Transposer as a practical musical tool for those actively involved in creative audio. It reflects our commitment to provide the highest quality signal processors with the features and performance that will satisfy the creative demands of today's musical artist. See your MXR dealer.

MXR Innovations, Inc., 247 N. Goodman Street,
Rochester, New York 14607, (716) 442-5320





Introducing The HR-1 Phase Coherent Studio Monitoring System!

Westlake Audio monitoring systems are recognized throughout the world as a reference standard. Designed for accurate reproduction of the most demanding sources the HR-1, first in a new series of high resolution monitors, continues in that tradition.

Coupled to its companion HR-1X crossover, the HR-1 directly addresses the problems of polarity and phase in multiple transducer reproduction. Critical listening by artists, engineers and producers point out the significant sonic improvements provided by its proprietary design. Low distortion, reduced ear fatigue, improved transients and a stereo image previously unknown to large 4-way monitor systems are examples of improvements most often noted. The system can be previewed at the facilities shown.

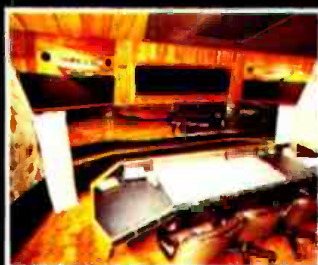

Westlake Audio Studio
Showroom & Sales
Facilities



Electric Lady N.Y.C.



HR-1X Active
Crossover System

from acoustic design
to down beat...

**Westlake
Audio**

6311 Wilshire Boulevard
Los Angeles, California 90048
(213) 655-0303
TELEX 698645

8447 Beverly Boulevard
Los Angeles, California 90048
(213) 654-2155

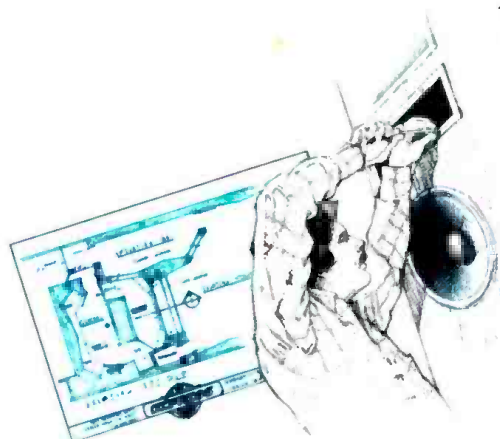
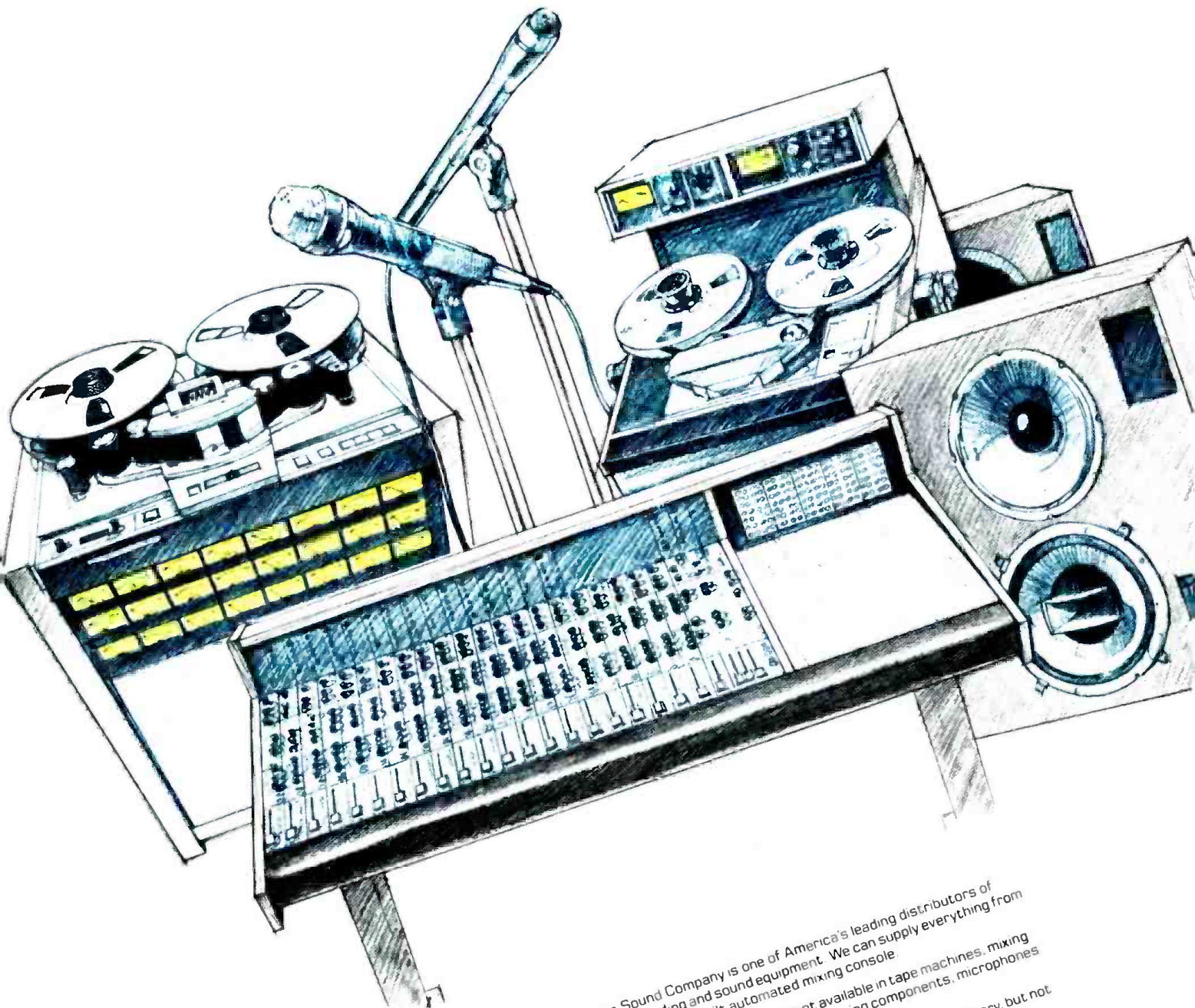

The Express Sound Company is one of America's leading distributors of professional recording and sound equipment. We can supply everything from blank tape to a custom-built automated mixing console.

We offer the finest lines of pro equipment available in tape machines, mixing consoles, monitors, amplifiers, signal processing components, microphones and support equipment.

And if the solution to your problem is something that exists in theory, but not in fact, Express Sound's design engineers will custom design it to your specifications. That's the Express Sound difference! The finest names in pro sound equipment — and the most knowledgeable and helpful people you'll find anywhere.

The Express Sound Company • Pro Audio Equipment Sales
 Turn-key Studio Design and Construction, 24-Hour Service, Nice People
 1833 Newport Boulevard, Costa Mesa, CA 92627 (714) 645-8501

EXPRESS

SOUND COMPANY

"...in reverent quest of the last dB."

SOUND WORKSHOP • OTARI • AMPEX • UREI • NEUMANN • ELECTRO VOICE • JBL • AKG • MARSHALL • AOR • TANGENT • LEXICON • TASCAM • DBX • TECHNICS • SONY • and many more

HELMHOLTZ RESONATORS

sweeps (Figure 14) and the sine sweeps (Figures 12, 13). Operator error is strongly suspected in view of the crude methods invoked, but not proven. One difference in procedure is that in the 1/3 octave sweep runs the Helmholtz box was closer to the loudspeaker (about 3 feet) and the runs were made indoors. Reverberation measurements (to be treated in a following section) would, however, indicate that the box was performing quite independently from the room, yet standing waves could have had their usual unexpected and devastating effect. There is no need to be too concerned by such discrepancies as we move on to more significant matters.

Octave Band Measurements

For octave band measurements, wideband pink noise was emitted from the loudspeaker at high level. The sound was measured both outside and inside the box with the aid of octave band filters which are an integral part of the B&K 2215 sound level meter. The sound level meter is acting normally in every respect, even though its microphone is on a long extension cord. Everything is held constant during the runs except for changing of resonator faces and internal glass fiber.

These curves beautifully depict resonance rise of inside sound pressure relative to outside pressure due to Helmholtz action. Each experimental point, shown by a circle, was obtained by subtracting from the inside dB sound pressure level the outside sound pressure level. The dB difference, plotted against frequency, shows the resonance effect, but in a subdued form because of the logarithmic compression. To dramatize the peaking effect, the dB difference was changed to linear sound pressure by solving $10^{dB/20}$

for each frequency. The peak sound pressure difference of about 4 in Figure 15(A) corresponds to a level rise of about 12 dB which is about that observed in Figures 12, 13, and 14. In this linear pressure form we have a better comparison between the various conditions under examination. For example, Figure 15(A) clearly shows the progression in resonance frequency with perforation percentage.

The curves of Figure 15(B) show the effect of 4" of 703 Fiberglas at the rear of the box and Figure 15(C) shows the effect of the same Fiberglas pressed against the inside face of the perforated cover.

The verticle scales of Figure 15(A), (B), and (C), are directly comparable, inviting comparison. The presence of glass fiber at the rear of the box, Figure 15(B), reduces peak pressure about 30% from the empty condition. Against the inside surface of the cover the reduction is nearer 60%. The significance of this will be discussed later.

The effect of perforation percentage in changing the peak frequency is well pronounced in Figures 15(A) and (B). When the glass fiber is against the inside face of the cover, however, all three perforations seem to resonate close to 63 Hz (Figure 15-C). In the slat type resonator of Figure 16 the curve for glass fiber against the cover also peaks near 63 Hz.

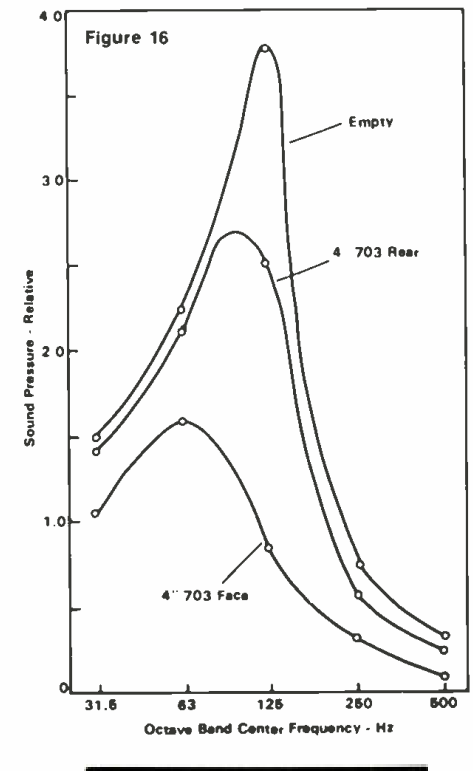
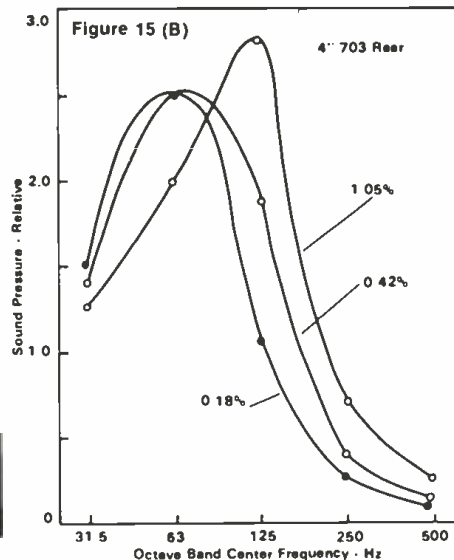
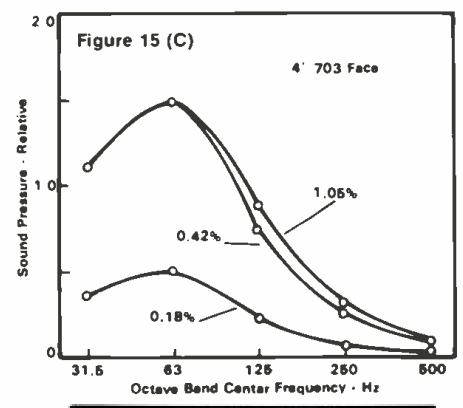
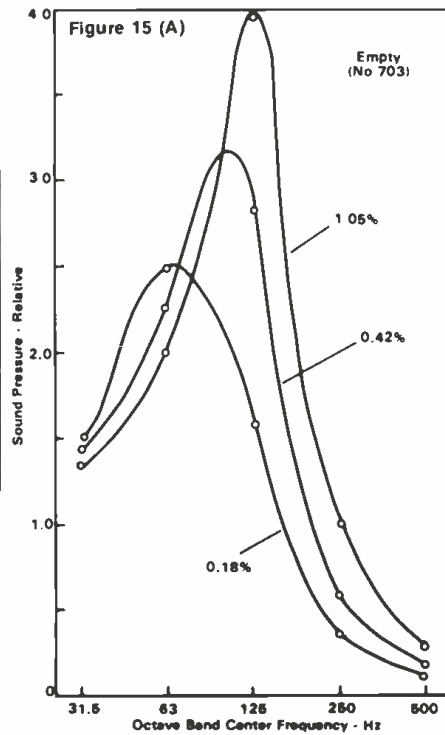
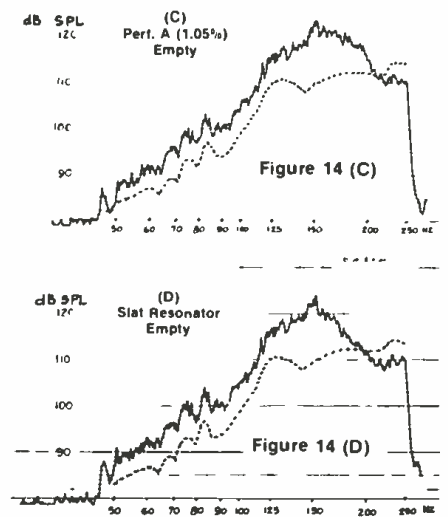
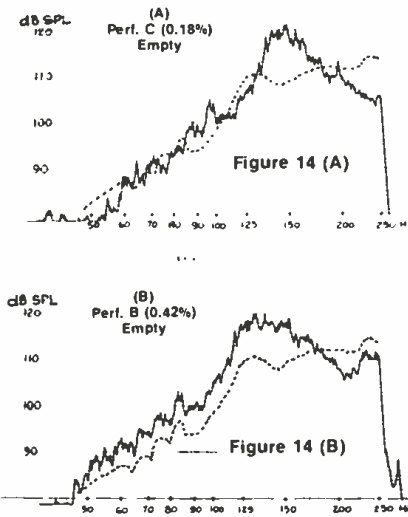

— continued overleaf ...

HELMHOLTZ RESONATORS

In octave band measurements such as Figures 15 and 16 there is often considerable uncertainty as to the location of the peak. This is especially true when the peak falls "in the cracks" between two octaves. Good examples of this are the 0.42% curves of Figure 15(A) and (B) and the 4" 703 rear curve of Figure 16. If, happily, the peak falls near the center of an octave it is more accurately delineated.

Figures 15 and 16 demonstrate clearly that the octave band approach can reasonably well determine experimentally the resonance frequency. If a 1/3 octave filter set were used, the peak could be found even more accurately.

The octave band approach thus gives an excellent tool for determining the frequency at which the actual resonance peak occurs. It avoids the excessive detail of the swept sine approach. It also conforms more closely to the 100 Hz critical bandwidth of the ear at these frequencies. Experimentally, octave measurements are simple point-by-point observations which do not require a graphic level or other recorder.

Absorption Characteristics

The methods we have just explored help us to determine the frequency to which a perforated or slat type of Helmholtz resonator is tuned. We have also noted that introducing an absorbent material into the

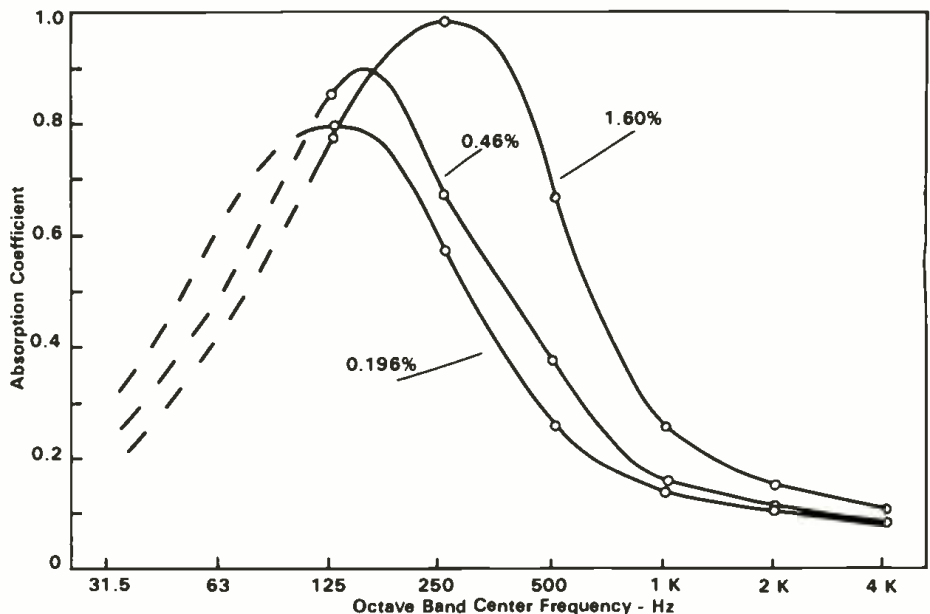

Figure 17: Absorption coefficients of three perforated face Helmholtz resonators described in Table 1 and reported by Mankovsky¹.

air cavity shifts the resonance peak to lower frequencies. From Figure 16 we can also deduce that a given amount of absorbent material has a far greater effect when placed against the inside face of the perforated or slat cover than against the back of the box away from the cover. This is understandable theoretically knowing that

the air particle velocity is greatest near the slots or holes of the cover and a fibrous material there would have its maximum frictional effect.

So, we have found the frequency to which our box is tuned. What is the relationship of this pressure curve to the absorption curve we must have for our calculations? To say the least, it is a relationship requiring mathematics beyond the scope of this article. But we do need some method of bridging this gap for, once the resonance frequency is pinned down, absorption coefficients are needed for room design.

Figure 17 presents the absorption coefficients reported by Mankovsky¹ for the resonator constructions listed in Table 1. The depth of his box (200 mm) is the same as ours (7-7/8") and, except for Perf-A, the perforation percentages are close. Each of the three curves of Figure 17 follows the same laws of resonance and their shapes are basically similar. As a result we can shift experimentally determined data of Figure 17 to other frequencies without doing violence to the laws of nature. The 1.60% perforation curve of Figure 17 peaks at 250 Hz. What if we wanted one peaking at 500 Hz? The easiest way to find coefficients for the 500 Hz peak is to lay a sheet of tracing paper over Figure 17 and trace the 1.60% perf curve on it. Sliding the tracing paper until the peak is at 500 Hz enables one to read off absorption coefficients for the standard frequency points.

Another approach is through the normalized curve. The data of all three curves of Figure 17 are replotted in Figure 18 in normalized form. This requires a simple arithmetic operation on both frequency and absorption coefficient. Note in Figure 17 that the peaks occur at different frequencies. Note also that the heights of the peaks differ. The frequency scale of Figure 18 is expressed as a ratio to the frequency of resonance, f_0 . For example, the 0.46% curve of Figure 17 peaks at 150 Hz. The 500 Hz point of this curve is plotted on

**Flanner
&
Hafsoos**
MUSIC HOUSE

ANNOUNCING
A Brand New Name For Our Pro-Audio Division:

**Flanner's
Pro
Audio**
Serving the
Broadcast
and Recording
Industries

A Division of Flanner & Hafsoos Music House Ltd. Est. 1891

The New Pro-Audio Company With An 88 Year Old Reputation For Excellence!

Due to the ever increasing complexity and specialization of the pro-audio industry, Flanner & Hafsoos Music House, Ltd., has decided it was time to show complete commitment to this industries needs. Therefore, we are proud to announce the creation of **Flanner's Pro-Audio**. Staffed by experienced, professional specialists who represent one of the greatest selections of pro-audio products in the nation, we know we can help you with your pro-audio requirements. We stock most of the products we represent for fast service to you. We currently have in stock the new Portastudio by Tascam! **Call Us For Your Next Audio Purchase!**

We're The Company Known By The Companies We Keep!

- ★ Ampex ★ Scully ★ Tascam ★ Otari ★ Studer/ReVox ★
- ★ Neotek ★ Auditronics ★ UREI ★ Eventide ★ Orban ★
- ★ McIntosh ★ DeltaLabs ★ Pentagon ★ Crown ★ JBL ★

To Name A Few!

CALL FOR A COMPLETE PRODUCT LIST!
NEW PHONE: (414) 259-9665

2500 N. Mayfair Road ★ Milwaukee, WI 53226

for additional information circle no. 40

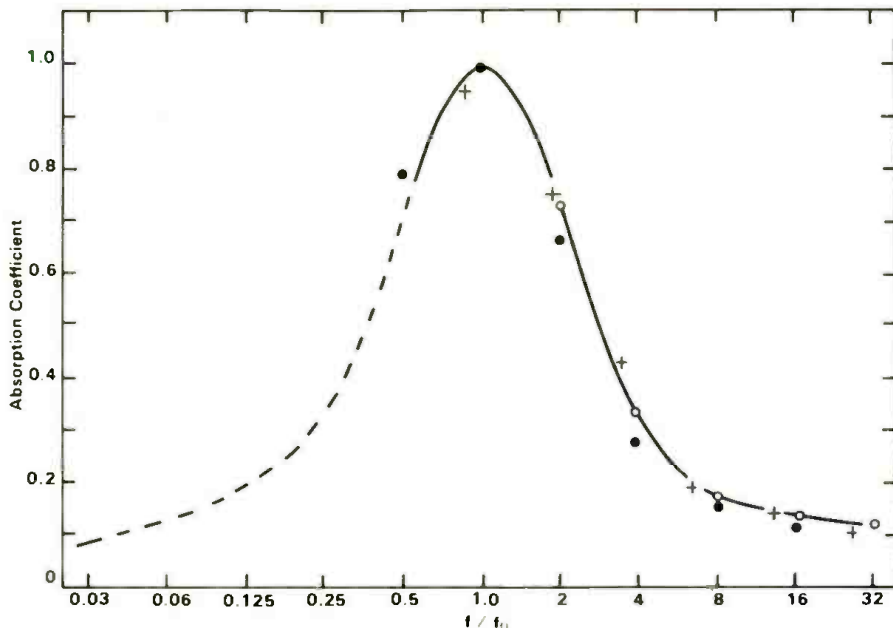

Figure 18: Normalized absorption curve developed from the three Mankovsky¹ measurements on perforated face absorbers having a depth of 200mm and 100mm absorbent filler; open circles - 1.60%, black circles - 0.196% perforation. the broken line has been drawn on a basis of strict symmetry which does not always hold for resonance phenomena.

the normalized coordinates of Figure 18 as f/f_0 or $500/150 = 3.33$ on the horizontal axis. Because the curve peaks at 0.9, it needs a vertical adjustment as well. The 500 Hz absorption coefficient is 0.39. Dividing this by the 0.9 peak factor gives 0.43 as the normalized coefficient for 500 Hz. This point is then plotted as the cross at

normalized frequency 3.33 and normalized coefficient of 0.43. Carrying this process through point-by-point for the 1.60%, 0.46%, and the 0.196% cases gives us the "standard" shaped absorption curve of Figure 18. It can be called a sort of "universal" resonance curve applicable to 200 mm (7-7/8") depth and 100 mm of

absorption material inside. Mankovsky does not tell us whether the filler is against the face or in the rear of the box. It would appear from our pressure data that it was in the rear of the box.

Calculation Of Resonance Frequency

We need both prediction and verification in designing Helmholtz resonators for studio treatment. Prediction of resonance frequency is accomplished by calculation, but the accuracy isn't all we would hope for. By glancing at Table 2 we can also conclude that there are numerous possible slips betwixt computed and experimentally determined resonance peaks, although we see good agreement between the octave measurements on the empty resonators and the calculated resonance frequencies. With this realistic outlook we can do our computing without taking the precise looking figure on the calculator as absolute truth. Michael Rettinger's book and papers³⁻⁶ are excellent as a guide in such calculations.

For perforated type Helmholtz absorbers the frequency of resonance is given by:

$$f_0 = 200\sqrt{p/((D)(t))}$$

where

- f_0 = frequency of resonance, Hz
- p = perforation percentage
- t = effective hole length, inches
= (panel thickness) + (0.8)
(hole diameter), approx.
- D = airspace depth, inches.

The Sound Workshop 262 Stereo Reverb is unmatched in its class.

BRINGING THE TECHNOLOGY WITHIN EVERYONE'S REACH.

Sound Workshop Professional Audio Products, Inc.
1324 Motor Parkway, Hauppauge, New York 11787
(516) 582-6210 Telex 649230

Table 2
COMPARISON OF RESONANCE FREQUENCIES

	Percent Perforation						Slat
	Perf-A		Perf-B		Perf-C		
Mankovsky Ours	1.60%	1.05%	0.46%	0.42%	0.19%	0.18%	
Mankovsky Reverb chamber msts	250 Hz		150 Hz		125 Hz		
Ours, Octave Empty		125 Hz		100 Hz		65 Hz	125 Hz
4" Filler at face		63 Hz		63 Hz		63 Hz	63 Hz
4" Filler at rear		110 Hz		72 Hz		58 Hz	95 Hz
Ours, 1/3 Octave Empty		150 Hz		130 Hz		140 Hz	150 Hz
Ours, Sine Empty		130 Hz		90 Hz		70 Hz	170 Hz
Calculated	169 Hz	126 Hz	91 Hz	80 Hz	59 Hz	52 Hz	107 Hz

HELMHOLTZ RESONATORS

For slat type Helmholtz absorbers, the resonance frequency is given by:

$$f_0 = 2160 \sqrt{r / ((d)(D)(w + r))}$$

where

- f_0 = resonance frequency, Hz
- r = slot width, inches
- w = width of slat, inches
- D = airspace depth, inches
- d = effective depth of slot, inches
- = 1.2 (thickness of slat), approx.

Verification Of Resonance Frequency

As noted in Table 2, the resonance frequencies determined by the various methods (octave, 1/3 octave, sine sweep) do not agree in many cases, nor do they always agree with the calculated values. On top of that, whether the absorbent layer is against the face or the back or absent altogether, also affects the result. Greatest confidence should be placed in the octave measurements as they are free of continually changing frequency and the problems of calibration and stability associated with the swept sine and swept 1/3 octave methods. Octave tests provide a simple method of verifying the actual

resonance frequency of the empty box. Once the frequency is determined the next problem is estimation of absorption coefficients.

The absorption measurements reported by Mankovsky were on boxes containing 100 mm (4 inches) of "PP80" absorbent. He does not define PP80, mention its density, nor its location in the box. Helmholtz resonators currently designed for studios usually specify only one inch, or at the most two inches, of absorbent, often of 3 lb/cu. ft. density such as Owens-Corning Type 703 Fiberglas or Johns-Manville Type 830PL Spin-Glas (both proprietary names). The recommended position is against the inside surface of the perforated or slat facing.

Resonator Q

The sharpness of resonance curves is often described in terms of Q, or dissipation factor. This Q of a resonant system can be defined as:

$$Q = f_0 / \Delta f$$

where f_0 is the frequency at resonance and Δf is the width of the resonance curve at the half power (-3 dB) points. The Coca-Cola bottles referred to earlier resonated at 185 Hz and had a bandwidth of 0.67 Hz, resulting in a truly phenomenal Q of 185/0.67 or 276. Qs of this magnitude in a studio could result in "ringing" problems. More on this later. The Qs of the three experimental perforations and the single slat facing vary from 0.78 to 1.44 through all conditions of internal absorbent, including empty, quite different from Coke bottles.

Passive vs. Reactive Absorbers

An opinion has been expressed that control rooms should be treated only with dissipative absorbers such as glass fiber and not with the reactive type such as panel and Helmholtz vibrating systems. A consultant in Hertfordshire, England, claims that reactive absorbers introduce sound into the room which is not directly related to the original sound or its normal pattern of reflections. This is the only negative note on resonance type absorbers the writer has encountered in the literature in the face of innumerable successful applications of Helmholtz resonators to studios and control rooms around the world. Perhaps the last word on this subject has yet to be heard.

Reverberation Control

The predominant use of Helmholtz type units is in providing tunable absorption to correct for deficiencies in other types of absorbers. A uniform reverberation time throughout the audible spectrum is generally taken as the optimum. With such a reverberation characteristic all components of speech or music die away at the same rate. The studio and control room design problem is centered in the fact that commonly available materials do not have uniform absorption throughout the band. This requires careful apportioning of many types of absorbers to finally arrive at the flat reverberation characteristic. Helmholtz units are invaluable in supplying needed absorption at low frequencies to make up

At Last!!!

A Hot Pressed, Glass Bonded SAKI Ferrite Playback Head
For Your ATR-100

Ferrite Heads Available for Most Professional Recorders



See us at
NAB and AES



SAKI MAGNETICS INCORPORATED
(A California Corporation)

5770 Uplander Way • Culver City, California 90230 • (213) 649-5983
Fox Hills Industrial Center

for additional information circle no. 42

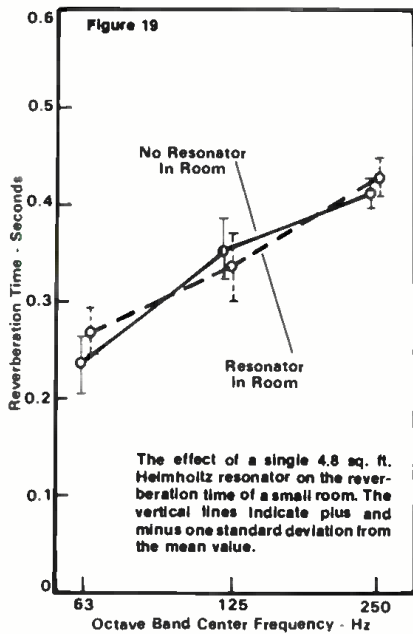

for deficiencies of carpet, drapes, acoustical tile and the like. They are also useful in filling in sagging midband absorption. The incorporation of Helmholtz resonators in specific design problems has been treated in an elementary form in great detail elsewhere.⁸

With all equipment in place for the other measurements reported in this article, the temptation to answer the question, "Would a single perforated absorber affect the reverberation time of this bedroom noticeably?", proved to be irresistible. Five decay measurements with octave noise bands were made at each frequency both with the empty Perf-A resonator in the room and not in the room, everything else being held constant. The results are shown in Figure 19. The effect at 125 Hz is more-or-less significant (we shall leave to the statistician just how significant) but what do you expect of only 4.8 sq. ft. of absorber tuned to this frequency?

Ringling Of Empty Resonator

The empty Perf-A resonator (1.05%) has the highest Q of all the experimental units, a Q of 1.44. The question came to mind, "Is it possible that it 'rings' too much?". With the microphone inside in the usual place (Figure 4) the reverberation time inside the box was measured at 135 Hz and found to be 0.201 second with a standard deviation of 0.027 with ten decays. This was done in the most convenient way with the resonator in the bedroom adjacent to the equipment room. To quiet the haunting fear that the room may have affected the measurements, the operation was repeated with the resonator outdoors. The mean value of the reverberation time over another ten decays was 0.222 second with a standard deviation of 0.023 which indicated that the room effect, if there at all, was small. Combining all 20 measurements yielded a mean reverberation time of 0.212 second with a standard deviation of 0.027. Compared to the room reverberation time at 135 Hz of about 0.35 second it would appear that the box decay was truly measured and found reasonable. Any ringing problem of our

"ringiest" resonator did not materialize.

Taming Room Modes

Another use of Helmholtz resonators is to apply sharply tuned units to control particularly troublesome room modes. This requires a sophisticated approach, both in identifying the mode and then in controlling it.⁹ The volume of the resonator must be mathematically determined to fit the job. Of course it would be futile to place the resonator at a node where that particular mode has zero effect, so even the placement becomes important, and when properly placed fine tuning is required. After all this, suitable damping (absorbent) is introduced to achieve the proper Q. But it can be done and resonators have been successfully used for this purpose.

Increasing Reverberation Time

Low Q Helmholtz resonators are capable of shortening reverberation time by increasing absorption. High Q resonators can increase reverberation time through storage of energy as described by Gilford.¹⁰ To achieve the high Q's necessary plywood, particle board, masonite, and other such materials would have to be abandoned and ceramics, plaster, concrete, etc., be used in resonator construction. By proper tuning of the resonators the increase in reverberation time can be placed where needed in regard to frequency. □ □ □

* I am indebted to William Siekman for this information. Bill was manager of the Riverbank Acoustical Laboratories at that

time and made the measurements for presentation as a paper before the Acoustical Society of America during its April 1969 meeting.

References:

- 1 - Mankovsky, V. S., *Acoustics of Studios and Auditoria*, Communication Arts Books, Hastings House, New York (1971), especially Tests #45, #46, #47, page 377.
- 2 - Beranek, Leo L., *Broadcast Studio Design*, Journal of the SMPTE, Vol. 64 (October 1955), pp 550-559.
- 3 - Rettinger, Michael, *Acoustic Design and Noise Control*, Chemical Publishing Company, Inc., New York (1973).
- 4 - Rettinger, Michael, *Low-Frequency Sound Absorbers*, dB Magazine, Vol. 4, No. 4 (April 1970), pp 44-46.
- 5 - Rettinger, Michael, *Low-Frequency Slot Absorbers*, dB Magazine, Vol. 10, No. 6 (June 1976), pp 40-43.
- 6 - Rettinger, Michael, *On the Acoustics of Multitrack Recording Studios*, J. Audio Engr. Soc., Vol. 19, No. 8 (September 1971), pp 651-655.
- 7 - Veale, Edward J., *The Environmental Design of a Studio Control Room*, Preprint No. A-2(R), 44th Audio Engineering Society Convention, 20-22 February 1973, Rotterdam.
- 8 - Everest, F. Alton, *How To Build a Small Budget Recording Studio From Scratch*, (1979) Tab Books #1166, available from R-e/p.
- 9 - Van Leeuwen, F. J., *The Damping of Eigentones in Small Rooms by Helmholtz Resonators*, European Broadcast Union Review, A.62 (1960), pp 155-161.
- 10 - Gilford, Christopher, *Acoustics for Radio and Television Studios*, IEE Monograph Series 11, Peter Peregrinus, Ltd., London (1972), pp 149-157.

TYPE 85 FET DIRECT BOX

WHEN YOU USE THE BEST YOU GET NO COMPLAINTS.

COUNTRYMAN ASSOCIATES INC.
124 STANFORD AVE. - REDWOOD CITY, CA. 94063

for additional information circle no. 43

THE NEW MULTI-CHANNEL SOUND, OPTICAL RELEASE FILM FORMATS

THE DOLBY SYSTEM

by
Robert Peterson
Dolby Laboratories

Much has been written about the state of motion picture sound since the 1930's. It is generally acknowledged that the quality of film sound has fallen below the picture quality in most theaters. During the past 30 years, there have been many attempts to develop a viable, improved sound system, reliable in the field, compatible with existing systems and economically feasible for both production companies and exhibitors.

A conventional monophonic track of the mid-1930's had a limited signal-to-noise ratio which was constrained by the recording medium and the available equipment. Early soundtracks were usually pre-emphasized to compensate for the limited frequency response of the playback equipment. As improved loudspeaker design increased the high frequency response, grain noise became audibly apparent, and new theaters were equipped with electrical roll-offs to maintain high frequency attenuation. As recording techniques improved, more pre-emphasis was added to compensate for the poor playback high frequency response. Thus, a vicious circle existed — films were recorded to match the theaters and theaters were designed to match the films.

Although film sound could have been improved significantly at any time during the last fifteen years, the industry did not believe that such an improvement would be worth the cost. A new recording standard would have to be established. Theaters would have to be modified so that they could play new "wide range" films as well as "Academy" films. Each installation would have to be considered individually, given the variations in installations.

In 1971, Dolby Laboratories investigated the application of A-type noise reduction to optical sound-tracks. The first film to be released with a Dolby encoded soundtrack was *A Quiet Revolution*, in 1972. In November, 1974, drawing from the experience of John Frayne, in conjunction with RCA and Eastman Kodak, Dolby Laboratories demonstrated a stereo system using variable area soundtracks at the SMPTE convention in Los Angeles. This system offered theaters sound quality with significantly improved bandwidth, lower noise and distortion, and, in addition, stereo width to match the picture. For the next four years there was little notice taken until two box office bonanzas, *Star Wars* and *Close Encounters of A Third Kind*, proved the commercial viability of this stereo sound process. Exhibitors throughout the world have found the cost for stereo optical sound is truly justified.

Installation

The Dolby stereo optical system uses contemporary thinking and hardware for motion picture sound. A Dolby cinema processor, when installed, becomes a permanent control center

... continued overleaf —

THE KINTEK SYSTEM

by
John Mosely
Kintek

The need and the desire to improve upon the quality of film sound, which was standardized in the early 1930s has long been recognized. Indeed the first serious commercial attempt was made by Walt Disney in 1940 with *Fantasia*. Fantasound,¹ which consisted of three audio tracks and a control track on a separate 35 mm film run in interlock with the picture, was only used with *Fantasia*. The recording and printing equipment were lost at sea during World War II, when it was on its way to Russia as part of the "Lend-Lease Program."

The first significant advance in film sound was made by 20th Century-Fox Film Corporation with the production of their CinemaScope system in 1953.² From the heated discussions that took place at that time the prevailing opinion was that photographic recording could not be improved so all energies were expended in the field of striped magnetic prints. Many theaters spent thousands for equipment to accommodate this new and exciting medium. Alas, its success was short lived. After a couple of years, few striped prints were available. The film companies blamed the exhibitors for not maintaining their equipment properly and the exhibitors blamed the film makers for not producing sufficient product to make the system worthwhile. Leaving the controversy aside, relatively few films are available in a multitrack magnetic strip due principally to their cost, and the limited number of theaters that can play them satisfactorily.

This author became interested in the film sound problem some five years ago when it was concluded that in realistic terms, it was not economically possible to enjoy satisfactory magnetic reproduction. At that time the Research Center of the Association of Motion Picture and Television Producers in Hollywood was investigating the possibility of making a multi-channel optical sound system with enhanced fidelity. This was done by means of modulating the red and green dye layers of the film in push-pull. I was invited to participate in this effort. It was concluded towards the end of 1975 that the Hue system did not satisfy all of the requirements for stereophonic sound and my team made a concentrated effort to examine other possibilities. After long and careful deliberation, it was decided to make a system using four independently modulated light-valve strings. This device was made available by Westrex and was an elaboration of a two-channel valve devised by Dr. Frayne in 1955.³ At the time it was rejected by the Industry, due to its lack of a solid center and poor monaural compatability. Further, it was inferior in performance to the magnetic system.

The performance of the light valve was greatly improved by specially designed electronics. Circuitry incorporating negative impedance made the modulator flat ± 2 dB from 2 Hz to 32.5 kHz. The limitations of the system therefore became almost totally

... continued overleaf —

Figure 1: A Comparison of Optical Edge Track Formats

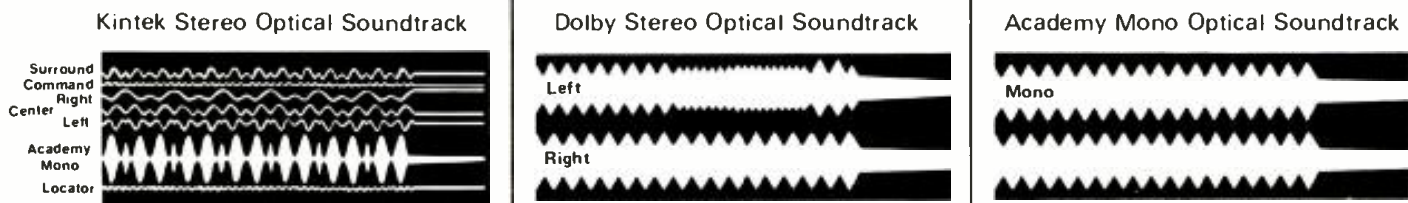

Our microphones are more often heard than seen.

We really don't have to broadcast the virtues of our equipment.

Especially if you've ever broadcast on our equipment.

Infact, go into almost any professional facility, and it'll be easy to spot Sony. With one exception:

Our miniature omni-directional electret condenser mike. The ECM-50PS is so small, you'd never expect such big performance. Yet this tie-tac microphone offers a wide frequency response, with full coverage from any direction.

On your visit you'll also come across the Sony C-37P. This is a professional condenser mike that's at home on stage or in studios. This versatility is enhanced by a selector switch that lets you go from omni to uni-directional. And thanks to FET circuitry, the 37P boasts a remarkably wide dynamic range, allowing sound pressures of up to 154 dB.

With the ECM-56F, Sony moves in the direction of a uni-directional condenser microphone. Offering Sony's exclusive Back Electret design, this unit combines a wide frequency response, with uncanny smoothness.

The Back Electret also sets the ECM-53FP ahead. The microphone, a flexible Cardioid for desk or podium.

The Sony C-74 microphone (not pictured), is a gun-type. You'll often see it at news conferences, where loaded questions are asked. This uni-directional condenser microphone is acknowledged as the standard in its category.

It's no stranger to theatres, sound stages, large halls and television studios. When you can't get proximity, make sure you're not at a distance from Sony.

Sony's line of microphones is as complete as you'll find anywhere.

But it also has Sony's disciplined quality and on-going perfectionism. Which you won't find anywhere.

SONY®

© 1978 Sony Industries, A Division of Sony Corp. of America
5 West 57 Street, New York, N.Y. 10019
Sony is a trademark of Sony Corp.



**THE NEW MULTI-CHANNEL SOUND,
OPTICAL RELEASE FILM FORMATS
DOLBY, continued . . .**

for the theater sound system, and is capable of accurate playback of conventional films in addition to Dolby sound-tracks. A minor modification to the existing projector is necessary; specifically a split solar cell, which picks up signals from the dual bilateral stereo soundtracks. It is installed in place of the single track cell. Compatibility between conventional and Dolby stereo prints is possible because the stereo tracks on the film occupy the same position as the conventional track. The two channel output of the solar cell is fed to the cinema processor. The Dolby CP-50 and CP-100 cinema processors are built to professional standards and are designed for easy maintenance. In many installations, as a theater owner updates his sound system, he replaces or updates the amplification and speaker systems as



The principal modification to the projector is the installation of a split solar cell. The film over the sound drum on a Bauer U2 projector has been cut away so that the cell is visible. The dual bilateral track on the film can also be seen.

well.

Films are normally mixed in an environment similar to that of a theater. The monitor chain in the past contained the same frequency limiting elements which would be present during theater screenings. The mix was equalized to get the best sound possible under these conditions. The monitor characteristic during a Dolby stereo optical mix approximates the conditions found in a theater equipped with a Dolby stereo processor. With the greater bandwidth of this system, less signal equalization will be required, in the post-production recording process.

More time is required to do a stereo mix, which results in a slightly higher production cost; however, the print costs are comparable to those of conventional soundtracks.

Dolby Stereo Optical Operation

The Dolby stereo optical system uses the signals from the two soundtracks to derive as many as four channels of information: left, center, and right information for the front speakers, and surround information for the rear can be obtained. Naturally, improvements of the original system have been made but modular construction of the CP-50 has allowed compatible upgrading. Most recently, an improvement in the center channel derivation circuitry has yielded more discrete channel separation.

Dolby 70 MM

Dolby introduced A-type noise reduction to six-track 70 mm magnetic films in 1975. The improvement offered by this process is familiar to the professional recording industry. Six separate magnetic tracks offer excellent separation and fidelity. In the original concept, five of the six tracks were fed to five stage speakers (i.e.: one center speaker with two speakers evenly spaced on each side). The speakers are counted one through five

THE AMAZING NEXUS PATCHBAY

The small studio owner's dream, here is a complete, ready to install (with no soldering) 96 hole patchbay. This unit is fully "normalled" with 1/4" "lifting" jacks on the front panel, wired to standard RCA type jacks on its rear panel. That's right, it's ideal for TEAC-TASCAM, SOUND WORKSHOP, etc. owners who need flexibility for their almost perfect eight track studios. (You 4 and 16 track movers should be interested also.)

Every circuit in this wonderful box is isolated from each other and the chassis. Only the finest SWITCHCRAFT parts are used with low capacitance shielded cable from ALPHA WIRE. It comes ready to rack mount in a sturdy and good looking INTRAFAB box. (With feet provided if you wish it to stand alone.)

Since this unit has all of its "normaling" built in, all you need

do is connect everything in your control room (inputs & outputs of the board, all tape machines and other equipment) to its back panel in the configuration most "normally" used. (We provide a standard plan.) Then when you want to do something special like patch in a peripheral device, phase shifter, compressor, equalizer, etc., just use a 1/4" to 1/4" patch cord (standard guitar cord will do) and go to work.

It will save you valuable time and alleviate much aggravation. Also your clients will save money because they won't need to sit back while you rewire the back of your board every time you want to do something tricky. It is the touch of professionalism you need to keep your place running smoothly and efficiently.

You technicians will also find this patchbay a great tool for your



An uncommon studio patchbay "The Nexus" audio bench. Scope, VTVM, oscillator, etc., may be hooked to it and each other in such a way as to eliminate the need for adaptors and birdsnests of probe wires. Troubleshooting becomes fun again without Esak's law: "The availability of an adaptor is inversely proportional to the need for it."

Get a NEXUS PATCHBAY for your place. We know you'll love it.

3 1/2"H x 19"W x 9"D **Price: \$320**

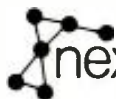

nexus inc.

50 Chuckanutt Drive, Oakland, N.J. 07436

(201) 337-0707

starting on the left for reference. The sixth, the surround track, feeds speakers mounted in the rear of the auditorium.

Originally, the six-track mix for 70 mm magnetic was achieved through very elaborate processes which included panning across each of the five behind screen speakers. Recently, however, conventional six track masters were normally derived from the four-track mix prepared from the 35 mm full-coat master. Tracks two and four of the six-track print simply contain a mix of the four-track's left, center, and right components respectively. This can cause two problems in playback, given the similarity of information carried on various speakers. The stereo effect is substantially diminished; in addition, much of the audience will hear confusing spatial effects due to acoustic phase problems.

The Dolby bass enhancement technique makes more effective use of speakers two and four; supplemental bass information extends the low bass response of the theater sound system. On these films, only low frequency bass information below 200 Hz is recorded on tracks two and four. Speakers one, three and five reproduce left, center, and right. Channel six reproduces the surround as before.

Conclusion

Technological capability has advanced in the many diverse areas involved in sound production and reproduction, from location recording techniques to the improvement of auditoria frequency response and the widespread availability of stereo sound systems. The technology for a significant improvement in film sound is now available. The increasingly sophisticated and demanding audiences of the contemporary motion picture theater can now enjoy a fidelity of sound reproduction which matches the dramatic visual qualities long associated with the motion picture medium. □ □ □

— continued from page 74 —

THE KINTEK SYSTEM

dependant on the resolution of the recording film and the size of the reproducer's optical slit. By using a Charge-Coupled Device Scanner and Eastman 5369 high contrast negative, satisfactory results were obtained to 20 kHz. Agfa-Gevaert ST8 and Fuji Sound Recording Negatives proved to be more economical substitutes. Technically the laboratories preferred the latter stocks, since they both use a gray base and did not have a red dye, the behavior of which varied, giving inconsistent prints. The quality of these tracks was excellent, stereophonically, in all aspects.⁴

It would have been possible to market the above system in 1977. However, in light of the problems that manifested themselves with all of the available and proposed systems, it was decided to do a thorough in-depth study of the requirements of the whole industry, rather than experimenting at the buyer expense. Careful studies were undertaken in the three areas most effected, these being Production, Distribution, and Exhibition. These investigations were invaluable and turned up much useful data, while at the same time clearly showing what was required.

The Producers demanded a system that would be compatible monaurally, while containing a minimum of four discrete wide range stereophonic tracks. And it needed to be capable of accepting any multi-track master, without imposing any mandatory requirements or restrictive limitations on the dubbing crew.

The Distributors required a single inventory of 35 mm prints for both economic and practical reasons since far too frequently

— continued overleaf . . .

990

THE BEST OP-AMP

Electrical design by Deane Jensen,
Jensen Transformers.

Packaging and production design by
John Hardy, Hardy Co.

LOW NOISE: -133.7 dBv $R_e: 0.775$ v
(Shorted input, BW : 20 kHz)

LOW DISTORTION: $.005\%$ THD
(20 kHz, $+25$ dBv, gain : 20 dB, $R_L : 600 \Omega$)

HIGH SLEW RATE: 18 V/ μ S, $R_L : 150 \Omega$
 16 V/ μ S, $R_L : 75 \Omega$

HIGH OUTPUT: $+25$ dBv, $R_L : 75 \Omega$

Complete specifications and
documentation available



(Enlarged view)

APPLICATIONS INCLUDE:

Input stages (mic, tape-head, phono, etc.)
Line outputs (line drivers)
Summing amps
Active filters

DIRECTLY REPLACES API 2520 MODULES

DIMENSIONS: 1.125 "sq. \times $.625$ " h

All 990's receive 24 hour active
burn-in at 100°C (212°F)

41 components on a 1 " square pc board

MIL-SPEC RESISTORS: RN55D
(1% metal film, ± 100 ppm)

ULTRA STABLE CAPACITORS: ± 30 ppm

Manufactured by and sold exclusively thru:

THE HARDY CO.
P. O. Box AA631
Evanston, Illinois 60204
(312) 864-8060

*Formerly marketed thru Bright Side Audio

**THE NEW MULTI-CHANNEL SOUND,
OPTICAL RELEASE FILM FORMATS**
KINTEK, continued

exchanges mix up prints having different formats, particularly when they look similar.

The Exhibitors were somewhat ambivalent concerning the advantages of stereophonic sound and fearful of investing in new equipment without the guarantee of product. Modern multi-screen theaters pose additional problems from the standpoint of the method of projection, where an additional maintenance burden would not be welcomed.

The solution was obvious, the film had to be truly compatible. It must play monaurally on any projector as well as the best Academy dub and at the same time give wide range multi-channel reproduction on a properly equipped machine. Put another way, the industry wants a satisfactory replacement for the mag-optical print. In light of the indubitable problems that exist in theaters and the need for more economical operation, a self-adjusting automatic fail-safe reproducer was indicated.

**The Development
of the Kintek System**

During the early research stages it became abundantly clear that there were two problem areas in theatrical projection sound systems. The first area is mechanical problems that manifest themselves as jump and weave of the film as it goes through the projector and secondly the changing and uneven light transmittance as exciter lamps weaken and dim with age or where dirt has built up. When considering a standard .076" recording read by a .084" system comprising only one channel, there is indeed room for error. But when there are a number of tracks in that same width, these problems become more serious. We therefore developed a scanning reproducer based upon a Charge-Coupled Device, which together with its associated

circuitry is blind to the problems stated above.⁵

Cross-modulation testing revealed that it was virtually impossible to hold tight tolerances when prints are generated on a variety of printers that differ in make, type and speed. Since the tolerances accepted in the marketplace for Academy prints are rather wide and would be unacceptable for high quality stereophony, it appeared that an easy method of circumventing the problem would be by the employment of push-pull tracks, which by definition are far less critical in this area. These, too, had the advantage of making themselves unreadable on a standard reproducer. Furthermore, such an approach would not place an onerous burden upon the laboratories. In fact push-pull tracks will give satisfactory reproduction, beyond the acceptable tolerance for a bilateral track.

Having reached this conclusion, another advantage became obvious. If approximately half of the track area were assigned to a standard bilateral track, and a push-pull or snake track was placed on the other half, one would have a truly compatible mono/stereo print. The only immediate disadvantages that were apparent were the loss of output level by 6 dB, assuming half of the track width and a worse signal to noise ratio. But the appealing advantages of combining a proper Academy track with its unique characteristics, and a wide range stereophonic signal made us conclude further tests were in order. Of course, there was no recorder that could prove the point. Not to be daunted, we built one. It did require a special cathode-ray tube and its associated circuitry, but the results were most encouraging. In order to verify the aspect of true compatibility, a recording was made placing an Academy track in the bilateral portion, tones were pulsed on the four stereophonic tracks. This film was run on a variety of projectors and film reproducers. In the worst case, the crosstalk was -50 dB from the reference level. Having regard to the fact that one would anticipate similar information in both

**TAKE
A
LOOK
INTO
THE
VMS**

Try
this new disc
cutting instrument from
Neumann for your next project.
It'll make the most of your music.

K disc mastering

A Subsidiary of Keycor-Century Corporation

6550 SUNSET BOULEVARD, HOLLYWOOD, CALIFORNIA 90028 - (213) 466-1323

segments, not only was this negligible, and acceptable, but it meant that one could envisage one print accommodating multi-lingual tracks.

In practical application it was obvious that some sort of positive track guidance was necessary since the individual stereo tracks would have a peak-to-peak modulation of only .010". It was decided the solution was a pair of locator tracks placed at the edges of the ANSI projector scan, modulated at 8 kHz in antiphase, thereby minimizing any crosstalk into the Academy reproducer in the presence of weave. Additionally these tracks perform other functions:

1) Confirm to the electronics the presence of a Kintek track and set it into the correct operating mode.

2) Provide 10^6 control functions by use of a touch tone coding system, FM modulated on these tracks.

3) Provide the means of extending the low frequency response of a theater system down to 20 Hz by means of an electronic crossover, whereby frequencies below 60 Hz are multiplexed into the two locator channels at the rate of 12 dB/octave and modulated in FM. (This has been done in order to avoid placing information into the stage loudspeakers and amplifiers, which they are incapable of handling properly.)

The two locator/command tracks, beside giving a more positive lock and guidance, also save the projectionist from having to remember what type of film is being run. This is all the more valuable in multiple-run houses which use film platters and not reels. A number of prints examined after returning from such houses revealed that very frequently the wrong leaders are used when the film is returned to the transportation reels. In most cases, the reel numbers are simply written on a piece of tape and stuck to the reels. If there is an absence or a loss of the locators, the system automatically fails safe into the Academy mono mode.

The Kintek Equipment

Figure 1 shows the track layout. Since it was decided to place the two locators on the edge of the ANSI scan, the dimensions available left few choices. The figure also shows the relevant peripheral data to support our solution.

It was decided to place the Academy section to one side, since it turns out that some projectors equipped for SVA (Stereo Variable Area) contain split cells with a .010" septum. If this track were placed in the middle, low level signals could be lost and such systems would be subject to cutting in and out. It was felt that any signal interruption would be less objectionable in the present position. The .040" allowed for this track make it 5 dB down when compared to 100% of a .076 track. In order to improve the signal-to-noise ratio, this signal is companded by a factor of 1.3, thereby reducing the apparent loss of level to 2 - 3 dB. The additional level requirement is within the ability of all theater equipment. This track utilizes standard ground noise reduction which reduces the basic noise of the playback system during the reproduction of quiet passages.

All of the snake tracks are .002" wide. The locators contain fixed modulation of ± 0.01 " and the four stereophonic tracks are permitted modulation of ± 0.005 ." In every case, there is a guard band of .002" between the tracks. These are guaranteed by hard limiters placed in the recorder circuitry. The signal to noise ratio of the system is sufficiently good, so that it is unnecessary to reach 100% modulation except on rare occasions.

Adequate brightness is available from the cathode-ray tube for correct negative exposure at real time. All testing of this modulator has been done on Agfa ST8, 35 mm sound recording negative. Its performance, stability and consistency are ideal for this application. Photographic results have been verified in five major Hollywood Laboratories, using different chemical processes.

... continued overleaf —

A PARTIAL USERS LIST

- Cherokee, Hollywood
- Kendun, Burbank
- Sunset, Hollywood
- Criteria, Miami
- Westlake, Los Angeles
- Sound 80, Minneapolis

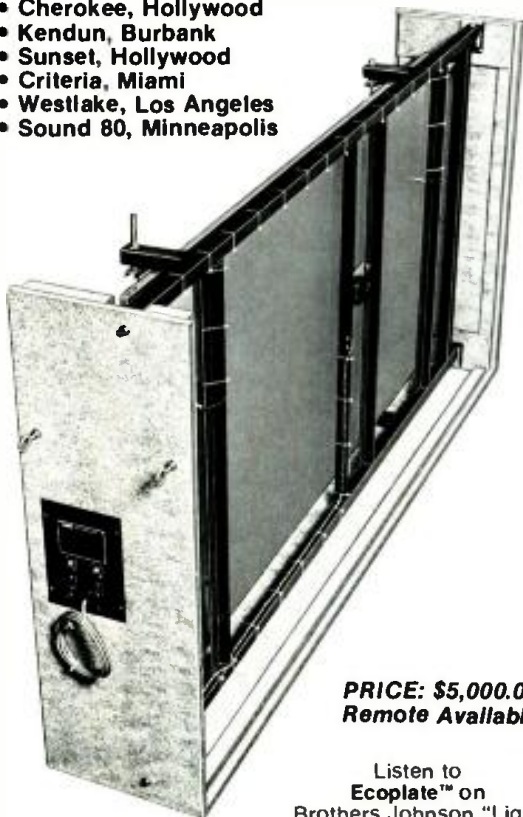

PRICE: \$5,000.00
Remote Available

Listen to
Ecoplate™ on
Brothers Johnson "Light
Up The Night," A&M Records

ECOPLATE™

THE NEWEST SOUND IN REVERBERATION

Here is what some of the top music mixers who use the ECOPLATE™ have to say about it:

"The sound is incredible . . . I've used many types of reverb and nothing compares with it . . . it really *lifts* the music." **Bruce Swedlen**, engineer for Quincy Jones, Michael Jackson, and Brothers Johnson.

"The density of reverberation and the shape of the reverb curve are such that I can use more if it, yet it doesn't swallow the music. It's just great." **Tom Jung**, President, Road 80 Recording.

"It's really great echo, I love the way it expands the music." **Gary Laviso**, STYX engineer and recent Grammy nominee.

Call your dealer or
PROGRAMMING TECHNOLOGIES, INC.
6666 N. Lincoln Avenue • Lincolnwood, IL 60645
(312) 676-9400
FREE DEMO TAPE AND BROCHURE AVAILABLE

The Recording Channel consists of a rebuilt RCA PR23 recorder, fitted with the CRT modulator and associated electronics. Separate dummies are provided for running the Mono, Stereo, and Code films. The whole system is run by a standard three-phase 1,200 rpm distributor. Visual and aural

Figure 2

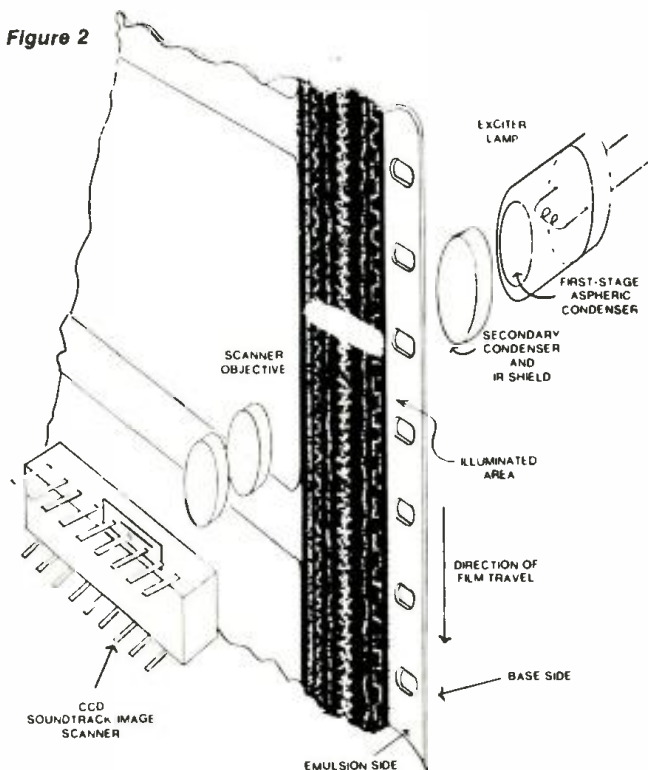

monitoring are provided for proper quality assurance. It has been shown that in nature, a dynamic range approaching 80 dB is desirable.⁷ In order to improve the performance of the basic track, a companding system has been designed especially to accommodate the anomalies of the medium, which is incorporated in the recorder electronics.

The reproducer is fitted with a CCD Scanner (figure 2). It should be pointed out that CCD scanning has substantial advantages for reading all variable area tracks. Electronically the CCD only reads the transition points where there is a change between light and dark. It will be realized that all of the required modulation data are contained at these boundaries. Since the boundaries of a standard dual bilateral track only occupy 10% of the available area, it follows that 90% of the area contributes only to the noise. It has been shown that with badly worn prints an improvement of 20 dB in the signal-to-noise ratio can be achieved. Additionally this system is also immune to wide changes in light level across the track. In simplistic terms, it ensures correct output level between machines. But more importantly it ensures that the expanding section of the compander will see precisely the correct level, hence the system will accurately reproduce the recording without operator intervention, or routine adjustment.

Conclusion

The Kintek compatible combined mono/stereo photographic soundtrack described in this article satisfies all of the requirements of the different phases of the Motion Picture Industry by the incorporation of "space age" technology. It can, however, be stated that its stereophonic performance exceeds what has been shown to date by other magnetic or optical systems, as well as satisfying existing requirements for Academy reproduction. Figure 3 illustrates the Kintek playback package

The Stephens 40 Track.

We've been putting 40 tracks on 2" tape since 1973. With 40 track capability in one machine, there is no need to go through the hassle of syncing up two tape machines to get as many tracks as you need for your session. Our 40 track machine is also available in portable cases, ready to go where you are. Stephens machines are also available in 4, 8, 16, 24 and 32 track formats. You can purchase your 40 track with 24 or 32 active tracks and the rest prewired, we'll add the additional electronics at a later date when you're ready to expand. Call us. We'll be happy to talk about why you should choose a Stephens when you buy your next recorder/reproducer.



SPECIFICATIONS

- **Signal/Noise Ratio:**
Tape stopped 75dB, @ 15 ips
69dB, @ 30 ips 70dB unweighted wideband
- **Frequency Response:**
@ 15 ips \pm 1dB, 40 Hz - 15kHz
@ 30 ips \pm 1dB, 50 Hz - 20kHz
- **Wow & Flutter:**
@ 30 ips .02% average
@ 15 ips .03% average
- **Rewind Time:**
Approx. 90 sec. for 2400 feet.
- **Height:** 58"
- **Weight:** 136 lbs.



**STEPHENS
ELECTRONICS, INC**

3513 Pacific Avenue, Burbank, Calif. 91505

Phone (213) 842-5116

Since 1956

Figure 3

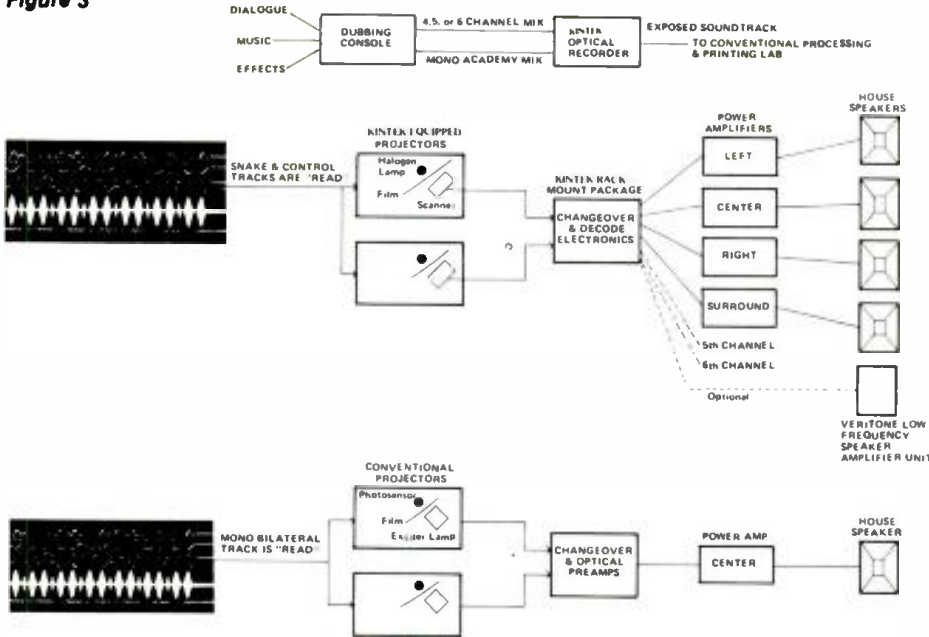

John Mosely has been actively involved in sound recording since 1948. He worked for Westminster Records and Audio Fidelity, in New York, and he was Chief Engineer of Pye Records, in London. He made the world's first commercial stereophonic records while at Pye in 1958. He was responsible for L. J. Scully entering the tape recording market and took an active part in the development of the Scully recorders. Although specializing initially in classical recording, he has more recently been involved in the pop field. He has designed and run sound recording studios in London, Los Angeles, New York, and Paris. Throughout his career he has been active as a consultant both in the engineering and recording aspects of sound. In 1974 he turned his full attention to working with motion picture film with the desire to improve its quality. He invented the Quintaphonic system used in Columbia Pictures' "Tommy," and is co-inventor of the Kintek system.

as compared to a conventional playback. The commercial equipment will be capable of reading other tracks with manual intervention by means of accessories. It is our fervent hope that this system will be examined carefully, with a view that it should become the new International Standard. □ □ □

References:

- 1 - *Fantastound*, J. SMPTE, 37:127, August, 1941, W. E. Garity and J. N. A. Hawkins. This picture was released on November 13th, 1940.

- 2 - Earl I. Sporable, et al., *Design Considerations of the CinemaScope Film*, J. SMPTE 63:1-4, July, 1954.
- 3 - J. G. Frayne, *A Compatible Photographic Stereophonic Sound System*, J. SMPTE, 64:303-308, June, 1955.
- 4 - J. Mosely, et al., *The Colortek Optical Stereophonic Sound Film System*, J. SMPTE, Vol. 87, No. 4, April, 1978, p. 222-232.
- 5 - U.S. Patent No. 4,124,784 and other worldwide patents pending.
- 6 - British Patent No. 394325.
- 7 - J. C. Steinberg, et al., *Symposium on Wire Transmission of Symphonic Music, and its Reproduction in Auditory Perspective*, Bell System Tech. J., 13:245, April 1934.

Eventide TM the new Harmonizer



The new Eventide model H949 Harmonizer gives you **pitch change** (one octave up, two down), **delay** of 400 ms on two outputs, **time reversal**, **flanging**, **repeat**, **randomized delay**, and **micro pitch change** for precise, stable settings near unison. Frequency response is 15 kHz, signal-to-noise ratio is 96 dB. See it at the AES Convention, or write for details.

Eventide Clockworks Inc. 265 West 54th Street New York NY 10019 (212) 581-9290

Harmonizer is a trademark of Eventide Clockworks Inc

February 1980 □ Re/p 81

NEUMANN

the history
of
Tube
Condenser
Microphones

by Winn Schwartau and
David Smith

From private conversations
with Stephen F. Temmer, President,
Gotham Audio

This is the story of the youngest of some 12 children born in 1898 to a railroad worker and his wife in the Berlin suburb of Chorin, Germany.

This is about a man of very few words; the virtual father of the modern day condenser microphone; of his apprenticeships, his inventions, his triumphs, the factories built and burned, his hand-built tools for lack of availability, and his career's culmination as an international pioneer in modern technology.

It is about Georg Neumann and the developmental history of the vacuum tube condenser microphone.

The early wireless industry of Germany, after the turn of the century, was largely dominated by two electro-conglomerates; A.E.G. (Associated Electric Industries) and Siemens. Germany was the world leader in theoretical physics and technological applications. Georg Neumann gained his first professional electro-acoustic experience by landing a job with A.E.G. in 1923.

A.E.G. was involved in various areas of electro-acoustic research, and Georg Neumann began an apprenticeship with a Mr. Reisz at A.E.G. Reisz was pursuing improvements in carbon-granule microphones; the basis for telephone transmission. Carbon-granule microphones had severe response linearity problems and Neumann set to work investigating them. After much research, his first major contribution to Reisz's work was the determination and isolation of the linearity problem: acoustical resonances. His subsequent solution was the ability to actually measure and control the resonances for optimum linearity performance. This breakthrough resulted in the Reisz microphone; a carbon-granule microphone built into a hollowed out chunk of marble. Marble was chosen as the support structure for the transducer because it would not vibrate in sympathy with the carbon granules inside, thus eliminating many of the microphone's prior limitations. Neumann also worked on magnetic cutterheads, turntables, and cartridges. These studies and his early interest in cutting lathes would later make Neumann a leader in more fields than just microphones.

While still at A.E.G. with Reisz, Neumann began his pioneering work on using condensers as microphone transducers rather than the conventional carbon.

Neumann's first attempt at a condenser capsule for commercial use was the CM-3. The CM-3 was a pressure transducer (omni) capsule, but it was not until 1930 that an amplifier unit was designed and built: the CMV-3. In 1928, however, Neumann left A.E.G. and Reisz with Erich Rickmann, to form *Georg Neumann and Company*, and that's where the subsequent CM series of microphones and capsules were developed.

At the time, 1930, there wasn't a recording industry as we know it. There was though, a very large, powerful and expanding broadcast industry which demanded the best technology available. In 1930 after the CMV-3 was developed, Telefunken, a subsidiary of A.E.G. and Siemens, took on the marketing rights to Neumann's microphone and sold it under the Telefunken number SO-16.

Neumann's first factory was in Berlin, Germany.

By 1932, Neumann had developed a series of plug-in heads for the CMV-3. Re-named the CMV-3a, or "The Neumann Bottle," it could take either the CM-7, Figure 8 head, the CM-8



Georg Neumann 1898-1976

cardioid, or the CM-9 omni form.

This was the first directional microphone made and utilized the first successfully manufactured double membrane capsules conceived by Braunmuhl and Weber, patented in Germany in 1927. Among his other early works, Neumann in 1931 built and marketed the AM31 cutting lathe, still in use today. He further patented in 1934, the first linear motion pen recorder, predecessor of the modern strip recorder and X-Y plotter.

While his company was manufacturing microphones which were being marketed as Telefunken's, Neumann began to re-pursue an interest which had intrigued him for some time. During much of World War II, in his Gefell factory, Neumann continued a line of research well out of his field; Chemical Engineering. He wanted to create a sealed storage cell which could be easily recharged. By the end of World War II, Neumann had not yet perfected his sealed NiCad battery, much of his factory in Berlin was in ruins, and there were few people interested in quality microphones. An old friend, by the name of Gottesmann, knew of Neumann's work and wanted to see him continue. Gottesmann talked to French officials, who also knew of Neumann's work,

so almost immediately after the cessation of hostilities in Europe, he was set up in a laboratory in Paris. He was able to complete the most important invention of his life and one of the few basic patents of this century: The gas tight rechargeable Nickel Cadmium Battery.

Georg Neumann's factory in Gefell was still intact and in the American Zone of Germany. But the Gefell region was ultimately ceded to the Russians in exchange for access routes to Berlin at the Potsdam Conference attended by Churchill, Stalin, and Truman. So Neumann left for Berlin in 1947, where he began the tedious process of re-tooling his old manufacturing company. The Gefell factory continued manufacturing Neumann microphones and Georg Neumann went to Gefell quite often to help their production efforts. They continued to use the original trademark used for so many years prior by Neumann, and he, himself, continued to use the same trademark in his Berlin factory, except enclosing it within the now famous diamond signature.

Gotham Audio, in fact, owns the trademarks for both the Gefell Neumann and the Neumann GmbH Berlin to insure against the East German microphones entering the country today.

(The Neumann trademarks are also useful to identify tube or transistor microphones. The diamond background is black for tubes and purple for solid state.)

In 1947 there was still a minimum of redeveloped German industry, so Neumann's personal machinist, Mr. Rehagen, who had been with him in Gefell and Paris, built from scratch the precision equipment needed to construct everything from wind screens to the tensioning mounts for the capsule membranes.

What first came off the production line in June 1948 has become the subject of intense debate and equally intense monetary appreciation: the immortal U47.

A CHRONOLOGICAL HISTORY OF NEUMANN VACUUM TUBE CONDENSER MICROPHONES FROM 1947 - 1967

U47 and U48

The Neumann U47 was originally marketed by Telefunken, the only post-war company able to actually properly handle the product on an international basis. In fact, much of German electrical manufacturing was distributed by the now wholly owned subsidiary of A.E.G. This is why many of the engineers today refer to the U47 as a "Tele."

The first microphones off the assembly line were the finest mikes of their day, though today we would call hand wire wound resistors made on a base of packing cardboard rather crude. The 32 mm gold sputtered PVC based diaphragm (K47) was a Braunmuhl-Weber dual membrane design housed in a hand tooled head and grill (KK-47). There were two pins connecting the head to body which carried signal and polarizing voltage to the diaphragms.

The preamp used was as simple as amps get. A metal encased glass pentode wired as a triode with cathode feedback for gain coupled to either a fifty or two hundred ohm output impedance, strappable transformer, provided the necessary matching circuitry to talk to other equipment. Because there was no post-war tube manufacturing yet in Germany, a pre-

Now, for the first time, you can play any cards.



And win.

Introducing the TTM 24-track Frame.

The world's only multi-track frame that can accept all the noise reduction cards on the market today.

And using only 12¼ inches (310 mm) of rack space—including the silent-fan equipped power supply.

- Transformer-less balanced input/output electronics.
- Simple to install and interface.
- Gold contact fail-safe relay switching.
- By-pass mode eliminates all electronics.
- LED alignment replaces meters.
- Delivery from stock in Europe and the U.S.

The TTM 24-track Frame. It doesn't just help you to reduce noise. It reduces your problems.

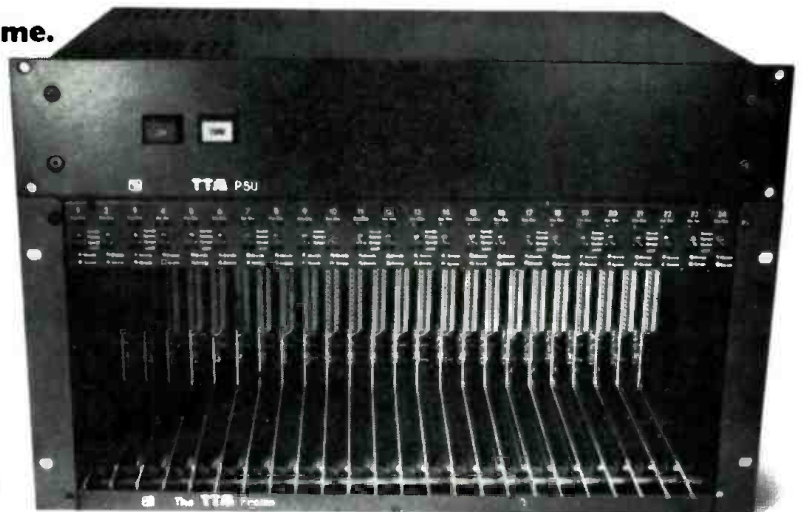

For additional information, contact:

GOTHAM
AUDIO CORPORATION

741 Washington Street, New York, NY 10014 • (212) 741-7411
West Coast Office: (213) 874-4444

February 1980 □ Re/p 83

war pentode was selected; the Telefunken VF-14. The VF-14 was a radio tube from the 1930s and employed a 55 volt filament. The highly microphonic VF-14 was mounted in a shock mount within the microphone body and the hand wound 1780-ohm filament resistor dropped the filament voltage to 37 volts. The lowered filament voltage insured an

exceptionally long life for the tube, superbly quiet operation and a hand-warming body.

Original U47s had hand engraved Neumann insignias on the body and were some 3" longer than those produced in later years. The separate power supply provided 105 volts for 60 V polarizing voltage and the directly heated cathode on the VF-14.

ENGINEERING THE CAPACITIVE MICROPHONE CAPSULE

Winn Schwartau and
David Smith

All microphones are electro-mechanical transducers which convert acoustical energy into electrical energy. A condenser (capacitor) microphone is essentially a capacitor with one fixed plate and one suspended plate which is free to vibrate in sympathy with acoustical vibrations impinging upon it.

The capacitance between the two electrodes (typical spacing .0015" [0.04 mm] or less) will vary as the freely suspended plate, known as the diaphragm moves with respect to the fixed electrode. If there is a potential difference (voltage) applied across the two plates, through a very high resistance, the charge on the plates will remain constant.

Equation #1:

$$E = q/c$$

E = voltage

q = charge

c = capacitance

Thus, as the capacitance changes with the impinged sound waves, and as the charge is held constant, the output voltage will vary inversely with the capacitance. For this varying voltage to be useful in audio, the output must be amplified. But because we are in a very, very high impedance circuit (>10⁹ ohms), which is primarily capacitive, an output load must be selected which will not in any way affect or cause the diaphragm to discharge. The ideal output for a condenser or diaphragm is a purely resistive load of very high impedance with no capacitive or inductive loading so as to maintain the constant charge (q) on the diaphragm. In practice, this requisite precludes the use of long wires from the condenser diaphragm, or the inclusion of any other components which can cause inductive loading.

The proper operation and construction of the condenser microphone element is determined by several variables, all of which must be specifically and accurately controlled.

Equation #2:

$$E_{in} = EPA/4DT$$

E_{in} = open circuit output voltage

E = polarizing voltage (across plates)

P = applied acoustical pressure
in Dyne/cm²

A = radius of diaphragm in/cm

D = distance between charged
plates in cm

T = membrane tension in Dyne/cm

The electrical output signal is quite complex by the number and function of mechanical and electrical parameters which can affect it. The most critical component involved in the microphone is the capsule itself. There are four considerations in its final design.

1 - Tension of the membrane (compliance) determines the low-frequency characteristics of the vibrating membrane. The stiffer the diaphragm is held on its support rings, the greater the low-frequency droop. The low end roll-off is dB/octave and the drop off point is shifted by various degrees of tension.

2 - Mass determines the high frequency response of the diaphragm's movement. As the mass of the diaphragm increases, the high frequency limit decreases. The mass of the diaphragm is affected by a combination of the thickness and composition of the membrane.

3 - The diameter of the head also determines the mass of the membrane, therefore affecting frequency response. Thus, the smaller diaphragm microphones have a different high frequency characteristic than do the large diaphragm microphones.

4 - The spacing between the plates obviously affects the capacitance of the circuit itself. Further and more importantly, the spacing creates an air pocket which acts like a spring cushion to the vibrating mass of the membrane, effectively affecting the system's compliance.

— continued overleaf . . .

Between June 1948, when the U47 was introduced, and June 1951 only 500 microphones were produced. By the time serial #3100 U47 was manufactured, in 1956, the body size was reduced from the long body tube with chrome head, to the smaller body tube and matte finish head. That same year, Neumann introduced the U48; different from the U47 in that it produced the cardioid or Figure 8 pattern rather than a choice of cardioid or omni.

To produce an accurate Figure 8 pattern, the front and rear diaphragms had to be matched exactly for frequency response and capacitance. The rejects of K47 capsules were often caused by a phenomenon known as "electret." An electret is a permanently polarized diaphragm. Simple enough. We know very well how to produce one, then and today; but we don't know why the diaphragm holds the charge, or as in Neumann's case, how to avoid it in production.

The U48 head had three pins to carry the out-of-phase split polarizing voltage of 52½ volts to each diaphragm. Later marketing techniques would sell U48 bodies with U47 heads, to provide the customer with the option of plugging a U48 head into the body when required.

When Telefunken was representing Neumann as an international distributor, the U.S. sales agency was American Elite, operating from a store front on Park Avenue and 34th Street, in New York City. One of their salesmen, Fred Cunow, was trying to sell a U47 to a tough customer, Stephen Temmer, then president of Gotham Recording. Temmer finally acquiesced in 1953 and purchased the overpriced U47 for \$390.00. (The next highest priced microphone on the market was the RCA 77D at \$135.00.) Temmer used this sole mike shortly thereafter to mix an entire orchestra and vocal group, The Ink Spots. A subsequent article by Temmer stated . . . "from now on we'll never need more than one microphone."

Temmer's only complaint from the microphone was its overload characteristics, as the dynamic range was limited to 108 dB. He and an engineer from Gotham redesigned the amplifier and changed it from a triode stage to a cathode follower. Temmer changed the U47s

— continued overleaf . . .

the authors

David Smith is 30 years old with an MSEE from RPI. He was chief engineer of A&R Recording, in New York, and presently is chief engineer of Phil Ramone, Inc., an independent production company. Dave has been an avid tube microphone collector and now boasts one of the finest and largest private tube microphone collections in the country. His Masters thesis with RPI involved the development of two condenser microphone capsules.

Winn Schwartau is a native of New York City. He got into professional audio in 1969, at the age of 16, at Mirasound Studios. In the following years he has worked in various aspects of the recording industry at a number of prominent New York Studios.

Currently, he is president of Empirical Audio, a New York based engineering firm which is now involved with studio design and installation, custom engineering and brokerage consultation and East Coast distribution of Trident products.

SYNCON

Logic and Music in Harmony

It is a fact that many medium priced consoles use ungraded VCAs and ICs resulting in signal degradation and unpredictable performance. Syncon uses top quality discrete circuitry on interchangeable cards which allow not only instant replacement but future upgrading.

Sophisticated PCB design has virtually eliminated hardwiring making Syncon not

only cost effective but incredibly reliable and serviceable, an important factor for studios without resident 'boffins'.

Add to this a superb status, routing and grouping system enabling 28 tracks or effects to be mixed through 14 stereo subgroups and you have a very logical alternative to the headaches of cut price automation.

SYNCON FEATURES

- 28 Input output capacity.
- 24 Track monitor.
- Quad mixing.
- Autosolo.
- 6 Auxiliaries.
- 2 Stereo and quad echo.
- Master and channel status switching.
- 26dB Output.
- Parametric eq.
- 3 Module inserts.
- Producer's desk and patchbay.
- Price range \$20,000-\$30,000.

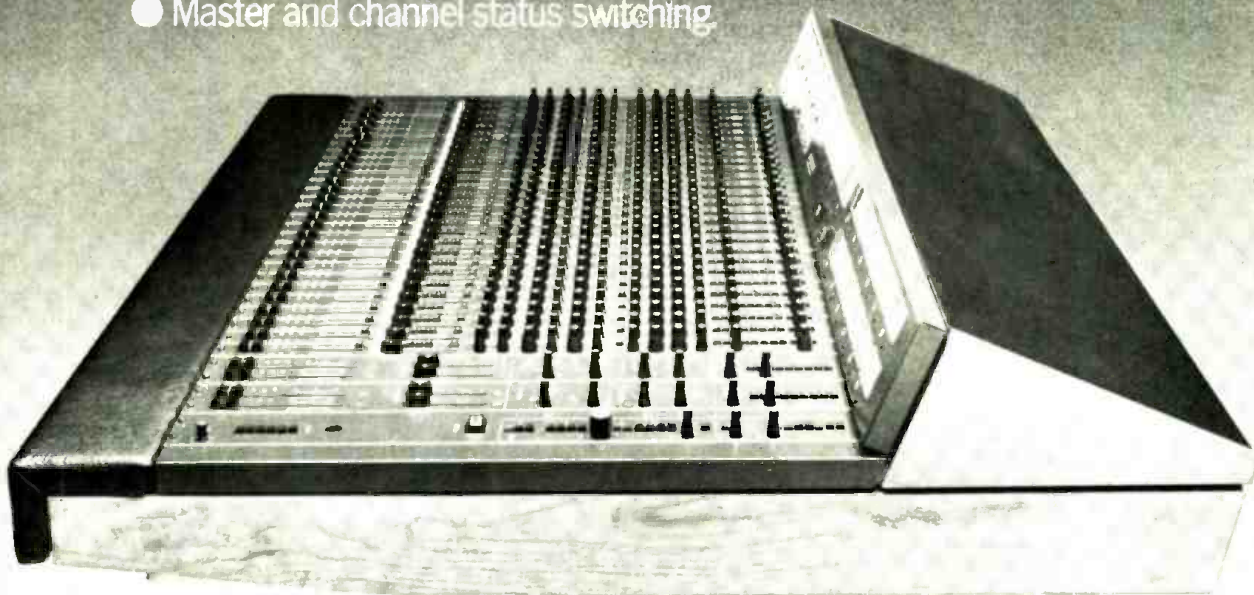

Made in England by:
ALLEN AND HEATH LTD.
Pembroke House
Campsbourne Road
London N.8.
Tel: 01-340 3291

AHB
ALLEN AND HEATH BRENNELL LTD.

audiomarketing Ltd
Glenbrook Industrial Park
Stamford, Connecticut 06906
U.S.A.
Tel: (203) 359 2312

for other studios, but only until 1957 when he went to Berlin and met Neumann's Physicist, Gerhart Bore.

In August 1957, Temmer was taking a trip through Europe and while in Germany he had the opportunity to visit the Neumann factory. The first person to meet Temmer in the waiting room was Dr. Gerhardt Bore, who immediately bristled angrily upon spying the man who changed the U47 circuitry. "How dare you . . .!"

Coincidentally, Neuman had pulled his distributorship from Telefunken as of April 1, 1958, as American Elite was on the verge of

bankruptcy. Temmer left Germany with the new stereo SM2 microphone as a gift and the possibility of becoming the U.S. Neumann sales representative. After some immediate success with selling Neumann stereo disk cutting lathes in New York, Temmer set up Gotham Audio Sales Corporation, and began distribution of the already extensive line of Neumann microphones and peripherals. The U47s were re-modified to the original triode preamp and remained that way thereafter.

Since Telefunken no longer sold the U47 or M49, or any other Neumann microphone, and as the U.S. based microphones came into

Gotham for repair and overhaul, the Telefunken insignias were summarily changed to the Neumann diamond. Telefunken soon commissioned another microphone manufacturer to produce a microphone to compete with the U47. The manufacturer was AKG. This Austrian-made microphone was marketed by Telefunken as the ELA-M251, the predecessor of the C-12 and 414.

M49, M249, M50, M250

After the war, the German broadcast industry re-grouped and the networks organized and formed the *Institute Fur Rundfunktechnik*: Broadcast Institute Labs, known as the IRT. The IRT is now based in Munich and forms the technical support base for the German broadcast industry. They set standards for all equipment, design equipment, manufacture equipment and set test practices in formal guidelines; in short, nothing goes on the airwaves without having been thoroughly selected and analyzed by the IRT, including every reel of tape.

In the early days of the IRT, it was decided to set standards for and have manufactured a microphone that would meet their stringent requirements. Dr. Herbert Grosskopf, an IRT scientist, was charged with the project and proceeded to design and construct the M49 condenser microphone. The revolutionary leap that Grosskopf made realized a patent in 1949: "A Capacity Microphone with Variable Direction Characteristics" (below). This

ENGINEERING THE CAPACITIVE MICROPHONE CAPSULE

(continued)

The manipulation of these variables, in very minute amounts, is the microphone designer's most formidable task. It was Georg Neumann's first professional success: The determination and control of the diaphragm resonant point. The solution found in eliminating, creating, or changing resonance in condenser elements, was the placement of holes through the backplate in very controlled and precise locations to damp or create resonances within the audio range and move others entirely out of it.

Condenser elements (with their associated backplate, known as capsules), built by Neumann or others, fall into three distinct mechanical categories:

1 - The pressure transducer (Figure 1) is a condenser capsule where only one side of the diaphragm is exposed to the sound field. This renders the diaphragm sensitive to pressure variations on its surface regardless of the location of the sound source relative to the capsule. The resultant pickup pattern is "omni-directional," sensitive to incident sound from "all-directions."

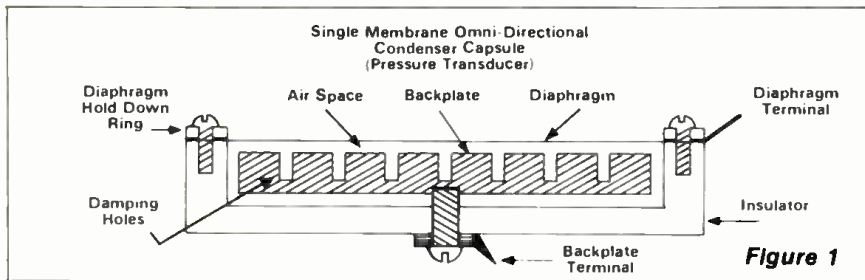

In this, as in all capsules, a metal or metal-coated plastic membrane (less than .001" [0.025 mm] thick) is stretched over a spacing ring and mounted .001" or so from the metal backplate. Perforations are made in the backplate itself to damp out various mechanical resonances, inherent in the physics of the membrane structure.

In the pressure transducer, the back of the diaphragm is airtight, so no acoustical energy reaches the rear of the diaphragm. The perforations in the backplate do not go through it completely to insure complete acoustic isolation.

The pressure transducer is also affectionately known as a fast-acting barometer.

2 - The pressure gradient capsule (see Figure 2) is similar to the pressure transducer, however, it operates on a slightly different principle. The pressure gradient or difference in pressure between the front and rear of the capsule diaphragm is created by admitting some acoustic energy to the rear of the diaphragm by making some of the damping perforations go completely through the backplate. These extended perforations are positioned such that any sound waves coming into the rear of the microphone impinge upon the rear of the diaphragm 180° out of phase from when they strike the front, thereby cancelling themselves. This is otherwise known as a cardioid or uni-directional microphone, responding to sound sources from the front of the capsule and rejecting

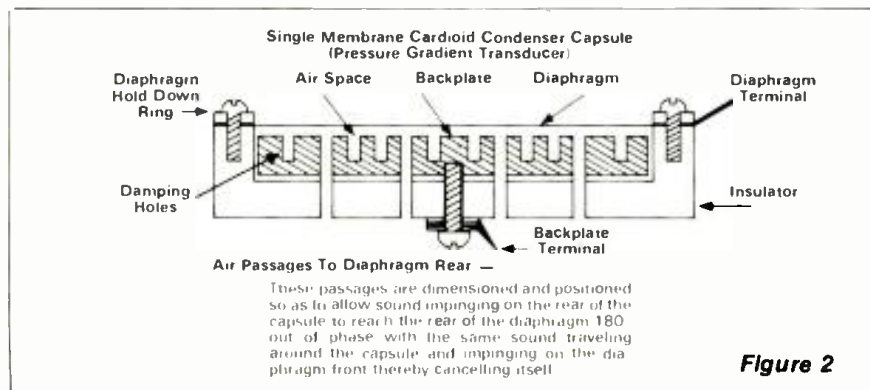

Simplified Schematic of Dr. Grosskopf's 1949 Pattern Switching Arrangement Patent As In The M49, M249

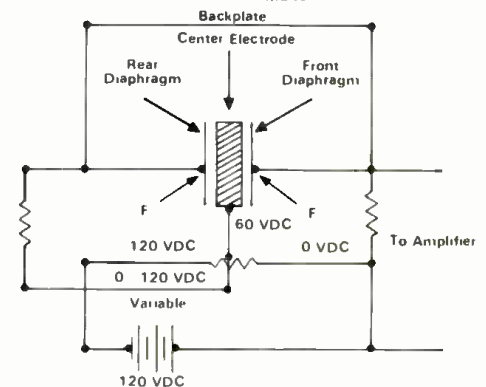

Pattern	Rear Diaphragm Voltage
Omnidirectional	0 volts
Wide Cardioid	30 volts
Cardioid	60 volts
Hyper Super Cardioid	90 volts
Figure 8	120 volts

was the world's first electrically variable multi-pattern, remote controlled condenser microphone. (Grosskopf in 1952 also developed a mechanical method of changing patterns and the right to manufacture these microphones were given Schoeps.)

The capsule used was Neumann's K48, PVC gold sputtered dual membranes as was used in the U48. The M49 does not resemble any other Neumann microphone because it was designed by the IRT, although Neumann did the manufacturing. The power supply

Now, The Good News.



Seated Brian Ingoldsby, Owner/President of Sound Master Recording Engineer Schools, North Hollywood, California. He purchased an automated Coronado console direct from Quad-Eight for immediate installation in his new school complex.

Meet David Hadler and Gail McCabe. They're the new factory direct sales team from Quad-Eight. They're ready to tell you why their boards deliver more performance, more reliability and more music for your money.

Whether your business plans call for a new console update or you're starting from scratch, one phone call to either Dave or Gail can save you a lot of bucks.

Because Quad-Eight wants your business in 1980, here's what backs up our new sales program:

- **No Dealers—No Middlemen.** It's the old line, but it's true. We're cutting our selling margins to the bone and putting you in direct contact with the factory—where you've always ended up anyway. On your large capital investment—your return can be maximized on a console that's going to keep you in business, or get you into it. And, at prices you won't believe.

- **The Factory Installs.** Skilled engineers will take you every step of the way. Console installation will have the proper preparation and on-site, hassle-free guidance for rapid

In 1980, Quad-Eight sells consoles direct to studio pros.

start-up.

- **The Factory One Full Year Parts & Labor Warranty.** Because our reputation precedes the fact that we "make em' to last," anything that requires our attention will get taken care of immediately. In addition to

comprehensive technical support for every console, we include a spares kit too. And there's experienced recording engineers at Quad-Eight just a phone call away.

When you call David or Gail, they'll be happy to assist in getting answers to any question: analog, automation, dB's or dollars.

To get a quick and straightforward response, just call. Of course, full color brochures are yours for the asking. And while you're at it, if you're ready to talk about bottomlines—Dave or Gail can be easily persuaded to show up on your doorstep for a one-on-one. You see, in 1980 we're out to show you we're the company that makes superlative consoles for the artist and businessman in every engineer. No matter what it takes. **We told you it was good news.**

The new factory direct sales program applies to domestic U.S. and Canadian sales only.



For The Artist *and businessman* in Every Engineer

Quad-Eight Electronics, 11929 Vose St., No. Hollywood, CA 91605. (213) 764-1516

for additional information circle no. 46

February 1980 □ Re/p 87

www.americanradiohistory.com

ENGINEERING THE CAPACITIVE MICROPHONE CAPSULE

(continued)

off-axis signals. The degree of uni-directionality is determined by the size, length, and positioning of the perforations in the backplate.

3 - The third type of capsule (see Figure 3) is a dual-membrane capsule with a

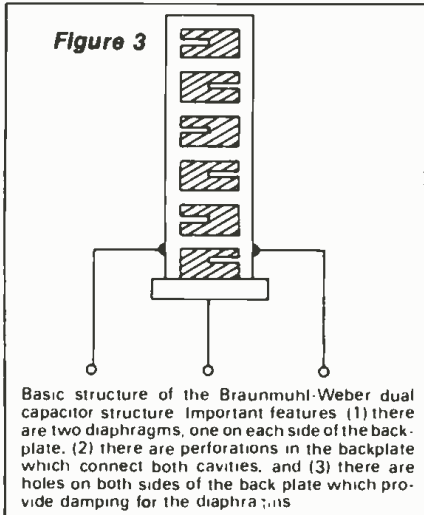

centrally-mounted backplate, or backplate and acoustic chamber combination. Basically, there are two back-to-back cardioid capsules in a single housing, giving the user a choice of several patterns depending upon the internal electrical arrangement. If the capsule outputs are connected together -in-phase,- an omni-directional pattern occurs. Either one of the capsules may be used to represent the cardioid pattern, or both capsules may be connected out-of-phase with each other, resulting in a third pattern; the figure-8. The figure-8 admits signals from both sides (front and back) of the capsule, but eliminates sources from the sides.

Once we have a linear response from the capsule and a pattern of our choice, we need to make this signal useable and audible. The next stage in any condenser microphone is the preamplifier.

If we had our druthers, what would that

that preamp be like? The ideal preamplifier for a condenser element would have:

- 1 - Infinitely high input impedance.
- 2 - Purely resistive input impedance.
- 3 - No internal noise source.
- 4 - Zero output impedance.
- 5 - No distortion.
- 6 - As much or as little gain or loss as desired.

The basic tube preamp used in many condenser microphone designs has been either a cathode-follower or a triode loss stage. Although neither choice reaches the aims of the ideal preamp, it remained basically unchanged until the transition was made to solid state devices.

The basic triode loss stage was used by Neumann throughout, so let's examine a typical preamp (see Figure 4).

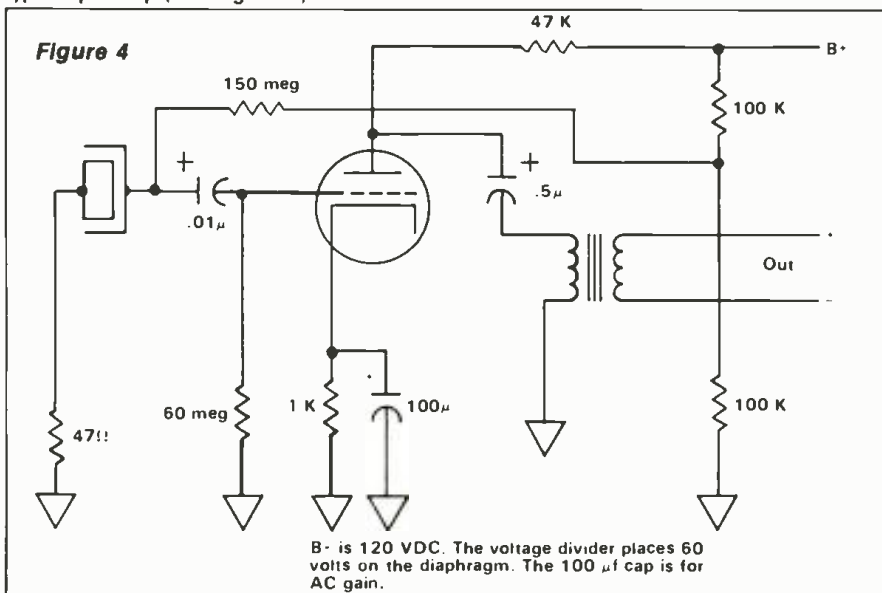

The preamp is a Class A stage with an input impedance of 60 megohms and a cathode bypass capacitor used for gain. The cathode resistor should be a low noise type as should be the plate resistor. The output transformer is simply for plate-to-line matching and to provide a balanced output audio line to connect to the real world. It should be noted that in 1927, as well as today, the preamplifier in any condenser microphone is the limiting factor for dynamic range, not the capsule.

Georg Neumann had an amazing array of technical problems to surmount in 1927 because a good deal of the previous discussion hadn't yet been discovered. Much of the tooling for the condenser and the manufacturing of the tools themselves had to be done by hand. The state-of-the-art of electronics was still in its infancy, as evidenced for example, by the size of some of the early capacitors; often approaching the size of our mega-micro farad electrolytics today. □ □ □

provided 120 volts which permitted various combinations of polarizing voltages on the diaphragm for a continuous sweep between the three basic patterns, while providing any intermediary patterns such as hyper-cardioid and super-cardioid.

The preamp chosen was based around a Telefunken triode, the low noise AC701k, specially designed for use in condenser microphones. The AC701k manufacture has stopped, but a quantity is still available today. The microphone had some problems, which were discovered unexpectedly when recording a live orchestra. The recording was found to have clicks and pops throughout it. Several hair-pulling months later, it was found the the AC701k was highly light sensitive and even inside the microphone body and black glass tube case, it would respond to photographic lightbulb flashes. Even today, the AC701k is painted densely black but a body shield enclosing the preamp prevents light from entering.

As the clout of the broadcast industry grew, manufacturing concerns responded to the requirements and designs of the IRT via the Brown Book, 'the operating standards of German broadcasting.' Germans felt they were building studios to last and things had to be as idiot proof and fail-safe as possible, so new standards arose.

The plug settled on, for example, was a 7-pin Tuchel connector, so the M49 with its 8-pin bayonet connector was rebuilt for the broadcast standard and known as the M249. The prefix "2" refers to the 7-pin connector. The prefix "M" referred to the AC701k preamp, which was the only mike preamp tube permitted to be used in broadcast. One further modification of the M49/M249 series microphones was their "b" and "c" versions which provided a strap position in the mike to keep the microphone in the cardioid position at all times, realizing a 6 dB improvement in signal-to-noise ratio. The "e" version provided cathode biasing.

The broadcast industry's desire for a single microphone for orchestral recording saw the development of the M50/M250 microphone. Neumann developed a special capsule for the IRT, a miniature nickel, single membrane pressure transducer mounted into a clear plastic sphere. Because of the spherical casing, the directional characteristics transitioned from omni to cardioid at the low end and became more uni-directional with increased frequency. Since most orchestra recordings are done at some distance from the sound source, there are high frequency acoustic transmission losses caused by the distance. Consequently, the AC701k preamp had an equalizer which achieved a 5 dB boost function at 2 kHz to compensate for this phenomena. The capsule which was utilized in the M50/M250 microphone was a radical change from the previous K47/48 capsules.

Neumann's special experiences with nickel in his NiCad research provided him with the unique opportunity to answer a new and growing television industry demand.

KM53, KM54, KM55, KM56

The television industry, in its black and white infancy was also required to follow the regulations of the Brown Book. The demand arose for smaller, less visible, high quality microphones of high quality was rising and Georg Neumann answered the call with the KM (Klein Mikrofon) small microphone series.

For busy studios

*Synchronizer
and Locator*



*from the
Tape Control Experts
at Audio Kinetics*

QLOCK 210 Synchronizer

At last there's an easy to use synchronizer—a complete, efficient unit designed by recording engineers *for* recording engineers.

The QLOCK 210 provides full transport control of two separate machines, together with all locate and cycle functions. It lifts the tape during fast winds—eliminating needless wear of expensive heads and protecting signal quality of master tapes.

The 210 has a built-in multi-standard SMPTE time code generator and two readers, 10 locate memories, Auto-Record drop in and out memories, and can be controlled by desk automation.

Best of all is its sensible, workable ease of operation. This and its many other features combine to make the QLOCK 210 the best buy in synchronizers today.

XT 24 INTELOCATOR

Free yourself from manual tape machine operation—or clumsy, inefficient auto-locators.

The Audio Kinetics XT 24 *Intelocator*, with its straightforward, sensible commands and one-button locate, is a time-saving must for busy studios.

The *Intelocator* remembers tape and transport behavior patterns, reducing subsequent locate time. It has two independent counters, master and intelocate, which together with six aim points provide a unique and practical way of working. Cycle and recycle modes allow automatic replay of tape. The unit has lever controls for easy counter setting, and even has a varispeed readout.

The *Intelocator* interfaces with most 24 track machines—to maximize performance, software is especially written for each machine type.

AK
AUDIO KINETICS

*For a demonstration or further information,
contact Ian or Carole at:*

QUINTEK DISTRIBUTION, INC.

4721 Laurel Canyon Blvd., Suite 209, North Hollywood, CA 91607
Phone (213) 980-5717 • Telex: 194781

The 15 mm diameter capsule required a new technology to match prior performance expectation. By using a smaller capsule and desiring to retain a high signal-to-noise ratio, the electrode spacing has to be diminished. Thus, the diaphragm had to be tensioned to limits greater than the PVC used would permit.

The substitute diaphragm material decided upon was nickel, as evidenced in the pioneering work of the M50. The nickel was grown electrolytically on a host base which was thereafter de-plated from the fine sheet of nickel remaining. The nickel sheet was able to be tensioned to the required limits, a new standard in microphones was born and the ever-present broadcaster's AC701k tube was the basis for the preamp. These pure nickel membranes have a thickness of only 0.7 um. It would take 1,428 membranes placed on top of one another to reach a thickness of one millimeter. The KM53 was an omni-directional pressure transducer with a single membrane of nickel. The KM54 was a single membrane also, but in order to achieve its cardioid pattern, an acoustical delay network behind the diaphragm made soundwaves originating from the rear, arrive at the rear of the diaphragm 180° out-of-phase with the same soundwaves arriving in front. The KM55 was a KM54 with slightly additional tensioning of the membrane for bass roll-off, and the KM56, a switchable three pattern unit, was two KM54 capsules back-to-back, effectively duplicating the effects of a dual membrane capsule.

The entire KM and M series of microphones had another novelty in them which was not replaced in design or repair until solid state technology caught up with Neumann's discovery of 20 years prior. In his NiCad research, Neumann had built bad storage cells as well as good ones. One of the NiCad failures was a cell that would not hold a charge, but would begin to pass current above a certain threshold voltage. He called these stabilytes. Stabilytes were 1.5 volt virtually unchargeable NiCads of varying current capabilities and had the filtering effect of 60,000 mf at 60 Hz power line frequency. These were used in all AC701k supplies as filament filtering units. The stabilytes were replaced about 1964 by a

complex solid state device.

The crowning achievement of the KM50 series is undoubtedly the KM56 microphone, but Neumann took the KM56 even one step further. He took two KM56 capsules on top of each other, so one could rotate one by 270° with respect to the other. In M-S stereo one capsule was set to a Figure 8, the other to cardioid and a pattern remote controller enabled one directly to alter the width of the stereo image. This, the SM-2, was Neumann's license in 1956 of a patent by Danish engineer Holger Lauridsen. Neumann, in turn, licensed AKG who, too, took two C-12 microphone capsules and built a stereo C-24.

For ten years the KM50 series microphones were made, but when a newer series of miniature microphones appeared, all but the KM56 were quickly replaced. The KM56 was the only one of the series that allowed changing patterns without changing microphone units. Other problems were to be solved by the new series including a much improved frequency linearity and hefty overload characteristics.

U64, KM63, KM64, KM65, KM66

Sennheiser made their first solid state, RF circuit condenser microphone in 1963. Stefan Kudelski, owner of Nagra, was the developer, and it was Sennheiser's entry into the condenser microphone field. Prior to this, Sennheiser had built only condenser shotgun microphones using their own interference tubes and a special Neumann single nickel membrane pressure transducer, the KM52.

RF was the method used to polarize the Sennheiser capsule and an FM discrimination technique recovered the audio signal. However, the stabilizing of the RF signal source and discrimination circuits was electronically a mean task and Georg Neumann decided to take a stand. He maintained, and as a company philosophy it remains today, that he was not in the electronics business and the key to a quality microphone was in the capsule . . . period.

Neumann's response was the U64, which used an RCA 7586 NuVistor, and was the first cardioid "linear admittance" microphone, with a virtually flat off-axis

frequency response. The new plastic film, Mylar™, developed by DuPont, had many advantages over the original PVC membrane. Mylar™ could be tensioned farther than PVC could and the long term stability of Mylar™ avoided the drying out and stiffening problems which aged PVC exhibited (droop in low frequency response).

The on-axis response of the U64 was virtually flat, bar an intentional 2 dB boost in the mid region to overcome the usual deficiencies of high end room absorption in a distant sound field and a roll-off below 40 Hz to compensate for tight mike proximity effects. The Mylar™ diaphragm was coated with a vacuum deposited gold layer only molecules thick. The acoustical delay network was redesigned and could be made much less expensively. Instead of drilling holes through the backplate, a miller was used to make a number of slits behind the diaphragm which achieved a linear pressure gradient response. Georg Neumann himself developed the cross slit technique and added this patent to his accumulation of nearly 400 already granted.

The U64 fit into the American market fine, but the German broadcasters had their standards, so Neumann had to build the KM63, 64, 65, and 66 which replaced the RCA NuVistor with the Brown Book compatible AC701k preamp.

The 63 was the omni version, the 64 the cardioid, the 65 was a low-cut cardioid, and the 66 had a three pattern switchable head. The KM63, 64, and 65 all had interchangeable capsules, an industry first, so one mike and a few capsules did a lot of jobs. The KM66 repeated the KM56 technique by placing the two KM64 heads back-to-back and the overload problems of the KM60s were helped by a switchable 10 dB capacitative pad placed between the capsule and the preamp input.

The end of the KM60 series mikes manufactured represented the last Klein Mikrofonen made with tubes. The "linear admittance" capsule, however, continues in the 70 series and 80 series microphones to this date.

U67, M269, SM69

Neumann's last large diaphragm tube microphone has joined the rare ranks of deified antique equipment even though it is still made in limited quantities today.

Neumann's design aim in producing a new microphone was twofold:

1 - Maintaining low frequency linearity at some distance from the microphone and minimizing the close mike proximity affect without having to change microphones.

2 - To maintain high frequency linearity in the microphone with distant miking techniques without having to place a high frequency boost in either the capsule or preamp to compensate for transmission losses in the air.

These formidable challenges to Georg Neumann were solved in a brilliantly simple package. The introduction of the U67 in 1960 (originally the U60 but changed for nostalgic reasons with the U47 in mind), generated a microphone capsule design so accomplished that it is still being used in today's solid state equivalents.

The proximity effect problem was solved by Gerhart Bore, Neumann's long-standing physicist in a novel preamplifier design. The proximity effect is a low frequency phenomena affecting directional and pressure gradient

THE FAMILY OF NEUMANN TUBE MICROPHONES. Top row: The large capsule models, left to right, top row are the U-47, M-49B and the U-67. Small capsule microphones appear top to bottom, center; KM-66 (next to it is a Z-29, 10dB pad), the KM-84, and the U-64us. Photo is from the author's collection.



Maybe you think
our prices are crazy.

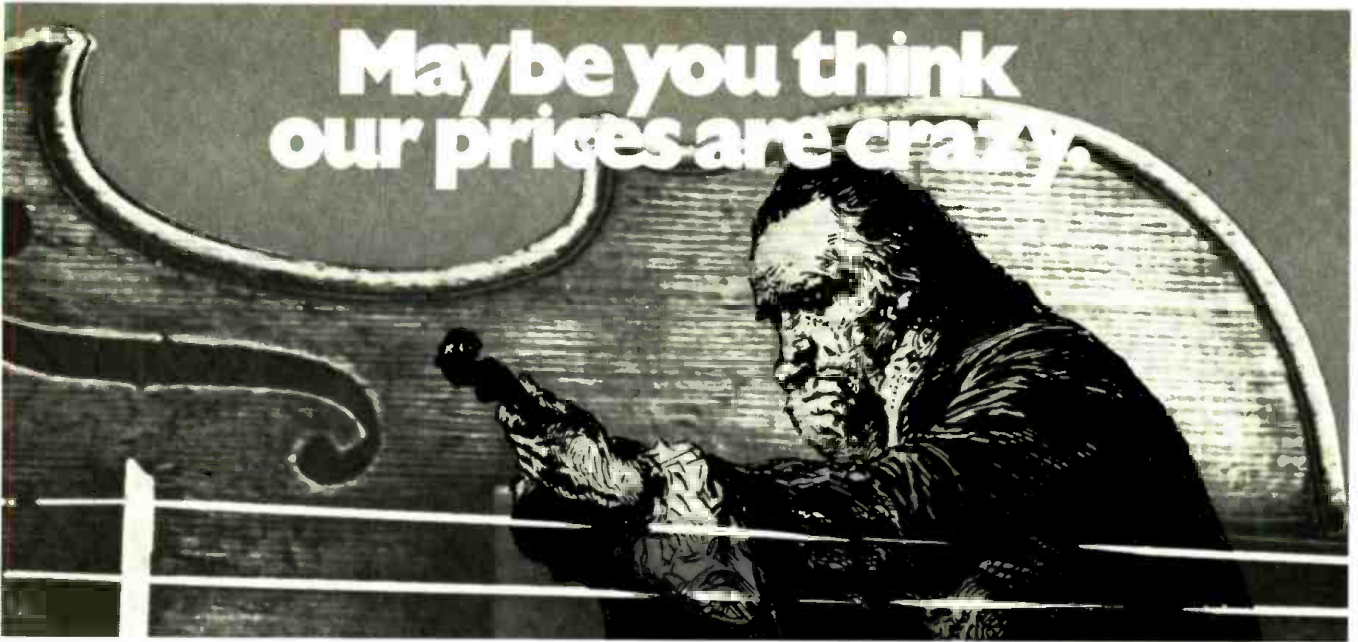

But Antonio Stradivari would have understood.

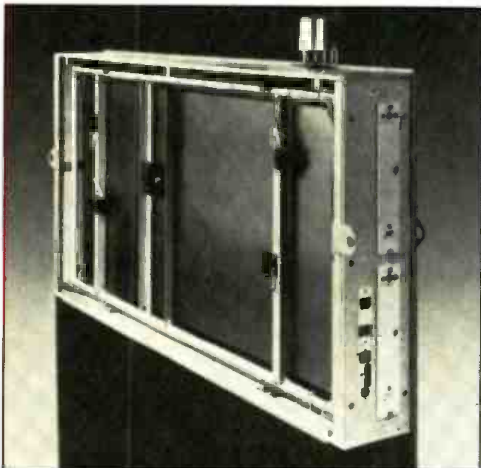

EMT 140 Stereo Steel Plate Reverb Unit. The 1956 classic, upgraded to solid state. The unit that started it all.

Right now, the *oldest* reverb unit in our line—the EMT 140—is priced higher than anyone else's *newest*. And our later models are even costlier.

Yet, this doesn't seem to discourage anyone. According to *Billboard's* recent equipment study, EMT reverbs are used by one-third of all the surveyed studios. That's almost *twice* the number using the next brand. And more than the second and third brands *combined*.

How come?

Mr. Stradivari could explain:

There's nothing so precious as

exactly the right sound. And once an artist discovers the sound he likes, he's reluctant to give it up.

No matter what the price. No matter how many years—or new models—come and go.

So, for all the people devoted to its singular sound, we have to go on making the EMT 140. Despite its costliness. And even though we can now offer its successor, the EMT 240 Gold Foil. As well as the EMT 250 and 244—the amazing digital units that redefine state of the art in reverberation.

Our situation is very much like Mr. Stradivari's. He stopped making violins in 1737, but the demand for his sound continues undiminished. And, in the same way, each of our four different models has its partisans—and demand goes on, year after year.

We do have one advantage, however:

Today a Stradivarius is priceless. An EMT is merely expensive.

EMT 250 and 244—Digital Reverberation Units. Fully Electronic Reverberation. EMT uses today's technology and again sets the fashion. Send for our extensive list of owners.

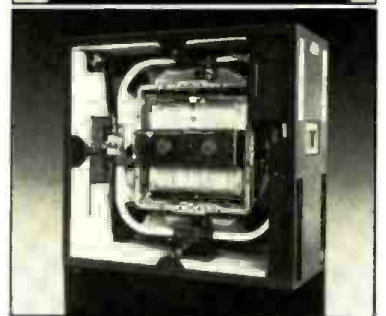

EMT 240 Stereo Gold Foil Reverb Unit. One fifth the EMT 140 Steel Plate reverb's size, virtually impervious to outside interference—ideal for mobile use.



For additional information, contact:

GOTHAM
AUDIO CORPORATION

741 Washington Street, New York, NY 10014 • (212)741-7411
West Coast Office: (213)874-4444

microphones beginning at a distance of one wavelength from the microphone. Starting at about 300 Hz, acoustic low frequency boost, due to proximity, of up to 20 dB, can cause the preamp to overload. Conventional attempts at solving this had included a mechanical windscreen and a high pass filter after the mike preamp.

Bore tackled electronically (see patent) the problem of mike amp overload at the low end. He accomplished a low cut filter in a 400 megohm circuit without inductors. The K67 capsule is used as a source for the audio signal as well as an element in the positive feedback chain from the plate through R1 - R3, C1 - C3, and back to the grid. The network is tuned for a low frequency rise as in curve "B" of Bore's patent. Negative feedback through closed S₂, R_x, and C₃ results in curve "A" or a high pass filter. The combination of positive and negative feedback paths results in a sharp 40 Hz cut-off as shown by curve "C." The engaged low end

roll-off switch on the U67 results in a curve similar to "C," without the hump, and when disengaged for distant miking gives a response as in curve "D."

The second linearity problem Neumann and Bore conquered was the uni-directional response of high frequency soundwaves at the capsule. The solution was a new capsule design; the K67. Instead of utilizing a single backplate dual membrane capsule, a dual backplate dual membrane combination was realized with a unique acoustic method of membrane isolation above 4 kHz. At those frequencies, the membrane isolation effectively made the microphone a pressure transducer or omni-directional. This resulted in a more naturally linear high end response without additional fudge factors (high frequency boosts) in the capsule or amp. The high end cardioid pattern which is exhibited in actual use, is caused by the mechanically induced acoustic shading of the capsule



The U-67 . . . last of the large diaphragm microphones.

structure itself.

This monumental achievement in microphone design has since seen the microphone appreciate from \$460.00 in 1967 to a price of over \$1,800.00 for the U67s sold today.

The U67 was the second large diaphragm microphone to gain acceptance into the realms of the German broadcast industry. When the German broadcasters' Brown Book had a turn, the U67 EF86 preamp was removed and the perennial AC701k was put in its place. So the M269 was born. The M269 followed early habits and was provided with a remote control aside from the three pattern switch.

Holger Lauridsen's concept from the 1950s of the M/S - X/Y pattern mixing for stereo recording prevailed and the SM69 intensity stereo microphone hailed from Neumann's lab. Two AC701k's, a pair of modified K67s for specialized directional characteristics, and remote controlled pattern switching, made this microphone system compatible with the earlier nickel membraned SM2s.

Georg Neumann continued his already successful microphone career with the 70 and 80 series of microphones. The U87 became as much of a standard in the 1970s as did the 47 and 67 in their days.

Georg Neumann died on August 30, 1976, perhaps the most respected and accomplished man the audio industry has ever known.

Subjectively Speaking

This presentation has attempted to give a brief history of Neumann's tube microphone career, but purposely did not touch on a few areas which would either take the story too far afield, or lead the reader to confuse certain conjecture with fact. There is much mystique to various areas of early tube microphones, but it largely is a matter of opinion as to whether the mystique is valid in our industry. In some cases there may be several variant opinions to the questions raised, so it is left to the reader to make up his own mind.

The original VF-14 version of the U47 has gained absolute notoriety as being the standard of sonic performance for certain instruments or vocals. What is it that differs in their mike from later K47 microphones?

Tony Bongiovi, *Power Station*, New York City: "The U47 is our favorite vocal mike. It has to do with the harmonics and the way they combine with soft music. On loud passages, it overloads some and we prefer the VF-14 to the NuVistor."

Some persons maintain that the key to the sound of the U47 is the fact that the VF-14 tube, would acoustically resonate with a sound source. The tube's shock mounting, they say, is insufficient to compensate for the highly microphonic nature of the tube. This explains to those adherents why the later modifications of the U47 from a VF-14 to the 13CW4 RCA NuVistor hampered the sound quality of the

Sept. 21, 1965

G. BORE

3,207,848

AMPLIFYING CIRCUIT FOR CAPACITIVE MICROPHONES

Filed Jan. 12, 1962

2 Sheets-Sheet 1

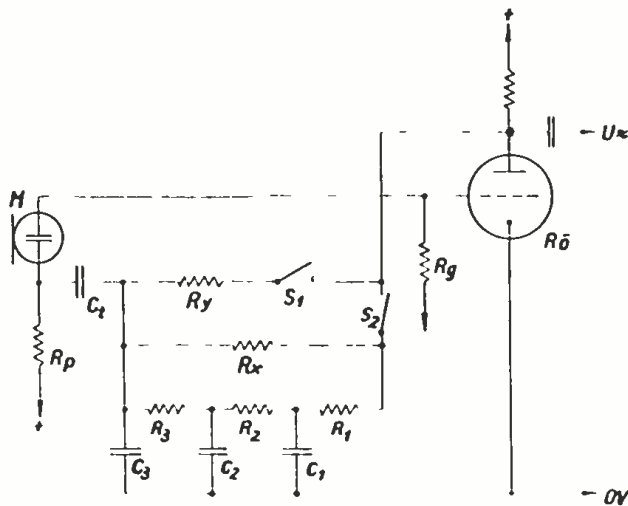

Fig. 1

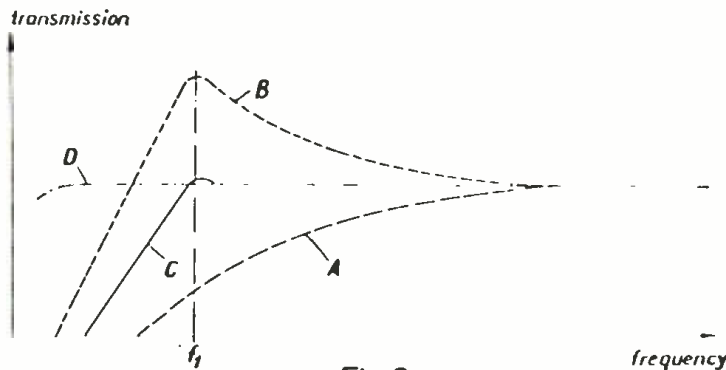

Fig. 2

Inventor:

Georg Bore
Prüfungsausschuss



The ubiquitous U-47, showing the VF-14 suspension system used to minimize mechanically generated harmonics.

microphone. For the further question of the harmonics generation and subjective evaluation of odd order transistor distortion versus even order tube distortion, it is best to refer to the Journal of the Audio Engineering Society 1973 article by R. Hamm (see reference).

Gotham Audio feels that the mystique of the "Tele" sound may be a multifold phenomena:

1 - That artists, producers, and engineers who made hits in the early 1950s and 1960s feel that they have to use the same mikes to achieve the same repeated success.

2 - A purely sentimental nostalgia for antique equipment which parallels our eye-opening responses to seeing a mint Model A Ford on 5th Avenue today, or

3 - The actual "smooth sound" of the old 47s is caused by a defective capsule.

The early K47s were made by sputtering a thin layer of gold on a poly vinyl chloride (PVC) sheet. The tensioned PVC would eventually begin to dry out and harden, thereby lowering the diaphragm's compliance. The brittle PVC

would permit less low frequency excursion and the low frequency drop-off point would rise. The U47s with the hardened PVC are then less susceptible to low frequency proximity effects. If the mike is put in for repair and the diaphragm is in this condition, it is replaced with the new Mylar™ K47 and suddenly the U47 takes on a new character.

How about maintenance on my older tube mikes?

There is very little you can do on a mike yourself, but a lot of preventive care will help.

1 - On the U47/U48 capsules, there is a 0.01 mfd capacitor in parallel with the capsule and its aging will tend to generate noise. It should be replaced with a 0.01 mfd low noise disc capacitor, *very carefully!* Remember, you are in a 400 megohm circuit.

2 - Replacing a defective VF-14 is simple enough if you can get hold of one. However, Gotham indicates that no VF-14 has ever failed! AC701k's are still available, for the time being, and in the U67 either an EF86, 6267, or 6CF8 may be readily had. The U64 uses the 7586 NuVistor.

3 - Power supply maintenance, if ever required, should be self-explanatory. For the older supplies, electrolytes are replaced by special PC board circuits.

4 - Moisture can be a problem on condenser capsules. When the humid breath from a singer strikes the capsule, adhering to the membrane and surrounding phenolic tensioning rings, a current leakage path is created which can allow the diaphragm to discharge via the screws in the rings. Later K47s and K67s do not exhibit this problem because the tensioning rings were built

differently and there was a more extensive use of insulators. Other than letting the microphone dry out itself (as the U47 virtually does by itself due to the 1780 ohm filament dropping resistor), it is recommended to use a pop screen around the microphone in these applications. Any severe symptoms of either noise or moisture should be referred to Gotham Audio, who is equipped with the specialized tools required for extensive microphone repair.

It has been said that the older mikes often don't require console preamps for adequate level. The average condenser mike level output is about 20 dB above that of a dynamic mike, and due to this the early consoles, with fixed gain preamps, often went into early overload. The only pads that could be used were attenuators before the preamp input transformer. Today's preamps, with true variable gain available, are much less susceptible to overload at high input level. □ □ □

References:

1 - *Audio Encyclopedia* — 2nd Edition by Howard Treiman, Howard Samos.

2 - *A Professional Condenser Microphone*, by R. Williamson, *Audio Magazine*, July 1963.

3 - *Microphones for Professional and Semi-Professional Applications*, by Dr. Ing. Gerhart Bore, 1978 by George Neumann GmbH, Berlin.

4 - *Microphones: Design and Application*, by Lou Burroughs, 1974.

5 - *Sound Recording*, John Eargle, 1976 Van Nostrand.

6 - *JAES*, Vol. 21, No. 4, 1973, *Tubes vs. Transistors, Is There A Difference?* R. O. Hamm.

7 - Miscellaneous Gotham Audio technical and sales briefs.

8 - U.S. Patent No. 3207848. Amplifying Circuit for Capacitive Microphones, G. Boire, 921 1965.

THE ADR COMPLEX-LIMITER DESCRIBED

Another original from **audio & design recording.**

Combining • a top-quality multi-ratio compressor • a fast peak limiter • a full-function expander/gate.

Including • dual mono/stereo capability • bypass switches on all functions • meter for visual indication of all gain reduction. **Featuring** excellent specs to provide the clean,

quiet, dependable Signal Processing that has been ADR's hallmark for more than 15 years.



© 1980 audio & design recording

Contact Nigel Branwell, P. O. Box 786, Bremerton, WA 98310 (206) 275-5009 TELEX 15-2426

Audio & Design (Recording) Ltd., 84 Oxford Rd., Reading, Berks. RG1 7LJ, England. TEL. (0734) 53411 TELEX. 847605 a/b Tillex G

Modifying the Classic U-47 for Line Level Output

David Coe and Tom Lubin

Advances in recording technology have improved almost every component used in the recording process. The studio audio chain is now extremely clean compared to years past, but it is also much more complex. The microphone signal is typically required to pass through the output transformer of the microphone, down 250 feet of cable at -40 dB, and into the microphone input transformer which usually raises the level of the signal typically by 20 dB. It is then amplified by the mike preamp. The signal will very likely now pass through a VCA for level control and, following that, another amp for gain recovery. Then there is an equalizer followed by a booster that feeds the buss; then the summing amp, another buffer and another transformer that feeds the tape machine. Regardless how clean the entire chain is, if all things are equal, as the number of amplifier links increase so does certain types of noise and distortion. Transient rise time and signal phase shift are also adversely affected with each additional amplifier. Obviously, the closer that the audio connection between the microphone transducer and the tape machine is to a straight wire the better the performance potential. In cases where a great deal of control of processing is not necessary, a possible alternative would be a microphone that puts out a line level signal that could go directly to the tape machine input. The problem with such

David Coe is owner of Salty Dog Recording. His background in electronic design comes from years of independent electronic consulting — and from maintenance work for both Producer's Workshop and Sheffield Labs. During his affiliation with them he worked on a number of specially-designed audio devices, including the line level microphone.

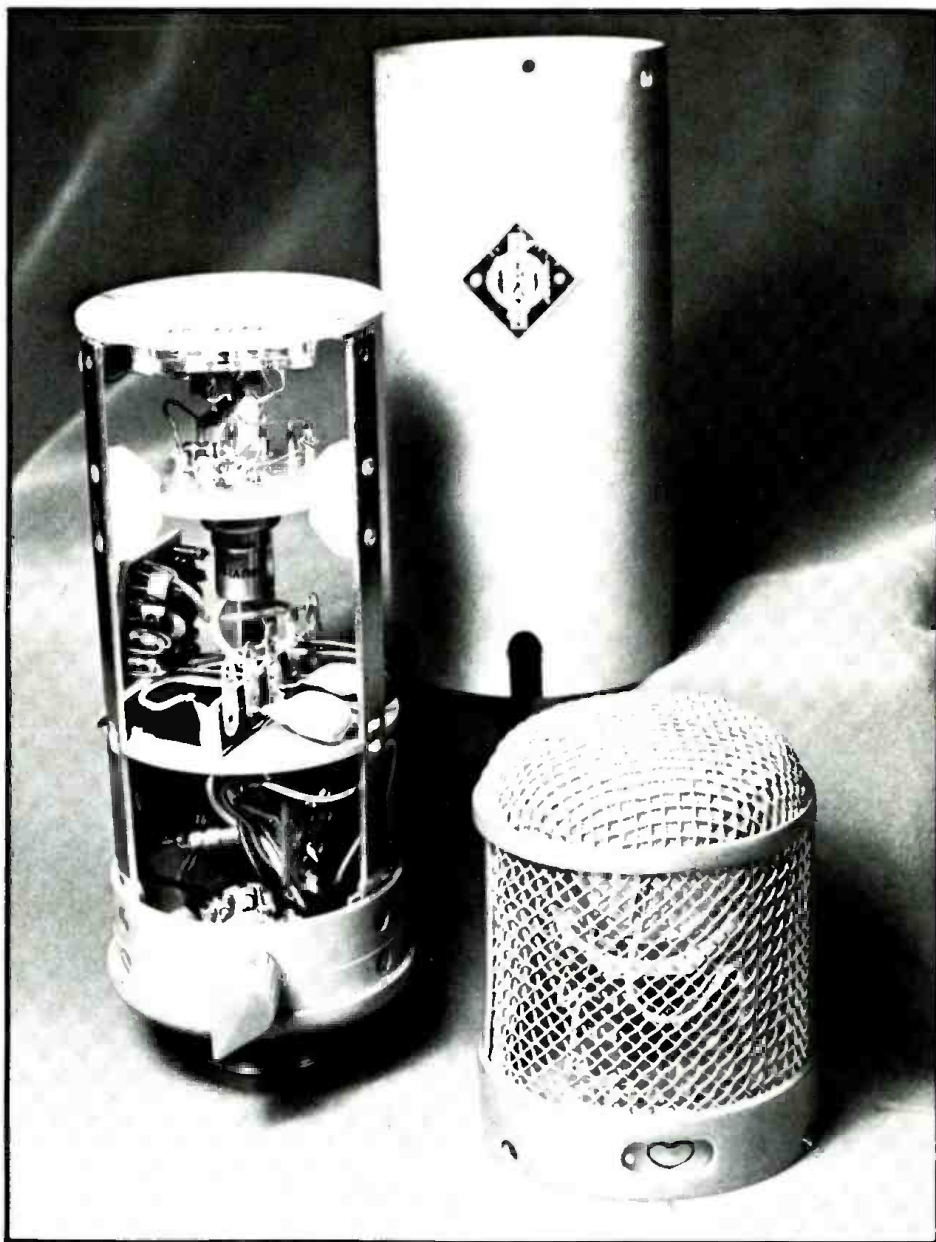

a system is its incompatibility with existing microphones and studio procedures.

While working with direct-to-disk pioneer Sheffield Labs and their parent company, The Mastering Lab, I had the opportunity to use a direct line level mike which they developed. While working as a technician for them I saw the promise of achieving both the expected sonic improvements and the electronic refinements a direct line level system requires to meet the challenge of a multi-miking situation. It needed to be reliable, convenient, and have no special requirements for its use.

When I opened my own studio, Salty Dog Recording, the opportunity arose to experiment further in refining such a system. The studio was designed to accommodate both the line level mikes and direct boxes as well as the conventional low level ones. Extra lines were run from each of the wall panels to the console.

The MCI JH-500 console required some modification so that the operator could select between the two systems. In this way the signal could be routed through either the entire system for the normal low level, or directly to the machine for the high level signal. The high

level path included a patch point at the console for the inclusion of any desired signal processing device.

Each of the studio wall panels were wired with the standard 3-pin XLR, with phantom supply, and 5-pin XLRs which provided a special bi-polar voltage to the line amps mounted inside or near the modified microphones as well as signal ground, and 48 volt polarizing voltage.

... continued overleaf —



FIGURE 1

TELEX[®]



AUDIOCOM[™] THE INTERCOM SYSTEM

A closed circuit headset intercom system for small, large, portable or fixed installations. AUDIOCOM, for concerts, stage productions, film or TV studios, sports stadium and race track, industrial, military or public safety applications.

AUDIOCOM, for short or long distance (over five miles), requires only simple wiring and readily interfaces with other sound systems including telephone circuits. Options include tone or light signaling, paging, program feed and rechargeable battery packs in case of power failure.



AUDIOCOM SWITCHBOARD, portable or rack mount, segregates six external intercom lines into three separate non-interfacing circuits; or stage, lighting and sound crews can communicate independently, jointly, or may be mixed. Contains 24 Vdc power supply with optional, rechargeable battery pack. Smaller power supplies also available.



AUDIOCOM INTERCOM STATIONS, belt pack or wall mount, can be "daisy-chained" by the dozens without degradation in signal quality or strength. Listening control and mike switch included. Unused inputs mute automatically to prevent system noise.



AUDIOCOM PAGING SPEAKERS, portable or wall mount, feature volume level switch. Also serves as a paging station.

AUDIOCOM ACCESSORIES. Noise canceling boom mike headsets or hand mike, even for high noise environments. Interface unit adapts to 2, 3 or 4 wire systems with balanced or unbalanced circuitry.

Cables, extension cords and "T" connectors for convenient, virtually limitless system layout.



TELEX

TELEX COMMUNICATIONS, INC.
9600 ALDRICH AVE. SO. MINNEAPOLIS, MN 55420 U.S.A.
EUROPE: 22 rue de la Legion-d'Honneur. 93200 St. Denis, France

for additional information circle no. 50

February 1980 □ Re/p 95

Line Level from the U-47

The line amp and associated pad can be mounted in small chassis boxes that can be clipped to the microphone stand since the shorter the cable is from the mike to the amp the better (Figure 1). All of the 3-pin XLR cords that we use for this purpose are 18" long. Certain microphones that happen to have an excess of internal space have the preamps mounted inside of them.

Though many professionals in the recording industry undertake equipment modification in order to improve performance, many manufacturers, including Neumann, will decline to repair units which have been altered. Also, a modification such as this or any other, should be thoroughly thought through so that on completion the unit will have maintained its professional integrity and market value.

Now that that's been said, most of the problems experienced in developing our system appeared with our first effort. We have subsequently modified a number of other models. The first, however, was unique because it was done to the ageless classic, the Neumann U-47. This particular microphone was chosen for a number of reasons, the first being its wide popularity, plus its physical size allowed the amplifier to be installed internally. Extra lines were available in the power supply cable which made it simple to get the extra voltages to the booster mounted inside. We also installed a ± 15 volt bi-polar supply inside the microphone's tube power supply. This was done so the U-47 could be operated at line level when it was used outside of the studio. This is particularly ideal for those long cable runs typically used in remote recording.

It should be noted that many U-47s have slightly different cable pin designations and

FIGURE 3

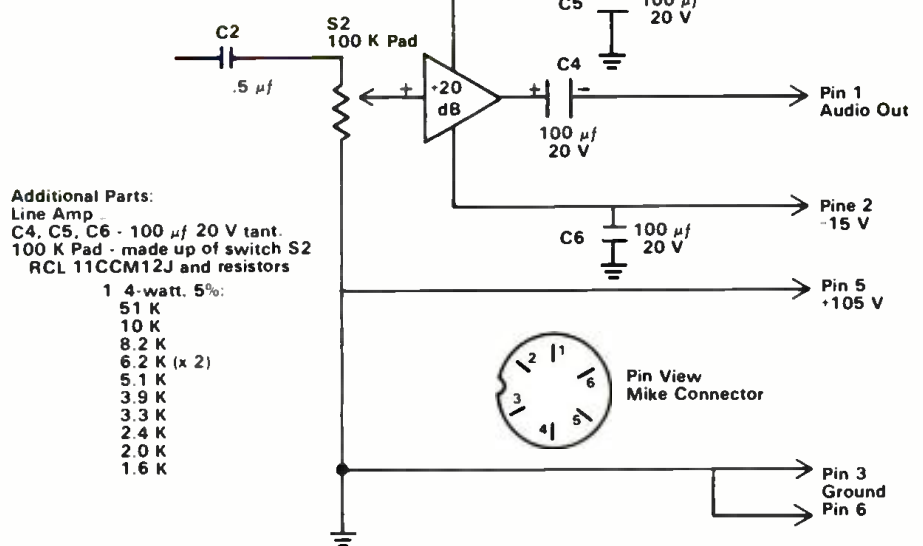

internal construction. This is equally true for many other brands and models of microphones, particularly the older units. Before proceeding with any sort of modifications the internal construction and electronic layout should be verified. Any departure from the factory supplied schematic should be documented so that you know what wire goes where when it gets time to put it all back together.

Modifying The U-47

First we analyzed the gain structure of the U-47 to determine what would be needed to make the mike output deliver a +4 dBv signal. It became evident that by simply removing the microphone's output transformer a gain of 22 dB could be achieved (Figures 2 and 3). With the introduction of the line driver circuit into the microphone, the low level balanced output transformer became unnecessary. The result gave us improved transient response and

phase response as well as a gain increase at this point in the audio chain. Since the microphone's normal output level is approximately -34 dBv with the average vocalist, the transformer's removal raised the level to -14 dBm, so another 18 dB of gain was needed to make the signal line level.

The amplifier that was developed for this application has 20 dB of gain with a 12 position switchable passive pad at its input. A switch was chosen over a pot because it allowed repeatable settings. It was designed to lower the microphone output 6 dB the first step, and 2 dB each step thereafter. This makes it very easy to look at the machine VUs and know how much pad is required. If the levels at the machine are too hot, the engineer can ask the artist to turn the pad a given number of clicks left or right.

The Power Cable

The first step in converting the tube U-47 is to take the microphone power cable and make a wiring change at each end. Once you have opened the connector check all the wires. If you are the first to open the connector since it left the factory, it may need some preventive maintenance re-wiring. The only change necessary from the stock configuration is the removal of the shield connection from pin #4. This needs to be done at both ends. When the microphone and power supply are opened up their respective connectors should also be checked and changed so that they don't defeat this modification.

The cable should be checked for correct continuity, making sure that there is no connection between any of the pins with the exception of pins #3 and #6, which are both connected to shield. The modified cable can continue to be used with normal U-47s, but they are the only cable that can be used with the modified system. If by accident a normal cable is tried with the line level units damage will occur to the bi-polar supply as pin #4, which carries +15 volts, would be shorted to ground.

Disassembling the U-47

To disassemble the U-47, first remove the three screws securing the capsule and cage to the top of the microphone and gently pull the head off the body. At the base of the microphone housing, near the power supply

FIGURE 2

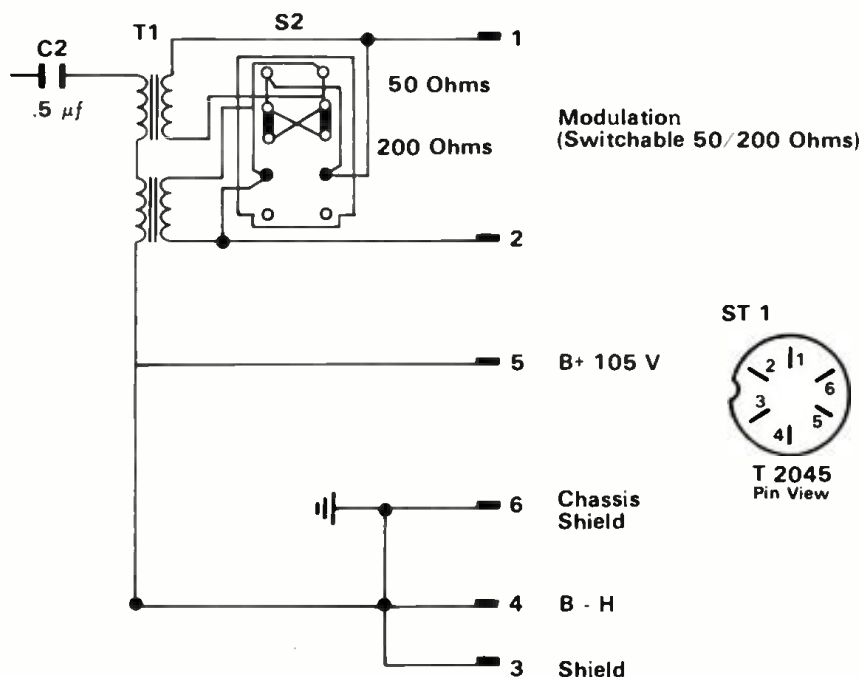



10 to 1 you'll like ours!

Every studio needs a \$1,000 microphone. It tells everyone you're serious about good sound, and it impresses the talent.

But when the session gets under way, all that counts is results. Not price tags. And judged *only* by what you hear, the new AT813 Unidirectional Electret Condenser from Audio-Technica is going to truly impress you... at about 1/10 the cost you might expect.

Recently a recording engineering class at a major university made simultaneous multi-track tapes comparing our AT813 side-by-side with some of the best microphones money can buy. The informed and critical students did the judging.

Surprisingly, in many cases they couldn't find a nickel's worth of difference. And some preferred the AT813 sound to the expensive competition.

You may agree with these student engineers when you hear the AT813. Or you may not. But at these odds, you can't afford to overlook us. And for new studios just getting underway, who can't afford a roomful of top-dollar microphones, the AT813 is an effective way to achieve full multi-mike capability. Write today for the AT813 spec sheet and A-T microphone dealer list. Then see your Audio-Technica sound specialist for great sound... right from the start.



audio-technica
INNOVATION □ PRECISION □ INTEGRITY

AUDIO-TECHNICA U.S., INC., Dept. 20RE 33 Shiawassee Avenue, Fairlawn, Ohio 44313

February 1980 □ Re/p 97

Line Level from the U-47

connector, is a single screw. Once this screw is removed the outer shell will slide off the top of the body. At this stage the insides of the unit should be examined, and verified against the manufacturer's schematic. If the mike has been converted to a Nuvistor version the job is easier because there is more room to work with. You will have to be a bit more creative if the original VF-14M tube is still in service as it occupies more of the available space.

In either case the tube should be removed from the housing before any modifications are undertaken. Utmost care should be taken in the handling of both the tube and the capsule. Both should be stored away from the workbench while the modifications are being completed as they are easily damaged by severe vibrations, and the capsule can be ruined if any particles are close enough to do damage to the diaphragms.

Secondly, in the course of removing the tube and working inside the housing, care should be taken not to touch any of the resistors since some of their values run as high as 100 megohms. Touching these components can put body oils on the parts which, in time, can attract dust build-up that will adversely affect the performance of the microphone.

Before removing the transformer the wires leading to it should be identified and marked as to where they go in the circuit. To remove it the three screws that hold it to the three side supports are taken out. Then, while holding the transformer, the two remaining screws in the circular metal plate are removed. Once the wires connecting it to the phenolic support piece are disconnected, the transformer can be pulled free from the housing. The two phenolic sections should be re-mounted on the circular plate using their metal brackets and the screws that were just removed. Two 1/2" spacers can be used to replace the thickness of the transformer body.

The wires running to the microphone connector pins should be removed and replaced with longer ones which will be hooked up subsequently. The junction of pins #3 and #6 should have four separate ground leads soldered to it. All the other pins, including pin #4, need one wire lead. Before disconnecting the old wires, double check where each one of them goes. Also, it's a good idea to maintain the original color code.

The 1 microfarad, 160 volt capacitor connecting the two phenolic pieces together should be replaced with a smaller style 1 microfarad, 100 volt polarized capacitor. This change is required to provide clearance for the new pad switch assembly.

The Pad Switch

Pre-wire the pad switch with the resistor values shown being particularly careful to keep all the resistors as close to the body of the switch as possible (Figure 4). All the resistors should be 1/4-watt, 5%, and either carbon composition or metal film. Because the switch is unique in regarding its size and the number of positions it has, and its make-before-break contacts, it was necessary to have it specially made. It is available from Electric Switches,

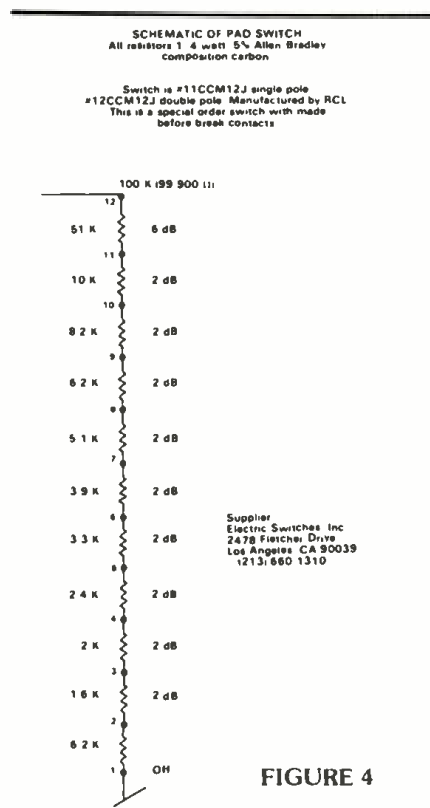

FIGURE 4

Inc., 2478 Fletcher Drive, Los Angeles, California 90039. Manufactured by RCL, the part number of 11CCM12J. Once the resistors are in place attach the three wires to the switch so that connecting it to the circuit will be easier once it is in the microphone shell.

To mount the pad in the case use a center punch and fix its placement 1/2" above the ridge that stops the microphone shell when it is in place. It should be lined up directly above the screw hole that secures the shell to the body. This will locate the switch so that it faces the performer when the microphone is in the cardioid pattern, as well as providing enough clearance for everything to be cleanly assembled. Before drilling the 1/4" diameter hole which is required for the mounting switch, a small pilot hole should be drilled to prevent the much larger bit from slipping on the curved

surface of the housing.

In order for the U-47's outer sleeve to fit over the new pad, a slot needs to be cut to accommodate the switch's bushing. Using the lower mounting hole as a guide, drill a 1/4" hole in the sleeve, about 1/2" up from its bottom edge. Once again a center punch and pilot hole should be used, and a minimum of drilling pressure exerted. After the hole has been drilled a fine tooth hacksaw should be employed to cut an open-ended slot from the hole to the edge of the sleeve. When the microphone is re-assembled the sleeve will slide down and around the switch housing.

All the drilling is now complete. Before proceeding thoroughly vacuum the insides. Be very sure there are no metal particles remaining in the unit or on the workbench you're using.

The pad switch can now be installed but should not be secured at this time as the slotted sleeve goes under the switch's lock washer and nut. The nut is secured after re-assembly. A lock washer should also be placed between the switch and the interior wall of the housing.

The Line Amp

The line amp we are using is a 741S op-amp circuit optimized for 20 dB gain, and is designed to be used in a non-inverting mode (Figure 5). The circuit uses the IC for gain and buffers the output with a class A-B stage. A 100-ohm resistor is in series with the output to protect the circuit from shorts. Typical distortion is .004% @ 1 K with a bandwidth of approximately 175 kHz. Clipping occurs at approximately +21 dB when the output is feeding a high impedance load and +19 dB into 600 ohms or less. We use this amplifier because it is so transparent, but other line amps could be used. It is very important, however, that the circuit selected does not add any sonic coloration of its own. It should also be noted that with any high quality amplifier circuit the physical layout of the parts is critical, and that their performance is often optimized when key parts are made by certain manufacturers. Similar components from different manufacturers are seldom exactly identical, at least not in this sort of critical application. The line amp is secured inside the body by attaching it to a five lug barrier strip. Sixteen gauge solid wire can be used as both a signal path and a stand-off for the amplifier. The center post of the

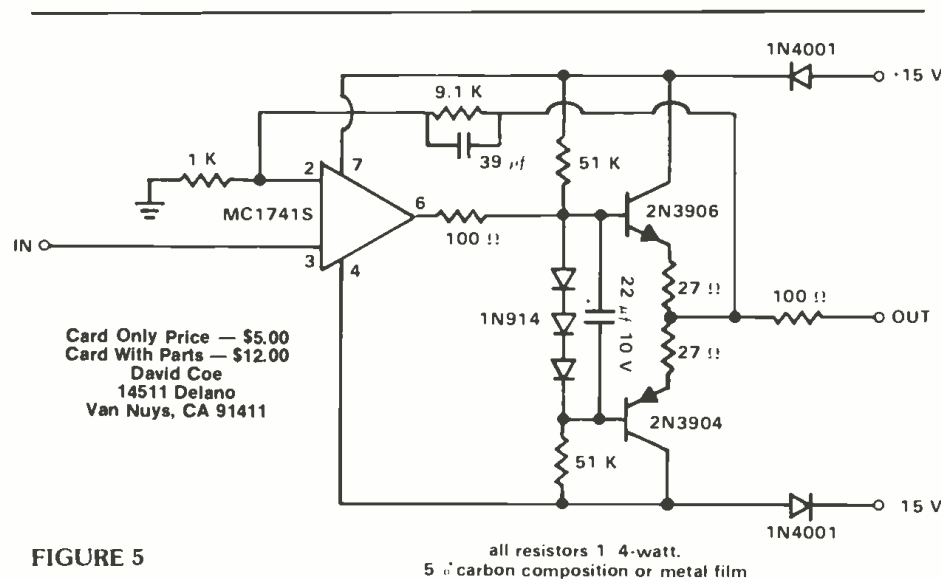

FIGURE 5

The Revox B77 records much more than music.



If you think of the Revox B77 as an extraordinarily well-made tape machine, with a great reputation among musicians and recordists, you're right.

But you're only partly right.

Because the B77 is now available with so many options and in so many configurations that it can be almost any kind of tape machine you want it to be.

Whether you need a deck for broadcasting, mastering, duplicating, security, education, medicine, lab research, sound effects, municipal services, A/V presentations, transportation, or cinema, we have a B77 just right for you. With the same quality that made Revox a legend in the music business. Look at all the possibilities:

FULL RANGE OF SPEEDS: any two from 15 IPS for mastering to 15/16 IPS for logging or surveillance.

QUARTER OR HALF TRACK operation is available.

OPTIONAL DOLBY B removes high frequency noise.

RACK-MOUNTED OR PORTABLE. All B77's have folding handles and available rack-mounting flanges.

VOICE-ACTIVATED CONTROL saves tape in broadcast logging, surveillance, courtrooms, forensic pathology, municipal services, etc.

TIMER CONTROL permits recording or playback at pre-selected times.

AND MUCH MORE: Remote control • Special narrow bandwidth third track • Self-Sync • Stereo slide sync • Variable pitch • High and low-z mic and line inputs.

With all that flexibility, plus the legendary Studer qual-



ity, and tape-protecting features like a motion-sensing logic-controlled switching system, the B77 is perfect for anyone who needs to record anything.

Visit your Studer Revox professional distributor and tell him what *you* need.

STUDER REVOX

Studer Revox America, Inc.
1819 Broadway, Nashville, TN, 37203 (615) 329-9576
Offices: Los Angeles (213) 780-4231 / New York (212) 255-4462
In Canada: Studer Revox Canada, Ltd.

Line Level from the U-47

barrier strip is grounded and should be attached by one of the two screws that once held the transformer in place. All connections to the amplifier are made through the barrier strip. Pin #1 is attached to the output of the line amplifier. Pin #2 goes to the -15 volt point. The function of pins #3 and #6 are connected to the case, amplifier, mike pad, and tube circuit grounds. Pin #5 supplies the 105 volt power to the tube's plate and heater circuit. Connect C2 (.5 mf) to the pad, being sure to attach it to the correct end of the pad. The signal should pass straight through to the amplifier when the switch is turned as far as it will go clockwise. The other end of the pad should have already been connected to the ground. Finally, the switch wiper is soldered to the line amp input (Figure 6).

Amp Power Supply

There is nothing terribly unique about the 15 volt bi-polar supply aside from it being well regulated and filtered. The circuit we've used in the self-contained systems is shown, but there is a wide selection of similar supplies on the market, and, of course, a larger supply would be necessary if it were centrally feeding a

FIGURE 6

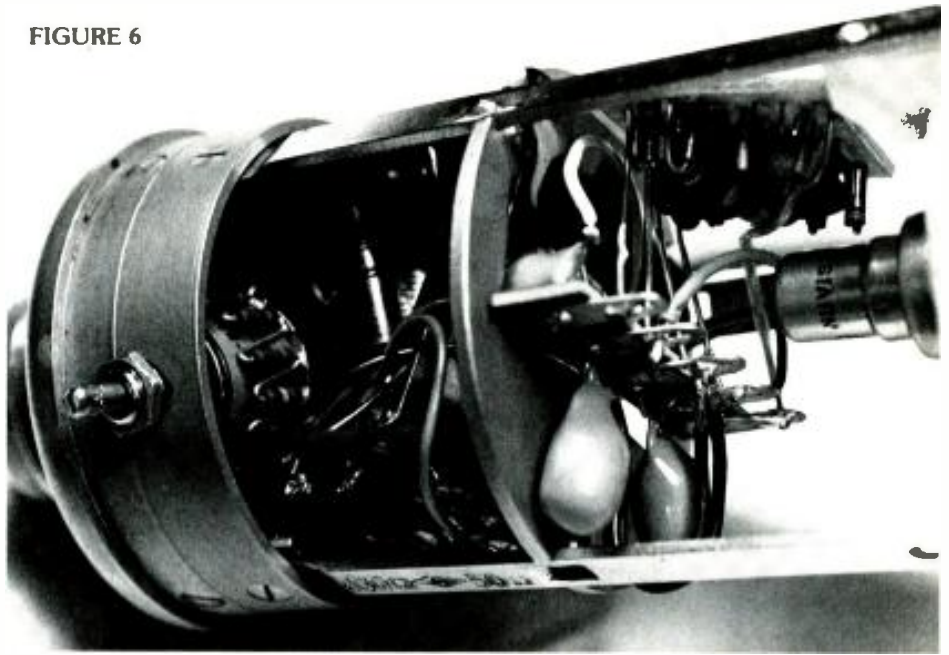

number of microphones.

The bi-polar supply is mounted on isolators that are attached to the inside top of the case.

Before installing, however, the necessary rewiring to the tube supply should be undertaken. Again, separate pin #4 from #3 and #6 and connect a single lead to it. The junction of pins #3 and #6 will require the addition of one wire to the two that are already there. These three wires go to the power supply case, the ground plane of the bi-polar supply and to pin #3 on the XLR 3-pin output receptacle. Pin #1 on the mike's power connector should be connected to pin #3 on the output XLR. Pin #1 of the output connector is used for shield only and should be wired to conform to the studio's shield system (Figure 7).

The bi-polar supply should get its AC feed through the Neumann power switch so that it is turned on and off with the tube voltage. The +15 volts is attached to pin #4, and -15 volts is attached to pin #2 of the microphone's power connector.

Our Neumann power supplies also have a five pin output so that the line level output will mate with Salty Dog's line level wall panel system.

After completing assembly of all of the parts, plug the multi-pin connector into the power supply and the microphone and check all

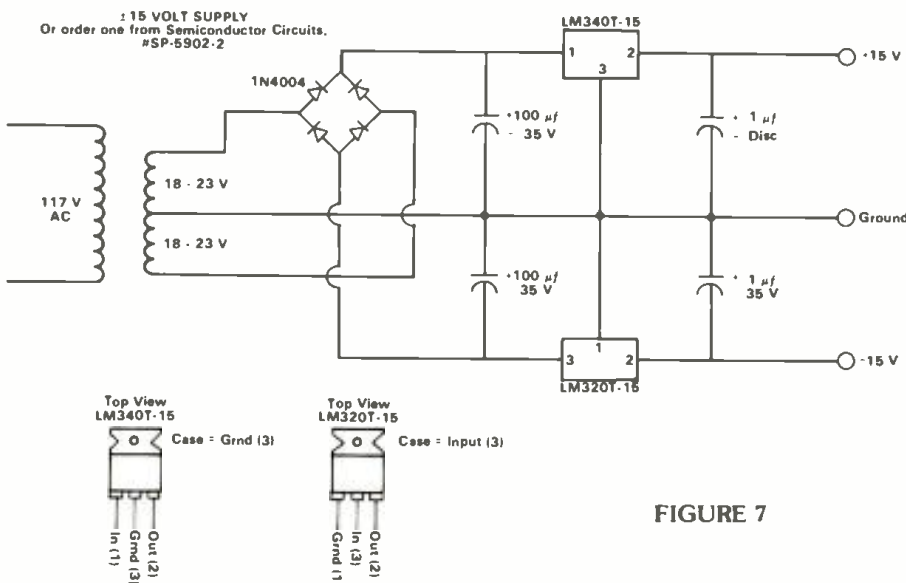

FIGURE 7

FIGURE 8

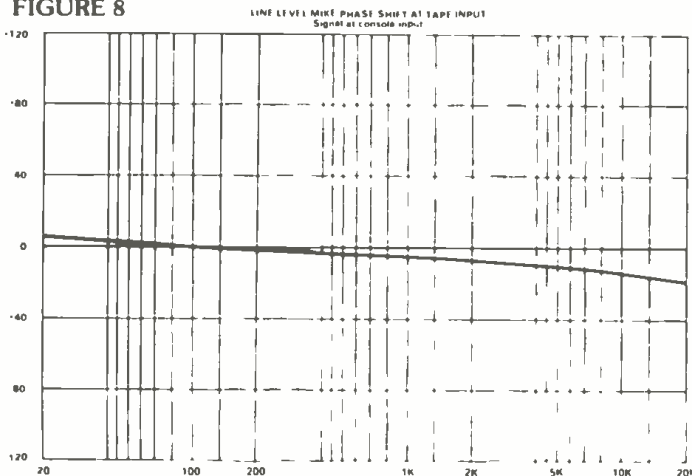
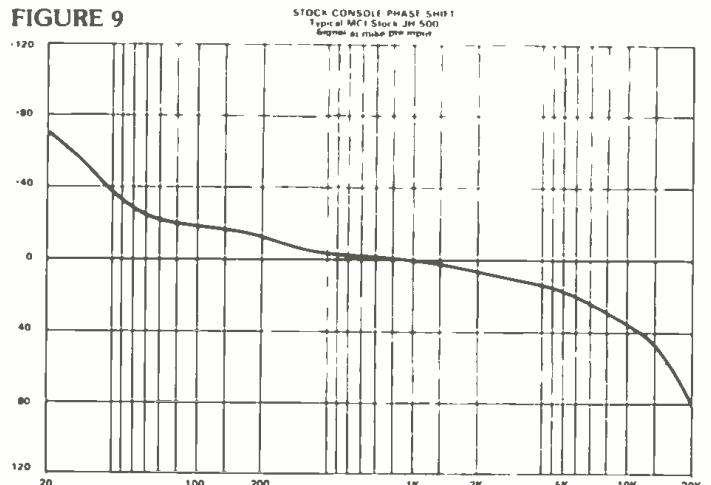

FIGURE 9



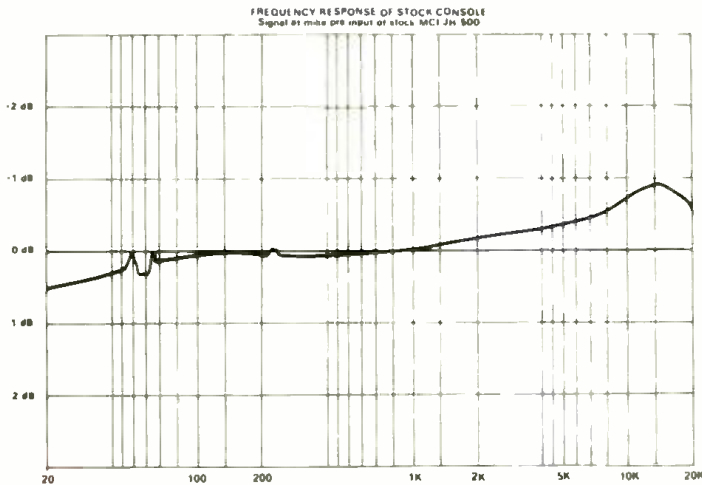

FIGURE 10

resistances and continuity before turning on the unit. Once you're sure everything is right, plug the supply in and measure the voltages at the tube socket and line amp connection tabs. If everything still looks right, replace the tube and measure the voltages again.

Before re-assembling the microphone be sure all loose wires are tied down to avoid buzzes, and that everything has enough clearance when the shell slides in place. When re-installing the tube and the capsule assembly it would be a good idea to clean the pins and receptacles of both. A cotton swab dampened with contact cleaner would do.

The Audio Output Performance

The audio output is an unbalanced signal at line level. Pin #1 is shield, pin #2 is ground, and pin #3 is hot. Signal levels should reach and exceed 0 dB at the console or tape machine.

The practical benefits are vocals that are very clearly heard in the mix, piano tracks that cut through, guitars that have bite without the addition of the usual EQ, and percussion that doesn't have any crunching sound because of inadequate rise times.

Comparing the output of the line level unit to a conventional one is difficult since the measurements are made at the tape machine input and will vary for the low level version, depending on what board is used. Brian Vessa, of Salty Dog Recording, and Mike Sanders, of The Pasha Music House, made the measurements using an Amber 4400A analyzer. (The development of this shared information has led to many improvements and refinements for the JH-500 consoles of both studios.)

All tests were done by injecting signal through a 47 pf capacitor into the front of the microphone where the capsule normally plugs in. The measured performance of the high level output was done without any of the signal passing through the board. The low level measurements were done with the same microphone but with the line amp bypassed and the output transformer still in the circuit. This signal was amplified through the JH-500 with all the gain settings within their prescribed limits. The VCA was included in the signal path but the equalizers were switched to the monitor position.

Brian and Mike found that when the signal passes through the normal audio chain the phase shift at 20 Hz is typically 65° and as much

as 98° at 20 kHz. With the direct line level system phase shift introduced by the electronics it is reduced to 8° at 20 Hz and 20° at 20 kHz. That all-important rise time with the full console signal chain is typically 12 ms with an overshoot of 15%. The rise time of the direct line level shows a considerable improvement over the conventional signal path and was measured at 4 ms with no measurable overshoot (Figures 8, 9, 10 and 11).

Applications To Other Microphones

This same circuit can be used as an external

LINE LEVEL MIKE FREQUENCY RESPONSE
AT TAPE INPUT
(Signal generated at capsule input)

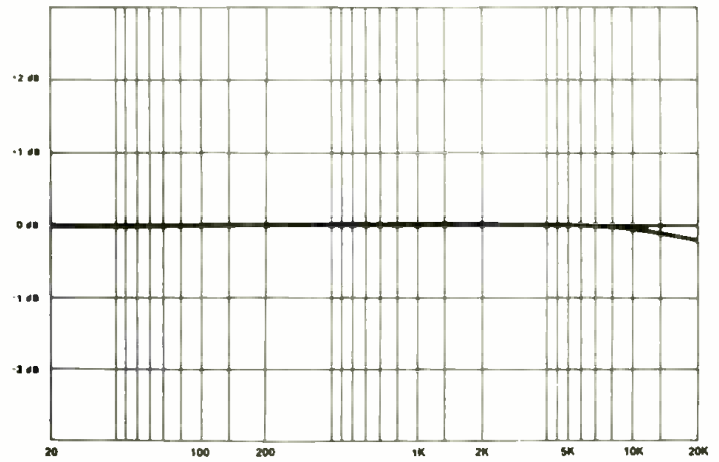

FIGURE 11

booster for many other microphones. In each case it's likely that some adjustments will have to be made, but essentially it will do well under many conditions.

One should be careful in the case of the self-contained versions not to plug them into a low level preamp. Obviously a modification of this sort is not for everyone; but it is well worth looking into for someone who does a great deal of critical recording. Sonically, once you compare the result between the conventional approach and the modified system, you will have no problem choosing between the two.

□ □ □

OUR PLATE EATS SPRINGS FOR LUNCH!

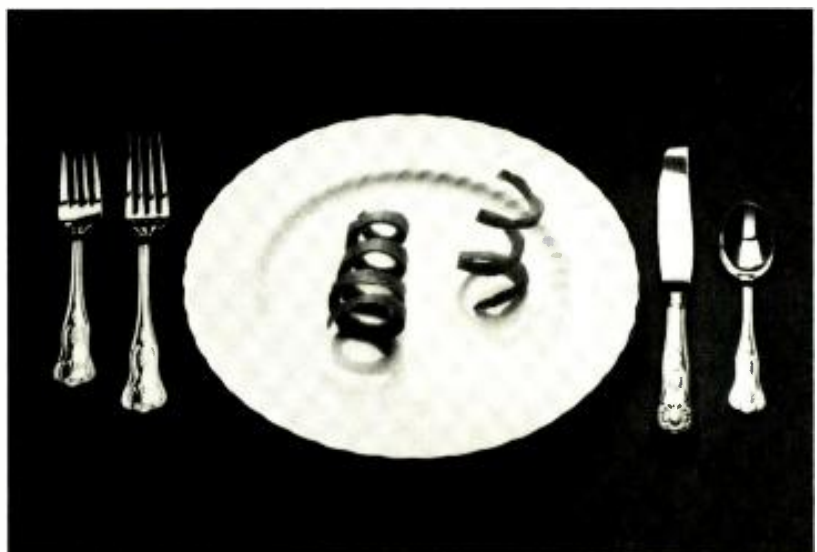

The Audi-Ence RFS-1 Plate Reverb, From \$3,329.00

AUDI-ENCE, INC.

Audi-Ence, Inc., 3325 Vista Oaks, Garland, TX 75043 214-226-2189

for additional information circle no. 101

OVERLOOKED SOURCES OF NON-LINEARITY IN MICROPHONES

by John Meyer

In the quest for high quality music reproduction, analog and digital circuits have been developed which have accuracy in the hundredths of a per cent range. Test equipment is readily available to evaluate preamps, power amps, and tape recorders for harmonic distortion, intermodulation distortion, phase shift, frequency response, flutter and wow, noise, power, transient distortion, and many other tests. Every major studio and sound company has test equipment which enables a technician to check audio equipment and determine if it's meeting the original specifications. Even speakers are being evaluated and checked with test equipment. Speakers are mostly tested for frequency response, but often a technician will sweep a speaker and listen for buzzes or other noises. The microphone stands out from other audio equipment in that the only test it receives occurs when it's being

used. It either works or it doesn't. And if it doesn't, it's sent back to the factory for repair. Objective testing of microphones with test equipment is virtually non-existent in the audio trade. This is probably due to the fact that there isn't any readily available test apparatus to check microphones with. The only specifications given with the microphones are frequency response, output voltage at a given sound pressure level, and its polar response. Rarely are distortion, phase shift, transient response or diffraction effects included with the specifications. Laboratory microphones do include more complete specifications but we are referring here to microphones used for recording and PA applications.

In our quest to build low distortion loudspeakers, we have observed several neglected non-linearity effects in microphones. First, the impulse response of many microphones is distorted. Two, the capacitance shunt, which is used as a pad in condenser microphones, intro-

duces distortion. Three, most of the transformers in the microphones introduce distortion. Four, the distortion increases off-axis on many cardioid microphones.

At this time we are not engaged in building microphones, but we have developed a power supply and balanced line amplifier for the B&K instrumentation microphones. Before discussing non-linear effects in recording microphones the properties of an instrumentation microphone should be defined as it is in these terms that our measurements are made. Further, these microphones are very well documented and are a suitable reference for evaluating other microphones.

The Reference

Bruel & Kjaer (B&K) makes fifteen different microphones with sizes ranging from an eighth of an inch to one inch in diameter. We have used some of the various half-inch types for recording music and voice and have found that they are excellent. They can reproduce without overload extremely high sound pressure levels which are encountered in close miking situations. Anyone wanting to experiment with these microphones should realize that they will produce voltages in excess of 10 volts in close miking situations, and can seriously overload the input of a recording console.

The B&K 4133 microphone with a B&K 2619 microphone preamp is called a "free field" type of microphone. This means when the microphone is aimed at a sound source the response will be flat ± 2 dB from 4 Hz to 40,000 Hz. The microphone cartridge has a built-in high frequency roll-off to counter the diffraction effects of the sound wave around the microphone. This effect is caused by the size of the diaphragm, not the type of microphone. There is an increase of sound pressure on the diaphragm when the wavelengths are comparable to the dimension of the microphone. For a half-inch diameter element, the pressure increase at 20 kHz is about 10 dB.

The B&K 4134 half-inch microphone is a pressure type which means there is no roll-off built into the microphone, and is designed to be used where there is no direction to the sound field, a random field. If the 4134 is used where there is a single source of sound, it should be oriented 90° to the sound wave or in the direction of the sound wave. The response will be flat to about 18,000 Hz,

... continued overleaf —

"THE PACKAGE"

- 1000 Pure Vinyl 45 RPM Records.
- Labels (One Color)
- All Metal Parts & Processing.
- Mastering by Dick McGrew using Neumann VMS 70 Lathe and SX 74 Cutter.

COMPLETE
PACKAGE..

\$365.00

(FOB DALLAS)

"THE PACKAGE" consists of full processing.
Re-orders are possible without re-mastering.

Call Toll Free for more information: 800-527 9026



record manufacturing corp.

902 Industrial Blvd., Dallas, Texas 75207
(214) 741-2027

for additional information circle no. 54

Eight good reasons to be a Beyer Buyer.

one The first reason is Beyer. We have fifty years experience making the world's finest microphones and headphones. And an unmatched reputation for quality, reliability and innovation. The choice of professionals everywhere.

two M 160. One of the world's best-loved and most versatile microphones. Warm, soft sound favored by vocalists and musicians alike. Dual ribbon design for high strength and fast transient response.



three Beyer headphones. A full range of high quality professional models for critical monitoring and reliable communication. DT 109 combines stereo headphones and boom-mounted microphone, ideal for on-air use and disco deejays. DT 444S wireless headphone receives sound from an infra-red LED transmitter up to



300 feet away. Full 20-20,000Hz frequency response. Six hour stereo operation on rechargeable NiCad batteries.

four The new M 400. A great performer's mic. Supercardioid pick-up pattern to minimize feedback. Rugged design for long life. Tapered frequency response with rising high end and rolled off lows, plus midrange presence boost. Built-in humbucking coil and pop filter. Dynamic design is unaffected by heat and humidity.

We're looking for a few more great dealers to handle the Beyer line. Contact Norm Wieland at Burns Audiotechnics



five Beyer microphone stands and booms. A full range of mic mounts for floor and desk use, with fixed and folding bases. Available with collapsible tubes for easy packing. Also heavy-duty stands for speaker cabinets.

six Beyer microphone accessories. Wind screens, impedance matching transformers, in-line switches, power supplies, wireless transmitters, stereo arms, goosenecks, clamps, thread adapters, anti-shock suspensions, and even a mic stand ashtray! The whole works. If you can use it with a mic, we make it.

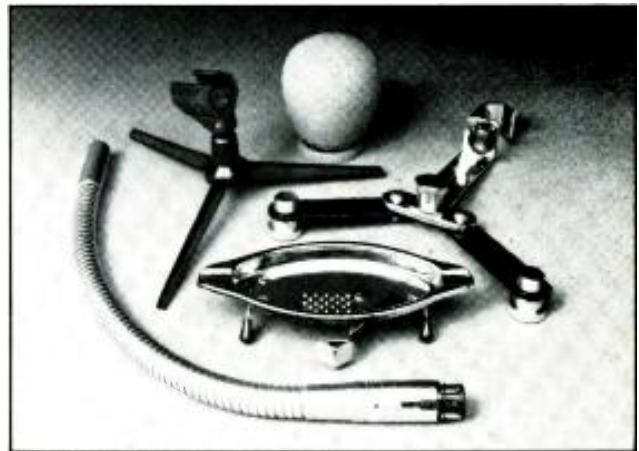

seven M 713.

One of our unsurpassed studio condenser mics. Modular system; accepts different transducer capsules and power supplies. Gold-vapored mylar diaphragm for high transient response. Mu-metal shield. Temperature and humidity stable.



eight See your dealer or write for information on our product line. You'll have many more reasons to be a Beyer buyer.

Beyer 
Dynamic

BURNS AUDIOTRONICS, INC.

5-05 Burns Avenue, Hicksville, NY 11801 • (516) 935-8000
In Canada, H. Roy Gray, Ltd.

NON-LINEARITY IN MICROPHONES (continued)

and 10 dB down at 40 kHz. In order not to get any diffraction effect in the audio range, the diaphragm size has to be reduced to one-eighth inch in diameter. Then there will be less than 2 dB variation in the sound pressure at 20,000 Hz regardless of the orientation of the microphone. Unfortunately, an eighth-inch condenser capsule has very little output; even with the best electronics the noise floor is around 65 dB SPL. A weighted. In order to get a good signal-to-

noise ratio, you have to use a very sensitive microphone cartridge such as the B&K 4165. This gives a noise floor of 15 dBa. The 4165 is a free field type and has a frequency response from 3 Hz to 20,000 Hz, ± 2 dB, and the 3% distortion overload point is 145 dB SPL when used with the B&K 2619 preamp. The B&K 4133 has a noise floor, with the same preamp, of about 25 dB SPL, and the 3% distortion point is 160 dB SPL. The main difference between the 4133 and the 4165 is that the 4165 has its diaphragm resonance at 12 kHz, where the 4133 has a diaphragm resonance at 25 kHz. Also, the diaphragm in the 4165 is thinner and closer to the backplate. The 4165 is more

sensitive than the 4133 which gives it an effective lower noise floor. Most condenser microphones are more like the 4165 in that they have the resonance in the audio bandwidth. The problem with the resonance in the audio bandwidth is that there will be a 90 degree phase shift at resonance which means that there will be a variation in delay throughout the audio frequency range.

I have plotted out two phase delay response curves for two types of B&K microphones (Figure 1). These are both

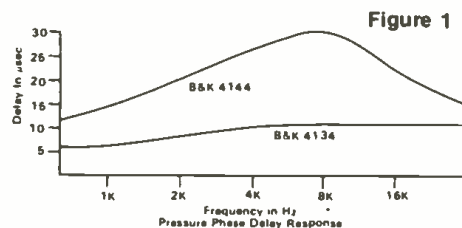

pressure microphones which means that we can evaluate these by using electrostatic fields which is analogous to the pressure of a sound wave. The 4144 has a resonance at 9 kHz, and the 4134 has a resonance at 23 kHz. The phase delay is derived from the phase shift by the following equation:

$$t = \phi / 2\pi f$$

where:

- t = phase delay
- ϕ = radians
- f = frequency in Hz

or:

$$t = -\phi / 360f$$

where ϕ is in degrees.

The amplitude frequency response of the 4144 is -3 dB at 10 kHz, and the 4134 is -3 dB at 25,000 Hz (Figure 2). For a reference, there is a phase delay response for two low pass filters where the 3 dB down points are 10,000 and

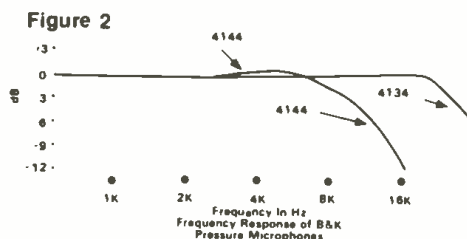
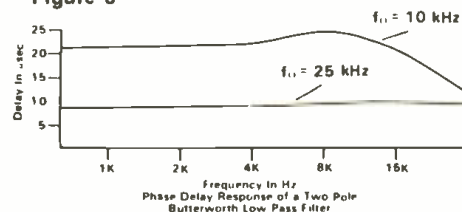

Figure 3



HOLD IT.



HOLD
INSTRUMENT AMPLIFIERS, STUDIO MONITORS,
RACK SYSTEMS, P.A. SPEAKER CABINETS, STAGE MONITORS,
STAGE LIGHTING EQUIPMENT, HI FI SPEAKERS.
ON
AUDITORIUM FLOORS, DISPLAY ROOM FLOORS,
STAGE FLOORS, MOUNTAIN TOPS, STUDIO FLOORS,
LIVING ROOM FLOORS, DESERT ISLANDS.
FOR
CONCERTS, CLUBS, WORK, CONVENTIONS,
PERFORMANCES, PRACTICE, RECREATION,
A.V. PRESENTATIONS, RECORDING SESSIONS.

THE MINI-MODEL SPEAKER STAND FROM ULTIMATE SUPPORT SYSTEMS.

Distributed by Ireland Corp. 2401 Saybrook Ave. Los Angeles, CA 90040 (213) 685-5141



The Quality Microphone That Isn't Made In Deutschland.



Before you assume you must go for the standard condensers from Germany, we think you owe it to your ears (and wallet) to consider The Swedish Alternative: PML. Since 1941, PML has maintained a tradition of handcrafted quality that is immediately apparent in the sound and design of each painstakingly crafted microphone. The essence of superb Swedish attention to detail and quality is exemplified in the DC-63 and DC-96 condensers. Each employ a unique rectangular dual membrane capsule together with a dual FET preamplifier that features low noise, high output level, and very smooth on and off-axis frequency response.

The VM40 (omni) or 41 (cardioid) are extremely rugged and compact mics that are particularly impressive for close range miking.

The '63, '96 and 40/41 are only 3 of a full line that includes electret lavaliers, advanced design XY-axis stereo mics, and complete accessories.

Please write us for full technical information and ask your pro-dealer for a demonstration.

We'll bet you dollars to marks you'll be surprised how much more you'll get with the Swedish Steal. Dealer inquiries invited.

Sverige Är Bäst.

PML PROFESSIONAL MICROPHONES

Exclusive U.S. Distributor: **Cara International, Ltd.**, P.O. Box 9339, Marina del Rey, Ca. 90291, (213) 821-7898
Worldwide Marketing: **Creative Trade, CTAB AB**, Knutsgatan 8, S-26500, Astorp, Sweden, Tel: 4642/515 21

25,000 respectively (Figure 3). The delay of the 4134 is very close to the delay of an ideal 2 pole Butterworth filter with an f_0 at 25 kHz (Figure 4). The impulse

Figure 4

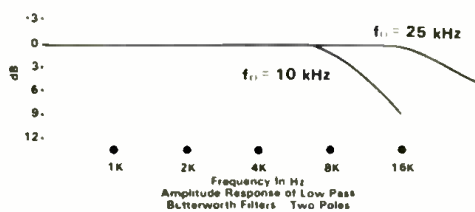

response shown in Figure 5 shows very little ringing for the 4134, but shows excessive ringing for the 4144, and this is due to the variation delay since the frequency response is very flat. The impulses were measured using an electrostatic actuator. We are now in the process of developing a controlled sound source to measure microphones for their

Figure 5

Square Wave Response
Frequency: 4,000 Hz



impulse response. We have an eighth-inch microphone which has less than 1-1/2 microseconds of delay below 100 kHz, which will add very little error to the measurements. The B&K 4133 has a very small change in the phase delay (see Figure 6), and would be a good choice for

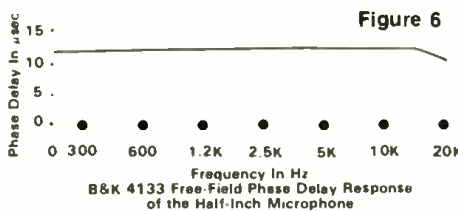

a general purpose test microphone. The results will be published some time in the future. Our preliminary results show that some microphones have very poor impulse response.

Overload

We have encountered peak sound pressure levels as high as 140 dB SPL one foot from a drum, and 154 dB SPL at the mouth of a trumpet when the player was blowing the trumpet as loud as he could. In Figures 7 and 8 we measure the distortion in some microphones which are being used for close miking in PA and studios. Figure 7 indicates second harmonic distortion, and Figure 8 shows third harmonic. The microphones shown here represent both dynamic and

condenser microphone types. We have not tested every microphone that is made, but these seem to be representative of the ones most commonly used. The Shure microphone marked SM56 (VC) has been modified by removing the small transformer inside the microphone case. We found that it was introducing distortion at low frequencies. The output drops by about 12 dB when the transformer is removed, which means that at 120 dB SPL the voltage output of the voice coil is 7 millivolts. Many of the microphones where we removed the transformers showed improvement in distortion characteristics.

Bad Distortion

Another test we set up was to determine if the pad switch in a condenser microphone introduces distortion. For this we built a very special 3,000 cycle horn where its distortion was less than .1% at 130 dB SPL. We observed that many of the microphones we tested had lower distortion at this frequency, which would be another indication that the transformers were probably more of a problem at the low frequencies than they were at the high frequencies. This would be the case of a condenser microphone. The diaphragm in a condenser mike has a constant displacement for frequencies below the resonance frequency. Therefore, the distortion is constant with frequency.

Distortion in a condenser microphone

for additional information circle no. 58

PRO AUDIO SEATTLE



WE'VE GOT IT ALL UNDER ONE UMBRELLA

- MCI** Recorders
- MCI** Consoles
- MCI** SMPTE
- MCI** Automation

And over 55 lines including: AKG, Ampex, Annis, Auratone, Beyer, BGW, DBX, Deltalab, ElectroVoice, Eventide, Gauss, Ivie, JBL, Klipsch, Koss, Leader, Lexicon, Master Room, MRL, Neumann, Orban, Otari, Revox, Roland, Sequential Circuits, Scotch, Sennheiser, Shure, Sony, Sound Workshop, Stanton, STL, Tangent, Tapco, Tascam, Teac, Technics, UREI, Vega

PROAUDIO SEATTLE
Professional Audio Equipment and Services
(206) 367-6800
11057 8th NE, Seattle, WA 98125

for additional information circle no. 59

Figure 7

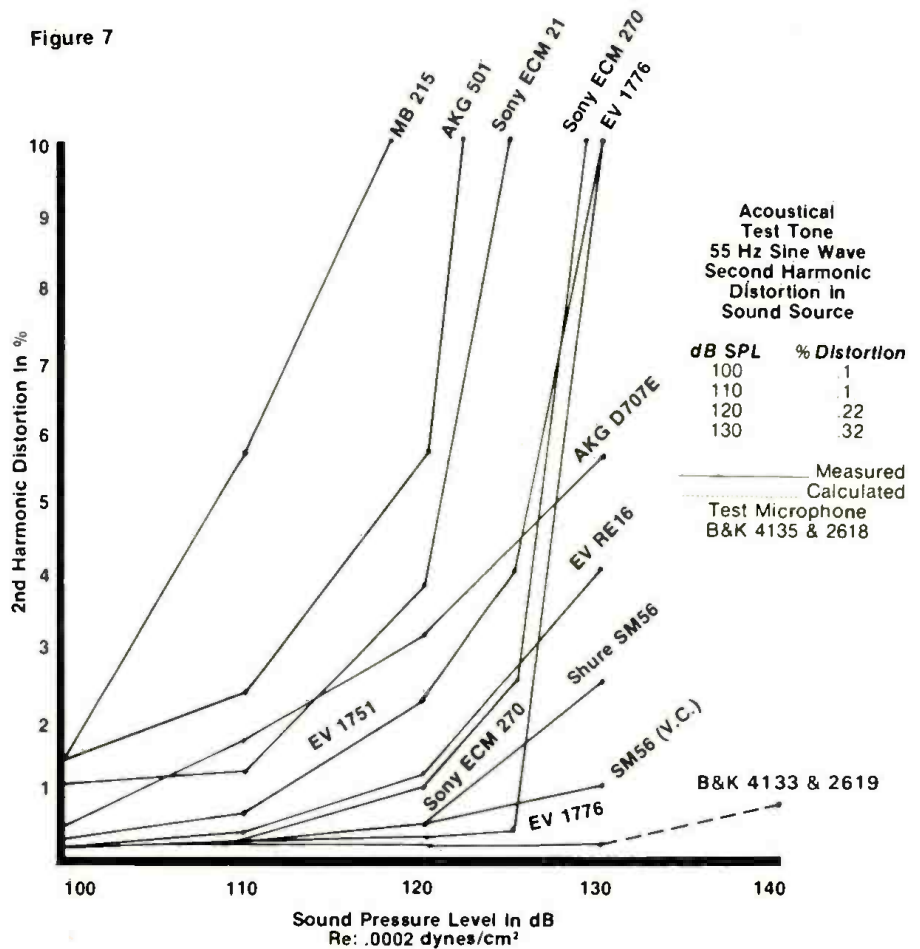
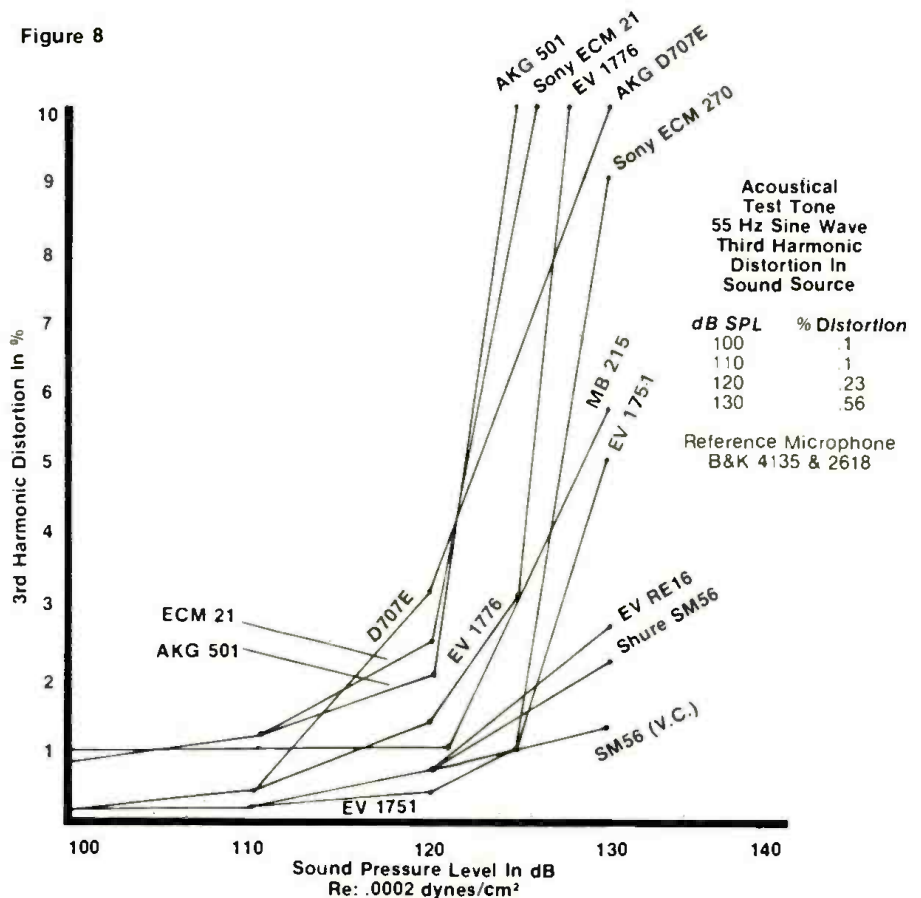

Figure 8



**OVERLOOKED SOURCES
OF
NON-LINEARITY
IN
MICROPHONES**
(continued)

(after Beranek, Equation 2):

$$\% \text{ distortion} = 50 e/E_0$$

E_0 = polarization voltage
 e = peak open-circuit AC voltage of the element.

This equation does not include the small changes in capacitance which are not proportional to pressure. However, the distortion produced by this effect is small compared to the equation given.

Figure 9

ACOUSTICAL TEST TONE 3,000 Hz Sine Wave Distortion Less Than .1% at 130 dB SPL Test Microphone		
Sound Pressure in dB SPL	Distortion in % (2nd)	
	With Pad (-10 dB)	No Pad
115	.3	.3
120	1.5	1
125		Preamp Clipped
130	1.87	

Our test was designed to see if the capacitor shunt as used in many condenser microphones for a pad would introduce distortion. The distortion mechanism was mentioned to use by a B&K microphone engineer as a disadvantage in that any shunt capacitance would introduce distortion. We selected one of the more expensive condenser microphones for the experiment. The distortion is shown in the table in Figure 9. You can see that there is more distortion at 120 dB SPL with the pad in than without it. The microphone preamp started to clip at 125 dB SPL when the pad was not used. This meant we could not test the effect of the pad at higher sound pressure levels.

Last, we observed that some of the cardioids showed higher distortion when they were oriented 30 degrees off-axis to the sound source. The SM56 showed a worse off-axis response than the RE16 where some microphones, such as the AKG 501, showed no change at all on- or off-axis. The distortion remained constant.

This is not a guide to selecting microphones, but should add to the understanding of why some microphones sound different from other microphones even though they have the same frequency response and polar response.

There have been several new microphones introduced recently which we have not tested at this time. Setting up for testing microphones is complicated, and takes a great deal of time. If there is interest in the results of the tests we will subsequently publish future results.

□ □ □

Why Pay For Degraded Performance? DeltaLab Has The Special Effects Digital Delay Line Featuring...

- Unique VCO with infinitely variable waveshape control.
- 512 milliseconds delay at full bandwidth
- 2.5 seconds delay with external memory module
- Flanging/Doubling/Echo
- Digital Octave Flanging (a new effect)
- Infinite (non-deteriorating) repeat
- 15k Hz Bandwidth at all delay settings
- Resonant and doppler effects
- Footswitch control of effects
- 90 dB min.; 95 dB typ Dynamic Range
- Limited 2 year warranty



DeltaLab Research, Inc.
27 Industrial Avenue, Chelmsford, Mass. 01824
Tel. (617) 256-9034

Canadian Distributor:

Heini Audio Developments, Inc.
Markham, Ontario, Canada
Tel: (416) 495-0688

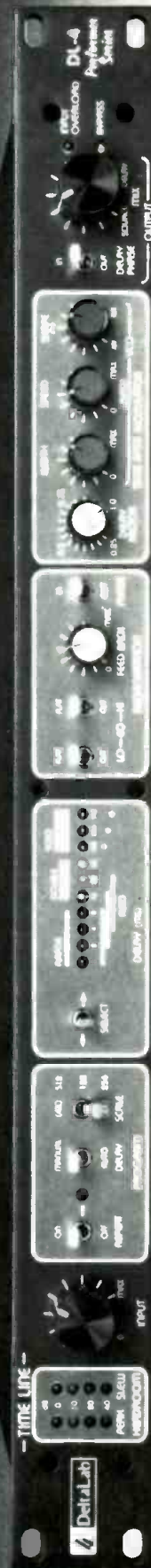

DL-4 Time Line™ Performer Series available at quality dealers

for additional information circle no. 60

**in-use
product review**

NEW DESIGN CONCEPTS IN
ELECTRET CONDENSERS

The SHURE SM81 Condenser Microphone

by

Rich Warren
WFMT, Chicago

At WFMT, in Chicago, we record, duplicate, and syndicate the Chicago Symphony Orchestra, the Lyric Opera of Chicago, the Milwaukee Symphony Orchestra, and consult in the recording of the Houston Grand Opera and the Saint Louis Symphony Orchestra. The Lyric Opera is broadcast live to Chicago radio audiences on opening nights, and classic concerts from the Chicago Public Library Cultural Center and the First Chicago Center are broadcast live on a weekly basis. In addition, an average of three events weekly are remotely recorded for subsequent broadcast.

WFMT owns a large quantity of AKG, Shure, and Beyer dynamic microphones; AKG, Neumann, Studer-Shoeps, Sony, and Shure condenser microphones, and even a couple of old RCA ribbon mikes. Studio recordings are done through custom designed and built audio consoles into Studer A-80 two-

track recorders with Dolby A. Remote recordings are done through Studer consoles into Nagra 4.2, with QGB large reel adaptors and Dolby A. From this equipment list it should be evident that technical quality is paramount and budget is not a severe limitation.

Because we do not use a permanently outfitted van, and must pack and re-pack

suitcases from car trunk to car trunk and occasionally to airline baggage, ruggedness is an all-important factor. This does not include more direct abuse where in a folk music recording the performer may accidentally knock over the microphone stand.

Since most of our recording is on location we rarely have the option of re-takes. We also place severe environmental hazards on our microphones. Some are suspended for four months to a year from the ceiling of the Lyric Opera House, or embedded in floor mounts on stage, which subjects them to considerable dust. WFMT tapes the Chicago Symphony Orchestra at its outdoor summer home at Ravinia Park, 25 miles north of Chicago. Humidity is consistently high, and it is not unusual for it to reach 98 per cent after a summer thunderstorm. The microphones are hung from the ceiling of the pavilion where temperatures may soar to over 90 degrees. During the summer of 1978 we lost a recording of a Mahler symphony when our condenser microphones began to sizzle and crackle from the humidity. There was, of course, no way that we could change mikes during the performance. Such is the diversity of the recording activity of WFMT, illustrative of the critical demands put upon our recording equipment. We are, however, ever searching for new and improved products to eliminate our acute exposure to failure.

This past summer (1979) we substituted the Shure SM81, an electret condenser, as the main recording mike at Ravinia. It performed without failure during various extremes in the weather and survived considerable abuse at folk music recordings. The SM81 has now been used regularly in our live weekly broadcasts, and also for recording the Milwaukee Symphony Orchestra and Houston Grand Opera. We have had eight SM81s in service for the past year, without problem.

- the author -

A native of New York City, Rich Warren is a graduate of the University of Illinois.

Beginning in 1968 his career has included both the print and broadcast media as well as a stint as founder and director of Nonesuch, Inc., the concert promotion agency.

Presently Warren is the producer/recording engineer at WFMT-FM (Chicago) in charge of all non-classical recording.

HPM-41 MIXER

- AC Line or Battery Power • High-Performance Electronics
- A-B and Phantom Power for Condenser Microphones

Our new little mixer gives you a myriad of useful features in a convenient easy-to-use package. Call or write for our detailed product brochure.

RTS SYSTEMS

100 W. CHESTNUT ST., BURBANK, CA 91506 213/843-7022 TX: 194855

for additional information circle no. 61

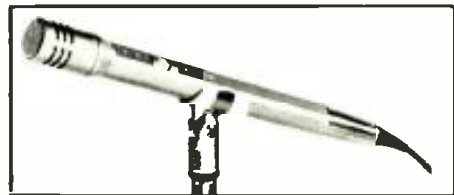

Electrets

The electret concept is not new. The name was suggested by Oliver Heaviside almost a hundred years ago.¹ (His own name is used for a layer of the atmosphere.) Electret condenser microphones were manufactured prior to World War II, using a mixture of carnauba wax and resin for the electrical material. The Japanese actually attempted to use them during the war, and learned first hand the effect

of the natural environment on the primitive electret. The result was quite a few squadrons unable to communicate.² What performed well in the lab was a disaster in the field. Long after the war, in the 1960s, some of the first electret microphones manufactured in Japan suffered similar difficulties for lack of proper electret material. It was not until research by Bell Labs, in the early-to-mid 1960s, recommended the use of Mylar™ and Teflon™ that high quality, durable electret mikes became practical.^{3*}

There continues to be some confusion and controversy concerning the difference between high voltage externally-biased condensers and the electret-biased condenser. In either system there must be a constant charge on the capacitor plates, so that the voltage will directly change as the spacing of the plates changes. With current technology there is no inherent difference in performance between the two different biasing systems. Regrettably, the profusion of inexpensive electrets designed specially for the mass consumer market have somehow given the electret design a bad name compared to professional externally-biased condensers.

The backplate generally carries the electret charge rather than the diaphragm because of the physical properties of the halocarbon substance used for the backplate (i.e., Teflon™ and Aclar). These materials are excellent electret materials, but substances such as polypropylene and polyester terephthalate (Mylar™) are more suitable as diaphragm materials.⁴ If a material such as Teflon™ were used to carry the charge as well as form the diaphragm the performance of the microphone would be less than optimum. In order to obtain

an adequate and stable charge the diaphragm would have to have a thickness of 25.4 um (1 mil). This would be most unacceptable since the thickness must be considerably less for acceptable results (approximately 5 um). By separating the charge and diaphragm functions each element can be optimized.^{5, 6}

The capsule connection is particularly important since its design can improve two electro-mechanical problems of major concern. In a condenser transducer first it is most desirable to increase the active capacitances while decreasing the dead capacitance in the capsule assembly. Secondly, the electro-acoustical output sensitivity should be maximized while still

maintaining environmental stability. An electrical equivalent is shown in Figure 1. The key elements associated with the system's electrical efficiency are illustrated. It can be seen from the drawing that the dead capacitance, or internal shunting (C₀), tends to reduce the voltage output that appeared at the input of the impedance conversion amplifier. Additional loss occurs through the transducer-to-electronics connection, (C₁), as well as the input capacitance of the electronics itself (C_p). These elements comprise a capacitive voltage divider with the loss in decibels computed with the following formula:

$$\text{Loss} = 20 \log C_A / (C_D + C_A + C_1 + C_p)$$

This capacitive voltage divider reduces the input signal more than the increase in total capacitance reduces the level of noise. In order to improve the microphone's signal-to-noise the active capacitance must be increased while the dead and stray capacitance reduced.

The SM81 has incorporated into its design a number of features to reduce this dead capacitance. By making the backplate from a non-conductive material and selectively depositing gold on only the surface which faces the active portion of the diaphragm, the capacitance formed by the backplate and the diaphragm ring is significantly reduced. Dead capacitance is further reduced by a non-conductive cup with a low dielectric constant separating the backplate and filter plate from the transducer's metal housing. Finally, the coaxial connector between the transducer and preamplifier reduces capacitance (C₁). By making the diameter of the center pin as small

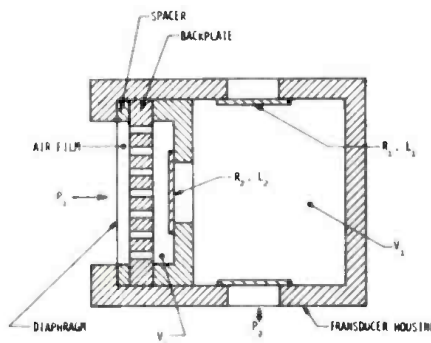
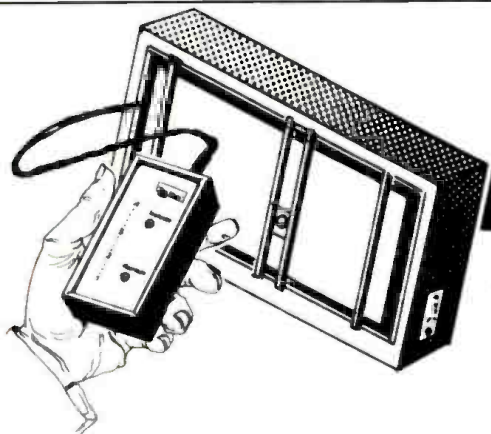

Figure 1
Simplified cross-sectional view of condenser transducer.

*Teflon™ and Mylar™ are trademarks of E. I. duPont de Nemours & Company, Inc.



the new standard in plate reverberation systems

The Plate

It's true! People still recognize a truly good thing when they hear it. The response to The Plate has been so overwhelming that we have already shipped dozens of units worldwide and we are filling orders as fast as

possible. Many buyers have been so impressed they have ordered a second. Don't settle for the studio sound of the 60's. Move into the 80's with the new standard in plate reverberation systems.

Remote Control

The Plate is indispensable, but you probably don't want to have to look at it, walk around it or use it for a couch in the control room. With the NEW Remote Control you can hide The Plate anywhere that's out of the way—in another room, an attic or a basement—and still control the decay time from the console. The Remote Control also features LED readout of the decay setting.

Small Plate

Do you have a mobile studio, a small studio or perhaps a crowded large studio? Now The Plate comes in a small size just for you. It's almost one-half the size of its larger counterpart (53% to be exact) and delivers the same clean reverb with only a small sacrifice in maximum decay time. Now there is no reason to let a lack of space keep you from having The Plate.

Retrofit Kit

For about half the New cost of The Plate, we can provide a retrofit kit which will convert your older, tube type plate reverb to the performance characteristics of The Plate. Monophonic units will be converted to stereo operation in the retrofit process. Why not bring your old unit up to the new standard in plate reverberation systems?

Dealer Inquiries, contact

PARASOUND, Inc. • 1200 Beechwood Avenue • Nashville, TN 37212 • 615-256-6900

PARASOUND, Inc. • 680 Beach St. • San Francisco, CA 94109 • 415-673-4544

— User Product Review —
The
SHURE SM81
Condenser Microphone

as practical and by selecting an insulating material with a low dielectric constant this capacitance can be made quite small, thus improving signal output. The spring-loaded pin seats deeply in the preamp well to avoid intermittences and failure common to mikes employing a short pin (Figure 2).

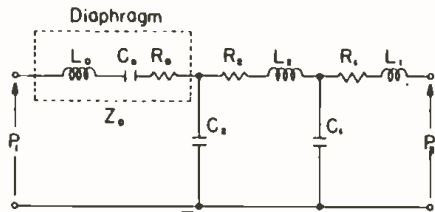

Figure 2
Electrical analog of condenser transducer

Signal-To-Noise

To achieve the best signal-to-noise ratio the capsule's bias voltage and the active capacitance (CA) should be made as high as possible. Increasing CA can be accomplished by using a large diameter diaphragm structure with a minimum of spacing between the diaphragm and the backplate. The diaphragm diameter, however, is restricted to approximately 25.4 mm (1 inch) in order to obtain an extended frequency response to 20 kHz. If a larger diameter is attempted, diffraction and phase difference effects can produce undesirable variations in the high frequency response of the microphone element.

There is also a practical limitation to the amount of bias voltage and physical spacing between the backplate and the diaphragm. For a given spacing and bias voltage the diaphragm's elastical restoring force must always exceed the electrostatic force of attraction between the microphone's active and passive electrodes.

The SM81 has a backplate diaphragm spacing of 25.4 μ m (1 mil) which was the design compromise reached between high capacitances and diaphragm stability over a wide range of temperatures and humidities. With this in mind, the diaphragm material that is used was selected for its high tensile strength, low mass, good high frequency vibration response, and tolerance of corrosive atmospheres. It is imperative that the diaphragm tension remain constant within defined acceptable tolerances. To achieve stability at extreme temperatures (74°C, 165°F) the diaphragm material is coated on both sides with gold. The element is then aged prior to assembly by successive exposure to high temperature, and wet and dry atmospheres.

Additional stability is obtained by the uniform charging of the electret elements. This problem is unique to electret elements. If the charge density is uneven an instability is more likely to occur than if there is an even charge distribution over the entire electret surface, even though in both cases the same sensitivity can be achieved. The solution Shure developed was a special system of charging and charge stabilization. The capsule has an effective bias of 100 VDC, with a charge

uniformity of $\pm 5\%$. The long term stability is ensured over a wide temperature and humidity range, -29°C to 57°C (-20°F to 135°F) at relative humidity levels up to 95%, and from -29°C to 74°C (-20°F to 165°F) at humidity levels up to 50%. Naturally, the use of an electret element does not obviate the need for an additional power supply for the capsule's impedance-matching preamplifier.

The fact that the microphone will work at much lower voltages than those commonly used in phantom powering situations is of particular interest (12 to 48 V) as the use of 48 volts in microphone supplies may soon come under close review by the United States Underwriters Laboratory and the Canadian's Standards Association. Both are against the use of voltages higher than 42.4 volts peak or DC appearing at the terminals of connectors. A situation commonly found in professional recording studios.

Acoustic "Lossy Ladder" (SM81)

This cardioid microphone is designed to operate as a first order gradient utilizing two sound openings.⁷ The front surface of the diaphragm is one, and the other is a rear entry consisting of several slots in the side of the capsule housing. The backplate is perforated. The combination of these elements Shure has described as a "lossy ladder" network.

To better describe the "lossy ladder" network, the acoustical elements are shown in Figure 3, and the electrical analog is illustrated in Figure 4. P₁ represents the sound pressure

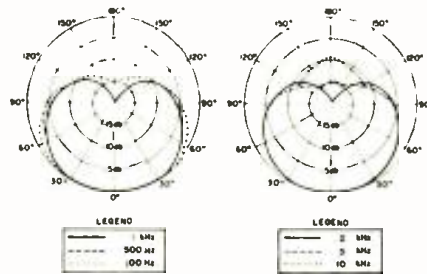

POLAR PATTERNS
Figure 3

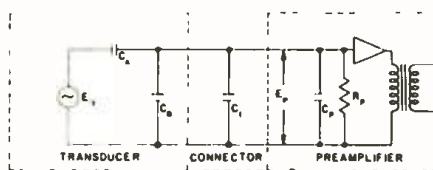

Figure 4
Electrical equivalent of a condenser transducer and preamplifier.

striking the front surface of the microphone. The other sound opening to the rear of the diaphragm consists of a number of openings in the side of the transducer body. The sound entering these ports is defined as P₂. The diaphragm element has an acoustical impedance — Z₀ — which includes the impedance of the thin layer of air between the diaphragm and the backplate. Since so many factors play a part in the resulting P₂ other elements should be considered in the mathematic and schematic analogy. P₂ pressure must pass through the screen mounted in the side ports which is considered resistance R₁ and inertia L₁, via the cavity V₁ with compliance C₁. P₂ must then pass through a second screen with resistance R₂, inertia L₂, a

cavity of V₂, and compliance C₂. The combination of these circuit elements L₁, R₁, C₁, L₂, R₂, and C₂, comprise a ladder network with lossy inertances which is called a "lossy ladder" network. The transfer characteristics of this network create a time delay to the pressure P₂. This creates the directional characteristics (cardioid) of the microphone. A sound source on axis to the microphone will have P₁, P₂ pressures that are complimentary to one another. On the other hand, sound entering from the back of the microphone will have P₁, P₂ pressures that will acoustically cancel one another at the two surfaces of the microphone's diaphragm.

This is true for low and mid frequencies. At high frequencies the attenuation P₂ caused by the "lossy ladder" is too great to allow much high frequency P₂ pressure to reach the rear of the diaphragm. In this audio range the microphone acts like an omni-directional unit that is influenced mostly by P₁. At these frequencies directional characteristics are arrived at by the diffraction of the high frequency sound around the suitably shaped mike housing.

Another characteristic of the "lossy ladder" is that it presents a predominantly resistive load to the back of the diaphragm. This minimizes the acoustic effects of air film resistances R₁. This factor is not a constant, but is dependent of frequency.⁸ A resistive load is required in condenser transducer designs to ensure a wide range flat response.

By the manipulation of each of these factors the microphone has been designed to have a very acceptable cardioid polar pattern at all frequencies (Figure 5).

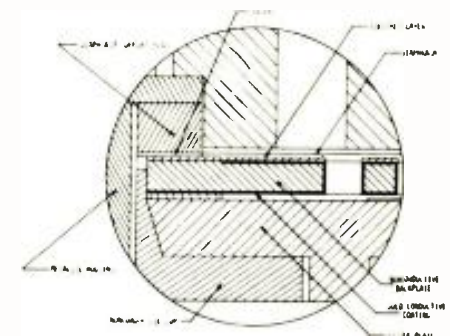
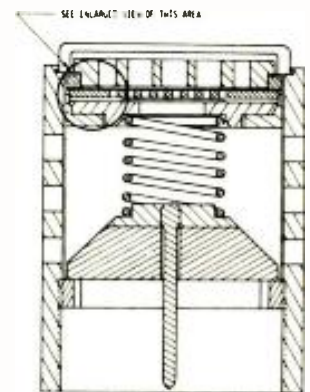

Figure 5
(a) Cross-sectional view of condenser transducer. (b) Detail of cross-section of condenser transducer.

Field Servicability

The Shure SM81 is totally field servicable. The microphone is constructed from seven

subassemblies, and their parts numbers are printed on the technical data sheet. The microphone may be disassembled in the field by any competent engineer. Even the XLR male output connector plugs directly into the SM81s output transformer, so that the entire circuit board may be removed and replaced without soldering.

The SM81 utilizes a multiple stage voltage follower with an FET input stage, a npn-pnp complementary follower output stage driving a step-up transformer. At each point in design, low noise and maximum headroom were stressed. The low frequency roll-off switch controls a high pass Butterworth filter at 80 Hz. Additional frequency contouring is achieved through a compound emitter-follower stage thus providing active filtering. The output transformer includes a damping network to minimize high frequency loss from different resistive loads and cable lengths. It displays a proximity effect of +13 dB at 100 Hz with a sound source placed 1 inch from the capsule. However, the in-board roll-off compensates well in most situations. There is a choice of 6 dB per octave at 100 Hz or 18 dB per octave at 80 Hz. The effect is surprising subtle. You can remove the mud from close miking of a guitar without losing the quality (or quantity) of its bass notes. On vocals the roll-off is ideal. It cuts room anomalies and bleed through from bass instruments while allowing a baritone voice to sound full and round. The optional A81WS windscreens is essential for vocal work since the microphone is sensitive to sibilants and popping of consonants.

The SM81 offers impressive sound quality. It

not only looks flat on paper, it displays a real neutrality on recordings. It has the substantial low-end of the Studer-Schoeps CMT-54 without the boominess of the AKG C-451E, and it has much of the sweet upper midrange and highs of the Neumann U-84. Obviously, in certain recording situations one of these mikes might do a better job than the Shure. It handles exceptionally high sound pressure levels without perceivable distortion. The unit includes a 106 dB pad that is rotary capacitive switch between the transducer capsule and the microphone handle. Shure specifies a maximum SPL of 145 dB at 1,000 Hz into 800 ohms with the attenuator "in." Since WFMT records classical and folk music, and avoids close miking for the most part, we cannot verify that claim. However, we have encountered no overload problems with the SM81. It remains unquestionably clean in all the recordings where it has been used.

Two Minor Limitations

Good recording of classical music involves considerable use of space. WFMT attempts to capture a reasonable amount of hall sound. This sometimes necessitates the use of an omni-directional microphone, and these are the situations where we cannot use the Shure. We also cannot use it for broadcasts from Lyric Opera where microphones are suspended from the ceiling four stories above. The management insists that the microphones not be easily visible to the audience. Other than these two situations we have rarely come across a recording where the Shure was not an ideal microphone. □ □ □

Primary Reference:

W. Bevan, R. Schulein, C. Seeler, *Design of a Studio Quality Condenser Microphone Using Electret Technology*, JAES, December 1978, Vol. 26, No. 12, p. 947-957.

References:

- 1 - O. Heaviside, *Electromagnetic Induction and Its Propagation, Section XII Electrization and Electrification, Natural Electrets*, Elec. Papers, Vol. 1, p. 488 (August 7, 1885).
- 2 - G. M. Sessler and J. E. West, *Electret Transducers: A Review*, JAES, Vol. 53, p. 1589-1600, (1973).
- 3 - M. Eguchi, *On the Permanent Electret*, Philosoph. Mag., Vol. 40, p. 178-192 (1925).
- 4 - J. van Turnhout, *Thermally Stimulated Discharge of Polymer Electret* (Elsevier, New York, 1975).
- 5 - M. C. Killion and E. V. Carlson, *A Subminiature Electret-Condenser Microphone of New Design*, JAES, Vol. 22, p. 237-243 (May 1974).
- 6 - R. Schulein, E. Seeler, and D. Smith, *Application and Design Considerations for a High-Quality Uni-directional Line-Level Microphone*, JAES (Project Notes/Engineering Briefs), Vol. 23, p.303-307, (May 1975).
- 7 - R. B. Schulein, *Microphone Considerations in Feedback-Prone Environments*, JAES, Vol. 24, p. 434-445, (July/August 1976).
- 8 - E. Rule, F. J. Suellentrop, and T. A. Peris, *Second-Order Instrumentation Systems with Frequency-Dependent Stiffness and Damping*, JAES, Vol. 31, p. 1457-1562, (November 1959).

Additional References:

Principles of Electricity Applied to Telephone and Telegraph Work, American Telephone and Telegraph Company, 1961, p. 89, 90, 125, 126.
H. F. Olson, *Microphone Thermal Agitation Noise*, JAES, Vol. 51, p. 425-432, (1972).

The Complete Stereo Processing System

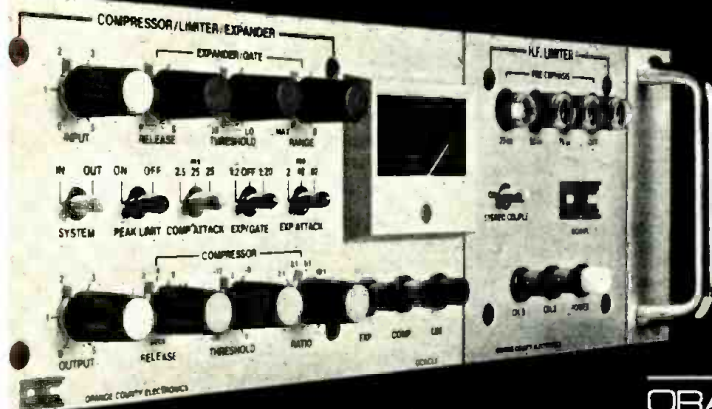

The Orange County CLX-S-FM belongs in your studio to assure you of transparent, accurate stereo or dual-channel processing with maximum control. It is a powerful new tool for the creative producer/engineer.

- Compressor with adjustable ratio, threshold, attack and release times, for loudness enhancement
- Fast peak limiter with 250:1 slope for overload protection
- Highly effective expander/noise-gate for noise reduction
- High frequency limiter with selectable pre-emphasis characteristics
- Extremely accurate stereo tracking
- Overall performance specs and construction to the highest industry standard

Also investigate the VS-3 Stereo Processor which offers internally pre-set functions for the budget-conscious user looking for great sound.



ORANGE COUNTY ELECTRONICS
INTERNATIONAL INC.

Exclusive Sales & Marketing:

Parasound

Dealer Inquiries Invited

680 Beach Street, San Francisco, Ca. 94109 (415) 673-4544

New Products



JH-110B-8-HP

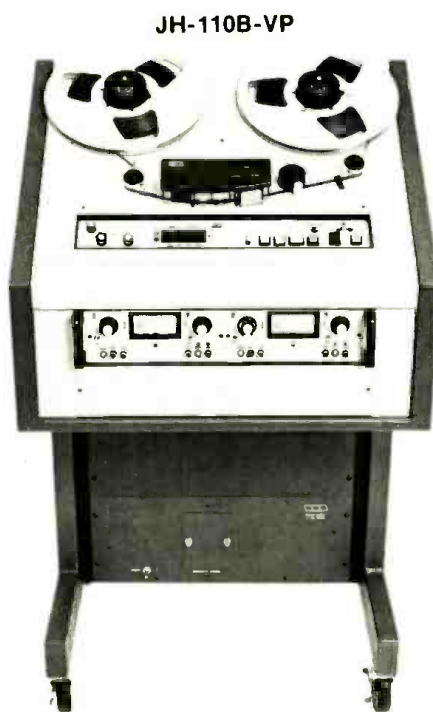

JH-110B-VP

NEW JH-110B SERIES TAPE RECORDER/REPRODUCERS

FEATURING TOTALLY TRANSFORMERLESS ELECTRONICS INTRODUCED

Replacing the JH-110A, the new series tape recorder/reproducers feature new electronic to provide even greater stability, flexibility and reliability for all applications: large and small recording studios, broadcasting, and disc mastering facilities.

The new electronics are complete transformerless — no head transformers,

line input/output transformers — resulting in improved immunity to magnetic fields and extended frequency response. Other changes are claimed to result in improved phase integrity and improved response with strict adherence to standardized EQ curves. The opamps used in the new design offer low noise, wider open loop bandwidth and improved drive capabilities. Simplified adjustments include NAB/CCIR switching without the need for re-equalization.

Mono to 8-track versions are available, all featuring 3-speed (except the 110BC) fully DC

servo controlled transports with variable speed capability and MVC (Manual Velocity Controls). Features include automatic sync switching for overdubbing, separate equalization and bias controls for three speeds, three speed timed bias ramp for QUIOR (Quiet Initiation of Record), ultra stable head alignment, constant tape tension for all speeds and reel sizes, and optional remote control. The JH-110B is compatible with the optional microprocessor based RTZ III and/or the JH-45 AutoLock. Variable profile or high profile cabinets are available for all systems, but transport, electronic drawers, and power supply are 19" rack mountable. Optional tape marker and tape cutting scissors (30°) may be ordered for 1/4" transports.

The JH-110BC is a standard DIN stereo/mono broadcast recorder with a monitor panel which enables mono/stereo operation with automatically switched record/reproduce levels, in/out metering and monitoring via the built-in speaker and amplifier or headphones. The RTZ III is standard on the JH-110BC.

MCI
4007 NORTHEAST SIXTH AVE.
FORT LAUDERDALE, FL 33334
(305) 566-2853

for additional information circle no. 65

INOVONICS' GORDON HEADROOM METER OFFERS THIRD ALTERNATIVE TO PROGRAM MONITORING

Introduced as a third alternative to program monitoring, the new Gordon Headroom Meter integrates the traditional aspects of the VU meter and the European Peak Programme meter.

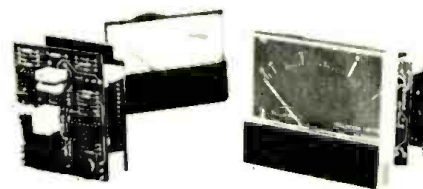

This new meter meets the UK/EBU standard for response to program peaks, but maintains a more conventional and artistically desirable "syllabic" response to music and speech. The complete unit retails for \$122; a VU conversion option is available for \$69.

INOVONICS, INC.
503-B VANDELL WAY
CAMPBELL, CA 95008
(408) 374-8300

for additional information circle no. 66

ROLAND INTRODUCES RACK PRODUCTS

Featured in the introduction of the new line of rack products are the Roland SBF-325 Stereo Flanger, the SVC-350 Vocoder, the new SPH-323 Phaser, and the Roland Dimension D.

The SBF-325 is a rack-mounting Stereo Flanger that produces a myriad of time delay effects which range from classic flanging to chorus and doubling. The addition of the second channel makes possible stereo

BUILDING A RECORDING STUDIO?

Make us your first call.

Audiotechniques (203) 359-2312

We're not only the biggest, we think we're the best, by far! We've been building studios for nearly eight years and have more years of combined professional audio engineering experience than we like to admit. Initial planning, financing, designing, equipment installation, maintenance . . . they're all our business. If your business is recording, you should be talking to us.

for additional information circle no. 64

Prime Time™

Digital Delay Processor

lexicon

PRIME TIME
DIGITAL DELAY



professional quality delay plus special effects



Lexicon's new Model 93 "Prime Time" digital delay processor gives recording studios and entertainers an easy-to-use professional quality time delay with special effects and convenient mixing all at a price you can afford. It combines a degree of flexibility and versatility never before offered in equipment of full professional quality.

- Two delay outputs independently adjustable from 0 to 256 ms
- Complete mixing for delay and reverb processing, freeing up main console channels and tape tracks
- Integral VCO for special effects like vibrato, doppler pitch shift, flanging and automatic double and triple tracking
- Long delay special effects — up to 2 seconds
- All dynamic functions can be footswitch controlled
- 90 dB dynamic range, total distortion below 0.08% at all delay settings

lexicon

Lexicon, Inc., 60 Turner Street
Waltham, MA 02154 (617) 891-6790

Export: Gotham Export Corporation, New York, New York

for additional information circle no. 67

February 1980 □ R-e/p 113

panning in all time delay modes, dramatically intensifying the effect. The Stereo Flanger has four operating modes — three of which are used in flanging, the other being used for chorus and doubling effects. Each mode is indicated by an LED for constant monitoring. LEDs also indicate sweep rate and overload status. While in each of the time delay modes there is complete flexibility over the sweep width and depth, as well as manual delay control (from .5 to 20 ms) as well as full regeneration capabilities. The Stereo Flanger lists for \$495.00.

The Roland **SVC-350 Vocoder** is said to be the first truly sophisticated vocoder to be priced within the range of musicians or engineers. The primary function of the vocoder is to process the spoken or sung human voice and use this information to trigger another musical signal, giving the instrument the ability to "speak."

This vocal synthesis is accomplished by processing the voice through a series of eleven Voice Character analysis filters. All of these filters are active and control an envelope follower which reacts according to the volume of that individual frequency. This information is then used to shape those frequencies of the carrier (musical) signal. The SVC-350 uses 10 filters for vowel sounds and there is also an extra filter that responds to the rapid transients of hard consonants, a feature not found even on higher priced units.

The Vocoder allows for both balanced and unbalanced program inputs and outputs, and contains a special guitar input that permits attenuation of the guitar's harmonics. The SVC-350 Vocoder carries a list price of

\$995.00.

Although the Roland **Dimension D** has only been on the market for a very short time, it has already gained widespread acceptance by the professional recording industry. According to Roland, the Dimension D's unique psycho-acoustic effect has already been dubbed "the Ro-Phex" by industry engineers in response to its dramatic quality of bringing richness and life to recorded music. The Dimension D's versatility enables it to be used with virtually any instrument (especially voice tracks) with incredible results.

Four pushbutton controls activate the



Dimension D's different spatial modes, and an array of LEDs constantly monitors the output. The Dimension D (model no. SDD-320) processes both mono and stereo signals with signal-to-noise ratio better than 95 dB. The list price is \$495.00.

Roland has also sneak-previewed a new rack product slated for early release — the Roland SPH-323 Phaser. The SPH-323, it is claimed, features probably the single most flexible phase shifter package ever offered. In addition to the total manual and external control over all phase-shift parameters, the SPH-323 features a dual LFO for unique multi-modulation effects. Scheduled for delivery in the Spring, the SPH-323 will sell for \$450.00 list.

ROLAND CORP., U.S.
2401 SAYBROOK AVENUE
LOS ANGELES, CA 90040
(213) 685-5141

for additional information circle no. 68

**COUNTRYMAN ASSOCIATES EM-101
COMPACT ELECTRET CONDENSER
MICROPHONE**

The new model's unusually small diaphragm (.2 x .3) contributes to its excellent transient response and transparency. It can easily be positioned to take full advantage of the enhanced sound pressure field near reflecting surfaces and at the same time eliminate sound coloration from these surface reflections.

The EM-101 is especially suited for pickup of acoustic instruments. Its small size allows inconspicuous mounting on the instrument itself while its high sound level capability provides undistorted output from even the loudest instruments. The EM-101 is an excellent alternative to vibration and acceleration type pickups where it often

**The Stage Monitor That Can Be
Heard!**



- Low distortion — patented horn-driver system
- High SPL without compression or limiting — 125 continuous with peaks of 135 dB
- Wide frequency response — 60-15,000 Hz.
- Built-in power protection circuitry — "SpeakerSense"

The UltraMonitor

Meyer Sound Laboratories, Inc.
2194 Edison Avenue
San Leandro, CA 94577 (415) 569-2866



provides better quality sound at lower cost. Specifications include: Pickup pattern, Omnidirectional; Frequency response, 20 Hz - 15 kHz, ±1.5 dB; Noise level, 25 dB SPL A weighted; Maximum sound level, 149 dB SPL; Power requirements, 48 V phantom power; Output, 150 ohm balanced; Sensitivity, -47 dB; Dimensions, .6" x .3" x .15".

COUNTRYMAN ASSOCIATES
424 STANFORD AVENUE
REDWOOD CITY, CA 94063
(415) 364-9988

please mention . . .
YOU SAW IT IN R-E/P

for additional information circle no. 69

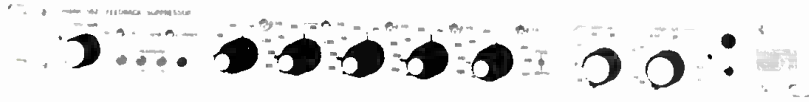

**P.A. FEEDBACK SUPPRESSOR
BOOSTS GAIN BEFORE HOWLBACK**

The UREI Model 562 Feedback Suppressor allows increased gain before howlback in sound reinforcement systems for auditorium, concert halls, meeting rooms, schools, churches, and stage monitor systems.

The 562's five active notch filters can be tuned to the most prominent ring modes. Gain can be increased 12 dB or more and intelligibility improved without undesirable changes in fidelity or room equalization. Tuneable high cut and low cut filters allow bandwidth restriction for added feedback control. A bypass switch allows A-B comparisons and a set-up switch protects speakers during tuning. XLR/QG connectors and barrier strips are provided for both in and output.

The Model 562 is available at UREI dealer priced at \$488.00.

**UREI
UNITED RECORDING
ELECTRONICS INDUSTRIES
8460 SAN FERNANDO ROAD
SUN VALLEY, CA 91352**

for additional information circle no. 71

**ADR COMPLEX-LIMITER AND
VOCAL STRESSER UPGRADED**

The ADR F760X-RS Compex Limiter and F769X-R Vocal Stresser have, as part of Audio & Design Recording's policy of continual improvement, been modified to provide optional preemphasis in the Peak Limiter 'side-chain' of 50 or 75 ms. Replacing the previous 'IN-OUT' Peak Limiter switch is an 'IN-OUT-PRE-EMPH' switch for selection. Although factory set to 50 or 75 ms as standard, a custom curve can be adopted very easily since the internal component change required is minor.



At no increased cost over the basic price this specification upgrade makes the Compex Limiter and Vocal Stresser immediately more suitable for broadcast users (to match transmitter characteristics) and in production and mastering work (with 100 ms custom curves) provides a useful de-essing or sibilance control.

On the construction side, the following improvements have been implemented:

— More reliable 3u gold plated Elma switches are now fitted throughout as

standard.

— Tougher 4 mm brushed and anodized aluminum front panels are now standard.

— Internal improvement in construction technique have eliminated most wiring harnesses, generally improving the reliability and availability of the product.

The photo shows the F760X-RS in Packhorse case.

**AUDIO & DESIGN RECORDING
84 OXFORD ROAD
READING RG1 7LJ, BERKS., ENGLAND
PHONE: READING (0734) 53411**

or in the U.S.

P. O. BOX 786

BREMERTON, WA 98310

(206) 275-5009

for additional information circle no. 72

**dbx® INTRODUCES TOTALLY
INTEGRATED SUBWOOFER SYSTEM**

The Model 510 Subwoofer System is the newest component in the dbx Sound Enhancement Series which also includes the Boom Box and dbx Dynamic Range Expanders. The Model 510 System features an exclusive speaker sensing circuit which provides complete overtravel and thermal protection for drivers. Protection is accomplished

by reduction of input signal for minimum disruption of output.

All components used in the system are specifically designed to complement each other for optimized performance. The system is said to provide up to 120 dB SPL at 23 Hz.

Additional features include: two custom-designed long-throw 15" drivers with 96 ounce ceramic magnet and vented pole piece construction with high temperature voice coil on aluminum former.

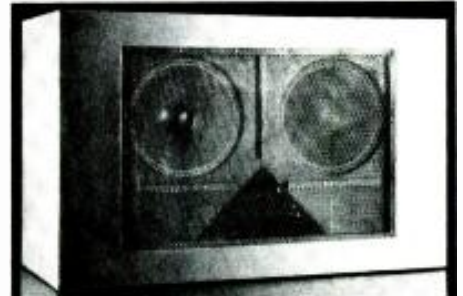

The Integrated Subwoofer System's protection circuitry makes the system so safe that dbx guarantees it. According to the company, as long as the unit is properly connected, it will not blow. Unlike other systems which turn off completely under stress, the dbx system temporarily reduces its volume level only as much as necessary to prevent damage.

Suggested retail price: \$1,200.

**dbx, Incorporated
71 CHAPEL STREET
NEWTON, MA 02195**

for additional information circle no. 73



HAS AN EQUALIZER FOR YOU



**SC-63
369 List**

**SC-66A
599 List**

We've been building Parametric equalizers for over six years now and our new SC-63 (mono) and SC-66A (stereo) reflect our experience. Our basic design has evolved to include the latest technology and a host of new features. You'll find that our clean, logical front panel layout takes the mystery out of Parametric equalization and you'll have more power to control real world sound problems than you believed possible. Equalize at just the right frequency and bandwidth to get precisely the sound you want, not just a close approximation. You'll also appreciate our heavy-duty construction and attention to detail which is unique in the industry. When you think about tone controls, think Ashly Parametrics, the world's most powerful equalization tools . . . designed and built by people who still care about quality and reliability.

For more information see your Ashly dealer or Call or write:

ASHLY Ashly Audio Inc.
Customer Service
100 Fernwood Ave. • Rochester, N.Y. 14621
(716) 544-5191 • Toll Free (800) 828-6308 (except N.Y.S.)

for additional information circle no. 74

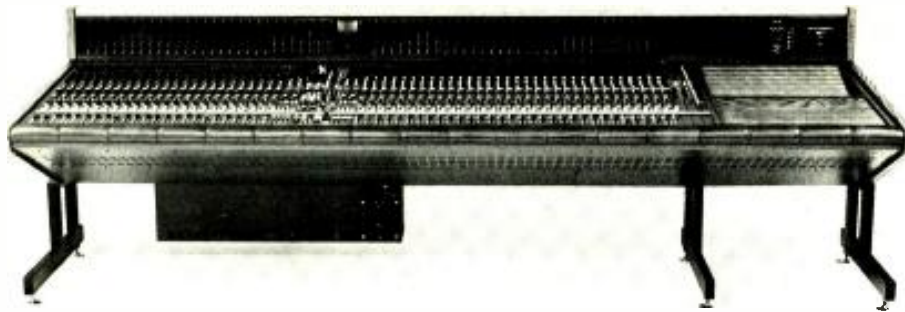

**MCI'S JH-556C
RECORDING/REMIXING CONSOLE**

Specifically designed to meet the needs of dual multitrack recording, the JH-556C is intended for use with MCI's JH-45 AutoLock SMPTE/EBU synchronizer and two JH-16 multitrack recorders.

The JH-556C can accommodate 24 inputs on one side and 32 on the other, with the master controls in the middle. Each side of the console is independently programmable, making it in effect two consoles when laying down tracks, and one console during mixdown. It also makes it possible for the operator to have a separate monitor console while laying down tracks. Standard features include the unique MCI Plasma Display for channel, mix, and send metering. JH-50 Automation and all of the JH-500C options are also available.

Word of the improved quality possible from this combination of equipment spread rapidly. "It's amazing how quickly our industry is reacting," says Lutz H. Meyer, vice president

of marketing for MCI. "Nearly a dozen Ultimate Systems have been installed in the short time since it became available, and orders for more than twice that number are being processed, with more arriving daily."

**MCI
4007 NORTHEAST SIXTH AVE.
FORT LAUDERDALE, FL 33334
(305) 566-2853**

for additional information circle no. 75

**ALTEC INTRODUCES
STANLEY SCREAMERS**

Designed and built in conjunction with Altec sound contractor Stanal Sound, headed by Stan Miller (Van Nuys, California and Kearney, Nebraska), Screammers have been seen and heard in major concerts with Neil Diamond, Bob Dylan, John Denver, Dolly Parton, Waylon Jennings, Mac Davis, and Rickie Lee Jones, just to name a few. And, at installations such as the Universal Amphitheatre and Greek Theatre in Los Angeles, sound by Stan Miller has long been a staple.

Versatile and practical, Stanley Screammers use such exclusive Altec components as the Mantaray constant directivity horns, Tangerine phase plug drivers and LF series loudspeakers.

The Model 1020-R Dual Subwoofer System includes two Altec Lansing 421-8LF low frequency, high power, sound reinforcement loudspeakers with a high output of 20 Hz to 80 Hz, and dimensions of 48"H x 48"W x 23 1/4"D. Model 3210-R three-way, Tri-amp Ready System includes two Altec Lansing 604-HPLN 15" duplex loudspeakers (less network); one 291-16F high frequency compression driver with Tangerine radial phase plug and low mass magnet; one Mantaray Constant Directivity Horn, dispersion 90 by 40 degrees, and a high output, extended range system with tri-amp ready inputs. Its dimensions are 51"H x 27"W x 21"D.



Enclosures, made from non-resonant plywood and covered with a durable fibreglas finish, are designed for specific Altec loudspeakers. This way, the enclosure and speaker work in harmony for maximum performance and high power usage.

Stanley Screammers are available in two versions, Road Finished and Utility Finished. The Road Finished have reinforced steel corner caps and are equipped with recessed carrying handles making them ideal for touring or rental applications. Some road models include fibreglas lids and/or hardwood skirts.

**ALTEC CORPORATION
1515 S. MANCHESTER
ANAHEIM, CA 92803
(714) 774-2900**

for additional information circle no. 77

NEW ASHLY EQUALIZERS

The new SC-66A parametric equalizer covers the entire audio spectrum with four overlapping bands per channel and provides 15 dB boost or cut. 5 1/2 octave tuning range per band and a bandwidth adjustable from 3.3 octave to 1/20 octave. Noise is -87 dBV and distortion is less than .05% at full output.

New features include balanced inputs, peak overload lights, ±15 dB gain controls, and an overall defeat switch. The SC-66A is housed in a rugged steel 19-inch rack mount enclosure.



The model SC-63 provides the same performance as the SC-66A but is a smaller 3-band mono format.

Suggested applications for Ashly Parametrics include feedback control, acoustical tuning, tape to disk transfer, hum filtering,



It's everything you need for fast, accurate one-third-octave sound-level and reverberation-time analysis... all in one easy-to-use package.

- Weighted or un-weighted SPL analysis
- Automatic or manual reference-level adjustment

- Digital display of RT60 with decay characteristic plotted on screen
- Built-in pink-noise generator
- Rear-panel connectors for external oscilloscope and digital peripherals
- AC and battery operation

Inovonics' Model 500 Acoustic Analyzer. The sound choice for analysis in downtown traffic, the auditorium, recording studio, and laboratory. For all the details, call or write today. Model 500 - \$2750.

Inovonics Inc.

503-B Vandell Way
Campbell, CA 95008
(408) 374-8300



Exclusive export distribution
Gotham Export Corp.
741 Washington Street
New York, NY 10014 USA
Telex 23-6779 GOTHM UR

for additional information circle no. 76

dialog equalization, and generation of special effects. U.S. price for the SC-66A is \$599.00; the SC-63 is \$369.00.

ASHLY AUDIO, INC.
100 FERNWOOD AVENUE
ROCHESTER, NY 14621
(716) 544-5191

for additional information circle no. 78

CERWIN-VEGA SOUND REINFORCEMENT SYSTEMS

The new V-35B full range sound system is said to be the result of many improvements and new drivers — a successor to the V-35A. The unit is a three-way system incorporating an 18" woofer. Frequency response is 40 Hz to 15 kHz while power handling capacity is 300 watts (RMS). The unit's sensitivity is 104 dB/W/m while dispersion is 45 degrees x 90 degrees; impedance is 8 ohms. The drivers include a 188EB, 18-inch low frequency woofer, MH-100 mid frequency driver and a H-25 high frequency horn with crossovers at 1.2 kHz and 5 kHz for exceptionally smooth and even sound reproduction. The rugged cabinet is vented with a directional baffle and has an exterior mounted presence control (1.2 kHz - 5 kHz) auto protect circuit, carrying handle and wheels.

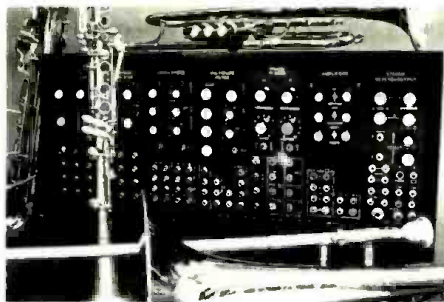

Producing a variety of harmonic and inharmonic tone colors, the Aries Instrument Modification System II incorporates balanced modulation, reverb, and phasing, as well as basic voice capabilities provided by dual VCO, multi-mode filter and dual VCA modules. For convenient control of system parameters, the 21"L x 10"H x 10"D instrument provides two foot pedals that can be patched to any module.

The Aries Instrument Modification System II is priced at \$2,138 assembled, or \$1,543 in kit form. Literature is available on request.

ARIES MUSIC, INC.
SHETLAND INDUSTRIAL PARK
P. O. BOX 3065
SALEM, MA 01970
(617) 744-2400

SCAMP MINI RACK

The mini rack widens Scamp applications into the PA, musicians, a/v, film, and rental areas.

Designed to make Scamp units portable, the new rack, which is built into a robust flight

case, is powered by the new S26 Power Supply Module, which fits the standard 19" Scamp. External connections are made via another new module — the S12 Jack Module. The flight case is fitted with convenient carrying handles and a useful "lid-bin" for mains and audio connectors.

Musicians can now configure a mini rack with the various Scamp units using the S02 Mike Preamp, direct inject at low level. The format is ideal for rental companies and for on-location film work where the mini racks portability will be much appreciated.

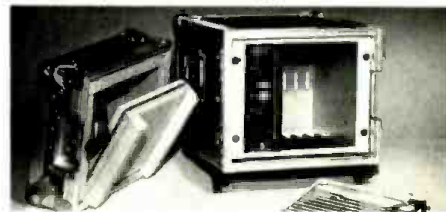

The complete mini rack in-flight case with S26 Power Supply Module, S12 Jack Module, patch cords and jacks costs \$295.00, or any part of the package may be purchased separately to fit into either standard 19" Scamp or the new Scamp mini rack.

AUDIO & DESIGN RECORDING
84 OXFORD ROAD
READING RG1 7LJ, BERKS., ENGLAND
PHONE: READING (0734) 53411
or in the U.S.
P. O. BOX 786
BREMERTON, WA 98310
(206) 275-5009

for additional information circle no. 81

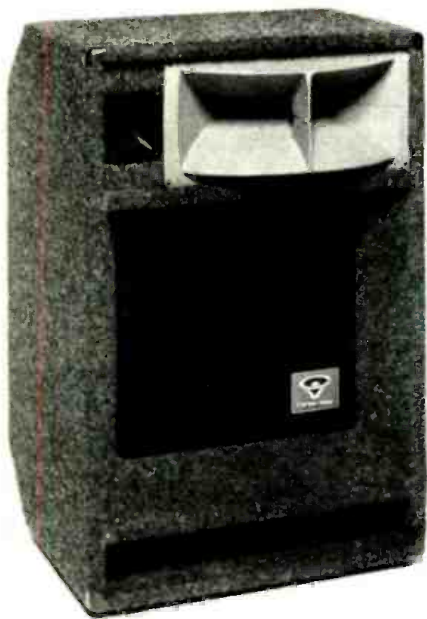

The RMH-2 is a high-power, mid/high frequency sound system. It is designed to be used with an ancillary bass unit, subwoofer or bass system.

CERWIN-VEGA
12250 MONTAGUE STREET
ARLETA, CA 91331
(213) 896-0777

SYNTHESIZER FOR SINGLE NOTE INSTRUMENTS REQUIRES NO KEYBOARD KNOWLEDGE

The Aries Instrument Modification System II is a modular synthesizer that simultaneously follows the pitch and dynamics of any single note instrument such as a trumpet, saxophone, and trombone, without requiring any knowledge of keyboards. It extends the tone qualities of single note instruments over the range of sounds produced by a typical synthesizer.

NOISE GATE GT-4

The remarkable low cost noise gate that is so simple and economical to use that people are finding new applications for them every day.



Use one channel for each mike in your P.A. System and drastically increase loudness without feedback. Gate your echo returns to adjust decay time without running to the chamber. Gate your cue feeds and rid the headphones of distracting hum and noise. Gate each mike on the drum kit, the sound is spectacular!

For the full story and a list of dealers call or write
Omni Craft Inc. Rt. 4 Box 40, Lockport, Illinois 60441 (815) 838-1285



OMNI CRAFT INC.
RT. 4 BOX 40
LOCKPORT, IL. 60441 815-838-1285

for additional information circle no. 82

STUDIO UPDATE

Midwest:

■ **CROSTOWN RECORDING** (Kalamazoo, Michigan) is the first U.S. studio to take delivery of a new Soundcraft Series 1624 recording console. Other equipment at Crosstown includes UREI Time Aligned™ monitors and a Teletronix LA-2A.

■ **SHADE TREE STUDIOS** (Lake Geneva, Wisconsin) has begun construction of its second 24-track facility which will feature a meeting room, lounge, and sauna, and will house the corporate offices of Recreational Recording, Ltd. Recently at Shade Tree have been **FLO AND EDDIE** producing **ROADMASTER'S** upcoming LP for **MERCURY RECORDS**, **DAN RILEY** doing an album for **ARMADA RECORDS** with **ED TOSSING** and **ANDY WATERMANN** producing, and **COALKITCHEN** recording an album with **TERRY LUTTRELL** producing and **DAVID PINKSTON** at the board. P. O. Boz 168, Lake Geneva, WI 53147, at the Playboy Resort. (414) 248-2400.

■ **TRC STUDIOS** (Indianapolis, Indiana) has just completed major upgrading and renovations including the addition of a Harrison 3232 console, an Allison Programmer, and ADR noise gates, compressors, and equalizers. The studio and control room, designed by **JERRY MILAM** in 1973, were left structurally intact, but underwent minor acoustic adjustments and major redecorating and refurbishing. The Sentry III monitors are now driven by a Crown PSA-2 through White 1/3-octave equalizers, and two additional monitoring systems are now offered. MCI 2-track machines have been added to the 24-track JH-114, and the room continues to offer Dolby noise reduction and a variety of sideboards. 1330 North Illinois Street, Indianapolis, IN 46202. (317) 638-1491.

■ **FIFTH FLOOR RECORDING STUDIOS** (Cincinnati, Ohio) has added a new Lexicon 224 Digital Reverberation unit to its studio where **FAZE-O** recently recorded a new album for **SHE/ATLANTIC**, and where **MC GUFFEY LANE** is currently laying down tracks. 517 West Third Street, Cincinnati, OH 45202. (513) 651-1871.

■ **SOUND RECORDERS** (Kansas City, Missouri) announces the construction of that city's first automated 24-track recording studio. The facility is equipped with an MCI Series 600 console, which is transformerless in/out and has built-in parametric equalization. The studio manager is **JIM WHEELER**, formerly with Dick Marx & Associates, in Chicago, and Applewood Studios in Denver. 3947 State Line, Kansas City, MO 64111. (816) 931-8642.

■ **RED SKY RECORDING STUDIO** (Steger, Illinois) has opened and is serving the Chicago-land area. A number of radio commercials and projects for local artists have already been completed, according to owners **MICHAEL** and **PAMELA ICZKOWSKI**. The facility is fitted with a Tascam 80-8, TAPCO power amps, reverb, and graphic units, and equipment by dbx, JBL, and Auratone. The studio also features an extremely large isolated drum booth. 3419 Sally Drive, Steger, IL 60475. (312) 754-6297.

■ **REELSOUND RECORDING COMPANY** (Manchaca/Austin, Texas) has just installed in its remote recording bus JBL 4313 monitors voiced with White 1/6-octave filters. The bus has been used on remotes of late by **JOHN PRINE** with **AL BEUNETTA** producing, **TRUTH** with **BOB MAC KENZIE** producing, and **TOM PETTY** for King Biscuit Radio with **CHARLES KAPLAN** producing. P. O. Box 280, Manchaca, TX 78652. (512) 472-3325 or 282-0713.

■ **CBS RECORDING STUDIOS** (Nashville) finds **WILLIE NELSON** in the newly remodeled Studio "A" working on his next album with **RAY PRICE**, while **EPIC** artist **DON KING** is also recording at the facility with CBS engineer **KEN LAXTON** producing. **KEITH STEGALL** is recording his new **CAPITOL** LP at the studios as well. 34 Music Square East, Nashville, TN 37203. (615) 259-4321.

■ **PANTEGO SOUND STUDIO** (Arlington, Texas) has expanded to 24-tracks with MCI equipment in the new control room and two completely remodeled recording rooms. Currently working at the studio are **RCA** country artist **DANNY WOOD** with **CHARLES STEWART** producing and New Wave artists **KENNY AND THE KASUALS** recording tracks for their latest LP. 2210 Raper Boulevard, Arlington, TX 76013. (817) 461-8481.

■ **ADVENT RECORDINGS INCORPORATED** (Memphis, Tennessee) has had **POINT BLANK** in studio recently recording their new album with **BILL HAM** producing with engineer **TERRY MANNING**. Other activity at the facility has been with **KWICK** finishing up their debut LP for **EMI/UNITED ARTISTS** with **ALLEN JONES** as the producer, and the **PHOTONS** working on their new album with **CHATTY CATHODE** producing. 2000 Madison Avenue, Memphis, TX 38104. (901) 725-0855.

4



INNOVATIVE

... best describes the Delta Lab DL-2 Acousticcomputer digital delay and special-effects processor.

True stereo — 2 in, 2 out. • \$1750. list • Call for demonstration



16055 VENTURA BL. SUITE 1001

ENCINO, CA 91436 (213) 995-4175

STUDIO UPDATE

■ **SPECTRUM SOUND, INCORPORATED** (Nashville) consultants for sound reinforcement, have moved their operations to new offices. The company handles the sales, installation, and 24-hour service of most major lines of sound reinforcement equipment. *50 Music Square West, Suite 101, Nashville, TN 37203. (615) 329-1982.*

■ At **WOODLAND SOUND STUDIOS** (Nashville) **ISLAND** is recording for **ATLANTIC RECORDS** with **KYLE LENNING** producing and **DANNY HILLEY** in the engineer spot. **CHARLIE DANIELS** and his band are laying tracks for their new **EPIC** LP with producer **JOHN BOYLAN** and engineer **PAUL GRUPP**, and **CONWAY TWITTY** is working on an album for **MCA** with producer **DAVID BARNES** and Hilley behind the desk. *1011 Woodland Street, Nashville, TN 37206. (615) 227-5027.*

■ **JACK CLEMENT RECORDING STUDIOS** (Nashville) has **COLUMBIA** artist **MOE BANDY** in working on another album with producer **RAY BAKER** and engineer **BILL SHERRILL**. **KEITH STEGALL** is starting sessions for his first LP on **CAPITOL** producing himself with **JIM WILLIAMSON** engineering. **CHRIS LEDOUX** is laying tracks for two more LPs on the **LUCKY MAN** label. **BILL HARRIS** produced these last sessions with engineer **CHARLIE TALLENT**. *3102 Belmont Boulevard, Nashville, TN 37212. (615) 383-1982.*

Northeast:

■ **STILLWATER SOUND STUDIOS** (Stamford, Connecticut) announces the addition of a 3M one-inch, 8-track machine to go with its Allen & Heath modified console and Ampex 351-2 mixdown machine. A full array of instruments, mikes, effects, and monitors is available. *11 Turn of the River Road, Stamford, CT 06905. (203) 322-0440.*

■ **SOUNDMIXERS RECORDING STUDIOS** (New York City) announces that its general manager, **BRUCE STAPLE**, has been named managing director of the studio's parent company, **SOUND ONE CORPORATION**.

■ **THE BARGE SOUND STUDIO** (Wayne, New Jersey) has completed its expansion to 16-tracks with the addition of an Auto-Tec L-16 recorder with dbx noise reduction. Other new gear includes a DeltaLab DL-2 Acousticcomputer, a Master Room XL-305 reverb system, and an Otari MX-5050 2-track recorder. The studio has just finished a single for **THE BANGS** utilizing the EXR Exciter on mixdown. *90 Lionshead Drive West, Wayne, NJ 07470. (201) 835-2538.*

■ **SIGMA SOUND STUDIOS** (Philadelphia) just concluded a stint with **CAT STEVENS**, who was working on some experiental concepts he is thinking of wedding to educational areas. Also in the studio, guitarist **GATO BARBIERI** is laying down rhythm tracks for his upcoming album on **A&M** with **TOM BELL** producing and **DIRK DEVLIN** engineering. **GLADYS KNIGHT** is working on her upcoming **CBS** LP with **ASHFORD** and **SIMPSON** co-producing with **ANDY ABRAMS** at the board. *212 North 12th Street and 309 Broad Street, Philadelphia, PA.*

to be represented in the next available issue write:

R-e/p STUDIO UPDATE
P.O. BOX 2449
HOLLYWOOD, CA 90028

5

continued overleaf . . .

4600 SMPTE Tape Controller

Before you do another multi-track session, call us for a personal introduction to electronic audio editing.



The BTX Corporation | 438 Boston Post Road, Weston, Massachusetts 02193 • (617) 891-1239
6255 Sunset Boulevard, Hollywood, California 90028 • (213) 462-1506



February 1980 □ R-e/p121

STUDIO UPDATE

■ **SIGMA SOUND STUDIOS** (New York City) was the taping site of a profile of **STEPHANIE MILLS** for **WESTINGHOUSE BROADCASTING'S** "Evening Magazine." Ms. Mills is in the studio recording an album for **20TH CENTURY RECORDS** with producers **JAMES MTUME** and **REGGIE LUCAS**. **JIM DOUGHERTY** is engineering. Also at Sigma's New York studios, **MELBA MOORE** is recording her next **EPIC/CBS** project with **BRUCE HAWES** and **VICTOR CARSTARPHEN** producing with **JAY MARK** engineering. *53rd Street and Broadway, New York, NY.*

■ **TROD NOSSEL RECORDING STUDIOS** (Wallingford, Connecticut) was the site of recording sessions by **NORTHERN RHYTHM**, **THE TROPICAL HOT DOG BAND**, **CHRIS SCOTTILE**, and **HIGH TIMES**. Mixing work has been completed by **VAN DUREN**, for his second LP, and by **ROGER C. REALE** for his second album. All sessions were engineered by **RICHARD ROBINSON**. *10 George Street, Wallingford, CT 06492. (203) 269-4465.*

■ **LATIN RECORDING SOUND STUDIOS** (New York City) announces the completion of their studio "B" vocal overdub/mixing room. The acoustical restructuring and redesigning was done by **TOMMY JAMELKA** and the upgrading includes the installation of a Harrison 24-track automated console, an Ampex MM-1200 recorder, an Ampex ATR-100 recorder, and an MCI 110 4-track machine. Monitors are **UREI A-13s** with White passive equalizers, and outboards include an **EMT 240 Goldfoil Echo Chamber**. There is also 26-tracks of Dolby noise reduction. *1733 Broadway, New York, NY 10019. (212) 541-6072.*



Recording Center

■ **THE RECORDING CENTER, INC.**, (Norwalk, Connecticut) celebrated its grand opening in January, according to studio manager **ILENE BRAUNSTEIN**, and in a short operating period has produced a number of jingles, commercials, and audio visual presentations for such clients as **SPEIDEL** and the **CONNECTICUT INSTANT LOTTERY**. Registration in the studio's course in engineering has been such that a second session has been scheduled to accommodate the applicants. Studio "A" features full stage lighting, two isolation rooms, and a curved drum booth. *25 Van Zant, East Norwalk, CT 06855. (203) 853-3433.*

■ **MINOT SOUND** (White Plains, New York) is recording Saturday Night Live star **GARRETT MORRIS** for his first R&B album on **MCA**, two albums for German recording artist **JAMES LAST**, and a project by **DAVID SPINOZZA** and crew. **DAVID SANBORN** recently finished his latest LP for **WARNER BROTHERS** at the studio, with **RAY BARDANI** engineering. *19 South Broadway, White Plains, NY 10601. (212) 828-1216.*

■ **SOUND CONCEPTS** (Woodbridge, Connecticut) a complete commercial, audio visual and jingle production house, announces updating of its present facility with a Neotek Series I Console, M&K Monitors, Bryston Amplifiers, studios and control rooms. Plans include purchase of a second Neotek Console, a 24/16 Series III for installation in a new production complex at the end of the year. **MIKE SALAFIA'S** Vision-Sound, of Englewood, New Jersey, is providing the entire equipment package and consultation. *30 Hazel Terrace, Woodbridge, CT 06525. (203) 397-1363.*

■ **ED LABUNSKI** announces completion of his studio facility at the new complex in the Poconos, near New York, in Millford, Pennsylvania. The emphasis of the studio design, by **STEVE DURR**, of Nashville, has been to produce a comfortable studio retreat with the high quality sound demanded by professional artists. Equipment includes a 36/24 Neotek Series III Console, Studer A-80 24-track, and Studer 2-tracks. According to engineer **VICKI FABRY**, the new group **SOUTH** will be recording their first album in the studio this winter. *Rural Route #1, Box 366, Millford, PA 18337. (717) 296-7468.*

■ **PCI RECORDING** (Rochester, New York) recently completed their expansion program adding 24 channel Dolby noise reduction to the Series III 32/32 Neotek recording console, and MCI 24-track package installed earlier this year. Completing his album for **POLYDOR RECORDS** is **JOHNNY PORRAZZO** with **TODD SCHAFFER** engineering. A video disk project for Porrazzo was also included by PCI's video facility. Current projects also include several tunes for the summer Olympics on **NBC**. *703 Atlantic Avenue, Rochester, NY 14609. (716) 288-5620.*

6

What you see is what you get...

For a catalog and a list of over 60 dealers in the USA and Canada, contact J. G. (Jay) McKnight at:

Magnetic Reference Laboratory, Inc.
229 Polaris Ave., Suite 4
Mountain View, CA 94043
(415) 965-8187

Exclusive Export Agent: Gotham Export Corp., New York, NY

The MRL Calibration Graph is your proof of the quality control that goes into every MRL Reproducer Calibration Tape. We guarantee each one to exceed the performance requirements of IEC, NAB, AES, and EIA Standards.

MRL Calibration Tapes are designed and supported by experts in magnetic recording and audio standardization... we help write the standards. Each tape comes with detailed instructions and application notes.

The MRL catalog includes tapes for all studio applications. In addition to the usual spot-frequency tapes, we make single-tone tapes, rapid-sweep frequency tapes, wideband or 1/3rd octave-band pink random noise tapes, and difference-method azimuth-setup tapes. Most are available from stock.



STUDIO UPDATE

■ **ALPHA INTERNATIONAL RECORDING STUDIOS, INC.**, (Philadelphia) recently installed UREI 815 monitors in its studio "A," marking one of the first installations of this system in any studio. Both 24-track rooms at Alpha are now UREI equipped with 813s having been placed in studio "B" last year. **AL FIERSTEIN**, of Acoustilog, advised in both installations. 2001 West Moyamensing Avenue, Philadelphia, PA 19145. (215) 271-7333.

■ **LUCAS/MC FALL WAREHOUSE RECORDING STUDIOS** (New York City) announce the completion of their new Hidley/Sierra control room and studio. The production facility is equipped for 48-track music recording on a Trident Automated Series 80 console, an MM-1200-24 interlocked to an MCI JH-16 with the EECO MQS Interlock system. Audio installation and the Trident console were supplied by Empirical Audio, of Ossining, New York. 320 West 46th Street, New York, NY.

■ **SOUNDMIXERS STUDIOS** (New York City) announces the renovation of their studio "B" complex. Owner **HARRY HIRSCH** is using a Sierra/Hidley control room design and an automated Trident TSM console. Soundmixers has four studios, two with Hidley designs. The room will permit full 48-track recording and mixing. 1619 Broadway, New York, NY 10019. (212) 245-3100.

■ **NASHVILLE/NORTH RECORDING** (New York City) has just completed their installation of an 8-track Otari and a 24-track Trident Flexmix console for remote recording. The remote facility is also equipped with Trident limiters and parametric equalizers, API EQ and limiters, Orban echo, MXR Phasers, and a variety of monitoring equipment. Owners **ROBERT OGDEN** and **WINN SCHWARTAU** have been recording for the **LONE STAR RADIO NETWORK**, among other projects.

■ **MUSICOR RECORDING STUDIO** (Philadelphia) has added an Akai color video tape recorder to its facility, which also includes a TEAC 80-8 with dbx noise reduction, a Tascam mixing console, and an AKG C-414 microphone. Currently in the studio is **TEDDY PENDERGRASS** keyboardist **ALFIE POLLITT** recording some original tunes with **CURTIS BRACEY** engineering. 2539 West Columbia Avenue, Philadelphia, PA 19121.

■ **RPM SOUND RECORDERS** (New York City) has installed a new Neve 8068 with Necam for operation early this year. Activity at the studio has been with **FILTHY RICH** recording with engineer/producer **RON JOHNSEN**, assisted by **DOMINICK MAITA** and **GENYA RAVAN** producing **RONNIE SPECTOR** with engineer **NEAL TEAMAN** assisted by **HUGH DWYER**. 12 East 12th Street, New York, NY 10003. (212) 242-2100.

England:

■ **ROCKSTAR RECORDING STUDIOS** (London, England) has acquired a 28 x 28 Allen & Heath desk as a part of their complete refurbishing. The board features full 24-track monitoring and will be used with an M79 tape machine. The sale was coordinated by **JOHN SOUTHARD**, of Trad Audio, for studio owner **JOHN SPRINGATE**. Charlotte Street, London, England. Telephone: 01-637-0999.

■ **ATV** (Birmingham, England) will take delivery in April of the new Neve Necam "D" mixdown system for television post-production. The Necam "D" will simplify laying down audio master material onto edited video tape while using SMPTE time codes to maintain correct synchronization. Other orders for the Necam have come from the BBC and the Australian Broadcasting Commission.

Indonesia:

■ **FLOWER SOUND** (Jakarta, Indonesia) has recently upgraded its M79 multitrack from 8- to 16-track. The new mixer, a Quad-Eight Pacifica, has also been installed by P. T. Yudha Teknik, of Jakarta. No. 34, Pluit Kencana Ruya, Jakarta, Indonesia. Telephone: 660789.

to be represented in the next available issue write:

R-e/p STUDIO UPDATE
P.O. BOX 2449 • HOLLYWOOD, CA 90028

7

Advancing the State of the Art

EVERYTHING
AUDIO

16055 VENTURA BOULEVARD • SUITE 1001 • ENCINO,



Lexicon's new
Model 224 digital
reverberation system

Call for demonstration

CA 91436 • (213) 995-4175

for additional information circle no. 87

Direct Boxes & "Mic-splitters"

Passive Direct Box SM-1A Active Direct Box SM-2

Deluxe Active Direct Box SM-3 Single "Mic-splitters" MS-1A

Quad "Mic-splitters" MS-4 8x2 "Mic-splitters" MS-8

12x2 "Mic-splitters" MS-9 16x2 "Mic-splitters" MS-10

Direct Boxes: Both active and passive SM-1A for guitars SM-2 and SM-3 for keyboards and electronic instruments

"Mic-splitters": Low impedance in and out. Will handle +6 dBm. Will pass phantom voltage. Isolated grounds

Thousands in use around the World!

We also manufacture audio transformers, snakes, audio modules

SEND FOR YOUR FREE COPY OF OUR NEW CATALOG
1111 Las Vegas Blvd., North
Las Vegas, NV 89101
(702) 384-0993, (800) 634-3457
TWX (910) 397-6996

Quality Engineered Sound Products

for additional information circle no. 88

Empty 10 1/2" Reels

with **3" NAB Center**

GREY PLASTIC OR SMOKEY SEE-THRU

CALL OR WRITE FOR OUR CATALOG OF EMPTY REELS & BOXES

Polyline Corp. 312/298-5300
1233 Rand Rd. • Des Plaines, IL 60016

16

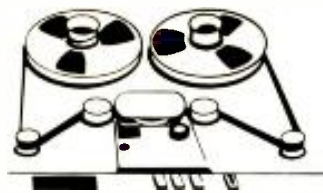

Classified

RATES
— \$51.00 Per Column Inch —
(2 1/4" x 1")

One-inch minimum, payable in advance. Four inches maximum. Space over four inches will be charged for at regular display advertising rates.

BOOKS

WALTER HURST'S BOOKS
\$10 © Copyright (New Law)
\$10 Copyright Registration, PA & SR
\$10 How To Be A Music Publisher
\$10 The Record Industry Book
P.O. Box 649 • Hollywood, CA 90028

HOW TO BUILD A SMALL BUDGET RECORDING STUDIO FROM SCRATCH . . . with 12 tested designs
by F. Alton Everest
Soft Cover . . . 326 Pages . . . \$8.95pp
R-e/p Books
P.O. Box 2449
Hollywood, CA 90028

... theory and working information and emphasis on practical uses

"MICROPHONES — HOW THEY WORK AND HOW TO USE THEM"

by Martin Clifford
224 Pages — 97 Illustrations
\$10.95 Hardbound; \$6.95 Paperback
Postpaid
R-e/p Books
P. O. Box 2449 • Hollywood, CA 90028

SOUND SYSTEM ENGINEERING
by Don & Carolyn Davis
□ 296 Pages □ 8 1/2 x 11
Hardbound — \$19.95
R-e/p Books
P. O. Box 2449 • Hollywood, CA 90028

R-e/p BACK ISSUES AVAILABLE

April 1975	Volume 6, No. 2
June 1975	Volume 6, No. 3
December 1975	Volume 6, No. 6
February 1976	Volume 7, No. 1
June 1976	Volume 7, No. 3
August 1976	Volume 7, No. 4
June 1977	Volume 8, No. 3
August 1977	Volume 8, No. 4
October 1977	Volume 8, No. 5
December 1977	Volume 8, No. 6
February 1978	Volume 9, No. 1
April 1978	Volume 9, No. 2
June 1978	Volume 9, No. 3
October 1978	Volume 9, No. 5
December 1978	Volume 9, No. 6
August 1979	Volume 10, No. 4
December 1979	Volume 10, No. 6

\$2.50 each
Mail orders to: R-e/p
P.O. Box 2449 • Hollywood, CA 90028
Foreign orders payable in U.S. funds only
by bank check or money order.

BOOKS

HANDBOOK OF MULTICHANNEL RECORDING
by F. Alton Everest
320 pages — 201 illustrations
The book that covers it all . . .
a comprehensive guide to all facets of
multitrack recording . . . acoustics . . .
construction . . . studio design . . .
equipment . . . techniques . . . and
much, much more.
Hardbound \$10.95 • Paperback \$8.95
R-e/p Books
P.O. Box 2449 • Hollywood, CA 90028

PROFESSIONAL SERVICES

Consulting in Performance and Presentation Technology



- ARCHITECTURAL ACOUSTICS
- ENTERTAINMENT SOUND SYSTEMS
- TIME DELAY SPECTROMETRY
- AUDIO-VISUAL SYSTEMS

1887 Tipperary Lane • Newbury Park • CA 91320 • (805) 498-4006

EQUIPMENT WANTED

WANTED
RECORDING EQUIPMENT
OF ALL AGES AND
VARIETIES

Dan Alexander • 6026 Bernhard
Richmond, CA 94805 U.S.A.
(415) 232-7933 or (415) 232-7818

EQUIPMENT FOR SALE

FREE CATALOG & AUDIO APPLICATIONS

CONSOLES
KITS & WIRED
AMPLIFIERS
MIC, EQ, ACN, LINE,
TAPE, DISC, POWER
OSCILLATORS
AUDIO, TAPE BIAS
POWER SUPPLIES

OPAMP LABS INC.
1033 N. SYCAMORE AVE.
LOS ANGELES, CA. 90038
(213) 934-3566

for additional information circle no. 89

FOR SALE: Sphere Eclipse C 40x40 automated console, 24 super graphics, 16 3-knob EQs, all with high pass filters. Allison EGC 101 VCAs. TransAmp mike pres, all 40 inputs, 12 returns, 44 light beams with VU overbridge, complete spare parts inventory including extra modules. One year old. \$125,000. Call (615) 244-4861, ask for Ben.

MIDAS CONSOLES
FOR RENT, LEASE — 40x8x2
20x4x2 — PR 03, 4, 5; 24x8+2
Monitor (PR 04) — Well maintained
Phone (213) 391-0952

FOR SALE
If you are looking for well-maintained recording equipment try calling **Criteria Recording Studios, (305) 947-5611**. We are always up-dating our studios and can offer consoles, tape machines, and many other items at a good price.

RECORD SAVERS
Poly-lined inner sleeves ten cents each, postpaid. Minimum 100.
DEO, INCORPORATED
Box 452K—Glenview, IL 60025

EQUIPMENT FOR SALE

FOR SALE

24-Track Package

MCI JH-114 24-track with AutoLocate, virtually no head wear. Auditorics 501 console in mint condition, 26 channels with producer's desk. Contact:

Jim Wheeler — (816) 931-8642

PIEZO SUPER TWEETERS

Good quantities in stock. Specifications sent if requested. \$4.91 - \$9.90 depending on quantity.

MUSIMATIC, INC.

4187 Glenwood Road

Decatur, GA 30032 (404) 289-5159

AMPEX, OTARI, SCULLY

In stock; all major professional lines; top dollar trade-ins; 15 minutes George Washington Bridge.

PROFESSIONAL AUDIO VIDEO CORPORATION

384 Grand Street • Paterson, NJ 07505
(201) 523-3333

EQUIPMENT FOR SALE

MCI JH-114, 24-track, daily service in major studio and well-maintained; complete with spare 8-, 16-, 24-track head stacks. Best offer. Call (212) 677-4700, ask for Hal or Alan.

FOR SALE: Tele LA-2A \$550; Crown VFX2 \$225; 2-UREI 175B \$200 each; TAPCO 4400 \$350; Pultec EQH2 \$450; Furman EQ para. \$175; 2-Sunn 12-band EQ \$50 each; Mac MC60 amp \$175; 10-Shure Audio Mstr \$85 each; 2-Shure Hi-Imp mixer \$50 each; ReVox HS77 2T \$500; Conn ST8 \$80; 12-10 amp Variac \$40 each; Scully 280 1/2" export only, needs work, no cabinet w/4T PB head, 4T ERP Scully harness \$350; Altec 6048G \$450; 2-JBL L-100 \$350 pr.; 2-JBL 4311 \$400 pr.; Senn. MKH405 mike w/pwr sup \$200; Avatar synth & guitar \$1,500; 2-Lang LBA-1 Dupe Bias Amps 500 kc \$200 each, \$325 pr.; some items negotiable.
(516) 331-2077, (516) 928-3998 — Dave

USED RECORDING EQUIPMENT, mint condition Tascam 80-8, 2 Model 5 Consoles, Crown 2-track, Altec Model 15 speakers, 16 mikes, much more. Send for list.

OSBORNE RECORDING

931 Shelby St. • Indianapolis, IN 46203
Or Call (317) 638-3524

RECORDING EQUIPMENT FOR SALE

MCI 24/24 console, MCI 16-track, Ampex & Scully 2-tracks, echo, JBL, UREI, Eventide, Crown, White EQ, Kepex, Yamaha 6 1/2-foot grand piano, assorted mikes, mike stands, headphones, etc., etc. All equipment is in superior condition. Call Mark 313/483-1383 or Don 313/629-1036.

QUAD-EIGHT Console For Sale QE 2082 20-in x 16-out. 10 years old. Well serviced. Excellent condition. Will consider all reasonable offers. Call **Kent Kesterson** at **KBK/Earth City Sound Studios.**
(314) 291-4840

EQUIPMENT FOR SALE

FOR SALE

Scully 8-track, 284-8 like new, motion sense, ATL, remote/sync, heads like new, walnut Formica console, up to full specs with test tape. Asking \$6,800.00.

(714) 448-6000 — Lou
Natural Sound Studios

FOR SALE: Ampex AG-440C Recorder/Reproducer. 4-track, 1/2" tape. DC motor with servo control. Used 80 hours. Mint. Portable model. Equipped record/play-back equalizers for 7 1/2 and 15 ips. Transport remote control.

Call (312) 579-9455

CONSOLE — FOR SALE

Electrodyne 120B. 16 inputs, 8 busses, 8 directs. 16-track monitoring, producer's desk, outboard patch. \$10,000.00. Call Chuck.

(816) 842-6854

FOR SALE

Ampex AG-440-B 8-track DC-Servo and remote control. Four speeds — all variable. Extremely good condition. (904) 399-8283.

FOR SALE

INTERFACE 16x4 RECORDING/MIXING CONSOLE, excellent condition. NEUMANN NK-48A phantom power supply (will supply up to 150 mics). For details call **Bill Castner, We Three Productions.**
(313) 767-7426

PARAMOUNT SOUND FOR SALE

MCI JH-538 Automated Console; MCI 2, 4, 8, 16 and 24 Track Tape Machines with JH-45 Synchronizers. All less than 150 hours use.

PARAMOUNT SOUND
(213) 956-3222

TANGENT 24-track record console, was \$21,000. Best offer. PA System 20 x 2 StudioMaster; 4 JBL speakers with horns, 400 watts. Cerwin-Vega Monitor System with 800 watts. Full outboard racks and Anvil cases, snakes and all mikes. Was \$21,000.00. B. O. Hank **(213) 655-1322.**

EQUIPMENT FOR SALE

Moog Series 2; with sequential controller. Best Offer. Call (212) 677-4700, ask for Hal or Alan.

FOR SALE

Ampex 300 mono with 351 electronics in console — \$1,000. Ampex 300 mono, old style electronics, unmounted — \$600. Curtain Infonics reel-to-reel 2-track high speed duplicator Model 74-M2, makes 3 high speed (30 ips) at a time — asking \$995. Starbird mike boom, new \$595 — asking \$290. Large supply of empty plastic 10 1/2" reels, small hole, .75c each, in a plain white box \$1.00 each. Wollensak Model 2770AV high speed cassette duplicator just reconditioned, one master and two slaves 30 ips, asking \$900.00.

Call Dan at (617) 426-3131

A SINGER'S DREAM!



REMOVES VOCAL FROM MOST STEREO DISCS

The Thompson Vocal Eliminator can actually remove most or virtually all of a solo vocalist from a standard stereo record and yet leave most of the background music untouched! Not an equalizer! We can prove it works over the phone. Write for a brochure and demo record below. **COST: \$249.00**

YOU SHOULD SEE US

- Studio Echo/Reverb
- Tape Noise Reduction
- For: • Parametric Equalization
- Electronic Crossovers
- Comp/Limiters

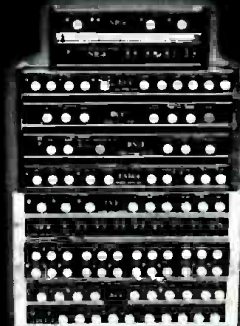

We manufacture a full line of high quality audio and recording equipment. You will probably have to pay twice as much elsewhere to obtain comparable quality. Only Direct Sales make our prices and quality possible. Send \$1 for a 20 page brochure and 20 minute demonstration record.

Write to: **LT Sound, Dept. RE,** P.O. Box 729,
Decatur, GA 30031. (404) 284-5155

WE'RE KNOWN BY THE COMPANIES WE KEEP!



- AKG
- ADR
- AMBER
- AMPEX
- BEYER
- COUNTRYMAN
- CROWN
- DBX
- EVENTIDE
- CLOCKWORKS
- JBL
- LEXICON
- MARSHALL
- ORBAN
- OTARI
- SOUNDRAFT
- TASCAM
- UREI
- WHITE

For Information on
The Products of These
Companies — Write or
Call (512) 824-8781



ARBODON SUN, INC.
P.O. Box 6520
San Antonio, Tx 78209

for additional information circle no. 91

We've got it.

The Belden 42 Strand Cable. Ends multiple wiring problems in the studio and on stage. Available in bulk or with custom plug configurations.



whirlwind

Whirlwind Music Inc.
P.O. Box 1075
Rochester, New York 14603
(716) 663-8820

for additional information circle no. 92

ECOPLATE Great reverb
ECOPLATE at a good price!
ECOPLATE L.A. Rental and
ECOPLATE Demos available!



SCHOEPS Mikes:
Natural sound even
"off mike" and
no transformers.



Ivie IE-17 and 30
Los Angeles Area
Rentals and Sales



Phono Preamp
Distribution Amp
IHf Interface

New Designs by Bill Isenberg

REVOX SERVICE & MODIFICATION
TO PROFESSIONAL STANDARDS
Variable Speed, 15 ips, etc.



1029 N. ALLEN AVENUE
PASADENA, CA 91104
(213) 798-9127

AUDIO ENGINEERING ASSOCIATES

for additional information circle no. 93

EQUIPMENT FOR SALE

"MUSIC COMPLEX"

Successfully operating, fully equipped 16-track recording studio. Established talent agency. Recognized record label. Publishing company. Front offices — all housed in a 2600 sq. ft. modern block building. References, pictures, and inventory list upon request. Also included three bedroom house. Principals only. Call (406) 245-2174 (Bob Hale) or write 423 Kuhlman Drive, Billings, MT 59101.

FOR SALE — 1 Crown RTAll, Brand new w/warranty including 7" Anvil Rack Case w/lids front & back & Anvil Suitcase type case form lined w/wheels for air transport \$1700 firm. Also, 1 UREI 100-A Soni Pulse complete w/case and warranty (Demo Unit) \$800 firm. (205) 589-2546.

RECORDING EQUIPMENT FOR SALE

MCI 24/24 console, MCI 16-track, Ampex & Scully 2-tracks, echo, JBL, UREI, Eventide, Crown, White EQ, Kepex, Yamaha 6½-foot grand piano, assorted mikes, mike stands, headphones, etc., etc. All equipment is in superior condition. Call Mark 313/483-1383 or Don 313/629-1036.

BEYER MICROPHONES - up to 40% off list on wide range of Beyer models including M500, M160, M200, M100, etc. New and remanufactured models available. Write or phone for prices and availability. ESSi, Beyer Microphone Offer. P.O. Box 176, Jericho, NY 11753 (516) 921-2249.

FOR SALE

Seven UREI 529 room equalizers. Two Big Red Systems with 604E-1 speakers and Mastering Lab crossovers. Contact: Mr. Whittler • (212) 245-3100

FOR SALE

Stephens 811D-103 1" eight-track recorder/reproducer. Complete with VSO, remote control and spare amplifier modules. 2½ years old. New cost over \$14,500.00. \$7,500.00. ASI — (512) 824-8781

FOR SALE: EMT 240 gold foil plate—two years old. Perfect condition. Electro-Voice Sentry Speakers. New woofers, diaphragms, tweeters. Must sell.

5TH FLOOR RECORDING

517 W. 3rd Street • Cincinnati, OH 45202
(513) 651-1871

FOR SALE: Loads of MC30, MC40 tube amps. Ampex AG300-2 @ \$1,000; AG300-1 @ \$800. 3M79-2 servo \$3,000; Neumann U48 each \$1,000; Sennheiser MD421U-DIN (6 pcs) @ \$110 each. Dolby-360 each \$600. MXR-DDL \$700. Mac-2100 @ \$500. Crown D75 @ \$225. SAE, ReVox other used equipment available from stock. Also: New and used TRIDENT consoles and parts. Complete parts for 3M79 series machines. Custom consoles and components: Melcor EQ, Electrodyne 709L, 710L, Gotham HW 600, Line amps, pre-amps, etc. Quantities available. Call for other brokerage listings.

EMPIRICAL AUDIO

3A Todd Place • Ossining, NY 10562
(914) 762-3089

EQUIPMENT FOR SALE

FOR SALE

ALL IN EXCELLENT CONDITION
3M-M64 2-Track Recorders in console
UREI Model 813 Speaker Systems
Ampex 351-2 with Inovonics Electronics
Ampex 300-2 in console
Ampex 300-4SS in console
Set of 8-Track Heads for 3M-M79
OP-AMP Labs Model SM 100 50W/Channel
Eventide 1745A DDL
Eventide 1745M DDL
Contact: FRANK TARSIA
(215) 561-3660

3M 8-TRK., & 4-TRK.
Series 400 w/Cabinets
Both run 15 - 30 ips
Meet Manufacturers Specifications
Best Offer: (314) 727-1055

used audio designs console

Sound 80 of Minneapolis, Minn. put this together for \$40M and it has made many a hit! • 16 inputs (12 with 3 band EQ/e with 7 band EQ) • 2 cue (fold back) systems • Talkback voice/tone slating • unique Audex Switching System for track assigns • 8 submaster modules each with hi-pass/lo-pass filters, echo returns, and line termination • Complete monitor mix section that has access to 16-track and 8-track buss or machine • 300 point patch bay • 4 machine remotes (5 function) • Quad monitor switching for control room to studio speakers • 16-3 in VU switchable to read various console outputs • 48 V phantom power • Picture on cover Nov/Dec 1973 Recording Engineer/Producer.

ALL ABOVE ASKING \$11,900
(714) 578-5500, Ext. 1222
(714) 448-6000 — Dick

RECORDING ENGINEER:



Come tune in to a kid's world.

Each week you'll have the chance to work on a variety of voice-toy projects with top creative people. We need your technical expertise, but we also want an individual who prefers not being stuck behind a board all day. The ability to solve problems, take directions, and express yourself well are all important qualifications. If you have an analog or digital circuit design background plus familiarity with physical acoustics, all the better. You'll work with our Ampex and Scully recording gear, as well as our B&K 2031 Narrow Band Analyzer in Mattel's fully-equipped studio.

We offer excellent compensation and a benefits package considered to be the best in the industry.

Even if your present situation is satisfactory, you owe yourself a closer look at this unique, creative position.

Please send resume and salary history in complete confidence to:
Ron Darden, Mattel Toys
5150 Rosecrans Ave.
Hawthorne, Calif. 90250

PERSON NEEDED to joint venture in studio project. I own newly constructed 400 sq. ft. studio in Santa Monica, CA. Also have \$15,000 in new equipment: AKG 450EB (3), RE20, Neumann U67, UREI 1176, Nakamichi 600 II, TEAC 3340S, 2300SD, etc. Recently had Ampex 24-track. (213) 828-2550, 828-6589 ext. 975.

EMPLOYMENT OPPORTUNITIES

EXPERIENCED MAINTENANCE PERSON
Major N.Y. Studio Expanding: Opening for experienced career-minded person; must have experience with Neve, Studer, 3M equipment. Call (212) 677-4700, ask for Hal or Alan.

— *Needed Immediately* —
EXPERIENCED MIXER for one of West Germany's top 24-track studios. Also need a professional MAINTENANCE engineer.
call for particulars:
(213) 273-4302

views

what the
AUDIO/VIDEO FUSION
can mean to the
RECORDING STUDIO INDUSTRY
(continued from page 17)

fully realize the full potential of the electronic effects, the originally recorded material must be of high quality.

"You have to have something on tape to start with," notes Bush, "in order to go to the effects and beyond."

In order for the artist to push to the limits of the medium at this level, a number of expensive side boards are required.

Rundgren comments on the equipment at Bearsville Recording Studios:

"There isn't another studio that has the vocabulary that this studio does in terms of visuals. We have a two channel "squeeze room." It's a two channel digital manipulation unit that costs about \$130,000. A Rutt-Etra synthesizer, a Spectre, Chromaton, and a computerized paint box. We have a collection of things that nobody else has to give the broadest range of visual possibilities."

Compact Video offers a similar collection of peripheral items in its video house, including what Kip Walton calls "the fastest editing equipment I've ever used." Such digital peripheral gear, according to Emory Cohen, can run from \$70,000 to \$150,000, pending on the quality and range of the unit. Compact also uses Dolby noise reduction in all of its audio post-production for video programming.

Video remote facilities similar to what Compact offers can rent for between \$3,000 and \$3,800 per day, and post-production facilities in video houses can increase in price per hour with every piece of gear added. At Compact, a computer editing room with three machines begins at roughly \$350.00 per hour and makes increases in increments of between \$100 per hour to nearly \$200 per hour with the

addition of more equipment.

For this reason, most initial editing is done in a 3/4-inch "off line" workprint format on less expensive equipment, rather than on the consoles linked to 1- and 2-inch "on line" tape machines.

The prices are expensive, particularly when compared to audio studio fees, but the equipment is more sophisticated in many instances and requires extensive maintenance which the companies such as Compact handle as part of their service.

The industry observer mentioned earlier feels that in order to compete with the theatrical release films, video music must offer these high quality production values to the public.

Opinions on video style do vary from New Wave on one end to the Super-Slick Pop work on the other.

It is the record companies that must pick up the costs and in as volatile a market as we are now seeing, the question of video becomes more and more difficult.

"You're talking about a half-hour of video disk material, again depending on how you approach it, costing in the area of \$100,000. This as a base to talk from," offers Levy. "However, I think it will come down and I think that there are productions that won't necessitate that high a cost."

Reluctance To Production Investment

In the face of million dollar albums by such recording artists as The Eagles and Fleetwood Mac, resulting in lower sales than anticipated, some record executives may be reluctant to invest such large sums of money in video with no guaranteed or even somewhat predictable market.

"At the risk of stepping on anyone's artistic integrity," says Levy, "that kind of spending is really unnecessary and I'd rather that that kind of money be spent on something like a video disk where we're exploring something new, and where we'll hopefully be able to bring the price down."

With labels making exploratory commitments to the video disk, "It seems to me that it will become cost effective."

Just who will be making video disks is another point raised by many in the industry. Not all artists will have the talent or the presence, or the knowledge to produce video music, and because of the costs involved, the labels will have to look very hard at who they back on such projects.

Even in the area of promotional video, record companies are not willing to give budgets to every artist.

"Right now we are being much more selective," says Tony Zetland, associate director of product management at Columbia, "because it's becoming much more expensive, and also we're talking about not only using the spot for a TV show, but for commercials as well."

The bands on Hollywood Heartbeat consist mainly of New Wave groups, concentrating on the L.A. club scene.

"There's more musical energy here right now than anywhere else, and it lends itself to video," says Smith.

"There are bands right now," offers Seal, "that are very big in audio, that will probably not make it in video because they don't have the visual presence."

"Then there are bands who have sold only a few thousand records who are going to be very

... continued overleaf —



DIRECT BOXES
* * *
CABLES
* * *
SNAKES
* * *
HEADPHONE DISTRIBUTION BOXES
* * *
CABLE TESTER
* * *
YAMAHA CONSOLE MODIFICATION

**Orders processed same day.
COD's accepted.**

Write for free catalog and price list.



Windt Audio Inc.
1207 No. Western Ave.
Los Angeles, CA 90029
(213) 466-1271

USED GEAR FOR SALE

Neumann: U47 Tube, U67 KM56, KM64, U64, SM69 FET, etc.

Schoeps: M221 (Tube), CMH32, CM61

AKG: C28A, C28C, C61, C12, D15, D20, D30

Telefunken: ELAM 251

RCA: 77DX

*Custom Supplies
For All Microphones
Built To Order*

- **Eventide 1745A**
- **Teletronix LA-2A**
- **UA-175 Limiter**
- **Ampex MM-1000 16/24**
- **Allison Gain Brain**

and much, much, more . . .

DAN ALEXANDER
6026 Bernhard
Richmond, CA 94805
(415) 232-7933

for additional information circle no. 94

for additional information circle no. 95

what the
AUDIO/VIDEO FUSION
can mean to the
RECORDING STUDIO INDUSTRY

continued

hot in video. The perfect example is Pere Ubu."

Levy sees video as working for an artist who may not have a visual impact on stage or television.

"Someone like that, but whose songs are totally visual and narrative, can create a promotional video without him really appearing in it in any major way so that it totally sells the artist and his material."

Marketing of video music is another proposition still to be explored. At this time, MCA has only one video music disk, a concert by Elton John, with the rest being motion pictures, certain sports disks, and what could loosely be called educational products. MCA, as of this writing, is not prepared to discuss video music by artists with its record label. RCA Records was also unwilling to discuss production or marketing plans for their video disks, even with Rundgren's demo completed.

"Right now, CBS is just entering that field," says Zetland. "The RCA stylus system is being used by us, and it will probably wind up being marketed by Christmas of this year or in January of 1981."

"Disks are now being sold through the Magnavox dealers that have the players," according to Ingram, "because that's the logical place for them. There will be widespread distribution of disks once we get up to speed."

The Market

Where disks are sold will certainly affect to whom they are sold. Teenagers have long been the staple buying market for the industry, and the disks' presence in record stores will probably be required to reach that market. But here, again, the price of the disk raises more questions.

Will a fifteen-year-old record buyer have the \$20 required to spend on one video disk, or will he or she spend that money on conventional recordings first?

"Video recorders right now," notes Seal, "are owned by mostly middle-aged professional people, but they have children. They have teenage sons and daughters who might want to look at something besides 'Jaws II.' Maybe they want to see what's going on in the L.A. club scene. Maybe they want to see some New Wave."

He also notes that the biggest selling video tapes right now are musicals, and that several retailers have approached him about video music.

"Don't forget that we're in a TV generation," reminds Levy, "and in the 80s the primary demographic group in this country is going to be people in their thirties and up. We're not heading into a decade where we're going to be a youth culture."

"We're talking about ageing rock and rollers who have grown up on TV. In the next generation, we'll be having a majority of the people in this country never having lived when there was no television."

"To me, that says a lot about the viability of video disk projects."

As can be seen, industry optimism about the

future of video is still present, and as the future becomes today, we will find just how much it is justified. Yet video for audio studios is still a serious question without a firm answer.

In the meantime, consider the possibilities of the medium, even if a piece of poetry may require \$2 million dollars in electronic hardware to produce.

In the next segment, we will be discussing other levels of video music — as a promotion device, as demos, and offer some suggestions as to where the audio studio might fit into this world of the Image Orthicon Tube. □ □ □

News

OTARI APPOINTS
SPECIAL PROJECT ENGINEER

Otari Corporation has recently announced the appointment of Tom Sharples as Special Project Engineer. For his first project, he will be in charge of the MTR-90 multitrack support program.

For the past three years Tom has managed Proper Sound, a studio maintenance, consultation, and recording equipment rebuilding service. During that time he was responsible for the design and installation of four 16- and 24-track studios as well as designing and building a number of 16- and 24-track recorders in relationship to custom engineering projects for various West Coast pro-audio companies, including Tewksbury Sound Recorders, in Richmond, California.

Tom is a former partner in Bear West Studios, a 24-track music recording facility, and is currently an owner of a 16-track music and commercial recording studio in San Francisco.

Steve Krampf, National Sales Manager comments, "We at Otari are excited about the prospects of Tom's work here, his overall studio/music background, in addition to his specific expertise in tape recorders, gives him a perspective that is lacking in many technically oriented people."

GOTHAM COMPANIES CELEBRATE
30TH ANNIVERSARY

On January 28, 1950 Gotham Recording Corporation opened its doors at 2 West 46th Street, in New York City, and boasted to be the very first independent recording operation in the world to be equipped with Ampex tape recorders. Prior to that date, only broadcast networks were so equipped.

Gotham Audio Development Corporation, the manufacturing subsidiary that built the 150 watt power amplifier which formed the Gotham/Grampian disk cutting system, was started four years later, and in 1956 Temmer sold his 50% interest in the recording operation to his partner Herbert Moss, continuing the manufacturing company himself.

A chance meeting in 1957 in Berlin with Georg Neumann began an association which has lasted to this day. Thus Gotham turned to the import of the finest professional audio products available in Europe. Over a period of 23 years, it has represented such world leaders as Neumann, EMT, Telefunken, Studer, Beyer, Lyrec, NTP, Pyral, Europa Film, etc.

Since 1972, Gotham has been exporting, world-wide, professional products manufactured by U.S. and Canadian companies such

for additional information circle no. 96

TOWARD BETTER UNDERSTANDING . . .



The Model 4240 Active Equalizer is a hybrid of ONE-SIXTH octave filters, which are concentrated in the *speech intelligibility* region between 250 and 2000 Hz, and broader bandwidth filters on either end. The intended application of the Model 4240 is the equalization of sound reinforcement systems employing *voice* as the main program material as in corporate boardrooms, meeting halls, legislative chambers and courtrooms.

Extremely high Q room modes which cause feedback, ringing and loss of intelligibility are excited by these mid-range frequencies. Equalization to suppress these modes using one-third octave or broader bandwidth filters can attenuate other frequencies necessary to *voice intelligibility*. Loss of intelligibility can not be compensated by increased gain.

By comparison the ONE-SIXTH octave filters used in the Model 4240 have TWICE the resolution as one-third octave filters. It is possible to equalize a sound system and affect only HALF as much program material.

The Model 4240 Equalizer is highly cost-effective for these applications since it is built on the same chassis as our one-third octave models. It has 27 filters like the one-third octave units, but 19 are ONE-SIXTH octave and concentrated in the midrange. The broader bandwidth filters on either end are more than adequate to shape the extreme low and high ends of the spectrum.

Our new System 200 Signal Analyzer features field interchangeable, plug-in filters and may be equipped to match the Model 4240 Equalizer making ONE-SIXTH octave adjustment as convenient as one-third octave.

Remember it, Where Voice Clarity is Important

White instruments, incorporated
P.O. Box 698 AUSTIN TEXAS 78767
PHONE AREA 512/892-0752

Distribution in U.K. & Western Europe
SCENIC SOUNDS EQUIPMENT
97-99 Dean St., London W1 Tel: 734-2812

as Allison, Amber, Inovonics, MRL, Switchcraft, and UREI. Today, Gotham is world renowned with representatives in over 34 countries.

In 1969, it opened a sales office in Hollywood, and in 1973 Gotham moved into its own headquarters building after 23 years at its original address.

DUFFEY NAMED 3M-MINCOM PRO-AUDIO MARKET DEVELOPMENT MANAGER

In his newly created position, Clark Duffey will work closely with marketing, sales research personnel, and with customers, to develop and expand the market for 3M's entire professional audio line, with emphasis upon the digital mastering systems. He will headquarter in St. Paul, Minnesota.



Mincom introduced multitrack analog equipment in the early '60s, and within the past year Mincom delivered the first six commercially produced multitrack digital mastering systems for studio use.

3M's digital equipment line includes 32 track, 16 track, and 4 track digital tape machines, an electronic digital editing system, and disk lathe preview units. Introduction of the line to European and Japanese markets will take place in February and March.

POLYLINE, RECORDING SUPPLY, PRO AUDIO SPECIALTIES MERGE

Polyline Corp. has announced that it has merged with its divisions, Recording Supply Company and Pro Audio Specialties Company.

The recording industry supplier manufactures plastic reels and boxes, and through its divisions offers audio and video tape and accessories and stocks a selected line of Switchcraft brand audio connectors. Separate catalogs — available free of charge to anyone

— will still be used for the different product lines.

The merger was accomplished, according to John Kaiser, president of the firm, "to eliminate any confusion among our customers that the multiple names may have caused, and also to improve service to them." The official name will now be that of the parent firm, Polyline Corp.

The company and its divisions have long prided themselves on stocking all items sold, resulting in same-day or next-day shipment of practically all orders. "We feel that the merger, which led to combining all our records, will speed up the processing and shipping of orders even more," adds Mr. Kaiser.

Polyline Corp. is located at 1233 Rand Road, De Plaines, Illinois 60016. Telephone: (312) 298-5300.

"MICROPHONE TECHNIQUES FOR RECORDING AND BROADCASTING" TO BE MAC'80 TOPIC

Following its tradition of providing in-depth coverage of important topics in audio and acoustics, the topic for the 1980 Midwest Acoustics Conference (MAC) will be "Microphone Techniques for Recording and Broadcasting." The Conference will be held at Hermann Hall, Illinois Institute of Technology, Chicago, Illinois, on Saturday, May 3, 1980, from 9:00 a.m. to 5:30 p.m. Featured will be speakers from the recording and broadcasting industries as well as researchers and experts in the field of audio perception and the creation of audio illusions.

Topics to be discussed will include Human Perception of Audio Images, Microphone Techniques for the Creation of Audio Illusions, Classical Music Recording, Live Orchestral Broadcasting, Film Sound Recording, Contemporary Multitrack Recording, and a look at future trends.

This year's conference is sponsored by the Audio Engineering Society, the Chicago Regional Chapter of the Acoustical Society of America, the Chicago Section of the Institute of Electrical and Electronics Engineers, the Chicago Acoustical and Audio Group, and the

Illinois Institute of Technology. Past Conferences have featured loudspeaker technology, recording media, quadrasonic sound, digital signal processing, acoustical instrumentation, sound reinforcement, audio transducers, and digital recording.

Among featured speakers for MAC 80 will be John Woram, editor of dB Magazine, Mitch Heller of radio station WFMT, free-lance recording producer Judith Sherman, Dr. Arthur Benade of Case-Western Reserve University, Louis Abbagnaro of the CBS Technology Center, and Dr. Mead Killion from Industrial Research Products, Inc.

Several manufacturers of state-of-the-art transducers, instrumentation, and equipment will be exhibiting and demonstrating their products in addition to the formal presentations planned.

For additional program and exhibitor information, contact: Tony Tutins, Knowles Electronics, Inc., 3100 North Mannheim Road, Franklin Park, Illinois 60131. Telephone: (312) 455-3600.

SEVERINSEN RECORDS TWO ALBUMS ON SONY DIGITAL RECORDING AND EDITING SYSTEM

Renowned trumpet virtuoso Doc Severinsen is releasing two digitally mastered albums recorded with Sony's PCM-1600 System and edited with Sony's working prototype DEC-1000 Editor.

According to Charles Underwood, producer of both projects, Severinsen recorded a pop and classical album. The pop album entitled "London Sessions" features Doc Severinsen and the National Philharmonic Orchestra of London. Its release is set for early March. The classical recording highlights Doc Severinsen and the London Symphony Orchestra. No title or release date has been set.

"There are tremendous advantages to going digital," Underwood explained. "It's so much more convenient than direct-to-disk. Although the results of direct-to-disk recording approach digital, the musicians and the talent involved are forced to remember how an entire side of an album goes — both in terms of the

PRS INC.

**For Equipment From
STAGE TO STUDIO
Systems Design
Equipment Installation
In House Service
Competitive Prices**

**Consoles/Recorders/Microphones /Signal Processing/ Noise Reduction/
APSI/Tangent/Otari/AKG/ Neumann /Crown/UREI/Lexicon/dbx... and more**

call PETER ENGEL at ...

(617) 254-2110

**Professional Recording and Sound
1616 Soldiers Field Rd., Boston, Mass. 02135**

arrangement and tempo. A pop album usually goes five cuts to a side, and the band can't stop playing until they finish that fifth song. With digital, all of these pressures are eliminated, allowing the artists to concentrate on each piece of music individually.

"The forthcoming recordings were both edited electronically, with no tape cutting. The DEC-1000 is so easy to edit on, that a non-technical person could learn how to use it in about 30 minutes. The only disadvantage to recording digital is that when you've got the volume turned up for editing, the music knocks you out of your seat," said Underwood. "The old adage that 'silence is golden' was never more appropriate."

"London Sessions" will contain such popular songs as "The Masquerade," and Grammy award winner "Sometimes When We Touch." A digitally mastered single of the Grammy winner is being distributed in advance to "beautiful music" stations and others using the pop format.

"Doc Severinsen and the London Symphony Orchestra" features the first trumpet concerto ever recorded. It was conducted by Dr. Frederick Fennell, conductor in residence at the University of Miami. After hearing the final reference tapes, Dr. Fennell wrote to Underwood and commented, "You know you are responsible for an unprecedented artistic achievement in sponsoring Severinsen to do the concert album. This is the first for which hundreds of trumpet players, conductors, and fans have been waiting for almost 20 years."

Both albums will be pressed on the German Teldec using Teldec Vinyl to insure superior

sound reproduction. European plating and pressing processes will also insure the finest quality albums. They will be released on Front Line Records, a Los Angeles based recording company.

The two projects were co-conducted by Al Viczutti.

HARRISON ANNOUNCES BAUCH AS ENGLAND, IRELAND AGENT

F.W.O. Bauch Limited will henceforth be representing the complete Harrison line of music-recording, post-production, broadcast, and live-performance consoles, as well as the Harrison automation systems.

Bauch is also the exclusive dealer of Studer products in the United Kingdom, and the appointment will unify Harrison marketing with that of Studer's. Harrison and Studer are already closely allied in many other parts of the world.

Expressing his satisfaction with the Bauch appointment, David Harrison, president of Harrison Systems, said, "We believe affiliation with the Bauch organization will prove to be a tremendous advantage for us. We consider it an honor that Bauch is distributing our products in Great Britain, and we look forward to a long and mutually fruitful cooperative venture there."

Bauch representatives Michael Bauch and Brian Whittaker recently spent a week at the Harrison facility in Nashville. Their visit to Harrison included a thorough familiarization with the complete product line.

Harrison continued: "This new alignment makes for a tremendous marriage of three great companies — Bauch, Harrison, and

Studer." As Bauch has never before elected to represent a console, Harrison said he is honored that the Harrison Systems console is the one Bauch has chosen to represent.

F.W.O. Bauch Limited has supplied professional sound equipment to the United Kingdom recording industry since 1950. The addition of a console to the line of products Bauch already represents puts them in a position to supply a complete studio package.

DELTA LAB EXPANDS

As of February 1, 1980, DeltaLab will double its size. This expansion follows on the heels of their relocation last February, and is a direct result of the rapid growth DeltaLab has experienced. The additional space will be used to expand engineering, sales and marketing, as well as accounting. Manufacturing will also double its capacity.

The expansion is said to allow more production space for their newly introduced products without restricting other company operations.

AUDIO RESTORATION LAB FOUNDED BY COUNTRY MUSIC FOUNDATION LIBRARY

The Laboratory is reported to be the most sophisticated facility in the United States for restoring the sound on pre-stereo recordings to their original quality. Designed and built by Art Shifrin, a leading sound restoration authority, the Foundation's Audio Restoration Laboratory is the result of over 18 months of planning and construction.

In addition to handling Country Music Foundation sound restoration projects, the Laboratory will be available to outside companies for commercial uses. The Laboratory will be especially useful to record companies involved in reissuing historical recordings.

"Our Laboratory is capable of producing master tapes from original recordings, test pressings, transcriptions, and early tape masters," said Danny Hatcher, the Country Music Foundation's Deputy Director for Library Operations.

Bill Ivey, Director of the County Music Foundation, said, "A primary use of our Audio Restoration Laboratory will be for our Library and Media Center to preserve the sound on materials that are deteriorating. The best example of this is acetate radio transcriptions, which literally fall apart with the passing of time.

"Secondly, we hope this lab, by being in the center of the country music recording industry, will stimulate the re-release of historical material in the country field. Country music has lagged behind jazz in reissuing historical recordings, and we'd like to spark an interest in this area.

"Thirdly, through licensing, leasing, and other cooperative arrangements, the Foundation hopes to reissue some historical recordings on its own label."

Ivey added that "with the holdings of our Library, our staff's knowledge, and the technical resources of our audio lab, we can help any record label develop reissues of their own product. This means we can do everything from developing a concept for an album and choosing selections, to producing master tapes."

Engineer Alan Stoker will operate the Audio Restoration Laboratory for the Country Music Foundation and Media Center.

for additional information circle no. 98

electro-media systems, inc.

**Recording Systems
for the Entertainment Industries**

You deserve the best. Let us design a system for you featuring one of the "No Compromise" consoles from **Harrison BA**.

Dan Gwynne • Electro-Media Systems, Inc.
8230 Beverly Blvd. Ste 27 • L. A., Ca. 90048 • (213) 653-4931

STEP OUT IN FRONT

With a giant step forward, the MR-1 has become the first of its kind—the first in a whole new generation of recording consoles.

Making its entry at the beginning of the eighties, the MR-1 is unquestionably a radically new and different breed of console from that of the seventies. Through its inception, a giant step toward digital has truly been taken.

For the first time—with the advent of the MR-1—many of the advantages obtained through digital have become both practical and available. By incorporating all existing cost-effective digital-control technology into advanced analog formats, Harrison Systems has designed and produced the industry's first digital-analog "hybrid" music recording console... the MR-1.

MORE VALUE — NOW

The MR-1 is clearly a console designed for the eighties, with the new technology of the eighties. Its technical advances allow for increased efficiency in the use of personnel and facilities by reducing redundant work load and increasing the throughput of the studio. Expanded automation opportunities,

many added features, ease of operation, increased reliability, and easier maintenance place the MR-1 way out front in terms of cost effectiveness, as well as ergonomics (human engineering).

NEW DCI CONCEPT

The digitally controlled, analog-signal-processing MR-1 utilizes the DCI (Distributed Control Intelligence) concept of placing software-controlled microcomputers into individual modules of the console. This digital-analog hybrid concept offers the end-user many advantages over previous hardware-logic-controlled consoles.

One of the most significant advantages of DCI is that the "personality," or operational characteristics of the console are under the control of software (computer code) rather than hardware. This software control allows the console to be modified for unique applications by simple programming rather than laborious, often-irreversible hardware modifications.

FOLLOW THE LEADER

As the digital-analog hybrid is destined to become the mainstay of the industry for some time to come, other console manufacturers are sure to follow the lead in the use of these new methods and technologies. But as of now, the concepts are unique to Harrison, and the MR-1 has moved out in front of its field.

The eighties hold many challenges for the audio industry, and Harrison offers a console to help you meet those challenges.

**...or stay back
with the pack**

HARRISON SYSTEMS, INC.

P.O. Box 22964, Nashville, Tennessee 37202 · (615) 834-1184, Telex 555133

for additional information circle no. 99

www.americanradiohistory.com

AS ALWAYS, NO COMPROMISE

Harrison 

**MR-1
Digital/Analog
Hybrid**

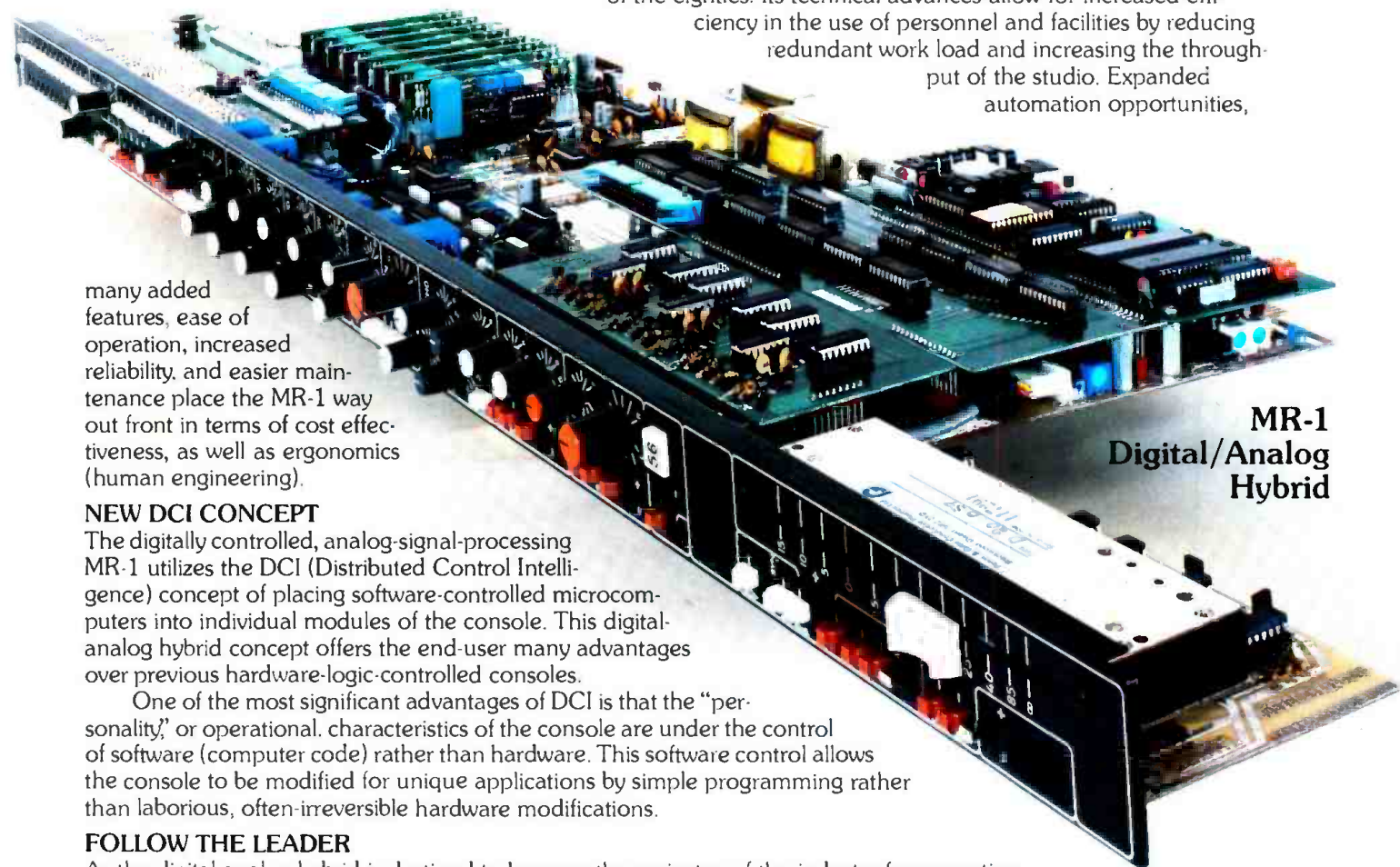



fact: this condenser microphone sets a new standard of technical excellence. & it sounds superb!

The Shure SM81 cardioid condenser is a new breed of microphone. It is a truly high-performance studio instrument exceptionally well-suited to the critical requirements of professional recording, broadcast, motion picture recording, and highest quality sound reinforcement — and, in addition, is highly reliable for field use.

Shure engineers sought — and found — ingenious new solutions to common

problems which, up to now, have restricted the use of condenser microphones. Years of operational tests were conducted in an exceptionally broad range of studio applications and under a wide variety of field conditions.

As the following specifications indicate, the new SM81 offers unprecedented performance capability — making it a new standard in high quality professional condenser microphones.



SM81 puts it all together!

- WIDE RANGE, 20 Hz to 20 kHz FLAT FREQUENCY RESPONSE.
- PRECISE CARDIOID polar pattern, uniform with frequency and symmetrical about axis, to provide maximum rejection and minimum coloration of off-axis sounds.
- EXCEPTIONALLY LOW (16 dBA) NOISE LEVEL.
- 120 dB DYNAMIC RANGE.
- ULTRA-LOW DISTORTION (right up to the clipping point!) over the entire audio spectrum for a wide range of load impedances. MAXIMUM SPL BEFORE CLIPPING: 135 dB; 145 dB with attenuator.
- WIDE RANGE SIMPLEX POWERING includes DIN 45 596 voltages of 12 and 48 Vdc.
- EXTREMELY LOW RF SUSCEPTIBILITY.
- SELECTABLE LOW FREQUENCY RESPONSE: Flat, 6 or 18 dB/octave rolloff.
- 10 dB CAPACITIVE ATTENUATOR accessible without disassembly and lockable.

Outstanding Ruggedness

Conventional condenser microphones have gained the reputation of being high quality, but often at the expense of mechanical and environmental ruggedness. This no longer need be the case. The SM81 transducer and electronics housing is of heavy-wall steel construction, and all internal components are rigidly supported. (Production line SM81's must be capable of withstanding at least six random drops from six feet onto a hardwood floor without significant performance degradation or structural damage.) It is reliable over a temperature range of -20° F to 165° F at relative humidities of 0 to 95%!

Send for a complete brochure on this remarkable new condenser microphone! (AL577)

SM81 Cardioid Condenser Microphone



Shure Brothers Inc., 222 Hartrey Ave., Evanston, IL 60204, In Canada: A. C. Simmonds & Sons Limited
Manufacturers of high fidelity components, microphones, sound systems and related circuitry.

for additional information circle no. 100

www.americanradiohistory.com