

Most - Often - Needed

1959

VOLUME R-19

RADIO
DIAGRAMS

and Servicing Information



Compiled by
M. N. BEITMAN

VOLUME R-19

PRICE **\$2⁵⁰**

SUPREME PUBLICATIONS

Most - Often - Needed

1959

Volume 19

**RADIO
DIAGRAMS**

and Servicing Information



Compiled by

M. N. BEITMAN

SUPREME PUBLICATIONS

RADIO DIAGRAM MANUALS

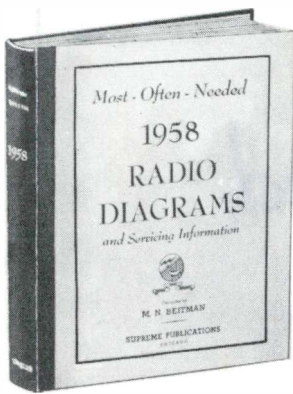

New 1958 **VOLUME 18**
Price \$2.50

Repair quickly all new 1958 sets as well as older radios. This big volume contains clearly printed, large schematics, needed alignment data, replacement parts lists, voltage values, and information on stage gain, location of trimmers, and dial stringing, for all important new 1958 sets. Includes material on portables, clock radios, record changers, FM, and auto sets. A worthy companion to seventeen previous volumes used by over 143,000 shrewd radio servicemen. Large size: 8½ x 11 inches. Manual style binding. Postpaid, only **\$250**

RADIO DIAGRAMS FOR PREVIOUS YEARS

Speed up and simplify all radio repairs. Service radios faster, better, easier, save money and time, use these **SUPREME Most-Often-Needed** diagram manuals to get ahead. At the low cost (only \$2 for most volumes) you are assured of having for every job needed diagrams and other essential repair data on 4 out of 5 sets you will ever service. Clearly printed circuits, parts lists, alignment data, and helpful service hints are the facts you need. Average volume has 192 pages, large size 8½ x 11 inches. Manual style binding.

- | | | | | | |
|--|--|--|--|--|--|
| <input type="checkbox"/> 1957
Volume 17
\$2.50 | <input type="checkbox"/> 1956
Volume 16
\$2.50 | <input type="checkbox"/> 1955
Volume 15
\$2.00 | <input type="checkbox"/> 1954
Volume 14
\$2.50 | <input type="checkbox"/> 1953
Volume 13
\$2.50 | <input type="checkbox"/> 1952
Volume 12
\$2.50 |
| <input type="checkbox"/> 1951
Volume 11
\$2.50 | <input type="checkbox"/> 1950
Volume 10
\$2.50 | <input type="checkbox"/> 1949
Volume 9
\$2.50 | <input type="checkbox"/> 1948
Volume 8
\$2.00 | <input type="checkbox"/> 1947
Volume 7
\$2.00 | <input type="checkbox"/> 1946
Volume 6
\$2.00 |
| <input type="checkbox"/> 1942
Volume 5
\$2.00 | <input type="checkbox"/> 1941
Volume 4
\$2.00 | <input type="checkbox"/> 1940
Volume 3
\$2.00 | <input type="checkbox"/> 1939
Volume 2
\$2.00 | <input type="checkbox"/> 1926-1938
Volume 1
\$2.50 | |

INDEX for all Radio and TV Manuals **25¢**

RADIO SERVICING COURSE

Here is your practical radio course of 22 easy-to-follow lessons. Review fundamentals, learn new servicing tricks. Just like a \$200.00 correspondence course. Everything in radio servicing. With self-testing questions. New edition. Price only **\$250**

Simplified Radio Servicing by COMPARISON Method

Revolutionary different **COMPARISON** technique permits you to do expert work on all radio sets. Most repairs can be made without test equipment or with only a volt-ohmmeter. Many simple, point-to-point, cross-reference, circuit suggestions locate the faults instantly. Plan copyrighted. Covers every radio set — new and old models. This new servicing technique presented in handy manual form, size 8½ x 11 inches, 92 pages. Over 1,000 practical service hints. 26 large, trouble-shooting blueprints. Charts for circuit analysis. 114 tests using a 5c resistor. Developed by M. N. Beitman. New edition. Price only **\$150**



How to Modernize Radios

Cash in by improving and modernizing all out of date radio sets and cabinets. Practical job-sheets with schematics and photographs make this work easy. Size 8½ x 11 inches. Your price only **\$1**



SUPREME TELEVISION MANUALS

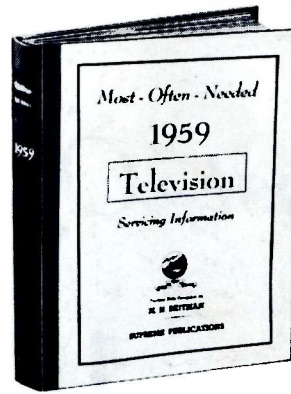

1959 TV Manual, TV-15

This new giant volume of 1959 television factory data will give you everything you need to repair and adjust all present-day TV sets. The **television series manuals** are amazing bargains and defy competition. The 1959 volume contains circuit explanations, 192 pages of alignment facts, test patterns, response curves, waveforms, voltage charts, hints, and dozens of mammoth double-page work-bench diagrams. Large size 8½ x 11 inches. Sturdy covers. Book binding opens flat. Amazing value. Price postpaid, only **\$3**

EARLIER TV MANUALS FOR 1958 TO 1948

Supreme TV manuals cover all needed service material on every popular TV set of every important manufacturer. Here is helpful, practical, factory-prepared data that will really make TV servicing and adjustment easy for you. **Supreme** giant TV manuals have complete circuits, alignment facts, test patterns, response curves, service hints, recommended changes, voltage charts, waveforms, and many double-page diagram blueprints. Here is your TV service material to help you do more expert work quicker; and priced at only \$3. **Radio** manuals described at left.

- | | | |
|--|---|--|
| <input type="checkbox"/> 1958 Television Manual, TV-14, \$3. | <input type="checkbox"/> ADDITIONAL 1957 TV, Vol. TV-13, \$3. | <input type="checkbox"/> EARLY 1957 TV Manual, TV-12, \$3. |
| <input type="checkbox"/> 1956 TV Volume TV-11 \$3.00 | <input type="checkbox"/> 1955 TV Additional, TV-10 \$3.00 | <input type="checkbox"/> 1955 TV Early, Vol. TV-9 \$3.00 |
| <input type="checkbox"/> 1954 TV Volume TV-8 \$3.00 | <input type="checkbox"/> 1953 TV Volume TV-7 \$3.00 | <input type="checkbox"/> 1952 TV Volume TV-6 \$3.00 |
| <input type="checkbox"/> 1951 TV Volume TV 5 \$3.00 | <input type="checkbox"/> 1950 TV Volume TV-4 \$3.00 | <input type="checkbox"/> 1949 TV Volume TV-3 \$3.00 |
| <input type="checkbox"/> 1948 TV Volume TV-2 \$3.00 | <input type="checkbox"/> 1957-58 RCA Volume \$1.50 | |

TELEVISION SERVICING COURSE

Let this new course teach you TV servicing. Amazing bargain, complete only \$3, full price for all lessons. Giant in size, mammoth in scope, topics just like a \$200.00 correspondence course. Lessons on picture faults, circuits, adjustments, short-cuts, UHF, alignment hints, antenna problems, trouble-shooting, test equipment, picture analysis. Special, only **\$3**

RADIO MATHEMATICS

Explains arithmetic and simple algebra in connection with units, color code, meter scales, Ohm's law, alternating currents, ohmmeter testing, wattage rating, series and parallel connections, capacity, inductance, mixed circuits, vacuum tubes, curves, the decibel, etc., and has numerous examples. Only **25¢**



Practical Radio & Electronics Course

Here is your complete home study course of 35 lessons designed to train any beginner to be an expert in radio and electronics. Covers every topic of radio, electronics, with lessons on test equipment, FM, TV, radio, etc. Giant 8½ x 11 inches, 3-in-1 volume, includes all lessons, instructor's notes, test questions. New edition. Only **\$395**

ANSWER BOOK to the above course **25¢**

Admiral 5W4 CHASSIS

Models 581 and 582

REMOVING THE CHASSIS

The front section of the cabinet is removable for alignment and for servicing the component side of the chassis.

To remove the cabinet front from the chassis, proceed as follows:

1. Remove the battery compartment cover.
2. Remove the batteries.
3. Remove the two Phillips head screws in the bottom of the battery compartment.
4. Pull the tuning knob off.
5. Remove the Phillips head screw at the left of the tuning shaft.

6. Gently lift the cabinet front from the cabinet back and chassis.

To remove chassis from cabinet back for servicing the wiring side of the chassis:

7. Remove the other two Phillips head screws in the battery compartment.
8. Make sure tuning gang is closed. Then remove the two Phillips head screws that are visible — one near the tuning capacitor and the other in lower left corner as radio is viewed from the front.
9. Lift speaker from cabinet and away from chassis.
10. Gently lift the printed circuit chassis out of cabinet.

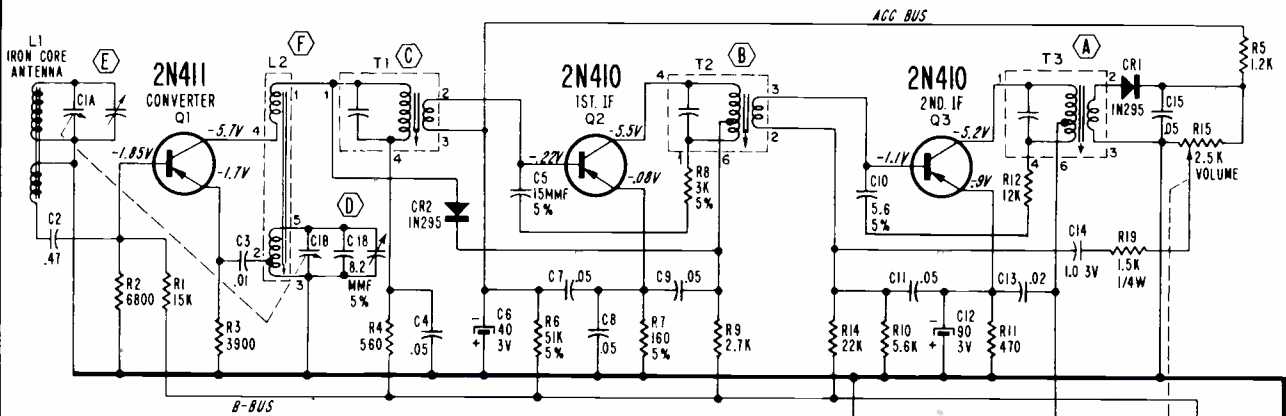

INTERMEDIATE FREQUENCY: 455 KC.

VOLTAGE DATA

Voltages shown measured with no signal, using fresh batteries. Volume control at minimum; dial set at low frequency end. All readings made with VTVM between transistor terminals and B plus (ground).

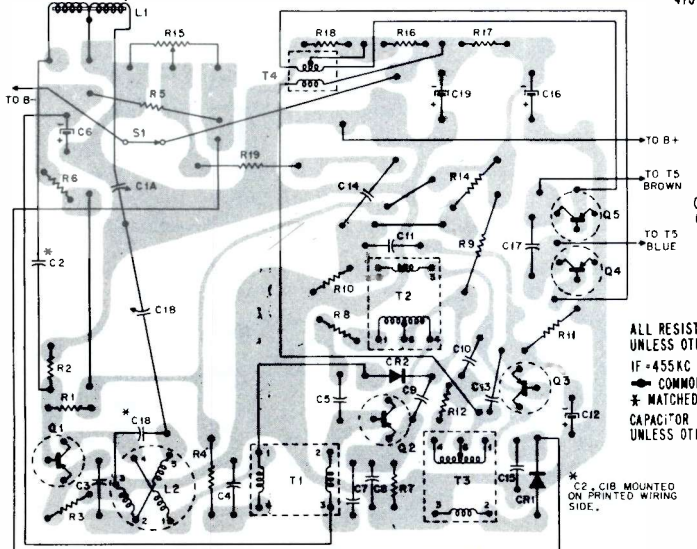
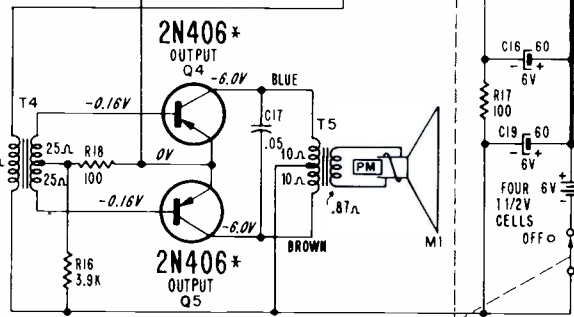

View of Printed Wiring Board. Gray area represents printed wiring black symbols and lines represent components.

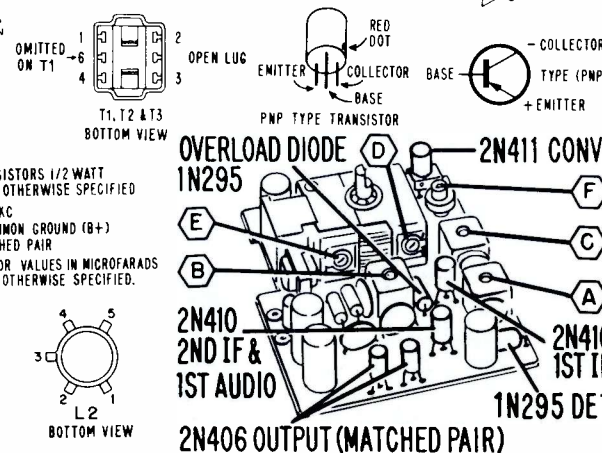

Admiral

CHASSIS 6T2
MODELS 521 • 528

I. F. 455 KC.

TOTAL CURRENT DRAIN APPROXIMATELY
10.5 MA WITH VOLUME CONTROL AT MINIMUM
AND NO SIGNAL APPLIED.

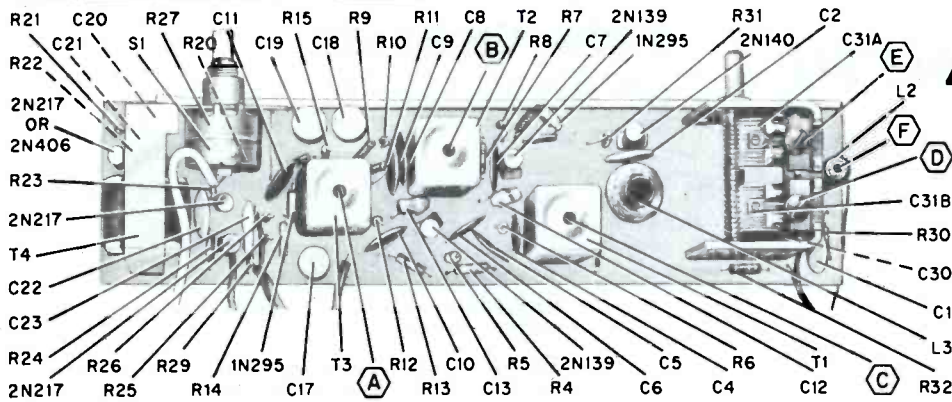

REMOVING THE CHASSIS

1. Remove Tuning knob and Volume control knob by working them forward and off the shaft.
2. Open cover on rear of cabinet.
3. Remove the battery case.
4. On the front of the cabinet, loosen the two Phillips head screws adjacent the tuning shaft.
5. Loosen the hex nut that secures the Volume control to front of case.
6. Hold the printed circuit board while removing the two screws and hex nut, to prevent damage.
7. Gently lift the circuit board from within cabinet.

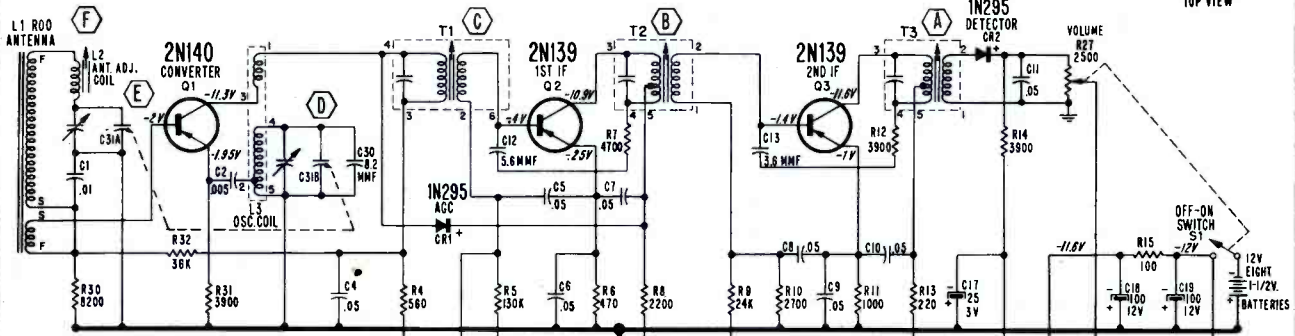
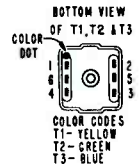

VOLTAGE DATA

DC voltages shown measured with no signal, using fresh batteries.

Volume control at minimum; dial set a low frequency end.

All readings made between transistor socket terminals and B plus (ground).

All voltage readings are negative.

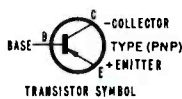
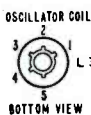

- NOTES:
 IF= 455K
 CHASSIS GROUND
 COMMON GROUND
 * MATCHED PAIR
 CAPACITOR VALUES IN MICROFARADS UNLESS OTHERWISE SPECIFIED.
 † NOT USED ON ALL CHASSIS.

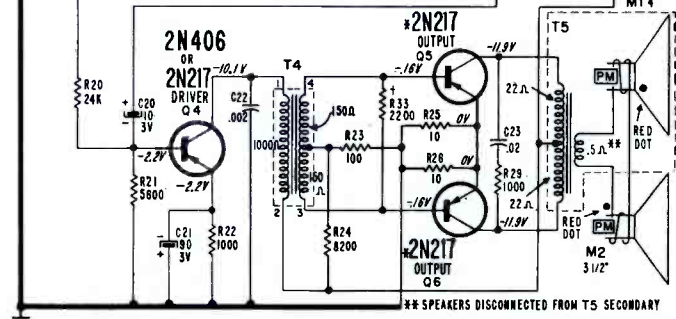

View of Printed Wiring Board. NOTE: Gray area represents printed wiring; black symbols and lines represent components and wiring on opposite side.

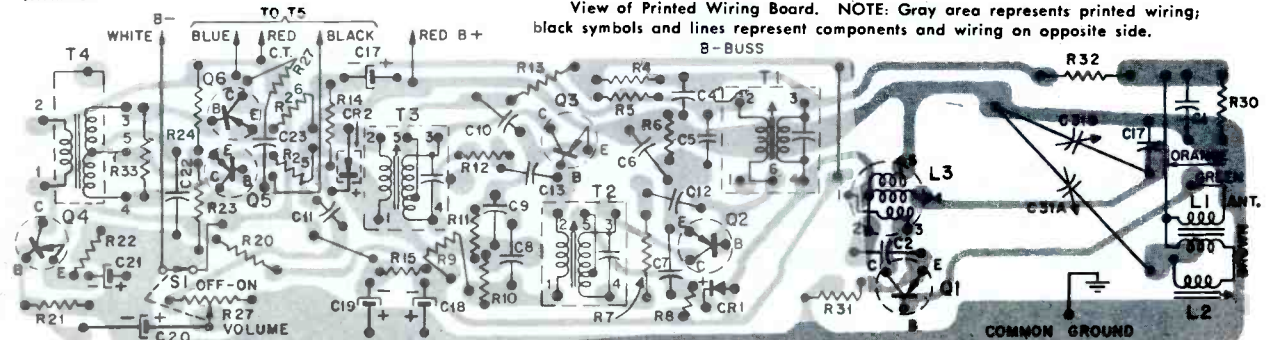

Admiral

CHASSIS 8M1 MODELS 801 • 802 • 808

REMOVING THE CHASSIS

To remove the cabinet front from the chassis, proceed as follows:

1. Remove the battery compartment cover.
2. Remove the batteries.
3. Remove the four Phillips head screws that are visible within the battery compartment.
4. The tuning knob hub is a thumb screw. Remove it by turning counterclockwise.
5. Remove tuning knob by working it forward and off the tuning shaft.

6. Remove the Phillips head screw at the left of the tuning shaft.
7. Gently lift the cabinet front from the cabinet back and chassis.
- To remove chassis from cabinet back for servicing the wiring side of the chassis:
8. Make sure tuning gang is closed. Then remove the two Phillips head screws that are visible—one near the tuning capacitor and the other in lower left corner as radio is viewed from the front.
9. Lift speaker from cabinet and away from chassis.
10. Gently lift out wiring side of chassis from cabinet.

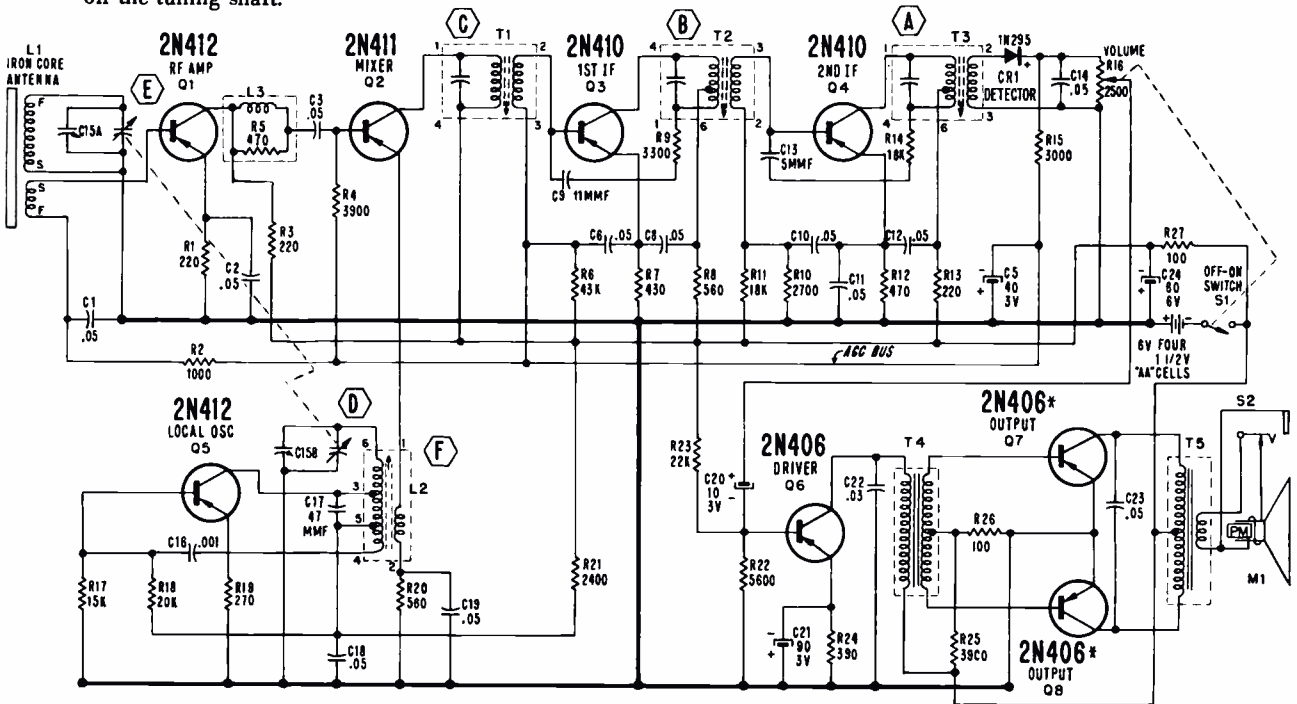

IF = 455 KC
 COMMON GROUND (B+)
 * MATCHED PAIR
 CAPACITOR VALUES IN MICROFARADS UNLESS OTHERWISE SPECIFIED.

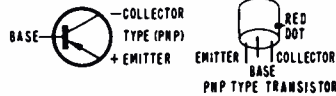

I. F. 455 KC.

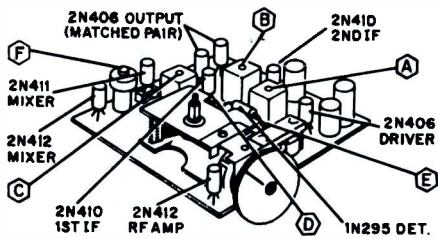

Transistor and Alignment Locations

VOLTAGE DATA

Voltages shown measured with no signal, using fresh batteries. Volume control at minimum; dial set at low frequency end. All readings made with VTVM between transistor terminals and B plus (ground). All voltages are negative.

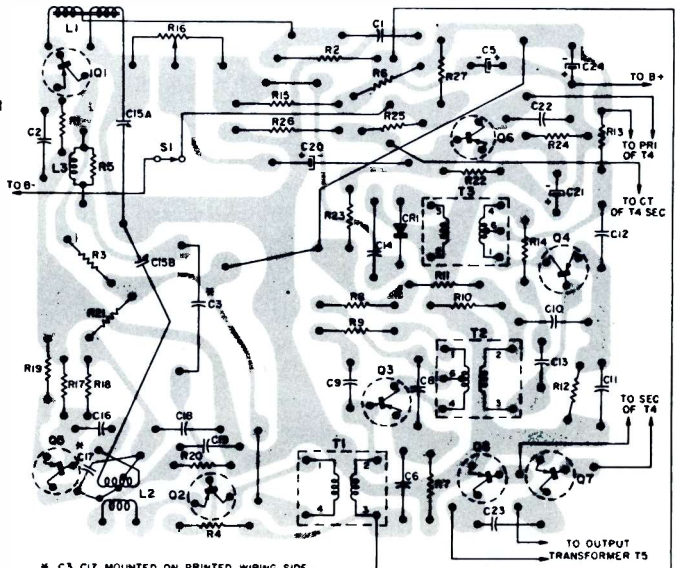

* C3, C17 MOUNTED ON PRINTED WIRING SIDE.

View of Printed Wiring Board. Gray area represents printed wiring, black symbols and lines represent components.

Admiral

Chassis 8S1, Models 561, 566, exact material.
Chassis 8S1A, Models 811, 816, include clock.

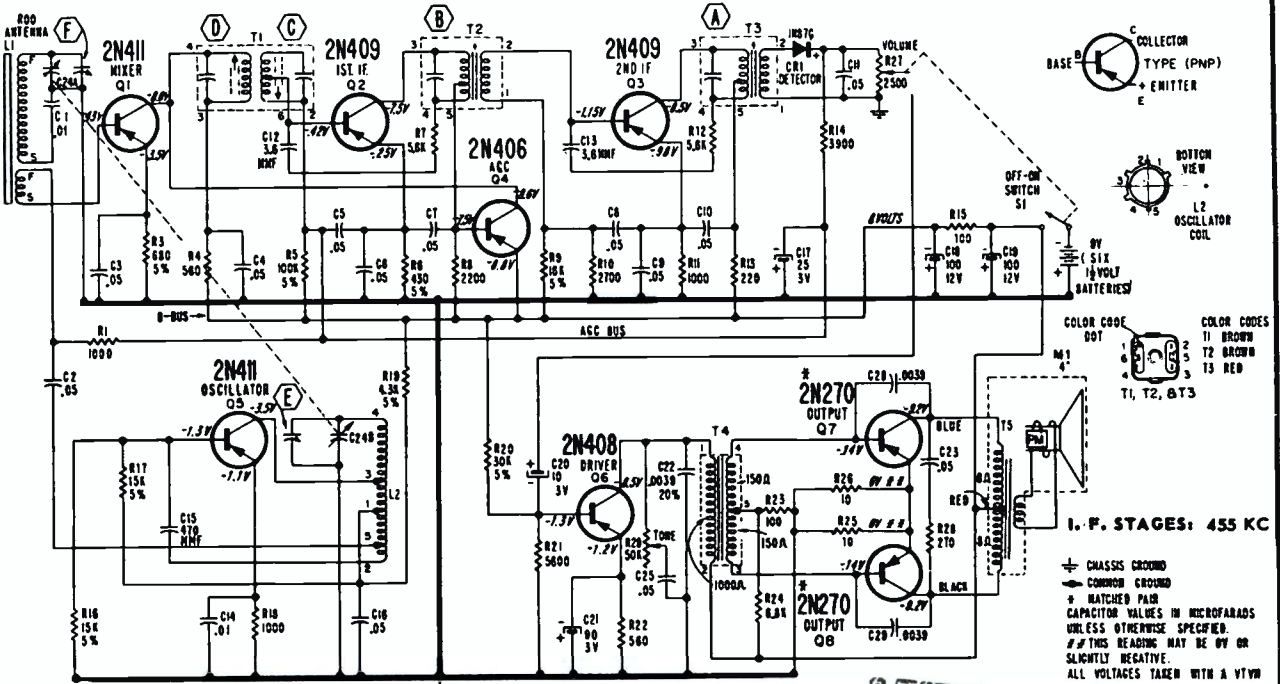

1. Remove 2 screws near front edge of cabinet bottom.
2. Remove 2 screws from upper section of cabinet back.
3. Pull chassis and front panel free of cabinet.

The speaker, volume and tone control, and printed chassis board are all fastened separately with screws to the front panel. Remove them individually as required by removing their mounting screws.

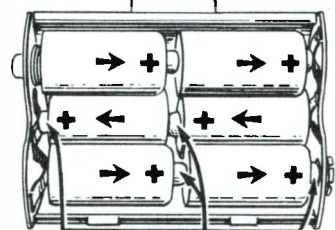
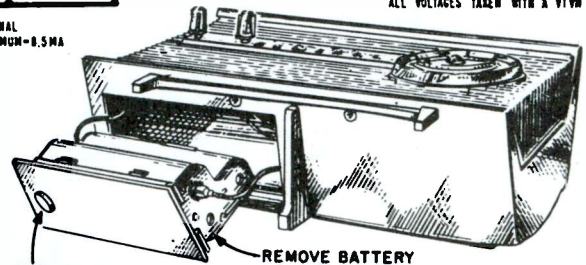

Battery Case Showing Batteries in Correct Position.

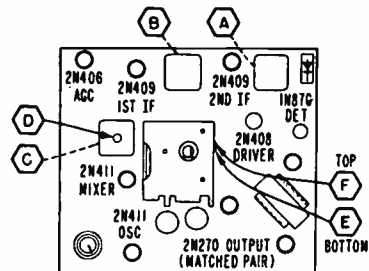

NOTE: DOTTED LINES INDICATE ADJUSTMENT UNDER BOARD

Transistor and Alignment Locations.

Admiral 12B1-12B1A-5T4A CHASSIS

Models 632, 633, 634, 642, 643, 644, 649, 654, 662, 663, 664, 671, use Chassis 12B1. Chassis 12B1A has a different panel; used in later Model 649. Same model numbers with prefix SS use auxiliary stereo unit 5T4A.

(Additional material on pages 10-11)

Run changes refer to 12B1 schematic diagram on next two pages.

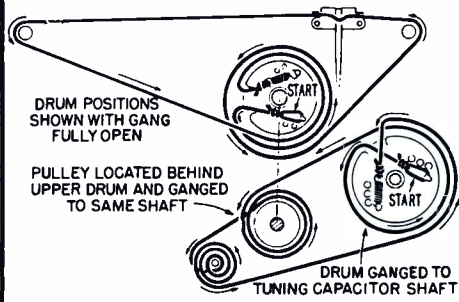

Stringing Diagram.
(Early Production)

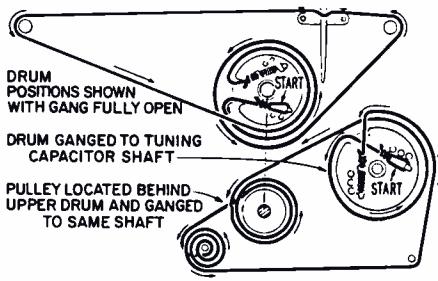

Stringing Diagram.

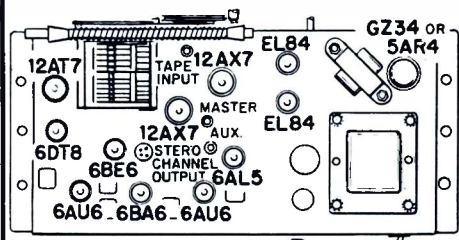

Top View of 12B1 Chassis, Tube Locations Shown.

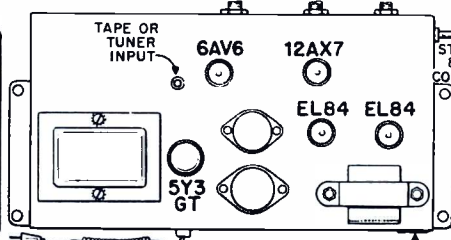

Top View of 5T4A Chassis

- 10 Start of production 12B1.
- 11 R25 (15K, 1W) changed to (22K, 1W) to permit full interchangeability 6BE6 tubes. R33 changed to (390K, 1/2W); R34 to (100K, 1/2W); and C39 to (.002MF) to improve AM operation. R70 (470K, 1/2W) added between M11 and M12 to minimize rumbles.
- 12 R70 (470K, 1/2W) removed to increase channel separation for stereo operation.
- 13 To insure proper operation of OFF-ON-POWER relay of low line voltages, R45 (39K, 2W) removed and R71 (33K, 2W) added in its place.
- 14 To reduce possibility of regeneration in string signal areas, C18 (.02MF) and C21 (.02MF) removed. R72 (75K 5%) and R73 (75K, 5%) added to 1F section. R65 (60K) connected to B+ 200V.
For standardization of parts, C19A and B (dual .004MF; V2 screen and filament bypass) removed. C19 (.01MF) V2 screen bypass and C72 (.005MF) V2 filament bypass added. C22A and B (dual .004MF, V3 screen and filament bypass) removed. C22 (.01MF) V3 screen bypass and C73 (.005MF) V3 filament bypass added. C24A and B (dual .004MF; V4 screen and filament bypass) removed. C24 (.01MF) V4 screen bypass and C74 (.005MF) V4 filament bypass added. V8 changed to ECC83. For improved frequency response, C55 changed to .02MF. C64 changed to .02MF. C66 and C67 each changed to .02MF. C75 (.001MF) added from plate to screen of V12. C76 (.001MF) added from plate to screen of V12 to increase AM audio output. R33 changed to 100K and R34 changed to 390K. R74 (100K, 1W) added.
- 15 R75 (10 ohms, 1/2 watt) added between pin 2 of V1B and R2 to reduce possibility of RF regeneration.

Schematic of 5T4A Amplifier Chassis Stamped Run 10.

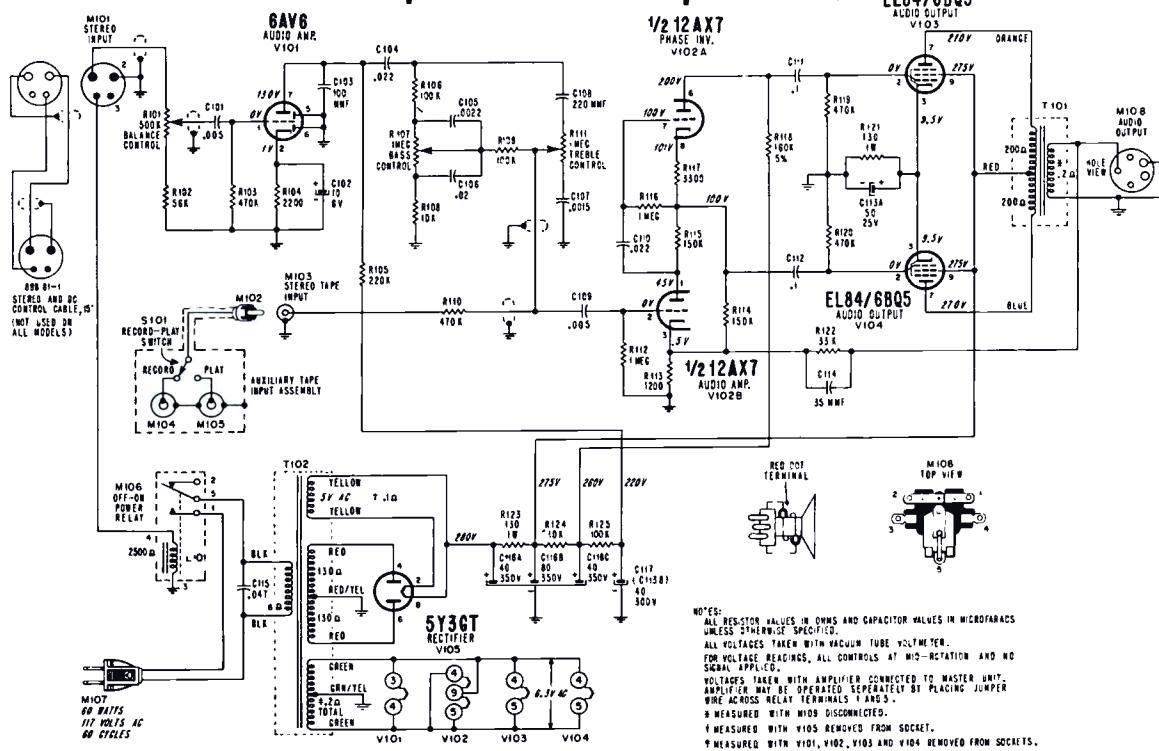

ADMIRAL Schematic diagram of 12B1, 12B1A, Run 15, Continued

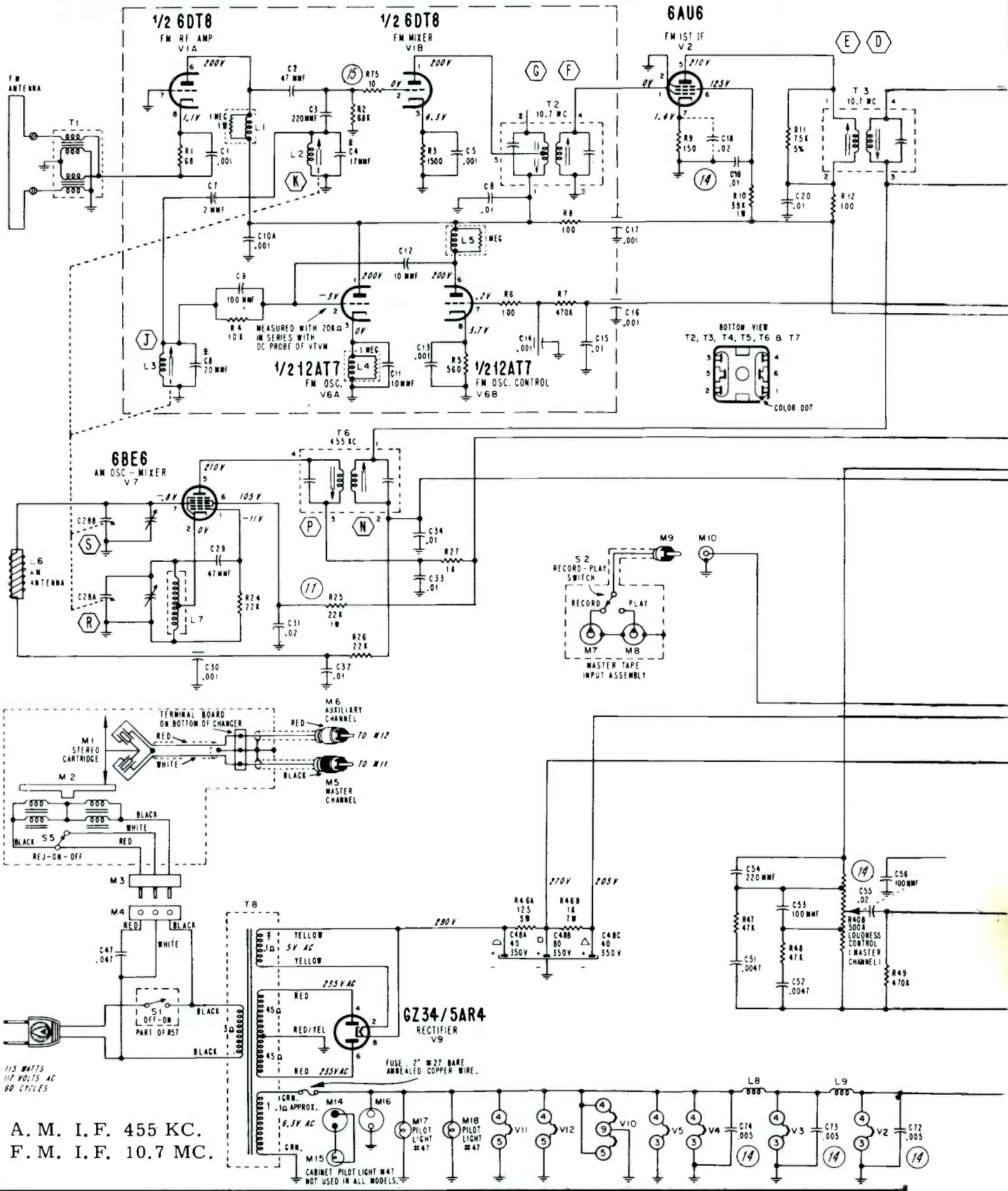

A. M. I. F. 455 KC.
F. M. I. F. 10.7 MC.

VOLUME R-19, MOST-OFTEN-NEEDED 1959 RADIO SERVICING INFORMATION

ADMIRAL Schematic Diagram of 12B1-12B1A Radio Chassis Stamped Runs 10 through 15.

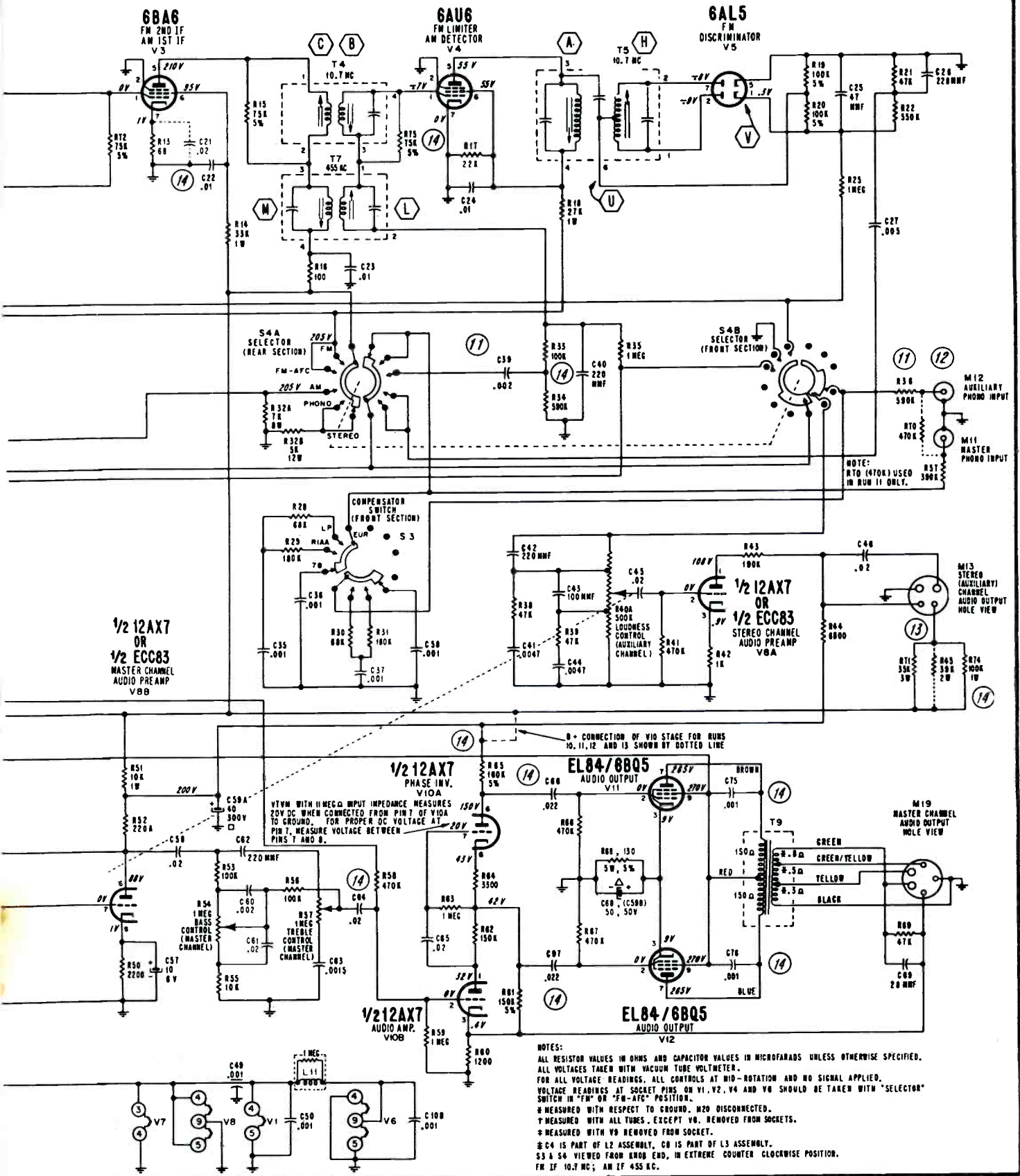

VOLUME R-19, MOST-OFTEN-NEEDED 1959 RADIO SERVICING INFORMATION

ARVIN
 Model 2585
 Chassis 1.45000

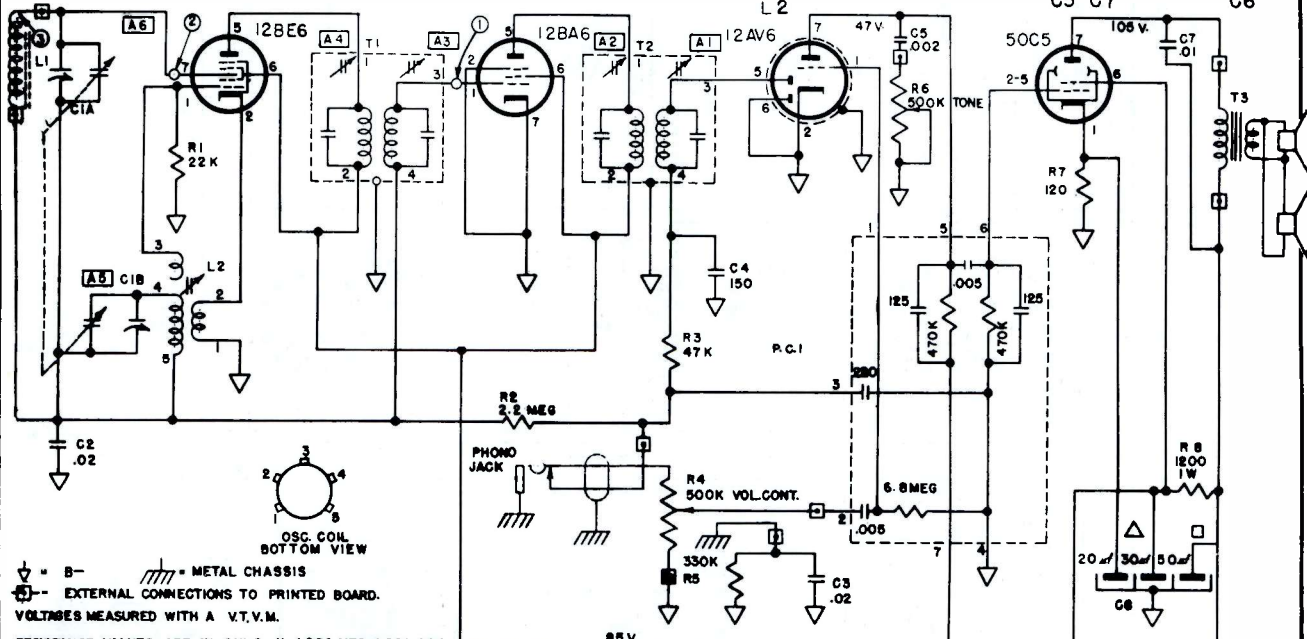
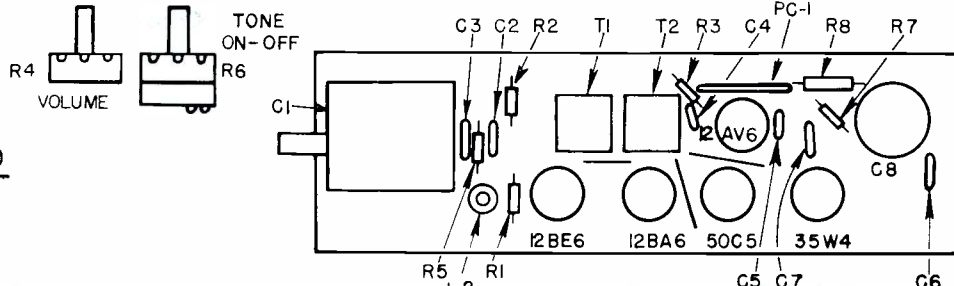

⏏ = B- METAL CHASSIS
 ⊕ = EXTERNAL CONNECTIONS TO PRINTED BOARD.
 VOLTAGES MEASURED WITH A V.T.V.M.

RESISTANCE VALUES ARE IN OHMS K=1,000, MEG=1,000,000
 CAPACITANCE VALUES LESS THAN (1) ARE IN MICROFARADS (μf),
 AND VALUES OF (1) OR GREATER ARE IN MICROMICROFARADS (μμf), UNLESS OTHERWISE INDICATED.

CIRCUIT POINT	DUMMY TO GENERATOR	INPUT FOR .05 WATT OUTPUT (0.4 VOLTS ACROSS 5 V.C.)	INPUT FOR .5 WATT OUTPUT (1.26 VOLTS ACROSS V.C.)
1	.05 μf AT 455 KC	2 000 U V	5 000 U VOLTS
2	.05 μf AT 455 KC	60	150
3	STANDARD LOOP AT 1000 KC	200 U V / M	500 U V / M

ALIGNMENT PROCEDURE

Output meter connection..... Across speaker voice coil
 Connection of generator ground lead Floating ground
 Position of Volume Control Fully clockwise

Position of Variable	Frequency of Generator	Dummy Antenna	Generator Output Connection	Trimmers Adjusted in Order Shown for Maximum Output	Functions of Trimmer
Open	455	.05 μf	Pin 7 12BE6	A1, A2, A3, A4	I. F.
Open	1670		* Test Loop	A5	Oscillator
1400	1400		* Test Loop	A6	Antenna
600	600		* Test Loop	Check Point	

* Standard Hazeltine Test Loop Model 1150 or 3 turns of wire about 6" in diameter placed about one foot from the set loop.
 The alignment procedure should be repeated in the original order for greatest accuracy. Always keep the output from the signal generator at its lowest possible value to make the AVC action of the receiver ineffective.

MOST-OFTEN-NEEDED 1959 RADIO SERVICING INFORMATION

ARVIN

Model 2581

Chassis 1.43800

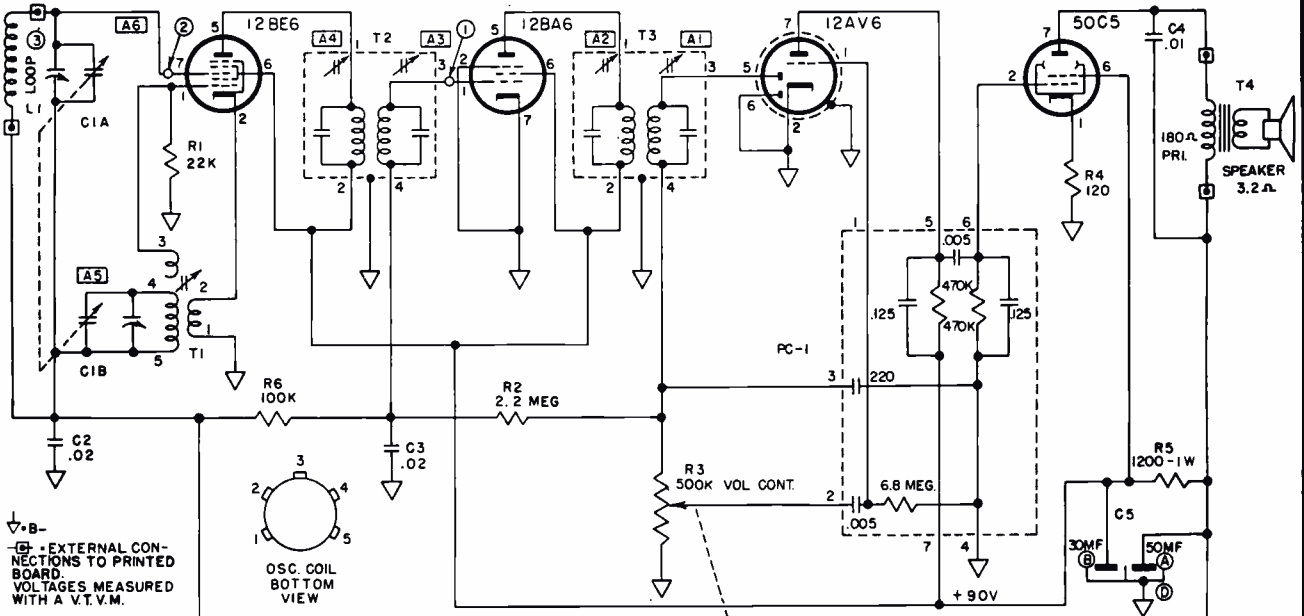
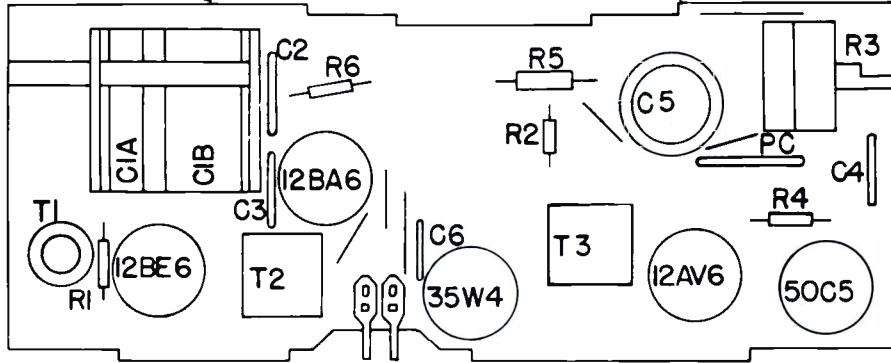

⊕-B-
EXTERNAL CONNECTIONS TO PRINTED BOARD.
VOLTAGES MEASURED WITH A V.T.V.M.

TO VOL. CONTROL SHAFT

RESISTANCE VALUES ARE IN OHMS K=1,000, MEG=1,000,000.
CAPACITANCE VALUES LESS THAN (1) ARE IN MICROFARADS (μF),
AND VALUES OF (1) OR GREATER ARE IN MICROMICROFARADS (μμF), UNLESS OTHERWISE INDICATED.

APPROXIMATE SENSITIVITIES

CIRCUIT POINT	DUMMY TO GENERATOR	INPUT FOR 0.5 WATT OUTPUT (0.4 VOLTS ACROSS VC)	INPUT FOR 5 WATT OUTPUT (1.26 VOLTS ACROSS VC)
1	0.5 μF AT 455 KC	2000 UV	5000 UV
2	0.5 μF AT 455 KC	60	150
3	STANDARD LOOP AT 1000 KC	200 UV/M	500 UV/M

ALIGNMENT PROCEDURE Output meter connection Across speaker voice coil
 Output meter reading to indicate 500 milliwatts (standard output)... 1.26 volts
 Connection of generator ground lead..... Floating ground
 Generator modulation 30% 400 cycles

Position of Variable	Frequency of Generator	Dummy Antenna	Generator Output Connection	Trimmers Adjusted in Order Shown for Maximum Output	Function of Trimmer
Open	455 Kc	.05 μ fd	Pin 7 12BE6	A1, A2, A3, A4	I. F.
Open	1670 Kc		* Test Loop	A5	Oscillator
1400	1400 Kc		* Test Loop	A6	Antenna
1000	1000 Kc		* Test Loop	Fan C1A Plates	
600	600 Kc		* Test Loop	Fan C1A Plates	

* Standard Hazeltine Test Loop Model 1150 or 3 turns of wire about 6" in diameter placed about one foot from the set loop.

VOLUME R-19, MOST-OFTEN-NEEDED 1959 RADIO SERVICING INFORMATION

ARVIN Industries
 Model 3588
 Chassis 1.45200

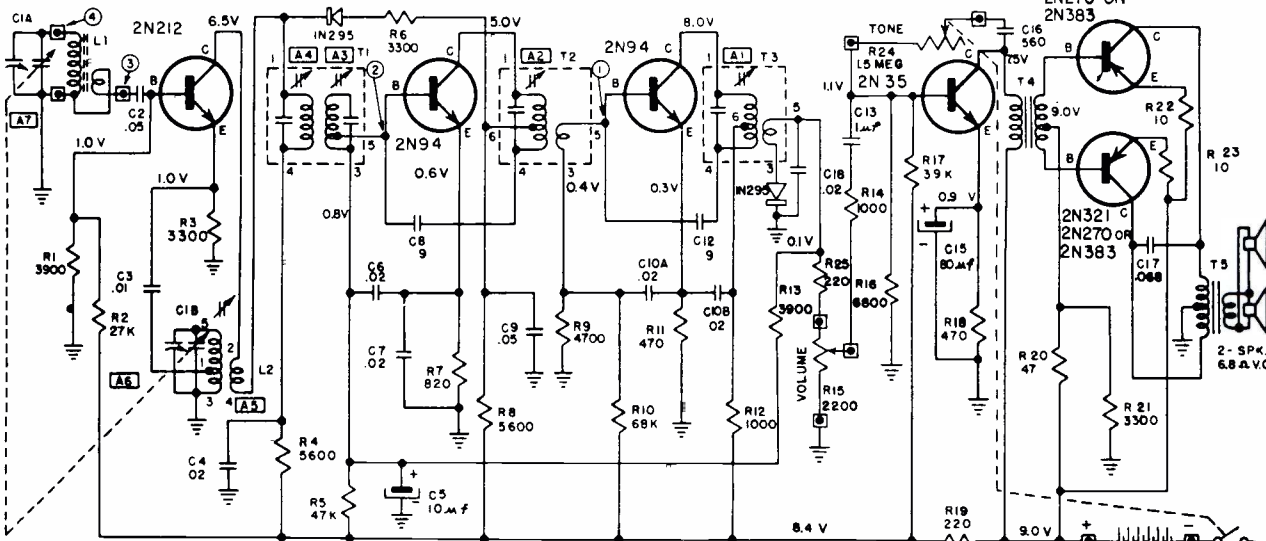
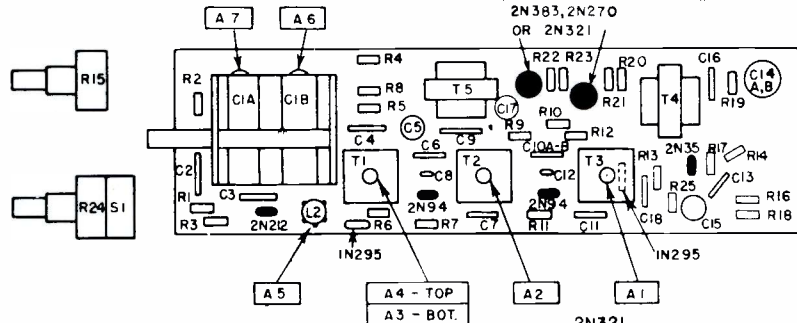

RESISTANCE VALUES ARE IN OHMS ; K = 1000.

CAPACITANCE VALUES LESS THAN 10 ARE IN MICROFARADS (μmf) AND VALUES GREATER THAN 1.0 ARE IN MICRO-MICROFARADS ($\mu\text{m}\mu\text{f}$) EXCEPT WHERE NOTED.

VOLTAGE READINGS TO COMMON GROUND ARE MEASURED WITH VACUUM TUBE VOLTMETER UNDER NO SIGNAL CONDITIONS WITH TUNING CAPACITOR CLOSED AND VOLUME CONTROL AT MAXIMUM CLOCKWISE ROTATION.

SIGNAL TEST POINT	TEST FREQUENCY	SERIES CAPACITOR TO GENERATOR	INPUT FOR 0.5 WATT OUTPUT (0.4 V ACROSS 3.2 Ω)
①	455 KC	.05 μf	2000 μV
②	455 KC	.05 μf	65 μV
③	455 KC	.05 μf	5 μV
④	1000	STANDARD LOOP	150 $\mu\text{V}/\#$

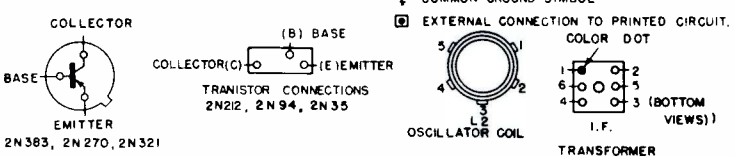

ALIGNMENT PROCEDURE

- Output meter reading to indicate 50 milliwatts 0.4V
- Output meter connection..... Across speaker voice coil
- Connection of generator ground lead..... Common Ground
- Generator Modulation..... 30% 400 cycles
- Position of volume control..... Fully clockwise

Position of Variable	Generator Frequency	Dummy Antenna	Generator Connections	Trimms Adj. in order shown for Max. Output	Function of Trimmer
Open	455 Kc	.05 μf	C1A	A1 (Top of T3) A2 (Top of T2) A3 (Bottom of T1) A4 (Top of T1)	I. F. I. F. I. F. I. F.
Open	1670 Kc		*Test Loop	A6	Oscillator
1400 Kc	1400 Kc		*Test Loop	A7	Antenna
600 Kc	600 Kc		*Test Loop	Check Point	

*Standard Hazeltine Test Loop Model 1150 or 3 turns of wire about 6" in diameter placed about one foot from the set loop.

ARVIN Industries
 Model 5583, Chassis 1.44200
 Model 2584, Chassis 1.44100
 differs from this material by
 not using a clock timer and in
 employing two speakers.

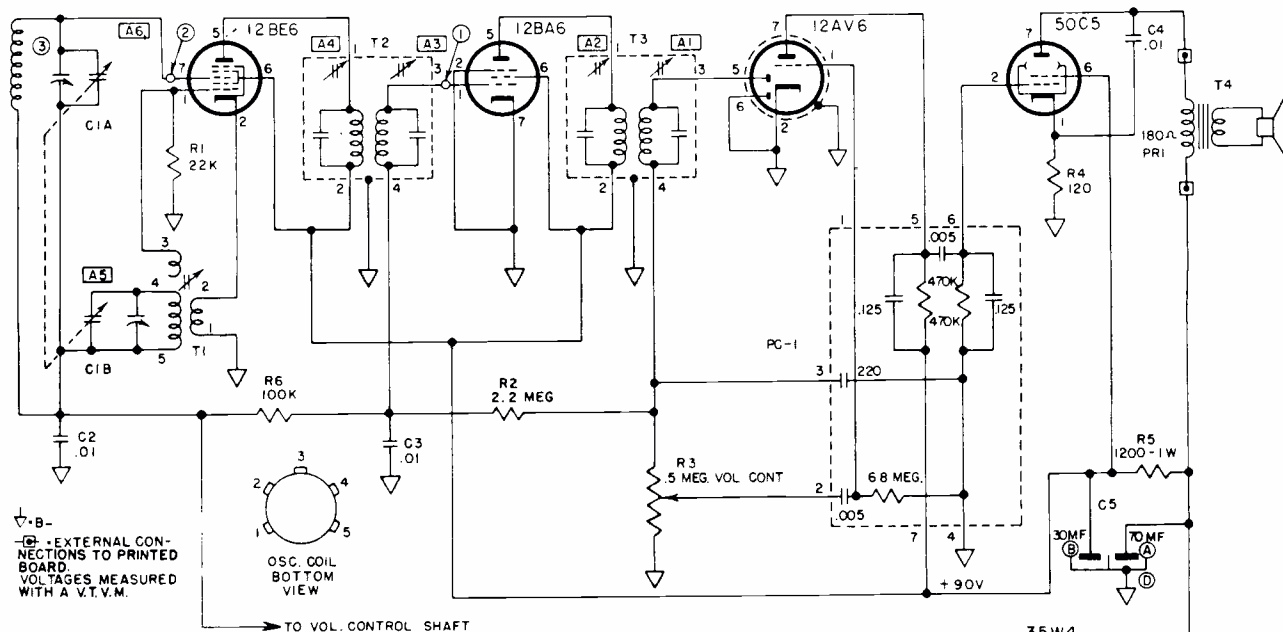
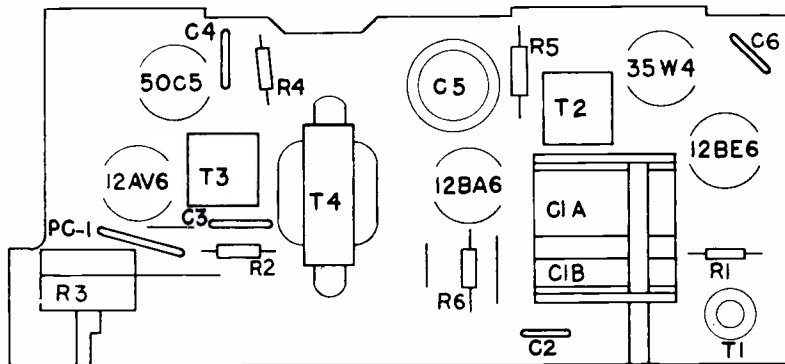

⊖-B-
 - EXTERNAL CONNECTIONS TO PRINTED BOARD. VOLTAGES MEASURED WITH A V.T.V.M.

OSC. COIL BOTTOM VIEW

RESISTANCE VALUES ARE IN OHMS K=1,000, MEG=1,000,000. CAPACITANCE VALUES LESS THAN (1) ARE IN MICROFARADS (μF), AND VALUES OF (1) OR GREATER ARE IN MICROMICROFARADS (μμF), UNLESS OTHERWISE INDICATED.

APPROXIMATE SENSITIVITIES

CIRCUIT POINT	DUMMY TO GENERATOR	INPUT FOR .05 WATT OUTPUT (0.4 VOLTS ACROSS VC)	INPUT FOR .5 WATT OUTPUT (1.26 VOLTS ACROSS VC)
1	05 μF AT 455 KC	2000 UV	5000 UV
2	05 μF AT 455 KC	60	150
3	STANDARD LOOP AT 1000 KC	200UV/M	500UV/M

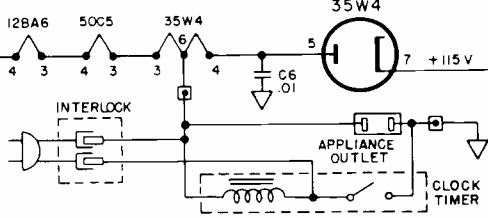

ALIGNMENT PROCEDURE Output meter connection Across speaker voice coil
 Output meter reading to indicate 500 milliwatts (standard output)... 1.26 volts
 Connection of generator ground lead..... Floating ground
 Generator modulation 30% 400 cycles

Position of Variable	Frequency of Generator	Dummy Antenna	Generator Output Connection	Trimmers Adjusted in Order Shown for Maximum Output	Function of Trimmer
Open	455 Kc	.05 μ fd	Pin 7 12BE6	A1, A2, A3, A4	I. F.
Open	1670 Kc		* Test Loop	A5	Oscillator
1400	1400 Kc		* Test Loop	A6	Antenna
1000	1000 Kc		* Test Loop	Fan C1A Plates	
600	600 Kc		* Test Loop	Fan C1A Plates	

* Standard Hazeltine Test Loop Model 1150 or 3 turns of wire about 6" in diameter placed about one foot from the set loop.

VOLUME R-19, MOST-OFTEN-NEEDED 1959 RADIO SERVICING INFORMATION

ARVIN Industries

Model 8584, Chassis 1.44600

SIGNAL TEST POINT	TEST FREQUENCY	SERIES CAPACITOR TO GENERATOR	INPUT FOR .05 WATT OUTPUT (0.4 V ACROSS 3.2Ω)
①	455 KC	.05 μf	5000 μV
②	455 KC	.05 μf	200 μV
③	455 KC	.05 μf	8 μV
④	1000 KC	STANDARD LOOP	250 μV/M

ALIGNMENT PROCEDURE

- Output meter reading to indicate 50 milliwatts 0.4V
- Output meter connection Across speaker voice coil
- Connection of generator ground lead Common Ground
- Generator Modulation 30% 400 Cycles
- Position of volume control Fully Clockwise

Position of Variable	Generator Frequency	Dummy Antenna	Generator Connections	Trimmers Adj. in order shown for Max. Output	Function of Trimmer
Open	455 Kc	.05 μf	C1A	A1 (Top of T3) A2 (Top of T2) A3 (Top of T1) A4	I. F. I. F. I. F. Oscillator
Open	1670 Kc		*Test Loop	A6	Antenna
1400 Kc	1400 Kc		*Test Loop	Check Point	
600 Kc	600 Kc		*Test Loop		

*Standard Hazeltine Test Loop Model 1150 or 3 turns of wire about 6" in diameter placed about one foot from the set loop.

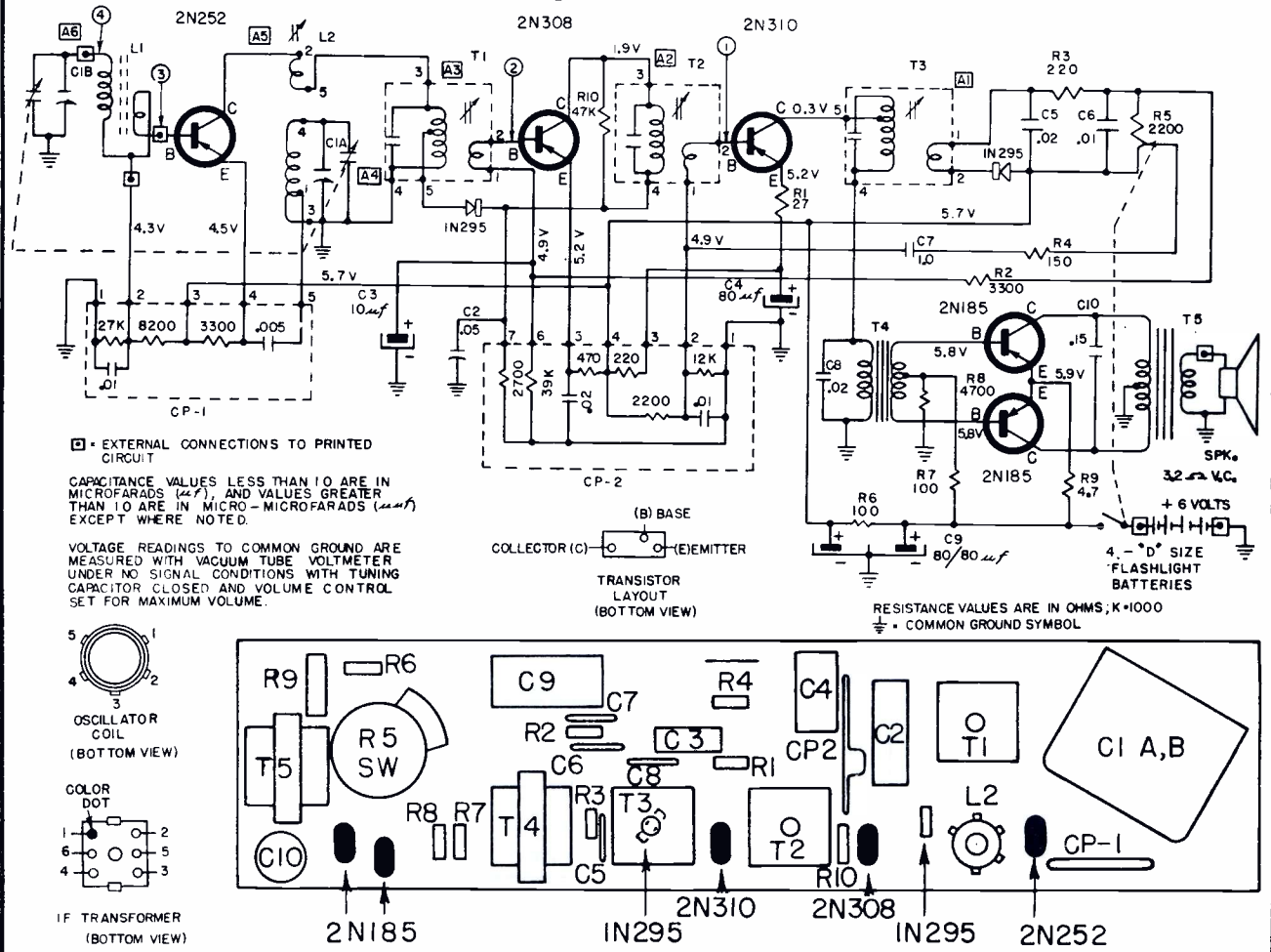

VOLUME R-19, MOST-OFTEN-NEEDED 1959 RADIO SERVICING INFORMATION

ARVIN Industries, Models 8581, 8583, Chassis 1.43700, 1.43900

ALIGNMENT PROCEDURE

Output meter reading to indicate .05 watt across voice coil 0.4V
 Generator ground lead connected floating ground
 Generator modulation 30% 400 cycles
 Position of Volume Control fully on

Position of Variable	Generator Frequency	Dummy Antenna	Generator Connections	Adjust Trimmers (In order shown)	Function of Trimmer
Open	455 Kc	.05 μ f	Mixer Grid	A1, A2, A3,	I. F.
Open	1670 Kc		Test Loop	A4	Oscillator
1400 Kc	1400 Kc		Test Loop	A5	Antenna
600 Kc	600 Kc		Test Loop	Check Point	

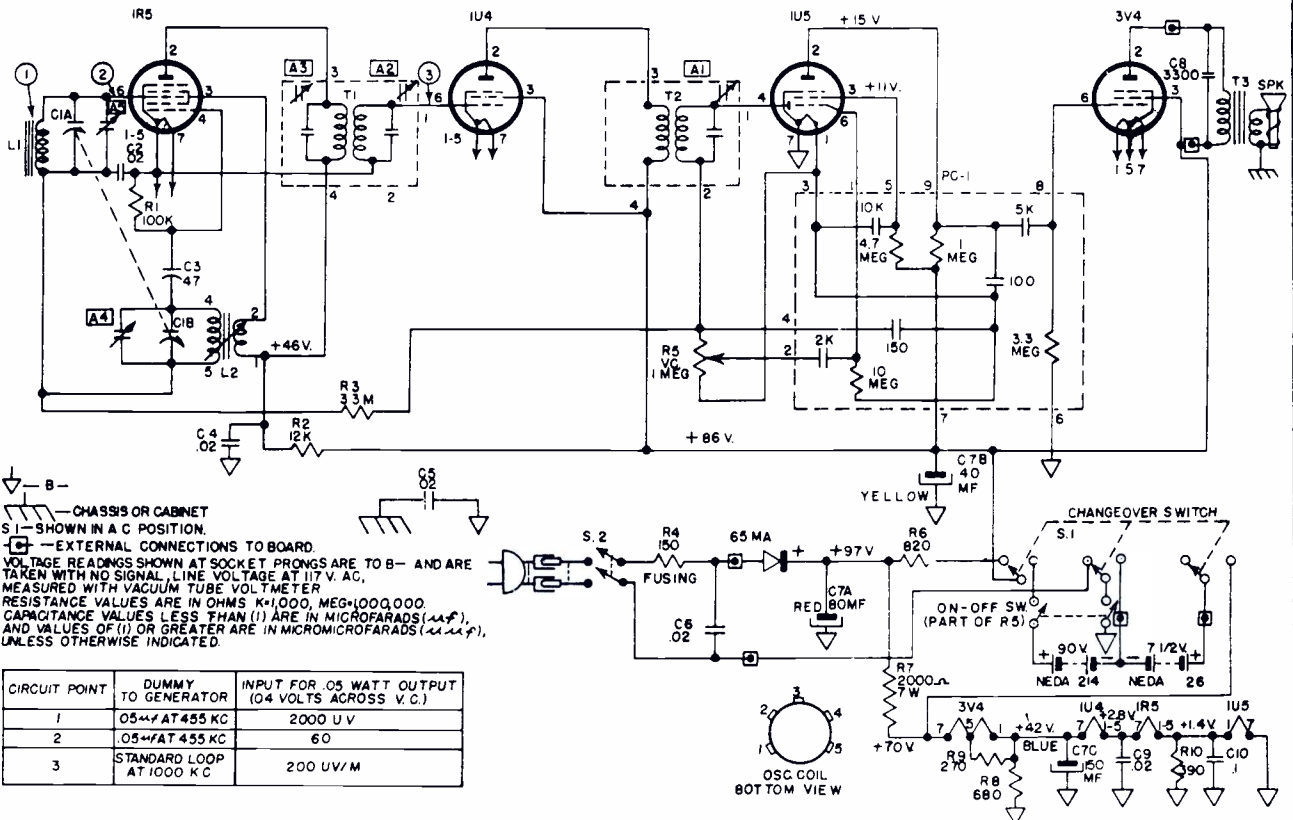
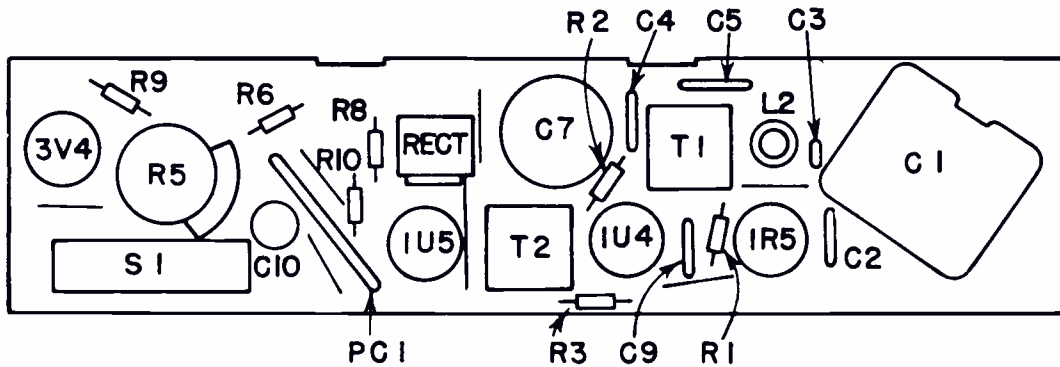

DELCO

BUICK 981968
(Continued from preceding page)

PART LAYOUT—TUBE VIEW

PARTS LAYOUT—CHASSIS VIEW

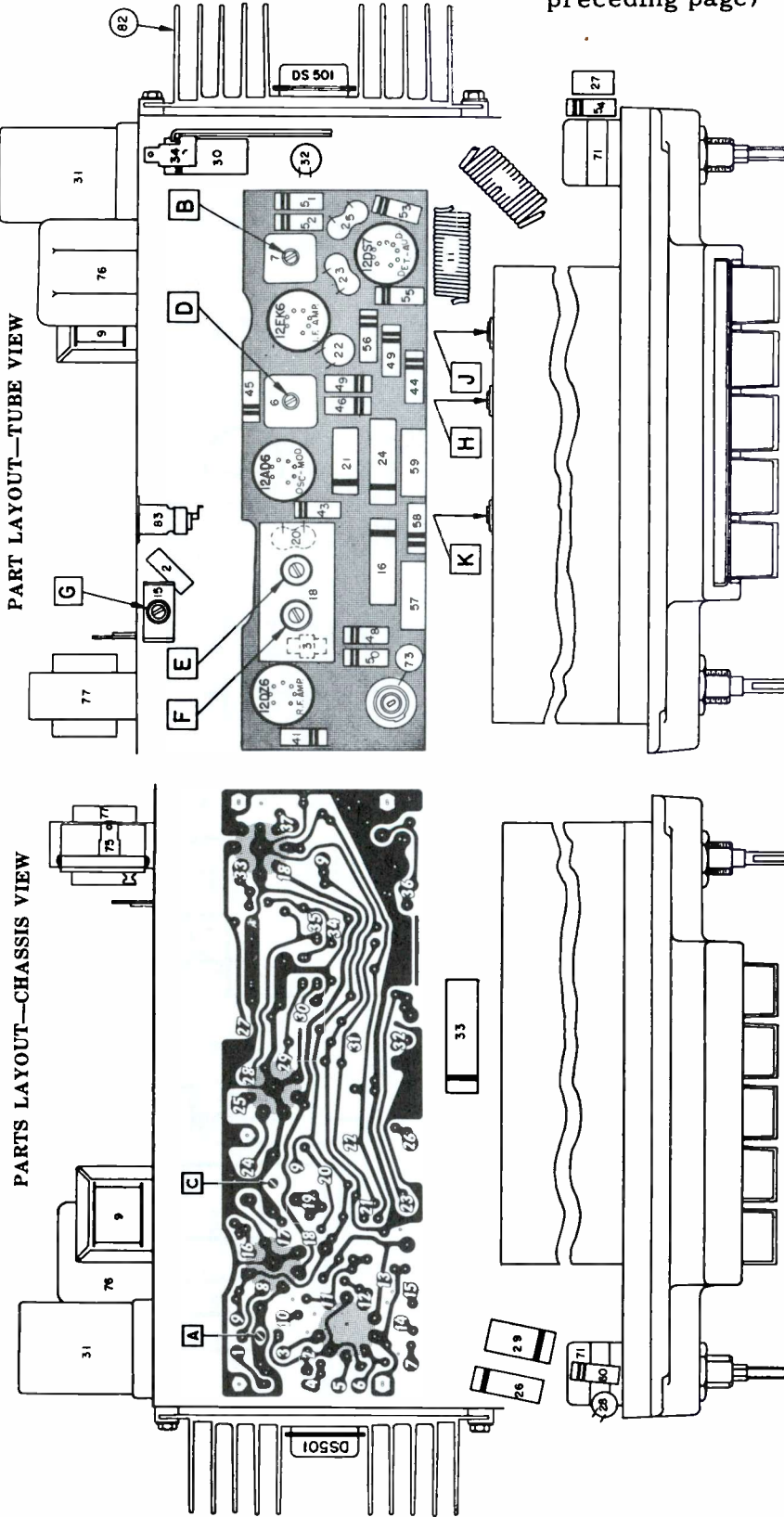

WHITE NUMBERS ON PRINTED CIRCUIT BOARD DRAWING CORRESPOND TO NUMBERS ENCIRCLED ON SCHEMATIC.

STEP	SERIES CONDENSER OR DUMMY ANTENNA	CONNECT SIGNAL GENERATOR TO	SIGNAL GENERATOR FREQUENCY	TUNE RECEIVER TO	ADJUST IN SEQUENCE FOR MAX. OUTPUT
1	0.1 Mfd.	12DA6 Grid (Pin #7)	262 KC	High Frequency Stop	A, B, D, C
2	.000082 Mfd.	Antenna Connector	1615 KC	High Frequency Stop	*E, F, G
3	.000082 Mfd.	Antenna Connector	600 KC	Signal Generator Signal	J, K
4	.000082 Mfd.	Antenna Connector	1615 KC	High Frequency Stop	F, G
5	.000082 Mfd.	Antenna Connector	900 KC	Signal Generator Signal	L**

ALIGNMENT PROCEDURE

- Output Meter Connections.....Across Voice Coil
- Generator Return.....To Receiver Chassis
- Dummy Antenna.....In Series With Generator
- Volume Control Position.....Maximum Volume
- Tone Control Position.....Treble
- Generator Output...Minimum for Readable Indication

*Before making this adjustment check mechanical setting of oscillator core "H." The rear of the core should be 1 1/2" from the mounting end of the coil form. (This measurement is readily made by inserting a suitable plug in the mounting end of the coil form.) Core adjustment should be made with a non-metallic screwdriver.

**L is the pointer adjustment screw which is on the connecting link, between the pointer assembly and the parallel guide bar. It should be adjusted so that the dial pointer corresponds with the 900 KC mark on the dial.

DELCO

BUICK 981970
 OLDSMOBILE 989172
 PONTIAC 988978

Continued on the next page,
 adjacent at right.

SCHEMATIC DATA

Voltages measured terminal to chassis with a VTVM—no signal. The portable unit voltages are taken with a battery voltage of 5.2 volts. Rack unit voltages taken with 12 volts at Illus. 37.

Total "A" Drain in Car 1.3 amps.
 Total "A" Drain of Portable 6 ma.
 Tolerance on Voltage $\pm 10\%$.

Resistances are $\pm 20\%$. Ohmmeter reading in transistor circuits are affected by meter battery polarity. Check in both directions and use highest reading.

- Before measuring transistor voltages, the shorting type speaker socket must be opened and a 4 ohm speaker connected. If transistor is replaced, adjust bias potentiometer (Illus. 84) to obtain proper collector voltage with 12 volts input to radio.
- Illus. 77 is a fuse resistor for the DS 501 transistor. An open fuse resistor will cause 0 volts at transistor collector.

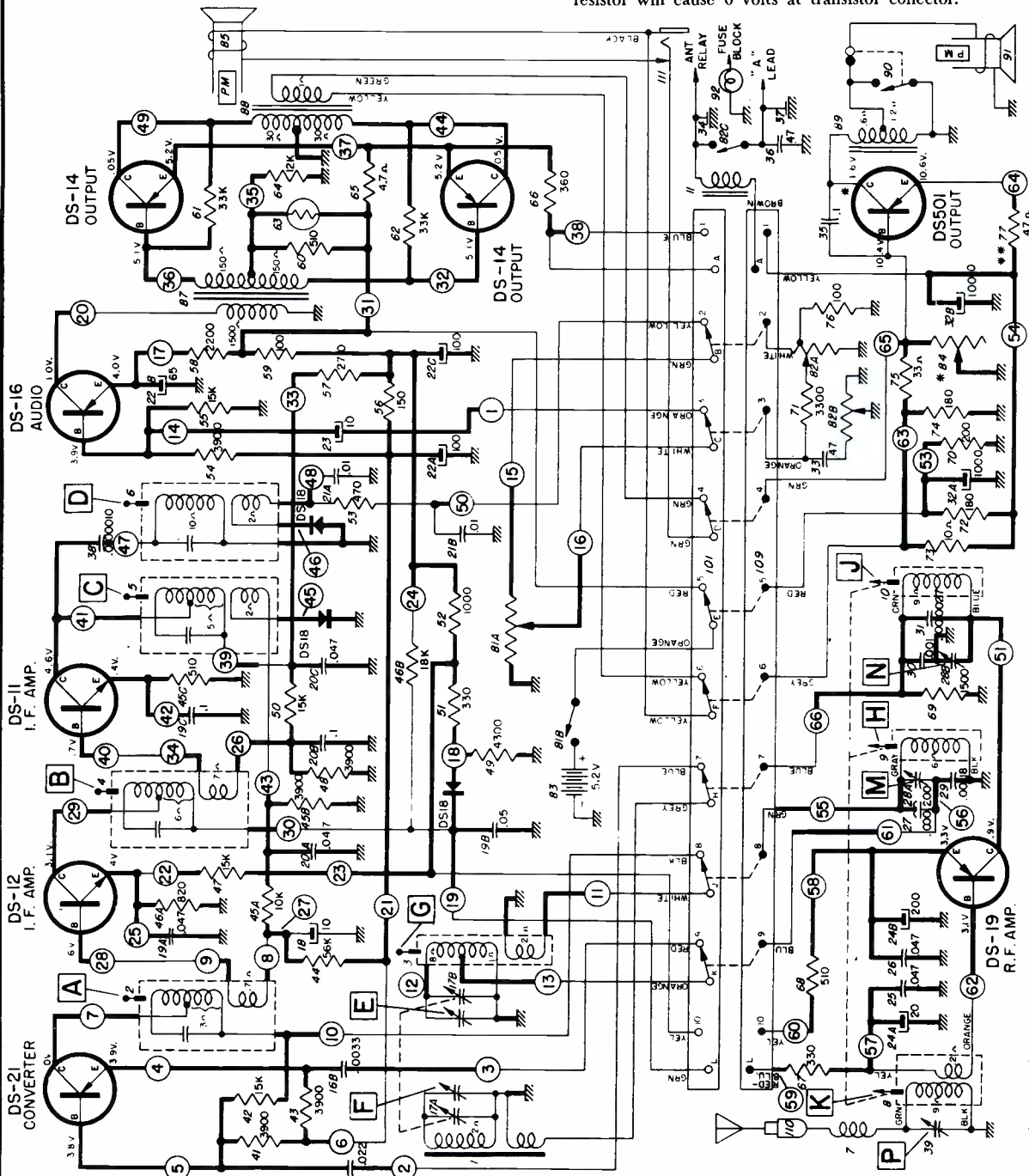

Isolate trouble to portable section or car unit by pulling portable section out of car.

- A. If it fails to operate as a portable, trouble is in portable unit.
- B. If it operates as a portable but not in the car, trouble is in car unit or car antenna.
- C. If it operates in car but not as a portable, check batteries, portable antenna and interconnecting socket

VOLUME R-19, MOST-OFTEN-NEEDED 1959 RADIO SERVICING INFORMATION

DELCO
BUICK 981970
OLDSMOBILE 989172
PONTIAC 988978

(Continued)

NOTE: WHITE NUMBERS ON PRINTED CIRCUIT DRAWINGS CORRESPOND TO ENCIRCLED NUMBERS ON SCHEMATIC DIAGRAM.

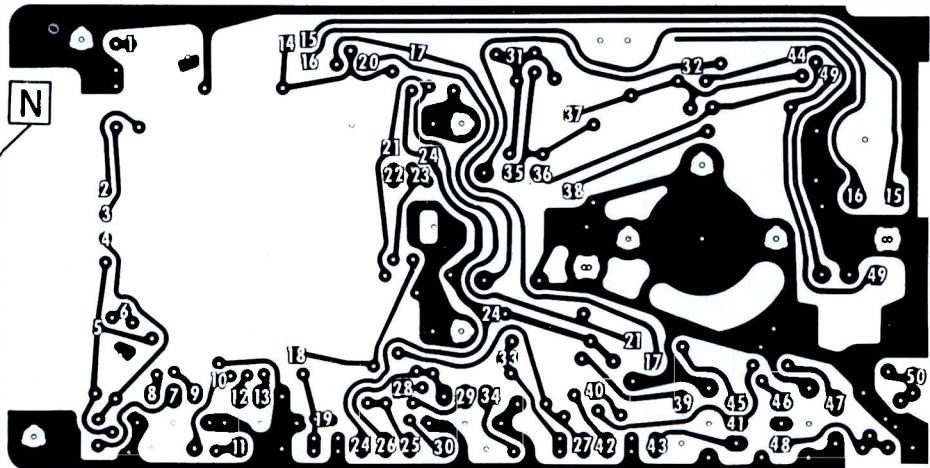
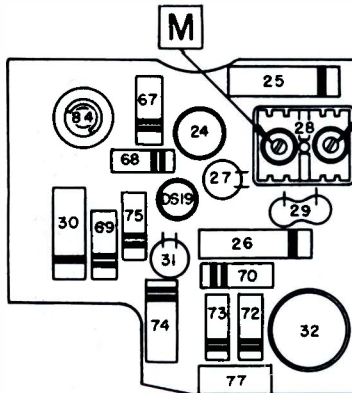
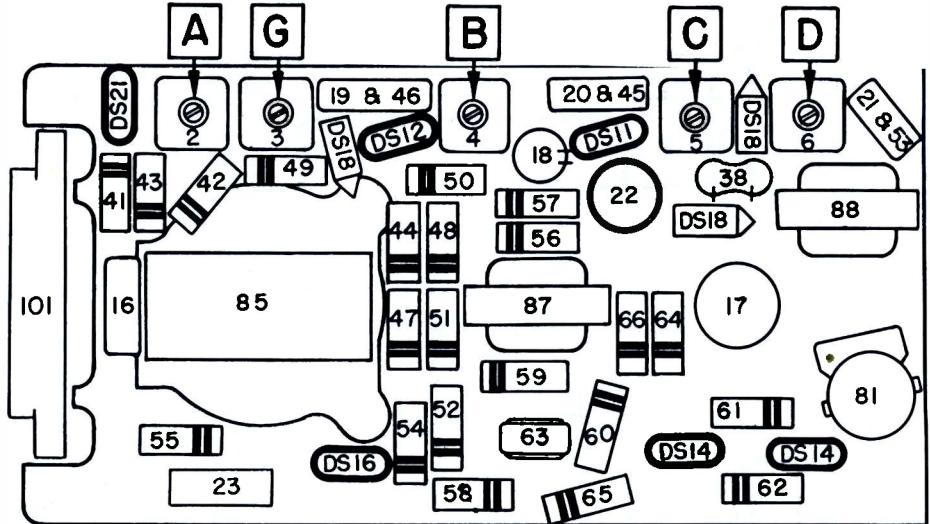
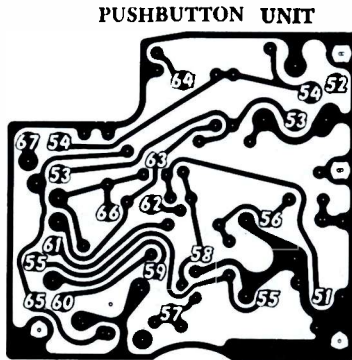

ALIGNMENT

Set radio volume control to maximum. Read output at speaker; keep below .5 volt.

Step	Method Of Connecting Generator	Connect Generator To	Signal Frequency	Tune Receiver To	Adjust In Sequence For Max. Output
1	Thru .1 mfd. Cap.	Converter Base (Island 5)	465 KC	High freq. stop	A, B, C, D E Trimmer on variable (near-est batteries)
2	Pick up loop	By induction to antenna	1680 KC	High freq. stop	F Trimmer on variable (near-est vol. control)
3	Do not use	Align on noise (Lights, razor, etc.)	Noise	Near 600 KC	G
4	Pick up loop	By induction to antenna	1400 KC	Signal Gen. freq.	F
If it is necessary to align pushbutton tuner, connect portable to it and follow the steps below.					
5	.000068 mfd., Cap.	Antenna connector	1615 KC	High freq. stop	*M, N, P
6	.000068 mfd., Cap.	Antenna connector	600 KC	Signal Gen. freq.	J, K
7	.000068 mfd., Cap.	Antenna connector	1615 KC	Signal Gen. freq.	N, P
8	.000068 mfd., Cap.	Antenna connector	1000 KC	Signal Gen. freq.	L**

*Before making this adjustment, check mechanical setting of oscillator core "H," with radio tuned to high frequency limit. The rear of the core should be 1/16" from the mounting end of the coil form. (This measurement is readily made by inserting a ruled plug in the rear of the coil form.)

**L is the pointer adjustment screw which is on the connecting link, between the pointer assembly and the parallel guide bar. It should be adjusted so that the dial pointer corresponds with the 1100 KC mark on the dial.

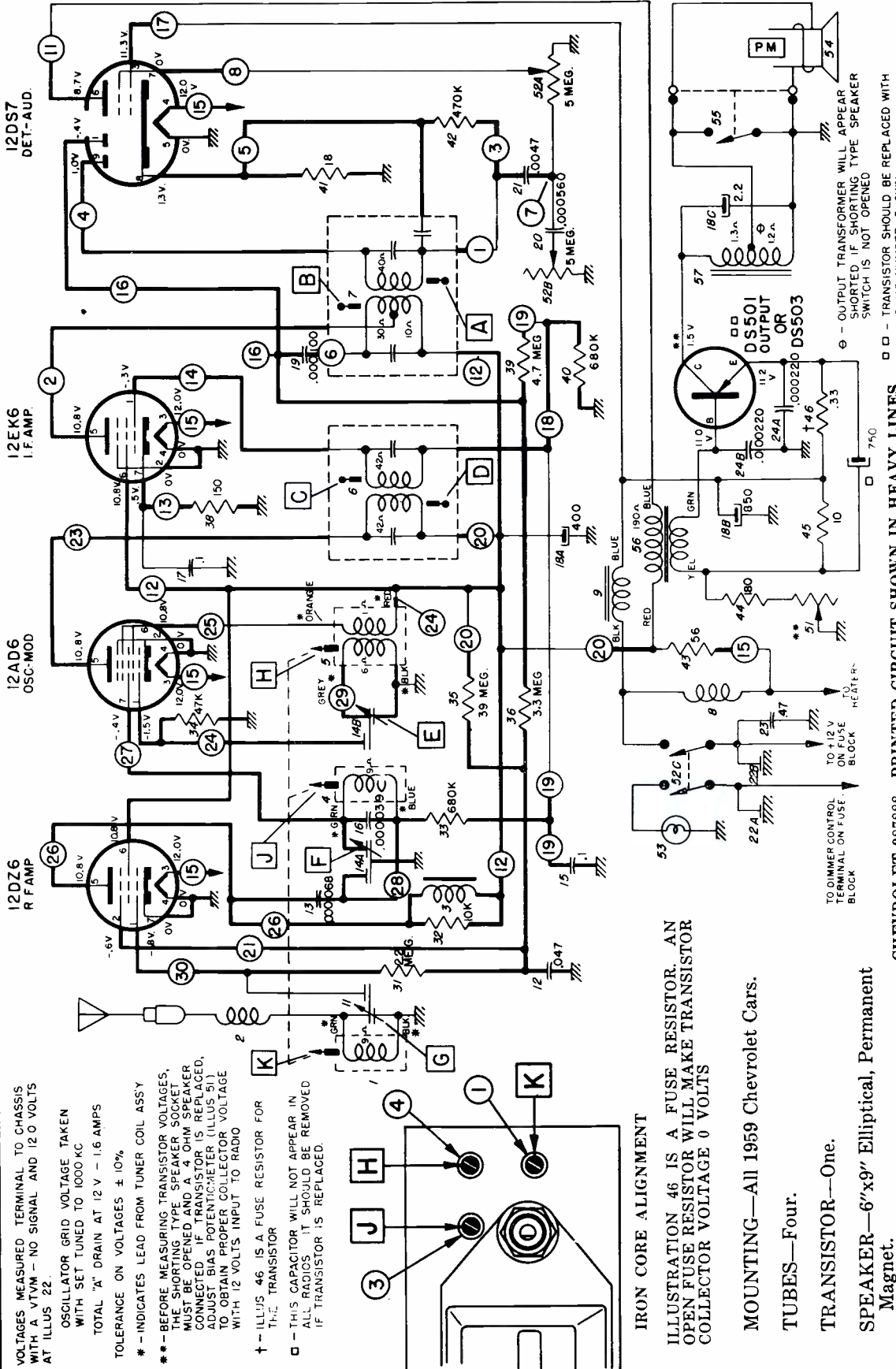

VOLTAGES MEASURED TERMINAL TO CHASSIS WITH A VTVM - NO SIGNAL AND 12.0 VOLTS AT ILLUS 22.

OSCILLATOR GRID VOLTAGE TAKEN WITH SET TUNED TO 1000 KC
TOTAL "A" DRAIN AT 12 V - 1.6 AMPS
TOLERANCE ON VOLTAGES ± 10%

* - INDICATES LEAD FROM TUNER COIL ASSY
** - BEFORE MEASURING TRANSISTOR VOLTAGES, THE SHORTING TYPE SPEAKER SOCKET MUST BE OPENED FROM REPLACER CONNECTOR TRANSISTOR 5 (ILLUS 51) ADJUST AS POTENTIOMETER 5 (ILLUS 51) TO OBTAIN PROPER COLLECTOR VOLTAGE WITH 12 VOLTS INPUT TO RADIO

† - ILLUS 46 IS A FUSE RESISTOR FOR THE TRANSISTOR
□ - THIS CAPACITOR WILL NOT APPEAR IN ALL RADIOS. IT SHOULD BE REMOVED IF TRANSISTOR IS REPLACED.

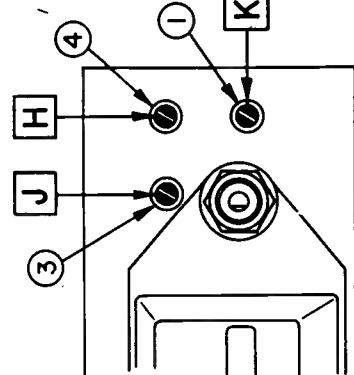

IRON CORE ALIGNMENT

ILLUSTRATION 46 IS A FUSE RESISTOR. AN OPEN FUSE RESISTOR WILL MAKE TRANSISTOR COLLECTOR VOLTAGE 0 VOLTS

MOUNTING—All 1959 Chevrolet Cars.

TUBES—Four.

TRANSISTOR—One.

SPEAKER—6"x9" Elliptical, Permanent Magnet.

ANTENNA TRIMMER COMPENSATION—for Antennas Between 0.000050 - .000100 Mfd.

TUNING RANGE—540-1600 KC.

CHEVROLET 987888—PRINTED CIRCUIT SHOWN IN HEAVY LINES.

DELCO

CHEVROLET MODEL 987888

(See next page for additional material)

⊖ - OUTPUT TRANSFORMER WILL APPEAR SHORTED IF SHORTING TYPE SPEAKER SWITCH IS NOT OPENED
□ - TRANSISTOR SHOULD BE REPLACED WITH SAME NUMBER SHOWN

DELCO CHEVROLET MODEL 987888
(Continued from preceding page at left)

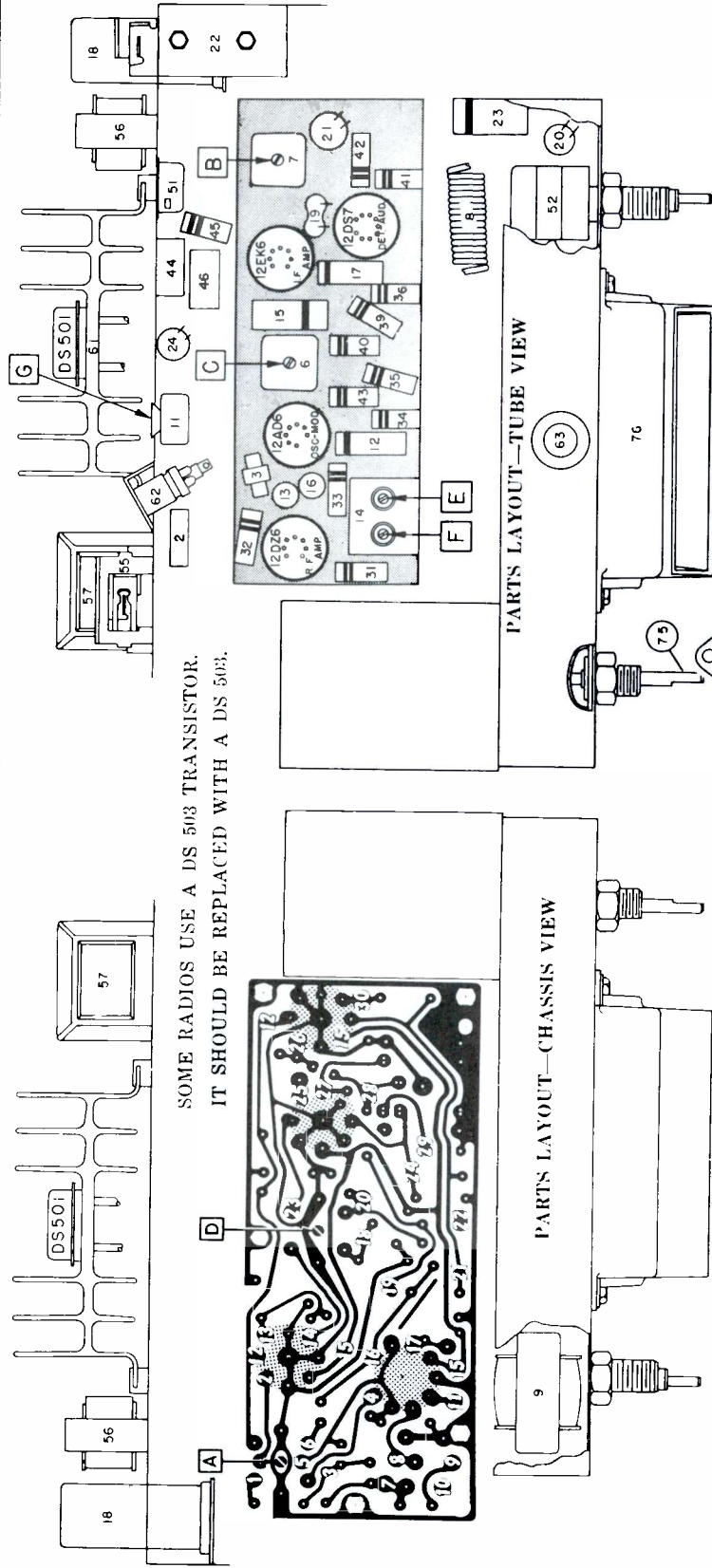

SOME RADIOS USE A DS 503 TRANSISTOR.
IT SHOULD BE REPLACED WITH A DS 501.

NUMBERS ON PRINTED CIRCUIT BOARD CORRESPOND WITH NUMBERS IN CIRCLES ON SCHEMATIC DIAGRAM.
CONNECT A. C. VOLTMETER ACROSS SPEAKER VOICE COIL DURING ALIGNMENT.

- Output Meter ConnectionsAcross Voice Coil
- Generator ReturnTo Receiver Chassis
- Dummy AntennaIn Series With Generator
- Volume Control PositionMaximum Volume
- Tone Control PositionTreble Position
- Generator OutputMinimum for Readable Indication



CHEVROLET MODEL 987888

(Continued)

ALIGNMENT PROCEDURE

STEPS	SERIES CAPACITOR OR DUMMY ANTENNA	CONNECT SIGNAL GENERATOR TO	SIGNAL GENERATOR FREQUENCY	TUNE RECEIVER TO	ADJUST IN SEQUENCE FOR MAX. OUTPUT
1	0.1 Mfd.	12AD6 Grid (Pin #7)	262 KC	High Frequency Stop	A, B, C, D,
2	0.000082 Mfd.	Antenna Connector	1615 KC	High Frequency Stop	*E, F, G,
3	0.000082 Mfd.	Antenna Connector	600 KC	Signal Generator Signal	J, K
4	0.000082 Mfd.	Antenna Connector	1615 KC	High Frequency Stop	F, G

*Before making this adjustment check mechanical setting of oscillator core "H." The rear of the core should be 1% from the mounting end of the coil form. (This measurement is readily made by inserting a suitable plug in the mounting end of the coil form.) Core adjustment should be made with a non-metallic screw driver.
With the radio installed and the car antenna plugged in adjust the antenna trimmer "G" for maximum volume with the radio tuned to a weak station between 600 and 1000 KC (see sticker on case.)

DELCO

CHEVROLET MODEL 987891

(For additional material see the next page adjacent at right)

GENERAL

MOUNTING—All 1959 Chevrolet Cars.

TUNING—Manual and 5 P. B. Mechanical.

ANTENNA TRIMMER COMPENSATION—for Antennas Between 0.000050 - .000100 Mfd.

TUNING RANGE—540-1600 KC.

PUSH BUTTON SETUP PROCEDURE

Pull Push Button out. Tune in desired station manually. Push button all the way in.

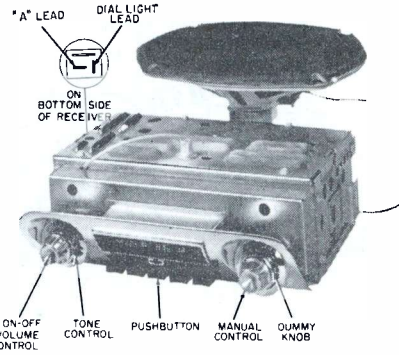

VOLTAGES MEASURED TERMINAL TO CHASSIS WITH A VTVM - NO SIGNAL AND 12.0 VOLTS AT ILLUS. 29

OSCILLATOR GRID VOLTAGE TAKEN WITH SET TUNED TO 1000 KC.

TOTAL "A" DRAIN AT 12 V - 2.2 AMPS TOLERANCE ON VOLTAGES $\pm 10\%$

* - INDICATES LEAD FROM TUNER COIL ASS'Y.

** - BEFORE MEASURING TRANSISTOR VOLTAGES, THE SHORTING TYPE SPEAKER SOCKET MUST BE OPENED AND A 4 OHM SPEAKER CONNECTED. IF TRANSISTOR IS REPLACED, ADJUST BIAS POTENTIOMETER (ILLUS. 73) TO OBTAIN PROPER COLLECTOR VOLTAGE WITH 12 VOLTS INPUT TO RADIO

† - ILLUS 60 IS A FUSE RESISTOR FOR THE TRANSISTOR

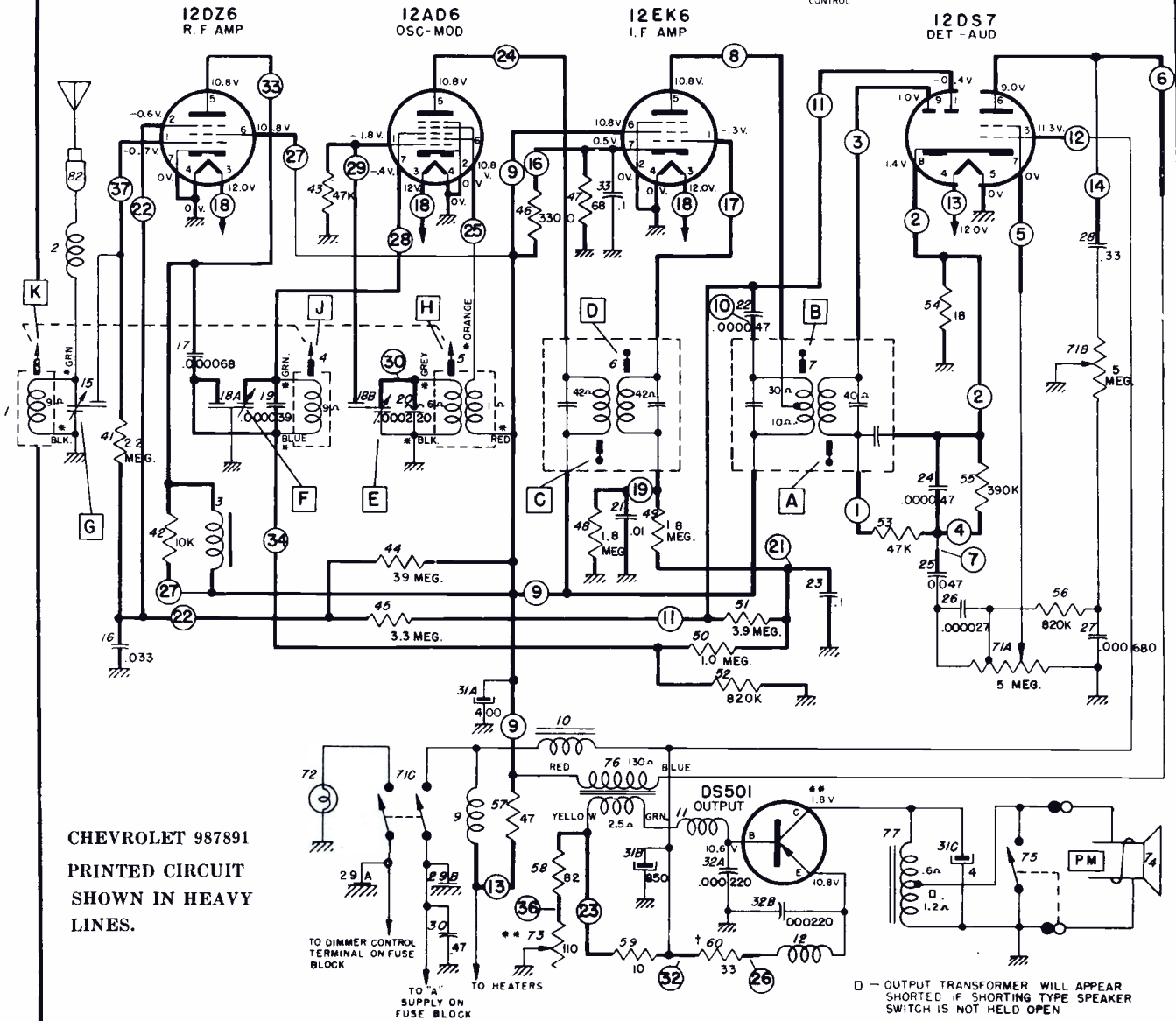

DELCO

CHEVROLET MODEL 987891
(Continued from preceding page)

PARTS LAYOUT—TUBE VIEW

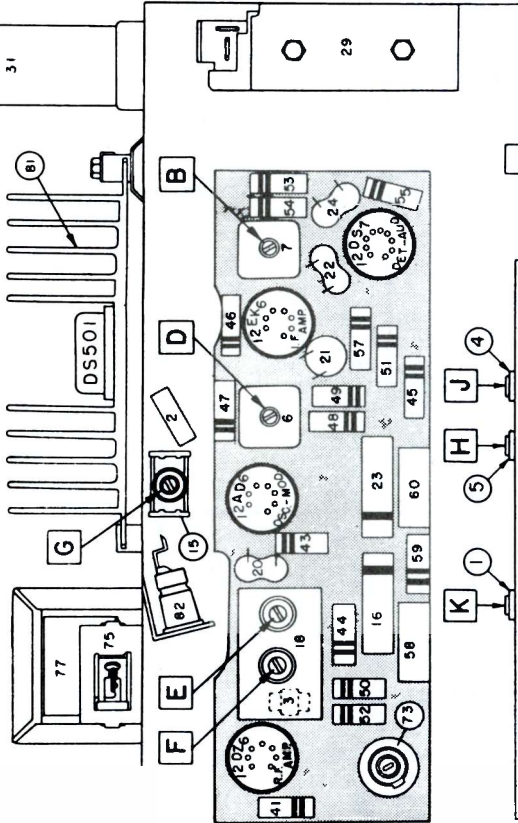

PARTS LAYOUT—CHASSIS VIEW

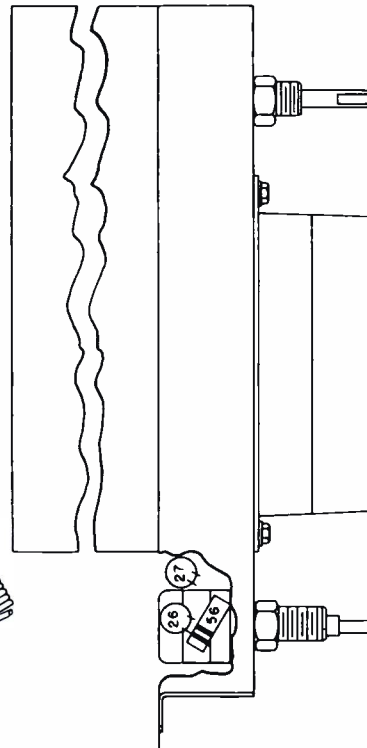
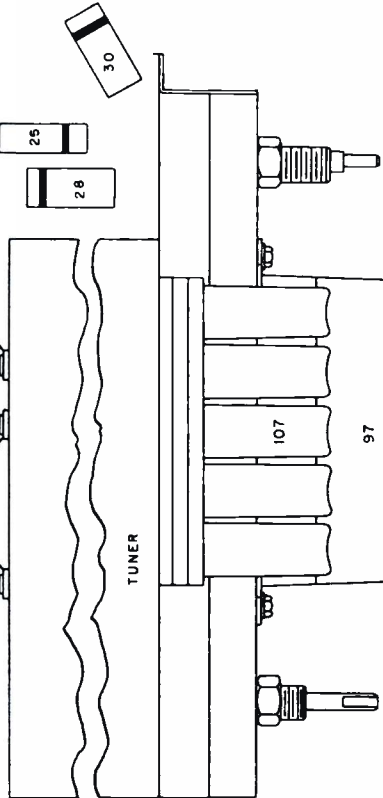
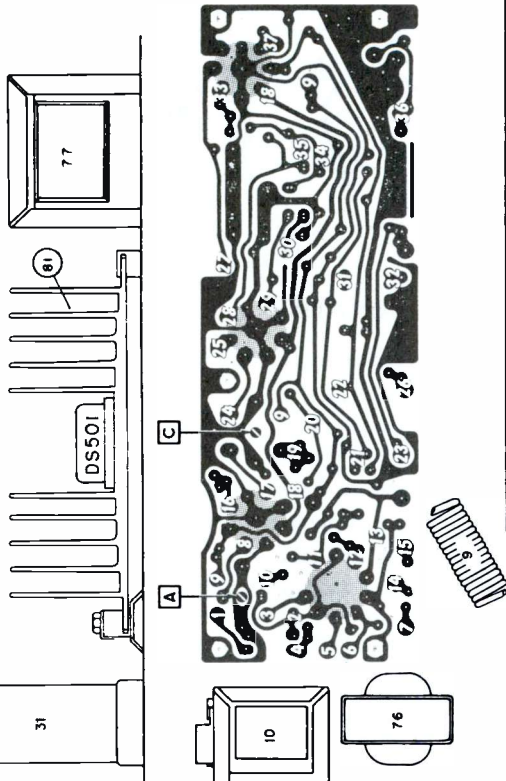

BASIC TROUBLESHOOTING PROCEDURE

1. Put ear next to speaker and turn radio on; if slight "thump" is heard as this is done, trouble is not in transistor stage—try new tubes.
2. If no "thump" at all is heard, measure voltage from transistor case to radio chassis. If 1-2 volts is present, transistor is operating normally and trouble is either in speaker or one of the tube circuits.
3. If no voltage is present in step 2, check transistor circuits and particularly the transistor fuse resistor, Illustration No. 60. This resistor is mounted between points 32 and 26 on circuit board

1. Put ear next to speaker and turn radio on; if slight "thump" is heard as this is done, trouble is not in transistor stage—try new tubes.

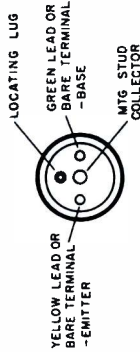

NOTE: ILLUS. 60 IS FUSE RESISTOR. OPEN FUSE RESISTOR MAKES TRANSISTOR COLLECTOR VOLTAGE 0 VOLTS.
CONNECT A. C. VOLTMETER ACROSS SPEAKER VOICE COIL DURING ALIGNMENT.
NUMBERS ON PRINTED CIRCUIT BOARD CORRESPOND WITH NUMBERS IN CIRCLES ON SCHEMATIC DIAGRAM.
ILLUS. 17, 19, AND 42 ARE LOCATED UNDER SHIELD OF DUAL TRIMMER ILLUS. 18.

Follow alignment procedure shown for Buick Model 981968, but use the above drawings for location of trimmers.

DS 501—Transistor Terminals

DELCO

PONTIAC MODEL 988976
(Additional material on next page at right)

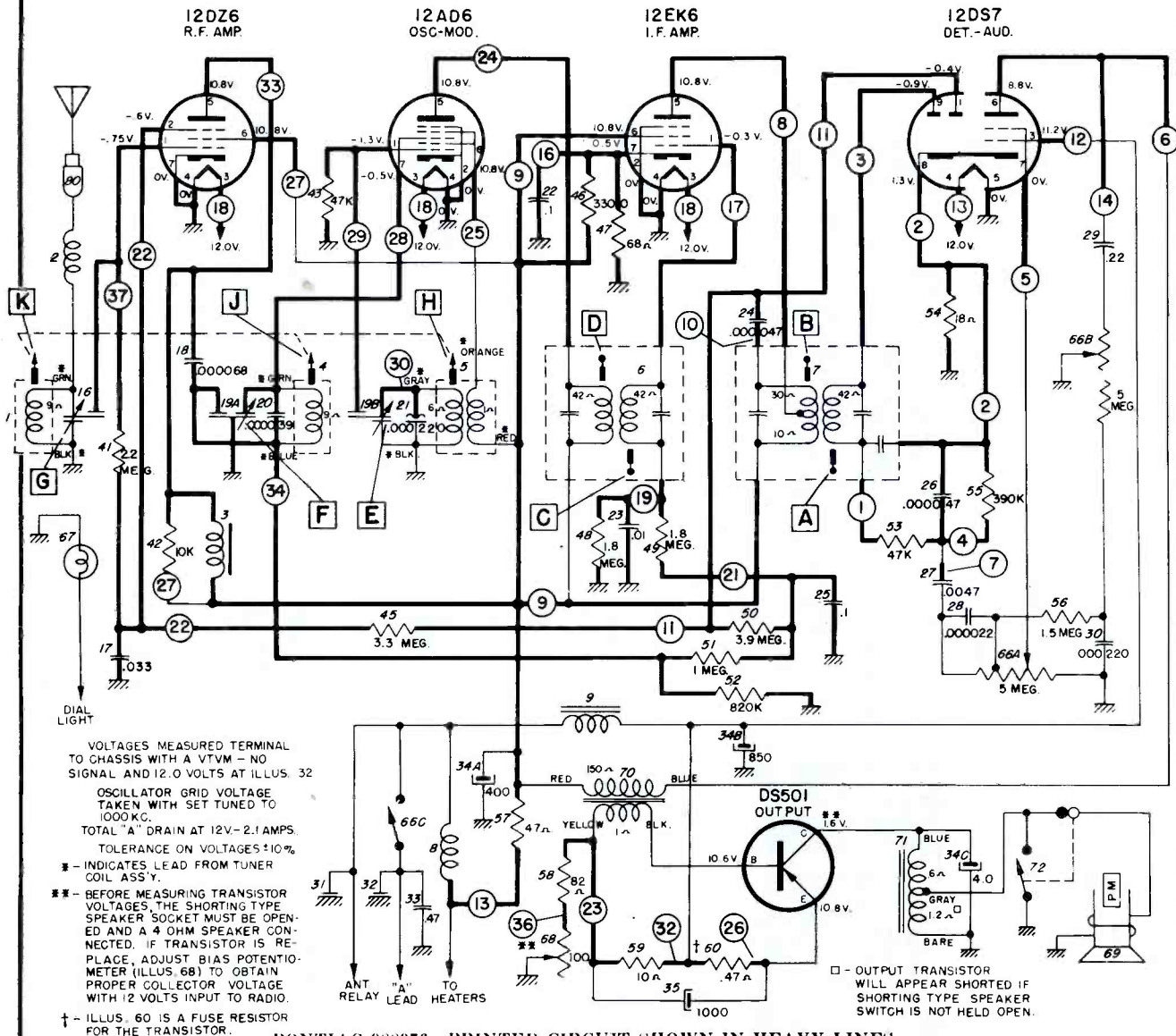

VOLTAGES MEASURED TERMINAL TO CHASSIS WITH A VTVM - NO SIGNAL AND 12.0 VOLTS AT ILLUS. 32
OSCILLATOR GRID VOLTAGE TAKEN WITH SET TUNED TO 1000 KC.
TOTAL "A" DRAIN AT 12V - 2.1 AMPS.
TOLERANCE ON VOLTAGES ±10%
* - INDICATES LEAD FROM TUNER COIL ASSY.
** - BEFORE MEASURING TRANSISTOR VOLTAGES, THE SHORTING TYPE SPEAKER SOCKET MUST BE OPENED AND A 4 OHM SPEAKER CONNECTED. IF TRANSISTOR IS REPLACED, ADJUST BIAS POTENTIOMETER (ILLUS. 68) TO OBTAIN PROPER COLLECTOR VOLTAGE WITH 12 VOLTS INPUT TO RADIO.
† - ILLUS. 60 IS A FUSE RESISTOR FOR THE TRANSISTOR.

PONTIAC 988976—PRINTED CIRCUIT SHOWN IN HEAVY LINES.

ALIGNMENT PROCEDURE:

STEPS	SERIES CAPACITOR TO DUMMY ANTENNA	CONNECT SIGNAL GENERATOR TO	SIGNAL GENERATOR FREQUENCY	TUNE RECEIVER TO	ADJUST IN SEQUENCE FOR MAX. OUTPUT
1	0.1 Mfd.	12AD6 Grid (Pin #7)	262 KC	High Frequency Stop	A, B, C, D
2	0.000068 Mfd.	Antenna Connector	1615 KC	High Frequency Stop	*E, F, G
3	0.000068 Mfd.	Antenna Connector	600 KC	Signal Generator Signal	J, K
4	0.000068 Mfd.	Antenna Connector	1615 KC	High Frequency Stop	F, G
5	0.000068 Mfd.	Antenna Connector	1100 KC	Signal Generator Signal	L**

*Before making this adjustment check mechanical setting of oscillator setting of core "H." The rear of the core should be 1% from the mounting end of the coil form. (This measurement is readily made by inserting a suitable plug in the mounting end of the coil form.) Core adjustment should be made with a non-metallic screwdriver.

**L is the pointer adjustment which is on the connecting link, between the pointer assembly and core guide bar (See tuner Dwg.). It should be adjusted so that when looking directly at the dial the pointer is on the 1100 KC mark. This setting is to give the correct relationship between the pointer and the dial when the radio is installed in a car.

DELCO

PONTIAC MODEL 988976

(Continued from preceding page at left)

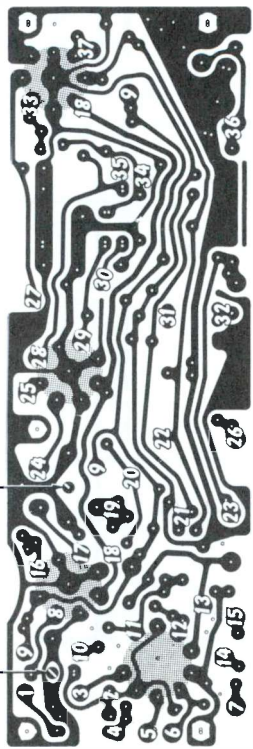
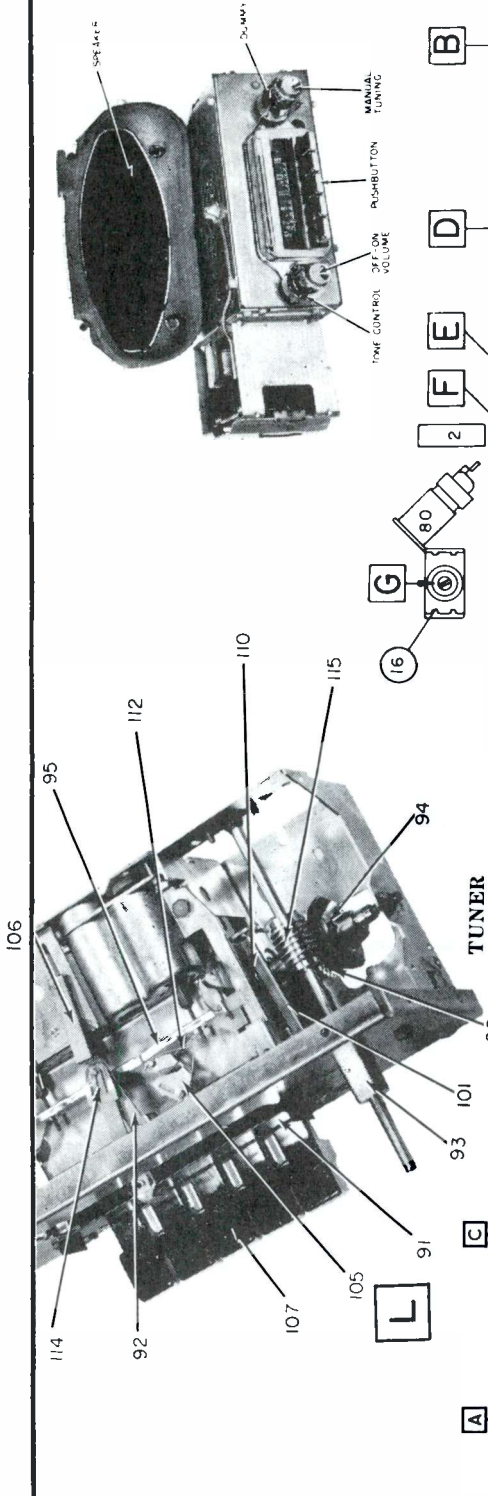

PARTS LAYOUT—CHASSIS VIEW

CONNECT VACUUM TUBE VOLTMMETER ACROSS SPEAKER VOICE COIL DURING ALIGNMENT NUMBERS ON PRINTED CIRCUIT BOARD CORRESPOND WITH NUMBERS IN CIRCLES ON SCHEMATIC DIAGRAM.

IMPORTANT

THE SPEAKER SOCKET, MOUNTED ON OUTPUT TRANSFORMER, IS A SHORTING-TYPE AND MUST BE MECHANICALLY OPENED WHEN TESTING RADIO ON BENCH.

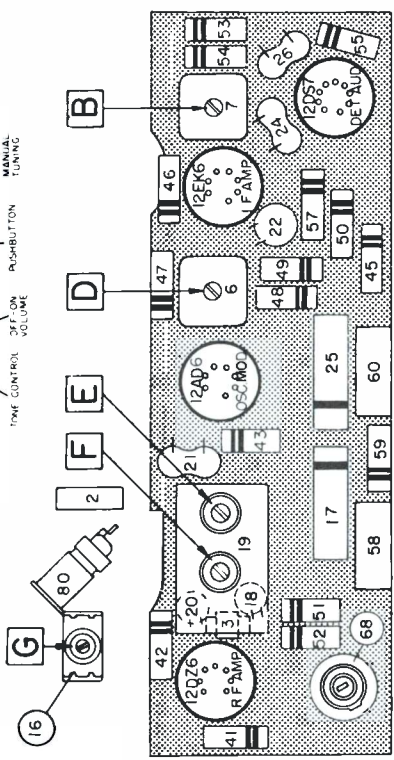
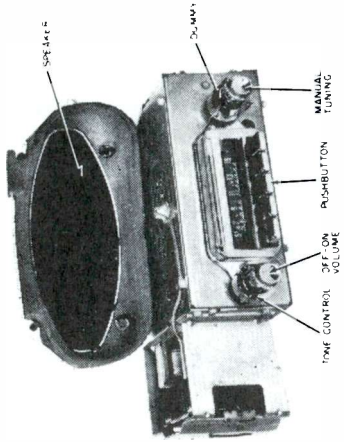

PARTS LAYOUT—TUBE VIEW

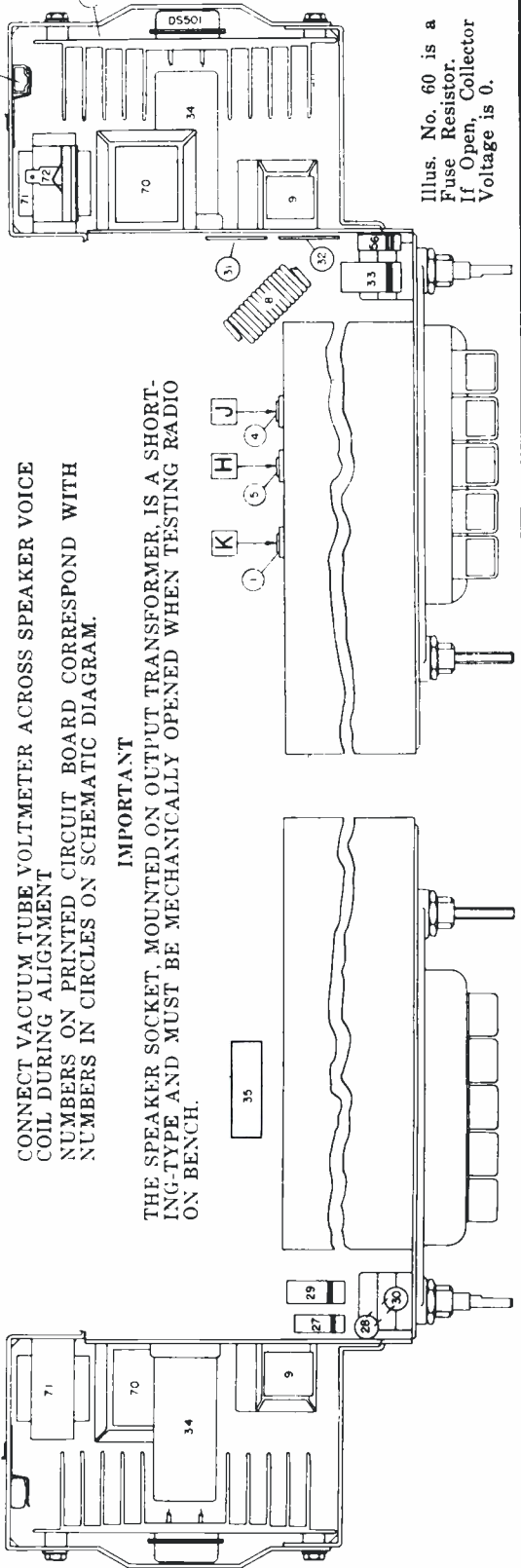

Illus. No. 60 is a Fuse Resistor. If Open, Collector Voltage is 0.

DELCO

OLDSMOBILE MODEL 989170

(For alignment and additional service information see next page adjacent at right)

GENERAL

MOUNTING—All 1959 Oldsmobile Cars.
SPEAKER—6"x9" Elliptical, Permanent Magnet.

TUNING—Manual and 5 P. B. Mechanical.

ANTENNA TRIMMER COMPENSATION—for Antennas Between 0.000050 - 0.000090 Mfd.

TUNING RANGE—540-1600 KC.

PUSHBUTTON SETUP PROCEDURE

Pull Pushbutton to the left and out. Tune in desired station manually. Push button all the way in.

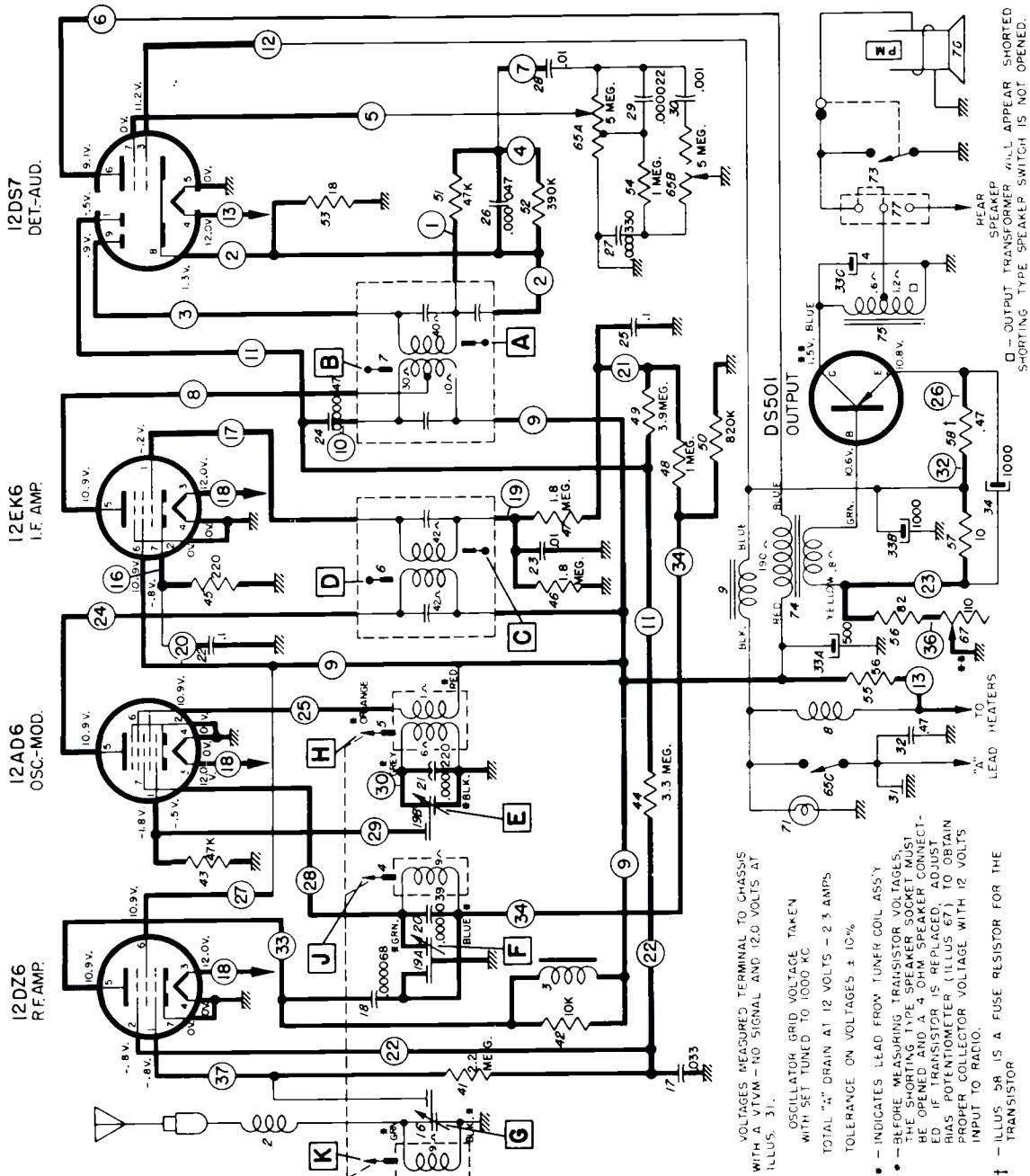

OLDSMOBILE 989170—PRINTED CIRCUIT SHOWN IN HEAVY LINES

ILLUS 77 IS SOCKET FOR REAR SPEAKER CONTROL AND INCORPORATES A SHORTING SWITCH. WHEN JUMPER OR CONTROL ARE REMOVED THE OUTPUT TRANSFORMER IS SHORTED.

- VOLTAGES MEASURED TERMINAL TO CHASSIS WITH A VTVM—NO SIGNAL AND 12.0 VOLTS AT ILLUS. 31.
- OSCILLATOR GRID VOLTAGE TAKEN TOTAL "A" DRAIN AT 12 VOLTS - 2.3 AMPS TOLERANCE ON VOLTAGES ± 10%
- INDICATES LEAD FROM TUNER COIL ASSY
- BEFORE MEASURING TRANSISTOR VOLTAGES, THE SHORTING TYPE SPEAKER SOCKET MUST BE OPENED. TRANSISTOR IS OPENED TO OBTAIN PROPER POTENTIALS (ILLUS 47). TO OBTAIN PROPER COLLECTOR VOLTAGE WITH 12 VOLTS INPUT TO RADIO.
- † ILLUS 58 IS A FUSE RESISTOR FOR THE TRANSISTOR

DELCO

OLDSMOBILE MODEL 989170
(Continued from preceding page)

ALIGNMENT PROCEDURE:

- Output Meter Connections.....Across Voice Coil
- Generator Return.....To Receiver Chassis
- Dummy Antenna.....In Series With Generator
- Volume Control Position.....Maximum Volume
- Tone Control Position.....Treble Position
- Generator Output.....Minimum for Readable Indication

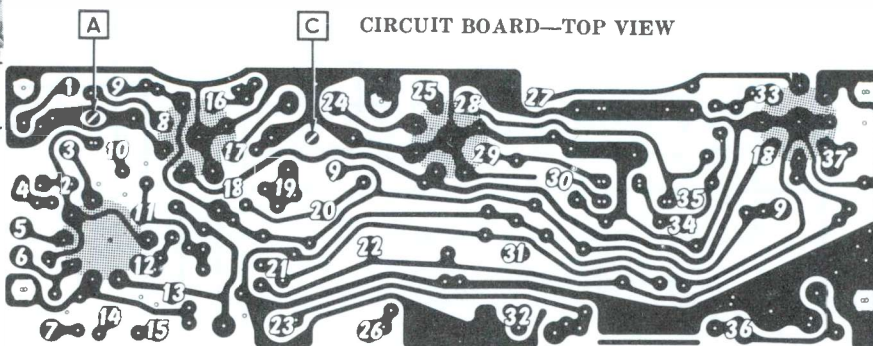
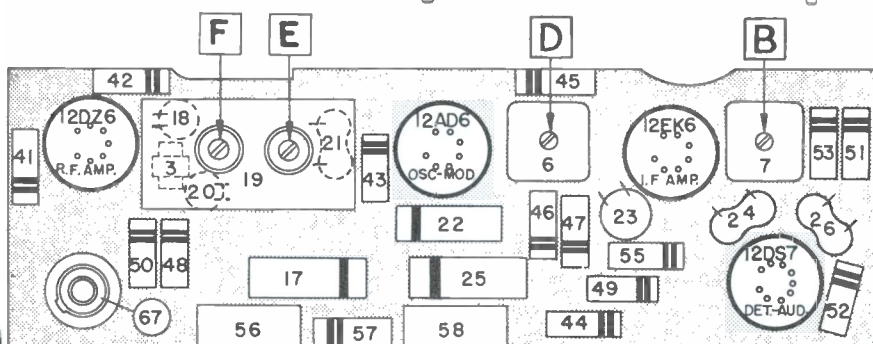
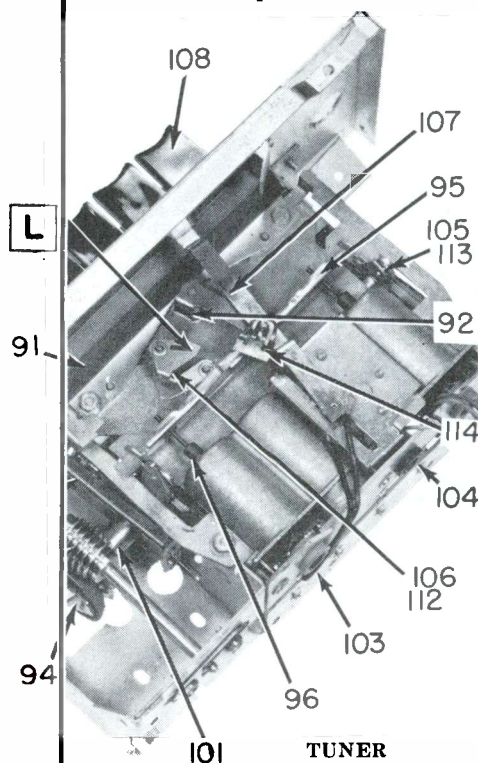
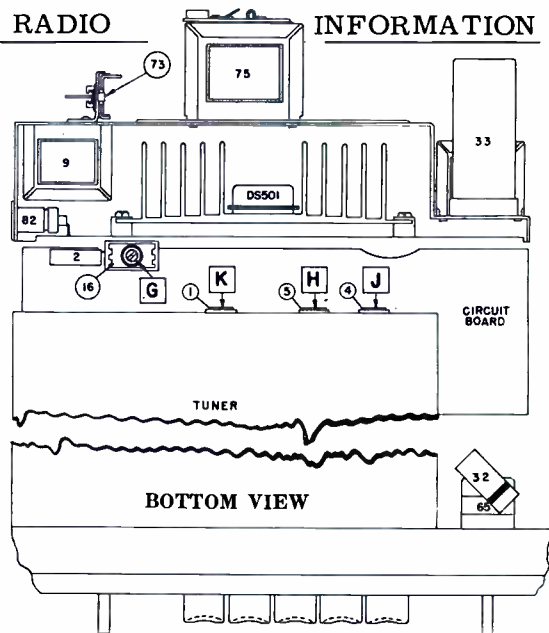

WHITE NUMBERS ON PRINTED CIRCUIT BOARD DRAWING CORRESPOND TO NUMBERS ENCIRCLED ON SCHEMATIC.

STEPS	SERIES CAPACITOR OR DUMMY ANTENNA	CONNECT SIGNAL GENERATOR TO	SIGNAL GENERATOR FREQUENCY	TUNE RECEIVER TO	ADJUST IN SEQUENCE FOR MAX. OUTPUT
1	0.1 Mfd.	12AD6 Grid (Pin #7)	262 KC	High Frequency Stop	A, B, C, D
2	0.000068 Mfd.	Antenna Connector	1615 KC	High Frequency Stop	*E, F, G
3	0.000068 Mfd.	Antenna Connector	600 KC	Signal Generator Signal	J, K
4	0.000068 Mfd.	Antenna Connector	1615 KC	High Frequency Stop	F, G
5	0.000068 Mfd.	Antenna Connector	1100 KC	Signal Generator Signal	L**

*Before making this adjustment check mechanical setting of oscillator core "H." The rear of the core should be 1/16" from the mounting end of the coil form. (This measurement is readily made by inserting a suitable plug in the mounting end of the coil form.) Core adjustment should be made with a non-metallic screwdriver.

**L is the pointer adjustment which is on the connecting link, between the pointer assembly and core guide bar (See tuner Dwg.). It should be adjusted so that when looking directly at the dial the pointer is on the 1100 KC mark. This setting is to give the correct relationship between the pointer and the dial when the radio is installed in a car.

DELCO

OLDSMOBILE 989171

Material below and the page adjacent at right is exact for Oldsmobile 989171. The following sets are practically the same electrically.

BUICK 981969,
CHEVROLET 987893,
PONTIAC 988977

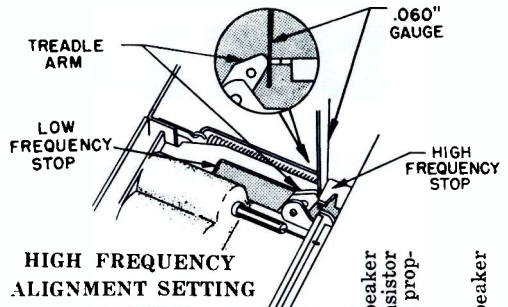

HIGH FREQUENCY ALIGNMENT SETTING

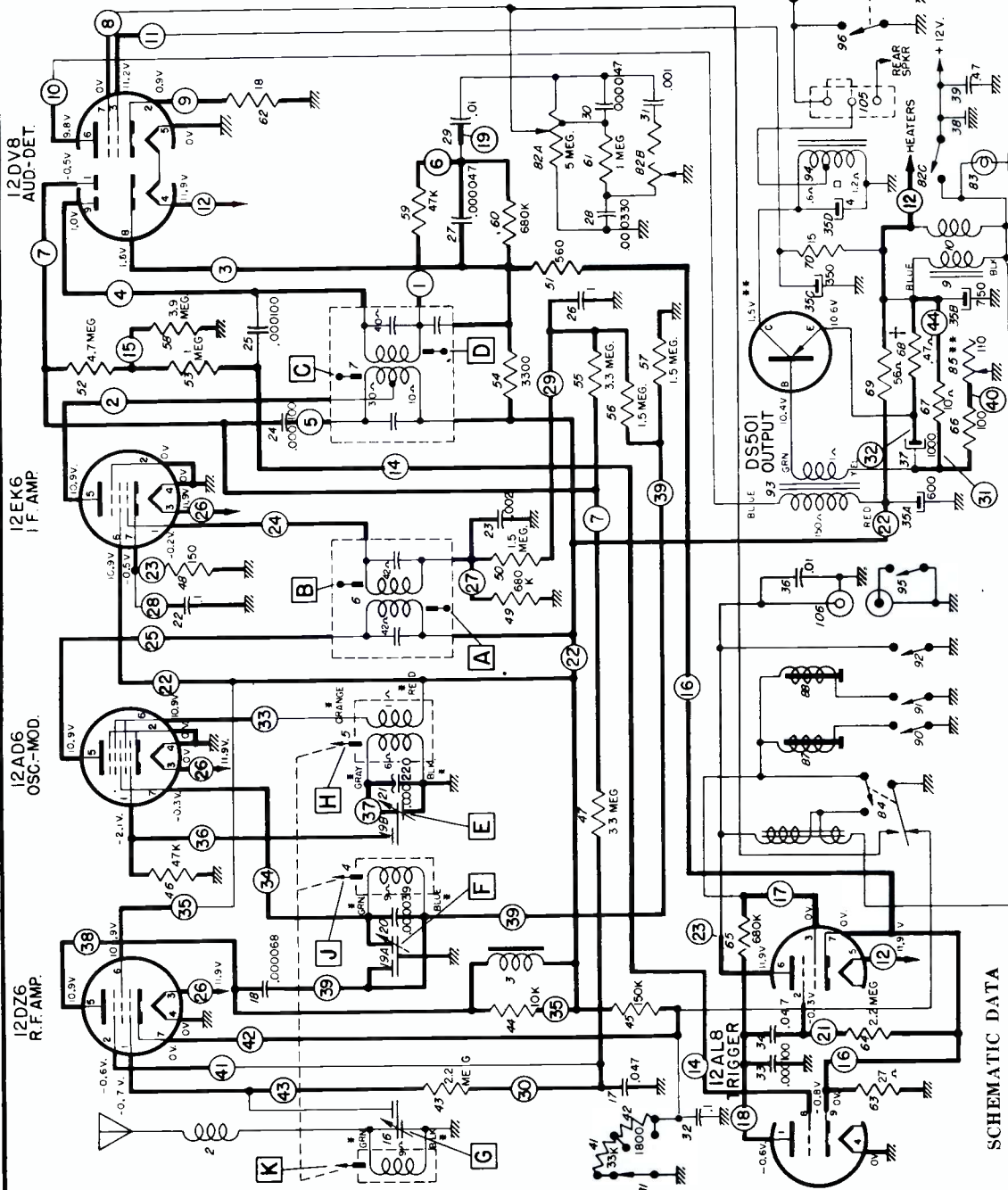

SCHEMATIC DATA

Volts measured terminal to chassis with a VTVM - No signal and 12.0 volts at Illustration 38.

Oscillator grid voltage taken with set tuned to 1000 kc.

Total "A" drain at 12 volts - 2.6 amps.

Tolerance on voltages $\pm 10\%$.

*—Indicates lead from tuner coil assembly.

**—Before measuring transistor voltages, the shorting type speaker socket must be opened and a 4 ohm speaker connected. If transistor is replaced, adjust bias potentiometer (Illustration 85) to obtain proper collector voltage with 12 volts input to radio.

+—Illustration 68 is a fuse resistor for the transistor.

□—Output transformer may appear shorted if shorting type speaker socket is not held open.

OLDSMOBILE 989171 PRINTED CIRCUIT SHOWN IN HEAVY LINES

DELCO OLDSMOBILE 989171 (Continued)

For list of similar models, see preceding page.

WHITE NUMBERS ON PRINTED CIRCUIT DRAWING CORRESPOND TO THE ENCIRCLED NUMBERS ON SCHEMATIC.

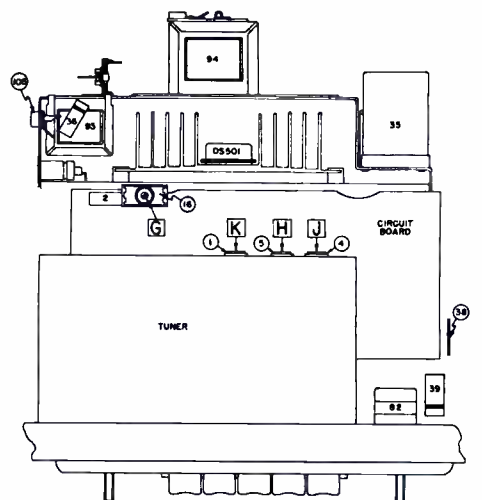
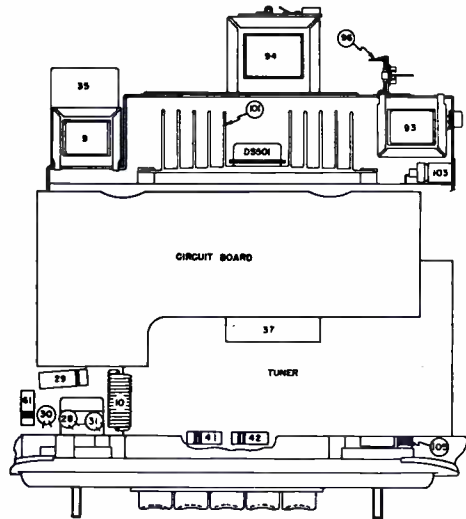
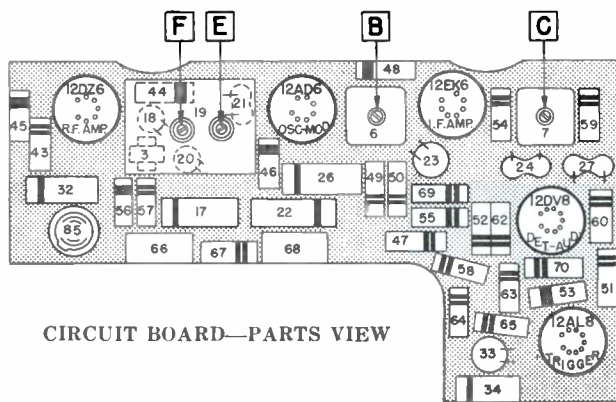
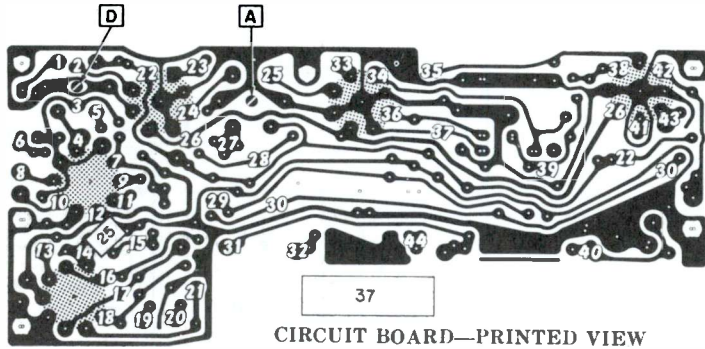

SIGNAL SEEKING TUNER ALIGNMENT PROCEDURE

NOTE: When aligning the signal seeker tuner type radio, be sure to use a vacuum tube voltmeter as indicated.

- Output Meter Connection.....VTVM from AVC line (#27 Island-Circuit Board) To Chassis Generator Return.....Receiver Chassis Dummy Antenna.....In Series With Generator Sensitivity Control.....Maximum Volume Control.....Maximum Volume Tone Control.....Treble Generator Output.....Not to exceed 2 volts at VTVM

STEP	DUMMY ANTENNA	CONNECT SIGNAL GENERATOR TO	SIGNAL GENERATOR FREQUENCY	TUNE RECEIVER TO	ADJUST IN SEQUENCE FOR OUTPUT INDICATED
1	0.1 Mfd.	12AD6 Grid (Pin 7)	262 KC	*High Frequency Stop	A, B, C (Max.), D (Min.)
2	.000068 Mfd.	Antenna Connector	1615 KC	High Frequency Stop	**E, F, G (Max.)
3	.000068 Mfd.	Antenna Connector	600 KC	Signal Generator Signal	J, K (Max.)
4	.000068 Mfd.	Antenna Connector	1615 KC	Signal Generator Signal	F, G (Max.)
5	.000068 Mfd.	Antenna Connector	1100 KC	Signal Generator Signal	***L

*To tune to high frequency, put a .070" feeler gauge in slot against the high frequency stop. (See Page 30. Depress station selector bar and allow the treadle bar arm to run against the feeler gauge. Turn the radio off and then back on. This positions the tuner near the point where the treadle switch closes.

**Before making this adjustment, check the setting of oscillator core "H." The rear of the core should be 1 5/8" from the mounting end of the coil form. This measurement is readily made by inserting a suitable plug in the mounting end of the coil form. The core adjustment is made from the mounting end of the coil form with a non-metallic screwdriver.

***"L" is the pointer adjustment slot on the pointer assembly—adjust so pointer reads 1100 KC. With the radio installed and the antenna plugged in, adjust the antenna trimmer "G" for maximum volume with the radio tuned to a weak station between 600 and 1000 KC (see sticker on case.)

VOLUME R-19, MOST-OFTEN-NEEDED 1959 RADIO SERVICING INFORMATION

EMERSON RADIO
Model 877, Chassis 120392B

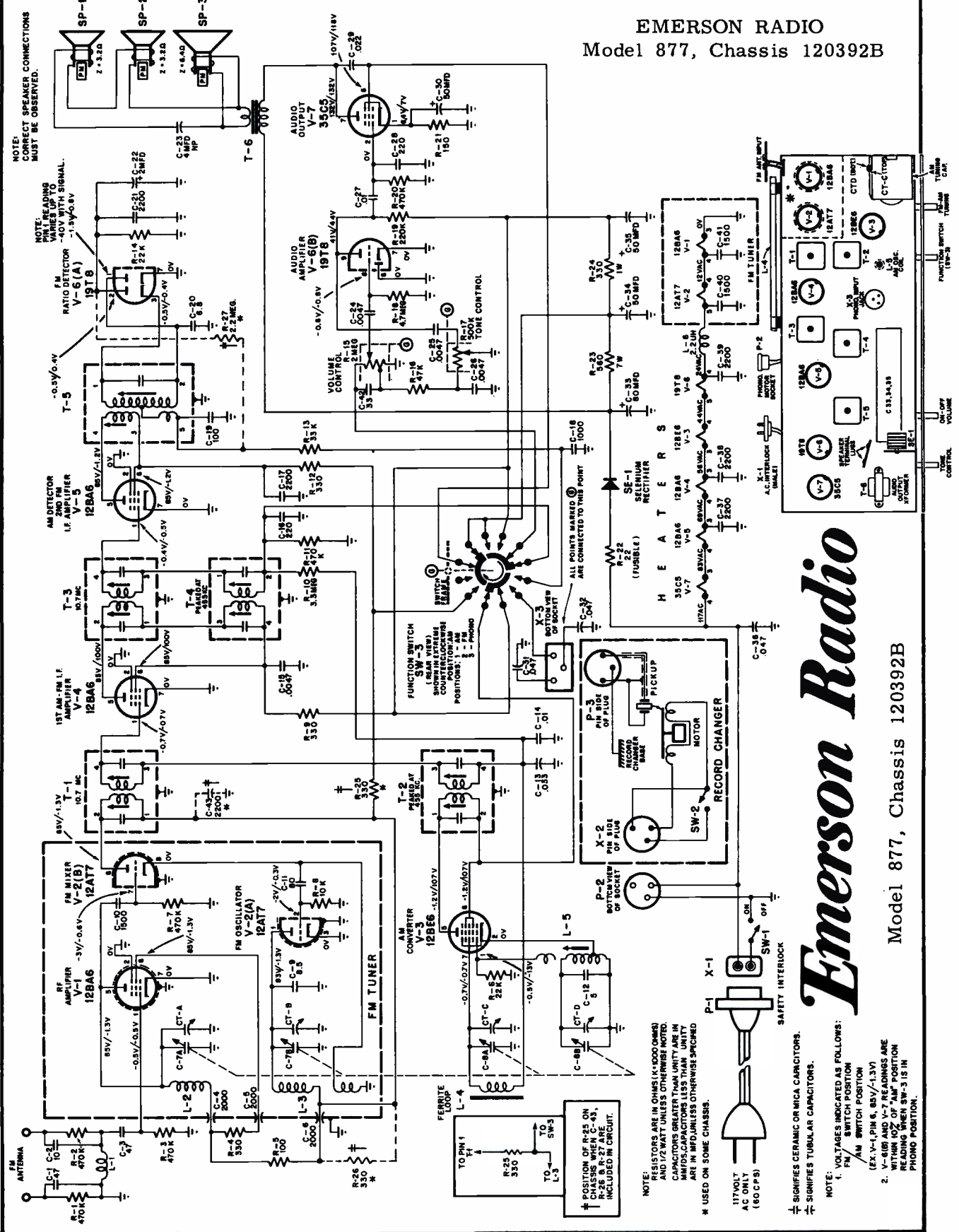

Emerson Radio

Model 877, Chassis 120392B

NOTE: RESISTORS ARE IN OHMS (K=1000 OHMS) AND 1/2 WATT UNLESS OTHERWISE NOTED. CAPACITORS GREATER THAN 100 μF ARE IN MFD. CAPACITORS LESS THAN 100 μF ARE IN PFD UNLESS OTHERWISE SPECIFIED. * USED ON SOME CHASSIS.

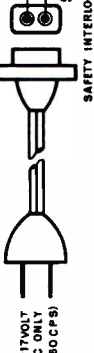

† SIGNIFIES CERAMIC OR MICA CAPACITORS.
‡ SIGNIFIES TUBULAR CAPACITORS.

- NOTE: VOLTAGES INDICATED AS FOLLOWS:
1. FM SWITCH POSITION
 2. WITH 100 μF OF PARALLEL CAPACITANCE
 3. IN PHONO POSITION
- (EX. V-4 PIN 6, 85V/1.3V)

NOTE: CORRECT SPEAKER CONNECTIONS MUST BE OBSERVED.

NOTE: VOLTAGES INDICATED AS FOLLOWS:

1. FM SWITCH POSITION
 2. WITH 100 μF OF PARALLEL CAPACITANCE
 3. IN PHONO POSITION
- (EX. V-4 PIN 6, 85V/1.3V)

HEATERS

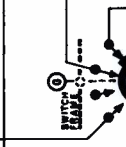
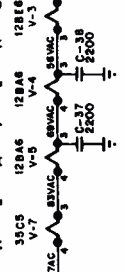

FUNCTION SWITCH (SW-1) SHOWING EXTREME POSITIONS: 1 - AM 2 - FM 3 - PHONO

ALL POINTS MARKED (C) ARE CONNECTED TO THIS POINT



POSITION OF SOCKET



RECORD CHANGER



117VOLT AC ONLY (60 C.F.S.)



SAFETY INTERLOCK

Emerson

Models 834X, 890, 892A, Chassis 120394B

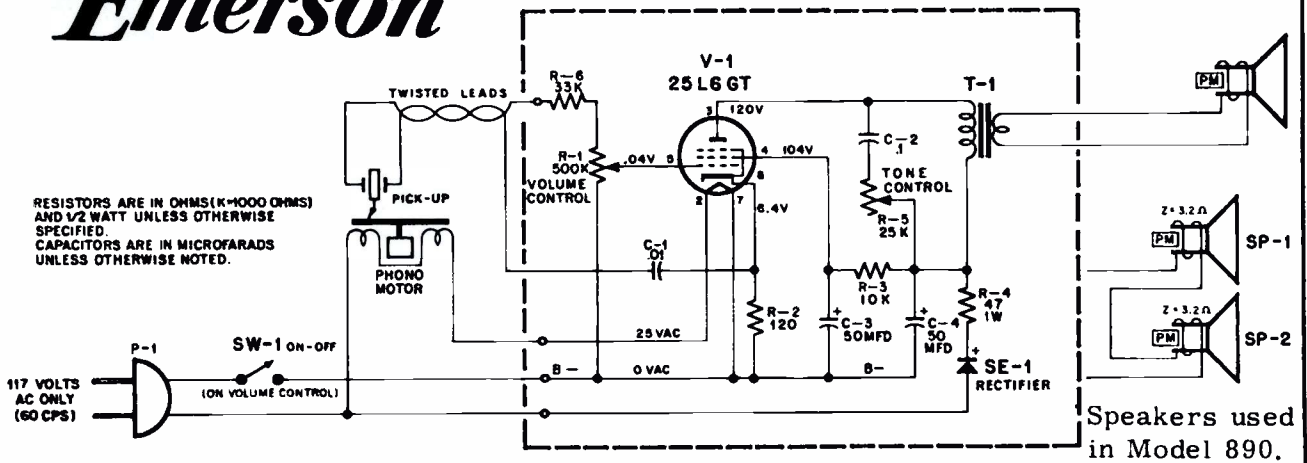

Emerson

MODELS:
893B, 894B

CHASSIS:
120430B, 432B

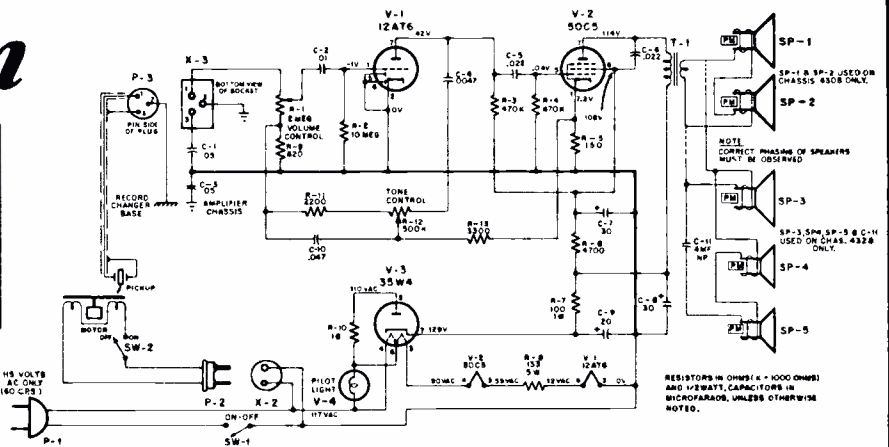

Emerson

Emerson

Model 891B, Chassis 120399B

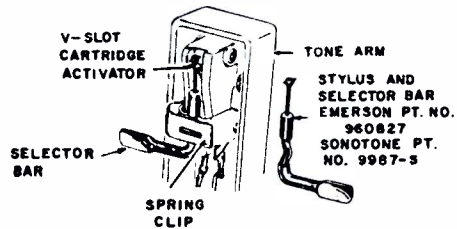
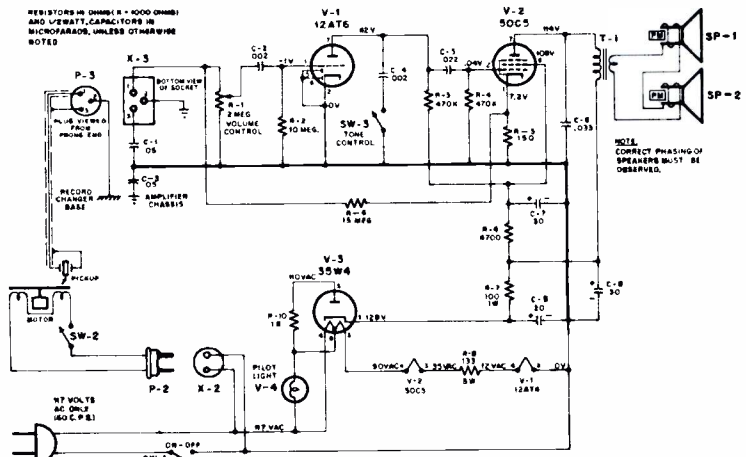

TO REPLACE STYLUS AND SELECTOR BAR

For best operation and record tracking, it is recommended that the stylus (needle) and selector bar (flip-over arm) be replaced as a single unit. To change this unit, proceed as follows:

1. Lift up tone arm.
2. With one hand, hold spring clip in a direction away from tone arm.
3. With other hand, slide out selector bar and stylus as shown in diagram.
4. To replace new stylus and selector bar, reverse above procedure.

1. Voltages indicated are positive d.c., resistances in ohms, unless otherwise indicated.
2. Measurements made with volt-ohm-myst or equivalent.
3. All measurements taken from pin to B neutral unless otherwise indicated.
4. Voltage measurements taken with:
 - a) Line voltage maintained at 117 volts a.c. only.
 - b) Volume control set for maximum volume.
 - c) Phono plugs disconnected.
5. Resistance measurements taken with:
 - a) Power line cord disconnected from outlet.
 - b) Volume control set for maximum volume.
 - c) Phono plugs disconnected.
6. Nominal tolerance on component values make possible a variation of $\pm 15\%$ in voltage and resistance readings.

Emerson Radio

MODEL 888
"TRANSTIMER"
CHASSIS 120416

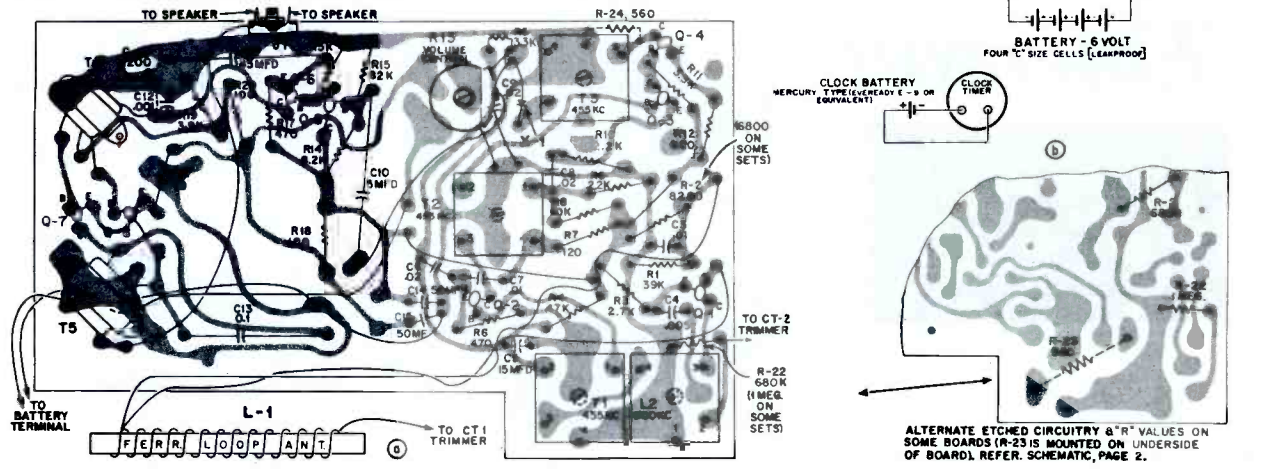
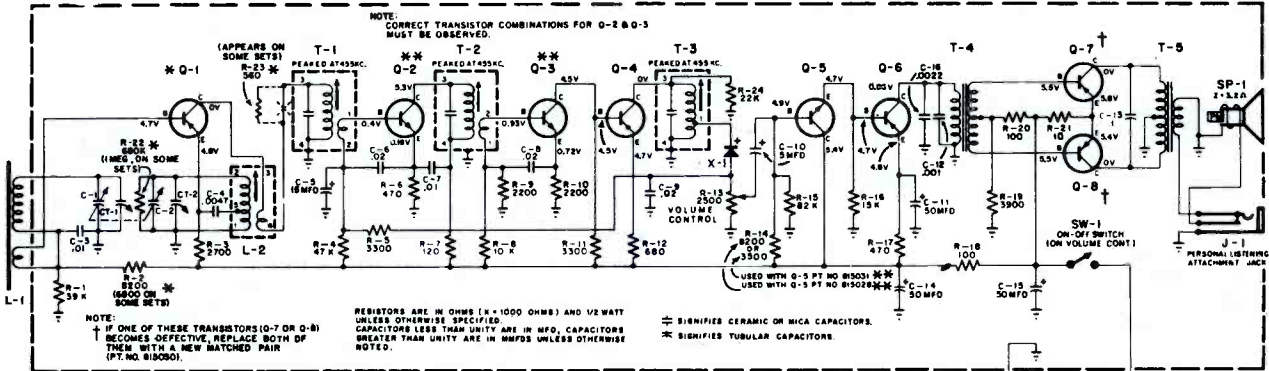

It will be seen from the schematic drawing of the 888 that certain transistors are used in pairs and are associated with specified resistors. Some individual transistors must likewise be used with specific resistors. Because of the small physical size of the transistors, the 1st three digits, "815", have been replaced by the letter, "E"

TRANSISTOR PAIRS			TRANSISTOR PAIRS			TRANSISTOR		TRANSISTOR	
Q2	Q3	ASSOCIATED R12	Q2	Q3	ASSOCIATED R12	Q5	ASSOCIATED R14	Q5	ASSOCIATED R14
815026C	815026A	680	815026C	815026E	680	815031	3800	815033	6800
815026B	815026B	680	815026D	815026D	680	815028	8200	815034	8200
815026B	815026D	680	815026C	815026F	330	815032	4700	815035	10,000

TRANSISTOR SUBSTITUTES		TRANSISTOR NOS.	TRANSISTOR SUBSTITUTES		TRANSISTOR NOS.	TRANSISTOR SUBSTITUTES		TRANSISTOR NOS.
FOR	USE		FOR	USE		FOR	USE	
815026B	815026D	Q2/Q3	815026F	No. Subst.	Q2/Q3	815033	815032	Q5
815026A	815026E	Q2/Q3	815028	815032	Q5	815034	815032	Q5
815026C	No Subst.	Q2/Q3	815031	815032	Q5	815035	815032	Q5

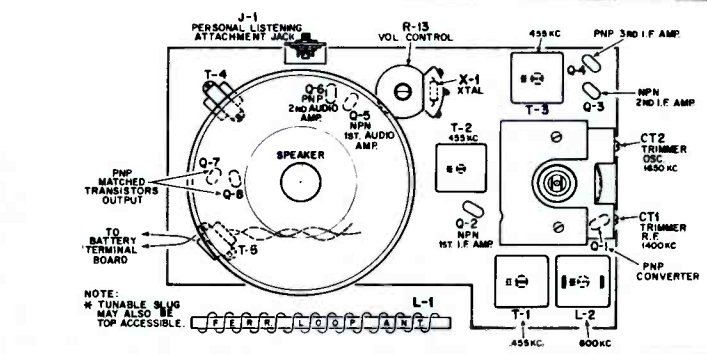
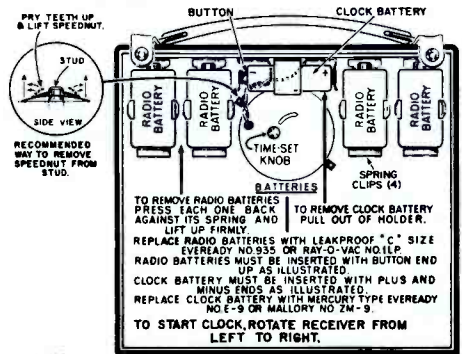

Emerson Radio

Model 895B, Chassis 120431B

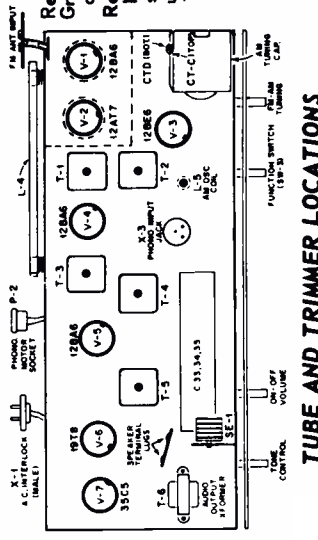
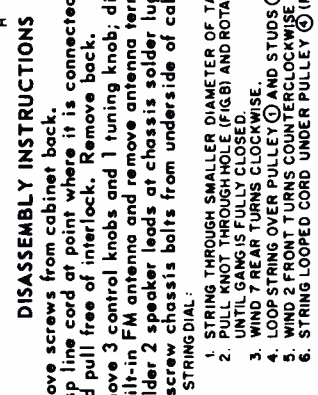
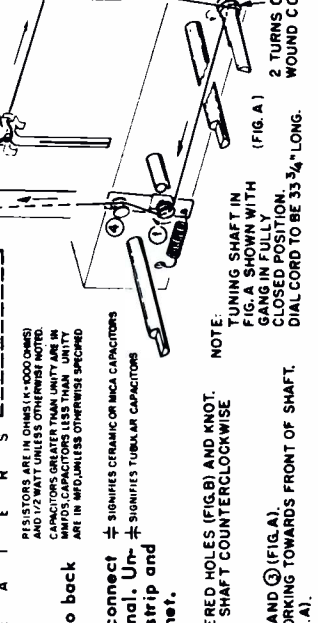
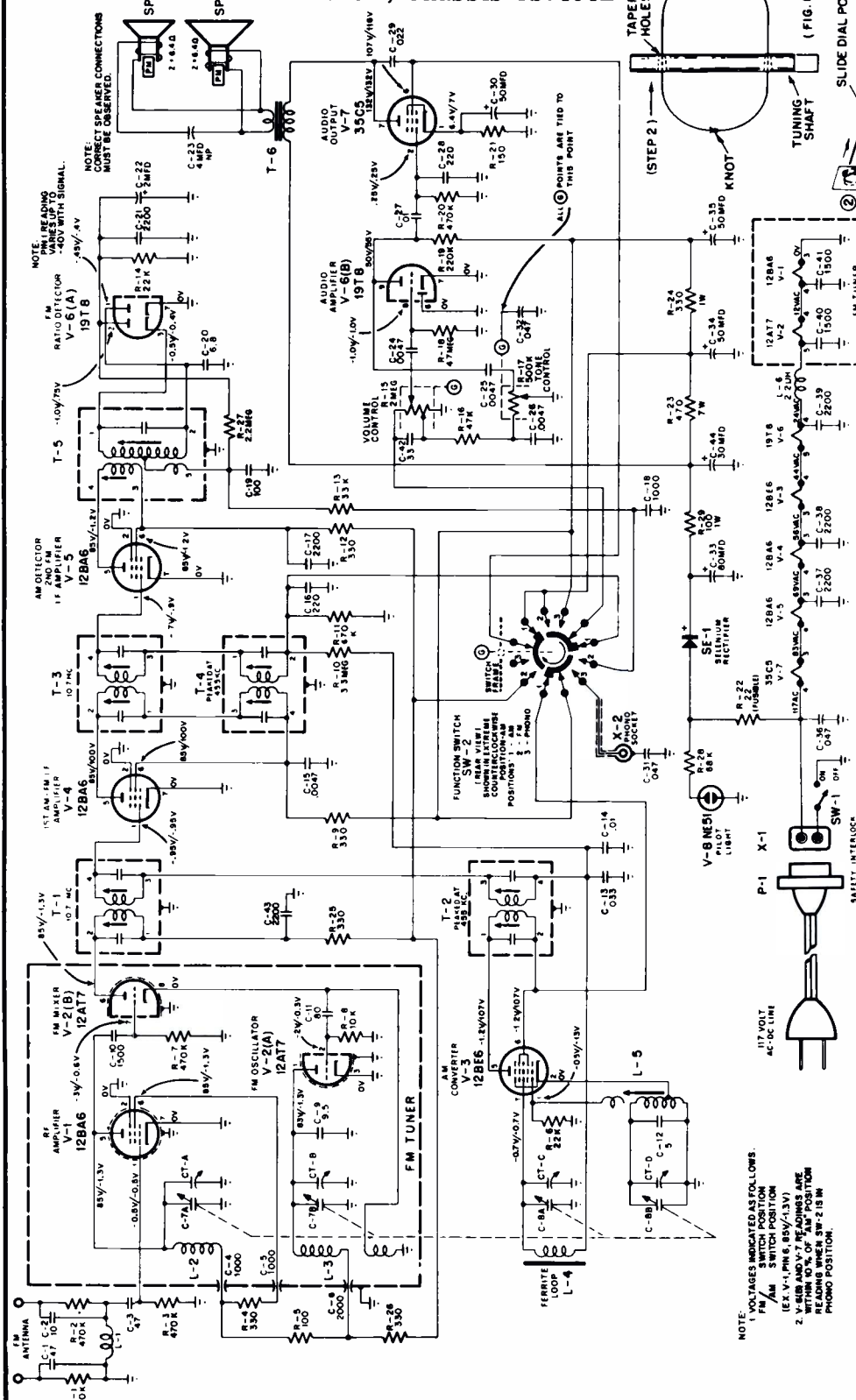

DISASSEMBLY INSTRUCTIONS
 Remove screws from cabinet back. Grasp line cord at point where it is connected to back and pull free of interlock. Remove back. Remove 3 control knobs and 1 tuning knob; disconnect built-in FM antenna and remove antenna terminal. Unsolder 2 speaker leads at chassis solder lug strip and unscrew chassis balls from underside of cabinet.

TO STRING DIA:
 1. STRING THROUGH SMALLER DIAMETER OF TAPERED HOLES (FIG. 8) AND KNOT. 2. UNTIL GANG IS FULLY CLOSED. 3. WIND 7 REAR TURNS CLOCKWISE. 4. LOOP STRING OVER PULLEY (1) AND STUDS (2) AND (3) (FIG. 1). 5. WIND 2 FRONT TURNS COUNTERCLOCKWISE WORKING TOWARDS FRONT OF SHAFT. 6. STRING LOOPED CORD UNDER PULLEY (4) (FIG. 1).

TUBE AND TRIMMER LOCATIONS

NOTE:
 1. VOLTAGES INDICATED AS FOLLOWS.
 FM SWITCH POSITION
 AM SWITCH POSITION
 (EX-V, PH-8, 85V/1.3V)
 2. WITHIN 10% OF TAP POSITION
 READING WHEN SW-2 IS IN
 PHONO POSITION.

VOLUME R-19, MOST-OFTEN-NEEDED 1959 RADIO SERVICING INFORMATION

EMERSON RADIO Model 999, Chassis 120433B, and Model 999R, Chassis 120433R

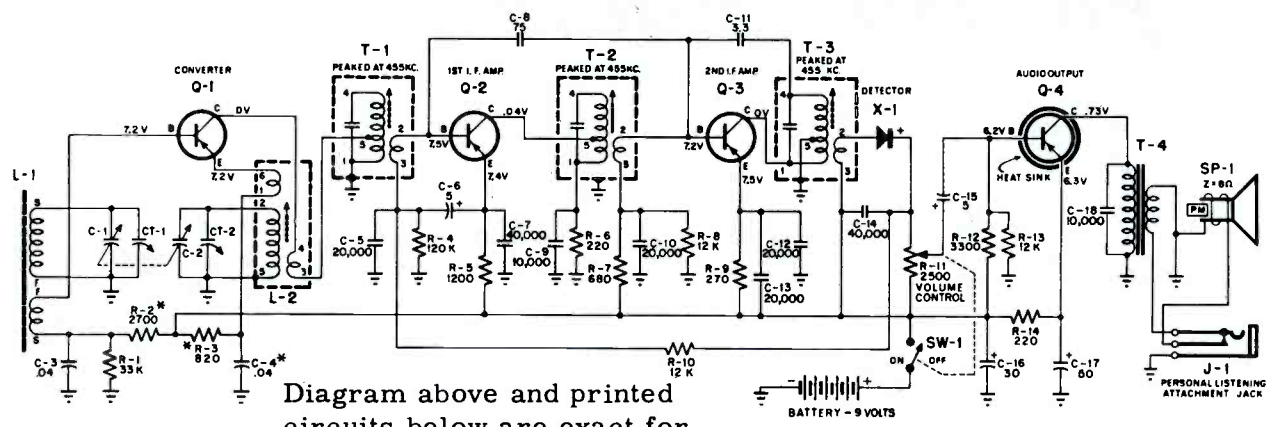
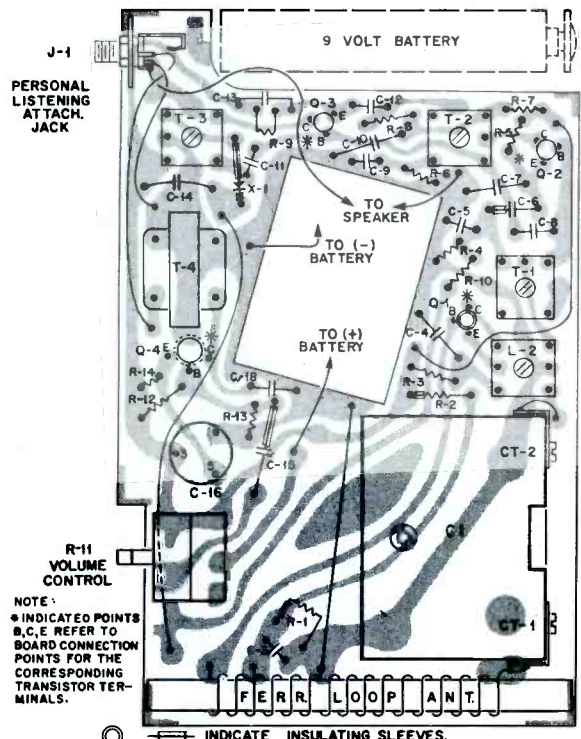
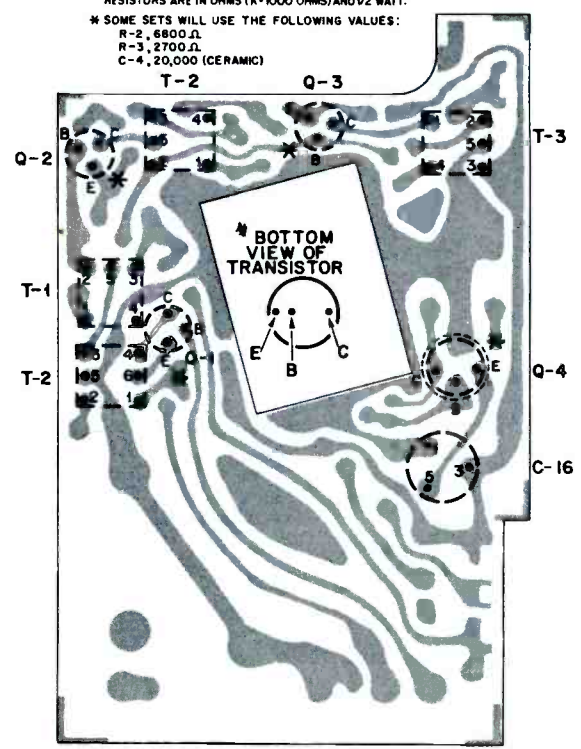

Diagram above and printed circuits below are exact for Chassis 120433B, Model 999.

- NOTES:
- ⊕ SIGNIFIES CERAMIC OR MICA CAPACITORS, CAPACITY IN MICRO-MICROFARADS.
 - ⊕ SIGNIFIES TUBULAR CAPACITORS, CAPACITY IN MICROFARADS. RESISTORS ARE IN OHMS (K=1000 OHMS) AND 1/2 WATT.
 - * SOME SETS WILL USE THE FOLLOWING VALUES:
 R-2, 6800 Ω
 R-3, 2700 Ω
 C-4, 20,000 (CERAMIC)



PRINTED CIRCUIT CHASSIS DIAGRAM (TOP VIEW)



PRINTED CIRCUIT CHASSIS DIAGRAM (BOTTOM VIEW)

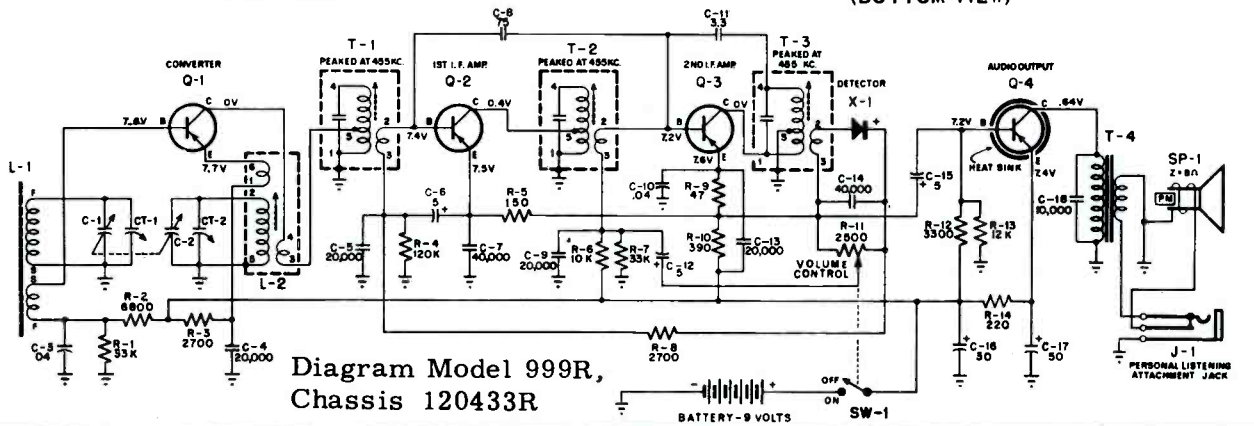
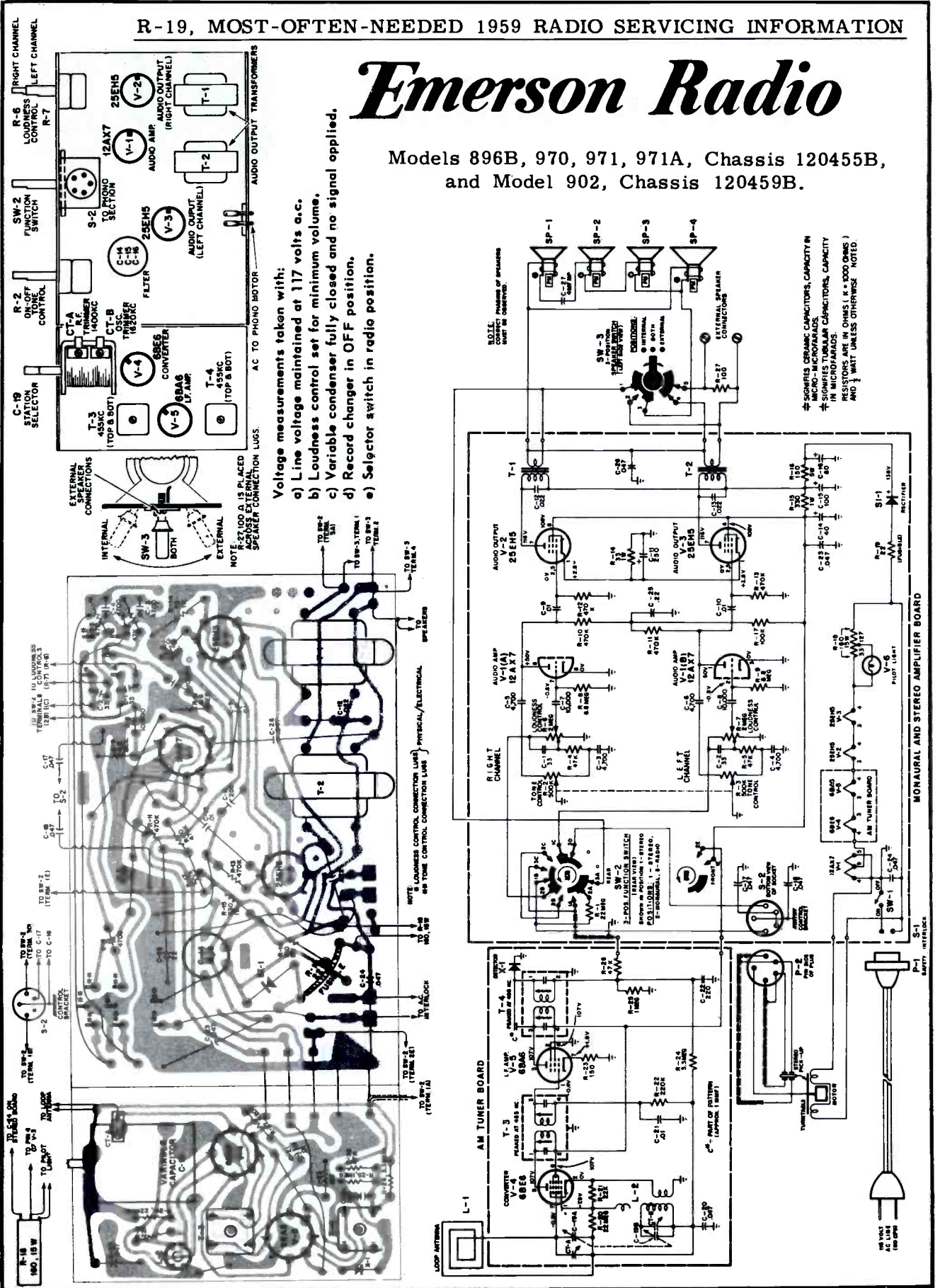

Diagram Model 999R, Chassis 120433R

Emerson Radio

Models 896B, 970, 971, 971A, Chassis 120455B,
and Model 902, Chassis 120459B.

- Voltage measurements taken with:
 a) Line voltage maintained at 117 volts a.c.
 b) Loudness control set for minimum volume.
 c) Variable condenser fully closed and no signal applied.
 d) Record changer in OFF position.
 e) Selector switch in radio position.



Emerson Radio

MODEL 898B
CHASSIS 120456B
MODELS 970, 971, 971A

MODEL 903, chassis 120462B, is electrically similar to model 898B, chassis 120456B. Therefore, all control panel information is directly applicable, with the addition that the speaker selector switch is mounted on the control panel in model 903.

DISASSEMBLY INSTRUCTIONS

NOTE: To replace tubes, only masonite back within cabinet need be removed.

Record Changer:

Remove three Phillips head screws holding masonite back to cabinet and remove back.

Remove four Phillips head screws holding changer mounting board to cabinet.

Tilt mounting board up and back to a stable vertical position.

Remove five-prong plug and AC plug and line cord from amplifier chassis. (Unstaple fishpaper wire holders.)

Remove record changer.

To reassemble, reverse procedure.

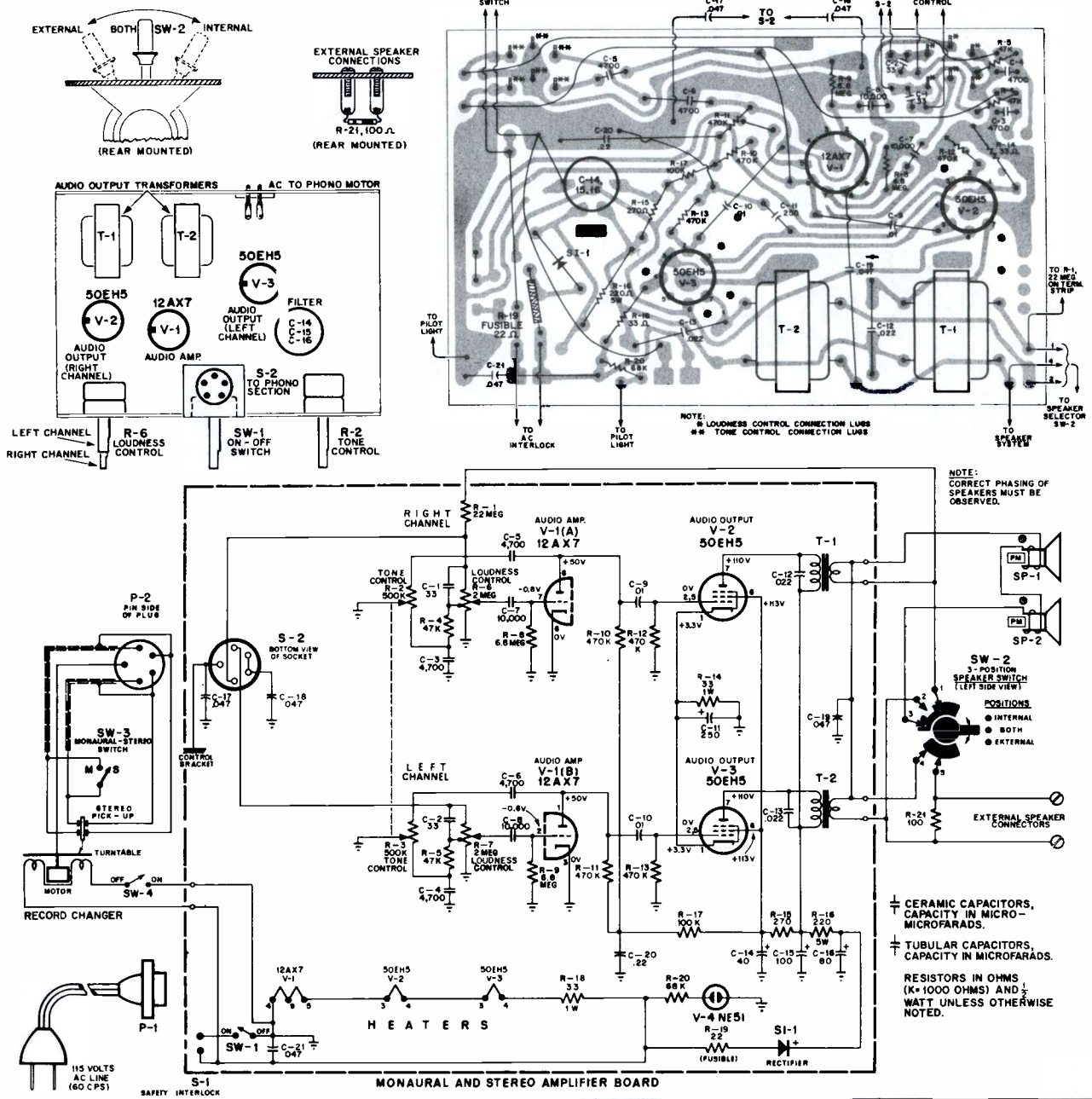

GENERAL ELECTRIC COMPANY

MODEL S
T105A
T106A,B
T107B

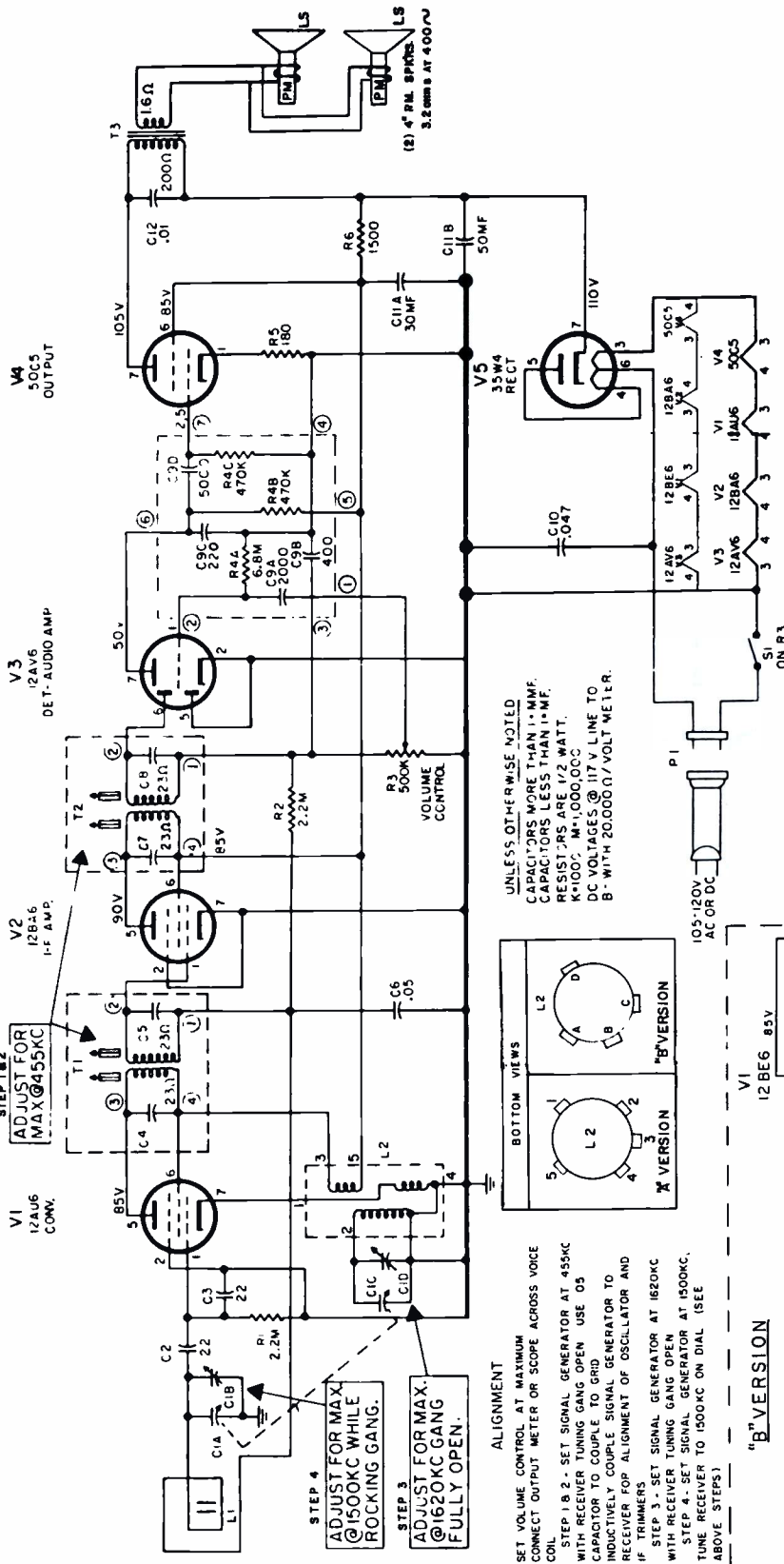

TO REMOVE CHASSIS FROM CABINET

To remove chassis from cabinet, remove cabinet back. Unsolder the output transformer leads from the speaker. Remove the four self-tapping screws, (hex heads) one on each corner of the chassis, and the single hex screw just below the tuning gang capacitor. Pull off the volume control knob. The tuning control knob is held to the cabinet, so the chassis must be pulled out of the cabinet, at the same time pulling it off the tuning knob, which remains on the cabinet. When pulling out the chassis, it is best to grasp the tuning capacitor (C1) by the thumb and forefinger of one hand, the tuning knob by the other hand and pull.

CAUTION: It is important to use extreme care replacing parts and/or soldering on this chassis. Too much heat on the chassis will cause the copper plating to become unbonded. Only apply the soldering iron long enough to melt the solder and pull out the part to be replaced.

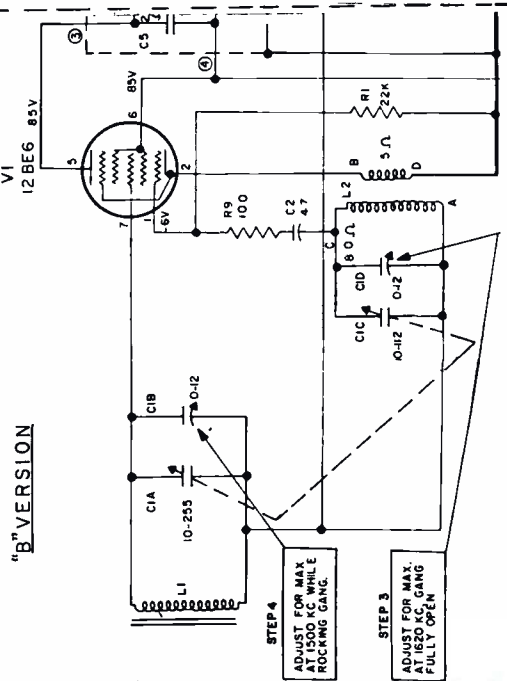

GENERAL ELECTRIC COMPANY

Models T125A, T126A, T127A

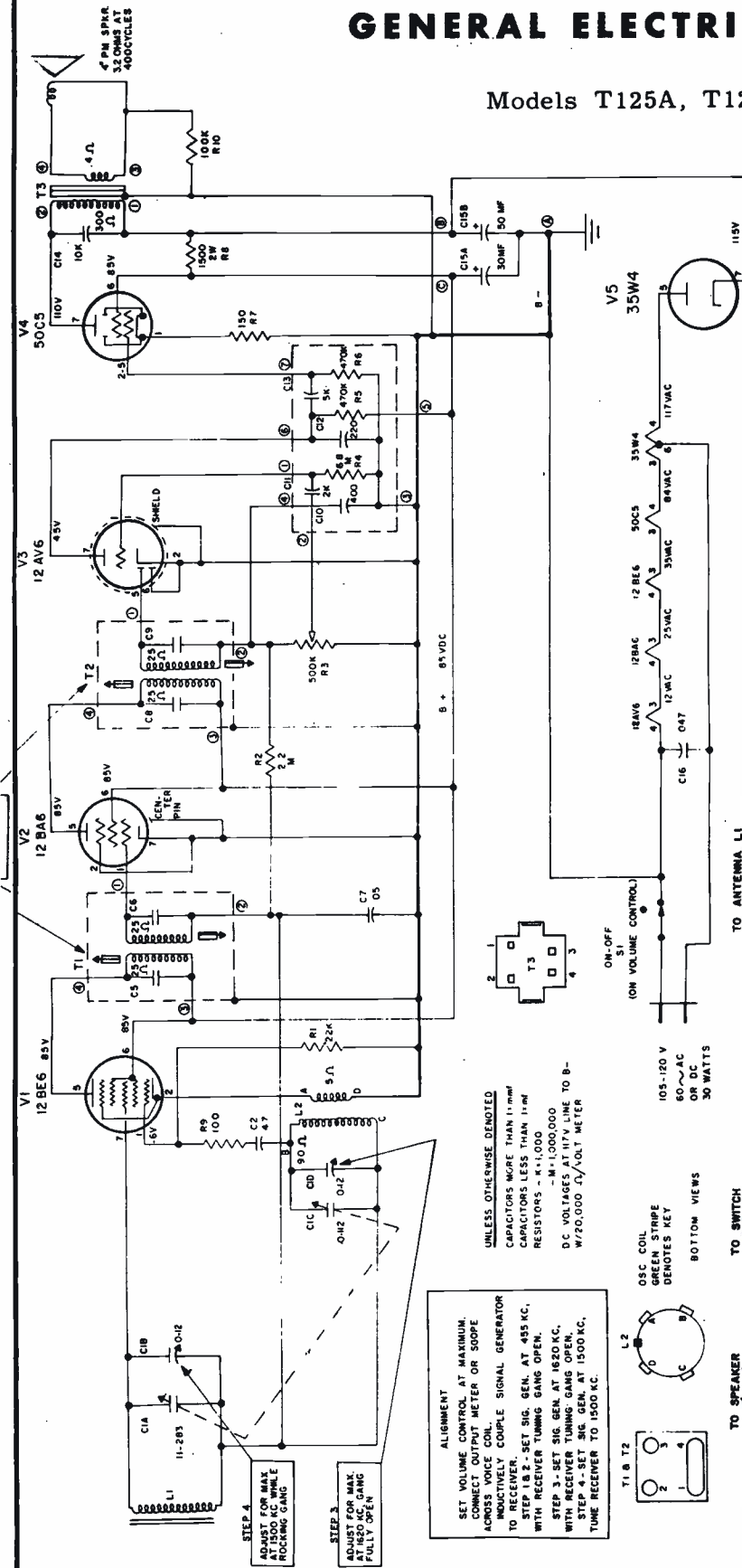

TO REMOVE CHASSIS FROM CABINET:

After removing cabinet back remove the screw on the cabinet bottom that holds the chassis board support. The tuning knob is a captive knob and remains in the cabinet front. Close the tuning gang to prevent any possible damage to the plates. Slide one hand under the printed chassis board placing the fingers over the front edge. Slide the board back out of the grooves on either end simultaneously removing the tuning gang shaft from the tuning knob. When replacing the chassis, close the tuning gang and line the flat side of the tuning gang shaft up with the flat in the tuning knob. Place the ends of the board in the grooves and push on the edge of the board, not on the components. The tuning shaft will enter the tuning knob and the front edge of the board will seat itself in the grooved bosses inside the cabinet front. Replace the board support and self-tapping screw.

ALIGNMENT
 SET VOLUME CONTROL AT MAXIMUM.
 CONNECT OUTPUT METER OR SCOPE
 ACROSS VOICE COIL.
 INDUCTIVELY COUPLE SIGNAL GENERATOR
 TO RECEIVER. SET SIG. GEN. AT 455 KC.
 WITH RECEIVER TUNING GANG OPEN.
 STEP 3 - SET SIG. GEN. AT 1620 KC.
 WITH RECEIVER TUNING GANG OPEN.
 STEP 4 - SET SIG. GEN. AT 1500 KC.
 TUNE RECEIVER TO 1500 KC.

UNLESS OTHERWISE DENOTED
 CAPACITORS MORE THAN 11-mmf
 CAPACITORS LESS THAN 11-mmf
 RESISTORS - R-1:1,000
 -M:1,000,000
 D.C. VOLTAGES AT 117V LINE TO B-
 W/20,000 Ω/VOLT METER

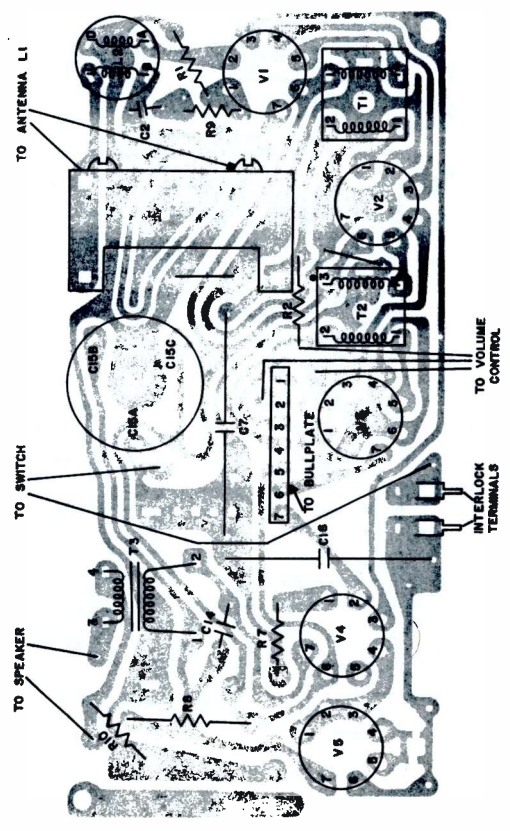
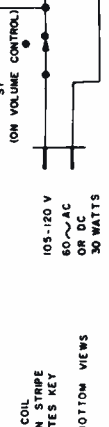

GENERAL ELECTRIC COMPANY

Models T130A, B, T131A, B, T132A, B

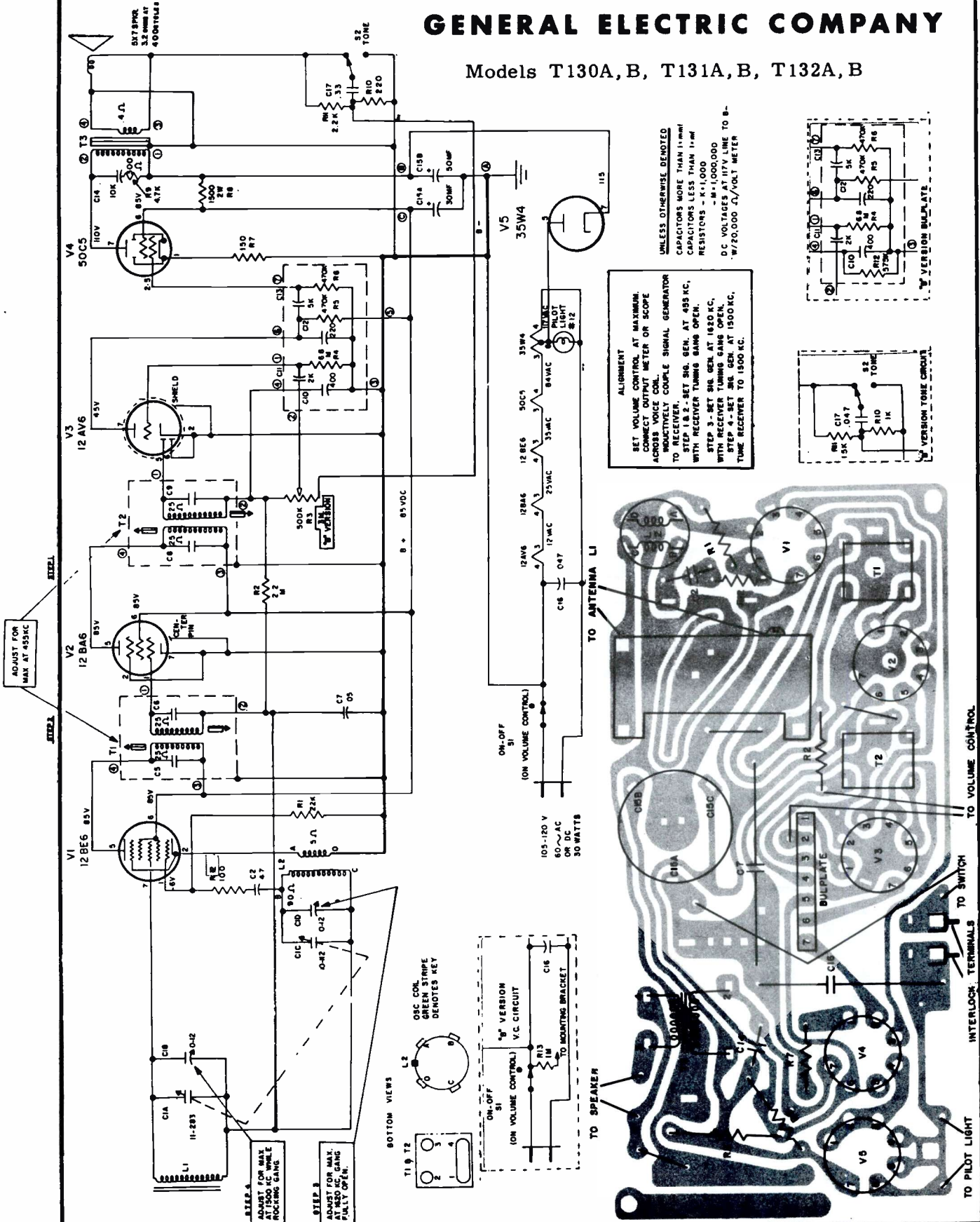

ADJUST FOR MAX AT 455KC

STEP A
ADJUST FOR MAX AT 500 KC WHILE TUNING GANG FULLY OPEN.

STEP B
ADJUST FOR MAX AT 450 KC GANG FULLY OPEN.

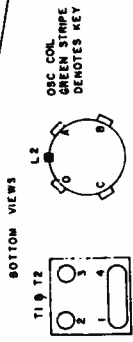

ALIGNMENT
SET VOLUME CONTROL AT MAXIMUM OUTPUT METER OR SCOPE ACROSS VOICE CONL. INDUCTIVELY COUPLE SIGNAL GENERATOR TO RECEIVER.
STEP 1-B-SET SIG. GEN. AT 455 KC. WITH RECEIVER TUNING GANG OPEN.
STEP 3-SET SIG. GEN. AT 1820 KC. WITH RECEIVER TUNING GANG OPEN.
STEP 4-SET SIG. GEN. AT 1500 KC. TUNE RECEIVER TO 1500 KC.

UNLESS OTHERWISE DENOTED CAPACITORS MORE THAN 1"MM CAPACITORS LESS THAN 1"MM RESISTORS - K=1,000 -M=100,000 DC VOLTAGES AT 117V LINE TO B- 1/20,000 Ω/VOLT METER

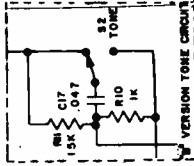
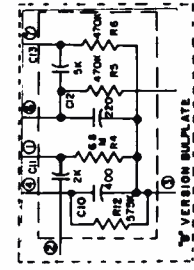

GENERAL ELECTRIC

Model T135A

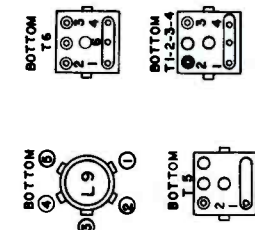
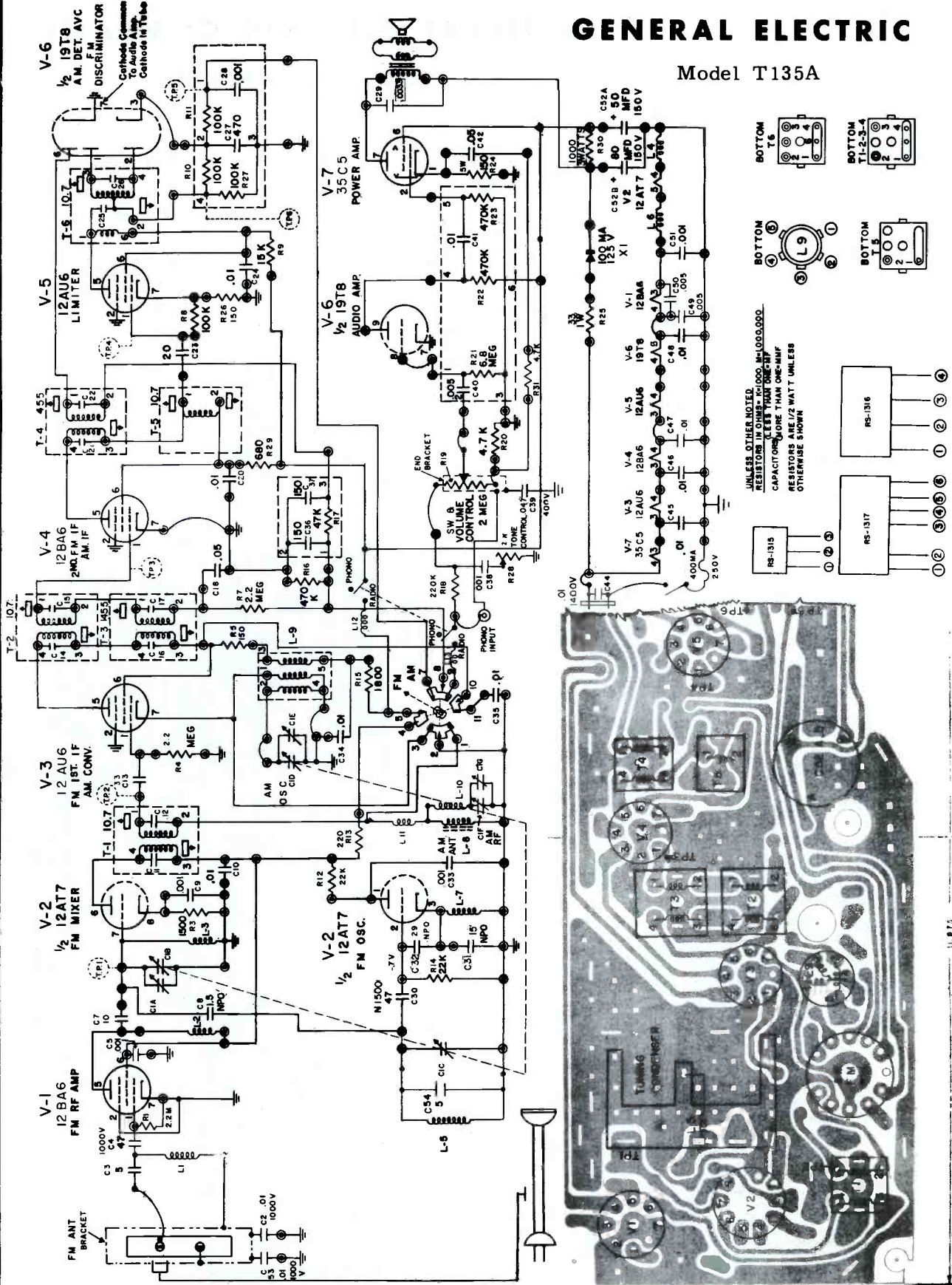

UNLESS OTHERWISE NOTED
RESISTORS IN OHMS-10,000-MH, 100,000-
CAPACITORS IN OHMS-10,000-MH, 100,000-
RESISTORS MORE THAN ONE-MHF
CAPACITORS ARE 1/2 WATT UNLESS
OTHERWISE SHOWN

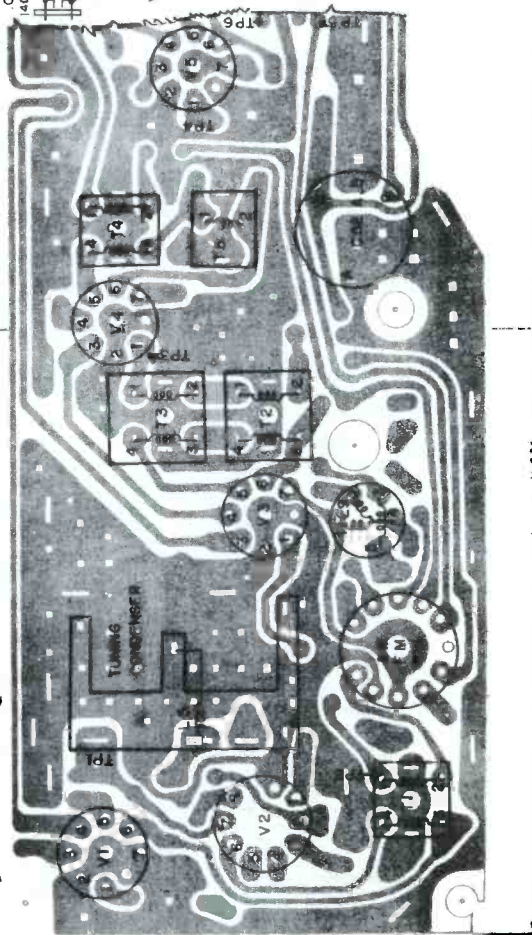
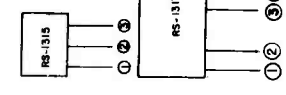

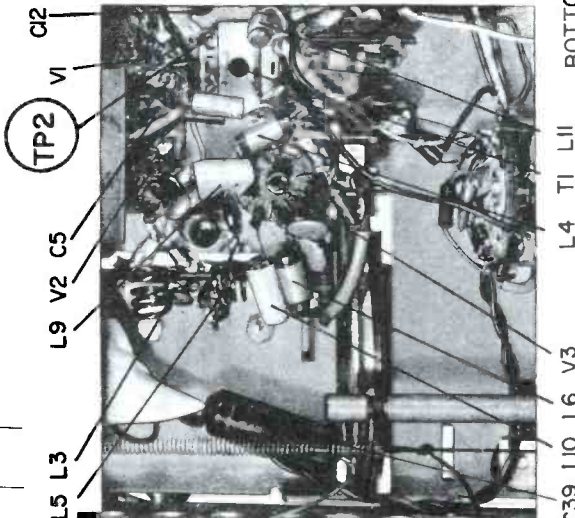
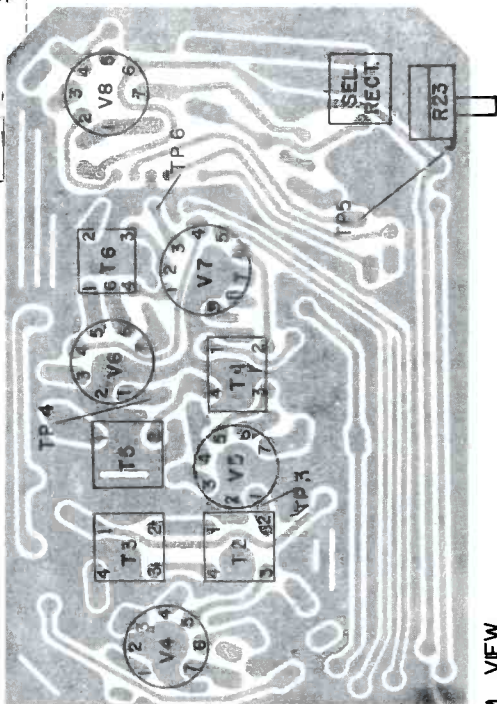
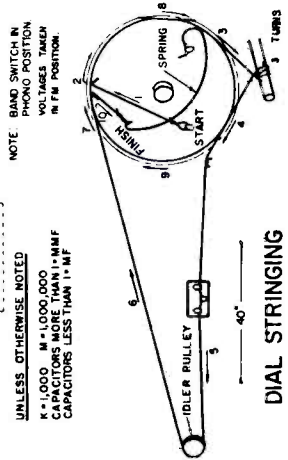
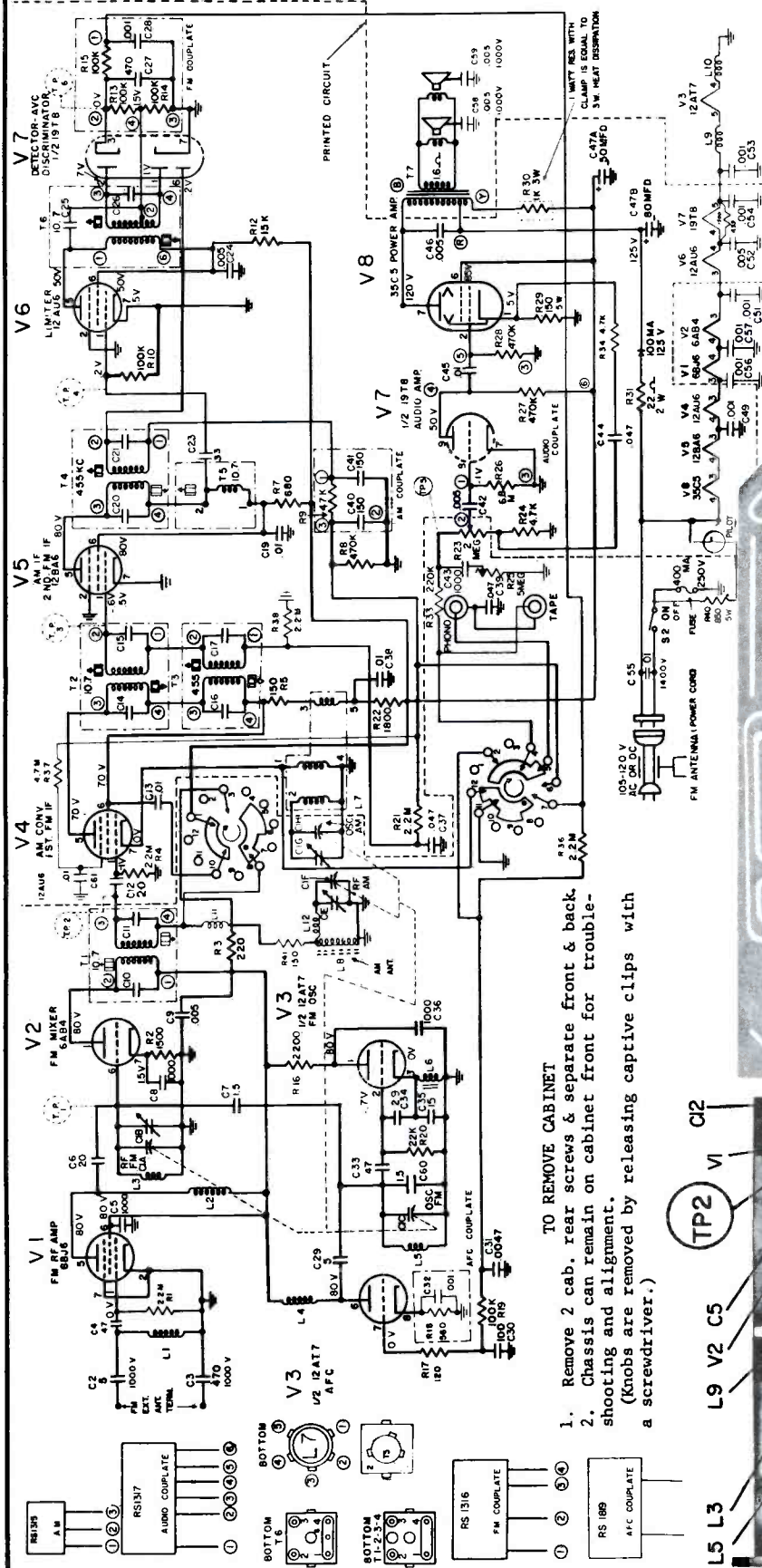

- TO REMOVE CABINET
1. Remove 2 cab. rear screws & separate front & back.
 2. Chassis can remain on cabinet front for troubleshooting and alignment. (Knobs are removed by releasing captive clips with a screwdriver.)

GENERAL ELECTRIC
Model T210A

GENERAL ELECTRIC COMPANY

Models C-400A, C-401A

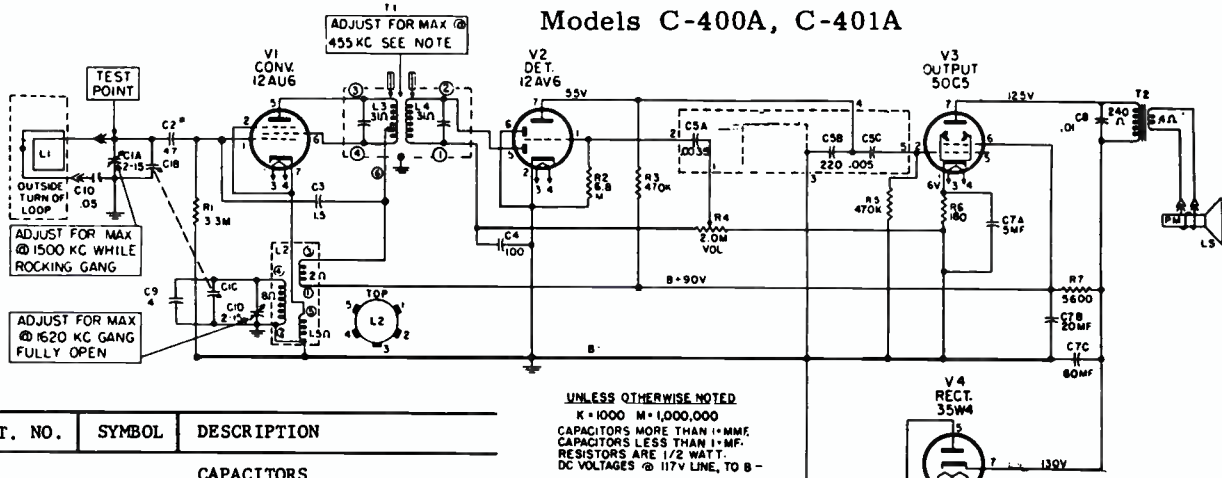

UNLESS OTHERWISE NOTED
 K = 1000 M = 1,000,000
 CAPACITORS MORE THAN 1-MMF.
 CAPACITORS LESS THAN 1-MMF.
 RESISTORS ARE 1/2 WATT.
 DC VOLTAGES @ 117V LINE, TO B -

ALIGNMENT NOTE
 RF

- STEP-1 ADJUST C10
 - STEP-2 ADJUST C1A
 - STEP-3 READJUST C10
- IF INPUT SIGNAL TO TEST POINT
 STEP-1 ADJUST L4.
 STEP-2 ADJUST L3.

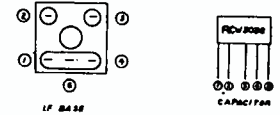
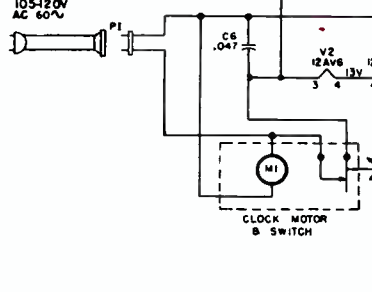

CAT. NO.	SYMBOL	DESCRIPTION
CAPACITORS		
RCE-217	C7A, B, C	5mF., @25V., 20mf., & 60mf., @150V., Electro....
RCN-048	C3 C6	1.5mmF., 20%, 500V., Ceramic .047mf., +40-10%, 600V., Molded.....
RCT-097	C1A, B C, D	Tuning Capacitor, Two Gang
RCW-3036	C5A, B, C	.0035mf., 220mf., .005mf. Bullplate.....
RCW-3079	C4	100mmF., 20%, 500V., Ceramic
RCW-3209	C9	4mmf., ±20%, 500V., Ceramic
RS-1022		.01mf., +40-10%, 400V. Ceramic
POTENTIOMETERS		
RS-1028	R4	Volume Control 2 meg.....
COILS & TRANSFORMERS		
RLC-135	L2	Oscillator Coil C400.....
RS-1414	L2	Oscillator Coil C401.....
RS-1027	T1	I. F. Trans. C400-C401....
RTO-176	T2	Output Trans. C400-C401..

TO REMOVE CHASSIS FROM CABINET:
 Remove cabinet back and interlock. Remove the five self-tapping screws (hex heads), one on each corner of the chassis, and the single hex screw just below the tuning gang capacitor. Pull off the volume control knob.
 The tuning control knob is a captive knob which remains with the cabinet. The chassis must be pulled out of the cabinet and separated from the tuning knob simultaneously. When pulling out the chassis, first close the tuning capacitor, grasp the tuning capacitor with the thumb and forefinger of one hand and the tuning knob with the other and pull the chassis out of the cabinet.

CAUTION:
 It is important to use extreme care while replacing parts and or soldering on this chassis. Too much heat on the chassis will cause the copper plating to become unbonded. Only apply the soldering iron long enough to melt the solder and pull out the part to be replaced. A 35 watt soldering iron is recommended.

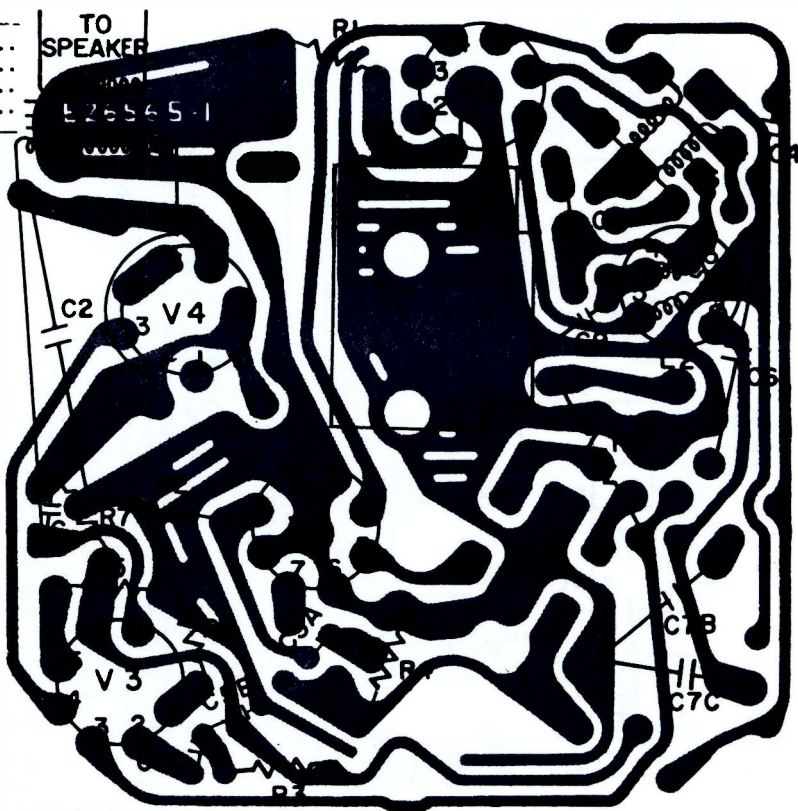

GENERAL ELECTRIC COMPANY

Models C405A, B, C406A, B

SPECIFICATIONS

CABINET:	Model C405A, B-- Gray and White Model C406A, B-- Pink
ELECTRICAL RATING:	105-120 volts AC 30 Watts @117 Volts AC
OUTPUT:	Undistorted .9 Watts Maximum 1.5 Watts

GENERAL INFORMATION

The main difference in the "A" and "B" versions of the C405 series of clock-radios is the oscillator-converter stage (V1). The "A" version uses a 12AU6 tube as V1 and the "B" version uses a 12BE6 as V1. The V1 stage for the "B" version is shown as a separate stage on the schematic.

The tuning knob is held to the cabinet and cannot be removed without first removing the chassis.

SERVICE NOTE

Always use an isolation transformer when servicing or aligning this receiver to protect personnel and test equipment.

When aligning, keep the signal input low so the AVC will not affect the output.

TO REMOVE CABINET FRONT

Remove the two screws located on each side of the cabinet back; unscrew the clock set knob; separate the cabinet front from the back. When separating the cabinet, the speaker leads must be unsoldered before complete separation of the cabinet can be accomplished. The speaker is mounted on the cabinet back with the radio chassis and clock mounted on the cabinet front.

TO REMOVE CHASSIS

Remove the volume control knob. Take out the four hexhead screws, one on each corner of the chassis board and one hexhead screw below the tuning condenser. Unsolder the one wire to switch on the clock and one to the clock motor.

Close the tuning condenser C1, and with the thumb and forefinger grasp the condenser and pull. The chassis will separate from the tuning knob which is left attached to the cabinet front.

TO REMOVE THE CLOCK

Separate the cabinet as described above. Unsolder the two leads, one from the switch to the circuit board and one from the clock motor to the circuit board. Remove the two screws holding the AC interlock to the cabinet. Remove the two clock knobs. Snap out the clock crystal starting from the left side. Then, remove the two nuts holding the clock to the cabinet and remove the clock.

TROUBLESHOOTING

Excessive loudness when adjusting the volume level to minimum is caused by excessive capacity between terminals 2 and 3 of RCW-3207. The excessive capacity can be eliminated without replacing the couplate or by removing the circuit board in the following manner:

1. Clip off couplate lead #3.
2. Solder a 220 mmF capacitor (Cat. No. RS-1203) across the two outside terminals of the volume control located on the component side of the chassis board.

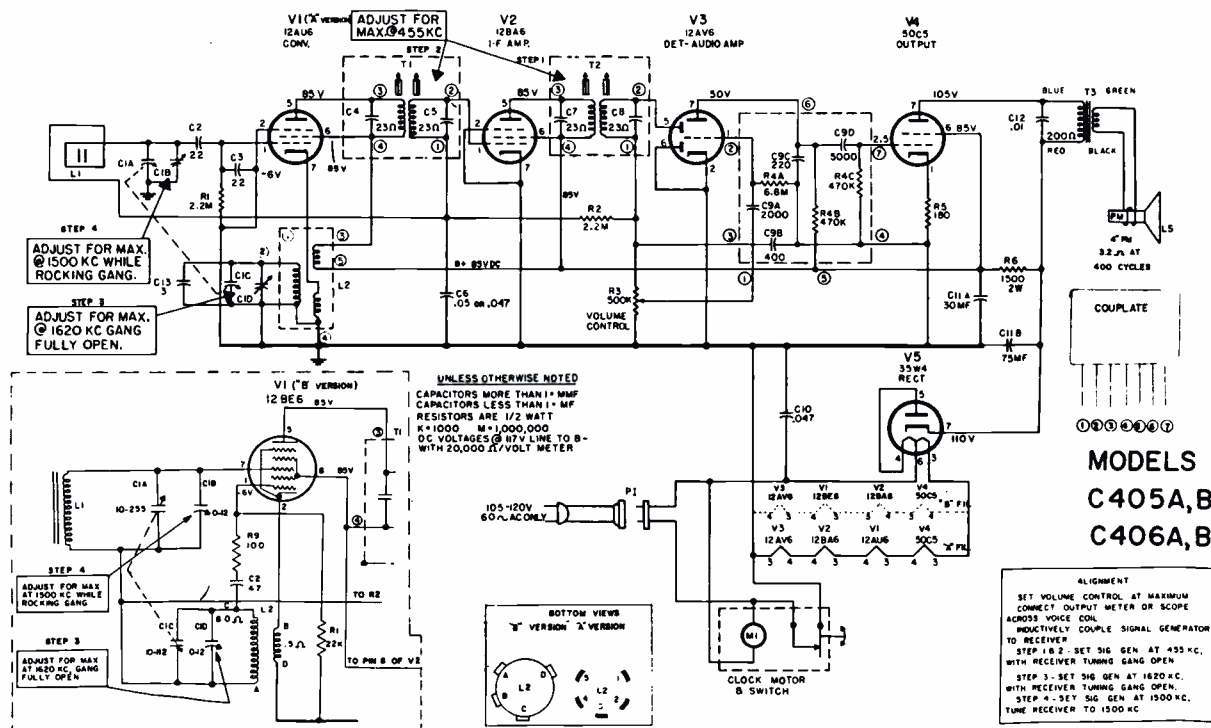

GENERAL ELECTRIC COMPANY

Model C435A

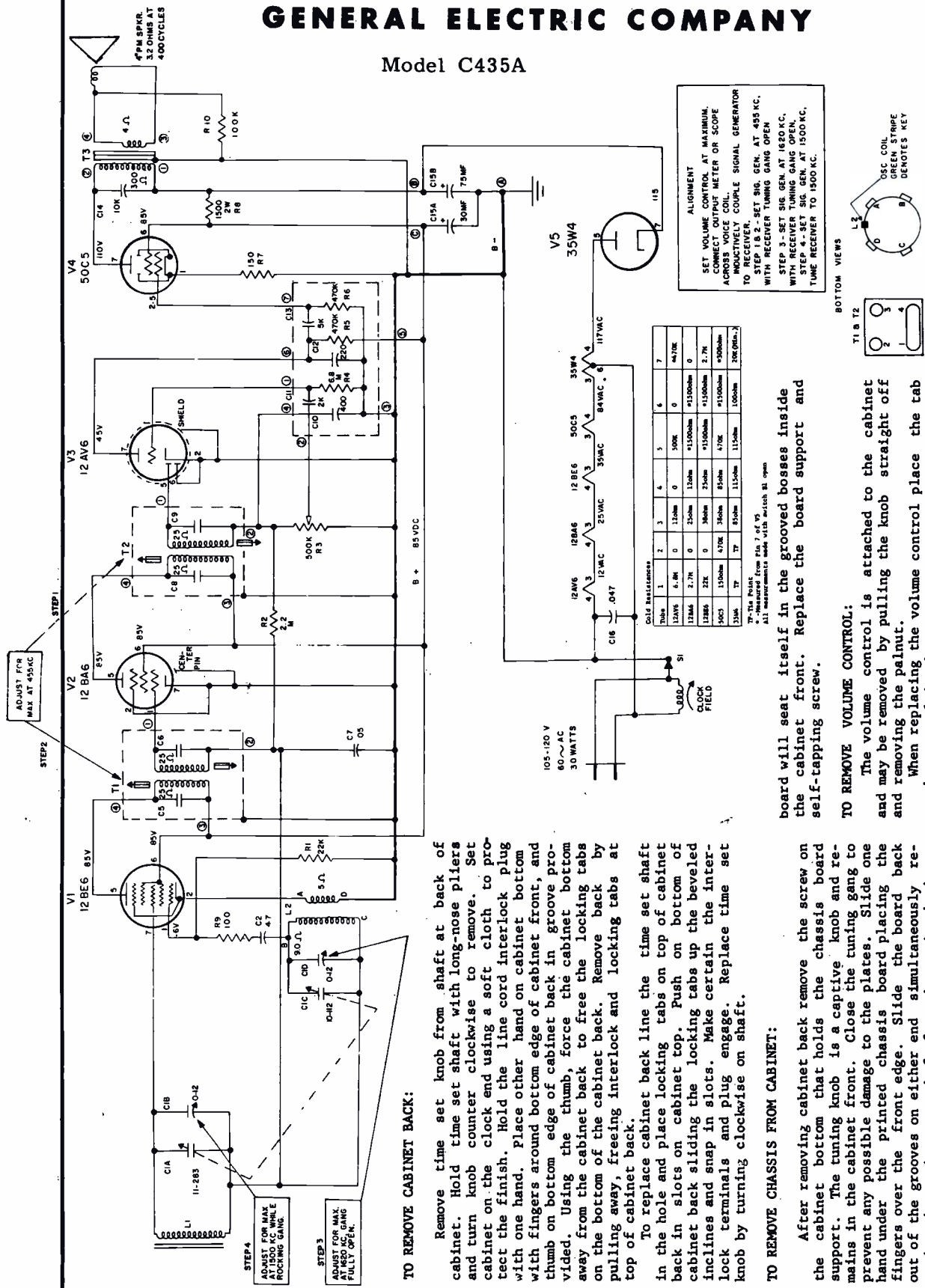

UNLESS OTHERWISE DENOTED
 CAPACITORS MORE THAN 1 μmf
 CAPACITORS LESS THAN 1 μmf
 RESISTORS - K = 1,000,000
 - M = 1,000,000
 Ω = 100,000
 W/250,000 Ω-VOLT METER

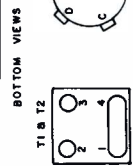

TO REMOVE CABINET BACK:

Remove time set knob from shaft at back of cabinet. Hold time set knob with long-nose pliers and turn knob counter clockwise to remove. Set cabinet on the clock end using a soft cloth to protect the finish. Hold the line cord interlock plug with one hand. Place other hand on cabinet bottom with fingers around bottom edge of cabinet front, and thumb on bottom edge of cabinet back in groove provided. Using the thumb, force the cabinet bottom away from the cabinet back to free the locking tabs on the bottom of the cabinet back. Remove back by pulling away, freeing interlock and locking tabs at top of cabinet back.

To replace cabinet back line the time set shaft in the hole and place locking tabs on top of cabinet back in slots on cabinet top. Push on bottom of cabinet back sliding the locking tabs up the beveled inclines and snap in slots. Make certain the interlock terminals and plug engage. Replace time set knob by turning clockwise on shaft.

TO REMOVE CHASSIS FROM CABINET:

After removing cabinet back remove the screw on the cabinet bottom that holds the chassis board support. The tuning knob is a captive knob and remains in the cabinet front. Close the tuning gang to prevent any possible damage to the plates. Slide one hand under the printed chassis board placing the fingers over the front edge. Slide the board back out of the grooves on either end simultaneously removing the tuning gang shaft from the tuning knob. When replacing the chassis, close the tuning gang and line the flat side of the tuning gang shaft up with the flat in the tuning knob. Place the ends of the board in the grooves and push on the edge of the board, not on the components. The tuning shaft will enter the tuning knob and the front edge of the

board will seat itself in the grooved bosses inside the cabinet front. Replace the board support and self-tapping screw.

TO REMOVE VOLUME CONTROL:

The volume control is attached to the cabinet and may be removed by pulling the knob straight off and removing the pinnut. When replacing the volume control place the tab on the control in the groove provided.

TO REMOVE SPEAKER:

After removing the chassis board remove four tubular speaker clips and lift the speaker out of the cabinet.



GENERAL ELECTRIC COMPANY

Models C440A and C441A

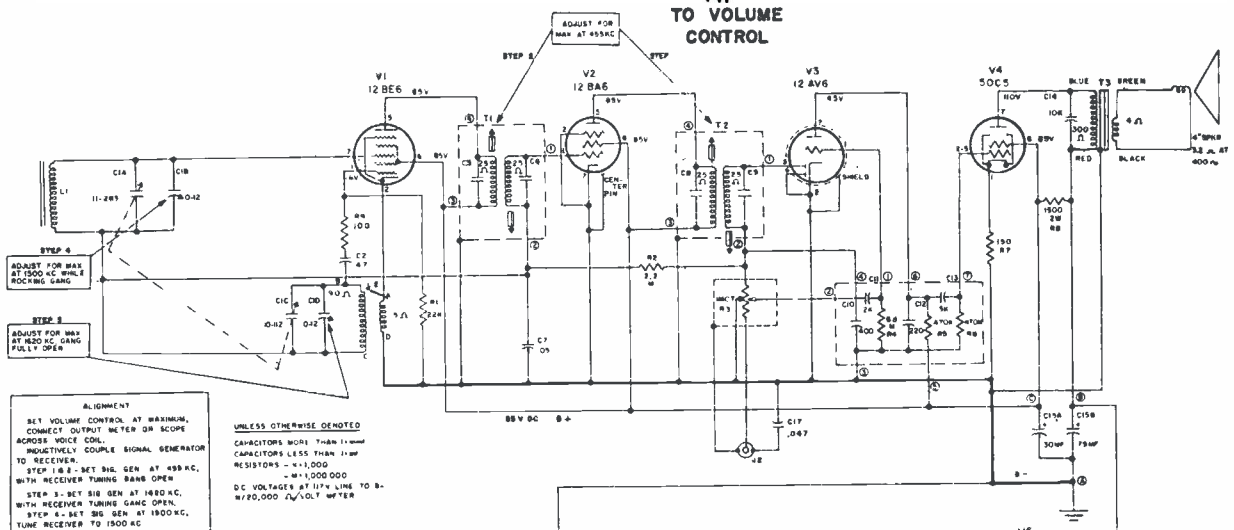
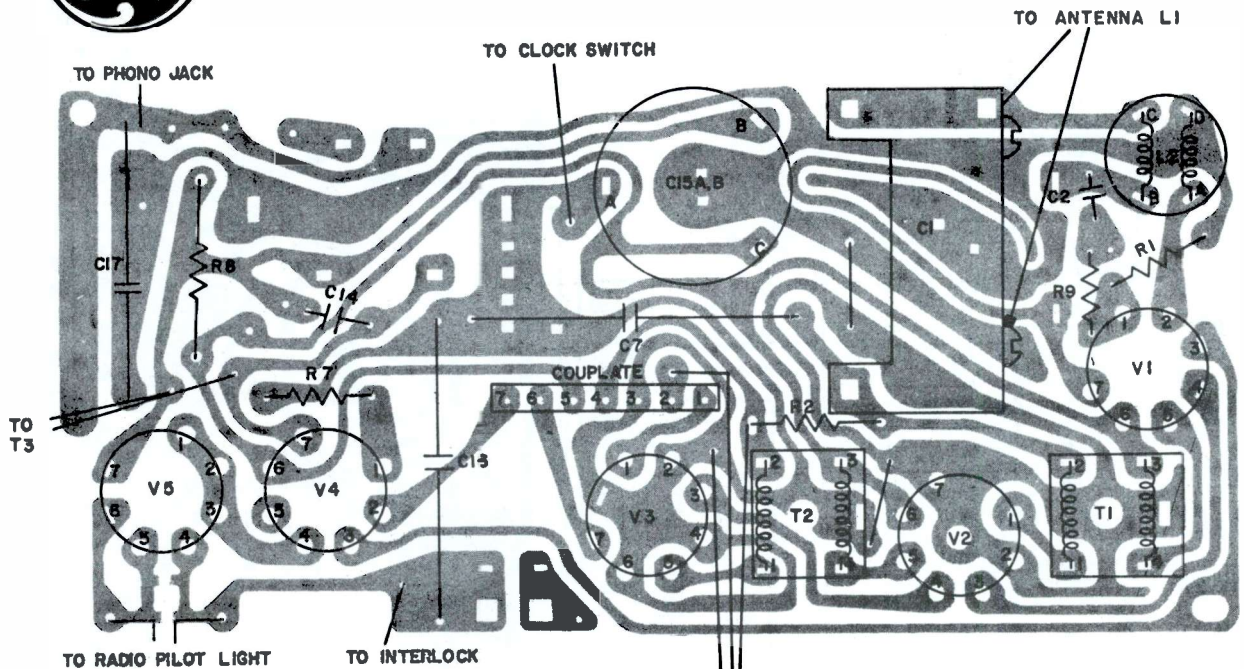

ALIGNMENT
 SET VOLUME CONTROL AT MAXIMUM, CONNECT OUTPUT METER OR SCOPE ACROSS VOICE COIL. INDUCTIVELY COUPLE SIGNAL GENERATOR TO RECEIVER.
STEP 4 - SET SIG. GEN AT 485 KC. WITH RECEIVER TUNING RANGE OPEN.
STEP 5 - SET SIG. GEN AT 1480 KC. WITH RECEIVER TUNING GANG OPEN.
STEP 6 - SET SIG. GEN AT 1500 KC. TUNE RECEIVER TO 1500 KC.

UNLESS OTHERWISE DENOTED CAPACITORS MORE THAN 11-pF CAPACITORS LESS THAN 11-pF RESISTORS - $\times 1,000,000$ - $\times 1,000,000$ D.C. VOLTAGE AT 1/4 LINE TO B- $\times 750,000$ Ω /VOLT METER

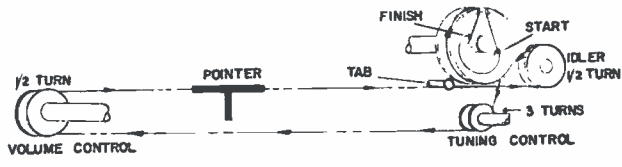

Tube Pin Resistance Chart

Tube	1	2	3	4	5	6	7
12AV6	6.8M	0	15	0	500K	0	*470K
12BA6	2.7M	0	25	15	*1500ohm	*1500ohm	0
12BE6	22K	0	35	25	*1500ohm	*1500ohm	2.7M
50C5	150ohm	470K	35	80	470K	*1500ohm	*300ohm
35W4	TP	TP	80	110	105	105	20 \times (min.)

TP-Tie Point
 * Measured from Pin 7 of V5
 Resistances measured with pilot light (Mazda # 12) in socket
 All measurements taken with respect to 3- unless otherwise designated.

GENERAL ELECTRIC

MODELS
P725B
P726B

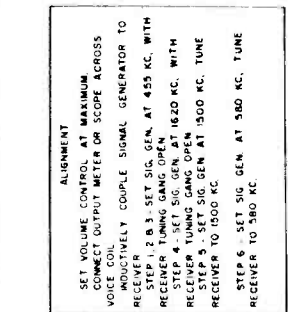
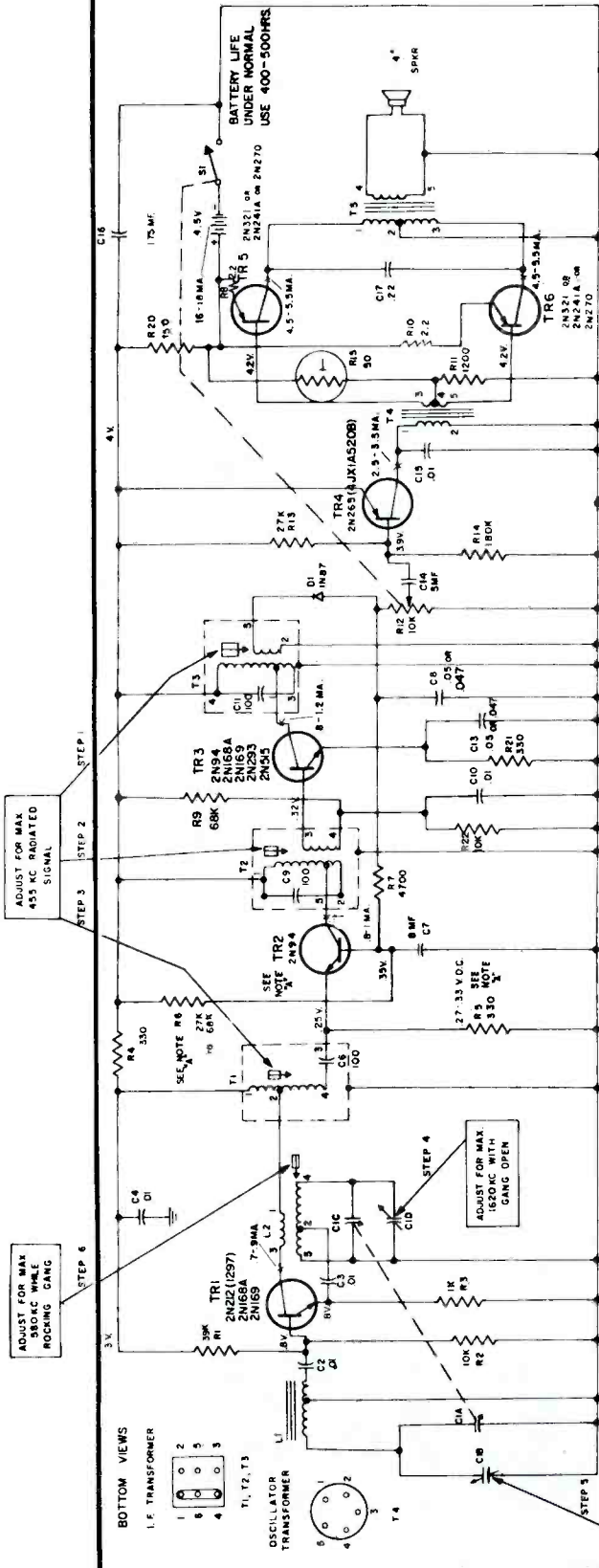

TROUBLESHOOTING

A check of battery condition and total current drain of the receiver should be made first. All current measurements are made at quiescence with the receiver turned on, volume control at maximum, tuning gang closed, and with no signal conditions. The total receiver current drain is 16 to 18 mls. This is measured by inserting a milliammeter in series with the batteries.

If an excessive total current drain is recorded, the individual collector currents of each transistor should be checked. An excessive current reading may mean a shorted transistor; no current will indicate that a transistor or associated circuit component is defective.

A single-edge razor blade is a satisfactory tool for cutting the copper circuit wiring so that a milliammeter can be inserted in series with the break to measure the current flow. After each current check is completed, solder the cut carefully to complete the circuit again.

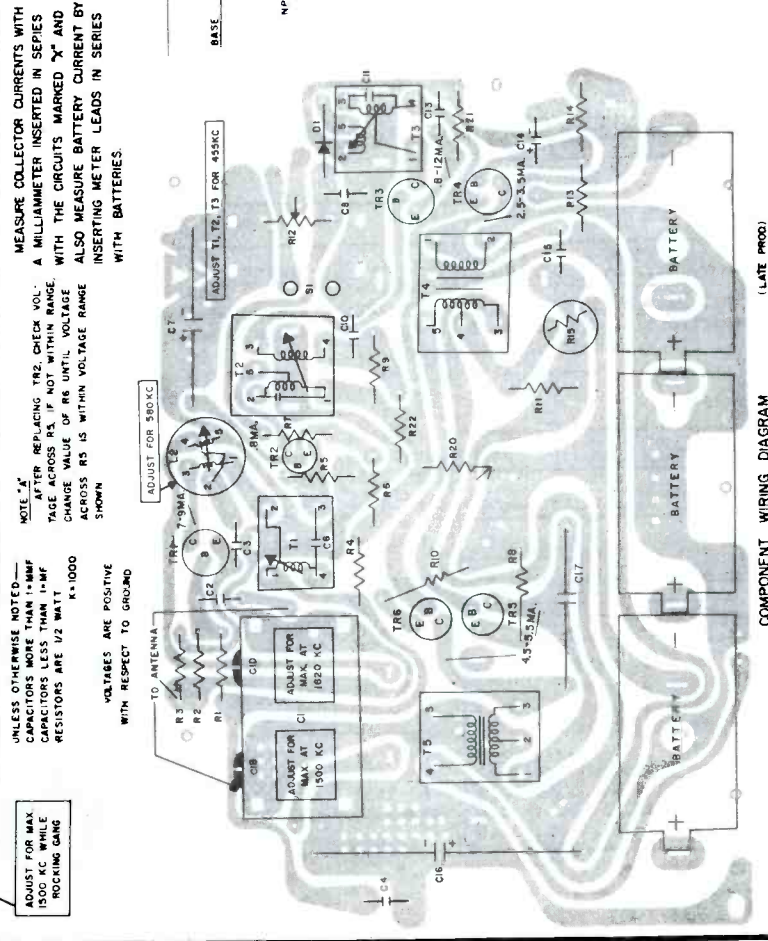

GENERAL ELECTRIC

MODELS
P735A
P736A

TO "X" ON POWER SUPPLY BOARD.
TO "A" BATTERY CONNECTION ON BATTERY SUPPLY BOARD.

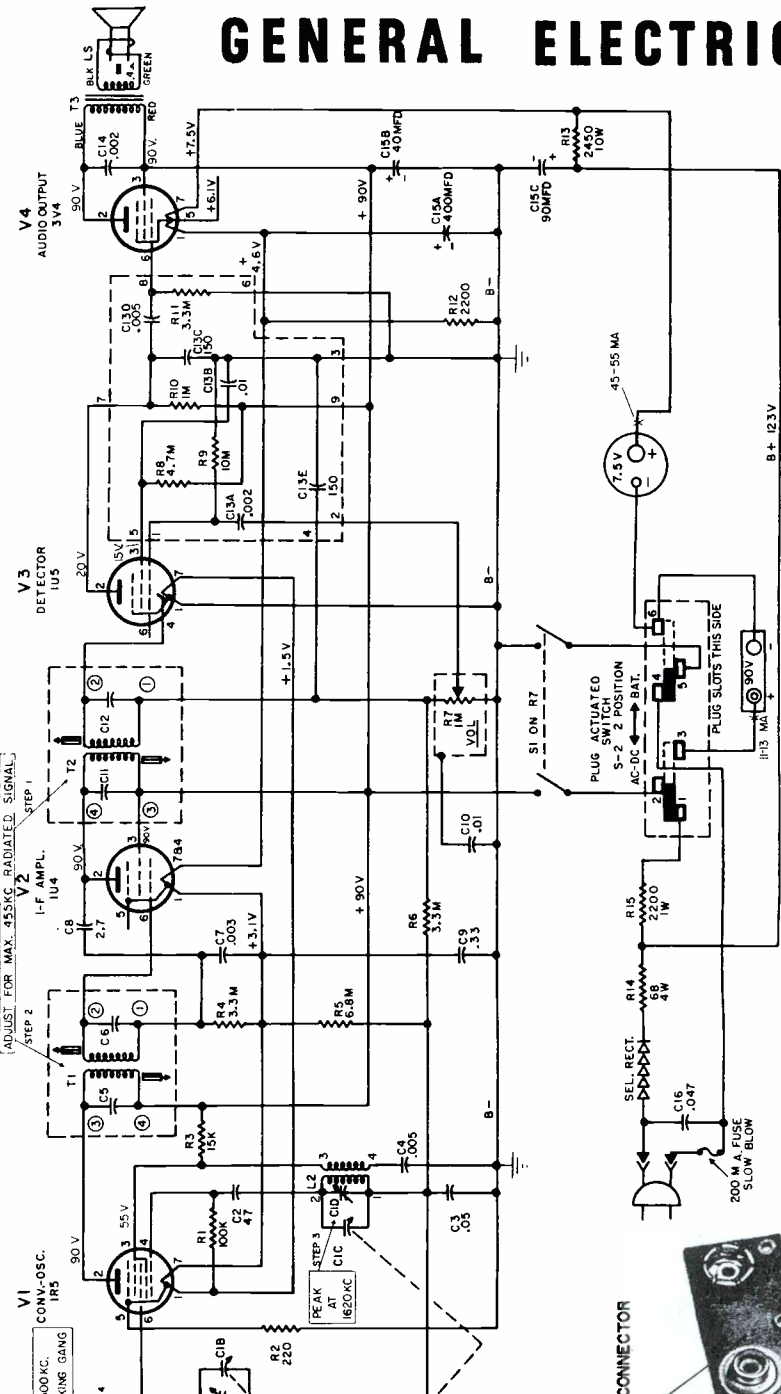

OPERATING FREQUENCIES:	Tuning range 540-1600 KC
AUDIO POWER OUTPUT:	I-F Amplifier..... 455 KC Maximum - 250-300 Milliwatts

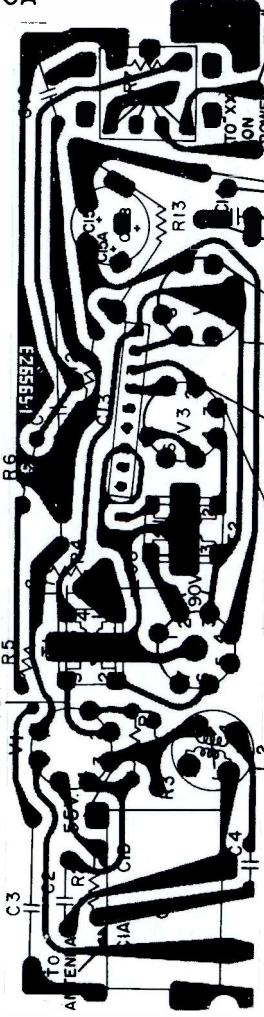

MAIN CHASSIS - COMPONENT LOCATION BOTTOM VIEW

ALIGNMENT
SET VOLUME CONTROL AT MAXIMUM.
CONNECT OUTPUT METER OR SCOPE ACROSS VOICE COIL.
INDUCTIVELY COUPLE SIGNAL GENERATOR TO RECEIVER TUNING GANG OPEN.
STEP 1.2 - SET SIG GEN AT 455 KC. WITH RECEIVER TUNING GANG OPEN.
STEP 3 - SET SIG GEN AT 1620 KC. WITH RECEIVER TUNING GANG OPEN.
STEP 4 - SET SIG GEN AT 1500 KC.

ADJUST FOR MAX. 455KC RADIATED SIGNAL
STEP 1 - ADJUST T1 FOR MAX. SIGNAL.
STEP 2 - ADJUST C8 FOR MAX. SIGNAL.
STEP 3 - ADJUST C12 FOR MAX. SIGNAL.
STEP 4 - ADJUST C14 FOR MAX. SIGNAL.

PEAK AT 1500KC. WHILE ROCKING GANG.
PEAK AT 455KC. WHILE ROCKING GANG.
PEAK AT 1620KC. WHILE ROCKING GANG.

SET VOLUME CONTROL AT MAXIMUM.
CONNECT OUTPUT METER OR SCOPE ACROSS VOICE COIL.
INDUCTIVELY COUPLE SIGNAL GENERATOR TO RECEIVER TUNING GANG OPEN.
STEP 1.2 - SET SIG GEN AT 455 KC. WITH RECEIVER TUNING GANG OPEN.
STEP 3 - SET SIG GEN AT 1620 KC. WITH RECEIVER TUNING GANG OPEN.
STEP 4 - SET SIG GEN AT 1500 KC.

SET VOLUME CONTROL AT MAXIMUM.
CONNECT OUTPUT METER OR SCOPE ACROSS VOICE COIL.
INDUCTIVELY COUPLE SIGNAL GENERATOR TO RECEIVER TUNING GANG OPEN.
STEP 1.2 - SET SIG GEN AT 455 KC. WITH RECEIVER TUNING GANG OPEN.
STEP 3 - SET SIG GEN AT 1620 KC. WITH RECEIVER TUNING GANG OPEN.
STEP 4 - SET SIG GEN AT 1500 KC.

Value	Pin 1	Pin 2	Pin 3	Pin 4	Pin 5	Pin 6	Pin 7
1875	ELL.	2200	15K	100K	ELL.	6.2K	ELL.
10K	ELL.	2200	2.2K	ELL.	ELL.	3M	ELL.
100	ELL.	1.8K	3M	1.5M	ELL.	10M	ELL.
30K	ELL.	2.2K	75K	100K	ELL.	1.5M	ELL.

RESISTANCE CODE
Pin 1 Pin 2 Pin 3 Pin 4 Pin 5 Pin 6 Pin 7
1875 ELL. 2200 15K 100K ELL. 6.2K ELL.
10K ELL. 2200 2.2K ELL. ELL. 3M ELL.
100 ELL. 1.8K 3M 1.5M ELL. 10M ELL.
30K ELL. 2.2K 75K 100K ELL. 1.5M ELL.

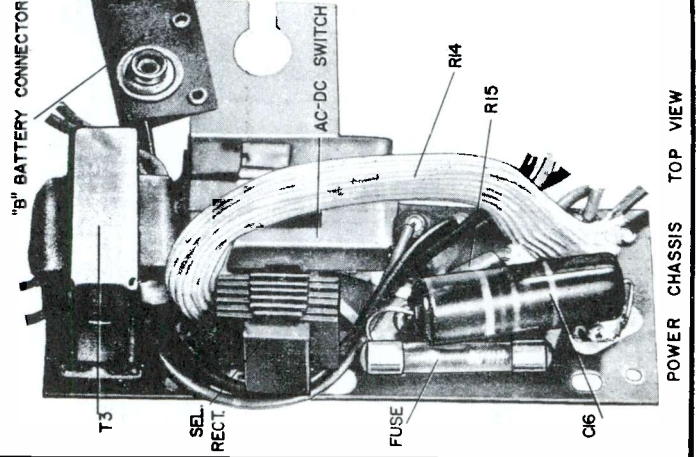

POWER CHASSIS TOP VIEW

UNLESS OTHERWISE NOTED
K = 1,000 M = 1,000,000
CAPACITORS MORE THAN 1-MMF
RESISTORS LESS THAN 100-Ω
RESISTORS ARE 1/2-WATT



GENERAL ELECTRIC

Models P755A, P805, and P806

TRANSISTOR CHART

TR1*	TR2	TR3	TR4	TR5
2N194A	2N135	2N169	2N192	2N241A
2N212		2N233A	2N324	2N270
(1297)		2N293	2N406	2N321
		2N314		2N408

*When TR1 is 2N169, resistor R1 is 82K.
When 2N212(1297) is used, R1 is 33K.

TO REMOVE CIRCUIT BOARD

1. Remove screw from the cabinet back.
2. Insert a coin in either slot on the cabinet bottom and twist to remove the cabinet back.
3. Remove screw holding tuning dial.
4. Remove 3 screws under tuning dial to release tuning gang from cabinet front.
5. Remove 3 hexhead screws and one 11/32" nut (bottom center of circuit board) holding circuit board to bosses on cabinet front.
6. Fold tuning gang and circuit board out of cabinet front toward the volume control end. It is not necessary to remove volume control to repair the circuit board.

TO REMOVE VOLUME CONTROL

1. Remove cabinet back.
2. Remove hex head screw from center of volume control knob.
3. Remove chassis.
4. Remove pal nut holding volume control to cabinet front boss.

TO REMOVE SPEAKER

1. Remove cabinet back.
2. Remove chassis.
3. Unsolder speaker wires.
4. Remove clips holding speaker to cabinet front.

TROUBLE SHOOTING

A check of battery current drain will indicate if a receiver is operating properly. To measure the current drain, remove cabinet back, unsnap ground section of battery terminal and swing away from battery. Connect milliammeter between battery terminal and battery contact.

The total current drain should be between 19.0 and 24.0 ma. The current drain is measured with no-signal-conditions (tuning gang closed) and volume control at maximum.

If an excessive current drain is recorded, the individual collector current readings should be checked on each transistor. Current drain is an important indication of the transistor operating conditions.

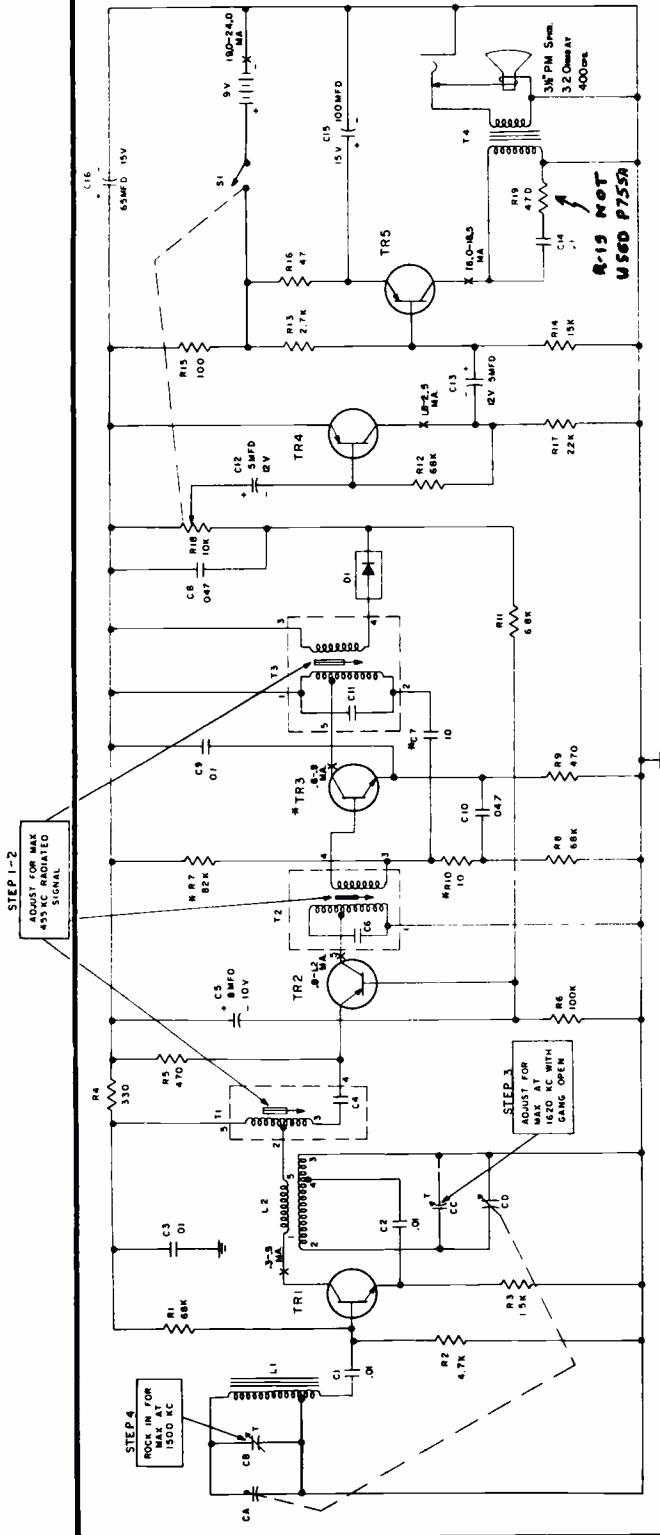

ALIGNMENT
SET VOLUME CONTROL AT MAXIMUM
CONNECT OUTPUT METER OR SCOPE
ALTERNATELY TO EACH OF THE
INDIVIDUALLY COUPLED SIGNAL GENERATOR
TO RECEIVER
STEP 1B-2 - SET SIG. GEN. AT 455 KC.
WITH RECEIVER TUNING GANG OPEN.
STEP 3 - SET SIG. GEN. AT 1620 KC.
WITH TUNING GANG OPEN.
STEP 4 - SET SIG. GEN. AT 1500 KC.
TUNE RECEIVER TO 1500 KC.

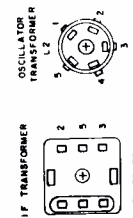

UNLESS OTHERWISE NOTED...
CAPACITORS MORE THAN 1.0 MF
CAPACITORS LESS THAN 1.0 MF
RESISTORS ARE IN OHMS UNLESS OTHERWISE NOTED
MEASURE COLLECTOR CURRENTS WITH A
MILLIAMMETER INSERTED IN BATTERY WITH
BATTERY CURRENT AT POINT MARKED "X"
IN BATTERY CIRCUIT
WHEN TR1 IS 2N194
R7-47K
R10 IS REPLACED BY A JUMPER

GENERAL ELECTRIC COMPANY

Models P671A,B, P672A,B, P673A,B, P674B

SPECIFICATIONS

CABINETS: (Plastic)	Models P671A,B - Black and White Models P672A,B - White and Terra Cotta Models P673A,B - Turquoise and White Model P674B - Green
ELECTRICAL RATING:	105-120 Volts A-C (50 to 60 cycles) or DC 1 "A" battery - 7 1/2 volt Eveready No. 717 or equivalent 1 "B" Battery - 90 Volt Eveready No. 479 or equivalent
OPERATING FREQUENCIES:	Tuning range 540-1600 KC I-F 455 KC

CHASSIS REMOVAL:

The chassis is easily removed by means of the following procedure:

1. Swing down cabinet front by grasping front at top edge under handle.
2. Remove tuning and volume control knobs by pulling straight off their shafts.
3. Remove the two small Phillips-head screws from the top rear edge of the metal chassis mounting bracket.
4. Slide chassis and bracket out of cabinet.
5. Remove bracket from chassis by unscrewing the 1/4" mounting screw from the bracket.

The power supply chassis is removed from the cabinet by removing the four small hex-head mounting screws.

The speaker is mounted on the cabinet front and may be removed by taking off the four speaker mounting clips which secure the speaker to the four bosses on the inside of the cabinet front.

IMPORTANT: Use care when replacing defective parts. Apply as little heat to terminals and connections as possible to remove parts, as excessive heat will damage the plated wiring on the chassis boards.

When replacing knobs, do not force them on, as too much pressure may cause circuit board to bend and crack.

VOLUME CONTROL REPLACEMENT:

The chassis must first be removed from the cabinet as described under CHASSIS REMOVAL, then replace volume control as follows:

1. Cut off the three control lugs and the four on-off lugs.
2. Heat the remaining part of the lugs on the circuit board and pull out with long-nose pliers.
3. Clean all mounting holes of all excess solder.
4. The volume control on-off switch (catalog no. RRC-367) is used as the replacement. This control has a combined mounting bracket which can be mounted with the control on the circuit board. There are four holes on the board in which the mounting bracket can be inserted and soldered on the dip-soldered side of the circuit board.

TO REPLACE A TUBE SOCKET:

Cut the socket free by cutting all of the socket terminals at the chassis. One socket (V2) has a center terminal which must be unsoldered. Now, heat the pieces of terminals remaining in the board only enough so they may be pushed out. The new socket can now be inserted into the holes left by the old one and soldered into place.

BATTERY INSTALLATION:

Insert batteries in place as shown in the Tube and Battery location illustration. Make sure the battery connections are well seated.

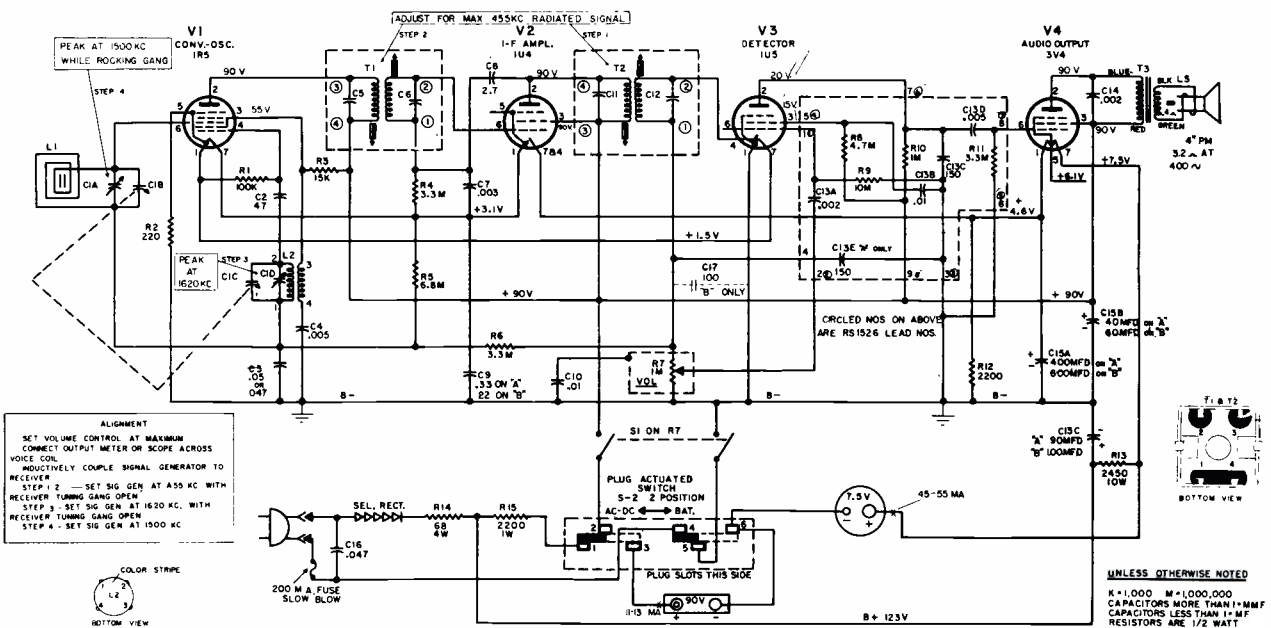

GENERAL ELECTRIC COMPANY

Model RP1110A

SPECIFICATIONS

ELECTRICAL RATING:	105-120 Volts 60 Cycle AC 45 Watts
POWER OUTPUT:	Undistorted: 1.5 Watts Maximum: 2 Watts
RECORD CHANGER:	Model CH10 four speed automatic with 90 Volt AC motor
PHONOGRAPH PICK-UP:	Dual Sapphire Stylus Astatic 81T or equivalent

TROUBLESHOOTING

The tube filaments and changer motor are connected in series. An open filament in an amplifier tube will prevent the operation of the changer motor. Be sure the tubes are operating properly before troubleshooting changer.

The input AC voltage rating of the changer is 90 volts. When testing a changer disconnected from amplifier, a 100 ohm 10 watt resistor may be used as a substitute in place of tube filaments, or a variac set at 90 volts must be inserted between changer and power line. Do not plug changer into a 105-120 volt outlet.

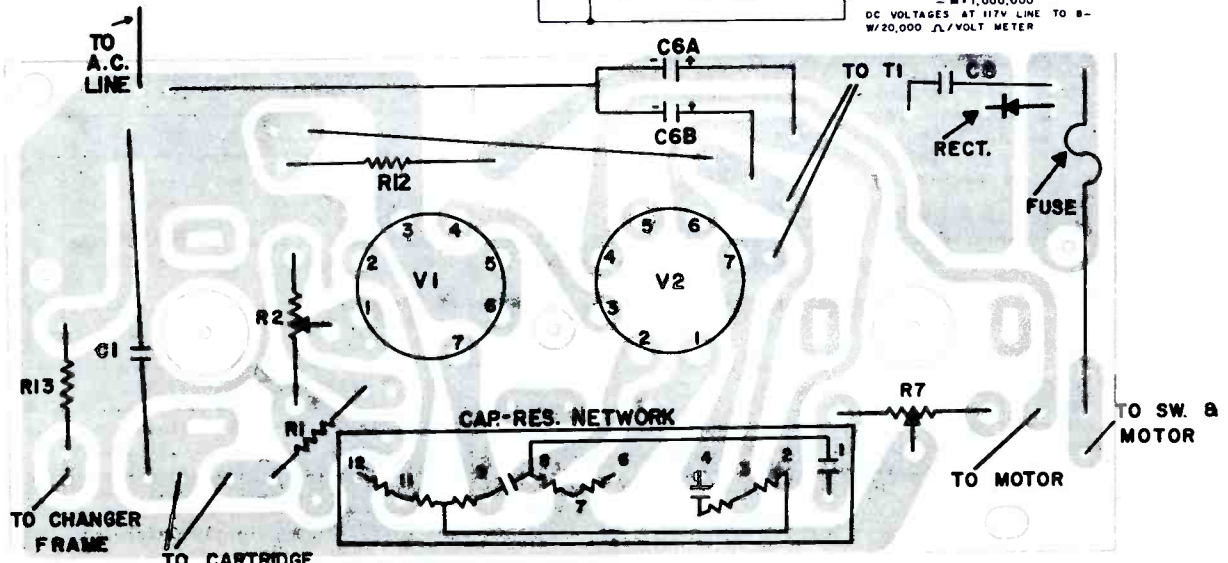
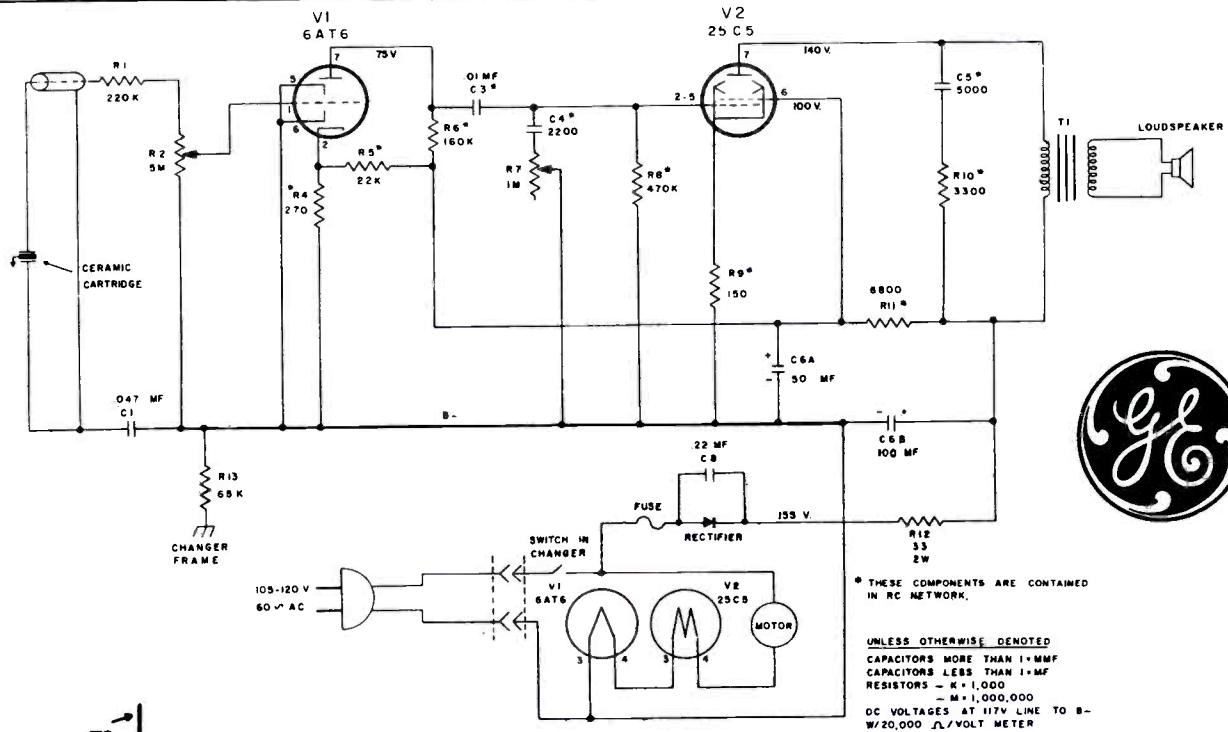

COMPONENT LOCATIONS - BOTTOM VIEW - RP-1110A

GENERAL ELECTRIC COMPANY Models RP1120A, RP1120B

TO REPLACE TUBES

1. Open cabinet lid.
2. Remove screws holding vent panel board and interlock.
3. Remove vent panel board (interlock is automatically disconnected.)

TO REMOVE AMPLIFIER CHASSIS

1. Follow steps 1 through 3 as above.
2. Remove loudness and tone knobs.
3. Loosen screws on interlock bracket; slide interlock out of mounting slot. (Mark location of bracket on cabinet before removing so that bracket can be "keyed" to correct location when replacing.)

4. Remove the three hexhead nuts from screws on cabinet brace above speakers and the three hexhead nuts from screws on cabinet brace under speakers.
5. Lift out grille (with all electronic components) and place down in front of cabinet carefully.
6. Unscrew two clamps holding wires from chassis to changer.
7. Remove amplifier chassis by unscrewing the three screws holding chassis to grille.
Before replacing knobs, turn control shafts fully counterclockwise; press on knobs with the knob indicator dot to the left of center at the bottom.

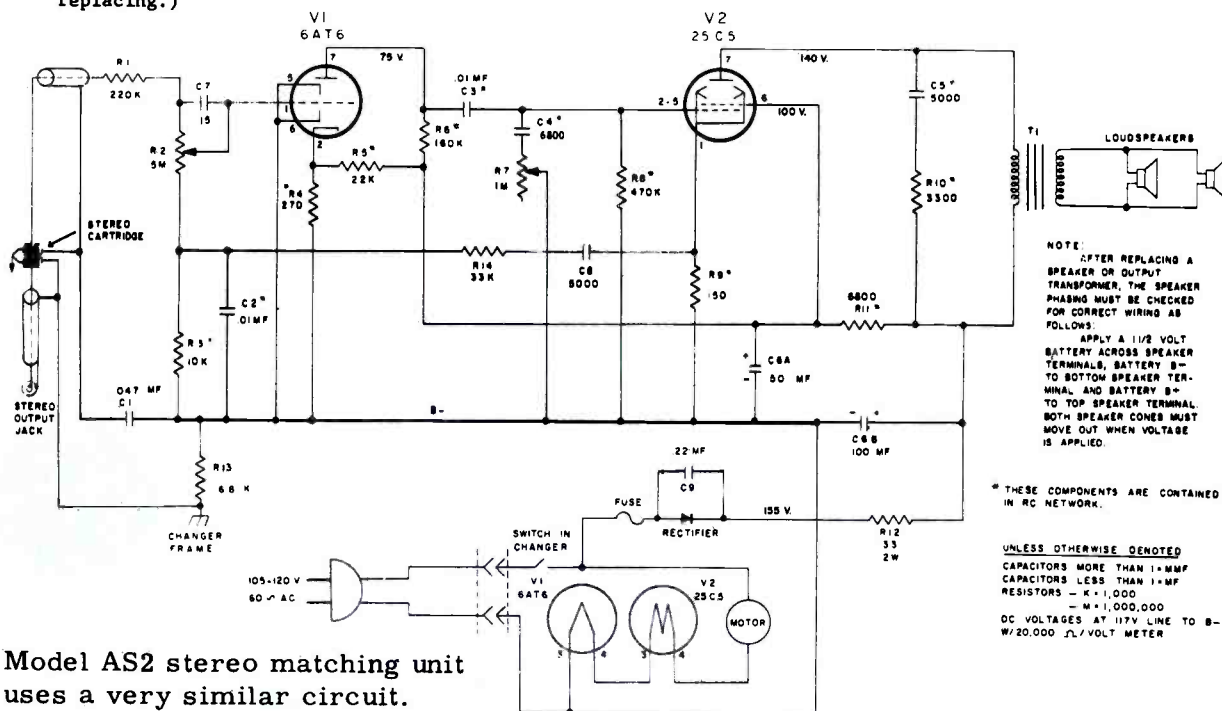

Model AS2 stereo matching unit uses a very similar circuit.

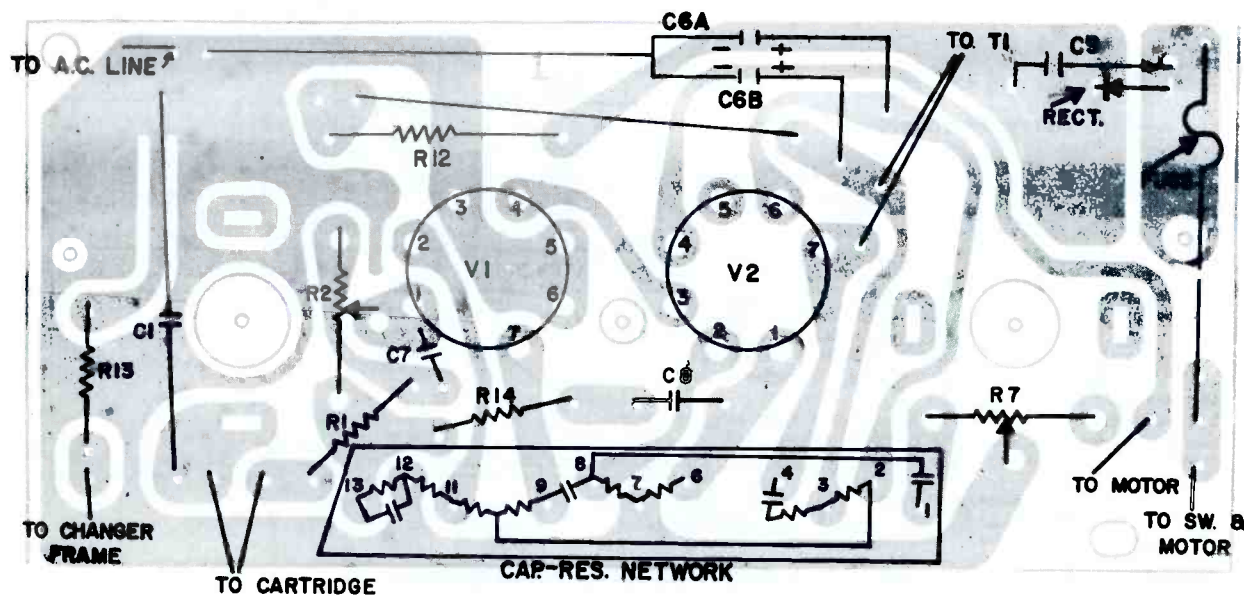

COMPONENT LOCATIONS - BOTTOM VIEW

GENERAL ELECTRIC

RADIO/PHONO
MODEL
RP1160A

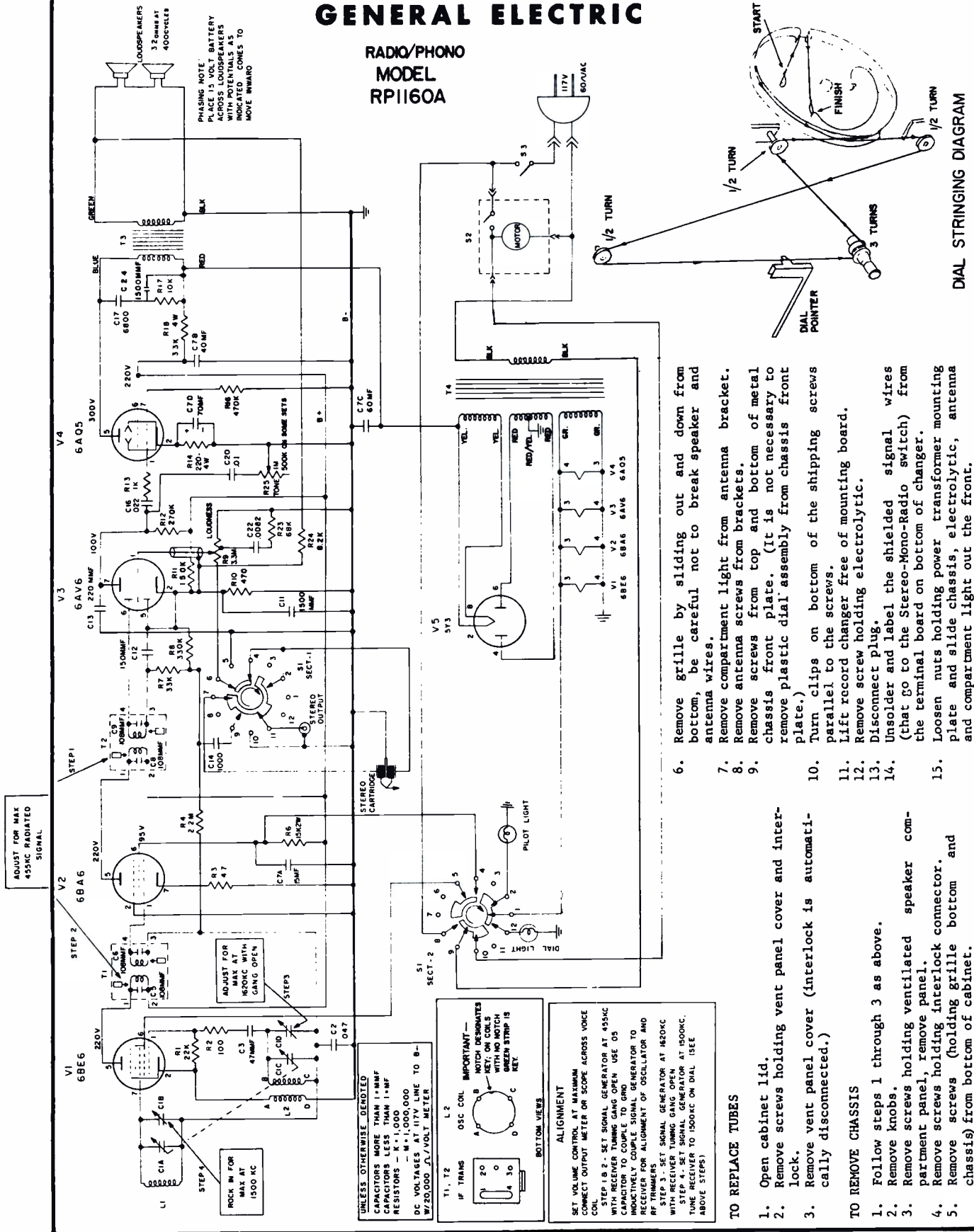

GENERAL ELECTRIC COMPANY

MODELS
RT1230A
RT1231A

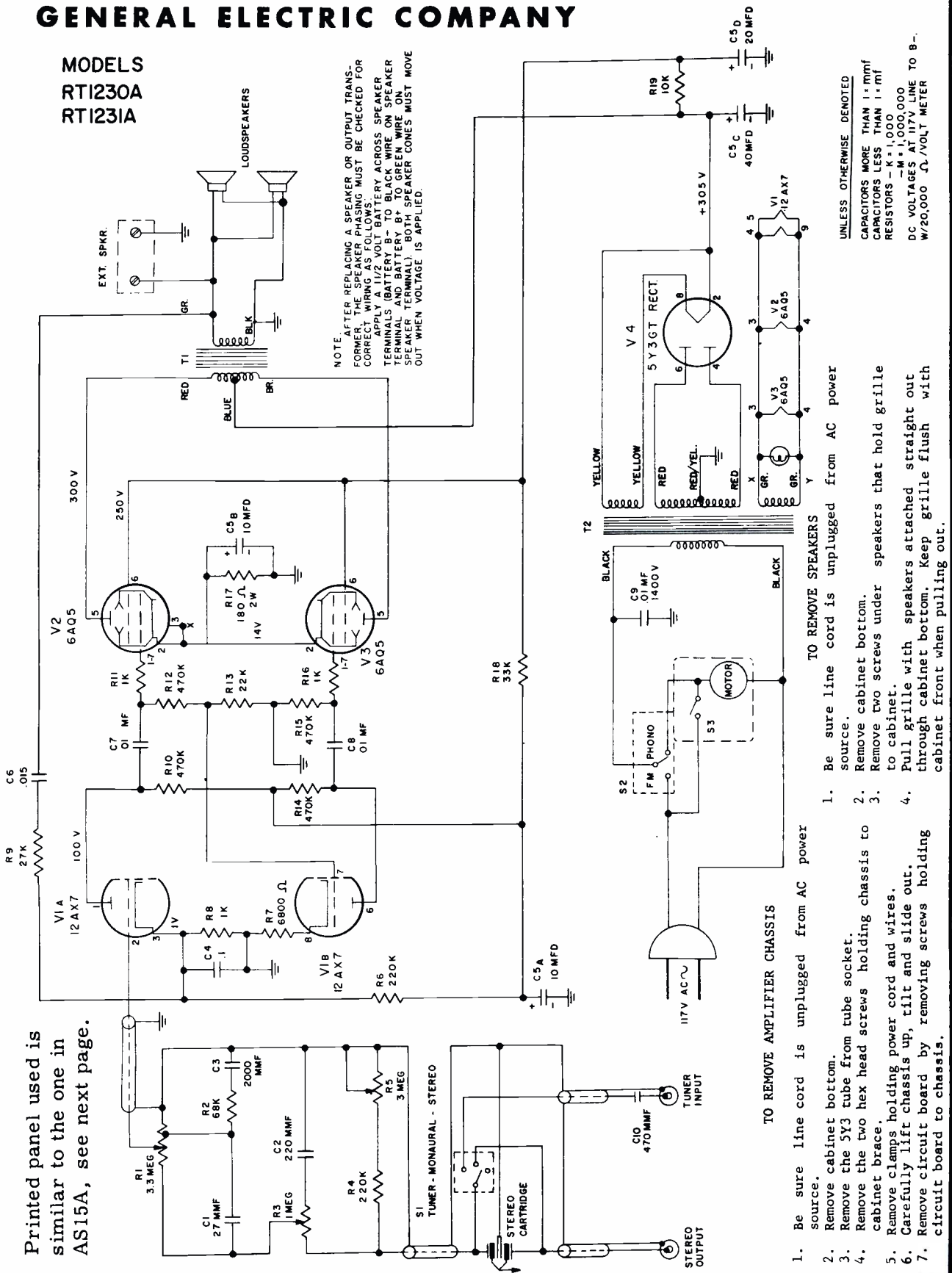

NOTE: AFTER REPLACING A SPEAKER OR OUTPUT TRANSFORMER, THE SPEAKER PHASING MUST BE CHECKED FOR CORRECT WIRING AS FOLLOWS: APPLY A 1 1/2 VOLT BATTERY ACROSS SPEAKER TERMINALS (BATTERY B- TO BLACK WIRE ON SPEAKER TERMINAL, BATTERY A- TO GREEN WIRE ON SPEAKER TERMINAL). IF BOTH SPEAKER CONES MUST MOVE OUT WHEN VOLTAGE IS APPLIED.

UNLESS OTHERWISE DENOTED
CAPACITORS MORE THAN 1 mmf
CAPACITORS LESS THAN 1 mmf
RESISTORS - K = 1,000
- M = 1,000,000
DC VOLTAGES AT 117V LINE TO B-
W/20,000 Ω/VOLT METER

- TO REMOVE AMPLIFIER CHASSIS**
1. Be sure line cord is unplugged from AC source.
 2. Remove cabinet bottom.
 3. Remove the 5Y3 tube from tube socket.
 4. Remove the two hex head screws holding chassis to cabinet brace.
 5. Remove clamps holding power cord and wires.
 6. Carefully lift chassis up, tilt and slide out.
 7. Remove circuit board by removing screws holding circuit board to chassis.
- TO REMOVE SPEAKERS**
1. Be sure line cord is unplugged from AC power source.
 2. Remove cabinet bottom.
 3. Remove two screws under speakers that hold grille to cabinet.
 4. Pull grille with speakers attached straight out through cabinet bottom. Keep grille flush with cabinet front when pulling out.

GENERAL ELECTRIC

Models AS15A and AS16A

SPECIFICATIONS

CABINET:	AS15A - Mahogany AS16A - Blond Oak
ELECTRICAL RATING:	105-120 volts 60 cycles AC 75 watts
POWER OUTPUT:	Maximum 10 watts 10% Distortion 8 watts

TO REMOVE CHASSIS FROM CABINET

1. Remove cabinet back.
2. Remove two screws holding chassis to cabinet.
3. Unscrew clamps holding connecting wires and remove screws holding electrolytic condenser and output transformer.
4. Pull pilot light holder off bracket.
5. Remove Chassis.

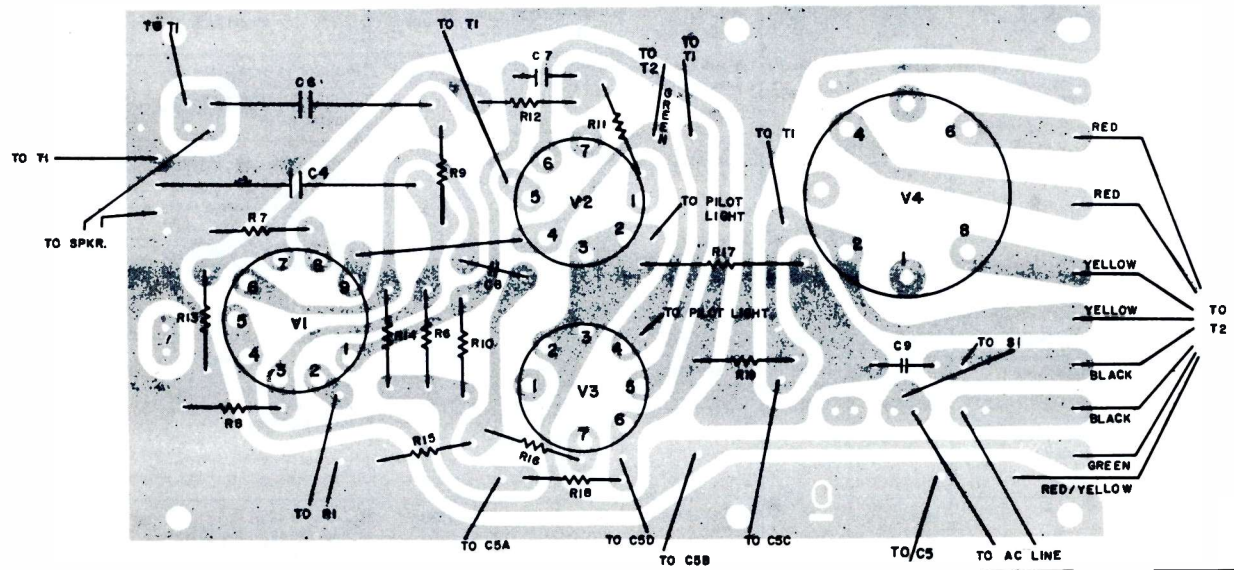
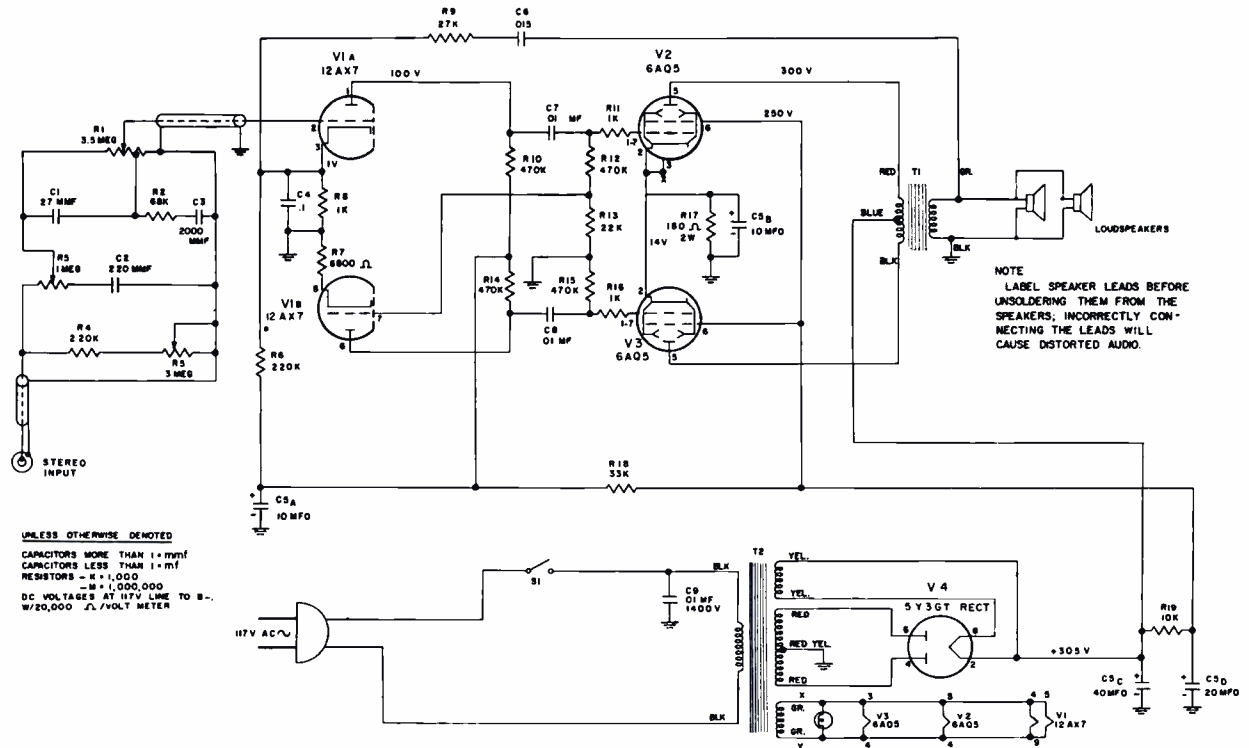

GRANCO PRODUCTS INC. MODEL 701 FM-AM RADIO

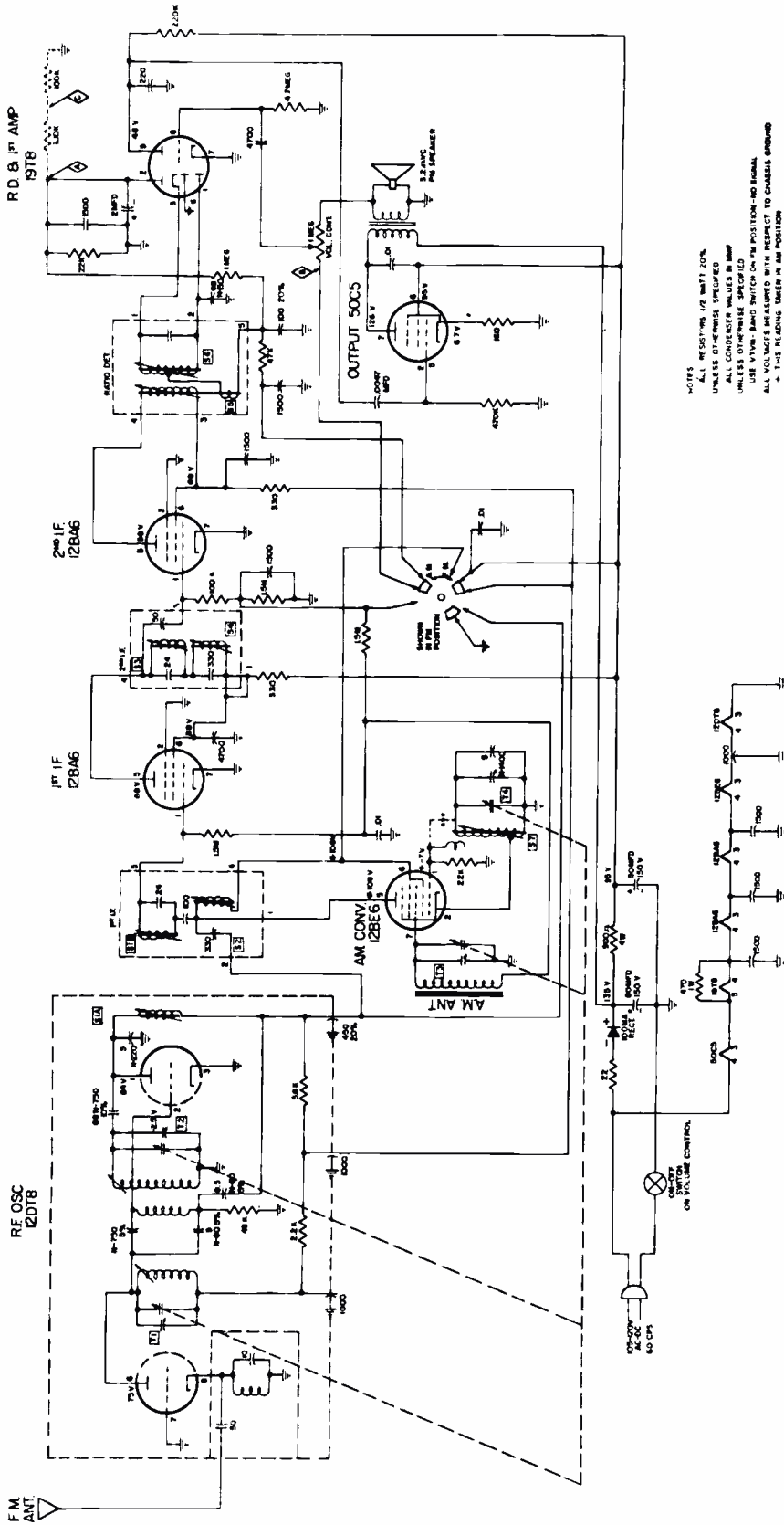

NOTES:
 ALL RESISTORS 1/2 WATT 20%
 UNLESS OTHERWISE SPECIFIED
 ALL CONDENSER VALUES IN MICROFARADS
 UNLESS OTHERWISE SPECIFIED
 USE VOLUME BAND SWITCH ON FM POSITION-NO SIGNAL
 ALL VOLTAGES MEASURED WITH RESPECT TO CHASSIS GROUND
 * THIS RELAYING TUBE IN FM POSITION

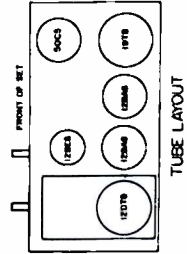

AM IF & RF ALIGNMENT

SIGNAL GENERATOR COUPLING	SIGNAL GEN. FREQ.	BAND SWITCH POS.	RADIO DIAL SETTING	CONNECT	ADJUST	REMARKS
TO PIN 7 (GRID) OF 12BE6.	455KC (400 MOD.)	AM	TUNING GANG FULLY OPEN.	ACROSS VOICE COIL	S4, S2	ADJUST FOR MAXIMUM DEFLECTION.
LOOP (RADIATED)	610KC	"	TUNE TO 610KC SIGNAL	"	S7	ADJUST FOR MAXIMUM DEFLECTION. WHILE ROCKING TUNING GANG.
"	1650KC	"	TUNING GANG FULLY OPEN.	"	T3, T4	ADJUST FOR MAXIMUM DEFLECTION. REPEAT STEPS 1, 2, & 3.

For FM alignment information see instruction under Model 601, on preceding page, which can be applied to this set as well.

MONTGOMERY WARD & CO.
 MODELS GEN-1115A, GEN-1116A

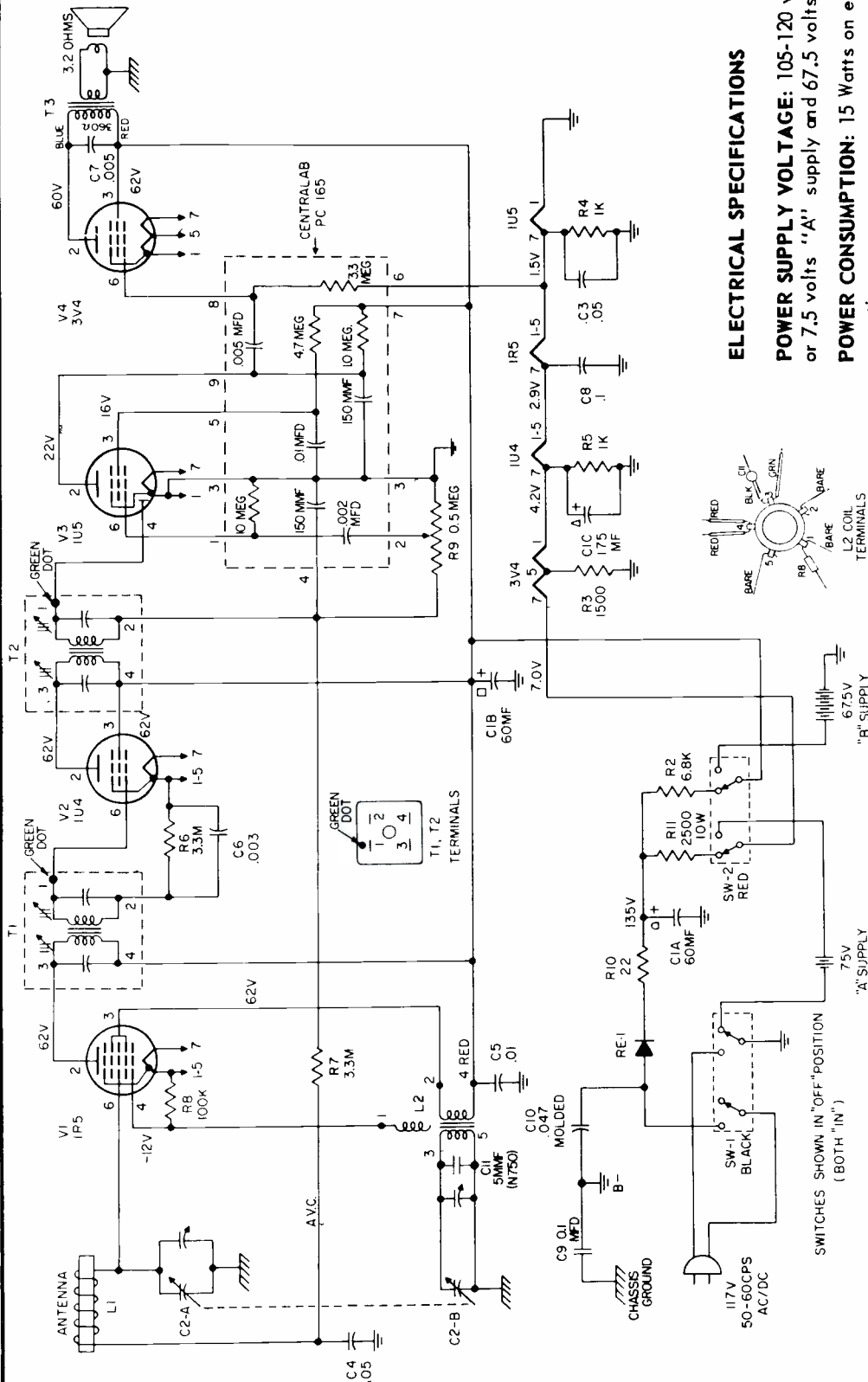

ELECTRICAL SPECIFICATIONS

POWER SUPPLY VOLTAGE: 105-120 volts AC/DC or 7.5 volts "A" supply and 67.5 volts "B" supply
POWER CONSUMPTION: 15 Watts on electrical operation.

BATTERY DRAIN: 50 MA at 7.5 V and 12 MA at 67.5 V.

TUNING RANGE: 540 KC-1620 KC

I.F. STAGE: 455 KC

LOUDSPEAKER: 4" PM

VOICE COIL IMPEDANCE: 3.2 ohms at 400 CPS

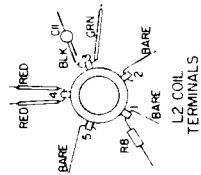

BLACK	RED
SW-1	SW-2
OFF	IN
BATTERY	IN
AC/DC	OUT

NOTE:
 ALL VOLTAGE READINGS MADE WITH VTVM.
 GROUND OF VTVM AT B- LINE VOLTAGE
 117 VOLTS 60 CYCLES. VOLUME CONTROL
 AT MAXIMUM CLOCKWISE POSITION WITH
 NO SIGNAL. ALL RESISTANCE READINGS
 MADE WITH RESPECT TO B-.

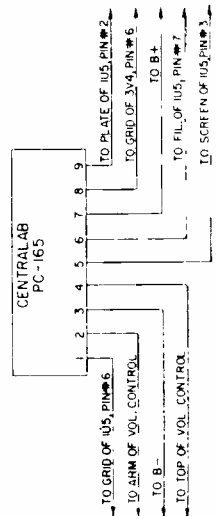

VOLUME R-19, MOST-OFTEN-NEEDED 1959 RADIO SERVICING

MONTGOMERY WARD & CO.

Model 1120A, -B

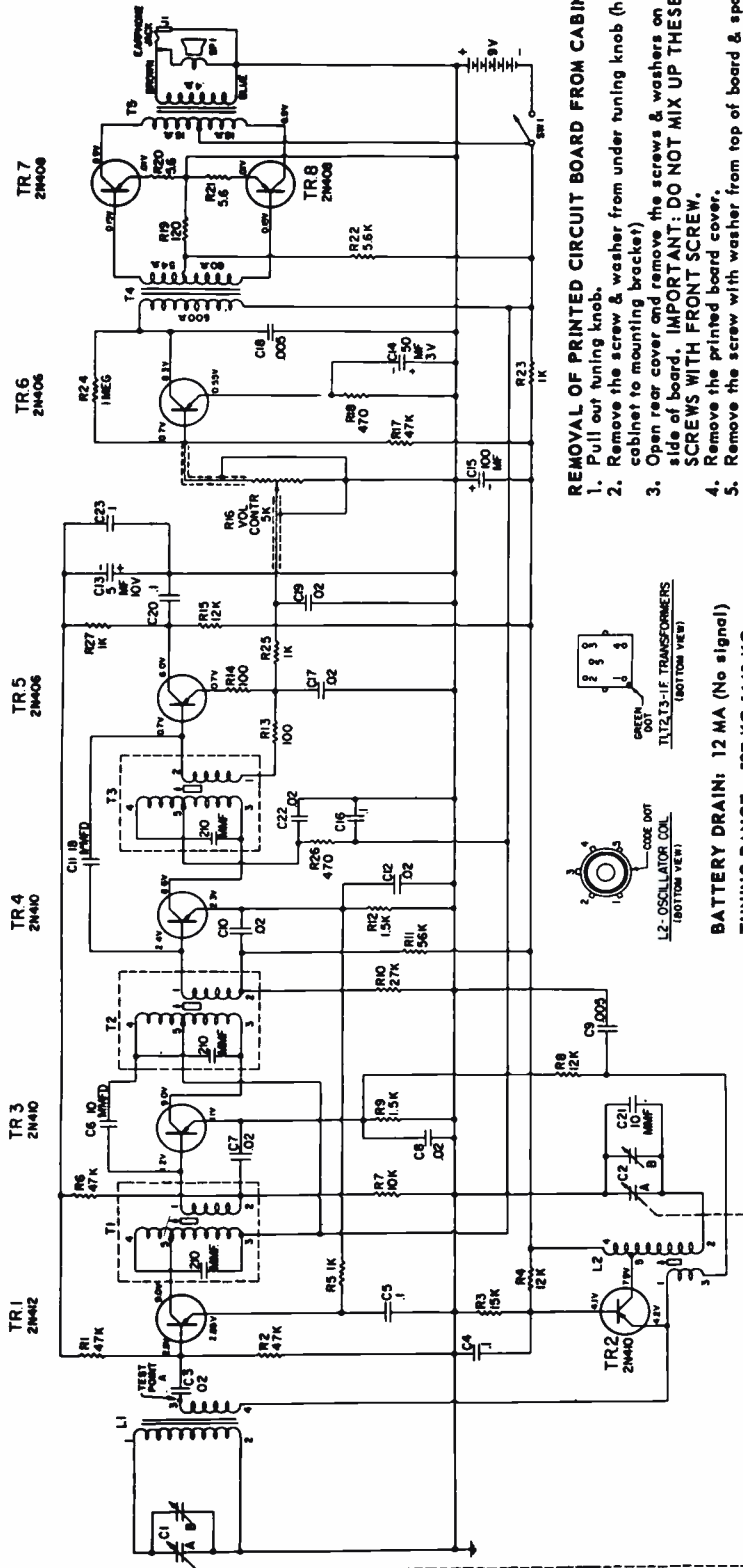

REMOVAL OF PRINTED CIRCUIT BOARD FROM CABINET

1. Pull out tuning knob.
2. Remove the screw & washer from under tuning knob (holding cabinet to mounting bracket).
3. Open rear cover and remove the screws & washers on each side of board. **IMPORTANT: DO NOT MIX UP THESE SCREWS WITH FRONT SCREW.**
4. Remove the printed board cover.
5. Remove the screw with washer from top of board & spacer beneath board (holding board out of speaker).
6. Lift the printed board out of cabinet.
7. Unsolder speaker leads, if servicing requires removal of board from cabinet.

BATTERY DRAIN: 12 MA (No signal)
TUNING RANGE: 537 KC-1640 KC
I. F. STAGES: 455 KC

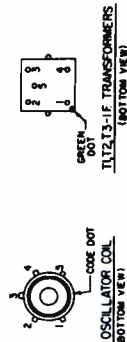

NOTES:
 1. VALUES SHOWN AT EACH TRANSISTOR ELECTRODE LOCATED MEASURED TO COMMON GROUND WITH A VTVM WITH NO INPUT SIGNAL AND VOLUME CONTROL SET TO MAXIMUM.
 2. ALL CAPACITANCE VALUES ARE IN MICROFARADS UNLESS OTHERWISE SPECIFIED.
 3. ALL RESISTANCE VALUES ARE IN OHMS, UNLESS OTHERWISE SPECIFIED.

TOP VIEW OF BOARD SHOWING ALIGNMENT ADJUSTMENT LOCATIONS.

- 1) 1st I.F.
- 2) OSC. COIL
- 3) TRIM. C1B
- 4) TRIM. C2B
- 5) 2nd I.F.
- 6) 3rd I.F.

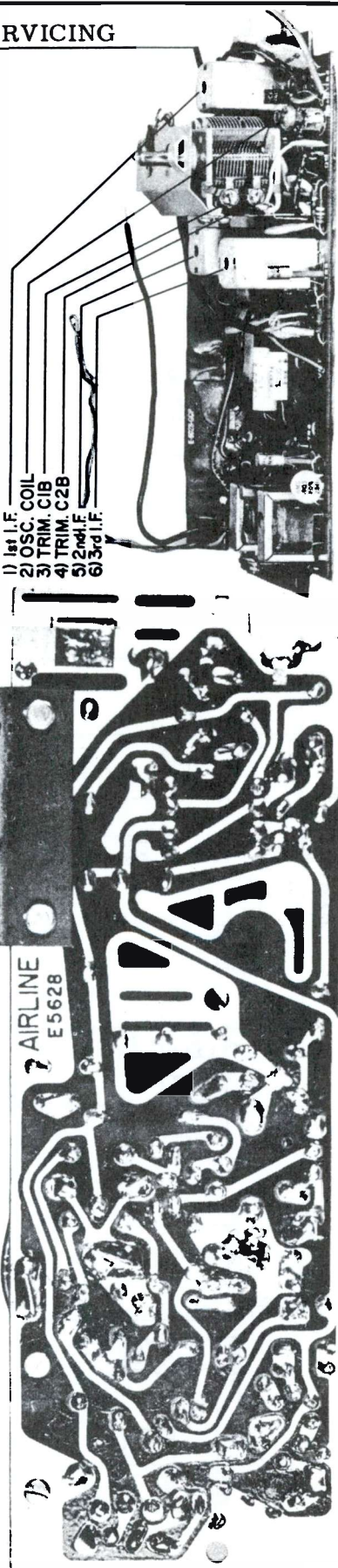

MONTGOMERY WARD & CO.
Model GEN-1628A

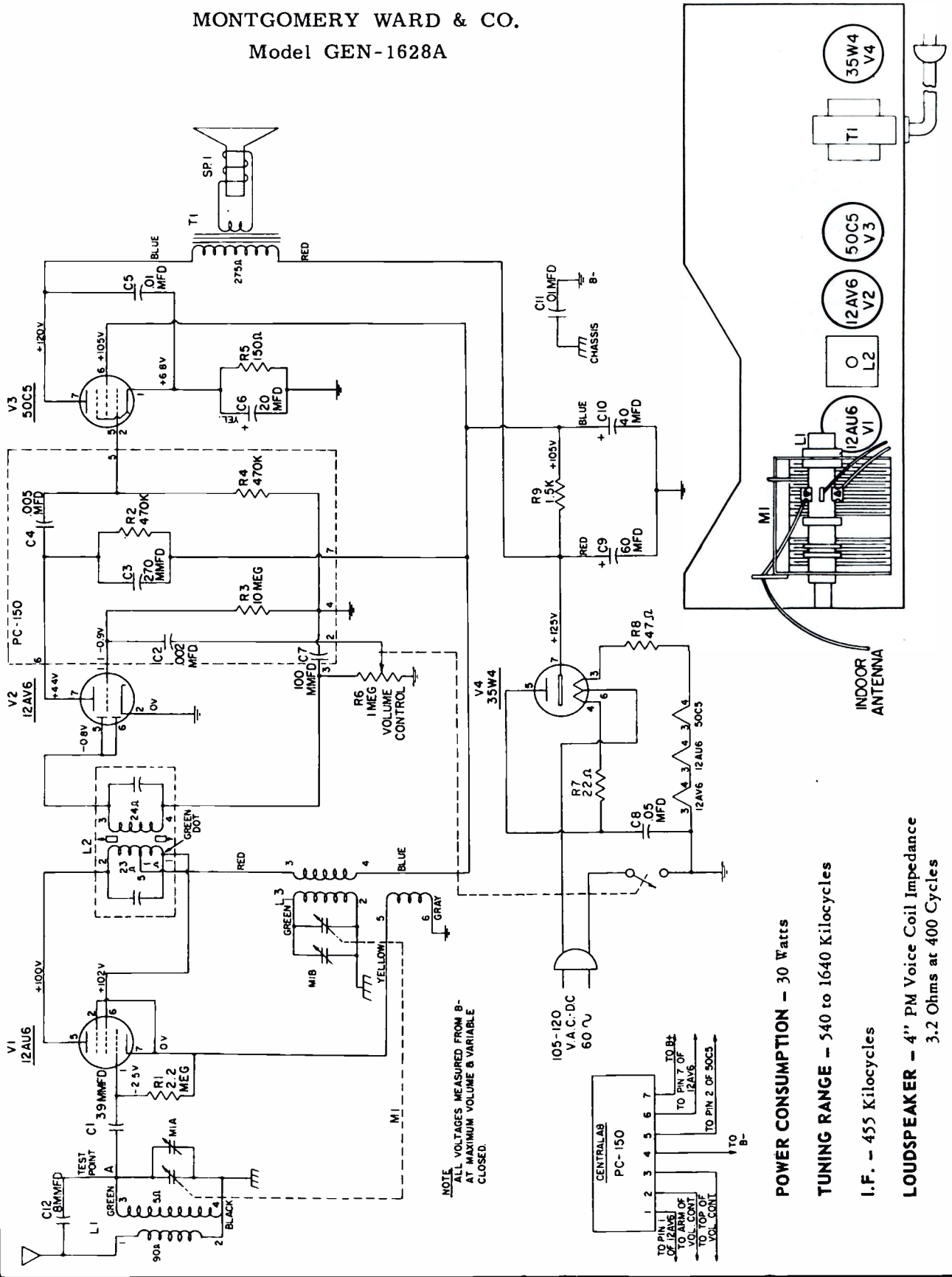

NOTE
ALL VOLTAGES MEASURED FROM B-
AT MAXIMUM VOLUME & VARIABLE
CLOSED.

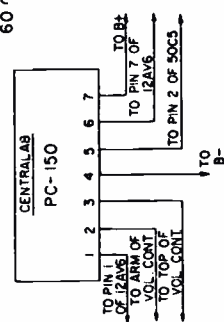

POWER CONSUMPTION - 30 Watts
TUNING RANGE - 540 to 1640 Kilocycles
I.F. - 455 Kilocycles
LOUDSPEAKER - 4" PM Voice Coil Impedance
3.2 Ohms at 400 Cycles

MOTOROLA

AUTO RADIO

MODEL
9AX

MMS3 OR 2N652
DRIVER

2N176
PWR AMP

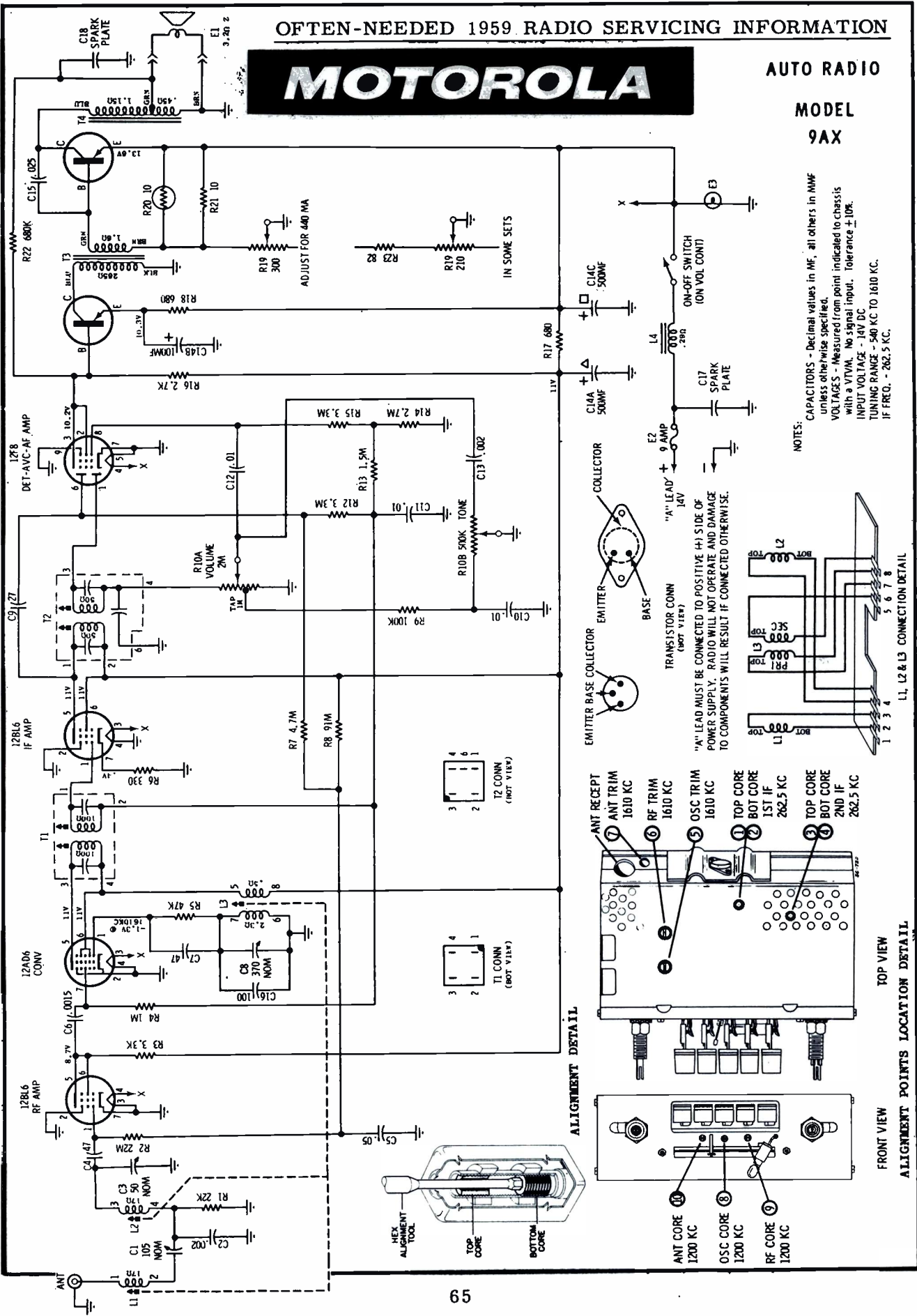

MOTOROLA

Model CTA9X
Models BKA9X, OEA9X, PCA9X,
are electrically very similar to
CTA9X covered on this page.

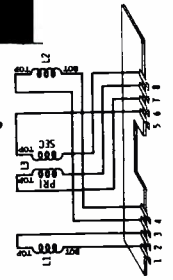
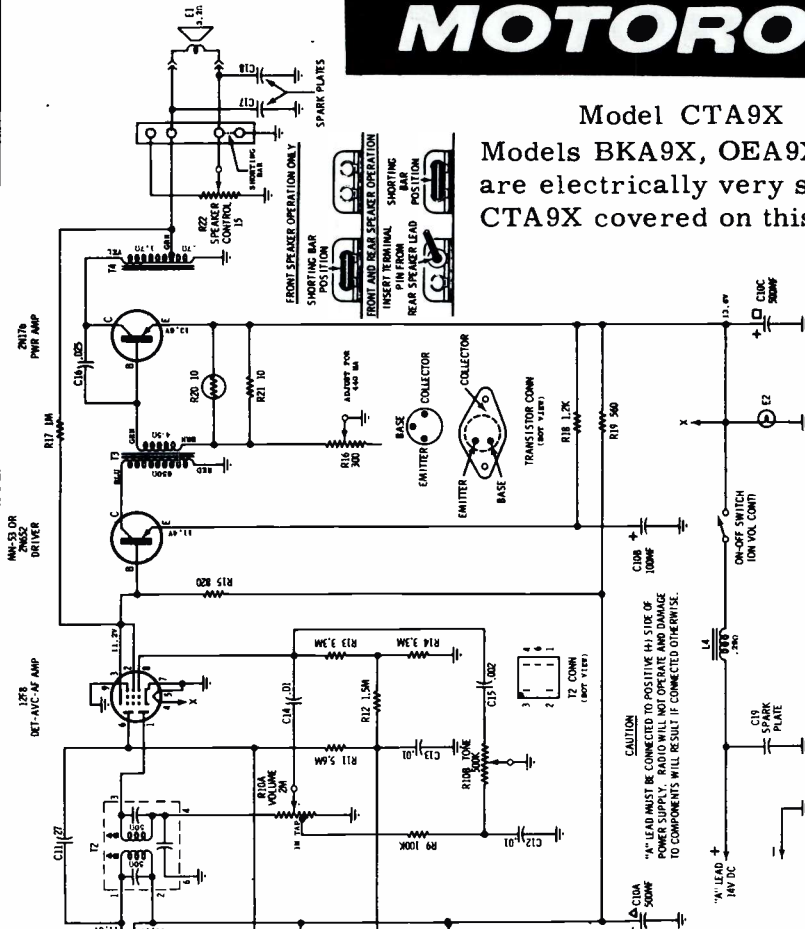

NOTES:
CAPACITORS - Decimal values in MF, all others in MUF
UNLESS OTHERWISE SPECIFIED.
VOLTAGES - Measured from point indicated to CHASSIS
GROUND.
INPUT VOLTAGE - 117V AC
TUNING RANGE - 540 KC to 1610 KC
IF FREQ. - 262.5 KC.

POWER TRANSISTOR CURRENT ADJUSTMENT - After a power transistor has been replaced, the collector current should be checked and adjusted for proper operation.

- a. Connect a 0-3 amp DC ammeter in series with the "A" lead.
- b. Remove output transistor from its socket.
- c. Turn radio on and read ammeter with 12.6 volts input to "A" lead (approximately 800 ma). NOTE READING.
- d. Turn radio off and replace transistor
- e. Turn radio on and adjust R-16 for a 360 ma increase over reading noted in step c with 12.6 volts input to "A" lead.

NOTE: Two values of radio input voltage are given as a convenience to service personnel in order to accommodate different power sources. The current value of 440 ma stated on the schematic is for 14 volts DC input to receiver "A" lead.

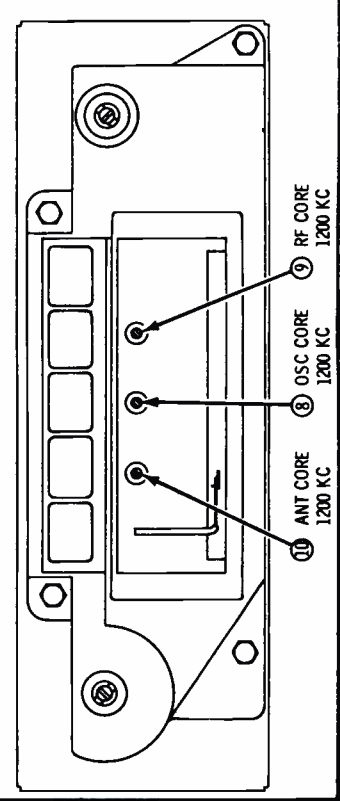
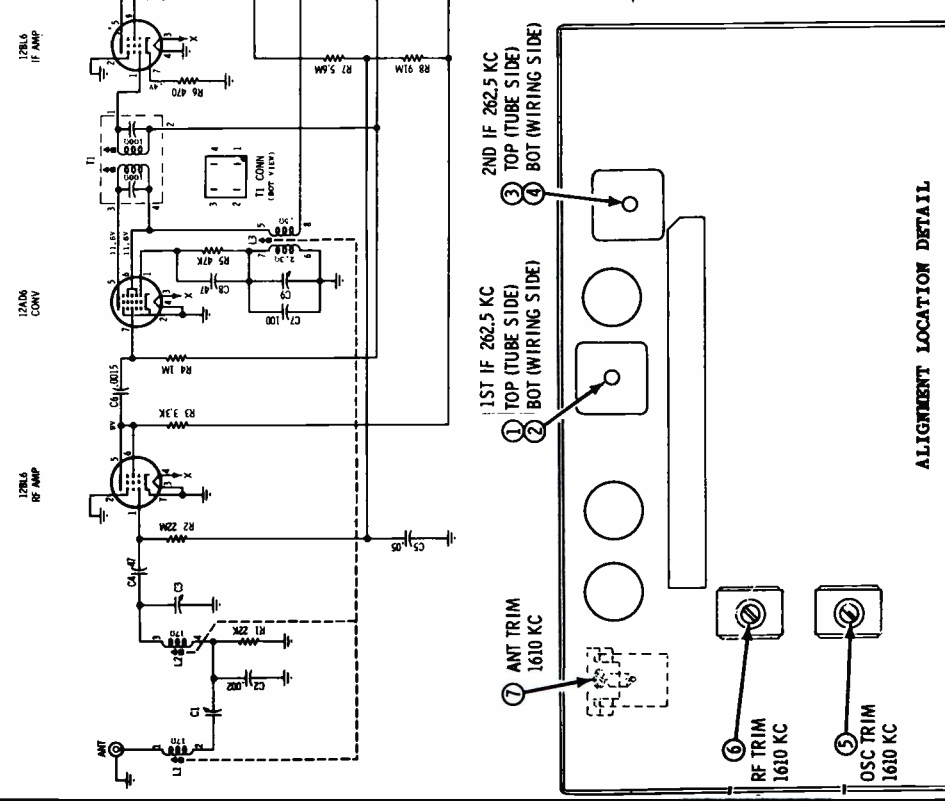

MOTOROLA

MODEL
CTM9X

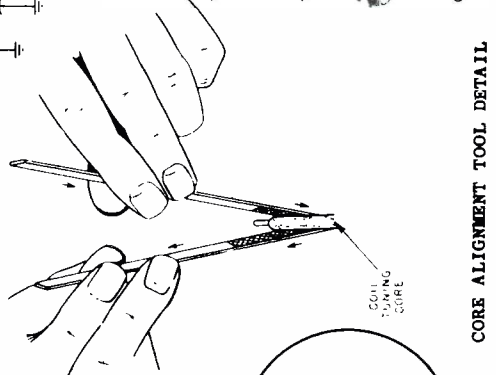
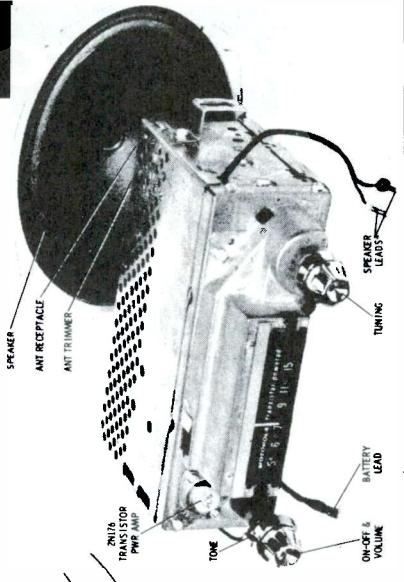
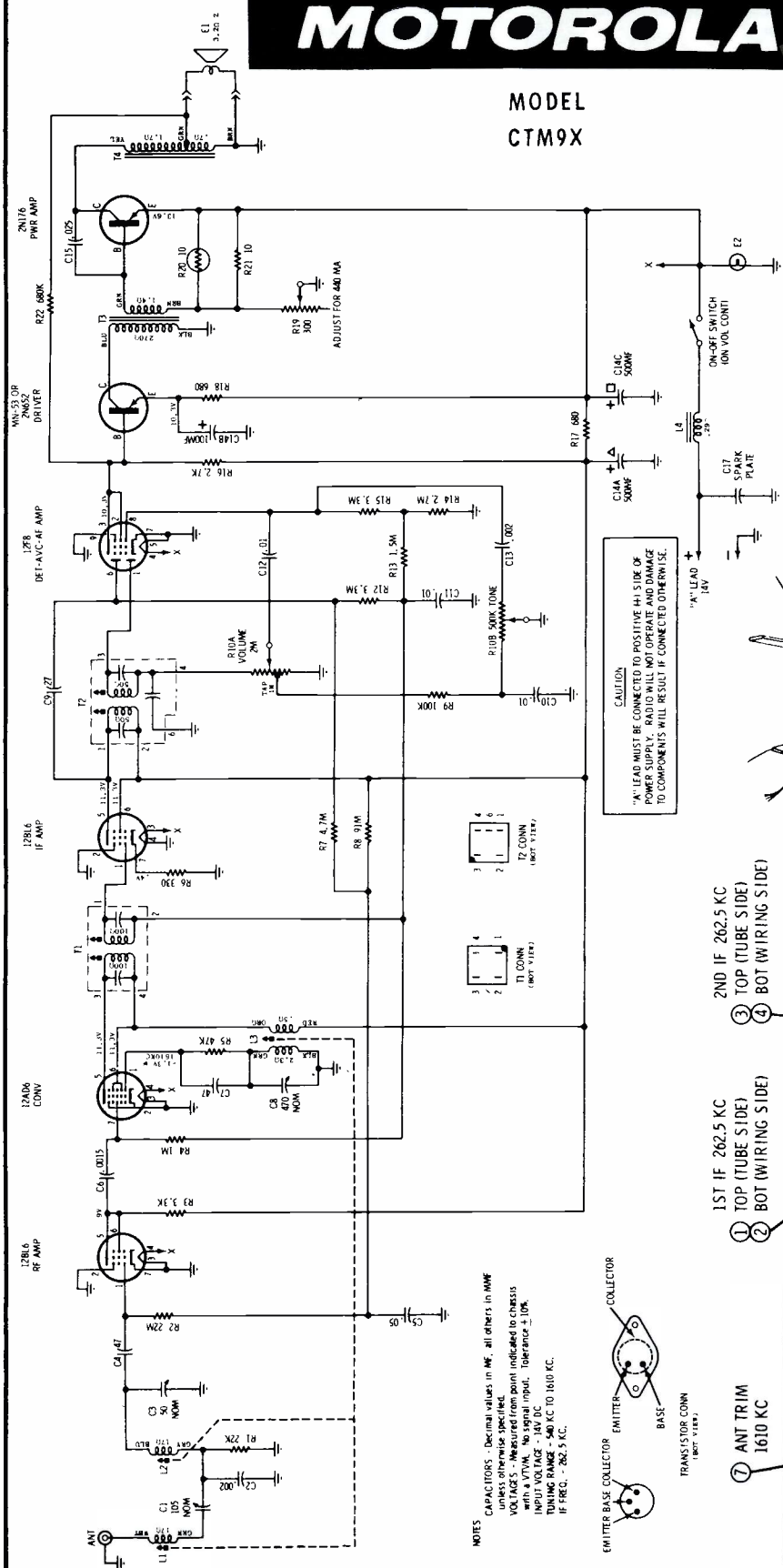

CAUTION
"A" LEAD MUST BE CONNECTED TO POSITIVE (+) SIDE OF POWER SUPPLY. RADIO WILL NOT OPERATE AND DAMAGE TO COMPONENTS WILL RESULT IF CONNECTED OTHERWISE.

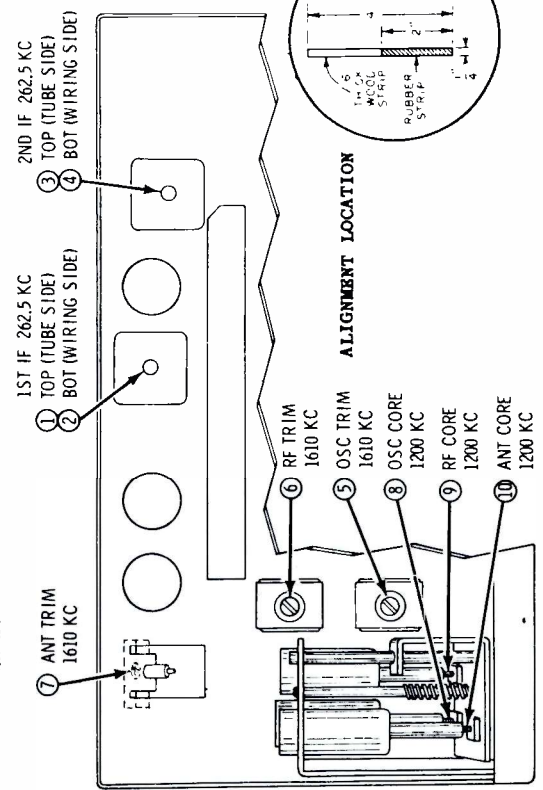

CORE ALIGNMENT TOOL DETAIL

NOTES
CAPACITORS - Decimal values in μ F, all others in MMF unless otherwise specified.
VOLTAGE MEASURED FROM POINT INDICATED TO CHASSIS UNLESS OTHERWISE NOTED.
INPUT VOLTAGE - 117V AC
TUNING RANGE - 540 KC TO 1610 KC.
IF FREQ. - 262.5 KC.

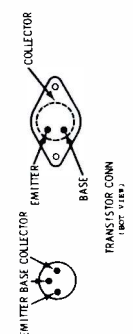

MOTOROLA

MODEL
AMERICAN MOTORS 8990582
MOTOROLA 93MR

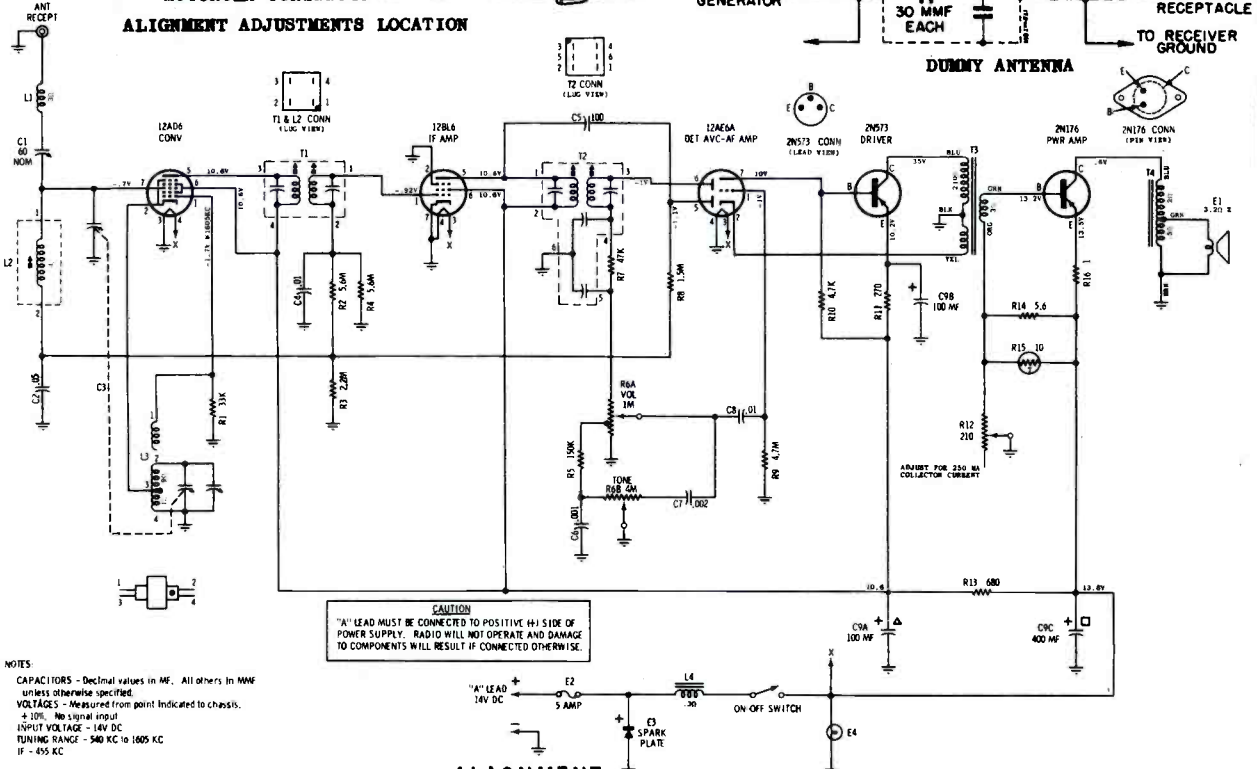
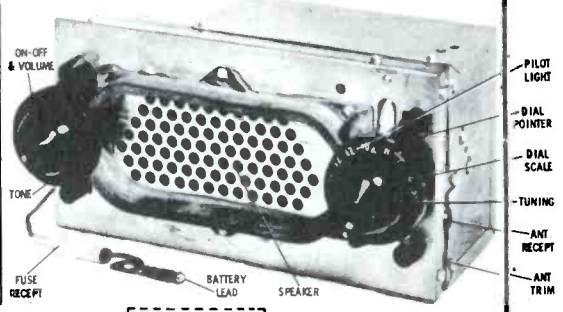
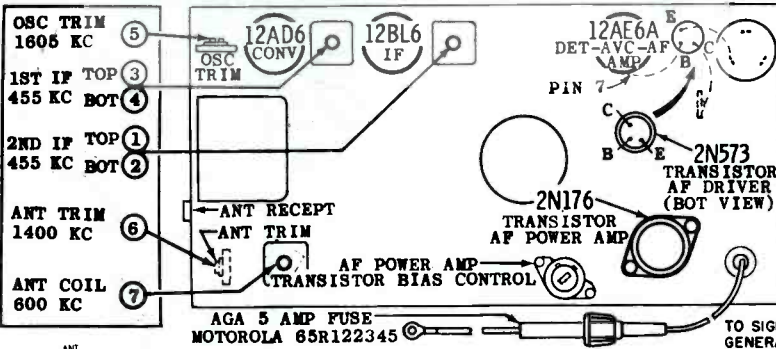

NOTES
CAPACITORS - Decimal values in MF. All others in MMF unless otherwise specified.
VOLTAGES - Measured from point indicated to chassis.
+10% No signal input
INPUT VOLTAGE - 14V DC
TUNING RANGE - 540 KC to 1605 KC
IF - 455 KC

ALIGNMENT

Connect an output meter across the speaker voice coil. Set tone control to high and volume to maximum. Attenuate signal generator output to maintain 1.3 volts on output meter to prevent overloading the receiver.

STEP	GENERATOR CONNECTION	GENERATOR FREQUENCY (400 cycle mod)	GANG SETTING	ADJUST	REMARKS
IF ALIGNMENT					
1.	Ant recept through .1 mf & chassis	455 Kc	Fully open	1, 2, 3 & 4	Peak for maximum.
RF ALIGNMENT					
2.	Ant recept through dummy antenna	1605 Kc	Fully open	5	Peak for maximum.
3.	"	1400 Kc	Tune for max	6	Peak for maximum.
4.	"	600 Kc	Tune for max	7	Peak for maximum while rocking gang.
5.	Repeat steps 3 & 4 until no further increase. The last adjustment should be the trimmer (6).				
ANTENNA TRIMMER					
6.	-	-	Tune to a weak station around 1400 Kc	6	With radio installed in car and antenna fully extended, peak antenna trimmer for max.

MOTOROLA

MODEL
AMERICAN MOTORS 8990576
MOTOROLA 94MA

VC
FOR ONE WATT OUTPUT
125V @ 400 CYCLES AT GRID OF 12A6GA
40X
262.5 KC TO 400 CYCLES
70X
1000 KC TO 262.5 KC
3.3X
1000 KC
6.3X
1000 KC
ANT

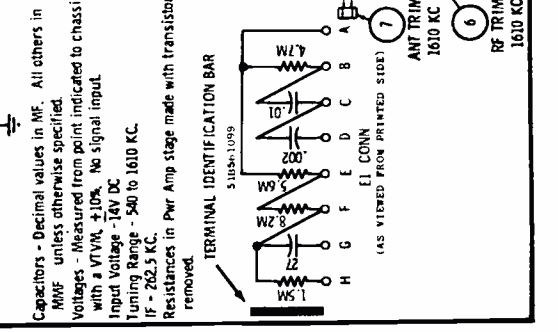
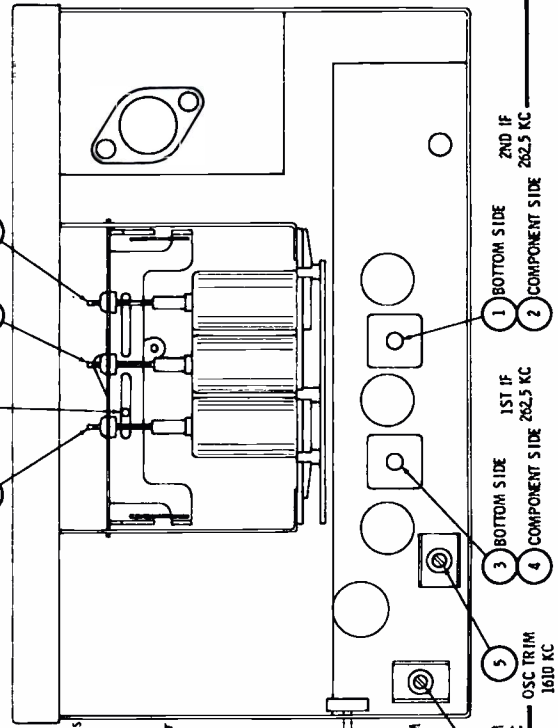
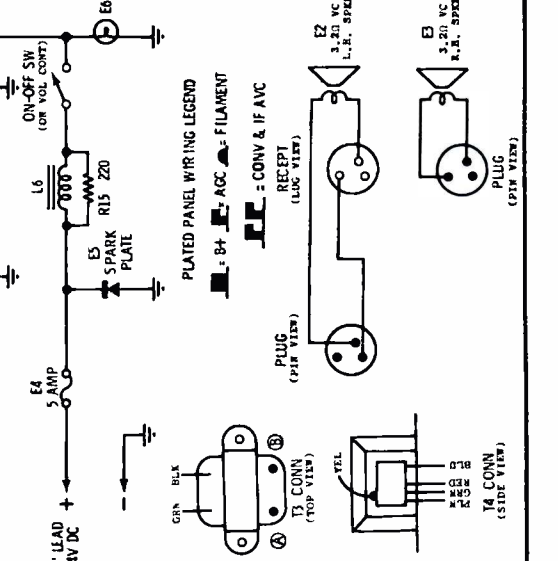
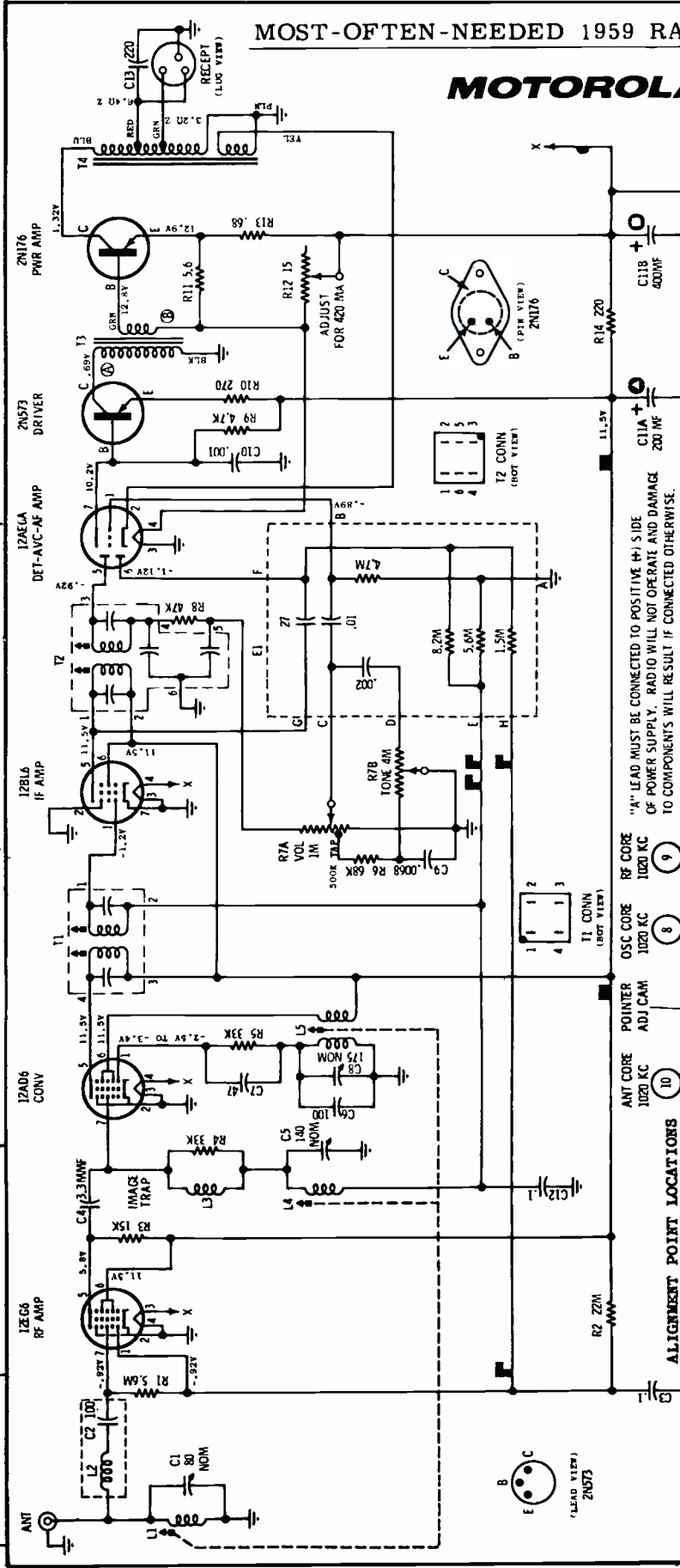

"A" LEAD MUST BE CONNECTED TO POSITIVE (+) SIDE OF POWER SUPPLY. RADIO WILL NOT OPERATE AND DAMAGE TO COMPONENTS WILL RESULT IF CONNECTED OTHERWISE.

Capacitors - Decimal values in MF. All others in MMF unless otherwise specified. Voltages - Measured from point indicated to chassis with a VTVM, $\pm 10\%$. No signal input. Input Voltage - 14V DC. Tuning Range - 540 to 1610 KC. IF - 262.5 KC. Resistances in Pwr Amp stage made with transistor removed.

MOTOROLA

MODELS
MOTOROLA 94MF, 94MFM
FORD B9FA-18806-C, B9FA-18805-E

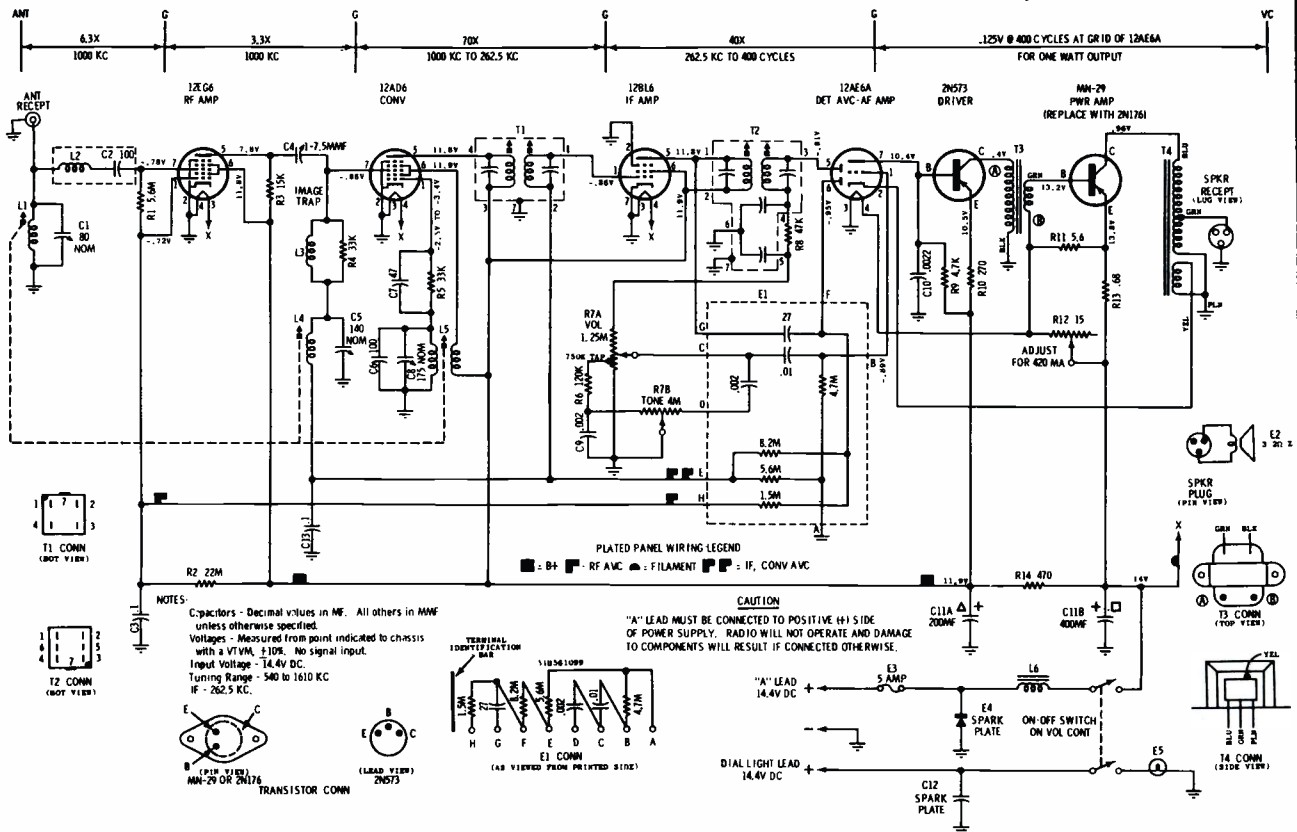

ALIGNMENT POINT LOCATION DETAIL

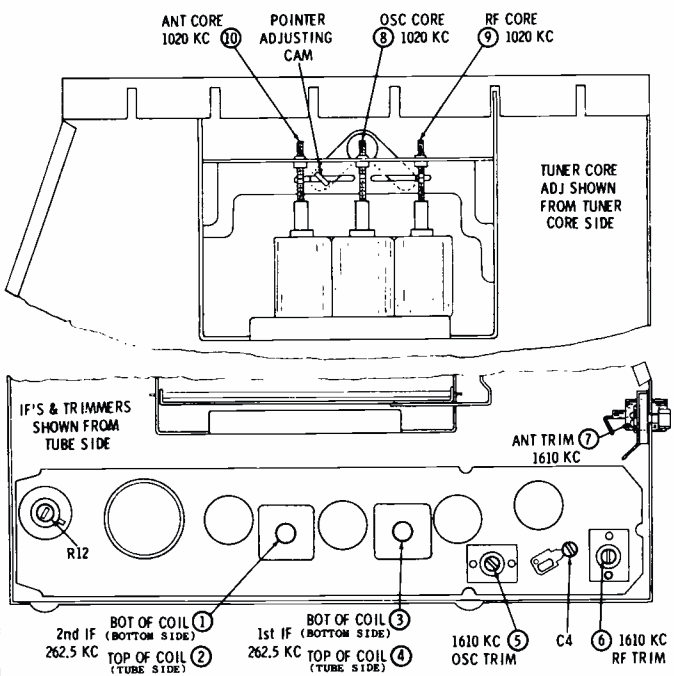

NOTE: Do not perform steps 3, 4, 5 & 6 unless tuner has been tampered with or components have been replaced. Before proceeding with step 3, back tuning cores 1-3/8" out of tuning coils to eliminate their effect on trimmer adjustment.

PLATED CIRCUIT COMPONENT REPLACEMENT

Most of the components can be removed from the panel with the aid of a soldering iron. When using a soldering pot, it may be difficult to dip some of the components close to the edge of the panel because of interference from the radio housing. To use a soldering pot on these components, it will be necessary to partially drop the panel from the housing, to do this proceed as follows:

- Remove two screws which hold radio housing to front plate (on volume control side of housing).
- Unsolder connecting lead from antenna spark choke at trimmer side.
- Unsolder plated panel support bracket from housing and panel, bend ears straight, and carefully remove from plated panel.
- Carefully remove plated panel from housing and drop below edge of housing.
- Replace screws removed from housing in step "a," so panel and housing will be more solid during soldering operation.

PLATED CHASSIS REMOVAL - If necessary to remove the plated panel completely from radio housing, proceed as follows:

- Remove two screws which hold radio housing to front plate (on volume control side of housing).
- Unsolder connecting leads to free panel. Where possible, avoid unsoldering leads at plated panel.
- Unsolder plated panel support bracket from housing and panel, bend ears straight, and carefully remove bracket from panel and housing.
- Plated panel will now be free for careful removal from housing.

MOTOROLA

**MODEL
MOTOROLA 95MF
FORD B9FA-18806-B**

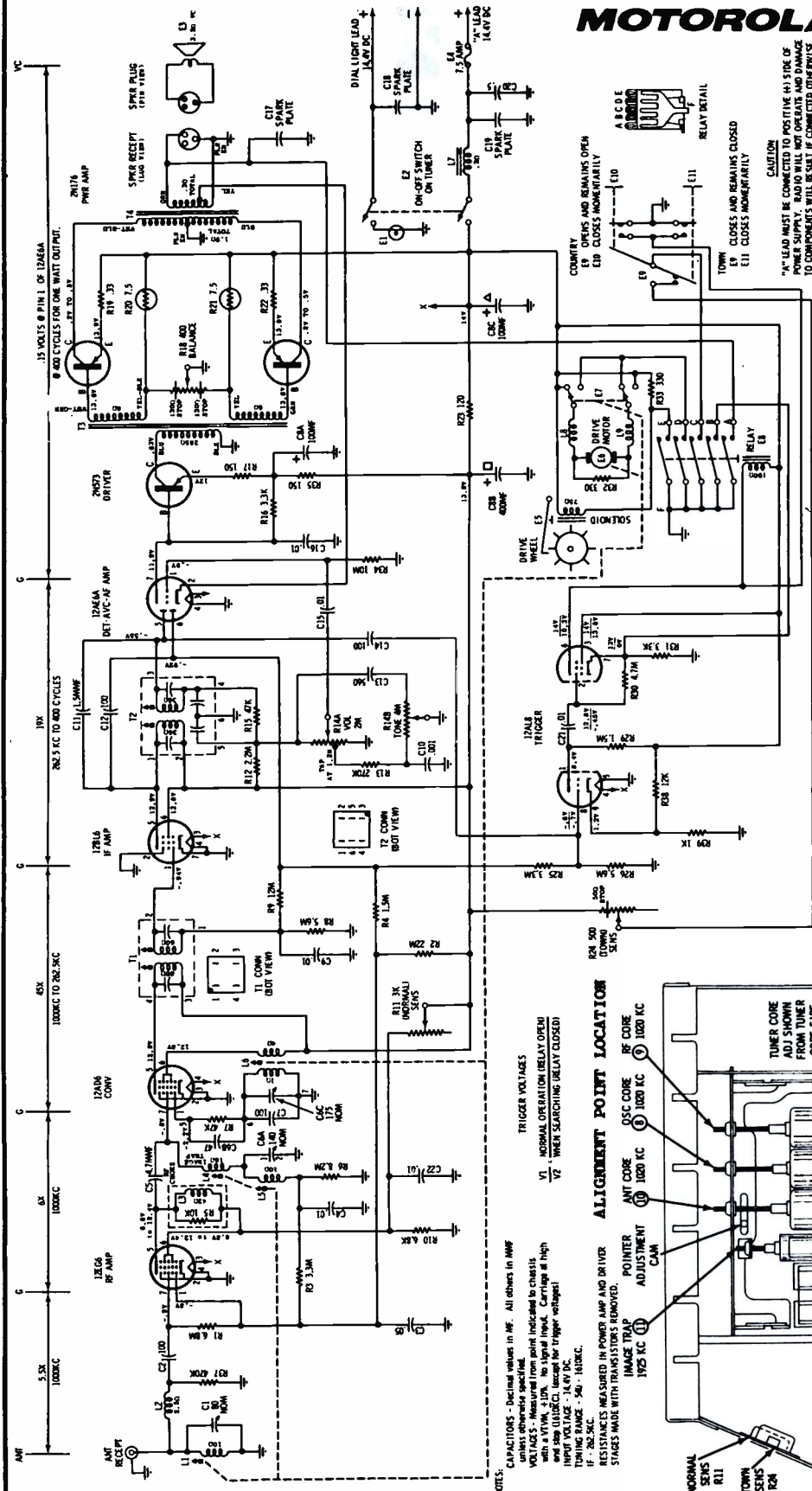

DRIVER TRANSISTOR REPLACEMENT - When replacing a driver transistor, the heat must be carried away from the transistor to prevent heat damage while soldering. This can be accomplished by grasping the transistor leads (between the transistor and soldering lug) with a pair of long-nose pliers.

TRANSISTOR CURRENT ADJUSTMENT - After replacing transistor and before connecting radio to power supply, set the transistor balance control (R-18) to the mid-position to prevent excessive current from damaging the transistors. Allow about 15 minutes warm-up time before proceeding with the following:

- Connect a VTVM from collector to collector. Be sure VTVM is accurately zeroed and set to a low voltage scale. NOTE: If VTVM has a center zero scale, use this scale.
- Adjust R-18 for zero DC reading on VTVM.

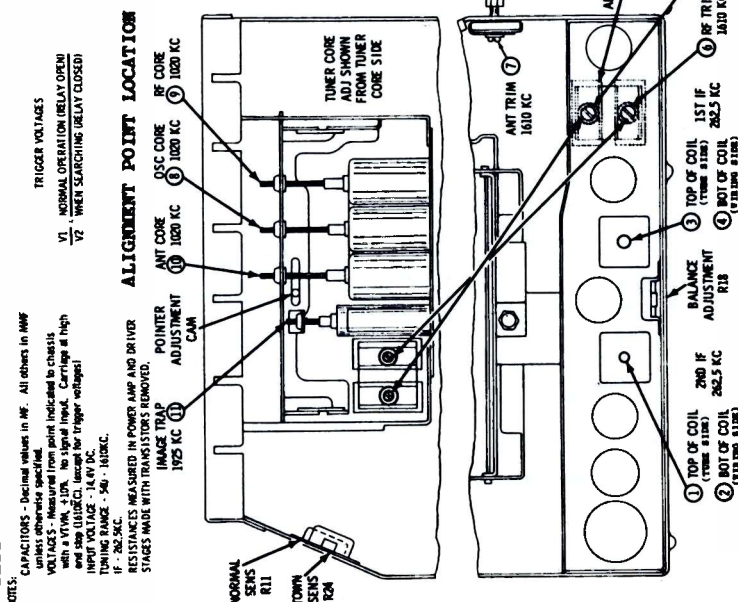
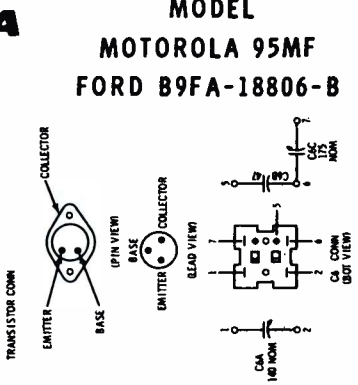

NOTES: CAPACITORS - Decimal values in MF. All others in MMF unless otherwise specified.
VOLTAGES - Measured from points indicated to chassis with a VTVM, 500 Ω . No signal input. Chassis at high potential. Input voltage - 120V AC.
TUNING RANGE - 540 - 1600 KC.
RESISTANCES MEASURED IN POWER AMP AND DRIVER STAGES MADE WITH TRANSISTORS REMOVED.

MOTOROLA

Models 300X and 301X

These are 12-volt sets designed for universal underdash installation. Model 300X, circuit on this page, is for use in cars with a negative ground electrical system. Model 301X, diagram on next page adjacent at right, is for cars with positive ground electrical system. Other material applies to both models.

MODEL 300X SCHEMATIC DIAGRAM

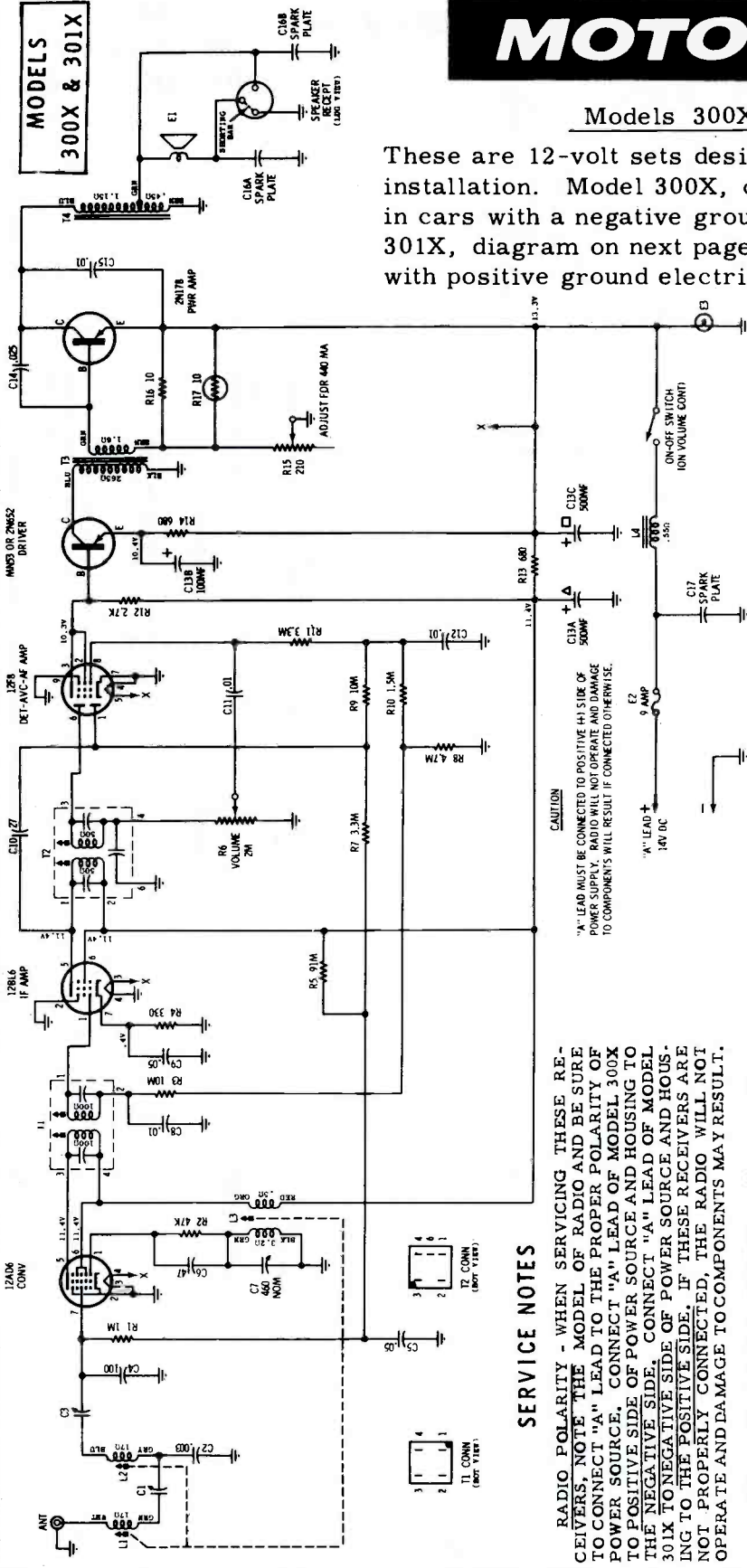

SERVICE NOTES

RADIO POLARITY - WHEN SERVICING THESE RECEIVERS, NOTE THE MODEL OF RADIO AND BE SURE TO CONNECT "A" LEAD TO THE PROPER POLARITY OF POWER SOURCE. CONNECT "A" LEAD OF MODEL 300X TO POSITIVE SIDE OF POWER SOURCE AND HOUSING TO THE NEGATIVE SIDE. CONNECT "A" LEAD OF MODEL 301X TO NEGATIVE SIDE OF POWER SOURCE AND HOUSING TO THE POSITIVE SIDE. IF THESE RECEIVERS ARE NOT PROPERLY CONNECTED, THE RADIO WILL NOT OPERATE AND DAMAGE TO COMPONENTS MAY RESULT.

POWER SUPPLY REQUIREMENTS - It is preferable to use a storage battery (without a battery charger) in place of a battery eliminator when servicing this receiver, because the average eliminator has an extremely high AC ripple content which may damage the transistor and other low voltage components.

POWER TRANSISTOR CURRENT ADJUSTMENT - After a power transistor has been replaced, the collector current should be checked and adjusted for proper operation.

- a. Connect a 0-3 amp DC ammeter in series with the "A" lead.
- b. Remove output transistor from its socket.
- c. Turn radio on and read ammeter with 12.6 volts input to "A" lead (approximately 800 ma). NOTE READING.
- d. Turn radio off and replace transistor.
- e. Turn radio on and adjust R-15 for a 360 ma increase over reading noted in step c with 12.6 volts input to "A" lead.

NOTES:
CAPACITORS - Decimal values in MF, all others in MMF unless otherwise specified.
VOLTAGES - Measured from point indicated to chassis with a VTVM. No signal input. Tolerance $\pm 10\%$.
INPUT VOLTAGE - 14V DC.
TUNING RANGE - 540 KC TO 1610 KC.
IF FREQ. - 262.5 KC.

NOTE: Two values of radio input voltage are given as a convenience to service personnel in order to accommodate different power sources. The current value of 440 ma stated on the schematic is for 14 volts DC input to receiver "A" lead.

POWER TRANSISTOR INSULATOR - When replacing a power transistor or power transistor insulator, be sure to coat both sides of insulator with DC-4 grease (Motorola Part No. 11M490487) to insure proper heat dissipation.

TRANSISTOR CHECK - The transistors used in this receiver can be expected to give unusually long trouble-free life. However, the following transistor checks are provided to facilitate servicing:

Substituting a known good transistor for a suspected one is the simplest and most positive way of checking transistors. When a transistor is not available for substitution, make a resistance check of the stage. If the values are within the tolerance rating, the bias network can be eliminated as a source of defect and the transistor safely suspected. Bias network defects can be located by resistance checks.

CAUTION
"A" LEAD MUST BE CONNECTED TO POSITIVE (+) SIDE OF POWER SUPPLY. RADIO WILL NOT OPERATE AND DAMAGE TO COMPONENTS WILL RESULT IF CONNECTED OTHERWISE.

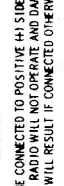

CAUTION

"A" LEAD MUST BE CONNECTED TO POSITIVE (+) SIDE OF POWER SUPPLY. RADIO WILL NOT OPERATE AND DAMAGE TO COMPONENTS WILL RESULT IF CONNECTED OTHERWISE.

CAUTION

"A" LEAD MUST BE CONNECTED TO POSITIVE (+) SIDE OF POWER SUPPLY. RADIO WILL NOT OPERATE AND DAMAGE TO COMPONENTS WILL RESULT IF CONNECTED OTHERWISE.

CAUTION

"A" LEAD MUST BE CONNECTED TO POSITIVE (+) SIDE OF POWER SUPPLY. RADIO WILL NOT OPERATE AND DAMAGE TO COMPONENTS WILL RESULT IF CONNECTED OTHERWISE.

MOTOROLA Models 300X and 301X, Continued

This page has the circuit of Model 301X, and other service material that is applicable to both 300X and 301X. See also the material on previous page, at left.

MODEL 301X SCHEMATIC DIAGRAM

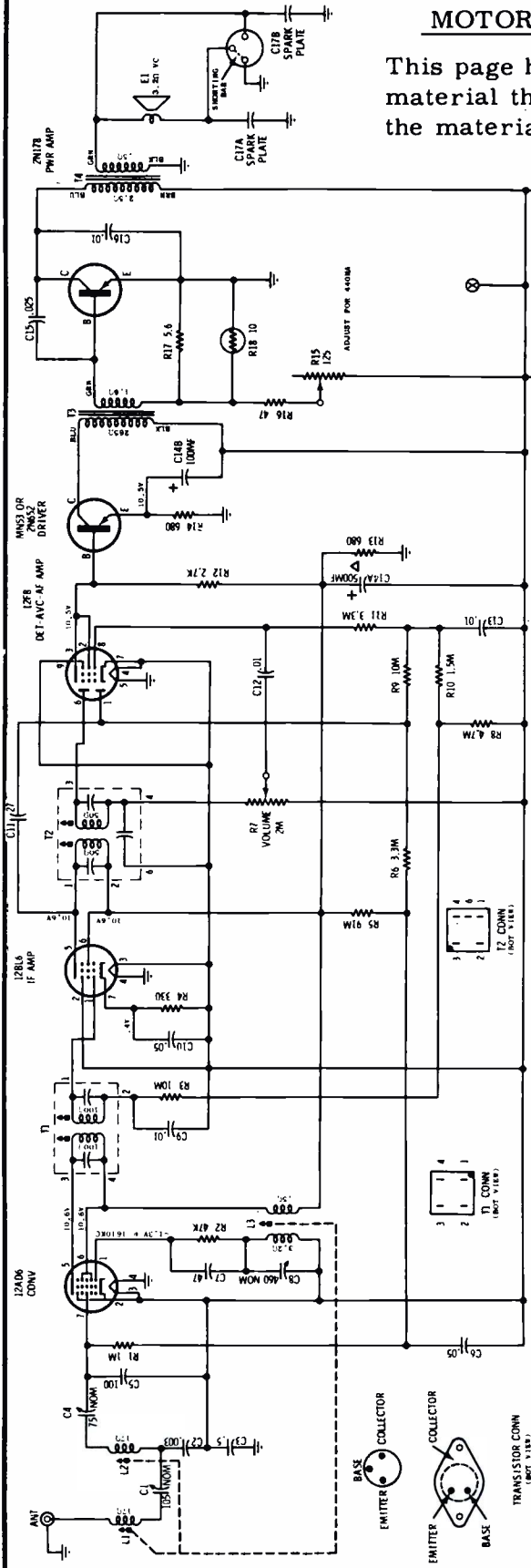

CAUTION
 "A" LEAD MUST BE CONNECTED TO NEGATIVE (+) SIDE OF POWER SUPPLY. ALSO, "B" LEAD MUST NOT BE CONNECTED TO COMPONENTS WILL RESULT IF CONNECTED OTHERWISE.

NOTES
 CAPACITORS - Decimal values in MF, all others in MMF unless otherwise specified.
 VOLTAGES - Measured from point indicated to earth with a VTVM. No signal input. Tolerance $\pm 10\%$.
 INPUT VOLTAGE - 117V AC.
 TUNING RANGE - 540 KC TO 1610 KC.
 IF FREQ. - 262.5 KC.

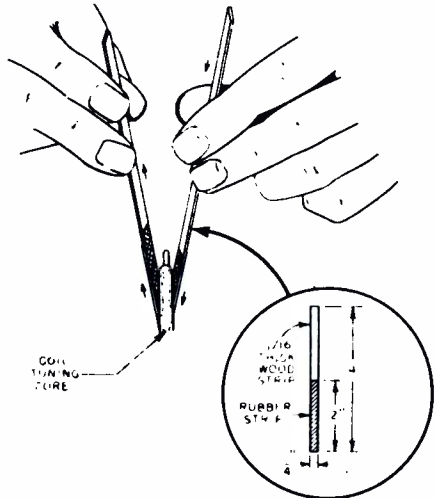

CORE ALIGNMENT TOOL DETAIL

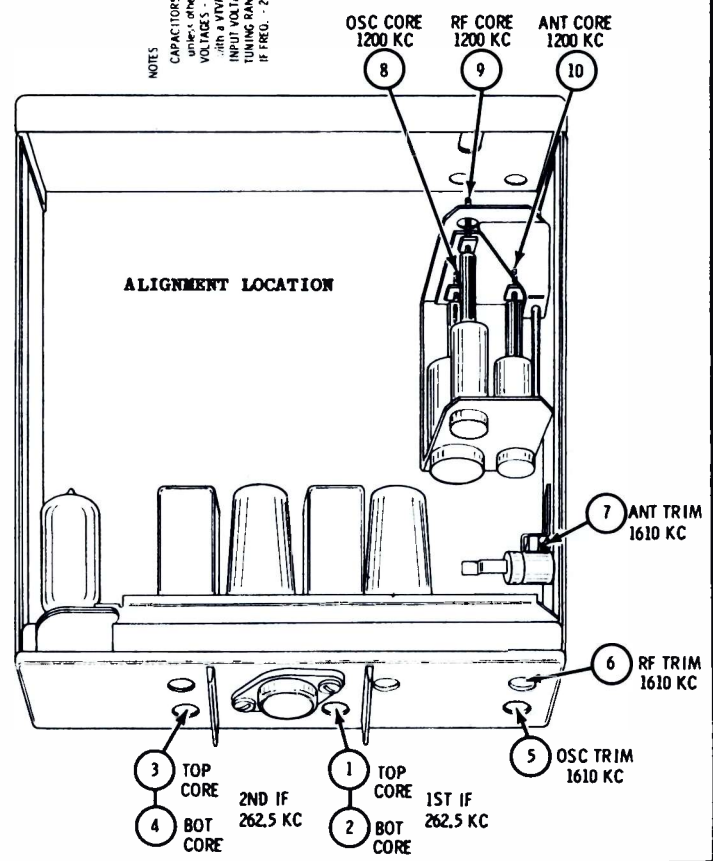

MOTOROLA

MODEL
406

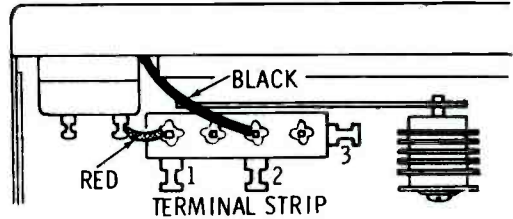

RADIO WIRING FOR CARS WITH A NEGATIVE GROUND ELECTRICAL SYSTEM - RED LEAD MUST BE SOLDERED TO TERMINAL NO. 1: BLACK LEAD TO TERMINAL NO. 2.

RADIO POLARITY - BEFORE CONNECTING RADIO TO A 6 VOLT POWER SOURCE, REMOVE BOTTOM COVER AND CHECK POLARITY WIRING AGAINST DETAIL. THEN CONNECT RADIO TO POWER SOURCE PER DETAIL. IF THIS RECEIVER IS NOT PROPERLY CONNECTED, IT WILL NOT OPERATE AND DAMAGE TO COMPONENTS MAY RESULT.

OUTPUT TRANSISTOR CURRENT ADJUSTMENT - After an output transistor has been replaced, the collector current should be checked and adjusted for proper operation.

- Connect a 3 amp DC ammeter in series with the "A" lead.
- Remove output transistor from its socket.
- Turn radio on and read ammeter with 6.3 volts input to "A" lead (approximately 2.0 amp). **NOTE READING.**
- Turn radio off and replace transistor
- Turn radio on and adjust R-14 for a 600 ma increase over reading noted in step c with 6.3 volts input to "A" lead.

NOTE: Two values of radio input voltage are given as a convenience to service personnel in order to accommodate different power sources. The current value of 720 ma stated on the schematic is for 7 volts DC input to receiver "A" lead.

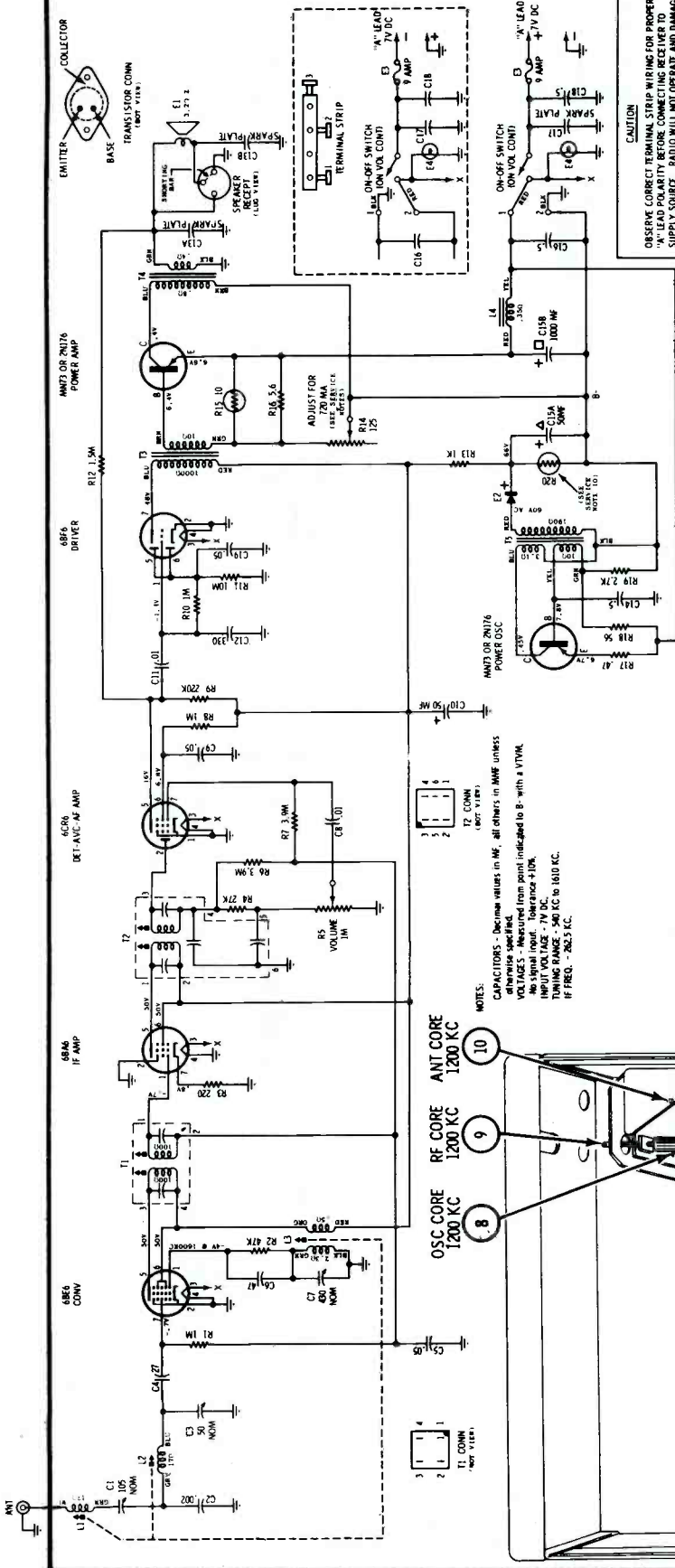

NOTES:
CAPACITORS - Decade values in MF, all others in MUF unless otherwise specified.
VOLTAGES - Measured from point indicated to B+ with a VTVM.
INPUT VOLTAGE - 7V DC. Tolerance ±10%.
IF FREQ. - 262.5 KC to 1610 KC.

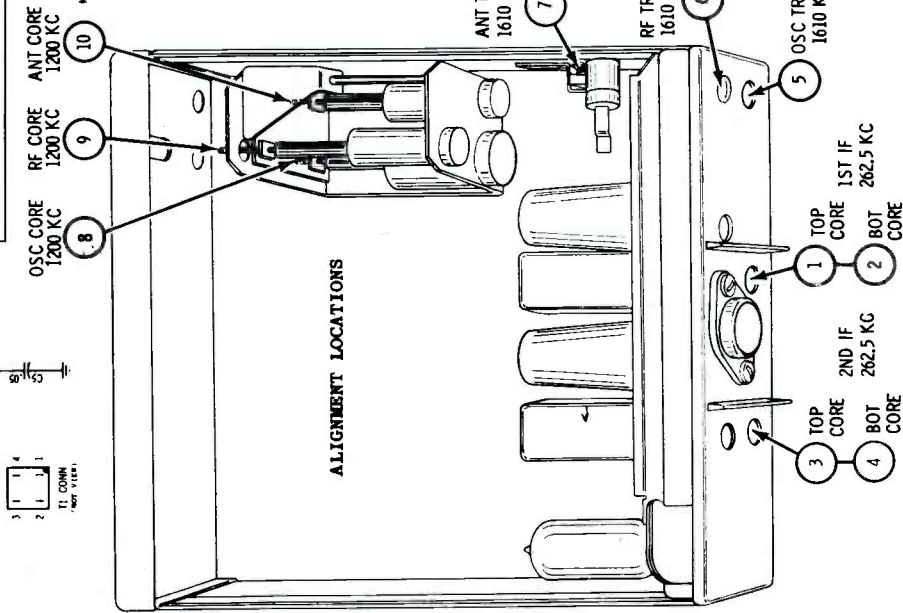

ALIGNMENT LOCATIONS

MOTOROLA

Auto Radio Model GV-800
(Continued on the next page at right)

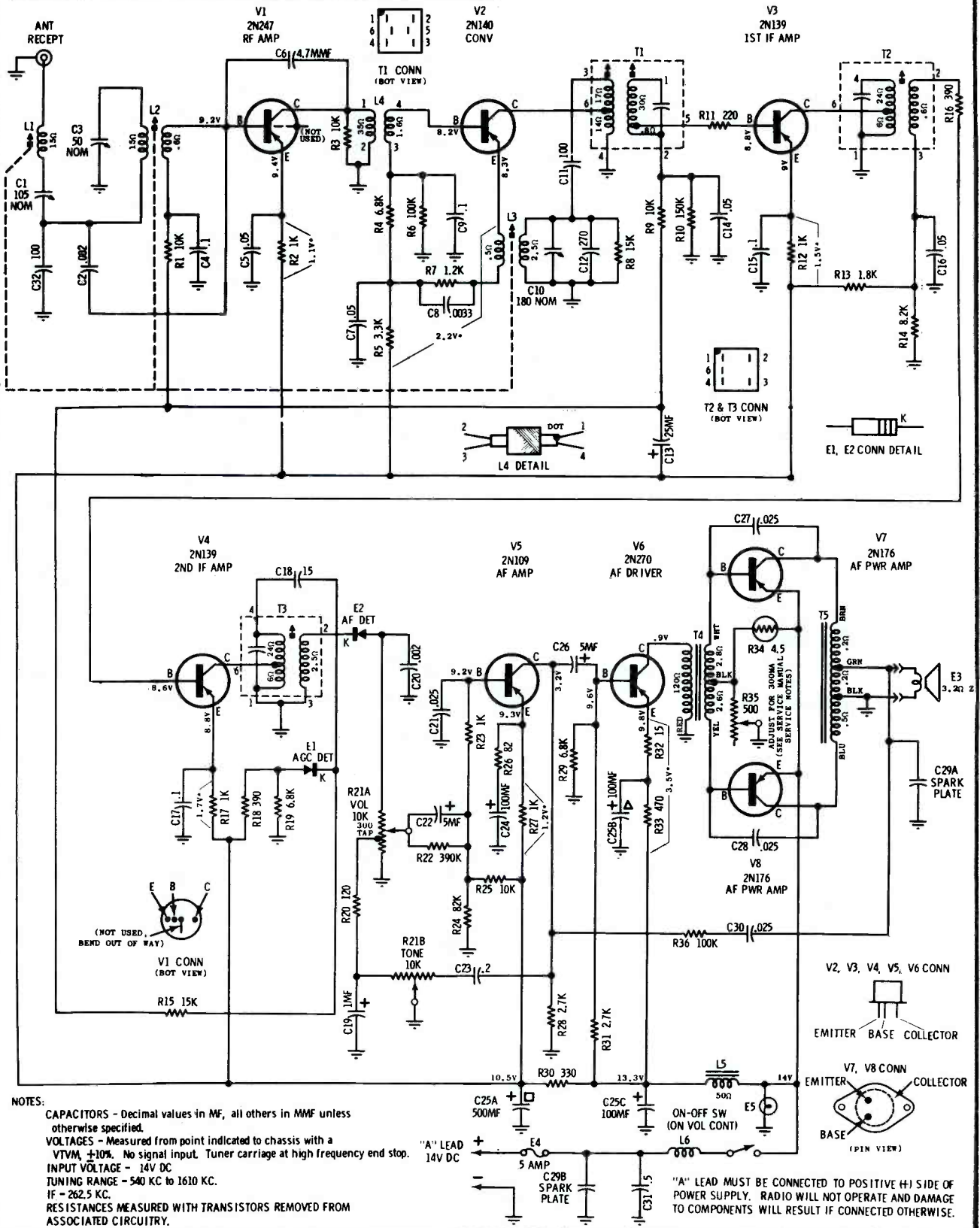

NOTES:
 CAPACITORS - Decimal values in MF, all others in MMF unless otherwise specified.
 VOLTAGES - Measured from point indicated to chassis with a VTVM $\pm 10\%$. No signal input. Tuner carriage at high frequency end stop.
 INPUT VOLTAGE - 14V DC
 TUNING RANGE - 540 KC to 1610 KC.
 IF - 262.5 KC.
 RESISTANCES MEASURED WITH TRANSISTORS REMOVED FROM ASSOCIATED CIRCUITRY.

"A" LEAD MUST BE CONNECTED TO POSITIVE (+) SIDE OF POWER SUPPLY. RADIO WILL NOT OPERATE AND DAMAGE TO COMPONENTS WILL RESULT IF CONNECTED OTHERWISE.

VOLUME R-19, MOST-OFTEN-NEEDED 1959 RADIO SERVICING INFORMATION

MOTOROLA Model GV-800, Alignment Adjustments & Parts Location. Continued.

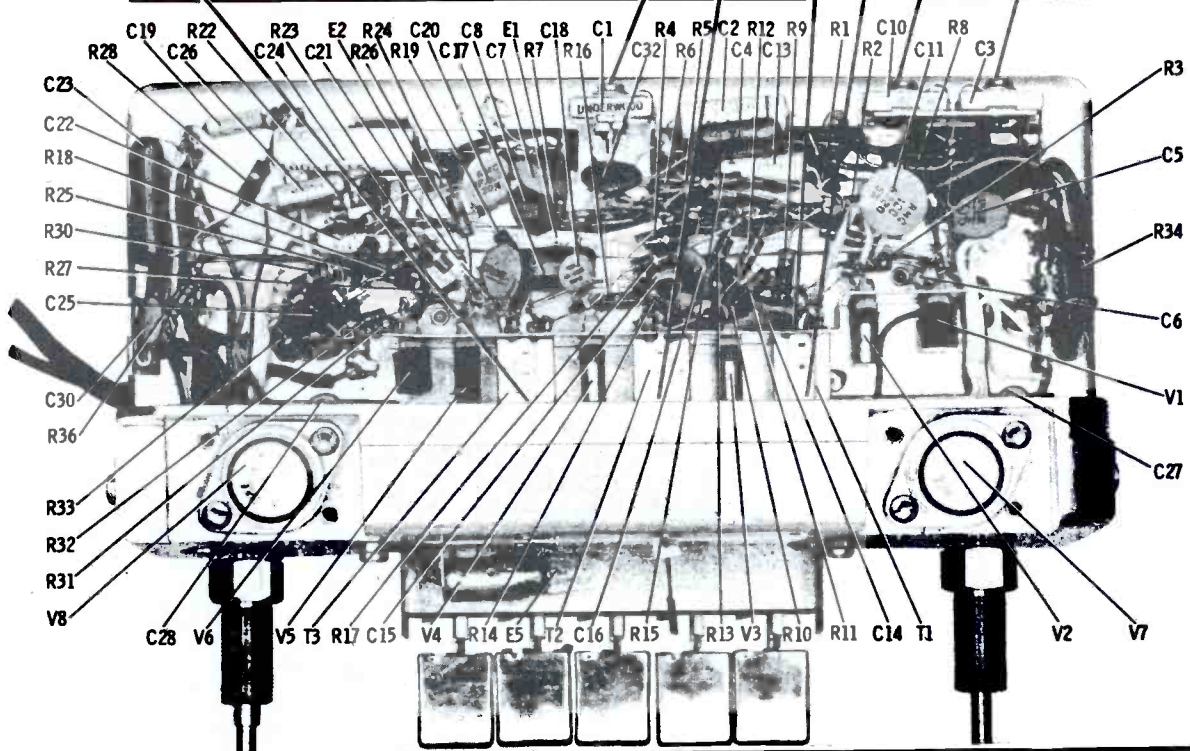
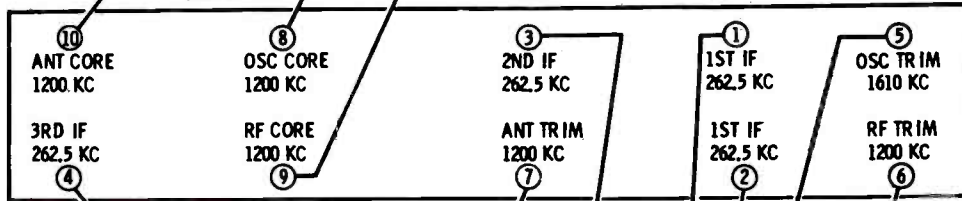
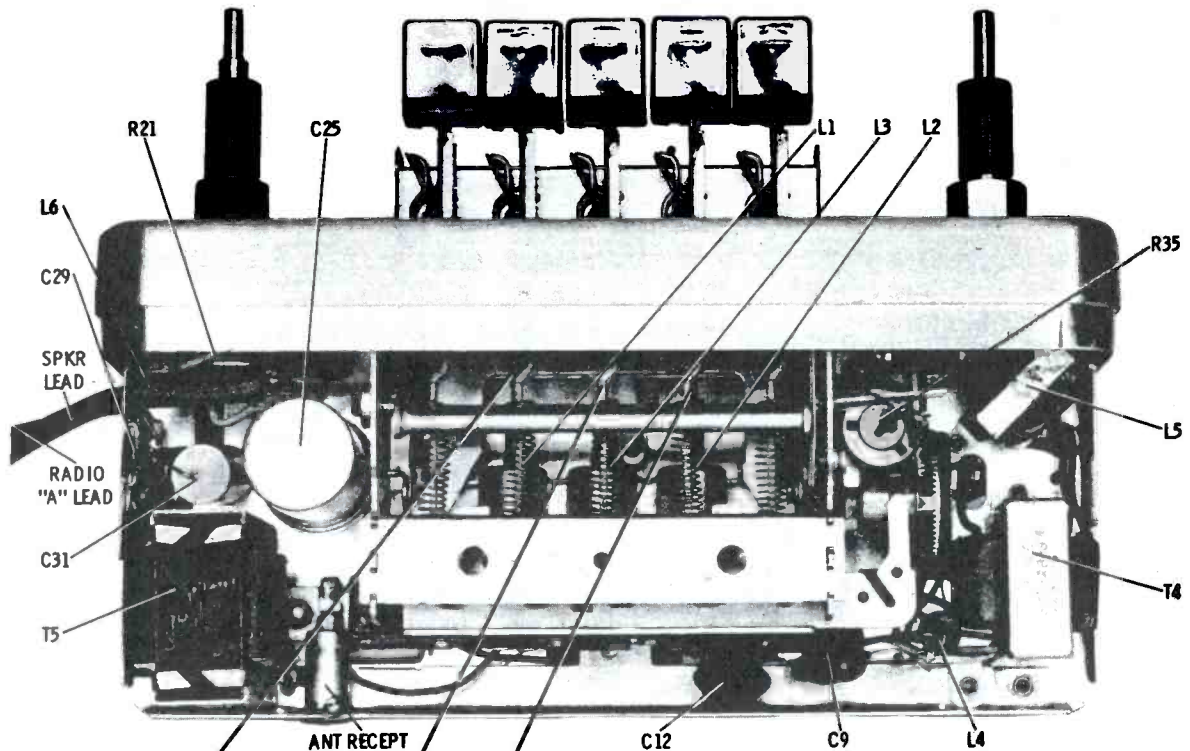

MOTOROLA

MODELS	CHASSIS
5P21B	HS-633
5P21N	HS-633
5P21R	HS-633

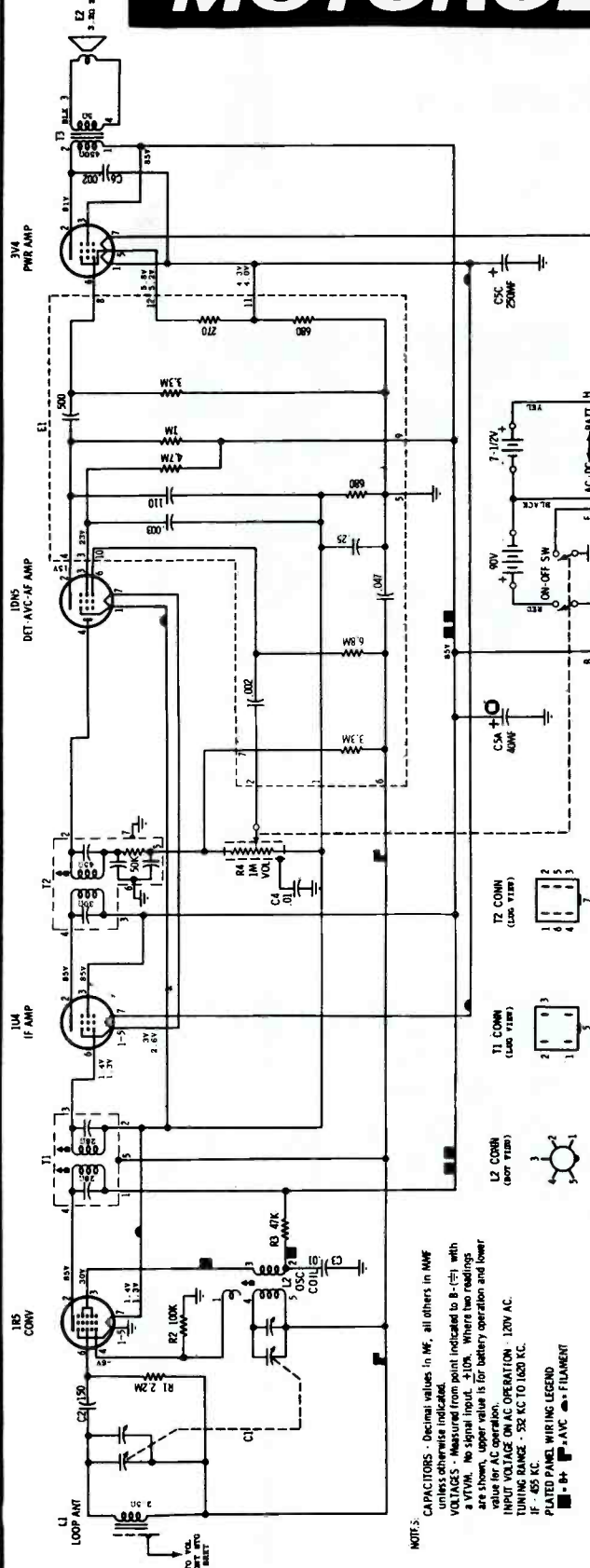

NOTES: CAPACITORS - Decimal values in MF, all others in MMF unless otherwise indicated.
 RESISTORS - Values in ohms indicated to B-(5) with no suffix. No special suffix. 50% where two readings are shown, upper value is for battery operation and lower value for AC operation.
 INPUT VOLTAGE ON AC OPERATION - 120V AC.
 TUNING RANGE - 532 KC TO 1620 KC.
 IF - 455 KC.
 PLATED PANEL WIRING LEGEND
 ■ - B+ □ - AVC ● - FILAMENT

- ① 2ND IF 455 KC
- ② TOP
- ③ BOT
- ④ ANT TRIM 1400 KC
- ⑤ OSC TRIM 1620 KC
- ⑥ OSC CORE 532 KC

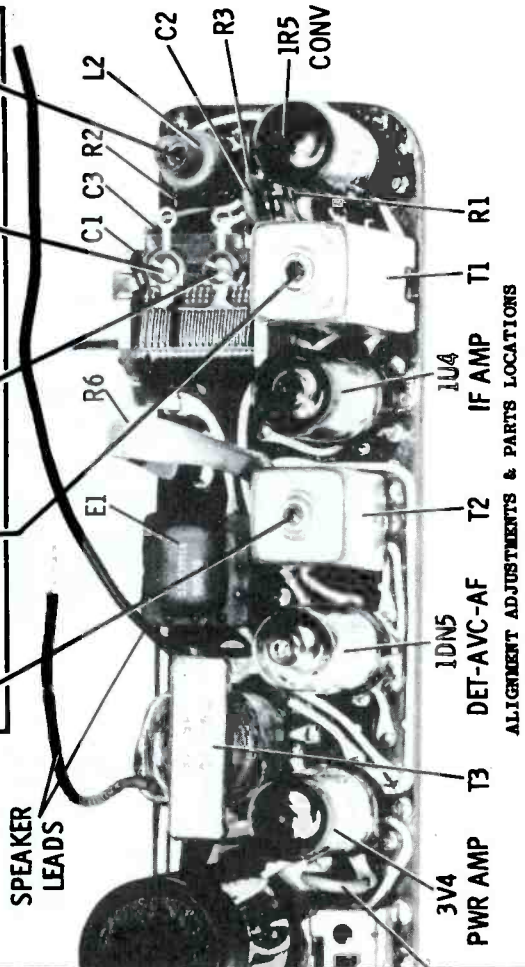

TO REMOVE CHASSIS FROM CABINET

1. Pull the control knobs from front of radio.
2. Remove the volume control mounting palnut and the machine screws under tuning knob of radio.
3. Unsolder speaker leads.
4. Unsolder antenna leads.
5. Remove chassis from cabinet.

ALIGNMENT ADJUSTMENTS & PARTS LOCATIONS

C6

MOTOROLA

MODELS	CHASSIS
6P25E	HS-637
6P25N	HS-637
6P25S	HS-637

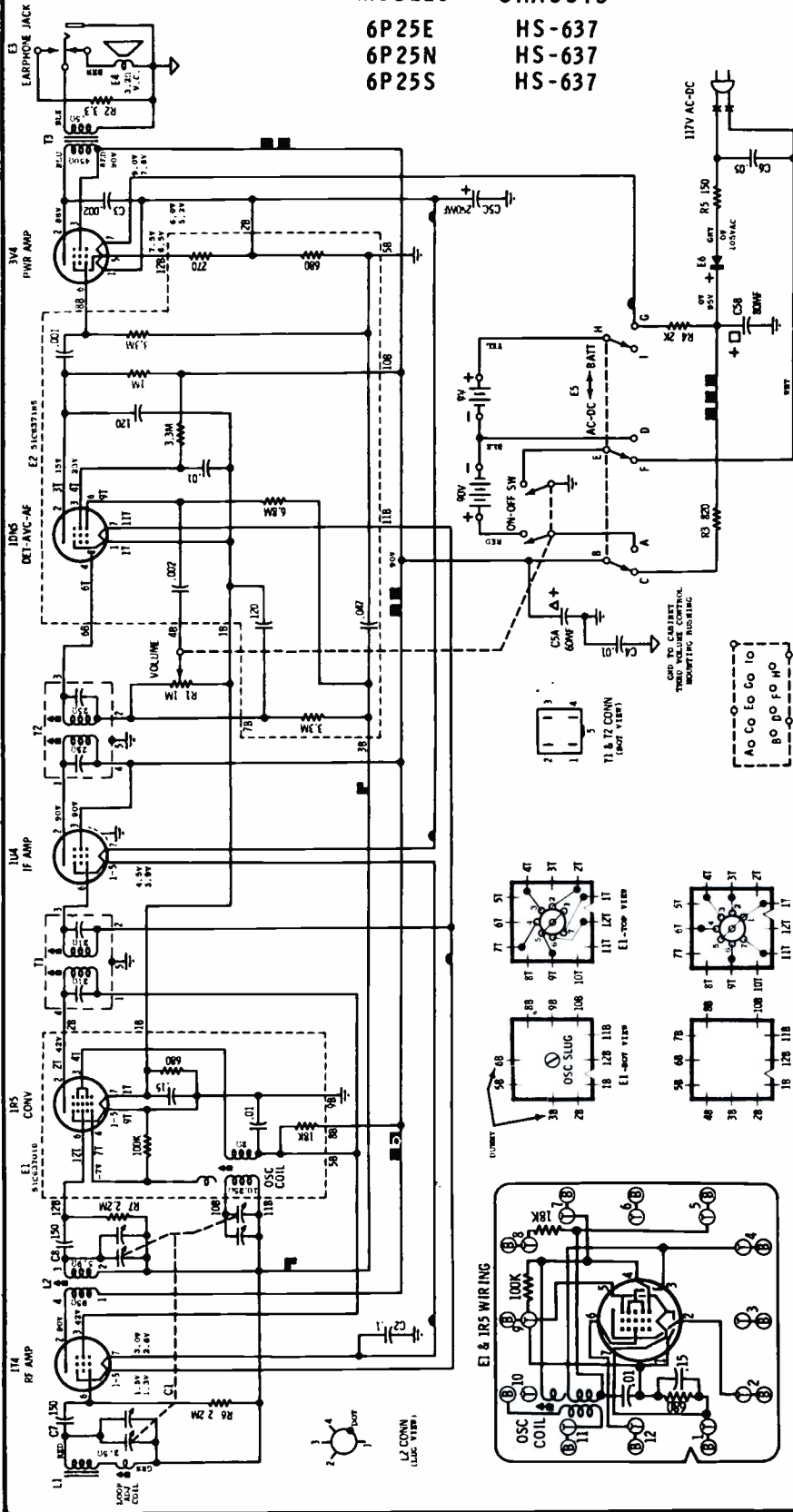

VOLUME R-19, MOST-OFTEN-NEEDED 1959 RADIO SERVICING INFORMATION

MOTOROLA

MODELS	CHASSIS
5T12B	HS-653
5T12M	HS-653
5T12P	HS-653
5T12W	HS-653
5T13P	HS-654
5T13S	HS-654
5T14GW	HS-654
5T14W	HS-654

NOTES:
 CAPACITORS - Decimal values in MF, all others in MMF unless otherwise specified.
 VOLTAGES - Measured from point indicated to B- with a VTVM, $\pm 10\%$. No signal input. Line voltage maintained at 120V AC.
 INPUT VOLTAGE - 120V AC/DC.
 TUNING RANGE - 555 KC TO 1620 KC.
 IF - 455 KC.
 ⇨ = CABINET BACK ⚡ = B-

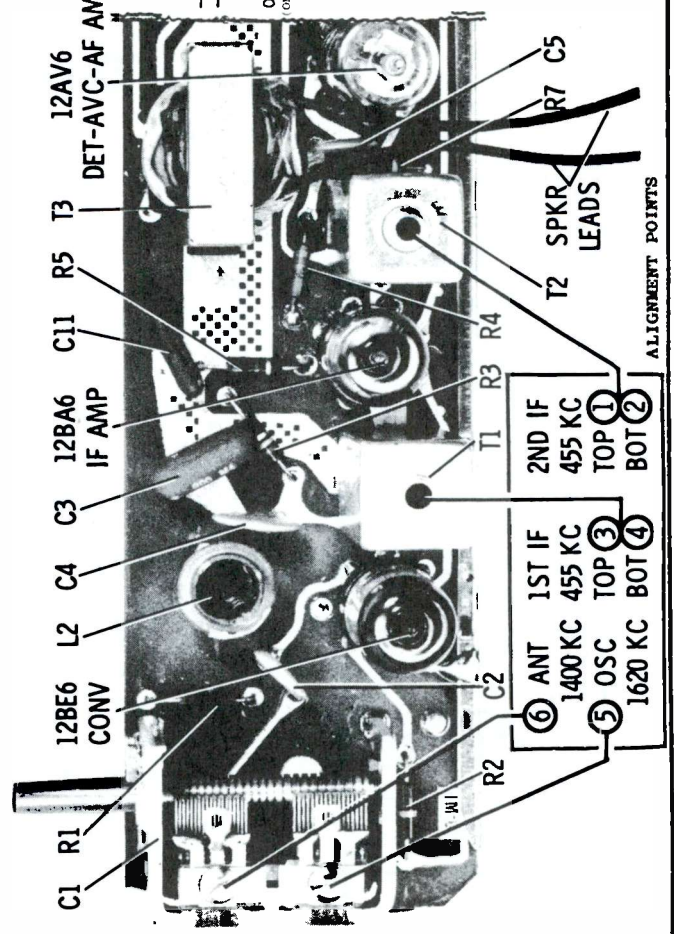
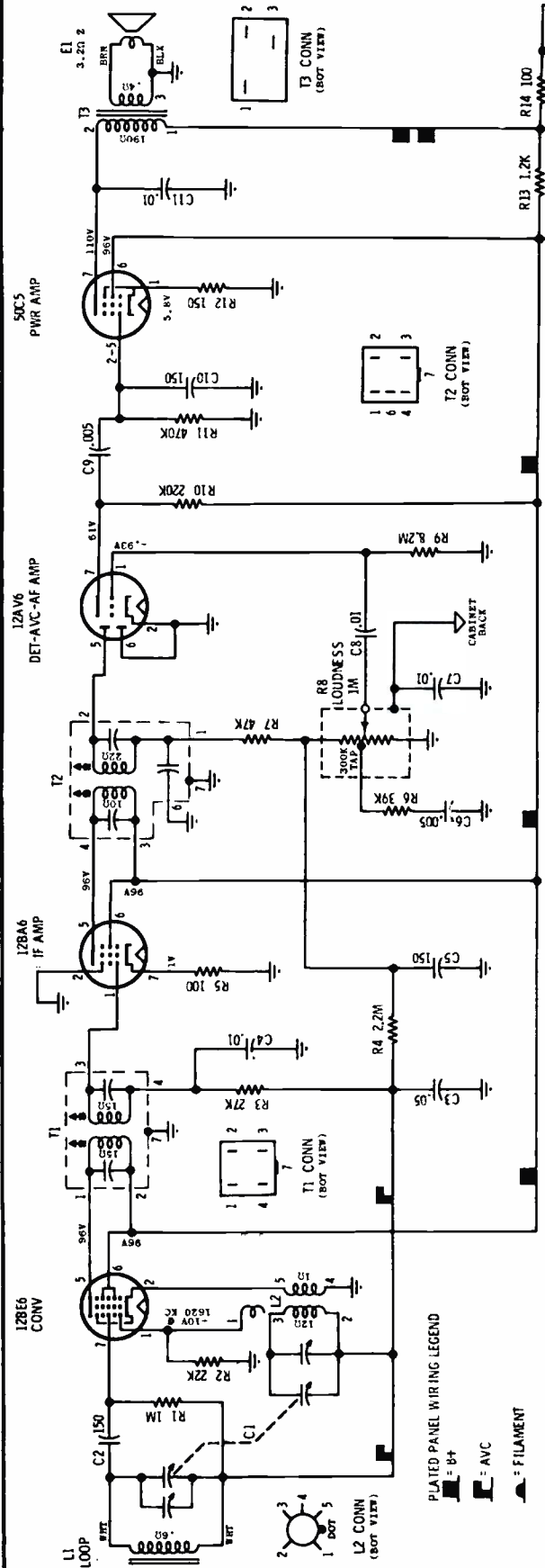

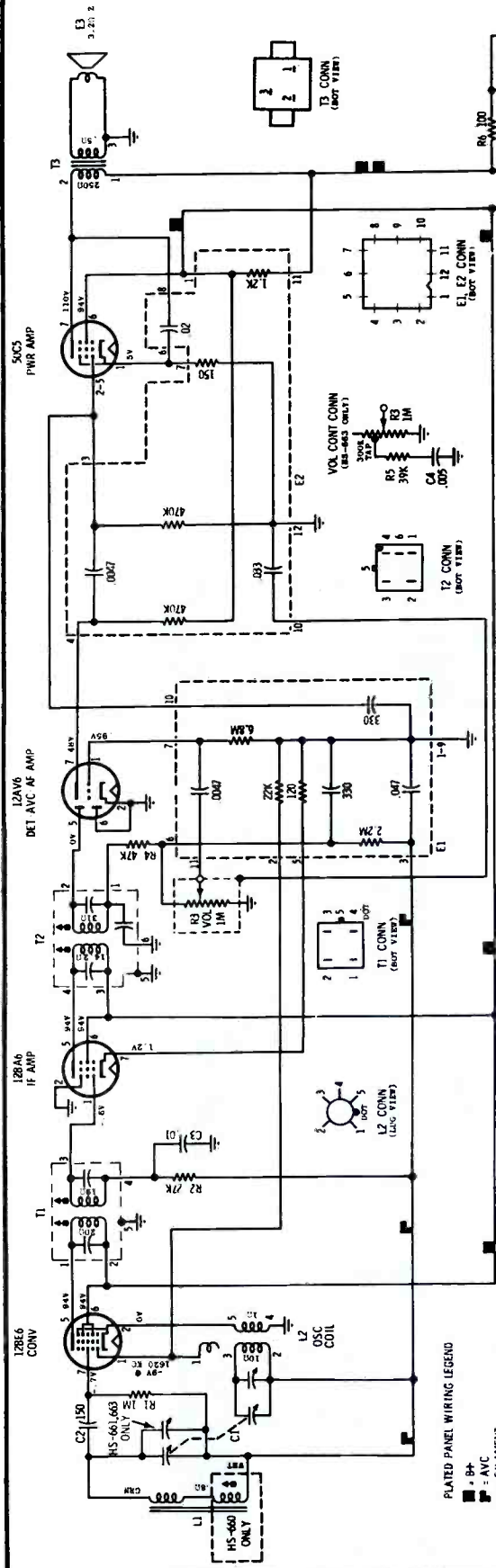

NOTES: CAPACITORS - Decimal values in MF, all others in MMF unless otherwise specified. VOLTAGES - Measured from point indicated with a VTVM, $\pm 10\%$. No signal input. INPUT VOLTAGE - 120V AC ONLY. TUNING RANGE - 530KC TO 1620KC IF - 455KC

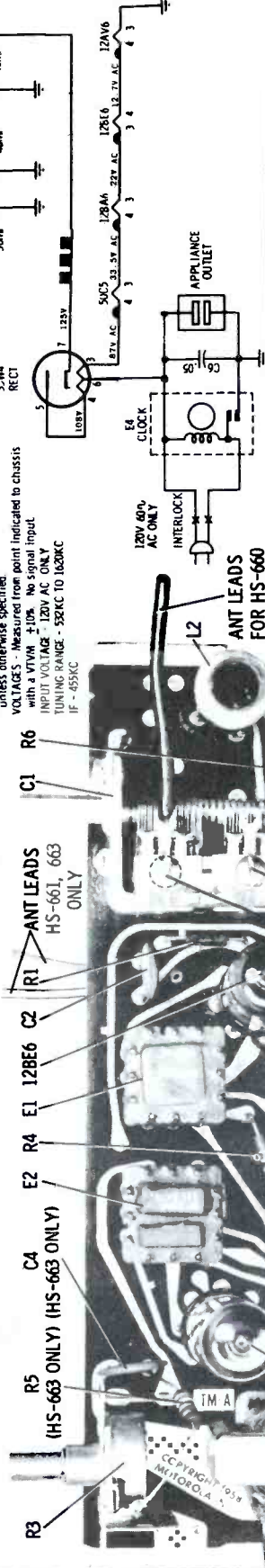

MOTOROLA

MODELS	CHASSIS
5C13B	HS-660
5C13M	HS-660
5C13P	HS-660
5C13W	HS-660
5C14CW	HS-661
5C14GW	HS-661
5C14PW	HS-661
5C16NW	HS-663
5C16W	HS-663

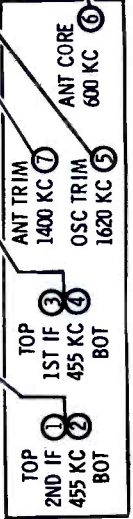

HS-660, 661 & 663 ALIGNMENT POINTS & PARTS LOCATIONS

VOLUME R-19, MOST-OFTEN-NEEDED 1959 RADIO SERVICING INFORMATION

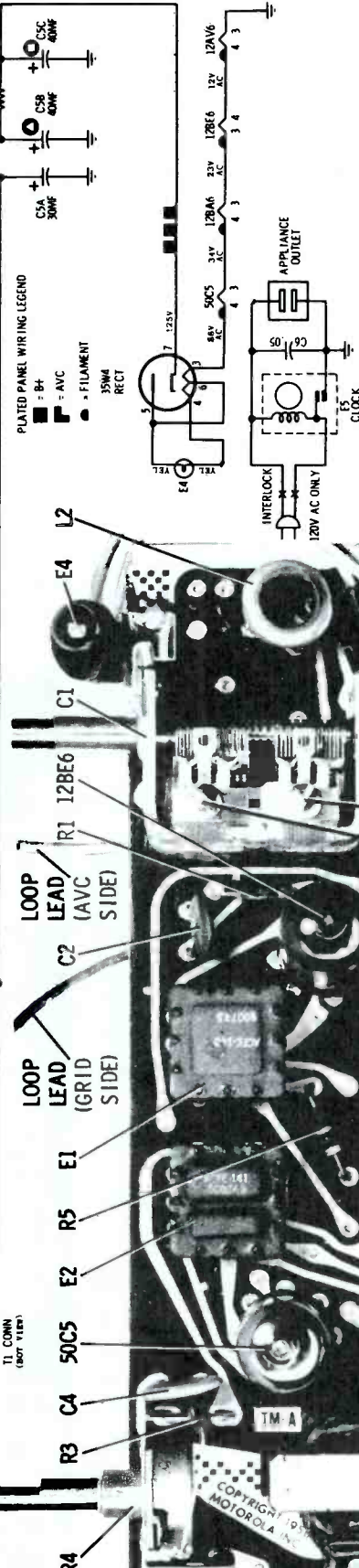
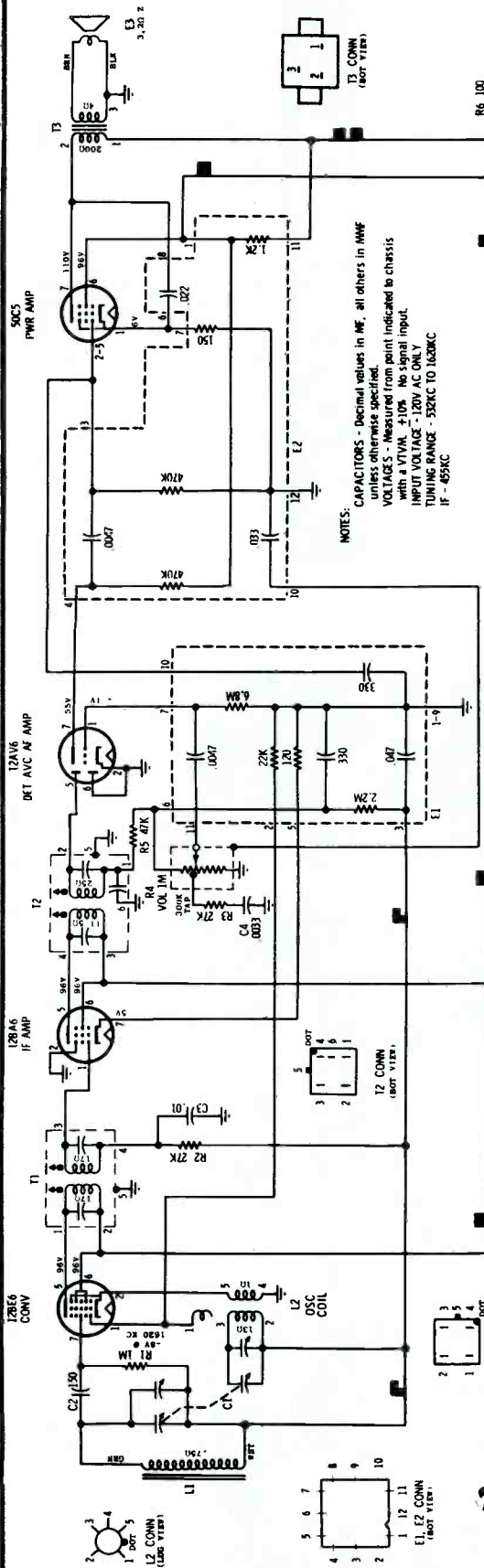

MOTOROLA

MODELS CHASSIS

5C15BW	HS-662
5C15GW	HS-662
5C15VW	HS-662

To Remove Chassis From Cabinet

1. Remove the dial scale, tuning and volume knobs.
2. From rear, remove the 2 rear cabinet mounting screws and pull out rear cabinet.
3. Remove the 4 chassis mounting screws.
4. Unsolder antenna, speaker, and AC power leads.
5. Remove chassis from cabinet.



MOTOROLA

MODELS CHASSIS
5R14N HS-670

To Remove Chassis From Cabinet

1. Pull off control knobs.
2. Remove 3 antenna panel mounting screws.
3. Remove antenna panel (disconnect line cord from interlock).
4. Disconnect antenna and speaker leads.
5. Remove 4 record changer board mounting screws.
6. Lift changer and mounting board up and out of the way.
7. Loosen 2 screws which hold interlock to cabinet; remove interlock from cabinet.
8. "Uncrimp" ends of chassis mounting brackets and melt solder at these points. CAUTION: Apply only enough heat to allow chassis to slide out of brackets; too much heat may damage the plated circuit board.
9. Slide chassis out of the brackets.
10. Disconnect record changer leads from chassis.

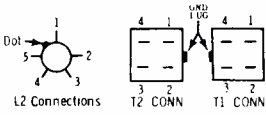
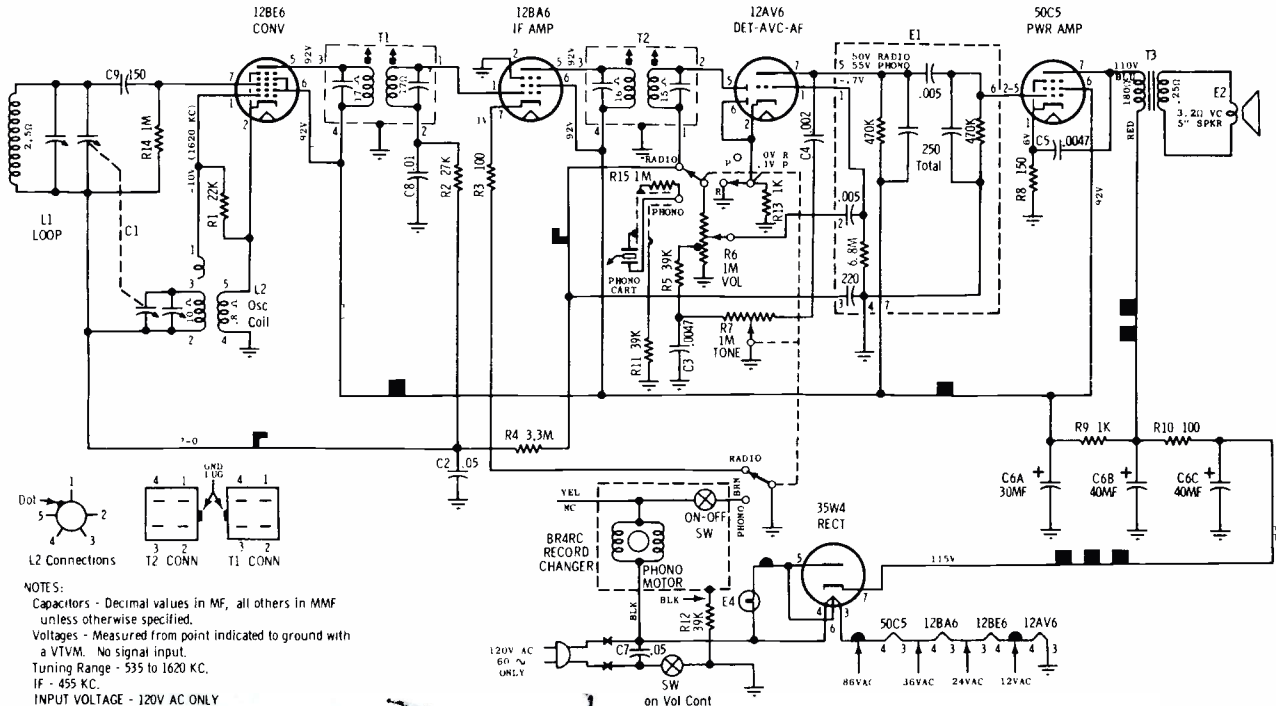

NOTES:
Capacitors - Decimal values in MF, all others in MMF unless otherwise specified.
Voltages - Measured from point indicated to ground with a VTVM. No signal input.
Tuning Range - 535 to 1620 KC.
IF - 455 KC.
INPUT VOLTAGE - 120V AC ONLY
PLATED PANEL WIRING LEGEND
■ - B+ □ - AVC ▲ - FILAMENT

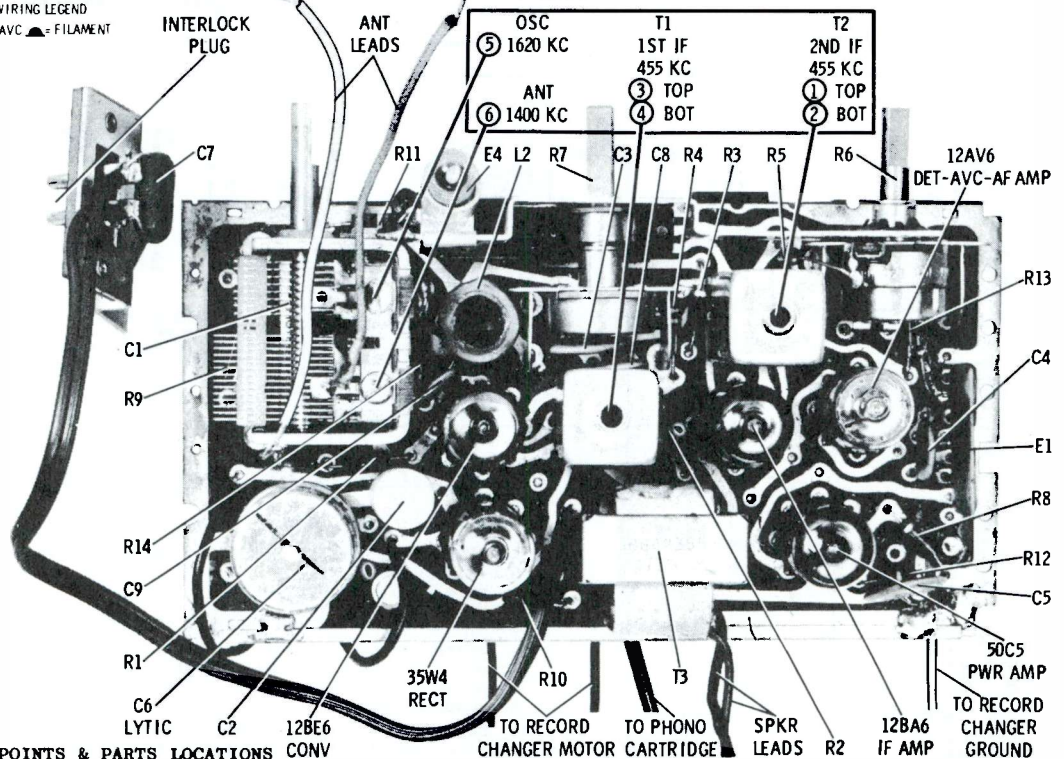

ALIGNMENT POINTS & PARTS LOCATIONS

MOTOROLA

MODELS	CHASSIS
5K11B	HS-673
5K11M	HS-673
5K11MC	HS-673
5K11W	HS-673

NOTES:

CAPACITORS - Decimal values in MF, all others in MMF unless otherwise specified.
 VOLTAGES - Measured from point indicated to chassis with a VTVM, $\pm 10\%$. No signal in.
 S1 & S2 conn details viewed from indicated sides with arrow indicating clockwise rotation as viewed from front of control.
 S1 SHOWN IN PHONO POSITION (R1AA)
 S2 SHOWN IN EXT SPKR POSITION
 = Chassis = Record changer base

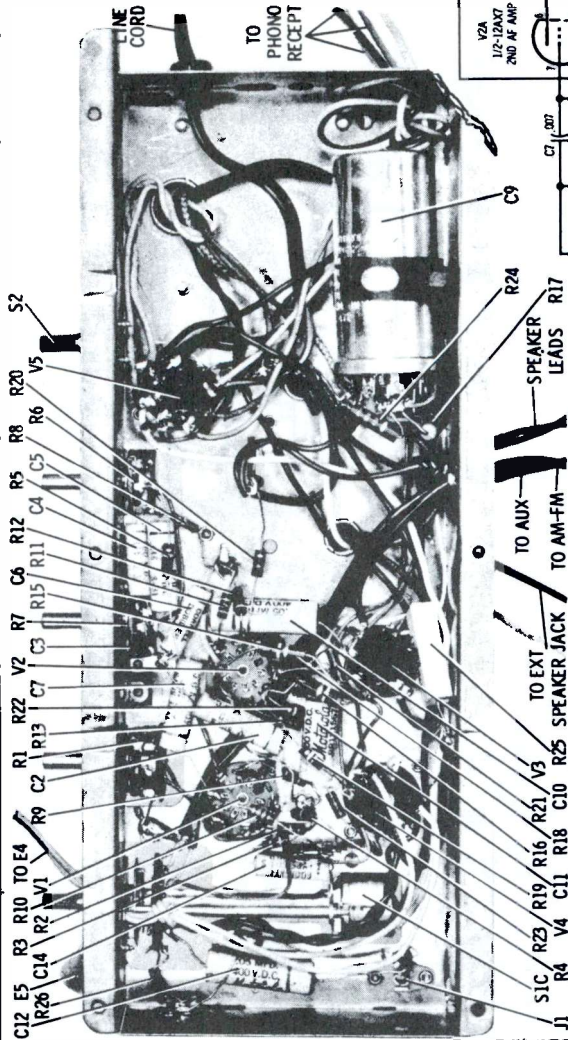

PARTS LOCATIONS

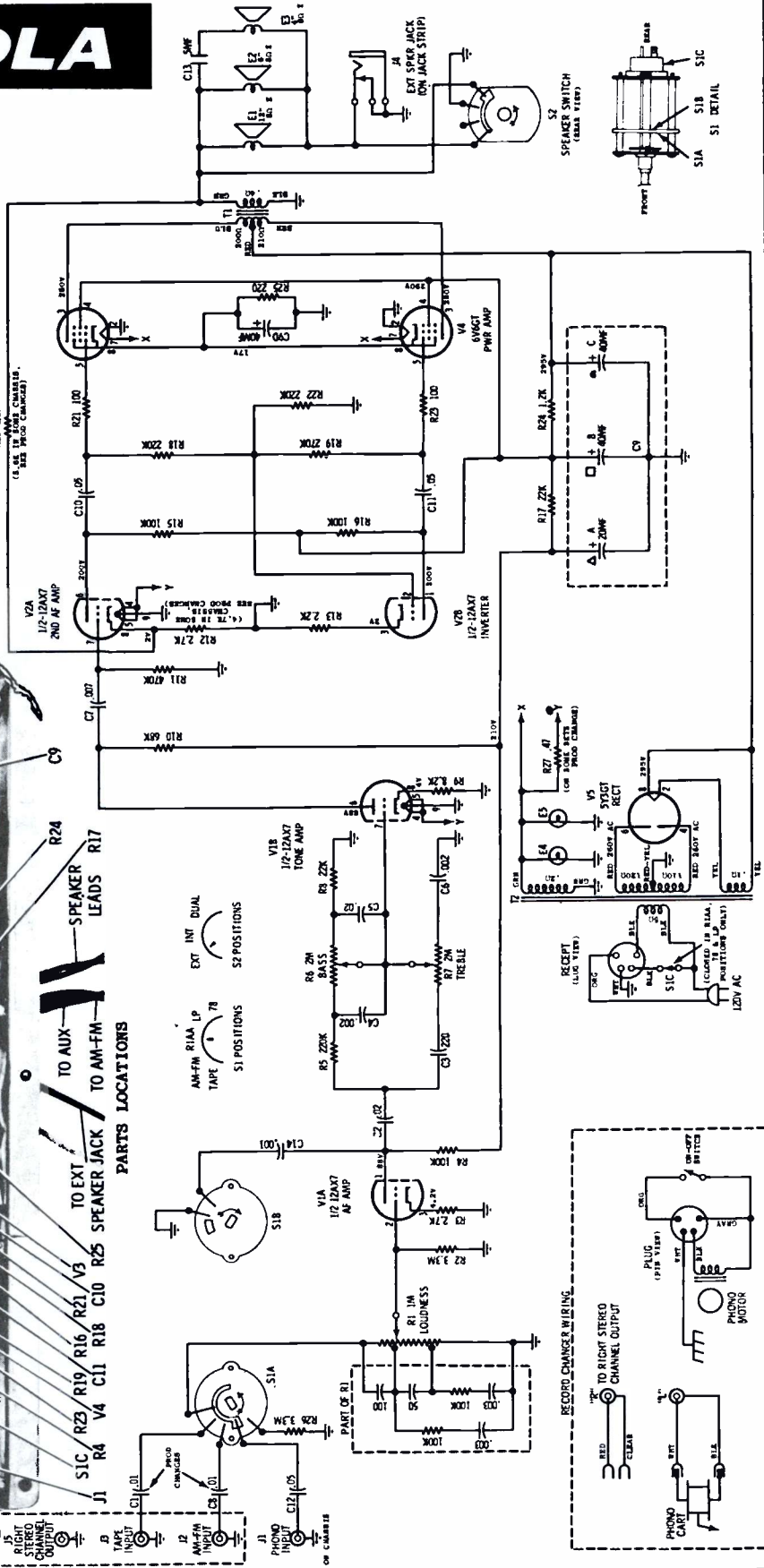

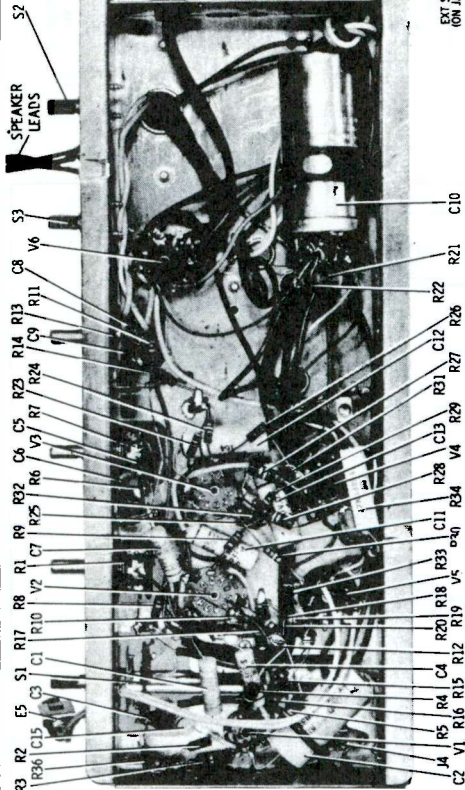

PARTS LOCATIONS

To Remove Chassis From Cabinet

1. Pull off the control knobs.
2. Remove cabinet back cover.
3. Disconnect leads from changer, auxiliary jacks and speakers.
4. Remove light shield and pilot light socket.
5. Remove three chassis mounting screws and remove chassis.

To Remove Record Changer From Cabinet

1. Remove back cover.
2. Disconnect all changer leads.
3. Turn the two record changer mounting screws fully clockwise (down flush against changer base).
4. From bottom of changer, turn the two Tinnerman nuts located at mounting screw ends so they are parallel with the screws.
5. Grasp changer by base and lift up.

To Replace Pilot Lights

1. To replace pilot light in record changer compartment, remove light shield, then bulb.
2. To remove pilot light on chassis, first remove chassis (see above), then bulb.

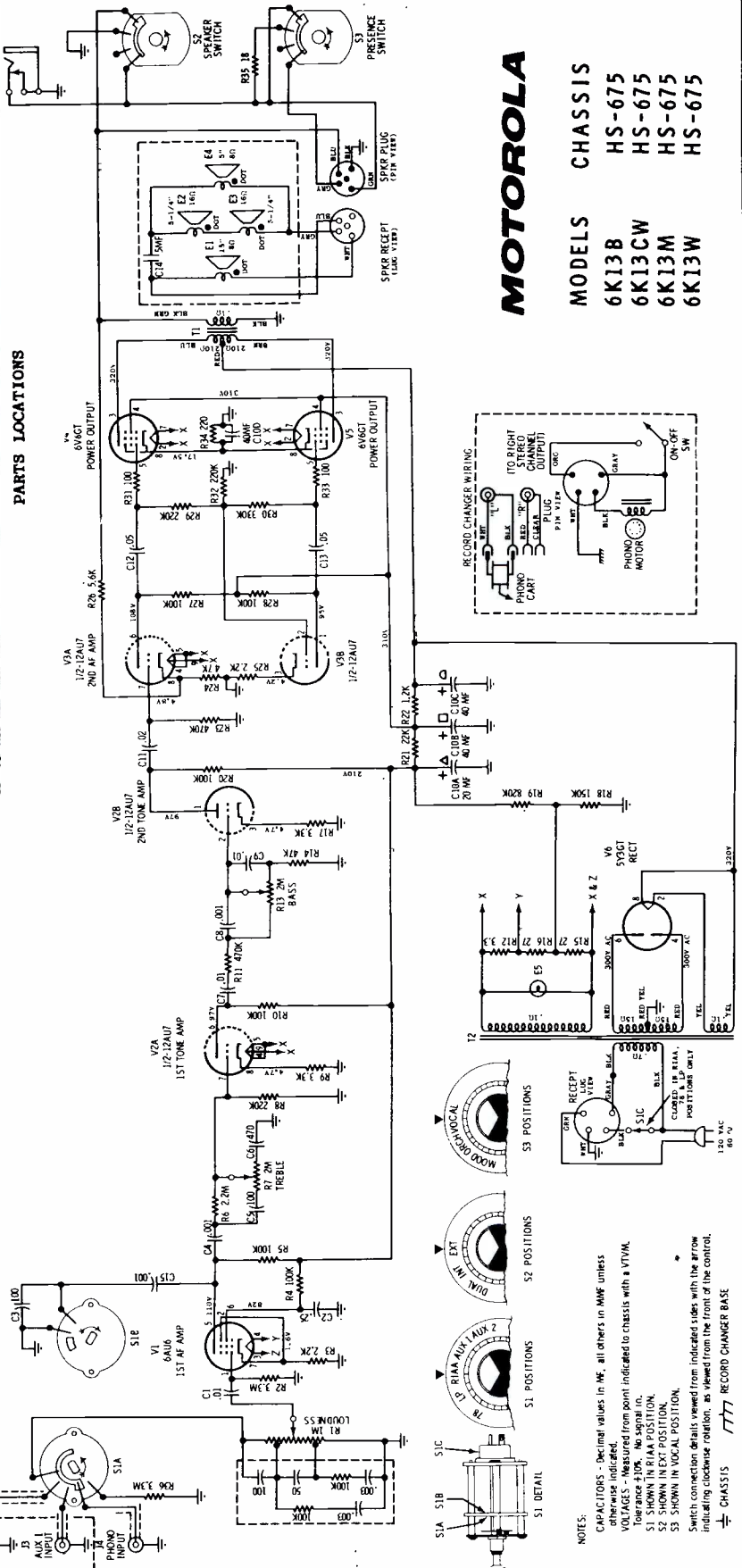

MOTOROLA

MODELS	CHASSIS
6K13B	HS-675
6K13CW	HS-675
6K13M	HS-675
6K13W	HS-675

NOTES:
 CAPACITORS - Decimal values in MF, all others in MAF unless otherwise indicated.
 VOLTAGES - Measured from point indicated to chassis with a VTVM. Tolerance $\pm 10\%$. No signal in.
 S1 SHOWN IN RIAA POSITION.
 S2 SHOWN IN EXT POSITION.
 S3 SHOWN IN VOCAL POSITION.
 Switch connection details viewed from indicated side with the arrow indicating clockwise rotation, as viewed from the front of the control.
 CHASSIS

VOLUME R-19, MOST-OFTEN-NEEDED 1959 RADIO SERVICING INFORMATION

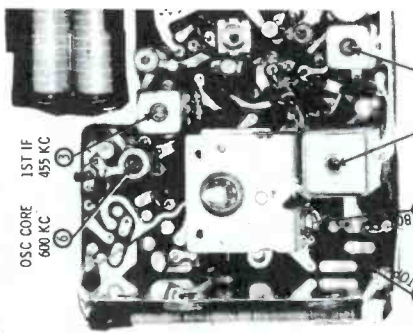
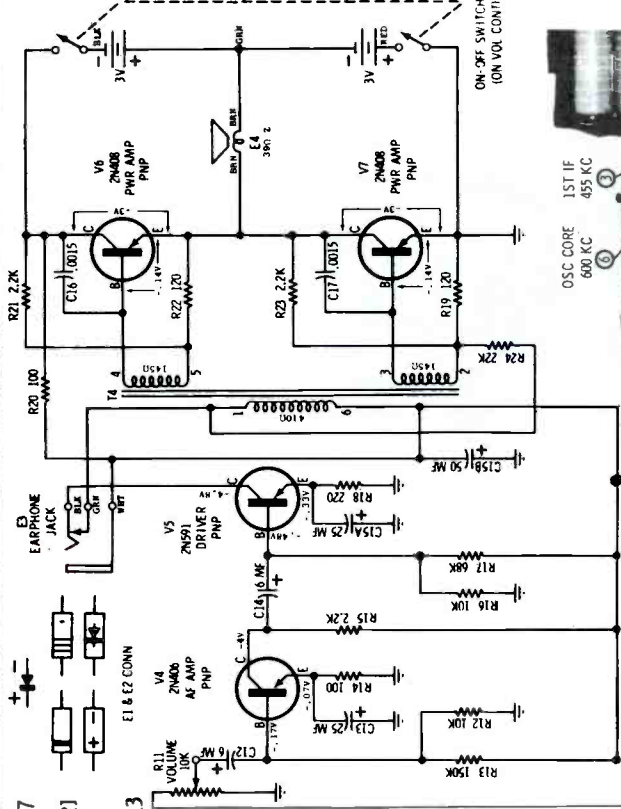
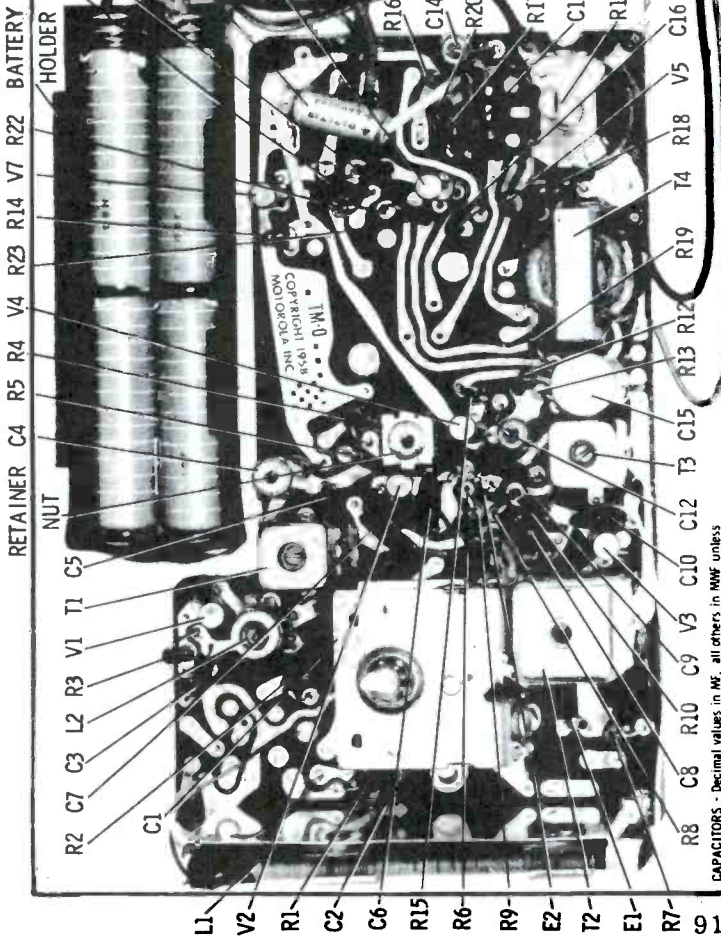

OSC CORE 1ST IF 455 KC
600 KC
2ND IF 3RD IF 1600 KC
ANT TRIM 1400 KC
455 KC

MOTOROLA

ALIGNMENT POINT LOCATIONS

MODELS CHASSIS
7X25P HS-678
7X25W HS-678

POWER-9 SERIES

RETAINER C4 R5 R4 V4 R23 R14 V7 R22 BATTERY HOLDER NUT R2 C7 C3 L2 R3 V1 T1 C5 C1 L1 V2 R1 C2 C6 R15 R6 R9 E2 T2 E1 R7 R8 C8 R10 C9 V3 C10 C12 T3 C15 R13 R12 R19 T4 R18 V5 C16 R16 C14 R20 R17 C11 R11

CAPACITORS - Decimal values in MF, all others in MMF unless otherwise specified.
VOLTAGES - Measured from point indicated to ground or across.
*No signal
-No signal
TUNING RANGE - 535 KC to 1620 KC.
Resistances measured with transistors removed from associated circuitry.

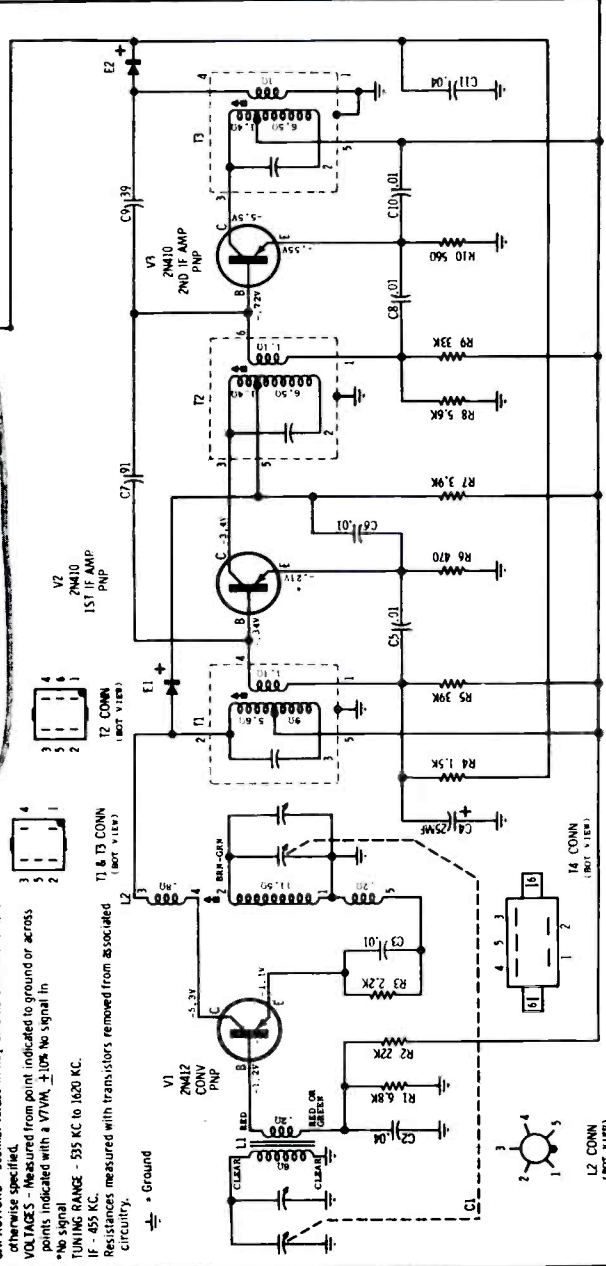

TA CONN (NOT SHOWN)

L2 CONN (NOT SHOWN)

VOLUME R-19, MOST-OFTEN-NEEDED 1959 RADIO SERVICING INFORMATION

MOTOROLA

MODELS 8X26E
8X26S
CHASSIS HS-679
HS-679

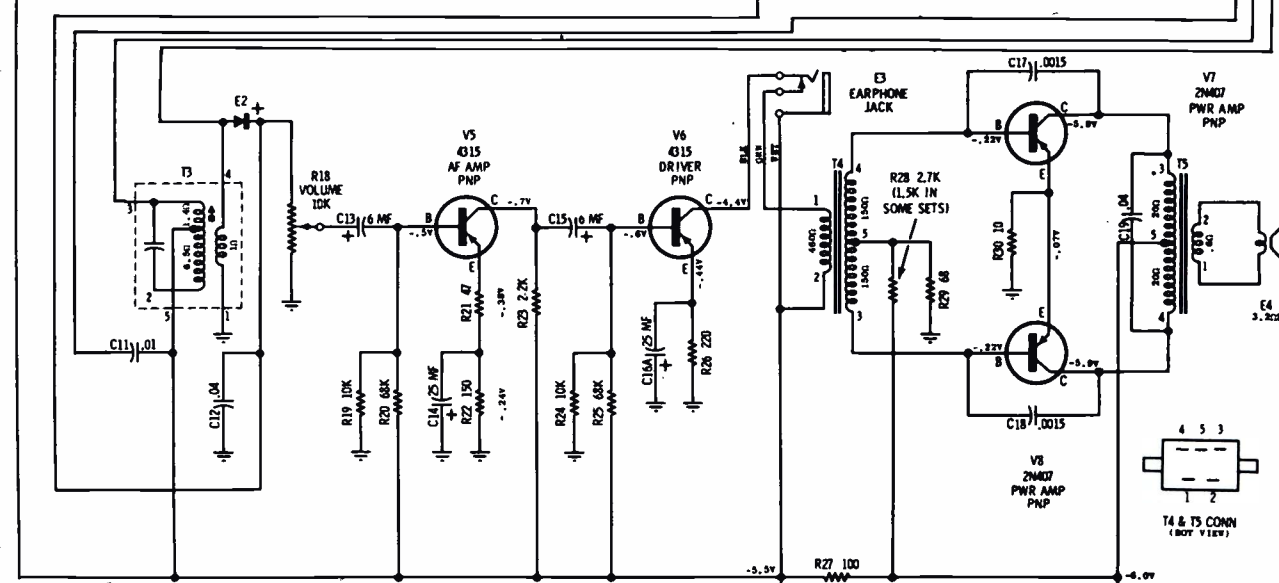
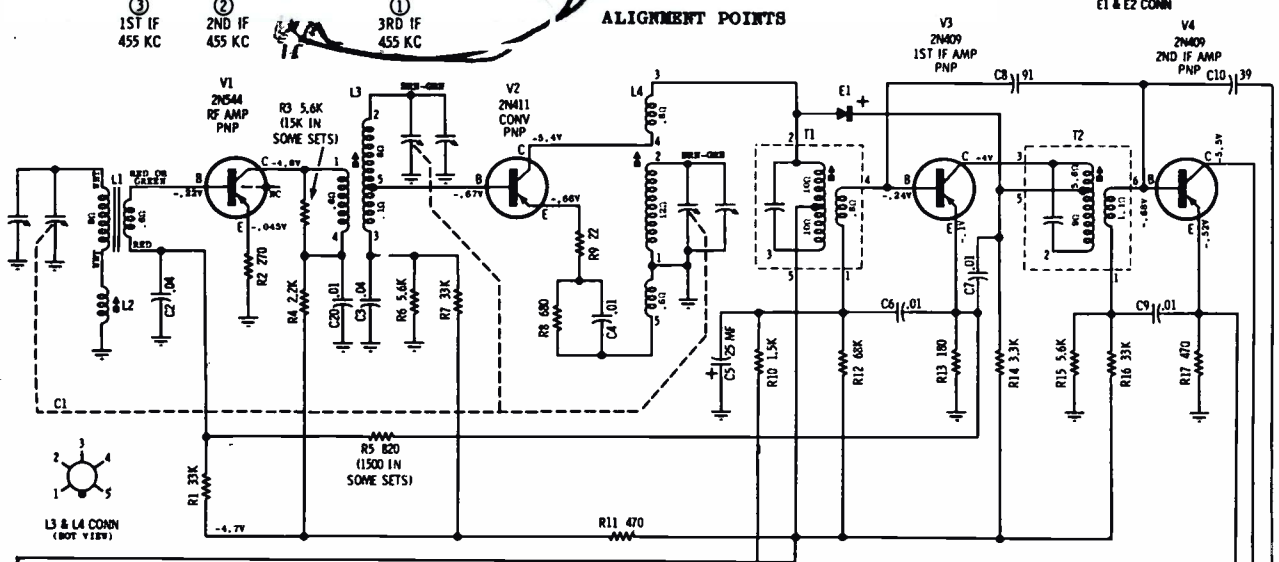
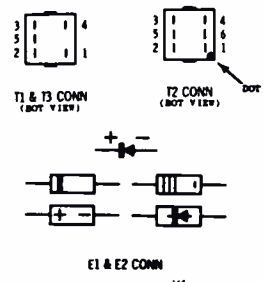
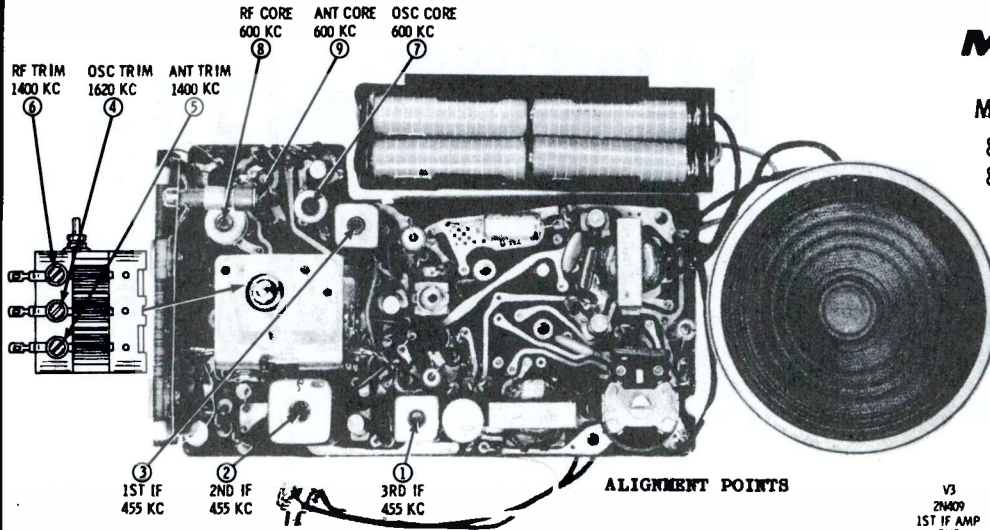

CAPACITORS - Decimal values in MF, all others in MMF unless otherwise specified.
VOLTAGES - Measured from point indicated to ground with a VTVM, +10K, No signal in.
TUNING RANGE - 535 KC to 1620 KC.
IF - 455 KC.
Resistances measured with transistors removed from associated circuitry.

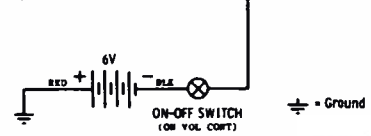

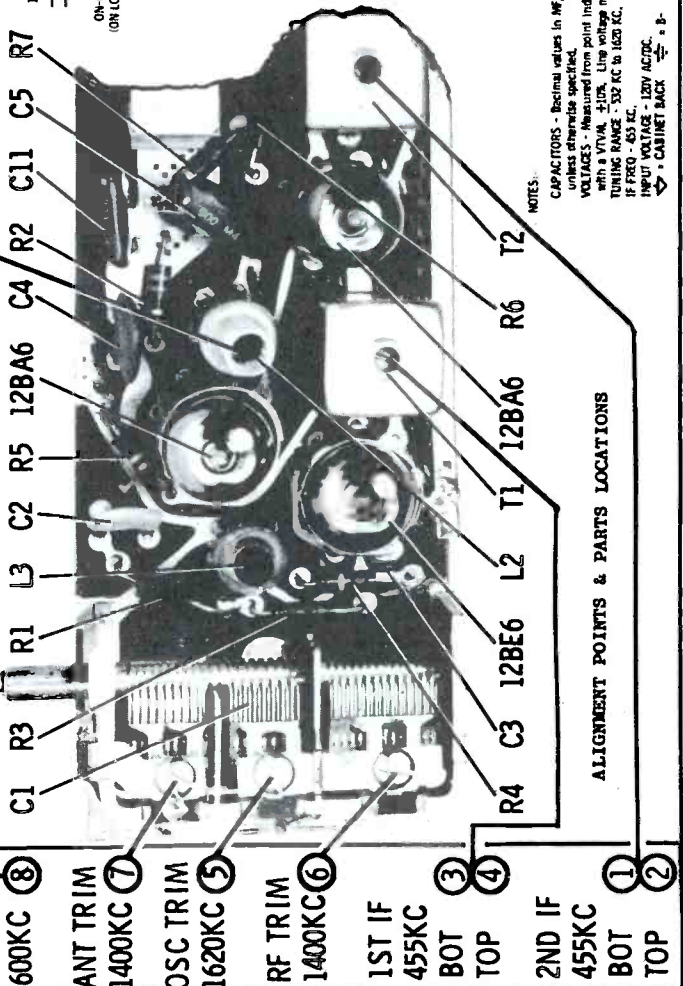
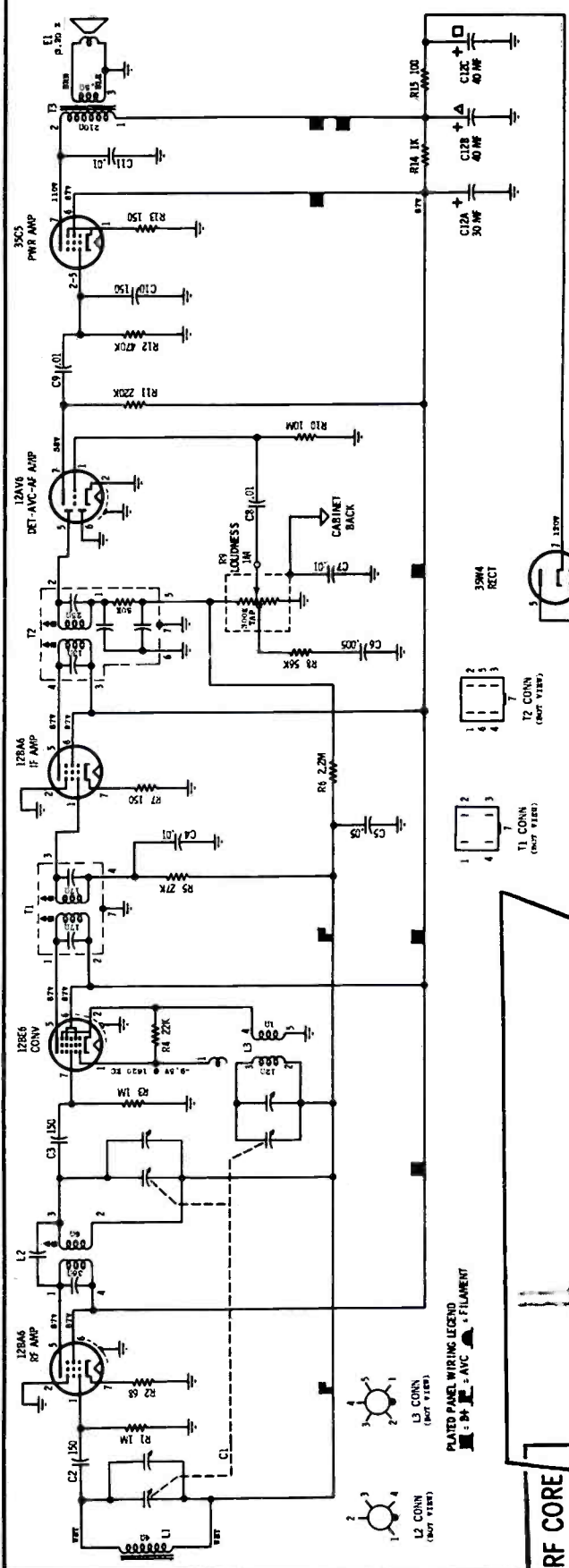

To Remove Chassis From Cabinet

1. Remove two screws on bottom of cabinet; separate rear cabinet from front cabinet and unscrew (from inside rear cabinet) the lead lug which connects chassis to rear cabinet.
2. Remove the insert knob sections on the Loudness control and the Dial Scale. (The two control knobs are each composed of two sections.)
3. Remove Dial Scale knob and the screw (located behind knob) that mounts chassis to cabinet.
4. From front of cabinet, unscrew palmnut from Loudness Indicator knob in order to free the chassis.
5. From rear of cabinet, remove the two screws that mount the plated panel bracket to cabinet.
6. Unsolder speaker leads, antenna leads, and remove chassis from cabinet.

MOTOROLA
MODELS CHASSIS
 6T15N HS-680
 6T15S HS-680

NOTES:
 CAPACITORS - Nominal values in MF, all others in MUF
 unless otherwise specified.
 VOLTAGES - Measured from point indicated to chassis
 with a VTVM - ±10%. Line voltage maintained at 120V.
 TUNING RANGE - 532 KC to 1620 KC.
 IF FREQ. - 455 KC.
 INPUT VOLTAGE - 120V AC/DC.
 ⇨ - CABINET BACK

MOTOROLA

MODELS	CHASSIS
7X23E	HS-688
7X24S	HS-688
7X24W	HS-688

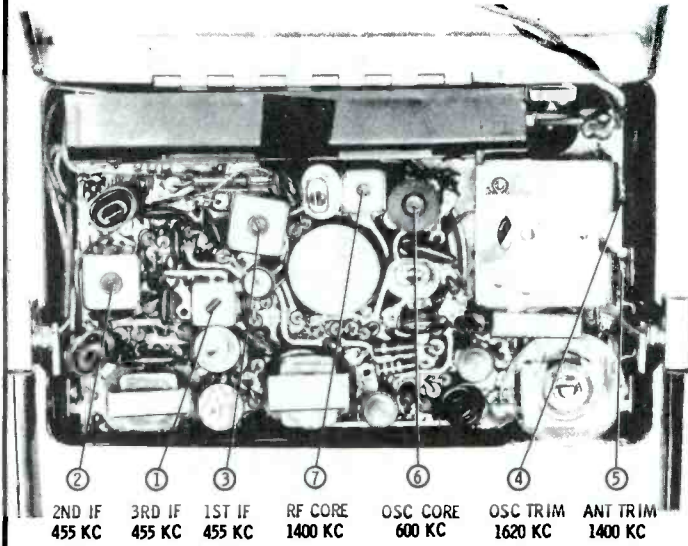

2ND IF 455 KC 3RD IF 455 KC 1ST IF 455 KC RF CORE 1400 KC OSC CORE 600 KC OSC TRIM 1620 KC ANT TRIM 1400 KC

ALIGNMENT POINT LOCATIONS

ESCUTCHEON & CHASSIS REMOVAL

1. From inside cabinet (below gang) remove escutcheon mounting screw.
2. Remove escutcheon by inserting small screwdriver into dent on edge of escutcheon and prying up. Work escutcheon free (use caution to prevent scratching cabinet and escutcheon.)
3. Remove dial and tuning knobs by pulling straight off.
4. Remove chassis mounting screw.
5. Turn handle perpendicular to component side of plated panel.
6. Grasp handle near one of its two mounting bushings and pull out from side of cabinet until the round portion of mounting bushing clears hole in side of cabinet, then lift this side of handle and chassis slightly out of cabinet. Perform the same procedure on the other mounting bushing, then lift handle, chassis and speaker plate out of cabinet.
7. Unscrew earphone jack.
8. Separate the plated chassis from the speaker mounting plate as follows: unsolder the wire that connects the gang to the plated chassis. Unsolder speaker lug, green lead from

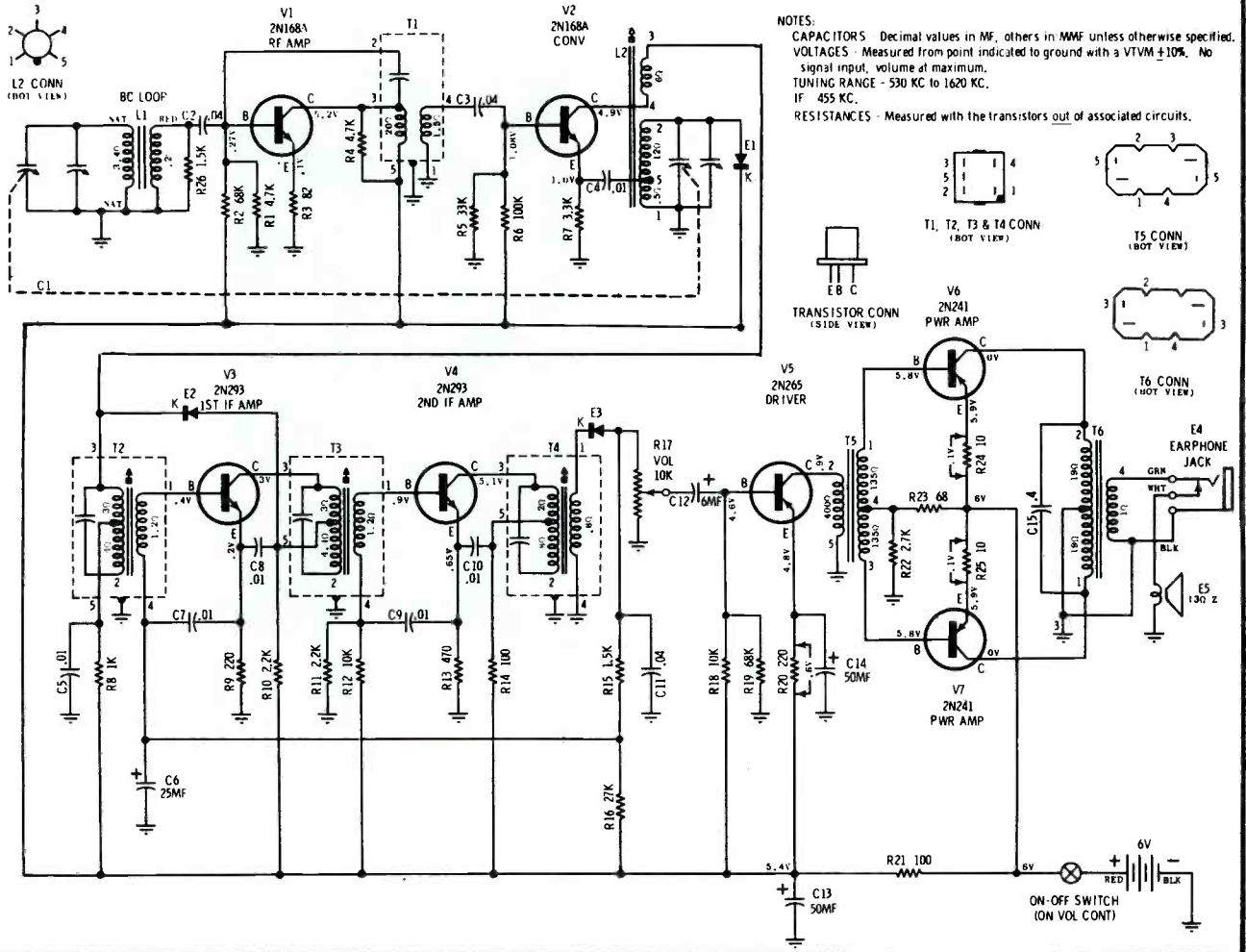

MOTOROLA

MODELS SF11B SF11N
CHASSIS HS-703 HS-703

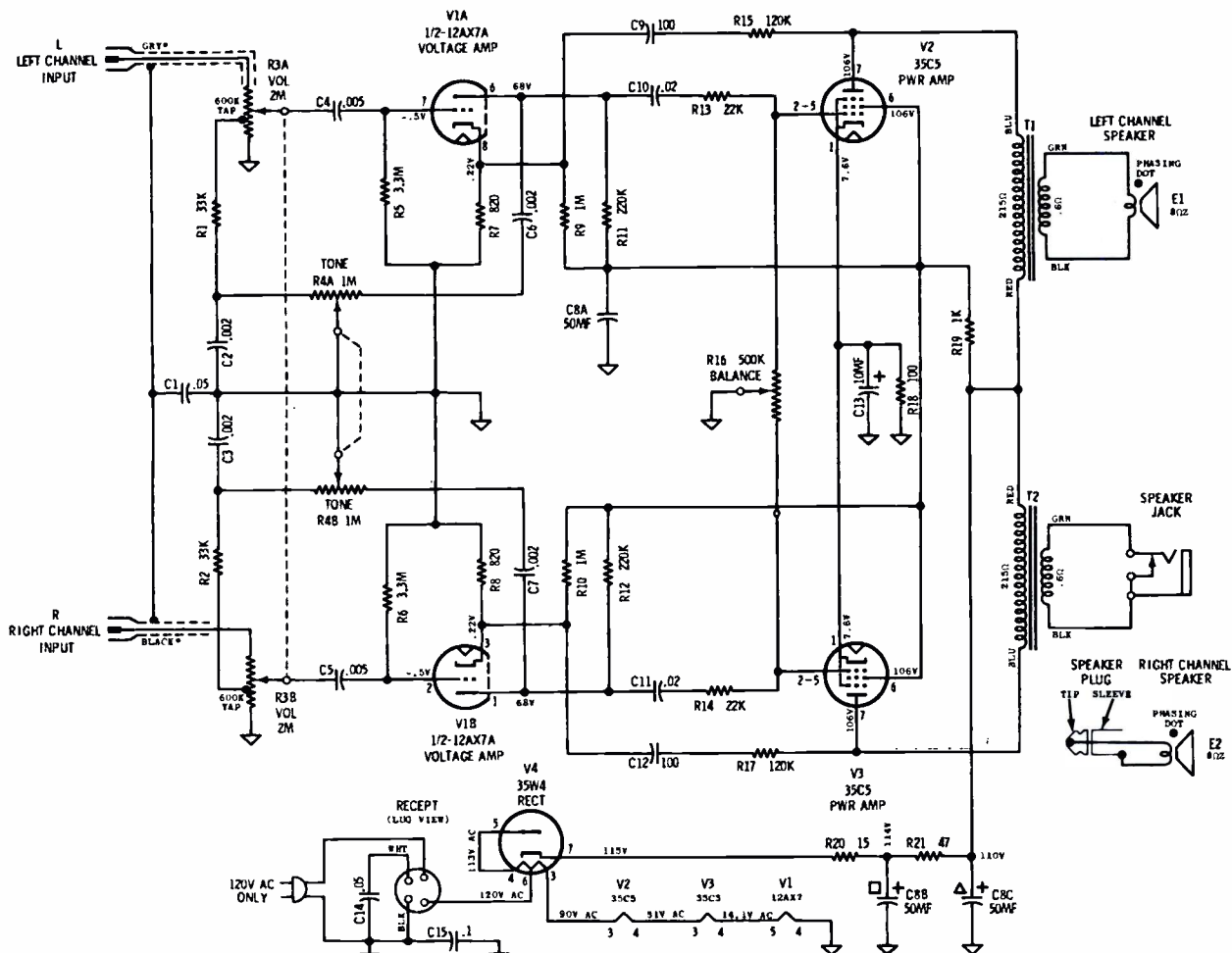

NOTES:
 CAPACITORS - Decimal values in MF, all others in MMF unless otherwise specified.
 VOLTAGES - Measured from point indicated to B- with a VTVM, $\pm 10\%$. No signal in.
 ∇ - B- ∇ - Chassis ∇ - Record changer frame
 *On some units, the phono input cable colors were reversed.

The chassis of this amplifier is isolated from the AC power line by a capacitor to eliminate the shock hazard when handling the chassis. However, as an additional precaution, when servicing this amplifier, an isolation transformer should be inserted between the power line and the chassis.

TO REMOVE CHASSIS FROM CABINET

1. Remove 3 control knobs.
2. Remove 3 baffle mounting screws and unscrew speaker jack mounted on baffle; then remove baffle.
3. Remove record changer mounting board screws.
4. Lift mounting board and record changer high enough to permit access to bottom of changer.
5. Unplug phono cables connected to record changer "R" and "L" jacks, also unplug phono power plug.
6. Remove 4 chassis mounting nuts.
7. Unsolder speaker leads.
8. Remove chassis from cabinet.

TO REMOVE RECORD CHANGER FROM CABINET

1. Remove 3 baffle mounting screws and unscrew speaker jack mounted on baffle; then remove baffle.
2. Remove record changer mounting board screws.
3. Lift mounting board and record changer high enough to permit access to bottom of changer.
4. Unplug phono cables connected to record changer "R" and "L" jacks, also unplug phono power plug.
5. Turn the two record changer mounting screws fully clockwise (down flush against changer base).
6. Place clips, located at ends of record changer mounting screws, so that they are parallel with the screws.
7. Remove record changer from cabinet.

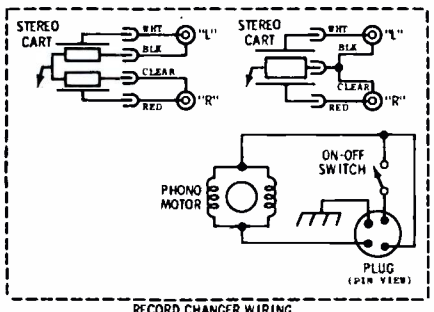

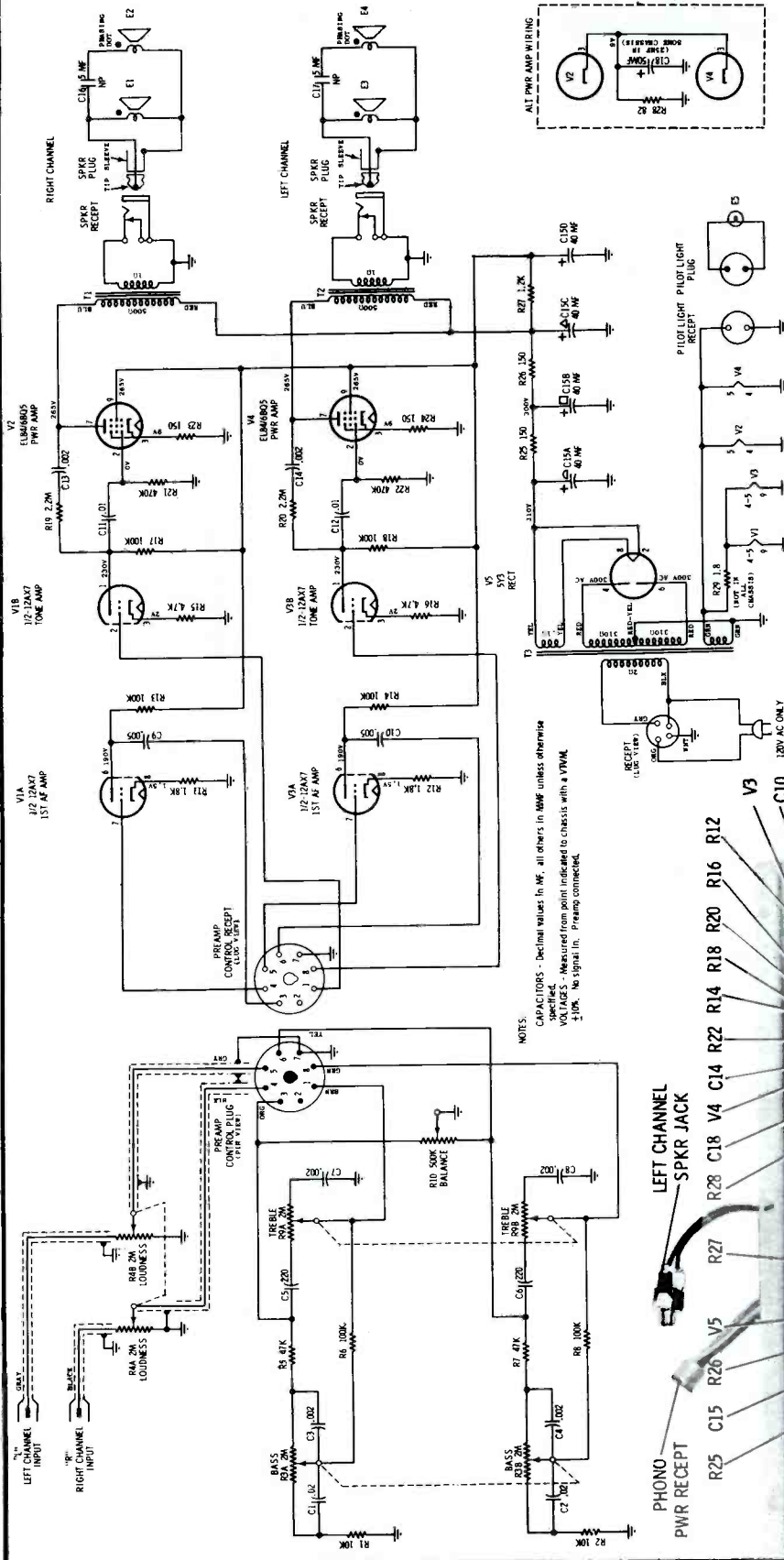

NOTES:
 CAPACITORS - Decimal values in μ F, all others in M μ F unless otherwise specified.
 VOLTAGES - Measured from point indicated to chassis with a VTVM.
 $\pm 10\%$ No signal in. Preamp connected.

MOTOROLA

MODELS
 SH12E
 SH12N
 SH12S

CHASSIS
 HS-704
 HS-704
 HS-704

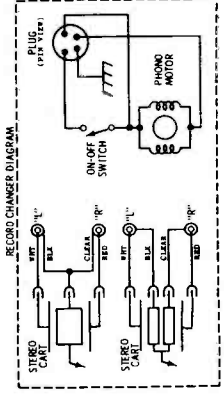
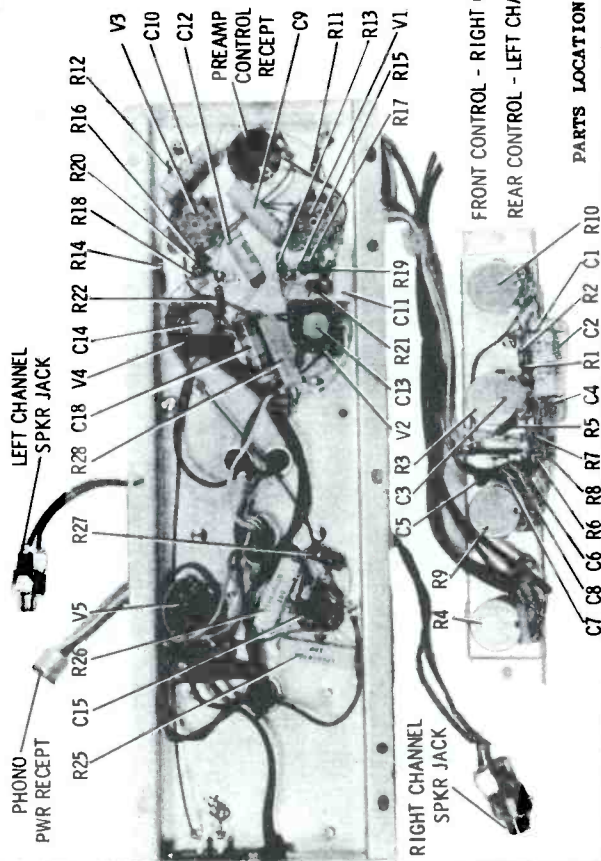

TO E5
 LINE CORD

MOTOROLA

MODELS	CHASSIS
SK21B, M	HS-735
SK23B, CW, M	HS-735
S21B, CW, M	-

Models SK21 and SK23 are console stereophonic phonographs containing four-speed record changers with stereophonic cartridge and multiple speaker systems. These models differ from each other in type of record changer used and cabinet design. Model S21 is the right channel speaker system used with SK21 and SK23 to complete the stereophonic system.

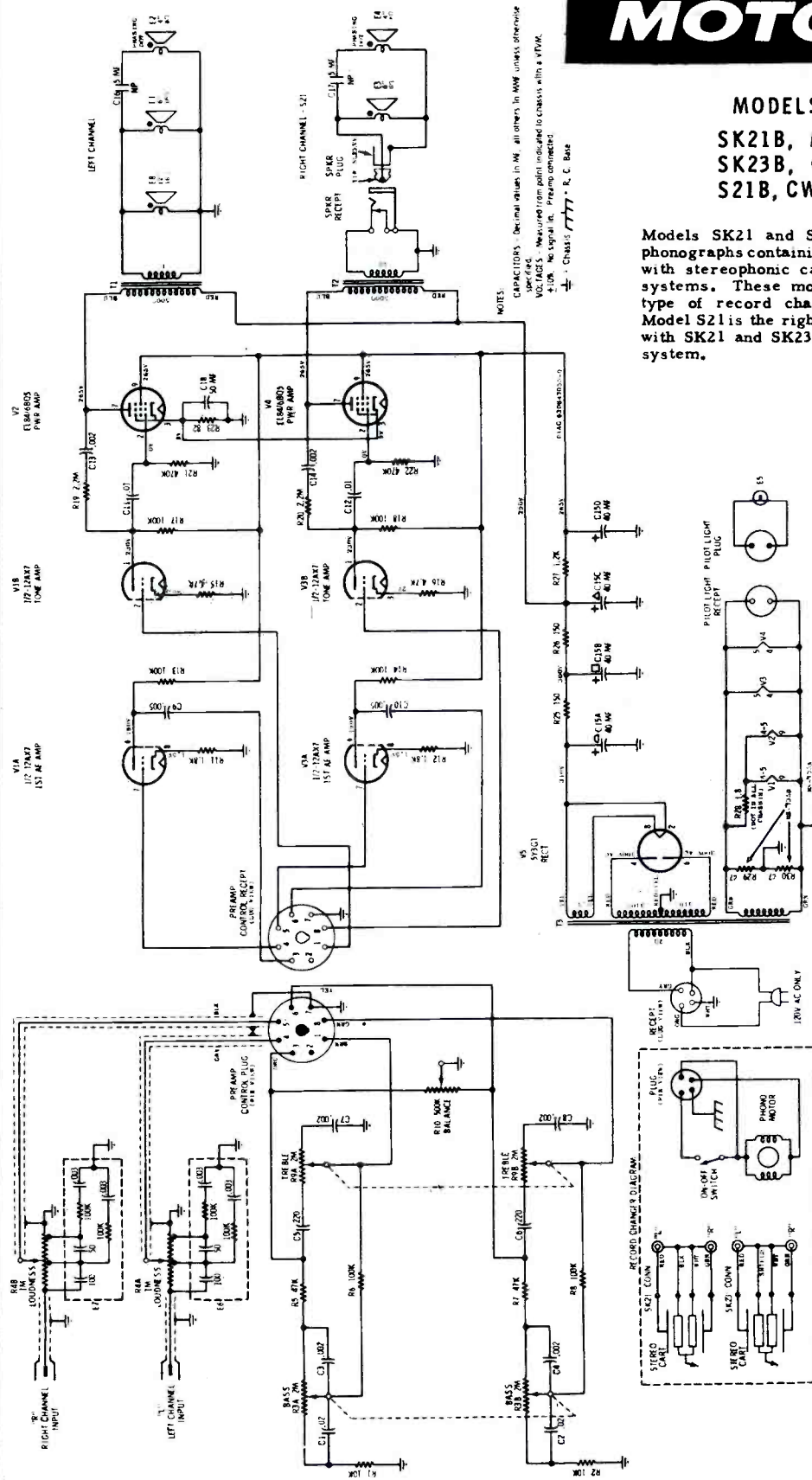

NOTES:
 CAPACITORS - Denom. values in μ F, all others in pF unless otherwise specified.
 VOLTAGES - Measured from point indicated to chassis with a VTVM.
 \pm 10% No signal in. Preamp. connected.
 CHASSIS - 7777 - R, C, Base

To Remove Record Changer from Cabinet (SK23 Series)

1. Remove back cover.
2. Disconnect all changer leads.
3. Turn two record changer mounting screws fully clockwise.
4. From bottom of changer, turn the two mounting clips located at mounting screw ends so they are parallel with the screws.
5. Grasp changer by base and lift up.

To Replace Pilot Light (All Models)

1. Remove cabinet rear cover.
2. From inside cabinet, unclip pilot light socket from mounting bracket.
3. Remove pilot light.

DISASSEMBLY INSTRUCTIONS

To Remove Chassis from Cabinet (All Models)

1. Pull off control knobs.
2. Remove cabinet back cover.
3. Disconnect all leads from changer and speakers.
4. Unplug pilot light at chassis.
5. Unplug control plug at chassis.
6. Remove nut from output jack and remove jack from mounting bracket.
7. Remove chassis mounting screw and slide chassis out rear of cabinet.
8. Remove 2 nuts from control unit mounting screws.
9. Remove control unit.

Olympic

MODEL 688

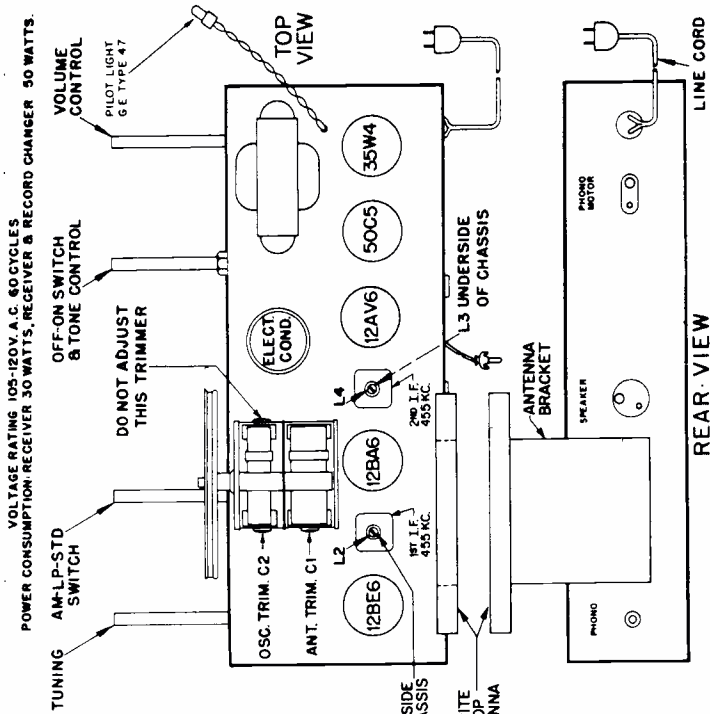

ALIGNMENT:

Equipment required: Modulated RF signal generator; output meter; insulated screw-driver; two .1 mfd 400 volt condensers.

To insure proper alignment, a radiated signal will be required during part of the alignment procedure. To radiate a signal, connect a loop of about 6 inches in diameter (one turn of #14 or #12 wire) across the output of the signal generator, and place this loop perpendicular to the Ferrite stick antenna of the receiver to be aligned, at a distance of about 10 or 12 inches.

Connect the output meter and signal generator as follows:

Output meter: Connect across the speaker voice coil and turn the volume control to maximum (extreme clockwise position).

ALIGNMENT PROCEDURE CHART

STEP	CONNECT HIGH SIDE OF SIGNAL GENERATOR TO -	TURN RECEIVER DIAL TO -	ADJUST THE FOLLOWING FOR MAXIMUM OUTPUT (KEEP SIGNAL FROM SIGNAL GENERATOR AS LOW AS POSSIBLE.)
1	ANTENNA SECTION TUNING CONDENSER IN SERIES WITH .1 MFD COND.	455 KC.	FULL CLOCKWISE POSITION (CONDENSER PLATES FULLY OPEN) (1ST. AND 2ND. I.F. TRANSFORMERS)
2		1500 KC	1500 KC. (150 ON DIAL) C 2 (OSCILLATOR)
3	USE RADIATED SIGNAL	1500 KC.	MAXIMUM SIGNAL (APPROX 150 ON DIAL) C 1 (ANTENNA)
4			REPEAT STEPS 2 AND 3

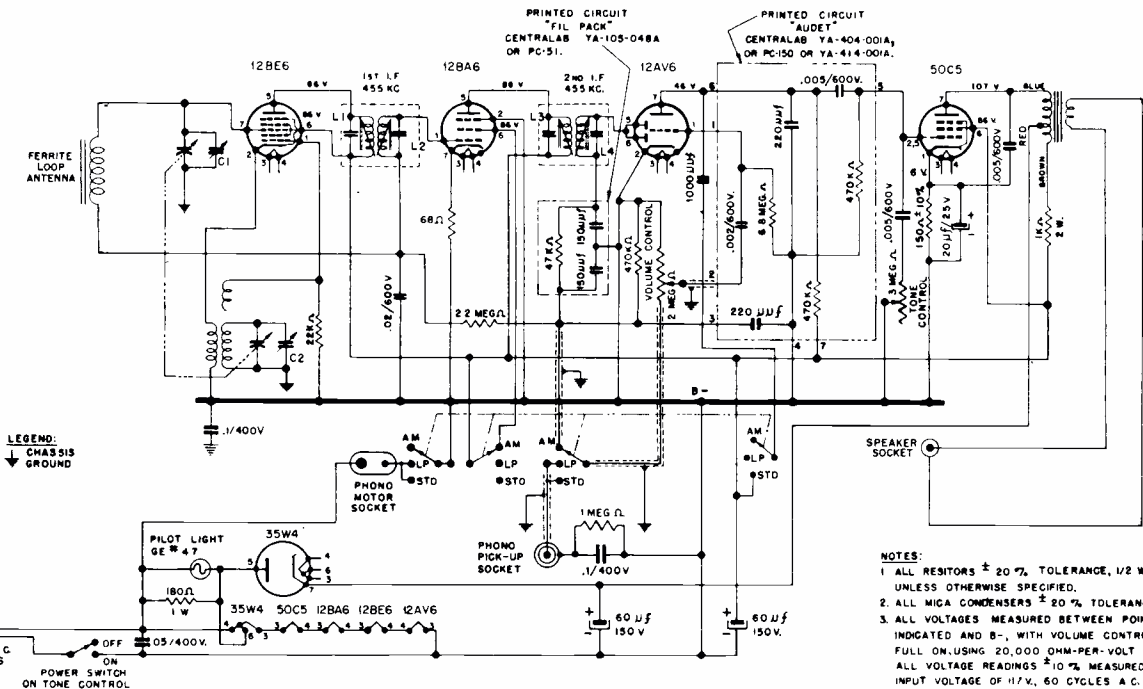

NOTES:
 1. ALL RESISTORS ± 20% TOLERANCE, 1/2 WATT, UNLESS OTHERWISE SPECIFIED.
 2. ALL MICA CONDENSERS ± 20% TOLERANCE.
 3. ALL VOLTAGES MEASURED BETWEEN POINTS INDICATED AND B-, WITH VOLUME CONTROL FULL ON, USING 20,000 OHM-PER-VOLT METER. ALL VOLTAGE READINGS ± 10% MEASURED WITH INPUT VOLTAGE OF 117V, 60 CYCLES A.C.

PACKARD BELL

TABLE MODEL RADIO 5R5

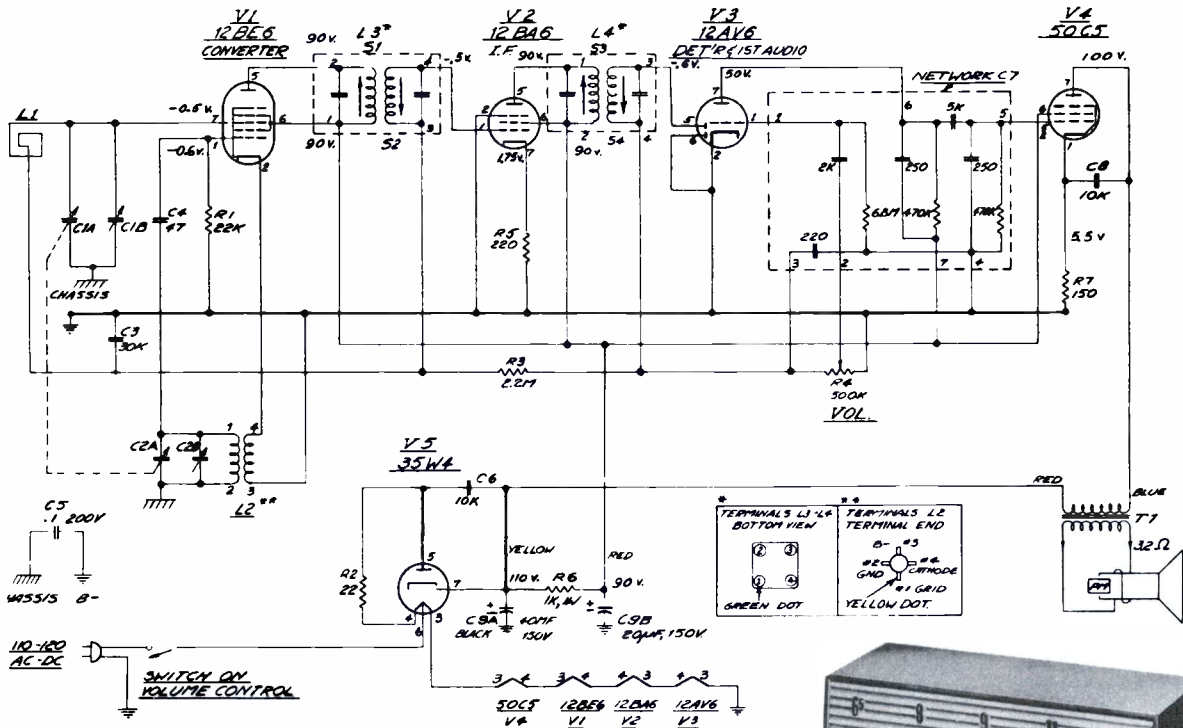

DC RESISTANCE MEASUREMENTS:

1st I-F Coil:

- Primary, 19 ohms
- Secondary, 19 ohms

2nd I-F Coil:

- Primary, 19 ohms
- Secondary, 19 ohms

Oscillator Coil:

- Primary, 1 ohm
- Secondary, 10 ohms

Socket voltages measured as follows:

1. Line voltage, 117 volts AC.
2. Volume control at maximum.
3. VTVM between socket terminal and B minus bus.
4. Only DC voltages measured. Allow 10% tolerance.

ALIGNMENT PROCEDURE:

The alignment of the set is accomplished by following the steps in the chart below. Connect output meter to speaker voice coil. Use isolation transformer, if available, for shock protection.

Each adjustment should be made using a minimum input signal. Connect oscillator through a .01 mfd capacitor in step one; loose-couple oscillator lead in steps two and three.

Step	Connect Test Oscillator To	Test Oscillator Frequency	Radio Dial Setting	Adjust
1.	Pin 1, V-1 (12BE6)	455 Kc.	540 Kc.	S-1, S-2, S-3, & S-4 for MAX.
2.	Loose-couple to antenna	1620 Kc.	1620 Kc.	C-2B for MAX.
3.	ditto	1500 Kc.	Tune to Osc. Signal	C-1B for Max.

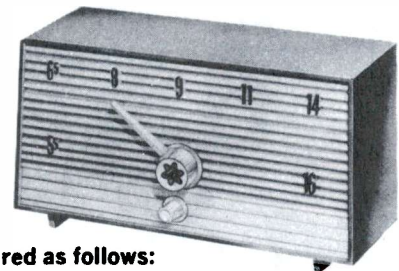
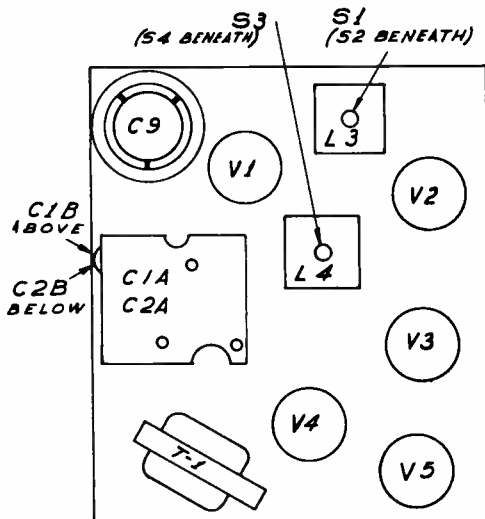

PACKARD BELL MODEL 6RT2 PERSONAL TRANSISTOR RADIO

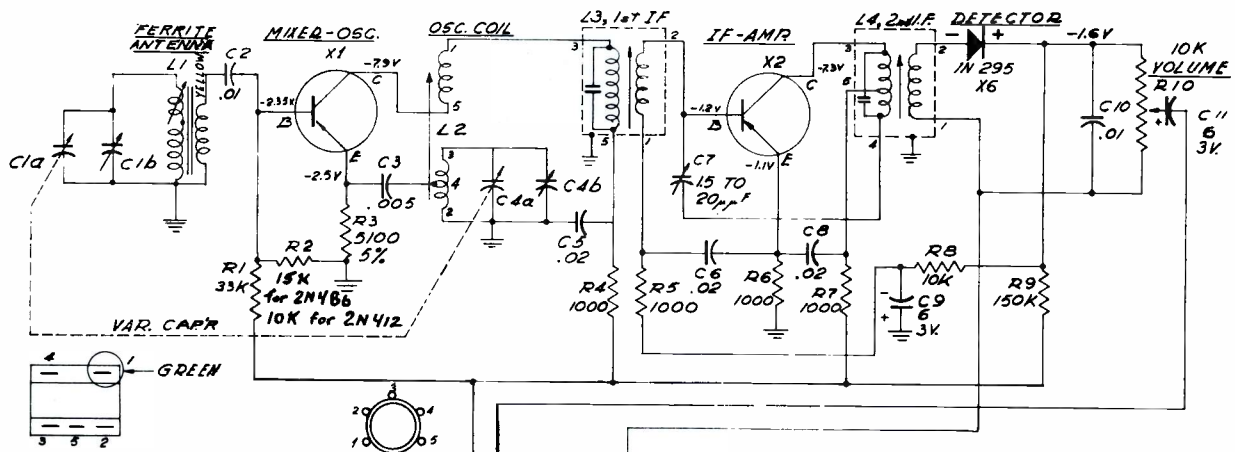

BOTTOM VIEW OF I-F AND OSCILLATOR COIL TERMINALS

- NOTE:**
 1. ALL RESISTORS 1/2 WATT ±10% UNLESS OTHERWISE NOTED
 2. K = 1000 OHMS
 3. ALL CAPACITORS IN MFD UNLESS OTHERWISE NOTED
 4. D.C. WORKING VOLTAGE IS 25V. UNLESS OTHERWISE NOTED
 5. D.C. VOLTAGES MEASURED WITH KIYVM. TO COMMON GROUND (POSITIVE) - NO SIGNAL VOL. CONT. AT MAX.

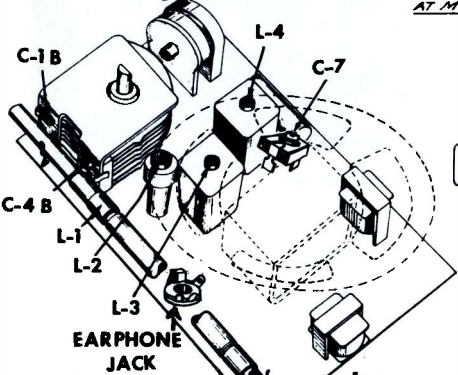

ALIGNMENT:

Leave speaker in place; adjust L-2, L-3, & L-4 from rear.

Step 1. Preset I-F amplifier neutralizer capacitor C-7 by turning completely clockwise (maximum

capacity) then back one eighth of a turn (45 degrees). See note after step seven.

Step	Connect Test Oscillator To	Test Oscillator Frequency	Radio Dial Setting	Adjust
2.	Variable, antenna section	455 kc	535 kc	L-3 & L-4 for MAX
3.	Couple to antenna	600 kc	600 kc	L-2 (osc) for MAX
4.	Couple to antenna	1620 kc	1620 kc	C-4B for MAX
5. Repeat steps two and three and check calibration at low end of dial (535 kc)				
6.	Couple to antenna	1500 kc	Tune to test osc. signal	C-1B for MAX
7.	Couple to antenna	600 kc	600 kc	L-1 (antenna) for MAX

NOTE: Optimum setting of neutralizing capacitor C-7 depends upon parameters X-2 and L-4. If, after alignment, regeneration occurs on stations near the high end of the dial, capacity of C-7 should be decreased (ccw). Too low a value, however, will result in loss of

sensitivity. If it has been necessary to change the setting of C-7 more than 45 degrees after completing the alignment, then the I-F adjustment (step two) should be repeated.

ITEM	TRANSISTORS	RAYTHEON	R.C.A.
X1	MIXER, OSC.	2N486	2N412
X2	I.F. AMP.	2N483	2N410
X3	AUDIO AMP.	2N363	2N406
X4,5	AUDIO OUT. #	2N632	2N408
X6	DETECTOR DIODE	1N295	

* MATCHED PAIR OR SAME GAIN GROUP NO.

PHILCO

MODEL T-3 — CODES 124, 126, 128 & 130

AUDIO TRANSISTOR SEE TABLE

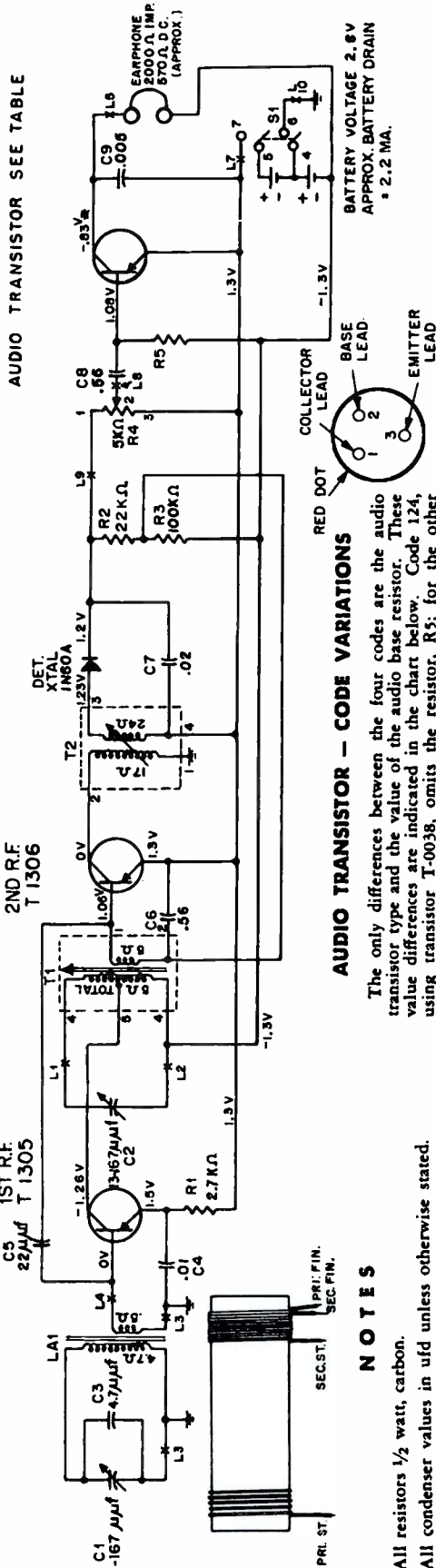

AUDIO TRANSISTOR — CODE VARIATIONS

The only differences between the four codes are the audio transistor type and the value of the audio base resistor. These value differences are indicated in the chart below. Code 124, using transistor T-0038, omits the resistor, R5; for the other codes, the value of R5 is as stated.

For audio transistor replacement purposes, only one type is used, the T-0041 of code 130, part number 34-6001-21. When this transistor is used as replacement in codes 124, 126 or 128, R5 must be changed in value as indicated in the chart.

There will be no difference in performance between the four audio transistors provided the base resistor, R5, is of the correct value.

CODE	AUDIO TRANSISTOR	BASE RESISTOR R5
124	T-0038	NONE
126	T-0039	100K Ω
128	T-0040	330K Ω
130	T-0041	180K Ω

NOTES

- All resistors 1/2 watt, carbon.
- All condenser values in µfd unless otherwise stated.
- Voltages measured with a V.T.V.M. from point indicated to ground, under "No Signal" condition, with volume control at minimum and 2.6 volts from the battery supply.
- *Audio collector voltage may vary between —.6 and —1.0 volt depending upon the transistor.
- Coil resistances measured with coil in the circuit.

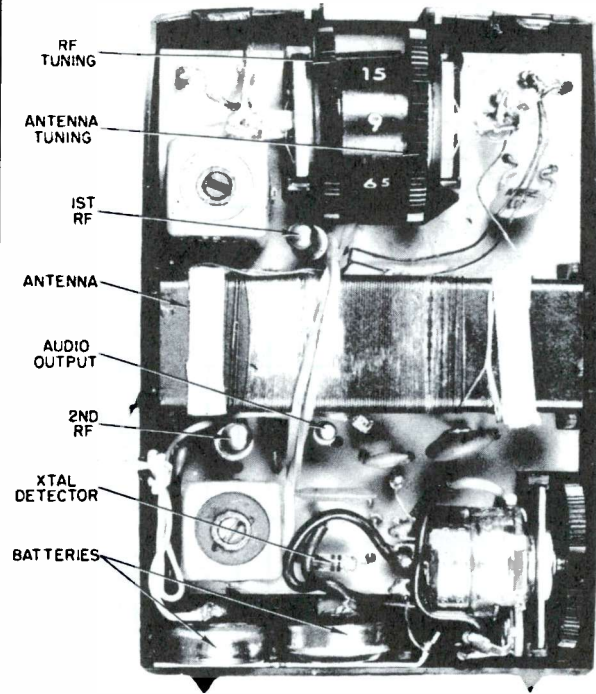

The T-3 Radio with Back Removed

ALIGNMENT PROCEDURE

- GENERAL**—Allow the test equipment to warm up for fifteen minutes before starting the alignment procedure.
- OUTPUT INDICATOR**—Connect the output indicator (a V.T.V.M. using the low voltage AC range or a calibrated oscilloscope) across the ear phone terminals.
- SIGNAL GENERATOR**—Use an AM r-f signal generator. Radiate the signal to the radio antenna. Use a 6 to 8 turn, 6-inch diameter loop made up of insulated wire. Connect to generator terminals and place about one foot from the radio antenna.
- OUTPUT LEVEL**—During alignment, attenuate the signal-generator output so as to maintain the output level at 0.63 volts.
- RADIO CONTROLS**—Set the volume control to maximum. Set the antenna tuning knob (the right-hand knob with the dial scale) to 600 KC. Without moving the antenna tuning, adjust the RF tuning knob to the mid-position of its fine-tuning range. **DO NOT DISTURB** the radio tuning once it is set.
- Step #1**—Set generator to 600 KC. Adjust the core of T1 (the 1st RF transformer) for peak. Rock the generator — NOT the radio tuning — and adjust for maximum.
- Step #2**—Set generator to 600 KC. Adjust the core of T2 (the 2nd RF transformer) for maximum. This transformer is very broad; there will be only a slight peak. The core may not extend above the top of the can.

PHILCO RADIO MODEL T-3 – CODES 132, 134, 136 & 138

138	T-0041	120K Ω
136	T-0040	220 K
134	T-0039	470 K
132	T-0038	1M
CODE	AUDIO TRANSISTOR	BASE RESISTOR R6

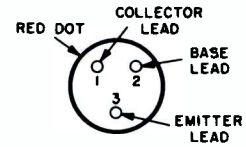

AUDIO TRANSISTOR – CODE VARIATIONS

The only differences between the four codes are the audio transistor type and the value of the audio base resistor. These value differences are indicated in the chart above.

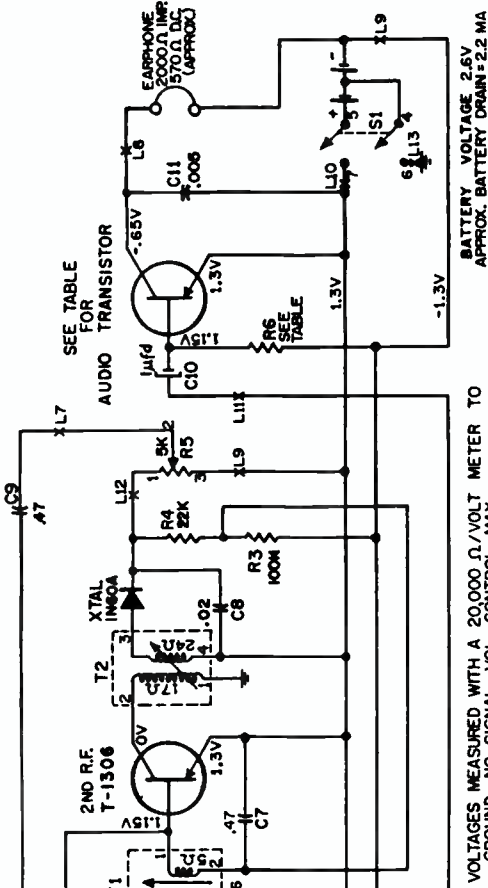

VOLTAGES MEASURED WITH A 20,000 Ω /VOLT METER TO GROUND, NO SIGNAL, VOL. CONTROL MAX.
RESISTANCES MEASURED WITH COILS IN CIRCUIT.

PANEL-WIRE TERMINAL IDENTIFICATION

- L1 Orange lead from r-f tuning, C2, to T1 lug 4.
- L2 Black lead from r-f tuning, C2, to T1 lug 3 and red jumper to terminal 6.
- L3 Orange lead from ant. tuning, C1, and plain lead from bottom of ant. pri. (LA1) to panel ground.
- L4 Red lead from bottom of ant. sec. (LA1) to junction of R1, C4 and C5.
- L5 Red lead from top of ant. sec. (LA1) to 1st r-f base.
- L6 Red jumper from terminal 2, black jumper to terminal 11 and junction of C6 and R2.
- L7 Yellow lead to arm of volume control (R5).
- L8 Earphone lead to audio collector.
- L9 Black lead from battery, -1.3 volts.
- L10 Red lead from switch S1 lug 7, +1.3 volts.
- L11 Black jumper from terminal 6 to C10, the lufd audio coupling.
- L12 Orange lead to top of volume control, R5 lug, 1.
- L13 Black lead from switch, S1, lug 6 to panel ground.

SHIELDING

To suppress possible regeneration, the leads of T1 are shielded by wrapping a small piece of aluminum tape around the can so as to cover the cut-outs. When replacing be careful not to cause shorts.

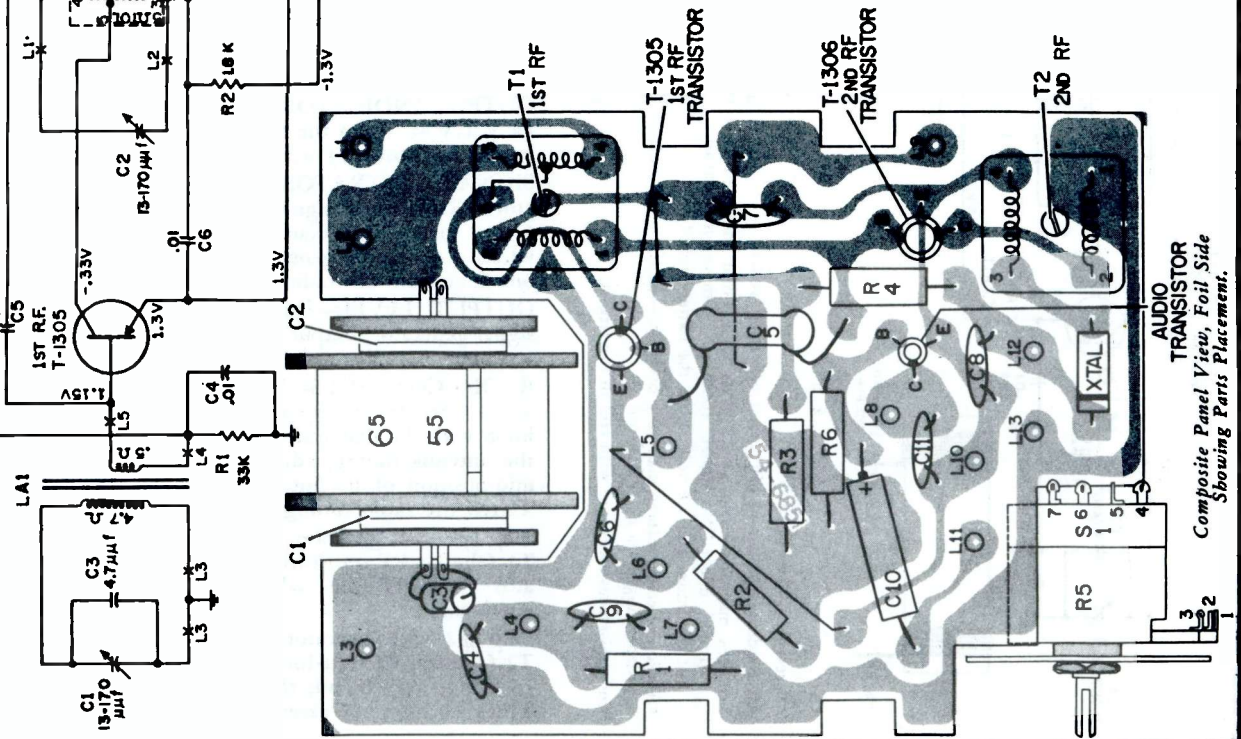
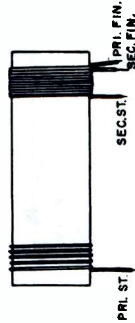

Composite Panel View, Foil Side Showing Parts Placement.

PHILCO

MODELS T-4 and T-4J - CODE 124

ALIGNMENT CHART

STEP	SIGNAL GENERATOR		RADIO		ADJUST
	CONNECTION TO RADIO	DIAL SETTING	DIAL SETTING	SPECIAL INSTRUCTIONS	
1	Panel must be removed from cabinet. Connect signal generator through a .1 uf condenser to antenna section of gang. Use the least generator signal necessary to give an ooutput indication.	455 KC	Tuning gang fully open.	Adjust for maximum output in order given.	Z3—3rd IF Z2—2nd IF Z1—1st IF
2	Use radiating loop (See note 1 below).	1620 KC	1620 KC (gang fully open)	Pre-set C2A (Ant.) 1/2 turn from tight. Adjust for maximum output.	C1B—osc. trimmer
3	Same as step 2.	1400 KC	1400 KC	Adjust for maximum output.	C1A—ant. trimmer
4	Same as step 2. Panel MUST be re-mounted in cabinet.	600 KC	600 KC	Adjust for maximum output. Rock tuning gang while making in this adjustment.	T1—osc. core
5	Repeat steps 2, 3 and 4 until no further improvement is obtained. Always stop on step 2.				

NOTE 1. Use a 6-to-8 turn, 6-inch diameter loop made up of insulated wire. Connect to generator terminals, and place about one foot from radio loop.

SCHEMATIC NOTES

Due to 2nd IF transistor variations the values of resistors R6 and R7 must be selected, within limits, for optimum performance.

When transistor R186 is defective, kit number 324-8003 must be ordered. This kit contains a R186 transistor and two resistors (R6 and R7) properly matched. All three components must be replaced.

The stage may be checked as follows:

The value of R6 is selected to allow the 2nd IF transistor collector to draw 2 milliamps. This is checked by measuring the voltage across R11, the 560 ohm collector return resistor. This voltage should be 1.12 volts, with a tolerance of approximately $\pm .12$ volts. The value of R6 falls within the limits of 27K to 390K.

All resistors are 1/2 watt, 10%, carbon.

Coil resistances read with coil in circuit.

Voice coil impedance = 14 ohms.

Voltages measured to ground with a 20,000 ohms/volt meter under no signal condition.

Emitter to base voltages were measured with positive lead to emitter, except for the 1st IF which is an NPN type and measured with the positive lead to the base.

Run #51 — to improve low end sensitivity. The value of R1 was changed to 15,000 ohms, part number 66-3158340. Some few sets may have a 10,000 ohm resistor for R1.

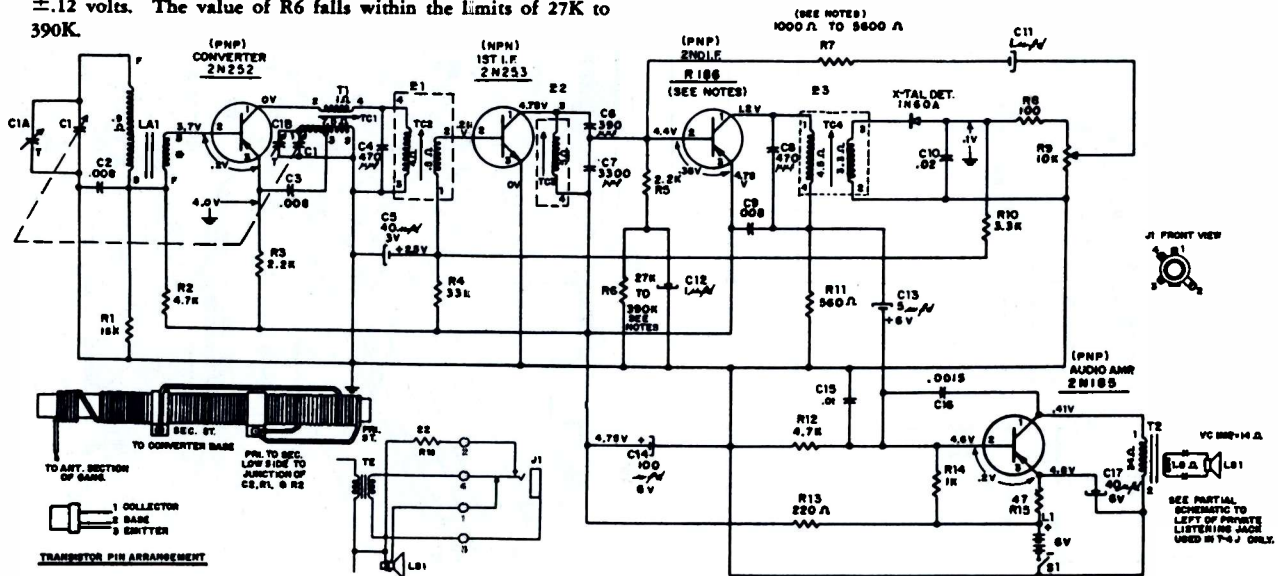

PHILCO

PHILCO TRANSISTOR RADIO MODEL T-5 — CODE 124

Schematic Diagram of Model T-5 — Code 124

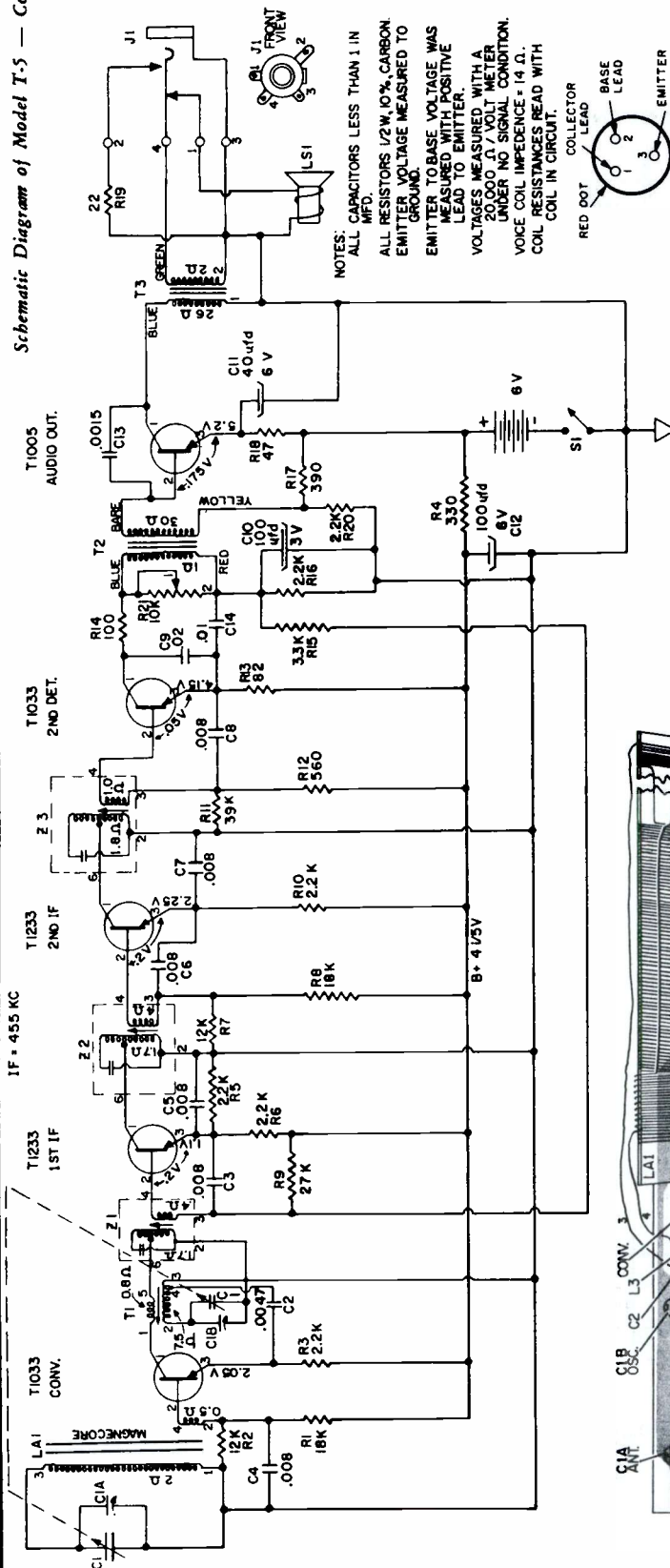

NOTES:
 ALL CAPACITORS LESS THAN 1 IN MFD.
 ALL RESISTORS 1/2 W, 10% CARBON. EMITTER VOLTAGE MEASURED TO GROUND.
 EMITTER TO BASE VOLTAGE WAS MEASURED WITH POSITIVE LEAD TO EMITTER.
 VOLTAGES MEASURED WITH A 20,000 Ω / VOLT METER UNDER NO SIGNAL CONDITION. VOICE COIL IMPEDANCE = 14 Ω. COIL RESISTANCES READ WITH COIL IN CIRCUIT.

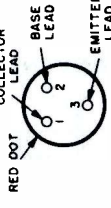

BATTERY VOLTAGE AND TYPE—6.0 volts from 4 penlight cells, type "AA", P-15, or mercury type "AA", P-9.
FREQUENCY COVERAGE—535 to 1620 KC.
INTERMEDIATE FREQUENCY—455 KC.

TERMINAL LUG IDENTIFICATION

- L1 Orange jumper to L4, 5 volt B+.
- L2 Yellow lead to T2.
- L3 To short antenna lead no. 4.
- L4 Orange jumper to L1, 4.5 volt B+.
- L5 Black jumper to ground lug L10.
- L6 Black lead to positive battery terminal (6 volts).
- L7 Green lead to end of R21.
- L8 Orange lead to T3.
- L9 Blue lead of T3.
- L10 Ground lug: black lead to speaker, black lead to L5 and black lead to on-off switch.

PRIVATE LISTENING JACK TERMINAL LEADS

- Terminal 1—Brown lead to speaker.
 - Terminal 2—One end of R19, P.L. shunt resistor.
 - Terminal 3—Black ground lead to on-off switch and other end of R19.
 - Terminal 4—Green lead of T3.
- NOTE: C14 wires under the panel, from L8 to the junction of C9 and the emitter (No. 3) of the 2nd detector.

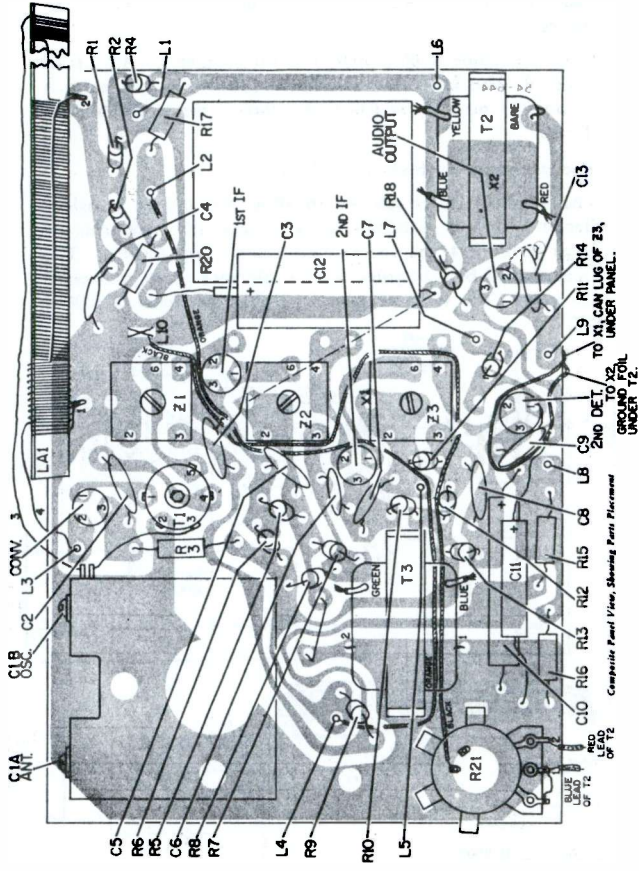

PHILCO

TRANSISTOR MODEL T-7X, CODE 128

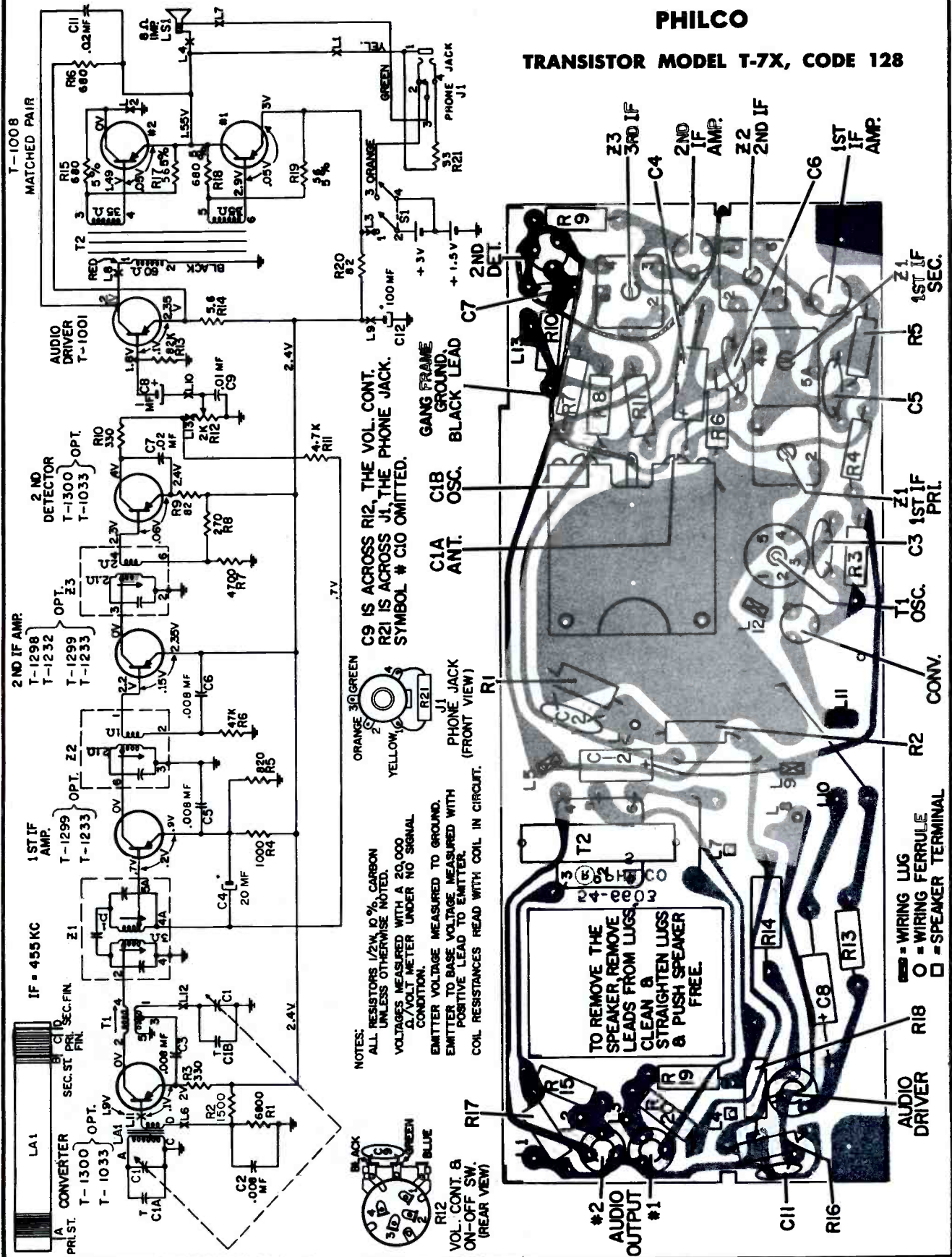

Schematic Diagram of Philco Transistor Portable Model T-7X, Code 128

PHILCO PORTABLE RADIO TRANSISTOR MODEL T-60, CODE 124

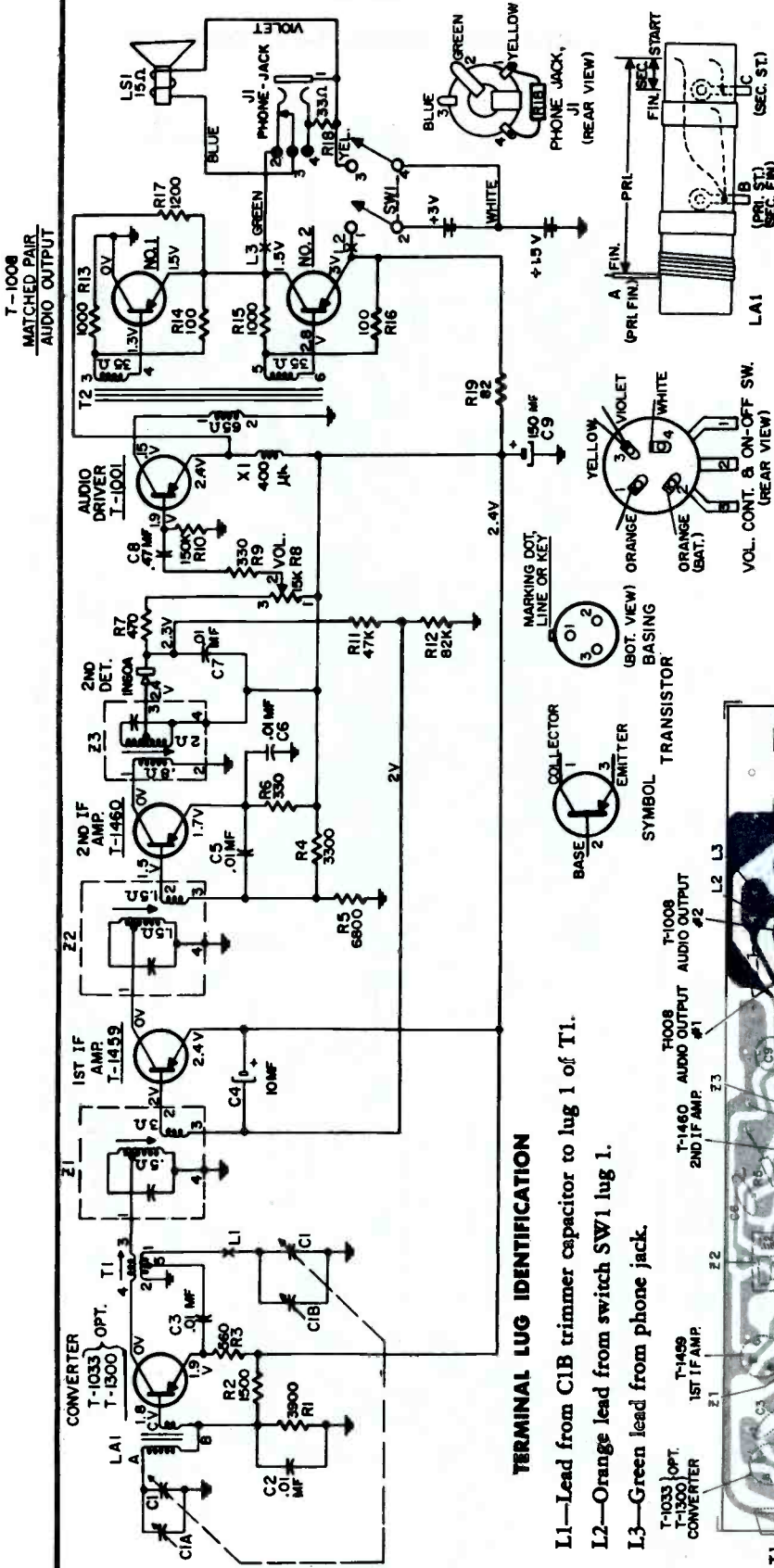

TERMINAL LUG IDENTIFICATION

- L1—Lead from C1B trimmer capacitor to lug 1 of T1.
- L2—Orange lead from switch SW1 lug 1.
- L3—Green lead from phone jack.

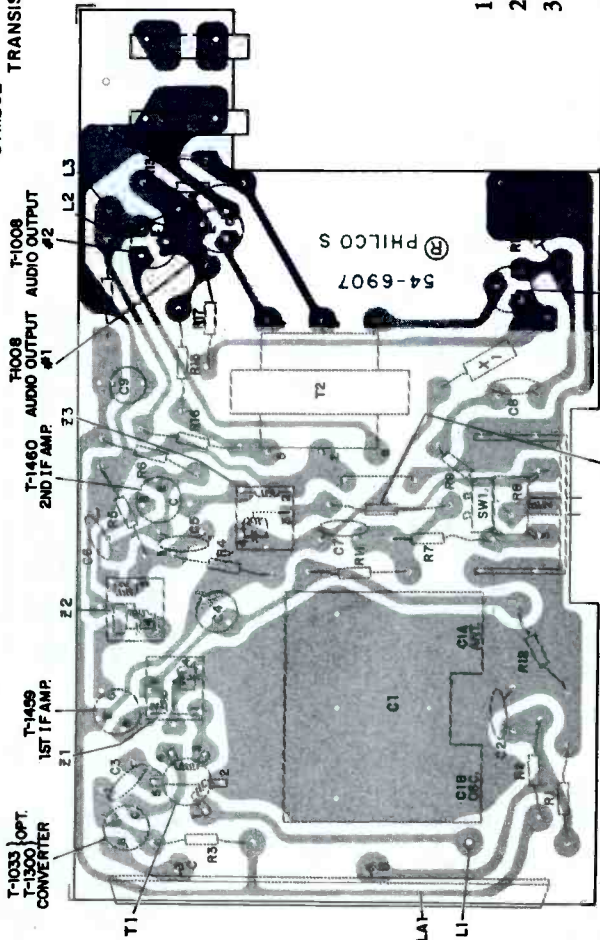

Component Panel Bottom View—Showing Parts Location

FREQUENCY COVERAGE—535 to 1620 KC.
INTERMEDIATE FREQUENCY—455 KC.
ANTENNA—Self-contained magnacor, high-impedance loop.
SPEAKER—2 3/4 in. pm., 15 ohm voice coil impedance. Jack provided for optional private listening attachment, part number 42-1975-4.

PRINTED-WIRE PANEL REMOVAL

1. Remove the snap-on back of the cabinet and the batteries.
2. Remove the tri-mount fastener next to the battery clips.
3. Carefully spread the sides of the cabinet to free the panel from each of the 4 slotted cabinet supports.
4. Withdraw the panel assembly by sliding it toward the speaker end of the cabinet to free the tuning knob.

PHILCO TRANSISTOR RADIO — MODEL T-65

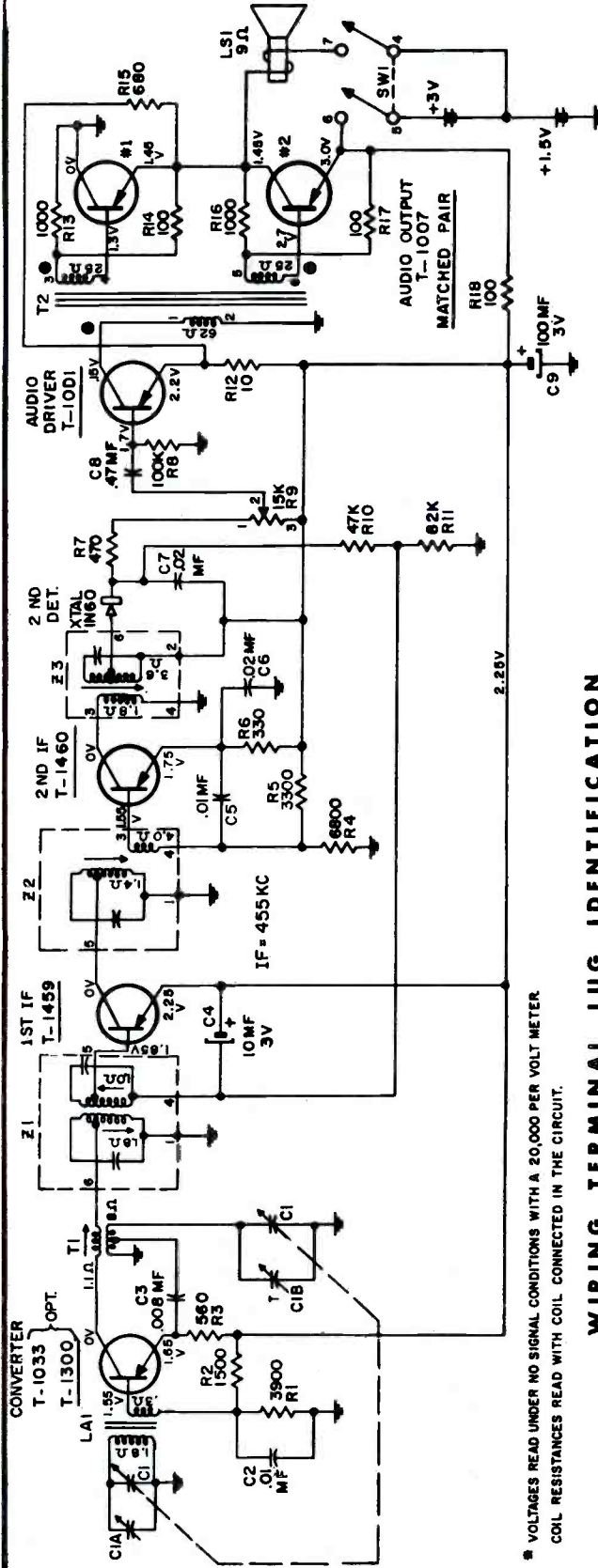

* VOLTAGES READ UNDER NO SIGNAL CONDITIONS WITH A 20,000 PER VOLT METER. COIL RESISTANCES READ WITH COIL CONNECTED IN THE CIRCUIT.

WIRING TERMINAL LUG IDENTIFICATION

- L1 Black lead, battery ground.
- L2 Orange lead, 1.5V battery.
- L3 Red lead, 3.0V battery.
- L4 Green lead, audio output to speaker.
- L5 Red antenna lead, low side of secondary, lead #3.
- L6 Red antenna lead, high side of secondary, lead #4.
- Antenna lead, high side of primary to ant. section of gang, lead #1.
- Antenna lead, low side of primary to gang ground lug, lead #2.
- Orange lead from speaker to terminal #7 of S1.

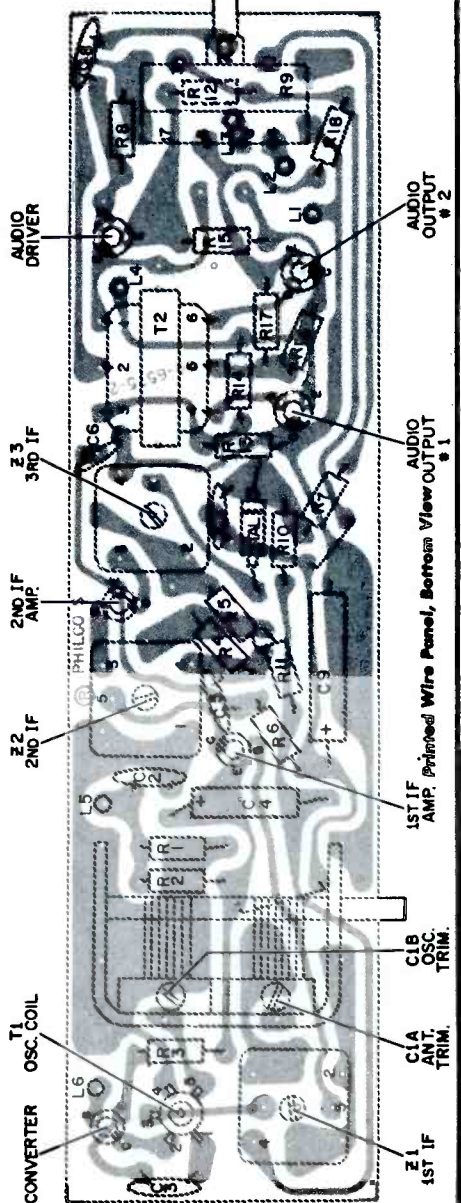
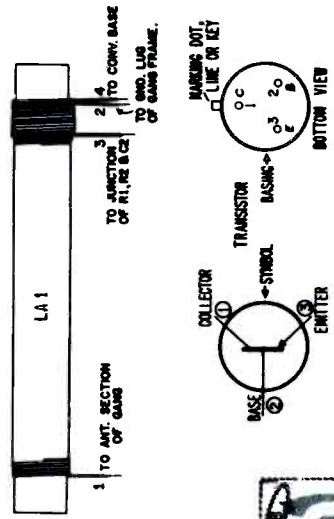

AUDIO OUTPUT—0.1 watt.

BATTERY VOLTAGE AND TYPE—3.0 volts from 2 standard "D" cells.

FREQUENCY COVERAGE—535 - 1620 KC.

INTERMEDIATE FREQUENCY—455 KC.

PHILCO PORTABLE RADIO MODEL T-75, CODE 124

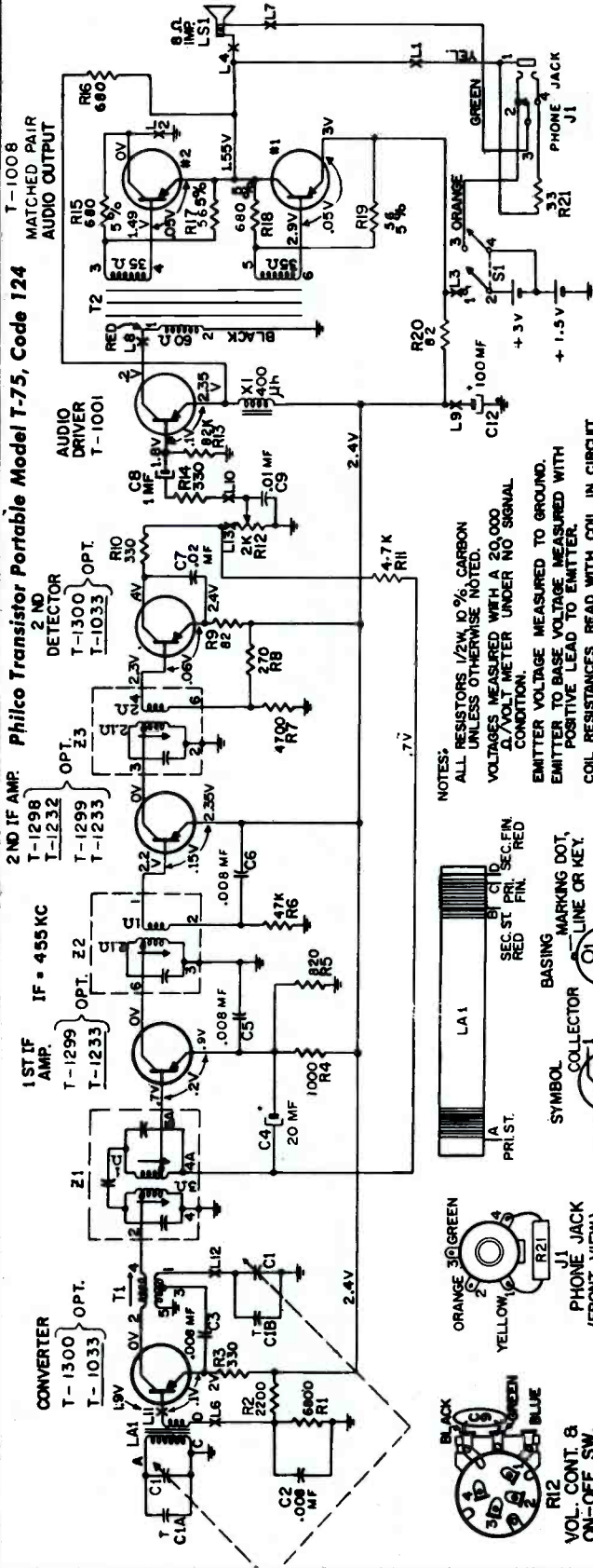

FREQUENCY COVERAGE—535 to 1620 KC.

INTERMEDIATE FREQUENCY—455 KC.

BATTERY SUPPLY—2 standard "D" cells, in 3 volt supply center tapped at 1-1/2 volts. Battery type P-907 or P-920 (metal clad).

SERVICE NOTES

When signal tracing, inject signal at transistor collector and limit input to keep signal across speaker below .6 volts.

Normally, the transistors should be the last item suspected.

If C12 opens serious audio oscillation will result.

Dress of black lead from top, center, frame lug of gang to end ground lug is important to reduce beat. See base layout for lead dress.

NOTES:
RESISTORS 1/2W, 10% CARBON ALL UNLESS OTHERWISE NOTED.
VOLTAGES MEASURED WITH A 20,000 Ω/VOLT METER UNDER NO SIGNAL CONDITION.
EMITTER VOLTAGE MEASURED TO GROUND.
EMITTER TO BASE VOLTAGE MEASURED WITH POSITIVE LEAD TO EMITTER.
COIL RESISTANCES READ WITH COIL IN CIRCUIT.

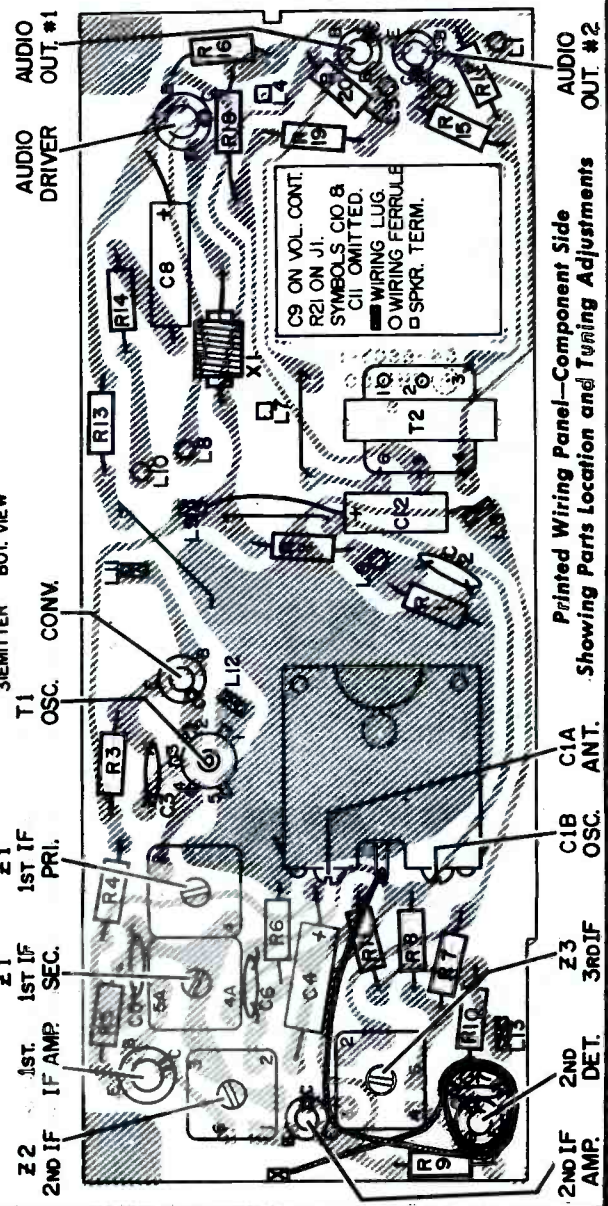
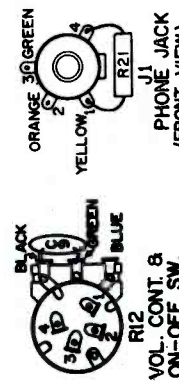
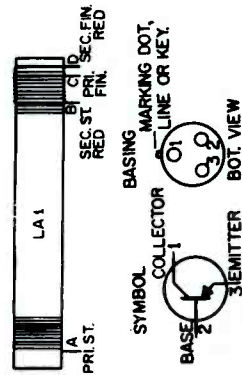

PHILCO RADIO

AM/FM TUNER — TYPE RT-202

Electrically all chassis are identical except the RT-202-2 and the RT-202-4. The RT-202-4 chassis contains a 560 ohm resistor and .01 mfd capacitor from the cathode of the AM-RF amplifier (V7) to ground. Lug L1 on the printed wire panel of the RT-202-4 chassis is grounded, thus returning the secondary of T10 and condenser C43 to ground instead of the AVC circuit. The RT-202-2 chassis uses an AM antenna coil while the remaining chassis use a magnecore antenna.

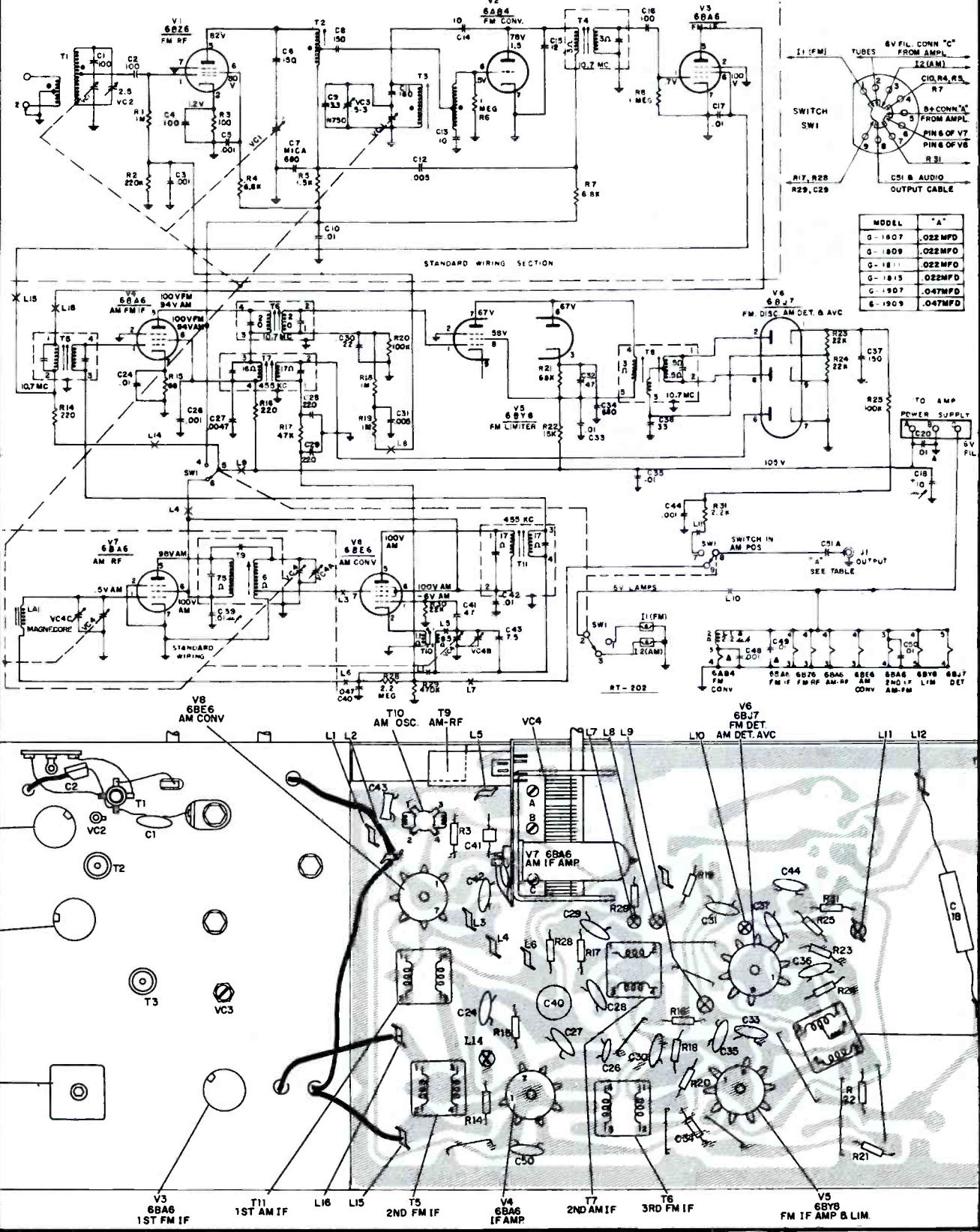

Top View — Showing Alignment Points, Tube Locations and Tie Lugs

PHILCO TRANSISTOR RADIO — MODEL T-6 — CODE 124

MODEL T-600 — CODE 124

Model T-600 identical to Model T-6 except C10 has been deleted and R5 has been changed from 1000 ohms to 330 ohms, part no. 66-1338340.

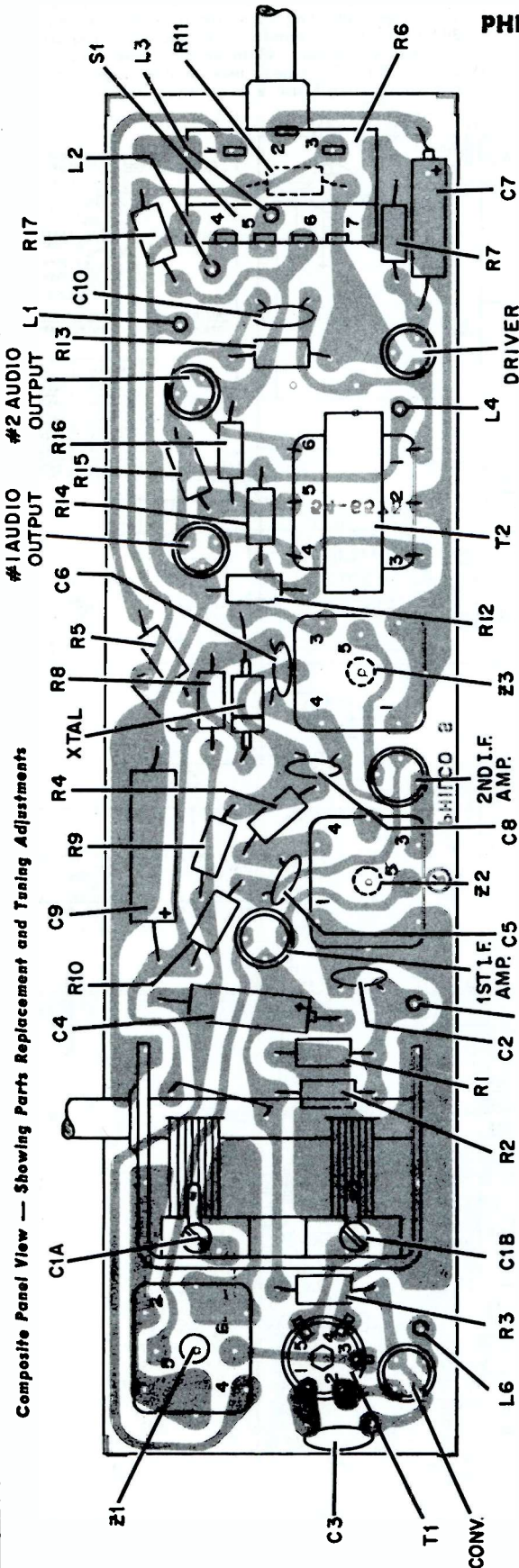

Composite Panel View — Showing Parts Replacement and Tuning Adjustments

INTERMEDIATE FREQUENCY—455 KC.

L1 Black lead, battery ground.

L2 Orange lead, 1.5V battery.

L3 Red lead, 3.0V battery.

L4 Orange lead, audio output to speaker.

L5 Antenna lead, low side of secondary, lead #3.

* VOLTAGES READ UNDER NO SIGNAL CONDITIONS WITH A 20,000 PER VOLT METER. COIL RESISTANCES READ WITH COIL CONNECTED IN THE CIRCUIT.

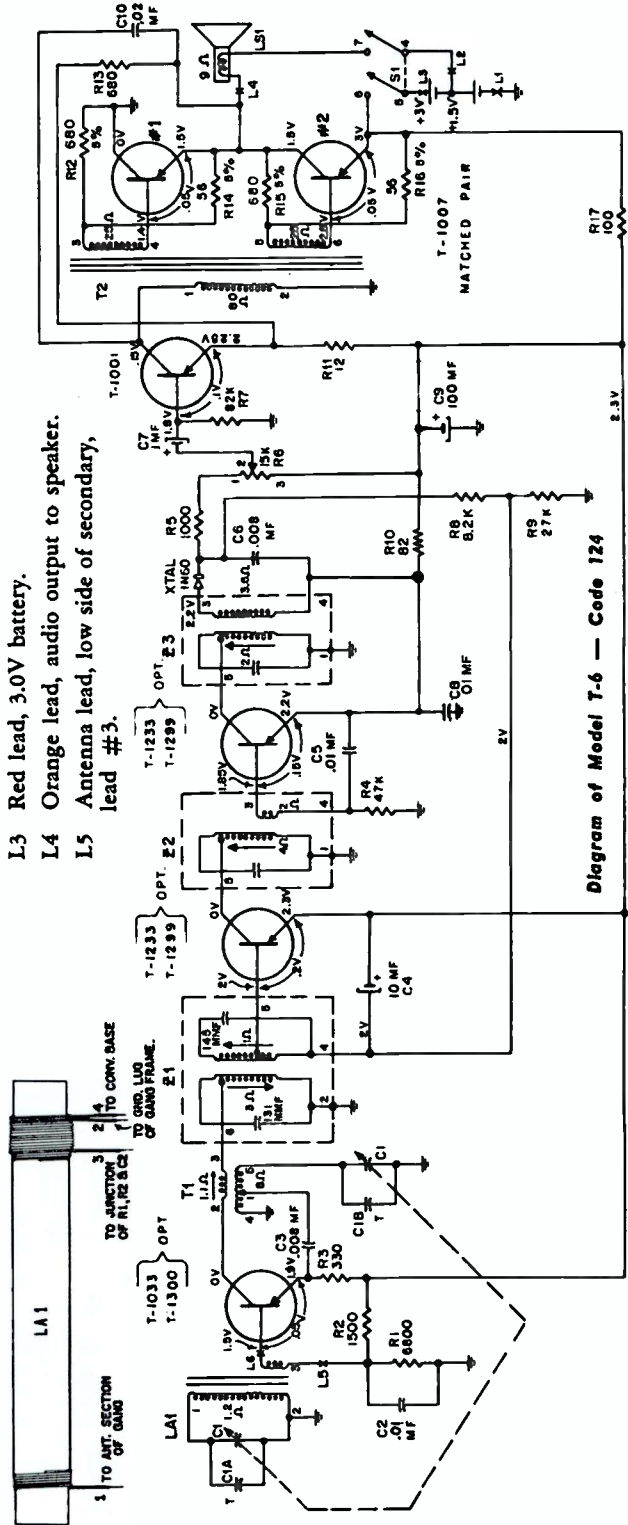
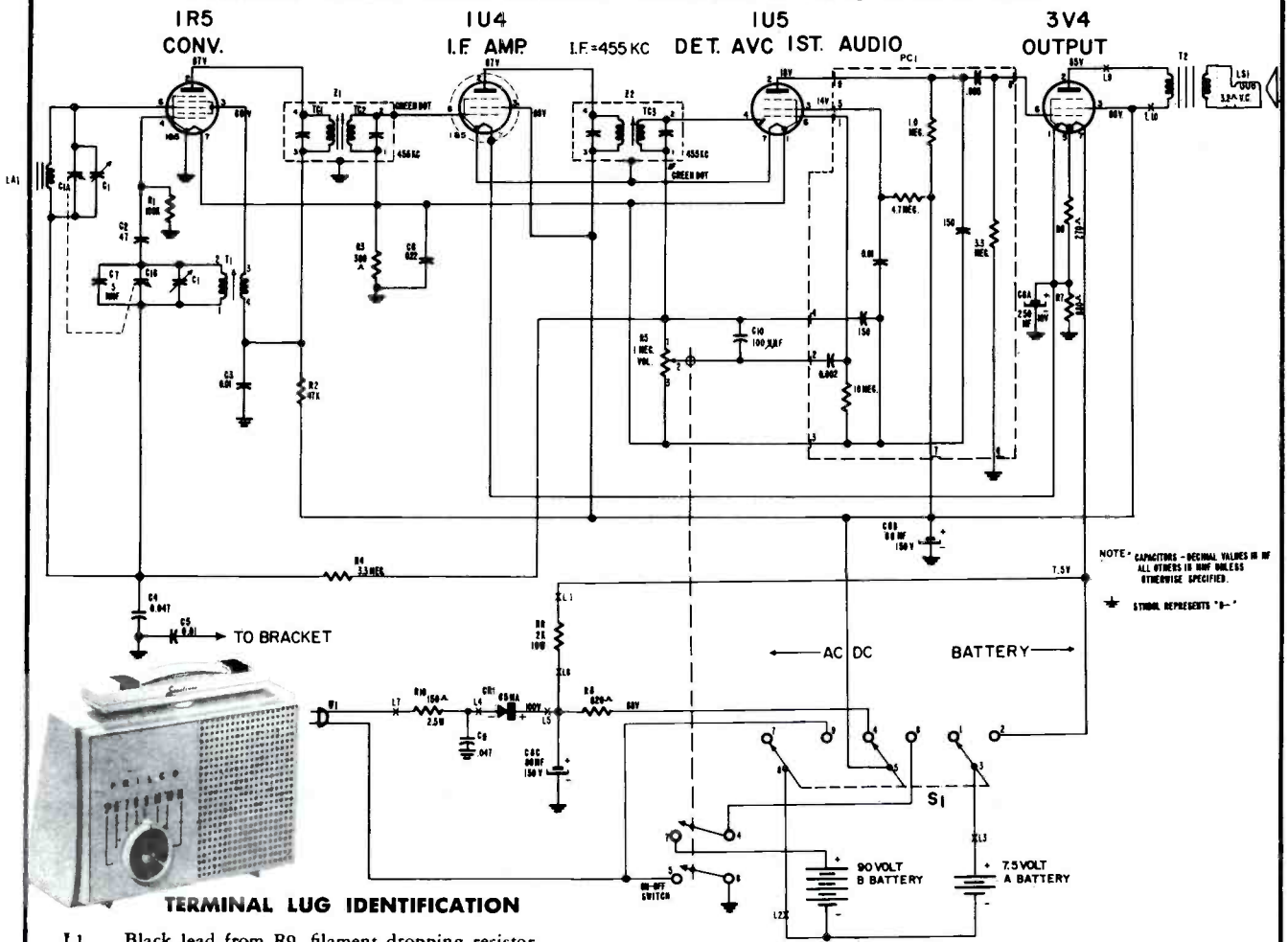

Diagram of Model T-6 — Code 124

PHILCO PORTABLE RADIO MODEL G-681, CODE 124



TERMINAL LUG IDENTIFICATION

- L1 Black lead from R9, filament dropping resistor.
- L2 B-, black lead from "A" battery and yellow lead from "B" battery.
- L3 A+, brown lead from "A" battery.
- L4 Black lead to selenium rectifier, CR1.
- L5 B+, red lead from CR1.
- L6 Brown lead to filament dropping resistor, R9.
- L7 White lead from AC interlock to R10.
- L8 Blue lead to L11, ground.
- L9 Blue lead from 3V4 plate to output trans., T2.
- L10 Red lead to output transformer, T2.
- L11 Blue lead to L8, ground.
White lead from AC interlock to lug 5 of ON-OFF switch.
Red lead from "B" battery to lug 7 of ON-OFF switch.

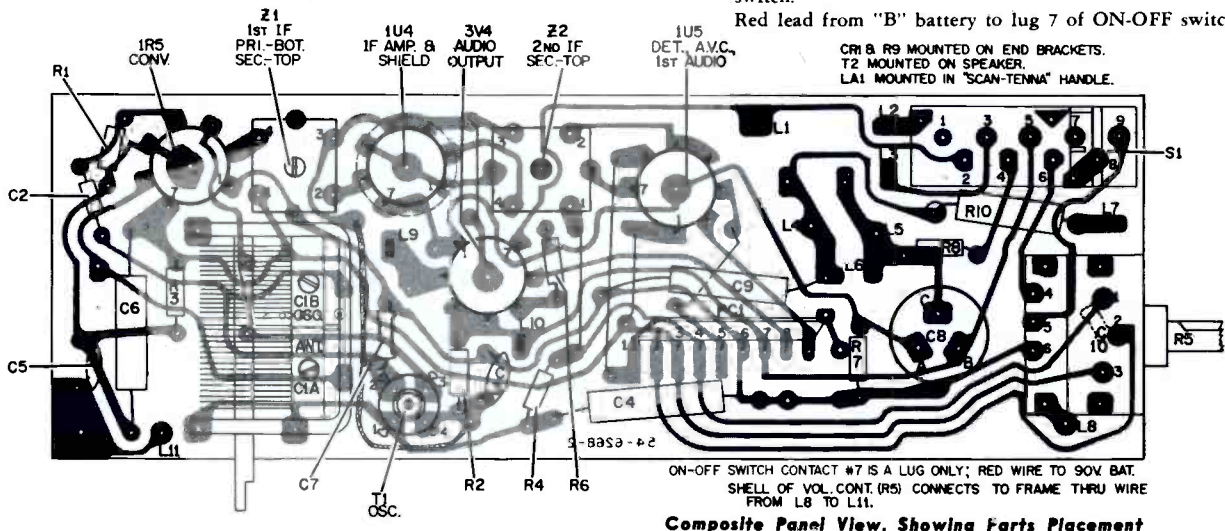

ON-OFF SWITCH CONTACT #7 IS A LUG ONLY; RED WIRE TO 90V BAT.
SHELL OF VOL. CONT. (R5) CONNECTS TO FRAME THRU WIRE
FROM L8 TO L11.

Composite Panel View, Showing Parts Placement

PHILCO PORTABLE RADIO MODEL H-691, CODE 124

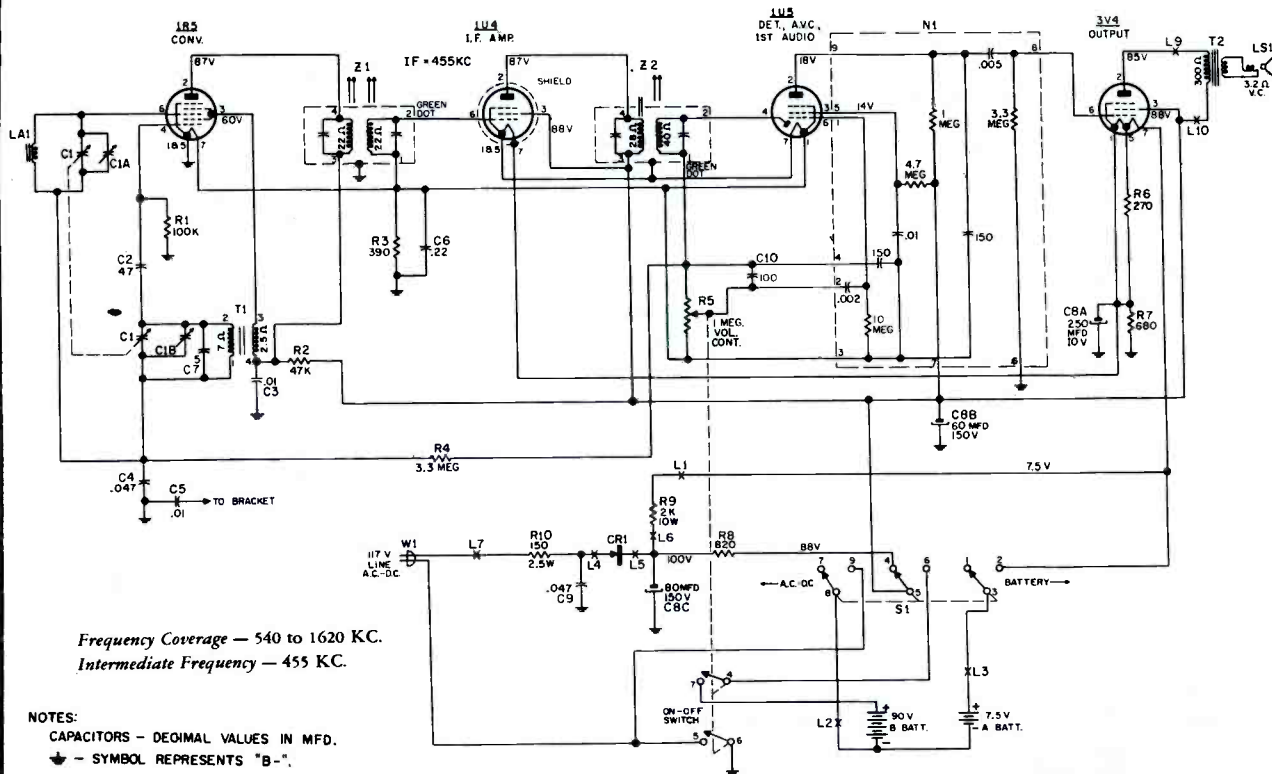

Frequency Coverage — 540 to 1620 KC.
Intermediate Frequency — 455 KC.

NOTES:
CAPACITORS — DECIMAL VALUES IN MFD.
⬇ — SYMBOL REPRESENTS "B-".

CRITICAL LEAD DRESS

1. Brown and black wires, from wiring panel on bracket, must be dressed below and away from R9 and in front of the tuning condenser, C1.
2. Brown and black "A" battery leads must be dressed over the output transformer, T2, and through the dress lug.
3. Red and yellow "B" battery leads must be dressed up through the AC interlock mounting bosses.
4. White AC interlock leads must be dressed toward the front panel.
5. All wires must be dressed clear of the current limiting resistor, R10.
6. C6, the filament condenser, must be dressed toward the bracket, away from C1, the tuning gang.

TERMINAL LUG IDENTIFICATION

- L1 Black lead from R9, filament dropping resistor.
- L2 B-, black lead from "A" battery and yellow lead from "B" battery.
- L3 A+, brown lead from "A" battery.
- L4 Black lead to selenium rectifier, CR1.
- L5 B+, red lead from CR1.
- L6 Brown lead to filament dropping resistor, R9.
- L7 White lead from AC interlock to R10.
- L8 Blue lead to L11, ground.
- L9 Blue lead from 3V4 plate to output trans., T2.
- L10 Red lead to output transformer, T2.
- L11 Blue lead to L8, ground.
White lead from AC interlock to lug 5 of ON-OFF switch.
Red lead from "B" battery to lug 7 of ON-OFF switch.

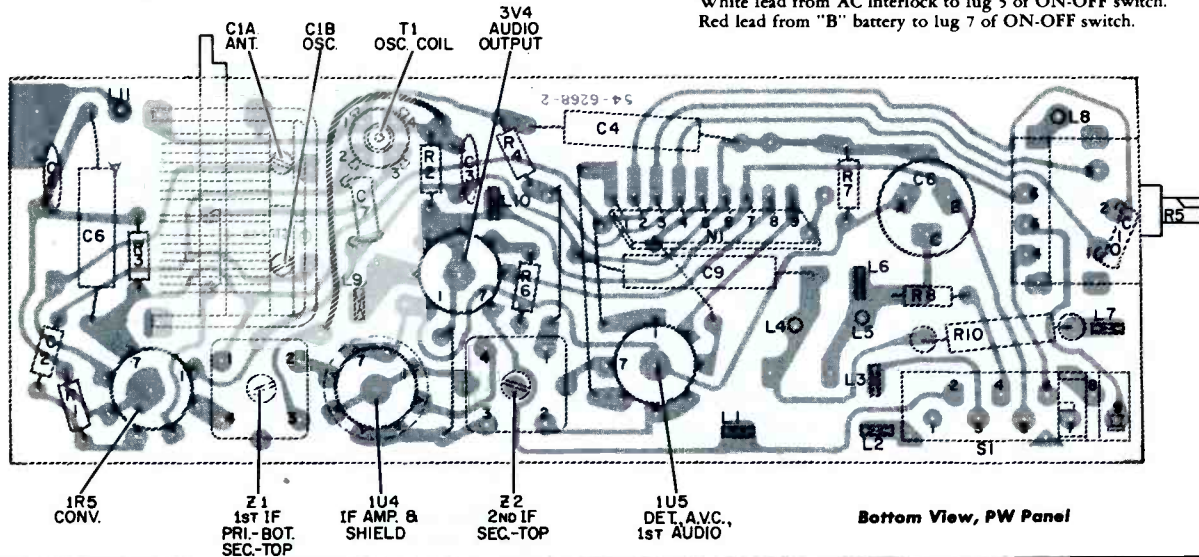

Bottom View, PW Panel

PHILCO AM/FM MODEL G-974

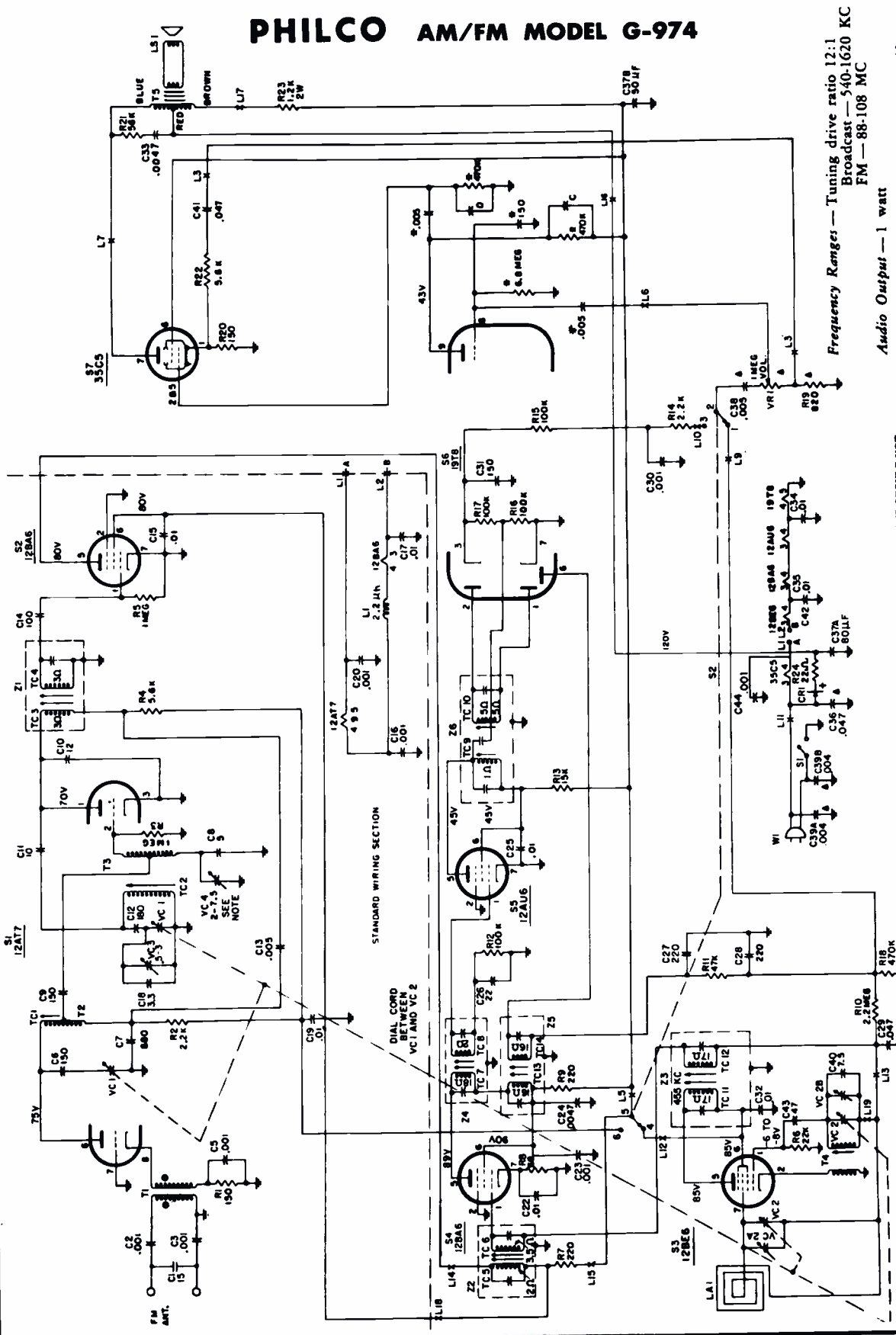

Frequency Ranges — Tuning drive ratio 12:1
 Broadcast — 540-1620 KC
 FM — 88-108 MC

Audio Output — 1 watt
 Operating Voltage — 105 - 120 volts, a.c./d.c.
 Power Consumption — 40 watts
 Intermediate Frequency — AM 455 KC
 FM 10.7 MC

VC1 IS A FACTORY ADJUSTMENT AND SHOULD NOT REQUIRE FUTURE ADJUSTMENT UNLESS REPLACED. IT MINIMIZES OSCILLATOR RADIATION. TO ADJUST, TUNE RADIO TO 100 MC AND ADJUST VC1 FOR MINIMUM INDICATION ON A FIELD STRENGTH METER TUNED TO THE OSC FREQ.

ALL RESISTORS ARE 1/2 WATT, 10% UNLESS OTHERWISE NOTED.
 ALL CAPACITORS ABOVE 1 ARE IN $\mu\mu\text{F}$ UNLESS OTHERWISE NOTED, ALL CAPACITORS BELOW 1 ARE μF .

* COUPLATE N1
 PART OF STANDARD WIRING
 INDICATES LESS THAN 1 OHM
 CONDENSERS C - D - 250 $\mu\mu\text{F}$

PHILCO RADIO AM/FM MODEL G-978

Schematic Diagram Model G-978

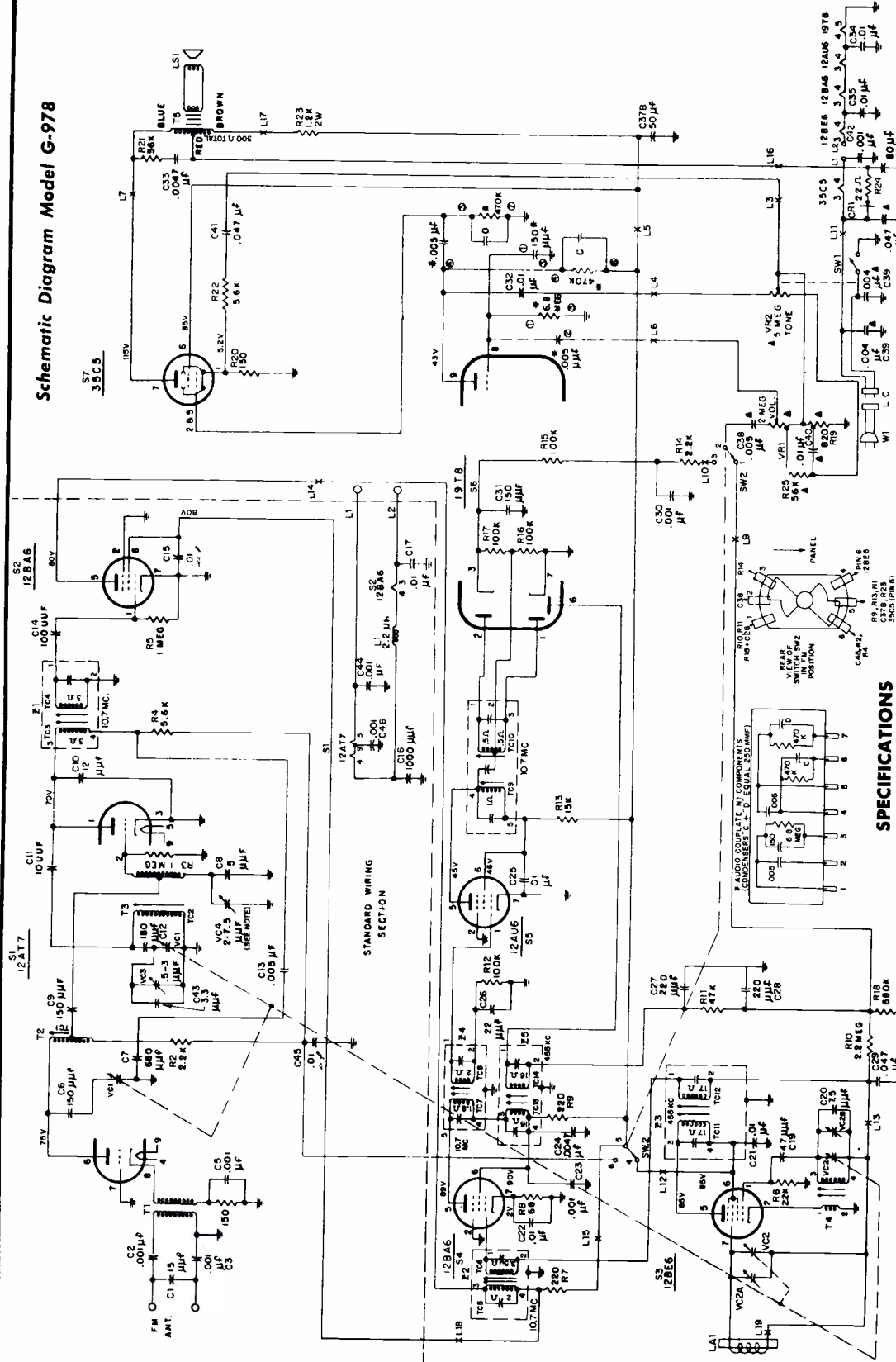

KNOB REMOVAL—The control knobs of the Model G-978 are mounted on the notched control shafts with spring clips which lock the knobs in position. To remove the knobs, release the spring clip with a screw driver blade before pulling the knob from the shaft.

SPECIFICATIONS

- Frequency Ranges—Tuning drive ratio 12:1
- Broadcast—540-1620 KC
- FM—88-108 MC
- Audio Output—1 watt
- Variable bass boost or treble cut tone control.
- Power Consumption—40 watts.
- Intermediate Frequency—AM 455 KC.
- FM 10.7 MC.

Components marked ▲ are part of chassis wiring.
 ● indicates less than 1 ohm.
 All resistors are 1/2 watt, 10% unless otherwise noted.
 VC4 is a factory adjustment and should not require future adjustment unless replaced. It minimizes oscillator radiation. To adjust, tune radio to 100 MC and adjust VC4 for minimum indication on a field strength meter tuned to the oscillator frequency.

PHILCO RADIO MODEL G-978 AM/FM RECEIVER

PHILCO PHONOGRAPH MODEL G-1410

SPECIFICATIONS

AUDIO OUTPUT—1.0 watt each channel.
OPERATING VOLTAGE—105-125 volts, 60 cycles a.c.
POWER CONSUMPTION—60 watts.
RECORD CHANGER—M-40, 4 speed automatic record changer with stereophonic pickup.

VOLUME-BALANCE CONTROL

The volume-balance controls for the two amplifier channels are mounted in tandem with concentric shafts. The inner shaft is spring loaded and locked to the outer shaft. Turning the shaft of one control simultaneously turns the shaft of the other control. Pushing in the inner shaft unlocks the controls to permit individual volume control adjustment.

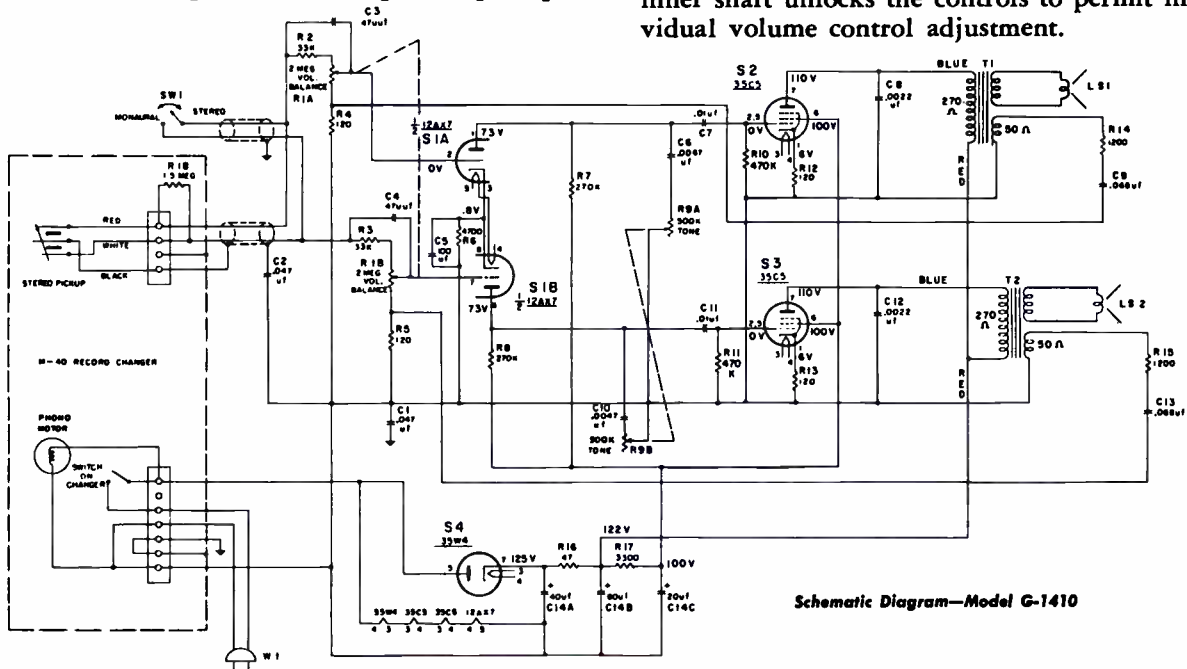

Schematic Diagram—Model G-1410

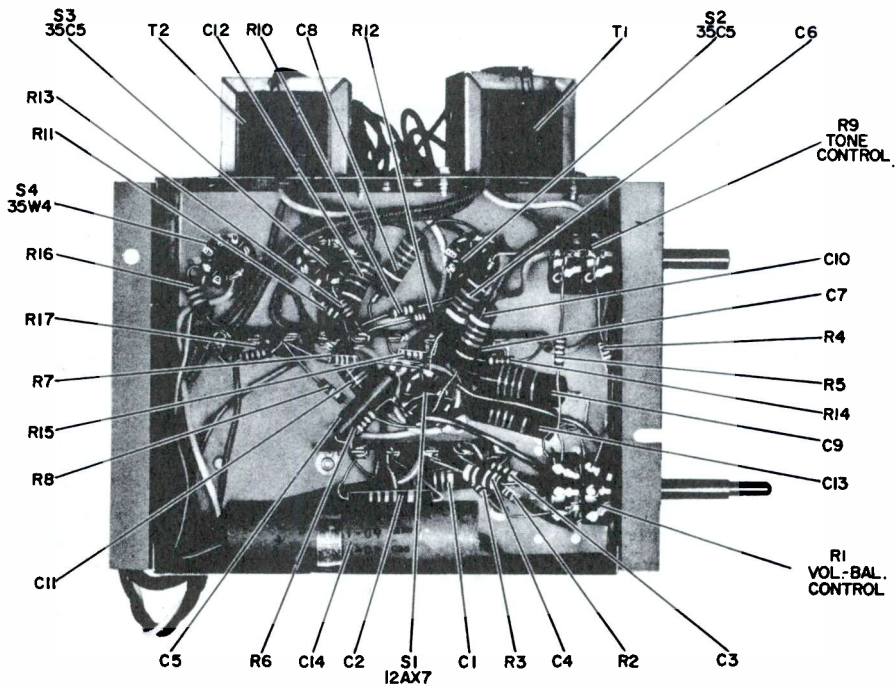

Base View, Components Layout—Model G-1410

PHILCO
MODEL G-1409, CODE 124

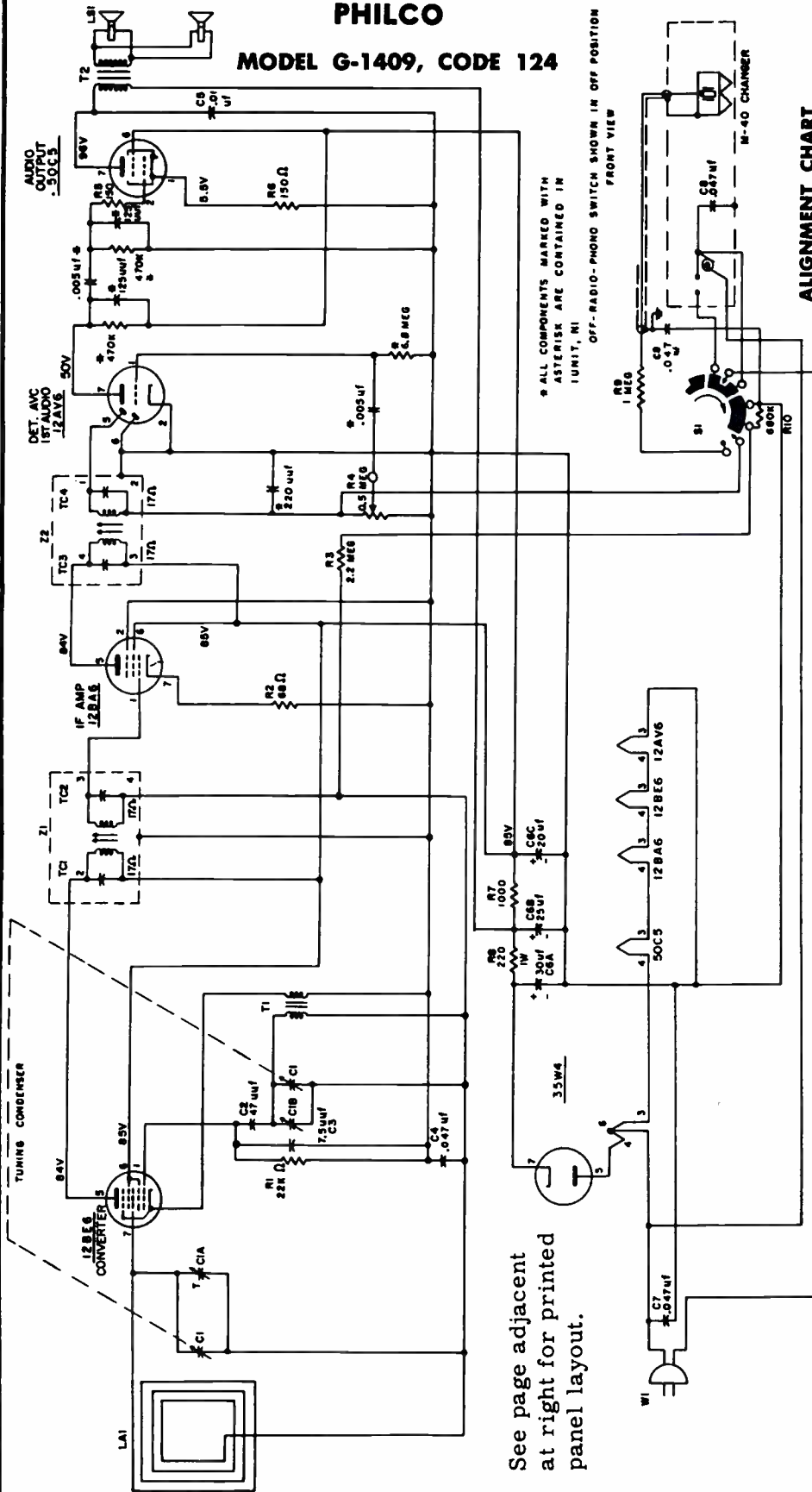

ALIGNMENT CHART

STEP	SIGNAL GENERATOR		RADIO		ADJUST
	CONNECTION TO RADIO	DIAL SETTING	DIAL SETTING	SPECIAL INSTRUCTIONS	
1.	Ground lead to B-; output lead through a .1 mf condenser to grid (pin 7) of 12BE6.	455 kc.	Tuning gang fully open.	Adjust tuning cores, in order given, for max. output. TC2 and TC4 are located on top of transformers.	TC4—2nd i-f sec. TC3—2nd i-f pri. TC2—1st i-f sec. TC1—1st i-f pri.
2.	Radiating loop (See note below).	1620 kc.	1620 kc.*	Adjust for maximum output.	C1-B—osc.
3.	Same as Step 2.	1500 kc.	1500 kc.	Adjust for maximum output.	C1-A—aerial.

ALIGNMENT PROCEDURE

Radio Controls—Set volume control to maximum. Set tuning control as indicated in chart.

Output Meter—Connect across voice coil terminals.

Signal Generator—Connect generator and set frequency as indicated in chart. Use modulated output, 30%.

Output Level—During alignment, adjust signal-generator output to hold output-meter reading below .5 volts.

NOTE: Make up a 6-8 turn, 6 inch diameter loop from insulated wire, connected to signal-generator leads, and place near radio loop. * For proper adjustment of the oscillator trimmer, fully open the tuning gang, and insert a .006 inch non-metallic shim between the heel of the rotor and the top of the stator plates. Close the tuning gang sufficiently to hold the shim in place, and then remove

VOLUME R-19, MOST-OFTEN-NEEDED 1959 RADIO SERVICING INFORMATION

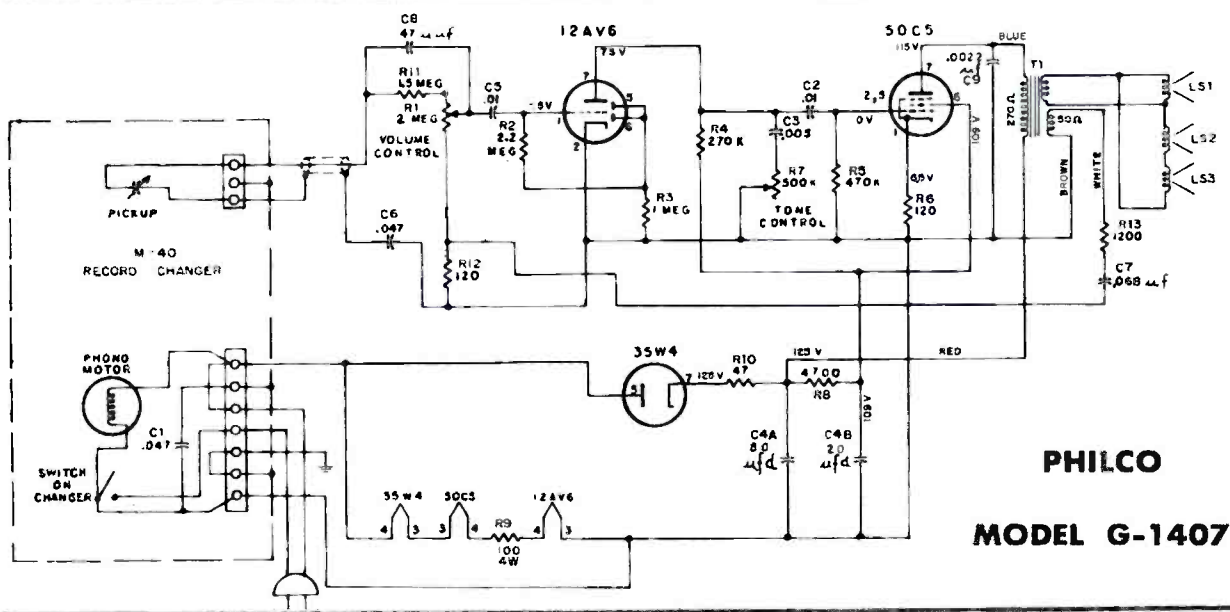
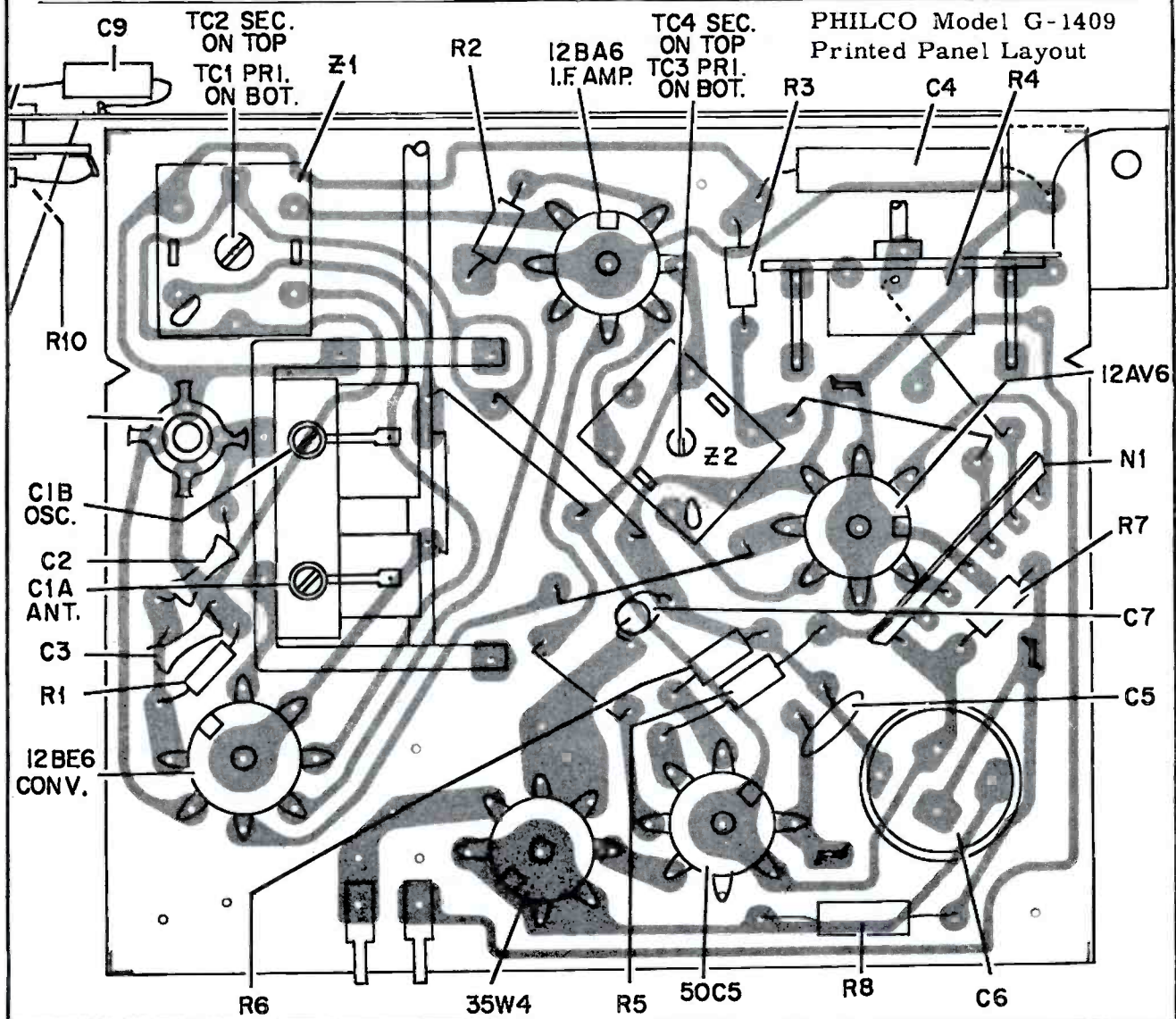

PHILCO
MODEL G-1407

PHILCO MODELS— G-1606, G-1606S-123 and SA-1000

Schematic Diagram, Model G-1606S. (See figures for Models SA-1000 and G-1606)

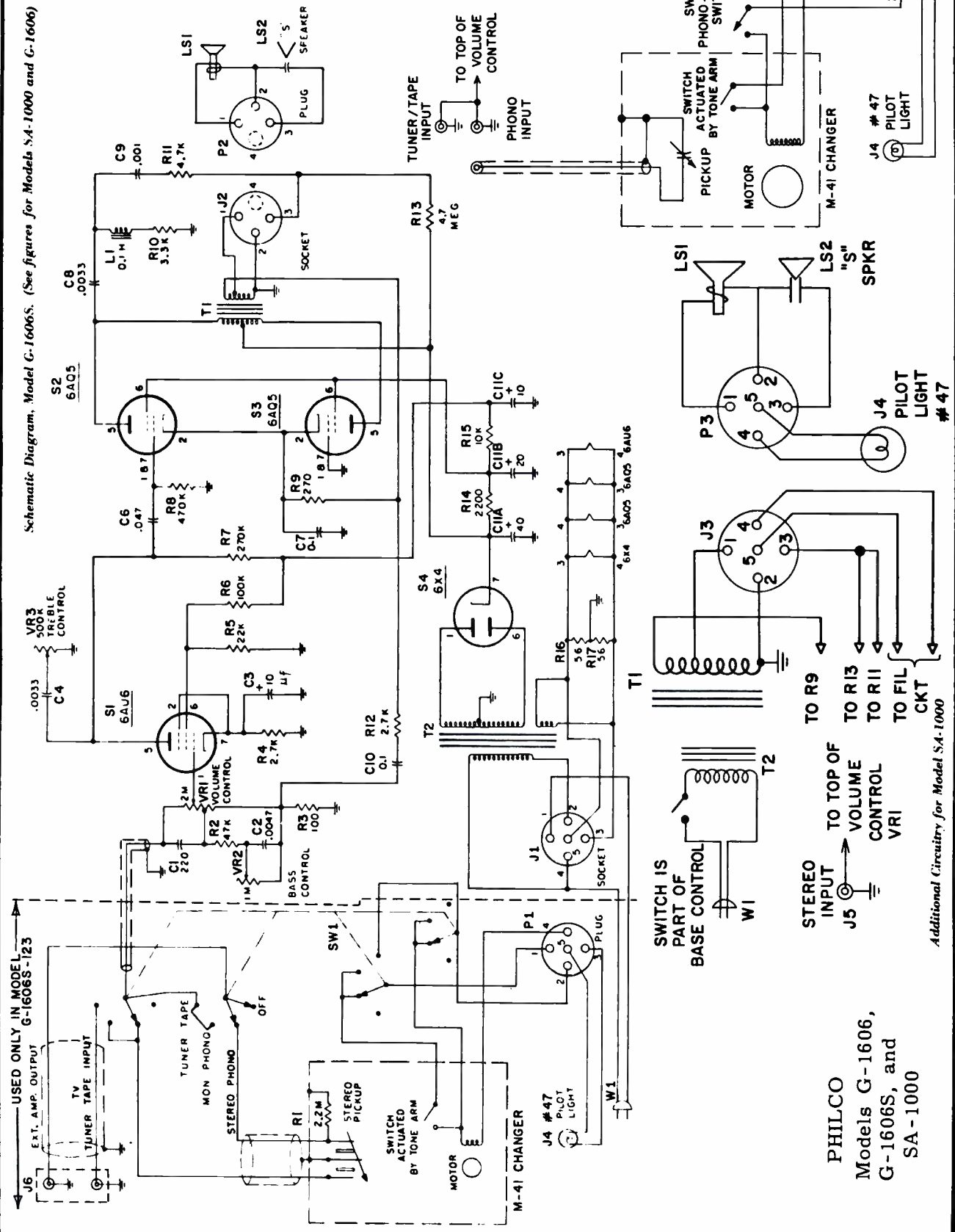

PHILCO
Models G-1606,
G-1606S, and
SA-1000

Additional Circuitry for Model SA-1000

Additional Circuitry for Model G-1606

PHILCO HI-FIDELITY PHONOGRAPHS MODELS G-1706, G-1706S, G-1707, G-1707S, SA-1500 and RT-150

(Continued on the page adjacent at right)

SPECIFICATIONS

NOTE: The G-1706 contains a three-tube-plus rectifier amplifier and a type M-41 record changer. The G-1706S is similar to the G-1706 except the function switch has a stereo position and the M-41 record changer has a stereo cartridge. The G-1707 is a G-1706 with changes to accept a radio tuner. The G-1707 includes an RT-150 AM-FM tuner. The G-1707S is similar to the G-1707 except the function switch has a stereo position and the M-41 record changer has a stereo cartridge. The SA-1500 is the slave amplifier used with the G-1706S or the G-1707S for stereo. Its amplifier is similar to the G-1706 with a different function switch and a-c wiring changes necessitated by the absence of a record changer.

PRODUCTION CHANGE

In later models, C7, C8, C9, C10, R7 and R8 of the amplifier are replaced by network, Philco part no. 58-1893. The physical location of C4 and R10 are changed to accommodate the network.

Circuit — Three-tube audio amplifier plus a rectifier. The amplifier includes bass, treble and loudness controls and a selector switch. Inputs are provided for phono stereo, (G-1706S and G-1707S only) phono monaural, tuner and tape recorder. Models G-1707 and G-1707S use the RT-150 AM-FM tuner. This tuner contains a six-tube superheterodyne circuit. Its operating voltages, B+ and filament, are supplied by the amplifier.

Schematic Diagram of Amplifier

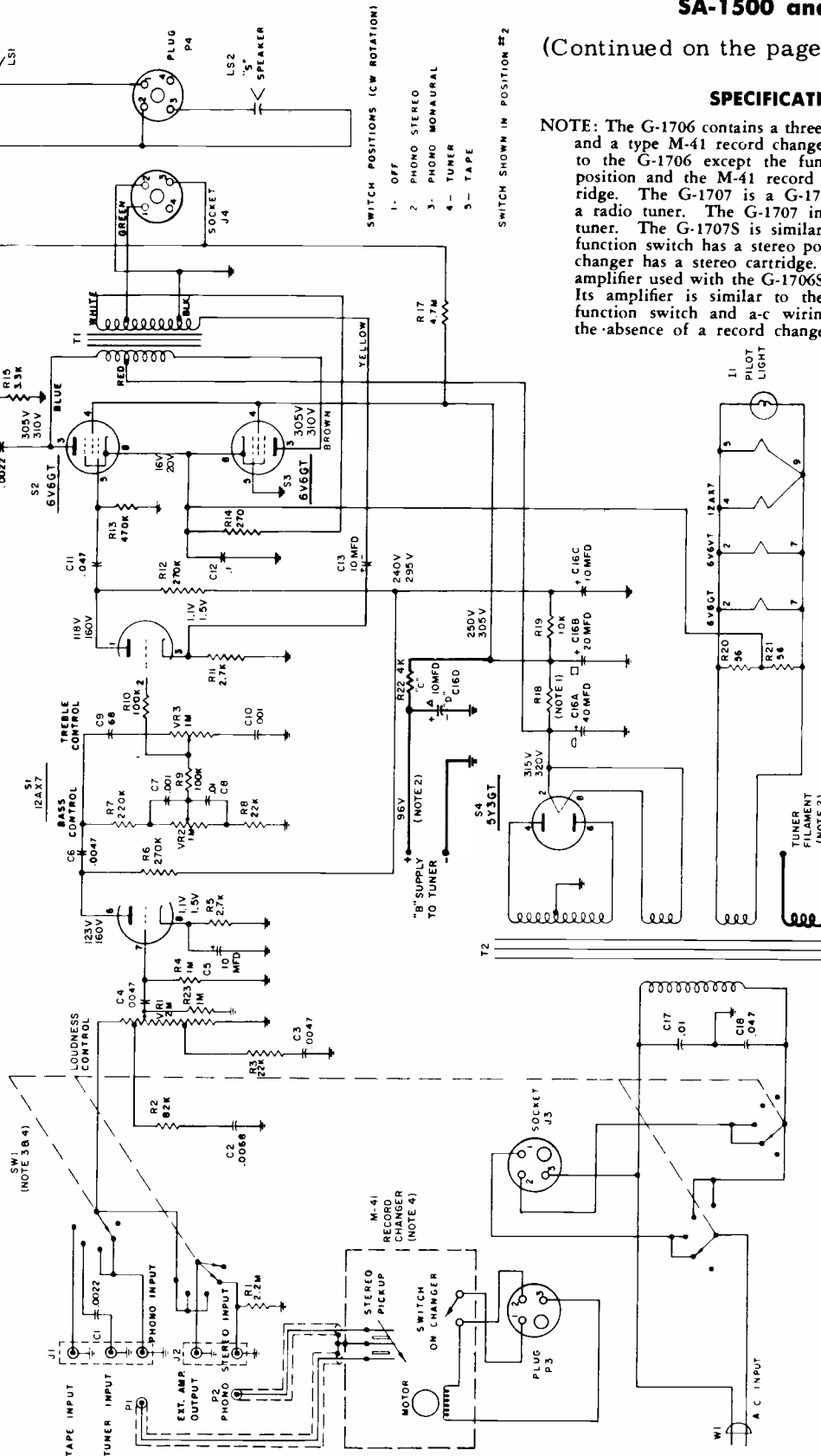

- SWITCH POSITIONS (CW ROTATION)**
- 1- OFF
 - 2- PHONO STEREO
 - 3- PHONO MONAURAL
 - 4- TUNER
 - 5- TAPE

SWITCH SHOWN IN POSITION #2

NOTES

1. In models G-1706, G-1706S and SA-1500, R18 is 3.3K.
2. Used in models G-1707 and G-1707S.
3. Models G-1706 and G-1707 do not have the stereo position. These models differ from the schematic in that the function switch has positions for OFF, PHONO, TAPE and TUNER. R7 and R8 are not required in these models.
4. Model SA-1500 does not have a record changer or associated motor. The function switch has a "RECORD" position. J2 and R1 are not required in this model.
5. Voltage measurements are taken with a VTVM under no-load conditions.
6. The above conditions shown for each test point, the upper one is for the G-1707 and G-1707S, the lower one is for the remaining models.

PHILCO HI-FIDELITY PHONOGRAPHS
MODELS G-1706, G-1706S, G-1707, G-1707S,
SA-1500 and RT-150

(Continued from the page adjacent at left.)

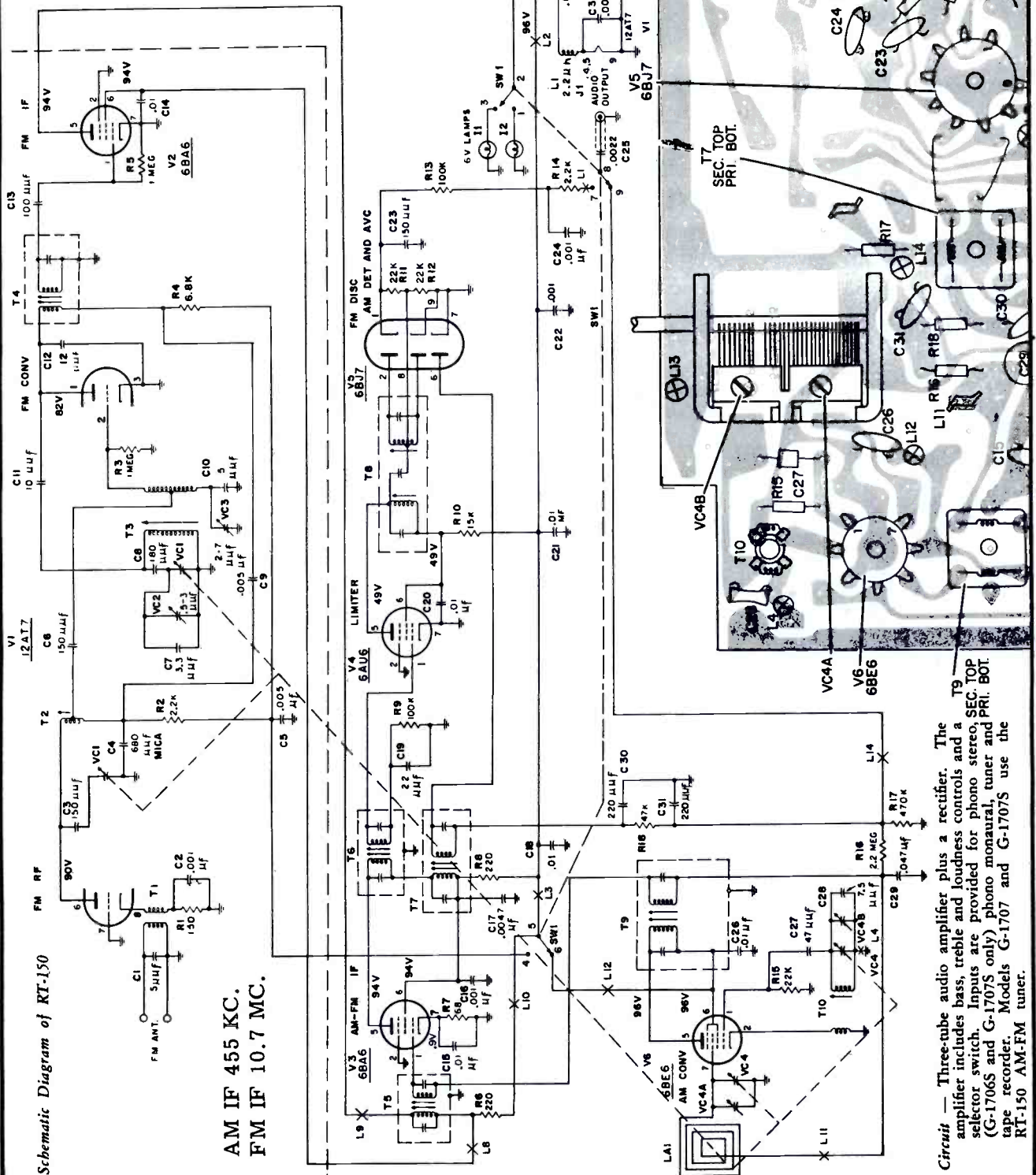

AM IF 455 KC.
 FM IF 10.7 MC.

Schematic Diagram of RT-150

Circuit — Three-tube audio amplifier plus a rectifier. The amplifier includes bass, treble and loudness controls and a selector switch. Inputs are provided for phono stereo, SEC. TOP (G-1706S and G-1707S only) phono monaural, tuner and PRI. BOT. tape recorder. Models G-1707 and G-1707S use the RT-150 AM-FM tuner.

Part of printed wiring panel of RT-150



RCA VICTOR

Amplifier/Speaker Combination MODELS SA-2 and SA-3 Amp. Chassis No. RS-151B

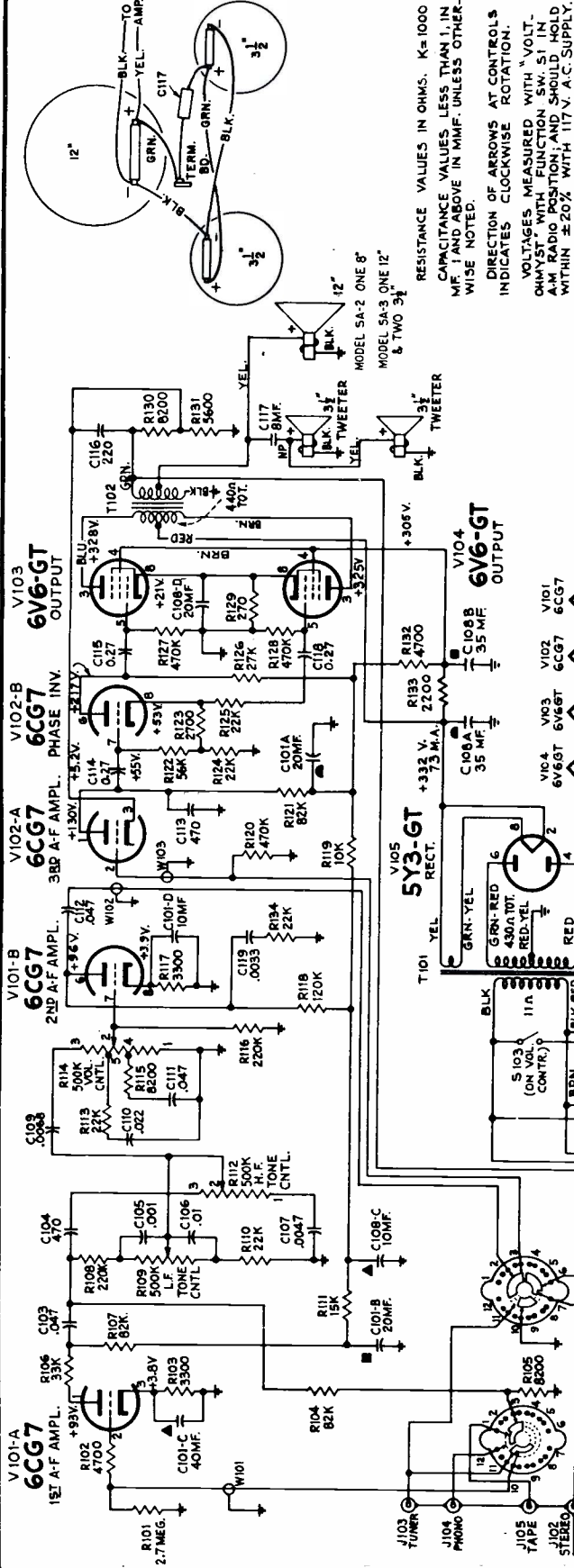

Schematic Diagram of Amplifier RS-151B

RESISTANCE VALUES IN OHMS. K=1000
 CAPACITANCE VALUES, LESS THAN 1, IN
 MF. 1 AND ABOVE IN MMF. UNLESS OTHER-
 WISE NOTED.
 DIRECTION OF ARROWS AT CONTROLS
 INDICATES CLOCKWISE ROTATION.
 VOLTAGES MEASURED WITH "VOL."
 OHMST. WITH FUNCTION SW. S1 IN
 A.M. RADIO POSITION; AND SHOULD HOLD
 WITHIN ±20% WITH 117 V. A.C. SUPPLY.

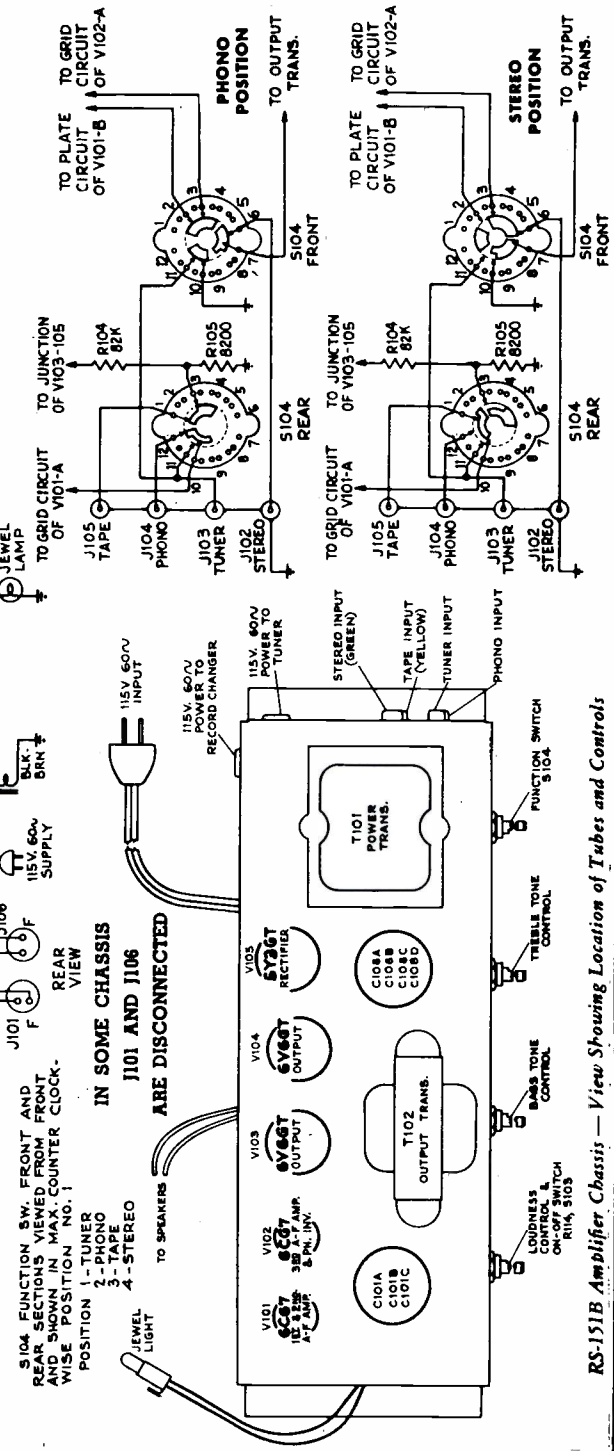

Simplified Schematic Diagrams of Function Switch in Amplifier Chassis RS-151B

RS-151B Amplifier Chassis — View Showing Location of Tubes and Controls



SHP-11 STEREO RECORD PLAYER
Chassis RS-171A

SHS-11 SPEAKER CABINET

TO EXTERNAL SPEAKERS
FOR LEFT CHANNEL

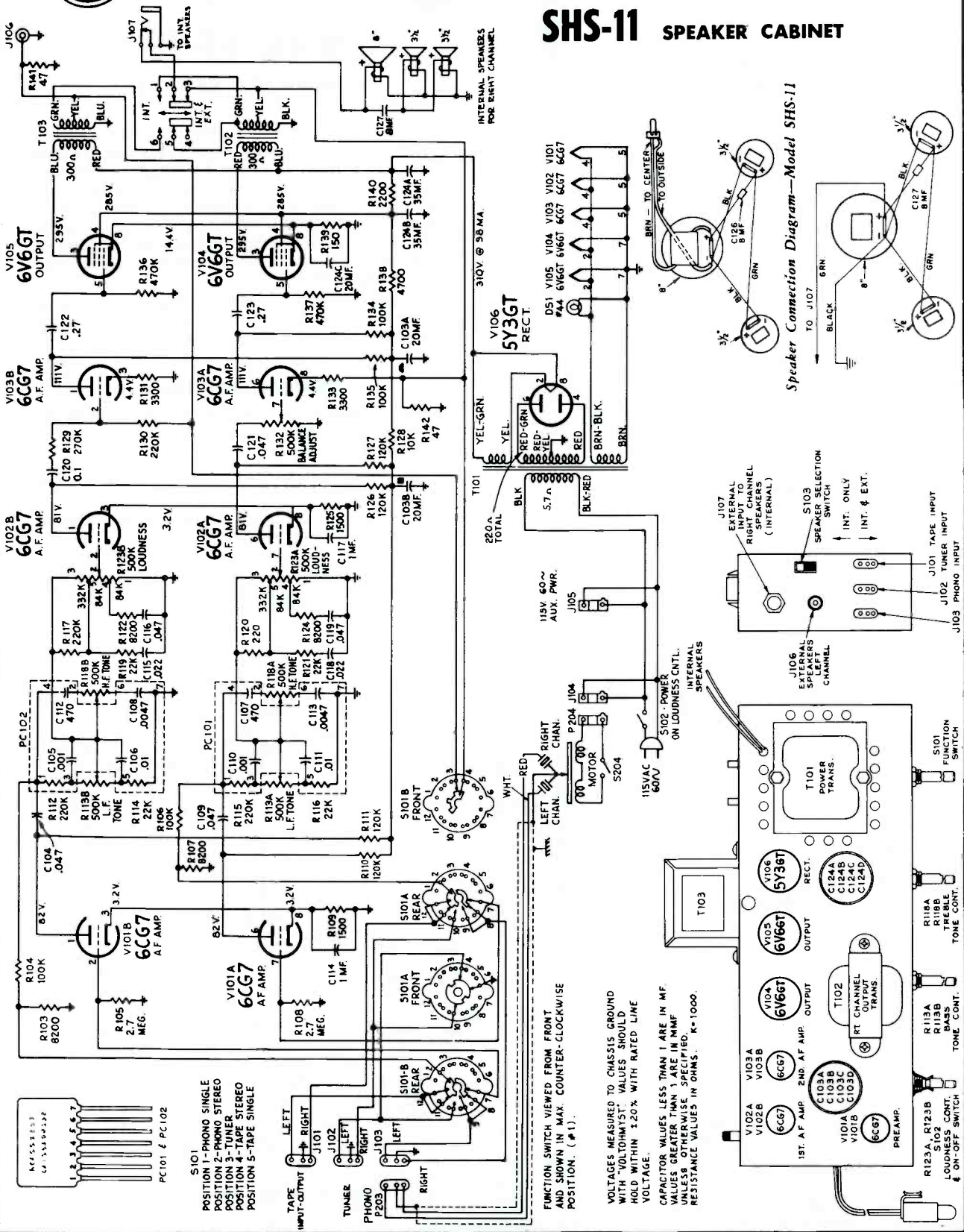

Speaker Connection Diagram—Model SHS-11

Speaker Connection Diagram—Model SHP-11

S101 1-PHONO SINGLE
POSITION 2-PHONO STEREO
POSITION 3-TUNER
POSITION 4-TAPE STEREO
POSITION 5-TAPE SINGLE

TAPE INPUT-OUTPUT
TUNER PHONO P203

FUNCTION SWITCH VIEWED FROM FRONT
AND SHOWN IN MAX. COUNTER-CLOCKWISE
POSITION. (P1).

VOLTAGES MEASURED TO CHASSIS GROUND
WITH "VOLTHM" ST. VALUES SHOULD
HOLD WITHIN 1.20% WITH RATED LINE
VOLTAGE.

CAPACITOR VALUES LESS THAN 1 ARE IN MF.
VALUES GREATER THAN 1 ARE IN MMF
UNLESS OTHERWISE SPECIFIED.
RESISTANCE VALUES IN OHMS. K=1000.

R123A, R123B
S102
LOUDNESS CONT.
& ON-OFF SWITCH

R113A
R113B
TONE CONT.

R118A
R118B
TONE CONT.

S103
SPEAKER SELECTION
SWITCH

J107
EXTERNAL
RIGHT CHANNEL
SPEAKERS
(INTERNAL)

J102
TUNER INPUT

J101
PHONO INPUT

J106
EXTERNAL
LEFT CHANNEL
SPEAKERS
(INTERNAL)

J107
EXTERNAL
RIGHT CHANNEL
SPEAKERS
(INTERNAL)

J107
EXTERNAL
LEFT CHANNEL
SPEAKERS
(INTERNAL)

RCA VICTOR

MODELS SHP-12, SHP-13, TYPE AK-1

Chassis No. RS-172

ACCESS TO TUBES AND CHASSIS

Model SHP-12

Turn cabinet on its side and remove ten wood screws holding the bottom cover to the cabinet.

Model SHP-13

Remove inside front panel, held by screws. Remove control knobs. Remove screws at edges of record changer mounting board; tilt board upward.

CRITICAL LEAD DRESS

Dress heater leads close to chassis. Dress all leads away from phono input socket. Keep leads of C4 and C7 as short as possible and dress all other components away from these capacitors. Record changer motor leads must be twisted to minimize hum.

NOTE—The "ON-OFF" switch is not part of the volume control. The record changer must be "ON" for power to be applied to the amplifier.

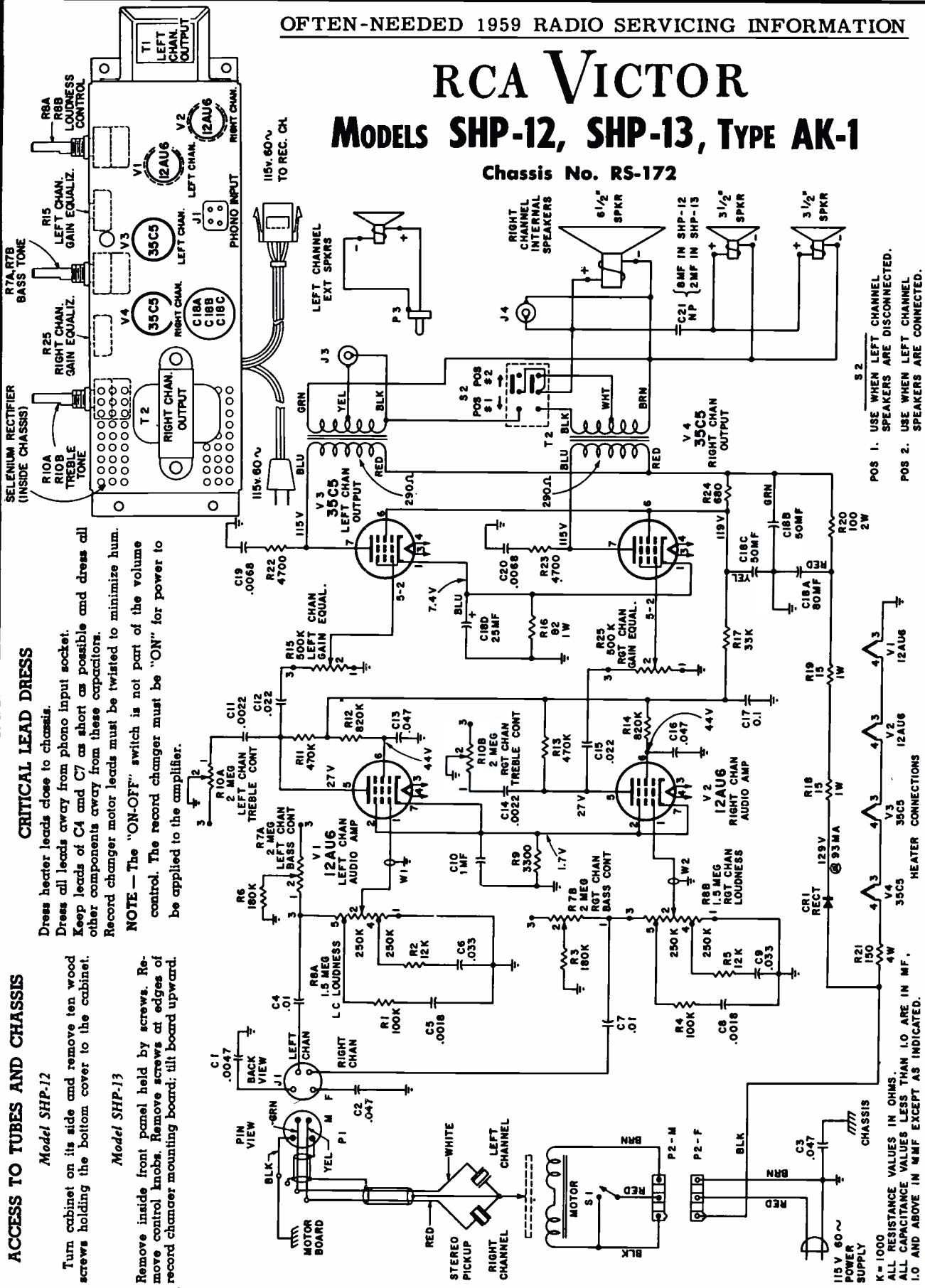

- POS 1. USE WHEN LEFT CHANNEL SPEAKERS ARE DISCONNECTED.
- POS 2. USE WHEN LEFT CHANNEL SPEAKERS ARE CONNECTED.

HEATER CONNECTIONS

ALL RESISTANCE VALUES IN OHMS.
ALL CAPACITANCE VALUES LESS THAN 1.0 ARE IN MF.
1.0 AND ABOVE IN uMF EXCEPT AS INDICATED.



RCA VICTOR

MODEL SES-6

Chassis No. RS-175

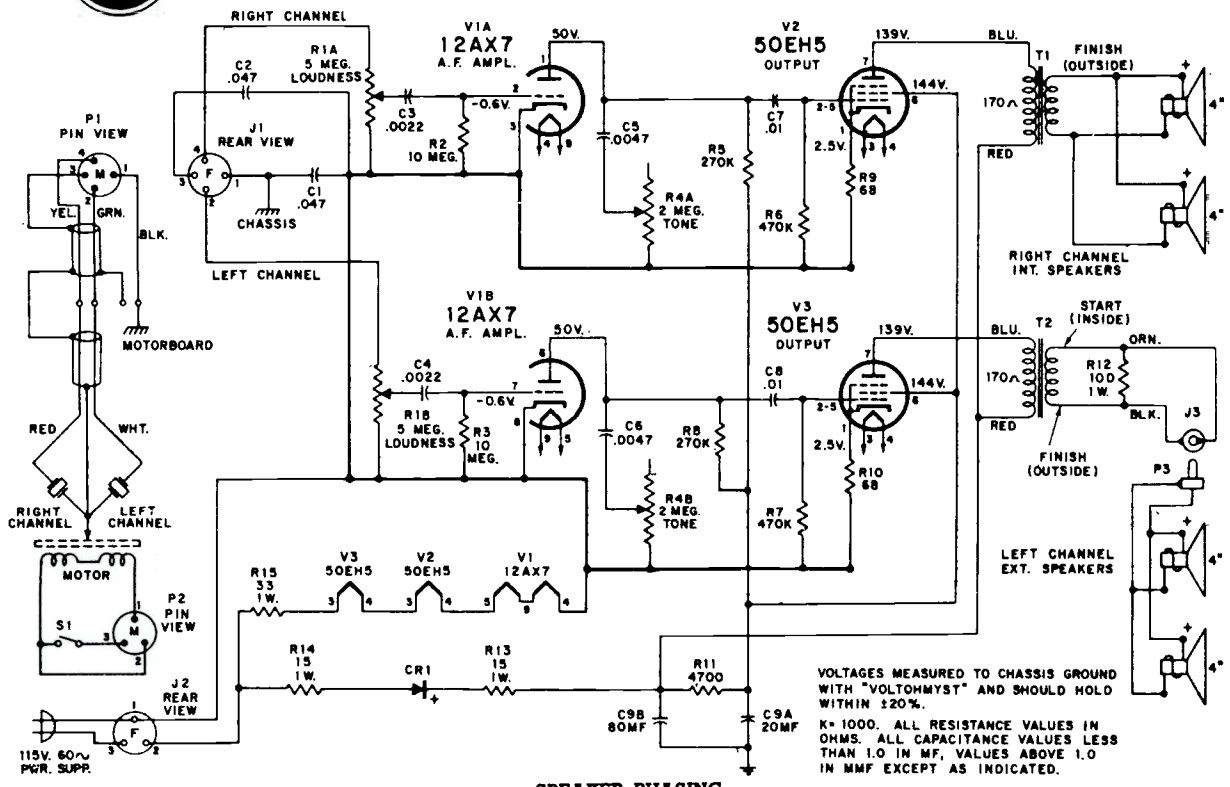

VOLTAGES MEASURED TO CHASSIS GROUND WITH "VOLTHOMYST" AND SHOULD HOLD WITHIN 120%.

K=1000. ALL RESISTANCE VALUES IN OHMS. ALL CAPACITANCE VALUES LESS THAN 1.0 IN MF, VALUES ABOVE 1.0 IN MMF EXCEPT AS INDICATED.

SPEAKER PHASING

The two speaker systems must be properly connected in order to have in-phase sound outputs. Incorrect connections will be evidenced by a "null point" in the sound when playing

a monaural record and listening from a point midway between the two speaker systems. For the same reason both speakers in each system should be phased with each other.

REPLACEMENT PARTS

Symbol No.	Stock No.	Description	Symbol No.	No. Stock	Description
AMPLIFIER ASSEMBLY RS-175			RECORD CHANGER WIRING		
CAPACITORS:			P1	101748	Connector—4-contact male for pickup cable
C1, C2	73553	paper, 0.047 mf., +100-0%, 400 v.	P2	101747	Connector—3-contact male for motor cable
C3, C4	77953	ceramic, 0.0022 mf., ±20%, 500 v.		101825	Connector—Closed end, for motor lead
C5, C6	103905	ceramic, 0.0047 mf., ±20%, 1000 v.		76301	Switch—"ON-OFF" power switch
C7, C8	73960	ceramic, 0.01 mf., +100-0%, 500 v.	SPEAKER ASSEMBLY		
C9A, C9B	101752	electrolytic, 80/20 mf., 150/150 v.		31048	Connector—Single contact male for remote speaker cable
CR1	106967	Rectifier—Silicon		79696-A	Speaker—4" PM
J1	101749	Connector—4-contact female with retainer for pickup cable			
J2	101750	Connector—3-contact female with retainer for motor-cable			
RESISTORS:					
Fixed, Composition, unless otherwise specified:					
R1A, R1B	106969	Control—Dual volume 10 megohm, ±20%, 1/2 w.			
R2, R3		Control—Dual tone 270,000 ohm, ±10%, 1/2 w.			
R4A, R4B	106968	270,000 ohm, ±10%, 1/2 w.			
R5		470,000 ohm, ±20%, 1/2 w.			
R6, R7		270,000 ohm, ±10%, 1/2 w.			
R8		68 ohm, ±10%, 1/2 w.			
R9, R10		4700 ohm, ±20%, 1/2 w.			
R11		100 ohm, ±20%, 1 w.			
R12		15 ohm, ±20%, 1 w.			
R13, R14		33 ohm, ±20%, 1 w.			
R15					
T1, T2	100272	Transformer—Output			
	70392	Cable—AC power cable with plug			
	74822	Socket—7-pin miniature for V2 and V3			
	79799	Socket—9-pin miniature for V1			

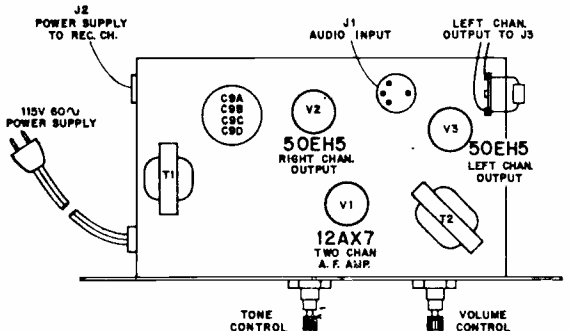

View of Chassis Showing Location of Tubes and Major Components



RCA VICTOR

Model 9-TX-2, Chassis RC-1156C

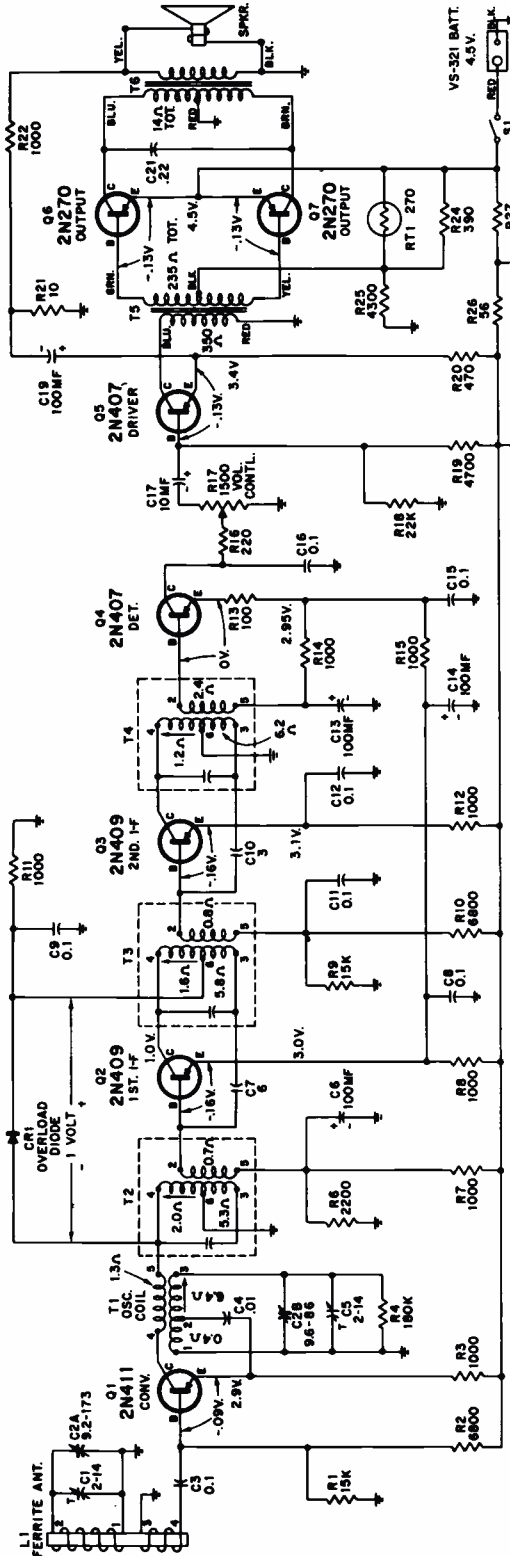

VOLTAGES MEASURED TO CHASSIS GROUND EXCEPT AS INDICATED AND SHOULD HOLD WITHIN ±20% WITH NEW BATTERIES.

TERMINAL CONNECTIONS FOR T2, T3 & T4

OSC. COIL CONNECTIONS

TRANSISTOR CONNECTIONS

COLLECTOR CURRENTS WITH NO SIGNAL INPUT

Q1	0.82 MA
Q2	0.9 MA
Q3	0.9 MA
Q4	0.9 MA
Q5	0.9 MA
Q6-Q7	0.2 MA

TOTAL BATTERY CURRENT K=1000

ALL RESISTANCE VALUES IN OHMS.

ALL CAPACITANCE VALUES LESS THAN 1.0 IN MF. AND 1.0 & ABOVE IN MMF. EXCEPT THOSE INDICATED.

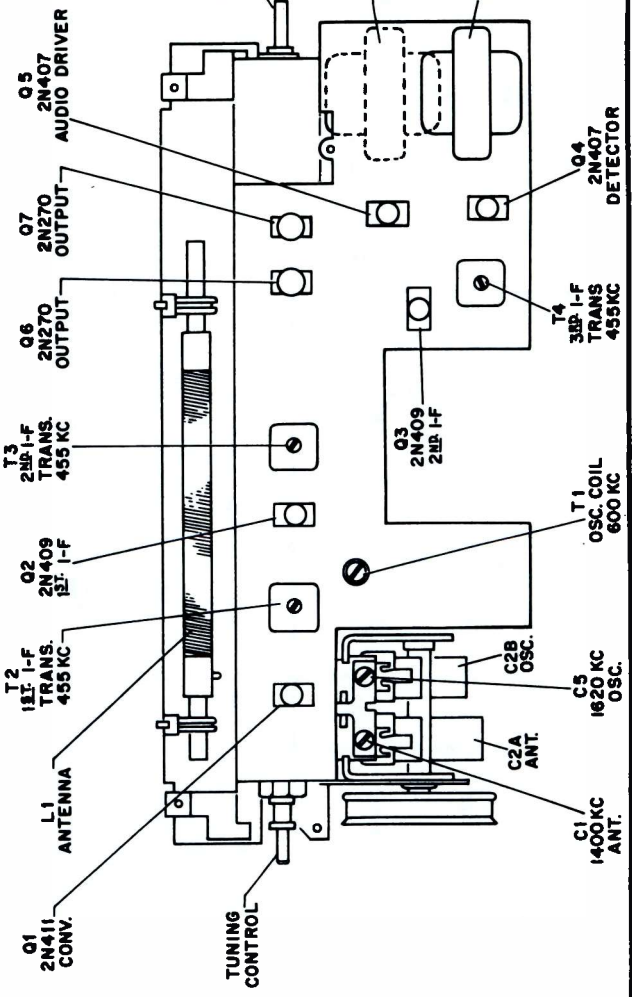

- CRITICAL LEAD DRESS**
1. Dress all bus and non-insulated pigtail leads away from chassis ground and other components to prevent shorts.
 2. Dress loop antenna leads direct and away from chassis, all other insulated leads down against chassis.
 3. Dress RT1 (thermistor) away from all other components.
 4. Maintain reasonably short pigtail leads on components associated with the detector circuit, to limit 910 kc "tweed."
 5. Insure good grounding of shield cover.
 6. Dress components which are enclosed in shielded compartment in such manner that short circuits are prevented.

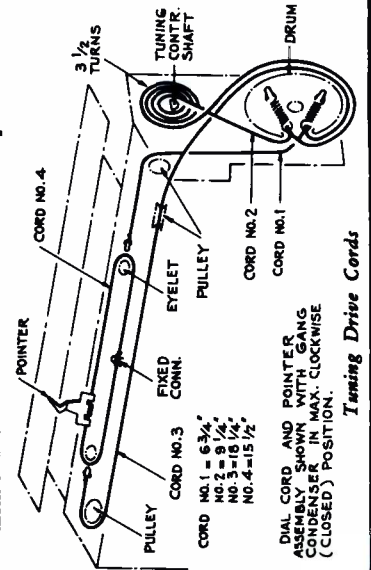

RCA VICTOR MODEL BC-3 MODEL BCS-4

Battery Charger Battery Charger/Speaker

MODEL 1-BT-2 SERIES

Chassis No. RC-1187

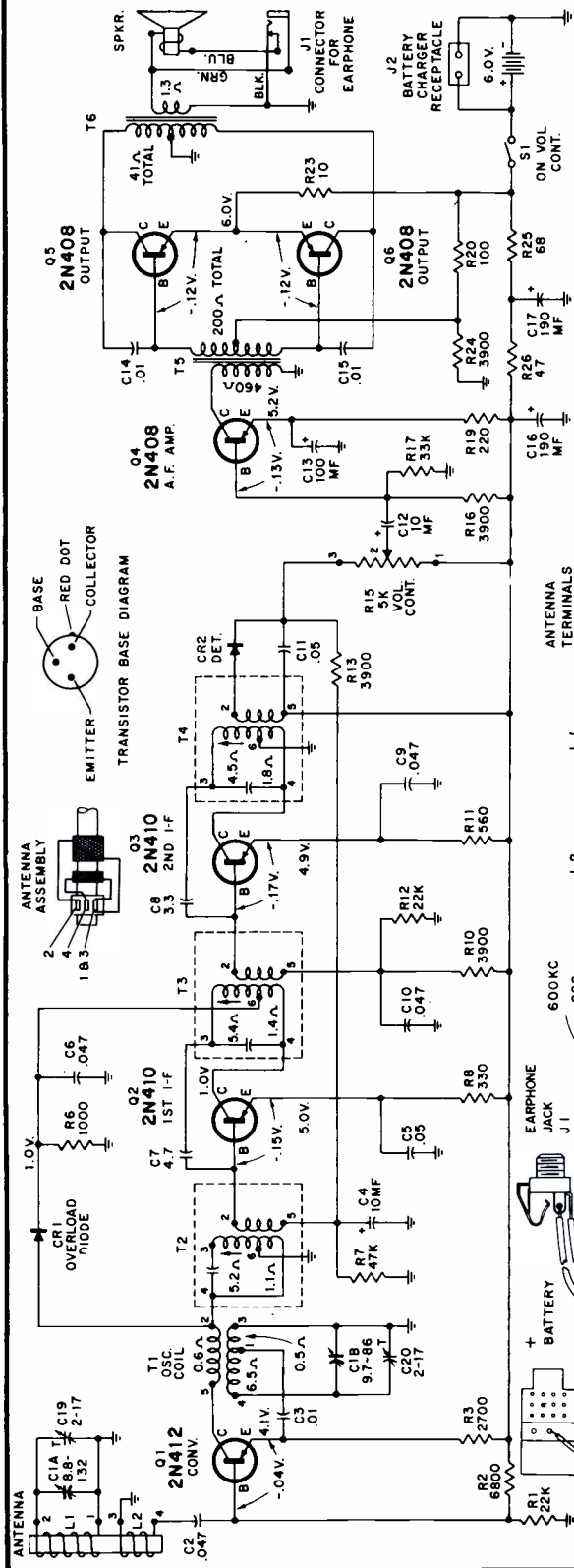

VOLTAGES MEASURED WITH "VOLTOHMYST" SHOULD HOLD WITHIN ±20% WITH NEW BATTERY. K=1000. ALL RESISTANCE VALUES IN OHMS. ALL CAPACITANCE VALUES LESS THAN 1.0 IN MF AND 1.0 & ABOVE IN MMF EXCEPT THOSE INDICATED.

EMITTER CURRENTS WITH 6.0V BATTERY AND NO SIGNAL INPUT AND NO SIGNAL OUTPUT

Q1	0.5 MA	Q2	8 MA
Q3	2.1 MA	Q4	20 MW
Q5	1.0 MA	Q5	28 MA
Q6	1.5 MA	Q6	50 MW
Q7	2.5 MA	Q7	42 MA
Q8	2.5 MA	Q8	MAX.

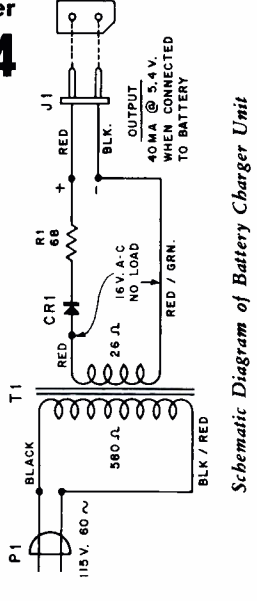
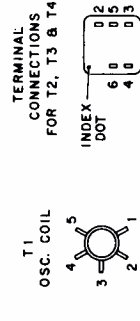

Schematic Diagram of Battery Charger Unit

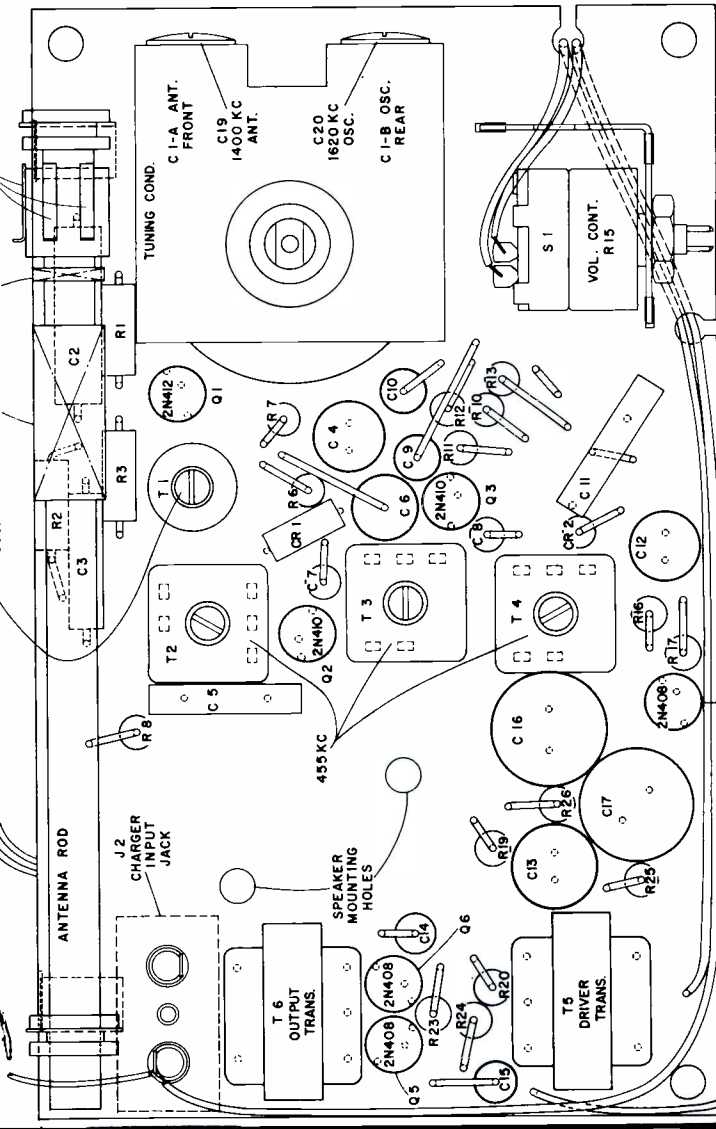

RCA Victor Model 1-BT-3, Chassis RC-1187A

RCA VICTOR

MODEL 1-BT-3 Series

Chassis No. RC-1187A

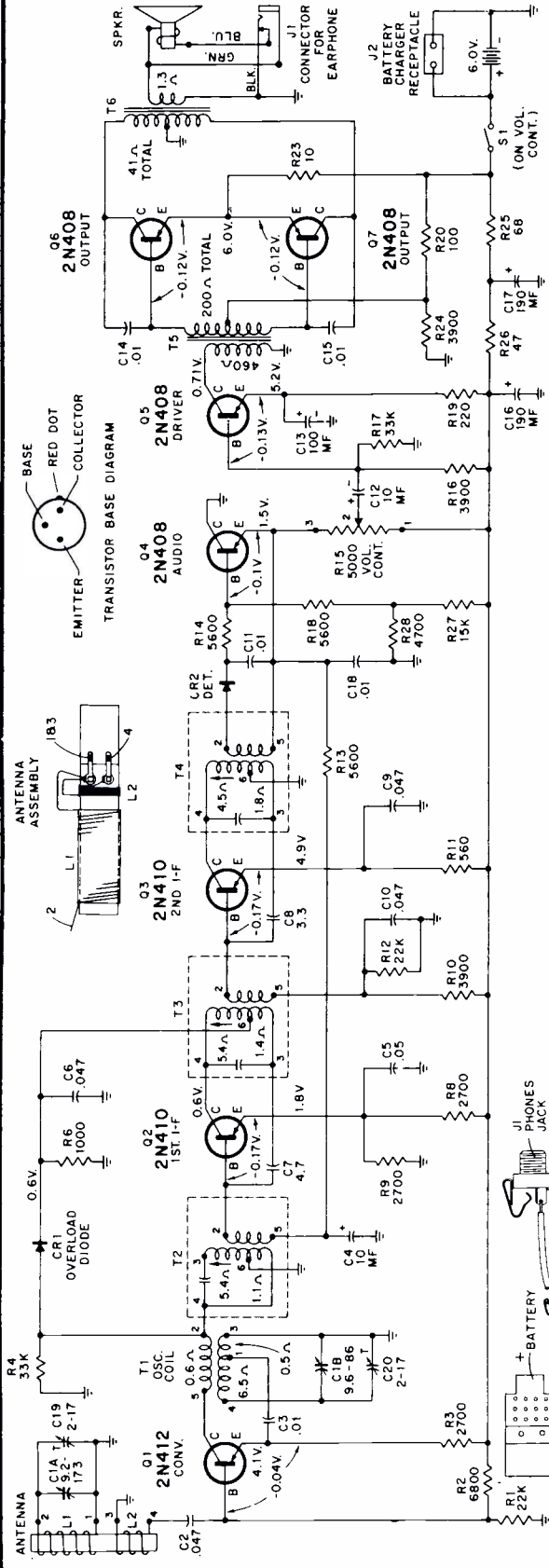

VOLTAGES MEASURED WITH "VOLTOHMYST" SHOULD HOLD WITHIN ±20% WITH NEW BATTERY. K=1000. ALL RESISTANCE VALUES IN OHMS. ALL CAPACITANCE VALUES LESS THAN 1.0 IN MF AND 1.0 & ABOVE IN MMF EXCEPT THOSE INDICATED.

EMITTER CURRENTS WITH 6.0V. BATTERY AND NO. SIGNAL INPUT

Q1	0.5 MA
Q2	0.6 MA
Q3	1.0 MA
Q4	0.7 MA
Q5	1.5 MA
Q6	2.5 MA
Q7	2.5 MA

TOTAL BATTERY CURRENT

CURRENT	OUTPUT
8.8 MA	0
22 MA	20 MW
29 MA	50 MW
43 MA	MAX.

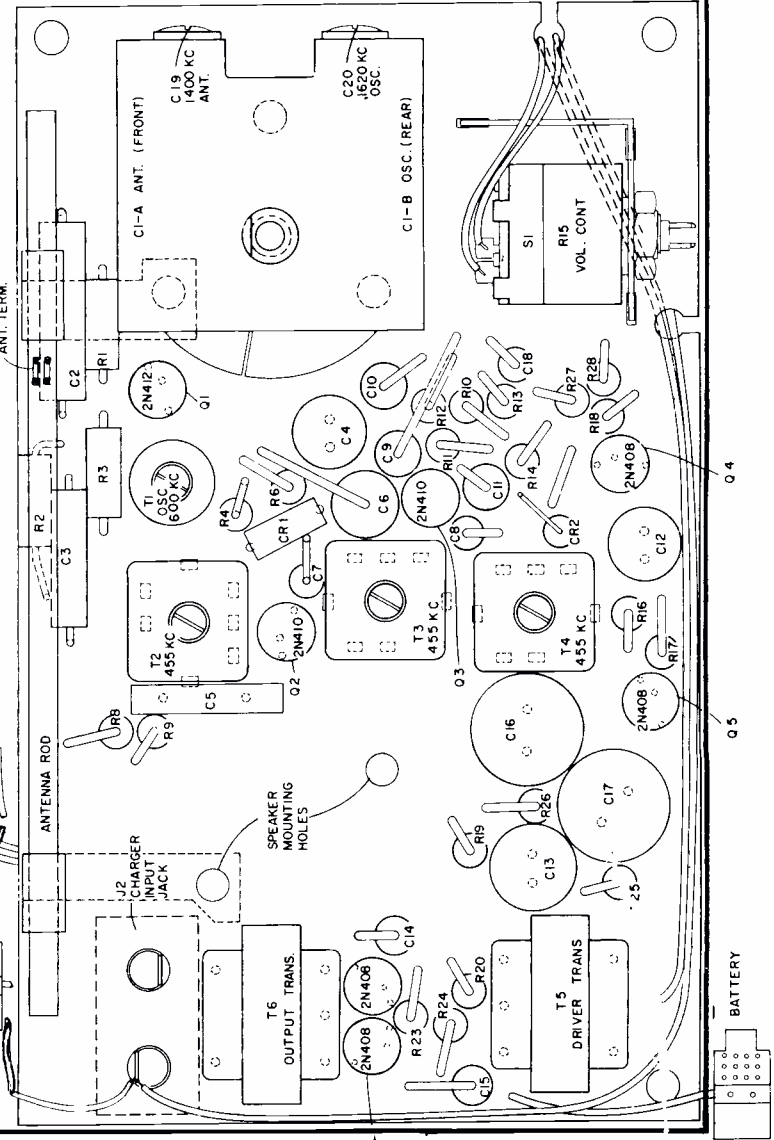
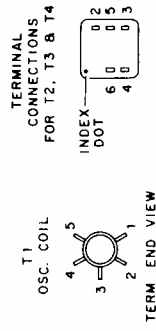

RCA VICTOR

**AC-DC Radio Receiver
X-1, X-2 SERIES
Chassis No. RC-1188**

C-1 Series, Chassis RC-1188A, is almost identical except for clock timer with its switch circuit.

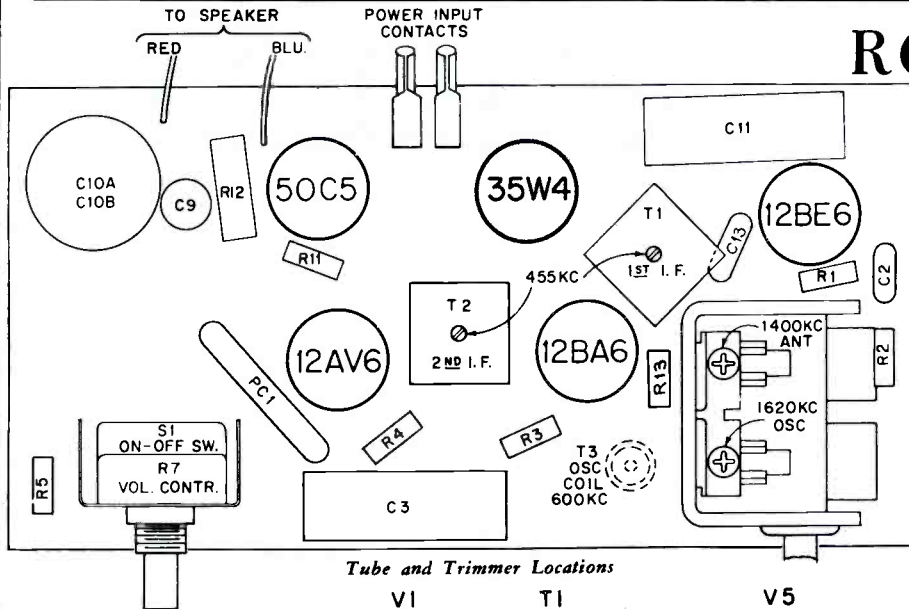

Tube and Trimmer Locations:

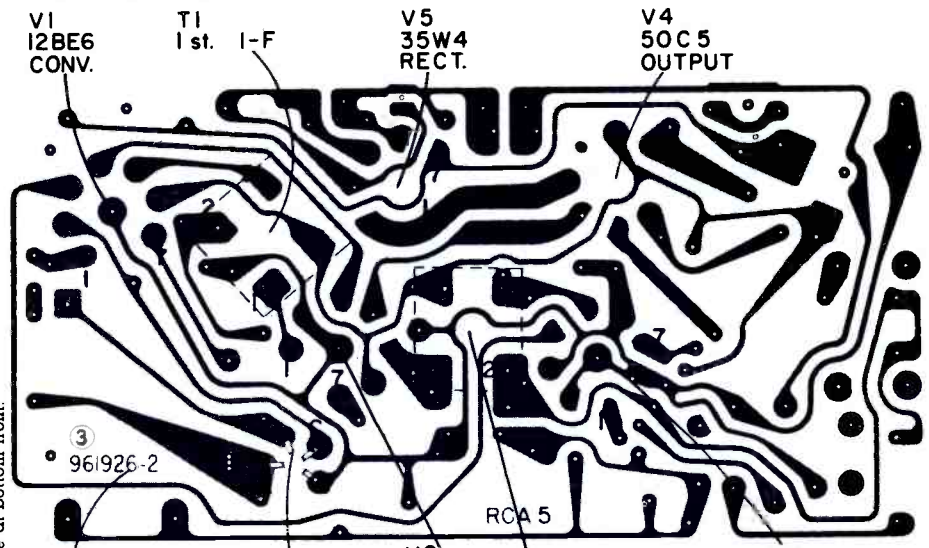

IDENTIFICATION NUMBER

OSC. COIL

V2 12BA6 I-F AMP

T2 2nd I-F

V3 12AV6 DET-AF AMP

Chassis Wiring and Components — View from Wiring Side

CHASSIS REMOVAL

1. Remove three cabinet holding screws; two at back of top lip and one at bottom front.
2. Grip cabinet with two hands allowing fingers to extend over edges of cabinet front.
3. Hold cabinet, front down, and shake in a vertical direction. Cabinet assembly will separate and the fingers will limit the separation.
4. The cabinet front and chassis assembly may now be separated completely.

CABINET REASSEMBLY

1. Place chassis front and chassis assembly on the cabinet back so that the ribs of the cabinet front rest on the bottom — inside of the cabinet back.
2. Push cabinet sections together firmly.
3. Insert three holding screws; two at back of top lip and one at bottom front.

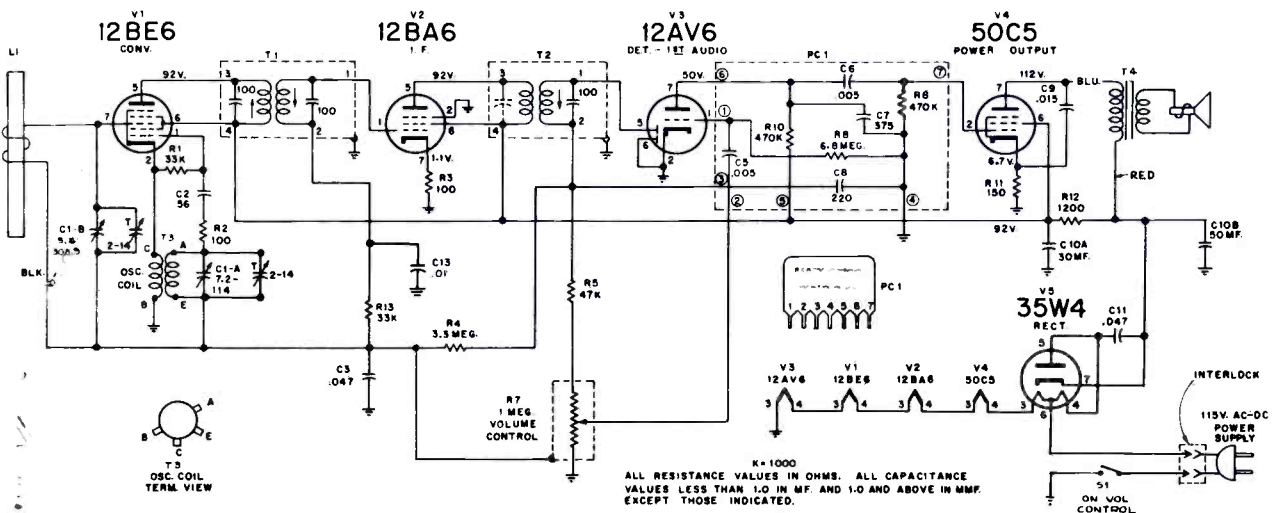

K=1000
ALL RESISTANCE VALUES IN OHMS. ALL CAPACITANCE VALUES LESS THAN 1.0 IN MF. AND 1.0 AND ABOVE IN MMF. EXCEPT THOSE INDICATED.



MODEL 71-483

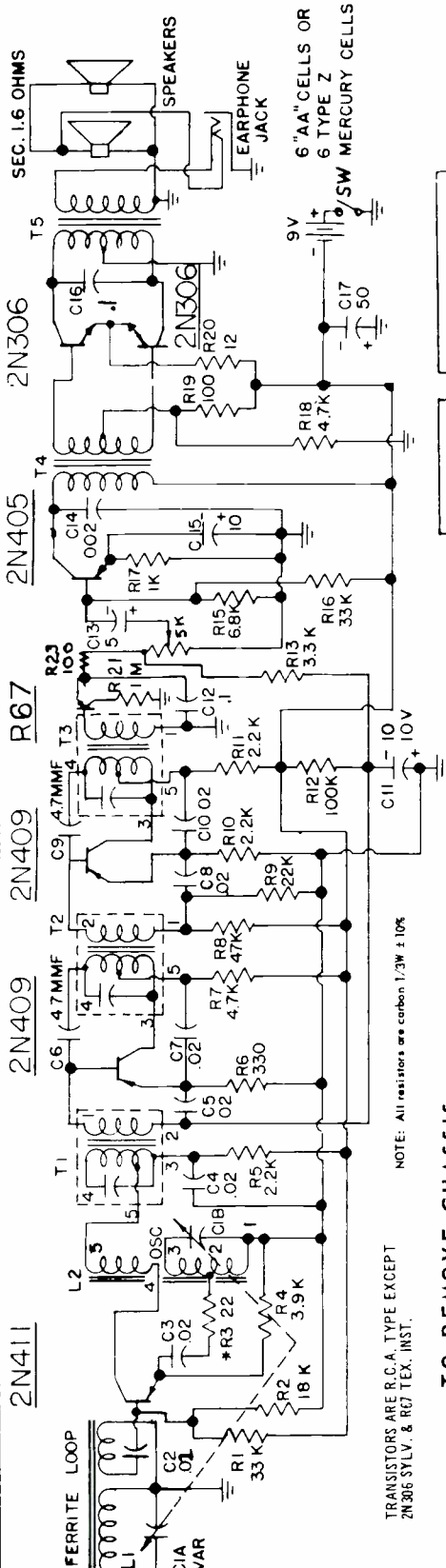

TRANSISTORS ARE R.C.A. TYPE EXCEPT 2N306 SYLV. & R67 TEX. INST.

NOTE: All resistors are carbon 1/3W ± 10%

TO REMOVE CHASSIS

1. Remove volume control knob by pulling away from case.
2. Move handle to rear.
3. Release spring clips on each side of cabinet and remove back.
4. Remove battery holder.
5. Unscrew the four chassis corner mounting screws
6. Remove one screw holding volume control bracket.
7. Slide down to bottom of case and out to clear tuning knob from case.

* INSTALLED IN SOME SETS AT FACTORY

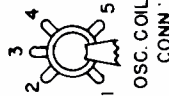

ALIGNMENT

Function	Generator Frequency	Dummy Antenna Conn.	Generator Conn.	Adjust for Max. Output	Remarks
1. I.F.	455KC	.1 Mfd Condenser in series with Gen. Lead	On Converter Base	T1, T2, T3	
2. Osc. Trimmer	1620KC		* Test Loop C1-B		Variable Condenser Set for Minimum capacity
3. Osc. Slug	540KC		* Test Loop L-2 Slug		Variable Condenser Set For Maximum Capacity ^{2a}
4. Ant. Trimmer	1400KC		* Test Loop C1-A		Tune 1400 Kc on Variable Condenser

* Standard Hazeltine Loop Model 1150 or 3 turns of wire about 6" diameter placed one foot from set.

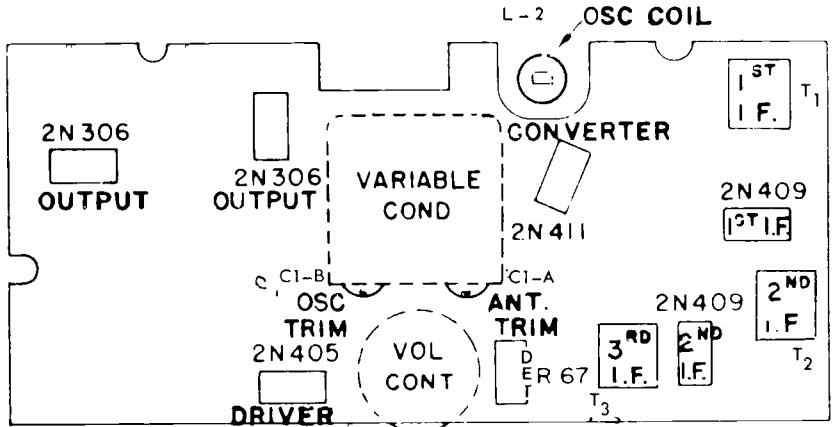

AM IF 455 KC.
FM IF 10.7 MC.

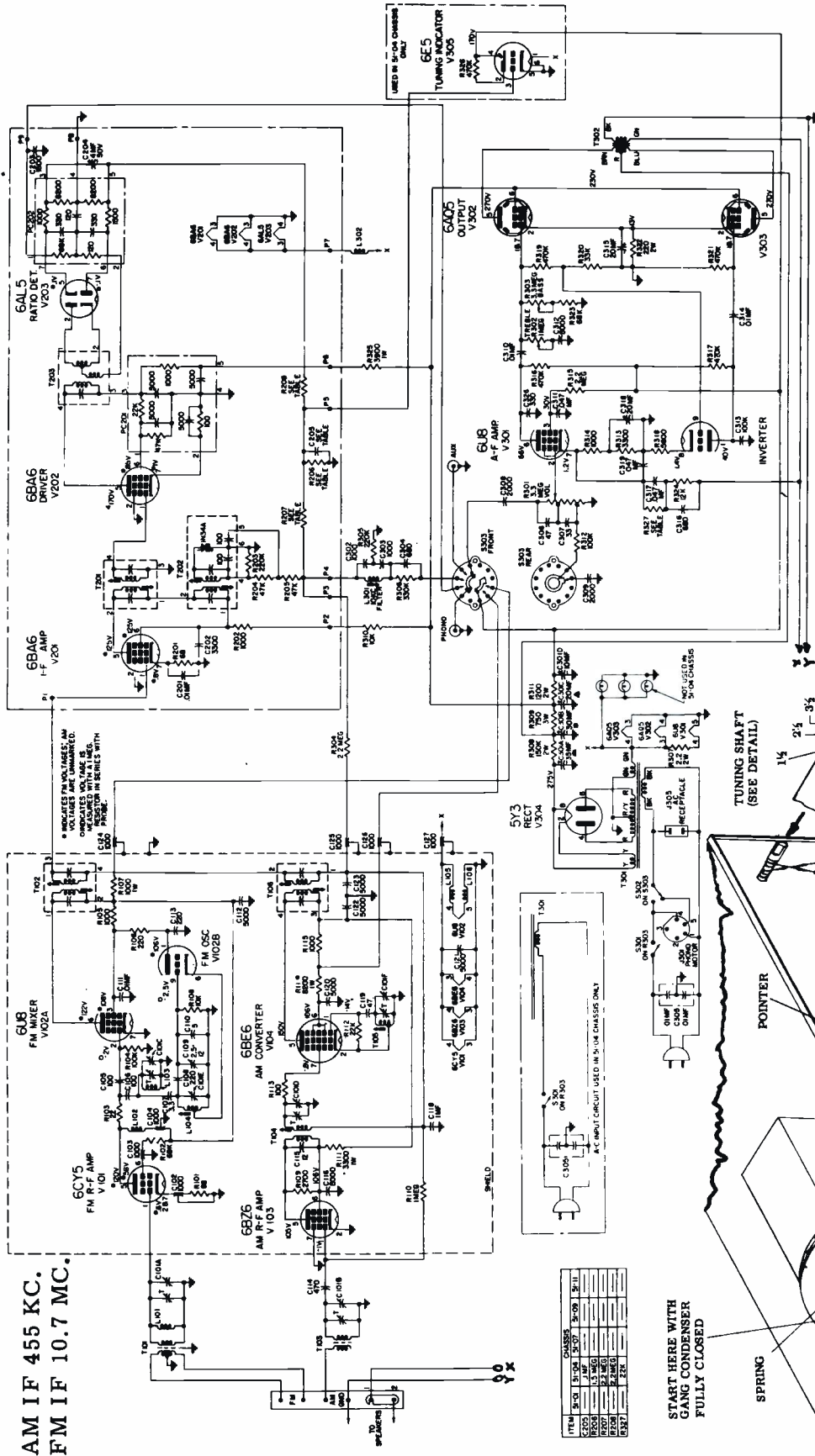

Spartan

(51-01, 51-04, 51-07, 51-09, 51-11)

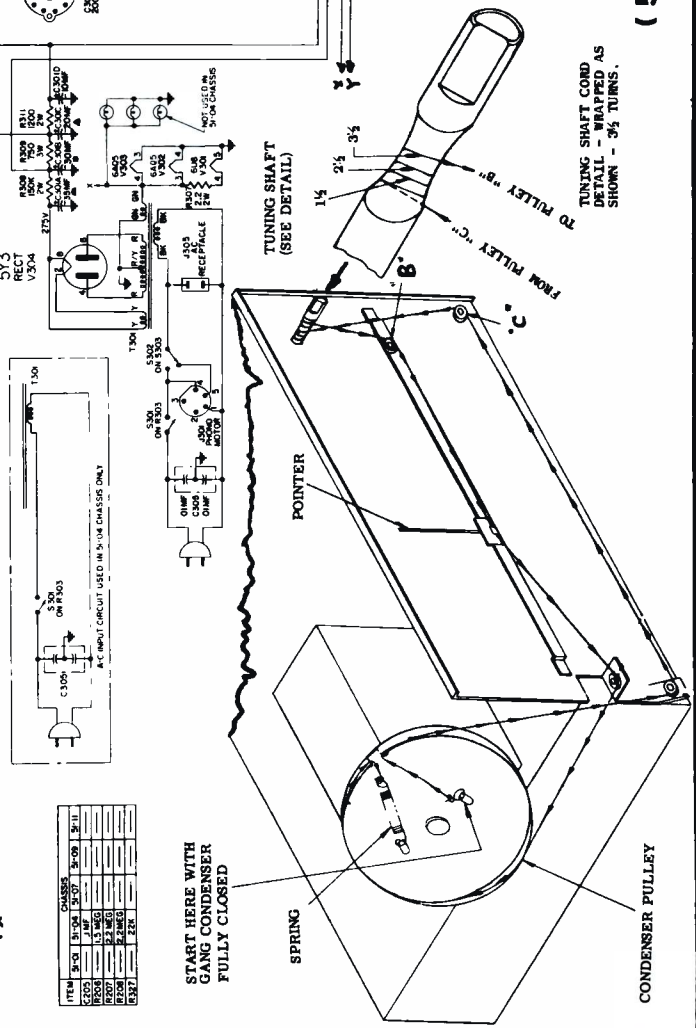

ITEM	QTY	DESCRIPTION
1	1	60V5
2	1	6G8
3	1	68Z6
4	1	68E6
5	1	68A5
6	1	68A6
7	1	68A6
8	1	68A6
9	1	68A6
10	1	68A6
11	1	68A6
12	1	68A6
13	1	68A6
14	1	68A6
15	1	68A6
16	1	68A6
17	1	68A6
18	1	68A6
19	1	68A6
20	1	68A6
21	1	68A6
22	1	68A6
23	1	68A6
24	1	68A6
25	1	68A6
26	1	68A6
27	1	68A6
28	1	68A6
29	1	68A6
30	1	68A6
31	1	68A6
32	1	68A6
33	1	68A6
34	1	68A6
35	1	68A6
36	1	68A6
37	1	68A6
38	1	68A6
39	1	68A6
40	1	68A6
41	1	68A6
42	1	68A6
43	1	68A6
44	1	68A6
45	1	68A6
46	1	68A6
47	1	68A6
48	1	68A6
49	1	68A6
50	1	68A6
51	1	68A6
52	1	68A6
53	1	68A6
54	1	68A6
55	1	68A6
56	1	68A6
57	1	68A6
58	1	68A6
59	1	68A6
60	1	68A6
61	1	68A6
62	1	68A6
63	1	68A6
64	1	68A6
65	1	68A6
66	1	68A6
67	1	68A6
68	1	68A6
69	1	68A6
70	1	68A6
71	1	68A6
72	1	68A6
73	1	68A6
74	1	68A6
75	1	68A6
76	1	68A6
77	1	68A6
78	1	68A6
79	1	68A6
80	1	68A6
81	1	68A6
82	1	68A6
83	1	68A6
84	1	68A6
85	1	68A6
86	1	68A6
87	1	68A6
88	1	68A6
89	1	68A6
90	1	68A6
91	1	68A6
92	1	68A6
93	1	68A6
94	1	68A6
95	1	68A6
96	1	68A6
97	1	68A6
98	1	68A6
99	1	68A6
100	1	68A6

START HERE WITH GANG CONDENSER FULLY CLOSED

TUNING SHAFT CORD DETAIL - WRAPPED AS SHOWN - 3/4 TURNS.

SYLVANIA ELECTRIC PRODUCTS

CHASSIS 1-609-7
MODELS: SC03 SERIES

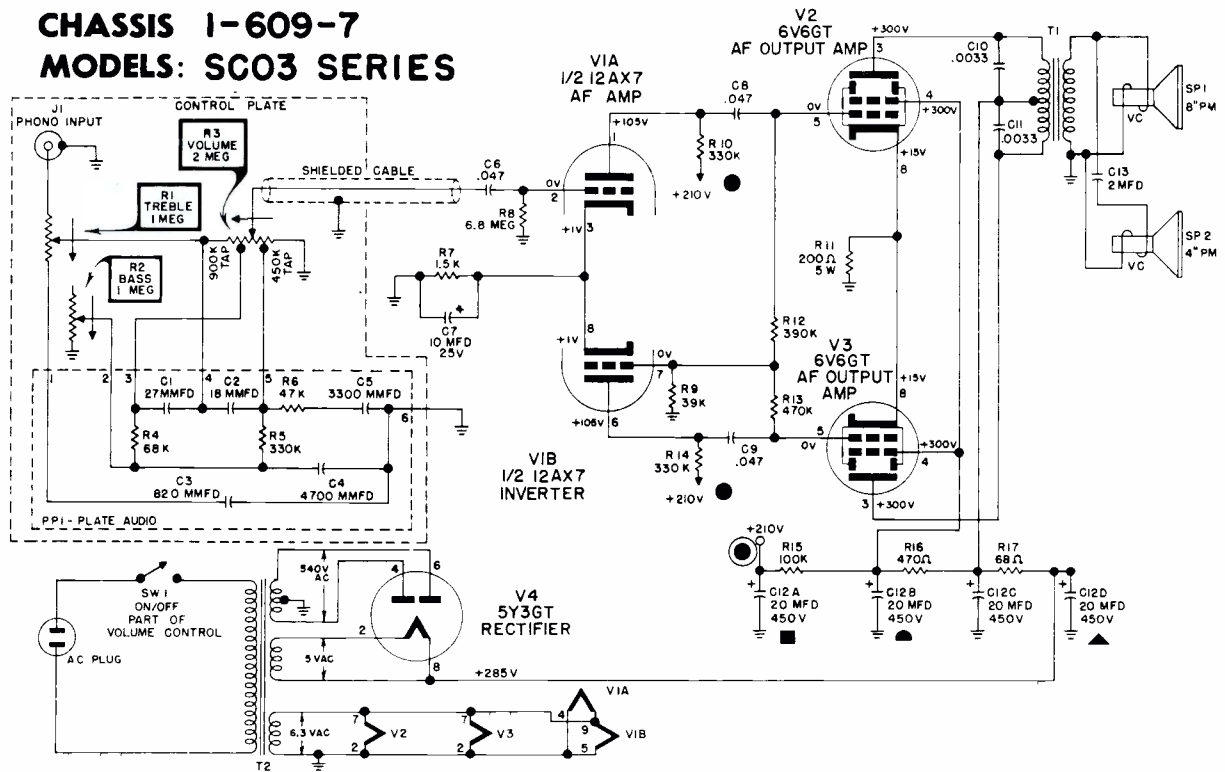

CHASSIS: 1-639-1
MODELS: 4312 SERIES

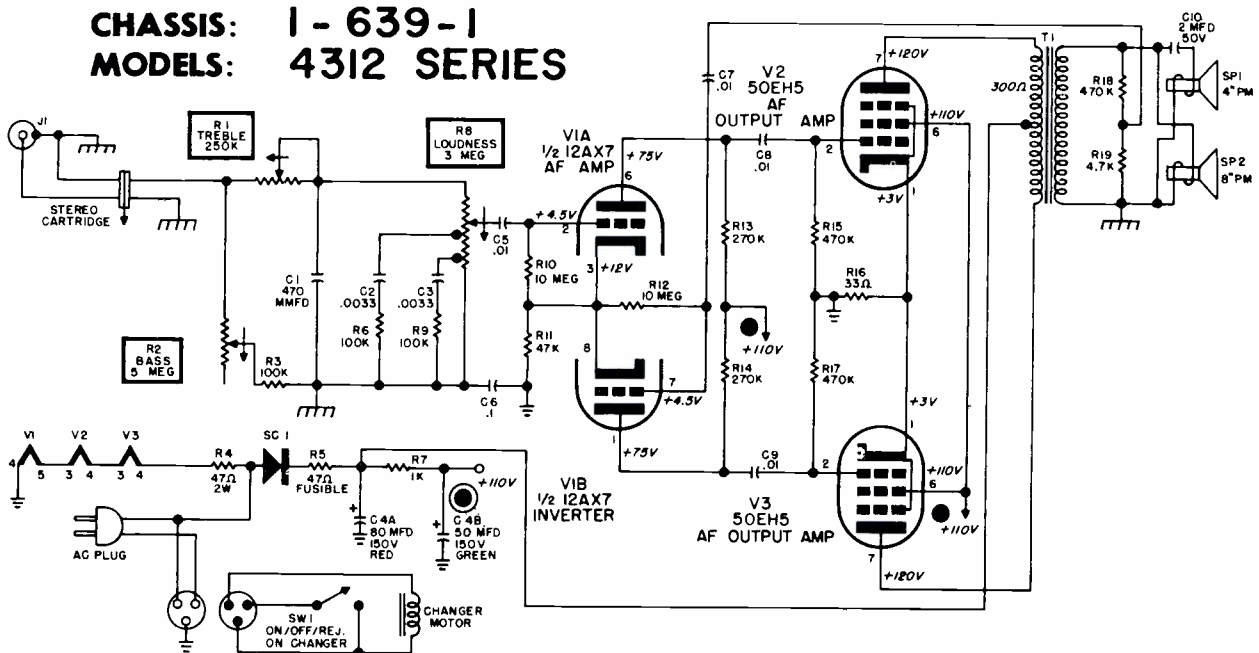

SCHEMATIC NOTES:

1. VOLTAGES SHOWN ARE AVERAGE READINGS MEASURED TO NEGATIVE "B" WITH NO SIGNAL INPUT. VARIATIONS MAY BE NOTED DUE TO NORMAL PRODUCTION TOLERANCES.
2. AC POWER SOURCE - 117V 60W "VARIAC REGULATED".
3. VOLTAGE SOURCE IS INDICATED BY ENCIRCLED SYMBOL \odot ; CORRESPONDING SYMBOL WITHOUT CIRCLE \bullet INDICATES VOLTAGE TIE POINTS.
4. $\text{---}\text{---}\text{---}$ DESIGNATES CHASSIS GROUND.
5. $\text{---}\text{---}\text{---}$ DESIGNATES NEGATIVE "B".

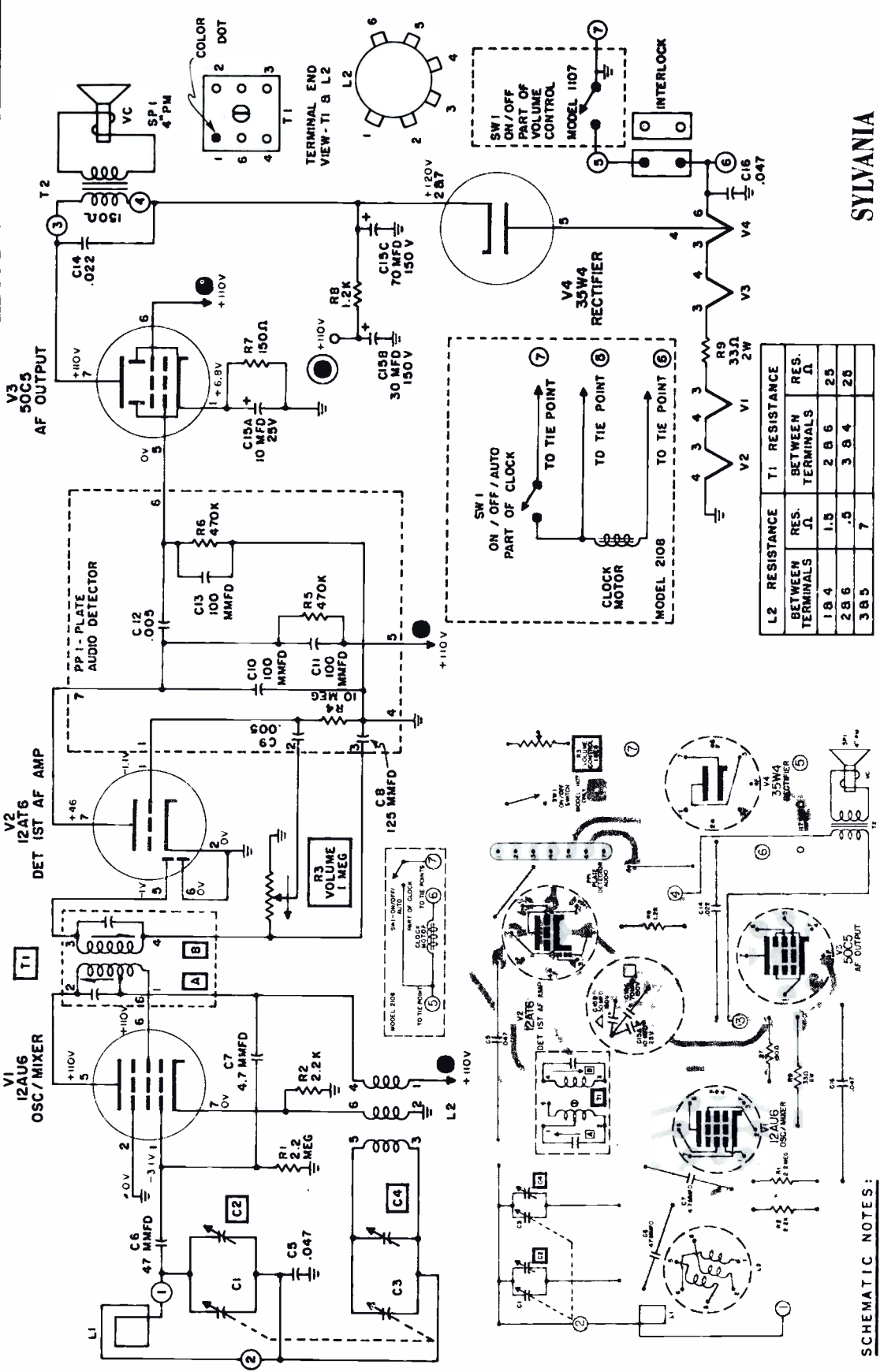

SYLVANIA
RADIO & TELEVISION

CHASSIS: 1-629-1,-2
MODELS: 1107 & 2108

L2 RESISTANCE BETWEEN TERMINALS	T1 RESISTANCE BETWEEN TERMINALS	RES. Ω
1 8 4	2 8 6	25
2 8 6	3 8 4	25
3 8 5	7	

SCHEMATIC NOTES:

COIL AND TRANSFORMER RESISTANCES ARE AVERAGE VALUES AND ARE TAKEN WITH COMPONENT CONNECTED IN THE CIRCUIT.
 INTERMEDIATE FREQUENCY 455KC.
 CIRCLED NUMBERS CORRESPOND WITH TIE POINTS ON PRINTED BOARD.
 VOLTAGE SOURCE IS INDICATED BY ENCIRCLED SYMBOL ⊕; CORRESPONDING SYMBOL WITHOUT CIRCLE ⊖ INDICATES VOLTAGE TIE POINTS.
 ⊕ DESIGNATES NEGATIVE "B".

SYLVANIA
RADIO & TELEVISION

CHASSIS: 1-630-1, -2
MODELS: 1108 & 2109

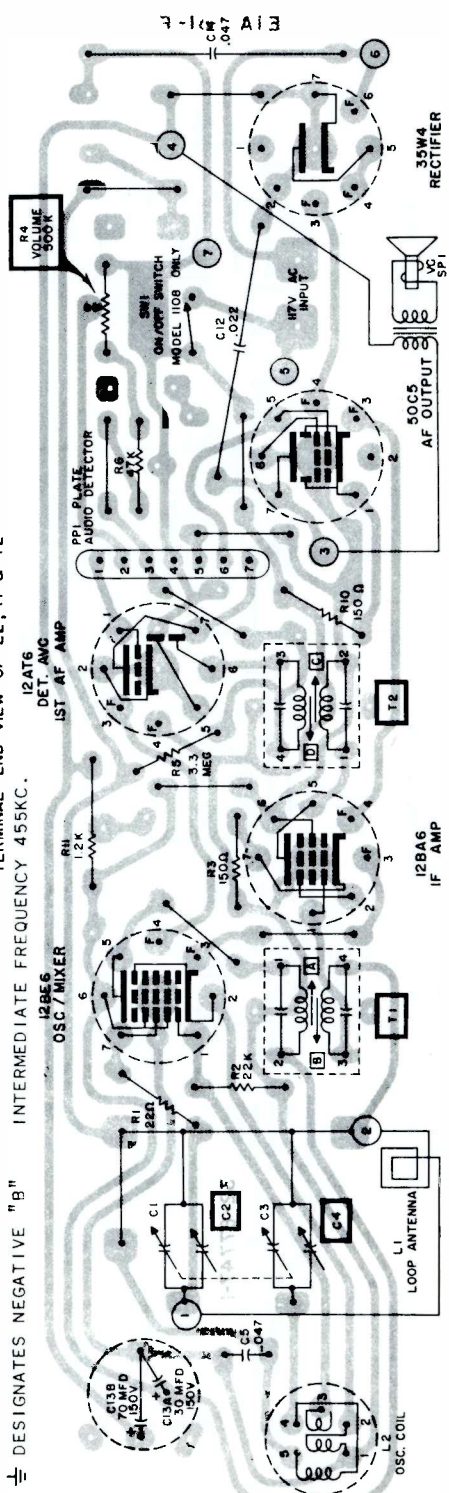
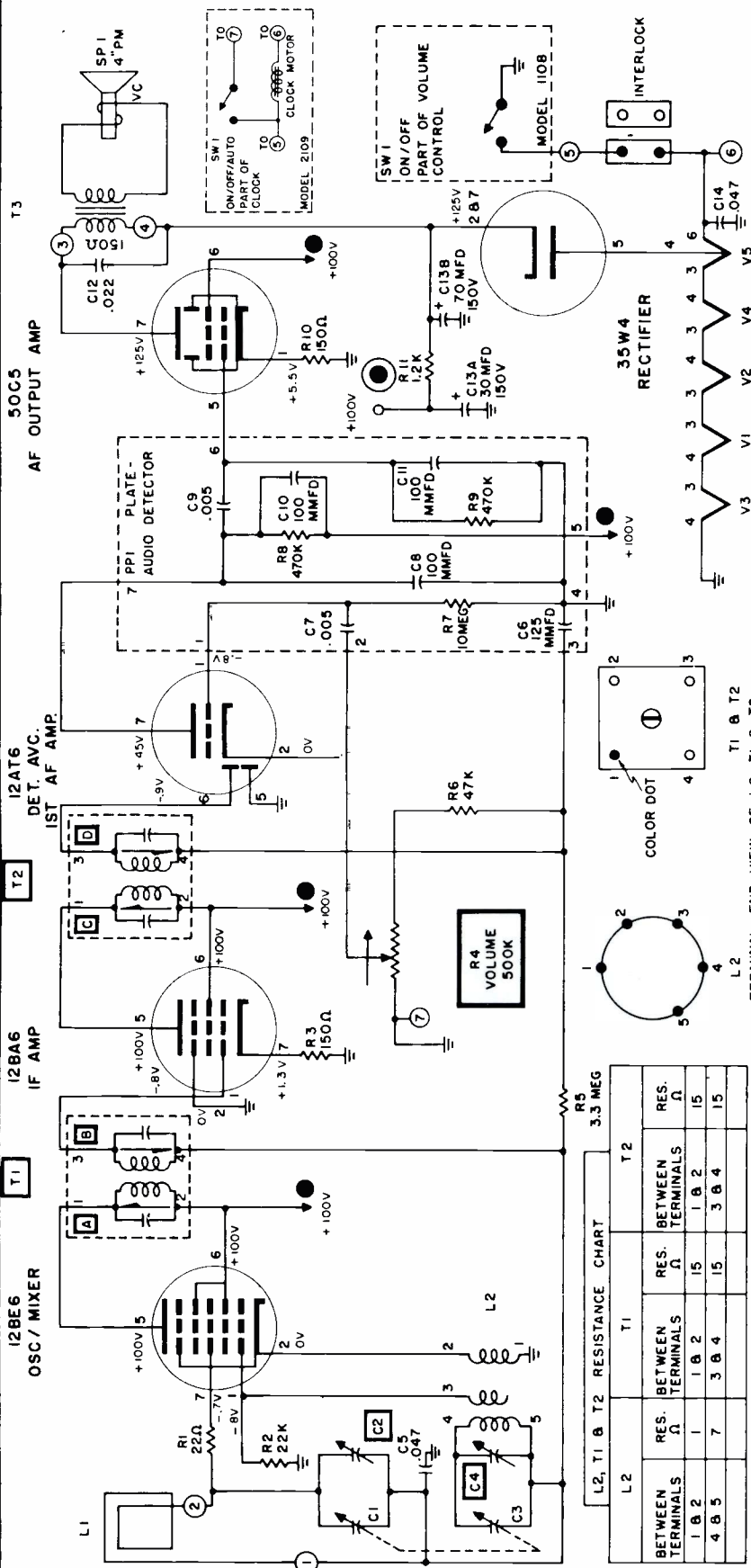

SYLVANIA Electric Products
Chassis 1-631-1, Model 1303

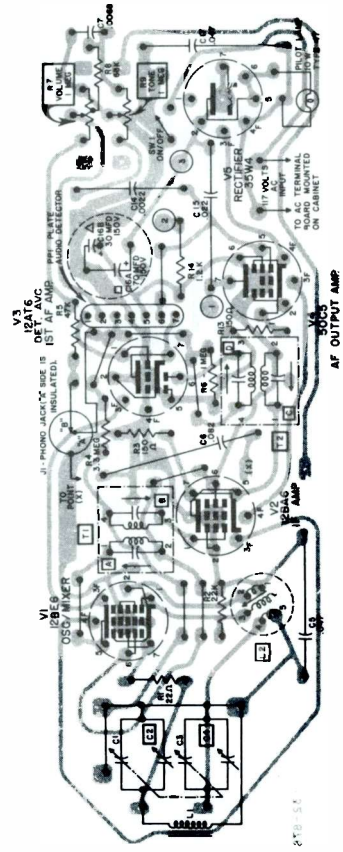
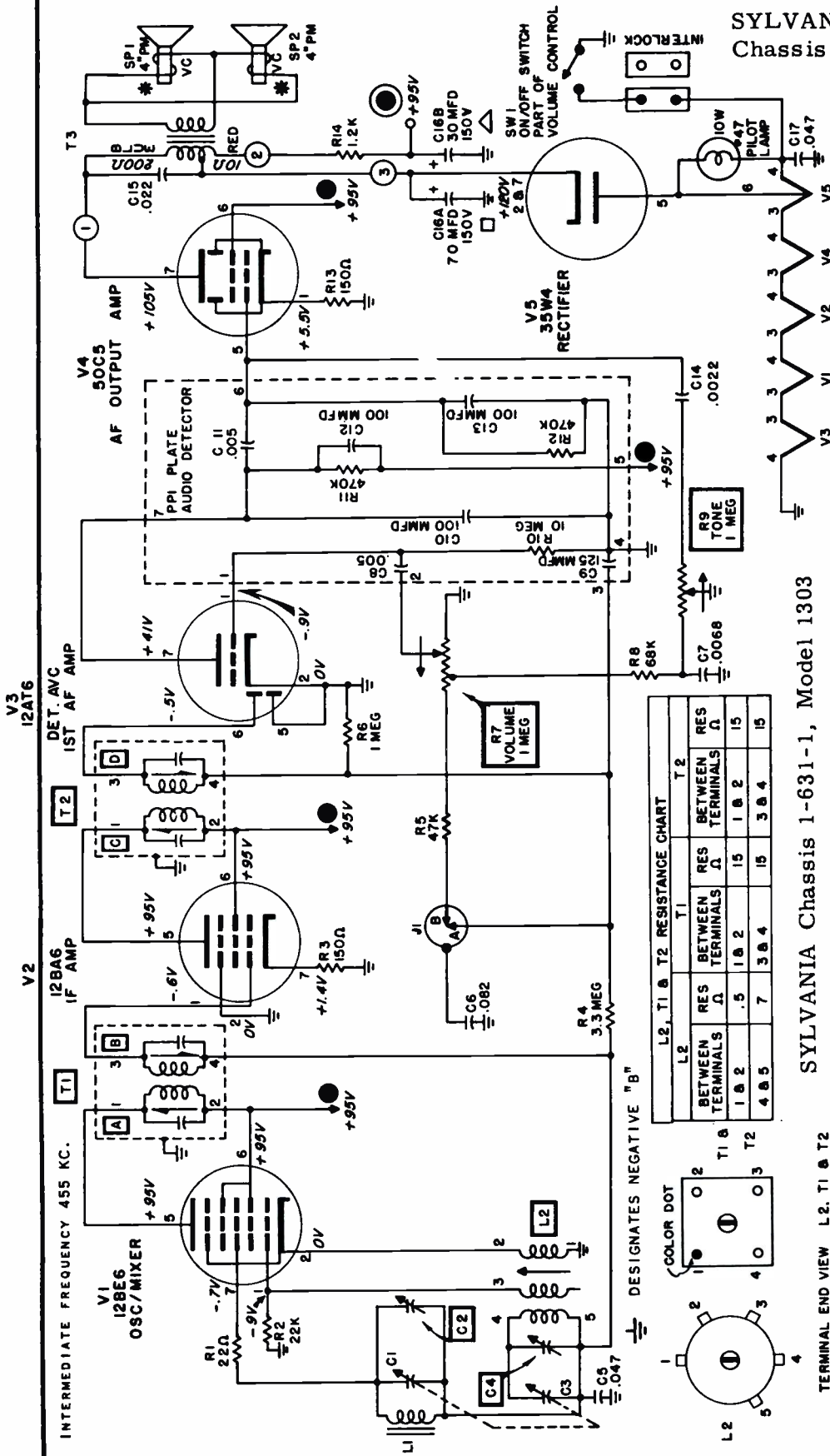

L2, T1 & T2 RESISTANCE CHART

L2	T1	T2
BETWEEN RES TERMINALS	BETWEEN RES TERMINALS	BETWEEN RES TERMINALS
1 & 2	1 & 2	1 & 2
4 & 5	3 & 4	15 & 15
		3 & 4
		15 & 15

SYLVANIA Chassis 1-631-1, Model 1303

DESIGNATES NEGATIVE "B"

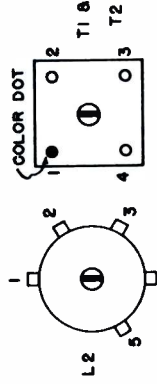

TERMINAL END VIEW L2, T1 & T2

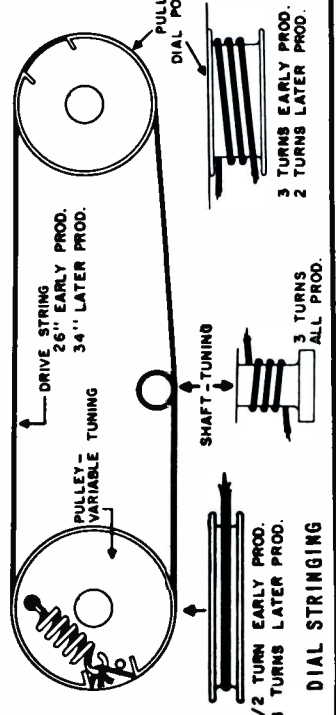

DRIVE STRING
26" EARLY PROD.
34" LATER PROD.

PULLEY - VARIABLE TUNING

SHAFT - TUNING

PULLEY - DIAL POINTER

1/2 TURN EARLY PROD.
3 TURNS LATER PROD.
DIAL STRINGING

3 TURNS ALL PROD.

3 TURNS EARLY PROD.
2 TURNS LATER PROD.

SYLVANIA

CHASSIS: 1-632-1,-2
MODELS: 1304 & 2305

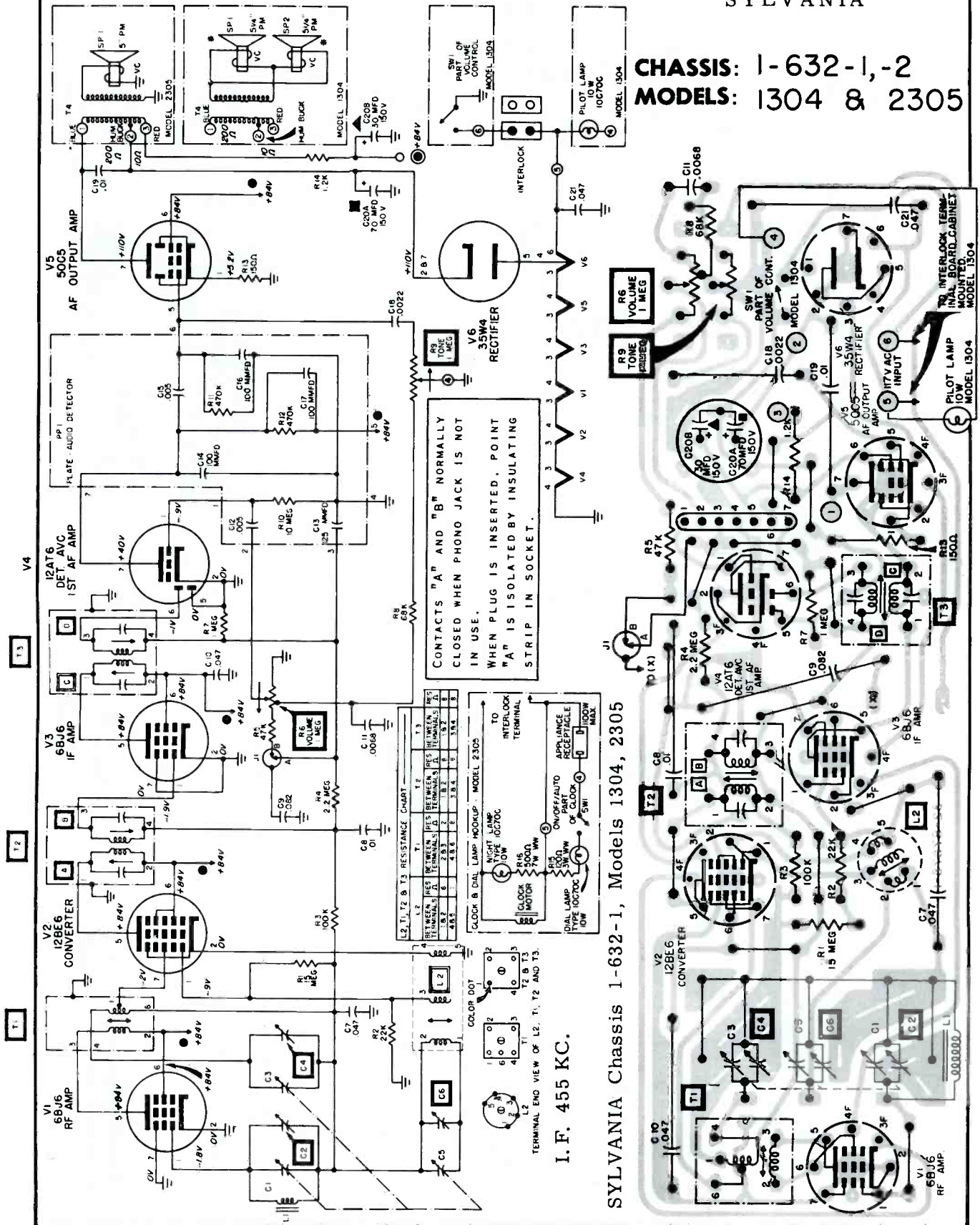

VOLUME R-19, MOST-OFTEN-NEEDED 1959 RADIO SERVICING INFORMATION

SYLVANIA ELECTRIC PRODUCTS Chassis 1-640-1, Model 4416

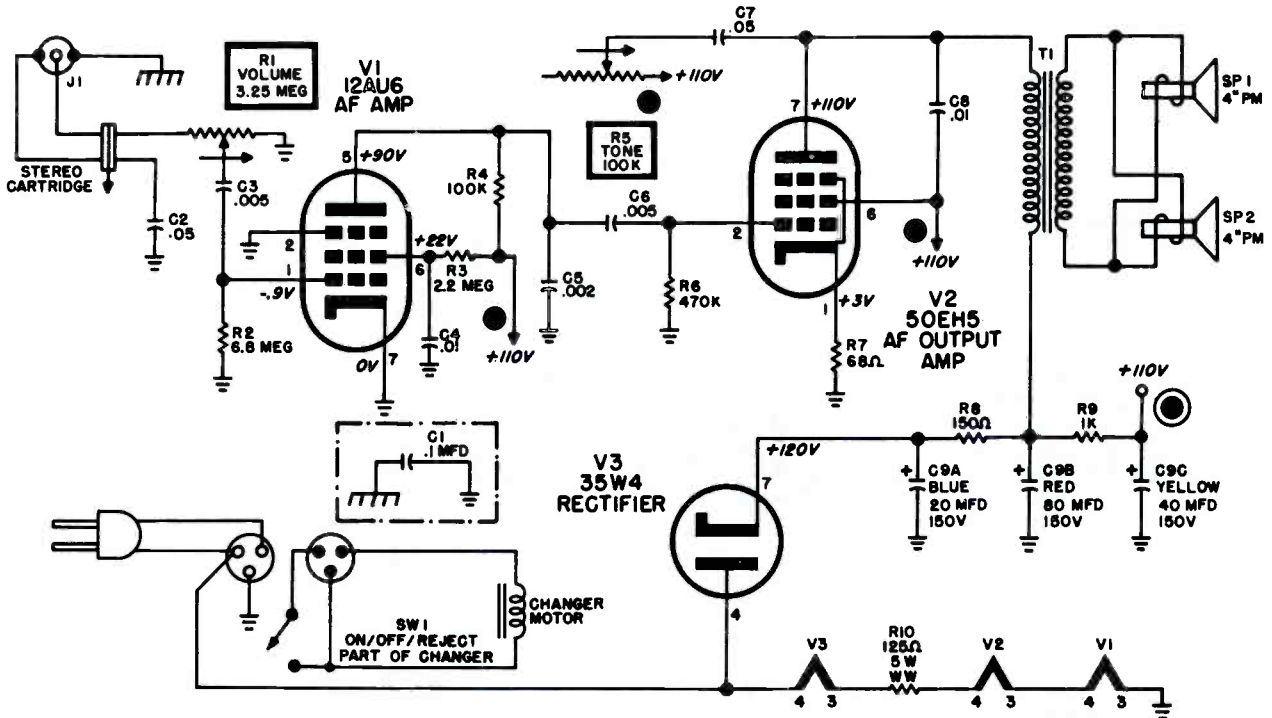

SYLVANIA Chassis 1-642-1, Model 4419

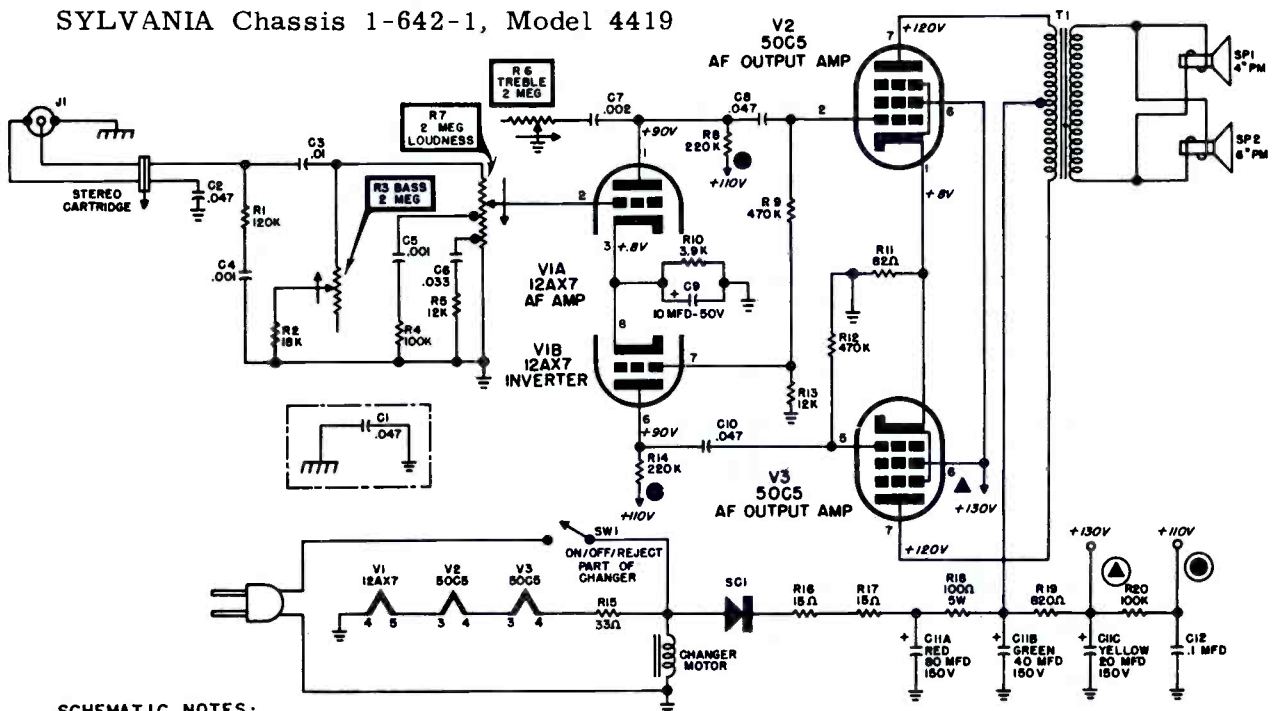

SCHEMATIC NOTES:

1. VOLTAGES SHOWN ARE AVERAGE READINGS MEASURED TO NEGATIVE "B" WITH NO SIGNAL INPUT. VARIATIONS MAY BE NOTED DUE TO NORMAL PRODUCTION TOLERANCES.
2. AC POWER SOURCE - 117V 60W "VARIAC REGULATED".
3. VOLTAGE SOURCES ARE INDICATED BY ENCIRCLED SYMBOLS (●) (▲): CORRESPONDING SYMBOLS WITHOUT CIRCLES (●) (▲) INDICATE VOLTAGE TIE POINTS.
4. --- DESIGNATES CHASSIS GROUND.
5. --- DESIGNATES NEGATIVE "B".

SYLVANIA ELECTRIC PRODUCTS Chassis 1-645-1, Models 4413, 4422

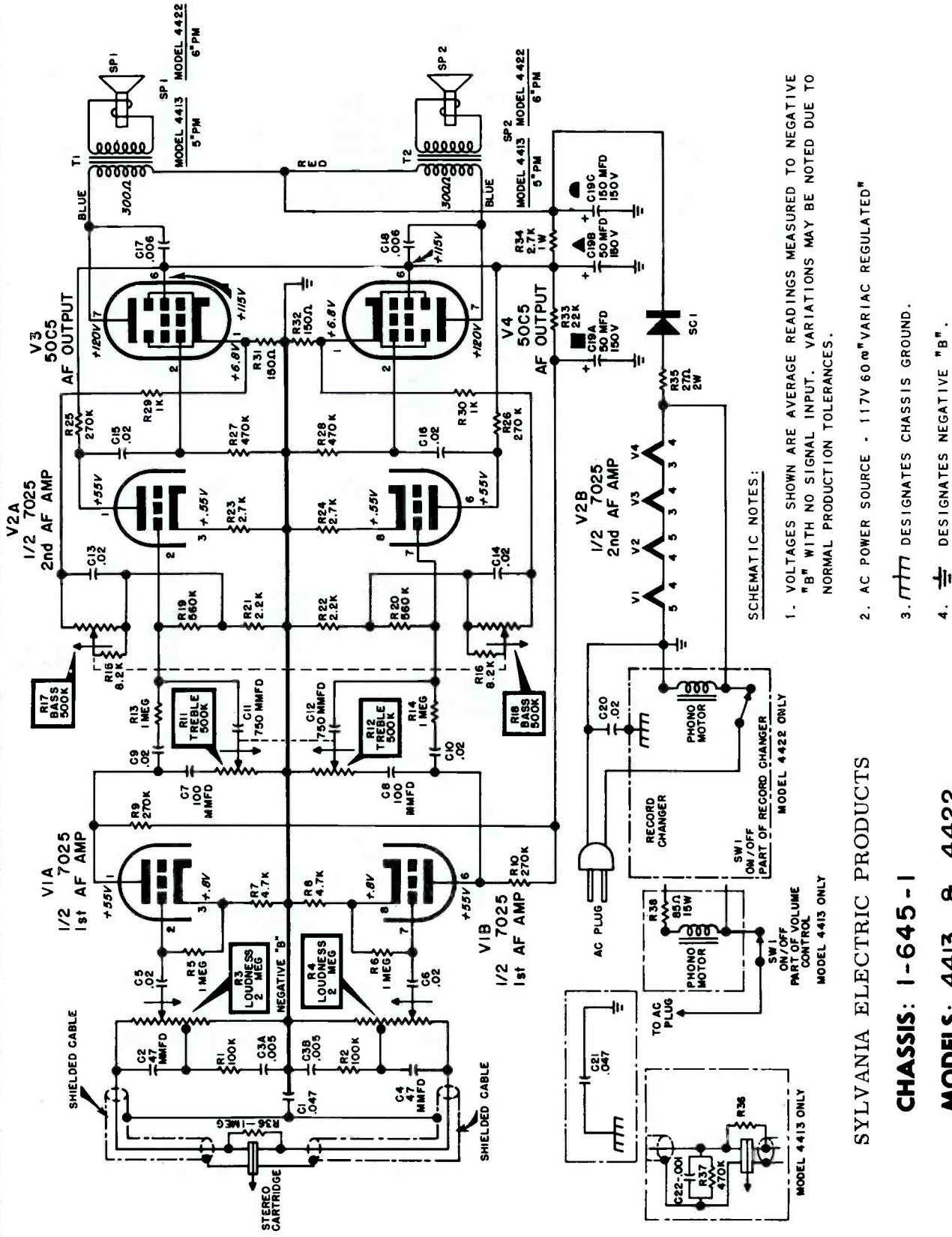

SCHEMATIC NOTES:

1. VOLTAGES SHOWN ARE AVERAGE READINGS MEASURED TO NEGATIVE "B" WITH NO SIGNAL INPUT. VARIATIONS MAY BE NOTED DUE TO NORMAL PRODUCTION TOLERANCES.
2. AC POWER SOURCE - 117V 60^{Hz} VARIAC REGULATED*
3. $\text{---} \text{---} \text{---}$ DESIGNATES CHASSIS GROUND.
4. $\text{---} \text{---} \text{---}$ DESIGNATES NEGATIVE "B".

SYLVANIA ELECTRIC PRODUCTS

CHASSIS: 1-645-1

MODELS: 4413 & 4422

TRAVLER MODEL 48-314

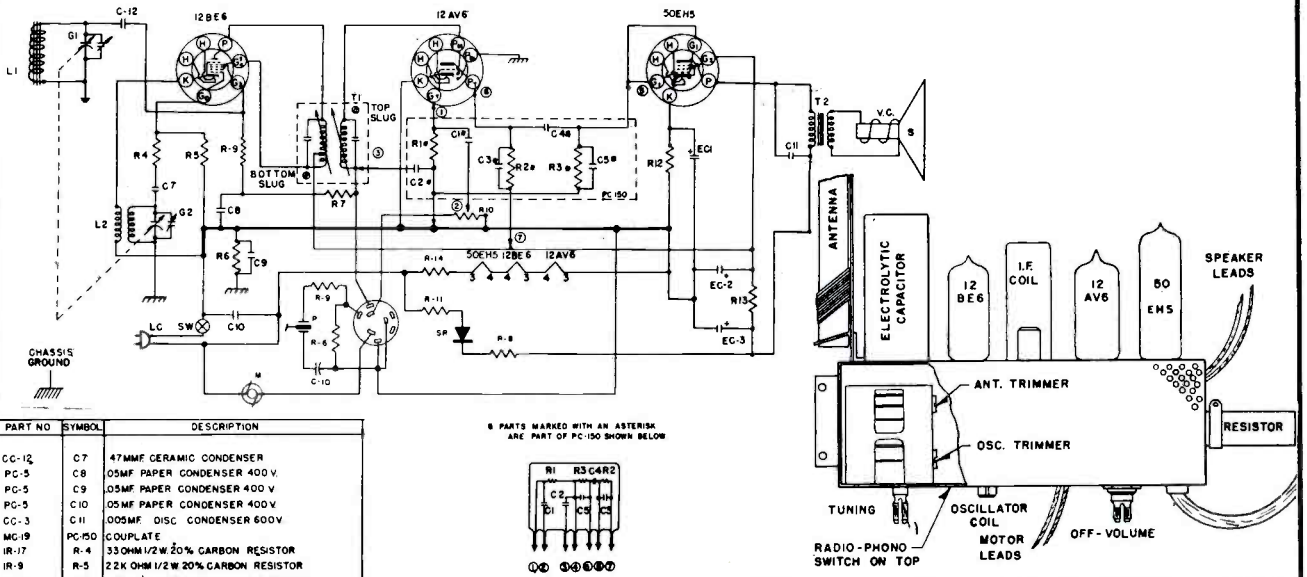

PART NO	SYMBOL	DESCRIPTION
CG-12	C7	.47MMF CERAMIC CONDENSER
PG-5	C8	.05MF PAPER CONDENSER 400V
PG-5	C9	.05MF PAPER CONDENSER 400V
PG-5	C10	.05MF PAPER CONDENSER 400V
CG-3	C11	.005MF DISC CONDENSER 600V
MG-19	PC-150	COUPLATE
IR-17	R-4	330HM 1/2W 20% CARBON RESISTOR
IR-9	R-5	22K OHM 1/2W 20% CARBON RESISTOR
IR-20	R-6	220K OHM 1/2W 20% CARBON RESISTOR
IR-23	R-7	3.3MEG OHM 1/2W 20% CARBON RESISTOR
IR-41	R-8	47 OHM 1W 10% CARBON RESISTOR
IR-12	R-9	1MEG OHM 1/2W 20% CARBON RESISTOR
CG-33	C-2	220MMFD 500V 20% CERAMIC TUB COND.
VC-64	H-10	1MEG OHM VOLUME CONTROL
IR-17	R-11	330HM 1/2W 20% CARBON RESISTOR
IR-14	R-12	150 OHM 1/2W 20% CARBON RESISTOR
IR-25	R-13	2200 OHM 1/2W 10% CARBON RESISTOR
EC-71A	EC-1	20MF-150WVDC ELECTROLYTIC CONDENSER
EC-71A	EC-2	30MF-150WVDC ELECTROLYTIC CONDENSER
EC-3	EC-3	40MF-150WVDC CONDENSER
CG-1	LC	AC LINE CORD
CO-15	G1	ANT SECTION WITH TRIMMER GANG
CO-15	G2	OSC SECTION WITH TRIMMER CONDENSER
LL-55	L1	FERRIMAG ROD ANTENNA COIL
LO-28	L2	OSCILATOR COIL
LI-12	T1	455 KC TAPPED PRIMARY-IF COIL
SPK-22-C	S	SPST SWITCH(PART OF VOLUME CONTROL)
	T2	OUTPUT TRANSFORMER P.M. SPEAKER
	VC	VOICE COIL WINDING SPEAKER
	5	SPEAKER

* PARTS MARKED WITH AN ASTERISK ARE PART OF PC-150 SHOWN BELOW

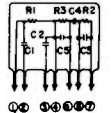

COMPONENTS & VALUES OF PC-150

PART NO	SYMBOL	DESCRIPTION
C1-2000	MMF	
C2-220	MMF	
C3-220	MMF	
C4-5000	MMF	
R1-6.8	MEG OHM	
R2-47	MEG OHM	
R3-47	MEG OHM	

PART NO	SYMBOL	DESCRIPTION
3-M-13	M	10 V. MOTOR-3 SPEED
PU-34	F	PICKUP UP FROM BSA-TC-18-M CARTRIDGE
WR-47	R-14	280 OHM-10 W. 5% WIREWOUND
SR-5	SR	25 MIL. RECTIFIER

I.F. 455 KC.

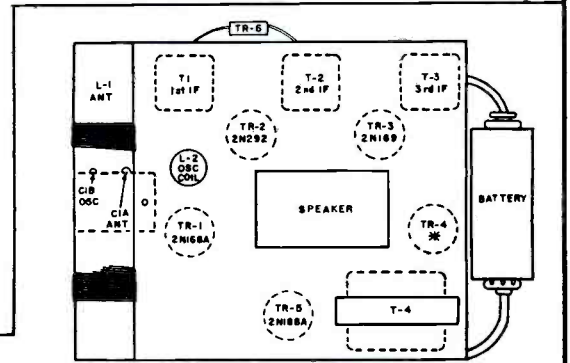

NOTE: REPLACE TRANSISTORS ONLY WITH TYPE FOUND IN RECEIVER
* TRANSISTOR PART NUMBER NO. 5C-12 OR GEN. ELEC. 2N107

MODELS-TR-280-A, 281-A, 282-A, 283-A

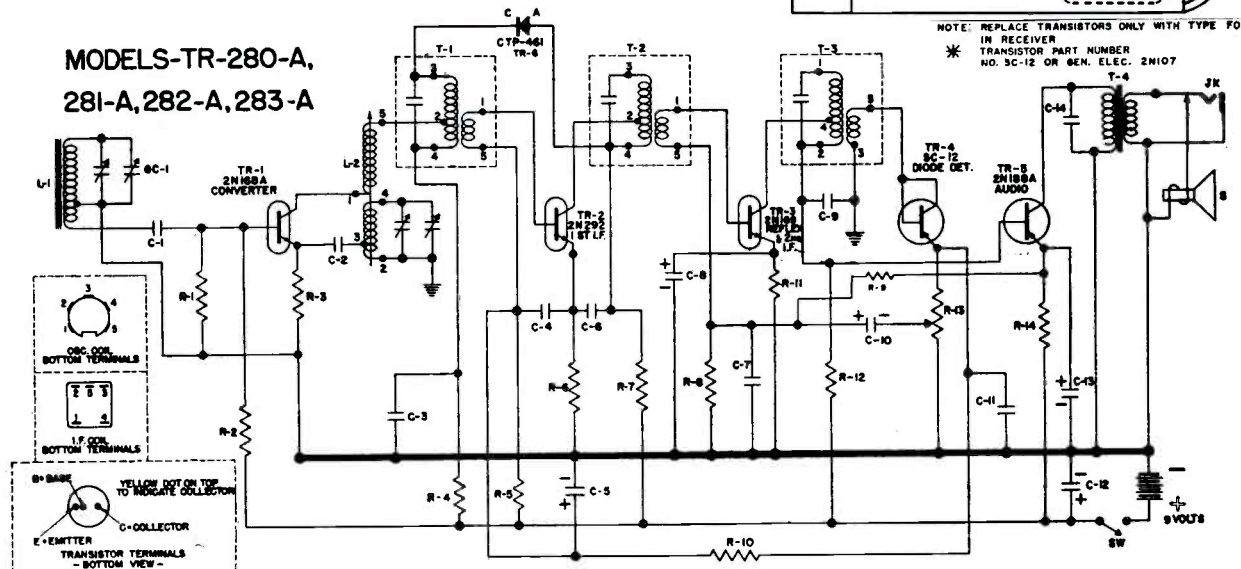

PART NO	SYMBOL	DESCRIPTION	PART NO	SYMBOL	DESCRIPTION	PART NO	SYMBOL	DESCRIPTION
CG-65	C-1	.02 MFD. CERAMIC DISC	IR-64	R-1	10K OHMS 1/2W 10% CARBON RESISTOR	LI-32	T-1	1ST STAGE I.F. TRANSFORMER
CG-35	C-2	.01 MFD. "	IR-158	R-2	33K "	LI-23	T-2	2ND "
CG-44	C-3	.01 MFD. "	IR-29	R-3	1500 "	LI-23	T-3	3RD "
CG-44	C-4	.01 MFD. "	IR-199	R-4	470 "	AT-33	TR-1	OUTPUT TRANSFORMER
CG-44	C-5	.01 MFD. "	IR-5	R-5	82K "	SC-8	TR-2	2N186A CONVERTER TRANSISTOR
CG-44	C-6	.01 MFD. "	IR-5	R-6	82K "	SC-9	TR-3	2N2922 1ST I.F.
CG-44	C-7	.01 MFD. "	IR-109	R-7	330 "	SC-10	TR-4	2N109 2ND I.F. REFLEX
CG-44	C-8	.01 MFD. "	IR-156	R-8	4700 "	SC-12	TR-5	2N186A 2ND I.F. REFLEX
CG-44	C-9	.01 MFD. "	IR-156	R-9	4700 "	SC-11	TR-6	2N186A AUDIO OUTPUT TRANSISTOR
CG-44	C-10	.01 MFD. "	IR-121	R-10	39K "	SC-7	TR-6	GTP-441 GLASS-GERMANIUM DIODE
CG-44	C-11	.01 MFD. "	IR-108	R-11	3300 "	SW	SW	SWITCH ON VOLUME CONTROL
CG-44	C-12	.01 MFD. "	IR-199	R-12	470 "	SPK-52	SPK	P.M. SPEAKER
CG-44	C-13	.01 MFD. "	IR-29	R-13	300 "	LL-48	L-1	ANT. ASSEMBLY
CG-44	C-14	.01 MFD. "	IR-404	R-14	100 OHM 1/2W 10% CARBON RESISTOR	LI-48	L-2	OSCILATOR COIL
						CG-1	G-1	GANG CONDENSER SECTION 2ND

TRAVLER MODEL 90-105

FOR LOCAL FM STATIONS THIRD WIRE IN LINE CORD.

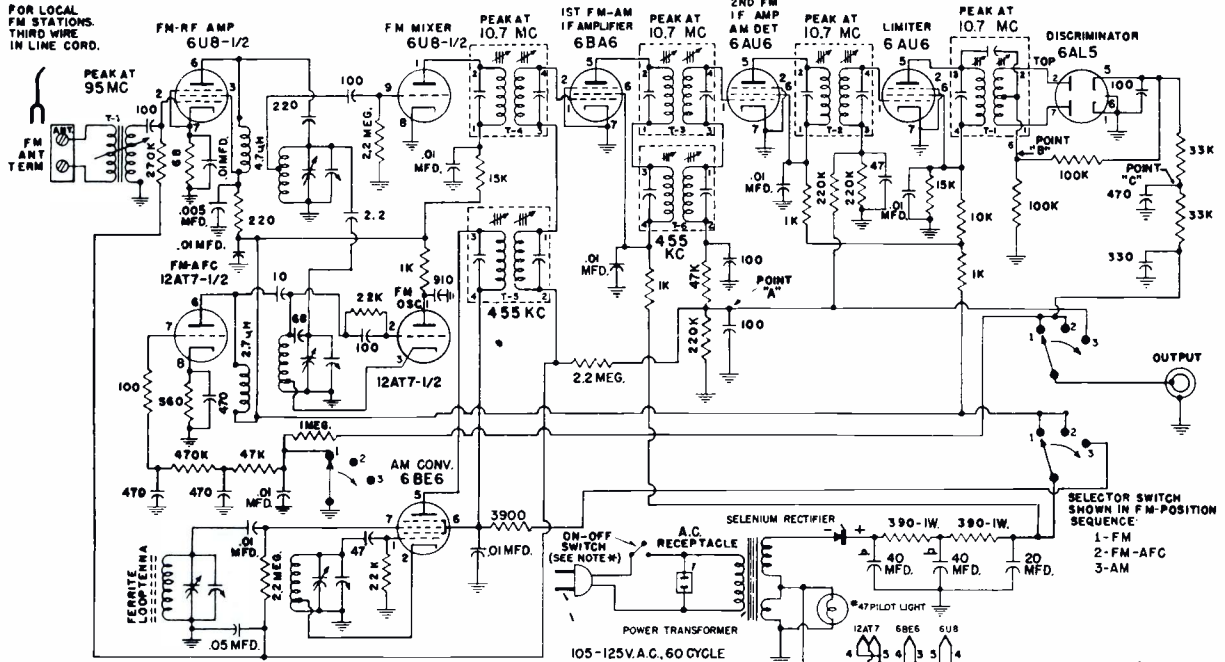

NOTE: ALL CAPACITANCE VALUES IN MMF. EXCEPT WHERE OTHERWISE SPECIFIED. ALL RESISTANCE VALUES IN OHMS EXCEPT WHERE OTHERWISE SPECIFIED.

* NOTE: SWITCH ON SELECTOR SHAFT IN TA-100 TUNER ONLY.

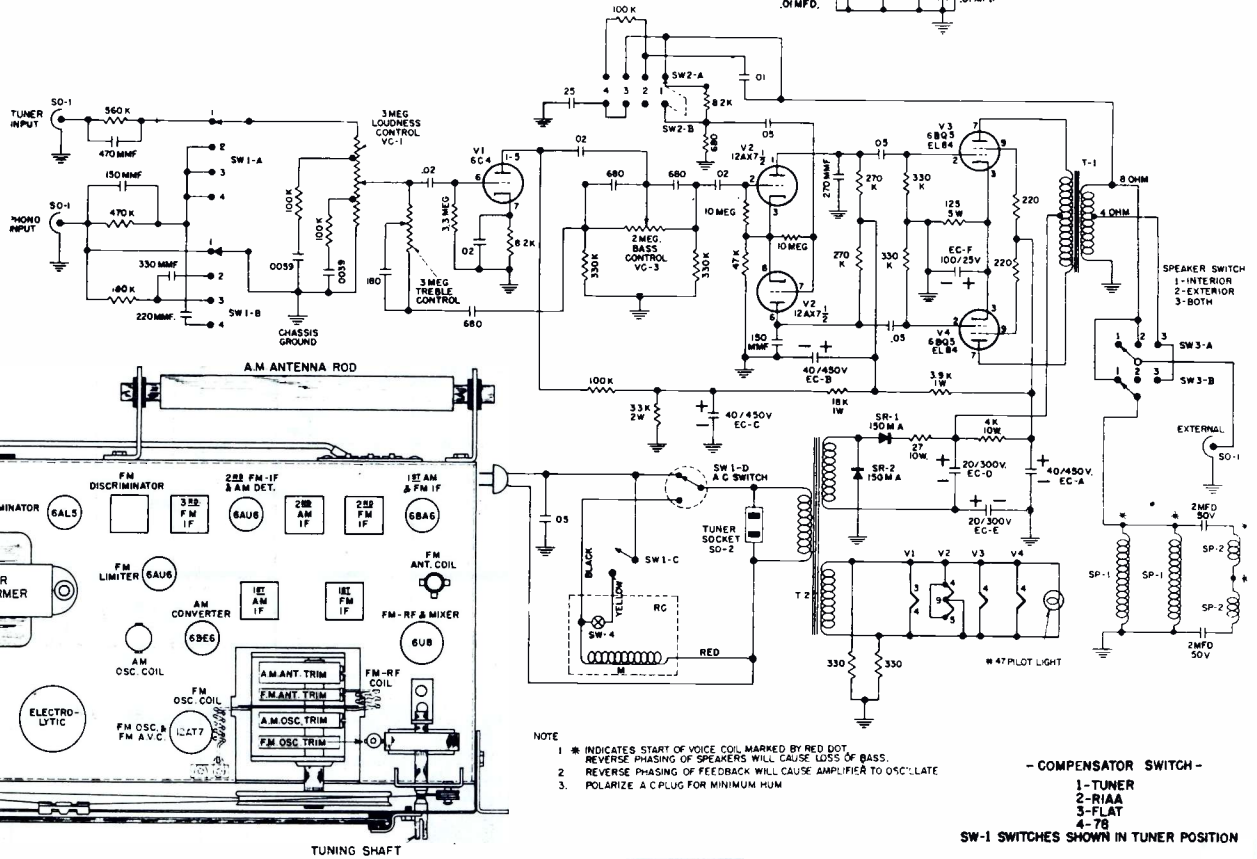

NOTE: 1 * INDICATES START OF VOICE COIL MARKED BY RED DOT. REVERSE PHASING OF SPEAKERS WILL CAUSE LOSS OF BASS. 2 REVERSE PHASING OF FEEDBACK WILL CAUSE AMPLIFIER TO OSCILLATE. 3. POLARIZE A C PLUG FOR MINIMUM HUM.

- COMPENSATOR SWITCH -

- 1-TUNER
- 2-RIAA
- 3-FLAT
- 4-78

SW-1 SWITCHES SHOWN IN TUNER POSITION

VOLUME R-19, MOST-OFTEN-NEEDED 1959 RADIO SERVICING INFORMATION

WEBCOR Models 1953, 1991, using AM Tuner 73X014-1, Amplifiers 14X278-1, -2

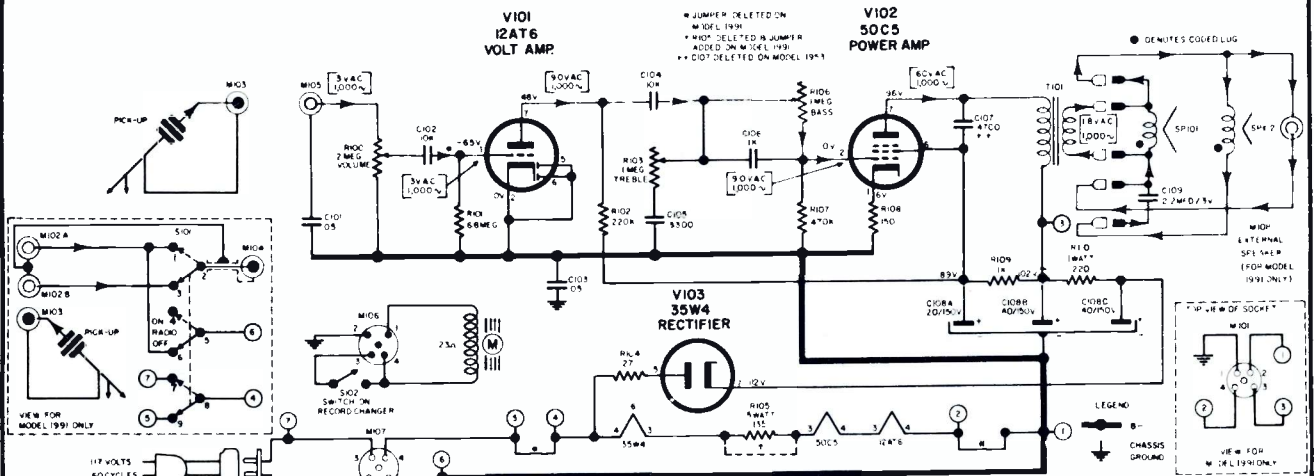

Circuit Diagram of 14X278-1 (1953) and 14X278-2 (1991) Amplifiers, Issue 1; and 73X014-1 (1991) AM Tuner, Issue 1.

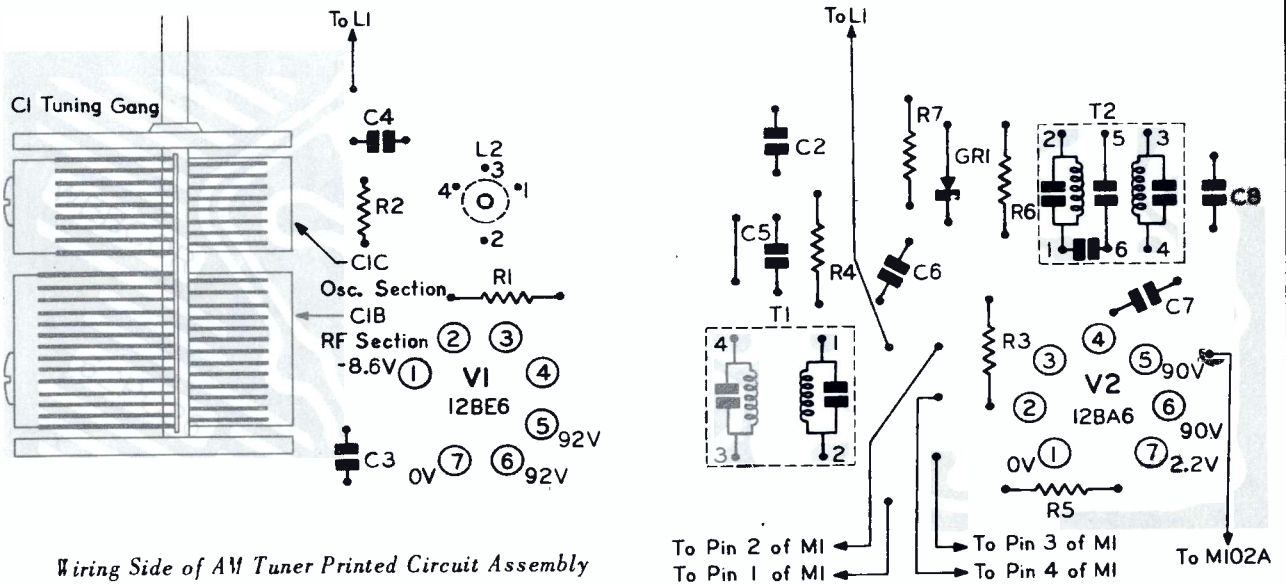
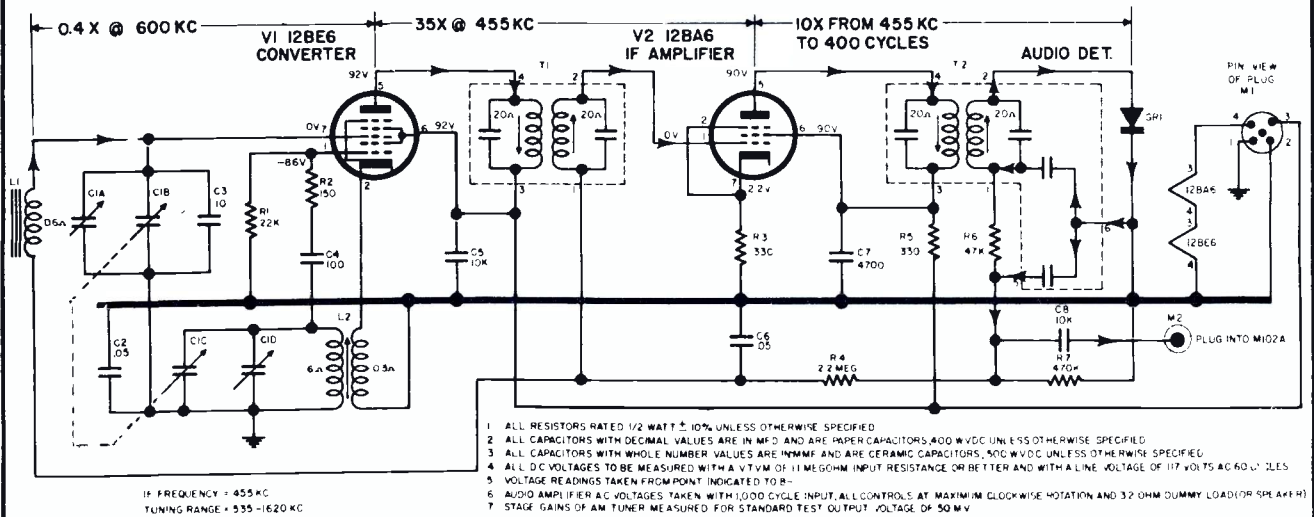

VOLUME R-19, MOST-OFTEN-NEEDED 1959 RADIO SERVICING INFORMATION

WEBCOR Model 1954-1, using Amplifier 14X280-1

NEEDLE AND CARTRIDGE REPLACEMENT

If distortion or harshness of treble tones is encountered, it is probable that the cartridge and needle assembly (Webcor Part No. 21P586) requires replacement. To replace the cartridge and needle assembly, grasp the cartridge with thumb and forefinger and gently pull cartridge free.

CONNECTION JACKS

Stereo Output Jack: The Stereo Output Jack on the rear of the Holiday Coronet Cabinet makes it possible to connect a second sound system (amplifier and speakers) for Stereofonic reproduction. Webcor Model 4905 Companion Stereofonic Sound System is designed for use with the Holiday Coronet. When using the 4905 Sound System, connection to the Holiday Coronet is made with Stereo Connecting Cord No. 2933.

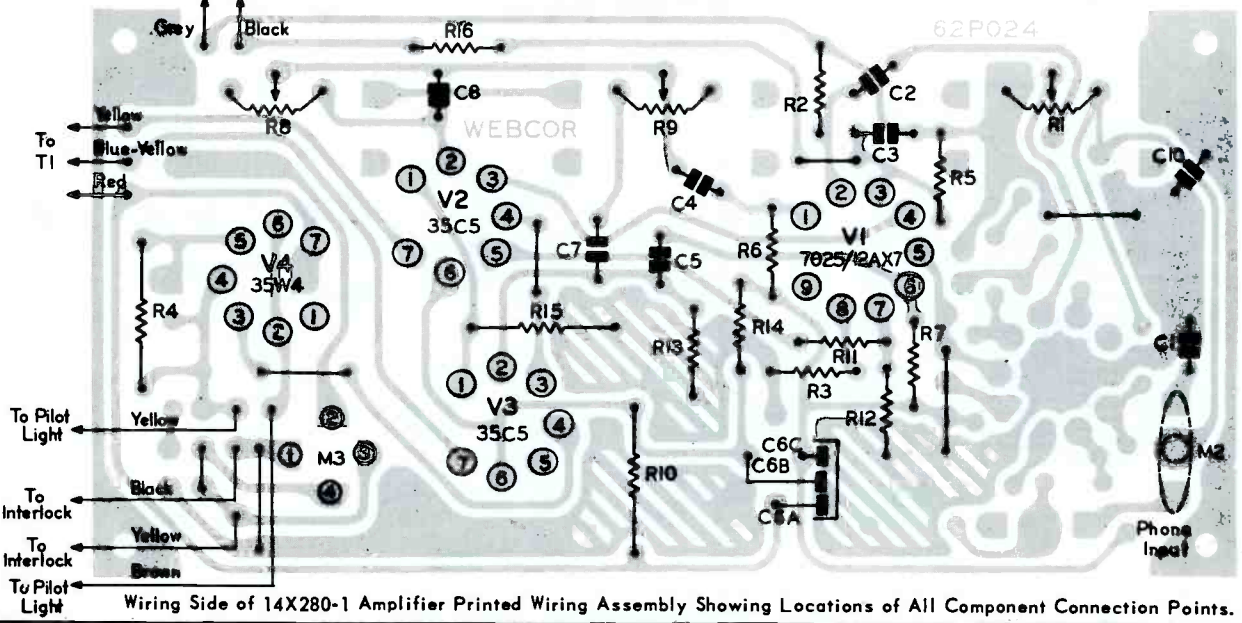
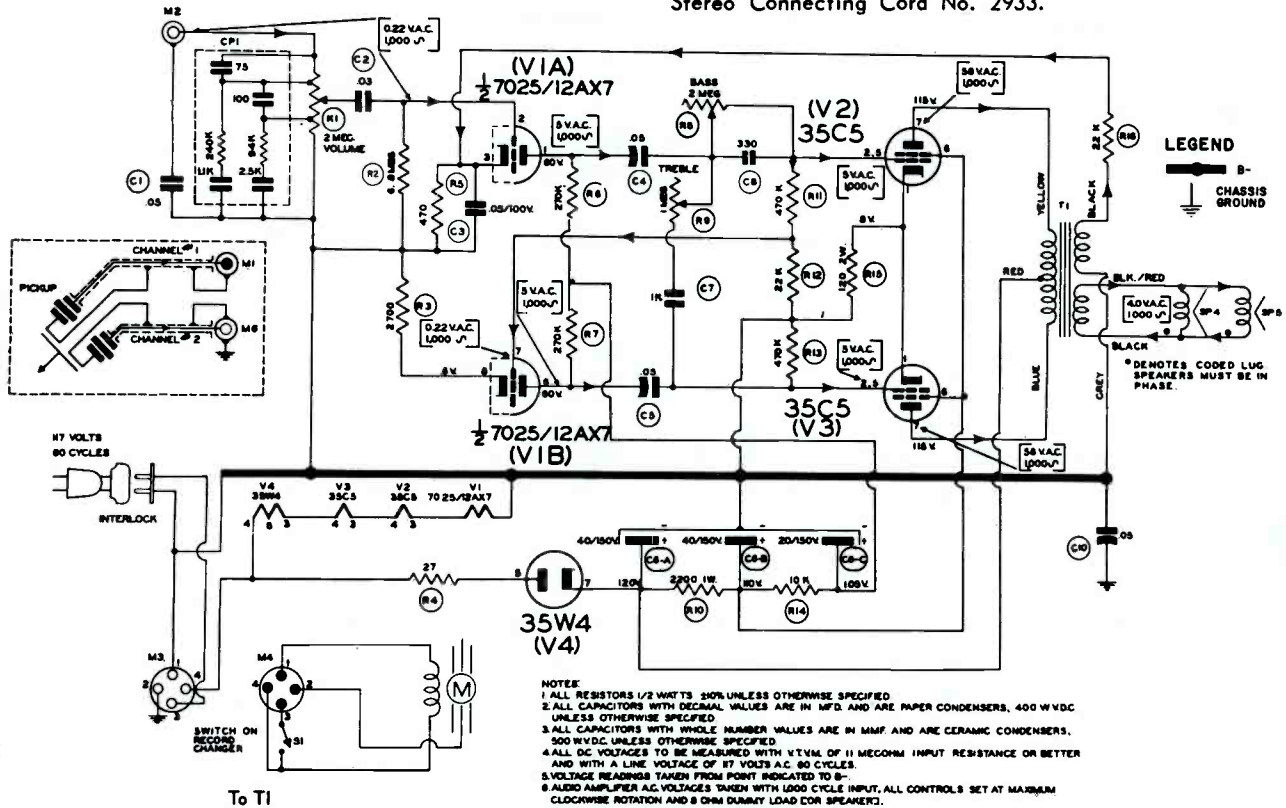

VOLUME R-19, MOST-OFTEN-NEEDED 1959 RADIO SERVICING INFORMATION

WEBCOR Model 1956, using Amplifier 14X307

Model 1956 is a Stereo-Fidelity Fonograf that contains a 5", 3.2 ohm speaker for the right channel (Ch. 1) and a 5", 3.2 ohm speaker for the left channel (Ch. 2). Each speaker is mounted in the case side by side at a 7 degree angle for better separation of the right and left channels. In addition an External

Speaker Output Jack is incorporated. This jack permits connecting a 3.2 ohm External Speaker System to the fonograf if additional separation of the 2 channels is desired. When an External Speaker System is plugged into the External Speaker Output Jack, the left channel speaker in the fonograf is cut out.

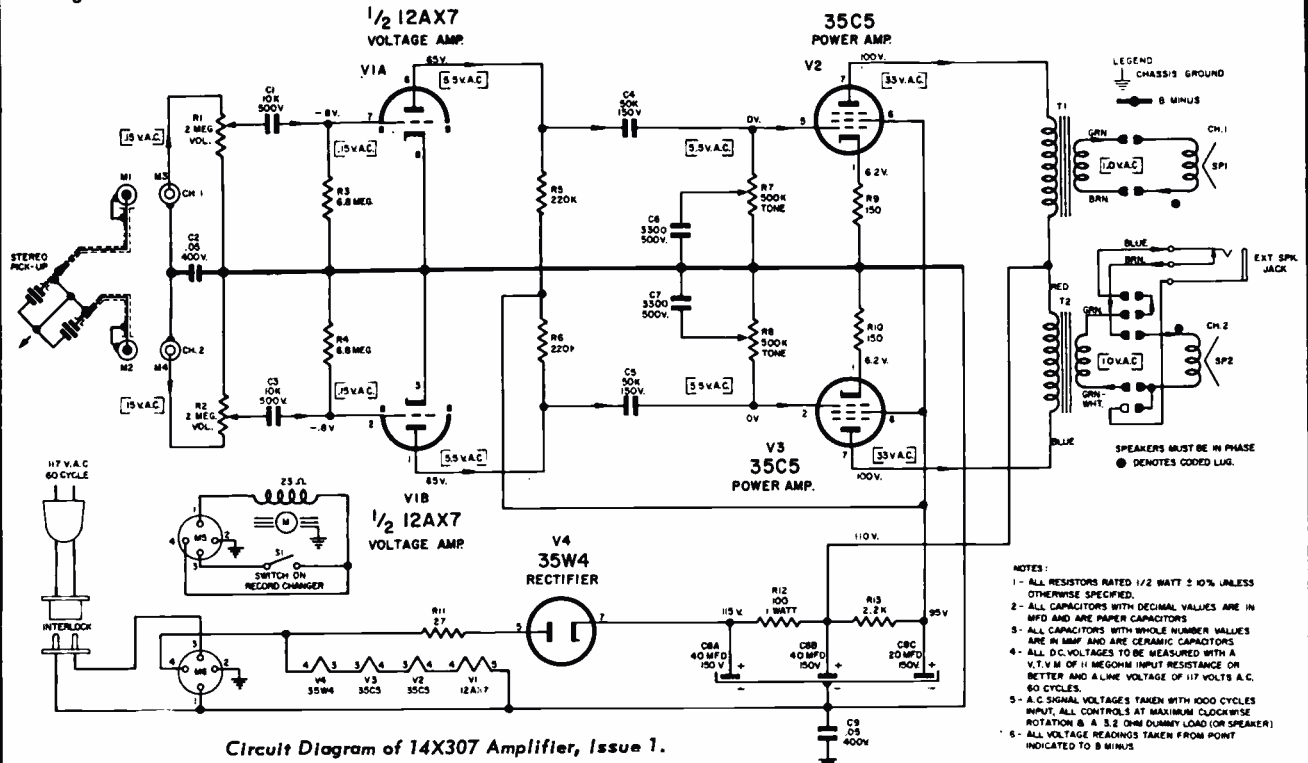

Circuit Diagram of 14X307 Amplifier, Issue 1.

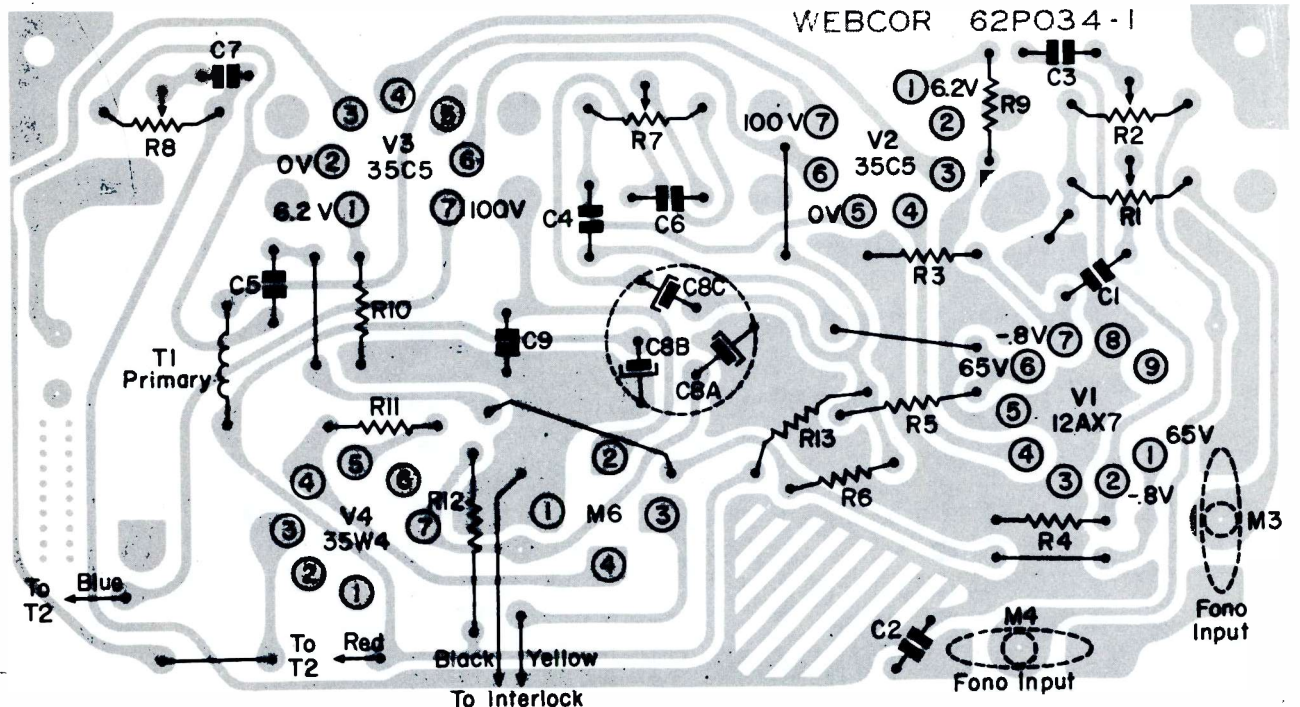

Wiring Side of 14X307 Amplifier Printed Circuit Assembly showing location of Component Connection Points.

WEBCOR Model 1963, using Amplifier 14X280-2

Stereo Output Jack: The Stereo Output Jack on the rear of the Holiday Imperial Cabinet makes it possible to connect a second sound system (amplifier and speakers) for Stereofonic reproduction. Webcor Model 4905 Companion Stereofonic Sound System is designed for use with the Holiday Imperial. When using the 4905 Sound System, connection to the Holiday Imperial is made with Stereo Connecting Cord No. 2933.

When replacing cartridge housing and bracket assembly (Webcor Part No. 21P587), connect leads from pick-up cord as follows:

1. Connect red lead to silver terminal.
2. Connect shield to terminal adjacent to silver terminal.
3. Connect white lead to gold terminal.
4. Connect black lead to terminal adjacent to gold terminal.

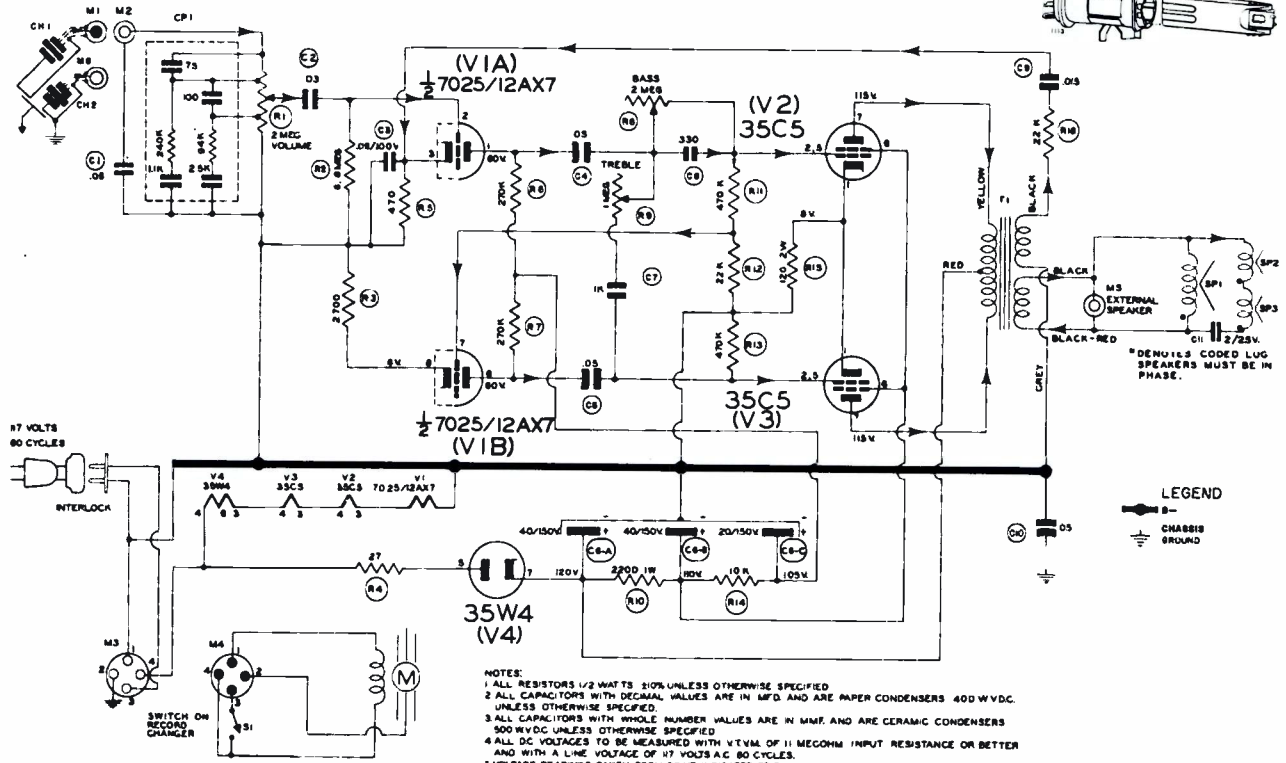
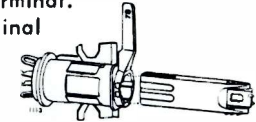

NOTES:
 1. ALL RESISTORS 1/2 WATTS 20% UNLESS OTHERWISE SPECIFIED
 2. ALL CAPACITORS WITH DECIMAL VALUES ARE IN MFD. AND ARE PAPER CONDENSERS 400 WVDC UNLESS OTHERWISE SPECIFIED.
 3. ALL CAPACITORS WITH WHOLE NUMBER VALUES ARE IN MMF. AND ARE CERAMIC CONDENSERS 500 WVDC UNLESS OTHERWISE SPECIFIED
 4. ALL DC VOLTAGES TO BE MEASURED WITH V.T.M. OF 11 MEGOHM INPUT RESISTANCE OR BETTER AND WITH A LINE VOLTAGE OF 117 VOLTS A.C. 60 CYCLES.
 5. VOLTAGE READINGS TAKEN FROM POINT INDICATED TO B.

Circuit Diagram of 14X280-2 Amplifier, Issue 1.

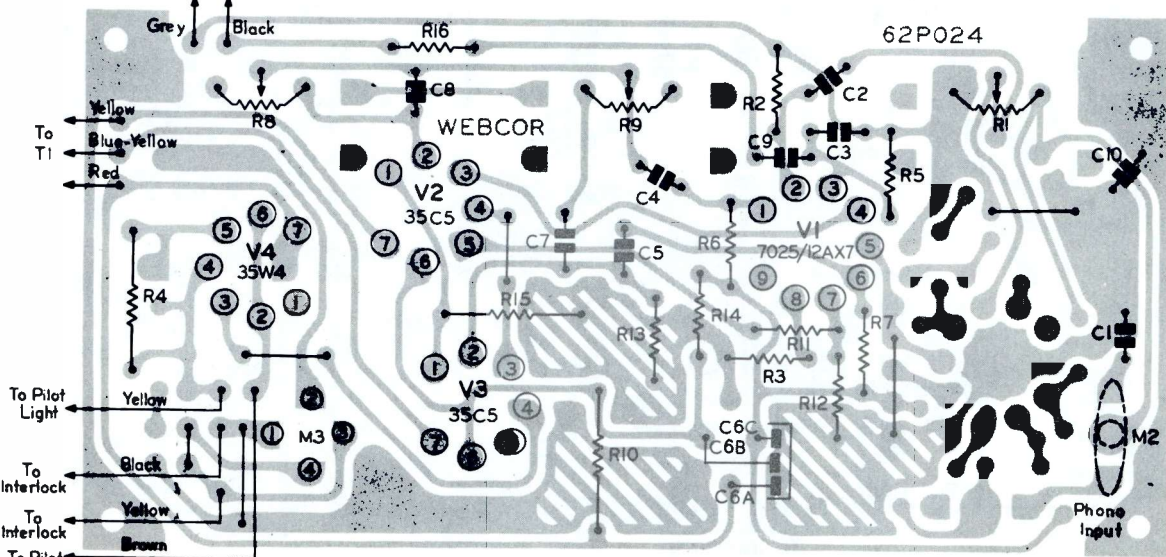

Wiring Side of Amplifier Printed Wiring Assembly Showing Locations of All Component Connection Points.

WESTERN AUTO SUPPLY CO.

MODELS D2832A & D2834A D2832B & D2834B

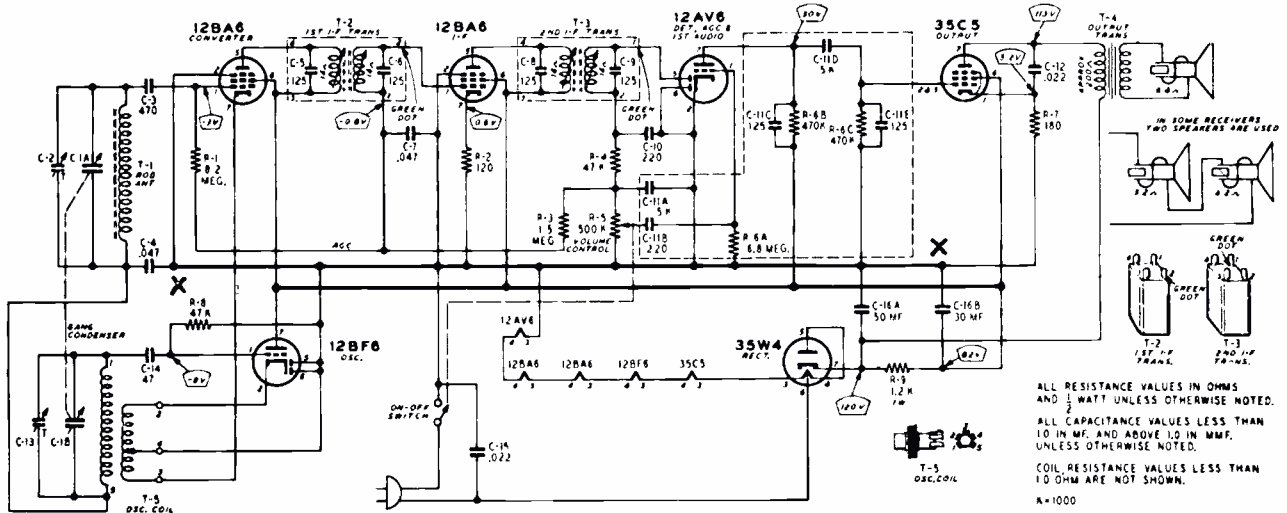

TUBE SOCKET VOLTAGES

Socket voltages are shown on the schematic diagram at the tube socket terminals. All voltages are between the socket terminal and "X" point. Voltages were taken with a vacuum tube voltmeter. Conditions of measurement are:

- Line voltage 117 Volts AC
- Signal Input None
- A Variation of $\pm 10\%$ is usually permissible.

SPECIFICATIONS

- 6 Tube Superheterodyne, including Rectifier Tube.
- Tuning Frequency Range..... 540 to 1600 KC
- Power Consumption..... 35 watts (At 117 volts AC)
- Power Output 1.3 watt maximum, 0.8 watt (10% distortion)
- Intermediate Frequency..... 455 KC
- Sensitivity..... .80 Microvolts Per Meter Average
- Selectivity..... 50 KC Wide at 1000 Times Signal
- Speaker..... 4" PM Dynamic

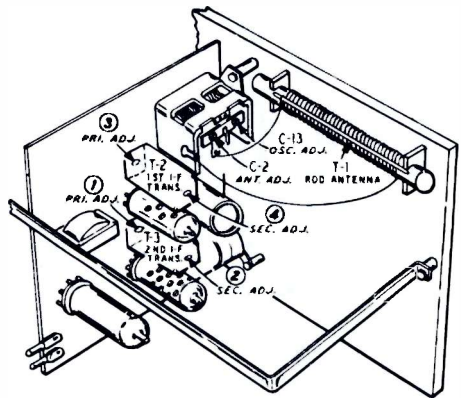

ALIGNMENT PROCEDURE

The following equipment is required for aligning: Signal Generator which will provide an accurately calibrated signal at the test frequencies as listed.
Output Indicating Meter: Non-Metallic Screwdriver.

Dummy Antennas—.1 mf., 50 mmf.
Volume Control—Maximum All Adjustments.
Allow Chassis and Signal Generator to "Heat Up" for several Minutes.

FREQUENCY SETTING	SIGNAL GENERATOR ANTENNA CONNECTION	GROUND CONNECTION	DUMMY ANTENNA	GANG CONDENSER SETTING	ADJUST TUNING SLUGS (I.F.) AND TRIMMERS TO MAXIMUM
455 KC	Control Grid 12BA6-I.F. Prong No. 1	"X" Point	.1 mf.	Turn Rotor to full open	2nd I.F. Pri. (1) & Sec. (2)
455 KC	Control Grid 12BA6 Mixer Prong No. 1	"X" Point	.1 mf.	Turn Rotor to full open	1st I.F. Pri. (3) & Sec. (4) 2nd I.F. Pri. (1) & Sec. (2)
1620 KC	Control Grid 12BA6 Mixer Prong No. 1	"X" Point	.1 mf.	Turn Rotor to full open	Oscillator (C-13)
1400 KC	Std. Loop Connected to Signal Generator			Tune Receiver to 1400 KC.	Antenna (C-2) Trimmer

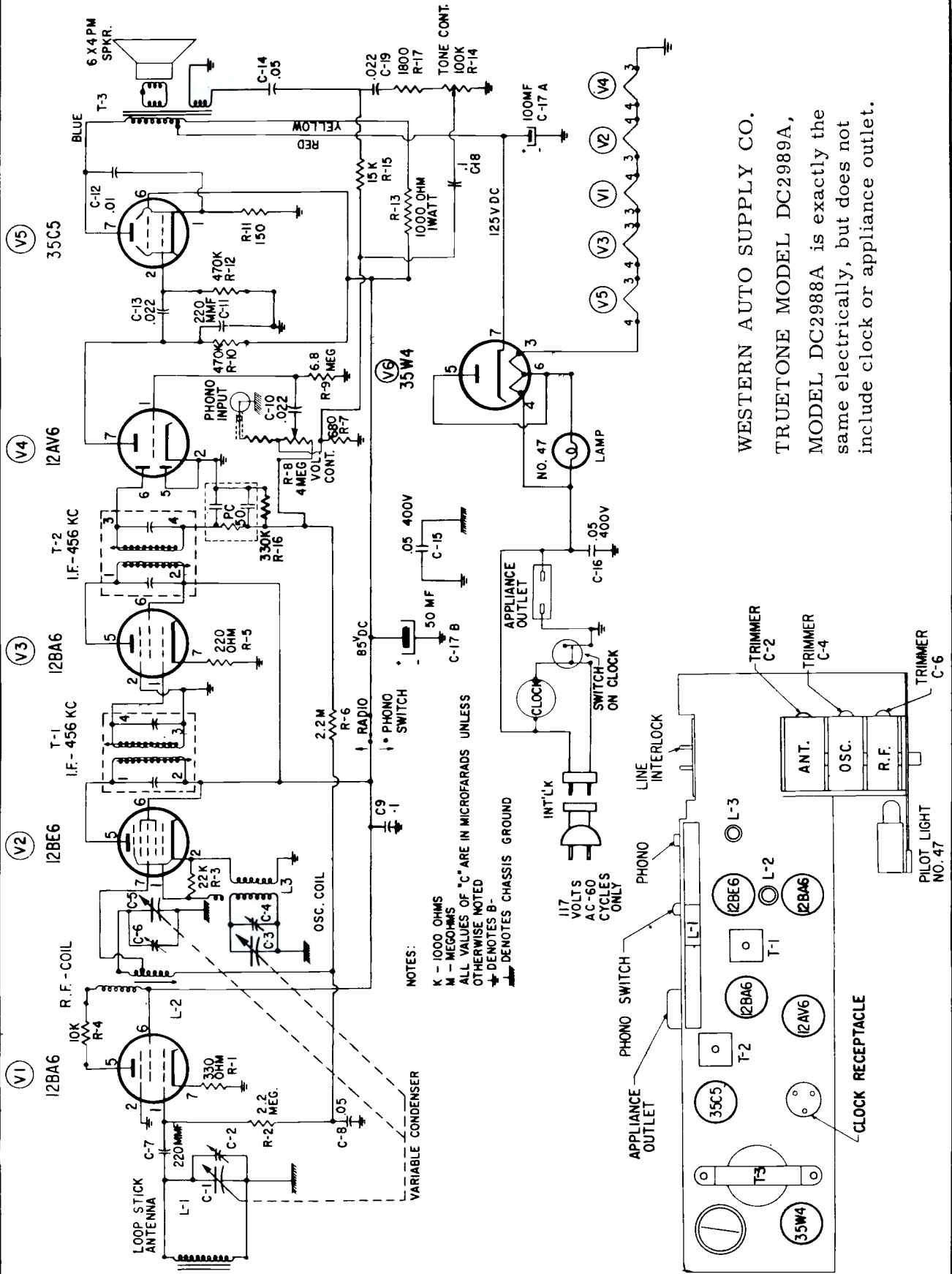

WESTERN AUTO SUPPLY CO.
 TRUETONE MODEL DC2989A,
 MODEL DC2988A is exactly the
 same electrically, but does not
 include clock or appliance outlet.

Westinghouse

MODELS H-629T4A, H-630T4A, H-631T4A,
CHASSIS V-2239-7

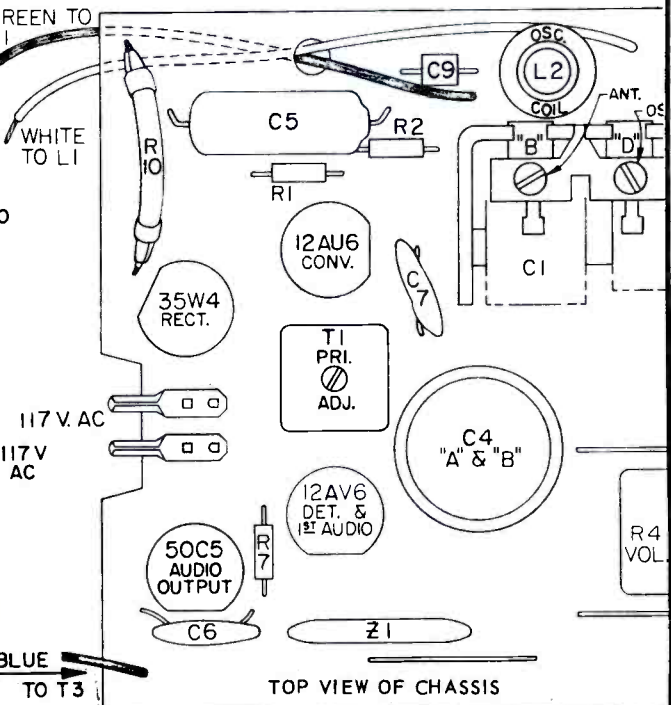
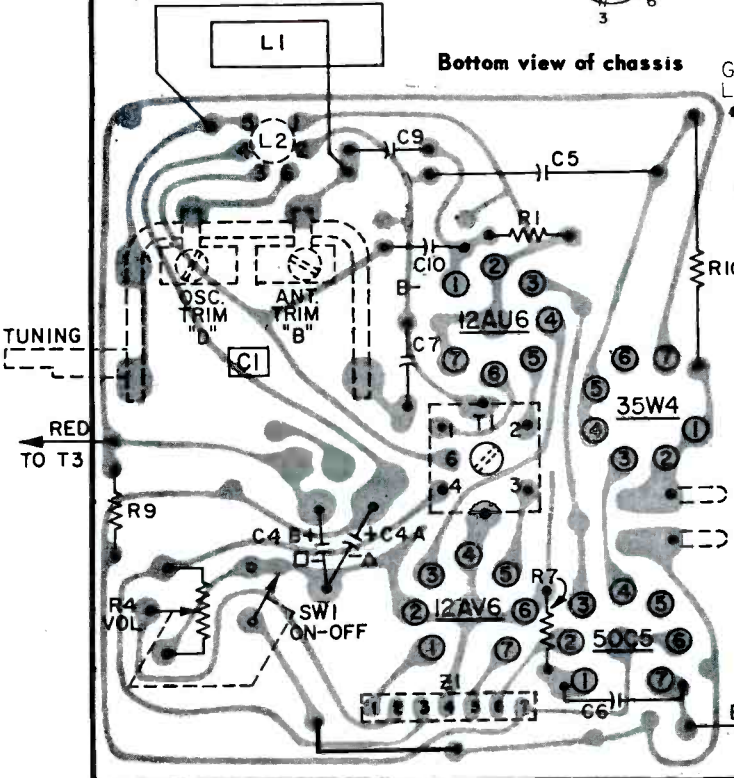
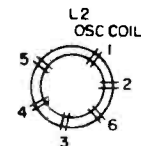
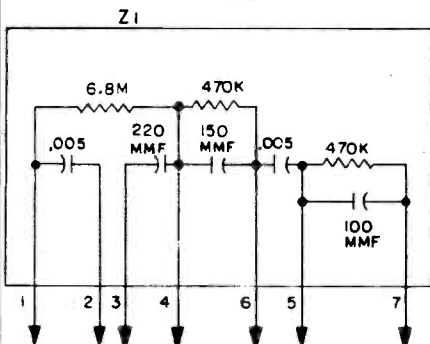
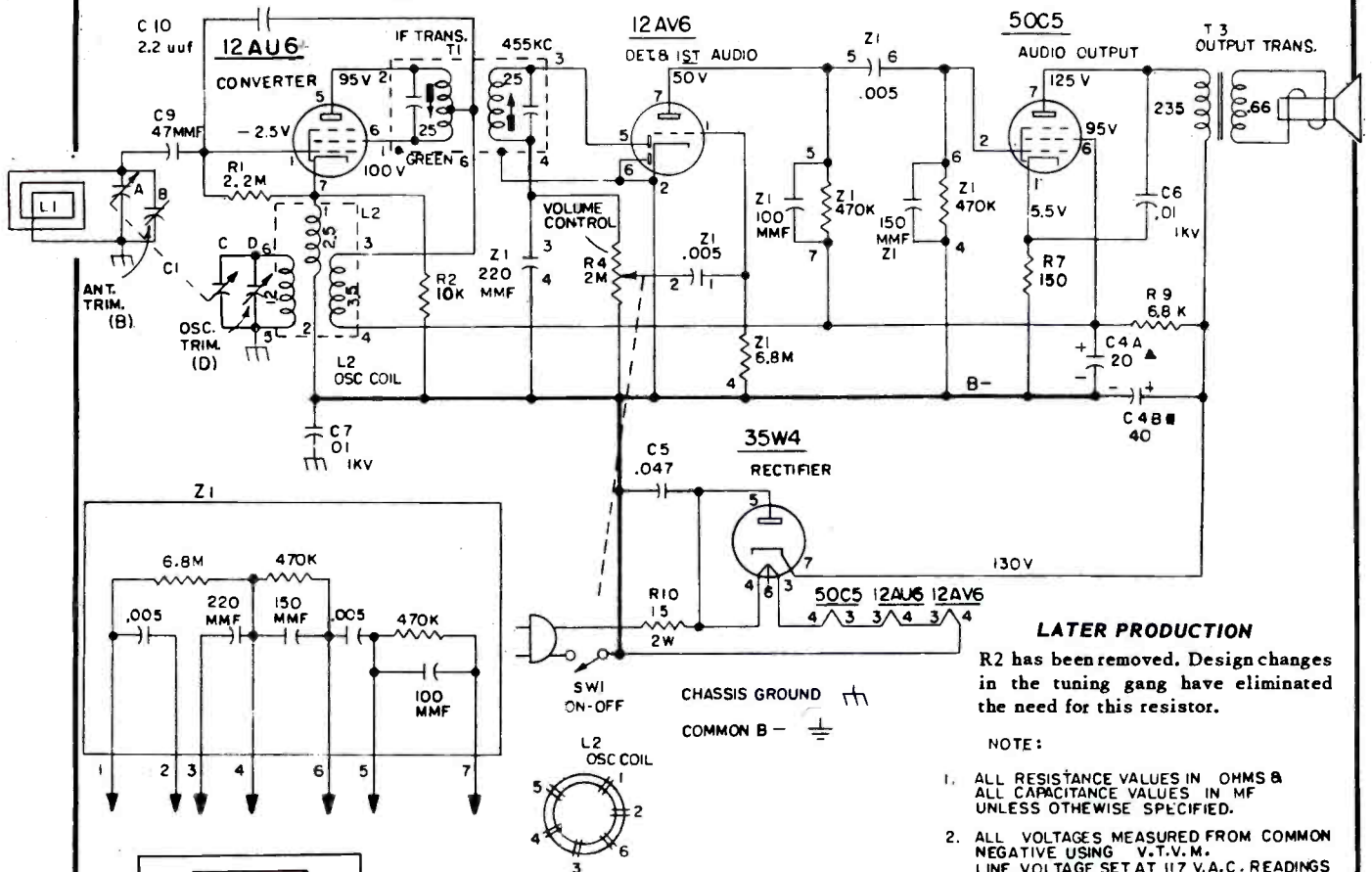

OFTEN-NEEDED 1959 RADIO SERVICING

WESTINGHOUSE Chassis V-2239-6,
Models H-677T4, H-678T4, H-679T4

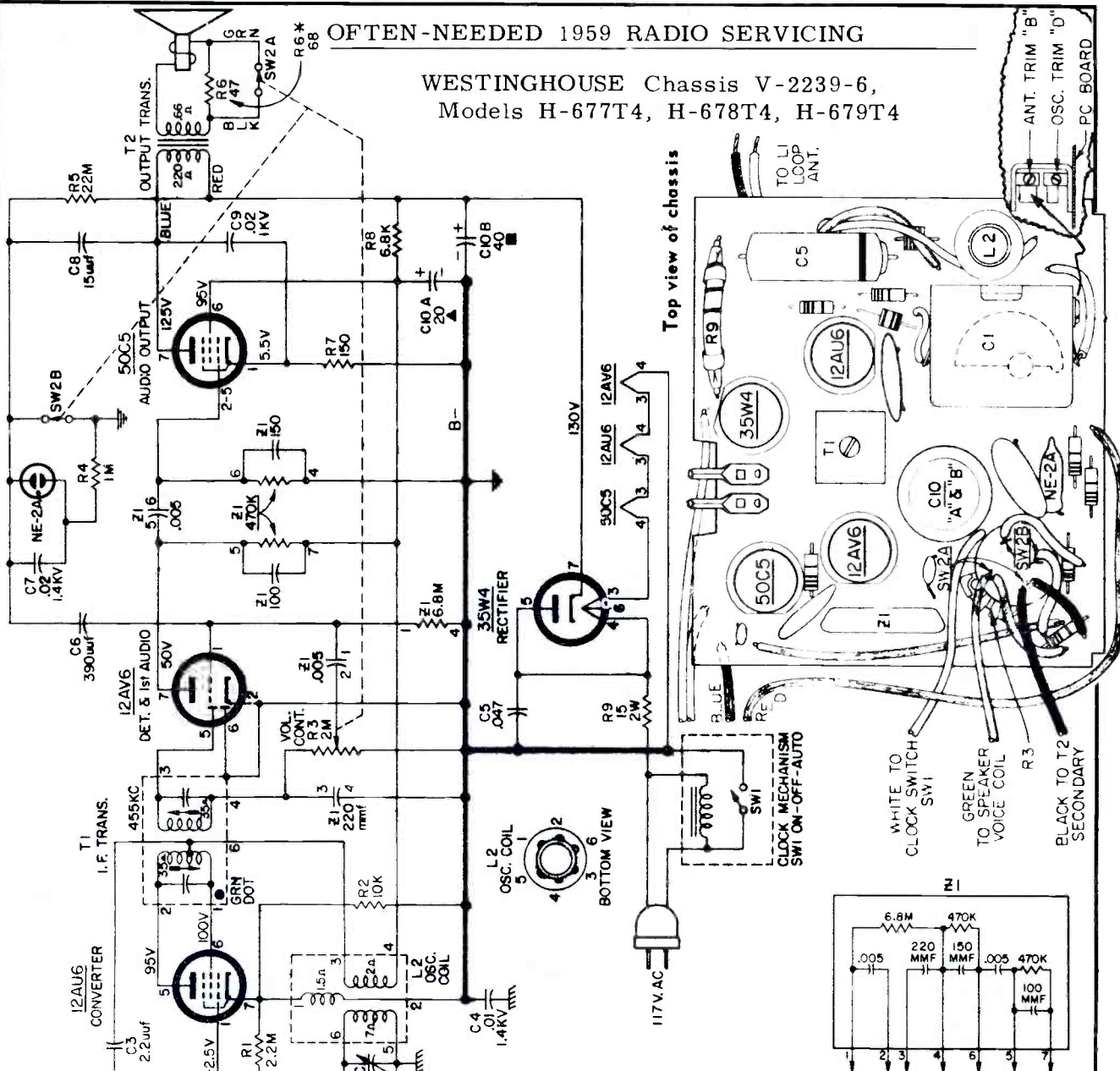

- NOTE:**
1. ALL RESISTANCE VALUES IN OHMS & ALL CAPACITANCE VALUES IN MFD
 2. ALL VOLTAGES MEASURED FROM COMMON NEGATIVE USING V.T.V.M. READINGS SHOULD BE AS SHOWN $\pm 20\%$. VOLUME CONTROL SET AT MAXIMUM.
 3. CHASSIS GROUND \blacktriangle COMMON B- \blacktriangledown
 4. SW2 IS SHOWN IN RADIO POSITION.
 - * 5. LATER PRODUCTION.

ALIGNMENT

While making the following adjustments, keep the volume control set for maximum output and the signal generator output attenuated to weakest usable signal level.

Step	Connect Signal Generator to -	Signal Gen. Frequency	Radio Dial	Connect VTVM Across Voice Coil and Adjust for Maximum Output -
1	Stator of ant. tuning capacitor (A) through a 200 mF capacitor.	455 KC 400 Cps. 30% Mod.	Minimum capacity	Top and bottom slugs of T1. *
2	Radiated signal	1625 KC	Minimum capacity	Oscillator trimmer (D)
3	Radiated signal	1400 KC	1400 KC	Antenna trimmer (B)

* It is recommended that a fiber aligning tool that snugly fits the slot in the powdered iron core be used to prevent chipping of the slot.

VOLUME R-19, MOST-OFTEN-NEEDED 1959 RADIO

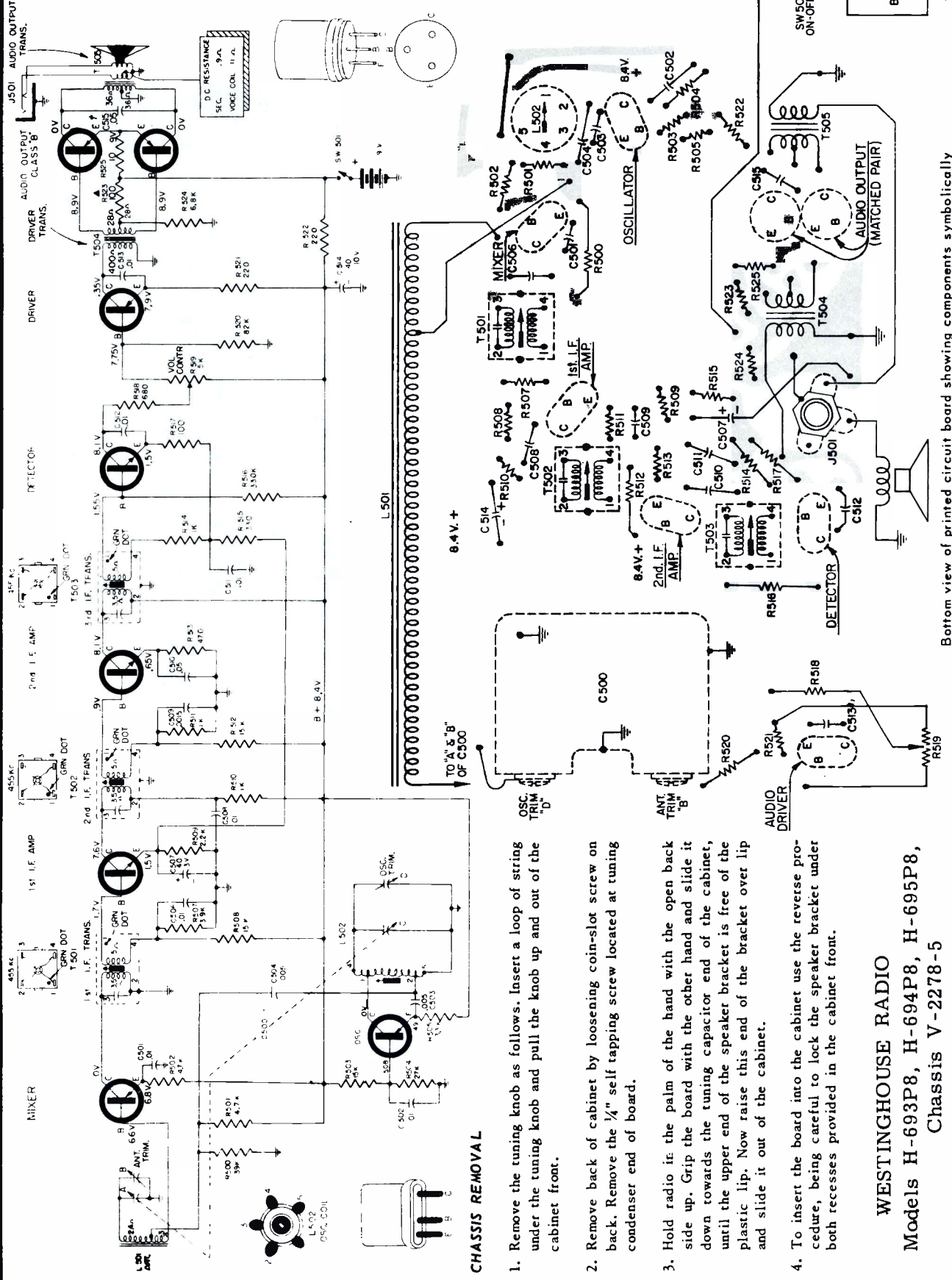

CHASSIS REMOVAL

1. Remove the tuning knob as follows. Insert a loop of string under the tuning knob and pull the knob up and out of the cabinet front.
2. Remove back of cabinet by loosening coin-slot screw on back. Remove the 1/2" self tapping screw located at tuning condenser end of board.
3. Hold radio in the palm of the hand with the open back side up. Grip the board with the other hand and slide it down towards the tuning capacitor end of the cabinet, until the upper end of the speaker capacitor is free of the plastic lip. Now raise this end of the bracket over lip and slide it out of the cabinet.
4. To insert the board into the cabinet use the reverse procedure, being careful to lock the speaker bracket under both recesses provided in the cabinet front.

WESTINGHOUSE RADIO
 Models H-693P8, H-694P8, H-695P8,
 Chassis V-2278-5

Bottom view of printed circuit board showing components symbolically

Westinghouse

Models H-632T5A, H-633T5A,
Chassis V-2390-4

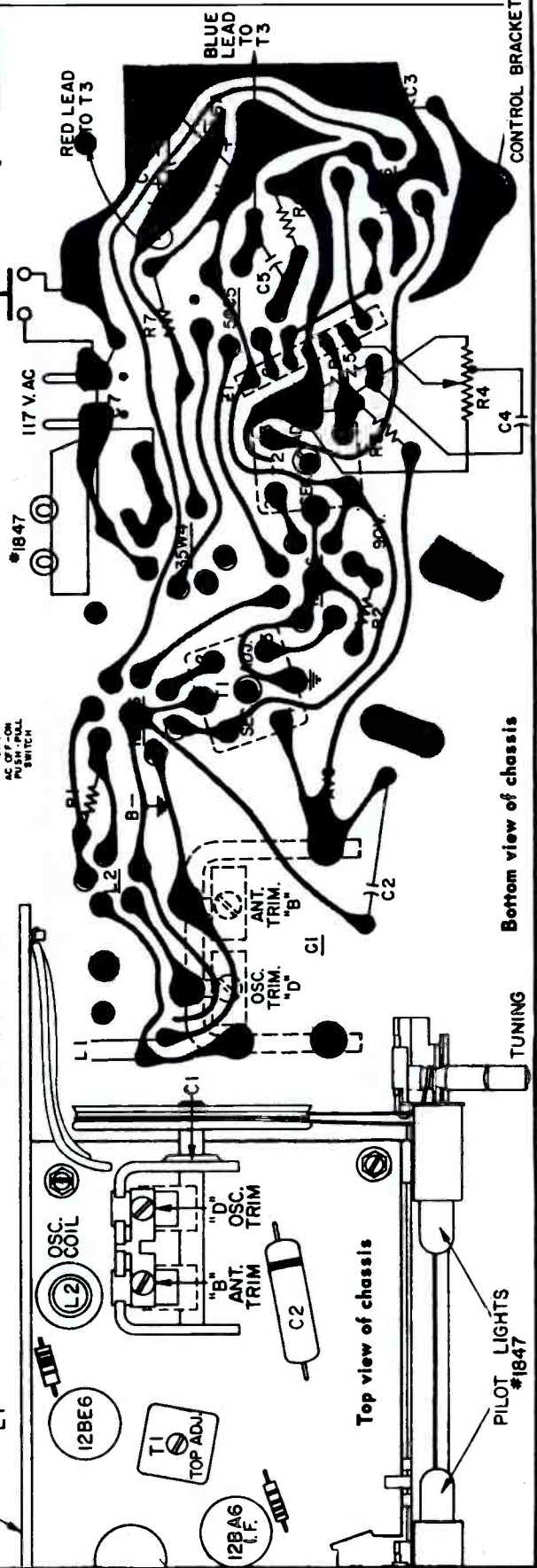
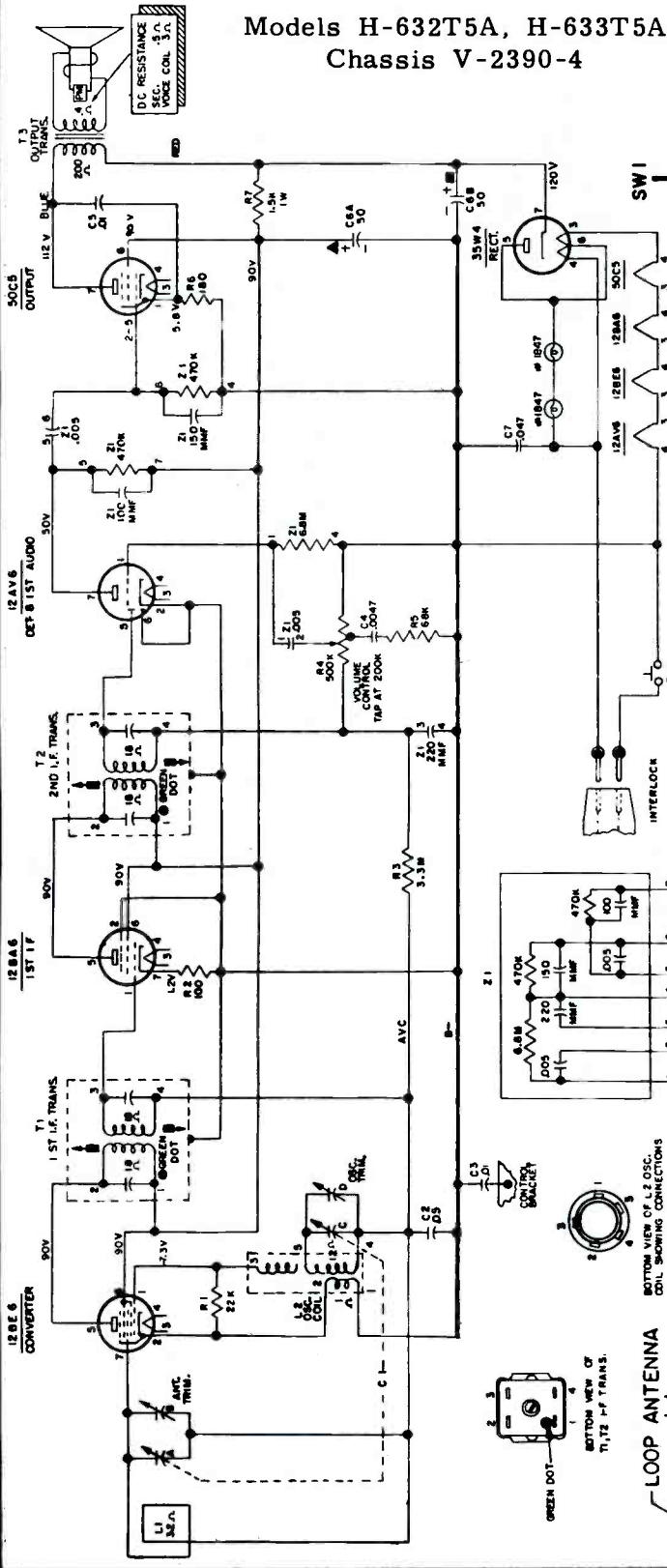

Westinghouse

Models H-649T7A, H-650T7A,
Chassis V-2392-4

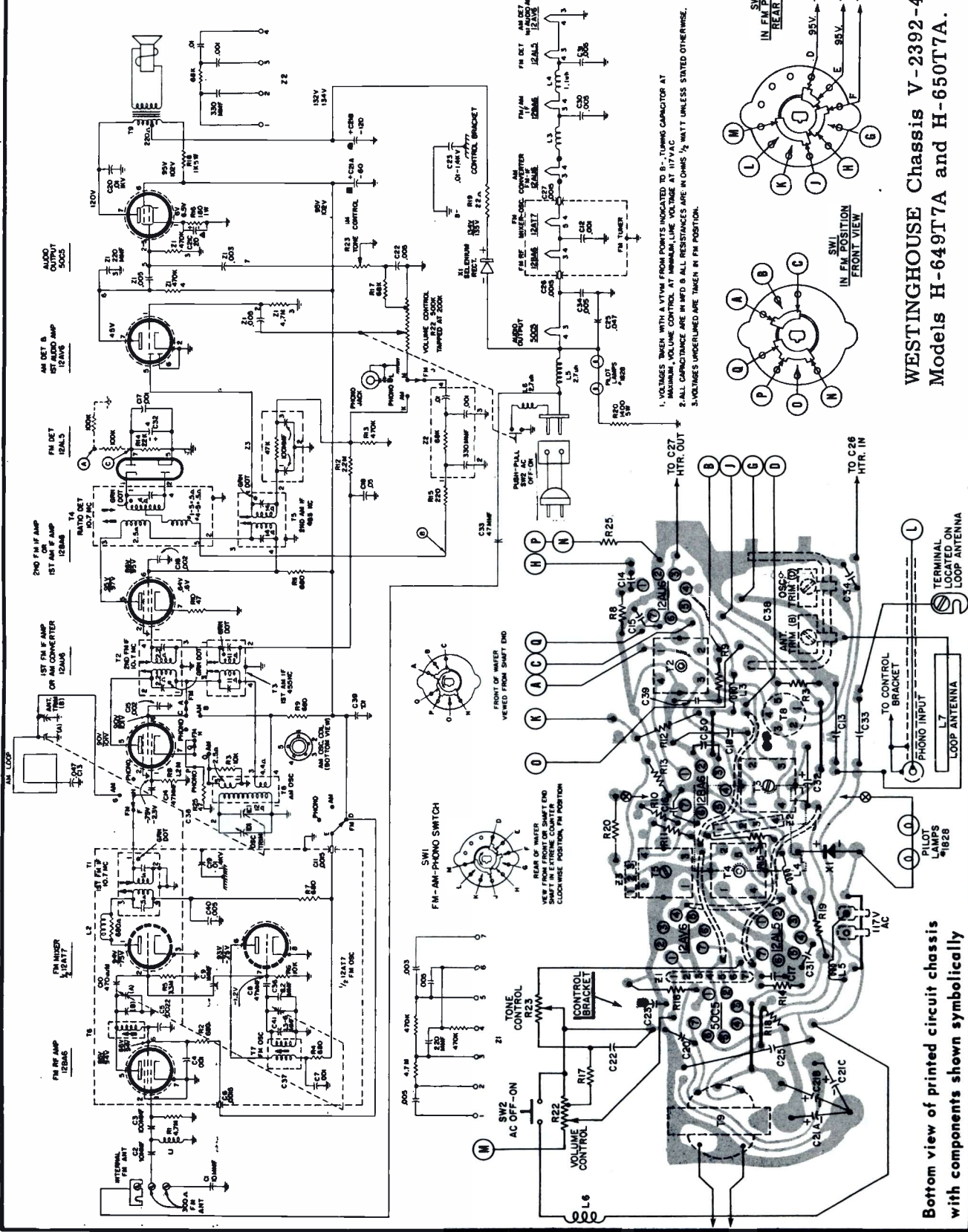

WESTINGHOUSE Chassis V-2392-4,
Models H-649T7A and H-650T7A.

Bottom view of printed circuit chassis
with components shown symbolically

1. VOLTAGES GIVEN WITH A VTVM FROM PORTS INDICATED TO B-, TURNING CAPACITOR AT MINIMUM, VOLUME CONTROL AT MINIMUM, LINE VOLTAGE AT 117V AC.
2. ALL CAPACITANCES ARE IN PFD. ALL RESISTANCES ARE IN OHMS $\frac{1}{2}$ UNLESS SITED OTHERWISE.
3. VOLTAGES UNDERLINED ARE TAKEN IN FM POSITION.

TO SPEAKER VOICE COIL

Westinghouse Chassis V-2393-1

Models H-655P5, H-656P5, H-657P5

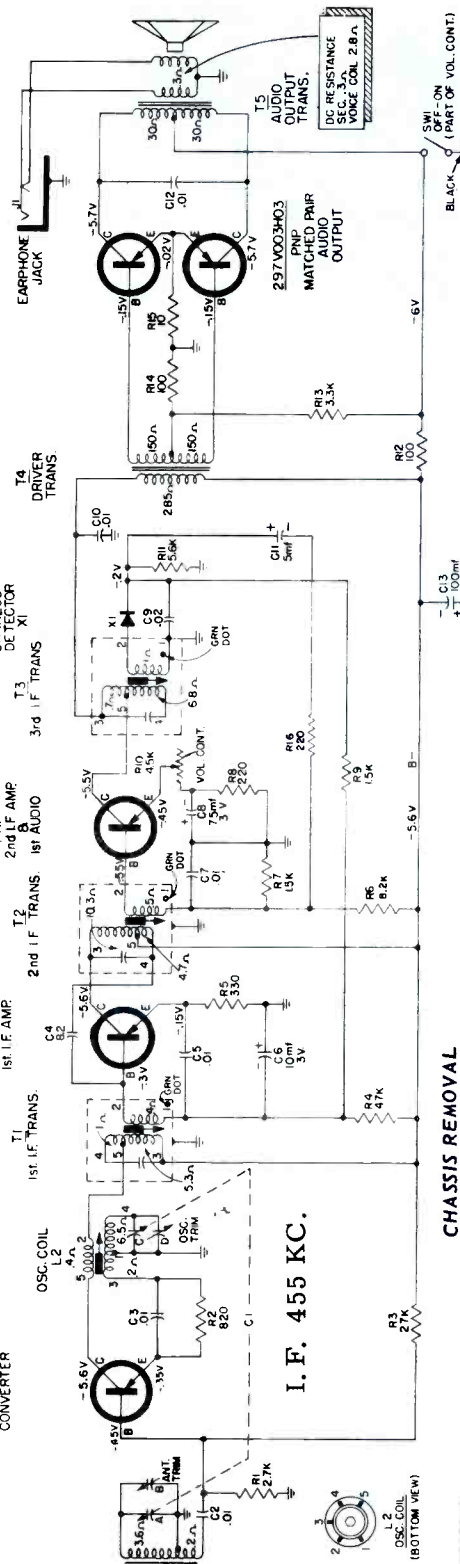

- CHASSIS REMOVAL**
1. Remove the tuning knob as follows. Insert a loop of string under the tuning knob and pull the knob up and out of the cabinet front.
 2. Remove the carrying handle. Grasp the handle on both sides and carefully spread it apart until it clears the holes in the cabinet sides.
 3. Remove the back of the cabinet by loosening the two coin-slot screws on the back.
 4. Remove the two 1" long hex head screws securing the chassis to the cabinet front.
 5. Remove the printed circuit chassis, battery case, speaker spacers, rubber grommet and speaker.
 6. To insert the printed circuit chassis back into the cabinet use the reverse procedure. *The tuning knob and cabinet back screws must be the same or identical to the original dimensions to prevent possible damage to the tuning gang.*

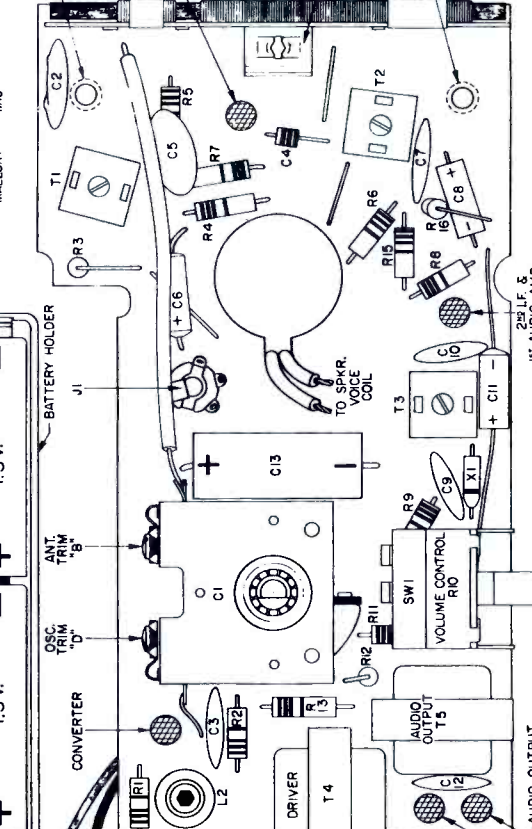
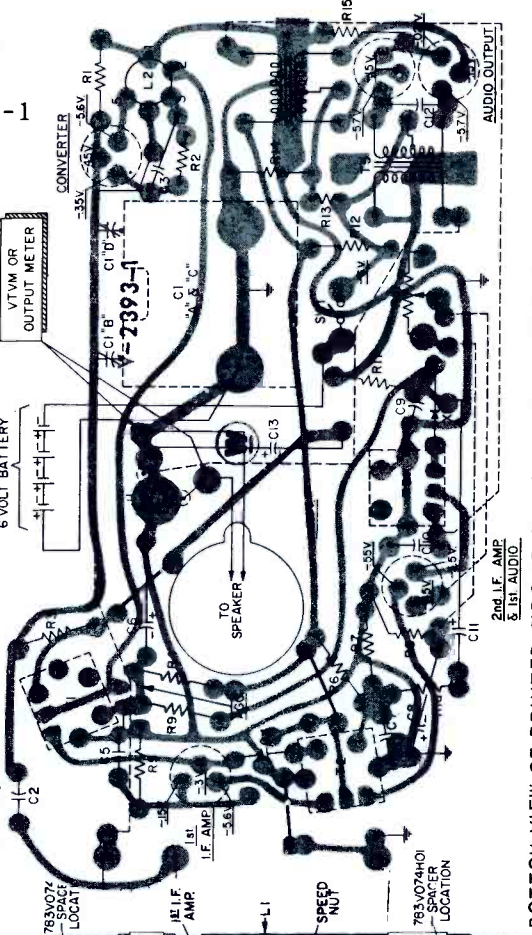
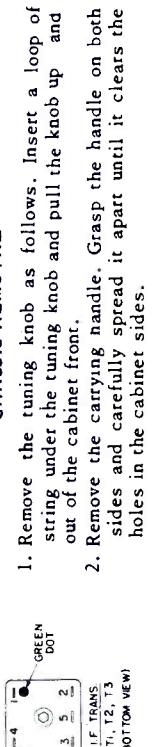

BOTTOM VIEW OF PRINTED CIRCUIT CHASSIS SHOWING COMPONENTS SYMBOLICALLY

TOP VIEW OF PRINTED CIRCUIT CHASSIS

Westinghouse

Chassis V-2394-1, Models H-659P4, H-660P4

CHASSIS REMOVAL (See figure 1)

1. Press in the two cabinet release buttons on either side of the receiver case. Open the case to expose the chassis and batteries.
2. Unsnap the battery cable assemblies from the "A" and "B" batteries.
3. Remove the two self-tapping screws securing the AC receptacle.
4. Remove the two self-tapping screws securing the chassis bracket to the top of the case.
5. Carefully slide the chassis out from the receiver case. The on-off-volume control knob is captivated and thus remains in the case as the control shaft is pulled off the knob.

When servicing with the receiver connected to the AC power line use an isolation transformer between the receiver and the AC line. To replace the chassis reverse the above procedure. Be careful to correctly seat the chassis in the cabinet mounting grooves.

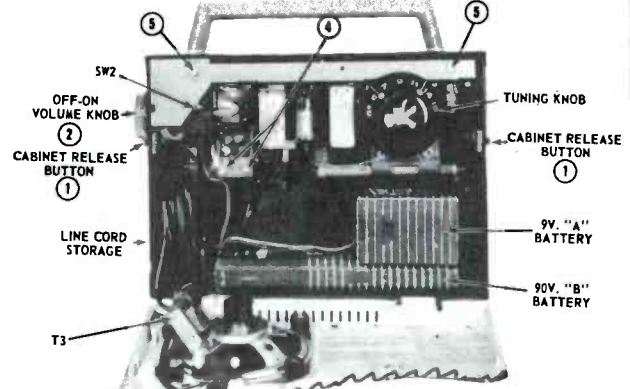
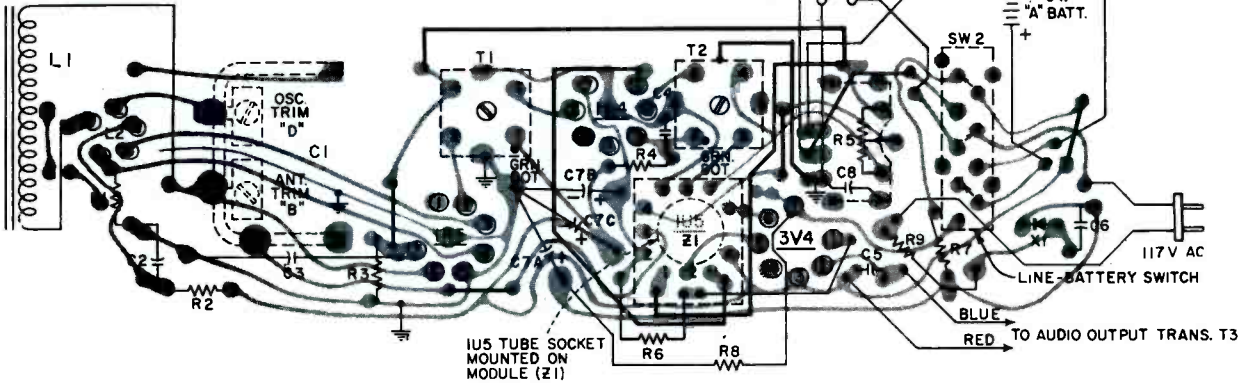
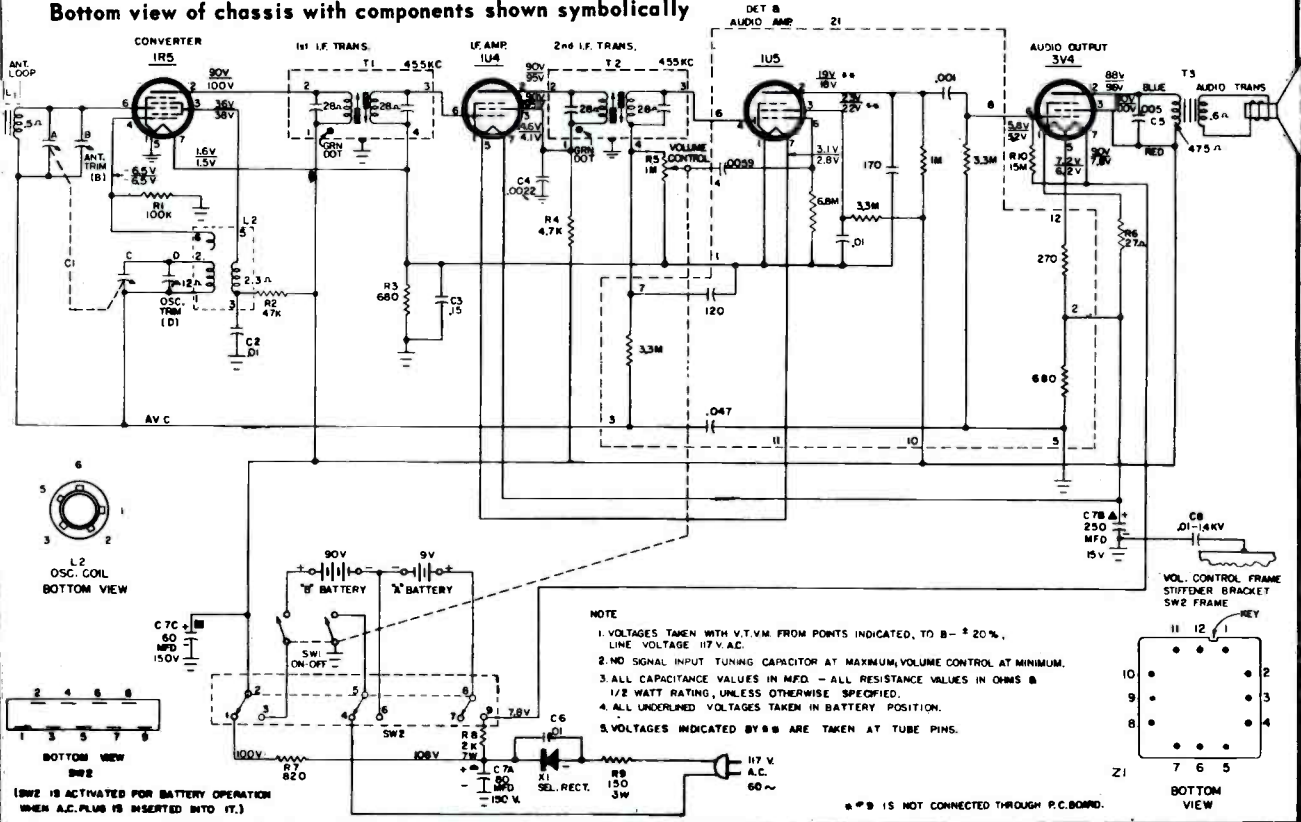
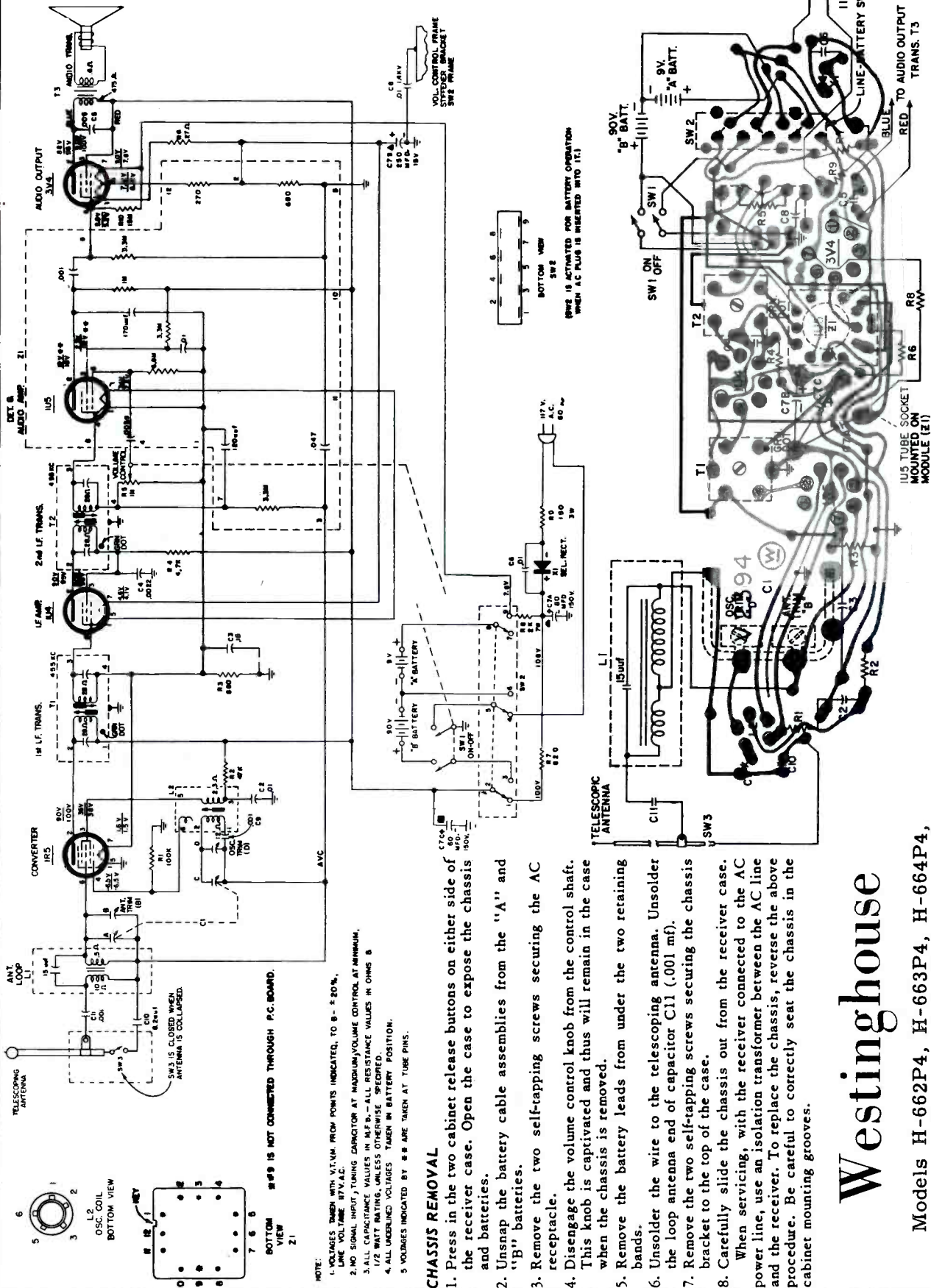

Figure 1



Bottom view of chassis with components shown symbolically





NOTE:
 1. VOLTAGES TAKEN WITH V.T. V.M. FROM POINTS INDICATED, TO B - ±20%.
 2. NO SIGNAL INPUT, TUNING CAPACITOR AT MAXIMUM VOLUME CONTROL AT MINIMUM.
 3. ALL CAPACITANCE VALUES IN M.F.S. - ALL RESISTANCE VALUES IN OHMS &
 1/2 WATT RATING, UNLESS OTHERWISE SPECIFIED.
 4. ALL UNDERLINED VOLTAGES TAKEN IN BATTERY POSITION.
 5. VOLTAGES INDICATED BY ## ARE TAKEN AT TUBE PINS.

CHASSIS REMOVAL

1. Press in the two cabinet release buttons on either side of the receiver case. Open the case to expose the chassis and batteries.
2. Unsnap the battery cable assemblies from the "A" and "B" batteries.
3. Remove the two self-tapping screws securing the AC receptacle.
4. Disengage the volume control knob from the control shaft. This knob is captivated and thus will remain in the case when the chassis is removed.
5. Remove the battery leads from under the two retaining bands.
6. Unsolder the wire to the telescoping antenna. Unsolder the loop antenna end of capacitor C11 (.001 mf).
7. Remove the two self-tapping screws securing the chassis bracket to the top of the case.
8. Carefully slide the chassis out from the receiver case. When servicing, with the receiver connected to the AC power line, use an isolation transformer between the AC line and the receiver. To replace the chassis, reverse the above procedure. Be careful to correctly seat the chassis in the cabinet mounting grooves.

Westinghouse

Models H-662P4, H-663P4, H-664P4,
 Chassis V-2394-2

Bottom view of chassis with components shown symbolically

Westinghouse

Models H-666P5, H-667P5,
Chassis V-2394-3

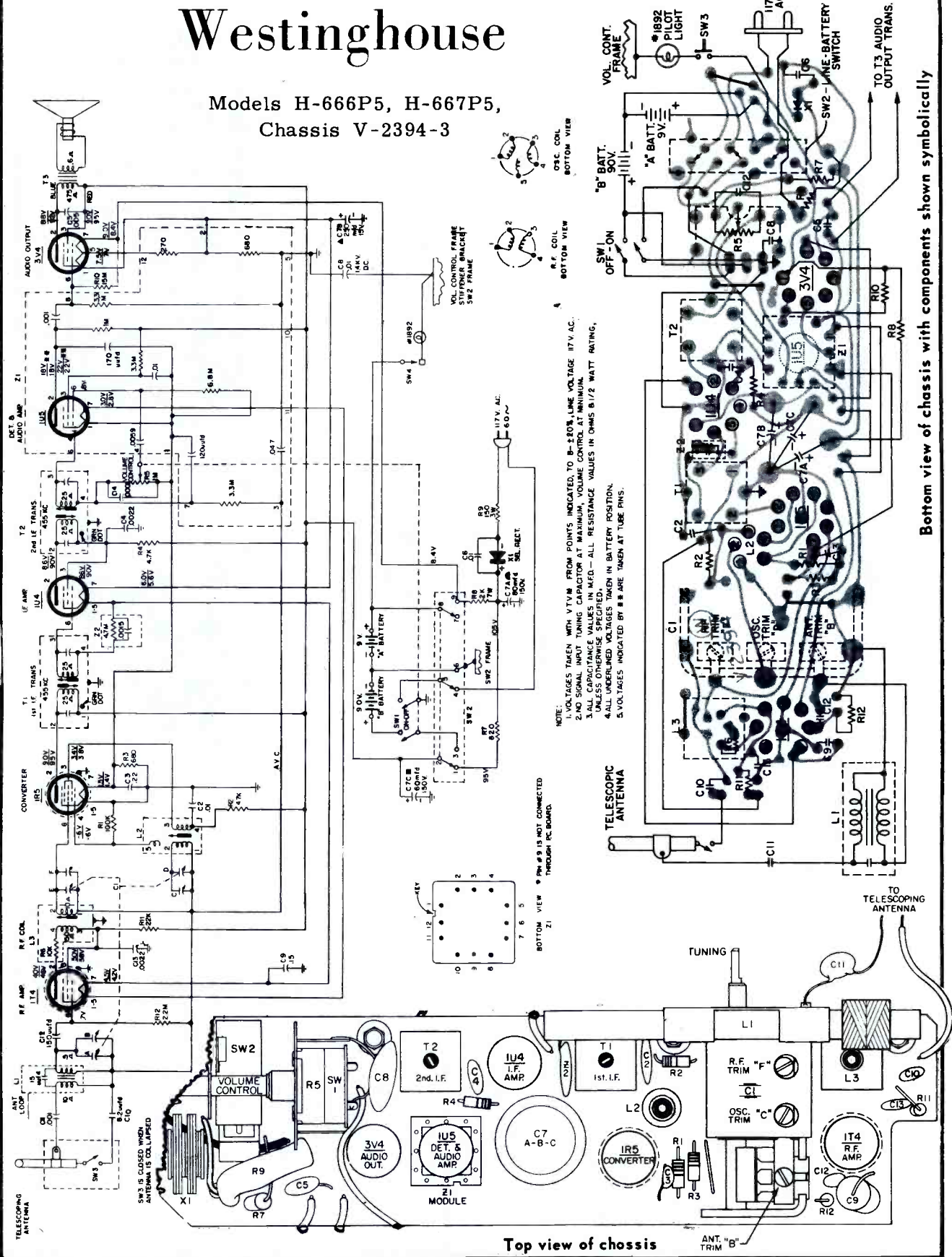

- NOTE:
1. VOLTAGES TAKEN WITH VTVM FROM POINTS INDICATED TO B-120V, LINE VOLTAGE 117V AC.
 2. NO SIGNAL INPUT TUNING CAPACITOR AT MAXIMUM, VOLUME CONTROL AT MINIMUM.
 3. ALL RESISTANCE VALUES IN OHMS UNLESS OTHERWISE SPECIFIED.
 4. ALL UNDERLINED VOLTAGES TAKEN IN BATTERY POSITION.
 5. VOLTAGES INDICATED BY # ARE TAKEN AT TUBE PINS.

Bottom view of chassis with components shown symbolically

Top view of chassis

Westinghouse

Models H-681T5, H-682T5, H-683T5,
Chassis V-2395-1

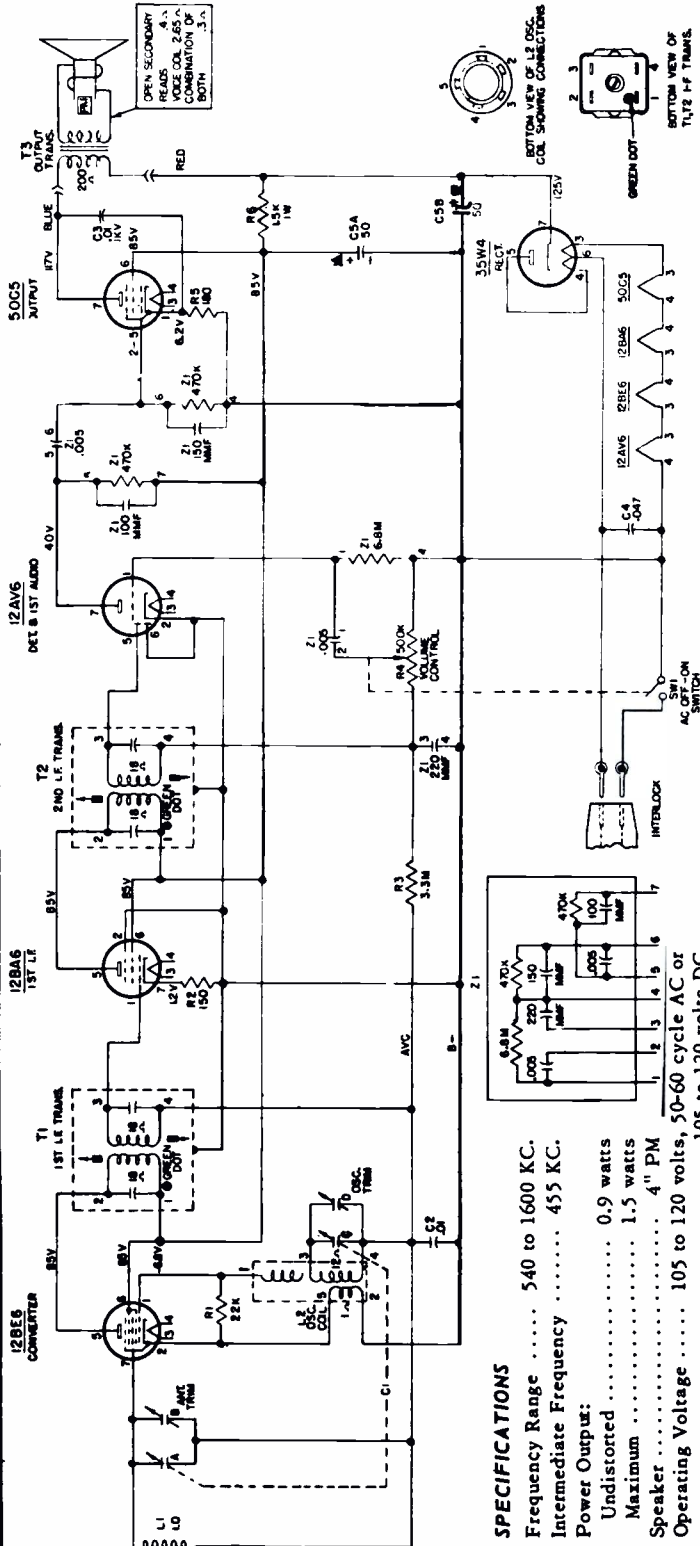

SPECIFICATIONS

Frequency Range	540 to 1600 KC.
Intermediate Frequency	455 KC.
Power Output:	
Undistorted	0.9 watts
Maximum	1.5 watts
Speaker	4" PM
Operating Voltage	105 to 120 volts, 50-60 cycle AC or 105 to 120 volts DC
Power Consumption	30 watts

PRINTED BOARD REMOVAL

1. Disengage captivated volume control knob (located on side of cabinet) from volume control shaft.
2. Remove two screws from rear of cabinet.
3. Loosen screw on bottom of cabinet slightly; then push forward on this screw to disengage AC line cord interlock.
4. Remove screw from bottom of cabinet. Front panel and attached PC board can now be removed from cabinet.
5. For PC board installation reverse the above procedure.

FRONT PANEL REMOVAL

1. Remove front panel and attached PC board as described under PRINTED BOARD REMOVAL.
 2. Unsolder red and blue leads from audio output transformer (transformer is mounted on speaker).
 3. Remove the screw securing loop antenna assembly to front panel.
 4. Remove two screws attaching PC board stiffener bracket to front panel.
 5. For front panel installation * reverse the above procedure.
- * NOTE: The tuning knob must be replaced before PC board assembly is attached to front panel.

NOTES:
1. ALL VOLTAGES MEASURED FROM COMMON NEGATIVE USING A V.T.V.M. VOLUME CONTROL AT MINIMUM, TUNING CAPACITOR AT MAXIMUM.
2. ALL CAPACITANCE VALUES IN MFD. AND ALL RESISTANCE VALUES IN OHMS UNLESS OTHERWISE SPECIFIED.

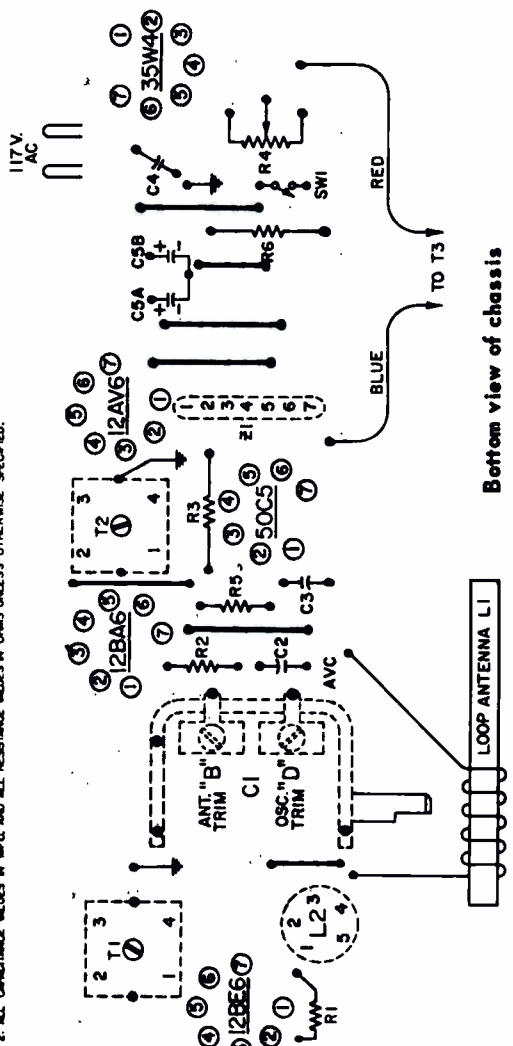

Bottom view of chassis

WESTINGHOUSE Chassis V-2396-1
Models H-685P8, H-686P8

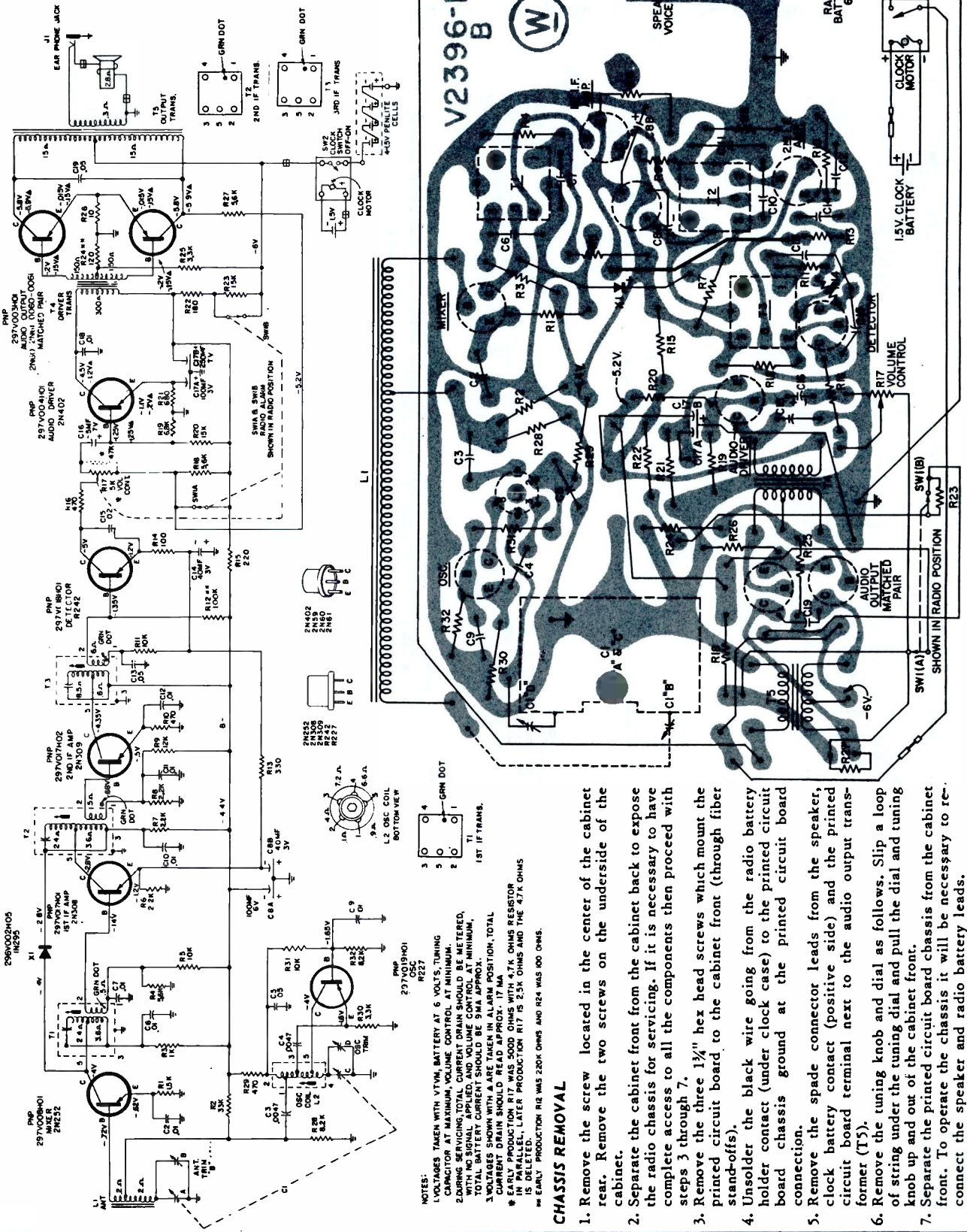

NOTES:
 1. VOLTAGES TAKEN WITH VTVM, BATTERY AT 6 VOLTS, TUNING CAPACITOR AT MAXIMUM, VOLUME CONTROL AT MINIMUM.
 2. DURING SERVICING, TOTAL CURRENT DRAIN SHOULD BE METERED, WITH NO SIGNAL APPLIED, AND VOLUME CONTROL AT MINIMUM. TOTAL BATTERY CURRENT SHOULD BE 9 MA APPROX.
 3. VOLTAGES SHOWN WITH A ARE TAKEN IN ALARM POSITION, TOTAL CURRENT DRAIN SHOULD READ APPROX. 17 MA. 7K OHMS RESISTOR IN PARALLEL, LATER PRODUCTION R17 IS 2.5K OHMS AND THE 47K OHMS IS DELETED.
 4. EARLY PRODUCTION R12 WAS 220K OHMS AND R24 WAS 100 OHMS.

CHASSIS REMOVAL

1. Remove the screw located in the center of the cabinet rear. Remove the two screws on the underside of the cabinet.
2. Separate the cabinet front from the cabinet back to expose the radio chassis for servicing. If it is necessary to have complete access to all the components then proceed with steps 3 through 7.
3. Remove the three 1 1/2" hex head screws which mount the printed circuit board to the cabinet front (through fiber stand-offs).
4. Unsolder the black wire going from the radio battery holder contact (under clock case) to the printed circuit board chassis ground at the printed circuit board connection.
5. Remove the spade connector leads from the speaker, clock battery contact (positive side) and the printed circuit board terminal next to the audio output transformer (T5).
6. Remove the tuning knob and dial as follows. Slip a loop of string under the tuning dial and pull the dial and tuning knob up and out of the cabinet front.
7. Separate the printed circuit board chassis from the cabinet front. To operate the chassis it will be necessary to reconnect the speaker and radio battery leads.

Bottom view of printed circuit board with components shown symbolically.

VOLUME R-19, MOST-OFTEN-NEEDED 1959 RADIO SERVICING INFORMATION

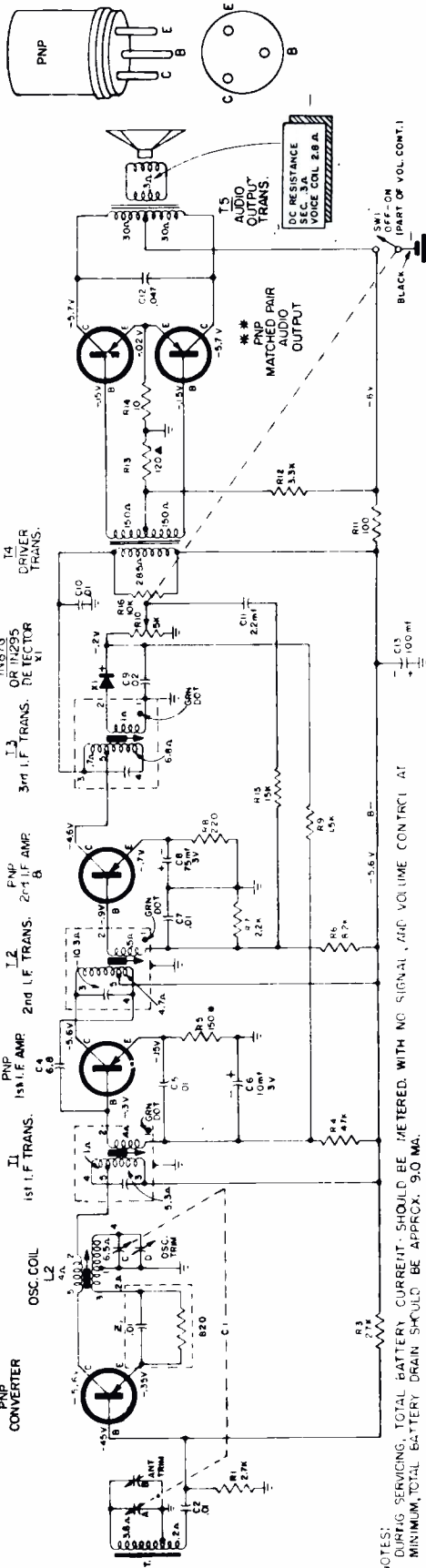

SPECIFICATIONS

- Frequency Range.....540 to 1600 KC
- Intermediate Frequency.....455 KC
- Power Supply—6 volts (four 1.5 volt "C" batteries)
- No Signal Current Drain......9 ma

CHASSIS REMOVAL

1. Remove the volume control knob.
2. Remove the tuning control knob.
Insert a loop of string under the tuning knob and pull the knob out of the cabinet front.
3. Remove the phillips head screw in the tuning control knob well.
4. Remove the back cover (loosen the two coin-slot screws).
5. Remove the two hex head screws securing the chassis to the cabinet.
6. Remove the chassis, with its battery holder, from the cabinet. The receiver can now be serviced. If it is necessary to also remove the speaker, then remove the two hex head screws securing the speaker and lift it out of its slot.
7. Use the reverse of the above steps to replace the chassis into the cabinet. If replaced, the mounting screw that is used in the tuning control knob well must be the same length as the original, so as to not damage the tuning capacitor.



Model H-690P5, Chassis V-2397-1

- NOTES:
1. DURING SERVICING, TOTAL BATTERY CURRENT SHOULD BE METERED, WITH NO SIGNAL, AND VOLUME CONTROL AT MINIMUM, TOTAL BATTERY DRAIN SHOULD BE APPROX. 9.0 MA.
 2. VOLTAGE MEASUREMENTS MADE WITH A VTVM FROM POINTS INDICATED TO GROUND, WITH TUNING CAPACITOR AT MAXIMUM, VOLUME CONTROL AT MINIMUM & BATTERY SOURCE AT 6 VOLTS.
 3. AUDIO OUTPUT TRANSISTORS 297VOC3108 & 297VOC3106 MUST BE MATCHED PAIRS.
 4. ALL CAPACITORS LESS THAN ONE ARE IN MFD, ALL CAPACITORS GREATER THAN ONE ARE IN MAFMFD, UNLESS OTHERWISE SPECIFIED. ALL RESISTORS ARE IN OHMS, 1/2 WATT.

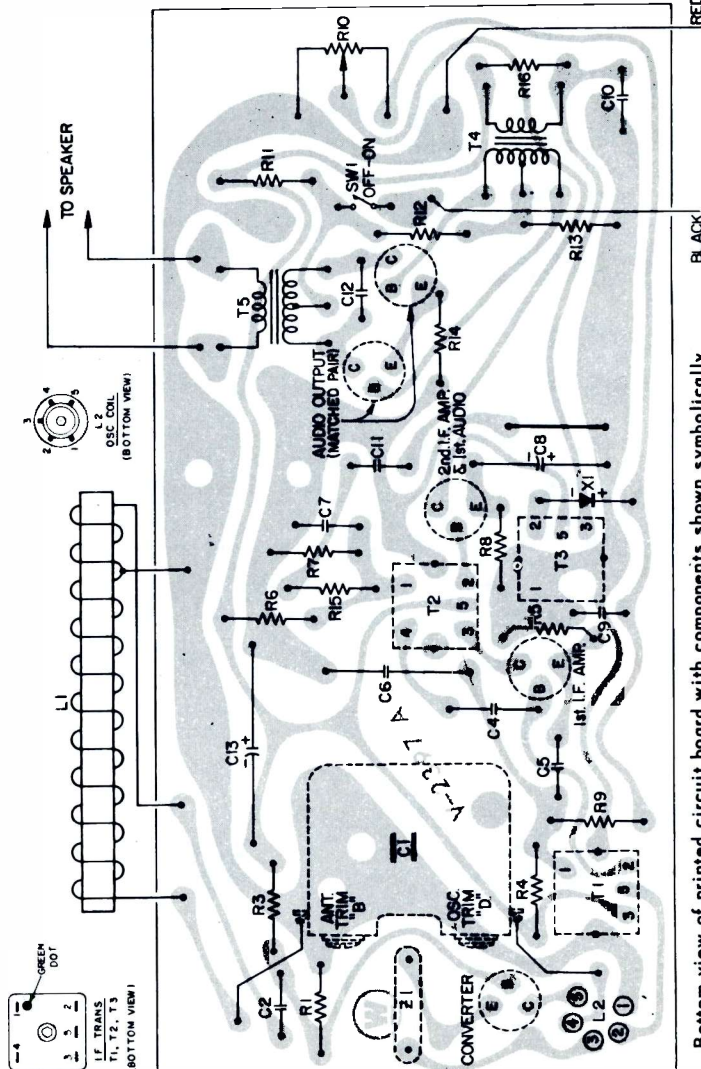

Bottom view of printed circuit board with components shown symbolically

Westinghouse

Models HF-110AN, HF-111AN,
Chassis V-2503-2

1. ALL CAPACITANCE VALUES IN MFD AND ALL RESISTANCE VALUES IN OHMS UNLESS OTHERWISE SPECIFIED.
2. ALL VOLTAGES MEASURED TO B-USING A VTVM., LINE VOLTAGE SET AT 117V AC, VOLTAGES SHOULD BE AS SHOWN $\pm 20\%$. NO SIGNAL INPUT, LOUDNESS AT MINIMUM.

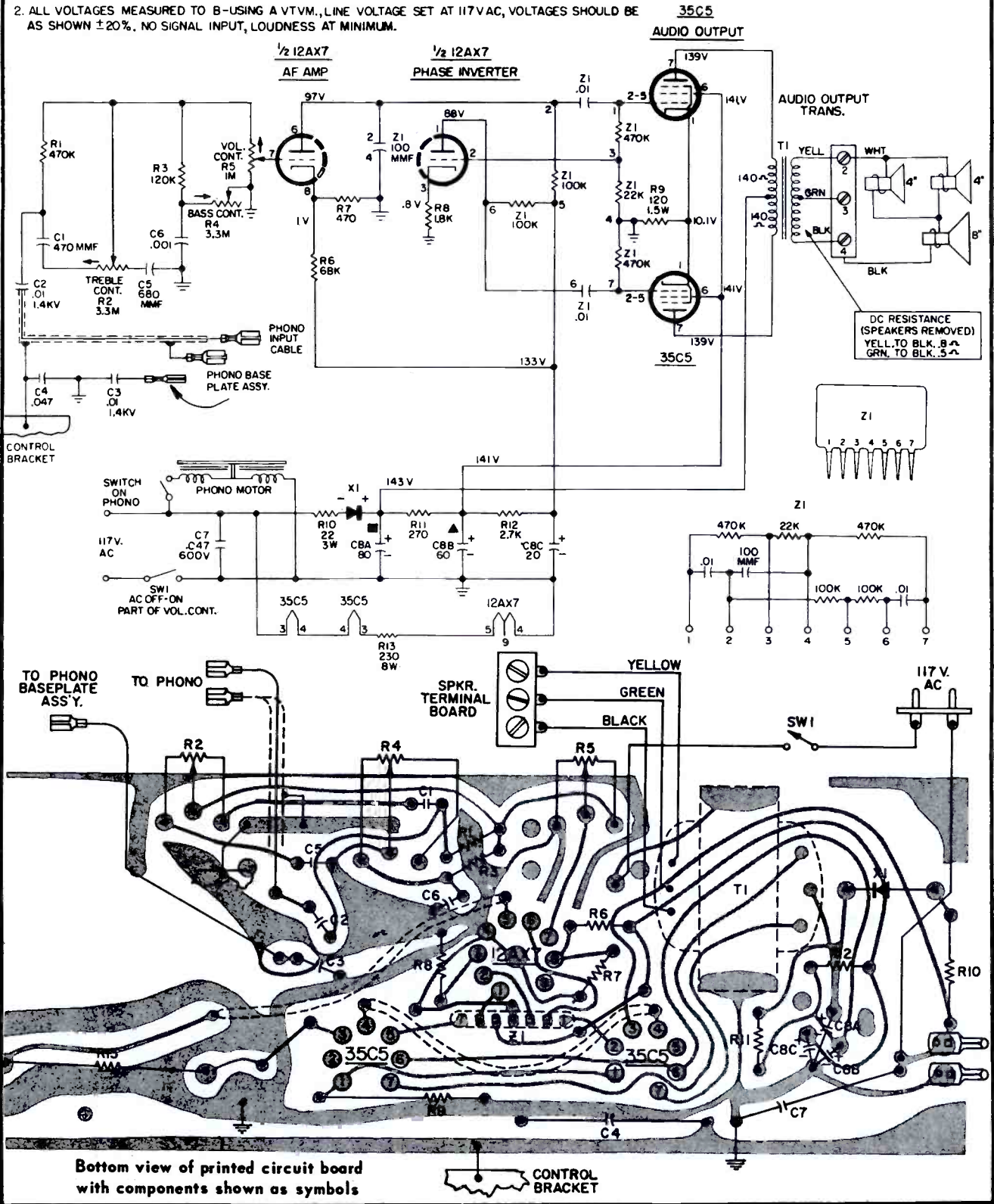

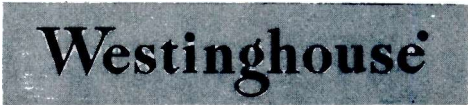

Models H-45AC1A, H-45AC2A,
Chassis V-2506-3

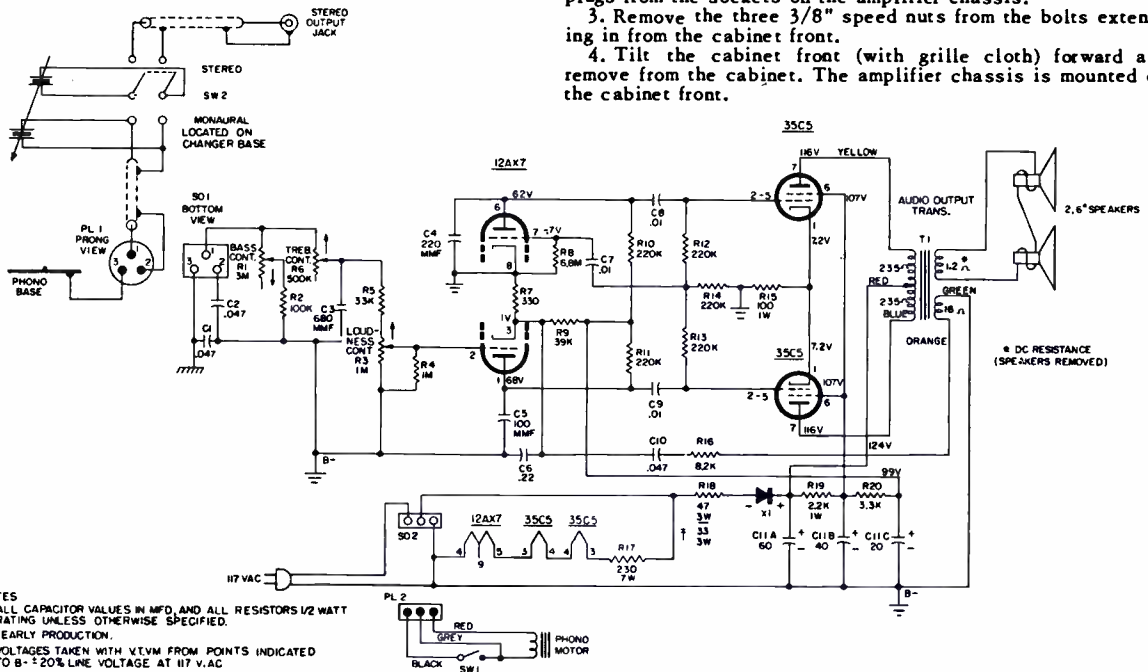

NOTES
 1. ALL CAPACITOR VALUES IN MFD, AND ALL RESISTORS 1/2 WATT RATING UNLESS OTHERWISE SPECIFIED.
 2. EARLY PRODUCTION.
 3. VOLTAGES TAKEN WITH VTVM FROM POINTS INDICATED TO B ± 20% LINE VOLTAGE AT 117 V.A.C.

TUBE REPLACEMENT

To replace the vacuum tubes it is first necessary to remove the cover at the rear of the speaker baffle. This cover has ventilating holes and is secured by two phillips-head screws.

CHASSIS REMOVAL

1. Remove the cover at the rear of the speaker baffle. This cover has ventilating holes and is secured by two phillips-head screws.
2. Remove the record changer mounting board. This is secured by four phillips-head screws, one in each corner of the board. Lift the board up and out of the cabinet. To completely detach the changer from the phonograph remove the two cable plugs from the sockets on the amplifier chassis.
3. Remove the three 3/8" speed nuts from the bolts extending in from the cabinet front.
4. Tilt the cabinet front (with grille cloth) forward and remove from the cabinet. The amplifier chassis is mounted on the cabinet front.

WESTINGHOUSE Models H-44AC1A, H-44AC2A, Chassis V-2506-2.

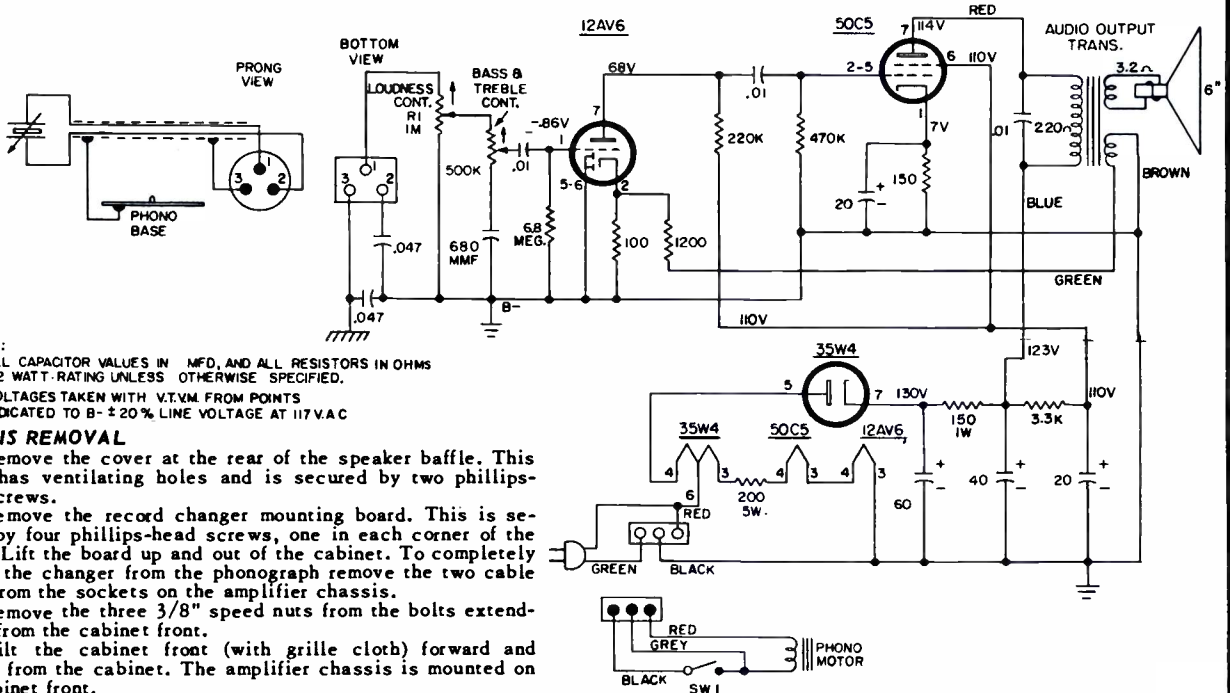

NOTE:
 1. ALL CAPACITOR VALUES IN MFD, AND ALL RESISTORS IN OHMS 1/2 WATT-RATING UNLESS OTHERWISE SPECIFIED.
 2. VOLTAGES TAKEN WITH VTVM FROM POINTS INDICATED TO B ± 20% LINE VOLTAGE AT 117 V.A.C.

CHASSIS REMOVAL

1. Remove the cover at the rear of the speaker baffle. This cover has ventilating holes and is secured by two phillips-head screws.
2. Remove the record changer mounting board. This is secured by four phillips-head screws, one in each corner of the board. Lift the board up and out of the cabinet. To completely detach the changer from the phonograph remove the two cable plugs from the sockets on the amplifier chassis.
3. Remove the three 3/8" speed nuts from the bolts extending in from the cabinet front.
4. Tilt the cabinet front (with grille cloth) forward and remove from the cabinet. The amplifier chassis is mounted on the cabinet front.

Westinghouse

MODELS

- H48SE1 (mahogany)
- H48SE2 (oak)
- H48SE3 (fruitwood)
- H48SE4 (walnut)
- H48SE5 (tutone)

CHASSIS V-2503-5

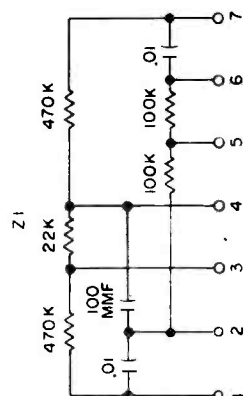
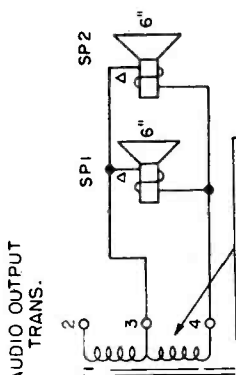
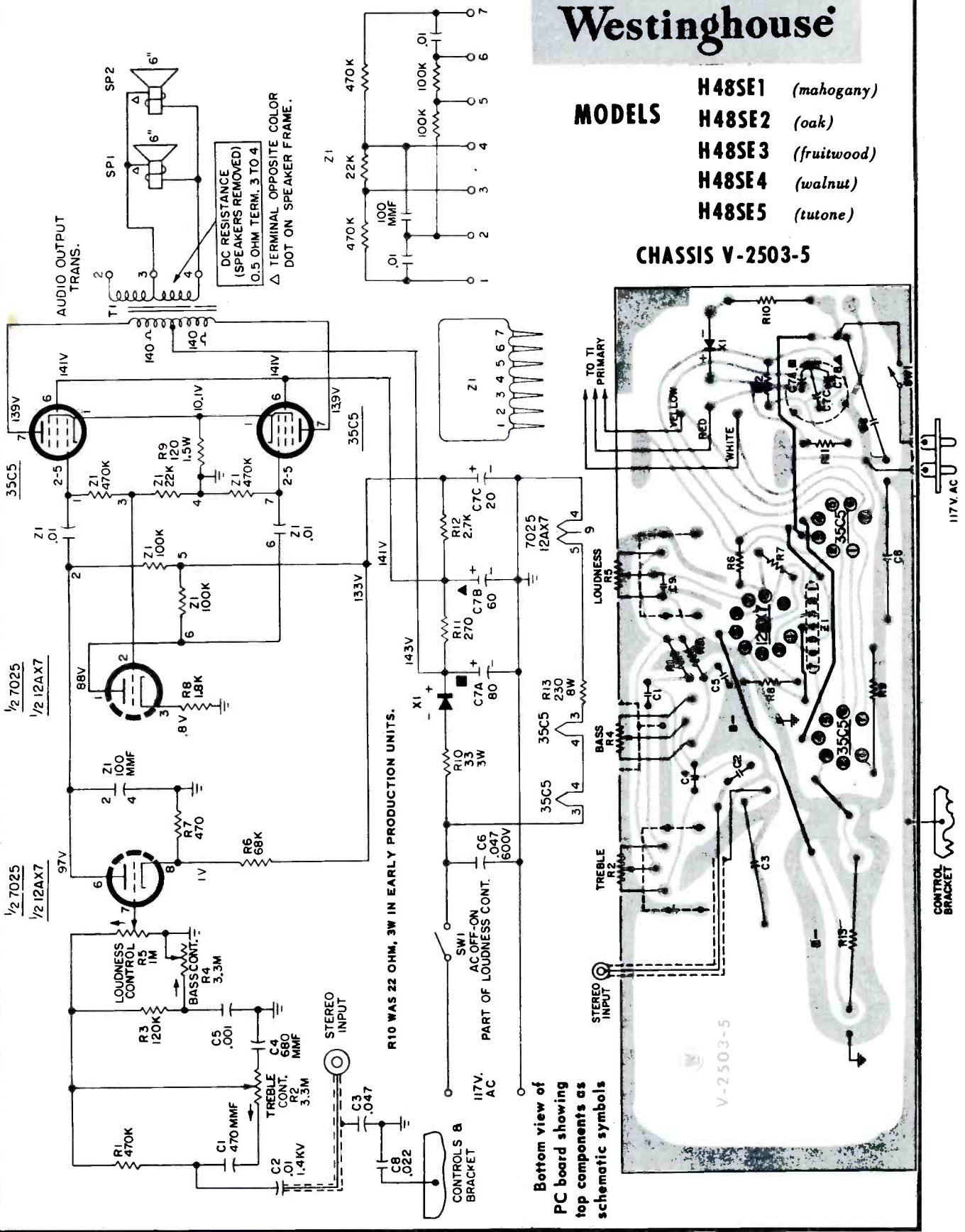

Bottom view of PC board showing top components as schematic symbols

ZENITH RADIO CORP. MODELS SF174R & SF177E & R

CHASSIS 4B22, 4B23, 3B30

(Continued on page 171)

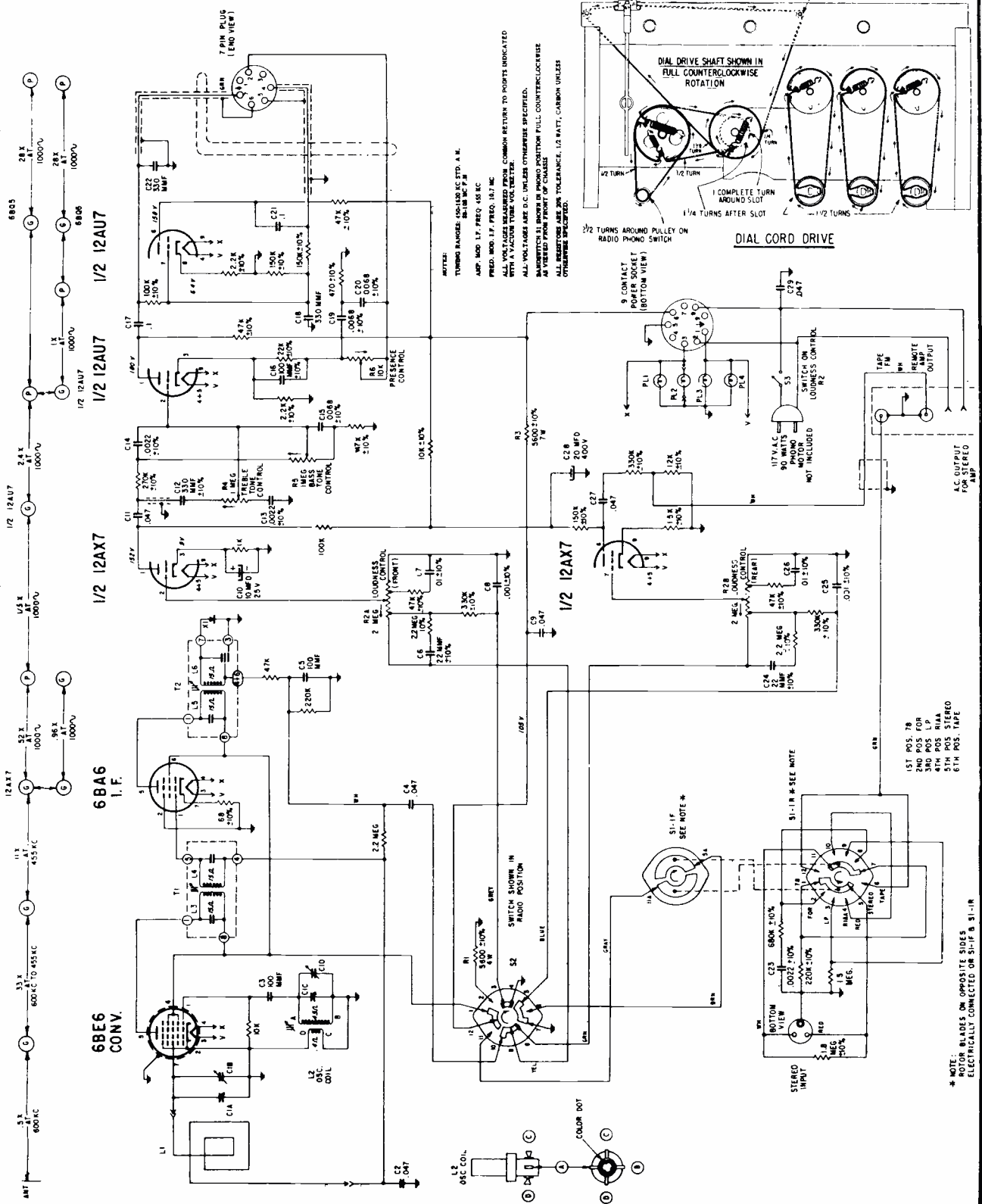

NOTES:
 TUNING RANGE: 540-16.0 MC STD. A. L.
 AMP. MOD. I.F. FREQ. 455 KC
 PRE-D. MOD. I.F. FREQ. 16.2 MC
 ALL VOLTAGE MEASURED FROM COMMON RETURN TO POINTS INDICATED
 WITH A VACUUM TUBE VOLTMETER.
 ALL VOLTAGES ARE D.C. UNLESS OTHERWISE SPECIFIED.
 SWITCH S1 SHOWN IN PHONO POSITION FULL COUNTERCLOCKWISE
 AS VIEWED FROM FRONT OF CHASSIS
 ALL RESISTORS ARE 2% TOLERANCE, 1/2 WATT, CARBON UNLESS
 OTHERWISE SPECIFIED.

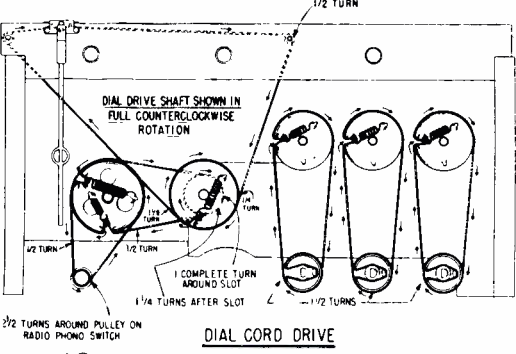

1ST POS. 7B
 2ND POS. FOR
 4RD POS. L.P.A.
 5TH POS. STEREO
 6TH POS. TAPE

* NOTE:
 MOTOR BLADES ON OPPOSITE SIDES
 ELECTRICALLY CONNECTED OR SH-1E, S1-1R

ZENITH RADIO CORP. MODELS SF174R & SF177E & R

CHASSIS 4B22, 4B23, 3B30

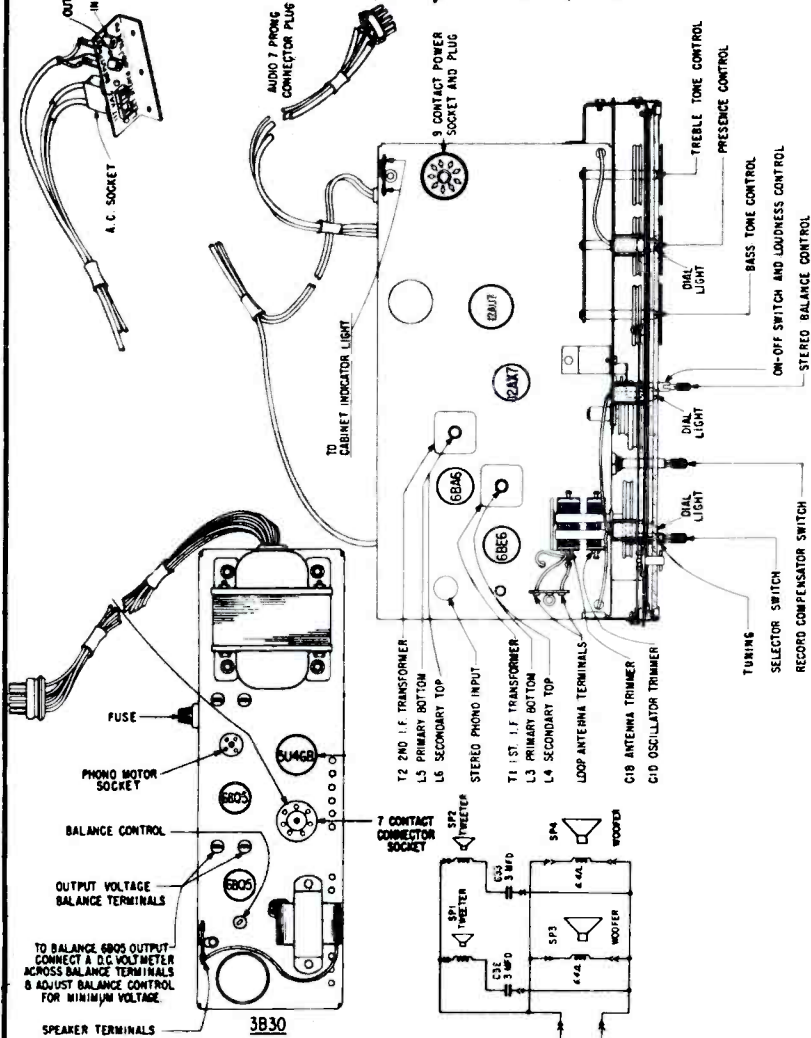

TUBE, TRIMMER LOCATION AND DETAILED VIEW OF I.F. TRANSFORMERS
ALIGNMENT PROCEDURE

Operation	Connect Oscillator to	Dummy Antenna	Input Sig- Frequency	Set Dial at	Trimmers	Purpose
1	Converter Grid	.5 Mfd.	455 Kc.	600 Kc.	L3, L4, L5, L6	Align I.F. for maximum output.
2	One turn Loop Coupled Loosely to Wave Magnet	-	1600 Kc.	1600 Kc.	C1D	Set Osc. to Dial Scale
3		-	1400 Kc.	1400 Kc.	C1B	Align Antenna Stage

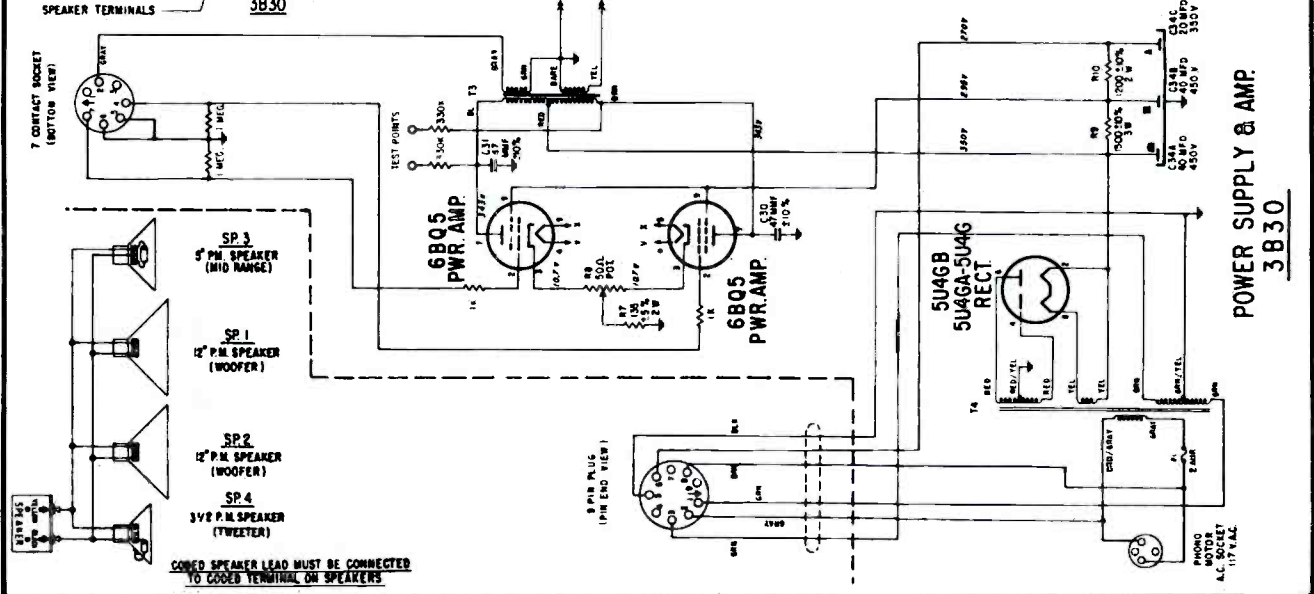

COVER SPEAKER LEAD MUST BE CONNECTED TO COVER TERMINAL ON SPEAKERS

ZENITH RADIO CORPORATION MODEL SF112, CHASSIS 4B24-4B25 & REMOTE SPEAKER SRS2

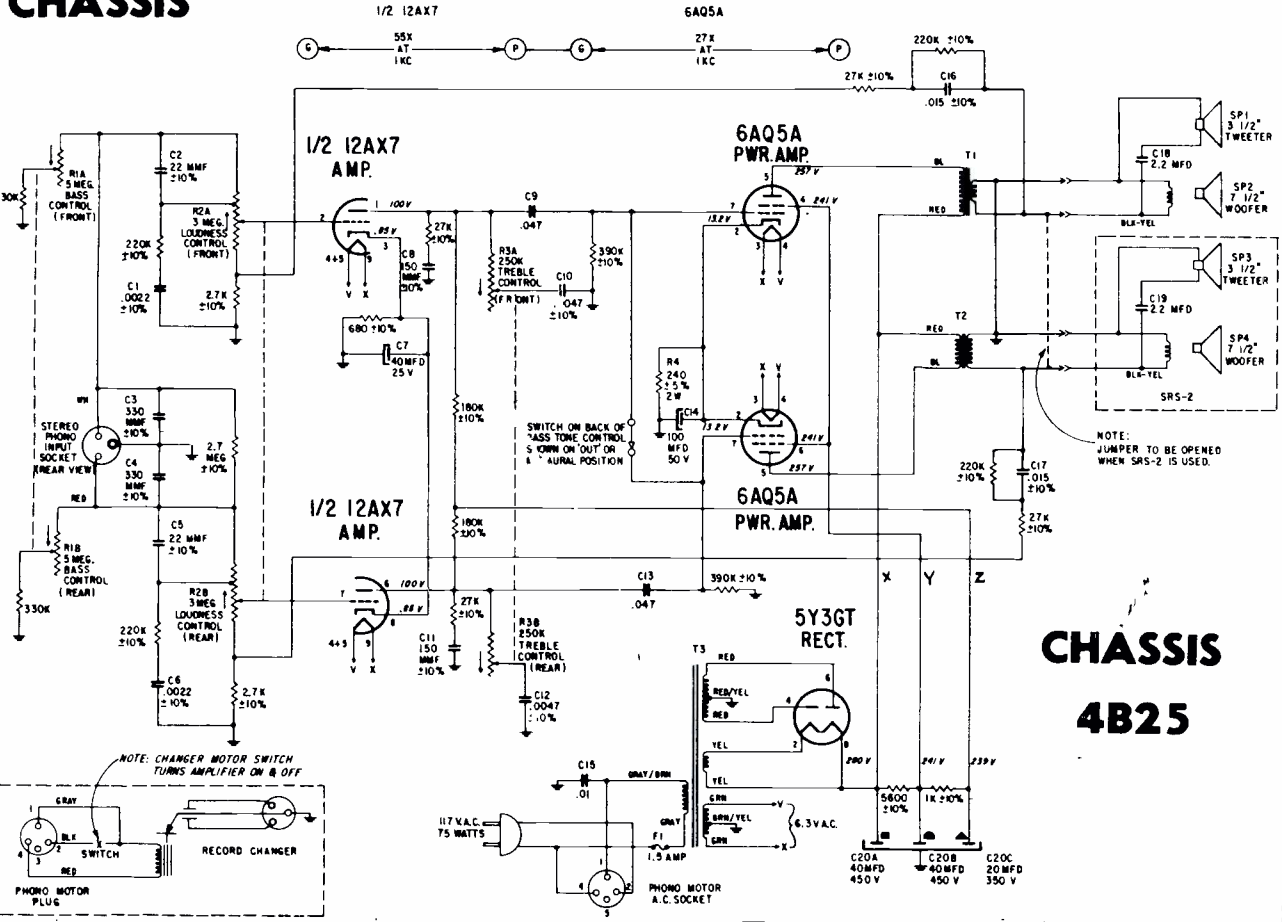
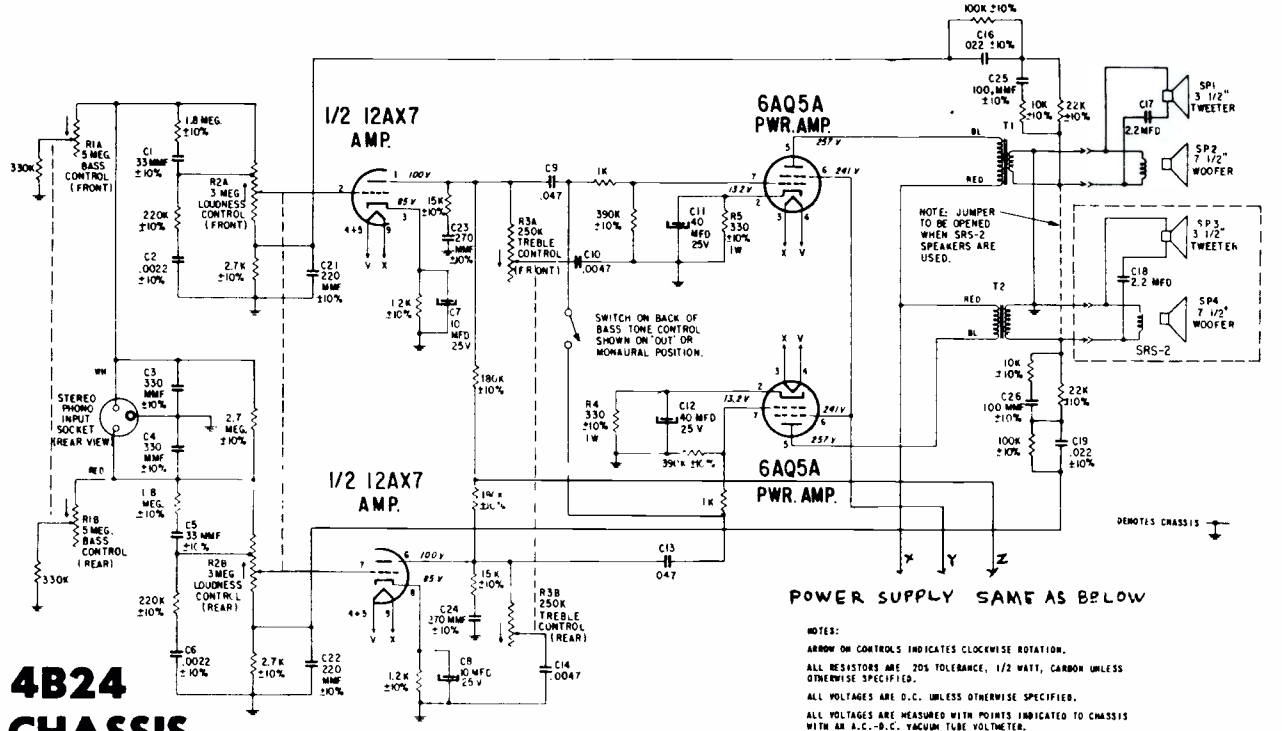

VOLUME R-19, MOST-OFTEN-NEEDED 1959 RADIO SERVICING INFORMATION

ZENITH RADIO CORPORATION MODEL B513Y, L, F, V, CHASSIS 5B01

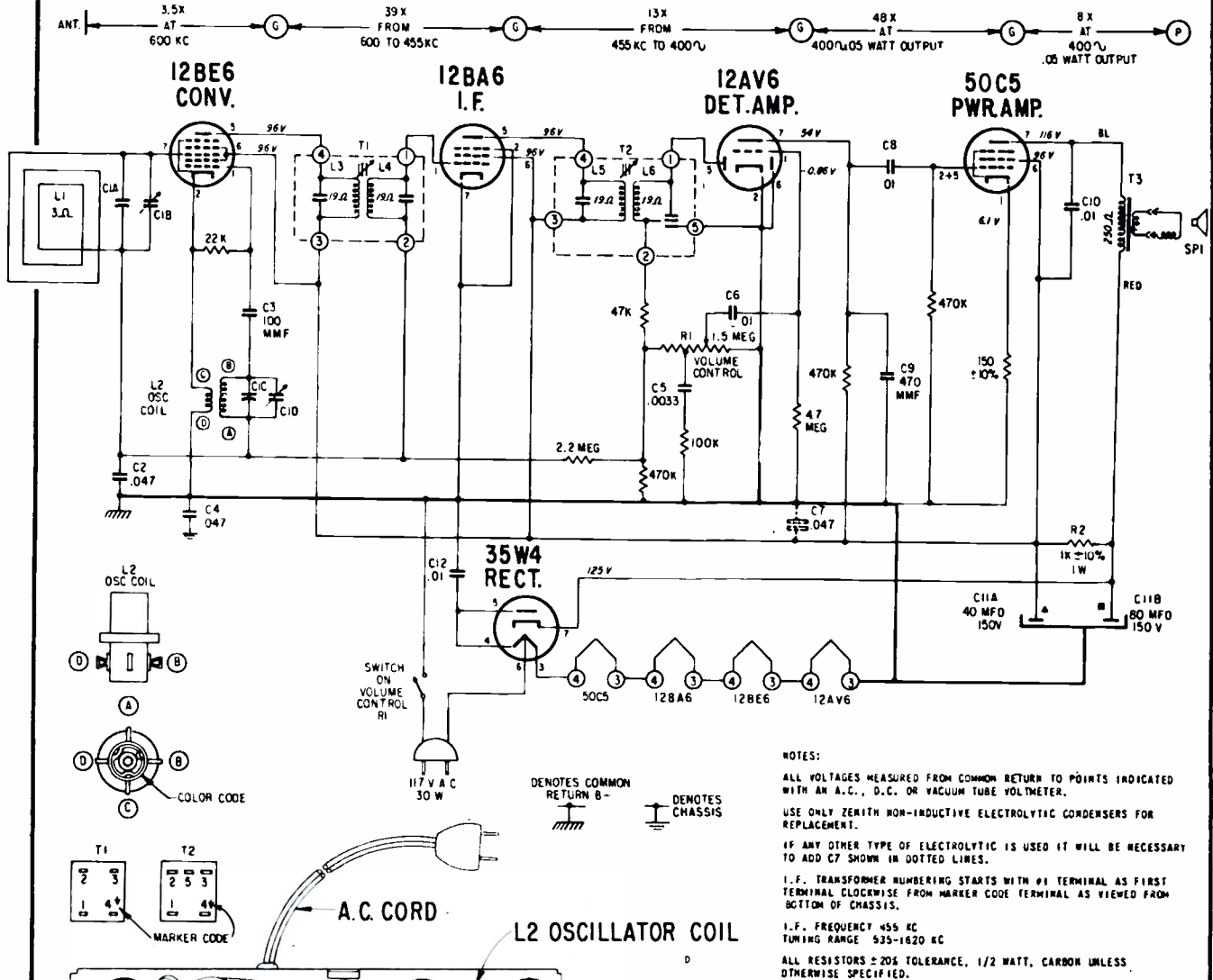

NOTES:

ALL VOLTAGES MEASURED FROM COMMON RETURN TO POINTS INDICATED WITH AN A.C., D.C. OR VACUUM TUBE VOLTMETER.

USE ONLY ZENITH NON-INDUCTIVE ELECTROLYTIC CONDENSERS FOR REPLACEMENT.

IF ANY OTHER TYPE OF ELECTROLYTIC IS USED IT WILL BE NECESSARY TO ADD C7 SHOWN IN DOTTED LINES.

I.F. TRANSFORMER NUMBERING STARTS WITH #1 TERMINAL AS FIRST TERMINAL CLOCKWISE FROM MARKER CODE TERMINAL AS VIEWED FROM BOTTOM OF CHASSIS.

I.F. FREQUENCY 455 KC
TUNING RANGE 535-1620 KC

ALL RESISTORS ± 20% TOLERANCE, 1/2 WATT, CARBON UNLESS OTHERWISE SPECIFIED.

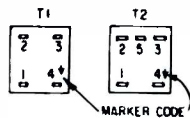

L2 OSCILLATOR COIL

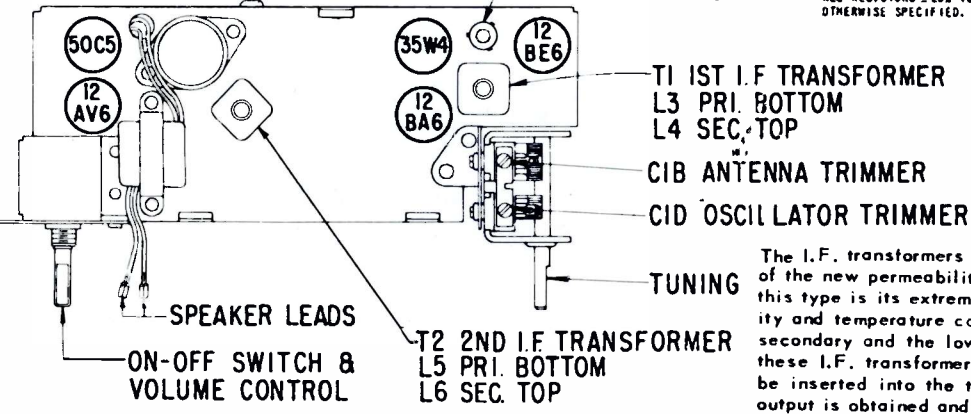

The I.F. transformers incorporated in this receiver are of the new permeability tuned type. The advantage of this type is its extreme stability under various humidity and temperature conditions. The upper coil is the secondary and the lower the primary. When adjusting these I.F. transformers, the tuning wrench 68-19 can be inserted into the top slug, rotated until maximum output is obtained and then dropped down to the lower slug and the same operation repeated.

ALIGNMENT PROCEDURE

OPERATION	CONNECT OSCILLATOR TO	DUMMY ANTENNA	INPUT SIG. FREQUENCY	SET DIAL AT	TRIMMERS	PURPOSE
1	Converter Grid	.5 Mfd.	455 Kc.	600 Kc.	L3, L4, L5, L6	Align I.F. for max. output.
2	One Turn Loop Coupled Loosely to Wave Magnet.	-	1600 Kc.	1600 Kc.	C1D	Set Osc. to Dial Scale.
3		-	1400 Kc.	1400 Kc.	C1B	Align Antenna Stage.

VOLUME R-19, MOST-OFTEN-NEEDED 1959 RADIO SERVICING INFORMATION
 ZENITH RADIO CORP MODELS B514F,W,C,V-B515B,P,G,Y CHASSIS 5B04-5B06

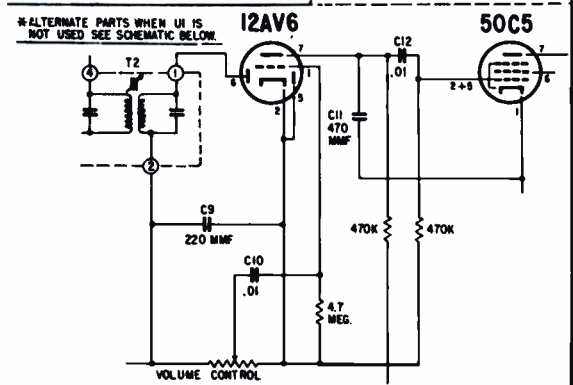
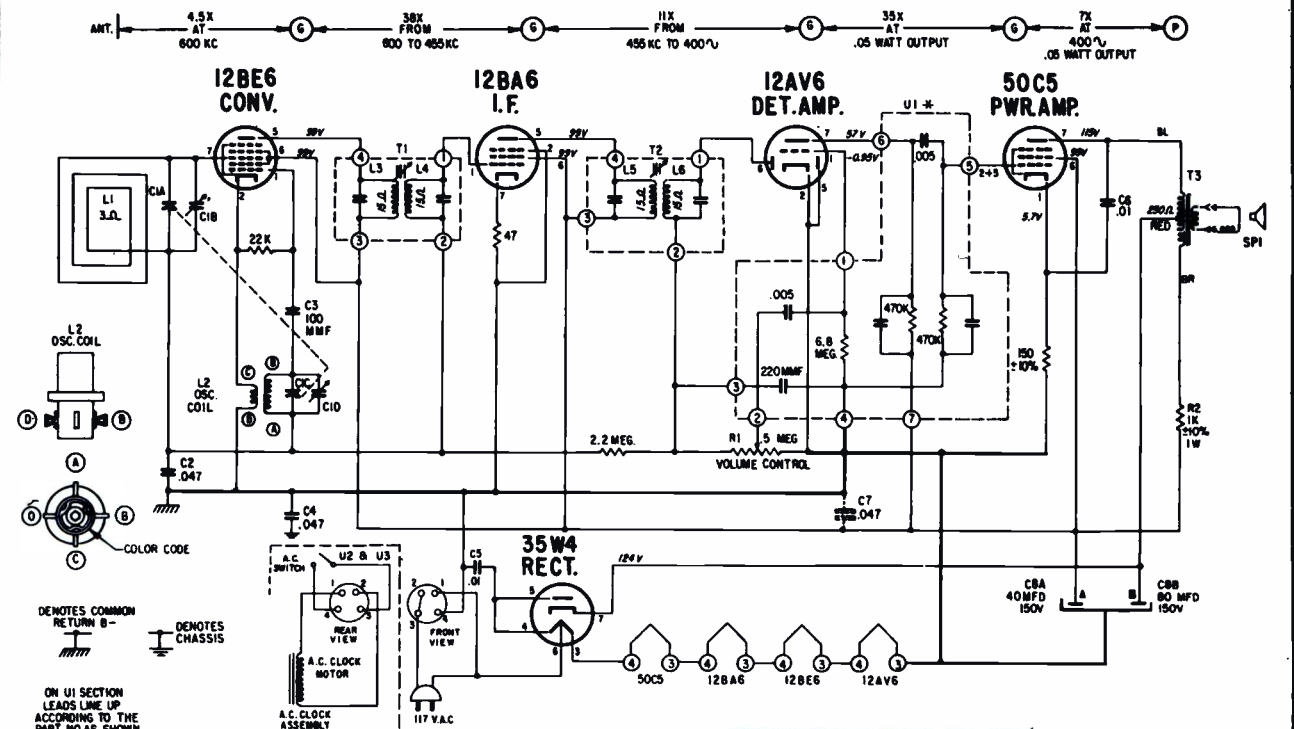

NOTES:
 ALL VOLTAGES MEASURED FROM COMMON RETURN TO POINTS INDICATED WITH AN A.C., D.C. OR VACUUM TUBE VOLTMETER.
 USE ONLY ZENITH NON-INDUCTIVE ELECTROLYTIC CONDENSERS FOR REPLACEMENT.
 IF ANY OTHER TYPE OF ELECTROLYTIC IS USED IT WILL BE NECESSARY TO ADD C7 SHOWN IN DOTTED LINES.
 I.F. TRANSFORMER NUMBERING STARTS WITH #1 TERMINAL AS FIRST TERMINAL CLOCKWISE FROM MARKER CODE TERMINAL AS VIEWED FROM BOTTOM OF CHASSIS.
 I.F. FREQUENCY 455 KC
 TUNING RANGE 535-1620 KC
 ALL RESISTORS ±20% TOLERANCE, 1/2 WATT, CARBON UNLESS OTHERWISE SPECIFIED.

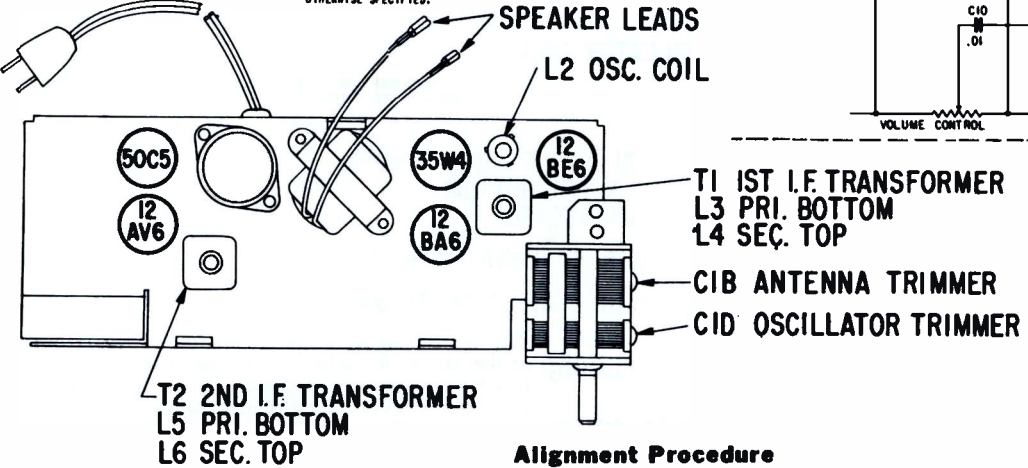
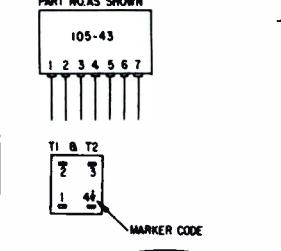

Alignment Procedure

OPERATION	CONNECT OSCILLATOR TO	DUMMY ANTENNA	INPUT SIG. FREQUENCY	SET DIAL AT	TRIMMERS	PURPOSE
1	Converter Grid	.5 Mfd.	455 Kc.	600 Kc.	L3, 4, 5, 6	For I.F. Alignment.
2	One Turn Loop Coupled Loosely to Wave Magnet	—	1600 Kc.	1600 Kc.	CID	Set Oscillator to Dial Scale
3	—	—	1400 Kc.	1400 Kc.	CIB	Align Antenne Stage

VOLUME R-19, MOST-OFTEN-NEEDED 1959 RADIO SERVICING INFORMATION

ZENITH RADIO CORPORATION MODELS B509C, P, V, F, CHASSIS 5B11.

MODELS B511 B, P, L, V, CHASSIS 5B10, are electrically the same.

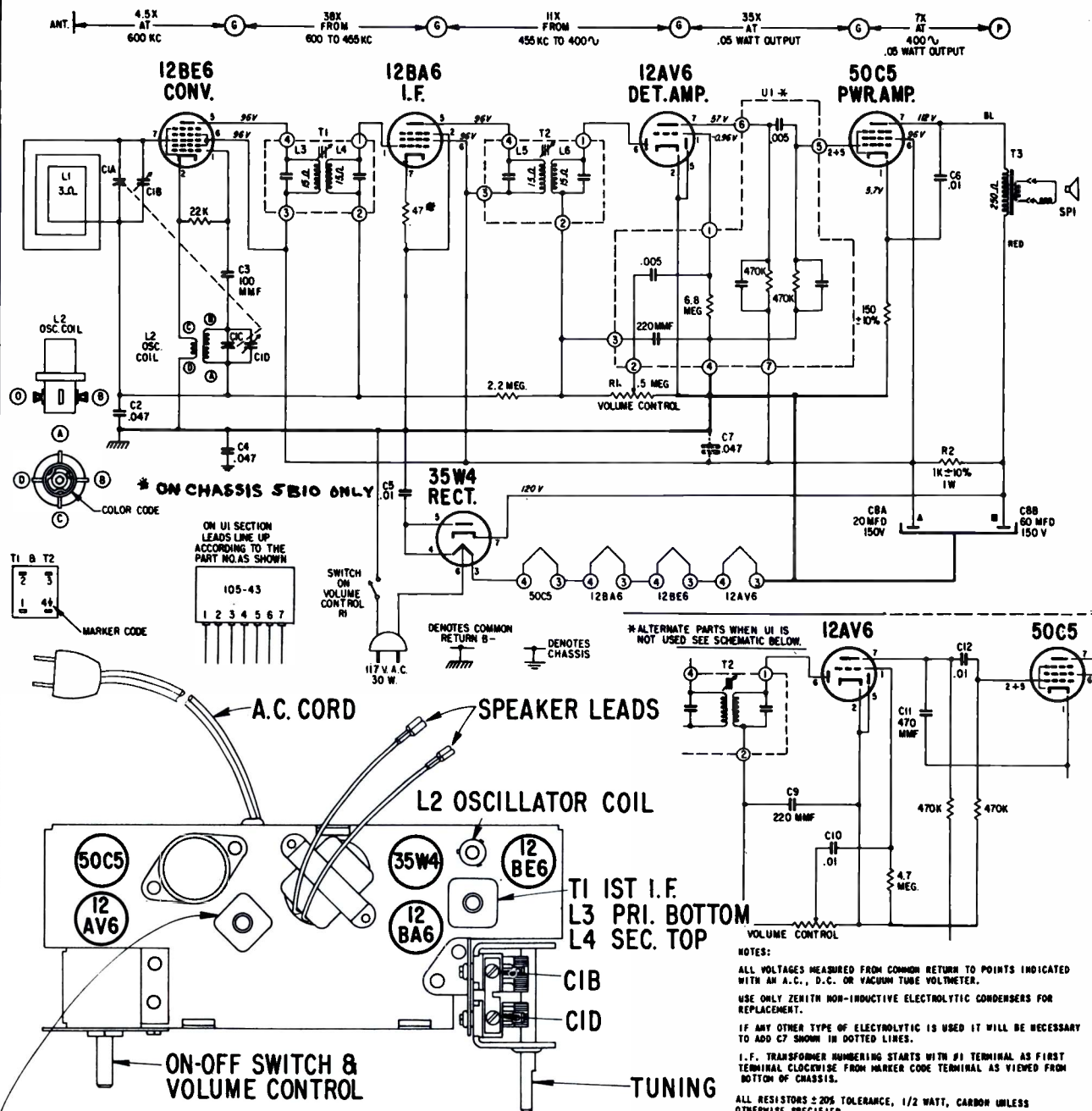

T2 2ND I.F. TRANSFORMER
L5 PRI. BOTTOM
L6 SEC. TOP

ALIGNMENT PROCEDURE

Operation	Connect Oscillator To	Dummy Antenna	Input Sig. Frequency	Set Dial At	Trimmers	Purpose
1	Converter Grid	.5 Mfd.	455 Kc.	600 Kc.	L3, L4, L5, L6	For I.F. Alignment.
2	One Turn Loop Coupled Loosely to Wave Magnet	—	1600 Kc.	1600 Kc.	C1D	Set Oscillator to Dial Scale
3	—	—	1400 Kc.	1400 Kc.	C1B	Align Antenna Stage

ZENITH RADIO CORPORATION

MODELS HF116E & HF116R

CHASSIS 5B20

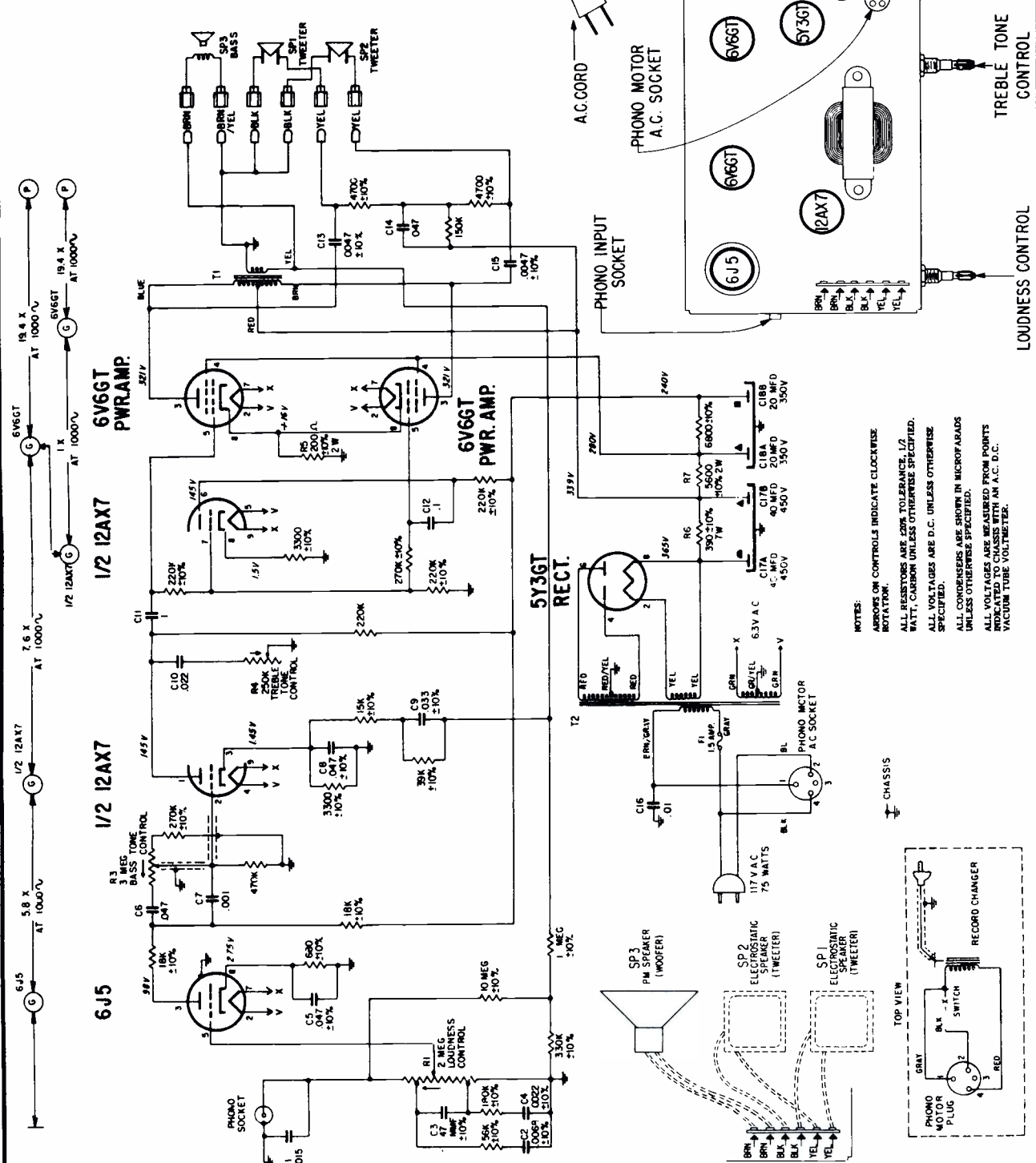

NOTES:
 ARROWS ON CONTROLS INDICATE CLOCKWISE ROTATION.
 ALL RESISTORS ARE 10% TOLERANCE, 1/2 WATT, CARBON UNLESS OTHERWISE SPECIFIED.
 ALL VOLTAGES ARE D.C. UNLESS OTHERWISE SPECIFIED.
 ALL CONDENSERS ARE SHOWN IN MICROFARADS UNLESS OTHERWISE SPECIFIED.
 ALL VOLTAGES ARE MEASURED FROM POINTS INDICATED BY ARROWS WITH AN A.C. D.C. VACUUM TUBE VOLTMETER.

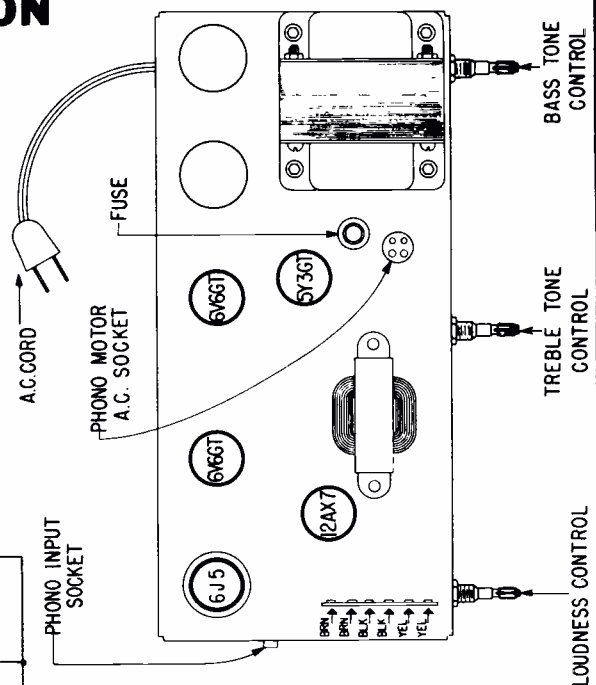

ZENITH RADIO CORP. MODELS HF117 & HF118 CHASSIS 5B22

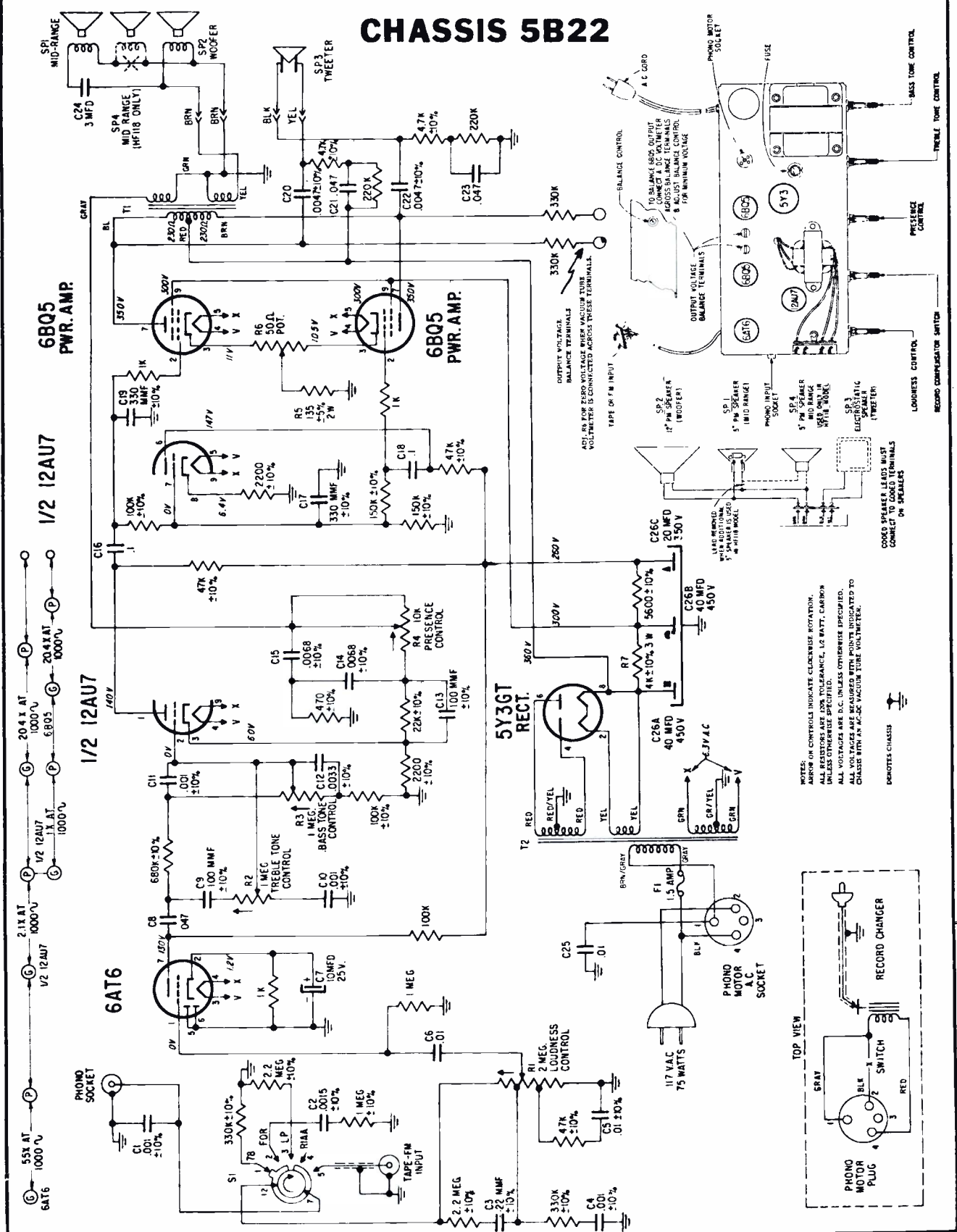

NOTES:
 ARROW ON CONTROLS INDICATE COUNTERWISE ROTATION.
 ALL RESISTORS ARE 10% TOLERANCE, 1/2 WATT, CARBON UNLESS OTHERWISE SPECIFIED.
 ALL CAPACITORS ARE 50V UNLESS OTHERWISE SPECIFIED.
 ALL VOLTAGES ARE D.C. UNLESS OTHERWISE SPECIFIED.
 CHASSIS WITH AN A.C. VACUUM TUBE VOLTMETER.

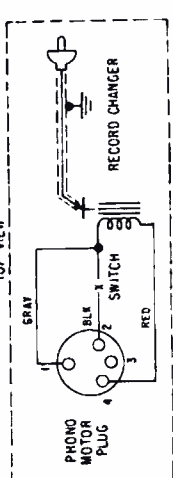

ZENITH RADIO CORPORATION

MODELS SRS10 & SRS15

CHASSIS 5B24

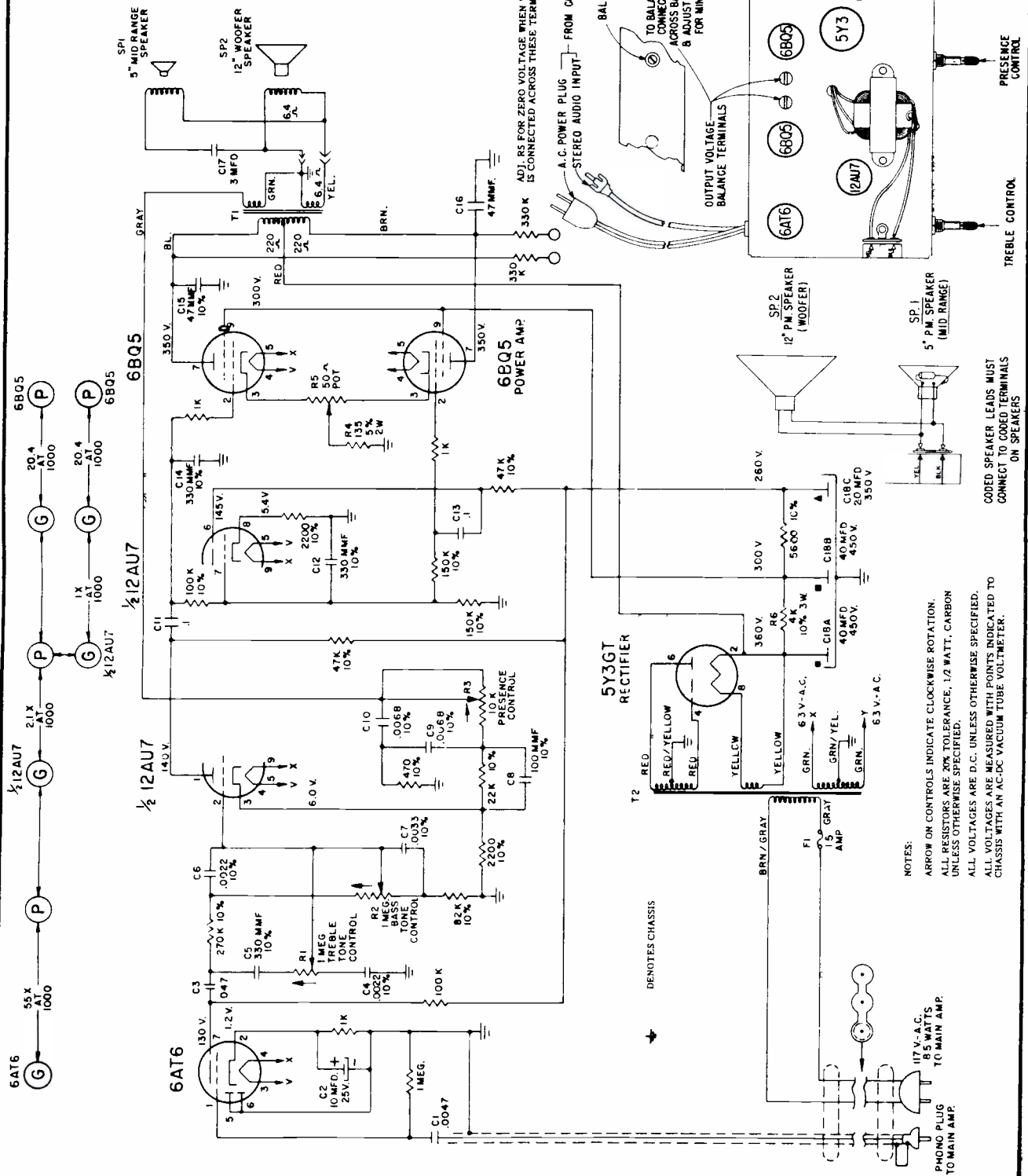

NOTES:
 ARROW ON CONTROLS INDICATE CLOCKWISE ROTATION.
 ALL RESISTORS ARE 20% TOLERANCE, 1/2 WATT, CARBON UNLESS OTHERWISE SPECIFIED.
 ALL VOLTAGES ARE D.C. UNLESS OTHERWISE SPECIFIED.
 ALL VOLTAGES ARE MEASURED WITH POINTS INDICATED TO CHASSIS WITH AN AC-DC VACUUM TUBE VOLTMETER.

CODED SPEAKER LEADS MUST CONNECT TO CODED TERMINALS ON SPEAKERS

→ DENOTES CHASSIS

PHONO PLUG TO MAIN AMP.

ZENITH RADIO CORPORATION MODELS B615L, F, G CHASSIS 6B05

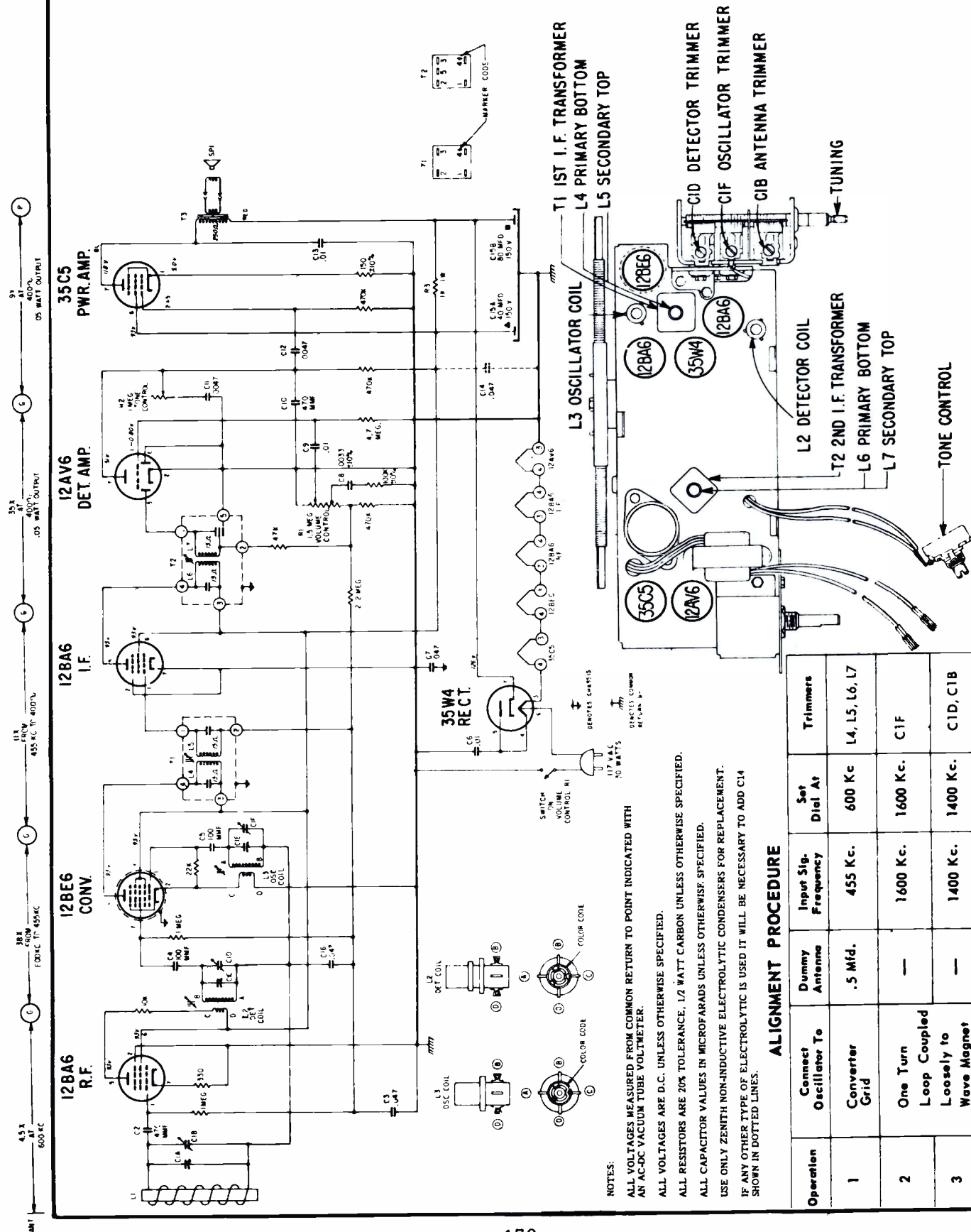

NOTES:
 ALL VOLTAGES MEASURED FROM COMMON RETURN TO POINT INDICATED WITH AN AC-DC VACUUM TUBE VOLTMETER.
 ALL RESISTORS ARE 20% TOLERANCE, 1/2 WATT CARBON UNLESS OTHERWISE SPECIFIED.
 ALL CAPACITOR VALUES IN MICROFARADS UNLESS OTHERWISE SPECIFIED.
 USE ONLY ZENITH NON-INDUCTIVE ELECTROLYTIC CONDENSERS FOR REPLACEMENT.
 IF ANY OTHER TYPE OF ELECTROLYTIC IS USED IT WILL BE NECESSARY TO ADD C14 SHOWN IN DOTTED LINES.

ALIGNMENT PROCEDURE

Operation	Connect Oscillator To	Dummy Antenna	Input Sig. Frequency	Set Dial At	Trimmers
1	Converter Grid	.5 Mfd.	455 Kc.	600 Kc	L4, L5, L6, L7
2	One Turn Loop Coupled Loosely to Wave Magnet	—	1600 Kc.	1600 Kc.	C1F
3	—	—	1400 Kc.	1400 Kc.	C1D, C1B

Zenith Radio Corporation Model HF660, Chassis 6B06

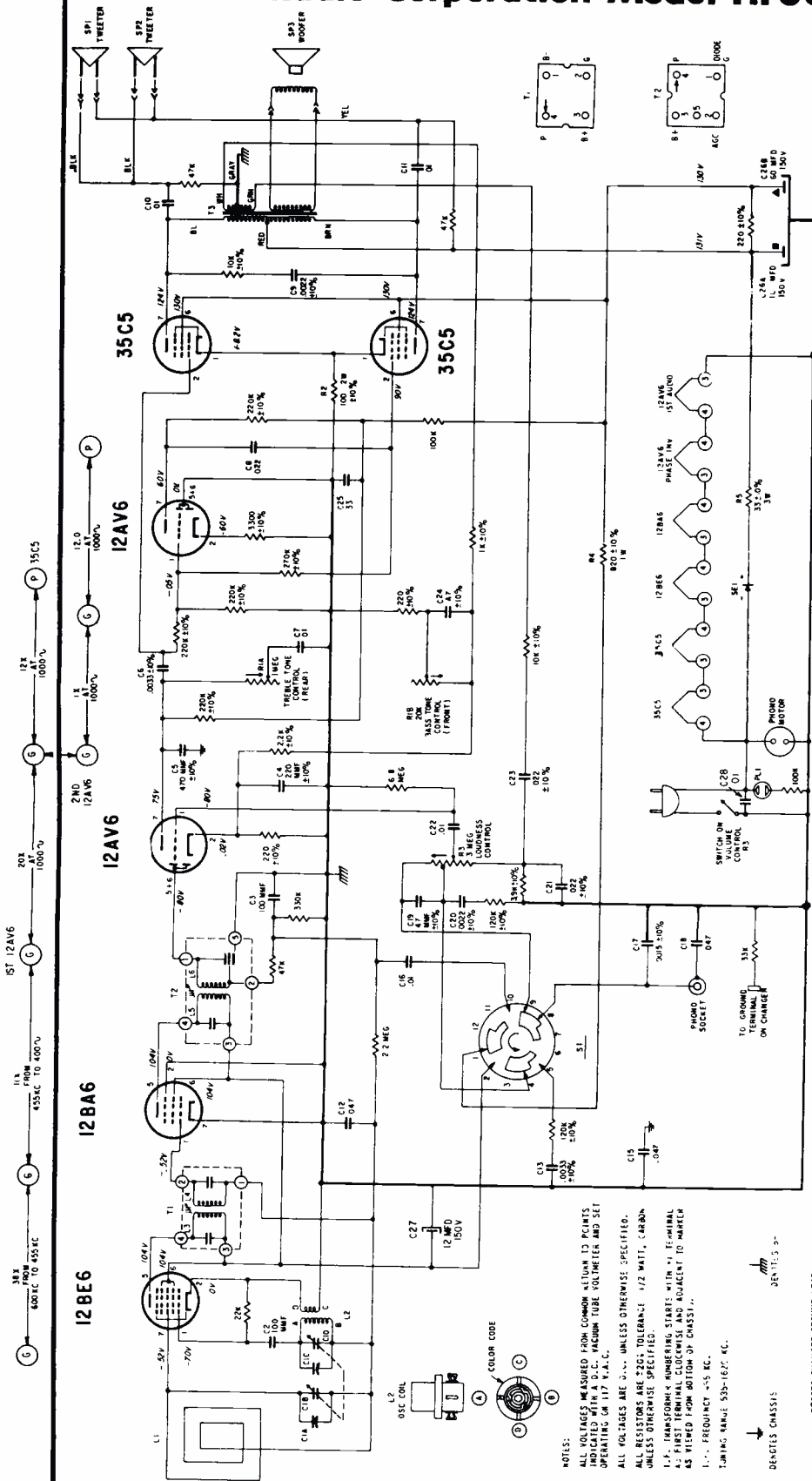

The I. F. transformers incorporated in this receiver are of the new permeability tuned type. The advantage of an I.F. transformer of this type is its extreme stability under various humidity and temperature conditions. The upper coil is the secondary and the lower the primary. When adjusting these I.F. transformers, the tuning wrench 68-19 can be inserted into the top slug, rotated until maximum output is obtained and then dropped down to the lower slug and the same operation repeated. The tuning wrench is so designed that turning one slug does not affect the adjustment of the other.

ALIGNMENT PROCEDURE

OPERATION	CONNECT OSCILLATOR TO ANTENNA	DUMMY ANTENNA	INPUT SIG. FREQUENCY	SET DIAL AT	TRIMMERS	PURPOSE
1	Converter Grid	.5 Mfd.	455 Kc.	600 Kc.	L3, L4, L5, L6	Align I.F. for maximum output
2	One Turn Loop Coupled Loosely to Wave Magnet	—	1600 Kc.	1600 Kc.	C1D	Set Oscillator to Dial Scale.
3	—	—	1400 Kc.	1400 Kc.	C1B	Align Antenna Stage

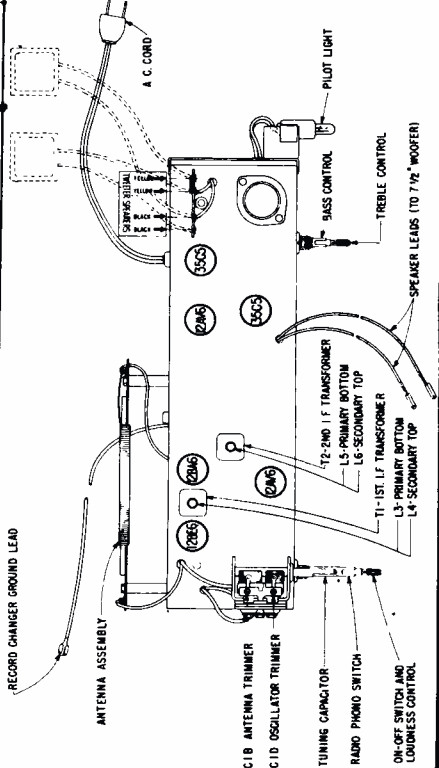

NOTES:
 ALL VOLTAGES MEASURED FROM COMMON RETURN TO POINTS ALL LEAD TO A D.C. VACUUM TUBE VOLTMETER AND SET OPERATING ON 117 V.A.C.
 ALL VOLTAGES ARE 0.5% UNLESS OTHERWISE SPECIFIED.
 ALL RESISTORS ARE 20% TOLERANCE 1/2 WATT, CARBON UNLESS OTHERWISE SPECIFIED.
 I.F. TRANSFORMER NUMBERING STARTS WITH 11 CENTRAL FIRST TERMINAL CLOCKWISE AND ADJACENT TO NUMBER AS VIEWED FROM BOTTOM OF CHASSIS.
 L... FREQUENCY 455 KC.
 TUNING RANGE 530-1625 KC.

ZENITH RADIO CORP.
 Model B728C, -F, -W, Chassis 7A03
 (Continued from page 182)

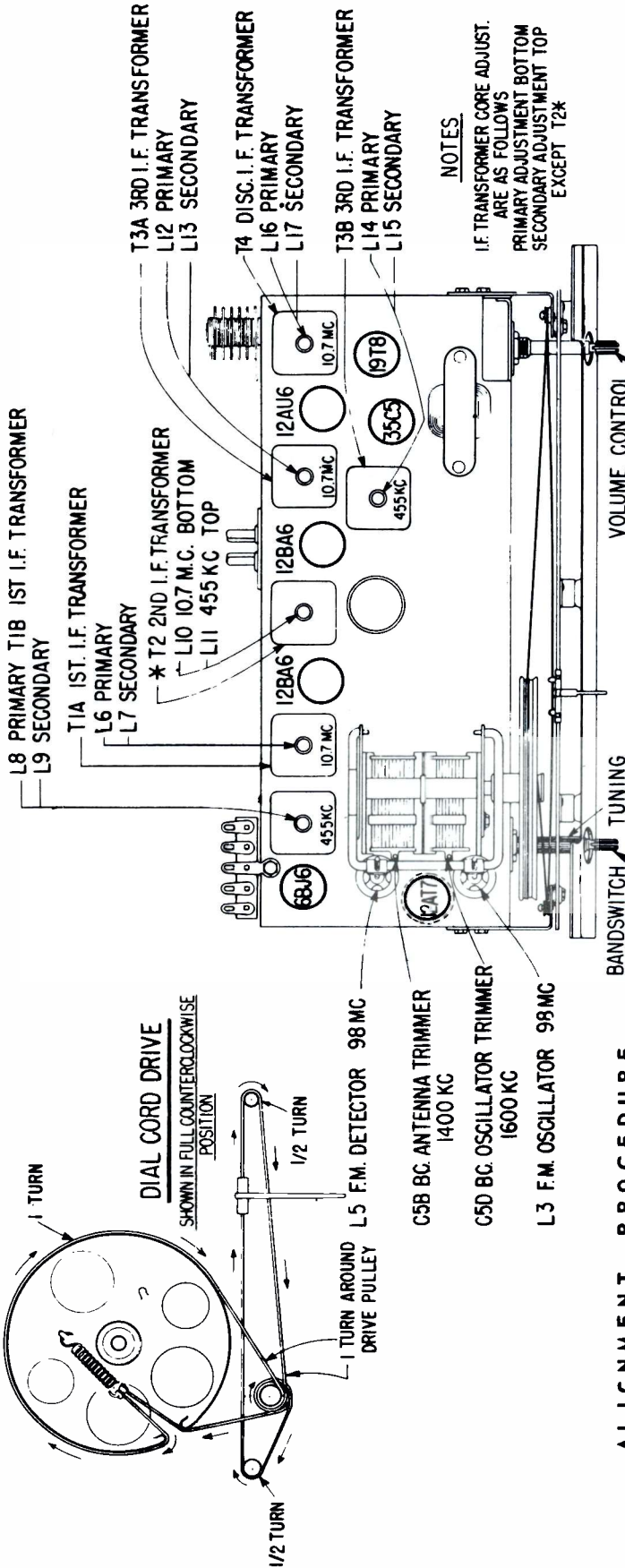

NOTES
 I.F. TRANSFORMER CORE ADJUST.
 ARE AS FOLLOWS
 PRIMARY ADJUSTMENT BOTTOM
 SECONDARY ADJUSTMENT TOP
 EXCEPT T2*

ALIGNMENT PROCEDURE

OPERATION	CONNECT OSCILLATOR TO	DUMMY ANTENNA	INPUT SIGNAL FREQUENCY	BAND	SET DIAL TO	ADJ. TRIMMERS	PURPOSE
1	Pin 2 12A7 Converter	.05 Mfd.	455 Kc. Modulated.	BC	600 Kc.	L8, 9, 11, 14, 15	Align I.F. channel for maximum output.
2	2 turns loosely coupled to wavemagnet		1600 Kc. Modulated.	BC	1600 Kc.	C5D	Set oscillator to dial scale.
3	2 turns loosely coupled to wavemagnet		1400 Kc. Modulated.	BC	1400 Kc.	C5B	Align antenna stage
4 (a)	Pin 1 (grid) on 12AU6 limiter	.05 Mfd.	10.7 Mc. Unmodulated.	FM		L16 coil slug Primary discr.	Align primary of discriminator for maximum reading.
5 (b)	Pin 1 (grid) on 12AU6 limiter	.05 Mfd.	10.7 Mc. Unmodulated.	FM		L17 coil slug sec. of discr.	Adjust secondary of discriminator for zero reading.
6 (c)	Pin 2 (grid) on 12BA6 2nd IF.	.05 Mfd.	10.7 Mc. Unmodulated.	FM		L12 & L13 Prim. & Sec. of 3rd IF trans.	Align 3rd IF transformer for maximum reading.
7 (c)	Pin 1 (grid) on 12BA6 1st IF.	.05 Mfd.	10.7 Mc. Unmodulated.	FM		L10 Prim. of 2nd IF transformer.	Align 2nd IF transformer for maximum reading.
8 (c)	Pin 2 (grid) on 12A7 converter tube socket	.05 Mfd.	10.7 Mc. Unmodulated.	FM		L6 & L7 Prim. & Sec. of 1st IF trans.	Align 1st IF transformer for maximum reading.
9 (c)	Antenna Post FM (Remove line ant.)	270 ohms	98 Mc. Unmodulated.	FM	98 Mc.	L3 Osc. Coil Slug	Set Oscillator to dial scale.
10 (c) (d)		270 ohms	98 Mc. Unmodulated.	FM	98 Mc.	L5 Det. Coil Slug	Align det. stage to maximum reading.

SCHEMATIC DIAGRAM FOR 7AT48Z

VOLUME R-19, MOST-OFTEN-NEEDED 1959 RADIO

ZENITH RADIO Model "ROYAL 200"
Chassis 7AT48Z, 7AT48Z2, 7AT48Z4

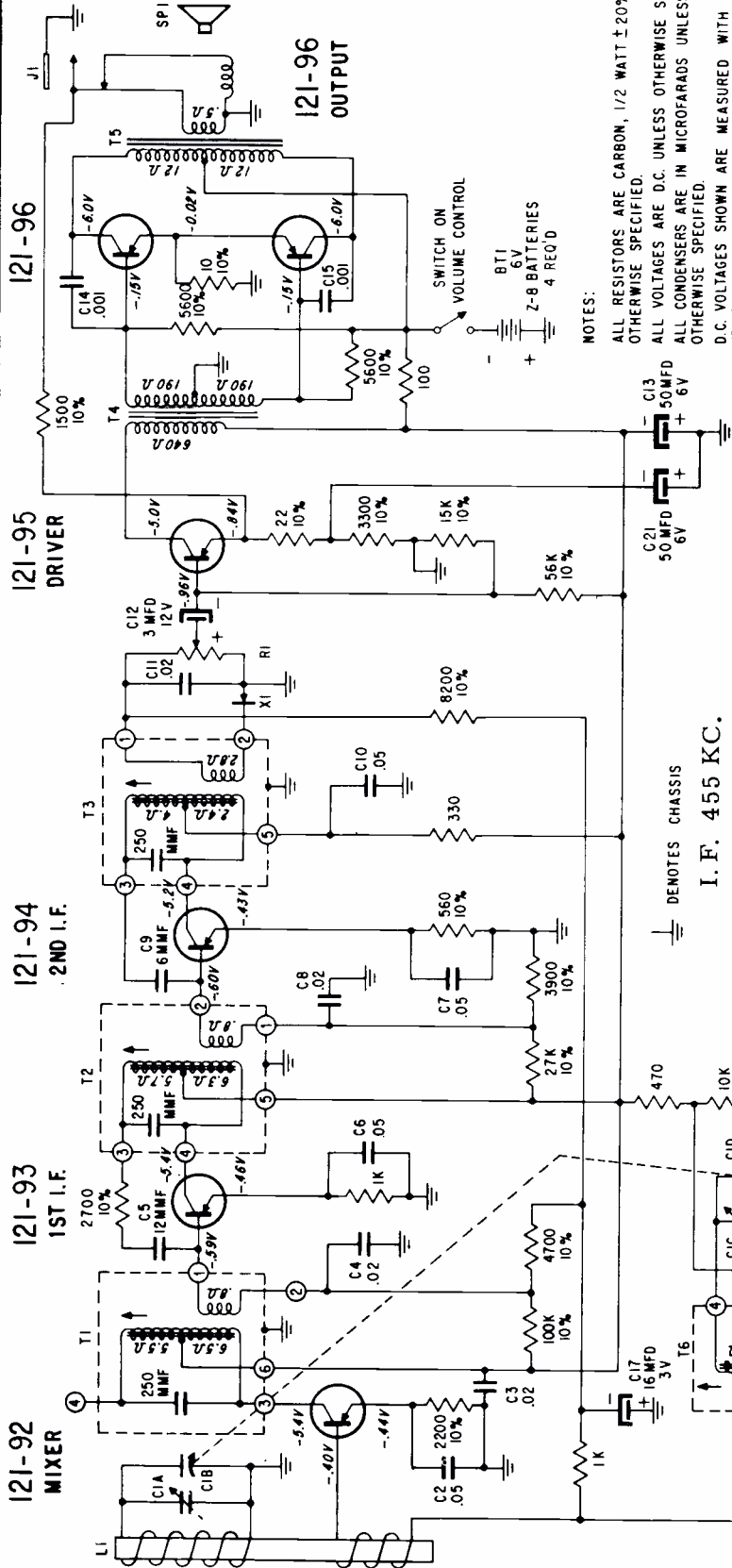

NOTES:
ALL RESISTORS ARE CARBON, 1/2 WATT ±20% UNLESS OTHERWISE SPECIFIED.
ALL VOLTAGES ARE D.C. UNLESS OTHERWISE SPECIFIED.
ALL CONDENSERS ARE IN MICROFARADS UNLESS OTHERWISE SPECIFIED.
D.C. VOLTAGES SHOWN ARE MEASURED WITH NO SIGNAL USING AN A.C.-D.C. OR VACUUM TUBE VOLTMETER.

CHASSIS INFORMATION CHART

Chassis	Transistor Layout Label Color	Part No.	Mixer	Osc.	1st I.F.	2nd I.F.	Crystal Diode Detector	Driver	Output-Output	Supplier
7AT48Z	Red 102-4234 or 102-4861	Zenith RETMA Type	121-92 2N485 PNP	121-91 2N483 PNP	121-93 2N483 PNP	121-94 2N482 PNP	103-19 1N87G	121-95 2N362 PNP	121-96 2N632 Matched Pair PNP	Raytheon
7AT48Z2	Black 102-4007 or 102-4862	Zenith RETMA Type	121-62 2N411 PNP	121-65 2N409 PNP	121-73 2N409 PNP	121-74 2N409 PNP	103-19 1N87G	121-64 PNP	Matched Pair PNP	R.C.A.
7AT48Z4	Green 102-4235	Zenith RETMA Type	121-83 2N414 PNP	121-82 2N413 PNP	121-79 2N413A PNP	121-80 2N413A PNP	103-19 1N87G	121-81 2N383 PNP	121-84 2N383 Matched Pair	Tung Sol

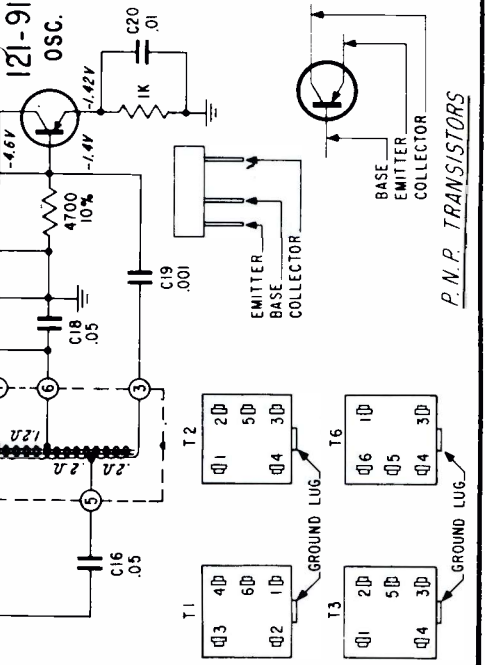

ZENITH RADIO CORPORATION

Model "Royal 750L" -- Chassis 8AT41Z2

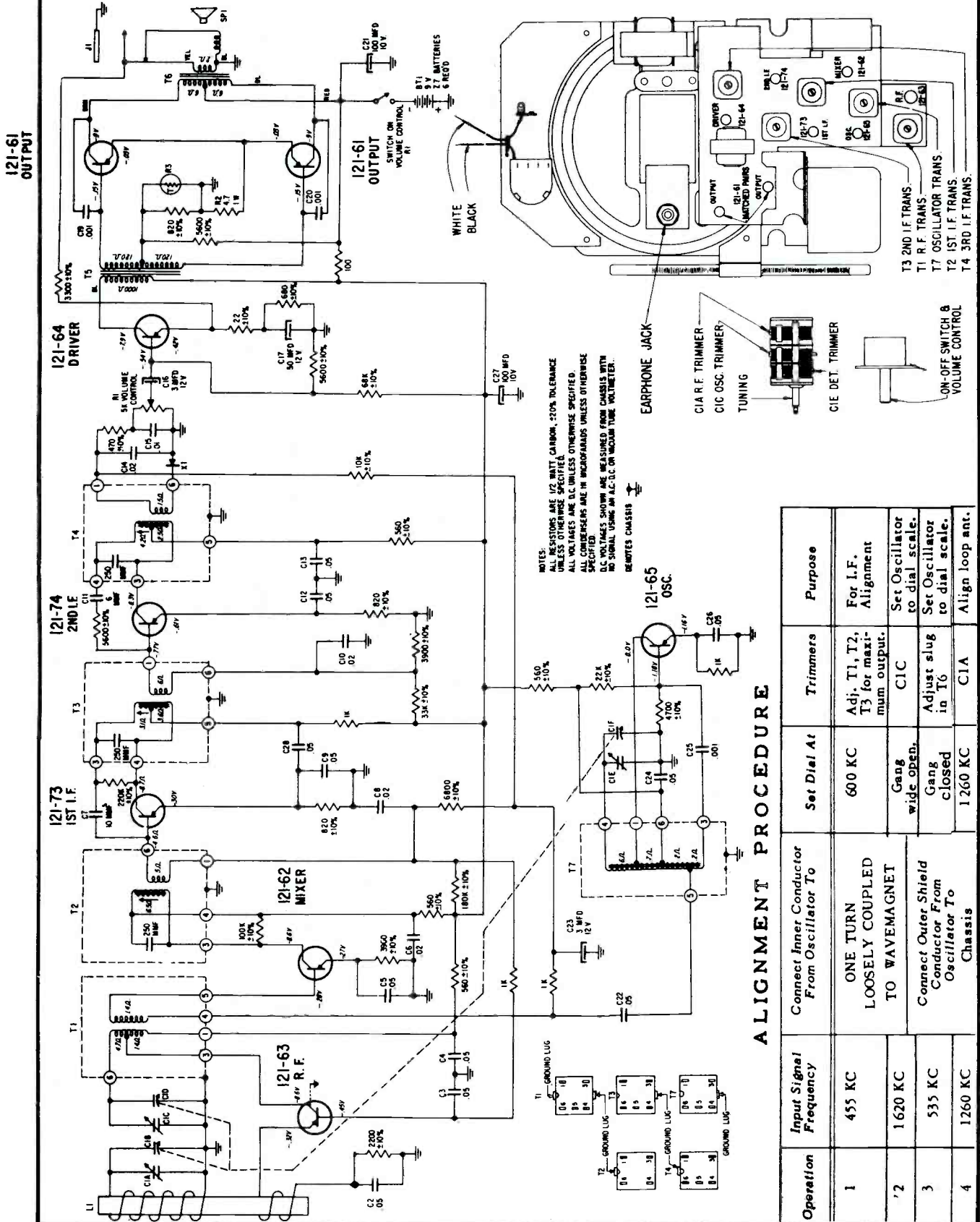

ALIGNMENT PROCEDURE

Operation	Input Signal Frequency	Connect Inner Conductor From Oscillator To	Set Dial At	Trimmers	Purpose
1	455 KC	ONE TURN LOOSELY COUPLED TO WAVEMAGNET	600 KC	Adj. T1, T2, T3 for maximum output.	For I.F. Alignment
2	1620 KC	Connect Outer Shield Conductor From Oscillator To Chassis	Gang wide open.	C1C	Set Oscillator to dial scale.
3	535 KC		Gang closed	Adjust slug in T6	Set Oscillator to dial scale.
4	1260 KC		1260 KC	C1A	Align loop ant.

121-96
OUTPUT

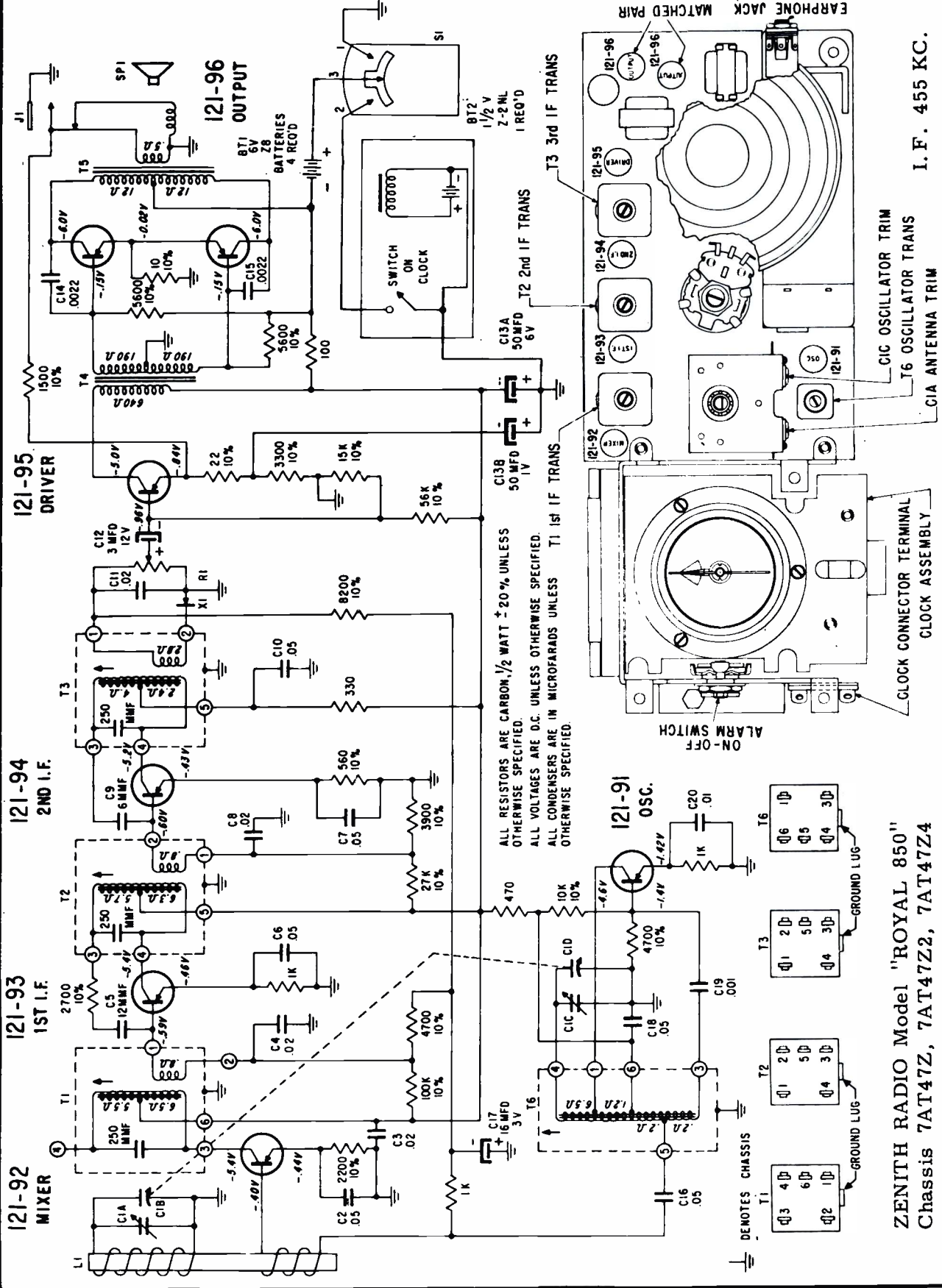

ZENITH RADIO Model "ROYAL 850"
Chassis 7AT47Z, 7AT47Z2, 7AT47Z4

I. F. 455 KC.

ZENITH RADIO CORP.

MODEL "ROYAL 760" RADIO CHASSIS 8AT42Z2

(Alignment information on page 189)

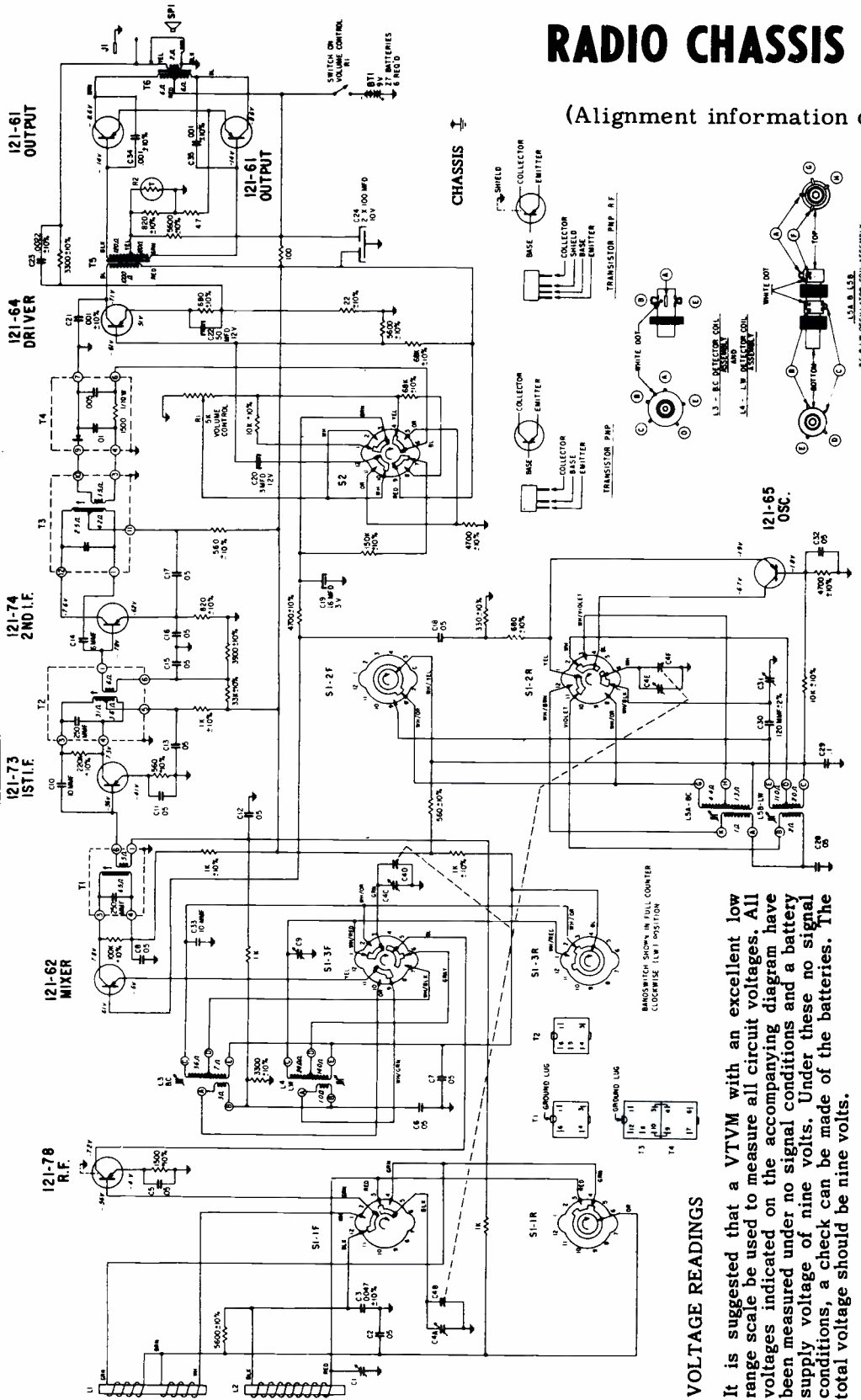

VOLTAGE READINGS

It is suggested that a VTVM with an excellent low range scale be used to measure all circuit voltages. All voltages indicated on the accompanying diagram have been measured under no signal conditions and a battery supply voltage of nine volts. Under these no signal conditions, a check can be made of the batteries. The total voltage should be nine volts.

COMPONENT REPLACEMENT

When soldering components at the base of the transistor socket, it is suggested that the transistor be removed to avoid any possibility of excessive heat being transferred through the socket to the transistor. When soldering the low voltage electrolytics and germanium diodes, it is suggested that the wire be held with a pair of long nose pliers while soldering. The long nose pliers will act as a heat sink.

NOTES:

- ALL RESISTORS ARE 1/2 WATT. CARBON ±20% TOLERANCE UNLESS OTHERWISE SPECIFIED.
- ALL VOLTAGES ARE D.C. UNLESS OTHERWISE SPECIFIED.
- ALL CONDENSERS ARE IN MICROFARADS UNLESS OTHERWISE SPECIFIED.
- D.C. VOLTAGES SHOWN ARE MEASURED FROM CHASSIS WITH BANDSWITCH IN BROADCAST POSITION AND NAVIGATE NORMAL SWITCH IN NORMAL POSITION WITH NO SIGNAL USING AN A.C. D.C. OR VACUUM TUBE VOLTMETER.

TRANSISTOR & TRIMMER LAYOUT FOR 8AT42Z2

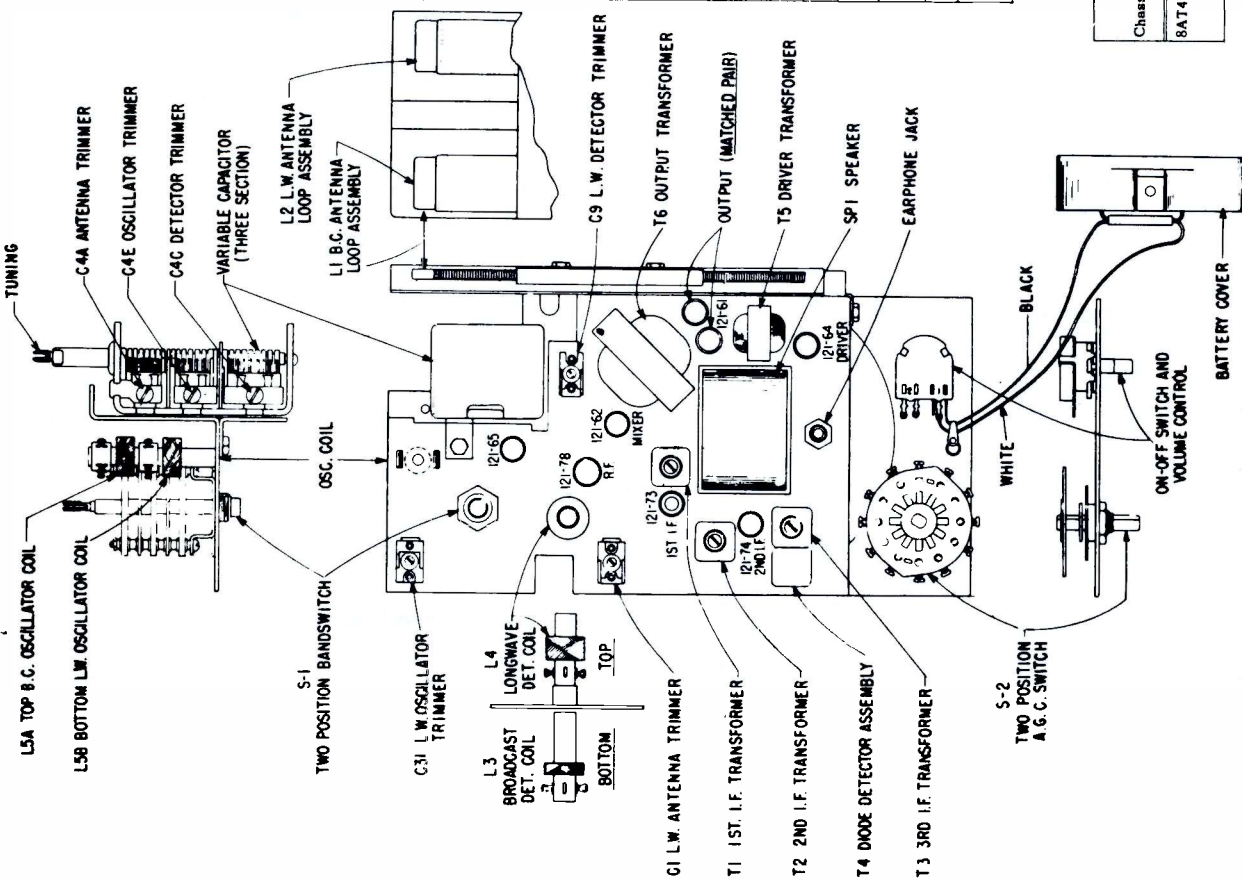

ZENITH RADIO CHASSIS 8AT42Z2
MODEL "ROYAL 760"
 (Continued from page 188)

ALIGNMENT PROCEDURE

NOTE: Alignment must be made with *Nor.* - Nav. switch in *Nor.* position.

OPER.	CONNECT GEN. TO DUMMY ANTENNA	INPUT SIG. FREQUENCY	BAND	SET DIAL AT	TRIMMERS	PURPOSE
1	One turn loop coupled loosely to Broadcast Wavemagnet	455 Kc	BC	1600 Kc	T1, T2, T3	Align I.F.
* 2	One turn loop coupled loosely to Broadcast Wavemagnet	600 Kc	BC	600 Kc	Rock Gang, Adjust L5A	Alignment of BC at 600 Kc
3	One	1600 Kc	BC	1600 Kc	C4E	Set osc. to scale
REPEAT OPERATIONS 2 & 3						
4	Turn Loop Coupled	600 Kc	BC	600 Kc	Rock, Adjust L3	Alignment of BC detector at 600 Kc
* 5	Loosely to Broadcast Wavemagnet	1400 Kc	BC	1400 Kc	C4C	Alignment BC detector
6	One	1400 Kc	BC	1400 Kc	C4A	Alignment of BC antenna
REPEAT OPERATIONS 5 & 6						
* 7	One turn coupled loosely to Long Wave Wavemagnet	165 Kc	LW	165 Kc	Rock Gang, Adjust L5B	Alignment of LW at 165 Kc
* 8	One	400 Kc	LW	400 Kc	C31	Set osc. to scale
REPEAT OPERATIONS 9 & 10						
9	Turn Loop Coupled	165 Kc	LW	165 Kc	Rock, Adjust L4	Alignment LW detector at 165 Kc
* 10	Loosely to Long Wave Wavemagnet	370 Kc	LW	370 Kc	C9	Alignment LW detector
REPEAT OPERATIONS 12 & 13						
11	One	370 Kc	LW	370 Kc	C1	Alignment of LW antenna
REPEAT OPERATIONS 9 & 10						
* 12	Turn Loop Coupled	165 Kc	LW	165 Kc	Rock, Adjust L4	Alignment LW detector at 165 Kc
* 13	Loosely to Long Wave Wavemagnet	370 Kc	LW	370 Kc	C9	Alignment LW detector
REPEAT OPERATIONS 12 & 13						
14	One	370 Kc	LW	370 Kc	C1	Alignment of LW antenna
15	One	370 Kc	LW	370 Kc	C1	Alignment of LW antenna

* NOTE: Rock tuning condenser when making alignment under Operations 2, 5, 9, 10, 12, 13.

Chassis	Chassis Color Dot	Transistor Layout Label Color	Part No.	R.F. Mixer	Osc.	1st I.F.	2nd I.F.	Crystal Diode Detector	Driver	Output-Output	Supplier
8AT42Z2	Black	Black 102-3497	Zenith Type	121-78 PNP	121-62 PNP	121-65 PNP	121-73 PNP	103-22 IN 295	121-64 PNP	121-61 PNP	R.C.A. Matched PNP

Index

<p>Admiral Corp.</p> <p>4S2 6</p> <p>5T4A 9</p> <p>5W4 3</p> <p>6T2 4</p> <p>7N1 6</p> <p>7N1A 6</p> <p>8M1 5</p> <p>8S1 8</p> <p>8S1A 8</p> <p>12B1,-A 9</p> <p>392 6</p> <p>393 6</p> <p>462 6-7</p> <p>463 6-7</p> <p>521 4</p> <p>528 4</p> <p>561 8</p> <p>566 8</p> <p>581 3</p> <p>582 3</p> <p>632 9</p> <p>633 9</p> <p>634 9</p> <p>642 9</p> <p>643 9</p> <p>644 9</p> <p>649 9</p> <p>654 9</p> <p>662 9</p> <p>663 9</p> <p>664 9</p> <p>671 9</p> <p>801 5</p> <p>802 5</p> <p>808 5</p> <p>811 8</p> <p>816 8</p> <p>American Motors</p> <p>8990576 69</p> <p>8990582 68</p> <p>Arvin</p> <p>2581 13</p> <p>2584 15</p> <p>2585 12</p> <p>3588 14</p> <p>5583 15</p> <p>8581 17</p> <p>8583 17</p>	<p>Arvin, Cont.</p> <p>8584 16</p> <p>1.43700 17</p> <p>1.43800 13</p> <p>1.43900 17</p> <p>1.44100 15</p> <p>1.44200 15</p> <p>1.44600 16</p> <p>1.45000 12</p> <p>1.45200 14</p> <p>Buick</p> <p>981968 18-19</p> <p>981969 30-31</p> <p>981970 20-21</p> <p>Chevrolet</p> <p>987888 22-23</p> <p>987891 24-25</p> <p>987893 30-31</p> <p>Delco</p> <p>981968 18-19</p> <p>981969 30-31</p> <p>981970 20-21</p> <p>987888 22-23</p> <p>987891 24-25</p> <p>987893 30-31</p> <p>988976 26-27</p> <p>988977 30-31</p> <p>988978 20-21</p> <p>989170 28-29</p> <p>989171 30-31</p> <p>989172 20-21</p> <p>Emerson Radio</p> <p>834X 33</p> <p>877 32</p> <p>888 34</p> <p>890 33</p> <p>891B 33</p> <p>892A 33</p> <p>893B 33</p> <p>894B 33</p> <p>895B 35</p> <p>896B 37</p> <p>898B 38</p> <p>902 37</p> <p>903 38</p> <p>970 37</p> <p>also 38</p>	<p>Emerson, Cont.</p> <p>971,A 37</p> <p>also 38</p> <p>999 36</p> <p>999R 36</p> <p>120392B 32</p> <p>120394B 33</p> <p>120399B 33</p> <p>120416 34</p> <p>120430B 33</p> <p>120431B 35</p> <p>120432B 33</p> <p>120433B,R 36</p> <p>120455B 37</p> <p>120456B 38</p> <p>120459B 37</p> <p>120462B 38</p> <p>Ford</p> <p>B9FA-18805E</p> <p>B9FA-18806B</p> <p>B9FA-18806C</p> <p>pages 70 & 71</p> <p>General-Elect.</p> <p>AS2 56</p> <p>AS15A 59</p> <p>AS16A 59</p> <p>T105A 39</p> <p>T106A,B 39</p> <p>T107B 39</p> <p>T115A 40</p> <p>T116A 40</p> <p>T120A,B 41</p> <p>T125A 42</p> <p>T126A 42</p> <p>T127A 42</p> <p>T130A,B 43</p> <p>T131A,B 43</p> <p>T132A,B 43</p> <p>T135A 44</p> <p>T210A 45</p> <p>C400A 46</p> <p>C401A 46</p> <p>C405A,B 47</p> <p>C406A,B 47</p> <p>C435A 48</p> <p>C440A 49</p> <p>C441A 49</p> <p>P671A,B 54</p> <p>P672A,B 54</p> <p>P673A,B 54</p> <p>P674B 54</p>	<p>G E Continued</p> <p>P715,B,D 50</p> <p>P716,B,D 50</p> <p>P725B 51</p> <p>P726B 51</p> <p>P735A 52</p> <p>P736A 52</p> <p>P755A 53</p> <p>P805 53</p> <p>P806 53</p> <p>RP1110A 55</p> <p>RP1120A,B 56</p> <p>RP1160A 57</p> <p>RT1230A 58</p> <p>RT1231A 58</p> <p>Granco</p> <p>601 60</p> <p>701 61</p> <p>Montgomery Ward</p> <p>H-667P5 160</p> <p>GEN-1115A 62</p> <p>GEN-1116A 62</p> <p>GTM-1117A 160</p> <p>1120A,B 63</p> <p>GEN-1628A 64</p> <p>Motorola</p> <p>2F11B,R 87</p> <p>2F12N,W 87</p> <p>3F13B,W 87</p> <p>5C11E 84</p> <p>5C12M,P,W 84</p> <p>5C13+ 85</p> <p>5C14+ 85</p> <p>5C16NW,W 85</p> <p>5C15+ 86</p> <p>5K11+ 89</p> <p>5P21B,N,R 78</p> <p>5P22+ 81</p> <p>5P23+ 81</p> <p>5R14N 88</p> <p>5T11G,M 82</p> <p>5T11R,W 82</p> <p>5T12+ 83</p> <p>5T13+ 83</p> <p>6K13+ 90</p> <p>6P25E,N,S 79</p> <p>6T15N,S 93</p> <p>6X28B,N 80</p>	<p>Motorola, Cont.</p> <p>6X28P,W 80</p> <p>7X23E 94</p> <p>7X24S,W 94</p> <p>7X25P,W 91</p> <p>8X26E,S 92</p> <p>9AX 65</p> <p>BKA9X 66</p> <p>CTA9X 66</p> <p>CTM9X 67</p> <p>OEA9X 68</p> <p>PCA9X 66</p> <p>SF11B,N 95</p> <p>SH12E,N,S 96</p> <p>S21B,+ 97</p> <p>SK21B,+ 97</p> <p>SK23B,+ 97</p> <p>93MR 68</p> <p>94MA 69</p> <p>94MF 70</p> <p>94MFM 70</p> <p>95MF 71</p> <p>300X 72</p> <p>301X 73</p> <p>406 74</p> <p>HS-633 78</p> <p>HS-637 79</p> <p>HS-638 80</p> <p>HS-647 81</p> <p>HS-652 82</p> <p>HS-653 83</p> <p>HS-654 83</p> <p>HS-658 84</p> <p>HS-660 85</p> <p>HS-661 85</p> <p>HS-662 86</p> <p>HS-663 85</p> <p>HS-666 87</p> <p>HS-667 87</p> <p>HS-668 87</p> <p>HS-670 88</p> <p>HS-673 89</p> <p>HS-675 90</p> <p>HS-678 91</p> <p>HS-679 92</p> <p>HS-680 93</p> <p>HS-688 94</p> <p>GV-701 75</p> <p>HS-703 95</p> <p>HS-704 96</p> <p>HS-735 97</p> <p>GV-800 76</p>
--	--	---	--	---

VOLUME R-19, MOST-OFTEN-NEEDED 1959 RADIO SERVICING INFORMATION

Motorola, Cont.	Pontiac	Sylvania, Cont.	Westinghouse+	Westinghouse+
8990576 69	988976 26-27	1107 137	H-46AC3 166	V-2506-2 167
8990582 68	988977 30-31	1108 138	H-48SE1 168	V-2506-3 167
	988978 20-21	1303 139	H-48SE2 168	
Oldsmobile		1304 140	H-48SE3 168	Zenith Radio
989170 28-29	RCA Victor	2108 137	H-48SE4 168	SRS2 172
989171 30-31	1BT2 131	2109 138	H-48SE5 168	3B30 170-171
989172 20-21	1BT3 132	2305 140	HR102S 164	3Z04 169
	AK-1 127	4312 136	HR103S 164	4B22 170
Olympic Radio	C-1 133	4413 142	HF-110AN 165	4B23 170
688 98	X-1 133	4416 141	HF-111AN 165	4B24 172
	SA-2 124	4419 141	H-629T4A 151	4B25 172
Packard-Bell	X-2 133	4422 142	H-630T4A 151	5B01 173
5R5 99	BC-3 131		H-631T4A 151	5B04 174
6RT2 100	SA-3 124	Trav-ler	H-632T5A 154	5B06 174
	BCS-4 131	48-314 143	H-633T5A 154	5B10 175
Philco Corp.	SES-6 128	90-105 144	H-636T6A 155	5B11 175
T-3 (early) 101	9TX2 130	TR-280A 143	H-637T6A 155	5B20 176
T-3 (late) 102	SHP-11 126	TR-281A 143	H-649T7A 156	5B22 177
T-4 103	SHS-11 126	TR-282A 143	H-650T7A 156	5B24 178
T-4J 103	SHP-12 127	TR-283A 143	H-655P5 157	6B05 179
T-5 104	SHP-13 127		H-656P5 157	6B06 180
T-6 110	SHP-14 129	Truetone, see	H-657P5 157	BP6B,L,V 181
T-7X 105	HF-99 125	Western Auto	H-659P4 158	7A03 182
T-60 106	RS-151B 124		H-660P4 158	7AT44Z1 190
T-65 107	RS-157D 125	United Motors	H-662P4 159	7AT45Z1 185
T-75 108	RS-171A 126	see Delco	H-663P4 159	7AT47Z 187
RT-150 122	RS-172 127		H-664P4 159	7AT47Z2 187
RT-202 109	RS-175 128	Wards, see	H-666P5 160	7AT47Z4 187
T-600 110	RS-175A 129	Montgomery	H-667P5 160	7AT48Z 184
G-681 111	RC-1156C 130		H-677T4 152	7AT48Z2 184
H-691 112	RC-1187 131	Webcor	H-678T4 152	7AT48Z4 184
G-749 113	RC-1187A 132	14X278-1 145	H-679T4 152	BP7F 181
G-751 113	RC-1188 133	14X278-2 145	H-681T5 161	8AT41Z2 186
G-753 113	RC-1188A 133	14X280-1 146	H-682T5 161	8AT42Z2 188
G-755 113		14X280-2 148	H-683T5 161	SRS10 178
G-820 114	Roland	14X307 147	H-685P8 162	SRS15 178
G-822 114	71-483 134	73X014-1 145	H-686P8 162	HF110G,J 169
G-824 114		1953 145	H-690P5 163	SF112 172
G-826 114	Spartan	1954-1 146	H-693P8 153	HF116E,R 176
G-828 114	51-01 135	1956 147	H-694P8 153	HF117 177
G-974 115	51-04 135	1963 148	H-695P8 153	HF118 177
G-978 116	51-07 135	1991 145	V-2239-6 152	SF174R 170
SA-1000 120	51-09 135		V-2239-7 151	SF177E,R 170
G-1407 119	51-11 135	Western Auto	V-2278-5 153	200 184
G-1409 118		D2832A 149	V-2390-4 154	450 185
G-1410 117	Sylvania Elec.	D2832B 149	V-2391-6 155	B509C,+ 175
SA-1500 122	1-609-7 136	D2834A 149	V-2392-4 156	B511B,+ 175
G-1606,S 120	1-629-1,2 137	D2834B 149	V-2393-1 157	B513F,L 173
G-1706,S 122	1-630-1,2 138	DC2988A 150	V-2394-1 158	B513V,Y 173
G-1707,S 122	1-631-1 139	DC2989A 150	V-2394-2 159	B514F,+ 174
G-1708S 121	1-632-1,2 140		V-2394-3 160	B515B,+ 174
G-1806S 121	1-639-1 136	Westinghouse	V-2395-1 161	B615,F,+ 179
G-1807S 121	1-640-1 141	H-44AC1A 167	V-2396-1 162	HF660 180
G-1808S 121	1-642-1 141	H-44AC2A 167	V-2397-1 163	B728C,+ 182
G-1809S 121	1-645-1 142	H-45AC1A 167	V-2502-5 164	750L 186
G-1811S 121	SC03 136	H-45AC2A 167	V-2503-2 165	760 188-189
G-1813S 121		H-46AC1 166	V-2503-3 166	850 187
SA-2000 121		H-46AC2 166	V-2503-5 168	900 190

Another
Supreme Publications
Service Manual

Supreme Publications are Available at All Leading Parts Jobbers