

SHORT WAVE CRAFT

Edited by
HUGO GERNSBACK

*Best Short Wave
Station List
of the World*

**When to hear
the
Foreign Stations**

**ALL IN THIS
ISSUE**

*P 678
Inductance
Charts*

**MARCH
1933**

**AUSTRALIA -
B'GOSH!!!**



**NOW
25¢
IN CANADA
30¢**

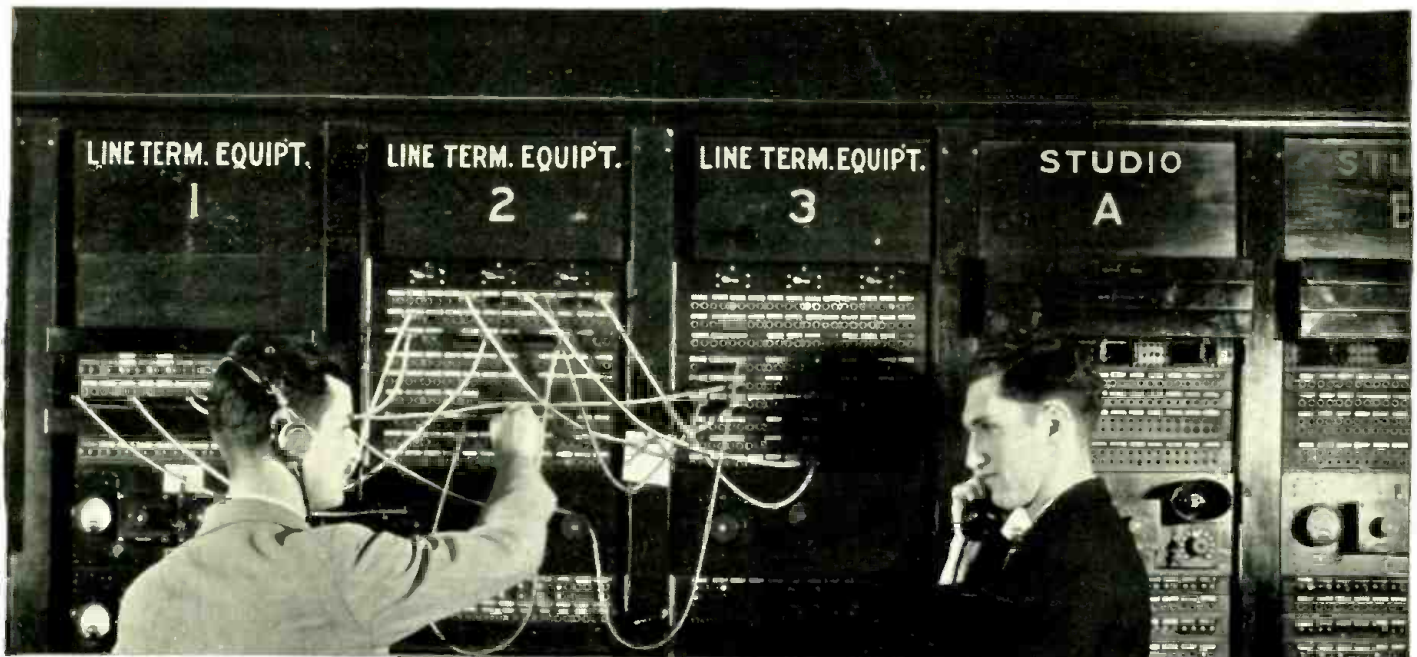

Courtesy of the National Broadcasting Company

WHAT YOU NEED TO S U C C E E D I N R A D I O

RADIO is a highly specialized business. As it develops it is becoming more exacting in its demands. But radio is the modern field of opportunity for those who keep step with its progress and pioneer in its opportunities!

There is a great need for *trained* men in the radio industry. There is no place for *untrained* men. Experience must be accompanied by technical knowledge.

A pioneer in home study, the International Correspondence Schools have kept pace of the times and offer courses prepared by authorities, which give practical instruction in fundamentals and latest developments alike. The courses are revised regularly.

Composed of 24 basic divisions, the Complete Radio Course is designed to give thorough instruction in the whole field of radio. The I. C. S. Radio Servicing Course was prepared specially for men who wish to become service experts. Study of it makes possible leadership over competition. The I. C. S. Radio Operating Course is vital to mastery of operating and transmitting.

We will be pleased to send you details of any or all of these subjects. Just mark and mail the coupon—the information will be forwarded without delay. Why not do it today—*now!*

I N T E R N A T I O N A L C O R R E S P O N D E N C E S C H O O L S

BOX 2977-D, SCRANTON, PA.

Without cost or obligation, please tell me all about the **NEW RADIO COURSE**

Name _____ Age _____

Street Address _____

City _____ State _____

If you reside in Canada, send this coupon to the International Correspondence Schools Canadian, Ltd., Montreal, Canada

I Will Show You Too

How to Start a Spare Time or Full Time Radio Business of Your Own Without Capital



J. E. SMITH, President
National Radio Institute

The man who has directed the Home Study Training of more men for the Radio industry than any other man in America.

Here are a few examples of the kind of money I train "my boys" to make

Started with \$5 Now has Own Business



that is play."—Howard Houston, Route No. 2, Box 454 E, Tucson, Arizona.

"I started in Radio with \$5. purchased a few necessary tools, circulated the business cards you gave me and business picked up to the point where my spare time earnings were my largest income. Now I am in business for myself. I have made a very profitable living in work

\$700 in 5 Months Spare Time



"Although I have had little time to devote to Radio my spare time earnings for five months after graduation were approximately \$700 on Radio, sales, service and repairs. I owe this extra money to your help during the time I studied and since graduation."—Charles W. Linsey, 537 Elati St., Denver, Colo.

\$7396 Business in 2 1/2 Months

"I have opened an exclusive Radio sales and repair shop. My receipts for September were \$2,332.16, for October \$2,887.77 and for the first half of November, \$2,176.32. My gross receipts for the two and one-half months I have been in business have been \$7,396.25. If I can net about 20% this will mean a profit of about \$1,500 to me."—John F. Kirk, Kirk Sales and Service, Union Block, Spencer, Iowa.

My Free book gives you many more letters from N. R. I. men who made good in spare time or full time businesses of their own.

.. NEW Radio Equipment for Broad Practical Experience Given Without Extra Charge

With the aid of this equipment you can work out with your own hands many of the things you read in our text books. From it you get the valuable experience that tells an expert from a beginner. In a short time you have learned what it would take years to learn in the field. It's training like this that puts the extra dollars in your pay envelope. Some of the many circuits you build and experiments you perform are: Measuring the merit of a tube, building an ohmmeter, tube volt-meter, and a Grid dip meter for service work. You actually make experiments illustrating the important principles in the 25 best known sets.

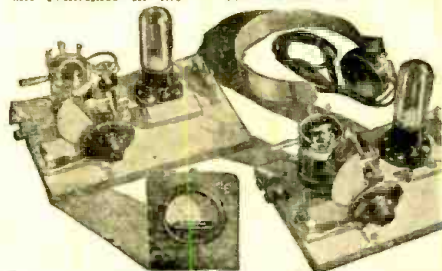

Without Capital

I give you instructions early in your Course for doing 28 Radio jobs common in every neighborhood. Many N. R. I. men begin making money soon after they enroll. I show you how N. R. I. graduates have built up good businesses of their own. I show you how to install and service all types of receiving sets. I give you radio equipment and instructions for building circuits, testing equipment, and for making tests that will give you broad, practical experience. I give you a Money-Back Agreement and Lifetime Employment Service. Clip the coupon below and get my free 64-page book, "Rich Rewards in Radio"—it gives you a full story of the success of other N. R. I. students and graduates, and tells how you can start a spare or full time Radio business of your own without capital.

Many N. R. I. Men Make \$5., \$10., \$15. a week in Spare Time While Learning

Many of the more than sixteen million sets now in use are only 25% to 40% efficient. I will show you how to cash in on this condition. I will show you how the plans and ideas that have enabled many others to make \$200 to \$1,000 in spare time while learning. G. W. Page, 1606-B Fifth Ave., N. Nashville, Tenn., writes: "I made \$935 in my spare time while taking your course."

Get Ready Now for a Radio Business of Your Own and for Jobs Like These

Broadcasting stations use engineers, operators, station managers, and pay up to \$5,000 a year. Radio manufacturers use testers, inspectors, foremen, engineers, service men, and buyers for jobs paying up to \$6,000 a year. Shipping companies use hundreds of operators, give them world-wide travel with board free and good pay besides. Radio dealers and jobbers employ hundreds of service men, salesmen, buyers, managers, and pay up to \$100 a week. Talking Movies pay as much as \$75 to \$200 a week to the right men with Radio training. My book tells you of the opportunities in Radio, Talking Movies, Set Servicing, Aircraft Radio, and other fields.

I Will Train You at Home in Your Spare Time

Hold your job until you're ready for another. Give me only part of your spare time. You do not need a high school or college education. Hundreds with only a common school education have won bigger pay through N. R. I. J. A. Vaughn jumped from \$35 to \$100 a week. The National Radio Institute is the Pioneer and World's Largest organization devoted exclusively to training men and young men by Home Study for good jobs in the Radio industry.

You Must Be Satisfied

I will give you an agreement to refund every penny of your money if you are not satisfied with my Lessons and Instruction Service when you complete my course. And I'll not only give you thorough training in Radio principles, practical experience in servicing sets, but also Advanced Training in any one of five leading branches of Radio opportunities.

My 64-Page Book Gives the Facts

Clip and mail the coupon now for "Rich Rewards in Radio." It points out the money-making opportunities the growth of Radio has made for you. It tells of the opportunities for a spare time or full time Radio business of your own, the special training I give you that has made hundreds of other men successful; and also explains the many fine jobs for which my course trains you. Send the coupon to me today. You won't be obligated in the least.

Get my new book It points out what Radio Offers You



J. E. SMITH, President
Dept. 3cB3
National Radio Institute
Washington, D. C.

THIS COUPON IS GOOD FOR ONE FREE COPY OF MY NEW BOOK mail it TODAY

J. E. SMITH, President,
National Radio Institute, Dept. 3cB3
Washington, D. C.

Dear Mr. Smith: I want to take advantage of your Special Offer. Send me your manual "Trouble Shooting in D.C., A.C. and Battery Sets" and your book "Rich Rewards in Radio," which explains Radio's Opportunities for bigger pay and your method of training men at home in spare time. I understand this request does not obligate me.

Name.....
Address.....
City..... State.....

Special Free Offer

Act now and receive in addition to my big free book, "Rich Rewards in Radio," this Service Manual on D.C., A.C., and Battery operated sets. Only my students could have this book in the past. Now readers of this magazine who mail the coupon will receive it free. Overcoming hum, noises of all kinds, fading signals, broad tuning, howls and oscillations, poor distance reception, distorted or muffled signals, poor Audio and Radio Frequency amplification and other vital information is contained in it. Get a free copy by mailing the coupon below.



Get the facts on my Lifetime Employment Service to all Graduates

IN THIS ISSUE: PROMINENT SHORT-WAVE AUTHORS
Schliephake • Millen • Hertzberg • Reinartz • Denton • Martin • Palmer



HUGO GERNSBACK
Editor

H. WINFIELD SECOR
Managing Editor

CONTENTS FOR MARCH, 1933

FEATURES:

Editorial—Wanted: Short Wave Improvements, by Hugo Gernsback..... 645

Ultra-Short Waves In Medicine, by Dr. E. Schliephake (Berlin)..... 646

Experimental 3/4 Meter Transmitters and Receivers, by James Millen, Of the National Company..... 648

5-Meter Waves Help Fire-Fighters, by Robert Hertzberg..... 650

The Beginner's 2-Tube "Go-Getter," by Harry D. Hooton..... 651

At Last! A 4-Tube Super-Het! By Clifford E. Denton More On The "Wunderlich" Detector—And The New "19" Amplifier Tube, by Louis Martin..... 652

How To Build A Power Amplifier, Short-Wave Beginner Series, by C. W. Palmer..... 656

The S-W Fan's Own 3-Tuber, by Clarence O. Wahner..... 660

The "Challenger" 9-Tube S-W Super-Het, by Harry Georges..... 668

How To Become A Radio Amateur—S-W Antennae, by John L. Reinartz, W1QP..... 674

S-W Tuning Inductance Charts—Direct Reading, by C. E. Denton..... 678

SHORT-WAVE RECEIVERS:

3/4 Meter Receivers, by James Millen, Of the National Company..... 648

5-Meter Receiver..... 650

The Beginner's 2-Tube "Go-Getter"..... 651

A 4-Tube Super-Het At Last!..... 652

AUTOMATIC VOLUME CONTROL With The "Wunderlich" Detector..... 654

How To Build A Power Amplifier—for the Battery Type S-W Beginner's Receiver, by C. W. Palmer.... 656

Find-All de Luxe S.W. Converter, by H. G. Cisin, M.E..... 658

The S-W Fan's Own 3-Tuber..... 660

The 2-Tube "Old Reliable," by Elmer A. Simmons..... 663

"Challenger" 9-Tube S-W Super-Het..... 668

Receiver Tuning Inductances—How To Find Number of Turns—Direct Reading Charts..... 678

SHORT WAVE TRANSMITTERS:

3/4 Meter Transmitters, by James Millen, Of the National Company..... 648

5-Meter Transmitter, Portable Type..... 650

A "Fly-Power" 20-Meter Transmitter, by Harry D. Hooton..... 664

A Condenser "Mike" For 10 Cents! By William J. Vette..... 665

Improving Your "Keying" With An Audio Oscillator, by A. Hazelton Rice, Jr..... 667

Short-Wave Transmitting Antennas, by John L. Reinartz, W1QP—No. 8 of a Series, "How To Become A Radio Amateur"..... 674

FOR THE BROADCAST LISTENER:

4-Tube Super-Het!..... 652

The "Find-All" de Luxe S.W. Converter..... 658

"Challenger" 9-Tube Super-Het..... 668

List of Short-Wave Stations of the World..... 670

MISCELLANEOUS:

Ultra-Short Waves In Medicine..... 646

5-Meter Waves Help Fire-Fighters..... 650

More On The "Wunderlich" Detector And the "19" Amplifier..... 654

FEATURES IN NEXT ISSUE

An Improved Super-Regenerative Receiver, by J. A. Grater.

An All-Purpose Receiver, by J. W. Cullen, W9CIN. This 2-tube instrument can be used as a portable receiver, test oscillator, wavemeter, monitor, modulated oscillator, or also as a low-power transmitter.

A New Form of Tuning Inductance—an interesting tuning device which combines a variable condenser with inductance, by Rinaldo de Cola.

A New Band-Switch Short-Wave Receiver, by Russell Harris.

The Crystal Detector Comes Back! by Hugo Gernsback.

The S.W.C. Readers' Ideal "Composite" Receiver, by Clifford E. Denton.

A High-Gain "2-Tube" S.W. Receiver, by H. V. MacMillan.

The New Lincoln R-9 S-W Receiver—Range 9 to 200 Meters.

Calibrate Your Wavemeter with a Lecher Wire System, by C. Bradner Brown.

Contents for MARCH—Continued

The New Hund "Filament-less" Tube..... 655

"Find-All" de Luxe Short-Wave Converter..... 658

Methods of Coupling To Speakers, by M. Harvey Gernsback..... 659

A "Quiet" A.C. Power-Pack For Small S.W. Receivers..... 662

A Condenser "Mike" For 10 Cents..... 665

Recording Altitude Variations In The K-H Layers..... 666

Short Wave Stations of the World..... 670

TELEVISION Stations..... 672

POLICE Short Wave Stations..... 672

SHORT WAVE LEAGUE..... 673

\$5.00 For Best Short Wave "KINK"..... 675

Letters From S-W Fans..... 676

S-W Tuning Inductance Charts—Direct Reading..... 678

Short Wave QUESTION BOX..... 680

When To Listen In..... 695

Swappers..... 702

Amateurs Who Made Good..... 703

OUR COVER

Australia! B'Gosh! Mr. Howard V. Brown has caught the spirit of the occasion when the young "Marconi" of the family lets out a shout of joy at 5 A. M. in the morn, when Australia comes roaring in. The set shown is the 4-tube Super-Het. See page..... 652

SHORT-WAVE CRAFT—Monthly. Entered as second class matter May 7, 1930, at the post office at Mount Morris, Illinois, under the act of March 3, 1879. Trademarks and copyrights by permission of H. Gernsback, 98 Park Place, N. Y. C. Text and illustrations of this magazine are copyrighted and must not be reproduced without permission. SHORT WAVE CRAFT is published on the 15th of every month. Twelve numbers per year. Subscription price is \$2.50 a year in the United States and possessions. Canada and foreign countries, \$3.00 a year. Single copies 25c. Address all contributions for publication to Editor, SHORT WAVE CRAFT, 96-98 Park Place, New York, N. Y. Publishers are not responsible for lost manuscripts. Contributions cannot be returned unless authors remit full postage. SHORT WAVE CRAFT is for sale at all principal newsstands in the United States and Canada. European agents: Brentano's, London and Paris. Printed in U. S. A. Make all subscription checks payable to Popular Book Corporation.

COPYRIGHT, 1933, BY H. GERNSBACK

Published by **POPULAR BOOK CORPORATION**
 HUGO GERNSBACK, President - - H. W. SECOR, Vice-President
 EMIL GROSSMAN - - - - - Director of Advertising
 Chicago Adv. Office - - - L. F. McCLURE, 737 No. Michigan Blvd.
 Publication Office - - - 404 N. Wesley Avenue, Mount Morris, Ill.
 Editorial and General Offices - - 96-98 Park Place, New York, N. Y.
 London Agent: HACHETTE & CIE., 16-17 King William St., Charing Cross, W.C.2
 Paris Agent: HACHETTE & CIE., 111 Rue Reaumur
 Australian Agents: MCGILL'S AGENCY, 179 Elizabeth St., Melbourne

ONLY SCOTT *Laboratory Technique* GIVES SUCH RECEPTION~



The chassis of the SCOTT ALL-WAVE DELUXE is a thing of beauty. Finished in gleaming chromium plate it is dust-and-weather proofed to keep its tremendous power always ready for service. Within this chassis is the perfection resulting from tests such as the one shown at the right—which matches coils to their antennae exactly within the third of a turn of wire.

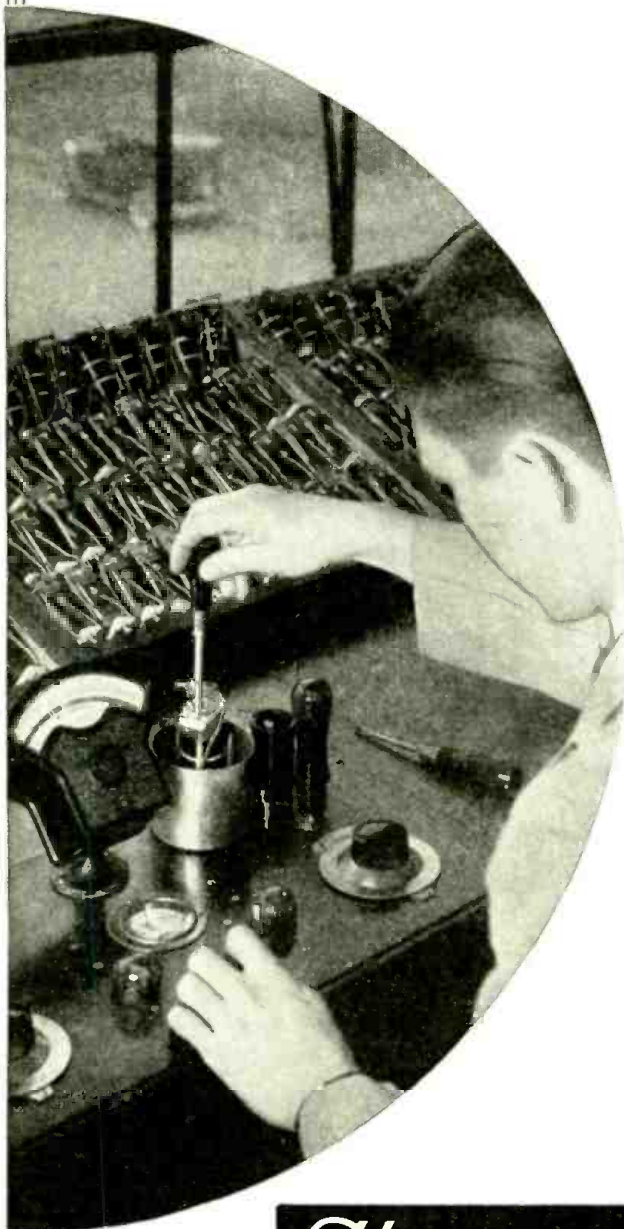

The New IMPERIAL GRANDE Console

Fittingly this newest addition to the group of distinctive SCOTT Consoles offers the most exquisite console for the world's finest receiver.

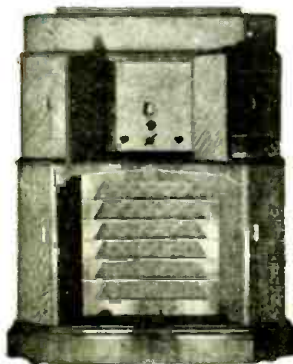

Of both Foreign and Domestic Stations

SCOTT Laboratory Technique begins with advanced engineering design . . . follows exacting specifications for every component part . . . includes custom construction by specially trained technicians who test and retest to assure the degree of perfection that gives SCOTT ALL-WAVE DELUXE Receivers the right to the title of "World's Finest Radio Receiver."

And how the SCOTT ALL-WAVE DELUXE lives up to its title! A twirl of its single dial brings magic music and the sounds of foreign tongues from stations 10,000 miles away as readily as it gives superior reproduction of familiar programs from homeland stations. Utter simplicity in changing from one wave band to another . . . just the turn of a switch—no plug-in coils, tapped coils or bothersome connections.

Tone . . . Sensitivity . . . Selectivity? What would you expect from a receiver known as "the world's finest"? Millions of words from us would bear less weight than the enthusiastic praise of SCOTT owners. More than 19,000 logs of foreign receptions have come to us from them within a year. In trial after trial SCOTT receivers continue to break all records for distance reception . . . for needle point selectivity . . . for gorgeous tone richness unrivalled in radio.

Before you buy any radio receiver learn all about the finest one . . . that is warranted to give true world-wide reception and every part of which (except tubes) is guaranteed for five years. You will be pleasantly surprised to find that, in spite of its custom-built superiority, a SCOTT ALL-WAVE DELUXE may be purchased for no more than many models of ordinary receivers.

E. H. SCOTT RADIO LABORATORIES, Inc.
4450 Ravenswood Avenue Dept. SWC-33
CHICAGO, ILLINOIS

Mail **The 15-550 METER SCOTT
ALL-WAVE Deluxe**
THIS COUPON FOR NEW BROCHURES

E. H. SCOTT RADIO LABORATORIES, INC.,
4450 Ravenswood Ave., Dept. SWC-33, Chicago, Ill.

Send me, without obligation, complete information about the new SCOTT ALL-WAVE DELUXE, including your new Brochures, "PROOF" and "The Creation of a Masterpiece."

Name.....
Address.....
Town.....
State.....



The World Is Yours with a

MIDWEST ¹⁶TUBE ALL-WAVE

Midwest Owner in Newfoundland Hears Trotsky in Copenhagen, Lord Lyttleton at Geneva and Picks up French, German and Italian Stations with Ease! Midwest 16-Tube Set Accomplishes What Nine Other Radios Could Not Do.

... and Mr. Hampton's experience is being duplicated daily by thousands of Midwest owners all over the world. Send for additional proof! The superlative performance of this powerful set has established entirely new records of radio reception. Clearness, selectivity, faithful reproduction of tone, tremendous volume under perfect control... a thousand new delights await the radio enthusiast who has never enjoyed the untold thrills of one hour with a Midwest 16-tube ALL-WAVE set.

With this masterpiece of radio engineering you can reach out to the far corners of the earth for the new, different and unique in broadcasting... or you can enjoy the programs of your favorite stations anywhere in the U. S., Canada or Mexico. Then when you've had your fill of jazz, classical music, daily news items, dialogs or the latest radio headlines, you can tune in police stations, airplanes in flight, ships at sea, amateurs, etc. A flip of a switch gives you your choice of the whole world of radio. Four distinct wave bands with a tuning range of 15 to 550 meters give you long or short wave broadcasts at home and from abroad... everything worth while that goes over the air

Only **\$39.95**
15 to 550 Meters
Completely Assembled with Large Dual Speakers

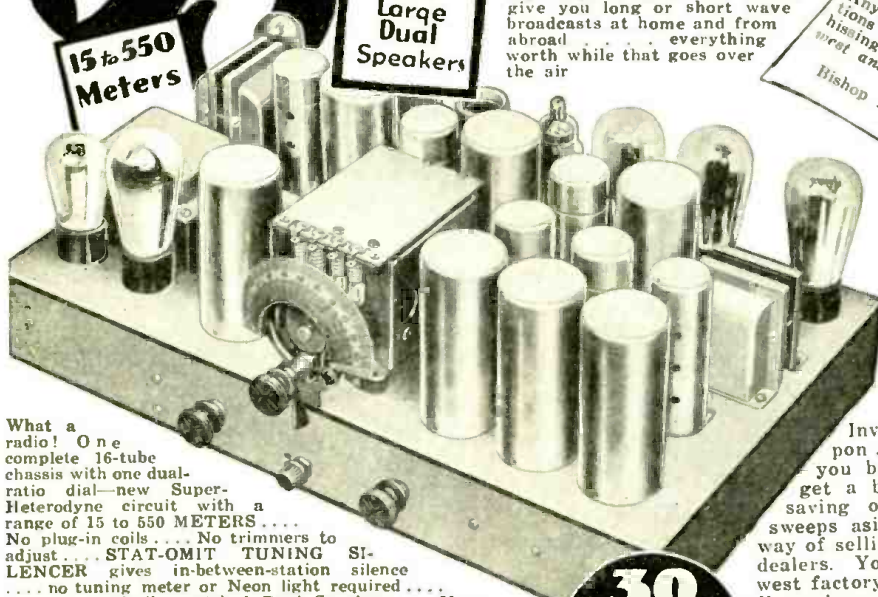

What a radio! One complete 16-tube chassis with one dual-ratio dial—new Super-Heterodyne circuit with a range of 15 to 550 METERS... No plug-in coils... No trimmers to adjust... STAT-OMIT TUNING SILENCER gives in-between-station silence... no tuning meter or Neon light required... Large acoustically matched Dual Speakers... New CLASS "B" PUSH-PUSH Super-Power Amplifier with six times the power of ordinary amplifiers... Full band Automatic Volume Control... Color-Lite Multi-Wave Band Selector... FULL FLOATING VARIABLE CONDENSER... Complete Scientific Shielding... Absolute tone fidelity... Image Frequency Suppressor... Fractional Microvolt Sensitivity... Latest TYPE TUBES, Super-Triodes, Dual and Triple Grids. Two Full Wave Rectifiers. DUAL POWERED—two separate power transformers. A bigger, better, more powerful, more selective, finer toned radio than you've ever seen before... offered at an amazingly low price direct from the big Midwest factory.

30 DAYS FREE TRIAL

Be convinced—TRY IT 30 DAYS before you decide to keep it. Don't send a penny. Mail coupon right now for amazing FREE trial offer and complete details. You'll be surprised.

MIDWEST RADIO CORP.
Dept. 195 (Est. 1920) Cincinnati, Ohio



Read This Letter

"Yesterday and today we have had Springfield on long wave since 3:00 p. m. U. S. Newfoundland time, or 1:30 I have been able to do before, or 1:30 U. S. A. time—something I have never had time to do before. I have any time after 3:00 p. m. although and time we can get French, German, Italian stations on long wave, speaking on short wave on Sunday, November 13th, on he would have heard Lord Lyttleton speaking on the China-Japan affair from Geneva. Anyone wishing to get far away stations hissing and frying, should without any effort and enjoy perfect radio." J. C. HAMPTON, Bishop Falls, Nfld., Dec. 2, 1932.



COMPLETE LINE OF NEW CONSOLES

The big new Midwest catalog shows gorgeous line of artistic consoles in the new all-lac design. Mail the coupon now. Get all the facts. Learn how you can save 30% to 50%.

Deal Direct With Factory
SAVE UP TO 50%

Investigate... mail the coupon... get all the facts before you buy a radio. Learn how to get a bigger and better set at a saving of 30% to 50%. Midwest sweeps aside the costly old-fashioned way of selling through distributors and dealers. You buy direct from the Midwest factory. You save all of the middlemen's profits. Mail the coupon now. Get the Midwest catalog. Learn about our sensationally low factory prices, easy payment plan and positive guarantee of satisfaction or money back. Mail the coupon, or write us a postal NOW!

RUSH THIS COUPON FOR AMAZING FREE TRIAL OFFER AND BIG BEAUTIFUL CATALOG

USER AGENTS
Easy EXTRA MONEY!
Check here for details

TERMS
as low as
\$5.00
DOWN

Midwest Radio Corp.
Dept. 195
Cincinnati, Ohio
Without obligation on my part send me your new 1933 catalog, and complete details of your liberal 30-day free trial offer. This is NOT an order.
Name _____ Address _____ Town _____ State _____



Wanted: Short Wave Improvements

An Editorial by HUGO GERNSBACK

● THERE seems to be an idea among many short-wave experimenters and constructors that everything worthwhile in short-wave radio has been invented, that the art has now settled down to a humdrum existence and that nothing more worthwhile need be invented.

Nothing could be further from the truth. No matter how good the average receiver that you build is, there is still a vast amount of work to be done before short-wave sets can approach in effectiveness broadcast receivers as we know them today.

This brings us face to face with the fact that the physical requirements of short-wave sets are of a totally different order than those of broadcast sets. The short waves, because of their enormously higher frequencies, present greater technical difficulties than the lower broadcast frequencies.

In this short talk, I shall only discuss a few of the more important problems which await solution. Inasmuch as the readers of *SHORT WAVE CRAFT* now number more than 80,000, there seems to be no reason why some of them could not solve one or more of these problems, and thus make the short waves more enjoyable and practical than they are today.

Automatic Volume Control

There is, for instance, the matter of *automatic volume control*. In the large 8 and 10 tube broadcast sets, the problem has been solved pretty well, but in the average short wave receiver, due to the smaller amount of energy which we obtain, the problem has not as yet been solved to our full satisfaction. I would suggest that experimenters work along these lines and see if, by means of some new hookups and with new tubes such as the Wunderlich and others, a distinct advance cannot be made along this particular line.

Automatic Regeneration

Then, we have the question of *automatic regeneration*, on which volumes could be written. It is a nuisance today to fiddle around with the regeneration control in order to strengthen the signal from a distant station, or indeed, to get the station at all. The control, usually effected by hand, is sometimes so critical that indeed it often requires an expert to bring in the station. What is sorely needed is a good *automatic regeneration control*, and while a number of experimenters are busily engaged in working out the problem, so far nothing worthwhile has been developed. The solution of this one problem alone will immediately command the attention and the pocketbook of all short wave experimenters and set-builders; it would also help the novice in operating his set.

Dead-Spot Elimination

Then, we have the matter of "dead-spots." These are usually caused by antenna absorption, and can be eliminated only by a troublesome adjustment of an aerial condenser. There are, however, other conditions that produce dead-spots which have nothing to do with the aerial. It should be possible to evolve a set in which dead-spots are

done away with entirely in an automatic manner, and the problem should not be so difficult of solution. Here is just one little hint that I might give on the subject. It is well known that when we use plug-in coils, we have as a rule to change the setting of the antenna variable condenser. There seems to be no reason why, for instance, a plug-in coil could not be provided with an extension which will press against a variable condenser of the leaf type, so that when different plug-in coils are used, the variable condenser would be automatically adjusted for that particular coil. I would like to see this idea worked out. It seems simple enough and easy for experimenters to put into use.

New Form of Band-Spreader Wanted

The nuisance of tuning is another bugaboo which has prevented the short waves from being adapted by the general public with the same enthusiasm as broadcasting. In short waves, it is necessary to tune exceedingly fine, and it requires a steady hand to do so until you learn the trick. There have been developed a large number of verniers which make tuning easier, but these, in my opinion, are not the solution. The solution lies in *band-spreading*. A number of articles on band-spreading have been published in the past, but even these ideas are mostly makeshift ones inasmuch as the band has still not been spread far enough apart and there are also other undesirable points which crop up when some of the band-spread systems in vogue now are used. What the radio public needs is an entirely new kind of band-spreader which will make the tuning of a short-wave set almost or just as easy as that of a broadcast set. The problem is not impossible of solution. It requires a good deal of experimentation, plus theoretical knowledge of coils, condensers and resistance to turn the trick. This problem alone, if successfully solved, will do more for the short waves than any one thing I can think of.

"Noise-Free" Antennas

The amount of noise heard at times in connection with short wave reception is notorious. Many fine programs are spoiled simply by extraneous man-made static. What is needed is a good *noise-free antenna*. While it is true that we have made considerable progress during the last year along these lines, by utilizing transposition lead-in systems, still the problem is not completely solved. In Europe, engineers are now beginning to construct shielded aerials, whereby a thin conductor is surrounded by a sort of rubber hose which has a woven metal sheath on the outside. Of course, such an antenna is expensive, and while it kills a good deal of extraneous noise, it is still not the ideal solution because of its capacity effect. A good deal of experimentation, to get away from this *man-made static* as far as aerials is concerned, is required, and the sooner such a system is evolved by our experimenters, the better will the future of short waves be.

SHORT WAVE CRAFT, of course, will be only too glad to receive new data on the foregoing. If anything worthwhile is found, the editors will be happy to present it to the rest of the readers for the benefit of all.

SHORT-WAVE CRAFT IS PUBLISHED ON THE 15th OF EVERY MONTH

This is the March, 1933, Issue - Vol. III, No. 11. The Next Issue Comes Out March 15th



Latest German ultra-short-wave apparatus in operation. Several different types and sizes of newest ultra-short-wave electrodes with special electrodes placed on chest and back of patient.

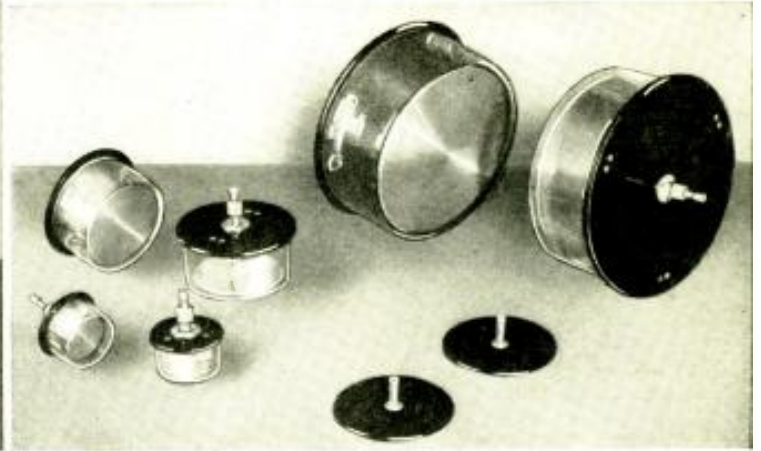

Ultra-Short Waves in Medicine

Latest Physiological Results Obtained and Treatment Described

● THE application of heat has long had great importance in medicine. The expanding of the capillaries at the warmed point and the stimulation of the cell metabolism are often able to decisively influence in a favorable manner the defensive action of the body against illness. By hot baths and compresses and by taking hot drinks, a heat effect can be produced, but this particular effect extends only to *superficial or relatively small areas*. To be sure, under a hot compress an expansion of even deeper-lying blood vessels can occur, but the heat applied hardly penetrates deeper than the subcutaneous fatty tissue, where it is carried away by the blood stream of the capillary network, which acts like a *cooler*. Such measures do not lead to a noteworthy rise in the blood temperature or else do so only very temporarily, for our heat regulation center located in the brain responds to the slightest rise in temperature and provides for the radiating of excess amounts of heat. Only in the case of failure of this heat regulator can it come to damming up of the heat and in certain cases *heat-stroke*.

Heat Effects Should Be Localized

Sharply differentiated from such an overheating of the body is *real fever*, which is produced through a stimulated condition of the *heat-center* by illness, under the influence of certain poisons and of a metabolism changed by illness.

If we wish to use heating for healing purposes, we can for one thing set about to bring the whole body to a higher temperature. It is, however, more important to apply the heat to very definite and specific parts.

By DR. E. SCHLIEPHAKE
(Berlin)

The heating of *deep-lying parts* is possible only through electricity. A direct current, which is sent through a human tissue, produces heat within it, the amount of which in a definite time depends on the resistance of the tissue and the square of the current intensity (I^2R). The use of direct current, however, encounters an objection in the excitability of our cells, especially our nerves; hence the danger of electric shock. This danger is also present in the case of the alternating currents generally used. Only at an extremely high frequency, more than a million per second, is the danger excluded, and we can without harm conduct through the body such high frequency currents, which we also call electric oscillations. In the current path there then results a more or less strong heating effect.

The process based on this fact is *diathermy*, founded by Von Zeynek and Nagelschmidt. In this case the high frequency current is mostly conducted through the body by means of two metal electrodes which are applied externally. Now while it was formerly believed that such a current flowed in a direct path from one electrode to the other, this view has been proven untenable, especially by my investigations. On the contrary the *diathermic* current, like every electric current, obeys Ohm's law and spreads in widely branched current paths to the individual tissues. The paths preferred are those of the blood vessels which offer the least resistance. So it happens that the current often flows around the organs

Ultra-short waves afford locally limited heating by tuned waves without touching the body with electrodes, in contrast to "diathermy." Thus definite nerve cells in the brain can be influenced, "pus-formers" killed, etc. The effect of ultra-short waves on warmth regulation and pancreatic gland and blood sugar were studied, also replacement of the malaria treatment by ultra-short waves in the case of paralysis. The author also discusses the treatment of boils, matteration in the jaw cavities, and pleurisy by ultra-short waves.

which are actually to be treated, especially if these organs are imbedded in poorly conducting capsules of connective tissue or fat.

20,000,000 Oscillations Per Second

These conditions change in the case of a frequency of about 20,000,000 oscillations a second.

The method of using these very high frequency oscillations differs fundamentally from the otherwise usual current conduction. Here we apply to the body no plates, brushes, and similar contacts, and we also allow no spark passage between electrode and skin, but use only the *electric fields*.

The electromagnetic fields resulting in the case of electric oscillation processes spread out in space like Hertzian waves and at the same time follow the laws valid for all electromagnetic waves, including light.

The application of these Hertzian waves for healing purposes has hitherto encountered numerous technical difficulties. The use of the electric field existing between two condenser plates, standing opposite each other, has proven very practical, as first proposed, independently of each other, by Scherschewski and Esau.

At both ends of a closed oscillatory circuit are placed two plates, standing opposite each other and thus forming a condenser. The secondary circuit must be tuned to the wave of the transmitter, which can be done by lengthening or shortening the secondary circuit or by changing the size and separation of the condenser plates or the composition of what is between them (*the dielectric*).

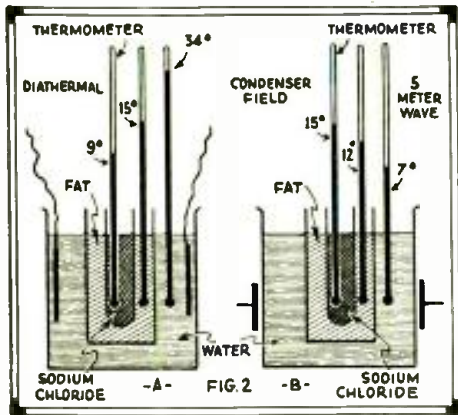

How diathermal current (A) and ultra-short waves (B) heat three solutions one within the other. In an outer glass vessel filled with distilled water are, one inside the other, two porous containers with animal fat and .5% sodium chloride solution. The diathermal current heats the outermost of the three "inter-stratified" substances most strongly, while the innermost "stratum" is only weakly affected. In the ultra-short-wave field on the other hand it is possible to warm the innermost stratum more strongly than the outer ones, if the wave length is selected in proper relation to the concentration of the substances in question.

Body Becomes Condenser Dielectric

In our case this dielectric is represented by the experimental animal or the part of the human body to be treated. The effect of the field makes itself evident, according to the make-up of this substance, in a more or less pronounced heating. This heat, however, is produced in the object in a very different way than that which takes place by means of conducted electric currents. In the case of the condenser field there are no electrodes in contact with the body, but instead we use merely the field effect, which goes uniformly through all strata. Every particle in the range of the field is independently influenced by it.

The strength of the heating can now no longer be reckoned in the ordinary fashion from resistance and current intensity; on the contrary, the conditions here are much more complicated. Both perfect insulators and very good conductors do not heat up at all. If, for example, we simultaneously expose different salt solutions to the condenser field, we note that they heat up with different intensity. If we change the wavelength, we see that the mutual relation of the heating of these substances is shifted. A substance which heated especially strongly in the case of the first wave warms up less in the case of another wave, and vice versa. As Pätzold has been able to show, the relation of the conductivity of the electrolyte to the wavelength plays a great rôle. For every electrolyte with definite conductivity and dielectric constant there is a definite wavelength in the case of which the heating of this substance in relation to other substances is especially strong. It is therefore possible by the choice of a suitable wavelength to pick out, as it were, one substance from among the others. This is shown very beautifully by an experiment described by Esau. If the emulsion of an aqueous salt solution in paraffin oil is exposed to the condenser field, it is possible to bring the tiny water drops in the mixture to the boiling and vaporization points, while the

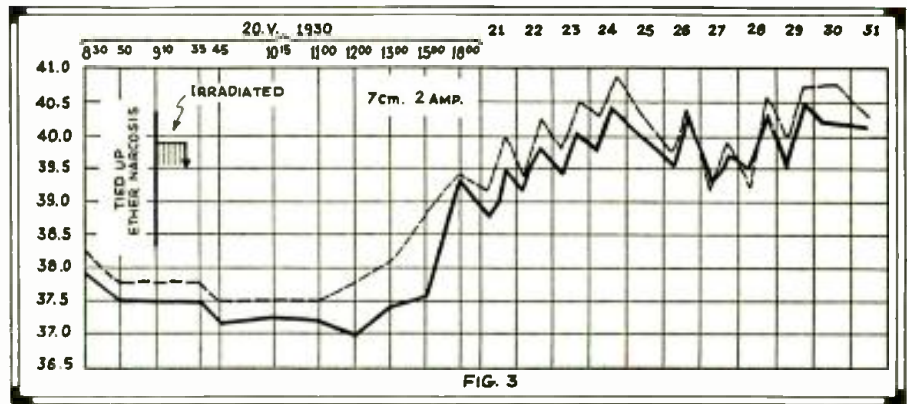

Fever curve of guinea pig after irradiation of the neck with ultra-short waves. Mouth temperature is indicated by solid line, rectal temperature by dotted line.

total temperature need not rise above 60 degrees Centigrade.

Selective Effects Noted on 4 Meters

The importance of these effects in medicine is quite obvious. Since every tiniest particle is affected by itself, it must be possible, by means of a definite wavelength, to influence certain cells or cell-groups in the body more strongly than others. In experiments which I performed together with Oster-tag on the brains of rabbits, it actually could be shown that very definite kinds of nerve cells can be destroyed, while other closely adjacent cells remain unharmed. This phenomenon, however, could be attained only with wavelengths of 4 (four) meters or less.

A dependence of the effect on the wavelength was also present in the case of bacteria. Pus-formers were killed in the condenser field already at temperatures which they otherwise perfectly well endured, and here too it appeared that the killing took place faster with a certain wavelength than with others.

What prospects does this give us for the treatment of ailments? Undoubtedly there exists a certain selectivity of the individual wavelengths, a possibility of influencing certain bodily fluids, cell complexes, or illness-producers especially strongly as compared with other parts. On the other hand we must not forget that most discoveries

thus far made have been on dead material and on bacteria which were irradiated outside the body or in parts of corpses. In the living organism, with the circulation of the fluids, there are entirely different conditions, and it is to be assumed that the make-up of the bodies of bacteria can change rather extensively inside living tissue. It is therefore in no way to be understood that the same wavelengths which act on bacteria in cultures are also especially and strongly effective against bacteria in the seat of illness; rather perhaps other wavelengths will give an optimal effect. To find these will be the main problem of future research, but it will require difficult and careful investigations. Thus we are compelled to search further and must be satisfied with the result learned so far, that all the wavelengths thus far used in the range from 3 to 15 meters exert a favorable influence on many of the phenomena of illness. The short-wave field acts on sealed-up seats of illness not in the way of the electric currents, which in a great measure flow around; on the contrary, the seats of illness are often more strongly heated than the surrounding tissues. This is explained from the fact that the blood stream in the tissues acts like a cooler and carries away the heat, while a pus-center contains no blood vessels, so that the heat is dammed up here.

Limited Depth Effects

Another important factor is the *limited depth effect*. Through the fact that we bring our condenser plates to the body in a very definite way, we can give the field a perfectly circumscribed direction and so act separately in the region of the infection. At the same time I have been able to prove a notable dependence of the depth effect on the distance between the plates. In general it is less a question of our producing the strongest heating at all possible than it is of having the heating at the site of illness as strong as or stronger than at the surface. In the case of *diathermy*, for example, the skin and the subcutaneous fatty tissue, in consequence of the formation of current loops, heat up more strongly than the deep parts. Past a certain current intensity the heating of the skin becomes so strong that it can no longer be endured. At the same time, however, the heating of the lower lying organs, which we actually want to reach, is perhaps only a small fraction of this skin heating.

(Continued on page 688)

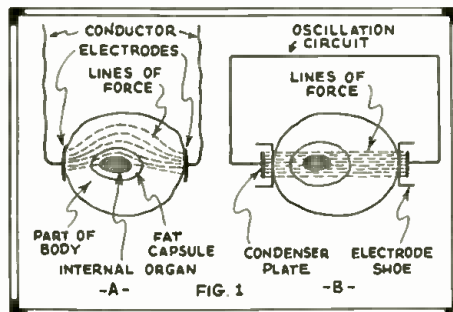

The lines of force: (A) with diathermy (high frequency currents of about 1,000,000 cycles in the short-wave field and (B) with ultra-short waves.

The current loops are most strongly bent where there is the least ohmic resistance, i. e., along the net of blood vessels and the sheaths of organs. Only a small part in the case of diathermy penetrates to the deep lying organ, enclosed in a capsule (e. g. the kidney). The ultra-short wave field on the other hand penetrates the organs in a straight line, even in the case of very different consistency.

Experimental $\frac{3}{4}$ Meter

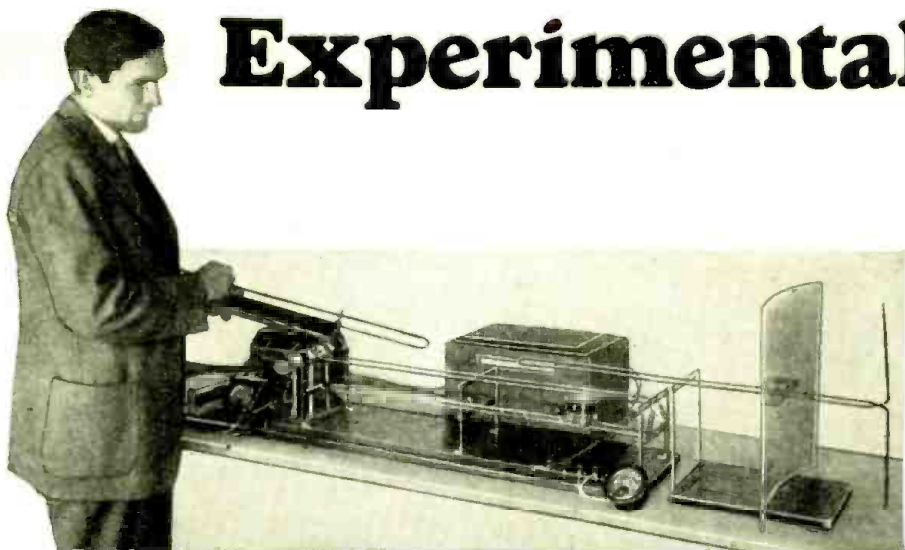

Figure 3—The use of a semi-parabolic reflector greatly increases the effective range of the quasi-optical transmitter. The author is checking the wave on an independent Lecher system, with an SW-58 receiver, in the background, modulating the transmitter.

Mr. Millen, widely known to the short-wave fraternity for the many engineering improvements and designs brought out by the National Company in the past few years, has recently performed some interesting experiments in the relatively new realm of the ultra short waves, that is waves in the vicinity of three-quarters of a meter in length. The wavelength in the circuit used by Mr. Millen is practically independent of the resonant conditions in the external load circuits and is governed practically entirely by the grid and plate voltages and the construction of the tube.

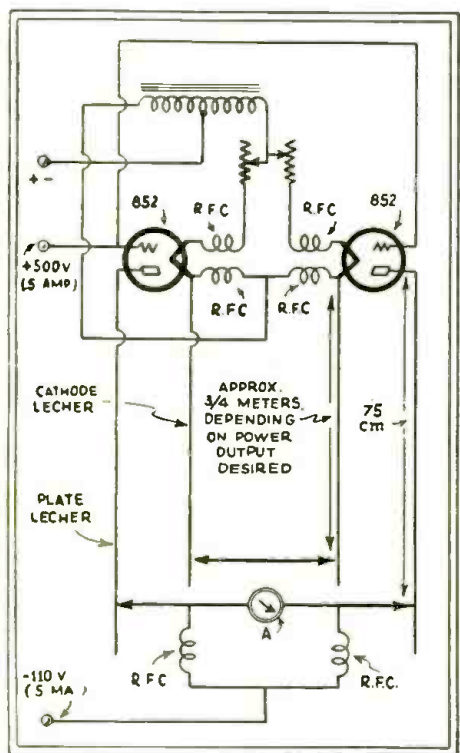

Figure 1—Circuit diagram of a successful three-quarter meter transmitter.

● THE adage of history repeating itself finds an anomalous application in ultra short wave transmission and reception. The world's first radio transmitter, built by Henrich Hertz in 1886, operated on wavelengths as short as 50 centimeters. For thirty years thereafter, scientists and engineers devoted their efforts to the perfection of longer and longer wave apparatus. Then the pendulum began its reverse swing, and today, some of the most interesting possibilities in wireless intercommunication exist in that ultra high frequency domain originally explored by the renowned Hertz. Peculiarly enough, the present day ultra short wave radiating systems, and even the receivers themselves, are more than reminiscent of prototypes from a far earlier era.

The only phase of sub-meter transmission distinctly modern in character is the modified use of the conventional vacuum tube, and the evolution of familiar circuits to ultra short wave arrangements provides an excellent insight into the practical and theoretical aspects of communication in the centimeter region.

Changed Regeneration Effects

In tube oscillatory circuits operating on wavelengths above five meters, the frequency is determined by the inductance and capacity of the tuned cir-

cuits—either the grid or plate circuits, or both. As a general statement, it may be said that the power output of such an oscillator increases as the various assisting oscillatory circuits approach the resonance point of the frequency determining circuit. For instance, in a typical tuned-grid-tuned-plate oscillator, the frequency will be largely determined by the grid circuit, and the power output will decrease as the plate circuit is detuned—until the circuit ceases to oscillate at all.

Such oscillations are, of course, accompanied by corresponding movements of the electrons within the vacuum tube, and at frequencies above 300 megacycles—300,000,000 cycles per second, or a wavelength of one meter—the electrons do not have time to complete the paths essential to oscillation. When such a condition exists, the distance the electrons must travel (the space between the tube electrodes) and the velocity at which they move (governed by grid and anode potentials) determine the wavelength or frequency, instead of the capacity and inductance of the circuits. Such a circuit is the Barkhausen-Kurz—familiarly, the "B-K." By varying the accelerating charge on the grid, which of course affects the velocity of the electron stream, the wavelength can be controlled over a considerable range, practically independent of the circuit constants. Such a circuit necessarily results in the unconventional arrangement where the grid is highly positive in respects to the cathode and plate. The B-K oscillator is not a particularly steady one, and is subject to what amateurs term "wobulation."

In a manner analogous to the tuned-grid-tuned-plate example cited above, it was discovered by Gill and Morrell that by tuning the grid and plate circuits close to the frequency determined electronically, the output of the B-K oscillator could be considerably increased. However, the tube capacity



Figure 2—The experimental arrangement with 852 tubes. The motor-generator power supply is shown at the left.

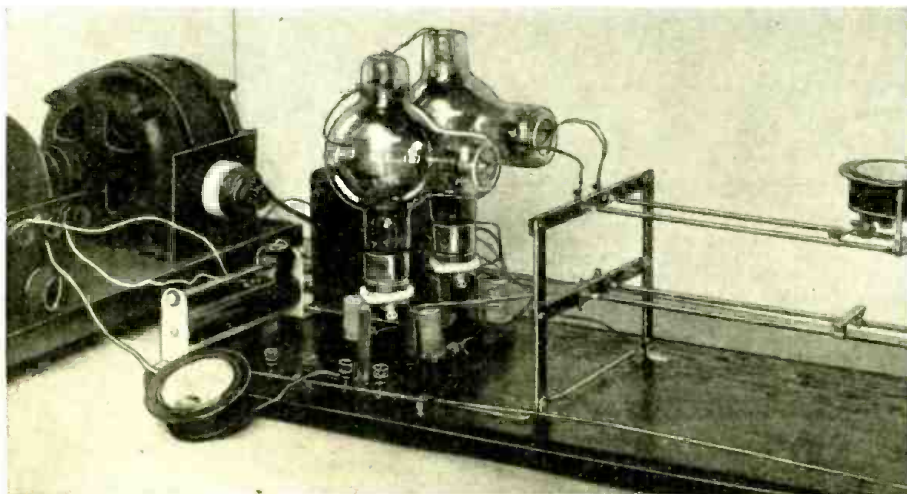

Transmitters and Receivers

Some New, Interesting and Easily Performed Experiments

necessarily limited the wavelength at which such an arrangement could be depended upon for stable, high power output.

The Kosanowski Oscillator

Kosanowski's experiments with the B-K circuit indicated that the oscillating phenomenon was due to the grid charge fluctuating spatially about the grid. It was a sort of a pendulum effect, pivoted at the grid, and swinging first toward the plate and then toward the cathode. It then seemed logical that the parts of the circuit to be balanced, or tuned, were the plate and cathode circuits—a conclusion that was quickly justified by further experimentation.

The circuit of the Kosanowski oscillator used by the author in $\frac{3}{4}$ meter experiments is shown in Fig. 1. The two circuits are tuned by plate and cathode Lecher wires, the length of the plate Lecher system governing the wavelength, and that of the filament system the power output—as might be suspected from our tuned-grid-tuned-plate parallel. However, it should not be assumed that we have here merely a modification of the familiar long wave circuit. The Kosanowski is a *bona fide* electronic oscillator, as is evident by the reversed potentials on the plate and grid and the fact that the wavelength is almost exactly equal to the length of the plate Lecher system, as measured from the plates of the tubes to the terminating ammeter bridge—irrespective of the inductance and capacity of the circuit.

The oscillating power generated by this circuit is considerably superior to the best heretofore obtained from a B-K oscillator. The highest output reported from a Barkhausen-Kurz oscillator, at the present writing, is a fraction of a watt at 75 centimeters, whereas the circuit of Fig. 1, with the indicated tubes and potentials, can be depended upon for *five full watts of power* at $\frac{3}{4}$ meter, with good stability.

Constructional details are suggested in Figs. 2, and 3, the latter showing the use of a highly effective semi-parabolic reflector and 27 type tubes (decidedly less efficient than the 852's).

The Lecher wires are made of $\frac{1}{4}$ inch copper rods, rigidly braced by R-39 and Isolantite supports. The filament choke coils consist of 15 turns of number 12 double cotton covered wire, wound with a $\frac{3}{4}$ inch diameter. The plate circuit chokes can be the same, or, if more convenient, wound with 20 turns of number 18 enameled wire on a $\frac{1}{2}$ inch diameter and stretched until they are two inches long. The radio frequency ammeter, A, should have a maximum deflection of about 2.5 amperes.

*The National Company, Malden, Mass.



Figure 6—Receiving $\frac{3}{4}$ meter signals on the B-K receiver, and amplifying to loud speaker volume through a standard audio channel.

Described By
JAMES MILLEN, M. E.*

Antenna System

While a simple antenna consisting of a 15 inch length of $\frac{1}{4}$ inch copper rod clipped to the plate Lecher system (the point of contact determining the degree of coupling) provides readily demonstrable results, the radiator shown in the photograph of Fig. 3 is far more effective. The antenna is a current fed doublet, located in the focus of the sheet brass reflector, the general dimensions of which are not particularly critical, and may be gathered from the illustration. The feeder system is one wavelength long and is coupled to the plate Lecher circuit as shown.

Three Quarter Meter Receivers

The most simple of possible receivers employs an iron pyrites crystal detector and is shown in Fig. 4. The distance between the ends of the antenna rods is $\frac{1}{2}$ wavelength—approximately 15 inches at 75 centimeters. A signal will be received only when the antenna rods are parallel with those of the radiator.

A more sensitive receiver is shown in Fig. 5—which is nothing more than a B-K oscillator, the wobulation effect here being useful in supplying the requisite degree of broadness. The tube is a type 99. Resistor R1 is the usual filament rheostat and R2 the grid bias resistor by which tuning is effected. The choke coils are wound with 20 turns of number 18 enameled wire, $\frac{1}{2}$ inch in diameter, and stretched to a length of 2 inches. The antenna system is identical with that of the crystal arrangement. The B-K receiver can be used either in an oscillating or stable state—for C.W. or phone reception. Oscillations are suppressed by increasing the plate voltage slightly.

Tuning is still effected with the variable grid bias resistor, adjusting the relaxation period of the tube to the frequency of the incoming wave, which is also favored by the dimensions of the antenna system. The output of this receiver can be amplified in the conventional fashion, as is suggested in Fig. 6.

With such a receiver, and the transmitter described, communication has been established over distances of *several miles*. Obviously a direct optical path must exist between the transmitter and receiver, as the characteristics of $\frac{3}{4}$ meter waves are very similar to those of visible light.

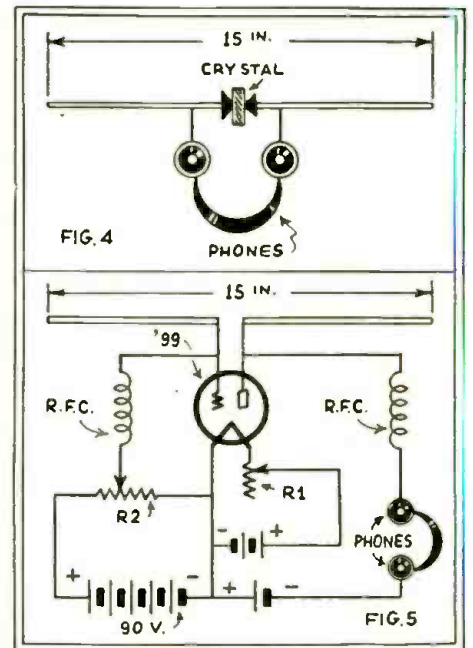
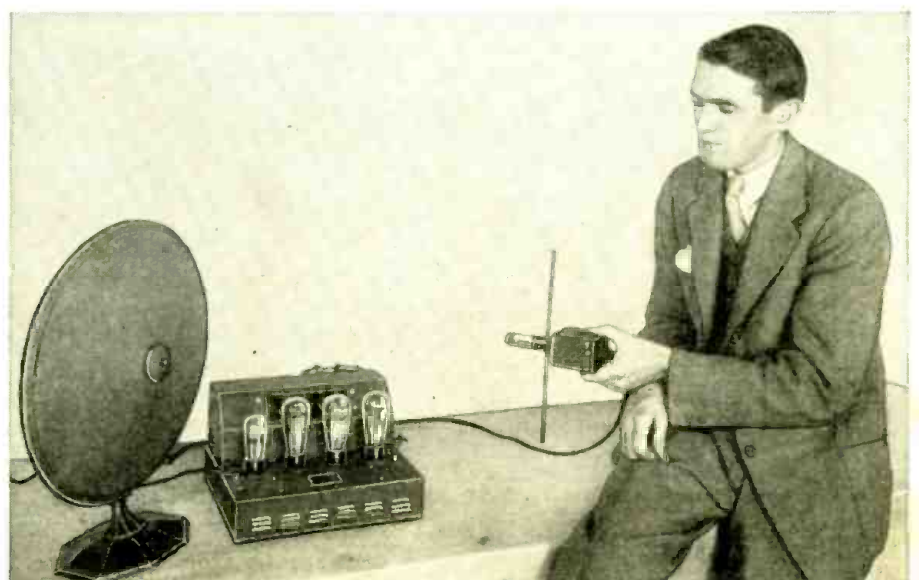

Figure 4—An elementary but efficient 75 centimeter receiver.
Figure 5—The B-K receiver used as a receiver.



5-METER WAVES HELP FIRE-FIGHTERS

By ROBERT HERTZBERG

Effective Use Made of Ultra Short Waves by the Conservation Department of the State of New York.



The radio-equipped patrol plane used by the Conservation Department of the State of New York. Note the mast aerial sticking out of the body.

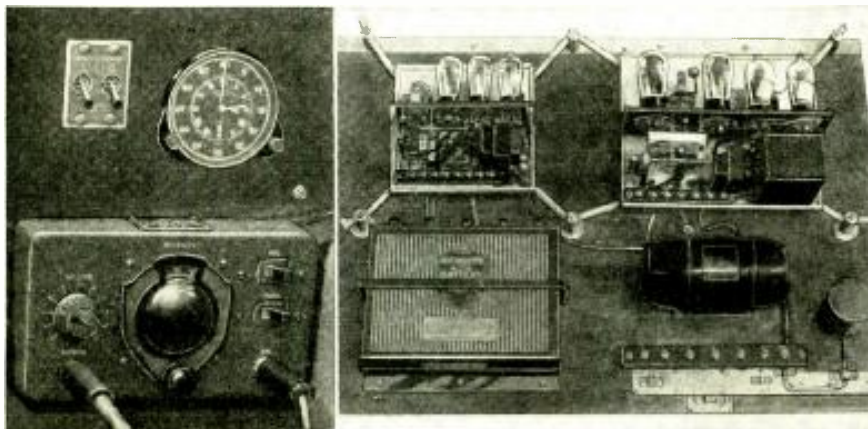

Left: close up of the remote radio control on the instrument board of the plane. Right: the complete transmitter-receiver. Upper left, remotely tuned receiver; lower left, receiver "B" battery. Upper right, fixed tune transmitter; lower right, dynamotor for transmitter. Shock cord mounting is important.

and is ready to hop off at a moment's notice, is loaded with one or two complete "portable" 5-meter outfits. These are dropped at the air-field nearest the fire, and from there they are transported by automobile as close as possible to the scene of the fire. One outfit goes into the fire tower (if it is not already equipped with a station), while the other goes out with a group of fire-fighters on foot. Meanwhile, the pilot of the plane, who is an officer of the Conservation Department, flies over the fire and from his vantage point aloft directs the men in the field, at the same time talking to the fire station. In hilly country the field men are most likely to be out of sight of the fire tower and are therefore helpless if the wind shifts or a change in tactics is made necessary for other reasons. The pilot can follow the fire very accurately and can order the men to more advantageous positions as quickly as the changes take place.

(Continued on page 683)

● FIVE-meter waves, hitherto regarded as playthings for radio experimenters, are now being put to practical use to help fire fighters and for general plane-to-ground communication by members of the Conservation Department of the State of New York. A permanent receiver and a 30-watt transmitter are operated at the headquarters of this important state department in the dome of the Capitol Building at Albany, N. Y., while a lower-powered outfit is maintained in a Waco cabin monoplane used by department officers for patrol and observation work. This system represents probably the first commercial application of the ultra-short-waves.

The very short ranges previously covered by amateur stations are greatly exceeded by the stations of the Conservation Department "net." With comparatively inexperienced operators at the controls, communication between the plane and a temporary ground station, such as illustrated on the right, has been carried on up to 30 miles; between the plane and a ground station in a fire tower, 60 miles; and between the plane and the lofty Albany station, a record of 125 miles has been established. This is all two-way duplex, the operators conversing as freely as over an ordinary land-line circuit.

The value of the 5-meter radio ap-



Charles Srebroff, president of the Radio Engineering Laboratories, demonstrating the portable ground station at Curtiss-Wright Airport, North Beach, L. I. Note the di-pole antenna behind the upright case.

paratus has already been demonstrated to the complete satisfaction of the authorities. For fire-fighting the system works out like this:

A fire is reported in a certain area by a ranger, who most likely telephones the news from his fire tower. The plane, which is based at Albany

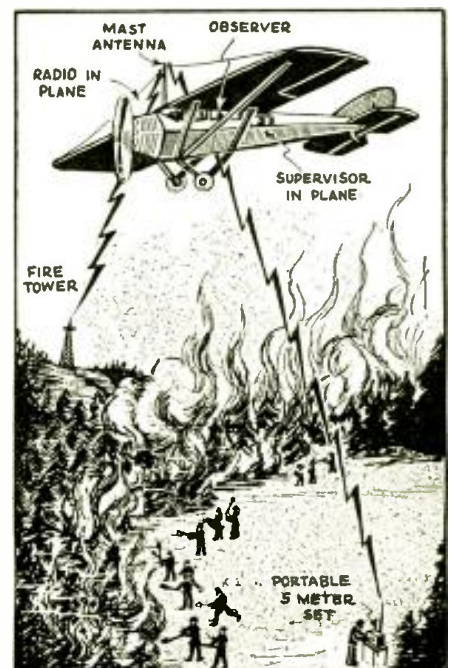

How the radio-equipped plane directs fire-fighters from aloft.

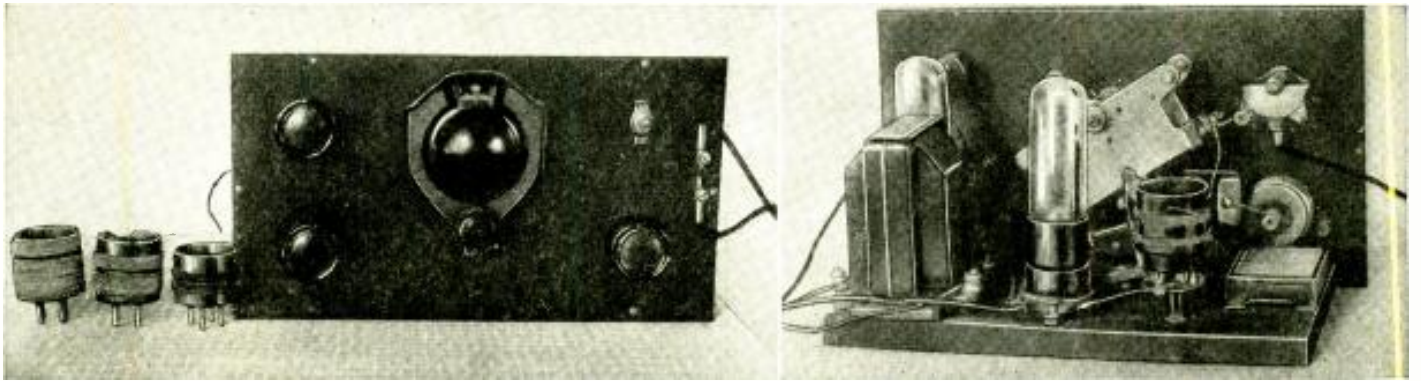

Photos Above Show Front and Rear Views of the Dandy Little 2-tube, battery-operated S-W Receiver Here Described, A-B-C Style, By Mr. Hooton.

The BEGINNER'S 2-Tube "GO-GETTER"

By HARRY D. HOOTON

Frequently the beginner in the short-wave field feels that he would like to start off with possibly a 2-tube receiver operated from batteries. Here is just such a receiver, designed for the average short-wave "fan" by Mr. Hooton, an experienced short-wave experimenter.

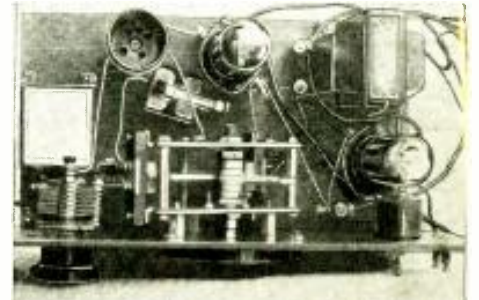

Above, Top View of the 2-tube "Go-Getter" a Simple S-W Receiver of Proven Efficiency; ideal for the Beginner.

● ALL experimenters agree that one-half the fun of *amateur radio* comes from building one's own short-wave receiver or transmitter. Yet, if the beginner—who probably doesn't understand the meaning of one-half the symbols used in the diagram—attempts to construct one of the complicated short-wave superheterodynes, or even the simpler tuned-radio-frequency receivers, his chances of success are slim indeed. The poor chap is confronted with a mul-

titude of parts, tubes, wires, etc., which must be placed in their proper relation to each other before the set will operate at all. It was with the hope of dispelling some of the bewilderment of this class that the little set to be described was built. *In spite of its simplicity, it is an excellent receiver, suited to the requirements of the average short-wave beginner.*

Simple Line-up: Detector and Amplifier.

The set consists of a detector in the standard regenerative circuit, and one stage of audio frequency amplification. It is designed for battery operation with type '30 tubes and has a continuous frequency range from 30,000 kc. to 3,000 kc. (10 to 100 meters). The tuning is accomplished by a single dial (see Fig. 1). The knob at the left of the dial operates the Pilot Resistograd regeneration control, that to the right turns the filament rheostat, while that at the extreme left and top handles the antenna series condenser. The switch in the upper right corner of the panel turns the filament current off and on. The two binding posts at the extreme

right of the panel connects the headphones in the circuit.

Arrangement of Parts.

Before any actual work is done on the receiver study the photographs and diagrams carefully. The arrangement of the parts in the receiver shown is best for efficient operation. After you have identified all the parts of the receiver, place your own parts on the base-board and shift them around until the arrangement has been duplicated as nearly as possible.

The panel should be drilled before it is fastened to the baseboard. This should be done very carefully as the outward appearance of the receiver will be spoiled if the holes are not drilled in the proper place; Fig. 2 is self-explanatory. A drilling template is included with the Cardwell tuning condenser, all the other parts are of the single-hole mounting type. The lines may be scratched on the *back* of the panel, with a knife point or other sharp instrument. The holes are drilled at the intersection of the lines.

Starting the Assembly.

After the panel has been drilled, mount the Cardwell tuning condenser by means of the brass screws which are included with it. Make sure that the shaft turns freely and does not bind against the panel. Next mount the regeneration control and the filament rheostat. Then place the "midget" condenser and the filament switch in their proper holes and tighten the nuts that secure them to the panel. The dial and knobs are placed in their respective positions and adjusted. Turn the tuning condenser rotor plate until it is set at maximum capacity, then adjust the dial until it reads 100. Place the disc portion of the dial on the shaft and tighten the nut which holds it in place. It will be necessary to adjust the disc several times before the dial

(Continued on page 686)

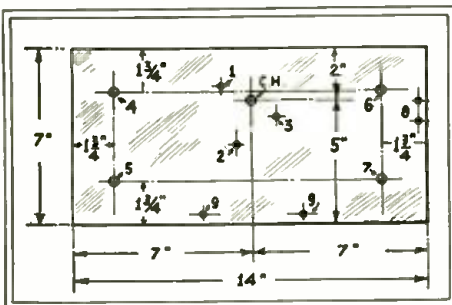

Panel Layout for 2-tube Receiver Here Described.

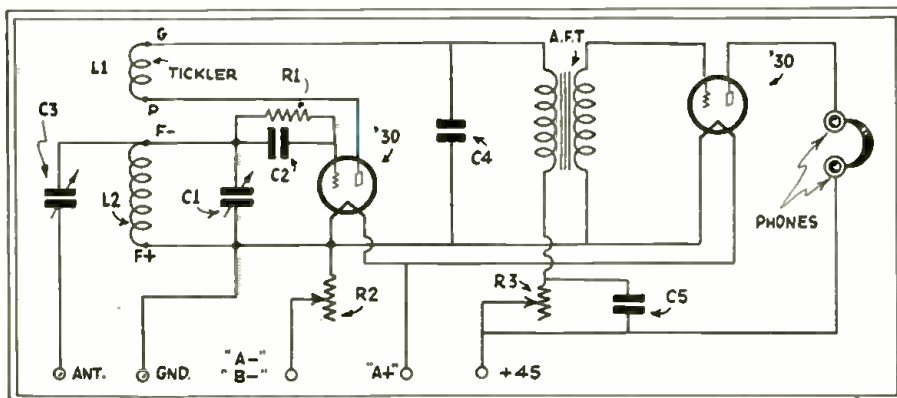

The Simple Diagram Above Shows How to Wire the Relatively Few Parts Used in Building the "Go-Getter" 2-Tube Receiver.

At Last! A

By **CLIFFORD E. DENTON**



Rear view of the 4-tube Superhet developed by Mr. Denton especially for Short Wave Craft readers; the four tubes include the rectifier. The first detector also serves as the oscillator, operating on the autodyne principle.

densers used leaves something to be desired along this line, satisfactory action will be obtained on all frequencies except the extremely high ones. As a compromise set-up for use with standard coils and condensers it works very well.

Regeneration in the second detector aids in two respects; it sharpens tuning and increases the sensitivity to a marked degree. If it is desired to receive C.W. signals then the second detector can be left oscillating. For tuning in weak signals tune the set and adjust the regeneration control so that the station whistle is audible. Then turn the regeneration control back until the speech or music clears up.

An autodyne first detector is used and works very well. The author has not had a chance to test for the relative efficiency of this method over the conventional separate oscillator. This is a point of interest and a suggestion to builders would be to try and see which method gives better performance.

Short-wave coils of the space-wound variety are hard to wind. At least the average amateur finds this true. Standard coils are used as shown in the illustrations. This is a convenience for the constructor. Normally, if the coils are left as purchased there will be a difference in the dial settings of the two tank condensers. This is due to the fact that the oscillator coil will tune to some frequency away from the incoming signal. This oscillator frequency will differ from the incoming signal by the intermediate frequency. The intermediate frequency of this set can be anything from 465 kc. to about 800 kc. This leaves the choice of the intermediate to the constructor. Some like 465 kc. and others like to have the intermediate frequency in the broadcast band.

Plug-in coils are still the standard as they offer the best electrical effi-

● **SHORT-WAVE** supers have received a lot of attention from the construction angle, but every design has called for at least six tubes. Here is the first information which has appeared in print of a real "super" that has only four tubes, including rectifier.

The set is small enough to fit into a standard midget cabinet and is so light in weight that, if placed in a carrying case, it can be used as an A.C. operated short-wave portable receiver.

Outstanding Features

So many points of the receiver design could be listed and discussed that a short paragraph covering each will be given.

- 1—Single dial control.
- 2—Four tuned circuits.
- 3—Band spreading.
- 4—Regeneration in the second detector for C.W. reception and increased sensitivity.
- 5—Autodyne first detector.
- 6—Uses standard S.W. coils for .00015 mf. condensers.
- 7—Plug-in coils.
- 8—New type tubes.
- 9—Pentode output.
- 10—Complete A.C. operation.
- 11—Provision for phones.

12—Low "hum" level in the output.

Superhet receivers using one dial are becoming more common today. In most cases there is a trimming condenser used to properly align all of the manually tuned circuits. In this receiver two large tank condensers are used with two small condensers which are ganged and used for tuning. By properly setting the tank condensers for various portions of the frequency band being covered, there will be real single dial control.

Most short-wave receivers of the four-tube type have only two tuned circuits. This receiver has four, which increases the selectivity to a very satisfactory degree. The selectivity of this receiver is increased by the use of regeneration in the second detector. This increases the sensitivity as well.

Band-spreading action is provided by means of the two tank and the two tuning condensers. The two tuning condensers have a capacity of 35 mmf. each and the tank condensers have a capacity of 100 mmf. each. Thus, the tank condensers can be set for a portion of a band and the tuning accomplished by means of the two tuning condensers. While this method of *band-spreading* with the coils and con-

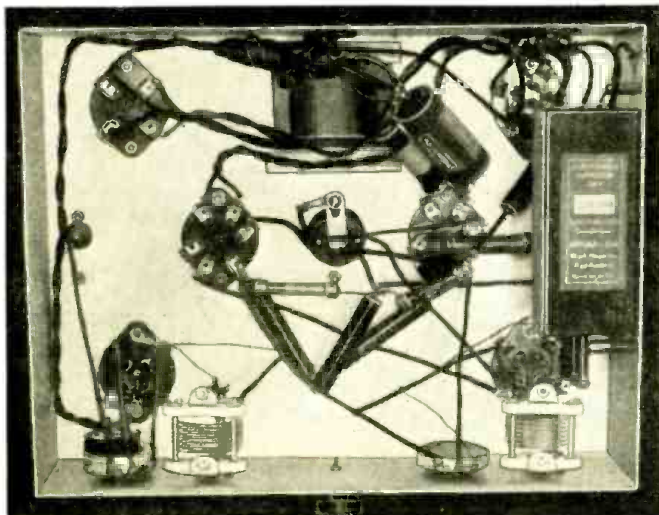

Bottom view of the 4-tube superheterodyne receiver.

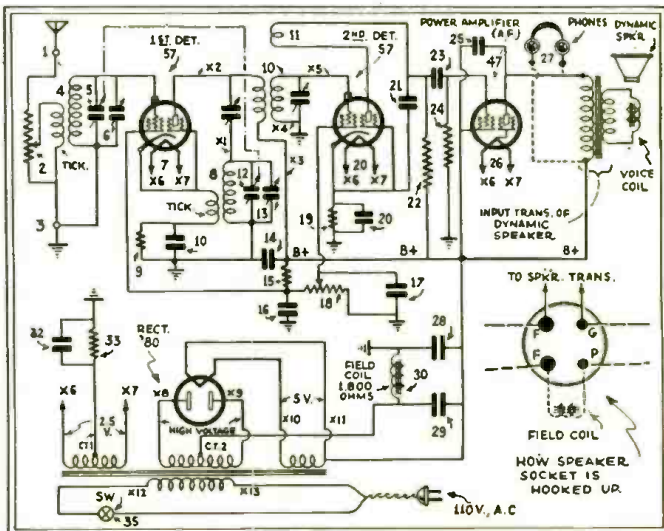

Schematic wiring diagram for the 4-tube Super-het.

4-Tube Super-het!

"Low price" and "smooth control" are two of the outstanding features demanded in any radio receiver today. Mr. Denton, well-known to all of our readers for the many excellent designs he has offered in past issues of SHORT WAVE CRAFT, has solved the riddle of providing the following features in a low-priced, yet efficient 4-tube superhet: single dial tuning, band-spread, regeneration for C.W. reception and increased sensitivity, pentode output, complete A. C. operation and provision for phones as well as loud speaker.

"Bob" Hertzberg testing the Denton 4-Tube Super-het here illustrated and described. It will operate a loud speaker or phones may be connected if desired.



ciency with the minimum of additional parts. The slight inconvenience of changing coils is more than off-set by the increase in efficiency.

The new type tubes offer higher gain and greater stability of operation. In this receiver there are two circuits connected to a common power supply. Both circuits must oscillate at times and both are stable and smooth in operation.

Pentode tubes, with their greater power sensitivity, are ideal for use with this receiver. The circuit is simple. Be sure to use the 25 mf. 30 volt electrolytic condenser across the bias resistor. This will smooth out the low frequency response of the output stage.

Complete A.C. operation, with the hum at such a low level that phones can be used without discomfort, is another feature. The hum is there but it never drowns out the weakest signal.

Phones can be connected across the output terminals going to the output transformer. The only thing to remember here is "Do not disconnect the

loud speaker with the power on"!

Construction Details

All of the parts are mounted as shown in the photographs. The electrolytic condenser covers the phone terminal connections, pentode grid coupling resistor and a portion of the second detector bias resistor and bypass condenser. This will be seen in the under view of the chassis. There is plenty of room to mount all of the parts without crowding.

There are some changes to be made in the intermediate frequency transformer and these will be described in detail. In Fig. 1A a drawing shows the position of the coils in the intermediate frequency transformer used. The changes are indicated in Fig. 1B. Note that the plate coil is used as the grid coil and that the grid coil is used for the plate coil. As these two coils consist of the same number of turns this will not change the characteristics of the transformer. The reason for changing the position of the two coils

is due to the fact that it is necessary to place the feed-back winding close to the grid inductance. This proved a simple matter when the coils were changed, as it permitted the feed-back coil to be mounted close to the grid coil. Note that the resonant circuit in the plate of the first detector is completed through the grid coil of the oscillator and the .1 mf. condenser connected between the "B" plus end of the I.F. plate coil and the ground. The feed-back coil is a standard radio frequency choke coil and can have an inductance between 1 and 35 mh. It is best to anchor the wire from the plate coil by means of a very small wood screw fastened into the wooden core on which the coils are mounted. The leads are run from the various terminals inside the intermediate frequency transformer shield can direct to their respective soldering points, so make all leads about eight inches long. This will permit of easy soldering. Except for this point already covered in

(Continued on page 696)

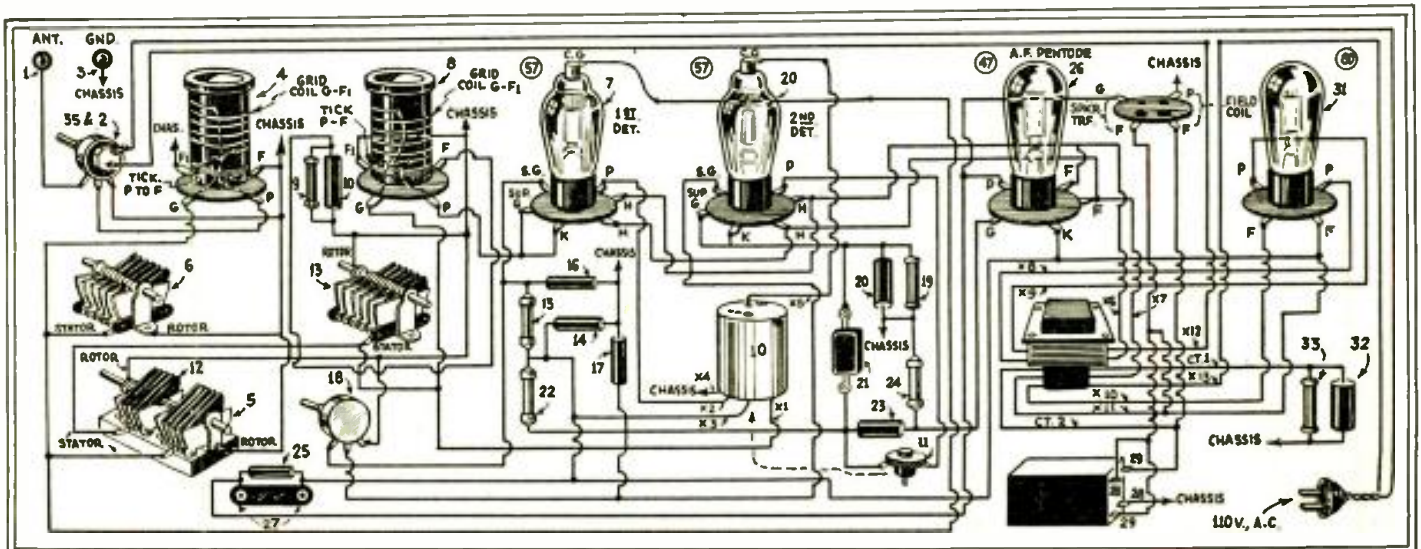

Picture diagram for the benefit of the inexperienced set builder, who would like to build this very interesting and efficient 4-tube Super-het short wave receiver. It works loud speaker or phones.

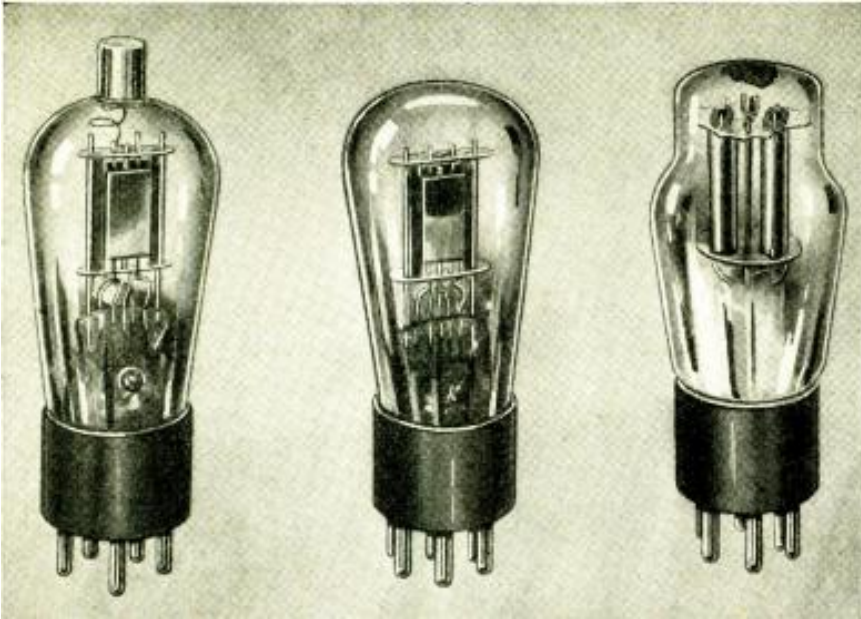

Two different types of Wunderlich detector tubes are shown at the left of the photo above, one with a cap electrode; the tube at the extreme right is the new No. 19 class B amplifier made by Sylvania.

More On

By LOUIS MARTIN

Mr. Martin explains in a clear manner the theory of operation of the Wunderlich detector tube and how it can be used to achieve A.V.C. (automatic volume control) in S. W. receivers, with data on circuit constants. The remarkable new "19" tube—comprising two separate "class B" tube elements in a "single envelope"—is also described.

● IT requires but a cursory examination of the tube field at this time to realize that special detectors are very much in vogue. The purposes of these tubes are many: they tend to obviate the necessity for an intermediate audio stage between the detector and the output stages; they deliver more power output at high signal voltages than their predecessors; and last but not least, they do not produce as much distortion. One of the first special detectors to make its appearance was the Wunderlich, or coplaner grid, tube.

This tube has many characteristics which warrant its use in present-day receivers. These characteristics may be better appreciated by examining the physical structure of the tube itself. Refer to Fig. 1. It is seen that the usual cathode surrounds the heater; there is a grid structure which consists of two separate, inter-meshed grids; and a plate surrounding the entire arrangement. It is this inter-meshed grid structure which controls the secret of the tube. Suppose the two grids are connected to the end-terminals of a standard tuning coil, and further suppose that the center tap of this coil be connected to the cathode through a familiar grid-leak and grid-condenser connection. Our result will then be as indicated in Fig. 2.

Action of The Two Grids

If an unmodulated signal is applied to the two grids by means of the tuning coil, G1 will become positive and attract electrons to the plate, increasing the plate current; while G2, at the same time, will become negative by an equal amount and decrease the current to the plate. The net result, therefore, is no R.F. in the plate circuit, regardless of the magnitude of the signal. But what happens in the grid circuit? While G1 is positive it is drawing current which appears as a voltage across the grid-leak, grid condenser combination. At the same time, when G2 is negative, it cannot attract electrons, and so there is no current drawn by it. The net result in the grid circuit is an

increase in current through the grid-leak, grid condenser combination due to the action of G1. On the other half of the cycle, the net increase in current through the combination is due to G2. Thus the action is similar in almost every respect to the ordinary power rectifier such as the 80.

If a modulated signal—one that has voice or music impressed on it—is applied to the grids, the action becomes a little more involved. The voltage developed across the grid-leak, grid-condenser combination varies in accordance with the modulated part of the signal, and is impressed, in phase, across the two grids. In other words, during the rectification process, one terminal of the grid-leak becomes positive and the other negative, as shown in Fig. 2; but the amount that one becomes positive and the other negative varies with the modulation of the carrier wave. It will also be noted that that terminal of the grid-leak which is always positive is connected to the cathode, and that the other terminal, which connects to the coil, is always negative. Thus the negative potential developed by the grid leak is impressed on both grids at the same time. Since both grids are negative, the current to the plate drops, and the amount of drop depends upon the mutual conductance of the tube, as in any other tube. (Mutual conductance, you remember, is the change in plate current per volt change in grid voltage.)

In summarizing, then, it may be said that the plate current in a Wunderlich tube is only varied when a modulated signal is impressed on the grids. What we have, therefore, is *full-wave grid-leak, grid-condenser action*.

Values of Grid Leak and Grid Condenser

The proper size of grid-leak and grid condenser to use has always been a problem. In this case, it may be stated without any theoretical discussion that the grid condenser should have a value of about .00005 to about .000075 mf. Regarding the size of the

leak, a little more leeway is afforded. For really good quality, make the grid-leak about .25 meg.; for louder signals and less "highs" the grid-leak should have a value of about .75 to 1 meg.

It is more practical to try several values until the results satisfy you—if your receiver is capable of amplifying small differences in the higher-frequency notes!

Automatic Volume Control

From the theory outlined at the beginning of this article, it is clear that as a signal—modulated or unmodulated—is being rectified, a D.C. voltage is present across the grid-leak, and that the nature of this voltage is similar to that obtained from the output of an ordinary 80 rectifier. If some means could be found to filter it, and so smooth it out, it might be used for automatic volume control purposes.

The primary requisite of an A.V.C. voltage is that it must vary in accordance with the impressed signal—the greater the signal, the greater the A.V.C. voltage must become. This requisite is satisfied by the Wunderlich tube. As the carrier increases, the voltage appearing across the grid-leak increases, and if, as stated above, it could be filtered, then a perfect A.V.C. voltage is available. The complete circuit of the Wunderlich tube with connections suitable for A.V.C. operation is shown in Fig. 3.

In this circuit, R1 is the grid-leak resistance, and should have a value of about, say, .5 meg.; R2 is an isolation resistor and should have a value of about 2 meg.; C1 is our .000075 mf. grid condenser; and C2 is a by-pass having a value of about 2 mf. For convenience, two R.F. or I.F. stages are shown connected to the A.V.C. circuit. The cathodes of the tubes of these two circuits have their usual connection to ground through bias resistors.

The addition of a tube of the type described here should prove a distinct advantage in receivers of the more sensitive type. When listening to foreign stations, for instance, the signal

the Wunderlich Detector

And the New "19" Amplifier Tube

may vary in intensity from time to time—a very annoying condition. With the addition of A.V.C., the signal may be maintained at an almost constant level, even though the actual signal is varying.

This situation may be easily watched—in actuality—by connecting a tuning meter in the plate circuit of the tubes under A.V.C. action, and tuning in a foreign station. As the station increases in intensity, the detector generates more A.V.C. voltage, which reduces the bias on the controlled tubes. This reduction in bias (more negative) causes the D.C. plate current in the tubes to diminish, resulting in a lower reading of the tuning meter. (A tuning meter is nothing more than a D.C. milliammeter connected in the detector plate circuit of a receiver; or in the amplifier plate circuit of amplifier tubes if those tubes are controlled by A.V.C. action.) In this manner the variations of the signal intensity may be watched, while it is heard at a constant level!

The New "19" Tube

With so many thousands of battery-operated short-wave receivers in use, very few can be said to operate economically and at the same time produce a good strong signal. This condition has now been alleviated by the introduction, by Sylvania, of the type 19—a complete class B amplifier tube—two separate triode class B tube-elements in

a single envelope! Read that last sentence over again!

The photograph of this tube is reproduced here, and the internal arrangement of the elements is shown in Fig. 4. The tube is of the dome-shaped type and of the same size as the 56. It takes a standard six-prong socket, the connections for which are shown in Fig. 5. Each triode section has its own filament, but they are connected in parallel, so that only two filament leads are brought out. The tube operates at zero grid bias, and the filament uses only two volts.

From the operating data below, it may be seen that the output of this tube is quite sufficient for all ordinary purposes, and certainly serves a field which heretofore has been neglected.

Operating Characteristics

Filament voltage, 2; filament current, .26-ampere; plate voltage, 135; grid voltage, 0, —3, —6 volts; plate current (no signal), 10, 4, 1, ma.; plate current with a signal of 50 volts on the grid, 27, 25, 22, ma.; input power required, 175, 130, 95 milli-watts; average power output, 2.1, 1.9, 1.6 watts; load resistance, plate to plate, 10,000, 10,000, 10,000 ohms.

The Filamentless Tube

One of the most important contributions to the radio field has just been announced by Wired Radio, Inc., in their new filamentless tubes, shown in Fig. 6. This tube operates on the general theory of ionization of gas, and represents a real step forward in tube design.

As an examination of the sketch shows, the tube consists of two wires about the size of No. 18 placed in a horizontal plane and overlapping by about 1/8 inch; the spacing between the wires is also about 1/8 inch. To the terminals of these wires is connected a D.C. source of voltage of about 100 volts, known as the ionizing potential. Surrounding this arrangement is a perforated cylinder also connected to a potential of about 150 volts. Thus, this cylinder, being at a higher potential than the two arc electrodes will attract the electrons (which are always negative) that are given off by the arc when they are placed in a glass envelope and about 10 to 20 mm. of some inert gas, like helium, is used.

The electrons attracted to the cylinder are able, due to their high speed, to go through the perforations and so reach out into space. Now, surrounding this cylinder is a grid, which is similar in construction to the grid in any other tube; this grid, in turn, is biased negatively, as in any other usual amplifier, with respect to the cylinder, which acts like the cathode in the usual tube. The plate surrounding this grid has a rather unique shape, as may be seen.

Due to mechanical difficulties, it is practically impossible to make a flat plate that would be equidistant from all parts of the cylinder. To overcome this difficulty, Dr. Hund, the scientist who invented this tube, corrugated the plate for two reasons: first, the plate then be-

comes mechanically rigid; and second, the effect is to make the plate have a greater effective area, thus minimizing any discrepancies because of irregularities in construction.

The characteristics of the tube are such that they may be operated with standard radio parts without any changes at all. According to Wired Radio, the tubes may become available within about one year. At that time, it will be interesting to note the changes that will be made in modern sets to accommodate this new filamentless tube.

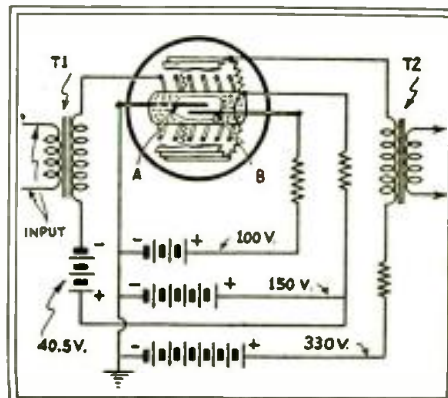

Diagram of the New Hund "Filamentless" Tube. Fig. 6.

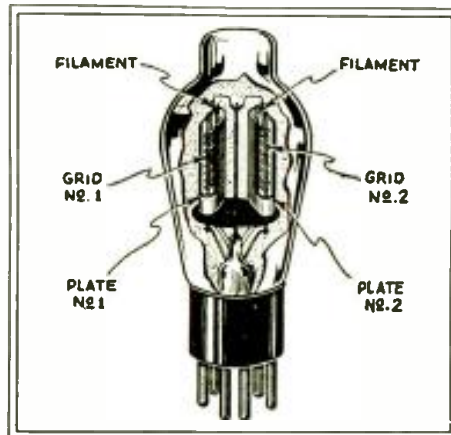

Fig. 4 Sketch showing the internal arrangement of the 19. Compare this with the socket connections given in Fig. 5, below.

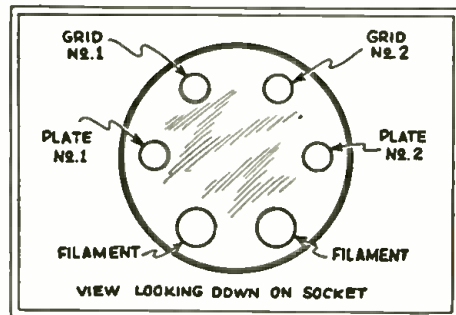

Fig. 5 Socket connections of the 19. Note the symmetrical connections of the grids and plates.

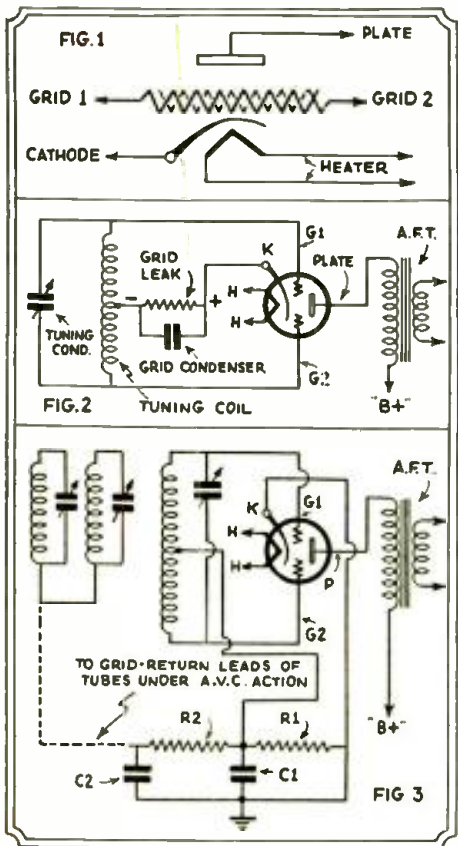
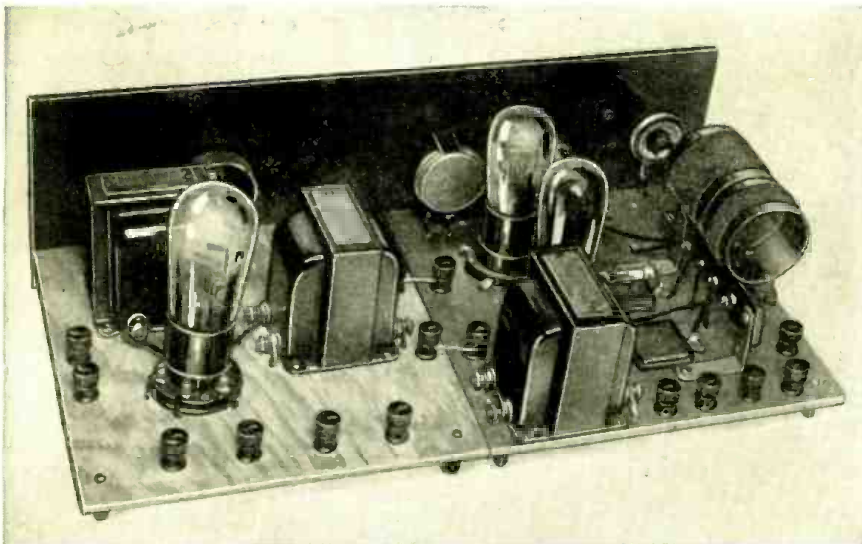

Fig. 1, above, arrangement of Wunderlich electrodes. Fig. 2, center, simple detection circuit. Fig. 3, below, detection with "AVC" circuit.



Rear view of the "Beginner's Receiver," plus the new power amplifier here described by Mr. Palmer, its designer.

Many readers have written to the editors from time to time asking for articles which would explain progressively how to build a beginner's short-wave receiver and an amplifier to match it.

Short-Wave

By C. W. PALMER

How to Build A

for the Battery-operated

● HOW many of you fellows have built the two-tube battery set described in the November, 1932, issue, and for some reason or other do not wish to electrify it; either through preference for battery operation on short waves, or because 110-volt-60 cycle current is not available?

From the response that has been received from SHORT WAVE CRAFT readers on this set, it has evidently struck a popular chord. Many fine "DX" records have been sent in by readers who built it. However, for *battery* operation, it has been limited to headphone operation up to now. Suppose, then, that we build a *power amplifier* to go with this set, so that those foreign stations can be heard all over the room.

We will remember that in the December issue we discussed the construction of a power-operated amplifier. In that issue we did not have sufficient space to discuss such things as the type of tube used. Perhaps some of you fellows have already recognized it as the "power pentode."

You will remember back in the beginning of this series, we mentioned that a tube consisted of an electric light bulb, equipped with a "grid" and a "plate" so that the electrons sent out

by the filament could be controlled and picked up. Well, when we apply signals that are too loud for this type of tube, it distorts the signals and they are very unpleasant to hear. The engineers who designed the tubes sought to overcome this trouble by making what is called "power tubes." First, they tried making tubes that did not amplify very much, but would handle very loud signals without causing distortion. These tubes were the *power tubes* familiar to radio fans several years ago, and still used a great deal. However, these tubes were not entirely satisfactory as they did not help to amplify the music very much. The trouble was caused by the plate, which would take only so many electrons at one time, very much like the small boy who tries to eat a piece of pie in a hurry so that he can have a second piece. When the capacity of the plate for accumulating electrons is exceeded, some of the electrons bounce back toward the filament; and as we know that a flow of electrons is a flow of current, we can understand that they disturb the normal operation of the tube by introducing "distorting currents."

Purpose of Two Grids in Pentode
The difficulty was finally solved by

the design engineers, by placing a fine mesh of wires between the plate and the grid, to carry these excess electrons to the ground where they would do no harm. Then, in order that the tube might amplify to the utmost, another grid was inserted between the regular grid and the filament and connected so that it increases the flow of electrons from the filament. The first wire mesh is known as the "suppressor grid" and the second as the "screen grid." Tubes are also made with only the latter type grid, for other purposes in the receiver. They are known as screen-grid tubes.

In our amplifier, though, we are only interested in the five element or "pentode tubes." Several pentodes are available; the type 47, which we employed in the A.C. power amplifier and the type 33, which we are going to use in the battery-operated amplifier, are two examples.

Peculiarities of the Pentode

It has been pointed out many times that to obtain the loudest signals, with the least amount of distortion, the impedance value of the loud speaker should be close to that of the power tube. Most of the speakers available now are made with an impedance to match the older types of power tubes. As the pentode has a much higher value, either a speaker with a high impedance must be used, or some means must be employed to compensate for the difference.

This can be done very nicely by the use of a transformer with windings of the correct impedance, connected between the tube and the speaker (providing a low impedance speaker is used).

Constructing the Amplifier

By referring to the photograph and diagrams, you can see that the *power amplifier* is made with a panel and base to match the receiver. With this construction, they may be placed side by side in a cabinet of the correct size, to form a very neat unit.

The amplifier comprises the input transformer, pentode tube and output transformer. The parts needed are as follows:

- 1—33 Pentode Tube—Arcturus (R. C. A.)
- 1—Audio Transformer—Thordarson Type R300

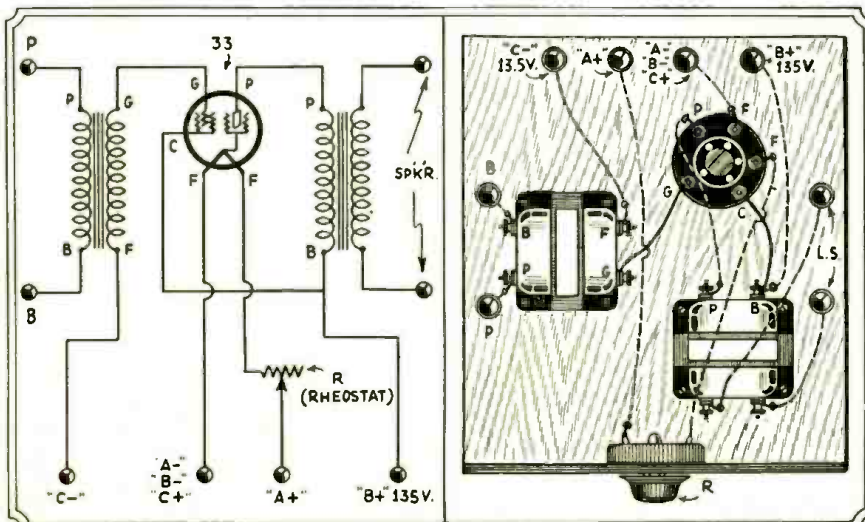

Above, at left, schematic diagram of the easily wired power amplifier; at right, picture diagram of amplifier. Figs. 1 and 2.

Mr. Palmer here explains in an easily understood style how you can build an extremely simple, efficient, "power amplifier" to use with your "Beginner's Receiver" of the battery-operated type

Beginner

No. 9 of a Series

"Power Amplifier"

Beginner's Receiver

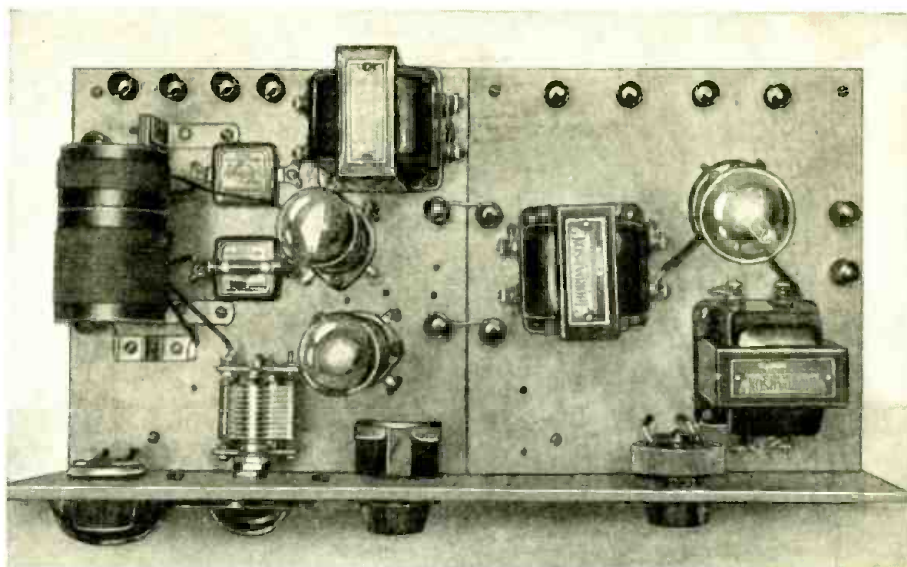

Top view of the battery-operated Beginner's Short-Wave Receiver, as previously described, plus the power amplifier.

- 1—Output Transformer—Thordarson type 4,843
 - 1—20 ohm Rheostat—Electrad
 - 1—5 Prong Tube Socket—Na-ald
 - 1—Panel 5x8 inches—3/16ths thick—Insuline Corp. of America
 - 8—Binding Posts—Eby Junior
 - 1—Baseboard 8x8x1/4 inches
 - 2—45 Volt "B" Batteries—Burgess type 10,308
 - 2—4 1/4 Volt "C" Batteries—Burgess type 2,370
- Hook-up wire, small brass angles, screws, etc.

Mount the rheostat at the central point of the panel and drill holes along the bottom of the panel for securing it to the baseboard with brass angles in a manner similar to that used when we constructed the receiver. Then mount the transformers, tube socket and binding posts in the positions shown in the picture diagram (Fig. 2).

Connect wires from the "P" and "B" terminals on the input transformer to the two binding posts on the left side of the baseboard (looking from the front panel). Connect a wire from the "G" terminal on the transformer to the "G" terminal on the tube socket. Solder another wire on the "F" terminal of the transformer and fasten the other end to the binding post on the extreme left at the back of the baseboard.

Next, connect a wire from one of the "F" terminals on the tube socket to the rheostat as shown; and complete the filament wiring by connecting a wire from the second "F" terminal on the tube socket to the second binding post from the left at the back of the baseboard, and connecting a wire from the third binding post from the rheostat to the third binding post from the right.

Now, solder a wire on the "P" terminal of the tube socket and run it to the "P" terminal on the output transformer. The "B" terminal on this transformer is connected to the binding post on the extreme right at the back and a second wire is run from this binding post to the "C" terminal on the tube socket. Complete the wiring by running wires from the two secondary terminals on the output transformer to the two binding posts on the right-hand side of the baseboard.

Operating the Amplifier

The amplifier is now ready to connect

to the receiver. The battery wiring diagram showing how this is done appears at Fig. 3. You will notice that the "B" and "C" batteries for both the set and amplifier are connected in series; that is, with the positive terminal of one wired to the negative terminal of the next. The connections for the receiver are then taken off at the required points.

The "P" and "B" terminals on the amplifier are connected to the phone binding posts of the receiver. *Make sure that you connect the "P" terminal to the receiver post that is wired to the plate of the first amplifier.*

Connecting the Loud Speaker

If a standard dynamic speaker is used, the regular input transformer in the speaker must be disconnected, so that the output transformer in the amplifier can be connected. An examination of the speaker transformer will show that it has four terminals or four wires running to other parts of the speaker unit. Two of these wires can be traced to the small coil at the apex of the cone (the voice coil). These two wires are the ones we are looking for. Disconnect them from the transformer and connect flexible leads from each of

them to the loud speaker binding posts on the amplifier.

If a speaker designed for the type 33 tube is used, no output transformer is needed in the amplifier (as mentioned before). In this case, the wires that are shown connected to the primary of the output transformer in the amplifier are connected to the two speaker binding posts and these, in turn, are connected to the input terminals of the speaker.

To operate the complete receiver, turn the rheostat on the set up to the usual point (at which the detector goes into oscillation) and turn the rheostat on the amplifier just high enough so that a bright red glow is seen from the filament of the tube. Then tune the receiver in the usual way and you will be surprised how loud even the weak stations are heard.

If you desire to tune with the phones, they are connected in the usual position across the phone binding posts of the set. If the volume is reduced in the speaker when the phones are connected, they may be removed after a station has been tuned in.

We have now completed the construction of the *Beginner's Receiver*, including both the A.C. and the battery operation. (Continued on page 688)

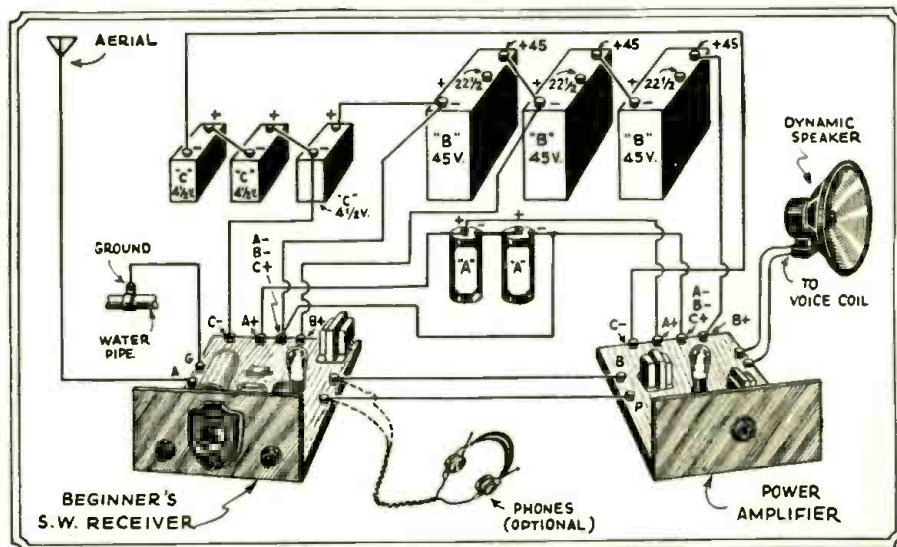

Picture diagram showing how to connect batteries to "Beginner's Receiver," plus power amplifier here described. Fig. 3.

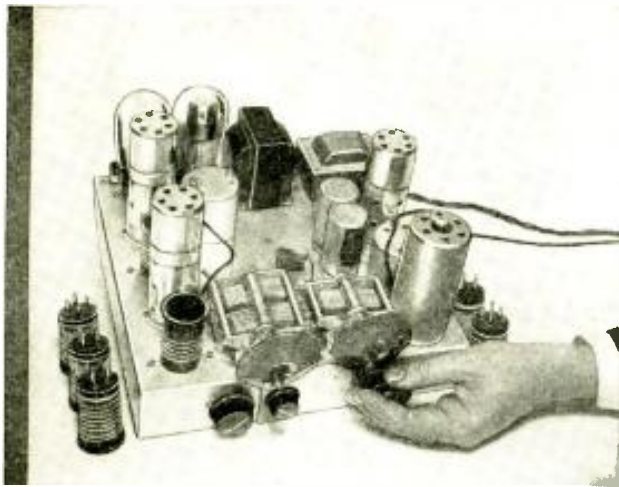

Above—General View of Mr. Cisin's DeLuxe Short-Wave Converter



Bottom View of the Find-All Short-Wave Converter; Can Be Used With Any "BC" Set

Find-All deLuxe S-W Converter

By H. G. Cisin, M. E.

● UP-TO-DATE radio receivers include short-wave reception as a matter of course. They are known as "dual wave" sets. They bring in the standard broadcast stations between 200 and 550 meters, and also foreign stations operating on short waves, radio amateurs, aircraft and police calls. Hundreds of thousands of very excellent receivers, however, do not include the new "dual wave" feature. These can be modernized quite readily by means of the Find-All DeLuxe Short Wave Converter.

Converts B. C. Receivers to Super-het.

The Find-All Converter is used to change any broadcast receiver into an excellent short wave superheterodyne. The circuit consists of an R.F. stage employing a 58 variable mu pentode (5), a screen grid 24 oscillator (18), a variable mu 58 detector (15) and an intermediate stage using a third 58 pentode (23). The converter has its own power supply, employing an 80 full wave rectifier, with a suitable filter system.

Here is a short-wave converter that should satisfy every "short-wave fan" who has ever thought of building one. It is a "superhet" converter provided with separate oscillator and it uses plug-in coils to change the wave-bands. This converter enables you to receive short waves on any broadcast receiver and makes an S-W superheterodyne of your present "BC" receiver.

Two sets of Alden short-wave coils are used with this converter. The coils are of the plug-in type. There are four to a set, permitting coverage of the short wave band from 20 to 200 meters. The coils are precision wound on Makelot color-coded coil forms. Coil (3) serves as the antenna coupler. The secondary of coil (11) is used as a tuned impedance between the R.F. stage and the detector. The primary of (11) inductively couples the plate of the oscillator (18) to the grid of the detector (modulator)

(15). In this way, both the signal voltage and the oscillator voltage are impressed on the grid of the detector. The resultant current, of the predetermined beat frequency, flows through the intermediate frequency transformer (16) from the plate of (15).

The secondary of the antenna coupler and the impedance (secondary of coil 11), are each tuned by a section of the dual .00015 mf. Cardwell "Midway" variable condenser. A single .00015 mf. condenser of the same type is used to tune the oscillator grid coil (20).

Separate Osc. Coil for Each Band.

A separate oscillator coil is provided for each of the four short wave bands covered by the Alden plug-in coil sets. The oscillator coils, however, are fastened in place permanently and the change-over from one coil to another is accomplished by means of a two-gang, four position selector switch of compact design. By

(Continued on page 681)

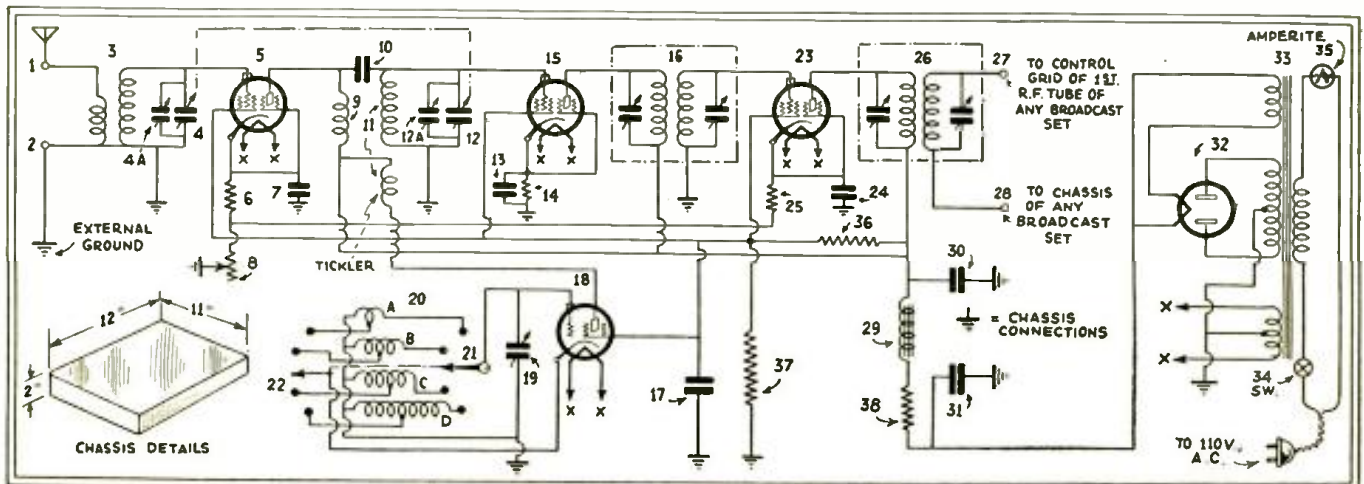

Schematic diagram of the Find-All DeLuxe Short-Wave Converter

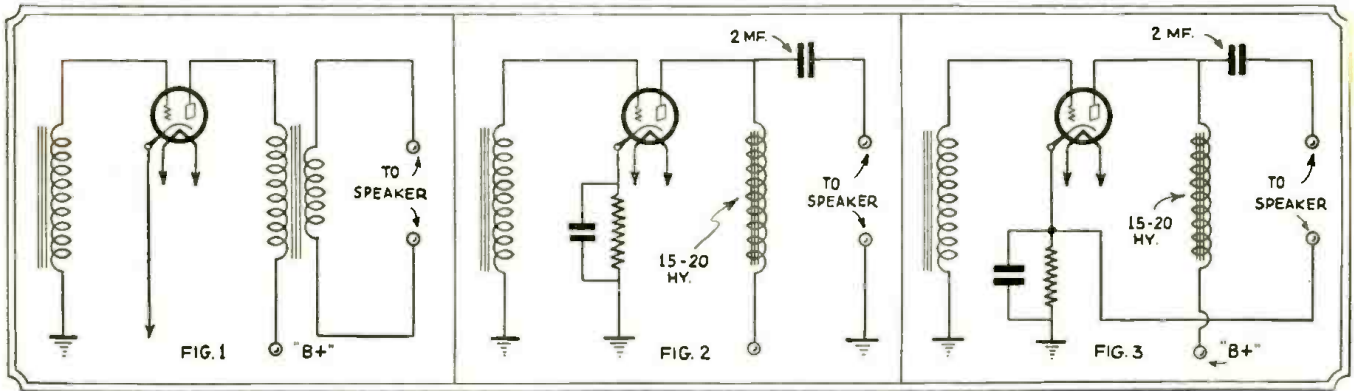

Fig. 1. Connecting triode to speaker by transformer.

Fig. 2. Coupling triode to speaker with choke and condenser.

Fig. 3. Still another choke-coil type coupling.

Methods of Coupling to Speakers

By M. HARVEY GERNSBACK

● ONE of the most important, but strangely neglected, points to be considered in the design of a short-wave, or for that matter any type of receiver, is the method of coupling the loud speaker to the output tube of the set. If this point is neglected much of the care put into the design of the receiver is wasted.

Failure to utilize a suitable method of coupling will result in lack of volume, mediocre quality of reproduction and in some cases violent distortion and instability.

It is the intention of the writer to discuss this problem in a critical manner from the standpoint of practical results.

First of all, why is an output coupling device necessary? An output unit serves two purposes. The first is to prevent the plate current of the output tube from passing through the delicate windings of the loud speaker. This plate current is quite considerable and if allowed to circulate in the coils of the speaker would demagnetize the speaker and possibly burn the windings out. If the output tube does not consume more than 8 milliamperes in its plate circuit, it is not necessary to protect the speaker windings in this manner.

The second purpose of the output unit is to match the impedance of the plate circuit of the power tube to the impedance of the voice-coil of the speaker. The impedances of differ-

ent types of speakers cover wide ranges. The average magnetic speaker has an impedance of 2000 or 3000 ohms, while the voice coil in a dynamic usually has an impedance of from 1 to 15 ohms. Quite a difference between the two types! In the light of these figures it is obvious that some sort of coupling device is absolutely necessary between the speaker and tube to adjust these wide differences.

Two General Coupling Schemes

There are two general types of couplings in use. The first is by means of a transformer placed between the speaker and the tube. The primary of the transformer is designed to conform to the plate impedance of the tube, while the secondary matches the impedance of the speaker. The transformer method is essential when using a dynamic speaker, as it is impractical to use any other method, due to the low impedance of the speaker's voice

coil. The secondary of the transformer must have an impedance equal to that of the voice coil. A discussion of the value of the primary impedance will be undertaken in a later paragraph. A diagram of the transformer type of coupling is shown in Fig. 1.

The second type of coupling makes use of an A.F. choke coil and a fixed condenser. The choke coil is placed in series with the plate lead of the output tube. The size of this choke varies with the type of tube used, but for the ordinary triode having a plate impedance of two or three thousand ohms a 15 or 20 henry choke should be sufficient. A fixed condenser of about 1 mf. should be connected to the plate terminal of the tube. The other side of this condenser is one terminal for the loud speaker. The other loud speaker terminal is taken to the ground of the receiver. If the receiver is operated from the light line and the bias for the output tube is secured by voltage drop in a resistor connected in series with the cathode of the tube and ground better low note response will be assured by returning the loud speaker terminal to the cathode of the output tube instead of to the ground. See Figs. 2 and 3 for complete details. The output of this type of coupling is suitable only for a speaker of fairly high impedance,

(Continued on page 699)

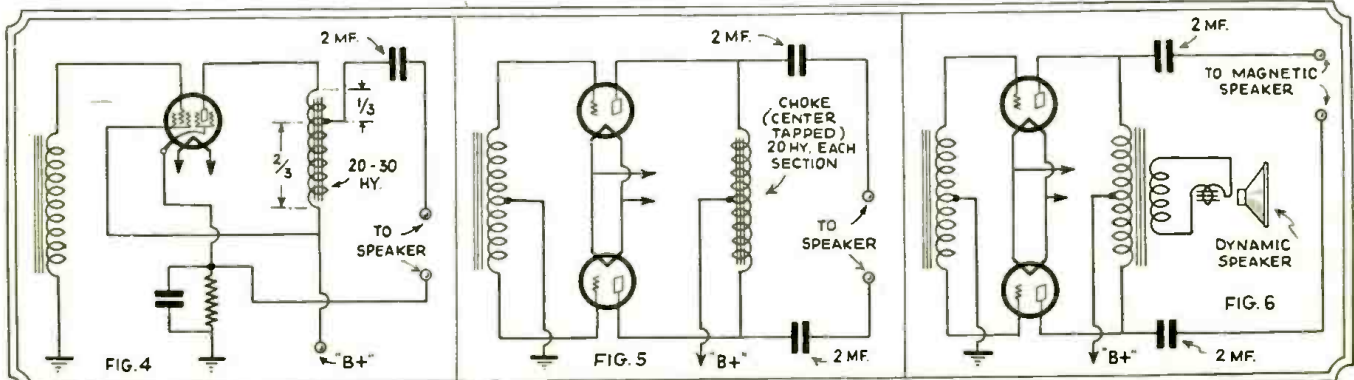
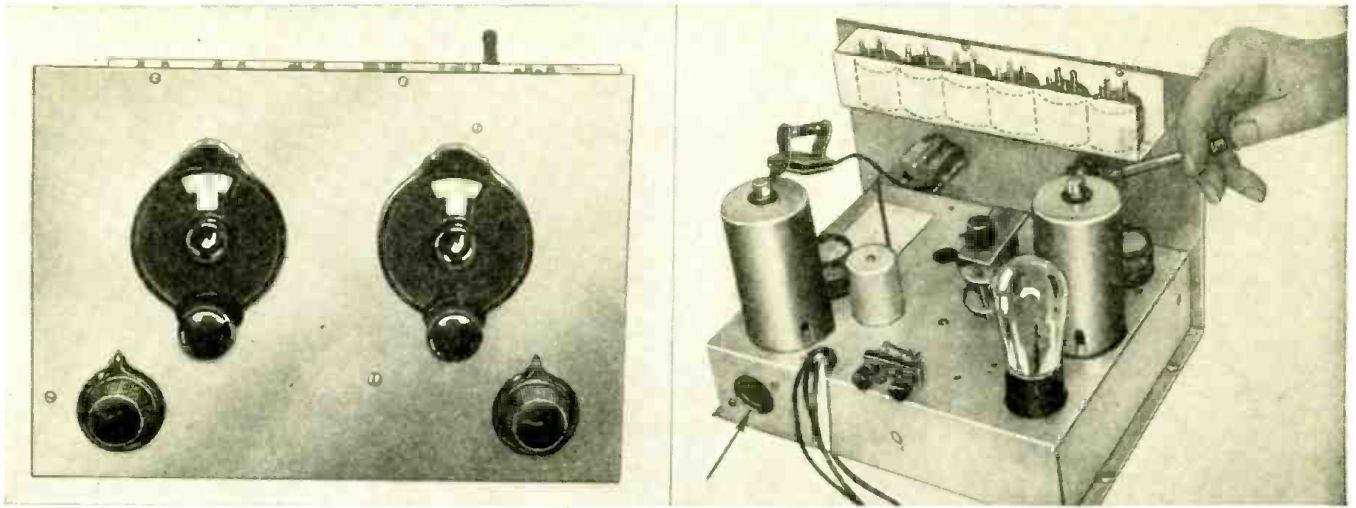

Fig. 4. Pentode coupled through tapped choke.

Fig. 5. Push-pull coupling through choke.

Fig. 6. Operating two speakers at once.



Front and Rear Views of Mr. Wahner's "Fan's Own" 3-Tube Short Wave Receiver, Which Embodies the Happy Combination of R.F., Detector and A.F. Stages. Pencil points to second variable condenser, just behind shield can.

The S-W Fan's Own 3-Tuber

By CLARENCE O. WAHNER

\$20.00 Prize Winner in December Contest

● THE set here described is a tuned radio frequency stage, screen grid regenerative detector and an audio stage combination. All of the features in this set have been taken from past issues of SHORT WAVE CRAFT magazine; notably from such authors as Messrs. R. W. Tanner and Edward Ingram. This set is the result of taking a few of each one's ideas.

The radio frequency stage is worked out from one of Mr. R. W. Tanner's circuits and the detector from Mr. Edward Ingram's. The audio I experimented with until the desired results were obtained. After completing this hook-up, I noticed from the September issue that Mr. Ingram had a similar idea.

As to the set itself, I have used plug-

in coils wound as described in your April, 1932, issue. They are of the National type with the exception of being wound on tube bases. There are primaries on all radio frequency coils, but I obtain better results with capacitive coupling of the antenna below 50 meters and had more success with the magnetic method above 50 meters.

The output of the first stage is fed to the detector circuit through a .0001 mf. condenser. A special short wave choke is used to provide a path for the "B" supply to the radio frequency tube, thereby differing from the usual method of utilizing the grid coil of the detector circuit, or having a separate primary winding for that purpose. I find that by using this system it is easier to obtain the correct impedance

necessary for the type 24 tube. This eliminates the necessity of juggling primary turns to attain this same end. By using this system I have been able to obtain wonderful amplification down to the lowest wave length to which this set can be tuned, about 16 meters.

Another feature to which the success of this set can be attributed is the lack of extreme sharpness, usually accompanying the lower wavelengths. There is also a variable potentometer in the screen-grid lead to this tube, which, though not absolutely necessary, helps a great deal in adjusting the sensitivity of the set.

The detector circuit uses a screen-grid detector of the 24 type with regeneration controlled by varying the voltage impressed on the screen grid.

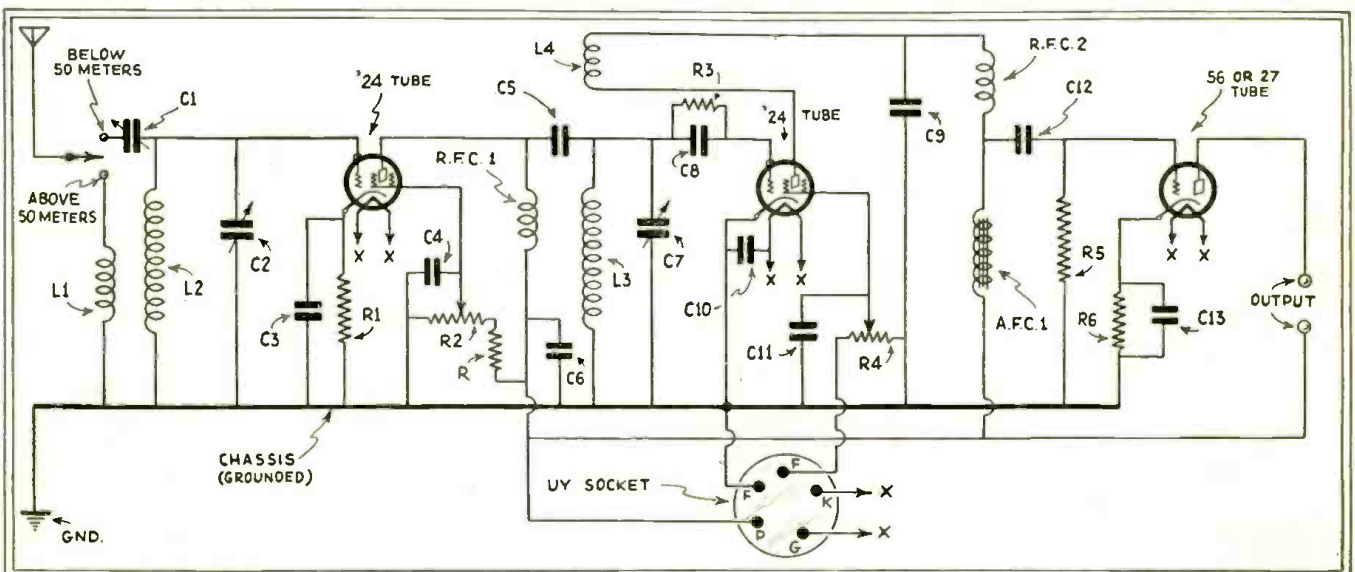

Schematic Wiring Diagram showing the Arrangement of the Three Simple, Yet Highly Efficient and Well-Designed Stages of Detection and Amplification Embodied in Mr. Wahner's 3-Tube Receiver

This is a very smooth form of regeneration and does not change the dial setting of the detector to any extent. The voltage control is a 50,000 ohm potentiometer. The grid circuit uses the conventional grid-leak (3½ meg.) and condenser (.0001 mf.). The condenser for regeneration is of the fixed type and should not exceed .00025 mf. for the best results. A Hammarlund short-wave choke is connected in series between the tickler and audio frequency choke.

One more feature to which I attribute the success of this set is the method of coupling the audio stage to the detector. By using an old type audio frequency transformer and connecting the primary and secondary in series, it forms a very efficient audio choke. A condenser of .006 mf. and a .5 megohm resistor complete the audio unit. This method of coupling certainly improves the regeneration qualities of the set.

In the A. F. stage I used a 27 tube, (or one of the new 56 tubes may be used.)

An ordinary 45 power amplifier can be added to this set, giving surprising volume on foreign stations. Using it in this manner I have been able to hear stations in Spain, England, France, Italy, Japan, and Mexico with considerable volume.

All power connections are brought to a five-prong socket on the rear of the chassis. This socket, plug, and cable serve to make connections more simple.

All external wires are color-coded and a code chart attached to the set where it can always be referred to.

The 3-Tube short-wave receiver, properly designed, is undoubtedly one of the most popular with the average short-wave fan. Mr. Wahner, an experienced short-wave experimenter, here tells in simplified fashion, how to build a 3-tube receiver which has picked up a surprising number of distant short-wave stations, as the specimen list given below testifies. This receiver embodies the happy combination of R.F., detector and A.F., stages.

Most of the internal wiring is done with stiff bus wire, preventing detuning effects by vibrating or shaking wires.

when writing to any of our contributors for information.—Editor.)

A Few of The "DX" Stations Received

Location	Call & Wavelength
Boundbrook, N. J.	W3XAL 49.15
Bowmanville, Ont.	VE9GW 49.17
Chelmsford, England	G5SW 25.53
Chicago, Ill.	W9XF 49.80
Cincinnati, Ohio	W8XAL 49.50
Madrid, Spain	EAQ 30.30
Mexico City, Mexico	XDA 25.50
Pittsburgh, Pa.	W8XK 25.24
Pittsburgh, Pa.	W8XK 48.83
Pontoise, France	FYA 25.6
Rome, Italy	I2RO 25.4
Schnectady, N. Y.	W2XAF 31.48
Springfield, Mass.	W1XAZ 31.33
Tokio, Japan	J1AA 19.83
Winnipeg, Canada	VE9CL 52.50

Parts List

- Variable Condenser, C1 .00045 Mf.
- Variable Condensers, C2, C7 .0001 Mf.
- Fixed By Pass Condensers, C3 .1 Mf.
- Fixed By Pass Condensers, C4, C6, C12 .006 Mf.
- Fixed By Pass Condensers, C5, C8 .0001 Mf.
- Fixed By Pass Condensers, C10 .001 Mf.
- Fixed By Pass Condensers, C11, C13 1. Mf.
- Fixed By Pass Condensers, C9 .00025 Mf.
- Fixed Resistor, R 50,000 Ohms.
- Fixed Resistor, R1 500 Ohms.
- Fixed Resistor, R3 3.5 Megohms.
- Fixed Resistor, R5 500,000 Ohms.
- Fixed Resistor, R6 2,000 Ohms.
- Variable Resistor, R2 100,000 Ohms.
- Variable Resistor, R4 50,000 Ohms.
- Radio Freq. Choke, R.F.C. 1 Special Short Wave Choke.*

Anyone desiring further information regarding this set may receive same by getting in touch with the writer. (Enclose stamped and addressed envelope

*Use special Short Wave R. F. choke such as the new National, with split sections to reduce the distributed capacity. An ordinary broadcast choke is worthless.

(Continued on page 682)

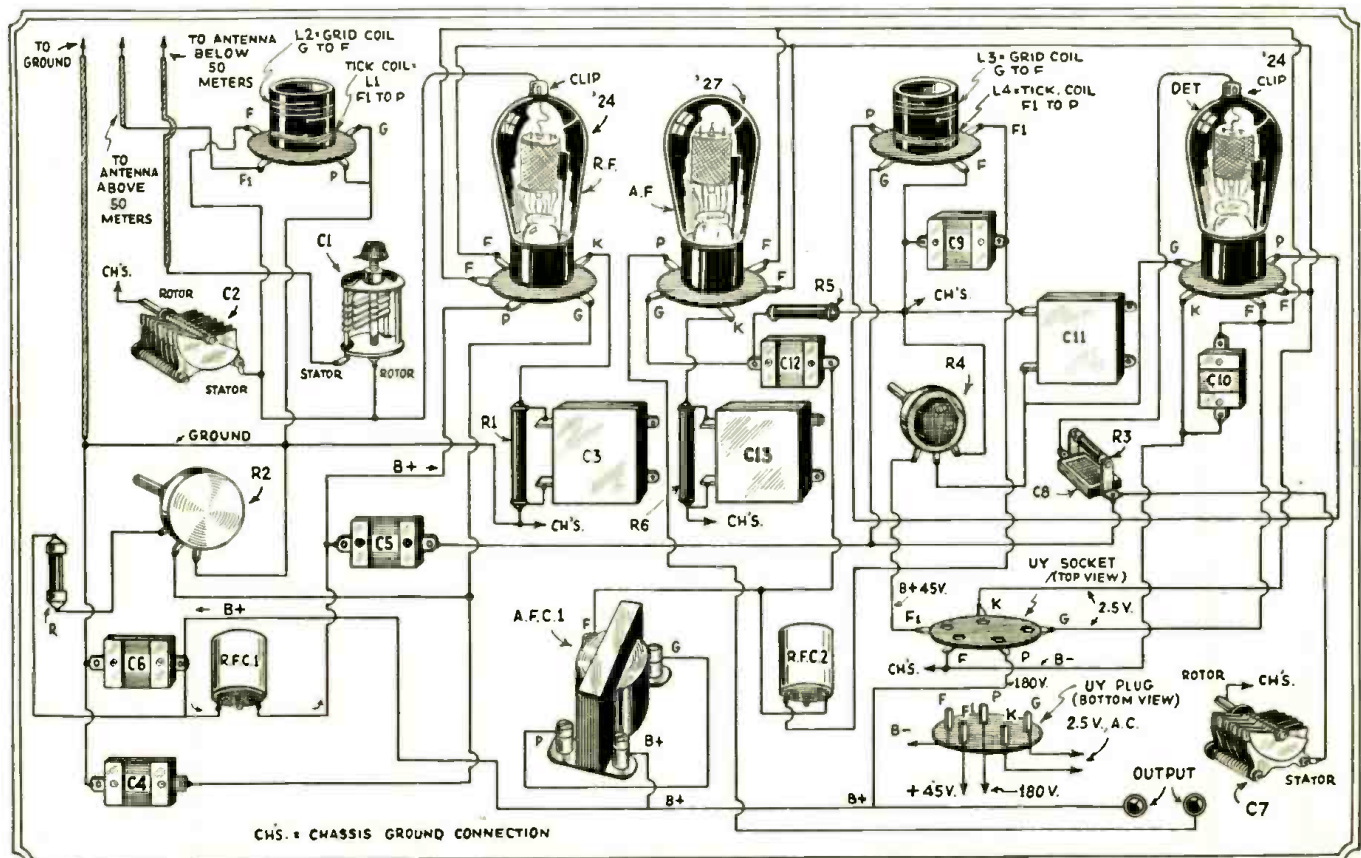

For the Benefit of the Reader Who Is Not so Familiar with the Schematic Diagram Shown at the Left, the Editors Had This Picture Diagram Especially Made so That Anyone, With a Little Care, Can Follow It and Build Themselves a Really Fine Short-Wave Receiver Suitable for Head-Phone Operation.

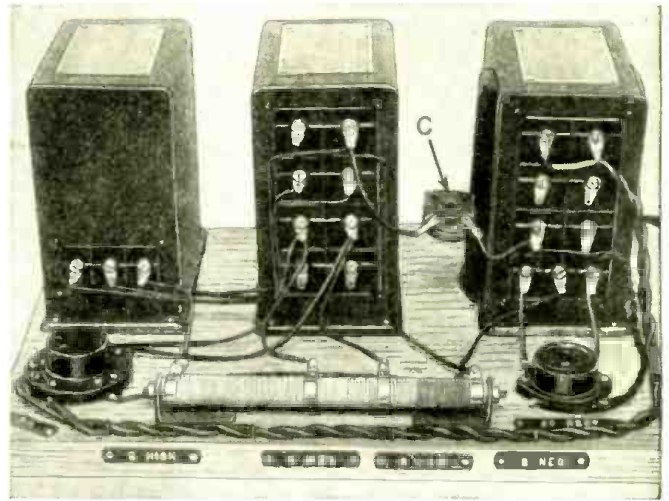
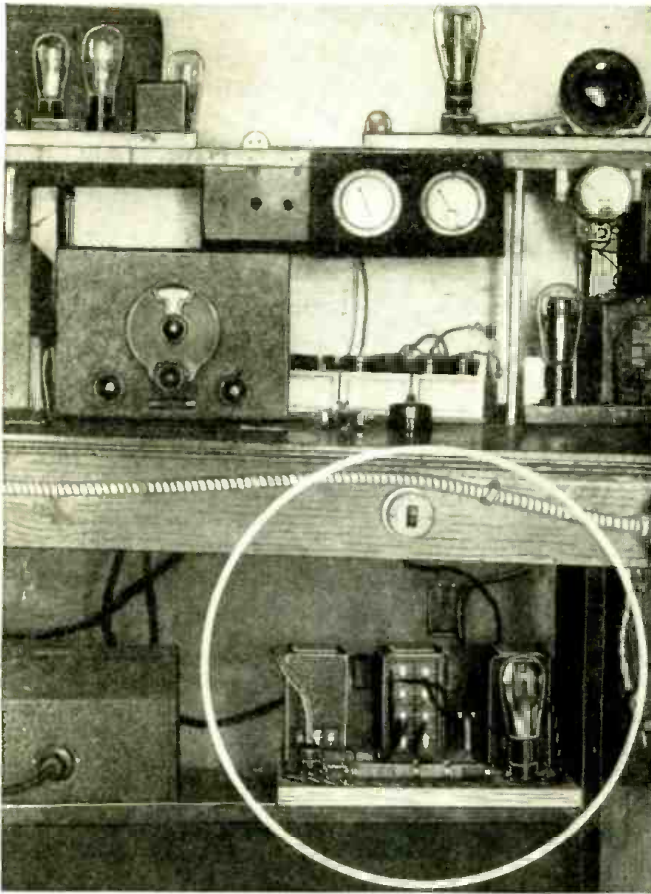

A complete A.C. power-pack for the S-W receiver. Note the R.F. choke "C" hanging in mid-air between the power transformer and the filter condenser. Socket on left for 5-wire cable and tube-base plug; socket on right for 80 rectifier. Any desired plate voltage up to 300 available.

A "QUIET" A.C. Power-Pack

for Small S-W Receivers

By ROBERT "BOB" HERTZBERG

A small, but "good," Power-Pack for use with small S. W. receivers is in great demand. Here's just the "job" you've been looking for. All "hum" is reduced to a minimum.

The right place for short-wave power-packs—away from the sets themselves. On the shelf just above the floor are (at the left) the factory-built power unit for the National SW-58, and (at the right) the "home-made" unit for the SW-3. A completely A.C. operated audio power-amplifier for the latter is mounted on a shelf above the tuners.

● ONE of the earliest and most persistent bugaboos in the short-wave game is that concerning A. C. operation. It is kept alive by the many ex-broadcast experimenters who are finding new thrills in the short waves, and whose experience with all-electric short-wave set operation dates back to the days when adequate filters and properly designed cathode-heater tubes were unknown.

Now there is nothing especially mysterious or magical about A. C. power-packs, and it is not necessary to depart very far from ordinary practice in order to make a unit that will work smoothly and quietly. Instead of looking for queer circuit arrangements and phoney "hum balancers," the constructor should merely use good parts and a reliable hook-up, and above all else learn to keep the completed pack a respectable distance from the sensitive receiver itself!

Let that last statement sink in! In the writer's experience, which embraces part of the design work, in collaboration with Robert S. Kruse and David Grimes, on the original Pilot Super-Wasp, the first commercially successful short-wave receiver for all-electric operation, more trouble is caused by having the pack too close to the receiver, than by any other single factor! This remark should not be construed as a criticism of sets which have the A.C. power supply on the same chassis with the tuner; this sort of thing is all right if the set is designed from the start

with the idea in mind and if the proper precautions are observed. When a man starts with a battery receiver and starts to "electrify" it, matters are altogether different.

Come to think of it, the manufacturer of some of the finest short-wave receivers on the market today insists on building the power-packs as entirely separate units, and supplies a long, heavy interconnecting cable with the advice that it be used *without being curled up*.

Built In One Evening

As an example of what can be done at little trouble and expense, the writer illustrates herewith a complete power-pack that he built in one evening, to go

with a regular National SW-3, which is an orthodox short-wave receiver using one T.R.F. stage, regenerative detector and one audio stage. This set had been working on batteries for about a year, and with the demise of the "B's" it was decided to eliminate all batteries in favor of AC. The unit worked perfectly from the start, with only the barest trace of a hum in the earphones to indicate the nature of the power supply.

Two simple little tricks helped matters considerably. One was the use of an R. F. choke in the high voltage lead from the filament of the 80 rectifier to the filter system, to keep para-

(Continued on page 693)

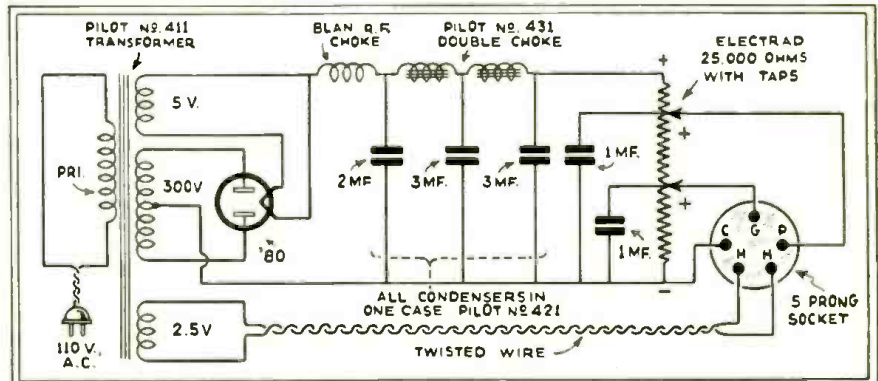

Diagram showing connections of various parts used in building the power-pack.

The 2-Tube "Old Reliable"

By ELMER A. SIMMONS



Appearance of Mr. Simmons' 2-Tube Short-Wave Receiver—ideal for the beginner. The cost of the parts is low and the capabilities of the set practically unlimited.

Just the type of short-wave receiver for the "beginner"—it employs two of the new two-volt dry-cell tubes. The cost of the set is extremely small and it is capable of receiving signals from all over the world. It is similar to the famous "Doerle" receiver.

● TO make the chassis of this instrument, procure an aluminum cooky sheet. These sheets are 12 x 15 1/2 inches (cut as in diagram). This can be cut with an ordinary wood saw. Take piece No. 2 and bend as in Fig. 1. If no vise is handy bend it in the jaw of a drawer. Next drill all holes or punch out, then finish with file. Note that the small hole already in the pan has been enlarged, and is now used for bringing the cable through. The 7 inch piece of aluminum is for a front panel. Care should be taken not to scratch the surface.

Next make the sides and front of wood, as shown, and fasten to the chassis with round head screws. When this is finished put the front panel in place, and mark through on to the wood to get centers for the switch and jack. These last two will hold the front panel in place when assembled. The set should next be assembled. The phone jack and the antenna condenser should be insulated from the panel with bakelite washers. The coil should be as high as possible above the chassis. The Pilot socket is OK for this.

Don't use a wafer socket; the losses would be so high that the set would be inefficient. The circuit should be followed carefully to avoid mistakes. Care should be taken to see that the grid leak is connected as shown. With the grid negatively biased there is a 5% loss in volume using the same type tubes, 30's.

The set should be wired with rubber covered stranded wire. It is not necessary to solder each wire if bolts are provided on the parts used, but have all wiring as strong and short as possible consistent with good electrical practice.

To make the coils obtain three tube bases. Make a hole over each prong by first filing a groove then punching through with an awl. Wind the coils with No. 18 enameled wire. Note that the tickler coil is reversed. This is not necessary but it helps the set to oscillate. The ends of each wire should be scraped clean of all enamel, then

pushed down into its own designated pin or prong. To hold these wires in place in the prongs, take a match, sharpen one end, then force this end down into the prong with the wire. Now snap the remainder of the match off. This makes a very neat job, and no solder is required.

The choke is jumble wound on a 1/2 inch core spool and consists of 150 turns of No. 24 wire. The 7 plate antenna series condenser should have one stator plate removed. This will allow the set to oscillate correctly when used with an aerial of 100 feet. The lead-in is brought in through a grommet in the right side of the set. The ground is connected directly to "A" minus on the "A" battery.

If the wood form is built according to directions it will prove very strong. The subpanel is fastened to it with three screws on each side and front and two on the back. Remember when cutting it is best to make all parts a little large, then file down to perfect fit. Two lengths of silk lamp cord make the battery cable. The A+ is red tracer with loop for binding post; the "A" minus is white tracer with loop for binding post; the "B" plus 90 is red tracer with plain pointed end for clip on the "B" battery; "B" plus 45 is white tracer with plain pointed end for clip on "B" battery; "B" minus connects to "A" minus.

The filaments are lighted from a two volt battery or from a battery of two dry cells in series, with a ten ohm rheostat in "A" plus or "A" minus. This set was constructed to see if it was possible for the average person to build an efficient, small and dependable set at home with no tools other than those found in every home; of material obtainable anywhere; and at little cost. It will receive every station the big sets are able to pick up, but not at loud speaker volume, of course. An amplifier is now being constructed for this set and in all probability will afford good volume when attached to the set.

(Continued on page 699)

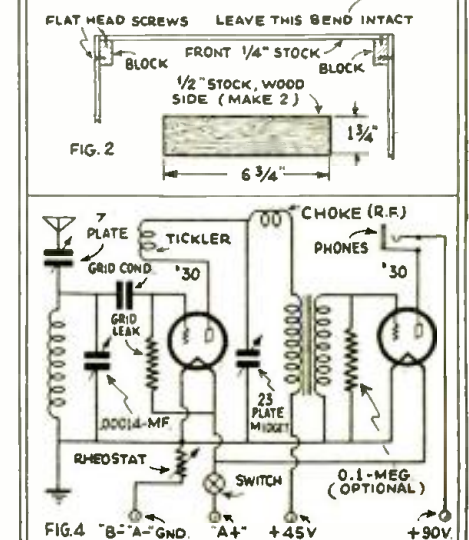
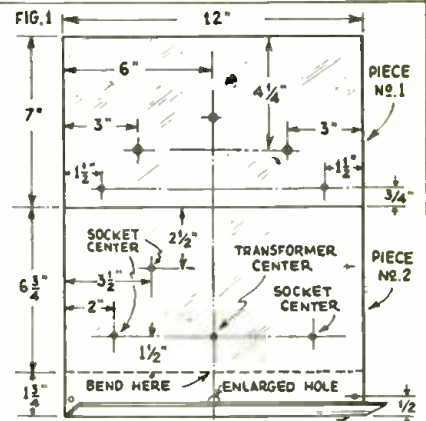
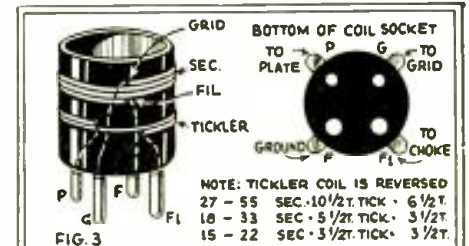

Details for building Mr. Simmons' 2-Tube Short-Wave Receiver, including wiring diagram.

A "Fly-Power" Transmitter

By HARRY D. HOOTON

● DURING the fall and winter of 1931-32 we had no power supply for a transmitter, other than that furnished by dry cell "B" batteries. Having been an amateur for several years we found it extremely difficult to keep off the air. Previous to this time we were rather skeptical about getting results with such low-powered tubes as 201a's or 112's. However, the transmitter shown in Fig. 1 was built up for operation on the 20 meter band. The little set worked so well that we decided to write it up—hence the reason for this article.

As may be seen from Fig. 2, the circuit is the Hi "C" Hartley. The set operates with a single 01a at 180 volts, 20 mils. (milliamperes) on the plate—approximately 3.6 watts input. The 20 meter coil consists of three turns of 1/4 inch copper tubing wound on a form 2 3/4 inches in diameter and spaced 1/2 inch. The "tank" or tuning condenser is a Hammarlund receiving type .0005 mf. capacity. The plate blocking condenser is a Sangamo, .0005 mf., the grid condenser is an Aerovox .00025 mf. and the grid leak is a 10,000 ohm resistor similar to those used for obtaining bias in A.C. operated receivers. The r.f. choke consists of two inches of No. 30 wire wound on a 3/4 inch paper tube. No filament by-pass condensers or resistors are necessary.

The transmitter is built up on two maple sticks 12"x1"x1/2". Holes are drilled for the Hammarlund condenser about one-fourth the distance from one end. Mount the variable condenser and the fixed condensers as shown in the photo. The tube socket must be placed close enough to the coil and tuning condenser so that the wiring will be fairly short and direct. Place the milliammeter on the end as far away from the tube socket and the tank circuit as possible. Mount the r.f. choke fairly close to the tube socket and at right angles with the tank coil. Solder all connections by using a hot iron and resin-core solder.

The antenna is the single wire "feeder" type. It is designed for operation on approximately 14,200 kcs. (kilocycles). The flat top or radiating part

The circuit used is the Hi "C" Hartley; the set operates with a single 01A on 20 meters.

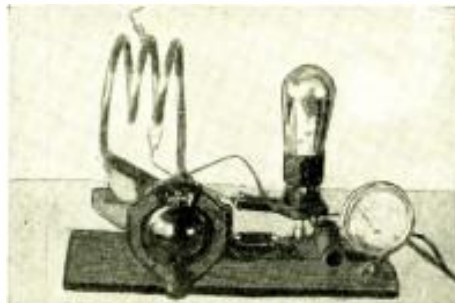

Photo of the finished "Fly-Power" 20 Meter Transmitter built by Mr. Hooton, who here describes how to build it.

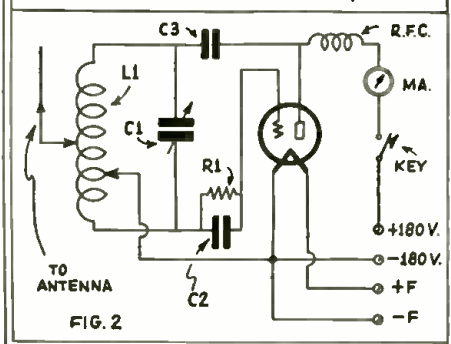
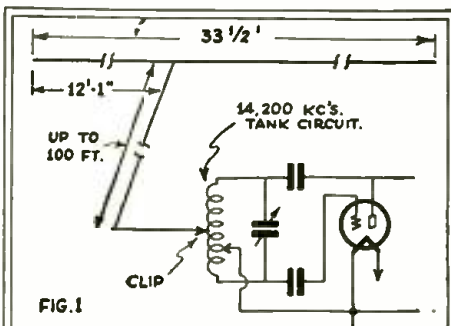

Diagram of the connections for 20 meter "Fly-Power" transmitter which uses an 01A tube, at 180 volts and 20 ma. plate current.

is 33 1/2 ft. long and the feeder wire is soldered to it at a point exactly 12 feet, 1 inch from one end. The feeder may be any length up to 100 feet. At the transmitter the feeder coupling is adjusted by means of a clip. From one to one and one-half turns of coupling is necessary for a good signal.

The tuning of this transmitter is simplicity itself. By means of a monitor or short-wave receiver set the frequency of the transmitter near the center of the 20 meter band. The tube should draw about 16 mils. with the antenna removed and the filament clip adjusted to about 1 1/2 turns from the grid end of the coil. Clip the antenna on to the plate end of the coil, about 1 1/2 turns from the filament clip and adjust the coupling until the milliammeter reads approximately 20 mils. Check the frequency again to be sure the transmitter is operating in the band.

The key is connected in the -180 volt lead wire.

If 40 meters operation is desired, wind the plate coil to five turns and multiply the dimensions of the antenna by two. The rest of the set is built as described above.

Either standard or heavy duty "B" batteries may be used. The standard size will last about two months if the set is operated three or four hours daily.

List of Parts for the "Fly-Power Transmitter"

- R1—10,000 ohm grid leak type resistor,
- C1—Hammarlund receiving condenser, .0005 mf.,
- C2—Aerovox fixed condenser, .00025 mf.,
- C3—Sangamo fixed condenser, .0005 mf.,
- L1—Plate coil see text,
- RFC—Radio frequency choke, see text,
- MA—Milliammeter, 0-25, may be "Read-rite" or "Jewell,"
- UX socket,
- Dial,
- 01A tube,
- Maple sticks, solder, etc.

\$20.00 Prize Monthly For Best Set

● THE editors offer a \$20.00 monthly prize for the best short-wave receiver submitted. If your set does not receive the monthly prize you still have a chance to win cash money, as the editors will be glad to pay space rates for any articles accepted and published in SHORT WAVE CRAFT.

You had better write the "S-W Contest Editor," giving him a short description of THE ACTUAL SET, as it will save time and the set and a diagram. BEFORE SHIPPING expense all around. A \$20.00 prize will be paid each month for an article describing the best short-wave receiver, converter, or adapter. Sets should not have more than five tubes and those adapted to the wants of the average beginner are much in demand. Sets must be sent PREPAID and should be

CAREFULLY PACKED in a WOODEN box! The closing date for each contest is sixty days preceding date of issue (February 1 for the April issue, etc.)

The judges will be the editors of SHORT WAVE CRAFT, and Robert Hertzberg and Clifford E. Denton, who will also serve on the examining board. Their findings will be final.

Articles with complete coil, resistor and condenser values, together with diagram, must accompany each entry. All sets will be returned prepaid after publication.

REQUIREMENTS: Good workmanship always commands prize-winning attention on the part of the judges; neat wiring is practically imperative. Other important features

the judges will note are: COMPACTNESS, NEW CIRCUIT FEATURES, and PORTABILITY. The sets may be A.C. or battery-operated. Straight Short-Wave Receivers, Short-Wave Converters, or Short-Wave Adapters. No manufactured sets will be considered; EVERY SET MUST BE BUILT BY THE ENTRANT. Tubes, batteries, etc., may be submitted with the set if desired, but this is not essential. NO THEORETICAL DESIGNS WILL BE CONSIDERED! The set must be actually built and in working order. Employees and their families of SHORT WAVE CRAFT are excluded. Address letters and packages to the SHORT WAVE CONTEST EDITOR, care of SHORT WAVE CRAFT Magazine, 96-98 Park Place, New York, N. Y.

A Condenser "Mike" for 10 Cents!

By WILLIAM J. VETTE

THIS article is a contradiction to the distorted idea entertained by some that the condenser microphone is an expensive piece of radio equipment. Sure it is, if of the type used around commercial broadcasting and recording studios, but inasmuch as the 'phone Ham's requirements are neither so rigorous nor as exacting as those imposed upon broadcasters, there seems to be no logical reason why we should not find more condenser "mikes" in use among the amateur fraternity.

Here is a condenser microphone head which cost the author just ten cents to make—and the quality of its output is better than the average double-button carbon mike—in fact, it is comparable to a condenser costing twenty dollars! But before we describe it, let us study the principles underlying the condenser microphone.

How Condenser "Mike" Acts

The condenser microphone is just what the name implies—a condenser, with air dielectric. In one of these mikes you will find a solid, immovable backplate, spaced about .01" from a movable diaphragm of some very thin and flexible metal, usually Duralumin of about .002" thickness, although I have used .0015" brass and .002" steel just as successfully—the only drawbacks being that brass is affected by atmospheric changes, and steel rusts badly. This diaphragm acts as the movable plate of a two plate variable condenser with the backplate as the stator. Thus it will be seen that sound waves striking the diaphragm vary the capacity in the amplifier tube grid circuit.

Simple in Construction

The condenser microphone, contrary to popular opinion, is quite simple to construct, for all practical purposes, if one is able to devise a scheme for stretching the diaphragm sufficiently. The tension on the diaphragm governs the quality of reproduction to be obtained; the tighter it is the better the quality of the output. And here it is that most home constructors meet their "Waterloo" when trying to build a condenser at a low price. However, it is possible to devise "haywire" stretching arrangements, as is evidenced in the following constructional "dope". The microphone herein described was built merely as an experiment, but it has proven itself worthy of attention—so worthy, in fact, that it has been sent to W5AOE to replace the mike in use until that time.

Mr. Vette tells us just how he built a very successful condenser type microphone from an old headphone receiver case, the case being of the metal type. The receiver case, together with a tube adaptor, a duralumin diaphragm and a small piece of brass, comprise the whole "mike." A condenser "mike" of the type here shown is now being used in several well-known "ham" stations.

Old Head-Phone Case Needed

To build this mike you will need an old head-phone case, with cap (I used a Holtzer-Cabot, but practically any kind should do, the only requirement being that it be a metal case), a Frost No. 611 tube adaptor, of the type to adapt a UV 199 tube to a UV 201 socket (no substitution here—this is the heart of the mike), a small piece of sheet brass for the backplate, and a few screws as given later.

How Adaptor Is Altered

We will prepare the adaptor first. This serve three purposes—it supports the backplate, serves as a base for stretching the diaphragm, and acts as a spacer between the backplate and diaphragm. This adaptor is shown in Fig. 1. The first thing to do with this is to cut off the end with the prongs, as shown in the diagram. No dimensions are given, as they will vary with the type of headphone case used. It should be cut so that the top of the adaptor projects about one-eighth of an inch above the top of the case, and the cutting should be done so that both ends of the adaptor are absolutely parallel.

Making the "Backplate"

Next, cut your backplate so that it will fit snugly within the external ring which projects above the adaptor ("a" in Fig. 1.) This backplate must be of sufficient thickness so as to be quite rigid, and not vibrate. For this reason a corrugated piece is most satisfactory. Now drill two or three holes in the backplate. While the placement or diameter of these holes is not important (don't make them too large, of course), they are necessary to the proper operation of the mike. They serve to prevent "cushion" effect—that is, they prevent a dead air space between the diaphragm and backplate. Were this condition present, the mike would be practically inoperative, as the diaphragm would not be able to vibrate in accordance with the sound waves impressed upon it. After cutting the backplate to the correct diameter (1 3/8") it should be dressed down on the face with very fine emery or ground glass, to remove any burrs from the edges.

A Little Lathe Work

Now we will lay the backplate aside for awhile and finish preparing the adaptor. Looking at the top you will see the lettering: "Frost Radio—No. (Continued on page 684)

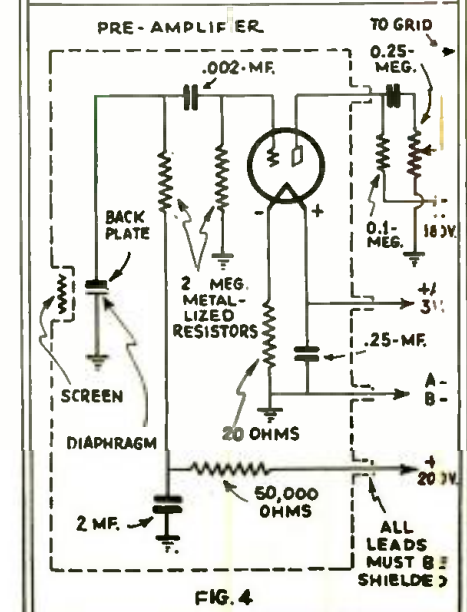
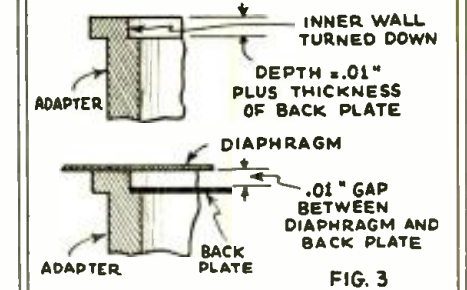
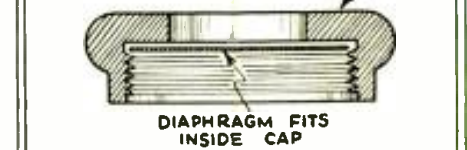
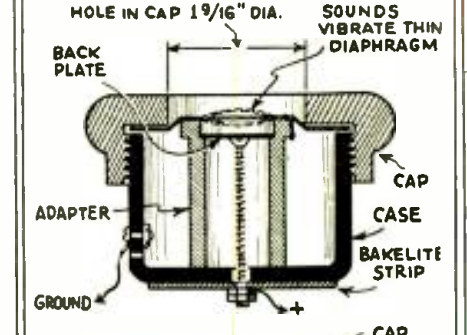
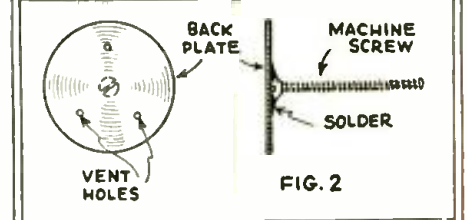
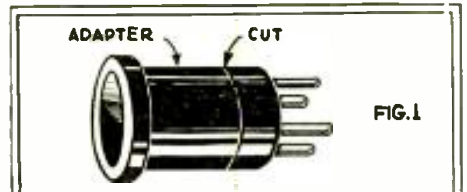

The drawings above illustrate the successive stages in preparing and assembling the condenser "mike," here described in complete detail by Mr. Vette. The diagram shows how to connect the "mike" through a simple amplifier, as described by the author.

How Altitude Variations in KENNELLY-HEAVISIDE Layers Were Recorded

By PAUL BERCHE

Little is known concerning the Kennelly-Heaviside layers and their altitudes. The apparatus described makes it possible to photographically record signals which have been reflected by these ionized layers of the upper atmosphere and thus provide data for further study.

● IT IS well known that the great ranges observed with short waves, the fading and the zones of silence, are explained by the existence of one or more ionized layers of the upper atmosphere, at which the electromagnetic waves undergo reflections and are sent back to the earth. The existence of these layers has long been considered hypothetical, but the experience of recent years have shown that it is possible to put in evidence phenomena of wave reflection which affirm that everything takes place as if, for each wave above 10 meters in length under certain conditions, there existed one or more reflecting layers located several dozen kilometers up in the atmosphere, whose height for a definite wave varies with the time of day and the season. These layers are the Kennelly-Heaviside layers.

There are several methods of showing the reflections undergone by a wave on the Kennelly-Heaviside layer or layers. The one most in favor in the United States, where numerous observations have recently taken place, is the method of G. Breit and M. A. Tuve, called the group retarding or tap.

How Signal Is Sent and Received

This method, very ingenious and very simple at the same time, consists of emitting at point A of the globe (Fig. 1) a very short Morse dot, a "tap" of 2 to 5 thousandths of a second duration and of registering photographically the reception of this tap in a receiver installed at a point B. Under certain conditions one observes at B for one tap transmitted at A not a single tap but several taps, spaced a fraction of a thousandth of a second apart, a very short time which however one measures very accurately, thanks to the means of registering employed.

These successive taps registered at B, when a single tap was transmitted at A, are explained as follows:

The waves transmitted from A reach B by various routes; one distinguishes these waves:

1. The direct wave, called the surface or ground wave, which follows the surface of the earth; the propagation of this wave is represented in Fig. 1 by the straight line AB.

2. The wave reflected by a first Kennelly-Heaviside layer (lower layer or layer E); this wave takes the course ACB.

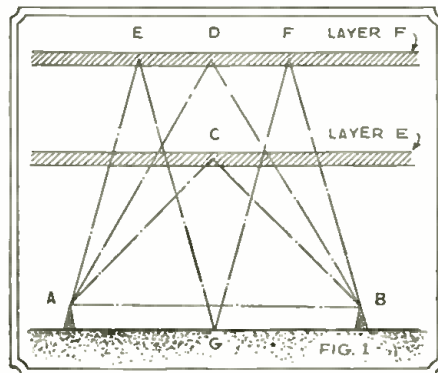
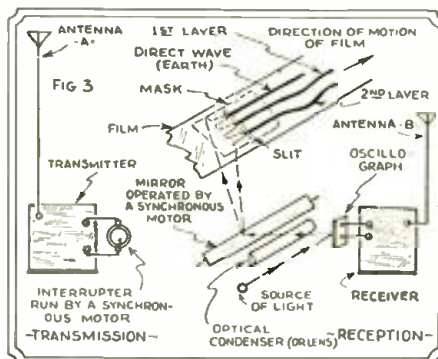

Fig. 1—This diagram shows the various routes followed by the electromagnetic waves between points A and B of the terrestrial globe, whose radius of curvature has been taken as infinite.



General arrangement of the Gilliland and Kenrick scheme for registering the arrival of short-wave signals reflected by Kennelly-Heaviside layers.

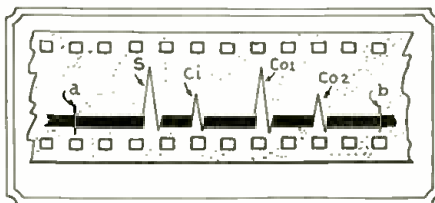

Fig. 2.

Type of oscillogram registering at station "B" a tap transmitted at station "A" (Fig. 1) and taking the various routes AB, ACB, ADB, and AEGFB.

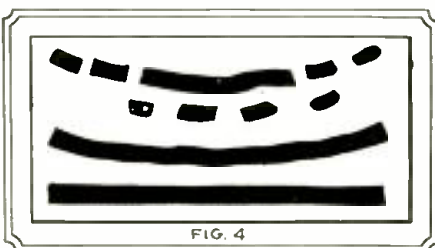

Fig. 4

Type of registration obtained by the Gilliland-Kenrick method. The lower straight line corresponds to the direct wave (earth). The two sinusoidal lines represent respectively the height of the lower and that of the upper Kennelly-Heaviside layers. Note spasmodic appearances of intermediate layers.

3. The wave reflected by a second Kennelly-Heaviside layer (upper layer or layer F); the course of this wave is ADB.

4. The wave twice reflected on the upper layer with an intermediate reflection on the earth; the rather complex course of this wave is represented by AEGFB.

How are these taps registered on reception?

Checking Signal Recorded on Film

The last tube of the receiver is connected to a very sensitive galvanometer whose movable element has a little mirror. At each tap the mirror is displaced. If one reflects on this mirror a fine pencil of light, the reflected ray will undergo displacements when the taps are received. These displacements of the ray or the "spot" are registered on a sensitive ribbon (motion picture film) moving at great speed. With the oscillograph thus obtained one gets for one transmitted tap oscillograms of the type of Fig. 2.

The first tap received, registered at S, corresponds to the surface wave, going directly from A to B. The second reception, registered at Ci, corresponds to the wave reflected by the first (lower) layer and reaching B by the route ACB. The third reception, registered at Co1, corresponds to the wave reflected by the second (upper) layer and reaching B by the route ADB.

The fourth reception, registered at Co2, corresponds to the wave having two reflections on the second layer and one reflection on the earth between A and B; this wave reaches B by the longest route AEGFB and arrives at B after the other three.

Since one knows the speed of motion of the film, the distance between the points a and b generally marking an interval of time of 1/200th of a second, one knows the interval of time separating the arrival of the direct wave and any reflected wave (the distances S-Ci and S-Co1, for example). One can therefore calculate the apparent height of the layer producing this reflection.

In practice one does not register merely a single tap but a series of taps spaced 1/30th of a second apart. Thus one gets a film on which is registered (about every 10 centimeters) a group of taps similar to that of Fig. 2.

This method gives a value of the height of different layers at a definite instant, that of the measurement, but it is hard to follow the variations of this height during 24 hours, for example. The application of this method would require a large staff of engineers and a considerable length of film (about 3 meters a second), anyway the film is very expensive, because it has to be very sensitive because of the speed of its motion.

(Continued on page 685)

Improve Your Keying with an Audio Oscillator

By A. HAZELTON RICE, JR.

This little device has been in constant use at W1UC and receives its full measure of credit for improving the operator's "fist." Its worth is particularly appreciated when operating a "bug" key, as its performance is above reproach.

● WHILE the various applications of the audio oscillator have been understood, in a general way, by the amateur fraternity since the advent of the screen grid tube, it is doubtful indeed if there are many amateurs who have attempted its use or appreciated its value in connection with the keying of their transmitters.

Lest some of my readers may not know what an audio oscillator is, let me explain that it consists, essentially, of a screen grid tube, such as the 24, which may be made to oscillate at an audio or audible frequency and this frequency may be controlled by the amount of capacity in the 22½ volt lead, across the speaker or phones. It is, in reality, a glorified high frequency buzzer with none of its usual vexing idiosyncrasies.

The writer conceived the idea of using such an oscillator in connection with his transmitter after hearing the introduction to an RKO motion picture. What amateur is there who has heard that sweet, flute like note without wishing that he too might duplicate it in his own "shack" while in actual contact with some friend half way around this wonderful old world of ours; not alone for the thrill of conscious achievement, but more particularly for the advantage that is his when he may hear his dots and dashes as they go out upon the ether, rather than the rumble and roar in his receiver that usually accompanies his periods of transmission?

Upon considering the possibilities of such an oscillator, and deciding to give it a trial, it was, of course, considered necessary to use a relay, in conjunction with it. Accordingly, one was installed but the objectionable clatter of the contacts more than offset the convenience. With that insatiable urge to experiment characteristic of all "dyed in the wool" hams, the writer discarded the relay and its accompanying batteries; held his breath, and connected the device directly across the key of the transmitter—a push pull, tuned plate—tuned grid affair. Nothing untoward happened! The anticipated fireworks were conspicuous by their absence, to use a trite phrase. So far, so good. The key was pressed and a hasty glance at the meters showed that everything was normal and, best of all, the shrill, steady whistle emanating from the loud speaker was little short of a symphony of sound to the ears of any operator. A check on the transmitter's note in the monitor revealed that it was in no way changed by the addition of the oscillator.

Of course, the transmitter may be continuously monitored, but the writer has found that it is much more convenient to check the transmitter with the monitor while tuning and testing and to turn on the oscillator on all other occasions when the transmitter is in use.

And now a few words relative to its construction. The writer happened to have a cabinet which had housed a one stage Bristol power amplifier, long since defunct, and which proved to be just the right size for the job. The dimensions are given in the diagram. It is an easy matter to make a similar cabinet of well seasoned birch or any of the softer woods, finishing it off with the usual mahogany stain and two or three coats of shellac, rubbed down with ground pumice stone, with a final coat or two of rubbing varnish, which can be rubbed down very carefully with rotten stone and oil. Of course, aluminum may be used for the cabinet, but this will necessitate considerable work in insulating binding posts, etc. The panel is of bakelite, its small size making it relatively inexpensive.

The lower left hand switch is a Pilot and is used for turning on and off the oscillator. The lower right hand switch is a duplicate of the first and is used for changing the tone of the oscillator to a lower frequency, which may be preferred at times as a relief from the steady high pitched whistle. The switch at the center of the panel is a midget double-pole, double-throw affair and is used to switch the loud speaker from the oscillator to the receiver and vice versa. Throwing it to the right connects the speaker to the oscillator and to the left connects the speaker to the receiver or audio amplifier output, as the case may be.

In this connection, the writer is using an old model Dictogrand speaker, which is extremely sensitive, and some speaker of this type, or a Baldwin unit should be used. A pair of phones may be used, if preferred, in place of the speaker, but use discretion! Slip them forward on the cheek bones while transmitting, as the volume is so great as to make it uncomfortable to wear them. When connecting the oscillator across the key of the transmitter, watch the plate milliammeter of the transmitter closely. If it jumps up a few "mills," disconnect the oscillator immediately, and reverse the leads to the key. If still louder signals are desired, this may be accomplished without an amplifier by increasing the screen voltage to about 90 volts. This will also facilitate oscillation, although this increased screen voltage is not, as a rule, necessary with the average tube.

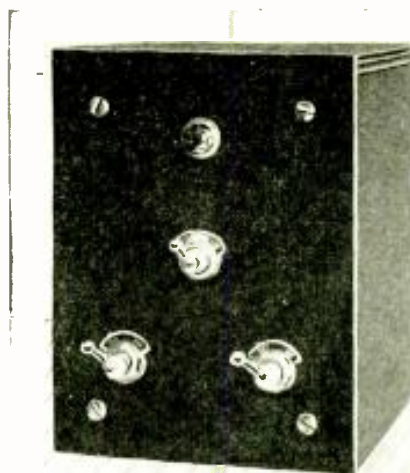

Appearance of the "keying" oscillator built by Mr. Rice and which will be found a boon to all operators of amateur transmitting stations.

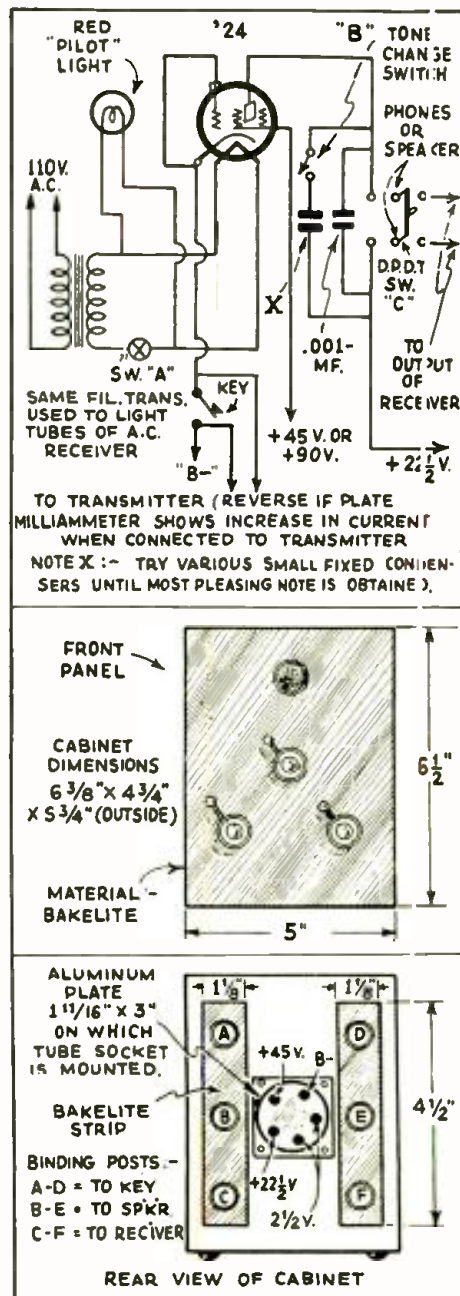

Above—Wiring diagram for building the "keying" oscillator, together with front panel view and also rear view of cabinet.

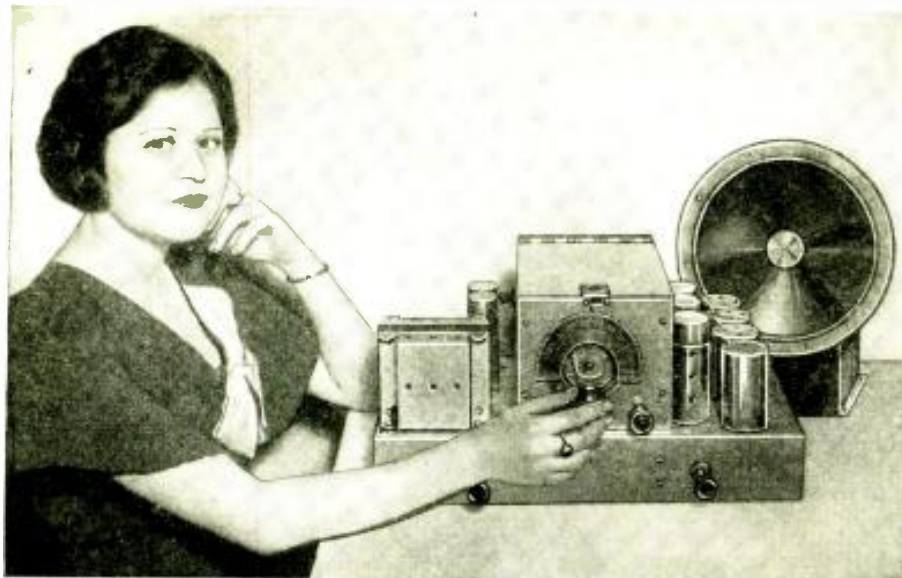

The Challenger 9-Tube Short-Wave Superhet in action; a dynamic speaker of the proper impedance, as specified, is used with it.

● RADIO fans seem to be divided into two opposing groups when it comes to building new receivers. On one side, we have those who favor a set with as few tubes as possible. This group eagerly looks forward to the day when a one-tube set will again serve every radio requirement. Diametrically opposed in their views are the proponents of the multi-tube receiver. These enthusiasts want every known improvement and refinement incorporated in the radio set. If extra tubes are needed to increase distance range, sharpen selectivity, improve tone quality or to attain any other desirable results, these tubes are cheerfully added to the circuit.

The latter school of thought is subscribed to by Mr. Steve Erdel, chief engineer of the Experimenters Radio Shop (New York), who designed the "Challenger" Nine-Tube Short-Wave Superhet. It was Mr. Erdel's ambition to produce a *de luxe* superheterodyne receiver containing every known worthwhile radio development and using the newest, most efficient tubes. He was so well pleased with the performance of this set that he decided to call it the "Challenger," defying other sets to

equal its record, regardless of the number or type of tubes used.

With all due allowance for the pride and enthusiasm of a radio fan in his brainchild, the "Challenger" has high merit. This set "delivers" and how! Its designer has logged Germany, France, Italy and South America—all in a single evening.

Analyzing the circuit of the "Challenger," we find that it is really unusually straightforward and simple for a nine-tube set. There is a first detector V1 using a 57 pentode tube and coupled inductively to the 56 oscillator V8.

There are three intermediate frequency stages employing 58 tubes (V2, V3, V4). The I.F. transformers are peaked at 465 kc. This high intermediate frequency has been selected as most desirable since it results in a close approach to "one spot" tuning.

The second detector employs a 24 tube (V5), with power detection. This is coupled resistively to the single audio output stage. Here we find two PZ power output pentodes (V6, V7) employed in parallel arrangement.

The full-wave 80 rectifier (V9) and its attendant filter circuit are of con-

ventional design. Following standard practice, the 1000 ohm speaker field is made to serve as one of the filter chokes. Electrolytic filter condensers are used at C24 and C25 and a 25 mf. 25 volt cartridge-type electrolytic condenser is used at C26 to by-pass the pentode bias resistor.

Having performed this preliminary circuit analysis, let us go back over the circuit again and pick out some of the more important features. The antenna coil L1 is wound on the same form as the oscillator plate and grid coils (L2). The coil form is of the plug-in type, three separate forms being used to cover the short wave bands from 20 to 200 meters. Details for winding these coils are shown in the accompanying sketch, or the coils may be obtained ready-wound. Coil L1 is tuned by a small-type .00010 mf. Hammarlund variable condenser. The oscillator plate coil is tuned by a small-type .00014 mf. Hammarlund condenser. Since the coils L1 and L2 are wound on the same form, this inductive coupling is the only coupling required. Condenser C22 is a Hammarlund 70 mmf. equalizing condenser used to compensate for varying length antennas. Condenser C3 is a 13 plate, 50 mmf. variable midget condenser used to permit finer gradations of tuning.

The two Hammarlund variable condensers C1 and C2 are ganged together by means of a metallic coupling in order to obtain single dial tuning. A Crowe double ratio dial rotates the condensers slowly enough to prevent one from passing the "hard-to-get" distant stations.

A 1,000 ohm potentiometer at R6 in the cathode return circuit of the three intermediate frequency tubes provides an excellent sensitivity control. Volume is controlled by means of the Electrad potentiometer R14, which in effect varies the load resistance in the detector circuit—that is, the resistance coupling between the second detector and the output stage. This method of volume control is efficient and results

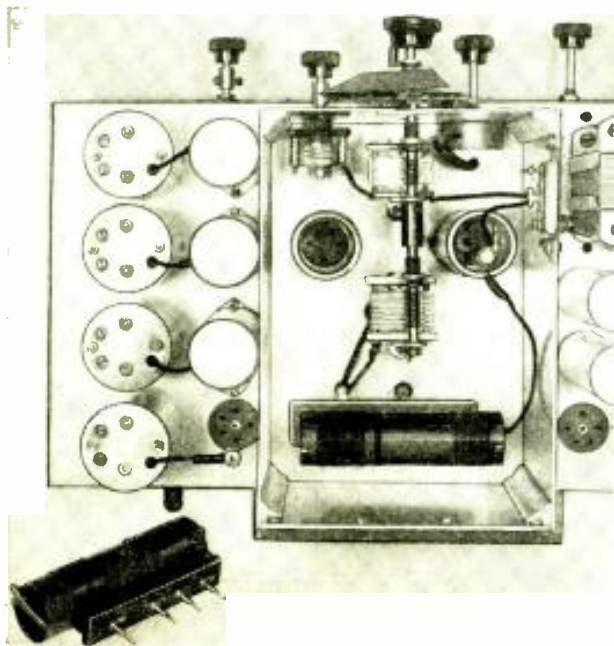

Photo, at left, shows close-up view of coil compartment; photo below, shows bottom view of the Challenger 9-Tube Superhet.

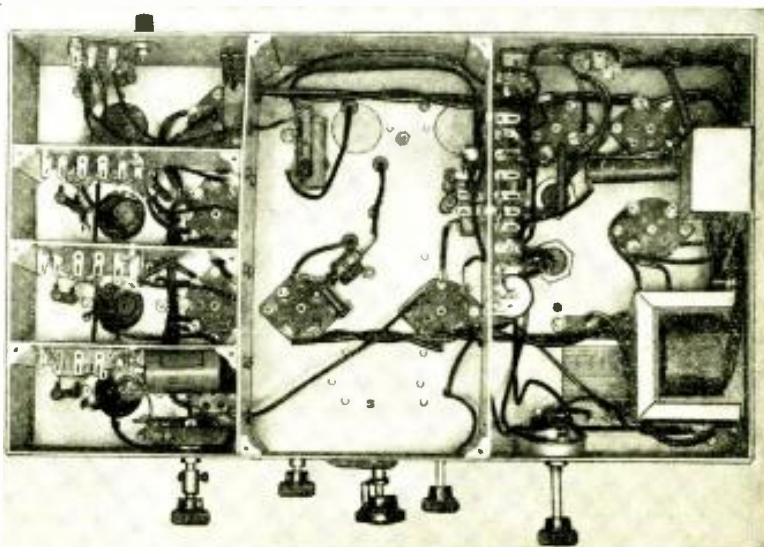

“Challenger” 9-Tube Superhet

By HARRY GEORGES

in a smooth, even variation, so that any desired volume may be obtained.

A jack is provided at J1, permitting the use of earphones after the detector stage, before audio amplification. Connecting the PZ pentodes in parallel doubles the power output, giving a total output of 6,000 milliwatts. This method of connection also reduces the output impedance from 7,000 ohms to 3,500 ohms, so that it is possible to use a dynamic speaker having an output transformer designed for use with a single 45 power output tube.

Condenser C17 and variable resistor R13 are connected between the plates of the PZ tubes and ground to act as a means of tone control. A 1 megohm Electrad potentiometer is used at R13. Varying this resistance permits one to obtain a preponderance of bass or treble according to personal preference.

It will be noted that wherever necessary, all plate and screen grid circuits are carefully isolated by means of suitable resistors by-passed to ground by small condensers. All tubes are shielded, including audio tubes and rectifier. The two variable condensers C1 and C2 are enclosed in a large shield and the various stages are also separately shielded.

The speaker used in connection with the “Challenger” is a Magnavox dynamic. This is able to handle the large power output without distortion and the tone quality is excellent. All in all, the “Challenger” is a high-quality short-wave receiver, well worth building. Its owner need not fear to match it against

Using six pentodes, among other features, this powerful short-wave superheterodyne receiver represents a fine piece of engineering design and workmanship. The advanced short-wave fan will surely want one of these receivers. After all is said and done, the superhet, especially when designed to use the latest tubes, such as the pentodes, is “boss of the deck.” With the tremendous amplification afforded by this receiver, plus the sharp selectivity, you are sure of putting European and other “DX” stations on the loud speaker. Calls heard—FYA, G5SW, I2RC, DFA, HKD, etc.

any other set with respect to sensitivity, selectivity or tone quality.

Complete List of Parts Required for the “Challenger” Nine-Tube Short-Wave Superhet

- C1—Hammarlund variable midget condenser, .0001 mf., type MC-100-M
- C2—Hammarlund variable midget condenser, .00014 mf., type MC-140-M
- C3—Hammarlund variable midget condenser, .000050 mf., type MC-50-S
- C22—Hammarlund adjustable padding condenser, 10 to 70 mmf., type MICS-70
- C4, C5, C6, C7, C8, C9, C10, C11, C12, C13, C14, C15, C16, C17—Aerovox 0.1 mf. cartridge condensers, type 281
- C18—Aerovox .02 mf. cartridge condenser, type 281 (Concourse)
- C19—Aerovox .001 mica condenser, type 1460 (Concourse)
- C20—Aerovox .5 mf. cartridge condenser, type 281 (Concourse)
- C21—Aerovox .0001 mf. mica condenser, type 1460 (Polymet)
- C23—Aerovox 2 mf. cardboard electrolytic condenser, type P5-2 (Concourse)
- C24, C25—Aerovox dry electrolytic condensers, 8 mf., type G5-8 (Concourse)
- C26—Aerovox 25 mf., 25 volt tubular electrolytic condenser, type PR25-25 (Concourse)
- R1—Electrad 5,000 ohm flexible resistor, type 2G5000 (Polymet)
- R2—I. R. C. (Durham) 80,000 ohm, 1 watt metallized resistor, type F-1 (Lynch)
- R3—I. R. C. (Durham) 30,000 ohm, 1 watt metallized resistor, type F-1 (Lynch)
- R4, R5—I. R. C. (Durham) 150,000 ohm, 1 watt metallized resistor, type F-1 (Lynch)
- R6—Electrad sensitivity control potentiometer, 1,000 ohm, type RI-276 (Concourse)
- R7, R8, R9, R10, R11—I. R. C., 1,000 ohm, ½ watt metallized resistors, type F½ (Lynch)

(Continued on page 687)

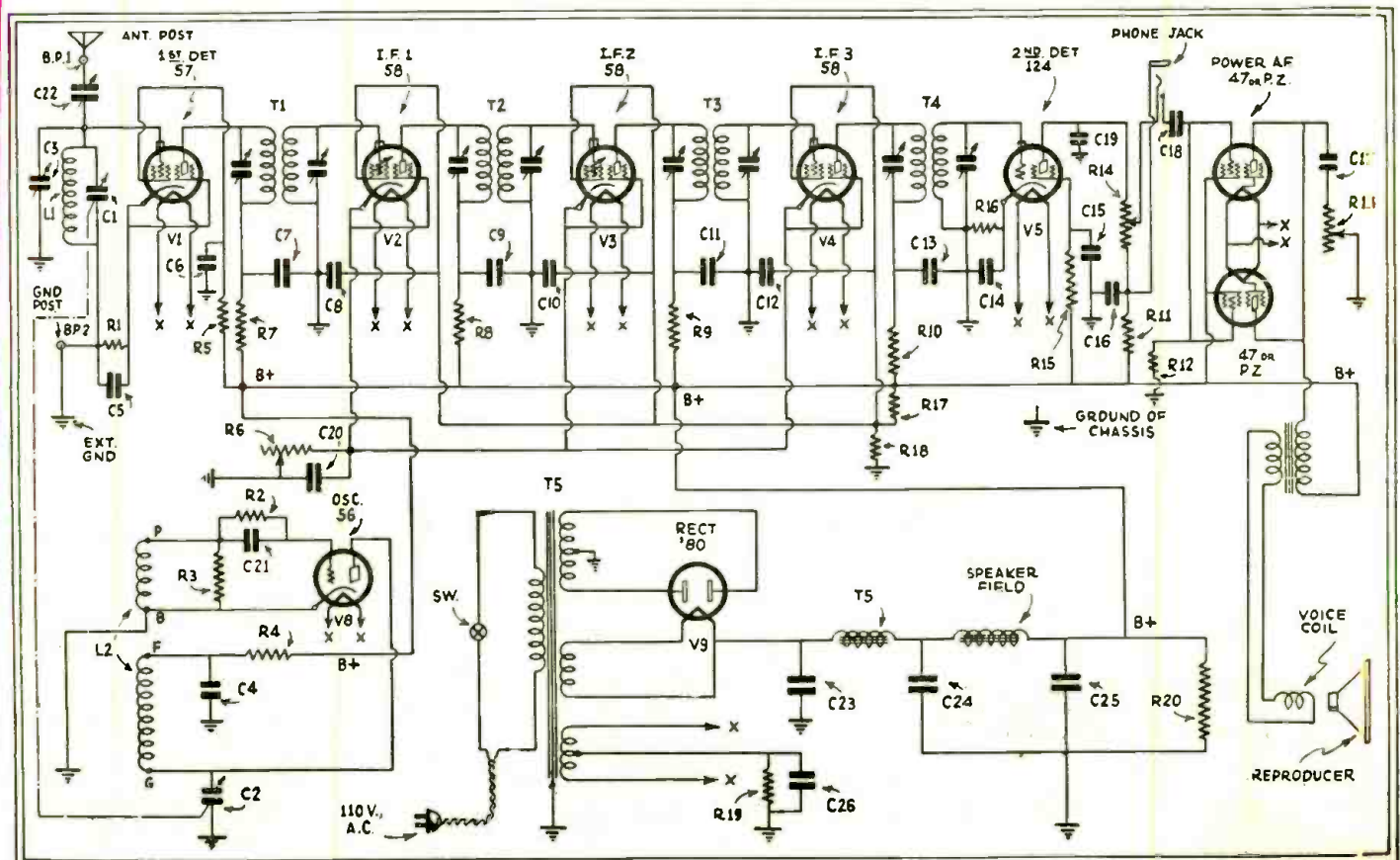

Wiring diagram of the Challenger 9-Tube Short-Wave Superheterodyne Receiver which, with the tremendous amplification afforded by the use of the six pentodes and carefully designed circuits, guarantees that you will hear European and other “DX” stations on the “loud speaker”—under fair operating conditions.

SHORT WAVE STATIONS OF THE WORLD

ALL SCHEDULES EASTERN STANDARD TIME: ADD 5 HOURS FOR GREENWICH MEAN TIME

Short Wave Broadcasting Stations

Wavelength (Meters)	Frequency (Kilocycles)	Call Letters	Address and Schedule	Wavelength (Meters)	Frequency (Kilocycles)	Call Letters	Address and Schedule	Wavelength (Meters)	Frequency (Kilocycles)	Call Letters	Address and Schedule
13.93	21,540	W8XK	Westinghouse Electric, East Pittsburgh, Pa. 7:30 a. m.-noon.	31.33	9,570	HBP	League of Nations, Geneva, Switzerland. Sundays, 5:00-5:45 p.m.	48.86	6,140	W8XK	Westinghouse Electric and Mfg. Co., East Pittsburgh, Pa. 5 p.m.-midnight.
13.97	21,470	G8H	Chelmsford, England.	48.99	6,120	W2XE	Westinghouse Electric & Mfg. Co., Springfield, Mass., 6 a.m.-10 p.m. daily.	49.10	6,110	VE9CG	Columbia Broadcasting System, 485 Madison Avenue, New York, N. Y. 7:00 a.m. to midnight.
15.93	18,830	PLE	Bandoeng, Java. Wednesdays, 4:00-8:00 a.m.	31.38	9,560	DJA	Poznan, Poland, Tues., 1:45-1:45 p.m., Thurs., 1:30-8 p.m.	49.15	6,100	W3XAL	Eiffel Tower, Paris, 5:30-5:45 a.m., 5:45-12:30, 4:15-4:45 p.m.
16.87	17,780	W3XAL	National Broadcasting Co., Bound Brook, N. J.	31.48	9,530	W2XAF	General Electric Co., Schenectady, N. Y., 5-11 p.m. daily.	49.17	6,095	VE9GW	Calgary, Alta., Canada.
16.88	17,770	W9XF	Downer Grove, Ill.	31.49	9,520	OXY	Skamleboek, Denmark, 2-7 p.m. daily.	49.18	6,100	W9XF	Downers Grove, Ill.
16.88	17,770	G8G	Chelmsford, England.	31.51	9,510	GSB	Chelmsford, England.	49.31	6,080	W9XAA	Chicago Federation of Labor, Chicago, Ill. 6-7 a. m., 7-8 p.m., 9:30-10:15, 11-12 p.m. Int. S. W. Club programs, from 10 p.m. Saturday to 6 a.m. Sunday.
19.56	15,330	W2XAD	General Electric Co., Schenectady, N. Y. Broadcasts 3-6 p.m. daily; 1-6 p.m. Sat. and Sunday.	31.55	9,510	VK3ME	Amalgamated Wireless, Ltd., 167-169 Queen St., Melbourne, Australia. Wed. 5:00-6:30 a.m., Sat. 5:00-7:00 a.m.	49.40	6,070	VE9CS	Vancouver, B. C., Canada. Fridays before 1:30 a.m. Sundays, 2 and 10:30 p.m.
19.65	15,270	W2XE	Wayne, N. J.	31.58	9,500	PRBA	Radio Club of Brazil, Rio de Janeiro, 4:30 p.m. to about 8:00 p.m.	49.46	6,065	SAJ	Johannesburg, South Africa. 10:30 a.m.-3:30 p.m.
19.68	15,240	FYA	"Radio Colonial," Pontoise (Paris), France. Service de la Radiodiffusion, 103 Rue de Grenelle, Paris. Daily 8:30-10:00 a.m.	31.70	9,460	Radio Club of Buenos Aires, Argentina.	49.50	6,060	W8XAL	Crosley Radio Corp., Cincinnati, O. Relays 6:30-10 a.m., 1-3 p.m., 6 p.m. to 2 a.m. daily. Sunday after 1 p.m.
19.72	15,210	W8XK	Westinghouse Electric & Mfg. Co., East Pittsburgh, Pa. 7:30 a. m. to 5 p.m.	32.00	9,375	EH90C	Berne, Switzerland, 3-5:30 p.m.	49.50	6,060	VQ7LO	Imperial and International Communications, Ltd., Nairobi, Kenya, Africa. Monday, Wednesday, Friday, 11 a.m.-2:30 p.m.; Tuesday, Thursday, 11:30 a.m.-2:30 p.m.; Saturday, 11:30 a.m.-3:30 p.m.; Sunday, 11 a.m.-1:30 p.m.; Tuesday, 3 a.m.-4 a.m.; Thursday, 8 a.m.-9 a.m.
19.81	15,140	G8F	Chelmsford, England.	32.26	9,290	Rabat, Morocco, 3-5 p.m. Sunday, and irregularly weekdays.	49.58	6,050	W3XAU	Hyberry, Pa. Relays WCAU.
19.83	15,120	HVJ	Vatican City (Rome, Italy) Daily 5:00 to 5:15 a.m.	35.00	8,570	RV15	Far East Radio Station, Khabarovsk, Siberia, 5-7:30 a.m.	49.59	6,050	VE9CF	Chelmsford, England.
19.99	15,000	JIAA	Tokyo, Japan. Irregular.	39.80	7,530	"El Prado," Riohamba, Ecuador, Thurs., 9-11 p.m.	49.75	6,030	VE9CA	Calgary, Alta., Canada.
20.50	14,620	XDA	Trens-News Agency, Mexico City, 2:30-3 p.m.	40.00	7,500	"Radio Touraine," France.	49.96	6,005	VE9DR	Canadian Marconi Co., Drummondville, Quebec, 6-10 p.m. daily.
20.95	14,310	G2NM	Gerald Marceuse, Nonnington-Thames, England. Sundays, 1:30 p.m.	40.20	7,460	YR	Lyon, France. Daily except Sun., 10:30 to 1:30 a.m.	49.97	6,000	YV2BC	Caracas, Venezuela, 7:45-11 p.m. daily except Mon. Eiffel Tower, Paris, France. Testing, 6:30 to 6:45 a.m.; 1:15 to 1:30, 5:15 to 5:45 p.m., around this wave.
21.50	13,940	University of Bucharest, Bucharest, Roumania, 2-5 p.m., Wed., Sat.	40.50	7,410	Eberswalde, Germany, Mon., Thurs., 1-2 p.m.	50.26	5,970	HVJ	Vatican City (Rome), 2-2:15 p.m. daily, Sun., 5-5:30 a.m.
23.35	12,850	W2X0	General Electric Co., Schenectady, N. Y. Antipodal program 9 p.m. Mon. to 3 a.m. Tues. Noon to 5 p.m. on Tues., Thurs. and Sat.	40.70	7,370	X26A	Nuevo Laredo, Mexico, 9-10 a.m.; 11 a.m.-noon; 1-2; 4-5; 7-8 p.m. Tests after midnight, I.N.W.C. programs 11 p.m. Wed. A.P.31.	50.80	5,900	HKO	Medellin, Colombia, 8-11 p.m. except Sunday.
23.35	12,850	W2XCU	Ampere, N. J.	41.07	7,195	VS1AB	Singapore, S. S. Mon., Wed. and Fri., 9:30-11 a.m.	51.40	5,835	HKD	Barranquilla, Colombia, 7:45-10:30 p.m., Mon., Wed., 8-10:30 p.m.; Sunday, 7:15-8:30 p.m. Elias J. Pellet.
23.35	12,850	W9XL	Anoka, Minn., and other experimental relay broadcasters.	42.00	7,140	HXX	Bokota, Colombia.	52.50	5,710	VE9CL	Winnipeg, Canada.
23.38	12,820	Director General, Telegraph and Telephone Stations, Rabat, Morocco, Sun., 7:30-9 a.m. Daily 5-7 a.m. Telephony.	42.70	7,020	EAR125	Madrid, Spain, 6-7 p.m.	51.02	5,550	W8XJ	Columbus, Ohio.
25.16	11,905	FYA	"Radio Colonial," Pontoise (Paris). See listing for 19.68 meters. Daily 1:00-2:00 p.m.	42.90	6,990	CTIAA	Lisbon, Portugal, Fridays, 5-7 p.m.	58.00	5,170	OKIMPT	Prague, Czechoslovakia 1-3:30 p.m., Tues. and Fri. Bandoeng, Java.
25.21	11,880	W9XF	National Broadcasting Co., Downers Grove (Chicago), Ill. 9-10 p.m. daily.	43.60	6,875	F8MC	Casablanca, Morocco, Sun., Tues., Wed., Sat.	60.30	4,975	W2XV	Radio Engineering Laboratories, Inc., Long Island City, N. Y. Irregular.
25.26	11,870	VUC	Cakutta, India, 9:45-10:45 p.m.; 8-9 a.m.	46.70	6,425	W9XL	Anoka, Minn.	62.56	4,795	W9XAM	Elgin, Ill. (Time signals.)
25.28	11,865	W8XK	Westinghouse Electric, East Pittsburgh, Pa. 4-10 p.m.	46.70	6,425	W3XL	National Broadcasting Co. Bound Brook, N. J. Relays WJZ. Irregular.	67.65	4,430	W9XL	Chicago, Ill.
25.31	11,840	G8E	Chelmsford, England.	47.00	6,380	HC1DR	Minsk, U.S.S.R. Irregular.	70.00	4,280	OHK2	Vienna, Austria, Sun., first 15 minutes of hour from 1 to 7 p.m.
25.31	11,840	W9XAO	Chicago Federation of Labor, Chicago, Ill. 7-8 a.m., 1-2, 4-5:30, 6-7:30 p.m.	47.35	6,335	VE9AP	Drummondville, Canada.				
25.36	11,830	W2XE	Wayne, N. J.	47.35	6,335	CN8MC	Casablanca, Morocco, Mon. 3-4 p.m., Tues. 7-8 a.m., 3-4 p.m. Relays Rabat.				
25.4	11,810	I2RO	"Radio Roma a Napoli," Rome, Italy, Daily, 11:30 a.m. to 12:15 p.m. and 2:00-6:00 p.m. Sunday, 11:00 a.m.-12:15 p.m.	47.81	6,270	HKC	Bogota, Colombia, 8:30-11:30 p.m.				
25.42	11,800	VE9GW	W. A. Shane, Chief Engineer, Bowmanville, Canada, Daily, 1-4 p.m.	48.00	6,250	HKA	Barranquilla, Colombia, 8-10 p.m. except Mon., Wed., Fri.				
25.45	11,790	WIXAL	Boston, Mass.								
25.47	11,780	VE9DR	Drummondville, Quebec, Canada, Irregular.								
25.50	11,760	XDA	Trens-News Agency, Mexico City, 3-4 p.m.								
25.53	11,750	GSD	Chelmsford, England.								
25.53	11,750	VE9JR	Winnipeg, Canada, Weekdays, 5:30-7:30 p.m.								
25.6	11,705	FYA	"Radio Colonial," Pontoise (Paris). See listing for 19.68 meters. Daily, 3:00-7:00 p.m.								
29.30	10,250	T14	Amondo Cespedes Marin, Heredia, Costa Rica, Mon. and Wed., 7:30 to 8:30 p.m.; Thurs. and Sat., 9:00 to 10 p.m.								
30.4	9,860	EAQ	Transradio Espanola, Alcala 43-Madrid, Spain, (P. O. Box 951), Daily for America, 6:30-8:00 p.m. for Europe and Canaries on Saturdays only, 1:00-3:00 p.m.								
31.10	9,640	H8P2	Broadcasting Service, Post and Telegraph Department, Bangkok, Siam, 9-11 a.m., daily.								
31.28	9,590	VK2ME	Amalgamated Wireless, Ltd., Sydney, Australia, Sun. 1-3 a.m., 5-9 a.m., 9:30-11:30 a.m.								
31.29	9,585	G8C	Chelmsford, England.								
31.30	9,580	W3XAU	Hyberry, Pa., relays WCAU daily.								

(NOTE:—This list is compiled from many sources, all of which are not in agreement, and which show greater or less discrepancies; in view of the fact that most schedules and many wavelengths are still in an experimental stage; and that wavelengths are calculated differently in many schedules. In addition to this, one experimental station may operate on any of several wavelengths which are assigned to a group of stations in common. We shall be glad to receive later and more accurate information from broadcasters and other transmitting organizations, and from listeners who have authentic information as to calls, exact wavelengths and schedules. We cannot undertake to answer readers who inquire as to the identity of unknown stations heard, as that is a matter of guesswork; in addition to this, the harmonics of many local long-wave stations can be heard in a short-wave receiver.—EDITOR.)

SHORT WAVE STATIONS OF THE WORLD

(Continued from opposite page)

Short Wave Broadcasting Stations

70.20	4.273	RV15	Far East Radio Station, Khabarovsk, Siberia. Daily, 3-9 a.m.	80.00	3.750	F8KR	Constantine, Tunis, Africa. Mon. and Fri.	84.24	3.560	OZ7RL	Copenhagen, Denmark. Tues. and Fri. after 6 p.m.
7.05	42,530	-----	Berlin, Germany. Tues. and Thurs., 11:30-1:30 p.m. Telefunken Co.	82.90	3.620	13RO DOA	Prato, Emerald, Rome, It., Daily, 3-5 p.m. Doberitz, Germany.	128.09	2.342	W7XAW	Fisher's Bend, Inc., Fourth Ave. and University St. Seattle, Washington.

Experimental and Commercial Radio-Telephone Stations

Wavelength (Meters)	Frequency (Kilocycles)	Call Letters	Address and Schedule	Wavelength (Meters)	Frequency (Kilocycles)	Call Letters	Address and Schedule	Wavelength (Meters)	Frequency (Kilocycles)	Call Letters	Address and Schedule
9.68	31,000	W8XI	Pittsburgh, Pa.	17.31	17,300	W8XL	Dayton, Ohio.	29.54	10,150	DIS	Nauen, Germany. Press (code) daily; 6 p.m., Spanish; 7 p.m., English; 7:50 p.m., German; 2:30 p.m., English; 5 p.m., German. Sundays: 6 p.m., Spanish; 7:50 p.m., German; 9:30 p.m., Spanish.
10.79	27,800	W6XD	Palo Alto, Calif. M. R. T. Co.	17.52	17,110	W00	Oakland, Calif. Anoka, Minn., and other experimental stations.	30.15	9,950	GBU	Rugby, England.
11.55	25,960	G5SW	Chelmsford, England, Experimental.	17.55	17,080	GBC	Deal, N. J. Transatlantic phone.	30.30	9,890	LSN	Buenos Aires, phone to Europe.
11.67	25,700	W2XBC	New Brunswick, N. J.	18.40	16,300	PCL	Ocean Gate, N. J. A. T. & T. Co.	30.64	9,790	LSA	Buenos Aires.
12.48	24,000	W6XQ	San Mateo, Calif.	18.50	16,200	FZR	Rugby, England.	30.75	9,750	GBW	Rugby, England.
14.15	21,130	LSM	Vienna, Austria, Mon., Wed., Sat.	18.56	16,150	GBX	Deal, N. J.	30.90	9,700	WMI	Deal, N. J.
14.27	21,020	LSN	And other experimental stations.	18.68	16,060	NAA	Lawrence, N. J.	30.93	9,600	LQA	Buenos Aires.
14.47	20,710	LSY	American Telephone & Telegraph Co., Lawrence, N. J., transatlantic phone.	18.80	15,950	PLG	Monte Grande, Argentina. (Hurlingham), Buenos Aires, Argentina.	18.90	15,860	FTK	Rugby, England.
14.50	20,680	LSN	Monte Grande, Argentina, after 10:30 p.m. Telephony with Europe.	18.93	15,760	JIAA	Podebrady, Czechoslovakia.	19.60	15,300	OXY	Tokyo, Japan. Up to 10 a.m. Beam transmitter.
14.58	19,240	DFA	Buenos Aires, Telephony with U. S.	20.65	11,530	LSA	Monte Grande, Argentina. Daily 3-6 p.m., Sunday, 10 p.m.	20.70	11,480	GGBW	Lyngby, Denmark. Experimental.
15.03	19,950	LSG	Paris-Saigon phone.	21.17	14,120	WNC	Buenos Aires, Argentina. Radio Section, General Post Office, London, E. C. 1.	21.17	14,150	KKZ	Bollinas, Calif.
15.07	19,906	LSG	Bandong, Java. After 4 a.m.	21.28	13,400	WND	Deal, N. J.	21.28	13,400	WND	Deal, N. J. Transatlantic telephony.
15.10	19,850	WMI	Nauen, Germany. Tests 10 a.m.-3 p.m.	21.41	12,790	GBC	Deal, N. J.	21.41	12,790	GBC	Rugby, England.
15.12	19,830	FTD	Monte Grande, Argentina. From 7 a.m. to 1 p.m. Telephony to Paris and Nauen (Berlin).	21.46	12,250	FTN	Deal, N. J.	21.46	12,250	FTN	Ste. Assise (Paris), France.
15.45	19,100	FRO.FRE	Nauen, Germany.	22.38	13,400	WND	St. Assise, France.	22.38	13,400	WND	Works Buenos Aires, Indo-China and Java. On 9 a.m. to 1 p.m. and other hours.
15.55	19,300	FTM	Monte Grande, Argentina. 8-10 a.m.	23.45	12,790	GBC	St. Assise, France. 10 a.m. to noon.	23.45	12,790	GBC	Rugby, England.
15.58	19,240	DFA	Deal, N. J.	24.41	12,290	GBU	Nauen, Germany.	24.41	12,290	GBU	Bandong, Java. 7:45 a.m. to noon.
15.60	19,220	WNC	Bandong, Java. 8-10-10:40 a.m. Phone service to Holland	24.46	12,250	FTN	Deal, N. J.	24.46	12,250	FTN	Rugby, England. Transatlantic phone to Deal, N. J. (New York).
15.94	18,820	PLE	Bodmin, England. Telephony with Montreal.	24.80	12,090	FQO,FQE	St. Assise, France.	24.80	12,090	FQO,FQE	Ste. Assise, France.
16.11	18,620	GBU	Rugby, England.	24.89	12,045	NAA	Tokyo, Japan. 5-8 a.m.	24.89	12,045	NAA	Arlington, Va. Time signals, 11:57 to noon.
16.33	18,370	PMC	Bandong, Java.	21.98	12,000	FZG	Annapolis, Md. Time signals, 9:57-10 p.m.	21.98	12,000	FZG	Saigon, Indo-China. Time signals, 2-2:05 p.m.
16.35	18,350	WND	Deal Beach, N. J. Transatlantic telephony.	25.10	11,945	KKQ	Rollins, Calif.	25.10	11,945	KKQ	Maraezy, Venezuela. (Also broadcasts occasionally.)
16.38	18,310	GBS	Rugby, England. Telephony with New York. General Postoffice, London.	25.65	11,670	K10	Kahulu, Hawaii.	25.65	11,670	K10	Drummondville, Canada.
16.44	18,240	FRO.FRE	Saigon, Indo-China, 1 to 3 p.m. Sundays.	26.00	11,530	CGA	Bodmin, England.	26.00	11,530	CGA	Drummondville, Canada.
16.50	18,170	CGA	Ste. Assise, France.	26.15	11,470	IBDK	S.S. "Elettra," Marconi's yacht.	26.15	11,470	IBDK	Nauen, Germany.
16.57	18,100	GBK	Drummondville, Quebec, Canada. Telephony to England.	26.22	11,435	DHC	Nauen, Germany.	26.22	11,435	DHC	Norddeich, Germany. Time signals, 7 a.m., 7 p.m.
16.61	18,050	KQJ	Bodmin, England.	26.44	11,310	DAN	Hollnas, Calif.	26.44	11,310	DAN	Deutsche Seewarte, Hamburg.
16.80	17,850	PLF	Hollnas, Calif.	27.30	10,980	ZLW	Bandong, Java ("Radio Malabar").	27.30	10,980	ZLW	Wellington, N. Z. Tests 3-8 a.m.
16.82	17,830	W2XAO	Bandong, Java ("Radio Malabar").	28.20	10,630	PLR	New Brunswick, N. J.	28.20	10,630	PLR	Bandong, Java. Works with Holland and France weekdays from 7 a.m.; sometimes after 9:30.
16.87	17,780	W8XK	Kootwijk, Holland. 9:40 a.m. Sat.	28.44	10,540	WLO	Westinghouse Electric and Mfg. Co., Saxonburg, Pa.	28.44	10,540	WLO	Lawrence, N. J.
17.00	17,640	Shis.	Phones to Shore.	28.80	10,410	PKD	Kootwijk, Holland.	28.80	10,410	PKD	Sydney, Australia. 1-7 a.m.
17.25	17,380	JIAA	"Leviathan"; "Majestic"; "GSLQ"; "Olympic"; "GDLI"; "Home-rie"; "GMJQ"; "Deigeland"; work on this and higher channels.	28.86	10,390	GBX	Hollnas, Calif.	28.86	10,390	GBX	Kootwijk, Holland.
			Tokio, Japan.				Buenos Aires, Argentina.				Rugby, England.

(Continued on next page)

"STAR" SHORT WAVE BROADCASTING STATIONS

The following stations are reported regularly by many listeners, and are known to be on the air during the hours stated. Conditions permitting, you should be able to hear them on your own short-wave receiver. All times E.S.T.

G5SW has been replaced by eight stations operating on various waves between 13.97 and 49.58 meters.

HVJ, Vatican City. Daily 5 to 5:15 a.m. on 19.83 meters; 2 to 2:15 p.m. on 50.26 meters; Sunday 5 to 5:30 a.m. on 50.26 meters.

VK2ME, Sydney, Australia. 31.28 meters. Sunday morning from 1 to 3 a.m.; 5 to 9 a.m.; and 9:30 to 11:30 a.m.

VK3ME, Melbourne, Australia. 31.55 meters. Wednesday 5:00-6:30 a.m.; Saturday 5:00-7:00 a.m.

FYA, "Radio Colonial," Paris. On 19.68 meters, daily 8:30-10:00 a.m.; on 25.16 meters, daily 1:00-2:00 p.m.; on 25.6 meters, daily 3:00-7:00 p.m.

Konigs-Wusterhausen, Germany. On 31.38 meters daily from 8 a.m. to 7:30 p.m.

HKD, Barranquilla, Colombia. On 51.4 meters, Monday, Wednesday and Friday, 8 to 10:30 p.m.; Sunday, 7:45 to 8:30 p.m.

VE9GW, Bowmanville, Ontario, Canada. 25.42 meters, from 1 to 10 p.m.

EAQ, Madrid, Spain. 30.4 meters, 6:30 to 8 p.m. daily; 1 to 3 p.m. Saturday.

RV15, Khabarovsk, Siberia, 70.2 meters. Daily from 2 to 9 a.m.

SHORT WAVE STATIONS OF THE WORLD

(Continued from preceding page)

Experimental and Commercial Radio-Telephone Stations

Wavelength (Meters)	Frequency (Kilocycles)	Call Letters	Address and Schedule	Wavelength (Meters)	Frequency (Kilocycles)	Call Letters	Address and Schedule	Wavelength (Meters)	Frequency (Kilocycles)	Call Letters	Address and Schedule
43.80	6.840	CFA	Drummondville, Canada.	62.80	4.770	ZL2XX	Wellington, New Zealand.	92.50	3.256	W9XL	Chicago, Ill.
44.40	6.753	WND	Deal, N. J.	63.00	4.760	Radio LL	Paris, France.	95.00	3.156	PK2AG	Samarang, Java.
44.99	6.680	F8KR	Constantine, Algeria. Mon., Fri., 5 p.m.	63.13	4.750	W00	Ocean Gate, N. J.	96.03	3.124	W00	Deal, N. J.
		HKM	Bogota, Colombia. 9-11 p.m.	63.79	4.700	W1XAB	Portland, Me.	97.53	3.076	W9XL	Chicago, Ill.
45.50	6.560	RFN	Moscow, U.S.S.R. (Russia) 2 a.m.-4 p.m.	72.87	4.116	W00	Deal, N. J.	193.5	1.550	W2XCE	Motala, Sweden. 11:30 a.m.-noon, 4-10 p.m.
46.05	6.515	W00	Deal, N. J.	74.72	4.105	NAA	Arlington, Va. Time signals, 9:57-10 p.m., 11:57 a.m. to noon.	199.35	1.560	W1XAU	Passaic, N. J. Boston, Mass.

Airport Stations

98.05	3.030	VE9AR	Saskatoon, Sask., Canada.	KRF	Lincoln, Neb.	WAEC	Pittsburgh, Pa.
53.25	5.630	WQDP	Atlanta, Ga.	KMR	North Platte, Neb.	WAEB	Columbus, Ohio.
86.00	3.490	WSDE	Tuscaloosa, Ala.	KQE	Cheyenne, Wyo.	WAEA	Indianapolis, Ind.
		WSDB	Jackson, Miss.	KQC	Rock Springs, Wyo.	KGTR	St. Louis, Mo.
		KGUK	Shreveport, La.	KQD	Salt Lake City, Utah.	KSY	Tulsa, Okla.
		KGUC	Dallas, Tex.	KKO	Eiko, Nevada.	KSW	Amarilla, Tex.
		KGUC	Fort Worth, Tex.	KJE	Iteno, Nevada.	KSY	Albuquerque, N. M.
		KGUL	Abilene, Tex.	KFD	Oakland, Calif.	KGPL	Kingman, Ariz.
		KGUG	Big Springs, Tex.	KRA	Idaho.	KGTL	Las Vegas, Nev.
		KGUA	El Paso, Tex. (Southern Air Transport Lines.)	KDD	Pasco, Wash. (Boeing Air Lines.)	KSI	Los Angeles, Calif.
53.53	5.600	WQDU	Aurora, Ill.	54.00	5.560	WAEE	Newark, N. J.
94.52	3.170	KQQ	Iowa City, Iowa.	96.77	3.100	WAEF	Camden, N. J.
		KQM	Des Moines, Iowa.			WAED	Harrisburg, Pa.
		KMP	Omaha, Neb.				

Television Stations

3.75 to 5 meters—60 to 80 megacycles.	103.3 to 109.1 meters—2.750 to 2.850 kc.	W2XR	Radio Pictures, Inc., Long Island City, N. Y. 48 and 60 line. 5-7 p.m.			
5.06 to 6.18 meters—48.5 to 50.3 megacycles.	W2XAB	Columbia Broadcasting System, 485 Madison Ave., N. Y. 8:00-10:00 p.m. Sight and Sound Transmission daily except Saturday and Sunday.	W3XAD	R. C. A. Victor Co., Inc., Camden, N. J.		
6.52 to 7.14 meters—42 to 48 megacycles.	W2XB0	Long Island City, N. Y.	W2XCW	Schenectady, N. Y.		
W8XF	The Goodwill Station, Pontiac, Mich.	W3XE	Philo Radio, Philadelphia, Pa.	W8XAV	Pittsburgh, Pa. 1,200 R.P.M., 60 holes. 1:30-2:30 p.m., Mon., Wed., Fri.	
W3XL	Philo Radio, Philadelphia, Pa.	W9XAA	Chicago, Ill.	W9XAP	Chicago, Ill. Kansas State Agricultural College, Manhattan, Kans.	
W6XL	WQAR Broadcasting Co., Cleveland, Ohio.	W9XG	Lafayette, Ind. 60 holes. 1:20 p.m. Tuesdays and Thursdays. 2:00 p.m., 7:00 p.m., 10:00 p.m.	142.9 to 150 meters—2,000 to 2,100 kc.	W2XAP	Jersey City, N. J.
6.89	43.500	W9XD	Milwaukee Journal, Milwaukee, Wis.	W2XCR	Jersey City, N. J. 3-5, 6-9 p.m. ex. Sun.	
W3XAD	Camden, N. J. (Other experimental television permits: 48,500 to 50,300 k.c., 43,000-46,000 k.c.).	W9XAL	First National Television Corp., Kansas City, Mo. to 2,200 kc.	W3XK	Wheaton, Maryland. 10:30 p.m.-midnight ex. Sun. Works with W3XJ.	
101.7 to 105.3 meters—2,850 to 2,950 kc.	W2VBS	National Broadcasting Co., New York, N. Y. 1,200 R.P.M., 60 lines deep. 72 wide. 2-5 p.m., 7-10 p.m. ex. Sundays.	142.9 to 150 meters—2,000 to 2,100 kc.	W2XCE	Passaic, N. J. 2-3 p.m. Tues., Thurs., Sat.	
W1XAV	Short Wave & Television Corp., Boston, Mass. 1-2, 7:30 to 10:30 p.m. daily ex. Sun. Works with W1XAU 10-11 a.m.	136.4 to 142.9 meters—2,100 to 2,200 kc.	W8XF	The Goodwill Station, Pontiac, Mich.		
W2XR	Radio Pictures, Inc., Long Island City, N. Y. 4 to 10 p.m. ex. Sundays. Silent 7-7:30 Sat.	108.8	2.758	VE9CI	London, Ont., Canada.	
105.9	2.833	W6XAN	Los Angeles, Calif.	130.4 to 136.1 meters—2,200 to 2,300 kc.	W9XAA	Chicago, Ill.
W7XAB	Spokane, Wash.	142.9 to 150 meters—2,000 to 2,100 kc.	W9XAD	Western Television Research Co., Chicago, Ill.		

Police Radio Stations

Wave-length (Meters)	Frequency (Kilocycles)	Call Letters	Location	Wave-length (Meters)	Frequency (Kilocycles)	Call Letters	Location	Wave-length (Meters)	Frequency (Kilocycles)	Call Letters	Location
120	2,506	KGZE	San Antonio, Tex.	122.8	2,442	KGFX	Denver, Col.	124.2	2,414	WRDR	Grosse Point Village, Mich.
121.5	2,470	KGOZ	Cedar Rapids, Ia.			WPDF	Flint, Mich.			WMO	Highland Park, Mich.
		KGNP	Davenport, Ia.			WPBE	Grand Rapids, Mich.			KGPA	Seattle, Wash.
		WPDZ	Fort Wayne, Ind.			WMDZ	Indianapolis, Ind.			WPDA	Tulare, Cal.
		WPDT	Kokomo, Ind.			WPDL	Lansing, Mich.			WKDU	El Paso, Tex.
		WPEC	Memphis, Tenn.			WPDE	Louisville, Ky.	175.15	1,712	KGPI	Beaumont, Tex.
		KGPI	Omaha, Neb.			KGPP	Portland, Ore.			WPDB	Chicago, Ill.
		WPPD	Philadelphia, Pa.			WPDH	Richmond, Ind.			WPDC	Chicago, Ill.
		KGPD	San Francisco, Cal.			KGZH	Klamath Falls, Ore.			WPDD	Chicago, Ill.
		KGPM	San Jose, Cal.				Muskegon, Mich.			WKDU	Cincinnati, Ohio
		KGPM	Salt Lake City, U.				Reading, Pa.			KVP	Dallas, Tex.
		WRDQ	Toledo, Ohio	123.4	2,430	WPDI	Columbus, Ohio			KGPL	Los Angeles, Cal.
			Klamath Falls, Ore.			KGPP	Portland, Ore.			KGJX	Pasadena, Cal.
			Akron, Ohio			WPDH	Dayton, Ohio			WPDU	Pittsburgh, Pa.
			Auburn, N. Y.			KGZD	San Diego, Cal.			KGPC	St. Louis, Mo.
			Charlotte, N. C.				Highland Park, Ill.			KGZI	Wichita Falls, Tex.
			Cleveland, Ohio				Toms River, N. J.				Newton, Mass.
			Rochester, N. Y.				Berkeley, Cal.				Shreveport, La.
			Syracuse, N. Y.				Buffalo, N. Y.				Somerville, Mass.
			Milwaukee, Wis.				Kansas City, Mo.				Arlington, Mass.
			New York, N. Y.				Vallejo, Cal.				E. Lansing, Mich.
			New York, N. Y.				New Orleans, La.				Fram'gham, Mass.
			New York, N. Y.				Washington, D. C.				Shreveport, La.
			Okla. City, Okla.				Minneapolis, Minn.	189.5	1,574	WPEH	Butler, Pa.
			Tulsa, Okla.				St. Paul, Minn.			WRDS	Greensburg, Pa.
			Wichita, Kans.				Atlanta, Ga.			WMP	Harrisburg, Pa.
			Chanute, Kans.				Bakersfield, Cal.			WPGY	W. Reading, Pa.
							Belle Island, Mich.			WBR	Wyoming, Pa.
							Detroit, Mich.			WJL	
										WBA	
										WMB	
										WDX	

Marine Fire Stations

187.81	1,596	WRDU	Brooklyn, N. Y.	192.4	1,558	WEY	Boston, Mass.
		WKDT	Detroit, Mich.			KGPD	San Francisco, Cal.
		WCF	New York, N. Y.				

SHORT WAVE LEAGUE



HONORARY MEMBERS

Dr. Lee de Forest
 John L. Reinartz
 D. E. Replogle
 Hollis Baird
 E. T. Somerset
 Baron Manfred von Ardenne
 Hugo Gernsback
Executive Secretary

Readers' Opinions of the 5 Meter "No-Code" Argument

Why Not Learn the Code!

Editor, SHORT WAVE CRAFT:

I have been a reader of your magazine for over a year now, and think it is very "F. B." for hams and short wave fans. I think that "Radio Fiction" is a good idea. I agree with Frank Mill, W9HQH-W9HWY about code-less licenses; if fans can't learn the code they can't learn to receive the transmitter in the frequency band. I think that ten words a minute is easy to learn. Most of the letters about code-less tickets are from fans that don't have a license. Why don't they learn the code?

CECIL HUMIS,
 340½ Water Street,
 Hallowell, Me.

From An "M. D."

Editor, SHORT WAVE CRAFT:

I want to say a word in defense of the amateurs. They are too modest to say it for themselves. Like many others, I get a great deal of enjoyment from listening to amateurs but I am too busy to qualify for an amateur license. Like many others, I fell into the habit of sending a QSL card to the "hams" whose conversation I enjoyed. I derived a lot of pleasure from getting QSL cards in return, until one night I heard a conversation that opened my eyes. One gentleman was discussing this matter of *Short-Wave Listener's* cards. He said that in one mail he had received fourteen *Short-Wave Listener's* cards and that while he would like to reply to them, the amount of postage involved was entirely too much for any reasonable man to be expected to pay. He said that this was just an average day's mail. I sent him a card—enclosed a stamp and got a prompt reply! So far as *Short-Wave Listeners* are concerned, the obligation is all on our side—it doesn't add anything to the information or the entertainment of the transmitting amateur, and if we wish them to acknowledge our short-wave listener's cards, the least we can do is to enclose *return postage*. The transmitting amateurs are gentlemen and good sports. We SHORT WAVE LEAGUE fans shouldn't take advantage of their good nature. It is suggested that you add a paragraph to your SHORT WAVE LEAGUE code of ethics—to read that *Short-Wave Listeners* shall *always* enclose return postage when sending S. W. L. cards.

G. W. TWOMEY, M. D.,
 U. S. V. A. Hospital,
 Fort Snelling, Minn.

Niagara Falls League Chapter Formed

Editor, SHORT WAVE CRAFT:

Here is proof that the SHORT WAVE LEAGUE is successful. In July of 1932 a group of four fans organized a league that was named "The Power City Short Wave League." To this date, including the enclosed application, our membership totals 12 fans who are all staunch readers of SHORT WAVE CRAFT.

We have already one station on the air, W8HNN, who has earned a reputation of being a first-class operator. Adding to this, we have three members who are waiting for their station call letters.

With the help of the news concerns of this city we have promoted much interest in "short-wave" radio.

Our meetings are held every Tuesday at 7:30 p. m. Code practice and discussions on radio problems fill our program. I would be only too glad to correspond with any "ham" or "leaguer" in regards to our experience in forming a division of the national SHORT WAVE LEAGUE.

I might also add that W8UC sure can write an interesting story.

Here is for a larger SHORT WAVE CRAFT, more divisional leagues and more fiction stories.

CARLOS A. HASINGS, Secretary,
 Power City Short Wave League,
 8150 West Rivershore Drive,
 Niagara Falls, N. Y.

Why One Should Learn Code

Editor, SHORT WAVE CRAFT:

I do not often write letters of this nature but I cannot refrain from keeping silent on this particular subject any longer. I believe your League can do a fine work and undoubtedly is doing much at the present time for the advancement of short-wave interest. For such honest endeavor on your part you deserve the praise and congratulations of all concerned in this interesting phase of radio.

But I cannot subscribe to the idea of permitting licenses to be granted for phone stations on 5 meters. I have been the holder of an operator and station license for more than four years. I have developed my "rig" from the old "self-excited," to the present "xtal" outfit. I have been on fone and C. W. I have listened and

operated on all bands from 5 to 160. I have passed through the stage in which the vast majority of your good members are now going through. That is the period when the desire to obtain a license and get on the air seems most important to one's existence. I can well remember the day when I too said that code knowledge should not be a prerequisite to phone operation.

Gentlemen, if you who are not the holders of a license, which gives to a man an aspect that you cannot get otherwise, you will well realize that it is not a "let-down" in the obtaining of the licenses which we really need, (which letting down the barrier on 5 meters would be) but a strengthening; a more rigid and strict examination is what is needed. The air is cluttered up at the present time with men who purport to know the code, *who don't know what they are doing!* It is easy and well enough to set about to build a transmitter with a set of drawings in front of you, but it is an altogether different matter to get it properly on the air. It is like night and day. I'm not feeding you a line either, I know. Friend Heaton of Canada says that the code is of no use to the radio amateur of today. Please believe me, when I say, with due respect to Mr. Heaton, that such utter rot is beyond belief. Gentlemen, I challenge you to take up that statement with such Honorary Members as Dr. Lee DeForest and John L. Reinartz.

I cannot find it possible to believe that either of these two distinguished men can fall in line with your 5-meter platform; I have too much in mind of the "ham" background of Messrs. DeForest and Reinartz to believe that they are in accord with this idea. Before any of the hot-headed youngsters take pen in hand to burn me up with a hot reply, may I remind you once again that I too once desired to get on the air and I too wished there were no code tests. I thank heaven today I was obligated to take that test and you will be too. Remember that. I note with no little interest that the vast majority of those favoring this 5-meter "new deal" are those holding no license. Keep up the good work you are promoting, gentlemen, every ham is back of you in that respect, but I wish you could be prevailed upon to drop this 5 meter agitation.

RICHARD W. PITNER,
 2518 Pierce Street,
 Sioux City, Ia.

More "Code" Argument

Editor, SHORT WAVE CRAFT:

I believe that your agitation on this "code-less phone license" is entirely foolish. There is no reason why a person should not go to the small effort of passing a slow code test to secure any radio license! If this code test does nothing other than to show a fellow's earnest desire for a license, it is still a good thing, but it does go much further than this! It helps to keep the phone bands clearer than they would be otherwise. It makes a fellow

(Continued on page 693)

Get Your Button!

The illustration herewith shows the beautiful design of the "Official" Short Wave League button, which is available to everyone who becomes a member of the Short Wave League.

The requirements for joining the League were explained in the May issue; copies of them will be mailed upon request. The button measures ¾ inch in diameter and is inlaid in enamel—3 colors—red, white, and blue.



Please note that you can order your button AT ONCE—SHORT WAVE LEAGUE supplies it at cost, the price, including the mailing, being 35 cents. A solid gold button is furnished for \$2.00 prepaid. Address all communications to SHORT WAVE LEAGUE, 96-98 Park Place, New York.

How to Become a Radio Amateur

No. 8 of a Series—Short Wave Antennas. By JOHN L. REINARTZ, W1QP.

● THE topic of antennas can be quite lengthy. When radio was young there were but a few types. The most prominent were the vertical wire and the inverted L types, with such modifications as the umbrella and fan types. Today, however because of the intense interest the amateur is taking in the shorter waves, the antenna is taking on different forms. While antennas are still antennas, and for the express purpose of providing a means by which the energy of the transmitter can be made useful to a receiving station at a distance, they are now not as imposing as they were when the amateur operated on 200 meters.

Two General Types of Aerials

Fundamentally we have two kinds of antennas, one that depends on the earth to be one part of the total system and the other that consists of a radiating conductor that is suspended above the earth and which does not depend on it to complete the system. The antenna that depends upon the earth for a completion of the system can be a vertical wire or of the inverted L type. In either case it must be an odd number of quarter wavelengths, i. e., it must be either a quarter wavelength long or any odd multiple of one quarter wavelength. It can never be operated at multiples of one-half wavelength.

Because of the interest the amateur is taking in the very short waves, the radiating system is scrutinized and that system is adopted which fulfills the requirements most readily. As the amateur generally cannot choose the location where he must live and that is at the same time ideal for the location of an antenna, he must needs adapt the antenna to the location; should the location be in an apartment building he is confronted with even greater problems.

The "Hertz" Antenna

Hertz first used the type of antenna that now bears his name. It consists of a radiating system that is suspended free of the earth and in no way depends upon it for the completion of the system. This type of antenna will work equally well when used in lighter-than-air craft or in modern planes, even though they may be many hundred or thousand feet above the earth. Here then is the solution for the amateur who is so located that he cannot with any degree of success use an antenna of the type that requires either a ground or a counterpoise. The Hertz type of antenna differs from the grounded form in that it is operated as a half wave antenna or multiples

A number of different styles of short-wave transmitting antennas are illustrated in the drawing, including "voltage" and "current" fed types; also the various wavelength relations of the feeders and the antennas proper.

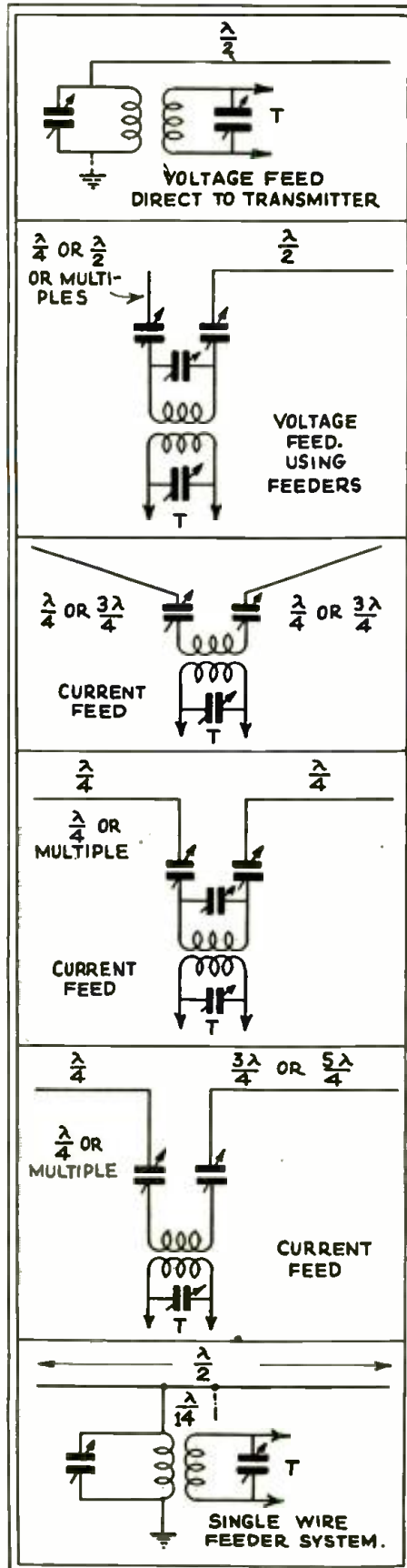

The style in short-wave aeri-als has changed quite markedly in the past few years, especially for those using transmitters. Mr. Reinartz gives us a clear explanation of the various antenna wavelength relations and the different methods of "feeding" the modern types of antenna.

thereof. A Hertz antenna can take on several forms, vertical, horizontal and various V shapes, depending on the space available at the transmitter location. In general it should be built to work on the lowest frequency that is expected to be used. It can then be operated on the higher frequencies provided they are multiples of the lower frequencies, i. e., an antenna built for 84 meters will work on 42 and 21 meters quite effectively.

When we have installed such an antenna the next problem is to feed it with power from our transmitter. This can be done in two general ways, by the *voltage feed* system and by the *current feed* system.

Voltage Feed

When we feed the antenna so that it becomes a *voltage feed* type, the connection cannot be made at the middle but at one end as shown in the diagrams. This type has the advantage that when the location is such that it becomes more convenient to feed it at one end it can readily be done. This in no way interferes with the ability to operate it at multiples of the fundamental frequency; when so connected it is termed a *zeppelin fed* antenna. When so located that one end can be brought directly to the transmitter location, coupling to the transmitter tank is by means of a separate tank coil to which the antenna end is connected. One advantage this voltage feed type has is that through the addition of a ground connection to the other end of the coupling tank, the system will be operative at twice the wave length for which it was built.

Should the antenna be so located that it is not convenient to bring one end directly to the transmitter location, feeder wires are resorted to. These wires are two parallel wires kept apart with wood separators that have previously been boiled in paraffine to improve their insulating qualities. The spacing can be from 4 to 6 inches; feeder wire length can be one-quarter wavelength or multiples thereof. When less than one-quarter and multiples the feeders are tuned with a variable condenser connected in

(Continued on page 697)

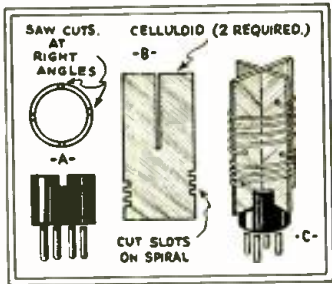

\$5.00 PRIZE SPACE-WOUND COILS

Many would like to make a space-wound coil with a high percentage of "air dielectric." This is easily accomplished with an old tube-base and a sheet of celluloid. For holding the coil, slots are cut in the tube base with a saw at right-angles, as shown in Fig. A. The coil form is made of two pieces of celluloid which are both alike as in Fig. B. The slots for fitting together and holding the wire can be cut with a coping saw. Care should be taken in making the slots for holding the wire. These slots should be made so the wire when wound will be in a spiral. A good glue for assembling and holding the wire in place can be made by dissolving celluloid in acetone until fairly thick. If the coil form is made of thin celluloid and is weak, small triangular pieces (braces) of celluloid can be glued on it. This same principle can be used in making plug-in coils with a base having a variable primary.—Jack Thorpe.

IMPROVED "GROUND"

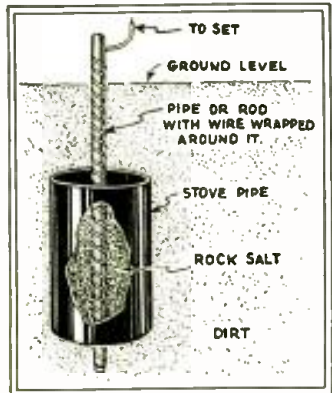

This "ground" works much better than an ordinary one. The following material is needed: An iron pipe or rod about 5 feet long, about 20 lbs., of coarse (rock) salt, a piece of No. 11 wire about 15 feet longer than is needed to reach from the "set" to the ground, and a section of stove-pipe. A hole is first dug in the ground big enough for the stove pipe to slip in. The insulation is scraped from about 15 feet of one end of the wire. This end is coiled around the rod and the rod is put in the pipe as shown in the illustration. Soil is then thrown in the hole and rock salt is mixed with it in the pipe. The hole is then filled with soil. The loose end of the wire is then connected to the set in the usual manner. A few holes punched in the stove pipe will increase the efficiency as more moisture is admitted. The stove pipe keeps the salt from washing away and the salt draws moisture.—Elbert Wehrhalm.

COIL HANDLE

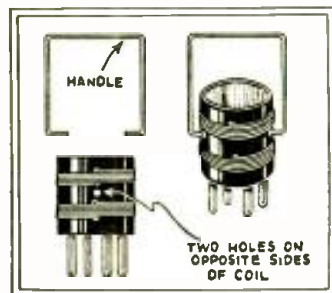

Here is a handle for quickly changing coils in a short-wave receiver; it consists of a piece of stiff wire bent in the shape shown in the diagram. It is inserted into 2 holes drilled in the coil forms and may be used for lifting or inserting the coils. To operate, the handle is compressed so that the two ends enter the two holes drilled on opposite sides of the coil; the coil is then inserted or removed. One handle can serve for all coils; it is especially useful for tube-base coils.— Clyde Probie.

\$5.00 For Best Short Wave Kink

The Editor will award a five dollar prize each month for the best short-wave kink submitted by our readers. All other kinks accepted and published will be paid for at regular space rates. Look over these "kinks" and they will give you some idea of what the editors are looking for. Send a typewritten or ink description, with sketch, of your favorite short-wave kink to the "Kink" Editor, SHORT WAVE CRAFT.

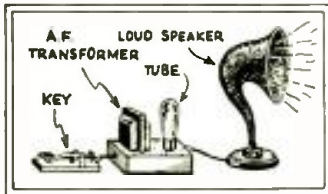

"LONG WAVE" ADAPTER

Here is a description of a "long wave" adapter for short-wave sets using plug-in coils. It consists of a variometer or variable tuning coil and an old tube-base. The tickler leads of the variometer go to the tickler prongs of the plug-in coil form

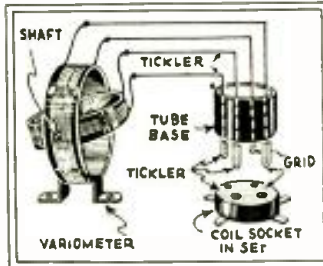

CODE PRACTICE FOR GROUP

Your February-March 1931 issue had a code practice outfit by Paul Skitzki, on page 388. The writer built this outfit and found it to be just what he wanted. But for "group" instruction of five people, the question of five pairs of head-sets and five keys was out of the question, so substituting a magnetic speaker and putting a 4 1/2 volt "C" battery in the plate circuit with positive to plate. It was found that we could hear and understand the code ten feet away from the speaker. I am passing this on to you as it might help some more fans to get up a "code practice" club with a few of their friends.—J. B. Vepper.

AERIAL TUNING CONDENSER

The accompanying sketch shows how I built an efficient series antenna condenser. The insulation is maintained at a high value by mounting the oppositely charged metal parts of the condenser on a bakelite or other equally efficient base. The capacity of the condenser is varied by turning the insulating handle mounted on one

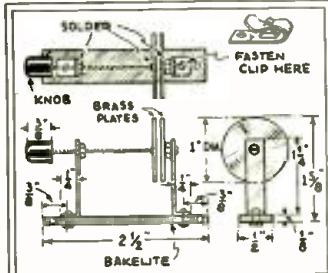

end of the threaded brass rod, the rod being threaded 8-32 or 10-32 pitch. The condenser members comprise two brass or other metal discs one inch in diameter, the thickness of the disc having no effect on the capacity. Not only will a condenser such as this be found extremely valuable to all short-wave operators, in helping to eliminate "lead-spots," but in some cases a set which will not oscillate at all can be made to do so by varying the capacity in the aerial circuit. If you have a fixed condenser in series with the antenna and your set is a little stubborn in one way or another, try this condenser and smile.—Joe Casaletti.

TICKLER REVERSAL

Being an experimenter I have several makes of plug-in short-wave coils and sometimes it becomes necessary to reverse tickler connections, so I hit upon the idea of placing a small D.P.D.T. switch close to the detector socket. Thereby I solved the problem of frequent soldering and resoldering of connections.—William S. Russ.

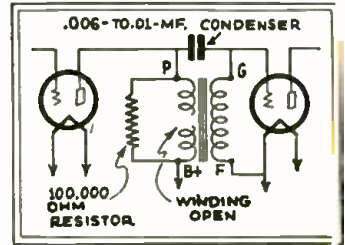
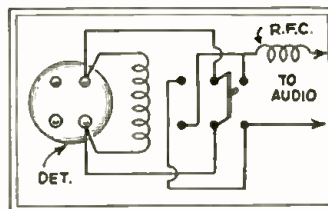

tone from even cheap transformers, but it will give slightly less volume. But why buy new ones when you can fix the old ones?—Alfred Oherstaedt.

TICKLER INSIDE COIL

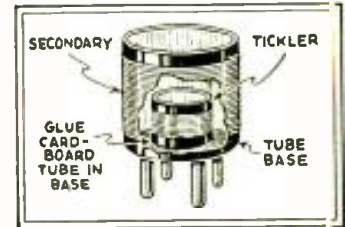

Tube-bases are often too short for both secondary and tickler windings. To overcome this the secondary is wound on the tube-base and the tickler is wound on a one inch cardboard or bakelite tube which is glued inside as shown. Connections are made to the prongs in the usual manner.—J. H. Wilson.

SUBSTITUTE "MIKE"

I proceeded to build a low-power transmitter out of the junk box which contained many receiving set parts of varied sorts. I got along well and finally got "it" done. Then came the question of a "mike." What to use for the "mike?" The cheapest "mike" on the market at that time was well above five dollars, which was one thing I didn't have. So instead of using the regular microphone transformer in the modulator, I substituted an ordinary audio transformer of "ancient vintage."

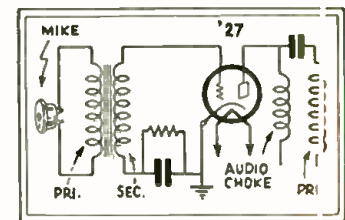

and with this I was able to use an old Vemco magnetic "speaker unit" with a little alteration as a "mike." To say the least, the results were excellent and much better than could be had from most carbon "mikes." The only alteration I made in the diaphragm, the old one is taken out, and a new one is made from the tin of a coffee can. Cut it out the same size and sand-paper down quite thin, replace, and it's ready. The output is good and strong and needs no pre-amplifier, but can be used with the conventional two-tube modulator. The quality is par-excelent. Here's my circuit in part—balance of request.—John Markovich.

IMPROVED VERNIER

Here is a quickly improvised and cheap substitute for the ordinary vernier dial. The materials used were one 10 inch phonograph record, one switch knob with shaft, one rubber washer, two metal washers, two nuts, and part of a connector of the type used to connect gang condenser shafts in broadcast receivers. The latter serves to connect the record to the condenser shaft. The knob assembly is shown in the sketch, a short length of thick-walled rubber tubing serving as a rubber washer, which makes firm contact with the rim of the record. If the set up is to be used for some time on a bakelite panel, a metal bearing should be provided for the shaft of the knob where it passes through the panel. A satisfactory scale may be laid out on heavy white paper and shellacked to the record; library past and the so-called "household cement" will not hold after they become dry.—H. O. Ervin.

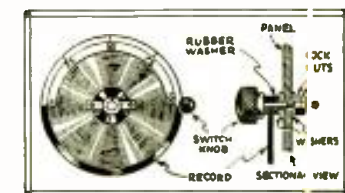

"PLUG-IN" CONDENSERS

I am a reader of your unique book, SHORT WAVE CRAFT, and am one of the many that really enjoys reading it and in doing so have accumulated much knowledge during the few hours I get to read it. I am enclosing herewith an idea which I think could be listed as a wrinkle either in short or long wave reception or transmission. Here is the done: "Plug-in" fixed condensers made by means of electric light plugs and sockets. The condenser is secured to the plug by means of bus wire as illustrated. In my case I flattened the wire up where the condensers are to go, so as to make the condenser easy to change to different values when experimenting. The sockets I used were of some white non-conductor porcelain which can be gotten from any electrical shop. This I believe is

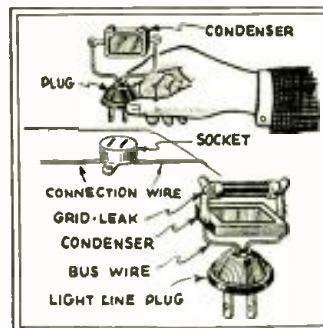

of most value to the experimenter, although also of value to the set-builder, whether he is a short wave or long wave "fan" or the man building transmitters.—George Funnell.

BURNT-OUT A. F. KINK

It is usually the primary coil of A. F. transformers which burns out, but they can be very satisfactorily fixed by connecting a 100,000 ohm resistor across the primary terminals, and a .006 to .01 mf. condenser between the grid and plate terminals of the transformer. You can fix these transformers in a very short time by making some clips which may be mounted on the binding posts of the transformer, which will hold the resistor and condenser very nicely. These connections provide a "resistance-capacity" coupling, with an "impedance leak" and will be found to give good

LETTERS FROM S-W FANS

A STRONG BOOSTER!

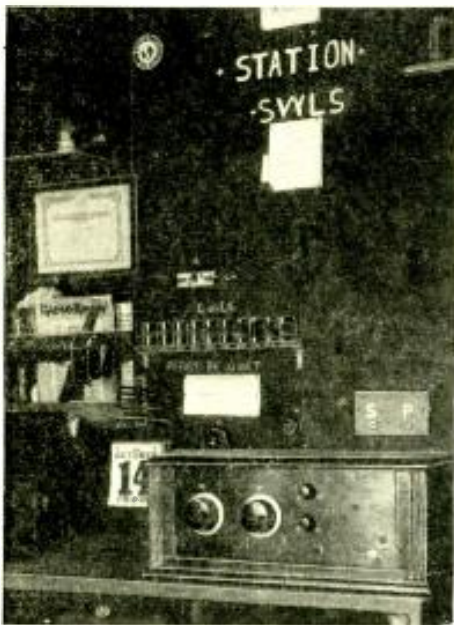

John Hoke's S. W. Listening Station. Come on Boys! Send us some good photos of your stations.

Editor, SHORT WAVE CRAFT:

Herewith is a picture of my Short Wave Listener's Station. I am taking SHORT WAVE CRAFT every month and I also belong to the SHORT WAVE LEAGUE. I have my button, as you can see if you look at the picture. I am a strong booster for the Craft! There are about twenty boys who meet at my house every two weeks and we all cannot say too much for SHORT WAVE CRAFT.

Well, I'll be saying 73,

Yours very truly,

JOHN HOKE,

214 Cottage Street, New Castle, Pa.

(Thanks very much, John, for sending us the interesting photograph of your short-wave "listening" station. You seem to have a real business-like receiver and plenty of plug-in coils we note. Let us hear from you again.—Editor)

MIGHTY SHADES OF 1930!

Editor, SHORT WAVE CRAFT:

This is the first time I have written to you. I like reading reports of other short-wave "fans" whose letters you publish in SHORT WAVE CRAFT.

My short wave "log" isn't to be compared to some of the logs sent into you, but it is great for a 1-tube receiver. I think.

I made the "Sun" Short-Wave Tuner, the circuit that was described by Jack Grand in the August-September, 1930 issue of SHORT WAVE CRAFT. Some fans didn't seem to have much luck with that set, but I can't kick. I have received the following short-wave stations with no amplification whatsoever: VE9GW-Bowmanville, Ontario; VE9JR-Winnipeg, Canada, VE9GR, VE9CL; 9XAA-Chicago; KEJ, KKZ, KKW, KEZ, KKQ, KET-California; W8XK-Pittsburgh; W8XL-Cincinnati, Ohio; VIT-Bermuda; GBS, GBW, GBA. G5SW-England; CMCI-Cuba; XDA-Mexico; HKM-Columbia; LSN-Buenos Aires, Argentina; J1AA-Japan. Honolulu calling KKW, Bolinas, California, I2RO, Rome, Italy, FYA-Paris, France; HRB-Honduras, Central America; W3XAL, New Jersey; WCAU-Philadelphia; W2XAF-Schnectady; WOO-Deal Beach, New Jersey and last but not least PMB-Bandoeng, Java, which I have verified reception; then not to forget the amateurs and police reports. These short wave "fans" tell about thrills listening to DX stations. They don't know what a thrill is until you get wrapped up in a pair of ear-phones and twirl the dial for "distant lands," on a 1-tube receiver made by yourself!

I hope you'll publish this on the "fan" page of SHORT WAVE CRAFT.

Hoping for long life for SHORT WAVE CRAFT.

Yours very truly,

KENNETH MORGAN,

80 Webster Ave.,

Port Washington, L. I. N. Y.

(You have the right dope, Kenneth—one-half of the radio world doesn't know of the wonderful thrills that the "other half" is experiencing, when they turn the dial on their first home-made receiver and hear Paris, Berlin, or Rome! It sure is the thrill that comes "once in a lifetime," only the short-wave fans never seem to tire of looking for "one more thrill."—Editor.)

HERE'S YOUR ANSWER

Editor, SHORT WAVE CRAFT:

Well to start off I want to say that the SHORT WAVE CRAFT is the one and only "mag." that is a true friend to the S-W Fan. I have been taking the "mag." for a long time. Sometimes I buy two of them as I keep every one of them on file (and make use of them!)

I experiment most of the time and need tips and in the future will give you a few new ones for the "mag."

I read the "Letters From S-W Fans" and noticed one letter by Forest Bigelow, a complaint of too many factory-made receivers in your magazine. Well I guess you both are right. I always want to know what the factory is going to do and a "service man" does because it helps him in his work. If we cut all the factory-made sets out, it would just be too bad; so it is just a split, we give the factory a break and they give us one.

What the service men want is simple things such as, the following:

Does shielding help in short waves?

What advantage and disadvantage?

More on R. F. ahead of the Det.; on the I. F.; on tubes best for S. W. chokes.

Service men want to see these in your magazine. Try it once, or ask some of them what antenna, choke, coil, etc., is best for S.W. and if they tell you, ask them "why" they are the best. Well, anyhow, this is what a radio man needs. It's no fun copying a factory set.

I took a circuit from your magazine and made some changes and now I use it with an RCA "82" with only one R.F. stage ahead of the 175kc. I.F. I connect my converter and I get G5SW; a German station around 19 meters—don't know who they are; EAQ, Spain; LSR, South America; One Russian station. These can be heard two blocks away and can be brought in using 5 feet of antenna!

Yours very truly,

G. BROCKWAY,

1350 Wilson Ave.,

Chicago, Ill.

(The service man needs a little of everything in a radio magazine, such as this, as you intimate, "G. B." and we have tried our best to try and please the short-wave fan, the general reader, and the service-man as well. You will probably note that we have not featured, or at least devoted as much space to factory-made receivers as we do to those of the experimental type. We realize that it is difficult for a short-wave fan to try and imitate an 8 or 10-tube factory-made set, but the service man and a certain class of fans do demand some descriptive matter and diagrams on the outstanding factory-built S-W. receivers. We will endeavor to achieve the happy medium of giving both classes of readers what they want, for after all SHORT WAVE CRAFT is "your" magazine.—Editor.)

MORE DOERLE DOPE!

Editor, SHORT WAVE CRAFT:

After reading nine issues of SHORT WAVE CRAFT, I am convinced that there is no better "mag."

Eight months ago, an issue of S. W. C. caught my attention on the news stands. That day I started to learn something about radio. I constructed the "Doerle" Receiver (all used parts) with a 31 in the last audio stage, and what RESULTS! The following are a few of the stations I logged:

VE9GW, Bowmanville, Can. (loudspeaker).

VE9DR, Drummondville, Can. (loudspeaker).

CMCI, Havana, Cuba.

DJB, Konigswusterhausen, Germany.

FYA, Pointoise, France (2 waves) (loudspeaker).

I2RO, Rome, Italy (loudspeaker).

EAQ, Madrid, Spain (loudspeaker).

VE9JR, Winnipeg, Can. (loudspeaker).

HKD, Barranquilla, Col., S. A.

W4XB, Miami, Fla.

W9XF, WOO, W9XAA, W8XK, W3XAL, W2XAF, W1XAZ, and many other broadcast and amateur stations.

But enough of this long-winded conversation, all I can say is that S. W. C. is great, and may it keep on growing!

If you have plenty of room I'd be glad to see this letter in S. W. C., and I'll answer ALL letters!! Thanks!

Hoping that this letter isn't too boring, I am,
Respectfully yours,

JOSEPH ORLAN.

8531-101 St., Richmond Hill, L. I., N. Y.

(What! Again? The Doerle receiver walks off with the honors. Our eyes must deceive us! But no, as we walk through our "back issue" store room, we find that the shelves marked "December '31-January '32" are all gone. WHAT A MAN AND WHAT A SET! So if you want a copy of that issue you will have to place a line in the "ham adv" column, we guess, or else broadcast a call over your short-wave station. —Editor)

DOERLE 3-TUBE "SIGNAL GRIPPER" A HIT!

Editor, SHORT WAVE CRAFT:

My first copy of SHORT WAVE CRAFT was purchased last January and since then I have not missed one and don't intend to.

I have built the Doerle "two tuber" and got fine results. The Doerle 3-tube "Signal Gripper" was put together with one change—a 33 was used in the AF stage and it worked "FB"—fine business.

The set which I used and still am using, when I first became interested in short waves, is a "3 tuber"—detector and two stages AF, amplification, using 199 tubes. With this set I have heard all nine districts, VE1, 2, 3, and 9's on phone. On CW I have heard all nine districts, VE1, 2, 3, and 4, Spain (EAR), Panama (RX), Brazil (PY), Germany (D), Cuba (CM), Netherlands (PAO), France (F8), England (G), Czechoslovakia (OKO), Belgium (ON4), and Costa Rica (T12). Also regular broadcasting stations, police, commercial, and airports.

Well 73's and good luck.

FREDERICK A. SMALLMAN,

79 Willett Street, Wollaston, Mass.

(Welcome news, Frederick, for while we invite and appreciate "brick-bats", when they contain real constructive criticism from our readers, we also appreciate a modicum of praise when the sets we describe in SHORT WAVE CRAFT "ring the bell."—Editor)

ANOTHER SET MAKES GOOD!

Editor, SHORT WAVE CRAFT:

I am taking the liberty of writing you about Mr. Doerle and his "Signal Gripper" short wave receiver. I have built his set and find it worked fine! I also added a few things myself and that is what I am writing about, so that others who have built the same set can try them. Instead of using the two small copper plates for the antenna condenser I put in a Chelton .00005 mf. midget tuning condenser and find you can separate stations nicely; I also added a copper shield can from an old Crosley receiver, that serves as a shield for the oscillating circuit coil. Next I took the 30 tube out of the A.F. socket and put in a 31, together with a "C" battery and find it has just about doubled my volume!

Hope this will help some of the boys and thank you for reading this letter.

W. H. WILSON,

181 Main St., Norwalk, Conn.

(Fine business O. M. Another improvement is to use a screen grid tube in the R.F. stage.—Editor.)

Here's Your Chance to "Get It Off Your Chest"

FROM LONDON

Editor, SHORT WAVE CRAFT:

Your correspondence seems very meagre from this side of the water. Therefore, as a reader of the Gernsback Publications I put into practice a long felt desire.

I have been a reader of SHORT WAVE CRAFT since number one, and can boast of every number of *Radio News* and *Amazing Stories* from number one until they ceased to belong to Gernsback! This, as you will agree, covers a number of years, and, although your original publications were considerably thicker, the essence of the articles is just as strong.

We English folks have nothing to touch SHORT WAVE CRAFT, and in spite of our excellent broadcasting system, we must come to you for our S.W. data. Our S.W. articles would give the average U. S. "ham" the blues; they mostly consist of something about three years old or a very cheap idea taken from a "Yank" magazine.

My previous short-wave receiver was O.V. 2; it would not be practical to give a list of stations received, but the bulk of main American stations usually came in at loud-speaker strength; some below 20 meters have been at very strong loud-speaker strength, with no aerial whatever! The range was 7 to 2000 meters and the wave band was covered by seven plug-in inductances. Collinson type of coils was used, and four coils covered 7 to 120 meters. Moscow at 50 meters. Königswusterhausen at 31 meters, and W2XAD at 19.5 meters, are usually considered very consistent "lighthouses," but Moscow is too much inclined to swamp, especially during the winter months, thus making it difficult to "log" our old friend W3XAL for any length of time.

I still consider that the *New York Times* S.W. Receiver will take a deal of beating; you will undoubtedly recall *Radio News* publishing details of this. Have you considered that some details of meter tuning would prove very interesting and useful to your readers?

Please keep going and "teach us our Radio."

Yours sincerely,

LESLIE SMITH,
351 Brownhill Rd.,
Catford, SE 6, London, England.

(Pleased to meet you, Leslie, and you sure have been a faithful reader of the Gernsback publications. We note what you have to say concerning the English radio magazines; we read most of them every month and find them very interesting. Concerning the *New York Times* short-wave receiver we believe you will find that most interesting descriptions now appear in the various periodicals of some of the new "Yank" professional-type short-wave receivers, such as the Hammarlund Comet "Pro" and the new National "AGS." These receivers give practically world-wide reception at the turn of a "single dial," through the use of specially designed superheterodyne circuits that get the last quota of energy out of the incoming radio wave. Mighty glad to hear from one of our English friends and hope you will write us again soon.—Editor.)

HE BUILT SIX OF 'EM!

Editor, SHORT WAVE CRAFT:

I am a reader of your SHORT WAVE CRAFT. It is the best magazine out. I have built six short-wave sets up to date. I made up the "Doerle" short-wave receiver. I will say that it is a knock-out and a wow for volume! It goes out and pulls them right in. I made plug-in coils and I used collodion to hold the winding together—it is the best "dope" I knew of.

I am a member of the SHORT WAVE LEAGUE. I will recommend the "Doerle" short-wave to get the stations. No one will make a mistake in building this set. I use a 50-foot antenna, 201 detector and 12 "first audio" stage.

Yours very truly,

OSCAR CORWIN,
250 W. William St.,
Frankfort, Ind.

(Hot Cha, Oscar! Congress will yet have to strike off a gold medal for Mr. Doerle. He's almost as famous as Lindbergh already. Well, we're glad to hear that you had success with his short-wave receiver and hope to hear from you whenever you build some of the other receivers described in SHORT WAVE CRAFT.—Editor.)

AMLIE'S "DX" CIRCUIT A WINNER!

Editor, SHORT WAVE CRAFT:

I wonder how many "hams" have tried "Oliver Amlie's" DX circuit which appeared in SHORT WAVE CRAFT, May issue, page 17? Quite a few, I expect. I have used this circuit for the last four months and believe me, for DX work it is going to take some set to beat it! Do you know that to get good reception here (New Zealand) from KF1, KMOX, KSL, WABC, requires six and seven valve jobs, but to get these stations on Oliver Amlie's DX circuit is really some achievement! I hold verifications from three of these stations. These stations come in at R 8-9 on the loud speaker but can get a few of the others at R 3-5. All this, using a sixty foot outdoor antennae. *Australian stations come in like locals!*

Now for the short wave side of the circuit. I use anything from four feet to twenty feet indoor antennae and no ground at all for short-wave work. For 80 meters I use 20 foot aerial, so when on 20 to 30 meters I use a 4 ft. to 6 ft. aerial. How would some of the boys like to get FYA, Paris, with this antenna and using two valves (tubes), one det. and one audio, for these stations, FYA, KKW, W3XAL, Bandoeng, Java, VK2ME, VK3ME, RV15, W2XAF, all come in at R5 on speaker? For full loud speaker strength I use 1 det. and 2 audio stages. The following stations also "roar in" or else are very weak which is not often. Here they are: G5SW, DJA, VK3LR, W1XAZ (I had this station at maximum strength during the Olympic Games) EAQ, J1AA, also hear W's working on 80 meter band and 40 meters. Well, how do you like this: VK, ZL, W, K6, K7, D, EAR, PA, PB, PC, G, VE, OZ, K1. I have received verifications from some of these stations and more to come in. So radio hams of the U. S. A., go to it and see if you can do as well. Amlie's DX circuit "is the goods"—and worth it.

Well, Mr. Editor, hoping I will not take too much space and I expect you have had sufficient talk from me, so I will say *cheerio* for the present and wishing SHORT WAVE CRAFT every success.
S. B. WOODLEY,
70 Hull Street, Oamaru, N. Z. (New Zealand.)

(We were sure glad to hear from you, SBW, from way "down under." We are more than pleased to learn that you have obtained such excellent DX results with Oliver Amlie's circuit, which appeared in our May issue.—Editor)

10,000 MILES WITH A.C. ADAPTER

Editor, SHORT WAVE CRAFT:

I built the A.C. adapter unit that took first prize in your third contest and rated at 3,000 range in miles; I stretched it to 10,000 miles and have a verification from VK2ME (with a total of four tubes) also G5SW, VE9GW, EAQ, DGA, W6CTK—Hermit, California; K6DAZ—Honolulu, Hawaii, (a m a t e u r s)—thanks to SHORT WAVE CRAFT. Since I saw the October-November, '31 issue of SHORT WAVE CRAFT I have been deeply interested in short waves and expect to have a transmitter in a few months. I would like to hear from any reader of about sixteen years of age.

Yours for best in radio each month.

CLIFFORD J. LEE,
1221 Kenton Street,
Springfield, Ohio

(Hot Ziggedy!! Who'd have think it, Clifford. Well we always did hold a card for short-wave converters and adapters and it has been our private opinion that they would some fine day come into their own. No reason why at all that a good S.W. adapter or converter should not "step out" and roll 'em in.—Editor)



Yep! New Zealand! S. B. Woodley at the controls of Amlie receiver.

AH! NICE JUICY BRICK-BAT!

Editor, SHORT WAVE CRAFT:

I have been a reader of ur magazine—have been I said! If you wud use common sense you mite hv abt 15,000 more readers alone in the United States. 75% of the hame don't read ur mag fer the simple reason that most of ur articles are impractical, the silly hook-ups that you publish fer the beginner I'm referring to. Everyone is on the same idea; det and one or 2 aud stages. The only diff is th there bi a diff writer. Here's an example in the November 1932 issue, u hv "Building the 2-Tube Gloie Trotter," and on another page u hv "The Beginners Set Gets An Amplifier." Wot the — is the diff between these two sets? Tell me! One has a cond for reg, the other has a resistance across the B plus fer reg. There is no diff both r the same in construction and mechanical details and if one gets England, so wud the other.

Another thing, wen u start an article on such and such a page, why the — not complete the article; not continue it way in the back of the book some place. The Reinartz article, "How To Become An Amateur," isn't bad, but bi the time a guy finishes it they'll be measuring his size for the coffin! When breaking a beginner into transmitting, forget xmtrs; give hook-up fer monitor es explain it fully, because a ham without one is in hopeless spot. Frg meter is OK but a monitor must be had under all conditions. This here in most cases seems to be neglected and it's more important than the xmtr itself.

Most of wot I mentioned the beginner an experimenter don't even notice, but this book I assume is supposed to be for the amateur as well as the beginner, so lets hv sum more cpe on xmtrs but none of them "trick" worthless stuff like u try 2 slap us with nw an tm. Give us practical dpe. Ths abt all. U always wanted a brickbat, so don't get sore. More pwr to u an ur mag vy 73's es cu agn.

ERNEST EDWARD MORVAY, W2ELB,
503 E. 78 Street,
New York, N. Y.

(A juicy brickbat now and then is relished by the best of men—and we presume that our readers will have quite a little fun stumbling over the S-W "shorthand" in your letter. We do not quite agree with you that most of the hams do not read SHORT WAVE CRAFT because the articles are impractical. As we have said before, SHORT WAVE CRAFT is "your" magazine and speaking to all the readers as a general class, we recently ran a special "beginners number" for the simple reason that we have been deluged with letters asking for more and still more simple short-wave hook-ups. We believe you will find that we have provide! a pretty well balanced "bill of fare" in the average issue of SHORT WAVE CRAFT, as we are constantly striving to keep in mind the "beginner" as well as the more "advanced reader" in the short-wave field.—Editor.)

S-W Tuning Inductance Charts

The accompanying charts enable the Short Wave Fan to ascertain the inductance of a certain size coil without having to perform lengthy mathematical calculations. The graphs given are "direct-reading"—the inductance in microhenrys of a certain diameter coil being quickly and easily found.

By **CLIFFORD E. DENTON**

● SO many readers write in for "dope" on building coils for short wave reception that this article should be of interest to all.

The average experimenter selects a condenser and then starts to figure or guess the values, both *mechanical* and *electrical*, for the proper size coil to cover the various bands.

Now various sets of specifications can be found in every issue of *SHORT WAVE CRAFT* but in many cases when the coils are wound, certain factors creep in which seems to make the coils very unsatisfactory and the reader starts to think that the wrong "dope" has been given.

Let's review some of the fundamentals and perhaps this will give the prospective coil builder a better idea as to just what he is doing.

The unit of self-induction is called the *henry* and is defined as "a rate of current change of one ampere per second giving an induced potential of one volt." The henry, as a unit, is suitable for solution of problems in the audio and power-supply band of frequencies, but when *short-wave coils* are being designed a smaller unit is used

and these subdivisions are the *millihenry* and the *microhenry*, respectively equal to one-thousandth and one-millionth part of a henry. A seldom-used unit of inductance is the *centimeter* which is equal to one billionth part of a henry; it is the smallest subdivision. Note that the unit of inductance is also the unit of length.

The *farad* is the unit of capacity and is defined as a condenser which requires one coulomb of electricity to bring a potential difference of one volt to its plates. A coulomb is the quantity of electricity that passes through a circuit in one second when the flow is one ampere.

Again we find a unit that is too great for use in practical problems and circuits, so we subdivide farads into *microfarads* and *micro-microfarads*, respectively equal to one millionth and one million, millionth part of a farad. Here the base unit is the centimeter and one centimeter is equal to one nine-hundred-thousandth part of a microfarad. Thus the micro-microfarad and the centimeter are nearly the same in size, one centimeter being equal to 1.1 micro-microfarad. The unit

of capacity is also a unit of length.

Let's see; the capacity of a sphere is found to vary as its radius, and in the electrostatic system, a sphere with a radius of one centimeter has unit capacity. Thus, a condenser in the form of a sphere having a capacity of one farad would have a radius of 5,592,329 miles. The radius of the earth is approximately 650,000,000 centimeters; so its capacity should be about 700 microfarads. Say, this world of ours is not so large at that.

We will use microfarads and microhenries in the solution of our problems but it is interesting to note what would happen if we had circuits using henries and farads. Suppose we had a capacity of one farad connected to an inductance of one henry. It would take six seconds to complete one cycle; slow motion, more or less. The wavelength in this case would be 1,800,000 meters. Substituting a capacity of one microfarad would cause the circuit to oscillate 1000 times in six seconds and the wavelength would be 1,800,000 meters.

The combination of a coil (inductance) and a condenser (capacity) forms a *resonant circuit* and has the

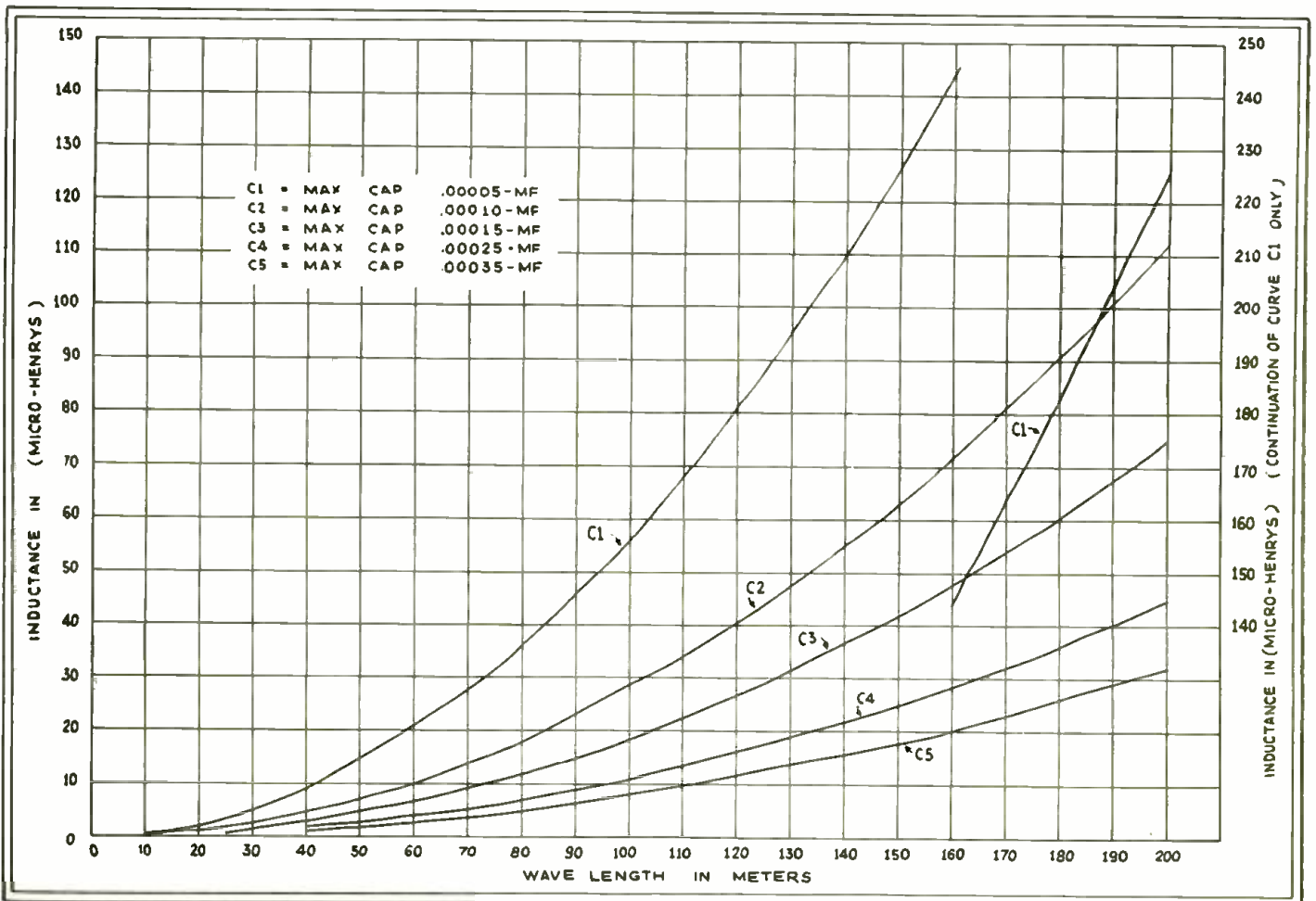

Chart showing relation between wavelength desired, condenser capacity and coil inductance in microhenrys.

ability to resonate large voltages and currents at some particular frequency. The frequency at which this phenomenon takes place depends upon the value of the capacity and inductance in the circuit. Thus,

$$f = \frac{159,200}{\sqrt{LC}}$$

Where f is the resonant frequency expressed in cycles,

L is the inductance in microhenries and C is the capacity in microfarads.

Instead of calculating the reader can refer to the LC Chart or Table of Fig. 1. This chart covers all wavelengths from one meter to two hundred meters. The chart is easy to use as the prospective coil-builder generally knows what type of tuning condenser he is going to use and its capacity. For example: A tuning condenser with a capacity of .00015 mf. is at hand. What must be the inductance of the coil to tune to a wavelength of 200 meters?

Referring to table 1 we find that the product of L times C corresponding to 200 meters is 11.26. Dividing this number by .00015 (the capacity of the tuning condenser in microfarads) we obtain 75,066 which is the inductance of the coil in centimeters. Now 1,000 centimeters equals 1 microhenry, so we must divide 75,066 by 1,000 to find the inductance expressed in the form of

(Continued on page 691)

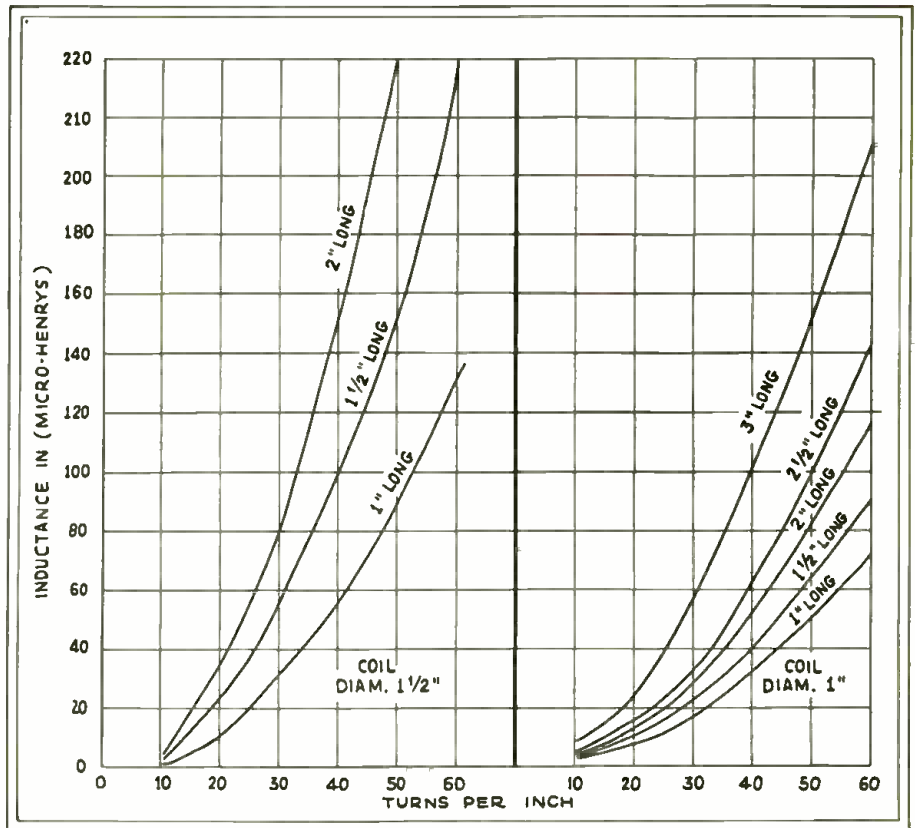

Additional "direct-reading" values of coil inductances with relation to the physical dimensions of the coil.

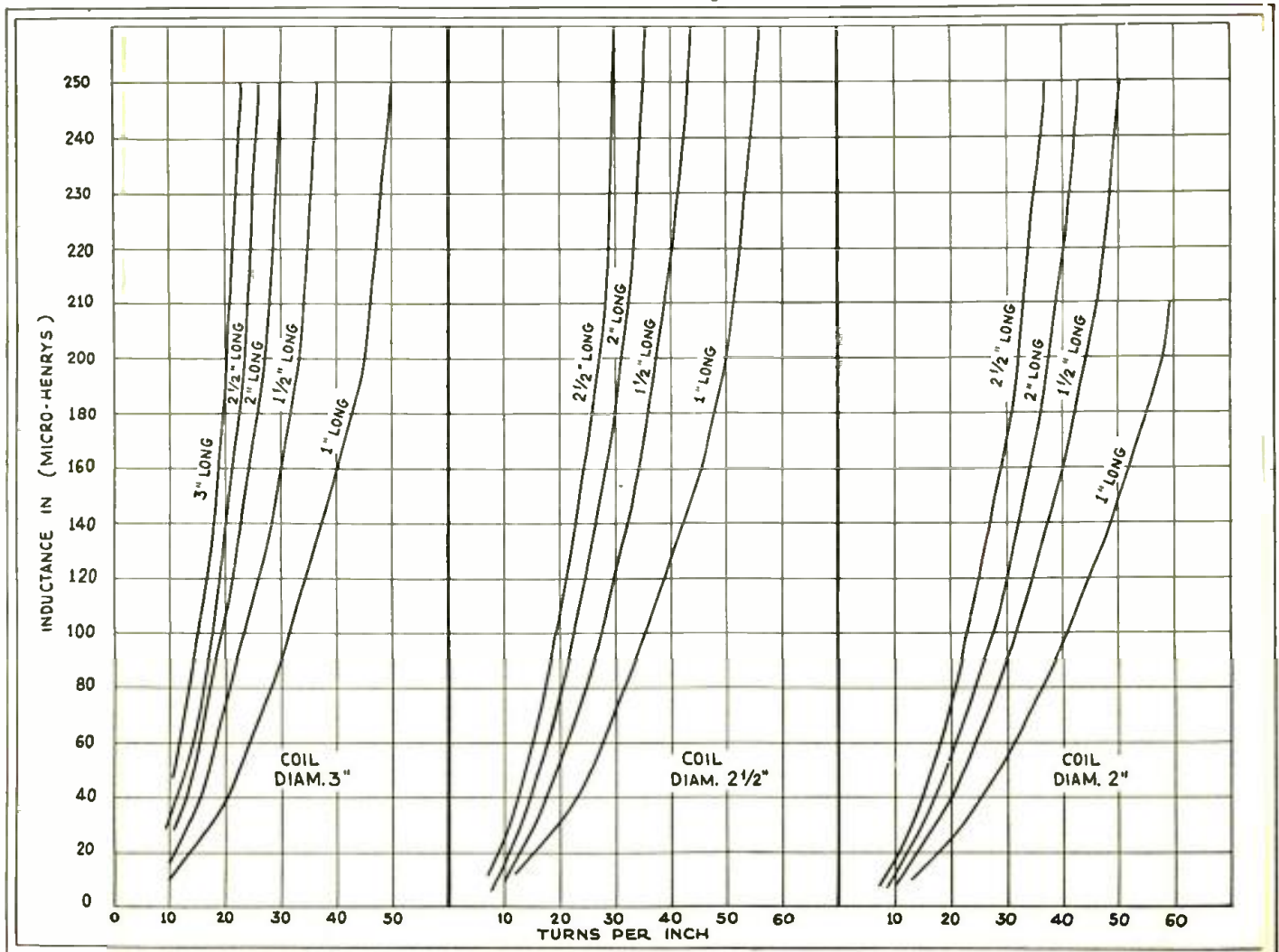

Graphs giving relations for various diameter coils and inductance in microhenrys.

Find-All de Luxe S-W Converter

(Continued from page 658)

using a six position switch and adding two additional oscillator coils, it is possible to cover the entire broadcast band with this converter, since two more Alden coils are available for use at (3) and (11) which permit operation of the converter up to 540 meters, using the same tuning condensers.

Volume is controlled in the Find-All Converter by an Electrad potentiometer (8) in the cathode return circuit of tubes (5) and (23). Hammarlund I.F. transformers are used at (16) and (26). These peak at 465 kc. Each transformer has a tuned primary and a tuned secondary. Tuning is accomplished by means of small adjustable mica condensers. The I.F. transformers are carefully shielded and the tuning condensers are mounted inside the shield, but in such a manner that they can be adjusted from the top of the shield. Since the success of a good "super" ultimately depends upon the I.F. transformers, only the best obtainable should be used. Resistor (38) in series with the audio choke (39) limits the plate voltage to the required value of 250 volts. An amperite, in series in the primary circuit of the power transformer, prevents fluctuations of the line voltage from affecting the operation of the converter.

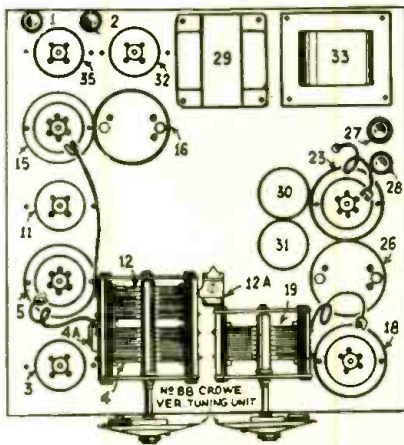

Oscillator Coil Data.

Holes are drilled in the front chassis wall for selector switch (21, 22) and combined Electrad volume control-power switch and these are mounted. The chassis is now turned upside down and the four special oscillator coils are mounted. All four coils are wound on fibre forms, 1 1/8" in dia. and 1 1/8" high and all are wound with No. 28 single silk covered wire. Coil (20A) consists of 5 turns spaced 3/4" apart. Coil (20B) consists of 11 turns spaced 1/16" apart. Coil (20C) consists of 19 turns spaced 1/16" apart. Coil (20D) consists of 37 turns spaced appx. 1/32" apart. A tap is taken out at the center turn of each coil. Coils may be obtained ready wound if desired.

The R.F. choke (9) should be fastened on the underside of the chassis as shown in the illustration. Condenser (10) is fastened directly to the bottom of the chassis. For making the connections to the caps of the four tubes, use armored braidite. Wire the four oscillator coils to the selector switch first. Then wire filament circuits, grid circuits, plate circuits, cathodes, negative returns and by-pass condensers. When wiring up a comparatively unfamiliar socket, such as the six prong socket, a sketch showing respective socket terminals should be worked from. Such sketches are available from tube charts. When wiring the Alden coil sockets, refer directly to the coils, noting that the lower ends of primary and secondary connect to the filament (thicker) prongs. Primary and secondary coils of the I.F. transformers are identical.

NATIONAL "AGS" RECEIVER DE-LUXE SHORT WAVE

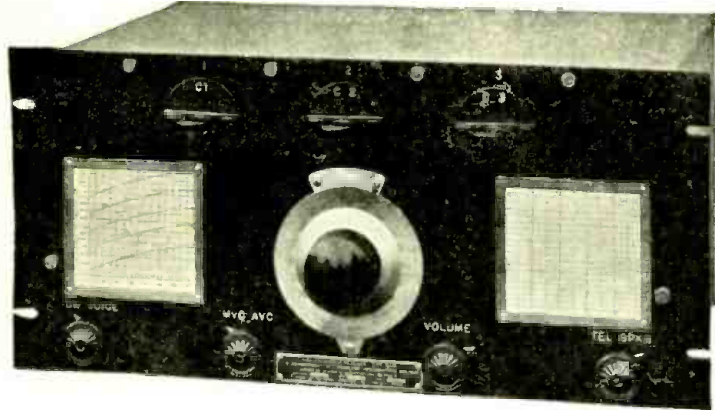

The NATIONAL "AGS" has been developed for the short wave radio user who recognizes and appreciates the refinements in design that give de luxe quality to radio equipment. The "AGS" is the de-luxe short wave receiver of the National Company line of Thrill Boxes, and gives the maximum short wave performance possible, regardless of cost.

The "AGS" has been developed in cooperation with the Airways Division of the U. S. Dept. of Commerce to meet the exceedingly strict requirements of aviation ground station service. Every latest development has been included to make the "AGS" the very best possible in performance and every day reliability.

5. Suppressed image.
6. Single control S. F. L. tuning by 270 precision Velvet-Vernier Dial with German silver scale and vernier reading to 1/10 division.
7. Calibration curves and tuning log on front of panel.
8. Phone or speaker output.
9. Relay rack mounting, extremely rigid all aluminum construction—front panel 8M x 19 1/2.
10. Frequency range 1500 to 20,000 kc. Band spread coils available.

OPERATED ON AC

NATIONAL Power Units for AC operation. RCA Licensed.

NOW AVAILABLE WITH BAND-SPREAD COILS

The "AGS" has band-spread coils for the 20, 40, 80 and 160 meter amateur bands either in place of the standard 15 to 200 meter coils or as additional equipment.

ELECTRON-COUPLED OSCILLATOR

Made with electron-coupled oscillator, the "AGS" has maximum stability.

OUTLINE SPECIFICATIONS

1. CW or Voice, by shift of one control.
2. Automatic and Manual volume-control by turn of switch.
3. Coil change from front of panel.
4. Tuned RF ahead of front detector. Very high signal-to-noise ratio, and high weak signal response.

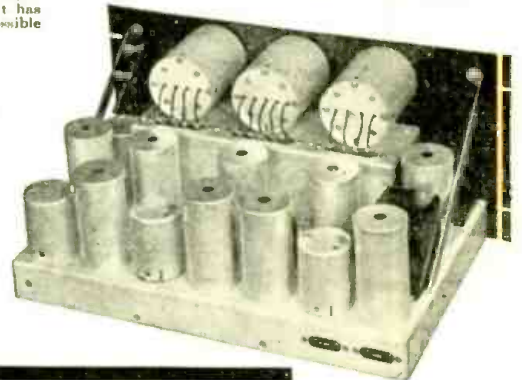

NATIONAL SW-58 THRILL BOX

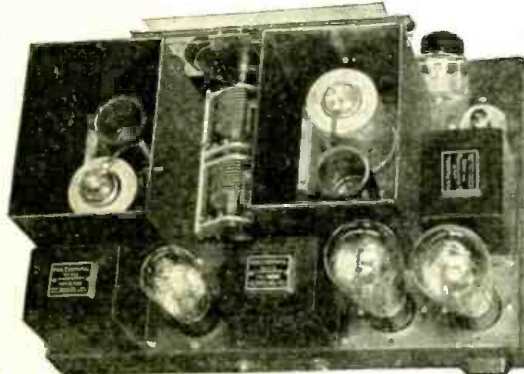

THE SW-58 THRILL BOX HAS

Utmost Sensitivity, Extremely Low Background Noise (highest signal-to-noise ratio), Unequaled Flexibility and Ease of Control—and MAXIMUM PERFORMANCE PER DOLLAR of ANY Short Wave Set available.

"Controlled Selectivity." An entirely new feature, found only in the SW-58, which allows the set always to be operated at the best selectivity consistent with signal strength and reception conditions.

Loud Speaker Performance. A Push Pull Stage with 245 tubes for best tone-quality gives fine loud speaker volume. There is also a jack for headphones.

Full AC or DC. The AC set operates with the NATIONAL 5880 Special SW Power Supply with extra shielding and filter sections for humless operation. RCA Licensed. Battery model also available for use where there is no AC current.

LEADING SHORT-WAVE BROADCAST RECEIVER FOR MORE THAN 4 YEARS

Each year the Thrill Box has been improved . . . kept in the lead with new and better tubes and new and better circuit design. The SW-58 Thrill Box now offers performance not dreamed of in September, 1928.

Send the coupon below for full information on the NATIONAL "AGS" and the NATIONAL SW-58 Thrill Box.

NATIONAL CO. INC., 61 Sherman Street, Malden, Massachusetts.

- Gentlemen: Please send me full information on
- NATIONAL "AGS" Receiver
 - NATIONAL SW-58 Thrill Box
 - Please send me 24 page Catalog of Short-wave parts and equipment

(I enclose 6c in stamps to cover cost of mailing.)

Name

Address

S.W.C.-3-33

NATIONAL

WORLD-WIDE RECEPTION

●
Guaranteed
●

●
IN YOUR HOME
●



WITH the whole radio world to choose from, the COMET "PRO" short-wave superheterodyne holds honor position in the service of the U. S. and Canadian Governments, leading air-transport and steamship companies, police departments, and key stations of broadcasting networks—faithfully performing their most exacting tasks.

The improved "PRO" uses four "58" tubes, two "57's," one "247" and an "80" rectifier.

It is even more *sensitive* and *selective* than before—yet surprisingly *easy to tune* with its simple band-spread system. Full loudspeaker volume. Electron coupling gives greater oscillator stability. Shielding is more effective, and the new metal cabinet prevents stray influences. Wood cabinet optional. A.C. and Battery Models.

The Mail coupon for 16-page folder describing complete details of this really **GREAT** receiver.

COMET

Custom-Built "PRO"
by
HAMMARLUND

HAMMARLUND MANUFACTURING CO.
424-438 W. 33rd St., New York

Please send 16-page illustrated folder describing COMET "PRO" Short-Wave Superheterodyne.

Name _____

Address _____

SW-3

Adjusting Converter.

The rectifier tube filament is wired in next, then the power supply circuit, including resistor (38), choke (29) and filter condensers (30, 31). Finally, the amperite and switch are connected in series with the primary winding of the power transformer. The tubes should be put in place and the converter should be connected to the 110-volt source. It is desirable to check voltages first. Plate voltages should be 250. If these are found to be too high, regulate resistance (38) by means of the slider. Screen grid voltages should be about 100 volts. Of course, the best way to peak the I.F. transformers is with an oscillator. If this is not available, connect ground wire to post (2). Connect post (27) to the control grid of the 1st R.F. tube of the broadcast receiver. Put two similarly colored short wave coils in the converter. Connect post (28) to the chassis or ground of the broadcast set. Turn on converter and set, tuning the latter to a position where WEAF (or station of approximately similar wavelength) usually comes in. Turn set volume all the way up and have volume control (8) of converter similarly adjusted. Connect the antenna wire to the cap of tube (23) and adjust I.F. transformer (26) for loudest volume. Put screen grid clip back on tube (23) and connect antenna wire to cap of tube (15). Adjust I.F. transformer (16) for loudest signal.

Leave the broadcast receiver as it is and connect the antenna to post (1) of the converter. The latter is now ready to operate by tuning the variable condensers (4, 12) and (19). Equalizer condensers (4A) and (12A) should be adjusted for loudest volume. Crowe No. 88 tuning units help to bring in "hard-to-get" short wave stations.

LIST OF PARTS REQUIRED FOR FIND-ALL S-W CONVERTER

- 1—Cardwell Two-Gang "Midway" Variable Condenser, .00015 mf. each section, "Featherweight" type 405-B Double (4, 12)
- 1—Cardwell "Midway" Variable Condenser (single), .00015 mf., "Featherweight" type 405-B (19)
- 2—Sets Alden Short-Wave Plug-In Coils—4 coils per set covering bands from 20 to 200 meters (3, 11)
- 1—Set 4 Special Oscillator Coils (See Winding Directions) (20-A,B,C,D)
- 1—Electrad tapered Volume Control, 15,000 ohms, type RI-201-P (8) with Switch (34) Clarostat
- 1—Electrad 5000 ohm Truvolt Wire-Wound Resistor, type B-50 (38)
- 2—Hammarlund, 465 kc. Intermediate Frequency Transformers, complete with I. F. Coils, tuning condensers and shields, type TR-465 (16, 26)

- 1—Aerovox .00015 mfd., Mica Coupling Condenser, type 1460 (10) Polymet
- 4—Aerovox .01 mfd., 200 volt Cartridge By-Pass Condensers, type 281 (7, 13, 17, 24) Polymet
- 2—Aerovox 4 mf., 500 volt Dry Electrolytic Condensers, type G-5-4 (in TD cans) (30, 31) Polymet
- 2—Electrad 500-ohm Flexible Resistors, type 2G-500 (6, 25) Polymet
- 1—I. R. C. (Durham) 15,000 ohms, 1 watt Metallized Resistor, type F-1 (14) Lynch
- 1—I. R. C. (Durham) 20,000 ohms, 1 watt Metallized Resistor, type F-1 (36) Lynch
- 1—I. R. C. (Durham) 50,000 ohms, 1 watt Metallized Resistor, type F-1 (37) Lynch
- 1—Amperite Regulating Line Voltage Control, type 5A-5 (35)
- 1—Trutest Flush-Mounting Power Transformer, type 4C-1490 (33)
- 2—Hammarlund Equalizing Condensers, 2 to 35 mmf. (4A, 12A)
- 1—Hammarlund Isolantite R. F. Choke, type CH-8 (9)
- 2—Hammarlund Four-prong Isolantite Sockets, type S-4 (3, 11)
- 3—Hammarlund Triple-Grid Tube Shields, type TS-50 (5, 15, 23)
- 1—Hammarlund Screen Grid Tube Shield, type TS-35 (18)
- 1—Yaxley Two-Gang, Four position Selector Switch, type F-6514 (21, 22) Best
- 4—Eby "Ace" Binding Posts (1, 2, 27, 28) Cinch
- 1—Trutest R-196 Audio Choke, type 4A242 (29)
- 3—Na-ald Six-prong Wafer-type Sockets (5, 15, 23)
- 1—Na-ald Five-prong Wafer-type Socket (18)
- 2—Na-ald Four-prong Wafer-type Sockets (32, 35)
- 2—Crowe Short Wave Single Speed Tuning Units, No. 88—Ratio 14 to 1 in 180 degrees
- 1—Roll Corwico Braidite Hook-up Wire, stranded (Cornish Wire Co.)
- 1—Aluminum Chassis, 14 to 16 gauge, 12"x 11"x2" high—Blan, the Radio Man
- 3—Variable Mu R. F. Pentodes, type 58 (5, 15, 23)
- 1—Screen Grid 24-type Oscillator (18)
- 1—Full-Wave 80-type Rectifier (32)

Note: Numbers in parentheses refer to corresponding numbers marking parts on diagrams.

The S-W Fan's Own 3-Tuber

(Continued from page 661)

Radio Freq. Choke, R. F. C. 2, Hammarlund Short Wave Choke -85 M. H.
Audio Freq. Choke, A. F. C. 1, an old audio transformer; see text.

- 2 Knobs
- 2 Vernier Dials (National or other make)
- 2 Tube Shields (National) (Hammarlund)
- 2-4 Prong Sockets (Na-ald)
- 4-5 Prong Sockets (Na-ald)
- A Metal Panel and Chassis (Blan-the-Radio Man)

L1-L2-L3-L4 Coil data are given below. They are of the National type, with the exception of the forms, which are UY tube bases.

Data on National "Short Wave" Coils for use with the Short Wave Receiver

The secondary winding of the coils is shunted by 90 mmf. (.00009 mf.) variable condensers. Diameter of coil forms 1 1/2 inches:

- No. 10 coils, covering from 9 to 15 meters:
Secondary 2% turns of No. 16 Enamel
Primary 1% turns of No. 34 Enamel
Tickler 3 turns of No. 32 Double Silk.
- No. 11 coils, covering from 14.5 to 25 meters:
Secondary 6 1/4 turns of No. 16 Enamel
Primary 3% turns of No. 34 Enamel
Tickler 3 turns of No. 32 Double Silk.
- No. 12 coils, covering from 23 to 11 meters:
Secondary 11% turns of No. 18 Enamel
Primary 7% turns of No. 34 Enamel
Tickler 3 turns of No. 32 Double Silk.
- No. 13 coils, covering from 40 to 70 meters:
Secondary 19% turns of No. 18 Enamel
Primary 12% turns of No. 31 Double Silk
Tickler 4 turns of No. 32 Double Silk.
- No. 14 coils, covering from 65 to 115 meters:
Secondary 31% turns of No. 21 Enamel
Primary 21% turns of No. 31 Double Cotton
Tickler 4 turns of No. 32 Double Silk.
- No. 15 coils, covering from 115 to 200 meters:
Secondary 62% turns of No. 28 Enamel
Primary 38% turns of No. 32 Double Silk
Tickler 5 turns of No. 32 Double Silk.
- No. 16 coil. Range 200 to 360 meters:
Secondary 98% turns of No. 32 Double Silk
Primary 4 1/2 turns of No. 32 Double Silk
Tickler 7 turns of No. 32 Double Silk.
- No. 17 coil. Range 350 to 550 meters:
Secondary 167 turns of No. 32 Enamel
Primary 83 turns of No. 32 Enamel
Tickler 9 turns of No. 32 Double Silk.

5-Meter Waves Help Fire-Fighters

(Continued from page 650)

Talking down to the ranger in the fire tower, the pilot can also order additional men and supplies, if needed, as most of the towers have telephones.

Even during casual flights the pilot has spotted many small fires and has prevented them from growing to dangerous proportions by establishing radio contact immediately and getting a force of men on the job. Amateur short-wave stations have co-operated in this valuable work.

The entire radio apparatus in the plane is mounted on a wooden board, which slips behind the rearmost seat in the cabin. It is entirely out of sight, being remotely controlled from the pilot's position. The transmitter is tuned and left alone, only the receiver being adjustable. The transmitter uses two 12A oscillators and two 89 modulators, and obtains its plate supply from a 250 volt dynamotor operating on the plane's 12-volt storage battery. The receiver is a simple affair, using two 37's and one 89 in a super-regenerative circuit. Frequencies of 60 and 80 megacycles are employed.

The transmitting aerial is a fixed streamlined rod sticking out of the fuselage. A short wire inside the plane is used for receiving.

The sets are extremely rugged, and are mounted on stiff shock cords to take up the terrific strains experienced in landings. Of course every single part is securely mounted, as the vibration in a powerful plane is continuous and terrific. An ordinary radio set falls to pieces in a couple of days under the shaking and jarring.

The portable ground stations are ingeniously constructed to occupy a minimum of space. The receiver and transmitter are combined in a single cast aluminum case, which is set up on the top of the wooden carrying case as shown in an accompanying illustration. The lower part of the box contains a storage "A" battery and a bank of dry "B" batteries. This is by no means a "one-man" outfit, but a couple of husky fire-fighters can lug it through woods and brush without much trouble. The aerial is a Hertz di-pole made of brass tubing. *The whole outfit can be set up in about two minutes!* All this apparatus is made by the Radio Engineering Laboratories, of Long Island City, N. Y., well-known manufacturers of short-wave equipment.

The writer witnessed a demonstration of plane-to-ground communication with this set-up, and was greatly impressed by its smoothness and effectiveness. There is no tinkering or hair-splitting adjusting to do; the stations are intended for operation by Conservation Department officials, not by radio experts, and must work with the simplicity of a house telephone. When a pilot is busy watching a fire and keeping the smoke out of his eyes he doesn't want to worry about tuning dials and the like!

Other uses for practical mobile equipment of this kind suggest themselves. Police officials are particularly interested, since the present radio-alarm systems, being one-way only, leave a lot to be desired under many circumstances. For recovery of drowned persons or submerged objects, the plan is to have a plane or dirigible circle overhead slowly, watching for the shadow of the body (which is often surprisingly plain from above), while a party in a boat does the actual grappling. With a "portable" in the boat, communication is direct and rapid and the body or object may be found very quickly. During the World War submarines were often spotted by planes in this way.

HARRISON RADIO CO.
 QUALITY MERCHANDISE ★ LOWEST PRICES ★ REAL SERVICE ★ EVERYTHING GUARANTEED

Now!

The Improved Doerle 12,500 Mile Two Tube Short Wave Receiver

\$4.75



The sensationally popular DOERLE 12,500 MILE receiver—improved—refined—and available in complete kits that are so easy to assemble! Read the letters in Short Wave Craft from constructors of this remarkable two tube receiver, praising its exceptional performance. Many are from purchasers of our modernized kit!

Our Engineering Department incorporated new features such as velvet regeneration control with no detuning effect, ultra low loss condensers of advanced design, friction drive (no back-lash) vernier dial for easy tuning, metal chassis and panel for efficient shielding, eliminating hand capacity, and other carefully selected and tested refinements, resulting in a receiver that by far outperforms the original!

These kits contain every necessary part of highest quality. All high frequency insulation is genuine Bakelite. The coils, which tune from 15 to 115 meters are wound on polished Bakelite forms. The sockets are Bakelite. All losses are minimized! The attractive crystal finished chassis and panel has all holes needed to mount the apparatus and the, together with our complete, detailed instruction sheets, simplifies construction.

Only by purchasing in large quantities are we enabled to offer these neat, professional appearing sets at such an amazingly low price! And the parts are all first grade, too!

DC MODEL

Uses two 230 tubes. Batteries required are two dry cells (for a 2-volt storage cell) and two 45 volt B Batteries. If you have a 6-volt storage battery you may use 201-A's.

COMPLETE KIT \$4.75
 Coils Wound 50c extra

ACCESSORIES

2 1/2 volt Filament Transformer, 95c. Heavy Duty, \$1.35. RCA licensed TUBES. Fully guaranteed for three months. 230-75c, 201-A-39c, 227-45c, 56-60c, 2N0-45c. Other types at lowest prices. Large Dry Cells-25c. Large 45 volt B Batteries-80c. Imported light weight Phones-\$1.35. Better grade, very sensitive, \$1.75.

AC MODEL

Uses two of the new type 56 tubes or two 27's. Power is obtained from the Model ED pack listed below or from any good eliminator delivering 90-200 volts and 2 1/2 volts. Or it may be run on a 2 1/2 volt filament transformer and two 45 volt Batteries.

COMPLETE KIT \$4.95
 Coils Wound 50c extra

Either set or power pack completely wired and tested—\$2.25.

MODEL ED Power Pack—Delivers all power for AC Receiver. Uses transformer and extra filtering insures quiet reception on short waves. Plug into 110 volt, 60 cycle house line. Stamped metal chassis. Uses a 280 tube.

COMPLETE KIT \$4.85
 For 110 volt, 25 cycle—\$5.85

The Old Reliable ROYAL SHORT WAVE RECEIVERS

Now Use "TRANS-X" Coupling

They were good before — NOW THEY'RE EVEN BETTER!



Features that really mean something—Screen Grid Detection and Pentode Audio with "TRANS-X" Coupling (An exclusive Royal development insuring maximum transference of energy and high signal gain)—Smooth regeneration control—Dual Ratio Full Vision Dial (60:1 for ultra-fine tuning)—Large plug-in coils covering from 14 to 200 meters—Amateur band spread coils available—Completely enclosed and totally shielded by an attractively finished art metal cabinet with hinged cover—Correctly designed and carefully constructed of the finest materials (not just thrown together to sell at a price!).

ORDER YOUR ROYAL TODAY AND SEE WHAT A REALLY GOOD RECEIVER CAN DO!

— ROYAL STAR — (The famous Model RP)

A two-tube with a sterling pedigree. This remarkable receiver is not to be confused with poorly designed sets cheaply thrown together to sell at "bargain" prices! Uses one type 232 super-sensitive detector and a type 283 power pentode.
 List Price \$25.00
\$14.70
 Complete Kit \$11.76
 Set of ROYAL Short Wave Tested Tubes \$2.55

AC STAR

Uses one of the new type 58 super-control screen grid pentodes, a 247 pentode audio amplifier, and a 2N0 rectifier. Especially designed for humless, quiet operation on Short Waves. Ready to plug into AC line.
 List Price \$40.00
\$23.52
 Complete Kit \$20.58
 ROYAL Tested Tubes 2.15

— ROYAL CHIEF —

A knock-out three-tube set embodying all the well known features of the STAR, plus a stage of high gain type 232 screen grid radio frequency amplification.
 List Price \$30.00
\$17.64
 Complete Kit \$14.70
 ROYAL Tested Tubes 3.75
 Full Set of Batteries for any ROYAL 3.95

AC CHIEF

THE AC STAR with an additional type 58 used as screen grid radio frequency amplifier.
 List Price \$45.00
\$26.46
 Complete Kit \$23.52
 ROYAL Tested Tubes 2.95

ENORMOUS STOCK OF RADIO SUPPLIES

If we haven't got it, we will get it for you AND SAVE YOU MONEY!

ROYAL OLYMPIC:

A four-tube receiver that absters all records for performance, quality, and price! Utilizes the basic structure of the ROYAL STAR, but incorporates a high gain screen grid R.F. amplifier stage and an additional booster Class A audio amplifier tube for super dynamic power. A separate control to modulate the signal down to any desired level is another feature. Uses two 232, one 230, and one 283 tubes.
 List Price \$35.00
\$20.50
 Complete Kit \$17.50
 ROYAL Tested Tubes 4.50

— AC OLYMPIC —

A De Luxe AC operated receiver employing two 58, a 56, a 47, and a 280.
 List Price \$50.00
\$29.40
 Complete Kit \$26.40
 ROYAL Tested Tubes 3.60

ROYAL Appearance may be copied — but ROYAL Performance cannot

SEE JANUARY Page 559 And FEB. Page 619 For Some Real Bargains!

Send for CATALOG!

REMEMBER!—We are national distributors for the following lines and we can supply all your radio material at REAL WHOLESALE PRICES—
 Royal, Universal Microphone, Jewell, Eby, National, Mayo, Weston, Reardite, Hammarlund, Cardwell, Burgess, etc., etc.

SEND YOUR ORDER NOW OR WRITE FOR PRICES.
 Prices F. O. B. New York.
 Deposit Required.
 VISIT OUR SALES ROOMS. One block south of Cortlandt Street.

HARRISON RADIO CO.
 ★★ THE HOME OF FOUR STAR SERVICE ★★
 Dept. C-17 New York City
 142 Liberty Street

"HAM" ADS

Advertisements in this section are inserted at 5c per word to strictly amateurs, or 10c a word (8 words to the line) to manufacturers or dealers for each insertion. Name, initial and address each count as one word. Cash should accompany all "Ham" advertisements. No less than 10 words are accepted. Advertising for the April issue should reach us not later than Feb. 18.

FIVE SHORT WAVE BLUEPRINTS. SEND 25c (coin) for these five real DX getters. Super Engineering, 1313-40th Street, Brooklyn, N. Y.

SHORT WAVE LISTENERS CARDS, JUST what you need for reporting the stations you hear. Write for free samples today. WIBEF, 16 Stockbridge Ave., Lowell, Mass.

SWAP. NEW STEWART-WARNER Converter and R. C. A. Teleplex. What have you? Joe Frasketi, Weirton, W. Va., No. 473.

PLUG-IN COILS. LOW LOSS, 14-200 M. AND R. F. choke \$1.00. M. Carney, 2041 So. Kensington Drive, Toledo, Ohio.

WORLDWIDE KNOWN SESSIONS ELECTRIC mantel or desk clock, for D. C. and A. C. current, beautiful design, black and silver, raised numerals, bent glass, \$1.65, parcel post, prepaid U. S. A. Gold Shield Products Co., 112 Chambers St., New York City.

BELGIAN, JEWEL STOPPANI COMPASS, made of phosphor bronze, fitted in hard wood case, 4x4, may be used as a galvanometer, for detecting electric currents in experimental or conventional radio apparatus. Ideal surveyors and sportsman instrument with elevated sights (worth \$30.00) \$4.50, parcel post, prepaid in U. S. A. Gold Shield Products Co., 112 Chambers St., New York City.

SENSATIONAL MICROPHONE VALUE—UNIVERSAL model "Y"—Experimenters single-button, watch model type, 200 ohms. Pure gold spot center diaphragm. Only \$2.00, including valuable 1933 general catalog with diagrams. Universal Microphone Co., Ltd., Inglewood, California.

I—\$18.00 CROSSMAN AIR GUN. \$7.50. \$75.00 Victoreen B.C. Superheterodyne, 5 volt D. C. model, 8 tubes, for \$15.00, includes Weston meter. I National B.C. Screen Grid Tuner (110 v. A.C.) and Thordarson Power pack, 8 tubes, make offer. 1—6 foot R.A.C. Victor Exponential Horn with electric pick-up, make offer. Satisfaction guaranteed. Dataprint Company, Ramsey, N. J.

TRANSFORMERS REWOUND OR BUILT TO your order. Speaker field coils. Pembler Laboratories, 921 Parkview, Fort Wayne, Ind.

PLUG-IN COILS ON BAKELITE FORMS, 15-200 meters, four for 75c coat paid, WIBTE, 455 North Warren Ave., Brockton, Mass.

PLUG-IN COILS. SET OF FOUR WOUND on bakelite four prong forms, 75c. Tune 15-210 meters with .0001 condenser. Noel, 419 Mulberry, Scranton, Pa.

TUBE BASES, FOUR OR FIVE PRONG, bakelite, 1 1/4 inch outside diameter. Brand new merchandise 5c each. Noel, 419 Mulberry, Scranton, Pa.

CODE MACHINES, TAPES AND COMPLETE instruction for beginners or advanced students—both codes—for sale or rent, very reasonable. Rental may apply on purchase of new equipment. Special offer to amateurs. Extra tapes for all machines. Instructograph, Dept. S, 912 Lakeside Place, Chicago.

SHORT WAVE CONSTRUCTION KITS, SETS, Supplies. Wholesale Catalog 5c. Federal Radio & Telegraph Co., 4224 Clifford Road, Cincinnati, Ohio.

SELL PILOT AC SUPERWASP COMPLETE, tubes, powerpack, cabinet, coils, fifteen to five hundred meters, forty dollars. Ben Erickson, Whitehall, Wis.

CELLULOID ULTRA SENSITIVE PLUG-IN Coils, set four 19-210 meters \$1.00. Any band 25c. Free circuits. Modern Radiolabs, 1508 23rd Ave., Oakland, Calif.

ANSWER FACTORY CAN HELP YOU WITH that receiver, transmitter, antenna. Send problem and ask for quotation. All work supervised by Robert S. Kruse, RFD No. 2, North Guilford, Conn.

SHORT WAVE RECEIVERS, ADAPTERS, power-packs, described in SWC or other magazines, built to order, wired. Send specifications for estimate. Lowest prices. All work guaranteed. V. Narvydas Radio Service, 542 Lorimer Street, Brooklyn, N. Y.

TRANSMITTING PARTS BOUGHT, SOLD, traded. Bulletin 3c. Spear Company, Waterville, Ohio.

What Say, Gang?

Editor, SHORT WAVE CRAFT:

Ever since I began reading SHORT WAVE CRAFT I thought I had better comment upon such a very "FB" magazine. I have not seen very many letters from Canadian readers, so I take this opportunity to let you know just how your magazine was getting along in Canada. To make a long story short, "it's the berries." I like it because of its very instructive contents which are so helpful to all who are interested and it sure lives up to the name "The Radio Experimenters' Magazine."

I have been off the air now for a month or so, during which time I have been rebuilding all my apparatus. I might say that I have been busy building my new 5-tube all A. C. receiver, which I think is "FB"—if I say so myself.

The reason I mention this is because I thought perhaps others would like to see just what kind of an outfit I'm using as a receiver here at the "shack." There are several novel ideas incorporated in the receiver which I think would appeal to all who want to build an all A.C. "ham" set. What do you say, gang? Would you like to get all the dope on it? If so get your letters into the editors and I'll do my part.

I'm satisfied now that I've got something off my chest, so I'll not take up any more room in your "mag." and let someone else say something for a change.

I'll be waiting around for your next issue so I can see this in print and would like to say again that

Jimmie ham was puzzled.

We sat back and laughed.

But Jimmie's no more puzzled

He bought a SHORT WAVE CRAFT.

Best 73's to you and thanks.

FLOYD GRIBBEN, VE3LR,
98 Glendale Ave.,
Toronto, Canada.

(Let us have the dope on your new five-tube A.C. receiver, Floyd, as we are sure that all SHORT WAVE CRAFT readers and fans will be glad to hear all about it. We do not believe in publishing every five-tube receiver that comes down the pike but we do believe that five tubes are capable of doing some mighty fine work in a short-wave receiver, if they are properly used. So here's hoping you will send us the "low-down" with diagram, photos and the "whole works" soon.—Editor.)

A "Wire-less" Lead-in

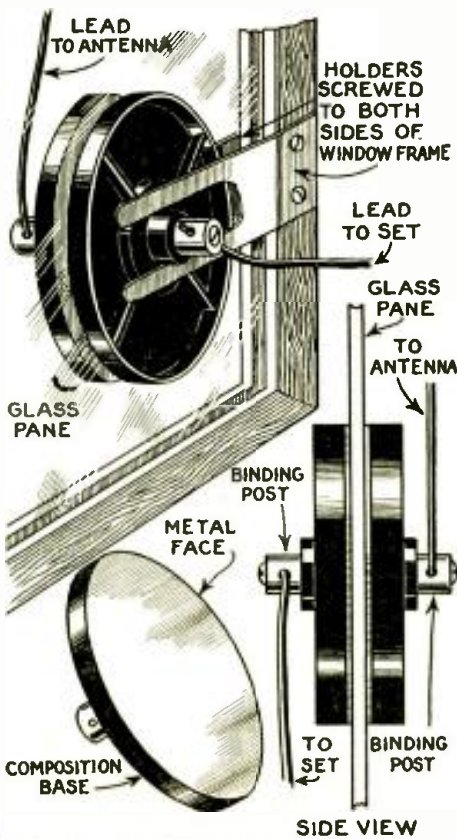

Latest "Wire-less" Lead-in from Germany

A Condenser "Mike" for 10 Cents!

(Continued from page 665)

611". Here is work to be done. And work of such a nature that you had best take it to a machinist, although some of you are perhaps prepared to do it yourselves. This inner wall must be machined down, leaving the external small ring intact. It should be turned out to a depth of .01", PLUS the thickness of your backplate. For instance—if you have a backplate of .05", the wall should be turned down to a depth of .06". Thus when the backplate is put in place, there will be a space of .01" between its face and the top of the adaptor, or, in the case of the finished mike, between it and the diaphragm. Now you see how this external ring acts as a spacer between the backplate and the diaphragm.

Cap to Have Larger Hole

When you are having this work done, you may as well have your machinist turn out the cap, too. This is turned out from the center, so that the hole is exactly centered, to a diameter of 19/16 inches, so as to fit over the top of the adaptor when the mike is fully assembled. When the mike is assembled, the diaphragm, cut so as to just fit in the cap, is placed over top of the adaptor, and when the cap is screwed down the diaphragm is stretched quite tightly. But we are getting ahead of ourselves.

Assembly of "Condenser Mike"

After the cap and adaptor are machined out, the next step is to assemble the adaptor, backplate, and case units. The backplate is made ready for assembly by soldering, as in the diagram of Fig 2, a flatheaded screw exactly in the center of the back of the backplate. This screw must be long enough to go through the back of the headphone case when the adaptor and case are put together. Now drill a hole in the exact center of the back of the case. Inasmuch as the case is of metal (it must be, to give us a connection to the diaphragm), this hole must be large enough so as to prevent the screw from "shorting" against the case. Now obtain either an insulated washer large enough to cover this hole, or bolt a strip of bakelite across the back of the case, with a hole in its center to accommodate the screw; the method used by the author. This done, mount the backplate and adaptor, and place a nut on the portion of the screw projecting from the back of the case. Tighten it down, tight enough to hold the backplate assembly firmly in place, but not so tight as to buckle the backplate. This would not do. After obtaining the correct tension here, it is advisable to solder the nut in place, so as to prevent loosening or turning. Now screw another nut in place, for establishing a connection between the backplate and its terminal equipment. The other connection may be made at any place on the metal case of the mike.

The condenser mike is now practically finished, the only remaining operation being to put the diaphragm in place and stretch it, by screwing it down with the cap. Screw the cap on just as tight as it is possible to get it, making sure, however, that the diaphragm does not buckle during this process. The tighter it is, the better the voice quality will be. As was said before, the best diaphragm to use is one of Duralumin, of about .002" thickness. Whatever you use, it must not be over .002", and do not try to use tinfoil!

A cross-section view of the mike is shown in Fig. 3.

Now that the head is ready to be mounted we will discuss some of the circuit requirements of the condenser mike.

Mike Should Be in Shielded Box

The first point to be considered is that the head must be mounted in a heavy shielded box of some sort. Otherwise pick-up of external interference will be greater than the voice pick-up. It is absolutely

(Continued on page 701)

TRAIN WITH R.T.A. TO BE A

Professional
RADIO MAN

THE TINKERER'S DAY IS DONE!

It's vital that you become a Radio technician through R. T. A. teaching NOW! New, complicated circuits . . . all require professional service men. Their future is unlimited. And R. T. A. can place you in their ranks quickly—easily—and surely through interesting home study that's understood by anyone who can read English.

**SET ANALYZER—
AT NO EXTRA COST**

Included with R. T. A. Training is this excellent set analyzer and trouble shooter. After a few lessons you will know how to use it, and it becomes an immediate means of earning as you learn. Many R. T. A. students make far more than enough to pay for their training by spare time service work, using this analyzer. In addition, R. T. A. gives you life membership in a great radio service men's association with the privilege of consultation on "tough" problems at any time, and an employment service that works to keep you at work.



WONDERFUL OPPORTUNITIES NOW!

You don't have to wait for a dim and distant future as an R. T. A. professional Radio Technician. Even though there was never another receiver built—even though all the tremendous progress in this gigantic industry stopped—there would be enough work in conditioning and reconditioning the sets now in operation to assure you a good living. Look into this great field of professional radio service work. Learn, too, of the many other glowing opportunities open to true Radio-technicians in this field. Fill out and mail the coupon—it will bring you FACTS that will surprise you—and that may open up for you a permanent way out of depression and job-fear.

FILL IN—MAIL TODAY

RADIO TRAINING ASS'N. OF AMERICA,
Dept. SWC-3 4513 Ravenswood Ave., Chicago, Ill.

Send me the FACTS about R. T. A. professional training, together with information about the opportunities in the radio service field, without obligation to me.

NAME.....

ADDRESS.....

PRECISION BUILT!



Actual photograph showing relative sizes of watch and Midway condenser. The condenser is a Midway Featherweight 2 gang condenser for broadcast receivers, 375 mmfd. per section 3 3/4" long (back of panel) 3" wide and 2 1/2" high (with plates extended), weight 8 oz. Note sturdy construction.

The precision-built CARDWELL Midway "Featherweight" is different from the usual small size condenser—as different as a fine timepiece is different from a dollar watch. The goodness is built in—to stay, because skilled artisans—not rivet presses—are employed in assembling all CARDWELLS.

Midway condensers are made for both transmitting and receiving, single and double or split-stator. Send for literature describing many other CARDWELL condensers, for receiving and for transmitting on high or low power.

The Allen D. Cardwell Mfg. Corp'n.
85 Prospect Street, Brooklyn, N. Y.

"THE STANDARD OF COMPARISON"

**PATENTS TRADE MARKS
COPYRIGHTS**

Consult us about how to protect your ideas. Send today for our FREE book—"How to Obtain a Patent" and FREE "Record of Invention" blank. We have successfully served thousands of inventors. Highest references—prompt service—reasonable charges—deferred payments.

VICTOR J. EVANS & CO.

Registered Patent Attorneys—Established 1898
651CC Victor Building, Washington, D. C.

The Beginners 2-Tube "Go-Getter"

(Continued from page 651)

is finally assembled, in order to have it read exactly 100 at the maximum capacity setting of the tuning condenser. Finally fasten the panel to the baseboard by means of the two screws at the bottom of the panel.

The next step is to mount the tube sockets, the coil socket and the audio transformer on the baseboard. The audio transformer is mounted at the extreme left corner of the baseboard (you are looking at the rear of the receiver) and fastened securely. Next mount the sockets for the audio and detector tubes. The detector tube socket must not be placed closer than two inches to the audio transformer as the iron core will cause serious radio frequency losses in the detector circuit. The audio tube socket is placed with the "G" and "P" terminals toward the left corner of the base-board, while those of the detector socket face the right corner. This method of mounting allows much shorter wiring than would be possible with any other method.

Position of Coil Is Important

We now come to the most important item in the whole job of construction—placing the coil and its socket. The coil must not be placed closer than two inches to any of the parts in the circuit or the losses mentioned above will rob the receiver of its efficiency. The socket is mounted on one or two bushings (depending on the type of socket used), one-half to one inch high, and placed with the "G" and "P" terminals facing the rear of the base-board. Place the by-pass condenser (C5), flat on the base-board, as close as possible to the Resistograd and fasten it securely.

Wiring a Simple Matter

We are now ready to wire the set. Use either the flexible hook-up wire or the usual No. 14 tinned bus wire. Solder all the connections by using a hot soldering which is clean! Be sure all wires to be soldered are scraped clean! Always use the rosin-core solder and the least amount that will make a good contact. Do not use metal clips or "lugs" but solder direct to the metal parts. The wire from the grid terminal of the detector socket to the grid condenser must be short (one-half inch at the most). All the other wiring must be as short and as direct as possible. Avoid making sharp bends or turns. A complete wiring diagram is shown in Fig. 3.

The grid condenser (C2) and the plate by-pass condenser (C-4) are supported by the wiring. If the 5 megohm grid leak is of the "pig tail" type it can be soldered directly into the circuit. Do not run the grid and plate leads parallel with each other!

While short wiring of the audio amplifier is desirable, it is not absolutely necessary. These wires are carrying battery and audio frequency current and may be up to several inches in length without causing appreciable loss in efficiency.

Constructing the Plug-in Coils

After the set has been completely wired we will proceed with the construction of the plug-in coils. These are wound on discarded UX tube bases. Five are required to cover the short-wave spectrum from 10 to 100 meters. The specifications for the complete set of coils are as follows:

Band	Turns		Size Wire
	on L1	on L2	
10-20 meters	3	2 1/2	No. 24 D.C.C.
20-30 meters	6 1/2	5 1/2	No. 24 D.C.C.
30-43 meters	6 1/2	8 1/2	No. 24 D.C.C.
40-65 meters	10	14	No. 24 D.C.C.
60-100 meters	10	29	No. 24 D.C.C.

The amount of turns necessary to cover a specific band of frequencies varies to a certain extent in different receivers due to the distributed capacity and inductance of

the wiring. If the circuit does not oscillate easily, remove or add a turn at a time until stable operation is secured. The grid coils listed above give a lap of about five points on the dial, with the Cardwell set for maximum capacity.

Wind the tickler (L1) first, to the correct number of turns and then solder the ends of the coil to the small pins of the tube base. The wires are pushed down inside the pins—the top of the tickler in the left or grid pin and the bottom of the coil in the right or plate pin. Now wind the grid coil to the required number of turns, in the same direction as the tickler. This is very important. If the coils are wound in opposite directions the circuit will be neutralized—a non-oscillating condition. The ends of the grid coils are soldered into the large pins in the same manners as the tickler—the top of the grid coil in the left or negative filament pin and the bottom of the coil in the right or positive filament pin. The spacing between the grid and plate coils is one-quarter inch.

Check over the set with Fig. 3 in order to make sure everything is O.K. Then connect a couple of dry cells in the "B" battery wires. Turn the rheostat up slowly, at the same time watch the tubes for signs of illumination. If the tubes light up it is a sure sign that there is a mistake in the wiring. In case of this refer to the diagram, Fig. 3, and go over the set until the trouble is located. If the tubes do not light up under the above conditions it is safe to assume that the set has been properly wired and is ready for operation.

Connect the batteries as shown in Fig. 3. Place the coil in its socket, turn the plates of the antenna condenser all out, set the regeneration control nearly at maximum and slowly turn up the rheostat. The tubes should light up, although the type 30 tube does not burn brightly. As the rheostat is turned about two-thirds way up a hissing sound should be heard in the headphones. This indicates that the set is oscillating. Now connect the antenna and ground wires to their respective places, adjust the "midget" condenser to just below the point where the receiver stops oscillating and rotate the tuning dial. After the signal is tuned in adjust the regeneration control for maximum volume. The rheostat should not be turned higher than the point where oscillation begins as the life of the tubes will be greatly reduced if they are run at too high a temperature.

When hunting for foreign stations and DX reception, remember that the time of day is extremely important. The European stations are generally received best in the afternoon, the Australian VK2ME around 6 to 8 a. m. in the morning, while the U. S. and Canadian broadcasters roll in at almost any hour of the day or night. The set is most sensitive to DX signals when it is barely oscillating.

List of Parts for Hooton "Go-Getter"

- C1—Cardwell tuning condenser, 2 plate, 201E Type (adjustable stator; range 10 to 50 mmf.)
- C2—Sangamo fixed condenser, .0001 mf. (Polymet)
- C3—Midget antenna condenser, Pilot .00001 mf. (Polymet)
- C4—Sangamo fixed condenser, .002 mf. (Polymet)
- C-5—By-pass condenser, 1 mf. (Concourse)
- L1, "T"—Tickler coil, see text
- L2—Grid coil, see text
- R1—5 meg. grid leak (Lynch)
- R2—Filament rheostat, 20 ohms
- R3—Pilot Resistograd, any 0-500,000 variable resistor will do (Clarostat)
- '30—Ux230 type tubes, Radiotron or Cunningham
- AFT—Audio frequency transformer, 3 1/2 to 1 ratio

(Continued on page 693)

The "Challenger" 9-Tube Superhet

(Continued from page 669)

- R12, R15—I. R. C., 1 meg., 1 watt metalized resistors, type F1 (Lynch)
- R13—Electrad tone-control potentiometer, 1 meg., type RI-206 (Clarostat)
- R14—Electrad volume control potentiometer, 250,000 ohm, type RI-208-P with switch SW1
- R16—I. R. C. 50,000 ohm, ½ watt metalized resistor, type F½ (Lynch)
- R17—I. R. C. 50,000 ohm, ½ watt metalized resistor, type F½ (Lynch)
- R18—I. R. C. 40,000 ohm, ½ watt metalized resistor, type F½ (Lynch)
- T1, T2, T3, T4—Gen-win I. F. Transformers, 465 kc.
- R19—225 ohm, 10 watt Atlas resistor (Kroblak)
- R20—Electrad or Atlas 25,000 ohm, 10 watt Resistor (Kroblak)
- T5—Trutest filter choke, 30 henry, 125 mil
- BP1, BP2—Eby binding posts (Cinch)
- J1—Pilot 1165 phone jack (Polymet)
- V1—Arcturus 57 type pentode tube—6-prong wafer-type socket (RCA)
- V2, V3, V4—Arcturus 58 type variable-mu pentode tubes—6-prong wafer-type sockets
- V5—Arcturus 124 screen-grid tube—5-prong wafer-type socket (RCA)
- V6, V7—Arcturus PZ power output pentode tubes—5-prong wafer-type sockets (RCA)
- V8—Arcturus 56 oscillator tube—5-prong wafer-type socket (RCA)
- V9—Arcturus 180 full wave rectifier tube—4-prong wafer-type socket
- T5—Trutest power supply transformer, type 4C 1,510
- L1-L2—Combined antenna tuning coil and oscillator coil, wound as per directions given in sketch. Three sets of coils required, each mounted on 6-prong plug

- Socket mounting for plug-in coil—6-prong (Na-ald)
- Pilot No. 275 phone plug for phone jack (Polymet)
- Metallic coupling to gang C1 and C2
- Five Hammarlund triple-grid tube shields, type TS-50
- One Hammarlund screen-grid tube shield, type TS-35
- Two 11-lug Cinch resistor mounting strips
- Eleven 5-lug Cinch resistor mounting strips
- One coil Corwico Braidite hook-up wire
- One Crowe No. 90 two-speed wedge drive tuning unit, type 90/58
- One Magnavox Dynamic Speaker with 1,000 ohm field and with output transformer matched to pentodes in parallel or single '45
- One five-prong wafer-type socket for speaker connection
- One Blan aluminum chassis, 18"x10"x3" high, 16 gauge, Blan-the-Radio-Man
- One Blan aluminum shield, 9¼"x6¼"x5½" high

In Next Issue!

All-Purpose Receiver—can be used as wavemeter, monitor, etc.

An Improved S-W Super-regenerator, with 3 stage Audio Amplifier.

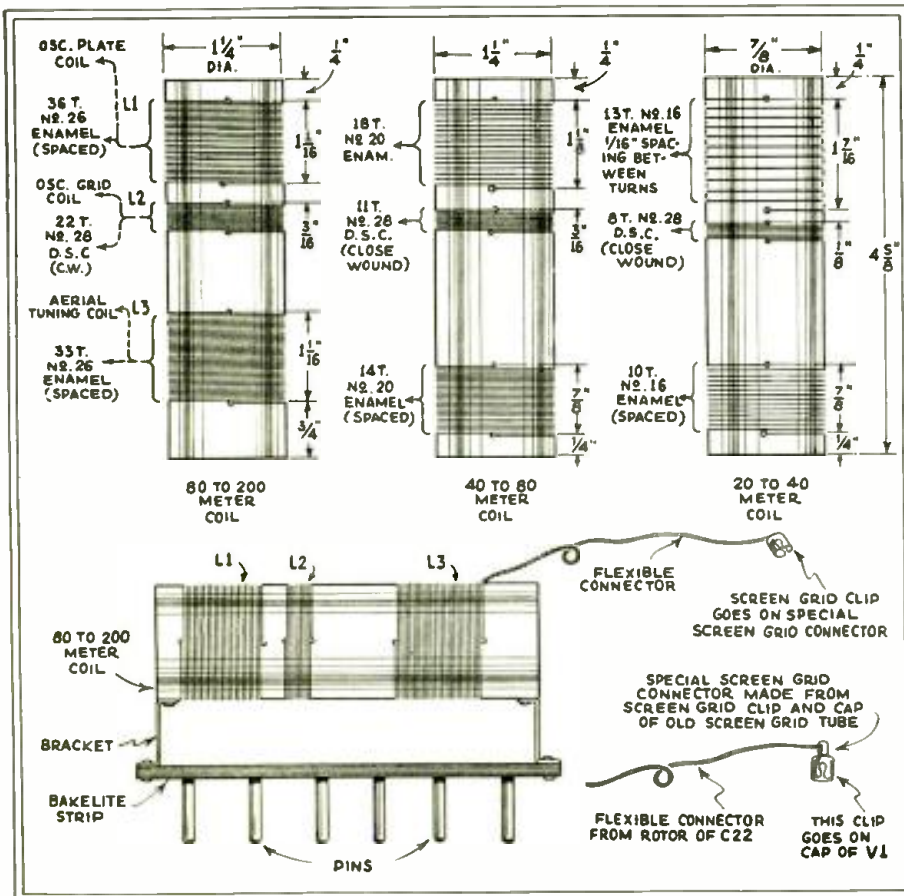

Details of plug-in coils for 9-tube Superhet.

Short Wave Parts

- Short Wave Coils
 - Set 4 plug-in coils for .00014 mfd. cond. ----- \$1.50
 - Set 3 precision coil with variable primary ----- 4.50
 - Hammarlund Short Wave Condensers, new type
 - .00014 mfd. ----- .95
 - .0002 mfd. ----- 1.05
 - R. F. Chokes
 - 50T duolateral chokes ----- .12
 - 300T duolateral for Set Plate SW ----- .20
 - 800T duolateral ----- .30
 - Audio Trans.
 - Pilot, Bakelite case 3 1/2 to 1 ----- .40
 - Samson Symphonic. List \$12.00 ----- 1.25
 - Two tube short wave kit, 15 to 200 meters, using Hammarlund condensers, plug-in coils, including 2 RCA or Eveready 230 tubes and blueprint, less the batteries and phones ----- 7.50
 - Resistors; all values; 1 watt and ½ watt; R. M. A. standard ----- .05
 - Potentiometer with AC switch; 5,000, 10,000, 25,000, 50,000, 250,000 ohms ----- .50
- We can supply any radio part or replacement on any commercial receiver a 10% less than any other mail order house. The reason for our low prices lies in the fact that we do not put out an expensive catalog. Send us your radio requirements

ROLAND RADIO CO.

35 Hooper Street Brooklyn, N. Y.

Your copy is ready.

HEADQUARTERS FOR RADIO REPLACEMENT PARTS—SPECIALISTS IN "HARD TO GET" ITEMS.

HAM SUPPLIES

BALTIMORE RADIO CORP.
725 BROADWAY Dept. 8 NEW YORK

Send for it today

A CONDENSER MICROPHONE at the right price

Nothing better for broadcasting and P A installations where highest quality reproduction and sensitivity are desired.

Model S-2
\$65.00 NET

Handsome crackle enamel finish. Comes complete with 2 stage amplifier and 25 ft. cord. Actually more sensitive than any other type and performs better than any carbon type microphone. Get our latest Catalog on Sound Equipment, Microphones and Accessories.

SOUND ENGINEERING CORP.
416 N. Leavitt St. Chicago, Ill.

FREE RADIO CATALOG

Write for this Big Free Book Today

The most complete line of radio sets, service men's supplies, replacement parts, test equipment at the lowest wholesale prices

ALLIED RADIO CORPORATION
837 W. Jackson CHICAGO

THE WHOLE WORLD SPEAKS—

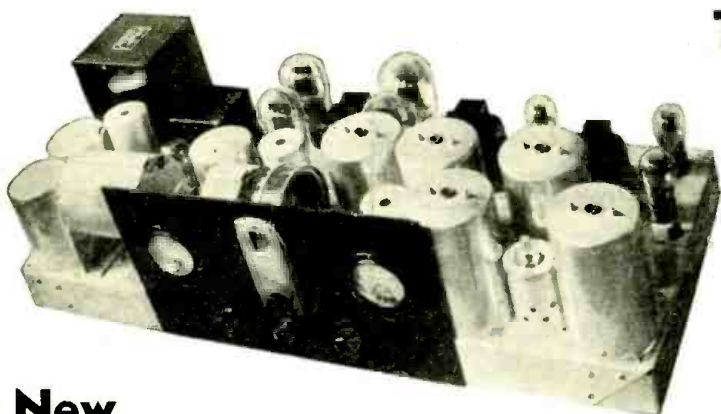

Thru

The New

ADMIRALTY SUPER-15

MULTI-WAVELENGTH SUPERHETERODYNE

In design and engineering, the world's most advanced Radio Receiver. This great new 16-Tube Model opens up a vast new stage of magnificent entertainment.

Dependable long distance reception with the lure of overseas programs via short waves, as well as your favorite broadcasts as they originate at the station. This is the true Romance of Radio that awaits you.

The Admiralty Super-15 provides the maximum in sensitivity, selectivity and quality of reproduction ever promised.

Complete literature sent on request. Address

NORDEN-HAUCK ELECTRIC & MFG. CO.

402 Cherry Street, Philadelphia, Pa. U. S. A.

"Builders of the Highest Class Radio Apparatus in the World."

How Altitude Variations in K-H Layer Were Recorded

(Continued from page 685)

110 kilometers for the wave of 1,600 kilocycles (187.5 meters).

120 kilometers for the wave of 2,000 kilocycles (150 meters).

130 kilometers for the wave of 3,000 kilocycles (100 meters).

250 kilometers for the wave of 5,000 kilocycles (60 meters).

2. That the height of the layers undergoes a diminution at the moment of sunrise and an increase at its setting (increase and decrease reaching sometimes 60 and 70 per cent).

3. That at less than 60 meters wavelength (more than 5,000 kilocycles) no reflection is produced during certain seasons. Thus from February to April, for example, the reflections are numerous for the 8,650 kilocycle waves (34.7 meters), while in August and September no reflection has been observed.

—L'Anetenne.

S-W Beginner

(Continued from page 657)

ated models. In making these receivers, we have tried to gradually build up a knowledge of the subject, so that we know the reason why each part is used and how it is connected. Up to this time, though, we have made our sets entirely from wiring diagrams that show pictures of the parts.

There is another type of wiring picture used by radio men, called a *schematic diagram*. In this type of wiring picture, symbols are used instead of pictures of the parts. The advantage is in the simplicity with which the various parts can be shown; and in the clarity with which the circuits can be followed. For example, while we know that a transformer contains two windings separated by insulation and enclosed within an iron core, the picture diagram does not show this. It merely shows a box with four terminals to which the connections are made.

The schematic, on the other hand, shows two parallel coiled lines, separated by three straight lines. The coiled lines represent the windings, while the straight lines represent the core. The ends of the coiled lines are attached to the lines representing the connecting wires. In this way, the path of the currents can be followed.

In the next issue, we will go further into the intricacies of schematic wiring diagrams. After you have learned what the various symbols represent, and how they are shown in the diagrams, you will, without doubt, choose this type of diagram in the next set that you build. If you are interested in examining a schematic hookup, look at bottom of page 651.

Ultra-Short Waves in Medicine

(Continued from page 647)

In the case of the short wave process we can bring about, by proper placing of the plates, an effect that is equally strong in all strata of a part of the body, and in fact this is the case when the plates are a few centimeters distant on both sides from the surface of the body. If we bring the plates close to the skin, there results a certain drop in the depth effect, though by no means in such a degree as with diathermy. The distance between the electrodes and the skin I produce by using so-called "electrode shoes"; glass cups which are put over the electrodes. Between the bottom of the glass cup and the electrode, glass rings are put in, which produce the correct distance, according to their thickness (Fig. 1). If the effect is

BIGGER VALUES AT LOWER PRICES!!!

A Real Outfit for "Ham" Equipment

700 Hy. chokes, 2700 ohms for screen grid detector coupling	.95
30 Hy. Victor chokes, 150 m.a., 200ohms	.39
Bradley Radiotats—new	5.28
Bradleytats—type E210	3.25
Hendrite d. c. milliammeters: 0-15, 0-25, 0-50, 0-100, 0-150, 0-200, 0-300, 0-400 M.A., each	.57
De Forest, new, types 410, 481 and 450, guaranteed, each	1.69
De Forest, new, 566 m.v. rectifiers, guaranteed	3.75
Baldwin type C headphones, set	3.25
De Forest 565, 511, 503A, 545 tubes, first, each	13.95
Beat Buy of the Year! Alum. cast desk stand with your call letters and two-button mike complete with springs	4.75
CRYSTALS:	
Unfinished blanks X or Y cuts, true cuts	1.00
Finished Oseil, blanks, X or Y cuts	1.90
80 or 160 meter crystals, accurate within .1 of 1% of your freq., guaranteed, X or Y cuts	3.45
25 watt tubes, 7 1/2 volt fila., 850 volt plate, guaranteed	3.98
15 watt 210 tubes, special, 90 day guarantee	1.20
281's and 250's, 90 day guarantee, each	1.20
HYTRON 866's heavy duty, spiral filament, cylindrical plate, 6 months guarantee, special	2.98
HYTRON 281's, 6 months guarantee	2.50
HYTRON 871's M.V. rectifiers, 6 months guarantee	1.85

WRITE! for big discount off on HYTRON tubes—6 months guarantee! RCA or Cunningham tubes—NEW—GUARANTEED—40% and 10% off list prices on all type tubes during month of March... BUY NOW and SAVE!

ARTURUS tubes in stock. Write for special discount. SPEED tubes—50%, 10%, 10% off list prices on all types. BILLEY high grade crystals in stock—prompt service—write for Billey price list.

Midget porcelain standoff insulators, new type... .08
Nationally known Transmitting Transformers. Prices very SPECIAL! Fully guaranteed:

Fila. transf. 2 1/2 v. 12 amp. c. t. and 5 v. 2 amp. c. t. 5 v. at 2 amp.	1.50
Plate Supply: Sec. 1000-1500-0-1500-1000; 375 V. A.	1.75
Plate Supply: Sec. 1500-2000-0-2000-1500; 850 V. A.	7.75
Plate Supply: Sec. 1500-2500-0-2500-1500; 850 V. A.	10.50
Plate Supply: Sec. 1500-2500-0-2500-1500; 850 V. A.	13.48
Plate Supply: Sec. 1000 volts c. t. at 150 M. A.	4.95

Plate Supply: Sec. 1500 volt. c. t. at 150 M. A.	5.85
Power Transf. Sec. 1500 volt. c. t. at 300 M. A. 2-7 1/2 volt windings each at 3 amps.	6.00
Filament Transf. Sec. 7 1/2 v. c. t. at 3 amp. and 7 1/2 v. c. t. at 3 amp.	3.98
Filament Transf. Sec. 2 1/2 volt. c. t. at 12 amp. eased	3.98
Filament Transf. Sec. 10 volt. c. t. at 7 amp. eased	3.98
Filament Transf. Sec. 12 volt. c. t. at 7 amp. eased	3.98
Filament Transf. Sec. 5 volt. c. t. at 20 amp. eased	5.85
Filter chokes: 30 Hy. 300 M. A. Xmitting type	6.95
Filter chokes: 30 Hy. 150 M. A. Xmitting type	3.50
Modulation chokes: 10 Hy. 300 M. A. special	7.50
Modulation chokes: 10 Hy. 150 M. A. special	5.75
VICTOR ABC power transf. for 245 P. P. transmitters	1.49
Genuine General Radio plugs 6c each and jacks 5c each	
Steinite 30 Hy. Filter Chokes, eased	.35
W. E. 211-E's alclity used, make good oscillators and modulators	2.98

PILOT parts in stock. Write for catalog!
American microphones and stands in stock—write for "special" prices.

UNIVERSAL MICROPHONES: Models "Y" \$1.17; "W" \$1.75; "X" \$5.87; "BB" \$14.69; "KK" \$29.40; "LL" \$44.10.

Hammarlund Comet "PRO" S.W. Super, latest model in metal cabinet, complete with tested RCA tubes. List \$162.55. Special \$95.56.

Hammarlund Isolantite Sockets, 4-5 and 6 prongs, each	.35
Hammarlund Isolantite Coil Forms, 4- and 6 prongs, each	.58
Latest Amateur Call Book issue, prepaid	1.00
New 1933 A. R. R. L. Amateur Hand Book, prepaid	1.00
Morris Universal Coil Winding Machines, complete	4.39

Genuine ACME—Solid enameled aerial wire. Write for BIG REDUCTION in prices on 10, 12 and 14 gauges—100-200 and 300 foot coils.

We are national distributors for the following manufacturers and can supply your complete radio equipment at WHOLESALE PRICES: Burderson, Jefferson, Sigal, REL, Eby, National Hammarlund, Cardwell, Weston, Jewell, Burgess, Aerovox, Electrad, Clorostat, Ohmita, Ward-Leonard, Yaxley, Best, Elkon, Tope Flechtman, Dublier, Cornell, Carter, etc. Write for free bulletin or any question you desire. Deposit required. Prices F. O. B. Schenectady, N. Y.

MAURICE SCHWARTZ & SON 710-712 Broadway Schenectady, N. Y.

"Ham" advertisements are always interesting and profitable to read.

See Page 684.

to go in deep, we take a greater distance. We can therefore give various form to the field and adapt it to the location of the seat of illness.

By this means it is possible to study in the human or animal body the function of definite bodies. I have been interested, aside from the blood glands, chiefly in the organs of heat regulation. We know that there are located in the brain *regulating devices* which keep the bodily heat of mammals (and other warm-blooded creatures) always at the same height. We can, even if only approximately, indicate where these central regulators must be located in the brain. If the region in question is injured, fever results; if it is heated, then follows increased giving off (radiation) of heat by the body. In the case of human beings attacks of shock in certain regions of the brain or swellings at the points in question can produce fever. We furthermore know that the fever in the case of diseases of infection depends on a poisoning of the heat center by bacterial substances.

Effects of Ultra Short Waves On Brain

In the case of rabbits we have exposed the neck region to a short wave field, so that certain parts of the brain were struck. Afterward there resulted very peculiar disturbances of the bodily heat. In the case of part of the animals there occurred some hours after the transmission a rise, and from then on the temperature permanently was one or two degrees higher. In the case of other animals, which were especially strongly irradiated, the temperature afterwards dropped. In the case of a further group a similar disturbance could not at first be demonstrated, but when we put them in a 50 degree Centigrade hot-air bath, some of the irradiated animals could no longer endure this temperature, while beforehand they had stood it without trouble. In the hot-air bath their bodily heat rose to such a height as we had never seen in the case of normal animals.

It was the reverse with a part of the animals, which were put in cold water. While before the irradiation an undue cooling could be equalized by the intact heat regulation, the irradiation had disturbed the regulating mechanism and the bodily heat sank to unaccustomed depths.

The brains of the experimental animals were investigated by Dr. Ostertag, who proved injuries to very definite brain cells. Indeed, the injuries in the case of the individual classes of animals are limited to different cell groups, for which the wavelength as well as the extent and strength of the field effect play a decisive rôle.

Effects on Internal Secretion Glands

Furthermore, by the use of the short-wave field there is offered a way to influence separately the internal secretion glands. Together with Weissenberg, I first made experiments on the irradiation of the pancreatic gland, which by its internal secretion keeps the blood sugar at a definite value. Aside from the pancreatic gland a center in the brain also takes part; therefore in one experiment we irradiated the pancreatic gland, in a second experiment the brain, and each time we investigated afterward at several intervals of time the height of the sugar content of the blood. The behavior was very varied. If the brain was irradiated, the blood sugar often rose to twice the initial value, to sink back again to normal only after two or three hours. After irradiation of the pancreatic gland however, there took place only a very short and slight rise, but later a sinking below the initial value which lasted a number of hours. Probably this discovery is attributable to a stimulation of the activity of the pancreatic gland.

Much more important for us are the ways which the foregoing results have shown us for treating the sick. One way is that of a local treatment of sites of infection, the other is that of general fever therapy (See Fig. 3).

Treating "Softening of the Brain"

The latter has principally attained importance through the pioneering work of Wagner von Jauregg, who infected patients suffering from progressive paralysis (progressive softening of the brain due to syphilitic infection of the brain) with malaria and in many cases cured the disease.

Acting on this basis, American physicians have recently conducted the experiment of producing high temperatures in the bodies of invalids by means of especially efficient diathermal apparatus, and lately a great condenser field was also used for the purpose, indeed using wavelengths of about 30 meters. When the invalids were packed in blankets, it was possible to keep them for several hours at a temperature of from 41 to 42 degrees Centigrade. According to the oral report of a New York doctor, who works with this process, the healing results are supposed to be nearly as good as with the malaria cure. An important difference as regards the ultra-short wave process used by me is that one does not treat the site of the illness, the brain, but the rest of the body, with the exclusion of the head. A general distribution of the heat takes place only through the circulation of the blood.

As compared with this wearisome and for the patient, very strenuous procedure, the ultra-short wave treatment offers a much simpler process. Here we can directly influence the illness of the brain without the occurrence of an especially strong heating. The patients suffering from paralysis (softening of the brain), whom we subjected to our treatment, *felt it to be absolutely pleasant!* There were no injuries, even with long treatment. Meanwhile at the psychiatric clinic of the University of Vienna such invalids have been treated in greater numbers, and the results furthermore appear absolutely promising. Naturally nothing conclusive can be said to-day, before our experience extends to a very great number of invalids and to a period of several years, since progressive paralysis can often show *spontaneous improvements* lasting several months.

Pus Infections

Thus far I have found the ultra-short wave treatment excellent for the treatment of pus infections, produced by staphylococci or streptococci. That I first turned my main attention to these illnesses is due to the fact that I, together with Haase, had already collected data on the pus-producers in question; also that, by accident, I had the chance for experimentation on myself. A painful nasal boil which had developed in my own case was completely healed on the day following a five-minute treatment with the condenser field! So it was only natural that boils and carbuncles were first treated, especially since these superficial infections are very accessible. In the case of some 300 boils, which in part had been very stubborn and had resisted all treatments, the *healing time was on the average four to five days!* During the period of treatment, in most cases, the ability to work was not affected at all, while with surgical treatment the parts of the body in question must generally be kept quiet for a number of days.

What distinguishes the ultra-short wave process beyond almost all other processes, is the possibility of the effect on deep-seated pus-infections, according to what has been said above. Thus pus-infections of the jaw cavities can be favorably influenced by short wave therapy. In the case of various invalids, complete freedom from the trouble was attained. Likewise very serious infections were cured in several cases. Thus the treatment of difficult pleurisy (with pus formation) repeatedly led to complete success. The invalids were restored in a space of time which seemed surprisingly short, in view of the seriousness of the disease. Investigations are being carried on with regard to other types of illness.

Short Wave Fans and Amateurs

Send for the BIG FREE 1933 M & H catalogue. It contains everything. It should—as we have been serving the mail order buyer for 35 YEARS. We guarantee everything we sell. It must be satisfactory to you! No one complains that deals with M. & H. Complete satisfaction assured.

Special de Forest Transmitting audions!
No. 510—15 Watt oscillator specially treated plate, gives high plate dissipation. Ideal for crystal control oscillators. **Special \$14.70.**
No. 511—50 Watt oscillator and R. F. amplifier, modulator or R. F. power amplifier. Induced a general purpose tube. **Special \$14.70.**
No. 503-A—50 Watt oscillator and R. F. power amplifier, the standard. 50 watt, not generally suited for Modulator Purpose. **Special \$14.70.**
No. 566-A "half-wave," hot cathode, Mercury vapor rectifier, 2.5 volts, 5 amps. on 61. Maximum peak, inverse voltage 7500. Ideal for amateur transmitter plate supply. **Special \$4.00.**

Ward Leonard Dependable Keying relays
Designed for Keying moderately powered transmitters. Model No. 507, single pole, single throw double break, operates on 2 1/2 volts D. C. **Special \$3.00.**
Model No. 608—Same as Model 507, excepting coil wound for 6 volts D. C. operation. **Special \$3.00.**

Dunco Vacuum Tube Relay
Ultra-sensitive unit for D. C. in coil circuit and either D. C. or A. C. in the control circuit. This unit is practically adapted to operation in the plate circuit of small vacuum tubes. Contacts rated at 2 amps. at 110 volts A. C. Size 2 7/8" long x 2 1/4" wide x 1 1/8" high. **Special \$5.00.**
We carry a complete line of Keying Time Delay and Remote Control Relays. All standard makes.

Complete line of Delta chokes. Transformers and power transformers at very low prices.

M. & H. De Luxe Monitor
For anyone desiring a permanent means of monitoring their transmitter carrier.
Constructed of the highest quality materials obtainable! Coils for 20, 40 and 80 meter amateur bands. Uses two number 4 Burgess dry cells and one No. 4150 B Battery. Contacts wired or kit form, with tubes, coils and batteries, wired complete. **Special \$14.00.**
Kit Only (assembled but not wired). **Special \$11.00.**

M. & H. Electron Coupled Frequency Meter
This new meter is an outstanding development of the year. Housed in one-piece cast aluminum box, with heavy aluminum front panel, suitably engraved.
Uses one type 24 tube, two 45 volts, portable type. Completely calibrated with all batteries and tube—**Special \$29.50.**

Chase Quality Quartz Crystals
Each crystal is individually calibrated. Guaranteed accurate under conditions specified in calibration sheet.
Supplied complete with new Chase holder with its frequency and temperature marked on a name plate.
1715 to 2000 K. C.—holders included—special..... \$ 8.00
25 to 4000 K. C.—holders included—special..... 8.00
7000 to 7300 K. C.—holders included—special..... 12.00
500 to 600 K. C.—Altrap Holder—special..... 9.00
Chase Crystal Holders only—special..... 2.50

For a limited time only, we offer special bargains on REARITE PANEL METER ALL KINDS
D. C. VOLTMETERS
From 0.1 Volts 30 Ohms to 0.25 Volts 1625 Ohms at 50c each.
No. 608—0.25 Volts 7720 Ohms..... \$1.47
No. 437—H. 0.50 Volts 1548 Ohms..... 1.77
No. 339—0.100 Volts 6500 Ohms..... 1.77
No. 338—H. 0.100 Volts 3088 Ohms..... 1.74
No. 609—0.750 Volts 23160 Ohms..... 2.94

D. C. AMPETERS
From 0.1 amperes to 20.0—20 amperes..... 59c each.
D. C. MILLIAMMETERS
From 50c to \$1.18 all types in stock.

A. C. VOLTMETERS
0.4-0.6 Volts—0.10 Volt—0.15 Volt..... \$1.47 each.
0.150 Volt \$2.36, 0.300 Volt \$2.94.
0.750 Volt special at \$4.12.
0.600 Volt—\$3.53.

A. C. AMPETERS
From 0.1 Amps. to 0.10 Amps. \$1.47 each. 0.50 Amps. \$1.77
A. C. MILLIAMMETERS
From 0.25 Milliamperes to 0.010 Milliamperes..... \$1.47 each.

As Specified in many of Short Wave Craft Articles
Octocells: Set of four, with wave length range from 15 to 200 Meters. The most rugged Short Wave coils ever designed in four distinctive colors—complete set of four..... \$2.95.
Broadcast coil, range 200-620 Meters, special 75c each.

M. & H. Telegraph Key. 13.8" tungsten contacts will handle W. K. W. ready. Made of highest quality. **Special 95c.**
Wireless Practice Set. Just the thing to master the code with. Comes with booklet on how to learn the code and full instructions on how to use instrument. Equipped with high frequency Radio buzzer. **Special \$1.95.**
We have what you have been looking for in Keys. Write us.

Electron Chassis Bases. Very handy for mounting all Radio Instruments and the three sizes make it possible to mount any type receiver. The height of each size is 3 inches which is standard for all type receivers and power packs.
No. 115E—10" x 12" x 3"..... \$1.61
No. 151E—10" x 23" x 3"..... Special..... 2.74
No. 1517—10" x 17" x 3"..... Special..... 2.20
A Popular Shield Can—Measures 4 1/4 x 3 3/8 inches, length 4 1/2 inches. For use in making condenser blocks or transformers. **Special 53c.**

We maintain a completely equipped machine shop to give prompt attention to your special order work, on the cutting of panels, etc. Send complete drawings and specifications for quotations on this type work.

Short-Wave Plug-in Coils—Suitable for receiver or transmitter up to 30 Watts. Six contacts. 4 1/2" long 2" diameter. Coil forms only. 84c. Base only, 84c.

A New Supersensitive Relay—By Piezo
Made in two styles—both have normal coil resistance of 1.300 Ohms. Operate on four milliamperes at six Volts.
Relay No. 1 is supplied with open Platinum Iridium contacts and will break 50 Watts easily. **Special \$11.25.**
Relay No. 2 is equipped with Burgess Vacuum contact and will continuously break 1320 Watts. **Special \$15.00.**
Replacement Burgess contacts. **Special \$3.75.**

Genuine Teleplex—The perfect self-instructor to develop speed in both sending and receiving.
For the advanced student of beginner. Your cost \$26.95. Original Martin Vileroplex—The new improved model, a handsome and efficient key. **Furnished in red, green, blue or black. Your cost \$16.50.**
Push lined Carrying Case for Vileroplex Key. **Special \$2.94.**

M. & H. SPORTING
M. & H. GOODS CO.
512 MARKET STREET PHILADELPHIA
NOTE:—Above prices include Govt. Tax. Mail orders filled same day—10% cash must accompany all C. O. D. orders.

WORLD'S BEST RADIO BOOKS

● IT IS always the well-trained man who wins out over the horde of thousands of superficially trained and incompetent men. You are reading this magazine because you are interested in radio. Sooner or later, the time will come when you will wish to cash in on your knowledge. Your chance may come over night, and then the big and vital question will be, "How well equipped am I to fill the job?" You are in radio because you like it. You also realize that, at the present time, there are many branches of the radio art which you do not know as thoroughly as you should. Knowledge, these days, can be gotten cheaper than ever before. It isn't necessary for you to go to college to become proficient in radio. Start today, to build a REAL radio library and become acquainted with all branches of this great and growing art. In this page are listed the world's best radio books. We have combed the market for the really important books in radio; so that, no matter what branch you are interested in, you can pick out the best books that are now printed. Start, now, to build a complete radio library. You do not have to get all the books at once, but make up your mind to get one book a month; so that, when your chance comes, you will be fully equipped to win out over the others not so well equipped.

IMPORTANT.—This list is changed every month to include the latest books. Note also new low prices.

THE RADIO HANDBOOK, by James A. Moyer and John F. Wostrel. Flexible covers, size 5½x8", 886 pages, 650 illustrations. Price **\$5.00**

Comprehensive data on short-wave apparatus, vacuum tubes, modern radio receivers and transmitters, photoelectric cells, television, sound motion pictures, tables, graphs, diagrams, etc. No radio man should miss it.

RADIO FREQUENCY ELECTRICAL REQUIREMENTS, by Hugh A. Brown. Cloth covers, size 6x9", 386 pages, 235 illustrations. Price **\$4.00**

One of the few great books on this important subject. Everything from thermionic-tube coefficients to piezo-electric measurements.

PRACTICAL TELEVISION, by E. T. Larnor. Cloth covers, size 5½x8½", 223 pages, 127 illustrations. Price **\$3.75**

This book explains television in full, including elementary principles, photo-electric cells, and all important types of television sets as well as basic principles of optics, images, mirrors, lenses, etc.

MAGNETIC PHENOMENA, by Samuel Robinson Williams. Cloth covers, size 6x9", 230 pages, 150 illustrations, and numerous tables. Price **\$3.00**

All electric motors, coupling coils, magnetic and dynamic loud speakers, transformers, choke coils, etc., are dependent on magnetic phenomena. This fine book is complete on the subject.

CINEMATOGRAPHY, by James R. Cameron. Stiff covers, size 7½x5", 240 pages, 150 illustrations. Price..... **\$4.00**

Everything on the subject from "silent" and "talkie" 16 mm. film to its manufacture and to the final projection is in this marvelous volume.

AUDEL'S RADIOMAN'S GUIDE, by Frank D. Graham. Cloth covers (flexible), size 5x8½", 220 pages, 300 illustrations. Price **\$1.00**

A practical, concise book presenting the theoretical and practical information for the proper operation, maintenance and service as applied to modern radio practice.

THE RADIO AMATEUR'S HANDBOOK, (New Revised Edition), by A. Frederick Collins. Cloth covers, size 5½x7½", 394 pages, 116 illustrations. **\$2.00**

If you wish to become a radio amateur (radio ham) this book tells you how. Everything in receiving and transmitter sets and how to build them.

EXPERIMENTAL RADIO, by R. H. Ramsey, Prof. of Physics, Indiana University. Cloth covers, size 7½x5½", 256 pages, 168 illustrations. Price, **\$2.75**

A marvelous book for the experimenter. Experiments galore in easy comprehensible language.

HOW TO ORDER We cannot ship C. O. D. Our prices are net, as shown. Some of the books sent prepaid (in U. S. only). Those that are not thus listed will be shipped by express collect if sufficient postage is not included by you.

FOUNDATIONS OF RADIO, by Rudolph L. Duncan. Cloth covers, size 5½x8", 246 pages, 145 illustrations. Numerous tables. Price **\$2.50**

This textbook gives you the fundamentals of electricity as applied to radio. It equips you for further study in the field of radio.

RADIO THEORY AND OPERATING, by M. T. Loomis, 5th revised Edition. Cloth-bound; size 5½x8½" thick; 1,000 pages; over 800 illus.; 450 review questions and answers. **\$4.50**

Written in textbook style, a tremendous amount of useful information has been crammed into this thin-paper, compact reference work. Radio transmission and reception have been covered, "from soup to nuts." A truly great book.

G. GERNSBACK'S RADIO ENCYCLOPEDIA (Second Edition). Red Morocco Flexible Binder, 352 pages, 2201 radio definitions, 1253 illustrations, 34 tables. **\$3.25**

The most comprehensive encyclopedia of its kind in print. Remarkably up-to-date in every way, with marvelous illustrations.

DRAKE'S CYCLOPEDIA OF RADIO AND ELECTRONICS, by H. P. Manly. Cloth covers, size 6x9", 1650 pages, 1080 illustrations. New 1932 Edition. Price **\$5.00**

The largest work of its kind ever put together by two covers. New and up-to-date; a standby for every radio man.

FUNDAMENTALS OF RADIO, by R. K. Ramsey, Professor of Physics, Indiana University. Cloth covers, size 9½x6", 372 pages, illustrated. Price prepaid..... **\$3.50**

The backbone of the radio art. This book gives you the foundation on radio from A to Z.

RADIO OPERATING QUESTIONS AND ANSWERS, by Nilson and Hornung. Fourth Edition. Cloth covers, size 5½x8", 350 pages, 131 illus. **\$2.50**

Contains over 600 questions and answers covering all phases of licensed radio operation. Revised to contain much new material. Nothing better in print for the transmitting and receiving amateur.

OFFICIAL RADIO SERVICE MANUAL, Volume I, by Huxo Gernsback and Clyde Fitch. Flexible loose-leaf binder, size 9x12", over 2,000 illustrations, 650 pages. **COMPLETE WITH SIX SUPPLEMENTS. \$4.50**

The Service Man's Bible. Greatest book ever published on the subject. Contains all old circuits of every imaginable commercial radio set up to 1931.

THE RADIO MANUAL, by George E. Stirling and Robt. S. Kruse, E.E. 2nd enlarged edition. Flexible fabrikoid covers. Size 5½x8", 805 pages 318 illustrations. Price **\$6.00**

A complete Radio Course for the operator, the technician, the amateur, the student and experimenter. Everything imaginable in the whole radio art is covered in this great book—the "radio Bible" of the amateur. **DON'T MISS THIS.**

EXPERIMENTAL RADIO ENGINEERING, by John H. Morecroft. Cloth covers, size 6x9", 346 pages, 250 illustrations. Price **\$3.50**

A student's book; devoted to the principles of radio apparatus; intended to accompany a course in electricity. The beat of its kind.

PRACTICAL RADIO CONSTRUCTION AND REPAIRING, by J. A. Moyer, S.B., A.M. and J. F. Wostrel. Cloth covers, size 8x5", 354 pages, 163 illustrations. Price **\$2.50**

A handbook that every radio set tester and general student must have. The diagrams alone are worth the price of the book.

A POPULAR GUIDE TO RADIO, by B. Francis Dashiell. Cloth covers, size 5½x8½", 286 pages, profusely illustrated. **\$3.50**

The fundamental principles of radio. From crystal rectifiers to the latest electron tube amplification, etc.

PRINCIPLES OF RADIO COMMUNICATION, by J. H. Morecroft, Prof. of Electrical Engineering, Columbia University. Cloth covers, size 9½x6", 988 pages, profusely illustrated. **\$7.50**

THE radio classic, by the dean of radio. Covers entire radio art as does no other book.

We herewith present the most complete collection of recent important radio books. We have, after an exhaustive study, selected these volumes because they represent the foremost radio books of their kind in print today. There is such a great variety that we are sure it will satisfy any taste as well as any requirement that the student of radio might have. We publish no catalog and ask you to be kind enough to order direct from this page. Prompt shipments will be made to you direct from the publishers. We merely act as a clearing house for a number of radio publishers and **OUR PRICES ARE AS LOW OR LOWER THAN WILL BE FOUND ANYWHERE.** Remit by money order or certified check. If you send cash, be sure to register it.

SHORT WAVES, by C. R. Leutz and R. B. Gable. Stiff covers. Size 6x9", 384 pages, 258 illustrations. Price, **\$3.00**

The biggest and most complete book on short waves. Covers every imaginable phase, including S. W. Superheterodynes. The authors are famous S. W. authorities.

SOUND PICTURES AND TROUBLE SHOOTERS MANUAL, by Cameron and Ilder. Cloth cover, size 8x5½", 1120 pages, profusely illustrated. **\$7.50**

The standby of every operator. It is the most thorough book on the subject.

ELECTRICITY AT HIGH PRESSURES AND FREQUENCIES, by Henry L. Transtrom. Cloth covers, size 7½x5½", 248 pages, 141 illustrations. Price Prepaid..... **\$2.35**

A marvelous book for the student in electricity and radio. General fundamentals lead up to a complete discussion of every type of Tesla and Oudin high-frequency coils, Geissler tubes, etc.; construction details of Tesla coils are given in great profusion. **THE ONLY BOOK OF ITS KIND.**

OFFICIAL RADIO SERVICE MANUAL, Volume II, by Huxo Gernsback, C. E. Denton and C. H. W. Nason, with 1932 Free Supplements, 1000 pages, 2000 illustrations. Flexible Loose-leaf Binder, size 9x12". **\$4.00**

The talk of the radio industry. This marvelous volume contains everything in radio, circuits and radio developments, for 1932. Not a line of duplication between 1931 and 1932 volumes. (Vol. I and Vol. 2.)

ORDER DIRECT FROM THIS PAGE

ELEMENTS OF RADIO COMMUNICATION, by Professor John H. Morecroft. Cloth covers, size 9x6", 270 pages, 170 illustrations. Price..... **\$3.00**

An authoritative volume embracing every imaginable phase in radio communication.

RADIO SERVICE MAN'S HANDBOOK WITH ADDENDA DATA SHEETS. Flexible covers. Size 9x12", 200 pages, 400 illustrations. Price **\$1.49**

The Service Man's standby. Contains the latest practical information on radio servicing.

HOW TO PASS U. S. GOVERNMENT RADIO LICENSE EXAMINATIONS, by R. L. Duncan and C. E. Drew. Flexible covers, size 9½x7", 170 pages, 92 illustrations, appendix. **\$2.00**

The most important book on the subject ever published. Gives every conceivable angle which will help you to pass a radio license examination successfully.

RADIO MOVIES AND TELEVISION, by C. Francis Jenkins. Cloth covers, size 9½x6", 144 pages, profusely illustrated. Price..... **\$1.00**

A complete volume by the master of television, giving everything in television, including constructional details for building your own television sets.

RADIO PHYSICS COURSE (2nd enlarged edition), by Alfred A. Ghirardi. Cloth covers, size 7½x9½", 992 pages, 510 illustrations, numerous tables. **\$3.50**

The finest and most popular book on electricity and radio. Each subject is clearly discussed, with the aid of dozens of excellent drawings. (Chapters on talkies, television, electronics and service work, etc. Biggest buy in radio books.)

RADIO VISION, by C. Francis Jenkins. Cloth covers, size 9½x6", 144 pages, profusely illustrated. Price prepaid..... **90c**

An excellent book. The Jenkins television system, as well as many other modern television systems fully described.

NEW LOW PRICE RADIO BOOKS

Here are 13 new, up-to-date books on every conceivable radio subject, just published. Modern in every sense. ALL BOOKS UNIFORM from 64 to 72 pages; 50 to 120 illustrations. All books written by well-known radio authors. Order by Number.

- No. 1 **RADIO SET ANALYZERS**, by L. Van Der Meel
- No. 2 **MODERN RADIO VACUUM TUBES**, by Robert Hertzberg
- No. 3 **THE SUPERHETERODYNE BOOK**, by Clyde Fitch
- No. 4 **MODERN RADIO HOOKUPS**, by R. D. Washburne
- No. 5 **HOW TO BECOME A RADIO SERVICE MAN**, by Louis Martin
- No. 6 **BRINGING ELECTRIC (RADIO) SETS UP TO DATE**, by Clifford E. Denton
- No. 7 **RADIO KINKS & WRINKLES** (for Experimenters) by C. W. Palmer
- No. 8 **RADIO QUESTIONS & ANSWERS**, by R. D. Washburne
- No. 9 **AUTOMOBILE RADIO & SERVICING**, by Louis Martin
- No. 10 **HOME RECORDING AND ALL ABOUT IT**, by Geo. J. Saliba
- No. 11 **FUNDAMENTAL PRINCIPLES OF RADIO**, by Louis Martin
- No. 12 **HOW TO BUILD AND OPERATE SHORT-WAVE RECEIVERS**, by the Editors of SHORT WAVE CRAFT
- No. 13 **HOW TO BECOME AN AMATEUR RADIO OPERATOR**, by M. F. Eddy

PRICE PREPAID EACH BOOK..... **\$.45**
PRICE PREPAID FOR ALL 13 BOOKS..... **\$4.85**

S-W Tuning Inductance Charts

(Continued from page 679)

microhenries. Thus the inductance necessary to resonate a condenser with a capacity of .00015 mf. to 200 meters has a value of 75 microhenries.

In most cases the tuning of a short-wave receiver is accomplished by means of a condenser with moveable plates, although some set-builders have used tapped or variometer type inductances. This article will deal only with the standard method of condenser control for frequency selection.

The desire for high voltage gains at the short wavelengths will lead the coil builder to the choice of high values of inductance in conjunction with a tuning condenser. This brings several points to our attention which should be studied so that a compromise for good operation can be developed.

Modern short-wave tuning condensers of the better type have their electrical losses reduced to a minimum. Thus it becomes necessary that the efficiency of the tuning coil and its associated components be raised to the highest degree. The reader will note that the losses in the various components are cumulative and unless care is exercised the losses will reach values that will nullify the efforts of the builder. An interesting graph showing the efficiency of various insulating materials used in condenser construction is shown in Fig. 2 and pictures the change in efficiency with the change in frequency. The base line for these tests has been defined by the efficiency of bakelite and the other materials have been judged as to the efficiency gain +, or loss -, as indicated.

Having selected a tuning condenser with low losses at the frequencies to be received, it follows that the coils and the remaining components associated in the tuned circuits have their losses reduced to a minimum.

The selection of the tuning condenser capacity will depend on the range of frequencies to be received with a given coil. This presents a problem that every experimenter should be able to solve if headaches are to be avoided.

If a wide band of frequencies is to be covered it is necessary that the ratio between the maximum and minimum capacity values of the tuning condenser be made as great as possible. For example: condensers having a maximum capacity of .00014 mf. may have a minimum of .000007 mmf. This is a good condenser and the low minimum capacity value should not be misused by having the associated input circuit capacity of the tuned stage so high that the effective tuning capacity range is reduced. The effect of this shunting capacity is indicated in Fig. 3. Dotted lines represent the lumped circuit capacity shunted across the tuning condenser, thus limiting the minimum effective tuning range.

Figure 4 shows the capacity range plotted against dial divisions for condensers with varying numbers of plates. This chart is printed by courtesy of the Radio Condenser Co., Camden, N. J. The minimum has a fairly high value and this must be due to the construction. Heavy cast metal end-plates and "bathtub" construction will not permit the condenser designer to obtain low minimums. These minimum values of Fig. 4 are satisfactory for all practical purposes and will permit excellent band coverage.

To find the minimum wavelength to which a variable condenser and a coil will tune, multiply the inductance in microhenries by 1,000 and then by the capacity of the condenser in microfarads. This will give the "LC ratio."

Look this figure up in the chart of Fig. 1 and read off the wavelength in meters. For example: A coil with an inductance of 75 microhenries is tuned by a condenser with a minimum capacity of .000007 microfarads and the remaining circuit capacity

λ Wave length meters	f Multiply values below by 1000	ω Multiply values below by 1000	CL C in (mf) L in cm
1	300000	1884000	0.0003
2	150000	942000	.0011
3	100000	628000	.0018
4	75000	471000	.0045
5	60000	377000	.0057
6	50000	314200	.0101
7	42000	269000	.0138
8	37500	235500	.0180
9	33300	209400	.0228
10	30000	188400	.0282
15	20000	125800	.0635
20	15000	94200	.1129
25	12000	75400	.1765
30	10000	62800	.2530
35	8570	53900	.3446
40	7500	47100	.480
45	6670	41900	.670
50	6000	37700	.904
55	5450	34220	1.20
60	5000	31420	1.61
65	4620	28970	2.15
70	4290	26900	2.90
75	4000	25120	3.88
80	3750	23520	5.20
85	3529	22120	6.99
90	3333	20920	9.42
95	3158	19830	12.7
100	3000	18840	17.1
105	2857	17940	23.0
110	2727	17130	31.0
115	2609	16390	41.5
120	2500	15710	55.9
125	2400	15070	75.0
130	2308	14480	100.0
135	2222	13950	133.3
140	2144	13450	177.8
145	2069	12980	237.0
150	2000	12560	315.0
155	1935	12150	418.0
160	1875	11770	559.0
165	1818	11410	750.0
170	1765	11080	1000.0
175	1714	10780	1333.3
180	1667	10470	1777.8
185	1622	10180	2370.0
190	1579	9910	3150.0
195	1538	9660	4180.0
200	1500	9420	5590.0

Fig. 1. "L C" Chart

Number A Wavelength (ft. & in.)	MAGNET WIRE TABLE: Turns Per Lineal Inch							
	Kind of Insulation							
	SC	DC	TC	Asb	En	En & SC	En & SS	
0000	2.14	2.10	2.07	2.06
000	2.39	2.35	2.31	2.30
00	2.68	2.63	2.57	2.56
0	3.00	2.93	2.87	2.85
1	3.36	3.28	3.19	3.17
2	3.76	3.65	3.55	3.53
3	4.21	4.07	3.95	3.92
4	4.71	4.54	4.38	4.34
5	5.26	5.05	4.86	4.81
6	5.88	5.68	5.43	5.35
7	6.57	6.32	6.01	5.91
8	7.34	7.12	6.83	6.60	7.63	7.30	7.52
9	8.30	7.91	7.55	7.28	8.55	8.14	8.41
10	9.35	8.94	8.55	8.07	9.61	9.17	9.43
11	10.4	9.93	10.8	10.2	10.5
12	11.7	11.0	12.1	11.4	11.8
13	13.1	12.4	13.5	12.7	13.2
14	14.6	13.7	15.2	14.1	14.7
15	16.2	15.1	17.0	15.7	16.5
16	18.1	16.7	19.1	17.4	18.4
17	20.1	18.4	21.4	19.3	20.5
18	22.3	20.3	24.0	21.4	22.9
			SS	DS				
19	24.8	22.3	26.4	25.1	26.8	23.6	25.5
20	27.4	24.4	29.4	27.8	30.1	26.1	28.4
21	30.8	27.4	32.8	30.8	33.6	29.2	31.5
22	34.1	30.0	36.6	34.1	37.7	32.2	35.0
23	37.6	32.7	40.7	37.6	42.2	35.5	39.0
24	41.5	35.6	45.2	41.5	47.2	38.9	43.1
25	45.7	38.6	50.3	45.7	52.3	42.7	47.8
26	50.1	41.8	55.7	50.1	59.0	46.6	52.8
27	55.0	45.1	61.7	55.0	65.8	52.1	58.2
28	60.1	48.4	68.3	60.1	73.8	57.0	64.3
29	65.5	51.9	75.4	65.5	82.3	61.9	70.6
30	71.3	55.5	83.2	71.3	92.4	67.5	78.0
31	77.4	59.1	91.5	77.4	102.8	72.8	85.3
32	83.7	62.7	100.5	83.7	115.6	79.0	93.9
33	90.3	66.3	110.1	90.3	130.2	85.6	103.3
34	97.0	69.9	120.4	97.0	144.8	91.7	112.3
35	104.0	73.5	131.3	104.0	163.5	98.9	123.2
36	111.1	76.9	142.9	111.1	181.8	105.3	133.3
37	118.3	80.3	155.0	118.3	208.1	113.0	145.9
38	125.5	83.6	167.6	125.5	229.1	119.5	157.1
39	132.8	86.7	180.8	132.8	261.0	127.7	171.5
40	140.0	89.7	194.4	140.0	290.3	134.3	183.7

Courtesy John A. Roebling's Sons Co.

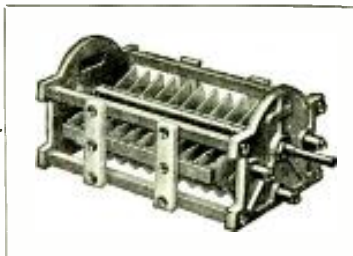

CONDENSER HEADQUARTERS

"HAMMARLUND" on a condenser or other radio equipment means that it is the product of more-than-thirty years of engineering experience—and it is your warranty of complete satisfaction.

Write for the new Hammarlund Catalog "33." It describes condensers of all types for transmitting and receiving—band-spread tuning, transformer tuning, padding and equalizing. Also many other essentials for short-wave experimenters.

Equalizing CONDENSERS



Small in size, but Hammarlund quality throughout. Mica dielectric, phosphor bronze flexible plate, bakelite base. Two ranges: 3 to 35 mmf. and 25 to 80 mmf.

Improved MIDGET CONDENSERS

Soldered brass plates. Sturdy frame. Smooth bearings. Four-point wiping rotor contact. Vibration-proof. Isolantite insulation reduces dielectric losses to the minimum, under all conditions of temperature and humidity.



Eleven Stock Sizes 3 mmf. to 320 mmf. Capacity

Write Dept. SW-3 for complete catalog of precision equipment for receiving and transmitting.

HAMMARLUND MFG. CO.
424-438 W. 33rd Street, New York



Two Great MAGAZINES for One Price

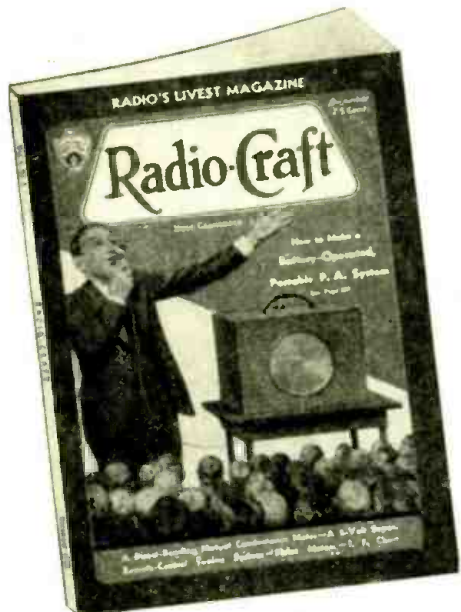

A Magazine Combination that covers practically every branch of Radio

Until the 31st of March, this opportunity is yours—this chance to read radio's two great magazines, SHORT WAVE CRAFT and RADIO-CRAFT, at a saving of \$2.00.

Regularly the rate for eight months of RADIO-CRAFT and SHORT WAVE CRAFT is \$4.00. FOR a brief period only, our readers can enter their subscription to receive both magazines for \$2.00. This is a reduction of 30 per cent and represents a saving of \$2.00.

SHORT WAVE CRAFT you have read, and it is needless for us to say that you are well pleased and want to read every issue. It is the "Town Crier" of new developments in the short wave field.

And RADIO-CRAFT, also edited by Hugo Gernsback, is the radio magazine selected by the greatest number of service men, dealers and radiotricians. Of course, thousands of amateurs read RADIO-CRAFT, too. Each month, men of outstanding prominence in the radio field contribute articles of real interest to all.

Mail Coupon TODAY!

SHORT WAVE CRAFT, SWC 3-11
100 Park Place, New York, N. Y.

As per your special offer, I enclose \$2.00, for which you are to enter my subscription to SHORT WAVE CRAFT and RADIO-CRAFT for the next eight months.

Name.....

Address.....

City..... State.....

is .000010 microfarads. What wavelength will the circuit tune to? 75 times 1,000 equals 75,000. Adding the two shunt capacities together gives us .000017 microfarads. .000017 times 75,000 equals 1.275. Refer to Fig. 1 and we find that the wavelength nearest this LC value is 70 meters. Note that most coil manufacturers specify that their coils for use with .00014 mf. condensers will tune from 80 to 200 meters. They figure, and rightly, that the builder will not have a condenser with a really low minimum and that the circuit capacities will be higher than the value used in the solution of the problem stated. If this coil is to tune to exactly 80 meters the lumped value of capacity at the minimum setting of the tuning condenser should be .000024 mf. If the minimum capacity of the tuning condenser is .000007 mf., then the circuit capacity must be the remainder or .000017 mf. Now we should be able to find the value of inductance to use with a given condenser to tune to a required wavelength and also know about what wave

ceded on the diameter of the coil form, try to use a ratio of length to diameter of one-to-one. If the diameter is one and one-half inches, then try and keep the length about the same. This refers to the length of the winding only.

Let a coil with an inductance of 100 microhenries be required; then, if the coil has a diameter of 2 inches and the winding is 2 inches long, a total of 54 turns will be required. With a winding length of two inches, a wire size should be selected that will wind 27 turns to the inch. This gives the necessary data for a coil without a lot of figuring.

The accuracy of these charts is close enough, for all practical coils being made by the "home-set" builder. Calculations involving ¼ turns would complicate the chart to such an extent that it would not be usable.

For the coils used on the very low wavelengths, the wire size will become larger, while the coils used above 80 meters will have comparatively fine wire.

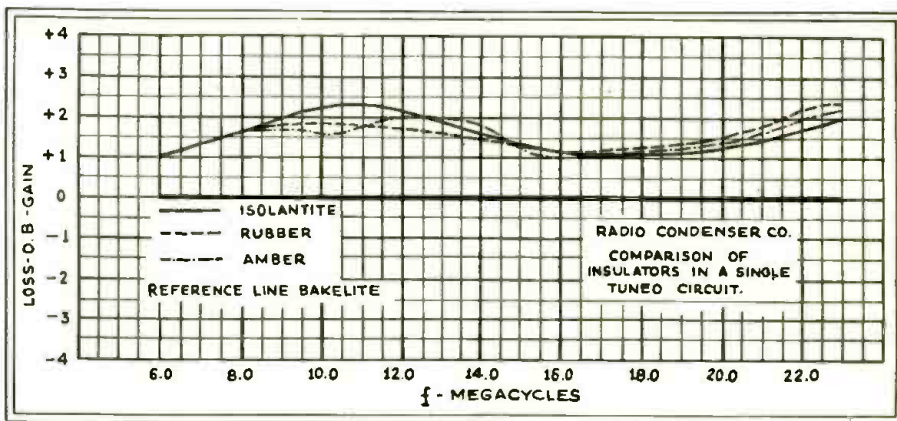

Fig. 2—Graph showing efficiency of different insulators at various frequencies.

band or range can be covered. How to Use the Charts.

Most coil builders want to have their coils designed for them, so the accompanying charts are given so that no mathematics are required at all. The best way to use these charts is as follows:

Ascertain the capacity of the tuning condenser that is to be used and then at the point of intersection between the wavelength desired and the tuning condenser curve, read the required inductance in microhenries.

Select the coil with a diameter suitable for use in the receiver in question. That is, the physical size of the coil. Having de-

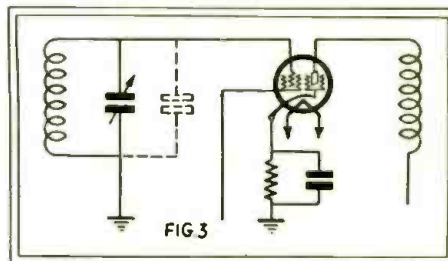

Fig. 3—Dotted lines represent the "lumped" capacity added by poorly designed circuit.

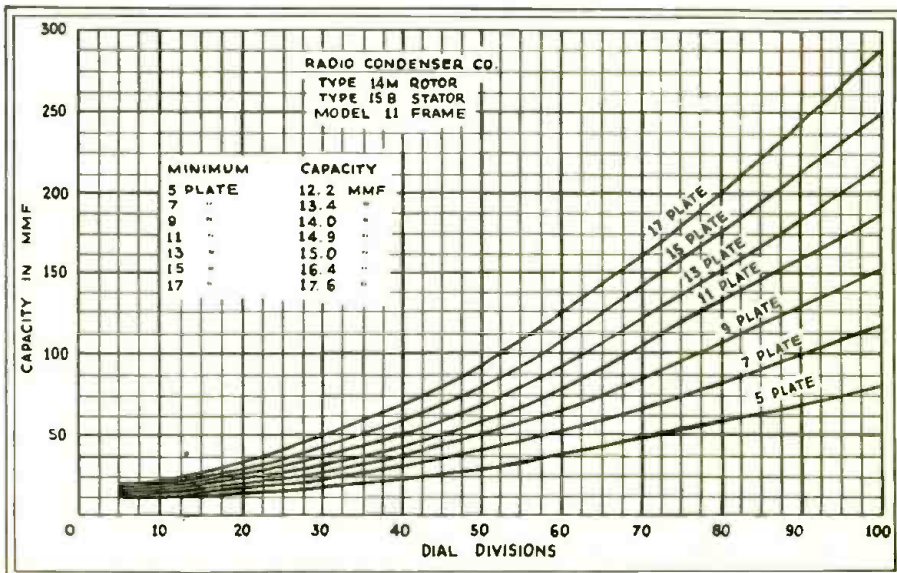

Fig. 4—Relation between capacity, dial divisions and condensers with different numbers of plates.

A "Quiet" A. C. Power-Pack

(Continued from page 662)

sitic radio frequency currents generated by the rectifier tube out of the D.C. output; the other was merely the removal of the pack from the operating table and its placement on a shelf just above the floor. One of the accompanying photographs shows the receiver layout, with the SW-3 on the table and the pack underneath. The other unit on the shelf, incidentally, is the separate power-pack of a National SW-58. The writer usually keeps both sets running at the same time, and has a lot of fun listening to both ends of phone conversations.

Assembly On Wood Base-board

The various parts of the power-pack are spread out comfortably on a wooden base board measuring 14 by 8 by 1 inches. The power transformer, the filter condenser block and the filter choke block (reading from right to left) occupy the back section. In front of the transformers is a four-prong socket for the 80 rectifier tube (preferred over the 82 because of its greater freedom from R. F. current). In front of the choke unit is a five-prong socket, at which the output wires terminate. Between the sockets is an Electrad 25,000 ohm wire-wound resistor with sliding taps.

The special Blan R. F. choke coil simply hangs in mid-air from its connecting wires between the transformer and the condenser block. This choke contributes noticeably to the quiet operation of the unit.

The wiring, as shown in the schematic diagram, is very simple. Note that heavy twisted wire (No. 14 flexible) is used between the 2½ volt filament terminals on the power transformer and the F posts of the five-prong socket. All other connections are made with No. 18 wire of the kind having push-back insulation.

Connection between the receiver and the power-pack is made through a flexible cable of five wires: two for filament, one for negative "B" and two for plus "B." If any particular set requires three different plate voltages, a six-prong socket may readily be used. The cable from the set terminates in a plug made from an old tube base. A neater plug designed for the purpose may be bought for a few cents.

Adjusting Output Voltages

By means of the sliding bands on the Electrad resistor, exactly the correct output voltages may be obtained. The values should be measured with a high resistance voltmeter. A fixed output resistor, or one having fixed taps, is absolutely worthless, as the voltages are never correct. If they are low, the set is weak and insensitive; if they are high, it is noisy and unstable.

Naturally the power units selected for a power-pack to fit a particular receiver must have sufficient capacity for the tube combination that is used. Don't work too close to the limit; the more margin you provide, the better. The units employed in the writer's pack are designed to supply a pair of 45's, in addition to a flock of the usual 24's and 27's, but the entire load imposed is less than 20 milliamperes, the tubes used in the SW-3 being two 35's and a 56. With this light drain the pack runs nice and cool, and there is no sign of the erratic behavior that indicates "saturated" choke-coil cores and "overworked" rectifiers.

Parts List

The following parts were used in the power-pack illustrated. The builder may use his discretion in making substitutions, depending on his own requirements. This pack will easily operate sets using up to six or seven tubes.

- 1—Power transformer, Pilot No. 411. 600 volt, center-tapped high voltage secondary; one 5-volt and two 2½ volt filament secondaries. (Franklin)

- 1—Filter condenser block, Pilot No. 421. One 2 mf., two 3 mf. filter sections, three 1 mf. by-pass sections.
- 1—Double choke unit, Pilot No. 431. Two 25 henry sections.
- 1—Blan special R. F. choke coil, uncased.
- 1—Electrad 25,000 ohm output resistor, with sliding taps. (R.T. Co. "Rite-ohm")
- 1—Four-prong socket for rectifier, Pilot (Alden)
- 1—Five-prong socket for connection cable. (Alden)
- 6—Special Blan block and white metal markers, as shown in photograph. These are very useful for labeling terminals, sockets, etc., in an unmistakable manner. Special labels will be made up to your special order.
- 1—Wooden baseboard, 14 by 8 by 1 inches.
- 1—Alden five-prong plug or old tube base.
- Wires, screws, odd hardware, etc.

The Beginner's 2-Tube "Go-Getter"

(Continued from page 686)

Additional Parts Required

- One bakelite or rubber panel 7"x14"
- One wood baseboard 6"x12"
- Three UX sockets, Pilot (Na-aid)
- Five UX201A type tube bases
- One spool No. 24 D.C.C. magnet wire
- One filament switch
- One vernier dial, Kurz-Kasch (National)
- Necessary head phones, batteries, solder, hook-up wire, etc.

Key to Fig. 2, panel drilling template. Holes No. (1), (2), (3), holes for Cardwell tuning condenser; (4), ant. condenser; (5), regeneration control; (6), filament switch; (7), filament rheostat; (8), head-set binding posts; (9), mounting screws for holding panel upright.

Short Wave League

(Continued from page 673)

take the license seriously, for what does anyone think of a scrap of paper that is received for little or no effort? But even a stronger argument than this is the usefulness of the code. Anyone listening in will frequently hear a phone station modulating with a buzzer to help communication, and what would a "code-less" phone man do around a code ham's shack in an emergency? The amateurs belong with the code and it is practically indispensable to them. I do not see why any ham could not possibly find a use for his code or why he would not wish to have it included in the test, or is it *laziness!*

JOSEPH STAR, W2ESA,
240 Union Street,
Lawrence, L. I.

Amateur Licenses Extended 2 Yrs.

Editor, SHORT WAVE CRAFT:

The Federal Radio Commission ordered, effective January 6, 1933, that all amateur station licenses be extended for a period of two (2) years from the date of expiration of existing licenses.

RULE 27 WAS AMENDED AS FOLLOWS:

"Strike out all of paragraph d and insert the following in lieu thereof:

"d. The licenses for ship stations below 1500 kilocycles will be issued for a normal license period of one year from the date of granting of a new license.

"e. The licenses for amateur stations will be issued for a normal license period of three years from the date of expiration of old license or the date of granting a new license or modification of a license."

QUALITY APPARATUS FOR Short Waves

GEN-WIN SHORT WAVE COIL KIT



These coils are considered the finest made. Each coil is precision wound on a different colored bakelite form for quick identification of wave lengths. Used and highly recommended by all short wave experts. Range (16 to 225) meters, using a .0001 or .00015 mfd. condenser. Recommended for the following sets: "The Globe Trotter," "The Overseas," "The Doerle 12,500 Mile Two Tube Receiver and Doerle Three Tube Signal Gripper," "The Metadyne."

4 Coil Enamel Wire Kit	\$1.50	4 Coil Litz Wire Kit	\$2.25
Broadcast Coil, (200 to 550 meters).....55			

GEN-WIN I. F. TRANSFORMERS
These are accurate I. F. Transformers, designed by America's Foremost Radio Coil Engineers. Engineers everywhere are using and recommending them because of dependable high gain performance, and excellent construction of quality material. Gen-Win I. F. Transformers are individually tested and peaked at our laboratory.

465 K. C. (used in Short Wave Receivers)	\$1.50 Each
175 K. C. (used in Broadcast Receivers)	
115 K. C. (used in All Wave Receivers)	

For the Wunderlich and 55 tubes the above I. F. Transformers (remitter included secondaries) \$1.75 each.

POLICE AND SHORT WAVE ADAPTER

Convert your broadcast set into a shortwave set tuning from 80 to 200 meters.

Get exciting police alarms from stations thousands of miles away. Airplane communications while planes are in flight. Amateur phone and international code communications. The biggest thrill and fun for installed in a fifty tube socket. Specify the detector tube in your set, or if uncertain as to detector tube, advise make and model number of set when ordering.

No. 200—for '27, '27, '37	\$1.39
and '56 Det. tube	Separately 10c.
No. 201—for '21,	\$1.39
'35, and '36 Det. tube	

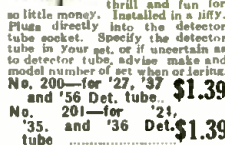

ALL-WAVE COIL KIT

Range 25 to 550 Meters. Comprises a precision wound tuning and R. F. coil, both having tapped secondary which permits you to enjoy both SHORT WAVE and B R O A D-C A S T P R O-G R A M S. If you own an Ambassadors or any other three circuit tuner receiver, you can easily convert it to set also an all wave receiver, by replacing the coil, with these new GEN-WIN ALL-WAVE coils. Coils may be had for use with either .00025 or .0005 Mfd. condenser. Specify which when ordering. Wiring diagram included free with coils. Separately 10c.

All Wave Tuner (as illustrated)	95c
All Wave R. F. Coil	75c



Send remittance in check or money order. Replyer letter if it contains currency.
GENERAL WINDING COMPANY
214 FULTON ST. NEW YORK, N. Y.



STOPPANI BELGIAN COMPASS

A Precision Instrument for Your Laboratory
Worth \$60
your price \$4.50

Gold Shield Products Co.
112 Chambers St. S. W. E.
New York, N. Y.

SUPPRESSED KNOWLEDGE OF THE AGES

Hidden, denied, but not lost, is the miraculous wisdom of the ancients. Their methods of mental power in achieving SUCCESS and MASTERY IN LIFE are available TO YOU. Write for a FREE copy of the "Wisdom of the Sages" and learn how to receive this rare knowledge. MAKE YOUR LIFE ANEW.
SCRIBE: D. Y. I.
ROSICRUCIAN BROTHERHOOD
SAN JOSE CALIFORNIA

OFFICIAL DOERLE WORLD-WIDE Receiver

Improved Doerle Receivers—Absolutely Fool Proof

There have never been produced short-wave receivers which have taken the whole country by storm as much as the now famous DOERLE Receivers. Mr. Doerle described his first receiver, the now famous TWO TUBE 12,500 MILE RECEIVER in the December-January issue of SHORT WAVE CRAFT. You have seen the many letters published in SHORT WAVE CRAFT lauding this receiver to the skies, and for a good reason. It is a low-priced receiver, yet, pulls in short-wave stations from all over the world, REGULARLY, in practically any location, not only in this country, but anywhere. Thousands of experimenters have built their own, and have obtained miraculous results, as hundreds of glowing testimonial letters from radio fans testify.

Recently, Mr. Doerle brought out another receiver, the THREE TUBE SIGNAL GRIPPER, which already has started to make history. There is no question that the three tube job will also make its triumphant tour all over the world. Despite the remarkable performance of these two receivers, our technical staff felt that they could obtain even better results with slight modifications of the circuit. This is especially true of the Three-Tube Signal Gripper. The first type 30 R. F. tube was replaced with a type 34 which is a high gain Screen-grid R. F. amplifier. This has increased the sensitivity and selectivity of these receivers considerably. Yet despite these changes, we have not raised the price of these instruments to you.

In the course of the year, we have received many requests for these receivers, and we have sold a great many parts for both receivers, but not until recently have we concluded our tests which now places us in a position to supply the two complete receivers so that you can either buy them completely wired or in kit form.

By special arrangement with the publishers of SHORT WAVE CRAFT, we are now in a position to sell you these official receivers so that all short wave enthusiasts who ever wished to own either of these fine sets can now be sure to buy them without a question in their minds that they will perform 100%.

It took a lot of labor, and much ingenuity to collect the correct parts to make sure that each receiver would work under all circumstances. This means that all the usual "bugs" have been ironed out by us in such a way that you may order every receiver with full confidence, that in practically every location, anywhere, they will do their stuff.

ONLY FIRST CLASS PARTS USED

It may be possible to buy the parts of the completed sets at a lower price. We admit this at once. But if you will look over our parts list, you will find that only first class material is used. We have done away with all losses. There is no "hand capacity." IN THESE TWO SETS ONLY THE BEST CONDENSERS—AND THAT MEANS HAMMARLUND—ARE USED. The sets could be produced for a considerable less amount if we used cheaper components. We have refrained from doing so because we wanted a first class product. And this goes for everything else in the sets. They are low in price, yet the quality is excellent considering the low price. Thus, for instance, we are using Kurtz-Kauch dials because we found them excellent for their purpose, and as everyone knows, they are really first class verniers. The baseboards are of laminated well-seasoned veneer wood, that will not

warp. Panels are polished aluminum, on which the condensers and other parts are mounted. These panels do away with hand capacity. The plug-in coils are of Bakelite, wound with enamel wire for low losses. In short, despite the exceedingly low price of these sets, we give you quality. Bakelite sockets only are used. Even the aerial condensers are of the Micanoid Equalizing type. We have even included pin-tip jacks, rheostats with "off" positions and binding post strips of Bakelite to keep down losses. In short, you will be pleased not only with the business-like appearance, but with the performance as well.

Only by making these sets in quantities can we afford to sell them at the extremely low prices quoted.

Note the testimonials printed on this page. They will give you an idea what can be expected from these great sets.

HOW DO THE TWO SETS DIFFER?

The TWO TUBE 12,500 MILE SHORT-WAVE SET is intended to be used with headphones, although it is bringing in right along, stations on the loudspeaker. We, however, do not make such a claim. For instance, stations 5,000 and 10,000 miles away come in only on headphones. This set uses two 230 two-volt battery type tubes.

The Improved THREE TUBE SIGNAL GRIPPER, as its name indicates, is a three tube set. It uses a type 34 screen grid R. F. amplifier followed by a Type 30 regenerative detector and finally a type 30 A. F. Amplifier. It is a great deal more powerful than the smaller set and will bring in stations from great distances on the loudspeaker. A good magnetic loudspeaker should be used. Thus, for instance, stations from all over the country come in on the loudspeaker, but, of course, stations 12,000 miles distant require the use of earphones.

The price of the two sets include a set of plug-in coils. Both sets are operated from ordinary dry cells. The "B" battery supply can be either 90 volts or 135 volts for the THREE TUBE SIGNAL GRIPPER. For the TWO TUBE SET, 90 volts is sufficient.

Both sets tune exceedingly easy, and the oscillation control is always under full control of the operator. The vernier dials are accurate so that stations can be logged and found in their allotted positions every time you use the set.

OUR OWN TESTS

Both sets have been tested by us, and we found that they do all and more claimed by Mr. Doerle, and other enthusiasts who built the sets, especially since they have been improved. We refrain from giving you the astonishing list of stations which we ourselves have logged because we do not wish to let our enthusiasm run away with us, and because you might not believe the actual results accomplished with this set. We much rather have others talk about the results.

Incidentally, we have, as yet, to receive a single complaint on these sets, although we sold a large quantity of parts for both of them.

WHAT THEY SAY!

"Does All You Say!"

I have built the Doerle short wave receiver and I want to say it does all you say it will.
J. Joseph Whalley, 401 Springdale Street, Cumberland, Md.

Some List!

I have just completed your Doerle two-tube. I received the following on the loudspeaker: NJA, LQA, GMB, VE9DH, VE9GW, KKQ, W1XAZ, W1XAP, W1XAL, W1XAL, W1XAB, W1XK, W1XAL, W1XK, W1XAA, Bermuda, Honolulu, Budapest, Hungary, and "hams" in 36 states

This is Going Some!

Today is my third day for working the Doerle set, and to date I have received over fifty stations. Some of the more distant ones I shall list: From my home in Maplewood, N. J., I received the following: W1R, Atlanta, Ga.; W1K, Ohio; W0BHM, Ft. Wayne, Ind.; W1AYR, Elm, Ill.; W1ERK, Girard, Ohio; and best of all, NJA, Mexico; PZA, Surinam, South America; THH, Carriago, Costa Rica, (GWM, Leeward, Etihad). I have also received stations WDC and PJQ, which I have not found listed in the call book.

A Good Word for the Doerle

I would like to put a word in for the Doerle 12,500 mile receiver. I recommend this set to all "set wreckers" in a big way! Hoping that this set "perks" for all "hams" in a big way.
H. J. Keilholz, 1508 Belt Street, Baltimore, Md.

A Doerle Enthusiast

I have just completed my two-tube Doerle, and it surely is a great receiver! It works fine on all the wavebands. Nobody could wish for any better job than this one. I can set W8XX and W9XAA to work on the loudspeaker at night, and the code stations come in with a wallop behind them.
Samuel E. Smith, Lock Box 241, Grayling, Mich.

Two Tube 12,500 Mile Doerle Receiver | Improved 3-Tube Doerle Signal Gripper



\$8.90

This receiver is exactly as illustrated in our photographs. Size of aluminum panel is 9 1/4 inches, base 9 1/2 inches. List of material used: 2 Hammarlund .00014 Condensers; 1 Carter 20 ohm Rheostat and Switch; 1 Peerless Audio Transformer; 2 Kurtz-Kauch Vernier Dials; 3 Bakelite Low Loss Sockets; 1 Micanoid Equalizer; Antenna Condenser; 1 .0002 Aerovox Pined Condenser; 1.5 medium Carburetorum Grid Leaks; 2 Telephone Pin Jacks; 1 Aluminum Panel; 1 Veneer Baseboard; 1 Bakelite Rheostat Knob; 1 Bakelite Binding Post Strip; 1 Set of 4 Bakelite Short Wave Plug-in Coils, Instructions for Operation; 1 Set of Hardware, Wire, etc. Complete shipping weight 5 lbs.

No. 2140. TWO TUBE 12,500 MILE DOERLE SHORT WAVE RECEIVER, completely wired and tested as per above specifications. **YOUR PRICE \$8.90**

No. 2141. TWO TUBE 12,500 MILE DOERLE SHORT WAVE RECEIVER KIT, with all parts as specified above, but not wired, with blue print connections and instructions for operation. Complete shipping weight 5 lbs. **YOUR PRICE \$7.70**

No. 2142. COMPLETE ACCESSORIES, including the following: 2 six months guaranteed Neutrons type No. 230 tubes; one set of No. 1078 Brandes Matched Headphones; 2 No. 6 standard dry cells; 2 standard 45 volt "B" batteries, complete, shipping weight 22 lbs. **YOUR PRICE \$5.40**



\$11.85

This receiver also, is exactly as shown in our photographs. The aluminum panel measures 10 3/4 x 7 1/4; baseboard 10 1/4 x 8 inches. It comprises the following parts: 3 Hammarlund .00014 Tuning Condensers; 1 Carter 20 ohm Rheostat and Switch; 1 Peerless Audio Transformer; 2 Kurtz-Kauch Vernier Dials; 2 Sets of Short Wave Coils; 1.5 Micanoid Carburetorum Grid Leaks; 2 RTR Grid Chokes; 3 Bakelite Low Loss Sockets; 2 Micanoid Equalizing Aerial Condensers; 1 Bakelite Binding Post Strip; 2 Telephone Pin Jacks; 2 Bakelite Knobs; 1 Aluminum Panel; 1 Veneer Baseboard, One Set of Directions and Instructions for Operation; 1 Set of Hardware, Wire, etc. Shipping weight 7 lbs.

No. 2143. Improved THREE TUBE DOERLE SET, completely wired, ready to use. **YOUR PRICE \$11.85**

No. 2144. Improved THREE TUBE DOERLE SET IN KIT FORM with all parts, as specified above, but not wired, with blue print connections and instructions for operation, complete. Shipping weight 7 lbs. **YOUR PRICE \$10.50**

No. 2145. COMPLETE ACCESSORIES, including the following: 2 six months guaranteed Neutrons type No. 230 tubes; one set of No. 1078 Brandes Matched Headphones; 2 No. 6 standard dry cells; 3 standard 45-volt "B" batteries; 1 B.B. 4 inch Coil; 1 Micanoid Equalizing Aerial Condenser; 1 Bakelite Binding Post Strip; 1 Bakelite Loudspeaker, complete. Shipping weight 32 lbs. **\$11.00**

GUARANTEE

We guarantee and warrant that all material furnished in the two sets described in this advertisement, whether in the completed set or in the kit form, is first class, in every respect; that the complete sets have been tested before shipping, and that we will stand back of these sets and kits in every way. We will replace any parts, with the exception of accidentally blown out vacuum tubes within three months, if parts are returned to us within that time.

PLEASE NOTE

We are short wave specialists. Please understand that the two sets here described are not the only ones which we produce. We can furnish parts in kit form, of practically any short wave receiver described in SHORT WAVE CRAFT or other radio magazines. Get our prices first. We will save you money.

ORDER FROM THIS PAGE | Send money order or certified check. C.O.D. only if 20% remittance accompanies all orders. Order NOW—TODAY

FREE 100-page Radio and Short Wave Treatise; 100 hook-ups, 1,000 illustrations, Enclose 4c for postage. Treatise sent by return mail.

RADIO TRADING COMPANY, 100A Park Place, New York City

When To Listen In

By ROBERT HERTZBERG

Reports from short-wave set owners regarding reception of the new British Empire stations have been rather meagre. GSA, on 6050 kilocycles (49.59 meters) and GSC, on 9585 kilocycles (31.30 meters) are supposed to be on the air between 8:00 and 10:00 p. m. E. S. T. for the benefit of Canada, but the writer has not been able to spot them on either of two receivers during several different evenings of listening. Apparently these stations are also testing earlier in the day, as they have been heard by Richard F. Shea of Ridgewood, L. I. With 20 kilowatts and a directional aerial they should come in with plenty of "sock."

While scanning the 31 and 49 meter channels recently, the writer heard some strange sounds that turned out to be Ed Wynn's program, being relayed through W2XAF, Schenectady, on 9530 kilocycles, which was very weak, and also by an extremely powerful station that later identified itself as W4XB, Miami, Florida. The latter, on 6040 kilocycles, literally blanketed the band and may quite possibly have been drowning out the British transmitter.

At ten o'clock, still on the 49 meter channel, another very strong station that had been broadcasting squeaky phonograph music, with announcement in Spanish, switched suddenly to English. "This is station YV1BC, broadcasting on a frequency of 960 kilocycles and also on 6120 kilocycles," said the voice. "We are located in Caracas, Venezuela, and welcome reports from listeners, which are all acknowledged."

According to the call lists, this station uses 6,000 kilocycles for its high frequency broadcasting, but the higher value checked correctly with the dial settings. Between (about) 8:00 and 9 p. m., but not later than 10:00 p. m. this station is unquestionably the star performer on the short waves at the present time.

Mr. William S. Russ, 227 Columbus Avenue, New York, N. Y., sent a report to Caracas and was rewarded with the most impressive acknowledgment we have ever seen. This takes the form of a 16-page booklet, printed in both Spanish and English and describing both the city of Caracas and the transmitting station. It is profusely illustrated and, even includes a full page map of North and South America, showing the distances between Caracas and various cities on the two continents. This is indeed a prize for short wave fans.

Regarding Commercial Phones

It is a waste of time and effort to write to any of the commercial trans-oceanic telephone stations with the idea of receiving acknowledgments. You will be told, quite politely but firmly, that the conversations you heard were none of your business and the stations are not maintained for your amusement, but for the transaction of business.

Those "Noise-Free" Antennas Again

The subject of "noise-free" antennas is receiving considerable attention from all radio users, and particular attention from short-wave listeners because noise on the short waves is very bad in many locations. To straighten out some common misunderstandings, the writer wishes to contribute the following remarks.

All of the "noise-free" antenna systems now on the market, regardless of the type of lead-in employed, depend for their operation on the complete isolation of the aerial wire itself, with the lead-in acting merely as a connector and doing no "aerialing" on its own accord. If the aerial cannot be placed free and clear of the main source of the local interference, the special lead-in is just so much money thrown away. Too many people expect the lead-in to accomplish magical results, and they are outspoken in their denunciation of it when they find it doesn't help much in their own locations. Contrary to

general opinion, the lead-in itself does not and cannot eliminate noises picked up by the aerial; it can only reject the noises it would pick up itself.

A case in point is the experience of a resident of New York who lives in one of those houses troubled with interference from elevator control switches. These switches and all the machinery associated with them are located in a roof-top penthouse, as they are in most buildings. These very penthouses, because of their height, make convenient places from which to hang radio aerials, as any traveler on the New York elevated railroad knows!

This man, after reading of the wonders of various "noise free" antennas, strung a special lead-in, and connected it to his previous aerial, strung from the elevator penthouse. Did the new lead-in eliminate the noise? Of course it didn't, because the arcing switches were only about eight feet, airline, from the end of the aerial wire.

The roof being six stories from the set owner's apartment, and the latter another eight stories above the street, this man tried another stunt at the suggestion of a radio engineer neighbor. He dropped a vertical wire from the edge of the roof down to his window, with the upper insulator about six feet below the roof. The roof aerial was discarded altogether. Result: a noticeable reduction of switch noise with no appreciable difference in signal strength. A vertical wire, if it is free enough, happens to be the best kind of aerial.

Moscow? Perhaps

A reader writes in to say that he heard a voice shout "Allo Moscow" in the middle of the crowded 49 meter band during a momentary let-up, and wants to know if he picked up that city. (This letter is typical.) The answer is, "Probably not." If the voice said "Allo" it was coming from another city, calling Moscow.

Please don't jump at hasty conclusions. An all-German program is likely to be coming through a "local" station under the sponsorship of a Yorkville beer garden; the writer once wasted an hour on such a "teaser" and discovered finally that he was hearing a harmonic of a station one-half mile away!

Short Wave Events of the month

The following events furnished by courtesy of Columbia Broadcasting System.

- Dec. 18—12:30-12:45 p. m.—"The News from Toy Town." Talk by the Mayor of Nuremberg from Nuremberg, Germany.
- Dec. 24—6:59-7:30 p. m.—Midnight Mass from the Church of the Madeleine, Paris.
- Dec. 25—12:30-1:00 p. m.—Christmas Carols from London, Paris, and Berlin.
- Dec. 31—5:55-6:15 p. m.—Students Chorus from Auerbach's Keller, Leipzig, Germany.

WHAT DO YOU KNOW ABOUT Super-Regenerators?

In the April Issue DON'T MISS

"The Oscillodyne"

A new 1-tube Super-Regenerator, based on a brand new principle!

NEW SENSATIONAL OFFER

Learn RADIO

PAY FOR TRAINING AFTER YOU GRADUATE



To a few honest fellows I am offering a 1 opportunity to get a training and pay for it after they graduate in easy monthly payments. You get Free Employment Service for life. And if you need part-time work while at school to help pay expenses, we'll help you get it. Coyne is 33 years old. Coyne Training is tested—You can find out everything absolutely free. Just mail the Coupon for My Big Free Book.

Jobs Leading to Salaries of \$50 a Week and Up

Jobs as Designer, Inspector and Tester—as Radio Salesman and in Service and Installation—as Operator or Manager of a Broadcasting Station—as Wireless Operator on a Ship or Airplane, as a Talking Picture or Sound Expert—Hundreds of Opportunities for fascinating Big Pay Jobs!

10 Weeks' Shop Training AT COYNE IN CHICAGO

We don't teach you from books. We teach you by Actual Work on a great outlay of Radio, Broadcasting, Television, Talking Picture and Code equipment. And because we cut out useless theory, you get a practical training in 10 weeks.

TELEVISION Is Now Here!

And Television is already here! Soon there will be a demand for Television Expert! The man who gets in on the ground floor of Television can have dozens of opportunities in this new field! Learn Television at Coyne on the very latest Television equipment.

Talking Pictures A Big Field

Talking Pictures, and Public Address Systems offer golden opportunities to the Trained Radio Man. Learn at Coyne on actual Talking Picture and Sound Reproduction equipment.

Get the Facts

Don't spend your life slaving away in some dull, hopeless job! Don't be satisfied to Work for a mere \$20 or \$30 a week. Let me show you how to make Real Money in Radio—the fastest-growing, biggest money-making game on earth! Get my big Free book and all details of my pay after graduation offer. Mail the coupon today.

H. C. LEWIS, President
Radio Division, Coyne Electrical School
500 S. Paulina St., Dept. 33-2K, Chicago, Ill.

Dear Mr. Lewis:
Send me your big Free Book: details of your Free Employment Service; and tell me all about your special offer of allowing me to pay for training on easy monthly terms after graduation.

Name

Address

City..... State.....

D. X. SPECIAL

CUT OUT INTERFERING STATIONS & ENJOY FOREIGN PROGRAMS

Just Fix a Pix in the aerial terminal and increase the range and selectivity—permits knife-edge tuning—two million European users. Once "fixed" you're fixed to bring in distant concerts.



FIX A PIX IN YOUR AERIAL

POSTAL RADIO
133-35 Liberty St., Dept. SW, N. Y. City

FREE 104 Page RADIO and SHORT WAVE TREATISE



Avail yourself now of the opportunity to receive the free 1933 winter edition of our Radio and Short Wave Treatise. No. 26, 104 solid pages of useful information.

Over 100 New Hook-Ups, Etc. 1000 Illustrations. Incidentally all our previous issues, you are familiar with the type of book we publish; but the new No. 26—what a book! The entire editorial section is new from beginning to end—not an old word remains. Considerable space has been devoted to articles for the radio beginner. This alone is worth its weight in gold. The Superheterodyne principle is thoroughly explained in this issue in clear, simple language. No. 26 is not just another catalog. It contains more valuable and up-to-date information than can be found in any radio text book on the subject.

PARTIAL LIST OF CONTENTS

Fundamental Principles of Radio—Ohm's Law—Discussion of New Tubes—Constructing a Triple Tuning Amplifier—Constructing a Tiny A.C.-D.C. Portable Receiver—All About Superheterodynes—Eliminating Man-made Static—Constructing a Two-tube Short Wave "Globe-trotter" Receiver—Completely revised and up-to-date Radio Tube Chart—\$5.00 Prize Suggestions—Radio Kinks, Etc., Etc.

WRITE TODAY. Enclose 4 cents for postage. Treatise sent by return mail.

RADIO TRADING CO.

100A Park Place New York City

New Way to At Learn the Code Home

Make Your Own Records

Easy to Make Easy to Read with



The NEW MASTER Teleplex

The only instrument ever produced that will record your own sending in visible dots and dashes and then repeat it to you audibly on headphones. Revolutionizes the teaching of code—makes learning easy, fascinating and rapid. No experience required. Designed for U. S. Signal Corps. Marvelous say radio and electrical engineers. Loaned with Complete Code Course without additional cost. Write today for folder BW-3 giving full details.

TELEPLEX CO., 76 Cortlandt Street, New York, N. Y.

PHILA. RADIO SCHOOL

Courses in Radio Broadcasting, Wireless Operating, Radio Servicing and Electric Refrigeration.

J. C. VAN HORN

(formerly Vice-Pres. R. C. A. Institutes)
1533 Pine Street, Philadelphia, Pa.

At Last! A 4-Tube Super-het!

(Continued from page 653)

the previous paragraph there is nothing in the assembly that should present difficulties.

Wiring

Every thing is mounted to the chassis by means of screws. It is wise to study just how the various connecting wires are to be run before starting wiring. As the various parts are mounted place soldering lugs under the nuts wherever a connection is to be made to the ground. This will speed things up considerably. All of the resistors and condensers are mounted by their pig-tails, except the electrolytic filter condenser, which is mounted by means of the bracket. This bracket is nothing but a strip of tin about 3/8 inch wide and long enough to make a strap around the condenser.

Run the wiring in a direct fashion for the best results. Make sure that every connection is a good one. The condensers and resistors are mounted and held in place by the soldered connections and poor soldering will result in high resistance contacts, making the set very unstable in operation.

A study of the photographs will show how most of the wiring is done. Follow the pictures for placement of resistors and tubular condensers. They are all placed in such a way that the leads supplied with the condensers are long enough to make all necessary connections.

The Oscillator Coil

The oscillator coil does not tune to the same frequencies that the antenna coil tunes. This is due to the fact that the oscillator has to tune to a frequency removed from the incoming signal by the value of the intermediate frequency. Thus, if the oscillator coil is not altered by the removal of turns from its winding, there will be considerable difference in the setting of the oscillator tank condenser when receiving signals. This difference will diminish with the increase in frequency of the incoming signal, but above 80 meters changes can be made in the number of turns on the oscillator coil so that the tank condensers will track. Do not remove turns from the oscillator coil until the intermediate frequency has been decided upon and the intermediate frequency circuits tuned to that frequency by means of a calibrated oscillator. When making the preliminary tests it is not necessary to change the oscillator coils. Simply set the oscillator tank condenser to a lower value of capacity.

Note that the loud-speaker connections are taken off through a 4-prong socket and plug, using 2 pins for the voice input and two for the field.

Operation

Place the tubes in their respective sockets as indicated in the diagram and plug in the speaker. Insert a set of coils with identical characteristics in the coil sockets and turn on the power. The power switch is mounted on the antenna volume control. Connect the antenna and ground. Set the tuning condensers at 100. Tune by turning both oscillator and antenna tank condenser knobs at the same time. Tune slowly because it is easy to pass stations with the

tank condensers. As soon as a signal is heard note the position of the tank condensers. If the tank condensers line up then try the regeneration control. A real increase in signal should be obtained as the regeneration control knob is rotated clockwise. If the second detector does not oscillate reverse the leads to the feed-back coil.

Use a good antenna and ground. The antenna should be about 40 feet long. Test reception from four foreign countries on the loud speaker testifies to the possibilities of this receiver.

IN NEXT ISSUE!!
The "S. W. C."
Readers' Ideal
"COMPOSITE"
Receiver
The One YOU Voted For!!

Conclusion

The reaction of the writer is that this is a very interesting circuit and that it is capable of great results. In fact it seems likely that more could be done along this line. Methods can be tried to increase the sensitivity. In fact, the author is going to try several things, including changing over to grid-leak and condenser in the second detector circuit, and using low values of condenser and low values of resistance in the grid-leaks. While the circuit is simple there are many pitfalls for the unwary constructor and extreme care should be followed in the construction and wiring for satisfactory results. It is very important that the builder have a test oscillator that is calibrated so that notations can be made of the various intermediate frequencies used. When the final choice of the intermediate frequency is made then the turns can be removed from the oscillator coil so that the tank condensers will track at the higher frequencies.

Parts List

- One Hammarlund MC35X Dual tuning condenser. 35 mmf. capacity (5, 12)
- Two Hammarlund MC 100 M, 100 mmf. midjet condenser. (6, 13)
- One National Velvet Vernier Dial. Type B Dual Range.
- Two National Screen grid clips.
- Two National Tube Shields Type T58 (Hammarlund)
- One Blan Special Chassis. Aluminum, drilled and folded.
- One Eby antenna ground terminal (1, 3) (Cinch)
- One Eby phone terminal strip. (27)
- One Acratest 10,000 ohm potentiometer and power switch. (2, 35) Type 6169 (Claro-stat)
- One Acratest 50,000 ohm potentiometer, Type 6156 (18) (Claro-stat)
- Two sets of Na-ald short-wave coils.

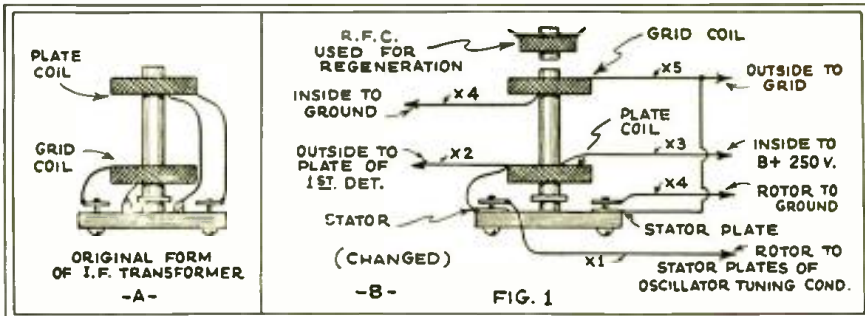

Details of changes in I.F. transformer so as to permit coupling of regeneration coil.

- Three four prong sockets, wafer type. (4, 8, and speaker connector) Alden.
- One four prong wafer socket marked 280. (31) Alden.
- Two six prong wafer sockets, (7, 20) Alden.
- One five prong wafer socket. (26) Alden.
- One 1800 ohm field dynamic speaker with output transformer for single pentode. (30)
- One Flechtheim Superior Electrolytic condenser Dual 8 mf. (28, 29) (Concourse)
- One Flechtheim Superior Electrolytic condenser 25 mf., 30 volts. (32) (Concourse)
- Four Flechtheim Tubular Condensers. .09 mf. 1000 volts Type Az-27. (14, 16, 17, 19)
- Two Flechtheim Tubular Condensers. .01 mf., 1000 volts. Type Az-17. (10, 23)
- One Flechtheim Tubular Condenser. .006 mf., 1000 volts. (25)
- One R.F. Choke, Blan special. (11)
- Gen-win 465 kc. I.F. Transformer. (10)
- One Acme four-tube, power transformer. (34) (Franklin)
- Two International resistors, One watt, 25,000 ohms. (9, 19) (Lynch)
- One International resistor, 1 watt, 75,000 ohms. (15) (Lynch)
- One International resistor, 1 watt, 300,000 ohms. (22) (Lynch)
- One International resistor, 1 watt, .5 meg. (24) (Lynch)
- One Acratest, 2 watt resistor, 400 ohms. (33) (Lynch)
- One Acratest mica condenser. .001 mf. (21) (Polymet)

Names given in parentheses indicate other makes of apparatus which may be used.

How to Become a Radio Amateur

(Continued from page 674)

parallel across the feeders at the coupling coil. When they are less than one-half wavelength long and multiples thereof, series condensers are used at the coupling coil. In any case the proper indicator for resonance and output is the plate meter; reduce the coupling if the oscillator stops functioning when resonance is approached. The feeders must be of the same length each, but only one is connected to the antenna as shown in the diagrams.

Current-feed systems, like the voltage-feed systems, are used as location dictates. When the location allows a "V"-form, the apex of which can be brought directly to the transmitter tank, coupling takes the form of a separate tank coil to which the antenna wires are connected; tuning can be by parallel or series condensers, depending on the amount of the inductance in the coupled circuit. The plate ammeter should be used for resonance indication. Should lack of space dictate the use of an antenna that is located away from the transmitter at some distance, feeder wires are resorted to. As in the case of voltage feed they are separated with wood spacers, which keep the feeders 4 to 6 inches apart. The feeder wires are the same length each and connect to the center of the antenna, or at points which are one quarter wavelength from one or the other end, while the longer end is three-fourths or five-fourths long. The feeder wires are coupled to the transmitter tank through a tank that is tuned with series or parallel condensers. An ammeter placed in each of the feeder wires should read the same current value, as otherwise the feeders will not be true feeders and will have a tendency to do a little radiating on the side. As in the other instances the plate ammeter is the best guide to resonance.

When two feeder wires are not convenient, a one-feeder wire system can be used; its connection to the antenna must be exactly at a point that is one fourteenth of the wavelength in meters the antenna is built for from the middle of the antenna. The feeder should come away from the antenna at right angles for best results; coupling is as usual through a tank coupled to the transmitter tank and Resonance indication is by plate ammeter.

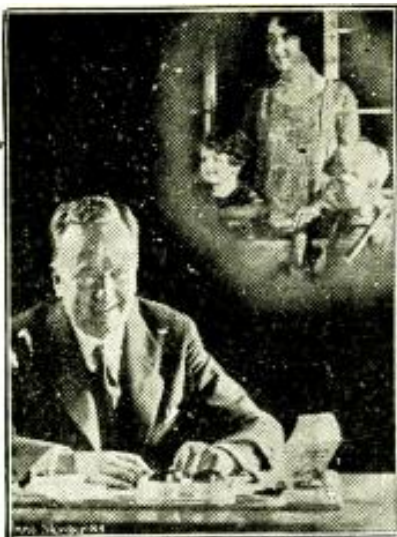

What Wouldn't You Do for Them

YET you may be overlooking the most vital thing of all for their future security and happiness—**MONEY.**

If you were taken away tomorrow, what would they have to live on? Could the children go on through school? Could mother earn enough for them?

Life insurance is now sold by mail at so small a cost **NO ONE** need be without its splendid protection. We now offer a special old line, legal reserve life policy for as low as \$4.13 at age 35 (other ages in proportion)—a policy paying you \$1,000 with an additional \$5,000 special travel accident benefit; disability benefits, loan values, and other advantages. Think of it! No family can afford to be without such protection, at so trifling a cost.

We sell entirely by mail, hence these savings—no agents' commissions, no medical fees, no extras, no red tape. **YOU** save the difference.

Mail the coupon below. We will send you a free sample policy which you can judge for yourself. If you like it, keep it. If you don't, there's not a cent of cost or obligation.

For your own peace of mind, for the security of those you love, get this low-cost protection while you **CAN.** Mail the coupon now.

FREE! Mail this coupon TODAY for sample policy and complete details.

Union Mutual Life Company of Iowa, (Box 214)
Des Moines, Iowa.

Send me above described Free sample policy and complete details—this is not to obligate me in any way.

Name.....

Address.....

Age..... Occupation.....

Get Started in RADIO



Write for free booklet telling about this growing and most promising industry. Resident courses in
RADIO OPERATING RADIO SERVICING

EDUCATIONAL DEPARTMENT
WEST SIDE YMCA 18 W. 63rd St. New York

SUN RADIO CO.

announce their removal to
227 FULTON ST.
COR. FULTON AND GREENWICH STS.
NEW YORK CITY

"If It's Radio—We Have It."

TREMENDOUS stock of
parts and accessories at
LOWEST PRICES

WE ARE OFFICIAL HEADQUARTERS for
Weston, Jewell & Supreme Meters
Set Testers and Tube Testers

All back numbers of SHORT WAVE CRAFT may now be had at 25c per copy.
Address: SHORT WAVE CRAFT, 98 Park Place, New York, N. Y.

New! New!! New!!! TWO NEW 25c SHORT WAVE BOOKS

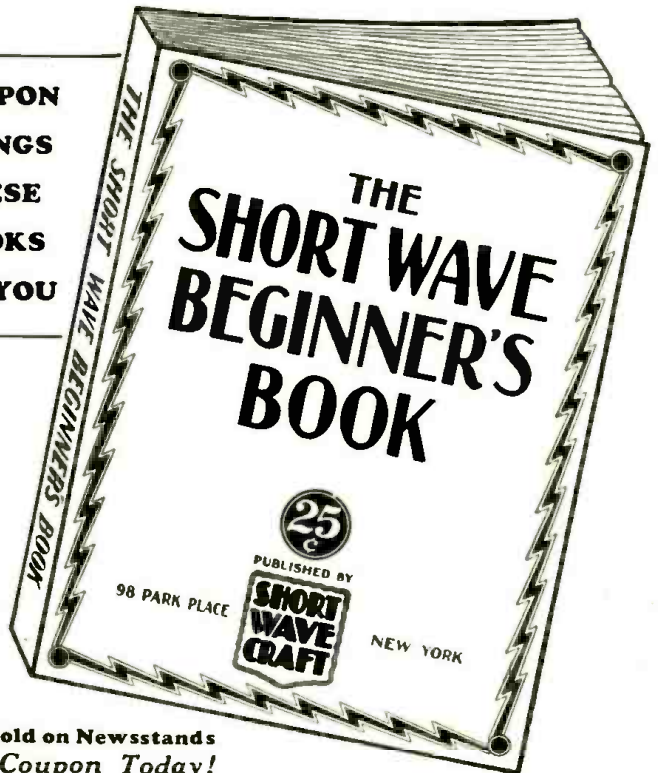
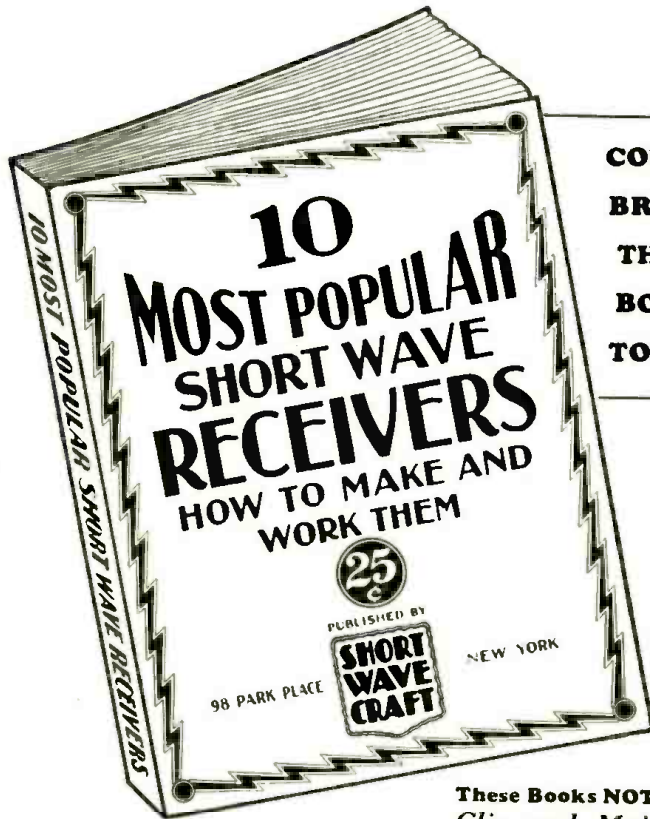

**COUPON
BRINGS
THESE
BOOKS
TO YOU**

**These Books NOT Sold on Newsstands
Clip and Mail Coupon Today!**

HERE IS GREAT NEWS

PURSUANT to many requests from our readers, we have decided to publish two new popular short wave books, for which there is a persistent demand at this time. These new books contain everything on the subjects worth knowing and both books will be welcomed by all short wave experimenters, short wave fans and short wave enthusiasts, the same as our former two books **HOW TO BUILD AND OPERATE SHORT WAVE RECEIVERS**, and **HOW TO BECOME AN AMATEUR RADIO OPERATOR** were welcomed by thousands of our short wave friends.

In conformity with the times these books have been priced at 25c

instead of 50c, which is the price of our other books. Yet the two new 25c volumes that we are offering now contain a tremendous amount of information and the type and illustrations have been chosen in such a manner as to give you almost as much for your 25c as you received for your 50c before. Only by increasing the press run enormously and making other printing economies has it been possible to price these books at such a low, popular price.

You will make no mistake in getting either or both of these new and popular books and we know in advance from our many years of experience with short wave enthusiasts that you will thank us for having made these books possible.

Ten Most Popular Short Wave Receivers. How to Make and Work Them

This new volume will be a revelation to all those who wish to build their own short wave receivers. The editors of **SHORT WAVE CRAFT** over a period of years have learned to know exactly what short wave experimenters and short wave set builders want to get. For that reason they have selected ten outstanding short wave receivers and these are described in the new volume. Everything worthwhile about every one of the ten receivers is described in the text. Each receiver is fully illustrated and complete, hookup and all worthwhile specifications, so there is nothing left to your imagination when it comes to building any one of these ten popular receivers. Everything from the simplest one tube set to a six tube superheterodyne is presented, complete as it is humanly possible to do. You can select any or all receivers and know beforehand that you will be able to successfully build and operate such a receiver and not waste your money in building some theorist's dream-child. You will also be shown how to operate the receiver to its maximum efficiency.

IMPORTANT

THERE IS NO DUPLICATION WHATSOEVER BETWEEN THIS BOOK AND OUR OTHER VOLUME — **HOW TO BUILD AND OPERATE SHORT WAVE RECEIVERS**. ALL THE MATERIAL PUBLISHED IN THE NEW BOOK HAS NEVER APPEARED IN ANY BOOK BEFORE.

This book has been edited by the editors of **SHORT WAVE CRAFT**, which alone is a guarantee that you will get satisfaction and that nothing has been left undone to give you between two covers the greatest selection of short wave receivers ever published.

**PRICE 25c PREPAID 40 PAGES
OVER 75 ILLUSTRATIONS**

A Short Wave Beginners Book

Here is a book that will solve your problems if you are new to the short wave game. It contains positively everything that you would wish to know in connection with short waves, leading you in easy stages from the simplest fundamentals to the present stage of the art in short waves as it is known today. It is the only low-priced reference book on short waves for the beginner, whether he be a short wave enthusiast, short wave listener or short wave amateur.

The book is profusely illustrated with all sorts of illustrations, explanations and everything worthwhile knowing about short waves in this interesting and growing field. Yet without, the book is not "technical." It has no mathematics, no "high-faluting" language and no technical jargon which would only serve to frighten you away. *The entire book is kept in popular language throughout.* Wherever technical words are used, explanations are given, leaving nothing to the imagination. You are shown how to interpret a diagram and a few simple sets are also given to show you how to go about it in making them. Yet everything has been done to make it possible to give you a complete understanding of short waves from the ground up.

After reading this book, you will never be at a loss for short wave terms and you will not have to consult other text-books or dictionaries. The editors of **SHORT WAVE CRAFT** who have edited this book have seen to it that everything has been done to make this volume an important one that will be used as reference for years to come by all those who wish to break into the short wave art. The book covers everything, "from soup to nuts" and will be of tremendous importance to everyone.

It abounds with many illustrations, photographs, simple charts, hook-ups, etc., all in simple language. It also gives you a tremendous amount of very important information which you usually do not find in other books, such as time conversion tables, all about serials, noise elimination, how to get verification cards from foreign stations, all about radio tubes, data on coil winding and dozens of other subjects.

The book is just chock full of information and you will never regret having gotten this important volume. You will keep referring to it every day in your work.

**PRICE 25c PREPAID 40 PAGES
OVER 75 ILLUSTRATIONS**

SHORT WAVE CRAFT 96-98 Park Place, New York City. **SW-3-33**

I enclose herewith 25c, for which please send me as soon as published, prepaid, a copy of your new book "Ten Most Popular Short Wave Receivers, How to Make and Work Them." The book to be sent to me immediately upon publication.

I enclose herewith 25c for which please send me as soon as published, prepaid, a copy of your new book "The Short Wave Beginner's Book." The book to be sent to me immediately upon publication.

I enclose 50c for which please send me, prepaid, as soon as published, your two books, "Ten Most Popular Short Wave Receivers, How to Make and Work Them," and "The Short Wave Beginner's Book." The books to be sent to me immediately upon publication.

(Send money order, check, cash or new U. S. stamps. Register letter if it contains currency or stamps).

Name _____
Address _____
City _____ State _____

DATAPRINTS

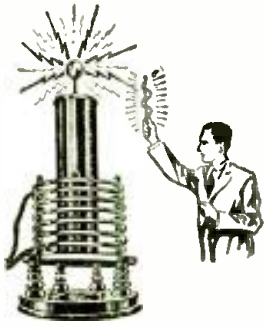

Give Technical Information on the Building of Worthwhile Apparatus

Dataprint containing data for constructing this 3 ft. spark Oudin-Tesla coil.

..... \$0.75
Includes condenser data.

OTHER "DATAPRINTS"

TESLA OR OUDIN COILS

- 36 inch spark, data for building, including condenser data\$0.75
- 8 inch spark, data for building, including condenser data 0.75
- Violetta type, high frequency coil data; 110 volt A.C. or D.C. type; 1" spark; used for giving "violet ray" treatments 0.75
- How to operate Oudin coil from a vacuum tube oscillator 0.75

TRANSFORMER DATA

- Any size, 200 to 5000 watts. (1 primary and 1 secondary voltage data supplied—specify watts and voltage desired)\$1.00
- 1 k.w. 20,000-volt transformer data, 110-volt, 60-cycle primary. Suitable for operating 3 ft. Oudin coil 0.50
- 1/4 k.w. 15,000-volt transformer data, 110-volt, 60-cycle primary. Suitable for operating 8-inch Oudin coil 0.50
- Induction Coils—1 to 12 inch spark data 0.75

MAGNET COIL DATA

- Powerful battery electro-magnet; lifts 40 lbs.....\$0.50
- 110 volt D.C. magnet to lift 25 lbs. 0.50
- 110 Volt D.C. solenoid; lifts 2 lb. through 1 inch 0.50
- 110 Volt D.C. solenoid, lifts 6 lb. through 1 inch 0.50
- 12 Volt D.C. solenoid, lifts 2 lb. through 1 inch 0.50
- A. C. Solenoid, powerful, 110-volt, 60-cycle..... 0.50
- MOTOR—1/16 H.P., 110 volt A.C. 60 cycle (suitable for driving 12" fan or light apparatus), constructional data 0.50
- 1200 cycle Synchronous motor 0.50
- 60 cycle Synchronous motor..... 0.50

TELEGRAPHONE—Records Voice or "Code" signals on steel wire by magnetism. Code can be recorded "fast" and translated "slow". Construction data (special)\$0.50

CLOCKS—Electric chime ringer. How to make one to fit on any ordinary clock 0.50

MISCELLANEOUS DATAPRINTS—

- Electric Ice Skates—How to make..... 0.50
- How to Thaw Pipes by Electricity 0.75
- 20 motor circuits—hook-ups 0.75
- 20 practical telephone hook-ups..... 0.50
- Treasure Locator 0.50
- 100 mechanical movements for inventors 0.50
- Polarized Relay—Ultra Sensitive 0.50
- Electro-medical coil (shocking coil) 0.50
- REFRIGERATION MACHINE — Dataprint —**
How to Make Data 1.00

SLIDE RULES—Specially Selected

- Students' 10-inch wood slide rule, accurately engraved (prepaid)\$1.10
- ELECTRICAL** Slide Rule, 10 inch size, with special electrical law ratios and indexes, wood with white Ivorine scales, prepaid 5.75
- 5" "Pocket" slide rule 4.00
- "Circular Pocket" slide rule. Fits vest Pocket, 2 1/2" diameter, leather case 4.00
- Student's circular slide rule 1.50

(Postage 10 cents extra on last three slide rules.)

The DATAPRINT COMPANY
Look Box 322 RAMSEY, N. J.

Methods of Coupling to Speakers

(Continued from page 659)

not less than 2000 ohms. It is useful for this reason with magnetic speakers and headphones.

When a pentode is used in the output stage the most common coupling method is to use a transformer. This transformer must have a much higher primary impedance than that used for a triode. If a *tapped choke* is available the choke method of coupling can be used. The choke should be tapped one-third of the way from one end. The total inductance of the choke may be about 20 or 30 henries; the plate of the tube should be connected to the end of the choke nearest the tap. The other end of the choke goes to "B" plus. A 2 mf. condenser is connected from the tap to one terminal of the loud-speaker. The other terminal of the loud speaker goes either to ground or cathode, as with the triode tube. This method of coupling for a pentode has been used but little in this country, but is very popular in England. See Fig. 4.

Push-Pull Output

When the output stage is push-pull type it is also possible to use either choke or transformer coupling. Figure 5 illustrates a simple method of coupling a magnetic type speaker to the output of a push-pull stage. See Fig. 5. This method may also be used where a transformer is used in the output of the amplifier. If the transformer has a low-impedance secondary for the voice coil of a dynamic speaker, it is possible to add a magnetic type speaker in this way. See Fig. 6.

The methods of determining the impedance of a transformer for the output of tube is quite involved, but for triodes the usual value of the load impedance is approximately twice the value of the internal impedance or A.C. plate resistance of the tube. If a tube has an internal impedance of 1900 ohms the load impedance will be about 3800 ohms. This is not an exact figure but is close enough. In the case of the pentode this relation does not exist. The load impedance of a pentode tube is always much *less* than the tube's A.C. plate resistance.

The following chart gives the recommended load impedances for a number of generally used tubes. All values are for use where the tubes are operating at the plate voltages mentioned. It is necessary of course that the correct grid bias be applied to the tube.

Tube	Load Impedance	Plate Volts
10	10200 ohms	425
12, 12-A	10800 ohms	180
20	6500 ohms	135
31	5700 ohms	180
33	700 ohms	135
38	13500 ohms	135
45	3900 ohms	250
45	4600 ohms	275
46 (Class A)	6400 ohms	250
46 (Class B)	5800 ohms (for 2 tubes)	400
47	7000 ohms	250
50	4350 ohms	450
71, 71-A	5350 ohms	180

The 2-Tube "Old Reliable"

(Continued from page 663)

List of Parts

- 1—Wolverine cooky sheet 12x15 1/2"
 - 1—fil, 3 inch
 - 2—knobs
 - 1—filament switch
 - 1—single circuit Jack
 - 1—Pilot (Hammarlund) 23 plate midget (Cap.-.0001 mf.)
 - 1—Pilot (Hammarlund) 7 plate midget (Cap.-.000025 mf.)
 - 1—tuning condenser 7 plate .00014 mf. (Hammarlund)
 - 1—Sub-base transformer Stromberg Carlson 4-1; a 6-1 size will result in more volume.
 - 2—wafer sockets (Na-ald)
 - 1—Pilot socket (Na-ald)
 - 1—Grid condenser .0001 mf. Aerovox (Polymet)
 - 1—5 megohm grid-leak Aerovox (Lynch)
 - 4—fibre washers
 - 3—tube bases, some No. 18 wire plus hookup wire
 - 1 1/2 dozen nickel brass screws (not steel)
 - 1—pair of good phones large size Brandes 2000 ohms.
 - 2—type 30 tubes
 - 2—"B" batteries 45 volt
 - 1—"A" battery
 - 1—Antenna system
 - 1—ground
- *oil data (see drawing)

Save Your Copies

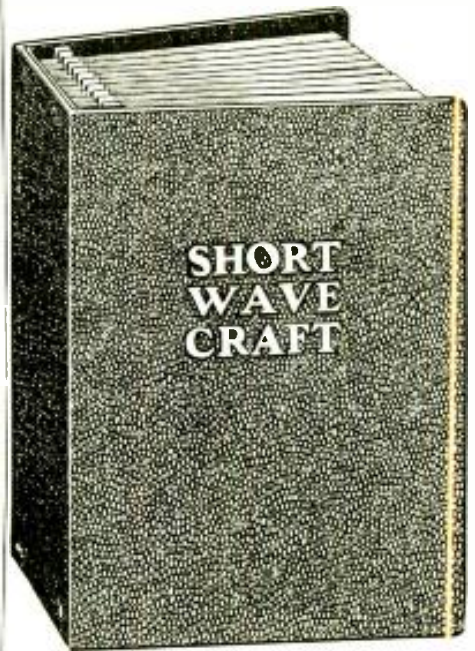

● SHORT WAVE CRAFT is not the sort of magazine that you read and then discard.

SHORT WAVE CRAFT readers keep their copies for years as a steady reference, and thousands of letters from them attribute to this fact.

We now have made it possible to save your copies in a way they should be saved, and for this purpose we have originated a splendid binder for you which holds twelve copies. The binder is made of heavy substantial material, and is covered with black grained leatherette. The name of the magazine is stamped in gold on the cover.

In addition to this, an ingenious mechanical arrangement is provided which makes it possible to hold the copies in such a way that they are not clamped tight, so that when reading the magazine from the binder no hardship is had. Binder opens flat on any part.

SHORT WAVE CRAFT Binder as described, prepaid in the United States..... \$1.25

Canada and foreign countries, 25c extra.

We accept money order, check, stamps or cash.

SHORT WAVE CRAFT

98 Park Place

NEW YORK, N. Y.

Noise Reduction On Short Waves Is Possible

By One Method Only

LYNCH

Transposed Transmission Line

Illustrated Instruction Booklet

FREE WRITE
LYNCH MANUFACTURING COMPANY

711 General Motors Bldg., New York, N. Y.

A STATEMENT

By Hugo Gernsback

**THIS MAGAZINE
COSTS YOU NOTHING
UNLESS YOU LIKE IT.
YOU TO BE THE
SOLE JUDGE!**

I HAVE been publishing radio magazines since 1908, and during this period I have learned to know what radio readers want.

Last summer I made a trip through central Europe, in order to acquaint myself with radio conditions as they are in Europe today. I was amazed at the tremendous amount of radio experimenting that is now going on, in practically all of the western European countries. I found conditions similar to those during the 1921-1923 boom in America. Radio stores were prospering and doing a land-office business. The reason, of course, is the intense interest of the European radio experimenters who are building sets on a scale undreamt of before.

The European radio publications are abounding with new circuits and new radio developments that have found their way slowly over to the United States. The reason is that, since there is such a tremendous amount of original radio engineering going on in this country, there has been no publication that catered to the foreign developments. All the American radio publications must, of necessity, report the American activities first and as a rule, have no room left for what is going on in Europe unless an epoch-making development appears.

I therefore conceived the idea of bringing to my American readers a totally different radio publication, the like of which has never been published before; and the result is RADIO REVIEW AND TELEVISION NEWS.

This is not entirely a new magazine; it is, really, two magazines in one. A section devoted to television has been retained, which will report in every issue, the major American and European television advances; but the big, front section is given over to an international radio digest. This magazine, therefore, will perform the function that, for instance, the LITERARY DIGEST is serving in literature. You may not be aware of the fact that there are some 160 radio publications printed outside of the United States; but from all of these publications RADIO REVIEW is extracting the best—the Radio Meat—which you want.

There are literally thousands of new circuits, due to the new tubes, and there is so much new material for the experimenter that I would have to fill several pages to tell you all about it.

RADIO REVIEW AND TELEVISION NEWS then is a new mirror, which will accurately show you a true perspective of what is going on in radio all over the world, and will give you material in such profuseness as you never have seen before. Hundreds of new radio hook-ups, special circuits, new time-saving kinks, new money-making ideas galore. You will find here the latest radio circuits and sets from France, Germany, England, Italy, Russia, Norway and even Japan.

Dozens of translators have been busy to make the first issue of the new combination magazine a memorable one, that you will not soon forget, and you will wonder why I hadn't done it before.

And now I will ask you for a favor. Go to the nearest newsstand and get a copy of RADIO REVIEW AND TELEVISION NEWS. Pay your quarter for it, go home and look it over. If at the end of a week, you find that for any reason you do not like the magazine, return it to me with a letter stating why you don't want it, and I will refund your quarter. I am that sure that you will not wish to be without this magazine in the future.

Remember, you don't have to pay for the magazine unless you think it is what you are looking for.

If your newsdealer is sold out or does not stock the magazine send 25c to us (see coupon); money refunded if you don't want the magazine.

I thank you in advance for your patience and for your confidence.

Cordially yours,

Hugo Gernsback

A few of the outstanding articles in the RADIO REVIEW section:

- | | |
|--|---|
| 1 Tube D. C. Power-Loud-speaker Special | Adding Automatic Volume Control |
| The VM-Three Receiver | A D. C. Super-Heterodyne Locating Hidden Pipes by Radio |
| The Diodon Screen-Grid Circuit | One Tube Super-Regenerative Loop Receiver |
| Improved Reinartz Hook-Up Preventing Radiation from the Local Oscillator | A Two for 7 Meters Review of American Radio Literature |
| Modern Tuning Coil Practice | Digest of American and Foreign Patents |
| The Shielded Antenna for Noise Reduction | Dozens of Circuits, Kinks and Practical Suggestions and NEW HOOK-UPS. |
| New Transmitting Antenna Decrease "Skip Zone" | |
| The Champion Three—a Prize French Receiver | |

Features in TELEVISION NEWS section:

- | | |
|---|--|
| A Combination Sight and Sound Receiver | Diode Detection for Television Receivers |
| A Powerful 7 Meter Super-Regenerative Television Receiver | Myers Mercury Vapor Television Lamp |
| New Baird Televisor Built Like Camera | Ideas in Television Circuit Improvement |
| Television Transmitter for Topical Events | Schedule of Active Television Stations |
| | Television Question Box |

Be sure to read full details in coupon!

IMPORTANT

Do not confuse the former TELEVISION NEWS with this magazine. RADIO REVIEW AND TELEVISION NEWS are two distinct magazines in one.

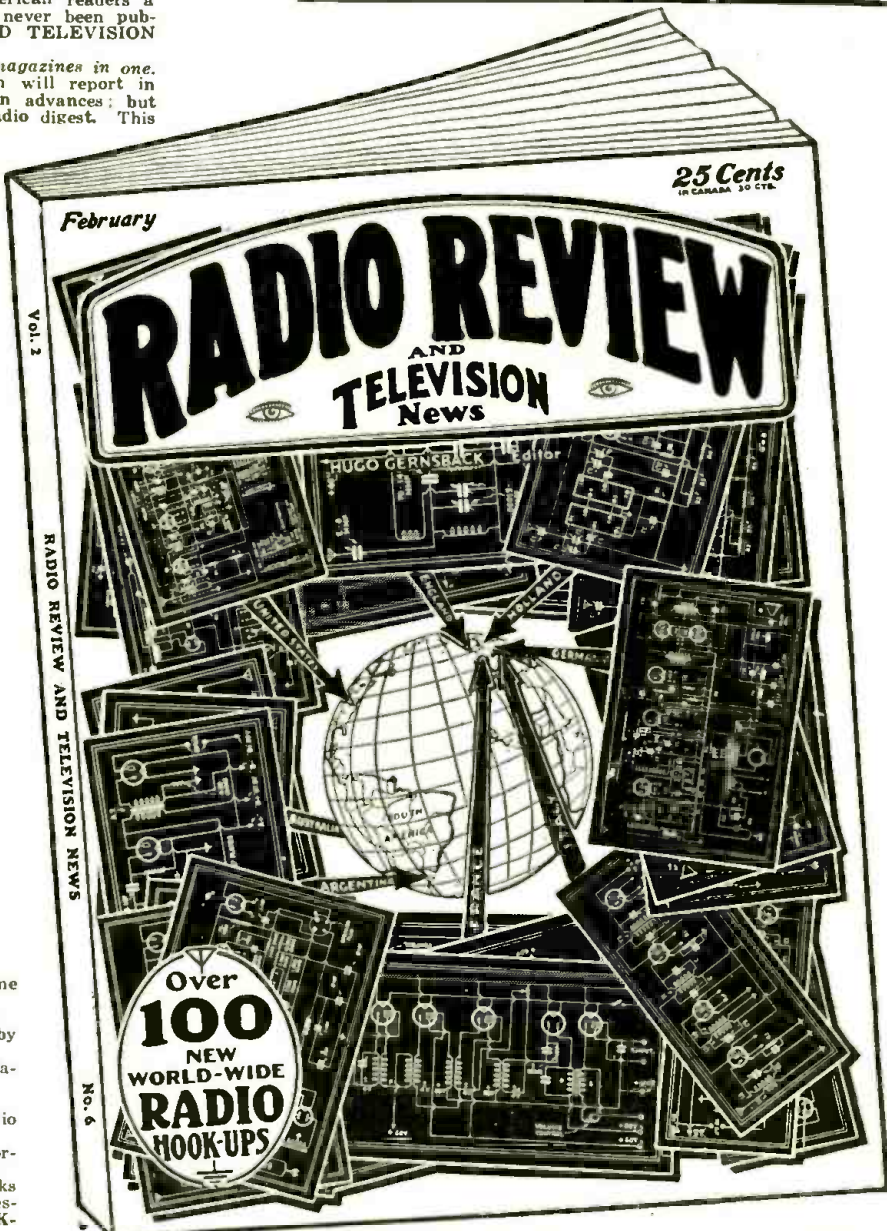

RADIO REVIEW AND TELEVISION NEWS

98 Park Place
New York City

(Mark X in Square Which Offer You Desire)
Gentlemen:

As per your special offer, I enclose \$1.25 (Canada and Foreign \$1.50) for which enter my subscription to RADIO REVIEW AND TELEVISION NEWS for one year

Send me the current issue of RADIO REVIEW AND TELEVISION NEWS, for which I enclose 25c (U. S. stamps or coin accepted) with the full understanding that if I do not like the magazine you will refund the money as explained above

Name

Address

City and State

—building, testing and repairing all kinds of radio receivers!



THE three volumes of this Library cover the entire field of building, repairing and "trouble-shooting" on modern radio receivers. The Library is up-to-the-minute in every respect and is based on the very latest developments in the design and manufacture of equipment. The rapidly-growing interest in short-wave and television reception is thoroughly covered in a complete section which deals with the construction of this type of apparatus.

Radio Construction Library

INCLUDING CONSTRUCTION OF SHORT-WAVE AND TELEVISION RECEIVERS

By JAMES A. MOYER and JOHN F. WOSTREL

Faculty, University Extension, Massachusetts Department of Education

Three Volumes—1087 Pages, 6x9
605 Illustrations

VOLUME I: presents the fundamental principles of radio so clearly and simply that anyone of average training will be able to read, understand and apply them. It gives actual working drawings and lists of materials for the construction of many typical sets.

VOLUME II: fully discusses all of the elementary principles of radio construction and repair. An explanation of the necessary steps for "trouble-shooting," repairing, servicing and constructing radio sets successfully. Practical data is also given on antenna systems, battery eliminators, loud speakers, chargers, etc. This volume includes complete instructions for the construction and operation of short-wave and television receivers.

VOLUME III: covers the essential principles underlying the operation of vacuum tubes in a non-technical manner as is consistent with accuracy. It discusses the construction, action, reactivation, testing and use of vacuum tubes; and an interesting section is devoted to remote control of industrial processes; and precision measurements.

EXAMINE these books for 10 days FREE

This Library is not only a thorough home-study course, but a handy means of reference for the more experienced radio experimenter, repair man, and radio shop-owner. To these men, as well as to those who desire to advance in the radio profession, this offer of a 10 days' Free Examination is made.

Simply clip, fill in, and mail this coupon

McGraw-Hill

FREE EXAMINATION COUPON

McGraw-Hill Book Company, Inc.
330 W. 42 St., New York City.
Gentlemen:—Send me the new RADIO CONSTRUCTION LIBRARY, all charges prepaid, for 10 days' Free Examination. If satisfactory I will send \$1.50 in 10 days, and \$2.00 a month until \$7.50 has been paid. If not wanted I will return the set at your expense.

Name.....

Home Address.....

City and State.....

Position.....

Name of Company.....SWC-3-33
(WRITE PLAINLY AND FILL IN ALL LINES)

A Condenser "Mike" for 10 Cents

(Continued from page 684)

necessary to incorporate a stage of resistance-coupled amplification directly within the same case as the mike. This is because the mike itself is not very sensitive (not as sensitive as a carbon mike), and were the mike used any distance over an inch and a half to two inches from its amplifier, a terrific hum would result, which would blanket the voice, due to pickup in the leads. Thus it becomes necessary to build a one or two-stage amplifier right in with the mike. The diagram of such an amplifier is shown in Fig. 4, with correct values of resistance, capacity, and voltage. These values are extremely critical, and substitutions should not be attempted. The resistors should be mounted "on air"—that is, resistors having stiff "pigtail" connections should be obtained, and should be mounted using these pigtails as supports.

A non-microphonic tube should be used in this stage—and there is only one such tube—the UX864. A 230 can be used, but you may have to weight it down to prevent microphonic noises.

An easy way to mount your mike is to obtain a 1 lb. Lipton's Tea can, cut a hole in the front to accommodate the head, and build the amplifier into the can. The mike will pick up less parasitic vibrations from the floor and table if it is suspended from the ceiling by a stout cord. This however, is not an absolute necessity.

If the instructions are followed closely, no trouble at all will be experienced in making this mike percolate properly—and you will surely get real quality from it. At any rate, you'll decide it's worth 50 times what it costs you to make it. You're wondering, after reading this, where I lay my claim to its costing me ten cents to make? Well, I had to buy the diaphragm. The rest is all from the old "junk box." Hi!

Now come on, you experts, tackle me! If in doubt what this mike will do, just give W5AOE a call, or W9HWR—the mike was first tested there!

Any comments would be appreciated, and the author will attempt to answer all "brickbats"—provided postage is included.

Arcturus New Safety Mercury Vapor Rectifiers

● IN view of numerous reports from the field that the newer sets using the types 82 and 83 mercury vapor rectifiers are being rendered inoperative, the Arcturus Radio Tube Company, Newark, N. J., has developed two new Safety Rectifiers to replace the present types. The trouble is principally due to the failure of the types 82 and 83 which invariably arc-over at the end of their useful life and burn out the transformer or fuse. This arc-over, or flash-over, is not indicative of a faulty rectifier or set. It is an inherent limitation of gaseous rectifiers, regardless of the skill and care taken in manufacture. In fact, the tube may operate perfectly until the time arc-over occurs.

A new form of Safety Rectifier has been developed by Arcturus where the unavoidable arc-over cannot cause damage to any part of the receiver. This tube automatically disconnects itself from the circuit when arc-over occurs, precluding damage to the transformer or fuse.

These new tubes have been designated as the Type AF, which replaces the type 82, and the Type AG replacing the type 83. The electrical and operating characteristics of these new Safety Rectifiers are identical to the tubes which they replace.

NEXT ISSUE!!

A New Method of Tuning will be described by Rinaldo de Cola.

AERO INTERNATIONAL ALL WAVE 11-TUBE SUPER-HETERODYNE DE LUXE



Completely Assembled With 2 Matched Full Dynamic Speakers \$29.75

At last! World wide reception at a sane price. 15 to 550 meters. Besides the regular broadcast band, it brings in foreign programs, amateurs, police calls, ships at sea and aeroplanes. One dial control. No plug in coils. Latest super-phonetic tubes.

AERO 4-TUBE MIDGET

\$10.95 less tubes
2.95 kit of tubes



The lowest priced quality Midget Receiver on the market today. Very selective brings in long distance like local stations.

AERO 5-TUBE MIDGET...\$11.95
AERO 6-TUBE MIDGET... 18.50

AERO WORLD WIDE



1-Tube SHORT WAVE SET for Heac- phone Operation \$5.95

Listen in DIRECT to London, Paris, Berlin, Buenos Aires and other broadcasting stations throughout the world via short waves. Your ordinary receiver cannot tune in these low wave stations. WORLD-WIDE RECEIVER gets 15 to 500 meters. Aero 2-Tube Short Wave Set \$8.75. The same as above set but it has 1 stage of Audio Frequency added to it.

Write for Complete Catalogue.

CHARLES HOODWIN CO.

4240 Lincoln Ave., Dept. A26 Chicago

When You Buy ALAN Short Wave Receiver, You Get

Unequalled Flexibility and ease of control
Multi-Mu Sensitivity
Low Background Noise
Super-Smooth Oscillation Control



Full A.C. or D.C. Op. Absolutely Humless A.C. Reception
Impedance Audio for Quality Phone Signal
Insulation throughout.

- Alan 2-B Battery Set requiring 1 type 82 Multi-mu tube and one 33 Pentode. Special.....\$ 7.45
- Build it Yourself Kit.....\$ 6.95
- Kit of 2 Tubes..... 1.55
- Alan 3-B Battery Set using 2 type 345 and 1 type 23..... 15.50
- Kit Price..... 13.70
- Alan 4-B Deluxe, using 2 type 345, one type 80 tube and one type 23..... 2.50
- Kit of Three Tubes for Above..... 18.20
- Kit Price..... 15.40
- Kit of 4 Tubes..... 2.95
- Alan III A. C. 4 Tube A. C. Receiver, using 2 Type 58 Tubes, 1 Type 56 and 1 Type 80. Absolutely humless, ready to plug into 110 Volt A. C. line..... \$23.50
- Kit Price (with diagram and directions)..... 19.95
- Kit Guaranteed Tubes..... 2.45
- Alan IV A. C. 5 Tube A. C. Receiver, utilizing 2 Type 58 Tubes, one Type 56 and one Type 47 Output Power Tube and one Type 80. Ready to plug in.....\$26.2
- Set of Tubes for Alan IV A. C..... 4.25

SEND FOR LITERATURE

ALAN RADIO CORP. 835 Cordoad St., New York

PATENTS—TRADE MARKS

All cases submitted given personal attention by members of the firm.

Information and booklet free

LANCASTER, ALLWINE & ROMMEL

PATENT LAW OFFICES

Suite 434 815-15th St. N. W., Washington, D. C.



"SUPER" NO-AERIAL

Overcomes all difficulties of outdoor aerial.

Loses nothing in volume.

Acts as Station Selector

Improves tone of radio

Diminishes electrical interference.

No further attention necessary.

Can be used on Battery, Electric or Automobile Sets.

Send your order direct to the manufacturer! Radio's greatest improvement. Special at 59c.

SUPER MFG. CO.
16 Hudson St., N. Y.

RCA INSTITUTES

(A Radio Corporation of America Subsidiary)

Resident Schools at

NEW YORK and CHICAGO

Technical training courses in radio and associated electronic arts.

PRACTICAL RADIO ENGINEERING.
SOUND TECHNICIANS' COURSE embracing Television Fundamentals, Public Address Systems, Recording, Sound Motion Pictures. Electronic Tube Applications.

BROADCAST TRANSMISSION in all its aspects including Studio and Control Room Operation.

RADIO SERVICING including Broadcast Receivers, Home Talkies, Rudiments of Television.

RADIO OPERATING—Aircraft, Marine and Police Alarm Systems.

EXTENSION COURSES for HOME STUDY under new "no obligation" plan, with privilege upon graduation of 2 weeks' intensive practical training without charge at either Resident School.

Mail Coupon for Illustrated Catalog.



RCA Institutes, Inc.,
Dept. SW-3
New York School and Headquarters:
75 Varick Street, New York, N. Y.
Chicago School:
1154 Merchandise Mart, Chicago, Ill.

Please send with no obligation to me:

() Full information on the New General Course in Radio.

() Illustrated catalog and information about specialized resident school courses in radio and allied arts.

() Information about extension course for study at home, together with illustrated catalog.

Name Age

Address

City State

FREE—C. S. Code Guild Sked. Daily C. S. practice programmes on amateur bands.



You Can Become a Fast, Capable RADIO OPERATOR at Home

With the Famous CANDLER Scientific System

FREE short wave press schedules. Learn to copy px from Candler trained ops, sending out of principal px stations. Amazing results in short time. FREE ADVICE IF "STUCK." Write Candler, No obligation. Junior Course for beginners. Advanced Course for ops with speed of 10 wpm or over who want to get in 30 to 45 wpm class and copy behind. Also Radio Typing Course. Save time and money by sending for FREE BOOK today.

"Candler training enabled me to copy 56 1/2 wpm for the all-time record."—T. R. McElroy, Official Champion Radio Operator of the World, 46 Everdean St. Boston, Mass.



CANDLER SYSTEM CO., Dept. 23
6343 S. Kedzie Ave., Chicago

World's Only Code Specialist

DO IT NOW

PATENT
REGISTER YOUR
TRADE-MARK BY
Z. H. POLACHEK
1234 BROADWAY
315 NEW YORK

REG. PATENT ATTORNEY, PROF. ENGINEER
WHAT IS YOUR INVENTION?
Send me a simple sketch or model for CONFIDENTIAL ADVICE

SWAPPERS

SWAPPERS are swappers of correspondence. During the past few years we have noted that Short-Wave enthusiasts love to get acquainted with each other by mail in order to swap experiences.

Use a postcard only. Never write a letter. Address postcard as follows:
SWAPPERS, c/o SHORT WAVE CRAFT, 96-98 PARK PLACE, NEW YORK, N. Y.

On the blank side of the postal PRINT clearly your name, address, city and State; nothing else! No charge for this service.—EDITOR.

- JOSEPH A. ADAMS
7735 Haskins Avenue, Chicago, Illinois.
- WAYNE AGNEW
702 S. Jackson Street, Frankfort, Indiana.
- RICHARD S. BAILEY
Centre Hall, Centre County, Pa.
- JOSEPH BAKUTIS
159 Fillmore Street, New Haven, Conn.
- H. BEADLE
13 Chandos Street, Kelghley, Yorkshire, England.
- JAMES C. BILYOU
Main Street, Marlboro, N. Y.
- MERTON BONNER
513 Temple Ave., Long Beach, Calif.
- M. C. BOSTICK
911 S. Garden Street, Columbia, Tenn.
- FRANCISCO BOU, JR.
2000 Wilmot Street, Philadelphia, Pa.
- CLARENCE E. BOWEN
Brevard, North Carolina.
- STANLEY E. CLARK
192 E. First Street, Corning, New York, (or)
8 Mulberry Street, Binghamton, N. Y.
- D. R. CLUSTER
1424 Lincoln Street, Eugene, Ore.
- JACK CREECH, W5BCW
Box 446, Olney, Texas.
- JAMES DAVIS
113 Flora Avenue, Atlanta, Ga.
- HERBERT THEODORE DRY
1421 S. 17th Street, Fort Smith, Ark.
- WILLIAM R. DUBOIS
400 Belmont Avenue, Newark, N. J.
- HILLIS R. ELLINGTON
Box 595, Wake Forest, N. C.
- ROY J. EMANUEL
1909 N. 57 Street, Milwaukee, Wis.
- DAWKINS ESPY, JR.
705 McClure Avenue, Taylor, Texas.
- DONALD FETTERS, W8BWV
11 Bell Street, Plymouth, Ohio
- ARTHUR J. FILKINS
138 Warren Street, Laconia, N. H.
- PHILIP FINNEAN
368 Silver Street, Marion, Ohio.
- THEO. R. FURMAN
1453 Dorchester Road, Upper Darby, P. O., Manoa, Pa.
- ARTHUR A. GABBURT
2015 Monroe Street, Swissvale, Pittsburgh, Pa.
- ALBERT R. GLASS, N.R.I. STUDENT
Castleberry, Ala.
- CARL V. GUEST, W8HBJ
Mt. Perry, Ohio.
- BEN L. GURTIZEN
422 W. Princess, York, Pa.
- CHARLES W. HANCOFF
c/o Hancoff and Deil Lab., 5105 Broad Avenue, Alton, Pa.
- WALTER HANSON
3906 Portland Avenue, Minneapolis, Minn.
- LEONARD HARDLAND
Petersburg, N. Dak.
- ROY M. HAWKINS
General Delivery, Sweetwater, Texas.
- JACK ILEF HEATON
Harrow, Ontario, Canada.
- ERNEST A. HECKLER
Box 194, Iron Mountain, Mich.
- MILTON HENRICH
1947 N. 6 Street, Milwaukee, Wis.
- DAVID R. HICKLAND
Orrington, Me.
- JOHN HILTON
1821 Gillingham Street, Frankford, Phila., Pa.
- HAROLD A. HODGE
1916 Nebraska Avenue, Saint Louis, Mo.
- CLAUDE D. HODGES, Baird Universal, No. 35
1109 Monroe Street, Lynchburg, Va.
- JOHN W. HOKE
214 Cottage Street, Newcastle, Pa.
- JOE HOLT, W8BDW
1214 Park Avenue, Little Rock, Ark.
- LAWRENCE HOOVER
4335 Oakwood, Pine Lawn, Mo.
- JESSE J. HOWARD
Nolansburg, Ky.
- RUSS HOWARD
R. F. D. No. 1, W. Caldwell, N. J.
- ALLEN HUDSON
521 Beaver Avenue, York, Nebr.
- WELTON JACKSON
Boaz, Ala., Route 4.
- G. E. JAQUITH
Ipswich, S. Dak.
- P. J. KAIN
22 James Street, North Sydney, N. S. W. Australia.
- HAROLD KROHNE
11 Kensington Place, Granite City, Illinois
- EDWARD B. KUBAITIS
P. O. B. 174 Huntley, Illinois.
- HENRY G. KUHN
3682 Delaware Avenue, Kenmore, New York
- C. R. LAWSON
Box 441, Watertown, Conn.
- A. N. LUMP
7 Street, Philadelphia, Pa.
- VENIZELOS MALLIS
702 9th Street, N. W., Washington, D. C.
- GORDON MARCH
1008 Houston Street, Muskogee, Okla.
- FRANCIS MILTNER
37 Nebraska Street, Painesville, Ohio.
- ERNEST E. MORVAY, W2ELB
503 E. 78 Street, New York, N. Y.
- E. W. PARSONS
71 S. Prospect St., Millers Falls, Mass.
- RAFAEL PEREZ
Arzuaga No. 12, Rio Piedras, P. R.
- LOUIS PFEIFER, W2EMY
596 McBride Avenue, Paterson, N. J.
- CLIFF PORTER
135 East Pittsburgh St., Greensburg, Pa.

Book Review

● **Peak Efficiency Design on Short Waves**, by James Millen, M.E. Size, 6 1/2 x 9 1/2, paper covers, 14 pages, well illustrated with line drawings and half-tones. Published by the National Company, Malden, Mass., 1933.

This interesting treatise describes the design and circuit features, shielding, etc., followed in improving and perfecting the 1933 model of the SW-3 Series S-W receiver, a universal A.C. or D.C. operated design, especially designed for amateur reception. This receiver has a specially designed screen-grid R.F. circuit, together with a screen-grid detector and power audio stage. Band spreading is also discussed and illustrated; there is also an interesting page of short wave "ham" abbreviations and their meanings. A booklet which every short-wave student will want to read and reread.

● **An Inexpensive Radiophone Transmitter**, by George Grammer. Size, 6 1/2 x 9 1/2, paper covers, 14 pages, illustrated with half-tones and diagrams. Published by the National Company, Inc., Malden, Mass., 1933.

Every short-wave fan interested in building a radiophone transmitter should read this authoritative and very comprehensive booklet written by Mr. Grammer, who is assistant technical editor of QST magazine. If you want to build a first class, low-cost phone-CW transmitter, here's all the dope. All coil, condenser and resistor data is supplied together with clear diagrams and photos, so that even the inexperienced "ham" can readily understand what it is all about. Data on the proper antenna to use and how to monitor the output is given, as well as a section on operation of the transmitter for CW (code).

New Noise-Reducing Antenna Suitable for S-W's

● A new antenna system, designed to reduce man-made static, has just been announced by the Lynch Manufacturing Co. of New York City. Some of the features of this new system, in addition to its nominal price, which makes it available for almost every user of a radio receiver, are technical improvements over existing devices of the same general nature for which the following claims are made by the manufacturer.

Total elimination of electrical noises, commonly called "man-made static." Great reduction of atmospheric electrical interference, generally called "static." Easy to install, with no tools other than an ordinary screw driver. May be attached to any existing antenna. Eliminates the necessity for cumbersome and expensive line-filter devices, which are effective in very few instances. Special short-wave features permits reception of police calls, aircraft radio and foreign broadcasting. Increases signal strength on all broadcast bands. Fully protected by pending patents.

Laboratory measurements on some of the various noise-reducing antenna systems indicate that they suffer materially in most cases on response to short waves, unless specially designed for short-wave use. One of the novel and very important features of the new Lynch design is found in the short-wave tap, which has been provided to permit this new antenna system to function on the short waves as well as the broadcast waves.

The new Lynch NO-STAT Antenna kit comprises two highly efficient transformers, one to be attached to the aerial, the other to the radio receiver and 50 feet of special, low-loss cable, which is run from the upper to the lower transformer. This system effectively shields your antenna from all electrical interference, with an actual increase in signals.

BRUCE D. RAGER
R. F. D. 2, Box 40, Pierceton, Ind.
THEODORE W. REX
Stryker, Ohio, R. F. D. No. 2

ALDEN S.W. COILS

Set of four precision wound short-wave coils—20 to 200 meters with .00014 mfd. condenser. 704SWS List Price \$2.00 set
Set of two coils to cover 100 to 540 meters with .00014 mfd. condenser. 704SWW and 704SWO List Price.....\$1.50

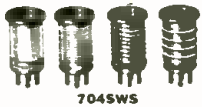

S. W. COIL FORMS

704 UX Coil form. List price 25c
705 UY Coil form (shown). List 25c
706 Six prong coil form. List 30c

NA-ALD DeLUXE DIALS

3043 3" Dia. Dial.....50c
3044 4" Dia. Dial.....50c
3044 5" Dia. Super Dial.....75c



These dials are just the thing for your short-wave receiver or transmitter. Backlash is impossible in a direct acting dial. Use the 5" Dia. Super size on your transmitter.

NA-ALD Short Wave Sockets



422—4-hole socket.....25c
423—5-hole socket.....25c
426—6-hole socket.....25c
427—7-hole socket.....35c
These sockets mount with a single 6-32 screw. All contact holes may be drilled hand-drill. Very compact.

All kinds of sockets available: single-hole, two-hole, baseboard, above panel, below panel and composite mountings.

Send for catalog of S. W. parts including all kinds of sockets, cable connectors, dials, binding posts, etc.

Servicemen's Discount.....35%
On orders amounting to \$10.00 List.....40%

Send 10c for 26-page NA-ALD Adapter data sheets showing 300 diagrams, tube connections, etc.



ALDEN PRODUCTS CO.
Dept. SW, 715 Center St.
BROCKTON, MASS.

CHALLENGER



1933 Model 9 Tube Short Wave Super-heterodyne in kit form.....\$39.50
Chassis completely wired and laboratory tested, with large dynamic speaker and tube.....\$79.50

Experimenters Radio Shop
80 Cortlandt Street New York City

Be a TELEVISION EXPERT

During the next few years, thousands will become rich in Television, the amazing new major industry. Will you be one of these? There is only one way for you to get into Television and that is with specialized training. Television experts are needed right now and this marvelous new business has hardly started. If you are over 17 years of age, send your name and address for full information about our plan whereby you may step out of the world's greatest Television School—occupying the three top floors of Missouri's tallest skyscraper—into a high pay position. Write Today.

Sid Noel, President
FIRST NATIONAL TELEVISION
2909 Power & Light Bldg.
Kansas City, Missouri

Announcing the New EXPLORER

series of low-priced short wave kits and receivers. One, two, and three tube models.

Write to-day for Free Literature

RIM RADIO MFG. CO.

691 Grand St. Brooklyn, N. Y.

Amateurs who made good

HENRY GROSSMAN

● HENRY GROSSMAN, Division Engineer of the Columbia Broadcasting System, in charge of technical operations in the New York area, is one of those fellows whose job, hobby, recreation, and pleasure is and always has been radio. Born in Buffalo, New York, Grossman moved to Cleveland, Ohio, at the age of 13 and received his early technical training in the midwest. He attended technical high school in Cleveland, working for the Marconi Company as radio operator on passenger and freight ships during his vacations. At engineering school he specialized in radio, making numerous original experiments of his own in his spare time.

After graduation from engineering school, Grossman joined the staff of KYW, the Westinghouse station in Chicago. It was at this time that the Department of Commerce lifted the ban on distributing radio transmitting licenses, and Grossman left KYW after a few months to return to Cleveland and open his own station, WLBJ. Within a year he was offered the position of chief engineer with the American Broadcasting Corporation. During his stay there, he completely rebuilt the studios and transmitting equipment of their two big stations, WGHP, Detroit, and WSPD, Toledo, the latter now a Columbia Broadcasting System outlet.



Henry Grossman.

While handling the engineering details of the broadcast of the Edison Golden Jubilee in 1929, Grossman came in contact with E. K. Cohan and other officials of the Columbia network, and a year later joined the Columbia engineering department. His first job was that of building Columbia's new outlet in Albany, WOKO, in 1930. Since that time he has handled many of the most difficult remote control broadcasts ever attempted. Grossman has been in charge of practically all of Columbia's broadcasts from the air: the Army air manoeuvres, the air races at Cleveland, the two-piano broadcast by Peggy Keenan and Sandra Phillips from the air, and many others.

Grossman's whole life is centered in radio; he is on duty virtually day and night. A private line connects his apartment in the Hotel Taft in New York with the master control room of the Columbia network, so that he can be reached at a moment's notice if necessary. In his quarters also are two short wave receiving sets, one for 5 and the other for 40 meters, several types of long wave receivers, television sets, and a 40-meter amateur short wave transmitting set, W2HM.

THE C. S. CODE GUILD

● The purpose of the C. S. Code Guild is to help develop the operating technique of all amateurs and thereby raise the standard of code operating efficiency. The C. S. Code Guild has a regular operating schedule and copies may be obtained by writing to the C. S. Code Guild, 6343 South Kedzie Avenue, Chicago, Illinois. These schedules give the days of the week, their hour, the stations from which the special Code Guild programs are broadcast, the wave frequency, and the type of program broadcast. A new schedule is gotten out for each month. The originating stations will appreciate a card or letter of comment.

TRANSMITTING TUBES

Perfect Unbranded
Guaranteed 6 Months

510—3.25	866—3.25
211—12.75	872—12.80
201A—12.75	875—25.85
845—12.85	242—12.90
204a—87.50	211E—12.85
201B—87.50	10—2.50
865—12.75	750—2.25
852—19.75	28—1.90

Seconds Unbranded
Guaranteed 3 Months

242—6.75	852—11.95
845—8.75	86—18.50
203A—7.25	88—6.75
872—0.25	88—1.50

Perryman & CoCo Receiving
Tubes. 50 and 10% off list.
20% deposit on C. O. D.

MERIT RADIO CO.
18 Hudson St., N. Y. C.

WESTON Meter BARGAINS



Model 301

Universal A.C.—D.C. With
5-Position Scale.....\$8.40
Complete Set Resistors and
Shunts.....7.95
0-1 Milliammeters (1000 Ohms
per Volt).....6.25
0-10 Milliammeters.....5.25
0-100 Milliammeters.....5.25
0-10, 15 or 50 D.C. Volt-
meters.....4.45
0-150 Voltmeters D.C.....5.88
0-15 A.C. Rect. Type.....6.00
0-150 A.C. Rect. Type.....6.50



Model 267

Milliammeters, 0-1, 0-10, 0-25,
0-50, 0-100, 0-300, 0-500 \$5.00
Ammeters 0-2, 0-3, 0-7.5.
0-10, 0-15.....5.00
Voltmeters D.C. 0-15, 0-20,
0-25, 0-50, 0-100, 0-200
0-500 0-500 \$7.40, 0-1000
\$8.50
A.C. Voltmeters, Rect. Type
0-15 or 0-50.....6.00
Milliammeters 0-1 (1000 Ohms
per Volt).....6.00

Postage included in above prices. 25% deposit with C.O.D. orders.
Send for Bulletin No. 4.
UNIVERSAL WIRELESS SALES CO.
416 N. Leavitt St., Chicago, Ill.

FREE 13th ANNIVERSARY RADIO CATALOG



132 pages containing the most complete listing of radio items for the amateur and experimenter at real bargain prices.

Send for your copy now!

AMERICAN SALES COMPANY

Wholesale Radio Distributors
8W-44 W. 16th St., N. Y. C.
The Oldest Amateur Supply House, Est. 1919

ROUND THE WORLD RECEPTION!

With Powertone Short Wave Receivers

Illustrated is a 3 tube A.C. Short Wave Set that actually brings in Short Wave Stations. Statements by HAMB, AMATEURS and those who have used the Powertone Set, verify the fact of ROUND THE WORLD RECEPTION. The use of the NEW TRIPLE GRID and SUPER TRIODE TUBES greatly increase reception sensitivity (1-56, 1-57, 1-280).



D. C. Model—Complete with coils and tubes. Coils cover wave length from 14-200 meters. Tubes-232 and 233.

\$9.95

A. C. Model—Complete with coils that will cover wave length from 14-200 meters. Price less tubes.

\$14.95

INFINITE VARIETY & VALUES

FREE!

Here is what you have been waiting for! Every Experimenter and Serviceman will find our Catalog replete with values on every type of radio part imaginable. We stock all items catalogued, thus assuring you PROMPT DELIVERY. Send for your copy today.

Try-Mo Radio Co., Inc.

Dept. 53, 85 Cortlandt Street New York, N. Y.

With

TRIAD



This corps of engineers, in their own secluded laboratory keep TRIAD tubes ahead of the procession. They are provided with the most modern laboratory apparatus and make periodical checks of every operation on every one of the many types TRIAD produces.

YOU GET

QUALITY

FROM A to Z



**TRIAD
QUALITY**

**IS A FACT--NOT MERELY
A CLAIM**

The easiest way to get a true estimate of any product's worth is to ask about it among its competitors. Ask any serviceman, dealer, jobber or manufacturer if any tubes are better than TRIAD QUALITY TUBES. We know the answers you get will induce you to send in the coupon, which will bring you the whole, interesting story.



Elaborate testing equipment developed by TRIAD engineers is found at the end of every production line. **QUALITY** is the watchword, **QUALITY** is demanded and an increasing number of satisfied users prove that TRIAD and **QUALITY** are synonymous.

PRICE LIST ON STANDARD TYPES RADIO TUBES

T-1	Mercury Half Wave Rectifier	2.60
T-01A	General Purpose Detector and Amplifier	.75
T-10	Power Amplifier	7.00
T-10S	High Voltage Power Amplifier	8.00
T-12A	D. C. Power Amplifier	1.50
T-22	D. C. Screen Grid Amplifier	3.00
T-24A	A. C. Screen Grid Amplifier	1.60
T-26	A. C. General Purpose Amplifier	.50
T-27	Detector or Amplifier having A.C. Heater	1.00
T-30	D. C. General Purpose Amplifier	1.60
T-31	D. C. Power Amplifier	1.60
T-32	D. C. Screen Grid Amplifier	2.30
T-33	D. C. Pentode Power Amplifier	2.75
T-34	D. C. Multi-Mu R. F. Amplifier	2.75
T-35	A. C. Heater Type Multi-Mu R. F. Amplifier	1.60
T-36	D. C. Screen Grid Amplifier, Heater Type	2.75
T-37	D. C. General Purpose Amplifier	1.75
T-38	D. C. Pentode Power Amplifier, Heater Type	2.75
T-39	D. C. Heater Type Multi Mu R. F. Amplifier	2.75
T-40	D. C. Voltage Amplifier	3.00
T-41	Power Amplifier Pentode	2.75
T-45	A. C. Triode Power Amplifier	1.10
T-46	A. C. Power Amplifier	1.50
T-47	A. C. Pentode Power Amplifier	1.55
T-48	Power Amplifier Triode (30 volt DC Heater)	4.50
T-50	A. C. Power Amplifier	6.00
T-51	A. C. Heater Type Multi-Mu R.F. Amplifier	1.60
T-55	A. C. Duplex Diode Triode	1.55
T-56	General Purpose Amplifier	1.25
T-57	A. C. Pentode R. F. Amplifier	1.60
T-58	A. C. Pentode Multi-Mu R. F. Amplifier	1.60
T-59	Heater Type Power Amplifier, Triple Purpose	2.50
T-864	D. C. General Purpose Amplifier	2.00
T-71A	A. C. or D. C. Power Amplifier	.90
T-85	D. C. Duplex Diode Triode	1.55
T-89	Triple Grid Power Amplifier	1.80
T-99X	Dry Battery General Purpose Amplifier	2.50
T-99V	Dry Battery General Purpose Amplifier	2.75
T-841	Power Amplifier	10.40
T-842	Heavy Duty Power Amplifier or Modulator	10.40
T-66	Half Wave Mercury Rectifier	6.75
T-80	Full Wave Rectifier	1.00
T-81	Half Wave Rectifier	5.00
T-82	Full Wave Mercury Vapor Rectifier	1.25
T-83	Heavy Duty Full Wave Mercury Rectifier	1.55
T-TEL	Television Scanning	Price on
T-CNA	Television Projection	Application
T-PEC	Photo-Electric Cell	

"HONOR



"BUILT"

TRIAD MFG. CO.,
Pawtucket, R. I.
(Gentlemen:—

Please send me full information
about TRIAD QUALITY tubes.

TRIAD MANUFACTURING CO.

PAWTUCKET, R. I.

BY POPULAR DEMAND • We Announce

9 to 200

METERS

The **LINCOLN R-9**
COMMERCIAL TYPE

A SUPER POWERED RECEIVER DESIGNED FOR STRICTLY SHORT WAVE RECEPTION



Repeated requests from commercial operators, communication systems, broadcasting stations and hundreds of individuals prompted us to put months of work on the new R9 commercial type receiver. A STRICTLY SHORT WAVE RECEIVER FROM ANTENNA POST TO SPEAKER JACK. Capitalizing on our years of experience in designing high powered receivers and utilizing the tremendous advantage of the new Litz wire duplex tuned amplifier of DeLuxe SW-33.

The short wave fan today wants short wave world-wide reception with a bang. He wants his receiver in his private den, figuratively speaking, thousands of miles away from the humdrum of chain advertising. The R9 is the

most powerful receiver for S.W. reception; the most selective and sensitive—not forgetting its marvelous tone—ever developed. It has everything the DeLuxe SW-33 has, minus the broadcast band, and plus every feature desirable for commercial voice and code reception. YOU have asked for this receiver in many letters and by personal request; so here it is—in a heavy satin finished case, a beautiful crackle leather finish 1/8" aluminum panel, and silver finish appointments.

Tubes used are 4-’58; 3-’56; 1-6P Wunderlich; 2-’45 and 1-’80.

- Band spread all frequencies
- C W Beat Oscillator
- Two Stages Push Pull
- Three High Gain Stages
- Intermediate amplifier
- 10 Tuned Circuits —I. F.—
- Litz wire
- Perfect Automatic Volume Control
- Visual Signal Indicator
- Instantaneous Band Selection—5 groups
- Double rectifying detector
- Silent Tuning

And — NOW YOU CAN BRING THE WORLD OF RADIO RIGHT INTO YOUR HOME WITH THE NEW & Improved LINCOLN DeLuxe SW-33



with even more amplification, more selectivity and sensitivity than we ever hoped to attain. Foreign stations are daily rolling into our laboratory, located in the heart of Chicago, with undistorted volume. Powerful locals are cut dead with fractional movement of the dial controlling the twelve tuned circuit.

Like everyone who first hears the DeLuxe SW-33, you will marvel at the heavy undistorted register and fidelity, as the result of the new balanced grid, double rectifying detector. Once you hear the tremendous power of this new model, you will under-

stand why it so far outperforms the average receiver.

Prove this in your home, as many have done, in comparison with any other receiver, for 10 days, with the privilege of return for full cash refund.

REMEMBER—Lincoln receivers grace many of the finest homes in this country.

Equipment is composed of chassis, power equipment, and giant M-20 Jensen, or Wright DeCoster speaker.

Write today for full information. New York Territory write to Valentine G. Hush, Division Drive, Dobbs Ferry, N. Y.

LINCOLN
DeLuxe Receivers

LINCOLN RADIO CORP.
Dept. SWC-17, 329 S. Wood St., Chicago, Ill.
Please send information on R9 SW-33

Name

Street

City State