

STUDIO

SOUND

JULY 1970 3s (15p)

INCORPORATING TAPE RECORDER

DOLBY A301 REVIEW

NOISE
AND ITS MEASUREMENT

GREAT CATHEDRAL ORGANS :
EMI AT ST. PAUL'S

APRS 70 · PREVIEW

RECORDING STUDIO
TECHNIQUES : 'BLACK BOXES'

CHILTON 100S FIELD TRIAL

INTERVIEW : JACQUES
LEVY, APRS CHAIRMAN



Neve

SOUND
CONTROL
EQUIPMENT



DESIGNED AND
BUILT FOR
C.T.S. STUDIOS

26 channel sound control console

One of the recent examples of Neve craftsmanship designed and built to the requirements of Cine Tele Studios Ltd., London.

This console incorporates 26 full mixing equalized input channels each with microphone and line inputs. There are eight output tracks with three mixed down groups for stereo and mono mastering, six echo groups, studio foldback, and an impressive list of built-in equalizers, compressors and other signal processing devices. A comprehensive communications system links the Studio floor, balance engineer, projection room and the producer.

The Neve organisation specialises in the design and installation of complex professional control consoles and systems for clients throughout the world.

Telephone 076 386 776 (Ten lines) Telex 81381

**Rupert Neve & Co. Ltd. Cambridge House, Melbourn, Royston, Herts, England.**

Neve

SOUND
CONTROL
EQUIPMENT

BCM 10/2

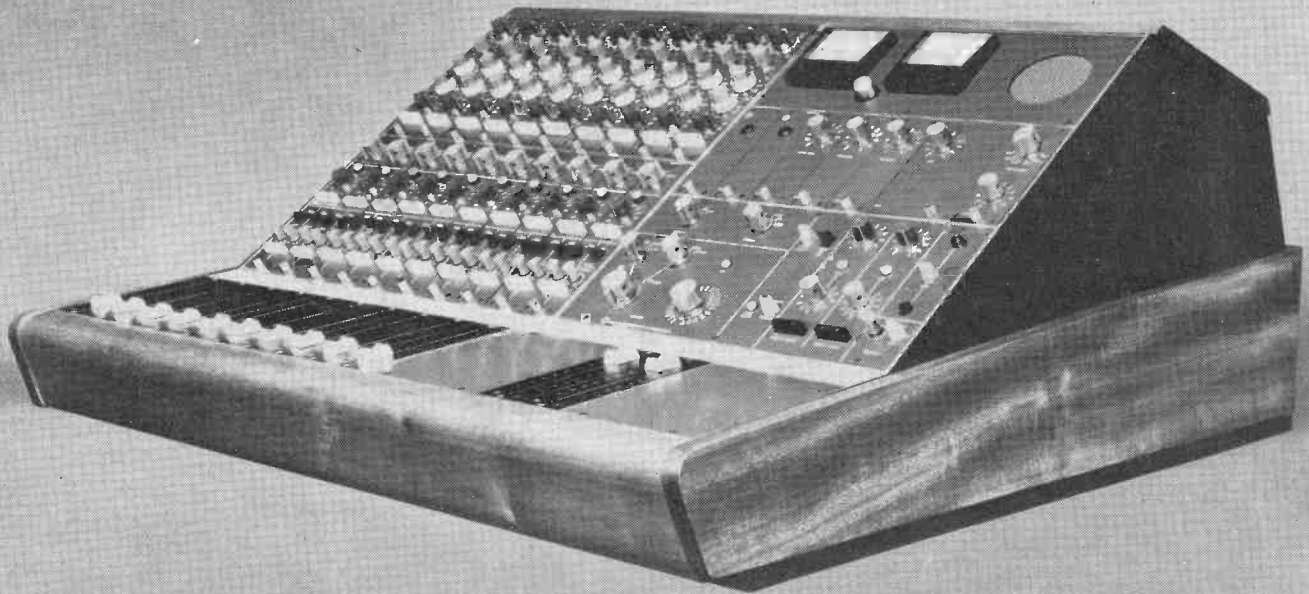

10 CHANNEL TRANSPORTABLE CONSOLE

**New compact
versatile design
by Neve
styled to the needs
of modern studios**

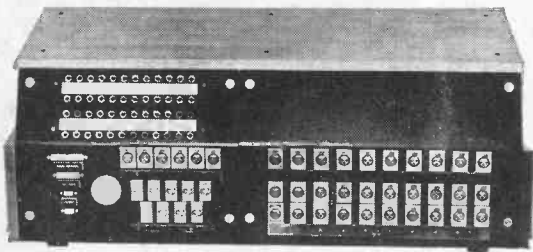

The Neve BCM 10/2 marks a new departure into the field of sophisticated audio control. It embodies ten full mixing input channels and two output groups and is conveniently transportable.

Facilities are included for echo, studio foldback and talkback communication, stereo monitoring, cueing and D.J. "combo" working.

All signal inputs and outputs are on XLR connectors at the rear. Thus the BCM 10/2 provides for every possible requirement within its class. It is competitively priced and available for quick delivery. Full specifications will be sent gladly on request.

Telephone 076 386 776 (Ten lines) Telex 81381

**Rupert Neve & Co. Ltd. Cambridge House, Melbourn, Royston, Herts, England.**

You take no chances when you purchase our brand new British Recording Tapes. Manufactured by reputable British firm. Fitted leaders, polythene bag and boxed (ex. 3"). These tapes are not to be confused with sub-standard imported or used tapes. All 100% tested and fully guaranteed.

This month free coloured leaders with all tape orders

Standard Play		Long Play	
3" 150'	2/-	3" 220'	2/3
4" 300'	4/-	4" 400'	5/-
5" 600'	6/-	5" 900'	8/-
5½" 900'	7/6	5½" 1200'	10/-
7" 1200'	9/-	7" 1800'	13/-
Double Play		Empty Spools	
3" 350'	4/-	3" ...	8d
4" 600'	6/-	4" ...	1/8
5" 1200'	11/6	5" ...	1/9
5½" 1800'	16/-	5½" ...	2/-
7" 2400'	19/6	7" ...	2/3

Compact tape cassettes. 100% perfect, fully guaranteed, not to be confused with Maxwell.

All supplied in plastic library cases.

C.60 7/6, C.90 10/-, C.120 14/6. P & p 2/- per order.

N. WALKER TAPES

28 Linkcroft Avenue, Ashford, Middlesex.

Phone: 53020



High-speed Compact Cassette Copying

Runs from 25 upwards

Fraser Peacock Associates Ltd.
94 High Street Wimbledon Village London SW19

01-947 2233 sole UK distributors of infonics

fpa

WE SPECIALISE IN BRAND NEW TOP QUALITY BRITISH P.V.C. MYLAR & POLYESTER RECORDING TAPES WITH FITTED LEADERS, Etc., EX 3"

Thanks to bulk purchase we can offer tensilised HI-FI tapes, manufactured by a British firm of world repute. All boxed individually (sealed if required) in polythene. Our tapes are not to be confused with imported sub-standard or used tapes. Full-money refund if not delighted.

This month — "DRY SPLICE" (3/9) given FREE with every order.

Length ea. 3 for	Std.	L.P.	D.P.	Boxed empty spls	
3" 150'	2/-	5/9	3" 400'	4/6 13/-	3" 7d.
4" 300'	4/-	10/-	4" 450'	6/9 19/6	4" 1/8
5" 600'	6/-	17/6	5" 900'	8/- 23/6	5" 1/9
5½" 900'	7/-	20/6	5½" 1200'	10/6 30/6	5½" 1/9
7" 1200'	9/-	25/6	7" 1800'	13/- 38/6	7" 2/-

All orders despatched by return.

Postage and Packing 1/9 per order.

STARMAN TAPES, 421 Staines Road, Bedfont, Middlesex

audix

"Studio 80" amplifier

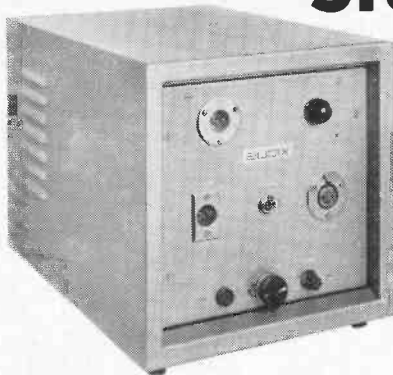

The "Studio 80" Power Amplifier has been produced to high performance standards for Studio and Laboratory applications.

Its proven characteristics puts it in a class beyond anything yet available in power, performance, and price, and is the ultimate in economic functional engineering design — Write for full details of guaranteed performance specification.

- POWER OUTPUT:** Max 80W into 8 ohm.
- POWER BANDWIDTH:** 5 Hz to 35 KHz at 80 W.
- FREQUENCY RESPONSE:** + 0 dB 20 Hz to 20 KHz.
- .5 dB
- TOTAL DISTORTION:** Less than 0.05 at 1 KHz.
- SIGNAL TO NOISE RATIO:** Better than -95 dB below maximum output.
- POWER SUPPLY:** 100/120-200/250 A/C 50-60 Hz.

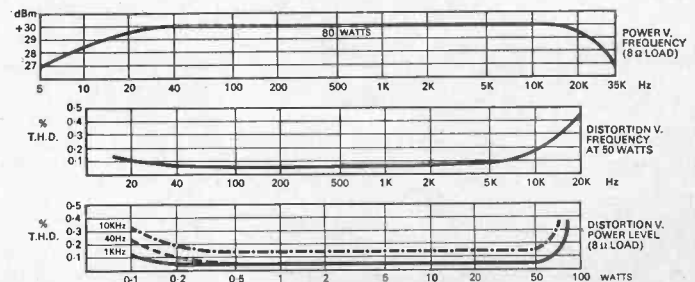

audix SOUND SYSTEMS

AUDIX B. B. LIMITED
STANSTED · ESSEX
Tel: STANSTED 3132/3437
(STD 027-971)

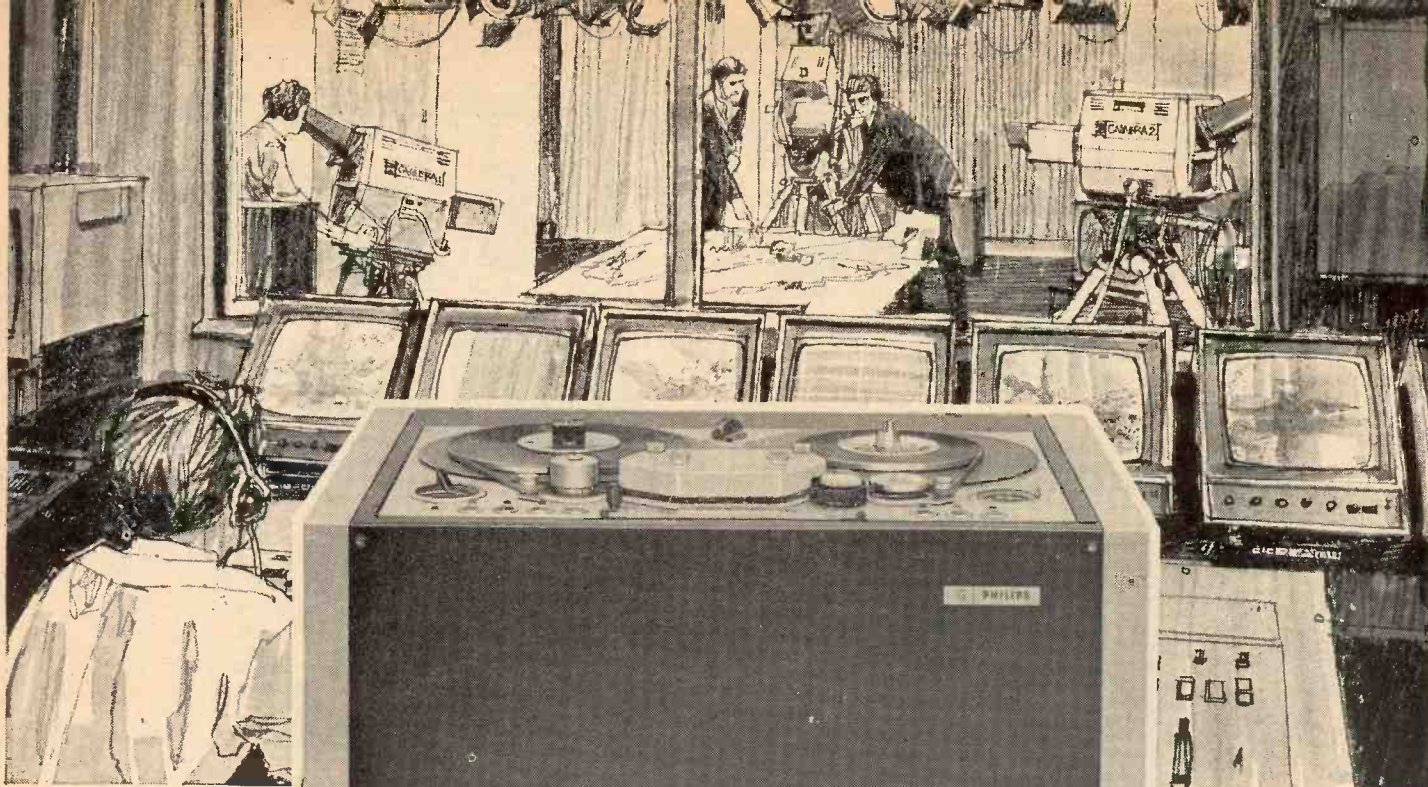

PHILIPS PRO' 51 MASTER RECORDER

Without equal in the field of professional
audio-recording.

Built into the Pro' 51 are the latest technical advances
resulting from Philips long experience and research in this field.

- | | |
|--|---|
| <input type="checkbox"/> Demonstrably easy servicing | <input type="checkbox"/> Clean tape handling |
| <input type="checkbox"/> Ferrite heads for long life | <input type="checkbox"/> Fully transistorised circuits |
| <input type="checkbox"/> Designed for working at all times | <input type="checkbox"/> Mono-stereo switch |
| <input type="checkbox"/> Automatic tape-lift | <input type="checkbox"/> Full-remote control facilities |

Please ask for full information



PYE TVT LIMITED

STUDIO EQUIPMENT DIVISION
Coldhams Lane, Cambridge
Telephone: Cambridge (0223) 45115. Telex: 81103

TVT 47

A new range of sound mixing consoles

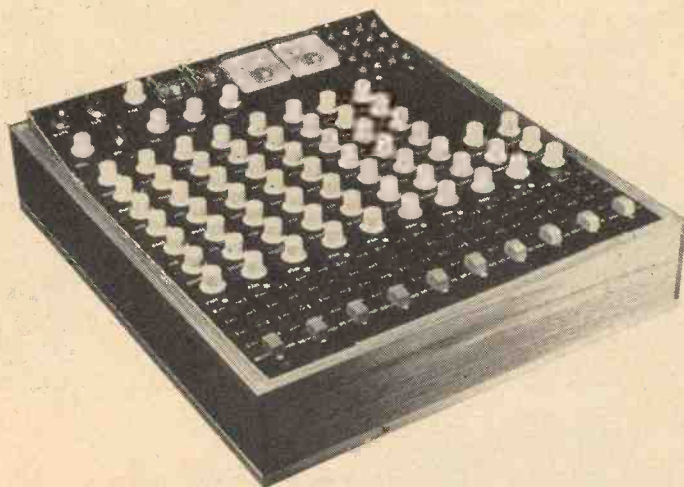

FROM ONLY £292

Built on a modular system that allows each mixer to be assembled to customers' individual requirements, Allen & Heath sound mixing consoles have been designed to give compactness, versatility and quality at reasonable cost.

There are two standard units, the smaller accommodates up to 20 modules (10 large and 10 small) and the larger up to 40 (20 large and 20 small).

In either case the basis [of the customised unit incorporates the following equipment:

- * Jackfield, employing two-way jacking system
- * Twin metering module
- * Oscillator or talkback module
- * Metered echo and foldback send modules
- * Voltage stabiliser and cue module
- * Monitor control module
- * Two output modules incorporating echo return and equalisation

Modules available for inclusion in the mixers are:

MIC/LINE INPUT MODULE
EFFECTS EQUALISER
LIMITER
STEREO HEADPHONE AMPLIFIER

Units are supplied in attractive teakwood cabinets or portable vinyl cases with GPO Jack sockets on rear, or, if required, in chassis form with tag strip connectors.

Write or phone for full details

ALLEN & HEATH LIMITED

Drummond House, 203-209 North Gower Street, London N.W.1.
Telephone 01-387-9611

The perfect partnership



DP4 MICROPHONE

The DP4 is famous for its remarkably wide sensitivity range—uniform response to all frequencies between 50 and 15,000 c/s.

PARABOLIC REFLECTOR

The ideal partner for the DP4 microphone. When you can't get close enough to record normally, the Grampian parabolic reflector is invaluable. It focuses a distant sound-source on to your microphone head—greatly amplifies it without loss of realism and cuts out all unwanted side noises. The reflector is 2ft. in diameter—aluminium matt-green finish. Complete with microphone holder.

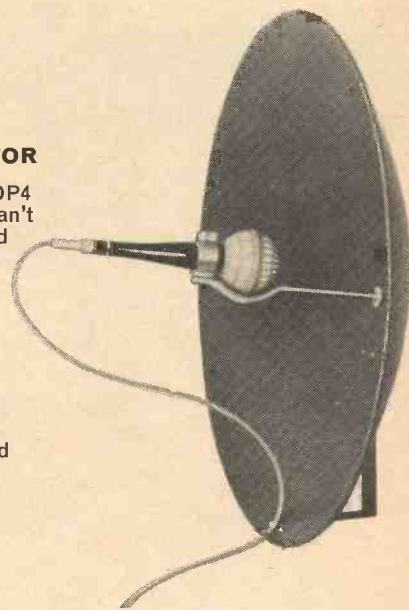

Grampian

sounds like the real thing!

Write or phone for illustrated leaflets
Grampian Reproducers Ltd., Hanworth Trading Estate,
Feltham, Mddx. 01-894-9141

De Lane Lea (Music) Limited, are building the largest recording studio complex in Europe and asked *SOUND TECHNIQUES LTD* to design and build the following equipment.

- 3 16 Output Recording Consoles
- 2 4 Output Remix Consoles
- 110 Sets of Tape Record/Replay Electronics
- 54 Monitor Amplifiers
- 15 Sets of Film Record/Replay Electronics
- 2 Mono/Stereo Disc Cutting Consoles
- 13 Digital Footage Counters/Stop Clocks
- 13 Patch in Universal Equalisers
- 8 Hi-Lo Pass Filters

In addition to all this equipment Sound Techniques are manufacturing and installing a total System Control making this the most integrated recording/film facility yet built.



SOUND TECHNIQUES LTD

Chiswick Avenue, Industrial Estate, Mildenhall, Suffolk.
0638-71-2428/9

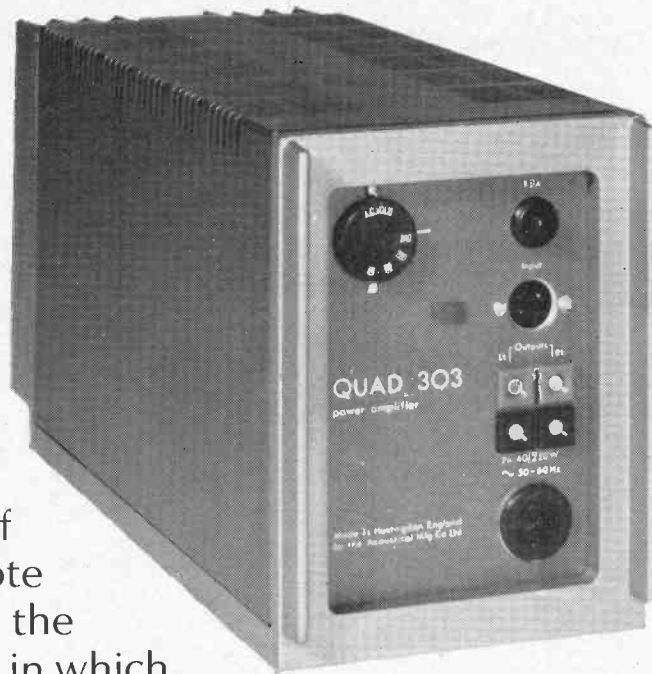

A number of customers wrote to us querying the advertisement in which we referred to the trend towards lower efficiency in loudspeakers. This is entirely factual. Improving the low frequency range of a given size of loudspeaker must involve a drop in conversion efficiency* and therefore

require higher power for the same loudness. The Quad 303 power and VA characteristics are designed to meet this need—now and for the future.

*From two factors—the speed of sound and the density of air ρc^2 it is possible to prove that a box of 2ft³ housing any loudspeaker and designed for flat response ($Q > 1$) down to 50Hz cannot possibly have an efficiency greater than 0.65%. For level response to 40Hz the box would have to be 4ft³ or the efficiency must drop to 0.3%. Similar limits apply to baffles or electrostatic doublets, a 2ft³ box being equivalent in possible conversion efficiency to a square radiating baffle with side=28".

QUAD

for the closest approach to the original sound

Send postcard for illustrated leaflet to Dept. 'SS',
Acoustical Manufacturing Co. Ltd. Huntingdon. Telephone: (0480) 2561/2

Studio Sound & tape recorder

JULY 1970 VOLUME 12 NUMBER 7

INCORPORATING
SOUND AND CINE

EDITOR
JOHN CRABBE

DEPUTY EDITOR
DAVID KIRK

ADVERTISEMENT MANAGER
ROBIN WELLS

ASSISTANT ADVERTISEMENT
MANAGER
TONY NEWMAN

Editorial and Advertising Offices:
LINK HOUSE,
DINGWALL AVENUE,
CROYDON, CR9 2TA
Telephone: 01-686 2599

© Link House Publications Ltd., 1970
All rights reserved

COVER PICTURE

Robin Cable operating a
Dolby system from a remote
switch panel mounted
in the mixing desk at Trident
Studios.

SUBSCRIPTION RATES

Annual subscription rates to *Studio Sound*
and its associated journal *Hi-Fi News* are
36s. (\$5 or equivalent, overseas) and
44s. (\$5.60) respectively. Six-month home
subscriptions are 18s. (*Studio Sound*) and
22s. (*Hi-Fi News*), from Link House
Publications Ltd., Dingwall Avenue,
Croydon CR9 2TA

Studio Sound is published on the 14th
of the preceding month unless that date
falls on a Sunday, when it appears
on the Saturday.

THE EVOLUTION OF sound recording techniques is now proceeding so rapidly that an article describing an original approach to quadratics became out of date before its author could put pen to paper. Hence the absence of Part Two in Granville Cooper's intended series, eclipsed by contributions from Michael Gerzon, to start in our August issue.

Alec Nisbett's survey of American 4-channel systems (March issue) provoked a letter from an anguished reader 'pointing out' that only two transducers are necessary to recreate a periphonic sound-stage—though he hadn't actually tried it. Recent experiments in Germany, the subject of an AES paper,* support this idea, which is taken up in a different way by Mr Gerzon: quadrasonic effects may be derived from two channels by exploiting phase relationships present in Blumlein stereo-pair recordings. The listener is placed midway between left and right loudspeakers carrying normal left and right information respectively. A loudspeaker directly in front of the listener carries in-phase sum (L+R) and a further speaker at the rear carries the outphase difference (L-R). The arrangement does not produce sensible results with multimiked material, but has been tested in practice using coincident-pair tapes produced by the Oxford University Tape Recording Society.

Several other methods of deriving quadrasonic effects from two information channels have received publicity recently, but so far only one, developed in the USA by Peter Scheiber, has received any kind of commercial backing. As reported on page 279, Decca are on the verge of promoting the Compact Cassette as an eventual successor to the LP disc. The domestic Dolby B system is being used to bring hiss to a more acceptable level, low enough to impress Decca sales staff at least. Now, assuming that four independent channels will be needed—despite Gerzon, Scheiber, *et al*, the four-track Dolbied cassette is the obvious format for quadrasonic material. Compared with cartridges, the cassette offers greater handling convenience, fast-wind facilities and longer life (no tape lubricant needed). In the USA, Vanguard are promoting four-track 19 cm/s reel-to-reel tape, some hissy samples of which were played to Sonex visitors. How about trying Dolby B on these?

The potential of four-channel cassettes, however promising, could hardly have been the reason for Decca's moving to tape. Nor was the prospect of increased short-term profit, since discs are substantially cheaper to stamp than cassettes are to dub. They are probably motivated by the American market, where

45% of recorded material sold in 1969 was on tape (reel-to-reel, cartridge and cassette).

It has been amusing to watch the hi-fi boys' reaction to these events. Typically, a complete volte-face from 33 r.p.m. disc, through the hitherto disparaged 19 and 9.5 cm/s reel-to-reel formats, to the ultra-slow ultra-narrow tracks of ultra-thin cassettes. Dolby B provides the sugar for this bitter pill: that and the realisation that tape itself has improved in the last few years.

Audio enthusiasts are, of course, still only a tiny minority of the record-buying public. Most people treat their gramophones like kitchen taps—putting on a disc is largely an unconscious operation. Open tapes treated this way curl or snap; discs, in these casual hands, become scratched and worn.

For the general public, then, cassettes are nearer to the ideal medium than anything so far developed. Whether this section of the market will show interest in quadratics remains to be seen. Provided the rear channels are demonstrated well above their natural level (subtleties are not appreciated by this kind of listener), all-round sound should catch on faster than two-channel stereo ever did.

FEATURE ARTICLES

- 280 EMI AT ST. PAUL'S
By Rex Baldock
- 285 RECORDING STUDIO TECHNIQUES:
Part Seven
By Angus McKenzie
- 290 NOISE AND ITS MEASUREMENT
By Anthony Eden
- 296 APRS 70 PREVIEW
- 304 A HIGH QUALITY MIXER: Part Two
By David Robinson

REGULAR COLUMNS

- 279 STUDIO DIARY
- 289 IMPRESSIONS
By John Shuttleworth
- 293 TAPE RECORDER SERVICE
By H. W. Hellyer
- 301 INTERVIEW: JACQUES LEVY
By Keith Wicks
- 309 NEW EQUIPMENT
- 317 FIELD TRIALS: CHILTON 100S
By David Kirk

EQUIPMENT REVIEWS

- 311 DOLBY A301 NOISE REDUCTION SYSTEM
By Angus McKenzie
- 314 MILLBANK AUDIO MODULES
By Stanley Kelly

Bob Auger is on holiday

*Correct Spatial Sound Perception Rendered by a Special Two-Channel Recording Method', R. Kürer, G. Plenge, U. Wilkens, Berlin Technical University.

VCS 3

E.M. SYNTHESIZER WITH ALL THE FEATURES OF THE BIG ONES AT A FRACTION OF THE COST

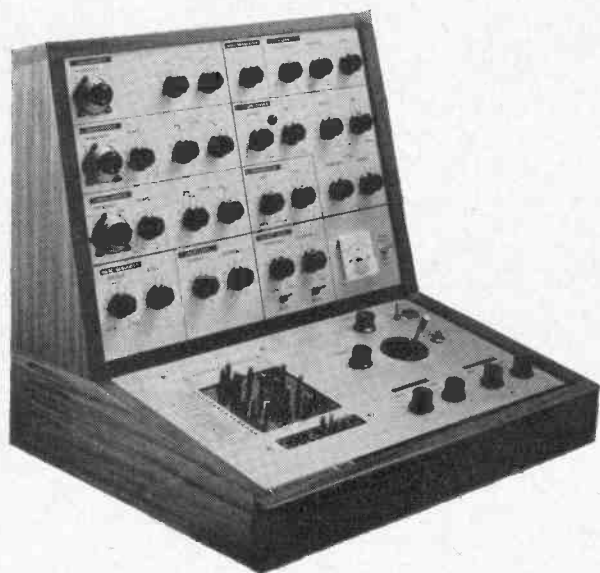

4 Tones Sources: Noise Generator: Filter: Ring Modulator: Envelope Shaper: Reverberation: Mic. Inputs: Built-in Monitor Speakers: Live Outputs: Stereo 'Phasing' and Panning: Latest Integrated Circuits: Pin patching eliminates loose cords: Dynamic (touch sensitive) Keyboard as an optional extra. †

THE VCS 3 HAS EVERYTHING

VCS 3 Complete — £330

DK 1 Keyboard — £150

ELECTRONIC MUSIC STUDIOS (LONDON) LTD.

49 DEODAR ROAD, LONDON S.W.15

Telephone: 01-874 2363

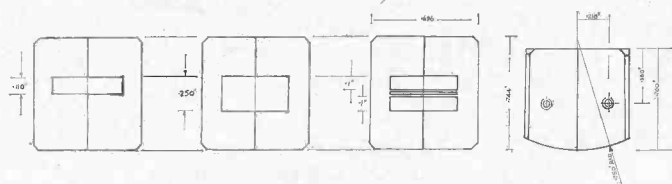

For 10 years we have been making tape heads. Heads of all shapes and sizes—heads for drum use—heads for film sound tracks—even heads for professional recording studios. We can offer a product which competes with the highest standards but not necessarily at the highest prices.

Above is one of our standard body designs which is produced in a number of track configurations. This type of head has been fitted to many different types of professional tape recorders as replacements as well as in original equipments.

HAVE YOU GOT A 'HEAD' ACHE?

PERHAPS WE CAN SUPPLY YOU WITH SOMETHING FOR IT



SCOPETRONICS LTD.

CROWN WORKS, CHURCH ROAD, KINGSTON UPON THAMES.

01-546-1275

01-546-4135

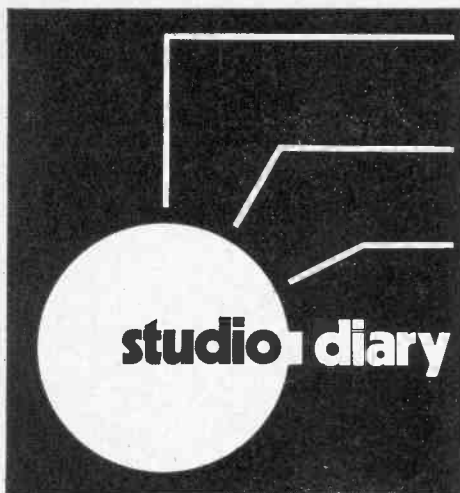

QUADRAHANDEL

THE FIRST quadraphonic recording of Handel's *Messiah* will be taped in the UK by Vanguard this summer. Performance will be by the English Chamber Orchestra and the Ambrosian Singers with Harold Lester (harpsichord), Margaret Price (soprano), Yvonne Minton (alto), Alexander Young (tenor) and Sir Geraint Evans (baritone). The Surround Stereo tapes will be released in conjunction with two-channel cassettes and LP discs before the end of the year.

DECCA TO PRODUCE DOLBIED CASSETTES
A POLICY involving the gradual run-down of discs in favour of Dolbied 4.75 cm/s cassettes has been announced by Decca. First issues in the new format are expected around August.

Europe's first 24-track recorder nearing completion at Unitrack. It was due for delivery in mid-May to Morgan Studios.

We understand that they will be promoted as compatible with conventional cassette players, irritated listeners being advised to turn down the treble. Independent plans are in hand to market a Japanese-manufactured stereo cassette unit with built-in Dolby processor/deprocessors at a provisionally estimated price of £80.

NEVE EXPORTS SHOW INCREASE

AN EIGHT-TRACK mixing desk has been installed by Neve in the Arne Bendiksen Studios, Oslo, with smaller consoles for Radio Ljubljana, Yugoslavia, and Radio Reveil, Switzerland. Two further desks for Acousti, Paris, have now been completed, and a film dubbing desk is being produced for Ardmore Studios, Dublin.

The company's Spanish agents, Sumistros Electricos Maldonado, have ordered eight-track consoles for Studios Hispavox and Navarete, plus switching equipment for TVE Madrid who are already equipped with Neve desks. A team under Dr Reichenthal recently visited Neve to discuss the design of an elaborate system for Supraphon, Czechoslovakia. A 24-channel 16-group console is due for delivery this month to Whitney Recording Studios Inc. on the west coast of the USA.

AKAI VTRs AT SONEX

TWO RELATIVELY low cost helical-scan VTRs were shown for the first time in the UK at the Sonex 70 exhibition in mid-April. Both employ 6.25 mm tape running at 28.6 cm/s, one being a mains model doubling as a 19 and 9.5 cm/s ¼-track stereo audio recorder, and the other a video-with-sound battery portable. The latter was not demonstrated as it arrived from Japan without the camera connecting cable. Picture quality of the mains VTR was remarkably good by industrial CCTV standards (judged on a Shibaden monitor), break-up between programme sequences being limited to a single frame. The two models were fully compatible. A miniature monitor screen is

incorporated in the battery model, the camera featuring a through-the-lens viewfinder and built-in forward-facing microphone. In common with all VTR equipment currently being marketed in the UK, the Akai units will be limited to industrial and educational customers.

THOUSANDTH A301

THE THOUSANDTH A301 noise reduction unit was manufactured by Dolby Laboratories in May and exhibited at the Audio Engineering Society's Spring Convention in Los Angeles. More than twice as many A301 units were produced in the year beginning April 1969 than in the entire preceding three years.

EXTENDED PEGS

TOWARDS THE end of Keith Wicks' article *PEG from the BBC* (April issues), criticism was made of the limited playing time available from PEG cartridges. The standard Programme Effects Generator cartridge has now been increased from 30 to 60 seconds at 19 cm/s, accommodated on a smaller spool hub and feeding an enlarged reservoir. An EP version with 90 seconds capacity is also available for specialised applications. Finally a *Jumbo* cartridge may be employed, containing EP tape in an enlarged container and running for five minutes at 19 cm/s. The latter obviously negates the near-instant rewind facility but was produced to meet a demand. The duration of all PEG cartridges may be doubled by operating at 9.5 cm/s. PEG is manufactured by Mellotronics Ltd., 28-30 Market Place, London W1N 8PH (Tel. 01-580-9694).

COMPETITIONS

TWO COMPETITIONS for amateur recording enthusiasts have been announced: the 1970 British Amateur Tape Recording Contest and the 3M Wildlife Sound Recording Contest.

£200 in prizes will be distributed among winners of the BATRC. Tapes may be submitted in any of seven classes: Speech and Drama, Documentary, Music, Reportage, Technical Experiment, Schools and Set Subject ('A Committee Meeting'). Details are available from John Bradley, 33 Fairlawnes, Maldon Road, Wallington, Surrey.

An Akai X5 stereo battery portable, three Bush TP60 cassette recorders, and reels of Dynarange tape are offered by the organisers of the Wildlife Contest 1970/71. Four classes: Individual species of birds (1), mammals and insects (2), wildlife 'atmosphere' (3) and Junior entries (4). Further information from W. R. Bowles, 3M Company, 3M House, Wigmore Street, London W1A 1ET.

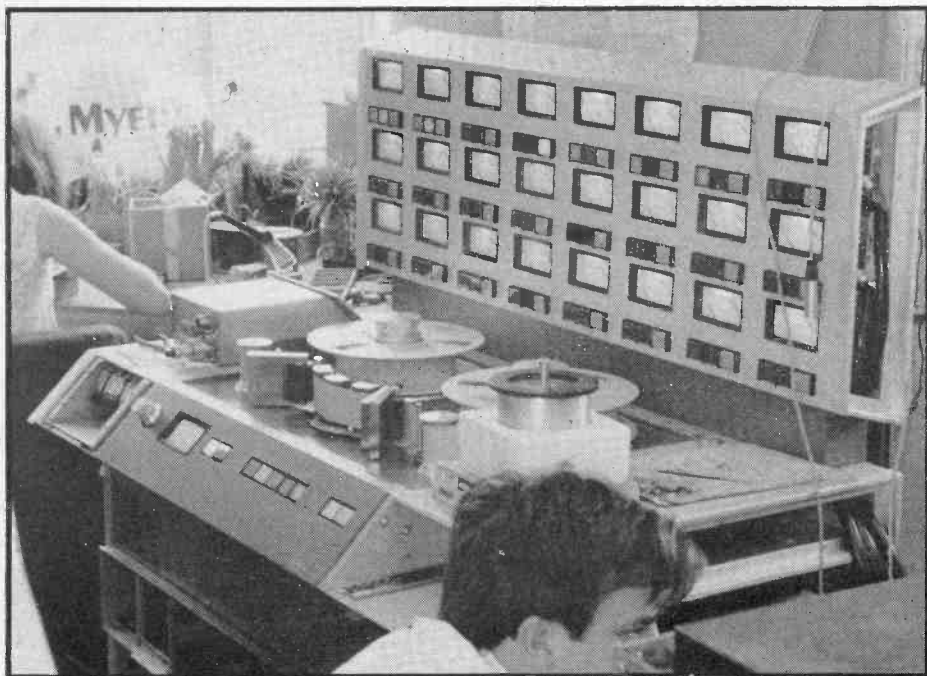

NEXT MONTH

'THE PRINCIPLES of Quadraphonic Recording' by Michael Gerzon, 'Videotape in Broadcasting' by Howard Dell, a visit to Spot Studios by Keith Wicks, and a field test of the Bang & Olufsen BM5 stereo ribbon microphone by John Fisher: part of the line-up for August *Studio Sound*. Alec Tutchings reviews the Uher 1000 Pilot Mk. 2 and Angus McKenzie the Calrec capacitor microphone.



EMI at St PAUL'S

Rex Baldock describes an EMI session in the Great Cathedral Organ Series



EARLY in 1968, EMI had agreed that I should describe the recording of the organ in St. Paul's Cathedral, then planned to be the next release in their *Great Cathedral Organ Series*, but various delays arose and it was not until the end of last Autumn that the recording sessions actually took place. So, on the evening of October 29, I made my way to Sir Christopher Wren's great building, now nearly 300 years old, its magnificence highlighted by contrast with the modern office blocks which have arisen around it. Five churches have been built on this site since AD 604, the longest lived so far being the Norman Cathedral, or 'Old St. Paul's', started in 1087 and destroyed in the Great Fire of 1666. This was also a very large building, having a spire of 489 feet (demolished by lightning in 1561) and I can lay claim to a connection, since in 1306 a distant relative, Ralph Baldock, was ordained there as Bishop of London.

Work commenced on the present cathedral in 1675 and its first organ was built by 'Father' Smith between 1695 and 1697 having '21 stops, part wood and part metal and six halfe stops', standing on the chancel screen in a case by Wren, with wood carvings by Grinling Gibbons. This might have been overshadowed by a proposal of Renatus Harris in 1712 to build an additional organ, having six manuals and pipes up to 40 feet in length for the west end of the nave. This came to naught, however, and the Smith organ, often played by Handel, remained more or less unchanged in the care of a succession of organ builders until the early 1860's, when Willis converted it to pneumatic action.

In 1873, Willis completed a new organ, incorporating a few of the old pipes, the old case being modified to form the present north choir case and a copy made to match it for the south side. This type of division, extremely rare at that period, was made possible by the pneumatic action, and the successful installation at St. Paul's led to a similar layout at Salisbury Cathedral completed in 1877, an instrument regarded by Stainer (then organist at St. Paul's) as even finer.

For those unfamiliar with the subject, it should be said that 'Father' Willis (or Henry

Willis 1; Henry Willis 4 is now governing director of the organ builders Henry Willis & Sons Ltd., with his son, Henry 5, also in the business) is counted amongst the most outstanding organ builders of the 19th century. At this period of his long career he was also involved with the design and construction of the huge concert instruments at the Royal Albert Hall (completed 1872; intact but highly modified) and the Alexandra Palace (1875; his second organ there following a fire—original pipework awaiting reassembly), of which he considered the latter amongst his greatest achievements, and whose qualities may be assessed on HQM 1199.

Since 1872 the firm of Willis has been solely responsible for the maintenance of the organ at St. Paul's Cathedral (as well as the Willis 'organ on wheels', an 1881 organ of only eight stops which has done valuable service at periods when the main organ was inoperative) and from time to time have enlarged and improved it, with additions both in the chancel and the N.E. and S.E. quarter galleries, situated below the whispering gallery. Currently the organ has 10 distinct sections, controlled from five 61-note manuals and a 32-note pedalboard, associated with 98 stops and 30 couplers, the total pipe complement being 6 505, almost half being contained within the north and south main cases. The pipes range in speaking length from 32 feet down to about $\frac{1}{2}$ inch and the wind pressures used lie variously between 3 and 30 inches water gauge.

The EMI recording team, directed by Brian Culverhouse, completed the recording work over three successive evenings, of which I attended the second. For undertakings of this nature, some of the cathedral maintenance and security staff have to be present and Willis' tuner stood by. One of the Willis directors, Mr Hamblen, supervised on this particular evening and was available to escort the Link House photographers and myself via spiral staircases and passageways to the N.E. quarter gallery. Here, some 60 feet above floor level, the four massive 32 foot pitch pedal pipe ranks are housed, together with other pedal pipes and the 366 pipes of the dome tuba section. The largest pipes of each 32 foot rank

give a note of pitch C₄ (16.35 Hz). This varies in quality from the almost pure and all-pervading effect given by the Double Open Bass (wooden flue pipe, about 26 x 22 inches internal by two inches wall; 1872), through the more string-like Contra Violone (mitred metal flue pipe, about 18 inch internal diameter; 1930) to the moderate growl of the Contra Posaune (serpentine wooden reed pipe; 1872) and finally the powerful bite of the Contra Bombarde (metal reed pipe; 1960). We rapidly became very dusty moving around this large gallery but managed to obtain the accompanying photographs. One has to be very careful when clambering inside pipe organs in order to avoid mistuning or even damaging the smaller pipes and mechanism. On this occasion there was also the extra hazard of near lethal sheer drops between some of the larger pipes!

We were just about to leave the N.E. gallery, when its associated blowers were switched on (22½ horse power total with a standby set) and the main bellows, some seven by four feet in size grew lazily before us, like an awakening giant, accompanied by eerie hissing noises. Fortunately we were spared the impact of the spun brass eight foot Trompette Militaire rank, reserved largely for fanfare effects and voiced on 30 inch wind. We gathered that the tuning of this rank is not a popular job, and is tiring even when wearing ear muffs. The 61 reed pipes and their soundboard were donated by the late Henry Willis 3 in 1930, himself the builder of notable organs at Westminster Cathedral in 1922 (Number 15 in the EMI disc series; *CSD 3648*) and Liverpool Anglican Cathedral in 1926 (Number one; *CSD 1534*) and with whom I had the privilege of several discussions on pipe organ matters.

Back at floor level again, we found the recording team finalising the microphone and cable arrangements under the eye of recording engineer, Stuart Eltham, while producer Brian Culverhouse discussed the musical aspects with the cathedral organist, Christopher Dearnley. Dearnley had already made one record for the series when organist at Salisbury Cathedral (Number 11; *CSD 3595*) with which he was associated from 1954-68. By transferring to St. Paul's at the appropriate time, he acquired the



Top left: Control room. Stuart Eltham seated at mixer with Brian Culverhouse listening.

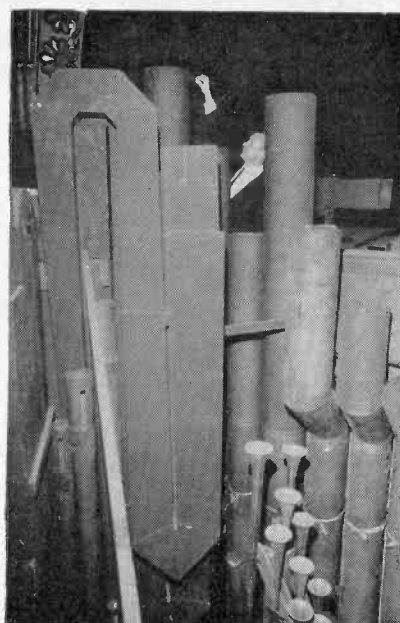

Top right: The author measuring the diameter of an open metal pipe. Folded wooden pipes on left are CCCC# and CCCC of 32 foot contra-posaune rank.

Middle: Christopher Dearnley at the five-manual console.

Bottom: Main bellows.



opportunity of a second recital.

After a short discussion with the EMI team, the photographers and I ascended the short spiral staircase leading to the organ loft, this being in the lower part of the north case, there being room for the five manual console, the organist and two or three others only. From here, the musical balance observed is completely different from anywhere else in the cathedral, since the 1 281 pipes of the Great organ and 122 pipes of the Tuba organ are only a few feet above the organist's head! Apart from the full contributions of the lower pedal stops and the famous Swell organ in the case opposite, this effectively masks anything else and a special sort of skill, based on experience and listening to others playing, is demanded in order to achieve optimum balance. I have heard visiting organists turn contrapuntal music into a formless 'wodge' through inappropriate selection of stops and inter-departmental balance.

As heard normally seated below the dome, the organ plus building acoustics has unique characteristics. In the type of music having a gradual build up of level, the organist will usually commence using the chancel sections alone, the apparent source area being fairly restricted and giving a reading on a sound level indicator round about 65-70 dB (ref. 0.0002 dynes/sq.cm.; C weighting). In such reverberant surroundings, the result of a total air volume of some 5 000 000 cubic feet with a 60 dB decay time of 11 seconds under the dome, the mean indicated sound pressure level can be amazingly steady in spite of changes in character of the music itself. In fact, I have several times observed that when the organist brings in the pipes of the dome diapason chorus, despite the aural effect of an increase in loudness, the meter reading remains almost unchanged. This can also occur as the organist changes the general register and emphasises that human hearing is a complex adaptive process influenced by spectral and spatial distribution in addition to the intensity itself.

As the organist gradually brings in more and more ranks of pipes the loudness slowly increases, until, finally, with the full Great and Swell organs operative supported by the whole

(continued on page 283)

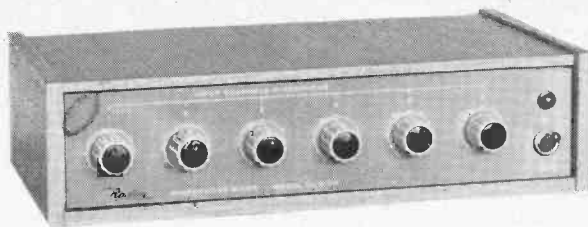

Frequency Response	10c/s (Hz) to 35 Kc/s (kHz) Level 30c/s (Hz) to 25 Kc/s (kHz)
Output	@6K ohms position 2.5v. max. @68 ohms position 0.025v. max.
Gain	x2 and greater than 5
Input Impedances	35 to 100 ohms (or Hi-K if required)
Hum and Noise	Better than 40dB down
Power Supply	220 to 240 volts 50c/s or 110 to 120 volts 50-60c/s Please state voltage required.
Size	Inches: 13 x 7 x 3½ Centimetres: 32.5 wide, 17.5 deep, 10.5 high
Weight	6lb. 8oz. 3½ kilos.

Also Available

Special "Audio Blocks". These are inexpensive all transistor, line-matching units, to solve all those 'High and Low' problems. They are small, battery-operated units, in all-metal cases, that can take the 'treatment' and give the results you want.

Model MLA/L1 —Low to High impedance.
Input 5 ohms to 1K
Output 10K to 50K. Typical gain 2000—according to impedance used. **£11.0.0** rec. retail

Model MLA/H2 —High to Low impedance.
Input 50K to 100K
Output 600 ohms. Gain 20dB @600 ohms 50mV in for 1v. @100K out. **£11.10.0** rec. retail

Available from Dealers, or in case of difficulty, write to: **Radon Industrial Electronics Co Ltd**
Brooklands Trading Estate, Orme Rd, Worthing, Sussex **Tel. Worthing 34904**

RADON'S DL6CM MIXER

Designed for Professionals at Unprofessional Prices

Nine transistors plus diode bridge rectifier are employed in this compact mains powered unit with the following features:

Lightweight and pleasing appearance, all controls numbered at the front to correspond with inputs at the rear, no ventilation ducting as there is no heat to dissipate, no waiting for warm-up on switching on, has high impedance output facility as well as low, with gains of x2 or x5 available at the flick of a switch, reliable standard jack sockets and a low noise level with absence of hum. The front panel is permanently engraved on grey laminate. The unit is housed in a satin polished wood cabinet.

Lo or Hi-K Standard Model **£49.19.8** rec. retail
200 ohm Balanced Line Model **£72.10.0** rec. retail

FRANCIS OF STREATHAM

Members of the Hi Fi Dealers Association

LONDON'S FOREMOST TANDBERG STOCKISTS

DECKS WITH PRE-AMPS

(Microphone extra)
Akai 4000D, Stereo
Revox 1102/4
Sanyo 801, 3 sp. 4 Tr. Stereo
Sony 355 3 sp. 4 Tr. Stereo
Sony 255 Stereo
Tandberg 6000X 3 sp. 2/4 Tr. Stereo
Tandberg 1600X
Telefunken 205 3 sp. 4 Tr. Stereo
Telefunken 203 Studio
Philips N.4505 3 sp. 4 Tr. Stereo
Philips PRO 12 2 sp. 2 Tr. Stereo

COMPLETE TAPE RECORDERS

Ampex 800 Series Stereo
Ampex 1100 Stereo
Ampex 2100 Stereo
*Akai 1710W Stereo
*Akai N.9 Stereo
*Akai 1800 Dual-purpose stereo 8 track cartridge and tape recorder
*Brenell Mk. 5/M Series III Mono
*Brenell Mk. 5 Series III Mono
*Brenell ST200 2 Tr. Stereo
*Brenell ST400 4 Tr. Stereo
*Ferrograph 713
*Ferrograph 702/4
*Ferrograph 722/4
Fidelity Studio 4 Tr. Mono
Fidelity 'Braemar' 2 or 4 Tr. Mono
Grundig 124 2 Tr. Mono
Grundig 144 4 Tr. Mono
Grundig 149 4 Tr. Mono Auto
*Grundig TK320 3 sp. 2/4 Tr. Stereo
Philips 4307 4 Tr. Single Speed Mono
Philips 4308 2 sp. 4 Tr. Mono
*Philips Professional PRO.12
Philips Stereo 4404 2 sp. 4 Tr.
Philips Stereo Cassette 3312
Philips 4407 3 sp. 4 Tr. Stereo
*Philips 4408 Prof. 3 sp. 3 Tr. Stereo

Pye 9123 2 sp. 4 Tr.
*Revox 77 Stereo Transistor
Sanyo 929 4 Tr. 2 sp. Stereo
Sanyo 939 4 Tr. 2 sp. Stereo
*Sanyo 990 3 sp. 4 Tr. Stereo
Sharp RD. 706 2 sp./2 Tr./Batt. Mains
*Tandberg 15 2 or 4 Tr./3 sp./Mono
*Tandberg Series 12X 3 sp. 2/4 Tr. St. Telefunken 204 T.S.
*Telefunken M207 2 sp. 4 Tr. Stereo
Telefunken 501 4 Tr.
Telefunken 203 Stereo/Mono 2 sp. 4 Tr.
Telefunken 201 Mono 4 Tr.
*Uher 714 4 Tr. Mono

SPECIAL OFFER
Philips EL3302 Cassette Recorder
£23.0.0 (p/p in UK 5/-)

BATTERY PORTABLE & CASSETTE

Philips RR482 Cassette/AM FM Radio
Philips RR290 Cassette/AM Radio
Standard Series 11-2
Ferguson Cassette 3240
Grundig Cassette C.200
Aiwa Cassette Batt./Mains
Philips 2205 Batt./Mains Cassette
Pye Cassette
Sharp 505 2 Tr./2 sp./BM
National 4 Tr./2 sp./Batt. Mains
Telefunken 302 4 Tr. 2 sp. Mono
*Uher 4000L 4 Tr. 2 sp. Mono
*Uher 4200/4400 2/4 Tr. 4 sp. Stereo

POWER PACKS, by Philips, Stella, Telefunken and Uher

● **MIXERS** by Uher, Eagle, Telefunken, D.J., etc.

* Microphones extra

FOR A FAIR AND DEPENDABLE DEAL IN

TAPE and HI-FI

- ★ Minimum Deposit and no Interest or Service Charges on H.P. up to 18 months
- ★ Free Service during Guarantee period
- ★ Fair Part Exchange Allowance on your old Recorder
- ★ Reconditioned Recorders available to personal shoppers only

AMPEX TAPE SPECIAL OFFER

Guaranteed Brand New 500 Series

(P—Polyester: A—Acetate)

7" L.P. 1800 ft. (P) ...	21/-
7" Standard 1200 ft. (P) ...	15/-
7" Standard 1200 ft. (A) ...	12/-
5½" L.P. 1150 ft. (P) ...	17/6
5½" L.P. 1150 ft. (A) ...	15/-
5½" Standard 850 ft. (A) ...	12/6
5" D.P. 1200 ft. (P) ...	17/6
5" L.P. 900 ft. (P) ...	12/6
5" Standard 600 ft. (P) ...	10/-

Postage 2/- per reel on orders up to £3.0.0. Over sent post free in U.K.

● MICROPHONES by

AKG, Hammond, Grampian, Reslo, Acos, Telefunken, Beyer, Sennheiser, etc.

Bib and E.M.I. splicers, Matching transformers, Defluxers, Bulk Erasers, etc.
Stands, booms, fittings.
Pre-recorded tapes and cassettes, etc.
Tapes in all grades and lengths by: B.A.S.F., Scotch, Philips, E.M.I., etc. Cassettes by Philips, etc.

Headphones by AKG, Ampex, Akai, Sansui, Nikko, Philips.

HI-FI DEPT.

● **AMPLIFIERS**
Quad, Rogers, Arena, Philips, Goodman, Nikko, Sansui, Sanyo, Leak, Armstrong, Tripletone, Tandberg, Teleton.

● **TUNERS**
Quad, Rogers, Leak, Armstrong, Tripletone, Arena, Nikko, Goodman, Huldra.

● **LOUDSPEAKERS**
Quad, Rogers, Kef, Wharfedale, Goodman, Tannoy, Lowther, Leak, Tandberg, Arena, Celestion.

● **MOTORS, PICKUPS**
GARRARD S.P.25 Mk. II less cartridge, post free U.K. £11.15.0 (p/p in U.K. 5/-).
Goldring Thorens
Connoisseur Tannoy
Audiotec Shure
Neat Empire
Acos Sonotone
Duel SME
BSR Pickering

Diamond styli, Microlifts, Pressure Gauges, Cleaning Accessories, Cabinets, etc.

169-173 STREATHAM HIGH ROAD, LONDON, S.W.16

Between St. Leonard's Church and Streatham Station

01-769 0466: 01-769 0192

Please note this is our only address. Free parking Prentis Road, 2 mins. away
OPEN ALL DAY SATURDAY—EARLY CLOSING WEDNESDAY

dome diapason and tuba sections, topped by the Trompette Militaire with all 'sitting' on the 32 foot Contra Bombarde and other pedal contributions, a sound level indicator will read 96 dB within close limits—a figure of little meaning, since the sound seems to arrive from an almost limitless area, is completely free from any irritation and yet is majestic and inspiring in the extreme. At the other end of the dynamic scale, some of the Choir and Altar organ sounds are so gentle that they can be missed if the audience is not very quiet and attentive.

In this case, from the producers and recording engineer's standpoint, the most favourable microphone layout, suitable for blending and integrating all the above sound into a two-channel stereo recording capable of giving the simulation of listening at an 'ideal' position within the cathedral, is none too easily achieved. Even allowing for polar diagram selection, a microphone does not have the subtle discriminative powers of the human ears and brain which can permit enjoyable listening at an

unfavourable spot and, in spite of what the 'purists' may feel on the subject, it is usually necessary to employ several for this type of work. It was clear, however, that the number, type and disposition of the microphones were the outcome of past experience, some common sense and careful adjustment following experiments, rather than any indefinable 'black magic'.

In fact, four Neumann stereo microphones were used, one for each of the quarter galleries suspended about 25 feet distant, with two for the chancel, one on a 30 foot stand between the north and south cases and the other on a 20 foot stand farther east to cover the Solo and Altar organ sections. Two 'fill in' microphones were available on the floor below the dome but were found not to be necessary.

All microphones were connected via a group of preamplifiers to the recording room situated in the crypt, about 12 feet by 8 feet 6 inches, in which were installed two monitor speaker enclosures housing LF and HF drive units, power amplifiers and an eight-channel EMI mixing and monitoring desk. This fed two Studer A62 transistorised tape recorders connected in parallel and running at 38 cm/s

(chosen partly for their portability) using EMI selected professional recording tape.

The desk incorporated four pairs of faders (one pair acting as master gain controls), channel amplifiers with preset equalisation facilities, two VU meters (preferred by many recording organisations in face of the theoretician's contention that only PPMs give meaningful readings!) and a correlation meter, giving a vertical display of the L/R signal ratio over a wide range of absolute levels. This is desirable in order to show that the two signals are largely in the in-phase mode, otherwise complete or frequency-selective cancellation may occur if they are reduced to mono. Additionally, any excessive difference signal would lead to large vertical modulations in the final gramophone record groove, so provoking tracking difficulties with some types of pickup.

Having just heard the organ live with the full dimensional characteristics of the sound impressed upon my memory, I initially found that conventional two-channel stereo in the recording room fell rather flat.

Between the musical items, a slight ambient hiss was noticeable direct from the microphones and thought to be largely the result of residual air leakage from the organ mechanism, emphasised by the proximity of the microphones, in contrast to a normal listening position within the cathedral, where conditions were fairly quiet and restricted to a low rumble from the evening traffic outside.

A recital that was both varied and appropriate to the organ's capabilities had been evolved (see list of items). When I was there, the Mendelssohn Sonata and Saint-Saëns Improvisations were being tackled. Naturally, because of retakes and other considerations, the programmes are not necessarily recorded in the final sequence. Brian Culverhouse was busy with stopwatch and musical score, whilst the recording assistant (Graham Kirkby—also responsible for the equipment) operated the tape recorders, noted the various take numbers and times, and generally looked after the tape handling and storage. Spliced corrections are avoided as much as possible but are used if a recording is otherwise particularly good.

Whilst Christopher Dearnley was busy warming up, Stuart Eltham was able to discover the maximum levels likely to arise and observe the general balance requirements. All recording channels were in fact used flat, except for a general overall lift of about 2 dB above 2 kHz. Fortunately, being driven from stabilised air supplies, the acoustical output of a pipe organ is predictable. A given registration and fixed microphone positions, coupled with the smoothing effect of the building's 11 second reverberation period, meant peak levels were not likely to be more than a dB or two different each time. In fact, apart from a few minor intermicrophone balance trims and slight resetting of the master gain controls, the equipment was frequently left set for several minutes at a time.

Levels of 0 VU on either channel were rarely exceeded and I did not observe over +1 dB at any time during this session. A large pipe organ exhibits a surprising dynamic coverage and the mean level was sometimes well down on the meters, probably some 30 dB below maximum.

A telephone link with the organist is vital if
(continued on page 287)

Eltham, Dearnley and Culverhouse listen to the playback.



ST. PAUL'S CATHEDRAL RECORDING : RECITAL PROGRAMME

Side 1	Approx. duration mins.
Purcell (Arr. Dearnley): Trumpet Tunes from 'King Arthur'	2½
Mendelssohn: Sonata No. 2, Op. 65	10
Saint-Saëns: Improvisations, Op. 150. No. 4	2½
No. 7	4
Bridge: Allegro marziale e ben marcato	4
Side 2	
Bliss (Arr. Ramsay): Three Fanfares	3½
Howells: Psalm Prelude, Op. 32, No. 1	6½
Ives: Variations on 'America' (1891)	10

GROUP 1 GROUP 2 GROUP 3 GROUP 4

CH1 CH2 CH3 CH4 CH5 CH6 CH7 CH8 CH9 CH10 CH11 CH12

CH13 CH14 CH15 CH16 CH17 CH18 CH19 CH20 CH21 CH22 CH23 CH24

CH25 CH26 CH27 CH28 CH29 CH30 CH31 CH32 CH33 CH34 CH35 CH36

CH37 CH38 CH39 CH40 CH41 CH42 CH43 CH44 CH45 CH46 CH47 CH48

CH49 CH50 CH51 CH52 CH53 CH54 CH55 CH56 CH57 CH58 CH59 CH60

CH61 CH62 CH63 CH64 CH65 CH66 CH67 CH68 CH69 CH70 CH71 CH72

CH73 CH74 CH75 CH76 CH77 CH78 CH79 CH80 CH81 CH82 CH83 CH84

CH85 CH86 CH87 CH88 CH89 CH90 CH91 CH92 CH93 CH94 CH95 CH96

CH97 CH98 CH99 CH100

AUDIO

DEVELOPMENTS

MODULAR MIXING

CH1 CH2 CH3 CH4 CH5 CH6 CH7 CH8 CH9 CH10 CH11 CH12

CH13 CH14 CH15 CH16 CH17 CH18 CH19 CH20 CH21 CH22 CH23 CH24

CH25 CH26 CH27 CH28 CH29 CH30 CH31 CH32 CH33 CH34 CH35 CH36

CH37 CH38 CH39 CH40 CH41 CH42 CH43 CH44 CH45 CH46 CH47 CH48

CH49 CH50 CH51 CH52 CH53 CH54 CH55 CH56 CH57 CH58 CH59 CH60

CH61 CH62 CH63 CH64 CH65 CH66 CH67 CH68 CH69 CH70 CH71 CH72

CH73 CH74 CH75 CH76 CH77 CH78 CH79 CH80 CH81 CH82 CH83 CH84

CH85 CH86 CH87 CH88 CH89 CH90 CH91 CH92 CH93 CH94 CH95 CH96

CH97 CH98 CH99 CH100

TEL: 054 33 4605
 (BROWNHILLS)
 01 504 6256

HALL LANE, WALSALL WOOD, STAFFORDSHIRE,
 ENGLAND.

RECORDING STUDIO TECHNIQUES

THIS month I propose to deal with some of the accessories and gimmicks used in the recording studio now and in the past, some of which are commonly nicknamed 'black boxes'.

Virtually all studio microphones used these days have floating balanced outputs, that is to say the studio output from the mike appears on two connections, neither of which is earthed. A third connection to the chassis of the mike usually also includes a metal gauze over the capsule—there not only to protect the capsule but also, just as important, to screen the capsule from external RF and electromagnetic fields. Most professional microphones have a socket on the mike itself into which a metal screened plug fits. This is earthed to the screen of the twin mike cable so that, in addition to the mike being balanced to reduce induction of hum and external fields, this entire wire is screened to reduce interference. Many years ago most input circuits to professional amplifiers were balanced with respect to earth, i.e. the centre tap of the primary to the input transformer was earthed to the chassis of the amplifier, such an input termination being called 'balanced'. It is now fairly common practice to omit this centre tap, such an input then being called floating balanced. I have never myself had any problems with microphone lines terminated by floating balanced input circuits which could be put right by centre tapping such a winding, and I have usually found it far better to take precautions in the design of the earlier amplification stages in low level preamplifiers. I have never forgotten the trouble that my colleagues and I had many years ago when the arrival of a huge new automatic coffee machine at the studio unfortunately coincided with the installation of one of the first large transistorised control desks made in Britain—incidentally largely designed by Richard Swettenham. One only had to insert 6d into the coffee machine to put the control room out of action for about half a minute with clicks, bangs and thumps radiated. Many engineers have also complained to me of interference when using transistorised equipment in the vicinity of a radio transmitter. I used to have a garage almost next door to my studio and the AA frequently transmitted from their vans just outside but very kindly issued instructions for no-one to transmit within a 100 yard radius. Even Decca had problems in West Hampstead with a well-known radio amateur transmitting opposite their studio and breaking in on a lot of their equipment. It is interesting to note that the amateur was not at fault in any way, and the Post Office spent many days assisting Decca to suppress the RF pickup in much of their equipment. This problem is also common to much transistorised 'hi-fi' equipment, so I propose to mention a few hints to engineers and enthusiasts on how to remove such interference.

The basic problem is that the switching transient not only contains RF energy, but this

is modulated, usually at the beginning and end of the transient. The bursts of energy are rectified usually between the base and emitter of a common transistor, or the grid and cathode of a valve for instance. Having rectified the RF, the AF components remain and are amplified in the normal way by the early stages of the equipment. The best way to remove such rectification is to common, as an example, the base and emitter of a transistor by fitting a small capacitor of 10 pF to 150 pF between these points, thus tying them together at RF and stopping both rectification and amplification of these components. If the cathode or emitter are well above chassis from an electrical point of view, there should also be a further capacitor (of similar value) to chassis. This form of protection will be found considerably more efficient than the usual method of using a small capacitor across the amplifier input, followed by a blocking resistor, in fact I have often found that the method described can be at least 20 dB better than other methods. In addition it is a good idea also to filter the mains or power input wiring at its input to the mixer by using small RF chokes obtainable from Radiospares, together with capacitors. By taking these precautions one can be reasonably sure that on a mobile recording, one can cut out interference fairly reliably. It may of course be necessary in serious cases of interference to apply the same technique to later amplifier

stages. This technique will also greatly reduce pickup of radio transmissions.

There has been some misunderstanding in the past about microphone impedances and the impedance at the input of microphone amplifiers. Most microphones prefer to look into an impedance considerably higher than their own output impedance and in fact it has been found that capacitor microphones will have a better overload capability in themselves if they are bridged by an impedance at least five times higher than their own. A 200 ohm capacitor microphone should be bridged by not less than 1 K for best performance, though it should be borne in mind that, as there is a power loss in such a connection, the following preamplifier must have a low noise level if the microphone is to be used for recording quiet sounds. Many early professional tape recorders had microphone inputs that seriously loaded the mike. One which was particularly sensitive to this was the STC 4033 cardioid which, although rated at 60 ohms, preferred to see not less than 300 ohms. Because of the matching system employed, there was considerable bass cut when the microphone was plugged into the microphone input sockets of tape recorders such as the EMI TR50 and TR51. Many engineers found that improved performance could be gained by removing the secondary load to the input transformers, or alternatively increasing its value. Such a modification may of course lead to a noticeable increase in HF if the microphone input transformer is other than of high quality. Such a boost is regarded by many as preferable to the severe loss of bass and poor noise level without the modification.

It is extremely important to ensure that all microphones and microphone leads used in any particular organisation are in phase with each other, and I am convinced that not enough care is taken in this respect by some recording studios. It is useful to have an emergency box available with input/output sockets and a switch for changing the phase of one leg of a stereo system or perhaps one microphone and I would particularly like to recommend some excellent dye-cast boxes of all sizes made by STC at Harlow, and Stratton & Co. (perhaps better known as *Eddystone*) in Birmingham. These boxes are also ideal for enclosing switchable microphone attenuators, passive frequency control circuits, microphone transformers, and so on.

In the days of valves it was only rarely necessary to insert what the engineers call 'pads' or fixed attenuators before the microphone preamplifiers since the overload capacity of valves was far better than it is on transistors nowadays. A transistor stage may overload at only 15 dB above the normal peak input level whereas a valve would frequently have 20 or 30 dB in hand. In the design of a microphone attenuator, two factors must be remembered, the first being that the mike must not be loaded

(continued on page 287)

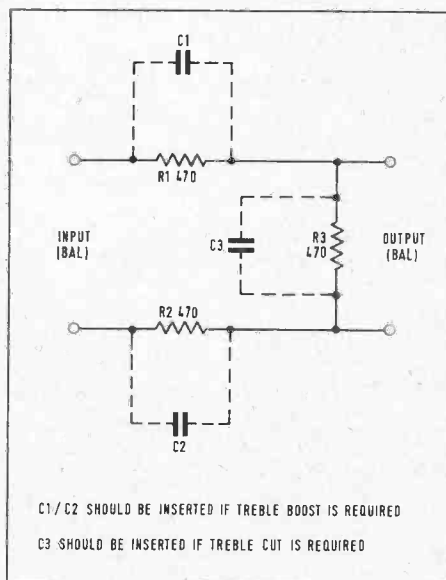

BY ANGUS MCKENZIE (Roundabout Records)

PART 7

BLACK BOXES

The majority of Recording and T.V. studios use **TANNOY** monitors



Tannoy Monitor Gold Dual Concentric Loudspeakers, accepted as the "Quality Standard" most specified for professional use by Recording, Broadcasting and TV companies as well as the World's largest manufacturers of professional Audio Equipment.

THE *Monitor*
GOLD *

THE NEW MONITOR GOLD now incorporates a Treble Roll Off Control and Treble Energy Control enabling precise adjustments to be made for room acoustics and programme material.

Frequency Response	30-20,000 cps
Power Handling	15" 50 watts
Capacity	12" 30 watts
	III LZ 15 watts
Impedance	8 Ω Nominal
	5 Ω Minimum

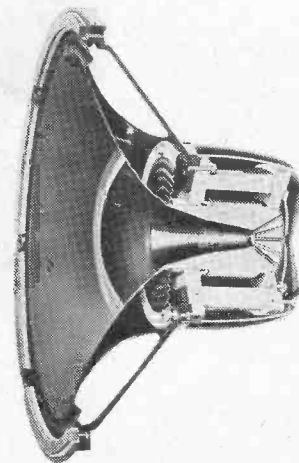

The same units provide professional standards in the home



Norwood Road, West Norwood,
London, S.E.27.

01-670 1131

● Norwood Road, West Norwood, London, S.E.27. 01-670 1131

RECORDING STUDIO TECHNIQUES CONTINUED

too heavily and the second that the input transformer should always see an impedance of not much more than the mike output impedance so that its response would not be materially affected. It is very inadvisable to use series attenuation resistors without the use of a terminating resistor, and a pad giving approximately 10 dB cut when in normal use is given by three 470 ohm resistors arranged as in fig. 1. The terminating resistor on the right can be reduced in value if more attenuation is required.

In the earlier days of recording, many passive mixers were used in which the pads consisted of steps of series attenuation without a terminating resistor. When a microphone was subjected to a particularly high level and the fader was taken a long way back, as much as 10 K in series with the mike could be present and with the poorer quality input transformers then available serious inequalities of frequency response could result. If such low level passive mixing has to be used therefore, it is advisable to terminate the output of the passive mixer with a resistor of approximately 600 ohms. Better still, this resistor could be inserted across the point of the fader, equivalent to about 8 dB of attenuation, so that when the mixer is used at full gain the effect of the terminating resistor is minimised with a consequent improvement of signal ratio.

Another black box often used is one containing switchable capacitors in series with the mike, these capacitors being switchable in both legs to avoid unbalance. A value of 4 μ F in each leg will give a useful bass cut below 80 Hz when the microphone input transformer has an input impedance of 1 K. A useful HF presence boost can be obtained if capacitors are switched across resistors R1 and R2 in fig. 1, a 0.03 μ F giving a useful boost above 7 kHz

as an example. The value of the terminating resistor in this case determines the maximum boost available as being equivalent to the attenuation of the network without the capacitor. Should treble cut be required, capacitors can be switched across R3 instead of across R1 and R2. I have mentioned these tips for the many readers who may be keen amateur or semi-professional enthusiasts and who may not possess frequency response controls in the recording channels of their equipment. It should be realised that the circuit described should only be used when the sounds to be recorded are of a fairly high intensity because the attenuation introduced requires more mike gain. This does not apply, however, to the bass cut network.

I have often been asked how recording studios manage to connect electronic musical instruments such as Hammond Organs and electric guitars directly into control desk input lines. This is done when no balanced line output socket is provided by having another black box consisting of a line bridging transformer with a ratio of 1:1 and two 2 μ F capacitors in series with the primary. The secondary is loaded with 10 K tapped at 600 ohms in the centre, switchable to 30 ohms. The input to the box is normally screened twin mike cable on the end of which are two crocodile clips that clip on to the loudspeaker of the instrument. The 600 ohm output tap will give a line level in the region of +8 dBm and a 10 ohm termination will give approximately 20 mV suitable for microphone inputs. These outputs assuming that the electronic instrument is peaking at a level of 50 W or so. The series capacitors are necessary in case the equipment is AC/DC or not earthed adequately and has poor insulation between the mains and the chassis. Unfortunately not uncommon with some older installations. A bridging transformer should of course be capable of taking

AC up to 30 V without saturation. Alternatively a volume control can be fitted on the primary.

In the past Cannon type connectors known as XLR plugs and sockets have not been so easy to obtain and I am pleased therefore that Radiospares have now included them in their catalogue. These plugs are particularly robust, although expensive, and do not easily fracture if dropped on to a hard floor. I well remember a number of large Cannon connectors being subject to metal fatigue, and hence fracturing, when they were in almost universal use up to about 10 years ago. For cheapness I can also recommend DIN plugs and sockets provided they are of the locking type. These are not really satisfactory, though, if the equipment is going to be used almost continually. At this stage I should point out that I have had a lot of trouble with Post Office Type 301 tip, ring and sleeve jack plugs, and therefore do not advise them. It seems that most of the plugs made in the past tend to oxidise fairly easily causing trouble such as spits and crackles and intermittences.

Microphone stands are now considerably better than those available some years ago. Whereas booms were extremely expensive in the early days of recording, they are now readily available together with various stereo cross bars and adaptors allowing microphones to be suspended from a bar attached to the top of the stand. We hope to Field Test some of these accessories in the future. Firms manufacturing or distributing them include Lustraphone, AKG and Keith Monks Audio. One thing horrifies me, and that is the lack, as far as I know, of really satisfactory antivibration mounts for mikes. Many, such as the AKG C12 and C24 are very prone to what is commonly called bonking when anyone walks near the stand, especially where the floor is wooden.

EMI AT ST. PAULS CONTINUED

time is not to be wasted and, after several short takes, Brian Culverhouse asked Christopher Dearnley down to hear the playback and offer his opinion. Dearnley later made several more trips to the crypt for playbacks and was always intrigued to hear how his playing sounded, since, as outlined earlier, much of the recital is not heard by the player himself.

Christopher Dearnley was satisfied with the first results and I returned with him to the organ console. Here, he ran through the Saint-Saëns *Improvisation No. 7*, Mrs Dearnley assisting with music page turning and stop changes, including the occasional piston (knobs below the keyboards which select groups of stops). Although organists normally operate all the controls themselves when giving public recitals, any reduction of purely mechanical activity is obviously of help in allowing fuller concentration on the musical interpretation.

When Christopher Dearnley had finished practising, he indicated that he was ready to record. I stealthily descended the spiral stairway and took a seat under the dome, so constituting the entire audience of one.

After this piece—one must remember to

wait quietly for at least 11 seconds after the final chord ceases in order not to mar the dying reverberation—I again joined the recording team in the crypt and stayed there whilst part of the Mendelssohn Sonata was recorded, during which no difficulties arose.

Attention was then turned to recording the Saint-Saëns *Improvisation No. 4*, which involved interplay between the flute stops of the Solo and Altar organs. The sounds from the Altar organ seemed to be getting lost somewhere and, after some discussion, we trooped up to the chancel to investigate. It is not always easy to determine where particular pipe ranks are sited, particularly with the quieter stops, and in the end Mrs. Dearnley played the lost stop, while everyone, including Christopher Dearnley, wandered around trying to locate it, the final pinpointing being achieved by the Willis tuner. The microphone covering the Solo and Altar organs was then moved nearer the Altar section and, on listening again down below, we found the balance excellent. It was reassuring that the recording personnel on this project were thoroughly aware of the live organ sounds that they were striving to capture; one hears reports of some recording engineers who have become so accustomed to the sound of their monitor speakers that they consider the real thing inferior and avoid it, if at all possible!

No technical hitches occurred with the recording equipment, but a reed pipe in the south organ case went sufficiently off-tune to warrant the tuner's attention. The sessions occupied some 3½ hours each evening, representing a significant expenditure when allowance is made for the number of people involved and the quantity of equipment withheld from other uses. A venture such as this is planned to a fairly tight budget and whether all the effort was justified will no doubt be revealed by the quality of the final disc (this article was finished in mid-April, with the disc due for issue on May 1).

Irrespective of what reviewers may feel, my impression on hearing a sample disc (CSD 3677) via wide-range gramophone equipment, was immediately highly favourable, particularly regarding musical balance, retention of dynamic range, ambience distribution and freedom from distortion in the climaxes. As heard via loudspeakers, the effect is comparable to that heard close to a wall below the dome, whereas with high quality headphones the 'all round' feeling experienced nearer the floor centre is simulated. Perhaps some day multi-channel recording will give even greater realism; in the meantime Messrs Dearnley, Willis and the EMI team must be congratulated on a notable achievement.

Ferrograph Y and P — tape recorders for science, industry, broadcasting.

Ferrograph tape recorders are world-famous for their superb quality and many recording facilities. Ferrograph reliability is renowned. Now Ferrograph introduce a new series of instruments, providing exactly what technical users have been asking for.

Models are available for full-track, half-track and twin-track operation, using standard $\frac{1}{4}$ in. tape. All have 3 speeds, solid-state electronics, 3 motors, 3 heads, built-in loudspeakers, $8\frac{1}{2}$ in. dia. reels with adjustable reel height. Very quick start and stop can be remotely

controlled or operated by time switch.

Series Y recorders are designed specifically for use in laboratories and monitoring services where long-term reliability and consistency of performance are essential. Three models cover the entire speed range from 15/16 to 15 in/sec. A 4-channel $\frac{1}{4}$ in. in-line head reproducer having 4 low-level equalised outputs is also available.

Series P instruments have been evolved for radio, TV and film recording in studios and for field work. They have 600 Ohm balanced inputs and outputs for all channels plus

everything else you expect from a Ferrograph recorder — excellent performance, robust construction, careful screening, reliability for years on end. Ring or write for details: The Ferrograph Co. Ltd, The Hyde, Edgware Road, Colindale, London NW9, Tel: 01-205 2241, Telex: 27774, or any of the following.

International Distributors

Leroya Industries Pty,
266 Hay Street, Subiaco,
Western Australia 6008, Australia;
Matelectric,
Boulevard Leopold II, 199,
1080 Brussels, Belgium;
H Roy Gray Ltd,
14 Laidlaw Boulevard,
Markham, Ontario, Canada;

Cineco,
72 Avenue des Champs Elysees,
Paris 8e, France;
Henry Wells & Co., KG,
1040 Wien 4, Danhausergasse 3,
Austria;
Ferropilot GmbH & Co., KG,
Hamburg 39, Sierichstrasse 43,
West Germany;
Hi-Fi Installations,
P.O. Box 2430, 276 Andries Street,
Pretoria, South Africa;
Elpa Marketing Industries Inc,
New Hyde Park, New York 11040,
New York, U.S.A.
There are Ferrograph Distributors
also in most other countries.
Please obtain details from the
London office.

Ferrograph

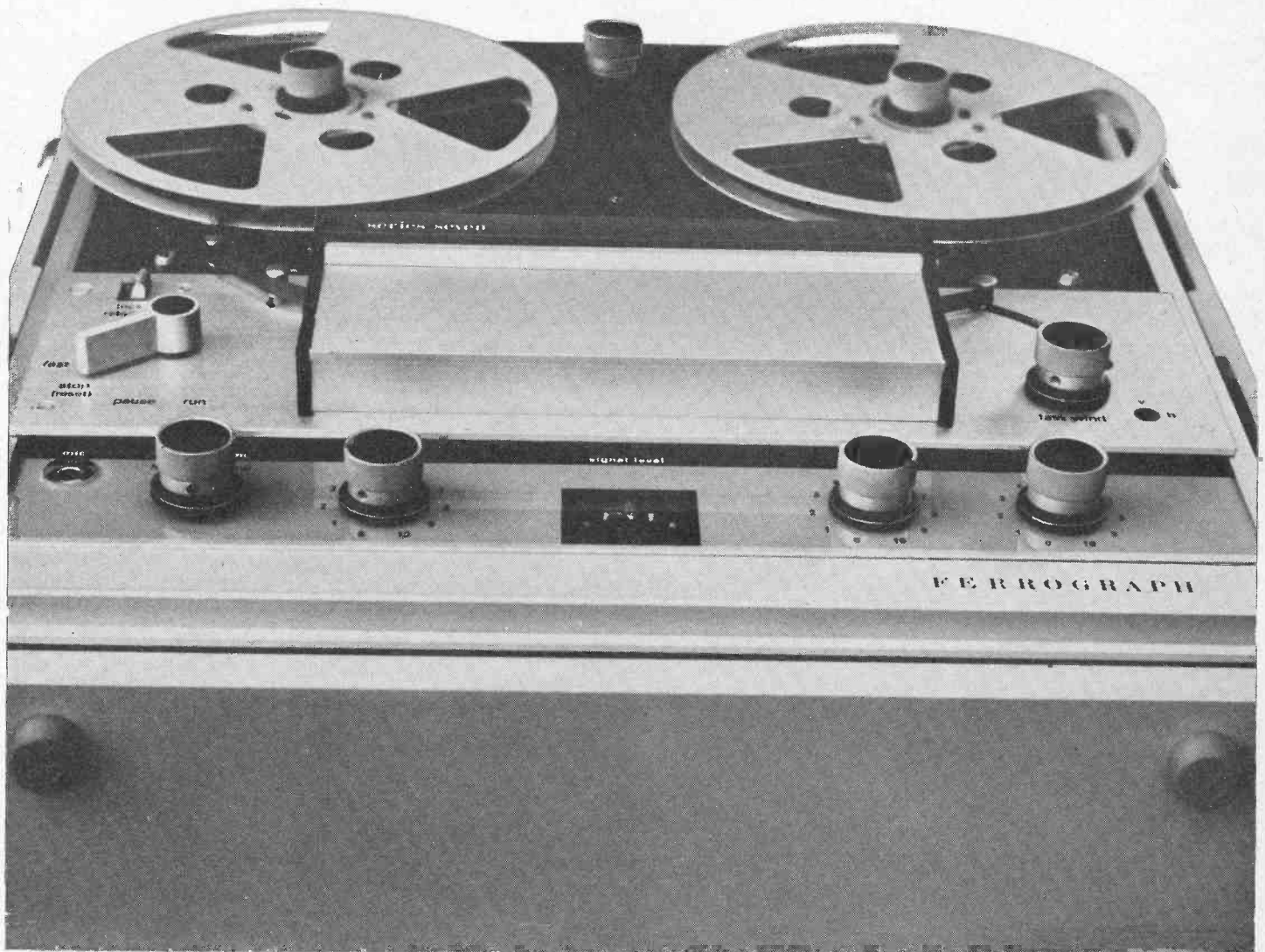

impressions

BY JOHN SHUTTLEWORTH

LOUDSPEAKERS AND MONITORING

HOW does one set about designing a loudspeaker? My method is to call at the local radio shop, buy a 150 x 100 mm elliptical unit of an ancient TV set for about 10s and shove it in a chipboard box of about 300 x 250 x 150 mm. I then adjust the damping by putting flock from an old mattress into the box until it sounds about right on music, seal it with Polyfiller (my carpentry is none too good), then decorate it with veneer and speaker grill. By all the rules it should sound dreadful, at best cheap and cheerful, but it is quite surprising what results can be obtained in this way.

One friend of mine, having heard a pair I made like this, has now discarded his (comparatively) expensive bookshelf speakers and tells me that with mine he now can really impress his friends.

A better method of designing speakers is to test various units in an anechoic room for smoothness of response and, if you can't find any good enough model, make your own. Then design a cabinet and electrical crossover/filter so that the whole unit is substantially flat from about 40 Hz to 15 kHz.

A large amount of listening should then be done, using the best possible programme source, white noise, speech and music. Finally the speaker should be used to reproduce sounds from an adjacent studio so that, by nipping through a soundproof door, one can hear and compare the real thing with the sounds coming from the speaker.

With experience, a bit of luck, and a lot of money, it should be possible to design a first class loudspeaker using this method.

When considering the relative merits of speakers now available, it would be wise also to consider the purpose for which the speaker is to be used. This sounds rather daft as it ought to be self evident that speakers are used to reproduce sound fed to them by amplifiers, but in fact there are at least three different situations where speakers are used, and the qualities of the speakers need to be different in each case.

I suppose the vast majority of loudspeakers are used for listening to music in the home, and for this purpose they need to give a pleasing (to the owner) sound which is easy to listen to, and to have a reasonably wide frequency response with reasonably low distortion.

The main types of loudspeaker generally available are:

Infinite baffle (i.e. completely closed box). These can be very small and give remarkably good results. One of the first small IBs was the Goodmans *Maxim*, and it still gives a very good account of itself in comparison with many larger systems.

Bass reflex enclosures. These are boxes with a lined vent which operates at low frequencies and improves the bass response of the speaker.

Such speakers are more difficult to design and some have more coloration than IB's but the really good ones give very pleasing reproduction, with effortless bass, and are very easy to listen to.

Horn loaded. These speakers, properly designed, give a beautifully clear open sound. As they are usually very efficient, they can be run by low-power amplifiers. They can have rather more coloration than some IB or bass reflex types but their other qualities make some listeners prefer them to all other types.

Full range electrostatic. At present this virtually means the Quad as no one else seems able to produce one for a reasonable price that actually works.

The Quad electrostatic is a good system at low sound levels and the fact that the BBC use it in quality control gives a fair indication of its performance. Its directional properties produce a vague stereo picture in some situations, however, and this should be checked before any purchase.

Most speakers have particular frequencies at which they are most efficient and, unless something is done to damp the output at these frequencies, the sound will be coloured. Whether we 'damp' the speaker at these frequencies electrically or mechanically, we have to absorb energy, consequently reducing the efficiency of the speaker.

Most speakers are very inefficient devices, the smaller IB types having an efficiency of the order of 1%. Say we have a small speaker designed to handle 10 W. Assuming 1% efficiency, we can expect 100 mW useful acoustic output, at most. If we try to obtain more sound by using a more powerful amplifier, we find the speaker is unable to cope and shows signs of distress. In extreme cases of overload, the electrical energy cannot be used mechanically by movement of the cone and is converted to heat in the voice coil which then burns out.

If we consider a speaker with 90% efficiency, rated for 10 W, we can of course get 9 W acoustic power out from 10 W electrical power in, and this speaker used with only a 1 W amplifier would give much more output than the 1% efficient speaker with a 10 W amplifier.

These considerations are not of vital importance for normal domestic listening. The average 'hi-fi' enthusiast probably uses about 10 W amplifiers into 1% efficient speakers very happily and finds his 100 mW acoustic output quite adequate and perfectly capable of annoying the neighbours.

When we want to reproduce high quality sound in a large hall or in the open air, the situation is rather different. We really do need more than 100 mW acoustic output.

The solution is to use more powerful amplifiers feeding a speaker system designed to handle the extra power (this is often done by using more drive units).

I have been involved in an open air Son et Lumière production, and two large Tannoy

speakers driven by Tannoy 30 W amplifiers produced very satisfactory sound on both music and speech, with sufficient power to satisfy an audience of over 2 000.

Studio monitors need not be very efficient, or even pleasant to listen to for long periods, but should faithfully represent the actual sound being recorded—microphone and all.

Most of us have, in our time, learned to appreciate good sound reproduction, and we all probably have friends who think it mad to record at 38 cm/s when 9.5 is good enough for them. The same consideration applies to monitor loudspeakers. After learning to listen to the good speaker, going back to the average speaker used in domestic surroundings is a shattering experience, and it is some time before one gets used to the coloration again. Loudspeakers designed for studio monitoring must in general handle high powers as many engineers listen at levels that would make even the 'hi-fi' man who 'likes to listen at a realistic level' shudder.

In my opinion, the best monitor loudspeaker available today is the one in most general use by the BBC, the *LS 5/5*. Cost is over £200 a time.

In a BBC monograph last year, a monitor loudspeaker particularly suited to small studios was described. This has the same characteristics as the *LS 5/5* but less power handling capacity and costs considerably less.

I have often read that placing a speaker on the floor or in a corner of the room improves its bass response and one might be tempted to put monitoring speakers in this position. Since a speaker placed in a corner of the room uses room resonances to give the impression of improved bass, this must add coloration to the sound.

For home listening this might be acceptable, as we are 'listening to the room' all the time we are in it, and our ears make adjustments for the room acoustics.

When monitoring a recording, however, we do not want to listen to the room, but to the true recorded sound. As a general rule, therefore, monitor speakers should not be placed in corners.

The same consideration applies to speakers placed on the floor. When monitoring we want to hear the speaker, not the floor vibrating, so monitor speakers should be mounted on a suitable mechanically isolating pedestal.

I have recently been able to try a version of the small monitor speaker described in the BBC Monograph I mentioned earlier, and my first impression was very favourable. The sound quality was first class and relatively free from coloration, it is quite small enough to be transportable, and seems able to handle plenty of power. I look forward to being able to do extended tests with a pair of these speakers in the near future, but my first impression is that it should be of great interest to the small studio and those of us who want high quality at home from a reasonably small system.

THIS article sets out to describe how noise is measured in an amplifier or tape recorder. Six methods of noise measurement are described along with the problems associated with each.

The theoretical background to the causes of noise in transistors has been covered very thoroughly in three outstanding articles. The first was published in *The Radio and Electronic Engineer* July 1968 and is the work of Dr E. A. Faulkner. The other two articles appeared in *Wireless World* November and December 1968 and were contributed by Peter Baxandall. In my opinion these are three of the most logical and lucid examinations of noise theory that have yet appeared.

A much simplified description of noise and its causes appeared in *Audio Annual* 1970 and provides all the basic information that the reader is likely to need. Hence it will not be covered again here. For the sake of completeness, however, the expression for the noise

NOISE

AND ITS MEASUREMENT

BY ANTHONY EDEN

FIG. 1 GRAPH SHOWING RELATIVE RESPONSE OF THE NOISE TO THE SIGNAL
SIGNAL 80dB
 NOISE 20dB ABOVE THRESHOLD OF HEARING (10-0002 DYNES/cm²)

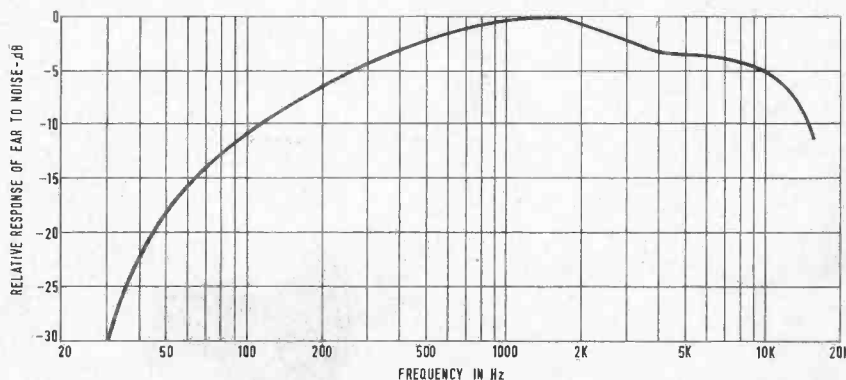
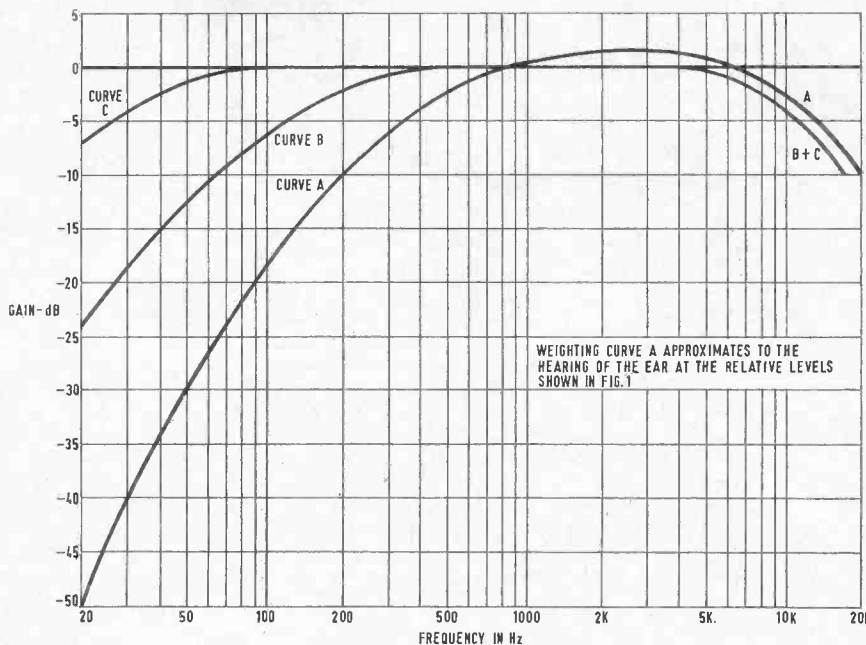

FIG. 2 GRAPH SHOWING I.E.C. WEIGHTING CURVES



voltage generated in a resistor is given again. It is given by:

$$V_n = \sqrt{4KTBR}$$

where V_n (or e_n) = noise voltage in resistor (RMS value)

- K = Boltzmann's constant (1.37 x 10²³)
- T = temperature as an absolute (°K).
- B = frequency bandwidth over which the measurement is made
- R = value of resistor in ohms.

Noise measurements

There are six methods in common use for assessing the noise content of an amplifier or tape recorder. Each method will now be described along with its attendant advantages and disadvantages.

1. *Noise: -80 dB.* This specification is quite frequently seen in literature and serves no use whatsoever. It is rather like trying to answer the question: 'How long is a piece of string?' Since the decibel is a relative measurement, all this information tells us is that the signal is 10 000 times greater than the noise. It gives no indication as to what caused the noise or what level of signal was being applied when the measurement was made. If this specification is applied to a tape recorder, one would assume that the signal level was the peak that could be recorded at some level of distortion. If the information has been given in such a meaningless form, there is a fair chance that the rest of the manufacturer's information may be taken with a pinch of salt!

2. *Noise: 1.5 μV.* At first sight, it would appear that such an expression has a meaning but a reference back to the expression for the noise voltage quickly reveals that we know nothing about either B (frequency bandwidth) or R (source resistance). Until we know something about both of these quantities, such a method of expressing the noise level is just as meaningless as Method 1.

3. *Noise: 60 dB below 1 mW in 600 ohms.* Another way of expressing the noise of this amplifier is -60 dBm ($m=1m$ W in 60 ohms, hence this is a power measurement). Yet another expression frequently encountered

is -60 dBV (V=1 Volt reference output level). These are the most common methods of referring to the noise level of amplifiers and are relatively simple to measure. A tape recorder noise specification would read: 60 dB below peak level and one would expect to see a reference elsewhere to the distortion content at this peak level (normally 2% or 3%). In the case of the tape recorder, this specification could be interpreted as follows: A 1 kHz signal is recorded on tape at peak level such as to give the stated level of distortion. On playback this signal level is measured on a millivoltmeter at the line output socket. Then the tape is erased with all volume controls turned to zero. This value of noise is then measured on a true reading RMS millivoltmeter, and the signal-to-noise ratio ascertained. Although this is a standard method of measuring the signal-to-noise ratio [Our italics—Ed.] it does not measure the performance of the recording amplifier before the volume control—only the ability of the tape recorder to erase well. The complete system performance is especially important if low level signals from microphones or magnetic pickups are to be recorded using the tape recorder preamplifiers. More correctly then, the signal to be recorded, should be injected at a level approximating to that of the microphone to be used (e.g. 70 μ V for a 30 ohm microphone, 200 μ V for a 200 ohm microphone, 400 μ V for a 600 ohm microphone and 2 mV for a 50 K microphone). The signal should then be removed, the input socket terminated with the appropriate source resistor, and the volume control left in the same position as for the first recording. The signal-to-noise ratio should now be compared. This is a much more realistic test since it simulates the noise level that would be recorded under practical conditions. Under such conditions, a value of 50 dB can be considered very acceptable.

Unfortunately even Method 3 can be misleading. For although we have a reference output point, we do not know whether a typical signal at the input terminals is capable of being amplified to this reference level. If this signal level is well below that required to give the reference voltage at the output terminals then the information must be interpreted in terms of the input signal level. For example, where the following specification is given:

Noise: -60 dB ref. 1 V; if the microphone amplifier has a gain of 60 dB and we wish to use the AKG D202 microphone with a typical output of about 200 μ V (-74 dBV), then we must interpret this as follows. Our typical microphone signal will be amplified to (200 μ V x 1 000) = 200 mV. But the reference level was 1 V for 60 dB signal-to-noise ratio. Therefore the noise level will be worsened by 1 000/200 = 5 times or 14 dB. Thus we can only expect a practical signal-to-noise ratio of 46 dB.

4. Noise: 60 dB below 1 V (weighted to IEC Curve A). The basic method of measurement has remained unchanged except that the noise response has been weighted approximately to the hearing of the ear relative to the signal. Since human hearing has a different frequency response at different sound levels, the relative effect of the noise can be much less disturbing than a straightforward measurement would indicate. If one is listening to music at a peak sound pressure level of 80 dB above the threshold of hearing, and the tape recorder or amplifier has a noise level of 60 dB below this level, then the ears' response to the signal will be quite different from that of the noise. The effect of low frequency noise will be considerably reduced (see fig. 1). A number of weighting curves have been agreed internationally and are known as the IEC Curve A, Curve B and Curve C. The three curves are required to allow the various levels of noise relative to the signal to be catered for (see fig. 2). Therefore this method of measurement has the advantage of giving some idea of the aural nuisance value of the noise. Since such weightings generally improve the signal-to-noise ratio, some manufacturers use it without making any reference to this fact in their specification.

5. Noise: -126 dBm referred to 150 ohm input (20 Hz bandwidth). This method of measuring noise is favoured in professional circles in America and Europe. It can be interpreted as follows: A power level of 126 dB below 1 mW in 600 ohms will give us a voltage level of 0.38 μ V noise at the input terminals. Now we are also told that the input source resistor has a value of 150 ohms. The noise voltage generated in this resistor can be calculated from the noise formula and gives a value of 0.22 μ V (on a 20 kHz bandwidth). This means that the noise

created by the amplifier is $\frac{0.38}{0.22}$ times the theoretically minimum noise that could be generated by the amplifier (i.e. 1.73 times or 4.8 dB). This method of measuring noise can only be applied to amplifiers but not to overall tape recorder performance. Such a means of measuring an amplifier's performance is the first method so far described for directly assessing the quality of an amplifier. However, it is rather clumsy and requires some interpretation to understand how good or bad the amplifier may be.

6. Noise Figure: 3 dB (measured on a 20 kHz bandwidth and with a 150 ohm source). This method of expressing the noise properties of an amplifier is a more elegant version of Method 5, and similarly can only be used with reference to amplifiers, not tape recorders. The noise figure of an amplifier coupled with the bandwidth and the value of source resistor is a complete statement of the relevant properties. We may calculate the performance of the amplifier as follows: if the voltage gain of the amplifier is 60 dB (1 000 times), the noise voltage of a 150 ohm resistor will be amplified to (0.22 μ V x 1 000) or 220 μ V. Now, since the amplifier has a noise figure of 3 dB, this means the noise will be 1.4 times worse than the theoretical noise of 220 μ V. Thus, we should expect to measure on a true RMS reading meter a value of 310 μ V, with a filter to restrict the noise measurement to 20 Hz. It is now easy to realise that when an amplifier's noise performance is stated in terms of a noise figure, coupled with its source resistance and bandwidth, then this measurement can be repeated by any other analyst and the results discussed in the same terms. This would obviate much of the pointless argument that goes on at present between manufacturers and reviewers!

At this point it is as well to ask why the noise figure measurement is not used more often, since it has been demonstrated that this is the most precise method of expressing the performance of an amplifier. The answer is partly due to sales influence and partly for technical reasons. Let us consider these reasons in turn. Sales people always try to show their equipment in the best light possible and so use a method which shows their equipment to the best advantage. Further, many people have a vague idea of signal-to-noise ratios but no idea of what is meant by noise figure. If all amplifying equipment were measured in terms of a noise figure, many prospective purchasers would quickly realise that units which at present may have identical specifications can differ dramatically in price and performance. Any piece of equipment described as having a signal-to-noise ratio of 55 dB is considered by many people to have a very good specification. It is not until the equipment is used for recording purposes that one discovers how good or bad the equipment really is.

The technical difficulties in measuring the noise figure are of much greater interest! The first difficulty occurs in measuring noise on a millivoltmeter. Many millivolts meters on the market today only record the true RMS when the input signal is a sine wave. True RMS meters are both expensive and of doubtful accuracy. A normal meter tends to read a higher value than the true reading for a noise voltage.

(continued overleaf)

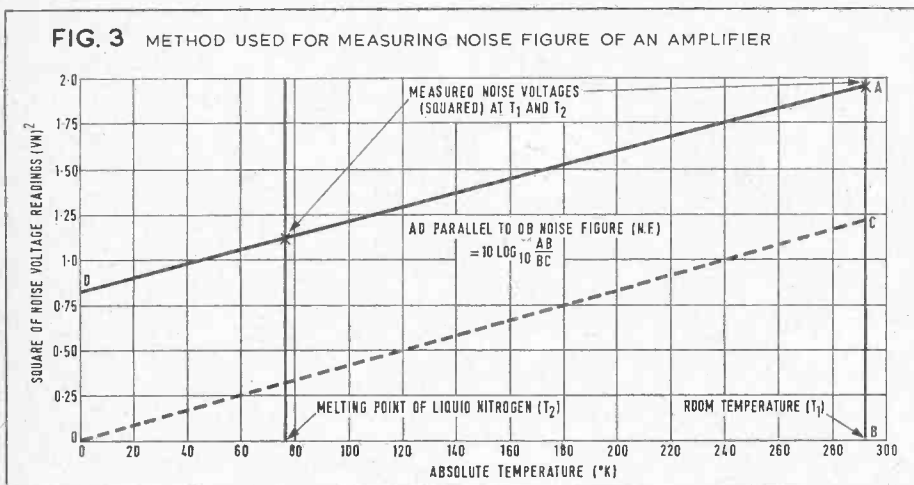

The second problem involved in measuring a noise figure is knowing the precise bandwidth over which the noise has been measured. Since the calculation of noise figure involves a term in B (frequency bandwidth), it is imperative to know what bandwidth is being used if any assessment of the performance of the amplifier is to be made. We mentioned earlier in the article that a resistor will produce random noise and this can be interpreted as a voltage occurring at any frequency with equal probability. Modern transistors also produce noise with a wide frequency range, and hence can be assumed to have a *uniform distribution* with regard to frequency.

Known Filter

Now when we talk of a 20 kHz bandwidth we refer to a system capable of measuring every frequency with equal sensitivity between DC and 20 kHz, after which the sensitivity drops to zero. Obviously no such measuring equipment exists, and thus if one is required to measure over a given bandwidth a different technique has to be adopted. The method employed utilises a filter of known characteristic which gives the same noise voltage magnitude as that of an abrupt 20 kHz cut-off. However such filters are of limited accuracy. A method which overcomes the difficulties was described in *Wireless World* December 1968 by P. J. Baxandall. The method is extremely accurate and relatively simple to use. It will now be described.

In the expression for the noise voltage of a resistor we found that $V_n = \sqrt{4KTBR}$. Now we have shown that V_n is difficult to measure accurately and it is difficult to ascribe an exact value to B . We cannot vary R to measure noise since mismatching the circuit by means of R will seriously degrade the frequency response and so artificially curtail the value of B and make any measurements meaningless. However we can vary the temperature and so obtain values for the noise at two widely differing temperatures.

Since the millivoltmeter is only measuring a difference in voltages it does not matter whether or not it measures the true RMS value. Neither does the frequency bandwidth matter since it will have the same value for both readings. Firstly a measurement is made at room temperature (293°K) using a 200 ohm source resistor (to simulate a 200 ohm microphone) and then repeating the measurement with another 200 ohm resistor (both matched to 0.05%) dipped in liquid nitrogen. Nitrogen liquifies at 77°K (all measurements of temperature are made on the absolute scale). The difference between the two values of noise voltage will give us two points on a graph from which the noise figure can be determined. Thus we have at room temperature:

$$V_{n1} = \sqrt{4KT_1BR}$$

At the temperature of liquid nitrogen:

$$V_{n2} = \sqrt{4KT_2BR}$$

From these expressions we get:

$$\frac{(V_{n1})_2}{(V_{n2})_2} = \frac{T_1}{T_2}$$

At absolute zero the noise of the amplifier should fall to zero (since V_n becomes 0 when $T=0$). If it does not, we then know that the amplifier is responsible for the additional noise. Considering fig. 3, we see that the point at which the extrapolated T_1, T_2 curve cuts the Y-axis gives a measure of the quality of the amplifier and from this the noise figure is calculated from reading off the value of AB/BC and translating this value into dB.

Manufacturer's problems

Let us now look at the problems of measuring noise from a manufacturer's point of view. If a manufacturer is making a quantity of amplifiers for low noise applications, one of the parameters over which he will have to exercise strict control is the variation of noise performance from one amplifier to another. The noise performance will vary due to variations in the transistors and certain resistors. The typical noise figure will normally be calculated from theoretical considerations and then measured on a prototype amplifier. Some manufacturers base their specifications on the performance of this prototype, but this can be non-representative of a batch and it may later be found that very few of the amplifiers in fact meet the specification.

Testing equipment can be an expensive job and even more so when components have to be changed. For this reason the original choice of components can greatly affect the cost of testing and it is not always worth buying the cheapest components nor is it always satisfactory to simply rely on a component manufacturer's specification.

PERFORMANCE POWER !

frequency response at
100 Watts

H||H ELECTRONIC
TRA100

10 100 1k Hz 10k 100k

H||H ELECTRONIC
Industrial Site Milton Cambridge CB4 4AZ Tel. 63070

THE diehards will tell you that the real heyday of the Ferrograph ended with the *Series 5*. For them, the 6 is an embellishment and the 7 an eyesore. They would accept the latter as a present very grudgingly, one is given to understand. I can sympathise with the mental wrench that was needed to jump from valves to transistors but it is harder to take the revulsion against what was, after all, a focusing of the ideas from South Shields into the last of the famous dreadnoughts.

The differences were subtle but profound. The repositioning of the autostop, on a feeler arm to the right of the head gate and separate from it, had come about during *Series 5* production. On the 6, the revolution counter received a tilt to make it easier to view. Three-speed machines were the order of the day, and a gated speed selector took up its central position on the deck. The record button on the function knob was given an interlock facility—leading to another source of trouble when clots more used to the earlier models try to force it round.

Braking was similar; the drive system had not altered fundamentally despite the speed-change gate, the leverage and the electrical safety switching had been retained but the bottom deck layout had changed to accommodate the new speed selector mechanism, and the hold-in solenoid had become more substantial. Again, this change took place during the *Series 6* run. If I am not in error, the 631 models had the old type of solenoid—the same type as *Series 4* models I have handled, whereas the 632, 633 and 634 had the later type. A minor point, but one to watch when ordering spares. Always quote the model, and if possible its serial number, when making enquiries. You will find the lads at South Shields most helpful—even if they are not quite so blessed with alacrity when a dealer is on the asking end.

No drawing should be necessary to explain the auxiliary socket fitted on the rear panel of some of these models. The noval base is standard, with numbering from the left of the gap clockwise when viewing the solder points. The connections are as follows: Pins 1 and 9, heaters; pin 7, earth; pin 5, smoothed HT; and pin 3 a tapping from the output valve anode. 1 A of LT (6.3 V AC) and 15 mA of HT (250 V DC) are available from this socket on, for example, the 631. It is a useful quick measuring point for preliminary tests. In a permanent installation it needs very little ingenuity to add further test connections to the unused four pins.

Test procedures vary, and Ferrograph have their own way of operating, but I must needs

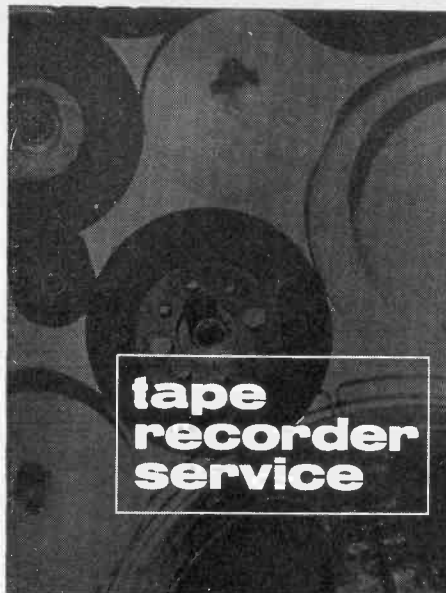

FERROGRAPH SERIES 6

BY H. W. HELLYER

outline the way we go about things in our own workshop. There, the first tests are always for correct playback. So many machines share at least part of the facilities and it is pointless to chase hares around the switch complexities or to search for an obscure recording fault until the playback operation has been proven in order. In the 631 we find the same amplifier used for each function. The other two divisions have separate record and play amplifiers so by tidying up the playback first we can use the monitoring facilities of the machine for record amp tests.

The playback amplifier can be split into two main sections, the preamplifier block and the output stages. (The 632/4 machines have a single monitor stage—the OSU1, Ferrograph's first venture into transistorisation giving 1 W output. The input of this small amplifier is normally connected to both channels, so the unused channel must be 'killed' by inserting a jackplug into the appropriate output socket if only one stage is being checked.) As a final

note, the internal speaker fitted by Ferrograph is a 3 ohm unit in this case, not the more usual 15 ohm.

Tests can be made by injecting a signal at the high level input of the 633, Input 2 (see fig. 1) or clipped to the grid of the first playback amplifier valve of the 632/4, where the input jacks are in the recording amplifier alone. With the AB switch in its source position, this allows one to test not only the main body of the amplifier but also the recording preamplifier and leaves only the playback preamplifier to be checked. To do this, we are again forced to get at the valve grid and I have always found that a clip-on probe lead to the actual tag is the best answer. Misleading results can be obtained from prodding about with a probe tip, from overloading the input and taking no account of frequency compensation, or from falling into the tempting trap of injecting at the convenient head socket. (Ferrograph have very effectively stopped us from falling into that trap on the *Series 7*—just wait till you have to dismantle that head assembly!)

The reason for this apparent omission of one link in the chain is to eliminate the head from suspicion—or, alternatively, to prove that it is to blame for impaired results. The obvious first test is to replay a standard tape and measure the output. This can be done at the cutout transformer secondary (via the 15 ohm socket) with quite a modest AC voltmeter. It needs only a relationship reading: one first measures carefully the output obtained at the reference frequency of 1 kHz and uses this figure as the basis of further tests. It does not matter what this figure actually is, so long as we can accept a couple of decibels variation from it, up and down.

(continued on page 295)

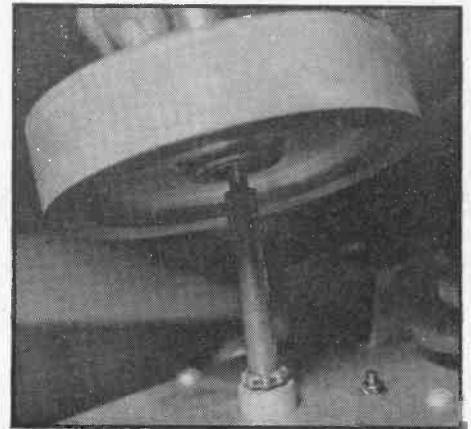

Fig. 2 (above): Lower capstan ballrace.

Fig. 3 (bottom left): Upper ballrace.

Fig. 4 (bottom right): Remember to reassemble top bracket.





Mike Claydon at IBC Recording Studios, completely equipped with A301 noise reduction units on their new Ampex MM1000.

DOLBY AND MULTI-TRACK IN LONDON

With the increasing number of multi-track machines in London Studios, more and more engineers are finding the DOLBY SYSTEM essential in preventing the noise problems inherent in this kind of recording. There are sixteen sixteen track recorders in London, and fourteen of them are completely equipped with Dolby A301 noise reduction units on each track.

One of the A301 noise reduction installations at Island Records' new studios, using three 3M sixteen track recorders all completely equipped with the Dolby System.

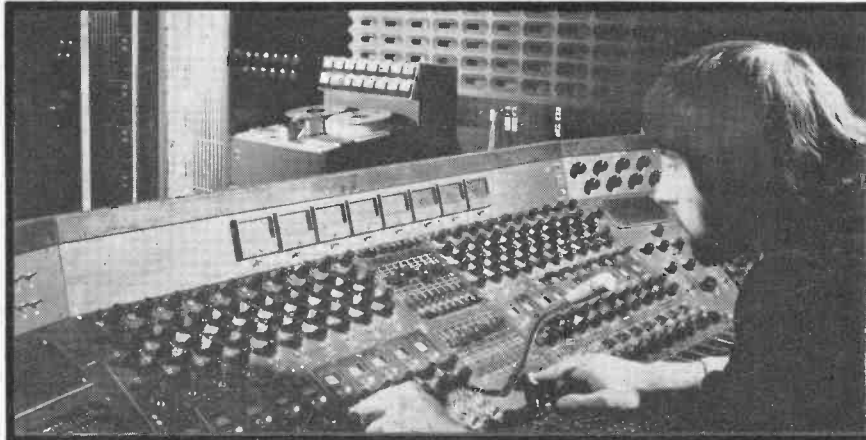
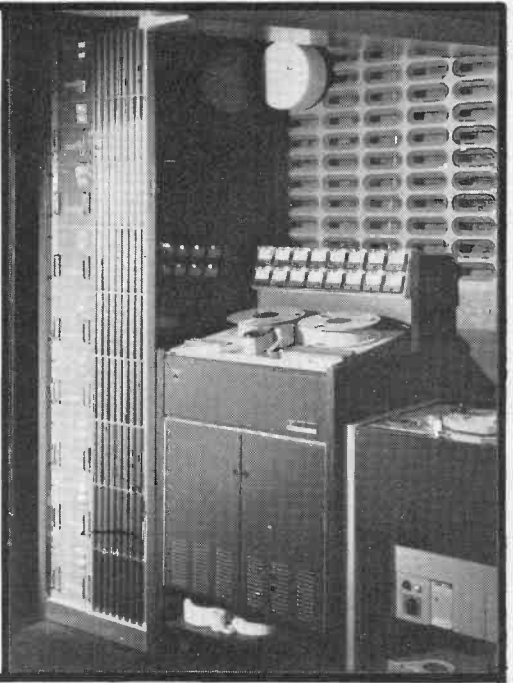

Frank Owen, Studio Manager at Island Records:

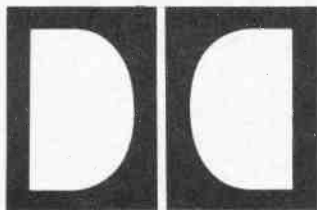

DOLBY LABORATORIES INC

346 Clapham Road London SW9 England
 telephone 01-720 1111 telex 919109 cables Dolbylabs London

333 Avenue of the Americas New York NY 10014
 telephone (212) 243-2525 cables Dolbylabs New York



Harry Davis and Zeke Lund at Morgan Studios, currently equipped with the Dolby System on eight and sixteen tracks, and shortly installing London's first twenty four track recorder.



Robin Cable at one of the Sound Techniques' mixing desks used at Trident Studios, now equipped with twenty-two A301 units on two sixteen track machines.

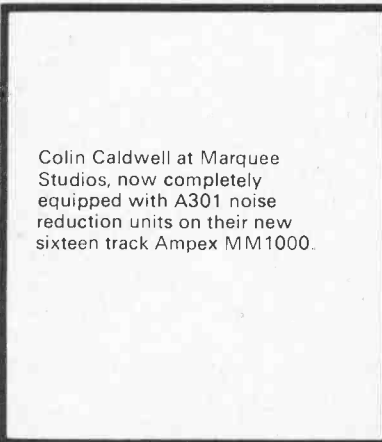

Colin Caldwell at Marquee Studios, now completely equipped with A301 noise reduction units on their new sixteen track Ampex MM1000.

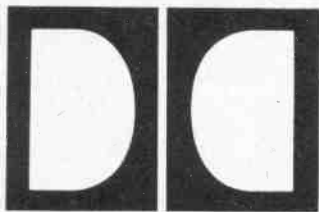
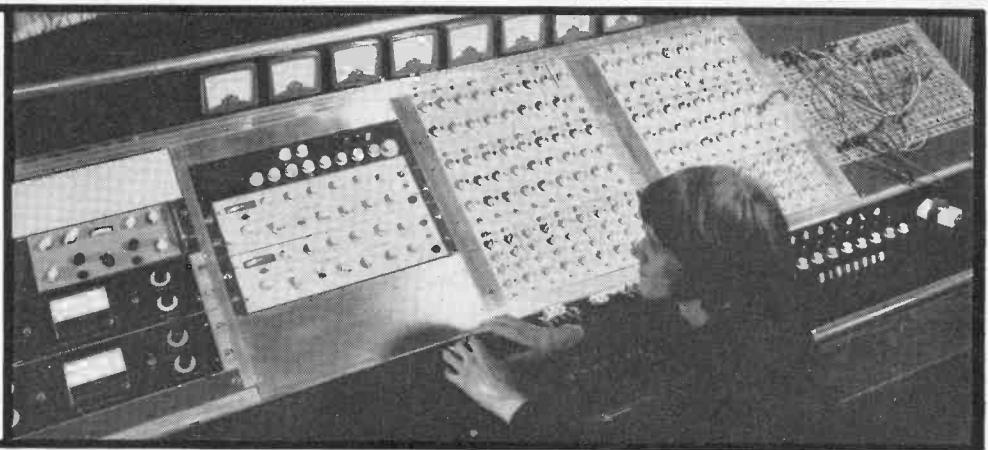

DOLBY LABORATORIES INC

346 Clapham Road London SW 9 England
 telephone 01-720 1111 telex 919109 cables Dolbylabs London

333 Avenue of the Americas New York NY 10014
 telephone (212) 243-2525 cables Dolbylabs New York

A PREVIEW OF THE ASSOCIATION OF PROFESSIONALS

AT 2.30 p.m. on Friday, June 12, the doors will open on the third annual APRS exhibition of professional audio equipment. First held in 1968 at the Waldorf Hotel, Aldwych, the exhibition moved to the Russell in 1969 and now returns to the Waldorf where it will occupy the Adelphi Suite. Admission will be limited to members of the recording and communications industry, tickets being obtainable from the APRS Secretary, John Borwick, either at 47 Wattendon Road, Kenley, Surrey (01-668-1554) or, in cases of difficulty, at the Waldorf itself. The exhibition closes at 9 p.m. on Friday and opens again from 10 a.m. to 7 p.m. on Saturday.

Ampex

Two recorders will be displayed by Ampex, the *MM1000* and the *AG440 B*. Ampex were the first to offer 16- and 24-track facilities and have enjoyed a monopoly in the market for nearly a year. The *MM1000* is based on a VTR transport and operates at 38 and 19 cm/s. Basic price of the 16-track is £12 500. Eight amplifiers are housed in two vertical stacks beneath the deck, the 16-track model illustrated having a further eight amplifiers in a penthouse rack. A side rack accompanies the 24-track version. The smaller *AG440 B* design is an improved version of the *440* and incorporates an acoustically quieter transport. Delayed tape lifters eliminate shrieking as the tape decelerates from fast wind. Single-track model costs £1 954. Two-, three- and four-track versions are available.

Audio & Design (Recording)

A range of low-distortion level control equipment including the *F600* and *700* limiters, *E800* equaliser and the new *F900* Noise Gate will be shown by Audio & Design. These are designed for rack (see photo) or individual mounting.



Neve BCM 10/2

Stereo and voice-over compressors will be demonstrated with a Helios mixer in conjunction with another exhibitor, Helios Electronics. A & D representative: Michael Beville.

Audio Developments

Centrepiece of the AD stand is a 12-channel four-group portable mixer with compressors, PPMs, talkback, monitoring and cueing facilities. Unusual feature is a matrix pin-board channel routing system. Representatives: David Rivett, Peter Leversley and Bob Cleverly.

Audio Engineering

The world's only battery-portable professional stereo recorder, produced in Switzerland by Stellavox, will be shown by Audio Engineering. The two-channel *SP7*, which is also available with synchrotone facilities, starts at £500. Spool capacity is 13 cm but adaptors may be added to accommodate 27 cm spools. Audio Engineering also import Sennheiser microphones and headphones.

Audix

The *Studio 80* power amplifier, delivering 80 W RMS into 8 ohms from 5 Hz to 35 kHz, will be displayed by Audix. Also exhibiting will be Cadac, an affiliate of Audix concentrating on sound mixers.

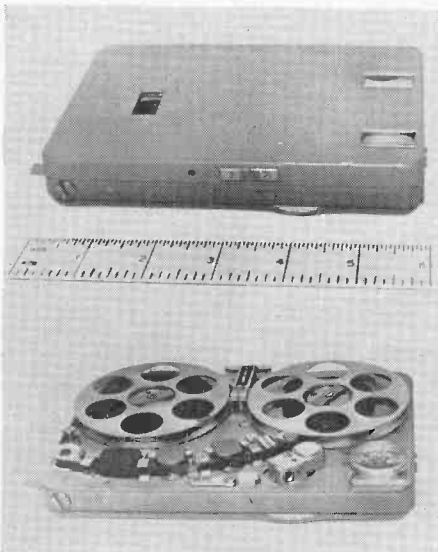

Nagra SN

F.W.O. Bauch

The equipment imported by this prolific company almost merits a preview of its own. Bauch now represent Konstantin Danner, a West Berlin company manufacturing sliding and rotary components, control knobs and racks for audio mixers. KD also produce microphone booms, table stands and goose necks. A monitor loudspeaker unit by Klein & Hummel of Stuttgart—Model *OY* incorporating a matching 30 W amplifier.

A *1176* FET limiter amplifier manufactured by Universal Audio (California) will be displayed. Variable input, output, attack and release controls are incorporated, with switchable meter calibration and compression ratios (20, 12, 8 and 4 to 1). The unit is powered from 220 to 260 V 50 Hz mains.

EMT, largest of the companies represented here by Bauch, offer the Studer *C37* console and *A62* transportable recorders. Four, eight and 16-track *A80* Studers are on the verge of delivery, we understand, and may arrive in time for APRS 70. Prices are very competitive, the 16-track being £9 800 against the £12 500 Ampex mentioned earlier, the £11 655 Scully and the £11 250 Unitrack. The reasons for these price differences remain to be seen.

The Studer *O89* is a 12-channel transportable mixer. Two PPMs calibrated in dB, plus two reverb level VUs, two output groups and elaborate monitor and talkback facilities.

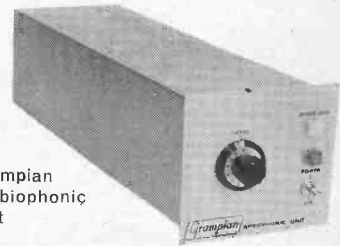

Grampian Ambiphonic Unit

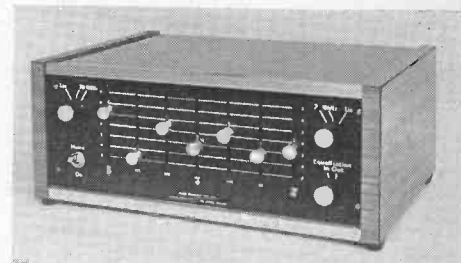

Leavers Rich A501

APRS 70

PROFESSIONAL RECORDING STUDIOS' ANNUAL EXHIBITION

Mains or battery powering, 66 kg weight, and a basic price of £4 392.

At £489, the EMT 104 is a miniature mixer with four inputs (lines or microphones) and two outputs. Compression and limiting, a 1 kHz line-up oscillator and a dB-calibrated PPM are featured. Power may be from internal or external batteries, or mains. Other equipment in the EMT stable: professional faders, stranded steel microphone suspension cable, an extensive range of specialised multicore audio cables, the 927 and 930 disc reproducers, VMS66 cutting lathe, SX68 stereo cutterhead, 420A wow and flutter meter, and 103 low-distortion signal generator.

Finally Neumann, currently producing a series of FET capacitor microphones, the KM84, KM85 and SRM84 cardioids, KM83 omni, KM86 omni/8/cardioid, KM88 omni/cardioid and KML lavalier cardioid. The SM69 is a coaxial stereo pair with omni/8/cardioid patterns. A range of cue lights, floor and table stands, shock absorbers and windshields support the microphones.

Lastly from Neumann, silicon transistor mixer modules, amplifiers, faders, equalisers, level indicators, oscillator, power supplies and rack assemblies.

And lastly from Bauch, the Syntronic magnetic film synchronisation system manufactured by Wilhelm Albrecht.



BASF

No new additions yet to the standard line of BASF professional tapes, LR56 and LGR30 (6.25 mm to 50.8 mm), SP52 and, primarily for battery portables, PES40. Details of the company's Calibration Tapes will be available. Representative: Bob Hine.

British Homophone

The British Homophone Company is planning a display illustrating the stages involved in disc processing. Visitors will be able to view aspects of disc groove waveforms through a microscope. Representatives: E. B. Pinnigar and P. Shrubsall.

Dolby Laboratories

More than a thousand A301 noise reduction units are now being used by nearly 250 companies. A domestic Dolby B is in the wind and so too is a second version of the professional system. Claimed improvement resulting from using A301 is a 10 to 15 dB reduction in noise. A review of the A301 is published on page 311 of this issue.

Feldon Recording Ltd.

A 16-track Scully 280-16 is to be shown by Feldon Recording. An unusual feature is a tape-cleaning roll mounted between the supply spool and head path. The recorder operates at 76, 38 and 19 cm/s, mid-speed specification being 0.08% RMS wow and flutter, 30 Hz to

15 kHz ± 2 dB frequency response, and 62 dB signal-to-noise using 3M 202. Remote control is available in the shape of the Sync/Master which includes a tape lifter defeat for remote cueing.

Hayden Laboratories

A miniature Nagra battery portable will make its UK debut at the APRS. The SN operates at 19 and 9.5 cm/s and employs 3 mm tape, reel to reel, frequency response being 60 Hz to 10 kHz ± 2 dB. Claimed wow and flutter is $\pm 0.1\%$. Signal-to-noise ratio is 60 dB, ref. 2% 3rd harmonic distortion. Hayden also represent Appel, whose 316/SS endless cartridge recorder will be displayed.

Fraser Peacock

Infonics cassette duplicators will be exhibited by the UK agent, Fraser-Peacock & Associates. From four to 25 copies may be recorded simultaneously from a 19 and 9.5 cm/s $\frac{1}{4}$ -track stereo master, dubbing all four channels simultaneously. Price of the four-cassette four-channel SRC4 is £2 600.

Grampian

With four-channel stereo attracting increasing interest, the Grampian 666 Ambiophonic Unit offers an inexpensive source of artificial reverberation, either at the recording or the listening ends. This is based on the successful 636 Reverberation Unit, a two input device employing spring delay lines. Grampian offer custom built mixing desks for budget-conscious studios.

Helios Electronics

Richard Swettenham's company, Helios Electronics, are participating in the APRS

(continued on page 299)

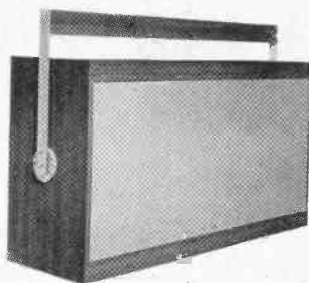

Ampex MM 1000 (left)

Lockwood LEI/S

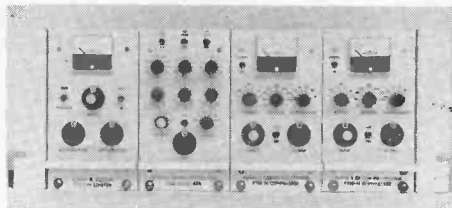

Audio & Design Modules

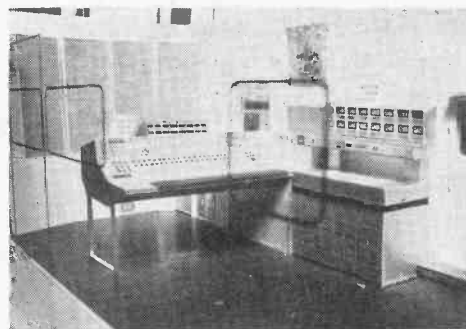

Helios/Unitrack/Tannoy Mobile Studio

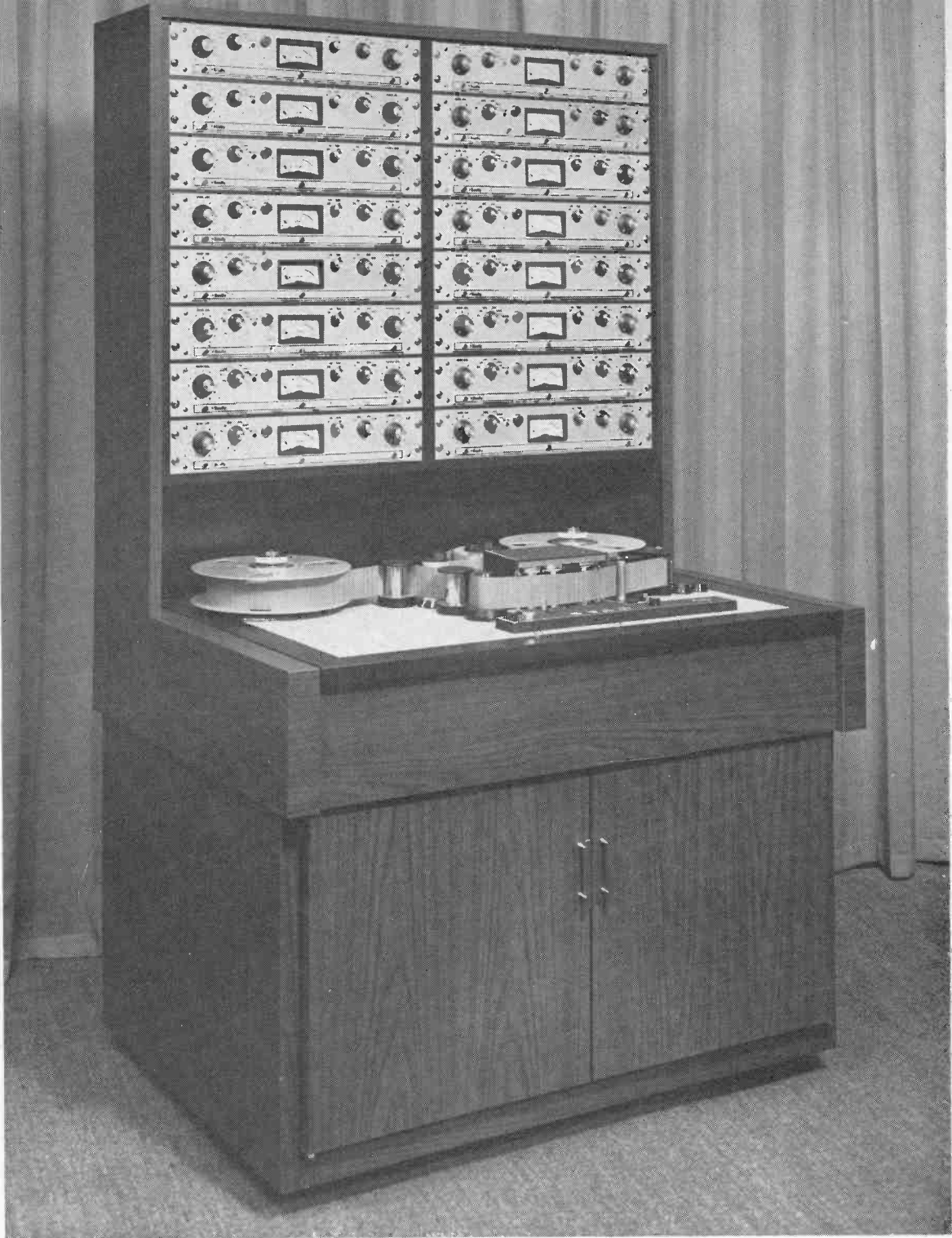

TOP PROFESSIONALS ARE NOW USING
THE NEW SCULLY 16-TRACK RECORDER
The latest in the Scully range of exclusive professional multi-track tape recorders extensively used in U.K. television and recording studios
FELDON RECORDING LTD 126 GREAT PORTLAND STREET,
LONDON, W1. TEL-01-580 4314

APRS 70

Exhibition for the first time. They are currently engaged in developing a studio-on-wheels for the Rolling Stones group. The illustrated model shows a Helios mixing desk between Tannoy Lockwood loudspeakers, Dolby A301s and a Uni-track *Uni-16* 16-track recorder. A separate compartment of the vehicle houses air conditioning equipment, voltage control unit and power cable drum.

HH Electronic

The *TPA25D*, capable of delivering up to 45 W RMS into 8 ohms, is among a series of power amplifiers being shown by HH Electronic. The unit is DC coupled and HH hope to have DC coupled versions of the *TPA 50* and *TPA 25-M* at the exhibition.

Leevers Rich

The 8-track Leevers Rich, now in its second year, will be displayed alongside the *Series E* stereo recorder and recently updated *A501* graphic equaliser. A 16 mm magnetic film recorder will also be exhibited, one of a range of 16 and 35 mm systems produced for the motion picture industry. The company has lately developed a high speed copying system for 6.25 mm 8-track cartridges and 3.8 mm Philips cassettes. Representatives: N. V. Nichols, P. B. Richards and Peter Lindsley.

Lennard Developments

Lennard Developments are the UK agents for Technish - Physikalisches Laboratorium

Dipl-Ing Bruno Woelke, a tongue-twister sensibly avoided by the *Miniflux* trade mark. Three items of test equipment will be shown, the *ME 102B* and *104* peak-reading wow and flutter meters and the complementary *MT 301* wave analyser. A review of the *301* will be published shortly. Test discs (33 $\frac{1}{3}$ and 45 RPM) for use with the above equipment will be displayed alongside the latest Miniflux professional audio tape heads. Representative: E. G. Lennard.

Lockwood

Several monitor loudspeakers in the Lockwood range will be shown and demonstrated at APRS 70. The *LEI/S Universal* illustrated houses an 8 ohm 380 mm Tannoy *Monitor Gold* dual concentric unit or is available with the earlier 15 ohm *Monitor*. Basic price is £136, or £220 with 50 W Quad transistor amplifier. A mounting saddle, if desired, raises the price of the latter version by £16. Representative: Stanley Timms.

3M

A 16-track Mincom is to be exhibited by 3M, alongside Dynarange recording tapes.

Rupert Neve

Two sound control consoles will be seen at the Neve stand, one being the new transportable 10-channel *BCM 10/2*. A choice of VU meters or EBU-standard PPMs is offered;

equalisation facilities are largely to custom requirement. The system is described as equally suitable for mono or stereo broadcasting or recording and operates from either AC or a 24 V DC supply. Neve will also show a 16-channel console with four output groups and loudspeaker monitor supplies, plus three-, two- and one-track reduction facilities, two reverb and foldback groups, four studio playback groups and eight-track monitor and foldback matrices. Other facilities include five VUs, line-up oscillator, talkback, monitor reverb and an integral jack panel.

Richardson Electronics

Angus McKenzie's two-track TRD/Richardson will be loaned for the duration of the exhibition to Richardson Electronics for display on their stand. Also to be seen is a 12-channel four-group transportable mixing console built by the company.

Scopetronics

The *1150* tape transport, a 12.7 mm version with full remote control facilities (Model *1151*), plus examples of the company's range of tape heads, will be shown at the Scopetronics stand.

Uni-track

A *Uni-16* 16-track will be seen at the Uni-track stand, this being the company's first participation in a national exhibition.

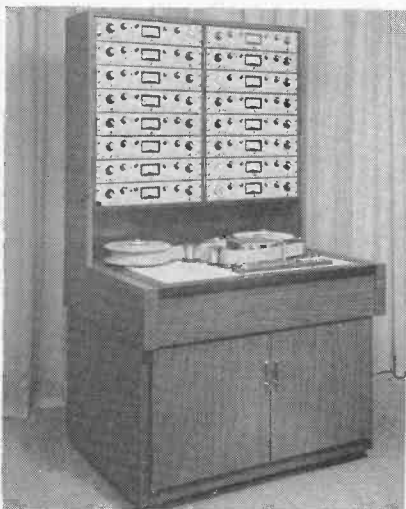

Scully 280-16

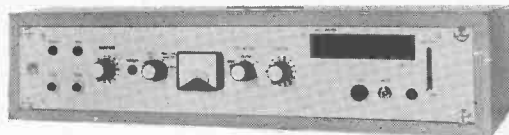

Appel 316/SS

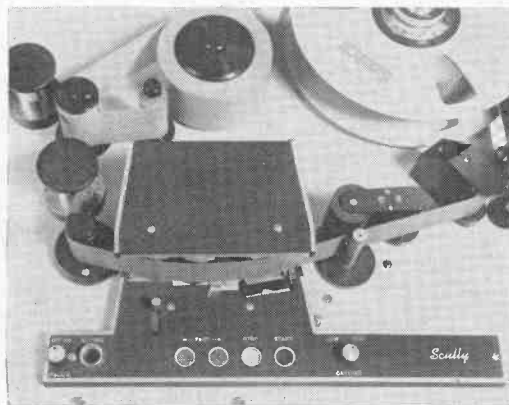

280-16 Tape Cleaner

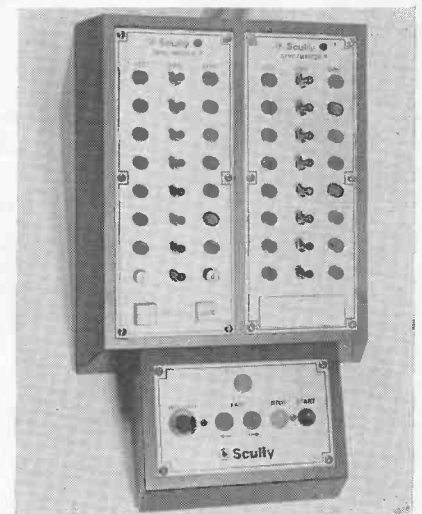

280-16 Sync/Master

ALICE MAKES VERY QUIET MIXERS———

WE DAREN'T SHOUT ABOUT IT OR EVERYBODY WILL WANT ONE

WRITE TO US QUIETLY ABOUT OUR SIX CHANNEL STEREO PORTABLE MIXER WITH BUILT IN COMPRESSORS, FOLD BACK, TALK BACK, ECHO SEND AND RETURN, COMPREHENSIVE EQUALISATION ON EACH CHANNEL, AMPLIFIED V.U. METERS, BUILT IN POWER SUPPLY, ETC., ETC., OR WHATEVER YOU SPECIFY

DELIVERY?

SIX WEEKS (PROVIDED EVERYBODY DOESN'T WANT ONE).

ALICE ELECTRONICS 1A BEXLEY STREET
WINDSOR, BERKS.
WINDSOR 61308

Stellavox

Portable Professional Tape Recorder · SP7

Interchangeable headblocks
Stereo plus synchrotone
Mono: full track neopilot
Stereo AGC
3.75 : 7.5 : 15 : 30ips
5" spools : 10.5 NAB
6 inputs (2 mic bal)
8lb. inc. batts + tape
10.5" x 8" x 2.5"



Audio Engineering Ltd, 33 Endell St., London, WC2

**Keith Wicks
talks to
Jacques Levy,
Chairman
of the APRS**

**inter
view**



K.W. *The APRS is now fairly well established. When did it all begin?*

J.L. In 1947. It became a limited company in 1951. We've been active from the very beginning of the private recording studios era when everyone made their own equipment. In those days people relied on their personal electrical and audio knowledge; it was a 'do-it-yourself' industry. Anything manufactured usually came from America.

K.W. *Why was the association formed?*

J.L. To improve the standard of sound recording, maintain strict business ethics so that people could rely on APRS studios for good quality recordings with decent business arrangements, and speak with one voice to outside bodies.

K.W. *If a studio were found to be guilty of dubious dealings, they would be expelled from the APRS?*

J.L. When we hear that something is wrong, somebody producing poor recordings or not paying their debts, then we tell the people concerned what we've heard and ask how they propose to rectify it. If they really are bad boys, either technically or in failing to reach decent professional standards, then we expel them. We listen to their side of the argument first, of course, as some people are inclined to complain unreasonably.

K.W. *Who formed the APRS?*

J.L. There was Derek Faraday, my brother Maurice Levy, John Hale, Lynton Fletcher and many other top men of the time. One of the first things they did was to get purchase tax exemption on pressings of up to 100 discs. At one time the authorities wanted to include in the value of a recording the cost of the session itself, in order to assess the tax payable. However, the APRS managed to obtain exemption on up to 100 discs, though above that number the recording is considered to be commercial rather than a private job, and purchase tax has to be paid. We recently negotiated similar exemptions for tape.

K.W. *What else has the APRS achieved?*

J.L. We have an agreement with the BBC that they will not infringe on our own world of private recording. In fact they invite us to send them lists of our members so that, when they get an enquiry for recordings or copies, they can refer people to the nearest APRS studio.

K.W. *The BBC have their own department, Radio and TV Enterprises, producing LP's for public sale. Don't you consider that this infringes the agreement?*

J.L. No. The BBC Charter restricts them to material originally recorded for broadcasting. They don't sign up artists for hundreds of records. An artist might do one for them, make a name for himself, and then be taken up by commercial interests.

K.W. *Why did the BBC agree to restrict themselves like this? I should have thought it would have been very much in their own interests not to make such an agreement.*

J.L. Well, according to some of the Corporation rules, they are not to compete with commercial interests. Anyway, we've had their reassurance in this matter quite recently. They are in fact almost *eager* to let us use broadcast material for a very small fee, subject to permission being obtained from the music copyright owners and the artists themselves.

More recently, we've secured for studios the right to apply for investment grants on all equipment purchased. The Board of Trade have agreed that we are part of a manufacturing chain so we can qualify for this grant which stands at 20% in London and 40% in the development areas in the north and west of England. If you're putting up a new studio, or improving your present one by buying new equipment—anything connected with the sound side—you get this allowance. This is a great victory for us. One has to pay say £10 000 for a multitrack recorder, so 20% is a marvellous

saving, and the reduction applies to anything costing down to £25.

K.W. *What about your more recent achievements?*

J.L. Well the APRS annual exhibition is now in its third year. We felt there was a great need for an exhibition which excluded the general public to make room for people genuinely interested in the industry. The last two years have been a great success; everyone has said what a pleasure it was to move freely and talk sense, and a lot of business was done. This year it is a larger two day show. We're fully booked and hoping to attract more visitors, including some from overseas, but not so many that it will make the show uncomfortable for everybody.

K.W. *Is the APRS hoping to get overseas members eventually?*

J.L. This is possible but at the moment we're content to solidify our position here and try to get one or two studios who are still a little slow and, we think, rather foolish. The members we have are all happy with what we do for such a small subscription. All members of the executive give their time without any form of payment, except the secretary.

John Borwick, ex-BBC, is extremely useful and our society is lucky to have such a man as secretary.

K.W. *How many member studios do you have at the moment?*

J.L. About 150, mostly in London, particularly the larger ones. London still seems to be the main centre, but we arrange out of town meetings for people in other parts of the country. We had one of these in Birmingham in November. Members in the provinces are kept fully acquainted with what is going on. We don't have many meetings other than those for the committee but it was recently suggested that we should hold a big London meeting. We want to get members together more to talk about what they are doing and to help each other.

K.W. *In what way does the APRS help individual member studios with problems.*

J.L. We invite members to write to us on any subject relevant to recording, whether it be a technical or a business matter. We receive lots of questions that we answer to the best of our ability. We have a lawyer who is *au fait* with copyright, and, until recently, an arrangement with a debt collection agency so that members got reduced rates.

K.W. *You don't have this service now?*

J.L. Not at the moment, no. The studios have become a little more wary of fly-by-night producers. There were a few black sheep about who used the studios as a credit card, hoping to pay them if they managed to sell the tape. All too often, the studios were left holding the baby.

K.W. *What does it cost a studio to become a member of the APRS?*

J.L. Very little. At the moment it is an annual subscription of 8 guineas, which is extremely cheap considering that we give very good service. Studios get newsletters frequently and, if a member has equipment for sale, we let everyone know so that he has a chance of disposing of it quickly. If a potential client writes to the association, he is sent a list of studios to choose from. Also, members pass work to each other, and there is a very nice feeling of helping each other.

(continued on page 303)

DC300

The Finest Power Amplifier in the World!

The CBS Lab Data taken on the DC300 represents in sum the highest performance yet encountered in an amplifier. (High Fidelity Mar. '69)

Coming as close to absolute perfection as any amplifier we have ever seen or investigated. (Audio Oct. '69)

Two DC300 amplifiers used by Frank Sinatra at the RFH

We tossed up whether to use a Dolly, or a photo of the DC300 or both, but decided to just give you the facts man! When you have read them, and if you know of any amplifier that is as good (not better) we'll buy you one! We're pretty safe!

DC300 power capability is 340 Watts RMS into 4 ohms, 190 Watts RMS into 8 ohms, 100 Watts RMS into 16 ohms each channel.

For power bandwidth we can claim at say 150 Watts into 8 ohms, that it is FLAT from DC to 35,000 Hz! -3dB point is 45,000 Hz.

Harmonic Distortion at 1,000 Hz at a level of 75 Watts into 8 ohms is a mere 0.007%. At 150 watts this becomes 0.01%. For comparison we can quote at 50 watts RMS at 20,000 Hz THD is 0.1%. At 150 Watts RMS at 20,000 Hz it becomes 0.2%.

Safe so far we feel!

Intermod. Distortion on the DC300 is typically 0.05% at all power levels from 0.01 Watt up to 150 Watts. Difficult to compare as few other amplifiers specify this, but remember it makes the difference between clean and woolly Bass.

Hum and Noise on the DC300 is better than 100 dB below 150 Watts.

Damping Factor is greater than 200.

DC300 is stable under any load condition. Ideal for Electrostatic speakers as it handles capacitive loads so well.

The DC300 is not cheap of course. But it is the best!

U.K. users include The National Physical Laboratory, Road Research Laboratory, Institute of Sound and Vibration, Queen Mary College, Electricity Research Council, University of Manchester, International Entertainers Services Ltd., Island Records, and many others. If you would like more data on the DC300 together with reprints of the reviews mentioned above please let us know.

Remember if you want the Best for your Studio, Disco, or whatever and not the second best, or best in class (whatever that means) the DC300 is now accepted as the one to go for.

CARSTON ELECTRONICS LIMITED
71 OAKLEY ROAD • CHINNOR • OXON
Telephone: Kingston Blount (08445) 8561

K.W. *What sort of qualification does a studio need to have to join the association? Do you perhaps visit the premises and judge the quality of the work?*

J.L. In the early days one couldn't be too critical, but in recent years we have raised the standard. When anyone applies for membership, they have to give a list of their equipment. Unless we know them, they have to submit a photograph of the studio and equipment, and also a sample recording.

K.W. *How qualified are your committee members to judge?*

J.L. Starting at the top, there is our patron, the Earl of Harewood. He knows what is going on in the industry, is technically minded, and is a keen musician. He was the Director of the Edinburgh Festival for many years.

K.W. *And your President, Arthur Haddy?*

J.L. He is a director of Decca and has been their chief engineer and director of technical services for a number of years. He was largely responsible for the development of their stereo system and has been Decca's guiding light, bringing them to the forefront of the sound recording world. Then there are the vice-presidents. Derek Faraday has a very fine studio of his own (Star Sound). It is one of the few studios that can hold an audience, and he has done lots of broadcasts over the years. He was the king-pin of the prize giving shows—'Double Your Money', that kind of thing.

K.W. *You are now the chairman of the executive committee. How did you first become involved with the recording industry?*

J.L. My brother and I ran a studio and factory under the name of Levy Sound Studios which made Auriole Records. I became a committee member and, about six years ago, the Chairman.

K.W. *And what sort of work do you do now?*

J.L. My studio was taken over by CBS. I was with them for 4½ years as their studio director and was also in charge of all their custom pressing—the manufacture of records for labels other than CBS. Quite a task, and I think I discharged my duties quite well. During the war I was the recording chief at the War Office, running their studio and doing sports broadcasts for troops. We also had a mobile truck for troop shows, such as the Carroll Levis 'Discoveries'. I often had to operate two Neumann disc cutters single handed and was awarded the Certificate of Merit for my efforts in this field. More recently I decided that I wanted to seek fresh fields to conquer, and at the moment I am an agent here for some well known firms, an important one being Audio Disc, considered one of the best manufacturers of recording blanks in the world. It's a very small field, only four or five firms in the whole world that can make them, which is remarkable. Neither Russia nor Japan can make blanks. It's a delicate and critical operation. With improvements in audio equipment, responsibility is thrown more and more on the master disc, and the processing, so the factory really has to be on the ball.

I am also an agent for American Saphires and for Pultec amplifiers and equalisation equipment. Over the years I've learnt a lot and have been fortunate enough to have done all the things in the industry—I've been through

the mill from beginning to end. From sound recording to disc cutting, processing, pressing and the handling of labels. I've got a pretty good all round knowledge. I'm not an expert on everything—on anything—but I've got useful knowledge which has stood me in very good stead. I have other big plans which I can't reveal at the moment.

K.W. *A studio?*

J.L. Well, we'll leave that open for the moment.

K.W. *Between them, these people seem to be experienced in most fields, but in my travels I've heard some criticism of the association, and a remark in a recent Studio Sound (February) interview upset one or two people. John Alcock of Unitrack Equipment made the comment that the APRS 'hasn't the authority'. He was referring to the laying down of standards for recording. Have you any comments on this, and do you think that in the future the APRS is going to be rather more specific about standards?*

J.L. I don't know what he means by 'authority'. It is a fact that we are looked up to and respected by the Board of Trade, and we're in close contact with the Customs and Excise. The Mechanical Copyright people look to us to arrange with studios the collection of copyright on their music. We've had negotiations with trades unions in the past. Any studio that operates film has to be a union member, although other studios do not have to be.

These are four major bodies, so we do have authority, and are regarded as the spokesman for the industry of private recording.

K.W. *As far as standards are concerned, what are the views of the association on the metric system?*

J.L. When it comes to standards, the British Standards Institute is responsible; it is not our job. We are represented on one or more BSI Committees. Musical standards and recording standards are not easy to lay down and we can only make recommendations. Our members have a tape which helps them to line up their machines, and we recommend that they buy certain types of test equipment. As far as quality is concerned, it's very difficult to decide—everyone has a different idea on quality. It's not like turning on a tap and out comes water—results are so varied.

K.W. *You mean that if a studio claim the quality they have obtained is what they were after, you can't really argue with them.*

J.L. That's right. No matter how good your tape machine is, things are still in the hands of the engineer and the producer who wants a certain sound. He says it pleases him, but it might not please the man next to him.

K.W. *You have mentioned the BSI and have said that it is their job to lay down standards but suppose, for instance, that members of the APRS were to disagree with the use of metric measurements in connection with tape recording? It is very convenient to talk about quarter inch tape, one inch tape, or whatever, and there seems to be a lot of feeling that we should stick to these.*

J.L. Whether it is going to be thrust upon us or whether we'll stick rigidly to what we are used to I don't know. We're all rather disinclined to get out of our groove. It's a form of laziness—Why the hell should we change now?—For whom?—Who's going to benefit? But we're changing without argument; we

don't use cycles any more, nearly everything is written in Hertz. Nobody argued about that, we changed automatically, though I haven't heard the word used. We read it but we still talk about cycles.

K.W. *Personally, I think that the change from cycles to Hertz was relatively small, whereas the change to the metric system can be rather cumbersome at times.*

J.L. Oh dear! Well I suppose people will continue to use inches in talking, two inch, one inch, or whatever it is, because it's easier to say an inch rather than so many millimeters or centimetres. But it'll be in print. It'll be forced upon us by magazines like *Studio Sound*, by newspapers and general technical publications. Eventually we'll change over for fear of being left behind or being out of date.

K.W. *Would the APRS move against this change if enough people don't want it?*

J.L. It is a nuisance. I don't think anybody really likes it [*Least of all us, we have to do most of the conversions—Ed.*] Our inches are so simple and of course America is not going metric. I would like to see it remain in inches if possible when referring to tape width. Tape speeds are easy—they're simple figures. You've got 19 and 38 or whatever it is, and this is easy. In any case, you don't have to ask what speed you're going to record at in studios—you know it's going to be 15. I think that inches, being so simple, should be retained purely verbally; let the literature become metricated, I suppose we shall fall into it sooner or later.

K.W. *Talking of changes, what are the future prospects of the studios now operating four or eight track but who can't afford to go 16 track? Do you think that some of these will go out of business?*

J.L. No. There's room for all types of studios provided that the equipment is good, well maintained, and operated by sensible engineers. Many clients don't need 16 track and will go to a smaller studio providing that it is efficient.

K.W. *I was thinking mainly of the pop scene. Some studios say that they're going 16 track because their clients like to think that they have the best facilities.*

J.L. It's a case of whether you want the world's best car or the world's second best car. You can pay £10 000 or you can get a marvellous car for £2 000 or £1 000. A lot of people don't want 16 track and haven't the money anyway. Eight track would probably suit many pop productions—and four track too. There is an enormous amount of work for small studios where speech alone is wanted, and a vast amount of time is taken up with language courses. Provided studios are well run with good modern equipment, there's room for everybody.

K.W. *Lastly, what are the main objectives of the APRS at the moment?*

J.L. We want to get all worthy professional studios as members. Those who have not joined are rather short sighted as their co-operation would give us an even greater strength as a spokesman for the industry.

K.W. *Well, perhaps when this is published they will give their reasons and you'll be able to sort it out from there.*

J.L. Yes. We hope eventually to spread our name far and wide as the one focal point to whom anyone can turn, whether it be a question or a complaint.

THE design and theory of the mixer were discussed last month, together with typical metalwork details to allow construction to begin. This month's article describes the fader rack construction using either commercially available linear faders or home-made quadrant faders. So that a start can be made on the electronics, a power supply circuit will be described. This unit is stabilised and fully protected against overloads and short circuits. It can also be adapted for use as a variable bench power supply.

The fader rack is a self-contained chassis, which allows the entire assembly to be removed from the mixer. This makes the unit much easier to wire, and simplifies the maintenance. All the electrical connections are brought out from multiway sockets on the rear of the chassis, which means the removal of the rack takes only minutes.

The prototype used home-made quadrant faders since cheap linear faders were unobtainable when it was built. Nowadays there are several varieties, some of which are illustrated in figs. 7 to 10. Constructors can make their own choice. Points to watch for are length of fader travel, smoothness of operation, ease of mounting, and type of knob. The home-made faders are 34 mm apart, whereas most of the commercial varieties can be spaced by the same amount as the plug-in amplifier, which can thus be immediately above their fader, with obvious advantages.

Above each fader on the rack are the channel-select switches, echo-select switches, and pan pot. The mixing resistors lead down to the mixing amplifiers which are contained on plug-in cards in the centre of the rack. The design of fig. 3 (shown last month) uses four mixer cards (two main, two echo) and two buffer cards (each containing two amplifiers). Thus a total of six cards are in the fader rack, which keeps the wiring to and from the rack to a minimum. The photographs show two faders on the right (left and right outputs); if echo facilities are used, the two echo send controls should be added next to these two. Colour coding of the knobs is an advantage—say white for channel faders, green for mains outputs, and blue for echo.

The metalwork drawings are for the home-made faders but obviously can be adapted to suit the commercial varieties. A professional stud-fader operates with a sliding contact on the moving arm, making contact with a row of plated studs; resistors are connected between the studs to form a potential divider which is thus tapped by the moving contact. An extremely long life is achieved but the studs need regular cleaning. There is little to choose so far as noise life is concerned, between stud-faders and sealed moulded carbon potentiometers. The stud type is only preferable when extreme accuracy is required for a given rotation of the control, since this is determined by the accuracy of the resistors in the chain. A stud-fader is very expensive to make; our design uses normal potentiometers with a pair

of gear wheels to provide the quadrant action. Two wheels are required per fader, one large (120 teeth, brass) and the other small (32 teeth, steel). Both gears are 64 dp. and can be obtained from S. H. Muffet Ltd., together with the 3/16 inch shaft and 1/2 x 1/4 inch brass collars.

The operating arm is made from steel, for strength (fig. 11). The topmost part is shaped to suit the type of knob chosen. The prototype used the Painton EM variety but these are a little expensive at about 5s each. It would be cheaper to adapt another type to suit or try to make some from fibreglass. The feel of the EM knobs was so obviously correct that for the prototype they were the only choice. The wider end is drilled with a 1/2 inch hole so that the arm is a snug fit over the boss in the larger

part two, fader construction and power supply

FIG. 7

Argo AD100,
110 x 22 mm,
76 mm slide.
£5.

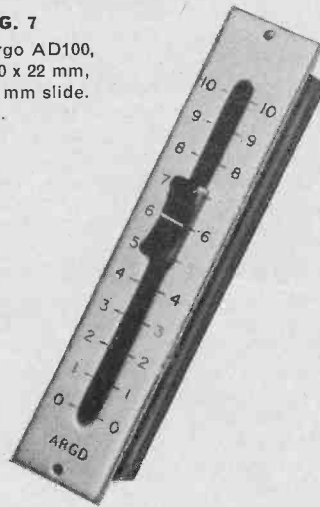

FIG. 8

Penny & Giles
PGF 1520 C/235,
174 x 45 mm,
118 mm slide.
£17 10s.

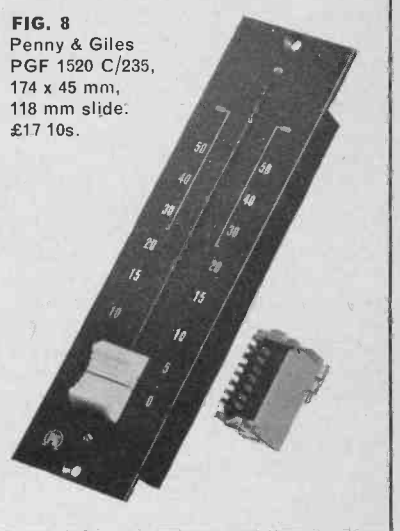
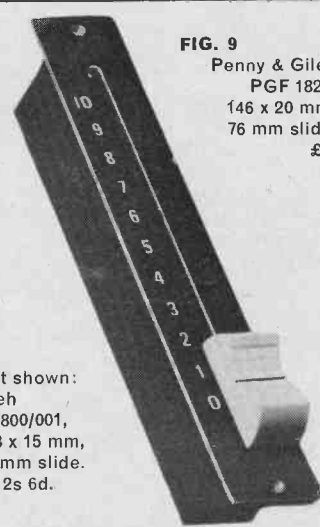

FIG. 9

Penny & Giles
PGF 1820,
146 x 20 mm,
76 mm slide,
£6.



Not shown:
Preh
66/800/001,
113 x 15 mm,
72 mm slide.
£1 2s 6d.

FIG. 10

Penny & Giles
PGF 1920,
188 x 44 mm,
105 mm slide.
£20.



A HIGH QUALITY MIXER

FIG. 12

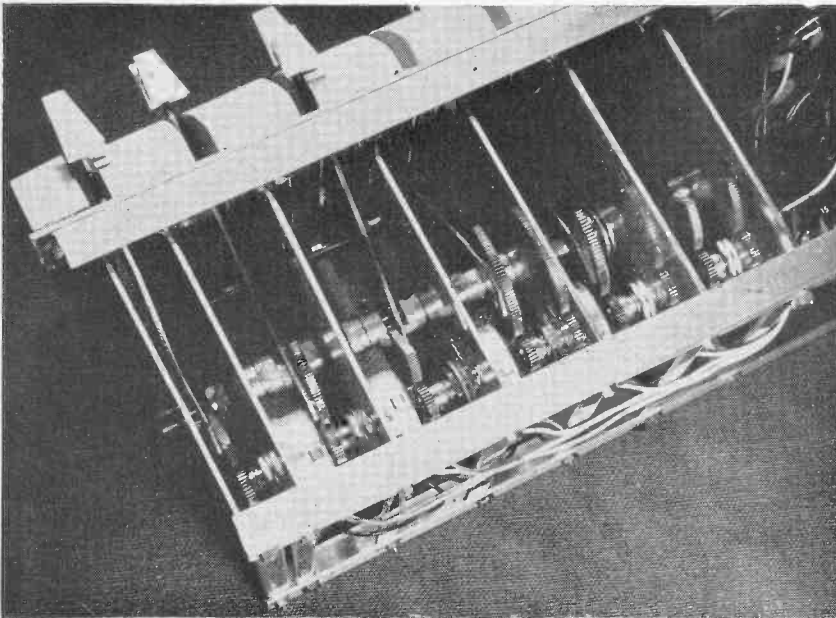

by david
robinson

FIG. 11 DETAIL OF POTENTIOMETER ARM

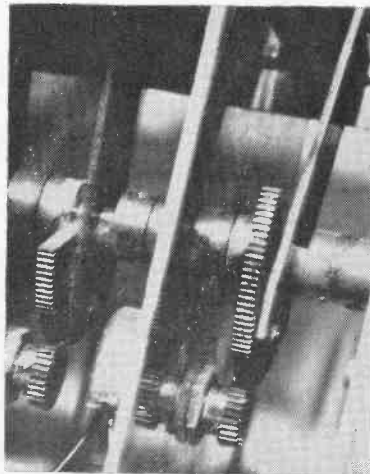
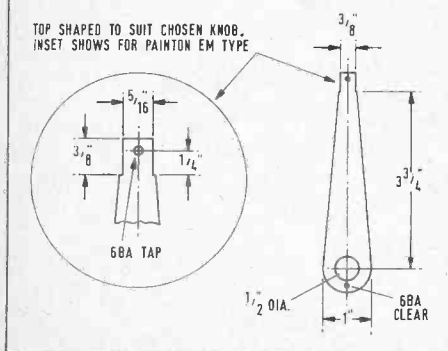

FIG. 13

gear wheel. It is fastened to the wheel by a 6BA screw into a tapped hole in the gear. For economy, the large gear wheel is cut in two, and to each side of each half is brazed one of the $\frac{1}{2} \times \frac{1}{4}$ inch brass collars.

The assembly method is shown in figs. 12 and 13. These refer to the first prototype and the method is thus different in minor respects from the mixer being described at present. For example, the buffer and mixer cards were not in the fader rack. They also show that Araldite was used in place of brazing; in use this has proved to be entirely satisfactory, although there is no doubt the brazing method is preferable.

Figs. 14, 15 and 16 together show the arrangement of the fader rack. The framework should be made first, commencing with 10 identical side pieces. If possible, a simple jig should be made (detail in fig. 14) to ensure that, when bent as shown, the holes on the centre line are concentric, since these are the ones which carry the shafts and potentiometers; the other hole is for a grommet and is used for the wiring. If it is not possible to make a suitable jig, the lower hole is best made slightly elliptical so that correct meshing of the gears can be achieved.

The deck plate is made in 16 SWG aluminium (Detail 2), with slots cut for the faders. This is very flexible so a piece of $\frac{1}{2} \times \frac{1}{4}$ inch angle, $\frac{1}{2}$ inch shorter than the plate, is fastened on each side, and this also forms a ledge for fixing the fader rack to the mixer box. The side pieces are then screwed to the plate, three at one end and seven at the other for the prototype, as shown in the exploded diagram. The outermost plate in the group of seven is reversed relative to the others so that the deck plate projects clear of the assembly for mounting. A further two angle pieces are then added to the bottom of the rack.

Shaft Assembly

Two shafts are used to leave the centre section free for the multiway electrical connections plugs and it is best if the short one is assembled first. The shaft is introduced from the outside end. A control arm assembly and $\frac{1}{2} \times \frac{1}{4}$ inch brass collar are added in order between the two sections. Finally, a collar is added on the outside of the shaft to prevent it sliding farther into the rack. The arm assembly is then pushed hard against the right-hand plate, looking from the front, and the collar on its left brought up to the assembly and screwed down to the shaft. In this way the assembly cannot move along the shaft but is free to rotate. It would be possible to devise a system of locking the arm to the shaft for ganging potentiometers together, but this would be an additional complication.

The centre hole in the 32-teeth steel gear wheel is then enlarged to $\frac{1}{4}$ inch diameter, if possible with a tapered reamer to ensure concentricity, and an 8 BA grub-screw fitted to the boss in a suitable place to hold the gear to a

(continued on page 307)

ENGLAND, SCOTLAND, IRELAND, FRANCE, BELGIUM, HOLLAND, GERMANY,
ITALY, GREECE, AMERICA, [SOUTH AFRICA, AUSTRALIA, NEW ZEALAND

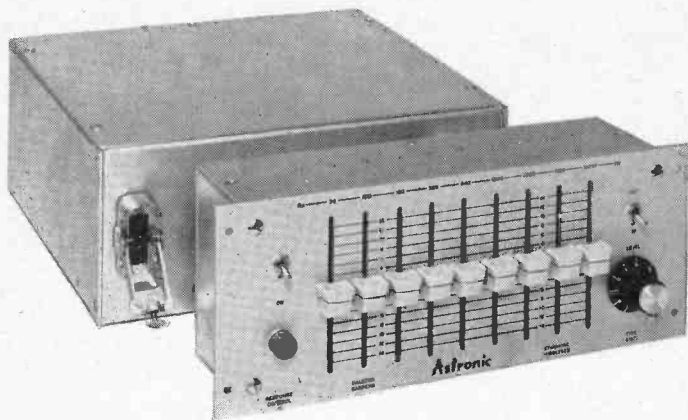

IN STUDIOS THROUGHOUT THE
WORLD YOU WILL FIND

“Astronic”

AUDIO RESPONSE CONTROL UNITS
TYPE AI671

The MKII version now available embodies
complete printed circuit board construc-
tion of main unit improved control panel
and changes in switch design.

Send for full details from **ASTRONIC LTD.**

DALSTON GARDENS, STANMORE, MIDDLESEX, HA7 1BL
Grams. Astronic Stanmore **Phone: 01-204-2125**

STUDER 089

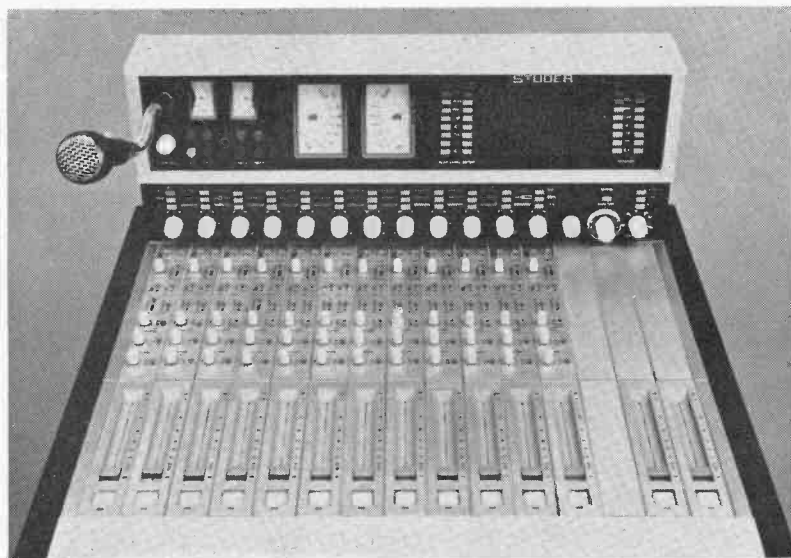

**12 CHANNEL STEREO
TRANSPORTABLE MIXING
CONSOLE**

Ex-Stock From:

F.W.O. BAUCH LTD.
49 Theobald Street,
Boreham Wood,
Herts.

Telephone: 01-953 0091

FIG. 15 END VIEW OF FADER RACK

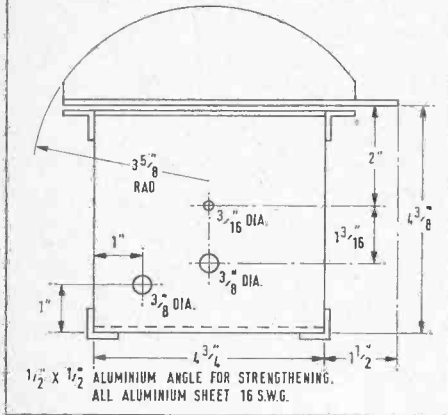
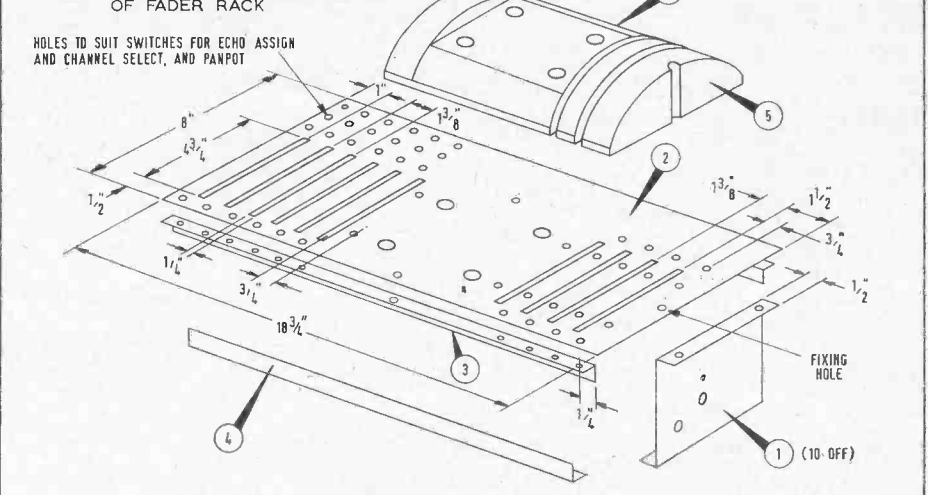

FIG. 14 MECHANICAL ARRANGEMENT OF FADER RACK



flat on the potentiometer spindle, which should be cut as short as possible. The potentiometer fits on the outside of the end plate, and the gear inside; all the controls are 5 K or 10 K with a log-law track. Meshing of the gears is important so that the control is neither too stiff nor slips teeth when moved. When this is correct, and the position such that the arm just does not hit the deck plate at either end of its travel, the potentiometer nut is tightened. The long shaft assembly is put together in the same way.

This completes the rack with the exception of the curved pieces which carry the cursor indications of the potentiometer settings. These proved to be difficult to make easily in metal, and the final technique adopted was to make the side pieces in Bakelite laminate cut to shape and then placed on either side of a wooden block which is about 1/8 inch undersized all round. Fibreglass paste is then spread over the mould, and when dry the surface is sanded smooth. The former is then withdrawn for the next piece. The centre section is made in a similar way except that an aluminium plate is let into the fibreglass for strength. Two holes are made in this to let the shafts of two subsidiary potentiometers pass through. In the prototype these were for earphone balance and earphone volume.

These curved pieces are then fixed with Araldite to the deck plate, although the main centre section is bolted so that it can be removed should it become necessary to change any of the potentiometers immediately below. The assembly is then painted and lettered to suit with either Letraset or Panel Signs transfers. An arbitrary scale of 1 to 10 was chosen; if required a dB scale could be used instead, although the log-law track in most potentiometers will only give an approximately linear scale in decibels.

The six amplifiers fit under the two rotary potentiometers in the centre section, with the edge connectors mounted on a false baseplate 12 mm from the bottom of the main assembly.

The spacing between the sockets is 25 mm. This finishes the mechanical work to the rack. All that remains to complete it entirely is the electrical wiring to the multiway sockets, which are held on a simple bracket between

two side pieces in the centre section. This can be seen in fig. 12 at the bottom, to the back. For all the wiring, single conductor PVC covered wire is suitable, since no screening of

(continued on page 319)

FIG. 16 CENTRE SECTION DETAIL

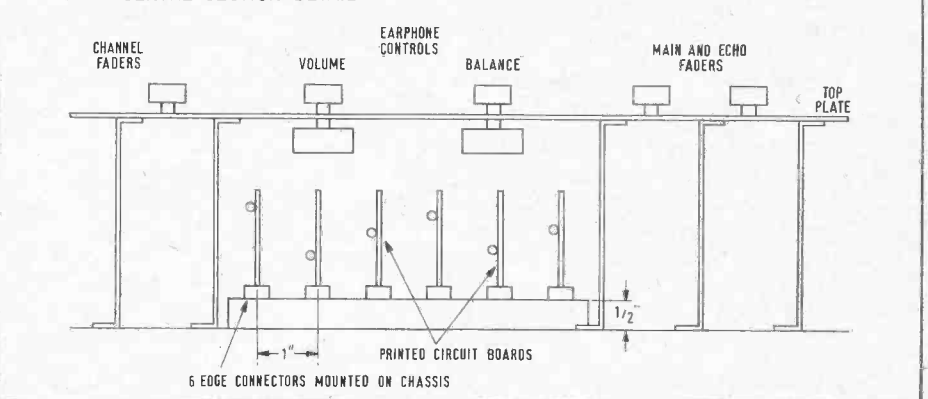
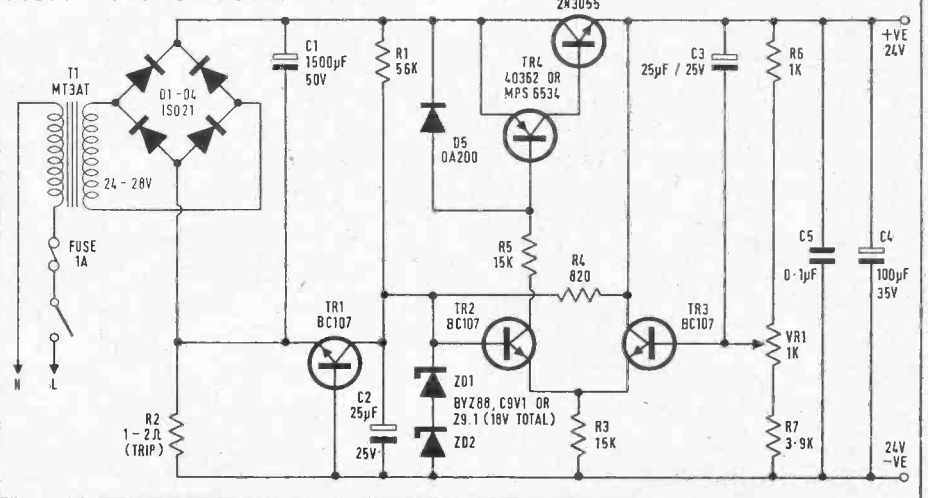

FIG. 17 STABILISED POWER SUPPLY



We'll turn you on gently.

With our linear motion studio faders. Our faders use mirror finish conductive plastics, together with multiple finger precision metal wipers to give superb reliability and noise-free output.

They give infinite resolution, last for years, have built-in switching, and work silently.

Still want convincing?

Clip the coupon and we'll tell all.



To: Penny & Giles Ltd, Mudeford, Christchurch, Hants.

I just might be in the market for a linear motion studio fader. Convince me please.

Name _____

Position _____

Company _____

Address _____

SS/7

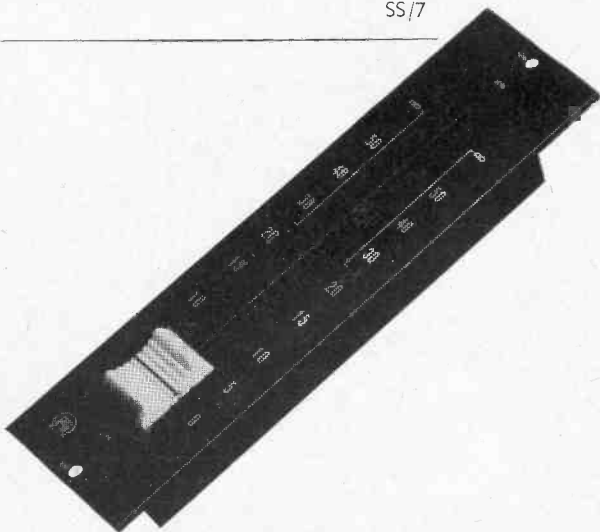

COME TO THE TAPE RECORDER CENTRE AND SAVE ££££'s

Why buy elsewhere when you can visit the Tape Recorder Centre and see the finest selection of tape recorders on display in Great Britain available at the lowest possible prices! As Britain's largest specialists we can't be beaten. Our tremendous purchasing power enables us to offer a vast range of tape recorders at rock bottom prices thus saving you ££££'s.

Not only do we quote you the lowest prices but we give full manufacturers guarantees PLUS Free After Sales Servicing. Our prices apply whether you are buying for cash or on our attractive H.P. Terms !!!!! Don't delay, call today, you won't obtain a better deal elsewhere.

TYPICAL EXAMPLES

	List Price	OUR PRICE
BRENELL STB2	£233 15 11	£205 14 10
REVOX 1112/1124	£216 6 0	£195 13 5
FERROGRAPH 722/724	£242 10 9	£213 8 9
REVOX 1102/1104	£187 19 0	£169 3 2
FERROGRAPH 713	£188 10 0	£165 17 8
UHER 4000S	£187 5 10	£164 15 8
TANDBERG 64X	£157 0 0	£138 3 3
TANDBERG 12/41X	£154 0 0	£135 10 5
BRENELL ST200/400	£145 0 0	£127 12 0
BRENELL MKVM	£145 11 10	£128 2 5
UHER 4000L	£145 10 0	£128 0 10
BRENELL MK5111	£116 15 6	£102 15 4
SANYO MR939	£112 5 0	£98 15 8
AKAI 1710W/L	£109 0 0	£89 5 0
SANYO 929	£97 5 0	£85 10 5
AKAI 4000D	£89 19 1	£79 3 1
TANDBERG 1600X	£89 10 0	£78 15 3
TANDBERG 15/41	£85 0 0	£74 16 0
SANYO 801	£69 15 0	£61 7 8

EXTRA SPECIAL OFFER!

SANYO M800—List Price £90.8.8

FEW ONLY AT OUR SPECIAL PRICE OF 59 GNS.

Send for illustrated brochure and comprehensive list detailing the fantastic range available at our lowest possible prices!

N.B.—Prices corrected at time of press. E & O E

THE TAPE RECORDER CENTRE

82 HIGH HOLBORN, W.C.1

Tel. 01-242 7401

NEW equipment

FOUR-CHANNEL HEADS

AN 80 MH PER segment four-channel in-line record/play head has been developed for transistor tape amplifiers by Miniflux. Crosstalk is -50 dB across adjacent segments and the price, Type FCN3, will be around £20 for one-off orders.

DISTRIBUTOR: Miniflux Electronics Ltd., 8 Hale Lane, London N.W.7.

AMPEX VIDEOTAPE

AMPEX 163 12.54 mm videotape is now being supplied on 13 cm reels playing for 20 minutes at 19 cm/s, to meet the demand created by users of portable VTRs. The company claims extended head life, longer still-frame operation, lower dropout, and superior signal-to-noise compared with other makes.

DISTRIBUTOR (UK and Scandinavia): Ampex GB Ltd, Acre Road, Reading, Berkshire (Tel. Reading 84411).



STEREOPHONES

SHRIRO SE-30 and SE-50 stereo headphones are now being imported by Shriro (UK) Ltd. The SE-30 illustrated costs £12 12s and is supplied with a 2.2 m cable and 3-conductor jack plug. Model SE-50 is similar but incorporates overall level and treble level controls in each earpiece and costs £19 3s 8d.

DISTRIBUTOR: Shriro (UK) Ltd, Lynwood House, 24/32 Kilburn High Road, London NW6.

VARIABLE-FREQUENCY POWER SUPPLY

A UNIT DELIVERING up to 82.5 VA three-phase at any frequency between 18 and 100 Hz has been developed by Mellotronics Ltd. Originally conceived to drive a Papst HSKM 32 capstan motor, it comprises a three-phase variable-frequency oscillator feeding three separate power amplifiers and delivering 240 V at 50 Hz, 480 V at 100 Hz. The unit is solid state, totally enclosed apart from heat sinks and vents, and incorporates a single 18-way plug carrying all connections.

MANUFACTURER: Mellotronics Ltd., 28-30 Market Place, London WIN 8PH (Tel. 01-580-9694).

ITT DIGITAL MULTIMETER

UP TO 1 kV AC or DC, with 100 μ V resolution, up to 1 A with 100 nA resolution, and up to 1 M with 0.1 ohms resolution may be measured on the DX703A digital multimeter now being imported by ITT. Input impedance is 10 M on all ranges, the unit being protected against 1 kV DC or 350 V AC on its most sensitive



ranges. Range selection is by pushbuttons and construction is on modular printed circuit boards. Dimensions are 230 x 160 x 80 mm. **DISTRIBUTOR:** ITT Components Group Europe, Edinburgh Way, Harlow, Essex (Tel. 0279-6-26811).

CLEANING CASSETTE

AN ACCESSORY cassette designed to clean the heads and transport of Compact Cassette equipment is now available from Philips. The 811/CT contains 18 m of cleaning tape in the

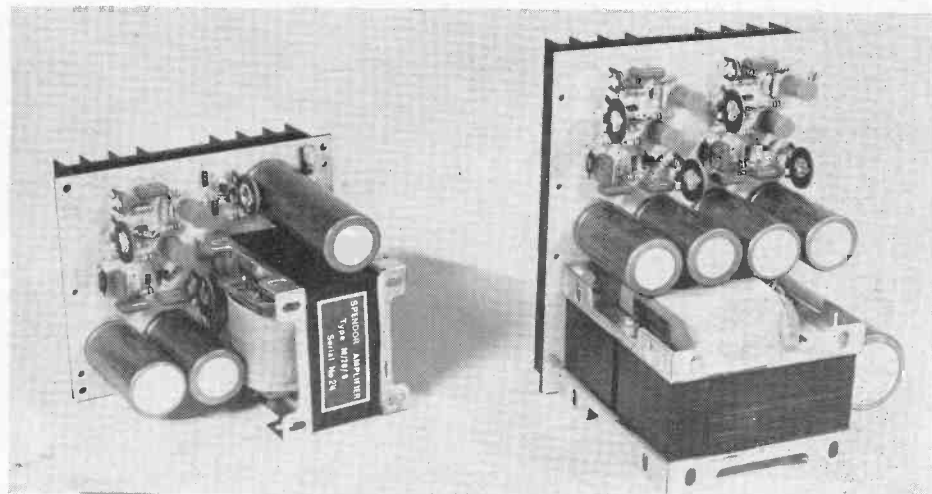

body of a cassette and may be used about ten times before the manufacturers recommend replacement. Price with tax is 17s 9d.

DISTRIBUTOR: Philips Electrical Ltd, Century House, Shaftesbury Avenue, London W.C.2 (Tel. 01-437-7777).

PANEL INDICATORS

ARGO ENGINEERING are now distributing a wide range of panel lights and indicators manufactured by Boss Industrial Mouldings Ltd. This comprises 17 basic types with some 160 available permutations, operating at between 5 and 24 V (filament) and 110 to 240 V (neon). A wide choice of colours and lens diameters is offered, with solid or flying lead connectors.

DISTRIBUTOR: Argo Engineering, 54 Lemonfield Drive, Garston, Watford, Hertfordshire (Tel. Garston 74601).

MONITOR AMPLIFIERS

SINGLE AND dual-channel transistor power amplifiers designed to feed studio monitor loudspeakers are now being manufactured by Spendor Audio Systems. The circuit employs complementary Class B output stages fed from constant-current collector-coupled feedback pairs, eliminating crossover distortion. Power efficiencies close to the theoretical 78% maximum are claimed. Voltage gain is 29 dB, giving 20 W continuous RMS output into 9 ohms minimum load for an input of 500 mV RMS. Input impedance is 200 K in parallel with 10 pF. Frequency response is 20 Hz to 50 kHz (20 Hz to 13 kHz power response) within -1 dB. Distortion is 0.03% at any level up to full power. Prices with integral mains power pack are £20 10s for the M20/9 single-channel and £30 5s for the stereo S20/9, both in skeleton form. A boxed S20/9 costs £32 10s. Also available, on request, are details of Spendor monitor loudspeakers. These and the amplifiers will be reviewed by *Studio Sound* in the near future.

MANUFACTURER (Mail orders only): Spendor Audio Systems, 22 Station Road, Redhill, Surrey.

DISTRIBUTORS: Merrow Sound Ltd, 229 Epsom Road, Guildford, Surrey. Centre of Sound Ltd., 153 Plumstead Road, London, S.E.18.

LEVEL CONTROL EQUIPMENT

Superb Performance—moderate cost

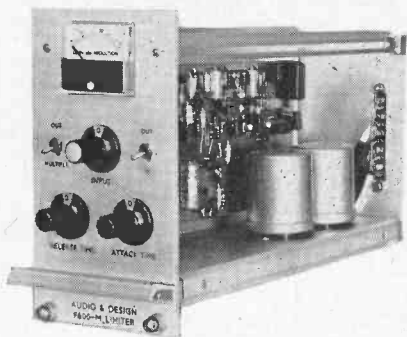

F600-M Mk 2

Limiter/
Compressor

A Mk. 2 version of the well established F600 unit. Gain within the system is normally 25dB with output level of 0dBm (+8dBm to order). Compression ratio better than 25:1; variable attack and release controls with auto network. Noise -70dBm. Response: 10Hz-50kHz for -3dB. Distortion: 0.1% for 25dB reduction at 1kHz.

also available

F700 Compressor/Limiter and E800 Equaliser

Audio & Design (Recording) Ltd.

10 Lower Rd., Cookham Rise, Maidenhead, Berks.

Tel: Bourne End 22231 (STD 06285-22231)

the Revox Clinic a new service for the enthusiasts

Bring your recorder, **Revox or not**, to the Revox Clinic. Here it will be measured free of charge and the frequency response curve provided. If it is a Revox A77 any adjustment needed will be done free of charge.

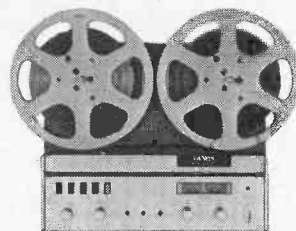

Revox delivers what the rest only promise

Revox 90 High Street Eton Windsor
Berkshire Telephone Windsor 63388

Also in USA and Canada

Revox Corporation 212 Mineola Avenue
Roslyn Heights New York 11577

New York USA

Tri-tel Associates Limited
Toronto Canada

you are invited to the Revox Clinic

Fairbotham and Company Limited
58-62 Lower Hillgate
Stockport June 29, 30, July 1

Hammonds Hi-Fi
63 Queens Road
Watford July 2, 3, 4

Peter Anson Electronics
165 Arkwright Street
Nottingham July 6, 7, 8

Audio Sound
38 Waterloo Street
Leicester July 9, 10, 11

Russells Audio
5-11 Wimbledon (Station) Bridge
London SW19 July 13, 14, 15

Carlow Radio Limited
6 St Loyes Street
Bedford July 20, 21, 22

Griffin Radio Limited
94 Bristol Street
Birmingham July 23, 24, 25

Lind-Air Audio
18 Tottenham Court Road
London W1 July 27, 28, 29

further clinics in other areas during
August and September - see next
issue.

REVOX

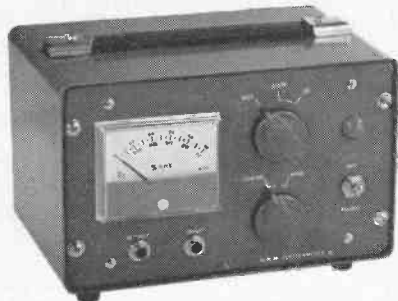

W.H.M.
WOW AND
FLUTTER
METER
(R.M.S.)
MODEL III

**SYDNEY HOUSE, 35 VILLIERS ROAD, WATFORD
WD1-4AL**

BEYER DYNAMIC

FAMOUS FOR MICROPHONES AND HEADSETS
FOR 40 YEARS

To: BEYER DYNAMIC (G.B.) LTD., 1 Clair Road, Haywards Heath, Sussex
Telephone: Haywards Heath 51003

Please send me full particulars and illustrated brochure of the Beyer
Dynamic products.

Name

Company

Address

INTRODUCING

THE PHASERITE

A device for testing phasing of micro-
phones, speakers and circuits

£60 nett

Other products include

MICROPHONES, CONDENSER & MOVING
COIL, FLOOR STANDS, BOOM ARMS
SWAN NECKS, ADAPTORS & BARS
RECORD CLEANING MACHINES
STUDIO MONITOR LOUDSPEAKERS

KEITH MONKS (AUDIO) LTD

54 Rounton Road, Church Crookham,
Nr. Aldershot, Hampshire

Tel. FLEET (02514) 3566

equipment reviews

DOLBY A301

MANUFACTURER'S SPECIFICATION. Audio noise reduction system. **Frequency response:** Better than ± 1 dB, 20 Hz to 20 kHz (record/playback). **Total Harmonic Distortion** ($+8$ dBm): Less than 0.1% at 1 kHz; less than 0.2% from 40 Hz to 20 kHz. **Noise reduction:** 10 dB from 20 Hz to 5 kHz, rising to 15 dB at 15 kHz. **Overall noise level:** Better than 80 dB (unweighted) below $+8$ dBm. **Crosstalk:** Better than 80 dB, processor to processor, 20 Hz to 20 kHz. **Matching between units:** Better than 1 dB at any level and frequency. **Output clipping point:** better than $+18$ dBm. **Stability:** Does not require routine alignment. **Operating temperature:** Up to 45°C . **Panel meter:** NAB and DIN level setting meters for recorder gain calibration. **Price:** £560. **MANUFACTURER:** Dolby Laboratories, 346 Clapham Road, London S.W.9 (Tel. 01-720-1111).

THERE have been many previous attempts at making a compressor-expander system with the aim of reducing noise between two components, without audible change in quality from the original programme. Such a compander, as it is called, can be used to improve signal-to-noise ratio of landlines and microwave links, or of tape recording systems. Virtually all systems prior to Dolby failed in one respect or another. For instance, valve compressors tended to thump when they changed gain and any change of volume in the lower register tended to vary the hiss level at the same time.

Before discussing the subjective and objective effects of the A301, I will briefly describe it and its operation. The unit is usually supplied fitted with XLR Cannon sockets intended to bridge a 600 ohm line at its input and to supply a 600 ohm feed at its output. A floating balanced input transformer loads the input line with approximately 10 K at all audio frequencies. The instrument is set up at the factory for the peak line level used in the studio and, in my own case as an example, this is 0 dBm representing a tape playback level of 32 mM/mm. As will be seen later, it is extremely important for the gain between the Dolby system and the tape recorder to be set carefully, such that a continuous 1 kHz sinusoidal tone on the DIN or NAB meter marks corresponds to a playback level from the recorder of 32 mM/mm depending upon the type of test tape and equipment in use. After the audio test meter point, the signal is divided into four different frequency ranges: 80 Hz and below (Range 1), 80 Hz to 3 kHz (Range 2), 3 kHz upwards (Range 3), and 9 kHz upwards (Range 4). Each frequency band crosses over to the next at approximately 12 dB per octave with the exception of Range 4 which operates additionally to Range 3 above 9 kHz. The tolerances of the crossovers are very tight so that the overall frequency response is held over the audio range to within 0.5 dB. The instrument has two distinct signal paths, the first being of unity gain

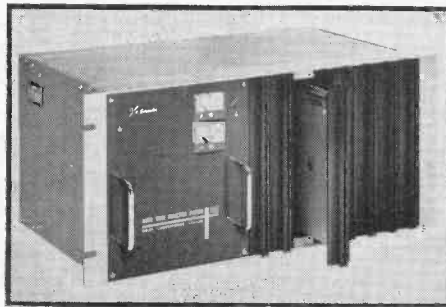

at all frequencies and the second being one of four compression or expansion paths depending on frequency. The characteristics of the second paths can be altered with presets in such a way as to set not only the point below which compression or expansion takes place, but also the maximum amount of compression and expansion. For all normal uses, the compression or expansion begins to take effect at a level corresponding to 20 dB below DIN level on the input meters, and the maximum amount of compression and expansion is 10 dB in Ranges 1, 2 and 3 and up to 15 dB in Range 4, which includes the additional effect of Range 3. I will not go into the psychology of the operation of the system since this was dealt with by Keith Wicks in the February and March issues. Suffice to say that the attack and decay time of the compansion is almost instantaneous and the operation of the Dolby is to all intents and purposes inaudible, provided that it is set up correctly.

The side chains of the different frequency ranges can all be switched simultaneously to either the record or play mode and the outputs of all the ranges are paralleled together again

to feed an output amplifier which is normally supplied to feed a 600 ohm line, floating balanced with a switchable 600 ohm termination. A further switch allows the compansion to be switched off. A complete Dolby A301 unit includes two processors which can be switched to record or playback independently, thus giving a mono tape recorder simultaneous compression on record and expansion on replay, allowing the tape to be perfectly monitored; alternatively both processors can be switched to the record or playback mode at the same time. Should both processors be switched to record, it is still of course possible to monitor the tape, but without deprocessing the sound is very topky and rather odd, as will be realised. The individual sections of the Dolby can be pulled out easily for service and alignment, for which purpose an alignment extender is available as an extra. This makes it possible to check alignment at any time whilst under test conditions without returning an A301 to the factory. There are eight pull-out sections on the rack-mountable front panel. Four for each processor, one amplifier module, one filter module and two compressors. Various test points are provided for setting up and experimental purposes. By earthing any of these, the appropriate expansion or compression circuit in a particular frequency band on either or both channels can be disconnected, making the channel gain linear in that frequency band. This is extremely useful (as will be seen later) in using the Dolby for unconventional purposes. The front also contains two meters for setting up and an indicator lamp to show the unit is on. The two inputs and two outputs are on the back with all the switching. The unit consumes 18 W and becomes only slightly warmer than the surrounding temperature. The complete unit weighs 13 kg and measures 225 x 483 x 270 mm. No ventilation is necessary, allowing several Dolbys to be rack mounted, virtually from floor to ceiling, if required. Many British studios employing multitrack equipment use Dolbys on every track so that a 16-track recorder, for instance, would require eight Dolbys capable of being independently switched from recording to playback modes. The Dolby can also be modified to work off 24 V batteries for mobile operations, although it is believed that nobody has yet done this.

In designing the equipment, Ray Dolby realised that to begin with any compander system, no matter how good, would have a strong bias against it from engineers, many of whom have tried and rejected other companders in the past. One well known company, I understand, spent tens of thousands of pounds in developing and making a system which was

(continued overleaf)

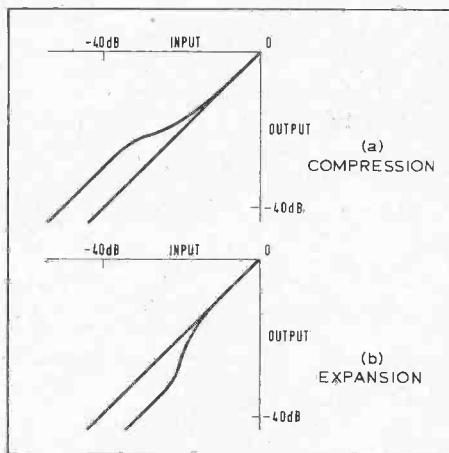

Your Local Dealer

LONDON AREA

HAVEN
196-198 SOUTH EALING RD.
HI-FI LONDON W.5
Tel. 01-560 0194

Laskys
Stockists for all the leading makes of Tape Equipment
207 EDGWARE ROAD, W.2. Tel. 01-723 3271
33 TOTTENHAM CT. RD, WIP 9RB
109 FLEET STREET, E.C.4 Tel. 01-636 2605
152/3 FLEET STREET, E.C.4 Tel. 01-353 5812
HIGH FIDELITY AUDIO CENTRES
42-45 TOTTENHAM CT. RD, WIP 9RD Tel. 01-353 2833
118 EDGWARE ROAD, W.2. Tel. 01-580 2573
MAIL ORDERS AND CORRESPONDENCE TO: Tel. 01-723 9789
3-15 CAVELL ST., LONDON, E.1 2BN
Tel. 01-790 4821

TAPE RECORDER HI-FI CENTRE (SHEEN) LTD
SPECIALISTS IN TAPE RECORDERS, ACCESSORIES, HI-FI EQUIPMENT
YOUR CENTRE FOR FRIENDLY HELP, SALES AND SERVICE
3 & 4 STATION PARADE, Open until 8 p.m. on Fridays
SHEEN LANE, SHEEN, PROSPECT 0985
LONDON, S.W.14 Opposite Mortlake Station, S.R.

CHESHIRE
Charlesworths
HI-FI & CINE CENTRES
112 FOREGATE STREET, CHESTER. Tel. 25075
and 28 HIGHTOWN, CREWE. Tel. 3327
For all leading makes of Audio and Photographic equipment
•Spacious demonstration studio •Easy Parking
•Half Day Wednesday

VIDEO AND HI-FI STUDIO

Hire or Buy	Listen to the Best
★ Cameras	★ Bryan
★ Monitors	★ Truvox
★ Video Tape Recorders	★ Leak
★ Ampex	★ Goodmans
★ Ikegami	★ Goldring
★ G.E.C.	★ Thorens
★ Loewe Opta	★ Eagle
FULL SERVICE OFFERED	ETC.

Holiday Bros. (A.V.) Ltd. 61b Shaw Heath Stockport

THE HI-FI CENTRE
Main B & O, Sony, Tandberg Specialists
Also: Ferrograph, Akai, Arena, Dynatron, Radford, Quad, National, Wharfedale, Rotel, Armstrong, Rogers, Dual, Trio, Bryan, Normandie, Eddystone, Goodmans, Grundig, Revox, Telefunken, Nikko, etc.
● Expert Staff Advice Service, Part Exchange, After Sales Service
● Home Dems., Comparator Dems., Private Car Park
● All Goods Post Free
GREEN LANE, WILMSLOW, CHES. SK9 1LR
For personal attention ring Mr. Bird, Wilmslow 22112 or 24766, or write for free folder. Closed Wed. 1 p.m.

DOLBY A301 REVIEW CONTINUED

rejected after a while due to engineers' complaints of its action being audible. It is hardly surprising therefore that Ray Dolby designed the equipment in such a way that the first engineers who used it were virtually unable to fault it, and its reputation spread.

Before actually reviewing the operating capabilities of the Dolby, I will quote two examples in the specification which will show its amazingly high standard. Recording engineers normally record with a frequency response tolerance theoretically of ± 2 dB from below 40 Hz to above 15 kHz; in practice this figure is usually tighter. Without the Dolby, the best professional tape recorders available have an overall signal-to-noise ratio of perhaps 65 dB per 3 mm track with respect to maximum recording levels often as high as 64 mM/mm. With the Dolby this figure expands to an attainable 77 dB and yet the basic noise of the Dolby in the playback position on my own instrument is 88 dB below the output level that would be given from playback of a 32 mM/mm recorded tone at 1 kHz; the input of course being loaded with a 600 ohm resistor in place of the tape recorder. Great lengths have been taken to smooth the DC power supply to a ripple level of less than 35 μ V. Even with the internal hiss expanded upwards in the recording position, the noise level on the loaded output terminals is approximately 80 dB down from the reference level quoted previously. The unit can be used with balanced or unbalanced inputs or outputs. The usual care should be taken with earth loops although I have not had any trouble in this respect.

Subjective Tests

I subjected the Dolby to almost every kind of treatment imaginable, both in different types of input programme material, tones and combinations of tones, and the instrument always worked well up to specification. I have not been able to detect any difference between a Dolbied and an un-Dolbied tape in terms of frequency response and transient response. Checks have been carried out with one section in the *send* mode with the other in the *receive* mode, comparing the direct signal with one sent through both sections. Subjectively I found that, using a Revox 77 at 9.5 cm/s on ordinary LP tape with the recorder carefully aligned for a frequency response ± 1.5 dB from 30 Hz to 15 kHz, results with the Dolby are very similar to those obtained with a high quality tape on a professional recorder at 38 cm/s *without*. This may be unbelievable to many readers, but instruments supported by many good pairs of ears can hardly lie. A series of tests was carried out using a professional tape recorder with and without the Dolby and the results are quite astonishing. On the recorder used, most of the noise recorded on the tape with the input level set to zero was 50 Hz and 100 Hz hum induced from the capstan and spool motors, a slight ripple in the recorder amplifier power supply, and tape hiss at the highest frequencies in the audio spectrum. The noise levels at different speeds with and without the Dolby under various conditions are quoted in the accompanying table. It should be remembered that the 9.5 cm/s speed replay characteristic has a bass roll-off of 3 180 μ S giving a reduced hum

pick-up figure, as well as an extreme top steep roll off above 15 kHz, and these two factors should be taken into consideration when noting the surprisingly good signal-to-noise ratio at the slow speed. Since it is also necessary to reduce the peak recording levels at these speeds to obtain recordings of similar peak distortion levels, we must observe the final column giving the calculated signal-to-noise ratios using the Dolby at different speeds, bearing in mind the lower recording levels recommended for the lower speeds. It is quite usual, when not using a Dolby, to record at peak levels corresponding to a tape playback distortion at middle frequencies of 3% third harmonic in order to achieve as good a signal-to-noise ratio as possible while at the same time not going too far into distortion. Thus with EMI 815 tape, for instance, an overall figure of 65 dB signal-to-noise ratio can just about be achieved running the tape at 38 cm/s to a distortion level of 3%. Using the Dolby system, the equivalent s/n ratio would then be approximately 77 dB. This is far more than is ever necessary in recording and therefore most engineers prefer to peak, when using the Dolby, at a lower level of perhaps a 1% distortion level which corresponds to between 32 mM/mm and 3 dB above this, depending upon the tape used. Thus a signal-to-noise ratio of at least 70 dB can be achieved together with a distortion level on middle frequencies of only 1%. The audible effect of all this is not only barely audible tape noise, even with one's ear close to the loudspeaker when replaying tapes at high volume, but of a much cleaner sound on the tape itself resulting from the lower inherent tape distortion, and also other lower distortions resulting from the use of the Dolby system. Should the recorder and tape generate distortion in what would be Range 3 of the Dolby system on fundamental frequencies in Range 2, then these distortion harmonics will themselves be reduced by the Dolby in the playback mode. Tape modulation noise is also greatly reduced, almost to inaudibility. The output on the DIN=0 dBm model was found to square off at +17 dBm, a far more than adequate overload level which I consider excellent.

The instrument which gains most from being recorded with the Dolby is the piano, and I was able to record a Steinway to confirm this point. Not only was the reproduction incredible when the tape was played back at home, but it was possible to advance my Quad preamplifier treble control to full treble without any tape hiss being noticeable. I consider, after doing all my tests, that any recording organisation not using the Dolby System is likely to be classed as behind the times. With multitrack recording, I consider its use absolutely vital to avoid the build-up of tape hiss when the outputs from different channels are subjected to equalisation and other electronic manipulation. It is remarkable to play back a multichannel recording and fade up any channel to a loud level representing the output from one or two mikes without hearing any more distortion or hiss than was present from the original mike. Some of the recent recordings of popular and big band orchestral music are quite astounding to listen to on high grade equipment.

I should here mention some words of criticism. Many users, or would be users, are

Your Local Dealer

LANCASHIRE (continued)

J. SMITH & SON

HI-FI EQUIPMENT — STEREOGRAMS
TAPE RECORDERS — 2 SHOWROOMS
B & O, Dynatron, Hacker, Quad, Leak, Radford,
Armstrong, Ferrograph, Revox, Truvox, Uher,
Decca, Garrard, Thorens, Goodmans, KEF, etc.
Comparator Demos — Closed all Tuesday
Specialists in 'SOUND' for 36 years

184 THE ROCK, BURY Tel: 1242

ST. HELENS'

Harold Stott Ltd

Audio Engineers

Stockists of all leading makes of Hi-Fi Equipment.
Appointed sole agents for: Revox, KEF, B & O, Quad,
Sanyo, Sony, Sansui, Dynatron, Hacker, Tandberg,
Armstrong, B. & W., etc., etc.

SURREY

FARNHAM

SURREY

- ★ Stockists of all good Hi-Fi apparatus.
- ★ Comparative demonstrations.
- ★ We offer a real after sales service.
- ★ Easiest of terms
- ★ No parking problems.

Lloyd & Keyworth Ltd.

THE RECORD SHOP
26-27 DOWNING STREET, FARNHAM
SURREY Telephone: Farnham 5534

SURREY AND HAMPSHIRE'S HI-FI SPECIALISTS

CROYDON'S TAPE RECORDER CENTRE

All leading makes in stock, Hi-Fi equipment, cabinets, etc. Service agents for AKAI Tape Recorders

SPALDING ELECTRICAL LTD.,
352/354 Lower Addiscombe Road,
CROYDON.

ADDISCOMBE 1231/2040

SUSSEX

A UNIQUE HI-FI SERVICE

BOWERS & WILKINS

Becket Buildings, Littlehampton Rd.
WORTHING Tel. 64141

WARWICKSHIRE

BIRMINGHAM

SOLIHULL

For the best in equipment visit

C.H. (HIGH FIDELITY) LTD

Hi-Fidelity Centre
167-169 Bromsgrove St.,
BIRMINGHAM 5
021-692 1487

12 Drury Lane,
SOLIHULL
WARWICKSHIRE
021-705 7999

Demonstrations by appointment

DOLBY A301 REVIEW CONTINUED

recording quality. At the same time I realised that some readers will not be happy unless figures are quoted, and therefore many dozens of measurements were taken. Tests were also carried out to prove objectively what the ear had heard subjectively. The frequency response was ± 0.3 dB from 20 Hz to 20 kHz with one processor on *send* and one on *receive*, measured input to output. The response held even when the processors were working hard at 40 dB below normal peak level. The distortion was measured and found to be approximately 0.14% at 30 Hz, the 1 kHz distortion at 0 dBm output was 0.02% second harmonic and 0.008% third harmonic, at 15 kHz the second harmonic distortion was 0.03% at the same output with third harmonic at 0.005%. The overall signal-to-noise ratio was 90 dB with respect to 0 dBm output, again with one processor in record feeding the second processor in replay. Probably the most difficult test I applied in the same way was square wave response and I initially chose a fundamental frequency of 250 Hz at 0 dBm output. It should be appreciated that harmonics of the square wave visible on the scope would extend well into Range 3 and even Range 4. The square wave was of course split by the record processor and then reconstituted by the replay processor and not only were the intensities of all the harmonics in the correct relationship but the phase relationship allowed the square wave to be excellently reconstituted at the output of the second processor. Very slight ringing was apparent at 30 kHz, the overshoot being approximately 4%. This was caused by a 30 kHz filter in the control circuits. The square wave test was repeated at -30 dBm, the shape of the square wave being almost perfect, this time with ringing after an overshoot of 11%. At lower frequencies the square wave improved very

considerably to virtual perfection at 40 Hz, and above 300 Hz the ringing became no worse at any audio frequency. I expected that the distortion would increase at lower levels but found the opposite to be the case, in fact at -30 dBm the 1 kHz distortion dropped to 0.01%. In an effort to try and fool the Dolby system into playing up, a tone burst generator was used to give bursts of one sine wave only at various frequencies. Only the most minute nick towards the end of the trace was noticeable, which looked like an imperfection of the cathode ray tube, although it was presumably caused again by the steep low pass filter. I would like to acknowledge with thanks the assistance of Ioan Allen and Peter Bath who brought over distortion measuring equipment and a tone burst generator since my own could not reliably read below 0.05% distortion and did not respond to harmonics above 20 kHz. It should be clear from these figures that Ray Dolby has made an astonishing piece of electronic equipment, the design and manufacture of which is up to the highest calibre. The orders of distortion in the equipment are between 10 and 100 times lower than that of a good tape recorder used with it, if the effect of the tape is included. I shall be very surprised if any listeners can honestly say that they can hear the Dolby System switched in and out provided that the tape medium is not interposed. It is almost impossible to hear any difference on the highest grade equipment when one compares direct with Dolbied tape.

Whilst finishing this review, I have just heard that later in the year a new model will be brought out which incorporates virtually all the features that I have recommended. One version of the new model should reduce the price by approximately 20%, but I understand that it will be necessary to purchase two units to do the same work as the single A301, although the combined cost will be lower.

Angus McKenzie

MILLBANK AUDIO MODULES

ALL engineers and most experimenters have at some time or another felt the need for standardised amplifier units. The sheer effort of designing and constructing even the simplest of amplifiers is out of all proportion to its value when only small quantities are required. Even on serial production, the availability of standard units from a specialised manufacturer can offer substantial savings, not only in design effort but also in production and testing. Millbank Electronics for some time have been offering a range of standardised printed circuit modules of various types. The dimensions of the modules are approximately 65 x 80 mm and fit the standard 12-contact edge connector of 4 mm spacing. Glass fibre laminate is used for the board, the printed circuit is roller tinned with close-tolerance components. Silicon transistors and integrated circuits are used in the construction. The units are designed to be fed from a 20 to 24 V rail.

A total of 20 different modules are available; these include equalised preamplifiers for magnetic and ceramic pickups and tape heads, mixers, power amplifiers of up to 2 W output, oscillators and power supplies. From this very

extensive range, four units were taken for evaluation. These are:

Type 051 Magnetic tape head equalised pre-amplifier

Type 054 30/50 ohm microphone preamplifier

Type 062 Balanced output amplifier

Type 064 General purpose power supply

The two preamplifiers are based on the familiar two-transistor circuit shown in fig. 1, from which the DC operating conditions are controlled by feedback from the emitter of the second transistor to the base of the first, and (because transistors of very high h_{fe} are used) the overall gain and frequency characteristic are determined by the AC feedback network from the collector of the output transistor to the emitter of the first transistor.

Module 051 Tapehead Preamplifier

The 051 has a nominal 3 mV sensitivity at 1 kHz and is equalised to CCIR 9.5 cm/s standards with a frequency correction of 150 μ S. The output under these conditions is 1 V, but the input could be increased to approximately 20 mV before clipping occurred. Distortion at 1 kHz and at rated output is second

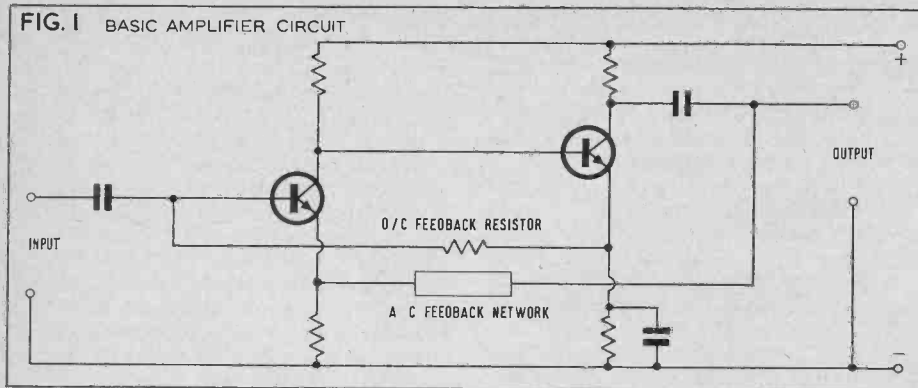

Mu-metal shield is effective and, when the 064 supply module was placed within a few centimetres of the input transformer, the induced hum was negligible. Current consumption is 2.8 mA at 24 V.

Module 062 600-ohm Balanced Output Amplifier
The specification is:

Output impedance: 600 ohm balanced. Electrostatic screen between primary and secondary.
Output level: 0 dBm for 200 mV input.
Maximum output: +15 dBm.
Distortion: better than 0.2% at 0 dBm; better than 2% at +15 dBm.
Frequency response: ± 1 dB, 40 Hz to 20 kHz.
Signal-to-noise ratio: better than 65 dB.

This module is built around the RCA 3020 integrated circuit. This IC, originally intended for military and industrial equipment, has a maximum operating frequency of 8 MHz and an overall gain of 75 dB. It has found wide acceptance as a stable, reliable unit. Maximum output power from the CA 3020 is 500 mW when fed from a 9 V 125 mA supply with

(continued overleaf)

harmonic -74 dB, third harmonic -80 dB, other harmonics negligible.

The overall frequency response is excellent and, when fed via a 150 μ S network (fig. 2), the response was within ± 1 dB from 40 Hz to 20 kHz, rising to +2 dB at 20 Hz (fig. 3). Signal-to-noise ratio is 68 dB. A level control is fitted across the output. Current at a supply of 24 V is 2.5 mA.

Module 054 30-ohm Microphone Preamplifier

The specification is: *Sensitivity:* -74 dB for 400 mV out, subject to the provisions of the instruction detail concerning termination.

Frequency response: ± 1 dB from 40 Hz to 15 kHz.

Distortion: better than 0.2% at rated input level.

Signal-to-Noise Ratio: better than 60 dB.

The basic circuit for this module is the same as the 051, with the addition of variable feedback control (varying the overall gain) and a screened and balanced matching input transformer. The maximum gain is 65 dB, and the minimum gain about 45 dB. There is a minor criticism regarding the preset gain control. This has a linear law and, because no limiting resistance is incorporated in the circuit, adjustment for low gain is critical and at minimum gain (zero feedback resistance) the circuit is unstable. The addition of a fixed resistance of a few hundred ohms and a log-law preset potentiometer would eliminate these difficulties.

The overall frequency response is shown in fig. 4, and the performance requirements of ± 1 dB from 40 Hz to 15 kHz are substantially met. The overload characteristics are the same as the 051 module, and the claimed distortion at 1 kHz of 0.2% at an input level of 200 μ V and maximum gain (worst case conditions) is met, being actually second harmonic -74 dB, third harmonic -85 dB. The overall signal-to-noise ratio was 78 dB for minimum gain and 63 dB for maximum gain.

FIG. 2 150 μ S NETWORK

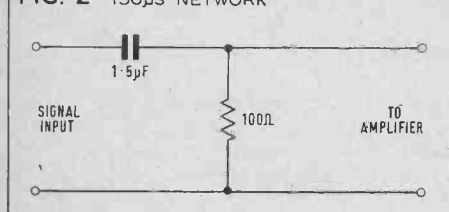

The input transformer is shielded and balanced and gives optimum matching for a 30 ohm microphone. All tests were performed using a 30 ohm balanced source. The primary is centre tapped, thus allowing either a floating, unbalanced, or balanced input circuit. The

FIG. 3 MILLBANK 051 TAPE HEAD PREAMPLIFIER, FREQUENCY RESPONSE

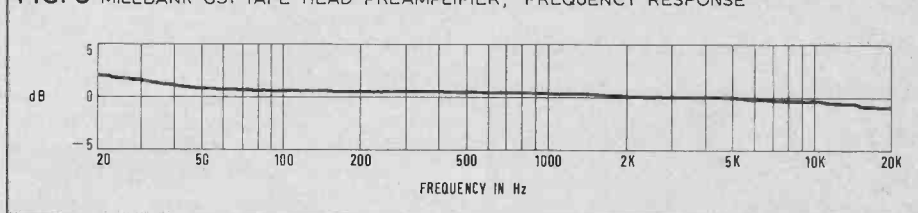

FIG. 4 MILLBANK 054 MICROPHONE PREAMPLIFIER, FREQUENCY RESPONSE

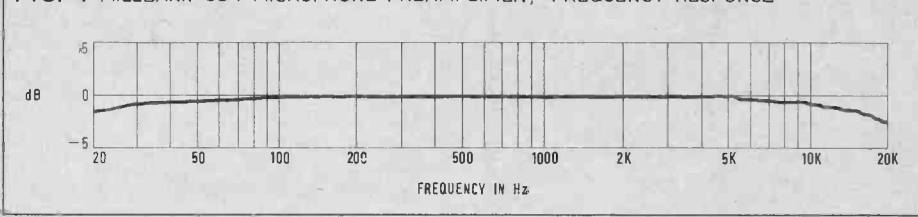
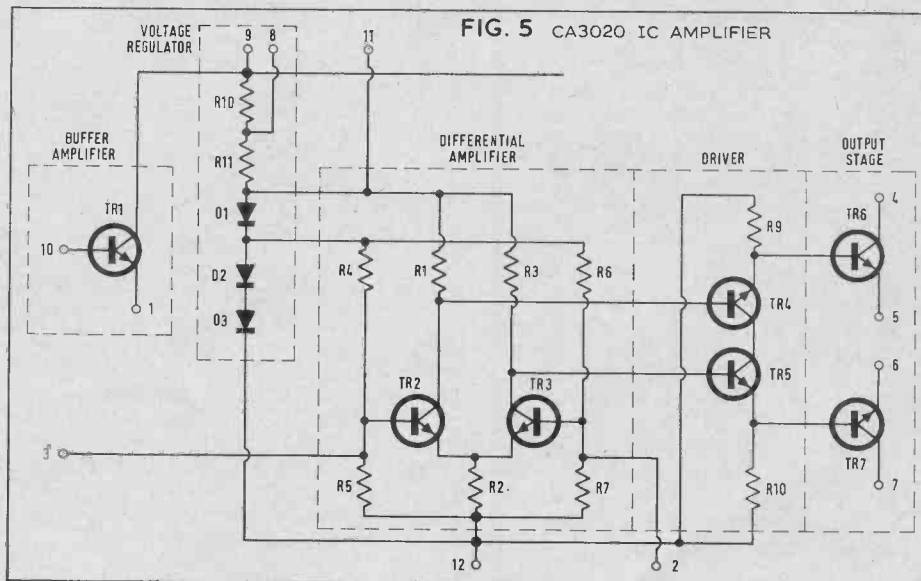

FIG. 5 CA3020 IC AMPLIFIER



Your Local Dealer

WARWICKSHIRE (continued)

GRIFFIN RADIO LTD

(the high fidelity people)

Fully comprehensive stocks and advisory service for

Monaural and Stereophonic High Fidelity, Radio, Tape and Disc Equipment

64 BRISTOL STREET

BIRMINGHAM 5 Telephone MID 1359

SCOTLAND

GLASGOW

Scotland's Leading Tape Recorder, Video and Hi-Fi Specialists

G. H. STEELE LTD.

Hear true Hi-Fi sound on our 22 speaker comparator system. 14 Hi-Fi combinations ready for demonstration.

SONY VIDEO CENTRE

Agents for: Armstrong, Leak, Fisher, Rogers, Quad, B & O, Goldring, Garrard, Thorens, Connoisseur, Goodmans, Wharfedale, Kef, Celestion, Decca, Truvox, Philips, Sony, Arena, Revox, Tandberg, Brenell, Ferrograph, Akai, Uher, Grundig.

CREDIT TERMS — PART EXCHANGES

Repairs and Servicing Tel. Douglas 7124

141 St Georges Road, Glasgow C3

A REGULAR COPY OF STUDIO SOUND COSTS FIVE MINUTES, A FOURPENNY STAMP AND A CHEQUE OR POSTAL ORDER FOR 30/- (12 MONTHS).

TO: Link House Publications Ltd., Dingwall Avenue, Croydon CR9 2TA.

Please send me a copy of each issue of STUDIO SOUND for months commencing with the issue for which I enclose remittance of £.....s.....d.

Name..... Address.....

Home 30/- (6 months 15/-). Overseas and U.S.A. \$5 (or equivalent)

MILLBANK MODULES REVIEW CONTINUED

maximum rating of 1 W dissipation, thus under the operating conditions used in the 062 module the rating is extremely conservative.

Fig. 5 shows the schematic of the integrated circuit and fig. 6 a functional block diagram of the unit. It will be seen that this integrated amplifier actually consists of five functional units; the key to the operation of the circuit is the voltage regulator consisting of the three diodes D1, D2 and D3, and the resistors R10 and R11, the circuit being arranged to provide accurately controlled voltages to the differential amplifier. The differential amplifier operates in Class A mode to supply the power gain and phase inversion required for the push-pull driver and output stages. The driver stages (transistors Tr4 and Tr5) are emitter-follower amplifiers which shift the voltage level between the collectors of the differential amplifier transistors and the base of the output transistors and provide the drive current required by the output transistors. Power transistors Tr6 and Tr7 are high-current devices capable of delivering peak currents greater than 0.25 A; inclusion of DC feedback in the various emitter circuits provide stable characteristics with varying temperatures and voltages.

In addition to the internal regulation of the IC, the 062 module uses a zener diode for stabilising the rail voltage of the CA 3020, thus rendering it insensitive to supply voltage variations, and the unit is biased for Class A operation throughout.

The output transformer secondary is centred-tapped for balanced line output, the centre tap is brought to a separate terminal allowing an independent earth to be used, and padding resistors in each line bring the amplifier output impedance to the standard value of 600 ohms. (Without these padding resistances the impedance looking in to the amplifier is only a few ohms.) The secondary is provided with an electrostatic shield ensuring symmetry of balance.

The input impedance is 10 K. Overall fre-

quency response is shown in fig. 7, and just fails to meet the claimed response of ± 1 dB from 40 Hz to 20 kHz; it is dead flat (± 0.1 dB) from 100 Hz to 20 kHz and gradually rolls off, being -1 dB at 60 Hz, -2 dB at 40 Hz, and -6 dB at 20 Hz. Because of the generous amount of feedback in this circuit, frequency response is independent of input and output loading conditions and the distortion at 1 kHz was second harmonic -50 dB, third harmonic -60 dB at 1 mW (claimed 0.2%) and second harmonic -45 dB, third harmonic -52 dB. Signal-to-noise ratio is 68 dB and input sensitivity is 0.17 V for 1 mW into 600 ohms output. Current consumption is 35 mA at 24 V.

By the time this review is in print, Messrs. Millbank inform me they hope to be in production with an improved version of this amplifier.

Power Supply Module 064

Unlike the other modules, this unit is mounted on a printed circuit approximately 55 mm square, with four fixing feet, intended to be fitted to the bottom of the main frame. The loaded output voltage can be adjusted by modifying a series resistance which is also used for smoothing. For an output of 24 V and a load current of 40 mA, the series resistance is 100 ohms and the ripple voltage is 3 mV. At 24 V and 3 mA, the resistance is 20 K and the ripple voltage is 45 μ V. Although only rated at 24 V 16 mA for an input of 250 V 50 Hz, the miniature transformer had a maximum temperature rise of less than 20°C when supplying the maximum load current of 40 mA to the 062 output module.

Comment

These modules are exceptionally well made. They substantially meet their specifications and, because of their small size, lend themselves to easy incorporation into mixers, preamplifiers, and other systems. In view of the quality of components used, the prices are quite reasonable, and I can confidently recommend them for use in both professional and amateur equipment. The 051 costs £4, the 054 £6, the 062 £8 10s, and the 064 £4 10s. Stanley Kelly

FIG. 6 BLOCK DIAGRAM OF CA3020 IC AMPLIFIER

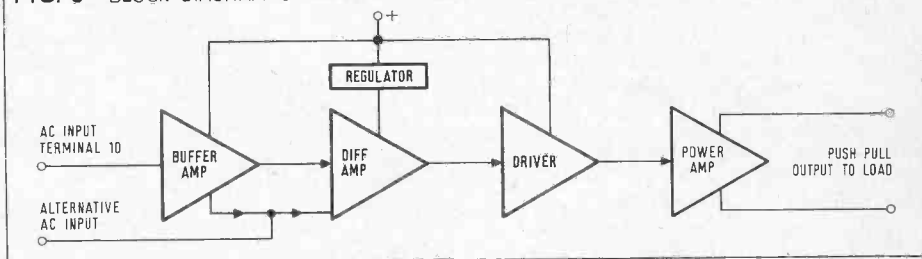
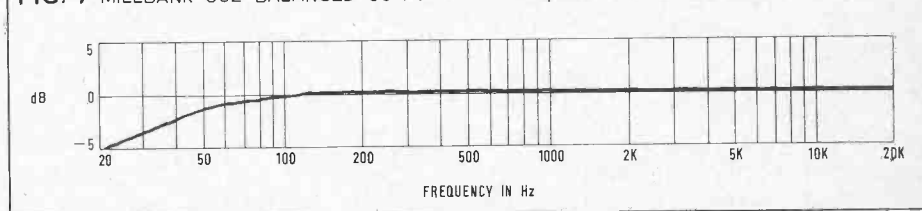

FIG. 7 MILLBANK 062 BALANCED OUTPUT AMPLIFIER, FREQUENCY RESPONSE



field trials

CHILTON 100S

A COUPLE of years ago, Tom Reps appeared at the other end of a telephone to ask what kind of tape recorder our Average Reader wanted. I passed on my conclusions: that most correspondents wished to spend up to £130, required 19 cm/s stereo units, and were not fussy about spool capacity. Some 15 telephone conversations later, Reps completed the development of a unit he thought would meet the demands of a fairly knowledgeable audio enthusiast: two PPM's, full solenoid control, AB monitoring, and a single-motor (Papst) transport. Would God forgive him for the latter? He (Reps) pointed out the disadvantages of three-motor machines: comparatively high cost, rising wow towards the end of a reel, two further sources of heat, weight and hum. He appreciated that slow rewind had been a characteristic of single-motor transports and claimed to have solved it. He also claimed one of the quietest mechanisms on the market—could I hear it from my end of the phone?

The following spring, purchase tax was added to domestic recorders. Our list of Recommended Designs shot up in price to the £180 mark and has since crept gradually towards £240. Salaries did not follow prices, however, and the old £130 ceiling for domestic equipment still applies. Reps was quite happy with the situation since it pushed his major competitors well above the price category of his machine. This was originally sold for £120 and rose, with partly absorbed tax, to around £145 (record and replay preamps only). Most people can find an extra £15 if a recommendation is strong enough. We had every reason to hope that the Reps (sorry, the *Chilton*) would be at least as good as similarly priced domestics and, with PPMs and solenoids, potentially better, so we sat back to await a test model. The first sample only came for a week (a recorder was required to show its face in a television programme and Reps was quite agreeable to the publicity). This was long enough, however, for us to feel safe about recommending it.

Now for a whole month (most Field Trials are based on some four months of use to uncover weak mechanical points) I have been left alone with the Chilton. The model submitted was $\frac{1}{2}$ -track stereo, 19, 9.5 and 4.75 cm/s, though anyone anticipating live recording can obtain a 38 cm/s $\frac{1}{2}$ -track stereo version for an extra £25. The higher speed comes from a faster (two-speed, giving four speeds overall) capstan motor, not from an enlarged capstan diameter. Consequently the wow and flutter performance should be better than the standard model. All $\frac{1}{2}$ -track Chiltons have additional Mu-metal head screening.

Controls and Facilities

All controls, with the solitary exception of the four-digit take-up spool rotation counter (clocking nine for every ten turns) are situated

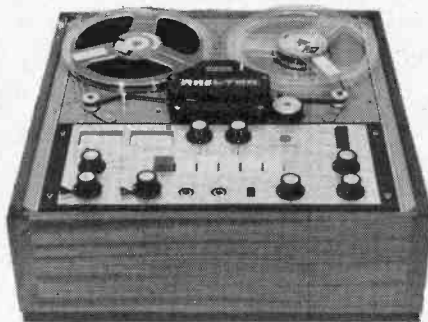

MANUFACTURER'S SPECIFICATION. Scotch Dynarange 203 at 19 cm/s. Three-speed $\frac{1}{2}$ -track stereo tape unit, optional power amplifiers and loudspeakers. **Wow and flutter:** 0.1% RMS maximum. **Frequency response:** 30 Hz to 18 kHz ± 2 dB. **Signal-to-noise ratio:** 50 dB. **Distortion:** 2% at 0 dB (1 kHz). **Equalisation:** IEC (NAB to order). **Replay tone controls:** ± 10 dB at 50 Hz and 10 kHz, Baxandall. **Crosstalk:** 55 dB (mono), 45 dB (stereo). **Oscillator:** 100 kHz push-pull. **Wind time:** 150 seconds for 18 cm LP reel. **Microphone input:** 800 μ V at 600 ohms to 50 K. **Radio input:** 80 mV at 100 K. **Gram input:** 2 mV at 47 K, RIAA. **Line output:** 500 mV at 2 K. **Radio output:** 250 mV at 10 K. **Loudspeaker output:** 10 W at 8 ohms. **Price:** £145 11s. **MANUFACTURER:** Magnetic Tapes Ltd., Chilton Works, Garden Road, Richmond, Surrey.

on an anodised aluminium front panel. Viewing this panel vertically, a three-position switch beneath the left PPM selects Channel 1, Channel 2 or Stereo operation, both record and replay, and illuminates the relevant meters. This knob must obviously be turned before the record pushbutton is pressed or the record head may be magnetised by the sudden cessation of bias. Two record potentiometers are located beneath the track selector, each with a four-position skirt switch selecting magnetic microphone, radio, gramophone pickup or opposite-track replay. Moving right, we find two unbalanced jack microphone sockets, amp/tape monitor switch, replay monitor level potentiometers and a tip/ring/sleeve headphone output jack socket. The latter accepts 6.25 mm diameter jack tips which are now fitted to most stereo headphones, rather than the non-shorting (of monitor amps) GPO type.

A five-position rotary switch above the right-hand level control governs the tape speed and (between speeds) neutralises the motor/capstan idler. The Instruction Booklet advises the operator to neutralise this selector if the recorder is 'not in regular use' (whatever that might mean), 'operated as an amplifier' or 'in transit or storage'. If the Polyurethane idler is left engaged for more than a few weeks, particularly in the 19 cm/s position, a flat may be formed. This is guaranteed temporary, however, and disappears gradually when the

pressure is released, or runs out after two or three hours operation, bringing mechanical rumble and speed fluctuation back to their low inherent level. The mains on/off switch is a large rocker just above the speed selector. I suggested that the idler problem could be entirely overcome by making the neutral speed position function as an overall off. This would leave the rocker to serve as an 'amplifier only' switch. Bang & Olufsen have just such an arrangement. Reps's reply revealed a compromise I had not considered: the circuitry would be subjected to a fast off/on/off/on whenever the speed was changed from one extreme to the other. These surges could only harm the amplifiers and probably account for the monitor amplifier fuses I have blown in other recorders. So the criticism is not valid.

Other front panel controls: Baxandall bass and treble cut/lift plus a yellow mains indicator. Six pushbuttons in the centre of the panel govern (left to right) record, play, rewind, forward wind, pause and stop. The record button is red (the rest are white) and interlocks with replay.

There are two types of solenoid control, one in which all the work is done electromagnetically (typically the Philips *Pro 20* and *Revox 77*) and another where half the work is manual—Ferrograph and Philips *Pro 12*. The Chilton is in the former category. The locking controls lend the Chilton very well to simple time-switch operation but seemed unnecessarily stiff to operate. I understand that they will now incorporate lighter springing.

The usual multitransfer facilities are provided, allowing a series of mono recordings to be superimposed by dubbing between the two tracks while adding a further signal. Variable input and off-tape gain controls come into circuit, making balancing a simple task. Both headphone channels are switched to monitor the on-going signals. These points may seem obvious but several designs boasting similar facilities are in practice almost useless for the purpose. I once considered the whole business rather a gimmick but the musicians among us evidently appreciate the facility. Further features are single-channel echo and, on the $\frac{1}{2}$ -track model, pre-echo.

Head Access

Removing the front plastic cover plate (two Posidrive screws) provides easy access to the three heads for cleaning and degaussing. A replay head shield retracts to a maximum 9 mm and may be turned out of the way for the Chinagraph brigade by slackening a 6BA screw. Tape rocking facilities are provided. Cueing during fast wind simply involves pushing the pinch wheel slightly forward—always an expensive practice with non-ferrites though. Under normal winding conditions, the tape is

(continued on page 319)

F CAVE

TOP DISCOUNTS

5 BRIDGE STREET
RICHMOND
SURREY.

Tel. 01-948 1441 up to 8pm

RECORD DEPARTMENT
CREDIT TERMS
DEMONSTRATIONS
REPAIR FACILITIES

TAPE RECORDERS



GRUNDIG
TK149
£46 19 0

	Suggested Retail Price	Cash Price
AKAI X1800SD...	£199 18 4	£175 10 0
AKAI 4000D ...	£89 19 1	£71 19 0
AKAI I710L ...	£109 0 0	£95 18 0
AKAI 4000 ...	£124 18 0	£110 0 0
AKAI X5000L ...	£177 19 6	£156 13 0
AKAI M-10L ...	£245 1 0	£215 13 0
GRUNDIG TK120 ...	£39 5 0	£28 18 0
GRUNDIG TK124 ...	£44 18 0	£35 7 0
GRUNDIG TK144 ...	£49 19 0	£42 5 0
GRUNDIG TK149 ...	£57 12 8	£46 19 0
MARCONIPHONE 4218 ...	£89 11 0	£80 10 0
MARCONIPHONE 4248 ...	£52 14 0	£47 7 0
PHILIPS EL3302 ...	£28 7 0	£20 19 0
PHILIPS EL3312 ...	£56 10 9	£48 13 0
PHILIPS 4302 ...	£35 17 6	£30 16 0
PHILIPS 4307 ...	£49 10 0	£42 10 0
PHILIPS 4404 ...	£83 0 0	£71 5 0
PIONEER T600 ...	£183 8 3	£161 3 0
PIONEER T500 ...	£167 11 3	£147 4 0
PIONEER C6000 ...	£325 1 2	£285 6 0
SANYO Cassette	£20 19 6
STANDARD Cassette	£15 15 0
TELETON SL40 ...	£37 10 0	£32 19 0
TELETON FXB 510D ...	£52 10 0	£46 0 0
TRUVOX R44	£45 10 0

HEADPHONES

	Suggested Retail Price	Cash Price
AKAI ASE9 ...	£6 10 0	£5 14 0
AKAI AEH10 ...	£20 0 0	£17 0 0
A.K.G. K50 ...	£9 10 0	£8 6 0
A.K.G. K60 ...	£13 10 0	£11 16 0
BEYER DT48 ...	£33 18 0	£27 19 0
BEYER DT48S ...	£33 14 0	£28 13 0
BEYER ET100 ...	£13 18 6	£11 17 0
BEYER DT109 ...	£23 18 6	£20 7 0
EAGLE SE1 ...	£4 19 9	£4 7 0
KOSS PRO 48 ...	£23 0 0	£20 0 0
KOSS ESP6 ...	£45 0 0	£37 10 0
PIONEER SE50 ...	£19 3 8	£16 6 0
PIONEER SE30 ...	£12 12 0	£10 14 0
PIONEER SE20 ...	£7 2 11	£6 2 0
PIONEER SE 2P ...	£6 15 5	£5 15 0
ROTEL RH600 ...	£5 10 0	£4 14 0
ROTEL RH711 ...	£9 0 0	£7 13 0
SANSUI S52 ...	£7 14 6	£6 12 0
SANSUI SS20 ...	£16 10 0	£14 0 0
SECOM 650	£3 12 0
TELETON SH31 3P ...	£3 10 0	£3 1 0
TELETON SH301P ...	£4 0 0	£3 10 0

MICROPHONES

	Suggested Retail Price	Cash Price
BEYER M64 ...	£10 7 0	£8 16 0
BEYER M64 SH... ..	£14 7 0	£12 4 0
BEYER M67 ...	£29 6 0	£24 18 0
BEYER M81HL ...	£11 5 0	£9 11 0
BEYER M818HL ...	£22 18 6	£19 10 0
BEYER M55HL ...	£8 18 0	£7 11 0
EAGLE DM58HL ...	£11 0 6	£5 13 0

Our stock of new equipment is extensive and carries full manufacturer's guarantee. The above list is only representative of the equipment stocked by us. Equipment can be installed in any part of London, customers rarely being kept waiting.

YOU CAN BUY BETTER AT CAVE'S

	Suggested Retail Price	Single Tapes	3 or more Cash Price	Cash Price
BASF Magnetic Tape-Library Pack				
SP. 52 5 1/2" / 900 PB ...	£1 14 5	£1 4 9	£1 3 0	£1 3 0
SP. 52 7" / 1200 PB ...	£1 19 7	£1 8 6	£1 6 4	£1 6 4
LP. 35 5" / 900 PB ...	£1 14 3	£1 4 9	£1 2 9	£1 2 9
LP. 35 5 1/2" / 1200 PB ...	£1 19 5	£1 8 6	£1 6 2	£1 6 2
LP. 35 7" / 1800 PB ...	£2 16 7	£2 1 3	£1 17 4	£1 17 4
D.P. 26 5" / 1200 PB ...	£1 19 3	£1 8 6	£1 6 0	£1 6 0
DP. 26 5 1/2" / 1800 PB ...	£2 16 5	£2 1 3	£1 17 2	£1 17 2
DP. 26 7" / 2400 PB ...	£3 9 7	£2 11 0	£2 5 9	£2 5 9
TP. 18 5" / 1800 PB ...	£2 16 3	£2 1 3	£1 17 0	£1 17 0
TP. 18 5 1/2" / 2400 PB ...	£3 9 5	£2 11 0	£2 5 7	£2 5 7
TP. 18 7" / 3600 PB ...	£4 6 7	£3 3 9	£2 16 10	£2 16 10

	Suggested Retail Price	Single	6 or more Cash Price	Cash Price
BASF Low Noise High Output Tape-Library Pack				
LP. 35 LH 5" / 900 PB ...	£1 17 9	£1 7 5	£1 5 0	£1 5 0
LP. 35 LH 5 1/2" / 1200 PB ...	£2 3 5	£1 11 6	£1 8 9	£1 8 9
LP. 35 LH 7" / 1800 PB ...	£3 2 1	£2 5 5	£2 1 0	£2 1 0
DP. 26 LH 5" / 1200 PB ...	£2 3 1	£1 11 6	£1 8 7	£1 8 7
DP. 26 LH 5 1/2" / 1800 PB ...	£3 1 11	£2 5 5	£2 0 9	£2 0 9
DP. 26 LH 7" / 2400 PB ...	£3 16 7	£2 16 3	£2 10 4	£2 10 4
TP. 18 LH 5" / 1800 PB ...	£3 1 9	£2 5 4	£2 0 7	£2 0 7
TP. 18 LH 5 1/2" / 2400 PB ...	£3 16 5	£2 16 3	£2 10 2	£2 10 2
TP. 18 LH 7" / 3600 PB ...	£4 15 1	£3 10 1	£3 2 4	£3 2 4

	Suggested Retail Price	Single	6 or more Cash Price	Cash Price
BASF Cassettes				
C 60 Std. Cassette ...	£17 7	£11 0	£9 9	£9 9
C 90 Std. Cassette ...	£1 5 1	£16 3	£14 9	£14 9
C120 Std. Cassette ...	£1 13 7	£1 6	£19 6	£19 6

AMPEX HIGH QUALITY TAPE CASSETTES AT 15% DISCOUNT.

Hi-Fi Equipment Available: Armstrong, Dual, Nivico, Goodmans, Gramplan, Leak, Lowther, Lux, Crown, Philips, Quad, Radon, Rogers, Jordan-Watts, K.E.F., Sanyo, Teleton, Celestion, Decca, Marconiphone, Connoisseur, Goldring, Thorens, Transcriptor, Vortexion, Tannoy, Kenneth J. Elwin, Ortofon, Bowers & Wilkins, Pioneer, Hitachi, Murphy, Monark, Rotel, J. E. Sudgen, Sound City, Bluespot, Beyer, Reslo-sound, Stanton, Dassette and many others.



CALREC TRANSISTORISED CAPACITOR MICROPHONES

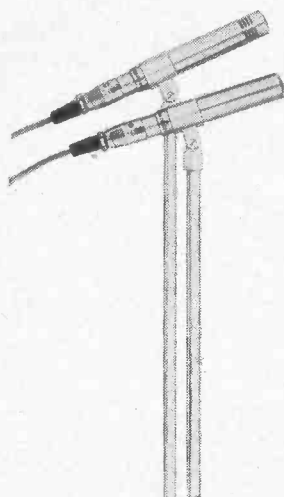

THE 1000 SERIES MICROPHONES OFFER ALL THE FACILITIES DEMANDED BY THE PROFESSIONAL USER AND, BEING OF BRITISH MANUFACTURE, CARRY NO IMPORT DUTY.

CM 1000 OMNI-DIRECTIONAL
£76 16 0 complete

CM 1050 ACCURATE CARDIOID
£81 6 0 complete

- Phantom Power—Balanced Line
- Cannon Plugs and Sockets Throughout
- Multi-Power Packs Available

The prices quoted are recommended retail and include power units, connecting leads, windshield and stand clip. Generous trade and professional discounts are available. For further details of the 1000 series, 800 series (miniature) and 600 series (unbalanced) please contact:—

CALDER RECORDINGS LIMITED
REGENT STREET, HEBDEN BRIDGE, YORKSHIRE
PHONE 2159

RAPID RECORDING SERVICE

L.P.'s from your own tapes. Master discs and pressings. Recording Studio. Multi-channel facilities for transfer to 8 or 16 mm film tracks. Sound effects library on discs.

Associated Company

EDUCATIONAL RECORDINGS LTD.

Have you a Positive or Negative Personality?
Are you at ease in company?
Can you take command in a difficult situation?
Your future will be what you make it—make it what you want it to be.
Send for particulars of this and 20 other tapes on self-improvement.
Distributors of the Cassette battery mains Sleep-o-matic Unit. Pillow speakers.
Time clocks.
Publications: "Sleep-learning, Its Theory, Application and Technique."
"Mental Power through Sleep-suggestion."

Brochures from:—

RAPID RECORDING SERVICE
21 Bishops Close, London, E.17

MORE QUALITY BARGAINS IN

EXCHANGE & MART

EVERY THURSDAY

if you are a RADIO, TV
or TAPE enthusiast

held off the capstan and all three heads. A switch mutes the replay hum occurring when the head shield is retracted; it is coupled to the shield itself.

Not the easiest machine in the world to thread, during the first few weeks, but one grows accustomed to its behaviour. Always press the stop button before rethreading after fast wind, for example, or the tape will hurtle away when the sprung left-hand autostop arm is pulled forward. The right-hand arm serves to protect the capstan during fast wind and also to reduce vertical tape movement during takeup. None of my plastic spools screamed against the tape, so I tried a thin metal one . . . !

Mechanical Design

Apart from the head covers, control knobs and (Polyurethane) pinch wheel, the entire deck surface is metal. The deck plate proper is 4 mm thick. A thinner metal panel around the spool turntables unscrews (two more Posidrive) to reveal three solenoids, a three-step (finely knurled brass) motor spindle, capstan and forward wind idlers (identical Polyurethane on metal, 60 mm approximate diameter), and a fast rewind pulley—a 5 mm diameter black rubber belt running round a pulley mounted on the rewind solenoid arm. This arm pushes the belt surface against a clutched wheel beneath the capstan step on the motor spindle and also releases the cork-lined steel brakebands. The forward-wind solenoid pulls its idler between the clutched wheel and takeup turntable, again releasing the brakes.

During record or playback, the takeup spool is driven through a clutch inside the turntable cup. Takeup drive comes from another 5 mm belt running round a small pulley beneath the capstan flywheel. Reverse tension is supplied by the simple and outstandingly effective method of relying on a pressure pad against the Ferrite erase head. The supply turntable runs free, though its slackness is inhibited slightly by the rewind belt and pulley. Tandberg have employed a similar arrangement successfully for years.

The capstan spindle is 6 mm diameter

high chrome steel, ground between centres. The pinch wheel is off-set slightly to the right of the capstan in what I understand to be the approved manner (more on this in later articles, if we can persuade Terry Long to write them). Rubber knuckles prevent the sprung rollers from clattering back against the metal control panel, there are no pressure pads beyond the tensioning pad, and the mechanism, for all its clutches, is very quiet-running. The noisiest deck component in the recorder I tested was the capstan idler, a slight rumble resulting probably from my repeatedly forgetting to neutralise the speed selector. The take-up clutch hiss was barely audible.

Wow at 19 cm/s, listening to the replay of a 1 kHz tone at various points along a reel, was practically inaudible. This either means the 100S transport is quite exceptional for its price or simply that I am deaf. I should therefore qualify the comment that three very much dearer recorders currently in my possession can all be heard wowing at 38 cm/s. Slight idler-frequency wow was audible at the two lower speeds.

Electronic Design

The medium-impedance unbalanced magnetic microphone inputs provided are common to all non-professional recorders. The cheaper capacitors and low-impedance magnetics can be matched externally so there is no longer any point in a manufacturer fitting internal input transformers. A stereo mixer to suit the Chilton is available to owners of the recorder at £45 and accommodates six balanced low-impedance microphones.

It would seem that the standard Chilton is supplied with DIN sockets since the model supplied had four 5-pin and two 3-contact loudspeaker connectors. If so, this seems inappropriate at a time when Revox, B & O, Tandberg, Akai, Sony and Ampex (believe it or not, on their domestics) have adopted Phono sockets as a less evil alternative to the jacks everyone used to be happy with. None of the four DINs on the Chilton would feed or accept stereo through any of the eight DINs at the back of a Philips *Pro 12*. Instruction Booklet investigation revealed that the Auxiliary socket

is a dummy, intended for individual wiring as a 36 V source, remote control connection or erase link. The 'Line' socket supplies 500 mV at 2 K from pins 3 and 5.

The Radio socket carries inputs and outputs at the low levels and high impedance specified for the DIN domestic standard.

Tape Recorder Maintenance Ltd produce a 5-pin to 5-pin coupling lead to connect this type of socket with an external amplifier, reference 216, price 16s. If one connects two recorders through such a lead, of course, inputs see inputs and outputs see outputs. A 517 lead with crossed-over wiring in one plug, again 16s, permits this kind of connection. TRM also produce a 5-pin DIN to four Phono plugs lead which costs 18s 6d.

Line-up presets comprise two output level controls (one per channel), two meter gains and two bias levels. The Chilton is supplied equalised (IEC or NAB to order) for Dynarange 203 (LP). Other tapes can be accommodated by adjusting trimmers in the record and replay preamp boards.

Signal-to-noise ratio and frequency response were found to be within specification on Dynarange 203 with the heads clean.

Finish

The Chilton supplied was a portable model with side-facing internal loudspeakers in a blue Rexine covered wooden cabinet. Acoustic qualities were good by internal speaker standards, being free of the usual rattles. Two key-locks are fitted to the lid.

Applications

If I were asked to recommend a recorder under £160 for home sound reproduction, it would be this one. The ergonomics are excellent, the heads are Bogens, the mechanism is proving to be reliable with none of the belt scrape-off seen on lesser designs. The 100S is ideally suited to small-scale copying installations. Studios looking for a good portable recorder for location work might consider the 38 cm/s ½-track Chilton before looking elsewhere, if they can work within 18 cm reels. Tax exemption is available to industrial and professional concerns.

David Kirk

A HIGH QUALITY MIXER CONTINUED

any of the leads is required; this is another benefit of low impedance transistor circuitry which certainly makes construction much simpler. The earthy ends of the controls are looped together and taken to a single pin on the plug. The metal frame of the rack is earthed to the main metalwork of the mixer via another pin.

It is possible to power the mixer from batteries, when the indicator lamps should be disconnected (the three lamps draw some 150 mA). While this is not high, it would soon drain flashlight batteries. Most recordings take place with a mains supply nearby, so a power supply was designed to provide a fully stabilised 24 V output from the mains. This unit is built in a separate box so that there is no possibility of any hum pick-up. It can also be used as a separate bench supply for testing the amplifiers as they are built. It is especially useful for this since it incorporates a short-circuit protection device.

Fig. 17 shows the circuit diagram. 28 V AC from the transformer is rectified by the diode bridge D1-4, producing 38 V DC on C1, roughly smoothed. This passes to the stabiliser whose function is to hold the output voltage constant, independent of varying loads and varying mains voltages. It operates by comparing the output voltage with a fixed reference; any error is amplified and used to control the output in such a way as to correct the error. The detailed operation is as follows:

Tr2 and 3 function as a differential amplifier; the signal on Tr2 base is an 18 V reference produced by the zener diodes, which are driven from the output voltage (since this is itself stable) through R4. Two zener diodes are used to give better temperature compensation. If the absolute value of 24 V at all temperatures is not required (as in the mixer application), then a single 18 V zener can be used. A known fraction of the output voltage is applied to Tr 3 base by the potential divider R6, VR1, and R1, which is adjusted to be 18 V as well. If the output voltage increases for any reason,

the base voltage tries to rise. This reduces the current flowing in Tr2 and hence in Tr4 base. This in turn reduces the current in Tr4 and so in the output, which reduces the output voltage to counteract the postulated increase.

There are some further points to note in addition to the basic circuit outlined above. The loop gain is increased by coupling the output direct to Tr3 base for AC signals (such as 100 Hz ripple) by C3. C4 and C5 provide low output impedance at very high frequencies, C5 taking over from C4 at extreme frequencies. Resistor R1 is necessary to ensure that the circuit starts properly on switch-on; initially the output voltage is at zero, and hence the zeners are non-conducting, and the bases of both Tr2 and Tr3 and at zero. Balance is thus achieved in the differential amplifier, and if nothing occurs to disturb this balance, the circuit will produce only zero volts. Even though this only occurs if the rest of the circuit is itself balanced (a most unlikely event) this condition is theoretically possible, and

(continued overleaf)

R1 is added to bleed a little current from the unregulated supply to turn on the zeners initially.

Finally there is the current limit circuit. A silicon transistor does not conduct until the voltage between base and emitter exceeds approximately 700 mV and this forms the basis of the protection circuit. The load current flows in R2 back to the rectifiers, and thus develops a voltage between base and emitter of Tr1. At low currents, this is less than 700 mV, so Tr1 is non-conducting. As the load current increases, it starts drawing current from the zener. At a given current Tr1 steals so much current from the zeners that they stop conducting, and the voltage on Tr2 base drops; the output voltage drops in sympathy as described above. The output voltage thus adjusts itself to keep the load current constant at this value; if even more current is demanded, eventually Tr3 base and hence the output are at zero. Current flowing is then less than 100 mA, even with a short circuit so the supply is totally protected.

Construction is not difficult, and can follow any desired form. There are no critical components except that Tr5 must be mounted on 50 x 62 mm aluminium plate. As with most of the circuits to be published, a printed circuit has been prepared and can be obtained from

the author (c/o *Studio Sound*) at 9s each (Board number 135).

If point to point wiring is adopted, it is important to follow the layout of the circuit diagram earth wire since, if another layout is used, it is possible to introduce hum generated by the large current pulses which flow in C1. For those who wish to use this unit as a variable supply, the performance is as follows: The noise on the output is 100 μ V RMS (typically) for all currents up to 150 mA, when the ripple component increases above the noise. At 500 mA, this is 400 μ V; at 1 A 1.1 mV. The output voltage changes by 200 mV over this range of currents. The output voltage can be adjusted from 23 to 28 V, by RV1, though a wider range can be easily achieved by altering the zener voltage to a lower value and making RV1 cover a wider fraction of the output voltage. Typical values of current trip resistor are 1 ohm for 610 mA, 2 ohms for 305 mA, etc. For the mixer, three 2.7 ohm resistors wired in parallel give about 700 mA for the trip current.

The final item in the power supply is a 24 V relay with a set of 500 mA mains-make contacts, which is operated by a key on the front panel of the mixer and feeds two utility sockets on the case of the power supply. Usually these are connected to green lights in the studio or recording room to cue the action to be recorded. Across the contacts is connected C6 and R4 to suppress any mains clicks (caused by the operation of the relay) which may pass to any other

equipment being used. The diode D6 across the relay coil damps the inductive voltage produced as the relay is de-energised.

Next month the plug-in input amplifiers will be described. These will suit magnetic and capacitor microphones, gramophone pickups, tape heads and high level signals.

COMPONENT SUPPLIERS

Faders

G.E. Electronics (London) Ltd., Eardley House, 182 Campden Hill Road, London W.8
Argo Engineering, 54 Lemonfield Drive, Garston, Watford, Herts.
Penny & Giles Ltd., Mudeford, Christchurch, Hants.

Power Supply

Printed circuit card from the author c/o *Studio Sound*, price 9s.
All transistors, diodes, transformers, etc., from Henrys Radio Limited, 303 Edgware Road, London W.2

Rack

Gears: S, H. Muffet Ltd., Mount Ephraim Works, Tunbridge Wells, Kent
120 teeth brass 12s 6d, delrin 14s 6d.
32 teeth brass 5s 6d; delrin 7s.
collars, $\frac{1}{8}$ x $\frac{1}{4}$ inch, brass 2s each.
shaft $\frac{1}{8}$ inch 4s for 12 inch length.
Edge connector for modules from Radiospares (from local shops) General Purpose 8-way 7s 2d, or Professional grade 8-way 8s 6d.
Alternatively type *KBS18/S103101* 6s from Intel Connectors, Vereker House, 1-6 Gresse Street, London W.1

TAPE RECORDER SERVICE CONTINUED

A better method is to read off the 15 mV or so which should be available at the Monitor socket, using a good millivoltmeter.

In all forms of amplifier testing, especially those where output will vary widely with frequency, great care must be taken to apply no more test signal than is necessary. For testing the 632/4 series, Ferrograph have suggested a 1000:1 attenuator (1 M and 1 K) at 40 Hz applied to the preamp grid to obtain a constant output (1 V is available), with a 100:1 attenuator at 1 kHz and at 15 kHz, rather than a constant input and a widely varying output. The specification figures can be used for testing but, as an example, I quote the 'kicking-off' reading for checking the 633: input to microphone socket, switch to source, 1 kHz fed in at 500 μ V, record Level Meter reads 4, meter at Output Two reads 130 mV, at monitor socket reads 4 V. Readings over the whole frequency range from 20 Hz to 20 kHz should be within ± 1.5 dB of that. But please note that for the frequency check it is wise to go all the way from microphone input to monitor output and to disconnect the loudspeaker in doing so. Using the Input Two position may be misleading because of velocity characteristic compensation that is provided.

Bestway to check the remaining section of, the playback chain is to inject at pin 7 of V2b the first grid, and read off at Output Two. This allows one to make a direct 'gain' computation, and Ferrograph kindly provide specimen figures for this gain. AB switch, in this case, will be to tape, because V4a is used for both tests. Gain, at 40 Hz, 550; 400 Hz, 90; 4 kHz, 17; and 14 kHz, 25.

Once or twice in previous talks I have disparaged the use of the recording level meter of the tape recorder as a means of setting it up, especially for accurate recording level over a wide dynamic range (i.e., where the lower inputs are dangerously near the noise level). To get an accurate picture of the response, we need to record at (as Ferrograph recommend, in this case) some 18 dB beneath peak recording level. For the recording channel tests, we need to feed in a signal that indicates between 0 and 1 on the meter. Reading the replayed output of this recording is much too chancy a business and we thus need a reliable external meter. If you are in any sort of semi-professional capacity, this is no problem, for a millivoltmeter is as indispensable a part of your rig as your wife/dog/pipe—delete as appropriate. Even an Avo 8 across the output section is better than a reliance on the inbuilt meter. The biggest and most common mistake is to advance the input until the reading, nearer mid-scale, is more readily correlated. That way lie the rocks of distortion.

Recording channel

After which homily, let's get on with setting up the recording channel. Details will be for the 633, to correspond with last month's circuit, but can be related to the similar amplifier circuit of the other models. The machine is set up for recording and the AB switch put to tape, with only sufficient input to move the meter between zero and the first mark. Use a frequency of 1 kHz, note the output reading, start at the high speed and record. The replay reading on the monitor meter should be kept within ± 3 dB at the two highest speeds of the standard model (between

± 4 dB at 4.75 cm/s) and at all three speeds of the high speed (633H) model. Frequency range for these speeds is: at 19 cm/s, 30 Hz to 16 kHz; at 9.5 cm/s, 40 Hz to 11 kHz; at 4.75 cm/s, 40 Hz to 6 kHz.

Adjustments for mid-range and extreme upper range are provided, the first in each case being a capacitor and the second a resistor, as follows: Standard model—19 cm/s, C26, R38; 9.5 cm/s, C25, R37; 4.75 cm/s, R36 only. H model: 38 cm/s, C26, R38; 19 cm/s, C25, R37; 9.5 cm/s, C53, R36.

Bias and erase: the oscillator of a Ferrograph is normally adjusted to suit the tape on which that particular range of machines has been tested, and will always be set for maximum output at 1 kHz. The actual value can be read across C5, which is beneath the recording head, using a valve voltmeter. This should correspond to the value marked on a label pasted to the underside of the deckplate. But it is as well to remember that this was for standard tapes and if current low-noise tapes are to be used to advantage a higher value of bias will be required. Indeed, the 633 has a 'High' and 'Low' bias switch, which is the next best thing to the present method of user control. Best noise conditions will be obtained by a judicious setting of R77 for optimum bias conditions and L4 for maximum bias trapping. This is so easily done on three-head machines that there is really no need to waste further space describing it. But if trouble crops up, do not forget the device employed by Ferrograph to maintain the correct bias at all speeds—a small point of perfection that is too often ignored. They switch extra resistors in at lower speeds by SW9, and you can get a higher noise level and increased distortion if this switch or the resistors become faulty.

CLASSIFIED ADVERTISEMENTS

Advertisements for this section must be pre-paid. The rate is 6d. per word (private), minimum 7s. 6d. Box Nos. 1s. 6d. extra. Trade rates 9d. per word; minimum 12s., Box Nos. 2s. extra. Copy and remittance for advertisements in **AUGUST 1970** issue must reach these offices by **19th JUNE 1970** addressed to: The Advertisement Manager, **Studio Sound**, Link House, Dingwall Avenue, Croydon CR9 2TA.

NOTE: Advertisement copy must be clearly printed in block capitals or typewritten.

Replies to Box Nos. should be addressed to the Advertisement Manager, Studio Sound, Link House, Dingwall Avenue, Croydon CR9 2TA, and the Box No. quoted on the outside of the envelope. The district after Box No. indicates its locality.

SITUATIONS VACANT

CANADA

GENEROUS
REMUNERATION

for
**RECORDING
ENGINEER/MIXER**

for
**NEW MULTI-
TRACK STUDIO**

Opening in September
1970

Submit full résumé with references and salary required
by AIR MAIL to:



MANTA SOUND Co. Ltd.
21 DUNDAS SQUARE,
TORONTO 2, ONTARIO, CANADA

AUDIO TECHNICIAN

to be responsible to Senior Engineer for the maintenance of professional sound recording systems. Applicants should be capable of developing, wiring and maintaining a wide range of audio equipment. Minimum qualifications C. & G. Electronics Tech. or Radio and TV 1st year. Age 18-21. Commencing salary £850. North London.

Write details to: Rupert Chetwynd Recruitment Ltd., 1 Crane Court (Ref. A.T), London, E.C.4.

Tape Recorder Engineer required, experienced most makes. Telesonic, 92 Tottenham Court Road, London, W.1. 01-387-7467.

Young man interested in tape recorders wanted to assist in running hire service. Magnegraph, 1 Hanway Place, London, W.1.

Fully qualified and Trainee Maintenance Staff required for (London) W.11. Recording Studios. Phone 229 1229.

FOR SALE—PRIVATE

Stereo pair Beyer M260 200 Ω Cardioid ribbon microphones with Blumlein technique floor stand and two 75 foot EHE screened cables, £35 the set. David Turner, 57 Cornwall Gardens, London, S.W.7.

Tannoy monitor gold matched stereo pair loudspeakers in Tannoy York rectangular enclosures. £120 the pair, buyer collects. Tel. 01-857 1455 (Eltham) after 6 p.m.

Fairchild Auto-Ten noise limiter hardly used £60. Leak Varilsope Mono pre-amp £5. Sunbury-on-Thames 87108.

E.M.I. Semi-Professional Tape deck, mechanics and heads only. V.G.C. £20. Phillips, 34 Mainstone Close, Cramlington, Northumberland.

FOR SALE—TRADE

RAPID RECORDING SERVICE

LPs FROM YOUR OWN TAPES
48-HOUR SERVICE

MASTER DISCS AND PRESSINGS
RECORDING STUDIO
DEMONSTRATION DISCS

MOBILE RECORDINGS—ANY DISTANCE

Multi-channel facilities for transfer to 8 or 16mm film tracks. Sound effects library on discs.

Brochure on request from:

Rapid Recording Service

21 BISHOPS CLOSE, LONDON, E.17

Copyright Free Sound Effects Discs. 7" E.P.s and 12" L.P.s. One free 7" E.P. with your first order. Catalogue from Rapid Recording Services, 21 Bishops Close, London, E.17.

Pre-recorded American Stereo Tapes. 7½ ips. Cheap as records. Bernsteins, Mahler, Maazels, Sibelius, Karajan, Beethoven Symphonies. £15 per set of 5 tapes incl. PT and duty (any duty or purchase tax charged by the postman will be refunded—see instruction slip in tape box). £3 cheaper than records. P.O. 5/- for complete catalogue. Postereo Tapes, 9 Darley Street, Harold's Cross, Dublin 6, Eire.

Lancashire. Tandberg, Ferrograph Tape Recorders, etc. Plus over 10,000 high fidelity systems. After-sales service. Holdings Photo-Audio Centre, 39-41 Mincing Lane, Blackburn BBA 2AF. Tel. 59595/6.

Get the most out of your tape machine with Peak Programme Meters by fully modulating your tape. Mono/Stereo versions available from Paul Eastman Electronics. Box No. 576 (London).

Mixer Modules. Building your own mixer, use our plug in modules. Microphone/line amplifier 45s., tone control unit 45s., p. & p. 2s. 6d. Other components supplied or we can build a mixer for you. Send order or write for details including typical arrangements for mono and stereo mixers to: R.A.C. (Dept T), 220 Alwyn Road, Rugby.

Pye Mark IV Television Camera Chain. Camera, Control Unit, Monitor Unit, Tripod. Purchaser collects. Best offer over £100. Hawley Studios, Nr. Liss, Hants. Telephone Blackmoor 351.

Shure, Goldring cartridges post free, G800 £7.17.6, M3D £5.5.0, M44/5/7, £7.17.6, M44E £8.19.6, M55E £9.19.6, M75E/2 £16.10.0, Garrard SP25 MkII £10.17.6, AP75 £16.17.6, P & P 7/6. Ultimate Electronics, 38 Achilles Road, London N.W.6. Mail order only.

E.M.I. TR.52 new professional stereo Tape Recorder. Choice of two machines 15 and 7½, and 7½ and 3½. Price £165—list price £250. Hawley Studios, Nr. Liss, Hants. Telephone Blackmoor 351.

UNIMIXER 4S

Stereo/mono mixing unit for battery or mains use. 1 stereo pair 2 pan mics. for stereo use or for mono channels. Meets professional requirements for frequency response (20-20,000 Hz +3 dB), noise (55 dB s/n with 180 uv at 200 ohms) distortion (0.05% at rated input) and overload performance (50 dB above rated input). Two outputs on each channel will feed any tape recorder or amplifier. Individual test certificate. Price £45 excl. freight. Further details from:

SOUNDEX LTD.

18 Blenheim Road, London, W.4. Tel. 01-995 1661

MISCELLANEOUS

Repairs. Our modern service department, equipped with the latest test equipment including a wow and flutter meter and multiplex stereo signal generator, is able to repair Hi-Fi and Tape Recording equipment to manufacturers' standards. Telesonic Ltd., 92 Tottenham Court Road, London W.1. Tel. 01-387-7467.

Dictating and Audio Service Ltd., 5 Coptic Street, London, W.C.1 (near the British Museum). Telephone 636-6314/5. Authorised Service Agents. Grundig, Philips and other leading makes of Tape Recording equipment repaired to Manufacturers' Standards by skilled staff using modern test equipment—audio generators, oscilloscopes, audio volt-meters, etc.

Studio Electronics (Bournemouth), Custom built studio equipment, repairs to professional and semi-professional tape and sound equipment, sound system installations, etc. Lincoln House, 141 Belle Vue Road, Southbourne, Bournemouth, Hants. Tel. (0202) 47403, 24-hour answerphone service.

Tape Recorder Repairs by Specialists. The Tape Recorder Centre, 82 High Holborn, London, W.C.1.

STUDIO FACILITIES

EDEN STUDIOS LTD.

Words getting around that the Studio that's having great success with its own recorded productions, also has a particularly fine pressing and disc cutting service. Please write or phone for leaflet.

11 EDEN ST., KINGSTON, SURREY
01-546-5577

Studio Sound Recording Studios. Recording and disc transcription service. Latest high-level cutting techniques. Mono and stereo records. Exceptional quality obtained from amateur recordings. Members A.P.R.S., 31-36 Hermitage Road, Hitchin, Herts. Telephone Hitchin 4537.

Your tapes to disc. 7in. 45—25/-, 10in. L.P.—55/-, 12in. L.P.—65/-. 4-day postal service. Masters and Vinylite pressings. Top professional quality. S.A.E. photo leaflet: Dero Studios, High Bank, Hawk Street, Carnforth, Lancs.

J & B Recordings. Tape to disc—latest high level disc cutting, all speeds. Mastering pressings, studio, mobile. 14 Willows Avenue, Morden, Surrey. MITcham 9952.

Graham Clark Records. Tape to disc pressings. 23 The Grove, Walton-on-Thames, Surrey. Tel. Walton 25627.

County Recording Service. Send your tape for transfer to disc to the people who care about quality. Full time disc recording engineers, using modern cutting techniques. Telephone Bracknell 4935. London Road, Binfield, Bracknell, Berkshire.

Pressing Specialists, stereo or mono discs manufactured from your own tapes. Mobile recording service. North Surrey Recording Co., 59 Hillfield Avenue, Morden, Surrey.

A.A.A.A. Progressive Sound. Top quality studio for mobile recordings. 4-track, 2-track or mono on new music scoring stage. Full facilities, book four hours or more, get free tape and disc. Resident musicians can be hired to back vocalists. Large selection of instruments available. We are England's number one studio catering for all types of music, recordings for people who care by people who care. Contact Bob Bloomfield for illustrated brochure (01-539-5263). Tour of studio may also be arranged for parties of no more than 25 people. Coffee lounge under construction.

High Quality mobile recordings (anywhere) to professional standard by top recording engineers on custom-built mobile studio console to mono 2-track, 4-track, 8-track or 16-track. For full details ring Edge Products, 653-7899 or write 52 South Vale, Central Hill, S.E.19

Studio Recordings (Bournemouth). Professional Sound Recording Services, full studio facilities, mobile unit, tape to disc, broadcast standard quality. Lincoln House, 141 Belle Vue Road, Southbourne, Bournemouth, Hants. Tel. 0202 47403.

Fanfare Records (A.P.R.S.) Tape-disc pressings, demo's, masters to B.S.S., any quantity. Studio/mobile. Neumann disc cutter, brochure 1 Broomfield Close, Rydes Hill, Guildford. Tel. 0483 61684.

mjb recording and transcription service

Vinyl pressings and acetate demodiscs. Limiting, compression and equalisation facilities; high undistorted cutting levels with feedback cutter heads. Booklet available.

10 LOWER ROAD, COOKHAM RISE,
MAIDENHEAD, BERKS.
Tel. Bourne End 22231 Member A.P.R.S.

TAPE EXCHANGES

"Tips for Tapespondents — International Message Making", free when you belong to Worldwide Tapetalk, 35 The Gardens, Harrow.

WANTED

Lee Electronics. The Tape Recorder and Hi-Fi Specialists wish to purchase good quality Tape and Hi-Fi Equipment for cash. 400 Edgware Road, W.2. Phone PAD 5521.

GOOD QUALITY TAPE RECORDERS PURCHASED FOR CASH. TELEPHONE 01-472-2185.

Best cash prices paid for good quality tape recorders and hi-fi equipment. Magnegraph, 1 Hanway Place, London, W.1. Tel. 580-2156.

Pre-recorded tapes wanted. 4-track mono or stereo, pop, jazz, classical, etc. Full details to Box No. 574 (Glasgow).

Ferrograph 632 wanted. Cash waiting. Tel. 01-857-1455 after 6 p.m.

£100 cash offered for half-track stereo record/replay machine. Box No. 580 (Middlesex).

Audio Annual 1970 is packed with features of interest for all hi-fi and tape recording devotees. Contents include:

- Are equipment reviews honest?
- How records are made
- A new theory of record wear
- Visit to a pop recording studio
- Noise, noise, noise
- Setting air in motion
- Articles and reviews by a dozen leading audio experts

A LINK HOUSE GROUP PUBLICATION
Obtainable at your local newsagent/bookseller,
or post-free from
Link House, Dingwall Avenue, Croydon CR9 2TA

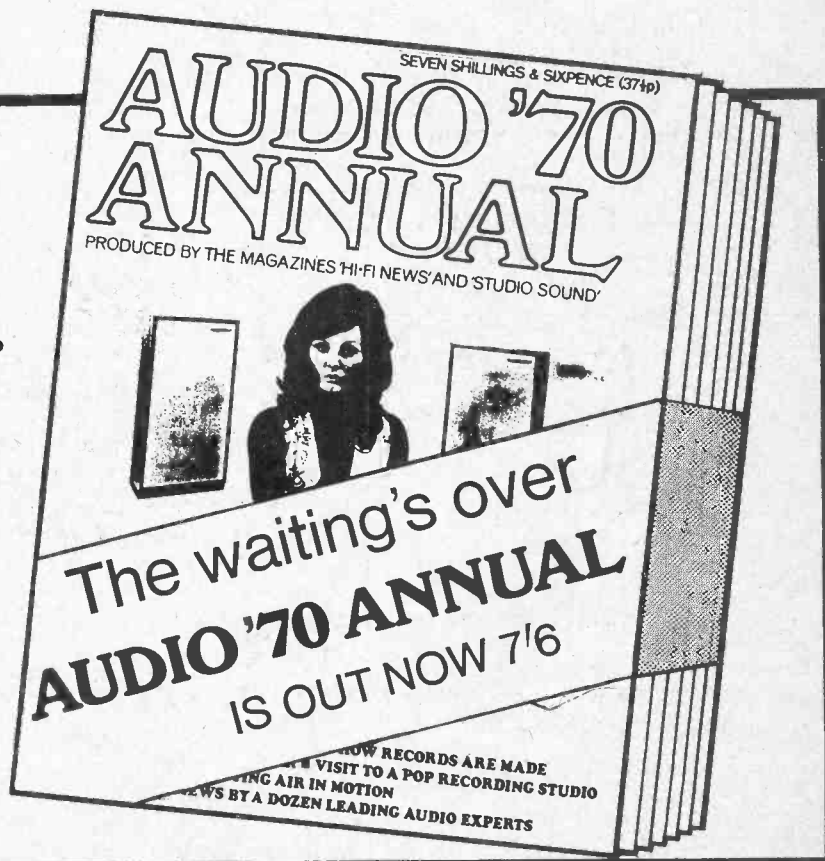

Thumbs up. Your tape patching days are over.

And your stereo pleasure just beginning. The all-new Sansui SD-7000 stereo tape deck, rich in tape protection devices, is here to put an end to all the awkward patching that until now seemed an inevitable drawback to owning a quality taping unit.

The end product after 10 experimental models and three years of research, the 3-motor 4-head SD-7000 goes to great lengths to save you most of that irritating splicing and fumbling. For example:

It precludes tape breaking or slack in going from either Fast Forward or Rewind to the Stop and the Play modes. It prevents the tape stretching that results from excessive tension. It minimizes resistance during Fast Forwarding. It ensures proper "pull" speeds, and it makes accidental erasures or reversing impossible.

No comparably priced tape deck on the market, in fact, offers so much in the way of tape protection. The SD-7000 wins. Hands down.

But Sansui gave it a lot more very attractive features as well. Like Automatic Rewind, Reverse and Repeat by either recorded 20Hz signals or sensing strips. Like a self-locking Pause control,

Sleep switch, spring-lock reel clampers, responsive pushbutton controls, and separate volume controls for two line inputs and another for headphones.

The tonal quality is unsurpassed. Frequency response is 15 to 25,000Hz, the S/N ratio is better than 60dB, and wow and flutter is less than 0.06% at 7½ ips.

The SD-7000 will be available soon at authorized Sansui dealers, and it will pay you to check it out more fully. Unless of course you want to go on playing patch-up stereo.



Sansui

England: BRUSH CLEVITE COMPANY LIMITED Thornhill, Southampton SO9 1QX Tel: Southampton 45166 / Ireland: RADIO CENTRE 122A, St. Stephen's Green, Dublin 2 / West Germany: COMPO HI-FI G.M.B.H. 6 Frankfurt am Main, Reuterweg 65 / Switzerland & Liechtenstein: EGLI, FISCHER & CO. LTD. ZURICH 8022 Zurich, Gotthardstr. 6, Claridenhof / France: HENRI COTTE & CIE 77, Rue J.-R. Thorelle, 77, 92-Bourg-la-Reine / Luxembourg: MICHAEL SHEN, EUROTUX 12, Route de Thionville / Austria: THE VIENNA HIGH FIDELITY & STEREO CO. A 1070 Wien 7, Burggasse 114 / Belgium: MATELECTRIC S.P.R.L. Boulevard Léopold II, 199, 1080 Brussels / Netherlands: TEMPOFOON BRITISH IMPORT COMPANY N.V. Tilburg, Kapitein Hatterasstraat 8, Postbus 540 / Greece: ELINA LTD. 59 & 59A Tritis Septemvriou Street, Athens 103 / South Africa: GLENS (PTY) LTD. P.O. Box 6406 Johannesburg / Italy: GILBERTO GAUDI s.a.s. Piazza Mirabello 1, 20121 Milano / Cyprus: ELECTROACOUSTIC SUPPLY CO., LTD., P.O. Box 625, Limassol / SANSUI ELECTRIC CO., LTD. FRANKFURT OFFICE 6 Frankfurt am Main, Reuterweg 93, West Germany / SANSUI ELECTRIC CO., LTD. 14-1, 2-chome, Izumi, Suginami-ku, Tokyo, Japan

J. RICHARDSON ELECTRONICS LTD.

for

STUDIO ════════════════════ **EQUIPMENT** ════════════════════ **TRANSPORTABLE**

PROFESSIONAL TAPE-TRANSPORT

—a new advanced range available later this year

D.C. solenoid operation with solid-state logic control enabling any function to function process. Spool capacity up to 11.5in., 19in. rack mounting. Speeds for .25in. are 3.75/7.5 or 7.5/15 i.p.s. and for .5 and 1in. are 15/30 i.p.s.

MODULAR TAPE ELECTRONICS

Built on 1in. x 7in. panels. 4 Electronically switched equalisations, 2 speeds, CCIR/NAB, all pre-set adjustable on front panels for time-constant and levels. Auto sel-sync. p.p.m. or vu meters. Master and slave oscillators. Up to any number of channels.

Rack mounting or console versions available to order.

HIGH QUALITY, LOW DISTORTION MODULAR MULTI-CHANNEL MIXER SYSTEMS

Versatile mixing desks built to customer's specifications using the highest quality components and latest techniques in circuitry. Any number of input channels by any number of output channels catered for. Electronic routing available.

TRANSISTOR AND VALVE MONITOR QUALITY POWER AMPLIFIERS

TRANSPORTABLE TAPE-RECORDER

D.C. solenoid operation with solid-state logic control enabling any function to function process. Spool capacity up to 11.5in. Speeds 3.75/7.5 and 7.5/15 i.p.s.

USING

SEMI-MODULAR TAPE ELECTRONICS

Mother board with plug-in daughter boards. Dual-concentric controls. Equalisation pre-sets accessible through front panel for 4 electronically switched equalisation on CCIR/NAB. Mono or two-channel machines available. 10 K ohm bridging input, 30/60 ohm mic. input, 3 watt monitor amplifier fitted, 600 ohm line output optional,

The sub-assemblies are based on 19in. rack mounting.

SEMI-MODULAR MIXERS AND MIXER PANELS

Carefully chosen channel and main faders. Continuously variable tone controls. Up to 12 inputs by 4 output channels available. Comprehensive channel design incorporated.

TRANSISTOR POWER AMPLIFIERS, PRE-AMPLIFIERS AND INTEGRATED UNITS

For further details write to :

J. Richardson Electronics Ltd., 57 Jamestown Rd., London, N.W.1 01-267 0723