

How to Make Walkie-Talkies

F.G. RAYER, T.Eng.(CEI), Assoc.IERE, G30GR

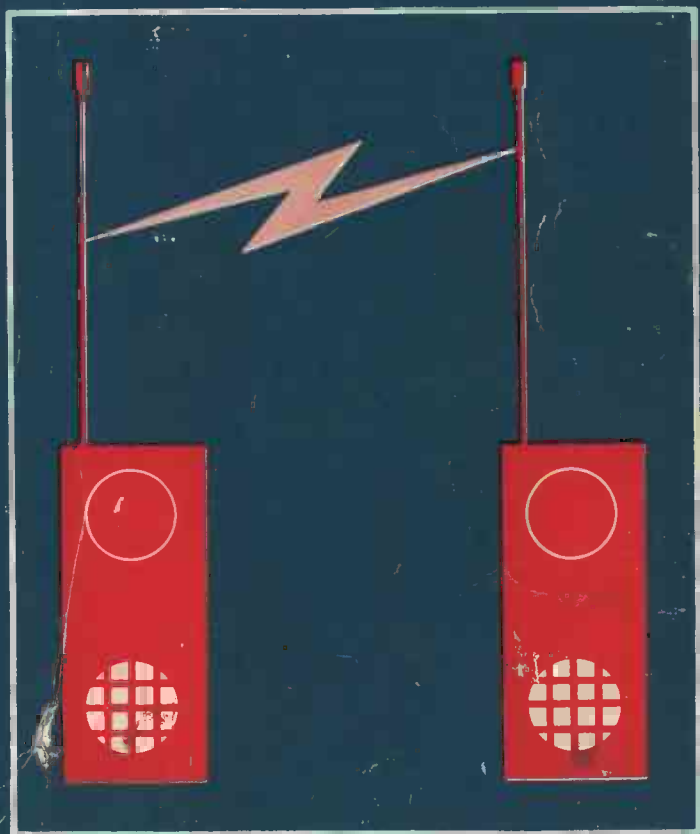

HOW TO MAKE WALKIE-TALKIES

ALSO BY THE SAME AUTHOR

- No. BP30 Two Transistor Electronic Projects
No. BP32 How to Build Your Own Metal and Treasure
Locators
No. BP35 Handbook of IC Audio Preamplifier and Power
Amplifier Construction
No. BP37 50 Projects Using Relays SCR's & Triacs
No. BP39 50(FET) Field Effect Transistor Projects
No. BP48 Electronic Projects for Beginners
No. BP57 How to Build Your Own Solid State Oscilloscope

HOW TO MAKE WALKIE-TALKIES

by

F. G. RAYER, T.Eng.(CEI), Assoc.IERE, G30GR

BABANI PRESS
The Publishing Division of
Babani Trading and Finance Co. Ltd
The Grampians
Shepherds Bush Road
London W6 7NF
England

Although every care is taken with the preparation of this book, the publishers or author will not be responsible in any way for any errors that might occur.

© 1977 BABANI PRESS

I.S.B.N. 0 85934 046 5

First Published – December 1977
Reprinted – July 1979

Printed and Manufactured in Great Britain by
C. Nicholls & Co. Ltd.

CONTENTS

Section 1: – Transmission	Page
Amateur and Citizens' Bands	8
Licence Department	9
Frequencies	9
Ranges	10
Choice of Mode	11
Crystal Control	12
Monitor/Wavemeter	15
Bulb Indicator	18
Input x Output	19
28 MHz Transmitter	20
Crystal Oscillator	21
Power Amplifier	25
Stability	26
Transformer Coupled Modulation	28
PNP Modulator	30
Modulator Matching	32
Modulation Monitoring	35
Audio IC Modulators	37
Matching	39
Audio Pre-amplifier	40
Series Modulator	41
3-Stage 144 MHz Transmitter	44
Transmitter for 80 or 160m.	48
RF Power Amplifiers	50
Transceiver Switching	55
PNP Transmitter	57
Section 2: – Reception	
28 MHz Super-regenerator	59
2-Metre Super-Reg Receiver	62
28 MHz Mixer/Oscillator	64
Mixer for 160 and 80m	66
465 kHz IF Amplifier	67
Crystal Controlled Receiver	70
Integrated Circuit IF Amplifier	73

	Page
2-Stage Audio Amplifier	75
Receiver Audio IC	76
Superhet for 2m	77
FM	86

Section 3:— Aerials and Additional Circuit Information

Aerials	87
144 MHz Verticals	90
Pi Tank	93
Capacitor Loading	96
Further Circuits	96
Simple Talkie	97
Super-regeneration	99
Carbon Microphone	100
Stabilisation	101
RF Blocking	102
27 MHz Citizens' Band Operation	103

SECTION 1

Transmission

Equipment for low power hand-held or portable operation need not be of a very complicated type. It falls much more readily within the scope of the home constructor than does medium and high powered transmitters, and multi-band receivers for the Amateur frequencies. There are several reasons for this simplification. The equipment will be for a single band, instead of for multi-band use, and this alone greatly reduces the number of components necessary.

Another saving naturally arises from the relatively low power employed for transmission. This considerably reduces the number and size of components and eases constructional work.

Again, with an Amateur band transmitter or transceiver (transmitter-receiver) the present-day trend is to use single sideband transmission. This offers maximum utilisation of power for voice transmission, but requires a balanced modulator and filter to remove the unwanted carrier and sideband. As these items themselves form a large part of a single sideband transmitter, they are not justified in low power equipment. As a result, amplitude modulation is general in these circumstances, and the generation of an AM signal needs very few components and circuitry, compared with the production of SSB signals.

In addition to these points, the practical needs of low power communication are often met by the use of only one or two pre-set frequency channels. This, in turn, brings more simplification, when adopted instead of the variable-frequency oscillator means of transmitter control.

Transmission and reception may take place on crystal controlled frequencies, and then there need be virtually no adjustments at all during use. Two transceivers of this type, built for use together, act as a familiar walkie-talkie link.

On the other hand, Amateurs have long found interest in lightweight portable operation, and fully tunable equipment is then of enormously greater scope. With it, other Amateur stations at considerable distances can be worked, especially when the other station is using medium or high power transmission, with a full aerial-earth system and sensitive receiver. In fact, portable or temporary location working forms a large part of the activity of some Amateurs, especially during summer months.

Amateurs will be familiar with the operation of "talk in" stations at rallies, with "fox hunting" (location of a hidden transmitter by directional means) and similar activities. These can easily be added to the more direct point-to-point contact afforded by a set of transceivers. In fact a single transceiver will in some cases be all that will be required, as it can provide two-way contact via the usual home station with its permanent transmitter and receiver.

It has been found in practice that "portable" operation covers a larger field than might be anticipated. Items which have been constructed and used for portable operation, or for activities in conjunction with portable equipment, include the following:

Lightweight pocket transceivers for relatively short point-to-point ranges; tunable pocket equipment for reception only, so that the enthusiast with no transmitting licence can participate as a listener; larger power equipment, easily transportable, for use as a base station in caravan, tent, or when on holiday etc. There are in fact those devoted largely or even wholly to QRP (low-power) working, and thus the circuits described could fall within their scope.

Amateur and Citizens' Bands

Equipment is intended for licensed operation, so will generally be used in one of the permitted Amateur frequency bands. One such allocation — the 28 MHz band — falls very near the popular USA Citizens' Band, where operation is around

27 MHz. Citizens' Band equipment working on 27 MHz cannot obtain a licence in Great Britain, but such equipment can in some circumstances be shifted into the permitted 28 MHz band used by Amateurs. In a similar manner, the circuits shown for 28 MHz can be set up to work in the 27 MHz Band, where this is permitted, and details for this are included.

In Great Britain, passing a test which includes Morse allows operation in all the Amateur bands, while if Morse is not attempted only very high frequency bands may be employed. This may have an important bearing on the working frequencies chosen.

Unlicensed operators are generally termed "pirates" and when their illegal operation is detected they should at least expect the GPO to confiscate their equipment. Receiver circuits in this book may be used by anyone, but transmitting circuits should only be operated by holders of a suitable licence.

Licence Department

The transmitting circuits described here are intended for use in the permitted Amateur bands, and an Amateur transmitting licence is required for the operation of such equipment. Details of the licences available for the use of transmitting equipment in Great Britain may be obtained from:

Home Office,
Radio Regulatory Department,
Waterloo Bridge House,
Waterloo Road,
London, SE1 8UA.

No special licence is necessary for the use of receiving circuits such as those included, or for reception of Amateur signals.

Frequencies

Licence conditions at present allow the use of the following frequency bands: 1.8–2.0 MHz, 3.5–3.8 MHz, 7.0–7.1 MHz, 14.0–14.35 MHz, 21.0–21.45 MHz, 28.0–29.7 MHz, 70.025–70.7 MHz, 144–146 MHz, 420–450 MHz, and various

extremely high frequencies. It is worth while referring to these individually.

The 1.8 MHz or 160 metre band has considerable use for low power Amateur activity, especially as transmitter power on this band is limited to 10 watts. This band would generally be expected to give contacts up to 25 miles or so, though naturally greater ranges are often covered. For present purposes, the 3.5 MHz or 80 metre band is somewhat similar, though greater ranges are covered. The band can be very noisy during evening or darkness hours. Either of these low frequency bands can give reliable short distance ground wave communication except when conditions are unfavourable.

The 7 MHz (40 m), 14 MHz (20 m) and 21 MHz (15 m) bands are generally used for very long distance communication, and are not of advantage here.

The 28 MHz or 10 metre band has little interference from very distant signals except during certain favourable conditions, and is popular for purposes such as those in view, being similar in character to the 27 MHz band.

The 70 MHz or 4 metre band has advantages for short range low power working, but the 144 MHz or 2 metre band is more used, and is popular with VHF operators. The 420 MHz and higher frequency bands are not very popular at present, due to device and other limitations.

Equipment can thus generally best be for the low frequency bands 160 m or 80 m; or for 10 m; or for 2 m. This does not of course completely rule out the other bands, which have their own advantages in some circumstances.

Ranges

Reliable contact is by ground wave, which falls away in strength as distance increases. Contact may also be hindered by hills or other obstacles in the signal path. Propagation conditions being equal, range is increased by raising the transmitter power, by increasing the receiver

sensitivity, or by using more efficient aerials with transmitter or receiver.

Greater ranges are obtained by a sky wave reflected from ionized layers above the earth. These layers suffer hourly and seasonal variation. As a result, strong communication by sky wave may be possible at one particular time, for some days, but may then cease or suffer fading and other defects. These effects permit very long distance contacts, but not essentially reliable communication. Effects of this kind arise with all high frequency signals, at other than ground wave distances. They will be familiar to all who listen to short wave broadcast or Amateur transmissions.

Choice of Mode

In view of the high efficiency and low voice duty cycle of the single sideband transmitter, this mode would be ideal for low power working. Unfortunately, the generation of any SSB signal poses considerable problems because of the circuitry necessary. The same filter and other items will be necessary for low power, as for high power SSB, and the equipment becomes costly and much less compact.

Frequency modulation on the VHF bands has some advantages, but can cause extra complication in the receiver, or make the use of a simple type of receiver impossible. FM thus becomes something of a luxury, in home built light-weight equipment (See FM page 86).

For voice transmission, amplitude modulation or AM thus has to be adopted in most cases. There is a loss over SSB as power is used to generate a carrier and two sidebands, but equipment is very much easier to construct, and is smaller and much less costly.

Some low power enthusiasts use CW (Morse) in order to work great distances with portable equipment. Ranges of thousands of miles are possible with milliwatts of power and such equipment may be carried to elevated locations.

Such expeditions by the Dx (long distance communication) enthusiast rely on high frequency band skip. For ground wave or 144 MHz working, power of perhaps 200 milliwatts (0.2 watt) would be more appropriate for a few miles, using AM. Range does of course depend enormously on the aerial, and the ranges obtained with efficient aerials can greatly exceed those when short whip aerials are in use. (Reference should be made to the information on propagation and aerials.)

Crystal Control

The use of crystal control of frequency means that circuits are simplified, and it is not necessary to keep to hand equipment which can verify the frequency. When correctly built, the crystal controlled circuit can only operate at the frequency of the crystal, and this is rigidly maintained. Drift due to changes in battery voltage or temperature, or random variations from mechanical vibration, are avoided.

A single crystal will provide one operating frequency only, but this limitation is not too important. Where it is wished to work other fixed location stations the latter will normally have fully tunable equipment, so can readily shift to the crystal frequency. For two or more channels, it is necessary to use more crystals, which can be selected by switching.

The transmitter can often use the stages shown at A in Figure 1. The crystal controlled oscillator works at the frequency of the signal to be transmitted. It is followed by a power amplifier (PA), to boost the transmitted power. The audio section has a preamplifier, followed by a stage which modulates the PA, and thus the transmitted signal.

For VHF working it will become necessary to multiply the crystal oscillator frequency, as at B. As example, a 72 MHz oscillator, followed by a doubler, would give 144 MHz operation. An extra stage is then required.

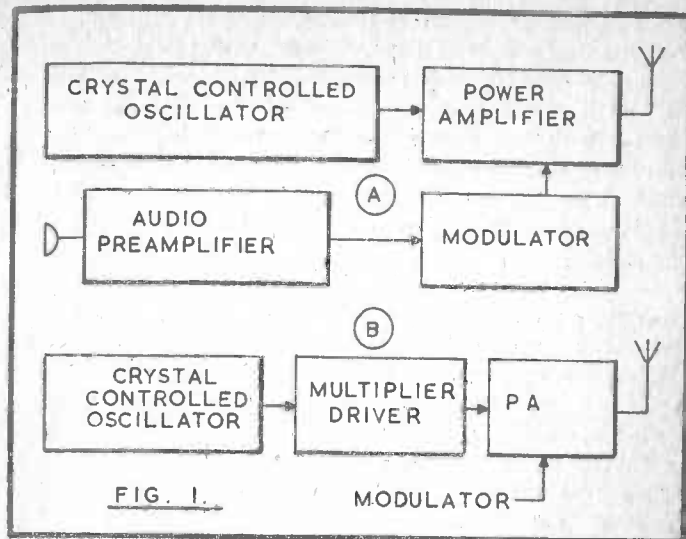

With some circuits modulation is also applied to the stage which precedes the PA, as by this means greater depth of modulation can be achieved.

For minimum size and low power, the arrangement at A will be most used, and is satisfactory on 1.8 MHz to 28 MHz bands. On some occasions oscillator, driver and PA stages all work on the same frequency, as more power can then be made available. This is practicable, but greater freedom from instability or similar troubles will be expected when the oscillator is followed by a multiplier. Again, in some circumstances it is easy to arrange so that an intermediate stage will operate either as a multiplier, or straight through, and thus two-band operation is obtained with a single crystal.

If two hand-held units are to be built to work together, they will work on the same frequency. If a home base or other station tunes up on this frequency, communication can then be 3-way if required.

Where the receiver is tunable, it can of course be adjusted to any signal it is wished to hear. However, for stability a crystal controlled receiver oscillator is popular. This will allow reception on one frequency only, so the crystal frequency has to be chosen to suit the transmitter.

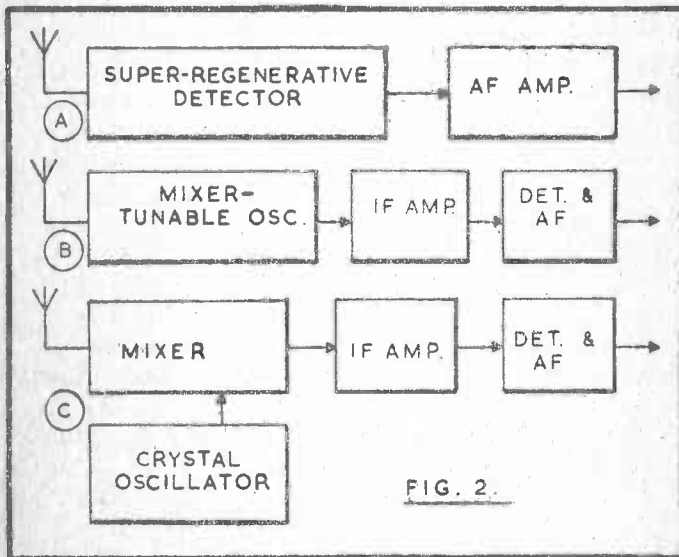

Figure 2 will clarify the situation here. At A, a tunable super-regenerative receiver is indicated, and this can be tuned to any wanted frequency. At B, a tunable superhet is shown. By tuning the oscillator, signals can be received on any wanted frequency. At C, a crystal controlled oscillator is used. This allows reception on one chosen frequency. As example, assume the transmitter operates on 28.5 MHz. The crystal in the receiver oscillator must differ from this by an amount corresponding to the receiver intermediate frequency. In the example, and assuming that the receiver IF is 460 kHz, the receiver oscillator crystal will be either 28.5 MHz *plus* 460 kHz (28.960 MHz) or 28.5 MHz *less* 460 kHz (28.040 MHz). Only when the crystal frequencies differ by the IF is reception possible. For this system, crystals can be purchased in pairs. The rigid control of both transmitter and receiver oscillators means that tuning is correctly maintained.

Crystal control of the receiver has the advantage that drift from the wanted frequency does not arise. However, the lower cost and greater scope of a tunable receiver can give it some advantage. It is also feasible to use the super-regenerative type of tuned receiver which has excellent sensitivity, and is much easier to build than a superhet.

It will thus be seen that crystal control of the transmitter is general for equipment of the type in view. For a 2-station link to be used for no other purpose, crystal control of the receiver is also recommended. But for simplicity in building and greater utility for other purposes, the receiver can be tunable.

A transceiver, or combined transmitter-receiver, could be made by using one circuit from Figure 1 and one from Figure 2. This has some advantages from the constructional viewpoint, as receiver and transmitter sections are separate, so can be built and tested individually. As an alternative to this, circuits can employ some stages in both transmission and reception. The audio section is most commonly used in this way, acting as modulator on transmission, and receiver audio amplifier for reception. This can reduce the number of components, and size of the equipment, but generally requires more complicated switching to change from transmit to receive.

Monitor/Wavemeter

A combined monitor and wavemeter is very easily constructed for the wanted band, and will prove extremely useful when testing and setting up a transmitter circuit. It will show that radio frequency energy is being produced in oscillator or amplifier stages, and also give an indication of signal strength, as an aid to tuning oscillator or other circuits. By plugging in headphones, it will enable the radiated signal to be checked for speech quality or modulation. With an aerial added, it can help in tuning a transmitter for best radiated signal strength.

Figure 3 is the circuit of this unit. RF energy is picked up by L1 and rectified by D1. This provides an indication on the meter. The jack socket must be of a type which shorts when

the plug is removed, and inserting the headphone plug here allows signals to be checked by ear.

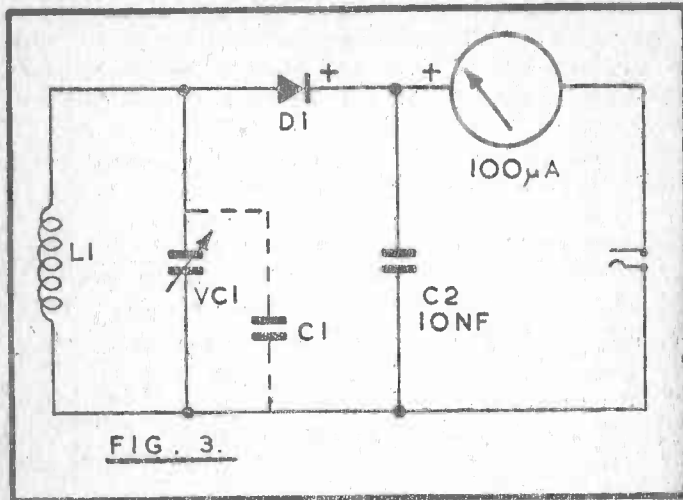

For 144 MHz, L1 can be four turns of 20 swg or similar wire, self-supporting, approximately 9 mm in outside diameter, and spaced so that the coil is about 18 mm long. VC1 is 25 pF and C1 is not required. For 70 MHz, use seven turns of 26 swg enamelled wire on a 11 mm or similar former, with turns spaced to occupy 15 mm. VC1 is again 25 pF, and C1 is omitted.

The 28 MHz band will require thirteen turns of 28 swg or similar enamelled wire, side by side on a 11 mm or similar former, also with C1 omitted. VC1 is 25 pF.

The low frequency bands require rather a large number of turns, so ready-made coils can be used. For 3.5 MHz, a Denco (Clacton) Ltd Range 3 Yellow Valve coil can be used. Connections are to pins 1 and 6. The core is completely removed, and VC1 is 100 pF with 22 pF for C1. The remaining LF band, 1.8 MHz, can use a Denco Yellow Range 2 coil, also with core removed, VC1 being 100 pF. C1 is not required. Pins 1 and 6 are used.

Alternative surplus coils will be satisfactory, and most medium waveband coils will reach 1.8 MHz when the core is removed. If necessary, some turns can be taken off.

A plastic box is recommended, as this allows coupling of L1 to other circuits, while protecting the components. The meter need not be a 100 μ A model, though a sensitive instrument (say 50 μ A to 250 μ A) will be most satisfactory. Medium or high impedance phones will be most suitable.

To use this instrument, L1 is brought near and approximately in line with the inductor in which RF should be present, and VC1 is tuned for maximum reading. Where appreciable power is likely to be present, do not bring L1 too near the inductor until it is seen that the meter will not be driven beyond its full-scale reading. A calibrated scale on VC1 will show whether circuits are working in the correct frequency band. This can be useful to check the frequency multiplication actually obtained by doubler or other circuits.

It is practical to build this unit to take plug-in coils, so that several ranges can be covered.

To check the field strength obtained from a transmitter, it is necessary to add an aerial to the monitor. This can be a self-supporting telescopic type as used for portable receivers. It can be coupled to L1 by using the primaries of the ready-made coils. Or coupling for all bands can be by direct connection to L1. This makes re-tuning by VC1 necessary. The monitor should be placed a little distance from the transmitter, and should be tuned for best meter reading. Any adjustments to the transmitter tuning which cause a rise in the monitor meter reading will then show that an increase in radiated field strength has been obtained. This will also allow a quick check to be made that the accustomed power is being transmitted.

Actual readings will depend on power, the length of the aerials and surroundings, as well as the distance from transmitter aerial to monitor aerial. A few tests will soon show

what to expect. Should communication become unsatisfactory and transmitter power fall off, a check of the transmitter or its batteries would be in order. But should transmitter output be as usual, investigation of the receiver would be indicated.

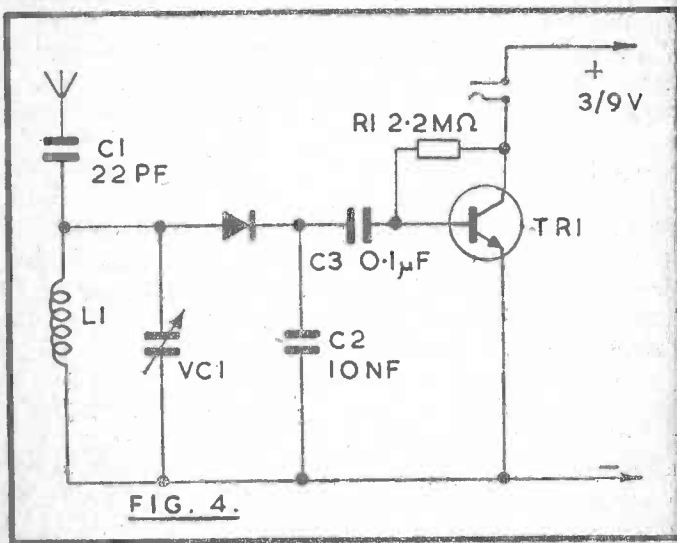

Figure 4 is a similar circuit, but it provides boosted phone reception for monitoring signals. Medium or high impedance phones of about 500 to 2,000 ohm will be most suitable. TR1 can be a BC108 or any small audio NPN transistor.

Bulb Indicator

A bulb can be extremely useful to show that a transmitter circuit is giving the expected power output. Radio frequency energy is allowed to flow through the bulb, or is supplied to the bulb instead of the aerial. The bulb will then light in accordance with the RF energy present.

For oscillators and low powered circuits, a 6 volt 0.06A or 60 mA bulb is suitable. When fully lit, this will be of about 100 ohm impedance, and will show that about 360 mW of

RF can be obtained. The 6 V 0.1 A bulb will be of approximately 60 ohm impedance when lit, and will show 600 mW or 0.6 W of RF.

Larger bulbs will only be required for larger power. Thus a 6.3 V 0.15 A bulb will be a little over 40 ohm, and require 950 mW, while a 6.3 V 0.3 A bulb will be a little over 20 ohm and need 1.8 W. As the impedance becomes too low, higher voltage bulbs are necessary for higher power, or bulbs in series. Thus a 12 V 2 W bulb would be of about 70 ohm impedance when lit.

Such lamps are available from garages, cycle shops, etc. The usual torch bulb, such as 3.5 V 0.3 A is of too low impedance (near 10 ohm) to act as a substitute for an aerial but can in some instances be in series with an aerial to indicate radio frequency current.

Generally, only an indication that the transmitter is working as it should will be required. For RF output measurements, a thermo-couple or other RF meter is needed, with a suitable non-inductive load. $I^2 \times R$ (current \times current \times resistance) will then show RF power. It should be noted that as current is squared, power rises rapidly. Thus a current of 0.1 A through 100 ohm would indicate 1 watt, while a current of 0.2 A would show 4 watts

Efficiency in radio frequency power output stages is not very likely to be over 66 per cent, and may well be less. Input to an RF power amplifier is $V \times I$, and output can be found as just explained. Lost power is mostly dissipated in the output transistor as heat. Thus incorrect tuning, as example, can cause poor RF output, and also overheating of the amplifier. This can set a limit on the direct current power input which can be allowed, if destruction of the transistor is to be avoided.

Input \times Output

As an example, assume the power amplifier were drawing about 80–90 mA with a 12 V supply, so that its DC input is

about 1 watt. If output lights a 600 mW lamp efficiency is about 60 per cent, and the remaining 400 mW will be lost and heat the transistor. Working would be safe if the transistor could dissipate 400 mW or over, so a 500 mW device would be suitable. But if incorrect tuning reduced output to, say, 300 mW, then about 700 mW would be dissipated in the transistor, causing overheating.

Except for very low power circuits, it may thus be wiser to make a first test with a reduced voltage, so that tuning can be adjusted. Should an amplifier transistor become hot, it is wise to switch off or reduce voltage until working conditions have been checked.

28 MHz Transmitter

Working on 28 MHz gives similar conditions to those which apply to signals on the 27 MHz Citizens' Band. Many of the adjustments which are required for a 28 MHz transmitter will be similar to those which are necessary for other frequency bands. It is thus worth while to consider the tuning up of a transmitter for low power use on 28 MHz in some detail.

Some well-known 27 MHz equipment of overseas manufacture operates with a power of about 200 mW. The transmitter here can be run with a power input of up to about 500 mW. This offers some increase in signal power, without becoming too costly in terms of battery current. It is quite feasible to reduce power by lowering the battery voltage, or by tuning in such a way that less drive is applied to the final RF amplifier.

The whole transmitter consists of crystal oscillator, RF power amplifier, and modulator. To avoid expensive batteries, it can be run from six 1.5 V cells, or an ordinary 9 V battery. (For lengthy use, rechargeable cells would eventually prove more economical.)

The transmitter may be completed before applying power and testing it, and may well need no further attention except for

tuning. However, a detailed check of the working of each stage can be made as described, either as work progresses, or to trace snags.

Crystal Oscillator

Figure 5 is the circuit of a typical crystal controlled oscillator here intended for the 28 MHz band. The crystal indicated is for 28.5 MHz, but naturally other frequencies can be used instead.

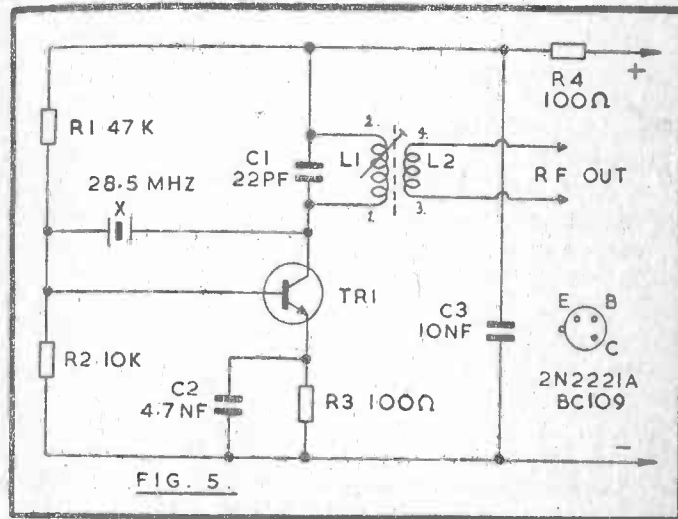

FIG. 5.

L1 is tuned to approximately the frequency of the crystal, by means of its adjustable core. The exact diameter of the former, or wire gauge, will not be important, but the type of core *must* be suitable for HF use (up to 30 MHz or higher). With a former of approximately 7 mm diameter, L1 can be fifteen turns of 26 swg enamelled wire side by side. For a slightly smaller coil, seventeen turns of 32 swg wire can be used on a 5 mm former. In each case L2 is four turns, tightly coupled to L1.

When making coils of this type, turns can be kept in place by spots of adhesive at each end of the winding. However, the whole winding should not be secured with varnish, wax,

or similar substances which will cause losses. "Bostik 1" is suitable, applied sparingly.

When adding L2, it may be noted that if coupling to L1 is very loose, the RF output available will be reduced. On the other hand, if coupling is very tight, the oscillator may not function. Best coupling will give a good transfer of RF energy, without stopping oscillation.

Many transistors will perform well in this circuit, and the BC109 or 2N2221A may be adopted. C1 is best a silver mica or other component suitable for HF. Resistor values shown will usually prove to be satisfactory, though they can be modified somewhat for other transistors.

When L1 is badly off resonance, no oscillation is obtained. The presence of RF can be found by bringing the wavemeter coil near to L1, and tuning the core for maximum deflection of the meter. Or temporarily connect L2 to a 6 V 0.06 A bulb. With the oscillator tuned for a dip of about 10 mA to 15 mA, sufficient RF should be obtained to light this bulb dimly. That is, at about similar brilliance to that seen if the bulb is connected to a 1.5 V or single cell battery.

It will be found that L1 has to be tuned slightly away from the setting which gives maximum possible brilliance, or the oscillator will not start again, if the battery circuit is interrupted, then restored. This is usual with crystal controlled oscillators of this kind. Correct tuning is that giving maximum output, with reliable starting.

With compact commercial and home-built equipment of this type, the number of stages are minimised. It is thus important to get the best RF output from the oscillator, or there will be insufficient drive to the following amplifier, and the transmitter output will be poor.

The supply need not be 9 V, and 12 V would increase output. It is of advantage to get the best efficiency from each stage, for good range without unnecessary battery power.

For small changes in frequency, such as result from alternative crystals, re-tuning of L1 will generally be unnecessary. Final tuning is approximately correct when carried out as explained, but when L2 is driving the following amplifier some small readjustment of the core of L1 will be required for maximum efficiency.

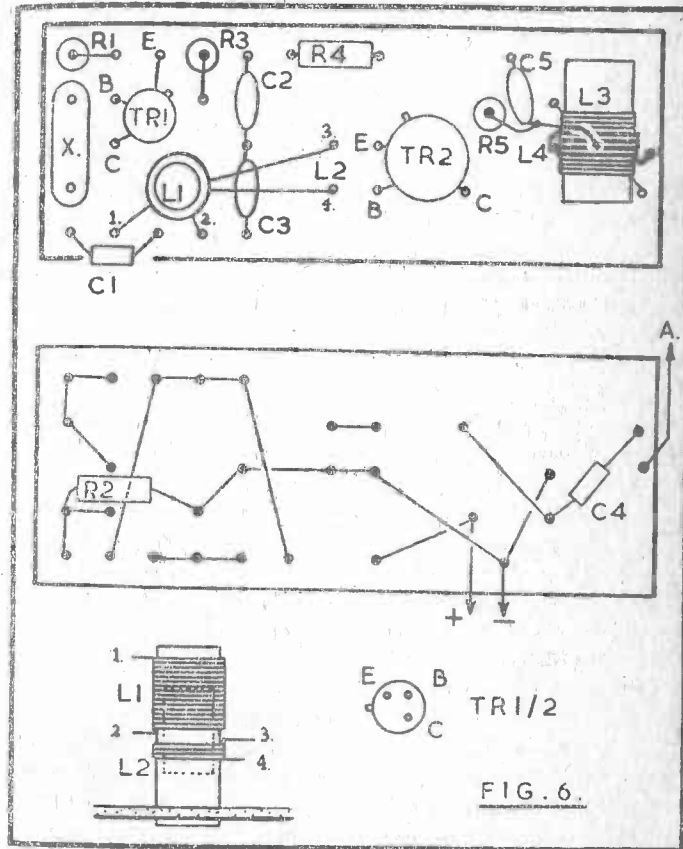

Figure 6 shows the assembly of this stage. If 0.15 in matrix perforated board is used, components can be placed exactly as indicated. Some further reduction in size would be possible, but if dimensions are reduced to the absolute

minimum constructional work becomes cramped and difficult.

The coil former is approximately 5 mm in diameter and 15 mm long. Start at point 1, near the top of the former, and wind on seventeen turns of 32 swg enamelled wire closely side by side, finishing at 2. Begin at lead 3, winding four turns in the same direction as L1, and ending at 4. Push these turns against L1. Secure the wires as described. The position of the coil core is approximately as shown though this will differ slightly with individual coils and wiring. Note the core is positioned for maximum coupling from L1 to L2, not out of L1 at the top.

C1 is a small silver mica capacitor, and C2 and C3 are low voltage disc ceramics. R2 goes flat under the board. A miniature crystal with holder is used, but wire-ended crystals can be soldered directly into circuit. The metal case of TR1 must not touch wires or other bare metal items.

This stage can be tested as described. If a meter is placed in one battery lead, current will dip as tuning of L1 becomes correct and RF is delivered to L2.

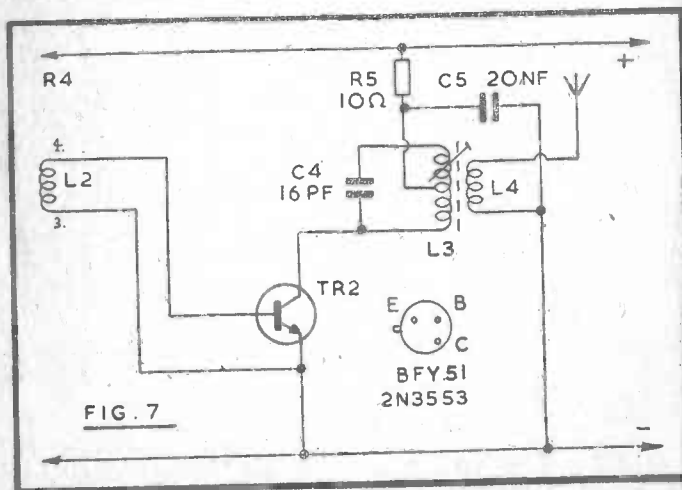

Power Amplifier

The circuit for the PA stage is shown in Figure 7. The coupling winding L2 supplies RF drive to the base of TR2. With this method, TR2 ceases to operate if drive is absent, and collector current is nearly zero. Final tuning of the oscillator can thus be for maximum collector current for TR2, provided the crystal starts when the circuit is switched on, as described.

Output from TR2 collector is to the centre-tapped coil L3, with parallel capacitor C4. L4 provides coupling to the aerial.

Numerous transistors will give good results with this circuit. The BFY51 is inexpensive and has a minimum f_T (frequency) of 50 MHz. The 2N3553 has a higher f_T and is a little more efficient. The small type of transistor as used in the oscillator stage can also give a good account of itself here. A finned clip on heat sink is required.

The indicating wavemeter will show if RF is present in L3, and tuning can be for maximum indication, and maximum brilliance of a 6 V 0.06 A bulb temporarily connected to L4. This should light quite brightly, with TR2 drawing about 40 mA. Only slight readjustment of tuning should be needed, when the bulb is disconnected and the aerial is in use.

Damage to TR2 is unlikely. It may arise when current input to TR2 is high, but RF output obtained is low, due to severely wrong tuning of L3. In these circumstances, virtually all the power flowing to TR2 is dissipated as heat. The larger type of transistor (BFY51) has a safe dissipation of 800 mW, so this is a safeguard, but the smaller type dissipation is around 300 mW, and these can in unfavourable conditions grow very hot here. Extra care is necessary if a 12 V supply is used, and current should be checked with a meter, or the circuit should be adjusted with a 9 V supply in advance.

With reasonable care, and with low voltage, it is not likely that any damage will be caused to TR2 during tuning-up.

Figure 6 shows the wiring layout for this stage. This gives a little separation between L1 and L3, as feedback can cause oscillation at frequencies not determined by the crystal. Coupling is reduced by placing the coils at right angles to each other. The layout could be a little more compact if a small can were used to screen L1. If the crystal is temporarily removed from its holder, RF output must cease, and battery current drop to a low level.

L3 is eighteen turns of 32 swg enamelled wire, side by side on a 5 mm cored former. The centre tap is scraped and tinned during winding. A single layer of paper or thin tape is put over L3, and L4 is wound on this, and has two turns each side the centre tap of L3. It is possible to raise the DC input to TR2 by providing greater aerial loading, increasing L4 to six turns. Optimum coupling does in fact depend somewhat on the actual transistor, as well as the battery voltage. Initially, the four turns can be used for the transistor types mentioned.

Built in this way, the oscillator and PA circuitry will need a board about 50 x 20 mm or $2 \times \frac{7}{8}$ in. This is compact, without going for the minimum size obtainable.

Stability

The likelihood of instability in the transmitter section of a transceiver depends on many factors. Difficulty of this kind may in some cases be introduced inadvertently.

It could be felt that using transistor holders would allow easy changing of transistor types, but holders are only generally possible in low frequency circuits. In VHF circuits in particular the extra capacitance and lead length can cause instability. (This is not so with some receiver circuits such as the super-regenerative detector, where collector-emitter feedback is needed.) Long transistor leads may also result in a circuit being unsatisfactory. In fact, even a 465 kHz IF amplifier which is unstable may need nothing more than shortening of base and collector leads, and stray feedback becomes more important as frequency rises.

There is a trend to the use of transistors with a typical f_T of hundreds of MHz and circuits with these are more likely to have VHF parasitics, than when transistors of lower f_T are fitted. A cure may be found in placing a ferrite bead on the base lead.

The gain of individual transistors varies, and in some cases substituting one transistor for another of the same type may result in instability. In such cases a miniature, low-value resistor in the base connection at the transistor (or sometimes the collector) will probably stabilise the circuit.

In VHF circuits in particular by-pass capacitors need to have the shortest practical lead length to avoid unwanted resonant effects. High value and low value capacitors in parallel may be needed to provide effective by-passing at both low and high frequencies. Capacitors in VHF circuits need to be components intended for such purposes, such as miniature disc.

Chances of instability develop as the power level rises and more stages are fitted using the same frequency. Oscillator and power amplifier, or oscillator, driver and power amplifier circuits need to be segregated both mechanically and electrically, when all working on the same frequency. Mechanical separation will allow screening between stages, while decoupling of the power line will prevent RF passing back from the power amplifier to the driver or oscillator. Circuits of the oscillator-PA, or oscillator-driver-PA type, with stages which follow the oscillator only operating when driven, should be absolutely "dead" in terms of RF, when the oscillator is temporarily put out of action.

Transistor damage can easily arise if a PA is operated with no load, or with a badly mismatched load. The PA may also be perfectly stable when working into a normal load, but unstable when the load is not present, so the latter does not necessarily indicate any fault.

In general, the circuits in this book will present no particular difficulty but it is not practical to relax normal precautions

such as by using transistor holders or allowing back coupling between inductors, without the possibility of trouble arising. Similar care would have to be taken in a receiver where two or more stages operate on the same frequency.

Transformer Coupled Modulation

To secure full modulation of the power amplifier by changing the collector voltage, potential at the collector will be swung from zero to twice the level present with no modulation. With this form of modulation, the instantaneous collector voltage could thus be expected to reach four times the supply voltage. Without modulation the collector potential may swing from zero to twice the supply voltage at radio frequency. With modulation applied, the potential to the collector would be doubled at positive peaks, so that the maximum RF peak is twice this, or four times the supply potential. As a result, the type of modulation which can be used for a PA, or the choice of the transistor, must allow for this.

Figure 8 shows a transformer coupled modulator, as used in a commercially manufactured transceiver. As this employs PNP transistors the circuit has a positive ground line.

TR1 is the first audio amplifier and driver, with base bias via R1/R2, and emitter bias by R3, which has the by-pass capacitor C3. T1 is the driver transformer, with a centre-tapped secondary, to drive TR2/3 in push-pull. R5, R6 and R7 set operating conditions in the output stage. C2 and R4 decouple the negative supply line to the first stage.

The speaker unit acts as microphone during transmission, and is switched to TR1 by switch section 1. C1 prevents disturbance of DC operating conditions as would arise if the speaker were directly across R2. Amplified audio signals are thus available in the output transformer T2, for transmission.

T2 has two secondaries, S1 and S2. Switch 3 applies the supply voltage through secondary S2 to the collector circuit of the power amplifier, thus modulating it.

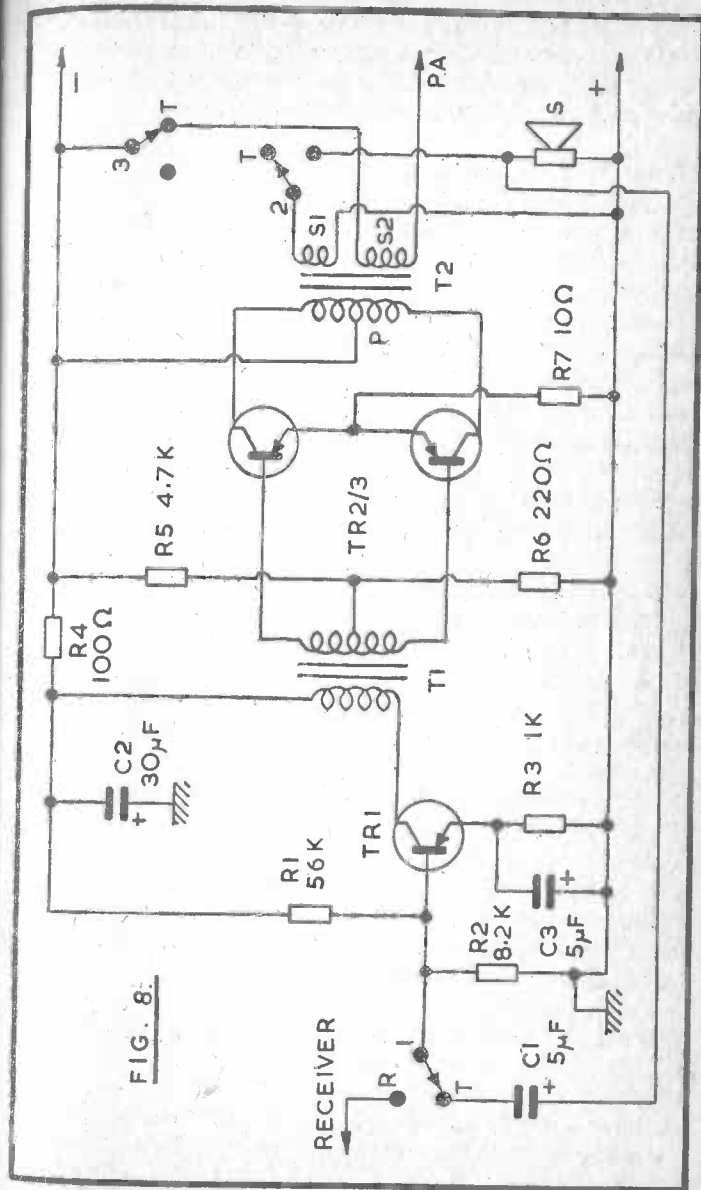

FIG. 8.

For reception, switch section 1 transfers TR1 to the receiver, while 2 connects the speaker to secondary S1, and switch 3 opens to interrupt the PA circuit. The same audio section can thus give speaker reception of signals received.

Except for the switching and T2, these stages are typical of many portable transistor receivers and amplifiers. Transformers such as T2 are not available generally, as they are made with individual turns ratio for the speaker (secondary S1) and transmitter section power amplifier (secondary S2). However, it is possible to obtain acceptable results by tolerating some mis-match, by resistance loading, or by using separate transformers or amplifiers.

PNP Modulator

Figure 9 is a circuit which can be constructed with a negative ground line. TR1 is again the first audio amplifier and driver for the output pair. The driver transformer T1 is of the type generally used in transistor portables or amplifiers with an output stage giving about 250 mW to 1 W. Typical transformers will have a ratio of about 2.6:1+1, to 3.6:1+1.

Normally, T2 would be to couple a 3 ohm or similar speaker, so would have a ratio of about 6.6:1 to 9.2:1, with a centre-tapped primary. If the amplifier were to be used for reception only, this could be retained. But for modulation purposes, a lower ratio is required. A high impedance speaker, such as a 75 ohm unit, is then used.

Base bias conditions for TR2/3 are determined by R5 and R6. If R6 is a pre-set component, as shown, satisfactory results can be obtained with quite a wide range of audio output transistors. If possible, TR2 and TR3 should be matched.

An initial test should be made with audio input to TR1 from a receiver, tuner, or other audio source. R6 is initially set at minimum value. A meter is placed in the battery lead, or connection to the centre tap of T2. R6 should then be carefully increased in value until objectionable cross-over

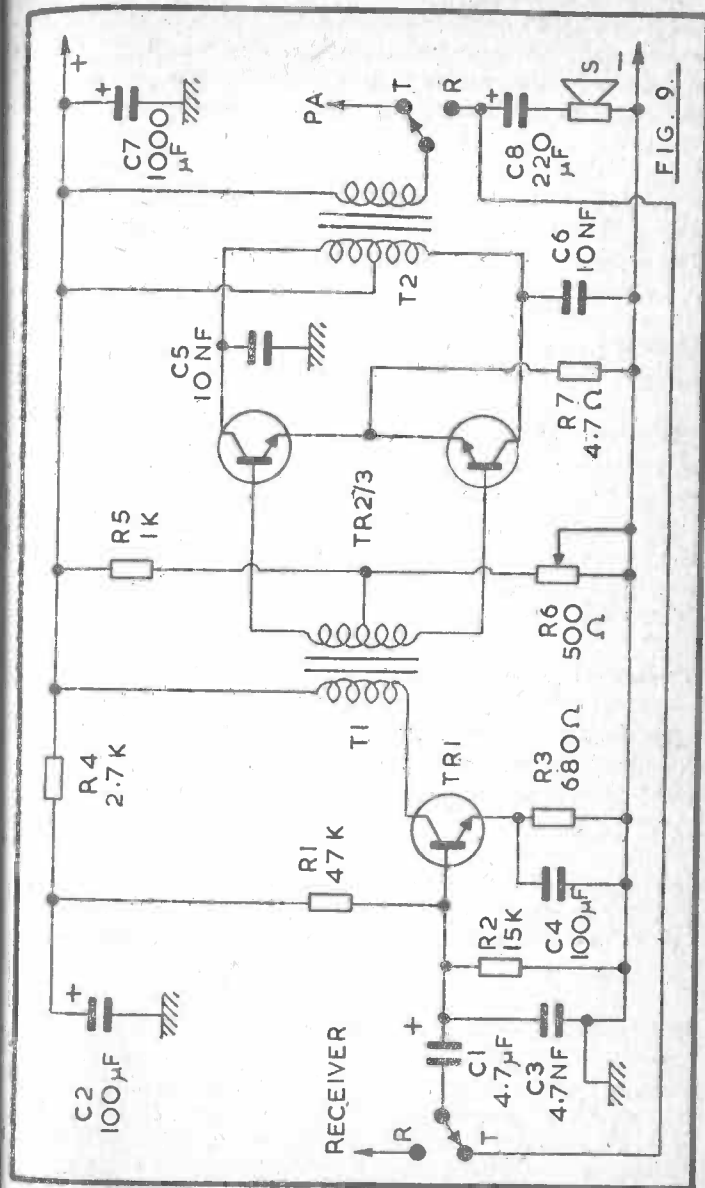

FIG. 9.

distortion ceases, but current is not over 10 mA or so, with no input. In these circumstances, current peaks at good volume will be 40 mA to 60 mA or so. If R6 is of too great a value, a large resting or no-signal current will flow in the output stage.

C3, C5 and C6 are to keep RF out of these circuits, and also reduce the higher audio frequencies. Reproduction through the amplifier should be of acceptable quality. R1, R2 and R3 will suit most audio driver type transistors.

Modulator Matching

The best ratio for the output transformer T2 is determined as follows:

$$\text{Ratio} = \sqrt{\frac{\text{Optimum load}}{\text{Speaker impedance}}}$$

As example, if the best load is 200 ohm, and the speaker is a 3-ohm unit, $\sqrt{200/3} = \sqrt{66} = 8$ (approximately) or 8:1.

An approximation of the modulating impedance of the PA can be found from V/I . As example, assume the PA draws 40 mA to 50 mA from a 9 V supply. This is a load of 225 to 180 ohm. So T2 can be approximately 1:1 ratio, ignoring the mis-match when operating the speaker.

Small transformers with a 1:1 ratio do not appear to be easily obtained. A transformer of near ratio, such as 3.6:1+1 can be utilised instead. It is also not too difficult to re-wind a transformer of the type which has not been dipped in wax or varnish. The core laminations should be taken out carefully, and put aside so that they can be replaced as originally. It will then be possible to unwind the bobbin, transferring the wire to a spare reel.

It is necessary to determine the number of turns required for the new winding. Because of the relatively low impedances, a very large number of turns will not be present, so that winding

by hand is not too difficult. Or it may be found that a better and more even winding can be achieved by making a simple mechanical winder. This can be an axle running in bearings, fitted with a handle one end, and clamping the bobbin between cones or wheels. (Constructional toy parts such as Meccano will be ideal for this.) The winder should be fixed to the bench, so that wire can be fed on with one hand, while turning and counting.

The turns ratio of the transformer can be found as described. With an output transformer, the primary or collector winding will be retained, and the speaker or secondary winding will be replaced. Some transformers have the secondary on top of the primary, and some have the positions of these windings reversed. If so, it will be necessary to take off the collector winding, before the speaker winding can be removed. The number of turns on the collector winding should be counted as they are taken off. From this, the number of turns on the new secondary can be calculated. As example, if the existing collector winding had 140 turns, and a 1:1 ratio is wanted, then the new secondary will also have 140 turns. A 1:1.4 turns ratio would be obtained with 100:140 turns, or 140:196 turns, and so on.

The wire used for the new winding will have to be chosen so that the turns can be accommodated. It will be of finer gauge than the speaker winding, and can generally resemble the collector winding gauge, but should not be unnecessarily fine. Turns will occupy the least space if kept neatly side by side. A layer of thin insulating material, extending the full width between the bobbin cheeks, should be put between primary and secondary.

Coloured sleeving can be used to identify the ends of the winding and all the laminations should be replaced as before. If the best ratio is not certain, the new secondary can have one or two taps, so that alternative connections will give a range of impedances.

In the interests of small size, the small or miniature type of

transformer will be required, and T2 can thus be of driver type, which will be of similar dimensions to a 250 mW or similar output transformer. The centre-tapped secondary will be connected as primary.

If T2 is intended for a much lower impedance load than that presented by the PA, the voltage swing will be much smaller than needed, and modulation of the signal will be weak.

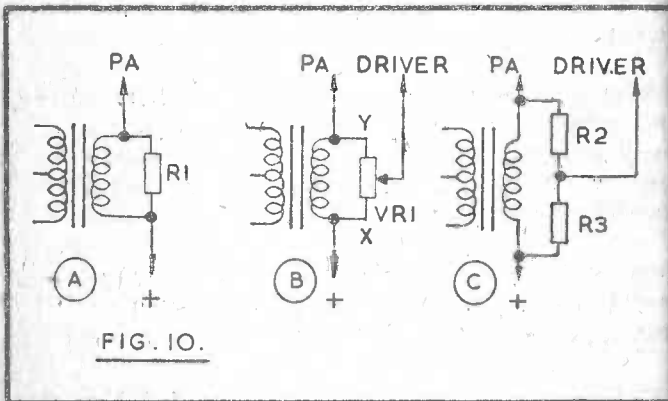

FIG. 10.

Should a transformer adopted for T2 require the load to be reduced, this can be done by adding a resistor as at A in Figure 10. This will also present a more linear load to the push-pull stage than does the PA, so that an improvement in modulation quality can be obtained. It will, however, waste some audio power. The load will be that of R1 and PA in parallel.

As mentioned, full modulation of a transistor PA does not give 100 per cent carrier modulation, so with some circuits the PA driver is also modulated. If so, modulation applied to the driver is at a reduced level. To avoid a tapped transformer, or one with multiple windings, a divider VR1, B Figure 10 can be used. Here, VR1 corresponds to the additional load resistor R1 at A. With the wiper at X, no modulation is applied to the driver. Modulation increases as the wiper is moved towards Y. The improvement in modulation can be checked

with a receiver. Values will depend on individual circuits. Generally the setting of VR1 is not very critical, and may be about one-third to one-half from X. Fixed resistors can then be substituted. At C, it is assumed that R1 should be about 100 ohm, so R2 and R3 are 68 ohm and 33 ohm, in the positions indicated.

Loading of this type can be useful when using an integrated circuit modulator, with adequate output power, but low impedance. A modulator of this type will be seen later.

It is quite usual to employ circuits in which modulation is only applied to the PA, and this may give 70 per cent or so modulation depth. But in some circuits extra modulation depth is quite easily secured by the application of some modulation to the driver.

It is practical to apply a limited degree of modulation to a crystal oscillator in a 2-stage circuit. Full modulation is not used, as this would interrupt the oscillator at audio frequency.

Full modulation requires a modulator supplying one-half the PA power. Thus if there were no losses a 250 mW modulator would be sufficient for a 500 mW PA. However, losses are present, and power available from the modulator can best be at least equal to that of the PA, or may even be substantially greater, with no disadvantage.

Modulation Monitoring

The speech quality obtained from a transmitter will be influenced by oscillator tuning and thus drive to the PA, as well as by PA tuning, aerial loading, and the degree of modulation applied. It is thus essential to employ some means of monitoring the signal, when first checking the transmitter.

This is very often carried out by means of a receiver, tuned to the signal. Such a method is satisfactory, provided overloading and feedback are avoided. Overloading of the receiver, due to the proximity of the transmitter, will be avoided by moving the receiver farther away, by using only a short pick-up aerial,

or by feeding the transmitter signal into a lamp load as described elsewhere.

Feedback of sound from the receiver loudspeaker to the transmitter microphone will cause howling. This is avoided by keeping the receiver volume low, or by using phones, as well as placing the microphone so as to avoid unnecessary pick up of sound from the receiver.

Modulation can also be checked by using headphones with the monitor/wavemeter described.

Some circuits will be found to be more tolerant of mis-adjustment than others. Attempts to raise modulation beyond the level which is appropriate will cause a considerable loss of speech quality. In any case of difficulty, it is worth while to test the modulator by feeding its output directly into a loudspeaker. If distortion is present, operating conditions in the audio amplifier have to be checked, as good speech quality cannot be expected from the transmitter.

On the other hand, if the audio amplifier used alone provides an acceptable audio signal, but transmission quality is poor, the fault must be sought in modulator matching, tuning or loading of the PA, the level of drive from the oscillator to the PA, or similar factors. It should be remembered that excess audio power may easily be applied to a low-power PA. This will be suspected if the speech quality of transmission improves when the audio level is reduced.

With the simple type of transmitter, it is usual to have a fixed level of audio gain. Correct modulation is then achieved by speaking at such a distance and volume as to give a normal audio output if the amplifier were operating a loudspeaker. For simplicity, and to avoid a high background noise and instability troubles, no high-gain microphone pre-amplifier is generally used, and the amplifier is intended for close speaking at about normal volume.

Audio IC Modulators

An integrated circuit audio amplifier will be found to give good results as modulator. There is not much saving in space over the driver/push-pull type of circuit with discrete components and using three transistors, but the IC will be expected to provide somewhat better speech quality and will have higher gain. Extra audio power will also be readily available.

Many popular audio ICs will give 1 W or more output, with a 9 V or similar supply. Though in some circuits the full output will not of course be required such ICs can have a low quiescent current, and operate excellently with good economy at the lower output level needed with a PA running at perhaps 250 mW to 500 mW input.

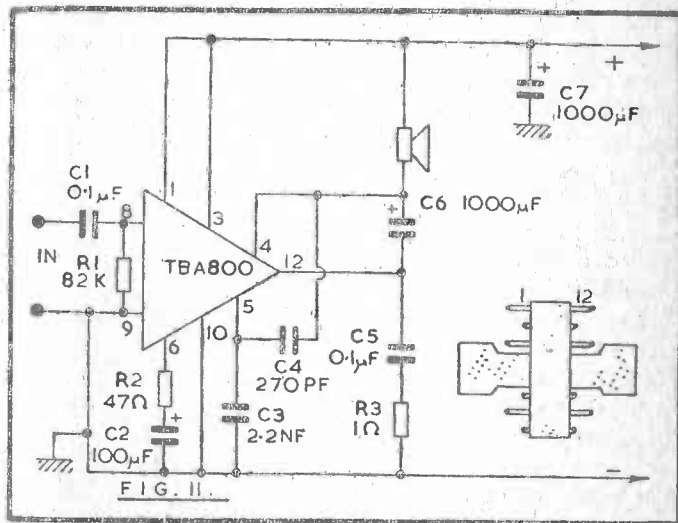

A useful IC is the TBA800, which can provide about 1 W with a 9 V supply, and does not require a very large number of other components. Figure 11 is a circuit for this IC. C4 should be closely connected to 4 and 5, and C3 is similarly near 5 and 10. Audio input is via the isolating capacitor C1, so operating conditions are not influenced by the DC resistance of the input circuit.

An 8 ohm load is suitable for this amplifier, which can be matched to the PA as described, by using a transformer. The ratio of this item will not prove to be too critical and as more audio is available than required for a low power PA it will be of advantage to load the secondary with a resistor, as explained.

Layout of this audio amplifier is not critical, provided input and output circuits are reasonably separated, and C3 and C4 are placed as mentioned. A 50 x 50 mm printed circuit for the TBA800 will be found in the "Handbook of IC Audio Preamplifier & Power Amplifier Construction" (Babani Press BP35) and this board can readily be incorporated in a transmitter or transceiver.

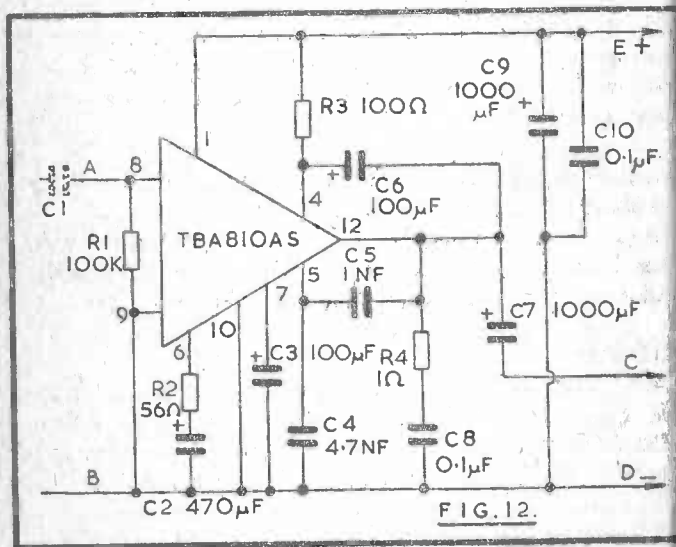

Figure 12 is the circuit of a somewhat more powerful audio IC amplifier, which will prove very satisfactory with a PA of increased input (say 1 W to 5 W). It may be used with a supply of down to 9 V, but is more appropriate for 3 watts output or over with a 12 V to 14 V supply, for a car, caravan, or similar transportable transmitter. With a 4 ohm load,

current peaks will be about 300 mA to 500 mA, for outputs of 1 W to 4 W, and though current is naturally lower with a smaller audio output, the IC with sink is rather too large for "pocket" equipment.

Audio input to 8 is by the isolating capacitor C1. It will be found that sufficient power is obtainable with a crystal microphone of high output type feeding the IC here. The IC requires a heat sink. With the load increased to 8 ohm, peak current falls to about 300 mA at 14 V, and output 3 W.

This IC can be fitted to a board along similar lines to that suitable for the TBA800 and no particular difficulty should arise in wiring this, or preparing a printed circuit.

An IC amplifier, in common with other amplifiers, should not be operated without a suitable load. The load must not be below the minimum quoted, or heavy peak currents may damage the IC.

A test should be made by feeding the audio amplifier into a 4 ohm or 8 ohm speaker. Input may be taken from a tuner or other convenient source, or from the microphone to be used. With the latter acoustic feedback from loudspeaker to microphone must be avoided in the usual way.

Matching

It is convenient to use a transformer for coupling the audio IC to the power amplifier of the RF section. This provides DC isolation of circuits, and also allows the choice of a suitable ratio to give satisfactory impedance matching.

With an audio IC, the output load intended will generally be low and may be from about 4 ohm to 16 ohm (actually designed for the direct connection of an appropriate speaker). So the coupling transformer will need to have a step-up ratio, since the modulation impedance of the PA will be greater than that appropriate for the IC amplifier. The ratio will naturally depend on operating conditions but may be around 1:2. This can be determined as described later. As an audio IC of the

type described will operate satisfactorily with a range of impedances (though with a falling off in maximum audio power output if the load is too high) there is useful latitude in the coupling ratio. The fact that excess audio power will be available for a lower power PA also means that resistive loading can be included. As this load is constant throughout the audio cycle, such loading will enhance operating conditions.

Figure 13 shows coupling of the IC amplifier in Figure 12 to the transmitter RF power amplifier, and where appropriate the driver can also be modulated as in Figure 10.

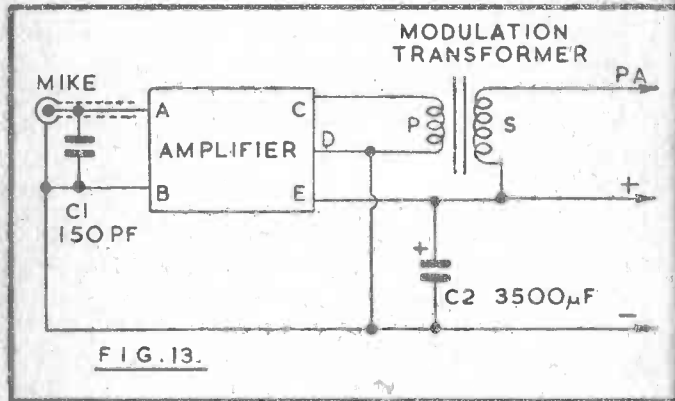

Audio Preamplifier

For additional gain with a microphone, or during reception, a preamplifier can be placed before the IC or 3-transistor type of modulator. The circuit in Figure 14 can be used. Typical values are: C1 1nF, C2 0.1μF, C3 0.1μF, C4 320μF, C5 0.5μF, R1 1.8 megohm, R2 8.2k, R3 1k, TR1 BC108, 2N3704. VR1 50k.

C1 is not required for reception only, but is often needed to help keep RF out of the audio section if an additional stage of this kind is provided as a microphone amplifier. The stage will have to be isolated from the RF section by layout or extra screening, or feedback may cause instability.

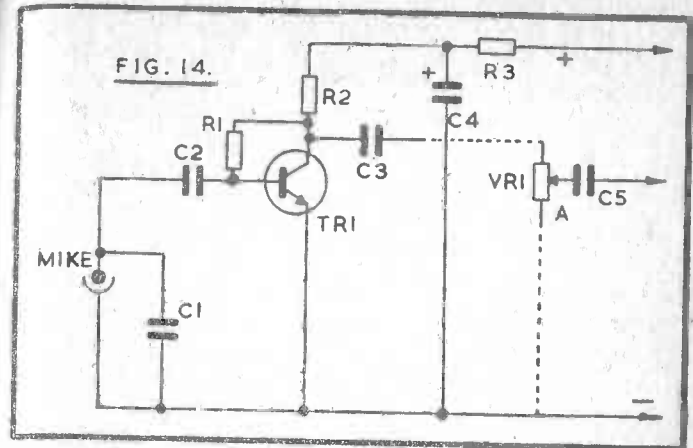

When this preamplifier is in use for reception, an audio gain control is needed. This may be present in the receiver detector circuit. If not, C2 or C3 may be taken to the wiper of a 100k or other volume control, as at A. (Where this potentiometer is the diode load in a superhet circuit, its value must be appropriate.) When fitting the gain control between the preamplifier and following stage, the potentiometer wiper will go to the IC input, or transistor driver stage base circuit.

In the interests of simplicity a pre-set audio gain control is more suitable for preamplifier-modulator units. This is left permanently adjusted to suit the normal speaking distance and microphone sensitivity.

Series Modulator

A series modulator will be found to give good speech quality in low power equipment, and it has the advantage that no modulation transformer is required, thus avoiding what may in some circumstances be a quite bulky, or difficult component. It can provide a signal which sounds well modulated in depth, and it is not particularly difficult to adjust.

Figure 15 is a circuit suitable for series modulation at low power. L1 and L2 are the oscillator and PA collector coils, and these stages are adjusted as already described, p.25.

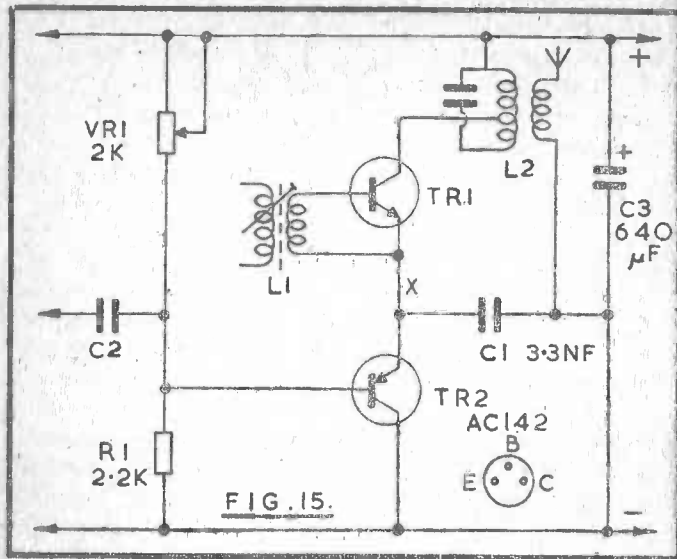

FIG. 15.

TR2 is the series modulator, and should be of similar or larger power handling rating than the input to TR1. Whereas TR1 is an NPN transistor, TR2 is a PNP device. For a BFY51 or other PA running at a few hundred milliwatts, an AC128, AC142, or similar audio type transistor will be satisfactory for TR2.

The base coupling coil for L1, supplying drive to TR1, is returned to the emitter of TR1, not to the negative line. C1 is a by-pass capacitor, and should be near TR1 emitter, offering a short RF path.

Base bias for TR2 is obtained from VR1 and R1. Adjustment of VR1 should begin with most of the resistance out of circuit. A high resistance voltmeter is clipped from X to negative line. TR1 should for preference have been already tuned up normally, as this, and the drive obtained from L1, will considerably influence the current TR1 would pass. VR1 is then adjusted so that the voltage at X is approximately half the supply voltage. That is, about 4.5 V for a 9 V supply, or 6 V for a 12 V supply.

Audio input applied to TR2 via the capacitor C2 ($2\mu\text{F}$). When the base of TR2 is driven positive, TR2 emitter current falls, while with negative drive emitter current rises. The voltage reaching TR1 is thus swung up and down at audio frequency, with consequent modulation of the carrier.

It will be found that speech quality improves if the voltage across TR2 — that is, from negative line to point X — is a little over one-half the supply voltage. This can be secured by appropriate adjustment of VR1. This setting is not very critical, and VR1 can be replaced by a fixed component of near value to that giving best results, VR1 being disconnected and measured with a meter.

If drive from L1, tuning of L2 and loading here, audio drive via C2, and VR1 are all adjusted, excellent speech quality can be obtained. But none of these adjustments are of a particularly tricky or critical nature. Audio input to C2 should be taken up to the point where the signal sounds strongly modulated, when tuned in by a receiver or monitor.

With X set at half the supply voltage, TR1 is operating at only half the voltage which could be present with transformer coupled modulation. As a result, RF output is lowered. However, a useful output is available. Compensation can be made to some extent by increasing the supply voltage — two extra $1\frac{1}{2}$ V cells will raise this from 9 V to 12 V. The rating of TR1 need only be twice the supply voltage (not four times, as with transformer modulation). Two audio stages will be the minimum to provide audio drive for TR2.

This circuit will function satisfactorily with a wide range of transistors and power inputs, from flea power to some watts input. In each case base bias for TR2 is set as described. With other than very small power, TR2 will require a heat sink to match that used with TR1.

The circuit can perform well when RF drive to TR1 is a little meagre. This is usually not so with transformer coupled

modulation of the collector, where drive requirements are high during those instants when the collector swings to approximately twice the supply voltage.

3-Stage 144 MHz Transmitter

If the number of stages in a VHF transmitter is to be kept down, it is necessary to start with an oscillator at a high frequency. This avoids the need for so many multipliers. Thus an oscillator working at 72 MHz to 73 MHz, followed by a doubler, will give an output in the 144 MHz to 146 MHz band. It is poor practice to energise the aerial from a doubler, because of the harmonic energy present, so the final power amplifier should work straight through at the same frequency. With these points in mind, a 3-stage transmitter for 144 MHz can consist of a 72 MHz oscillator, doubler operating with 72 MHz input and furnishing 144 MHz output, and PA functioning at 144 MHz. The circuit described here is of this type.

TR1 in Figure 16 is the crystal controlled oscillator. Collector current is about 4 mA to 5 mA with the stage not oscillating, and 8 mA to 10 mA when oscillating. Collector current, and RF output, can be adjusted to some extent by changing the value of R1 or R2.

L1 is ten turns of 32 swg enamelled wire, side by side, on a 4.5 mm diameter former, with VHF grade core. The crystal can be a miniature plug-in or wire ended type. Adjust tuning of L1, with the aid of an indicating wavemeter, for maximum RF, assuring the oscillator always starts when switched on, as explained earlier. Check that the RF is at 72 MHz, as harmonically cut crystals can be tuned to operate at a different multiple of their fundamental. Various other transistors than the type shown will be found to operate in this stage. As there are only three stages in all, and because of the reduced gain at VHF, it is essential to obtain the best efficiency from each section — oscillator, doubler, and final amplifier — to avoid the need for an extra transistor between doubler and TR3.

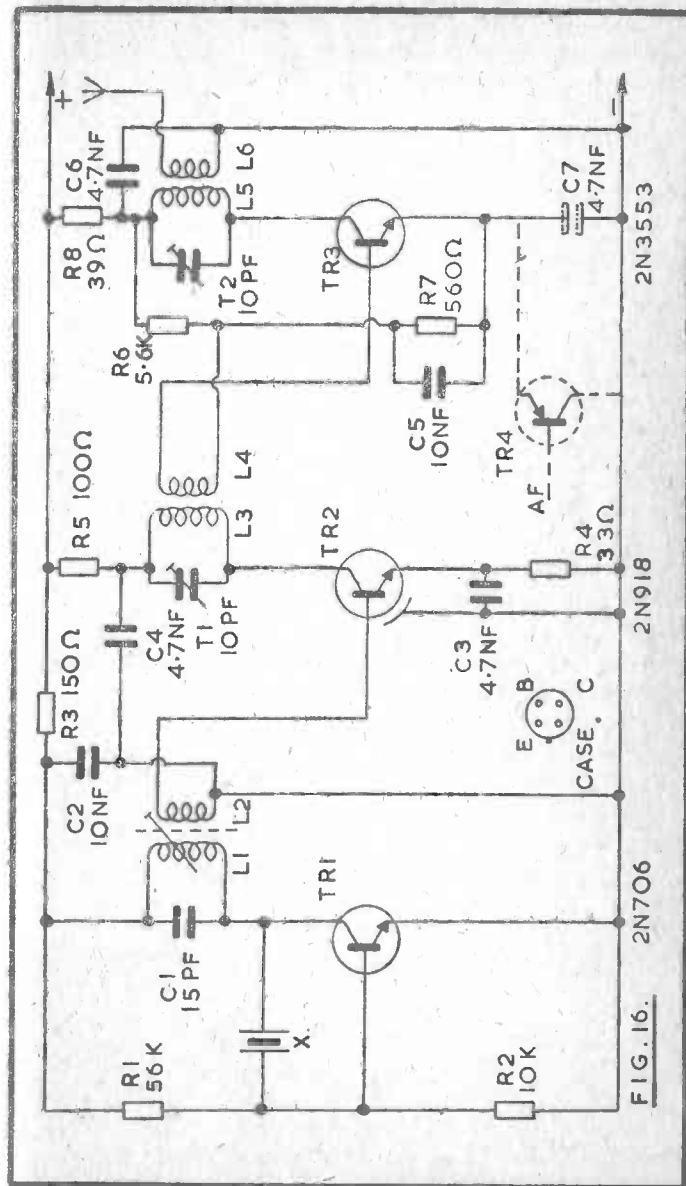

FIG. 16.

L2 is three turns, overwound on L1. Too tight coupling can prevent oscillation, while loose coupling will result in less power for the following stage. Adjustment to the position or number of turns on L2 can be worth while, to secure best drive to TR2.

L3 is tuned to 144 MHz, and consists of five turns of 20 swg wire, self-supporting, as a coil of 7 mm outside diameter, and with turns spaced so that the winding is 7 mm long. A suitable coil will be obtained by winding the wire on a 1/4 in diameter rod. Place the wavemeter near L3 and adjust the trimmer for best RF indication. This adjustment is quite critical, despite the small trimmer capacitance.

L4 is three turns of thin insulated wire, of the same diameter as L3. Its turns are pushed between those of L3. TR3 has some bias from R6 and R7. Inexpensive transistors suitable for 200 MHz or higher, such as the 2N706, will operate in the TR3 position. Collector current is about 20 mA and R7 may need selecting for best results, but can be 680 ohm or so for the 2N706, or 560 ohm for the VHF 2N3553. L5 is the same as L3. L6 is two turns of insulated wire coupled to L5. The tuning of all stages, and coil coupling, should be carefully adjusted for best RF output.

A series modulator will allow the whole equipment to be kept down in size, and will be found to give very good speech quality. It is placed in the emitter circuit as shown and can be adjusted as described. Modulation may also be provided by the other methods dealt with.

Initial tuning up of this and similar circuits would not generally be attempted without an indicating wavemeter. This is positioned so that suitable coupling is provided with L1, L3 and L5, in turn. The wavemeter reading is peaked up by tuning the wavemeter, and the transmitter circuits are then tuned and adjusted for the best wavemeter indication. Once L1 and L3 are provisionally set so that an indication is obtained at L5, all adjustments can be directed towards securing the best RF output at L5. But initially it may not

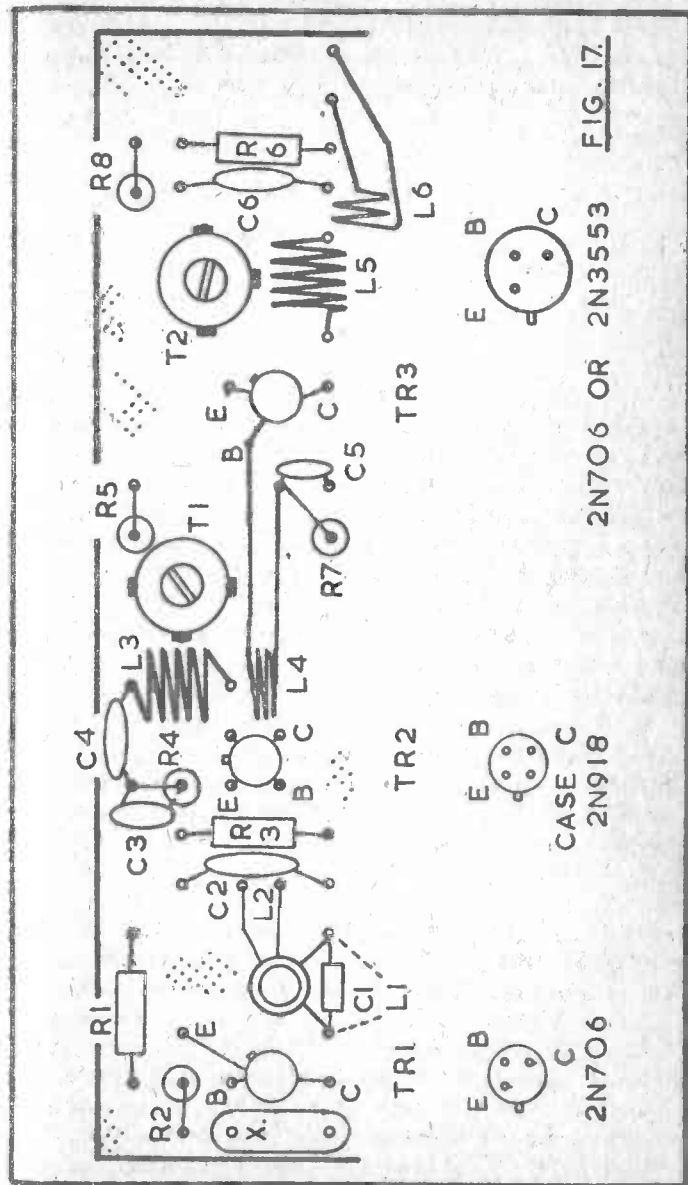

FIG. 17.

2N706 OR 2N3553

CASE C
2N918

2N706

be practical to check for RF at L5 only, as should L1 be mis-tuned TR1 will not oscillate, while wrong tuning of L3 can also cause a complete absence of output from TR3.

Figure 17 is the layout of components for this circuit. L4 is shown separated from L3 for clarity. This also applies to L6, which is of insulated wire, with turns between those of L5.

Connections should be as short as possible, this including emitter, by-pass capacitor and other earth returns. It will not be feasible to drive the 2N3553 type of transistor to full output, but its VHF performance is better than that of the 2N706. Once the circuit is providing output at 144 MHz, individual adjustment to component values, and tuning and coil coupling, will allow the best possible performance to be achieved with the three stages.

Transmitter for 80 or 160 m

The 3.5 MHz band offers local short range contacts and longer distance working by sky wave, while the 1.8 MHz band is quite often used for low power. Transmitters for these frequencies are easily constructed and can operate with good efficiency. Many transistor types exist for use at frequencies under about 4 MHz, and those chosen can best be for frequencies up to 10 MHz or so. Higher frequency types are satisfactory, but the chances of high frequency parasitics increase with HF and VHF transistors. It is thus a disadvantage to fit devices which could operate up to the VHF region, when the equipment is for the low frequency bands.

In Figure 18 TR1 is the crystal controlled oscillator, with a fundamental frequency crystal X. It will thus be 3.5 MHz to 3.8 MHz for the 80 m band, or 1.8 MHz to 2.0 MHz for 160 m. For CW operation on 80 m, the operating frequency is generally from 3.5 MHz to 3.6 MHz. R1 and R2 provide base bias, and C1 is for decoupling, with R3 in the positive line. L1 is tuned approximately to the crystal frequency, in the way described. C2 and C3 in series are across L1, and their junction provides a drive point for the base of TR2. This

stage has base bias from R5 and R6, and output is into the tapped coil L2. L3 is for aerial coupling.

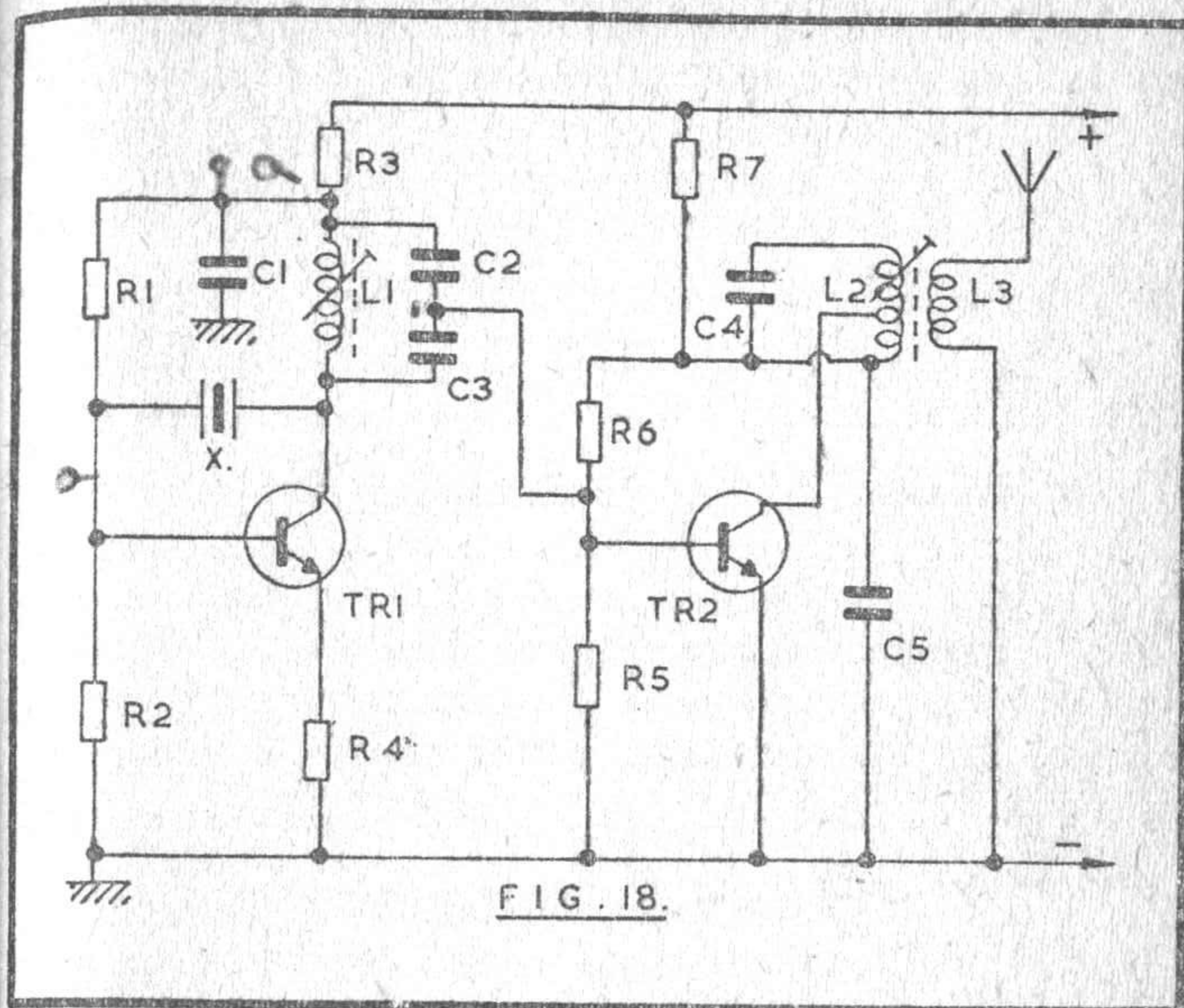

FIG. 18.

Component values for Figure 18

R1	33 k
R2	10 k
R3	270 ohm ½ W
R4	22 ohm
R5	10 k
R6	33 k
R7	33 ohm
C1	0.1 μF
C2	1.5 nF silver mica
C3	1 nF silver mica
C4	400 pF silver mica
C5	20 nF
TR1	BFY51 etc.
TR2	BFY51 etc.

80 m inductors. L1 is thirty-two turns of 32 swg enamelled wire, wound side by side on a 3/16th in or 5 mm diameter former, with core. It might in some circumstances be necessary to change the number of turns slightly, for crystals near the band edges, according to the type of core and tolerances of C2 and C3. L2 is wound with 24 swg enamelled wire on a 3/8th in or 10 mm former, and is twenty-three turns, with the collector tapping seven turns from the C5 end of the winding. L3 is four turns, overwound on L2, but coupling here can be changed to suit the aerial.

160 m inductors. L1 is increased to fifty-five turns, in a compact pile. The core for L2 is a piece of ferrite rod 1 in x 3/8th in in diameter, and L2 is twenty-eight turns of 24 swg enamelled wire, tapped at eight turns, with L3 having five turns, overwound. The turns are on a thin card tube so that the ferrite core can be moved for tuning purposes.

The circuit will operate with a wide range of voltages, up to the maximum for the transistor types, and where necessary allowing for modulation as described. R7 may be disconnected for collector modulation of TR2. It is possible to modify the relative values of C2 and C3, and the position of the tap on L2, to suit the operating voltage or transistors. Miniature plug in crystals will allow moving to various frequencies on the band. Check that all RF output ceases when the crystal is removed.

RF Power Amplifiers

With a final radio frequency power amplifier running with an input of about 200 mW to 400 mW or so, economical operation is possible from small batteries. This power is sufficient for point to point contact over reasonable distances. But for larger yet still portable equipment an increase in power level may be wanted, and it may be practicable to draw current from a vehicle accumulator in some cases, or to have this as an alternative to a 12 V or similar dry-battery supply. Even

with a small battery, an increase in power is feasible if it is realised that earlier replacement of the battery pack will be necessary.

With many circuits it is possible to add a larger power amplifier. In some circumstances this can replace the existing PA, but in others the low-power PA can perform as a driver stage for the new PA, which will have a higher power rating.

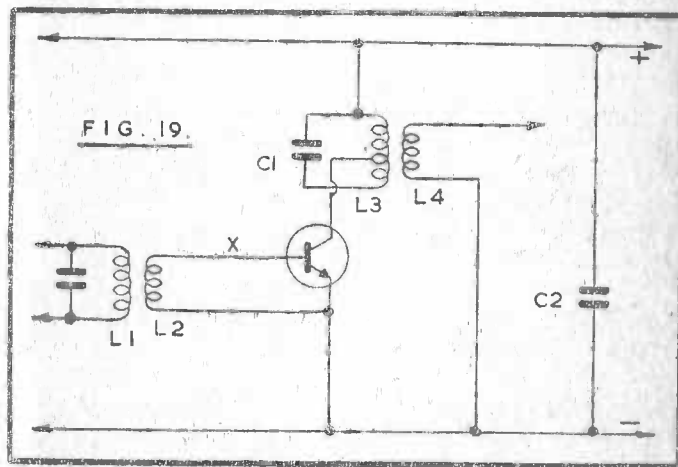

Figure 19 shows the basic PA output stage, and this can be a basis for increasing power on 160 m to 2 m. This stage may run with the same voltage as the remaining circuits of the transmitter, or may be operated from a different voltage, where necessary, and it can be modulated by any of the methods described.

If the existing PA transistor is to be changed, L1, L2, L3 and L4 will be present. But where the stage will be additional to the existing circuit, L1 will be the old PA collector winding, and L2 the aerial coupling winding, so that a further transistor, with L3, L4 and associated components, will be added.

As an example of adding this further stage as power amplifier, it can follow the 2-transistor circuit in Figure 18. L1 and L2 will thus be present. L3 and L4, Figure 19, can be wound in the same way as L2 and L3, Figure 18, for 80 m operation. A 400 pF capacitor is used across L3 (Figure 19) and tuning is by the adjustable core. A suitable transistor is the BD139. Tuning up of all stages will be as already described, and for test and tune-up purposes L4 can be connected to a 12 V 2.2 watt bulb. The stage can be modulated by the larger IC modulator shown, transformer coupled to the collector circuit.

Layout must avoid feedback from L3 or associated circuits, to L1, or the base circuit. This is best arranged by having the new stage in a small screening box, or at least having a screen between this and the previous stage. Remember that in all transmitters the RF output should cease if the crystal is disconnected or taken out. If this is not so, oscillation is arising elsewhere and must be prevented. To improve stability, a 10 ohm to 22 ohm resistor may be inserted at X, near the base.

C1 and L3 will of course depend on the working frequency. C2 is a by-pass capacitor, and should be arranged to offer a short RF path from L3 and L4 to PA emitter and ground line. C2 cannot be of large value when collector modulation is used, as it is effectively across the audio output of the modulator. It can generally be about 10 NF for LF circuits, but can be reduced to 4.7 NF or 1 NF for 28 MHz or 144 MHz. With series modulation (Figure 15) the same considerations apply to the capacitor which will be from PA emitter to ground line. With this form of modulation, C2 can now be 0.1 μ F or larger for LF transmitters, as it is no longer across the modulator output.

With three stages, modulation can now also be applied to the driver, as shown. This increases the overall modulation depth.

Modulator or RF voltages must not be allowed to travel along the positive line to earlier stages, such as a microphone

pre-amplifier or oscillator. It may be necessary to place a resistor as RF stopper in series with L3 at the positive end, with C2 directly from L3 to ground. The resistor has to be of low value to avoid loss of voltage, and 10 ohm can be fitted. A large capacitor – say 1000 μ F or more – should be connected across the modulator positive and negative lines, near the modulator.

When initially setting up a PA stage such as that in Figure 19, a meter should be included in the positive supply, so that current can be checked. A multi-range instrument set to its 1 ampere range will generally be suitable.

Adjustable cores are not shown for L1 and L3, but are used for the LF bands or 28 MHz. For 144 MHz, tuning may instead be by small pre-set capacitors, with self-supporting coils. If core-tuned coils are employed, it is essential that the core material is of a grade suitable for these frequencies.

The following list of transistor types will give the more important operating conditions. The suggested uses are not of course the only ones to which a particular transistor could be put. Transistors with high collector voltage ratings will be of special use where transformer coupled collector modulation is to be used. Figure 20 gives lead information on the types listed. It is not possible to list all transistors which might be

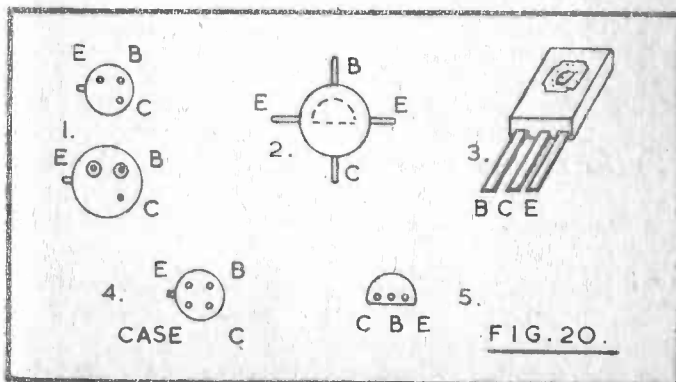

Type	Base	IC	V _{ce}	P	f _T	Typical uses
2N918	4	50 mA	15V	200 mW	600 MHz	doubler, driver
MPS3563	5	100 mA	12V	200 mW	200 MHz	oscillator, driver, amplifier
2N706	1	200 mA	20V	300 mW	200 MHz	oscillator, driver, amplifier
2N3641	1	500 mA	30V	350 mW	250 MHz	oscillator, driver, amplifier
2N2222A	1	800 mA	40V	500 mW	300 MHz	oscillator, multiplier, amplifier
BFY51	1	1 A	30V	800 mW	50 MHz	oscillator, driver, amplifier
2N3053	1	700 mA	40V	1 W	100 MHz	amplifier
BD139	3	1.5 A	80V	6.5 W	250 MHz	amplifier (not VHF)
2N3553	1	1 A	40V	1 W	250 MHz	VHF amplifier
2N5995	2	1.5 A	14V	10.7 W	175 MHz	HF, VHF amplifier

used in the RF section of a transmitter, and there are other types which will prove to be satisfactory. The upper frequency limit of a transistor should be substantially higher than the actual working frequency required.

Data are in the following order: Lead information (Fig. 20), IC or maximum rated collector current, V_{ce} or maximum collector to emitter voltage, P or maximum device rated power dissipation, and f_T (frequency).

No single rating should be exceeded. Maximum operating conditions may thus be limited by current, voltage, or power dissipated. Heat sinking is necessary for the larger transistors unless used at such lower power that the temperature rise is not important. All are NPN types.

Transceiver Switching

Switching from reception to transmission can be with a push-switch (push to talk) or a small rotary switch, marked with receive and transmit positions. With the latter type of switch, it is convenient to fit a 3-way component, and the third position can be used for "off" to avoid a separate on-off switch.

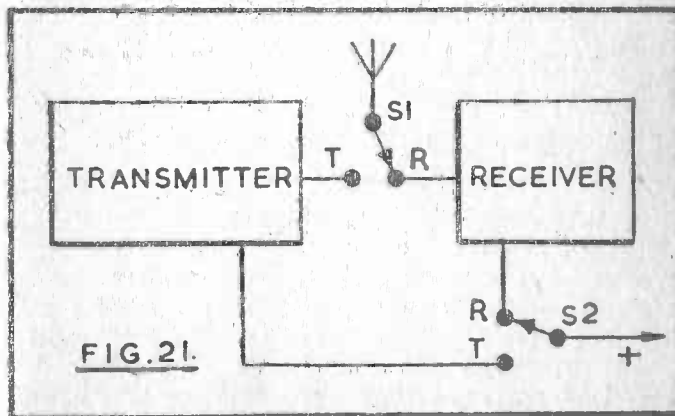
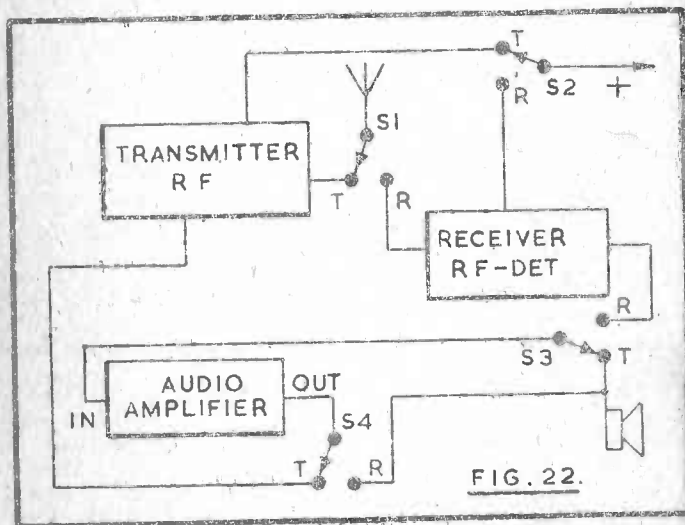

FIG. 21.

Where the transmitter and receiver are separate units, a 2-pole switch is adequate, as in Figure 21. During reception, section S1 takes the aerial to the receiver, and S2 applies battery voltage to this section. The loudspeaker is permanently connected and the receiver has its own audio amplifier.

This method has some advantages. The transmitter, with its modulator, will be a completely separate unit. The receiver will operate alone, and can be changed or replaced without disturbing any part of the transmitter circuit. Switching is simplified. A disadvantage is that the receiver requires its own audio amplifier, but this need take up little space.



In Figure 22 switching has been added so that a single audio amplifier is in use for both transmission and reception. Switch sections S1 and S2 operate as before. S3 transfers the input circuit of the audio amplifier to the receiver for reception, and to the speaker (as microphone) for transmission. S4 switches the audio output to the speaker for reception, or radio frequency section of the transmitter to provide modulation, as required.

The receiver now needs no audio amplifier or output stage, but there is additional switching, with interconnection of units. It is necessary to avoid unwanted coupling of RF energy from S1 or the aerial circuit, to S3 or the audio amplifier input, as feedback of this type will cause instability on speech peaks or continuous instability.

Modifications of these circuits are possible. In Figure 22 the speaker is switched from receiver output stage to modulator input stage, so that a separate microphone is not required. This is most easily arranged by having the speaker returned to the negative line for both circuits, with capacitor coupling, so that a further switch pole will transfer the speaker as shown (see Fig. 8). But as a microphone need occupy little space, it may be preferred to retain the speaker for reception only.

With some commercial equipment, additional switch poles are present, so that greater isolation can be secured between audio amplifier input and output circuits, or between audio input and aerial circuits.

For push-button change-over, no intermediate off position will be available and the main on-off switch may then be separate, or may be incorporated in the receiver audio gain control when present. The best method of change-over is by push-button switch, which automatically returns to "receive" when released. A spring biased toggle switch, similarly used, is also satisfactory. Easily obtainable small push switches have a limited number of poles, and this may in part help decide what type of change-over switching can be used.

PNP Transmitter

Figure 8 is the circuit of a modulator which has a positive ground line, and using PNP transistors. Figure 23 shows a positive ground line oscillator and power amplifier intended for use with this modulator, and running at about 200 mW. It will be seen that the circuit arrangement follows that employed with NPN transistors and a negative ground line. No modulation is applied to the crystal controlled oscillator

TR1. Current drawn by the oscillator is about 5 mA, with about 30 mA for the PA.

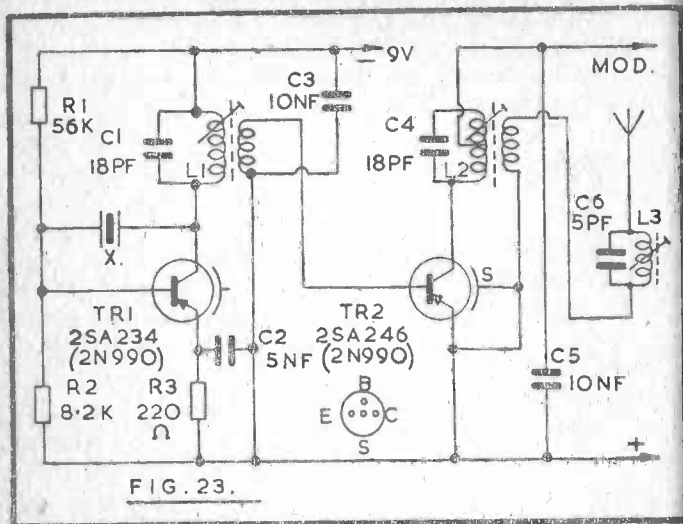

Tuning up and working of this circuit would be as already explained. The additional coil, L3, with parallel capacitor, provides loading for the aerial circuit, as explained in the section on aerials and aerial coupling. This enables greater efficiency in terms of radiated power to be obtained.

SECTION 2

Reception

28 MHz Super-regenerator

A super-regenerative receiver can be very sensitive, and may exceed the performance of the simpler type of superhet in this respect. It requires relatively few components, and has no alignment difficulties. Such receivers have seen considerable use in walkie-talkie equipment.

Disadvantages of the super-regenerative receiver are lack of selectivity, background hiss, and possibility of causing interference by radiation. Generally, with point to point and similar communication, high selectivity is not essential. The loud hiss, characteristic of this type of receiver, ceases when a signal is tuned in. Radiation is reduced by fitting an RF stage to help isolate the regenerative detector from the aerial. Radiation is also at a low power level, so is likely to cause interference only when the receiver is used quite near other stations operating on a similar or adjacent frequency.

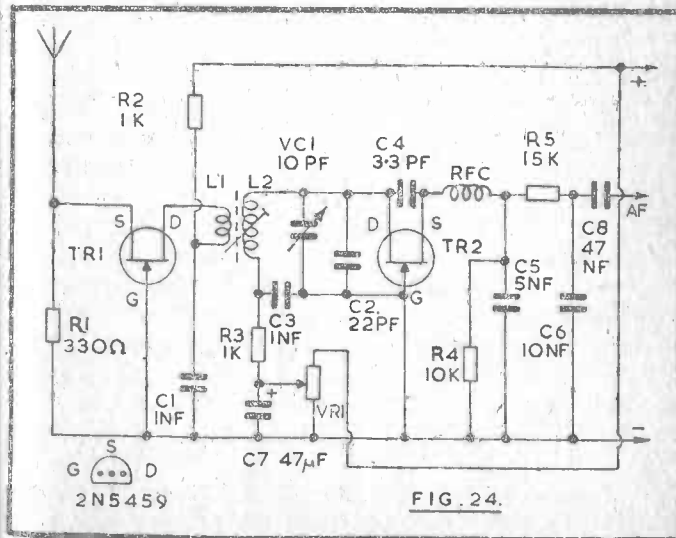

Figure 24 shows the RF and detector stages of a super-regenerative receiver for 28 MHz. TR1 is primarily a buffer, and no amplification is expected here. It is scarcely worth while providing a tuned circuit, though it would improve efficiency. R1 is for source bias of TR1.

TR1 drain is coupled to L2 by L1, and L2 is the only tuned circuit present. VC1 allows reception over the whole 28 MHz band. C2, and the core setting of L2, determine the actual frequency range.

Regeneration arises by the feedback via C4, and is quenched by the network R4/5 and C5/6. Transistors such as the 2N5459 give excellent results in this circuit. There is some slight advantage in using a VHF type of FET for TR1, but this type may result in too strong regeneration in the TR2 position. Regeneration is controlled by VR1, and the hiss should commence with this rotated about half to two-thirds from its zero (negative end) position. C4 has considerable influence on regeneration and can generally be as shown, though 1.8 pF to 4.7 pF can be tried if necessary, or a 5 pF trimmer.

The circuit is followed by an audio amplifier. For a very small receiver for phones, a single stage is adequate. A 2-stage amplifier will provide reasonable loudspeaker reception. The amplifier may be that used as modulator on transmission.

L2 is wound on a former approximately 5 mm in diameter, and is fourteen turns of 32 swg enamelled wire, side by side. L1 is eight turns, near the C3 end of L2. A space of about 2 mm between L1 and L2 will be satisfactory. If L1 is very near L2, regeneration may be prevented, while unnecessarily loose coupling will reduce volume. The core of L2 is adjusted so that the wanted frequencies are found with VC1 about half closed.

The RF choke can be wound on a carbon 2.2 megohm resistor which is about 3½ mm in diameter and 10 mm long, or upon a

piece of insulated material of similar size. It has one hundred turns of 42 swg wire, in two compact piles each of fifty turns. The wire ends are soldered to the resistor leads, which support the choke. The turns must not be varnished or waxed, but touches of adhesive can be used to avoid them coming loose.

VR1 has to be turned beyond the point where oscillation begins, so that a loud hissing is heard. This ceases, as mentioned, when a signal is tuned in. Adjustment of VR1 is not very critical, except with very weak signals. The usual type of telescopic aerial is fitted.

Layout of the components does not prove to be too important provided short leads are possible for TR1, L1/L2 and TR2, including C3, and the variable capacitor with C2. A suitable layout for 0.15 in matrix perforated board is shown in Figure 25. A miniature tuning capacitor of the type made by Jackson Bros. (the C.1604) will allow size to be kept down, though any small capacitor of low value will give the same results.

A rim control potentiometer, as used in pocket and small radio receivers for audio gain, will also save space. As this component is a potential divider any value from about 5 k to 25 k is satisfactory. Alternative, a small linear potentiometer of ordinary type can be fitted to the case near VC1. The finished receiver will more easily slip in a pocket if the knobs are at the top. It would be possible to accommodate these components on a somewhat smaller board, but is not easy to obtain speaker units of less than about 2¼ in in diameter, so this item sets one minimum dimension.

If the layout shown is followed, wiring should be quite easy. Position the coil slug towards the L1 end of the coil. The RF and detector sections of the receiver may be tested by connecting medium or high impedance phones from C8 to the negative line.

This circuit, followed by a simple AF amplifier, can be used for a receiver to be employed alone. Current can then be

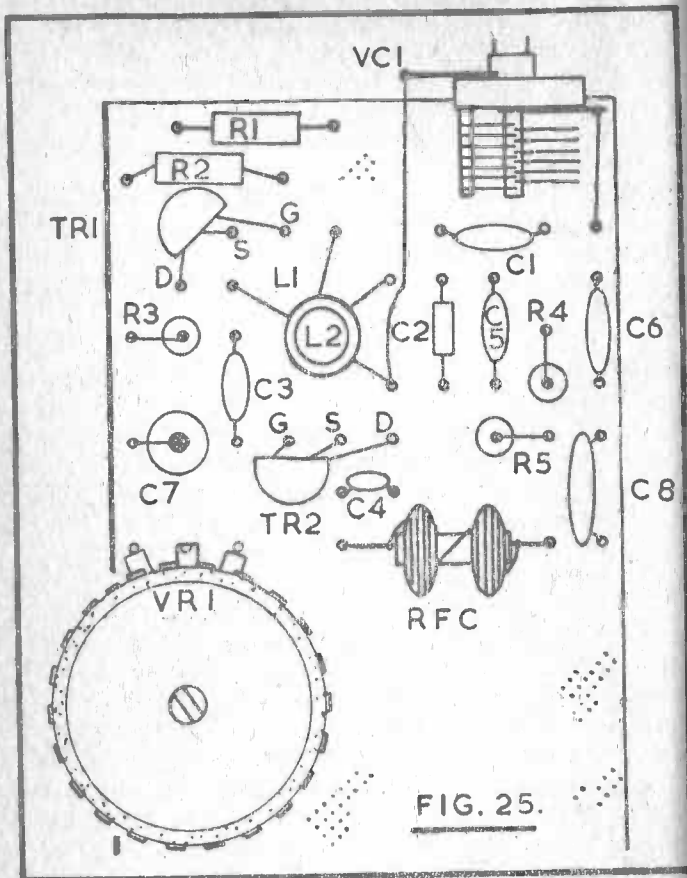

FIG. 25.

taken from a small 9V layer battery. If the circuit is fitted in a transceiver, power is drawn from the transmitter section batteries.

2-Metre Super-Reg Receiver

The simplicity of the super-regenerative receiver makes it of advantage for 144 MHz, provided its limitations are remembered. It is readily adapted to tune the VHF bands, and a superhet of equal sensitivity would need considerably more components.

The circuit can be basically as shown for 28 MHz (Fig. 24). Both FETs should be for VHF use, with a top frequency of 200 MHz or higher. It will be necessary to modify L1 and L2, and the RF choke. Self-supporting coils are convenient, in view of the small number of turns necessary. The choke may be constructed along the same lines as described for 28 MHz, but is wound with turns-side by side, over a length of about 8 mm. L2 is three turns of 18 swg wire, self-supporting, and arranged as in Figure 26. It is 12 mm diameter and 17 mm long. C2 is a miniature 15pF pre-set. L1 is two turns, near L2, spacing being adjusted for best reception. Very short leads should be obtained in the RF circuits.

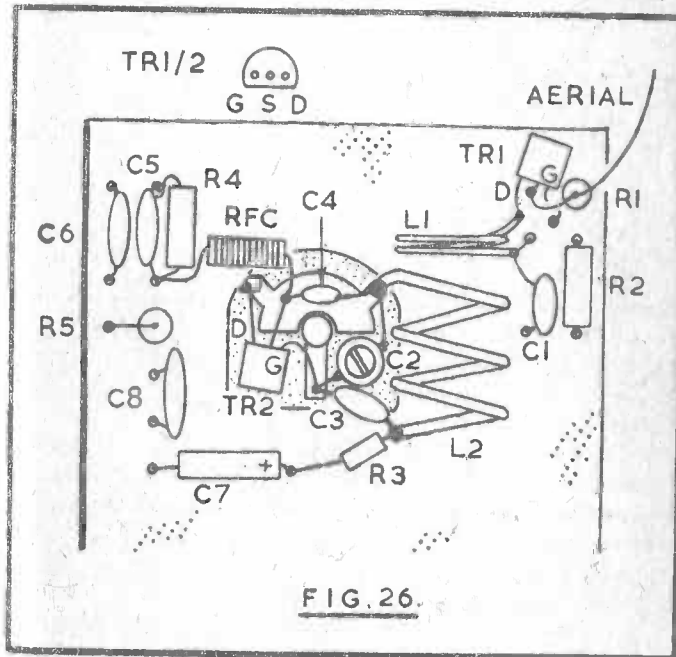
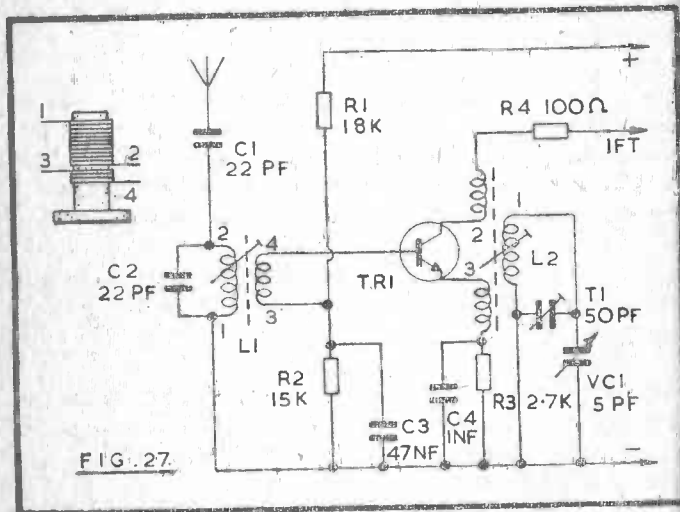

FIG. 26.

This section is followed by a 2-transistor, or transistor and IC amplifier, for loudspeaker reception. C8 runs to an audio gain potentiometer, AF being taken from the control wiper.

28 MHz Mixer/Oscillator

A self-oscillating mixer for use in the 28 MHz band is shown in Figure 27. The whip aerial is coupled by C1 to the aerial coil L1, which has the parallel capacitor C2. The secondary of L1 provides input to TR1, and R1 and R2 provide base bias.



The oscillator coil L2 has coupling windings for emitter and collector. Trimmer T1 and the core of L2 allow setting up for the 28 MHz band, and manual tuning is by the small variable capacitor VC1. R3 provides emitter bias. Output from the mixer is via R4, to the primary tapping of the first IF transformer. It will be found in some cases that R4 is not necessary to maintain stability, but it is required if continuous whistles accompany reception.

As aerial tuning is relatively flat, and only a narrow band of frequencies will be required, variable tuning is not necessary here. Instead, the core of L1 is peaked up for best reception on the wanted frequency, or at about the middle of the range of frequencies which will be received.

L1 is wound with 32 swg enamelled wire, using a 5 mm or similar diameter former, with adjustable core. Begin at point

1 and fix the wire with a spot of adhesive. Wind twelve turns side by side, and finish this coil at 2. A very small space is left, and the wire is fixed at 3. Four turns are then wound in the same direction as before, and the coil terminates at 4. The wire ends are long enough to reach the various connecting points. The core is located towards the bottom of the twelve turn winding.

The oscillator coil L2 is wound on a similar former. It has seven turns for the tuned winding, four turns for the collector winding, and two turns for the emitter winding. The wire can be 32 swg enamelled as before, or thinner wire may be used for the two smaller windings. Points 1, 2 and 3 are the start of each individual winding, and all windings are in the same direction. The seven turn winding is put on first, and the two smaller windings are placed on top of this, to be tightly coupled.

Adjustment of T1 and the core allows the 28 MHz band to be tuned without too violent oscillation, and VC1 covers an adequately large band. By fitting a small capacitance here, the need for a reduction drive is avoided.

When testing this circuit for the first time, note that the frequency coverage depends on L2 and T1 (with VC1). When coverage is suitable, the core of L1 is merely peaked for best volume. The positive supply line from R1 passes to the positive line of the IF board, or pin 3 of IFT1.

With an intermediate frequency of 465 kHz, L2 may be tuned either 465 kHz above the reception frequency, or 465 kHz below this frequency. This has no practical effect on efficiency, but it is more usual to have the oscillator tuned HF of the aerial circuit.

A range of NPN mixer and oscillator transistors will operate in this circuit. The BF194 is recommended, but other transistors with fT going up to 200/250 MHz, and hFE of 100 or so will operate.

Mixer for 160 and 80 m

The low frequency bands, 1.8–2.0 MHz (160 m) and 3.5–3.8 MHz (80 m) are favourites for low power working with some operators. They have seen considerable Amateur mobile service, and there is a power limit of 10 watts for 160, so that reduced power is on a more favourable footing than on those bands where high power is in order. Hand held equipment for these bands is practical when a home 160 m or 80 m station is to be contacted, but the aerial situation is not a good one due to the very short length which is practicable, and the need for loading this for low frequency working. Easily portable equipment which can be set up at a camping or holiday locality can have the advantage of a long aerial. This greatly improves transmission, so that useful distances can be worked. Such an aerial may be a temporary wire of random length, supported by any means which may be to hand, and operates as described in the section on aerials.

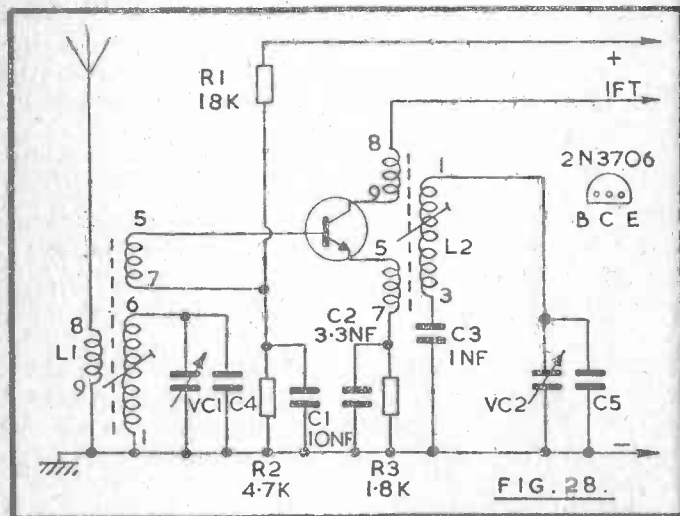

A self-oscillating mixer for the LF bands is shown in Figure 28. L1 is the aerial coil, with aerial coupling and base coupling windings. R1 and R2 are for base bias. L2 is the oscillator coil, and R3 is for emitter bias. C2 should be as shown, or not much larger, or squegging may arise on some frequencies.

In view of the fairly large number of turns needed, ready-made coils are most suitable. For L1, a Denco (Clacton) Ltd "Blue" Range 3T coil is satisfactory, and pin numbers are for this. L2 is the "Red" Range 3T coil by this manufacturer. C3 is a padder, and although this should be 1100 pF, a value of 1000 pF is satisfactory. A silver-mica component is preferred. With a 39/352 pF capacitor swing, these coils will tune from 1.67 MHz to 5.3 MHz. So by employing suitable fixed capacitors for C4 and C5, and selecting VC1 and VC2 to suit, either 160 m band or 80 m band operation is possible. For 160 m, C4 and C5 are each 250 pF, with a 2-gang 75 pF capacitor for VC1/VC2. For 80 m, C4 and C5 are each 75 pF and the ganged capacitor is 20 pF each section.

Band coverage obtained with the swing of VC1/VC2 depends on the core setting of L2. The oscillator operates at 465 kHz above the aerial frequency. When L2 core is set for suitable coverage, the core of L1 is adjusted for best sensitivity and volume.

A very short aerial (e.g., telescopic whip) may be taken directly to 6 of L1, for maximum sensitivity. But other aerials are connected to 8, to employ the coupling winding.

Circuits of this and similar type will often have no radio frequency amplifier, as results can be adequate without this extra stage. Where a higher performance is required, and a quite ambitious set of portable equipment will be made, an RF stage can be added. Suitable details will be found in "50 Field Effect Transistor Projects" (Babani Press BP39). A tuned RF stage will increase range and sensitivity, as well as reducing second channel interference.

465 kHz IF Amplifier

An intermediate frequency of 455 kHz to 470 kHz offers good gain and selectivity for equipment operating in the bands up to 28 MHz. A higher IF would increase second channel rejection, but more stages would be required. Commercial walkie-talkie receivers can have superhet circuits quite typical of small broadcast band portables, and these are capable of excellent

results. Suitable transformers for this frequency are readily available.

Figure 29 is the circuit of a 465 kHz IF amplifier using two BF195 (or 2N3704) transistors. Two double tuned and one single tuned transformers allow very good results, and all components can be fitted in a small space. A little saving here would be accomplished by using three single tuned transformers.

IFT1 receives input from the mixer. The connection is to 1 for a dual-gate FET mixer, but otherwise to tapping 2.

Secondary output from tapping 5 is to TR1 base. Base bias is largely determined by R1, R4, and VR1, so these items must be of the values shown. TR1 collector output is to the primary of IFT2, and the secondary couples to TR2 base via C2, with base bias for TR2 from R3. TR2 supplies the single tuned IFT. The decoupling components R5 and C3 can prove to be unnecessary with the 2N3704s.

Any AM receiver detector diode or similar diode will be suitable for D1. Its polarity must be as shown, because signals can then shift TR1 base negative, via R4 and R2, to provide automatic volume control. After demodulation by D1, audio signals are taken at any wanted level from the slider of the volume control VR1.

IFT pin identification is for Denco (Clacton) Ltd components. These are pre-aligned, so the cores should be left as they are, except for a final touching up after the circuit has been found to operate satisfactorily. A properly shaped trimming tool is advised (such as that available from the IFT maker) as a wedge-shaped blade can crack and jam the cores. Final IFT adjustment is best by providing a steady signal, and clipping a high resistance voltmeter across VR1. The cores are then set for maximum reading, which corresponds to the highest AVC voltage.

The circuit will provide very good gain and sensitivity. If it is

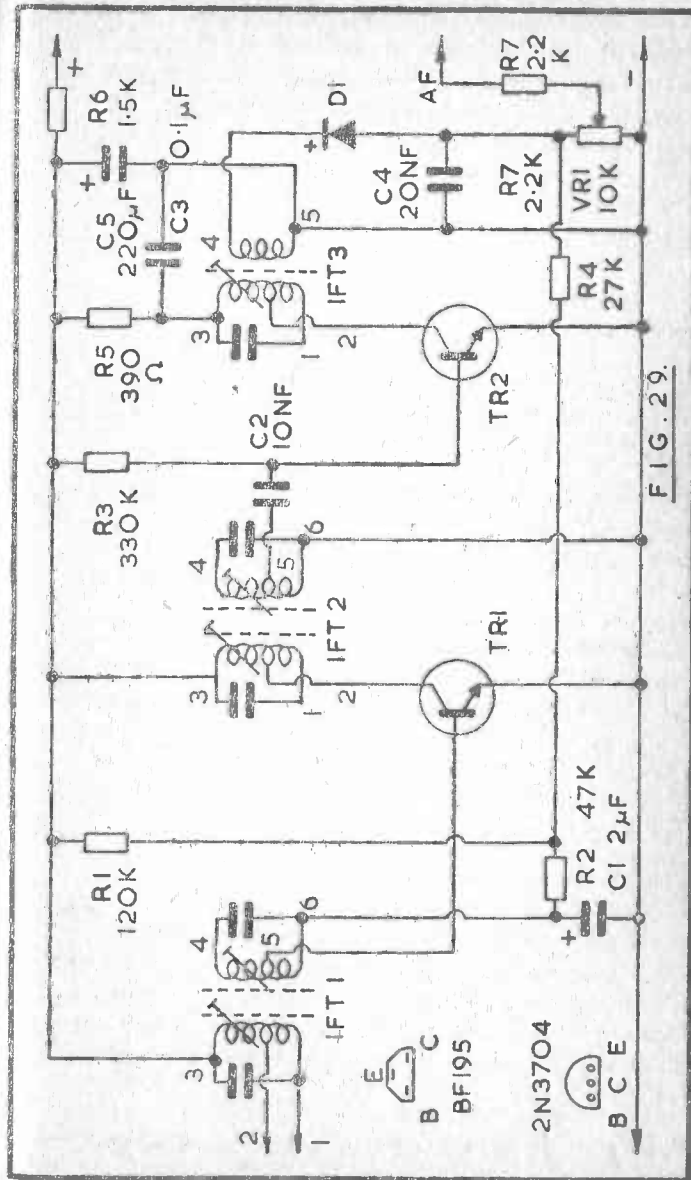

FIG. 29.

found that instability arises with alignment correct, this can be prevented by adding a resistor between the IFT secondary and base of the stage; or between collector and the following primary. The transistors mentioned have a wide spread in gain, so it may be necessary to try values from about 47 ohm to 470 ohm or so, using the lowest values which allow stable operation at low signal levels. The resistors should be close up against the transistor, with very short leads, but will not prove to be critical in value.

This amplifier may be constructed as an individual unit, or can be assembled on a board carrying mixer and oscillator components. The layout of parts can best be similar to that in the circuit, with stages following each other and input and output circuits at the ends of the board.

It will be appreciated that this same IF strip can be used with a variety of mixer and audio circuits, for any band up to 28 MHz. It will be of advantage when minimum size is not essential. A rather smaller 465 kHz strip is described later.

Audio output via R7 can best be to a preamplifier (such as that in Figure 14). This can be followed by a driver and push-pull audio panel. The audio section will then have four transistors in all. Alternatively, an audio IC can be used. If somewhat less audio gain can be tolerated, then R7 may be connected to the driver or audio IC input, the preamplifier being omitted.

Crystal Controlled Receiver

The tunable receivers described have the advantage that other transmissions can be copied on adjacent frequencies, so that their scope is increased. However, for 2-way contact a crystal controlled receiver offers several advantages. Its frequency of reception is rigidly controlled by the crystal, so that it is always correctly tuned. In fact, no manual tuning control will be present. It is not susceptible to changes in frequency due to battery voltage, vibration or similar factors. It cannot, of course, be used for the reception of signals on any other frequency for which a crystal is not available. Such a receiver

will generally be used with a second unit, also crystal controlled. It is possible for a home or base station to tune up for transmission to suit the crystal controlled receiver, but there is not much latitude for error and the transmitter will normally be crystal controlled.

For communication in one direction the transmitter and receiver will employ a pair of crystals which have a frequency difference equal to the intermediate frequency of the receiver. An identical pair of crystals can be used for communication in the other direction. A third station operating on the same frequency will then be heard by both listening stations.

It is more usual to have the receiver oscillator working at a higher frequency than the transmitter, though there is no very important reason why it should not operate on the low frequency side of the signal. So if the transmitter is to operate on, say, 28.5 MHz, and the receiver intermediate frequency is 465 kHz, the receiver oscillator can use either 28.965 MHz, or 28.045 MHz. In each case mixing of the signal and oscillator frequencies will give an output from the mixer stage of 465 kHz, to pass to the intermediate frequency amplifier.

A circuit incorporating a crystal controlled oscillator is shown in Figure 30. L1 is the aerial coil, and the whip aerial is coupled to this by C1. L1, with parallel capacitor C2, is tuned to the transmitter frequency, or 28.5 MHz in the example given. R1 and R2 are for base bias of the mixer, and coupling is by the secondary of L1. Collector output of this stage passes to the IF amplifier.

TR2 is the separate oscillator, and the frequency here is determined by the crystal, which can be 28.965 MHz, as explained. C6, with the RF choke, allows feedback to the emitter. The choke can be any small component effective at these frequencies. It may be wound with 32 swg enamelled wire, on a ¼ in diameter insulated rod or tube, fifty turns being provided. Oscillator coupling is by C5 to TR1 base.

With such a circuit, L1 is merely tuned for best reception, and

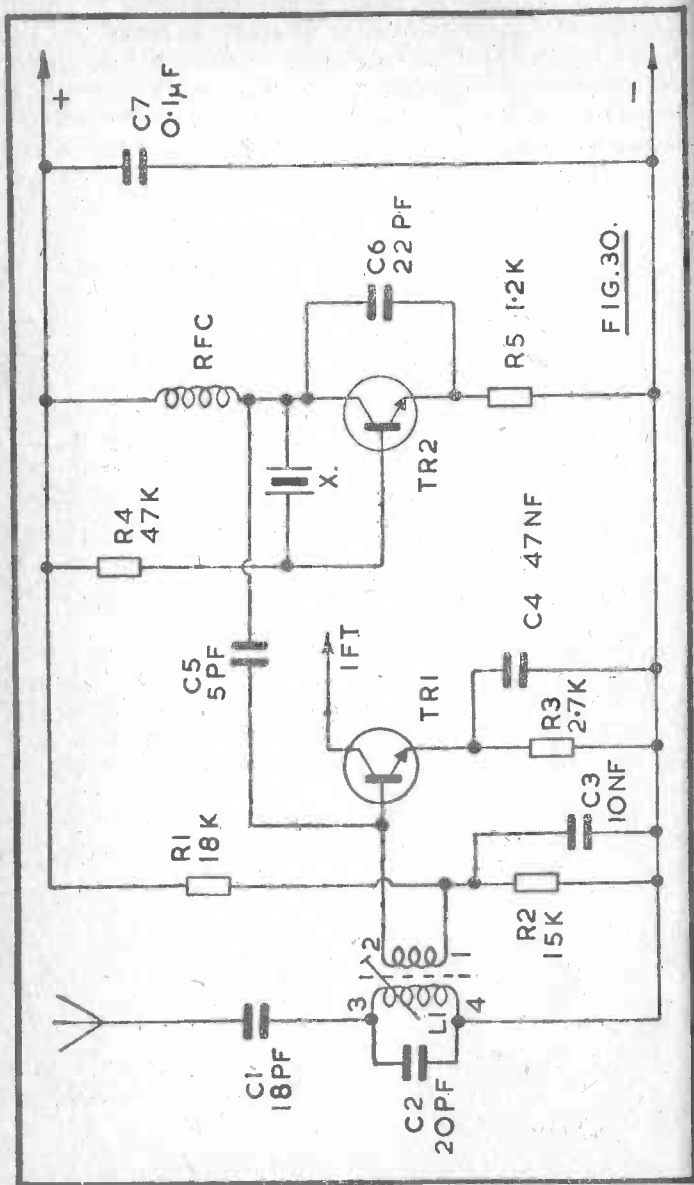

is not very critical. As is usual with a superhet circuit, the critical frequency is that of the oscillator, and this is fixed by the crystal. Normally, virtually no tuning of the receiver (except to peak the core of L1) will be required. However, the cores of the intermediate frequency transformers can each be given a small adjustment, if this proves necessary, so that they fall exactly on the mixer output frequency. This will compensate for any slight errors in the frequencies of the crystals. With the transmitter with which the receiver will be used operating normally, and the IFT cores and L1 adjusted, the equipment should remain correctly set up for long periods.

Should the channel not be clear, it is not possible to tune to another frequency, unless optional crystals for this are provided in both the transmitter and receiver. The crystals can be changed by removing them and plugging in a different pair; or a switch can be fitted for changing channel. Normally no other adjustments will be necessary with either the transmitter or receiver. For 2-way communication of the type for which such equipment will generally be used, in the 28 MHz band, interference is not very likely.

Where the intermediate frequency of the receiver will be some other figure, the oscillator crystal must of course be chosen to suit this. For an IF of 470 kHz, transmitter oscillator and receiver oscillator crystals would differ by 470 kHz. Though an IF of 455 kHz to 470 kHz does not allow the receiver to have good second channel rejection at 28 MHz, intermediate frequencies of this order are usual as they provide good selectivity and sensitivity with simple IF amplifiers.

Integrated Circuit IF Amplifier

The circuit of a 465 kHz intermediate frequency amplifier with a small number of components is shown in Figure 31. Input to the IF transformer can be from a mixer with crystal controlled oscillator, or from a tuned oscillator/mixer, to pins 1 and 2, as explained. The secondary of this transformer provides the input for the integrated circuit, IC1.

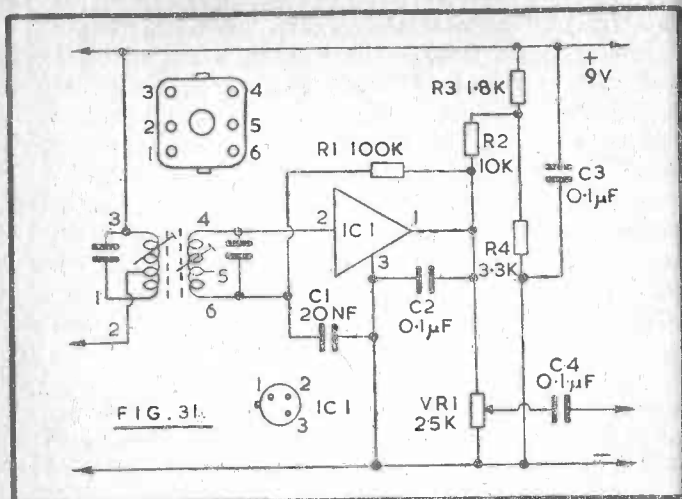

noted that VR1 is part of the potential divider. So if a gain control is not wanted here, a 27 k resistor should be connected across C2. If the potential at 1 is low, sensitivity and output will be poor; on the other hand, if the voltage is too high, whistles and instability will arise. The correct figure will generally be between 1.25V and 1.4V. This can be checked with a high resistance meter. If necessary, fine adjustments to the voltage can be made by using a miniature 2 k pre-set potentiometer for R3. It can then be reduced carefully from maximum value until the correct voltage is obtained at 1. There will be a slight change in voltage when tuning a signal, due to the AVC operation within the IC.

In the interests of stability, lead 2 can be soldered directly to pin 4 of the IFT, and the layout can place lead 3 between leads 1 and 2. The power gain of the IC is 70 dB.

Selectivity with this circuit is less than with an IF amplifier having three single-tuned IFTs, or two double-tuned and one single-tuned transformers. But for 2-point 28 MHz working, this is not of any particular disadvantage. Where a tunable oscillator/mixer stage provides the input to the IFT, the actual intermediate frequency is not important, so the cores are simply adjusted for best volume. When a crystal controlled oscillator is employed, the intermediate frequency must agree with the difference between the transmitter and receiver crystals, as explained, so that it is necessary for the cores to be set for this.

2-Stage Audio Amplifier

Figure 32 is the circuit of a compact audio amplifier which will provide good gain, and reasonable volume for a small loudspeaker. TR1 is a high amplification stage, with base bias from R1 and R2 as collector load. Output from this stage is coupled by C1 to the output transistor, TR2. Here, R3 and R4 set base operating conditions, while emitter bias depends also on the speaker resistance. A speaker of quite high impedance (75 to 80 ohm) is preferable. If necessary, either R3 or R4 can be selected so that TR2 passes about

The ZN414 has three stages of RF amplification, a transistor detector, and automatic gain control. Audio frequency output is obtained at 1 and is available at the volume control VR1. R1 is the feedback resistor for the IC, and R2 the output circuit load and provides the positive supply. C2 is the output by-pass.

The IFT is a small double-tuned component, and could be intended for a different intermediate frequency. Pin numbers are for the Denco (Clacton) Ltd IFT18/465, which is a small transistor receiver IFT. The IC input 2 is high impedance, so a tapping is not used on the secondary of the IFT.

Layout should allow leads 1 and 2 of the IC, and adjacent components and circuits, to be separated, and C2 should be directly from 1 to the earth lead 3. Unnecessary feedback will cause instability to arise before full gain is obtained.

The IC operates with a low potential at 1 — typically 1.3V. The voltage here is fairly important, and a change of even 0.1V or less can produce a considerable drop in sensitivity, or may cause instability. With a 9V supply, the values shown for R2, R3 and R4 will usually be satisfactory, but it must be

15 mA to 20 mA or so. Reducing the value of R3 raises collector current, and increasing the value of R3 causes collector current to be lower. The stage cannot operate very well with a very low current, but an unnecessarily high current will bring no advantage and will increase the load on the battery.

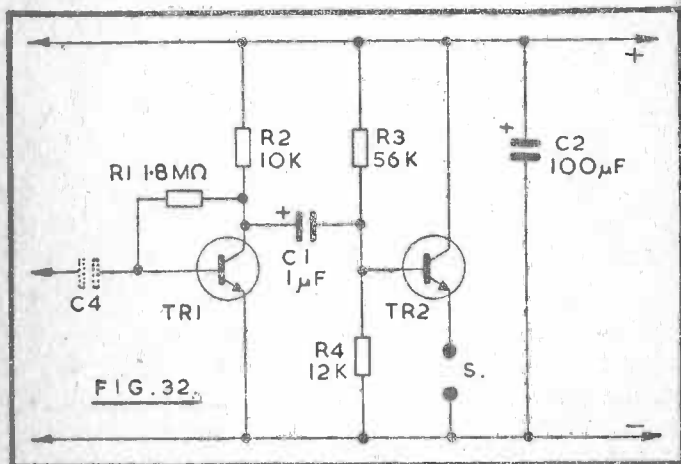

Various transistors will work in this circuit, but TR1 is for preference a type having high gain.

This amplifier may be used in conjunction with the IC IF amplifier shown in Figure 31, or the IF strip in Figure 29.

Receiver Audio IC

During reception, a lower level of audio power output and speech quality will generally be considered adequate, than would be appropriate for normal listening. For this reason, and because listening will generally be intermittent, a simplified type of audio and output circuit can be used satisfactorily. This might consist of two or three transistors as audio amplifiers and Class A output stage.

Where switching will allow the same audio amplifier to be used for both transmission and reception, adequate audio power

will be available. But where it is felt better to have a separate audio amplifier for reception, a low power audio IC can be fitted, to save battery current during reception, and increase loudspeaker output.

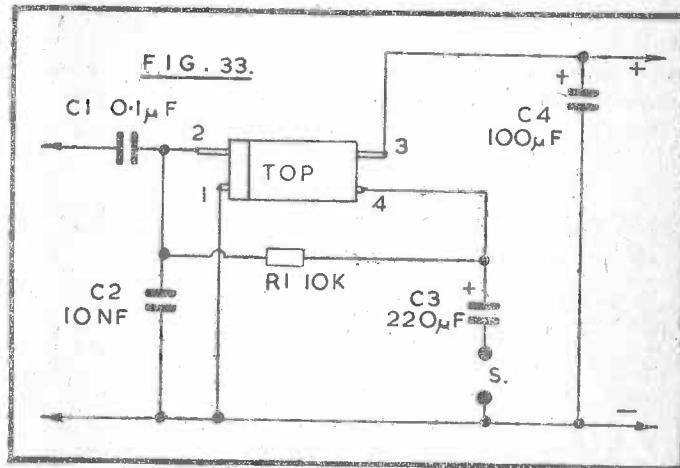

A suitable IC for this purpose is the MFC4000B, Figure 33. This will give excellent results from a 9V supply, and current drain with no signal is about 3.5 mA. Maximum output is about 250 mW with a 16 ohm speaker. The IC incorporates driver and output stages, and is of very small size. It requires few external components, and no heat sink. C1 is the input coupling capacitor, giving DC isolation from earlier circuits. R1 is for negative feedback. The speaker is driven via C3, while C4 is a power circuit by-pass capacitor. Values are not too important (except for R1). With small components, the whole amplifier can be constructed as a very compact unit.

Superhet for 2 m

A superhet designed for 144 MHz reception will generally be a single conversion type with high intermediate frequency (e.g., 10.7 MHz) or of double conversion type. The latter is described here. Essentially such a superhet consists of a VHF converter followed by a receiver operating in the 2 to 30 MHz range, which itself has an intermediate frequency of 455 kHz to 470 kHz.

This will allow a 2 MHz band (e.g., 144–146 MHz) to be tuned with a first conversion oscillator which is crystal controlled, and so can have the required frequency stability for good results. The operating frequency of the crystal oscillator will depend on the frequency which is chosen as the first tunable intermediate frequency. As example, if the 144–146 MHz band is to be covered, and the first mixer receives an oscillator input fixed at 140 MHz, then the output from this section will require that the next section tunes from 4 MHz to 6 MHz. Similarly, oscillator injection could be at 116 MHz. The difference between 144 MHz and 116 MHz is 28 MHz, and the difference between 146 MHz and 116 MHz is 30 MHz. Thus the tunable section of the circuit would need to cover 28 MHz to 30 MHz, to permit tuning in signals over the 144–146 MHz band.

It will be seen that by choosing the oscillator injection frequency virtually any 2 MHz wide segment may be adopted. However, high frequencies such as 28–30 MHz offer better rejection of unwanted second channel signals, and there is less chance of breakthrough of transmissions here, than with a lower frequency, such as 4 MHz to 6 MHz.

The first mixer oscillator injection frequency will be high, so will generally be obtained by multiplication. As example, a 58 MHz crystal controlled oscillator, followed by a doubler, would provide 116 MHz. Combining 144 MHz to 146 MHz signals with 116 MHz in the mixer will give 28 MHz to 30 MHz for the tunable IF section, as explained

Figure 34 is the oscillator chain to provide 140 MHz for the mixer. X is a miniature wire-ended crystal for 35 MHz, and L1 is tuned to near this frequency. When setting up the circuit, check first that this stage is oscillating. TR2 is a grounded base doubler with L3 tuned to 70 MHz, R5 is for emitter bias here. TR3 doubles to 140 MHz, and L1, L3 and T1 are all adjusted for maximum reading on an indicating wavemeter whose coil is near L5. Check that the crystal controlled oscillator always starts, as described earlier, and that the harmonic multiplication (2×2) is correct. This

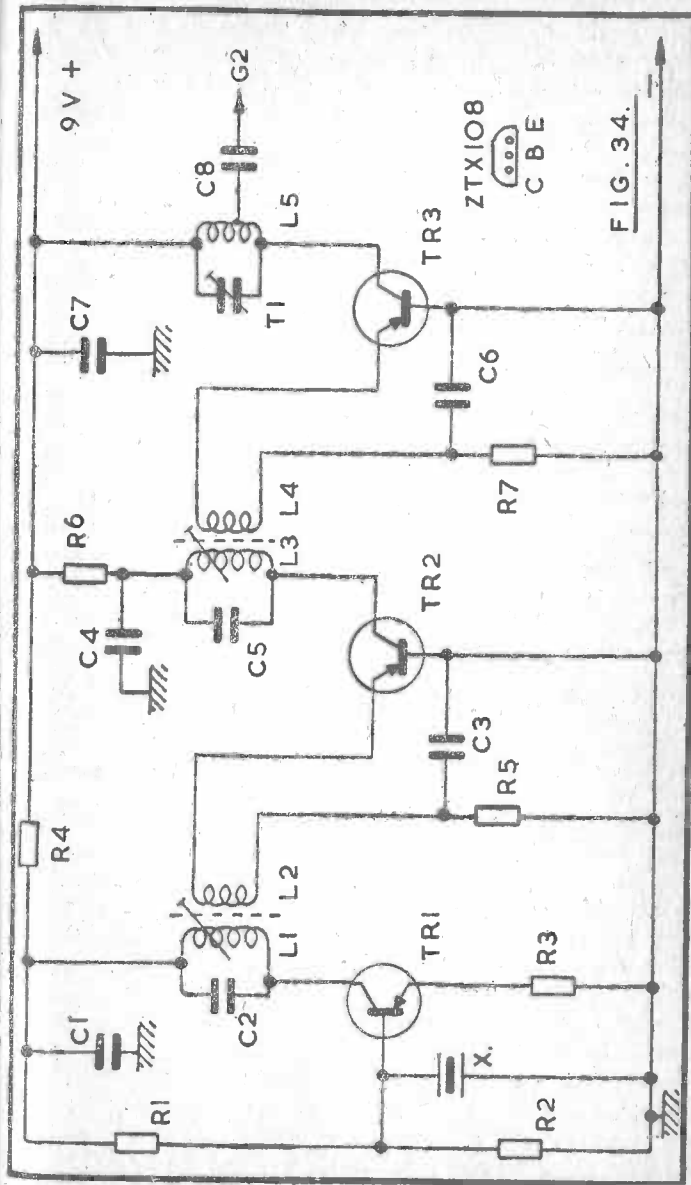

Component values for Figure 34

R1	56 k
R2	5.6 k
R3	100 ohm
R4	120 ohm
R5	68 ohm
R6	120 ohm
R7	47 ohm
X	35 MHz
TR1	2N706
TR2	ZTX108
C1	1 nF
C2	11 pF
C3	1 nF
C4	1 nF
C5	20 pF
C6	1 nF
C7	1 nF
C8	5 pF
T1	10 pF trimmer
TR3	ZTX108

provides a stable 140 MHz oscillator input to the mixer, so that 144 MHz to 146 MHz signals come out at 4 MHz to 6 MHz. Other frequencies may be arranged as explained earlier.

Home-wound inductors may need pruning, though the cores of L1 and L3 give a fairly wide adjustment to frequency. With 6.5 mm diameter formers for L1 and L3, windings can be as follows: L1, begin at bottom of former for TR1 collector and wind fifteen turns (26 swg) side by side, leave no space and wind L2 in the same direction, commencing at C3/R5 end, providing five turns. L3, nine turns, with two turns for L4, arranged in the same way. L5 is self-supporting, 20 swg wire, and has five turns 8 mm outside diameter and 9 mm long. This coil can be slightly stretched or compressed if necessary so that T1 is about half screwed down.

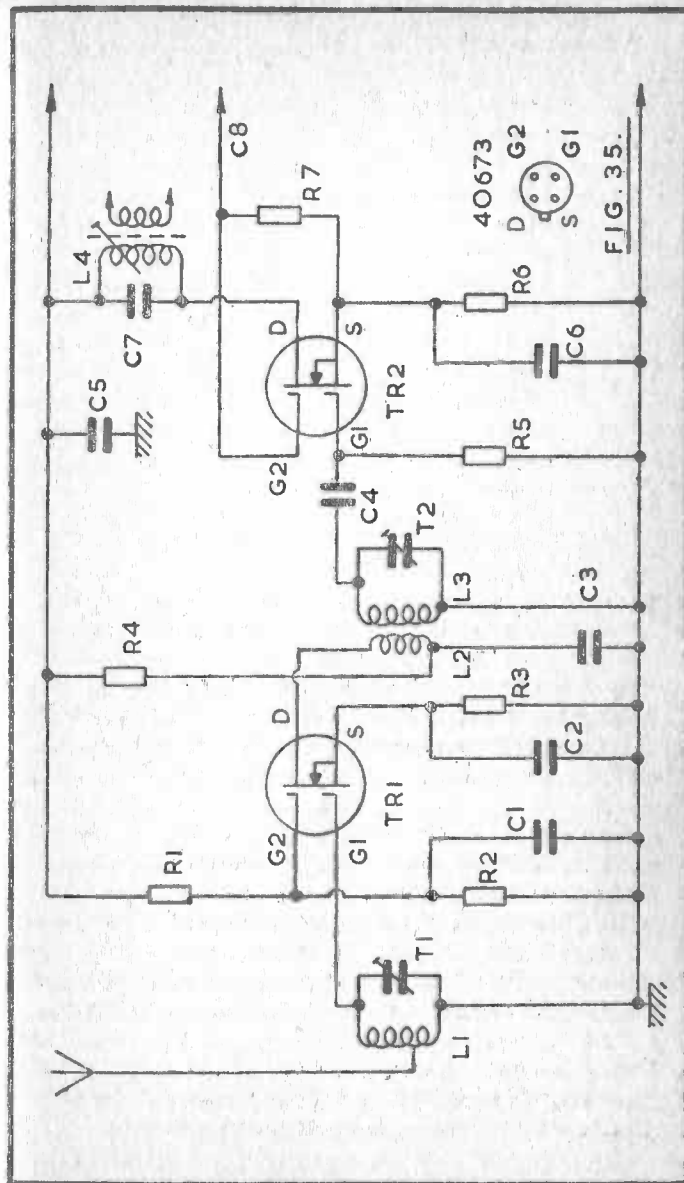

FIG. 35.

Component values for Figure 35

R1	100 k
R2	47 k
R3	270 ohm
R4	470 ohm
R5	100 k
R6	120 ohm (see text)
R7	82 k
TR1	40673
TR2	40673
C1	1 nF
C2	1 nF
C3	1 nF
C4	47 pF
C5	1 nF
C6	1 nF
C7	10 pF
T1	10 pF pre-set
T2	10 pF pre-set

The layout can best place the components along a strip of insulated board, stage by stage in a similar manner to Figure 34, and allowing short connections to ground line for bases of TR2 and TR3, C3, C4, C6 and C7. C2, C5 and T1 are directly across the windings. C8 can be soldered to the middle turn of L5, though the level of oscillator injection to the mixer can be modified by moving this tapping point along L5.

Figure 35 is the RF and mixer section. Signal input is to gate 1 of the dual-gate FET TR1. R1 and R2 provide gate 2 voltage. Drain output is to L2, which is coupled to L3, for signal input to gate 1 of TR2. In this stage, gate 2 is used for oscillator input, from the coupling capacitor C8 in Figure 34. It can be worth while to experiment with the value used for R6.

Output from the mixer TR2 will be at frequencies from 4 MHz to 6 MHz, for reception from 144–146 MHz, and L4 is tuned to approximately the middle of this band, or to the

range of frequencies of most interest. A 1.6 MHz miniature IF transformer was found suitable here, with its internal 250 pF capacitor removed. This is replaced by C7 (10 pF) and core adjustment then allowed tuning to about 5 MHz. Variable tuning is not employed in this coupler for simplicity. L1 and L3 are wound as described for L5 in Figure 34. The aerial tap is one turn from the grounded end of L1. L2 is two turns of insulated wire situated near L3. As the 40673 is a protected gate device, no particular precautions have to be taken when soldering. Unprotected devices *must* be protected by a shorting loop until installed.

When the circuits in Figures 34 and 35 are operating, 2 metre band signals will appear at 4 MHz to 6 MHz in L4, so the following circuit tunes this band to select the wanted 2 m transmissions.

Figure 36 is the tunable section of the receiver. Input to the base of the RF amplifier TR1 is from the coupling coil of L4, Figure 35. R1, R2 and R3 set the DC operating conditions for this stage, which is coupled to the mixer base circuit, tuned by VC1. VC2 is the oscillator coil tuning capacitor, and C5 the series padder. The trimmers T1 and T2 are adjusted at the high frequency end of the band to give suitable coverage and best sensitivity, and the signal frequency coil and oscillator coil cores of TR2 stage are similarly adjusted at the low frequency end of the band. In order to avoid unnecessary break through of 4 MHz to 6 MHz signals, this section of the equipment should be screened, as should the input coil for TR1. A metal case will provide sufficient screening. Layout needs to avoid feedback over TR1 in particular, or instability may arise at some frequencies.

Output from the mixer TR2 passes to the final intermediate frequency amplifier, which can operate at 455 kHz to 470 kHz and can use circuits such as those already shown. Accurate calibration of frequencies over the 144 MHz to 146 MHz range will be obtained by calibrating the scale of VC1/2 throughout the 4 MHz to 6 MHz range.

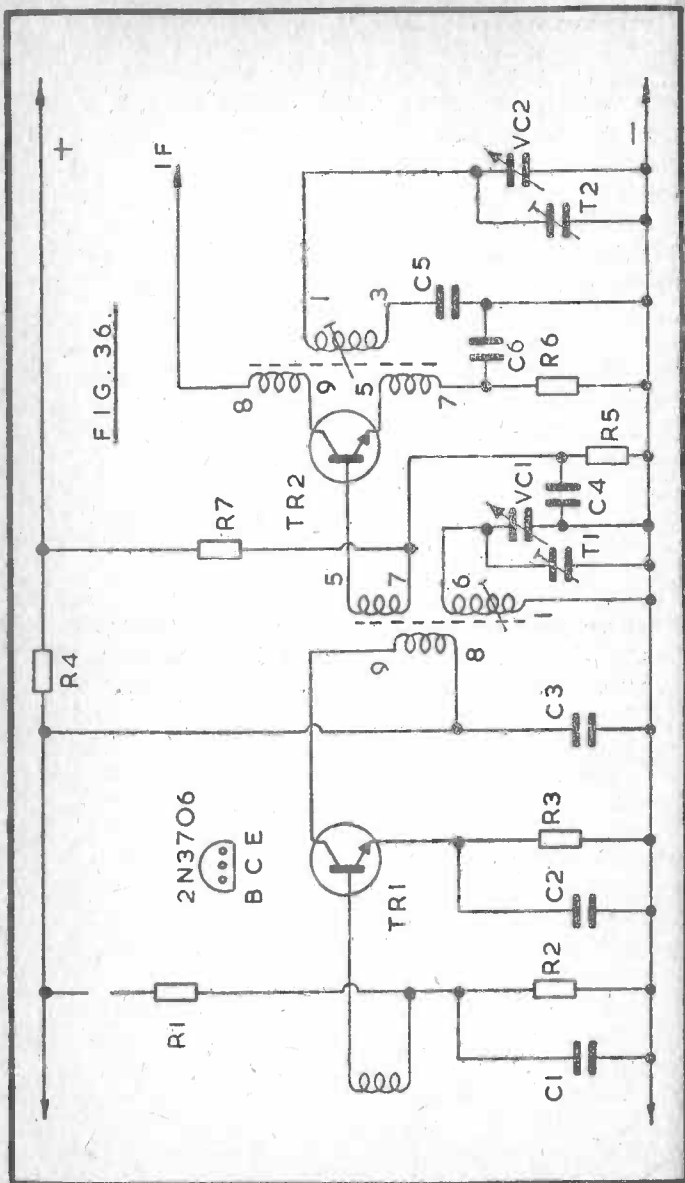

Component values for Figure 36

R1	56 k
R2	15 k
R3	1 k
R4	470 ohm
R5	4.7 k
R6	1.8 k
R7	18 k
VC1/2	35 pF
"Blue" 3T and "Red" 3T coils (Denco, Clacton, Ltd).	
TR1	2N3706
C1	47 nF
C2	0.1 μ F
C3	0.1 μ F
C4	10 nF
C5	1 nF or 1100 pF silver mica
C6	3.3 nF
T1	60 pF trimmer
T2	60 pF trimmer
TR2	2N3706

It will generally be found that there is little difficulty in securing good overall stability because the various sections of the receiver are operating on different frequencies.

For 2m mobile working, frequency modulation is largely used, direct or through repeaters activated by an audio tone. These signals are heard with VHF commercially made portable or other receivers covering 144–146MHz.

FM signals are most readily generated by modulating an 8MHz or 12MHz crystal oscillator by means of a varicap diode, multiplier stages giving output in the 2m band.

For 2m mobile and similar work aerials are usually vertical. Power is generally about 1–10 watts, giving a range of some miles with a ¼-wave whip.

The home station having a good communications type receiver not designed for FM can obtain satisfactory FM reception by tuning slightly off the signal (slope detection) a converter being fitted between aerial and receiver so that the latter uses 28-30MHz or some other available band as described earlier.

Aerials and Additional Circuit Information

Aerials

The purpose of the aerial is, of course, to radiate the signal as effectively as possible. Generally the aerial will be of reduced efficiency, because it will not be long enough, or high enough, to give radiation equal to that of a dipole. Despite this, practical aerials will give satisfactory results.

The length of a half-wave dipole in feet can be found from 468/MHz. Thus approximate half-wave lengths for the various bands are as follows: 1.8 MHz 260 feet, 3.5 MHz 130 feet, 28 MHz 16½ feet; and 80 inches for 70 MHz, with 38½ inches for 144 MHz.

It is clear that the long aerials are quite impossible in many circumstances, and even unlikely for the lower frequencies with a semi-permanent station. This is overcome by using a quarter-wave or even shorter aerial, and by methods of loading which give an increase in the *electrical* length of the aerial. It will be apparent that these methods apply to bands such as 1.8 MHz, 3.5 MHz, and often 28 MHz, but would not be necessary in most circumstances with 144 MHz.

For hand-held portable use, the aerial must be a whip fixed to the transmitter. For mobile use, or semi-portable stations such as at a caravan, a somewhat larger type of self-supporting aerial can be employed. For fixed semi-portable locations, it may be possible to erect a temporary dipole for 28 MHz, or random-length end-fed aerial for the low frequency bands. These will permit much greater ranges to be worked.

In Figure 37, A shows a full-sized dipole aerial, which will give very good results. For a frequency of 28.5 MHz, the top can be 16 ft 5 in overall. It can be made from 7/26 or similar flexible wire and three small egg insulators, one being used at

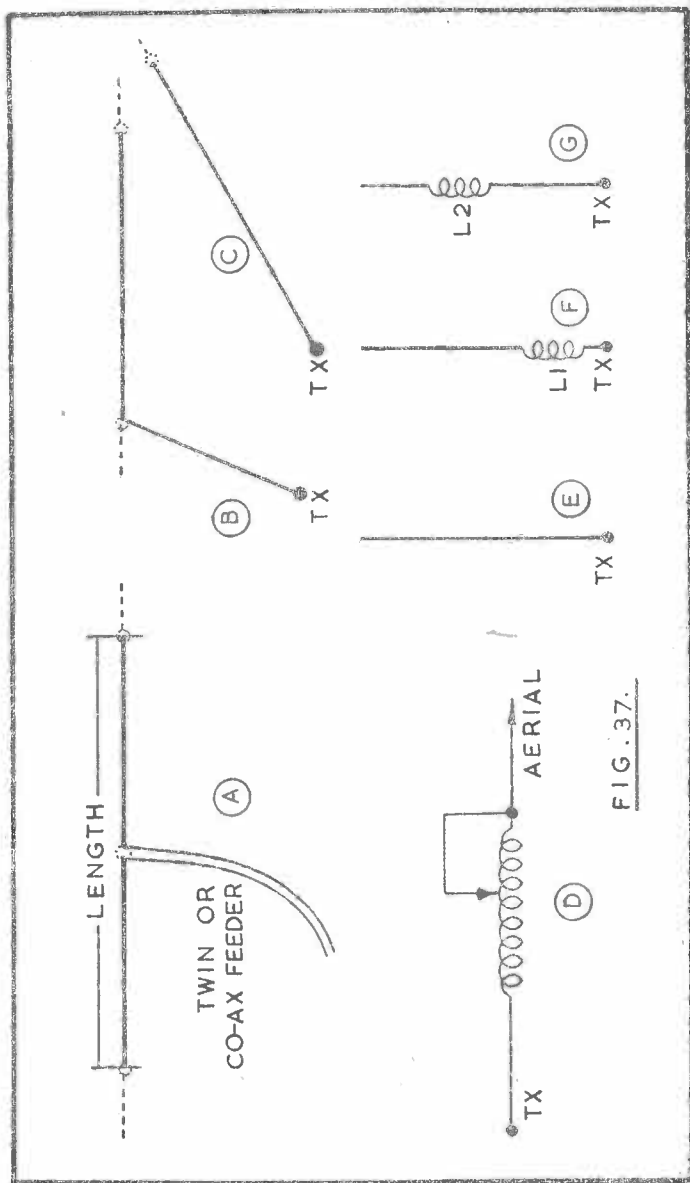

FIG. 37.

the centre. The length of the feeder is not important and it can be 75 ohm or similar twin feeder, or co-axial cable. With the latter, one top section is soldered to the centre conductor, and the other top section to the outer brading.

Such an aerial is often practical for semi-portable use, as the overall length is not great. It can, if necessary, be held up by one fairly high support only, the other end sloping down to near ground level. The whole, with two thin cords, is easily carried when rolled. It can give excellent signal strength.

A similar aerial is practical for 70 MHz and 144 MHz bands, and it can be erected horizontally, sloping, or vertically, as circumstances permit. Such an aerial can be appropriate for a camp, tent or caravan. Best signal strength will be obtained if it is high or at least above surrounding objects.

For the low frequency bands (1.8 MHz and 3.5 MHz) a dipole of this type generally becomes impracticable, so an end-fed aerial is used. This is shown at B. Here, a portion is horizontal, and the remainder descends to the transmitter. However, the aerial can be sloping as at C, or may take on other shapes, as convenient, provided the wire is not folded back on itself.

Such an aerial is often of random length. This means that the length actually used will depend on circumstances, and some 50 ft to 100 ft of wire would generally be employed. As such a random length will often not present a suitable load to the transmitter, a simple coupler such as that at D will be necessary. This allows sufficient turns to be brought into circuit to load the transmitter.

An aerial such as B can be of quite thin, insulated flexible wire, and may find supporting points at trees or hedges, and need not be very conspicuous. It can allow long distances to be worked.

Such aerials are appropriate for a base station and will give very much improved signal strength on the LF bands than can be obtained with short aerials.

It is worth noting that mobile aerials can be purchased for any band. These are excellent for LF bands or VHF working when they can be fitted to a car or caravan.

For hand-held operation, a telescopic aerial is necessary. This can be represented as at E. For 144 MHz it can be a quarter wave, or more. But for the lower frequencies, the aerial will be very much shorter in terms of wavelength. For example, at 28 MHz it would need to be some 8 ft or so long.

There are several means of using such aerials, which are in themselves too short for the operating frequency. The aerial can be used as it is, and can radiate reasonably, provided suitable coupling allows loading of the transmitter. Or a loading coil L1 can be fitted near the base, on the aerial, or in the transmitter, so that working resembles that obtained with D and C together. Or the coil can be moved up the aerial, being L2 at G. This is more efficient than F, as current is moved up the lower section.

It is clear that considerable experiment can be made with the aerial system. For maximum portability, E or F will be adopted. Aerials of type G are available for the 27 MHz (model control) band, and can be modified for 28 MHz. Arrangements similar to F can be made, when operation is to be on one of the LF bands.

In some cases it will be convenient to be able to attach a better aerial when using the equipment at home or when circumstances permit this. This may extend the range from a few miles, to a hundred miles or more, according to the band, and conditions.

144 MHz Verticals

A $\frac{1}{4}$ -wave aerial for 144 MHz is about 19 in long and is operated against earth — the latter often in the form of a vehicle or caravan roof. This is shown in Figure 38. A coaxial feeder is used here, with its inner conductor to the base of the vertical aerial, and outer conductor to earth. If the

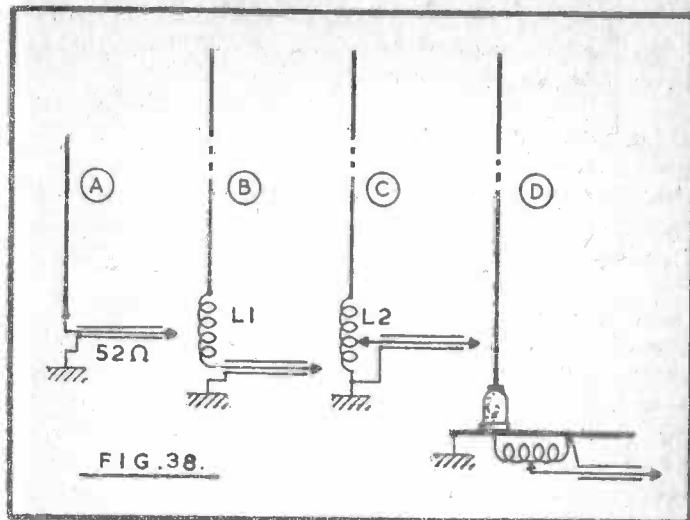

aerial is of correct length, there will be a smooth flow of power along the feeder, with small losses. The feeder is thus a convenient means of allowing the aerial to be situated to best advantage. Magnetic mounts avoid any need to drill the roof.

In the case of a hand-held transmitter, earth is provided by the equipment case, and to some extent by the user's body. This is less effective but has to be tolerated.

When the aerial is $\frac{1}{4}$ -wavelength long, the relationship between voltage and current at its base is such, that the impedance is around 52 ohms, or sufficiently near for 52 ohm feeders to be used.

If the aerial is lengthened, to increase radiation, the base impedance may change considerably. As example, if it were twice as long, or a $\frac{1}{2}$ -wave, the relationship between current and voltage is now changed, current being low, and voltage high. As a result, the impedance is very high (many hundreds of ohms) and a 52 ohm feeder can no longer be used. But if the length of the aerial is even further increased, so that it is about a $\frac{3}{4}$ -wave in length, the impedance at the base is again low, allowing a 52 ohm feeder.

Where the length is not electrically correct, matching to a 52 ohm or similar feeder or output circuit can be arranged by means of a loading coil. This fact, and the short physical length of a $\frac{1}{4}$ -wave or similar aerial at 144 MHz, allows longer aeri- als to be used without too much difficulty.

In Figure 38, B is an extended aerial with loading coil, while C is also an extended aerial, this time with a base coil used as a matching device by employing a suitable tapping for the feeder.

It is possible to use any practical lengths for B or C, provided coils L1 and L2 (and the tap on L2) are adjusted correctly. Correct adjustments can be found by tuning for maximum radiated signal strength; or by using a standing wave ratio indicator in the feeder, and tuning the aerial for lowest reflected power.

For semi-permanent use, a telescopic aerial offers an easy means of adjusting the aerial length, but for a stronger and weatherproof aerial a solid conductor is preferred. This can be a metal rod about $\frac{1}{8}$ in in diameter, or very stout self-supporting wire. A light alloy tube can also be used, with its top pinched shut or plugged. The coils should be of stout wire — say 14 swg.

A length of 5 ft is suggested for aerial B, and 4 ft for aerial C. L1 can then be ten turns spaced over about $1\frac{1}{2}$ in winding length, on a $\frac{1}{4}$ in diameter insulated rod. L2 can be seven turns, $\frac{1}{2}$ in in diameter and 1 in long. The tap is two to three turns from the bottom.

The aeri- als can be tuned by changing their length, or by altering the coil. The simplest method is to use temporarily a wire of similar gauge to the rod, beginning with it too long, and to cut a little at a time from the end, until radiation is at a maximum and the SWR low. This should be done with the aerial in its intended location. Note results, and finally have the rod at the length which gives best results.

A vertical such as A, or rod alone, is readily supported by a stand-off insulator or similar mounting at the bottom. Radiation of B and C is best if L1 and L2 are vertically in line with the aeri- als. It is thus necessary to have a paxolin tube or some similar means of providing a support for the bottom of the aerial. This needs to be of sufficient strength to resist wind pressure or vibration. Failing this, the coil can be situated at the feeder side of the mounting, as at D, in the interests of obtaining a strong fixing for the aerial itself.

Similar arrangements to these are practical for 28 MHz, or indeed for the low frequency bands. However, the aerial itself should then be as long as reasonably practicable, and the loading coil will need to be of larger diameter, and have many more turns.

With hand-held equipment for 144 MHz, the simplest solution is to fit a $\frac{1}{4}$ -wave in the form of a telescopic aerial cut to correct length. However, aeri- als longer than $\frac{1}{4}$ -wave are readily possible at this frequency, and are often employed to improve radiation. For hand-held equipment at 28 MHz, G in Figure 37 offers best results with a telescopic aerial, but the coil is often moved to position F to allow it to be inside the transmitter. It can be a cored coil similar to that used for collector tuning. This also applies to the use of hand-held transmitting equipment on the lower frequencies.

Pi Tank

As operation will be on a single frequency in many cases, with an aerial of particular length, suitable coupling can be arranged from a secondary, closely situated to the final amplifier collector coil. In order that the amplifier can work satisfactorily, the aerial must present an approximately suitable load. This is arranged by using the correct number of turns on the secondary, and positioning this to achieve proper coupling. With correct coupling, the PA is loaded so that it draws a suitable collector current, and RF energy is transferred to the aerial, to be radiated.

To avoid modifying the number of secondary turns, or moving these in relation to the collector coil, a pi tank is occasionally used. Such a tank is almost universal in larger equipment, but requires a few more components. By a choice of suitable values, almost any aerial can be matched correctly to any PA. Large transmitting equipment will have variable capacitors and generally a switched coil, but to keep size down a plain or tapped coil, or coil with adjustable core, can be substituted, with a combination of fixed and pre-set, or pre-set capacitors.

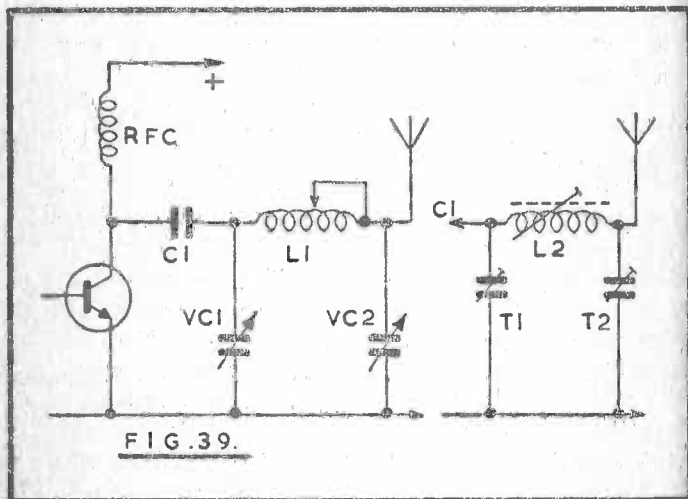

FIG. 39.

In Figure 39 the collector is supplied by the radio frequency choke, and C1 couples RF to the pi network. This consists of VC1, L1, and VC2. L1 is tapped so that its inductance can be adjusted. When VC1, VC2 and L1 are of suitable values for the frequency and input and output impedances (transistor and aerial) adjustment will give maximum transfer of RF energy to the aerial.

Dimensions can be made more practical for small equipment by using compression trimmers at T1 and T2, and having an adjustable core for L2, to give some control over inductance. L2 can generally resemble the collector coil which would otherwise be employed. T1 and T2 can be 1250 pF compres-

sion trimmers for 80 m, in many circuits. For very low impedance aerials, a similar fixed capacitor may be needed in parallel with T2. Where L2 is of suitable inductance, it need not be adjustable, but this does give some extra latitude to secure proper matching. For 28 MHz or VHF the inductor will be appropriately smaller, and can be air-cored, with suitably smaller capacitors.

The RF choke is suitable for the working frequency, and can best be a small cored type, of low DC resistance. C1 can be 0.1 μ F for the low frequency bands, with 1 nF for higher frequencies.

With circuits of the type described, a dip in collector current does not agree completely with best RF output, so adjustments should be directed towards securing the highest reading on an indicating wavemeter, fitted with a pick-up aerial, and near the transmitter. At the same time the collector current should be checked with a meter, during initial adjustments, to make sure loading does not result in current becoming too great for the transistor.

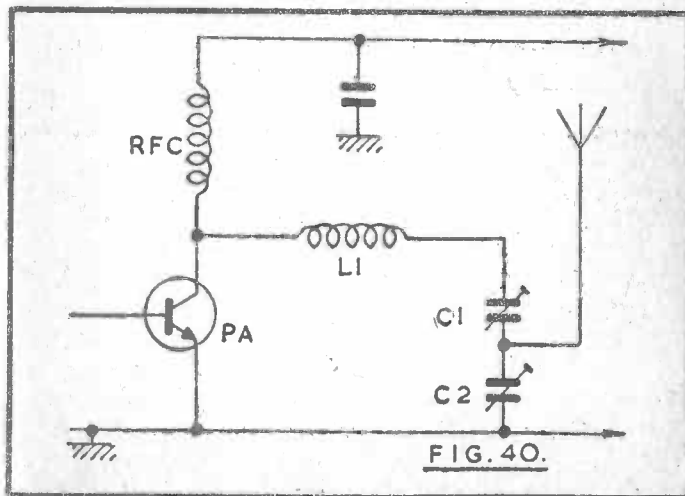

FIG. 40.

Capacitor Loading

Figure 40 is a circuit which may be used to allow adjustment of loading by the aerial. If the power amplifier transistor is to draw correct current from the battery and deliver this as radiated energy from the aerial, some form of impedance matching is required. Here, C1 and C2 are an alternative to using a coupling winding in conjunction with the coil L1.

The RF choke needs to be of low DC resistance, and must be suitable for the working frequency. For 144 MHz, it can be twenty-five turns of 28 swg enamelled wire, on an insulated former about 5 mm in diameter. L1 can be five turns of 18 swg wire, 6 mm inside diameter and with turns spaced to occupy 12 mm. C1 can be 25 pF and C2 60 pF.

The capacitances C1 and C2 in series resonate the circuit, but setting C2 to a lower value and increasing the capacitance of C1 has the effect of moving the aerial coupling point nearer to L1. To adjust this circuit, begin with C2 at fairly high capacitance, and tune L1 to resonance by C1. Resonance is shown by an indicating wavemeter, or by a suitable bulb replacing the aerial, as explained. A lamp load will be from the junction of C1/C2 to negative or ground line. With tuning for maximum output by means of C1, slightly change the setting of C2, re-adjusting C1 for maximum output. If this is greater than before, repeat adjustments in the same direction. Continue this until RF output is at maximum, but note that the DC input to the PA is not taken beyond the safe level.

A similar circuit can also be used between stages, with drive to the base of a following transistor from the junction of C1 and C2. One or both capacitors may be fixed, with LF circuits. See Figure 18.

Further Circuits

The circuit information in this section should prove to be of interest; and will assist in the construction of equipment of the general type described. Tuning up and initial testing will be on the lines already described in detail.

Simple Talkie

The selection of transmitter and receiver circuits from those given will depend on the frequency required, and the eventual size, weight, and complication of the finished equipment. Where a pair of low power units are to be used for two way communication, the receivers incorporated need to be of good sensitivity. Where communication is to be between a hand-held unit and a higher power station, the talkie receiver can be of a simpler type. Lower transmitter power will also be possible when one station has a highly sensitive communications type receiver.

A good set of equipment can be made from a transmitter section running 300 mW to 500 mW or so, with a crystal controlled superhet receiver. On the other hand, equipment can be cut down considerably when a more modest performance is sufficient, and Figure 41 shows the circuitry for a small talkie somewhat similar to low priced commercially made equipment.

TR1 is the power amplifier, driven by L1, and is thus the second transistor in an oscillator/amplifier arrangement of the type already covered in detail. L1 and L2 will be tuned to the chosen band. Here, 28 MHz is suggested, p.21.

TR2 is an audio amplifier, driven by the loudspeaker, which serves as a microphone for transmission purposes. TR2 should be a high gain amplifier, with hfe of 400 or higher (the BC109 is typical). If necessary, R1 or R2 (or both) may be adjusted in value to secure optimum gain. This stage is decoupled by C3 and R4, and coupled to TR3 by C2.

TR3 is the series modulator for TR1. By using the NPN type of transistor, gain is substantially higher than with the circuit in Figure 15, but operating conditions are more critical. A pre-set resistor to adjust base bias (and hence the relative voltages across TR1 and TR3) is essential. Begin with VR1 set at low value, increasing this until the voltage available from the supply is approximately equally divided across TR1 and TR3, with TR1 loaded and tuned. R5 is an audio para-

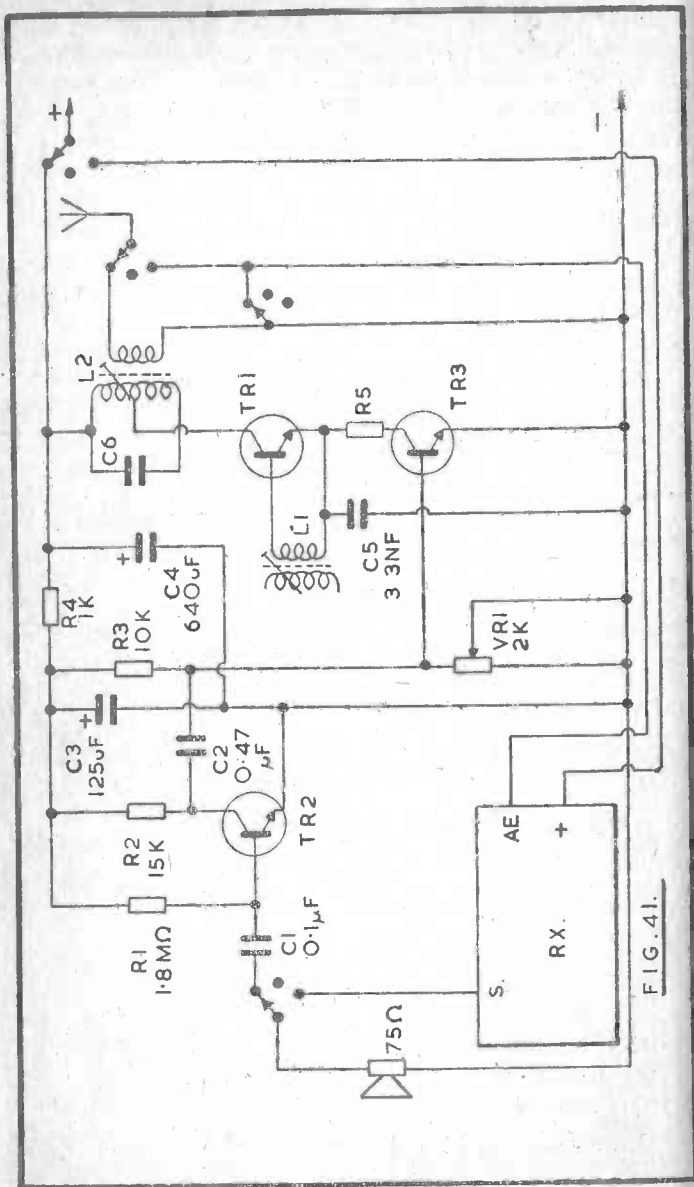

FIG. 41.

stic stopper, and is of the lowest value found adequate (220 ohm or less). Since the supply voltage is not fully available for TR1, a 12V battery pack is best. For best performance, aerial loading, tuning of L1 and L2, VR1, and volume of speech into the microphone (loudspeaker) all have to be adjusted.

The simplest receiver for 28 MHz will be seen in Figures 24 and 25, followed by a two-stage audio amplifier, Figure 32. This allows the speaker unit to be returned to the negative line, so that a single switch can transfer this item from receiver output at S to C1 for operation as a microphone. A further switch pole takes the aerial to receiver aerial input at AE, or to the secondary of L2. Another pole switches on transmitter and receiver sections. The final pole shows how RF may be kept out of the receiver first stage by shorting the receiver input, to protect the RF transistor when required. A 3-way switch allows a central "off" position.

Instability and similar troubles are unlikely during reception. With the transmitter circuits, the most likely cause of difficulty can be feedback of RF into the first audio stage. Layout and switching must be arranged to avoid this. Such feedback is usually heard either as a continuous whistle or howl accompanying transmission, or as spurious sounds accompanying speech. However, the latter can also be very severe overmodulation, and with TR3 having substantial gain (say hfe of 250, or typically a BC108) loud speech near the microphone is not necessary. If necessary, capacitors of about 470 pF to 1 nF from TR2 base or TR3 base to negative line will help keep RF out of these stages.

Super-regeneration

Figure 42 is a further super-regenerative detector circuit. Cx is a very small capacitance, and can be made by twisting together two insulated wires for about ¼ in of their length. Alternatively, a coupling winding could be used. Values are primarily for 1.44 MHz but the circuit can be used on 28 MHz. Coil details will be found in the information provided with

earlier circuits. The value of VC1 can be modified to obtain the wanted coverage, or may consist of pre-set and variable capacitors in parallel.

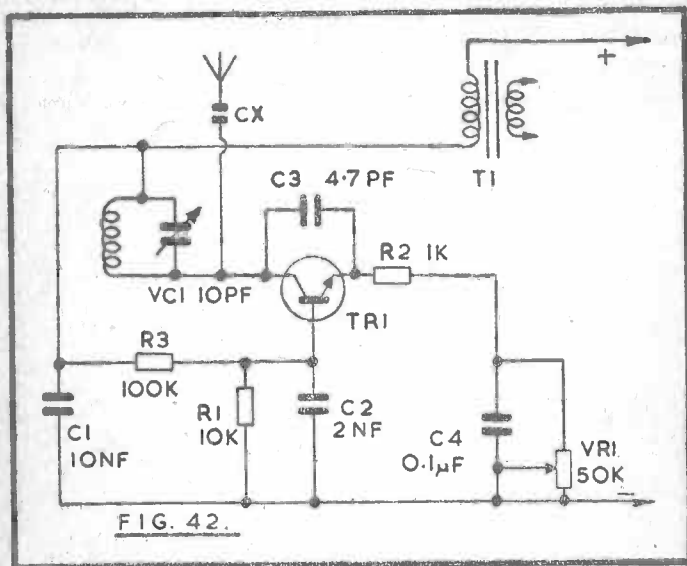

Regeneration is controlled by VR1. Numerous transistor types will operate with this circuit, and the value of C3 may be changed if necessary to secure satisfactory regeneration.

T1 is a coupling transformer, to drive the base circuit of the first audio amplifier. Resistance capacitor coupling can be used here instead. The operation of this circuit and its adjustment will be similar to that of the super-regenerative detector shown in Figure 24.

Carbon Microphone

For some equipment the use of a carbon microphone will allow simplification of the audio amplifier. Such a microphone can give a relatively large audio signal, so that reduced amplification is sufficient. A carbon microphone does not produce any audio output voltage itself, but is a device whose resistance varies at audio frequency. It is thus necessary to

pass a direct current through the microphone. This can be done by using a microphone transformer. This is a component with a step-up ratio of about 1:50 to 1:100. The carbon microphone, transformer primary, and a source of DC (about 1.5V to 4.5V) are connected in series. A very large audio signal voltage is obtained from the transformer secondary.

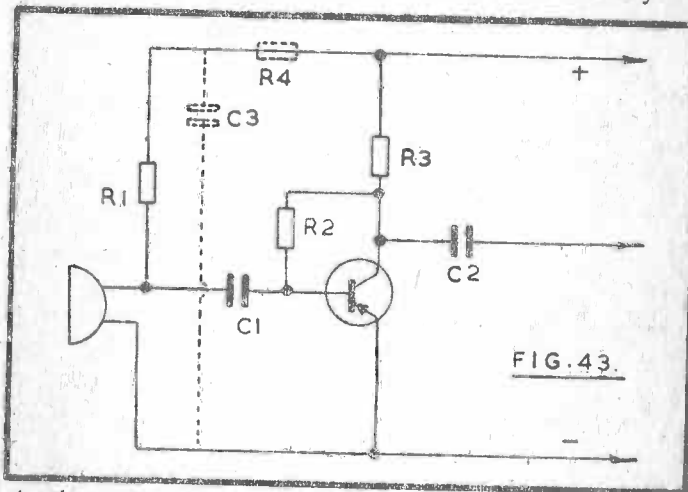

An alternative circuit which avoids the need for a transformer is shown in Figure 43. Direct current for the carbon microphone is obtained through R1. The audio signal at C1 is amplified in the usual way. R2, R3 and C2 can be typical for the stage — C1 and C2 may be 0.1 μF, with a 1.8 megohm for R2, and 10 k for R3.

R1 is best chosen so that optimum microphone current is provided. About 100 ohm is generally suitable. Unnecessarily low values here will increase battery drain, and tend to cause noise. C3 and R4 will only be necessary where audio fluctuations in battery supply cause feedback of other troubles, and R4 can typically be a few hundred ohms, with 220 μF to 640 μF for C3.

Stabilisation

With a pair of transistors in a push-pull modulator (or

similar IC modulator) the current drawn rises sharply as appreciable audio power is provided. This can cause a dip in battery voltage. Most crystal controlled oscillators are not too badly affected by this, especially when the batteries are in good condition, and a reservoir capacitor is present across the supply or circuit to the oscillator stage.

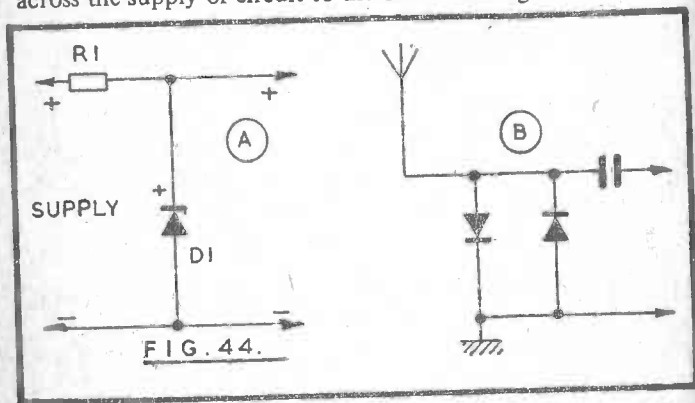

In other cases, a zener diode can be used to stabilise the oscillator supply, as at A in Figure 44. D1 can be a 400 mW device. R1 needs to be selected so that the dissipation in D1 is not exceeded but an adequate current must still flow here, even with the oscillator stage drawing its maximum current. Thus if D1 were 6.2V 400 mW, current through the diode should not exceed about 60 mA. The minimum value for R1 is then found to be near 100 ohm. Assuming that the oscillator stage draws 20 mA and that 10 mA stabilising current will be sufficient, the total current through R1 will be 30 mA. If the supply were to be 12V, approximately 6V would be dropped in R1, so a value of 220 ohm would be sufficiently near. By keeping R1 fairly high in value, battery drain is reduced.

RF Blocking

When the transmitter section is working, stray coupling in the transmit/receive switching and elsewhere can result in coupling of RF energy into the receiver aerial circuit. For low power equipment, this is unlikely to damage the

receiver first stage transistor. Figure 41 includes a method of helping to keep RF away from the receiver. Another method is to fit two diodes as at B in Figure 44. There can be 1N629 or similar devices. They have virtually no effect during reception, when the voltage is exceeding low, but conduct when a higher voltage is present, to protect the first transistor in the receiver. The coupling capacitor can be about 10 pF to 18 pF.

27 MHz Citizens' Band Operation

The 27 MHz and 28 MHz bands are so near in frequency that very little modification is required to change 28 MHz circuits for 27 MHz use. The Monitor/Wavemeter (Figure 3) will be suitable for 27 MHz with no modification.

In the case of crystal controlled oscillators primarily designed for 28 MHz working (such as that in Figure 5) the 28 MHz crystal is replaced by an appropriate 27 MHz crystal. Slight re-tuning to a lower frequency is then necessary, and falls within the normal adjustments of the coils. There is no need for a change to circuit values, or for any modification to inductors. All adjustments can be made as described, but will of course be at the wanted lower frequency.

With the simple super-regenerative receiver (such as that in Figure 24) no change to circuit values will be necessary, and 27 MHz will be reached with the coil core set slightly further in its winding. Similar considerations apply to the use of a superhet having a tuned oscillator (Fig. 27). Here, adjustment of T1 and the core of L2 will allow frequency to be shifted for 27 MHz operation. The aerial circuit, L1, can then be peaked up for reception on the actual frequency in use.

For crystal controlled receiver oscillators (as described for Figure 30) the receiver crystal must also be changed to suit the new frequency. This means that the transmitter crystal frequency and receiver oscillator circuit crystal frequency will differ by a figure corresponding to the intermediate frequency of the receiver, exactly as explained for the

28 MHz band. Thus, for 27 MHz, the receiver crystal can be 27,465 kHz, or 26,535kHz (27.465 MHz or 26.535 MHz) where the receiver IF is 465 kHz, and according to whether the oscillator is to operate at the high frequency or low frequency side of the transmission frequency. Where the receiver IF is 470 kHz or some other frequency, the receiver oscillator crystal is chosen to suit, as explained.

In the case of aerials, the approximate length of a half wave can be found from $468/\text{MHz}$, the result being in feet. As example, this is about 17.33 ft for 27 MHz and 16.7 ft for 28 MHz. It will be seen that these are quite close to each other, and a result of this is that adjustable whip and similar systems can generally be tuned from 28 MHz to 27 MHz with little difficulty. The 27 MHz aerial will need to be a little longer, or its loading inductance will have to be slightly greater.

As mentioned earlier in relation to Amateur activities in Great Britain, reference should be made to the appropriate local authority regarding conditions of operation.

OTHER BOOKS AVAILABLE BY THE SAME AUTHOR

BP30: TWO TRANSISTOR ELECTRONIC PROJECTS

ISBN: 0 85934 033 3

Price: 85p

Approx. Size: 180 x 105 mm

96 Pages

This book is written by Mr F.G. Rayer, a very experienced and popular author, who has written many books and contributes regularly to the monthly electronic magazines. It covers 28 popular projects that can be built using only two transistors. Mr Rayer initially describes in detail the various methods of construction, Tag Board, Veroboard, or printed circuit and then carefully details the various projects to be constructed. An ideal book for beginners and more advanced enthusiasts alike.

BP32: HOW TO BUILD YOUR OWN METAL AND TREASURE LOCATORS

ISBN. 0 85934 035 X

Price: 85p

Approx. Size: 180 x 105 mm

96 Pages

This book contains complete electronic and practical details on the simple and inexpensive construction of Heterodyne Metal Locators. This is one of the most fascinating applications of electronics and an ideal book to capture the interest of the beginner, also just as applicable to the more advanced enthusiast.

BP35: HANDBOOK OF IC AUDIO PREAMPLIFIER AND POWER AMPLIFIER CONSTRUCTION

ISBN: 0 85934 038 4

Price: 95p

Approx. Size: 180 x 105 mm

112 Pages

This book is divided into three parts: Part I, understanding audio IC's, Part II, Preamplifiers, Mixers and Tone Controls, Part III, Power Amplifiers and Supplies. Includes practical constructional details of pure IC and Hybrid IC and Transistor designs from about 250 mW to 100 W output. A "must" for the library of both beginner and experienced enthusiast alike.

BP37: 50 PROJECTS USING RELAYS, SCRs and TRIACs
ISBN: 0 85934 040 6

Price: £1.10

Approx. Size: 180 x 105 mm

112 Pages

Relays, silicon controlled rectifiers (SCRs) and bi-directional triodes (TRIACs) have a wide range of application in electronics today. These may extend over the whole field of motor control; dimming and heating control; delayed, timing and light sensitive circuits and include warning devices, various novelties, light modulators, priority indicators, excess voltage breakers, etc.

This book gives tried and practical working circuits which should present the minimum of difficulty for the enthusiast to construct. In most of the circuits there is a wide latitude in component values and types, allowing easy modification of circuits or ready adaption of them to individual needs.

An ideal book for both beginner and advanced enthusiast alike.

BP39: 50 (FET) FIELD EFFECT TRANSISTOR PROJECTS

ISBN: 0 85934 042 2

Price: £1.25

Approx. Size: 180 x 105 mm

112 Pages

Field effect transistors (FETs) find application in a wide variety of circuits. The projects described here include radio frequency amplifiers and converters, test equipment and receiver aids, tuners, receivers, mixers and tone controls, as well as various miscellaneous devices which are useful in the home.

It will be found that in general the actual FET used is not critical and many suitable types will perform satisfactorily. The FET is a low-noise, high gain device with many uses, and the dual gate FET is of particular use for mixer and other applications.

This book contains something of particular interest for every class of enthusiast — shortwave listener, radio amateur, experimenter or audio devotee.

A valuable addition to the library of all electronic enthusiasts.

Please note overleaf is a list of other titles that are available in our range of Radio and Electronic Books.

These should be available from most good Booksellers, Radio Component Dealers and Mail Order Companies.

However, should you experience difficulty in obtaining any title in your area, then please write directly to the publishers enclosing payment to cover the cost of the book plus adequate postage.

BABANI PRESS & BERNARDS (PUBLISHERS) LTD
THE GRAMPIANS
SHEPHERDS BUSH ROAD
LONDON W6 7NF
ENGLAND

BP1	First Book of Transistor Equivalents and Substitutes	60p
BP2	Handbook of Radio, TV and Ind: & Transmitting Tube & Valve Equiv.	60p
BP6	Engineers and Machinists Reference Tables	50p
BP7	Radio and Electronic Colour Codes and Data Chart	25p
BP11	Practical Transistor Novelty Circuits	40p
BP14	Second Book of Transistor Equivalents	1.10p
BP22	79 Electronic Novelty Circuits	75p
BP23	First Book of Practical Electronic Projects	75p
BP24	52 Projects using IGT41	95p
BP25	How to Build Your Own Electronic and Quartz Controlled Watches & Clocks	85p
BP26	Radio Antenna Handbook for Long Distance Reception & Transmission	85p
BP27	Giant Chart of Radio Electronic Semiconductor & Logic Symbols	60p
BP28	Resistor Selection Handbook (International Edition)	60p
BP29	Major Solid State Audio Hi-Fi Construction Projects	85p
BP30	Two Transistor Electronic Projects	85p
BP31	Practical Electrical Re-wiring & Repairs	1.00p
BP32	How to Build Your Own Metal and Treasure Locators	85p
BP33	Electronic Calculator Users Handbook	95p
BP34	Practical Repair & Renovation of Colour TVs	1.25p
BP35	Handbook of IC Audio Preamplifier & Power Amplifier Construction	75p
BP36	50 Circuits Using Germanium, Silicon and Zener Diodes	1.10p
BP37	50 Projects Using Relays, SCR's and TRIAC's	75p
BP38	Fun & Games with your Electronic Calculator	1.25p
BP39	50 (FET) Field Effect Transistor Projects	2.50p
BP40	Digital IC Equivalents and Pin Connections	2.75p
BP41	Linear IC Equivalents and Pin Connections	75p
BP42	50 Simple L.E.D. Circuits	1.25p
BP43	How to make Walkie-Talkies	1.45p
BP44	IC 555 Projects	1.25p
BP45	Projects on Opto-Electronics	1.35p
BP46	Radio Circuits using IC's	1.35p
BP47	Mobile Discotheque Handbook	1.35p
BP48	Electronic Projects for Beginners	1.45p
BP49	Popular Electronic Projects	1.35p
BP50	IC LM3900 Projects	1.25p
BP51	Electronic Music and Creative Tape Recording	1.45p
BP52	Long Distance Television Reception (TV-DX) for the Enthusiast	2.25p
BP53	Practical Electronic Calculations and Formulae	1.35p
BP54	Your Electronic Calculator and Your Money	1.45p
BP55	Radio Stations Guide	1.45p
BP56	Electronic Security Devices	1.50p
BP57	How to Build your own Solid State Oscilloscope	1.35p
BP58	50 Circuits using 7400 Series IC's	1.50p
BP59	Second Book of CMOS IC Projects	1.45p
BP60	Practical Construction of Pre-Amps, Tone Controls, Filters and Attenuators	95p
BP61	Beginners Guide to Digital Techniques	40p
100	A Comprehensive Radio Valve Guide - Book 1	40p
121	A Comprehensive Radio Valve Guide - Book 2	40p
126	Boys Book of Crystal Sets	25p
138	How to Make Aerials for TV (Band 1-2-3)	40p
143	A Comprehensive Radio Valve Guide - Book 3	40p
157	A Comprehensive Radio Valve Guide - Book 4	75p
180	Coll Design and Construction Manual	40p
178	A Comprehensive Radio Valve Guide - Book 5	15p
196	AT-RT Reactance - Frequency Chart for Constructors	50p
200	Handbook of Practical Electronic Musical Novelties	35p
201	Practical Transistorised Novelties for Hi-Fi Enthusiasts	1.00p
202	Handbook of Integrated Circuits (IC's) Equivalents and Substitutes	60p
203	IC's and Transistor Gadgets Construction Handbook	75p
205	First Book of Hi-Fi Loudspeaker Enclosures	60p
206	Practical Transistor Circuits for Modern Test Equipment	75p
207	Practical Electronic Science Projects	75p
208	Practical Stereo and Quadraphony Handbook	1.00p
210	The Complete Car Radio Manual	95p
211	First Book of Diode Characteristics Equivalents and Substitutes	1.00p
213	Electronic Circuits for Model Railways	85p
214	Audio Enthusiasts Handbook	85p
215	Shortwave Circuits and Gear for Experimenters and Radio Hams	1.00p
216	Electronic Gadgets and Games	85p
217	Solid State Power Supply Handbook	85p
218	Build Your Own Electronic Experimenters Laboratory	85p
219	Solid State Novelty Projects	85p
220	Build Your Own Solid State Hi-Fi and Audio Accessories	95p
221	28 Tested Transistor Projects	95p
222	Solid State Short Wave Receivers for Beginners	95p
223	50 Projects using IC CA3130	95p
224	50 CMOS IC Projects	95p
225	A Practical Introduction to Digital IC's	1.20p
226	How to Build Advanced Short Wave Receivers	1.25p
227	Beginners Guide to Building Electronic Projects	1.25p
228	Essential Theory for the Electronics Hobbyist	10p
RCC	Resistor Colour Code Disc Calculator	

BABANI PRESS BP43

How to Make Walkie-Talkies

■ Equipment for low power hand-held or portable operation need not be of a very complicated type to give excellent results and it falls more readily in the scope of the home constructor than does, say, medium or high powered transmitters and multi-band receivers.

■ In this book, the very experienced author Mr. F. G. Rayer, G30GR, presents an excellent treatise on Low Power Transmitter-Receiver or 'Walkie-Talkies' as they are more popularly called, covering many aspects from licencing requirements and bands, through practical circuitry and construction to the various types of aërials that may be used.

Divided into

- three sections:
- I Transmission
 - II Reception
 - III Aerials and Additional
Circuit Information.

■ A book of great interest not only to the licenced operator, but also to those enthusiasts without transmitting licences who can participate as listeners with the receiver equipment described.



BABANI PRESS
The Grampians
Shepherds Bush Road
London W6 7NF
England

ISBN 0 85934 046 5

£1.25