

maintaining

HI-FI

equipment

Joseph Marshall

maintaining

hi-fi

equipment

joseph marshall

published by gernsback library, inc.

new york, n. y.



© 1956 Gernsback Library, Inc.
All rights reserved under Universal,
International, and Pan-American
Copyright Conventions.

Library of Congress Catalog Card No. 56-7938
cover design by muneef alwan

contents

chapter

page

1

High-fidelity standards

Frequency response. Sine and square-wave measurements. Amplifier definition. Transient response. Distortion. Nonlinear distortion. Intermodulation. Transient distortion, hangover, ringing. Power output, efficiency and sensitivity. Damping factor.

9

2

Test instruments

Audio instruments. Audio signal generator. Audio generator requirements. Test records. Playback response curves. Scopes. Scope frequency response. Vacuum-tube voltmeter. Meter sensitivity. Audio wattmeter. Intermodulation analyzer.

27

3

High-fidelity circuits

Power amplifiers. Cathode loading. Switching transients. Drivers. Bootstrapping. Inverters. Preamplifiers and control units. Treble boost and attenuation. Loudness controls. Rolloff. Dividing networks. Variable damping controls.

41

4

Preliminary diagnosis

Classes of troubles. Typical tube types. Complete inoperation of system. Testing with headphones. Parts replacement. Audio signal tracer. System operating, but faulty. The misadjusted system. Adjusting controls. Room acoustics. Speaker placement.

67

5

Distortion

Tracing distortion. Overloading. Distortion and weak tubes. Improper operating parameters. Incorrect bias voltages. Imbalance within push-pull stages. Cancellation of distortion. Positive feedback, parasitic oscillation, and improper feedback.

79

6

Low-level distortion

Using the intermodulation analyzer. Amplifier load. Balancing push-pull stages. Checking the feedback loop. Decoupling networks. Ringing. Testing low-frequency stability. Using the scope and the intermodulation analyzer. Parasitic oscillation.

93

7

High-level distortion

Using a wattmeter. Phase-shift patterns. Phase relationships. Interpreting patterns. Distortion indications. Clipping. Symmetrical and asymmetrical in-phase distortion. Transformer magnetizing distortion. Analyzing the amplifier.

105

8

Bass and treble faults

Overboost. Speaker resonance. Matching speaker to enclosure. Insufficient damping. Boosting due to amplifier fault. Room resonance. Distortion of bass. Equalization. Loudness control. Speaker placement. Treble faults.

117

9

Common audio troubles

Low-frequency instability. Blocking of sound. Breathing. Ringing or fuzzy highs. Hum. Minimizing hum by proper adjustment. Diagnosing and locating hum. Causes of hum. 60-cycle hum. Tuners. Amplifiers. Ground loop problems.

141

10

Phono pickups and styli

Visual inspection. Needle wear. Indirect methods. Stylus distortion testing. Sapphire and diamond styli. Needle alignment. Tracking angle. Overhang. Needle pressure. Arm friction. Replacing needles and repairing cartridges.

165

11

Turntables and equalizers

Rumble. Turntable lubrication. Wow. The stroboscopic disc. Equalization. Checking equalization. Test record light patterns. Cartridge load. Equalizing circuits. Adjusting the pickup load. Loading effects on crystal pickup.

179

12

Tuners

AM tuners. Signal distortion. Distortion in FM receivers or tuners. Misalignment. Regeneration in tuners. Excessive limiting. Impedance matching. Pre-emphasis and de-emphasis. Discriminator and ratio detectors. Receiver noise. Capture ratio.

193

13

Final adjustments

Adjustments to be made. Balance. Making balance adjustments. Hum controls. Output tube bias. Changing tubes. Frequency response. Checking the response curve. Speaker response. Damping. Overall adjustments of acoustic balance.

203

Index

217

introduction

Presented with the opportunity and the problems of servicing a high fidelity installation for the first time, the average service technician with little or no background in the field of high fidelity is likely to approach the job either with too much respect or too little. Either attitude is bad. Too little respect can produce more damage than good, too much respect can result in an unprofitable waste of time.

High-fidelity reproduction is not achieved easily. It is the product of meticulous engineering, utilizing special and sometimes unique circuitry, precision components and a high degree of craftsmanship. The rather casual servicing procedures normally applied to the audio sections of radio and TV receivers, the tolerances permissible for replacement parts, and the very informal ear tests for quality, cannot be carried over into high-fidelity servicing.

On the other hand, despite the mystic fervor of audiophiles and the special language of high-fidelity literature, there is nothing mysterious about high-fidelity equipment and the results it achieves. Faithful reproduction is not attained by accident; but neither is it produced by magic or miracles. Although it may not resemble the familiar audio section of a radio or TV set, or even that of public-address amplifiers, the circuitry is largely based on familiar principles. And, although special instruments are most helpful, a good part of high-fidelity servicing can be done with only the instruments normally used for high grade radio and TV servicing. Therefore, the service technician, equipped with the knowledge and understanding of basic electronic theory, craftsmanship and instruments required to do a good job of servicing radio or TV, need have no fear of accepting the challenge presented by the servicing of hi-fi equipment. And he can cash in on the growing need for such servicing by some study of hi-fi theory and circuitry, accumulated experience and the purchase of a few instruments and tools.

Ninety percent of the problem in servicing any mechanism lies in diagnosis — recognizing the symptoms of trouble and finding their cause. Once the trouble is identified and the cause located, the actual cure or repair is usually a relatively simple matter. This is true whether the mechanism involved is a human body or a piece of machinery; and the best doctors, mechanics and service technicians in any field are those possessing an unusually high ability or gift for diagnosing ills quickly and accurately.

Accurate diagnosis requires three things: first, we must know and be thoroughly familiar with the *normal* state and operation of the mechanism involved. Secondly, we must be able to recognize and to identify any departures from normality. Third and finally, we must be able to account for the abnormal operation by deducing or discovering the fault in the mechanism which produces that abnormal behavior. Once that is done, almost anybody with an elementary skill in the craft is capable of making the needed repairs.

It is the purpose of this book to provide the service technician with the basic information needed to become competent in performing these steps when called upon to deal with the various complaints which arise when a high fidelity system is not giving customer-satisfying performance. The various sections of the book more or less parallel the steps outlined in the preceding paragraph. The first section presents the minimal background needed to recognize normal operations and departures from it. It also covers briefly the circuitry peculiar to high-fidelity equipment and the instruments and methods needed to measure various high-fidelity qualities and characteristics.

The second section deals with high-fidelity faults and their causes. Its purpose is to enable the service technician to recognize and identify abnormalities and to account for them. The relationships between the abnormalities heard by the ear and the electrical or acoustical fault in the system which produces them, is often indirect and sometimes subtle. For example, good definition, or the ability to reproduce the very fine details of music played by a large orchestra, is perhaps the most important single virtue of a high-fidelity system as compared with an ordinary radio or sound system. But good definition is not produced nor degraded by any single portion of a system; there is no place in a system where a resistor or capacitor failure will degrade definition and nothing else. Definition is a function of several things — wide bandwidth, very low distortion and a good transient response.

In servicing electronic systems we tend to concentrate entirely on the electrical portions of the systems. Most treatments of radio and TV servicing concentrate on circuit elements and circuit faults. But high fidelity is only partly the result of good electrical performance. There are also mechanical, acoustical and even psychological and physiological elements involved. Quite often the fault lies in these elements rather than the purely electrical portions of the system. Knowing circuit diagrams and possessing instruments adequate to diagnose circuit faults is, of course, highly important; but in many cases, to solve the problem which bothers the customer, the service technician will have to understand and deal with the acoustical, mechanical and even the psychological factors.

Furthermore, in radio and TV servicing one almost always deals with faults which either involve complete non-operation or operation so poor that it is obvious to even the most uncritical ear or eye. In high fidelity, on the other hand, a considerable percentage of complaints will involve equipment which is not only operating but, to the uncritical ear, operating very well. For both these reasons the service technician will have to possess higher standards, a more critical ear and a greater tolerance for human beings. Unless he does possess these, many of the complaints he hears will seem unjustified; and unless he has knowledge enough to understand and appreciate the differences very slight faults produce, he is obviously incompetent to diagnose and to correct them.

The final section of the book deals with the purely electrical portions and with specific units of a high-fidelity system. It presents several methods of testing with special emphasis on routines which are fast, economical and therefore profitable as well as effective.

The reader who goes straight through this book may find a few repetitions. These are deliberate. It is my intention to make this book not only an introduction and manual of servicing but a handbook for troubleshooting. The index is arranged to be, in effect, a troubleshooting index. Some space could have been saved by avoiding repetition and cross-referencing instead in the text. But personally, I find nothing more annoying than to consult a book for assistance, find the place where it might logically be treated and then find myself referred to some other portion of the book; and in the belief that most busy people share my annoyance for this sort of doubtful economy of space, I have tried to avoid it as much as possible.

The organization of a book is conditioned largely by the thinking processes of the author, and the same material could be presented in a dozen different ways by a dozen different authors. My logic in writing this book is revealed in these paragraphs and stresses diagnosis of troubles and therefore symptoms; consequently, the book is largely organized to facilitate diagnosis through their audible symptoms. Any organization of a book is likely to produce some strange results. Thus, a look at the chapter headings of this one will show that although chapters have been devoted to phono pickups and turntables, there are no chapters devoted to amplifiers or to loudspeakers. In actual fact the largest portion of the text deals with amplifiers; and loudspeakers are also very thoroughly covered in various chapters. It seemed to me to be more logical, for example, to consider insufficient damping of speakers or improper matching of speaker to enclosure, in the chapter concerned with faults evidenced by deficiencies in bass — in other words, to consider possible troubles in terms of the audible symptoms they produce, rather than in terms of the location in the chain of equipment in which they occur. To my mind this provides the most suggestive help in isolating and localizing troubles with a minimum of repetition and cross-references in the text. The reader interested in speaker faults may be forced to consult the index to find the information he desires; on the other hand, when pursuing a symptom to find its breeding ground, he is given the most complete and convenient coverage of all possible causes in a logical manner and is spared the nuisance of being asked to turn to various other chapters in the book. The result, no doubt, will please some more than others; but no organization could please all readers all of the time.

Some of the material in this book has appeared serially in RADIO ELECTRONICS magazine and I am greatly indebted to the editors not only for sympathetic and effective editing and guidance, but also for the opportunity of undertaking to write this book. I am also greatly indebted to the Heath Company and the Precise Development Corporation for supplying much helpful information and for the use of typical instruments in developing and testing the techniques and routines, so that the text could be applied with representative and easily available equipment. I am also indebted to many manufacturers of high-fidelity equipment for supplying servicing information and for permission to use accurate diagrams of their products.

JOSEPH MARSHALL

high-fidelity standards

High fidelity is unique. Possessing a much more critical audience than radio listeners or TV viewers, audio equipment calls for greater attention to fine servicing details. Frequently all that is necessary is an adjustment or simple tube replacement. In many cases the audiophile is more than competent and with helpful suggestions and advice can make repairs or replacements to his entire satisfaction. In other instances, the help of a service technician will be required.

This book, then, is written with a dual purpose in mind. It has been designed for the service technician who feels, correctly, that maintenance of hi-fi equipment is part of his job. At the same time this book will also serve the numerous audio fans who have constructed their own amplifiers, set up their own systems, and who insist upon a high level of performance. Quite often the audio listener knows as much about his hi-fi setup as the service technician. Neither in radio nor in television do we have a similar situation. High fidelity is unique.

Frequency response

A high-fidelity system must be capable of passing any waveform in the audible spectrum from 20 to 20,000 cycles with as little modification as possible. In the early days of high fidelity, the frequency response was considered to be the primary consideration and high-fidelity equipment was judged primarily by the width of its frequency response. Today we know, on the one

hand, that an adequate bandwidth or frequency response is the easiest of all qualities to obtain and, on the other hand, that a wide bandwidth is acceptable only when the total distortion of all types is insignificant. It is no trick with modern tubes, circuits and other components to provide a passband from 20 to 20,000 cycles or wider. The real thought in designing high-fidelity equipment is directed at holding the distortion to a level so low that it neither annoys the ear nor modifies the character of the signal passed through the system.

The electronic portions of all modern high-fidelity systems will be flat within 1 or 2 db from 20 to 20,000 cycles. The better-

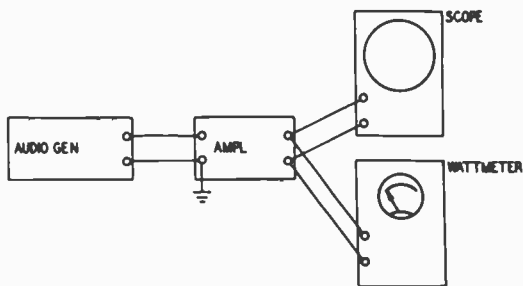

Fig. 101. Arrangement for checking the power response of an audio amplifier.

quality power amplifiers and preamplifiers will have much wider bandwidths. In some cases they are flat within 1 db from below 10 cycles to beyond 50,000 cycles, and a few are quite flat at low levels from 2 to 200,000 cycles. It is debatable whether such extreme bandwidths are necessary to reproduce sound frequencies; they are employed, however, to obtain the high amounts of feedback needed to reduce distortion to an insignificant minimum without producing instability in the form of ringing, motorboating, breathing, etc.

Ideally the performance of any piece of equipment ought to be measured and judged with the material it is normally called upon to handle. And, indeed, the final, crucial test of all high-fidelity equipment is that made by listening with a critical ear as it reproduces various types of music and speech.

Unfortunately, the waveforms of music and speech are too complex to use for measuring the electrical specifications and characteristics of amplifiers and they cannot be duplicated in the form of standard signals. However, we can get a pretty accurate idea of performance by measuring the response to waveforms such

as sine and square waves. At one time we depended nearly entirely on sine-wave measurements; today we know that sine-wave measurement, though quick and convenient, is not adequate in itself. Therefore, we also measure and test response to square waves—a waveform which resembles the waveforms of complex music but is even more difficult to reproduce with faithfulness than musical waveforms—rather on the principle that a garage big enough to handle a Cadillac will take a Chevy nicely.

With most modern high-fidelity equipment sine-wave measurement of frequency response at low levels is not particularly revealing or instructive. There is, however, real merit to measuring the frequency response at the maximum power output point. This requires the use of a signal generator as a source and a scope and

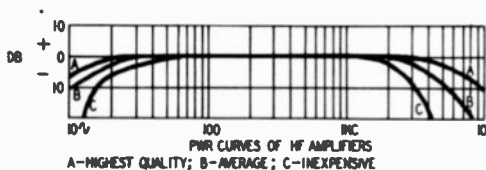

Fig. 102. Power-output curves of three audio amplifiers.

wattmeter as indicators. See Fig. 101. With a 1,000-cycle sine-wave signal adjust the controls so the trace on the scope just begins to show signs of clipping or deformation. The power output is noted on the wattmeter. The procedure is now repeated at a dozen or so points in the range from 20 to 20,000 cycles. There will usually be a drop in power output of from 2 to 6 db below 50 cycles and in some cases above 15,000 cycles. Fig. 102 shows such power curves for several classes of high-fidelity amplifiers. There is a strong presumption that any amplifier which does not come somewhere within the limits of these curves is faulty. Possible causes of failure to come up to these standards are covered in a subsequent chapter dealing with various system faults.

Low-level sine-wave measurement is of greater value in the case of control units, preamplifiers and those amplifiers which contain tone controls and equalizers. The function of these controls is to modify the frequency response of the system in a way which compensates for slopes in recording, transmission, room acoustics or the human ear. A typical high-fidelity system will employ several networks to modify the frequency response. It will, to begin with, have a phonograph equalizer — with as many as a

dozen fixed equalizers for reproducing the many makes of records. It will also have separate adjustable networks for boosting and attenuating both bass and treble response. There are no uniform standards for such bass and treble controls. However, in

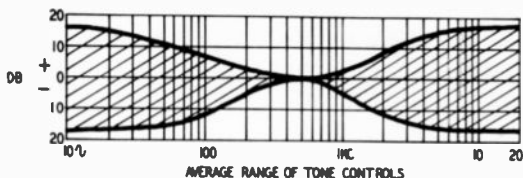

Fig. 103. *Tone controls permit attenuation or boost at low- and high-frequency ends of response curve.*

most instances the bass control will provide either a 15-db boost or a 15-db attenuation at 20 or 30 cycles, while the treble control will provide at least 10-db boost and 15-db attenuation at 10 or 15 kc. There may also be a loudness control which boosts both bass and treble to correct the hearing curve of the ear at various levels of loudness. Fig. 103 shows the average range of tone con-

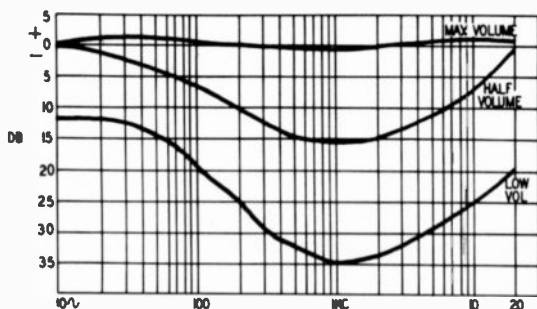

Fig. 104. *Loudness control curves at different volume levels.*

trols while Fig. 104 displays curves of loudness controls at various volume levels. Frequency-response runs with sine waves provide a convenient means of checking and properly adjusting these various networks.

Square wave measurements are more useful in routine testing and measurement. The overall response can be gauged roughly but adequately by observing the shape of 200- and 2,000-cycle square waves. If these waves are square and have flat tops, the system can safely be presumed to be flat from 20 to 20,000 cycles. Square waves are also invaluable for testing response in the sub-

sonic and ultrasonic regions and for testing amplifier stability. The shape of square waves in the range from 20 to 60 cycles gives an excellent indication of the response curve below 20 cycles. In most equipment there will be some slope in the top of square waves below 60 cycles. If the slope at 60 cycles does not exceed 50% of the height of the square wave, the response can be considered satisfactory. A few of the very finest amplifiers will not show a 50% slope even on a 20-cycle square wave. At the high

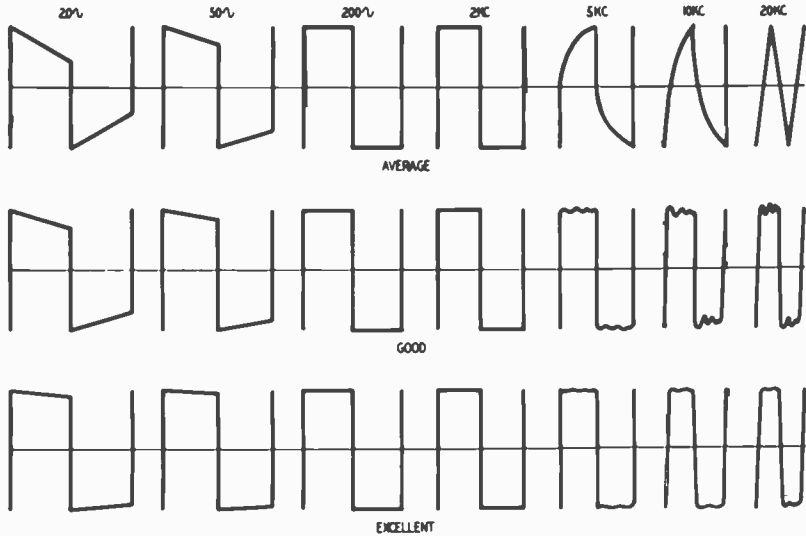

Fig. 105. Quality amplifier shows minimum deformation of square-wave response. Slope of flat top portion of wave generally increases at frequencies below 200 cycles. At frequencies above 5 kc, the waveform may show rounding of the edges, or ringing, as illustrated in the drawings above.

end, the response curve is indicated by (1) the slope of the leading edge of the square wave and (2) the squareness of the leading corner. Any high-fidelity amplifier should reproduce a 2,000-cycle square wave perfectly. A very few of the finest amplifiers will reproduce a 10- or even a 20-kc square wave with reasonable accuracy; most, however, will show some rounding off on square waves between 5 and 20 kc, or some degree of ringing. If the rounded edge is not over 50% of the height at somewhere between 5 and 10 kc, it can be presumed to be satisfactory. The use of square waves for measuring transient stability will be covered in a subsequent section. Fig. 105 gives square wave responses of several classes of hi-fi amplifiers.

Definition

An amplifier with good definition maintains the distinctness of the individual elements of the signal. Definition in an amplifier can be compared to resolution in a camera. A camera with good resolution will show individual blades of grass and individual hairs in a coiffure; a camera with poor resolution blurs the separate components so that they cannot be distinguished. Similarly, an amplifier with good definition reproduces the individual notes and instruments distinctly; one with poor definition will blur the individual tone elements and instruments until they cannot be distinguished separately.

Definition in an amplifier is very largely a function of transient response and low distortion. An amplifier with good transient response and stability is nonresonant, nonregenerative and non-oscillating. It is always merely a reproducer, never a generator. Unfortunately, this is much easier to stipulate than to achieve. Most amplifiers are regenerators or oscillators of the triggered type. At some point in the frequency range they are resonant, have a regenerative feedback loop and will break into oscillation if triggered by a strong-enough impulse. These oscillations are not always audible as such in the output. They are manifested not as constant tones but as *hangover effects* and consist of a series of echoes of the signal. They may even be pleasing to some because they give a resonant effect which sometimes simulates room resonance, but they reduce the definition of the amplifier, blurring the individual elements and instruments instead of maintaining their distinctness.

The effect of hangover in degrading definition is indicated in Fig. 106. In Fig. 106-a we have a series of sharp pulses, such as might be produced by rapidly and violently striking a wood block with a drumstick. There are definite valleys between the separate tones in the original sound even when the keying is very rapid. Any tendency of the reproducing system toward hangover, however, will prolong each pulse with a whole series of spurious pulses—hangovers or echoes—which change not only the shape of the original pulses but also fall into and partly fill the valleys between the pulses. The result is indicated in Fig. 106-b. The separation between pulses is no longer distinct and sharp, the total effect is blurred and the definition or resolution is greatly degraded.

There is no simple electrical means of measuring definition directly. The ear is the only test tool. However, there are indirect electrical tests. Since definition is so dependent on transient stability and on low distortion, it is clear that measuring distortion and transient response gives us some indication of definition.

Transient response

Although for purposes of simplification we design audio equipment with certain sine-wave response characteristics, sine waves

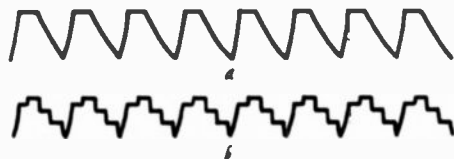

Fig. 106-a, -b. Clean waveform (a) shows hang-over effect (b).

themselves bear very little resemblance to the waves handled by a system reproducing voice, music or almost any natural noise. All of these sounds are complex waves consisting of complicated combinations or resultants of many sine waves plus various transient waves. The single tone of a single musical instrument is composed of a fundamental and various harmonics. When two or more instruments are played together, the waveform combines the fundamentals and harmonics of both. The waveform of a symphony orchestra is obviously an extremely complex one. In fact, these complex waveforms are more closely related to square or sawtooth waves — which are also combinations of fundamental and many harmonics — than to sine waves. Clearly, then, if a system is to be capable of reproducing such complex waves, its characteristics must be considerably better than those required to reproduce a simple sine wave.

Moreover, the production of music (and voice for that matter) is accompanied by the production of genuine transient waveforms. For example, the violinist makes sudden starts and stops every time his bow string changes direction; the pianist applies sudden and rather violent force when he hits a piano key hard; the drummer produces a sudden and violent rise in amplitude of sound when he strikes the drum hard. These sudden and violent excitations produce a very steep wavefront very much resembling the leading edge of a square wave, pulse or sawtooth. Unless the

quency transients. On a fine system the separate dots and dashes will be distinctly reproduced even from high-speed commercial stations with mechanical senders.

Distortion

No matter how carefully we coddle the signal as it passes through a reproducing system, we inevitably distort it. Some of these changes are not significant, but others are so serious that they not only destroy the fidelity of the system but may be outright annoying. In good high-fidelity systems distortion is always held below the point of annoyance. However, even small amounts of distortion, not noticeably annoying in themselves, may destroy the realism of the system by masking the more subtle components of music, thus destroying the ability to distinguish the fine details. There are many forms of distortion:

1. *Nonlinear distortion* produces sounds which are harmonics of the original sound. For instance, harmonic distortion of a 400-cycle tone would produce sounds of 800, 1,200, 1,600, 2,000, etc., cycles. This type of distortion is not too serious in small amounts since the harmonics resemble the natural harmonics produced by musical instruments themselves, although it will degrade the definition. The situation is rather like that existing when a pedigreed bitch has a litter by an equally pedigreed dog; there are more dogs than one wants, and it is more difficult to choose any specific dog, but since all are thoroughbreds the overall aesthetic effect isn't too bad. The effect is different with intermodulation.

2. *Intermodulation (IM)* produces sounds which are the sums and differences of two or more frequencies passing through the system. Thus a 60-cycle tone and one of 2,000 cycles would produce sounds of 1,940 and 2,060 cycles, respectively. These new sounds have no relation to the original and are nonmusical since they are not in the musical scale. It is as if the pedigreed bitch had strayed across the tracks and produced a litter of ugly, non-descript and dissimilar mutts.

Obviously the situation is much worse if the nonlinearity produces multiple components, for if we have not only the 60- and 2,000-cycle tones but also their harmonics, then the sum and difference frequencies increase fantastically. We would have not only the intermodulation product of the original two tones but also the products of the harmonics of each tone, the harmonics of one

beating with the harmonics of the other and even the sum-and-difference products of the intermodulation sounds themselves.

There is considerable difference of opinion about permissible levels of distortion in high-fidelity systems. Generally speaking, most popular equipment has an amplitude- or harmonic-distortion level of less than 2% at rated power output, and in some of it distortion has been reduced to levels as low as 0.1% at maximum rated output.

Measuring harmonic distortion is rather complicated. Moreover, until recently, harmonic distortion analyzers were very expensive. An excellent instrument is now available in kit form and

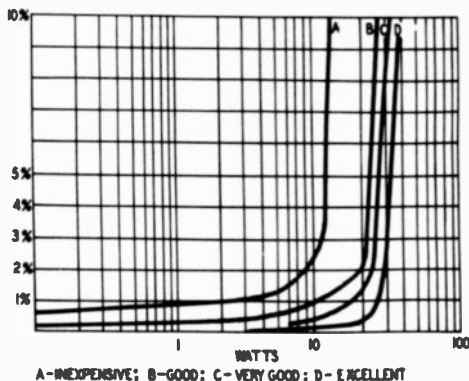

Fig. 108. *Types of intermodulation curves. Intermodulation curves are helpful in indicating amplifier performance.*

its use will probably increase the importance of ratings in terms of harmonic distortion and also simplify its measurement. Actually, however, in most cases harmonic distortion is not as significant in indicating overall performance as intermodulation (IM) distortion and IM measurements are relatively simple to make.

There is a relationship of some sort between harmonic and intermodulation distortion. Both are products of nonlinearity and they are invariably found together. Unfortunately, however, we do not as yet know exactly what this relationship is. It used to be accepted that intermodulation and harmonic distortion were present in a ratio of approximately 4 to 1, with the intermodulation on the high side of the ratio line. This simple and convenient relation, however, has not stood the test of greater knowledge. It does appear to hold fairly well for high-output and high-distortion levels, but breaks down at low-output and low-distortion levels. In any event, the measurement of intermodulation distor-

tion is the most important single measure of audio distortion; and present high-fidelity practice calls for intermodulation distortion levels of 2% or less at an output power of 6 watts or more. Fig. 108 gives typical intermodulation curves. Any hi-fi amplifier should fall somewhere within the range of these curves.

3. *Transient distortion, hangover or ringing.* If any portion of the reproducing system is resonant, it may turn into a generator and produce sounds of its own. It may do so constantly, if it is oscillating, or it may do so only when triggered into momentary oscillation by a suitable signal. The triggering signal does not have to be related to the resonant frequency of the guilty system. Any strong signal may do the job, just as a stick, stone or even a ripe tomato will produce a boom if they hit a drum hard enough. The jukebox boom of some speaker cabinets is just such a generated tone—the generator being the resonant cavity of the enclosure.

Particularly serious is the transient distortion produced by resonant points in a power amplifier. In good amplifiers the resonant points are at the extremes of the frequency range and are produced by phase reversals in the feedback loops. The oscillations or transients produced by these resonances may not be audible to the ear. Nevertheless, they have two disastrous effects: First, they multiply the intermodulation distortion, and, second, they may be of such high amplitude that they drive one or more stages of the amplifier into the nonlinear portions of their curves and produce violent distortion of all forms even at low signal input levels where the distortion ought to be insignificant. When these oscillations occur at subsonic frequencies, they are known as *motorboating* or, when completely inaudible, as *breathing*. Motorboating is easily recognized but breathing may pass completely unnoticed if the loudspeaker cone is not visible, for it is evidenced in the form of very slow movements of the cone at the rate of a few cycles a *minute*. However, breathing will also betray itself by occasional audible thumps or by completely blocking the amplifier with high excitation, especially by drums, and producing a null in sound output. When any of these effects occur, open the speaker cabinet and check for breathing.

In the ultrasonic range this type of transient distortion takes the form of ringing—constant or periodic oscillation at some ultrasonic frequency. A simple check and measure are provided by observing square waves in the region between 10 and 20 kc.

Ringling is indicated by a ripple on the top of these high-frequency square waves. Amplifiers with a considerable sloping of the leading edge at 10 kc or lower will usually be free of ringling. However, amplifiers with a flat response beyond 50 kc will invariably show some sign of ringling on a 10- or 20-kc square wave. Fig. 109 shows various examples of ringling. The violent oscillations in a and b will produce serious effects; the slight effects in the others are acceptable and, indeed, only an occasional very high quality amplifier will be as free of ringling as the final trace. It is not necessarily costly to achieve this!

A related form of distortion is produced by a system which, though not resonant or only broadly resonant, is not highly

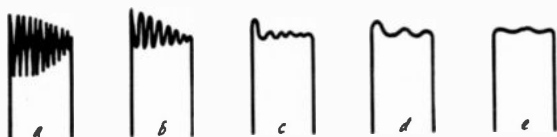

Fig. 109-a to e. Effects of ringling on square-wave response. Waves shown in a and b are severe; the others are less so.

damped. The condition is very much like that which exists when one depresses the loud pedal of a piano: The undamped strings will now produce sound if the piano case is struck; and when a key is struck, we obtain not only the tone produced by the original striking of the string but also echoes of the original which continue for some time. Similarly, a poorly damped reproducing system—especially a loudspeaker—will produce echoes of each peak of the waveform. A certain amount of hangover is not unpleasant, since it gives a vibrant, live effect, similar to that produced by playing an instrument in a room with very live acoustics. Indeed some loudspeakers have been designed deliberately to produce hangover and thus to increase the illusion of presence. It is clear, however, that such echoes not only change the character of the original music, but also degrade the definition by obscuring the fine detail of the music. Hangover is best measured with a step transient and a scope. A keyed 1.5-volt battery will provide the transient. Perfect reproduction would produce a trace like a in Fig. 110. This is unlikely of realization and traces like b and c are more representative of the finest equipment, while d might be average and e very poor and unsatisfactory.

Another form of transient distortion occurs due to a change of amplification occasioned by the transient. This often happens

because supply voltages change when the signal level changes, and the voltage adjustment takes time. This effect can most easily be demonstrated by keying a tone from an oscillator. Fig. 111-a shows the input waveform used (which should also appear at the output, enlarged) while Fig. 111-b shows a common form of distortion that happens. This kind of distortion can show up when no other forms of distortion are measurably present. Unlike the other forms of transient distortion, this does not add a ringing effect at a spurious frequency, but will make sudden tone bursts sound unnatural.

4. *Phase distortion* does not ordinarily produce additional sounds, but it is of great practical importance in obtaining and maintaining high performance. To increase the bandwidth of a

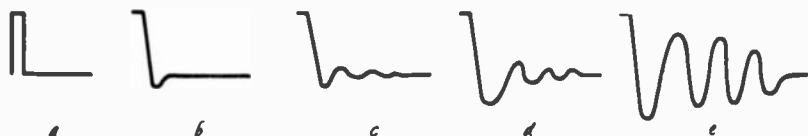

Fig. 110-a to e. *Ideal amplifier gives perfect reproduction of step transient (a), but in practice, waveforms b to e are more generally obtained.*

system and to reduce the distortion we use large amounts of feedback. How much feedback we can use without generating transient distortion depends principally on the phase shift of the amplifier. Therefore, the measurement of phase shift is one of the more valuable procedures in servicing high-fidelity equipment.

Power output, efficiency and sensitivity

None of these items is of really critical importance in high-fidelity performance. A system needs adequate power to handle the dynamic range of the signal and a little to spare; but at present most high-fidelity amplifiers are, if anything, overdesigned in this respect because this is the easiest way to achieve low distortion. Sensitivity and efficiency are way at the bottom of the high-fidelity totem pole. Nobody cares how much of the power supplied is wasted in heat; and, as for sensitivity, another very easy way to achieve low distortion is to operate every stage at a very low level, throwing away much of the possible gain.

However, power output and sensitivity are both significant clues to the behavior of a high-fidelity system. For instance, a falling off in tube performance decreases the power output, and measuring the power level while changing tubes is one of the best indi-

cations of the value of new tubes. Similarly, reduced gain may result in distortion through overloading or through a shifting of the operating curves; and gain measurements provide clues to the point in the system where loss of gain is producing the harmful effects.

Damping factor

Definition is probably the most important single quality of a high-fidelity system. Good definition is the result of a combination of excellent transient response, wide bandwidth, low distortion and freedom from hangover. The loudspeaker system plays a dominant part in establishing several of these qualities and is

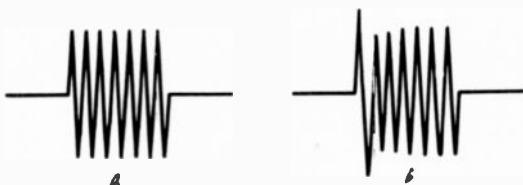

Fig. 111-a.-b. Form of transient distortion due to changes in gain; at (a) input waveform; at (b) the distorted waveform.

particularly critical from the point of view of hangover; and the better modern amplifiers have become, the more critical the part played by the speaker system. Being mechanical devices with large mass, affected by considerable and very complex forces; speakers have a tendency, once set in motion, to continue in motion at a rate determined by the stimulating signal or their own physical characteristics. Set in motion for example by a single sharp 60-cycle pulse, they have a tendency to continue to vibrate, producing a series of echoes or hangover of the stimulating signal. The effect is precisely comparable to that produced when a piano key is struck with the loud pedal applied; one hears, not only the sound produced by the original blow, but also a continuing series of echoes of it produced by the continuing vibration of the string. Obviously this hangover would add a whole series of sounds not present in the original signal and degrade definition tremendously. A great deal of ingenious thought has gone into speaker design to overcome this tendency but even the best modern speakers are not free of hangover and the presumption is that it would be impossible to design a speaker system free of it and yet capable

of reproducing very minute variations in waveform.

One solution is to damp the speaker system electrically with a parallel resistance so low that it absorbs all or most of the hang-over motion. This is accomplished by reducing the internal resistance of the amplifier which feeds the speaker. One way to reduce it is to use triode output tubes but even this does not produce a low enough internal resistance. The resistance can be reduced greatly, however, by the application of negative feedback. In general the larger the amount of negative feedback put around the output tubes, the lower the internal resistance. In modern

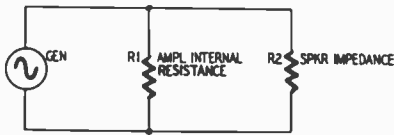

Fig. 112. Relationship of amplifier resistance and speaker impedance.

amplifiers the total net resistance of the amplifier at the 8- or 16-ohm tap of the output transformer is typically from 8 ohms to a fraction of 1 ohm.

The low resistance of the amplifier swamps the resistance of the speaker system and increases, as it were, to such a degree the friction against which the speaker mechanism must work that, though it is free to respond to the motion of the signal, its tendency to vibrate on its own is suppressed or absorbed — in much the same way that the damping felt over a piano string suppresses the tendency of the string to continue vibrating.

There is another fault in speakers correctable by damping. Speakers are resonant and at their resonant point their impedance is several times that at other frequencies. The same current would therefore produce a much higher voltage drop at the resonant frequency and consequently a much larger movement and a much louder sound. This would result in a one-note bass — the one-note bass of the old-fashioned jukebox and radio *was* produced by this resonant peak. The resonant peak, however, can be swamped out by paralleling the speaker with a lower resistance. A little simple arithmetic shows what happens: Fig. 112 is the equivalent circuit of a speaker system and the internal impedance of the amplifier to which it is connected. R1 is the internal resistance of the amplifier and R2 is the speaker impedance. Let us assume the speaker impedance is 16 ohms except at the

resonant frequency where it rises to 75 ohms. The net impedance is:

$$R_x = \frac{R_1 \times R_2}{R_1 + R_2}$$

Clearly, the lower the value of R_1 (the lower the internal resistance of the amplifier), the more constant the net impedance. For example, let us assume an amplifier resistance of 1,000 ohms. In that case we have at the resonant peak

$$\frac{1000 \times 75}{1000 + 75} = \text{approximately } 69 \text{ ohms;}$$

and in the rest of the spectrum we have

$$\frac{1000 \times 16}{1000 + 16} = \text{approximately } 15.7 \text{ ohms.}$$

Now suppose we reduce the internal resistance of the amplifier to 2 ohms (a not unlikely value in modern amplifiers). In that case we have

$$\frac{2 \times 75}{2 + 75} = 1.94 \text{ ohms}$$

at the resonant frequency and

$$\frac{2 \times 16}{2 + 16} = 1.77 \text{ ohms}$$

in the rest of the range. With an amplifier resistance of 1,000 ohms, the voltage at the resonant frequency would be more than four times higher than the voltage in the rest of the range and this would produce a peak of 12.8 db. On the other hand, with an internal resistance of only 2 ohms the peak would be a mere 0.8 db or completely insignificant.

The damping factor of an amplifier is quite easily measured and calculated with this procedure: Feed a sine-wave signal into the amplifier with a resistive load equal to the impedance of the output tap (16-ohm resistance on the 16-ohm tap, or 8-ohm resistance on the 8-ohm tap, etc.). Connect an output meter across the load and adjust the input to produce a reading of exactly 1 volt. Disturbing nothing else, remove the load resistor. The reading will rise to some degree. Note it. The internal resistance of the amplifier can now be calculated from the simple formula:

$$R_1 = \frac{R_L}{V_L} (V_0 - V_L)$$

in which R_L is the load resistance, V_0 is the voltage reading without load and V_L is the voltage reading with the load. For example, let us assume that with a 16-ohm load the voltage reading is 1 volt and with no load it is 1.1 volts. Then

$$R_1 = \frac{16}{1} (1.1 - 1) = 1.6 \text{ ohms}$$

The damping factor is calculated from R_L/R_1 in which R_L is the load resistance and R_1 the internal resistance of the amplifier. In the case given we have: $16/1.6 = 10$, or a damping factor of 10.

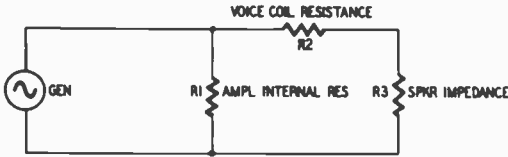

Fig. 113. The voice-coil resistance, R_2 , limits the usefulness of progressively higher damping factors.

The damping factors of modern hi-fi amplifiers range from about 0.3 to 20 or more. Actually, damping factors in excess of 10 have little practical effect because the d.c. resistance of the speaker voice coil is effectively in series with the speaker and is the dominant component in the net impedance (Fig. 113). Beyond a certain point the increase of damping has very little effect on net resistance. For example, a 16-ohm speaker will have a d.c. resistance of around 12 ohms. Connected to an amplifier with a damping factor of 10 the net impedance would be around 13.6 ohms. A damping factor of 40 would reduce the net impedance only to 12.4 and the difference would produce audible effects so slight as to be inaudible and in fact scarcely measurable. Since speaker systems vary in design and need for damping, no single damping factor can suit all speakers although the higher the damping factor *the smaller the difference* will be with different speakers. Obviously, every speaker has a critical damping point and the ideal arrangement would be one which provided the speaker used with a specific amplifier with exactly the damping required to produce critical damping. Many high-fidelity amplifiers now provide means of varying the damping factor. The chapter on circuits (see page 64) gives typical circuits for precise adjustment of damping factors.

test instruments

It is possible to provide emergency servicing of high-fidelity equipment with only a v.t.v.m. and a pair of headphones, but to do a really good job some specialized instruments are necessary. High fidelity is achieved principally through patience with a number of little details. Very often the condition which mars the performance of a unit is the result of a very small departure from permissible tolerances. Often it is impossible to locate and correct this without proper instruments. The shop which does (or expects to do) a good deal of high-fidelity servicing will greatly increase its ability to turn out a high-grade job at a profit by investing in a few specialized audio instruments.

Audio instruments

At one time, good audio instruments were fully as expensive as they were scarce. Today, however, the market offers at very moderate prices every type of equipment necessary for servicing. Particularly noteworthy are the many excellent instruments offered in kit form. Many are well designed and of more than sufficient accuracy for good servicing.

All the tests essential for servicing and adjusting amplifiers can be made with four or five instruments: an audio signal generator, frequency test records to provide standard signals for phono testing, oscilloscope, a.c. v.t.v.m., audio wattmeter, and intermodulation analyzer.

Audio signal generator

For high-fidelity servicing an audio signal generator should have these specifications:

1. *Adequate frequency range* — at least from 20 to 20,000 cycles. A range of 2 to 200,000 cycles would be even better and is often used for design purposes; however, it is difficult to obtain so wide a range without some sacrifice of other necessary qualities, and such instruments are more costly.

2. *Constant output*. To simplify the setup necessary for accurate frequency runs and to reduce the number of instruments, the output of the generator should be as nearly as possible uniform over the full range. Most commercial instruments and kits will deliver an output, over the full range of 20 to 20,000 cycles, which does not vary by more than 1 db. This means that it is not necessary to monitor the output of the generator as well as the output of the equipment under test — a saving of one instrument, although where extreme accuracy is necessary it is a good idea to monitor the generator as shown in Fig. 201.

3. *Low distortion*. Since, as we have seen, the permissible distortion of high-fidelity equipment has to be extremely low, it is very important that the signal used for testing and measuring distortion be as free as possible of all forms of distortion. The R-C type generators, fortunately, produce almost pure sine waves; and if the associated amplifiers are adjusted for minimum distortion, the total distortion can be held below 1%. Incidentally, the distortion of such generators can often be reduced by as much as 50% simply by adjusting the feedback network for minimum gain and minimum output. This may reduce the normal 10-volt output to 5 volts or even 2, but actually this is more than sufficient. However, beware of adjusting the feedback too low, because this can adversely affect the constancy of output. See point 2.

4. *Provisions for supplying square waves*. Suitable square waves can be produced by clipping the output of a sine-wave generator. Many generators include such a clipper and therefore provide a source of square waves as well as sine waves. The squareness of a clipped sine wave depends on how much of the wave is lopped off, and this should be taken into account in making tests. Examine the square wave at the output of the generator on a scope and note its shape — especially departures from classic square-wave patterns — so that you will not ascribe such departures to the behavior of the amplifier under test. A square-wave range of 20 to 20,000

cycles is ideal for high-fidelity purposes, although a 60- to 15,000-cycle range will serve.

5. *Adequate range of output.* For servicing purposes the test signal does not have to be high. The 10-volt output of typical generators is more than sufficient, and as little as 2 volts will do. It is more important that the minimum output be low enough to feed into low-level stages without overloading them. A minimum output of 50 mv or less will permit one to check phono preamplifiers, mike input transformers, etc., without causing them to operate at distortion-producing high levels.

Test records

An audio generator can be used to test the preamplifying stages of record playing systems, but the pickup, turntable, etc., can be

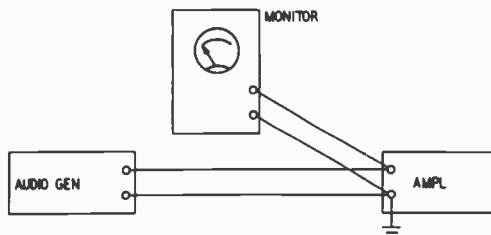

Fig. 201. In running a check on an amplifier, it is essential that the generator output be as constant as possible throughout the test range. The monitor can be a v.t.v.m., or a scope calibrated as a voltmeter.

tested only by using suitable recordings. A wide and most useful range of test recordings is available.

The comments applying to signal generators apply equally to test records, but relatively few records meet audio generator standards. Most records do not deliver any useful signal material below 50 or above 10,000 cycles. One very conspicuous exception is the Cook Laboratories series 10 (or 10 LP) which covers the range from 20 to 20,000 cycles.

No recording has constant output in the sense applied to signal generators. Recording problems require that the low portion of the spectrum be attenuated. The high portion must almost always be boosted. Record manufacturers usually provide test records cut to the curves used for their commercial recordings. If played back on a properly equalized system, they will be adequately flat. However, the most useful test records for general

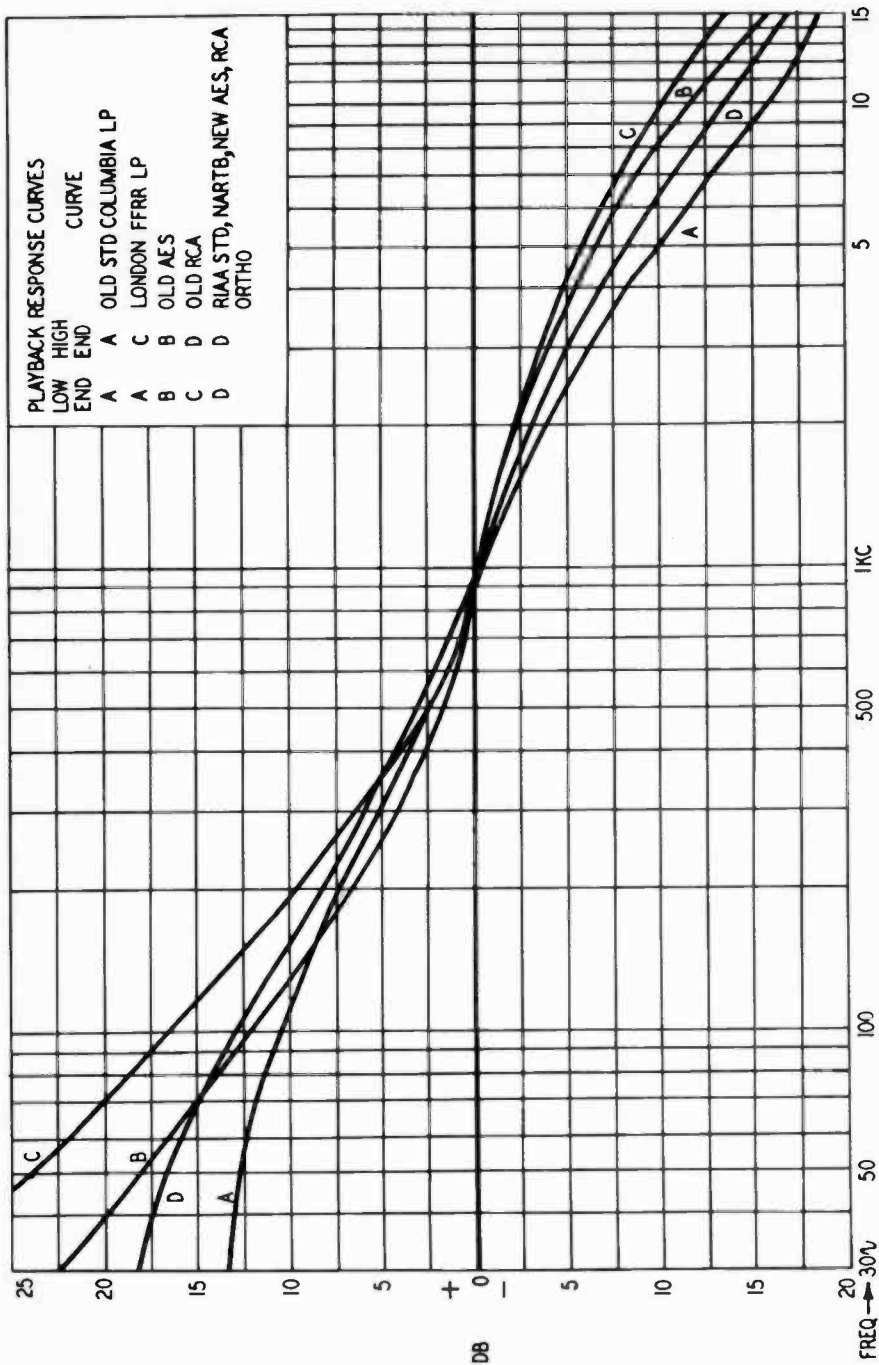

Fig. 202. Representative playback response curves. These curves are the inverse of those used in making recordings.

servicing and development work are those recorded with a 6 db slope below 500 cycles and flat above that value. This permits the charting of frequency response curves of various equalizers with relative simplicity. The resulting curve above 500 cycles can be compared directly with the *playback* curves of the various makes (Fig. 202) and departures quickly spotted. The curve below 500 cycles will need more care in interpretation. Here, when the test record is played back through an equalizer designed for a given playback curve, the departure from flatness below 500 cycles will indicate the degree to which the desired playback curve is reproduced. The exceptions occur when the turnover point of the desired curve is higher or lower than 500 cycles. In this case the comparison is not direct. It will require a more detailed interpretation, particularly in the crossover region. For example, if a test record with a 6 db-per-octave slope below 500 cycles is played through an equalizer for European 78 r.p.m. records whose playback curve calls for a crossover of 250 to 350 cycles, the frequency run will show a rise in response in the region between 250 and 500 cycles. However, by plotting both the playback and the recording curves of each of the two types of recordings, we can interpret the degree to which we do or do not duplicate what we want.

The Dubbings Company manufactures a test record useful for testing phonograph equalization. This D-101 record gives frequency runs for the four common American recording curves: LP, ORTHO (and new RIAA), NARTB and AES. With this recording the phono-equalizer for each type should produce the nearest thing to a straight line.

A test record must be used with caution. Some brands are carelessly produced. The result is that the claimed response curve is recorded with considerable variation from the ideal (sometimes over 5 db at a given frequency).

The flatness of a test record can be determined by examining its light pattern. Examine the record under a bright light, tilting it this way and that until the pattern appears. The more closely the sides of the pattern approach straight lines, the flatter the response. Good test records will be flat to within 1 db or better and the points at which the recording departs from linearity are plainly evident when examining the light pattern. This test can be applied only to records made with a *flat* characteristic. Records which reproduce commercial recording curves cannot be

modulation test records since an excess of either will increase the intermodulation distortion.

Tests of transient response, which are really tests of the damping of a system, are very valuable diagnostic tools. It is difficult to find acceptable sources and standards of transients, especially for use with phono systems. The Cook series 20-White Noise record offers such a signal and can be most useful. Thermal noises are nothing but transients and cover the entire audible band and more. The Cook record offers a carefully proportioned series of thermal noises in switchbands in which the high- and low-frequency components of the noise are progressively filtered. By comparing the sound of the noise output of a system as the record goes through these switchbands, we obtain a quick idea of the transient response and transient cutoffs of the system. The record is useful for listening tests and can also be used for more subtle diagnosis with a scope. Indeed, with experience and skill it is possible to estimate not only transient response but bandwidth, distortion, hangover or ringing and even pickup tracking.¹ The leading edge of the Clarkstan Sweep records is also valuable for checking transient stability.

Scopes

Scopes first proved their value in audio work. It is to them we owe most of what we know today about audio waveforms and their behavior in amplifiers. They provide the only means by which we can actually observe what is happening, at the very time it is happening. As a diagnostic tool they are indispensable.

For high-fidelity servicing a scope must possess some qualities not essential for TV or radio work. Most of today's scopes have more than adequate response at the high-frequency end, but not all are adequate in low-frequency response. We are rapidly improving our ability to record, transmit and reproduce the lowest octaves of sound from 16 cycles up. The response of a system at these low frequencies affects the overall behavior of the whole system and, from the point of view of distortion, more than at any other portion of the spectrum. This is partly because the low-frequency components are of high amplitude and are usually boosted in amplifiers to make up for attenuation in transmission.

¹"White Noise Testing Methods," Emery Cook; *Audio Engineering*; March, 1950.

and deficiencies in loudspeakers. The result all too often is that the system is first overloaded in this region. Since a high fidelity system is very flat beyond this point, any distortion produced there is passed easily to the output; whereas distortion at high frequencies may not be audible at all because the response, at least of speakers, slopes rapidly beyond 12 or 13 kc. Finally when these low frequencies occur in music, the resultant waveform most nearly resembles a square wave, and it is in this region, therefore, that square wave testing is most significant.

Fig. 205. The overall-frequency response of an amplifier system can be seen on the face of a scope. Pips can be inserted at various intervals along the waveform to indicate the frequency. The vertical amplifier in the scope must be capable of reproducing (equally well) all the frequencies being checked. For good low-frequency response the scope amplifier should be a direct-coupled type.

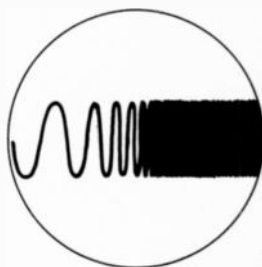

Obviously, if the scope itself does not have good behavior with low-frequency square waves, it is going to be much more difficult to use square-wave testing methods. It is necessary that the scope be able to pass at least a 60-cycle square wave (preferably a 20-cycle square wave) without significant deformation. Direct-coupled amplifiers are, therefore, very much worth while in a scope which is to be used for high-fidelity work.

High-frequency response is less of a problem since most modern scopes are flat to at least 500 kc. The distortion level of the scope should be very low and for this reason a scope with push-pull amplifiers is to be preferred. High sensitivity is also very important. Often serious trouble occurs in low-level stages and to trace it, a scope should be able to give an acceptable trace with input levels at least as low as 100 and preferably 10 millivolts. Other audio indicators are usually calibrated in r.m.s. volts. A scope can indicate and measure the peak-to-peak value. A means of calibrating the scope for peak-to-peak reading in volts is very helpful. A reticule or grid, marked off in a square over the scope tube face is very useful, especially in the phase-shift method of diagnosis. It offers a most convenient and accurate means of interpreting the behavior of the signal as it goes through various stages.

It is also desirable that a scope permit push-pull as well as single-ended input. A large part of the quality of high-fidelity

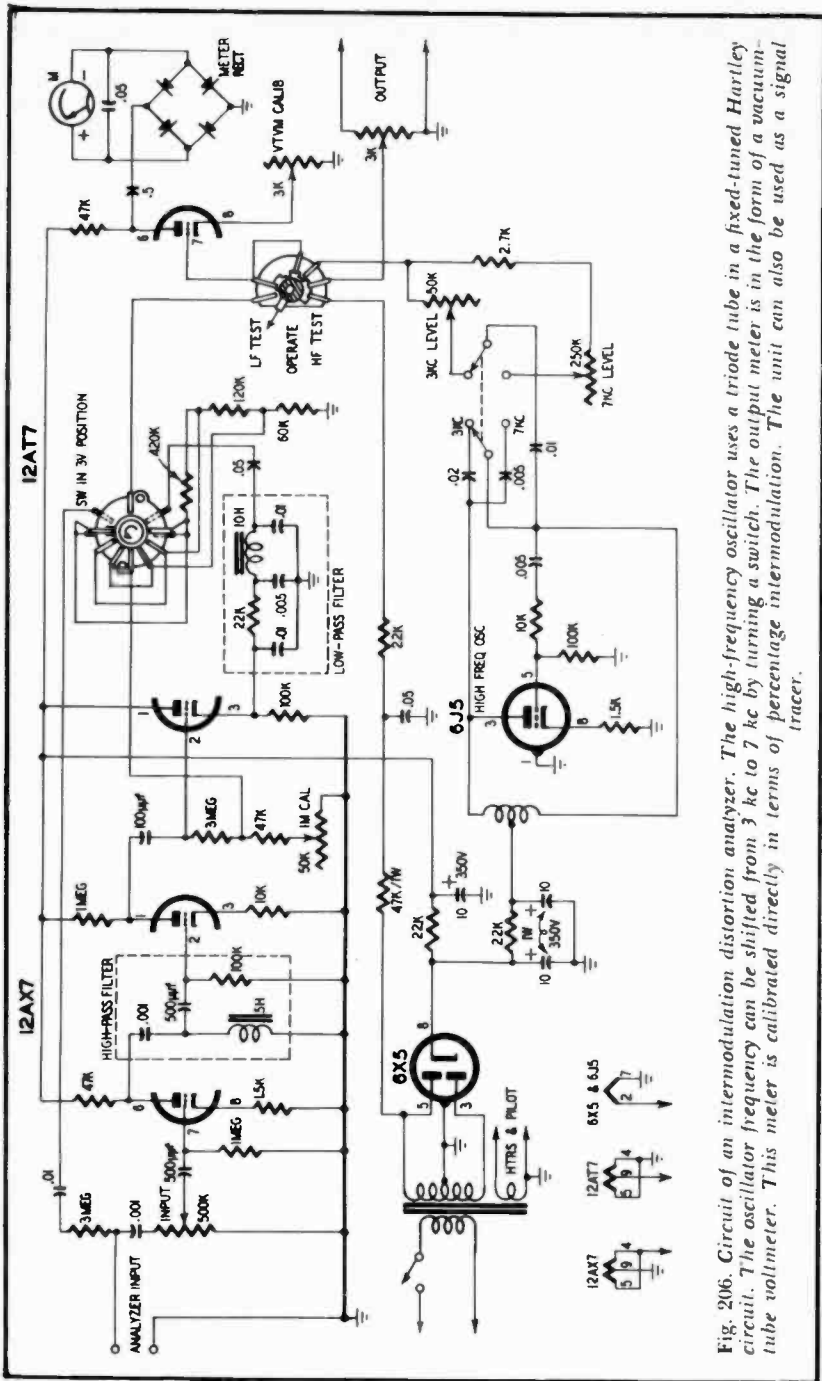

Fig. 206. Circuit of an intermodulation distortion analyzer. The high-frequency oscillator uses a triode tube in a fixed-tuned Hartley circuit. The oscillator frequency can be shifted from 3 kc to 7 kc by turning a switch. The output meter is in the form of a vacuum-tube voltmeter. This meter is calibrated directly in terms of percentage intermodulation. The unit can also be used as a signal tracer.

equipment is due to the use of push-pull circuitry in output and driver stages. Some equipment may contain several stages of push-pull, and a means of observing the behavior of such stages can be very helpful. If a scope is to be purchased for combination audio, TV and radio use, keep in mind the special qualities needed for high-fidelity measurements.

Vacuum-tube voltmeter

A general service type v.t.v.m. can be used in audio work, but consideration should be given to some serious deficiencies which limit its usefulness. One is its lack of sensitivity. The average v.t.v.m. has a lowest scale reading of 3 volts—or at best 1 volt — full scale and is usually not linear for reading. Often there is a need for measurement of a signal within low-level stages. For this reason a scale reading of .01 volt or less should be available. Such sensitivity, accompanied by good linearity and a frequency response quite flat from 10 to 100,000 cycles, is offered by a.c. vacuum-tube voltmeters which are available in several price ranges and in at least one inexpensive kit-type instrument.

An a.c. v.t.v.m. and a multipurpose v.t.v.m. can both be used for monitoring generator output and determining stage-by-stage gain. However, a.c. meters offer greater linearity, sensitivity and accuracy of measurements.

Audio wattmeter

Power output measurements are most helpful in the routine diagnosis of troubles and adjustments of power amplifiers. Power output can be calculated by measuring the voltage drop across a specified load resistance and using Ohm's law to derive power dissipation. The formula is

$$P = \frac{V^2}{R}$$

However, with the use of a wattmeter, this procedure is not necessary. Some commercial instruments make possible the direct reading of power output from 10 microwatts to 50 watts across the normal circuit loads. These loads are provided by the instrument itself, and usually no translation or interpretation of any sort is necessary. A flat response from 10 to 100,000 cycles and an overall accuracy of $\pm 5\%$ will place such an instrument well within limits permissible for servicing. One of the wattmeter's most

practical jobs is that of indicating the improvement made by a change in tubes, and it can pay for itself very quickly in this way. A most significant rating of hi-fi equipment is in terms of the amount of intermodulation distortion present at rated power output. A wattmeter permits this measurement to be made when used in conjunction with an intermodulation analyzer.

The purpose of the servicing equipment is to restore faulty equipment to normal specifications. What better proof of good restoration than performance which meets the output and distortion standards established by the manufacturer?

Intermodulation analyzer

Rivaling both the scope and generator in usefulness as a service instrument in diagnosing high-fidelity-system defects is the intermodulation analyzer. Aside from outright inoperation caused by a tube or component failure, a large percentage of complaints involve higher-than-normal distortion. Since distortion is not too easy to trace or to correct, a simplified means of checking is, therefore, most advantageous. Here, too, until recently, the service technician was deprived of a valuable tool by high cost. But today there is at least one intermodulation analyzer available at a low cost. Fig. 206 shows the circuit of an intermodulation analyzer. This unit supplies a low-frequency source of 60 cycles and a choice of either 3 or 7 kc as a high-frequency source available in any ratio from 1:1 to 10:1. Fig. 207 shows the diagram of the switching circuits employed in Fig. 206.

The operation of the unit is fairly simple. The mixed 60- and 3,000- (or 7,000-) cycle signals are fed to the input of the amplifier under test. The output of the amplifier is fed to the analyzer section where it passes through a two-stage amplifier which also acts as a high-pass filter and eliminates (for all practical purposes) the 60-cycle component. The remaining signal, now consisting of the high-frequency tone plus the intermodulation, is passed into an infinite-impedance detector which demodulates it. The 3,000-cycle component is eliminated in the low-pass filter which follows, and the intermodulation products only are fed to a v.t.v.m. which measures the signal and reads it directly in terms of percentage intermodulation. The analyzer portion can also be used with other signal sources such as the previously mentioned intermodulation test records, since the filters of the analyzer section are suited to the frequencies employed on these records.

The signal output of the analyzer can also be used for signal tracing. Even if the device has no means for turning off either the high- or the low-frequency generators and the output is always a mixed signal, we have a tracing signal which gives some indication of both the low- and the high-frequency response. Since the analyzer portion of the unit is very sensitive, an input of only 50 millivolts may be sufficient to permit accurate intermodulation measurement. This would allow the instrument to be used at the

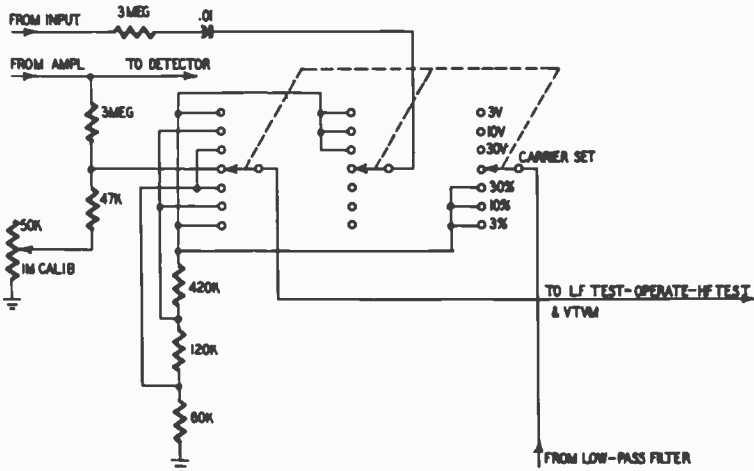

Fig. 207. Switching circuits of IM analyzer.

output of an initial amplifier stage or phono preamp, or even to be used directly at the output of a pickup. In tracing distortion the analyzer input can be easily moved from stage to stage.

Other test equipment

The close attention to many details that must be paid to hi-fi repairs can be very time-consuming, and it is essential that test equipment be purchased or constructed wherever its use can conceivably cut down the labor that must be spent on servicing. In addition to the normal complement of test equipment that we have just discussed, we consider the following to be extremely useful:

1. A good-quality narrow-band sweep generator suitable for FM and AM alignment.
2. Crystal-controlled markers to accurately align bandpass on high-fidelity receivers.

3. High-fidelity amplifier.
4. A 12-inch, or preferably 15-inch, loudspeaker mounted in at least a bass-reflex speaker enclosure.
5. FM tuner.
6. Phonograph turntable equipped with VR and crystal arms.
7. Other test instruments which are very desirable, but of fairly limited usefulness, because you may not have sufficient information about the design of the equipment under test to interpret correctly measurements like total harmonic distortion, over-all gain, and similar characteristics. Although manufacturers' specifications are usually available, they generally do not reveal any indication of how much a given unit may deviate from the specifications without being rejected, or of the exact conditions under which the manufacturers' measurements were made. Tests of performance of this sort should be made only when the customer specifically requests them or if you wish to have a detailed analysis of an amplifier for your own personal use.

high-fidelity circuits

The high quality of performance delivered by modern high-fidelity equipment is largely due to highly specialized and sometimes unique circuitry. The service technician who looks for the first time at the wiring diagrams of commercial hi-fi equipment is very likely to be puzzled and perhaps even shocked by some highly unorthodox and unfamiliar circuits. It is appropriate, therefore, before going into the specific problems and techniques of servicing to review briefly the circuits that will have to be dealt with. These circuits can be divided into two general categories: 1. Those applying to power amplifiers. 2. Those applying to control units, preamplifiers and accessories.

Power amplifiers

Power amplifiers consist of two sections: the power output stage whose function it is to deliver to the speakers anywhere from 10 to 50 watts of power with minimum distortion; the driver which must supply sufficient signal voltage to the output stage to drive it to maximum output. The driver can be transformer-coupled to the output stage or can be a phase inverter (or a phase splitter) to convert a single-ended input signal to a push-pull signal, since almost all power amplifiers employed in high-fidelity equipment use push-pull circuits. Quite often the driver itself is a push-pull stage receiving its signal voltage from a phase inverter.

The classic power output circuit is the familiar push-pull one of

Fig. 301 in which two triodes or beam pentodes are arranged with plates loaded and grids driven in push-pull. In the older, inexpensive high-fidelity amplifiers, the circuit is usually used with 6V6 tubes as pentodes. It is difficult, however, to obtain high power outputs with receiving type tubes. One of the first steps in the rapid progress of high-fidelity design was the use of transmitting type tubes in the output stages.

Where regular receiving type tubes must be driven into non-linear operation to deliver 10 to 15 watts of output, transmitting tubes can deliver this output over the most linear portion of

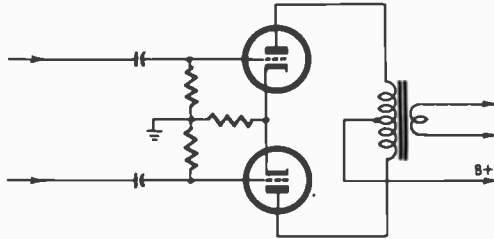

Fig. 301. *Typical push-pull amplifier circuit.*

their curves while operating at only a small fraction of their maximum capabilities and strictly class A. Thus, distortion could be reduced to a small fraction of that resulting from receiver type tubes. By this time it had become very clear that low distortion was the primary consideration and that a wide bandwidth was tolerable only when distortion was reduced to insignificant levels. The use of transmitting tubes provided a simple means of achieving the required low distortion.

This trend found its most notable expression in the amplifier designed by D. T. N. Williamson, an engineer of the well-known British firm, Ferranti. It was one of the most successful designs in electronic history. Even now, most commercial amplifiers use either some modification of the Williamson circuit or portions of it. The original used two tetrodes connected as triodes and coupled with an output transformer of hitherto unprecedented bandwidth, low distortion and very large size. The biasing arrangement was complex but provided excellent balance as well as precise adjustment of bias.

A number of improvements were made as the circuit was applied to commercial equipment. One modification splits the self-bias resistors of the output tubes. About half of the bias for each tube is developed in an independent unbypassed cathode resistor.

This provides some current feedback to reduce distortion further. Output transformers were improved still further and bandwidth extended to 100,000 cycles and beyond. It was always difficult to maintain stability in the feedback loop at the extremes due to the large amount of overall feedback, without internal stabilizing loops. One expedient was to incorporate within the loop a bypass network affecting only the frequencies around and above 100 kc.

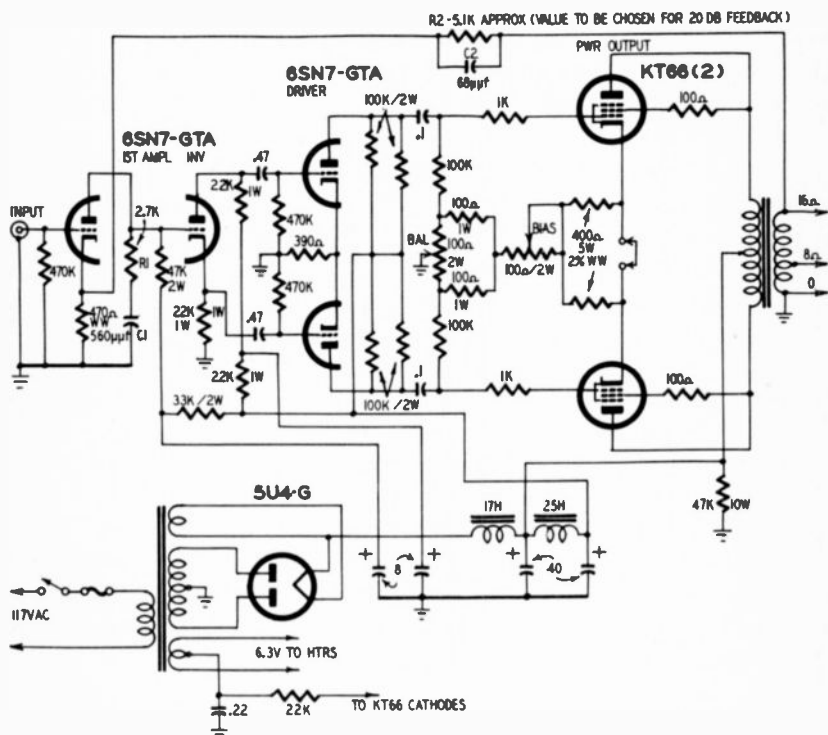

Fig. 302. Diagram of a Williamson-type amplifier. Some circuit features are described in the text.

This took the form of a capacitor and a resistor in series in the plate circuit of the input tube which served to hold the gain down at the unstable frequency. These are indicated in R1 and C1 in Fig. 302. Also, a phase shifting capacitor C2 was added in parallel with the feedback resistor chosen to provide a shift in phase, opposite to that of the output transformer, at the ringing frequency or in that region. Fig. 302 diagrams the Craftsman C-500 amplifier, a typical, modern Williamson using triodes.

The year 1951 saw the introduction of David Hafler's Ultra Linear circuit, which in 1952 was combined with the Williamson.

It made only a very slight change in the normal push-pull circuit; the screen grids were connected to taps on the primary of the output transformer.

There is some controversy about how this circuit actually operates but the consensus is that connecting the screens in this way applies a certain amount of negative feedback. In any event, the connection has some very great virtues. First, the operating curve is more linear than that of either triode or tetrode operation. Second, the power output capabilities are nearly as much as those of tetrode connection and about double those of the triode connection, so that, with the same plate supply voltage and drive the use of the Ultra-Linear configuration provides a doubling in output power over that available in the triode Williamson. More important than the increased power output is the fact that the distortion is decreased at all output levels. Finally, operated in this fashion, the tube capacitances are practically the same as in tetrode operation. This eliminates or at least greatly minimizes Miller effect at high frequencies and not only makes possible an extension of the bandwidth upward but, more importantly, reduces the phase shift in the region of 100 kc. The internal feedback and the extended response makes it possible to use larger feedback factors for an equal degree of ringing. A high proportion of today's commercial amplifiers are Ultra-Linear versions of the Williamson. Fig. 303 gives a typical circuit.

Meanwhile, considerable work was being done on cathode loading of power-output tubes. It was known that such loading produced high power with very low distortion, because this circuit gives almost 100% voltage feedback on the output stage. Unfortunately, because of this, cathode followers have no voltage gain; hence the drivers have to supply somewhere between 150 and 200 volts of drive per side. This is a serious problem since it is difficult enough to supply even 60 volts of drive with low distortion.

Though complete cathode loading poses too many problems, it was quickly seen that partial cathode loading would provide a compromise that did not involve raising the driving requirements out of practical reach. Several circuits of this type were developed, differing only in the ratio of plate-to-cathode loading. Typical examples are the British QUAD amplifier and the American Bogen DB15G. A simplified circuit is given in Fig. 304.

Both of these use tetrode operation and obtain a low output impedance by effectively utilizing the local cathode feedback and the voltage feedback obtained from an overall loop. Since tetrodes,

even with cathode-loading feedback are more sensitive than triodes, a simpler driver can be used. The Bogen amplifier uses merely the first two stages of the Williamson front end; the QUAD uses a pair of pentode tubes in a paraphase phase-inverting circuit.

It was obviously possible to combine the Ultra-Linear circuit with partial cathode loading and this was done in the Fisher 70A amplifier. A simplified circuit is shown in Fig. 305.

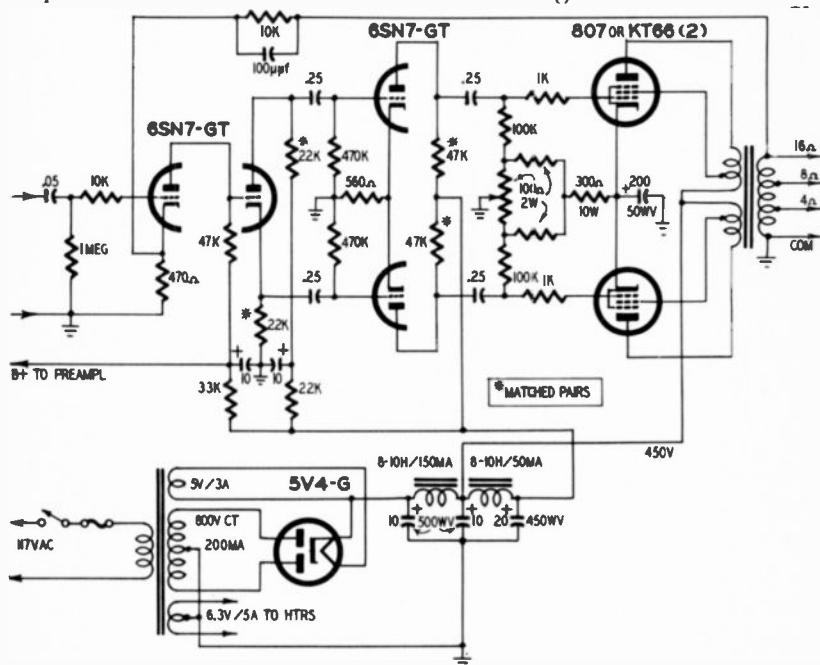

Fig. 305. Ultra-Linear version of the Williamson amplifier. Note the connections of the screen grids in the push-pull output circuit.

An arrangement which looks rather similar is that of the McIntosh amplifiers. In these, bifilar windings are used for the plate and cathode portions of the transformer primary and, in addition, the screens are cross-coupled to the opposite plates. In effect, this makes each screen have the same a.c. fluctuations as its cathode, so the circuit is virtually a tetrode operated push-pull stage with 50% cathode coupling. McIntosh calls it "unity coupling" because the plate and cathode windings are equal, tightly coupled by the bifilar winding. This arrangement permits class-B operation with very low distortion and without the switching transients normally produced by such operation. Thus, a pair of 6V6's can deliver outputs in excess of 20 watts. In Fig. 306 we have a simplified circuit showing the output of the McIntosh amplifier.

Switching transients occur when output tubes are driven to and beyond cutoff. The transient is produced by leakage reactance of the output transformer that results in collapsing currents at the cutoff point and produces a parasitic oscillation audible in the out-

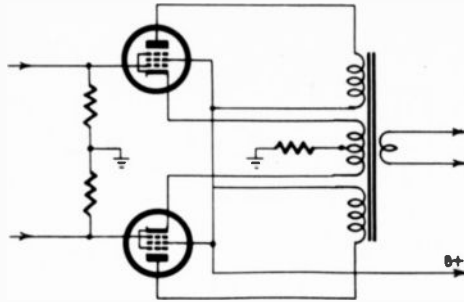

Fig. 304. *Circuit using partial cathode loading.*

put as a very annoying thump which tears up the signal. Because these transients occur at cutoff or beyond, high-fidelity power stages avoided such operation and that meant, in practice, that they were limited to strictly class-A operation. Unfortunately, class-A operation is very inefficient and it is difficult to obtain

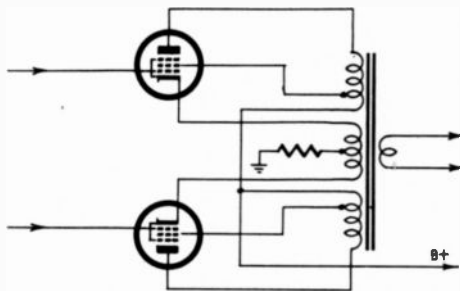

Fig. 305. *Ultra-Linear circuit combined with partial cathode loading.*

high power outputs with it. Much thought has therefore been expended on obtaining class-AB or B operation without switching transients.

Before going into that we might mention two expedients for obtaining high power outputs with class-A operation. One is a style of operation called A2. In this the tubes are never cut off, but they *are* driven into the grid-current region. Of course, this produces higher distortion, but its effects can be minimized by careful design of the drive stage. The first American commercial

amplifier to employ this mode of operation was the Brook amplifier. In this type of operation the grids draw considerable current, and consequently the grid impedance must be very low. The driver is therefore a cathode follower with transformer coupling to the output tubes. The transformer has unity ratio and is bridged

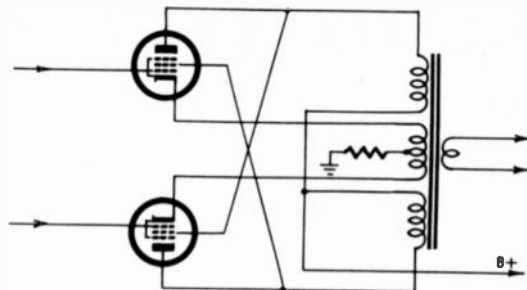

Fig. 306. The output transformer is bifilar wound.

with capacitors. The transformer extends low resistance coupling at the low frequencies while the capacitors take care of the higher frequencies. Fig. 307 shows the basic circuit.

Another possible arrangement not used at present in a commercial amplifier is *extended class-A* operation. Here four identical

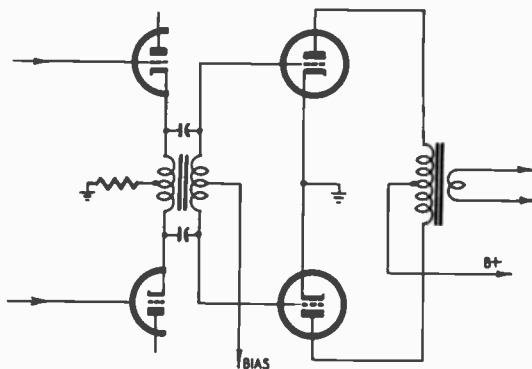

Fig. 307. Cathode-follower driver with unusual coupling arrangement.

tubes are used, one pair operating as triodes and the other as tetrodes. At low levels the tetrodes are cut off and do not contribute anything. At a certain point in the dynamic range, however, as the increased driving voltage reduces the effective bias, the tetrodes begin to contribute and at maximum output they are the dominant developers of power. Operation is always class A, but high power outputs are possible. Fig. 308 diagrams such an output stage.

One of the possible ways of using two tubes in a power stage is that of loading the cathode of one and the plate of the other. Recently this possibility has been realized and appears in two different forms in two commercial amplifiers: the National Unity-Coupled Horizon and the Electro-Voice Circlotron.

Since the circuit diagrams of these amplifiers do not make the operation clear, let us examine the circuit in simplified form. The general idea is expressed in the simple diagram of Fig. 309-a. Here we have, in effect, two tubes in series as far as the output is con-

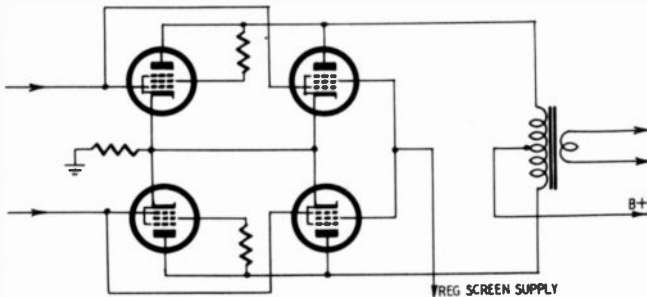

Fig. 308. Circuit of extended class-A amplifier.

cerned but in push-pull as far as the input is concerned. The transformer is connected in the middle of the circuit at the point where the two tubes are connected in series. The transformer is in the plate circuit of the lower tube but in the cathode circuit of the upper one. Push-pull operation results because the two grids are fed by out-of-phase voltages and, therefore, as the plate current of one tube rises, the current of the other falls. Moreover, there is a common load for both sections so that distortion products can cancel in it.

National and Electro-Voice have traveled two different paths to obtain a practical amplifier with this configuration. Electro-Voice turns the circuit into a bridge as indicated in b of Fig. 309. This requires two power supplies (indicated by batteries for simplicity's sake), but, as long as the bridge is well balanced, no d.c. can flow through the output transformer. This simplifies the design of a good output transformer. It also makes possible the use of class-AB operation, approaching class B without switching transients. This, in turn, makes it possible to develop high power outputs with high efficiency. Triodes, tetrodes or pentodes can be used and, since the output impedance is very low, tetrode and pentode operation in this mode produces as good or better damping

factors than triode operation in conventional push-pull stages. Furthermore, the load resistance required is only one-fourth that required in plate loading and this makes the problem of producing a high-quality transformer much simpler. Since the output stage has no gain, high driving voltages are required. To obtain them a special driver circuit was developed. In this circuit, the plate loads of the drivers are returned to the plates of the output

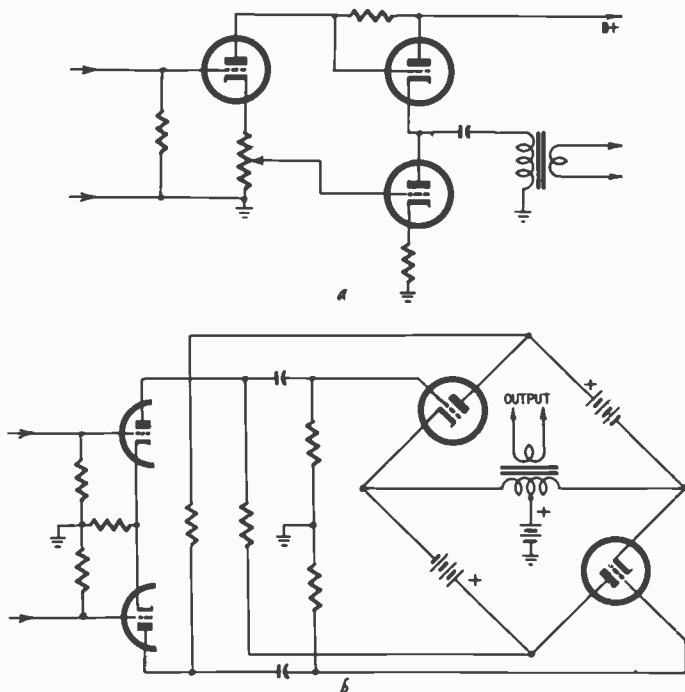

Fig. 309-a, -b. Techniques for using tubes in power-output stages.

tubes. This has the effect of doubling the plate supply voltage and thus increasing the output capabilities of the driver stage.

National avoids the need for two high-current power supplies by arranging the circuit as in Fig. 309-c. The output transformer has two primaries with unity coupling, one of which is connected in the plate circuit of one tube and the other in the cathode circuit of the other. The coupling capacitor between cathode and plate of the two tubes improves the high-frequency response. Not quite so much drive is required in this circuit and the preceding amplifier is simplified in that the driver consists of a single triode.

Another form of this so-called "single-ended, push-pull" style

has been used in one commercial amplifier (the Stephens OTL) and may be employed in the future because it permits the coupling of speakers directly to the amplifier without an output transformer. Fig. 310 gives a very simplified diagram of one form of this circuit. The two grids receive out-of-phase signals. Two power supplies are used and balance is achieved by returning one grid to an appropriate negative voltage in series. The output is taken off the junction of plate and cathode. The impedance can

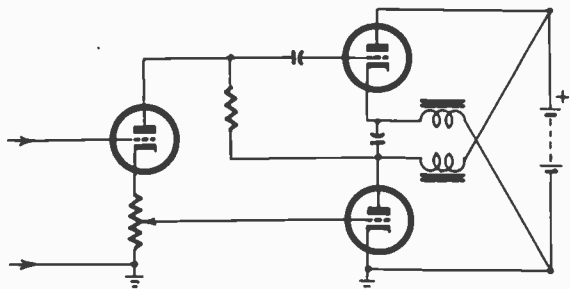

Fig. 309-c. Output circuit arrangement. Compare with those shown in Fig. 309-a, -b.

be made low enough by paralleling a number of tubes to match the low impedance of a 500- or even a 16-ohm speaker.

Drivers

Occasionally, the output stage of hi-fi amplifiers is driven directly by a cathodyne inverter, but in the majority of cases the inverter is followed by a push-pull driver stage. The majority of drivers are push-pull arrangements of low-mu triodes capable of high-voltage outputs with low distortion. Fig. 311-a is representative. The tube is most often a 12AU7 or 6SN7-GT, though the 12BH7 and 6CG7 are finding usage.

A slight modification is that using independent unbypassed cathode resistors. This provides some current feedback which reduces distortion. Fig. 311-b indicates such a modification. In some instances the cathode resistance may be split, half being independent to each tube and the other half common to both. This provides a smaller amount of degeneration, with a larger amount available for reducing out-of-balance effect.

With the new unity-coupled circuits and those employing partial or total cathode loading in the output stage, the driver must deliver high voltages. An expedient which makes this possible is

a circuit in which the plate resistors of the drivers are returned to the plates (or, in some cases, the screens) of the opposite output tubes. This was shown in Fig. 309-b and is called "bootstrapping."

When fixed bias is used on the output tubes, a low grid impedance is necessary. A common means of supplying this conveniently is the use of a cathode-follower driver as diagrammed in Fig. 312. The actual bias applied to the output tube grids is the net resultant of the positive voltage developed in the cathode load of the driver bucked by the negative voltage supplied by connecting the

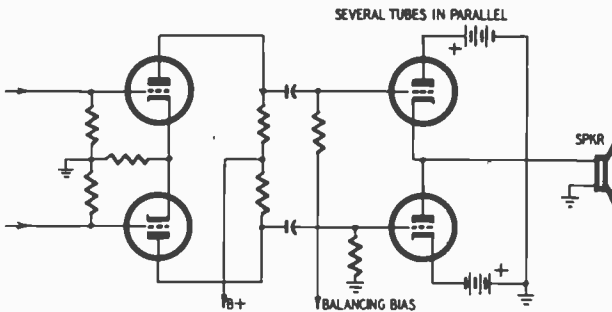

Fig. 310. This circuit eliminates the need for an output transformer.

cathode loads to a source of negative voltage, about -105 volts. To permit an adjustment of the output tube bias, the grids of the follower are returned to a more positive point chosen through a pot across the bias supply. By varying the voltage on the grid the current through the cathode resistors is varied. In turn this changes the positive voltage drop and therefore the net bias.

When output tubes are driven into the grid-current region, even the low impedance of such a follower is not low enough and in such cases transformer coupling is used between follower and output tubes as in Fig. 307. Bias of the driver is established by the resistance of the transformer primary plus a common external resistance; bias of the output tubes is supplied through the center tap of the secondary and is usually regulated. The cathode follower has a gain of less than 1 and must be preceded by a normal push-pull driver.

The complicated circuits employing some combination of plate and cathode loading have very unusual driving requirements and call for special driver stages of strange configuration. These differ from circuit to circuit.

Inverters

No portion of a high-fidelity amplifier is more important than the inverter since it establishes the initial balance of the push-pull

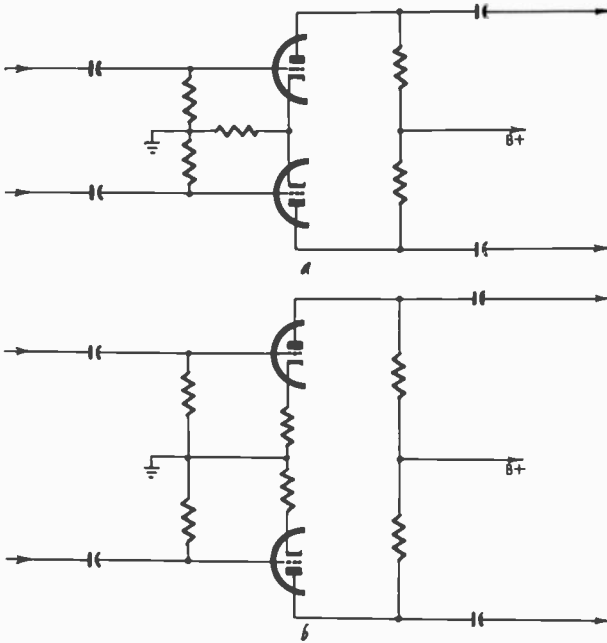

Fig. 311-a, -b. Push-pull driver stages often show slight differences in design.

stages. Four types of inverters will be found in high-fidelity amplifiers. The least expensive use the well-known paraphase type dia-

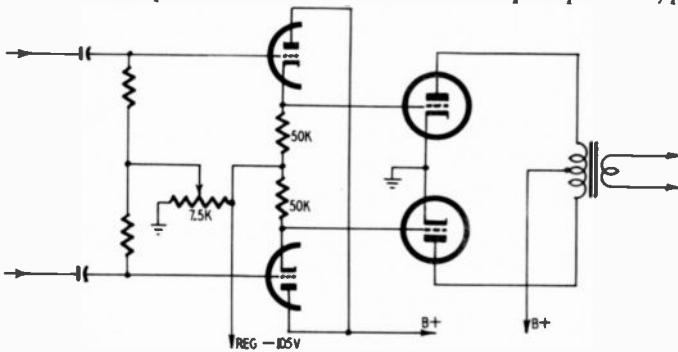

Fig. 312. Cathode-follower driver can be used to swing push-pull output tubes.

grammed in Fig. 313-a, in which the second section of the inverter obtains its drive from the output of the first. This is not a very

satisfactory inverter for high-fidelity use because it is seriously unbalanced.

The most common inverter is the cathodyne or split-load inverter shown in *b*. This uses a single tube whose load is divided between plate and cathode circuits. A satisfactory inverter for most purposes, it can have some unbalance at high frequencies. It is used in the Williamson circuit and its many derivatives and is often direct-coupled to a preceding voltage amplifier. One of its faults is

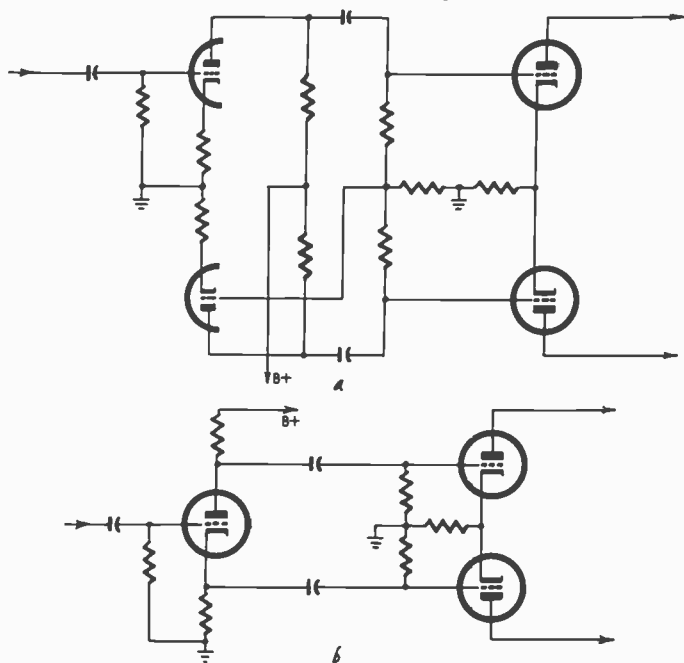

Fig. 313-a, -b. Two types of phase inverter circuits.

the high cathode voltage which can cause heater-cathode leakage and, therefore, residual hum. This can be corrected by biasing the filament with a positive voltage. This inverter has no gain. Its performance requires excellent balance and close matching of plate and cathode loads. In many instances 1% resistors are employed, for this purpose.

Not so frequently used is the long-tailed pair or cathode-coupled inverter diagrammed in *c*. It is, in effect, a combination of grounded-cathode and grounded-grid sections. The upper section is a normal grounded-cathode amplifier obtaining its drive through the grid. The lower section is a grounded-grid amplifier

obtaining its drive through the cathode. The current variations produced by the signal on the grid of the upper tube through the common cathode resistor also affect the plate current of the lower tube, but in an opposite direction. Therefore, the two plates deliver signals 180° out of phase. This is one of the finest inverters, very well balanced because of the large common cathode resistor.

Another good inverter is a modification of the cathodyne, shown in Fig. 313-d. Here the high input impedance of this circuit is used

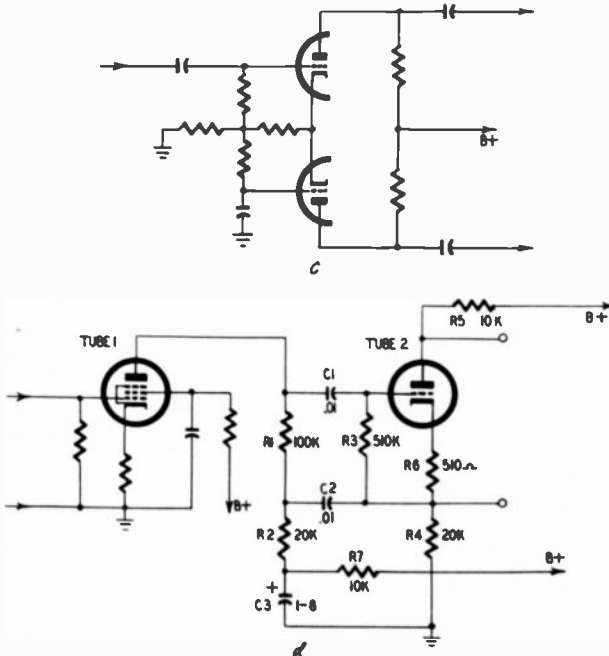

Fig. 313-c, -d. Phase inverters. See also Fig. 313-a, -b.

as a plate load for the previous pentode stage, getting a bigger-than-normal gain from this tube, to make up for the loss in the inverter itself. Note that, as a cathodyne, the plate part of the load is R5, while the cathode part is R2 in parallel with R4, with which it is coupled by C2 and C3. The *effective* plate resistor for tube 1 is R1 in parallel with R3, multiplied by the effective degeneration in tube 2 — in the region of 10:1.

Not often used in commercial equipment but in great favor in custom-built hi-fi amplifiers is the cross-coupled inverter diagrammed in Fig. 314-a. It is rather difficult to explain briefly the operation of this inverter. It is most easily understood if we look

at the circuit of Fig. 314-b, which consists of the input cathode follower and only one of the two cross-coupled tubes. You will readily see that the second tube measures the voltage difference between the two cathodes of the input cathode follower and that this voltage difference will be proportional to the signal applied

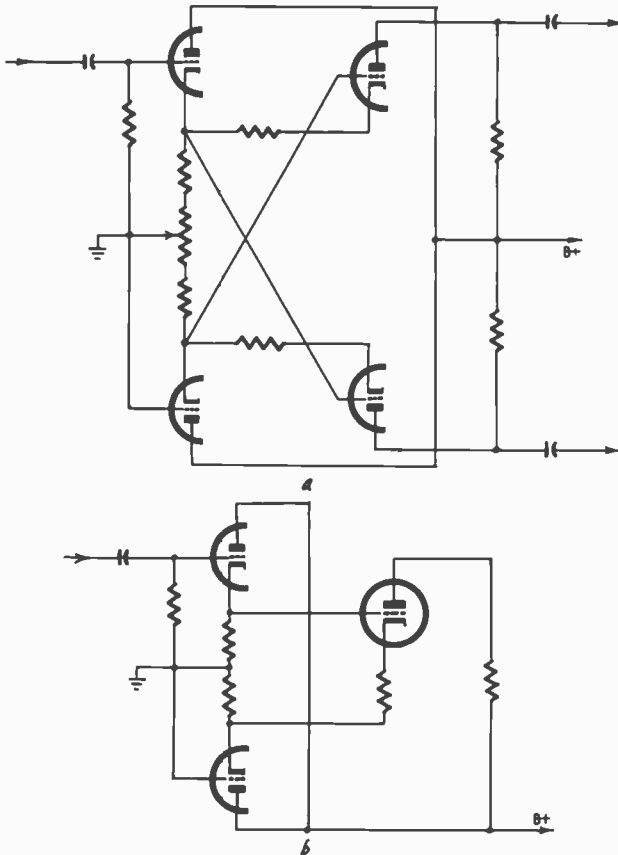

Fig. 314-a, -b. Cross-coupled inverter (a) is rearranged (b) for ease of explanation.

to the two grids. This is, in essence, a v.t.v.m. Now then, if we add the other cross-coupled stage, we have another v.t.v.m. but one which reads the difference in opposite phase. Therefore, the same signal will produce voltages of opposite phase at the plates of the two cross-coupled tubes. The circuit has many other ramifications which are immaterial for the moment. It has the virtue of being dynamically self-balancing at all frequencies. Unlike the cathodyne and the long-tailed pair, the cathodes are at relatively low

potentials and therefore hum problems are minimized. The cross-coupled inverter is often used in direct coupling to a driver stage for it permits excellent balance of two or more direct-coupled stages.

The grids of both the long-tailed pair and the cross-coupled inverter provide very convenient points for applying negative feedback. Because the inputs are uncritical as to resistance the feedback parameters are easily juggled to provide the best effect, particularly to minimize ringing. It is possible to use the lowest tap on the output transformer and still maintain a high enough resistance so as not to load either the transformer or the circuit to which feedback is applied.

Preamplifiers and control units

This portion of the high-fidelity chain performs the following functions:

1. Amplifying the low output of magnetic pickup cartridges to a level high enough to drive a succeeding amplifier.
2. Equalizing the characteristics of disc recordings.
3. Switching in various input sources such as phonographs, tuners, TV, tape, etc.
4. Producing modification of frequency response to compensate for losses in recording, transmission, speaker and room characteristics.
5. Compensating with a loudness control for the varying acuity of the ear over the audio range with changes in loudness.
6. Reducing annoying noises such as scratch, static pops, rumble and hum in records, interchannel interference in AM radio, etc., through high-and low-frequency rolloffs.

There is an almost infinite variety of—and a few standardized ways of attaining these various ends.

Especially various are the ways of obtaining bass and treble boost and attenuation: indeed, almost every control unit uses a different one. Two generalized circuits are worth noting because with modifications they are widely employed. Fig. 315-a is the circuit employed in the Rauland 1811. Both the treble and bass sections operate as interstage bypass networks. The mid-frequencies are given a uniform loss by careful choice of parameters. But both the admittance and the bypassing of both the highs and lows is varied by adjusting the controls so that at one end there is little or no loss and, therefore, a boost over mid-frequencies is produced.

At the other end, there is a greater loss than at mid-frequencies and attenuation is produced.

Finding ever greater application in commercial amplifiers and control units is the British Baxendahl circuit of Fig. 315-b. The parameters are similar but here the networks are in a feedback loop. The feedback remains constant at mid-frequencies but varies at the extremes, being greatest when the controls are set for

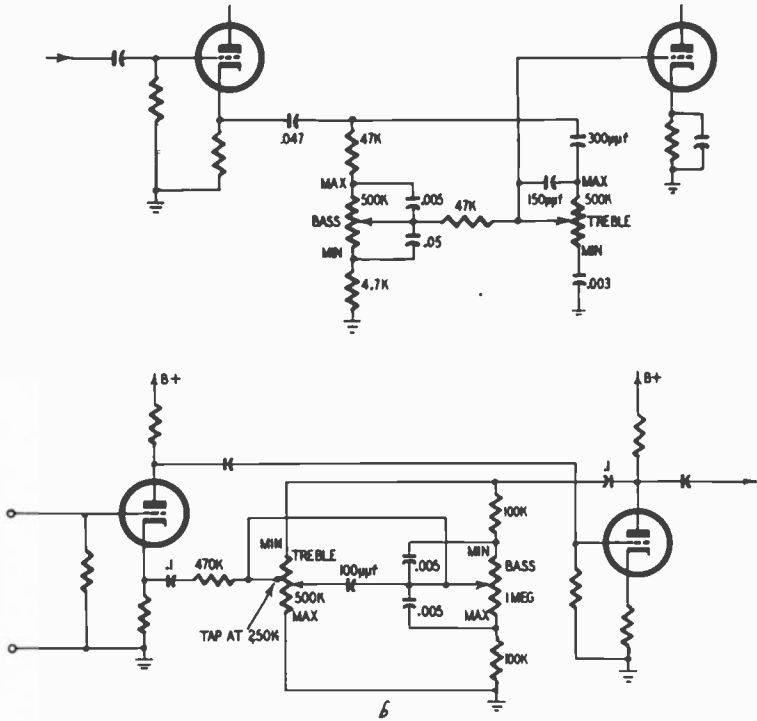

Fig. 315-a, -b. Techniques for obtaining bass and treble boost and attenuation.

maximum attenuation and lowest when set for maximum boost. The circuit has many virtues. Among them are greatly reduced distortion because of the feedback employed; crossovers which vary with the amount of boost or attenuation, so that small amounts of boost or attenuation can be applied to the extremes of the frequency range with no effect on the greater part of the frequency response; simplicity; no insertion loss and indeed a small gain.

Similarly, there is a great variety of loudness controls. The

broad idea is to boost both the treble and the bass, but to different extents, as the volume control is rotated. In general, this is achieved by using tapped controls which insert bass-and treble-boosting capacitances as the slider moves toward the ground end. A widely used loudness control is the Centralab Compentrol diagrammed in Fig. 316. More elaborate control units have so-called loudness contour selectors which adjust the amount of boost at any position of the loudness control. The simplest way of achieving this is simply to precede or follow the loudness control with a normal gain or level control. By adjusting the level control, it is possible to control the amount of rotation of the loudness control. Since the amount of boost of the loudness control is proportional

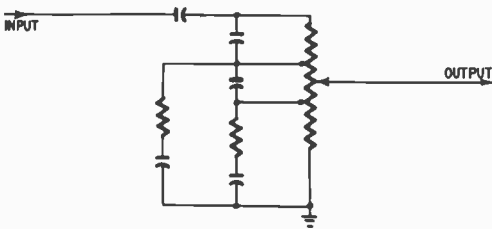

Fig. 316. Loudness control circuit. A loudness control differs from a volume control in that it can be made frequency selective in addition to attenuation of signal level.

to its position, increasing or decreasing the level and then re-adjusting the loudness control for the same volume will produce a change in the slope of the bass and treble boost. The Centralab Senior Compentrol is a concentric combination of such loudness and level controls. The two controls may appear in cascade in the same stage or they may be used in entirely different portions of the circuit. Most loudness controls which do not provide means for selection of the contour have switches for removing the bass and treble boosts.

A very simple loudness control not found in any commercial unit but widely copied in custom and home-made equipment is diagrammed in Fig. 317. It consists of an ordinary volume control to the bottom end of which a fixed resistor is connected. A feedback loop with a capacitance chosen for the desired slope connects to the junction of pot and resistor. The capacitor in the feedback loop has high reactance at low frequencies, little at mid-and high frequencies; therefore, mid-and high frequencies are attenuated more than the bass frequencies. The overall effect at the output is a bass boost. The amount of feedback and, therefore, of boost is determined by the setting of the volume control for it varies the feedback-voltage divider; the boost is highest when the control is

at minimum and lowest when it is at maximum. Therefore, the relative bass output varies with the volume. This control provides no boost of treble but many people prefer this form of loudness control.

Rolloff

Although modern recordings have improved tremendously in the reduction of the amount of noise they produce and in their lowered distortion characteristics, occasionally a need arises to attenuate the high end of the response to minimize scratch or distortion. Moreover, in AM reception, interchannel interference and

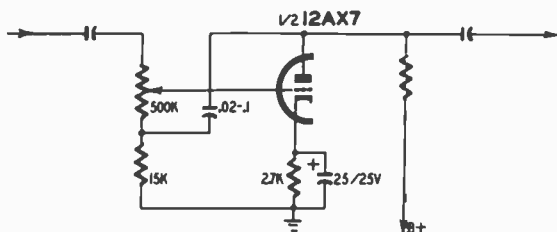

Fig. 317. A volume control can be modified into a loudness control.

the 10-kc adjacent-channel beat note can be most annoying. When a tuner has no whistle filter to attenuate such interference, it is convenient to provide a rolloff filter in the control unit.

In average equipment, attenuation is provided by the attenuation range of the treble control, but in the more elaborate control units there is often an independent rolloff which provides either a continuous adjustment of rolloff or a choice of several degrees of rolloff or several cutoff points. The variety of these is about as great as the number of control units employing them. Everyone seems to have his own idea of how to achieve a satisfactory rolloff.

The average arrangement uses a low-pass filter with an inductance as the series element (Fig. 318-a). Varying the resistances and capacitances provides a means of varying both the slope and the crossover or cutoff point. Slopes are usually 12 db per octave and cutoffs move between 7,500 and 15,000 cycles. Some networks use two inductors and one or two use variable inductors.

The same end can be achieved with a quadratic network produced by a two-stage R-C low-pass filter inside a feedback loop. Two variations of the circuit are given in Figs. 318-b, -c. Both produce similar results; but in the first the crossover or cutoff point is

varied continuously with the ganged pots, while in the second a choice of capacitances provides a choice of cutoff frequencies. These, too, produce a rolloff of 12 db per octave. Representative curves are given in Fig. 319.

There is a similar need for rolloff at the opposite end of the scale to minimize turntable rumble and high-level transients produced

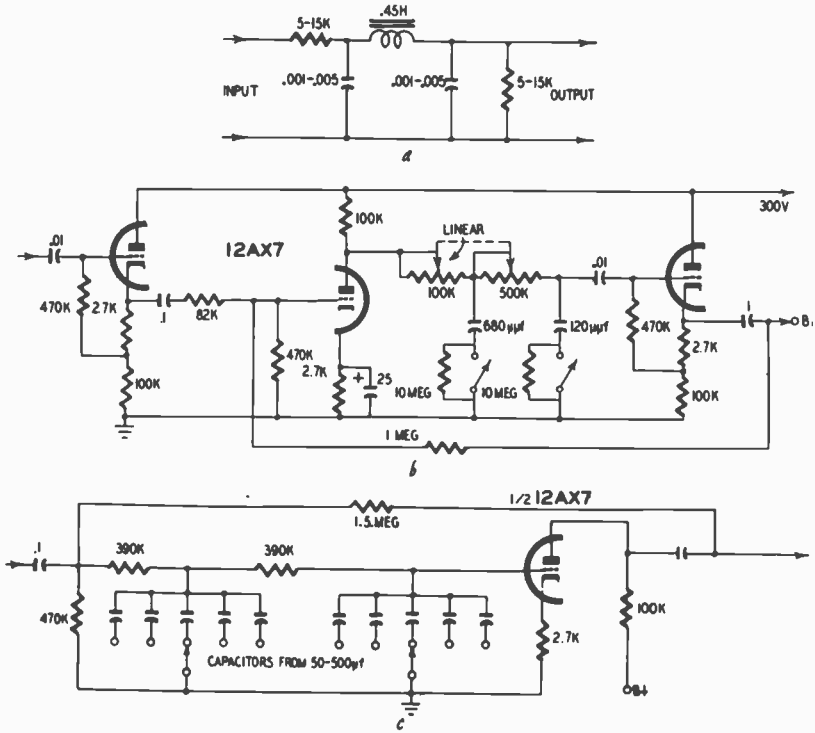

Fig. 318-a, -b, -c. Various types of rolloff circuits. Rolloff, slope and cutoff can be changed by varying resistance, or capacitance, or both.

by various causes, such as records with eccentric holes, etc. Once again there is a very wide variety of means, some rather elaborate, involving the use of high-pass or band-rejection filters, either with inductors in pi and M-derived networks or R-C combinations in T networks. Many control units and amplifiers, however, use a very simple cascaded R-C network which often passes unnoticed but is quite effective. As shown in Fig. 320, it consists simply of repeating the interstage R-C coupling either two or three times. The double network produces a rolloff of 12 db per octave while the triple one approaches 18 db per octave. Typically the time

constant (R in megohms $\times C$ in μf) ranges between .05 and 0.1 for cutoff frequencies somewhere below 25 cycles.

One of the early and highly effective suppressors of noise at both ends whose operation produced the least loss of musical value was the Dynaural Noise Suppressor developed by H. H. Scott and still

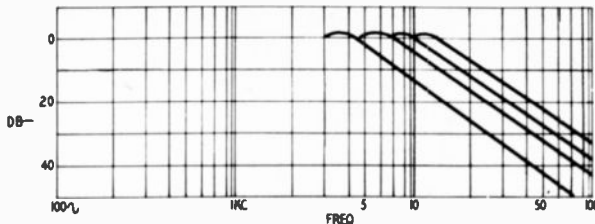

Fig. 319. Representative rolloff curves.

employed by them in their hi-fi equipment. The operation of the circuit has been described many times. Briefly it consists of low-pass and high-pass filters, actuated by gates operated by the signal. The filters provide a maximum suppression in the absence of a

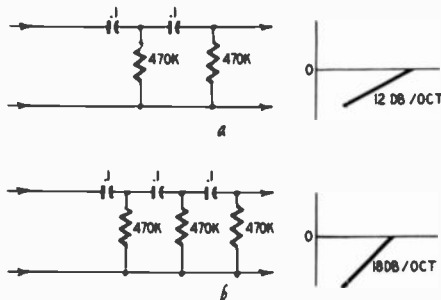

Fig. 320-a, -b. Cascading interstage coupling increases rolloff slope.

low- or high-frequency signal and decreasing degrees of suppression when the signal contains significant components of very-low- or very-high-frequency elements.

Dividing networks

Because it is difficult to design and build a single speaker capable of covering the whole audio range from 20 to 20,000 cycles with equal efficiency and low distortion, many systems employ several speakers, each designed for best results over a narrow band of frequencies. These require dividing networks to provide a proper

match with the amplifier output and to divide the signal so that each speaker receives only that portion of the spectrum it is best able to reproduce. There are several types of such networks, but most of the commercial units are of the constant-resistance kind. They all involve the use of inductances and capacitances in various configurations. Those diagrammed in Fig. 321-a produce an attenuation below crossover of 6 db per octave; those in Fig. 321-b

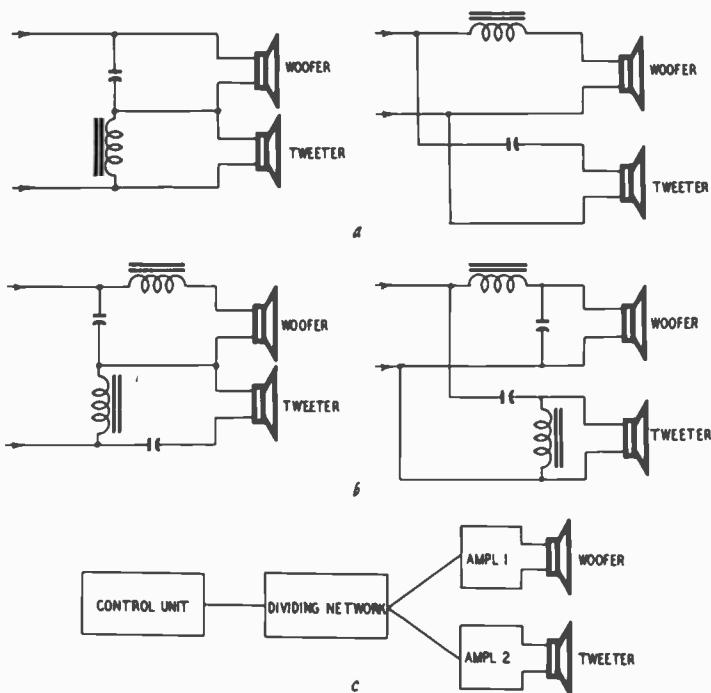

Fig. 321-a, -b, -c. Various circuit arrangements can be used to drive a woofer-tweeter combination.

produce a 12-db attenuation and are used in the better and more elaborate networks. In many cases, the dividing network consists simply of a single capacitance in series with the tweeter to cut off the lower frequencies.

In some systems, where cost is no object, frequency division is achieved ahead of the amplifiers and two or more amplifiers are employed to feed individual speakers as block-diagrammed in Fig. 321-c. This has several advantages, including that of dispensing with inductors. A typical network of this kind used in White Powrtron amplifiers is diagrammed in Fig. 321-d.

Variable damping controls

It is desirable for an amplifier to have a means of varying the damping so that each specific speaker can be critically damped. The damping factor can be varied by changing both the amount and type of feedback. Negative voltage feedback increases damping; negative current feedback decreases damping. Positive current feedback increases damping so sharply that *negative* damping factors can be achieved. Various combinations of adjusting these types of feedback have been developed and applied to commercial amplifiers. Fig. 322 gives two typical examples.

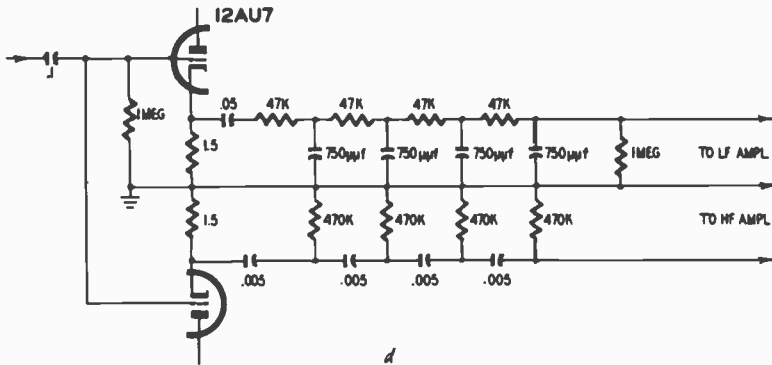

Fig. 321-d. *Separate amplifiers can be used to drive the woofer and tweeter with frequency division taking place prior to the amplifier. This is a more expensive (but more desirable) method than those shown in Fig. 321-a -b -c.*

In Fig. 322-a we have the circuit of the Bogen variable damping control. In this the amount of negative *voltage* feedback remains constant, but the current feedback can be either positive or negative and varying proportions of each can be applied. Current feedback is developed in the small resistors in series between the transformer and voice coil. Whether it is positive or negative will depend on whether it is taken off the transformer side of the ground or the speaker side. The 25-ohm pot bridges this circuit and inserts it in series with the cathode of the input tube. At some point near mid-rotation of the pot, the positive and negative currents cancel each other and no feedback is applied. On one side of this point the positive feedback is dominant, on the other side negative feedback prevails. Of course, these variations of feedback would vary the overall feedback of the amplifier and therefore the gain, distortion, frequency response, etc., if some measures were not taken to avoid this. In this instance, a low-pass filter consisting of the 220-

ohm resistor and the 4- μ f capacitor is inserted so that the variation in feedback applies only to frequencies below 600 cycles; at all higher frequencies the voltage-feedback loop alone applies. This is especially necessary because of the use of positive feedback which, if not thus restricted, might very well make the amplifier highly

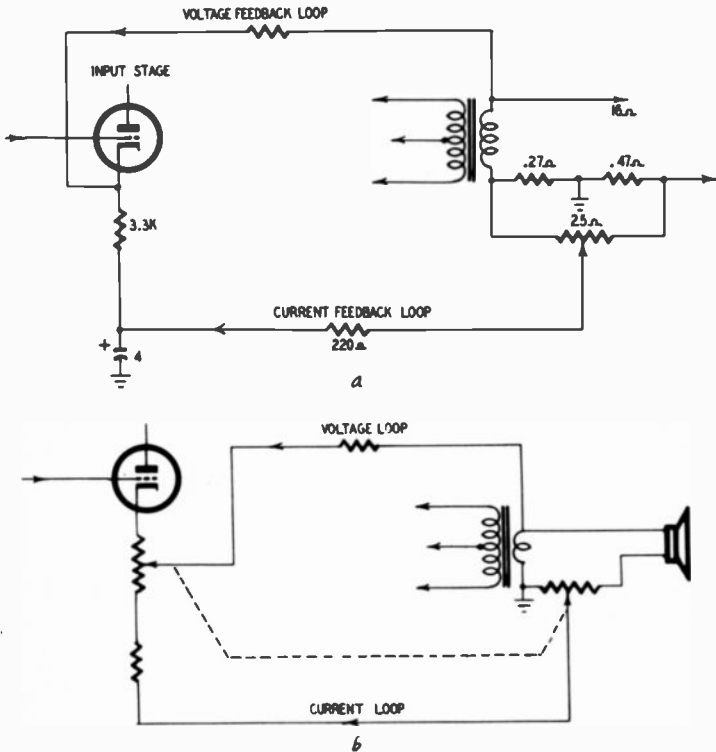

Fig. 322-a, -b. Examples of variable-damping controls.

unstable at ultrasonic frequencies. This circuit permits a tremendous variation in feedback factor and damping.

Electro-Voice uses a somewhat different approach (Fig. 322-b). Believing that a variation in damping factor from about 0.125 to approximately 10 is sufficient for today's speakers, Electro-Voice uses only negative voltage and negative current feedback to change the damping factor. Each loop is capable of providing a feedback factor of between 18 and 20 db. By using carefully matched tandem potentiometers, the amount of negative voltage feedback is reduced by the same extent that the negative current

feedback is increased. The variation then is from 18 db of voltage feedback to 18 db of current feedback and any point in between. The total feedback remains constant and, therefore, the gain, distortion, hum and other qualities determined by feedback also remain constant. No trouble with instability is experienced because current feedback, when applied around an output transformer, improves high-frequency response and, consequently, the amplifier is more stable with current feedback than with the same amount of voltage feedback. If the amplifier is made stable with a given amount of voltage feedback, the change to current feedback will not produce instability.

Other manufacturers use different applications of these same principles and, in general, their damping controls fall somewhere between these two types.

Damping considerations

For a given speaker, the amount of damping can be varied by changing the value of the external resistance and consequently the value of the braking current. There is one value of damping at which the cone returns to rest in the quickest possible time without going past the rest position. This condition is called the *critically damped state*. Transient distortion is greatly reduced and the low-frequency response is more nearly uniform.

Excessive damping returns the cone slowly to its rest position. If the speaker is driven by a voltage source with very low internal resistance, the low-frequency response lacks intensity. (The action now is similar to pushing a pendulum while it is submerged in grease or heavy oil.)

High damping factors should not be considered byproducts of inverse feedback, *but should be controlled*. They play a very important part in the reproducing chain. Neither should an amplifier be designed with very high damping factors only. A good high-fidelity amplifier demands that the damping factor be variable within wide limits. It is important not only to present the correct load impedance to the amplifier, but also to present the correct load impedance to the speaker. These two load values are seldom the same. The means of true amplifier-to-speaker matching is obtained with the aid of correct amplifier damping factor selection. The answer to the question of why one particular amplifier A works better than another amplifier B with a given speaker is that the damping factor of amplifier A more nearly critically damps the speaker than amplifier B. With a resistive

load, the two could perform in an identical manner. With the variable load of the speaker, the operation becomes entirely different.

Sometimes an inexpensive speaker may seem to have more bass than a more expensive high-fidelity unit because it works in an underdamped condition, whereas the hi-fi speaker may be heavily overdamped.

Speakers vary greatly in their requirements of source impedances to critically damp the cone and achieve optimum speaker performance. Laboratory curves conclusively show that best speaker performance occurs with critical damping. No one value of amplifier internal impedance can satisfactorily match all speakers and enclosures.

preliminary diagnosis

For several reasons, the service technician must be prepared to do a large proportion of service work in the customer's home. For one thing, unless he himself is a high-fidelity listener, the chances are that the customer will be a better judge of the performance of his own equipment. The technician is more likely to be tolerant of imperfections, particularly of distortion, than the owner. Therefore, it is very prudent, as well as diplomatic, to respect and indeed to satisfy the ear of the customer.

Another reason is that hi-fi installations are likely to be complicated. They may consist of several individual units, such as a preamplifier, amplifier, record player, master control unit and a speaker system, which may be located separately throughout the house, (Fig. 401). Removing the whole system to the shop may involve too much work and expense. Also, the installation itself may offer better provisions for listening than the service shop. For example, ordinary bench test speakers will never be adequate for testing hi-fi equipment, and it is seldom practical to take the speaker system to the shop. Sometimes the customer's recordings contain better test material than is available in the shop. Therefore, when you get a call to service a hi-fi installation, be prepared to do most of the initial diagnosis as well as the final adjustment and perhaps even the repairs themselves in the customer's home.

This leads to the question of what instruments, tools, parts, etc., to take when making the call. Careful questioning of the customer can be of great help. Find out the make and model of the several

component units. If you do not have a service manual covering the equipment, you can at least look in catalogs for the specifications and thus determine the tube types. A large percentage of amplifiers use some modification of the Williamson circuit.

Your normal TV and radio servicing tube kit probably includes most of the tubes used in tuners and voltage amplifying sections of hi-fi amplifiers, as well as preamplifiers and control units. Most useful are the various twin-triodes, both octal and miniature such as the 6SN7-GT, 6SL7-GT, 12AU7, 12AX7, 6SC7 and 12BH7. Your kit is not likely to include such special hi-fi tubes as the 12AY7 and Z729, used in preamps, or such output tubes as the 807, 1614, 5881 and KT66. If you have these in stock, by all means take a pair along. Capacitors should be of the best quality and carry a 600-working-volt rating. Standard $\frac{1}{2}$ - and 1-watt resistors can be made to serve, at least temporarily, but you will find that some amplifiers use precision and low-noise resistors, frequently rated at 2 watts.

As for instruments, a v.t.v.m. or v.o.m. capable of measuring audio frequencies as well as normal d.c. voltages, current and resistance is a necessity. The ideal combination of instruments would be an audio analyzer (which combines an intermodulation meter, a generator of low and high-frequency tones, a wattmeter, an a.c. v.t.v.m.) and one of the miniature 3-inch scopes. This combination, available in kit form, represents a fine investment for any shop which does or expects to do considerable hi-fi servicing. It permits rapid trouble shooting and accurate adjustment with a minimum disassembly of the hi-fi system.

Either the Cook series 10LP test record or the Dubblings D-100 and D-101 combination is extremely useful and will substitute in a pinch for a signal generator. If you have some experience with high fidelity and have some favorite hi-fi demonstration or test records with which you are thoroughly familiar, take them along.

A valuable diagnostic tool is a pair of headphones with a good high-frequency response and fitted with alligator clips. Surplus HS30 type units are excellent and obtainable at low cost. Crystal phones are good, provided you are careful to isolate them from d.c. voltages and protect them from overloads. A very handy signal tracer can be built out of a surplus Signal Corps BC366 jackbox rewired as indicated in Fig. 402. This will provide a dummy load to replace speakers and a volume control to adjust volume when checking high-level portions of the circuit. You can block d.c.

voltages by putting a capacitor (.01 μ f or higher) in series with the input (ungrounded) lead.

Approach

The hi-fi service technician will be faced with two classes of troubles: (1) complete inoperation of some element of the system or (2) faulty or imperfect operation. We will not spend much time on the first category since it presents problems very similar if not



Fig. 401. In this illustration we have the various units of a high-fidelity system.

identical to those which exist in an inoperative radio or TV and which can be serviced with the same procedures.

Complete inoperation

The first step is to isolate the failure and determine if one of the signal sources is at fault. This can be done by switching in the various tuners, record players, tape recorders, etc., one by one. If the system is operative with one or more sources but inoperative with another, the fault clearly is in the signal source. If the system remains inoperative with all input sources, the fault lies somewhere between the signal source and the speakers.

Inoperation of the power amplifier can sometimes be de-

terminated by listening to the speakers. If they are completely dead and utter no sound at all, it is an almost certain indication of a failure in the power supply of the main amplifier. If the speakers emit some noise—usually a combination of hum and tube noise—but no signal, the fault is obviously somewhere in the chain of amplifiers. This is where the headphones come in handy.

First, clip the phones across the speaker terminals. You can thus determine whether the amplifier is delivering a signal to the speakers. If it is but the speaker utters no sound, the trouble obviously lies with the speaker or the crossover network. If no sound is heard in the phones, the next step is to pull the plug from the signal source to the amplifier or control unit and connect the headphones to the output of the signal source. If the signal is present at this point, the trouble clearly lies between signal source and output of power amplifier. Reinsert the plug from the signal source. If the preamplifier or control unit is independent of the power amplifier, remove the plug from control unit to amplifier and check the output of the preamp. By tracing the signal in this fashion from unit to unit, the faulty section is quickly isolated. It can now be removed from the cabinet for more detailed diagnosis.

In the case of complete nonoperation, the cause is usually not difficult to find. The fault will generally be a defective capacitor, tube, resistor, etc. and the diagnosis is precisely similar to that involved in an inoperative radio or TV. The service technician can use whatever testing routines or instruments he employs most effectively in trouble-shooting radios or TV. Only two points are worth calling attention to: First, *when replacing faulty components, always use replacements which duplicate the original as exactly as possible.* Much of the high quality of hi-fi equipment is the result of very precise adjustment of operating parameters by the use of precise components or components of very low departure from specifications. Casual replacement of resistors with the normal 10% tolerance is very seldom safe. Always choose a replacement as close to the specified or marked value as you can. In any three, four or five resistors of a nominal value one can usually be found which meets the specified value by 5% or less. Always use resistors having a wattage rating at least equal to that of the original. If the original shows signs of overheating, use one of higher wattage. Nor is it safe to depart from the specified or marked value of electrolytic capacitors in the decoupling and filter networks. In most hi-fi amplifiers the capacitors are carefully

selected to provide (with the decoupling resistor) a time constant which compensates for the time constants in the interstage coupling. A higher or lower capacitance may disturb the designed boost or attenuation sufficiently to produce instability in the feedback loop or loops. It is safer to depart from specifications in the case of the first two filter capacitors in the power supply filter, but even here it is preferable to use exact replacements since a change in capacitance may increase or decrease the plate supply voltage and thereby disturb operating parameters of some critical stage.

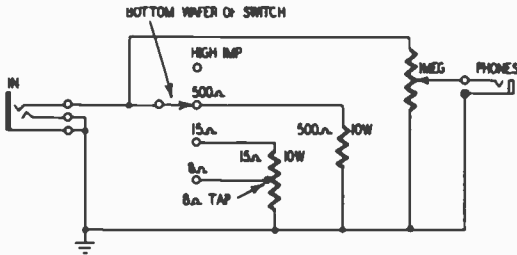

Fig. 402. Simple audio-signal tracer circuit.

There is no such thing as a universal output transformer for hi fi. In every case when a replacement is necessary, *the identical model of the identical manufacturer should be used*. One of the most critical factors in the design of high-fidelity amplifiers is the stability of the feedback loop, which is dependent on the output transformer used and the corrections made within the feedback loop for phase shifts within the given output transformer. There is always sufficient tolerance in these adjustments so that production runs of one make and model will produce good results. But the characteristics of another make and model will almost always differ enough to disturb the delicate balance. Substitution may produce serious instability in the ultra or subsonic region. Therefore, such substitution cannot be made safely unless the service technician has the knowledge, equipment and skill necessary to adjust the feedback loop to compensate for the difference in transformer characteristics. In any case, after replacing an output transformer make the necessary checks for transient stability in the audio amplifier.

Second, after restoring a system to operating condition it is extremely prudent to adjust the *whole* system. The adjustments necessary for optimum performance may have been disturbed by the replacement of defective parts; even if this is not true, the

system may be drifting due to ageing, temperature changes, etc. Therefore, it is both wise and good insurance to readjust the whole system.

System operating, but faulty

The real headaches in high-fidelity servicing are provided, not by faults which produce inoperation, but by faults which result in imperfect operation. If the complaint is some variation of "it doesn't sound right," the service technician's task in this instance is: first, to listen to the system and determine in what way the sound is poor or bad: then to identify the exact fault and to determine and correct the cause of the trouble.

One of the things likely to surprise the newcomer to hi-fi repair is that he may be called to service a brand-new system. In some instances, the purchaser may not have put it together properly and the system is completely or partially inoperative. This is a simple problem. Going over the interconnections of the units will usually reveal some simple error: input plug inserted in the output jack or not making proper contact, power line plugs not inserted or inserted at the wrong point. Some hi-fi units have power receptacles on the chassis so that preamps, control units, boosters, tuners, etc., can be turned on and off simultaneously with a single switch. In such cases, the power switches on the remote units are left in the ON position. If they are inadvertently placed in the OFF position, the unit will not become operative by the common switch until the integral power switch is also turned on. Interconnecting cables may be and often are faulty. Overheating when soldering cable to plug may have melted the thermoplastic insulation so that the inner conductor shorts to the plug. The cable may have passed factory tests but developed a short when it was twisted into interconnecting units. Loudspeakers may be tied to the wrong taps on the amplifier output. Ignorance and unfamiliarity with electrical and electronic practices can produce a wide variety of quite ridiculous errors.

The misadjusted system

Equally as often the complaint is: "This thing sounded fine in the showroom when I was buying it, but after we hauled it here and put it up it sounded lousy. Is something wrong or did I buy a lemon?"

Nine times out of ten the system is merely misadjusted. As the market for hi-fi continues to broaden, more and more systems are being bought by persons who do not have any technical understanding of what a hi-fi system really is designed to do and how it does the job; and therefore, do not know how to operate a hi-fi system properly.

A hi-fi installation may include from two to four or even five volume controls in the chain from signal source to loudspeakers. Improper setting of these controls may result in overloading of a tube somewhere in the chain even at low output levels. For lowest distortion, all volume controls should be wide open except the very first one in the chain, which should be used to set overall volume. It is surprising how many cases of distortion in complicated hi-fi systems can be cleared up simply by manipulating the volume controls.

The purpose of high fidelity is to deliver to the *mind* of the listener a sound as nearly as possible like the original sound in the auditorium, studio or concert hall. On the one hand this calls for a system which will itself faithfully reproduce the signal fed into it without modifying it either by the addition of undesired sounds such as distortion or the subtraction of desired sounds by poor frequency response, narrow bandwidth, etc. On the other hand, however, both the conditions under which the program is transformed to recordings or broadcast and those under which the high-fidelity system is listened to in the home modify the original sound and therefore call for compensation to restore original qualities. The hi-fi system must be capable of making these compensations.

For example, recording technique requires that the bass end of the sound spectrum be attenuated. When the record is played back, this attenuation must be corrected by a complementary boost. To reduce noise, the high end is boosted and on playback it must be attenuated just enough to restore the original balance. Similarly, in FM broadcasting the high end is boosted to reduce noise. The FM tuner must modify the response in a complementary manner so that the signal fed into the hi-fi amplifier has a tonal balance as flat as the original.

At the listening end, we run into similar problems. For one thing, music in the home is seldom heard at the same volume level as in the auditorium or studio. Even when played very loudly the volume level will be 20 or 30 db below concert-hall

level. Unfortunately, the human ear is not perfectly flat to begin with and its response curve varies very greatly with the loudness of the sound. In Fig. 403 let us say that curve C is the response of the human ear at concert-hall levels and is therefore the curve we want to reproduce in the home. But at home-listening levels the curve of the ear is as in curve A, with severe slopes in both the bass and treble ends. Without some compensation a "flat" signal fed to the ear would be very deficient in bass and treble and would be far from correct. For this reason a loudness control is incorporated into the amplifier to produce the boost indicated in B. The resultant curve is indicated in C. The boost corrects the

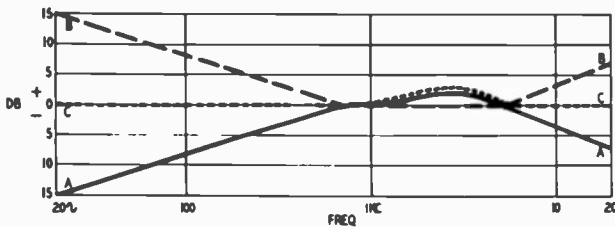

Fig. 403. Room acoustics can produce bass or treble boost or attenuation.

ear's insensitivity at low levels and the result is that to the *mind* the program now sounds as it would in the concert hall at much higher levels.

But that's not all. Rooms have deficiencies which have to be corrected if a faithful balance is to be maintained. Some rooms are very live, absorb little sound and, on the contrary, reflect much more of it than a studio or concert hall does. This, in effect, produces a rising response because the average concert hall or studio, especially with an audience, absorbs a considerable quantity of the treble end of the sound. Some rooms ring at low frequencies. They may have a resonant frequency and, when stimulated by a signal at this frequency, will produce much louder levels than existed at the studio or auditorium. Or they may not be able to take more than so much bass without excessive reverberation. This, too, has the effect of producing a boost. The curve of such a live, ringing room might be indicated as at B of Fig. 403. On the other hand, other rooms are dead; they absorb more of the high frequencies, reflect less of them; they seem to need more bass than average rooms. The curve of such a room might be as indicated in A. Here, too, the hi-fi system is called

upon to supply correction in the form of either boost or attenuation. The position of the speaker in the room has a *tremendous* effect and may be the only thing wrong with the setup.

Speakers are by no means as flat as we would like them to be and require boosts at the low and high ends if they are to deliver to the room a bass as awesome and a treble as brilliant as the original; once again the system has to provide compensation. The overall result is that in a properly adjusted hi-fi system the tonal balance is flat only at the output of the tuner or phono-equalizer and in the mind of the listener. At all intermediate points it is

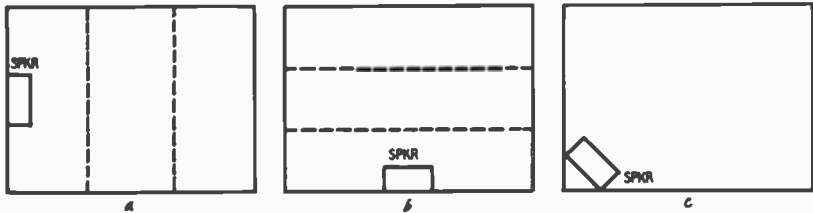

Fig. 404-a, -b, -c. The three illustrations shown above indicate some of the different positions at which a speaker can be placed in a typical room. The dashed lines represent one of the possible standing-wave frequencies that will be over-emphasized.

deliberately modified, or distorted if you like, to make up for deficiencies of source, room, ear or other elements, not to mention personal preferences.

To achieve all this, hi-fi systems are quite complicated and contain anywhere from five to nine controls for the various necessary adjustments. It is quite possible for an unskilled and unknowing person to misadjust the controls of the finest system to produce a perfectly horrible sound. Indeed, it takes some teaching and experience to learn how to get the best sound out of any system.

Another common cause of complaint arises from poor placement of the loudspeaker in the room. As is only natural, this is often chosen by the purchaser to suit his existing furnishings. He may consider the middle of one side a position where the loudspeaker "looks good." But it will probably not sound good there. When a loudspeaker is placed facing an opposite wall, it is apt to accentuate acoustical resonances in the room at frequencies for which the wavelength of sound is a multiple of the distance from the speaker to the opposite wall. Two such placements are shown for a room of typical dimensions in Fig. 404-a, -b. Fig. 405 shows the kind of response caused by this placement. The ideal place for

a loudspeaker in most rooms is in one corner (as shown in Fig. 404-c) where it avoids room resonances.

Where the complaint is a legitimate one of poor quality, the first thing to do is to adjust the system. If the service technician has some experience with high fidelity, this will be a very small problem. However, even the inexperienced man can do a good job by following a few simple rules.

It is very important when testing any system whose quality is questioned to be sure of the signal source. The experienced hi-fi man undoubtedly has several recordings with which he is completely familiar and with which he can, therefore, judge performance and adjust the system to produce a sound satisfactory to *his* ear. The inexperienced man is handicapped and will be much more dependent on his customer's ears and preferences. Note: Records are dangerous as tests unless you have a replacement phono cartridge known to be *ok* and of identical characteristics to the one in the system being tested.

Place the record on the turntable and be sure it is properly equalized. Almost all recordings made in the United States subsequent to September, 1954, use the RIAA curve or some modification of it so slight, that an RIAA (or an ORTHO) equalizer will be within 1 db or so. Many recordings made earlier, or which do not use the RIAA curve, give the playback curve on the back and bottom of the sleeve, jacket or album. Next, adjust the tone controls on the system to neutral or flat position. This is the position which produces neither boost nor cut. If the system has both a level or gain control and a loudness control, set the loudness control full on and adjust the volume with the level or gain control. If the system has a loudness control but no level or gain control, it will probably have a switch for disabling the loudness network; disable it. Now adjust the volume as loud as the room and the people can tolerate. This will be the maximum volume they are likely to use, but in any case a loud level. Now listen to the bass and treble ends. If bass seems lacking, boost it with the bass tone control; if the bass is too heavy, reduce it with the bass tone control. If treble is lacking, first check to see if the speaker system has a treble control. If it does, set it for a satisfactory balance of treble to mid-range; if it does not, use the treble tone control to boost. If treble is too high, reverse the procedure. If you obtain a good balance of bass and treble in this way, switch in the loudness control and turn it down to normal room volume.

Assuming a good loudness control and normal ears and not too bad a room, the balance should remain pretty good as the loudness control is turned up or down.

The adjustments will be a little more complicated if the hi-fi setup, like many of the newer amplifiers, has a damping control. This varies the amount of damping which an amplifier imposes on the speaker system and thereby affects both the amplitude of the bass at the low end and the transient response.

However, you can, if you are so inclined, obtain a rough setting by ear sufficient to test a system by adjusting the damping con-

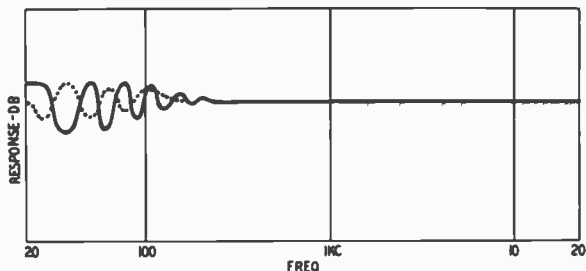

Fig. 405. Effect of poor speaker placement on frequency response. The solid curve represents the speaker in Fig. 404-a. The dotted curve represents the speaker in Fig. 404-b. The plotted response shows the effect of room resonances on the overall sound.

trol at high volume level, with the bass control in the flat position, for the most satisfying but not "one-note" bass with a given speaker in a given room. Generally, in live rooms the "deader," more highly damped bass is both more natural and more pleasant to most ears. In dead rooms, on the other hand, less damping adds presence and liveness to the bass.

If, with these adjustments and a familiar record, you obtain a sound which is good to *your* ears, you know the system is not at fault. If the customer is now satisfied, you have solved the problem. And in a surprisingly large number of cases this procedure will in fact do just that. You can explain the operation of the system, how to manipulate the controls properly, the need for equalizing records exactly and so forth until the customer understands it clearly. It is also prudent to place temporary pencil markings on the panel to indicate the positions the controls should occupy for the "normal" operation which you have now obtained, so that if the customer in an experimental mood loses the combination, as it were, he can always restore the controls to positions which produce a good sound.

The customer may not agree with you that the sound is good. There is, of course, a wide range of personal opinion and preference for tonal balance and quality. It should be quite possible, in that case, to readjust the balance with the bass and treble controls to suit his taste or ear. If you cannot make him happy, although you can produce a sound very good to your ears, one of you is terribly wrong about what constitutes high fidelity. Assuming you are right and he is wrong, the problem is one of diplomacy. If you can persuade him without angering him that this trouble lies in his own misconception of what a high-fidelity system can do, your job is done.

On the other hand, if this adjustment and preliminary test do not produce a satisfying result, the presumption is that there is a fault in the system somewhere and the problem is to find, identify and rectify it.

There are various possible ways of organizing the analysis of high-fidelity faults and their causes. By far the most frequent, troublesome and complicated fault is that represented by distortion in its many forms, and we shall therefore consider it first.

distortion

The most frequent complaint the high-fidelity service technician will hear is that of too much distortion—nobody, of course, complains of too little. Distortion can occur anywhere in the chain from original transmission or recording to the speakers.

The initial diagnosis will have to be made in the home or the place where the system is installed. The basic problem is to isolate the trouble. First, determine if it is one of faulty signal sources. This is easily done by switching in the various tuners, record players, etc., one by one. If the distortion is audible with only one source, the trouble lies with that source; but if the distortion remains fairly constant with all sources, the fault lies somewhere between the sources and the ear.

Also check the setting of the treble boost control. Many hi-fi addicts are inclined to overboost the highs. This results in abnormal distortion, first, because the distortion present in the program is accentuated and possibly multiplied and, second, because succeeding stages are driven harder at the high frequencies and therefore generate considerably more distortion in this region.

Finally, before starting to chase small amounts of distortion, check whether the distortion is present in the program itself. All recordings and radio programs have some distortion which is made worse by the radio detector or the phono-pickup. This is fairly easy to determine. If the distortion is present in the signal, it will be constant at all volume levels. Therefore, first vary the volume control while listening to the distortion carefully. If it is audible

at low as well as high volume, a fairly safe assumption is that it is either in the program itself or caused by the tuner detector or phono-pickup.

If all these tests do not locate the distortion, adjust the controls until the distortion is plainly audible and then, with the headphones, trace the signal from front to back until you pinpoint the unit in which the distortion first occurs.

If the preamp or control unit is independent of the amplifier, the connecting audio plug can be pulled and the output of the control unit checked with the phones. Next check whether the distortion is being caused in the loudspeaker or is present in the output from the amplifier. First bridge the phones across the voice-coil terminals, and listen with the phones pressed close to exclude sound from the loudspeaker. If the distortion is audible in the phones, it is still possible that the speaker may be reflecting it back into the amplifier circuit. Next remove the speaker connection (switching off while you do this, to protect the output tubes) and connect a dummy load of appropriate resistance (using the one in Fig. 402). If the distortion goes when this change is made, the loudspeaker is responsible for it, but if it is still present, the source is in the amplifier somewhere.

When the unit is spotted the tubes should be checked, preferably by substitution. Then, if the unit is the power amplifier, it should be adjusted to eliminate the possibility that the trouble is due simply to a drifting of adjustment. If this does not clear the trouble, the unit can be removed from the cabinet for further testing.

The headphones are equally useful for stage-by-stage testing of amplifiers. With one terminal grounded, the other can be touched to the grid terminal of each tube until the inoperative or distorting stage is located. The specific fault can then be found by voltage and resistance measurements in the indicated stage.

If the fault is quickly found in this way, fine. Usually, however, when the distorting unit is found, it is safer and preferable to remove it from its position in the system, take it to the shop and check it with instruments.

In general, distortion can be produced by the following faults:

Overloading

This is caused by driving a tube into the nonlinear portion of its operating curve with too strong a signal. It is easily checked since reducing the input signal will lower or eliminate the distor-

tion. In a properly designed hi-fi system, overload distortion should occur only at or beyond the maximum rated output and should not be very serious even at this level. However, the distortion curves of hi-fi amplifiers rise very steeply beyond a certain output level. A Williamson amplifier designed to deliver 10 watts with only 1% distortion may generate 5 to 10% distortion if an attempt is made to drive it to 15 watts. The intermodulation distortion will rise even more steeply. Some less critical hi-fi listeners try to get more out of their amplifiers than they can deliver. If the overload distortion disappears or is scarcely audible at the maximum rated output of the amplifier (usually at about 10 watts and equivalent to approximately 8.5 volts across an 8-ohm load and 12.5 volts across a 16-ohm load), it is safe to assume the trouble lies with the customer rather than the equipment. If overload distortion is serious at rated output or occurs at lower than maximum rated output, the fault may be caused by weak tubes. The most likely offenders are the driver tubes, the ones preceding the output stage, but *any tube which fails to deliver rated amplification can result in overload distortion*. Weak output tubes can also be guilty since they must be overdriven to produce rated output. Look for this particularly in amplifiers using four tubes in push-pull parallel. Any one tube being only slightly weaker than the others can cause serious distortion. If changing tubes does not clear the distortion, it is safe to assume (in the case of commercial units) that the trouble lies elsewhere.

Improper operating parameters

To obtain maximum amplification with lowest distortion, a vacuum-tube circuit must be carefully designed to preserve certain relationships between plate and grid voltages. The tolerances permissible within this relationship are very much lower in hi-fi circuitry than in ordinary radio circuits. Therefore, if this relationship is disturbed by some change in one or more of the components in the circuit or the voltages supplied to it, distortion may become too high for good hi-fi reproduction.

In effect, a tube is either overbiased or underbiased by such changes. In either case, it will generate distortion with a lower-than-normal driving signal. In overbiasing, the bend of the curve is advanced; in underbiasing, the grid is driven positive on a lower signal.

An audio generator and a scope are extremely helpful in tracing this type of distortion. The signal generator can be fed into the amplifier input, while the scope input is moved from stage to stage and the trace examined for evidence of clipping (Fig. 501). In this way the faulty stage can be located quickly, the type of distortion identified and corrected.

In the absence of this equipment, the trouble can usually be located by voltage measurements, aided by a wiring diagram or a tube manual. Measure the grid and plate voltages and check them against the operating characteristics given in the tube manual or in the voltage tables of the manual for the amplifier. If checking against a tube manual, measure grid voltage from grid to cathode and plate voltage from plate to cathode, rather than to ground. Some hi-fi amplifiers employ direct coupling and the net grid voltage in such cases can be determined only by grid-to-cathode measurements. If the voltage departs by more than 10 or 20% from that specified on the diagram or in the tube manual, check the plate and cathode resistors in the circuit. If these resistances vary from the specified value by more than the percentage specified in the manufacturer's schematic, replace them. (Be sure, however, that your meter is accurate. Check it against 1% precision resistors). If it is in error, make careful allowance for the known error.

In amplifiers using resistors rated for less than 1 watt, the plate resistors are most likely to change in value as a result of overheating. It is never wise to use a substitute part of lower rating. Occasionally a resistor will show obvious signs of overheating, and in such a case it is advisable to substitute a unit of higher rating. Choose a resistor as close to the specified value as possible by measurement with an accurate ohmmeter. In any group of four or five stock resistors of a given nominal value, one can usually be found which is within 5% of the desired value. If the replacement resistor is to be used in a push-pull stage, match it as closely as possible to its opposite mate.

Low or high plate supply voltages may disturb operating conditions sufficiently to produce either under- or overbiasing. It is always advisable to check the power supply.

A possible cause of underbiasing might be a leaky interstage coupling capacitor. Measure the voltage between grid and ground with a high-impedance v.t.v.m. on the 2.5- or 5-volt range. If the meter indicates a voltage in excess of 10% of the bias voltage, replace the capacitor. This d.c. voltage bucks the bias voltage,

thereby reducing it, as illustrated in Fig. 502. Since the bias of early stages may be as little as $\frac{1}{2}$ volt, any appreciable leakage through a capacitor may upset operating parameters quite seriously.

A similar effect can be produced by tubes which draw grid current. This is most likely to occur in the case of power output tubes.

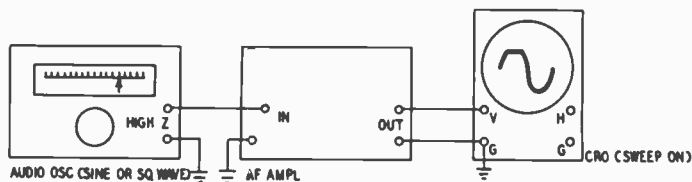

Fig. 501. A scope is valuable for locating distortion.

This too can be checked with a high-impedance v.t.v.m. by measuring grid-to-ground voltage. The meter impedance should be at least 11 megohms; a lower impedance would reduce the grid resistance and yield a lower reading than exists under actual operating conditions. If any appreciable voltage exists, try substituting

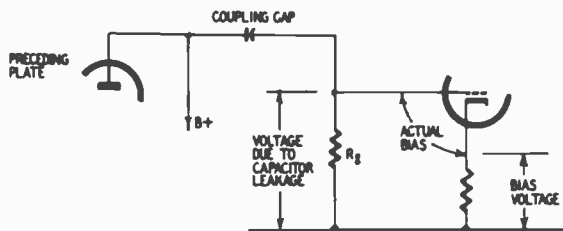

Fig. 502. A leaky coupling capacitor reduces the bias voltage.

tubes. If this doesn't help, check the grid resistors. Most output tubes with self bias can tolerate a grid resistance up to 500,000 ohms without noticeable effects, but many hi-fi amplifiers use grid resistors as low as 100,000 ohms.

Imbalance within push-pull stages

The great virtue of the push-pull amplifier in audio design is its ability to cancel even-order harmonic distortion. This feature allows us to drive tubes harder and get more than twice the output of a single tube if we wish. It also improves the low-frequency response by reducing unbalanced d.c. in the output transformer primary which might saturate the core and reduce the inductance

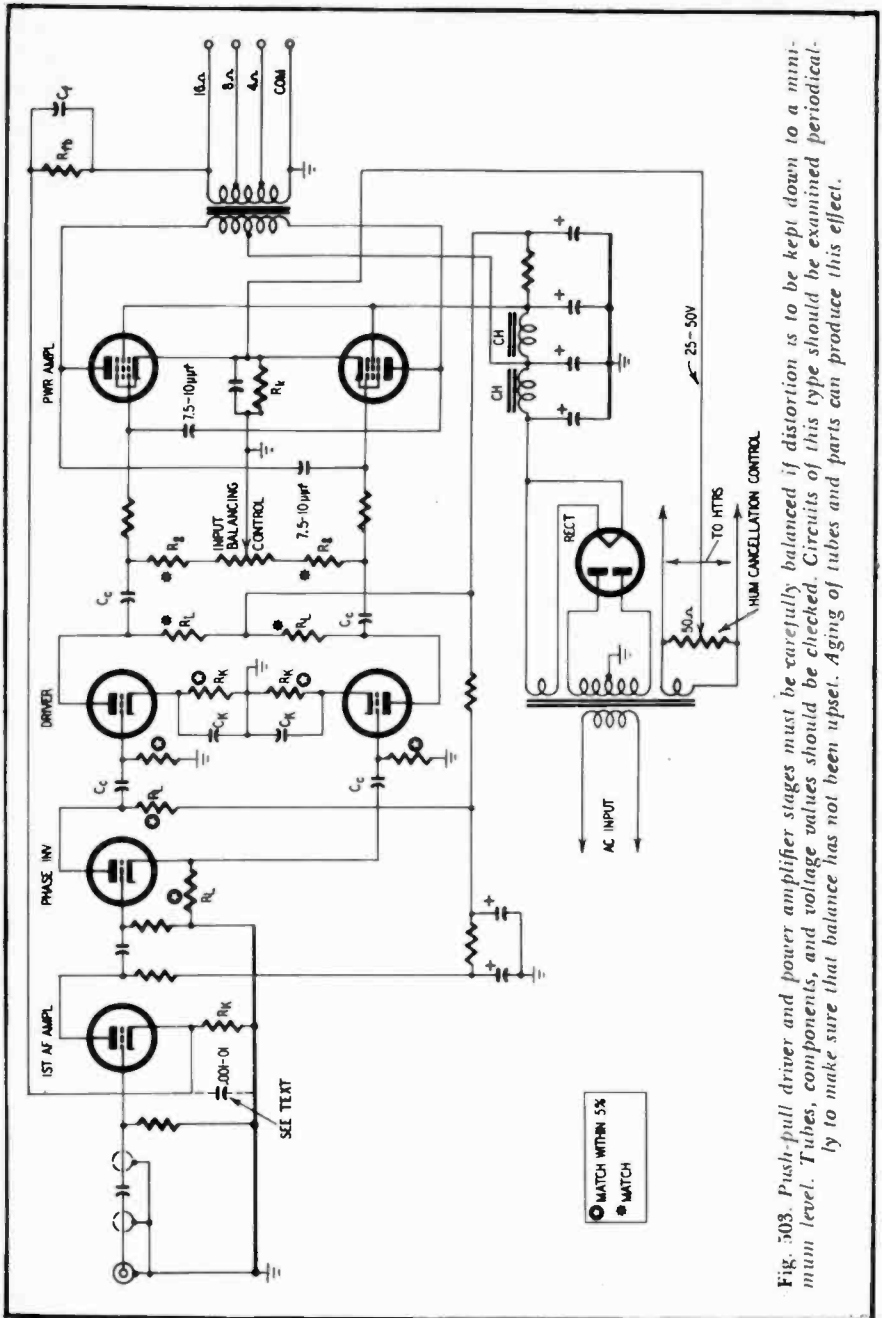

Fig. 503. Push-pull driver and power amplifier stages must be carefully balanced if distortion is to be kept down to a minimum level. Tubes, components, and voltage values should be checked. Circuits of this type should be examined periodically to make sure that balance has not been upset. Aging of tubes and parts can produce this effect.

of the windings. In addition, push-pull operation almost entirely eliminates hum and noise from the power supply, but the principal reason for using it remains the distortion-canceling feature. However, it is a very rare push-pull amplifier which fully exploits these distortion-canceling characteristics. Very few of them realize even 75% of the possible benefits, and many push-pull amplifiers produce even more distortion than a properly designed single-ended amplifier.

The fact that a push-pull amplifier utilizes only 75% of the distortion-canceling abilities of the circuit may not be serious in speech-range public-address equipment, but in high-fidelity amplifiers enjoyment of the wide-frequency response is entirely dependent on reducing distortion to an absolute minimum. The amplitude of most music and voice sounds around 10,000 cycles and above is normally 30 or 40 db below the average sound level. Even 1% distortion of mid-range sounds is louder than normal high-frequency components and not only masks them but also makes them annoying to hear. To insure acceptable reproduction of the high frequencies, distortion must be reduced to the smallest possible fraction of 1%. This improvement is attainable by making the most efficient use of push-pull design.

The distortion-canceling property of a push-pull amplifier depends entirely on balance. Complete cancellation is achieved only when equal signals are fed to both sides, when both sides amplify equally and when both produce the same amount of distortion. On the other hand, if the output and distortion of one side are 10% greater than the other, at best only nine-tenths of the distortion is canceled.

The situation actually becomes even worse at some points in the dynamic range, especially at the points of maximum drive. For example, we deliver equal signals to both sides, but one side is overbiased either because the tube draws more current or because its cathode resistor is higher in value than that of the other tube. Thus the overbiased tube reaches the bend of its curve earlier and may generate 10% or more second-harmonic distortion while the correctly biased tube generates only 5%. After cancellation, the net second harmonic distortion will be 5%, where there should have been complete cancellation.

Output stages should be balanced to 1 or 2%. R-C coupled voltage amplifier, driver and phase-inverting stages, should be bal-

anced to at least 5%. To check the d.c. balance, connect a high-resistance d.c. voltmeter from plate to plate of the push-pull stage. A completely balanced stage will show zero voltage. Many high-fidelity amplifiers have provision for balancing the output stage with an adjustable resistor in the cathode circuit. Adjust this resistor until the plate-to-plate voltage is as close to zero as possible.

Checking the d.c. balance of the output stage in this manner is dependent on the two halves of the output transformer primary winding having equal resistance values. This should be checked. If the values are not close enough to enable this method of measurement to be used — within 1 or 2% — d.c. balance of the output tubes must be checked by inserting a milliammeter of appropriate range in each plate lead in turn. Switch off while inserting it, as disconnection of the plate of an output tube can cause damage to the tube by seriously overheating the screen. A d.c. unbalance of more than 2% in winding resistance does not indicate a bad transformer — it may still preserve good electrical balance if the winding resistances differ between halves by as much as 5%, and will not be too serious if it is as much as 10%, because this resistance value is small compared to other values in the circuit.

Plate-load resistors in push-pull voltage stages and phase inverters (R_L in Fig. 503), should also be matched to 1 or 2% but seldom are, except in the highest-quality amplifiers. However, if measurement shows that the difference is much greater than 5%, one resistor should be replaced. Choose one whose resistance is equal within 1 or 2% to that load resistor which comes closest to the specified value. Be careful, when wiring, not to overheat the resistor; this may very easily change its value permanently.

If the two sides of the stage use different cathode resistors (R_K), check these for balance also and replace if one is more than 5% higher or lower than the other. Except in the case of output power stages, grid resistors R_G are not critical. However, they should match at least to 10%; and in output stages which may draw grid current, it is important to preserve balance in the grid resistors.

An open coupling capacitor C_c can produce serious unbalance, and can be spotted with the headphones. If the phones show a much stronger signal on one grid than the other, check and replace the capacitor.

If the reactance of one capacitor is considerably higher than that of the other, there will be unbalance at low frequencies and harmonic distortion may not be completely canceled. The harmonic distortion of bass tones is not in itself as noticeable or annoying as

distortion at higher frequencies. However, it leads to increased intermodulation distortion. The situation is aggravated because in most high-fidelity installations there is considerable boosting of the low frequencies in the preamplifier or control unit. Succeeding stages are driven harder and produce more distortion not only within the low-frequency range but also in the mid- and high-frequency ranges.

To check capacitors for balance or to match them, feed a 60- to 100-cycle tone into the amplifier. If no audio generator is available, use the 6-volt filament circuit. Adjust the input control to

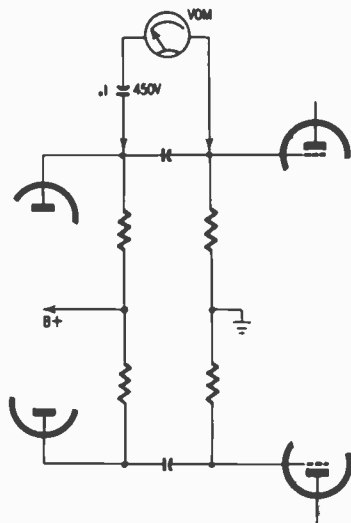

Fig. 504. Technique for checking capacitors for balance.

give a voltage at each stage about half of the maximum level. Then measure the a.c. across each coupling capacitor with a high resistance volt-ohm-milliammeter and a series capacitor. The reading across each should be nearly the same, and the difference should not be more than 1% of the a.c. voltage across that grid resistor. For example, if the voltage across each grid resistor is 25, and that across the capacitors at 60 cycles is in the region of 3, the difference between them should be within 1% of 25, or 0.25. The method of making this measurement is shown in Fig. 504.

If there is more than one push-pull stage, measurements should start from the first one, to check balance all along the line.

When a push-pull stage uses a common cathode resistor, the re-

sistor should be bypassed by a high capacitance, otherwise even harmonics will appear across the resistor and get injected into the circuit. Check this capacitor by removing it. When it is connected there should be no appreciable a.c. across it, and connecting it should not appreciably change the d.c. across the resistor.

Positive feedback, parasitic oscillation, improper feedback

Hi-fi amplifiers invariably employ from 12 to 30 or more decibels of inverse feedback through one or more loops. Serious distortion may result if the feedback loop or loops operate improperly. Under certain conditions the feedback can turn positive and result in parasitic oscillation. This oscillation may occur at radio frequencies and therefore be inaudible to the ear. There are two simple checks for this type of oscillation. The first is to turn on a broadcast-band radio and tune it slowly. If the amplifier is oscillating at frequencies above 20 kc, harmonics will beat with the stations selected by the receiver. If the beat disappears when the amplifier is turned off, you can assume that the amplifier is generating parasitics. The second method is to break into the B plus lead to the output transformer and insert a milliammeter. Disconnect the feedback loop momentarily. If the plate current drops, you can be sure that regeneration and even perhaps oscillation is occurring. Parasitic oscillation is easily noted, of course, on scope traces by the severe deformation of waveshapes or the presence of spurs or riders and by spreading of the line in the absence of audio.

Commercial amplifiers are designed to avoid parasitic oscillations. If they occur after a period of use, a component failure or deterioration is indicated. First, change the tubes. Tetrodes used as triodes usually have resistors from 100 to 1,000 ohms in series with the grid and plate circuits. Check to see if these are still stable. Check the value of the feedback resistor and the resistor across which the feedback is applied (usually a cathode resistor in an early stage). If the feedback resistor is lower, or the cathode resistor above the value specified, the feedback has been increased over that of the original design. Replace one or both as necessary. If replacing tubes and feedback resistors does not produce stability and the output tubes are triodes, there is an excellent chance that the trouble can be cured by neutralizing the output tubes. Typical tetrodes used as triodes (6L6's, 1614's, 807's, 5881's, KT66's, etc.) have plate-to-grid capacitances ranging between 7.5 and 10 μmf . A pair of 6.8- μmf ceramic capacitors wired from the plate of one tube

to the grid of the other and vice versa will produce adequate neutralization in most cases. It is particularly helpful in minimizing ultrasonic ringing and parasitics.

Most recent amplifiers use a phase-shift capacitor across the feedback resistor. Its value is chosen to offset the phase shift produced in the output transformer. Check this capacitor (C_F in Fig. 503) for an open or short. If the amplifier does not have such a capacitor, it may be well to check whether one would improve it. This is best done while observing a 10- or 20-kc square wave on a scope. Try various capacitors in the range from 5 to 3,000 μf and

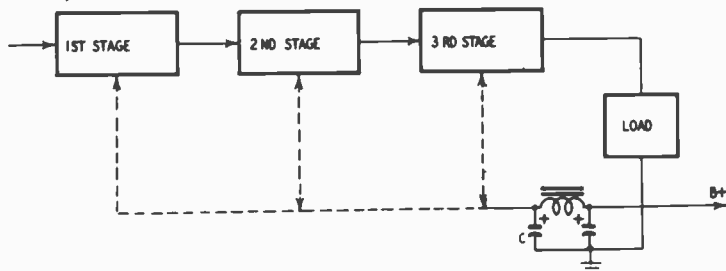

Fig. 505. Block diagram of a three-stage audio amplifier using a single power supply. Although the output impedance of the power supply may be quite low, it has a finite value, is common to the three stages, can produce positive feedback and instability.

choose the one which produces the least ringing and the flattest top, without producing any significant rounding of the leading corner of the wave.

If the amplifier uses a driver stage with independent cathode resistors, it may be possible to cure the trouble by applying cathode bypass capacitors (C_K in Fig. 503) of low value. If the cathode resistors are around 1,000 ohms, capacitors of about .003 μf will be about right. If the resistors are higher, decrease the value of the capacitors proportionately. The addition of these capacitors has the effect of reducing the local degeneration at ultrasonic frequencies and therefore of increasing gain and decreasing overall phase shift. Since the oscillations are caused by a shift in phase at the extreme end of the response, this slight boost is often sufficient to eliminate instability.

Another expedient which may be tried is to bypass the cathode resistor to which feedback is applied with a capacitor of between .001 and .01 μf , the smaller the better. This has the effect of reducing the overall feedback at higher frequencies. However, it should be employed only if absolutely necessary for it tends to neutralize the feedback at the top end and degrade the transient

response. If none of these measures work, it may be necessary to reduce the feedback. This can be accomplished by replacing the series feedback resistor with one of higher value. Reduce feedback only if you have no alternative and then only as much as is necessary to kill the parasitics. Further reduction may not produce enough cancellation of distortion for optimum performance.

Critical amplifiers may be triggered into oscillation. This may occur either at subsonic or ultrasonic frequencies. When it is at very low frequencies it is at least as much the fault of poor decoupling in the B plus supply loop as it is of the feedback loop.

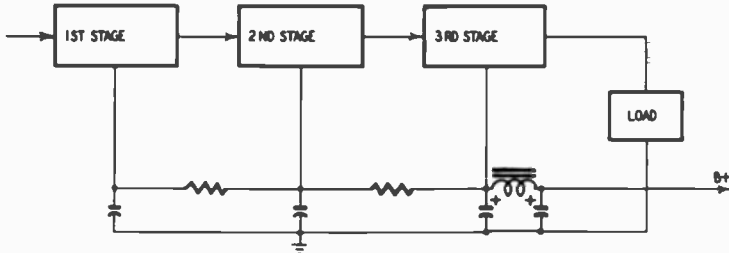

Fig. 506. In this block diagram the three-stage audio amplifier still uses a common power supply, but the tendency toward positive feedback is reduced through the use of R-C filters.

Feedback loops are inescapable in any amplifier when several stages are fed from the same power supply. Fig. 505 is a block diagram of a three-stage audio amplifier with a common power supply and no decoupling filters. The dashed lines are the feedback loops created by the common plate-supply line. If capacitor C does not bypass all audio voltage on the line to ground, part of the audio voltage in the output stage will be fed back to the first and second stages. Regeneration will occur where the feedback is in phase with the stage signal, and oscillation will start if regeneration is sufficient at any frequency.

With three resistance-coupled or two transformer-coupled stages the feedback will always be in phase over some portion of the frequency range. To minimize feedback we must insert lowpass filters in the feedback loops—filters which will pass the d.c. plate currents but will bypass most if not all of the signal frequencies. Typical R-C decoupling networks are shown in Fig. 506. If this form of instability occurs, the decoupling capacitors should be checked and replaced if necessary. A V-R tube may also be inserted at an appropriate point in the power supply connection to the input stage or stages to improve amplifier stability and response further. An example of this is shown in Fig. 507.

Although we have suggested the matching of resistors and capacitors, do not make such changes too prematurely or enthusiastically. Commercial hi-fi units are designed and constructed with reasonable tolerances. If the distortion is of sudden origin and very bad, it is highly likely that it is due to a component which departs from specifications by more than 5 or 10%. Usually it will be based upon outright failure of a component part. The more subtle measures described here should be taken only in the case of residues of distortion that cannot otherwise be corrected.

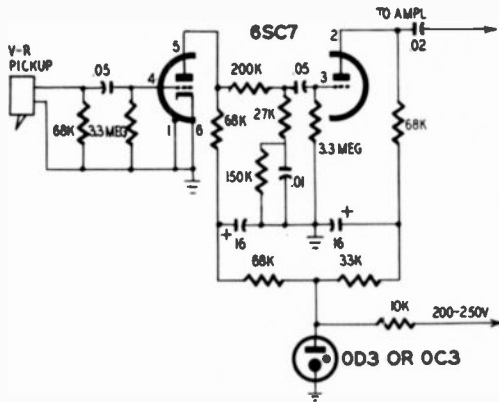

Fig. 507. *V-R tube improves amplifier stability.*

Distortion can also be produced in the tuner or phono pickup. Tuner distortion in AM receivers is usually the result of the diode detector circuit. If the diode load is shunted with too low a resistance, distortion of peaks may be very serious. In FM receivers, distortion is usually due to poor alignment or too narrow a band-pass in the i.f. stages. The narrow bandwidth can be caused by regeneration.

Excessive limiting at the broadcast station can produce a phase distortion which is not reduced much, if any, by the limiters in FM receivers. Furthermore, many FM sets have no limiters. The audible effect of this type of phase distortion falls into the 10,000- to 15,000-cycle range principally and can be very annoying. Nothing, of course, can be done if the distortion is in the signal itself. However, antenna orientation will tell you whether it is due to multiple-path reception (another cause of distortion) or to limiting.

A worn needle or stylus can produce very serious distortion from

phonograph records. Sapphire styli are by no means as permanent as once advertised. Only a few score playings will produce sufficient wear to increase distortion. Examine the stylus and replace it when necessary.

Be careful not to be drawn into a fruitless search for the Holy Grail of distortion-free reproduction. Any signal or program passed through a hi-fi setup will have some distortion. The best speakers alone will contribute 2 or 3% distortion. Before you start tearing apart a unit and replacing components in wholesale lots, be sure that the cause of distortion is not primarily present in the program or signal source. Unless you are experienced and possess some distortion-measuring equipment you may ultimately do more harm than good. In any case you may consume more work time than the customer will be willing to pay for.

low-level distortion

Measurement and testing routines for servicing high-fidelity equipment differ from those used for measuring system characteristics in development and production work. Whereas the laboratory or production test bench is interested in how closely the equipment meets ideal specifications, the service technician is interested in discovering how and why the equipment *departed* from specifications, and in doing so in the quickest, most labor-saving way. His problem is not actually measurement, but diagnosis; and his objective is to use available instruments in a way which will enable him to find the trouble most effectively and quickly. The real headaches in hi-fi servicing come from equipment with higher than normal distortion, and it is here that effective routines are most needed and profitable.

Let us suppose that you have visited the installation, made a preliminary diagnosis and decided that the high distortion is being produced in the main amplifier. You have removed the offending unit from its place in a clothes closet and have brought it to your shop. Now you're ready to find out what's ailing it and where. If you have none of the specialized instruments discussed in the chapter on instruments, the job will be tougher. But you can trace the trouble with a signal provided by a record, radio or the tone of your test generator, and with headphones or a v.t.v.m. for indicator as detailed previously. But we will assume that you are equipped with some or all of the instruments mentioned: intermodulation analyzer, signal generator, scope, a.c. v.t.v.m. and wattmeter.

Using the intermodulation analyzer

The first step is to find out how bad the situation is. This is most quickly ascertained with the intermodulation analyzer. Provide a load for the amplifier. If you have a wattmeter, it will supply the load as well as output indication. If you do not have one, use a 20-watt resistor of 8 or 15 ohms. A 15-ohm adjustable 20-watt resistor with the slider set halfway, is for this purpose, a very useful addition to any shop. Measure the intermodulation for levels of 0.1, 1.0 and 10 watts. If you have a wattmeter, read the output directly on it. Keep in mind that for two frequency signals in a ratio of 4 to 1, the actual r.m.s. power output, equivalent to that of a single sine frequency, will be about $1\frac{1}{2}$ times the meter reading. If you do not have a wattmeter, set the volume control until you obtain the following voltages as indicated on the intermodulation analyzer meter when it is used as a voltmeter. *These voltages apply only to the composite 60- and 3,000- (or 7,000-) cycle signals in a ratio of 4 to 1.*

Load Resistance Ohms	Watts	Volts
8	0.1	0.69
8	1.0	2.20
8	10.0	6.90
15	0.1	0.95
15	1.0	2.80
15	10.0	9.50

Compare the intermodulation readings you get with those of the specifications for the amplifier in question. Most high-fidelity amplifiers specify 2% intermodulation or less at 10 watts and a fraction of 1% at 0.1 watt. Published distortion figures on commercial amplifiers are usually an averaged value based on production sampling. Any given amplifier may depart from the average figure and still be within the manufacturer's acceptable tolerance range. Few manufacturers publish their tolerance figures. Your reading may be anything from these figures up to and exceeding 30%. The higher the distortion level, in general, the easier it is going to be for you to find the trouble. If the figure is only slightly off, say only twice as high as specified, *you are well advised to stop, think and decide whether you ought to spend any more time at all on it.*

In the latter case check the balance of the output tubes and adjust it if there is a balancing control, or try a new pair of tubes to find a better-balanced pair. (Two methods used for static balancing of push-pull stages are shown in Fig. 601-a-b.) If this does not bring the intermodulation close to specs, try changing the other tubes, especially the rectifier. If this tube has too high an internal voltage drop, it may be disturbing the operating curve of one or more tubes and causing abnormal distortion. If, after this, the intermodulation is reasonably close to the specified value,

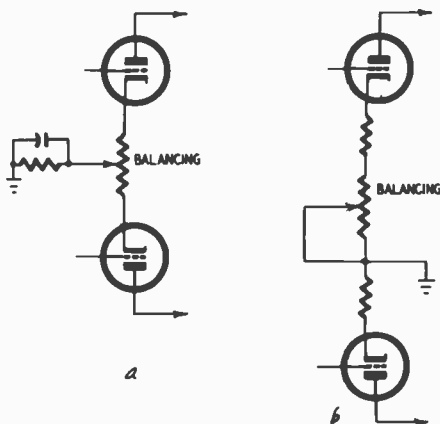

Fig. 601-a, -b. Techniques for balancing push-pull stages.

ask yourself if you didn't make a mistake in tracing trouble at the installation. Unless your ears are very sharp and well accustomed to judging distortion, it is very unlikely that you could discern the difference between 2% or even 4% intermodulation and more; and the same goes for your customer. If you heard distortion in low-level testing, but found no more than 5% intermodulation on measuring, chances are very high that the trouble lies either in the preamp, control unit, tuner or even the turntable. Thus, there is little point in doing much more work on the amplifier, since it is certainly going to be troublesome to reduce the remaining distortion any further. Indeed it may not be possible at all without going to such extremes as changing plate and cathode resistors, etc. In any case, the audible difference, even with a speaker load, is going to be insignificant and perhaps indiscernible. Furthermore, unless you're a real high-fidelity expert, there is always the danger that you may make matters worse.

But let us assume that you found more distortion than this, or that in any case, you want to reduce it. The most effective procedure you can follow will be determined by the amount of low-level distortion you found. If it was less than 10%, your best bet will be to continue with the intermodulation analyzer. In most cases you will find that a scope gives no significant information when the intermodulation is less than 10 or 12%. Intermodulation distortion does not, of course, show up on sine waves; and amplitude or harmonic distortion does not show up clearly until it exceeds 3%, which usually means an intermodulation of 10 or 12%. So when the analyzer shows less than that amount, it is by far the most sensitive and effective diagnostic tool. It is this ability of intermodulation analysis to reveal clearly distortion which other methods do not indicate at all, that makes it so valuable a tool for high fidelity.

It may help, if the intermodulation is less than 5%, to exaggerate the distortion. This can be done by adjusting the analyzer to deliver a mixed signal in a 10:1 ratio instead of the normal 4:1. In most cases this will at least double the indicated distortion.

Checking the feedback loop

Having determined that the tubes are not the principal cause of the trouble and having obtained the best balance possible, the next step is to disconnect the feedback loop temporarily and take another intermodulation measurement. The distortion should increase by a factor of from 2 to 10 when the loop is disconnected.

You must, of course, reduce signal input to bring the output back down to the same level. If distortion does not increase markedly, check how much the input had to be turned back to get the same output. If the change in gain is about the same as the change in distortion, there is something wrong with the feedback, and this needs further attention; maybe there is lost gain somewhere, or the resistor values have changed in the feedback path. But if the gain reduction is normal, and the distortion reduction is not, look for overload conditions in the amplifier which get worse when the feedback is connected. This must be checked by connecting the analyzer to points, stage by stage through the amplifier, and removing and reconnecting the feedback at each stage. This will reveal some point at which the operating conditions are wrong. These can then be diagnosed and corrected.

The presence of a capacitor in the loop usually means that the

loop starts at a point (such as the plate of a tube) where d.c. voltages are present. Therefore, check the capacitor for leakage, likely to increase with age or overheating. Even a little d.c. leakage may throw the stage to which feedback is applied into the curved portion of its operating range. The feedback resistor can be checked with an ohmmeter. A difference from specified or marked value of $\pm 20\%$ will not be significant ordinarily; but a wider difference, especially on the low side, might well be, and in that case replace the resistor with one as close as possible to the exact specified value.

If the feedback loop checks out, the next step is to see if it produces instability. Measure the current of the output tubes with and without the feedback loop; if the current rises significantly when the loop is connected, you have either outright or parasitic oscillation. First, check the parasitic suppressors. These are resistors of between 30 and 1,000 ohms in series with the grids or plates, or both. (Usually, too, when a tetrode is used as a triode, there is a resistor of between 100 and 1,000 ohms between the screen and plate.) Test all of these for opens or shorts, since moderate departures from specified values do not usually matter. (A scope will quickly show oscillation.)

Decoupling networks

The next step is to check the decoupling networks. These consist of one or more resistors in series with the plates and the supply voltage, bypassed by paper or electrolytic capacitors on one or both sides. This is also part of the hum-filtering network. Leakage may produce distortion by lowering the voltage, yet it does not harm the decoupling; so an open condition is what you want to look for. The simplest check is to take an electrolytic capacitor of around 20 to 40 μf (the larger the better) with a 400-volt rating and place it in parallel with each of the filter or decoupling capacitors in turn. If this causes the plate current to drop to normal, replace the faulty capacitor with one of the same capacitance.

However, if this still hasn't solved the problem and the output tubes are triodes or, as in the Williamson type amplifier, tetrodes used as triodes, it will almost certainly do no harm to neutralize the output tubes. You are quite unlikely to make matters worse and may very well clear up the instability.

If this does not help, try the several other measures suggested in the previous chapter. In an extremity it may be necessary to

reduce feedback by using a larger feedback resistor. In any case, when you are confident you have removed the instability, it is very wise to check the transient stability. The loop may now be stable at static levels but may be driven into momentary parasitic bursts or heavy ringing by violent excitation. The best test requires a scope and a square-wave signal from 10-to 30-kc. Connect the scope to the output of the amplifier loaded with a resistor and the signal generator to the input. Feed in a 10- or 20-kc square wave at a level well below maximum. You may get shapes of the type anywhere in the range of those illustrated in Fig. 602.

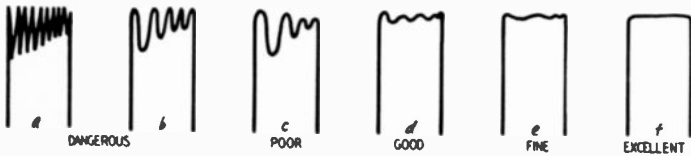

Fig. 602-a to f. Ringing is indicated by a damped wave superimposed on the d.c. level of a square wave.

If the ringing is similar to that of the first three traces, the loop does not have sufficient margin. You can try reducing the ringing by adjusting capacitance across the feedback resistor or across the resistor to which feedback is applied as suggested in the last chapter. Observe the top of the square wave and choose a capacitor which reduces the ringing to a tolerable level.

If the square-wave shape resembles the next two traces, the loop is all right but it would be well to check it with a reactive load. It should be stable with either kind of reactance. Try substituting capacitors in the range of .001 μf to 0.1 μf across the amplifier output, in place of the resistance load. A loudspeaker usually provides an inductive load at these frequencies. Try either a loudspeaker known to be fairly inductive at high frequencies, or make a dummy load. If you can find a cheap, or old line transformer, designed for matching something to 600 ohms, this winding will have a resistance in the region of 15 ohms, and when the other winding is shorted, the leakage inductance will simulate the inductance of a voice coil, as in Fig. 603. The waveforms should not be worse than Fig. 602-c with either loading.

Low-frequency stability is best tested with a step transient and a triggered or very slow sweep. The very useful device that is used to check damping of speakers makes an excellent step-transient source. The more stable the amplifier, the flatter the tail of the trace. Fig. 604 shows some typical traces. Any trace

better than trace b will probably insure complete stability.

Suppose the loop is stable but the intermodulation remains high. Continue, with the loop disconnected, to make a stage-by-stage analysis with the intermodulation analyzer. If you equip the leads to the analyzer portion of the unit with insulated alliga-

Fig. 603. An inductive dummy load can be made by using an old transformer and shorting the secondary winding.



tor clips, you can measure the intermodulation in each stage and thus isolate the one in which the trouble is occurring. The analyzer does not permit balanced measurement of push-pull stages; you have to measure the intermodulation on each side of a push-pull stage by moving the hot lead from one grid, or plate, to the other. Keep in mind that measuring one side of a push-pull stage will give you a higher intermodulation reading than actually exists from side to side, because cancellation due to push-pull operation is not indicated. This, however, is all to the good, since the distortion is magnified and therefore easier to follow and locate.

You should find a point at which the distortion falls very markedly if you trace from output to input, or rises markedly if you trace from input to output. You will also get an excellent indication of unbalance since such a stage will probably give you a higher reading on one side than the other.



Fig. 604-a, -b, -c. The flatter the trace, the better the low-frequency stability.

Having found this stage, check the voltages, etc., as outlined in a previous chapter and make the corrections indicated. It is difficult to set standards for intermodulation distortion in individual stages. Modern amplifiers with 20 db or more of feedback can tolerate considerable distortion in individual stages at or near maximum output. However, an intermodulation of 5% for a single-ended stage will usually be reduced by feedback to less than 1% and intermodulation of 10 or even 15% per side in push-pull stages will be reduced by cancellation to 2 or 3%, so that such values are tolerable. When you have reduced the distortion in the guilty stage to this or lower values, take another overall reading with the loop connected. Unless there is

additional trouble, you should now get an acceptable intermodulation level, and the residue can usually be lowered further by careful rebalancing.

This is a very useful method for diagnosis of today's first-class equipment when the distortion is low but still above specifications. It will continue to give very sharp indications of trouble long after all other methods have indicated that the equipment

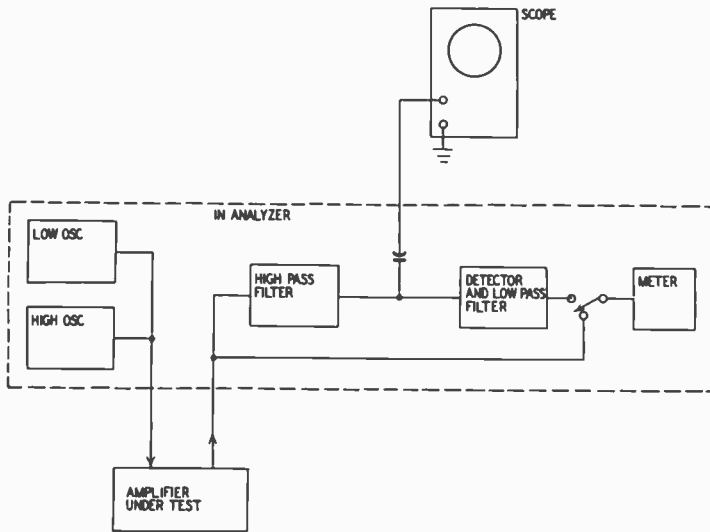

Fig. 605. A scope can be connected to an intermodulation analyzer for visual inspection of intermodulation distortion.

is as clean as a pure sine wave. It has a couple of faults, however. First, it is a static method. That is to say, you cannot get a continuous reading of the variation in intermodulation; the readings are only for a given operating condition. Second, although the indications of distortion are extremely sensitive, they give no clue as to its cause.

Alternate method

There is a modification which corrects both faults, although it does this at the expense of some sensitivity. We recommend it highly, nevertheless, for it makes diagnosis extremely rapid. This method requires a scope in addition to the intermodulation analyzer. Also, it is necessary to get into the analyzer and provide an output terminal at the point where the signal enters the high-pass filter. This is very easily accomplished by adding a

binding post and connecting it through a .001 μf mica or ceramic capacitor to the input end of the lowpass filter in the analyzer. The technique for doing this is illustrated in Fig. 605.

The intermodulation analyzer feeds the amplifier under test as usual and the output of the amplifier goes to the analyzer input. The vertical channel of the scope goes to the new binding post

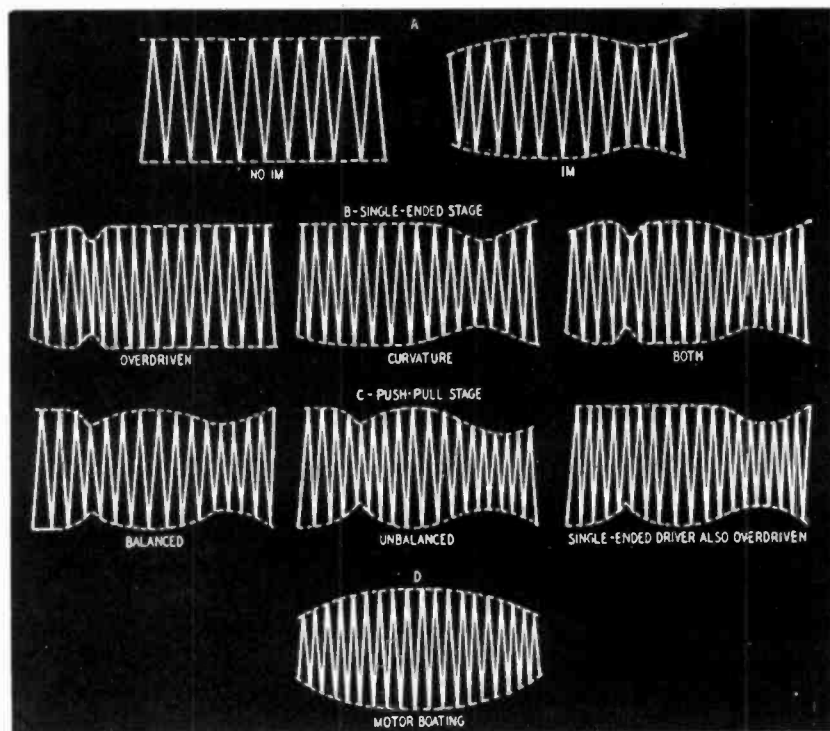

Fig. 606. Waveform technique for measuring and analyzing intermodulation distortion. This method requires the use of an intermodulation analyzer and a scope. A proper understanding of the waveforms will reveal the cause or causes of the distortion. Absence of intermodulation distortion is indicated by a wave of uniform amplitude.

and ground of the analyzer. The sweep is adjusted for 60 cycles (or if your analyzer has another low frequency, for that frequency). This will produce a pattern such as indicated in Fig. 606-a. If there is no intermodulation present, the top and bottom of the trace will be flat. If there is any intermodulation, the high frequency will be modulated by the low frequency and both the top and bottom will acquire some sort of curve or notches. The depth of the notches is proportional to the intermodulation;

the number of them is proportional to the aberrations causing the intermodulation.¹

The exact amount is not too important for servicing. What is significant is that the notches yield important clues to the causes of distortion. Most of the important ones are indicated in Fig. 606.

If the intermodulation occurs in a single-ended stage, the pattern will have two or four notches, counting both those on the top and bottom of the trace. Overdrive or underbias is indicated by sharp, rather narrow notches on one end; distortion due to curvature or overbias is indicated by wider, smoother notches on the other end. Which end the respective notches will occur on depends on the number of stages in the amplifier and the characteristics of the scope. In most cases the overdrive notch will occur on the left. However, this is not too important, since the two types can be distinguished, if the scope trace is sharp and large enough, by the difference in the notch shape.

If the single-ended stage is so badly overdriven that the positive peak is clipped and the negative peak rounded by curvature, four notches will appear—two on top and two on the bottom. If these four appear simultaneously or in quick succession as the signal input is increased, the stage is operating very close to the center of its curve. When there is something wrong, however, one form will appear long before the other. If the sharp overdrive notches appear first, the trouble is underbias; if the more gentle curvature notches appear first, the trouble is overbias. Some sort of notches will appear with any amplifier, even one in perfect shape, at or near maximum output. It is when they occur below maximum output that trouble is indicated.

When the intermodulation is produced in a push-pull stage, four notches are normal. If the stage is well balanced, the notches top and bottom will appear simultaneously or in rapid succession as the input signal is increased. If the stage is unbalanced, the notches will appear first on one side and then the other; the degree of unbalance is indicated by the difference in depth between the notches on the top and those on the bottom. Here, too, the notches on one end are due to overdrive and the notches on the other to curvature. Since, in well-balanced push-pull stages, one half of the circuit will be driven into positive

¹ LeBel, "New Method of Measuring and Analyzing Intermodulation," *Audio Engineering*; July, 1951.

bias and the other half into cutoff at about the same point, four notches of equal depth, top and bottom, indicate normal operation. An examination of the trace, as the input signal is varied around the point at which the notches being to show up, will indicate the trouble.

If the distorting push-pull stage is driven by a single-ended stage which is also overdriven, one of the notches will be reduced or completely eliminated. When this happens at a point much below maximum rated output, it is a good sign of trouble in the power supply, since such simultaneous overdrive is almost always produced by unduly low plate voltages.

Finally, parasitic oscillation or regeneration, especially motor-boating at frequencies below 40 cycles, is evidenced by bumps and bulges instead of notches. Low-frequency parasitics will produce a rounding off of the whole pattern which will also grow vertically; high-frequency parasitics will put a lot of small bumps or spikes on the pattern.

You will note that most of the causes of distortion are indicated by the patterns of Fig. 606. The significant thing is the point in the dynamic range of the equipment at which they appear. Therefore, a wattmeter makes this method extremely reliable. Any amplifier can be overdriven, but this should not occur until near the maximum rated power output. If an overdrive notch occurs at half rated-power output or less, it is clearly a definite indication of underbias.

This method is not as sensitive an indicator of distortion as the intermodulation analyzer with the meter. Theoretically, if the trace were large enough, very low values of intermodulation would be indicated. In practice, however, it is extremely difficult to synchronize a trace with low distortion if (as in most analyzers) the high frequency is more than 20 times that of the low frequency. Moreover, 2, 3 or 4% intermodulation will produce notch depths which are sometimes no deeper than the thickness of the scope trace; hence, unless very high accelerating potentials are used in the scope, the low percentages are obscured.

This is not critical for servicing for the signal input to the amplifier can usually be increased until the distortion is visible. The fine feature of this method is that it does give definite clues as to the cause of the trouble in that the intermodulation is indicated dynamically and can be observed to change as signal input is varied or as circuit adjustments are made. If this procedure is used with the same sequence setup described earlier for

the intermodulation analyzer alone, diagnosis will be much more rapid.

It will take some experience to get accustomed to it. Excellent training can be obtained by equipping a simple amplifier with variable resistors in the cathode and plate circuits. As these are varied, the variations in notches which follow overbiasing, underbiasing, too low a plate load, unbalance, etc., can be observed, and the effect of making corrections noted.

high-level distortion

The testing routine using the intermodulation analyzer with or without a scope, as discussed in the previous chapter, is by far the most effective when the intermodulation is below 10 or 12%. But when the intermodulation distortion is above this, harmonic distortion usually exceeds 3%. In this case, using an audio generator and a scope to give a phase-shift pattern

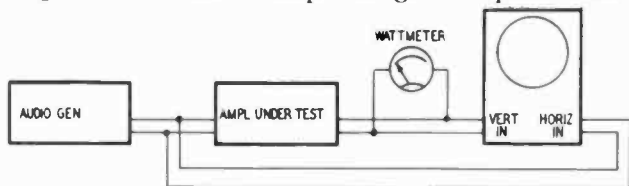

Fig. 701. Setup for making a check of high-level distortion. A resistor having the proper wattage rating can be substituted for the wattmeter. A v.t.v.m. can then be shunted across the output resistor, and the output power calculated. A wattmeter (if available) is much more convenient.

analysis is faster and yields more information. This method has been described many times, but seldom from the point of view of the service technician—that is, with the purpose of pointing out how it may be used most effectively to diagnose trouble.

The layout for this type of testing is shown in Fig. 701. The amplifier is loaded by the internal load of a wattmeter or, if no wattmeter is available, by an appropriate load resistance. The wattmeter is most helpful as an indicator of the output level at which distortion begins.

The intermodulation analyzer should be handy for making intermodulation runs, since it is still the best measure of real

high-fidelity performance. All that is necessary to make an intermodulation run is to substitute the signal from the analyzer for that coming from the audio generator and to shift amplifier output from scope to the analyzer portion of the instrument. For this purpose the shop specializing in hi-fi servicing might very well construct a junction and switch box (Fig. 702). Thus the instruments could be connected to the junction box more or less permanently. All that would be necessary to make a test would be to run three wires from the amplifier under test—a common

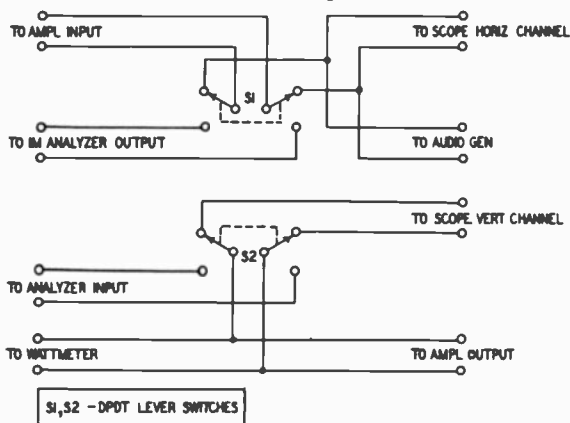

Fig. 702. The use of a junction and switch box facilitates testing. Switching arrangement is illustrated above.

ground, a hot input and a hot output. The double-throw switch would automatically change the setup from scope to intermodulation analysis.

The test procedure is simple once it has been tried a few times. We will assume your scope has a square on the ruled grid. If not, ink one on or make a new one of thin plastic to slip over the present one. Such a reticule is of great assistance in interpreting the pattern and diagnosing causes of changes in it.

Phase-shift patterns

Set the audio generator for around 1,000 cycles. Adjust the generator output, the amplifier gain, the scope gain and positioning until you obtain a straight line running diagonally from corner to corner of the square as in Fig. 703. If you do not get a straight line but some sort of oval or ellipse, shift the generator frequency until you find a point at which a line is formed. It will take some experimenting to learn how the various controls

are manipulated to obtain this diagonal line. It will help if you remember that increasing the vertical amplitude or gain of the scope or the volume control of the amplifier will tilt the line upward, while increasing horizontal gain will tilt it downward. Concentrate at first on obtaining a line of any length which tilts the necessary 45° . When you have this, position it in the center of the square. Now an increase or decrease of generator output will either stretch the line or contract it so that it goes from corner to corner of the square without changing the tilt.

Fig. 703. Scope patterns indicate phase relationship between generator and audio-amplifier output. Straight line indicates zero or 180-degree shift.



The straight line indicates that the voltage applied to the horizontal plates of the scope is exactly equal to that applied to the vertical plates and that there is zero (or 180°) phase shift between generator output and amplifier output. Any change in the output of the generator, the gain of the amplifier, and any shift in phase, will be indicated by a change in the pattern.

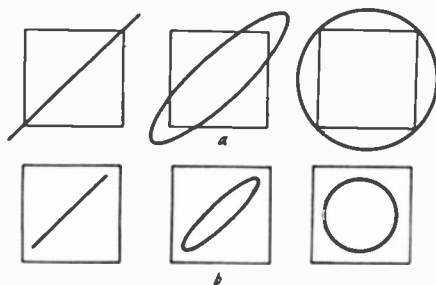

Fig. 704-a, -b. Scope patterns resulting from changing generator output with amplifier gain constant, but varying in phase.

Changes in output or gain will change the size of the pattern; changes in phase will change the form or shape and possibly the size too. Moreover, you can tell at a glance whether the change is caused by amplifier, generator or both, for the pattern reflects any changes, in either or both.

The foregoing statement assumes that both the scope amplifiers are flat and without phase shift. If you have any cause to doubt this, make a check. Connect the generator to both horizontal and vertical inputs of the scope, and set the input controls to various positions that produce an angle of 45° . At each setting, run the

generator frequency up and down, making sure that the line remains at 45° and does not open out into an ellipse. If the latter happens, note the frequency at which it begins to occur, because this is the useful limit of the scope's range for this kind of testing.

For example, let us suppose the amplifier is flat but the generator is not. If generator output increases or decreases, the pattern will enlarge or contract in both directions. If generator output increases, the straight line will expand beyond the square; if lowered, it will contract inside the square. If, instead of a line, there is an ellipse or circle, these too will either expand beyond the square or contract within it. Ordinarily a change in genera-

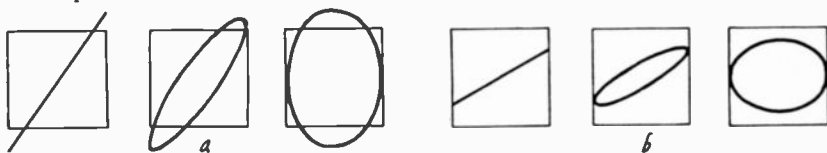

Fig. 705-a, -b. Changes in amplifier or generator gain or phase can produce these forms.

tor output will not produce a change in the forms of the pattern. These changes are detailed in Fig. 704-a-b.

If the generator output is constant, but the amplifier gain varies, the pattern may shift in form because of phase difference, and will enlarge or contract in the vertical direction. As long as the generator output is constant, the extremes of the pattern will continue to touch the sides of the square; but, if amplifier gain varies, they will no longer touch the top and bottom. These effects are shown in Fig. 705-a-b. You may have a shift both in size and form. If amplifier gain is constant, but there is a phase shift within it, the size of the pattern will be the same, but the line will turn into an ellipse or vice versa. On the other hand, you may have both a change in phase and a change in gain; in that case the form will change and the pattern will enlarge or contract vertically. The important thing to keep in mind is that whatever the change in the pattern, if it continues to contact the two sides, the change is due entirely to a shift in amplifier characteristics.

There may be a combination of effects. The generator output may change and the amplifier gain may simultaneously increase or decrease. The change in the trace will depend on the net effect and can be analyzed by examining the relation of the trace to the sides of the square. Thus, if the generator output decreases but

amplifier gain increases to a greater extent, the pattern will no longer touch the sides of the square and will pass through the top and bottom. Conversely, if generator gain increases but amplifier gain falls off to a lesser extent, the pattern will pass through the sides of the square but will no longer touch top and bottom.

There is no necessity for monitoring the output of the generator or the amplifier, since the scope simultaneously monitors both. The drawings in Fig. 706 show the effects of changes in generator output and amplifier gain occurring simultaneously.

Distortion indications

Almost all forms of distortion which occur in amplifiers are indicated on the phase-angle patterns. For instance, clipping due

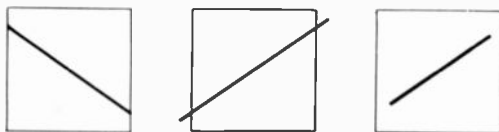

Fig. 706. These waveforms are produced by a simultaneous increase in generator and amplifier gain.

to underbiasing or overdriving will be indicated by a very sharp bend of the line toward the outside of the square and an extension of the line parallel to the top or bottom as the overdriving becomes more severe. If you will recall what has already been said about the behavior of this setup, you can understand this readily. Clipping means that the amplifier is saturated; its gain stops and a further input of signal produces no further increase in output. Therefore, the signal delivered to the vertical plates of the scope does not increase. On the other hand (assuming that we control gain and produce the distortion by increasing generator output) the input to the horizontal plates continues to increase. As a result the line pattern stops growing upward but continues to grow sideward. Because the relation between the two forces has changed, the angle of the line at its end changes, and this accounts for the sudden bend in the line pattern.

At any rate, clipping due to either overdriving or underbias produces a *very severe and sharp bend* as indicated in Fig. 707. If the clipping occurs only on the positive or the negative peak, the bend will show on one end of the line only. If it occurs on both positive and negative peaks, you have a similar bend on

Fig. 707. The illustrations at the left show clipping due to grid current or some similar action. For example, if the tube has insufficient bias, the operating point on the tube characteristic will move up toward the tube's saturation region. This will reduce the useful portion of the linear characteristic. A strong signal will also result in clipping.

Fig. 708. These illustrations (lower left on this page) indicate curvature due to the tube characteristic.

Fig. 709. These waveforms, illustrated at the top half of page 111, are forms of in-phase distortion.

Fig. 710-a, b. The first group of waveforms (a) shows transformer magnetizing distortion, while the bottom group (b) illustrates high-frequency parasitics in a power output stage.

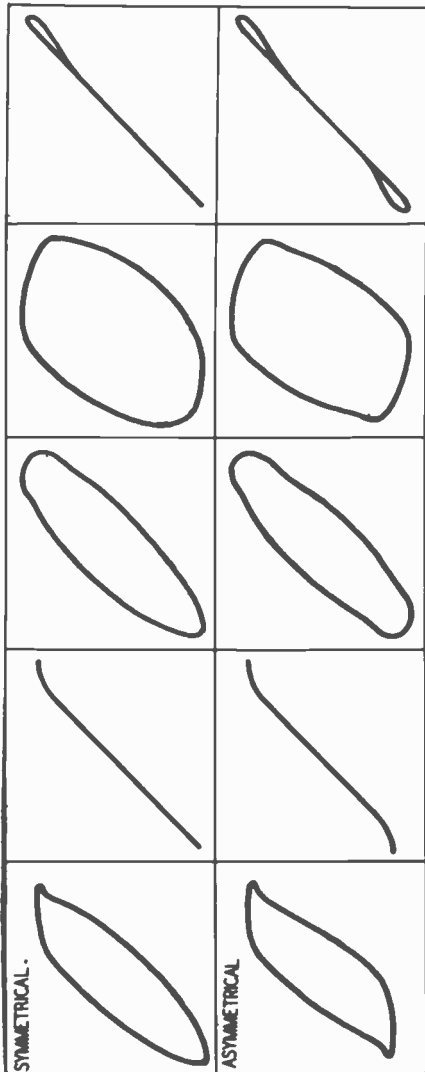
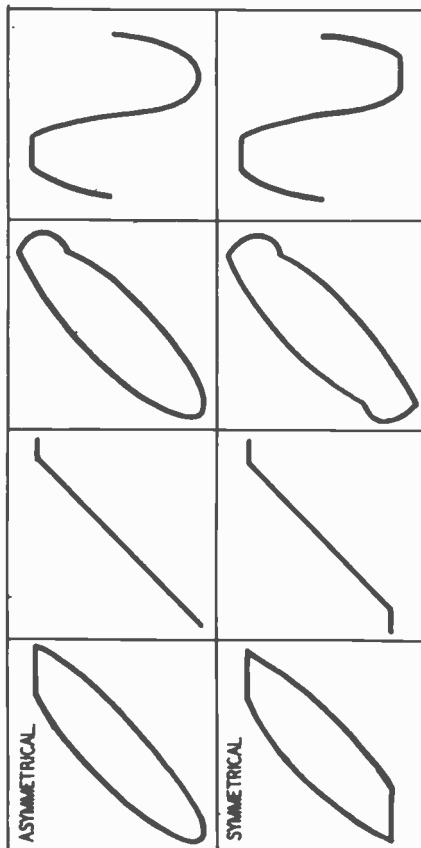

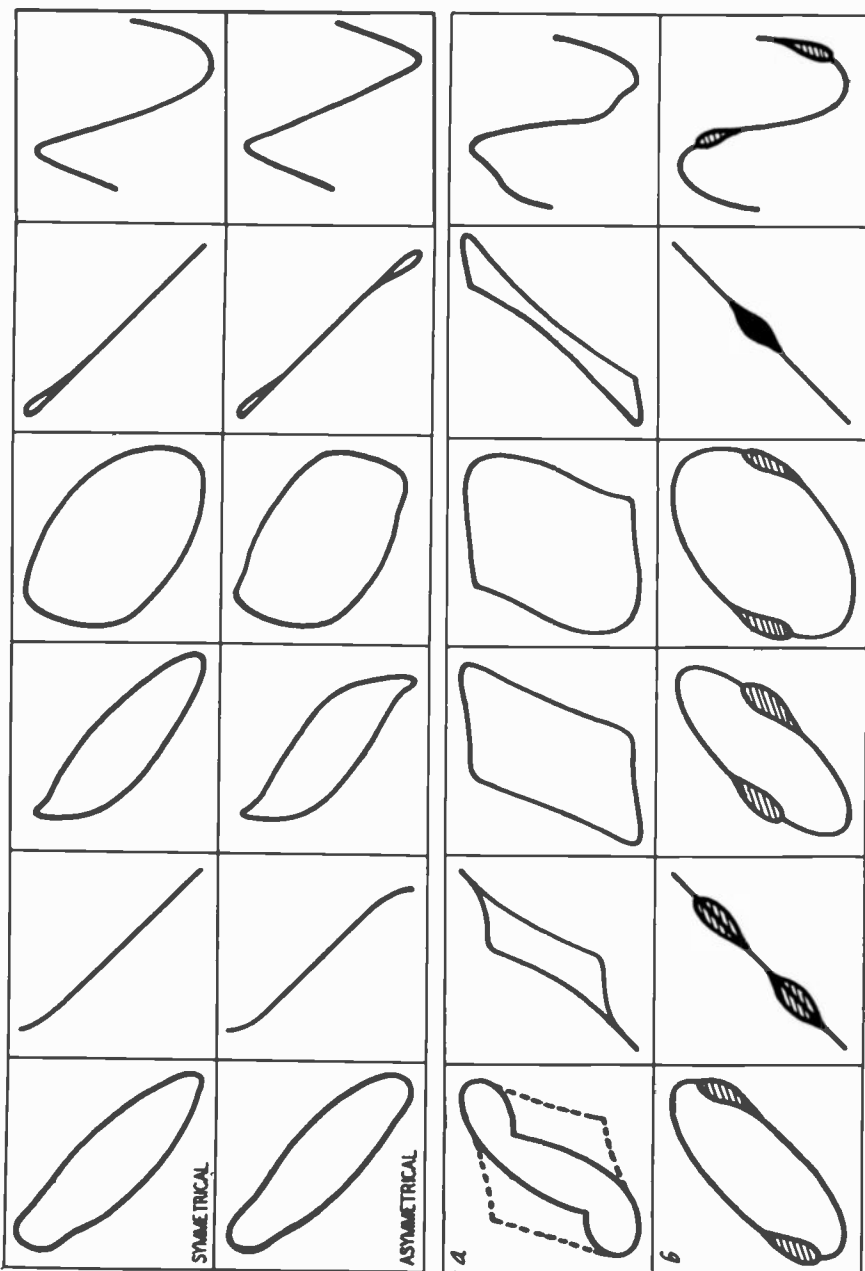

both ends. A single bend may result from overdriving a single-ended amplifier such as a preamp or it might be the result of overdriving one side of an unbalanced push-pull stage. Symmetrical bending occurs only in push-pull stages. If the two bends appear at about the same signal input level, the stage is well balanced; but if one bend appears long before the other, the stage is unbalanced.

How can you tell whether the distortion is due to overdriving or underbiasing? Very easily. In a well-designed amplifier, overdriving occurs only near maximum output. Watch the wattmeter as you force the bend to appear by increasing generator output. If the bend starts reasonably close to maximum rated output, it is caused by overdriving; but if it occurs considerably below maximum rated output, it is due to an underbias condition caused by some shifting of the operating characteristics of one or more stages. Be sure to consider line voltage. If it should be unusually low, the bend will appear considerably below rated output even in a perfect amplifier; while if the line voltage is much higher it might appear around rated output in a bad amplifier. Often, excess distortion is due to nothing more serious than low line voltage.

The effect of overbiasing or operation on the bend of a tube's characteristic curve is indicated in Fig. 708 for the various shapes. The bend due to clipping is a very sharp one; the bend due to curvature is much more gentle, really a curve rather than a bend.

When the pattern is an ellipse or circle, curvature merely flattens the ends, whereas clipping turns them into straight lines. The crimp in the outside edge is more gentle and more kidney-shaped. When in doubt, however, you can always turn the scope to the internal sweep position, synchronize and look at the sine wave. Clipping squares the top severely—in extreme cases makes a square wave out of the sine wave—while curvature merely spreads the peak, producing a wider bend.

The bend due to curvature may also be symmetrical or single-ended. Here, too, the single-ended one can be due to a single-ended stage or to an unbalanced push-pull stage, and the unbalance can be determined by the difference in the appearance of the two bends.

It is possible to have clipping on one end and curvature on the other end. This would appear when the operating point of a stage is very close to the middle of its operating curve. The positive peaks would be clipped when the grid turns positive, and

the negative peaks would be curved when the tube gets close to cutoff. Although, theoretically, this should occur often, in practice it seldom does, since few operating curves are that symmetrical. This form can also occur in a poorly balanced push-pull stage, especially one with a balancing control. In this case one half can be overbiased and the other underbiased.

In high-fidelity amplifiers in which most or all stages operate class A and not beyond AB1, clipping is likely to occur earlier than curvature. This happens since in a class-A stage the quiescent operating point is usually nearer the zero bias than the cutoff point. If a curvature bend occurs before a clipping bend, an abnormal overbias condition is indicated.

In-phase distortion

The common forms of distortion are out of phase with the original signal, but there are some forms of distortion which are in phase. These are indicated by a bend toward the *inside* of the square as shown in Fig. 709. The shape of the bend is similar to that of curvature, but the direction is opposite. The figure will often expand vertically a little, but this is not usually very noticeable. The single-ended type of in-phase distortion is sometimes found in amplifiers like the Williamson, which use the split-load or cathodyne inverter. This happens if the output tube or amplifier driven by the cathode is overdriven hard enough to draw grid current. When this happens, the cathode of the inverter is partially shorted. The result is that the plate-side gain increases to more than 1. This is easily spotted because shifting to the sine-wave pattern will show that the sine wave is sharpened, instead of being flattened or squared.

Fig. 710-a indicates the changes in the pattern caused by transformer core saturation or magnetization. It will occur with almost any amplifier at half-power output (or more) below 40 cycles. If it happens below the half-power point, it could be due to unbalance in the output tubes since this would cause the uncanceled d.c. in the primary to increase and thus produce earlier saturation and magnetization. It is easily distinguished from all others by the extreme squaring off of two sides of the pattern. When the effect is really bad, you may get two parallel straight lines joined by curves or loops.

In Fig. 710-b we have the effect of parasitics. Very aptly the pattern acquires riders similar to those produced on an i.f. alignment curve by a marker generator.

Analyzing the amplifier

1. Set the generator at around 1,000 cycles and establish the reference line from corner to corner of the square.

2. Make a quick sweep of the whole audio spectrum at a low input and output level. Do this with the tone controls in their flat position. Observe the behavior of the trace. In today's good hi-fi amplifiers the phase shift from 1,000 cycles downward and upward will be small—usually the pattern will not pass beyond a narrow ellipse up to 10,000 and down to 50 cycles. Beyond those points the ellipse may expand into a circle, which indicates a phase shift of 90° .

You might think that since an amplifier is said to be flat within this range, the line ought to remain straight and not open into an ellipse. But you can also have a constant and gradual phase shift from one end of the range to the other without a significant change in gain or flatness. If the phase shift does not go beyond a circle at the two extremes, the situation is all right. But if it does and approaches a straight line inclined in the other direction, which would be a phase shift of 180° , there is serious danger of instability, motorboating, ringing and a poor transient response.

3. Check what maximum output can be obtained at 20 cycles and 20,000 cycles. Scope attenuator settings will probably need changing for this.

4. Determine how bad the distortion is. Return the generator to around 1,000 cycles and, remembering to change the attenuator settings, increase the generator output and amplifier gain, if necessary, until you obtain evidence of some kind of distortion. Determine by watching the wattmeter, or by interpreting the output voltage as read on a voltmeter, at what point in the dynamic range the distortion occurs. If it occurs only at or near maximum output, the amplifier is in pretty good shape, and balancing and a change of tubes ought to bring it around to good condition. But if it occurs at a lower output level, something is seriously wrong.

5. Analyze the type of distortion from the illustrations and descriptions given. If necessary to make sure of the type, shift the horizontal channel of the scope to internal sweep and examine the sine wave. Note whether the distortion is an overdrive or curvature type, single-ended or symmetrical.

For instance, suppose you get a sharp, overdrive type bend at half rated output. This would indicate a single-ended stage being overdriven because it is underbiased. To check, increase the

generator output to see if you can produce another bend in the other end. If you do not get it up to or near maximum output, you're pretty safe in deciding it is in fact a single-ended stage that's causing trouble.

But suppose that by driving the amplifier a little harder you get another similar bend on the other end. You know now it cannot be single-ended because a single-ended stage won't clip both positive and negative peaks. So the indications are that it is an underbiased and unbalanced push-pull stage. You can judge the amount of unbalance by noting how much additional input voltage is necessary to produce the second bend.

What if driving harder produces a curvature bend on the other end? A little reflection will show you that two things could account for this: First, it could happen with a single-ended stage—the overdrive type of bend being produced when the positive peak is clipped and the curvature type being produced when the negative peak reaches the knee of the curve. You can judge how far the quiescent point is from the center of the operating curve by noting how much difference in input voltage is necessary to produce the second bend.

The appearance of a trace with an overdrive bend on one end and a curvature bend in the other could occur in a push-pull stage which has a balancing potentiometer across both cathodes. A misadjustment of such a potentiometer would underbias one side, overbias the other and produce the asymmetrical double-ended bend. A push-pull stage in which the two tubes have separate bias resistors also could produce this effect if one tube draws much more current either because the bias resistor is too low, the tube itself is abnormal, or the plate load has changed or has been partially shorted. Since it is almost impossible that a single amplifier would have all three types of amplifier stages, a look at the circuit diagram should make it possible to put the finger on the most likely cause.

If the output stage has a balancing potentiometer, you can check that possibility by adjusting it. If the distortion is really produced in that stage, changing the balancing adjustment will change the pattern, removing one or both bends or transposing them. Even if the potentiometer doesn't affect the bends, you can adjust balance, which will be indicated by making the line straight again, by putting similar bends on both ends, or by a point at which the line or pattern is narrowest and least deformed. The last situation is almost conclusive proof that a single-ended stage

is involved. In this case a point will be found in varying the balance control at which the pattern will open and close. The bend will remain; but as you move the potentiometer slightly on each side, the pattern will tend to open. The proper setting is at the point where the pattern is most completely closed. If you observe the wattmeter, you will see that this point also produces maximum output with a given input signal—another indication of good balance.

6. Now that you have some idea of the trouble and its seriousness and location, you can open the amplifier and examine the stage which is the most likely offender. If your scope permits push-pull input, so much the better. If not, you will have to look first at one side and then at the other; and you'll want to do this in any case when the push-pull stage is the offending one, since the trouble usually is in one side only.

7. When you have definitely isolated the stage, you can proceed with ohmmeter and v.t.v.m. to determine the exact trouble.

8. Having reduced the distortion in the offending stage so that it no longer occurs or is present only at or beyond maximum rated output, it would be wise to take an intermodulation reading to see if there are any other smaller troubles. If not, balance the amplifier, with the scope trace if you like. If you do balance with the trace, take intermodulation readings both at maximum output and a low output. Sometimes balancing at maximum output like this will unbalance the stage at lower levels. In that case, re-balance the stage for low levels. This is important because the distortion is more objectionable there.

9. Make another frequency run at low levels and then one at or just below maximum output. In the first instance watch to see that the response is flat and the phase shift small; in the latter see if the distortion remains fairly constant as the frequency is varied.

10. If the amplifier has tone controls, you can set them for the flattest response. Set the generator at 50-60 cycles and boost or attenuate with the bass control to produce the straightest line or narrowest oval; do the same with the treble at 10,000 cycles.

11. If your audio generator permits a square-wave output, it won't take more than a couple of minutes to check the response to square waves at 20, 60, 1,000, 10,000 and 20,000 cycles. This will give you a good idea of the amplifier curve below and above audibility. If the waveform is fairly good at 60, 5,000 or 10,000 cycles (with not over 50% slope at 50 cycles and neither too much ringing nor too much rounding off at 10,000 cycles), the unit is flat enough for hi-fi use.

bass and treble faults

Although distortion in some form or other covers most of the troubles to which hi-fi systems are subject, there are many faults which are evidenced by unsatisfactory frequency response or a poor balance between the various portions of the frequency range. The midrange between 200 and 2,000 cycles is seldom affected by system faults, but the two extremes on the bass and treble ends are very easily modified by even slight departures from proper operation. The bass end is most frequently involved and the complaint is too much or too little bass. Since the causes of excessive bass are simpler to deal with, let us dispose of them first.

Overboost

The most obvious cause of excessive bass is an overboost somewhere in the chain of equalizers or tone controls. First check the phono equalizer to see that the proper equalizer is used for a given record. Most records are made to the RIAA (Record Industry Association of America) curve, since 1954. The NARTB (National Association of Radio and Television Broadcasters), the new AES (Audio Engineering Society) and the ORTHO (RCA new orthophonic) all closely follow or are identical with this curve. The old LP curve (before standardization) was also close to this at the bass end. But the old AES and the CCIR (International Radio Consultative Committee) 1953 standard gives about 6 db more boost at 20 cycles than the others. Some systems use the latter curve for all purposes, and hence will, technically, give too much

extreme low frequency response on most American recordings. Generally this is good, because the difference does not show up until below about 60 cycles, and most speakers — even the best — can do with a little boost down there. But occasionally it may be desirable to correct this because the room happens to accentuate these frequencies. In any event, the cure is simple. The bass is attenuated slightly with the bass tone control when RIAA and I.P records are played. A permanent cure can be achieved by correcting the equalizer through the addition of a resistor in parallel with the capacitor which determines the turnover point. In most cases, a suitable correction is achieved if the new resistor and the turnover capacitance have a time constant of about .0025. Thus, if the turnover capacitor has a value of .0015 μf , a resistor in the range between 1.5 and 1.8 megohms will level off the boost somewhere between 60 and 100 cycles. The lower the resistance and the higher the frequency at which bass boost levels out, the greater the reduction in bass boost. The higher the resistor, the lower the reduction in boost, and the lower the frequency at which the boost levels out. See Fig. 801.

The most likely cause of excess boost is a misuse of the loudness control. Loudness controls provide very steep boosts — in some cases about 25 to 30 db. If misadjusted, the boost may be far greater than needed to compensate the Fletcher-Munson curve. In most cases the loudness control can either be completely cut out or adjusted in connection with a volume, gain, level or contour selector control to provide only the boost necessary at a given volume level to satisfy the ear. To adjust the loudness control proceed as follows:

1. Cut out the loudness control completely if it has a switch or turn it full on to the position which gives maximum volume. In this position a loudness control provides almost no boost of either treble or bass.

2. With a separate volume or gain control, or the contour selector, adjust the volume to produce the loudest level the customer is likely to employ in the room—in any case a very loud level. This level should provide a satisfactory balance of bass and treble. If it does not, boost or reduce the bass or treble with the tone controls until you achieve a balance satisfactory to the customer. The system is now “flat to the ear” at loud levels.

3. Leaving all the other controls as they are, turn the loudness control to a position which represents the normal listening level for the customer. The balance of bass and treble should still be

satisfying. If it isn't, you can make some readjustments with the tone controls or the contour selector to produce a satisfying balance. The balance should now be pretty good as the loudness control is turned to produce louder or softer levels.

4. Finally, mark the positions of the level, contour and tone controls. If the panel has no calibrations, it can be marked lightly with a pencil. If the customer will henceforth take care to see that these controls are placed in these marked positions, the loudness control will operate without producing excessive bass. Where the complaint is excessive bass, instruct your customer especially

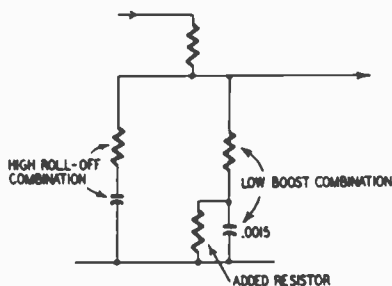

Fig. 801. A resistor can be added, as shown, to control bass boost.

to keep the loudness control on the loud side and the volume control on the quiet side.

Speaker resonance

Another very likely cause of excessive bass is resonance of the speaker or the speaker and enclosure. Most speakers have a resonant peak somewhere between 30 and 100 cycles. Many enclosures of the enclosed infinite baffle, bass-reflex or Helmholtz resonator types also have a resonant point. In properly matched speaker systems these resonances are carefully manipulated and controlled to complement each other and to extend the range of the speaker downward. Fig. 802 shows at a the curve of a speaker alone and at b the curve of the same speaker in a bass-reflex enclosure properly designed and adjusted for that speaker. You will see that the peak of the speaker has been greatly reduced and that another peak has appeared about an octave lower in frequency; whereas the peak of the speaker alone is some 14 db above the level of the rest of the spectrum. In the combination the peak has been reduced to only about 6 db, which in the case of loudspeakers represents a pretty good degree of flatness.

It is obvious that if the speaker system had the curve a, it could very well produce an overwhelming one-note bass. Indeed, the thumping bass of some jukeboxes is produced precisely by manipulating speaker and enclosure to produce such a peak. This situation is not at all likely to exist if the speaker system, enclosure and all, is the product of a single manufacturer. In that case the manufacturer has carefully matched and adjusted the two to produce the best effect. However, many hi-fi addicts assemble their own speaker systems, choosing a speaker of one make and an enclosure of another. Often the two are entirely noncomplementary. For example, a woofer designed to be used with a Klipsch type horn is inserted in a bass-reflex cabinet, or a bass-

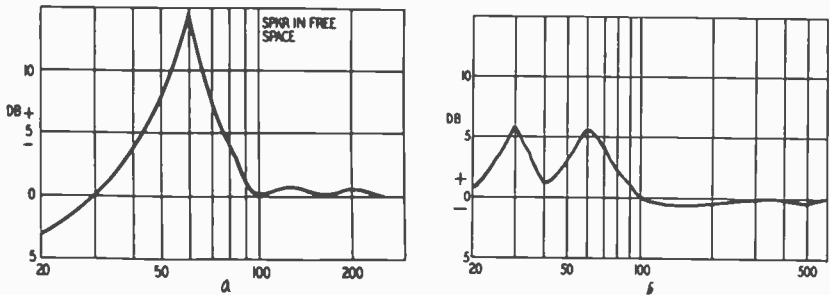

Fig. 802-a. -b. Curve of speaker alone (a) and enclosed (b).

reflex cabinet with a volume and port area designed for a 12-inch speaker with a resonance of 55 cycles is used with a 15-inch speaker with a resonance of 40 cycles. Sometimes this mismatch can be corrected. If you run into a case of excessive bass and especially an excessive one-note bass, check the speaker combination to see if it is matched. Verify in the literature and instructions whether the enclosure is one recommended by the speaker manufacturer for the specific speaker and vice versa. If not, it may well be that the trouble lies in the speaker system and the next step is to try to correct any mismatch.

Matching speaker to enclosure

Nothing much can be done in the case of totally enclosed infinite baffles, corner horns or R J type Helmholtz resonators. But, it is quite possible to improve performance with bass-reflex enclosures up to a point. Two faults are likely to account for poor performance: (1) a cabinet of too small a volume for the speaker

used and (2) too small or too large a port for the speaker used. Accurate matching of speaker to bass-reflex enclosure is a complicated matter and requires considerable calculation based on the resonance and piston area of the speaker, the volume of the enclosure and the area of the port. These matters are covered in most of the standard hi-fi texts and it would be pointless to include them in this work. Those who are buying or building such enclosures are advised to consult them. We will concentrate

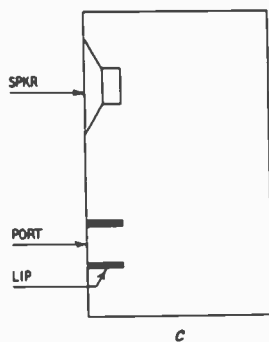
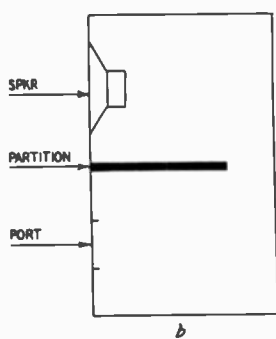
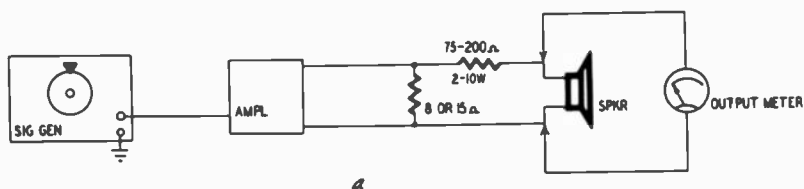

Fig. 803-a, -b, -c. The illustrations shown above demonstrate the techniques for matching a speaker to an enclosure.

entirely on making the best of the bad situation presented by a bass-reflex cabinet already on hand and a speaker which does not match it.

The first step is to measure the resonant effects of the combination by inserting the network of Fig. 803-a between amplifier and speaker. This consists of a load for the amplifier and a high series resistance which isolates the speaker from the damping resistance of the amplifier so that any resonant peaks will thereby not be reduced. Connect a signal generator to the amplifier input and an a.c. vacuum-tube voltmeter, wattmeter or output meter across the loudspeaker terminals. Sweep the range between 20 and 100 cycles, taking readings every 5 to 10 cycles and converting

these readings to a curve. The ideal curve of a properly matched speaker and bass-reflex cabinet should have two peaks about 6 db high separated by about an octave, as indicated in curve a of Fig. 804. If you get a curve with some resemblance to this, it will be quite possible to produce a good match. The worst possible match presents a single very steep peak usually accompanied by minor peaks harmonically related at higher frequencies (as in curve b of Fig. 804). If this occurs, close the port of the bass-reflex completely by firmly holding a piece of board or a large book or something similar against the port, and take another sweep.

You may very well find that there will be a similar single peak but ordinarily at a somewhat higher frequency. If the peak with the port closed is very much higher (more than 10%) than the peak with the port open, the enclosure is too small. It may be possible to improve this situation by inserting a partition inside the cabinet between port and speaker (Fig. 803-b). The enclosure should fit the sides and front of the cabinet tightly and leave a space from 4 to 10 inches wide (say one-third to one-quarter the depth of the cabinet) at the rear. The partition should then be thoroughly padded, top, end and bottom with sound-absorbing material—glass wool, ozite or similar materials, or even parts of old quilts. The effect of the partition is to increase the length of the air column and thereby to drop the resonant frequency. Another sweep with the port open and closed should decrease the amplitude of the peaks and lower the frequency at which they occur.

Next make the same sweeps with portions of the port closed off. If closing off part of the port produces a curve more closely approaching the ideal, the port is larger than needed. It should be possible by progressively decreasing this size to obtain something close to the curve a of Fig. 804. If this occurs, it is only necessary to mark the size, and inside the cabinet, screw in tightly a piece of wood to close off the desired portion of the port.

Optimum ports are usually between one-half and unity times the piston area of the speaker, *provided* the resonance of cabinet and speaker are identical or nearly so. Given the same cabinet volume, the lower the resonance of the speaker the smaller will be the required port area; while the higher the resonance of the speaker, the larger the needed port area. When a very fine speaker with a very low resonant point is used in a given cabinet, the port area can be reduced to produce a better match. The

performance will not be as good as it would be if the same speaker were used in a cabinet whose volume is proportioned on the basis of optimum port area as well as similar resonance; but it will be better than it would be if the enclosure were not tuned.

In the opposite direction, a speaker with a high resonant point tends to require a port of larger than optimum area, if the enclos-

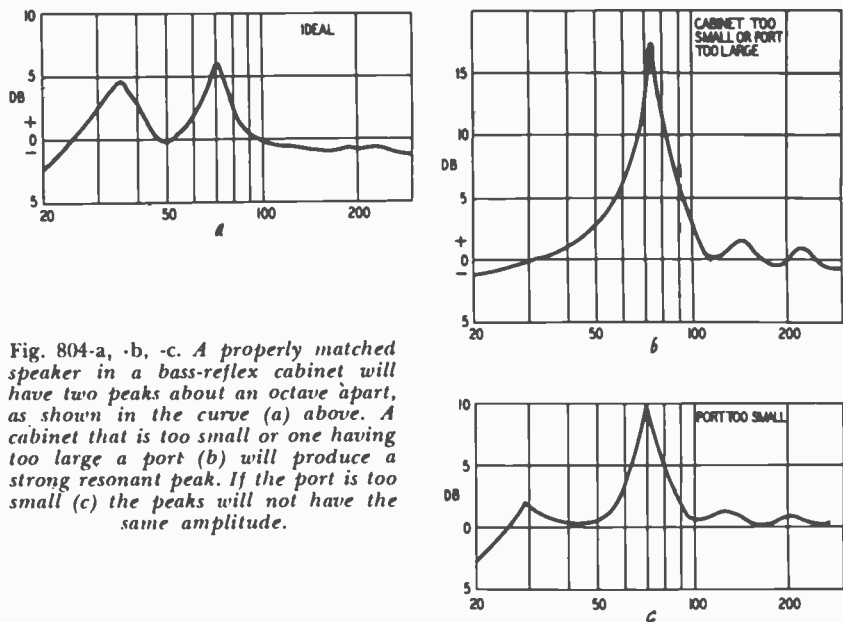

Fig. 804-a, -b, -c. A properly matched speaker in a bass-reflex cabinet will have two peaks about an octave apart, as shown in the curve (a) above. A cabinet that is too small or one having too large a port (b) will produce a strong resonant peak. If the port is too small (c) the peaks will not have the same amplitude.

ure volume is not based on port area and speaker resonance frequency. But increasing the port area is not as effective in correcting matters when the error is this way, as reducing it is when the speaker resonance is too low. There is another improvement that can be made when the cabinet is smaller than optimum for the speaker resonance. Instead of just reducing the size of the slot, which reduces its radiating area, reduction in size is combined with increasing its length, to get a better match without so much reduction in area. This is achieved by building a lip into the interior of the enclosure. This lip is simply a box with no bottom and no top, that just fits on inside the port, as shown in Fig. 803-c. This increase in length has the same effect (as far as acoustic loading on the volume of air in the box is concerned) as making the port smaller. But it allows this to be achieved with

the movement of much more air, hence produces the effect outside equivalent to a larger port.

This procedure will not always produce optimum results with a given speaker; this is possible only when all factors—cabinet volume, port area and speaker resonance—are matched for optimum. But it will make the best of a given combination and in many instances will eliminate or minimize a boomy, one-note or overpowering bass.

A port of the correct dimensions will have, approximately, a curve like that in a of Fig. 804. Too small a port does not reduce the resonant peak enough and the secondary peak at a lower frequency is not high enough (as in curve c of Fig. 804). Too large a port raises the resonant frequency too far above the natural resonance of the speaker and also does not provide enough damping of the peak, as in curve b of Fig. 804.

Insufficient damping of speakers

There is one fault in an amplifier which may cause an excessive peaked bass even with a properly matched speaker system. Modern high-fidelity amplifiers provide a high degree of damping for the loudspeakers. This is accomplished with negative voltage feedback by reducing the internal resistance of the amplifier to a value considerably lower than the impedance of the speaker. This low resistance swamps the variations in impedance of the loudspeaker so that even at its resonant point the speaker is flattened.

However, it will be evident that if the damping were suddenly removed, the speaker system would acquire a marked rise in volume at its resonant point and this would cause an excessive bass. The damping could be removed if the feedback loop in the amplifier failed for some reason or other. If all the other tests indicate a satisfactory condition, it might be well to remove the amplifier and check to see if the feedback loop is operating properly.

There will be some variation in damping with different amplifiers and the same speakers. For the same amount of feedback, amplifiers using pentodes will have less damping than triodes or tetrodes used either as triodes or in an Ultra-Linear configuration. Speaker systems with pronounced peaks will, therefore, have more bass with some amplifiers than with others.

Recently many commercial amplifiers have provided a means

of varying the damping factor by manipulating *current* feedback. *Negative* current feedback raises the internal resistance of an amplifier and therefore reduces the damping; *positive* current feedback reduces the internal resistance of an amplifier and therefore increases the damping. By adjusting the damping control

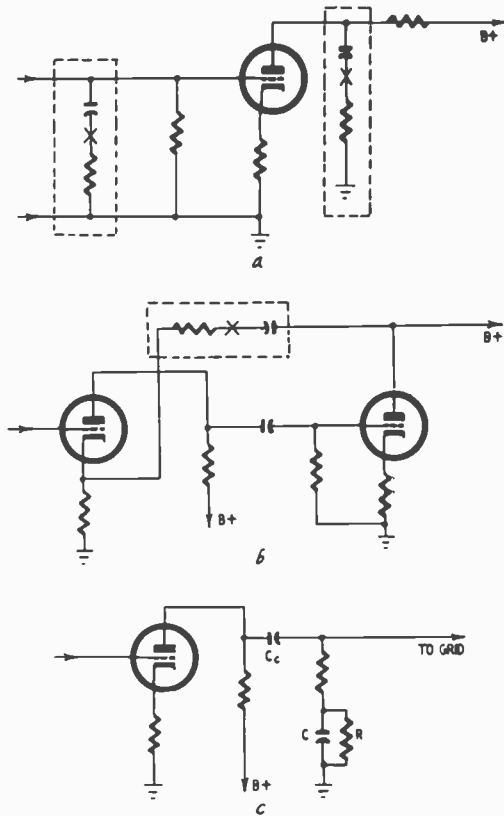

Fig. 805-a, -b, -c. Accidental grounding of points marked X in illustrations a and b will produce excessive bass boost. If resistor R in the bottom drawing (c) should open, there would also be an increase in bass.

(usually a potentiometer), it is possible to vary the damping of the speakers over a very wide range. If the amplifier in the installation possesses such a control, the excessive bass is most likely due simply to a misadjustment of it. In that case, adjustment of the damping control should produce the degree of damping which, in turn produces a satisfying bass with the particular speaker combination in the particular room.

Boosting due to amplifier fault

If excessive bass is accompanied by a severe loss of highs as well, and if this condition exists even when the tone controls are in their neutral positions and the loudness control cut out, it is possible that the fault may lie in some portion of the amplifier or control unit. This situation could exist if somewhere in the chain a part failure or an accidental disturbance of the wiring produced severe bypassing of the highs and, therefore, a severe bass boost. There is only one set of conditions which would produce such a result. Somewhere a capacitor would have to be connected between ground and the hot end of the signal channel. The highs would be bypassed to ground while the lows would be passed through the signal channel. Although the condition is very unlikely, it can and has occurred. There are several points in high-fidelity circuits where it could arise.

In Fig. 805-a we have a capacitor and a resistor in series connected from grid or plate to ground to provide controlled bass boost. This could be found in the equalizer or tone control portion of a circuit. If the junction (point X) of the resistor and capacitor were accidentally grounded, the curve of the network would be shifted quite violently and the bass boost would depart from normal and become much more violent.

In Fig. 805-b we have a feedback loop from the plate of one tube to the cathode of another with a capacitor to block the d.c. and, perhaps, to control the frequency response. Such a network is found in many phono preamps. It may also be found in power amplifiers as a feedback loop from the primary of the output transformer; if it is a push-pull amplifier, there are two such loops. Again we can see that if for some reason the loop should be grounded at the junction (point X) of the resistor and the capacitor, we would get a violent bypassing of highs and, therefore, a severe bass boost.

Though this condition doesn't appear to be likely it has happened twice in our experience. In one case the capacitor was grounded while signal-tracing an amplifier, but in the other case the fault occurred in shipment from factory to customer and apparently the capacitor was grounded by vibration or shock in handling.

One other possibility exists. In Fig. 805-c we have a bypass type bass-boosting network, RC, with a resistor in shunt with the capacitor. This resistor limits the boost at the low end of the

bass-boost curve. Circuits of this type are used in equalizers particularly to obtain RIAA, LP and NARTB bass equalization. If this resistor should open for some reason, the limitation would be removed and the bass-boost would increase very considerably at the low end. Again this is an unlikely condition since such networks occur in circuits with little, if any, current flow and, therefore, little strain on the resistor. But it is a possibility to look into if all else fails. Such a resistor is often mounted on a switch and may have broken loose for mechanical reasons.

Room resonance or ringing

Some rooms can stand only so much bass and no more. After a point, though the bass would not be excessive by ordinary standards, it becomes intolerable because it produces ringing of the room. Many exhibitors at Audio Fairs have discovered that hotel bedrooms or suites converted to demonstration rooms are sometimes sadly prone to ringing and therefore limit the ability to demonstrate bass output of even the finest systems. The effect is particularly disturbing if by a sad coincidence the room resonance coincides with speaker resonance. In that case, it is practically impossible to obtain a bass which is not painfully excessive at some point in its range.

Room ringing is most easily recognized by the fact that it produces a bass with a marked booming even when the speaker is horn-loaded or is completely nonresonant. The critical point can be located by gradually increasing the volume of bass fed into the room, either by increasing overall volume or by increasing the bass boost. At the critical point, the sound will suddenly seem to acquire a boom and an echo or hangover. After the critical point the effect is so abnormal that the listeners begin to be definitely uncomfortable. *The bass loses directional quality and seems to arrive from all directions.* It becomes much less natural and more boomy. The dull *glump* of a damped drum turns into a resonant, rounded *glooomp*. These effects could occur in almost any room if the bass level is increased abnormally. It is a serious factor, however, only when it occurs at what would be, for a normal room, a normal bass level.

The placement of the speaker system usually makes a great difference in rooms prone to ringing — some position can usually be found which minimizes it. Don't be afraid to break rules of speaker placement in such cases. Thus, though it is usually more

desirable to place a speaker along the narrow wall of a long room, or in one of the corners, in a room prone to ringing the best position may well be part way against one of the long walls. Although a speaker is usually best close to the floor or corner, in a ringing room it may work best above the floor.

Amplifiers with damping controls provide a simple means of adjusting a given speaker system to produce tolerable results in a ringing room. By increasing the damping it is often possible to minimize ringing and to obtain a bass response which, if not ideal, is at least tolerable.

Distortion of bass

Another complaint is this: "The bass is fine at low levels, but when you play at concert-hall levels it distorts in the peaks." The most likely cause of this is saturation of the output transformer, produced by unbalanced output tubes. Such an imbalance may increase the d.c. flowing through the primary to the point where saturation occurs at a much lower level than it should. The solution is quite simple; balance the output tubes.

Another possible cause of bass distortion is a pair of badly mismatched coupling capacitors in the two sides of the push-pull stage. At very low frequencies such a mismatch will drive one side of the stage harder than the other; one side may thus be driven into serious distortion at the bass end much sooner than the other. Moreover, since there is a phase difference between the two sides at low frequencies, the distortion is not cancelled in the common load and appears in the output of the system. The reactance of the opposite capacitors can be checked easily with an a.c. voltmeter (or the a.c. range of a v.t.v.m.) and a signal generator. See Fig. 504.

If the capacitors are producing a phase shift which is unbalanced by 5% or more, it would be a good idea to replace one of them with a value which comes closer to producing the same drop as the other side. An even simpler way than replacement is this: connect in parallel with the capacitor which is giving the larger phase-shift voltage another small capacitance which will increase the net capacitance to a point which approaches equality with the opposite mate. Thus, if the nominal value of the interstage capacitors is 0.25, try adding an .05- or an 0.1- μ f unit in parallel. Repeat the reading and see if the situation isn't improved. By adding a capacitor somewhere in the range between .02 and 0.1,

you should be able to produce a balance between the phase shift voltages at 60 cycles of 5% or better.

Too little bass

This is a frequent complaint even from owners of superb systems. Some people simply cannot obtain enough bass to suit them. Unless at every volume level they are shaking the floors and rattling the china in the cabinets they are unhappy. Many people have what can only be called a perverted idea of what constitutes a natural bass; others just don't give a darn whether the bass is natural or not—they simply want to confound and impress their listeners. Faced with such a character, the tech-

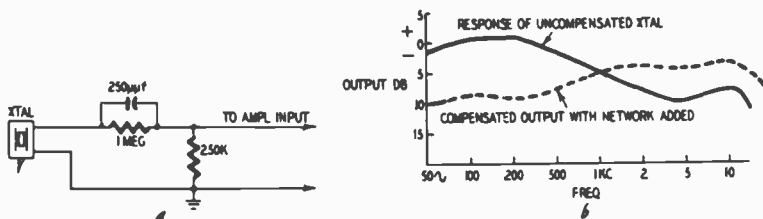

Fig. 806-a, -b. Crystal pickup circuit (a) and effect of equalization (b). Crystal and ceramic cartridges do not need preamplifiers.

nician has a choice of either washing his hands of the whole matter or helping the customer get the bass he desires.

In some cases, the state of mind is produced by a misconception about what constitutes enough bass. Almost any jukebox will have a louder and more pronounced bass than a good high-fidelity system. On a high-fidelity system, however, the bass will be more natural, sharper, cleaner and better defined. If the installation is producing a good bass and the customer simply doesn't recognize this fact, you may be able to solve the problem by pointing out how good the bass actually is, and why a jukebox is louder.

However, there are many instances of justifiable complaints of inadequate bass.

Equalization

A high proportion of complaints of too little bass can be traced to the equalization of the record player. To begin with, there is the customer who is using a crystal or ceramic cartridge which is not properly equalized. Manufacturers of these devices overdo advertising claims about their not needing equalization.

Crystal and ceramic cartridges do not need preamplifiers, but they definitely *do need* equalization (Fig. 806) to provide good performance—and particularly they need it to provide adequate highs to balance the bass.

Improper equalization of magnetic cartridges may result in insufficient bass (Fig. 807). To begin with, not all equalizers provide complete equalization at the bass end. This happens because

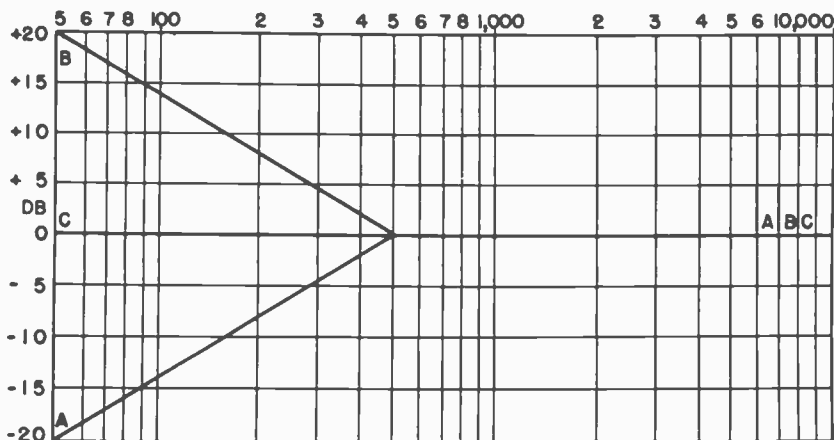

Fig. 807. This illustration shows the need for equalization at the low-frequency end when using magnetic or velocity-type cartridges. Curve A shows the response that will be produced without equalization, due to the recording characteristic; curve B, which is the inverse of curve A, the equalization curve required; curve C, the overall characteristic, formed by adding curves A and B.

less equalization is required and extra gain can be added. The remedy is to replace the present equalizer with a more elaborate one which provides full equalization. It may also be necessary to increase the gain.

It is assumed that the possibility of a fault in the equalizer tube has been taken care of. Try replacing the equalizer tube first. A weak tube with low gain will reduce the equalization. If this doesn't help, check the circuit for open or shorted capacitors, and resistors which have become defective or have changed considerably in value.

Fig. 808 shows a simple adjustable bass boost circuit, together with its response (with and without the adjustable feature).

Loudness control

Improper adjustment of the loudness control can also result in less bass. Since considerable space has already been devoted to

this, we will not go over the problem again. The loudness control should also be adjusted. If that still doesn't provide enough bass, try turning the loudness control lower and the volume control higher. Assuming there is no other fault in the system, it should be possible to find a combination of gain and loudness control setting which yields a satisfactory bass at any listening level.

Loudspeaker system

The bass response below about 70 cycles is very largely a function of the speaker system. There are many systems which yield

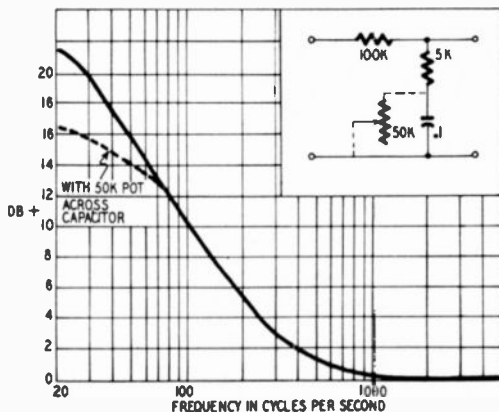

Fig. 808. The inset shows a simple bass boost circuit. Addition of a potentiometer provides an adjustable bass boost.

a bass down to 40 cycles; there are few which go much below this and all of these run into size and money. It is probably about as safe as anything in high fidelity to say that, to get a good bass below 50 cycles, you've got to be prepared to spend at least \$100 on the speaker system and the price just about doubles for every 10-cycle increase in range below that, until a system capable of yielding any real response at 20 cycles can be expected to cost at least \$500.

The only sensible way to assemble a high-fidelity system is first to buy the best speaker system one can afford and then choose the other components to bring out its best capabilities. Unfortunately, many people will spend \$150 or \$200 on an amplifier, feed it into a \$50 speaker system and then complain because the outfit doesn't deliver flat output from 20 to 20,000 cycles.

Furthermore, people do not always choose a system which conforms to their taste. Some speaker systems deliver a clean, well-defined, beautifully dull, but not spectacular bass. Others deliver a less well defined, but a more rounded and spectacular bass. Back-loaded horns are more efficient in the bass end than true infinite baffles. The same electrical input will produce a louder bass with horns or a Karlson enclosure, than with such infinite-baffle types as the Hartley and Vilchur systems. That is not to say that any one is necessarily better than the others. But one type will suit a particular taste better than another and people should have sense enough to choose systems which do deliver the kind of bass they like. However, the less efficient system can be provided with more bass boost; beyond that it will merely take a little living with to gain appreciation of its fine qualities. After getting used to it, the customer may find he likes it better after all.

In the case of the inadequate system, the only solution is to improve it either by complete replacement or by changes. The bass response of an inexpensive system may often be improved somewhat by adding another, but relatively inexpensive system and operating both side by side or one on top of the other, and this may be cheaper and simpler than replacement with a single much more expensive system. The increased efficiency is derived by mutual coupling. As the piston or radiating area is increased by adding other pistons or radiators, the efficiency at low frequencies increases by the *square* of the increase in piston area. Thus two identical systems placed side by side, to provide mutual coupling, will have four times the efficiency in the bass end that either of the systems possesses. If the speaker is excellent but the enclosure is not optimum, the enclosure might be replaced with a folded horn or Karlson.

Speaker placement

The placement of the speaker system in the room makes a great difference in bass response. Folded and corner horns need a corner. Some need also, a tight fit between the enclosure and the wall. Sometimes the same horn works better in one corner than another because the horn extends farther into the room. If a living room has a dining or study alcove at one end, more spectacular results may often be obtained by placing the corner horn in one corner of the alcove. In such cases the smaller room extends the horn better and the transition to the larger room is accomplished more smoothly and with more efficient coupling.

Bass-reflex and infinite-baffle enclosures also may improve with location. In a corner, they too will obtain greater efficiency in the bass end and therefore a louder bass. There are positions in some rooms in which a speaker actuates the room resonances without producing ringing and thereby achieves a more spectacular bass. Whenever a speaker does not deliver quite the bass it should, moving it around the room is a worth-while expedient.

Damping

If you remember our discussion on damping you will appreciate that the more thoroughly a speaker system is damped, the cleaner and more natural the bass, but also the lower the possible volume of bass. Speakers can sometimes be overdamped. A few speakers, when mounted in the correct system, are practically nonresonant. But practically any loudspeaker shows an impedance rise at the low end, so the damping can be reduced and the bass may in consequence receive more emphasis. Indeed, the use of current feedback, instead of voltage feedback, may be justified. With speakers having resonant peaks, current feedback tends to exaggerate them. With relatively nonresonant speakers with no pronounced peaks, current feedback yields an effect very close to dynamic bass expansion—the bass becomes louder. If the amplifier has a damping control, it should be adjusted with such speakers to produce only a moderate amount of damping.

The damping control will produce even more spectacular results with systems which have resonant peaks. As the peaks are less damped, the bass becomes louder. Of course, this is achieved at some sacrifice in the form of greater hangover and inferior definition with a one-note-bass quality. But at some point in the range of the damping control there may be found a position in which a heavier bass is achieved without too much sacrifice in definition—and in any case, a bass which satisfies the customer more.

If the amplifier has no damping control, it is possible to decrease the damping by decreasing the feedback in the amplifier. This can easily be done by increasing the size of the feedback resistor. It is not an expedient that is recommended too highly, for reducing feedback will increase distortion; but in an extremity it may be worth trying with speaker systems which do not have too pronounced a peak and when the customer insists above all on a heavy bass.

Amplifier faults

When commercial amplifiers are involved, there are few possibilities that a fault in the amplifiers can result in bass attenuation. If the equalizer is not providing the requisite bass boost, the fault may be due either to a weak tube and a loss of gain or to failure of a capacitor or a resistor in the discriminating network. All bass-boosting equalizers involve a combination of series capacitor and resistor which is employed either to bypass the highs to ground or to reduce the feedback of lows in a feedback loop.

Thus, an open capacitor (C) in Fig. 809 would eliminate the boost, but would also raise gain due to loss of feedback completely;

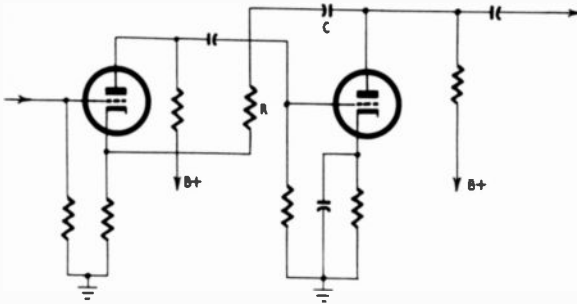

Fig. 809. The feedback components are indicated by R and C. Amplifier faults due to these parts are described in the text.

a capacitor with a value lower than specified would shift the crossover point upward and raise the frequency of boost; a capacitor with higher value would shift the crossover downward and lower the frequency of boost. A change in the value of resistor R will also affect the equalization: an increase will reduce feedback, and also the amount of boost available; a decrease will produce more feedback, and also more boost. A change in tube gain also modifies the boost. The mid-range gain is set by the feedback, but the gain of the two stages, above this, determines the boost available when feedback drops off at the low end. If the gain drops to the point where there is no appreciable feedback the boost practically disappears. If a tube with higher gain is used the boost will be increased. For example a 12AT7 in a circuit intended for a 12AU7 will raise gain — but watch out for distortion in making this change: the 12AT7 will not handle so large a signal, and is also a less linear tube than the 12AU7, so this change should only be tried if the bass boost is in low level circuits.

A very simple test for an open capacitor in such a network is this: take another capacitor of approximately the same value or slightly larger value, and clip it into the circuit in parallel with the suspected capacitor. If the volume of bass decreases, the circuit capacitor is not open; but if all signals decrease markedly, the suspected capacitor is open. The reason is quite simple: if the suspected capacitor is good, the addition of a shunt capacitance will increase the total capacitance which will decrease the reactance at low frequencies, which, in turn, will bypass more lows and therefore decrease the bass boost. But if the suspected capacitor is open, there is no feedback as well as no boost. Closing the circuit

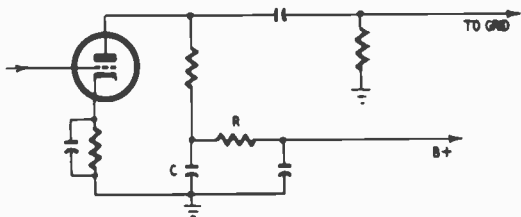

Fig. 810. *The decoupling circuit consisting of R and C helps provide some bass boost.*

with a good capacitance will restore feedback, reducing the gain, and also introduce the bass boost.

Another possible amplifier fault resulting in bass attenuation is the deterioration of a cathode bypass capacitor. The unbypassed cathode resistor will reduce gain, through degeneration, by 3 to 12 db, according to circuit values. A low value of bypass will cause this much gain to be lost at the lower frequencies. If a pentode is used in a preamplifier or the voltage amplifier section of an amplifier, the removal of the screen capacitor may reduce gain by as much as 20 db. A low value will cause bass loss.

In some amplifiers the decoupling elements of C and R (see Fig. 810) are chosen to provide a little bass boost—enough to make up for the loss through coupling capacitors and sometimes more. In this kind of an amplifier an open capacitor which removes the capacitance from the circuit will result in decreased bass. A change of the capacitance to a higher value will also reduce bass. Be careful therefore, when replacing these capacitors or when trying to improve decoupling, to see that the increase of the capacitance does not deteriorate the bass.

If any coupling capacitor in an amplifier becomes open, it may cause a very severe loss of bass, because only the high frequencies

will get transferred across the residual capacitance provided by the wiring around the capacitor. Shorted turns on a transformer can also result in severe attenuation of all frequencies except the extreme highs.

But, all in all, unless the fault occurs in an equalizer or tone control stage, the failure of a component in an amplifier is not likely to produce a very large attenuation of bass and there is little point going into the amplifier unless all other possible sources of trouble are exhausted and the loss of bass is over 6 db or so.

To summarize: the most likely causes of insufficient bass are to be found either at the very beginning of the high-fidelity chain—the equalizer, or the very end—the speaker system. It is at these points that the effect even of small faults is greatest.

Treble faults

People, unsophisticated in high-fidelity, are very prone to demand either less or more treble than is required to maintain a natural balance in music. Those very thoroughly accustomed to the lack of highs in a radio or TV may at first dislike the sharp highs of a good high-fidelity system. Others, in revolt against the lack of highs in a radio and intoxicated with hi-fi sound, may demand more highs than a natural balance calls for. There are, however, many legitimate complaints of deficiencies in high-frequency response of a system.

When diagnosing a case of too much treble, the most likely part of the chain to start trouble-shooting in is once more the equalizing portion. Both recordings and FM radio transmissions arrive with a highly pre-emphasized treble—anywhere from 10 to 16 db up at 10,000 cycles in relation to 500 or 1,000 cycles. FM receivers should have a de-emphasis network to equalize this pre-emphasis and restore flatness. If the complaint occurs with FM reception only, check the receiver as suggested in the chapter on tuners. If it occurs with records only, and not when a receiver is used as a source, the fault is almost certainly in the equalizer, or the pickup. Check especially that the pickup is properly loaded at the preamp. For example, a Pickering pickup cartridge connected to an equalizer with a 50,000- or 100,000-ohm load suitable for flat response from a G-E cartridge will show very marked boost in the treble end. A lower value of resistance is recommended for the Pickering.

If the outfit produces too much treble with all sources, the fault is to be found in the control unit or beyond. There are few

electrical faults whose product is an excessive treble. Indeed, the possibility is limited almost entirely to a failure of the potentiometer or capacitor in the treble boost control, and is very unlikely even here.

For example in Fig. 811, treble control is provided by the 1-megohm potentiometer; maximum boost occurs when the slider is at the top end. Should the potentiometer, through wear, develop an open segment of the resistance element so that the capacitor to ground is, in effect, disconnected, the highs will rise very markedly, particularly in what should be the neutral or "cut"

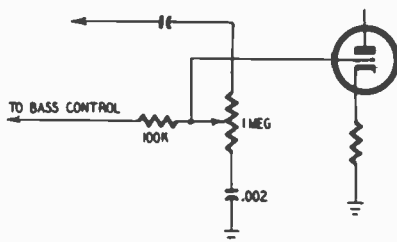

Fig. 811. *A defective potentiometer will produce excessive highs.*

end of its range. The same effect would occur, if the capacitor to ground opened. An open capacitor or shorted turns on a transformer can attenuate all except the extreme highs, which might be diagnosed as excess treble.

A more likely cause of excess treble would be a misadjusted tweeter. Many speaker systems with independent tweeters use a treble level control to set the level of the tweeter, which usually has a higher efficiency than the mid-range speaker or the woofer. Set for maximum volume, the tweeter may well be providing excessive highs. Readjust it to produce a satisfying balance for the customer.

Not enough highs

There are more possible causes of insufficient highs. Again diagnosis should start with the equalizer. The complaint may be due entirely to ignorance in the use of an equalizer. For example, most of the modern equalization characteristics use much more high roll-off than that required for the old LP characteristic (before standardization) or the European 78's. If you play either of these kinds with the more general equalizer settings, they will sound deficient in treble. The loss may also be due to a poor needle, to an improperly loaded pickup or to too long a shielded

cable from pickup to preamp or from preamp to control unit or amplifier. An unequalized ceramic or crystal cartridge will also be deficient in highs. (See Fig. 806.)

A failure of the tone control circuit may produce the loss. This is easily checked by turning the control throughout its range while a high frequency tone or a record with a lot of highs is being played. For example, if the capacitor at the top end of the 1 megohm potentiometer in Fig. 811 became open, or if a break occurred in the top end of the potentiometer, there would be a loss of highs. The control should provide a good range of boost and cut; if it doesn't, check the circuit for open or shorted capacitors, bad resistors, weak tubes and other defects.

Any increase in capacitance between the hot side of the signal channel and ground or chassis in any portion of the amplifying or tone control sections can produce loss of highs. The same amplifier faults, which we discussed previously as leading to increase of bass, will also produce a loss of highs. The extreme-highs, say around 10,000 cycles and beyond, may be lost through stray capacitance produced by moving components in an amplifier or pre-amplifier. Interstage coupling capacitors, especially if moved into contact with the chassis, may have enough capacitance to ground to bypass the very high frequencies.

The failure of a feedback loop may cause considerable loss above 10,000 cycles, especially in the less expensive hi-fi amplifiers and in any amplifier having one or more single-ended stages. Some Williamson type amplifiers have a treble bypass network in the input stage as in Fig. 812. If the resistor is shorted (at junction X), the bypass effect increases and produces considerable loss of highs.

In the speaker system the loss of highs may be due to a burned-out tweeter. The most likely cause of burn-out is that the amplifier becomes unstable and bursts into parasitic oscillation in the ultrasonic region. This might well feed 10, 15 or 20 watts of signal into the tweeter with fatal effect. Whenever replacing a tweeter, be sure, therefore, to check that the amplifier is stable and not generating parasitics.

The extreme-highs may be lost or accentuated by the speaker grille. Commercial enclosures use grilles with an open weave which does not absorb the highs significantly. However, in assembled systems the speaker grille may have been supplied by an interior decorator with more knowledge of color harmonies than high fidelity and the material may be too closely woven and too ab-

sorbent to pass the highs without severe attenuation.

The location of the listener in relation to the radiation pattern of the tweeter has a marked effect on the audible treble response. It may be that the customer's favorite chair is located at so large an angle from the speakers that his ears do not receive the direct component; and if the walls are absorbent, he will not hear a reflected component. If the highs are plainly audible directly in front of the speaker system, but not in the position normally

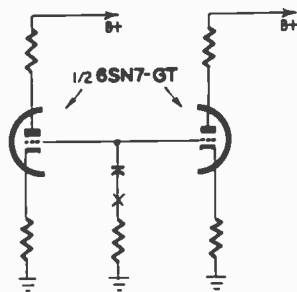

Fig. 812. There will be a marked decrease in highs if the resistor is shorted at point X.

occupied by the listener, a change in the position either of the speakers or the listener's favorite chair will solve the problem.

Tonal balance

Some speaker systems, particularly multiple units using cross-over networks, are susceptible to wide variations in tonal balance as their impedance changes. In many cases, changing the connection at the output transformer from the recommended impedance to a higher or lower impedance will produce very marked changes in the balance between lows, highs, and middle.

The impedance characteristics of a complex loudspeaker network involving inductances and capacitances, as well as the voice coils of the speakers, are very different from those of a simple, single speaker. And in many instances such systems will have impedance peaks at several points within the audio range.

Amplifiers with large amounts of feedback are less critical as to variation in loading and at first thought one would think that they ought to be able to handle systems with several impedance peaks without trouble. And so far as the loading of the tubes is con-

cerned, this is relatively true. However, remember that the feedback network is affected by the voltage developed across the speaker-system load and the voltage in turn will vary with changes in impedance. So long as the *total* impedance is constant, the load on the tubes will be constant. But in a dividing network the total load may be constant whereas at various points in the frequency range the impedance of individual sections of the load may be greater or lesser. The feedback loop will reflect this variation.

If the impedance of the bass section rises while the impedance of the mid-section falls, the feedback voltage of the bass will rise while that of the middles will fall. Though the overall output will be the same, the tonal balance will be different.

The rated impedance of such a multiple speaker combination is a compromise value which the manufacturer has found or believes will give the best tonal balance with most amplifiers. In some instances, however, it may be that the use of the recommended rated impedance with some amplifiers will result in an excessive bass or treble or mid-frequency boost. In such cases, the fault may be minimized by changing to the next higher or lower tap on the output transformer. Such a change may affect the output power or distortion characteristics of the amplifier. In some instances, and more or less as a last resort in trying to obtain a good tonal balance which is difficult or impossible to obtain otherwise, it is worth trying.

common audio troubles

One of the most difficult problems to deal with is that of unstable amplifiers which go into continuous or momentary oscillation. One form of this is evidenced in the complaint: "I can't get enough bass because when I boost it beyond a certain point the outfit starts motorboating or chopping up the sound."

Low-frequency instability

This is the result of poor low-frequency stability and is most likely to occur when all the units of a system are fed by the same power supply and the bass boost of the phono equalizer continues to 30 cycles or below. If the system is an integrated commercial unit, it is usually safe to presume that it was designed to give performance free of these effects and that the trouble is due to some failure in the power supply or some element in the chain of amplifiers. A possible cause is an open filter or decoupling capacitor. Electrolytic capacitors gradually fall off in capacitance value with age, due to drying up of the electrolyte. This loss of capacitance is more likely to be the cause of the fault than a direct open condition. A leaky capacitor may or may not reduce the voltage but usually it does not affect the decoupling; an open or low-value capacitor, however, fails to provide an adequate bypass path for signal frequencies and these may be fed into early stages by the plate supply and result in positive feedback and oscillation. A simple check is to take a 20- to 40- μ f capacitor and clip it in parallel with each capacitor in turn. If at some point this addition elim-

inates the motorboating or instability, the suspected capacitor can be replaced.

Another possible cause is the reduction in value through overheating, aging, etc., of the feedback resistors in the feedback loop or loops. With the lower resistance, feedback is increased—perhaps to the critical point. If this is the case, a replacement with a resistor of the specified value will restore the original feedback factor and stability.

If somewhere in the chain there is a low-frequency rolloff circuit and it is disabled, the amplifier may be forced to handle much lower frequencies than it was designed to pass safely and instability can result. If there is a rolloff, check the component parts and be sure it is operating. If the system has no bass rolloff, it may help to add one to reduce response below 25 or 20 cycles (Fig. 901-a). This can always be done very inexpensively by adding one or two more sections to the interstage R-C coupling network at some point in the system. The most convenient point is probably either the input of the power amplifier or the output of the control unit; but the best point is at an earlier level, preferably at the output of the phono preamp and the input for the other channels. The addition of each section will increase attenuation of very low frequencies by 6 db per octave. Use the same value of coupling capacitor and resistor already used. Thus if the amplifier has a 0.1- μ f capacitor working into a 470,000-ohm resistor, add another section ahead consisting of another 0.1- μ f capacitor and another 470,000-ohm resistor as diagrammed in Fig. 901-b.

This arrangement is only likely to avert instability if both units use a common power supply.

Blocking of sound

Momentary blocking of the sound is evidence of temporary overloading. During the short time that this condition lasts, it blocks some tube to cutoff. This is produced by high-level transients, usually far below audibility, such as: (1) those produced by an eccentric hole in a record, (2) a severe warp or hump in a record, (3) beat notes between two radio stations on the same channel whose carriers are 1 cycle or even less apart, (4) the charge and discharge of an a.v.c. filter network on very slow fading in the broadcast or shortwave bands and (5) the switching of a squelch circuit. The wider the response of a system, and particularly the better the low-frequency response, the more likely this is to occur. Many fine amplifiers are only 10 db down

at 1 cycle and some can respond to some degree to signals a fraction of 1 cycle. Since these ultra low components can be of very high amplitude, it is quite possible that, despite the attenuation, the amplifier can be overloaded momentarily. This is more likely to happen because such amplifiers use large amounts of feedback and the stability is poorest somewhere in the region below 5 cycles. If this occurs only when poor, warped records are played or when the tuner is used, the amplifier is clearly innocent. The thing to do in the case of the tuner is to add another section or two of R-C coupling at the output to attenuate the very low fre-

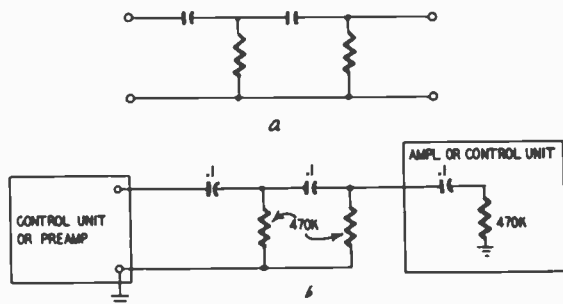

Fig. 901-a, -b. Techniques for reducing low-frequency response.

quencies further. For warped records or ones with eccentric holes, the solution is either not to play them at all or to attenuate the bass when playing them. However, it will usually do no harm at all to also add another R-C section at the input to the control unit or amplifier to attenuate the effect to the point where it will not block the amplifier or produce instability.

In many cases the instability may never reach the point of continuous audible motorboating or oscillation. Sometimes the effect is merely to degrade the transient response at low frequencies and to increase hangover. The drums, instead of being sharp and definitive, are boomy and resonant.

Breathing

Many Williamson type amplifiers, particularly the home-built ones, but occasionally also the commercial ones, are prone to "breathing" or oscillating at a frequency so low that it is completely inaudible. The better the speaker and the more free from distortion it is, the more completely inaudible the breathing. Fine speakers produce little frequency doubling or tripling and hence the oscillation is never extended into the audible range. A sharp

and experienced ear can usually recognize breathing by the effect it has in increasing the distortion of the audible signal. The distortion rises cyclically at a rate equal to the frequency of the breathing. Since that may be at the rate of a few cycles a minute, this is not easy to discern. But in any instance of cyclical distortion, tendency to block, or low-frequency instability, it is wise to open the speaker cabinet and observe the cone to see if breathing is occurring. If you have a very wide range a.c. vacuum-tube voltmeter or wattmeter with a flat response to 20 cycles or lower, it is very probable that it will indicate breathing even at very slow rates on one of the more sensitive ranges. A good place to measure it is with a d.c. range on the plate of an R-C coupled stage. The needle will swing rhythmically, like a slow clock pendulum.

Correcting breathing is not a simple matter since the fault is not infrequently inherent in the design. The troubles and checks indicated for audible motorboating or blocking apply here also. If the breathing occurs only when the whole system is interconnected, it is due to inadequate decoupling and can probably be corrected as indicated later. If, however, it occurs when only the amplifier is connected and even when there is no input signal, the problem is more difficult. First, check the feedback loop to see that original values are still maintained. If the values have drifted and the feedback is increased above original specifications, correcting the resistors may remove the breathing. Check also, the interstage capacitors. If the capacitance is lower than design specifications call for, the increased phase shift at the low end may be causing the trouble. In that case increase the capacitance either by replacement or by paralleling with smaller capacitances. Try the latter first. If the increase in capacitance solves the trouble, make a permanent replacement.

Most often the complaint arises when people have assembled a system themselves, using a control unit and preamplifier without a separate power supply and feeding them from the power supply of the main amplifier. The surest cure is to install a separate power supply for the preamplifier or the preamplifier and control unit. Often, the tuner can provide the small amount of plate and filament current needed without being overloaded. If not, a separate small power supply can be built.

In some cases the instability can be eliminated without a separate power supply by inserting a V-R tube somewhere in the decoupling network between the main amplifier and phono pre-

amplifier, as indicated in Fig. 902, or between the control unit and preamplifier. A V-R tube is the best possible decoupling element since any device which will bypass small and slow irregularities in direct current will obviously bypass very-low-frequency audio, a.c. or transient waves. An 0D3 (or 0A2) is most suitable. It should be connected at some point in the power supply where the voltage is at least 190, preferably at the final filter element if the voltage is high enough at this point. The series resistor should be adjusted to a value which makes the V-R

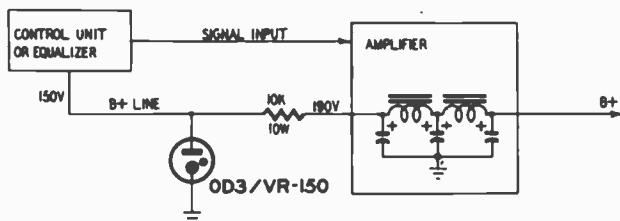

Fig. 902. Gas-tube improves power-supply regulation. The tube acts as an additional filter.

tube glow brightly all the time. Usually a value of around 10,000 ohms in a 10-watt rating will be good. A combination of the V-R tube for improved decoupling and a sharper high-pass filter by cascading R-C couplings can clear up very stubborn cases of low-frequency instability.

Ringing or fuzzy highs

Instability at high frequencies, usually in the ultrasonic range between 30 and 200 kc, is evidenced either by audible ringing or by fuzzy highs. Ringing is almost impossible to describe but once heard is not likely to be forgotten because of its unpleasant and even painful effect. The curious tinny echo often heard on telephones is a type of ringing; however, ringing in hi-fi audio amplifiers takes place at much higher frequencies and is not precisely comparable. A good sign of ringing is provided by objections of the females of the household to the sound of high fidelity. Sometimes these objections are due simply to too high a volume level; but if the customer's wife complains that the hi-fi gives her headaches, the first thing to do is to check for severe ringing or parasitic oscillation at ultrasonic frequencies. Similarly if the highs are fuzzy and indistinct, instead of sharp and

clean, the amplifier probably is oscillating at some ultrasonic frequency. A wide range a.c. vacuum-tube voltmeter or wattmeter will usually indicate such oscillation by giving a high reading even when there is no signal input.

Observation of a 10-kc square wave on a scope offers the best measure of ringing. The less ringing, the flatter the top of the square wave; the more ringing, the more wiggle. Ringing is controlled by a capacitance in parallel with the feedback resistor; and to correct it, increase the value of the capacitance in small steps. Too much capacitance will not only remove the ringing, but will round off the leading edge. The trick is to use the smallest capacitance that will reduce the wiggle or oscillation without rounding of the leading edge too much.

Hum

The achieving of a satisfactory hum level is a much more difficult problem in high-fidelity equipment than in radio and TV. Where the latter use a bass roll-off to help lose the hum, this procedure is not acceptable for high-fidelity systems. Also, the average listener to radio or TV is not critical if there is an audible hum, provided it is not loud enough to be annoying — many users will not complain provided they can still hear the program above it! In high-fidelity systems, the hum should be inaudible under all playing conditions. This can prove to be a very exacting requirement.

What can you expect?

It is quite simple to determine whether equipment is living up to its designed signal-to-hum ratio. All that is required is a sensitive a.c. voltmeter—preferably a v.t.v.m.—capable of reading 10 millivolts or less. Connect the meter across the voice coil of the amplifier with speakers connected or with a resistive load. Adjust the tone controls *to the maximum-boost position* and the volume and loudness controls full on. Switch the input selector first to one of the high-level channels—tuner, TV or tape. Disconnect the cable from control unit or amplifier to the tuner, and terminate the input with a resistance equal to the nominal output impedance of the tuner. Then take a reading. It may be necessary to shield the terminating resistor with a suitable can connected to ground with a clip lead.

Hum ratios are usually figured on the basis of maximum out-

put and an absolutely accurate determination calls for the ratio of the voltage read against the voltage developed at full output. Still, for convenience we can assume a maximum output of 10 volts across an 8-ohm load, and the assumption produces a very simple rule of thumb test. The ratio of the noise voltage measured to 10 volts gives the signal-to-noise ratio—largely the hum ratio. The following table gives ratios in db for given readings of hum and noises:

Hum and Noise Ratios

Voltage	Noise Ratio (db)
1 volt	20
300 mv	30
100 mv	40
30 mv	50
10 mv	60
3 mv	70
1 mv	80

If you have the specifications of the equipment, you can compare the ratio you get with the ratio specified. Practically all hi-fi amplifiers plus control units should give a noise ratio on a high-level channel of 60 db or better with the bass control in the maximum-boost position. Now change the selector switch to the phono position, pull out the cable from preamp to pickup, insert a suitable terminating resistor, screen it, and take another reading. The hum level will probably be higher than for the high level input. In the best systems it will range between 50 and 60 db and possibly better; in less expensive ones it may be no more than 30 db. In other words, if on a high-level channel you get a reading across an 8-ohm speaker line of 10 millivolts or less, and with magnetic phono input of 30 millivolts or less, the equipment is pretty close to the optimum noise figure, and the chances are that you can make some slight—and that's all—improvement by adjustments and tube changes as detailed later. If, on the other hand, the meter reading exceeds these figures, some more serious fault is involved.

Repeat the same process but this time with the cables from tuner and pickup connected to the amplifier or control unit. The reading may rise slightly. If it rises markedly, start looking for hum in the tuner or pickup and turntable combination.

Minimizing hum by proper adjustment

In many cases residual hum can be reduced as much as 20 or 30 db simply by adjusting the equipment properly. Many hi-fi amplifiers have hum controls, usually a potentiometer across the filament string which produces exact balance in the filament loop. (R_0 , in Fig. 903-a.) Watching the voltmeter, adjust this control to produce the lowest reading. An independent control unit or preamp may also have a hum control. Adjust this too.

Some amplifiers do not have such a balancing arrangement, but the heater winding on the transformer is provided with a center tap, which is return to ground, as in Fig. 903-b. If there is serious

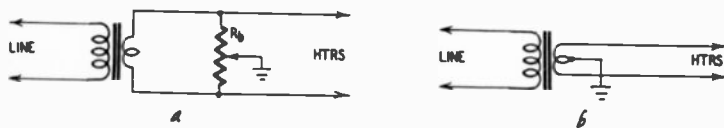

Fig. 903-a. -b. Methods of minimizing hum. If the filament transformer does not have a center tap, a variable resistor can be shunted across the filament winding as shown.

60-cycle hum, check the heater grounding. If you cannot see any connection to ground, try making a temporary connection with a clip lead. If there is a center-tap ground you did not know about, connection of the clip will make a spark, due to shorting out half of the winding (don't keep it shorted!). If there is no spark, but the hum drops considerably, it is evident that the heaters were not grounded, so a suitable connection must be added permanently.

Balance of output tubes has a significant effect in decreasing hum. Output tubes are usually fed plate voltage from a point in the power supply where the ripple is quite high, and hum reduction is achieved by the cancellation due to push-pull operation. For greatest cancellation, the output tubes should be balanced as closely as possible. To do this, remove the driver tube (if the amplifier does not use a direct-coupled driver) or the inverter (if the amplifier does use direct-coupled drivers) and adjust the balance control (R_0 of Fig. 904) for minimum reading on the voltmeter. If minimum reading is obtained at the extreme position of the balance control, the chances are high that the tubes are too badly matched to be balanced exactly. First, try reversing the tubes and adjust again. If you obtain balance somewhere short of the extreme position, okay; but if again minimum hum is obtained only in the extreme position (this time the other extreme), replace one or preferably both

tubes and try again. If the amplifier has no balancing control, try changing tubes and choose a pair which produces the lowest hum.

Diagnosing hum

Having reduced hum due to the output stage to a minimum, we can proceed to track down hum coming from earlier stages. The first problem is to determine the nature of the hum. Hum will be either 120- or 60-cycles or both, but usually one will dominate. If the hum is sufficiently audible, you can analyze it by

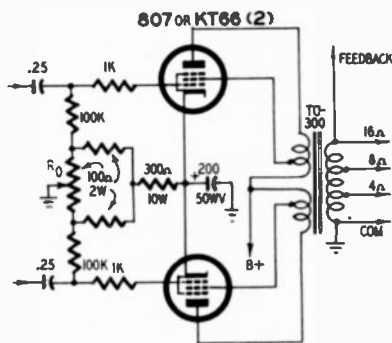

Fig. 904. Setting of potentiometer R_0 helps balance output tubes.

listening. Hum of 120 cycles is higher in pitch; 60-cycles is very low in pitch. A scope will provide positive identification. Connect it across the amplifier output. Feed a 60-cycle sine wave into the horizontal sweep channel. Some scopes provide an internal 60-cycle sine-wave sweep; if yours does not, use an audio generator or feed a portion of 60-cycle line voltage from the filament string. The scope pattern will show whether the hum is 120 or 60 cycles or a combination. A straight line, circle or ellipse will be produced by 60-cycle hum; 120-cycle hum will produce a lazy-8 pattern or a line with a dip or hump as indicated in Fig. 905.

A 120-cycle hum is produced by full-wave rectifiers; 60-cycle either by half-wave rectifiers or by pickup, leakage or induction, from a 60-cycle line or transformer. If the hum is 120 cycle, you know the trouble is in the power supply, filter or plate supply circuits. If it is 60-cycle hum, you can eliminate the power supply as a trouble source unless it is a half-wave supply—this may be the case in preamplifiers and control units which use selenium rectifiers.

Locating hum

The next problem is to locate the hum by a process of elimination. With the meter across the voice coil or speaker line, disconnect the input from the control unit to the power amplifier (if the two are independent units). If the hum reading falls markedly, the power amplifier can be eliminated; if the reading remains the same or is reduced only slightly, and is still higher than it ought to be, the amplifier is at fault. Assuming the amplifier is eliminated, disconnect various inputs to the control unit and again watch the meter. If disconnecting one of them reduces the reading to a satisfactory level, the trouble lies in the unit disconnected. That unit can now be taken to the shop for more careful analysis, troubleshooting and repair.

The causes of hum

A 120-cycle hum is simply dealt with. It is invariably caused by a fault in the power supply or the decoupling filters. Since this is a problem with which every service technician is presumably familiar and one which is treated precisely the same way as it would be in a radio, we will not waste much time on it. The following list covers almost all the possibilities:

1. Defective rectifier tube or one with unequal emission from the two sections. Try a new tube.
2. Defective electrolytic filter capacitors. Check that values have not deteriorated by paralleling equal values and noting the reduction in hum. If one gives more than a little reduction, remove from the circuit and give a thorough check on capacitor test equipment, or replace.
3. Defective choke; very unlikely but worth checking. Simplest check is to measure the a.c. voltage drop across it. Most likely trouble is a short; the short may be complete or partial by shorted turns. The a.c. voltage drop should be practically equal to the ripple voltage on the first capacitor.
4. Defective filter resistors. Some recent hi-fi amplifiers have no choke at all; all amplifiers and control units use resistors in the final filter or decoupling network. Check these to see that they provide the resistance specified on the diagram or indicated by their markings. Replace them if they don't meet required resistance value within $\pm 20\%$.
5. A.c. line voltage too high or too low.
6. Power supply overloaded. This can occur if accessory units

drawing too much current have been connected into an amplifier power supply or if a bleeder resistor is defective, drops in resistance value and bleeds a much heavier current.

A simple technique for tracing hum is this: Apply the a.c. voltmeter (with a series capacitor to block d.c.) to various points in the filter network, starting at the output of the rectifiers. The meter should show steadily decreasing readings. If at some point the reading does not decrease over that in the previous leg, that is the point of trouble. On the other hand, if the reading decreases but still remains high, the trouble is either in the rectifier or all the filter capacitors have deteriorated more or less uniformly. The

Fig. 905-a, -b. *The advantage of knowing the frequency of a hum voltage is that this information will enable you to do a faster troubleshooting job. Hum due to filament wiring, power transformer or line is 60 cycles, while rectifier output and filter hum is 120 cycles.*

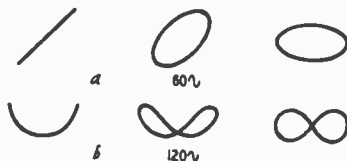

latter is hardly likely except in equipment which is old or in which filters have been damaged by temperature, or have deteriorated by too long an idle period.

60-cycle hum

A 60-cycle hum is much more troublesome and can be a real headache. In the following discussion as in the rest of this book we are assuming that commercial equipment is involved. Home-built equipment presents an entirely different problem and one so complicated by the possibilities of errors in design, construction and wiring that covering all the possibilities would merely confuse the discussion concerning commercial equipment. In dealing with commercial equipment it is fairly safe to assume that any serious increase in hum will be due to a *single* cause. A caution to all service technicians: *When commercial equipment is involved, exhaust all the simple possible causes before starting to tear up equipment or to look for subtle causes.* Following are several suggestions:

1. Try reversing the a.c. plugs of the various units of the system. Although the better systems work equally well whichever way the a.c. plug is inserted, some are particular in this respect!

2. Check to see that the jacks of the interconnecting cables produce good grounding. They may be loose or dirty. Often the joint between cable shield and plug is loose, broken, open or intermittent; resolder it.

3. Be sure the hum does not originate in the phono pickup, turntable, or cable between pickup and preamplifier. This is easily verified by disconnecting the cable at the preamp and closing the circuit with a suitable resistor, shielded, if necessary; if hum falls to an acceptably low level, the trouble is in the pickup or turntable. Reconnect the cable to the preamp and now check the hum reading when the phono motor is running and the pickup is on blank grooves of a record; when the phono motor is shut off and the pickup is at rest. If in the latter case the reading is about the same as when the pickup cable is removed from the preamp, the trouble is in the turntable or the coupling of pickup cable to the turntable motor or a.c. line. Touch the tone arm with your finger. If hum is reduced, ground the arm. This is most likely to be necessary when the arm is mounted on wood. A ground can be run from one of the mounting screws of the arm to the grounding lug on the motor.

Check the hum reading, with the phono motor running, as you move the arm just above the turntable. If the hum increases as the arm is in certain positions above the table, it is due to pick up of the magnetic field of the motor either by the pickup itself or the leads from pickup to terminals.

The lead from the pickup to the arm terminal may be either a twisted pair or a shielded wire. First check to see that the joints at the pickup itself are firm. Many modern arms use slides which plug into brass clips. Check these to see that when the slide is inserted, the contact with the clips is solid and does not have a high resistance. Clean the contacts and plugs. Push them together so that they definitely grip the pins. In many systems the connection between cartridge and slide or cartridge and cable is through sliding clips. Check to see that these give a good connection. If the lead is soldered to the pickup, check the joint. In many cases a loose or high-resistance solder joint here will produce very high hum levels. Sometimes one lead of the pickup cable can be completely disconnected and still produce sound; but if it is the ground lead which is disconnected, the hum will be very high.

In many cases hum can be reduced very greatly by using a two-conductor shielded pair from the terminal on the arm to the preamplifier. Connect the two internal leads to the two terminals on the arm or the two leads from the pickup; connect the shield only at the preamplifier or amplifier. Then if hum is not completely reduced, try running a separate ground from motor frame

to amplifier or preamplifier chassis. This is indicated in Fig. 906.

If, after all this, the hum with the pickup connected to amplifier is still high, but with it disconnected from amplifier it is low, the chances are very high that you can do nothing more short of replacing the turntable and/or pickup with units capable of lower hum.

Tuners

Similarly, before digging into amplifiers, be sure the hum is not located in the tuner or tape recorder. Again this can be

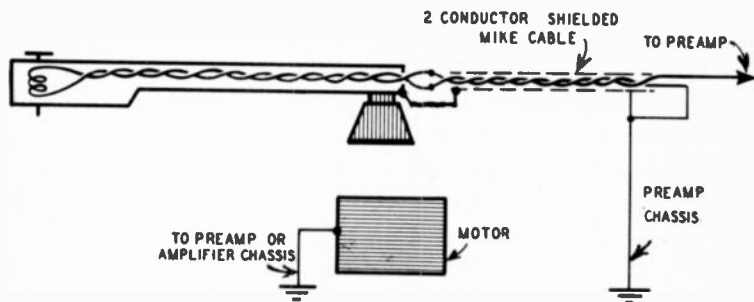

Fig. 906. Technique for reducing hum pickup in tone-arm leads. It often helps to run a separate ground to the motor frame.

checked by noting hum readings with and without disconnecting the tuners or tape recorder.

Hum in tuners caused by inadequate filtering of the power supply is due to the same causes as those previously listed. The cause of hum peculiar to tuners is modulation. This hum is usually tunable and may be greater when the station is tuned in than when the tuner is between stations. It is generally due to defective or missing line-filter capacitors, to heater-cathode leakage in r.f. tubes or to inadequate filtering of the plate-voltage supply to the oscillator in a superheterodyne. All of these problems should be familiar to the radio or TV service technician.

Amplifiers

Assuming all the previously discussed causes have been eliminated, the next assumption is that the fault is within the amplifiers or due to a ground loop. First, determine which of the units is at fault—if power amplifier and control units are separate. Do this by watching hum reading when the control unit is dis-

connected from the amplifier. If disconnecting it produces a ratio very close to the design ratio of the amplifier, the trouble is in the control unit. On the other hand, if disconnecting the control unit does not reduce hum to a value completely acceptable, the trouble is in the main amplifier or a ground loop in the system.

There is a great variety of possible causes of hum in amplifiers; but in commercial equipment the cause is likely to be quite simple and single, though it may be hard to find. Following is a listing of the more common causes.

1. Misadjustment of balance and hum controls.
2. Faults in power supply.
3. Hummy tube. This is the most frequent and common cause of hum in commercial amplifiers. The most likely offenders are the miniature twin-triodes so commonly used—12AX7, 12AU7 and 12AT7. They may develop heater-to-cathode leakage after a period of use or after being subjected to some shock. The service technician who does a lot of hi-fi servicing is well advised to have a set of these tubes which he knows to be free of hum. Replace tubes one by one and note the meter reading or audible hum. In as many as half the cases of hum, this simple change of tubes will solve the problem. Tubes may become magnetized, and as such will be considerably more susceptible to hum pickup. This is most likely to happen when an amplifier is placed in the vicinity of the field of a loudspeaker magnet. If you have demagnetizing equipment, try demagnetizing hummy tubes; also the shield around input tubes. In some cases the shields of these low-level audio tubes have been removed or lost. Check for this, replace if necessary; and wherever a tube is shielded, check to see that the shield makes a firm contact with the chassis.
4. A very simple cause of increased hum is the accidental grounding of one side of the filament string in amplifiers using positive bias on the filaments as shown in Fig. 907. This grounding is not likely to occur when the amplifier is in normal use; but it can occur when troubleshooting, signal-tracing or resoldering joints or when a loose piece of solder or end of wire rolls against a filament lug on a socket. Grounding one side of such a filament loop will remove the biasing and therefore the hum reduction it provides; it will also unbalance the loop. A simple ohmmeter check can show this up. In a biased filament string the reading from either filament contact on a socket to ground should provide a high resistance—at least 300 ohms if the positive bias comes

from the cathodes of the output tubes as in Fig. 907-b and probably anywhere from 5,000 to 20,000 ohms if the bias is provided by a voltage divider across the power supply as in Fig. 907-a. If the resistance is zero, the string is grounded; search for the point of grounding. It may be nothing more than a filament lug bent down so it contacts a grounding lug on the socket frame. A tube with a heater-cathode short will do it, too.

In some cases, hum control is obtained simply by a potentiometer across the filament string, without positive bias (Fig. 903-a). Again the grounding of one side can increase hum by as much

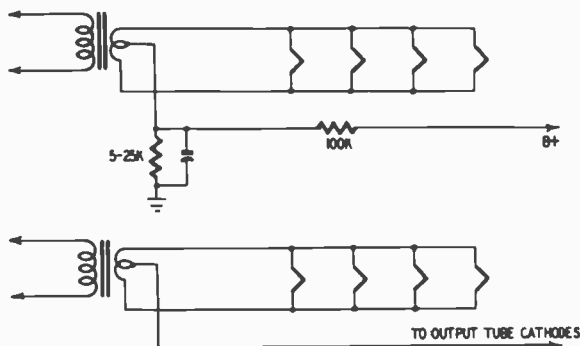

Fig. 907-a, -b. Biasing the filament strings will help reduce hum.

as 10 db or more. Such loops have no center tap on the filament transformer; and again grounding will be indicated by zero resistance to ground, whereas proper configuration will be indicated by a resistance of a few ohms at least.

5. Bad cathode or screen bypass capacitors can produce hum. An open cathode bypass has two effects. It decreases gain which may reduce the signal-to-noise ratio and it increases the effect of heater-cathode leakage by eliminating the low-impedance path through the capacitor. Many hi-fi amplifiers, however, use unbypassed cathode resistors to obtain negative current feedback and, in such cases, the amplifiers should provide a good hum ratio without such capacitors.

6. Hum can increase by mismatch in the two sides of a push-pull stage, particularly a form of modulation hum that changes with signal. The same situation can arise in earlier stages. Measure the plate load resistors on opposite sides of a push-pull pair. In hi-fi equipment they should be equal certainly to within 10% and preferably to 5% or less. If the difference is high, replace one

resistor with one as close as possible in value to the other. A match is especially important in the cathode and plate loads of the cathodyne phase inverter used so commonly and diagrammed in Fig. 908. The total cathode resistance and the plate resistance should match to 5% or better. The total cathode resistance is the total from cathode to ground; in many cases this consists of two resistors as indicated. When making adjustments change only the lower one; the upper sets the bias on the tube and should not be changed from the design or specified value.

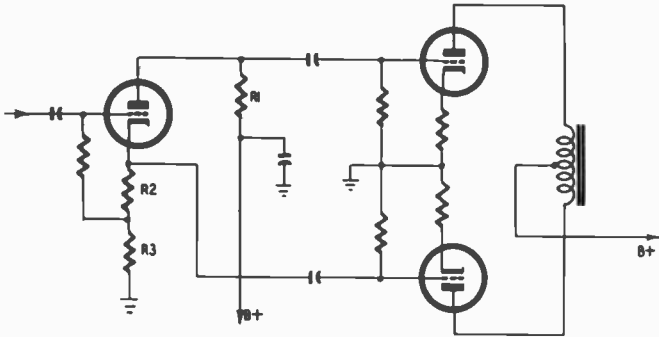

Fig. 908. In the cathodyne phase inverter, plate load $R1$ should equal the sum of cathode resistors $R2$ and $R3$.

7. The failure of a feedback loop can increase the hum greatly. In any case disconnecting it should produce higher hum. If it does not, the trouble is in the loop itself. It is possible that closing of the loop increases the gain at 60 cycles, due to a peaking effect, while it reduces the gain at all other frequencies. This would be one cause that could reverse the usual effect. Correct by the methods outlined for eliminating low-frequency peaks.

Do not overlook the loops in feedback pairs in control units. They appear as in Fig. 909. Sometimes these loops are used for tone-control purposes but in many cases they are there to reduce distortion. Failure of capacitor C_{FB} may open the loop, which will increase hum in two ways. First, by increased amplification of hum developed in previous stages and second, by eliminating hum reduction produced by feedback. An open capacitor can be checked simply by clipping a good capacitor across the one in the circuit. If gain decreases, the capacitor is open; if gain stays the same, the capacitor is good. Excessive bass boost, amounting to peaking, can also produce hum.

8. Leakage across tube sockets from heater pins to cathode or grid pins can increase hum. Check for and clean off dirt or grease

on the socket. Also check to see that tube pins make a firm contact in the socket. These remarks also apply to any plug and socket connections.

9. Improper bias may cause increased hum in some stages. This can be the result of a failure of the bias resistor or leakage in the cathode bypass or the coupling capacitor. Check resistance with and without the capacitor connected. If it is greater with it out, the capacitor has too much leakage and should be changed. Bias may vary, however, by as much as 25% from specified value

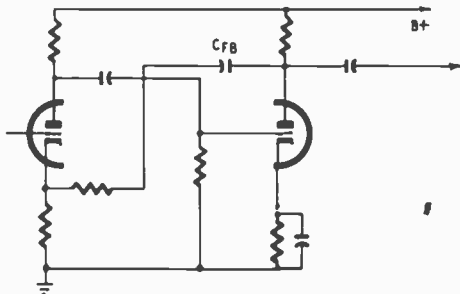

Fig. 909. *Opening of the feedback capacitor will increase the hum level.*

without serious effects; change the resistor only if the variation is much greater than this.

10. If a lot of signal tracing and prodding has been done on the amplifier looking for other faults, it is possible that grid leads have been shifted too close to filament leads or dressing in general has been disturbed. Try locating the lead whose position affects the hum level. You can do this by using an insulated prod or screwdriver and pushing the grid leads this way and that.

If none of the previous measures solves the problem, then the probability is high that the hum is due to a ground loop in the entire system or some portion of it. Commercial units can be presumed to be free of built-in ground loops; however, especially in highly complicated assemblies, ground loops can easily be provided by interconnecting cables.

Ground loop problems*

A ground loop has some of the most puzzling characteristics imaginable. For example, the better the grounding connection, the worse the hum becomes.

*Based on the article "Ground Loops and Hum," by Hector E. French; RADIO-ELECTRONICS Magazine, April 1954; p. 56. Copyright 1954 Gernsback Publications, Inc.

The reason for this unusual result is easy to understand when the ground loop is reduced to its basic form, as shown in Fig. 910. The ground side of the signal circuit ties the chassis together and the individual lead from each chassis to ground completes a loop. This loop has no apparent source of voltage; but this circuit is actually a one-turn pickup loop, which immediately proceeds to couple itself enthusiastically to every power line in the vicinity. Since there are a.c. lines often running through the floors and walls, it isn't hard to visualize the induced circulating current.

Once this circulating current is set up, there will be a voltage drop along the ground wire between the two chassis, which appears

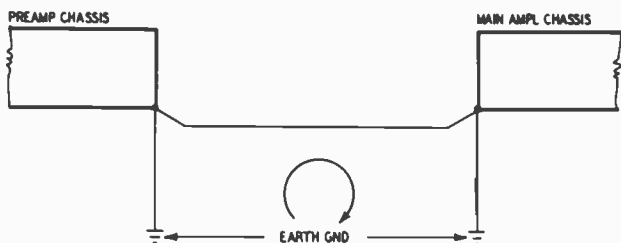

Fig. 910. Ground loop acts like a single-turn hum pickup coil.

at the input to the main amplifier as a 60-cycle hum mixed with the signal (or 50-cycle hum, in the 50-cycle power areas). To make things even worse, the lower the resistance from each chassis to ground, the higher this circulating current and the louder the hum.

The cure is simple. Since the amount of hum depends on the area of the loop, reducing the loop area should reduce the hum. Fig. 911 shows how this can be done by running the grounding wire of the preamplifier right along with the other conductors. This approach makes the circulating current vanish when the area of the loop becomes very small.

This might be all right with just one amplifier and preamplifier, but when there are a number of preamplifiers feeding one main amplifier (such as a phono preamplifier, a tape preamplifier, an FM preamplifier, etc.), the resulting wiring can become a major project. Then it becomes much easier to break the ground loop completely. This is done by grounding only the main amplifier and depending on the ground side of the signal circuit from each preamplifier to bring all the chassis to the same potential, as shown in Fig. 912.

But even here it is possible to run into trouble if a few simple

precautions are not observed. Each ground line between the chassis must be solidly made with heavy wire. Each preamplifier must have its own individual ground wire to the main amplifier, and these grounding-line connections must be made between points on the various chassis that are a true ground potential.

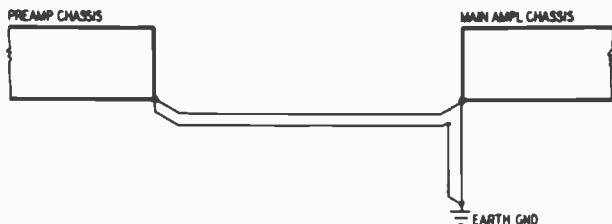

Fig. 911. Method for reducing ground loop effect.

The reasons for using a low-resistance connection between the chassis is obvious, since the whole intention of the connection is to bring the two chassis to the same potential. If the ground side of the signal circuit has a questionable resistance, as is sometimes the case with braided shielding, it will do no harm to run a heavy

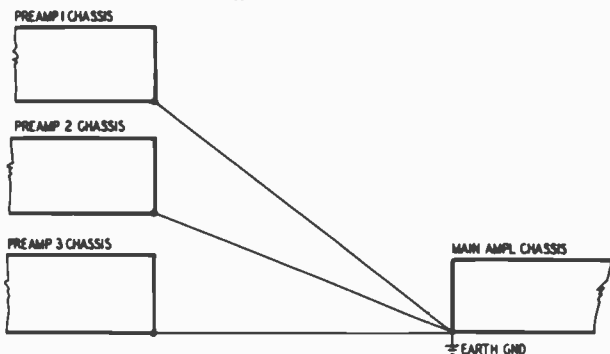

Fig. 912. Ground loop is broken in this procedure.

chassis-to-chassis wire in parallel with the signal-circuit wiring to make sure the resistance is low. Be careful to keep this wire as close to the signal circuit as possible, otherwise another one-turn inductive loop may be set up and the same old trouble will appear again. Or use a multiconductor shielded cable between the chassis, with the extra conductors as the chassis-to-chassis connection.

Capacitive coupling

The precaution that each preamplifier have its own individual ground wire to the main amplifier is to remedy a certain disagree-

able habit of power transformers, phonograph motors, tape drive motors, and similar components of creating capacitive coupling to the power line through the transformer or motor.

This coupling effect is usually shown as being due to one equivalent capacitor, connected to one side of the power line, as

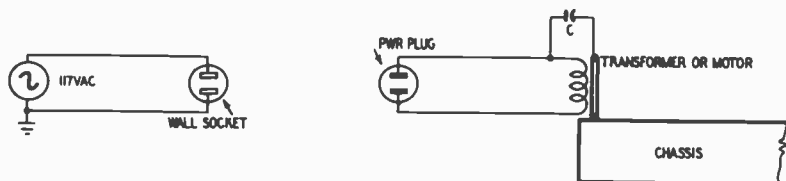

Fig. 913. Capacitance between motor windings and core can result in electrostatic transfer of hum.

in Fig. 913. Since one side of the power line is grounded, with the standard grounded-neutral wiring, it is obvious from following through the schematic that, when the power plug is inserted the wrong way, the entire power-line voltage is capacitively coupled to the chassis. To demonstrate, connect an ordinary 1,000 ohms-per-volt a.c. meter between the chassis of an amplifier and a water-pipe ground. With the meter set to the 10-volt scale, each

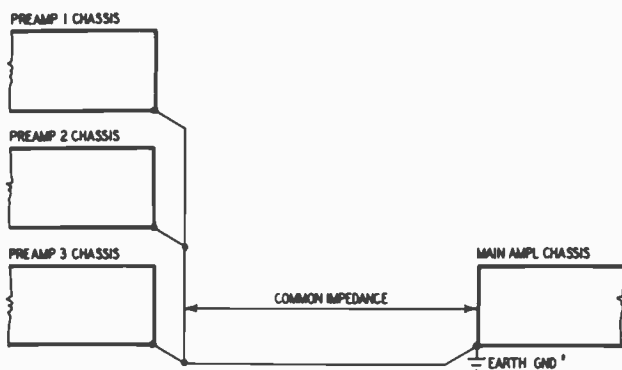

Fig. 914. This is not a good technique. Each preamp should have its own ground line.

volt indicated on the meter means 100 microamperes of charging current is flowing into the capacitor and then to ground through the meter. Reversing the power plug will change the current.

Ordinarily, this charging current flows directly to ground and can be forgotten. But when more than one preamplifier is connected to the same chassis-to-chassis ground wire, the current from one preamplifier will raise the potential of the next chassis above

ground again (Fig. 914). This is the same old trouble that existed at the beginning, where the different chassis all had different potentials with respect to ground. Plugging in the power cord the right way on all the units will reduce the effect, but it is obviously better to avoid the whole problem by providing each pre-amplifier with its own grounding wire to the chassis of the main amplifier.

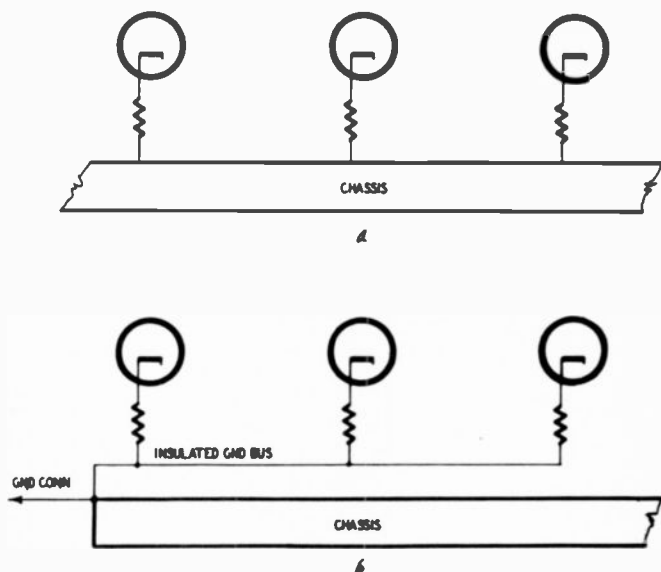

Fig. 915-a, -b. Hum voltages in the chassis (a) can be avoided by using an independent ground line (b).

Connecting two capacitors in series across the power line *inside the chassis*, with the junction of the two capacitors grounded to the chassis, is often given as a sure cure for hum reduction or prevention. The reason this does not always work is that it is effective only for shorting out the *high-frequency* interference, which is often hum-modulated and therefore appears as hum when it is rectified somewhere inside the equipment. The *power-frequency* charging current is always increased by this type of simple filter, and this current can cause additional hum if it is not allowed to flow to ground through its own ground wire.

Grounding the connections between points on each chassis which are at a true ground potential is especially important when a power transformer or motor is mounted near the chassis. The magnetic field around the motor or transformer will induce circu-

lating currents in the chassis itself. As a result, two points only a few inches apart on the chassis can be at different potentials, even with a good, heavy chassis. So if any part of the chassis is included in the signal circuit, a hum problem can develop. Some of this hum is introduced into the signal by the grounding of the individual stages of the amplifier, as shown in Fig. 915-a. If the heater current of the tubes or the charging current of the first filter capacitor should pass through the chassis, a hum problem is practically built into the equipment.

The only sure way to avoid this kind of hum is actually very simple and requires only a little planning when wiring the equipment. This is to use an insulated ground bus inside the chassis for the ground point of all the circuits. Then connect this bus to

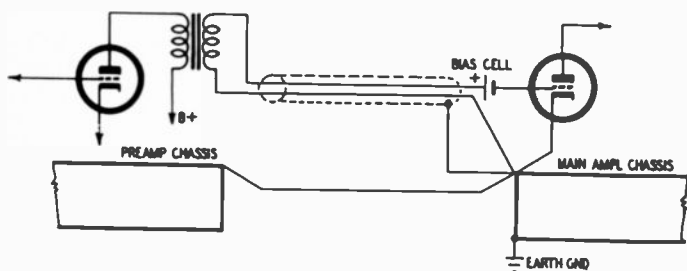

Fig. 916. Method for minimizing hum due to long line between preamp and main amplifier.

the chassis at only one point—the point where the ground connection *between* the chassis is connected as shown in Fig. 915-b.

Even after taking all these precautions, there is sometimes a small amount of hum present. In such a case, especially with high-gain equipment or when there is a considerable distance between the preamplifier and the main amplifier, there is a simple change in the circuit design which will usually eliminate all remaining traces of chassis-to-chassis hum. This change requires only a transformer at the preamplifier, with the connections made as shown in Fig. 916. With this hookup, the signal-circuit ground line and the chassis-to-chassis ground line are in two separate circuits, and any hum developed between the chassis does not appear in the signal circuit. Using a grid bias cell instead of the usual cathode biasing resistor and capacitor, adds the finishing touch to what can be an entirely hum-free installation.

In the case of home-built equipment, if the preceding measures

do not solve the hum problem, advise the customer to rebuild completely, adding the following safeguards:

1. Put power supply on separate chassis.
2. Build amplifier portion on nonmagnetic chassis.
3. Apply such hum-reduction measures as bias on filament string or d.c. on filaments of preamp.
4. More thorough shielding:

In some cases equipment may be living up to the specified hum ratio but the hum is still higher than the customer can tolerate. Hum can be decreased by these measures:

1. A turntable and pickup with lower hum.
2. Building a small d.c. filament supply for the phono preamp and control unit.
3. Increasing the filtering of the power supply by increasing capacitance of filters, adding V-R tubes, replacing resistors with chokes, etc.
4. Adding a balancing potentiometer to output stages which have no balancing provisions.
5. Applying positive bias to the filament string.
6. Covering power transformers with sheet-iron cans well grounded to chassis.
7. Using a piece of sheet aluminum or copper on the shelf on which amplifiers, tuners, etc. are placed to provide a low-resistance common ground and shield.

Hum caused by motor or pickup

Hum can be due to the motor type, its location in relation to the pickup, and the sensitivity of the pickup to hum. In general, the lower the output of a pickup, the more susceptible it is to hum. So, when hum is very annoying, it may be worth while to replace the cartridge with one of a higher output and a better signal-to-noise ratio. In many cases, the new high-fidelity ceramic cartridges might well be used. Their frequency range and distortion characteristics are scarcely distinguishable from those of the lower-priced magnetics and they are much less susceptible to hum pickup.

Sometimes, a low-impedance magnetic pickup will improve the hum ratio because the hum picked up by the leads is lower in proportion to the desired signal. Such a pickup will require a matching transformer which must be positioned carefully.

If we seem to have spent quite a bit of time on this subject of hum, it is only because it is an ever-present problem, and an

extremely common audio trouble. Often the difficulty is a simple one, involving only the replacement of a filter capacitor or a tube. Sometimes the source of hum can be an extremely exasperating thing to track down and may be due to factors which are by no means evident.

Other problems of phono pickups (and styli) are described in the next chapter, beginning on page 165.

phono pickups and styli

No section of a high-fidelity system has as many opportunities for marring performance as the phono playback portion. Moreover, few audiophiles and not all service technicians know how to diagnose phono troubles. As a result, many systems may be operating at only a fraction of their possible high performance.

Most people are well aware of the fact that a poor stylus can noticeably increase distortion and ruin records. Unfortunately, there is still a great deal of confusion about needles, their care and testing. All needles wear with use. Even diamond tips need replacement if record wear is to be avoided and true fidelity is to be maintained. The primary problem is how do you know when to replace a needle? It would be most convenient if there were some categorical answer such as 20 hours for a sapphire tip and 100 hours for a diamond tip, but the sad fact is that there is no simple guide and there can never be one. The only foolproof way of determining whether a stylus needs changing is to check its condition often. There are several methods which together or separately can determine needle condition very accurately.

Visual inspection

The oldest method is that of visual inspection with a magnifying glass or microscope. Although this is common practice, it is not always positive in its results. When inspection shows that a needle is chipped or has visible flats, one can safely conclude that the needle should be changed (See Fig. 1001). But on LP needles

particularly, it takes an experienced hand and eye to recognize flaws capable of causing distortion and severe record wear. These defects are not revealed by direct observation, but rather by differences in the reflection of light. They require that the needle or pickup be turned and a light source moved to hit the needle from various angles. A perfect stylus will have a uniform appearance

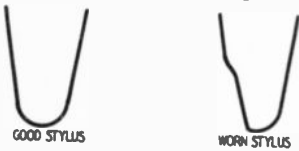

Fig. 1001. It is often difficult to detect needle wear, particularly without the use of a magnifying glass. Sharp reflections when the needle is held up to the light indicate flats. Uniform light reflection shows that there is no perceptible wear.

and reflection of the light on all sides. A needle with flats will produce an increased reflection of light on the sides having the flats.

Styli accumulate considerable dust and grime, often enough to obscure visible damage. Before examining them, first clean with a fairly stiff dry brush and then with a softer one dipped in

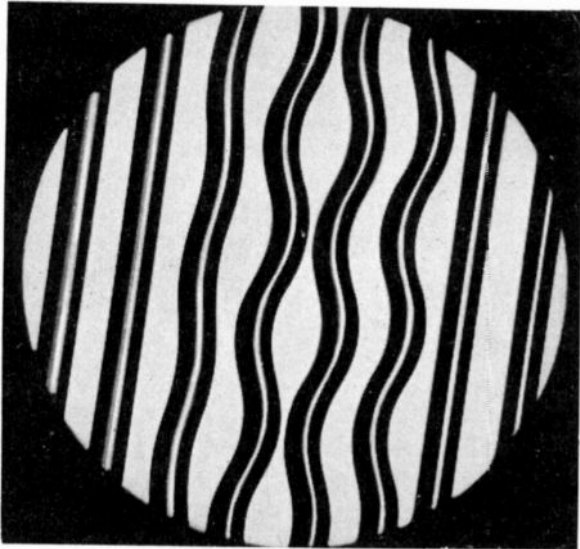

Fig. 1002. Microphoto of record showing grooves with and without modulation.

cleaning fluid, so that the film is removed and the surface of the jewel is exposed.

Indirect methods

There are substitute methods for visual inspection more effec-

tive in diagnosing early damage. An old technique, and still a good one, is to use a soft lacquer recording disc, part of it with unmodulated grooves (Fig. 1002). The needle is first placed on the portion without grooves. A quarter can be placed on top of the cartridge to weight it down a little, and the pickup is kept from skating clear off the disc with a light pressure of the finger on the inside, which guides the pickup in a spiral. The record surface is then inspected. If the stylus leaves any considerable scratches or

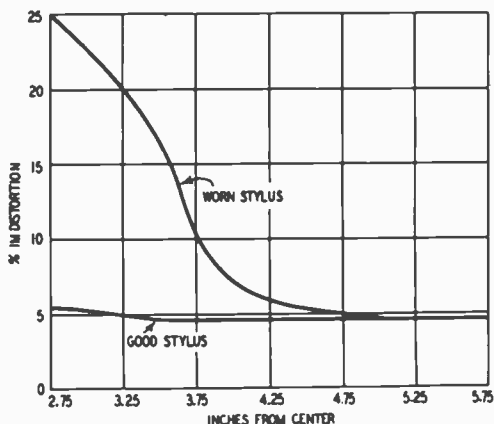

Fig. 1003. A properly tracking needle will produce little IM over the entire disc radius.

grooves, it is undoubtedly cracked or chipped at the point. A good 78-r.p.m. needle will leave almost no sign of scratches or grooves; microgroove styli may leave a barely visible mark, but they should not dig a definite groove. This procedure checks the stylus point itself. In checking for flats on the sides, the needle is allowed to run in the unmodulated groove. The groove is then examined through a magnifying glass with an oblique light. A cutting needle leaves a very distinctive pattern, uniform and constant. When a needle with sharp edges is run through it, the pattern is changed. A comparison of the grooves through which the playback needle ran and those untouched will indicate the extent of the record damage.

Actually, testing needles for the damage they can do to records, though important, is not conclusive from a high-fidelity point of view. A needle can be good enough to cause no visible damage to a record long after it has reached a state where the distortion it contributes is not tolerable for true high-fidelity performance

(Fig. 1003). Until recently the total distortion of record reproduction was very high since it involved the distortion recorded on the disc, which increased with use, and the portion produced by stylus and pickup and finally a considerable amount contributed through the hum, wow and other characteristics of the turntable. The industry has been hacking away effectively at these residues. Recorded distortion is today only a fraction of its former counterpart. Cartridges and pickups have also been greatly improved in this respect. Engineers have been hounding the hum and rumble problems of turntables until it has often been reduced to so low a level that it can be disregarded. Thus, today, the stylus accounts for a much higher portion of the overall distortion than ever before. A pair of "before and after" photos of styli are shown in Fig. 1004.

Stylus distortion testing

The Cook series 10 test records offer one of the earliest and still one of the most effective means of testing needle condition. To measure the translation loss of a needle at high frequencies you make a note of the pickup's output level at 10,000 cycles on the outer band of band A of side 1, then move it to the innermost band of the same side, which contains a sequence of 1,000- and 10,000-cycle tones. After readjusting gain so that the output at 1,000 cycles is the same as that of the 1,000-cycle band at the start of the record, you note the reading for the 10,000-cycle tone. The normal translation loss from outer to inner grooves at 33 r.p.m. is a little over 6 db. If the needle on the innermost 10,000-cycle groove gives a reading of between one-third and one-half that on the outer 10,000-cycle band, the needle is fair to good; but if the reading is between one-fourth and one-third or less, the needle is poor. This is a very sensitive method and will spot needles no longer capable of giving high-fidelity performance even when other methods pass them.

Distortion tests can be made with the Clarkstan intermodulation records or the intermodulation bands of the Cook series 10, plus an intermodulation analyzer. The Clarkstan record is the more sensitive indicator because it covers the whole side and exposes differences more sensitively. The intermodulation bands of the Cook record, though very valuable, occupy only the middle portion of the record and therefore do not provide as good a test of the intermodulation due to unequal tracking at various groove diameters.

A good and properly tracking needle will produce very little difference of intermodulation over the entire diameter of the Clarkstan disc. A rise of from 4% on the outermost groove to 6% on the innermost groove might be considered excellent for a good needle, tracking well on a good turntable. A worn needle, however, may produce 25% or even more on the innermost groove,

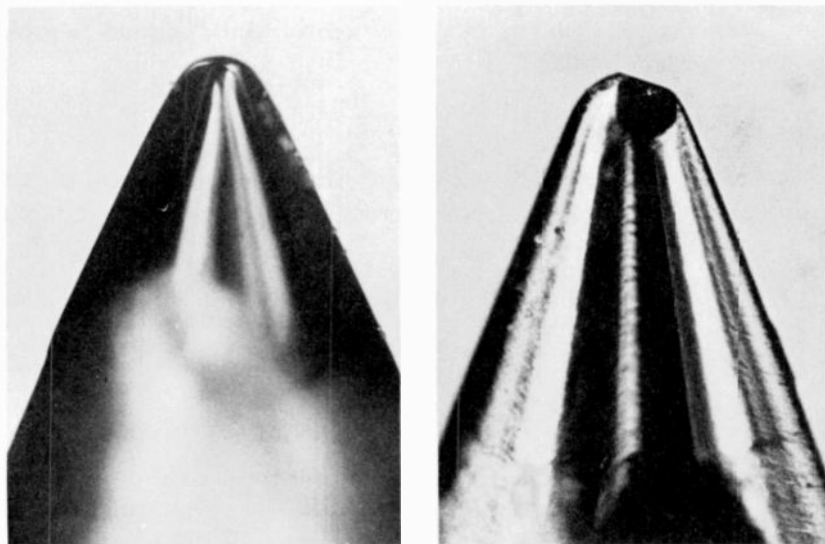

Fig. 1004. The illustration at the left shows a stylus in good condition, while that at the right indicates evident wear. A worn stylus can damage records, produce serious distortion.

though starting with only 4% on the outermost groove. It should be noted that intermodulation records require the use of test equipment and therefore are not well suited for use by the audiophile himself, but rather, are intended for the service technician.

The Cook series 50-NA beam test record can also be applied for this purpose without the use of test equipment. If the increase of IM over that on the disc exceeds 2%, the coded signal audibly changes. This gives a go-no-go indication, provided the distortion of the system from the pickup to amplifier output is less than 2%. The condition of the needle will be indicated by a change in the audible sound as the pickup travels toward the inner end of the disc. If this change occurs at the outer half of the disc, the stylus or its tracking are at fault. If it does not occur until the needle reaches the innermost grooves, it is a fairly safe indication of a good needle.

Sapphire and diamond styli

Although there still seems to be some question of sapphire versus diamond needles, there is no discernible difference in their playback performance. The diamond is superior simply because it takes much longer to wear and yields fine performance for a much longer period (Fig. 1005). When records are played only occasionally, the sapphire is probably the most economical needle; but when they are played more frequently, the diamond is probably the better choice.

Needle alignment

Relatively few people are aware that the alignment of the needle in relation to the groove is very important. A properly cut



Fig. 1005-a, -b, -c. The diamond stylus has a much longer playing life than other types of needles. Although more expensive, it should be used to protect record grooves against damage by easily worn styli.

groove is modulated on both sides. To reproduce the sounds perfectly, the needle should respond equally to the modulations on each side. It can do this only when the angle of the needle is perpendicular to the surface of the disc. A lean to either side of as little as 3° to 5° can increase distortion and record wear very markedly (Fig. 1006).

Checking needle alignment is very simple and so, in the majority of cases, is correcting the alignment. Take a small mirror (such as the unframed one milady probably has in her handbag) and place it on the turntable instead of a record. Gently place the pickup on the mirror. Facing the front of the pickup or cartridge, observe both the needle and its reflection in the glass. Even very small angles are easily observed because the mirror image has the effect of doubling the angle. For perfect performance the needle and its mirror image should make a perfectly straight line (Fig. 1007).

No pickups and few tone arms permit an adjustment for needle angle. Among the tone arms that do are the Pickering, G-E and Gray viscous-damped. In all of these the adjustment is made by varying the pressure of mounting screws which fasten the arm to the table. The Gray has knurled nuts which are individually

adjustable. In Garrard arms the insert into which the cartridge mount plugs can be revolved by loosening a setscrew in the arm.

To correct alignment of arms which offer no adjustment, first remove the cartridge from the pickup. Make a shim of a small piece of paper, thin plastic or old photographic film and insert it

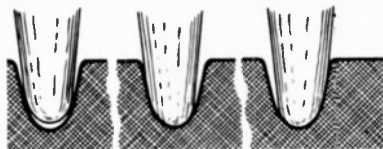

Fig. 1006. For proper sound reproduction, the needle should sit in a perpendicular fashion in the groove. Any tilting to left or right will increase distortion and record wear.

between the cartridge and its mount on one side so that the whole cartridge will be tilted in a direction opposite to the tilt of the needle. Then screw the cartridge back in and test again with the mirror. Ordinarily it will take only one or two thicknesses of 20-pound typewriter paper to produce perfect alignment. If mis-

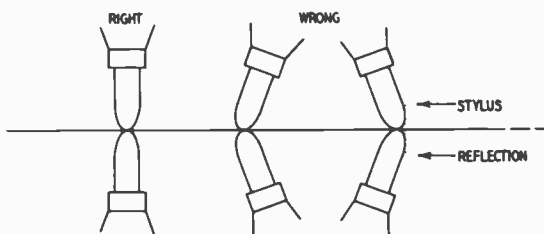

Fig. 1007. Needle alignment can be checked through the use of a small mirror.

alignment is bad, you may have to use a piece of light card stock. In such cases first check the mounting of the arm to the table. It may be loose or unequally tightened.

Alignment in the other plane, that is along the length of the groove, is not quite so important. When a single-play turntable is used, it is generally possible to correct for this angle too. Usually a slight forward angle of from 3° to 5° is best. This will prevent the point from digging into the bottom of the groove. On changers, this angle will vary with the number of records on the turntable, and nothing much can be done about it. However, you should check to see that with only one record on the turn-

table the needle does not dig into the groove. If it does, a shim can be placed at the back of the cartridge to lower the angle.

In variable-reluctance cartridges, particularly the G-E and Audak, the alignment of the needle and its mount in relation to the pole pieces is also important (Fig. 1008). This alignment is adjusted at the factory and should be quite satisfactory—even with the G-E Triple Play in which the whole needle assembly must be moved to change points. Occasionally the needle mount has been distorted by a violent blow or the pole pieces have become bent toward the needle by striking the edge of the record or turntable.

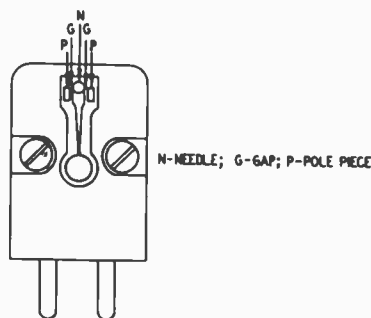

Fig. 1008. *Variable-reluctance cartridge.*

The G-E cartridge calls for an equal clearance of about $10/1,000$ inch between needle and pole pieces. This is best checked with the aid of a thickness gauge of the sort used by auto mechanics to measure spark gaps. However, two thicknesses of 20-pound bond paper are approximately $10/1,000$ inch in thickness. If you take a small piece of such paper, fold it in two and crimp the edge with your fingernail, you will have a gauge which is very close to $10/1,000$ inch. It should slide through both gaps with equal friction. If it doesn't, the adjustment necessary to produce balanced alignment can be made by slightly bending one or both pole pieces toward or away from the needle as needed. No adjustment is possible on other cartridges. We strongly recommend that, if the gap appears to be wrong, the cartridge be returned to the factory.

Tracking angle

The tracking angle of a cartridge is extremely important from a distortion point of view, particularly so with symmetrical cart-

ridges like those used today and with piezoelectric types. Fig. 1009 shows the structure of a crystal cartridge. The ideal motion is one which is exactly at right angles to the faces of the two poles or the planes of the crystal. Since the angle of the arm in the groove varies as the stylus moves from the outside to the inside of the disc, this ideal cannot be met at all points. The tracking angle is a function of the length of the arm and its curve, or the head mounting angle, and the distance between the arm pivot and the turntable center. These quantities can be presumed to have their correct relationship in changers and manual players which come with built-in arms, except when a new type of cartridge has replaced the original.

A good rule of thumb check is: Place a 12-inch record on the turntable and set the pickup so the needle is about half-way be-

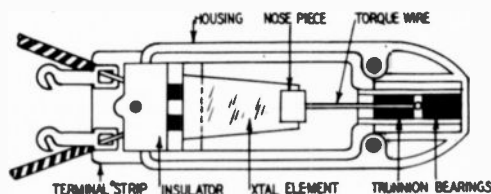

Fig. 1009. Structure of a crystal cartridge.

tween the outermost and innermost grooves. Now sight along the edge of the cartridge, the needle mount or the edge of the lever to which the needle is attached. Estimate whether the line formed by this edge is more or less tangent to the curve of the groove. If it is not tangent, try the same thing on both the innermost and the outermost grooves. If the tracking is tangential or close to it at one of these three points, you can assume that the tracking angle is reasonably good (Fig. 1010). If the tracking seems to miss the tangent by anything over 10° or more at every point, it is an excellent idea to check the instructions which come with the arm or changer. Verify the recommended mounting and check to see that the arm is actually set in accord with these specifications.

Overhang

The simplest measure of correct tracking is the so-called *overhang* of the needle. Carefully place the cartridge on or as close to the center pin as possible. Now observe how far past the center of the hole or pin the needle lies. The proper overhang depends

on the length of the arm. (The length of any arm is the shortest distance from its mounting center to the point of the needle.) In curved arms, it will be the bowstring line on the inside of the curve. The following table gives the proper overhang for arms of various lengths:

Length (inches)	Overhang (inches)
6.5	0.64
7.0	0.60
7.5	0.56
8.0	0.52
9.0	0.47

Unfortunately, the differences are very slight and exact equipment is needed for precise measurement. Generally, it can be assumed that the overhang is close to $\frac{1}{2}$ inch. This offers a rough

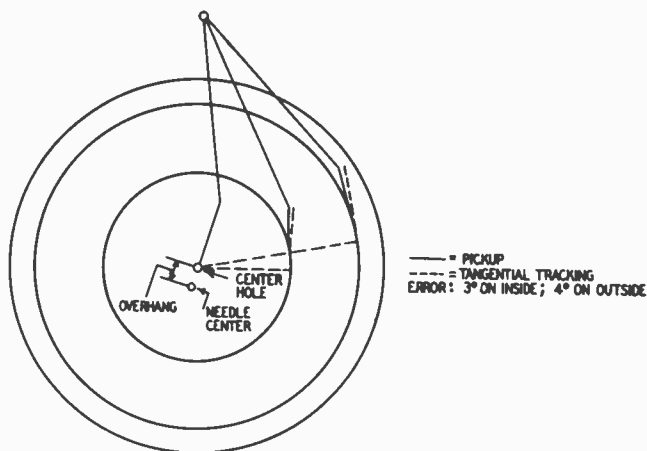

Fig. 1010. The amount of overhang depends upon the length of the pickup arm. See the table near the top of this page for the relationship between overhang and pickup arm length.

rule-of-thumb check. If the overhang is around $\frac{1}{2}$ inch, it is probably okay; if less or more, you'd better check manufacturer's instructions before going further.

In changers, a replacement with a new type of cartridge will often alter the tracking angle. This occurs because the distance

from mounting center to needle center is not standardized. The difference is likely to be greatest when a crystal pickup has been replaced by a magnetic (Fig. 1011). Check the overhang and, if much more or less than $\frac{1}{2}$ inch, see if the cartridge can be moved forward or back enough to produce the proper overhang. Unfortunately, this is not always possible. The G-E for instance, allows no leeway in this respect. The Pickering cartridge comes with a special mount and it can be positioned more closely. If you should be asked to install a new cartridge, you would do well to check the effect on the tracking angle of the new cartridge. If the angle will be badly disturbed, you may be able to use a cartridge which permits adjustment or one whose dimensions

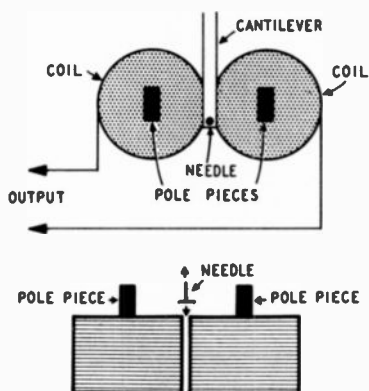

Fig. 1011. *Magnetic pickup cross section.*

will produce good tracking. If a new cartridge would disturb the tracking angle greatly, the customer may be better off with the old cartridge (even if it is of inferior quality) because a poor tracking angle will multiply the distortion so severely that overall performance may be much poorer.

Don't jump at conclusions about tracking angle. Keep in mind that opinions differ and that appearances can be very misleading. The Ferranti pickup for example, will appear at first glance as if it produces a terrible tracking angle. Actually, the element of the Ferranti pickup is mounted at an offset angle of 23° in relation to the axis of the arm so that the angle is very good indeed. In the Pickering arm the actual cartridge mount has an angle and therefore the tracking angle is not accurately indicated by the overhang which should be $\frac{1}{4}$ inch for 12-inch records.

Needle pressure

There is an optimum pressure for each cartridge and the manufacturer's recommendations should be followed as closely as possible. Listed in the following chart are some of these recommendations.

Manufacturer	Type	Pressure (grams)
Audak	all	6-9
Clarkstan RV	78-r.p.m.	20
Clarkstan 204	microgroove	6-9
Clarkstan 204	78-r.p.m.	9-15
Elac		6-8
Electro-Voice Ultra-Linear		6-8
Fairchild		4-6
Fentone		6-8
Ferranti (fixed in arm)	microgroove	3
	78-r.p.m.	5
G-E	78-r.p.m.	9-16
G-E	microgroove	6-8
G-E Triple Play		6-8
Pickering Turnover		4-6
Pickering D-120M	78-r.p.m.	13-16
Pickering D-140S	microgroove	6-8
Pickering Fluxvalve		2-6
Recotone Goldring		6-8
Ronette		3-6
Titone		6-9
Weathers		1-3

Up to a point, the lower the pressure the better; but when pressure is reduced to a degree where the pickup shows any tendency to skip or to skate, both record and cartridge may be

damaged. Moreover, with too low a pressure, the pickup may not track on high amplitude peaks. Many pickup arms provide a means for varying needle pressure. We do not suggest reducing pressure below the minimum recommended by the manufacturer. Although some cartridges will track with lower pressures, the advantages gained are usually not worth the danger of damage from skipping, skating or groove locking.

The only satisfactory way to measure needle pressure is with a gauge specifically designed for the purpose. Several are available at modest prices and any service technician who does con-

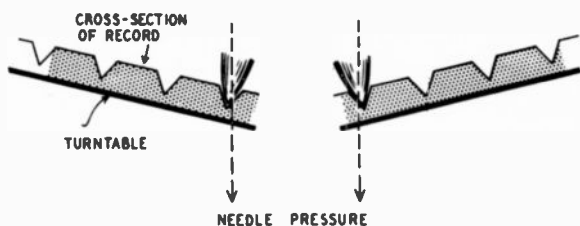

Fig. 1012. For correct needle positioning and pressure, turntable must be level.

siderable phono servicing should own one. Measuring needle pressure is not a casual routine. Unless done properly, the error may exceed 50%, which in the LP range can be serious.

Arm friction

Always measure pressure at the level the pickup is in when a record is on the table, and be sure the needle is free to move in the cup of the gauge the small distance it will have to move as the scale is depressed. As important as the static pressure is the pressure developed when the needle moves upward or downward. If the arm mass is high or the vertical bearings have too much friction, the pressure with a slight vertical displacement may change by as much as 200%. If it is possible, move the gauge up and down about $\frac{1}{8}$ inch from the reference level and observe the reading on the gauge. The pressure will increase as the pickup is raised and decrease as it is lowered. The variation should be not more than about 2 grams for an LP cartridge with a normal pressure of 6 to 8 grams. If it exceeds this (or more than 25% with other normal pressures), examine the vertical bearings of the arm. Adjust and lubricate if necessary. A touch of very light graphite grease or a drop of oil is sufficient. Too much lubricant attracts and holds dirt and increases friction.

When examining the arm for vertical friction, check also the lateral friction. This is very difficult to measure and a delicate touch and good judgment are necessary. For LP records the lateral pressure necessary to move the arm across the record should be not more than 2 grams. The arm should move with the slightest touch and be perfectly free throughout its whole arc. (The Gray viscous-damped arm is an exception). If it does not or if the needle has a tendency to lock in a groove, check the lateral bearings. These are usually one or more ball bearings. An extremely light dab of oil will ordinarily set matters right, unless the bearings have rusted or the grease has solidified, in which case the bearing should be cleaned thoroughly with penetrating oil or cleaning fluid and then dressed with a cloth dabbed with jeweler's rouge. Repack with oil or grease, as recommended by the manufacturer.

Finally, the more mobile the arm, and the lower the pressure, the more likely that a significant departure of the table from level will produce skating or locking. A small mason's level or a string level is a most useful tool for checking table levelness. Balance the turntable in both planes. Level can usually be corrected by changing the pressure on the springs used under the mounting holes. In some instances it may be necessary to level the entire cabinet containing the turntable. Fig. 1012 shows how the stylus may ride the disc on an unlevel turntable.

Replacing needles and repairing cartridges

Of the commonly available cartridges, the Audak, Clarkstan, Elac, Pickering Fluxvalve, Recotone Goldring, Ronette and Titone permit needle changes by the owner or service technician. The rest must be sent to the factory for needle changes. Make no attempt to remove the needle on such cartridges or to make any adjustment. Always use the correct replacement. It is recommended that the cartridge be removed from the arm for all needle changes. This makes the job simpler and provides insurance against damage to arm bearings or cartridge.

turntables and equalizers

The phonograph turntable or changer affects performance principally by masking portions of music with hum and rumble, and by increasing intermodulation distortion because of the hum, rumble and wow. In a few turntables, hum, rumble and wow have been reduced to a point where they have no significant effect on the playback characteristics, but all others have a certain amount of these features which must be tolerated. When these have increased over their original or design value, the service technician may be able to correct the trouble.

Hum can be caused electrically or mechanically. The mechanical variety only occurs when the pickup is on the record. To check this, rest the stylus in an unrecorded groove at the start or finish of a record. Occasionally a hum modulation gets recorded in the start or finish groove, so either be sure you do not have such a record for this purpose, or double check with another disc. If the hum starts as soon as the stylus touches the disc, it is due to a 60-cycle vibration in the table itself, transmitted from the motor. Check the absorbent mounting to see if it has become mechanically short-circuited by the solid parts touching where they should not.

Electrical hum is due to the motor type, its nearness to the pickup, and the sensitivity of the pickup to hum. In general, the lower the output of a pickup, the more susceptible it is to hum. So, when hum is very annoying, it may be worth while to replace the cartridge with one of higher output and better signal-to-noise ratio. In many cases, the new high-fidelity ceramic cart-

ridges might well be used. Their frequency range and distortion characteristics are scarcely distinguishable from those of the lower-priced magnetics and they are much less susceptible to hum pickup.

When hum is bothersome with low-impedance pickups using a transformer, check the orientation of the transformer not only to the phono motor but to any power transformers on the same or adjoining chassis. Such transformers are often triple-shielded and sometimes have two grounding points; it may help to ground

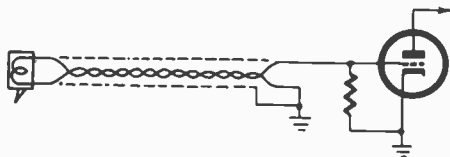

Fig. 1101. Hum pickup can be reduced by using shielded cable from the pickup arm. Ground the shield braid at the preamp.

the outermost shield to the turntable or motor and the inside shield to the preamp chassis or common ground bus.

Quite often the hum is picked up by the cable from pickup to preamp. Check to see that this cable does not pass close to the motor or a power transformer.

Sometimes a considerable improvement can be produced using a two-conductor shielded cable with the shield grounded only at the preamp (Fig. 1101). Often the hum can be decreased by simply transposing the power-line plug of changer or amplifier; in other cases, it may be worth while to ground the motor frame.

When assembling a single-play turntable and arm, *check to see that the arm and drive are positioned so the cartridge is always the maximum distance from the motor.*

Short of replacing a turntable or changer with a low-noise model the above are the only steps a service technician can take to improve hum level.

Rumble

Rumble is produced by motor vibrations reaching the needle by way of the turntable. Ordinarily, the rumble is set by the design and there is little a service technician can do about it. Occasionally one of the rubber mounts of the motor ruptures. This either increases the vibration or decreases the damping—check for it.

Most tables and changers are mounted on springs which not only absorb the external shocks but also damp the motor vibrations. Check to see that the table is actually floating on these springs; often the bolts have been tightened down to such an extent that the cushioning effect has been nullified.

The turntable runs on some sort of bearing requiring grease or oil. The lubricant not only reduces friction but often also serves as a viscous damping element (Fig. 1102). Check the

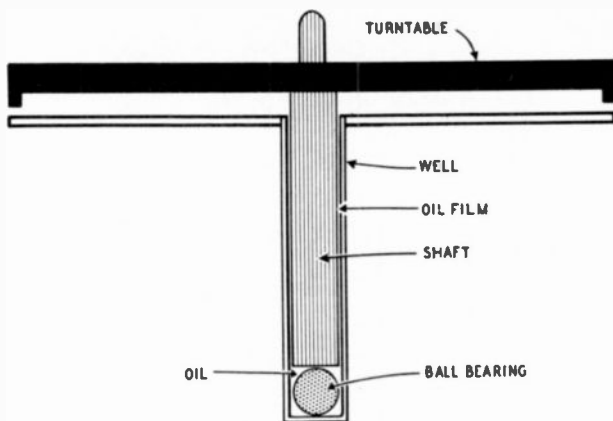

Fig. 1102. Cross-sectional view of turntable, shaft, and support bearing.

lubrication as per the manufacturer's recommendations. Be careful not to overlubricate—excess oil may spray the drive wheel, causing slippage; excess grease may increase friction or catch dust and dirt.

The padding of the turntable, whether felt, flocking, rubber or what not, also serves as a damping element. If its resiliency is gone, the damping is decreased. The new foam rubber turntable cushions may prove a help in reducing rumble.

Wow

Variations in turntable speed, due either to variations in the line voltage or to play and wear in the drive mechanism, produce *wow*. Check with a stroboscopic disc; wow will be indicated by a more or less rhythmic tendency of the pattern to slip backward or forward one or more times each revolution (Fig. 1103). A simpler way is to listen to the tones on a test record. If the

pitch of the tone is constant, there is very little wow; but if the pitch rises and falls, there is considerable wow.

Most hi-fi changers and turntables are driven by a rubber idler, and an increase in wow is almost invariably the result of wear or distortion in this drive wheel. With the table revolving, touch the edge of the turntable to increase the friction and drag. The turntable will slow down but the pull should remain con-

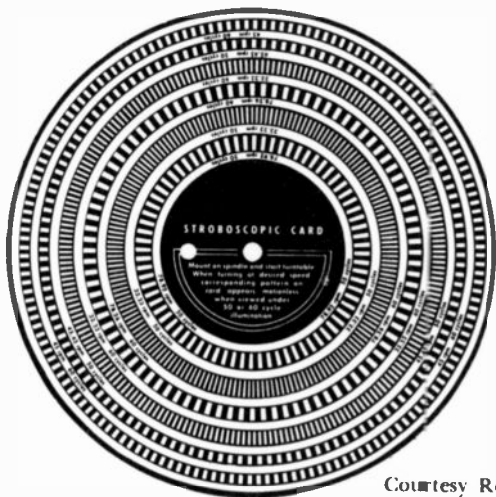

Courtesy Rek-O-Kut Co.

Fig. 1103. Wow can be checked with stroboscopic disc.

stant and smooth. If the drag the finger feels is reduced in some portions of the turntable's revolution, the idler is slipping at these points (Fig. 1104).

If idler and turntable remain in contact in the "off" position, flats may form on the idler, especially if the changer or turntable is used infrequently (Fig. 1105). Such flats are easily felt when the above test is made. The drive wheel or idler should be replaced whenever the wow increases. In fact, it is probably a good idea to replace the idler every 6 months.

Always examine both idler and the turntable rim for any evidence of oil or grease. Overoiling sometimes results in the turntable spraying the rim and idler with the excess oil. The rim can be cleaned off with cleaning fluid. If oil is found on the idler, it can be cleaned off with either alcohol or cleaning fluid. Unfortunately, the wrong fluid is likely to damage the idler and unless the manufacturer's recommendations are available there

is no way to tell which is called for. However, idlers are inexpensive and it is probably the best idea anyhow to replace them. If a new one is not available, you can try one fluid or the other and see what happens.

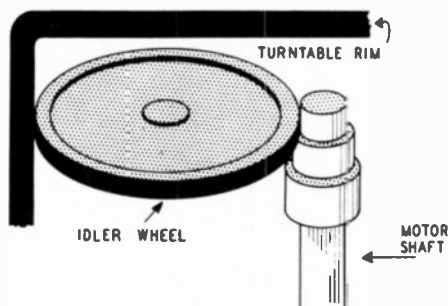
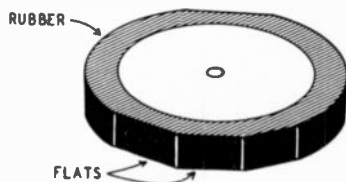

Fig. 1104. The motor shaft drives the idler. The turntable is rotated by the idler.

In most cases the idler is held in position against the turntable rim and the motor shaft by a spring and a slotted mounting. Check to see that this spring is still live enough to maintain pressure. Some service technicians adjust this spring by cutting off a portion of it to increase the tension. This is not a safe practice. It may

Fig. 1105. Made of rubber, the idler can become worn or be deformed. Constant pressure across a small area can produce a flat. If the idler wheel is made of natural (non-synthetic) rubber, keep oil and other lubricants away from it.



temporarily reduce the wow of a worn idler but it is likely to increase the rumble by reducing the damping the spring provides. It is much better to replace the idler or spring entirely.

Equalization

To be heard at their best, records should be played back on systems whose playback curves complement the recording curves. Until recently there has been a confusing variety of recording curves and therefore an equally confusing variety of playback curves. We now have, for American recordings, a standardized curve called the RIAA. However, not all manufacturers even among those professing adherence to the RIAA curve follow it faithfully; many labels depart from it by from 1 to 2 db at various points and sometimes more at the extremes. Still the RIAA

playback curve will provide quite satisfactory reproduction of most American records made since September 1954.

The playback equalization may change with time and correction may become necessary. The simplest and most frequent cause of a shift in playback characteristics is a worn stylus. The translation loss at high frequencies increases rapidly as flats are formed on the needle. Long before a needle becomes dangerous to records, (Fig. 1106) its ability to trace the frequencies above

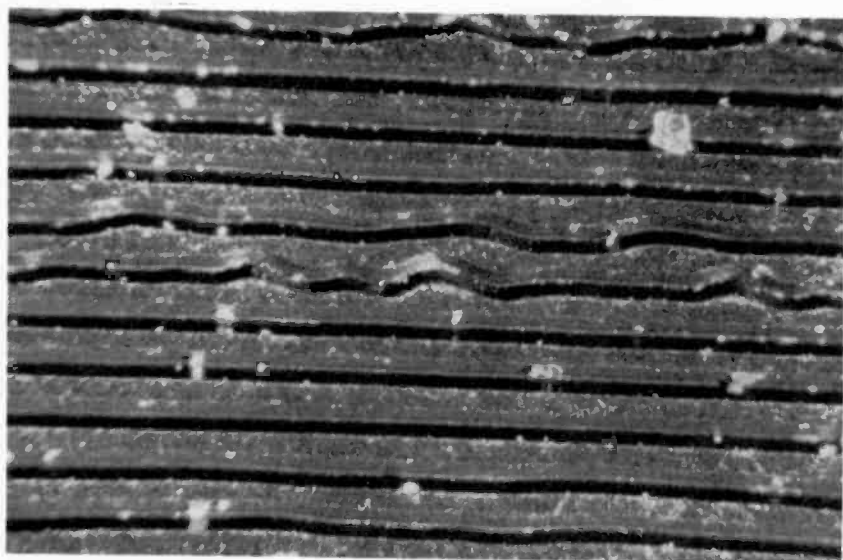

Fig. 1106. Grooves of record after being played with worn stylus.

7,000 cycles deteriorates enough to reduce output above this region by as much as 6 db. The simplest and best check for this is the translation-loss test on the Cook series 10LP record.

Another excellent way in which to check equalization is with the Clarkstan 102-M sweep-frequency test record and a scope. This disc is recorded with LP pre-emphasis. Played back with a good LP equalizer it will produce a reasonably flat trace. Played back with old AES, new RIAA standard, or other equalizers, the trace will show variations from flatness on both ends. The rise at the high-frequency end for the new RIAA standard will be about 2 or 3 db, and for the old AES about 4 or 5 db at 10,000 cycles. Fig. 1107 shows the light pattern of the Clarkstan 102-M disc.

While using the sweep record, watch for possible signs of distortion, resonances and poor transient response. If your scope is sensitive enough, it is best to connect it directly to the output

of the preamp so that troubles caused by following portions of the system are eliminated. Distortion is evidenced by a doubling of the trace at the high-frequency end and by a sharpening of the wave shape at low frequencies into a triangular, rather than sine-wave form. Resonances are indicated by bulges at the resonant frequencies or band of frequencies. Transient response can be checked by watching the very beginning of the trace. If the system reacts to the synchronizing pulse by producing echoes or hang-

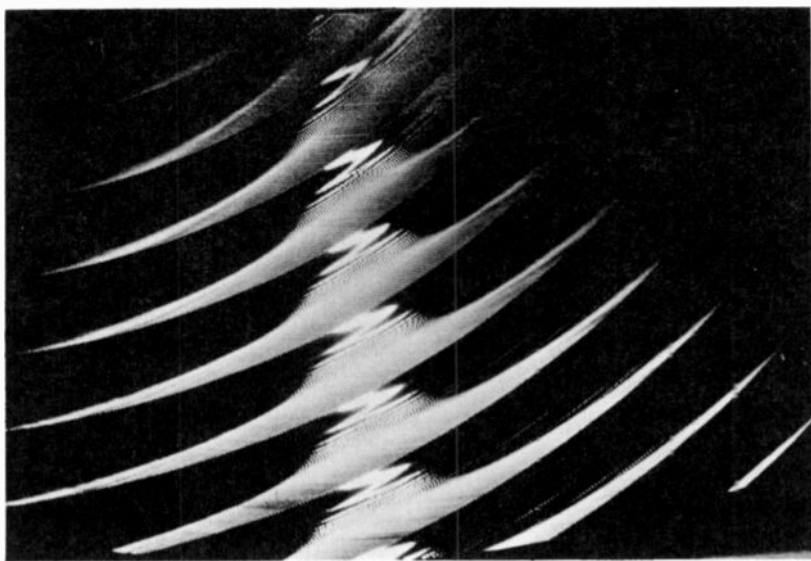

Fig. 1107. *Light pattern of the Model 102-M test record.*

over, the initial portion of the trace will be followed by a weaving curve rather than a smooth one. Some of these effects are indicated in the drawings of Fig. 1108.

If a scope has a sweep magnifying circuit, it is possible to examine the trace minutely from beginning to end and the exact point at which any distortion occurs—as well as its nature—is much more easily determined. A study of the leaflet which comes with the Clarkstan record, and some experience, will soon make you familiar with the various patterns and their significance.

A more exact, though more tedious method of checking equalization involves the use of a steady-state test-frequency record and an output indicator. When the budget for test records is limited, the Cook series 10 is probably the most useful single record because it permits the greatest variety of tests. It is also the only

one which covers the complete audio range from 20 to 20,000 cycles and is, therefore, the only one which offers a measure of the response of those very high quality pickups which go beyond 10 or 12 kc. A useful procedure with this record is this:

1. Play side B with the equalizer set for the LP curve. Watch the output indicator or wattmeter. The reading should be almost the same (say within 2 or 3 db at most) for all the test tones in band 1. Listen for a fluctuation in pitch on each tone; such a change will indicate wow.

2. Measure the intermodulation at the beginning and end of each of the two intermodulation bands. When the record is new, the intermodulation should run from about 4-6% with the finest pickups to 8% with average pickups on the outermost band, and should not rise to more than 10% on the innermost one. If the rise does exceed 2 or 3%, check the needle, alignment, and tracking. If you do not have an intermodulation analyzer, it is possible that you can detect a rise in intermodulation by ear. It takes a very critical ear to discern a rise from 3 to 5%; but if you do perceive a rise from the outermost to the innermost grooves, the chances are you have at least that much rise and probably a good deal more.

3. Band 3 of side B sweeps the low end of the spectrum down to 20 cycles. The output meter should give a uniform response (with the LP equalizer) at least down to 50 cycles and preferably all the way down to 20 cycles. Listen carefully through this band for it will reveal arm and cartridge resonances, speaker resonance, and tracking and compliance troubles. Resonance is indicated by a sudden rise in output at some portion of the sweep band. Poor tracking or compliance will be evidenced by a buzzing or a fuzzy tone. This is also an excellent band for checking frequency doubling in loudspeakers. Since very few systems are capable of reproducing fundamentals below 40 cycles, listen very carefully as the tone sweeps below that point. On a speaker with no distortion, you should get a sudden, very marked reduction or complete cutoff at some point below 40 cycles. Most speakers, however, do produce frequency doubling and so they will continue to emit sound; but this sound will suddenly rise about an octave in pitch.

4. Turn the record over to side A and change the equalizer to the flat position of treble. This side will play back flat only with an equalizer which does not de-emphasize the highs. Amplifiers which do not provide a flat position will show a slope at the

high-frequency end, and the slope at 10,000 cycles gives a good check of equalization. We suggest that you play the 1,000-cycle band to adjust the output level, and then move the pickup to the sixth band, the 10-kc band—unless the pickup is one of the very wide range type. This is suggested because the bands above 10 kc are subject to rapid wear and should be reserved for use when they are really needed.

If the amplifier in question does not have a flat position, this series of bands can be played back with an LP equalization. The

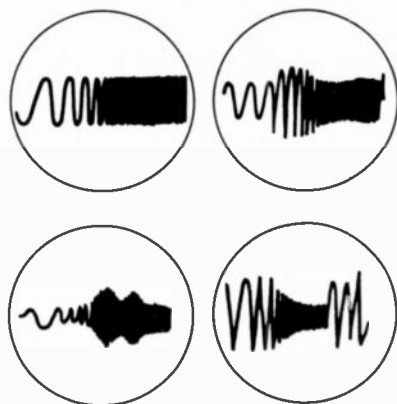

Fig. 1108. Waveforms obtained with test records help trace amplifier distortion.

bulletin which comes with the records gives a table showing the readings for an LP curve. If this portion gives a reasonably flat response, the chances are it will provide good equalization in all equalizer positions.

5. Note the reading on the 10,000-cycle band as compared with the *reference reading on the initial 1,000-cycle band*. This is necessary for the translation-loss test to come. It also gives a pretty good check of equalization. The following table gives the

Curve Response: 1 volt at 1 kc	
Curve	Reading at 10 kc
LP	-15 db or 0.15 to 0.20 volt
New RIAA	-14 db or 0.20 to 0.25 volt
Old AES	-12 db or 0.25 to 0.33 volt

approximate readings at 10,000 cycles for the several commonly used curves when the 1,000-cycle tone is set for 1 volt. The new RIAA standard is identical with both the new AES and the ORTHO curves.

Don't expect exact readings. A variation within the range given will be generally indistinguishable to the listener.

6. When you get to the innermost band, reset your volume control to get the same reading for the 1,000-cycle tone as at the beginning.

Now take a careful reading of the level of the following 10,000-cycle tone. Compare this with the reading noted in step 4. If the reading in step 6 is from one-third to one-half that in step 4, the needle is still satisfactory; if it is less than one-third, the

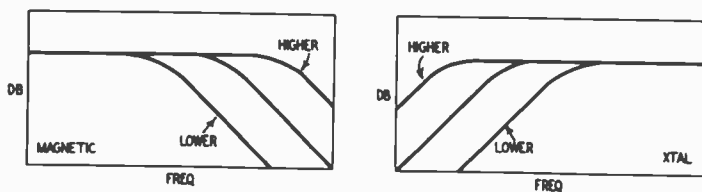

Fig. 1109. These curves show how a change of resistance loading value modifies the response in two common types of pickups — magnetic and crystal.

needle (or alignment) is poor. I would check the alignment first, correct it if necessary, and run another check. If this reading comes within tolerance, the needle is all right. In that case, repeat the intermodulation measurement on side B: chances are it, too, has been improved.

If the outfit is not producing a reasonably flat response curve, the equalization is off. If the departure is entirely above 5 or 7 kc, check the translation loss as in step 6. If it is too high, chances are very good that the needle alone is at fault. Change the needle and try again. If you still are off on the high-frequency end, check to see if you get about the same variation, or at least in the same direction, on all equalization positions. If the curve is off in the same direction at all positions, it is almost certainly due to either high-frequency losses in the cable from pickup to equalizer or improper loading of the pickup, or both.

Every cartridge, whether magnetic or piezoelectric, must work into an optimum load to provide a flat curve. In magnetic pickups variations in the resistive load produce variations in high-frequency response; in piezoelectric pickups, the variation is in the low-frequency response. In either case, as the resistance of

the load is increased, so is the response at the affected end. Fig. 1109 shows a comparison of how pickup types differ. This principle is very often employed in equalizers to produce desired high-frequency equalization, as in Fig. 1110-a. Check the diagram or circuit to see if that is true in this instance.

But before doing anything at all about it, first determine if the equalizer was designed for the cartridge in use. The Pickering requires a load about half that of the G-E and will produce a rising response at high frequencies with a G-E load; a G-E on the

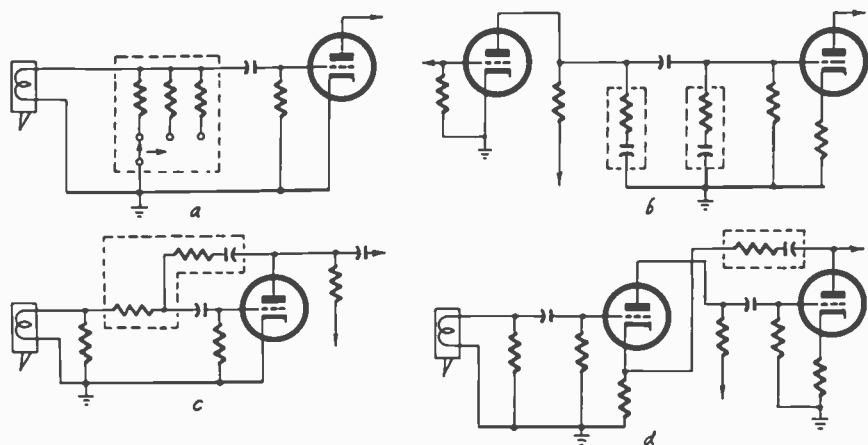

Fig. 1110-a to d. Four types of equalization used to compensate for reproduction characteristics of pickup units.

other hand, when used with a Pickering load, will produce a falling response. Many of today's amplifiers and preamplifiers have a switch which changes the load resistance for different pickups. Check to see if that is the case with your equipment.

In many equalizers the load remains constant (Fig. 1111-a) and the equalization is obtained either in a feedback loop as shown in Fig. 1110-c, d or by an interstage bypass as in Fig. 1110-b. If you get a constant variation in response at 10,000 cycles in the same direction on all equalizer positions, you can probably correct the slope by adjusting the load. If the response rises at high frequencies on all positions, you can shunt the preamp input with a resistor (Fig. 1111-b). The best thing to do is to connect a 250,000-ohm potentiometer across the preamp input or cartridge output, and adjust it to obtain the flattest possible response in all equalizer positions at 10 kc. When you have found the right position, replace it with a fixed resistor.

If, on the other hand, the variation is downward, put the potentiometer in series with the load resistor (Fig. 1111-c) and again adjust for the flattest possible response. If you can't achieve complete equalization with a change in load, shorten the pickup cable or replace it with one of lower capacitance.

When the departure is only on one curve, check the values of the resistors and capacitors and check for opens or shorts. Resistors should be within 10% of the specified value. Fig. 1112 shows graphically, ideal equalization.

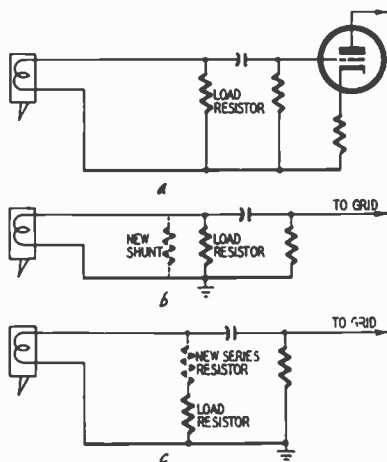

Fig. 1111-a, -b, -c. The pickup load can be adjusted to improve response.

Most amplifiers which have an input for crystal or ceramic cartridges provide a load of approximately 500,000 ohms. One or two European types (notably the Ronette) will be properly equalized with this load. However, most other types will be down anywhere from 6 to 20 db at 30 cycles. Played into a 500,000-ohm load, even the best ceramic cartridges will be very deficient in bass as compared to a properly equalized magnetic, so much so that all the available bass boost of the tone controls will not provide satisfying results.

To obtain best results from piezoelectric cartridges the load will have to be changed to anything from 2 to 5 megohms. However, such high values sometimes upset the operation of the input tube to which they are connected. It is usually safer, therefore, to shunt the piezoelectric cartridge with a capacitance in the region from .001 to .005 μf — a value of .003 μf is a good compromise with the new ceramic cartridges. This has the effect of reducing the

cartridge output considerably. Most amplifiers can provide the required gain easily because this type of cartridge has a high output to begin with. Fig. 1113 shows the curves attainable with a typical crystal cartridge and various combinations of loading.

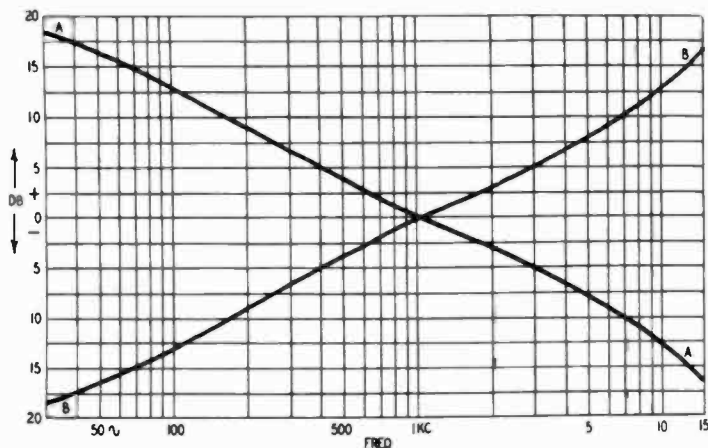

Fig. 1112. *Ideal equalization would mean that recording curve B would be the inverse of reproducing or playback response curve A*

The Dubbings Company has met the need for a test record suitable for rapid testing of phono conditions with its D-100 and D-101 records. The former offers a frequency band with flat treble

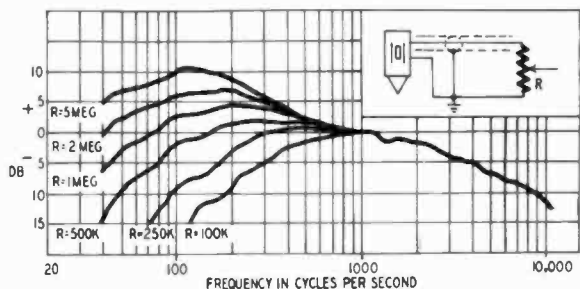

Fig. 1113. *Loading effects on a crystal pickup.*

equalization and a 6-db-per-octave slope below 500 cycles; it also has bands for testing rumble, hum, wow and flutter, as well as stylus compliance and tracking. The D-101 is unique in offering test runs for the four American curves: LP, RIAA, old NARTB, and old AES.

The D-100 will test all aspects of a phono system except needle condition and intermodulation—though the tracking bands offer

some clue of needle condition. The first 13 bands are frequencies from 30 to 12,000 cycles. The next band is unmodulated for checking hum and rumble. The following band has a tone suitable for checking wow and flutter. The five innermost bands are unique in that they offer a simple test for compliance tracking ability. These bands are modulated with a 400-cycle tone whose amplitude increases by 4 db from band to band, so that the innermost band is 16 db higher than the outermost. Poor compliance or tracking is indicated by a buzzing or a fuzziness of tone. Only the highest quality professional pickups and arms will track all five bands perfectly; good home systems, however, should track at least the first three perfectly.

Tracking ability can often be improved by changing the needle pressure. Increase the needle pressure adjustment of the pickup to obtain the lowest amount of fuzziness or buzz on the five tracking bands. Now measure the pressure with a gauge to see that it does not exceed the limit for the pickup being used. If it does, reduce the needle pressure slightly until it is within the rated tolerance of the pickup. In this way you can obtain the best compromise between tracking ability and low record wear.

When using D-101 to check the equalization curves, do not expect complete flatness. Few equalizers provide exact equalization for all curves. As long as the variation does not exceed 2 or 3 db, for any curve, reproduction will be acceptable.

tuners

The servicing of hi-fi tuners differs very little from that of ordinary radio and TV receivers, and in most cases the normal routines and methods are completely applicable. Two factors, however, demand special consideration and care. These are noise and distortion.

In both AM and FM tuners, distortion must be kept to a minimum. The better the amplifiers and speakers which follow the tuners, the more noticeable and annoying the distortion contributed by the tuner. Indeed, in a good system the total distortion at the final output consists largely of the distortion present in the output of the tuner.

Some present practices in broadcasting are not exactly conducive to low distortion. Most radio programs are heavily limited, and, while limiting amplifiers operate much better today than they once did, it is still true that limiting cannot be obtained without the addition of some amount of distortion. Moreover, even if the limiters themselves contributed very little distortion, the radiated signal is so heavily modulated that the receiver detector often operates within that portion of its curve in which distortion is greatest. In fact, though the signal radiated by most stations may meet FCC standards regarding distortion, it will considerably exceed these standards when received on average receivers. As a result you can always expect at least 1% harmonic distortion (or approximately 4% intermodulation distortion) from even the best stations and on most stations the figure will double or triple. Clearly then, it is highly essential to minimize the distortion produced by the tuner as completely as possible.

AM tuners

In AM tuners, distortion is very largely a function of the detector. Most tuners use diode detectors. To hold down the distortion, the diode load in the best tuners is kept very high either through grid-leak biasing in the following audio stage or by using a cathode follower after the diode. In the first case, the diode load sees a grid resistor of 3 to 10 megohms. See Fig. 1201-a. In the second case, the grid resistor may be 1 megohm or less; but since the effective input resistance is multiplied up to 10 times by the current feedback of the cathode follower, it appears

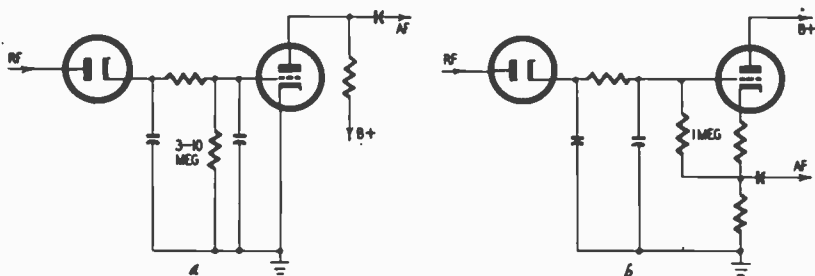

Fig. 1201-a, -b. Two types of diode detectors for AM; (a) followed by grid-leak biased a.f. stage; (b) the first audio stage is a cathode follower.

to the diode like 5 to 10 megohms (Fig. 1201-b). However, the diode should be capable of handling high modulation percentages with acceptably low distortion. If this is not the case, a check of the diode detector and its associated amplifier is indicated.

A few AM tuners use the infinite-impedance or cathode-follower detector, which is capable of handling high percentages of modulation with low distortion. In circuits of this type, the cathode load is sometimes critical and a departure from design specifications may cause the unit to develop high distortion. If you find this to be the case, check the value of the cathode resistor and the r.f. bypass and blocking capacitors for leakage or shorts (See Fig. 1201-c). The important feature is that the operating condition must be such that the tube is cut off for part of the r.f. cycle, even in the modulation troughs.

Distortion in FM receivers or tuners

Distortion in FM tuners is principally the result of misalignment of the i.f. amplifier and detector. For lowest distortion, the i.f. bandwidth should preferably be from 180 to 240 kc and not

less than 150 kc at the -6-db level, and its curve should be extremely symmetrical. The detector curve should be linear and the straight portion should extend to at least 100 kc and preferably more on either side of the mean carrier frequency. In the case of the National Criterion and H. H. Scott tuners the discriminator curve should be linear for 1 mc on each side of center. To insure such curves, careful alignment with a scope, sweep generator and accurate markers is absolutely essential.

Regeneration is another source of distortion in FM tuners. It is always evidenced by a badly shaped trace on the scope in visual alignment. If extreme peaking of coils distorts the curve, it is evidence of regeneration. If it cannot be eliminated, a slight de-

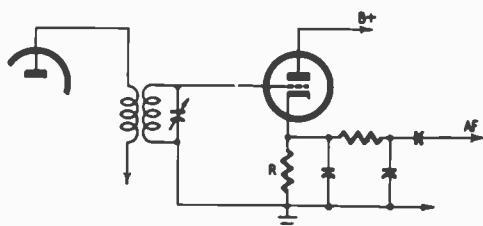

Fig. 1201-c. Infinite-impedance detector. The resistor R is the critical value.

tuning will often produce a more symmetrical curve.

Distortion in FM tuners is often the result of multiple-path reception. When the same signal arrives by different paths, one longer than the other, there will be a difference in arrival time or a phase shift. Since a phase shift is very similar to the frequency shift of frequency modulation it becomes evident after detection as a most annoying distortion. The effect occurs principally when weak signals are being received in fringe areas, usually in hilly or mountainous terrain. There is only one cure: an antenna with enough directivity to accept the signal coming over a single path and attenuate those coming by other paths. Try revolving the antenna to favor the station suffering from this effect; if necessary install a highly directional antenna and a rotator.

Excessive limiting at the broadcast station can produce quite similar phase distortion. The audible effect of these two types falls principally in the region above 7,500 cycles and is especially annoying with excellent tweeters. Nothing, of course, can be done if the distortion is produced in the broadcasting station; and if reorienting the antenna does not reduce the distortion,

it can be presumed that the distortion is produced at the station.

However, an effect similar to that of multiple-path reception can be produced by a mismatch of antenna, transmission line and receiver, or when a balanced line is coupled to an unbalanced receiver input. When the signal strength of most desired stations is high enough to afford some loss, the resistive networks indicated in Fig. 1202 can be employed to match a 72-ohm line to a 300-ohm receiver input or vice versa. Although the resistances indicated are not standard values, the nearest standard value

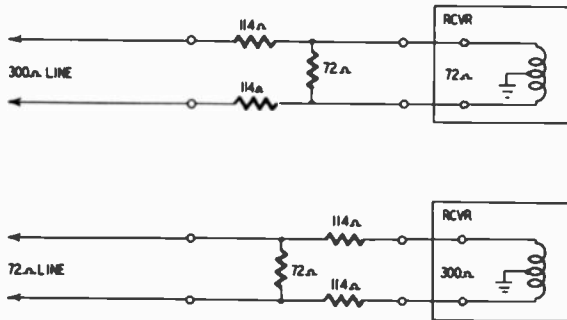

Fig. 1202. Resistive networks can be used to match transmission line impedance to receiver input.

will do. When a signal loss cannot be tolerated, matching transformers of the TV type should be used.

Still another possible cause of increased distortion may be found in the de-emphasis network which follows the FM detector. Under present standards, FM transmission calls for a treble boost of 13.7 db at 10,000 cycles provided by a 75-microsecond pre-emphasis network. The receiver should have a complementary de-emphasis network of 75 microseconds which produces a loss of 13.7 db at the same frequency. The pre-emphasis at the station has a tendency to accentuate distortion as well as treble tone. If the receiver does not provide complete or accurate de-emphasis, the result is higher audible distortion. Occasionally poor de-emphasis is the fault of design, but more commonly it is the result of component failures which cause a shifting of the slope. Fig. 1203 shows both a pre-emphasis and a de-emphasis curve.

Fig. 1204 shows typical de-emphasis networks for both the Foster-Seeley circuit (a) and the ratio detector (b). The network consists of a series resistor and a shunt capacitor. The individual

values are not important and may vary for many reasons. The important thing is that the time constant should equal 75 microseconds. You can calculate the constant with the formula $R \times C = t$, where R is in ohms, C in μf and t in μsec .

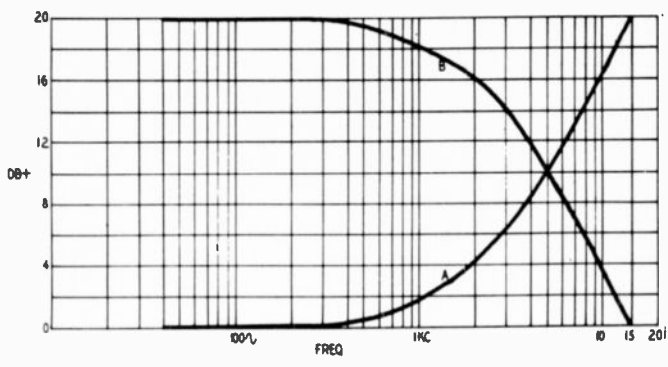

Fig. 1203. Pre-emphasis curve (a) and de-emphasis curve (b).

You can also check the slope with an audio generator and meter. Apply the audio generator signal to the input of the de-emphasis network and measure its output. Check the difference in read-

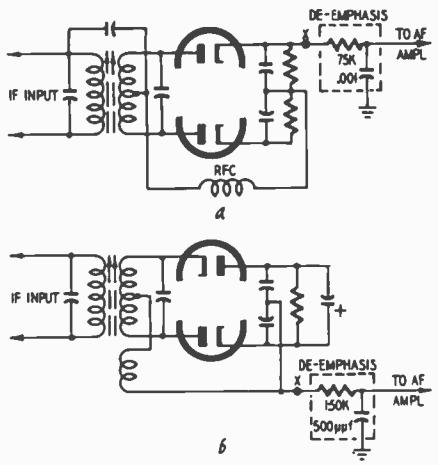

Fig. 1204-a, -b. Discriminator detector (a) and ratio detector (b).

ing between 1,000 and 10,000 cycles. It should be between 13 and 14 db down at 10,000 cycles.

Since FM and AM signals are not as free of distortion as we would like them to be, you must be careful not to ascribe distortion faults in the signal to the receiver. Tuner distortion will

be fairly constant from station to station with either live or recorded material; signal distortion will vary from station to station and from record to record.

Receiver noise

Aside from hum, noise in hi-fi tuners appears in the form of interchannel interference on AM and incomplete noise suppression on FM.

Good reception of AM stations presents a difficult dilemma. For a good treble response the bandwidth should be wide, but this increases the interference from adjacent-channel stations. This problem is much more critical in high-fidelity receivers. If the following amplifier and speakers have a flat response to 15 or 20 kc, the interference is considerably more audible than in an ordinary radio.

Designers try to beat the problem in two ways. The first approach is using a wide bandwidth in the i.f. section, but following it with some sort of lowpass or band-rejection filter in the audio section to cut out the interfering noise. The second is to make the bandwidth just narrow enough to attenuate the interference to a level low enough to minimize annoyance. When faced with the problem of excessive interference, first ascertain whether the tuner uses a *whistle* filter. This is usually of the lowpass or band-rejection type, and can be recognized easily by the fact that it requires one or more inductances in the audio channel and/or a complicated network of resistors and capacitors. It usually follows the detector and precedes the first audio amplifier. The simplest way to test the operation of this filter is to introduce an audio generator ahead of the network and measure the output of the stage following. Sweep the generator from 5,000 to 15,000 cycles. Severe attenuation (20 db or more) in the region between 7,500 and 11,000 cycles should be evident. If it is not present, check the components of the network for opens, shorts and extreme departures from specified values.

In many cases the whistle filter is adjustable with a trimmer or screw plug, accessible on the chassis or the can containing the network. This can be set to minimize the most objectionable whistles.

Careful tuning of the r.f. and i.f. channels is very important in AM tuners. Visual alignment is highly recommended. If the tuner uses a whistle filter, align the tuner for the flattest top

up to 10 kc on each side of center frequency. This will provide good audio response.

If no filter is used, careful alignment is even more important. Two objectives should be met. The top of the response curve should be as flat as possible, and the sides of the curve should be as steep as possible, with an attenuation at 10 kc each side of center of at least 20 db. A combination of listening (for lowest interference when tuned to a station) and scope observation of curve response for flattest top should produce the best possible compromise for any given tuner.

If your r.f. oscillator or generator permits the injection of an external audio frequency, an effective alignment procedure is as follows:

1. Put the Clarkstan sweep-frequency record on a turntable.
2. Equalize it with the preamp to produce the flattest and straightest trace as observed on a scope.
3. Inject the equalized a.f. sweep into the signal generator and adjust gain for modulation of approximately 30%, and inject the modulated r.f. into the tuner.
4. Observe the trace at the output of the tuner.
5. Align the tuner to produce as complete an attenuation as possible at 10 kc and the flattest trace from 50 to 7,500 cycles.

Interchannel-interference noise is often a byproduct of too much sensitivity. Quite often you will find that reception of a favorite station can be improved from a noise point of view by reducing the antenna pickup. This is best done by inserting an attenuator between the antenna and the receiver input.

In FM tuners noise is principally the result of incomplete limiting. It is well, however, to ascertain first if the noise is originating in the audio end, particularly in tuners which also contain control units and preamps. The gain may be extremely high and tube or component noise may be accentuated. If the tuner has an input selector switch, try turning it from FM to another channel (preferably one of equal or higher signal level). If the noise is still present, the fault is within the audio end. Also, with the switch in the FM position, remove the detector tube. If the noise continues, this is further evidence of a faulty audio section. However, if it is greatly or entirely reduced, it is indicative of a fault in the tuner.

Incomplete limiting is almost always the result of either low sensitivity or improper limiter or detector action. Fig. 1205-a shows the curve obtained when the detector system is correctly

balanced. Fig. 1205-b shows the curve resulting from imbalance or phase distortion. If noise suppression is not complete, even on the strongest stations, it is well to check the limiter and detector stages for faulty tubes or components. If replacements are necessary, be sure to use exactly the values specified in the diagram or parts list. Limiters are designed with very critical time constants which can be maintained only by adhering to original design values.

In fringe areas, limiting action is at a minimum, and with some stations the signal strength may be at a level incapable of

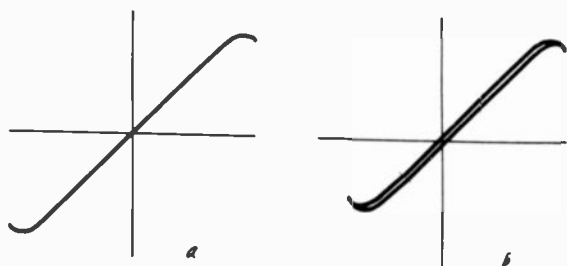

Fig. 1205-a, -b. S-curve (a) shows properly balanced detector while distortion or lack of balance is shown in other curve (b)

saturation of the limiter circuit. Signal boosting is the only means in such cases of obtaining a good signal-to-noise ratio. With a given tuner this boost can be obtained either by using a better antenna or a booster and, in extreme cases, by a combination of both. High-gain commercial antennas cut for the FM band are scarce and hard to find. However, some—but not all—broad-band TV antennas maintain excellent gain throughout the FM band. Some such antennas deliberately introduce a notch in this region to minimize TV interference by FM stations. It is well to check, therefore, before buying one. A very effective antenna is a “hay-wire” V from 25 to 30 feet long on each leg. It can be erected with ordinary antenna wire and three insulators, either over the roof of a house or from the house to trees or poles. Fig. 1206 gives a rough sketch of such an antenna. The impedance is about 600 ohms but a 450 open-wire line will produce an adequate match. If twin line is to be used, the final 2 feet leading to the antenna can be fanned out to about 4 or 5 inches at the antenna end to produce a fair match. Service technicians experienced with TV techniques will be familiar with methods of producing more exact matches as well as with antennas suitable for the needs of fringe reception.

Often the antenna used for TV reception will work fine on the FM band. This is worth trying. If it works, a switch can be inserted in the transmission line to switch the antenna from TV to FM tuner.

Several TV boosters will also cover the FM band. Electro-Voice and Regency produce excellent high-gain, low-noise, fixed-tuned boosters, specifically for the FM band. These boosters have a gain of 20 db or more which should be sufficient with average tuners with a sensitivity of 15 microvolts or less to produce noise-free reception of most FM stations.

Because of the noise-reducing properties and relative freedom from same—or adjacent-channel interference of FM receivers, it

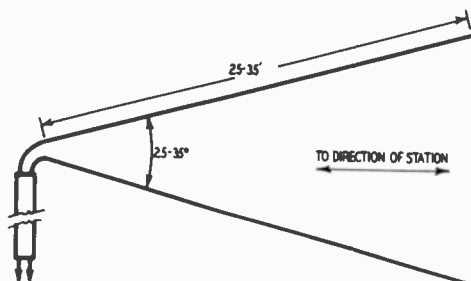

Fig. 1206. V antenna for FM reception.

is quite possible today with the best tuners and adequate antennas to enjoy fully acceptable, high-fidelity reception of FM stations at distances considerably beyond the line of sight. Some of the newer tuners have sensitivities ranging from 1 to 5 microvolts for 20 or 30 db of quieting. Given a few db of antenna gain, signals as low as $\frac{1}{2}$ microvolt can provide enjoyable reception. It is well, however, to try several tuners at the location and choose the best.

Capture ratio

Good FM tuners have high immunity to audible interference from stations on the same or adjacent channel. The *capture ratio*, or ability in a receiver to choose the stronger of two signals on the same channel and to suppress the weaker, varies with design and condition. Proper alignment of i.f. and especially r.f. stages is a factor in maintaining a good capture ratio. Optimum limiting is another factor. When, therefore, an FM tuner begins to fail in its ability to discriminate against weaker signals, check

these points. However, the best FM receiver cannot discriminate in favor of two stations of *equal* signal strength on the same channel. When a single channel has two stations of equal or nearly equal field strength, reception is likely to be intermittent—first one station takes over, then the other station; part of the time both are heard, or the presence of the other is evidenced through phase distortion. The correction for this is reorientation of the antenna or the use of one with greater directional discrimination. More often than not, rotating the antenna a few degrees will reduce the strength of one of the signals to a point low enough so that it is suppressed. The antennas with so-called “electronic” directivity often work very well on the FM band and the switchable directivity provides an easy means for minimizing phase distortion, multiple path reception and interference from same—and adjacent-channel stations. Their performance on the FM band can often be improved markedly by increasing the spacing between two bays to about 4 feet.

final adjustments

Much of the fine performance of high-fidelity systems is due to the fact that the parameters under which the system operates are adjusted precisely either by using components of very small tolerance or by incorporating controls which permit an adjustment to compensate for tolerances in parts or the drift in performance due to aging or a change in characteristics of tubes and other components. In many cases a deterioration in performance can be corrected simply by readjusting the system. When a high-fidelity system is serviced, it is always necessary to adjust the equipment for peak performance at least once. Sometimes it must be done twice — once at an early stage in diagnosis, simply to determine if the trouble can be eliminated by “tuning up,” and then again at the very end when the fault has been found and corrected and before the system is turned over as repaired.

There are many possible routines which can be used to accomplish this tuning-up process, depending on the instruments available and the preference of the man doing the job. For example, the phase-shift method of diagnosis detailed in Chapter 7 provides an excellent routine for adjustment. On the other hand, the job can be done with equal effectiveness with other instruments. In the following discussion, therefore, we will mention the various ways in which each of the various steps in the process can be accomplished leaving the choice to the reader or to circumstance.

Systems may provide one or more of the following adjustments:

- (1) balance of the output stage; (2) hum; (3) output-tube bias;
- (4) frequency balance, either through tone controls or through

level controls on the speaker system, or both, and (5) damping factor. Very few systems will have all these adjustments and a few have none at all. In most cases it takes only a few minutes to adjust them all.

Balance

Whatever the routine used and whatever the adjustments available, if the outfit has a balance adjustment, it should be corrected first because it has considerable effect on others — hum, for instance. If the adjustment is being made at the site of the installation and without dismantling or pulling out the individual units, hum is the easiest indicator of balance in the output stage. The output stage of power amplifiers is always fed from a point in the filter where the hum is fairly high. A low hum level is achieved by



Fig. 1301. Forms of 120-cycle hum as seen on the face of a scope. This is the frequency of power-supply ripple in the output of a full-wave rectifier.

the cancellation provided with a well-balanced push-pull operation. The more perfectly the two tubes are balanced, the lower the hum. A very sensitive indicator is necessary, however. A wattmeter with a lowest range of 50 milliwatts full scale will work, but even better is an a.c. vacuum-tube voltmeter with a lowest range of 10 to 50 millivolts full scale. Clip the meter across the voice coil or the speaker line. If there is a choice, connect it to the highest impedance tap — 16 or 500 ohms, if there is one.

We want to read the hum of the output stage alone and we therefore want to eliminate any hum contributed by previous stages and also the hum cancellation provided by a feedback loop. The simplest way to insure this is to remove the driver tube — assuming it is not a cathode follower directly coupled to the output tubes. If the driver is a cathode follower directly-coupled to the output tubes (this can be verified from the wiring diagram or the description of the amplifier in the catalogs), then remove the preceding tube, probably an inverter. Adjust the meter range to give a good reading of the hum. Watching the meter, adjust the balance control for minimum reading; the point at which the meter dips the most is the point of balance.

If there is no balancing control, the only way of producing balance is to change output tubes. This is likely to be the case only with inexpensive amplifiers using types such as the 6V6. Your tube caddy probably has several of these, so trying new ones will not be difficult. If new tubes produce a lower reading, they are better balanced. Given a few tubes, it is possible to find a pair giving the best balance and lowest hum reading.

This is an excellent way to adjust balance even if the amplifier is on the bench. However, you can also adjust it, perhaps more closely, with a d.c. voltmeter by applying the meter from plate to plate and adjusting balance for a zero-voltage difference.

The scope can also be used as an indicator of hum level and therefore of balance. This is particularly true if the scope has a

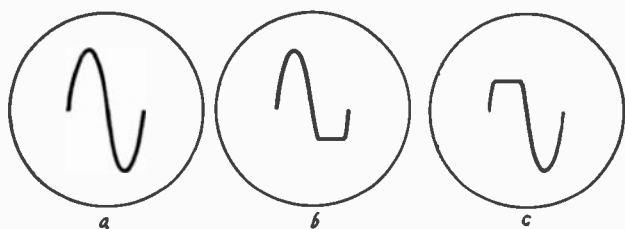

Fig. 1302-a, -b, -c. The sine wave (a) shows bottom clipping (b) and top clipping (c). An overdriven amplifier will clip the waveforms.

60-cycle sine-wave sweep as well as the normal sawtooth sweep. The hum in the output-tube circuit will be largely 120-cycle power-supply ripple. When applied to the vertical channel of a scope whose horizontal channel is swept by a 60-cycle sine wave, the 120-cycle hum will produce a pattern as shown in Fig. 1301 — quite similar to a lazy-8. Adjust the balancing controls so that this trace is reduced to the smallest possible height on the most sensitive range of the scope.

Balance can also be adjusted with a scope and generator. Feed a 1,000-cycle sine wave into the amplifier and adjust the level so that the trace on the scope begins to show clipping. Now adjust balance so that the clipping starts on both peaks at the same time. If the amplifier is unbalanced, the clipping will start on one peak before it starts on the other (Fig. 1302).

Possibly the finest method of balancing is with the intermodulation analyzer. Adjust the setup to produce an output of about 1 watt. Take an intermodulation reading. Now adjust the balance control for lowest intermodulation. This method produces an

overall balance at a.c. and therefore compensates for unbalance in previous stages, loss at low frequencies and unbalance due to dissimilar coupling capacitors, etc. If the amplifier is used at high levels, balance at a point just below maximum output. If this method is used in the home, balancing at the 1-watt level will result in the lowest distortion in the dynamic range usually employed in the home.

Hum controls

Many systems provide a hum control somewhere in the chain — the main amplifier, the control unit or the preamp equalizer. This hum control is almost invariably a small potentiometer across the filament string or loop which balances the two sides of the loop by centering the grounding point. The best indicator is again a sensitive output meter; the more sensitive the meter, the more accurately the control can be set. Often, however, it may be possible to set the control by listening to the hum by ear.

If a single power supply is used for preamp, control unit and amplifier, the single hum control will adjust the hum level of the entire system. In that case adjust the control for minimum reading on the meter or for the least hum in the speakers. You can accentuate the hum by raising the volume control to maximum and boosting bass control to maximum too.

If the control unit, preamp and power amplifier have separate power supplies, and the hum control is on the power amplifier, disconnect the cable from control unit to amplifier and adjust the hum control for minimum hum in the power amplifier alone. Perhaps the control unit or preamp has another hum control. If so, reconnect the cable and adjust that control for minimum hum.

A sensitive meter is the best indicator for hum. However, often an intermodulation analyzer may be used. Adjust the signal input for the lowest level at which you can take an intermodulation reading. You can do this by setting the input level control of the analyzer section to maximum and then injecting just enough signal to produce a full-scale reading in the carrier-set position. Now take an intermodulation reading and adjust the hum control for the lowest reading. This will not work when the hum is low and the amplifier very linear; but especially if you use intermodulation analysis for a testing routine, it is always worth trying and, if it works, will save the need for changing setups.

Of course, a scope can also serve as a hum indicator, particularly

if it has a 60-cycle sine-wave sweep. The trace may be an ellipse or a flat circle if no 120-cycle hum is present as shown in Fig. 1303 or it may be a lazy-8 indicating 120-cycle hum. In the latter case, the output balance control may eliminate it; otherwise a search for deficient B+ is indicated.

Output tube bias

Some power amplifiers have a control to set the bias on the output tubes. This adjustment cannot be made without pulling out the amplifier, unless the amplifier has a jack for reading cathode current.

If the amplifier has a jack for taking total cathode or plate current, the bias can be adjusted by plugging in a milliammeter and



Fig. 1303. Trace seen on scope can be circle or ellipse in absence of 120-cycle hum.

adjusting the bias control to produce the current specified in the amplifier manual — about 40 ma per tube if the tubes are operating as triodes, or 45–50 ma per tube if operating Ultra-Linear. These values are for 807's, KT66's, 1614's and 5881's in typical high-fidelity circuits and assume a plate voltage of between 375 and 450 and class-A operation.

If the amplifier must be removed, the bias can be measured with a voltmeter and adjusted to the value recommended by the manufacturer of the amplifier, usually between 38 and 40 volts in the case of the tubes mentioned.

Changing tubes

Relatively small deterioration in tubes may make a pretty big difference in performance. The intermodulation analyzer or a scope, with or without the wattmeter, provides an excellent indication of improvement in performance with new tubes. With the wattmeter and a resistive load, arrange an input of a 1,000-cycle signal to produce just under maximum rated output. If the scope is also available, hook it up and adjust the input so the trace clips, then back off until it just stops clipping. Now change tubes, read-

justing balance if it is the output tubes that are changed. When other tubes are changed the gain may need readjusting. If the output goes up and the clipping occurs at a higher output than before, new tubes are justified. If the change in tubes makes no difference in performance and the clipping occurs at the same level as before, the new tubes are not required.

The intermodulation analyzer is even more conclusive than the scope, although the scope, being more visual, provides a better rapid check. Again set it for a level just below maximum output and take an intermodulation reading. If the change of tubes produces a lower intermodulation level and does not reduce the power output but increases it (you can check this by switching to the carrier-set position and noting whether you still have full-scale deflection or more) the new tubes are justified. On the other hand, if the tube replacement produces no significant change at the same output level, tube substitution is not justified. Remember, again, to rebalance if the output tubes are replaced.

Frequency response

Most systems provide tone controls with which the frequency response curve can be modified. The reference, flat or neutral position of these controls should provide a flat response curve. Often, however, after a period of use this neutral position is lost either because the knobs have slipped or because drift has changed system characteristics. It is always a good idea, therefore, to check this and adjust if necessary. If the job is being done at the site of the installation, the simplest way is to use a test tone record and an output indicator. It is not necessary to make a complete frequency run in most cases.

First, take a reading at 1,000 cycles. Now change the pickup to the 10,000-cycle band and take another reading. If the reading is not identical, adjust the treble control until you get the same reading. Shift the pickup to the 50-cycle band and adjust the bass control to obtain an identical reading. If you like, you can now make a sweep of the whole range to see just how flat the system is.

If you have the system in the shop, the simplest way to do the same thing is with a square-wave input and a scope. Look at a 2,000-cycle square wave and adjust the treble control to give you the flattest top; now change to 200-cycle square wave and adjust the bass for flattest top. If both are flat, you have a flat response from 20 to 20,000 cycles.

If you use the phase-line method of analysis, you can make the

adjustment using sine waves between 20 and 50 cycles on the low end and 10 kc and 20 kc at the high end. Adjust the controls to produce a straight line or the narrowest ellipse at the extremes.

Whichever method you use, mark the position of the knobs when the desired effect is achieved. If this coincides with the flat or zero marking on the panel, fine. If it doesn't, you can loosen the knobs and reset them so they do. If the control knobs are push-on types, remove the knobs, loosen the nut holding the

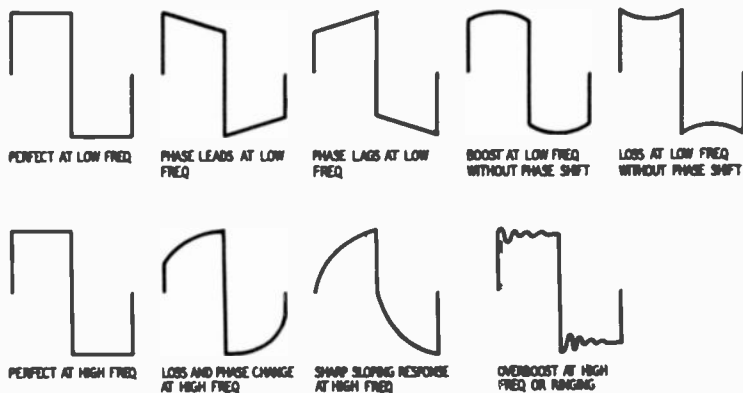

Fig. 1304. Square-wave testing of an audio amplifier may reveal these waveforms at various frequencies. The significance of the various shapes is indicated in the illustration.

control to the panel and rotate the whole control the small distance necessary to line up the indicator on the knob and the panel mark.

Speaker response

Some systems using two or more speakers to cover the entire audible range have from one to three level controls so that the response of the whole system can be adjusted. If you have a scope and signal generator at the site of the installation, the flat position of these controls can be determined easily by connecting the scope across the speaker line and the square-wave generator to the amplifier input. We assume that the amplifier itself has been previously adjusted to be flat for square waves between 200 and 2,000 cycles. Sweep the generator from 200 to 2,000 cycles and observe the trace, keeping the output level as low as you can and still obtain a good trace. You will probably find that the tops of the square waves vary greatly as you sweep this range. They may show any or all of the variations diagrammed in Fig. 1304. The

tilts and misshaping of the tops are due to various phase and amplitude differences. The significance of the various traces is indicated on the diagram. This, however, is not particularly important. The desired end is to adjust the level controls on the speaker system to provide a flat top, or the nearest thing to it, throughout the range of 200–2,000-cycle square waves. Adjust the various controls — as, for example, the bass control with a 200-cycle square wave, the mid-range and treble controls with a 2,000-cycle square wave, to see if you can get a uniform flat top or close to it. When and if you achieve this, you have adjusted the system for flat test response and minimum phase shift throughout its range. Again mark the positions of the controls producing this result.

However, this condition may not give the impression of level response, because of non-uniform sensitivity in the individual loudspeaker units — woofer, mid-range and tweeter. In this event, adjust for best *sound* balance, as this is most important.

Damping

Many late-model amplifiers have damping controls which adjust the damping of the speakers by varying the amount of feedback within the amplifier. The purpose of damping is to flatten the response of speakers at the low-frequency end as well as to improve their transient response. Most speakers have a resonant point somewhere between 20 and 120 cycles. Moreover, many types of speaker enclosures also have resonances within this range. The resonances of enclosure and speaker are manipulated to produce the best response at the low end. However, if these resonant points are not flattened, the speaker system will have a severe boost at the resonant frequency, resulting in a one-note bass or boomy reproduction. If the speakers are fed by a source of very low resistance, that low resistance will damp the speakers and particularly it will knock down the resonant peaks. Furthermore, this damping greatly improves the transient response of the speaker and minimizes hangover.

However, speakers differ in their resonances, the height of the resonant peak and their need for damping. Moreover, they can be overdamped and underdamped. Each speaker has a point of critical damping at which its response to transients is cleanest. By varying the feedback factor and thereby varying the resistance of the amplifier, it is possible to provide a means of adjusting the damping to the critical degree. Manufacturers present recommen-

dations for adjusting such controls and these should be followed whenever possible.

The adjustment can be made by ear. First, feed a sine-wave signal of 500 cycles into the amplifier, raising the volume so that the sound is as loud as the room and its occupants can tolerate. Turn the bass control to the flat position and turn off the loudness control. Now sweep the generator downward to 40 cycles. The loudness should be more or less uniform. If below 80 cycles or so the volume either rises or falls markedly, the damping is incorrect. (We are assuming a speaker system capable of fairly flat response

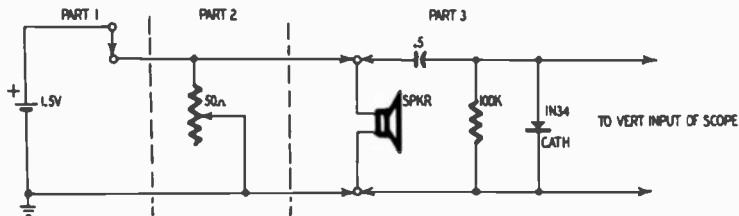

Fig. 1305. A 1.5-volt cell can be used to generate a step transient. The switch can be a telegraph key. The potentiometer should be set for the equivalent resistance of the amplifier. This technique checks the transient response as the damping factor is varied.

down to 50 or 40 cycles). Adjust the control while shifting the generator between a point in the 40-60 cycle region and 500 cycles to obtain as nearly equal a loudness as you can. Listen, particularly, for a boomy resonance in this range and try to eliminate it by adjustment of the control.

The adjustment must be made at a high volume level for at low levels the ear's sensitivity to low frequencies is violently reduced and its indications would be very inaccurate. It is not desirable to use the damping control to compensate for the slope of the ear. Though it is possible by manipulating the damping control to produce a bass boost, such a boost is obtainable only at the price of greatly decreased feedback and damping and therefore of a high increase in distortion and hangover. Once the speakers are flat, compensation for the Fletcher-Munson curve should be made either with the loudness control or with the tone controls.

The most exact adjustment requires the measurement of the transient response of the speaker as the damping factor is varied. This can be achieved by means of the gadget diagrammed in Fig. 1305 and developed by Electro-Voice. It consists of 3 parts distinguished in the diagram by the dotted dividing lines. The front portion generates a step transient by keying a 1.5-volt battery.

A Morse code key is excellent for the purpose although any momentary pushbutton switch will serve. The potentiometer provides a means for simulating amplifier internal resistance. The part on the right side of the dotted line consists of a filter to stabilize the scope trace when the key is closed in rapid sequence and prevents jumping or joggling of the trace on the scope. As Electro-Voice uses it, the procedure is to disconnect the speaker from the amplifier and connect the gadget in its place. The potentiometer is varied as the key is operated; the trace is observed and the idea is to find a position of the potentiometer which produces

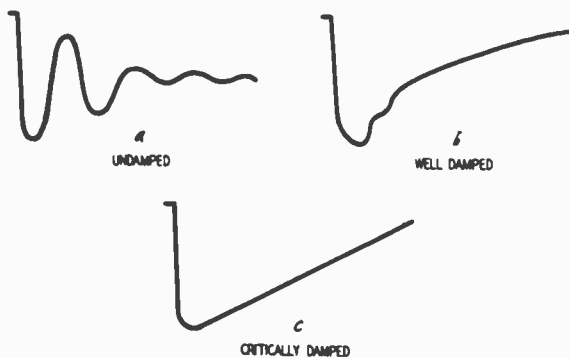

Fig. 1306-a, -b, -c. Types of traces obtained by using the method shown in Fig. 1305.

a trace free of hangover. Fig. 1306 indicates various types of traces and the desired trace. When this is achieved, the resistance used is measured. This gives the necessary internal resistance of the amplifier to produce critical damping. The damping control of the Electro-Voice and some other amplifiers are calibrated and the internal resistance is achieved simply by turning the knob to the appropriate mark.

The method is adaptable for use with an amplifier to provide immediate indication of the damping achieved. The gadget is simply split in two and the 50-ohm potentiometer removed. The generator end is connected to amplifier input, the filter input end is connected to the voice coil of the speaker and the scope to the other end. First take a reading of the transient response of the amplifier by substituting a resistor load. This will give you some idea of the transient response of the amplifier itself. Unfortunately, many amplifiers have so poor a transient response that it will be impossible to obtain anything resembling the nice smooth curves of critical damping. However, the idea is to get the best

curve possible. Adjust the damping control while keying the input until you obtain the position which gives the smoothest curve. Be careful not to overdamp. This is easy to do if the amplifier itself has an imperfect transient response, for after a certain point any increase in damping makes no difference whatever on the overall transient response. Adjust, therefore, for the point at which additional damping makes no further improvement in the trace or a point at which the traces, with a speaker load and with a resistive load are just about identical. The procedure used by Electro-Voice is obviously safer; but with care somewhat better overall results can be achieved by using the routine which includes the amplifier.

Checking other elements

When you have gone this far, you have made all the adjustments provided by modern hi-fi systems. It is wise, however, to check the remaining elements: the condition of the needle and pickup, tracking, phono turntable, tuner, etc., and to make any adjustments needed at these points as discussed in the appropriate chapters.

Overall adjustment of acoustic balance

There is only one remaining and final adjustment — that of the overall system for the room, the listening level and the ear and preferences of the customer. Having made this check you can make final listening tests with various types of program material to check the performance factors. If these show residual deficiencies, you can correct them; if not, you have done your best and you can collect your fee with a good, clean conscience.

A few final words

All distortion adds additional sounds to those present in the original and that is true equally of harmonic, intermodulation or transient distortion. A loudspeaker which generates a lot of distortion, especially at low frequencies, will produce harmonics by doubling and tripling. It may produce subharmonics through its own resonances; it will produce an apparent multiplication of low frequencies through intermodulation and hangover and finally it may generate low frequencies at the resonant points of speaker and enclosure. So a speaker which generates a lot of distortion will produce a lot more total audible bass than a perfect speaker

system. To make matters worse, bass distortion is not as unpleasant to most ears as treble distortion; in fact, to the uncritical ear it may sound very well indeed.

Total sound level

On the other hand, a combination of harmonic and intermodulation distortion may increase the total sound level above 5,000 cycles by 25% and above 10,000 cycles by several hundred. For example, the highest audible tone on a record may be 10,000 cycles, but a distorting system may extend the sound content to 20,000 cycles by producing harmonics or intermodulation products and thus extend the apparent bandwidth of the system by an octave or more. Similarly, the tendency of some speakers to produce subharmonics may appear to extend the bandwidth on the bass end by an octave or more. So that, though the jukebox may have a response which actually slopes at both ends, the addition of distortion products may bring up the output so the system seems flat to either the ear or a meter.

Indeed, this gives us a very useful criterion of high-fidelity quality. *All other things being equal* — that is, assuming the same or better frequency response, the same input source and the same adjustment of overall tonal balance with tone controls — the wider and flatter the bandwidth of a system, the lower the distortion and the less the resonant effects of the system, *the smaller the proportion of both highs and lows in the overall sound*. For, the system which adds no distortion will have a smaller total of sound at the two extremes.

Instrument power levels

Furthermore, our ears and minds have been conditioned by circumstance and habit to expect more bass and treble in reproduced sound than actually exists "live." One of the jokes in the musical instrument business is that of the purchaser of a fine double-bass viol who returned it with the complaint that it was not as loud as the double-basses heard through jukeboxes. Now the double bass can be pretty overwhelming by itself and in a small room, but it is by no means capable of the loudness most of us expect. The total *peak* acoustic power of the double bass when heard at a distance of only 3 feet is about 150 milliwatts. This compares with 275 mw for a bass sax or piano, 200 mw for a tuba, 300 mw for a trumpet and about 50 mw for most of the woodwinds and triangle. The peak power of a 15-piece orchestra

is around 9 watts and that of a 75-piece orchestra 65. In other words the bass viol is only some 5 db (or two audible steps) louder than a clarinet and actually softer than a trumpet, piano, tuba or bass sax. A single double bass in a 15-piece Dixieland band will be 30 db under the overall sound or scarcely audible at all — and indeed, anyone who listens to live jazz bands of as few as five or six men is familiar with the way the double bass seems to disappear as soon as the whole band starts playing. And yet most of us are very disappointed if the double bass on our hi-fi systems doesn't rise above all this volume to overwhelm all the other instruments and rattle a few loose windows besides. Catering to this conditioning, recording and broadcast engineers manage to accentuate the double bass by various tricks of microphone placement and gain riding. Even so, expecting a double bass, especially a single one, to rattle the windows, particularly at normal living room volume, is clearly calling upon it to act very unnaturally indeed.

The pedal tones of the organ, on the other hand, are quite formidable and we have every right to expect them to vibrate the floors and walls. Unfortunately, they are so powerful and occur so high a percentage of the total interval (30 to 40%) that it is difficult to record them in their full natural intensity, even with modern variable-pitch techniques. The same thing is true of drums and cymbals. A 36-inch bass drum at a distance of 3 feet produces a peak power of 24 watts and that, you can be assured, is more than enough to rattle windows and loose floors. A snare drum will deliver 12 watts and a cymbal 9.5. Such bursts of sound are so steep and their amplitudes in relation to the average level so high that it is almost impossible to put them in the grooves (especially microgrooves) and reproducing them calls for such reserves of power, so superb a transient response and freedom from instability and hangover, that few systems can reproduce them in full when they are well recorded.

Recording vs. listening

The amplitudes quoted here are those which exist at full volume in a studio or auditorium at a distance of 3 feet. High-fidelity listening levels in the home will be 20, 30 or 40 db lower. Even after compensating with loudness controls to produce a response flat to the ear, the amplitude will be very much lower than exists in the studio or auditorium, and there is all the less reason to expect the double bass, tuba, etc. to rattle the windows. On the

other hand, because of recording difficulties the organ pedal and drums are somewhat lower in amplitude to begin with and unless they are boosted out of all balance they too cannot be expected to do much house shaking at home listening levels. It takes power to vibrate a structure as heavy as a home. With a really efficient speaker system 20 electrical watts can begin to do it. Even this is amazing for 20 electrical watts is about 1/37th of a horsepower, an amount of power which you can easily develop yourself and yet, if you've ever tried to vibrate the house by your own energy, you will have found that it is by no means easy.

Similarly, because in radio and TV listening we have been deprived of treble response we tend, when converted to high fidelity, to expect also a much exaggerated treble. The fact is that there is only one instrument in the orchestra capable of producing any respectable amplitude at frequencies above 5,000 cycles: the cymbal. Its peak output, when struck violently, can be as high as 9.5 watts and a lot of this falls in the range above 8,000 cycles. But the peak output of a triangle is only 50 mw and in any moderately loud passage of an orchestra it is nearly completely lost. Here again, however, recording and radio engineers, catering to an artificial taste, tend to exaggerate the high-highs to produce hi-fi effects.

Clearly then, the mere volume of bass and treble can be very deluding indeed, whether it is measured with the ear or a sound-level meter, and it is obvious that attaining legitimate judgment takes care and skill.

A

A. C. Vacuum-Tube Voltmeter, Advantages of	37
Acoustic Balance, Overall Adjustment of	213
Adjustable Bass Boost Circuit	131
Adjusting Pickup Load to Improve Response	190
Adjustments:	
Balance	204
Damping Control	125
Final	203
Alignment of Needle	170
AM Tuners	194
Amount of Damping	124
Amplifiers:	
Analyzing	113
Critical	90
Diagnosis	67
Fault, Boosting Due to	126
Faults in	134
Hum in	154
Internal Impedance of	124
Internal Resistance of	26
Oscillation in	14
Overall-Frequency Response of	35
Power	41
Push-Pull	42
Resistance of	24
Square Wave Response of	13
Analyzer, Intermodulation	38
Analyzing Intermodulation Distortion	101
Analyzing the Amplifier	113
Angle, Tracking	172
Antenna, V	200
Arm:	
Friction	177
Length of Pickup	174
Lubrication of	177
Attenuation, Bass	135
Audible Thumps	20
Audio Engineering Society	117
Audio:	
Generator Frequency Range	28
Generator Output	28
Instruments	27
Signal Generator	28
Signal Tracer	71
Troubles, Common	14
Wattmeter	37
Aural Check of Intermodulation Distortion	33
Average Range of Tone Controls	12

B

Balance:	
Acoustic	213
Adjustment	204
Adjustment Using Scope	205
Checking Capacitors for	87
Control, Misadjustment of	154
Controls, Hum	148
D. C.	86
Of Output Tubes	148
Balanced Detector	200
Balancing:	
Controls	95
Of Push-Pull Stages, Static	95
Potentiometer, Output stage	115
With the Intermodulation Analyzer	205
Bandpass Whistle Filter	198
Bandwidth	198
Bass:	
Adjustable	131
Attenuation	135
Boost Circuit	57
Boost Circuit, Adjustable	131
Boost Circuit, Response of	131
Boosting Equalizers	134
Distortion	128
Excessive	117, 126, 127
Faults	117
Insufficient	129, 130, 136
One-Note	120
Reflex Enclosures, Improving Response	131, 132
Response, Improving	132
Rolloff, Adding	142
Bending, Symmetrical	112
Bias, Hum Due to Improper	157
Bias, Output Tube	207
Biasing Filaments	155
Bifilar Windings	45
Blocking	20
Blocking of Sound	142
Booming	127
Boomy Bass, Eliminating	124
Boost Circuit, Bass	57
Boost Circuit, Treble	57
Boosting Due to Amplifier Fault	126
Bootstrapping	51
Breathing	20, 143
Breathing, Correcting	144
Bridge Circuit, Power Amplifier	49
Bypass Capacitor, Cathode, Deterioration of	135
Bypass Capacitor, Open Cathode	155

C

Cabinet Too Small 123
 Cancellation of Distortion 85
 Capacitive Coupling to the Power Line 160
 Capacitive Reactance 86
 Capacitors:
 Checking for Balance 87
 Defective Electrolytic Filter 150
 Electrolytic 141
 Leaky Coupling 82
 Mismatched Coupling 123
 Open Cathode Bypass 155
 Open Coupling 86
 Open Decoupling 141
 Phase-Shift 89
 Values of 70
 Capture Ratio 201
 Cartridges:
 Crystal 173
 Pressure 176
 Repairing 178
 Variable-Reluctance 172
 Cathode:
 Bypass Capacitor, Deterioration of 135
 Bypass Capacitors, Hum Due to Defective 155
 Follower Detector 194
 Follower Driver 52
 Loading 44
 Loading, Partial 46
 Resistor, Common 87
 Resistor, Unbypassed 135
 Cathodyne:
 Inverter 53
 Modified 54
 Phase Inverter, Adjustments in 156
 Causes of Distortion 103
 Causes of Hum 150
 CCIR 117
 Ceramic Cartridges:
 Equalization of 130
 Load 190
 Unequalized 138
 Changing Tubes 207
 Charging Current, Power-Frequency Chassis, Hum Voltages in the 161
 Checking:
 Capacitors for Balance 87
 Equalization 184, 185
 Feedback Loop 96
 Flatness of Scope Amplifiers 107
 Wow and Turntable Rumble 33
 Choke, Defective 150
 Circuits:
 Decoupling 135, 145
 High-Fidelity 41
 Intermodulation Analyzer 36
 Rolloff 60
 Class A, Extended 47
 Class A2 46
 Cleaning Styl 165
 Clipping 109, 113
 Common Audio Troubles 141
 Common Cathode Resistor 87
 Compensation in Equalizers 189
 Complex Waveforms of Sound 15
 Component Replacement 70
 Composition of Sound Waves 15
 Connections, Ground 162
 Constant Output of Audio Generator 28
 Contour Selector, Loudness 58
 Controls:
 Average Range of Tone 12
 Balancing 95
 Circuit, Failure of Tone 138
 Curves, Loudness 12
 Hum 155, 206
 Hum Balancing 148
 Loudness 57, 130

Loudness, Misuse of 118
 Treble 137
 Units 56
 Variable Damping 63
 Core Saturation, Transformer 113
 Correcting Breathing 144
 Coupling Capacitors:
 Leaky 82
 Mismatched 128
 Open 86
 Critical Amplifiers 90
 Critical Damping 210
 Cross-Coupled Inverter 55
 Crossover Networks 62
 Crystal:
 Cartridge 173
 Cartridge, Unequalized 138
 Cartridges, Equalization of 130
 Load 190
 Pickup, Loading Effects on 191
 Current Feedback 125
 Curves:
 De-Emphasis 197
 Intermodulation 19
 Loudness Control 12
 Playback Response 30
 Power Output 11
 Pre-Emphasis 197
 Speaker 123
D
 Damped Waves 98
 Damping:
 Amount of 124
 Control, Adjustment of 125
 Controls, Variable 63
 Critical 210
 Decreasing 133
 Factor 23
 Factor, Calculating the 25
 Increasing 125
 Insufficient, of Speakers 124
 Removal of 124
 D. C. Balance 86
 Dead Room 74
 Decoupling:
 Capacitor, Open 141
 Circuit 135, 145
 Networks 97
 Decreasing Damping 133
 De-Emphasis Curve 197
 De-Emphasis Networks 196
 Defective Choke 150
 Definition:
 Degraded 14
 Testing 15
 Degraded Definition 14
 Detector:
 Balanced 200
 Cathode-Follower 194
 Diode 194
 Discriminator 197
 Infinite-Impedance 194
 Ratio 197
 Diagnosing Hum 149
 Diagnosis of Amplifiers 67
 Diamond Styl 170
 Diode Detector 194
 Disc, Stroboscopic 182
 Discriminator Detector 197
 Distortion:
 Audio Generator 28
 Bass 128
 Breathing 144
 Cancellation of 85
 Causes of 103
 Excessive Limiting 195
 FM Receivers 194
 Harmonic 19
 High-Level 105

Indications	109
In-Phase	113
Intermodulation	18
Low Level	93
Needle	167
Nonlinear	18
Permissible Levels of	19
Phase	22
Ratio, Intermodulation and Harmonic	19
Second-Harmonic	85
Stylus	91
Symmetrical In-Phase	113
Testing, Stylus	168
Transient	20
Tuner	91, 193
Types of	18
Dividing Networks	61
Driver, Cathode-Follower	52
Driver Stages, Push-Pull	52
Drivers	50
Dummy Load	98

E

Echoes	14, 127
Effects of Ringing on Square-Wave Response	21
Efficiency	22
Electrical Transient, Keyed	17
Electrolytic Capacitors	141
Electrolytic Filter Capacitors, Defective	150
Emergency Servicing	27
Enclosure Resonance	119
Enclosure to Speaker, Matching	120
Enclosure too Small	123
Enclosures, Bass Reflex, Improving	120
Equalization:	
Ceramic Cartridges	130
Checking	184, 185
Crystal Cartridges	130
Insufficient	130
Playback	184
Types of	189
Equalizer:	
Bass-Boosting	134
Compensation in	189
Faults in	134
Tubes, Changing	134
Excessive Bass	117, 126, 127
Extended Class A	47

F

Factor, Calculating the Damping	25
Factor, Damping	23
Failure of Feedback Loop	156
Faults, Bass and Treble	117
Faults in Equalizers	134
Faulty System	72
Feedback:	
Current	125
Factor, Varying the	210
Improper	88
In-Phase	88
Loop, Checking the	96
Loop, Failure of	138, 156
Loops	90
Positive	88
Positive Current	125
Resistors, Reduction in Value of	143
Fidelity Standards, High-Filament String, Grounded	9
Filaments, Biasing	154
Filaments, Blasing	155
Filter:	
Capacitors, Defective	150
Open	141
Operation, Testing	198
Whistle	198

Final Adjustments	203
Flatness of Scope Amplifiers	107
Flatness of Test Record	31
Flats in Idler	183
FM Receivers, Distortion in	194
Frequency:	
Hum	151
Range, Audio Generator	28
Range of Test Records	29
Response	9, 208
Friction of Arm	177
Fuzzy Highs	145

G

Gain Control	58
Generating a Step Transient	211
Generator:	
Audio Signal	28
Distortion	28
Square-Wave	28
Grille, Speaker	138
Ground:	
Connections	162
Loop Problems	157
Loops, Curing	158
Grounded Filament String	154

H

Hangover	17, 20, 127
Hangover Effects	14
Harmonic and Intermodulation Distortion Ratio	19
Harmonic Distortion	19
Headphones	68
Headphones, Using in Testing	80
Heater-to-Cathode Leakage	154
High-Fidelity:	
Circuits	41
Standards	9
System	69
High-Frequency Instability	145
High-Frequency Interference	161
High-Level Distortion	105
High-Level Transients	142
Highs:	
Fuzzy	145
Loss of	126
Overboosting	79
Hum:	
Amplifiers	154
Balance Controls	148
Caused by Leakage Across Tube Sockets	156
Caused by Mismatch in Push-Pull Stage	155
Causes of	150, 151
Control	155, 206
Control, Misadjustment of	154
Diagnosing	149
Due to Improper Bias	157
Electrical	179
Frequency of	151
Level	147
Locating	150
Mechanical	179
Minimizing	148
Modulation	155
Motor	179
Ratios	146
Residual	148
Sixty-Cycle	148, 149
Techniques for Minimizing	163
Tracing	151
Tubes	154
Tuners	153
Voltages in the Chassis	161

Ideal Speaker Curve	123
Idler	182
I, F. Misalignment	194
IM:	
Analyzer	38
Analyzer, Balancing With	205
Analyzer, Circuit of	36
Analyzer, Using the	38, 94
Aural Check of	33
Curves	19
Distortion	18
Distortion, Aural Check of	33
Distortion, Measuring	101
Distortion, Percentage of	95
Records	169
Test Records	32
Imbalance Within Push-Pull Stages	83
Impedance:	
Amplifier, Varying the Internal	125
Matching Networks, Transmission Line	196
Rise of Loudspeakers	133
Speaker	24
Improper Bias, Hum Due To	157
Improper Feedback	88
Improper Operating Parameters	81
Improving Bass Reflex Enclosures	120
Improving Bass Response	132
Incomplete Limiting	199
Indications, Distortion	109
Infinite-Impedance Detector	194
Inoperative Audio System	69
In-Phase:	
Distortion	113
Distortion, Symmetrical	113
Feedback	88
Instability	143, 144
Instability, High-Frequency	145
Instability, Low-Frequency	141
Instruments, Audio	27
Instruments, Test	27
Insufficient Bass	129, 130, 136
Insufficient Damping of Speakers	124
Insufficient Treble	137
Interchannel Interference	198
Interference, High-Frequency	161
Interference, Interchannel	198
Intermodulation:	
Analyzer	38
Analyzer, Balancing With	205
Analyzer, Circuit of	36
Analyzer, Using the	94
Curves	19
Distortion	18
Distortion, Aural Check of	33
Distortion, Measuring	101
Distortion, Percentages of	95
Records	169
Test Record	32
Internal Impedance of Amplifier	124
Internal Impedance of Amplifier, Varying the	125
Internal Resistance of Amplifier	26
International Radio Consultative Committee	117
Inverters:	
Adjustments in Cathodyne	156
Cathodyne	53
Cross-Coupled	55
Split-Load	53
J	
Jacks, Defective or Dirty	151
K	
Keyed Electrical Transient	17

Leakage Across Tube Sockets	156
Leakage, Heater-to-Cathode	154
Leaky Coupling Capacitor	82
Length of Pickup Arm	174
Level Control	58
Level, Hum	147
Levels of Distortion, Permissible	19
Life of Needle	170
Light Patterns of Test Records	31, 185
Limiting, Distortion Due to	
Excessive	195
Limiting, Incomplete	199
Line Voltage, Excessive	150
Line Voltage, Insufficient	150
Listener, Location of	139
Listening Test for Transient Response	17
Load:	
Ceramic Cartridge	190
Crystal	190
Dummy	98
Pickup	136, 188
Reactive	98
Loading, Cathode	44
Loading Effects on Crystal Pickup	191
Locating Distortion With Scope	83
Locating Hum	150
Location of Listener	139
Long-Tailed Pair	54
Loop:	
Checking the Feedback	96
Failure of Feedback	138
Feedback	90
Problems, Ground	157
Loss of Highs	126
Loudness:	
Contour Selector	58
Control, Adjustment of	131
Control Curves	12
Control, Misuse of	118
Controls	57, 130
Loudspeaker (see Speaker)	
Low-Frequency:	
Instability	141
Oscillation	143
Rolloff Circuit, Disabled	142
Stability	98
Low-Level Distortion	93
Low-Level Sine-Wave Measurements	11
Lowpass Whistle Filter	198
Lubrication of Arm	177
Lubrication of Turntable	181
M	
Magnetic Pickup	175
Magnetization of Transformer Core	113
Magnetized Tubes	154
Matching Speaker to Enclosure	120
Measurements:	
Sine-Wave	11
Square-Wave	12
Voltage	82
Measuring IM, Waveform Technique for	101
Minimizing Hum	148
Minimizing Ringing	128
Misadjusted System	72
Misadjusted Tweeter	137
Misadjustment of Balance and Hum Controls	154
Mismatched Coupling Capacitors	128
Misuse of Loudness Control	118
Modulation Hum	155
Momentary Blocking	142
Motor Hum	179
Motorboating	20, 141

N

N-A Intermodulation Test Record ..	32
NARTB	117
National Association of Radio and Television Broadcasters	117
Needle:	
Alignment	170
Cleaning of	165
Condition	165
Distortion	91, 167
Distortion Testing	168
Inspection of	165
Life	170
Pressure	176
Replacing	178
Sapphire and Diamond	170
Tilt	171
Negative Current Feedback	125
Networks:	
Crossover	62
Decoupling	97
De-Emphasis	196
Dividing	61
R-C Decoupling	90
Neutralizing Output Tubes	88
Noise	147, 193
Noise, Receiver	198
Noise, Thermal	34
Nonlinear Distortion	18

O

One-Note Bass	120
Open Cathode Bypass Capacitor	155
Open Coupling Capacitor	86
Open Decoupling Capacitor	141
Open Filter	141
Operating Parameters, Improper	81
Optimum Ports	122
ORTHO	117
Oscillation:	
Amplifier	14
Continuous	141
Low-Frequency	143
Momentary	141
Parasitic	88
Periodic	20
Triggered	20
Oscilloscopes (see Scopes)	
Output:	
Curves, Power	11
Power	22, 41
Stage Balancing Potentiometer	115
Stages, Balancing	85
Tube Bias	207
Tubes, Balance of	148
Tubes, Neutralizing	88
Overall Adjustment of Acoustic Balance	213
Overall-Frequency Response of Amplifier	35
Overbias, Indication of	113
Overbiasing, Causes of	82
Overboost	117
Overboosting Highs	79
Overdamping	133
Overdriving	109
Overhang	173
Overloaded Power Supply	150
Overloading	80

P

Padding, Turntable	181
Pair, Long-Tailed	54
Parameters, Improper Operating	81
Parasitic Oscillation	88

Parasitic Suppressors	97
Parasitics	113
Partial Cathode Loading	46
Parts Replacement	70
Pattern of a Test Record	32
Pattern of Test Record, Light	185
Patterns, Phase-Shift	106
Peaks, Speaker	119
Periodic Oscillation	20
Permissible Levels of Distortion	19
Phase Distortion	22
Phase Inverters:	
Adjustments in Cathodyne	156
Cathodyne	53
Cross-coupled	55
Split-Load	53
Phase-Shift Capacitor	89
Phase-Shift Patterns	106
Phono Pickups	165
Pickup:	
Arm Length	174
Load	136, 188
Magnetic	175
Phono	165
Piezoelectric Cartridge Load	190
Placement of Speakers	75, 127, 132
Plate-Load Resistors	86
Playback Equalization	184
Playback Response Curves	30
Port Too Large	123
Port Too Small	123
Ports, Optimum	122
Positive Current Feedback	125
Positive Feedback	88
Potentiometer, Output Stage Balancing	115
Power Amplifier Bridge Circuit	49
Power Amplifiers	41
Power-Frequency Charging Current	161
Power Line, Capacitive Coupling to the	160
Power Output	22, 41
Power Output Curves	11
Power Supply Overloaded	150
Preamplifiers	56
Preamplifiers and Control Units, Functions of	56
Pre-Emphasis Curve	197
Pre-Emphasized Treble	136
Pressure, Needle	176
Pulse Definition	14
Push-Pull:	
Amplifier	42
Driver Stages	52
Stages, Imbalance in	83

R

Range of Audio Generator, Frequency	28
Range of Output, Audio Generator	29
Ratio:	
Capture	201
Detector	197
Hum	146
Intermodulation and Harmonic Distortion	19
R-C Decoupling Networks	90
RCA New Orthophonic	117
Reactance, Capacitive	86
Reactive Load	98
Receiver Noise	198
Receivers, FM, Distortion in	194
Record Industry Association of America	117
Record, Sweep	17
Record Waveforms, Test	187
Recording Problems	29
Records, Intermodulation	169
Records, Test	29

Rectifier Tube, Defective	150
Regeneration in Tuners	195
Repairing Cartridges	178
Replacing Needles	178
Replacing Parts	70
Residual Hum	148
Resistance, Amplifier	24
Resistance of Amplifier, Internal	26
Resistors:	
Common Cathode	87
Defective Filter	150
Plate-Load	86
Values	70
Resonance:	
Enclosure	119
Room	127
Speaker	24, 119
Resonant Point, Speaker	210
Response:	
Bass	131, 132
Bass Boost Circuit	131
Curves, Playback	30
Frequency	9, 208
Speaker	209
Square-Wave	98
Transient	15
RIAA	117
Ringling:	
Analysis of	20, 98, 145
Effects of on Square-Wave Response	21
Minimizing	128
Room	74, 127
Testing for	146
Rolloff:	
Analysis of	59
Bass, Adding	142
Circuits	60
Curves	61
Slope	61
Room:	
Acoustics	74
Dead	74
Resonance or Ringing	127
Ringing	74
Rubber Idler, Defective	183
Rumble	180
Rumble, Checking	33

S

Sapphire Stylil	170
Saturation, Transformer Core	113
Scopes:	
Amplifiers, Flatness of	107
Balance Adjustment Using	205
Frequency Response of	34
Locating Distortion With	83
Screen Bypass Capacitors, Hum Due to Defective	155
S-Curve	200
Second-Harmonic Distortion	85
Sensitivity	22
Servicing, Emergency	27
Signal Generator, Audio	28
Signal Tracer, Audio	71
Sine-Wave Measurements	11
Slope of Rolloff	61
Sound, Blocking of	142
Sound Waves, Composition of	15
Speaker:	
Curve, Ideal	123
Curves	123
Enclosure, Matching to	120
Grille	138
Impedance	24
Impedance Rise of	133
Insufficient Damping of	124
Overdamping of	133
Peaks	119
Placement	75, 127, 132

Resonance	24, 119
Resonant Point	210
Response	209
System	131
Split-Load Inverter	53
Square-Wave:	
Generator	28
Measurements	12
Response	98
Response, Effects of Ringing on	21
Response of Amplifiers	13
Testing	209
Stability, Low-Frequency	98
Stability, Transient	17
Standards, High-Fidelity	9
Static Balancing of Push-Pull Stages	95
Step Transient	98
Step Transient, Generating a	211
Step Transient Waveforms	22
Stroboscopic Disc	182
Stylus:	
Alignment	170
Cleaning of	165
Condition	165
Distortion	91, 167
Distortion Testing	168
Inspection of	165
Life	170
Pressure	176
Replacing	178
Sapphire and Diamond	170
Tilt	171
Suppressors, Parasitic	97
Sweep Record	17
Sweep Records, Using	184
Switching Circuits of IM Analyzer	39
Symmetrical Bending	112
Symmetrical In-Phase Distortion	113
Systems:	
High-Fidelity	69
Loudspeaker	131
Misadjusted	72
Operating, But Faulty	72

T

Test:	
Instruments	27
Record, N-A Intermodulation	32
Record, Pattern of	32
Record Waveforms	187
Records	29
Records, Determining Flatness of	31
Records, Examining	31
Records, Light Patterns of	31, 185
Testing:	
Definition	15
Filter Operation	198
Ringing	146
Square Wave	209
Stylus Distortion	168
Thermal Noise	34
Thumps, Audible	20
Tilting of Needle	171
Tone Control Circuit, Failure of	138
Tone Controls, Average Range of	12
Tracer, Audio-Signal	71
Tracing Hum	151
Tracking Ability	192
Tracking Angle	172
Transformer Core Saturation	113
Transformer, Shorted Turns	136
Transient:	
Distortion	20
Distortion Waveform	23
Generating a Step	211
High-Level	142
Keyed Electrical	17
Response	15

Response, Checking	211
Response, Degraded	143
Response, Listening Test for	17
Stability	17
Step	98
Waveforms	22, 212
Transmission Line Impedance	
Matching Networks	196
Transmitting Tubes in Audio	
Amplifiers	42
Treble:	
Boost Circuit	57
Control	137
Faults	117, 136
Insufficient	137
Pre-Emphasized	136
Triggered Oscillation	20
Troubles, Common Audio	141
Tubes:	
Bias, Output	207
Changing	207
Hum in	154
Magnetized	154
Neutralizing Output	88
Sockets, Leakage Across	156
Transmitting, in Audio	
Amplifiers	42
V-R	90
Weak	81
Tuner:	
AM	194
Distortion in	91, 193, 194
Hum in	153
Regeneration in	195
Turntable:	
Lubrication	181
Padding	181
Rumble, Checking	33
Tweeter:	
Cause of Burn Out	138
Misadjusted	137
Replacing	138
Types of Distortion	18
U	
Ultra-Linear Circuit	45
Ultrasonic Instability	145

Unbypassed Cathode Resistor	135
Underbiasing	109
Underbiasing, Causes of	82
Unequalized Ceramic Cartridges	138
Units, Control	56
Using the Intermodulation Analyzer	94

V

V Antenna	200
Vacuum-Tube Voltmeter	37
Values of Capacitors	70
Values of Resistors	70
Variable Damping Controls	63
Variable-Reluctance Cartridge	172
Varying the Feedback Factor	210
Visual Inspection of Stylus	165
Voltages:	
Chassis, Hum	161
Excessive Line	150
Measurements	82
Volume Control, Modified	59
V-R Tube	90
V-R Tube, Installing a	144
V.T.V.M.	37

W

Wattmeter, Audio	37
Waveform:	
Sound, Complex	15
Step-Transient	22
Technique for Measuring IM	101
Transient	212
Transient Distortion	23
Waves, Damped	98
Weak Tubes	81
Wear of Needle	165
Whistle Filter	198
Williamson-Type Amplifier Circuit	43
Woofer-Tweeter Combinations	62
Wow	181
Wow, Checking	33