

The Radio Amateur's Handbook

A Manual of Amateur Short-Wave Radiotelegraphic Communication



PRICE
ONE
DOLLAR



PUBLISHED BY THE AMERICAN RADIO RELAY LEAGUE - HARTFORD

The
RADIO AMATEUR'S HANDBOOK

A MANUAL *of* AMATEUR HIGH-FREQUENCY
RADIO COMMUNICATION

BY
THE HEADQUARTERS STAFF
OF THE
AMERICAN RADIO RELAY LEAGUE

SEVENTH EDITION



HARTFORD, CONN.
The AMERICAN RADIO RELAY LEAGUE, Inc.

1930

COPYRIGHT 1930 BY THE
AMERICAN RADIO RELAY LEAGUE, INC.

First Edition, November, 1926	5,000 copies
Second Edition, First Printing, January, 1927	5,000 copies
Second Edition, Second Printing, April, 1927	10,000 copies
Third Edition, First Printing, October, 1927	10,000 copies
Third Edition, Second Printing, April, 1928	10,000 copies
Fourth Edition, December, 1928	10,000 copies
Fifth Edition, May, 1929	10,000 copies
Sixth Edition, First Printing, November, 1929	10,000 copies
Sixth Edition, Second Printing, March, 1930	10,000 copies
Sixth Edition, Third Printing, June, 1930	7,000 copies
Seventh Edition, October, 1930	25,000 copies

Printed in U. S. A. by
RUMFORD PRESS
CONCORD, N. H.

The
RADIO AMATEUR'S HANDBOOK

July
LMLVH
12724

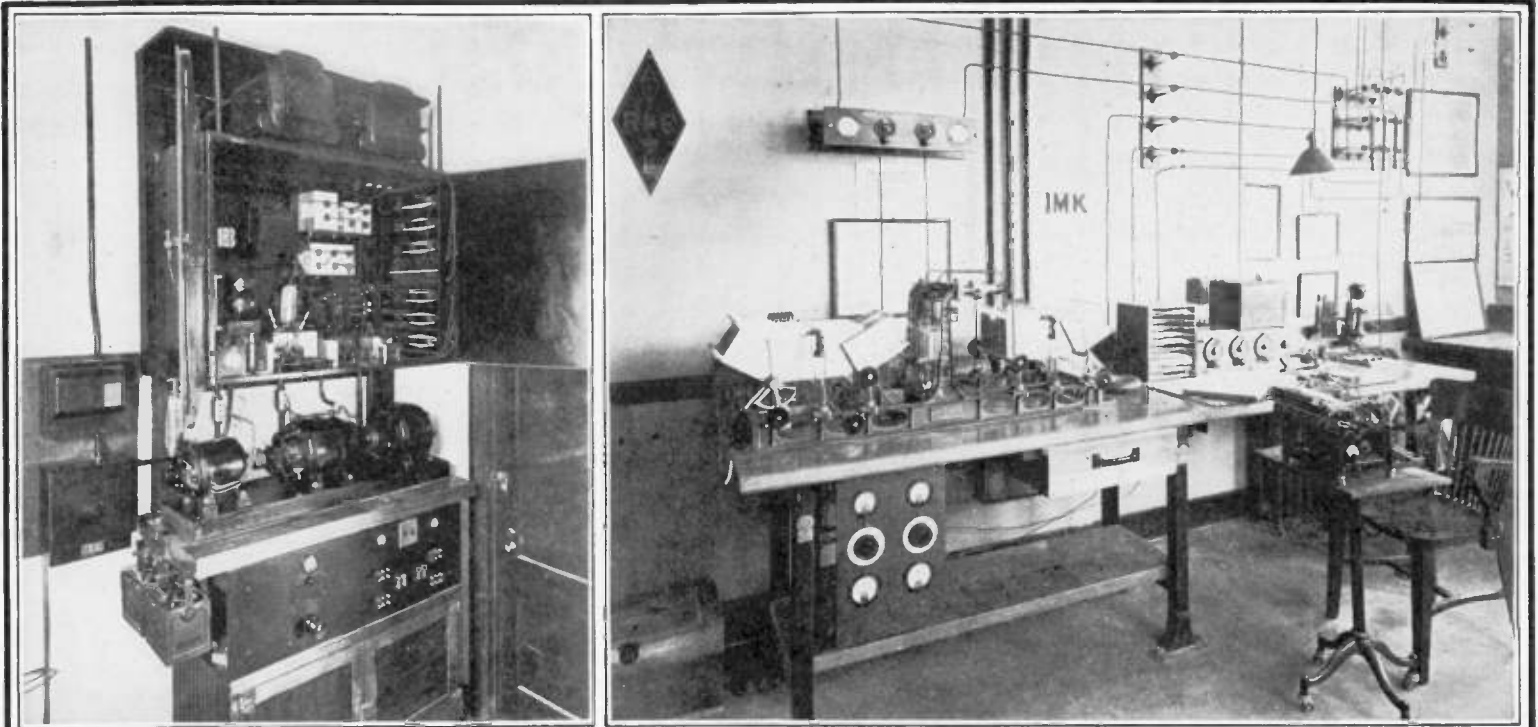

WIMK, THE HEADQUARTERS STATION OF THE A.R.R.L. AT HARTFORD, CONN.

The power supplies and the operating position are shown. Note the neatness and accessibility of every feature of the station arrangement. High voltage d. c. to the main and auxiliary transmitters is obtained from a motor-generator and a mercury-arc rectifier and filter. Fuses, relays, batteries, charging equipment and the like are all in the power-supply room. The receiver is in front of the operator, key and controls at his right, and the message file box at his left. Ample space is provided for the monitor, frequency meter, and station log when not in use. Two-wire

voltage (Zeppelin) feed is used to separate antennas for the different transmitters and there is a separate receiving antenna to facilitate "break-in" work. The Official Broadcasts to A.R.R.L. Members are sent simultaneously on 3575 and 7150 kc. The main transmitter unit has interchangeable coils of heavy tubing with compression-type threaded brass couplings and may be shifted quickly to any of the different amateur frequency bands. WIMK is a busy station but always ready for a call from any "ham." Operating schedules are published regularly in *QST*.

FOREWORD

IN presenting a wholly revised seventh edition of *The Radio Amateur's Handbook* the publishers can only hope that it will be found as helpful as previous prints of this book and enjoy as wholehearted a reception at the hands of the amateur fraternity.

The *Handbook* is intended both as a reference work for member-operators of the American Radio Relay League and other skilled amateurs and as a source of information to those wishing to participate in amateur radio activities but having little or no idea how to get started. The choice and sequence of material have been planned with particular thought to the needs of the beginning amateur but each subject has been developed to embrace the most modern amateur practice in that particular department of activity. Designed to be a practical rather than a theoretical work, theoretical discussions have been made as simple and fundamental as possible and the chief effort directed at practical means for securing results — which, after all, is the principal aim of the amateur in radio.

This book is made available by the American Radio Relay League, the radio amateur's own organization. Written by amateurs, for anyone and everyone interested in amateur work, it is hoped that it will continue to be a helpful manual to those active in amateur work and instrumental in assisting beginning and prospective amateurs to get into the game and get the maximum of enjoyment out of it by directing their efforts along the lines that bring results most quickly, surely and inexpensively.

In 1925 Mr. Francis Edward Handy, for many years the League's communication manager, commenced work on a small manual of amateur operating procedure, at the direction of the A.R.R.L. Executive Committee. It was deemed desirable to include a certain amount of "technical" information, since an amateur's results are so greatly influenced by the disposition and adjustment of his apparatus. When Mr. Handy completed his manuscript he had written a considerable-sized book of great value. It was published in 1926 and enjoyed an instant success. Produced in the familiar format of the League's magazine, *QST*, unusual as that is for a publication of this nature, it was possible to distribute for a very modest charge a work which in volume of subject-matter and profusity of illustration surpassed most available radio texts selling for several times its price — and which, because it was written by an eminently practical amateur, was of the greatest possible value as a guide to other amateurs. Three successive editions were revised by Mr. Handy as reprinting became necessary.

Throughout the year 1928 the League conducted a technical development program at its headquarters laboratory for the purpose of developing new apparatus and methods which would overcome the handicaps of reduced space in the radio spectrum which were to become effective upon the radio amateur at the beginning of 1929, by virtue of the then newly-signed international radio treaty. This work was under the direction of Mr. Ross A. Hull, well-known Australian amateur and technical journalist, and was brilliantly successful. In 1928, then, Mr. Hull joined Mr. Handy as co-author of the *Handbook*, and three additional editions have since appeared under their joint authorship.

To a total of ten printings the fame of the *Handbook* has echoed around the world. Its success has been really inspiring. Quantity orders have come from many a foreign port; schools and technical classes have adopted it as a text; most important of all, it has become the right-hand guide of practical amateurs in every country on the globe. But amateur radio moves with amazing rapidity and the best practices of yesterday are quickly superseded by the developments of to-day. Ever since the day the sixth edition rolled from the presses another revision has been seen to be necessary — the *Handbook* must keep up to date. Now in the headquarters establishment of the League there are many skilled amateurs, each a specialist in his field. We have been increasingly aware, the last few editions, that the *Handbook* was becoming a family affair, with more and more of us participating in its composition. When it was time to prepare a seventh edition we found that a natural division of the labor brought many members of our establishment into the picture, and so this edition is presented as the work of the headquarters staff of the A.R.R.L.

The book has now been completely revised, with every chapter modernized in the light of current amateur practice. Naturally it continues to be based on Mr. Handy's earlier work. As our communications manager no one is better fitted than he to write the chapters on operating a station and on the work of the A.R.R.L. Communications Department. Natural to him, too, as the member of our staff most interested in the early instruction of new operators, is the authorship of the chapters on getting started, on electrical fundamentals, and on how our radio signals are sent and received. The opening chapter, a general exposition of amateur radio, is from the pen of Mr. A. L. Budlong, the assistant secretary of the League. The seven bulky chapters in the central part of the book, dealing with the construction and operation of all types of appa-

ratus, are the joint work of Mr. James J. Lamb, the technical editor of *QST*, and Mr. George Grammer, the assistant technical editor of *QST*. In their work on our magazine they are, of course, constantly abreast of the latest thought in amateur technical circles, and to them fell the arduous task of completely revamping the apparatus chapters in terms of present best practice. As before, the production of the book has been

handled by the personnel which produces *QST*.

We shall all feel very happy if the present edition succeeds in bringing as much assistance and inspiration to amateurs and would-be amateurs as have its predecessors.

K. B. WARNER

EDITOR

HARTFORD, October, 1930

CONTENTS

Headquarters Station W1MK	<i>Frontispiece</i>
Foreword	v
The Amateur — His Code of Ethics	viii
Chapter I — Amateur Radio	1
Chapter II — Getting Started	13
Chapter III — Fundamentals	26
Chapter IV — How Radio Signals Are Sent and Received	39
Chapter V — Receivers	53
Chapter VI — Frequency Meters and Monitors	74
Chapter VII — Transmitters	85
Chapter VIII — Radiotelephony	117
Chapter IX — Power Supply	131
Chapter X — Keying and Interference Elimination	152
Chapter XI — Antennas	159
Chapter XII — The A.R.R.L. Communications Department	170
Chapter XIII — Operating a Station	177
Appendix	197
Index	213
Membership Application Blank	217
O. R. S. Application Blank	218

The Amateur's Code

- I *The Amateur is Gentlemanly.* He never knowingly uses the air for his own amusement in such a way as to lessen the pleasure of others. He abides by the pledges given by the A.R.R.L. in his behalf to the public and the Government.
- II *The Amateur is Loyal.* He owes his amateur radio to the American Radio Relay League, and he offers it his unswerving loyalty.
- III *The Amateur is Progressive.* He keeps his station abreast of science. It is built well and efficiently. His operating practice is clean and regular.
- IV *The Amateur is Friendly.* Slow and patient sending when requested, friendly advice and counsel to the beginner, kindly assistance and coöperation for the broadcast listener; these are marks of the amateur spirit.
- V *The Amateur is Balanced.* Radio is his hobby. He never allows it to interfere with any of the duties he owes to his home, his job, his school, or his community.
- VI *The Amateur is Patriotic.* His knowledge and his station are always ready for the service of his country and his community.

PAUL M. SEGAL, W9EEA,
Director, Rocky Mountain Division, A.R.R.L.

The RADIO AMATEUR'S HANDBOOK

CHAPTER I

Amateur Radio

AMATEUR radio to-day is an established institution. Thousands of people pursue it as a hobby; a powerful and prosperous organization bonds together these followers and protects their interests; an internationally-respected radio magazine is published solely for their benefit. The Army and Navy seek the coöperation of the amateur in developing communication reserves; the public depends on amateur services in major emergencies; the countries of the world recognize him as one of the established branches of the radio art and provide space on the air for him when writing up international radio treaties.

Thirty odd years ago amateur radio did not exist — the name, had it been used, would have meant nothing. All the development just mentioned, then, has taken place within the comparatively short time represented since the opening of the present century.

It is the purpose of this chapter to trace, briefly, this development.

WHO was the first amateur?

Long familiarity with the breed has made possible a most likely assumption. It is probable that within a few days of the announcement by Marconi of the successful termination of his first experiments in radio communication, an ambitious young Italian with an insatiable curiosity had wormed himself into the confidence of the illustrious Senatore and acquired enough of the rudiments of the new art to attempt a duplicate of the original apparatus. He was the world's first amateur. Our conviction of his existence is in no wise lessened by the fact that history neglects to mention him.

History does come to our aid as soon as we turn to the American amateur. Prior to the advent of radio telegraphy there existed a class of young fellows whose hobby centered around "electrical experiments." They built electric motors and wet cells to run them; they assembled Wimshurst static machines; they constructed backyard telegraph lines.

When Marconi announced that it was possible to send messages without wire and proved it by

transmitting the letter "S" across the Atlantic Ocean, the older heads murmured in awe and consulted their Bibles. Our youthful electrical experimenters, on the other hand, perceived immediately that here was something a hundred-fold more engrossing than "electricity." With one voice they asked, "How does he do it?" and with one purpose of mind they proceeded to find out for themselves.

At least one American youngster had a receiving set built at the time of Marconi's first transatlantic experiment, nor was his enthusiasm dampened by the fact that he did not have sufficient knowledge of the new art to make his apparatus function.

So early in the radio picture, then, we see the beginning of *amateur* radio — the pursuit of radio, not as a business or means of profit, but as a hobby to be indulged during one's spare time for the love of the work and the pleasure it returns to the individual. Aside from its early beginnings, the sheer spontaneity of the start of Amateur Radio is significant. No one said, "Let us have Amateur Radio" and then proceeded coldly to develop it. Instead, it blossomed independently in the minds of hundreds of American youths and men who saw in the new scientific marvel a means for personal enjoyment and a new agency for personal inter-communication. Once begun, it grew and grew. Nothing has stopped it yet.

It is difficult to clamp a definite date on the beginning of any widespread movement, but we may regard the year 1901 as the one in which Amateur Radio received its start in this country.

FOR ten years progress was slow, crude and fraught with difficulties. There were few books on the subject, none of a popular nature. There were no radio magazines. Much of an amateur's transmitting and receiving equipment was homemade, of necessity, the glorious era of ten-cent-store radio being some twenty years in the future. Only a few concerns in the country carried radio equipment of any kind.

But progress was made. The coherer and microphone detector gave way to the crystal, with

its enormously increased sensitivity. The single-slide tuner displaced the straight aerial-to-ground hookup, and was itself displaced by the more flexible three-slide tuner. This, in turn, was superseded by the loose-coupler with variable-condenser tuning. There were rumors filtering through of a new type of detector, the audion bulb, invented by DeForest, which was even superior to the crystal and which needed no adjustment.

The transmitters were all spark. The beginners used spark coils, straight spark gaps and — sometimes — a simple kind of antenna tuning. Their more wealthy brothers used high-voltage transformers. Power was limited by one's pocket-book, and some pocket-books did not stop short of the five-kilowatt mark.

Rotary gaps were developed and were pounced upon.

Wavelengths were to a certain extent accidental — but the aim was high. Unfortunates with limited antenna facilities had to be content with 250 or 300 meters; most of the big fellows were from 300 up — as likely as not, around 1000.

By 1912 ranges had increased to the point where the fellow with several kilowatts was sometimes heard three and four hundred miles, in favorable sections of the country. The average radio amateur, however, contented himself with more moderate distances, and used his set for the most part in conversing with friends on the other side of the city.

At this point it is well to remember that there was as yet no governmental regulation of any kind when it came to "wireless." Anyone who wanted to put a radio transmitter on the air could do so. He could use any power he chose, assign himself a call of his own, pick his own wavelength, or change it at will, and operate either as an amateur or a commercial when and as he pleased.

There were probably in the neighborhood of six hundred amateurs in active operation by the end of 1911, with the total Navy and commercial stations coming to only some 25 per cent of this figure.

THE law came for the first time in 1912. Government representatives returned from an international radio meeting in London armed with detailed regulations to govern the newly-arrived industry and sundry announcements were immediately made to all amateurs as follows: Every amateur operator must henceforth take out a license for himself and his station. Amateurs would have to keep their power down to a maximum of one kilowatt. They could not operate above two hundred meters. Commercial and Navy stations now had definite rights, and their traffic was to be accorded priority. Official call letters would be issued to each station and were to be used by it when transmitting. A few special

licenses would be issued to operate on 375 and 425 meters.

Initial alarm in the amateur ranks at these pronouncements was soon allayed when it was found by experiment that if the matters of obtaining licenses and of showing consideration to the commercial and government stations were complied with, observance of the other features was not particularly necessary. "Two hundred meters" would cover anything from 250 to 375. "One kilowatt" could be stretched to two without much fear of government admonishment. Regulation, in a word, was not accompanied by enforcement beyond the bare essentials, either in the amateur ranks or in any other branch of radio, in those first early days.

Under this happy state of affairs the amateur grew and prospered, and by the first part of 1914 had increased in number to about 2000. Except, however, for a slight increase in transmitting range to four or five hundred miles for the big fellows, and the use of audion bulbs — non-regenerative — by some of the more advanced stations for receiving detectors, the art remained in about the same state.

IN the early part of 1914, Hiram Percy Maxim, an ardent amateur in addition to being a world authority in the field of sound, desired to send an amateur radiogram from his home in Hartford, Connecticut, to another station in Springfield, Massachusetts. His own transmitter not having sufficient range to reach Springfield he conceived the idea of having it relayed by an intermediate station at Windsor Locks, Connecticut.

It was done.

Now it is not claimed that this in itself was unusual. Ships were using the relay principle to get messages from mid-ocean to shore with the assistance of other ships. It is reasonable to assume that amateurs themselves had previously relayed messages beyond the limits of their own particular sets.

The act itself, therefore, had no particular significance. The application of the act, however, had all the significance in the world. Maxim had for many months thought of starting a national amateur organization. He had not carried it further than the idea state because he could think of no prime moving force, no basic principle around which to rear the structure. Americans have always been great "joiners," but if an amateur organization were ever to progress beyond the paper stage it must offer something more than one's name on the rolls. In short, unless he could find something definite for such an organization to do, he could not justify its existence.

The morning after the Hartford-Springfield relay while his thoughts were harking back to the previous evening's success, the old ideas about

the national organization wandered through his mind — something clicked — and the problem was solved!

For here, without a doubt, was the idea around which the organization could be successfully and strongly built. The missing block in the puzzle had been found and fitted. The organization would be a *relay* organization. It would have as its object the developing of relay routes over all the country among all the amateurs, so that by this means an amateur in one part of the country could send a message hundreds of miles to an amateur in another part; perhaps even send a message from one coast to another!

WITHIN a week, a name had suggested itself suitable for this new organization, and a month later it was decided to start the ball rolling. Witness, then, in May, 1914, H. P. Maxim and another Hartford amateur, C. D. Tuska, sitting down and writing a letter to each one of the amateurs listed at that time in the government call-book, announcing the formation of the *American Radio Relay League*, outlining its purposes, and soliciting membership. There were no dues; membership was free on application.

Response was immediate and enthusiastic. Applications came back in every mail. In the early summer of 1914 was issued the first publication of the American Radio Relay League — a little blue-bound call-book listing the names, addresses, calls, power, range, receiving speed and operating hours of three hundred League members. This sold for 50 cents.

By letter and radio the word was spread. Membership increased rapidly. In January, 1915, the League was incorporated under the laws of the State of Connecticut as a non-commercial organization with no capital stock. In March, 1915, a second call-book was issued, listing some six hundred members. In the meantime, through radio contacts and correspondence, attempts were being made to build up the relay routes for which the organization had been formed. Some success was being had in this line. In late summer of 1915, however, a serious difficulty loomed and demanded attention. It was proving a real task to acquaint the growing membership with the plans and schedules by means of letters only. Increasingly it became evident that a bulletin of some kind was necessary. The League, however, had no funds; membership was still free and the call-books were sold at cost.

What to do?

The answer came in December of 1915 when each member of the League received in his mail a sixteen-page magazine called *QST*. This, it was announced, was being published privately at the expense of Maxim and Tuska and was thenceforth to be the official publication of the

League. League membership continued to be free. Any League member who wanted to get the magazine could have it by sending in \$1.00 for a year's subscription.

Response was again immediate; *QST* continued, and, except for a period during the War, has since been published monthly as the official organ of the League. Since the War the League has owned it.

HAVING now a journal in which to chronicle the activities of the membership, Amateur Radio rolled up its sleeves, hitched its belt and settled down to business. A member, discovering some new improvement for his apparatus, would write an article on the subject, and within a month everyone was benefiting by it. Manufacturers, invited to advertise, found a new and responsive field for their wares. Some of them began to manufacture apparatus peculiarly suited to amateur needs.

Early in 1916 a plan for an organized relay system was promulgated; by the end of that year six major trunk lines had been established and four of them were being actively developed under trunk line managers.

Earlier in the year — February 22, 1916 — occurred the first attempt at a nation-wide relay test when Kirwan, 9XE, of Davenport, Iowa, inaugurated the first Washington's Birthday Relay with a message from Col. W. P. Nicholson, of the Rock Island Arsenal, addressed to the governors of every State in the Union. The Pacific Coast got the message fifty-five minutes after it had been started at 9XE; the Atlantic Coast, sixty minutes after; New Orleans had it in twenty minutes and Canada had it in twenty minutes. The success of this test, though far from 100 per cent, created the greatest enthusiasm and led to a prediction in *QST* that a transcontinental message would eventually be sent with but two intermediate relays.

It was during the summer of this year, too, that Charles E. Apgar, an amateur at Westfield, N. J., copied on phonograph records all the transmissions of the supposedly neutrality-observing German radio station at Sayville, and thereby provided evidence for the Government to take it over.

As a fitting close to the year, two manufacturers brought out special amateur regenerative receivers — instruments which so marvelously increased the sensitivity and range of receiving apparatus that a transcontinental relay was immediately proposed.

Here, indeed, was high adventure!

THE year 1917 had no more than dawned when an amateur message did cross the country. On January 27th three messages were started from the station of the Seefred brothers, 6EA, on the Pacific Coast, and passing by quick

jumps through 9ZF, 9ABD and 2AGJ, ended up at Maxim's station, 1ZM. But this accomplishment was almost immediately overshadowed by a greater one. On February 6th a message was started from the East Coast, relayed to the West Coast, and an answer returned in the record time of one hour, twenty minutes! Though the calls of most of the stations participating in this epochal event are now in other hands, mention of the routing is nevertheless justified. It was, starting from 2PM on the East Coast, through 8JZ, 9ABD, and 9ZF to 6EA, on the West Coast, and back via the same stations.

In this same month an important change took place in the A.R.R.L. For nearly three years Maxim and Tuska had been acting as self-appointed president and secretary, respectively. By 1917 the League had grown to such an extent that a more business-like organization was deemed advisable. On February 28, 1917, then, a group of amateurs met at the call of Mr. Maxim in New York. When they dispersed, after a two-day session, they had written and adopted a constitution that outlined the policies of the League, specified the machinery for the election of officers, divided the country into six divisions, to be supervised by division managers and assistants, and had elected by vote twelve A.R.R.L. directors and four officers. These officers were: president, Hiram Percy Maxim; vice-president and general manager, A. A. Hebert; secretary, C. D. Tuska; and treasurer, C. R. Runyon, Jr.

With a real organization now behind it, with transcontinental relays a reality, with manufacturers at last catering wholeheartedly to amateur wants, with the trunk lines beginning to move traffic regularly, with a report of a west coast station hearing an east coast station direct and with a League membership of nearly 4000, organized amateur radio in early 1917 was poised for tremendous strides in development.

IT was two years before those strides were taken, however.

For, coincidentally with its declaration of war on Germany in April, 1917, the United States Government placed a ban on the operation of all amateur apparatus. Amateur antennas were lowered; amateur transmitters were sealed; amateur receiving apparatus was ordered dismantled.

But wait a moment —

A representative of the Navy Department met with President Maxim and Vice-President Hebert in New York and requested the aid of the A.R.R.L. in enlisting its skilled relayers as radio instructors and operators for the duration of the war. The need, it was explained, was desperate.

"How many do you want?" asked Mr. Maxim.

"Five hundred!" replied Lt. McCandless.

"How soon do you want them?"

"Immediately!"

"Can you put that in terms of days?"

"Yes — we want them within ten days!"

A last broadcast went out over the League's relay routes. Within ten days the Navy had its five hundred operators!

Thereafter, deprived of its basis of existence and steadily losing members to the armed forces of the United States, the League kept on as best it could for the benefit of those who were too old or too young to enlist and to bring the able-bodied members into the service. Everything possible was done to keep going. Hope was held out during the summer of 1917 that the war ban would not prevent experimental work with dummy antennas. It was a vain hope. Further orders were issued, strictly prohibiting the use of radio apparatus for any purpose whatsoever. The order was a death-blow. *QST* stopped publication with the issue of September, 1917, after having been run for several months at a loss.

The League closed its desk, locked the office, hung a "Not In" sign on the door knob, and went to war.

Before it was over, three thousand additional A.R.R.L. members had followed those first five hundred pioneers.

THE war ended on November 11, 1918.

Eleven days later the old Board of Direction met in New York, authorized President Maxim to attend a hearing on a proposed radio bill in Washington, and adjourned after agreeing to meet again for the purpose of getting the League started.

In February, 1919, the Board met again and listened to a report by Vice-President Hebert on the condition of the League. This report stated that all membership dues had lapsed, and that there was but \$33 in the treasury. It ended by recommending that if the League were reorganized, a paid secretary should be employed, and that *QST* should be bought from its owner, Mr. Tuska, and become the property of the League.

That Board had nerve and determination. On the first of March it again met, and voted to reorganize the League. Further, it voted to purchase *QST* for the A.R.R.L. The fact that there was only \$33 in the treasury and that the purchase price of *QST*, including several months' unpaid printing bills, was close to \$5000, did not deter it one whit. It appointed a committee to devise a financing plan, told them to go to it, and adjourned.

Before the month was up, another meeting was held, attended this time by several of the old members of the League temporarily in New York. The first action taken at this meeting was to draw up a new constitution. It was done. New officers were elected then as follows: president, H. P. Maxim; vice-president, R. H. G.

Mathews; treasurer, C. R. Runyon, Jr.; secretary, C. D. Tuska; traffic manager, J. O. Smith. The last-named office was a new one created under the new constitution.

It was immediately determined to advise as many former League members as could be reached of the reorganization plans. Orders were given to the secretary to print up a miniature two-page *QST* and send it out. When it was pointed out that to send out such a bulletin would cost nearly \$100, the eleven men present stopped the meeting temporarily, dug down in their pockets, and in a few minutes had placed \$100 on the table. The men who thus made possible the first step toward reorganization were. Victor Camp, H. L. Stanley, J. O. Smith, W. F. Browne, A. A. Hebert, K. B. Warner, R. H. G. Mathews, C. D. Tuska, H. P. Maxim, A. F. Clough and H. E. Nichols.

When they met two weeks later, applications were beginning to come in. It was voted to resume publication of *QST*, and K. B. Warner, formerly of Cairo, Illinois, was elected the paid secretary of the League.

On May 3, 1919, the Board again met to listen to a plan proposed by the Finance Committee. Briefly, it was to borrow \$7500 from former League members, issuing in return certificates of indebtedness payable in two years with interest at 5 per cent per annum. The proposal was approved. It was also voted to purchase *QST*. Secretary Warner was instructed to lay plans immediately for the first issue of the magazine.

In June the first post-war issue of *QST* was printed with money loaned for the purpose by the printer himself, and the A.R.R.L. bond issue was advertised to the members. It was stated that if the League were to continue, \$7500 must be subscribed by the membership. No security could be offered — the League had no assets. The loan would be a loan on faith only.

Amateur spirit is a very wonderful thing. If you don't believe it, consider this: as one man the old League members subscribed to that bond issue. The League went on.

THE A.R.R.L.'s first job was to get the ban on transmitting lifted. Eight months had passed since the termination of hostilities but transmitting was still prohibited. The League sent protests, appeals and entreaties to Washington, but month dragged after weary month with no results. Amateur radio fumed, swore and turned to building long-wave receivers for diversion. It was a poor sop, at best.

October — and the ban was lifted! An immediate headlong rush to get on the air took place. Manufacturers were hard put to supply apparatus fast enough. Each night saw additional dozens of stations joyously crashing out over the air.

Gangway!

KING SPARK! Grown now to full maturity, it reached its highest peak in the succeeding eighteen months. We have already seen that the way had been cleared for this development just prior to the war. Thousands of war-trained amateurs had returned home with the re-opening of their stations as their first thought. They had lost none of their knowledge. It had, in fact, been augmented by experience in the signal services of the Army and Navy, and to this had been added valuable training in discipline and organization. The period of enforced waiting immediately after the close of the war had simply added to the pressure, and when the ban was finally lifted, an unprecedented period of activity resulted.

Those who operated amateur stations during this period will never forget it. Every evening heard scores of distinctive notes booming and echoing from one end of the country to the other. It was a time of extreme competitive effort, pitched to the nervous tempo of post-war tension.

In all fairness, however, it must be chronicled that the interference was terrible!

BUT it was an era of progress. Records were made and broken, and broken again. A message was relayed from Hartford to Los Angeles and an answer returned in 6½ minutes. 6ZK in California was heard in New York City. 9ZN in Chicago was heard in Panama. 2RK in New York was reported by a ship operator at Gibraltar. Relay routes grew over night; traffic mounted higher and higher. It became necessary to make the position of Traffic Manager a paid job, and Fred H. Schnell, of Chicago, came to Hartford as the League's traffic official. The League paid off its bonded indebtedness, and began to put money in the bank. An official emblem was adopted — the now-familiar diamond. At the request of Canadian amateurs, A.R.R.L. operating territory was extended to include Canada, and four Canadian divisions were created. The Bureau of Standards at Washington requested and secured the coöperation of League members in a nation-wide fading test. The First National Convention of the League was held in Chicago (Aug. 30th–Sept. 3d, 1921) and was attended by four hundred amateurs from all over the United States.

ONE of the principal characteristics of amateur radio is the rapidity with which current practice, regardless of how good it may be, is thrown aside — lock, stock and barrel — for something that is proved to be better. No more conclusive demonstration of this can be cited than the despatch with which tube (C.W.) transmission replaced spark transmission in the amateur stations of this country.

Continuous wave transmission for the amateur was an outgrowth of his war experience. While

servicing in the Army and Navy he had seen five-watt tubes covering very respectable distances. Interesting stuff, this C.W. Something to think about.

An undercurrent of C.W. experimentation began with the resumption of post-war transmission in 1919. It was confined to a small group for one very excellent reason: power tubes were not yet commercially available. Only a favored few were in a position to acquire government war-time tubes. The acquiring, it may be said, was done by devious methods.

Those experimenters made some highly interesting discoveries. C.W. traveled incredibly long distances with low power. It was sharp. It did not create vicious local interference. It cut through static.

Such decided advantages could not be overlooked. When power tubes became available commercially early in 1921, the A.R.R.L. started a campaign advocating the adoption of C.W. for amateur use. Conversion, at first, proved a slow process. The rank and file refused to be stampeded by the slide-rule minority, and remained loyal to the spark pending what it considered definite proof of the superiority of the tube transmitter.

This proof, as we shall see, was not long forthcoming.

IN December, 1921, thirty American amateur stations were heard in Europe! It electrified the amateur world — but it was not an accident. All but three of those thirty stations were logged with American amateur equipment operated by an American amateur who had been sent to England at the expense of the League solely for that purpose. Not that we doubted the ability of our British cousins to do a good job on the receiving end, but — well, safety first. They had had little experience with 200 meters. So Paul Godley was sent over, and put up an antenna at the very edge of the sea on a bleak moor in Scotland. For ten bitter cold rainy days he made his home in a drafty tent with the receiving equipment, while every American amateur who could get a set on the air shot signals at him. When he dismantled his apparatus at the conclusion of the tests it had been demonstrated for all time that amateur signals on 200 meters could span the Atlantic.

Something else had been accomplished, too. More than two-thirds of the signals that got across were from C.W. stations. Here was an argument that could not be laughed off. The spark contingent thought it over, sighed resignedly, and began poring through catalogues of C.W. equipment. From that time on, the future of tube transmission was assured.

C.W. proved a most accommodating playmate, and immediately started out to justify the faith placed in it by the amateur world. The

excitement of the transatlantics had not yet died down when a young fellow named Dow wrote from Hawaii to say that he was having no difficulty at all in copying dozens of American signals. Within a few months two-way communication with Hawaii was taking place nightly, and in the fall of 1922 all previous amateur records were shattered to bits when Maxim started a message to Hawaii and had an answer back in less than four and a half minutes! Only one intermediate relay station was needed to bridge the gap from Hartford to Hawaii. The year closed with another transatlantic test. If further proof of the merits of C.W. were needed, this test supplied it. Three hundred and fifteen American calls were logged in Europe. What was more, one French and two British stations were heard on this side. Two-way communication with Europe loomed as a possibility.

Hardly had the year 1923 opened when, too, New Zealand amateurs reported logging stations from every district in the United States. In mid-summer of the same year this news was eclipsed by reports from Australia that they were hearing many American amateur signals from all but the eastern districts, and coincident with these reports word came that several ships in Chinese and Japanese waters had logged West Coast amateurs.

It was becoming just a bit bewildering to keep up with developments.

INERTIA is more than a name in the physics text book and a factor in mechanical problems. It is something to be reckoned with in many lines of activity — including amateur radio.

When Marconi began his communication experiments he chose long wavelengths because spark apparatus was easier to handle at long wavelengths. Followed a natural inference on the part of the radio world: long waves are best. The mistake, of course, lay in assuming that because the apparatus functioned better at a long wavelength the wavelength itself was a superior one for communication. The 1912 London Conference fostered this belief by doling out the longest waves to the long-distance services. As wavelengths got down around 1000 meters, they were apportioned to services with more limited range requirements. When it came to our resulting United States law, the amateur, being more or less of a nuisance at the time, was limited to a maximum of 200 meters. It was the firm conviction of most folks that this would effectually prevent him from getting out any farther than his backyard.

To a certain extent, then, the amateur must be forgiven if for the first twenty years of his existence he persisted in a belief that the only way to get DX was to boost the wave as high as possible. Even after the law made its appearance in 1912 the majority continued on the high

side of 240 meters. Grumbings and dark glances greeted moves on the part of the Radio Inspectors to get amateur stations down to at least 220 meters in 1921 and 1922. Nor did the overwhelming success of the 1922 transatlantics suggest to the amateur world generally that there might be a catch in this matter of wavelength. The transatlantic success was a success in spite of the wavelength, and that was all there was to it. To-day we say it was indeed in spite of the wavelength, but we mean it differently.

As is always the case, however, the experimentally-minded class of amateur was at work, and was seriously interested in the business of determining the real value of the traditionally worthless wavelengths below 200 meters. It started in to find out. During the first part of 1922, Boyd Phelps, then assistant editor of *QST*, wrote an account of successful communication between Boston and Hartford on 130 meters. Results were excellent. Early in 1923, under the leadership of *QST*'s then technical editor, R. S. Kruse, a systematic effort was made to determine the communications possibilities of wavelengths in the vicinity of 100 meters. Three separate transmitters in various parts of the country transmitted alternately on pre-arranged schedules, starting at 200 meters and going down in jumps of ten meters until 90 meters was reached. Listening stations recorded the results at various distances. In every case better signals were logged as the wavelength dropped, and articles on the possibilities of short-wave transmission began to appear in *QST*.

ON November 27, 1923, was accomplished the first amateur two-way work across the Atlantic, when Schnell, 1MO, and Reinartz, 1XAM, worked for several hours with SAB, Deloy, in France! It was a great accomplishment, but the significant fact was this: all three stations used a wavelength in the vicinity of 110 meters.

There was the possibility, of course, that it was a "freak" performance, but any suspicions in this direction were quickly dispelled when additional stations dropped down to 100 meters and found that they, too, could work easily two-way across the Atlantic. The exodus from the 200-meter region started.

In early 1924 the Hoover Radio Conference assigned amateurs bands at 20, 40 and 80 meters. It must be admitted that the move from 100 to 80 was made with misgivings by many. There was magic in 100! It speedily developed that there was just as much magic in 80 — perhaps a little more. Many other European countries were worked, two-way.

Thought turned to 40 meters. A pretty low wavelength, to be sure — but you never could tell about those short waves. What had worked once might work again. Forty was given a whirl,

and responded instantly by enabling two-way communication with Australia, New Zealand and South Africa.

Surely this must stop somewhere! It stood to reason that 20 was too low for any use. But — it was given a try-out. No good? Almost immediately it showed undreamt-of possibilities by enabling an east coast station to work a west coast station direct at high noon. The dream of amateur radio — Daylight DX!

This capped the climax. Downward, ho! A year later, as far as the average amateur was concerned, a plugged cent would have bought the entire wavelength spectrum above 100 meters.

From this time to the present represents a period of unparalleled accomplishment. The short waves proved a veritable gold mine. Country after country came on the air, until the confusion became so great that it was necessary to devise a system of international intermediates in order to distinguish the nationality of calls. The League began issuing what are known as WAC certificates to those stations proving that they had worked all the continents. Several hundred such certificates have been issued. Representatives of the A.R.R.L. went to Paris several years ago and deliberated with the amateur representatives of twenty-two other nations. On April 17, 1925, this conference formed the International Amateur Radio Union — a union of national amateur societies. We have discovered that the amateur as a type is the same the world over.

IT is usually difficult to conceive of improvement on the latest developments. The perspective, of course, is too close. Wherefore, each year in amateur radio sees some who are convinced that at last the ultimate has been reached, and that further improvement or development is impossible.

It was this class that decided there were no more worlds to conquer after spark had attained its peak of development in 1921. Yet, within a year, the introduction of tube transmission had opened unlimited fields for endeavor. C.W. development on 200 meters represented an "ultimate" until we uncovered the 100-meter region, and that in turn was regarded as a stopping point by the pessimists until the majority had shown what could be done with 80 meters, and 40, and 20. Twenty meters, at the present time, represents the lowest of the amateur wavelength assignments that is useful for communication purposes with any degree of dependability, but this has not kept enterprising amateurs from exploring the still higher frequencies. At the amateurs' own request, the international radio treaty of 1927 assigned them narrow bands in the vicinity of five and ten meters. Both regions have since been subjected to experiment and scrutiny, the ten-meter region in particular

having been given detailed study and made the basis of world-wide coöperative tests with very interesting results.

When it became possible for an amateur to communicate all over the world on short waves with nothing more than a 7½-watt tube, the ultimate element cried that here at last was a stopping point.

Well, there is more to amateur radio than DX. It is true that we have reached the ultimate when it comes to distance — earthly distance, that is. Yet at no time in the history of amateur radio have we made greater strides, or had broader horizons ahead of us, than at present. We are learning to work our world-wide communication with less power and equipment, both through transmitter development and perfection of receiver design. New tubes and equipment emerge from the laboratory, and we devise ways to utilize them to maximum benefit in amateur experimentation. No sooner do we learn how to permit the satisfactory operation of two stations where only one could operate before, than we make four work where the two did, and then six or eight where the four transmitted. The relative values of given wavelengths were catalogued only to observe that these values are changing from year to year due, presumably, to variations in sunspot activity. Amateurs, as never before, are turning to the apparatus that has done so much for them, finding out what makes it "tick," and seeking to make it tick better. Greater stabilization of transmitter frequency is being attained; more accurate standards of measurement for that frequency are constantly being developed.

A belief that there are no more fields to conquer is merely proof of mental stagnation on the part of the believer. History alone furnishes us sufficient assurance of the fact that there will never be an "ultimate."

LEGISLATION has always been the arch enemy of the amateur. We have already seen that but for human erring on the part of the early lawmakers in 1912, the first encounter with this formidable antagonist would very likely have ended in virtual extinction.

Due to the intervention of the Great War, no further international threat was to be made until 1927. Meanwhile, however, plenty of trouble of this kind made itself felt within the borders of our own country. As the state of the art advanced, more and more attempts at radio legislation were fostered in Congress. Most of these in their original form were detrimental to the welfare of the amateur. To list the various bills and outline their histories would tire the reader and accomplish no useful end. Let this statement suffice: since the organization of the A.R.R.L. in 1914 there has never been presented in either House of Congress a single bill pertaining to radio legislation without the amateur cause being personally

represented by one or more officers of the League.

A menace of another kind put in its appearance during 1926 and 1927. There appeared a tendency on the part of municipalities to create city ordinances restricting local amateur operation. For six months the League waged a battle in two States against the constitutionality of such ordinances, and in 1927 obtained a court opinion denying the right of municipalities to regulate or restrict amateur operation.

Perhaps the greatest legislative crisis in all amateur history came in the fall of 1927. At that time, world delegates assembled in Washington for another international radio conference — the first since the London Conference of 1912. Such international meetings were supposed to be held every five years, but the Great War had caused their postponement. The Washington Conference was a critical one for the amateur. In 1912 he did not exist in sufficient numbers to be given consideration, from a world standpoint. In 1927 he did, but unfortunately our Government was practically the only one in the world that had actively sponsored amateur radio during the 15 years which had elapsed since London. Amateur representatives at the 1927 gathering, then, faced an overwhelming majority of hostile delegations — nations which not only did not wish to recognize the amateur but who, in many instances, wanted to see him forever ruled off the face of the earth. The short waves he had pioneered were proving very valuable for other purposes. Only sustained effort on the part of League representatives, backed by the consistent and splendid support of the United States and a few other friendly delegations, made it possible to emerge from that conference with the amateur privileges we enjoy to-day.

It must not be assumed that amateur radio is now past all legislative perils. It probably never will be. But the fact above all others that is stressed with respect to the Washington Conference is that it resulted in the amateur, for the first time in history, being officially written into an international document and recognized as one of the classes entitled to space in the radio spectrum. Future international conferences may seek to restrict the amateur, but they cannot any longer deny his existence.

AMATEUR radio is one of the finest of hobbies, but this fact alone would hardly merit such wholehearted support as was given it by the United States delegation at recent international conferences. There must be other reasons to justify such backing. There are. One of them is a thorough appreciation by the Army and Navy of the value of the amateur as a source of skilled radio personnel in time of war. The other is best described by the words "public service."

We have already seen 3500 amateurs contribut-

ing their skill and ability to the American cause in the Great War. After the war it was only natural that cordial relations should prevail between the Army and Navy and the amateur. Several things occurred in the next few years to strengthen these relations. In 1924, when the U. S. dirigible *Shenandoah* made a tour of the country, amateurs provided continuous contact between the big ship and the ground. In 1925, when the United States battle fleet made a cruise to Australia and the Navy wished to test out short-wave apparatus for future communication purposes, it was the League's Traffic Manager, Fred Schnell, who was in complete charge of an experimental high-frequency set on the U. S. S. *Seattle*.

Definite friendly relations between the amateur and the armed forces of the Government were cemented in 1925. In this year both the Army and the Navy came to the League with proposals for amateur coöperation. The radio Naval Reserve and the Army-Amateur Net are the outgrowth of these proposals.

One of the most brilliant examples of amateur coöperation with the military was furnished in January of 1930 when, at the request of the War Department, League operators organized a communication net for contact with the "Arctic Patrol" flight of the Army's First Pursuit Group from Michigan to Spokane, Washington, and return. Amateur stations all over the country co-operated to maintain communication with the accompanying transport plane when it was in the air, and with the flight personnel at the various stopping places. The service furnished elicited the highest praise from War Department and Air Service officials.

The public service record of the amateur is a brilliant one. These services can be roughly divided into two classes: emergencies and expeditions. It is regrettable that space limitations preclude detailed mention of amateur work in both these classes, for the stories constitute some of the high-lights of amateur accomplishment. As it is, only a general outline can be given.

Since 1919, amateur radio has been the principal, and in many cases the only, means of outside communication in more than eighteen storm and flood emergencies in this country. The most noteworthy were the Florida hurricane of 1926, the Mississippi and New England floods of 1927, and the California dam break and second Florida hurricane in 1928. In all of these amateur radio played a major rôle in the rescue work, and amateurs earned nation wide commendation for their resourcefulness in effecting communication where all other means failed.

It is interesting to note that one of the principal functions of the Army-Amateur network is to furnish organized and coördinated amateur assistance in the event of storm and other emergencies in this country. In addition, Red Cross centers in various parts of the United

States are now furnished with lists of amateur stations in the vicinity as a regular part of their emergency measures program.

In 1923 the American Railway Association sent a representative to the A.R.R.L. National Convention at Chicago to talk over plans for amateur coöperation in railroad emergencies. In 1924, 1925 and 1926 the League maintained an emergency network of some eighty stations for the benefit of a large eastern railroad. Five times this network rendered service when wires went down.

Amateur coöperation with expeditions started in 1923, when a League member, Don Mix, of Bristol, Conn., accompanied MacMillan to the Arctic on the schooner *Bowdoin* in charge of an amateur set. Amateurs in Canada and the United States provided the home contact. The success of this venture was such that MacMillan has never since made a trip without carrying short-wave equipment and an amateur to operate it.

Other explorers noted this success and made inquiries to the League regarding similar arrangements for their journeys. In 1924 another expedition secured amateur coöperation; in 1925 three benefited by amateur assistance, and by 1928 the figure had risen to nine for that year alone. Today practically no exploring trip starts from this country to remote parts of the world without making arrangements to keep in contact through the medium of amateur radio.

When the Byrd Expedition went to the Antarctic, three of its four operators were amateurs, and amateur stations in the United States furnished a great part of the communication with this country.

Even in aviation the amateur contributes his services. Byrd utilized it in both his Arctic and Antarctic trips; Wilkins took along an amateur operator to the polar regions when he made his flights over the great wastes north of the American continent, and on both this and his Antarctic trip utilized communication with amateurs for the handling of traffic. When the ill-fated *Dallas Spirit* went out over the Pacific searching for lost Hawaiian flyers, amateur stations on the West Coast copied its transmissions right up to the fatal tailspin which sent the plane plunging into the sea. Service of a slightly different nature was furnished for the National Air Races both at Los Angeles and Cleveland, when amateurs installed and operated the entire equipment necessary to maintain instantaneous communication between the judges' stand and the outlying pylons, checking planes in the races, reporting "down" planes, and furnishing immediate details of all fouls, etc. So successful was this work, particularly at Cleveland, that it is probable similar coöperation will be sought by National Air Race officials in every future meet.

Emergency relief, expeditionary contact, and countless instances of other forms of public service, rendered as they always have been and always

will be, without hope or expectation of material reward, have made amateur radio one of the integral parts of our complex national life.

SO ends this story of amateur radio. It has been the aim to make it an accurate story, with no attempts to glorify the amateur beyond his just due, nor any effort to smooth over rough spots in amateur progress.

To-day the amateur's position is fixed forever in the radio world. He has a name for being a progressive, resourceful and capable type. He has a growing list of glorious accomplishments to his credit. He is, to-day, law-abiding to the extreme; the quickest critics of amateur off-wave operation are amateurs themselves.

The story as related has necessarily been brief. Many stirring incidents have gone unmentioned entirely, through lack of space; such incidents as have been included have been accorded only a sentence or two, where a chapter would be necessary to record all the absorbing details. Yet we hope that through it all the reader has glimpsed that indefinite and elusive something which always has been and for all time will be an integral part of amateur radio, prized as one of its most cherished possessions — a something which casts aside all marks of rank, caste or creed and binds together amateurs the world over — a something which, for want of a better name, we call Amateur Spirit.

THE AMERICAN RADIO RELAY LEAGUE

The American Radio Relay League is to-day not only the spokesman for amateur radio in this country but is the largest amateur organization in the world. It is strictly of, by and for amateurs, is non-commercial and has no stockholders. The members of the League are the owners of the A.R.R.L. and *QST*.

The League is organized to represent the amateur in legislative matters. It is pledged to promote interest in two-way amateur communication and experimentation. It is interested in the relaying of messages by amateur radio. It is concerned with the advancement of the radio art. It stands for the maintenance of fraternalism and a high standard of conduct. One of its principal purposes is to keep amateur activities so well conducted that the amateur will continue to justify his existence. As an example of this might be cited the action of the League in sponsoring the establishment of a number of Standard Frequency Stations throughout the United States; installations equipped with the most modern available type of precision measuring equipment, and transmitting "marker" signals on year-round schedules to enable amateurs everywhere to accurately calibrate their apparatus.

The operating territory of the League is divided into thirteen United States and six Canadian divisions. You can find out what division

you are in by consulting *QST* or the *Handbook*. The affairs of the League are managed by a Board of Directors. One director is elected every two years by the membership of each United States division, and a Canadian General Manager is elected every two years by the Canadian membership. These directors then choose the president and vice-president, who are also directors, of course. No one commercially engaged in selling or manufacturing radio apparatus can be a member of the Board or an officer of the League.

The president, vice-president, secretary, treasurer and communications manager of the League are elected or appointed by the Board of Directors. These officers constitute an Executive Committee to act in handling matters that come up between meetings of the Board, their authority subject to certain restrictions.

The League owns and publishes the magazine *QST*. *QST* goes to all members of the League each month. It acts as a monthly bulletin of the League's organized activities. It serves as a medium for the exchange of ideas. It fosters amateur spirit. Its technical articles are renowned. *QST* has grown to be the "amateur's bible" as well as one of the foremost radio magazines in the world. The profits *QST* makes are used in supporting League activities. Membership dues to the League include a subscription to *QST* for the same period.

The extensive field organization of the Communications Department coordinates practical station operation throughout North America.

HEADQUARTERS

From the humble beginnings recounted in the story of amateur radio, League headquarters has grown until now it occupies an entire floor in a new office building and employs more than two dozen people. Work at Headquarters is divided into the following departments: executive and secretarial; communications; advertising; editorial and technical; accounting; information; and circulation. It is interesting to note that with two exceptions every man in the headquarters establishment is a licensed amateur; and one of the two exceptions is a new office boy who is even now studying to become an amateur!

Members of the League are entitled to write to Headquarters for information of any kind, whether it concerns membership, legislation, or general questions on the construction or operation of amateur apparatus. If you don't find the information you want in *QST* or the *Handbook*, write to A.R.R.L. Headquarters, Hartford, Connecticut, telling us your problem. All replies are directly by letter; no charge is made for the service.

If you come to Hartford, drop out to Headquarters. Visitors are always welcome.

W1MK

For many years it was the dream of the League's officers that some day Headquarters would be able to boast a real "he-station" and a permanent operator to run it. In 1928 this dream became an actuality, and the League to-day owns and operates the station shown in the frontispiece, operating under the call W1MK. The sole duties of one of the members of Headquarters are to operate this station day and night.

W1MK has two transmitters. A tuned-plate tuned-grid transmitter using two UV-204-A's is employed for 3575-kc. operation, and when desired can be used on 7150 kc. with equal facility. During the summer of 1930 a crystal-controlled transmitter with a Type '61 output stage was installed, working equally well on 7150 kc. or 14,300 kc. This is used on 7150 kc. when both transmitters are keyed simultaneously in sending Official Broadcasts to League members on the schedules announced monthly in *QST*. It is expected that this equipment will be modified to permit transmitting standard frequency or "marker" signals in connection with A.R.R.L. standards.

Power supply to the two transmitters is obtained from a motor-generator and a mercury vapor (Type '72) tube rectifier and filter system. A mercury arc is available for use in emergency.

The shielded receiver employs screen-grid r.f. amplification, and in addition the operator can utilize "peak" audio selectivity if desired.

A dynatron-oscillator frequency meter is provided in addition to crystal and absorption-type standards to facilitate accurate checking of the frequency of received signals. It might be pointed out, too, that every dot and dash transmitted by the station is monitored, so that troubles in adjustment or apparatus are thus quickly apparent to the operator.

Two horizontal Hertzian antennas (half-wave and either one-wave or two-wave) are used. Zeppelin feed lines from the transmitters excite these antennas at the proper frequency. A separate receiving antenna is provided to facilitate break-in operation.

The current operating schedules of W1MK may be obtained by writing the Communications Department at Headquarters or by consulting the current issue of *QST*. While much of the operating time is devoted to pre-arranged schedules, the station is always ready for a call from any amateur.

TRADITIONS

As the League has come down through the years, certain traditions have become a part of amateur radio. Developments in radio have altered the apparatus used by amateurs a great deal in the last decade but through all the changes

some personalities have stood out above the rest, typifying the spirit of the amateur.

The Old Man with his humorous stories on "rotten radio" has become one of amateur radio's principal figures. His pictures of radio and radio amateurs are characteristic and inimitable. The Old Man sits in his shack and reflects on the "rotteness" of everything. He glares at "Kitty," spitting out his grouch to all who care to listen. There is much speculation in amateur circles concerning the identity of T.O.M., but in fifteen years of writing he has not once given a clue to his real name or call.

The Wouff-Hong is amateur radio's most sacred symbol and stands for the enforcement of law and order in amateur operation. It came into being

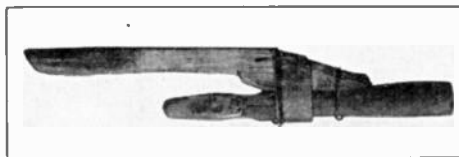

THE WOUFF-HONG AND THE RETTYSNITCH
(Photographs are not to the same scale)

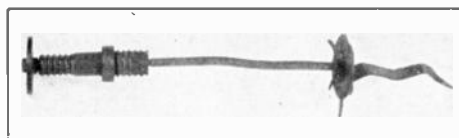

originally in a story by T.O.M. For some time it was not known just what the Wouff-Hong looked like, but in 1919 The Old Man himself supplied the answer by sending in to League Headquarters the one and only original Wouff-Hong, shown here. It is now framed and hangs on the wall of the Secretary's office at A.R.R.L. Headquarters.

The *Rettysnitch*, another weird instrument of similar origin, is used to enforce the principles of decency in operating work.

JOINING THE LEAGUE

The best way to get started in the amateur game is to join the League and start reading *QST*. Inquiries regarding membership should be addressed to the Secretary, or you can use the convenient application blank in the rear of this book. An interest in amateur radio is the only qualification necessary in becoming a member of the A.R.R.L. Ownership of a station and knowledge of the code are *not* prerequisites. They can come later.

Learn to let the League help you. It is organized solely for that purpose, and its entire headquarters personnel is trained to render the best assistance it can to you in solving your amateur problems. If, as a beginner, you should find it

difficult to understand some of the matter contained in succeeding chapters of this book, do not hesitate to write the Information Service stating your trouble. Perhaps, in such a case, it would be profitable for you to send for a copy of a booklet published by the League especially for the beginner and entitled "How to Become a Radio Amateur." This is written in simple, straightforward language, and describes from start to

finish the building of a single simple amateur installation. The price is 10 cents, postpaid.

Every amateur should read *QST* each month. It is filled with the latest amateur apparatus developments, "dope" on current expeditions which use short-wave radio for contact with this country, and the latest "ham" news from your particular section of the country. A sample copy will be gladly sent you on request.

CHAPTER II

Getting Started

HIGH points in the history of amateur radio have been chronicled briefly for the benefit of the newcomer. Amateur radio is a tremendously fascinating hobby. There is lasting enjoyment in its many varied angles and worth-while possibilities. There is the enduring satisfaction that comes from doing things with the apparatus put together by our own skill. With a low-power station it is possible to communicate all over the world and to keep in touch with the hundreds of fellows who have equipment similar to your own. Amateur radio has been said to be the only medium which makes it possible to communicate beyond the range of the speaking voice without paying tribute to some commercial communications organization.

To understand and profit from radio fully we must understand all that takes place. Most people know about broadcasting and broadcast reception but have slight conception of what is going on in the whole radio spectrum of frequencies. The broadcast listener has scarcely touched on the possibilities of radio enjoyment and his interest in the novelty of hearing musical programs and speeches soon palls or wears off in a matter of months. The greatest distances that sometimes thrill new broadcast listeners with faint music are just beginning distances to high-frequency receivers. The high frequencies constitute a new but now quite well-developed field of interest that insures any individual a wealth of new experiences unknown in the narrower field of broadcast listening or one-way radio. If listening only is considered it will be found that the many different things going on in the high-frequency bands are more interesting than those in the rest of the radio spectrum. But the joy of the fellow who builds a station and is at once in touch with the throbbing pulse of two-way radio is different from that of a mere listener. It is the difference of being a participant at a banquet and not a mere onlooker.

The low frequencies (below the broadcast band) bring us a horde of flute-like signals if we care to listen. Press messages, storm warnings, weather reports, radio beacons and ship-shore traffic tell a story to whoever will listen. Some stations send slowly and leisurely. Even the beginner can read them. Others race along furiously so that whole sentences become meaningless buzzes. Ship stations operate just outside the broadcast band, reporting their positions daily. Hundreds of human-interest messages are sent to and from the shore stations every day.

The high frequencies (above the broadcast band) contain even a greater number and variety

of radio services. Numberless amateur two-way conversations in voice and code, trans-ocean commercial radiotelephone and telegraph messages, high-frequency international broadcasting of voice and music, transmissions from government and experimental stations including facsimile picture transmission and television services, airplane dispatching, police radio broadcasts, and signals from private yachts and expeditions exploring the remote parts of the earth are among other attractions that lie here. Recently a number of the long distance and trans-ocean fliers have taken high-frequency radio equipment and reliable operators along. With suitable but simple apparatus one can listen and follow the progress or take down the story of the flight far in advance of the newspaper rumors and official reports.

The process of designing and constructing radio equipment develops real engineering ability. Operating an amateur station with even the simplest equipment likewise develops operating proficiency and ability. Many an engineer, operator or executive in the commercial radio field got his practical background and much of his training from his amateur work. So, in addition to the advantages of amateur radio as a hobby, the value of systematic amateur work to a student of almost every branch of radio cannot well be overlooked. An increasing number of radio services, each expanding in itself, require additional personnel, technicians, operators, inspectors, engineers, executives, and in every field a background of amateur experience is regarded as valuable.

Amateur radio makes it possible to develop friendships with other men who have stations in every part of the U. S. A. and Canada, or for that matter it may be said that friendships in every part of the world follow two-way communication. We do not mean to say that the first contacts are going to be with foreign amateurs. Experience in adjusting the simple transmitter, in using the right frequency band at the right time of day when foreign stations are on the air, and practice in operating that will make it second nature for you to do the right thing at the right time will lead up to the day when you communicate with the first foreign station. There is nothing hard about it. High power is unnecessary. No continental limits confine the DX possibilities of high-frequency work.

A high-frequency receiver alone brings the almost endless possibilities to light. A low-powered and inexpensive radio telephone may be built to use in talking with other stations over considerable distances. However, all amateurs

must learn the Continental telegraph code (so-called because it is used on the European continent for both wire services and radio, and to distinguish it from the Morse code used on land wires in this country). Most amateur station owners prefer to use telegraphy for most of their contacts, although there has been some growth of interest in voice communication in certain sections of the country. There are two reasons in the main for the preference for radiotelegraphy. The apparatus is far less expensive and complicated to adjust. Less equipment and power are required and fewer tubes are used. Code signals will easily cover four or five times the distance possible for the same or more complicated radiophone equipment. The reliability of radiotelegraph communication is far better than that of voice work. Telegraphy is less susceptible to interference, fading, distortion and the like. In all communication accuracy comes first and telegraphy of course avoids misunderstanding and confusion due to the eccentricities of speech and the similarity of certain phonetics.

There is nothing difficult about building a receiver and transmitter. The parts are inexpensive; the construction is simple. In "getting started" the first step is to spend some evenings patiently learning the code. Before doing any operating it is necessary to obtain a station license from the Federal Radio Commission and an operator's license from the Radio Division of the Department of Commerce. These licenses are supplied free of charge and both are obtained through the office of the Supervisor of Radio of the Department of Commerce located in your inspection district. The addresses of the different Supervisors will be given later in this chapter. Before we are ready to apply for licenses we must build the station, get the transmitter ready to operate, and learn the code.

Don't let any of these things worry you. Take one thing at a time. First purchase or build a simple receiver. There are plenty of high-frequency receivers manufactured or available in kit form but it's not a bad plan to put one together from some of the data given in Chapter V of this book. Building the first receiver often results not only in a more satisfactory job but in dispelling that hasty and false conclusion that amateur receivers and transmitters are complicated and expensive. You can gain confidence and such elementary technical knowledge as may be required as you go along. Of course there are advanced forms of amateur equipment that are intricate, complicated to build, hard to understand and adjust, and it will be best to avoid these until the rudiments of the game have been learned. Such elementary theory as is required to get your government licenses is fully explained right in this book. Anyone can assemble the few pieces of apparatus required in our simplest receiver which is recommended for beginners, or the

transmitter which has become most popular for starters-in.

The A.R.R.L. has available a little booklet describing just the simplest kind of a station with the details of getting the first station on the air separated from all the advanced apparatus descriptions. If you would like to have this or want the information sent to a friend that you believe would benefit therefrom, send ten cents to cover printing and mailing costs and the pamphlet "How to Become a Radio Amateur" will go forward direct from Headquarters.

MEMORIZING THE CODE

While the receiver is under construction it is well to start memorizing the code. A few letters a day can be memorized, each day reviewing the four or five studied the previous day. In two weeks you can know the whole alphabet. Then it is necessary to keep going over the letters and Continental characters to increase familiarity and proficiency until the characters can be put to-

A	· —	N	— ·
B	— · · ·	O	— — — —
C	— · · · ·	P	· — — —
D	— · · ·	Q	— · — —
E	·	R	· · —
F	· · · ·	S	· · ·
G	— · —	T	—
H	· · · ·	U	· · — —
I	· ·	V	· · — —
J	— — — —	W	· — — —
K	— · — —	X	· · — — ·
L	— · · ·	Y	· — — —
M	— — —	Z	— · · ·
1	— — — — —	6	· · · · ·
2	· · — — —	7	— — — · ·
3	· · · — —	8	— — — · · ·
4	· · · · —	9	— — — — ·
5	· · · · ·	0	— — — — —

LETTERS AND FIGURES OF THE CONTINENTAL CODE

gether quickly as received or sent, just as we use groups of letters in reading and writing to make words and express thoughts.

The easiest way to learn the code is for two people to practice together or in connection with the work of a larger group. Two individuals can use a key and buzzer to send to each other. A single individual can also use a buzzer to see how signals should sound. Another method, learning by listening, is useful for an individual learner and so both methods are outlined here.

In the Appendix are the Continental Code characters. There are also phonetic symbols to help in learning quickly. The Continental Code is a dot and dash system used all over the world by radio operators.

In receiving code signals each letter must be associated directly with the sound heard. The code must first be memorized. Learn the code, pronouncing the symbols "dit darr" rather than

"dot dash." Do not visualize the letter *A* as a dot and a dash. Recognize the sound "dit darr" as *A* directly. Learn a few letters every day until the alphabet and figures have been mastered. Have a friend ask you the letters in non-alphabetical order. Repeat them in terms of "dit-darr" language until familiar with them all. Practice until you know the sounds as letters without pausing to think of them in terms of dots and dashes.

Don't expect to learn it all in a day. Take things easily. Learn a few symbols at a time. Review each day the letters learned the previous day. Be optimistic. You will be surprised at your progress.

Here is one way to memorize code characters which may prove helpful to some. Several dozen small cards are procured. At the bottom of each card a letter of the alphabet, a figure, mark of punctuation or phrase that is much used in radio work is written. On the same side of each card and at the top edge is given the corresponding code symbol in dots and dashes. In use the cards are shuffled and reviewed by the individual who is learning Continental while either the top or bottom edge of the card is kept covered with the thumb or a blank card. Such cards may be readily carried about and used at odd intervals.

As soon as the code has been memorized, actual practice in using it (receiving) should be attempted. Proficiency in code speed is gained, as in other things, by constant practice. Good sending at moderate speeds is harder to learn than receiving.

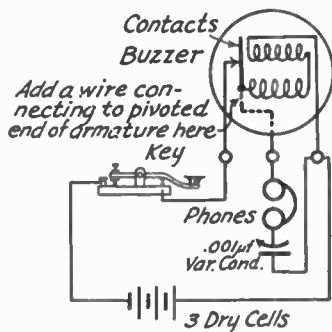

CONNECTIONS OF A BUZZER CODE PRACTICE SET WITH A TELEPHONE HEAD SET

The intensity of the signal can be varied by changing the setting of the variable condenser. The phone and condenser are connected either across the coils of the buzzer or across the vibrator contacts. The condenser may be omitted and the tone may be changed by changing the number of dry cells.

ing. It is best not to use a key or try to send much until ten or twelve words a minute can be read and copied.

PRACTICING WITH A BUZZER

A buzzer practice set is one aid to learning code, especially if someone who is a good operator can

help by sending to you. A buzzer, a telegraph key and a dry cell connected as shown in the diagram make a buzzer practice set. Using a head-set will give more nearly the conditions that obtain in actual radio receiving. It will keep out outside noises. A variable condenser of about .001 μfd. max. shunted by another small fixed capacity

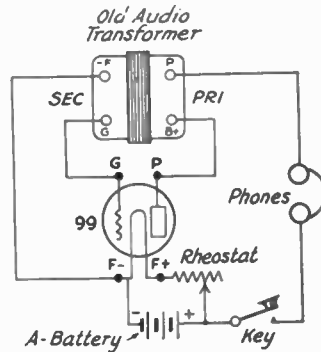

CONNECTING AN AUDIO OSCILLATOR (HARTLEY) FOR CODE PRACTICE WORK

(determine this value experimentally) can be used to control the audibility if desired. A high-pitched buzzer signal is helpful in learning the code. The small sum of money any apparatus for learning the code costs is a good investment.

ANOTHER GOOD CODE PRACTICE OUTFIT

The chap in cramped quarters whose roommate objects to buzzer practice for learning the code can use a Type '99 or 01-A tube connected as an audio oscillator. An old audio amplifying transformer with good windings, a pair of 2000-ohm headphones, a telegraph key, three No. 6 dry cells, a Type '99 tube and socket, and a 20- to 50-ohm filament rheostat are all the equipment required. A diagram explains the connections. (The circuit is a Hartley.) The "B" supply comes from the plus A terminal as shown. This means that it is important that the A-battery polarity be just as shown or the outfit will not work. The lead from the key can be connected to a point of lower positive potential on the A-battery or rheostat with about as good results. If nothing is heard in the 'phones with the key depressed after everything has been connected, reverse the leads going to the two binding posts at either transformer winding. Reversing both sets of leads will have no effect. Keying gives a fine signal in the 'phones without making any noise in the room.

In picking out a key for a practice set some care should be taken to get a well-balanced, smooth-action key. A fairly "heavy" key with large contacts is best to use right from the start. It will save buying another key for the station later on. Good sending depends partly on the key.

USING A KEY

The correct way to grasp the key is important. The knob of the key should be about eighteen inches from the edge of the operating table and about on a line with the operator's right shoulder, allowing room for the elbow to rest on the table. A table about thirty inches in height is best. The spring tension of the key varies with different operators. A fairly heavy spring at the start is desirable. The back adjustment of the key should be changed until there is a vertical movement of about one-sixteenth inch at the knob. After an operator has mastered the use of the hand key the tension should be changed and can be reduced to the minimum spring tension that will cause the key to open immediately when the pressure is released. More spring tension than necessary causes the expenditure of unnecessary energy. The contacts should be spaced by the rear screw on the key only and not by allowing play in the side screws, which are provided merely for aligning the contact points. These side screws should be screwed up to a setting which prevents appreciable side play but not adjusted so tightly that binding is caused. The gap between the contacts should always be at least a thirty-second of an inch, since a too-finely spaced contact will cultivate a nervous style of sending which is highly undesirable. On the other hand too-wide spacing (much over one-sixteenth inch) may result in unduly heavy or "muddy" sending.

Do not hold the key tightly. Let the hand rest lightly on the key. The thumb should be against the left side of the key. The first and second fingers should be bent a little. They should hold the middle and right sides of the knob, respectively. The fingers are partly on top and partly over the side of the knob. The other two fingers should be free of the key. The sketch shows the correct way to hold a key.

A wrist motion should be used in sending. The whole arm should not be used. One should not

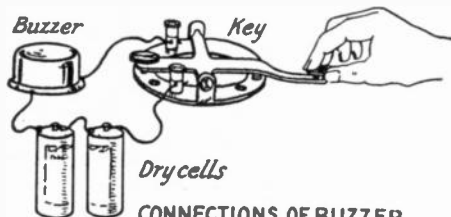

CONNECTIONS OF BUZZER
KEY, BATTERIES AND THE CATLIN GRIP

send "nervously" but with a steady flexing of the wrist. The grasp on the key should be firm, not tight, or jerky sending will result. None of the muscles should be tense but they should all be under control. The arm should rest lightly on the

operating table with the wrist held above the table. An up-and-down motion without any sideways action is best. The fingers should never leave the key knob.

The code is made up of different combinations of dots and dashes. The sending of intelligible signals depends on proper keying by the transmitting operator. The dots and dashes must be of the proper relative length. Suitable spaces must be left between letters and words. A dash is equal in length to three dots. The space between parts of the same letter is equal to one dot. The space between two words is equal to five dots. The exact time intervals depend on the rate of sending. Beginners key a bit stiffly, making a *C* like two *N*'s. Muscle control improves with a few hours' daily practice.

RECEIVING

Now that we have memorized the code we must begin to practice sending and receiving using the code practice set. Someone who is already a good operator should be enlisted to send the first signals.

Go over the code and name the different letters as they are sent on the buzzer. The letters should be sent while you name them. Don't try to compare different letters. Learn each by its own individual sound. Each letter combination should be sent in a snappy way. A slow rate of sending should be secured by leaving long spaces between letters, not by dragging out the characters. Practice on letters and then on groups of letters. Write down what you receive to better coordinate the process of receiving and recording signals. Do not try to write down the dots and dashes; *put down the letters*.

Code groups are more valuable for ordinary practice than straight English texts. The frequency with which certain letters appear in common writing gives more practice on some letters than on others. Concentrate on the practice work and be patient. All the effort you spend in learning the code will repay you fifty-fold.

Always have the letters sent you for practice a little faster than you can comfortably receive. Do not stop to think too long about a letter or word that has been missed. Go right on to the next one or each "miss" will cause you to lose several characters. When the sending is so fast that you can copy just two out of every three letters, your mind will be speeded up and you will try to get that other letter.

SENDING

When sending do not try to speed things up too soon. A slow, even rate of sending is the mark of a good operator. Speed will come with time alone. Leave freak keys alone until you have mastered the knack of properly handling the standard-type telegraph key. Because radio transmissions are seldom free from interference a "heavier" style of

ending is best to develop for radio work. A rugged key of heavy construction will help in this.

When signals can be copied "solid" at a rate of ten words a minute it is time to start practicing with a key in earnest. While learning to receive, you have become fairly familiar with good sending. Try to imitate the machine or tape sending that you have heard. This gives a good example of proper spacing values.

When beginning to handle a key do not try to send more than six or seven words a minute. A dot results from a short depression of the key. A dash comes from the same motion but the contact is held three times as long as when making a dot. A common mistake of beginners is to make it several times too long. There is no great space between the parts of a letter. An *S* is made by three down-and-up motions of the key in regular sequence. The letter *G* is made by holding the first two contacts and making the third one without any pause at the contact. Key practice should not be extended over too long periods at first. The control of the muscles in the wrist and forearm should be developed gradually for best results.

Individuality in sending should be suppressed rather than cultivated. Sending is something like writing, however. Individuality is bound to show in all hand-sending. Unless the spacing is even and regular, reception becomes guess-work. The operator who practices on a buzzer until he has developed a good "fist" is appreciated by everyone he "works." His sending is legible and gets favorable attention.

A good rule is never to send faster than you can receive. Then you can tell what your signals sound like to the operator who must copy them. Speed needs to be held in check. "Copiability" is what we want. Repeats waste valuable time. When you find that you are sending too fast for the other fellow, slow down to his speed. Attempting to send dots nervously in as rapid succession as possible is the first step in acquiring a "glass arm."

A word may be said about the "Vibroplex" and "double-action" keys. The "Vibroplex" makes dots automatically. The rate of making dots is regulated by changing the position of a weight on a swinging armature. Dots are made by pressing a lever to the right. Dashes are made by holding it to the left for the proper interval. A side motion is used in both types of keys.

These keys are useful mainly for operators who have lots of traffic to handle in a short time and for operators who have ruined their sending arm. Such keys are motion savers. However, a great deal of practice is necessary before readable code can be sent. The average novice who uses a "bug" tries to send too fast and ruins his sending altogether. The beginner should keep away from such keys. After he has become very good at handling a regulation telegraph key, he may practice on a "bug" to advantage.

Good sending *seems* easier than receiving, but don't be deceived. A beginner shouldn't send fast on *any* type of key. Keep your transmitting speed down to the receiving speed, and rather bend your effort to sending *well*, remembering to space between characters with more space between words, but leaving no disproportionate spaces between parts of a character.

LEARNING BY LISTENING

Another method of learning the code will appeal to some individuals. We all want to try our skill on some real messages when we have progressed this far. The next step after memorizing the letters is to put into practice on an actual receiving set what you have learned.

A number of high-power stations can be heard in every part of the world. Many commercial high-frequency stations send on frequencies above 3,000 kilocycles (3,000,000 cycles) and can be copied with the simple receivers described in this book. A one-tube or two-tube receiver can be quickly and cheaply put together for code practice. Formerly it was considered necessary to construct special low-frequency receivers to get code practice. To-day, however, there are powerful trans-ocean stations in operation on high frequencies. Many of them use tape transmission. The sending is perfectly regular. Often words are repeated twice. Both understandable English and secret code (most excellent for code practice) are used in the text of the messages. These stations send at speeds depending on the reception conditions at the time of transmission. It is usually possible to pick a station going at about the desired speed for code practice.

After building a receiver and getting it in operation, the first step in "learning by listening" will be to hunt for a station sending slowly. Listen to see if you cannot recognize some individual letters. Use paper and pencil and write down the letters as you hear them. Try to copy as many letters as you can.

Whenever you hear a letter that you know, write it down. Keep everlastingly at it. Twenty minutes or half an hour is long enough for one session. This practice should be repeated three or four times a day. Don't become discouraged. Soon you will copy without missing so many letters. Then you will begin to get calls, which are repeated several times, and whole words like "and" and "the." After words will come sentences. You now know the code and your speed will improve slowly with practice. Learning by this method may seem harder to some folks than learning with the buzzer. It is the opinion of the writer, who learned in this way, that the practice in copying actual signals and having real difficulties with interference, static, and fading, is far superior to that obtained by routine buzzer practice. Of course the use of a buzzer is of great value at first in getting familiar with the alphabet.

Many short cuts have been proposed for quickly memorizing the code or increasing speed of reception. Most of them have some good points. Learning the code is mostly a matter of getting practice, however. An omnigraph is of some assistance if a large number of records can be obtained. It is an expense that few can afford. Unless many different sets of "copy" are available one soon becomes familiar with the material and it is of no more value. Phonograph records of code signals can be obtained but have similar drawbacks. Examinations for operator's licenses are conducted using some form of machine sending. Therefore it is desirable to become familiar with tape or omnigraph sending to insure easily passing the examination. "Machine sending" on low or high frequencies is about as good as an omnigraph except that the speed cannot be controlled at will.

"Tape" or "machine" transmission and reception is used to speed up traffic handling to the limit fixed by relays and atmospheric conditions. Most beginners are puzzled by certain abbreviations which are used. Many code groups are sent by different commercial organizations to shorten the messages and to reduce the expense of sending messages which often runs as high as 25 cents a word. Unless one has a code book it is impossible to interpret such messages. Five- and ten-letter cypher groups are quite common and make excellent practice signals. Occasionally, a blur of code will be heard which results when tape is speeded up to 100 words per minute and photographic means are used to record the signals.

In "learning by listening" try to pick stations sending just a bit faster than your limit. In writing, try to make the separation between words definite. Try to copy the whole of short words before starting to write them down. Do the writing while listening to the first part of the next word. Practice and patience will soon make it easy to listen and write at the same time. Good operators can often copy several words "behind" the incoming signals.

A word of caution: the U.S. radio communication laws prescribe heavy penalties for divulging the contents of any radiogram to other than the addressee. You may copy anything you hear for practice but you must preserve its secrecy.

VOLUNTEER CODE PRACTICE STATIONS

If our new receiver is adjusted first to the 1715- to 2000-kc. amateur band we may be able to pick up amateur stations voluntarily transmitting code practice to help beginners. They also assist newcomers to gain proficiency by working with them on the air as soon as they get licenses. Each fall and winter season the A.R.R.L. solicits volunteers, amateurs using code only, or often a combination of voice and code transmission, who will send transmissions especially calculated to

assist beginners. These transmissions go on the air at specified hours on certain days of the week and may be picked up within a radius of several hundred miles under favorable conditions. Words and sentences are sent at different speeds and repeated by voice, or checked by mail for correctness if you write the stations making the transmissions and enclose a stamped addressed envelope for reply.

The schedules of the score or more volunteer code-practice stations are listed regularly in *QST* during the fall and winter. Information at other times may be secured by writing Headquarters. Some of the stations have been highly successful in reaching both coasts with code-practice transmissions from the central part of the country.

INTERPRETING WHAT WE HEAR

As soon as we finish our receiver and hook it up we shall begin to pick up different high-frequency stations, some of them perhaps in the bands of frequency assigned to amateurs, others perhaps commercial stations belonging to different services. The loudest signals will not necessarily be those from near-by stations. Depending on transmitting conditions which vary with the frequency, the distance and the time of day, remote stations may or may not be louder than relatively near-by stations.

The first letters we identify probably will be the call signals identifying the stations called and the calling stations, if the stations are in the amateur bands. Station calls are assigned by the government, prefixed by a letter (W in the United States, VE in Canada, G in England etc.) indicating the country. In this country calls will be made up of such combinations as W9CYQ, W8CMP, W3BZ, W1MK, etc., the figure or district number indicating the radio inspection district and giving a general idea of the part of the country in which the station heard is located. The reader is referred to the chapter on "Operating a Station" for complete information on the procedure amateurs use in calling, handling messages, and the like. Many abbreviations are used which will be made clear by reference to the tables of Q Code, miscellaneous abbreviations, and "ham" abbreviations included in the Appendix. The table of international prefixes, also in the back of the book, will help to identify the country where amateur and commercial stations are located.

The commercial stations use a procedure differing in some respects from amateur procedure, and to some extent the procedure of Army, Navy and government stations is different from this, each service having a modified procedure meeting its own requirements. On the other hand, the International Radiotelegraph Convention has specified certain regulations, abbreviations and procedures which govern all services and insure basic

uniformity of methods and wide understanding between stations of all nations, regardless of services.

LCO and *LCD* in the prefix of commercial messages refer to the text as being "language of country of origin" or "language of country of delivery." *RP* means "reply prepaid." Also the prefix often shows the class of traffic and the station to whom the message is going. The low-frequency commercial stations number messages periodically. Ship and shore stations start a new series of message numbers each day and with each new station worked. The commercial stations use "de" for an intermediate. Army and Navy stations will be observed to use "v" in place of the "de."

The communication laws specify that a call shall be made by sending the call letters of the station called three times, the intermediate "de" (meaning *from*) once, and following this with the call letters of the calling station three times. The full form of a call is like the following, "GBR GBR GBR de CKA CKA CKA." The answer, "CKA CKA de GBR K," signifies that GBR is ready for traffic.

High-speed automatic telegraphy, television and facsimile or picture transmission all involve rapid rates of modulation and each form of transmission sounds somewhat similar to the others, even to the experienced ear, although good operators will be able to distinguish the telegraphy from the others if the speed is only moderately high. To the beginner, each will sound like a steady buzz and be quite meaningless.

Commercial traffic is classed as "ordinary"; "deferred"; "urgent"; and "rush." "Ordinary" messages have a straight prefix. *P* in the prefix of a message indicates that it is "paid" or "personal" traffic rather than business falling under some other classification. *TR* is the prefix to a position report. *SVC* shows that a service message is coming. The letters *GOVT* indicate that a government message will be sent. *GOVT S B*, *GOVT W B*, or *GOVT HYDRO* in the preamble indicate that the message to follow contains official business of the U.S. Shipping Board or Weather Bureau. *GOVT* is also transmitted as the first word in the address and is counted as one word. Other signs in the preamble indicate different classes of radiograms. A collated radiogram is indicated by *TC* sent in the preamble and as the first item of the address, and such messages must always be repeated back to the sending station for verification. The number is sent first in a commercial radiogram. *W*, *WDS*, *CK*, or *GR* refers to the number of words or the check of the message. A short commercial message with a "radio" check might be sent from WAX to RXC (Panama) as follows:

RXC WAX P 36 W11 MIAMI FLA 317P 30 TO
FRANK CLARK CARE SS HARBINGER BALBOA

----- ADVISE NEW MACHINERY REQUIRED
----- PATTERSON AR

When the receiving operator is uncertain of a word or part of a message because of poor reception of automatic transmission he asks a repeat from the transmitting station at the first opportunity. *RQ* is the prefix that tells what is meant. *RQ* is used when the receiver questions the message. "RQ WAX 36 CLARK THIRD" means, "What is the third word in the text of WAX's number 36 addressed to Clark?" The answer to an *RQ* is a *BQ* and in this case might be, "BQ WAX 36 THIRD MACHINERY."

WEATHER REPORTS

A number of stations regularly transmit marine weather, aviation weather¹ and upper air reports, navy press, time signals, etc., on high frequency and since the detailed reports are sent at moderate speed, amateurs have found them useful for code-practice purposes as well as interesting for their own sake. A 12- to 15-word per minute code speed is employed. Arlington, NAA, for example, sends such information simultaneously on 4015, 8030, and 12,045 kcs. daily at 1315 G.C.T.† and at other times on these and other frequencies.

LEAGUE O.B.S. SYSTEM

Official Broadcasting Stations of the A.R.R.L. send the latest Headquarters' information addressed to members *on amateur frequencies*. The messages are often interesting and many of them are sent slowly enough for code practice between 15 and 20 words a minute. Lists and schedules appear frequently in the membership copies of *QST*.

The latest *official* and *special broadcasts* are sent simultaneously on 7150 and 3575 kc. (41.9 and 83.8 meters) from Headquarters Radio Station W1MK at the following times (E.S.T.): 8 p. m. Sunday, Monday, Tuesday, Thursday, and Friday; 10 p. m. Monday and Friday; midnight Sunday, Tuesday and Thursday.

LEARN BY DOING

Many amateurs have asked, "Will a correspondence school course help me in learning code and studying the technicalities of radio?" Perhaps. You may find a radio course with or without personal instruction helpful or a source of valuable information. It depends on the individual's ability to absorb by mail. Good books are valuable

¹ These broadcasts are made in the regular Weather Bureau word code, which can be easily translated by means of *Weather Bureau Code, 1924, W. B. No. 814*, copies of which may be procured from the Superintendent of Documents, Government Printing Office, Washington, D. C., at \$1.25. These broadcasts are made for the benefit of Army, Navy and commercial aviation fields, for marine services, business organizations and as a general public service.

† See index for reference to "time conversion" to translate this into your local time.

for study and reference. Use this manual which covers practically everything pertaining to amateur station and operating work — then jump in

The map shows how the country is divided into inspection districts, nine in number. The addresses of the different Supervisors, and the territory in

District	Territory	Address, Supervisor of Radio
First	Maine, New Hampshire, Vermont, Massachusetts, Rhode Island and Connecticut.	Customhouse, Boston, Mass.
Second	New York (counties of New York, Staten Island, Long Island, and the counties on the Hudson River to and including Schenectady, Albany and Rensselaer) and New Jersey (counties of Bergen, Passaic, Essex, Union, Middlesex, Monmouth, Hudson and Ocean).	Sub-Treasury Bldg., Wall, Nassau and Pine Sts., New York, N. Y.
Third	New Jersey (all counties not included in second district), Pennsylvania (counties of Philadelphia, Delaware, all counties south of the Blue Mountains, and Franklin County), Delaware, Maryland, Virginia and the District of Columbia.	Ft. McHenry, Baltimore, Md.
Fourth	Alabama, Tennessee, North Carolina, South Carolina, Georgia, Florida and the Territory of Porto Rico.	Federal Bldg., Atlanta, Ga.
Fifth	Mississippi, Louisiana, Texas, Arkansas, Oklahoma and New Mexico.	Customhouse, New Orleans, La.
Sixth	California, Nevada, Utah, Arizona and the Territory of Hawaii.	Customhouse, San Francisco, Calif.
Seventh	Oregon, Washington, Idaho, Montana, Wyoming, and the Territory of Alaska.	1012 Exchange Bldg., Seattle, Wash.
Eighth	New York (all counties not included in the second district), Pennsylvania (all counties not included in the third district), West Virginia, Ohio and Lower Peninsula of Michigan.	30th Floor, David Stott Bldg., Detroit, Mich.
Ninth	Indiana, Illinois, Wisconsin, Michigan (upper peninsula), Minnesota, Kentucky, Missouri, Kansas, Colorado, Iowa, Nebraska, South Dakota and North Dakota.	2022 The Engineering Bldg., Chicago, Ill.

and enjoy the experience of operating a station and "being an amateur." Learn by doing!

OBTAINING GOVERNMENT LICENSES

As soon as you are able to copy ten words per minute and have mastered the elementary theory you are ready to think about obtaining your amateur operator's license. It is well to be able to copy one or two words faster than ten-per, perhaps, to make up for the effect of any nervousness



U. S. INSPECTION DISTRICTS

which may handicap you as it does most of us during any sort of examination. While you will need no license in the United States to operate any kind of a receiver, both an operator's and a station license are required before you can lawfully send a single dot or dash over the air. Happily, neither license costs anything to obtain. The first step toward getting them is to write to or call on your government Supervisor of Radio at the main or a branch office in your inspection district, requesting application blanks for amateur station and operator's licenses.

each of the nine districts, are indicated in the tabulation above.

OPERATORS' LICENSES

Amateur operators' licenses are issued in three grades. Amateur Extra First Class Radio Operator, Radio Operator Amateur Class, and Temporary Amateur Operator's Certificate are the names by which these licenses are known.

The *Temporary Amateur Certificate* is given amateurs who do not live near the Supervisor's office and cannot conveniently present themselves for examination, after they have passed a brief examination by mail. Temporary Amateur Operator's Certificates are issued to be effective only until the applicant can appear to be examined in person, which is required within a reasonable distance of the points where examinations are regularly given. When you have studied the code and are properly qualified, you can readily get one or two licensed operators in your vicinity to make affidavit to the fact that you can send and receive at 10 words per minute as required by the Secretary of Commerce. It is to be noted that this temporary Certificate will authorize its holder to operate only a *particular station*, also that such certificates are issued for periods *not exceeding one year*. You should be ready for examination at any time for it is probable that in a few months from the time a "temporary" is issued the Supervisor will be making a periodic inspection trip through the district, and will notify you where to appear in your own locality for examination for a full-grade Amateur Class "ticket."

The regulations are quoted as follows with regard to the license issued for *Radio Operator, Amateur Class*:

"Applicants for this class of license must pass a

code test in transmission and reception at a speed of at least ten words per minute in Continental Morse Code (five characters to the word). An applicant must pass an examination which will develop knowledge of the adjustment and operation of the apparatus which he desires to use and of the International Regulations and Acts of Congress insofar as they relate to interference with other radio communications and impose duty on all classes of operators. A percentage of seventy will constitute a passing mark. This license is valid for the operation of licensed amateur radio stations only."

To be eligible for the examination for an *Amateur Extra First Class Radio Operator's License* the applicant must have had at least two years' experience as a licensed radio operator and must not have been penalized for violation of the radio laws. The code speed requirement is 20 words per minute receiving and transmitting plain language and a speed of at least 16 words per minute in handling coded groups. Applicants must pass a special examination in which 75 per cent will constitute a passing mark. The possession of one of these "extra first" operator's licenses is a special mark of distinction and proficiency. The superior grade of license is a stimulus to better operating and should be the goal of every operator. It is a mark of achievement and every amateur is urged to apply for this form of operator's "ticket" as soon as he can qualify.

PASSING THE EXAM

The requirements for passing the amateur operator's license examination are not difficult in any way. A written examination is necessary as proof of the ability of the operator and assurance of his understanding the equipment he proposes to operate. All amateurs are required to know the Continental code. Special attention and study should be given to the regulations which concern amateur stations, to the important international regulations, and to a number of the most-used "Q" signals. The full text of the regulations for amateur stations, and extracts from the radio law, the Radio Act of 1927, which explain the administration of the regulations and the penalties for certain violations, are included in the Appendix. Know the regulations for amateur stations and the various penalties prescribed in the Radio Act thoroughly. Be able to draw a complete schematic diagram of your transmitter and receiver and explain their operation briefly. All the information necessary to get an amateur license is right in this book.

Applicants are expected to be familiar with amateur receiving and transmitting equipment. The construction and function of each part of the apparatus should be studied to make it easy to explain the operation and elementary theory.

In the examination the applicant is required

to tell what apparatus he expects to use, to draw a simple diagram of connections, and to explain the operation. The diagram should show switches and ground connections just as they are in the station. The applicant must be able to identify a distress signal (SOS) and to understand the signal used telling him to stop sending (QRT) when he is causing interference (QRM).

Refer to the following chapters for explanations of how a vacuum tube oscillates in the receiver and transmitter, what might prevent oscillation (several reasons), schematic diagrams showing circuits similar to your own, including the source of power, the filter, oscillator, receiver, antenna and ground, etc. Be able to explain how regeneration is controlled and what other methods could be used, how the receiver is tuned and what is meant by tuning, how a vacuum tube detects and amplifies, how you determine whether your transmitter is operating in the amateur frequency bands, what frequency stability is and how it may be affected by different adjustments, types of power supply, etc. Then know the regulations regarding quiet hours, the powers of the Federal Radio Commission, the international regulations relative to the exchange of communications between the amateur stations of different countries, regarding superfluous signals, secrecy of messages, constancy of frequency and freedom from harmonics, meaning of SOS, CQ, QRT, etc., and the penalties for different violations.

Applicants who fail to qualify may be re-examined after three months from the date of taking their unsuccessful examination.

When existing operator's licenses expire, a renewal must be applied for and will be issued to all classes of operators (except commercial extra first class) without examination provided the operator has had three months' satisfactory service in the last six months of the license term. One year of such service out of the two-year license term may be accepted at the discretion of the examining officer.

All of this sounds fearfully complicated but it really isn't — as many tens of thousands of licensed amateurs have proved. Progress is amazingly fast once you start.

STATION LICENSES

It is easy enough to give the matter a little study and pass the operator's license examination. As for the *station* license, there is no examination in connection with that. It is necessary to fill out the application blanks the Supervisor sends you quite completely, however, answering all questions and returning the forms to the Supervisor's office.

In addition to entering the main facts concerning your proposed station, such as the location, power, etc., the name, age, and citizenship of the station owner are required. Aliens may not obtain station licenses. It will be noted in the amateur

regulations that the F.R.C. has ruled that amateur stations, as a general class, are in the public interest so that detailed explanation on this point is not required. The station license allows the station to be operated. The man who holds the license is responsible for the proper operation of the station under the terms of the license.

The Federal Radio Commission licenses amateur telegraph stations to work in *any* or *all* of several frequency bands. If voice is to be used, the station must be built to work in the 1715-2000, 3500-3550, or 56,000-60,000 kc. (150-175, 84.5-85.7, or 5-5.36 meter) bands, except that the holders of Extra First Class operator's licenses may now also receive, upon special application, authority to operate 'phone in the additional band 14,100-14,300 kc. (20.98-21.28 meters).

Applications for renewal of station licenses must be filed so as to be received at the offices of the Supervisors of Radio in charge of the district in which the station is located at least thirty days prior to the expiration date of the license sought to be renewed, and failing this it is necessary for the licensee to cease operating until action has been taken on the application in due course.

POSTING OF LICENSES

It is also ordered by the Federal Radio Commission that every station license shall be posted by the licensee in a conspicuous place in the room in which the transmitter is located, and the license of every station operator shall be posted in a conspicuous place in the room occupied by said operator while on duty.

AMATEUR REGULATIONS

The full text of the amateur regulations is given in the Appendix including the basic definitions of an amateur and what constitutes commercial correspondence. In general the text of the regulations is self-explanatory but some of the more important points to be observed should be mentioned and discussed at this point.

"An amateur is a person interested in radio technique solely with a personal aim and without pecuniary interest." Only individuals who can qualify as an amateur will be licensed. The right to use the amateur frequencies is extended only to amateurs and then only for amateur purposes. This provision protects us from the attempts of commercial enterprises to make use of amateur frequencies. *Bona fide* amateur clubs or organizations will have no difficulty in obtaining station licenses, providing an official individually accepts full legal responsibility for operation of the station.

"Amateur stations shall not transmit or receive messages for hire nor engage in communication for material compensation, direct or indirect, paid or promised." This proviso gives further protection against commercial enterprises masquerading as amateurs, and defines the test of commercial traffic as that involving any sort of "compensa-

tion" for the handling thereof. Accordingly, insofar as this country is concerned, an amateur may handle any traffic he sees fit to handle, so long as he receives no compensation of any kind. It must be remembered, however, that the International Convention restricts the exchange of communications between different countries (internationally) so that messages must be in plain language relating to experiments in progress, or remarks must be limited to those of a personal nature and of such unimportance that they would not normally be transmitted by way of commercial telegraph, radio or cable.

Portable amateur stations will be licensed but must confine operation to definite points for which an itinerary has been filed in advance of trips with the Radio Supervisor. Note that portable stations may not be used while in motion under which condition they fall under the classification of mobile stations. Amateur mobile stations are not at present licensed.

"The licensee of an amateur station shall keep an accurate log of station operation, in which shall be recorded the time of each transmission, the station called, the input power to the last stage of the transmitter, and the frequency band used." Amateur stations are authorized to use a maximum power input into the last stage of a transmitter of one kilowatt. The Radio Act requires that the records of a station must be available to the radio authorities on demand. Such logs then assist the Supervisor in investigating interference cases, alleged off-frequency operation or other violations, determining when changes in frequency and power were made, what conditions interfere and which do not, etc. The A.R.R.L. has designed a log-book especially to take care of this government requirement which will be described when we come to the discussion of "Operating a Station." An accurate and complete station log is compulsory.

"Amateur stations must use adequately filtered direct current power supply or arrangements that produce equivalent effects to minimize frequency modulation and prevent the emission of broad signals." The intent is to do away with a. c. signals and to prohibit transmitters with inherent frequency instability from producing "wobbly" signals on the air, using an unfair amount of the frequency territory to effect transmission. This parallels the regulation that requires that the minimum amount of power necessary to effect communication over a certain distance be used. As will be seen in subsequent chapters, variations in plate voltage effect the frequency of an oscillator, so that it takes a d.c. power supply to comply with the regulations in every example of a self-controlled oscillator. Only oscillator-amplifier transmitters (crystal-controlled or self-excited oscillators) can be permitted to use a.c. plate supply, and even they only under the provisions (1) that they have a

buffer stage so that the changing plate voltage on the amplifier has no opportunity to get back into the oscillator and affect its frequency and (2) that the oscillator and buffer stage are, of course, fed with d.c. In ham language, modulated signals are still permitted but "wobulated" signals are prohibited.

In general it is evident throughout the regulations that amateur stations should be judged by their external effects. Whenever general interference with broadcast reception on receiving apparatus of modern design exists, the Commission regulations regarding quiet hours must be observed, and these will continue in effect until it can be shown that adjustments or alteration of the transmitting arrangement or methods of treatment of the receivers to do away with the trouble have eliminated the difficulty. The quiet hours shall be eight to ten thirty p. m. local time, daily, and, in addition, quiet hours shall be observed on Sunday morning from 10:30 a. m. until 1 p. m. It should be noted that if use of one frequency band causes local interference but another band does not, the station remains free to operate on the bands that do not give rise to this difficulty. Even operation on a different frequency in the same band may be used for operation if it can be shown that it overcomes the trouble.

Amateur stations are not permitted to communicate with commercial or government stations unless authorized by the licensing authority except in an emergency or for testing purposes. This restriction does not apply to communication with small pleasure craft such as yachts and motor boats holding limited commercial station licenses which may have difficulty in establishing communication with commercial or government stations.

Amateur stations are not authorized to broadcast news, music, lectures or any other form of entertainment.

No person, firm, company or corporation within the jurisdiction of the United States shall knowingly utter or transmit, or cause to be uttered or transmitted, any false or fraudulent signal of distress, or communication relating thereto.

All persons who may have knowledge of the text or simply of the existence of radio telegrams, or of any information whatever, obtained by means of the radio service, shall be bound to maintain and insure the secrecy of correspondence.

All amateurs should be familiar with the laws and regulations, especially those provisions and penalties respecting violation of terms set forth in station and operators' licenses, secrecy of messages and malicious interference. A penalty of \$500 fine for each and every offense is stipulated (in addition to other penalties provided by law) for conviction of a violation of any provision of the Radio Act or regulations made under that

Act or of the provisions of treaties ratified and adhered to by the United States.

The Radio Act of 1927 provides for the licensing of radio operators by the Secretary of Commerce. Operators' licenses may be suspended by the Secretary of Commerce for a period of not more than two years upon satisfactory proof that the licensee (a) has violated any provision of any Act or treaty (or regulations made under such Act or treaty) binding on the United States which the Secretary of Commerce or the Commission is authorized by this Act to administer; or . . . (d) has transmitted superfluous radio communications or signals or radio communications containing profane or obscene words or language; or (e) has wilfully or maliciously interfered with any other radio communications or signals.

OUR AMATEUR BANDS

The amateur has accustomed himself to many changes of different kinds in the last seven or eight years. Following each change in regulations there has been a readjustment to meet the new conditions. The number of stations working in our different amateur bands depends on the individual purpose, convenience and enjoyment each man finds in using a certain territory. The reliability of communication on a given frequency at a given time of day, the suitability of a given band for traffic or DX, the desires of the individual amateur in choosing his circle of friends with whom he expects to make contact on schedule, the amount of interference to be expected at certain hours, and the time of day available for operating—all influence the choice of an operating frequency. Many amateurs can use any one of the several available frequency bands at will.

All our bands are in approximate harmonic relation, although the graphical representation shows that some bands are "wider" than others and that this relation is not exact and holds true for only certain sections of some bands. The bands are commonly referred to by amateurs as the 1750-kc., 3500-kc., 7000-kc., 14,000-kc., 28-mc., and 56-mc. bands, so named for the portion common to each in this harmonic relationship.

The sketch shows the several amateur bands. The density of the shading indicates the relative amount of amateur operation or amateur communication going on in each different band in the spring of 1930. The amount of room in the bands is roughly proportional, for amateur purposes, to the width of the bands in kilocycles. The number of point-to-point services that could be accommodated without interference in the same amount of frequency territory is limited by the frequency stability possible to obtain by present methods, which of course are subject to constant improvement, but since amateurs work in bands and expect interference the consideration from

the standpoint of the number of stations that can operate without interference does not strictly hold. A rating of our bands by "commercial channels" available shows 60, 52, 18, 13, 33, and 25 channels available, starting with the 1750-kc. (160-meter) band. By our own communication methods and practice a great many more contacts than this can be managed, however. The commercial-channel rating is based on the fact that

tances in daylight. At night many records have been made using frequencies of 1750 kc., 3500 kc., 7000 kc., and 14,000 kc. The 28-mc. band opened for amateur work by the Federal Radio Commission at the request of the A.R.R.L. early in 1928 has proved itself very useful for long and moderate distance communication on different occasions. It is still too early to predict its ultimate field of usefulness. Our experimenters have ob-

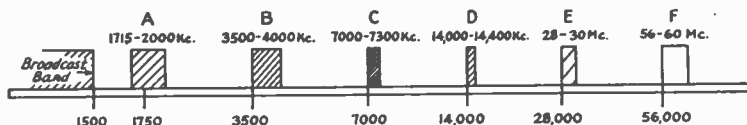

RELATIVE POSITION AND WIDTH OF THE AMATEUR BANDS IN THE HIGH FREQUENCY SPECTRUM
(There is also a band from 400 to 401 Mc., not shown in this drawing)

at twice the frequency a signal takes twice the space in the spectrum or at least that it approaches this as a limit, depending on frequency stability. Of course this is not exactly true but the figures are presented as of possible interest since the F.R.C. follows the plan of allocating point-to-point channels, allowing a certain small percentage of the frequency as a channel width, and using a convenient even number of kc. which approximates this value for assignments in different portions of the high-frequency spectrum.

The amateur bands are usually talked about in amateur circles by reference to the frequency in kilocycles or megacycles that is indicated below each band shown on the chart. Most of these are in round numbers and in harmonic relation. The bands may be expressed in terms of either frequency or wavelength as shown in the following table:

Kilocycles	Meters
400,000 to 401,000	0.7496 to 0.7477
56,000 to 60,000	5.00 to 5.36
28,000 to 30,000	10.00 to 10.71
14,000 to 14,400	20.83 to 21.43
7,000 to 7,300	41.1 to 42.9
3,500 to 4,000	75.0 to 85.7
1,715 to 2,000	150.0 to 175.0

The four last mentioned frequency bands have proved most useful in carrying on actual communication over great distances. The purpose of the Government in assigning many bands to amateurs is to give the amateur the freedom which has always been his due. Only thus can knowledge of the behavior of the high frequencies incidental to actual communication be developed most fully. The experimenter is most interested in the two or three first mentioned frequency bands about which least is known.

The 7000- and 14,000-kc. bands have proved most generally useful for low-power work over long distances both day and night. 14,000 kc. is the best frequency to use to cover great dis-

tances in daylight. At night many records have been made using frequencies of 1750 kc., 3500 kc., 7000 kc., and 14,000 kc. The 28-mc. band opened for amateur work by the Federal Radio Commission at the request of the A.R.R.L. early in 1928 has proved itself very useful for long and moderate distance communication on different occasions. It is still too early to predict its ultimate field of usefulness. Our experimenters have ob-

tained good trans-ocean communication on this frequency on several occasions and find it similar to 14,000 kc. in some of its effects. We must look to them for information which will make this band of increasing practical use. The 3500-kc. frequency is regarded as best for all consistent domestic communication. It is good for coast-to-coast work at night all the year except for a few summer months. It is recommended for all amateur message-handling over medium distances (1,000 miles for example). Much of the friendly human contact between amateurs is in the 3500-kc. band. It is the band from which we make excursions to the higher frequencies on occasions when we desire foreign contacts.

The 1750-kc. band contains many beginning amateurs, practicing code by listening to transmissions arranged for their benefit. Many beginners may also be heard here making their first two-way contacts with each other. In addition to this, 1750 kc. is a popular band for the radiophone men, and to a few traffic pushers who keep schedules on this frequency. It is also open to amateur television and picture-transmission.

Using the higher frequencies, there is often difficulty in talking with stations within three or four hundred miles, while greater distances than this and also very short distances of ten or twenty miles can be covered with ease.

In summer, transcontinental and foreign daylight work is best accomplished using 28,000 kc. and 14,000 kc.; 14,000 kc. and 7000 kc. also may be used at night for the same purpose. 1750 kc. is good at night for moderate distances. Amateurs once conducted a great deal of foreign contact work on 3500 kc. in addition to the domestic work on this frequency, but this has been for the most part abandoned with the rush to the higher frequencies. The 1750-kc. frequency has the advantage that it is best for working with stations one or two hundred miles away. This band offers some excellent advantages to the chap who is getting started, due to less congestion and

interference from other amateur stations, although there are lots of good things to listen to on the other frequencies.

CANADIAN REGULATIONS

Canadian amateurs wishing operators' licenses must pass an examination before a radio inspector in transmission and reception at a speed of ten words per minute or more. They must also pass a verbal examination in the operation of amateur apparatus of usual types, must have a working knowledge of procedure, and must have a little operating ability prior to taking the examination. Nothing is likely to be asked which is not covered

in this Handbook. The fee for examination as operator is 50 cents and is payable to the Radio Inspector who examines the candidate.

The form for application for station license may be obtained either from a local Radio Inspector's office or direct from the Department of Marine and Fisheries, Radio Branch, Ottawa. This consists of a blank form with spaces for details regarding the station equipment and the uses to which it is to be put. The applicant must also sign a declaration of secrecy which, as a matter of fact, is executed at the time of obtaining the operator's license. The annual fee for station licenses for amateur work in Canada is \$2.50.

CHAPTER III

Fundamentals

BEFORE we go on to study the problem of economically building a station and getting it working, we should get an idea of how radio signals can be sent and received.

To understand the things that happen in the process of sending and receiving radio impulses we ought to know something about electricity and the laws that determine its behavior as we understand it. The books described and recommended in the appendix will cover the ground very well on this subject. However, we are going to mention some elementary principles that will help in getting a picture of what happens. A thorough groundwork of fundamental knowledge can be gained through consistent reading and through experience in handling apparatus.

ELECTRICITY

Almost everyone has rubbed a cat's fur and noticed the little sparks in it that can be seen in the dark. "Frictional" electricity is present. Sometimes lightning discharges take place between two clouds or between clouds and earth. This is another example of the liberation of "static" electricity which is manufactured by wind friction under certain temperature conditions.

We use electric lights, electric heaters, telephones, flashlights, street cars and motors and know that the mysterious agent that has been harnessed is "electricity." We call this "current" electricity, as distinct from the other kind of electricity. Current electricity always manifests itself by heating effects and magnetic effects. All that is known about electricity is known by its effects when it is used in certain ways.

Every substance is made of mixtures or chemical combinations of different elements. Any chemical combination can be divided and redivided into smaller particles of the same chemical make-up. The chemist calls the smallest possible piece of any one such substance a "molecule." Molecules are in turn made of atoms of chemical elements. The atom of hydrogen, copper, or carbon combines with atoms of sulphur or chlorine to make "molecules" of different compounds which the chemist names appropriately. These atoms themselves are made of still smaller particles called electrons, which are of exceedingly small mass and size. The electron is negative electricity. A positive nucleus (center), surrounded by a group of electrons, makes up the "atom" or smallest particle of every element. So every substance is

made up of millions on millions of electrons. The electron itself can be considered the smallest possible quantity of negative electricity.

THE ELECTRIC CURRENT

The everyday uses of current electricity we have mentioned. A free flow of electrons in any body constitutes an electric current. When the electrons in a body flow readily we say the body is a "conductor." If they do not flow quite so readily we say that the substance offers more "resistance" to the electric current. If the electrons hardly flow at all we say the body is an "insulator."

The "resistance" of most substances varies somewhat with temperature. Sometimes the variation is so great that a body ordinarily considered an insulator becomes a conductor at high temperatures. The "resistance" of metals usually increases with temperature. The resistance of liquids and of carbon is decreased with increasing temperature. Copper, silver and most metals are relatively good conductors of electricity while such substances as dry glass, mica, rubber, dry wood, porcelain, shellac and gutta percha are good insulators.

MAKING CURRENT ELECTRICITY

The ordinary electric cell and the electric generator are the sources of all our electric current. The electric cell may take the form of a so-called dry cell; it may be a wet cell; it may be a storage cell. In any case the source of current is a chemical source. In the first two forms mentioned the chemical action of the fluid (there is such a fluid in even the "dry" cell) tears down the structure of one of the elements or "poles" of the cell to supply the electric energy current. In the storage cell the chemical change is reversible and the cell can be "recharged." The heating, chemical and magnetic effects of the electric current have been briefly mentioned. These effects are reversible ones, too. The electric generator has wires moving through a magnetic field which generate the electric current that we are talking about.

SERIES AND PARALLEL CONNECTIONS E.M.F., CURRENT FLOW

A number of cells or generators grouped together as a source are termed a "battery." By connecting a number of cells together a more powerful current source is obtained than is given by a single cell. Any high school physics book will explain about the different kinds of

electric batteries. Certain chemical solutions and elements are best suited for making cells for certain jobs. Electric cells and in fact all pieces of electrical apparatus may be connected in "series"

The current flows in the same direction through every part of the circuit. If we examine conditions *inside* the dry cells shown in the diagram we find the flow just opposite from the directions

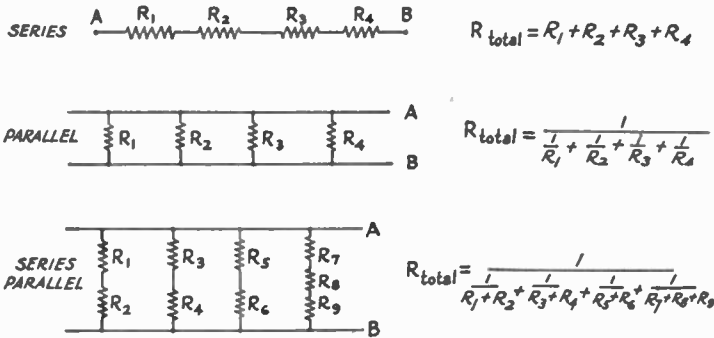

RESISTANCES CONNECTED IN SERIES, PARALLEL, AND SERIES-PARALLEL

or "parallel" or "series-parallel," depending on which way is best for a given purpose.

In any electric cell there are two different chemical elements in a solution. Depending on the choice of elements and solution, a certain *electromotive force* will be developed and maintained. One terminal will always be *positive* (+) while the other terminal will always be *negative* (-) with respect to it. When the two terminals are connected by a wire or conductor an electric current flows.

In the circuit *external* to a battery the current is said to flow from positive to negative. The electrons, on the other hand, are said to flow

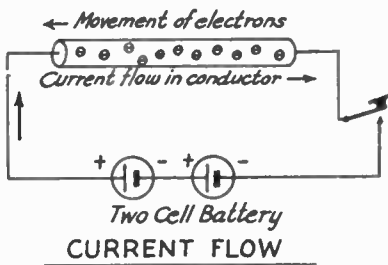

from the negative pole of the battery to the positive. Thus we must always think of the flow of negatively charged particles as an "electron flow," *toward* the positive terminal of the battery. The electric current is a "current flow" *away* from the positive terminal. The diagram shows what is intended. Only because the electron theory had not been advanced when the conventional definition of positive and negative was made do we need to make this distinction.

indicated for the external circuit. When the key is closed the electric current flows around the external circuit from positive to negative. When the key is open there is an insulating medium or non-conductor between its contacts. No current of any consequence can flow. We speak of the conditions with the key closed as "closed-circuit" conditions. When the key or any part of the circuit is open or broken we speak of the conditions as "open-circuit" conditions.

When a steady current flows in any electric circuit, the size or amplitude of the current is determined by the *electromotive force* in the circuit and the resistance of the circuit. The relations that determine just what current flows are known as Ohm's Law. In order that we may speak conveniently of electrical pressure, current and resistance, certain units of measure are used. The commonly accepted *unit of current* is the ampere. The *unit of electro-motive force* or electrical pressure is the volt. The *unit of resistance* is the ohm. When one volt (e.m.f.) is applied in a circuit having one ohm resistance, a current of one ampere will flow.

When I is the current in amperes, E is the electromotive force in volts and R is the circuit resistance in ohms. A simple formula expresses Ohm's Law:

$$R = \frac{E}{I} \quad I = \frac{E}{R} \quad E = RI$$

The resistance of the whole circuit can be found by dividing the voltage by the current. The current can be found by dividing the voltage by the resistance. The e.m.f. is equal to the product of the resistance and current flowing. It is at once evident that if any two of the quantities

are known, the other may be found by applying the formula.

A good analogy can be made by considering for a moment some fluid acting in a mechanical

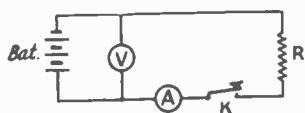

A - SCHEMATIC DIAGRAM

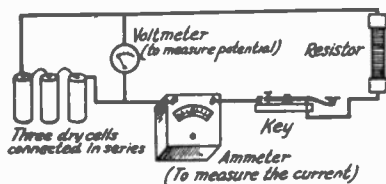

B - PICTURE DIAGRAM

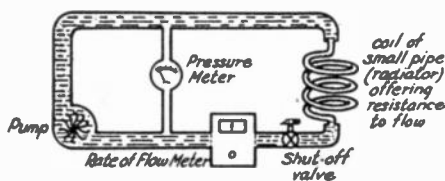

C - MECHANICAL ANALOGY

THE ELECTRIC CIRCUIT AND MEASURING INSTRUMENTS

circuit. In C the pump has a similar function to that of the battery. A shut-off valve controls the current flow in the pipe similarly to that of the key in the electric circuit. The walls of the pipe offer "resistance" to the flow of fluid just as the atomic structure of the connecting wires and resistor holds back the flow of electric current in the electric circuit. A water pressure meter and a "rate-of-flow" meter have the same uses in such a circuit that the voltmeter and ammeter have in measuring the electrical pressure and rate of current flow in the electric circuit.

The higher the "pressure" the more fluid will flow around the pipe. The smaller the pipe the greater its "resistance" and the less the current permitted to flow.

USING OHM'S LAW

Every part of an electric circuit has some resistance. We have shown how cells can be connected in series, how resistances can be connected in series. Different electrical instruments can be connected in series in the electric circuit. In the diagram on the next page, the tubes,

the rheostat, and the three cells of the storage battery make up the series circuit. The two vacuum tubes are connected in parallel, but they are in series with respect to the rest of the circuit. The rheostat is a variable resistance and is used to change the current flowing in the circuit by changing a part of the resistance of the whole circuit and therefore in effect changing the whole resistance which is the sum of all the parts. The rheostat has part of the circuit resistance, the exact value depending on the position of the rheostat arm and the amount of resistance wire that it includes in the circuit. The cells themselves have some internal resistance, depending on their condition. The filaments have an increasing resistance with increase in temperature. This in turn depends on the current through the tubes. The circuit resistances of the lead wires are so small that they can be neglected for practical computations. If the lead wires are of copper and have a large cross-sectional area (the kind of wire and the size wire used determine the "conductivity" [mhos] which is the reciprocal of the resistance in such a circuit) their resistance is so small that we need not consider it. If dry cells are used, their resistance may be neglected if they are new. Storage cells always have a very low internal resistance if they are cared for and kept charged.

VOLTAGE DROPS

When current flows through a resistance we have what is called a "voltage drop" across the resistance. The voltage drop is always equal to the voltage which causes the current to flow through the resistance. The voltage drop across the filament of a vacuum tube can always be found by Ohm's Law and is the resistance (of the filament) times the current flowing through it. The sum of all the voltage drops across the various pieces of apparatus in a series circuit is always equal to the voltage of the source (or the sum of the voltages in the circuit if there be more than one source). This law is known as Kirchoff's Law. So the combined voltage drop across the rheostat and the paralleled filaments will always be equal to the voltage of the storage battery (six volts).

Keeping these relations in mind we can find the resistance of any part of the circuit. For example, we have a detector and one stage audio amplifier using two UX-201-A tubes. What resistance (R_x) should we connect in the circuit to use a six-volt battery with this outfit?

On the box in which the tube came we find that the manufacturers specify a terminal voltage of 5 volts and a filament current of .25 ($\frac{1}{4}$) ampere for each tube. This, then, will be the voltage drop or terminal voltage of the tube under operating conditions. We have two tubes each requiring .25 amperes, so our storage battery will have to supply $2 \times .25$ or .5 ($\frac{1}{2}$) ampere. If pos-

sible, always find the current and voltage (or the effective resistance) of the portions of the circuit in parallel before trying to find out about the series branches of the circuit.

Because the summation of the voltage drops equals the voltage of the source, the drop across the rheostat equals 6 volts minus 5 volts or 1 volt. We have assumed that the drops in the battery and leads are negligible, which is nearly true.

Now we know two things about the rheostat. The voltage drop across it must be 1 volt. The current through it is .5 ampere. By Ohm's Law, the resistance is:

$$R = \frac{E}{I} = \frac{1}{\frac{1}{2}} = 2 \text{ ohms.}$$

A six-ohm rheostat, giving about three times this resistance, should be chosen for this purpose, assuring the full necessary variation and making it possible to compensate for any excess voltage after the battery has been on charge, or to reduce the voltage below five volts if desired.

The resistance of a vacuum-tube filament varies with its temperature but for rated voltage and current can be determined closely by Ohm's Law and the information supplied by the manufacturer. A five-volt tube having a filament current of one-fourth ampere, for example, has a resistance of 5 divided by $\frac{1}{4}$, or 20 ohms. When two tubes are connected in parallel the resistance of the combination is:

$$R = \frac{1}{\frac{1}{R_1} + \frac{1}{R_2}} = \frac{R_1 R_2}{R_1 + R_2} = \frac{20 \times 20}{20 + 20} = 10 \text{ ohms}$$

We can check the accuracy of our problem solution by using our answers and the e.m.f. in the circuit and solving for the current:

$$I = \frac{E}{R} = \frac{6 \text{ volts}}{10 \text{ ohms} + 2 \text{ ohms}} = \frac{1}{2} \text{ ampere}$$

R = combined resistance of tubes plus resistance of rheostat at proper setting

For practical purposes the internal resistance of storage cells in good condition can be neglected, since these resistances are small in comparison with vacuum-tube and rheostat resistance. Thus it is that in the vacuum-tube circuit shown in the large diagram the wiring, and R_1 , R_2 and R_3 are neglected.

HEATING EFFECT AND POWER

The heating effect of the electric current is due to molecular friction in the wire caused by the flow of electricity through it. This effect depends on the resistance of the wire; for a given time (seconds) and current (amperes) the heat generated will be proportional to the resistance through which the current flows. The power used

in heating or the heat dissipated in the circuit (which may be considered sometimes as an undesired power loss) can be determined by substitution in the most convenient of the following equations.

$$\text{Power (watts)} = I^2 R = EI = \frac{E^2}{R}$$

It will be noted that if the current in a resistor and the resistance value are known, we can readily find the power. Or if the voltage across a resistance and the current through it are known or measured by a suitable voltmeter and ammeter, the product of volts and amperes will give the instantaneous power. Knowing the approximate value of a resistor (ohms) and the applied voltage across it, the watts power dissipation in that resistor will be E^2/R .

$$\text{Heat (British Thermal Units)} = I^2 R T (9 \frac{1}{2} \times 10^4)$$

Just as we can measure power dissipation in a resistance we can determine the plate power input to a vacuum-tube transmitter, oscillator or amplifier by the product of the measured plate voltage and plate current. Since the plate current is usually measured in milliamperes or thousandths of amperes, it is necessary to divide the product of plate volts and milliamperes by 1000 to give the result directly in watts.

Part C of the diagram showing the variation of output of a generator with different resistance loads suggests how a voltmeter and ammeter may be connected for measuring the power output of the generator or the power dissipated in the resistor. The power will be $E \times I$ in all cases, but this product will be zero in either A or B where either I or E is zero. As shown by the sketch the maximum power in the load is obtained when the load resistance equals the internal resistance of the battery or generator. That is why it is often desirable in radio work to adjust the load of vacuum-tube amplifiers or oscillators to match the constants of the tube plate circuit so that good output can be obtained. (Maximum power output is secured when the resistance of the external load equals the plate resistance of the tube. It has been found that for maximum *undistorted* power output the load resistance must equal twice the plate resistance but that is entirely apart from our basic discussion here.)

ELECTROMAGNETISM

Magnetic effects are always present when a current flows in a circuit. Lines of magnetic force or influence surround the current-carrying conductors. When a conductor is wound into a coil of many turns the *magnetic field* becomes stronger because there are more lines. The laws of the magnetic circuit are similar to those of the electric circuit but we do not use them as often in elementary work. The magnetic force is spoken of in terms of magneto-motive force (m.m.f.) which depends on the number of turns

of wire, the size of the coil, and the amount of current flowing in the coil. If ten amperes flow in one turn of wire the magnetizing effect is 10

the influence is removed they just as quickly resume their former positions. When current flows around a soft iron bar we have a magnet.

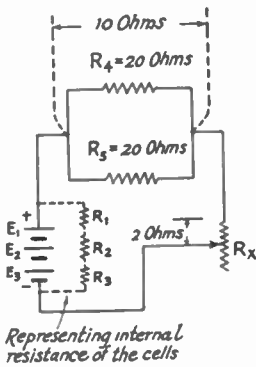

Representing internal resistance of the cells

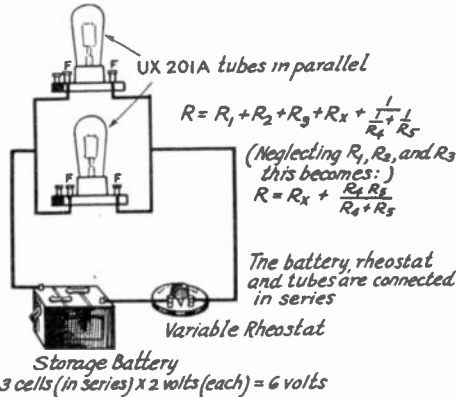

$$R = R_1 + R_2 + R_3 + R_x + \frac{1}{\frac{1}{R_4} + \frac{1}{R_5}}$$

(Neglecting $R_1, R_2,$ and R_3
this becomes:)
 $R = R_x + \frac{R_4 R_5}{R_4 + R_5}$

The battery rheostat and tubes are connected in series

Storage Battery
3 cells (in series) x 2 volts (each) = 6 volts

SERIES-PARALLEL CONNECTION SHOWING HOW TO SOLVE FOR THE TOTAL RESISTANCE IN THE CIRCUIT

ampere-turns. If one ampere flows in ten turns of wire the magnetizing effect is also 10 ampere-turns.

The length of the magnetic circuit, the material of which it is made and the cross-sectional area, determine what "magnetic" current or flux (Φ) will be present. Just as the resistance of the wire determines what current will flow in the electric circuit, the reluctance (μ) of the magnetic circuit (depending on length, area and material) acts similarly in the magnetic circuit.

$$I = \frac{E}{R} \text{ in the electric circuit; so}$$

$$\Phi = \frac{\text{m.m.f.}}{\mu} \text{ in the magnetic circuit.}$$

The magnetic field about wires and coils may be traced with a compass needle or by sprinkling iron filings on a sheet of paper held about the coil through which current is passing. When there is an iron core the increased magnetic force and the concentration of the field about the iron is readily discernible.

Permeability is the ratio between the flux density produced by a certain m.m.f. and the flux density that the same m.m.f. will produce in air. Iron and nickel have higher permeability than air. Iron has quite high permeability, is of low cost, and is therefore very commonly used in magnetic circuits of electrical devices.

The permeability of iron varies somewhat depending on the treatment it receives during manufacture. Soft iron has low reluctivity, another way of saying that its permeability is extremely high. The molecules of soft iron are readily turned end to end by bringing a current-carrying wire or a permanent magnet near. When

the circuit is broken so the current cannot flow, the molecules again assume their hit-or-miss positions. Little or no magnetic effect re-

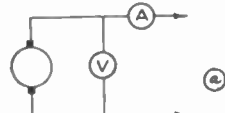

OPEN CIRCUIT
Full voltage at terminals but no current, therefore no output

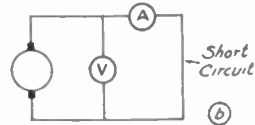

SHORT CIRCUIT
Very large current but no voltage at machine terminals therefore no output, although much power is being used up inside the machine

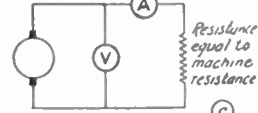

LOAD FOR MOST OUTPUT
Half the generated voltage at machine terminals, heavy current, large output.

NOTE: Conditions (b & c) shown above are impractical for generator operation, however for vacuum tubes we want largest possible output

ARIATION OF OUTPUT AS LOAD RESISTANCE IS CHANGED

mains. When a steel bar is subjected to the same magneto motive force in the same way, it has less magnetic effect. However, when the current is removed, the molecules tend to hold their end-

then in the other. The speed of the reversals depends on the time in which the pump acts in each direction before reversing. In an alternating current generator the number of poles in the magnetic field of the machine and the speed of rotation determines the number of alternations or reversals in current that takes place in one second. A complete cycle has two alternations or reversals of current. The diagram shows the way in which a rotating coil cuts a magnetic field, and the changes in the direction of the current with time are indicated by the second part of the

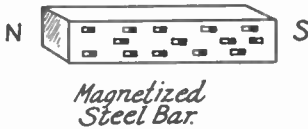
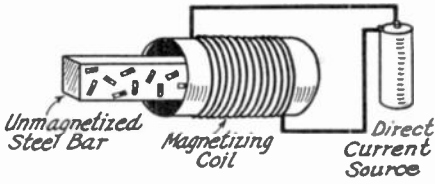

HOW PERMANENT MAGNETS ARE MADE

to-end positions and we have produced a permanent magnet. Compass needles are made in this way. Permanent magnets lose their magnetism only when subjected to a reversed m.m.f., when heated very hot or when jarred violently.

The direction of the magnetic field can be found by what is called the right-hand rule. Grasp the wire in the right hand with the fingers around it and the thumb pointing along the conductor in the direction in which the current is

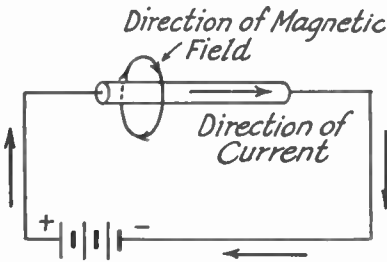

flowing. The fingers then point in the direction of the magnetic field.

ALTERNATING CURRENT

Thus far we have considered current electricity as a flow of electrons in one direction around a circuit. This sort of a current is known as "direct" current (d.c.). In many applications to-day we have to think about "alternating" current (a.c.). Instead of a unidirectional current in the circuit, the current that flows goes first in one direction and then in the other. Instead of having a pump (dynamo with commutator) to make the water flow in one direction in a pipe, we now have a double-acting pump, and the water (electrons) flows first in one direction and

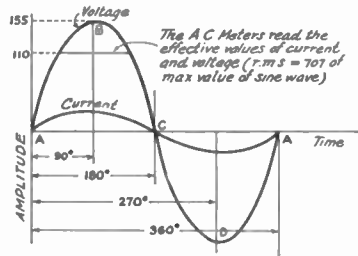
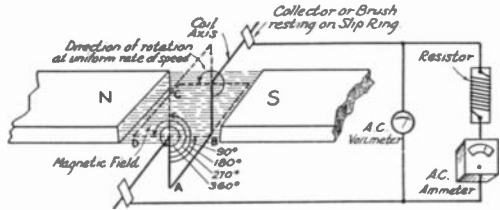

SIMPLE ALTERNATOR CIRCUIT

Diagram shows instantaneous values of current and voltage with electrical degrees of coil rotation - there are 360 electrical degrees for every pair of poles so that one complete mechanical revolution may correspond to more than one electrical revolution.

diagram, as well as the amplitude or size of current flow during different parts of the cycle.

We shall be concerned with alternating currents, as all radio work involves the behavior of high-frequency alternating currents. The number of cycles that takes place each second is called the "frequency" of an alternating current. Power circuits frequently use 25-cycle current. Electric lighting circuits are usually 60-cycle circuits. Ship radio generators are often wound for 500-cycle operation. Radio transmission circuits require energy at frequencies of 15,000 to several millions of cycles per second. These higher frequencies can be produced in several ways. We are concerned with the equipment that is necessary. High-frequency alternators and "arc" sets can best be used to produce the lower radio frequencies. "Spark" transmitters have been in use for years for ship-shore communication. Vacuum-tube transmitters are most efficient and inexpensive of all. They are widely

used to-day for all sorts of radio services. The older equipment is interesting, but we shall study the tube transmitter mainly.

INDUCTION

When current passes through a coil it sets up a magnetic field around the coil. The strength of this field varies as the current varies. Conversely, if a field of varying strength passes through a coil, an electro-motive force is induced in the coil. If a permanent magnet is thrust in and out of a coil a voltage is induced in the coil. The time rate of cutting flux determines the value of the induced voltage.

This principle is utilized in large direct-current and alternating-current generators, in transformers and in all sorts of electric motors and rotating electrical machinery. In generators and motors, magnets (or field poles) set up an electrical field which links conductors (armature coils). The relative motion of the field poles and the armature determines the rate of cutting flux and the voltage that is induced. In transformers the parts are stationary but the flux is alternating or changing in value and direction. The value of the induced voltage depends on the rate at which the magnetic field changes and on the number of turns in the coils. Changes in flux follow changes in current directly. All coils have that property known as "self-inductance," or electrical inertia. A decreasing current causes a decreasing flux. The decreasing flux induces an e.m.f. in the coil which tends to prevent any further decrease in current. The direction of the induced voltage always tends to prevent the change of current which makes the induced voltage. When changing flux links other coils which are near the coil in which a varying current flows, a voltage is set up in each coil, the value depending on the rate of change of the flux linking each coil and on the turns in the respective coils. The induction between coils is known as "mutual" induction.

Energy is stored in the magnetic field which surrounds a current-carrying coil.

Inductance is measured in "henries." This property of a coil depends on its number of turns, the diameter of the coil, and on the permeability of the magnetic material of the core. In 25-cycle and 60-cycle work an iron path is usually provided for the flux. The permeability of iron is much greater than that of air at these frequencies. All iron and steel shows a "magnetic lag." The flux in the iron lags somewhat behind the current producing it. This phenomenon is known as "magnetic hysteresis." When the magnetizing force (H) is increased, the flux density (B) increases very rapidly at first if an iron core is used. However, for large values of magnetizing force, the intensity of magnetization becomes constant and the magnetic substance is said to have become "saturated." A further increase in

flux density (B) can only be made by a disproportionate increase in magnetizing force (H). In radio-frequency circuits, iron introduces a hysteresis loss. The higher the frequency the lower the permissible flux density. The iron cannot follow the rapid changes in flux. It is worthless at the higher radio frequencies.

FIXED AND VARIABLE INDUCTANCE

Coils used in radio circuits are made having either fixed or variable inductance values. Fixed coils have a fixed self-inductance (L). Sometimes two coils are arranged in series so that they may be rotated with respect to each other. When the fields add, the mutual inductance of the combination ($2M$) can be added to the self-inductance of each of the coils. When the fields are opposed, the mutual inductance ($2M$) is subtracted from the self-inductance of the two coils. When the fields of the coils are at right angles, the mutual inductance is zero and the inductance of the combination is the sum of the inductances of the two coils. This arrangement is commonly known as a variometer.

CAPACITANCE AND CONDENSERS

The property of a dielectric between two conductors that makes it possible for the combination to become charged is known as capacitance. Coils have inductance; condensers have capacitance. Usually a number of metal plates of large area are separated by air, mica, glass or some other dielectric. The capacitance of a condenser depends on the number of plates, the area of the plates, the distance by which they are separated and the material between the plates which is known as the dielectric.



The "electric" field, sometimes called the "electrostatic" field of the condenser, is concentrated mostly in the space between the plates. When the plates are connected to a direct-current source, a heavy current flows for an instant, and decreases to zero. The condenser is said to be "charged" and if the dielectric is good, it will hold the charge for some time. If the current source is taken away and a wire connected across the plates, the condenser will discharge through

the wire. A large condenser charged with several hundred volts will give a visible spark and discharge with a crash. It will also cruelly "jolt" one who plays thoughtlessly with its terminals.

Energy is stored in the electric field of a condenser just as it is stored in the magnetic field of a coil. The energy in the field of a coil or condenser is potential energy. Water stored in a tank high above the earth has potential energy due to its position with respect to the center of the earth.

Capacitances can be connected in series or in parallel like resistances or inductances. However, connecting condensers in parallel makes the total capacitance greater. In the case of resistance and inductance, the value is lessened by making a parallel connection. Capacitance is measured in "farads" or more commonly (in radio work) in the smaller units known as the microfarad or micro-microfarad.

CONDENSERS IN SERIES AND IN PARALLEL

The equivalent capacity of condensers connected in parallel is the sum of the capacities of the several condensers so connected:

$$C = C_1 + C_2 + C_3$$

The equivalent capacity of condensers connected in series is expressed by the following formula which can be simplified as shown when but two condensers are considered:

$$\frac{1}{C} = \frac{1}{C_1} + \frac{1}{C_2} + \frac{1}{C_3} \quad C = \frac{C_1 C_2}{C_1 + C_2}$$

It is sometimes necessary to connect filter condensers in series, as this increases the breakdown voltage of the combination while it of course decreases the capacity available. Condensers of just the *same* size are most effectively connected in series for this purpose. Voltage tends to divide across series condensers in inverse proportion to the capacity, so that the smaller of two series condensers will break down first if the condensers are of equal voltage rating. High-resistance units are often used in such applications to equalize the voltage drops and protect condenser banks from unequal voltage distribution. As the resistors are placed directly across the terminals of each condenser and across the high-voltage line, they are necessarily wasteful of power. Before selecting filter condensers the operating conditions, voltage peaks and r.m.s. values should be carefully considered. For complete information on such things, reference to the chapter of this *Handbook* on Power Supply is suggested.

The formula for determining the equivalent capacity of two series condensers may be used to advantage in designing a transmitter using the Colpitts circuit.

DISTRIBUTED INDUCTANCE, CAPACITANCE AND RESISTANCE

Thus far we have considered three properties of electrical circuits and apparatus. Coils, condensers and resistors are all built to have as much of one of these properties as possible without having a great deal of the other two. These "lumped" properties can be connected in a circuit to produce a certain effect on the current and voltage distribution. Condensers will not permit the passage of a steady direct current. Radio-frequency impulses act readily through a condenser, however. Choke coils and large inductance coils tend to prevent rapid changes in current. Radio-frequency impulses do not act through properly built coils. Direct or continuous current, however, flows unhindered by the inductance of coils.

In every sort of coil or condenser and in every electrical circuit, we find not the one property for which the instrument was built but a combination of all the electrical properties we have mentioned. Most design work is a compromise, to approach nearest the ideal results we have in mind. Every coil and transformer winding has resistance and distributed capacitance between the turns as well as the inductance that makes it a useful device. Every condenser has resistance losses also. Power lines, telephone circuits, cables and radio antennas all have *distributed* inductance, capacitance, and resistance throughout their entire length. *Lumped* values are introduced at intervals and at the terminals to produce certain effects. The distributed properties have to be carefully considered also.

OHM'S LAW FOR ALTERNATING CURRENT

Alternating current behaves much the same way as direct current in circuits that contain resistance only. However, its behavior is somewhat changed by the addition of capacitance and inductance to a circuit.

We have mentioned the fact that the *rise of current* in a circuit containing inductance was somewhat *delayed*, that the inductance had the effect of electrical inertia. The effect of much inductance is to tend to prevent any increase or decrease of current in the circuit. It is also true that current must flow into the plates of a condenser *before* any potential difference can exist between its plates. Because of these facts, we say that the current "lags" behind the voltage in a circuit which has much inductance and that the current "leads" the voltage in a circuit where capacitance predominates.

In a direct-current circuit containing either inductance or capacitance, the current increases to a maximum value or decreases to zero as the case may be, coming to a constant rate of flow after a few moments. In an alternating current circuit, the voltage is alternating in character as we have seen and the *instantaneous* values of

current and voltage are constantly changing. Some curves show the amplitude-time relations of current and voltage in circuits where there is

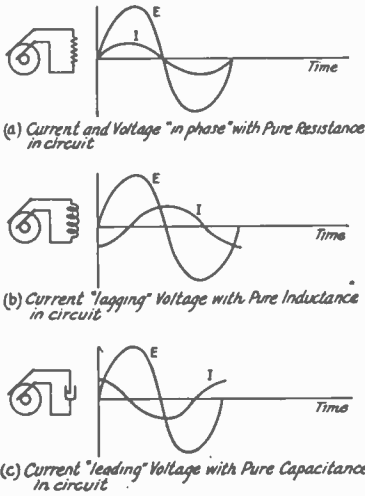

SHOWING AMPLITUDE-TIME RELATIONS OF CURRENT AND VOLTAGE FOR A COMPLETE CYCLE (360 Electrical Degrees)

- (a) resistance, (b) inductance, (c) capacitance. Ohm's Law for alternating currents:

$$E = IZ \quad I = \frac{E}{Z} \quad Z = \frac{E}{I}$$

In an alternating-current circuit, the current flow is determined by the voltage of the source and by the resistance (*R*) and reactance (*X*) of the different parts (i.e., the impedance, *Z*) of the circuit. *R*, *X*, and *Z* are expressed in ohms.

Sometimes it is useful to show the relations between *R*, *X* and *Z* in a vector diagram. The length of the lines in such a diagram can be made to represent the size or magnitude of the electrical quantities, while the angles between the lines can show "lead" and "lag" in the circuit. In the impedance triangle shown *OA* can

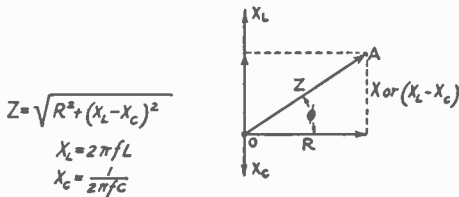

THE IMPEDANCE TRIANGLE
(showing relations between impedance and its components, reactance and resistance)

be taken as unit radius of a circle drawn about the center *O*. Distances upward represent inductive

reactance while distances downward from *O* show capacitive reactance. Either may predominate and govern the conditions in a circuit. *X_L* and *X_C* are always opposite in their effects and therefore can be subtracted directly if the values are plotted to scale.

Reactance is a property which we have not discussed before. Reactance is a property of a coil or condenser. It is that property depending on the frequency and inductance (or capacity) which determines the behavior of the coil (or condenser) in limiting the current that flows when an alternating voltage is applied. The reactance is but one component of the impedance. The inductive reactance of a coil is meant by the symbol *X_L*; the capacitive reactance of a condenser is meant by the symbol *X_C*. Some resistance is also always present in electrical circuits and must be taken into consideration.

We have spoken of "lead" and "lag." The relations of the voltage drops caused by resistance, inductive or capacitive reactance, and impedance can be shown in a diagram and will help in understanding these terms better.

Alternating voltages and currents have thus far been shown on a magnitude-time chart. The values of amplitude are shown from instant to instant throughout the whole cycle (a complete cycle is 360 electrical degrees of rotation). A vector diagram can be used to show the angular relations and magnitudes at a given instant. In a series circuit, the current is the same through each piece of apparatus. In a parallel circuit the voltage of the source is common to each piece of apparatus connected in the circuit. Either a current vector or a voltage vector may be taken as a reference vector, depending on the particular circuit we are talking about.

The diagram shows a circuit containing resistance, inductance and capacitance *in series*. The vector (*I*) is the reference vector showing the current flowing in such a circuit. There is a "voltage drop" across each part of the circuit just as in the case of a direct-current circuit. The algebraic sum of all the voltage drops around the circuit is equal to the voltage of the source. In an alternating-current circuit some of the voltage drops may be positive and others may be negative. The voltage (*E = RI*) is effective in causing current to flow through the resistance of the circuit. It is "in phase" with the current. The voltage (*E_L = IX_L*) is effective in overcoming the inductance of the coil. It is 90° ahead of the current vector, for the current in a coil lags the voltage, and when the coil has pure inductance the angle is 90°. The voltage (*E_C = IX*) causes current to flow in and out of the condenser plates. It is 90° behind the current vector, for the current in a condenser leads the voltage. Right away one can see that voltages across coils and condenser in the circuit are about 180° out of phase. When they are equal in amplitude and exactly opposite

in phase, the condition known as electrical "resonance" obtains. The current in the circuit is "in-phase" with the voltage. Its value is determined only by the resistance of the circuit. This is called "series resonance" or "voltage resonance." Sometimes the voltages across the condenser and coil in a circuit like this build up to values much higher than that of the voltage source. Then they become dangerous to both life and equipment. In a vector diagram where size and angle are correctly shown, the "in-phase," "leading" and "lagging" components of the voltage can be separated. The leading and lagging components are 180° apart. Subtraction gives the "effective" reaction vector. Combining this with the "in-phase" vector by the old law of triangles (that the square of the hypotenuse equals the sum of the squares of the other two sides) we can find the "impedance drop," which is the diagonal of the impedance triangle.

In the second diagram a circuit with resistors, coils, and condensers in parallel is shown. The

and the "resistance" or "reactance" of the path we are considering. In the condenser branch, the current will "lead" the applied voltage; in the coil branch, the current will "lag" behind the

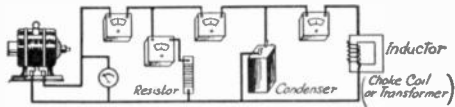

PICTURE DIAGRAM

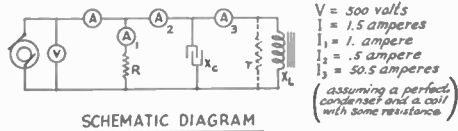

SCHEMATIC DIAGRAM

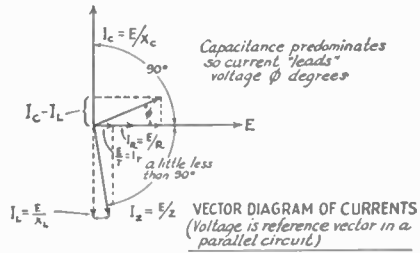

PARALLEL ALTERNATING CURRENT CIRCUIT

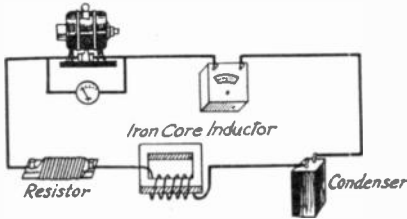

PICTURE DIAGRAM

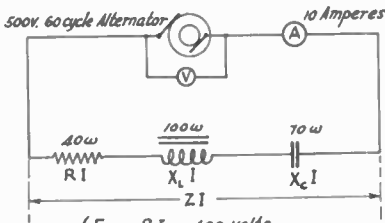

Voltage Drops $\left\{ \begin{array}{l} E_R = R I = 400 \text{ volts} \\ E_L = X_L I = 1000 \text{ volts} \\ E_C = X_C I = 700 \text{ volts} \\ E_{alt} = Z I = 500 \text{ volts} \end{array} \right.$

SCHEMATIC DIAGRAM

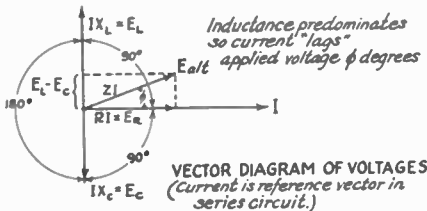

VECTOR DIAGRAM OF VOLTAGES (Current is reference vector in series circuit.)

SERIES ALTERNATING CURRENT CIRCUIT

voltage impressed on each device is common to all devices in the circuit. The current in each of the three paths is determined by the applied voltage

applied voltage; and in the resistance the current will be in phase with the applied voltage. If the current in the coil and that in the condenser happen to be of the same value, the current supplied by the alternator will be the same as that taken by the resistance alone. A much higher current will be present in the leads between the condenser and coil. This condition is known as "parallel" or "current" resonance.

If we know the values of inductance, capacitance and the frequency, we can always figure out the "reactance" and find the current that will flow in the coil or condenser when a certain voltage is applied. If resistance, inductance and capacity are all present, they must all be considered in the proper relation. Complicated networks are hard to solve but usually we can divide the circuit into sections and treat each one independently. When the resistance of a device is small in proportion to its inductance we can neglect the resistance and simplify calculation.

POWER AND POWER FACTOR

In a direct-current circuit the power in watts equals the product of volts and amperes ($P = EI$). In an a.c. circuit the instantaneous power equals the voltage times the current "in phase" with that voltage: $P = E (I \cos \Phi)$.

We have mentioned the "leading" and "lagging" currents that flow electrically "ahead

of" or "behind" the voltage. The angle between the current and voltage is called the "phase angle" (Φ). The cosine of this angle is the "power factor." In the diagram the current (OI) is shown leading the voltage (OE) by the angle (Φ). The cosine (in-phase component of the current) is OLC . The sine or 90° out-of-phase

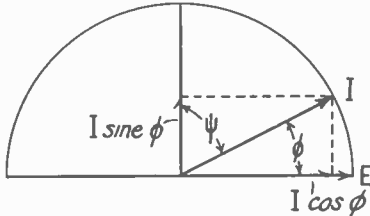

IN THE VECTOR DIAGRAM $I \cos \Phi$ IS THE COMPONENT "IN PHASE" WITH THE VOLTAGE AND $I \sin \Phi$ IS THE "QUADRATURE" COMPONENT

The origin of vectors is indicated by O . Current and voltage vectors are shown with a full arrowhead while the components of the current have the half arrowhead.

component of the circuit is $I \sin \Phi$ in the diagram. This is sometimes known as the quadrature or the "wattless" component of the current. $I \cos \Phi = IC$. Any trigonometry text has tables of sines and cosines of different angles.

Strictly speaking the cosine is the ratio $\frac{OIC}{OI}$.

OI is taken as unity radius for the semicircle so the cosine can be expressed as OIC , some fraction of unity. The power factor is the ratio of the actual power dissipated in a circuit (watts) to the volt-amperes (combined power and wattless power). The volt-ampere rating of a circuit is often known as the "apparent" power. When OI lies along the line OE , $\Phi = 0$ and $\cos \Phi = 1$. This condition is referred to as "unity power factor" and when it obtains $P = EI$ as in direct current circuits always.

PHASE DIFFERENCE OF A CONDENSER

The angle between voltage and current in a good condenser is nearly 90° . The power factor of such a condenser ($\cos \Phi$ or $\cos 90^\circ$) is almost zero.

Ψ is the angle of phase difference. It is the angle expressing best the amount by which the condenser falls short of being a perfect condenser.

The better the dielectric of a condenser the lower the phase difference. The power factor of a condenser is the ratio of its resistance to its reactance. $P.F. = R/X = 2\pi fCR$.

A condenser with imperfect dielectric behaves like a perfect condenser having a low series or a high parallel resistance.

PRACTICAL ELECTRICAL UNITS

The practical unit of electric pressure and potential difference is the *volt*. The electromotive force (e.m.f.) or voltage in a circuit is what causes the flow of current, just as pressure in fluids causes the flow of water or gas in pipes. Current always tends to flow from a point of higher to a point of lower potential.

The practical unit of the rate of current flow is the *ampere*, determined by a fixed rate of the electro-deposition of silver under specified conditions.

The practical unit of resistance is the *ohm*, defined as the resistance of a mercury column of certain dimensions under specified conditions. An e.m.f. of one volt is required to produce a current of one ampere in a resistance of one ohm.

The practical unit of capacity is the *farad*. The ability of the dielectric between the plates of a condenser to become charged electrically determines the permittance or capacitance of a given condenser. A capacity of one farad is defined as that capacity which will have its plates charged to a potential difference of one volt when that quantity of electricity known as one coulomb (one ampere flowing for one second) flows into it. In radio engineering the farad is much too large for practical work so that sub-multiples are commonly used. The microfarad ($\mu\text{fd.}$) and micro-microfarad ($\mu\mu\text{fd.}$) are units used in common radio practice. The micro-microfarad ($\mu\mu\text{fd.}$) is sometimes referred to as a picofarad (pfd.), which is a simpler expression standing for the same electrical quantity.

1 farad (fd.) = 1,000,000 microfarads ($\mu\text{fd.}$)

1 microfarad ($\mu\text{fd.}$) = 1,000,000 micro-microfarads ($\mu\mu\text{fd.}$) or picofarads (pfd.)

The practical unit of inductance is the *henry*, which has such a value that if the current flowing through it varies at the rate of one ampere per second, an e.m.f. of one volt is induced. In radio engineering work the henry is too large as noted above in the case of the farad, so that smaller subdivisions, the millihenry and the microhenry, are employed.

1 henry (h.) = 1,000 millihenries (mh.) or 1,000,000 microhenries ($\mu\text{h.}$)

Energy and power should be carefully differentiated. Energy is simply the capacity for doing work. Power represents the expenditure of energy and is a measure of the rate at which work is done. Power is measured in watts; work done is measured in watt-hours. Most electrical devices are rated by their power consumption in watts. One horse power (h p.) = 746 watts.

A complete glossary of quantities and units, with conversion tables, is outside the main purpose of this *Handbook*. For complete and reliable information covering both terms and graphical symbols the reader is referred to "The Report

of the Committee on Standardization," published by the Institute of Radio Engineers (New York), and to the "Standard Handbook for Electrical Engineers."

WORKING PRACTICAL PROBLEMS

It is surprising how many practical uses may be found for the fundamental information and formulas set forth in this chapter. A brief study of the equations and explanations with the few examples that will now follow will enable you to apply Ohm's Law and other electrical relations to determining practical things that arise in planning, building and operating even the simplest amateur station equipment. The problems which follow will serve as examples of some of the different things taken up in this chapter.

Plate Power Input

A certain transmitter has an output stage in which a single 203-A tube is employed. A high-voltage voltmeter is connected across the plate supply circuit and a milliammeter of suitable range used in the circuit so as to measure the current of this tube only. We have seen that $P = E \times I$. Therefore, assuming that the meters read 1125 volts and 125 milliamperes, the plate input

power will be $1125 \times \frac{125}{1000} = 140.6$ watts.

Resistance of a Grid Leak

It is necessary to determine whether a resistor has a resistance of five, ten or fifteen thousand ohms which would make it suitable for a grid leak for a Type '10 transmitter, either used separately or in connection with other resistors of the same type. A 90-volt B-battery and a 0-50 mil scale milliammeter are available. The battery is connected to the unknown resistor through the meter which is observed to read 10 milliamperes. The resistance is next calculated from Ohm's Law: $R = E/I$. $90 \div .010 = 9,000$ ohms.

Measuring Grid Bias

When the grid-leak resistance is known, the current through the grid leak measured by a milliammeter of suitable range enables us to calculate the voltage drop across the resistor, which is the same as the bias between grid and filament. For example, two 5000-ohm resistors are used in series as a biasing resistor to a Type '10 tube used as the r.f. amplifier stage in a small oscillator-amplifier transmitter. A milliammeter connected in series with the resistors reads 21 milliamperes. Calculating the voltage drop by Ohm's Law ($E = RI$) we have the bias as (2×5000) times .021, which equals 210 volts.

Capacities

A fixed condenser of 250 micro-microfarads is connected in parallel with two variable air con-

densers having a maximum capacitance of 140 micro-microfarads and .0005 μ fd. respectively. What is the total capacitance obtainable for any adjustment or setting of the condensers? First it is necessary to change the ratings to either microfarads or micro-microfarads to get the three units on the same basis. The answer will be either:

$$250 + 140 + 500 = 890 \mu\mu\text{fd. (micro-microfarads or picofarads) or}$$

$$.00025 + .00014 + .0005 = .00089 \mu\text{fd. (microfarads).}$$

Assume the three capacities to be connected in series. Let us determine the equivalent lumped capacity:

$$\frac{1}{C} = \frac{1}{C_1} + \frac{1}{C_2} + \frac{1}{C_3} = \frac{1}{250} + \frac{1}{140} + \frac{1}{500} =$$

$$.004 + .00715 + .002 = .01315$$

.01315 C = 1

C = 76.1 $\mu\mu$ fd. (micro-microfarads or picofarads).

Condenser Reactance

A high-voltage power-supply transformer may, under certain conditions, require protection of the windings from voltages built up due to leakage of high-frequency currents back through r.f. chokes and the filter, or due to r.f. induced in power-supply leads located in the field of the high-power stage of a transmitter. The same circumstances can cause break-down of insulation in filament transformers. At any rate it will be assumed that we have a 7200-kc. transmitter and that it is desired to connect a small condenser across the high-voltage winding. Remembering that *the higher the frequency is, the lower the reactance of a condenser*, we judge that a small condenser will sufficiently by-pass the radio-frequency current, preventing the undesired r.f. voltage from building up across our transformer winding (or a choke coil, milliammeter or other piece of apparatus could be protected similarly).

Finding a .02-microfarad mica-insulated transmitting condenser available, rated to withstand 2000 volts, we decide to consider what may happen if we connect it across the high-voltage alternating current source.

First of all to see if it will be practical and accomplish the result we want, let's see (a) what the reactance of the condenser to the 7200-kc. (7,200,000-cycle) voltage which has strayed into the circuit will be; and (b) what the reactance will be to the 60-cycle source. In the formula the units are cycles and farads so we must remember to use the proper conversion factors.

(a) $X_c = 1 \div 2\pi fC$
 $= 1 \div 6.28 \times 7,200,000 \times .02 \times 10^{-6}$
 $= 1 \div 6.28 \times 7.2 \times .02$
 $= 1/.905$
 $= 1.105$ ohms

reactance at this frequency. This is an extremely low value which will readily by-pass r.f. and prevent any harmful voltages building up across an inductance.

$$\begin{aligned} \text{(b) } X_c &= 1 \div 2\pi fC \\ &= 1 \div 6.28 \times 60 \times .02 \times 10^{-6} \\ &= 132,800 \text{ ohms} \end{aligned}$$

reactance at 60 cycles.

Current Through a Reactance

The transformer is a small one and so we cannot be sure until we figure it out whether the secondary current taken by the protective condenser and the set combined will be likely to overheat the transformer or not. The plate transformer we happen to have has a ratio of 10:1 and delivers 1100 volts (effective value) when run normally. The 60-cycle current through the condenser will be:

$$I = \frac{E}{X_c} = \frac{1100}{132,800} = .0083 \text{ amperes} = 8.3 \text{ ma.}$$

Transformer Output Current to Resistance Load

The transformer is rated at 100 watts (VA) which means that it will deliver

$$I = \frac{W}{E} = \frac{100}{1100} = 91.1 \text{ ma.}$$

Resistance Value for Dropping Plate Voltage

The transformer output goes to a tube rectifier through a filter which has a 70-henry choke in one lead. After keying in the negative lead the current passes through a 3-henry "keying" filter choke to the plates of two Type '10 tubes. There is some voltage drop in the rectifier tubes and in the resistance of the two choke-coil windings. In addition to this, a resistor may be added in series with the keying choke winding to further drop the voltage so our tube will operate normally with about 400 volts d.c. in its plate circuit. The proper size of this resistor is quickly found by using Ohm's Law. If it is desired to produce a drop in voltage of about 100 volts, divide this value by the estimated plate current, let us say 100 mils or .1 ampere. ($R = E/I$)

$$\frac{100}{.1} = 1,000 \text{ ohms.}$$

Size Resistor to Handle a Given Current

In purchasing resistors, be sure they are of ample size to dissipate the heat that will be produced by the current they will have to carry. The power that must be dissipated in heating is $W = RI^2$ (watts).

$1000 \times .100^2 = 10$ watts, which must be dissipated by the resistor for dropping the plate

voltage to the two Type '10 tubes, considered above. Examining manufacturers' lists, this size can be used, but a 20-watt resistor is recommended to give long life and keep the maximum temperatures low. It is best to allow 40 per cent or 50 per cent factor of safety, since resistors are rated for their maximum allowable dissipation mounted in free space. Actually the heat radiation is limited by mounting resistors near other apparatus. This heat should be kept away from filter condensers or apparatus whose life varies inversely with temperature.

Total Transformer Current

Each tube takes a current of 45 milliamperes. While Type '10 tubes can handle a rated plate current of 60 ma. (oscillating), we shall assume that with conservative plate voltages, suitably loose antenna coupling, and proper adjustment, the current is but 45 mils $2 \times 45 = 90$ ma. total. The .02- μ fd. condenser across the transformer takes a "leading" 60-cycle current of 8.3 ma., assuming a perfect condenser and no leakage. There are filter condensers across the high-voltage line. These, however, change the wave-form of the rectifier, boost the d.c. voltage, and improve the regulation in addition to having a filtering effect. They are across *rectified* d.c., however, and do not affect the transformer current in the same way as the .02- μ fd. condenser which is across the a.c. supply. Assuming that the transmitter operates at nearly unity power factor (current in phase with the voltage) as is the case with a tube transmitter, the resultant current taken by the transmitter and the .02- μ fd. condenser will be 90.35 ma.

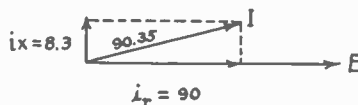

This is easily computed by using the law of squares previously referred to.

$$I = \sqrt{(I_T)^2 + (I_x)^2} = \sqrt{90^2 + 8.3^2} = \sqrt{8169} = 90.35 \text{ m.a.}$$

So our transformer *will* operate at full load with the condenser and transmitter load connected continuously. Transformers can be operated *intermittently* at 150 percent of rated load without much danger so we know that in c.w. telegraph service 60 mils per tube instead of 45 mils per tube will not give rise to burn-out or any very serious operating condition. However, before connecting many different kinds of loads to a transformer we should figure out about what is going to happen. Suitable protective fuses should be installed.

CHAPTER IV

How Radio Signals Are Sent and Received

IN THE previous chapter we have seen how a flow of electrons through a wire constitutes an electric current, and how this (direct) current under certain conditions gives rise to electric and magnetic effects as changes in the current flow take place. It was also noted that when the electron flow was first in one direction, then in the other, the alternating current would give rise to a continuously alternating electric and magnetic field. The magnetic and electric lines of force go through the same variations as the current that sets them up. Electric power and light are supplied by low frequency (25 and 60 cycles per second) alternating current. The pulsations of *low-frequency* electric current are conducted from the alternators at power stations along wires to points where the electricity is used, with slight losses from the wires. For the transmission of radio signals special apparatus for the production and utilization of *high-frequency* alternating currents is necessary.

An electric current (or movement of electrons to and fro) at frequencies of 15,000 to 50,000,000 or more cycles per second creates magnetic and electric effects (lines of force) far more difficult to confine to the immediate vicinity of the wire circuits. In fact when such currents are induced to flow in a conductor or network of conductors arranged favorably in free space (not screened or shielded by surrounding objects to any extent) the rapidly alternating electric, magnetic, and radiation fields (constituting radio waves) have an effect which may extend a long distance from the sending station, which after all is just an assembly of apparatus designed to create and control the high-frequency alternating current. The choice of the high frequency, the power, and the conditions in the transmitting medium which vary somewhat from day to day, and season to season, will determine the extent of the effect at different distances from the sending station.

Antennas, as the special systems of wires designed to radiate the energy supplied by the high-frequency alternating current are called, are of different types, the efficiency with which they operate and the directional properties of the radiation varying with the design. Having distributed inductance and capacitance, an antenna structure has a natural period or response frequency, and can be tuned by addition of coils and condensers whose constants can be varied. Antennas can be arranged in different patterns for directional transmission. Adding coils and condensers makes it possible to operate antennas above or below the natural electrical period determined by the physical dimensions. They can

be operated readily on their natural frequency or on harmonic frequencies, deriving their alternating current supply direct from the sending apparatus or via a single- or two-wire transmission line designed to have low copper and radiation losses. The whole subject is so important that antennas will receive detailed explanation elsewhere. For the moment it may be enough to say that an antenna can be considered electrically as simple as a circuit containing a condenser, a coil and a resistor connected together, these "lumped" circuit elements being substituted for the distributed capacitance, inductance and resistance.

Antennas located well in the open and of considerable physical proportions work best in setting up a "radiation field" capable of creating a "potential gradient" as the lines of force sweep across a remote receiving antenna. "Lumped" circuit elements and well-balanced properly-coupled feeder lines show desirably poor radiation characteristics. Discontinuities in any electric circuit, feeder lines whose impedance is not properly matched to the load, etc., for example, give rise to radiation effects and losses from that circuit, depending on the extent of the reflections that take place and the amplitude of the so-called standing waves that are set up on the conductors. The radiation field or direction of wave propagation from a simple antenna is at right angles to both the electric and magnetic fields of the antenna. These latter fields decrease in intensity to a negligible value within a few wavelengths of the antenna, beyond which point the radiation field is the only one that can be detected by its effects.

Summarizing our view of transmitting, then, we use apparatus that generates radio-frequency alternating currents from a high-voltage commercial source. The radio-frequency energy is coupled into an antenna or radiating system. Here it sets up lines of force that radiate in all directions.

In receiving radio signals we use apparatus similar to the sending equipment and reverse the procedure. The lines of force from the sending antenna sweep across our receiving antenna, induce radio-frequency potentials in it, and these cause currents similar to those in the sending antenna to flow back and forth. These of course are very feeble impulses compared to those at the sending station. It is merely necessary to detect these impulses and magnify their effect somewhat so that the impulses can be turned off and on or varied in more complicated ways, depending on the nature of the communication desired.

For a few purposes it is convenient to regard the propagation of the radiation field to a distance from the viewpoint of wave-motion, the waves carrying energy and spreading outward from the sending station or source with a definite speed and frequency somewhat like water waves and, like other waves, subject to reflection and refraction. However, the velocity is not known exactly. Frequency can be stated, checked, or measured exactly against a standard time interval determined by astronomical means. For this reason, all radio assignments are made in terms of frequency, primarily.

The approximate velocity of light waves, electricity and radio waves through space may be assumed to be 300,000,000 meters (186,000 miles) per second, or a figure based on the latest scientific measurement can be used. The velocity of propagation in a given medium is constant, and the fixed relation between the velocity, length, and frequency of radio waves can be expressed by formula.

$$f = \frac{V}{\lambda}$$

Where
f is frequency (cycles)
V is velocity of propagation (meters/sec.)
λ is the wavelength (meters)

WAVELENGTH-FREQUENCY CONVERSION

shown on charts and tables in this book and elsewhere is based entirely on substitution in the above formula. *V* is a constant whose accurate value may be taken as 299,820,000 meters per sec. Using this and any desired wavelength, the corresponding frequency is quickly found. Dividing the result (cycles per sec.) by 1,000 gives the frequency in kilocycles.

We shall be concerned a great deal with the way this high-frequency energy can be generated, controlled and received. The apparatus described in the following chapters has been carefully designed to fit amateur needs. But first some general explanations which will help to understand "how it works" are in order. The lower radio frequencies can be produced by rotating machinery (Alexanderson alternator) made possible by refinements in equipment like that used in power stations for generating 25- and 60-cycle current. However, circuits containing condensers and coils, chosen to have a certain natural period or frequency, are most often used in converting direct current (or alternating current of commercial frequency) to high-frequency alternating current useful for radio communication. In practice, the electric arc, the spark gap, and the vacuum tube have all been used with condensers and coils (combinations having the desired natural frequency) for this purpose. The older methods of creating radio-frequency power have been gradually supplanted and the equipment retired from service until to-day the more convenient and versatile vacuum tube reigns practically supreme.

OSCILLATIONS

If we put a weight on a spring and release it, the weight bobs up and down for several minutes.

The weight has inertia; the spring has elasticity. Coils have inductance or "electrical inertia." Condensers have capacitance or "electrical elasticity." Mechanical and electrical oscillations are very similar in most respects.

We can compare our electrical oscillations to the mechanical oscillations of a pendulum also. Given one impulse, the number of times the pendulum swings back and forth depends on the medium around it. It will swing longer in a vacuum than in air. If it is placed in water, it will stop quickly. The work done in overcoming molecular friction slows it to a standstill. The "viscosity" of the water or air is the measure of this sort of friction. For a given impulse, the amplitude of swing will not be so great if the motion is hindered by some sort of friction (resistance in any electrical circuit). If we continue to give our pendulum a slight push each time it swings back and forth the frictional losses are overcome and the backward and forward movements are continuous and maintain a certain amplitude instead of the pendulum coming to rest.

In creating high-frequency alternating currents for sending radio signals we find the spring, escapement and pendulum of a clock a close mechanical analogy to the power supply, vacuum tube and condenser-coil circuit, respectively. The condenser-coil combination has a natural period or frequency of oscillation similar to that of a pendulum. The vacuum tube acts like the escapement of the clock in that it supplies a series of timed pushes that keep the electric current in the condenser and coil going back and forth at constant amplitude. The power supply, like the spring, provides the energy used in giving these pushes to the oscillating circuit. Unless the energy is supplied to our electrical circuit at the right time to keep it oscillating the high frequency currents soon drop to zero due to the resistance of the circuit, just as the oscillations of the pendulum are stopped by the friction of the medium in which it swings if we disconnect or remove the spring.

TUNING

When a high voltage is free to act in a circuit containing a coil and condenser, the current surges back and forth in a transient oscillation just as the displaced weight bobs up and down on the spring, or the pendulum swings back and forth. If we continue to supply voltages to "push" the oscillating circuit combination at the right time, the oscillations take place steadily at constant amplitude. The resulting electrical surges take place at the natural frequency determined by the values of inductance and capacity in the circuit. Just as a pendulum has a natural rate of swinging back and forth determined by its length and weight, every circuit has such an "electrical" period which depends

on its inductance and capacity (coil-condenser). By changing the weight and length of a pendulum the period of swinging back and forth will be changed. Similarly, changing inductance and capacity in the electrical circuit change the period of swinging back and forth which we call the frequency of oscillations. This process of changing either inductance or capacity or both to alter the frequency is called "tuning."

To better understand "tuning" let us assume a condenser and a coil connected together, and review briefly the process of setting up oscillations in this simple circuit. Since no vacuum tube or auxiliary apparatus is provided to supply voltages or "timed pushes" we must also assume that the condenser is already charged so that a voltage is impressed in the circuit. At a given instant one of the condenser plates will have a positive charge with respect to the other, and the moment the coil and condenser are connected together the current will flow from this positively charged plate, tending to equalize the potential difference of the condenser. This current has to make its way through the coil (inductance) and here it encounters electrical inertia. The inductance tends to prevent the flow of current by changing the energy into the electromagnetic field which opposes the current flow. All the energy in the condenser is finally changed into electromagnetic lines of force around the coil, no longer existing as electrostatic lines of force between the condenser plates. The current flow from the condenser, at first prevented from building up due to the inertia of the inductance presented by the coil, has now reached its maximum value and the voltage of the condenser has dropped to zero. At this point the magnetic field about the coil collapses, returning energy to the circuit in the form of current, which continues to flow in the same direction (inductance-inertia prevents change), charging the condenser to opposite polarity. Finally when all the energy has been restored to the electrostatic field of the condenser (now charged in the opposite direction) the current falls to zero, and the accompanying magnetic field is also zero. The voltage is maximum and is now exerted in the opposite direction, causing the current to reverse in another attempt to equalize the potential difference of the condenser. The same cycle takes place again, a magnetic field being created as a result of the opposition of the coil to the current flow. This action would continue indefinitely except for the resistance (which is always an element in practical circuits) tending to reduce the alternating current to zero, and which we overcome by means of the vacuum tube, adding energy to the circuit to make up for its losses due to resistance, and so that the oscillations can be continuous. There is a continual changing back and forth between the potential energy of the magnetic and electric

fields and the kinetic energy represented in the flow of current.

It should be clear that if the coil (inductance) is made larger it will take the current longer to flow out of the condenser in a given direction, because the inertia will be greater. Likewise if we have a larger capacity it will take it longer to become charged to the maximum voltage (just as it takes a longer time to fill a larger tank with water). As has been stated, the velocity of the electric current or movement of electrons is constant. It is at once clear that the circuit with larger coils or condensers is going to take a longer period to go through a complete cycle of oscillation as explained in the last paragraph than a circuit where the inductance and capacity are kept small. So the smaller the coils and condensers used in tuning our radio circuits the faster the oscillations will take place, the lower will be the time constant, and the higher the frequency (cycles-per-second or kcs.-per-sec.). The longer the antenna wire the greater the distributed inductance and capacitance and the lower its natural frequency of oscillation.

TUNED CIRCUITS

In all radio work such tuned circuits are used a great deal. Radio receivers and transmitters alike make use of tuned circuits. "Tuning" a transmitter simply means changing the values of inductance and capacitance so that the "resonant" frequency of the circuit is the desired value. A transmitter is usually tuned to one frequency and the circuit adjusted for maximum effectiveness. If more than one frequency is used, the adjusting is carefully done for each and the size of coils and settings of condensers carefully noted in the station record or log.

"Tuning" a receiver simply refers to the changing of the variable element (usually capacitance, but which may be either inductance or capacitance) to change the received frequency to that of the station it is desired to hear.

There is a very definite relation that can be expressed between the size of the coil and condenser, and the frequency at which the combination will oscillate. Simple calculations can be made directly from the formula:

$$f = \frac{1}{2\pi\sqrt{LC}} \times 10^9$$

$$f = \frac{159.15}{\sqrt{LC}}$$

$$(\lambda = 1885 \sqrt{LC})$$

When L is the inductance in microhenries,
 C is the capacitance in microfarads,
 f is the frequency in kilocycles per second,
 λ is the wavelength in meters.

The "sharpness" of tuning and the "amplitude" of electrical oscillations are greatest when the "resistance" of a circuit containing a condenser and coil is lowest. The diagram shows a tuned circuit which has a variable resistance as well as a certain amount of inductance and capacity. The high-frequency generator G impresses a constant voltage in the circuit. The currents that flow vary in broadness and amplitude depending on the amount of resistance in

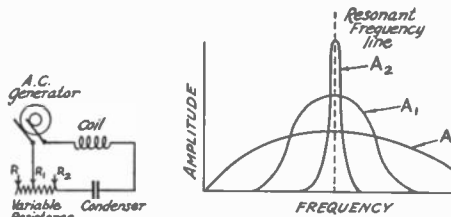

HOW RESISTANCE IN A CIRCUIT BROADENS TUNING

the circuit. We get the loudest signals with a receiver having low resistance circuits.

THE ANTENNA

High-frequency currents can produce radio waves. If these currents are confined to circuits containing lumped inductance and capacitance, they are not very effective in producing radio waves, however. An antenna-ground or antenna-counterpoise circuit has distributed inductance, distributed capacitance, and also a comparatively high "radiation" loss. Such a circuit is often referred to as a "radiator" or "radiating system." The physical dimensions are quite large and the lower the frequency the larger they have to be to "radiate" successfully.

The antenna or "radiator" is built expressly for the purpose of setting up the radio waves. Antennas have a number of shapes. The T, the inverted L, the V, the umbrella, and the coil or loop antenna are common types. The last named is very poor for most transmitting purposes but can be used effectively with the *very* short waves. Directional transmission is effected by building antennas of certain shapes. A loop radiates most energy in both directions along the plane of the loop. The inverted L transmits best in the direction opposite from that in which the horizontal part points. Radio waves like other kinds of waves can be reflected and refracted. Suitable reflectors make a "beam" transmitter that has marked directional characteristics. The short antennas used for high-frequency short-wave transmission do not have any marked directional effects and we do not have to worry about these. Most amateur antennas to-day are single wires.

There should not be the slightest hesitation in constructing a station on the grounds that it will "interfere" or "draw lightning." A receiving or

transmitting antenna properly grounded will "leak" off a charge gradually to ground, *preventing* the accumulation of voltage that might cause a disruptive discharge with danger to life and property. An antenna is a protection, not a hazard.

COUPLING

How do we get the radio frequency energy into our antenna, does someone ask? The energy transfer is accomplished by the use of *coupled* and *tuned* circuits. A pendulum has a certain natural period of swinging back and forth. We can move the pendulum back and forth at any rate we wish by applying enough force. By far the greatest response is shown when we pay attention to the natural rate of swing and *time* our application of force accordingly. If one of two pendulums of the same natural period is set in motion and there is a common link between them that transmits even a very tiny amount of energy, the other pendulum will gradually get into motion. Mechanical resonance exists when the two pendulums are tuned to the same natural rate of vibration. The pendulums are "coupled" by the common link which makes the energy transfer possible.

(a) When the common link in two electrical circuits is a condenser, we refer to the coupling as "capacitive" coupling. (b) When a resistor is used, we speak of "resistance" coupling. (c) When a coil is used, the coupling is "inductive"

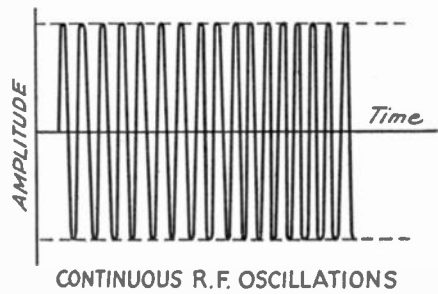

coupling. These three types of direct coupling are sometimes called "conductive," as shown in the diagram.

The "voltage drop" across the common link (C , R , or L) caused by current circulating in $L_1 C_1$ is effective in producing currents in the $L_2 C_2$ circuit. The $L_1 C_1$ current and the value of C , R , or L determine what takes place in the $C_2 L_2$ circuits.

The circuits may also be coupled less directly as shown in the second diagram.

These methods of coupling are known as indirect capacitive coupling and magnetic coupling, respectively.

Most amateur stations using short wavelengths use "magnetic" coupling. In such an arrangement the coupling value may be changed

by changing the number of active turns in either coil or by changing the relative position of the coils (distance or angle between them).

The value of the condensers and coils used for coupling and the value of high-frequency currents (causing a voltage drop across the first circuit) determine the power transfer between the two circuits. Whether the coupling is "inductive" or "capacitive" is determined by whether the two circuits are linked by a magnetic or an electrostatic field. Sometimes both kinds of coupling exist and this is known as complex coupling.

All of the above coupling schemes may be classified as either tight or loose. Coupling cannot, as is commonly supposed, be measured in "inches" separation of coils. The separation between the coils (distance and angle between axes) and the number of turns in each determines the coefficient of coupling. Many turns in two coils very close together give us tight coupling and a big transfer of power. Few turns at right angles or far apart give us loose coupling with little actual energy transfer.

When the coupling between two circuits is very small the two circuits can be tuned readily to be resonant to the same frequency. As we increase or "tighten" the coupling, the mutual inductance increases. The quantity of power transferred is greater and greater as the coupling gets tighter and tighter. With most transmitters there is a certain critical value of coupling that gives best results. With a tube set, too close (tight) coupling causes instability. The transmitting frequency becomes unstable or "wobbly" and in extreme cases the tube may stop oscillating. Too close coupling gives a big reading on the antenna ammeter but the signal is hard to hold. It breaks or becomes unsteady due to frequency

the coupling reduced, when a self-controlled oscillator is used directly for transmission.

THE VACUUM TUBE

The usefulness of the vacuum tube is known to most of us. Its action as a rectifier or detector, as an amplifier, and as an oscillator is known but not so well understood.

A vacuum tube is familiar to most folks as an evacuated glass vessel containing three or four elements, filament, plate, control grid and sometimes a screen grid. Small vacuum tubes are used for radio reception. Large tubes are used as

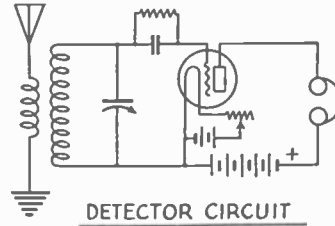

amplifiers of speech or of weak radio-frequency signals. Every time we make a long distance telephone call hundreds of V.T. amplifiers are put into use for our benefit. Still larger tubes are used in making powerful radio-frequency currents for sending out radio waves of long and short length. The biggest tubes handle many kilowatts of energy. They sometimes have water jackets for cooling the plates which waste some power as heat. Any three-element vacuum tube can perform all three kinds of action if we use it properly.

All substances are made of electrons. When most metals are heated some of the electrons in their make-up "boil" off. The purpose of the filament in our vacuum tube is to give off electrons. Any light that it gives is simply incidental to the heating process. A tungsten filament has to be heated very hot before it gives up its electrons. It takes lots of energy to do this and much light is given off in the process. Thoriated filaments are used in modern tubes since better electron emission and filament life are obtained with thoriated tungsten. A coating of barium and strontium oxides on a filament also parts readily with electrons. Such tubes do not take so much power for filament heating. Plenty of electrons are available and but little light is thrown off, as the temperature is not very high.

Electrons are negative particles of electricity. In a tube full of some fluid like air, electrons given off will fall back into the filament. When there is a vacuum around the filament the heated parts are protected from oxidation and the electrons easily boil out and fill this tube. The grid is next to the filament and if it is well insulated so the electrons cannot leak away it will collect electrons until it is negatively charged. Like

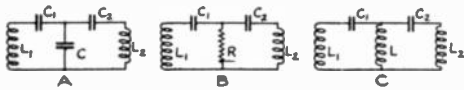

Direct coupling with condenser, resistor, or coil.

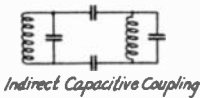

Indirect Capacitive Coupling

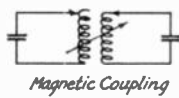

Magnetic Coupling

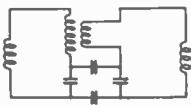

Magnetic and indirect Capacitive Coupling

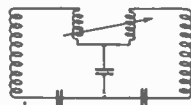

Magnetic and Direct Capacitive Coupling

TYPES OF COMPLEX COUPLING

variations and inherent instability. To improve "copiability" and eliminate inexcusable interference the antenna circuit must be detuned, or

charges repel and most of the new electrons coming off the filament will then fall back into it. Out beyond the grid is the *plate*. If we connect a battery between the filament and plate with the positive terminal next to the plate, the positive plate will attract the negative electrons. As fast as the electrons come off the filament they fly over to the plate. Electrons in motion make an electric current. The amount of current depends on the size and temperature of the filament, the voltage of the battery and the resistance in the different parts of the circuit. The potential of the grid has a marked influence on the current, too. An ammeter or milliammeter anywhere in the circuit will measure the current that flows. A change in the voltage of the plate battery does not change the plate current exactly in accordance with Ohm's Law. The temperature of the filament plays a part in limiting the electron emission and possible current flow. The electrons come from the heated filament. The grid and plate are seldom hot enough to give off electrons under normal conditions. The current can only flow one way through the tube. If alternating

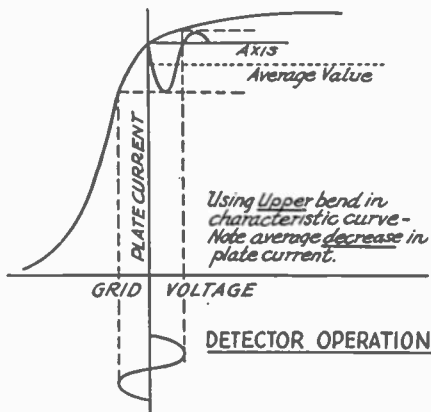

current is applied in the plate of our direct current B-battery, the electrons will only be attracted to the plate during the parts of an alternating current cycle when the plate is positive. The tube is acting as a "rectifier."

The *grid* is the controlling element of the vacuum tube. A two-element vacuum tube is a good rectifier. It can act as a "valve" in the circuit, allowing the current to flow in but one direction. It is good for little else, however. The grid is of open construction and it is placed near the filament. A battery (C) can be connected in the grid circuit (between the grid and filament) which makes the grid either positive with respect to the filament or negative with respect to the filament.

When the grid is positive, the negative electrons are attracted more and they get started away from the filament with more velocity so that more of them reach the plate. A plate current

meter shows that the plate current has increased. When the grid is negative, the negative electrons are repelled and the plate current is decreased. The grid is near the filament and any change in grid potential has a large effect on the plate current. If the grid potential is varied while the filament current and plate voltage remains constant, the effect on the plate current varies as shown in the diagram. The filament temperature limits in the emission of electrons causing the bend at the top of the curves, as saturation is approached. The bends (A, B, C, D in the curves of amplifier operation) can be used for detection. The straight section of the characteristic curve is useful for non-distorted amplification.

HOW A VACUUM TUBE "DETECTS"

For simple detection the circuit shown is usually used. A tuned circuit is coupled to the antenna and connected through a small condenser which is shunted by a high resistance to the grid and filament of a vacuum tube. The whole connection is called the *input* circuit to our tube. The filament current is provided by a low-voltage battery (the A-battery). The headphones and a higher-voltage battery are connected between the filament and plate of the vacuum tube. This is the *output* circuit of our tube. The B-battery, as it is called, usually has a voltage between 15 and 25 volts.

The electric and magnetic field from a sending station set up voltages in the antenna causing oscillating high-frequency currents in the antenna coil. The resulting field about this coil links the coil in the input circuit to our tube. This circuit is tuned to resonance at which point there is a maximum voltage across the condenser and coil. One of the terminals of the grid condenser connects to one side of the condenser and coil. This point becomes first positive and then negative at radio frequency. At a given instant let us say that this terminal of the grid condenser is positive. The other plate of the condenser takes on a negative charge of equal value by robbing the grid of some of its electrons. This leaves the grid itself positive with respect to filament. The *resistance* of the grid leak is so high that practically no charge is lost through leakage in the very small time required for a half-oscillation. The positive grid attracts more electrons from the filament through a momentary increase in the plate current. As soon as the negative half of the radio-frequency cycle comes along, the other plate of the grid condenser becomes positive and the grid itself has a charge of electrons. The negative grid repels further electrons but *holds all that it has received*. It continues to gain electrons during each positive part of the radio-frequency cycles that occur. The result of a continued modulated group of oscillations is to make the grid more or less negative. This causes a dip in the plate current. Between every group of

oscillations the negative charge has time to "leak" off the grid through the high resistance of the grid leak, allowing the plate current to increase again. When receiving modulated speech the process becomes continuous and the variations in telephone current are therefore at speech frequencies.

A tube can detect without the grid condenser and leak by adjusting it to work on the "bend" in the curve. Radio-frequency changes in grid potential will make radio-frequency changes in plate current. The decrease in plate current when the grid is negative will be greater than the increase in plate current when the grid is positive (at that "bend" in the plate-current grid-voltage curve which comes just before saturation).

If we wish, we can leave out the grid leak and grid condenser, substituting a C-battery to put a negative bias on the grid of our detector tube. Just the right bias must be used so that the tube will detect on the lower bend of the plate-current grid-voltage characteristic curve. The set recovers quickly from static crashes when this is done. It is quieter in operation than a set with a poor grid leak.

Grid-condenser-and-leak detection gives superior sensitivity to weak signals when it is compared with plate detection or so-called "power detection" which offers superior fidelity when handling a received voltage of relatively high amplitude.

Please note that in explaining detection simply and in our subsequent account of amplification, the statements made apply only for extremely small signals. A family of "curves" and much detailed explanation is required to show "dynamic vacuum tube characteristics" or the behavior of the tubes under actual working conditions.

Take our grid-voltage plate-current curves for example, the readings shown applying for a constant plate voltage. Actually when the grid of an amplifier or detector become more positive the plate current increases and the plate voltage decreases, because the plate-filament resistance is lowered and the external plate resistance becomes a greater proportion of the total plate-circuit resistance, thus absorbing more of the applied B-voltage. With several "static characteristic curves" taken at different plate voltages we could follow the tube action (dynamic) by hopping about from curve to curve to account for changing tube conditions.

Don't get the idea that the static characteristics are unimportant, for that is not the case. While the action may not be explained exactly for working conditions, this type of curve is basic and understanding of this is prerequisite to any more advanced study.

HOW A VACUUM TUBE "AMPLIFIES"

A small change in grid potential always makes quite a large change in plate current. This makes

it possible to apply currents of any frequency to our grid and to use the effect of the varying plate current in a transformer or "coupler" of some sort to produce greater voltages and currents at the same frequency. The power of course comes from the local B-batteries and the grid simply controls that local power supply.

Several tubes can be used one after another in an amplifier. They are coupled by any of the methods we mentioned under the subject of

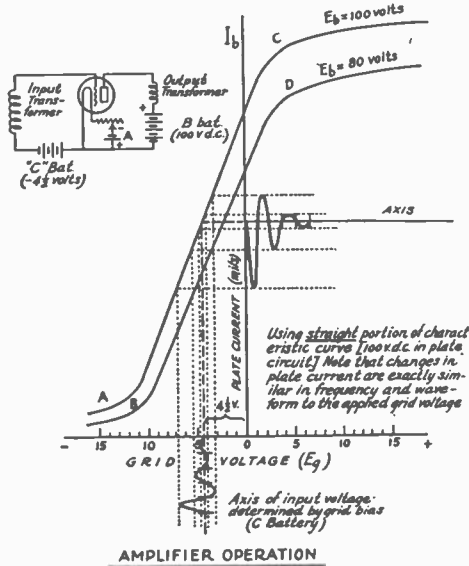

coupling. Magnetic coupling is perhaps most commonly used. Radio and audio frequency transformers are the simplest examples of magnetic coupling for amplifying voltages of different frequencies.

The action of amplification is quite similar to detector action. No grid condenser or leak is necessary. To give undistorted amplification the tube must be connected in a circuit so that it operates on the straight portion of its plate-current grid-voltage curve. The grid voltage must be kept down below certain limits, and a C-battery

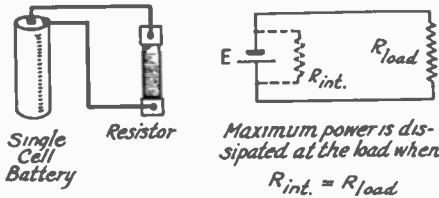

CONDITION FOR MAXIMUM POWER IN A CIRCUIT

or bias potential to shift the axis of the input voltages will often prevent distortion and save

battery consumption, although not necessarily giving more amplification. The figure shows how undistorted amplification is secured.

Maximum voltage amplification is desired between tubes. Between the last step of an amplifier and 'phones or loud speaker we want maximum power transfer. This is obtained by matching the tube impedance to the primary impedance of the output transformer. The secondary impedance of the output transformer is made equal to the impedance of the winding on 'phones or speaker to give best results. Just as in the case of the dry cell or generator, the maximum power is transferred when the load and internal impedance characteristics are matched. To give most power output without harmonic distortion, a more complicated condition must be satisfied, and the

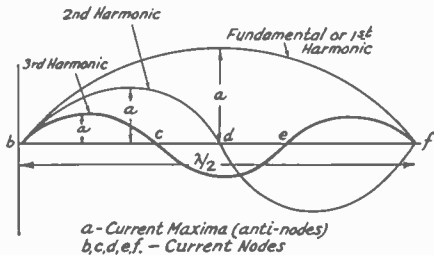

CURRENT AMPLITUDE OF 1ST, 2ND, AND 3RD HARMONICS
(Oscillations in a half-wave antenna)

external impedance must be twice the tube impedance.

HOW A VACUUM TUBE "OSCILLATES"

We have mentioned that vacuum tubes can and are used to generate undamped high-frequency currents. The production of undamped oscillations is accomplished by adding energy in "timed pushes" to each oscillation. A tube can be made to oscillate by coupling the input and output (grid and plate) circuits. The inductance and capacitance in the grid circuit usually determine the frequency of oscillation, although the values of inductance and capacitance in other parts of the circuit may control this. A coil in the plate circuit (tickler coil) sometimes couples a part of the plate circuit energy magnetically to the grid circuit, thus keeping the amplitude of oscillations unchanged despite the losses that tend to make them decrease. Every tube has some capacitance between the elements. When there is a coil in the plate circuit there is bound to be a "reactance voltage drop" across this coil. This voltage couples some energy back to the grid circuit through the grid-plate capacitance of the tube. Often a tube which refuses to oscillate can be brought into oscillation by adding a small condenser between the grid and plate. A few inches of insulated wire connected to each and twisted together will serve this purpose. Increasing the size of the coil in the plate circuit will do the same thing.

HARMONICS

Just as a violin string may be made to vibrate giving overtones or harmonics in addition to the fundamental vibration, an antenna circuit may be made to resonate at a number of harmonic frequencies. The fundamental frequency is the lowest frequency for which the current becomes a maximum. The harmonics are always higher frequencies and exact multiples of the fundamental. In radio practice, the fundamental itself is called the first harmonic, the next higher frequency the second harmonic, etc. (differing from musical practice in which the next higher multiple frequency would be termed the first harmonic or overtone). For example, an antenna having a fundamental (first harmonic) of 1790 kc. per second also will oscillate or operate on its higher harmonics at the following frequencies: 3580, 5370, 7160, 8950, 10,740, 12,530, 14,320 and 16,110 kc./sec. as the 2nd, 3rd, 4th, 5th, 6th, 7th, 8th and 9th harmonics, respectively. The higher harmonics usually give a weaker response, but piezo-electric quartz crystal oscillators often have useful harmonics as high as the three hundredth.

A coil-condenser circuit having low resistance resonates only at a single frequency. Circuits (such as antennas) containing much stray distributed capacity and inductance and having effective changes in resistance, capacity and inductance with frequency more readily respond at harmonic frequencies. A free antenna (Hertz) may be operated at the fundamental or any harmonic frequency, while an antenna of the grounded (Marconi) type will respond only at the odd multiples such as the third, fifth, seventh harmonic, etc.

PRODUCTION OF HARMONICS

Distortion in vacuum tube amplifiers often causes harmonics and we purposely adjust vac-

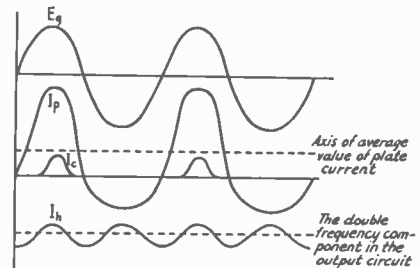

- E_g - Sine-wave input impressed on grid
 I_p - Distorted output plate current wave
 I_c - Grid current - when grid becomes positive occurring at right time intervals to set up second harmonic.
 I_h - The harmonic component of the output current

HOW DISTORTED WAVE FORMS CAUSE HARMONICS

uum tube circuits to give us maximum distortion when we desire an output at either radio or audio

frequencies that is rich in harmonics or has strong harmonics. The amplitude of harmonics depends on the grid bias and upon the difference between the average fluctuating current and the steady value of the plate current. High input voltage amplitudes or grid swing and high negative bias are favorable for the production of harmonics. Due to curvature in the plate-current plate-voltage characteristic curves and the fact that there is a different plate-voltage plate-current (static characteristic) for each value of impressed grid voltage, the current wave-form in the plate circuit becomes distorted, resulting in the generation of harmonic frequencies. A positive swing of the grid may, for example, cause an increase from the average value of the plate current of 45 milliamperes, while an equal negative swing will cause a decrease of only 15 milliamperes from the average value. A low plate-load (external) resistance or impedance will emphasize such distortion. Even with a high grid bias, large inputs to the grid circuit will also cause the grid to become positive during part of the input cycle, causing grid current to flow, thus decreasing the grid-filament resistance of the tube. This results in an uneven load and produces further distortion and harmonics. The way in which distortion in the output waveform introduces a harmonic impulse or component is indicated in our diagram.

Note that harmonics cannot be generated at frequencies below the fundamental but always occur at higher frequencies. Nevertheless it is possible sometimes to pick up a radio signal when listening on half the frequency of a transmitting station if some tube in our receiver is oscillating and a harmonic is present *in the receiver*. In this case the harmonic in the receiver may be beating with the fundamental frequency of the transmitter.

In working with transmitters careful distinction must be made between "frequency doubling" and harmonics. That is, if we arrange a distortion amplifier to double the 1790 kc./sec. frequency of our example, we may secure 3580 kc./sec. alternating current in the output (which happens to be the same as the 2nd harmonic). However, if we double frequency again we arrive at 7160 kc. in the output of this stage. A third doubler would give us 14,320 kc. in the output. By properly biasing tubes and tuning the output circuit to a desired frequency, a vacuum tube may be operated as a frequency doubler or frequency tripler, etc.

REGENERATION

There is always some feed-back through the tube inter-electrode capacity. Usually detection and amplification are accomplished in one tube. Oscillation takes place only when there is enough feed-back from the output to the input circuits so that the action is continuous as long as power is

supplied and the coupling is sufficient, and where the feed-back is sufficient to compensate for the losses in the circuit. Whenever any energy is "fed back" to the input of the tube we refer to the process as "regeneration." A signal impressed in the grid circuit (*SC*) produces changes in the plate circuit (*T*) at the same frequency. These changes have greater magnitude than the impressed signal because they take power from the plate battery. Whenever some of the energy is coupled back to the grid circuit we have "re-

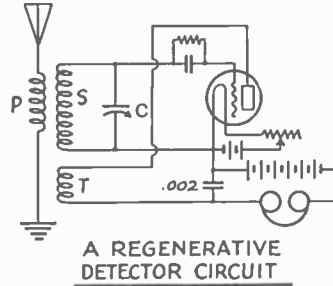

generation." The response to weak signals is greatly increased by using regeneration because the original voltage impressed on the grid is much increased by the feed-back. When there is sufficient regeneration we have "oscillation." By varying the tickler coupling, the plate current, the capacitance across grid and plate, or the turns in any coils that may be in the plate circuit, we can control the amount of regeneration and the ease with which the set goes in and out of oscillation. In receiving 'phone signals we want our tube to be adjusted for maximum regeneration *without* oscillation. To receive a continuous wave signal we want the set to just oscillate.

In a broadcast receiver we always want to prevent oscillation. "Neutralization" refers to any of the various methods by which oscillation is prevented. The coupling between grid and plate through the inter-electrode capacity of the tube always feeds back some high-frequency voltage to the grid circuit. To neutralize the effect of this we adopt some method to feed back another equal and opposite voltage (a voltage equal and 180° out of phase) to our input circuit. To get some regeneration is desirable, so we usually do not neutralize completely—the neutralizing voltage is opposite but not quite equal.

HETERODYNE AND AUTODYNE C.W. RECEPTION

The best and most common way to receive continuous waves is to use a vacuum tube to produce weak oscillations of *nearly* the same frequency as the incoming continuous wave (c.w.). The local oscillations and the incoming oscillations are added together in the input circuit to one vacuum tube.

Two tuning forks of slightly different frequency

"beat" upon each other, alternately adding to and neutralizing each other. The "beats" are of low frequency (the difference of the frequencies of each tuning fork) and the amplitudes of the two forks add so that the beat has first the sum of the amplitudes, then the difference (zero).

In radio work, the high-frequency alternating current impulses are ordinarily received by the "beat" method. Inaudible high frequencies are combined to produce an audible beat note. Millions of cycles can be generated locally in a small vacuum-tube oscillator. This oscillator is coupled to the grid circuit of a vacuum tube. The incoming oscillations are also coupled to this same circuit. The beats between the two frequencies are present in the output. The beat frequency equals the difference of the two frequencies. "Heterodyne" comes from two Greek words meaning "other force." When a tube is used especially to generate the local frequency, serving no other purpose but this, we have the heterodyne method of c.w. reception.

"Auto-dyne" means "self-force." The standard amateur regenerative tuner employs the autodyne method of reception. One vacuum tube

is for receiving weak impulses to amplify and convert into understandable characters, the business of tuning is important. Tuning is the process of adjusting the coils or condensers so that the circuit will respond to certain frequencies which correspond to certain stations that we want to receive. When signals are to be received, the sending and receiving stations must have their apparatus and circuits tuned to the same frequency.

Our antenna has distributed inductance and capacitance. It therefore tunes to a certain frequency. We can add lumped inductance and capacitance to tune it if we please. The maximum response occurs when the antenna circuit is tuned to the incoming frequency. The small potential induced by the advancing electric waves causes oscillations to take place in the antenna circuit. The radio-frequency voltages in this circuit can be applied directly or indirectly to the grid of a vacuum tube used as a self-heterodyne or autodyne for beat-note reception. Of course an r.f. amplifier can be used to magnify weak signals before receiving them by the self-heterodyne method.

Usually sending stations use some fixed frequency while receiving stations "tune" for the station that is wanted. Either the condenser or the coil may be the variable element in the receiving circuit. Sometimes both are made variable. The proper ratio of capacitance to inductance in a circuit has long been the subject of controversy. Good receiving results are obtained over quite wide limits. Therefore, for simplicity of control just the coil or just the condenser is made adjustable.

Using a coil with a small variable condenser and a number of fixed condensers makes it possible to cover a wide range of frequencies with the desired nicety of adjustment. When a large condenser is used a vernier knob or dial helps to give easy control. By using one small variable condenser and a number of removable coils it is possible to design a practical and efficient "tuner" that will cover any or all the frequencies used by amateurs to-day.

Tuning controls should be few in number and easy to operate. Adjustments should stay put and body capacity effects must be avoided, especially so in a high-frequency receiver.

Almost everyone who reads this *Handbook* has seen, used, and perhaps constructed a receiver of some sort for broadcast or amateur frequencies. There is little difference in the procedure followed in making a one- or two-tube broadcast receiver and in building a good high-frequency tuner except that the latter is usually a simpler, more straightforward design than the modern broadcast receiver. The fundamental change that must be made is simply to reduce the size of both the coils and condensers used.

In broadcast reception we are careful to use

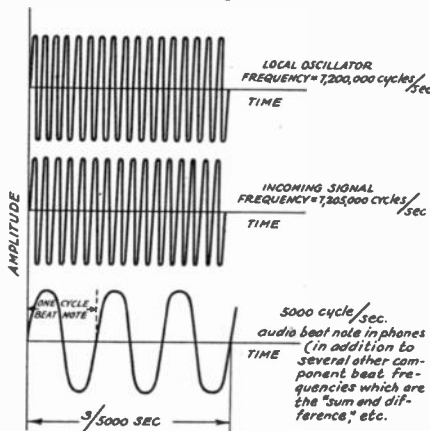

RECEPTION OF CONTINUOUS WAVE TELEGRAPH SIGNALS
(By self-heterodyne or autodyne oscillator)

generates oscillations. Incoming signals are coupled into the grid circuit of this same tube direct or often through one or more stages of tuned or untuned radio-frequency amplification. A single tube thus acts as oscillator, detector, and amplifier. The oscillations at the natural period of the circuit will beat with the frequencies of received signals to produce audible effects. Also harmonic oscillations in a receiver, although weaker, can beat with other incoming frequencies and sometimes cause reception of two frequencies simultaneously or other unusual effects.

RECEPTION — GENERAL

In all radio work, whether the apparatus is for sending out radio-frequency energy or whether it

amplifying transformers that do not amplify certain frequencies in the musical scale much more than others. In code reception we can use the same instruments if we please or we can pick out some so-called "distortion" transformers to give us more amplification on some one frequency. By heterodyning or autodyning the incoming signal to give a beat note of the desired frequency we can readily get maximum amplification from such a transformer. Static and signals of different frequency from that of the transformer "peak" will not be amplified to the same extent as the signal we want to read. The signal will stand out clearly against a background of little noise.

Reception of high-frequency signals is usually accomplished by the autodyne method. Our local receiver oscillates. Our adjustment of the condenser-coil circuit determines the frequency of oscillation. The antenna circuit is coupled to the condenser-coil circuit. Oscillations are set up in the antenna circuit by the changing field from the transmitter. The field about the antenna coupling coil (if one is used)¹ links the coil in the tube circuit. The grid of the vacuum tube has impressed on it voltages of two frequencies. The output circuit of the vacuum tube contains the *difference* between these two grid-circuit frequencies. When the two frequencies (one from the antenna and one locally generated) are exactly the same, we have "zero beat" and *no* sound in the 'phones *unless* the incoming signal is modulated.

In receiving code signals the regeneration control is set so that the receiver oscillates over the whole range of frequencies that can be covered by the set. The tuning dial of the condenser-coil circuit is turned slowly while the regeneration control is moved just the little necessary to keep the tuner *on the edge of oscillation*. When the amplitude of the local oscillations is just equal to that of the incoming signals, the beat note will be strongest. In receiving signals the energy from the antenna circuit is always very weak. The best results (maximum sensitivity) are obtained with the regeneration control not far beyond the point where oscillations begin in the local circuit.

Most vacuum-tube receivers to-day utilize the principle of regeneration. Part of the energy in the output circuit (plate circuit) of the detector tube is coupled back to the input circuit (grid circuit). The feedback voltage may be applied to the grid either through the plate-grid intra-tube capacity or by an inductive feed-back obtained by using a "tickler" coil.

MODULATION

When something that we do varies the amplitude of the current in a circuit, we have modu-

¹ When the antenna is connected directly to the grid end of the condenser-coil circuit through a small fixed condenser, the oscillations of the antenna circuit take place as usual and the voltage drop across the coil and condenser is applied directly to the grid of the detector tube.

lated the current. Speech modulation is usually accomplished by speaking into a microphone. Microphones for speech only are quite satisfactory when made of a stretched metal diaphragm in front of some carbon granules whose resistance varies, depending on the position of the diaphragm. For musical reproduction the condenser microphone and the pallophotophone are quite useful even though they must work through a large amplifier before there is energy enough to control large amounts of power.

Microphones and modulators vary currents by varying the resistance or impedance of the cir-

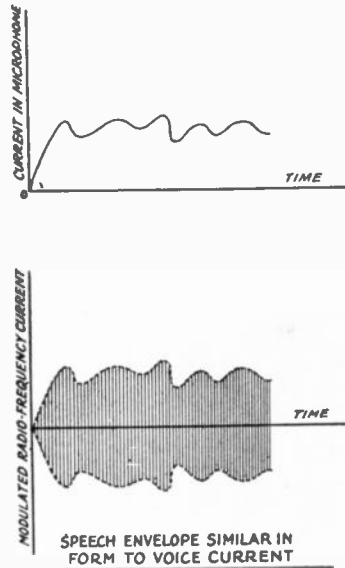

cuits of which they are a part. In modern radio-telephone transmitters the microphone works into a number of amplifiers, cascaded and coupled together to produce uniform amplification over the desired audio range. Sometimes part of the amplifiers are right at the microphone. The speech or music goes over telephone lines for some distance to the point where the station is located and there more amplifiers are used. The amount of power that can be controlled directly by a microphone is very small. Thus combinations of vacuum tubes used as amplifiers are necessary to build up the energy to a value which will permit complete "modulation" of the radio-frequency output of a large transmitter.

While a certain amount of modulation can be obtained by a number of crude methods, the radio regulations to-day require high frequency stability, and since the power lost by incomplete modulation is considerable, it is profitable to consider use of only certain types of equipment that are necessary to produce adequate results. Therefore the use of microphones directly connected to

speech input circuits, used in "absorbing" radio-frequency circuits or in the antenna itself, will not be discussed. Instead a whole chapter of modern radiophone practice has been included.

The system of modulation most widely known to-day is the Heising method. In the simplest version of such a transmitter we have two vacuum tubes. One is used to generate radio-frequency power to apply to the antenna. This is connected as an oscillator. The other tube is of equal size to the oscillator but is employed as a modulator tube. Both are fed from a common plate supply source through a large iron-core coil. The reactance of the choke coil (X) is so great

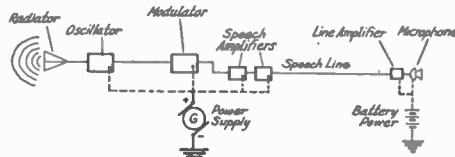
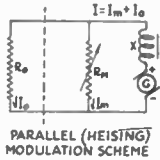

A SIMPLE RADIOPHONE CIRCUIT (with Heising Modulation)

that the current through it is practically constant and cannot vary at speech frequencies or higher frequencies. Thus when the transmitter is working the current from the source is constant. For this reason the Heising system is sometimes known as the *constant-current modulation system*.

The oscillator works steadily and the radio frequency is coupled into the antenna circuit. A radio-frequency choke coil keeps h.f. current from leaking back into the modulator and supply circuits. The load which the modulator tube takes varies. As the grid voltage of the modulator tube is changed at speech frequencies, its plate current is made larger and smaller accordingly. The microphone and its amplifiers have complete control over the plate current of the modulator tube. The plate currents of the modulator and oscillator normally are about the same. When the microphone is spoken into, the modulator plate current can vary from nearly zero to about twice its average value. The reactance coil (X) keeps the current from the source and the voltage across both tubes practically constant. Therefore while the modulator plate current is varying from zero to twice its average value, the oscillator plate current must vary inversely from twice its normal value to about zero. The high-frequency output of the oscillator varies directly with its input. Thus we have a high-frequency carrier wave completely modulated with a speech "envelope."

FADING AND SKIP DISTANCE

No discussion of amateur radio or of high-frequency phenomena can be complete without mentioning the commonly accepted theory advanced in explanation of the things that have been observed in connection with high-frequency transmission. It appears that just as light waves

can be reflected (by a mirror) and refracted (when passing into a medium of different density such as water) so it is with radio waves. The behavior of radio waves or radiations set up by different alternating current frequencies is harder to understand because these waves are not visible or audible except by artificial means of detection. The frequency spectrum used for radio communication is a wide one and the determination of what happens is further complicated by the continuous variations taking place in the medium traversed by the radio waves. The bending or refraction of radio waves is attributed to the presence of free electrons in the ionized portions

of the earth's upper atmosphere. The ionization passes through a daily and seasonal variation depending on sunlight and changes in barometric pressure.

Changing reflecting and refracting properties of the Kennelly-Heaviside layer² are sometimes supposed to account for the minute-to-minute changes in the intensities of received signals (fading). Changes in the strength of vertical and

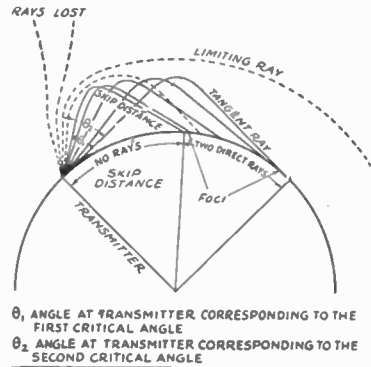

SHOWING THE VARIOUS POSSIBLE PATHS OF RADIATION

The vertical and near-vertical rays penetrate the ionized layer and wander away. When one reaches the "limiting angle" the ray just does get bent enough to be kept from wandering away, but it continues to graze the layer and is after all worthless. Below this angle we have progressive reflection (or refraction) and the ray returns to earth. As the angle of departure from the transmitter is chosen flatter the energy strikes so far away as to miss the earth, possibly going out to the ionized layer again, and perhaps even being reflected down a second time if it has energy enough left.

horizontal components of radio waves due to varying polarization³ also account for fading.

²The Kennelly-Heaviside layer is so named for the investigators who first suggested the existence of an ionized region above the earth's surface which might have an influence on the propagation of radio waves. It can be shown mathematically that such ionized layers can transmit an electro-magnetic wave with a higher velocity than it would have when travelling through un-ionized space. There is a more or less increasing state of ionization in the higher levels

A diagram explains what is commonly referred to as the "skip" distance, that distance that signals skip over. The signal decreases in intensity as we leave the transmitter due to spreading out and to energy absorption. It finally drops below a useful value, remaining out (Y) until we reach a great distance from the transmitter, after which it unexpectedly gets strong again, gradually dropping in intensity at still greater distances. Assuming radiation from a transmitter at a great many different angles, the first diagram shows the different directions in which radiation takes place.

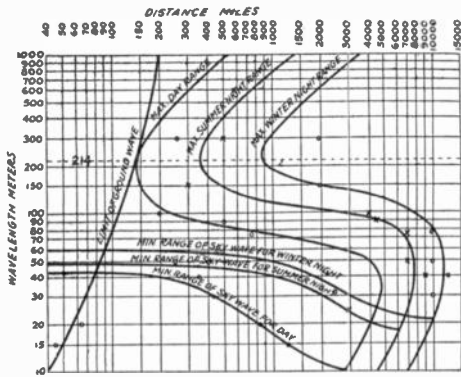

APPROXIMATE AVERAGE TRANSMISSION PERFORMANCE OF DIFFERENT WAVELENGTHS AT DIFFERENT DISTANCES

The received signal is assumed to have a field-strength of 10 microvolts per meter at the receiving point. The transmitter is assumed to have 5000 watts in the antenna. The chart is rather confusing but may be explained as follows. To the left of the line marked "limit of ground wave" it should be possible to receive at all times. After that, one must pick a pair of curves of the same sort (that is for the same time) and if the distance is between the curves one should hear the signal. Thus, a 30-meter wave should be reliable at all times to 70 miles for the conditions mentioned. From there to 400 miles its daylight performance will probably be uncertain while from 400 on it will gradually die down until at 4600 it will again be below 10 microvolts per meter. There are, of course, numerous exceptions where one does hear it when it should be absent. The curves are mainly from data by A. H. Taylor.

The signal may of course be received near the transmitter due to the ground wave and also in the area between the "two direct rays" shown. The skipped distance at night is much greater than in the day time. It gradually increases up to about midnight. The skipped distance also is known to be greater in winter than in summer which seems reasonable because the ionization

of the earth's atmosphere. Explaining ionization we might say that it must be thought of as the breaking up of neutral gas molecules into positive and negative constituents by ultra-violet light from the sun and by direct bombardment of the outer layers of the earth's atmosphere by electrons thrown off from the sun — notably from sun spots.

Polarization refers to a change produced by the medium through which the radio waves travel by which the transverse vibrations in the medium are limited to a single plane. Near any transmitter the vibrations take place more or less indifferently in any plane about the line of propagation depending, to some extent, on the type of radiator used.

should be less then, due to shorter periods of sunlight.

Fading is reported less violent at very long distances due to the fact that radiation can arrive by many routes, thus averaging conditions and giving a fair signal in spite of fading along some paths. Right at the edge of the skip distance interference effects may occur with very severe fading, while beyond this point the rays of high-angle radiation die out, giving a better chance for a steady signal. In general high-frequency communication results go to prove that the skip distance for any given time decreases with decreasing frequency. While skip-distance effects are important on our high frequencies they are not as noticeable on the broadcast band and less important still on low frequencies.

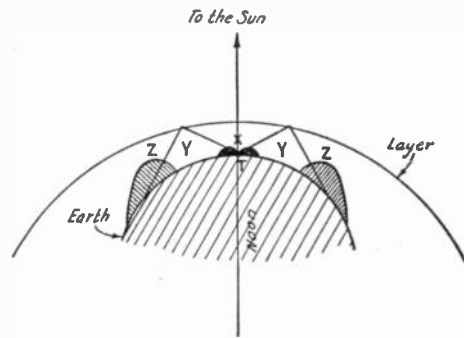

THE NATURE OF "SKIPPED DISTANCE"

- T — Transmitting point.
- X — Local signal due to earth-bound or ground wave.
- Z — Region of refracted or reflected signal.

There is nothing absolute about any of the rules that different investigators have devised for determining whether a signal from a certain transmitter can be heard at a given point. However, some charts and rules are useful when studying the subject of transmission phenomena, even though they are approximate. Such a chart is shown reprinted from *QST* with some explanation of what it means. It shows roughly what may be expected of different frequencies or the corresponding wavelengths in radio communication.

Amateur experience seems to indicate that the power of a transmitter is one of the less important considerations in high-frequency work. Extreme distances are covered day and night with less than ten watts in the antenna using 14,000 and 7000 kc. frequencies, and the signal strength of high and low power stations is much the same. The conditions which obtain in the medium itself are undoubtedly the most important factor in determining the results.

READING DIAGRAMS

Schematic diagrams show the different parts of a circuit in skeleton form. Pictures show the

apparatus as it actually appears in the station or laboratory. A little study of the symbols used in schematic diagrams will be helpful in understand-

by reference to the illustration on this page. Most of the diagrams shown are plainly labelled or worded so that it is only necessary to know the

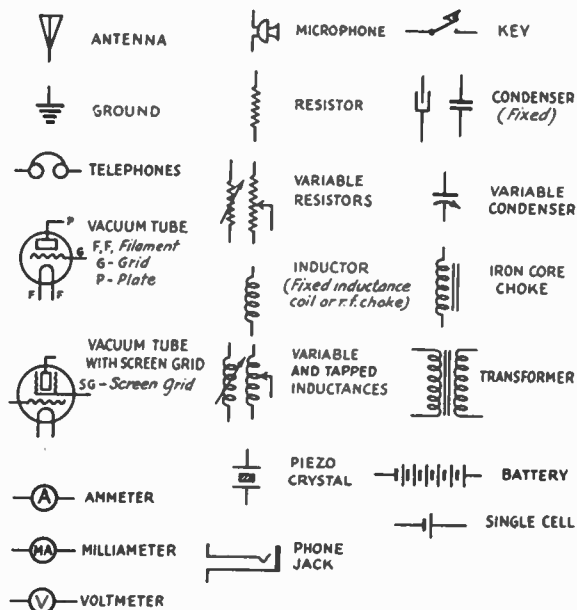

ing the circuits that appear in *QST* and in most radio books. The diagrams are easy to understand once we have rubbed shoulders with some real apparatus and read about it. Schematic diagrams are used in all electrical work because they save so much space and time when discussing the various circuits. Photographs of apparatus show the actual arrangement used better, but the wiring is not as clear as in the schematic diagrams. In building most apparatus a schematic diagram and a photograph will make everything clear. It is suggested that the beginner carefully compare a few picture and schematic diagrams if not entirely familiar with the latter.

The symbols used in schematic diagrams throughout this book will be easily understood at once

general scheme which differentiates coils, condensers, and resistors to read the diagram. Reference to the text will help in understanding fully what is intended, since diagrams and text have been prepared to complement each other. In general, coils are indicated by a few loops of wire, resistances by a jagged line, and variable elements in the circuit by arrowheads. If a device has an iron core it is usually shown by a few parallel lines opposite the loops indicating coils or windings.

When you can draw and talk about circuits in terms of the various conventional symbols you are on what is familiar ground to every amateur and experimenter. Then you can meet the dyed-in-the-wool expert and understand what he talks about.

CHAPTER V

Receivers

And an Introductory Discussion of Station Assembly

TO get the greatest fun and benefit from amateur radio work you will want to get into the game with a complete station. Perhaps some readers of this *Handbook* wish to "experiment" and to build equipment for testing purposes only. Some individuals get their chief pleasure in making measurements comparing the performance of apparatus by laboratory methods. Some are never happy unless they are continually examining different circuits, becoming familiar with their operation and tearing them down again. Advanced experimenters enjoy making a series of actual transmitting tests to find out more about radio wave propagation as it varies with frequency, distance, and time-of-day. However, if you are like most amateurs, you probably will prefer to put together a complete but inexpensive station and get your enjoyment from its operation.

Perhaps you think that building a station involves many complicated pieces of apparatus, a special building, separate power supply, intricate circuits and, last but not least, a considerable investment of funds. Such an idea is quite erroneous. While a station may involve all these things if an individual is wealthy, it means nothing of the kind as a rule. Not more than 4 or 5 percent of the thousands of active radio amateurs in this country boast a quarter-kilowatt transmitting tube, not to mention the other equipment. The *average* amateur carries on both local and international communication with a solitary 7½-watt transmitting tube and rarely with anything larger than a 75-watter.

A "station" is nothing more nor less than a transmitter and receiver, correlated by suitable controls. Do not get the impression from a hasty glance at the amount of material in the next few chapters that a lot of complicated equipment is necessary. In the first part of each chapter descriptions of the simplest equipment will be found. At the start one should pick out one of the simple receivers described in this chapter, build a monitor and frequency meter according to instructions in Chapter VI, construct one of the low-power transmitters in the first part of Chapter VII, and get information on power supply, keying, station arrangement and adjustment from the proper chapters. Then the equipment may be properly installed on a table or desk in any convenient part of the home. That's really all there is to building a station.

There is, of course, some constructional and experimental work to do. There is a great deal of satisfaction in the act of building, considered

just by itself. The good station must have a good transmitter and an equally good receiver. The mechanical and electrical details of these instruments offer interesting problems to the beginning amateur. It is the purpose of this book to make the path smoother for him.

Although we describe receivers and transmitters in detail, it is not necessary to follow our mechanical arrangements exactly to get good results. A few parts and tools, a little ingenuity, some planning with pencil and paper (mixed with a little common sense) result in the best station at the lowest cost. A few hours spent in looking over the suggestions given here will save money and enable one to get started right.

After the planning is done, the materials should be ordered. Your local dealer will have some supplies but probably will not have them all. Condensers, coils, meters, insulators, transformers, batteries, tubes or whatever is needed are carried by advertisers in *QST*.

QST refuses advertisements containing false claims. New apparatus is examined by the Headquarters' staff. Editorial mention is only given when it appears that the apparatus is really worth calling to the attention of the members. "Ham-ads" always contain a variety of used apparatus for sale or exchange. Once in a while complete receivers and transmitters are offered for sale in these columns, but to get just what one wants and to save money, most amateurs prefer to "build their own."

While it is possible to put a set together with the aid of only the proverbial jackknife, a few good tools of the proper sort will be found invaluable in saving time and helping to make a good job mechanically. The following list is typical of the tools which most amateurs consider highly desirable, if not indispensable:

- Soldering iron (preferably electric)
- Large and small side-cutting pliers
- Large and small screwdrivers
- Hand drill stock with a few drills of different sizes (Nos. 11, 18 and 28 will be most useful)
- File (not too large)
- Knife (Boy-Scout kind)
- Hammer
- Vise (the small 4" size will do)
- Steel rule (6" or 12")

With these tools it is possible to construct practically any of the apparatus ordinarily built at home. Others will be found useful at times, however. A small tap-holder, a die-holder and three or four taps and dies covering the 6-32, 8-32 and

10-32 sizes can be obtained from a hardware store at reasonable cost. With the dies you can thread brass rod and run over threads that become "bunged-up" on machine screws. With the taps you can thread the holes you drill so that they

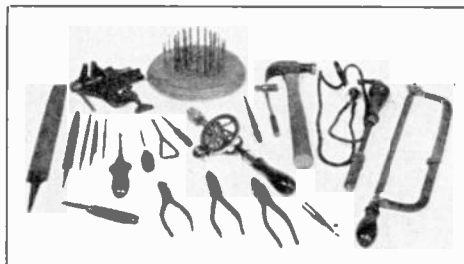

TOOLS FOR CONSTRUCTION

All are convenient but not entirely necessary. A set of small taps and dies, a circle cutter to use in mounting meters on panels, a bit brace and a set of socket wrenches will be useful in addition, if regular construction work is planned.

will take machine screws to hold the apparatus you wish to mount. A hacksaw, reamer, center-punch, scriber, tweezers, square and some other inexpensive tools are also desirable but not entirely necessary.

In building equipment for experimental purposes and for temporary use it is just as desirable to use system in laying out the apparatus and in wiring up as when the more permanent panel job is built. Some square "breadboards," a bunch of General Radio plugs and jacks, Fahnestock clips, some scrap bakelite pieces for building terminal boards, angles for supports and an assortment of different sized brass machine screws, wood screws, nuts, and washers will make it easy to build up and try out new circuits or to wire up auxiliary apparatus to go with the transmitter. It is a good idea to keep some bus wire on hand, and various sized spools of magnet wire will prove useful in doing temporary wiring if you are an experimenter.

A table of drill sizes giving the proper numbered drill to use for passing a screw through a panel or for tapping to take a certain size of machine screw is included in the Appendix. Only the sizes most used in radio constructional work are given. Wood screws also come in various sizes and lengths. Usually the numbers correspond to the drill-size numbers, the diameter given being that of the screw just below the head. Wood screws are stocked by most hardware stores in lengths to the nearest quarter inch of what you want. Round-head screws look best. Whether blued or nickled screws are used is mainly a matter of choice.

SOLDERING AND WIRING

In wiring different pieces of apparatus a neatly soldered job will repay the builder in good appearance and reliable operation. Good connections

may be made without solder, but a well-soldered job has low contact resistances. A soldered outfit works quietly and uniformly over long periods of time. Soldering is decidedly worthwhile when properly done.

Making soldered joints is a quite simple matter. A few points should be kept in mind for best results. A hot well-tinned soldering iron, clean, bright surfaces, a *small* amount of rosin-core solder or rosin and "half-and-half" soft solder will do the trick. Tinning the parts to be soldered before completing a joint will be helpful.

Soldering flux keeps the clean surface from becoming oxidized when heat is applied. Acid fluxes or soldering pastes made by the action of hydrochloric acid on zinc and supported in a low-melting base should especially be avoided. They are good for mending tin pans and gutter pipes but cause corrosion of electrical connections. The melted "paste" can cause a set to operate poorly or to become inoperative by adding leakage paths across coils and condensers. Use lump or powdered rosin that can be obtained for a dime from any drug store, or buy "rosin-core" solder.

"Half-and-half" simply means that the solder is an alloy, half tin and half lead. "Tinning" the soldering iron is done by filing the point bright and clean and rubbing it in hot solder with a little flux until the point is covered with clean solder. Scrape connections with a knife or file before soldering, to save time and make a joint good electrically and mechanically. The soldering iron must be re-tinned occasionally if it becomes overheated. It should always be used when very hot but not allowed to become red hot. A hot iron makes soldering easy.

Bus wiring is neat and effective. The wires are laid out in straight lines running straight back, horizontally and vertically. The corners are made square. Hold bus wires firmly with pliers while a little solder "runs" into the joint.

In receiver wiring, battery leads may be bunched to good advantage. Radio-frequency circuits should have the leads well spaced. Wires should cross at right angles when crossing is necessary. Connections between coils and condensers should be as short as possible. However, coils and condensers must not be jammed together too much as this increases the effective resistance and lowers the sensitivity. Leads a couple of inches long are permissible and will allow mounting the condenser out of the field of the coil.

The antenna lead and all the connections from the condenser and coil should be kept away from other wiring. The wiring in the audio amplifier can be spaced, and short leads are good, but they are not nearly so important here as in the detector and antenna circuits. To avoid undesirable feedback the plate and grid leads should be kept well separated.

The transmitter should be wired with the same

points in mind as in receiver wiring. At the same time, the power supply and high-voltage wiring must be well insulated and sufficiently separated from other equipment to insure safety to life and property. The insulation of lead-in and high voltage conductors should comply with underwriters' rules.

In the pages that follow we are going to describe in detail some successful short-wave tuners. Constructional "dope" for moderately-priced transmitters with world-wide range is also given. We have discussed some fundamentals of electricity. The diagrams and constructional information are quite complete. We suggest that the constructor study the books mentioned in the Appendix for more complete theory and general information. The descriptions of stations in *QST* frequently give good ideas on station arrangement. *QST* itself keeps you informed about new developments that are useful and noteworthy.

STATION ARRANGEMENTS

A complete station consists of a transmitter, a receiver, a monitor and frequency meter, and suitable antennas for transmitting and receiving. The exact arrangement of these units is not usually of great importance as far as their electrical effectiveness is concerned, but the matter is worthy of careful consideration so that the station may be operated with the greatest convenience and comfort to the operator.

The items which are handled most frequently are the receiver, power switches, key, frequency meter and monitor. It is well, therefore, to group these so that they can be operated conveniently. Perhaps the most popular practice is to place the receiver towards the left of the table on which the apparatus is to be mounted. The monitor is located alongside the receiver on the right (where it is near enough to give a good signal in the receiver) and the key is screwed to the table slightly to the right of this and far enough back to give a good support for the operator's arm.

Since the filaments of the transmitting tubes should be lighted before the high voltage is applied, two switches are necessary — one in the primary of the filament transformer and one in the supply circuit to the plate supply apparatus. These switches can be mounted under the front edge of the table in a position convenient for right-hand operation. With low-power transmitters the filament and plate power are often supplied by one transformer; in such a case only one power-line switch will be necessary.

Since the transmitter is left at one adjustment for much longer periods than the receiver, it is as well to mount it clear of the other apparatus where it will not be influenced by the "body-capacity" of the operator or the vibration of keying. One possible scheme is to mount it on a shelf above the right-hand side of the operating table. The transmitter should be near the antenna

or feeder leads, however, and in some cases a different placement may be advisable. In order to reduce the vibrations reaching the transmitter it is often mounted on four rubber sponges or suspended on heavy rubber strips.

It should not be necessary to give the plate-supply apparatus frequent attention; therefore it can be on a shelf near the floor or, particularly if it is a generator, can be rigged in the basement. In the latter case, of course, particular attention must be given to the insulation of the high-voltage leads between the supply system and the transmitter.

There are scores of possible arrangements for the station and they will be varied in individual cases by the arrangement of the room, the size of the table or bench and the type of apparatus. It may be a good plan for the amateur to arrange the apparatus in temporary fashion at first so that he can change things around when he has gained some experience in the operation of the station.

UNDERWRITERS' RULES

The specific rules covering radio equipment are given in Article 37 of the National Electric Code, under the heading of "Radio Equipment." Some states have adopted this code or a more strict version of it. Certain cities have adopted it, too, and they enforce their regulations through municipal inspectors. Before making an installation it is well to find out if the apparatus and wiring are subject to a state and city inspection as well as to inspection by insurance interests.

"Approved" refers to devices designed for the purpose used in accordance with recognized practice. The device must be acceptable to the inspection department having jurisdiction (there may be a city or state inspector in addition to the insurance rating or inspection bureau). When there is no inspector for the city or state, insurance interests inspect through their rating organizations, one of which covers each part of the United States. Your local insurance agent can advise you in whose territory you are located so you can get in touch with the proper authority.

A conference with the inspection department *before* making an installation or change will save inconvenience and expense later. Your own interests and those of fellow citizens will be best protected from an insurance and fire-hazard standpoint by having such a conference.

The wiring must follow the requirements observed in your particular community. In some instances a separate power line must be run directly to the watt-hour meter. A few feet of "BX" from the nearest outlet to a "Square-D" switch box, properly fused at the switch, will usually be satisfactory. The installation of high-voltage apparatus and wiring must be done in approved fashion. High-tension cable, supported on porcelain pillar insulators, keeping the high voltage away from all woodwork and neighbor-

ing conductors, is a safe type of construction.

A receiving antenna can be connected to ground before it gets to the set through either the in-door or out-door type of lightning arrester.

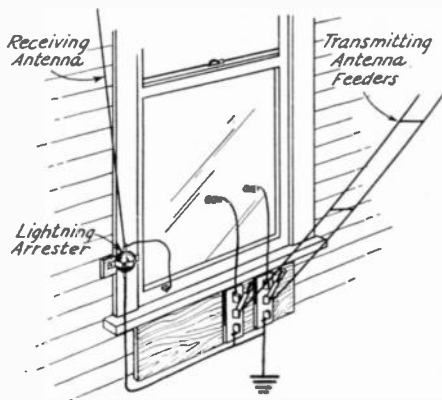

ANTENNA AND FEEDER GROUNDING METHODS FOR LIGHTNING PROTECTION

Lightning switches are used on the transmitting antenna lead-in or feeders. A lightning arrester is satisfactory for the receiving antenna.

Several approved types are sold by local dealers with complete instructions for installation. These arresters usually are simply spark-gaps sealed in a vacuum to lower the voltage break-down. The ground can be made by scraping a water pipe or ground rod clean and bright with a file. A 10-cent ground-clamp will make a good connection to the pipe. A yearly inspection will insure a good ground. An approved lightning arrester operating at a potential of 500 volts or less is required for each lead-in conductor of a receiving station. There are no requirements for indoor antennas, however.

Transmitting antennas or feeders must be grounded by means of lightning switches. The switch should be of the single-pole double-throw type having a minimum break distance of 4 inches and a blade of at least .0625 square inch cross-section. The switch should be in the most direct line between lead-in and ground but can be located either outside or inside the station. Live parts of the switch must clear the wall (or other conductors) by 3 inches. The switch must be connected to the ground wire whenever the station is not in operation.

Antennas for receiving and low-power transmitting stations should be supported and insulated similarly to public service communication lines, while for medium- and high-power stations the requirements for constructing supply lines for transmitting electrical energy in like situations must be met. Antennas should not cross over or under supply lines or telephone and telegraph wires nor should they run above and parallel to them in such a way that a falling antenna might

come in contact with a live wire. Antennas should not cross railroad tracks or public thoroughfares. They should not be attached to poles owned and maintained by local public utilities for supporting power lines or communication cables or wires. In most cases local ordinances forbid such construction as a menace to the public welfare. When antennas are put up in such hazardous locations special precautions should be taken to have ample strength in the antenna wire and its supports, as well as ample clearances. Antennas should not be supported on chimneys. When a tree is used there should be some provision for keeping the antenna from snapping when the tree sways in the wind.

Any size of wire can be used for a receiving antenna. Probably No. 14 B. & S. (American Wire Gauge) hard-drawn copper wire, enameled to prevent corrosion, will have the best balance of electrical conductivity and mechanical strength for that purpose. Transmitting antenna wires for medium or high power amateur stations should have a strength not less than that of No. 10 hard-drawn copper wire and should be insulated with insulators having a minimum creepage distance of 10 inches.

The lead-in wires must be brought into the station through approved lead-in bushings. A good but cheap way to bring in the antenna lead is to drill a hole in the center of a large windowpane. A brass machine screw with rubber gaskets will

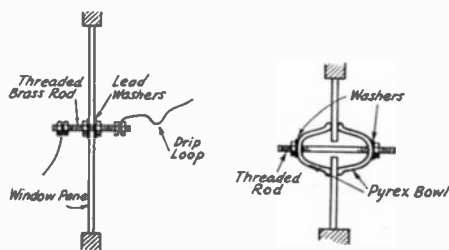

TWO GOOD METHODS OF BRINGING THE TRANSMITTING ANTENNA LEAD-IN THROUGH A WINDOW

go through this and make an excellent lead-in. The lead-in insulator must have a 3-inch clearance beyond the wall of the structure. Antenna leads must never come within 5 inches of supply wires. A wooden board at the top or bottom of a window will make a good support for lead-in bushings under most circumstances. Pyrex bowls make good bushings. Lead-in bushings or tubes must be rigid, noncombustible, nonabsorptive, and have good insulating properties.

Everyone who owns an amateur station or who plans to have one should send ten cents (not in stamps) to the Superintendent of Documents, Government Printing Office, Washington, D. C., for the booklet *Safety Rules for Radio Installations*, Handbook of the Bureau of Standards No. 9. This gives a number of rules for installing amateur radio equipment.

DESIGNING THE RECEIVER

The first apparatus to be built for the station should be a receiving set. Fortunately the short-wave receiver is not a complicated affair like the broadcast receiver. In its most practical form it may consist of two, three or four tubes, but even a single tube can serve to receive amateur signals over long distances. The first requirement in the receiver is a detector tube connected to a tuned circuit and provided with a tickler coil so that it may oscillate. A regeneration control must be provided so that the detector can be maintained in a condition of weak oscillation for the reception of telegraph signals or held at the point just below oscillation for 'phone reception. Most amateurs prefer louder signals than a single tube can give, and therefore additional tubes are used to provide amplification. Radio-frequency amplification is used between the antenna and the detector to make the receiver sensitive to weak signals, and audio-frequency amplification follows the detector to make all signals louder. More than one stage of radio-frequency amplification is rarely necessary at amateur frequencies, and a single stage of audio is usually sufficient for good head-set reception, although two audio stages are often used.

The arrangement of the parts in the receiver and the wiring of them are important matters. Many amateurs screw the apparatus on a wooden baseboard, but this scheme has the disadvantage that dust and dirt soon collect on the condensers and coils and noisy operation results. A panel-mounted receiver fitted in a cabinet is really much preferable and need not be much more expensive. The panel and cabinet will afford protection to the apparatus and will give a much more pleasing appearance than the baseboard covered with apparatus and wires. In addition, the panel will usually permit a more convenient arrangement of the controls.

It is as well to spend some time in considering the lay-out of the parts so that the leads in the detector circuit may be reasonably short without cramping the apparatus, and so that the tuning coil is convenient to the tuning condenser and the detector tube without being too close to any large metal parts. It is difficult to specify definitely the separation that should be maintained, but an approximate idea of suitable spacing can be obtained by studying the photographs of the receivers. The wiring in the detector circuits should be made with bus-bar or enamelled copper wire of about 14 or 16 gauge so that it will not vibrate or shake and so "shimmy" the signals. In the audio-frequency amplifier, the wiring can be done with rubber-covered flexible wire and the difficulties of bus-bar wiring avoided. Bus-bar can be used throughout, of course, if a neat appearance is desired. If the receiver is to be reliable and quiet in operation it is essential that all joints in the wiring be well soldered. When the wiring

has been completed it should be checked over carefully before connecting any batteries. Before connecting the B battery, the A battery should be hooked up to make sure that the filaments can be lighted and controlled by the rheostat or switch. If all the tubes do not light the trouble should be found before proceeding any further. It is a good plan to connect a flash-lamp bulb in series with the lead to the negative terminal of the B battery so that any fault in the wiring which ordinarily would result in burning out the tubes will merely blow the bulb. If the bulb is blown when the B battery is connected, the wiring should be checked with care and the fault located before another attempt is made. The ease with which wires can be misplaced in such a way as to connect the B battery to the tube filaments is surprising. Even the more experienced amateurs make mistakes of this kind and the protection of the flash-lamp bulb should not be disregarded. When connecting batteries to a receiver always connect the wires to the set before hooking on the batteries. Shocks and inadvertent short-circuiting of the batteries will then be avoided. When the 'phones are plugged in, a loud click should be heard and a similar or louder click should be obtained when any of the connections to the B battery are made or broken. At this stage it should be possible to make the set oscillate by adjustment of the regeneration control. If this control is moved gradually the detector should go into oscillation with a soft thud. A rustling sound produced by static and miscellaneous electrical noises will show that the tube is oscillating. If there is any doubt whether oscillation is being obtained, the terminal of the grid condenser which is connected to the tuning coil can be touched with the finger. If the tube is oscillating a thump will be heard as the finger touches the terminal and another thump as it is removed.

TUNING ARRANGEMENTS AND BAND SPREADING

Since the amateur frequency-bands comprise narrow slices of territory widely separated, it is

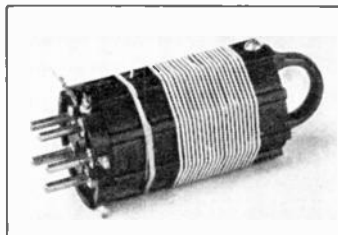

TYPICAL COIL CONSTRUCTION WITH MANUFACTURED FORMS

not possible to cover them all effectively with one coil and condenser in the tuner. Many schemes have been evolved to provide suitable coils and coil sockets, the present trend being towards the

use of a tube base or a special form of larger size plugging into a tube socket. A manufactured form of this type is illustrated on page 57, while others are pictured later on with the constructional details of the receivers in which they were used. Larger coils with a horizontal row of plugs fitting into a similarly-arranged row of sockets are also used in some cases. The important requirements are that the coils should be readily interchangeable; the contacts should be positive; the coils should be mechanically strong so they will not be deformed in handling; and they should be small in diameter in order to avoid the existence of an extensive magnetic field around them.

Tuning condensers used in high-frequency receivers differ greatly in size from those employed for the broadcast band and lower frequencies. The usual 350- or 250- μfd . condenser will, at high frequencies, cover so much territory that tuning becomes extremely difficult, and the amateur bands occupy only a few divisions on the usual 100-scale dial. Many amateurs remove plates from standard-size condensers to reduce the maximum capacity, or use midget condensers rated at 50 μfd or less. If the receiver is to cover all frequencies between 20,000 and 3000 kc., common practice is to use a tuning condenser rated at 150 μfd . with three plug-in coils, but even this arrangement crowds the amateur bands in a very small proportion of the dial scale. Most amateurs prefer to spread the bands over a large

which spreads one band satisfactorily will not give the same spread on others. In order to make each band cover the same number of dial divisions, the ratio of maximum to minimum capacity must be different for each band. One method of making the change is to use plug-in midget tuning condensers, such as are described in connection with the four-tube receiver farther along in this chapter. The standard midget condensers will not

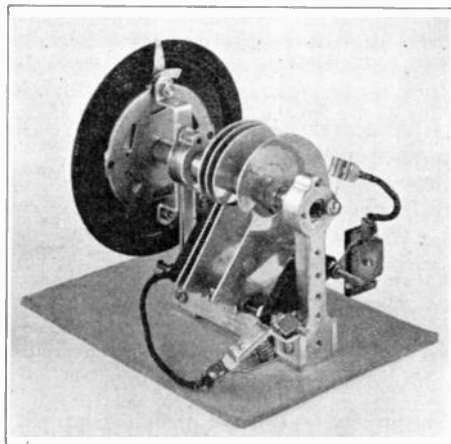

TWO SEPARATE STATOR ASSEMBLIES ARE USED IN THIS CONDENSER

One stator section may be used alone or both may be connected in parallel by the clip. The two stators are insulated from each other. In this particular condenser one stator is mounted on each of the insulating pieces at the ends. The condenser gives two capacity ranges without the necessity for the clip when connected as shown in the 3-tube a.c. receiver.

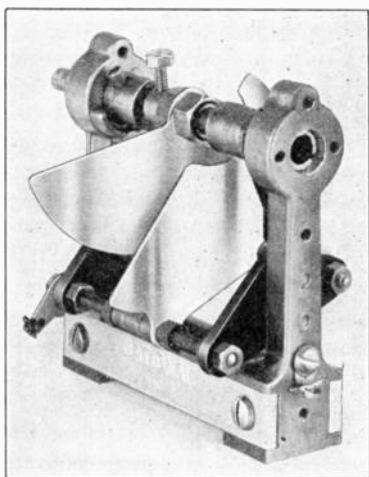

THE "SLIDING ROTOR" CONDENSER

The space which each band occupies on the dial can be adjusted by changing the spacing between the rotor and stator plate.

part of the dial, and to effect this a number of methods have been devised.

Unfortunately our bands are not entirely in harmonic relation, and therefore a condenser

always work satisfactorily, and plates must therefore be removed until each band is spread as much as desired. Another successful arrangement is to reconstruct a regular 250- μfd . condenser, removing all plates except one stator and one rotor, and arrange the rotor plate so it can be moved toward or away from the stator plate, thus changing the capacity ratio. The illustration shows how such a condenser may be constructed. Notches may be filed or drilled in the rotor shaft after the proper settings of the rotor plate for different bands have been determined, so that the set screw can be fitted into a notch with the assurance that the plate has been returned to the exact position desired. Still another system is to use two tuning condensers in series, the second condenser allowing the maximum capacity in the circuit to be set to any desired value within comparatively wide limits. If both condensers are of about 100 μfd ., each band can be spread as much or as little as desired, and the spread may be changed at will.

The amount of spread to use will vary with the preferences of the individual. A full dial range of 750 kc. will be ample for easy tuning in most cases, and will allow plenty of clearance on each

side of the various bands. If one is willing to compromise a little, however, the same tuning capacity can be made to serve for both the 1715- and 3500-kc. bands, and a second value for the 7000- and 14,000-kc. bands. Only two capacity ranges are required in this case. Any of the schemes mentioned above may be used in this way, and yet another method is permissible. The stator plates of a large condenser may be divided into two sections, insulated from each other, and the number of plates in each section adjusted until the two capacity ranges are obtained. Another illustration shows such a condenser.

himself. The best plan is to construct the sets as described and then add or subtract turns on the coils and make adjustments to the tuning condensers with the aid of a frequency meter or by listening to commercial stations whose operating frequencies are near the amateur bands. The "Radio Amateur Call Book" lists commercial stations by frequency, and will prove invaluable in adjusting the tuning of a receiver.

REGENERATION CONTROL

The regeneration control is the next most important item in the receiver. Almost any arrange-

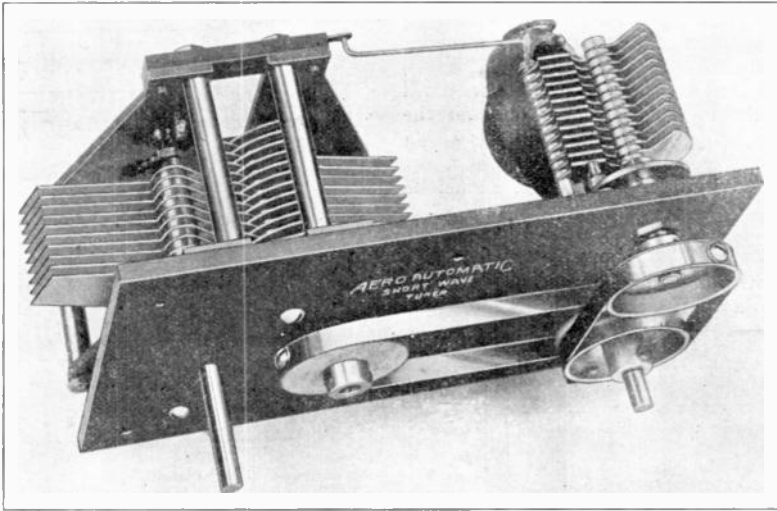

A TUNING UNIT WHICH COVERS FROM 3000 TO 15,000 KC. WITHOUT INTER-CHANGEABLE COILS

A dial spread of 1500 kc. may be obtained at any part of this range. This is a manufactured tuner, and its construction in the home workshop is impractical.

A new type of tuning unit has recently been developed by Hoffman and Mix of the C. F. Burgess Laboratories, which has a continuous tuning range from 15,000 to 3000 kc., and permits full-scale tuning over a band 1500 kc. wide at any part of the range. It comprises a variometer and two variable condensers, one with plates cut to a special design, all being ganged together. The unit may be used in place of the usual plug-in coils and condensers in any of the circuits shown in the following pages. An illustration of this tuner, which is manufactured by Aero Products, Inc., is shown.

The exact adjustment of condensers for band-spreading is not a matter for close specifications or calculation, but must be determined by experiment. The same is true of the construction of tuning coils. In the pages which follow approximate specifications will be given for coils and condensers, but it must be understood that these values may not be exact in all cases, and that the final adjustments must be made by the set builder

ment of the tickler coil and feed-back control can be depended upon to give similarly loud signals, but some of them have the advantage of being more convenient and of permitting adjustment of regeneration without detuning the signal. It is also a great advantage if the regeneration control is absolutely quiet in action; if it permits a gradual adjustment up to and past the point of oscillation; and if it permits the tube to oscillate gently all across the frequency band on which the receiver is working without the necessity of touching anything but the tuning control.

Several methods of controlling regeneration are shown in the diagrams. Those at "B" and "D" are the most commonly used, the latter being probably more popular than any other. Resistance control is used in the receivers described in this chapter, and is strongly recommended, since it gives smooth control of oscillation with a minimum of detuning. It is important, however, that the resistor be of good quality if noisy operation is to be avoided. Even with the best resistors it is

advisable to connect a fixed condenser of 1 μ fd. or more across its terminals to reduce the possibility of noises being caused by poor contact between the movable contact and the resistance element. The carbon-compression resistors seem to be the best for this purpose, although the types using a movable contact on a resistance strip are in most cases quite satisfactory. Wire-wound resistors ordinarily give poor results for this purpose.

It is usually desirable to make the tickler much smaller in diameter than the tuning coil to reduce the tuning effect of the regeneration control, particularly when the throttle-condenser method is used. In all methods it is essential that the tickler be mounted or wound at the filament end and not the grid end of the tuning coil. In the interests of smooth control it will be found advisable to use just as few turns on the tickler as will allow the tube to oscillate easily all over the tuning range. If the tube starts oscillating with a sudden thump instead of a smooth rushing noise, a lower value of grid leak resistance should be used.

RADIO-FREQUENCY AMPLIFIERS

A regenerative detector followed by a stage or two of audio amplification will bring in signals

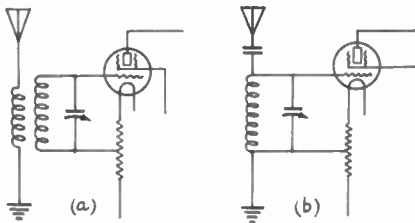

HOW A SCREEN-GRID ANTENNA COUPLING TUBE MAY BE CHANGED INTO A TUNED R.F. STAGE

A tuned circuit (covering the same band of frequencies as the detector circuit) is substituted for the resistor or choke ordinarily employed in the antenna circuit. The antenna may be coupled to the tuned circuit by either of the methods shown. At (a) a primary of a few turns is used, while at (b) coupling is provided by a small condenser (two brass angles facing each other).

from all over the world on high frequencies, but many amateurs like to have the additional sensitivity and selectivity which a stage of radio-frequency amplification will provide. Screen-grid tubes are well suited to r.f. amplification, although three-element tubes are almost useless. A tuned radio-frequency amplifier can be added to any of the receivers described in this chapter with very little change in the sets themselves. Those equipped with a screen-grid antenna coupling tube are easily adapted to tuned r.f. amplification, by simply substituting a coil and condenser of the proper values for the various bands instead of the resistor or r.f. choke connected between grid and filament of the coupling

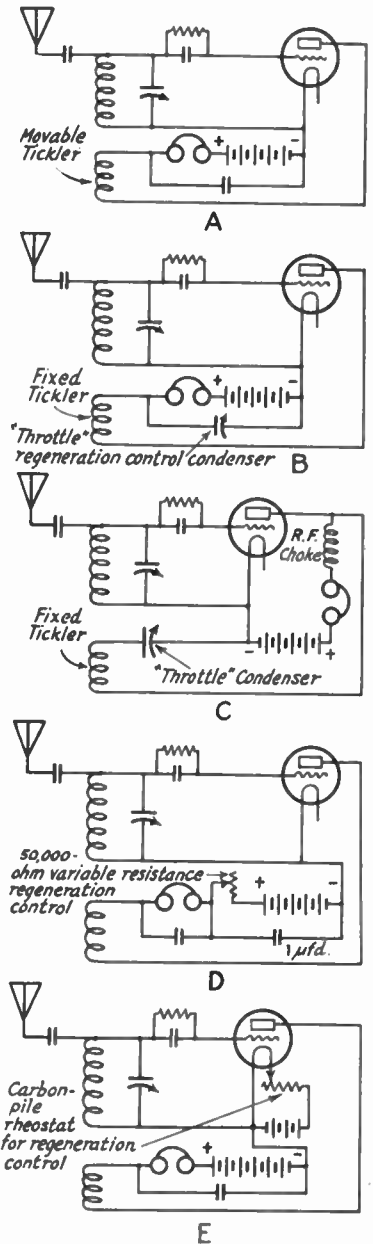

FIVE METHODS BY WHICH REGENERATION CAN BE CONTROLLED IN THE DETECTOR CIRCUIT

In the arrangement shown in diagram A the regeneration or feed-back is varied by rotating the tickler coil which is mounted at the filament end of the tuning coil. In scheme B the tickler is fixed in relation to the tuning coil and the regeneration is controlled by the variable throttle or feed-back condenser. Circuit C is a similar arrangement to the latter but with parallel or shunt plate feed. In scheme D, which is the most popular of all, control of feed-back is effected by the variable resistance in the detector plate lead. In arrangement E the tickler is fixed and regeneration controlled by adjustment of the filament.

tube. The coils and condensers will be approximately the same as those used in the detector circuits of the same receivers. The antenna should not be connected directly to the grid of the first

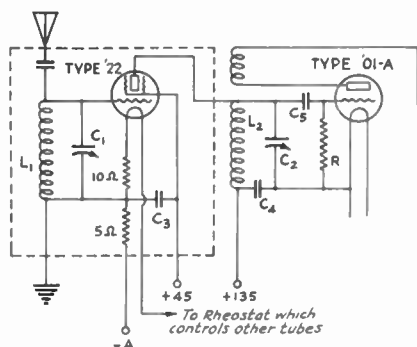

ADDING A TUNED R.F. STAGE TO A REGENERATIVE DETECTOR

The tuned circuit L_1, C_1 , will have the same constants as L_2, C_2 , the detector coil and condenser. C_3 should be a fairly large (.006 μ f. or more) by-pass condenser. C_4 , .006 μ f., is used to prevent short-circuiting the plate voltage. The grid leak, R , must be connected across grid and filament of the detector tube, as shown, and not across the grid condenser. No other changes need be made in the receiver. The part of the circuit shown in dotted lines should be thoroughly shielded and the shield grounded.

tube, but should be coupled either through a small condenser, such as C_4 in the two-tube receiver, or by a primary coil of a few turns. The diagrams show both methods. It is always advisable and sometimes necessary to place the r.f. amplifier tube and its associated coils and condensers within a grounded shield to prevent feedback from other parts of the circuit, which would reduce its effectiveness.

A radio-frequency amplifier can be added to receivers in which the regenerative detector is coupled to the antenna by a few simple changes in the set. These are indicated in another diagram. A.c. (heater type) tubes may be used, the heater and cathode connections being made in the customary manner for such tubes.

AUDIO-FREQUENCY AMPLIFIERS

The problem of sensitivity is taken care of by the regenerative detector and r.f. amplifiers, but in order to obtain "comfortable" signal strength audio amplification is required. Audio-frequency amplification for high-frequency receivers is, in a great many cases, no different from that used for broadcast reception, and the usual connections for transformer or resistance coupling may be employed.

For reception of amateur code signals, it is unnecessary and even undesirable to have the distortionless amplification which is the aim of designers of broadcast receivers. Expensive audio transformers with excellent frequency characteristics are therefore not required. In fact, a trans-

former which has a decided "hump" at some portion of its frequency curve is preferable, particularly if the hump is in the neighborhood of 1000 cycles. Such a transformer will provide "audio-frequency selectivity," since it amplifies one frequency a great deal more than others. This is decidedly helpful in receiving signals in the more crowded amateur bands, because two signals are rarely on exactly the same frequency, and the beat notes between the oscillating receiver and the received signals are usually sufficiently far apart in the audio scale to allow selection of the desired signal at the audio transformer "peak" frequency, with the result that there is greater amplification of the desired signal than of the unwanted ones.

A different method of obtaining audio-frequency selectivity is incorporated in the four-tube receiver described a little farther on. A large coil is tuned by means of small fixed condensers to 1000 cycles, and the combination forms a coupling impedance which acts as a rejector circuit. Beat notes at about 1000 cycles cannot pass through this tuned circuit and are, therefore, passed on to the grid of the next tube, while those of higher or lower frequency are by-passed to a large extent. Impedances of this type are obtainable from at least one manufacturer.

For 'phone reception the same principles should be applied as for ordinary high-quality amplification. Plate voltage and C bias on the amplifier tubes are important, and should be those recommended in the instruction sheets accompanying the tubes or may be taken from the table in Chapter VII under "Class A" amplifiers. The audio transformers should be suited to uniform amplification over a wide range of audio frequencies.

SCREEN-GRID DETECTORS

Many amateurs have found that screen-grid tubes used as regenerative detectors are much superior in sensitivity to the three-electrode tubes. Either d.c. or a.c. tubes may be used. Usual practice is to place the tickler in the plate circuit in the same manner as it is used with the triode, but the regeneration control is often placed in the lead to the screen-grid. For best results the plate voltage should be the maximum recommended for the type of tube being used, but the screen-grid voltage should be approximately 20 volts. The usual sizes of grid condenser and leak for the control-grid circuit are satisfactory.

It must be remembered that the output of a screen-grid tube either as a detector or audio amplifier cannot be satisfactorily fed into a pair of 'phones or the primary of an audio transformer of customary design. The plate impedance of screen-grid tubes is so much higher than that of ordinary triodes that the use of equipment designed for the plate circuits of the latter tubes will result in the loss of nearly all the amplifica-

tion which the screen-grid tube provides. For this reason resistance or resistance impedance coupling is ordinarily used. When using the Type '24 tube as a detector the resistance in the plate circuit should be of the order of 200,000 ohms for maximum results. With the Type '22, 400,000 to 500,000 ohms will be about right.

More detailed discussion of the advantages of this type of detector will be found in *QST* for April, 1930, and September, 1930.

SOME PRACTICAL RECEIVERS

The receiver descriptions which follow are intended to illustrate the points just discussed. The various arrangements need not be followed slavishly by the constructor, providing principles

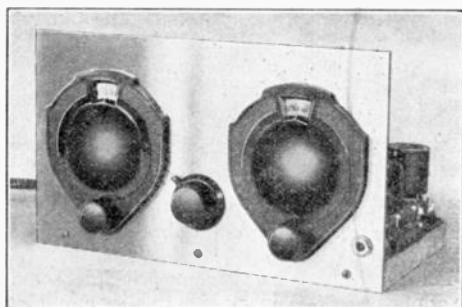

THE PANEL LAY-OUT OF THE TWO-TUBE RECEIVER

The vernier dial on the left is the main tuning control, that on the right-hand side being the regeneration control. The knob in the center controls the filament rheostat.

of good design are not violated. For instance, any of the various band-spreading schemes may be substituted for the one in the particular set in which you are interested, if such substitution should be desirable. If you prefer to use manufactured coil forms in a set in which the prescribed coils were wound on old tube bases, by all means do so, but at the same time remember that some modification of the coil sizes given will be necessary if the forms differ in diameter very much from the tube bases. Audio systems may be interchanged, likewise. A little common sense applied to most of the problems you may encounter will solve nearly all difficulties.

A TWO-TUBE RECEIVER

The two-tube receiver illustrated is one of the simplest types that can be built. It is, however, a thoroughly practical one which can be depended upon to give readable signals, when conditions permit, over even the longest distances. The wooden base-board measures 11" x 6" x $\frac{7}{8}$ " thick and upon it is mounted all of the apparatus with the exception of one of the variable condensers, the rheostat, and the variable resistor used as a regeneration control. These elements

are mounted on an aluminum panel 11" x $6\frac{1}{2}$ " x $\frac{1}{8}$ " thick. Aluminum of this thickness can be obtained at most tin shops and hardware stores and should be cut to shape in the heavy shears with which these shops are usually equipped. The panel can be given a pleasing finish by stripping it in a strong solution of washing soda. When removed from the solution the aluminum will have a clean matt surface which can be preserved, after the panel has been well washed in clean water, by giving it a thin coat of clear lacquer. A metal panel of this type is useful in reducing the effects of "hand-capacity." A panel of bakelite or hard-rubber, which is preferred by some amateurs, can be used. In any event the panel can be secured to the base by three or more round-head wood screws in the manner shown in the front view of the set.

When a metal panel is used it is necessary to insulate the frame of the variable resistor and the telephone jack from it. This can be accomplished by drilling holes large enough to give clearance between the panel and the resistor shaft and the jack and by using washers of thin card or other insulating material between the panel and the frame of the apparatus mounted on it.

From the circuit diagram it can be seen that two variable condensers are used in series across the tuning coil L_1 . The condenser C_1 is the main tuning control and is a high-grade condenser of 50 μ fds. capacity. It is made from a standard 250- μ fd. condenser by removing all except three

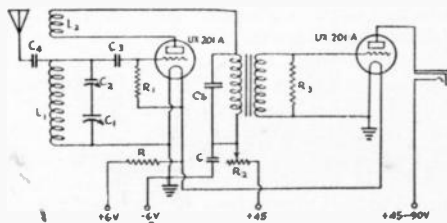

THE SIMPLE WIRING OF THE TWO-TUBE SET

Apparatus required:

- Two Type '01-A or '99 tubes and sockets.
- C — 1- μ fd. by-pass condenser.
- C_1 — 50- μ fd. tuning condenser (straight line frequency).
- C_2 — 100- μ fd. midget variable condenser.
- C_3 — 100- μ fd. fixed grid condenser.
- C_4 — Antenna coupling condenser — two $\frac{1}{2}$ "-square brass plates about $\frac{1}{8}$ " apart.
- C_5 — 2000- μ fd. fixed by-pass condenser.
- R — 20-ohm rheostat.
- R_1 — 2- or 4-megohm grid-leak.
- R_2 — 50,000-ohm variable resistor.
- R_3 — 0.1-megohm fixed grid-leak type resistor.
- L_1, L_2 — Tube-base coils described under photograph.
- One good audio-frequency transformer.
- Baseboard measuring 11" x 6". Aluminum or bakelite panel 11" x $6\frac{1}{2}$ ".
- 'Phone jack, miscellaneous wood screws, machine screws, brass strip, etc.

stator and two rotor plates, and is controlled by the dial on the left of the panel. The midget condenser C_2 is of 100 μ fd. capacity and is mounted just behind the tuning condenser. It is used in

series with the main tuning condenser to reduce the capacity range of the latter so that almost full scale coverage can be obtained on any of the amateur bands. When the receiver is operated on the 1715- or 3500-kc. bands this midget is set near its maximum capacity, the exact position being determined experimentally, so that the capacity range of the tuning condenser will be limited to

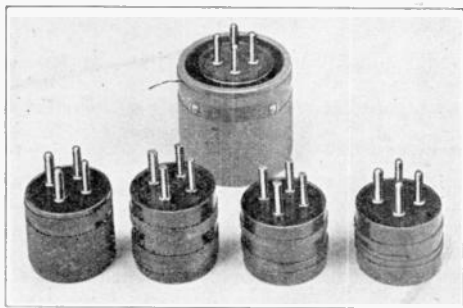

THE TUBE-BASE COILS USED IN THE TWO-TUBE RECEIVER

Both grid coils and ticklers in these coils are wound with 24 gauge d.s.c. wire. The numbers of turns used are as follows:

Band	Grid Turns	Tickler Turns
1715 kc.	49	8
3500 "	33	7
7000 "	15	6
14,000 "	6	5
28,000 "	3	3

No spacing is used between turns except in the grid coil for 28,000 kc., where the spacing is $\frac{1}{8}$ ". As can be seen, the 1715-kc. coil is wound on a 2"-diameter bakelite tube mounted on a tube base.

the value necessary to give full-scale coverage on those bands. For the 7000-, 14,000- and 28,000-kc. bands the midget condenser is set at lower values—each value being predetermined experimentally

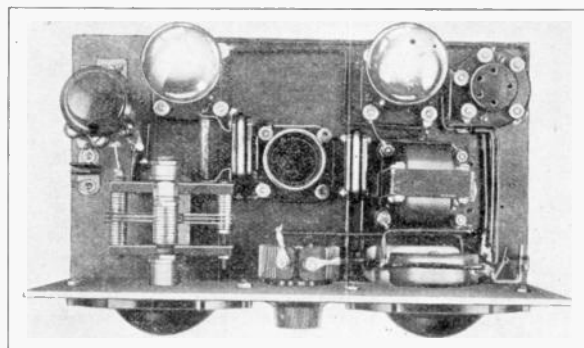

A PLAN VIEW OF THE TWO-TUBE RECEIVER

The main tuning condenser and the midget condenser (mounted on a brass bracket) can be seen at the left of the receiver. To the left of the tuning condenser is the antenna coupling condenser and behind the rheostat are the tube-base coil, the grid condenser and leak and the detector tube. On the right-hand side are the variable-resistor regeneration control and its dial, with the audio transformer, amplifier tube and battery-connection socket behind them.

—so that the effective capacity range of the tuning condenser is progressively lower for the higher frequency bands. An understanding of the reason why a lower setting of the series midget condenser reduces the capacity range of the tuning condenser can be obtained by studying the explanation of the action of condensers in series in Chapter III. The methods of band spreading used in the other receivers described in the chapter could be incorporated in this two-tube set.

The tuning coils are wound on bakelite bases taken off burnt-out tubes. The approximate number of turns needed for the various bands is given under the illustration of the coils. The exact number of turns needed will depend to some extent on the placement of the apparatus and the arrangement of the wiring. It is a good plan first to wind the coils with the number of turns given. Exact adjustment of the inductance can then be made by spreading out one or two of the end turns. When the correct adjustment has been found the turns can be held in place with a few spots of Duco cement or other adhesive. The coils plug into an ordinary tube socket which can be seen in the plan view of the set near the center of the baseboard.

The antenna is coupled to the receiver through a very small capacity indicated on the diagram at C_4 . It consists of two pieces of brass about $\frac{1}{2}$ " square separated $\frac{1}{8}$ ". The two brass pieces are in the form of small angle pieces held with machine screws to the baseboard. It is important that this condenser be mounted close to the lead from the end of the tuning coil to the grid condenser C_3 or the stator plates of C_2 , and that its capacity be kept small. Some adjustment of its capacity may be found advantageous after the receiver has been put into operation. This can be accomplished by bending one of the brass pieces away from or towards the other.

The tickler coil L_2 is fixed in its position with respect to coil L_1 and is wound on the same tube base about $\frac{1}{4}$ " from the filament end of L_1 . The number of turns used in this coil is not very critical but if the number specified in the list of windings does not cause the detector to oscillate with the regeneration-control resistor R_2 at about the half-way position, experiment with other values will be advisable.

Condenser C_5 is the radio-frequency by-pass condenser across the audio-frequency transformer. Its use is very important though its capacity is not critical. Without it the detector could be made to oscillate only by using an abnormally large tickler or very high plate voltage. The most satisfactory plate voltage for the detector is about $22\frac{1}{2}$. It might be thought from the

diagram that 45 volts is used in this set. This is not so, however, since the resistance of R_2 at about half-scale setting is sufficient to drop the voltage to the point where only about 22½ volts are placed on the detector plate.

The fixed resistor R_3 is connected across the secondary of the audio-frequency transformer to eliminate a howl or "squawk" which is often produced at the point where the detector starts oscillating. Experiment with the value of this resistor is desirable since in some receivers a very high resistance is all that is necessary. The higher this resistance is the less will be its effect on the

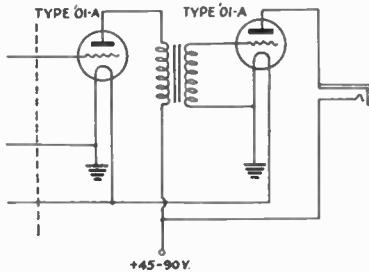

ADDING ANOTHER AUDIO AMPLIFIER TO THE TWO-TUBE RECEIVER

The primary of the additional audio transformer is connected in the plate circuit of the second tube in place of the jack shown in the other diagram.

volume of the signals. In some cases it may not be needed. The resistor R is a 20-ohm filament rheostat.

The UY-type tube socket (5-terminal), to be seen at the extreme right-hand corner of the base-board, is used to provide connections to the A and B batteries. A standard battery cable (which can be obtained in most radio stores) is used, its wires, at the receiver end, being soldered to the prongs of a UY-type tube base. A battery plug of this type is very useful in permitting all batteries to be disconnected in a moment for experiment with the receiver without any danger of burning out the tubes.

In addition to the parts in the list given under the diagram it will be necessary to have an A battery and a B battery. The A or filament battery can be a storage battery of between 60 and 100 ampere-hours capacity for the Type '01-A tubes, but should Type '99 tubes be used instead, the filament battery can well consist of three dry cells. It is not necessary to use a heavy duty B battery for a receiver of this type since the drain from it is only of the order of a few milliamperes.

The operation and adjustment of this and other receivers will be described later in this chapter.

A second audio stage may be added to this receiver by using the connections shown in the diagram. The primary of the additional audio transformer is connected in the plate circuit of the present amplifier in place of the 'phone jack. The baseboard may be made a little larger to accommodate the extra apparatus.

A THREE-TUBE A. C. RECEIVER

Many amateurs prefer to eliminate batteries and obtain power for the receiver directly from the a.c. house mains, and the development of heater-type tubes has made such operation entirely practical and satisfactory. The receiver illustrated here is one of a number of different arrangements which may be employed, and incorporates an untuned r.f. coupling amplifier, a screen-grid detector, and a single stage of impedance-coupled audio amplification.

For the amateur interested in obtaining effective communication over long distances the screen-grid antenna coupling tube or untuned r.f. amplifier offers several advantages. This tube gives an appreciable increase in sensitivity and eliminates any influence of the antenna dimensions on the calibration of the detector tuning circuit. It also eliminates radiation from the oscillating detector. In a receiver to be used for 'phone reception such a radio-frequency amplifier is a distinct advantage, since it greatly improves the sensitivity of the receiver when the detector is in a non-oscillating condition. The screen-grid detector is likewise more sensitive than the triode detector, further increasing the over-all sensitivity of the receiver. The single stage of audio

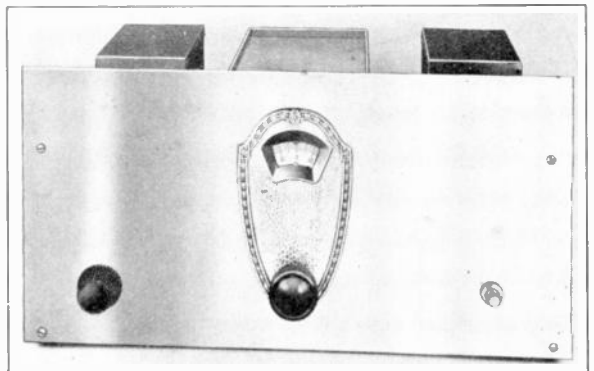

PANEL VIEW OF THE THREE-TUBE A.C. RECEIVER
The tuning dial is in the center. The small knob at the left is the regeneration control, and the switch at the right is in the filament circuit.

amplification will, therefore, generally give ample signal strength for reception with the headphones, although a second stage may be used if desired. Additional audio amplification is likely to lead to hum difficulties with a.c. supply unless reception is to be entirely by loud-speaker.

The top view of the set shows clearly how the parts are arranged on the baseboard. Separate shields have been provided for the coupling tube, detector, and audio amplifier and their associated equipment, although the shielding can be omitted without detriment to the operation of the re-

clearly how these changes are made. The detector coil socket is a 5-prong tube socket, and the connection from the larger stator section goes to the cathode post, that from the smaller stator section to the grid post, and the rotor is connected to the filament post nearest the cathode.

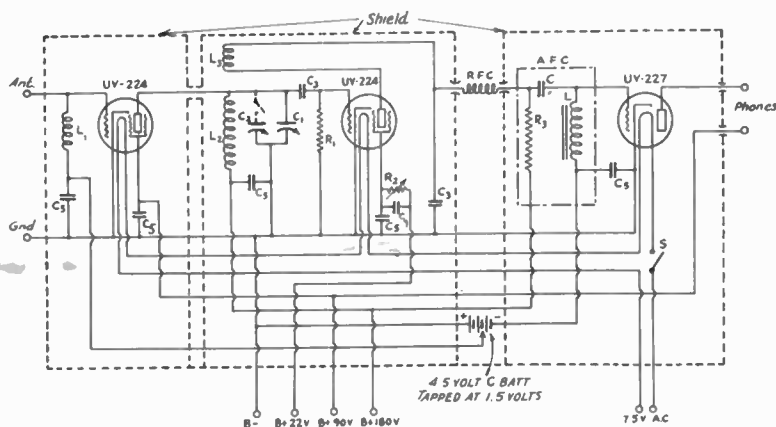

THE CIRCUIT OF THE A.C. RECEIVER

- L_1 — Antenna coupling inductance. See text and table for details.
- L_2 — Tuning inductance. See the table for details.
- L_3 — Regeneration coil. See the table for details.
- C_1 — 10- μ fd. tuning condenser.
- C_2 — 100- μ fd. tuning condenser.
- C_3 — 100- μ fd. condenser.
- C_4 — 1- μ fd. condenser.
- C_5 — 0.01- μ fd. fixed condenser.
- R_1 — 2-megohm grid leak.
- R_2 — 100,000-ohm regeneration control resistor.
- R_3 — 250,000-ohm plate coupling resistor.
- S — Filament switch.
- RFC — Radio-frequency choke coil.
- AFC — Audio-frequency coupler. Satisfactory constants for the resistance, inductance and capacitance are, respectively: R_3 , 250,000 ohms; L , 30 henries; C , 0.01 μ fd.

ceiver. The lead between the plate of the first '24 and the grid end of L_2 is carried from the first shield to the second through a piece of copper tubing. The regeneration control resistor, R_2 , the filament switch, and the tuning condenser dial are the only parts mounted on the panel.

The tuning condenser is a rebuilt 17-plate National girder-type condenser with the stator divided into two sections, similar to the one illustrated earlier in this chapter. One section has one plate and the other two. Plates are also removed from the rotor to correspond with the stator sections. The top view of the receiver shows

The coil data for this receiver are given in the following table (Coil No. 1 is a commercial broadcast-band choke coil mounted on an old 5-prong tube base for convenience in plugging in. Nos. 2 and 3 are wound on Silver-Marshall plug-in forms, while 4 and 5 are wound on old 5-prong tube bases. No. 26 d.s.c. wire should be used for L_2 , and the same or smaller sizes for L_3 . It is probable that the values given will work out only approximately with different layouts, tubes, etc., so that each of the coils should be adjusted individually until the desired spread over each band is obtained. L_1 in the diagram is simply one of the

Coil No.	Approximate Frequency Coverage in Kilocycles	No. of Turns		Form Diameter	Remarks
		L_2	L_3		
1	r.f. choke coil for antenna circuit for reception in 1750-kc. band.
2	1700-2050	60	18	1.5"	Both tuning condensers used.
3	3400-4100	31	10	1.5"	Both tuning condensers used. Turns are space wound.
4	6950-7450	14	7	1.375"	Small tuning condenser used.
5	13,800-14,500	6	5	1.375"	Small tuning condenser used.

Unless otherwise indicated, all coils are "close wound."

unused detector coils. In general, best reception will result when the coil next lower in number to the detector coil is used at L_1 . For instance, if Coil No. 3 is in the detector socket Coil No. 2 should be used in the antenna, and so on. Coil No. 1 is an antenna coil only. A 10,000-ohm resistor may be substituted for L_1 , but interference

control resistor should be one which gives smooth control of oscillation, and is by-passed by C_4 to prevent noise.

The filaments may be operated on either a.c. or d.c. The diagram shows them connected in series, but they will operate equally well connected in parallel, in which case the heating source may be a 2.5-volt transformer. Ordinarily no difficulty will be experienced with hum when the heater supply is a.c., but if objectionable hum appears it may be reduced by connecting one side of the heater wiring to ground through a 1- μ fd. condenser in the case of series wiring, or grounding the midpoint of a center-tapped resistor of about 50 ohms connected across the heater supply in the case of parallel wiring. B-battery substitutes are productive of more hum than the heater wiring in most cases, and unless the output of the substitute is extremely well-filtered it may be advisable to use batteries for B supply. Eliminators designed especially for high-frequency receivers have recently appeared on the market and should obviate this difficulty.

If the filaments are to be operated from a.c. it is important to use twisted-pair leads in the receiver to minimize the possibility of hum pickup. The

heater wiring should be kept as far from other wiring as possible, and should cross other wires at right angles. Never parallel heater leads with other wiring.

A FOUR-TUBE RECEIVER

This receiver further illustrates some of the principles previously discussed, and incorporates a stage of untuned r.f. amplification, regenerative detector and an audio amplifier designed to give maximum response at a frequency of approximately 1000 cycles, greatly increasing the sensitivity and selectivity over the commoner arrangements.

From the diagram it will be seen that the antenna is coupled to the grid circuit of the first tube by means of the resistor R , which replaces the coils used in the three-tube a.c. receiver. The latter method will function equally well if preferred by the constructor.

A tuned circuit could be used in place of the resistor but its use would mean the addition of a second major tuning control, which to some amateurs is a disadvantage for rapid and easy tuning.

The plate of the first Type '22 goes directly to

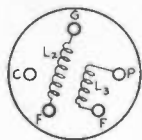

CONNECTIONS FOR
4,000 Kc AND 7,000 Kc BANDS
A



CONNECTIONS FOR 3,500-Kc
AND 1750 Kc BANDS
B

COIL CONNECTIONS IN THE A.C. RECEIVER

from local broadcast stations will generally be less if the antenna coils are used.

The drawing shows how the coil connections are made in the pins. With the connections from the condenser to the coil socket made as described above, the correct tuning capacity is automatically connected in the circuit when the coil is plugged in.

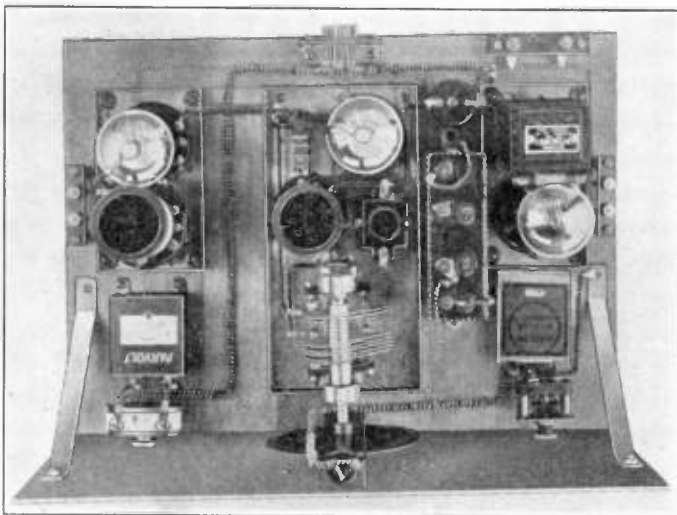

TOP VIEW OF A.C. RECEIVER WITH SHIELD COVERS REMOVED

The regeneration control resistor and its by-pass condenser are in the left foreground. The left-hand shield contains the antenna choke coil and the coupling tube. The fixed condensers with this stage are underneath the coil socket. In the center shield are the special tuning condenser, the detector coil, grid condenser and leak, and the detector tube. The audio coupling impedance and the amplifier tube are in the right-hand shield. The C battery fits in the space between the last two shields, as does also the r.f. choke. Note the twisted pair heater wiring. The panel switch at the right is in the heater circuit.

The coupling impedance (AFC in the diagram) may be made up of the values shown or may be purchased complete from a number of manufacturers advertising in this *Handbook* or *QST*. Bias for the amplifiers is provided by the 4.5-volt C battery shown in the diagram. The regeneration-

the end of the tuning coil in the grid circuit of the detector tube. The plate voltage is fed to the tube through this coil and consequently it is necessary to insulate it from the filament circuit with a fixed condenser C_2 . The detector circuit is arranged in

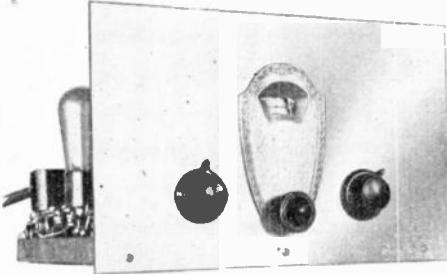

THE FOUR-TUBE PEAKED-AMPLIFIER RECEIVER

The drum dial in the center is, of course, the main tuning control. The knob on the left is the volume control while that on the right is for adjustment of regeneration. The 'phone jack is mounted on the baseboard near the rear left corner instead of on the panel.

much the same way as in the previous receivers but an alternative scheme is used to provide different capacity ranges for the tuning condenser C_1 so that all the bands will have full-scale coverage. In this receiver, C_1 consists of plug-in midget condensers which have had some of their plates removed until they are of a capacity suited to the

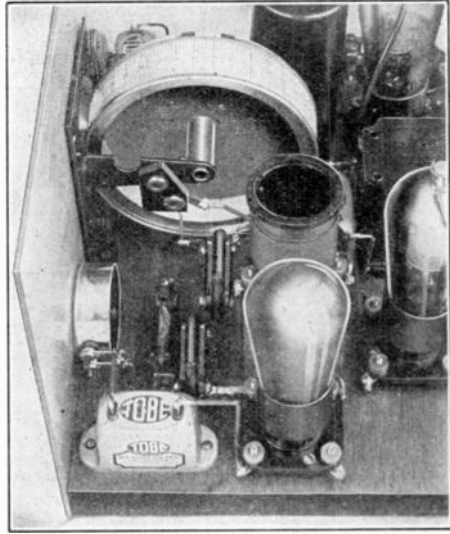

A CLOSE-UP SHOWING THE MOUNTING FOR THE PLUG-IN TUNING CONDENSERS

The two G.R. sockets are mounted in a piece of hard rubber. One of them serves to secure the assembly to the frame of the dial and at the same time make contact between the rotor of the condenser and the frame. The frame, of course, makes contact with the panel and this is connected to the copper sheet on the under side of the filament baseboard. This copper sheet forms one side of the filament circuit and is indicated in the diagram as a ground.

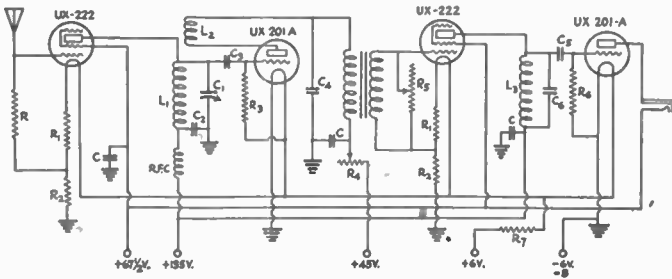

THE CONNECTIONS OF THE FOUR-TUBE RECEIVER

Apparatus required:

Two Type 01-A and two Type '22 tubes and their sockets.

C — 1- μ fd. by-pass condenser (3 required.)

C_1 — Plug-in midget tuning condensers (see photograph).

C_2 — 4000- μ fd. fixed condenser.

C_3 — 100- μ fd. grid condenser.

C_4 — 2000- μ fd. by-pass condenser.

C_5 — 6000- μ fd. audio grid condenser.

C_6 — .01- μ fd. audio tuning condenser (experiment necessary).

R — 10,000-ohm gridleak-type resistor.

R_1 — 10-ohm fixed filament resistor.

R_2 — 5-ohm fixed filament resistor.

R_3 — 6-megohm grid leak.

R_4 — 50,000-ohm variable resistor.

R_5 — 200,000-ohm variable resistor for volume control.

R_6 — 8-megohm grid leak.

R_7 — Filament ballast resistor for .75 amperes.

L_1, L_2 — Plug-in coils. See photograph.

L_3 — Secondary winding of Ford ignition coil.

R.F.C. — Receiver-type short-wave radio-frequency choke. Aluminum panel 12" x 7½", baseboard 12" x 8", drum dial, one audio-frequency transformer, 'phone jack, and a variety of screws, wire, etc.

band on which they are used. Some idea of the arrangement of the sockets for these condensers can be obtained from the close-up of the receiver.

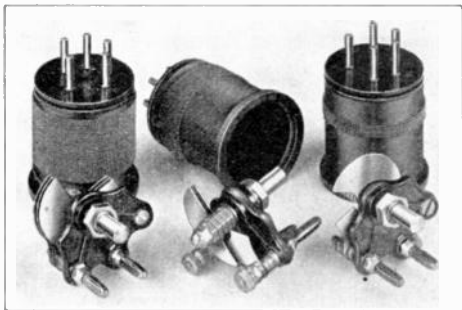

COIL-CONDENSER COMBINATIONS FOR THREE BANDS

A separate tuning condenser is used with each inductance in the four-tube receiver to give full-scale dial coverage for each band. The grid coils are wound with 20 gauge d.s.c. wire. As a rough guide it can be said that 6 turns are used for the 14,000-kc. band; 14 turns for the 7000-kc. band; 31 turns for the 3500-kc. band. The ticklers found suitable are of 30 gauge d.s.c. wire, 5 turns being used for 14,000 kc., 7 turns for 7000 kc., and 9 turns for 3500 kc. It is almost certain that these figures will vary in individual receivers.

The two G.R. sockets are mounted on a piece of hard rubber which is held to the frame of the drum dial by one of these sockets. It is important that the sockets be spaced accurately so that the condensers will plug in firmly and not rock as the dial is rotated. The fitting of the G.R. pins to the midjet will depend upon the type of condensers used. With the Pilot condensers illustrated, the pin connected to the rotor plate is inserted in the bakelite end plate in place of the machine screw which ordinarily holds the spring contact. For the stator connection a G.R. pin, the threaded portion of which has been sawed off, is soldered to the head of the machine screw which supports the stator plates of the condenser. When it is desired to change from one band to another the coils are first changed. Then the dial is set at 100 degrees, the set screw on the dial loosened and the condenser removed. The condenser to be used is then set at its maximum capacity and plugged into place, the set screw being tightened to hold the shaft securely. The battery cable plug should be removed before changing condensers.

The coils for this receiver are wound on special coil forms which can be obtained at most radio stores. Tube bases could be used for the coil forms, or other types of coils could be substituted.

The first audio-frequency amplifier in this re-

ceiver is a Type '22 screen-grid tube. It is used in this position since it is particularly suited to give highly-peaked amplification when a tuned audio circuit is connected to its plate. The filament of this tube, as well as the r.f. amplifier, operates at 3.3 volts, and if the other tubes in the set are 5-volt tubes the resistances R_1 and R_2 will be required to drop the filament voltage to the correct value. The grid returns of both tubes are made to the junction between R_1 and R_2 in order to provide suitable bias.

The inductance L_2 can be the secondary winding of a Ford ignition coil with the primary and core removed. Such a coil, shunted by a condenser C_5 of about .01 μ fd., will tune to approximately 1000 cycles and will make the amplifier peak at this frequency. Since such coils differ considerably in characteristics, the exact capacity at C_5 to give the peak at a suitable frequency had best be determined by experiment. Several condensers in parallel make it easier to arrive at the correct value. The final audio amplifier is a Type '01-A tube. It is not needed to give additional amplification but its use is essential since the 'phones could not be operated satisfactorily in the plate circuit of the '22.

The peak to be obtained with a Ford coil secondary as the coil of the tuned audio circuit is not by any means the sharpest peak that can be produced. In fact a Ford coil is used simply because its resistance is high enough to flatten the

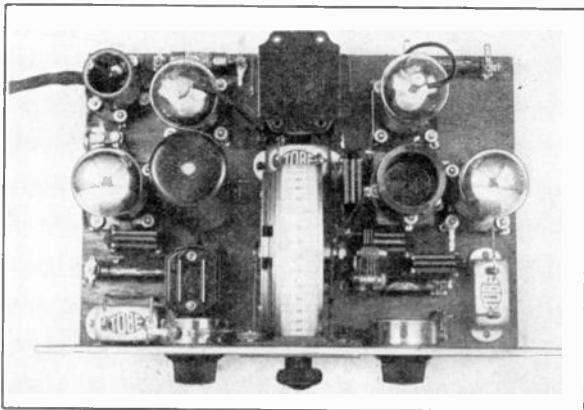

THE FOUR-TUBE RECEIVER IN PLAN

Behind the drum dial is the audio-frequency transformer. Beside the transformer and to the right of it is the screen-grid antenna coupling tube. In front of this tube is the tuning coil and the detector tube. The plug-in tuning condenser can be seen projecting from the shaft of the drum dial. The assembly to the left comprises the two audio tubes, the Ford coil secondary (enclosed in an aluminum tube shield) and the fixed tuning condenser for this coil.

peak to a sufficient degree. With a very sharply peaked amplifier it is difficult and sometimes impossible to copy signals which are not steady. Greater selectivity and a consequent reduction in interference between stations can be obtained by

using a more pronounced peak. This may mean the sacrifice of some of the unsteady signals, however. To obtain a sharper peak the Ford coil secondary should be replaced by a coil of lower resistance. One suitable type of coil can be wound with 3000 turns of No. 30 gauge s.s.c. wire "scramble"-wound in five $\frac{3}{4}$ "-square slots turned in a wooden former of 2" outside diameter. Approximately .07 μ fd. will be required across this coil to tune it to 1000 cycles. Experiment with other forms of coils will be found of interest and value. A commercial peaked coupling device, such as the Aero Hi-Peak, can be used in place of the home-made coil and condenser combination.

THE SUPERHETERODYNE

Amateurs who desire the utmost in sensitivity and selectivity will do well to build a superheterodyne receiver. For ordinary c.w. reception the additional advantages of this type of receiver are generally outweighed by its greater cost and increased difficulty of construction, but for high-frequency 'phone reception its performance is unequalled. No other receiver of the types commonly employed for high frequencies can compare with it in selectivity on 'phone signals, and the disadvantages of reception by means of a regenerative detector are eliminated.

Since a comparatively small number of amateurs are interested in building this type of receiver no constructional details will be included in this Handbook. Readers who wish complete information on such receivers are referred to the March 1929, September 1929, and June 1930 issues of QST.

THE SUPERHET CONVERTER

If one has a modern broadcast receiver it is possible to obtain the advantages of super-

heterodyne performance for 'phone reception without the necessity for expensive or compli-

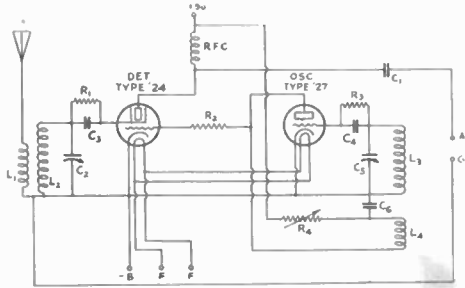

WIRING OF THE CONVERTER

- C₁ — 500 μ fd.
 - C₂ — 50- μ fd. midget condenser.
 - C₃ — 100 μ fd.
 - C₄ — 100 μ fd.
 - C₅ — 50- μ fd. midget condenser.
 - C₆ — 2000 μ fd.
 - R₁ — .75 megohm.
 - R₂ — 50,000 ohms.
 - R₃ — .5 megohm.
 - R₄ — 50,000-ohm variable resistor.
 - RFC — Radio-frequency choke suitable for broadcast band.
- Coil Data:

Approximate Range	Detector		Oscillator	
	L ₁	L ₂	L ₃	L ₄
5000-7000 kc.	12	16	20	9
8000-13,000 kc.	7	8	9	4
13,000-19,000 kc.	5	5	5	3
3500-kc. band.	15	30	30	10
7000-kc. band.	7	12	13	6

All wound with No. 22 d.s.c. on forms $1\frac{1}{2}$ inches in diameter, with no spacing between turns. The spacing between coils on the same form is about $\frac{1}{4}$ ".

ated receiver construction. The broadcast receiver supplies the intermediate frequency amplifier, second detector and audio amplifier; the only units which the constructor need furnish are the first detector and oscillator. The photographs show one form of converter for this purpose which has proved entirely satisfactory.

While it is possible to so construct the converter that its plate and filament supplies can be obtained from the broadcast receiver by inserting a plug in the first r.f. tube socket, this method is not recommended if maximum performance is desired. The plate and filament power should be provided either by separate batteries (or substitutes) or else taken directly from the receiver power-pack. With separate power supply for the converter, either a.c. or d.c. tubes may be used in it, whether or not the broadcast receiver is a.c. operated.

The diagrams show how the converter is wired for both a.c. and d.c. tubes. The posts marked A and G are connected to the antenna and ground posts, respectively, on the broadcast receiver.

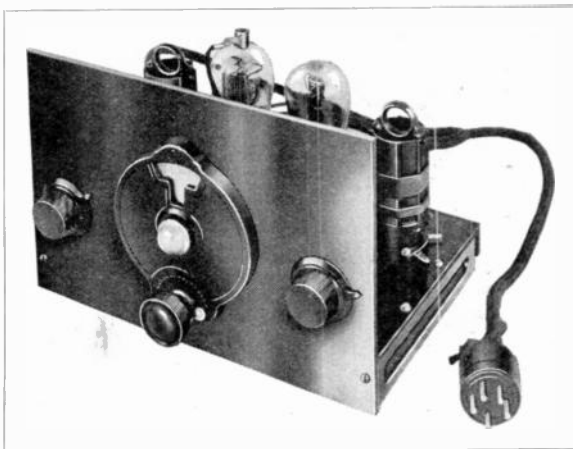

A SUPERHET CONVERTER FOR A.C. OPERATION

The small knob at the left is the detector tuning control, the dial in the center the oscillator tuning, and the knob at the right the regeneration control.

The antenna is transferred to the converter, while the ground remains permanently connected to the broadcast receiver. The first detector is a screen-grid tube, arranged for "space-charge" detection.

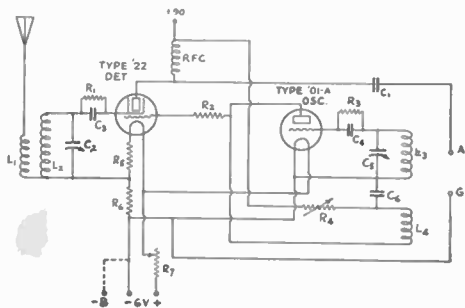

THESE CONNECTIONS ARE USED WITH D.C. TUBES

- R₁ — 10 ohms.
- R₆ — 5 ohms.
- R₇ — 20-ohm rheostat.

All other constants same as in other diagram. The negative B-battery post is not used in most cases as this connection is usually made in broadcast receivers.

The oscillator circuit is the usual tickler circuit, with the resistor R₄ controlling regeneration. R₂ serves as a coupling link between the oscillator and detector, and also regulates the bias for the inner grid of the detector. Condenser C₁ is included in the circuit to prevent short-circuiting the plate supply when the converter is hooked up to the antenna coil of the broadcast receiver.

In this outfit no attempt has been made at spreading the bands over a large portion of the

therefore be tuned to a frequency between 550 and 1500 kc. above or below the frequency of the incoming signal. The coils have been so proportioned that the setting of the detector knob will be approximately the same (as judged by eye, since there is no scale on this knob) as the setting of the oscillator dial.

The method of winding coils on the forms and making connections to the pins are shown in a drawing. In making the oscillator coils the same principles which apply to coils for an oscillating detector should be followed, and the tickler coil should be adjusted, if necessary, to obtain smooth oscillation at all points on the oscillator dial. The values given will usually work out satisfactorily.

To get the set working, tune the broadcast receiver to about 600 kc., and set the detector knob

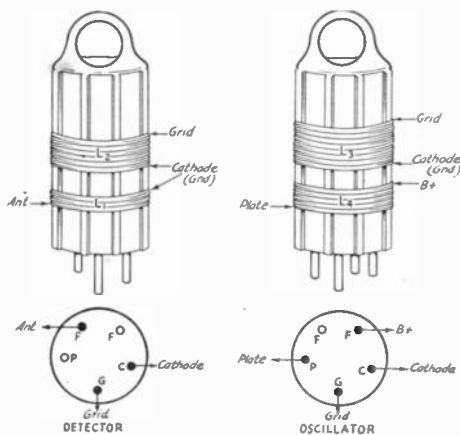

ARRANGEMENT OF THE COILS AND COIL SOCKETS IN THE CONVERTER

Only the connections on the sockets marked with the solid black circles are used.

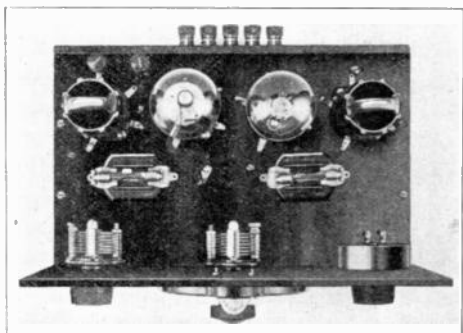

THE CONVERTER FROM ABOVE

On the panel are, from left to right, the detector tuning condenser, oscillator tuning condenser, and regeneration control resistor. In the center are the grid condensers and leads for the detector and oscillator. In the rear, from left to right, are the detector coil, detector tube, oscillator tube and oscillator coil.

dial scale, because the tuning is done largely on the broadcast receiver itself. The intermediate frequency will lie between 550 and 1500 kc., depending on the frequency to which the broadcast receiver happens to be set, and the oscillator will

to about half scale. Then turn the oscillator dial slowly until a signal is picked up, and reset the detector knob for maximum volume. Further tuning over a 1000-kc. band can be done entirely on the broadcast receiver, with possibly a slight readjustment of the detector knob now and then for maximum volume. The coils will cover approximately the ranges shown in the table, and most of the high-frequency broadcasting can be picked up on the first three sets of coils. The 3500-kc. coils will cover amateur 'phone stations in that band. The 7000-kc. coils are given for the benefit of those amateurs who may wish to listen to code signals on that band. After a little exploring and experimenting with different dial settings it will be possible to identify the various 'phone and broadcasting bands and log the dial settings so they can be returned to at any time. The converter is not entirely satisfactory for the reception of unmodulated c.w. signals because no beat note will be heard unless the second detector is made

to oscillate, which ordinarily cannot be done with a modern broadcast receiver. A separate oscillator

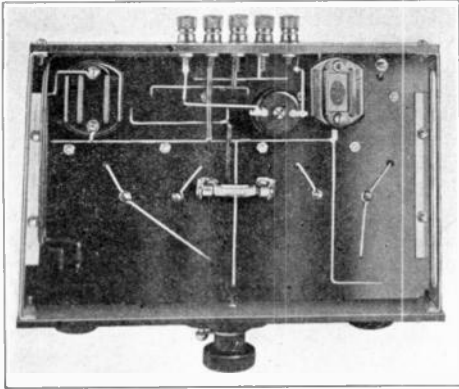

UNDER THE SUB-PANEL

The coupling resistor, R_s , is in the center, with the r.f. choke just behind it. The fixed condenser to the right of the choke is C_2 in the diagram. The other fixed condenser is C_1 .

can be hooked up to cover the broadcast band and coupled to the receiver, but this adds another control. A more complete description of the converter and its operation appeared in the July, 1930, issue of *QST*.

OPERATING THE RECEIVERS

When the receiver has been completely wired and the wiring has been checked, the batteries should be connected as shown in whatever diagram is being followed. A flash lamp bulb should always be connected in the negative B-battery lead to act as a fuse to prevent the tubes from burning out should anything be connected incorrectly. When the antenna has been connected, the filaments lighted and the 'phones plugged into the jack, the regeneration control should be turned toward its maximum position until the "live" sound of oscillation is obtained. For the reception of telegraph signals it will be found that the greatest sensitivity will be had at the point where oscillation begins. Hence for the reception of very weak signals it is usually advisable to "back off" the regeneration control until the detector is just about to stop oscillating. This critical adjustment is, of course, necessary only for the reception of the weakest signals. If the tickler coil has the correct number of turns in the receivers using r.f. amplifiers or coupling tubes, it will be found that the receiver can be operated for an entire evening on any one band for medium distance work without the necessity of touching the regeneration control. In the other receivers, which have the antenna coupled to the tuning coil through a condenser or primary coil, some trouble may be had from "dead spots" on certain portions of the bands. Sometimes they can be eliminated by reducing the capacity of the cou-

pling condenser or adding or subtracting turns on the primary, but in other cases it is necessary to place a coil or condenser in the antenna lead.

Possibly it will be found that the receiver howls just as the detector starts to oscillate and that reception at this point is impossible. This "fringe-howl," as it is termed, can be cured by reducing the value of the resistance connected across the secondary of the first audio transformer. A resistance not lower than .1 megohm should cure the trouble completely, but it should be kept in mind that the lower this resistance the greater will be the reduction in amplification caused by it.

When the receiver has been made to oscillate quietly, attention should be given to its calibration. If the coils have been wound according to the details given it probably will tune somewhere near the specified bands. However, it is almost certain that a final adjustment of the coils will be necessary to make the edges of the bands come near the top and the bottom of the dial scale. One simple method of adjusting the coils is to make them slightly larger than necessary in the first place, afterwards spacing one or two of the end turns until the correct value of inductance is obtained. It is not essential that the bands be tuned in across the entire dial, but time spent in careful adjustment of the particular tuning system used, so that the band is spread between at least 15 degrees and 85 degrees, will be well worthwhile. The edges of the bands will not be

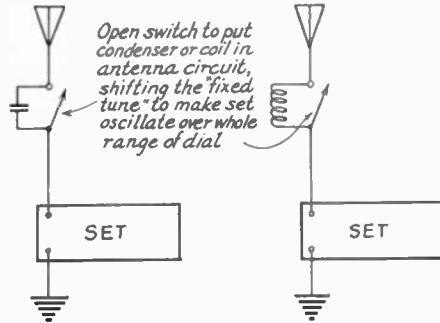

TWO WAYS OF SHIFTING THE "DEAD SPOT" ON A TUNER.

hard to find. During the evening, when amateurs are busiest, the place on the dial where the amateur stations leave off and the commercial stations begin should be quite well defined. At most times the commercial stations located at edges of the amateur bands should be operating and should serve as a guide.

Just as soon as the tuning system has been adjusted, attention can be paid to the audio-frequency amplifier to make certain that it is operating correctly. If audio transformers are used in a "broadcast-receiver" type amplifier, there is very little that can be out of adjustment.

In the peaked amplifier, however, it is quite possible that the tuned audio circuit of the screen-grid amplifier is not tuned to a suitable frequency. A check can be made by tuning in a steady signal with a pure note. As the beat note is varied from the lowest to the highest audible frequency — by tuning the receiver — the signal should increase in strength sharply at one point and then fall off sharply as this point is passed. The frequency at which this sudden increase in signal strength is obtained should be at about 1000 cycles or some other frequency that is comfortable to read. If the peak occurs at a higher frequency than this, more capacity should be connected across the Ford coil secondary or the particular inductance used. If the peak frequency is too low the capacity across the coil should be reduced.

In the operation of any receiver it should be remembered that batteries must always be in good condition and that poor results are often caused by poor tubes. The batteries and the tubes should be given first consideration if the receiver becomes noisy or sluggish in operation. If all joints in the wiring have been carefully soldered, noises in the receiver will be caused by poor batteries and by poor contacts between the tube pins and the sockets. If the noise occurs only when the condenser is turned it is probably the result of dust between the plates or of poor contact between the rotor assembly and the lead to it. In some cases a noise of this type is caused by the shaft or the dial, if it is metal, rubbing against the panel or some other metal object. Yet another source of noise is the antenna system or outdoor wiring near the antenna. Any two wires in poor contact in or near the antenna can cause serious noises when they are blown about by the wind.

Quiet operation in the short-wave receiver is of extreme importance. It is well to aim at sensitivity and open-scale tuning, but the value of these characteristics is nullified very greatly if there is not freedom from extraneous noise.

HUNTING FOR TROUBLE

A pair of 'phones, a dry cell, and a d.c. voltmeter are the most useful instruments for locating faults in the set. If the tube does not light, it should be tested for an open filament. Then the filament or heater circuit wiring should be traced carefully. The rheostat should be examined for an open wire, the socket for a sprung prong. With the B batteries disconnected, trace the filament wiring from the A battery (or heater transformer) to the socket, using either the click in the 'phones or the voltmeter across the line. With a.c. filament supply an a.c. voltmeter should be used since the d.c. voltmeter will give no indication. A couple of pins on the ends of the voltmeter leads will make it possible to pierce the insulation for testing purposes.

If a regular clicking sound is heard in the 'phones when they are connected to the set as in

regular operation, it probably means that the grid leak is open or of too high value. A lower-resistance leak will remedy this condition. A pencil mark between grid and filament (or grid and cathode) terminals on the bottom of the tube (or a line of India ink) will serve in an emergency. Two brass machine screws in a small piece of hard rubber or bakelite with the "leak" drawn between them will be a better arrangement.

If the filament lights but there is no sound in the 'phones, trace the plate circuit wiring carefully, paying attention to the jack to see that the

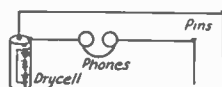

Shorted condensers or closed circuits are indicated by just the same click as given by touching the terminals together or by a full voltmeter reading

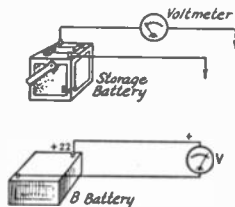

Opens in wiring or coils are indicated by no reading on voltmeter or by no click in phones. A weak click or low voltmeter reading indicates a circuit closed through a resistance which may be a transformer winding or other part of the set.

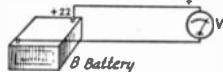

A D.C. voltmeter only reads correctly when properly connected. It may be used to indicate polarity. 2 1/2 volt units should be discarded when they fall below about 16 volts.

LOCATING FAULTS

'phones are not shorted there. If there is a by-pass condenser across the 'phones, this should be checked with 'phones or voltmeter and battery to see that it is not shorted inside or by some solder across the terminals. The grid and plate terminals of the socket may be bent.

An open secondary coil or grid circuit lead may cause a clicking similar to that when there is no grid leak. The winding may be tested with the voltmeter or 'phones for an open circuit. If no signals come through and there is no "tuning," probably the variable condenser is not solidly connected across the secondary coil. Decreased signal strength may indicate that the antenna coil is open or that the antenna or ground is off. A shorted grid condenser may give the same effect. If no "clicking" is heard with the grid leak removed from the set there may be a shorted grid condenser, a soldering paste "leak" within the socket or across the grid condenser, or a poor tube (open grid). Try a new tube, test the grid condenser with the 'phones or voltmeter or clean up any leaky paths that are found between grid and filament.

THE RECEIVING ANTENNA

A good antenna is desirable for the short-wave receiver, though it will be found surprising how simple and crude the antenna can be without greatly hampering the operation of the receiver. Many amateurs use a receiving antenna consisting of some fine cotton-covered wire run along one side and end of the room on the picture mold-

ing. An antenna of this type is completely effective with a sensitive receiver such as the four-tube outfit described in this chapter. With the simpler receivers, however, an outdoor antenna is recommended. If the receiver is used in conjunction with a transmitter, the transmitting antenna can be employed by fitting an antenna switch to connect the receiver to some point on the leads from the transmitter to the antenna or feeder wires. If it is desired to work the station "break-in," a separate receiving antenna is necessary. With such an arrangement both the receiver and transmitter are in operating condition at the same time and all that is necessary to transmit is to press the transmitter key. To receive, nothing more is necessary than to release the transmitting key.

A satisfactory outdoor antenna may be made with a length of 14 to 16 gauge enameled copper wire strung horizontally between insulators at a height of between 10 and 50 feet above ground. The length of the wire in the antenna is not a very important consideration but the longer the an-

tenna, up to a certain point, the louder the signals. Some amateurs find a very long low antenna, even 800 feet, of distinct advantage in obtaining a better ratio between the strength of the signals and the strength of static and other extraneous noises. When separate antennas are used for receiving and transmitting they should be kept as far apart as possible and preferably at right angles to each other. This is necessary to reduce the amount of energy absorbed from the transmitter by the receiving antenna.

And now, when the receiver has been built, adjusted, and placed in satisfactory working condition it will be permissible to sit back and take a long breath. For the receiver is one of the essential parts of an amateur station. If it has been correctly built and if the location of the station is satisfactory it will receive as far as any transmitter can send. If it has open tuning scales; if it has lots of sensitivity and amplification; and if it is smooth and quiet in operation, it will be a very great comfort and a source of splendid pleasure.

CHAPTER VI

Frequency Meters and Monitors

ONE might suppose that, having finished the receiver, the next piece of equipment to be built would be the transmitter. *It is not.* Before the transmitter can go on the air the station must be provided with some means of checking the frequency and quality of the emitted signals; and this is beyond the scope of the receiver itself.

The amateur may be guilty of failing to adjust his transmitter to give the cleanest signal, so causing unnecessary interference; he may fail to observe regular operating procedure and cause annoyance to all with whom he communicates — and for these actions he may be scorned by those

transmitter is within the limits of the band in which it is to work, the amateur has no right in the world to send even a single dot.

It is fortunate that when the station has been equipped with a monitor — the shielded oscillator which is indispensable in adjusting the transmitter correctly — it is also provided with what is probably the cheapest and most effective apparatus for setting the transmitter frequency within the band. Truly, the monitor is an essential part of the station equipment. Without it the amateur is about as handicapped as a blindfolded motorist would be if someone had run off with the steering wheel.

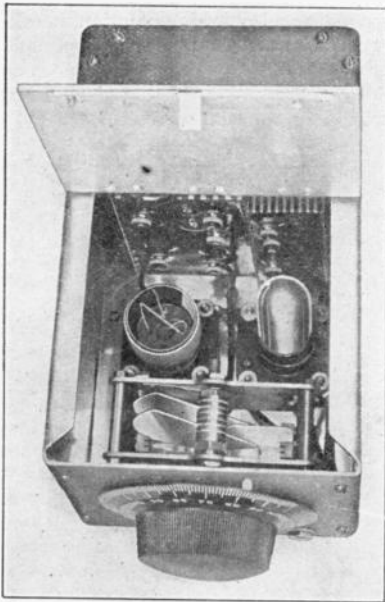

ONE POSSIBLE ARRANGEMENT OF THE MONITOR

In this case a "C" battery is used for filament supply, so permitting a compact lay-out. With a three-plate treble-spaced tuning condenser and coils wound on tube bases the number of turns used was as follows:

Band	Grid Turns	Plate Turns	Wire
3500 kc.	43	18	No. 30
7000 kc.	19	15	No. 28
14,000 kc.	7	7	No. 20
28,000 kc.	3	3	No. 20

fellow amateurs who hear him. There is one thing, however, which constitutes an unforgivable sin in amateur radio. It is that of operating the transmitter outside the boundaries of the amateur frequency bands. Without the facilities to determine definitely whether the frequency of his

BUILDING A MONITOR

The monitor need not be a costly or elaborate affair. Just how simple it can be is shown by the example illustrated. The constructional work probably would not occupy more than a Saturday afternoon.

The chief requirements of the monitor are that it oscillate steadily over the bands on which the station is to be active; that the bands be at least fairly well spread across the dial so that tuning will not be excessively critical; and that the pick-up of the headphone cords be sufficiently nullified and the shielding complete enough to permit the monitor to sit near the transmitter and to beat with its fundamental frequency without producing more than a good readable signal. The parts used in it should be of good quality, and the construction of the monitor should be such that it will "hold calibration" (return to the same frequency at a given point on the dial with a given coil) regardless of the handling to which it is subjected in ordinary use in the station.

The circuit used in the monitor illustrated is given. In it a Type '99 tube is connected in a split-coil series-feed Hartley circuit, the filament being supplied from a 3-volt dry-battery source and the plate from a small 22½-volt unit.

The monitor shown is built in an aluminum shield. This shield is built up of 1/16"-thick aluminum, the bottom and front being of one piece folded, the sides and back of another piece folded and the top of two pieces, one of them hinged to provide an opening to change the coils, tube or batteries. The apparatus is assembled on the piece constituting the front and bottom and, when the oscillator is in running condition, the sides, back and top are fixed in place with small machine screws.

The tuning condenser for this monitor is built from an eleven-plate Cardwell condenser, plates being removed until one stator and two rotor

plates are left. The rotor plates are treble-spaced in order to give just sufficient capacity range to bring the 3500-kc. band within the limits of the dial. No arrangement is made to reduce the capacity range of the condenser for the 7000-kc. or higher frequency bands and tuning on these bands is therefore rather critical. The coils, wound on tube bases, are described under the photograph. To reduce the effect of the pick-up from the 'phone cords a receiver-type radio-frequency choke is inserted in one of the 'phone leads at the point shown on the circuit diagram. Without this choke the monitoring of the transmitter

operation control — nor can one be used if the frequency calibration is to hold.

INSTALLATION AND ADJUSTMENT

In order to make full use of the monitor it must be placed carefully with respect to the receiver and transmitter so that the signal in it from the transmitter is not too loud and so that the signal produced by it in the receiver also is of reasonable strength. If the receiver is located several feet from the transmitter a satisfactory location for the monitor will be found alongside the receiver on the side farthest from the transmitter. If the transmitter is a low-powered one it may be found necessary to place the monitor on the transmitter side of the receiver in order to get enough pick-up. In any case it is essential that the monitor be so placed that it is in the immediate vicinity of the receiver and preferably so that its 'phones can be worn whenever the controls of the transmitter are adjusted without the necessity of moving it from its normal place in the station. If the receiver is across the room from the transmitter it will be necessary to move the monitor to a spot convenient to the transmitter whenever adjustments are to be made. Of course, the monitor can be placed alongside the receiver for frequency setting and monitoring of the transmitter during transmissions. It may be found that the pick-up with the lid of the shield closed is not enough to give a pleasantly loud signal. In such a case the lid can be opened until the required signal strength is obtained and left in that position for monitoring.

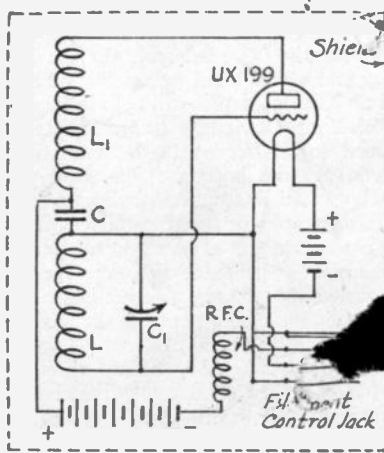

THE WIRING OF THE MONITOR

- Apparatus necessary:
 C — 1000- μ f. by-pass condenser.
 C₁ — In the first monitor a three-plate treble spaced condenser is used.
 L, L₁ — Tuning coils described under the photograph.
 RFC — Short-wave receiver-type radio-frequency choke. 150 turns of 32-gauge wire wound on a 1/2" wooden dowel would serve.
 One Type '99 tube and socket.
 One filament-control 'phone jack.
 Aluminum shield of suitable size.
 Filament and plate batteries, miscellaneous wire, screws, etc.

during adjustment is made difficult by the fact that the tuning of the monitor and the strength of signal produced by it vary greatly in accordance with any movement of the operator's body in the vicinity of the transmitter.

In building the monitor it may help to consider it simply as a single-tube receiver — and adjust the coils and tuning condenser for band-spreading in just the same way as with the receiver. The data under the diagram should be used simply as a guide, because it will probably be found that slight changes in the number of turns on grid and plate coils will be required to spread the band properly and maintain smooth oscillation over the entire dial scale. The latter must be secured by proper proportioning of the plate-coil turns, since the monitor has no regen-

eration control. It is a very worthwhile plan to fit the receiver with a small double-pole double-throw switch so that the 'phones can be thrown from the receiver to the monitor. In this way it is possible to monitor all transmissions simply by flipping over the switch when a change is made from the transmitter to the receiver. Ordinarily the transmitter makes a tremendous and very uncomfortable thump in the receiver 'phones during operation. If it is possible to throw the 'phones over to the monitor this thump is then replaced by a moderate signal which will be almost a replica of the signal that the other fellow has to copy. This makes for much snappier and more readable sending and provides a continuous check on the signal. Should anything go wrong with the transmitter or antenna to cause the frequency to change, the trouble is immediately apparent. For continuous monitoring in this way it would be as well to make the monitor large enough to accommodate standard-size dry cells for filament supply. Such cells should give months of operation without renewal.

CHECKING THE TRANSMITTER FREQUENCY

The simplest method of using the monitor for frequency setting is first to find a suitable place in the band with the receiver, transferring this

frequency to the monitor by beating the receiver with the monitor and then putting the transmitter there by tuning it until it is heard in the monitor. This method does not provide the means for setting the transmitter on any definite frequency unless there is a known station there to mark it, but it does enable the transmitter to be tuned to, say, the center of the band, to a spot a quarter of

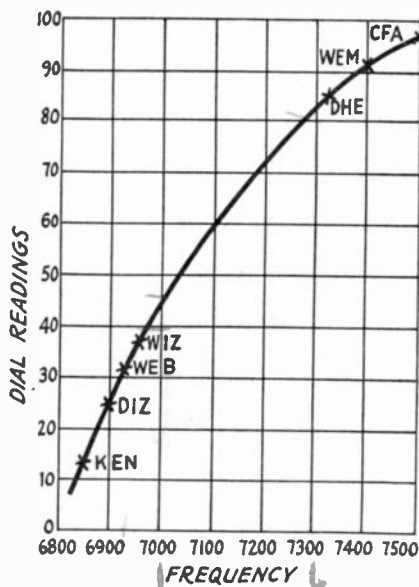

SAMPLE CALIBRATION CURVE

made from calibration points supplied by commercial "marker" stations. Such a curve may be made for the receiver or monitor, providing either is capable of holding a calibration, and will aid in determining the limits of the amateur bands. It is impossible to measure frequency exactly, however, with this type of calibration, and the transmitter should be set well inside the indicated limits to be certain that all transmissions will be inside the band. Each of the above blocks represents a half-inch square on ordinary cross-section paper. The intermediate lines are not shown because of the difficulty of reproduction in printing.

the way from the top, or to any roughly estimated point. It is not often that the amateur finds it essential to tune his transmitter to within a kilocycle or so of a given frequency but if such is the case there are means involving greater difficulties which can be used. They will be detailed later. The prime requisite usually is to have the transmitter within the limits of the band and perhaps in some particular section of it. For this work the simple monitor is all that is necessary.

The first step is to determine as accurately as possible the frequency limits of the band or bands on which the transmitter is to operate. The approximate limits can be found easily by listening to the congregations of amateurs in each of the bands, but it is not safe to assume that all of these stations are inside the band. A good

way of getting an approximate calibration of the monitor or receiver is to identify commercial and government stations of known frequency which are operating near the edges of the bands. Such stations, which have been aptly called "marker" stations, are listed in the "Radio Amateur Call Book," in the section which lists commercial stations of the world by their frequency assignments.

No specific examples will be given here because the assignments are often changed, and the latest call book should be consulted for accurate information. Suppose, however, that a station is heard whose frequency, as shown by the list, is 6980 kc. This is only 20 kc. outside the 7000-kc. band, and therefore serves as an approximate marker for the 7000-kc. end. On the high-frequency end of the band we might find a station listed at 7350 kc. which will help in locating the 7300-kc. limit. Obviously the transmitter cannot be tuned to all frequencies between these two markers, because both are somewhat removed from the actual limits of the band, and it would be easily possible for the transmitter to be set to some frequency not assigned to amateurs. Due allowance must be made therefore for the fact that marker stations are never actual markers of the actual limits, but are outside the bands by an amount.

The receiver may be calibrated roughly — provided its construction is such that it will hold calibration — by picking up a number of such marker stations at various frequencies near the amateur bands and plotting the tuning-dial reading for each frequency, in the fashion shown in the drawing. The general shape of the curve can be determined from the plotted points and drawn in. In the illustration shown the actual limits of the band would be at 44 and 83 on the tuning dial, although the nearest marker stations are outside these limits. A curve plotted in this way is not entirely accurate, but is good enough to show approximately where the band lies.

When making up such a curve, be sure the receiver tuning will not change appreciably from day to day. Receivers with antenna coupling tubes are particularly good in this respect, because the effect of a swinging antenna — or even a change in antennas — on the tuning of the receiver is eliminated. Be sure also that the regeneration control is set at a fixed value which will allow oscillation over the entire band when the curve is plotted, or that the receiver is just on the edge of oscillation at each reading. An oscillation control which has negligible effect on tuning — as mentioned in the receiver chapter — is desirable in this respect. Fortunately the curve can be checked at practically any time if there is reason to suspect that the receiver tuning has changed.

If the monitor has been carefully constructed and a good condenser is used, it may be calibrated

directly from the marker stations in the same way. The monitor, as has been mentioned previously, should be placed on the operating table near the receiver so that, when listening on the receiver, the oscillations can be detected on the latter in the same way as ordinary signals. In order to get the monitor oscillating, of course, a plug must be inserted in the jack which controls the filament current so the tube will heat, and the plate circuit of the monitor tube must be closed also. In ordinary operation of the monitor the 'phones do both of these things automatically when plugged in the jack. If an extra pair of 'phones is handy they should be used for this purpose, listening being done on another pair on the receiver. If no extra pair of 'phones is available, a 2000-ohm resistor (or resistor equal to the resistance of the 'phones ordinarily used with the monitor) should be connected to the monitor jack. The resistor will automatically place the same voltage on the plate of the monitor tube as it gets when the 'phones are used, and thus avoid changes in calibration due to plate voltage changes.

When the signal from the monitor is audible, the marker stations should be tuned in and the monitor frequency adjusted to zero beat with the marker signals. The monitor dial readings should be plotted on a piece of cross-section paper as shown in the drawing. When calibrating the monitor be sure that it will be used for checking transmitter frequency under exactly the same conditions — that is, be sure the lid is closed tightly because the position of the lid is quite likely to change the tuning of the monitor more or less seriously. If it is necessary to open the lid slightly to get a good signal in the receiver the calibration may change considerably when it is closed. In such a case it would be better to put a few small holes in the shield in preference to opening the lid, and use the monitor at a greater distance from the transmitter for checking the frequency and quality of the signal.

When a calibration curve has been drawn up for either the receiver or monitor it should be checked at every opportunity. Battery voltages are particularly important, because even a small change in the "A" or "B" battery voltages, particularly the former, can change the calibration by a fairly large percentage. Batteries should be checked every week or so, particularly those used in the monitor, because they are usually the smallest size obtainable and their life is short. The accuracy in frequency measurement with a calibrated receiver or monitor is never as good as that with the frequency meter described later in this chapter, and such a calibration should be depended upon only for approximately locating the limits of the bands. The calibration should be checked against commercial marker stations every time the station is in operation. Such a check takes only a few seconds and will show im-

mediately whether the calibration has changed.

In order to put the transmitter frequency in its place it is first necessary to switch on the receiver and explore the band on which operation is desired to find a comparatively clear spot — inside the band limits as shown by the curve, of course. Do not try to work too close to the limits, because the calibration curve may be "off" by several kilocycles even though extreme care is used in making it up. Always be on the safe side and keep well within the band so that there is no possibility of working off frequency. When the spot has been decided upon the receiver is left running at that setting and the monitor tuning condenser is adjusted until the beat note between the monitor and receiver is heard. This beat can then be set at the zero-beat or silent point. The 'phones are now plugged into or switched onto the monitor, without disturbing its tuning condenser setting. Then the transmitter is switched on and its frequency adjusted until the beat note between the transmitter and monitor is heard. When this beat has been tuned to the silent point the transmitter frequency will be the same as that on which the receiver is set. At this stage the adjustment of the transmitter can be completed to give the cleanest and steadiest signal, the monitor being left at the same adjustment, and the transmitter frequency being held to beat with it all the time. With practice it will be found that the frequency variations caused by certain amounts of dial movement on the monitor can be estimated with fair accuracy and that slight adjustments of the transmitter frequency can be made without difficulty when the request is made to QSV to avoid interference.

Of course, the opposite procedure can be followed to find the approximate frequency of the transmitter. In this case the transmitter frequency is found in the monitor and then, with the transmitter switched off, transferred from the monitor to the receiver where it can be determined approximately from its relation to known points on the receiver dial. It might be explained that the usual receiver, even if it is shielded, cannot be used for this monitoring work since the pick-up of the battery leads and external wiring is so great that the signal from the transmitter is nothing more than a heavy rumble across most of the dial. In some cases where both the receiver and its batteries are shielded the receiver can replace the monitor but even then the antenna lead to the receiver would have to be removed when the transmitter is checked, so disturbing any settings made from received signals of known frequency.

If an oscillating crystal is available, the fundamental frequency or harmonics of which fall within the bands in which the transmitter is to be operated, it can be used with a Type '01-A or Type '99 tube to provide a splendid monitor.

With such an arrangement one can avoid the complications of crystal-controlling the transmitter, yet maintain an almost perfect check on the frequency. Of course, if the transmitter is controlled by an accurately calibrated crystal the transmitter frequency-setting problem is at once solved. The monitor, however, is still a necessity for signal checking, since even the crystal-controlled transmitter can misbehave.

In adjusting the transmitter it will be found advantageous to use an amplifier and loud-speaker with the monitor so that it will not be

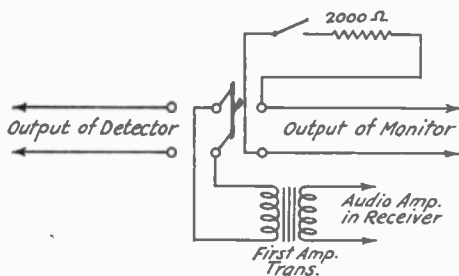

HOW THE MONITOR OUTPUT MAY BE CONNECTED TO THE RECEIVER

The double-pole double-throw switch throws the primary of the first audio transformer in the receiver to the plate circuit of either the monitor or the detector in the receiving set. The single-pole single-throw switch closes the plate circuit of the monitor through the 2000-ohm resistor so that the signal from the monitor can be picked up in the receiver when the audio amplifier is connected to the detector.

necessary to wear the 'phones, particularly when the transmitter is located at some distance from the receiving table on which the monitor is usually placed. A separate audio amplifier for the monitor is not always required; most amateur receivers have sufficient audio amplification for loud-speaker reception, and the output of the monitor can be connected to the input of the audio amplifier on the receiver, preferably through a double-pole double-throw switch, so that the amplifier can be used on either the receiver or monitor at will. The diagram shows how this can be accomplished. The extra resistor is placed in the monitor plate circuit when the single-pole single-throw switch is closed, and is used only when the audio amplifier is connected to the receiver and it is desired to listen to the monitor signal for frequency-checking purposes.

MORE PRECISE METHODS

So far we have outlined the simple procedure necessary to determine definitely whether the transmitter frequency is within the limits of the band and roughly in what part of the band it is located. Most amateurs will be interested in knowing how a transmitter can be tuned to within a few kilocycles of a given frequency. For this work some calibrated standard will be necessary against which to compare the frequency of the

transmitter. For approximate work the standard may be nothing more than the simple monitor which we have described. Indeed, if the monitor is solidly constructed it may well be used for quite accurate work providing the tuning condenser used is of a type likely to retain its calibration, and the dial can be read closely and accurately. The condenser in the monitor already described can be used, but it may be that the constructor will prefer to spread each of the bands over as much of the dial as possible. One type of condenser which is particularly suited to band spreading is that illustrated. It is made from a 500- μ fd. Cardwell taper-plate condenser so as to provide a condenser which has three capacity ranges.

In order to build such a condenser, all except two stator and two rotor plates are removed. Then the brass mounting of the stator plates is cut as shown on the diagram so as to isolate the two stator plates. The unit then really consists of two condensers, the capacities of which can be altered by varying the spacing of plates B and C and by moving them on the shaft nearer to the stator plate A or D. When the coil is connected between the terminals 2 and 3 the capacity between the plates C and D is used. When the coil is connected from 1 to 3 the larger condenser constituted by plates A and B is used. If one end of the coil is connected to both 1 and 2 and the other end of the coil to 3, the two condensers are in parallel and a still larger capacity is obtained.

In the next monitor illustrated, this type of condenser is used so that each band can be spread out to occupy a large segment of the dial. A small

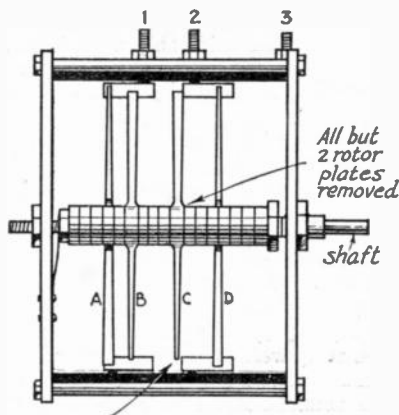

Stator mounting cut away to insulate the two remaining stator plates

SHOWING THE REBUILT CONDENSER USED IN THE CALIBRATED MONITOR

switch is provided as shown in the diagram so that the different capacities provided by the condenser can be connected when required. For the 1715- and 3500-ke. bands the two condensers in

parallel are used. For the 7000-kc. band the capacity between plates *A* and *B* is connected to the coil. On the 14,000- and 28,000-kc. bands the plates *C* and *D* are brought into use.

A well-built monitor such as this will hold calibration quite well if the coils are handled carefully and the windings are securely fastened with coil "dope" to the forms. The coils may be wound on tube bases or preferably regular plug-in coil forms, and the specifications will be approximately those of the previous monitor. The spacing between the condenser plates and the coil turns must be proportioned by experiment so that each of the bands is covered and spread properly over the dial. This may be done by checking against marker stations, as described previously.

A good monitor is worthy of a better calibration than can be obtained from marker stations alone. Sooner or later every amateur wishes to know his frequency as closely as possible, and while the type of calibration curve obtainable from marker stations will indicate whether the

bration signals transmitted for amateurs are therefore based on the national frequency stand-

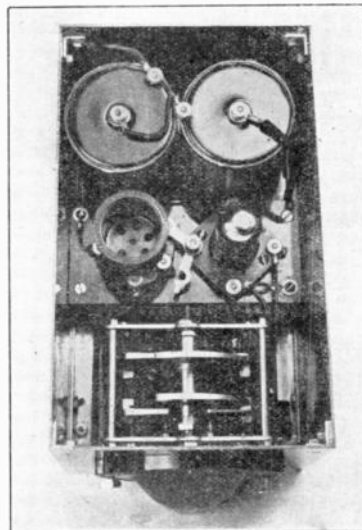

PLAN VIEW OF THE CALIBRATED MONITOR

In this instrument particular care was taken to obtain mechanical rigidity and generally substantial construction. The switching arrangement for throwing in any of the three possible capacity values can be seen between the tube and the coil. The shield of this monitor is made of heavy copper plate built up on aluminum angle-pieces.

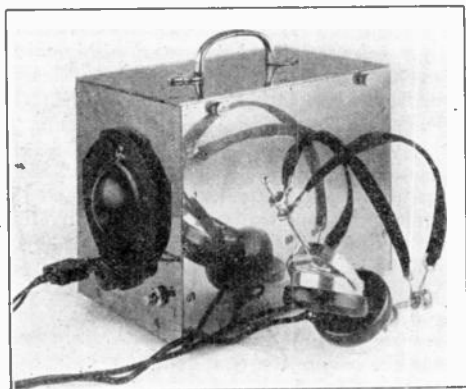

A MONITOR WHICH IS WELL SUITED TO CALIBRATION FOR FAIRLY ACCURATE WORK

It is not, however, as good as the frequency meter described later in the chapter for precise measurement of frequency.

transmitter is in the band or not — provided no attempt is made to work too near either edge — a better calibration is necessary if frequency is to be measured with any degree of accuracy. It is for the purpose of supplying this need that the A.R.R.L. Standard Frequency System has been built up.

The A.R.R.L. Standard Frequency System consists of a group of three Standard Frequency Stations located in different sections of the country which transmit calibration signals for the use of amateurs. Each of the stations is provided with a frequency standard which is accurate to better than one part in 10,000 or 0.01%. These standards have been calibrated against the national standard, located in the laboratory of the Bureau of Standards at Washington. The cali-

ard. Current schedules and information about the transmissions are given in every issue of *QST*.

It is the aim of those carrying on the work of the Standard Frequency System to have at least one transmission of calibration signals every week, and every amateur is urged to make the fullest possible use of the transmissions. In general, they consist of signals which mark accurately the limits of each of the amateur bands — usually one night is devoted to each band — with intermediate points 100 kilocycles apart and such additional points as may be desirable. For instance, the 3500-kc. band Standard Frequency Transmissions cover the following frequencies: 3500, 3550 (to mark the upper limit of the 'phone band), 3600, 3700, 3800, 3900 and 4000 kc. From these points an excellent calibration curve for the monitor or frequency meter can be made. The exact form of the transmission is indicated in each issue of *QST*, and generally takes the form of an eight-minute period for each frequency, the first part of which is devoted to a QST — general call to all A.R.R.L. stations — then a series of long dashes followed by an announcement of the exact frequency, and a final short period in which the frequency of the transmission to follow in a few minutes is announced.

The same procedure should be followed in calibrating the receiver or monitor from Standard Frequency Transmissions as in calibrating from

marker stations. It is a good plan to make up a preliminary calibration from marker stations as described and use it as a guide for locating the Standard Frequency Transmissions. If the moni-

tor transmissions so that it will be possible to tell afterwards whether the calibration is holding or not. If the marker stations are found to shift appreciably from the dial settings logged, the monitor should be recalibrated at the next Standard Frequency Transmission.

With such a calibrated monitor the frequency of the transmitter can be found by locating it on the dial and finding from the calibration curve the frequency corresponding to this dial reading. Conversely, the dial setting for some definite frequency can be found from the curve, the dial left at this setting, and the transmitter tuned until its beat-note is heard in the monitor.

Aside from the more careful and solid construction employed in this second monitor, its limitations in frequency measurement are the same as those of the first monitor. The calibration is sure to change as the batteries run down with use, and will be found to vary from day to day from various causes, one of which is the temperature of the tube. The frequency drift as the tube warms up is quite noticeable with any circuit of this kind, and may amount to several kilocycles. For this reason the calibration should be checked against marker stations every time the monitor is to be used for frequency checking, and the batteries should be checked regularly. When the batteries or tube are replaced the monitor must be recalibrated.

The dial must be one which can be read accurately to at least half a scale division, and the calibration curves must be carefully drawn if any accuracy in frequency measurement is to be attained. A separate curve sheet should be used for each band to avoid confusion in reading. The plug-in coils must also be handled carefully, because even a minute shift in one of the turns will change the calibration considerably. If all these precautions are observed and the calibration is checked regularly from Standard Frequency Transmissions the frequency measurements can be depended upon within 0.25% of the actual frequency. When greater accuracy is to be obtained a good frequency meter of the type now to be described must be constructed.

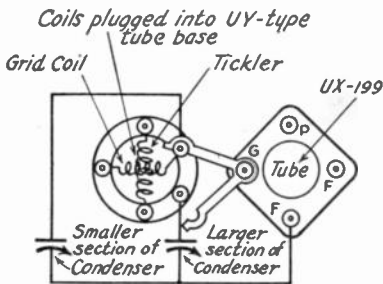

Wiring of coil and setting of switch for the 14,000-k.c. band.

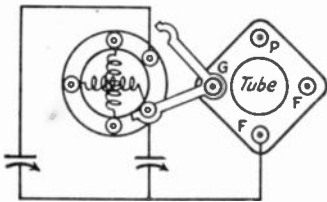

Wiring of coil and setting of switch to connect larger section of condenser across grid coil for the 7000-k.c. band.

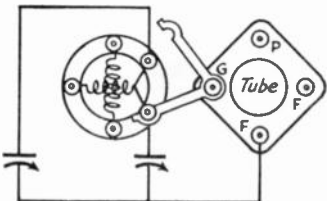

Wiring of coil which connects both sections of condenser in parallel for the 3,500 k.c. band. The switch can be in either position. In other respects the wiring is similar to that of the other monitors.

THE WIRING OF THE CALIBRATED MONITOR

showing the switching device for connecting any of three possible capacity ranges to the coil. The coil plugs into a 5-hole UY-type tube socket. Two of the terminals provide for the tickler winding. One of the others is the filament end of the grid coil. The grid end of this coil is connected to one or the other of the remaining two prongs on the coil-form, depending upon which capacity range is desired in association with it. The two capacitances are connected to the corresponding terminals on the socket. There are thus two alternative connections from the grid, each connecting, through the switch, with the proper capacitance. When the combined capacitance of both capacity ranges is desired, the grid end of the coil is connected to both of these prongs, rather than to a particular one, and thus both capacitances are in circuit regardless of which the switch is connected.

tor is to be calibrated the dial readings for some of the marker stations should be checked at the time of calibration from Standard Frequency

THE FREQUENCY METER

To obtain greater precision in measuring frequency it is necessary to use a device designed especially for the purpose. While a simple monitor and roughly calibrated receiver or a calibrated monitor are good enough for approximate measurement when there is no necessity for knowing the exact frequency on which the transmitter is working, it is impossible to approach very closely the edges of the bands with any assurance that the transmitter is actually "inside." The chart shows clearly how this works out for different percentages of error in frequency measurement. For instance, if the measurement of frequency can only be depended upon to

0.5%, the transmitter can be set only to frequencies between 14,070 and 14,328 kc. on the 14,000-kc. band, because between the band limits and these frequencies the error is large enough to allow the transmitter frequency to be outside the band, even though the frequency is inside the band according to the receiver or monitor. This effect becomes increasingly important at the higher frequencies, so it is well worth while to have an accurate frequency meter in the station. The meter to be described will, when carefully calibrated from Standard Frequency Transmissions, maintain an accuracy within 0.1% with reasonable care in use. The rough calibration from marker stations previously described will ordinarily be within 0.5%,

the frequency meter and the monitor. The frequency meter is not used as a miniature receiver at all, but is simply an oscillator whose signal is picked up by the receiver in the same way that the signal from the monitor is picked up when

Band - 1715 - 2000 Kc.
0.1% - 1717 - 1998 Kc.
0.25% - 1720 - 1995 Kc.
0.5% - 1724 - 1990 Kc.
1.0% - 1732 - 1980 Kc.
2.0% - 1750 - 1961 Kc.

Band - 3500 - 4000 Kc.
0.1% - 3504 - 3996 Kc.
0.25% - 3509 - 3990 Kc.
0.5% - 3518 - 3981 Kc.
1.0% - 3535 - 3960 Kc.
2.0% - 3572 - 3922 Kc.

Band - 7000 - 7300 Kc.
0.1% - 7007 - 7293 Kc.
0.25% - 7018 - 7282 Kc.
0.5% - 7035 - 7264 Kc.
1.0% - 7070 - 7228 Kc.
2.0% - 7143 - 7157 Kc.

Band - 14000 - 14400 Kc.
0.1% - 14014 - 14386 Kc.
0.25% - 14035 - 14364 Kc.
0.5% - 14070 - 14328 Kc.
1.0% - 14141 - 14257 Kc.
2.0% Useless

Band - 28000 - 30000 Kc.
0.1% - 28028 - 29970 Kc.
0.25% - 28070 - 29925 Kc.
0.5% - 28141 - 29850 Kc.
1.0% - 28282 - 29703 Kc.
2.0% - 28572 - 29412 Kc.

HOW TRANSMITTER TUNING IS RESTRICTED BY ERROR IN FREQUENCY MEASUREMENT

The transmitter must be tuned to frequencies (as shown by the frequency meter) within the shaded blocks in order to be certain that the transmissions are not outside the band. The smaller the percentage of error in frequency measurement the nearer the edges of the bands the transmitter can be set. Always play safe in setting transmitter frequency.

while the more carefully constructed calibrated monitor will be within 0.25% if calibrated from Standard Frequency Transmissions.

There are several points of difference between

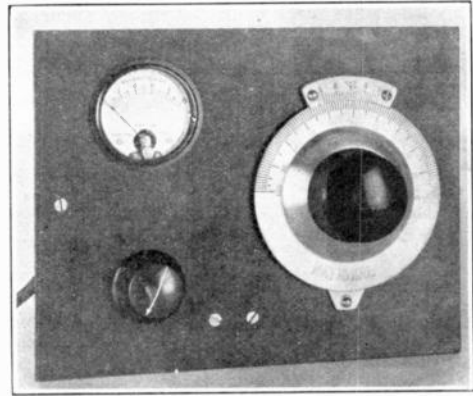

THE DYNATRON FREQUENCY METER

The 0-10 milliammeter for reading space current is in the upper left-hand corner, the potentiometer being immediately below it. The vernier dial is used for precise reading.

setting the transmitter to a pre-determined point in the band. Furthermore, the oscillator used in the frequency meter must be very stable; that is, the frequency of oscillation at a given dial setting must be practically the same under any conditions. No plug-in coils are used in the frequency-meter; one solidly built and firmly mounted coil is permanently installed in it, and the oscillator covers one band only. A low-frequency band is used for this purpose, and when the meter is to be used on the higher-frequency bands its harmonics instead of the fundamental oscillation are picked up by the receiver. With no plug-in coils, one of the worst sources of loss of calibration is eliminated. The single coil can be mounted in a much more solid fashion, and since it is not subject to continual handling such as plug-in coils receive, the turns will not be loosened or pulled out of place.

The frequency meter must possess a dial which can be read precisely to fractions of divisions. To obtain an accuracy within 0.1% it is necessary to read to at least a fifth of a dial division, and ordinary dials such as are used for receivers are inadequate. The 4" National Type N dial illustrated is provided with a vernier scale for reading to a tenth of a scale division, and is excellent for this purpose. There are a few other dials on the market which are suitable, but care must be used in selecting one which has fine lines for division marks, and in which the indicator is very close to the dial scale itself so that the readings will not be different when the dial is viewed from different angles.

It should be pointed out here that, although

the frequency meter is vastly superior to a calibrated monitor for measuring frequencies, it does not supersede the monitor in its original function of providing a means for constantly checking the quality of the signal from one's own trans-

form of feed-back, and no grid condensers and leaks are required. But most important of all, the changes in calibration accompanying loss of voltage in batteries and aging of the tube can be eliminated if a milliammeter is connected in the circuit so that it reads the total "B" current taken by the tube and this current is maintained at a fixed value when the frequency meter is calibrated and whenever it is used. Frequency variations of ordinary oscillators cannot be checked in this simple fashion.

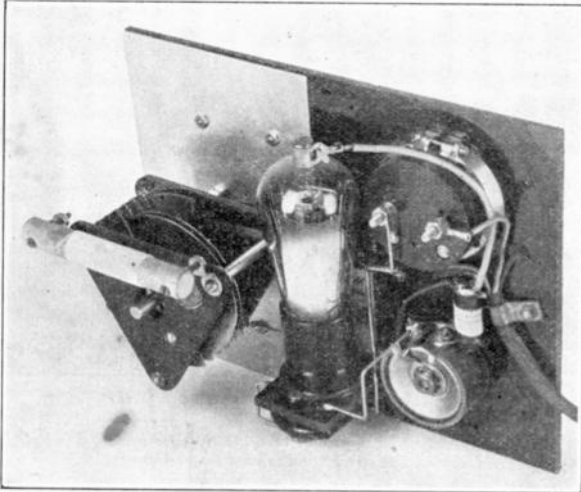

REAR VIEW OF THE DYNATRON FREQUENCY METER

The special tuning condenser, with the coil mounted on its terminals, is on the left behind the aluminum sheet. The tube is mounted on a small piece of bakelite serving as shelf. The plate by-pass condenser is mounted on the under side of the shelf, and the screen-grid by-pass condenser is partly visible between the tube and the panel. The milliammeter and potentiometer are at the right. This model uses a Type '22 tube, and the fixed resistor between the milliammeter and potentiometer drops the voltage to the proper value for the filament of the tube. It is better to use a rheostat, as shown in the diagram, for regulating filament voltage, however. The same layout may be used with a Type '24 tube.

Either a Type '22, '32 or '24 tube may be used as the oscillator. With the Type '22 and '32 a separate filament supply from that used for the receiver must be provided, although the "B" batteries may be the same ones used on the receiver — in fact, the use of the same "B" batteries is recommended, because they furnish all the coupling necessary between the frequency meter and receiver to enable the signal from the meter to be heard in the receiver. With the Type '24 tube the same heater supply may be used on both frequency meter and receiver, as well as the same "B" supply.

The frequency meter illustrated is designed to spread the 3500-kc. band over about 75 degrees on the dial, the size of the coil and the spacing between the two rear circular condenser plates being adjusted until the desired spread is obtained. This adjustment may be made with the aid of marker stations, as described previously. The frequency meter may be considered simply as an oscillating moni-

mitter. The modern station should have both a monitor and a frequency meter, separate in their functions. The monitor is still needed, particularly as a device for reproducing what the transmitter sounds like at the distant point of reception, so that stability, tone and all the other qualities of the signal may be under constant observation.

A frequency meter which meets the requirements is shown in the photographs. The simplicity of construction is apparent from these views and the wiring diagrams. A screen-grid tube is used as the oscillator, and when connected up in the fashion shown is said to be operating as a "pliodynatron" or, more simply, "dynatron" oscillator. A frequency meter of this type is known as a dynatron frequency meter. The dynatron oscillator is the best type of oscillator available for frequency-meter work at the present time, as it possesses a number of advantages over the other forms of vacuum-tube oscillators. In stability it approaches the crystal-controlled oscillator when used in a properly-designed circuit. It is easy to construct — the oscillatory circuit consists simply of a coil and condenser, with no necessity for ticklers or any

tor, the signal from which is beat against the incoming marker signal.

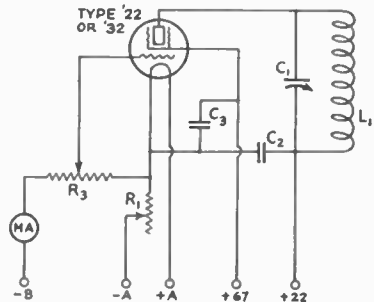

THE D.C. DYNATRON FREQUENCY METER

L₁ — 75 turns of No. 30 d.c.c. wire on 1/2-inch form, no spacing between turns.

C₁ — General Radio Type 557 condenser.

C₂ — .006 μfd. or larger.

C₃ — 0.5 μfd. or larger.

R₁ — 60-ohm rheostat.

R₂ — 2000-ohm potentiometer.

MA — 0-10 d.c. milliammeter.

The condenser is a General Radio Type 557, which is designed especially for amateur frequency-meter work. The two circular rotary plates at the rear are held to the shaft by set screws, making it possible to change the spacing between them slightly to obtain proper band spreading. In this particular frequency meter these plates are both moved toward the stationary plate between them so that the separation is about 1/16". The aluminum plate on the back of the panel is used to prevent hand-capacity at the tuning dial.

When the frequency meter has been constructed and connected up, the receiver is operated on the 3500-kc. band and the signal from the frequency meter tuned in. Then the receiver should be placed on the 7000-kc. band and the strength of the second harmonic of the frequency meter noted. The harmonic can be picked up easily by setting the receiver at some point inside the band and slowly turning the frequency-meter dial until the usual whistle is heard. The same procedure is then followed with the receiver on the 14,000-kc. band. The potentiometer on the frequency meter should then be adjusted until the 14,000-kc. signal is strong enough to be useful. It is an advantage to keep the milliammeter reading at the lowest possible point consistent with good signal strength, to prolong the life of the tube.

With the milliammeter reading set at a satisfactory value for good signal strength on all

The meter should be calibrated from Standard Frequency Transmissions in the same manner as the calibrated monitor described previously. Before calibrating, however, the tube should be allowed to warm up for about half an hour to

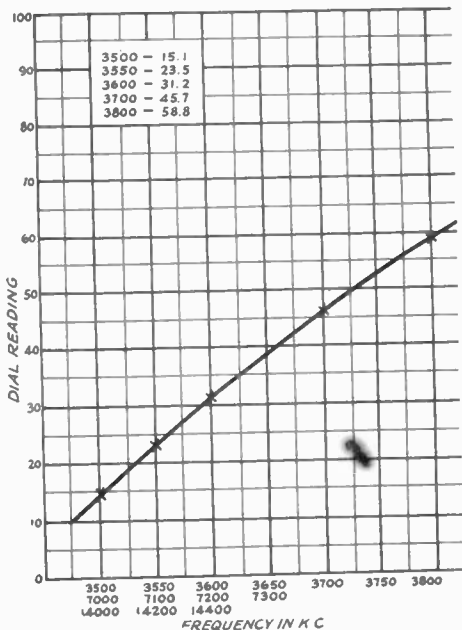

TYPICAL CALIBRATION CURVE FOR THE FREQUENCY METER

Each of the small blocks represents a half-inch block on ordinary cross-section paper. The chart must be large enough so that tenths of divisions can be read accurately on the dial reading scale, and the frequency scale must be spread out sufficiently to allow easy reading to within a few kilocycles.

reach a stable operating temperature, since the frequency will drift slightly as the tube elements expand. This is particularly important with the Type '24 tube, since the filament operates at a rather high temperature. This effect is minimized by the use of a tuning condenser which has a small amount of fixed capacity in parallel with the variable capacity. The condenser illustrated provides this feature through the medium of the two circular rotary plates. If there is no fixed capacity in the circuit the drift will be great enough to change the calibration by a few kilocycles — a change which becomes important in accurate frequency measurement.

It is unnecessary to shield the frequency meter if it is placed by itself in a comparatively clear space. Other objects, particularly of metal, should not be brought close enough to the frequency meter to affect the calibration. If the frequency meter must be placed close to other apparatus it is better to shield it.

The frequency of incoming signals may be measured, once the meter is calibrated, by

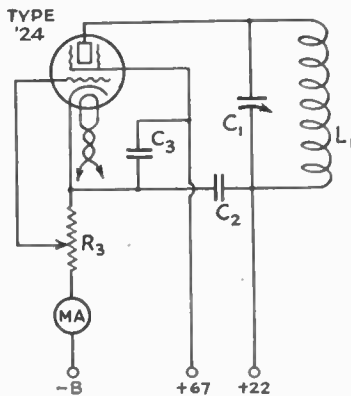

WIRING OF THE A.C. DYNATRON FREQUENCY METER

Circuit constants are the same as in the d.c. diagram. When using a.c. on the heater it is necessary to use a tube which does not introduce modulation (hum) on the signal.

bands, the value of current indicated should be jotted down or memorized, because the meter should be calibrated and always used with the reading at the same value. If the setting is not at the same value at which the meter is calibrated the dial readings will not be correct, and the accuracy of the frequency meter will be impaired.

adjusting the frequency meter dial until the signal (either the fundamental or one of the harmonics) from it is at zero beat with the signal whose frequency is to be measured. The frequency shown on the chart for this dial reading will then be the frequency of the signal. To check the transmitter frequency, the signal from the transmitter should first be picked up on a monitor of the variety previously described; then the transmitter is turned off and the signal from the monitor — keeping the same dial setting on the monitor — is tuned in on the receiver, and the frequency meter adjusted to zero beat with the monitor signal as with any other incoming signal. In making such measurements it will be helpful to have the receiver just out of oscillation so that the signal from the frequency meter can be beat directly against the monitor or incoming signal, thus really using the frequency meter as a separate heterodyne.

Before calibrating the frequency meter from Standard Frequency Transmissions a rough calibration from marker stations should be obtained. This will aid in locating the various frequencies which are sent by the Standard Frequency Station. When using the Standard Frequency Transmissions, be sure to adjust the frequency meter accurately to zero beat with the calibration signals, and note the dial readings as closely as possible — to the nearest tenth of a division if possible. It is not necessary to wait for a transmission which covers the 3500-kc. band if other Standard Frequency Transmissions are available in the meantime, because the meter can be calibrated equally well on its harmonics and the calibration will be just as accurate for the fundamental, although only the low-frequency

end of the scale can be covered in this manner.

After the dial readings for various frequencies have been secured, they should be plotted carefully on a curve sheet. The curve should not be "cramped" — that is, the scale should not be so small that accurate readings of frequency from the curve cannot be made. The illustration shows a satisfactory way of making up such a curve. The paper used is standard cross-section paper (20 lines to the inch), and each of the blocks shown in the drawing represents a half-inch block on the paper. It may be necessary to use two sheets to draw the entire curve, one for the low-frequency half of the band and the other for the high-frequency half. The harmonic frequencies should be numbered in as well as the fundamental. The dial readings will be the same for each band, except that on the 7000-kc. band the fundamental frequency will be multiplied by 2 and on the 14,000-kc. band the fundamental frequency will be multiplied by 4.

In using a calibrated monitor or frequency meter always play safe when setting the transmitter frequency. Make allowance for all possible errors in frequency measurement and then set the transmitter well inside the limits of the band. Take every opportunity to check the monitor or frequency meter to make sure that nothing has happened to the calibration. *Know* whether you are in the band or not — that part is easy if no attempt is made to crowd the edges. Accurate determination of frequency is becoming increasingly important, but the amateur who follows the simple directions given earlier in this chapter can at least be certain that he is operating in his legally assigned territory, even though no elaborate methods are used for actual measurement of frequency.

CHAPTER VII

Transmitters

THE transmitter is truly the most important piece of equipment in the amateur station. It is the station's mouth-piece through which the operator conveys his thoughts to other amateurs the world over. Distant amateurs must therefore judge the station by the quality of the transmitter's output and by the way it is operated. The amateur is judged by the signal he owns. A steady signal with a clean "pure d.c." note is the finest testimonial an amateur station can have and is well worth attaining, not only because it indicates possession of a good transmitter intelligently operated but also because it shows that the station's operator is not "hogging" more than his share of the amateur bands — as he would with a rough, wobbly, creeping signal. Moreover, the steady pure d.c. signal is acknowledged to be far superior to all other types for communicating under adverse conditions. Although it may not be the grossly loudest signal heard at the receiving end, the "PDC" signal with its penetrating flute-like whistle will be easiest to copy through interference of all kinds. This is particularly true when a receiver having a selective "peaked" audio-frequency amplifier is used at the other end. Therefore, the transmitters described in this chapter are designed to deliver steady clean-cut d.c. signals when built and used according to specifications.

HOW TRANSMITTERS WORK

All modern high-frequency transmitters are of the vacuum-tube type and an understanding of the vacuum tube as a generator of high-frequency alternating current is essential to the understanding of transmitter operation. Although there are many vacuum-tube oscillator circuits, all function on the same general principle.

The capability of a vacuum tube to oscillate comes from its amplifying properties. When the tuned output circuit of a vacuum-tube amplifier is properly coupled to its input circuit, a variation of the output current will cause a voltage change in the input circuit which — by virtue of the amplifying action of the tube — will cause a current variation of greater amplitude in the output circuit. In turn, this augmented variation will be impressed on the input circuit — and so the oscillation builds itself up. The input circuit of the oscillator is the grid and the output is the plate circuit.

The maximum amplitude to which oscillations will build up depends on a number of factors. These involve the characteristics of the tube, the

circuit constants and mean electrode voltages (negative grid-bias and positive plate voltages). The frequency of oscillation will be determined largely by the circuit constants, principally by the inductance and capacity values in the tuned circuit. The coupling between the grid and plate circuits may be inductive (coupling between coils) or capacitive (through a condenser). Resistance coupling is sometimes used for very low frequencies. The capacity between the grid and plate within the tube itself is utilized for the feed-back coupling in many amateur transmitters and may be considerable even where other coupling methods are intended.

For satisfactory oscillator operation the amplitude of the grid excitation voltage should be sufficient to cause large amplitudes of plate current to flow during a small part (the peak) of the excitation's positive half-cycle. Since no plate current flows during the negative half-cycle of the excitation voltage, the plate tank circuit receives a "kick" on alternate half-cycles only. These timed impulses are sufficient to maintain oscillation in the plate tank circuit, because of its "fly-wheel" effect, and the output is essentially sinusoidal even though the energizing impulses are quite distorted.

Grid bias is usually obtained by means of a grid leak. During the positive half-cycle of excitation voltage there is a considerable flow of electrons from the grid to the filament through the external circuit. By connecting a blocking condenser between the grid and its excitation circuit, this rectified current may be made to flow through a resistance connected across the blocking condenser or between the grid and filament. The resulting voltage drop across this resistor will maintain the grid at a mean potential negative with respect to the filament, and so provide the necessary grid bias. The resistance of the leak and the mean value of the rectified grid current will determine the mean grid-bias voltage. The value of grid-leak resistance is not very critical, usually being between 5000 and 20,000 ohms. A resistance of 10,000 ohms will be satisfactory for most oscillators. Battery bias or a combination of battery and leak bias may be used, but the leak alone is generally most satisfactory with oscillators. When leak bias is used it must be remembered that grid current flows only when the tube is oscillating. When oscillation ceases there is no grid current and consequently the tube loses its bias. The plate current under this condition becomes excessive and is limited only by the plate resistance of the tube. If the tube is of low plate

resistance, it may be sufficient to wreck the tube. Therefore, caution should be exercised to avoid loss of bias.

PRACTICAL OSCILLATOR CIRCUITS

Fundamentally there are two general divisions of oscillating circuits: those employing capacitive coupling (condensers) to feed back energy from the plate to the grid circuit, and those using inductive coupling (coils) for the same purpose. All circuits are modifications of these two general classes.

The choice of a transmitting circuit is not of great importance, for if the circuit is arranged to suit the particular tube or tubes used, and is adjusted properly, similar results can be obtained with any of them. In every transmitter provision

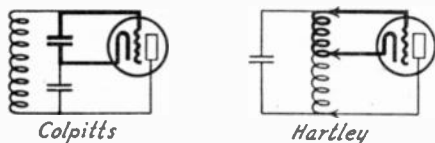

CLASSES OF OSCILLATING CIRCUITS

is made to tune the condenser-coil circuits to the required frequency, to tune the antenna circuit substantially to resonance with the plate circuit, and to vary the amount of energy fed into the grid circuit from the plate circuit (the grid excitation). Other means are provided to adjust the grid bias, to match the impedance of the tube, and to adjust the antenna load to that value which will allow the most efficient transfer of energy from the plate circuit. Some method of making all of these adjustments is to be found in every satisfactory circuit. In fact a circuit is nothing more than a combination of the necessities for making such adjustments, the object in making them being to get the largest output into the antenna without exceeding the input rating of the tube and always maintaining a steady clean-cut signal.

The circuits in most general use are the Hartley, Armstrong or tuned-grid tuned-plate, Colpitts and Ultraudion. Also there is the oscillator-amplifier circuit (which is an oscillator using one of the above circuits and feeding a radio-frequency amplifier). The crystal-controlled circuit (a crystal oscillator feeding one or more radio-frequency amplifiers) is a special type of oscillator-amplifier circuit.

In the Hartley oscillator the tank circuit, which is a feature of all of the circuits, has its ends connected to the grid and plate of the tube. The filament circuit of the tube is also connected to the coil at a point nearer the grid end of the coil than the plate end. In this way the coil is really divided into two sections, one in the grid circuit and a larger one in the plate circuit. Oscillations are maintained because of the inductive coupling between these two sections.

In the tuned-grid tuned-plate circuit there are two tank circuits, one connected between the grid and the filament of the tube and the other between the plate and filament. In the high-frequency transmitter these two circuits are not coupled inductively and the capacity of the tube itself is utilized to provide the coupling between the grid and plate circuits which is necessary to cause oscillation.

The Colpitts circuit is arranged so that the filament is connected to the junction of two condensers which are in series across the coil. In this way the grid and plate circuits share the voltage drop across the condensers, and oscillation is produced in this manner.

A great many variations of these fundamental circuits have been evolved and it is not surprising that the newcomer is often confused by them. It is well to remember that however complex or unusual the circuit may appear, it can without doubt be "boiled down" to one of the fundamental arrangements. And, what is more important, when it has been adjusted carefully it will provide almost an identical performance to that of any other circuit.

FREQUENCY STABILITY AND EFFICIENCY

The factors affecting frequency stability and efficiency are generally interdependent, although the conditions for best frequency stability are not always those giving the highest efficiency with any oscillator circuit. Frequency stability is ever the first consideration and factors affecting it are therefore of utmost importance.

The causes of frequency instability can be roughly divided into two groups, those which are "mechanical" in nature and those which are "dynamic." Mechanical instability results from variations in the circuit constants due to mechanical vibration and thermal effects. Mechanical vibration will cause rapid fluctuations in frequency by varying the spacing between condenser plates, the separation between coil turns or the distance between the tube elements. These are avoided largely by rigid construction and by reducing the vibration. Frequency fluctuation ("creeping") due to thermal effects results from variation in spacing of the tube elements (variation in inter-element capacity) with changes in temperature. Creeping can be minimized by keeping the power dissipated in the tube at or below its normal rating, by choosing tubes having internal construction particularly intended to reduce frequency-creeping, and by using circuits which have large capacities in parallel with the tube's input and output capacities. Such circuits are popularly known as "High-C" circuits. The use of a large shunting capacity in the plate circuit is particularly effective.

"Dynamic" instability is caused by anything which affects the tube's characteristics, especially its plate impedance, during operation. Any varia-

tion in plate impedance must cause a change in frequency. The principal cause of dynamic frequency instability — sometimes called “frequency flutter” — is the variation in plate voltage which results when a poorly-filtered plate supply is used. It is most pronounced when the tube has insufficient grid bias and is over- or under-excited. It is therefore essential that the plate supply be the best “pure d.c.” obtainable and that the grid bias — or grid leak — be sufficiently high in value. Moreover, too much care cannot be exercised in adjusting the grid excitation. Dynamic instability can be reduced by careful circuit design and here again the use of a High-C plate tank is very effective. Such a tank circuit is capable of reducing the amplitude of frequency fluctuations with variations in plate impedance.

The characteristics of the load circuit (which include the plate tank circuit and the antenna circuit) and the losses in the grid circuit affect the oscillator's plate efficiency. The plate efficiency is the ratio of radio-frequency power output to plate power input, although power consumed in the filament should be considered also in determining the true over-all efficiency. The losses in the grid circuit are largely the power dissipated by the grid leak and the losses due to radio-frequency displacement currents between the grid and filament. The latter may be considerable at high frequencies with tubes having large grid-filament capacity.

There is no simple method of accurately determining the plate efficiency of a high-frequency oscillator. If the tube is operated at normal plate dissipation, usually indicated by dull red coloring of the plate, the power output will be approximately the difference between total plate input (d.c. plate voltage multiplied by the plate current in amperes) and the rated plate dissipation in watts. For a more exact determination, the power dissipated in the grid leak should be subtracted also. The power dissipated in the grid leak is the resistance of the leak in ohms multiplied by the square of the grid current in amperes.

TRANSMITTING TUBES

The type of tube to be used should be given consideration before a start is made with the construction of any of the apparatus for the transmitter. The design of almost every item in the transmitter will be influenced by the tube with which it is to be operated. The rating of the transformers, the current-carrying capacity of the filter, the rating of the fixed condensers, the type of variable condensers and the design of the inductances, all will depend upon the power and voltage rating of the tube.

Fortunately there is a splendid array of transmitting tubes from which to choose. What is more, the tubes available are of high quality with satisfactory characteristics. If they are

handled carefully and operated correctly they will give wonderful service.

The amateur usually uses the lowest-power transmitting tube, the Type '10 — or even a receiving tube — for his first transmitter. This practice is a good one. The use of low power enables the transmitter to be built cheaply and yet provides full opportunity for the amateur to gain a knowledge of the operation and handling of a transmitter. Many of the most experienced amateurs actually prefer a low-power transmitter of this type, knowing that they can readily communicate over many thousands of miles under good conditions. The distance that can be covered by a transmitter is, in fact, not very much dependent upon the power of the transmitter. Even a receiving tube in the hands of an experienced amateur can send across the world when conditions are very good. The higher-powered transmitters can send no farther than this but they have the advantage of being able to put signals into far distant countries with greater reliability and readability.

Many amateurs use tubes having a higher power output rating than the 7.5-watt Type '10. Such tubes are listed in the table which is a part of this chapter. Screen-grid power tubes are included also but these are more applicable to the amplifier stages of oscillator-amplifier transmitters than as oscillators in self-excited transmitters. The explanation of the Class A, B and C designations is given in the following chapter on radiotelephony.

The type designation of transmitting and receiving tubes in this table, as well as of the rectifier tubes in Chapter IX and the modulator tubes of Chapter VIII, are generally applicable to standard tubes of American manufacture. The designation consists of the last two figures of the manufacturers' type number preceded by an apostrophe and the word “Type.” The only exceptions are for tubes which are made exclusively by one concern or where two entirely different types of tubes happen to have the last two figures of their type numbers in common, as with the UX-245 and UV-845.

(Of course the tube transmitter is not the whole of the transmitter assembly, and the circuit looks much more complicated when the power-supply system, the filter, and the keying arrangement are added. The usual complete transmitter may be divided into five sections. The first section is the power supply of (generally) 110-volt 60-cycle alternating current supplying the plate and filament transformers. The plate transformer steps the alternating current up to a voltage between 400 and 2,500 (depending on the tube used in the transmitter) while the filament transformer steps down the voltage to the rated value of the tube filament. Any variation of the high voltage usually is obtained by changing taps on the secondary winding. Adjustment of the output of

RECEIVING AND TRANSMITTING TUBES											
Type	Use ¹	Output (Watts)	Plate Volts ² (E_b)	S.-G. Volts (E_d)	Plate M.a. (I_b)	Negative Grid Bias (E_c) Volts ³	Fil. Volts (E_f)	Fil. Amps (I_f)	Typical Characteristic Values		
									Amp. Factor (μ)	Plate Impedance (r_p) Ohms.	Mutual Conductance (g_m) Micromhos
'99	G. P.		90		2.5	4.5	3.3	.063	6.6	15,500	425
'20	A	110	135		6.5	22.5	3.3	.132	3.3	6300	525
'30	G. P.		90		2.0	4.5	2.0	.060	8.8	12,500	700
'31	A	170	135		8.0	22.5	2.0	.130	3.5	4000	875
'32	V. D.		135	67.5	1.5	3.0	2.0	.060	440.0	800,000	550
'01-A	G. P.		135		3.0	9.0	5.0	.250	8.0	10,000	800
'12-A	G. P., A	260	180		7.6	13.5	5.0	.250	8.5	5000	1700
'71-A	A	700	180		20.0	43	5.0	.250	3.0	1850	1620
'40	V		180		0.2	3.0	5.0	.250	30.0	150,000	200
'22	V. D.		135 135	67.5 45.0	3.3 1.5	1.5 1.5	3.3 3.3	.132 .132	290.0 300.0	600,000 850,000	480 350
'26	V. A	180	180		7.5	13.5	1.5 (a.c.)	1.05	8.2	7300	1125
'27	G. P.	165	180		5.0	13.5	2.5 (a.c.)	1.75	9.0	9000	1000
'24	V. D.		180	90	4.0	3.0	2.5 (a.c.)	1.75	400.0	400,000	1000
'50	A, M	4.6	450		55.0	84.0	7.5 (a.c.)	1.25	3.8	1800	2100
'45*	A B C	1.6 5.0 5.0	250 250 250		34.0 50.0 50.0	50.0 90.0 180.0	2.5 (a.c.)	1.50	3.5	1750	2000
'10*	A B C	1.6 7.5 7.5	425 350 350		18.0 30.0 60.0	39.0 50.0 100.0	7.5 (a.c.)	1.25	7.5	5000	1600
841	V		425		7.5	8.0	7.5	1.25	30.0	21,500	1400
842	A, M C	3.0 7.5	425 350		28.0 60.0	100.0 250.0	7.5 (a.c.)	1.25	3.0	2500	1200
'65*	B C	7.5 7.5	500 500	125 125	30.0 60.0	40.0 90.0	7.5 (a.c.)	2.0	150.0	200,000	750
'03-A	B C	75.0 75.0	1000 1000		85.0 175.0	50.0 112.0	10.0 (a.c.)	3.25	25.0	5000	5000
'11	A B C M	10.0 75.0 75.0 75.0	1000 1000 1000 1000		72.0 85.0 175.0 20.0	55.0 100.0 200.0 70.0	10.0 (a.c.)	3.25	12.0	3400	3530
845	A, M	20.0	1000		75.0	150.0	10.0 (a.c.)	3.25	5.0	2100	2380
'52*	B C	75.0 75.0	2000 2000		50.0 100.0	150.0 300.0	10.0 (a.c.)	3.25	12.0	6000	2000
'60*	B C	75.0 75.0	2000 2000	300 500	50.0 100.0	75.0 150.0	10.0 (a.c.)	3.25	200.0	150,000	1350
'04-A	B C	250.0 250.0	2000 2000		140.0 275.0	100.0 200.0	11.0 (a.c.)	3.85	25.0	5000	5000
'49	A, M B C	100.0 350.0 350.0	3000 2000 2000		100.0 175.0 350.0	132.0 100.0 200.0	11.0 (a.c.)	5.0	19.0	3200	6000
'61*	B C	500.0 500.0	3000 3000	500 750	175.0 350.0	100.0 200.0	11.0 (a.c.)	10.0	300.0	133,000	2250

* Particularly suited to use as an oscillator or radio-frequency power amplifier at frequencies above 3000 kc. (wavelengths below 100 meters).

¹ A — Audio-frequency output amplifier. B — Radio-frequency power amplifier, particularly as a linear amplifier for modulated radio-frequency. C — Oscillator or modulated radio-frequency power amplifier. D — Detector. G. P. — General purpose receiving tube. M — Plate (Heising) audio-frequency modulator. V — Audio-frequency voltage amplifier. A more detailed explanation of the transmitting tube designations will be found in the chapter Radiotelephony.

² Plate voltage specified for receiving tubes is maximum. Plate voltage for B and C use is maximum for modulated operation. Unmodulated, values may be slightly higher.

³ Bias measured from filament center-tap or cathode with a.c. filament supply.

the filament transformer is obtained by the use of a rheostat or variable reactor in the primary circuit of the transformer.

From the secondary of the high-voltage transformer the alternating current is led to the rectifier — the second division — where it is changed into pulsating direct current. This current then goes through the third section — the filter — where the pulsations are smoothed out so that the current becomes a steady direct current. This d.c. supply is then led to the tube transmitter proper which converts the direct current into radio-frequency power. The fifth section of the transmitter is the antenna system. It is tuned to the frequency of the transmitter and takes its power from the plate circuit of the tube. In this chapter we will consider chiefly the transmitter — the apparatus in the fourth section. The power supply, rectifier, filter, keying and antenna systems will be discussed separately.

PLANNING THE TRANSMITTER

The low-powered transmitter really can be considered as an oversize oscillating receiver. There are few essential differences in its arrangement and not much more difficulty involved in its construction. The chief thing to remember is that, whereas extremely minute currents flow in the tuning circuits of the receiver, very heavy currents flow in even the low-power transmitter. This means that the first constructional difference between the transmitter and receiver is in the size of conductors used for the tuning coils and the leads connecting them to the tuning condensers. Heavy wiring is required in most other parts of the transmitter but it is of greatest importance in the tuning circuits, where the currents obtained are many times greater than those in any other portions of the circuit.

Another essential difference between the receiver and transmitter is that the fields around the coils and condensers of the transmitter are very much more intense than in the receiver. Consequently greater spacing between the coils and other apparatus is desirable and the elimination of unnecessary heavy insulating material supports inside the coils is important.

Yet another prime difference is that the voltages in the transmitter are of a much higher order than in the receiver. Insulation throughout the transmitter must therefore be given particularly careful consideration.

There is a splendid field for the exercise of thought and originality in the arrangement of the apparatus of the transmitter. The shortness of leads and the placement of the coils and condensers with respect to the other apparatus are matters of such importance that the amateur will always be rewarded for time spent in consideration of the problem. In the pages that follow some examples of satisfactory layouts will be given. These will serve to give a general idea of

how the transmitter can be arranged. However, they are not the acme of perfection. Neither are they applicable to all types of apparatus. The use of even a different variable condenser than that shown in any one of the examples — a condenser with its terminals in a different place — may make some entirely different lay-out preferable. The amateur should not allow this discussion to dishearten him, however, for it cannot be denied that excellent results are being obtained every day in amateur stations all over the world with the apparatus arranged in quite different fashions.

Most of the transmitters to be described are baseboard-mounted with all the apparatus exposed and readily accessible for adjustment or experiment. If desired, the apparatus can be mounted on a baseboard and a vertical panel in a manner somewhat similar to the receiver. Unless the apparatus is arranged with great care, however, this type of construction is likely to mean a sacrifice of convenience in making alterations and adjustments.

THE SINGLE-CONTROL TRANSMITTER

The construction of a simple transmitter can be accomplished in the shortest time and with the least difficulty by mounting the apparatus on a baseboard in somewhat the manner shown in the illustrations. We will use this transmitter as an example and describe it in detail. If the reader studies the circuit diagram, the photographs and the description carefully he will find that the transmitter is even simpler than it looks. If he understands just what it is all about he will find it easier to modify the arrangement to suit the particular apparatus at his disposal.

This transmitter is perhaps the simplest and most nearly fool-proof ever designed. It contains the very minimum of parts and is therefore extremely low in cost. The construction is in no way complex and the adjustment is easily accomplished by even the inexperienced operator. The circuit is a modification of the popular tuned-grid tuned-plate, with but one tuning control. Despite its simplicity, the set has excellent frequency stability and efficiency, comparing favorably with more complicated arrangements.

The frequency is determined by the tuning of the plate tank circuit and the excitation is dependent on the constants of the grid circuit. Since one excitation adjustment is satisfactory over a considerable range of plate-tank tuning, it is possible to use a fixed coil in the grid circuit for each amateur band. The necessity of a separate tuning control for the antenna circuit is eliminated by using a single-wire untuned feeder for connecting the plate circuit to the antenna. The set is designed to use a Type '10 tube with a 500-volt d.c. plate supply and a 7.5-volt a.c. filament supply, or a Type '01-A tube with a 135-volt d.c. plate supply and a 6-volt d.c. filament supply.

CONSTRUCTION OF THE SET

The schematic wiring diagram is given, together with the constants, and the photographs show how the set looks when constructed. The layout chosen is one which allows short r.f. leads.

The grid coils L_2 , are wound with No. 30 d.c.c. wire on $2\frac{1}{2}$ -inch length of 1-inch tubing, which may be of bakelite, paper, wood or any other of

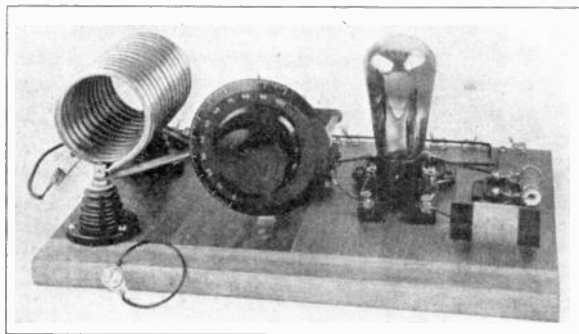

THE SINGLE-CONTROL LOW-POWER TRANSMITTER

The plate tank circuit is at the left. The grid coil, leak and grid condenser are to the right of the Type '10 tube.

the common insulating materials. The coils should be given a coat of collodion or clear Duco varnish to maintain their characteristics. Two small brass angles, obtainable from any hardware store, serve both as connections and supports for these coils, the ends of the winding being brought out to small machine screws inserted at the ends of the coil forms.

The baseboard itself is a bread-board $13\frac{1}{2}$ inches long by 10 inches wide. Two General Radio stand-off insulators are mounted at one end, as shown in the photographs, and serve as a support for the plate coil, L_1 . These insulators should be placed $4\frac{1}{2}$ inches apart between centers. This mounting is very solid mechanically, and allows easy changing of coils. If changes from one band to another are frequent, it might be advisable to use wing-nuts to fasten the coils down instead of the hexagonal nuts furnished with the insulators.

The plate coils themselves are $\frac{1}{4}$ -inch soft copper tubing, wound around a pipe $2\frac{3}{8}$ inches outside diameter. The ends of the coils are flattened in a vise and drilled to fit over the machine screws in the G. R. insulators. The 3500-kc. coil should have the turns so spaced that when finished it will just fit on the insulators without having the ends bent out, as is done on the coils for the higher-frequency bands. The spacing between turns on the 7000-kc. coil is about $\frac{3}{16}$ -inch, and on the 14,000-kc. coil about $\frac{1}{8}$ -inch. After the coils are finished they should be polished with fine steel wool, thoroughly cleaned with alcohol, and given a coat of clear Duco, greatly diluted with "thinner," to keep them bright.

The tuning condenser C_5 , in this case a 21-plate

Cardwell, is mounted on small brass angles of the same type used for mounting the grid coil. Connections between the condenser and the coil are made by pieces of copper tubing, since the leads in the tank circuit must be as heavy as the inductance itself. The connection to the insulator at the front of the baseboard should be from the rotary plates (the condenser frame), that to the rear insulator going to the stationary plates. This puts the "hot" end of the coil at the back of the set and reduces the effect of hand capacity.

The plate by-pass condenser, C_2 , is mounted close to the tuning condenser on the baseboard. The radio-frequency choke, L_3 , is just behind it. The filament by-pass condensers, C_3 , are directly behind the tube socket. The purpose of these condensers is to provide an easy path for radio-frequency currents flowing to the filament of the tube which would otherwise have to go through the resistor R_1 . When the filament of the tube is heated from alternating current these "center-tap" resistors are necessary to avoid having the alternating voltages on the filament reach the

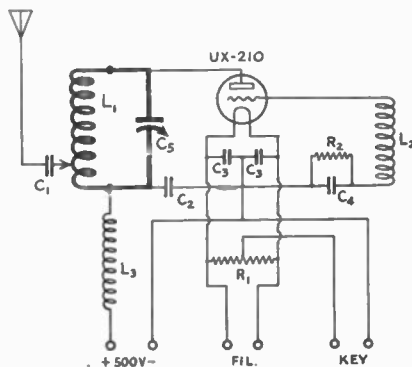

THE CIRCUIT OF THE SINGLE-CONTROL TRANSMITTER

L_1 and L_2 —Plate and grid coils. The specifications are given under the illustration of the coils.

L_3 —A commercial "short-wave" receiving-type radio-frequency choke will do or one can be made by winding a two-inch length of half-inch tubing or wooden dowel with No. 38 d.c.c. or d.c.c. wire.

C_1 —2000- μ fd. (.002 μ fd.) mica fixed condenser, receiver type.

C_2 —2000- μ fd. (.002 μ fd.) mica fixed condenser, receiver type, if plate voltage does not exceed 500.

C_3 —5000- μ fd. (.005 μ fd.) mica fixed condenser, receiver type.

C_4 —250- μ fd. (.00025 μ fd.) mica fixed condenser, receiver type.

C_5 —500- μ fd. (.0005 μ fd.) variable condenser. Any good receiving condenser will be satisfactory.

R_1 —Center-tapped resistor, 75 to 100 ohms total resistance.

R_2 —Grid leak resistor, 10,000 ohms. Any small resistor rated at 5 watts or more will do.

Two General Radio or similar stand-off insulators will be necessary, as well as 7 Fahnestock clips, some miscellaneous small machine screws and nuts, and a few feet of bus wire.

grid, for this would cause modulation or "ripple" on the transmitted signal. The voltage at the leads to the filament is constantly changing at the 60-cycle supply frequency but the voltage at the center point of the resistor R_1 is constant. Another method of accomplishing the same result is to use a center tap on the filament-supply winding of the transformer. The center-tap resistor arrangement is sometimes preferable, however, since it permits the use of a filament rheostat in the secondary of the filament transformer instead of the primary. Rheostats for the secondary winding are more readily available than the other type. In place of the resistors, Christmas-tree lamps or automobile headlight lamps can be used. They are equally effective.

The grid condenser, C_4 , and leak, R_2 , are to the right of the filament by-pass condensers. The condensers in this set, which are Sangamo, are mounted flat by means of machine screws running up through the baseboard. The antenna insulating or blocking condenser, C_1 , is mounted on the left rear corner of the board, one side going to a Fahnestock clip for the antenna connection, the other to a piece of flexible wire 8 inches long terminating in a small spring clip which fastens on the plate coil. The filament center-tap resistor, R_1 , is mounted directly on top of the filament by-pass condensers.

All connections are run to the rear of the board where they terminate in Fahnestock clips. From

pling to a Hertz antenna by a single-wire feeder, other types of antenna or feeder systems may be inductively coupled to the plate-tank circuit by adding an antenna coupling coil and a tuning condenser. Such coupling arrangements are shown with the other transmitters in this chapter. *In no case should the antenna (radiator) itself*

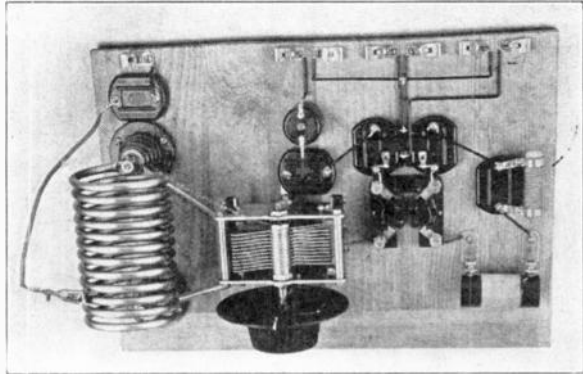

PLAN VIEW OF THE TRANSMITTER

The antenna-blocking condenser C_1 is to the rear of the plate inductance. The fixed condenser, C_2 , and the radio-frequency choke are behind the tuning condenser, C_3 . The two fixed condensers behind the socket are the filament by-pass condensers C_4 . The filament center-tap resistor, R_1 , is mounted on top of these condensers. The grid condenser, C_4 , and grid-leak resistor, R_2 , are to the right of the socket. The grid inductance, L_2 , is in front of the grid condenser and leak. The connections to the Fahnestock terminals are explained in the text.

be connected directly to the plate coil. Such coupling arrangements are illegal in the U. S. A. Complete instructions for designing and constructing the single-wire-fed Hertz antenna will be found in Chapter XI.

TUNING THE TRANSMITTER

These instructions for tuning this transmitter are for its use with an antenna which is fed by a single-wire feeder. They are also applicable to other antenna systems except that tuning of the antenna system will also be necessary. Such tuning adjustments are described in connection with other transmitters in this chapter.

Since the current in the single-wire feeder is extremely small, a radio-frequency ammeter in the feeder is of little utility as a resonance indicator. If a plate milliammeter is connected in the negative high-voltage lead, a sharp rise in its reading may be taken as an indication of resonance when the plate tank condenser is tuned through resonance, but the simplest indicator is the flash-light bulb connected in a single turn of wire, shown in front of the set in the illustration. Its use will be described later.

Disconnect the feeder clip from the plate coil and set the plate tank tuning condenser for about the middle of the band on which operation is to take place. If the constructional specifications have been followed closely this setting will be

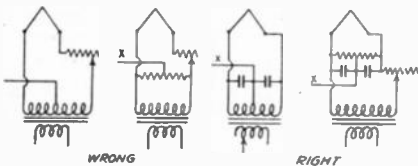

METHODS OF CONNECTING TO THE "ELECTRICAL CENTER" OF THE FILAMENT CIRCUIT

right to left in the photograph, the first two clips are for the key, the second two for filament supply, and the last two are for "minus" and "plus" high voltage, respectively. The wiring of the whole set is quite simple, and in case it is to be duplicated no difficulty should be experienced in following the diagram and photographs.

The 500-volt power supply described in Chapter IX is an excellent one to use with this transmitter when the transmitter tube is a Type '10. If a Type '01-A receiving tube is used, the plate supply can be a 135-volt "B" substitute or 135 volts of "B" batteries. Filament supply can be from a 6-volt battery, through a 6-ohm rheostat.

Although the transmitter is intended for cou-

with the rotor plates about four-fifths meshed for the 3500-kc. band; about three-quarters meshed for the 7000-kc. band; and about half meshed for the 14,000-kc. band. The antenna system should

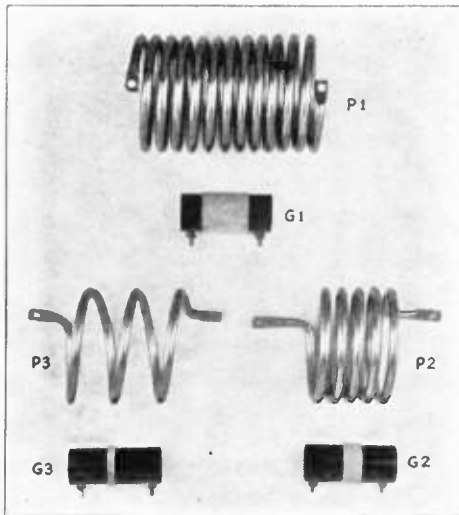

THE PLATE AND GRID COILS

A description of these coils is contained in the text, while the number of turns on each is given below.

Coil	Band	Turns
P-1	3500	12
P-2	7000	5
P-3	14,000	3
G-1	3500	60
G-2	7000	25
G-3	14,000	9

For the 1750-kc. band, a plate coil of 25 turns of No. 14 d.c.c. on a 3" diameter form with spacing between turns equal to the diameter of the wire; a grid coil of 150 turns on the same size form as the other grid coils. The number of turns on the grid coils may require some modification. Turns should be added or removed until the set operates stably and efficiently over the required frequency band.

have been constructed to specifications for a frequency in the middle of one of the bands, preferably for about 3575 kc. in the 3500-kc. band. This will permit operation in all three bands, the antenna working at its second and fourth harmonics on 7150 and 14,300 kc., respectively.

Tuning for operation on the 3500-kc. band (with the 12-turn plate coil), set the condenser with the rotor plates four-fifths in, turn on the power supply and close the key. If the resonance indicator is now held near the front end of the plate coil the bulb should glow, indicating that the set is oscillating. The loop should not be held too close to the coil, however, because the bulb is likely to burn out. The frequency should now be checked with the frequency meter following the method described in the preceding chapter. If the frequency is outside the band, the transmitter should be retuned to a frequency inside the band.

The antenna clip should now be put on the

plate coil four or five turns from the front end (the end connected to the rotor of the condenser). Hold the loop steady a few inches from the coil, and swing the tuning condenser over the upper portion of the scale. As the dial is turned the lamp will get dimmer, and if the loop is held far enough from the inductance a point will be found where it will go out. Moving the condenser beyond this point will make the lamp get brighter again. The point at which the lamp goes out is the point at which the oscillator is tuned to the antenna. Check the frequency with the frequency meter.

Now move the antenna clip toward the front end of the coil one turn at a time, swinging the tuning condenser, as before, each time a change is made. The dip will always occur at about the same place on the condenser, but as the clip is moved toward the front of the coil it will be less pronounced. Continue this until the dip is just perceptible. Then move the clip back toward the plate end of the coil one turn, tune as before and, as a final adjustment, set the condenser at slightly less capacity than the point at which the dip occurs. The signal should be checked at this point by means of a monitor, since the final adjustment of the tuning condenser sometimes has a very noticeable effect on the tone. There should be just enough detuning to make the frequency stable and the note clear.

The tuning for the 7000- and 14,000-kc. bands is done in a similar manner, except that the clip should be moved only a fraction of a turn at a time. The number of coupling turns will vary somewhat, depending on the frequency used and whether the antenna is being operated on its fundamental or on a harmonic. In general, about 3 turns will be sufficient on the 3500-kc. band, 1 on the 7000-kc. band, and 1/4 to 1/2 turn on the 14,000-kc. band.

Since a Hertz antenna will work quite well within a narrow band of frequencies about its fundamental, tuning over a small range of frequency is permissible.

The resonance peaks, as shown by the indicator, will not be so sharp on the bands which are harmonics of the antenna's fundamental frequency. Careful checking of the frequency with the frequency meter and monitor is therefore even more important on the higher-frequency bands.

After a further check of the frequency, tests can be made to see whether the keying is clean and whether keying chirps exist. The various methods by which keying can be accomplished, and their adjustment, are treated in another chapter so we will not touch upon them here. At this stage of the adjustment process, however, the checking of keying is all that is necessary before the first CQ can be called.

Successful tuning is greatly a matter of experience and the amateur will soon find that many improvements in the signal can be made by slight

adjustments here and there. Just so long as the signal is observed continually in the monitor, these adjustments and their effect will soon be found. When he has had some experience the amateur will find that he can anticipate the effect on the signal of every adjustment he makes.

Summed up in a few words, the aim in all transmitter tuning is to get the steadiest and cleanest signal consistent with reasonable antenna power at the rated input to the tube.

A HARTLEY TRANSMITTER

Like the Single-Control transmitter, this set is built up on a breadboard although its mechanical construction is somewhat more complicated. It also differs from the simpler transmitter in that it uses the Hartley circuit, with magnetic coupling between the grid and plate, and has a separate

The tube is a Type '10 and the 500-volt power supply described in Chapter IX is well suited for use with this transmitter.

The baseboard measures 10" x 12". The apparatus on it is grouped in two units—the tube and its associated equipment on the left, and the antenna coupling coil, antenna condenser and ammeter on the right. Every effort has been made to make the leads in the oscillator circuit as short as possible, at the same time permitting the coil to be in a clear space by itself. The condenser C_2 in the circuit diagram is that at the left of the baseboard, and on which the tube is mounted. The tube base is supported from the condenser by two small brass angles, well insulated from the socket terminals, one of which can be seen in the first illustration of the set. The tube is placed in this position so that the terminals on the socket

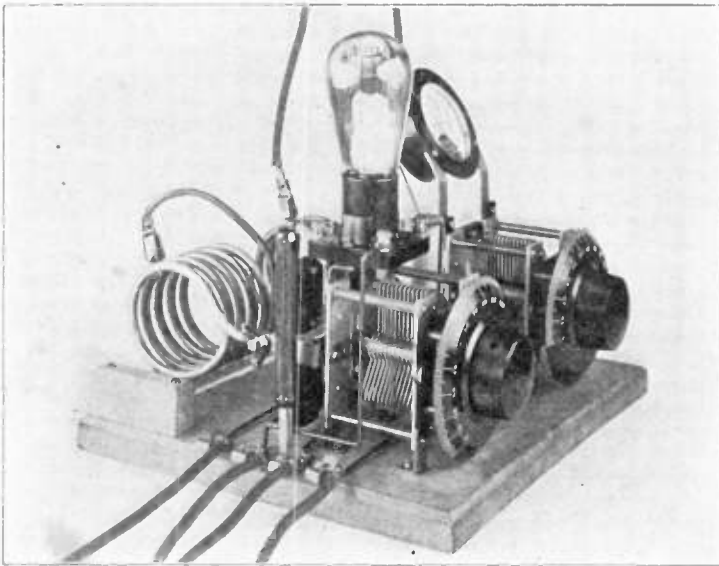

THE LOW-POWER HARTLEY TRANSMITTER

The tube socket is mounted by brass angles on the rear of the tank condenser. The socket terminals should be well insulated from the supports.

adjustment for excitation. In addition, it incorporates a tuned antenna circuit inductively coupled to the plate circuit, adapting it to almost any type of antenna system. The plate power is fed to the plate through a radio-frequency choke shunting the tuned circuit, instead of through the plate inductance as in the first transmitter. The shunt-feed arrangement is fully as satisfactory as the series feed, providing the radio-frequency choke has a sufficiently high impedance at the operating frequency. It does introduce an element of uncertainty, however, because it is difficult to get a radio-frequency choke having sufficiently high impedance over a wide band of frequencies.

are convenient to the apparatus to which they are connected and so that the tube itself is out in the open where the heat developed can be radiated rapidly.

In the close-up of the transmitter the condensers C_3 and C_4 can be seen connected to the grid and plate terminals of the tube socket with small angle-pieces of brass strip. Below these are the two filament by-pass condensers indicated as C_5 on the diagram.

The most important item of all is the tank circuit consisting of the coil L_2 and the condenser C_2 . It is this tuned circuit that sets the frequency of the transmitter and it is the resistance of this circuit that influences to a very great extent the

efficiency and general performance of the transmitter. Even with a 7.5-watt tube the radio-frequency current circulating in this circuit can be as high as 5 amperes, and the avoidance of clips or other poor contacts, or the use of small conductors, is therefore essential. The transmitter can take very high plate currents, can

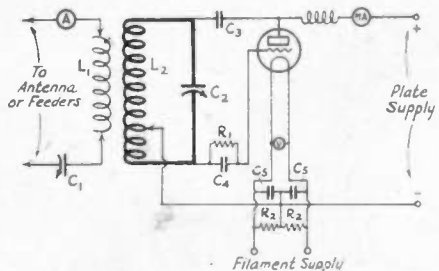

CIRCUIT OF THE HARTLEY TRANSMITTER

- A — Thermocouple ammeter, 0-1 amps.
 V — Alternating current voltmeter, 0-10 volts.
 MA — Direct current milliammeter, 0-100 milliamps.
 C₁ — 500- μ fd. receiver-type variable condenser.
 C₂ — 500- μ fd. receiver-type variable of good quality.
 C₃ — 500- μ fd. fixed condenser.
 C₄ — 250- μ fd. fixed condenser.
 C₅ — 2000- μ fd. fixed condensers.
 (These fixed condensers should be high-grade 500-coil receiver-type condensers or special transmitting type.)
 R₁ — 10,000-ohm transmitting grid leak.
 R₂ — 50- or 100-ohm fixed resistors or Christmas-tree lamp.
 RFC — 160 turns of No. 30 gauge d.c.c. wire on $\frac{1}{4}$ "-diameter wooden rod.

L₁, L₂ — Plate and antenna coils described under illustration. Wooden baseboard 10" x 12".

Two glass towel bars and wooden supports for same. Four terminals or Fahnestock clips, miscellaneous wood screws, machine screws, wing nuts, clips, copper strip for connections and brackets, 14 gauge enamelled copper wire for connections shown in light lines.

Power supply, antenna and keying systems for this and the other transmitters are discussed in separate chapters.

operate unstably or can fail to oscillate at all just because there is a poor contact in this circuit or because the conductor is too small. In this transmitter the coils are wound of $\frac{1}{4}$ "-diameter soft copper tubing which can be obtained at most hardware stores or automobile supply houses.

The coils can be wound on a piece of 2 $\frac{3}{8}$ " outside diameter iron water pipe or on a wooden former of the same size.

The wing-nuts and the connector strips can be seen in the close-up view of the transmitter. The connector strips are of $\frac{3}{8}$ "-wide heavy copper. The lead from the coil to the center-tap of the filament circuit carries relatively little current. It is therefore possible to use a clip on the coil to permit adjustment. The grid leak R₁ can be seen in the illustrations standing vertically alongside the variable condenser C₂. It is pushed over a wooden rod which in turn is pushed into a hole in the baseboard. The radio-frequency choke is the only other item in the oscillator circuit. It can be

seen on the opposite side of the variable condenser from the grid leak. This choke serves to prevent the radio-frequency current generated by the tube from getting back into the power supply. The operation of the transmitter is greatly dependent upon its effectiveness. The dimensions given under the diagram should make a satisfactory choke but it is advisable to experiment with slightly different values. A neon bulb is very useful in checking up on the performance of radio-frequency chokes. If it is held by the glass portion and one of its contacts is held on a wire carrying radio-frequency current, the lamp will glow brightly.

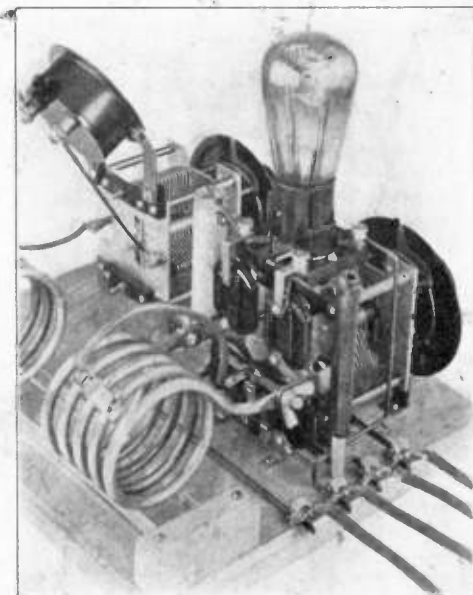

A "CLOSE-UP" SHOWING THE HEAVY "TANK" LEADS AND SOLID CONSTRUCTION

The plate and grid fixed condensers are mounted immediately under the tube socket. Below them are the two filament by-pass condensers and the center-tapped filament resistor. On the far side of the tube socket is the plate choke supported from the plate terminal. On the near side is the grid leak pushed over a wooden peg in the baseboard. Heavy flexible wire is used for the filament lead to the inductance, a clip being permissible in this case on account of the low current to be passed by it. Relatively enormous currents flow in the coil-condenser circuit and in this case connections between the two must be made with wing nuts, or some similar device, to avoid serious losses.

When such a lamp is touched on the lead from the choke to the tube plate it will therefore light. If the choke is operating properly there will be only a slight trace of radio-frequency current at the other end of the choke and when the lamp is put in contact with the lead from this end it will light very dimly or not at all. In a low-powered transmitter of this type the choke would not be considered effective if the neon tube lighted brightly enough to be visible in daylight. A

wooden handled screwdriver can be used in a somewhat similar manner. When the screwdriver is held by the wooden handle and its metal end touched on a wire carrying radio-frequency current a spark will be seen as the contact is made or broken. An appreciable spark should be obtained at the plate end of the radio-frequency choke and none at all at the opposite end.

The second section in the transmitter is the antenna coupling and tuning unit. It consists of the variable condenser C_1 which sits alongside condenser C_2 ; the 0-1 ampere thermocouple ammeter, which is mounted above the condenser C_1 ; and the antenna coil L_1 , which can be seen resting on the two glass towel bars which run the length of the baseboard at the rear. These glass rods are used to prevent the coils from vibrating, to insulate them from the baseboard, and to permit the antenna coil to be moved away from or near to the plate coil, thus varying the antenna coupling.

In the illustration of the coils for this transmitter, coils for five frequency bands are shown. This does not mean that all of them must be built. Though there are six frequency bands available to the amateur, it is best for the newcomer to attempt operation on one of them only until he has mastered the adjustment and operation of the equipment. One reason for this is that the antenna system is quite a simple affair for any one band but becomes complex and difficult to adjust when an attempt is made to make it operate on several bands. Then, it is a little difficult to adjust the transmitter for maximum performance on any one band, let alone adjusting it for several. Any of the four lower-frequency bands are satisfactory for the first attempt, though of these the two higher-frequency bands — the 7000-kc. and 14,000-kc. bands — will permit of communication over the greater distances.

This transmitter is designed for use with a Type '10 tube and it should be clearly understood that it will not prove satisfactory with a tube of higher power rating or widely different characteristics.

TUNING THE HARTLEY

The tuning of any transmitter is a matter of the greatest possible importance. The performance of even the best transmitter can be spoiled by the slightest misadjustment, and on the other hand almost any transmitter can be made to perform well by an amateur experienced in the work. Even the most experienced amateur, however, cannot tune the transmitter effectively unless he is able to listen to it as he adjusts the controls. The use of some sort of monitor to listen to the signal as the transmitter is tuned is essential. A detailed description of simple monitors will be found in Chapter VI. It should be studied and a monitor built before any attempt is made to tune the transmitter.

When the transmitter has been assembled;

when the antenna and its leads or feeders have been tightened; when it has been found that the leads and coil, or the transmitter itself, will not vibrate, the filament supply should be switched on and the filament voltage adjusted to the rated value — 7.5 volts. Now the filament clip should be adjusted to about the position shown in the illustrations where the ratio of grid to plate turns is about 1 to 4 or 1 to 5. A low plate voltage should be used for the first test, about 250 or 300 volts being a suitable value. The antenna coil should be

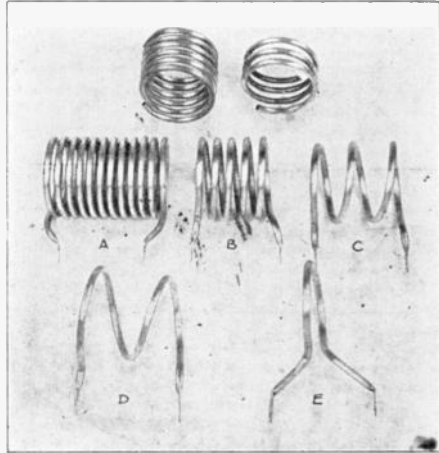

PLATE AND ANTENNA COILS FOR THE HARTLEY SET

Coils A, B, C, D and E are used for the 3500-4000 kc. ("80-meter"), 7000-7300 kc. ("40-meter"), 14,000-14,400 kc. ("20 meter"), 28,000-30,000 kc. ("10 meter") and 56,000-60,000 kc. ("5 meter") bands, respectively. They have an inside diameter of $2\frac{3}{8}$ " and were made by winding the $\frac{1}{4}$ " soft copper tubing over a length of $2\frac{3}{4}$ " (outside diameter) iron water pipe by hand. To facilitate the winding process holes were first drilled in the pipe and the tubing, one end of the copper tubing being secured to the iron pipe with a machine screw before the winding was started. The ends of the coils are hammered flat and drilled to fit under the wing nuts which hold them to the condenser leads. Two antenna coils — to be seen above the plate coils — serve for use with coils A, B, C and D. Their size will be determined to some extent by the type and constants of the antenna. The method of winding the coils is illustrated at the end of this chapter.

taken off or coupled very loosely to the plate coil when this plate voltage is switched on, and the filament clip should be readjusted to give a plate current of about 20 or 25 milliamps. The plate current should be switched off before any readjustments are attempted, since a serious, perhaps fatal, shock would result from contact with wiring connected to the plate supply. Contact with other metal parts of the set while it is running probably would mean a bad radio-frequency burn. The frequency should now be checked by one of the methods described in the chapter on frequency measurement, and when it has been made certain that it is within the band the adjustment can proceed. The plate voltage can now

be increased to normal. The antenna coil at this time can be coupled more closely and the antenna tuning varied until maximum current is indicated. The antenna coupling can be increased until the greatest possible antenna current is obtained. This value should be noted carefully as something to avoid using at all costs. Without delay the antenna coupling should now be backed off, retuning the condenser as each adjustment of coupling is made, until the current is about 85% of the highest value. Now the antenna should be detuned until the current has dropped to about 85% of the last value. Particular notice should be taken of the signal in the monitor as this detuning is done, since the signal probably will be much clearer with the antenna detuned on one side of resonance than on the other.

OTHER CIRCUITS — THE COLPITTS

There are several other circuits in which the apparatus described could have been arranged. The performance obtained with all of them would be almost identical once the adjustment had been

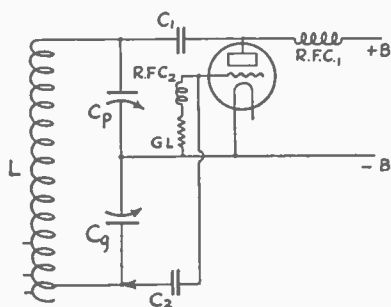

SIMPLEST FORM OF COLPITTS

mastered. Though it is impossible to describe in detail a transmitter with each circuit available, we will mention their different features so that their use will be understood.

In the Hartley circuit a magnetic feedback from plate to grid causes oscillation. In the tuned-plate tuned-grid arrangement a capacitive feedback from plate to grid is responsible for the action that takes place. The Colpitts circuit action is based similarly on a capacitive or electric feedback, though not through the inter-element capacity of the vacuum tube itself.

In the Hartley circuit the grid connects to one end of the coil, the plate connects to the other end and the filament goes in between the two. With r.f. currents flowing in the coil-condenser circuit there is a "voltage drop" across each section of the coil (due to its inductive reactance). This "voltage drop" always acts so that the grid voltage is exactly opposite to the plate voltage. When the r.f. grid voltage swings up, the r.f. plate voltage swings down. The filament is between the grid and plate in potential.

In the Colpitts circuit, coils and condensers have been swapped around so that in effect the filament is tapped to the center of a condenser with the grid and plate connections at the outside terminals. With r.f. currents flowing in the coil-condenser circuit there is a "voltage drop" across each section of the condenser (due to its capacitive reactance). This acts as above explained. The "voltage drops" of plate and grid circuits are exactly opposite in phase, with the filament in between the plate and grid as far as voltage is concerned. Hartley action is dependent on voltage drops across different parts of a coil. The Colpitts action is dependent similarly on voltage drops across different sections of a condenser.

The differences in all circuits are principally in ease of adjustment and control. The Colpitts controls somewhat differently than the others. Output and efficiency will remain about the same, however. In looking at the circuit diagram the first thing we notice is that the grid leak connects from the grid directly to the filament with a small choke in series to keep r.f. leakage currents down. While we had some choice in the matter in the Hartley and t.p. t.g. circuits, this connection of the grid leak is quite necessary in the Colpitts circuit. A leak connected across C_2 would be useless as C_2 would not afford a return path (the filament C_g acting as a blocking condenser with infinite impedance as far as d.c. is concerned). Increasing the capacity of C_p raises the wavelength and increases the grid feedback. Increasing C_g also lowers the frequency but reduces the grid excitation. It is simply a matter of adjusting the proportion of voltage drops across the two condensers by changing their size (and therefore their reactance). A frequency change is also caused, because changing either condenser changes the effective capacity across the coil. To keep the grid excitation constant and change the frequency, C_g and C_p can be increased or decreased together. A separate control of grid excitation can be had by making grid condenser C_2 variable or by adding a clip connection to L so that the lead from C_2 does not necessarily connect to the extreme end of the L - C circuit.

In using a practical form of the Colpitts circuit for transmitting, the controls must be kept down to a reasonable number and so it may be desirable to forego separate clip connections for control of grid excitation, particularly as extra leads hung on a circuit at different points tend to bring in double tuning effects at the higher frequencies.

By using a balanced arrangement and modifying our simplest form a little we can get rid of the necessity of using plate and grid r.f. chokes. This is a splendid idea for use in an outfit for work on different frequencies because one doesn't have to worry about plug-in chokes for the highest efficiency — a practical necessity if we plan to change our frequency over a very wide range. The

Colpitts circuit as shown goes down to our shortest waves with ease. As soon as C_g and C_p have been put on the same shaft or otherwise coupled together mechanically, the adjustments are as easy as with the other circuits and the wavelength can be changed with the grid excitation constant.

In the first paragraphs of our discussion of the Colpitts circuit attention was called to the fact that there is always a point of zero voltage between plate and grid, both between the two ends of the coil and between the two condensers. That means that there is no r.f. voltage between points x and y (even though there is the entire d.c. plate potential between them). Sketch "A" discloses that the plate blocking condenser C_1 has been taken out and that the plate supply is being fed to the center of coil L_1-L_2 . The high voltage is all over the coil and stator plates of both tuning condensers—but we have eliminated the necessity for a plate choke coil.

If C_g and C_p have the same capacity, L_2 and L_1 will be about equal in turns, but if C_g is larger, as it sometimes is, the arrangement will be in balance again when the voltage feed point B is moved down so that L_2 is smaller. The voltage node (zero) moves down the coil somewhat as the grid excitation is decreased by using a larger capacity at C_g without a proportionate increase in the capacity of C_p .

A good way to find the nodal point is to put an r.f. choke in the B-plus lead and to hunt r.f. voltage over the whole coil with a neon-tube indicator or insulated metal object. Insulation is important here as the coil is alive and dangerous. Hands off! The connection for the plate feed should be made to the zero point on the coil when it is located. If it's not exactly right, leave the r.f. choke in the plus lead to keep what little voltage is present where it belongs. The choke is relieved of the major part of its regular job, at any rate.

If a large capacity be placed at C_3 , as shown in sketch "B," it will have very little effect on the distribution of r.f. voltages over the coil. It will give us two points at about the same r.f. voltage and insulated with respect to d.c. voltages. This condenser should be capable of withstanding the plate voltage and handling the circulating current and should be at least ten times the capacity of the tuning condensers. The grid leak and B-plus leads may now be connected as diagrammed. No chokes of any description are left in our circuit. Neither is a grid condenser absolutely needed. C_3 keeps high-voltage d.c. off the grid.

C_g and C_p both carry the circulating current and must be transmitting condensers or at least double-spaced receiving condensers if much power is used. Remember that condensers in series have a smaller effective capacity than either condenser taken by itself. Two 500- μ fd. condensers on the same shaft in series will behave like a

single tuning condenser with a maximum of 250 μ fd. Use the effective capacity value when determining coil sizes in designing a transmitter.

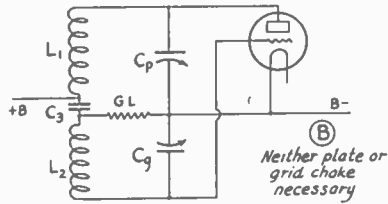
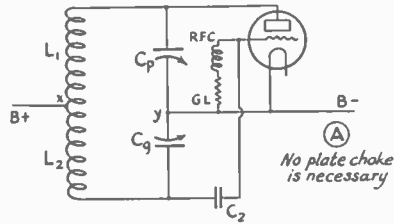

SOME VARIATIONS OF THE HOFFMAN BALANCED COLPITTS CIRCUIT

C_g should have twice the capacity of C_p to make the grid excitation have the optimum value unless a small grid condenser is used to limit the r.f. grid voltage.

Having determined the equivalent capacity necessary to cover a certain frequency range, a trial value for C_g or C_p may be substituted in the formula for series capacities (see chapter on "Fundamentals") and the value for C_p or C_g accurately determined.

THE ULTRAUDION

One popular arrangement is shown in the diagram referred to as the ultraudion circuit. The

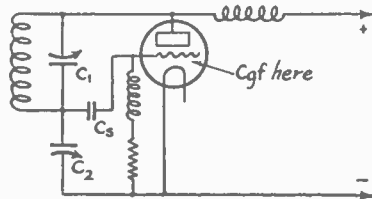

A SHUNT-FEED ULTRAUDION CIRCUIT

tuned circuit consists of the tank between the plate and grid. The frequency can be increased by the simple process of cutting down the size of the coil. When the coil is cut down to a mere connecting lead, tubes may be made to oscillate nicely on frequencies as high as 300,000 kc., the limit depending on the size of the grid-plate tube capacity which is different in different tubes.

The distributed capacity in the plate choke very likely by-passes some r.f. energy to the fila-

ment by way of the power supply (filter condenser). This is avoided in the practical and final arrangement of apparatus by moving the plate choke connection to the grid end of the tuned

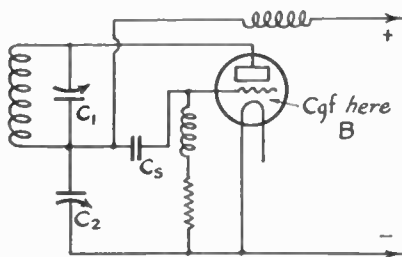

SERIES-FEED ULTRAUDION

condenser-coil circuit as shown in the next diagram. This is in reality a change from shunt or parallel plate feed to series feed. The harmful distributed capacity is now in shunt with C_2 where it does some good. There is also less r.f. voltage at the choke using the series arrangement, which is better. A variable high-resistance leak of 10,000 or 15,000 ohms will permit adjustment of the bias to the best operating value.

The plug-in coils for a practical ultraudion set are constructed just like the coils described in the first part of this chapter.

PUSH-PULL OSCILLATORS

Push-pull transmitting circuits are becoming increasingly popular among amateurs because

in series across the tuned circuits, thereby effectively halving the total effect of shunting tube capacities. This raises the upper frequency limit at which the circuit can oscillate, increases efficiency by reducing the losses due to high inter-electrode capacity, and improves frequency stability. The second commendable property is that the plate tank circuit receives an energizing impulse on each half cycle of its resonant frequency instead of on alternate half cycles, as with the single-ended types of circuits. A further advantage is that each tube is across but half of the tuned circuit, thereby permitting the realization of exceptionally good frequency stability with a lower capacity-inductance ratio than with single-ended circuit arrangements.

All of the "standard" circuits are adaptable to conversion to push-pull but some are better qualified than others. The essential difference between the set-up of a push-pull circuit and a single-ended circuit is that in the push-pull circuit the plates of the tubes are connected to opposite ends of the output circuit and the grids are connected to opposite ends of the input circuit. A study of the various Hartley, Colpitts, Ultraudion and tuned-grid tuned-plate arrangements immediately shows that their push-pull versions are of various degrees of complication in construction and adjustment. The push-pull tuned-grid tuned-plate circuit is outstandingly the simplest and most straightforward. It actually requires fewer parts than a single-ended set of the same circuit, with the exception of the additional tube. Recent investigations made by the QST Technical Staff

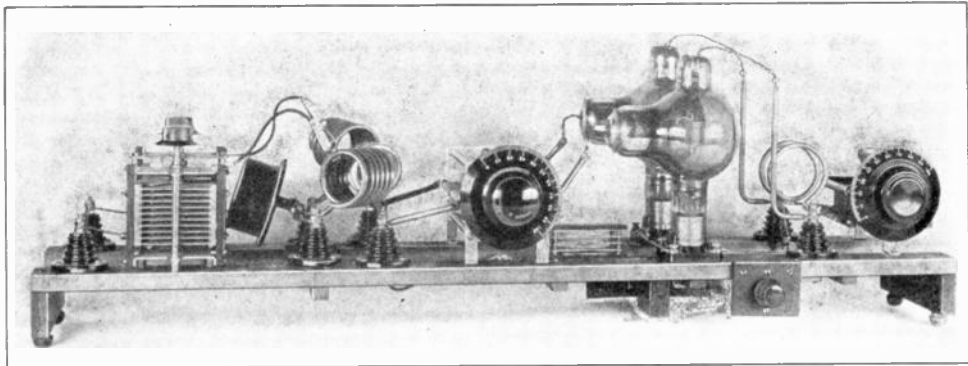

THE 150-WATT PUSH-PULL TRANSMITTER

The tuned-grid circuit is to the right of the tubes and the tuned-plate circuit is to their left. The antenna ammeter is supported by brass strips bolted to the wall insulators on which the two sections of the antenna coupling inductance are mounted. Filament- and plate-supply connections as well as the key-jack are on a terminal strip at the back. The antenna system connects to the two wall insulators at the extreme left of the assembly.

they have numerous advantages over "single-ended" circuits at amateur frequencies. These advantages become particularly noticeable on the 14,000-kc. and higher frequency bands. The improvement is attributable to several properties of the push-pull arrangement. The first is that the input and output tube capacities are

have shown that this type transmitter requires no filament by-pass condensers, no plate-blocking condenser and no grid condenser. In fact the operation of the transmitter is more satisfactory without these components than with them because anything not essential to the proper working of a high-frequency transmitter is better out of

the set than in it. As an additional attraction of this circuit, radio-frequency chokes in the grid return and plate feed either may be omitted entirely or used without doubt as to their efficacy, since both the plate-feed and grid-return connections are made at zero radio-frequency potential points of the output and input circuits

A PRACTICAL PUSH-PULL TRANSMITTER

The set shown in the illustrations uses two 75-watt Type '52 tubes. Although intended primarily for operation in the 14,000-ke. and

The National transmitting condenser, originally a single-section affair, requires some remodeling to convert it to a two-section type. This is easily done, however, since changes in the stator assembly only are necessary. The stator is removed by taking off the nuts on the supporting rods and then unfastening the supporting Crolite insulators. The stator is completely disassembled and the rods are each cut in the center. Copper washers are soldered to the unthreaded ends of the six half-rods and the stator is reassembled with the center plate left out. The result is two

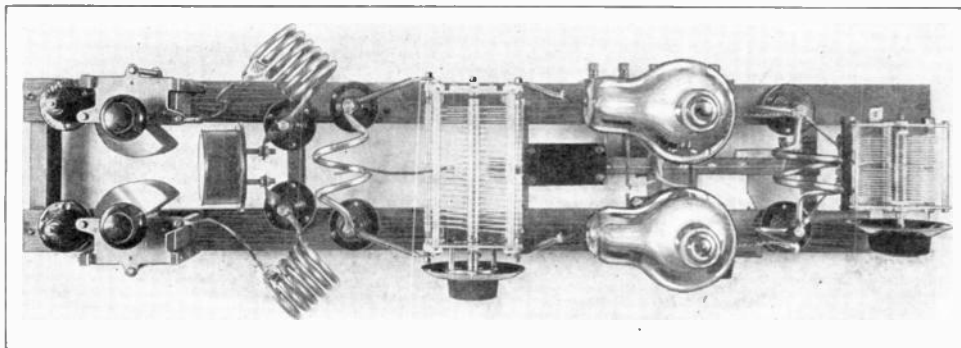

ALL TUNED CIRCUITS ARE SYMMETRICAL

The air-dielectric blocking condenser is between the tubes and the plate-tank condenser. The inductances shown are for the 28,000-ke. band.

28,000-ke. bands, it is easily adapted to the lower frequencies by making a few additions to the equipment. It requires a plate supply capable of delivering 1500 to 2000 volts d.c. at about 250 ma. for rated output. The filament supply should be 10 volts a.c. The antenna coupling arrangement is for use with a two-wire feed system. The coupling might be modified to make it suitable for use with a single-wire feed system but the two-wire system is better for coupling to a push-pull output circuit.

The simplicity and straightforwardness characterizing the layout of the transmitter are graphically brought out in the illustrations. The foundation for the assembly is a skeleton frame made of printers' "furniture." The wood is cherry impregnated with linseed oil and is obtainable at printers' supply houses and at most large printing plants. It comes in 36-inch lengths with one cross-sectional dimension of approximately $\frac{5}{8}$ inch and the other ranging from approximately $\frac{3}{8}$ inch to $1\frac{1}{2}$ inches. The side-rails in the transmitter are two pieces each 36" long and $1\frac{1}{2}$ " wide. The overall depth is $6\frac{1}{2}$ ". The grid- and plate-tank condensers are mounted on angle-brackets bolted to the side rails, the grid condenser being a Cardwell "multiple," type 153-B, and the plate condenser a rebuilt National type TM-450, the latter having Crolite insulation.

The Cardwell condenser is a standard multiple-type receiving condenser and needs no remodeling.

separate stators, each supported by three rods held fast to the insulators by hex nuts. In re-assembling the condenser, care should be taken to get identical spacing between the plates and proper alignment of the two sections. This can be done quite accurately by "sighting" across the plates and along the rods. When finally lined up, the plates should be tightened carefully. Too much tension will pull the rods out of the washers soldered to the ends but insufficient tightening will cause high resistance contacts between adjacent stator plates. Long brass bolts of the proper length, diameter, and thread would be better than the revamped rods, if they could be obtained.

A ready-made multiple-type condenser may be used if rebuilding is distasteful. The Cardwell type 157-B and the General Radio type 334-Z have approximately the same characteristics as the rebuilt National used in this transmitter and may be substituted in its place.

The fixed air blocking condenser, C_4 , is made up from the surplus stator plates of a National straight-line capacity receiving condenser which had been double-spaced. These plates are stacked up triple-spaced with the same washers used as separators in the variable condenser of which they are relics. The end plates are pieces of bakelite and the supporting crews are 6-32 brass flat-heads. The total number of plates is 8 and the capacity is approximately 75 μfd . Its breakdown voltage is approximately 3000

volts at 60 cycles. A good view of the condenser is shown in one of the illustrations.

The spacing between the various pieces of apparatus can be determined with sufficient accuracy by studying the illustrations. The spac-

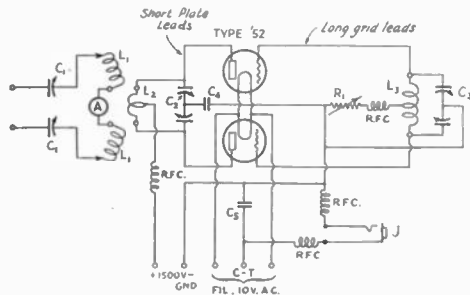

THE PUSH-PULL TRANSMITTER CIRCUIT

*L*₁ — Split antenna inductance. Each section has 5 turns of ¼-inch copper tubing and is 2 inches in diameter. Both sections are wound in the same direction.

*L*₂ — ¼-inch copper tubing plate inductance. 2 turns 2 inches in diameter, spaced 1½ inches between turns, for 28 mc. 4 turns 2 inches in diameter, spaced ½ inch between turns, for 14 mc. Inductances tapped at centers.

*L*₃ — ¼-inch copper tubing grid inductance. 2 turns 2 inches in diameter, spaced 1 inch between turns, for 28 mc. 6 turns, spaced ½ inch, for 14 mc. Tapped at center.

*C*₁ — Cardwell 43-plate receiving condensers double-spaced. Capacity, maximum 200 μfd., minimum 60 μfd.

*C*₂ — Rebuilt TM-450 National transmitting condenser. See text. Cardwell Type 157-B or General Radio Type 334-Z may be used instead.

*C*₃ — Cardwell Multiple Type 156-B receiving condenser. Each section has a capacity of 500 μfd.

*C*₄ — Fixed air-dielectric insulating condenser, 75 μfd. See text for details. May be omitted at reduced plate voltage (1500 or less).

*C*₅ — Spark-absorption condenser for key, .0012 μfd. May be omitted if key-thump filler is used.

*R*₁ — Allen-Bradley Type E-210 Bradyleak. Fixed resistor of 20,000 ohms might be substituted.

RFC — 28-mc. radio-frequency chokes. May be omitted but are recommended. See text for details.

J — Single-circuit telephone jack for key connection.

Tubes are Type '52 75-walters.

Modifications to adapt the circuit for 7000- and 3500-ke. operation are given in the text.

ing need not be followed exactly, of course, but adherence to the layout in general is recommended.

An interesting feature of this transmitter is that the leads from the grids to the grid tank are much longer than the leads from the plates to the plate tank. This high ratio of grid-lead length to plate-lead length eliminates the possibility of the spurious or parasitic ultra-high-frequency oscillations which usually result when the grid and plate leads are of nearly equal length. The elimination of parasitic oscillations is a considerable problem in high-frequency transmitters having more than one tube and is especially important in push-pull circuits.

The plate leads go directly to the plate tank circuit tuning condenser and each lead is 3.5 inches long. The grid tank circuit arrangement

is a bit different from the usual in that the inductance is mounted between the tubes and the tuning condenser. This allows sufficient length in the leads from the grids to the tuning condenser terminals without overly stringing out the assembly. The total length of each grid lead — measured from the tube envelope to the condenser terminal — is 13.5 inches. The connections within each tank circuit (between condenser and coil terminals) are necessarily short, direct, and heavy. The connections within any tank circuit should always be short, of course, because it is in these circuits that large r.f. currents flow and losses must be kept down to the very minimum.

The grid and plate inductances are supported on General Radio wall insulators and are fastened in place by bolting through holes drilled in the flattened ends of the copper tubing of which the coils are made. Clips are not used for making the center-tap connections to the coils but leads are permanently soldered to the inductances at their exact centers (as estimated by inspection). Most of the clips available are made of steel, and become very hot in the intense field about a transmitter inductance. This heating is good evidence of losses. The clip is therefore put on the other end of the lead, where it will be out of the tank-inductance field. Specifications for the inductances are given under the circuit diagram.

The grid leak is an Allen-Bradley type E-210 Radioleak, and is fastened to a small bakelite panel on the front rail of the frame. A variable leak is used because it has been found that adjustable grid bias is advantageous in getting the best signal quality and efficiency at very high frequencies. Adjustment of the grid bias is the final operation in tuning the transmitter and, although it is not extremely critical, as a tuning refinement it is well worth having.

The radio-frequency chokes are designed for the 28-mc. band and are all alike. Each consists of 48 turns of No. 30 d.c.c. wire wound over a 2-inch length of wooden dowel ½ inch in diameter. The method of winding is to measure off 2 inches on the form and wind 24 turns per inch over the two inches, estimating the spacing at slightly more than the diameter of the wire. After the winding is completed, it should be doped with acetone or collodion to prevent the wire from slipping. Wood-screws through holes drilled in the forms hold the chokes in place on the transmitter.

Although the transmitter's plate circuit is not symmetrical with respect to the grid circuit, the plate circuit of one tube must be symmetrical with respect to the plate circuit of the other as must also be the grid circuit of one tube with respect to the grid circuit of the other. The two grid connections to the grid tank must be of identical length and so must be the two plate connections to the plate tank.

In addition to symmetrical connections between

the tubes and the respective tank circuits, the tank circuits themselves must be symmetrical about their respective electrical "centers." This requirement calls for not only an exact center tap on the tank inductance but also for tuning condensers which have symmetrical electrical properties. Tuning condensers of the double stator and single

specified for the higher frequencies and should have 8 and 18 turns, respectively, both coils being 3 inches in diameter. Quarter-inch spacing between turns will be satisfactory. The grid coil for each band may be the same as the corresponding plate coil.

Like the grid- and plate-tank circuits, the an-

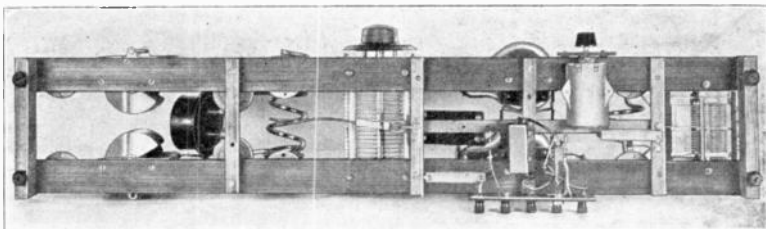

D.C. AND LOW-FREQUENCY A.C. WIRING IS RUN BENEATH THE FRAME
The terminal strip, by-pass condenser for key, grid-leak and r.f. chokes are grouped beneath the tubes in the neutral area of the radio-frequency field.

rotor type have this feature and such condensers are used for tuning the tank circuits in the transmitter.

The two sections of such a condenser are in series across the tank circuit and the rotor is grounded. Since the rotor is at zero r.f. and d.c. potential to ground, the danger of shock as well as the serious detuning of the set when the dials are touched is eliminated. Moreover, the insulation of one section of the condenser is in series with the insulation of the other (across the high r.f. potential ends of the inductance) and the insulation is thereby made doubly effective. Since the two sections are in parallel with respect to the d.c., the d.c. flash-over voltage is the same as if a single-section condenser of the same plate spacing were used. It is usually r.f. voltage rather than d.c. voltage that breaks down condenser insulation, however, and a fixed insulating condenser between the rotor and negative high voltage will be adequate insurance against d.c. flashover with standard types of tuning condensers.

The total capacity across the tank circuit is approximately half the capacity of one section (since the two sections are in series) and a condenser of comparatively high capacity per section is necessary for "High-C" at the lower amateur frequencies. Since the balancing of the tank circuits is not so critical at the lower frequencies a 200- μ fd. single-section variable condenser having the same spacing between plates (same voltage rating) as the double-section condenser may be mounted on top of the plate-tank condenser and connected in parallel with it to give the necessary High-C for frequency stability on the 7000-kc. and 3500-kc. bands. The grid tuning condenser specified has a sufficiently high maximum capacity for these bands.

The plate coils for the 7000-kc. and 3500-kc. bands may be of the same size tubing as the coils

specified for the higher frequencies and should have 8 and 18 turns, respectively, both coils being 3 inches in diameter. Quarter-inch spacing between turns will be satisfactory. The grid coil for each band may be the same as the corresponding plate coil. Like the grid- and plate-tank circuits, the antenna coupling circuit is symmetrical. The inductance is in two identical sections (both wound in the same direction) one on each side of the plate coil. The r.f. ammeter is connected between them. This places the ammeter at the point of maximum current in the feeder system. The current value may be quite high and a 5-ampere meter is recommended. If a meter of lower current capacity is used, it should be shunted by piece of No. 12 or 14 copper wire. The antenna coils are mounted on General Radio wall insulators and to loosen coupling are swung out from the plate coil, with flexible leads equipped with clips connecting the coupling coils to the tuning condensers.

TUNING ADJUSTMENTS

Preliminary tuning should be done with the plate voltage reduced to about 1000 volts. This will preclude the possibility of blowing things up at the start. The grid leak should be set at approximately half resistance and the antenna coils should be loosely coupled to the plate coil. The antenna tuning condensers are set at maximum. Set the plate tank condenser at near full capacity and switch on the power supply. Holding the key down with one hand, slowly turn the grid tuning condenser with the other while watching the plate-current milliammeter. At one setting of the grid condenser the plate current will take a sudden dip. The grid tuning condenser capacity should be set at a value *slightly greater* than that at which the dip occurs. Now check the frequency with the frequency meter and monitor. If it is outside the band, retune the plate-tank condenser and repeat the whole process.

After the set has been tuned to a frequency within the band, the plate voltage can be raised to normal and the antenna circuit tuned to resonance. The antenna tuning condensers are both varied at once, tuning from maximum capacity

"down." A setting should be found where the current indicated by the meter is a maximum. The capacity of the condensers should be increased from this setting until the antenna current drops about 20%. If the set should stop oscillating during the tuning process, slightly increase the capacity of the grid tank condenser. When the antenna draws power from the plate

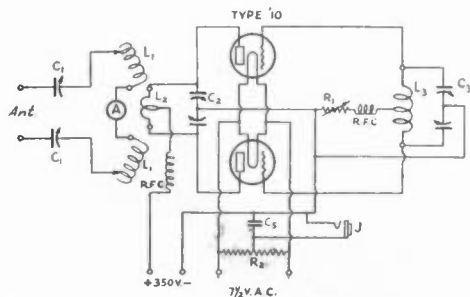

A PUSH-PULL T.G.T.P. CIRCUIT FOR TYPE '10 TUBES

The construction is similar to that of the 150-watt set. Two Type '10 tubes are required as well as a 350- to 500-volt plate supply and a 7.5-volt filament supply. The parts are the same as those of the larger set with the following exceptions:

C_1 — 250- μ fd. receiving type variable condensers.

C_2 — Same as C_1 . (See Circuit Constants page 100.)

R_2 — 200-ohm center-tapped non-inductive resistor. Not required if a center-tapped filament winding is used.

tank the excitation available for the grid circuit drops and often necessitates readjustment of the grid tuning. Increasing the capacity of the grid tuning condenser increases grid excitation.

After the antenna circuit has been properly tuned, another check on the frequency should be made. If it has changed appreciably, slight retuning adjustments should be made all around. If the monitor shows that the note is rough, detune the antenna coupling circuit a little more, adjust the grid excitation slightly by tuning the grid tank and increase the resistance of the grid leak by turning its knob to the left. When these adjustments have been completed and the signal is "steady d. c.," the transmitter is ready for operation.

OSCILLATOR-AMPLIFIER TRANSMITTERS

The oscillator-amplifier circuit is so named because the oscillator, instead of feeding the antenna circuit as in the foregoing self-excited sets, excites one or more amplifier stages which in turn supply power to the antenna circuit. The oscillator amplifier set therefore is capable of greater frequency stability than the self-excited set since it has to furnish only sufficient power

to supply the grid excitation and the grid losses of the amplifier which follows and its load is very nearly constant, even with variations in antenna tuning. The frequency stability can be further improved by using oscillator circuits of extremely stable characteristics and the low-power requirement makes possible a sacrifice of oscillator efficiency in the interest of better frequency stability.

The oscillators used in modern oscillator-amplifier transmitter are of two general classes. The first is the self-controlled type, using one of the standard High-C oscillator circuits, in which the frequency of oscillation is determined largely by the inductance and capacity values in the tuned circuits. The second is the crystal-controlled type in which the frequency of oscillation is determined by the natural vibration frequency of a quartz plate connected in the oscillator grid circuit.

SELF-CONTROLLED OSCILLATOR-AMPLIFIER TRANSMITTERS

The low-power transmitter shown in the illustrations is a good example of self-controlled oscillator-amplifier set construction. The oscillator has a High-C Hartley circuit with a Type '10 tube, operated at reduced power, and excites a neutralized amplifier using a Type '10 tube worked at full power. The rated output of the transmitter is about 7.5 watts. The oscillator unit is mounted on the right side of the baseboard on an aluminum disk and in operation it is enclosed in a shield consisting of an inverted aluminum

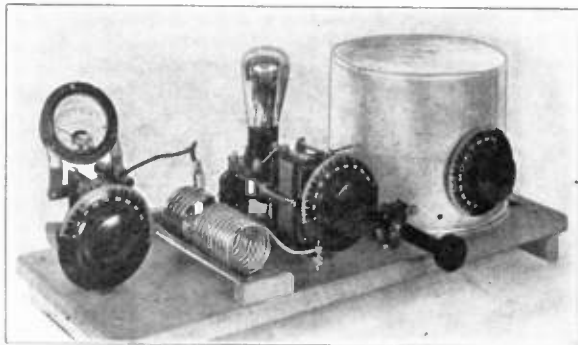

THE LOW-POWER OSCILLATOR-AMPLIFIER TRANSMITTER

The oscillator is inside the inverted aluminum kettle at the right with the neutralized amplifier and antenna-coupling circuit to its left. This unit may be used to excite a high-power amplifier.

kettle. This shield avoids changes of frequency which otherwise would be caused by the "body capacity" of the operator moving near the set and also serves to isolate the oscillator more thoroughly from stray fields about the amplifier, thereby contributing to frequency stability.

The use of such a shield, however, hinders the

ventilation of the tube and it is necessary to drill several $\frac{1}{4}$ " holes around its edge near the base and several in the top to obtain a circulation of air. Without these holes the tube would heat badly and the frequency would creep in consequence.

The tank condenser is supported by bakelite

amplifier would oscillate as a tuned-grid tuned-plate circuit if no provision were made to prevent it. Neutralizing the amplifier grid-plate capacity effectively precludes any possibility of such oscillation. The neutralizing circuit includes the lower portion of the amplifier plate coil and the condenser C_1 in the diagram. To make this arrange-

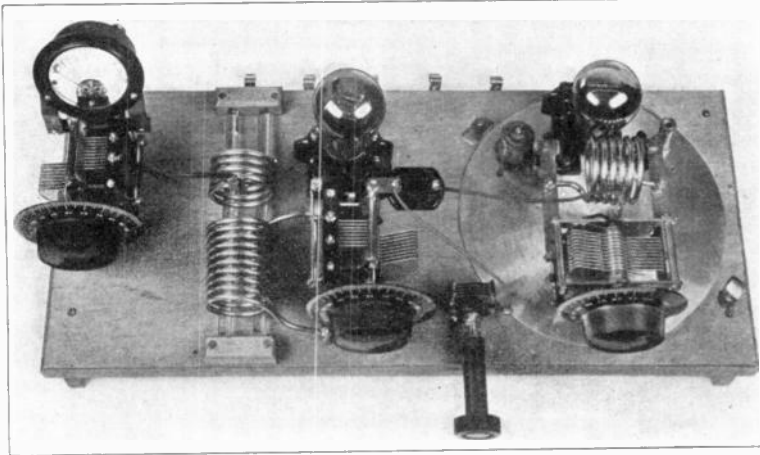

THE TRANSMITTER WITH THE OSCILLATOR SHIELD REMOVED

The amplifier receives excitation through the lead tapped on the oscillator inductance. A connection is made by a clip at the center of the amplifier tank inductance. The neutralizing condenser is connected between the grid of the amplifier tube and the front terminal of the tank inductance.

strips bolted to the base with angle brackets. The frame of the condenser must be insulated from the metal shield.

The tube socket is mounted on the aluminum disk. The fixed grid and plate condensers are supported in a vertical position from the grid and plate terminals of the tube socket; these condensers, in turn, hold the heavy copper strips that form the connections to the tuning condenser. At the center of these strips G.R. jacks are fitted and into these the tuning coils are plugged. The mounting of the apparatus and all the wiring should be perfectly stiff, since any vibration will make a steady frequency output impossible.

The grid of the amplifier receives its excitation through a coupling condenser C_1 from the oscillator coil. The lead is made to a clip on the coil and this clip is varied in its position to control the amount of grid excitation. The amplifier tube, which is of the same type as the oscillator, is mounted on small brass brackets from the amplifier plate tuning condenser. The plate tank of this tube has a smaller condenser and more turns than that of the oscillator, in order to get the highest possible efficiency. A high value of capacity is not necessary to stabilize the frequency, since this has already been effected in the oscillator.

Since both the grid and plate circuits of the amplifier are tuned to the same frequency, the

ment possible, the d.c. plate voltage is fed to the plate coil at its center as shown in the diagram. This puts the point of low radio-frequency potential at the center of the coil. The radio-frequency potential at the plate end of the coil is opposite in phase to the potential at the end to which the neutralizing condenser is connected. If the coil is tapped exactly at its center, the circuit will be neutralized when the capacity of the neutralizing condenser equals the grid-plate capacity of the amplifier tube. The method of adjusting for this condition will be explained later.

The placement of this neutralizing condenser and the apparatus in the amplifier can be seen in the plan view. The full plate voltage in series with the grid bias is across the neutralizing condenser and to avoid the possibility of shock and to reduce difficulties in adjustment introduced by "hand capacity," it is fitted with an insulating extension handle.

The amplifier plate coils, like those in the oscillator, are fitted with G.R. plugs which fit into jacks mounted in copper strip extensions from the condenser terminals. The plate coils rest on two glass rods so that vibration is eliminated. On these same rods the antenna coil rests. Antenna coupling is varied by sliding the antenna coil with respect to the plate coil. The antenna tuning condenser and ammeter are mounted on the extreme left end of the baseboard. The grid of the amplifier

tube is maintained at a suitable operating voltage by a bias battery which is connected to the grid through a radio-frequency choke. This choke is under the amplifier tube socket. The choke in the positive high-voltage lead to the amplifier is behind the tube.

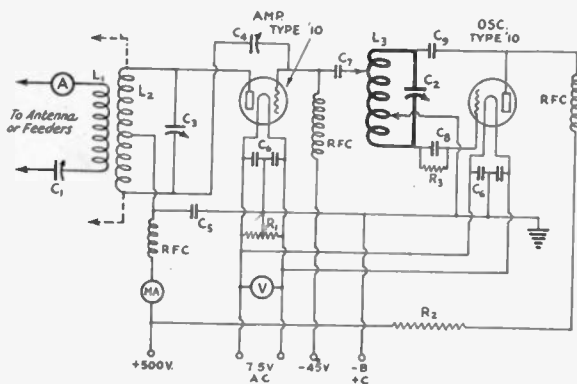

THE CIRCUIT OF THE OSCILLATOR-AMPLIFIER TRANSMITTER

Apparatus required:

Two Type '10 tubes and sockets.

C₁, C₂—350 μ fd. receiver-type variable condensers.

C₃—500 μ fd. ditto.

C₄—100- μ fd. midget condenser, double-spaced.

C₅—2,000 μ fd. fixed by-pass condenser.

C₆—1,000 μ fd. filament by-pass condensers.

C₇—100 μ fd. fixed coupling condenser.

C₈—250 μ fd. fixed oscillator grid condenser.

C₉—1,000 μ fd. fixed oscillator stopping condenser.

R₁—100-ohm, center-tap resistors or Christmas-tree lamps.

R₂—100-watt 10,000-ohm grid leak to drop plate voltage for oscillator.

R₃—10,000-ohm grid leak for oscillator (10- or 25-watt size).

RFC—Radio-frequency chokes each consisting of three sections of 50 turns of 30 gauge d.c.c. wire wound in $\frac{1}{2}$ "-slots in a 1"-diameter wooden former and connected in series. The tubular chokes described before should be equally satisfactory.

L₁, L₂, L₃—Antenna, plate and oscillator coils described under illustration. Aluminum kettle and disk for oscillator shield, baseboard $9\frac{1}{2}$ " x $2\frac{1}{2}$ ", five terminals or Fahnestock clips, wood screws and machine screws, towel bars and wooden supports for same, brass angles, copper strip, and 14 gauge wire for connections.

The power supply, antenna and keying systems are treated in later chapters.

TUNING AND NEUTRALIZING

In tuning the oscillator of this transmitter the same process will apply as that outlined for the other transmitters. It is well to have the grid lead to the amplifier attached when the tuning is done but the plate supply to the amplifier should be disconnected. Just as soon as the oscillator has been tuned to give the steadiest signal on the required frequency (as checked by the frequency-meter and monitor) the preliminary neutralizing can be undertaken. For this work a two-turn coil connected to a flashlight bulb should be coupled closely to the amplifier plate coil. With the plate supply disconnected from the amplifier but with the oscillator running, the neutralizing condenser should now be set at zero and the amplifier plate tuning condenser rotated until the maximum indication is obtained in the bulb. At this stage

the neutralizing condenser should be adjusted until no such indication is obtained. After the neutralizing condenser has been adjusted to the point where the flash-lamp bulb shows no glow, the amplifier tank tuning condenser should be re-adjusted. It is quite probable that the bulb will indicate r.f. in the tank circuit at some other setting of the tank tuning condenser. Again adjust the neutralizing condenser until the bulb goes out. Keep adjusting the neutralizing condenser until there is no sign of r.f. in the tank for any setting of the tank tuning condenser. A more exact neutralizing adjustment can be obtained by continuing to adjust the neutralizing condenser further until another setting is found where the bulb glows. The best setting will be half way between the two settings at which the lamp indicator shows r.f. in the tank circuit.

Even more accurate neutralization can be obtained by connecting a small thermo-couple galvanometer or milliammeter across a few turns of the plate inductance and using it as an indicator of r.f. in the tank circuit. The method of neutralizing is the same as with the flash-lamp and loop indicator. Be sure to remove the meter before turning on the plate voltage. Otherwise it is likely to burn out.

This method of making neutralizing adjustments is the best for all neutralized amplifiers and the operator of any transmitter containing an amplifier which is supposed to be neutralized should practice the procedure until he is completely familiar with it. The amplifier is never completely neutralized until there is no indication of r.f. in the tank circuit.

With neutralization of the amplifier completed, the plate voltage can be connected to the amplifier and the key closed. The amplifier tank circuit should be tuned until the plate milliammeter of the amplifier indicates minimum plate current.

It may be that the frequency of the oscillator has been changed somewhat during the neutralizing process and it should be carefully checked with the frequency meter before the antenna is tuned to resonance. The frequency may be corrected by retuning the oscillator and amplifier tank circuits. No further adjustment of the neutralizing should be required. After the frequency has been given a final check the antenna circuit is tuned to resonance. Unlike the antenna tuning with a self-excited transmitter, the antenna condenser should be adjusted for maximum antenna current. The coupling between the antenna coil and the output tank coil should not be too close

OTHER COMBINATIONS

In high-power transmitters of the oscillator-amplifier type a similar lay-out and construction can be used with modifications to accommodate

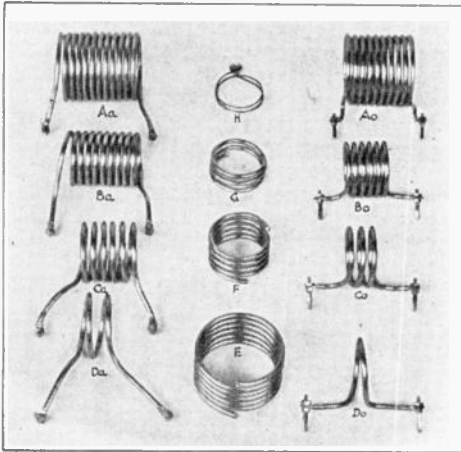

OSCILLATOR, AMPLIFIER AND ANTENNA COILS FOR FOUR BANDS

All coils are made of 3/16-inch copper tubing.

Oscillator Coil	Inside Diameter	No. Turns	Band
A _o	2.5"	10	3500-kc.
B _o	1.75"	6	7000-kc.
C _o	1.75"	3	14,000-kc.
D _o	1.75"	1	28,000-kc.
Amplifier Coil	Inside Diameter	No. Turns	Band
A _a	2.5"	12	3500-kc.
B _a	1.75"	10	7000-kc.
C _a	1.75"	6	14,000-kc.
D _a	1.75"	2	28,000-kc.
Antenna Coil	Inside Diameter	No. Turns	Band
E	2.5"	6	3500- and 7000-kc.
F	1.75"	5	14,000-kc.
G	1.75"	3	28,000-kc.

H is the coil and lamp used as a neutralizing indicator. The coils for the low-power push-pull amplifier have the same specifications as the amplifier coils in this transmitter.

more powerful tubes. An additional amplifier might be added to the transmitter just described, for instance. This amplifier might consist of two Type '10 tubes in push-pull or a single Type '03-A or Type '52.

A satisfactory stage of push-pull amplification is illustrated, together with its circuit diagram. The tuning method for the push-pull stage would be similar to that just given. The neutralizing process is the same except that both neutralizing condensers should be adjusted simultaneously. The coils for the push-pull stage are identical with the coils for the amplifier stage. Their specifications are given beneath the illustration of the coils for the oscillator-amplifier transmitter.

If an additional amplifier using a single 50-watt or 75-watt tube should be added, the circuit would be identical with that of the first amplifier

and the coils should be of the same size but should be made of 1/4-inch copper tubing. The plate tank condenser should have spacing between adjacent plates of at least 3/16 inch and have a maximum capacity of approximately 350 μμfd. The neutralizing condenser should have the same spacing and a maximum capacity of at least 50 μμfd. The fixed by-pass condenser in the plate circuit should have a voltage rating of 5000 volts

In connecting the input of the push-pull amplifier to the plate circuit of the single-ended

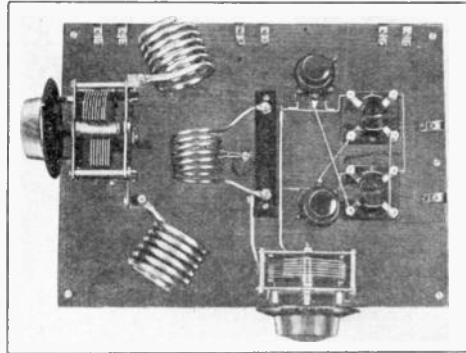

PLAN VIEW OF THE LOW-POWER PUSH-PULL AMPLIFIER

It uses two Type '10 tubes and makes an excellent output amplifier following the oscillator-amplifier transmitter.

The tank inductances plug into jacks on a bakelite terminal strip mounted 1.5 inches above the wooden base-board. The plate-tank center-tap is made by a clip connected to a lead which runs through the base. The neutralizing condensers are supported vertically by the wiring between the tube terminals and the plate tank. Radio-frequency chokes, by-pass condensers, coupling condensers and the key jack are underneath the base-board. Another view of this amplifier is part of a later illustration.

amplifier, the grid terminals of the push-pull stage are connected to the two ends of the first amplifier's plate inductance (the dotted lines). The antenna coupling circuit of the first stage is not used. Coupling to the 50-watt stage would be similar to that between the oscillator and first amplifier.

In any transmitter of this type the prime considerations are that the oscillator must be worked below the rated power of the tube used and the plate supply for the oscillator must be pure direct current. When using a Type '10 as the oscillator tube its plate voltage should not be over 250 volts. The oscillator determines the frequency stability for the whole transmitter and every precaution should be taken to make it the best possible.

CRYSTAL CONTROL

In each of the preceding transmitters the frequency of oscillation is determined by a self-controlled oscillator. The many factors which can influence the frequency of oscillation have been

repeatedly pointed out and it is evident that they are not only of considerable number but also

cause amplitude modulation of the output but can cause practically no frequency flutter. For this reason the note produced by a properly adjusted crystal-controlled transmitter is always of a piercing musical character.

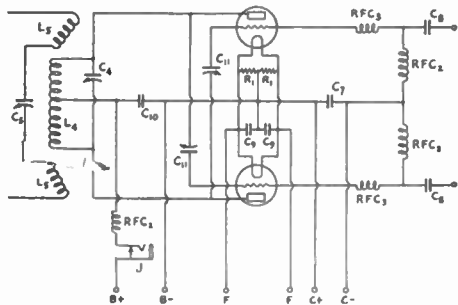

THE PUSH-PULL AMPLIFIER CIRCUIT

- L₁ — Center-tapped plate coil. See coil illustration for specifications.
- L₂ — Split antenna inductance. Made of 1/4-inch copper tubing, 6 turns each, 2.5 inches inside diameter.
- C₄ — 250-μfd. receiving-type variable condenser.
- C₆ — 350-μfd. receiving-type variable condenser.
- C₇ — C₈ — 100-μfd. 5000-volt coupling condensers.
- C₉ — 1000-μfd. filament by-pass condensers.
- C₁₀ — 100-μfd. by-pass condenser, 5000-volt rating.
- C₁₁ — Neutralizing condensers, 100-μfd. "midget" variable condensers, double-spaced. (Final capacity, 25 μfd.)
- RFC₁ — Radio-frequency chokes. Each 100 turns of No. 38 d.s.c. on a 1/2-inch wooden form.
- RFC₂ — Parasitic suppressors. Each 20 turns of No. 24 d.c.c. wire on a 1/2-inch wooden form.
- J₁ — Plate milliammeter jack.

difficult to overcome. It is because the crystal-controlled oscillator almost entirely surmounts all these difficulties that its popularity is continually increasing. The frequency-controlling element in the crystal controlled oscillator is a small slab of quartz crystal which, because of its electro-mechanical properties, will oscillate at a frequency determined almost entirely by its dimensions. When it is properly connected in the

CRYSTAL CUTS AND GRINDING

Good active quartz plates are no longer the scarce and expensive articles they were a few years ago and the better understanding of crystals and their operation now available has erased the formerly prevalent idea that crystal control was something for only experienced amateurs to play with. Even the inexperienced can now be assured of success with crystal-controlled transmitters. In some ways the use of crystal control actually simplifies transmitter construction and adjustment.

Although some amateurs, experienced in crystallography and possessing the necessary equipment, cut active slabs from chunks of "raw"

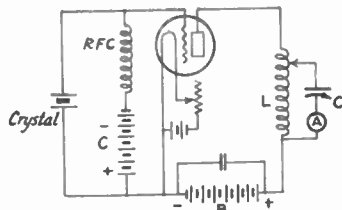

ELEMENTARY CRYSTAL CIRCUIT

quartz, it is more economical to purchase a ground crystal or unfinished "blank," particularly if only one or two crystals are wanted. Finished crystals are now so reasonably priced that it is hardly worth while even to buy an unfinished blank and finish the grinding. The experience to be gained from the grinding process is valuable, however, and many amateurs do buy partially ground blanks and finish the plates themselves

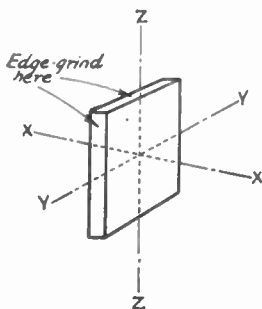

RELATION OF THE AXES OF AN X-CUT QUARTZ PLATE

controlling oscillator circuit, the antenna can swing, the line voltage can vary and the tubes can heat without seriously affecting the output frequency of the transmitter. It is almost impervious to the usual causes of dynamic frequency flutter and a bad ripple in the plate-supply voltage may

A quartz crystal has three major axes, designated X, Y and Z. The Z axis is the optic axis. The Y axis is the mechanical axis. The X axis is the electric axis and is the one used as a reference in designating the cut of the plates used in oscillators. A plate cut with its major surfaces perpendicular to an X axis is known as an X-cut plate. This cut is also referred to as the "perpendicular" and "Curie" cut. Plates cut with their major surfaces parallel to an X axis are known as "Y," "parallel," and "30-degree" cuts. The most accepted terms for these two cuts are X-cut and parallel or 30-degree cut.

Each of these cuts has characteristics of its own and these characteristics determine its suitability for different services. For a given frequency, an X-cut plate is thicker than a 30-degree-cut plate. The X-cut plate has but one major frequency of oscillation which is a function

of its thickness but a 30-degree cut plate sometimes has two, generally a kilocycle or so apart. The 30-degree cut plate is usually the more ready oscillator although properly ground and mounted plates of either cut oscillate quite persistently in well-designed power circuits. The X-cut plate is more generally used in power oscillators, although many amateurs have a preference for the 30-degree cut.

When a finished crystal or unground blank is purchased, a statement of the cut should be obtained from the seller. This is particularly important when a blank is purchased because the grinding cannot be done so easily if the ratio of thickness to frequency is not known. For X-cut plates $f \times t = 112.6$ and for 30-degree-cut plates $f \times t = 77.0$, where f is the frequency in kilocycles and t is the thickness in inches. From these relations the thickness for a desired frequency of a crystal of known cut can be determined quite accurately by measurement with a good micrometer such as the Starrett No. 218-C, $\frac{1}{2}$ inch. This tool also can be used to make sure that the crystal is the same thickness at all points and that bumps or hollows are not being ground in. The best crystals are about 1" square, perfectly flat, and the two major surfaces are parallel.

Since the thickness of an oscillating crystal is inversely proportional to its frequency, the plates become very thin and fragile at frequencies above those in the amateur 3500-kc. band. For this reason the most satisfactory amateur crystals are those ground for the 1750-kc. and 3500-kc. bands. If the transmitter is to be operated on the 3500-kc. and higher frequency bands only, a crystal having a suitable frequency in the 3500-kc. band will be best. The higher frequencies are obtained from such a crystal by means of the harmonic generators or frequency doublers to be described further on. Some carefully-ground 7000-kc. crystals are now being used in amateur transmitters but they require very careful handling. There are even instances of successful operation of 14,000-kc. crystals but they are exceptional.

Grinding is usually done by rotating the crystal in irregular spirals on a piece of plate glass smeared with a mixture of No. 120 carborundum and water or kerosene. It is better to have the crystal stuck to a perfectly flat piece of thin brass or a glass microscope slide than to bear down on the surface of the crystal with the fingers. Even pressure over the whole area of the crystal is essential for flat grinding. The crystal will stick to the flat brass plate or slide if the top of the crystal is moistened with kerosene. The crystal should be frequently tested for oscillation in a test circuit such as that shown in the diagram. If the crystal should stop oscillating during the grinding process the edges should be ground as indicated in the illustration of an X-cut plate. The frequency also can be checked by listening to the signal in a receiver and measuring the

frequency as described in Chapter VI. When the frequency is within a few kilocycles of the desired value it is well to use a finer grade of carborundum powder for finishing. The FF and FFF grades are suitable for the final grinding.

CRYSTAL MOUNTINGS

To make use of the piezo-electric oscillation of a quartz crystal, it must be mounted between two metal electrodes. There are two types of mountings, one in which there is an air-gap of about one-thousandth inch between the top plate and the crystal and the other in which both plates are in contact with the crystal. The latter type is simpler to construct and is generally used by amateurs. It is essential that the surfaces of the metal plates in contact with the crystal be perfectly flat. Satisfactory mountings can be pur-

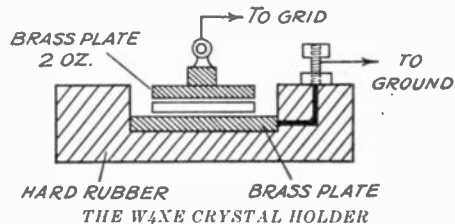

chased from most dealers in crystals or can be made up by the amateur.

The simplest way for the amateur to rig his own mounting is to make up two flat brass plates, the crystal being placed on one of them and the other being arranged to rest on the crystal with no more pressure than that provided by the weight of the brass. A crystal mounting of this type is illustrated. The plates preferably should be turned flat in a lathe and then ground to a fine finish. Successful plates can be made, however, by cutting them with a hack-saw from $\frac{1}{8}$ "-thick brass plate, then grinding them in much the same way as the crystal would be ground. A suitable size for the plates is about 1" square.

Though it is possible to operate the crystal between such plates merely by arranging the plates and the crystal in the form of a sandwich on a piece of insulating material or on the table top, it is a very much better plan to make up some form of holder out of which the crystal or plates cannot be jarred. The arrangement illustrated is one suitable type. Connection to the upper plate can be made by means of a very light leaf of spring brass but a small spiral of very fine copper wire usually is more satisfactory. This wire can be soldered to the plate if care is taken to use an absolute minimum of heat in the soldering process to avoid warping the plate.

POWER OSCILLATOR CIRCUIT

The best crystal oscillator circuit for transmitters is that known as the Pierce circuit. It is

similar to the tuned-grid tuned-plate except that the crystal replaces the grid tank circuit. Its action is identical with that of the t.g.t.p. circuit. When the plate tank circuit is tuned to a frequency slightly higher than the natural frequency of the crystal, the feed-back through the tube excites the grid circuit and the crystal, due to its piezo-electric properties, oscillates at its natural frequency — and at that frequency only. A very good power oscillator arrangement is that shown in the accompanying illustration. The tank circuit for a 3500-kc. oscillator may consist of 18 turns of No. 14 wire or small copper tubing on a

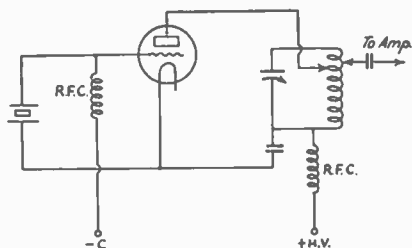

THE POWER CRYSTAL OSCILLATOR CIRCUIT

The plate tap on the tank inductance permits control of the grid excitation.

3-inch diameter and a 250- μ fd. receiving-type variable condenser. The plate connection to the oscillator tube should be made at about the center of the inductance and the excitation tap for the amplifier taken directly from the plate of the oscillator tube. This connection is shown in the transmitter circuit which follows.

The reason for making the plate connection near the center of the coil is to limit the grid excitation and to secure maximum power output from the oscillator. Since the feed-back is through the grid-plate capacity of the tube, its value will be set by the amount of plate-tank inductance between the plate connection and the filament of the tube. The tube may draw more plate current and work at reduced efficiency but the power output will be greater and the oscillator will operate more stably. Another advantage of keeping the grid excitation down to the minimum required is that the frequency stability of the oscillator is improved. Excessive grid excitation heats the crystal, because of the radio-frequency current through the crystal circuit, and causes the frequency to creep. This is because all crystals have a temperature-frequency coefficient. The temperature coefficient of X-cut plates is negative, that is, the frequency goes down with rising temperature. The temperature coefficient for 30-degree cut plates is positive, the frequency increasing with rising temperature. To completely overcome creeping with change in temperature, crystals are operated at constant temperature. This is accomplished by mounting the crystal in a compartment equipped with electric heating units

controlled by a thermostat. This arrangement is the best for maintaining the frequency constant but is not essential in amateur transmitters.

The tube most generally used in the oscillator is the Type '10. Low-impedance tubes such as the Type '45 and Type '42 are also very satisfactory as crystal oscillators. The plate voltage should be of comparatively low value, preferably not over 250 volts. In no case should the plate voltage be greater than 400 volts. Low plate voltage precludes possibility of wrecking the crystal from over-excitation and gives the best frequency stability. Grid bias for the oscillator is supplied through a choke shunting the crystal and is usually obtained from a dry "B" battery. The bias for a Type '10 tube is usually 22.5 volts. Bias for low-impedance tubes will be greater. The Type '45 and Type '42 will operate satisfactorily with negative bias of 67.5 or 90 volts. Grid-leak bias may be used also, the value of the grid-leak resistance being about 50,000 ohms.

Grit or an oily film on the surface of a crystal will affect its operation and will sometimes prevent oscillation. The crystal should be cleaned whenever erratic behavior or stoppage of oscillation gives evidence of a dirty condition. Carbon tetrachloride (Carbona) or grain alcohol are the best cleaning fluids. Handling of the crystal is especially likely to give it an oily surface, and the crystal should always be cleaned after it has been touched by the hands.

AMPLIFIERS

Because the power output of the crystal oscillator is comparatively small, one or more stages of amplification are necessary to realize useful power output from the transmitter. These amplifiers are identical with those of the oscillator-amplifier transmitter, since a crystal-controlled transmitter is nothing more than an oscillator-amplifier transmitter using a crystal-controlled oscillator. In addition to increasing the power output from the oscillator, the amplifiers may be used also to increase the frequency of the crystal oscillator by integral multiples of the crystal frequency. Such amplifiers are called "frequency multipliers." The plate-tank circuit of a frequency-multiplying amplifier is tuned to a frequency which is harmonic of the exciting frequency. If the output of the amplifier is tuned to twice the exciting frequency the amplifier is known as a "doubler." This doubling action is caused partly by excitation from the second harmonic output of the oscillator (or preceding amplifier) and partly by distortion in the amplifier itself. Although it is possible to triple frequency with frequency multipliers, doubling is most generally applicable in amateur transmitters because the amateur bands are in even harmonic relation and greater output can be obtained from an amplifier by doubling than by tripling.

When an amplifier's output is tuned to the excitation frequency the amplifier is known as a "straight" amplifier and the circuit must be neutralized unless a screen-grid tube is used.

mitter with the exception of the oscillator adjustment. The tank condenser is adjusted to a slightly lower capacity (higher frequency) than that at which the oscillator tube draws minimum plate

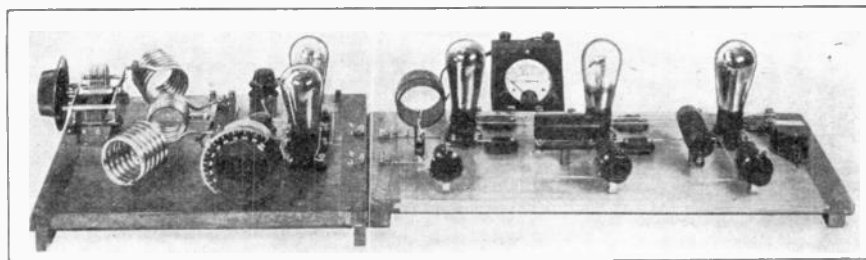

A CRYSTAL-CONTROLLED TRANSMITTER WITH TWO FREQUENCY DOUBLERS
 The push-pull amplifier is the one previously described. The oscillator is at the extreme right with the frequency doublers to its left. "Midget" type variable condensers are used for tuning the oscillator and doubler tank circuits.

Frequency-doubling amplifiers should not be neutralized, however, and three-element tubes are better doublers than screen-grid tubes. Low-impedance tubes (such as the Type '45) are not satisfactory as frequency multipliers. The high-impedance type (such as the UX-341) and the medium-impedance Type '10 are more suitable. Frequency doublers require comparatively high bias and ample excitation. A doubler is very in-

current. The push-pull amplifier may be added, the connections to its grid circuit being made to the plate tank of the first amplifier as indicated by the dotted lines.

The first amplifier may be operated as a frequency doubler by setting the neutralizing condenser at zero capacity and using the 7000-kc. inductance in its tank circuit, assuming that a 3500-kc. crystal is being used. The bias on the tube should be increased to about 67.5 volts. When the plate circuit is tuned, resonance will be indicated by minimum plate current or maximum brilliance of the lamp indicator loosely coupled to the tank inductance. The push-pull amplifier also should be tuned to 7000 kc. When the push-pull amplifier has been neutralized for one band, no readjustment of the neutralizing condensers is required when changing to coils for the other bands.

Push-pull amplifiers are very poor frequency doublers because the even harmonics cancel in the output circuit and further doubling in the push-pull stage of this set (to get 14,000-kc. output, for instance) would be impractical. For 14,000-kc. output it would be better to use an arrangement such as that

illustrated in the photographs. This uses the same push-pull amplifier previously described, preceded by a 3500-kc. oscillator and two frequency-doubling amplifiers. The set may be operated on the 7000-kc. band by plugging in center-tapped 7000-kc. coils in the push-pull and last doubling stages, removing the tube from the first doubler, and connecting a jumper from the grid to the plate of the first doubler. There should be no coil in the plate tank of the first doubler. Otherwise the plate and grid-bias supplies will be shorted.

For 3500-kc. output it will be necessary to add

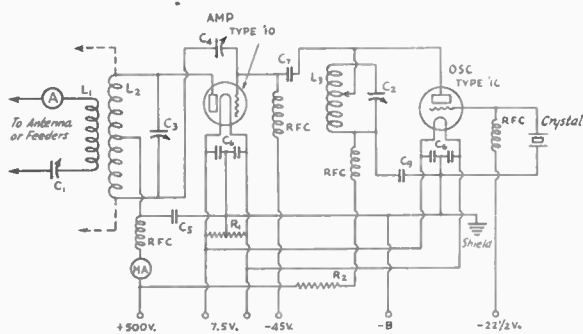

CIRCUIT OF THE LOW-POWER OSCILLATOR-AMPLIFIER SET WITH CRYSTAL CONTROL

The specifications are the same as those for the self-controlled circuit. Modification of the oscillator circuit only is required to convert the set to crystal control.

efficient at best, however, and is not satisfactory as the final output amplifier of a transmitter. The final amplifier should always be a neutralized or screen-grid stage operating on the same frequency as the preceding doubler.

PRACTICAL TRANSMITTERS

The oscillator-amplifier transmitter described in the preceding pages is readily convertible to crystal control, the only changes being in the oscillator circuit. The modifications are shown in the accompanying circuit diagram. The tuning is identical with that for the self-controlled trans-

a neutralizing connection on the second stage. This connection would be identical to that of the amplifier in the low-power oscillator-amplifier transmitter. Then the 3500-kc. coils would be

controlled by plugging in a fixed-tune inductance in place of the crystal. The specifications for this grid coil will be approximately the same as for the 3500-kc. grid coil of the single-control trans-

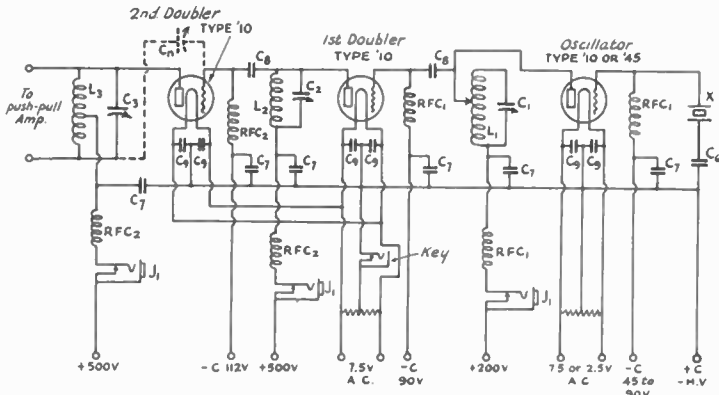

THE OSCILLATOR AND FREQUENCY-DOUBLER CIRCUIT

- L₁ — 35 turns No. 24 d.c.c. on tube 1.5" diameter (3500-kc.)
- L₂ — 18 turns No. 24 d.c.c. on tube 1.5" diameter (7000-kc.)
- L₃ — 6 turns No. 14 d.c.c. on tube 2.5" diameter (14,000-kc.)
- C₁ — 100-μfd. midget oscillator tuning condenser.
- C₂ — 100-μfd. midget tuning condenser.
- C₃ — 50-μfd. midget tuning condenser. 100-μfd. might be used.
- C₄ — .006-μfd. crystal-circuit blocking condenser.
- C₇ — 1000-μfd., 1000-volt by-pass condensers.
- C₈ — 100-μfd., 1000-volt coupling condensers.
- C₉ — 1000-μfd. filament by-pass condensers.
- R₁ — 75-ohm filament center-tap resistor.

- J₁ — Plate milliammeter jacks.
 - RFC₁ — Radio-frequency chokes; each 200 turns No. 38 d.c.c. on 1/2" form.
 - RFC₂ — Radio frequency chokes; each 100 turns No. 38 d.c.c. on 1/2" form.
 - X — 3500-kc. crystal and mounting.
- Modifications for operation on other frequencies are suggested in the text. The plate milliammeter should have a range of 0-100 ma. Methods for keying are given in Chapter X.
- Connections for neutralizing the second stage are shown in dotted lines. C_n is of 25-μfd. capacity (100-μfd. midget double-spaced).

put in the push-pull and second doublers. An extra 3500-kc. coil, equipped with a center-tap, would be necessary for the single-ended amplifier. This coil may consist of 36 turns of No. 24 d.c.c. wire on a 1.5-inch diameter tube, tapped at the center. The first doubler would be omitted, as for 7000-kc. operation. By these modifications

mitter described in the first part of this chapter. The constructional details of this transmitter are shown by the illustrations and the circuit diagram.

HIGH-POWER AMPLIFIERS

The output of the push-pull stage of the transmitter just described may be used to feed a

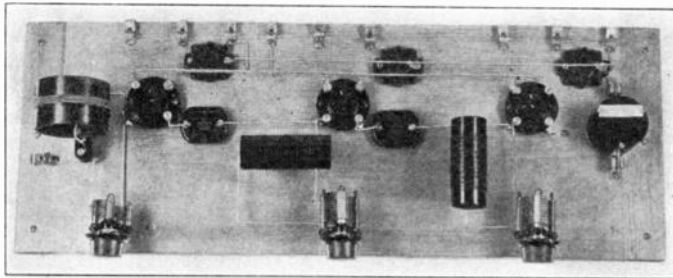

THE OSCILLATOR AND DOUBLER STAGES WITH THE TUBES REMOVED

The crystal mounting is to the right of the oscillator tube. It may be replaced by a fixed-tune grid coil for self-controlled operation. The plate circuit by-pass condensers and radio-frequency chokes are beneath the bread-board base.

operation on three amateur bands is made possible with but a few minutes time required to change from one to the other.

The oscillator of this set can be operated self-

still more powerful amplifier instead of being coupled to the antenna circuit. Sufficient excitation should be available to excite a pair of Type '52 75-watt tubes in push-pull operating on the

same frequency, as one instance. With careful adjustment and efficient operation it is quite possible that even a pair of 250-watters in push-pull could be excited to full output. One satisfactory arrangement of such an amplifier is illustrated. It is designed for use as either the output amplifier of a telegraph set or the linear amplifier of a radiotelephone transmitter. Its use for the latter service will be taken up in the following chapter.

The amplifier consists of two Type '52 tubes in push-pull and is arranged for coupling to the antenna tuning circuit of the low-power push-pull

table or mounted on the wall. The circuit is similar to that of a push-pull tuned-grid tuned-plate transmitter with the exception that pro-

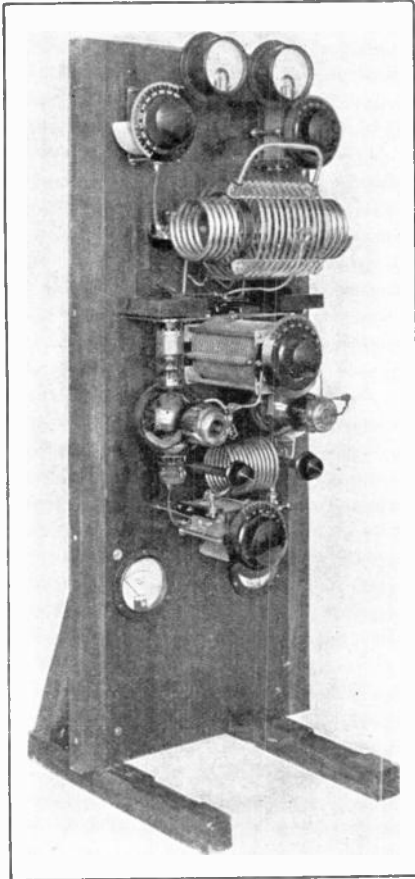

A HIGH-POWER AMPLIFIER OF THE PUSH-PULL TYPE

This would make an excellent high-power stage to follow the low-power push-pull amplifier. It is designed for use as either the power amplifier of a telegraph transmitter or the linear amplifier of a radiotelephone set.

stage. It may be coupled inductively to the output circuit of any amplifier capable of sufficient power output, of course. The apparatus is arranged on a vertical panel which may be placed behind the exciting amplifier on the operating

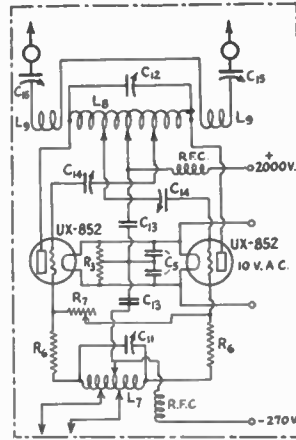

THE 150-WATT PUSH-PULL AMPLIFIER CIRCUIT

The specifications given are for the 3500-kc. band. The amplifier may be adapted to operation on the other amateur bands by substituting suitable inductances in the tuned circuits. Specifications for these coils would follow those given for other transmitters in this chapter.

- C₁₁ — 1000- μ fd. receiving-type variable condenser.
 - C₁₂ — 200- μ fd. 6000-volt transmitting condenser.
 - C₁₃ — 1000- μ fd. 5000-volt by-pass condensers. (May be omitted as in 150-watt push-pull transmitter.)
 - C₁₄ — 25- μ fd. 6000-volt neutralizing condenser. Should have very low minimum capacity.
 - C₁₅ — 250- μ fd. variable condensers, double-spacing.
 - C₅ — 2000- μ fd. filament by-pass condensers. (May be omitted as in 150-watt push-pull transmitter.)
 - R₃ — 100-ohm filament center-tap resistor, non-inductive.
 - R₆ — 100-ohm parasitic suppressors — must be non-inductive.
 - R₇ — 10,000-ohm variable resistor for adjusting grid excitation. Required only for radiotelephone transmission. See Chapter VIII.
 - L₇ — Grid-tank inductance. 10 turns 3/16" copper tubing, 3" inside diameter.
 - L₈ — 3500-kc. R.E.L. inductance.
 - L₉ — Split antenna inductance. Each 5 turns 1/8" copper tubing, 3" inside diameter.
- Antenna ammeters should have 5-ampere capacity. Plate milliammeter, 0-500 ma. Filament voltmeter, 0-10 volts.
RFC — 3500-kc. radio-frequency chokes.

vision is made to neutralize the grid-plate capacity of the tubes. The inductances are plug-in and although specifications are given for the 3500-kc. band only, inductances for the higher frequency bands may be substituted. Specifications for other inductances will correspond with those previously given for other transmitters.

Neutralizing Type '52 tubes introduces one difficulty. The grid-plate capacity of these tubes is so small that neutralizing condensers of very low minimum capacity are necessary if they are to be connected grid-plate grid in the usual push-pull neutralizing circuit. Most variable condensers have a minimum capacity of about 15

$\mu\mu\text{fd.}$, which is too great. For this reason, the neutralizing condensers in this amplifier are tapped in on the plate inductance. Condensers with a minimum capacity of about 5 $\mu\mu\text{fd.}$ and a break-down voltage rating of 6000 volts would

details which have been given in this chapter, the ingenious amateur should be able to work out the combination which best suits his own needs and stock of equipment.

RADIO-FREQUENCY CHOKES

Radio-frequency choke coils should be constructed to work best on the particular wavelength to which the transmitter is tuned. Often one choke will work in the set for several frequency bands.

Every radio-frequency choke coil has a natural period of its own due to its inductance and distributed capacitance. When connected in a tube circuit the choke-period is changed. For every apparatus layout and tube equipment there will be a "best" choke. The best we can do is to

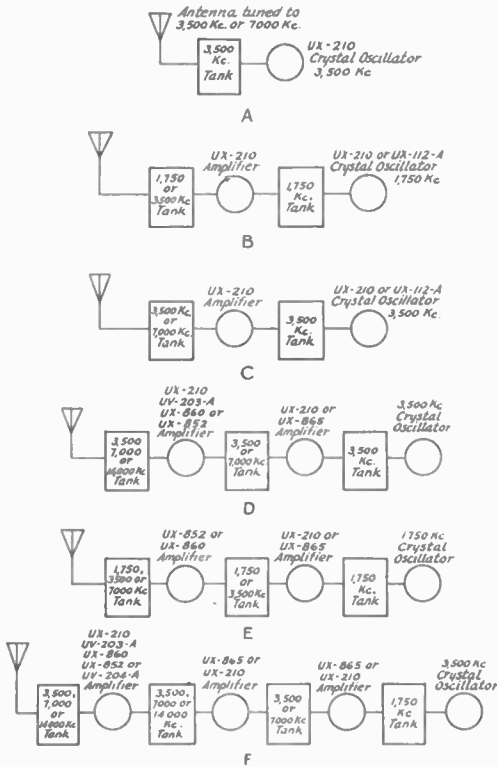

ADDITIONAL SUGGESTIONS FOR TUBE COMBINATIONS IN CRYSTAL-CONTROLLED TRANSMITTERS

eliminate this difficulty. The neutralizing condensers of this amplifier are mounted behind the panel and are operated by insulated shafts extending out in front. The adjustment of this amplifier will be given in the following chapter.

OTHER COMBINATIONS

It is obviously impossible to describe in one chapter all the possible tube combinations which can be built into amateur transmitters. It would be difficult to cover the subject adequately in a book even larger than this one. New arrangements are constantly appearing in *QST*, however, and the latest developments in transmitter construction are chronicled there. To stimulate the imagination of the experimenter a few additional tube and circuit combinations are outlined in the block-diagrams of the accompanying illustration. By studying these suggested arrangements and incorporating the principles and constructional

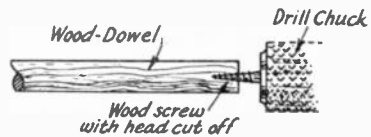

WHEN A WOODEN DOWEL IS USED AS THE form for the radio-frequency choke, it may be mounted on a wood-screw held in the chuck of a hand drill. The head of the wood-screw should be cut off.

specify what works best for our particular set. Mount the choke at right angles to the main coil and at a distance from it and everything else. Keeping coils away from each other and isolated

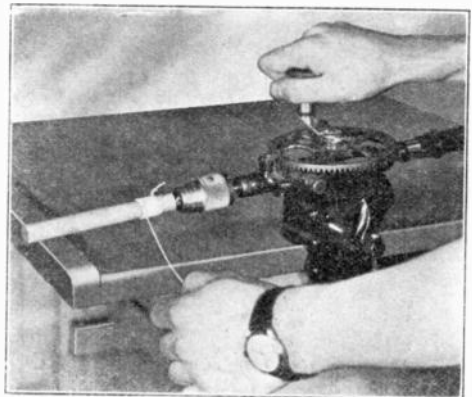

WINDING CHOKES

Knowing the ratio of crank to chuck revolutions, the number of turns wound on the choke can be determined easily by counting the crank turns. The frame of the drill is clamped in a small bench vise.

as much as possible makes their losses lower and keeps induced voltages out of the argument.

For a short-wave transmitter the best chokes appear to be those that tune more sharply to a given frequency. Investigation usually proves that the chokes have standing waves on them under operating conditions. Single-layer coils,

space-wound, not over two inches in diameter, seem to make the best chokes. Spacing the windings decreases the distributed capacity and, what is more important, raises the voltage break-down values at the end turns where the voltage-per-turn is always high in a sending set of any power.

filament, the life of the tube may be much shortened by improper operation. An indicating device for the filament is, therefore, a matter of economy. Next we need an antenna ammeter. The antenna ammeter can be placed at the point in the antenna circuit where the antenna current

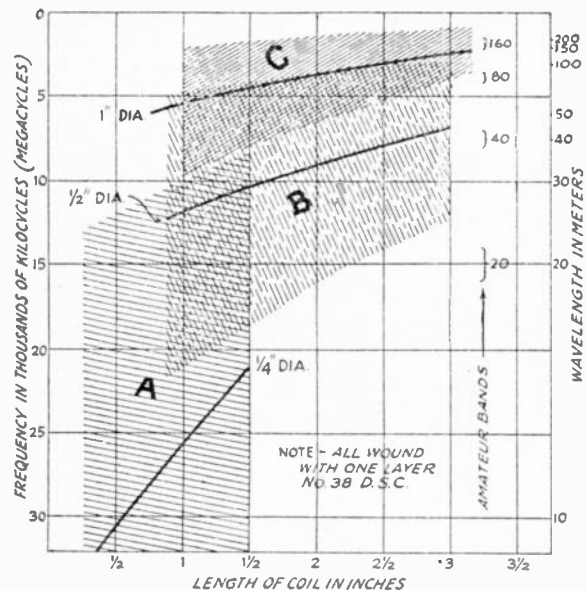

is greatest (at the voltage node or current loop) but its indication will be useful wherever it is and the exact location is not extremely important. If we can afford it we should have a plate milliammeter of the proper range. All meters should be selected with regard to the tubes employed and the current and voltage that we may expect in the different circuits of the transmitter. With these three meters we can get along very well indeed in operating our transmitter. A plate voltmeter can be used if it is available but is not very useful after the circuit is once adjusted. Another milliammeter for the grid-leak circuit may be purchased after all the above have been obtained.

COIL CONSTRUCTION

The tuning coils of the transmitter are extremely important items. Modern self-excited transmitters have large values of capacity across the coils to aid in obtaining a steady output frequency and in consequence the currents in the coils are of a high order. If the coils are made with a conductor which is too small, their resistance will cause serious losses in the circuit which will make themselves evident in the form of heat. In even a low-powered transmitter the coils can become too hot to touch if the coils are made with wire, tubing or strip which is too small. In such cases the transmitter

WINDING DATA CHART FOR R.F. CHOKES

Area A is the approximate useful frequency range for chokes of 1/4" diameter, the heavy line showing the resonance frequency for windings of various lengths (measured along the form). Areas B and C are for chokes wound on 1/2" and 1" diameters, respectively. All data are for No. 38 d.s.c. wire wound in a single layer without spacing between turns. (Approximately 100 turns per inch). The plate current for high-power transmitters can be handled by several chokes in parallel, the connections between them being made with No. 38 wire and the chokes being spaced well apart. Data given do not apply to any size of wire other than No. 38 d.s.c.

METERS

The meters shown in the diagrams that we have discussed so far are really necessary to

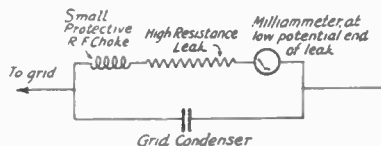

LOCATING THE GRID MILLIAMMETER IN A TRANSMITTER TO AVOID BURNOUT

adjust the circuit properly for best efficiency. After the set is once adjusted and in operation, meters are useful but not necessary. We should have as many meters in the set as we feel we can afford. A filament voltmeter is of first importance. If we do not use a filament voltmeter or some indication of the operating temperature of the

usually oscillates unstably unless excessive grid excitation is used. It is quite common to hear the complaint that the plate current of the transmitter cannot be kept down to the rated value without the tube going out of oscillation. Almost invariably this is due to losses in coils which are not sufficiently heavy, or in high-resistance connections between the coils and their tuning condensers. In the transmitters described, heavy copper tubing was used for the coils but this does not mean that it is the only satisfactory conductor. It is, however, readily available, easy to wind, and it enables the construction of coils without the need of wooden, bakelite or hard-rubber insulating supports for the turns. It is absolutely essential that the coils be mechanically substantial — that they do not vibrate — since the slightest movement of their turns will mean variation in the output frequency of the transmitter. Coils made of copper or brass strip usually will vibrate unless the

strip is very heavy or unless a supporting frame is used.

One satisfactory type of coil using strip is that illustrated. Copper strip $\frac{3}{8}$ " wide can be used for low-powered transmitters but $\frac{1}{2}$ "-wide strip is preferable for a power of about 50 watts. For a transmitter of 250 watts or more the self-

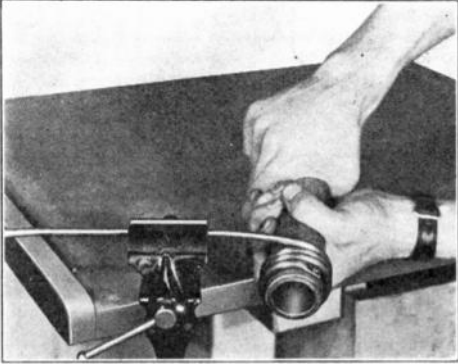

WINDING A COPPER-TUBING INDUCTANCE

One end of the tubing is held in the vise and the other is flattened out and bolted to the pipe used as a winding form. Pulling on the tubing and turning the pipe in the hands, the operator walks towards the vise. The turns should be wound as closely together as possible and spaced later.

supporting strip inductance could be used. In this case $\frac{3}{4}$ "-wide strip $\frac{1}{8}$ " thick is used.

CONDENSERS

The performance of any transmitter can be impaired seriously if the insulation between

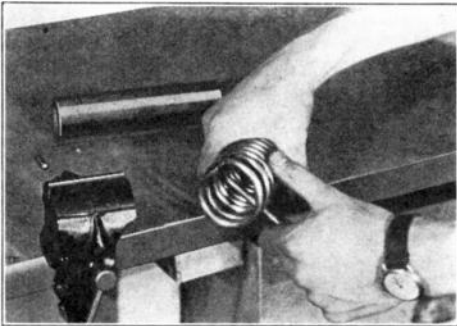

THE TURNS ARE SPACED EVENLY by spiraling a round wooden or metal shaft through the coil. The spacing will depend on the diameter of the tool used.

points of high voltage is poor. A common location for trouble of this type is in the condensers. Without any external indication, there can be radio-frequency leaks through the insulation which will make it impossible to obtain a clean note from the transmitter. In some cases the signal emitted under such conditions is a rough "hash" and no amount of tuning will improve it.

A great deal of trouble will be avoided if the best condensers available are built into the set at the start.

The variable condensers for transmitters operating from a plate supply of 500 volts or less may be of high-grade receiver type. For transmitters operating from higher voltages than these, special transmitting condensers are desirable. Several makes of such condensers are well advertised. They are available in many capacities and voltage ratings.

It is not necessary that the condensers specified for the transmitters described should be variable over the entire range, since they will be operated

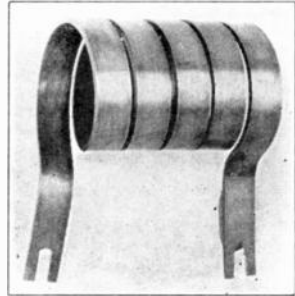

PLATE TANK INDUCTANCES for a high-power transmitter can be made in this fashion. The copper strip is $\frac{1}{8}$ " thick and $\frac{3}{4}$ " wide.

chiefly at values between 200 and 500 μf ds. Variable condensers of 200 or 250 μf ds. can be connected in parallel with fixed air-dielectric condensers of about the same capacity. Such fixed condensers can be bought but the resourceful amateur will find that they can be built up from copper sheet or aluminum dish pans supported with glass rods or glazed porcelain. Many possible constructional methods present themselves, the chief considerations being to keep down the size of the unit so that its field will not be too extensive, to reduce the supports to a minimum without sacrificing solidity, and to provide good contact between the plates and heavy conductors to them.

The fixed condensers in other parts of the set also are important. Mica or glass dielectric is satisfactory for these, and several types of suitable condensers are available. Receiver-type condensers, providing they are rated at not less than 500 volts, can be used in transmitters employing the UX-210 tube but special transmitting condensers will be necessary when higher plate voltages are used.

TRANSMITTER ASSEMBLIES

As we have already mentioned, it is by no means necessary to arrange the apparatus in the transmitter in the manner shown in the illustration. Many other excellent schemes are

possible. The board on which the apparatus is mounted can, for instance, be arranged in a vertical position, with the wiring, transformers, chokes, etc., behind it and the remaining apparatus in front. Alternatively the apparatus can be mounted chiefly on a baseboard, with the meters and controls on a vertical panel in front of it. The panel could be of bakelite or hard-rubber or may be made of well-dried wood. The important points to watch in arranging the apparatus are to make sure that the leads, particularly in the tuning circuits, are short; to see that the coils are well clear of the condensers or other large metal bodies; and to arrange the parts in such a way that the controls are convenient and all apparatus is accessible.

HIGH-IMPEDANCE TUBES

The transmitters described in this chapter were all designed for use with the tubes specified and they will not operate with the same efficiency if tubes of widely different characteristics are employed. Many of the European tubes and some manufactured in this country have a very high plate impedance and the circuits in which they operate most effectively may be different from those given. In the first place the high impedance of the tube makes it necessary to have a radio-frequency choke of very high reactance in shunt-feed circuits (such as that given for the low-powered Hartley transmitter) to attain reasonable efficiency. In practice, due to the difficulty of making high-reactance radio-frequency chokes, the shunt-feed circuits are often almost inoperative when used with the high-impedance tubes. No such difficulty is experienced when series feed circuits (such as that given for the high-powered transmitter) are employed. The large values of capacity specified for the tank circuits of the transmitters in this chapter also would result in low efficiency if used with high-impedance tubes. A greater number of turns and less capacity would be desirable. In addition, much higher-resistance grid leaks will be necessary. Some of the European tubes operate effectively with values even as high as 50,000 ohms.

PARASITIC OSCILLATIONS

Parasitic oscillations usually occur when tubes are operated in parallel or push-pull, especially in high-frequency oscillators and amplifiers. The parasitic oscillations are of ultra-high frequency and are due to the tube capacities and stray inductance and capacity of the circuit wiring. They are usually indicated by excessive heating of the tube, particularly of the grid and plate leads inside the envelope. They cause poor efficiency, a rough note and sometimes "singing" of the tube. An amplifier afflicted with parasitics is almost impossible to neutralize. They may be prevented by proper proportioning of the grid

and plate leads, as in the push-pull oscillator described in this chapter, or by inserting small resistors or chokes in each grid lead at the tube terminals. The resistors should be of about 100 ohms each and should be non-inductive. If chokes are used, each may consist of about 20 turns of fine wire on a 1/2-inch diameter.

UNSTEADY SIGNALS

One of the chief problems in transmitters other than those of the crystal-control type is to maintain a steady frequency. First there is the frequency creep due to heating of the tube or other apparatus in the set. This can be reduced to a minimum by tuning the set for greatest efficiency. The greater the antenna power for a given input the less will be the heating of the tube. The aim is, therefore, to keep the input at or below the rated value and to tune the set until the tube operates with the least heating. With a good antenna most tubes can be operated at the rated input without the plate showing any color. With any tube the plate should never be allowed to get hotter than a dull red. This is most likely to happen during the preliminary adjustment when the tube stops oscillating or is operating in an inefficient manner. For this reason, during adjustment, it is advisable to have the key or a convenient switch so arranged as to permit shutting off the plate power quickly when necessary.

The detuning of the antenna circuit mentioned in the paragraphs on tuning does not result in appreciably lowered efficiency in the tube. When it is said that the greatest antenna current should be obtained for a given input to keep the tube coolest it is meant that the greatest antenna current *with the antenna detuned in the manner described* should be obtained. When the antenna is detuned the plate current drops. The grid excitation should therefore be adjusted so that the normal plate current will be obtained with the antenna circuit in the detuned condition.

Another common cause of frequency instability is vibration or swinging of the antenna or feeders. The effect of such vibration or swinging is reduced considerably by the detuning of the antenna circuit but it is essential that the antenna be supported in such a way that it is steady even in a high wind. This point will be given consideration in the chapter on antennas.

Leaky insulation also is often a serious offender in this regard. Not only can a leak destroy the character of the note but it can be responsible for a wobbly frequency. Trouble of this type often can be detected by removing the antenna circuit and listening to the transmitter in the monitor. Sometimes the leak is visible in the form of a thin arc. If the leak is through bakelite a swelling on the surface of the insulation often will be noticed.

Perhaps the most common cause of all is vibration of the coils or wiring. A vibration which

results in serious frequency instability often is too slight to be noticeable. The coils and wiring should be watched very carefully during operation to make sure that the movements of keying, the humming of a transformer or the vibration of a generator are not transmitted to the set. The mounting of the set on rubber sponges often will aid in the elimination of the trouble.

It is only by careful and prolonged attention to such details that the performance of the transmitter can be maintained at a high standard. It is fine to aim at a neat station, an elaborate lay-out, or an imposing antenna. Of infinitely greater importance than these things, however, is the signal — the only part of the station that the whole world can examine.

CHAPTER VIII

Radiotelephony

BECAUSE the radiotelephone transmitter is something more than just a c.w. outfit equipped with a modulating system, the technic of 'phone transmission is considerably more complex than that of c.w. transmission, for the 'phone set contains not only all the radio-frequency equipment of a very good c.w. transmitter but also incorporates the coördinated audio-frequency equipment necessary to supply voice modulation. Moreover, the demands made by voice modulation on the radio-frequency elements of the 'phone transmitter are greatly different from those made by hand keying on the c.w. transmitter. With a good c.w. transmitter the wave emitted is of a single frequency and constant amplitude while the key is closed, or of zero amplitude while the key is open. The plate voltage and power input to the transmitting tubes are constant while a signal is being transmitted and slight imperfections in the emitted wave do not seriously affect the utility of the signal. Contrast these simple circumstances with those which surround the 'phone transmitter. Primarily, the carrier radio frequency must remain constant with modulation as well as without modulation. The most practicable modulation methods require relatively tremendous swings in the plate voltage and power input to the radio-frequency power tubes during modulation — but the carrier frequency must remain constant in spite of these large variations. Moreover, imperfections in the transmitted carrier which might be negligible for code transmission become intolerable for voice transmission. This means that all except intended modulation of the carrier must be eliminated — the plate supply must be real continuous direct current and the transmitter adjustment must be well nigh perfect.

Fortunately, the attainment of this idealism in radiotelephone practice is realized by following well-defined rules and without trusting to hit-or-miss guessing. Several years' experience with amateur 'phone transmitters has tried the definite principles which are given in this chapter; and these rules and principles are also those on which the most modern commercial transmitters are designed. The amateur can profit by following them closely.

MODULATION

The process of voice modulation consists of varying the amplitude of the radio-frequency current in the antenna in exact accordance with the voice-frequency vibrations affecting the microphone. If the modulating tone is a single frequency the variations in antenna current am-

plitude will be as shown in the illustration. Here three degrees of modulation are shown. In *A* the current amplitude varies between twice the unmodulated carrier amplitude and zero, and the modulation factor is unity or 100%. *B* shows less than 100% modulation and *C* illustrates over 100% modulation. Since the variation

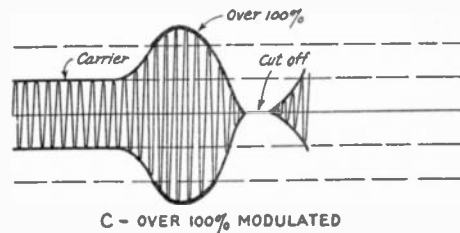
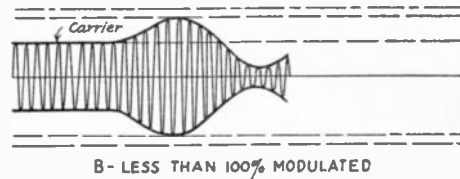
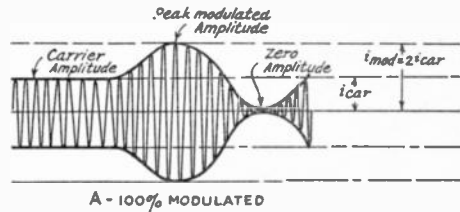

in field intensity is proportionate to the percentage of modulation, it is desirable to make the modulation factor as great as possible without exceeding complete modulation and running into the distorting condition shown by *C*. A high modulation factor (above 70%) is especially desirable for amateur work because the carrier interference range is less in proportion to the signaling range and, correspondingly, the signal range with a high modulation factor is greater for a given carrier output. As a specific instance, a 10-watt carrier modulated 100% is practically as effective as a 40-watt carrier modulated 50%; the carrier power required for a given value of field intensity variation is inversely proportional to the square of the modulation factor:

$$\frac{P_1}{P_2} = \frac{M_2^2}{M_1^2}$$

P_1 and P_2 represent two carrier power values in watts, and M_1 and M_2 represent the respective modulation factors expressed as decimals. This relation might be used to compare approximately

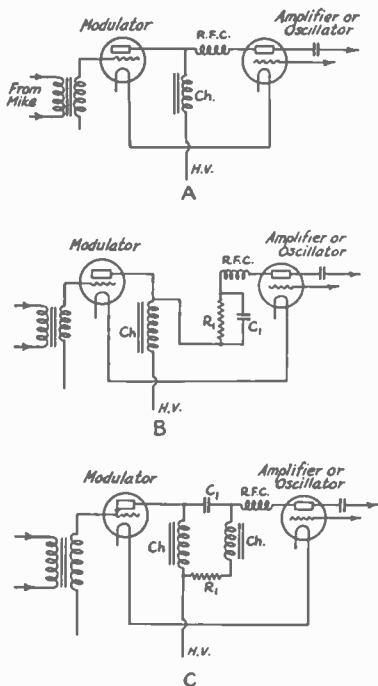

the effectiveness of two transmitters at various values of carrier power and modulation factor.

When high values of modulation factor are used particular care must be exercised to guard against the frequency instability condemned in the preceding chapter. It has been shown that frequency "wobulation" is a serious defect in c.w. transmission and it must be realized that frequency modulation is far more objectionable in 'phone transmission. It not only causes unnecessary interference with other stations working on adjacent frequencies in the same band but also can cause interference with services operating on greatly different frequencies. An amateur 'phone working on the 3500-kc. band is even likely to cause interference on the broadcast band, as a result of the frequency "wobulation" accompanying modulation of an oscillator and the consequent radiation of spurious frequencies over a band of hundreds of kilocycles. Frequency modulation is also a likely cause of distorted reception because the waves radiated on different frequencies travel over separate paths and arrive at the receiver out of phase with each other. Modulation of the oscillator in an amateur transmitter is therefore poor practice and is not recommended because any practicable method of

modulation applied to an oscillator is bound to cause frequency modulation as well as amplitude modulation, even though the modulation factor be low. Even when a radio-frequency amplifier following an oscillator is modulated, precautions are necessary to insure against affecting the oscillator's frequency. An extremely stable oscillator circuit is necessary, preferably isolated from the modulated stage by a buffer amplifier.

METHODS OF MODULATION

A great many methods of modulating the high-frequency output of a transmitter have been suggested, all of which may be grouped into two general classes. One is the modulation of the high-frequency output current directly and the other is the modulation of the d.c. input power to the transmitter. Any form of modulation operating on the high-frequency circuits of the transmitter is bound to affect seriously the electrical characteristics of the tuned circuits and usually introduces unavoidable distortion. All such methods are now obsolete and are not recommended.

Modulation methods affecting the power input to the transmitter can operate on either the r.f. tube's grid (grid modulation) or its plate circuit (plate modulation). Grid modulation operates to vary the mean grid bias on the tube, thereby affecting its plate resistance and power input. The audio-frequency power required is relatively small, but the relation between grid-bias variation and r.f. output is linear over but a small part of the transmitting tube's characteristic with the result that distortionless modulation is limited to about 20% in practicable circuits.

One form of plate input modulation utilizes a modulator tube with its plate circuit connected in series with the d.c. plate supply to the r.f. tube, the power input to the r.f. tube varying with the changes in plate resistance of the modulator caused by audio-frequency variation of its grid voltage. The necessity for having the filament of the modulator tube at the same d.c. potential as the plate of the r.f. tube is a serious handicap to this system and complete undistorted modulation of the r.f. output is impossible because of the non-linear plate characteristics of the modulator tubes available.

Parallel plate modulation, also known as constant current and Heising modulation, is most suitable for completely modulating the radio-frequency output of a transmitter and is used in all modern transmitters of high modulation capability. Three simple schematic arrangements for Heising modulation are shown in the accompanying illustrations.

The simplest arrangement is that shown in diagram A. In this system the modulator tube may be considered as an audio-frequency linear power amplifier, impedance-coupled to the plate circuit of the modulated radio-frequency amplifier, the same value of d.c. plate voltage being

applied to both tubes. The modulator tube is biased to operate on the linear portion of its grid-plate characteristic while the r.f. tube is biased and excited so that its power output varies as its plate power input, the antenna current varying directly as the plate voltage. The modulator tube therefore operates as a Class A audio-frequency linear amplifier and the r.f. tube operates as a Class C amplifier. A Class A amplifier operates so that the plate output wave shapes have essentially the same form as those of the excitation voltage and the output is therefore practically undistorted, particularly when the output load is a pure resistance of proper value. The operating characteristics of a Class A amplifier or modulator tube are shown in the figure

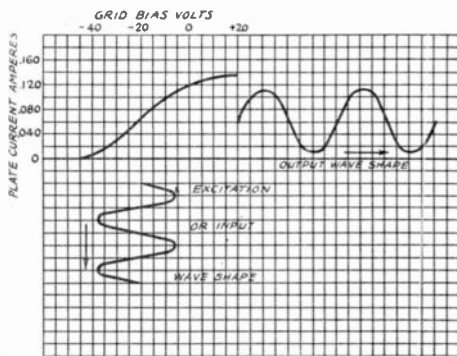

CLASS A AMPLIFIER OR MODULATOR

herewith, and the corresponding characteristics of a Class C amplifier are illustrated farther on.

The choke *Ch* must have extremely high reactance at speech frequencies (100 to 3000 cycles) so that the full audio-frequency plate swing of the modulator tube will be applied to the plate circuit of the r.f. amplifier. The plate circuit of the Class C amplifier being the plate load for the modulator, the mean value of its resistance is determined by the d.c. plate voltage and plate current to the r.f. tube. It is just as necessary for the modulator to work into a load resistance of proper value for maximum undistorted modulation as it is for an audio output tube to work into the proper load resistance for maximum undistorted power output. Therefore, there is a definitely proper value of Class C amplifier plate current for any modulator-amplifier combination and the amplifier must be operated at this value of plate current if maximum undistorted modulation is to be obtained. A fault with many amateur transmitters (and some commercial transmitters) is to operate the Class C modulated amplifier or oscillator with excessive plate current. This lowers the effective load resistance into which the modulator tube must work and makes impossible the attainment of anything but a low value of modulation factor without distortion. This "over-

loading" of the modulator causes the kind of distortion sometimes called "over modulation."

To obtain 100% modulation of the Class C amplifier's output it is necessary to swing its plate voltage from zero to twice the mean value. This is impossible when the modulator and Class C amplifier are operated at the same value of mean plate voltage, because the modulator plate voltage cannot swing from zero to twice its mean value without introducing serious distortion in the output. To obtain 100% modulation it is necessary, therefore, to operate the modulator at a higher mean plate voltage than that of the Class C amplifier. Two methods of accomplishing this are shown at *B* and *C*. In *B* a resistor of proper value to give the desired drop in d.c. voltage is connected in the supply lead to the Class C amplifier plate. This resistor is by-passed by a large condenser to provide a low-reactance path between the two plates for audio-frequency power. Arrangement *C* operates in the same way but separate chokes are used for the modulator and the Class C amplifier supply circuits, with the dropping resistor on the supply side of the amplifier choke. The coupling condenser *C*₁ should be capable of withstanding the maximum a.f. plate voltage swing of the modulator tube. In both arrangements *C*₁ must be of low reactance for the lowest modulation frequency to be transmitted; in broadcast transmitters a capacity of 8 μfd. is deemed none too large although 1 or 2 μfd. will be sufficient in amateur transmitters where only voice frequencies need be considered.

MODULATOR TUBES

The best modulator tubes are those falling in the classification of audio output power amplifiers. They are generally of comparatively low impedance and amplification factor. These characteristics are not entirely reliable as indicating a good modulator, however, and the plate-current plate-voltage characteristics of the tube must be consulted for the whole story. The tubes most satisfactory as modulators, together with their proper operating voltages and loads, are listed in the modulator-amplifier table, and the method of determining the capability of any tube as a modulator by means of its plate characteristic curves is explained at the end of the chapter. Many popular tubes are very poor modulators and should never be used as such. These are the Type '10, Type '03-A, Type '52, and Type '04-A. The tubes designated as modulators in the accompanying table and the tube table of Chapter VII are greatly superior and should be used in their stead.

It has previously been mentioned that there is one proper value of Class C amplifier plate current for a given modulator and set of operating conditions and *this holds true regardless of the type of tube used as a Class C modulated amplifier.* Moreover, the proper value of plate current will

be the same whether one or more tubes are used in the modulated amplifier. If the amplifier plate current is greater than that specified for a certain type modulator tube operating at specified

tubes (grid swings up to 100 volts) will require one stage of transformer-coupled speech amplification — using a Type '01-A, '12 or '27 tube — with a single-button carbon microphone. A

RECOMMENDED MODULATOR-AMPLIFIER COMBINATIONS FOR HIGH MODULATION

Modulator							Class C Amplifier					
Type Tube	Rated Plate Dissip. Watts	D.C. Plate Volts E_b	D.C. ¹ Plate M.A. I_b	Neg. Grid Bias, Volts E_c	Grid ² Swing Volts E_g	Dropping ³ Resistor Ohms	Type Tube	D.C. Plate Volts E_b	D.C. Plate M.A. I_b	Neg. Grid Bias E_c (Approx.) Volts	Carrier ⁴ Output Watts (Approx.)	Percent Modulation
842	12	425	22	100	96	5000	'10	300	25	90	5	83
		425	22	100	96	5000	'45	300	25	180	5	83
		500	24	118	114	8000	'10	300	25	90	5	100
		500	24	118	114	8000	'45	300	25	180	5	100
'50	25	500	50	100	96	5000	'10	300	40	90	7.5	95
		500	50	100	96	5000	'45	300	40	180	7.5	95
'11	75	1000	20	70	65	15,000	'11*	600	27	110	10	100
845	75	1000	75	150	145	5550	'11**	600	72	110	25	100
		1250	60	196	191	3570	'03-A	1000	70	90	50	90
		1250	60	196	191	3570	'11	1000	70	180	50	90
'49	300	2000	125	75	69	11,100	'03-A	1000	85	90	60	100
		2000	125	75	69	11,100	'11	1000	85	180	60	100
		3000	100	132	127	10,000	'52	2000	100	330	140	100
		3000	100	132	127	10,000	'04-A	2000	100	180	140	100

¹ Plate current per modulator tube.

² A.c. filament supply with grid return to filament center-tap.

³ Divide by 2 if modulators in parallel are used with Class C amplifier drawing twice specified amplifier plate current.

⁴ Amplifier plate efficiency assumed as 70%.

* One Type '10 might be used but is liable to break-down on modulation peaks.

** Two Type '10 tubes might be used in push-pull or parallel but are liable to break-down on modulation peaks.

values of plate voltage and bias, additional modulator tubes must be connected in parallel to supply the load. The ratings specified in the table should be closely observed.

SPEECH AMPLIFIER AND MODULATOR CONSTRUCTION

The design and construction of a speech amplifier and modulator unit is quite similar to that of a good audio-frequency power amplifier and the same practice should be followed. The speech amplifier section should be capable of delivering the necessary grid swing to the modulator without overloading or distortion, and since the speech amplifier is really a voltage amplifier and not a power amplifier, it should use tubes having fairly high amplification factor in order to give the greatest possible voltage amplification per stage. The value of voltage amplification necessary is set by the grid swing required by the modulator and the voltage swing generated across the secondary of the microphone transformer. The latter, in turn, is determined largely by the type of microphone used. As a general rule, Type '50, Type '11, or UX-842 modulator

double-button microphone will necessitate an additional transformer-coupled stage. Higher-power modulators such as the Type '49 and UX-845 (peak grid swings up to 190 volts) will need two stages of speech amplification for single-button microphones, the second stage using a Type '10 tube with 350 volts on its plate and the first stage being the same as the single-stage amplifier for lower-power modulators. A three-stage amplifier using tubes such as the Type '27 or '12 in the first two stages and a Type '10 in the last stage will be necessary for high-power modulators when using a double-button microphone. Condenser type microphones which incorporate a stage or two of amplification will operate satisfactorily with the same type of speech amplifier used for double-button carbon microphones.

When a Type '10 tube is used in the final stage of a speech amplifier its output preferably should be impedance coupled or impedance-resistance coupled to the grid of the modulator, although there is no practical objection to transformer coupling if a suitable transformer is employed. The tubes of the speech amplifier are operated as linear audio-frequency amplifiers

and the electrode voltages given in the tube table of Chapter VII should be followed. The peak grid swing to the modulator can be limited to the value where distortion begins by adjustment of the gain control across the secondary of the microphone transformer.

Resistance-coupled amplifiers are also suitable but the gain per stage is less than when transformer coupling is used unless high- μ amplifier tubes (such as the Type '40 and UX-841) are employed. It will be necessary, therefore, to use at least one more stage of amplification with resistance coupling than with transformer coupling to realize the same over-all voltage amplification. The resistance-coupled amplifier is of no real advantage in amateur work, however, since only voice frequencies are to be amplified and the excellent frequency characteristic obtainable with a resistance-coupled amplifier is not necessary.

When two or more stages of speech amplification are used particular care must be taken to prevent "motor-boating" and distortion resulting from inter-stage feed-back. The coupling transformers should be isolated from each other and all supply circuits should be adequately by-passed. It is advisable to keep the modulation reactor well away from the other audio equipment when more than one stage of speech amplification is used since the strong magnetic field about the choke is quite likely to induce feed-back in nearby audio transformers. As a further precaution all transformer cases should be connected to the negative side of the plate supply and grounded. One lead of the microphone circuit should also be grounded and a shielded microphone cable is advantageous, particularly for eliminating radio-frequency pick-up in the microphone leads. R.f. overloading of the grid circuits of the speech amplifier and modulator is one common cause of "singing" and every precaution to eliminate it will prove worthwhile. Liberal use of radio-frequency chokes in the power and bias supply leads, particularly the high-voltage leads between the modulator and Class C amplifier, together with removal of the audio-frequency equipment from the vicinity of the radio-frequency units, can go a long way towards eliminating troubles from radio-frequency overloading. Complete shielding of the speech amplifier and modulator unit is decidedly good practice but should not be demanded in any but extreme cases, such as where it might be necessary to place the audio equipment right next to the radio-frequency units.

When modulator or speech-amplifier tubes are operated in parallel or push-pull, a non-inductive resistor of about 100 ohms should be connected in the grid lead to each tube to prevent parasitic ultra-high frequency oscillation and consequent overloading of the grids. Such resistors are also helpful in reducing grid overloading from induced r.f.

MICROPHONES AND THEIR CARE

A good microphone is a decided asset to any amateur 'phone transmitter although the possession of even the best microphone obtainable is no guarantee of perfect transmission. Any microphone capable of transmitting the frequencies of the speaking voice with good fidelity should be adequate and the outlay for an expensive microphone is a waste of money if the transmitter itself is not capable of nearly distortionless transmission. Inexpensive single-button

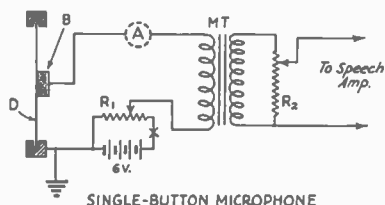

SINGLE-BUTTON MICROPHONE

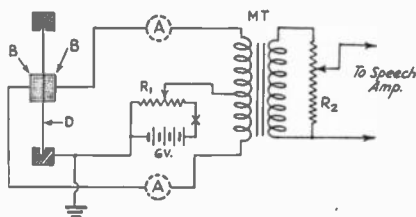

DOUBLE-BUTTON MICROPHONE

CARBON BUTTON MICROPHONES OF TWO TYPES

The diaphragms are designated by D and the buttons by B. R₁ may be 400 ohms and the gain control R₂ a 100,000-ohm potentiometer. The microphone frame should be grounded and the leads should be shielded to prevent r.f. pick-up.

carbon-grain microphones, similar to those used for wire telephony, are used successfully by many amateurs and are capable of transmitting very intelligibly when used with a properly adjusted outfit. The microphone transformer for this type should have a primary impedance of 100 ohms and is quite reasonable in cost. Excellent double-button carbon-grain microphones admirably suited to amateur use are now available at reasonable prices and are generally used in the better amateur stations. The double-button microphone transformer should have a center-tapped primary of 200 ohms impedance. The double-button microphone is considerably less sensitive than the single-button type and therefore requires a speech amplifier of greater voltage gain, as has been explained previously. Condenser-type microphones are considered the best for faithful response over a wide range of frequencies but their high cost (including the special amplifier they require) makes their use by amateurs quite limited.

Carbon-grain microphones, both single- and double-button, convert sound waves into pulsat-

ing electrical current by the variation in the resistance with pressure between carbon granules in contact with a metal diaphragm which is caused to vibrate by the sound waves striking it. In the single-button microphone, one connection is made to the metal diaphragm and the other is made to the cup containing the carbon granules, called a button. The microphone terminals are connected in series with a battery and the primary winding of a transformer. The current through the primary is a pulsating direct current which induces alternating current in the secondary winding, the resultant alternating voltage across the secondary being applied to the grid circuit of the speech-amplifier tube. In the double-button microphone there is a carbon element on each side of the diaphragm. The buttons are connected to the two ends of the primary winding of the microphone

7000 cycles. This makes the microphone's sensitivity comparatively low but improves its frequency characteristic.

Condenser microphones utilize an entirely different principle — that the variation in electrostatic capacity between two plates causes a change in the potential difference between them. In the microphone one of the plates is thick and incapable of vibration but the other is of thin metal, tightly stretched, separated from the fixed plate by about a thousandth-inch. A high d.c. potential is applied between the plates and the variation in the potential which results when the thin plate vibrates in response to a sound wave is applied across the grid circuit of an amplifying tube. The voltage variation is extremely small and a two-stage microphone amplifier is necessary to bring it up to the value obtainable from a double-button carbon microphone. This amplifier is usually attached to the microphone stand.

A microphone of any type is a piece of apparatus requiring careful handling if it is to do its intended work properly. It should never be moved or even touched while current is flowing through it because the slightest jar will give the diaphragm a jolt far greater than that caused by a loud sound. The carbon microphone should never be operated with excessive current through the buttons because the heat generated by high current may fuse the carbon granules together, causing "freezing." A current of not more than 10 or 15 milliamperes per button is usually safe and the microphone battery voltage should be adjusted to give this value of current when the microphone is first connected. The transmitter plate milliammeter can be used

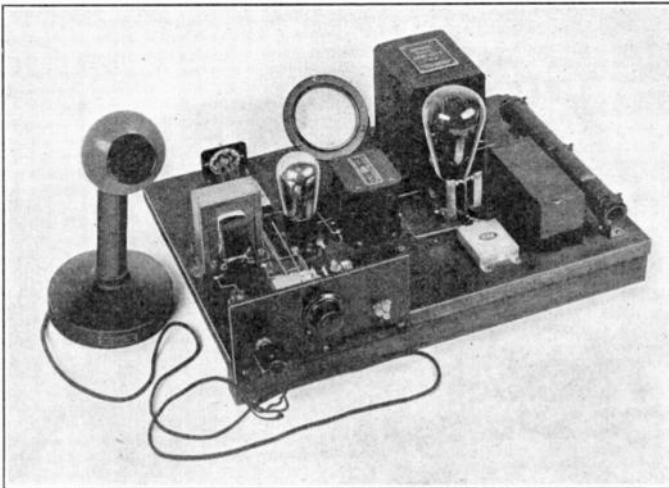

A SUITABLE SPEECH AMPLIFIER AND MODULATOR FOR THE LOW-POWER 'PHONE

It will modulate a single Type '10 or '45 Class C amplifier 95% and should be used with a single-button carbon microphone. The microphone jack, gain control and microphone battery switch are on the front panel. The microphone transformer and Type '27 speech amplifier are behind this panel with the Type '50 modulator tube, double plate choke, dropping resistor and by-pass condenser at the right.

transformer and the diaphragm is connected in series with a battery to the center of the winding. The granules in one button are compressed and their resistance is reduced while the granules on the other side loosen and their resistance is increased when the diaphragm is vibrated, with the result that there is an increase in current flow between one button and the diaphragm while there is a decrease in current flow between the other button and the diaphragm. The current flow through the common circuit and the battery will remain constant if the buttons have been properly adjusted. The diaphragm of a double-button microphone is "stretched" to make its natural resonant frequency well up in the audio-frequency range, usually to some value above

in making the adjustment. The current to each button of a double-button microphone should be of the same value and sometimes adjustment of the pressure on the buttons may be necessary to make it so. This adjustment must be made very carefully, preferably by an experienced microphone repair-man.

If a carbon microphone should become "frozen" the granules may be loosened by lightly tapping the frame with one finger *after the microphone battery circuit has been opened*. The microphone should be suspended by springs in a frame or hung from the ceiling in preference to having it unprotected from shock and vibration on the operating table. A good shock proof mounting will eliminate a lot of the "back-

ground" noise which afflicts many amateur outfits. A light cloth sack pulled over the microphone will keep out insects and dust as well as protect the diaphragm from corrosion by moisture condensed from the speaker's breath. An ordinary conversational tone should be used and it is better to talk "across" rather than directly at the microphone because breath striking the diaphragm gives the speech a hissing characteristic.

PRACTICAL TRANSMITTER ARRANGEMENTS

Two speech amplifier-modulator units are illustrated as examples of practical arrangements for low-power amateur transmitters. The first is an excellent modulator for one Type '10 or '45 Class C amplifier and is designed for use with a single-button microphone. The second makes an excellent modulator for a Class C amplifier using two Type '10 or '45 tubes in push-pull or parallel and is designed for use with a double-button microphone. When operated according to specifications either is capable of 95% modulation of a suitable Class C amplifier. The first unit might be used to modulate the single-ended amplifier of the low-power crystal-controlled transmitter described in Chapter VII or, still better, a single-ended Type '10 or '45 following a buffer amplifier. The second unit is admirably suited to modulation of the push-pull amplifier also described in Chapter VII. The construction of both units is based on the principles outlined in the preceding paragraphs and their specifications are given

circuit of the modulated amplifier and the other is designed to use a single modulation choke which is connected in the positive supply lead to the unit but is not incorporated in the assembly. Both units are intended for operation with rectified a.c. plate supply, a.c. filament supply and battery grid bias.

The positive high-voltage output terminal is

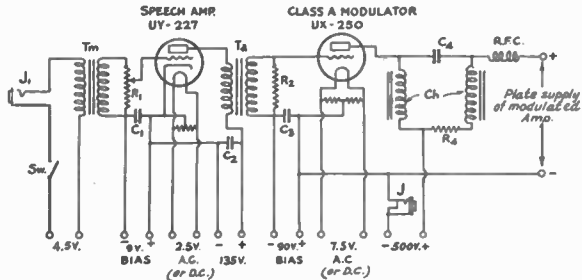

THE SINGLE-TUBE MODULATOR UNIT

- T_m* — Microphone transformer.
- T_a* — Audio frequency amplifying transformer.
- Ch* — National type 80 double B eliminator choke.
- C₁* — 1- μ fd. by-pass condenser.
- C₂* — 1- μ fd. 300-volt by-pass condenser.
- C₃* — 1- μ fd. by-pass condenser.
- C₄* — 1- μ fd. 1000-volt audio coupling condenser.
- R₁* — 200,000-ohm Frost potentiometer.
- R₂* — 250,000-ohm resistor, grid leak type.
- R₃* — 100-ohm filament center-tap resistors.
- R₄* — 5000-ohm Ward Leonard No. 507-A resistor, 80 m.a., 44 watts.
- R.F.C.* — Silver-Marshall type 277 or Aero type C-248 choke.
- J* — Closed circuit milliammeter jack.
- J₁* — Open circuit microphone jack.

connected to the corresponding terminal of the modulated amplifier stage and to that stage only. The negative high-voltage connection is common to all units of the transmitter, as is also the positive grid bias. It is advisable, however, to run separate leads from each unit of the transmitter to the negative tap on the plate supply and to the positive tap on the bias supply, to reduce inter-stage coupling. The modulator plate supply should deliver 500 volts of pure d.c. and should have a current capacity of about 100 m. a. for the single-tube modulator transmitter or 200 m.a. for the transmitter using the two-tube modulator. The d.c. plate voltage for the Class C amplifiers will be reduced to about 300 volts by resistors *R₄* and *R₂* when the respective modulated amplifiers are adjusted to draw their proper values of mean plate current. This adjustment is extremely important and must be made exactly.

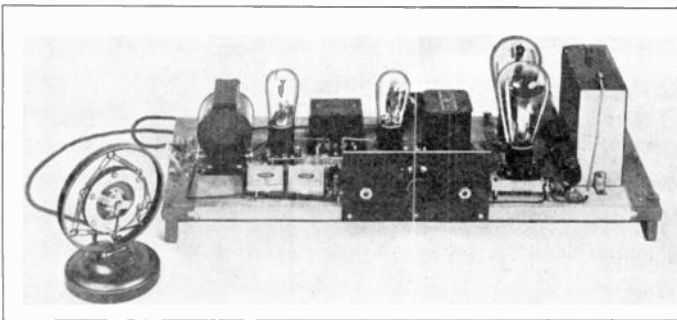

SPEECH AMPLIFIER AND MODULATOR FOR THE LOW-POWER PUSH-PULL CLASS C AMPLIFIER

With this unit it is possible to completely modulate the output of two Type '10 or '45 tubes used as Class C amplifiers. The gain control is on the small panel with the microphone and plate milliammeter jacks on either side. The amplifier is intended for use with a double-button carbon microphone.

beneath the circuit diagrams. Each utilizes the Type '50 as a modulator and Type '27 tubes as speech amplifiers. The output of one is provided with a double choke for coupling to the plate

CLASS C MODULATED AMPLIFIERS

When a radio-frequency amplifier operates so that its power output varies directly as its plate power input over a wide range of plate voltage values (as a modulated amplifier should work) it is known as a Class C amplifier. To accomplish this it is necessary that the negative grid bias be relatively high and that grid excitation of considerable amplitude be supplied. The value of the grid-bias voltage should be approximately *twice* the value required to reduce the plate current to

zero occur at every half-revolution of the crank.

The proper value of negative grid bias for a three-element tube used as a Class C amplifier is easily calculated by dividing the plate voltage value by the tube's amplification factor and multiplying by 2. Since the plate voltage on the Class C amplifier in this case is 300, the proper value of bias for Type '10 tubes (amplification factor 8) is about 90 volts and that for Type '45 tubes (amplification factor 3.5) is about 180 volts. It is advisable to make the bias a little

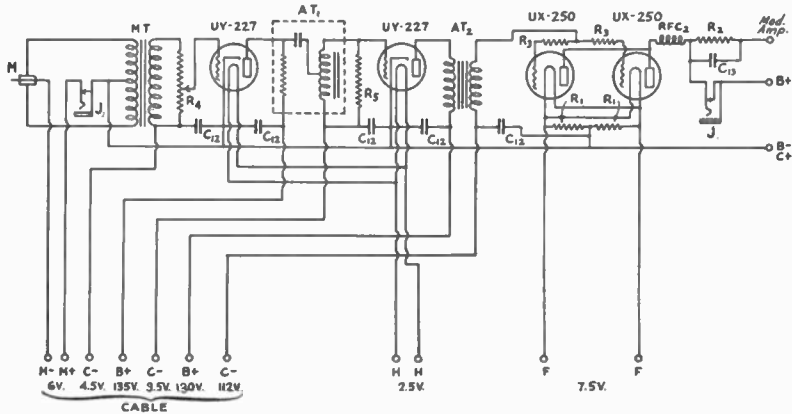

THE CIRCUIT OF THE TWO-STAGE SPEECH AMPLIFIER AND MODULATOR

- | | |
|---|---|
| C_8 — 1000- μ fd. filament by-pass condenser. | R_5 — 100,000-ohm resistor. |
| C_{12} — 1- μ fd. by-pass condenser. | AT_1 — Silver-Marshall No. 255 Audio Transformer. |
| C_{13} — 2- μ fd. audio by-pass condenser. | AT_2 — Audio-frequency transformer 3/1. |
| R_1 — 75-ohm filament resistor | J_1 — Plate current jack. |
| R_2 — 2500-ohm plate voltage dropping resistor. | J_2 — Microphone current jack. |
| R_3 — 100-ohm grid resistor. | M — Double-button microphone. |
| R_4 — 100,000-ohm gain control (potentiometer). | MT — Microphone transformer. |

zero (cut-off) without grid excitation, and the excitation amplitude must be sufficient to swing the grid positive over a portion of half the excitation cycle, as shown in the graphical representation of this operating condition. Large amplitudes of plate current flow during the peaks of the least-negative half cycles of excitation voltage and no plate current flows during the remainder of the excitation. The output waves are quite distorted and "kick" the plate tank circuit on alternate half-cycles only, but because of the tank's "fly-wheel" effect the transmitter output is practically sinusoidal. The action is analogous to that of a single-cylinder two-cycle gas engine whose crank has practically true harmonic motion because of the smoothing effect of the fly-wheel, even though the power impulses are delivered to the mechanism over but a small portion of each revolution. In a push-pull Class C amplifier or oscillator the two plates alternate in supplying half-cycles of energy and the tank circuit receives a "kick" on both halves of the cycle, this action being analogous to that of a two-cylinder two-cycle engine in which the explo-

higher than that computed by the above method because actual cut-off bias is always slightly greater than that calculated. It is not necessary to use battery bias alone for Class C amplifiers, and a combination of battery and automatic grid-leak bias is recommended. This may be obtained by connecting a transmitting grid leak in series with battery bias sufficient to reach cut-off. A 10,000-ohm grid-leak will be satisfactory for both Type '10 and '45 tubes as well as for most of the larger tubes.

Once the bias has been set, the next step is to switch on the transmitter and tune the circuits to one of the bands authorized for amateur 'phone. This process is exactly the same as the tuning of a c.w. transmitter and has been completely covered in Chapter VII. It is recommended that a dummy antenna like the one shown in the diagram be used in place of the radiating antenna in order to reduce interference to other stations while the transmitter is being given its preliminary adjustment. It is always evidence of good technical practice as well as of amateur courtesy to use such a non-radiating

load for transmitter experiments which actually do not require a radiating antenna. Following this, adjust the antenna tuning and coupling so that the Class C amplifier plate current is exactly the value specified in the table for the operating conditions and tube combination being used (40 m.a. for the single modulator or 80 m.a. for the two-tube unit). *Do not attempt to tune for maximum antenna current.* The amplifier's plate-current value is the index of proper operating conditions, let antenna current be what it may. If it should be impossible to make the plate current as much as the value specified, even with "tight" antenna coupling and all circuits tuned to resonance, the excitation to the modulated amplifier is insufficient and must be increased. The bias should not be reduced to make the tube draw more plate current and increase the carrier output; the bias must be that specified and nothing less. The excitation should be increased by increasing the output of the preceding stage

amplifier current. This should be 50 m.a. for the single Type '50 modulator or 100 m.a. for the two Type '50's in parallel. Sounding a prolonged "Oh-h-h" into the microphone, slowly advance the gain control from minimum to maximum

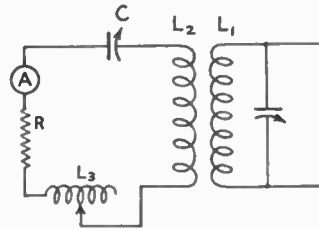

A SUITABLE DUMMY ANTENNA FOR TRANSMITTER TESTING

- L₁ — Transmitter tank inductance.
- L₂ — Antenna coupling coil.
- L₃ — Loading coil, similar to transmitting inductance
- C — Antenna tuning condenser.
- R — Non-inductive resistor. A Ward-Leonard "plaque" type 70-ohm resistor or a 100-watt lamp will serve for low-power sets. A bank of lamps can be used for high-power outfits.
- A — Radio-frequency ammeter.

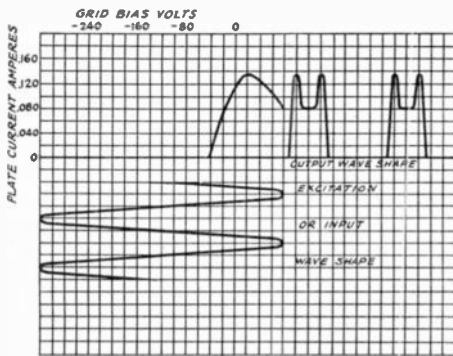

CLASS C AMPLIFIER

either by adjusting its bias, increasing its plate voltage or, perhaps, by slightly increasing the plate voltage and output of the oscillator.

Class C modulated amplifiers require more excitation than similar power amplifiers in c.w. telegraph transmitters and a surplus of excitation is always desirable. An approximate check on the sufficiency of the excitation can be made by short-circuiting the voltage dropping resistor in the modulator unit. This will increase the amplifier power input and antenna current, the increase in the latter being directly proportionate to the increase in plate voltage or plate current if the excitation is sufficient. When these preliminaries are finished the transmitter is ready for modulation.

The milliammeter should be connected in the plate supply lead to the modulator unit, through which also flows the plate current for the modulated amplifier. The value of current indicated is the sum of the plate current for both modulator and amplifier tubes, the modulator current being the difference between the total and the known

until the plate milliammeter begins to show an increased reading. This indicates distortion and the gain should be reduced slightly. The antenna ammeter should show an upward deflection of about 25% for complete modulation but the modulator and amplifier d.c. plate current should be absolutely constant.

A decrease in antenna current with modulation may mean that the modulator bias is improper, that a modulator tube is defective, or that the modulator is "over-loaded."

The quality of the transmission can be checked by listening on the vacuum-tube monitor tuned to zero beat with the carrier; the speech should be clear and distinct even with the monitor tube oscillating. If the speech sounds "mushy" it is an almost certain indication of frequency modulation — which can be prevented by the methods outlined in the early part of this chapter. A handy monitor for continuously checking the

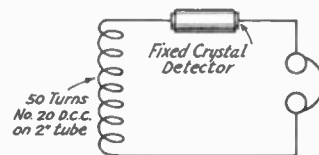

CRYSTAL-DETECTOR MONITOR

speech quality is the crystal detector rig whose schematic circuit is shown. It will give signals of good strength with the coil almost anywhere in the immediate vicinity of the transmitter and is also useful for exploring the modulator, plate-supply and house wiring for r.f. picked up from

the transmitter. When the frequency stability and quality have been checked the transmitter is ready to go on the air.

Although screen-grid transmitting tubes can be used as Class C modulated amplifiers they are not so well adapted as three-element tubes to usual circuit conditions because of their plate characteristics.

CLASS B LINEAR AMPLIFIERS

The power output of a low-power 'phone transmitter may be increased by adding a suitable linear r.f. amplifier operating on the same frequency as the modulated amplifier. One suitable unit for operation with either of the transmitters just described is the high-power amplifier described in Chapter VII. There would be little gain in adding a linear amplifier of lower power because the carrier power output of a tube used as a linear amplifier is but quarter the carrier power output obtainable from the same tube used as a modulated Class C amplifier.

The construction of a linear amplifier is much the same as that of any other power amplifier excepting the provisions for adjusting its grid

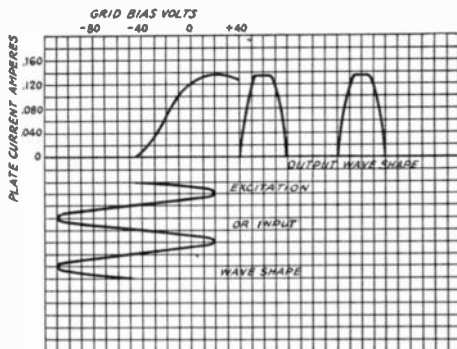

CLASS B AMPLIFIER

excitation and for obtaining good grid regulation. In this high-power push-pull amplifier these are, respectively, the adjustable input coupling and the resistor shunting the grids.

The Class B linear amplifier operates so that its power output is proportional to the square of the grid excitation voltage, and with 100% modulation the unmodulated carrier output is one-fourth the peak or normal rated power output. The Class B output rating of the high-power push-pull amplifier is therefore 37.5 watts carrier and 150 watts peak, the latter being the normal output rating of the tubes. This is about double the carrier rating of the low-power push-pull rig using two Type '10 or Type '45 tubes as Class C modulated amplifiers.

The figure illustrates the relation between excitation-voltage and plate-current wave shapes. The negative grid bias must be of cut-off value,

approximately equal to the mean plate voltage divided by the amplification factor of the tube, or about 180 volts for the Type '52 at a plate voltage of 2000 volts d.c.

The procedure for putting a Class B linear amplifier into operation is first to adjust its unmodulated excitation until the antenna current is the maximum obtainable and then to reduce the excitation until the antenna current becomes half that value. This adjustment is made with the high-power amplifier described by the coupling between its input circuit and the tank of the modulated amplifier or by the grid shunting resistance, or by varying both coupling and resistance. Since the primary function of the resistor is to provide a fixed minimum load across the output of the exciting amplifier during the more negative swing of the excitation voltage — when the grid circuit would otherwise present an extremely high resistance load — it is better as well as more convenient to keep the resistance fixed and make use of the coupling adjustment only. Each change in coupling will necessitate re-tuning of the exciting amplifier's tank circuit as well as the linear amplifier's grid circuit and, possibly, the output tank and antenna circuits. It is essential that all circuits be tuned to exact resonance before reliable readings can be taken for any adjustment. If the carrier excitation is adequate, the total d.c. plate current at excitation coupling for maximum antenna current should be about 200 m.a. (100 m.a. per tube) and at half maximum antenna current the total d.c. plate current should be about 100 m.a. (50 m.a. per tube) with 2000 volts on the plates. The antenna current reading should increase about 25% with complete modulation of the carrier and the d.c. plate current should remain constant.

RECEIVERS FOR RADIOTELEPHONY

Just as the transmitter requirements for radiotelephony are more exacting than for radiotelegraphy, so are the receiver requirements. Radio-frequency selectivity is even more necessary for minimum interference in amateur 'phone reception than it is in broadcast reception. The usual amateur regenerative receiver is fairly selective when the detector is oscillating for beat-note c.w. reception but it loses much of its selectivity when the detector is non-oscillating, as it is for 'phone reception. A regenerative receiver with a stage of tuned r.f. amplification ahead of the detector is considerably more selective than one without, and at least one such tuned stage is recommended. For maximum selectivity on amateur 'phone frequencies, however, a receiver of the super-heterodyne type is even better. A broadcast receiver chassis, whose tuned r.f. amplifier was used as an intermediate-frequency amplifier, in conjunction with the high-frequency super-heterodyne converter described in Chapter V, would make an ideal arrangement.

ACCURATE PERFORMANCE MEASUREMENT

A more accurate check on transmitter performance than that possible by the methods which have been described can be made with a simple adaptation of the peak vacuum-tube voltmeter which is known as the modulometer. Among the practical uses of the rig are the measurement of percentage modulation and of speech-amplifier gain, the detection of audio- and radio-frequency feed-back in the audio system, and the many other r.f. and a.f. measurements which can be made with such a vacuum-tube voltmeter. Although a Type '99 tube is shown in this instance, any d.c. or a.c. type tube having similar grid-plate characteristics would be satisfactory. The peak value of an a.c. voltage applied to the grid circuit of the tube is equal to the negative d.c. bias voltage required to balance it and bring the plate current milliammeter indication back to the same value as with no grid excitation. This reading of the plate milliammeter is known as the "false zero" and may be the first scale division above true zero. To obtain it the tube is operated at a set value of minimum bias determined by adjusting the potentiometer R_3 . The additional bias required to balance grid excitation voltage of 9-volt or less amplitude and bring the plate current back to false zero, is determined by adjustment of the potentiometer R_2 and is measured by the d.c. voltmeter V . Additional bias in series with that across R_2 is necessary for measurement of amplitudes of more than 9 volts. It is connected to the "Additional Bias" terminals shunted by the voltmeter V_1 . The sum of the readings of V and V_1 then gives the value of the peak voltage

(secondary) rather than across a plate-load circuit because the d.c. voltage drop due to plate current through a transformer primary or coupling resistor would cause an error in measurement. A.F. voltage measurements should never be attempted

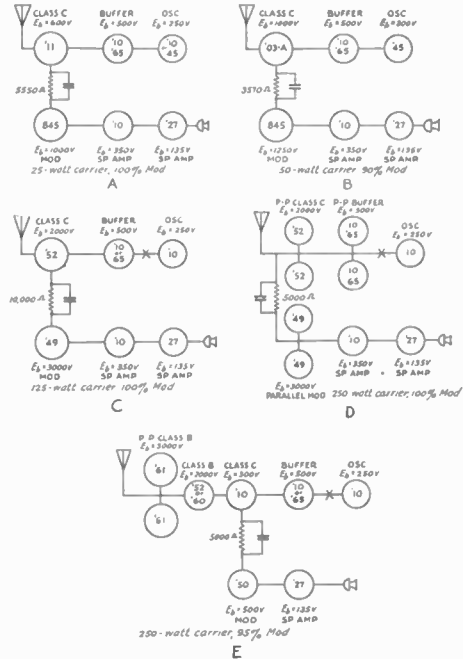

SOME ADDITIONAL TRANSMITTER COMBINATIONS BASED ON DATA GIVEN IN THE MODULATOR AMPLIFIER TABLE

The speech-amplifier arrangements are for single-button microphones; double-button microphones will require an additional stage ahead of the first one shown. The oscillators may be crystal-controlled or self-controlled and should operate on the carrier frequency. Frequency multipliers will be necessary for output frequencies higher than the oscillator frequency and they may be inserted at the points designated X on the diagrams.

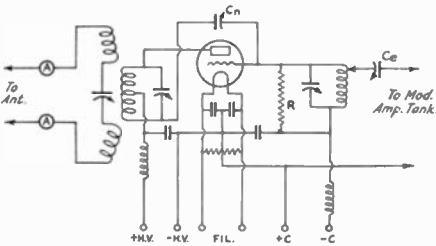

CIRCUIT OF A SINGLE-ENDED LINEAR AMPLIFIER

The non-inductive grid-regulation resistor, R , should be of about 2500-ohm resistance and capable of dissipating approximately 50% of the exciting amplifier's power output: "Ohm-spun" units are often used in high-power outfits. The excitation can be adjusted by the coupling condenser C_n as well as by the clips on the coils. The constants are similar to those of other r.f. power amplifiers, depending on the frequency and power.

being measured. The "Additional Bias" terminals should be shorted when no battery is connected.

For audio-frequency peak-voltage measurements the terminals marked "Audio Input" are connected across a grid circuit (transformer

in any circuit across which there is a d.c. voltage, such as grid bias. The radio-frequency voltage of amplifier or detector circuits in a receiver might be measured by connecting to these terminals, the ground side of the receiver circuit being connected to the right-hand terminal, but the circuit capacity of the modulometer in parallel with the tuned circuit of the receiver would seriously affect the accuracy of the measurements; also, the measurement of small amplitudes would be practically impossible.

Percentage modulation measurements are made with S_2 thrown to the left. The coil L_2 is coupled to the output circuit of the transmitter and the r.f. current through the circuit causes a voltage drop across R_1 which is directly proportional to the current through the resistor. Variations in the amplitude of the antenna cur-

rent will therefore cause proportionate variations in the r.f. voltage across R_1 and the amplitude of the positive half-cycles of this voltage is measured by the peak voltmeter.

It is necessary to supply the speech amplifier input circuit (microphone transformer primary) with audio frequency of constant amplitude for these measurements and an audio oscillator such as that described in Chapter II will do very nicely, the primary terminals of the microphone transformer being connected in place of the 'phones. The transmitting antenna should be replaced by a dummy antenna, of course. The

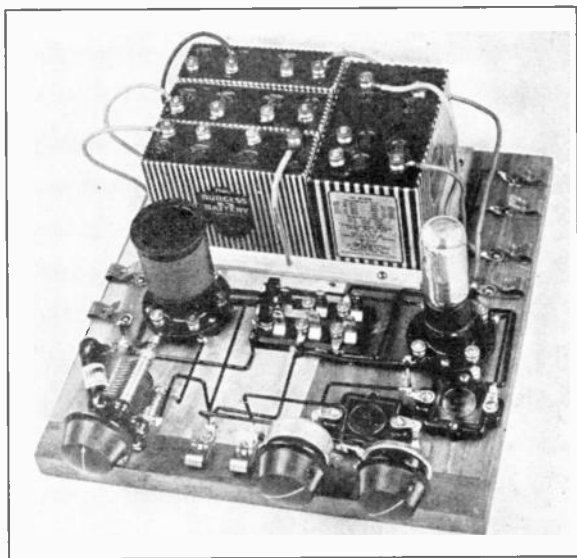

AN EXPERIMENTAL MODEL OF THE MODULOMETER

The non-inductive resistor is to the left of the variable condenser. The d.p.d.t. switch in the center is for changing from "audio input" to r.f. input for the measurement of percentage of modulation.

maximum modulation capability of the transmitter is checked with the gain control advanced to the point where the modulator and Class C amplifier plate current milliammeter begins to show a variation in reading, indicating that the point of distortion has been reached. The pick-up coil of the modulometer should be coupled to the antenna inductance and the coupling adjusted so that the amplitude of the voltage across R_1 measures 5 or 6 volts. The gain control is then set at zero, leaving the carrier unmodulated, and a second measurement is made. The percentage of modulation is the difference between the two voltages divided by the unmodulated carrier voltage, multiplied by 100:

$$M = \frac{E_{\text{mod}} - E_{\text{carr}}}{E_{\text{carr}}} \times 100$$

M is the percentage of modulation, E_{mod} is the voltage amplitude with modulation, and E_{carr} is

the voltage amplitude for the unmodulated carrier.

The gain of the speech amplifier is found by measuring the audio voltages on the grid of the first speech amplifier tube and on the grid of the modulator, the ratio of modulator grid voltage to the speech-amplifier grid voltage being the voltage gain of the amplifier. A performance curve for the transmitter can be made by plotting the percentage of modulation for various values of speech-amplifier signal voltage against the signal voltage values. Such a curve is shown for a transmitter using the equipment described in this chapter.

Audio-frequency feed-back in the speech amplifier is detected by making measurements of the signal voltage on the grid of one of the amplifier tubes with the modulator plate voltage "on" and "off." If the signal amplitude is greater with the modulator "on," there is feed-back. Radio-frequency pick-up is similarly detected, the r.f. excitation (oscillator) being switched on and off, an increased amplitude with the carrier "on" indicating r.f. in the audio circuits. Audio- and radio-frequency feed-back can be eliminated by following the suggestions given in earlier parts of this chapter.

MODULATOR TUBE CALCULATIONS

The proper operating conditions for any type of modulator tube for a given set of circuit conditions can be determined graphically from the plate-voltage plate-current characteristics of the tube. The procedure is quite the same as that for determining the optimum plate load for maximum undistorted power output for a tube used as a Class A audio-frequency power amplifier and is comparatively simple. The method is best shown by an example using one of the modulator tubes listed in the modulator-amplifier table — in this case the Type '49, whose average plate characteristics are shown.

The rated plate dissipation of the tube is given as 300 watts. Assuming that the maximum rated d.c. plate voltage is to be used, the maximum safe value of plate current is the plate dissipation divided by the plate voltage, or 100 m.a. The intersection of the 3000-volt and 100 m.a. coordinates fixes the operating point and, by interpolation, the proper grid bias is -132 volts. When the tube is operated with a.c. filament supply the maximum grid swing on either side of the operating point will be less than the bias value by one-half the filament voltage, or from -132 volts down to -5.5 volts and up to -258.5 volts, the peak amplitude of the grid swing being, nearly, 127 volts. For distortionless operation the grid swing

must never be greater than this value and the plate load resistance must be of the proper value to limit the distortion (second harmonic) to 5%. The load resistance is determined by the mean plate voltage and plate current of the modulated Class C amplifier.

Experience shows that for 100% modulation with most modulator-amplifier combinations the optimum ratio of modulator to Class C amplifier mean plate (d.c.) voltage is approximately 3/2. With 2000 volts as the mean plate voltage for the

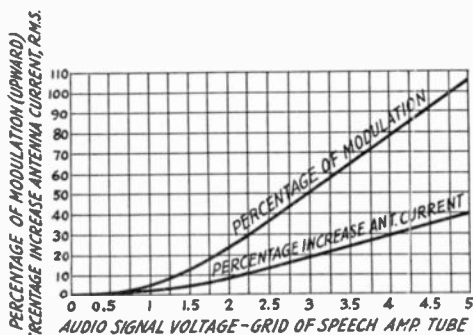

MODULOMETER PERFORMANCE CURVES OF A 'PHONE TRANSMITTER

Class C amplifier, the plate voltage swing of the modulator tube will have to be 2000 volts for 100% modulation. A line should be drawn through the operating point and the grid-swing limit curves approximately at points where they intersect the 1000- and 5000-volt lines. These intersec-

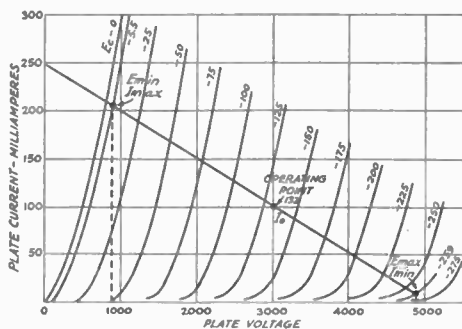

MODULATOR LOAD LINE FOR 100% MODULATION PLOTTED ON THE PLATE CHARACTERISTIC CURVES OF A TYPE '49 TUBE

tions need not be hit exactly as long as the plate voltage values are different from each other by twice the plate swing or 4000 volts. The line should be extended to where it intersects the zero plate-voltage line. The slope of this line is the proper load resistance value. That is,

$$\frac{E_{\max} - E_{\min}}{I_{\max} - I_{\min}} = R_p$$

The current and voltage maxima and minima are indicated on the curves. If the modulator and Class C amplifier were both operated at the same value of mean plate voltage (3000 volts) the

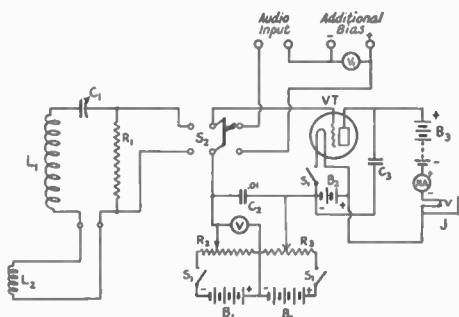

SCHEMATIC CIRCUIT OF THE MODULOMETER

L₁ — For 3500 kc. use 40 turns of No. 28 d.c.c. wire on a Silver-Marshall plug-in coil form. The same number of turns wound in a 2-inch diameter "hank" would serve as well.

L₂ — Pick-up coil. 2 or 3 turns of lamp cord, any size convenient.

C₁ — 100-μfd. midget variable condenser. Any variable will do.

C₂ — .01-μfd. fixed condenser.

C₃ — 1000μfd. fixed condenser.

R₁ — 1500-ohm Ward-Leonard resistor No. 507-55. Any good "non-inductive" resistor of 1500 or 1000 ohms might be used.

R₂ — 200-ohm wire-wound potentiometer.

R₃ — 2000-ohm potentiometer.

B₁ — 9 and 4.5-volt "C" batteries.

B₂ — 2 dry cells in series (3 volts).

B₃ — Small size 22.5-volt "B" battery.

S₁ — Triple-pole single-throw switch.

S₂ — Double-pole double-throw battery type switch.

V — 0-10 volt d.c. voltmeter.

V₁ — 0-120 volt d.c. voltmeter

MA — Weston Model 375 Student Type Galvanometer or 0-1 d.c. milliammeter.

J — Closed-circuit phone jack.

VT — Type '99 tube.

value of amplifier plate current to give this load would be the total plate current value at the intersection of the load line and the zero voltage line (250 m.a.) minus the modulator current (100 m.a.), and the modulation factor would be the modulator plate voltage swing divided by the mean plate voltage, or 66.6%. With different values of modulator and amplifier mean plate voltages, however, the difference between modulator and total current values (150 m.a.) must be multiplied by the ratio of modulator to amplifier mean plate voltage to give the proper value of amplifier current for optimum load conditions. That is,

$$150 \text{ m.a.} \times \frac{2000}{3000} = 100 \text{ m.a.}$$

The proper amplifier d.c. plate current is therefore 100 m.a. for 100% modulation with a modulator peak grid swing of 127 volts. The speech amplification between the microphone and modulator grid must be adequate to supply this

grid swing on the peaks and the plate voltage dropping resistor should be of 10,000 ohms to give a voltage difference of 1000 at 100 m.a.

PRACTICAL OPERATING HINTS

The radiotelephone transmitter may require some "trouble-shooting" at times and a short summary of the symptoms of the more usual ailments will be useful. The troubles cited will not occur if the design and adjustment are according to the information previously given in this chapter, however.

"Downward" modulation, indicated by a decrease in antenna current when the carrier is modulated, is caused by a reduction in power output with modulation when there should be an increase in power output. It may be due to any of the following: Improper modulator bias; insufficient Class C amplifier bias; insufficient Class C amplifier r.f. grid excitation; excessive Class C amplifier plate current, causing overloading of the modulator. If a linear amplifier is used following the Class C modulated amplifier, downward modulation will result with 100% modulation if the carrier excitation to the linear amplifier is greater than that giving one half the maximum antenna current obtainable or if the bias on the linear amplifier is less than that required for plate current cut-off.

In an improperly designed transmitter, downward modulation may be the indication of a poor modulation choke or an audio-frequency by-pass across the modulation reactor. A too large by-pass or blocking condenser in the plate circuit of the Class C amplifier will cause this trouble. The capacity of this condenser should be not greater than .002 μ f. and circuits not requiring such a by-pass condenser are preferable where high modulation frequencies are used, as in television transmission.

When the transmitter is operating properly

the plate current to each tube in the set should be the same with modulation as without modulation, and the antenna ammeter should show an increase in antenna current with modulation. Any variation in modulator or speech amplifier plate current is a certain indication of audio-frequency distortion. The greater the variation, the worse the distortion.

TRANSMITTER POWER SUPPLY

The filament supply for amateur transmitters is usually alternating current for the modulator and radio-frequency tubes, and either a.c. or d.c. for the speech amplifier tubes. Direct-current filament supply for all tubes is used in most broadcast transmitters where the elimination of all but intended modulation is necessary but is not required for the transmission of speech only. The plate power for the speech amplifier may be from B batteries or a B substitute while that for the modulator and radio-frequency tubes is usually from d.c. generators or a.c. rectifiers. The power supply for the oscillator and buffer amplifier stages should be separate from that used for the modulator and Class C amplifier because modulation invariably causes some fluctuation in the modulator and Class C amplifier supply voltage unless extraordinary precautions are taken to guard against it. The plate supplies described in Chapter IX will be satisfactory if the particular features pointed out therein as desirable for telephony are incorporated.

The negative grid bias for low and medium power transmitters can be obtained from dry B batteries. Rectifiers are satisfactory for supplying grid bias to audio-frequency units but, because of their poor regulation, are not so well suited to supplying bias for the r.f. power tubes. D.c. generators make the most satisfactory grid bias supplies for high-power r.f. amplifiers, particularly for Class B linear amplifiers.

CHAPTER IX

Power Supply

FROM Chapter VII the impression might be gained that a simple transmitter consists only of a tube and the tuning circuits associated with it. However, it must be understood that the transmitters described are not complete and cannot operate until they are provided with a power supply. This power supply, though involving only simple apparatus in most cases, is always of the greatest importance. Care expended in its installation and adjustment will be well rewarded by improvement in the signal and in the over-all effectiveness of the transmitter.

The power supply system of any tube transmitter consists of two units — the supply for the tube filaments and the supply for the plate circuits. It is to the latter that we shall give first consideration.

THE PLATE SUPPLY

If the transmitting tube is to function steadily and produce a pure musical signal at the receiving end, the plate supply must be a steady direct current. This is of great importance. Rapid fluctuations in the plate supply voltage cause similarly rapid fluctuations in the antenna power. This, in turn, results in the production of modulation and added interference. Much more serious, however, is the fact that in the self-excited oscillator such voltage fluctuations cause not only power fluctuations but frequency fluctuations or frequency "flutter." The extent of this "flutter" can be reduced greatly by the use of a high value of capacity across the tank coils in the transmitter and by careful tuning adjustment (as described in Chapter VII) but, with the possible exception of the crystal-control transmitter, the "flutter," the "mushy" note and the interference which accompanies it can never be completely avoided *unless the plate supply is pure d.c.*

Slow variations in the plate voltage also must be avoided since these result in slow frequency changes or frequency "creep," making it necessary for the receiving operator constantly to retune his receiver to hold the signal. Yet another possible defect to be avoided in the plate supply is poor regulation (to be discussed in detail later) which results in the plate voltage changing with every change in load on the plate-supply system. Trouble of this sort gives rise to a sudden frequency change — a frequency "chirp" — whenever the load is changed. It is when the transmitter is keyed that this effect becomes so apparent.

Frequency flutter is so undesirable and productive of so much unnecessary interference that the use of plate supplies which do not produce un-

modulated direct current is definitely prohibited by the U. S. government regulations under which amateur stations are licensed unless the transmitter is one in which flutter cannot occur. In practice this means that the supply must be pure d.c. on any form of oscillator, and that a.c. or rectified and partially filtered a.c. can be used only on the amplifier stages of a transmitter which is crystal-controlled or excited by a very stable self-controlled oscillator followed by a buffer amplifier, both of which must be supplied with pure d.c. Careful attention therefore must be paid to the power supply system or the transmitter cannot be operated legally.

PLATE SUPPLY SYSTEMS

The simplest form of plate-supply system is nothing more than a battery of dry cells or storage cells. For the low-powered transmitter such a supply is not only inexpensive but particularly desirable because it provides steady and absolutely pure direct current. For a transmitter of any appreciable power, however, both the installation and upkeep costs mount rapidly and battery supply is no longer practicable.

For the medium- and high-power transmitters there are two alternatives — to use a high-voltage generator of ample rating for the tube or tubes, or to step up the commercial alternating current to a suitable voltage, then convert it to direct current with a rectifier system, and smooth out the fluctuations or ripple with a suitable filter. The latter arrangement is that most generally used in amateur stations.

REGULATION

When we speak of the voltage regulation of a transformer, generator, rectifier, filter, or rectifier-filter combination we mean the variation in the voltage the device delivers with the "load" that it handles.

Suppose a rectifier-filter system delivers 350 volts, 45 m.a., to a Type '10 oscillator with the key closed. We open the key and the voltage at the output terminals of the filter rises to 500 volts. The regulation from full load (key closed) to no load (key open) is the difference, or 150 volts. This regulation is often expressed as a percentage. Voltage regulation is the ratio of the difference between full-load and no-load voltage to the rated-load voltage.

In this case it is:

$$500 - 350 = 150$$

$$\frac{150}{350} = .428 = 42.8\% \text{ regulation (rather poor)}$$

The tube load is not necessarily full load for

this rectifier. If we design our rectifier-filter to give an output of 350 volts, 100 m.a. (35 watts), and happen to be using it under-loaded we have 42.8% as a value of regulation for about half-load. A regulation curve for the outfit can be plotted showing what the percentage regulation of volts delivered will be for different loads.

The regulation of a battery depends on the internal resistance of the cells of which it is made up. This in turn depends on the depolarizer used and increases with the age of dry cells. The internal resistance of storage cells is very low and the regulation correspondingly good (small).

The voltage regulation with various types of rectifiers and filters will be considered farther along.

DRY CELLS AS PLATE SUPPLY

Dry-cell "B" batteries usually can be obtained in 22½- or 45-volt units for plate supply work.

The 22½-volt batteries (4" x 4¼" x 8" size) usually have about 570 milliampere-hours capacity when discharged intermittently at rates not in excess of 30 milliamperes. 200 hours of operating use can be expected when using such batteries with a Type '10 transmitting tube. With Type '01-A tubes even longer life can be expected. Of course the quality of the battery will have a great deal to do with this life. These figures are merely representative of some of the batteries available from reputable manufacturers.

Battery capacity will be reduced if batteries are kept in too dry a place, especially if they are not well sealed, because the electrolyte will dry out. In damp climates there is apt to be leakage between the cells of high-voltage batteries if precautions are not taken. In cold climates batteries keep very well but may show a temporary loss of voltage as the activity of the chemicals is decreased by coldness. In this case the voltage will rise as current is drawn from the batteries because of the heat generated internally.

The life of the battery will depend on its capacity. The "heavy-duty" type will give much better service than the smaller sizes, although the first cost is of course higher. Since they are designed for comparatively high discharge rates, however, there is probably more service per dollar in the heavy-duty batteries than in the standard sizes. For maximum service the batteries purchased should always be those of a reputable manufacturer.

Dry-cell batteries are not suited for use with larger sets than those using one Type '10 tube. The economy is rather poor beyond a 50-milliampere discharge rate. The beginning amateur will have no trouble in starting off with a set using small tubes with a dry-cell battery of two or three hundred volts for plate supply.

STORAGE CELLS

Storage cells are expensive and many of them

are necessary for high-voltage power. Either Edison (alkaline) batteries or lead (acid) cells can be used. Equipment must be provided for charging them. Distilled water has to be added to replace that lost by evaporation. In cold climates they must be kept fully charged to prevent freezing of the electrolyte. After a few years the storage cells must be rebuilt or replaced and so the up-keep is also quite high.

"B"-BATTERY SUBSTITUTES

"B" substitutes are made to be used with receiving sets, but they enter the picture here because they can be used also with low-powered transmitters.

These battery "eliminators" are designed to connect to the 110-volt alternating current circuit. There are many types on the market, all containing a step-up transformer, rectifier, and filter. They differ from one another principally in the type of rectifier used and the means for determining and regulating the output voltages.

A few of the "B" substitutes give a good direct-current output at between three and four hundred volts with fairly good regulation. One of these on a small transmitter will give excellent results.

MOTOR-GENERATORS AND DYNAMOTORS

A direct-current motor-generator is an excellent source of plate power for any transmitter. The rated output of the generator (watts) is equal to the product of the plate voltage (volts) and plate current (amperes). The terminal voltage should match the rated plate voltage of the transmitting tubes. It is convenient but not necessary to have a rheostat in the field of the generator to regulate the terminal voltage. The regulation of most of the motor-generators on the market is good. By using a series field winding or "compounding" a machine, an increase in load current makes the field in which the armature rotates stronger, which compensates for the several factors causing a drop in voltage. A machine having the same full-load and no-load voltages is known as "flat" compounded. If the full-load voltage is greater than the no-load voltage, the machine is "over-compounded." A motor-generator set is the simplest plate supply source but it is also probably the most expensive.

The motor that drives the generator can be direct-connected or belted. In any case it should drive the generator at about its rated speed. It should be rated at about 1¼ to 1½ times the generator capacity since it has to take care of its own and the generator's losses.

An a.c. supply with a filter is usually cheaper than the motor-generator set. However, a motor-generator of the right size will save the expense of big filters for the rectifier. A small filter to take out the commutator ripple is all that is necessary.

The motor-generator set is mechanically noisy, which makes it unsuited to some jobs. However, it is usually very convenient if one has the ready money to spend on power-supply equipment.

A dynamotor is simply a double-armature machine with a common shunt field, running on one winding as a motor usually driven from a six- or twelve-volt storage battery. The high-voltage winding delivers several hundred volts to the plates of the transmitting tubes. With respect to ripple it is much the same as the generator but its voltage regulation is generally poorer.

THE RECTIFIER-FILTER SYSTEMS

Assuming that alternating-current power is available at 110 or 220 volts, a very effective high-voltage supply system can be built up from a high-voltage transformer, a rectifier system and a filter. The details of the transformer and the filter are to be given complete treatment later in the chapter and for the moment we will limit the discussion to the rectifier.

An understanding of how a rectifier functions may be obtained by studying the diagram. At (1) is a typical a.c. wave, in which the polarity of the

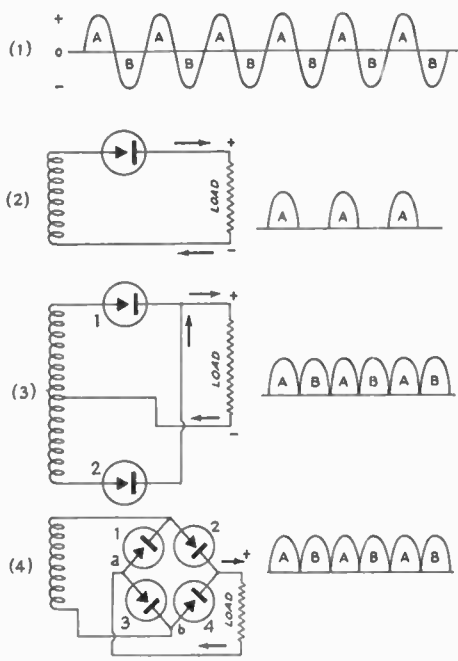

FUNDAMENTAL RECTIFIER CIRCUITS

At (1) is the conventional representation of the a.c. wave; (2) shows a half-wave rectifier; at (3) is the full-wave center-tap system; and (4) is the "bridge" rectifier. The output wave form with each type of rectifier is shown at the right.

current and voltage goes through a complete reversal once each cycle. The object of rectifica-

tion is to transform this wave into one in which the polarity is always the same, although the amplitude of the current and voltage may vary continually. At (2) we have the secondary of a power transformer connected to a single rectifier element, represented by the arrow and dash enclosed in the circle. The rectifier is assumed to be "perfect," that is, current can only flow through it in one direction, from the arrow to the plate. Its resistance to flow of current in that direction is zero, but for current of opposite polarity its resistance is infinite. Then during the period while the upper end of the transformer winding is positive, corresponding to A in (1), current can flow to the load unimpeded. When the current reverses, however, as at (1) B, it cannot pass through the rectifier, and consequently nothing flows to the load. The drawing shows how the output from the transformer and rectifier looks. Only one-half of each cycle is useful in furnishing power to the load, and this arrangement is known as a "half-wave" rectifier system.

In order to utilize the remaining half of the wave, two schemes have been devised. At (3) is shown the "full-wave center-tap" rectifier, so called because the transformer secondary winding must consist of two equal parts with a connection brought out from the center. In (3), when the upper end of the winding is positive, current can flow through rectifier No. 1 to the load; this current cannot pass through rectifier No. 2 because its resistance is infinite to current coming from that direction. The circuit is completed through the transformer center-tap. At the same time the lower end of the winding is negative and no current can flow through rectifier No. 2. When the current reverses, however, the upper end of the winding is negative and no current can flow through rectifier No. 1, while the lower end is positive and therefore rectifier No. 2 passes current to the load, the return connection again being the center-tap. The resulting wave shape is again shown at the right. All of the wave has been utilized, and the amount of power which can be realized at the load is doubled. In order to maintain the same output voltage (instantaneous, not average) as at (2), however, each half of the transformer secondary must be wound for the same voltage as that furnished by the whole winding in (2); or, conversely, the total transformer voltage with the connections shown in (3) must be twice the desired output voltage.

If the transformer has no center-tap, or if the total voltage it furnishes is the same as the desired output voltage, scheme (4), known as the "bridge" rectifier, may be used to obtain full-wave rectification. Its operation is as follows: When the upper end of the winding is positive, current can flow through No. 2 to the load, but not through No. 1. On the return circuit, current flows through No. 3 back to the lower end of the transformer winding. It might be thought that

current would at point *a* flow through No. 1 in addition to No. 3, and at point *b* through No. 4 as well as back to the transformer secondary, since the current is flowing in the proper direction to pass through them at these points. This does not occur, however, because these points are at a lower positive potential than the other sides of No. 1 and 4; and since current can flow only from a point of higher to a point of lower potential, these rectifiers pass no current in this case. When the wave reverses and the lower end of the winding becomes positive, current flows through No. 4 to the load and returns through No. 1 to the upper side of the transformer. The output wave shape is shown at the right. Although this system does not require a center-tapped transformer, and the voltage of the winding needs only be the same as that desired for the load, four rectifier elements are required, so that the center-tap may actually prove to be more economical, all things considered.

TYPES OF RECTIFIERS

The perfect rectifier would allow current to flow through it in one direction without loss of voltage and would have no leakage; that is, it would permit absolutely no current to flow through it in the opposite direction. The perfect rectifier has not yet been built and probably never will be, although some of the present-day rectifiers approach perfection, within their operating limits, in one or more respects. Several types of rectifiers are available, each having its own set of advantages and disadvantages. The most commonly used ones may be divided into five general classifications: electrolytic or chemical, thermionic gaseous-conduction, hot-cathode mercury-vapor, and mercury-arc.

CHEMICAL RECTIFIERS

The chemical rectifier is perhaps the cheapest of all, particularly for low-voltage installations. Its construction is simple, and it will give very satisfactory results if properly handled. The voltage drop and leakage are somewhat higher than with other types of rectifiers. The output is not hard to filter and this, together with its low cost, should recommend the chemical rectifier to those using low-power outfits.

Such a rectifier may be bulky or compact, depending upon the type of cell and solution used. With inorganic solutions, such as borax or bicarbonate of soda dissolved in water, the maximum voltage per cell should not be much higher than 40 to 50. With organic solutions, such as the one to be described later, the voltage per cell may be 160.

INORGANIC SOLUTION RECTIFIER

One type of cell is shown in the drawing. A jelly glass or preserve jar holds the solution, and the electrodes are usually lead and aluminum

strips. The size of the electrodes is determined by the current which the rectifier must pass. A current density of 50 to 100 milliamperes per square inch of immersed aluminum surface should be used. For best results the elements and the com-

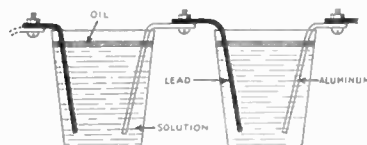

TYPICAL CHEMICAL RECTIFIER CELLS

ponents of the solution should be as nearly chemically pure as possible, and material of this sort is sometimes hard to obtain. Other disadvantages are that the rectifier must be formed initially, and reforming is necessary if it is allowed to remain idle for any length of time; water evaporates from the solution and must be replaced at more or less frequent intervals; and the solution sometimes creeps and makes a

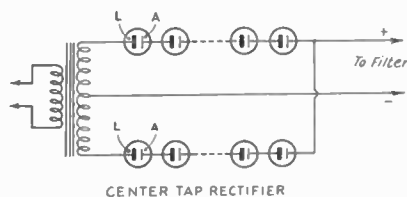

CENTER TAP RECTIFIER

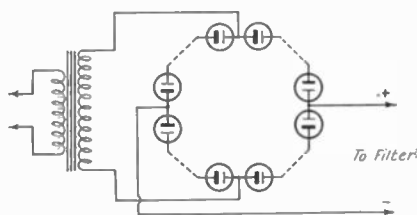

BRIDGE RECTIFIER

CHEMICAL RECTIFIER CIRCUITS

One jar should be used for every 40 or 50 volts furnished by the transformer with solutions of borax or bicarbonate of soda. A transformer whose voltage is 550 each side of center-tap therefore requires about 24 jars, 12 on each side. With the bridge arrangement, two sets of jars are across the total transformer voltage, and although this voltage is cut in half for the same d.c. output voltage, the number of jars required remains the same, i.e., 24 jars will be necessary for a 550-volt transformer.

messy job. Electrically, however, it is entirely adequate for the purpose when properly built. The connections for both the center-tap and bridge rectifier circuits are shown.

In designing a chemical rectifier one must be sure to use sufficiently large jars to prevent undue heating of the solution. A dilute solution ($\frac{1}{2}$ oz. to a gallon of water) of sodium bicarbonate

(baking soda) gives good results with low cost. The use of borax requires a saturated solution. A layer of transformer oil on top can be used to reduce evaporation. If baking soda is used a heavy white precipitate will form at the aluminum electrode and will settle to the bottom. As this does not appear after the aluminum is formed, an old solution can be used for forming and the electrodes put into a clean solution after they are formed. Lead and iron work well as auxiliary electrodes with a borax solution or with the dilute baking-soda solution.

An example may help. We have two Type '10's that normally take 45 m.a. each, making a total of 90 m.a. The transformer gives 550 volts on each side of the center-tap. Assuming 110 m.a. maximum load, 2 sq. in. of aluminum must be immersed in each jar to carry the current. Allowing 50 volts per cell, 11 jars are necessary for each leg of the rectifier (upper diagram). Twelve jars should be used to give the necessary 10% factor of safety. In calculating the total area of aluminum electrode, include both sides of the plate. For instance, in this example if the electrode is a piece of sheet aluminum one inch wide, the length of the strip immersed in the solution should be one inch, since both sides added together will give 2 sq. in. The size of the lead electrode is not critical but a good rule is to make it the same size as the aluminum electrode.

The rectifying action of the lead-aluminum cell depends upon the formation of a rectifying film by electro-chemical action on the aluminum electrode when current is sent through the cell. Special care must be used in first forming an electrolytic rectifier, especially if the cells are formed in series across a high-voltage transformer. When the circuit is closed it is almost a dead short-circuit across the transformer secondary, and the current will be quite high until the film is partially formed. The unformed cells are not able to rectify effectively and so act as a short-circuit across the high voltage winding. If fuses

transformer. Putting lamps in series limits the transformer load to one it can stand. As the rectifier begins to form, the series lamps get dimmer and larger lamps or more of them can be used until the rectifier will withstand the full voltage.

The maximum current density should not be exceeded by the normal operating density. The jars must not be allowed to heat, as the film on the aluminum plates begins to break down at about 120° F. If there is sparking the rate must be reduced, as the film on the aluminum will be destroyed as fast as it is made. A well-formed aluminum electrode will be smooth and have a thin dull white surface. After several hours of forming the rectifier will keep in condition with occasional use. There should be no fireworks or scintillating sparks on the plates. That is a sign of too much voltage per jar and means that some other "dead" cells are not working. Each plate should have a uniform phosphorescent glow. A dark cell *may* be working. If there is enough voltage the phosphorescence will prove it is working. The current-carrying capacity of electrolytic rectifiers seems to be limited mainly by the heating in the cells.

When a large filter is used there is a "back-voltage" or counter electromotive force from the charge left in the filter condensers which has an effect in the rectifier circuit as soon as the key is up. This voltage is applied to the rectifier at the same time the transformer is applying high voltage alternating current to it. This may make the voltage-per-jar too high so that some of the aluminum films break down, sparking and making a "noise" that does not filter out easily. A few more jars added to a rectifier usually will cure this trouble permanently. The transformer voltage that causes break-down is always the "peak" of the a.c. cycle, which is nearly one and one-half times the effective value of voltage at which a.c. circuits are rated.

ORGANIC SOLUTION RECTIFIER

A better type of chemical rectifier can be made with an organic solution. A good form of cell construction is shown in the drawing. The aluminum electrode is No. 14 pure aluminum wire, commercially known as "rectifier metal," which has a surface area of 0.201 sq. in. per inch of length. The current density for this type of cell should be not less than 50 m.a. per sq. in. of aluminum surface immersed in the solution. In a cell which is to pass a load current of 100 m.a., the length of wire will be such as to give a surface area of something less than 2 sq. in. A length of 9 inches will be about right in this case. The inert electrode is a carbon rod about 4 inches in length, taken from an old "B" battery cell and thoroughly cleaned in boiling water. With the organic solution used in this cell, carbon gives better results than the lead or iron used with mineral solutions.

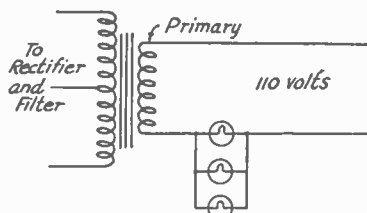

FORMING THE ELECTROLYTIC RECTIFIER

More lamps are screwed in as rectifier forms. When nearly formed, the lamp bank may be bridged by a wire. If there is appreciable heating, cut off the forming current until rectifier is again cool.

do not blow, the transformer probably will burn up. A resistance or bank of lamps should be placed in series with the input to the plate

The solution should be made up in the following proportions:

Ammonium citrate	425 gms.
Citric acid	368 gms.
Ammonium phosphate	150 gms.
Potassium citrate	8 gms.
Distilled water	1000 gms. (cc.)

It is advisable to have the solution mixed by the druggist when the materials are purchased. A cell of the type pictured (the test tube is 6 in. long and 7/8 in. in diameter) will take about 20

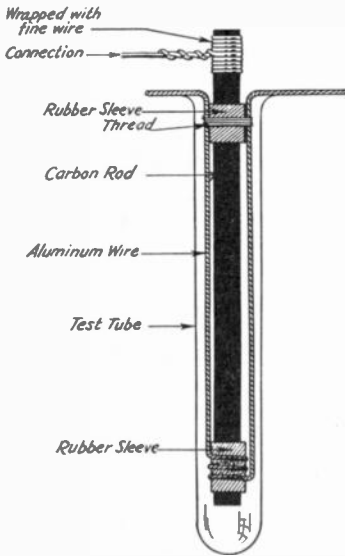

A BETTER TYPE OF RECTIFIER CELL

The active electrode is No. 14 pure aluminum wire and the inert electrode is the carbon rod from an old "B"-battery cell. Twenty of these cells in a bridge will rectify 750 volts a.c. (r.m.s.) and deliver at least 100 ma. for a pair of Type '10 tubes.

cc. of solution. The safe operating voltage per cell may be as high as 160 volts (r.m.s.) so long as

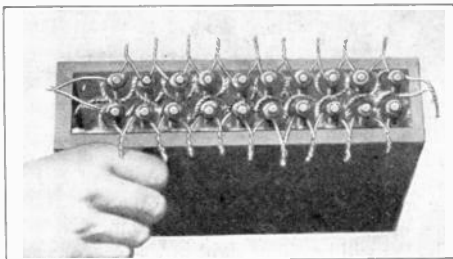

A COMPLETE RECTIFIER FOR 750 VOLTS

The organic-solution type of cell is used. The photograph shows how compact the whole assembly may be made.

the temperature is kept below 120° F. An organic solution will last much longer than simple

borax or baking-soda solutions, so that changes of solution are less frequently required. The photograph of a completed 20-cell rectifier shows how well such cells lend themselves to compact construction. Either the bridge or center-tap connection may be used, the aluminum electrode being positive and the carbon negative.

THERMIONIC RECTIFIERS

Thermionic tube rectifiers, such as the Type '80 and '81, are now generally used only for the lower voltages. They have been displaced at

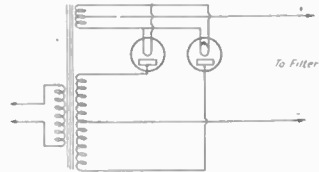

FULL-WAVE RECTIFICATION WITH THERMIONIC OR MERCURY-VAPOR TUBES

higher voltages by the more efficient mercury-vapor rectifiers. However, like the chemical rectifier, they are entirely suitable for low-power work and in many respects constitute the most desirable rectifier for sets employing a Type '10 tube or those of lower voltage rating. A Type '81 rectifier will pass 85 milliamperes. With a pair of tubes in a full-wave circuit, the allowable current is 170 m.a.

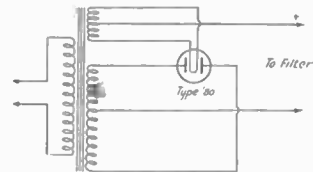

CONNECTIONS USED WITH A TYPE '80 TUBE

The connections for a full-wave rectifier using Type '81 tubes are shown in the diagram. The half-wave rectifier circuit requires only one tube, and the transformer secondary need not be center-tapped, but since the output has only half as many "humps" per second as with a full-wave rectifier, it is more difficult to filter. Thermionic tubes are not recommended for use in a bridge rectifier, because their high resistance and lack of close uniformity prevent the tubes from dividing the load properly.

The Type '80 tube is designed for lower voltages, and in itself is a full-wave rectifier. The applied voltage should not be greater than about 400 per plate, and the tube will pass 125 m.a. It is thus suitable for sets employing a Type '10 or smaller tube where the voltage required is not over 400. The connections of the Type '80 tube in

a full-wave rectifier circuit are shown in a diagram. This tube should not be used when the power transformer furnishes more than 400 volts each side of the center-tap.

Thermionic rectifiers are very easily installed, are compact, noiseless in operation, require no particular attention, and will last a long time with reasonable use. Their cost is comparatively low, and they can be obtained at almost any radio store. The voltage drop through them is not so high as to present any particular difficulty with an amateur transmitter, and is of about the same order as the drop in a good chemical rectifier. They are not as good in this respect, however, as the more expensive hot-cathode mercury-vapor rectifiers.

GASEOUS-CONDUCTION RECTIFIERS

Gaseous-conduction rectifiers, such as the Raytheon BH, can be used in transmitters employing a receiving tube as the oscillator, or for the low-power stages of an oscillator-amplifier transmitter where the voltage required is not more than about 300. At the present time these rectifiers are not manufactured for higher volt-



A TYPICAL HOT-CATHODE MERCURY-VAPOR RECTIFIER TUBE

ages. Since the tube has no filament, it is unnecessary to have an extra winding on the power transformer for rectifier tube filaments. In the field where such a rectifier can be employed, the other advantages are the same as those of thermionic rectifiers.

HOT-CATHODE MERCURY-VAPOR RECTIFIERS

Mercury-vapor rectifier tubes such as the Type '66, '72 and Rectobulbs are intended for all voltages up to about 3500, depending upon the kind of rectifier circuit used. They are, therefore, the tubes to use with sets employing Type '03-A, Type '52 and Type '04-A tubes. The ratings on these rectifiers are somewhat different from those of thermionic rectifiers. With a thermionic rectifier,

the voltage which the tube will stand is limited almost entirely by the insulation in the tube itself, particularly between the wires in the glass stem. This is not the case, however, with

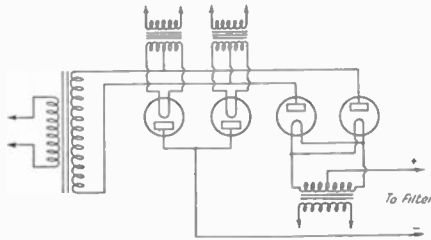

A BRIDGE RECTIFIER WITH MERCURY-VAPOR TUBES

This arrangement is used when the power transformer has no center-tap, or when the d.c. voltage required is more than 2000. Four tubes and three separate filament windings are necessary.

mercury-vapor rectifiers, because as the voltage is increased beyond a certain critical value, known as the "arc-back" voltage, a heavy current will flow in the opposite direction and ruin the tube. The maximum current which the tube can safely pass is limited by the filament emission. For these

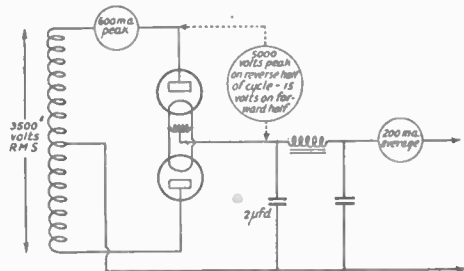

TWO MERCURY-VAPOR TUBES IN A FULL-WAVE CIRCUIT

With condenser input to the filter, the peak current through each tube is approximately three times the average output current from the two tubes. This filter arrangement should be used where the output voltage is relatively high and the output current is low.

reasons, the tubes are rated at "maximum inverse peak voltage" and "peak current." The inverse peak voltage is the highest voltage which the tube can stand, applied in the opposite direction to normal current flow. The term "peak current" is self-explanatory.

The inverse peak voltage is the peak voltage furnished by the transformer, and in the case of a pure sine wave will be 1.41 times the total voltage across the transformer terminals. For instance, with a full-wave rectifier using a center-tapped transformer, if we assume that the transformer gives 1500 volts on each side of the center-tap, the total secondary voltage will be 3000, and the

inverse peak voltage which each rectifier tube will have to stand will be 3000×1.41 , or 4230 volts. The maximum safe total transformer voltage for tubes with a 5000-volt inverse peak

center-tap rectification. Hot-cathode mercury-vapor rectifiers lend themselves very well to the bridge arrangement, because the internal drop is small and the tubes match up well. The drop is

TUBE RECTIFIERS

Tube	Fil. Volts	Fil. Amps.	Max. Voltage per plate (A.C. r.m.s.)	Max. Milliams. per plate (A.C. r.m.s.)	Rect.
Type '80	5.0	2.0	400	110 (total)	Full-Wave
" '81	7.5	1.25	350	125	"
" '66	2.5	5.0	750	85	Half-Wave
" '72	5.0	10.0	5000 (inverse peak)	600 (peak)	"
Rectobulb				2500	"
Type R3	10.0		3000	250	"
" RS1	7.5		750	150	"

rating is 3500 volts. The peak current depends upon the type of filter employed or, more particularly, is determined by the layout of the input side of the filter. If a 2- μ f. or larger condenser is connected directly across the rectifier output, the peak current through each tube is three times the load current (assuming two tubes in the rectifier). In other words, a load of 200 m.a. will mean a peak current of 600 m.a. through each tube, which is the maximum safe current for a Type '66. If an inductance of 10 henrys or more is connected between the rectifier and the first filter condenser, the factor drops to 1.5. Under these conditions, however, the voltage is not as high as with a

only about 15 volts regardless of the current through the tube.

A table of rectifier-filter arrangements for use with various transmitting tubes is given. From

OSCILLATOR		RECTIFIER		RECTIFIER	FILTER		
TUBES	VOLTAGE	AMPERE	TUBES	TOTAL TRANSFORMER VOLTAGE	PEAK PLATE CURRENT PER TUBE	DIAGRAM	● FILTER
UX-210 O	450	0.060	2 UX-866	1250	0.090		120-VOLT DROP
UV-211 or UV-203 A O	1250	0.175	2 UX-866	3500	0.265		350-VOLT DROP
UX-852 or UX-860 O	2000	0.100	2 UX-866	3500	0.300		200-VOLT DROP
UX-852 or UX-860	3000	0.100	4 UX-866	3500	0.150		200-VOLT DROP
UV-204 A	2500	0.275	4 UX-866	3500	0.400		550-VOLT DROP

NOTES.
 ● 1000 ohms chosen as resistance of typical choke.
 * Approximate values
 ○ Two tubes may be used in parallel without overloading rectifier.

THE ABOVE TABLE INDICATES A suitable rectifier and filter arrangement for transmitters employing six different types of tubes commonly used by amateurs.

this table it will be possible to obtain sufficient information to plan a plate-supply system using mercury-vapor rectifiers for any of the transmitters previously described.

In building up a plate-supply unit employing tubes of this type it should be remembered that the filament current is quite high. Not all tube sockets are suitable for currents greater than one or two amperes. Poor contact at the filament prongs, overheating of the connections and possible tube damage are to be avoided. Therefore the socket should be selected with care. A further important point to watch is the filament voltage at which the tubes operate. Satisfactory service and normal life are obtained only when the filament is held at the rated voltage.

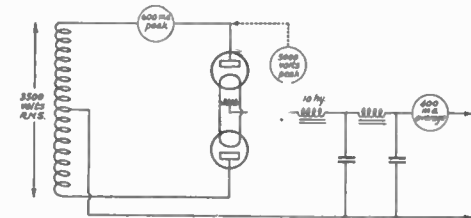

IN THIS CIRCUIT ARRANGEMENT THE FILTER INPUT IS THROUGH A CHOKE

Here the peak current through each tube is only approximately one and a half times the average output current obtained from both tubes. A sacrifice in output voltage results, though, and this type of filter should be employed in cases where the output voltage may be low but where high output current is necessary.

condenser across the rectifier without a choke in series. The explanatory diagrams will make this clearer.

The connections for these tubes are shown in the diagrams. The inverse peak voltage with either the center-tap or bridge arrangement is the same (total transformer voltage times 1.41) so that the bridge connection will give approximately twice the d.c. voltage obtainable with

In the mercury-vapor tubes having an exposed filament it is necessary to apply the filament voltage 20 or 30 seconds before the plate voltage, to permit the filaments to come up to their normal temperature before operation starts. In the case of the heater-type tubes a much longer delay is necessary between the application of the filament and the plate voltage because the cathode is heated indirectly. In actual operation of the station this delay would be a decided disadvantage and general practice is now to leave the rectifier filaments running continuously during periods when the station is being operated.

MERCURY-ARC RECTIFIERS

For high-powered amateur transmitters a popular rectifier is the mercury arc. Such rectifiers will handle over six thousand volts if necessary and are capable of withstanding very much higher inverse peak voltages and peak currents than the smaller types of mercury-vapor tubes available to amateurs.

The efficiency of such rectifiers is very high, since drop in plate potential within the tube is only about 15 volts as in the case of the hot-cathode mercury-vapor tubes. The overall efficiency of course is lowered an amount depending on the "keep-alive" circuit used and the instantaneous load values on the tube. Mercury-arc rectifiers are easy to filter, too. The device used for keeping the hot-spot on the mercury pool and the inductance for keeping the tube operating stably will be of most interest.

A "keep-alive" circuit is necessary in using this rectifier with amateur transmitting sets for telegraph work. An auxiliary electrode near the base of the tube is ordinarily provided for use in starting the arc by an initial flash on the main pool — and this starting arc is kept in operation continuously by "keep-alive" circuits so that the tube will be kept filled with mercury vapor even when the key is up as in intermittent telegraph work. The auxiliary and main mercury pools are connected through an inductance coil (to steady the keep-alive current and prevent the arc from going out) and a rectifier, to a source of low-voltage alternating current (about 50 volts on either side of the center-tap). Tungar or Rectigon tubes such as are used in low-voltage battery chargers can be used or, lacking these, an electrolytic rectifier made up in two half-gallon battery jars will prove very satisfactory. In operating the tube the glass next to the keep-alive arc gets hot so that one should take the precaution of mounting the mercury-arc tube in an oil bath to a level somewhat above the mercury pools to protect the glass. Use light gas-engine oil of any kind convenient for cooling purposes.

The transformer supplying the "keep-alive" circuit must be well insulated because, just as in the case of the filament-heating transformer for tube rectifiers, the filament circuit of the rectifier

is at plate potential above ground. If no one-to-one ratio transformer with a center-tapped secondary is available for the keep-alive circuit, a 50-volt supply can be used with four large chemical rectifier jars connected in a bridge arrangement.

The choke can be built easily if a spare transformer winding of the necessary inductance is not available. Some resistance in series with the choke will help in limiting the current used in the "keep-alive" circuit to a value which will just keep the arc operating stably, preventing the wasting of power and getting away from the danger of over-

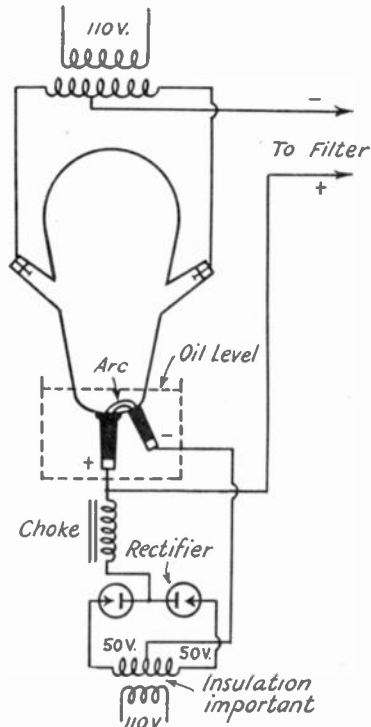

CIRCUIT FOR MERCURY-ARC RECTIFIER
Connections for the keep-alive circuit are also shown.

heating the glass at the auxiliary electrode. One amateur used a choke having about 800 turns of No. 18 or No. 20 wire wound on a closed core $1\frac{1}{4}$ " square (cross-section). The primary of some transformer in almost every experimenter's "junk box" will be found to serve in an emergency. The voltage used and the necessary adjustments are not critical. About 2 amperes "keep-alive" current is necessary for stability.

The connections of the mercury-arc rectifier in transmitting circuits are just the same as those of any of the other rectifiers. The diagram shows a typical arrangement. Most amateurs use the small 110-volt 10-ampere tubes successfully. So many styles and varieties of tubes are avail-

able that we cannot be too specific regarding any particular rectifier tube. In general, the tubes are not critical and a little careful experimenting will

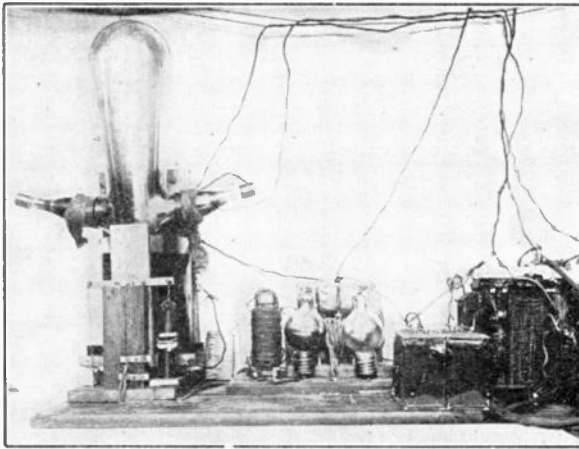

A PRACTICAL MERCURY-ARC INSTALLATION

Note the framework supporting the tube and the solenoid used for tilting it by remote control.

enable you to get one going at your station.

In handling the tubes, remember that mercury is heavy and it must be poured carefully to prevent cracking the glass. If a tube is defective due to a poor vacuum it will not operate. A tube having a good vacuum will give out a clicking sound when the mercury is shaken about carefully so that it splashes a little. If there is much air in a tube the mercury will oxidize on trying to start the arc. In mounting the rectifier tubes the glass should be clamped so that there is no mechanical strain on it or it is almost sure to fracture after a few hours of operation.

In one typical amateur installation the mercury-arc rectifier tube is mounted with the oil jar in a wooden frame and remote-controlled by the arrangement shown in the photograph and diagram. The tube with its frame is pivoted on a line through the center of gravity (point A in the circuit diagram) in a second larger wooden support. A rod B is fastened to the frame of the tube as shown, a coiled spring pulling down on one end of the rod and an iron solenoid armature of cylindrical shape arranged on the other end of the rod so that when the coil of wire (solenoid) around the armature is energized by the closing of the proper relay, the magnetic pull will tilt the tube. The low-voltage rectifier circuit supplies the current for operating the solenoid. In the keep-alive circuit is a reverse-connected relay, the contacts of which are held closed whenever there is no

current in the circuit leading to the auxiliary electrode. A storage battery energizes the power and keying relays. When the switch closes the circuit to relay W, the power transformer for aer P and the Tungar rectifier are connected to the 110-volt mains. The circuit through the solenoid being closed, the current goes through the solenoid windings, pulling down one end of the rod and tipping the tube. The mercury flows over, covering both lower electrodes and allowing current to flow in the keep-alive circuit. This energizes the reversed relay, breaking the solenoid circuit so the spring can pull the tube into an upright position, striking an arc as it does so.

DESIGNING THE FILTER

Once the type of rectifier has been decided upon, the next problem to be considered is the filter. The purpose of the filter is simply to smooth out the "humps" in the rectified a.c. so that the voltage applied to the transmitting tubes will be continuous and have no "ripple." As explained when the action of rectifiers was being considered, the rectifier output voltage is continually changing in value from zero to maximum and back to zero again, repeating these alternations at a rate which

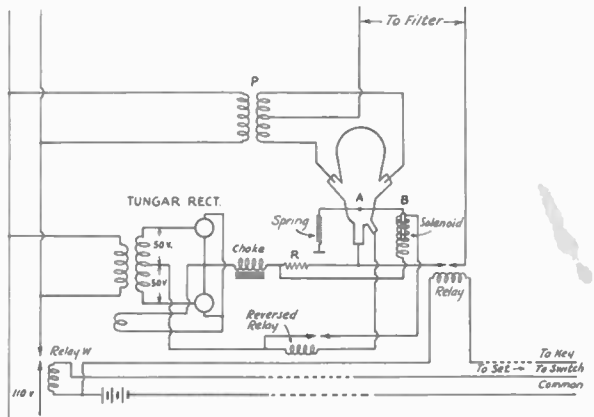

THE WIRING OF THE MERCURY-ARC INSTALLATION

shown in the photograph

In this case the tilting of the arc is accomplished by means of a remotely-controlled solenoid.

depends on the a.c. supply frequency and the type of rectifier; that is, whether half-wave or full-wave.

Many transmitters will exhibit the characteristic which has been aptly termed "wobulation" when the plate-supply voltage is varied. This means that the frequency of oscillation is dependent on the value of plate voltage to some

extent, and if the plate voltage varies rapidly, as it does when no smoothing filter is used, the transmitter frequency will wobble back and forth many times per second, resulting in a mushy note and a broad wave. Such signals are highly undesirable, since they occupy many times the room in the frequency spectrum that a steady signal will, and create much unnecessary interference. Such a transmitter characteristic is not tolerated under the U. S. Government amateur regulations. If the transmitter is not entirely free from "wobulation" the plate supply must be one which is entirely steady and free from ripple.

Practically all self-excited transmitters will have some "wobulation" although by good design it can be reduced to a minimum. In the great majority of cases, the only transmitters which are certain to be steady enough to allow the use of a.c. or unfiltered rectified a.c. on the plates are those which are crystal-controlled, although not all crystal-controlled transmitters are entirely free from "wobulation." A good filter will be required for the plate supply with all but a small percentage of amateur transmitters.

Filters may take a variety of forms, although those used for plate-supply work have been pretty generally reduced to one or two simple combinations. Condensers and iron-core choke coils of different values connected in various circuits will provide the necessary smoothing effect. The amount of inductance and capacity to use and the best ways of connecting them will depend on the particular problem in hand.

Actual tests on plate-supply filters indicate that the first condenser — the one next to the rectifier — has the greatest effect on the d.c. voltage output and regulation. In general, the larger its capacity, the higher will be the output voltage and the better will be the regulation, but there seems to be no particular advantage in increasing the capacity beyond $2 \mu\text{fd.}$ The second filter condenser has less effect on the voltage and regulation, but has a very noticeable influence on the ripple, and the larger its capacity the less will be the ripple voltage passed through. Here again, tests indicate that there is no important advantage gained by using a capacity larger than 2 to $4 \mu\text{fd.}$ The chief function of the last condenser in a 2-section filter (such as the first three combinations in the diagram) seems to be to act as a reservoir to supply momentarily large demands on the plate-supply system, and the larger its capacity the better will be the tone quality of a receiver plate supply or the modulation in the case of a 'phone transmitter supply. For c.w. work this is a comparatively minor consideration and the 8 or more $\mu\text{fd.}$ ordinarily used for audio-frequency work can be reduced to $2 \mu\text{fd.}$ or less without any deleterious effect. These tests were based on full-wave rectification with 60-cycle supply, and would require some modification for lower frequencies, since more filter is necessary

with lower supply frequencies. It should be understood, however, that the various condensers do not have clean-cut distinctions in their functions but that these functions are more or less inter-

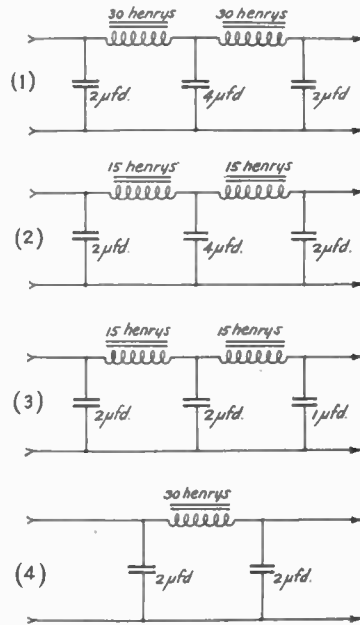

SOME DIFFERENT FILTER COMBINATIONS

The two-section filters (with two chokes and three condensers) will give more complete smoothing than the "brute force" filter at (4), but the latter is usually sufficient for most amateur purposes. The builder should start with the simpler filters and increase both inductance and capacity until the monitor indicates that the note is pure and steady. For 'phone work (1) or (2) will give best results. The capacity of the last condenser should be increased to 8 or more $\mu\text{fd.}$ to improve the quality of modulation.

mingled, and a change in any part of the filter will affect all three.

The "brute-force" filter — Circuit (4) in the diagram — is a good arrangement for general amateur work. Actual experience with it shows that it is capable of giving excellent results if the transmitter is carefully adjusted.

The more elaborate filter combinations will be found better if "wobulation" is bad, or for 'phone transmitters. The quality of voice transmission will be improved as the size of the last filter condenser is increased. Circuit (1) will be found excellent for a 'phone transmitter if the capacity of the third condenser is made $8 \mu\text{fd.}$ or more.

As the ripple frequency is lowered, more filter will be necessary to give a fixed degree of smoothing. The amount of both inductance and capacity required is, roughly, inversely proportional to the ripple frequency. It is well to experiment a little with the filter, after having first made the trans-

mitter as free from "wobulation" as possible, by checking the character of the signals in the monitor. Careful adjustment of the transmitter is sure to save money in filter condensers and chokes.

FILTER CONDENSERS

Aside from tubes, there is probably no other item in an amateur transmitter which requires more frequent replacement than the filter condenser. This is not usually the fault of the condenser manufacturer but is more often caused by the failure of the amateur himself to take into account the conditions under which the condenser must work.

Manufacturers have generally adopted the practice of rating condensers at their maximum d.c. working voltage. This is not the a.c. effective voltage supplied by a transformer. The peak transformer voltage will be 1.41 times the rated voltage, provided the wave form is of sine shape.

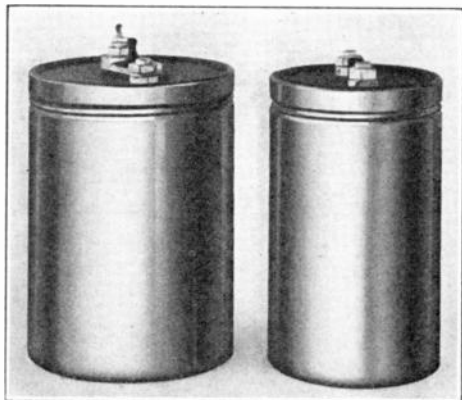

ELECTROLYTIC FILTER CONDENSERS

The container is the negative electrode, the positive electrode being immersed in the solution inside. This type of condenser is made in large-capacity units which occupy a small space, but cannot be operated at high voltages unless several condensers are connected in series.

If often happens that the wave form is considerably distorted by the time a transformer at the end of a long line is reached, and the peak may very readily be higher than this value. A fairly good working rule to follow is that the filter condensers should be rated to stand at least 50% more voltage than the transformer secondary gives. In the case of a full-wave rectifier working from a center-tapped transformer winding, only the voltage on each side of the center-tap is considered, because so far as the filter condensers are concerned, the two halves of the transformer are in parallel.

As an example, a filter condenser to work with a transformer giving 550 volts each side of the center-tap should be rated to stand 1.5 times 550,

or 825 volts. The standard safe voltage rating nearest to this is 1000, and 1000-volt condensers are therefore the size to use. Similarly a transformer giving 1500 volts each side of the center-tap would require condensers rated at 2250 volts, and a 2000-volt transformer will necessitate the use of 3000-volt condensers.

Failure to observe this rule in buying filter condensers is almost sure to result in very short condenser life. It is therefore well to invest a little more money in adequately-rated condensers in the beginning and obviate the necessity for replacement later on.

There are two types of condensers now generally available, electrolytic (d.c. only) and paper (a.c. or d.c.). For d.c. voltages of 1000 or less, the electrolytic condensers are cheaper per microfarad than the paper type. However, since electrolytic condensers are not made to stand

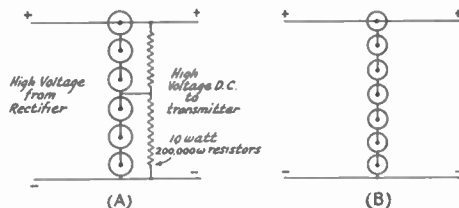

HOW ELECTROLYTIC CONDENSERS MAY BE USED IN SERIES

for high voltage. The purpose of the resistor in (A) is to equalize the voltages across the condenser and thus prevent breakdown of a condenser which might take more than its share of the load. In (B) an extra condenser is used in the string so that all condensers will work at voltages well within their ratings, thus obviating the necessity for equalizing resistors.

voltages much higher than 500 per unit, it is necessary to use the proper number of them in series for higher voltages, so that the difference in cost for voltages over 1000 is small.

The leakage current with electrolytic condensers is much higher than is the case with good paper condensers; but on the other hand, if the voltage rating is exceeded, the electrolytic condensers will not puncture, but simply allow more leakage current to pass. The usefulness of the condenser is not impaired, although the capacity drops off rapidly as the rated voltage is exceeded. With paper condensers the punctured section is useless and must be replaced by a new one.

If electrolytic condensers are to be used with a high-voltage rectifier, or if paper condensers of lower voltage rating than that desired are available, they may be connected in series or series-parallel and made to operate safely. For instance, two 1000-volt condensers connected in series will work satisfactorily on 2000 volts if they both have the same capacity. The resultant capacity, however, will be only half that of a single condenser. Condensers which do not have the same capacity rating should not be connected in series

because the voltage will not divide evenly across them, the smaller condenser always taking the larger share of the voltage. To insure equal division of voltage drop across condensers in series, it is advisable to connect resistors across each section. Groups of condensers in series may be connected in parallel to increase the total capacity of the bank.

FILTER CHOKES

Manufacturers' ratings on filter chokes are often confusing because the inductance of the choke varies greatly with the amount of d.c. flowing in the winding, and it has not been the practice to state whether the inductance measurements were made with the rated d.c. flowing; or whether the rated current is simply the maximum which the winding can safely carry, and the inductance is measured with a.c. only. A choke which is rated at 30 henries with no d.c. flowing in the windings can very easily drop to 10 henries or less with a current which does not tax the capacity of the wire.

Good chokes are made with air-gaps at some point in the core. This prevents magnetic saturation of the core, and at the same time reduces the inductance of the choke, but under load conditions it is quite possible that the inductance will be higher with a choke which has an air-gap of proper size than would be the case with a choke of much higher "a.c. inductance" with no air-gap. This point should be kept in mind in selecting a manufactured choke, or in building one at home.

The design of filter chokes of different inductance values for almost any type of amateur transmitter is covered farther on in this chapter.

A PRACTICAL POWER SUPPLY

Most amateurs are interested in transmitters using one or two Type '10 tubes, and the power supply unit pictured on this page will give entirely satisfactory results with such sets. It uses two Type '81 rectifier tubes in the full-wave rectifier circuit, with the "brute-force" filter. The transformer is a manufactured one supplying 550 volts each side of the center-tap on the high-voltage winding, and containing two center-tapped 7.5-volt filament windings. One of these is used to heat the rectifier filaments and the other supplies the filaments of the Type '10 tubes in the transmitter.

The filter condensers are 2 μ f.d. each, rated at a working voltage of 1000 d.c. The inductance of the choke is 30 henries, and the current-carrying capacity necessary will depend upon the number of tubes in the transmitter. A rating of 75 or 80 milliamperes will be about right for a single Type '10, and 150 m.a. for two of them. In wiring the power supply care should be taken to insulate well the leads carrying high voltage and keep them away from the other wires. Otherwise no

special precautions as to layout or wiring are necessary. The chart shows how the output volt-



COMPLETE POWER SUPPLY

For a transmitter using one or two Type '10 tubes.

age can be expected to vary with different load currents.

SMALL TRANSFORMERS

A transformer is a device for changing electrical power at one voltage and current to power at an-

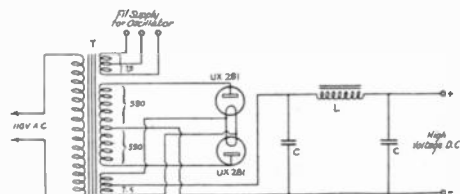

CIRCUIT DIAGRAM OF THE POWER SUPPLY

T — Power transformer. Should have a center-tapped 1100-volt winding and two 7.5-volt center-tapped filament windings.

C — 2- μ f.d. 1000-volt (working voltage) filter condenser.

L — 30-henry choke. Current-carrying capacity should be about 80 m.a. for one Type '10 oscillator and 150 m.a. for two '10's.

Two Type '81 rectifiers, and sockets for them, will be required.

other voltage and current. A step-down transformer takes its power at a high voltage and small current, delivering a *lower* voltage and more current. A step-up transformer delivers *higher* voltage than it takes at its input.

The input winding connects to the source of supply and is called the *primary* winding. The output connects to the load and is called the *secondary* winding. Any transformer may be used for either step-up or step-down work. To avoid confusion it is best to refer to the transformer windings as high-voltage and low-voltage windings.

Most transformers that amateurs build are for use on 110-volt 60-cycle supply. The number of turns necessary on the 110-volt winding depends on the goodness of the iron core used and on the

cross-section through the core. Silicon steel is best and a flux density of about 50,000 lines per square inch can be used. This is the basis of the table of cross-sections given in this article.

The size wire used depends on the current expected. This will vary with the load on the transformer. A circular mil is the area of the

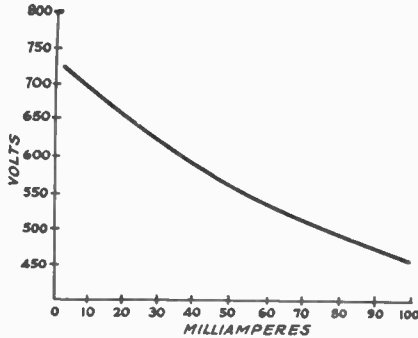

THIS CURVE SHOWS HOW THE output voltage varies as the load current changes. Different tubes, transformers, etc., from those actually used will probably change the values slightly. This curve shows why the filter condensers should be rated at higher voltage than the transformer gives. The output voltage of the transformer was actually 550, but the voltage at light loads is much higher.

cross-section of a wire one thousandth of an inch in diameter. When a small transformer is built to handle a continuous load, the copper wire in the windings should have an area of 1500 circular mils for each ampere to be carried. For intermittent use, 1000 circular mils per ampere is permissible.

The transformer uses a little energy to supply

Input (Watts)	Full-load Efficiency	Size of Primary Wire	No. of Primary Turns	Turns Per Volt	Cross-Section Through Core
50	75%	23	528	4.80	1 1/4" x 1 1/4"
75	85%	21	437	3.95	1 3/8" x 1 3/8"
100	90%	20	367	3.33	1 1/2" x 1 1/2"
150	90%	18	313	2.84	1 5/8" x 1 5/8"
200	90%	17	270	2.45	1 3/4" x 1 3/4"
250	90%	16	248	2.25	1 7/8" x 1 7/8"
300	90%	15	248	2.25	1 7/8" x 1 7/8"
400	90%	14	206	1.87	2" x 2"
500	95%	13	183	1.66	2 1/8" x 2 1/8"
750	95%	11	146	1.33	2 3/8" x 2 3/8"
1000	95%	10	132	1.20	2 1/2" x 2 1/2"
1500	95%	9	109	.99	2 3/4" x 2 3/4"

losses in the core and windings. Because of the resistance of the windings and the magnetic leakage paths, the voltage of the secondary may drop materially under load. In our filament-heating and plate-supply transformers we can arrange the windings compactly, make good solid joints in the core, use large low-resistance wire in the windings, and keep the length of the magnetic

path fairly short and of good cross-section. This will keep the secondary voltage nearly constant under load.

A table is given showing the best size wire and core to use for particular transformers. The figures in the table refer to 60-cycle transformers. The design of 25-cycle transformers is similar but a slightly higher flux density is permissible. Because the frequency is much lower the cross-sectional area of the iron must be greater (or the number of turns per volt correspondingly larger). Otherwise the inductance of a certain number of turns will be too low to give the required "reactance" at the reduced frequency. If one builds the core so that its cross-section is 2.1 to 2.2 times the value of area worked out from the table, the same number turns of wire may be used in a primary coil for 25-cycle operation. If the same core and more turns of wire are used a larger "window" will be needed for the extra wire and insulation. Increasing both the number of turns per volt and the cross-section of the core gives the best-balanced design.

Most 60-cycle transformers will behave nicely on a 25-cycle supply if the applied voltage is sufficiently reduced. Up to 52 volts at 25 cycles may be applied to a 110-volt 60-cycle winding without harm. Knowing the transformer voltage ratio, the output voltage will be known. The current-carrying capacity will be the same as at 60 cycles. The KVA (kilovolt-ampere) rating will be about half the 60-cycle value.

DESIGNING A PLATE TRANSFORMER FOR TWO 7 1/2-WATT TUBES

Suppose we want to build a plate transformer for two Type '10 (7 1/2 watt) tubes. General ama-

teur practice is to supply two of these tubes with about 100 milliamperes at 500 volts.

There will be some voltage drop in the rectifier — the magnitude depending on the type of rectifier used — which will be compensated for to some extent by the filter system. Suppose a chemical rectifier or Type '81 tubes are to be used, and that the filter will be the usual "brute force"

type. The overall loss of voltage will be not more than about 100 volts at 100 mils if the transformer is carefully built. The secondary should therefore be wound for 600 volts output.

600 volts \times .100 amperes = 60 watts transformer output.

The table gives us a probable efficiency of about 80% for a transformer of this size.

The number of turns in the secondary winding is governed by the number of turns in the primary and the desired secondary voltage (in this case 600). Before the number of secondary turns can be found out we must know how many turns per volt there are in the primary. This can be found by dividing the number of primary turns by the primary voltage and is given directly in the table. The number of turns for the secondary can now be found by multiplying this figure by the desired secondary voltage. As we have decided to build the 75-watt transformer (the one nearest the requirements of our problem) the number of secondary turns can now be found easily ($600 \times 3.95 = 2370$ turns). The size of wire to be used for the secondary depends on the secondary current and the allowable current density, and can be found in the same way as for the primary wire from the wire table given in the Appendix. For this layout, look for a size of wire for the secondary that will safely carry 100 milliamperes (.1 amp.). This is given in the wire tables as No. 30 B&S. It is a good idea to add 3% to 5% of the number of secondary turns to the winding to make up for the voltage drop that will occur at full load due to the transformer losses and regulation. ($105\% \times 2370 = 2489$ turns).

Ordinarily the rectifier system rectifies both halves of the cycle, using a separate secondary winding for each half-cycle. This means that unless the bridge rectifier connection is used, two 2489-turn secondaries will be required. It is possible to use smaller wire in the secondary in view of the fact that each winding is passing current but half the time, but it is better to stick to 1000 circular mils per ampere and be safe. Using good-sized wire will help to improve the regulation. The core specifications and the number of turns to use in the primary are given in the table.

Before going ahead with the construction it is necessary to figure out the opening or window size that will be necessary in the core to just get the windings on without wasting any space. The best thing to do is to decide on a tentative length of winding, making a full-size drawing of the transformer on a sheet of paper. From the wire table find out how many turns of wire per layer can be put in the primary winding. Leave at least $\frac{1}{4}$ " between the end of the winding and the adjacent leg of the core. Divide the total number of turns that will be needed in the winding by the number of turns per layer to find out how many layers will be needed. The depth of the winding can next be ascertained. Be sure to allow

$\frac{1}{8}$ " between the core and the inside layer of wire for insulation. Allow for insulation between layers if there is to be any, too. Having finished these computations, draw in the outline of the winding, just as it will look when finished. The depth of the secondary winding can be figured in the same way, using the same length of winding as in the primary. If enameled wire is used, allow for a layer of thin paper between each layer of wire.

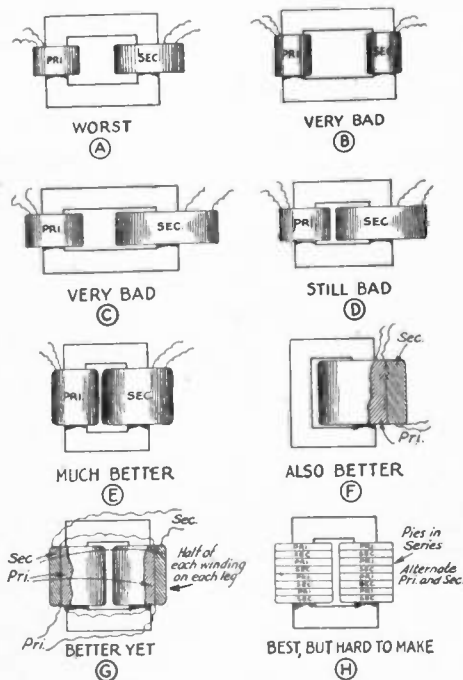

HOW THE ARRANGEMENT OF THE CORE AND WINDINGS AFFECTS THE VOLTAGE REGULATION OF CORE TYPE TRANSFORMERS

Although enamel-insulated wire has the best space factor, single-cotton-covered enamel is best to use. Double-cotton covered wire can be used but is not so economical of space.

When the depth of both primary and secondary windings has been computed, their sum plus $\frac{1}{4}$ " (for a factor of safety) will give the width of the window in the core. If the drawing begins to look like D instead of B (see the sketch showing different arrangements of core and windings), it will be necessary to try a different value for the length of the winding, figuring the size of the window all over again. A transformer with a large core and a relatively small amount of wire is best from the standpoint of the amateur builder because wire in smaller sizes is expensive while transformer iron is cheap. It is hard for most amateurs to wind many turns by hand unless a convenient winding jig is available.

After a little juggling with pencil and paper, the design of the transformer will be complete.

The next step will be to obtain the materials and start the process of construction.

Any kind of transformer iron or silicon steel will make a good core. Sometimes an old power transformer from the local junk yard or from the electric light company can be torn down to get good and cheap core materials. It is not worth while to

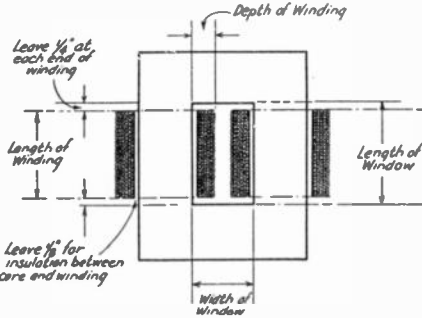

A FULL SIZE DRAWING OF THE TRANSFORMER should be made showing the space to be occupied by the windings and insulation. Be sure the window is large enough to get the windings on but do not make it any larger than essential or the regulation will be impaired.

try to cut out core materials yourself or to use ordinary stove-pipe iron, as it will not lie flat. Laminations of about 28-gauge thickness should be used, as thicker iron pieces will give a large loss from eddy currents in the core and the heating will be objectionable. The iron must be carefully cut so that good joints can be made if the transformer is to have passably good regulation. L-shaped laminations are convenient to use in building a transformer but separate pieces for the four sides can be used if they are more readily obtained. The method of assembling a core is shown in one diagram. Three sides can be built

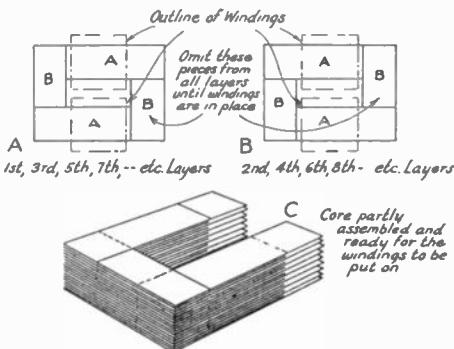

HOW TO PUT A TRANSFORMER CORE TOGETHER

up, the windings put on, and then the fourth leg put in place one lamination at a time. All laminations should be insulated from each other to prevent eddy currents flowing. If there is iron rust or a scale on the core material, that will serve

the purpose very well — otherwise one side of each piece can be coated with thin shellac. It is essential that the joints in the core be well made and be square and even. After the transformer is assembled, the joints can be hammered up tight using a block of wood between the hammer and the core to prevent damaging the laminations. A cigar box with two adjacent sides knocked out and the cover removed will be helpful in building up the core evenly. When three legs are completed, the whole can be tied with string, clamped in a vise, and the legs on which the windings are to be slipped wound with friction tape to hold them firmly in place and to keep the iron from damaging windings and insulation.

It is convenient to wind the coils on varnished fullerboard. At any rate the coils should be wound on a wooden form and if some fullerboard or pliable cardboard can be put over this it will make it easy to slip the finished coils from the form to the core without mechanical injury. The wires cannot get out of place when so wound and they are well insulated from the core besides. The

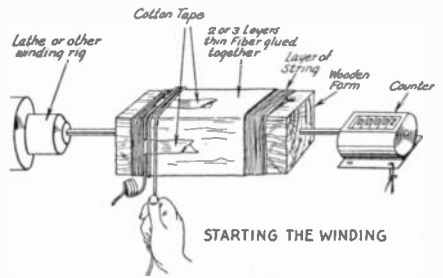

wooden block should be slightly larger than the leg of the core on which the winding is to be put and it should be a few inches longer than the winding. The block must be smooth and of just the right size. Several pieces fastened with small screws at the ends will make a form which can be easily taken apart when the winding is finished.

Diagrams suggesting ways of starting the winding, finishing the winding and bringing out taps are shown. If a lathe is not available for holding and rotating the form, a bicycle, grinder, sewing machine or hand drill clamped in a vise can be adapted for the purpose. For secondary windings of many turns, a revolution-counter should be used to make the work easy and to insure the right number of turns. It is exasperating to lose track of the number of turns when a winding is nearly finished.

If a solid block is used as a winding form, a layer of string should be wound over the form before the wire is put on. The ends of the string are fastened to tacks and this string can be removed as soon as the winding is finished, to leave room for slipping the winding off the form. The fullerboard, some thin fiber or heavy fish-paper goes over this string, serving as a permanent

support for the winding and as insulation from the core. In high-voltage windings, some layers of Empire cloth (varnished cambric) should be included in addition, and if a transformer to give very high voltage is built a micarta barrier will be necessary.

The winding itself is quite simple. The wire is wound on in layers as it takes least space when wound that way. Strips of paper between layers of small enameled wire are necessary to keep each layer even and to give added insulation. Thick paper must be avoided as it keeps in the heat generated in the winding so that the temperature may become dangerously high.

Transformers built by the amateur can be painted with insulating varnish or waxed to make them rigid and moisture proof. A mixture of

such a way that the following turns hold the first one in place. Coil up enough wire on the end to provide a lead from the inside of the coil to the terminal board after the transformer has been mounted. After making a good start, the winding process can be speeded up. In winding the coil, feed the wire with a cloth over your hand about

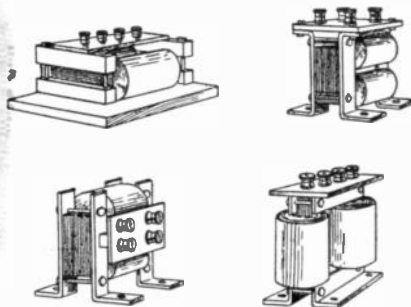

WAYS OF MOUNTING TRANSFORMERS

two or three feet away from the rotating form. Keep the wire as tight as possible without danger of breaking it. Wind the wire in even layers with no turns directly on top of each other to take best advantage of the available space.

When about half an inch from the end of the first layer, lay on some more pieces of cotton tape to bend back under the second layer, thus holding the end turns securely in place. If very thin paper or no paper at all is used between layers the same thing can be done at the end of each layer. Using very fine wire with paper between layers, no additional support for the end turns will be necessary, especially if the precaution of ending the layers about one eighth inch from the edge of the paper is observed. Where no paper is used, run the layers as near to the end of the form as possible, keeping the wire tight.

Keep watch for shorted turns and layers. If just one turn should become shorted in the entire winding, the voltage set up in it would cause a heavy current to flow which would burn it up, making the whole transformer useless.

Taps can be taken off as the windings are made if it is desired to have a transformer giving several voltages. The diagram plainly shows the method to be used in making taps and in finishing the winding. The more taps there are, the more difficult becomes the problem of avoiding weakened insulation at the points where they are made. Taps should be arranged whenever possible so that they come at the ends of the layers. If the wire is very small, the ends of the winding and any taps that are made should be of heavier wire to provide stronger leads. Unless the finished winding is well taped, a piece of fullerboard or heavy paper should be put over it to avoid mechanical injury to the winding as well as to improve its appearance.

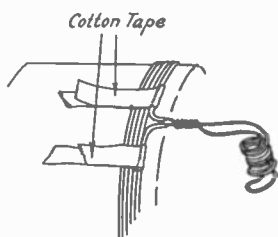

BRINGING OUT A TAP

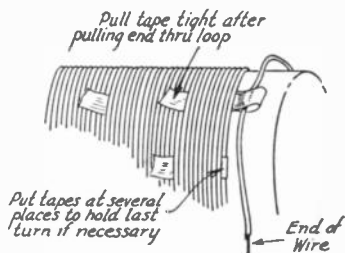

FINISHING OFF THE WINDING

melted beeswax and rosin makes a good impregnating mixture. Melted paraffin should not be used because it has too low a melting point. When possible, the transformer can be suspended in a tank of cooling and insulating oil, though this is not good for indoor use as the fire hazard must be considered. Double-cotton-covered wire can be coated with shellac as each layer is put on. However, enameled wire should never be treated with shellac as it may dissolve the enamel and hurt the insulation, and it will not dry because the moisture in the shellac will not be absorbed by the insulation. Small transformers can be treated with battery-compound after they are wound and assembled.

In starting the winding, hold the loose end on each side of the winding form by folding a two-inch piece of cotton tape around the first turn in

High-voltage coils should be taped with varnished cambric tape. Low-voltage coils can be taped with friction tape or with untreated cotton tape and varnished later. Always lay the tape on smoothly so that each turn advances half the width of the preceding one. Pull the tape tight but not so tight as to pull the winding out of shape.

The leads should be well insulated. High-voltage leads can be run through varnished cambric tubing or "spaghetti." Pieces of flat tubular shoe lacing are good enough to cover the low-voltage leads.

When slipping the coils on the partially-assembled core, be sure that the leads do not touch the core. If the windings fit loosely some small wooden wedges should be driven in place at each end. Last of all, the other leg of the core is put in place and driven up tight. If the coils are wedged firmly and wound tightly and the core is taped, clamped or bolted between some strips of wood or bakelite, the transformer will not hum. After leaving the primary winding connected to the line for several hours it should be only slightly warm. If it draws much current or gets hot there is something wrong. Some short-circuited turns are probably responsible and will continue to cause overheating and possibly fire-works later.

Some $\frac{1}{8}$ " x 1" angle iron, or iron strap of the right size, makes an excellent mounting. The core is clamped tightly by several bolts at the corners. The terminal board should be of bakelite and situated so that there is plenty of room for the leads to come up under it from the windings below. Several ways of mounting transformers and putting on the terminal board are shown. Be sure to separate the terminals from the different windings as much as possible so that there is no danger of their becoming crossed. Ordinary binding posts, 8-32 or 10-32 machine screws, or even Fahnestock clips can be used on the terminal board for making connections.

DESIGNING AND BUILDING CHOKE COILS FOR THE FILTER

The design and construction of choke coils to use in filtering the plate supply can be carried out in the same way that the building of a transformer was developed. The basic design principles are the same and the building of a choke coil is even simpler because no taps are necessary and only one coil is required on the core.

The full-page chart shows the dimensions for chokes that will meet most needs of the amateur in filter systems. Chokes of inductances between the values given in the table can be made by using less turns of wire in the winding. Inductance varies about as the square of the number of turns so that using half the number of turns specified gives one-fourth the inductance. More turns than those specified must not be used as the core will

become saturated. Dimensions b and c given in the table can be understood by reference to the diagram. The arrangement of core and winding is supposed to be that of the diagram, also.

The best core material is the same as that specified for building transformers — silicon steel sheet. The laminations should be .014" (or less) thick, covered with shellac or rust to reduce eddy-current losses. Fine iron wire is excellent as a core material, also. While interleaved corners are almost a necessity for a good transformer core, the core of the choke coil should be made with butt joints. An air-gap is needed in any case to prevent saturation of the core and to offer a means for adjustment of the inductance. After the gap is adjusted the core should be clamped firmly so that the magnetic pull will not change the adjustment and to insure quiet operation. Besides clamping the core, a substantial brass "air" gap can be used or a wooden or cloth wedge inserted in the gap to prevent vibration and make the adjustment permanent. The total air-gap, if

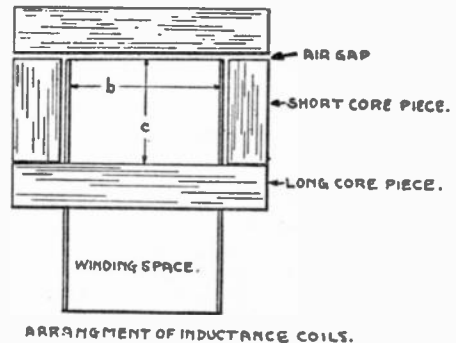

there is more than one, will of course be the sum of the length of the separate air-gaps.

Wire with thin insulation should be used to make an economical design. Large wire uses a great deal of space without giving much inductance. It is best to wind directly on the core with just a single layer of tape between. More insulation will be required for chokes that are to be placed in high-voltage plate-supply lines but this should not be any thicker than is necessary. Before starting the winding on the core, put some cotton strips along it and fasten some heavy cardboard or thin micarta end flanges in place. After winding the coil, the tape can be tied over it to keep the wire from spreading. Too much tape should not be put on or the choke will not keep cool under load conditions. The wire sizes in the table are conservative and 10% more current can be carried continuously and even more than this intermittently. If the winding is very deep, the cooling will be better if the coil is split into two sections to slip onto each long core piece. 10% more turns will then need to be added to

DESIGN DATA FOR INDUCTANCE COILS WITH IRON CORES *Weight of Steel taken as 480 ^{lbs} / ^{cu ft} = 0.28 pounds / cubic inches*

CORE SIZE Cross Section	INDUCTANCE HENRYS	EQUIV GAP (G)	*ACTUAL GAP Decimals	GAP Nearest Fraction	NO TURNS (N)	FLUX DENS. (B) LINE INCHES	WINDING FORM		MEAN TURN inches	FEET OF WIRE	RESISTANCE (D C)	WEIGHT OF COPPER	CORE DIMENSIONS		POUNDS STEEL
							b	c					Long Piece	Short Piece	
1/2 x 1/2	0.5	.040	.017	1/64"	1600	6500	0.42"	0.28"	3.0	4.00	82.5	1.002	1/2 x 1.6	1/2 x 5.0	0.30
	1.0	.041	.019		2300	9000	0.50	0.33	3.2	6.15	127.0	1.5 "	1/2 x 1.7	1/2 x 5.5	0.31
	5.0	.043	.023		5200	20000	0.75	0.50	3.8	1670	345.0	4.0 "	1/2 x 1.92	1/2 x 7.5	0.37
	10.0	.046	.030	1/32"	7600	27000	0.90	0.60	4.2	2640	545.0	6.5 "	1/2 x 2.1	1/2 x 8.5	0.41
	15.0	.048	.035		9500	32000	1.00	0.68	4.5	3510	725.0	8.5 "	1/2 x 2.2	1/2 x 8.5	0.43
3/4 x 3/4	5.0	.043	.023		3500	13000	0.62"	0.42"	4.5	1310	271	3.25oz	3/4 x 2.4	3/4 x 7.5	1.0
	10.0	.046	.030		5000	18000	0.73	0.49	4.75	2000	411	5.0 "	3/4 x 2.5	3/4 x 7.5	1.0
	15.0	.048	.035		6300	21000	0.82	0.55	5.0	2630	544	6.5 "	3/4 x 2.6	3/4 x 7.5	1.05
	20.0	.052	.044	3/64"	7600	24000	0.91	0.60	5.2	3280	678	8.0 "	3/4 x 2.7	3/4 x 8.5	1.1
	50.0	.070	.100	7/64"	14000	33000	1.25	0.83	6.0	7000	1445	11.1 "	3/4 x 3.0	3/4 x 1.0	1.25
1 x 1	10.0	.046	.030	1/32"	3800	14000	0.64"	0.43"	5.6	1760	364	4.25oz	1 x 3.0	1 x 7.5	2.1
	15.0	.048	.035		4800	16000	0.69	0.49	5.8	2310	478	5.0 "	1 x 3.0	1 x 7.5	2.1
	20.0	.052	.044	3/64"	5700	18000	0.78	0.52	5.9	2800	580	6.75 "	1 x 3.1	1 x 7.5	2.2
	50.0	.070	.100	7/64"	11000	25000	1.10	0.75	6.7	6130	1270	15.0 "	1 x 3.5	1 x 1.0	2.5
	100.0	.100	.250	1/4"	18000	29000	1.40	0.93	7.4	11000	2280	18.10 "	1 x 3.8	1 x 1.1	2.75
2 x 2	100.0	.100	.250	1/4"	8900	14000	0.97"	0.65"	10.4	7700	1590	16.3oz	2 x 5.5	2 x 1.0	14.5
	0.5	.040	.017	1/64"	1600	13000	0.55"	0.38"	3.4	4.50	46	2.2oz	1/2 x 1.6	1/2 x 0.63	0.31
	1.0	.041	.019		2300	18000	0.66	0.45	3.6	700	72	3.5 "	1/2 x 1.75	1/2 x 0.70	0.35
	5.0	.043	.023		5200	39000	1.00	0.68	4.5	1950	200	9.5 "	1/2 x 2.0	1/2 x 0.95	0.43
	1.0	.041	.019		1500	12000	0.53"	0.37"	4.3	540	56	2.7oz	3/4 x 2.0	3/4 x 0.63	0.87
3/4 x 3/4	5.0	.043	.023		3500	26000	0.83	0.56	5.0	1470	151	7.2 "	3/4 x 2.5	3/4 x 0.80	1.05
	10.0	.046	.030	1/32"	5000	35000	1.00	0.67	5.4	2250	230	11.0 "	3/4 x 2.6	3/4 x 0.95	1.12
	5.0	.043	.023		2600	20000	0.71"	0.49"	5.8	1250	130	6.1oz	1 x 2.8	1 x 0.75	2.0
	10.0	.046	.030	1/32"	3800	27000	0.86	0.58	6.1	1940	200	9.5 "	1 x 3.0	1 x 0.85	2.2
	15.0	.048	.035		4800	32000	0.96	0.65	6.4	2550	260	12.5 "	1 x 3.1	1 x 0.90	2.25
1 x 1	10.0	.046	.030	1/32"	1900	13000	0.60"	0.42"	9.5	1500	160	7.5oz	2 x 4.66	2 x 0.60	11.5
	15.0	.048	.035		2400	16000	0.68	0.46	9.7	1900	200	9.5 "	2 x 4.75	2 x 0.66	12.3
	20.0	.052	.044	3/64"	2900	18000	0.75	0.51	9.8	2400	250	11.5 "	2 x 4.85	2 x 0.75	12.5
	50.0	.070	.100	7/64"	5300	24000	1.00	0.70	10.5	4600	480	18.65 "	2 x 5.50	2 x 0.95	14.0
	100.0	.100	.250	1/4"	8900	28000	1.33	0.90	11.2	8300	860	21.8oz	2 x 5.90	2 x 1.15	16.0
1/2 x 1/2	0.5	.040	.017	1/64"	1600	32000	0.90"	0.60"	4.2	550	22.5	7oz	1/2 x 2	1/2 x .85	0.40
	1.0	.042	.020	1/8"	3200	32000	1.30	0.85	5.1	1350	55	11.1 "	1/2 x 2.5	1/2 x 1.10	0.50
	0.5	.040	.017	1/64"	1000	21000	0.72"	0.46"	4.7	390	16	5oz	3/4 x 2.3	3/4 x 0.71	0.96
	1.0	.041	.019		1500	30000	0.90	0.58	5.1	640	26	8 "	3/4 x 2.5	3/4 x 0.83	1.05
	1.0	.041	.019		1100	22000	0.75"	0.50"	5.8	530	22	6.5oz	1 x 2.9	1 x 0.75	2.10
3/4 x 3/4	5.0	.043	.023	1/32"	1300	23000	0.82"	0.53"	9.7	1050	43	13oz	2 x 4.9	2 x 0.80	12.7
	10.0	.050	.040	1/64"	2000	32000	1.05	0.68	10.5	1750	71	11.6 "	2 x 5.2	2 x 1.0	13.8
	15.0	.056	.200	1/64"	3300	28000	1.35	0.86	11.1	3060	125	21.6 "	2 x 5.5	2 x 1.1	14.7
	20.0	.104	.280	9/32"	4000	32000	1.43	0.95	11.5	3820	156	21.15 "	2 x 5.6	2 x 1.2	15.2
	10.0	.046	.030		1300	22000	0.81"	0.53"	14.0	1510	62	11.8oz	3 x 6.9	3 x 0.8	39
1 x 1	15.0	.048	.035		1600	26000	0.90	0.60	14.2	1900	77	11.7 "	3 x 7.0	3 x 0.85	40
	20.0	.052	.044	3/64"	1900	30000	1.00	0.65	14.4	2300	93	11.12 "	3 x 7.1	3 x 0.9	41
	50.0	.140	.330	1/2"	5000	28000	1.60	1.10	15.9	6600	270	51.2 "	3 x 7.8	3 x 1.35	46
	100.0	.200	.600	19/32"	8400	34000	2.10	1.40	17.0	12000	485	91.3 "	3 x 8.3	3 x 1.65	50
	1.0	.041	.019		1100	22000	0.75"	0.50"	5.8	530	22	6.5oz	1 x 2.9	1 x 0.75	2.10
2 x 2	5.0	.043	.023	1/32"	1300	23000	0.82"	0.53"	9.7	1050	43	13oz	2 x 4.9	2 x 0.80	12.7
	10.0	.050	.040	1/64"	2000	32000	1.05	0.68	10.5	1750	71	11.6 "	2 x 5.2	2 x 1.0	13.8
	15.0	.056	.200	1/64"	3300	28000	1.35	0.86	11.1	3060	125	21.6 "	2 x 5.5	2 x 1.1	14.7
	20.0	.104	.280	9/32"	4000	32000	1.43	0.95	11.5	3820	156	21.15 "	2 x 5.6	2 x 1.2	15.2
	10.0	.046	.030		1300	22000	0.81"	0.53"	14.0	1510	62	11.8oz	3 x 6.9	3 x 0.8	39
3 x 3	15.0	.048	.035		1600	26000	0.90	0.60	14.2	1900	77	11.7 "	3 x 7.0	3 x 0.85	40
	20.0	.052	.044	3/64"	1900	30000	1.00	0.65	14.4	2300	93	11.12 "	3 x 7.1	3 x 0.9	41
	50.0	.140	.330	1/2"	5000	28000	1.60	1.10	15.9	6600	270	51.2 "	3 x 7.8	3 x 1.35	46
	100.0	.200	.600	19/32"	8400	34000	2.10	1.40	17.0	12000	485	91.3 "	3 x 8.3	3 x 1.65	50
	0.5	.016	.35	11/32"	3200	32000	1.80"	1.20"	6.4	1700	35	21.8oz	1/2 x 3	1/2 x 1.45	0.62
1/2 x 1/2	0.5	.016	.35	11/32"	3200	32000	1.80"	1.20"	6.4	1700	35	21.8oz	1/2 x 3	1/2 x 1.45	0.62
	0.5	.008	.170	11/64"	1480	30000	1.25"	.83"	6.0	735	15	11.8oz	3/4 x 2.9	3/4 x 1.1	1.26
	1.0	.016	.35	11/32"	3000	30000	1.75	1.20	7.2	1800	37	21.13 "	3/4 x 3.5	3/4 x 1.5	1.6
	0.5	.004	.02	11/64"	800	30000	0.90"	0.60"	6.2	410	8.5	0.81oz	1 x 3.0	1 x 0.85	2.2
	1.0	.0082	.17	11/64"	1600	30000	1.30	0.85	7.1	945	19	11.8 "	1 x 3.5	1 x 1.0	2.5
1 x 1	5.0	.0387	.75	3/4"	7800	30000	2.90	1.90	11.0	7000	143	10.14 "	1 x 5.2	1 x 2.4	4.2
	1.0	.004	.019		560	22000	0.75"	0.50"	9.8	460	94	0.81oz	2 x 4.9	2 x 0.75	12.7
	5.0	.0086	.170	11/64"	1800	32000	1.35	0.90	11.3	1700	35	21.10 "	2 x 5.5	2 x 1.15	15.0
	10.0	.0184	.40	13/32"	3800	33000	2.00	1.30	12.8	4100	83	6.6 "	2 x 6.2	2 x 1.5	17.3
	5.0	.043	.023		860	30000	1.00"	0.60"	14.2	1000	21	11.8oz	3 x 7.1	3 x 0.85	40.0
3 x 3	10.0	.092	.20	13/64"	1840	31500	1.40	0.92	15.3	2350	48	31.10 "	3 x 7.5	3 x 1.15	43.5
	15.0	.130	.30	19/64"	2620	32000	1.65	1.10	16.0	3500	71	51.7 "	3 x 7.8	3 x 1.4	46.0
	20.0	.175	.38	3/8"	3500	32000	1.90	1.25	16.6	4850	99	71.8 "	3 x 8.1	3 x 1.5	48.0
	50.0	.432	.80	15/16"	8700	32000	3.00	2.00	19.2	14000	282	211.8 "	3 x 9.3	3 x 2.3	58.0
	100.0	0.900	1.50	1/2"	16700	31500	4.10	2.80	22.0	31000	620.47 "	511.3 "	3 x 10.5	3 x 3.1	68.0

All wound with No. 33 enamelled wire
206.6 ohms per 1000 ft. 6.591 ft. per lb.
Carrying Capacity 0.65 amperes.

All wound with No. 30 enamelled wire, 103 ohms per 1000 ft. 3.917 ft. per lb. Carrying Capacity 0.10 amperes.

All wound with No. 26 enamelled wire, 40.15 ohms per 1000 ft. 1.801 ft. per lb. Carrying Capacity 0.25 amperes.

All wound with No. 23 enamelled wire, 20.32 ohms per 1000 ft. 6.484 ft. per lb. Carrying Capacity 0.50 amperes.

* The Actual Gap can only be an approximation owing to the many factors which may affect fringing of flux, permeability of core, etc. It must be adjusted by trial until the proper value of inductance is obtained or better yet, until the set up operates at the best point.
 † The values of (B), the flux density, are those obtained with all D.C. & 60 AC, or the effective B if all AC. The maximum value in the latter case will be 1.4 x B as given. In the case of rectified AC applied to coil with no previous smoothing the maximum B may be 1.57 times the values given.

each coil to make up for the magnetic leakage between coils which is increased by splitting the winding. Heavy flexible leads should be soldered to the ends of the coil and taped down to prevent their breaking off.

Windings from spark coils, amplifying transformers, or any old coils of many turns of small wire can sometimes be pressed into use for plate-supply equipment for a low-power transmitter. All that is necessary is to mount them on the right sort of a core and to adjust the air-gaps. A transmitter using a Type '10 or larger tubes, however, should be provided with a filter using a manufactured choke of proper rating or one of the choke coils whose dimensions are given in the table. Sets of lower power using receiving tubes can sometimes be filtered by making use of some old spark coils such as find their way into every experimenter's "junk box."

The simplest way to adjust the air-gap is to connect the filter to the load with which it is to work, changing the gap until the best filter action is observed when listening to the output of the

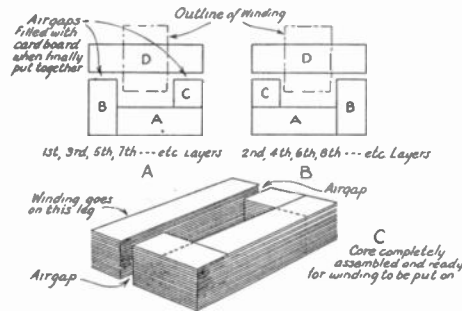

HOW TO PUT A CHOKO COIL CORE TOGETHER



ANOTHER METHOD OF BUILDING A CORE FOR A CHOKO COIL

transmitter in the monitor. A too-large air-gap will reduce the inductance and the choke will be ineffective. A too-small gap will allow the core to become saturated, and the choke will be just as ineffective.

The right value for the air-gap is one that uses up about nine-tenths of the ampere-turns of the coil to maintain flux in the gap. The rest of the magnetomotive force magnetizes the core. As the permeability of air is unity and that for sheet steel is about 3,000 (average), the ratio of air to iron can be determined approximately but the iron varies so much that the exact value must always be decided by trial. For a core of 10" total length, an air-gap of about .05" or a little less will meet average requirements.

THE FILAMENT SUPPLY

The second division of the power supply for the transmitter is the supply to the filaments of the tubes used. Though batteries are sometimes used for this supply, alternating current obtained from the house current through a step-down transformer usually is more practical and more satisfactory. In some cases the filament-supply wind-

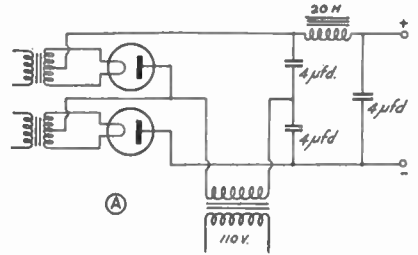

(A)

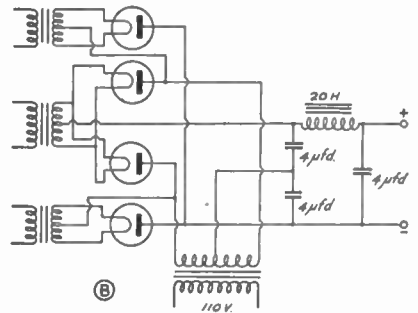

(B)

VOLTAGE DOUBLING CIRCUITS

Diagram (A) is used with two rectifier tubes and a transformer without a center-tap. In (B) four rectifiers are required, and the transformer must have a center-tap. The voltage regulation will be better with (B) than (A), and in addition the rectifier will furnish twice the current obtainable from (A).

ing is wound over the core of the high-voltage transformer, thus eliminating the necessity for a separate filament transformer. This practice, however, is not always to be recommended. The filament supply must be constant if the transmitter is to operate effectively, and with both filament and high voltage supplies coming from one transformer this constancy is obtained only with great difficulty, since changes in the load taken from the high-voltage winding cause serious changes in the voltage obtained from the filament winding — unless the transformer is operating well under its rating or unless special compensating apparatus is employed. Wherever possible the high-voltage and filament transformers should be separate units operating, if it can be arranged, from different power outlets, particularly with transmitters using tubes larger than the Type '10.

The important points to observe in installing

the filament supply are that a means is provided for a center-tap; that a filament voltmeter is connected in the circuit as near as possible to the filament terminals of the tube; and that a suitable rheostat is provided for the adjustment of the filament voltage.

Examination of any of the power-supply circuits will make it obvious that the filaments of the rectifier tubes must be well insulated from the filaments of the oscillator tubes. The filaments of the rectifiers provide the positive output lead from the plate-supply system while the filaments of the transmitter tubes are connected to the negative side of the high-voltage supply. The fact that the two filament supplies must be insulated does not, however, mean that two transformers are required. The two windings can be on the same core, the necessary insulation being provided between them. Should the filament transformer be bought and should it have no windings suitable for the filaments of the rectifiers, an extra winding usually can be fitted without difficulty. For Type '66 rectifiers two No. 12 gauge wires in parallel should be used for the winding,

the number of turns being determined by the "cut and try" method. With most transformers, only a few turns will be necessary to give the required voltage. The rectifier-filament winding can be center-tapped or a center-tapped resistor can be used across it in the manner described for the transmitter filaments.

VOLTAGE DOUBLING

If for any reason a higher plate voltage is desired than an available transformer will furnish, special circuits may be employed that will give a d.c. output voltage approximately double that to be expected from normal rectifier circuits. Two types of voltage-doubling circuits are shown in the diagrams, one for a transformer with a single high-voltage winding and one for a center-tapped transformer. The load current in circuit *A* should not exceed the rated current for *one* tube. Tubes may be used in parallel to boost the current output and improve regulation. In circuit *B* the load current will be the same as with ordinary full-wave rectification; that is, twice the rated current for a single tube.

CHAPTER X

Keying and Interference Elimination

IN ORDER to utilize the transmitter for telegraphic communication, it is necessary to break up its output into long and short pieces which, at the receiving end, will constitute the desired dots and dashes. There are many simple ways of so breaking up the output of the transmitter but careful adjustment both of the transmitter and of the keying system usually is necessary to avoid the production of key-thumps (which may interfere with broadcast reception) or key-chirps (which may make the signal very difficult to read).

METHODS OF KEYING

The diagrams show various forms of keying as applied to an oscillating tube. At (A) the key is inserted in the negative lead from the high-voltage supply, a method which gives positive keying since the plate voltage is completely disconnected when the key is up. At (B) the key is inserted in the lead between the center-tap of the filament transformer or center-tap resistor and the point where the grid return and the negative lead from the plate supply join the connection between the filament by-pass condensers. This is known as center-tap keying, and both grid and plate circuits are broken when the key is up. Method (C) is known as grid-leak keying. The grid leak must be connected between the grid and filament (with a radio-frequency-choke in series at the grid end) instead of directly across the grid condenser in order to avoid hand-capacity effects at the key. When the key is up the grid is "open" and the voltage on it builds up to a negative value sufficient to prevent the flow of plate current provided there is no leakage in the tube or socket between grid and filament, or between the key contacts. As such leakage is often present in sufficient quantity to allow the tube to oscillate when the key is up, this method is not always satisfactory because a back-wave may be emitted.

(D) and (E) are two forms of "blocked-grid" keying. The principle of this method is to automatically provide a sufficiently high negative bias when the key is up to prevent the flow of plate current. In (D) this additional bias is supplied by the battery connected across the key in series with the resistor R . The voltage of the battery will depend on the plate voltage and the kind of tube in the transmitter, and must be greater in value than the plate voltage divided by the amplification factor (μ) of the tube given in the table in Chapter VII. For instance, if the transmitting tube is a Type '10 with 500 volts on its plate, the voltage of the bias battery must be more than $500 \div 7.7$, or 65 volts. A 90-volt bat-

tery would serve very well in such a case. The resistor R is used simply to prevent a total short circuit of the battery and consequent short life. Its value would be roughly 5,000 ohms for each 45 volts of bias.

In (E) the bias is obtained from a pair of dividing resistors across the plate supply. In this case the ratio of R_1 to R_2 should be less than the μ of the tube, or in the case of a Type '10 less than 7.7. A ratio of 5 or 6 to 1 will be satisfactory. The value of resistance must be high enough to prevent undue current drain from the rectifier-filter system. R_1 may be made to serve as the "drain" resistor mentioned later in this chapter. Representative values for a Type '10 with 500 volts on its plate would be 25,000 ohms for R_1 and 5,000 ohms for R_2 . An inspection of the diagram will show that the negative side of the power supply is connected to the grid of the tube when the key is up, and the junction point of R_1 and R_2 is connected to the filament center-tap. The voltage across R_2 which with the values given would be one-sixth of the plate voltage, will act as grid bias, while the key shorts out R_2 when closed, thus connecting the negative power supply lead to the filament center-tap.

In any of these diagrams the center-tapped resistor across the filament supply may be omitted if the filament transformer winding is center-tapped. Simply connect the center-tap of the winding to the wire which in these diagrams goes to the midpoint of the resistor.

The high-voltage power supply may be any of the systems mentioned in Chapter IX, including batteries. Likewise, if a storage battery is used to light the transmitting-tube filament, the diagrams will remain unchanged provided the center-tapped resistor across the filament supply is left in the circuit. In this case the polarity of the battery is unimportant — the positive and negative terminals may be connected to either side of the filament. If this resistor is omitted the connection which goes to its midpoint should be connected to the negative terminal of the filament. In such a case diagram (B) cannot be used, although any of the others will work satisfactorily.

KEYING OSCILLATOR-AMPLIFIER TRANSMITTERS

With an oscillator-amplifier transmitter it is always best to allow the oscillator to run continuously and key the amplifier. If the amplifier has more than one stage, it is usually better to key in one of the low-power stages before the final amplifier is reached, as this results in less back-wave and is not so productive of key-clicks as keying the final tube. In a multi-stage crystal-

controlled transmitter with doubling amplifiers, one or more of the doubler tubes should be keyed.

All of the systems shown in the accompanying diagram are applicable with some modifications. With circuit (A) the key must be placed in the positive lead from the plate supply to the tube being keyed, because if placed in the negative lead the plate voltage would be removed from both oscillator and amplifier, unless separate plate supplies are used for each tube. With circuit (B) the tube being keyed must have a separate filament supply from that used for the other tubes in the transmitter. (C) may be used with common filament and plate supplies for all tubes in the transmitter, but keying is not very positive because enough r.f. gets through to cause a pronounced backwave, and the grid rarely blocks completely, as it should for good keying. Circuit (D) is a good one, resulting in very positive keying, and may be used with transmitters in which the filament and plate supplies are common to all tubes. (E) will also give positive keying, but necessitates a separate filament supply for the tube being keyed. In this case the values of resistors R_1 and R_2 cannot always be calculated as described above, because the amplifier tube is not self-controlled. R_2 must be large enough in relation to R_1 to reduce the plate current on the tube being keyed to zero, and this will depend on the amount of excitation supplied by the oscillator. The oscillator itself may take the place of R_1 if allowed to run continuously and if supplied with plate power from the same source as the amplifier. The correct value for R_2 should be determined by experiment.

ELIMINATING KEY CLICKS

Key clicks, the sudden thumps which result at the beginning and end of a dot or dash when oscillation is started and stopped, not only create interference with other amateur stations but are likely to cause interference with nearby broadcast listeners as well. The clicks are often audible on frequencies far removed from the transmitter frequency and so must be eliminated or at least reduced as much as practicable.

Clicks will be much more serious if the keying system is one which throws all load off the plate supply when the key is up. The reason for this is that with no load on the plate-supply apparatus the condensers of the filter system become charged to the peak voltage of the transformer. Then, when the plate voltage is applied, the tube not only starts oscillating suddenly but starts oscillating with abnormal force because of the peak voltage which accumulated in the filter. This peak voltage is, of course, soon reduced to normal but the result will have been a heavy key-thump.

In modern amateur transmitters it is considered good practice to have a load or "drain" resistor always connected across the output of

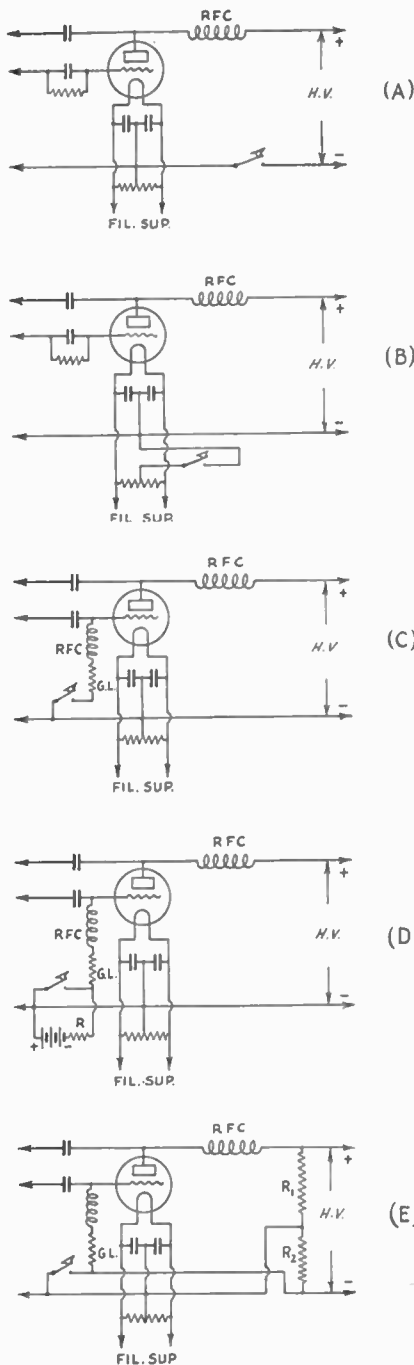

FIVE METHODS OF KEYING AN OSCILLATOR OR AMPLIFIER

(A) Plate keying; (B) Center-tap keying; (C) Grid-leak keying; (D) Blocked-grid keying with additional bias supplied by batteries; (E) Blocked-grid keying with additional bias supplied by voltage divider in plate supply.

the plate-supply system. In this way, even if the transmitting tube is disconnected during keying there is always a load on the filter and its condensers are never charged to high peak voltages. A practical value of current through such a load resistor is about 25 per cent of the tube plate current. In a transmitter employing a single Type '10 tube this would be approximately 15 m.a. The value of the resistance necessary to limit the current to this amount is obtained from Ohm's Law, $R=E/I$. For a 500-volt supply it would therefore be 500 divided by .015, the result being about 33,000 ohms. In some cases, particularly if mercury-vapor rectifiers are used, a greater drain current than this can be permitted. A resistor of 20,000 ohms, giving a drain of 25 m.a., would be suitable for a Type '10 tube under these conditions. An inexpensive load resistor can be made up from "B-eliminator" voltage-divider resistors which are often available at low prices. Transmitter-type grid leaks are also suitable for the purpose.

With some such means as this to prevent the building up of high voltages in the filter when the transmitter is not taking power, the keying problem is much simplified. In some locations where the antennas of broadcast receivers are not close to the transmitting antenna, the simple connection of the key in the center-tap to the filament transformer as in circuit (B) may serve. In most cases, however, such an arrangement would produce interference on account of the key-thumps caused by sparking at the key and by the sudden starting and stopping of oscillation.

Sparking at the key can be prevented or greatly reduced by connecting a condenser and resistor in series across the key contacts. The capacity of the condenser is not critical, values between .5 and 1 μ f. generally being sufficient. The condenser absorbs the spark when the key is opened but releases the energy so stored when the key is closed, so that a bad spark would appear on closing the key if the series resistor were not used. The resistor must be adjusted so that its value is low enough to allow the condenser to charge up quickly and absorb the spark when the key is opened, and yet must be large enough to dissipate most of the energy in the condenser when the key is closed so no spark will appear at the contacts. A 500- or 1000-ohm variable resistor will usually suffice. In addition the condenser and resistor combination functions as a "lag" circuit and helps the eliminate clicks when the key is raised.

Since clicks result from sudden starting and stopping of oscillation, they can be prevented by causing the oscillations to start and stop gradually. "Lag" circuits have been devised for this purpose. These are formed by the proper choice of inductance and capacity and their insertion in appropriate parts of the transmitter circuit. It is the property of inductance to oppose the sudden rise of current. By causing the plate current

on the tube to rise gradually, clicks are prevented when the key is closed, and by causing it to decay gradually the same effect is obtained when the key is opened.

Practical ways of slowing up the rise and decay of plate current are shown in the diagrams. The time required for oscillations to build up and

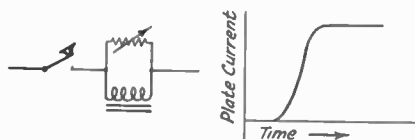
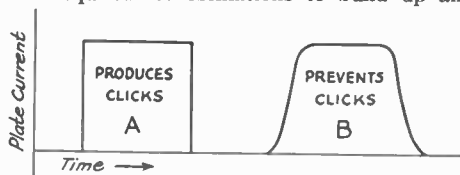

HOW "LAG" CIRCUITS PREVENT KEY-CLICKS

If the plate current is thrown on and off suddenly in keying, as at "A" in the upper drawing, serious clicks will result. In "B" the plate current is made to rise and fall with comparative slowness, which eliminates or greatly reduces clicks.

The condition shown in "B" may be accomplished by "lag" circuits such as are diagrammed. Inductance in series with the key causes the plate current to rise slowly, and capacity across the key causes it to decline slowly, each time the key is closed and opened. The purpose of the variable resistors is explained in the text.

cease may be only a small fraction of a second but will effectually stop clicks. By the use of suitable values of inductance and capacity the lag can be made great enough to eliminate clicks and still not so great as to interfere with clean keying. It is not possible to say with any exactitude just what value of inductance will work, since this depends a great deal on where it is connected in the circuit and the adjustment of the transmitter. Values between 5 and 50 henrys will usually be found to be satisfactory. The purpose of the variable resistor connected across the choke is to allow adjustment of the effective impedance to the best operating value.

The values specified above for eliminating sparking at the key contacts will usually also provide sufficient lag to eliminate the click when the key is opened.

These click-elimination methods may be applied to any of the keying systems described. The condenser-resistor combination is always

connected directly across the key, wherever it may be placed, but the inductor-resistor combination may be inserted either in one of the leads from the high-voltage supply or in series with the grid leak (or "C" bias battery), or right next to the key, as shown in the diagram. If connected in series with one of the leads from the plate supply, or next to the key in systems (A) and (B), the choke must be capable of carrying the full plate current of the tube or tubes in the circuit. In circuits (C), (D), and (E) the choke-resistor combination should be placed either in the negative plate-supply lead or between the grid leak and the key. When connected in the grid-leak circuit it need carry only about 10% of the plate current.

When the plate current builds up and decays slowly the transmitter frequency is likely to vary until the current reaches a steady value, giving rise to keying chirps or "yooping," which makes the signal difficult to read. High-C circuits will overcome this to a large extent, and this effect is not noticeable with a well-designed oscillator-amplifier or crystal-controlled transmitter. The key-thump filter should be adjusted so that the maximum of click elimination will be secured with a minimum of chirps. Much depends on the transmitter and its adjustment, and no exact specifications can be given for click-eliminators which can be guaranteed to work under any conditions. If the principles outlined above are followed intelligently it will be possible to reduce clicks to a satisfactory point, but *the exact values of inductance, capacity and resistance must be determined by experiment for each individual transmitter.*

It is impossible to cover in this *Handbook* all the methods of key-click elimination which have been proposed from time to time, but suggestions are often published in *QST* which may be successfully applied to the particular conditions existing in one's own transmitter.

INTERFERENCE WITH BROADCASTING

Amateurs are often unjustly blamed for code interference. Foreign ships and commercial radio-telegraph services sometimes cause bad interference to radio broadcasting. This may be cured in many cases by long-wave traps similar to those for short-wave work that will be described later. Power leaks from electrical distribution systems, disturbances from thermostats in heating pads, flatirons and oil heaters, interference from street car lines, dial telephones, loose electric lamps, ignition systems, vibrating battery chargers, mechanical rectifiers, and violet-ray apparatus are other possible sources of interference, not to mention the neighbor who operates a "blooper" (an oscillating receiver which itself is a miniature transmitter without a license). Many of the broadcast receivers sold to-day are still not properly selective. All this points to the

conclusion that the broadcast listeners as well as the amateur concerned must approach the interference problem with an open mind and a cooperative attitude.

When the transmitter has been set up and adjusted, the operator should ascertain whether or not interference is caused in nearby broadcast receivers. If your neighbors appreciate that you are as much interested in preventing interference to their enjoyment of broadcast programs as they are, much more can be accomplished than by acrimonious disputes. It is better to settle the interference problem right at the beginning than to trust to luck with the possibility of an unfavorable reaction towards amateur radio in general and yourself in particular on the part of nearby broadcast listeners.

In most cases interference can be prevented by the use of key-click filters and some other simple devices. If the amateur is unable to solve the problem, quiet hours must be observed from 8:00 p.m. to 10:30 p.m. (local time) and on Sunday mornings between 10:30 a.m. and 1:00 p.m. upon the frequencies which cause such interference. The regulations state that the station must "cause general interference with broadcast reception on receiving apparatus of modern design" before quiet hours are obligatory. In effect, if a good many receivers are in the vicinity and only one or two of them experience interference, the inference is that the broadcast receiver is at fault, and not the transmitter. Likewise interference with a non-selective broadcast receiver is not sufficient cause for compulsory observance of quiet hours. The amateur should cooperate with such listeners to the fullest possible extent, however, and his aim should be to eliminate interference at *all* hours of the day with reasonably good broadcast receivers.

Interference may be caused in a variety of ways. When the receiving antenna is close to the transmitting antenna, the former will be shocked into oscillation from the key-clicks of the transmitter unless the clicks are prevented. This is one of the commonest forms of interference and may be eliminated by the click-filters described.

Another form of interference is the "blanketing" of broadcast programs when the key is held down. This may also be accompanied by clicks unless a click-filter is used. Blanketing is the result of "blocking" the grids of the r.f. tubes in the broadcast receiver by the energy picked up from the transmitting antenna. This may be partially or completely cured by separating the antennas or running them at right angles to each other instead of parallel. Blanketing may not be completely eliminated, however, and in such a case the transmitter power must be reduced, at least during quiet hours, or a wave-trap, tuned to the transmitter frequency, may be placed in the affected receiving antenna lead-in. Such a trap consists simply of a coil and condenser connected as

shown in the diagram. The condenser may be an old one with about 150 or 350 $\mu\text{fd.}$ maximum capacity and need not be an especially efficient one. Most amateurs have "junk boxes" with several such condensers in them.

the power-supply system of the transmitter. In the former case radio-frequency choke coils connected to each side of the 110-volt line at the point where it is connected to the receiver will help. If the r.f. is getting back through the trans-

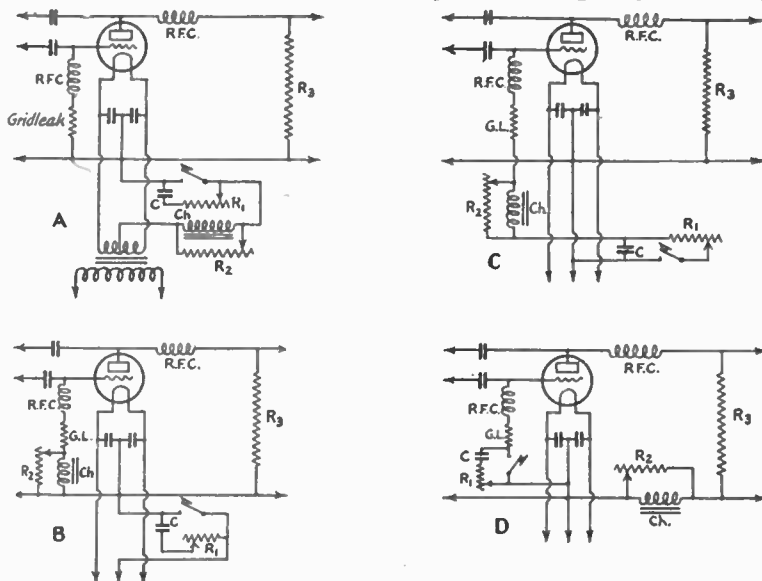

HOW LAG CIRCUITS MAY BE ADDED TO SOME REPRESENTATIVE KEYING METHODS

In all circuits the condenser-resistor is connected across the key, as shown in the other diagram. In "A" the inductance-resistor is in series with the key, which in this case (center-tap keying) breaks the full plate current. The choke must therefore be capable of carrying this current. In "B" (also center-tap keying) the choke is placed in series with the grid leak, and should be capable of carrying about 10% of the plate current. In "C" the lag circuit is applied to grid-leak keying. The choke should have the same current-carrying capacity as at "B." Grid-leak keying is also used at "D," but the choke is in the negative high-voltage lead, and therefore must carry the full plate current. The actual values of capacity, inductance and resistance must be determined by experiment, as explained in the text. These are by no means all the combinations which could be worked out, but simply illustrate the principles involved.

The size of the coil will depend upon the frequency on which the transmitter is working. Representative values are given in the table.

Frequency of Interfering Signal	Coil (3" dia.)
1,715-2,000 kc.	20 turns
3,500-4,000 kc.	8-10 "
7,000-7,300 kc.	4-5 "
14,000-14,400 kc.	3 "

Bell wire (No. 18) or a size near to it may be used. When the trap is installed the transmitter should be started up and the condenser in the trap adjusted to the point where the interference is eliminated. This trap will not affect the operation of the broadcast receiver.

With a.c. broadcast receivers (including battery sets equipped with "A" and "B" substitutes) interference may be caused by r.f. from the transmitter getting into the house wiring and feeding into the receiver. House wiring may pick up r.f. either directly from the antenna or through

mitter power-supply system the chokes should be connected between the 110-volt outlet and the power transformer, at the transmitter. The size of the chokes will depend upon the transmitter frequency, and had best be determined by experiment. The wire must be heavy enough to carry the current taken by the receiver or power-supply system. No. 14 or No. 16 will be sufficient in most cases. Mailing tubes make a good winding form for these chokes. Between 100 and 300 turns will be required, depending on the transmitter frequency. Tuned traps of the same construction described above may also be used instead of the chokes. A pair of condensers connected in series across the line will often improve the results. By-pass condensers such as are used in receivers (about 0.1 $\mu\text{fd.}$) rated at 200 volts or more will serve. The diagram shows how the chokes and condensers should be connected.

If the 110-volt line is found to be picking up energy directly from the antenna it is advisable to change the location of the antenna, if possible,

or run it in a different direction, not only because of possible interference to broadcast reception but because energy so picked up is useless for radiation and decreases the effective range of the transmitter. This is particularly important when, as often happens, electric lamps in different parts of the house are found to glow when the key is

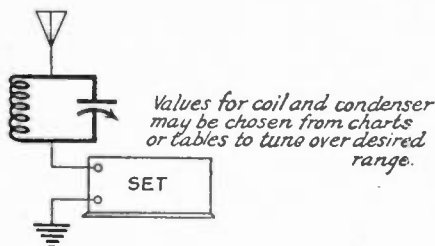

pressed. The energy used in lighting the lamps is lost.

When an a.c. broadcast receiver and the transmitter are on the same 110-volt line interference may be caused when the transmitter is keyed because the load is being rapidly thrown on and off the tube, resulting in a voltage variation which appears as a noise in the broadcast receiver. Such interference can only be eliminated by reducing power sufficiently or transferring the load to a part of the line which is more lightly loaded and sufficiently removed from the receiver so that the fluctuations in load will not affect reception. If the load is heavy it may be necessary to have a separate line installed for the transmitter.

With transmitters used exclusively for 'phone work, key-click filters are ineffective. In general, it is more difficult to eliminate interference with broadcast reception with a 'phone transmitter, although wave-traps and choke coils in the supply lines will usually prove effective. The methods described above may be applied in the same ways as with c.w.

Interference usually decreases as the transmitter frequency is raised. In many cases where bad interference is caused on the 1750- and 3500-ke. bands, changing to 7000 or 14,000 ke. will cure it. If none of the usual methods is sufficiently effective a reduction in power will often allow the station to be worked during quiet hours without bothering the neighbors. This in fact may be the only answer with a high-power transmitter in a closely-populated district. It is a little unreasonable to expect that interference can be entirely eliminated with a high-power transmitter whose antenna is only a few feet from broadcast receiving antennas. With the average amateur transmitter using a Type '10 or even a Type '52 tube a satisfactory solution to the interference problem can in most cases be reached by the intelligent application of one or more of the methods described above.

BREAK-IN OPERATION

Listening on the receiver while sending constitutes the basis of every break-in system. A short antenna for the receiver may be put up at right angles to the sending antenna. Some magnet wire strung across the room or put behind the picture moulding will bring in high-frequency signals in fine shape and avoid the difficulties of changing over the antenna from the sending to receiving set. Often the signals can be picked up without any antenna at all if the receiver is unshielded or if there is some coupling to the transmitter due to its adjacent location. In this case there will be trouble in working break-in on frequencies close to that on which the sending set operates. If the transmitter is close and the key is in the negative high-voltage lead, it may be impossible to copy stations sending on your own frequency. There may be trouble even when the key is up from oscillations of the transmitting tubes caused by voltages from the filament transformer which come from an unbalanced center-tap arrangement. If this cannot be cured

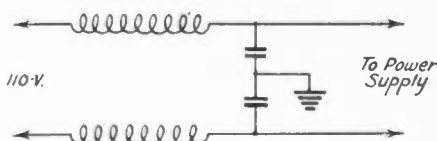

R.F. SUPPRESSORS FOR THE POWER LINE

A combination of choke coils and condensers, the constructions of which is described in the text, may be connected in the power line before the plate-supply equipment is reached, to prevent r.f. from feeding back from the transmitter to the line and thus causing interference with broadcast listeners. The choke-condenser combination may also be used with an a.c.-operated broadcast receiver in the same way as used with the transmitter.

by putting in a true center-tap, it will be best to locate the transmitter farther away from the receiver and to use remote control. In this case a relay should be used to key the transmitter.

KEYING RELAYS

A keying relay can easily be made from an old telegraph sounder. The photograph shows a single-contact relay made from a sounder. The brass sub-base should be removed and a piece of bakelite of the same size substituted. This can be drilled, using the brass base as a template. Two additional binding posts should be added to the device to make it easy to connect to the contacts. $\frac{1}{4}$ " x $\frac{1}{4}$ " silver slugs $\frac{1}{16}$ " thick obtained from a jeweler make dependable contacts. Two silver coins with the faces filed flat will be equally good. These can be fitted into notches filed in the armature and frame of the sounder and soldered in place. A piece of copper braid or a thin brass spring should be connected between the U-shaped part of the frame and the armature so that the pivots do not carry any current. In addition it will be necessary to fasten a bit of insulation

between the armature and the back-stop screw to keep the armature from closing the circuit when the key is open. This can be threaded and glued to the back-stop screw itself or may be part of the armature. Such contacts are heavy enough

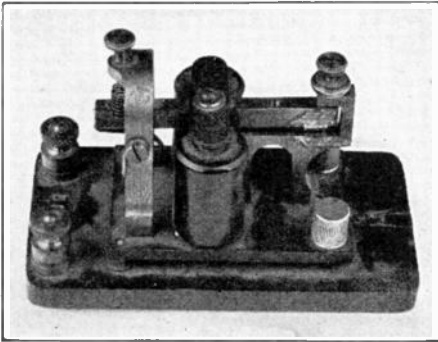

A GOOD KEYING RELAY MADE FROM A TELEGRAPH SOUNDER

to key any amateur transmitter. The relay may be operated from the same storage battery that heats the filaments of the receiving tubes, or from a separate battery. It can be adjusted to work well at almost any desired speed without bad sparking or sticking.

Automobile generator cut-outs can also be transformed into keying relays for low-power transmitters. They can be obtained for a dollar or so from any automobile supply house. A connection should be brought out from each of the contacts to take the place of the key in the transmitter, care being taken to see that the windings on the cut-out do not connect to either of the contacts. There are two windings on the magnet, one of which has only a few turns of coarse wire, the other having many turns of fine wire. The latter winding will usually operate the armature satisfactorily from a 6-volt battery, but if not both windings can be removed and a new one put on, using as much No. 30 d.c.c. wire as can be put in the space. Such a relay is very fast in operation and will follow a "bug" key at high speeds.

Ready-made keying relays can be obtained from several concerns advertising in this *Handbook* and in *QST*. Several different types, designed to operate under different conditions, are available.

REMOTE CONTROL

If the location is such as to allow the transmitter to be installed some distance from the receiver, the transmitter may be remotely controlled. This will make it easy to use break-in and save worrying about losses in poor dielectrics which are certain to be in the field of the lead-in or feeders if brought right down to the operating room.

In a remotely-controlled installation, relays

can be used in one of several ways depending on the distance and the individual application. The problem is merely one of turning the filament-heating and plate-supply power on and off and keying the transmitter, using a minimum number of relays and as small an amount of wire as possible.

One simple method of using two relays, requiring the use of only three wires, is shown in the diagram. With this arrangement the filaments of the rectifier tubes can be lighted before the plate transformer is connected and can be allowed to remain lighted during an entire period of communication, which is good practice.

All relay contacts should be large enough to avoid the possibility of sticking if the set is remote-controlled. The outfit also must be built substantially and adjusted to operate stably. There is a lot of pleasure in operating a set some distance away and the improved break-in work makes it well worth considering. If a motor-generator is used an automatic starting compensator operated by a suitable relay will be necessary for starting up the set.

The beginner should limit his efforts to building a simple and inexpensive low-power sending set and a good receiver and not attempt to start off with a remote-controlled transmitter. Remote

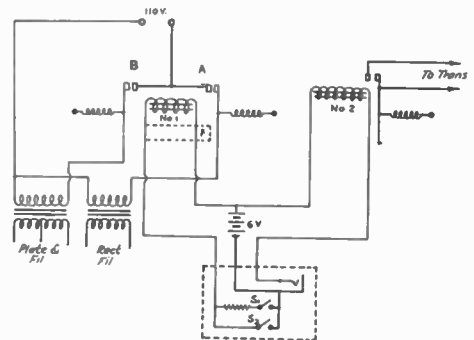

A SUCCESSFUL REMOTE-CONTROL SYSTEM

Only three wires need be used between the operating table and the transmitter. The part of the circuit enclosed in the dotted rectangle is the only part within reach of the operator. In practice, Relay No. 1, which has two sets of contacts, is adjusted so that the contacts at "A" will close when S_1 is closed, the contacts at "B" remaining open. The latter contacts close when S_2 is closed. Such a relay may be home-constructed with two separate armatures, the spacing between the armatures and the pole pieces and the tension on the springs being adjusted for proper operation. Relay No. 2 is the keying relay. This arrangement permits the filaments of the rectifier tubes to be lighted before the plate load is thrown on. S_1 may be left closed during a period of communication, thus keeping the rectifier tubes ready for instant operation.

control is not absolutely necessary for break-in work and it can always be added after the elements of a station have been built and are in operation. Remote control is the best possible thing for the fellow with the cold out-door shack or the radio room in the attic where the temperature hits the 100° mark in summer.

CHAPTER XI

Antennas

THE antenna equipment of the amateur station is no less deserving of consideration than the transmitter or receiver, since the finest of apparatus inside the station can easily be nullified by a poorly designed and carelessly erected aerial system. Although almost any sort of antenna usually serves well enough for receiving purposes, no degree of care in design and construction is too great where the transmitting antenna is concerned, for in almost every case the station's transmitting effectiveness will be directly proportionate to the care and effort expended in constructing the transmitting antenna. And this is true in some degree for the receiving antenna as well, because the sensitivity and selectivity — particularly the selectivity — of even the best high-frequency receiver can be improved by substituting a well designed antenna for the usual nondescript scrap of wire hung up anywhere.

One of the best ways of guaranteeing a good receiving antenna is to use the tuned transmitting antenna for receiving also; another is to use some simple modification of the more elaborate transmitting arrangements, such as the doublet shown in the illustration, equipped with a twisted pair

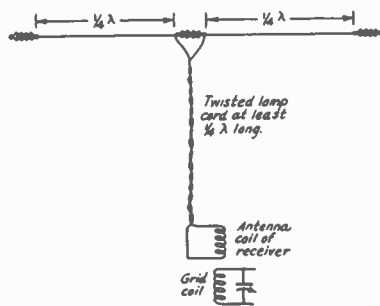

DOUBLET RECEIVING ANTENNA

(lamp-cord) as a feeder and loosely coupled to the input inductance of the receiver by a tuned or untuned coupling coil. The dimensions of the antenna and feeder components correspond with those of the transmitting antennas of a similar type which are described later.

Before any attempt is made to explain how the transmitting antenna systems operate, or to describe their construction, it is necessary to differentiate between the terms "antenna" and "antenna system." The treatment of short-wave antenna systems in understandable and explicit language is a difficult enough business but at least it is simplified to some extent if we can talk

of the antenna — meaning that portion of an antenna system which is intended to do the radiating of energy into space — and so separate it from the feeders and other adjuncts of the antenna system which would otherwise so complicate the discussion.

TYPES OF ANTENNAS

Notwithstanding the great variety of antenna systems to be seen in operation, the antennas are, for all practical purposes, of but two distinct

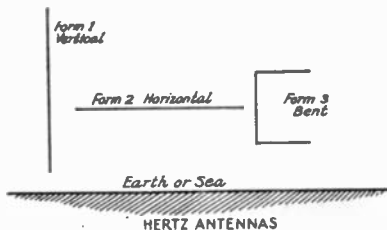

types. Those in which the ground is an essential part are known as Marconi antennas. In some cases antennas of this type are connected directly to a ground system but in others the connection is obtained through the capacity to ground of an extensive counterpoise. The second type of antenna is the Hertz antenna, in the operation of which the ground does not play an essential part. The Hertz antenna is not connected directly to ground and, in its purest form, consists of a single wire suspended sufficiently high above the earth or earthed objects to have an inconsequential capacity to ground. The Hertz antenna, though it was originally used by the experimenter after which it was named nearly half a century ago, is now used almost exclusively for short-wave transmission.

A single wire such as that comprising the Hertz antenna, irrespective of whether it is vertical, horizontal or bent into a V or other shape, has inductance, capacity and resistance in much the same way as the tuned circuits of the transmitter have inductance, capacity and resistance. The Hertz antenna is therefore really a simple oscillatory circuit having a natural frequency in the same way that the tuned circuits of the transmitter have natural frequencies. The chief difference is that in the antenna the inductance, capacity and resistance are distributed throughout its length, whereas in the transmitter tuned circuits they are concentrated or lumped. The Hertz antenna is known as an open oscillatory circuit and has the ability to radiate effectively the energy oscillating in it. The tuning circuits in

the transmitter are known as closed oscillatory circuits and have a very limited ability to radiate the energy in them.

In order to calculate the natural frequency of a closed oscillatory circuit it is necessary to use a relatively complex formula (given in Chapter IV) in which the capacity and inductance in the circuit are involved. In an open oscillator of the type of the Hertz antenna, however, there exists a very simple relation between the natural period and the length of the wire. The natural wavelength of the wire (the highest wavelength at which it will oscillate) will be its length in meters multiplied by a factor between 2.1 and 2.07. If the velocity of an electric wave on a wire were always 300,000,000 meters per second (the approximate velocity in free space and the velocity on which all wavelength specifications in this book are based) the

time the relationship between wavelength and frequency should be kept in mind continually.

The fact that a Hertz antenna is approximately half as long as its fundamental wavelength makes it convenient to refer to such an antenna, operated on its fundamental, as a half-wave antenna. This, however, is not the only way in which it can be operated. In the same way that the tuned circuits of the transmitter will oscillate at harmonics of their fundamental wavelengths or frequencies, so the Hertz antenna will oscillate at its harmonics and far more readily than a closed circuit. An antenna with a fundamental wavelength of 84.46 meters (3,550 kc.) will be a half-wave antenna at that wavelength. However, it is also possible to make it oscillate on 42.23 meters (7100 kc.), when it will have two half-waves on it. It would then be said to be operated at the second harmonic. The same antenna would also oscillate on 21.11 meters (14,200 kc.), when it would have four half-waves on it. In this case the antenna would be working on the fourth harmonic. If it was fed from a transmitter tuned to 10.56 meters (28,400 kc.) this same antenna would still oscillate. It would then have eight half-waves on it and would be operating on the eighth harmonic.

These statements may seem confusing at first but it is essential that they be studied until they are understood if it is desired to appreciate just how antennas are designed and operated. It may help to examine the third diagram in which Hertz and Marconi antennas are shown operating at various harmonics. It will be seen that all the

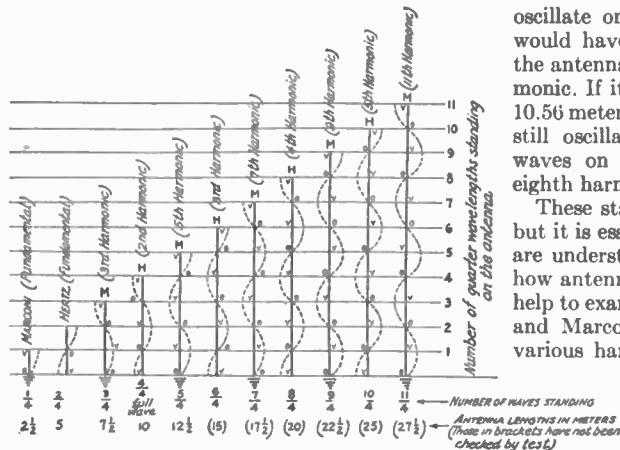

28,000-KC. (10-METER) RADIATING SYSTEMS

drawn to illustrate possible methods of operating both grounded and ungrounded antennas. The grounded or Marconi systems are labelled M while the ungrounded or Hertz systems are marked H. The dotted lines show the voltage distribution. The points "O" are the voltage nodes or point of minimum voltage. They are also points of maximum current (current antinodes) and it is at these points that current-feed can be used to best advantage. Points "V" are points of maximum voltage. Voltage-feed systems are connected at or near these points. While the systems are shown vertical they can be operated in almost any other position.

natural wavelength of the wire would be exactly twice the length of the wire in meters. The velocity of a wave on a wire is always something less than the velocity in free space, however, and the natural wavelength is therefore slightly greater than twice the length of the antenna.

From this it can be seen that the highest wavelength to which a Hertz antenna tunes — its natural wavelength — is approximately twice its length in meters. In other words, the length of the antenna is about half the wavelength to which it tunes. This simple relation makes it very useful to speak of wavelengths instead of frequencies when explaining the action of antennas, and this practice will be adopted in this chapter. At the same

Hertz antennas have an even number of quarter waves on them while the Marconi types have an odd number. No particular notice need be taken of the Marconi types since they are rarely used in amateur work and will not be treated in detail in this discussion. The wavy dotted lines on this diagram indicate the distribution of voltage along the antenna. In the Hertz antenna there is always a point of maximum voltage and minimum current at both ends of the wire. This is shown more clearly in the next diagram in which both the voltage and current distribution are shown. It can be seen that wherever the voltage is highest the current is at a minimum and wherever the current is highest the voltage is at a minimum. The important point, however, is that in the Hertz antenna there is a point of highest voltage and no current at both ends. It is common practice to term the points of no voltage "voltage nodes" and the points of no current "current nodes." Conversely, the points of highest voltage or current are sometimes known as voltage or current "antinodes" or "loops."

It must always be kept in mind that there will be a definite number of half waves on the antenna when it is oscillating; there will be no odd quarter or eighth waves left over. This can be seen clearly in the diagram just referred to. When oscillating on its fundamental there is one half-wave along the antenna; on its second harmonic, two half-waves; on its third harmonic, three half-waves; on its fourth harmonic, four half-waves, and so on. If the fundamental of this antenna was 85.66 meters (3500 kc.), the next frequency at which it would oscillate would be the second harmonic. This would be twice the frequency, 7000 kc., or half the wavelength, 42.83 meters. The next frequency at which it would oscillate would be the third harmonic, which is three times the frequency — 10,500 kc. — or one-third the wavelength — 28.55 meters. And this example could be carried on to the twenty-fourth or forty-fourth harmonic if we had the space. In all of these cases, however, there would be points of highest voltage at both ends of the antenna. And since points of highest voltage are always points of lowest current, when the antenna is oscillating, these ends will be points of lowest current also. There will be other points of no current and high voltage along the antenna as can be seen from the same diagram to which we have been referring. A knowledge of the location of these points is of the greatest importance in the planning of the feeding system, as we shall see.

DETERMINING THE LENGTH OF THE ANTENNA

It has previously been mentioned that the natural wavelength of a Hertz antenna is from 2.1 to 2.07 times its actual length instead of exactly twice its actual length. The reason for this is that the antenna has effective distributed capacity and inductance. The value of the distributed capacity and inductance will be influenced by various factors, such as the presence of nearby conductors and the size of the antenna wire, and their effect on the natural wavelength of the antenna will become greater as the frequency is higher. At frequencies of 28 mc. and above (wavelengths below 10 meters), the ratio of natural wavelength to actual antenna length may be even greater than 2.1. The length of the antenna is not an extremely critical dimension, however, because the antenna itself is a circuit having a quite broad resonance characteristic — the total of its ohmic and radiation resistance is something like 70 ohms — and deviations as great as 2% from the ideal length for a given set of conditions will not seriously affect its radiating properties. Although specific formulas are given in the following pages for calculating the proper length of the antenna for use with different types of feed systems, this formula can be generally used for calculating the length of a simple Hertz antenna:

Length in feet = 1.56 × desired natural wavelength in meters; or
 Length in meters = 0.475 × desired natural wavelength in meters.

In terms of frequency:

$$\text{Length (feet)} = \frac{468,000}{\text{Freq. (kc.)}} = \frac{468}{\text{Freq. (mc.)}}; \text{ or}$$

$$\text{Length (meters)} = \frac{142,500}{\text{Freq. (kc.)}} = \frac{142.5}{\text{Freq. (mc.)}}$$

These formulas are based on a 2.1/1 ratio of natural wavelength to actual length. Expressed another way, the actual length is approximately 95% of one-half the natural wavelength. The length should be measured off accurately, of

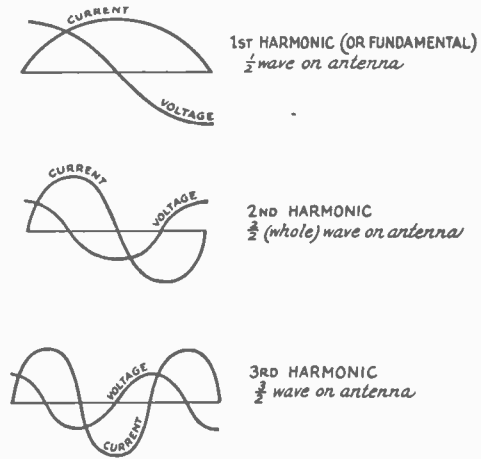

VOLTAGE AND CURRENT DISTRIBUTION OF ANTENNAS OPERATING AT HARMONICS

course, preferably with a good steel tape, yard stick or meter rule. Cloth measuring tapes are unreliable.

FEED SYSTEMS

We now have some idea of the manner in which a Hertz antenna can oscillate but it is certain that the antenna cannot be strung up in the air and be expected to oscillate of its own accord. It must be supplied with power from the transmitter. The process of supplying power to the antenna is termed "feeding" or "exciting" the antenna.

It must be emphasized that the type of feed in itself does not make one antenna system more efficient than another. If the whole system is designed, erected and tuned according to specifications, the antenna itself will radiate just as effectively with one feeder arrangement as with another. The choice of a feed system is almost solely based on convenience and will be governed by local conditions. The adaptability of each of the systems described can be determined best by a

study of available locations for the antenna system and the exercise of individual judgment. There is no "best" antenna system for all locations.

Primarily there are two types of feed systems in general use by amateurs — those which employ a tuned non-radiating link between the transmitter's output circuit and the antenna, and those which employ an untuned feed circuit whose characteristic (surge) impedance is matched at the antenna terminal end by a suitable coupling arrangement. The tuned feeder systems are classed as either current or voltage feed, since they couple to the antenna at either a current or voltage loop. The matched impedance systems are of two types — single-wire and two-wire. The tuned feeder arrangements are simpler and more popularly used by amateurs, and will be described first.

CURRENT FEED SYSTEMS

It is immediately apparent that we cannot attach a current feed system to the ends of a Hertz antenna because there is no current there. But reference to the two previous diagrams will show that there are other places in the antenna

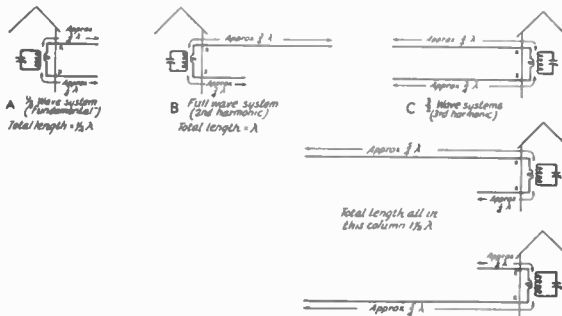

NOTE — Losses tend to be high at points X unless they are near voltage node. Antenna forms shown are general and outside parts may be slanting or vertical.

CURRENT-FEED ANTENNA SYSTEMS

In the past, antennas of the type shown at A or C have been widely used by amateurs and referred to rather inappropriately as "antenna-counterpoise" systems. In reality they are just bent Hertz antennas. Their effectiveness usually is improved if the two portions are led from the station in opposite directions, so making the antenna in the form of a straight line or a wide "V". The important point is that in any such antenna system the coupling coil must be inserted at or near a point of maximum current. This will be at one or an odd number of quarter-wavelengths from the end. One or two variable condensers can be connected in series with the antenna inside the station to permit precise tuning of the system.

where there is high current and at any of these places a current-feed system could be connected. When the antenna is operating on its fundamental there is a point of highest current at the center and the feed system could well be attached at this point. Such an arrangement provides what is probably the simplest antenna system that the amateur can use. It is shown at A in the above diagram. The fundamental antenna — approximately one half-wave long — is bent so that its middle portion is within the station. At the

center, the antenna coil is connected and coupled to the plate coil of the transmitter. If the antenna itself had a fundamental of the frequency on which it was desired to operate, the insertion of the antenna coil would disturb it. Hence, in actual practice, a tuning condenser is connected in series with the coil — or one on each side — so that it is possible to compensate for the loading effect of the antenna coil and tune the antenna to the required frequency. If the antenna is being operated on some harmonic there will be other places of maximum current at which the feed system could be introduced. Some of these are shown in the same diagram. It will be noticed that these points of maximum current are either one or an odd number of quarter-wavelengths from an end of the antenna.

The antennas illustrated in this diagram, particularly at A and C, would not be very effective in practice because the antenna is doubled back on itself. The trouble is that the current at a given point on one half of the antenna is opposite in phase to the current at a similar point on the other half. The field around one of the halves will therefore tend to cancel the field around the other half and the effectiveness of the antenna as a radiator will be reduced. It is very much preferable to arrange things so that a considerable portion of the antenna is out in the open away from the influence of the remainder. Other desirable schemes would be to fold only a small portion of the antenna or to arrange it in the form of an open V. In some stations, for instance, where the transmitter is in an attic, it may be possible to make the antenna a straight wire entering the room on one side and leaving it on the other.

The schemes so far described have the disadvantage that the antenna is brought into the station where its radiation can be absorbed by the building, and where it may be unnecessarily close to the ground. It is better to leave the complete antenna strung up in a place well clear of trees or buildings, feeding it with a feeder system which is purposely arranged to play no part in the business of radiating. Arrangement D in the next diagram is preferable to the others in this respect because the vertical portion between the

antenna coupling coil and Z has been eliminated as a part of the antenna and converted into a feeder with little radiating ability, for when the whole system is properly proportioned and tuned the fields about the two feeder wires will be opposite in phase and will cancel. To reduce radiation from the feeder to a minimum, the two wires should be not more than 10 or 12 inches apart. The construction of the feeder system is described farther on.

This type of antenna system is known as the

two-wire current-feed when the feeder couples to the antenna at a current loop and the feeder is tuned to a multiple of $\frac{1}{2}$ wavelength (an even multiple of $\frac{1}{4}$ wavelength). The lengths of the antenna and feeder wires can be determined from the formulas just given. The system can be operated at harmonics of its natural frequency, of course, and it is particularly adaptable to locations where it is convenient to run the feeders from the station to the middle of the antenna. The feeders need not be run in a straight line from the antenna to the transmitter but can be arranged as shown in the illustration of an antenna system designed for operation on three or more amateur bands. In this system the antenna operates as a current-fed Hertz on its fundamental frequency and as two voltage-fed Hertz antennas in parallel on its even harmonic frequencies. The construction and adjustment for each band are given beneath the illustration.

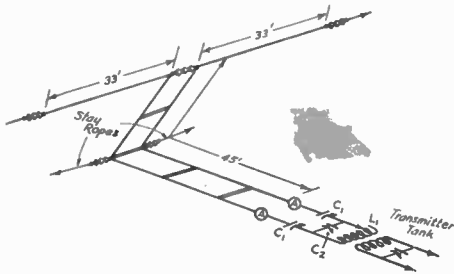

A CURRENT-FEED SYSTEM FOR SEVERAL BANDS

The antenna has a fundamental frequency of 7100 kc. and is operated on its second and fourth harmonics for 14,200 and 28,400 kc., respectively. Parallel tuning is used on 7100 kc. and series tuning for 14,200 kc., parallel tuning again being used for 28,400 kc. The system operates as two voltage-fed Hertz antennas in parallel on the two higher frequencies. The arrangement will also work quite well on the 3500-kc. band with parallel tuning of the tank circuit, the whole system being approximately a half-wave antenna with all but the two end eighth-waves "folded back on itself." With a fundamental 3500-kc. antenna (total length about 133 feet) better all-band operation could be obtained with feeders of the length given. The condensers C_1 and C_2 can be of 250- or 350- μ fd. capacity. The feeders can be pulled back as shown if the distance between the antenna and the station is less than 45 feet.

VOLTAGE FEED SYSTEMS

Some of the most practical and popular amateur antenna systems are of the voltage-feed type which differ from the current-feed types in that the energy is fed to the antenna at one of its voltage loops (current nodes) instead of at a current loop (voltage node) as in the current-feed type. One form of voltage feed is shown in which one end of the antenna is brought into the station and attached to a tank circuit which is coupled to

the output of the transmitter. This system is quite simple but has the disadvantage of making it necessary to bring the radiating portion of the antenna system into the station. The antenna length is determined by the general formula pre-

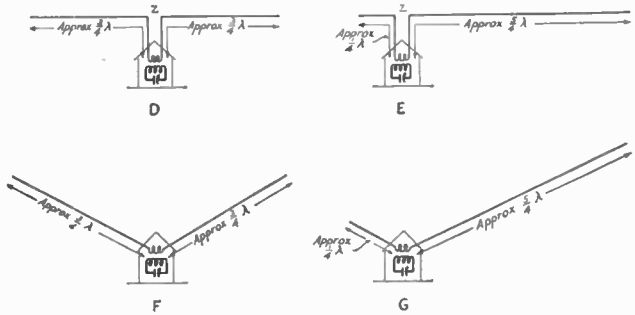

OTHER POSSIBLE CURRENT-FEED ANTENNA SYSTEMS

viously given and the antenna can be operated at its harmonics as well as at its fundamental frequency. Moreover, this system is readily convertible to operation as a Marconi (grounded) antenna for operation at half of the natural frequency (twice the natural wavelength) which it has as a Hertz antenna. This is accomplished by grounding one side of the antenna coupling tank circuit, as shown in the diagram. The antenna should never be connected directly to the output tank of the transmitter since such direct coupling of the antenna itself to the transmitter tank circuit is illegal. This system is not to be confused with the single-wire-feed antenna system which will be described later.

The two-wire voltage-feed system is perhaps the most generally used of all amateur antenna systems. It is popularly known as the Zeppelin or Zepp antenna and utilizes a tuned two-wire feeder attached to the Hertz antenna at one end. Since there is always a voltage loop at this feed point, the system operates as a true voltage-feed system at all harmonics as well as at its fundamental frequency. It is especially adapted to locations where it is most convenient to feed the antenna at one end. The length of the antenna should be determined from the same formula used for the preceding systems and the feeder system should be equivalent to an odd multiple of $\frac{1}{4}$ -wave long; that is, each wire is approximately an odd multiple of $\frac{1}{4}$ -wave in length or the tuning is so arranged that the same effect can be realized. If the feeder wires are each an odd number of $\frac{1}{4}$ - or $\frac{3}{8}$ -waves long for the frequency being used, the system can be tuned to resonance by means of series condensers. If they are slightly less than a multiple of a half-wave long, parallel tuning will do the trick. A table gives some useful feeder lengths and tuning arrangements for the operation of Zeppelin antennas of various fundamental frequencies on their fundamentals and harmonics.

Diagrams show the coupling arrangements for series, parallel, and combination series and parallel tuning. A suitable Zeppelin antenna for operation on three or more bands is also illustrated.

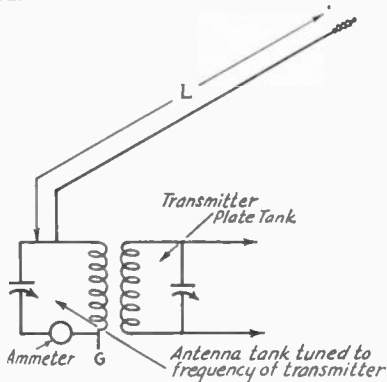

A SIMPLE VOLTAGE FEED SYSTEM

Should the length of the antenna *L* be 264 feet, the antenna could be operated on any of the amateur bands merely by tuning the transmitter and the antenna tank circuit to the required frequency. If the length *L* is 132 feet the antenna will have a fundamental of approximately 3550 kc. (84.46 meters) and it could be operated on the 3500-kc. band or any of the four higher-frequency bands. When the antenna is approximately 66 feet long its fundamental will be at 7100 kc. (42.23 meters) and operation will then be possible on the 7000 kc. band or any of the three higher-frequency bands. By connecting a good ground system at the point *G* the antenna system is converted to a Marconi type and operation can then be had at half the fundamental frequency of the antenna itself. Thus an antenna 132 feet long — with a fundamental of 3550 kc. — could be operated on the 1716-kc. band in conjunction with a ground connection and on all other bands by disconnecting the ground and using the voltage-feed system. The antenna need not be bent as shown in the diagram. In some locations it could be made horizontal and in others vertical. Even if one portion is sloping, another part vertical and the remainder horizontal it will still operate. It should be as much in a straight line as well as clear of trees and buildings as possible.

The principal requirements for this type of antenna system are that the feeder system be symmetrical (both feeder wires of exactly the

true indication of how well the system is operating. If the meters happen to be connected at or near current nodes (voltage loops) they will indicate very little current. This is particularly likely to happen when parallel tuning is used and the feeders are nearly multiples of 1/2-wave long for the frequency being used. The meters do indicate proper balance, however, when the current in both feeders is of the same value. If the current in one feeder is much different from that in the

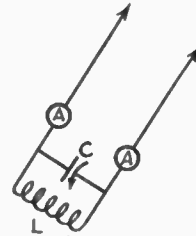

PARALLEL FEEDER TUNING

other it is quite probable that the feeder system is unbalanced and that there is radiation from the feeders because their respective fields are not canceling each other. The construction of the

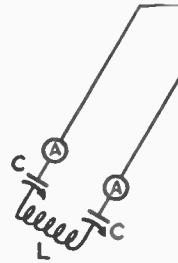

SERIES FEEDER TUNING

Zeppelin feeder system is like that of the other two-wire arrangements and is described in a later paragraph.

TUNING

The tuning of voltage- and current-feed systems is quite similar and the tuning practices recommended in Chapter VII should be observed to obtain the maximum output compatible with good frequency stability. When series tuning is used with either of the typical antenna systems shown in the diagrams, the parallel tuning condenser should be set at minimum capacity and the series condensers at maximum. After the transmitter has been set on the desired frequency the antenna coupling coil should be coupled to the transmitter tank and the series condensers tuned simultaneously, from maximum capacity down, until the radio-frequency ammeter shows maximum feeder current and the plate milliammeter shows maximum plate current. If the transmitter should stop oscillating or the meters show two points of maximum current, the coupling

APPROXIMATE LENGTH OF EACH WIRE, FEET	TUNING ARRANGEMENT FOR VARIOUS BANDS				
	1750 kc (160 m.)	3500 kc (80 m.)	7000 kc (40 m.)	14000 kc (20 m.)	28000 kc (10 m.)
120	SER	PAR	PAR	PAR	SER OR PAR
90	PAR	SER	SER	PAR	SER OR PAR
60	PAR	SER	PAR	PAR	SER OR PAR
40	(---)	PAR	SER	PAR	PAR.
30	(---)	(---)	SER	PAR	SER OR PAR
15	(---)	(---)	PAR	SER	PAR.
8	(---)	(---)	(---)	PAR	SER.

SER - Series Tuning PAR - Parallel Tuning (---) - Not Recommended.

SOME SUGGESTED ZEPPELIN FEEDER LENGTHS AND RECOMMENDED TUNING METHODS FOR THE VARIOUS AMATEUR BANDS

same length) and that the antenna be of the right length for the desired fundamental frequency. The actual value of the feeder current indicated by the antenna ammeter or ammeters is not the

should be loosened. After tuning for maximum current the capacity of the feeder series condensers should be increased until the current drops about 15%, if the transmitter is a self-excited rig. With an oscillator-amplifier set the best tuning adjustment is the one which gives maximum feeder current, of course. The procedure with parallel feeder tuning is similar except that the series condensers are set at maximum and the parallel condenser is tuned from maximum capacity down. If the feeder current should be very low in value with parallel tuning, the plate input as shown by the plate milliammeter will be a better indication of resonance. Plate current should be the greatest when the feeder circuit is tuned to resonance unless the feeder tuning has affected the transmitter tuning enough to necessitate readjustment of the transmitter circuits. Such readjustments should be made according to the directions given for the various transmitters in Chapter VII.

THE TWO-WIRE UNTUNED FEEDER SYSTEM

In the tuned feeder systems just described the feeders are coupled to the antenna at points of

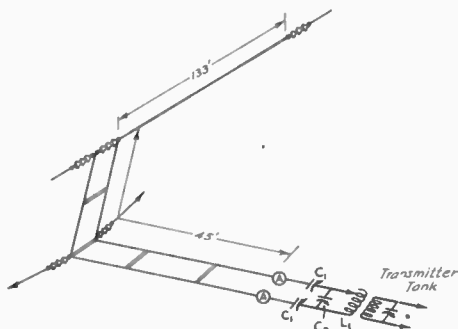

A ZEPPELIN (VOLTAGE FEED) ANTENNA FOR SEVERAL BANDS

The antenna has a fundamental frequency of 3550 kc. but could be of any fundamental frequency between 3500 and 3600 kc. Since the feeders are less than a quarter-wave long for 3550 kc., parallel tuning should be used for this band. Series tuning will be best on the 7000- and 14,000-kc. bands and probably for the 28,000-kc. band. The condensers C_1 and C_2 may be of 250- or 350- μ fd. capacity.

either maximum current or maximum voltage. The feeders have voltage and current loops and nodes distributed along them just as the antenna has, and are prevented from radiating appreciably only because the field about one feeder wire cancels that of its mate. The feeders for voltage or current feed must be tuned to allow any transfer of radio-frequency energy through them because they connect to the antenna at either a point of very high impedance for voltage feed, or a point of practically zero impedance for current feed. It is well known that a radio-frequency transmission line will have standing waves on it

when its terminal impedance is either infinite or zero, if the length of the line bears a suitable relation to the exciting frequency or, in other words, is tuned to the exciting frequency. The

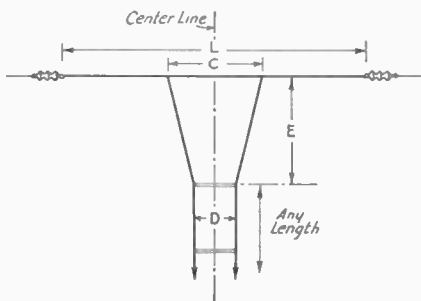

TWO-WIRE MATCHED-IMPEDANCE ANTENNA SYSTEM

tuned voltage- and current-feed systems operate because they meet these requirements and they have standing waves on them in the same way that the antenna itself has points of current and voltage maxima and minima. Now if the feeder system could be made to transfer energy efficiently from the transmitter to the antenna without the necessity for standing waves on the feeder wires, the length of the feeder system could be anything convenient and tuning of the feeder system would be eliminated. This can be accomplished with what is known as a matched-impedance feeder system.

Any two-wire transmission line has a characteristic (surge) impedance that is dependent on the spacing between the conductors and on the diameter of the wires, and which is practically independent of the length of the wires. If the line is terminated by an impedance exactly equal to its characteristic (surge) impedance, there will be no reflection from the terminal and consequently no standing waves on the wires when they are supplied with radio-frequency power. Moreover, the line will transmit power very efficiently from its input to a suitable terminating load. This follows from the principle that the maximum transfer of power from one circuit to another is possible when the output circuit impedance is equal to the line impedance.

In the antenna system shown in the diagram, the characteristic (surge) impedance of the feeder is matched by the impedance across the portion C of the antenna. The antenna length L , the feeder clearance E , the spacing between centers of the feeder wires D , and the coupling length C are the important dimensions of this system. The system must be designed for exact impedance values as well as frequency values and the dimensions are therefore more critical than those of tuned feeder systems.

The length of the antenna is figured as follows:

$$L \text{ (feet)} = \frac{492,000}{F} \times K; \text{ or}$$

$$L \text{ (meters)} = \frac{150,000}{F} \times K$$

where L is the antenna length in feet or meters for a desired fundamental frequency F , and K is a constant depending on the frequency. For frequencies below 3000 kc. (wavelengths above 100 meters) K is 0.96; for frequencies between 3000 and 28,000 kc., K is 0.95; and for frequencies above 28,000 kc. K is 0.94. F is the frequency in kc.

The value of the antenna coupling dimension C is computed by this formula:

$$C \text{ (feet)} = \frac{492,000}{F} \times K_1; \text{ or}$$

$$C \text{ (meters)} = \frac{150,000}{F} \times K_1$$

K is 0.25 for frequencies below 3000 kc., 0.24 for frequencies between 3000 and 28,000 kc., and 0.23 for frequencies above 28,000 kc. F is the fundamental frequency in kilocycles.

The feeder clearance E is worked out from this equation:

$$E \text{ (feet)} = \frac{492,000}{F} \times K_2; \text{ or}$$

$$E \text{ (meters)} = \frac{150,000}{F} \times K_2$$

K_2 is 0.30 for all bands, and F is the frequency in kilocycles.

The above equations are for feeders having a characteristic (surge) impedance of 600 ohms and will not apply to feeders of any other impedance. An impedance of 600 ohms is both convenient and standard, however, and is entirely satisfactory for amateur systems. The proper feeder spacing for a 600-ohm transmission line is computed to a sufficiently close approximation by the following formula:

$$D = 98 \times d$$

where D is the distance between the centers of the feeder wires and d is the diameter of the wire. If the wire diameter is in inches the spacing will be in inches and if the wire diameter is in millimeters the spacing will be in millimeters. These data are given in the wire table of the Appendix.

The length of the feeder system can be anything convenient, successful operation with feeders as long as 1200 feet being quite common. This type of feeder system should be constructed quite the same as the other two-wire systems with the exception of the antenna end and the transmitter coupling terminal. Since the feeder spacing is the critical dimension determining the line impedance, the wires should be kept taut and the spacing should be kept constant all the way down to the transmitter. The feeders may be run

around corners if suitably insulated and rigidly supported, but sharp right-angle bends in the wires must be avoided. Particular care should be

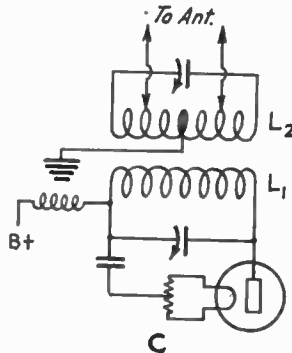
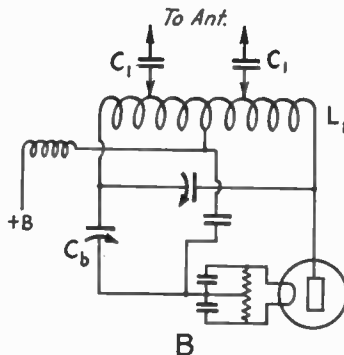
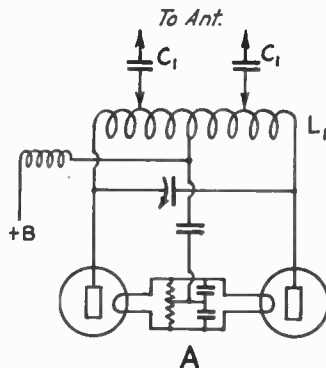

THREE ARRANGEMENTS FOR COUPLING THE TRANSMISSION LINE TO THE TRANSMITTER

A is for coupling to a push-pull oscillator or amplifier, while *B* and *C* are two methods for coupling to single-ended stages. The condensers C_1 are blocking condensers of about .002 μ fd. capacity which prevent shorting the d.c. plate supply if the feeder system should become grounded. They are not necessary with the inductive coupling method shown in *C*.

taken to run the feeder clearance portion E straight away from the antenna. Each side of E should be of exactly the same length and the

feeder wires should tap the antenna an equal distance on either side of its exact center.

Three possible methods of coupling the transmission line to the transmitter output circuit are diagrammed. This system is particularly fine for coupling the output of a push-pull oscillator or amplifier stage to a Hertz antenna, as shown in the diagram at A. The feeders should be clipped onto the tank inductance an equal number of turns on either side of its center because it is essential that the load on each tube be the same. The correct places for the taps can be found by starting at the center and moving the taps farther along the coil until the tubes are drawing their proper input power. The fixed condensers *C* are used as a precaution to prevent short-circuit of the plate supply in case the feeders should become grounded. Since the feeder current is very small in value, the usual antenna ammeter will be unsatisfactory for indicating maximum power input to the antenna. The plate current milliammeter reading will serve, however.

Diagram *B* illustrates the plate tank arrangement satisfactory for coupling the two-wire feeder system to the output of a single-ended stage. The condenser *C*₁ is connected from the "free" end of the tank circuit to the filament circuit and should be equal in capacity to the tube plate-filament capacity. Its purpose is to make the tank circuit electrically symmetrical about the center. Diagram *C* illustrates the method of connecting this type of feeder to the output of a transmitter when it is impossible to arrange the plate tank to give the required balance. The feeder tank circuit will be similar in construction to the usual transmitter tank circuit. As with the other arrangements the clips are adjusted on either side of the inductance's center until the maximum power is being transmitted to the antenna. This will occur, of course, when the impedance across the feeder input is equal to the surge impedance of the transmission line.

SINGLE-WIRE FEED

The single-wire matched-impedance feed system operates on the same principle as the two-wire feed: There will be no standing waves on the feeder and consequently no radiation from it when its characteristic impedance is matched by the impedance at its terminal. The single-control transmitter described in Chapter VII is designed to operate with this type of feed. The principal dimensions are the length of the antenna *L* and the distance *D* from the exact center of the antenna to the point at which the feeder is attached. These dimensions can be obtained from the chart, for an antenna system having a fundamental frequency in any of the amateur bands. The antenna should be designed for the lowest frequency band which is to be used, and operated on its harmonics in the higher-frequency bands.

Although the dimensions shown in the chart are for the 3500-kc. band, the dimensions for the 7000-kc. band can be obtained by multiplying the

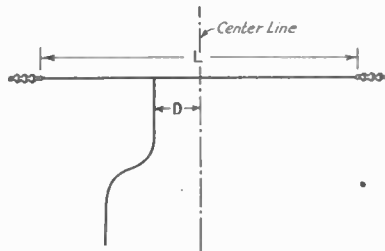

SINGLE-WIRE FEED SYSTEM

The length *L* and coupling *D* are determined from the chart.

frequency by 2 and dividing the lengths by 2; and for the 14,000-kc. band by multiplying the frequency by 4 and dividing the lengths by 4. When the antenna is to be operated on harmonic frequencies the length must be such that the harmonics of the antenna's fundamental frequency fall inside the higher frequency bands. Suppose

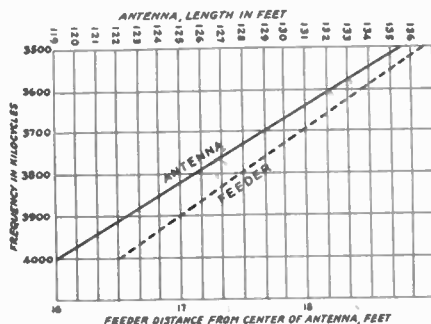

SINGLE-WIRE FEED DATA CHART FOR NO. 14 WIRE FEEDER

that the antenna is to be used for the 3500-, 7000- and 14,000-kc. bands. Since the limits of the 14,000-kc. band are 14,000 and 14,400 kc., the fundamental frequency of the antenna must lie between 3500 and and 3600 kc. The antenna length should be, therefore, somewhere between 132 and 135.5 feet. The feeder should be tapped onto the antenna at a distance from the antenna center of 18' 9" for operation with an antenna of 135.5' length, or at 18' 2" for an antenna of 132' length.

In constructing an antenna system of this type the feeder must run straight away from the antenna (at a right angle) for a distance of at least 1/3 the length of the antenna. Otherwise the field of the antenna will affect the feeder and cause faulty operation of the system. There should be no sharp bends in the feeder wire at any point. The process of adjusting the coupling between the transmitter and the single-wire feeder is given with the description of the single-control transmitter in Chapter VII.

DIRECTIONAL ANTENNAS

Directional antennas for both transmitting and receiving are particularly advantageous at the higher amateur frequencies, especially in the 28- and 56-mc. bands because at these frequencies

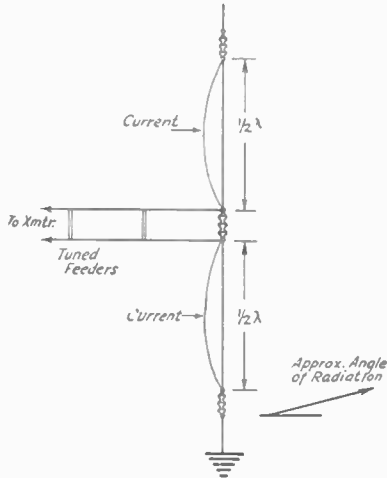

A SIMPLE ANTENNA SYSTEM FOR LOW-ANGLE RADIATION

The current in the two antennas is in phase and radiation is in all directions of the compass at a low angle to the earth's surface.

the dimensions of practicable directional systems are small enough to make them adaptable to the space most amateurs have available. Directional antennas are not only useful for concentrating the radiated energy in a desired compass direction but also for concentrating the radiated energy on a favorable angle of radiation. Experiments on the 28,000-kc. band, for instance, show that radiation at high angles to the earth's surface is futile for communicating with other stations of the world and the useful part of the total radiation is that transmitted at low angles.

Two simple arrangements for directive transmission are illustrated, both designed to concentrate the radiated energy in low angles to the surface.

The directional properties of systems of the types shown depend on the phase relations of the currents in the wires. When two antennas a half-wave apart are excited in phase their radiation is concentrated along a line at right angles (broadside) to their plane. Also, a half-wave antenna spaced a quarter-wave from the fed antenna and parallel to it (but not connected to it) will act as a reflector with the result that the radiation is concentrated in the direction away from the reflector. Both of these principles are utilized in the second directive antenna shown.

The feeder system is arranged to supply four half-wave antennas so that the currents in all four are in phase. This is accomplished by voltage-feeding all the antennas from one pair of feeders and transposing the feeders between the lower and upper antennas. A typical transposition insulator is illustrated. The four antennas alone

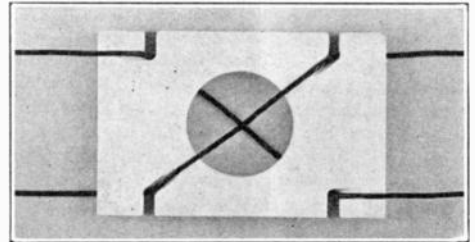

AN ISOLANTITE FEEDER TRANSPOSITION INSULATOR

The separation between the wires is 1 3/8".

would make an excellent bilateral directive system, of course, but the addition of the four reflectors increases the concentration of the radiation in the direction of the arrow and makes the system unilateral. The dimensions given on the diagram are for a frequency of 29,000 kc. Antenna lengths for other frequencies can be worked out from the formulas given for Hertz antennas in the first part of this chapter. The half- and quarter-wave spacings between the antennas should be actually one-half and one-quarter of the wavelength.

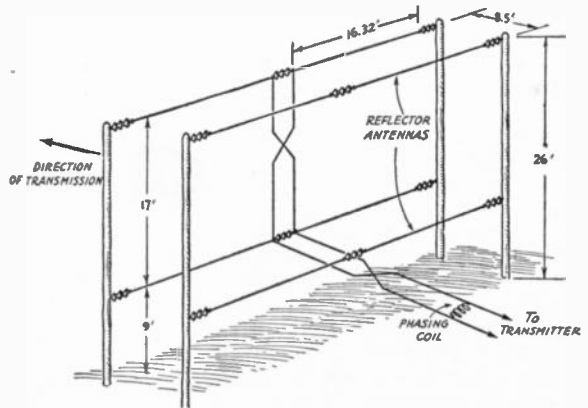

A 28-MC. DIRECTIVE ANTENNA SYSTEM

Four in-phase antennas backed up by four reflectors concentrate the radiation in the direction indicated by the arrow.

ANTENNA CONSTRUCTION

For the purpose of this discussion let us divide the antenna system into two parts—the conductors and the insulators. If the system is to operate most effectively the conductors must be

of low resistance. On the other hand the insulators must be of the highest possible resistance. For low- or medium-powered transmitters an entirely satisfactory conductor is No. 14 gauge soft-drawn enamelled copper wire. For higher-powered transmitters No. 12 gauge is preferable. Every effort should be made to make the wires in one piece so that the only joints are at the output terminals of the transmitter. Where joints cannot be avoided they should be thoroughly soldered. It should always be possible to make the Hertz antenna-portion in one piece.

If the feeder system is of the tuned type the currents in it will be of the same order as those in the antenna and the same care in avoiding joints is necessary. In the untuned feeder system, however, the currents are relatively low and this

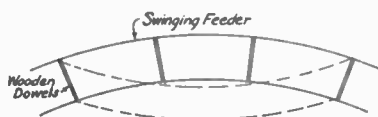

THE USE OF LIGHT WOODEN DOWELS IN THE FEEDER

permits the system as a whole to swing. In this case the effect of movement of the feeder would not be as noticeable.

consideration is therefore not as important. In these cases smaller wire can be used if necessary.

In building a two-wire feeder the wires should be separated by wooden dowels which have been boiled in paraffine. In this way the feeder is given a tendency to swing in windy weather as a unit. When heavy glass or porcelain spacers are used the tendency is for each wire to vibrate with respect to the other, so causing changes in the capacity between the wires and consequent changes in the emitted frequency. The wooden dowels can be attached to the feeder wires by drilling a small hole in the dowels, then binding them to the feeders with wire.

A good insulation to use throughout the antenna system is Pyrex glass. Glazed porcelain also is very good. It should be kept in mind that the ends of tuned feeders or the ends of the antenna are points of maximum voltage. It is at these points that the insulation is most important. A 12" Pyrex insulator is quite satisfactory for amateur transmitters of any power. For the low-powered transmitters one of the smaller sizes, or two in series, would be satisfactory.

Probably the most satisfactory method of leading the antenna or feeders into the station is through holes drilled in the centers of the window panes. The drilling can be accomplished by using an ordinary steel twist drill if plenty of turpentine

is provided at the point of the drill. It is best to remove the panes before drilling is attempted, since it will be difficult to avoid breaking them if the work is done when they are in the window. Large Pyrex bowls are also satisfactory as lead-in insulators, the bowls being mounted over large holes cut in a board of such a size that it fits



WHEN HEAVY GLASS SPACERS ARE USED

in the feeder construction there is a tendency for the wires to vibrate as shown, so causing a wobbly frequency from the transmitter.

snugly under the lower or above the upper sash when it is partially opened.

It is hardly possible to give practical instructions for the suspension of the antenna since the methods used will vary so widely in individual instances. In most cases poles are desirable to lift the antenna clear of surrounding buildings but in some locations the antenna is in the clear when strung from one chimney to another or from a chimney to a tree. Small trees are not usually satisfactory as points of suspension for the antenna on account of their movements in windy

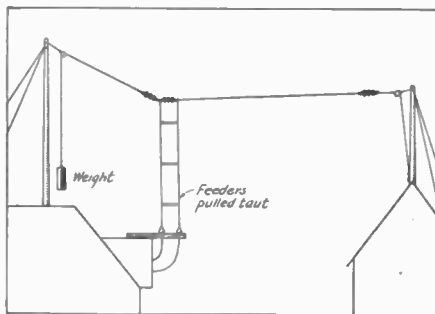

A TYPICAL EXAMPLE OF GOOD ANTENNA CONSTRUCTION

One halyard is tied fast while the other has a heavy weight on its lower end. The weight keeps the tension on the antenna constant and compensates for stretching and shrinkage of the rope.

weather. If the antenna is strung from a point near the center of the trunk of a large tree this difficulty is not as serious.

In most locations a variety of possible arrangements will present themselves. It will be well for the amateur to try the antenna in different positions or to try different types of antenna. Time expended in such experiment undoubtedly will be well worth while.

CHAPTER XII

The A.R.R.L. Communications Department

THE Communications Department is concerned with the practical operation of the stations of League members. Its work includes arranging amateur operating activities, establishing standard operating procedure, encouraging good operation, improving message relaying, and concluding tests to these ends.

The aim of the Communications Department is to keep in existence an active organization of League stations made entirely of privately-owned radio stations covering the entire continent of North America. One of its objectives is to create a body of skilled operators whose services and abilities will further the general knowledge of the art of radio communication. The relaying of friendly messages between different parts of the country without charge is one of the most important phases of the work coming under the supervision of the Communications Department. Amateur operators have also always been of great assistance to our country in times of emergency in which quick communication has been a factor, especially when other methods of communication have failed.

These objects of our organization must be borne in mind at the same time we, as individuals, are getting the most enjoyment from the pursuit of our chosen hobby. Only by operating our stations with some useful end in view can we improve the service which we give others and increase the pleasure we get, at the same time justifying our existence.

The activities of the Communications Department are arranged and recorded through *QST* and by special correspondence. Tests and relays are arranged from time to time to develop new routes for traffic handling, to prepare ourselves to render emergency service in time of need, and to bring to light additional general radio information. In this way all members of the League benefit from the experience of certain individuals who excel along specified lines of work.

The policies of the Communications Department are those urging members to adopt uniform operating procedure and to use system in their station operating. The Communications Department constantly works to make our communication system as efficient as a non-commercial message-handling organization can be. Compliance with government regulations, orderly operating, and coöperation with each other and with outside interests for the advancement of the art, are a part of its policies. The first duty of the department to member-stations is to supervise operating work so well that the amateur will continue to justify his existence in the eyes of his

Government. Then he will be allowed a continuance of the privileges which he has received as his due in the past.

Records of worth-while traffic handling, of message routing, and of specific tests conducted between the different stations are kept in the files of the Communications Department and recorded in the Official Organ of the League, *QST*.

It is obviously impossible to distribute up-to-the-minute information in a monthly periodical. Therefore mimeographed circular letters are used on special occasions. The active stations are thus kept informed of the developments in such a rapidly progressing system. Through such letters, through *QST* and through a large volume of routine correspondence with individual members, the contact is kept good and the activities we have outlined are effectively carried out by the interested member-stations.

Official Broadcasting Stations have been appointed to improve on even the arrangement we have just outlined. Every day of the week at certain hours about one hundred stations send a telegraphic broadcast that is copied by hundreds of members. The broadcasts carry the very latest information that is available from League Headquarters.

In these pages we are going to explain the organization of the Communications Department, the proper message forms to use, and some special practices which experience has proved best. We urge that you help strengthen amateur radio by studying the operating practice suggested and by adopting uniform operating procedure. Keep this book in your station for ready reference.

Everyone at League Headquarters welcomes criticism that is accompanied by constructive suggestions. In fact it is only through the boosts and suggestions which come from every member and operator that we can improve our service to others, thereby increasing the pleasure we ourselves get from our hobby.

In some department of the A.R.R.L.'s field organization there is a place for every active amateur who has a station. It makes no particular difference whether your interest lies in getting started and learning the code, traffic handling, DX, friendly contacts by 'phone, or other aspects of amateur radio. Whatever your qualifications, we suggest that you get into the game and coöperate with your Section Manager by sending him a monthly report of the particular work you are doing. As you become experienced in amateur work of different kinds it is likely that you will qualify for appointment as Official Relay Station, or that you can accept other important responsibilities in connection with the

conduct of A.R.R.L. work in the different sections. Operating work and the different official appointments will be explained in detail in this and the following chapter. We want to make it clear right at the start that the Communications Department organization exists to increase individual enjoyment in amateur radio work, and we extend a cordial invitation to every amateur and reader of this book to participate fully in the different enterprises undertaken by and for amateur operators.

ORGANIZATION

The affairs of the Communications Department in each Division are supervised by one or more Section Communications Manager, each of whom has jurisdiction over his section of a Division.

For the purpose of organization the A.R.R.L. divides the United States and Possessions (plus Cuba, the Isle of Pines, and the Philippine Islands) and Canada (plus Newfoundland and Labrador) into divisions as follows:

ATLANTIC DIVISION: Delaware, District of Columbia, Maryland, Pennsylvania; that section of New Jersey within the Third Federal Inspection District, and that section of New York within the Eighth Federal Inspection District.

CENTRAL DIVISION: Illinois, Indiana, Kentucky, Michigan, Ohio and Wisconsin.

DAKOTA DIVISION: Minnesota, North Dakota and South Dakota.

DELTA DIVISION: Arkansas, Louisiana, Mississippi and Tennessee.

HUDSON DIVISION: The entire Second Federal Inspection District, consisting of certain counties of New Jersey and New York States.

MIDWEST DIVISION: Iowa, Kansas, Missouri and Nebraska.

NEW ENGLAND DIVISION: Connecticut, Maine, Massachusetts, New Hampshire, Rhode Island and Vermont.

NORTHWESTERN DIVISION: Idaho, Montana, Oregon, Washington and the Territory of Alaska.

PACIFIC DIVISION: Arizona, California, Nevada and the Territory of Hawaii. The Philippine Islands are attached to this Division for Communications Department activities.

ROANOKE DIVISION: North Carolina, Virginia and West Virginia.

ROCKY MOUNTAIN DIVISION: Colorado, Utah and Wyoming.

SOUTHEASTERN DIVISION: Alabama, Florida, Georgia, South Carolina and the Island of Porto Rico. The Republic of Cuba and the Isle of Pines are attached to this Division for Communications Department activities.

WEST GULF DIVISION: New Mexico, Oklahoma and Texas.

MARITIME DIVISION: The provinces of New Brunswick, Nova Scotia and Prince Edward Island, Newfoundland and Labrador are at-

tached to this Division for Communications Department activities.

ONTARIO DIVISION: Province of Ontario.

QUEBEC DIVISION: Province of Quebec.

VANALTA DIVISION: Provinces of Alberta and British Columbia and Yukon Territory.

PRAIRIE DIVISION: Provinces of Manitoba and Saskatchewan and the Northwest Territories.

Each United States Division elects a Director to represent it on the A.R.R.L. Board of Directors and the Canadian Divisions elect a Canadian General Manager who is also a Director. The Board determines the policies of the League which are carried out by paid officers at League Headquarters. When the Board is not in session, the officers of the League, constituting an Executive Committee, can act for the Board, subject to certain limitations.

The Communications Department has a field organization made up of officials selected by the membership in a way similar to the Directors. Each Director and the Communications Manager at League Headquarters decide the proper sectionalizing of each Division, after which each Section holds an election for Section Communications Manager. These field officials are listed on page 5, while the names and addresses of the Directors are printed on page 6, of each *QST*.

It is for more efficiently collecting reports from the active stations and supervising the activities of the Communications Department that the operating territory is divided into Sections. In each Section there is a Section Communications Manager who, under the direction of the Communications Manager, has authority over the Communications Department within his Section. He is responsible to, and reports to the Communications Manager, except in Canada, where he reports to the Canadian General Manager.

Whenever a vacancy occurs in the position of Section Communications Manager in any section of the United States, its island possessions or territories, or the Republic of Cuba, the Communications Manager announces such vacancy through *QST* or by mail notice to all members of the Section, and calls for nominating petitions signed by five or more members of the Section in which the vacancy exists, naming a member of the Section as candidate for Section Communications Manager. The closing date for receipt of such petitions is announced.

After the closing date, the Communications Manager arranges for an election by mail or declares any eligible candidate elected if but one candidate has been nominated. Ballots are sent to every member of the League residing in the Section concerned, listing candidates in the order of the number of nominations received. The closing date for receiving ballots is announced. Immediately after this date, the

Communications Manager counts the votes. The candidate receiving a plurality of votes becomes Section Communications Manager. The Canadian General Manager similarly manages such an election for a Section Communications Manager whenever a vacancy occurs in any section of the Dominion of Canada, Newfoundland or Labrador.

Section Communications Managers are elected for a two-year term of office.

The office of any Section Communications Manager may be declared vacant by the Executive Committee upon recommendation of the Communications Manager, with the advice and consent of the Director, whenever it appears to them to be in the best interests of the membership so to act, and they may thereupon cause the election of a new Section Communications Manager.

COMMUNICATIONS DEPARTMENT OFFICIALS AND APPOINTMENTS

The following portions, relating to Section Communications Managers, to their appointment of different qualified and responsible officials to cover specific phases of A.R.R.L. communication work, to the duties of each in reporting, etc., are reprinted from the "Rules and Regulations of the Communications Department" and set forth the regulations which govern these matters within the department.

SECTION COMMUNICATIONS MANAGER

1. The Section Communications Manager is responsible to the Communications Manager at League Headquarters for the efficiency and coöperation of his personnel. His policies are the democratic policies of the League itself.



2. His territorial limitations are determined by the Division Director and the Communications Manager.

3. He recommends the appointment or cancellation of Official Relay Stations in accordance with the rules pertaining to the Official Relay Station Appointment.

The Section Communications Manager examines application and question forms, signing the prescribed certificate of appointment and forwarding it to the station owner when the appointment can be properly made. Form 4 appointment card bearing the certificate number is forwarded to League Headquarters with the questionnaire forms properly filled out by the applicant. Cancellations (Form 4C) are made for inactivity or for violations of any of the rules or provisions of the Rules and Regulations of the Official Relay Station Certificate.

An applicant who fails to qualify may again apply for appointment after three months have elapsed.

4. He shall be responsible for the maintenance of the Official Broadcasting Station System within his section, recommending such appointments (Form 4) or cancellations (Form 4C) as may be necessary. Due consideration shall be given the distribution of stations on the different frequency bands and the qualifications of stations and operators for this service.

5. He is responsible for the traffic activities of his section. He shall appoint Route Managers, Official Observers and any other such assistants for specific work as may be deemed necessary by the Communications Manager. These officials will have full authority within the section over the activities indicated by their titles. They will report and be responsible to the Section Communications Manager for their work. With the consent of the Communications Manager the Section Manager may, if necessary, designate a competent Official Relay Station appointee or League member to act for him in a particular matter in any part of his territory. He shall be careful to instruct such an appointee properly in the duties he is to execute while acting for the S.C.M.

6. He shall conduct investigations of radio organizations and interference cases whenever such cases are referred to him by the Communications Manager or the Division Director.

7. He shall appoint Vigilance Committees in the centers of activity where amateur interference conditions appear to make such committees desirable in helping to lighten the load of complaints received by the Supervisors of Radio. Amateur club organizations are to be encouraged to organize interference committees to keep closely in touch with this situation everywhere, coöperate with the press, and coordinate amateur work.

8. He shall have referred to him by his various appointees any correspondence that may relate to matters of general policy, or suggestions for improvements in conducting the affairs of the League.

9. He may requisition necessary Communications Department supplies provided for making appointments and supervising the work in his

section. He may render an itemized postage expense account monthly. Section Managers are entitled to wear the distinctive A.R.R.L. pin with red background, similar in other respects to the regular black-and-gold A.R.R.L. membership pin.

10. He shall render a monthly report to Headquarters, consolidating all the reports by subjects into a comprehensive summary. This report shall reach Headquarters on or before the 26th of each calendar month. It shall be made up from all reports from O.R.S. and other active stations, together with the reports from special appointees (5) and as mentioned under the subject of reporting.

OFFICIAL OBSERVERS

Each S.C.M. recommends for appointment a suitable number of Observers who report regularly to the S.C.M. on off-frequency operation noticed, sending out notification forms (provided from Headquarters) to help amateurs in keeping within the assigned bands. Official Observers also make general observations on operating conditions, taking the proper action to bring about improvement, always reporting the action taken to the Section Communications Manager.

Each Official Observer shall have an accurately calibrated monitor or frequency meter or shall be equipped to carry on his work in checking stations beyond the limits of the amateur bands against calibrations from the Standard Frequency Station transmissions and checks from government or commercial "marker" stations of known frequency operating adjacent to our own amateur channels. Observers shall be supplied with notification postal card forms and with report blanks on which the stations logged off-frequency and notified shall be reported to A.R.R.L. Headquarters (through the office of the S.C.M.) just as rapidly as the blanks are filled out. While observers work directly under their Section Managers, their observations shall include all amateur stations in the U. S. or Canada or wherever there are representatives of the A.R.R.L. field organization.

On logging a station the notification form shall be completed and mailed in each case when the station logged is found to be operating with an amateur call signal outside the confines of the amateur bands. Not more than two notification forms shall be sent to one such station by one observer, but observers should continue logging and reporting cases of flagrant violation to Headquarters so that the matter may be followed up definitely to check operation on extra-legal frequencies. A duplicate of the reporting form may be kept by observers to enable them to check on stations continuing off-frequency after having received friendly notification. Observers shall also get in touch with stations by radio when this seems necessary and practical.

From time to time the attention of appointees in the A.R.R.L. observing system will call to particular situations and particular bands requiring their special attention and at other times their work may be distributed on different frequencies as time permits and conditions seem to warrant.

Observers when possible shall report harmonic or parasitic radiations and other operation of commercial or government telegraph services or broadcasting stations causing interference in the amateur bands, these being reported direct to the S.C.M. or Headquarters as promptly as possible so that suitable remedial action may be taken.

The notification service to amateurs is designed as a friendly move to protect amateur privileges from official government restrictions which may be endangered by careless or intentional disregard of regulations by individuals who might thus jeopardize the enjoyment of all amateurs. This service has been successfully operated since June 1926 and the cooperation of all amateurs is asked on behalf of our observers who are picked by the Section Managers as the best qualified, interested and reliable guardians of the air.

ROUTE MANAGERS

While the Section Communications Manager is the traffic executive of the section, the Route Manager has the principal traffic station in his

THE AMERICAN RADIO RELAY LEAGUE

ROUTE MANAGER APPOINTMENT

Name.....**ARON C. TRAY**.....
 Call.....**NAE**.....Territory.....**NEW JERSEY**.....

YOU ARE HEREBY APPOINTED ROUTE MANAGER

The Route Manager shall have a station actively on the air maintaining good local contacts, lining up stations and seeing that traffic handling.

While the S.C.M. is the traffic executive of the Section, the Chief R.M. and the R.M. are the line-up traffic stations. The R.M. is the station of a communication "net" which he organizes himself, dropping inactive stations as it becomes necessary and adding live stations to keep the section on the map in traffic handling.

The R.M. is to attempt to cover all the larger towns and cities as well as possible, to encourage and improve local traffic work.

The R.M. lines up traffic routes between different parts of his section. He also keeps posted on stations already in operation within the section, and on the between-section schedules within his jurisdiction.

The R.M.s are to report to the Chief R.M. on the 15th monthly. The Chief R.M. is to forward these reports to the S.C.M. with notations on the 15th monthly.

Signed.....*Arthur H. White*.....
 - Section Communications Manager
 Date.....**Nov. 22, 1926**.....

particular locality. Section Managers generally appoint one Route Manager to every twenty or twenty-five Official Relay Stations, depending on the radio population of the Section concerned and the amount of organized activity. Route Managers maintain good local radio contacts regularly so that stations can be lined up and routes developed and operated by radio.

Route Managers cooperate actively with all active stations in their districts so that each Route Manager is the nucleus of a communication net which he organizes himself, and for which he is responsible at all times to his Section Communications Manager. Route Managers arrange schedules for local traffic handling between the different towns and cities in their territory as well as keep many schedules at their own station and keep track of between-Section Schedules, reporting monthly to the S.C.M., who in turn reports to A.R.R.L. Headquarters. The Route Manager also keeps posted on schedules already in operation within the Section, on the between-Section schedules and those kept with foreign points by stations within his jurisdiction (which is determined by the S.C.M.). The R.M. reports to the S.C.M. monthly (at the same time the O.R.S. report) including in his report a complete list of all routes and schedules known to him brought just as up-to-date as possible and covering the specific activity of routes and schedules.

OFFICIAL BROADCASTING STATION

Each Official Broadcasting Station appointee shall receive information on timely subjects from Headquarters each week or at other intervals to be put on the air at various scheduled times during the week following receipt of the information. Section Managers shall give preference to stations having available considerable



amounts of power, or stations whose operators are especially qualified to give good service in view of the geographical location, the frequency bands in use, or the timely choice of schedules or frequency with which schedules can be kept. Consideration shall also be given to the ability of such stations, especially at great distances from Headquarters, to copy the information in advance of its receipt by mail as sent by Headquarters station W1MK.

Applicants for this appointment must submit their qualifications to the Section Manager with the proposed dates, times and frequencies for

transmission of the broadcasts. In deciding on the times of transmission schedules, preference should be given to those times when the largest number of amateurs are listening, that is, the hours between 6:00 p.m. and midnight. Section Managers are instructed to cancel the appointments of stations not adhering to the schedules agreed upon, and the appointments of stations not returning information on current or revised schedules when periodic surveys of the broadcasting system are made.

THE OFFICIAL RELAY STATION

The Section Communications Manager shall recommend for appointment as Official Relay Stations such stations of League members as apply for and merit such appointment. The recommendation shall be based on the ability of the applicants to come up to a specified set of qualifications. The applicant shall have a loyal, cooperative attitude; he shall follow standard A.R.R.L. operating practices (understanding and using the proper message form, finish signals, service message, cable-count check on important messages, and so on); he shall have a transmitter and receiver capable of operation at any time, and he must be able to send and receive Continental code at a rate of at least 15 words per minute.

1. It shall be the duty of each Official Relay Station appointee to report monthly to his Section Communications Manager, to keep the station in readiness to operate, to use A.R.R.L. operating practices exclusively, and to take in the activities of the League whenever possible. The message file must be held for three months ready for call by the S.C.M. at any time. *Reports are due on the 16th of each month if the station is located on the mainland of the United States.*

2. Each Official Relay Station shall receive an appointment certificate to be displayed prominently in the station, a quarterly bulletin newsletter from Headquarters, and Form 1 reporting cards on which to turn in the regular monthly reports to the Section Communications Manager.

3. When a station is of necessity inoperative for six months or less, the appointment may be held on an inactive list by the Section Communications Manager, providing the station owner has reported the facts of the case and requested that he be excused from active operating and reporting during this time. Inactive lists shall be turned in to Headquarters by the Section Communications Manager with his monthly report. O.R.S. appointments shall be transferable from one Section to another, with the consent of the Section Communications Managers concerned, who must alter their records and notify Headquarters of such changes. Such appointments shall not be transferable from one station-owner to another.

4. The violation of the provisions made above for operating and reporting shall be sufficient reason for the Section Communications Manager to recommend cancellation of the appointment. The Section Communications Manager shall notify the Official Relay Stations that this action

Section Communications Managers shall not transmit the reports received by them to Headquarters except on a request to do so, but shall consider the reports as for their information and from them prepare a condensed report of the month's activities and the status of amateur affairs in the territory under their jurisdiction.



is pending when the first and the second report have been missed. The appointment shall be cancelled automatically when the third consecutive report fails to come through on time. Such cancellations shall be classed as "complete." New application and question forms must be filled out and evidence of better performance submitted before reappointment can be considered. If an O.R.S. resigns his post after consistent work, an "honorable" cancellation shall be issued; and reinstatements within one year may be made on application without filing new papers.

REPORTS

Each Official Relay Station report shall include the number of messages originated, delivered, relayed, and the total. The Form No. 1 reporting card furnished by the A.R.R.L. shall be used when it is available but the non-arrival of this form shall not constitute an excuse for not reporting.

The Section Communications Manager shall condense all reports received, leaving out any "negative" information. His report shall not mention inactivity or non-reporting. Traffic figures shall be separately listed at the end of the report and shall not be included in the body of the report. The most consistent traffic stations and the ones doing most experimental and other useful work are the ones deserving credit and to whom space shall be given. When possible, the Section Communications Manager shall send in his report typewritten and double-spaced.

MORE ABOUT THE O.R.S. APPOINTMENT

The Official Relay Station appointment of the Communications Department deserves some further explanation. Telegraphing members who hold amateur licenses are most interested in this work.

Before the war our League was a much smaller organization than it is to-day. What traffic handling was done was performed in a very easy-going manner. Messages were not taken seriously by those who sent them or by those who handled them. Because there were fewer stations operating, it was harder to relay messages to their destinations. Deliveries were the exception rather than the rule.

As the League expanded more stations came on the air. It became increasingly possible to land messages right at the city of destination. More messages came our way from the public who began to realize that messages were actually being delivered and handled in good time. As the service improved, more people availed themselves of its use. Regular trunk and branch traffic routes were arranged so that messages could be handled reliably in almost any direction. However, with the advent of the war, this organization became inoperative with the closing down of all stations by the government.

After the war, the new organization went through some violent changes. New developments were principally along the lines of tube transmission. Next came the change to higher frequencies, making a complete revamping of our communication system necessary. The granting of appointments right and left, the increase in numbers of inexperienced operators, the new conditions under which we were operating (on several frequency bands), each left its mark on our communication system. Once a man could handle a certain number of messages a month, he was granted an appointment without much questioning. Before the war newcomers automatically got operating experience by listening to commercial and government long wave stations. By the time their stations were in workable shape to handle relay traffic, the necessary operating experience had been gained. After the war, newcomers threw sets together from the information then made available. Stations capable of communicating over thousands of miles on short

waves were operated by operators whose tuners no longer reached frequencies where good commercial traffic was being efficiently handled. Lack of this preliminary training was responsible for poor operators. Unreliable stations and operators, out for "DX records" only, slowed up traffic. Complaints were received on the unreliability of operators and on the poor delivery of messages everywhere.

Finally, it was decided to abandon the old system and to start afresh. The need of placing a greater responsibility on the traffic handling of stations was felt keenly. A class of stations that could be depended upon should be created! An iron-bound set of qualifications and a set of Rules and Regulations for Official Relay Stations were drawn up as a standard and a foundation for the present traffic-handling organization was built. Appointments under the new system of things are no longer given without investigation. A set of questions to be answered for Communications Department files and recommendations to the Section Communications Manager are necessary. The present system of Official Relay Stations, which has been in successful operation for many years, is the result.

WHY YOUR STATION SHOULD BE AN OFFICIAL RELAY STATION

Official Relay Stations are the best regulated and the most active stations in League operating work to-day. Every Official Relay Station receives an attractive certificate of appointment. The certificate is a mark of distinction, putting the operator in a class above the average "ham." The operators of Official Relay Stations are well known as "reliable" operators and amateurs of good standing. The badge of honor carries some weight with everyone who visits the station, including the Supervisor of Radio. Vacancies in the ranks of the League officials are filled from the ranks of the Official Relay Stations. Every owner of an Official Relay Station receives a bulletin letter from A.R.R.L. Headquarters quarterly with the latest schedules, news, and procedure hints and helps. Special reporting cards for the convenience of the Official Relay Station operators in reporting their traffic-handling work and records are sent out with the bulletin.

O.R.S. appointees are entitled to wear the distinctive blue A.R.R.L. pin which is similar to the regular membership pin except that it has a blue instead of a black background.

HOW TO BECOME AN O.R.S.

To secure an appointment as Official Relay Station is quite a simple matter if you have the

qualifications and a little experience. After building the station and gaining some code speed, get in touch with your Section Communications Manager. Arrange some schedules for traffic-handling by cooperating with your Route Manager and by writing a few letters to the best stations you hear consistently in different directions from your own station. Collect and handle some traffic regularly and don't forget to report your work to the S.C.M. on time each month for a few months. Then ask your local traffic official to furnish you with an application blank to become an Official Relay Station (or use the one printed for your convenience in the rear of this book). Fill out the application blank and send it to Headquarters.

You will get some question blanks to be filled out and returned to the S.C.M. If you have the necessary knowledge and qualifications, the S.C.M. will be able to follow his instructions and make the appointment. In this event the information you have sent him will be turned over to the Communications Manager for Headquarters' files. If you cannot answer all the questions correctly or are not quite able to make the grade, your application may be tabled for two or three months in which time you can study and practice operating until you can make the grade. It may be that you miss out on some of the questions but get a letter from the Section Communications Manager explaining the answers and notifying you what action can or cannot be taken regarding an appointment.

Being recognized as an Official Relay Station is very much worth while. It is not difficult to obtain an appointment but certain requirements must be met and lived up to if the appointment is to be kept valid. Otherwise it would not be worth while. Cancellations of appointment follow failure to report for two successive months; continued failure to operate according to A.R.R.L. practices; failure to observe government regulations; failure to keep a receiver and transmitter in commission, and failure to comply with the spirit of the rules on the application form or certificate.

When a station is inoperative of necessity and the Section Communications Manager has been duly notified, the appointment is gladly held on an inactive list over a certain period of time. New operators are needed among the "reliables" every day. The appointment is one made with mutual advantage to yourself and to our Communications Department. Fill out the application form as soon as you can qualify!

CHAPTER XIII

Operating a Station

THE enjoyment of our hobby usually comes from the operation of our station once we have finished its construction. Upon the *station* and its *operation* depend the traffic reports and the communication records that are made. We have taken every bit of care that was possible in constructing our transmitter, our receiver, frequency measuring and monitoring equipment and in erecting a suitable antenna system. Unless we make ourselves familiar with uniform standard operating procedure, unless we use good judgment and care in operating our stations, we shall fall far short of realizing the utmost in results achieved. More than this, we may make ourselves notorious unless we do the right thing, because we may interfere with other stations or delay their work.

After a bit of listening-in experience you will hear both kinds of operators and realize the contrast that exists between the operation of the good men and that of "lids" and "punks" who have never taken the trouble to familiarize themselves with good practice. Occasionally you will pick up an amateur whose method of operating is so clean-cut, so devoid of useless efforts, so snappy and systematic, that your respect is gained and it is a pleasure to listen and work with him.

For efficient traffic handling, the transmitter should be adjusted for stable, satisfactory operation on one or two known but different frequencies in the amateur band. Known condenser settings for definite frequencies will enable the operator quickly to change frequency (QSV) at any time. Whenever such a change is made, be sure to check the frequency accurately. There is *no excuse* for operating off frequency. Any frequency calibrations should be checked often to guard against variations.

Make a practice of checking frequency each time you open the station for operation. Take no chances. Do not try to work on the edge of an amateur band but keep well within the known accuracy of your frequency measuring equipment and methods.

The operator and his methods have much to do with limiting the range of the station. The operator must have a good "fist." He must have patience and judgment. Some of these qualities in operating will make more station records than many kilowatts of power. Engineering or applied common sense are as essential to the radio operator as to the experimenter. Do not make several changes in the set hoping for better results. Make one change at a time until the basic trouble or the best adjustment is found.

An operator with a clean-cut, slow, steady method of sending has a big advantage over the poor operator. Good sending is partly a matter of practice but patience and judgment are just as important qualities of an operator as a good "fist."

The good operator sends signals which are not of the "ten words per minute" variety, but they are slow enough so that there is no mistaking what he says. The *good* operator does not sit down and send a long call when he wants to work someone. He puts on the 'phones and *listens in*. He goes over the dial thoroughly for some time. The fellow that is admired for his good operating is the one who is always calling some particular station instead of using the "inquiry signal." Because he *listens* until he hears someone to work and *then* goes after him, our good operator gets his man nearly every time. A good operator chooses the proper time to call, he makes plain signals, and he does not call too long. A short call is sufficient because if a station does not get the call it is likely that he is listening to another station. A long call makes the receiving operator lose patience and look for someone else.

The adjustment of the receiver has much to do with successful operation, too. The good receiving operator notes the dial setting and when he has completed calling in proper fashion, he waits a moment and then tunes above or below the logged dial setting just in case something has shifted slightly in the receiver or transmitter. The best operator has patience and waits a few minutes in case of delay at the transmitter or in case fading signals make a second answer necessary.

COMMUNICATION

After all, communication has as its object the exchange of thought between two minds. Sometimes those minds are near each other and it is possible for the individuals concerned to converse at length and exchange their thoughts freely. At other times, and this when radio communication is involved, the individuals are miles apart and the thoughts to be transmitted must be condensed to just a few words. Then these words must be relayed or passed on from mind to mind or operator to operator. When they reach their ultimate destination someone can interpret them fully if they have been properly and carefully handled by the intermediate operators.

Time is involved in making any exchange of thought. Because every man's life and experience is measured by time, this factor becomes important in everything we do or say. The number of messages handled, the number of distant stations worked, the number of records made at our station, all depend in some degree on the time available for our hobby. The more time we spend at the set, the more well known we become and the greater the summation of our accomplishments.

As time is a factor, uniform practices in operating have become necessary to insure a ready understanding of what is going on in the minds of each operator. "Q" signals and abbreviations of various sorts have been devised and are in

general use to-day just because of the time element involved, to enable every operator to exchange intelligible thoughts with as little waste effort as possible. So proficiency in the commonly-used abbreviations and in knowledge of uniform operating practices is to be desired. Proficiency comes with practice. In the Appendix are the "Q signals" and some abbreviations used by amateur operators. We will mention some of the time-saving things that have become standard practice among good operators and following that a few words about relay procedure will show how a station is operated to best advantage.

Accuracy is of first importance. Then speedy transmission and handling of radiograms must be considered. Very often, transmission at moderate speeds moves traffic more quickly than fast sending. A great deal depends on the proficiency and good judgment of the two operators concerned. Fast sending is helpful only when two fast operators work together.

OPERATING RULES AND REGULATIONS

The Official Relay Stations follow some general requirements for law-abiding operation which are mentioned on the appointment certificate. Some specific rules and regulations have been made to raise the standard of amateur operating. Official Relay Stations observe these rules carefully. They may be regarded as "standard practice."

Any actively-operating stations will do well to copy these rules, to post them conspicuously in the station, and to follow them when operating.

1. The calling station shall make the call by transmitting not more than three times the call signal of the station called and the word DE, followed by its own call signal sent not more than three times, thus: VE9AL VE9AL VE9AL DE W1MK W1MK W1MK. In amateur practice this procedure may be expanded somewhat as may be necessary to establish communication. The call signal of the calling station *must* be inserted at frequent intervals for identification purposes. Repeating the call signal of the called station five times and signing not more than twice (this repeated not more than five times) has proved excellent practice in connection with break-in operation (the receiver being kept tuned to the frequency of the called station). The use of a break-in system is highly recommended to save time and reduce unnecessary interference.

Stations desiring communication, without, however, knowing the calls of the operating stations within range, may use the signal of inquiry, CQ, in place of the call signal of the station called in the calling formula. The A.R.R.L. method of using the general inquiry call (CQ) is that of calling three times, signing three times, and repeating three times. CQ is not to be used when testing or when the sender is not expected or looking for an answer. After a CQ, the dial should be covered thoroughly for two or three minutes looking for replies.

The directional CQ: To reduce the number of useless answers and lessen needless QRM, every CQ call shall be made informative when possible. Stations desiring communication shall follow each three-times-sent CQ by an indication

of direction, district, state, continent, country or the like. Stations desiring communication with amateur stations in a particular country shall include the official prefix letters designating that country after each CQ. To differentiate domestic from foreign calls in which the directional CQ is used, the city, state, point of the compass, etc., is mentioned only after the third CQ just before the word DE and the thrice-repeated station call. Examples follow. A United States station looking for any Canadian amateur calls: CQ VE CQ VE CQ VE DE W1MK W1MK W1MK. A western station with traffic for the east coast when looking for an intermediate relay station calls: CQ CQ CQ EAST DE W6CIS W6CIS W6CIS. A station with messages for points in Massachusetts calls: CQ CQ CQ MASS DE W3QP W3QP W3QP. In each example indicated it is understood that the combination used is repeated three times.

2. Answering a call: Call three times (or less); send DE; sign three times (or less); and after contact is established decrease the use of the call signals of both stations to once or twice. Example: W1BIG DE W1MK GE OM GA K (meaning, "Good evening, old man, I am ready to take your message, go ahead").

3. Ending signals and sign off: The proper use of AR, K and SK ending signals is required of all Official Relay Stations. AR (end of transmission) shall be used at the end of messages during communication and also at the end of a call, indicating when so used that communication is not yet established. K (invitation to transmit) shall be used at the end of each transmission when answering or working another station, almost carrying the significance of "go ahead." SK (or VA) shall be used by each station only when signing off, this followed by your own call sent once for identification purposes. SK (end of work) indicates to others that you are through with the station which you have been working and will listen now for whomever wishes to call. Never CQ after signing off until you have covered the dial thoroughly looking for stations calling you. Examples:

(AR) G2OD DE W1AQD AR (showing that W1AQD has not yet gotten in touch with G2OD but has called and is now listening for his reply). Used after the signature between messages, it indicates the end of one message. There may be a slight pause before starting the second of the series of messages. The courteous and thoughtful operator allows time for the receiving operator to enter the time on the message and put another blank in readiness for the traffic to come. If K is added it means that the operator wishes his first message acknowledged before going on with the second message. If no K is heard, preparations should be made to continue copying.

(K) ZL2AC DE W6AJM R K. (This arrangement is very often used for the acknowledgment of a transmission. When anyone overhears this he at once knows that the two stations are in touch, communicating with each other, that ZL2AC's transmission was all understood by W6AJM, and that W6AJM is telling ZL2AC to go ahead with more of what he has to say.) W9APY DE W3ZF NR 23 R K. (Evidently W9APY is sending messages to W3ZF. The contact is good.

The message was all received correctly. W3ZF tells W9APY to go ahead with more.)

(SK) R NM NW CUL VY 73 AR SK W7NT. (W7NT says "I understand OK, no more now, see you later, very best regards, I am through with you for now and will listen for whomever wishes to call. W7NT signing off.")

4. If a station sends test signals to adjust the transmitter or at the request of another station to permit the latter to adjust its receiving apparatus, the signals must be composed of a series of V's in which the call signal of the transmitting station shall appear at frequent intervals.

5. When a station receives a call without being certain that the call is intended for it, it shall not reply until the call has been repeated and is understood. If it receives the call but is uncertain of the call signal of the sending station, it shall answer using the signal - - - - - (?) instead of the call signal of this latter station.

6. Several radiograms may be transmitted in series with the consent of the station which is to receive them. As a general rule, long radiograms shall be transmitted in sections of approximately fifty words each, ending with - - - - - (?) meaning, "Have you received the message correctly thus far?"

7. A file of messages handled shall be kept, this file subject to call by the Section Manager at any time at his discretion. Only messages which can be produced shall be counted in the monthly reports, and these under the A.R.R.L. provisions for message-counting.

Above all, the operator will never make changes or alterations in the texts or other portions of messages passing through his hands. However slight or however desirable such changes may seem, the changing of a message without proper authority or without the knowledge of the originator of the message may be considered the "unpardonable sin." The proper thing to do of course is to notify the party filing the message or the originating station of your observations, secure permission from the proper source for making the change by sending a "service message" or other means. If the case seems urgent, the traffic should not be delayed but should be delivered or forwarded with appropriate notation or service accompanying it.

In acknowledging messages or conversation: Never send a single acknowledgment until the transmission has been successfully received. "R" means "All right, OK, I understand completely." When a poor operator, commonly called a "lid," has only received part of a message, he answers, "R R R R R R R R R R, sorry, missed address and text, pse repeat" and every good operator who hears, raves inwardly. The string of acknowledgments leads one to believe that the message has been correctly received and that it can be duly filed away. By the time this much is clear it is discovered that most of the message did not get through after all, but must be repeated. Perhaps something happens that the part after the string of R's is lost due to fading or interference, and it is assumed that the message was correctly received. The message is then filed and never arrives at its destination.

Here is the proper procedure to follow when a message has been sent and an acknowledgment is requested. When all the message has been received correctly a short call followed by "NR 155 R K" or simply "155 K" is sufficient. When most of the message was lost the call should be followed by the correct abbreviations (see Appendix) from the international list, asking for a repetition of the address, text, etc. (RPT ADR AND TXT K). When but a few words were lost the last word received correctly is given after ?AA, meaning that "all after" this should be repeated. ?AB for "all before" a stated word should be used if most of the first part of the copy is missing. ?BN AND (two stated words) asks for a fill "between" certain sections. If only a word or two is lost this is the quickest method to get it repeated.

Do not send words twice (QSZ) unless it is requested. Send single unless otherwise instructed by the receiving operator. When reception is very poor, a QSZ can be requested to help make better copy. When conditions are even moderately fair, a QSZ is unnecessary. Few things are as aggravating as perfect transmission with every word coming twice. Develop self-confidence by not asking others to "QSZ" unless conditions are rather impossible. Do not fall into the bad habit of sending double without a definite request from the fellows you work.

Do not accept or start incomplete messages. Omission of the fundamental parts of a message often keeps a message from getting through to its destination. Official Relay Station appointments are subject to cancellation for failure to make messages complete enough.

OPERATING NOTES

A sensitive receiver is often more important than the power input in working foreigners. There is not much difference in results with the different powers used, though a 250-watter will probably give 10% better signal strength at the distant point than a Type '52 or '10's, other factors being the same. It will not do much better than this because the field strength drops so rapidly as we get away from the antenna. In working foreign countries and DX stations you should be able to hear ten or a dozen stations before expecting that one of them will hear your call. In general, just hearing an occasional foreign station does not mean that that country can be worked at your own pleasure.

A common fault among amateurs who do not get in touch with DX stations readily is that their calls are too short. Often they do not send enough *short* CQ's indicating the country or place desired even when the receiver is sensitive enough to bring in several stations located at the desired spot. Of course the type of radiator can always be blamed or the antenna location but usually the operator has only himself to blame.

The signal "V" is sometimes sent for two to five minutes for the purpose of testing. When one station has trouble in receiving, the operator asks the transmitting station to "QRV" while he tries to adjust his receiving set for better reception. A decimal point is often sent by the letter "R". Example: 2:30 PM is sent "2R30 PM". A long

dash for "zero" and the Morse C (. . .) for "clear" are in common use. An operator who misses directions for a repeat will send "4", meaning, "Please start me, where?" These latter abbreviations, like others in our present day practice, are hybrids, originating in wire practices and Morse usages.

Improper calling is a hindrance to the rapid dispatch of traffic. Long calls after communication has been established are unnecessary and inexcusable. Some stations are slow to reply to a call. However, the day of the station with dozens of switches to throw is past. Controls for both receivers and transmitters are simpler, fewer in number, and more effective. The up-to-date amateur station uses a "break-in" system of operation and just one switch controlling the power supply to the transmitter.

Poor sending takes the joy out of operating. There are stations whose operators are not able to send better and those who can send better but do not. The latter class believe that their "swing" is pretty. Some of them use a key with which they are not familiar.

Beginners deserve help and sympathetic understanding. Practice will develop them into good operators. The best sending speed is a medium speed with the letters quickly formed and sent evenly with proper spacing. The standard type telegraph key is best for all-round use. Before any freak keys are used a few months should be spent in practicing with a buzzer.

No excuse can be made for a "garbled" text. Operators should copy what is sent and refuse to acknowledge messages until every word has been received correctly. Good operators never guess at anything. When not sure of part of a message they ask for a repeat. The "lid" operator can be told very quickly when he makes a mistake. He does not use a definite "error" signal and go on with his message but he usually betrays himself by sending a long string of dots and nervously increasing his rate of sending. The good operator sends "?" after his mistakes and starts sending again with the last word sent correctly. Unusual words are often sent twice. After the transmission "?" is sent and then the word is repeated for verification.

The law concerning superfluous signals should be noted carefully by every amateur. Some operators hold the key down for long periods of time when testing or thinking of something to send. Whenever this is done during operating hours, someone is bothered. Unnecessary interference prevents someone from getting in contact with (QSO) someone else, and if messages are being handled the copy is ruined. If you must test, disconnect the antenna system and use an equivalent "dummy" antenna (made of lumped resistance, capacity and inductance). Always send your call occasionally when operating with the antenna. You may be heard in Africa. Pick a time for adjusting the station apparatus when few stations will be bothered.

USING A BREAK-IN SYSTEM

A break-in system of operation makes it possible for us to interrupt the other fellow if we miss a word or do not understand him. With a tele-

phone we stop talking as soon as the distant party speaks and interrupts us. In a telegraph office the operator who misses a word opens his key so that the sending is interrupted and cannot go on until the receiving operator has had his say and again closed the circuit. In a radio system using a break-in the receiving operator presses the key and makes some long dashes for the transmitting operator to hear. As soon as he gets the signal he stops transmitting and listens to what the receiving operator says, after which the sending is resumed.

A separate receiving antenna put up at right angles to the transmitting antenna makes it possible to listen to most stations while the transmitting tubes are lighted. It is usually necessary to pause just a moment occasionally when the key is up to listen for the other station.

Much useless calling and unnecessary transmission is prevented if break-in is used. Two stations can use the system to mutual advantage. When messages are being handled, if some interference comes in or if a word is missed due to swinging signals, a few taps of the key will set things straight in a jiffy. "BK BK GA ROANOKE" (or whatever was the last word received correctly) will save time and unnecessary sending. If the trouble continues, the sending station can "stand by" (QRX) or it can take traffic until the reception conditions at the distant point are again good.

For example, suppose W8SF has a message for New York City. He calls, "CQ CQ CQ NY DE W8SF W8SF W8SF," repeating the call three times and concluding with "AR". W2PF hears him, answering "W8SF DE W2PF BK ME BK ME." When W8SF hears W2PF, W8SF immediately holds his key down and makes some long dashes. W2PF, who is of course receiving "break-in" while he calls, stops sending when he hears the dash. W8SF then calls in the regular manner, saying "W2PF DE W8SF GE HR MSG AR." Then W2PF gives him a "GA OM" and the message is sent without further preliminaries. Since both stations are using break-in, they can interrupt each other at any time when something goes wrong or a letter is dropped, and traffic can be handled in half the usual time. There is a real "kick" from working a break-in arrangement.

In calling, the transmitting operator sends the letters "BK," "BK IN," or "BK ME" at frequent intervals during his call so that stations hearing the call may know that a break-in is in use and take advantage of the fact. He pauses at intervals during his call, to listen for a moment for a reply from the station being called. If the station being called does not answer, the call can be continued. If the station called answers someone else, he will be heard and the calling can be broken off until he has finished his business and is again listening for more stations to work.

EMERGENCY WORK

Amateurs have always given an excellent account of themselves in many emergencies of local and national character. In every instance, the amateurs who have considered the possibilities of an emergency arising *before* the trouble actually

came to pass were the ones who must be credited with doing the most important work. They were ready, prepared for the crisis when it came. It behooves all of us to think upon these matters, to likewise prepare ourselves for doing a creditable job in each future opportunity. The very least we can do is to study the history of such cases so that we may proceed correctly and systematically about our business without losing our heads and passing up glorious opportunities for service in a crisis.

Priority must be given messages from a stricken point asking for relief measures such as food, antitoxin, blankets, doctors, nurses and necessities of life. Next in order of importance (and also in order of transmission) are the press messages informing the outside world of all that has taken place, the extent of the disaster, perhaps containing public appeals for assistance if the authorities in the affected area believe this necessary. A third class of messages is between friends and relatives, messages of inquiry or messages of assurance to and from the stricken territory. In each emergency many amateur stations at as many different points all over the country get on the air with such messages from anxious friends on the outside. Of course it is necessary for stations with such traffic to stand-by until the relief and press messages are off the hook and opportunity is given for clearing such private messages.

During emergencies it is often possible to send broadcasts to the press generally (or addressed to U. P., A. P., N. A. N. A., etc.) between the transmissions of relief priority traffic. Invariably such messages are correctly delivered to local member-newspapers in such associations, the public kept informed, and amateur radio credited. Such broadcasts should be sent at regular intervals if possible. They have sometimes been overlooked in the rush.

Perhaps the last duty of the emergency station but a duty nevertheless is a full report of the work that was done so that the whole achievement can do its bit for amateur radio. *Stations outside an "emergency zone" and in communication with relief stations in that zone are requested to inform A.R.R.L. Headquarters of this situation by telegram to facilitate traffic movement and for the information of the press.*

Considerations of an emergency power supply are of first importance in many cases where radio is destined to play a part. If local electric service mains are crippled one may have recourse to B batteries, dynamotors driven from storage batteries, and the like. By consulting with other amateurs and putting all the available facilities together in the most favorable location a station can be made operative in short order. An order from some competent authority will make supplies of batteries or temporary service from a public utilities company available for emergency stations. It is sometimes as easy to move the amateur station to a power supply as to collect a power supply together and bring it to the amateur station. This is especially true if the transmitter and receiver are built as independent units that may be moved about at will. In some emergencies B batteries have been provided from local electrical supply stores. In other cases broadcast

listeners have been called upon to contribute their individual batteries to the common cause.

It is impossible to tell just when or where will be the next call on amateurs to render service in an emergency. In the North, sleet storms and crippled wire service threaten public safety during at least three months of each year. Floods periodically threaten different sections of the country at different times of the year. In the southeastern states, storms of hurricane intensity are common. The situation in all such emergencies is a serious one. The entire question is one of preparedness for the individual station. Shall we be ready or not, if and when an emergency arises? *Be ready for the emergency call, QRR, when it comes. Jump into the breach with your station if feasible or stand by and avoid interference to those handling emergency traffic if this seems to be the right thing to do. "Standing by" is sometimes the harder but wiser course if the important communications are being handled satisfactorily by others and your traffic is "public correspondence" for individuals.*

If you live along the line of a railroad you should get in touch with the local representative of the railroad so he will communicate with you in case amateur radio can help in an emergency. You should likewise make note of the address of Red Cross headquarters, of local military units, police departments, representatives of press associations and the like, if possible putting your station on record with such organizations and other competent authorities so that you will be called upon to assist when emergency communication is necessary. When storms approach or disaster threatens it is best to keep in touch with the situation by radio and again to offer service to these agencies well in advance of the actual emergency. Emergency work reaps big returns in public esteem and personal satisfaction.

MESSAGE TRAFFIC

One activity of the League that is quite important is the accepting and relaying of messages. Station owners may originate traffic of any kind going to any part of the United States, Hawaii, Porto Rico, Alaska, or the Philippines. Canadian messages may be handled under certain restrictions. Important traffic in emergencies or messages from expeditions for delivery in Canada must be put on a land wire by the U. S. amateur station handling. The international law prohibiting the handling of important messages to most foreign countries must be observed.

Messages may be accepted from friends or acquaintances for sending by amateur radio. Such messages should be put in as complete form as possible before transmitting them, and incomplete messages should not be accepted. As messages are often relayed through several stations before arriving at their destination, *no abbreviations should be used in the text* as mistakes are bound to happen when the text is shortened in this manner. To people not acquainted with radio abbreviations, messages written in shortened form are meaningless. Delivering stations must be careful to see that messages are written out fully.

In handling messages we are doing something

really worth-while. We want to start only good worth-while messages from our stations. Our efforts should be directed to making the quality of our message service high. The number of messages we handle is of secondary importance. The kind of messages we originate or start from our stations and the speed with which the messages pass through our station and the reliability or accuracy with which the messages are handled are the things of paramount importance.

AMATEUR STATUS

It is most important that individually and as an organization we be most careful to preserve our standing as amateurs by doing nothing to harm that most precious possession, our amateur status.

No brief can be held for the amateur who accepts direct or indirect compensation for handling specific messages. This is in direct violation of the terms of the amateur station license, the regulations of the Federal Radio Commission and the agreements in regard to the use of vacuum tubes and equipment "for amateur and experimental use." Such violations may be responsible for not only bringing individual amateurs into great trouble but may even throw a shadow of disrepute on the good name and record of amateur radio considered as a whole. The penalties are too great and neither the violations nor the violators can be tolerated. Accepting compensation of *any* kind is dangerous business!

It is the purpose of these paragraphs to warn amateurs to avoid being "used" by commercial interests in unethical ways. An amateur asked our advice recently on accepting a whole set of fine station equipment from a business house — the only string being that he should consistently try to handle some traffic with a certain foreign point. A hotel on the Pacific Coast offered an amateur radio club a fine meeting place with free light, power and heat — provided the amateurs would establish an amateur station and relay messages for guests of the hotel. A certain newspaper planned to "organize an amateur radio club" and establish a "net" for the collecting of amateur news for the paper. It offered the amateurs a club room and the facilities of a powerful station that it would install as "net control station" in return for the things it could gain by making amateurs violate their amateur status!

There are plenty of legitimate activities in which amateurs may participate. The League approves amateur cooperation with worthy enterprises, sponsors tests to show the utility of short-wave communication, encourages worth-while service to expeditions in getting their messages from the far parts of the earth. Be assured that there is nothing wrong in accepting trophies and prizes of any sort for legitimate amateur competition in communication contests. Watch carefully and refuse to enter into any agreements or alliances through which you accept anything in the nature of a consideration for services rendered in connection with your amateur radio station. There is no question of the good intentions of the amateurs involved in the several cases cited. Very great damage can be done unless there is strict observance of both the spirit and letter of

the regulations involving amateur status. Avoid sugar-coated promises and opportunities which might be construed as direct or indirect compensation and a violation of amateur status. Seek competent advice before you jump at chances to get something for nothing. Preserve your most valued possession, your status as an amateur.

(Our right to handle friendly communications of worth-while character and to engage in valuable work of all kinds in emergencies and with expeditions remains unquestioned. A "consideration" of any nature whatsoever absolutely establishes the "commercial" nature of any traffic, however.

A case came to our attention in which a station owner was reported to have accepted a prize (?) from a commercial organization for originating a large quantity of messages of a direct advertising nature for the company presenting the prize (?). The messages were of course of the "rubber stamp" variety so that they had to be thrown out of the totals in accordance with the A.R.R.L. policy expressed elsewhere in this book. Possibly it is all right for an amateur to handle such messages as long as he accepts no compensation — a legal opinion probably would substantiate the right of the amateur to handle this business under those circumstances. But we question whether or not "compensation" was present in this instance. And we do not condone the procedure of burdening fellow amateurs with such a load of worthless traffic.

MESSAGE FORM

Each message originated and handled should contain the following component parts in the order given:

- (a) City of origin
- (b) Station of origin
- (c) Number
- (d) Date
- (e) Check (optional)
- (f) Address
- (g) Text
- (h) Signature

(a) The "city of origin" refers to the name of the city from which the message was started. If a message is filed at League Headquarters by someone in Hartford, Conn., the preamble reads, *Hr msg fm Hartford Conn W1MK Nr 457 April 9, etc.*

If a message is sent to your radio station by mail the preamble reads a little differently to show where the message came from and from what city and station it originated as well. If a message was filed at A.R.R.L. Headquarters and if it came by mail from Wiscasset, Maine, the preamble would run like this to avoid confusion: *Hr msg fm Wiscasset Maine via Hartford Conn W1MK Nr 457 April 9, etc.*

(b) The "station of origin" refers to the call of the station at which the message was filed and this should always be included so that a "service" message may be sent back to the originating station if something interferes with the prompt handling or delivery of a message. In the example of preambles just given W1MK is the station of

origin, that call being the one assigned the League Headquarters Station.

(c) Every message transmitted should bear a "number." Beginning on the first day of each calendar year, each transmitting station establishes a new series of numbers, beginning at Nr. 1. Keep a sheet with a consecutive list of numbers handy; file all messages without numbers; and when you send the messages, assign numbers to them from the "number sheet," scratching off the numbers on that list as you do so, making a notation on the number sheet of the station to which the message was sent and the date. Such a system will keep things straight and be very convenient for reference to messages originated.

The original number supplied each message by the operator at the originating station is transmitted by each station handling the message. No new numbers are given the message by intermediate stations. If a message is filed at W1MK on April 9 and when sent is given the number "nr 458," this same call, date and number are used by all stations handling this message. The number and date become a part of the city-and-station-of-origin identification used for the purpose of tracing. Only at stations where a message originates or is filed can a number be assigned to a message. Intermediate relaying stations neither change numbers nor supply new ones to messages.

(d) Every message shall bear a "date" and this date is transmitted by each station handling the message. The date is the "day filed" at the originating station unless otherwise specified by the sender.

(e) Every word in the address text and signature of a message counts in the check using radio cable-count. Words and abbreviations in the preamble are not counted.

In the address the names of cities, states, countries or other divisions of territory each count as one word regardless of the number of letters they contain. Proper names in the address and signature are counted at the rate of one word for each 15 letters or fraction thereof. The words "street," "avenue," "square" or "road" are always to be counted each as one word separately from the name of the street, etc., whether written with it or separately. Names of ships are counted as one word irrespective of the number of letters they contain. When there are two ships of the same name, the name and the call letters of the ship are together counted as one word. The name of the state is always counted as one word in addition to the name of the city. Initials in the address are counted each as one word. Each group of house or street numbers is allowed to pass as one word, however.

It is customary to omit the count of the name of a state in the check when it is written and sent in parentheses in the address.

If a telephone number is included in the address, the word "telephone" or "phone" counts as one word. The name of the exchange is an additional word in the check. Each group of five figures or fraction thereof counts as one word. A hyphen indicating the word "ring" may be substituted for one figure in a telephone number

without increasing the check. *Phone Charter 328-5* counts as 3 in the check. *26039* counts as 1 in the check. *2603-9* is a six-character group and accordingly counts as 2 in the check. Mixed letter and figure combinations are counted as a word to

THE AMERICAN RADIO RELAY LEAGUE			
HEADQUARTERS HARTFORD, CONN. U. S. A.			
RADIOGRAM			
CITY OF ORIGIN HARTFORD, CONN.		STATE OF ORIGIN CONN.	DATE OCT 6 47
TO HEN & MELBAIN WPCBC		THIS MESSAGE WAS RECEIVED AT BY DATE	
BY IOWA		RELAY CHAIN BEING ORGANIZED BY BIRDS OF ILLINOIS TO OPERATE BETWEEN THE PACIFIC COAST AND CHICAGO CALLS FOR CLOSEST COOPERATION BETWEEN IOWA AND ILLINOIS STOP SUGGEST THAT YOU COMMUNICATE WITH W3APY ON THE SUBJECT	
LOUIS & BUBER			
Rec'd	FROM STATION	LOCATED AT	DATE
Sent	TO STATION	PORT RADISON IOWA	10/9/38 8:32 p

TO EMPHASIZE PROPERLY THE STANDARD MESSAGE form used by the A.R.R.L. we are illustrating a sample message herewith. It is a simple matter to record the date and time of receiving and sending a message if a calendar and clock are kept handy in the station. If these data and the calls of the stations concerned are placed right on the message blank itself, there is never any question about the routing or speed of handling messages that cannot be answered at once by reference to the message file.

each character. A house number followed by a letter counts as but one word, however.

Radio calls are often included in the address to make proper routing easy. *W5XAY* counts as one word in the address but as five words when it appears in the body or signature of the message.

In the text, words are counted for every fifteen characters or fraction thereof if the message is a plain language message. A word containing from 16 to 30 letters counts 2 in the check.

Names of cities in the address count always as one word while in the text they may count as more than one word depending on how written and transmitted. *New York City* counts as one word in the address but three words wherever it appears in the body of the message. *New York City* is counted as one word when written and sent without spacing between the parts.

Isolated characters each count as one word. Five figures or less in a group count as one word. Words joined by a hyphen or apostrophe count as separate words. A hyphen or apostrophe each counts as one word. However, they are seldom transmitted. Two quotation marks or parenthesis signs count as one word. Punctuation is never sent in radio messages except at the express command of the sender. Even then it is spelled out. In the text of messages, the names of ships are counted at the rate of 15 letters to a word if the names are written out separately. If all parts are joined to form one word, each 10 letters or fractional part counts as one word.

Messages may be classed as plain language messages, coded messages or cipher messages. A plain-language message bears the same thought indicated by the dictionary meaning of the words used in the text. All ordinary messages are plain-

language messages. Every 15 characters or fraction thereof counts as one word. Numerals are counted in groups of five or less. A fraction bar or decimal point counts as one character or figure. An underline counts as an extra word wherever it appears.

Examples (plain language):

USS	1 word
ARRANGEMENT	1 word
UNCONSTITUTIONAL	2 words
X-RAY	2 words
(the hyphen is not transmitted)	
91¾	1 word
396¾	2 words
2961	1 word
85772	1 word
171186	2 words

In coded messages the words are all pronounceable but their arrangement is not necessarily in sentences to express the thought. Several selected words or word groups express more extensive thoughts. Every ten characters or less count as one word. Either dictionary or artificial words may be used but all words must be pronounceable. Words containing 11 to 20 letters count "2" in the check. When one has a copy of the simple and commonly used codes the business of coding and decoding is easy.

Examples (coded):

CAUSTIC	1 word
COMBINZUBIOUS	2 words
AVIABLOSKI	1 word
HOOTBAFF	1 word

In cipher messages the letters or figures in each uninterrupted series are counted at the rate of 5 (or fraction thereof) per word. Groups of letters are checked at the same rate as groups of figures. Mixed letters and figure combinations count a word to each character. *R4TG* counts as four words unless it is an established trade mark or trade name. Radio calls are always counted as cipher. *W1MK* counts as four words in the text or signature of a message (though but one word if sent "en groupe" in the address). For accuracy it should be written *watch one mike king*. Abbreviated or misspelled words are counted at the 5-letter rate in any message where they accidentally appear. A misspelled word with missing letters takes the same count as though it were correctly spelled.

Examples (cipher count):

XYPQ	1 word
D6W	3 words
CKQPWL	2 words

If a message is written partly in plain language, partly in cipher, and partly coded, the words in plain language and code are counted at the 10-letter rate while the other parts of the messages are checked at the 5-letter rate.

When messages are written in plain language and cipher, the passages in plain language take the 15 letter count and the passages in cipher take the 5-letter count.

Messages in plain language and code take the 10-letter count.

When the letters "ch" come together in the

make-up of a dictionary word, they are counted as one letter.

Either whole or fractional numbers spelled out so each group forms a continuous word may be checked at the 15-letter rate. *FOB, COD, SS, ARRL, QST*, and such expressions in current use, are counted five letters to a word wherever they appear. Each group must of course be sent and counted separately to indicate separate words. Groups of letters are not acceptable in the address but must be separated and checked as one word each.

Here is an example of a plain-language message in correct A.R.R.L. form and carrying the "cable-count" check:

(HR MSG FM HARTFORD CONN W1MK NR 83 — 217p MAY 3 CK 50 TO)
 H B ALLEN
 416 MOUNTVIEW AVE
 MOUNTHOLLY NEW JERSEY

PLEASE COMMENT ON PROPOSED OLD TIMERS' WEEK USING 3500 KILOCYCLES STOP BACK NUMBER OF QST WAS FORWARDED MONDAY STOP WHAT FREQUENCY IS MOST IN USE AT W3ATJ QUESTION 73 TO YOU AND NEW JERSEY GANG

(sig) ARRL COMMUNICATIONS MANAGER

The count on each part of the message is added to give the "check" shown. Address, 8; text, 39; signature 3. The check is the sum of these three or 50 words. The parts of the message in parentheses are always transmitted but do not count in the check.

The following words that give most trouble in counting this message add into the "check" as follows:

H	1
B	1
416	1
AVE	1
NEW JERSEY	1
3500	1
QST	1
W3ATJ	5
73	1
NEW JERSEY	2
ARRL	1

The use of a check on amateur messages is optional. Where employed, however, it is a matter of courtesy to see that the check is correct and is handed on along with the rest of the message. Very important messages should be checked carefully to insure accuracy, and if an important message is received with no check, a check should be added.

(f) The "address" refers to the name, street and number, city, state, and telephone number of the party to whom the message is being sent. A sufficiently complete address should always be given to insure delivery. When accepting messages this point should be stressed. In transmitting the message the address is followed by a double dash or break sign (—...—) and it always precedes the text.

(g) The "text" consists of the words in the body of the message. No abbreviations should

ever be substituted for the words in the text of the message. The text follows the address and is set off from the signature by another break (—...—).

(h) The "signature" is usually the name of the person sending the message. When no signature is given it is customary to include the words "no sig" at the end of the message to avoid confusion and misunderstanding.

The presence of unnecessary capital letters, periods, commas or other marks of punctuation may alter the meaning of a text. For this reason commercial communication companies use a shiftless typewriter (capitals only). The texts of messages are typed in block letters (all capitals) devoid of punctuation, underlining and paragraphing except where expressed in words. In all communication work, accuracy is of first importance.

FOREIGN TRAFFIC RESTRICTIONS

Amateur traffic may be handled freely between two countries only when so agreed between the two governments. Otherwise governments will permit experimental communication between their amateurs and those in other countries, at the same time prohibiting the handling of messages for third parties.

In England, France, Germany, Belgium, South Africa, Spain, Ireland, Denmark, Madeira, S. India, Indo-China, and Uruguay only "experimental" traffic can be handled by amateur radio. Messages that would normally be transmitted by cable or commercial radio cannot be accepted by amateurs in these countries on penalty of losing their privileges. Experimental traffic is usually defined as that which does not compete with or lessen government revenue from existing government telegraph and cable services. Messages between amateurs regarding the technicalities of station construction, adjustment or operation, messages regarding short-wave amateur tests, those concerning I.A.R.U. and A.R.R.L. activities — in short, messages that can be classified as relating to non-commercial business conducted by non-commercial organizations — can be freely handled, while personal messages and business messages either to or from anyone except an experimenter cannot be accepted by a foreign station.

Any and all kinds of traffic may be handled between amateur stations in different parts of the United States, Hawaii, Alaska, Porto Rico and the Philippine Islands. There is no qualification or restriction except that amateur status must be observed and no material considerations become involved in the communications.

International message handling by amateurs is forbidden under the terms of the Washington Convention "unless the interested countries have entered into other agreements among themselves." The A.R.R.L. undertook to bring about such an agreement between this country and Canada, for there is no international border in our amateur radio and we have long enjoyed free interchange of traffic with our Canadian members. The League's effort met with a degree of success and it is hoped that similar arrangements may be negotiated with Australia, New Zealand,

and other countries. Messages have been handled rather freely with Brazil, China and Chile in the past, and it is understood that the Chinese government is expected to license its amateurs soon, with the right to handle personal, although not commercial, traffic internationally.

There is thus a splendid opportunity for handling messages not only in each of these localities but also between each country listed just above. There are chances to render a real service to local communities everywhere that an amateur puts up a station and gets on the air, and especially in time of emergencies. Excellent work in traffic handling comes to our attention regularly. Many expeditions and exploring parties go to the far parts of the earth — and now they always take high-frequency equipment along for contact work.

THE CANADIAN AGREEMENT

The reciprocal agreement concluded between our country and the Dominion of Canada permits Canadian and U. S. amateurs to exchange messages of importance under certain restrictions. Article 6 of the General Regulations annexed to the International Radio Telegraph Convention contemplates the exchange of plain language messages and private remarks of such relative unimportance that recourse to public telegraph services is unwarranted. So this agreement is an expansion of the international regulations to permit the handling of more important traffic.

This "more important" traffic exchanged with Canada must be of such nature as would not normally be sent by any existing means of electrical communication, except during emergencies or from isolated points not connected by any regular means of electrical communication, and in both of these exceptions the amateur has the obligation of putting such messages on the established commercial telegraph system at the nearest possible point. It is to be understood that this refers only to international traffic between the two countries.

The authorized traffic is described as follows:

"1. Messages that would not normally be sent by any existing means of electrical communication and on which no tolls must be charged.

"2. Messages from other radio stations in isolated points not connected by any regular means of electrical communication; such messages to be handed to the local office of the telegraph company by the amateur receiving station for transmission to final destination, e.g., messages from expeditions in remote points such as the Arctic, etc.

"3. Messages handled by amateur stations in cases of emergency, e.g., floods, etc., where the regular electrical communication systems become interrupted; such messages to be handed to the nearest point on the established commercial telegraph system remaining in operation."

The arrangement applies to the United States and its territories and possessions including Alaska, the Hawaiian Islands, Porto Rico, the Virgin Islands, the Panama Canal Zone and the Philippine Islands.

ORIGINATING TRAFFIC

Every message has to start from some place and unless some of us solicit some good traffic

from friends and acquaintances there will be no messages to relay. Of course the simplest way to get messages is to offer to send a few for friends, always reminding them that the message service

operator when he is ready to go out after something to do. When conventions or exhibitions come to a city there are always opportunities for getting a lot of real messages to send. Some hotels are glad to accept messages from guests to be sent through near-by amateur stations.

NUMBER SHEET OF ORIGINATED MESSAGES AT RADIO STATION _____					
Message Numbers	Sent to Station	Date	Message Numbers	Sent to Station	Date
1	8CWK	6/10/26	31		
2	5AGN	6/10/26	32		
3	40A	6/11/26	33		
4	1BTG	6/12/26	34		
5	6BUR	6/12/26	35		
6	3BZ	6/13/26	36		
7	7LR	6/14/26	37		
8	8ASY	6/14/26	38		
9	6CGO	6/15/26	39		
10	8ADG	6/16/26	40		
11	8EU	6/17/26	41		
12	1BIG	6/19/26	42		
13	98PY	6/20/26	43		
14	8ASY	6/21/26	44		
15	9ET	6/22/26	45		
16			46		
17			47		
18			48		
19			49		
20			50		
21			51		
22			52		
23			53		
24			54		
25			55		
26			56		
27			57		
28			58		
29			59		
30			60		

does not cost them a penny and that no one can be held responsible in case a friendly message does not arrive at its destination or if it suffers some delay.

A number of our most enthusiastic traffic handlers who are interested in handling messages in quantities have taken more aggressive steps to secure results. One man at least has advertised in the local papers that messages may be phoned him for transmission via A.R.R.L. radio stations. Another amateur we know has made arrangements to handle a daily report on live-stock and butter-and-egg market conditions. Radio stations at Madison and Milwaukee, Wisconsin, are responsible for conducting the first daily and speedy market service of its kind. A number of the amateur fraternity have distributed pads of message blanks to a number of local stores and business houses. A neatly typed card is displayed near-by explaining the workings of our A.R.R.L. traffic organization, and listing the points to which the best possible service can be given.

The time of collecting messages and the list of schedules kept may also be posted for the benefit of those interested. Wide-awake amateurs have distributed message blanks to the nearest tourist camps during the summer seasons of recent years and lots of good traffic has been collected through a system of message-collection boxes placed in public buildings and hospitals. A sign prominently displayed outside the radio station has in some instances proved a good source of obtaining worth-while messages. Other similar ways of obtaining message traffic will occur to the station

TROUBLES TO AVOID IN ORIGINATING TRAFFIC

Incomplete preambles seem to be the most common fault in message handling. The city of origin, the station of origin, the number, the date, and the check are all a part of the preamble which goes at the beginning of every message. The city and station of origin are most essential. Without them it is impossible to notify the sender that his message could not be delivered and without this information it is not possible to route the reply speedily. The number and date are essential in servicing and tracing radiograms. All Official Relay Stations are instructed to refuse to accept messages without this necessary information. Every station should demand an "office of origin" from stations who have messages, and traffic may be rightly cancelled (QSK) on failure to include it. Thus messages will never get on the air without a starting place.

Many messages carry an insufficient address and cannot be delivered. Originating stations should refuse to accept messages to transmit when it is apparent that the address is too meagre.

Some stations lose track of the messages which they accept for delivery or transmission. They use scratch pads to copy signals on and they never clean up the operating table or have a place for things. The remedy is to adopt a few of the principles of neatness and to spend about two minutes each time you are through operating to put things in order. Write messages on message blanks of a uniform size when they arrive at the station. Keep together the messages to be sent. A good system to use is to mark the state of destination in the upper right hand corner of each message, arranging the messages in a heavy clip so that the names of the states are in easy view. A file box may be similarly arranged. A simple log book, a good filing system, an accurate frequency meter and an equally accurate clock, are sure signs of a well-operated station. The apparatus on the operating table will tell a story without words.

NUMBERING MESSAGES

An accurate and complete log and a "number sheet" posted on the wall of the station or kept attached to the log sheet that is in use, will help in keeping the records straight and in avoiding possible duplication of numbers on messages. Guess work and confusion are eliminated in a station of either one or several operators if a "number sheet" is used. A "number sheet" system enables any operator quickly to tell just what number is next; it helps the operator in counting the number of messages originated in a given month; and it may also give a convenient check with the log in showing to whom each message was sent.

Take a blank sheet of paper and put a consecutive list of numbers on it starting with the current message number. Run the numbers in columns, ten numbers to each group or column, and allow

sufficient space between columns for entering station calls and the dates messages were sent.

File the messages in complete form except for the number and when you have a station ready to take a message, consult the number sheet, assign the next available number to the message, and when the station acknowledges the message, cross off the number used, putting the station call after this number and writing the number on the message blank.

A new number sheet can be made as often as necessary. A sheet that is in use looks something like the illustration. Number 16 will be the next number originated at the station using this number sheet.

ACCEPTING AND TRACING MESSAGES

Messages that are not complete in every respect shall not be accepted for relaying. The city of origin, station of origin, number, date, address, text, and signature constitute a complete message. All these parts are necessary to make a message of value to the recipient, to make possible to deliver the message and to route an answer back to the sender.

Tracing messages is sometimes necessary when it is desired to follow the route of a message or to find where it was held up or delayed. Tracing is usually accomplished by sending a copy of the message and a letter requesting that the time, date, and station calls of the stations from whom the message was received and to whom the message was given, be noted in the proper place on an enclosed sheet. The letter asks that the sheet and message be forwarded in rotation to all the stations handling the message until it has overtaken the message, when the tracer is mailed back to its starting point with the information collected from all the logs along the route.

RELAY PROCEDURE

Messages shall be relayed to the station nearest the location of the addressee and over the greatest distance permitting reliable communication.

No abbreviations shall be substituted for the words in the text of a message with the exception of "service messages," to be explained. Delivering stations must be careful that no confusing abbreviations are written into delivered messages.

Sending "words twice" is a practice to avoid. Use it only when expressly called for by the receiving operator when receiving conditions are poor.

Messages shall be transmitted as many as three times at the request of the receiving operator. Failing to make a complete copy after three attempts, the receiving operator shall cancel the message (QTA).

Let us assume that a station in Hartford, Conn., receives a message whose destination is Dallas, Texas. The message is at once written out on a message blank, filling in the city and station of origin, leaving only the "number," "rec'd," and "sent" spaces vacant.

The operator is anxious to get the message started. He sits down in front of the set and listens. He does not hear any western stations so he decides to give a directional "CQ" as per A.R.R.L. practice. He calls, CQ CQ CQ TEXAS

DE W1MK W1MK W1MK, repeating the combination three times and ending with only AR.

He listens and hears W9CXX in Cedar Rapids calling him, W1MK W1MK W1MK DE W9CXX W9CXX W9CXX AR.

Then he answers W9CXX indicating that he wishes him to take the message for Dallas. W1MK says W9CXX W9CXX DE W1MK R QSP DALLAS? K.

After W9CXX has given him the signal to go ahead, the message is transmitted, inserting the "number" in its proper place, and assigning the next number indicated on the "number sheet." The message is sent in A.R.R.L. sequence.

"HR MSG FM HARTFORD CONN W1MK NR 247 NOV 11 CK 31 TO FRANK M CORLETT W5ZC 2515 CATHERINE STREET DALLAS TEXAS —...— COMMUNICATIONS DEPARTMENT SUPPLIES AND MEMBERSHIP LIST ARE GOING FORWARD TODAY PLEASE SEND YOUR REACTION TO GENERAL NUMBER 372 OUR ARMY FILE —...— SIG HOUGHTON AR W1MK K.

W9CXX acknowledges the message like this: W1MK DE W9CXX NR 247 R K. Never should a single R be sent unless the whole message has been correctly received.

The operator at W1MK now writes in the number of the message, scratches off number 247 on the "number sheet," putting W9CXX after the number, and in the "sent" space at the bottom of the message blank he notes the call of the Cedar Rapids station, the date, time, and his own personal "sine." At the same time he concludes with W9CXX something like this: R QRU 73 GB SK W1MK, meaning, "All received OK, I have nothing more for you, see you again, no more now, best regards, good-bye, I am through with you and shall at once listen for other stations who may wish to call me. W1MK is now signing off."

W9CXX will come back with IR GB AR SK W9CXX, meaning "I understand, received you OK, good-bye, I am through." Then he will listen a few minutes to see if anyone is calling him. He will listen particularly for Texas stations and try to put the message through W5ZC or a neighboring station. If he does not hear someone calling him, he will listen for Texas stations and call them.

DELIVERING MESSAGES

The only service that we can render anyone by handling a message comes through "delivery." Every action of ours in sending and relaying messages leads up to this most important duty. Unless a message is delivered, it might as well never have been sent.

Right now, delivery conditions are pretty good. Periodically, however, we have an influx of new operators who are willing to get all the fun out of handling messages by radio and who are not willing to give anything in return. If a message comes their way, it gets filed or thrown in the waste basket. Often the man who sent the message expects an answer. Sometimes he writes to confirm his message or to inquire if it was received. It is then that our League gets a black eye because of the unreliability of some individual who has allowed a message to die at his station or who

had been too lazy to deliver a message after it had been received and acknowledged.

There is no reason for anyone to accept a message if he has no intention of relaying it or delivering it promptly. It is not at all discourteous to refuse politely to handle a message when it will be impossible for you to forward it to its destination.

Occasionally message delivery can be made through a third party not able to acknowledge the radiogram he overhears. When a third party happens to be in direct contact with the person addressed in the message he is able to hand him an unofficial confirmation copy and thus to make a delivery much sooner than a delivery could be made otherwise. It is *not* good radio etiquette to deliver such messages without explaining the circumstances under which they were copied, as a direct delivery discredits the operator who acknowledged the message but who through no fault of his own was not able to deliver so promptly. With a suitable note of explanation, such deliveries can often improve A.R.R.L. service and win public commendation. An operator's oath of secrecy prevents him from giving out information of any sort to any person except the addressee of a message. It is in no manner unethical to deliver an unofficial copy of a radiogram, if you do it to improve the speed of handling a message or to insure certain and prompt delivery. Do not forget that there are heavy fines prescribed by Federal laws for divulging the contents of messages to anyone except the person addressed in a message.

There are several ways of delivering messages. When it is possible to deliver them in person, that is usually the most effective way. The telephone is the most serviceable instrument in getting messages delivered without undue labor. When the telephone does not prove instrumental in locating the party addressed in the message, it is usually quickest to mail the message.

To help in securing deliveries, here are some good rules to follow:

Messages received by stations shall be delivered immediately.

Every domestic message shall be relayed within forty-eight (48) hours after receipt or if it cannot be relayed within this time shall be mailed to the addressee.

Messages for points outside North America must not be held longer than half the length of time required for them to reach their destination by mail.

We are primarily a radio organization, and the bulk of our messages should go by radio, not by mail. The point is that messages should not be allowed to fall by the way, and that they should be sent on or delivered just as quickly as possible. When a message cannot be delivered, or if it is unduly delayed, a "service" message should be written and started back to the "office of origin."

Each operator who reads these pages is asked to assume personal responsibility for the accuracy and speed of each message handled so that we can each have reason to take personal pride in our operating work and so that we will have just cause for pride in our League as a whole. Do your part that we may approach a 100% delivery figure.

COUNTING MESSAGES

So that we can readily keep run of our messages and compare the number originated and delivered each month to learn some facts about the "efficiency" of our work in handling messages, a method of counting is used. Each time a message is handled by radio it counts one in the total.

A message received in person, by telephone, by telegraph, or by mail, filed at the station and transmitted by radio in proper form, counts as one message originated.

A message received by radio and delivered in person, by telephone, telegraph, or mail, counts as one message delivered.

A message received by radio and sent forward by radio counts as two messages relayed (one when received and again one when sent forward).

All messages counted under one of the three classes mentioned must be handled within a 48-hour (maximum) delay period to count as "messages handled" with but one exception. Messages for all continents except North America may be held one-half the length of time it would take them to reach their destination by mail. A "service" message counts the same as any other type of message.

The message total shall be the sum of the messages originated, delivered and relayed. Each station's message file and log shall be used to determine the report submitted by that particular station. Messages with identical texts (so-called rubber-stamp messages) shall count once only for each time the complete text, preamble and signature are sent by radio.

By following the above rules, the messages handled during the "message month" may be counted readily. A monthly report should be sent to the local traffic official of the A.R.R.L. as mentioned under the subject of "Reporting." The closing date of the "message month" is the 15th of each month (the last of the month in Hawaii and the Philippines). Reports must go forward the next day.

Let us assume that on the 15th of the month one operator of a large amateur station receives several messages from another station. (a) Some of these messages are for relaying by radio. (b) Some of them are for local delivery. (c) There are still other messages the disposal of which cannot be accurately predicted. They are for the immediate neighborhood but can be either mailed or forwarded to another amateur by radio. A short-haul toll telephone call will deliver them but the chances of landing them nearer the destination by radio are pretty good. This operator's "trick" ends at midnight on the 15th and he must make out the report with some messages "on the hook" to be carried over for the next month's report.

(a) The messages on the hook that are to be relayed have been received and are to be sent. They count as "1 relayed" in the report that is made out now, and they will also count as "1 relayed" in the next month's report (the month during which they were forwarded by radio).

(b) By mailing the messages or phoning them at once, they can count as "1 delivered" for the current month's report. By holding them until

the next day they will count in the next report as "1 delivered."

(c) The messages in this class should be carried forward into the next month. If they have to be mailed they will count in the next report as "1 delivered." If they are relayed, we count them as "2 relayed"; "1 received" in the preceding month being carried forward and added to "1 sent" makes the "2 relayed." If the operator wishes to count this message at once (for the current month) it must be mailed promptly and counted as "1 delivered."

Some examples of particular counting problems follow:

The operator of Station A gets a message by radio from Station B addressed to himself. This counts as "1 delivered" by himself and by Station A.

The operator of Station A takes a verbal message from a friend for relaying. He gives it to Station B over the telephone. Operator A does not handle the message by radio. Station B and operator B count the messages as "1 originated." A cannot count the message as he did not start it on the air.

The operator and owner of Station A visits Station B and while operating there takes a message for relaying. The operator and owner of B cannot operate for a day or two so the message is carried back to Station A by operator A who relays it along within a few hours. The traffic report of both Station A and Station B shows "1 relayed" for this work. Operator A gets credit for "2 relayed" if he is personally entered in a message-handling contest and gives details of his work at both stations specially for the contest.

Messages originating at any station count only in the "originated" column. Messages received by radio and delivered, count only in the "delivered" column. The relayed column can contain either an odd or even number of messages, depending on the messages left over for next month, the circumstances in a given case, and so on. The total is the sum of the figures in originated, delivered, and relayed columns.

"RUBBER-STAMP" MESSAGES

Because, now and again, our stations fall into the habit of originating quantities of so-called "rubber-stamp" messages with such texts as "Your card received will QSL"; "Greetings by radio" and the like, the identical text being addressed to a large number of addressees, it becomes necessary to reaffirm our policy with respect to such messages. The history of our organization shows the demoralizing effect of an influx of such stereotyped messages in quantity. Because they mean little individually and because there is much labor and little pleasure in handling them the result has always been a decrease in the delivery column while the totals of originated and relayed messages rise to unprecedented heights—that mean nothing at all. Because the net effect is to clog the hooks of traffic-handling stations until they can no longer function, it was decided long ago to kill large quantities of such messages at their source by a rule which put a premium on delivering good messages promptly and not counting the rubber-

stamps when figuring out totals for the report under the honor system. While there is nothing against and much in favor of handling individual friendly greeting messages which do have significance to the general public, it is necessary to maintain a firm policy with respect to counting rubber-stamp messages to further efficient traffic handling with a good percentage delivery in our national scheme of affairs.

Obviously, a station in handling a rubber-stamp message has to exert only a small amount of effort in receiving the text and signature once. Then by handling the address to different points *en groupe* a large number of messages (?) can be received and transmitted with little time and effort. The League's system for crediting points for messages handled is based on giving one credit each time a complete message is handled by amateur radio, i.e., one credit for each originated message, one credit for each delivered message and two credits for each relayed message (one credit for the work in receiving it and one for the work in transmitting it). Only every message handled by radio with a complete preamble, address, text, and signature shall be counted.

Example (showing a claimed and revised count on R.S. messages): A certain station takes an R.S. message to 10 addresses and relays it onward to another station, claiming "relayed 20" for his work. This station shall be credited with "relayed 2"; one for receiving a complete preamble, address, text, and signature, one for sending a complete message on its way. For receiving and relaying to three stations (requiring the complete message to be sent three times) a total of four might be justly claimed in the relayed column. (This should not be construed to mean that any message to a single address should be given to more than a single reliable station.)

REPORTING

Whether the principal accomplishments of the station are in traffic handling or other lines, what you are doing is always of interest to A.R.R.L. headquarters. Our magazine, *QST*, covers the entire amateur field, keeping a record of the messages handled in different sections of the country, giving mention of the outstanding work that is done in communicating over great distances using small amounts of power, and summarizing all the activities.

We have mentioned the Official Relay Stations and the Communications Department organization. A special section of *QST* is devoted to the Communications Department. Each month a special form postal is sent the active stations in the relay system for reporting purposes. Blanks on the card are provided so that the number of messages originated, the number delivered, and the number relayed can be inserted, together with the message total. There is also space to tell about the most important traffic handled, the frequency used during the reporting month, the "DX" worked, and other station records and activities, together with a list of the stations with whom schedules are kept. Items of general interest, changes in the set, and addresses of new amateurs also come in on this card.

This information is wanted from every opera-

tor of an active amateur station in the United States. Each month on the 16th (the 1st in Hawaii and the Philippines) the active stations send reports to their local officials. These officials forward all the reports sent them to Headquarters. They are next prepared for the magazine. Only representative space can be given each



section of the country and almost every report received has to be squeezed in order to get it in. Reports must have the dead material edited out of them to allow room for as much active and interesting news as can be gotten in. Sometimes paragraphs have to be cut down or left out altogether to make the material fit the space it is allowed. Reports about what someone is "going to do next month" and about "burnt out tubes," "no traffic" or "non-operation" get deleted. The more worthwhile a report is, the more of it gets in print. If something comes in that is worth special mention, it gets more space in another part of the magazine. Traffic figures and calls of active stations always get full space. The readers of this Handbook are cordially invited to send in their reports to the local traffic official just as soon as they have a station in operation. Write the nearest traffic official whose name appears on page 5 of each *QST*. Make your report as informative and interesting as possible.

Especially important work that has a news value should be sent direct to League Headquarters at Hartford. Get in touch with your local man soon, and ask him just when he must get a report from you, so that he can include it with other reports on the day he makes up his official report. Be sure to make your report as full of information as possible, including some of the things we mentioned if possible.

Contributions to *QST* are welcomed by the Editors! Authors must remember that only a small percent of the received material can be printed and that it is impossible for an organization like our to pay for articles. Ours is a "family" organization supported by and for the amateur. By carefully selecting material the members get the best magazine that can be made. *QST* is noted for its technical accuracy. Getting into the reading pages of *QST* is an honor worth working for.

OPERATING ON SCHEDULES

Traffic handling work can be most advantageously carried on by arranging and keeping a few schedules. By arranging schedules and operating the station in a business-like way, using an accurate frequency meter and a clock, it has been proven many times that a maximum amount of business can be moved in a minimum of time and effort. The message "hook" can be cleared in a

few minutes of work on schedule and the station will be free for DX or experimental work.

Every brass-pounder is urged to write letters to some of the reliable and regular stations heard, asking if some schedules cannot be kept a few times a week especially for traffic handling. The Route Manager is very frequently able to help in arranging schedules. Write your S.C.M. (see page 5, *QST*) and through him get lined up with your R.M. With reliable schedules in operation it is possible to advertise the fact that messages for certain points can be put through with speed and accuracy, and the traffic problem will take care of itself.

THE FIVE-POINT SYSTEM

To make our relaying more systematic the "five-point system" of arranging schedules was proposed and has worked out very nicely in many cases. After getting the station in good operating condition, each station's operator arranges to work four stations, one north, one east, one south, and one west. These directions are not exact but general. The distances are not too great but they must be distances that can be worked with absolute certainty under any conditions.

A good way to select the four stations is to listen in and to pick out the stations heard most regularly, operating most consistently, and in the right direction. It is a good scheme to work these stations a few times. Write them letters and get acquainted; then try to arrange some schedules. Short schedules are the best. A half or quarter hour each day is enough.

There is no excuse for failure to keep a schedule. After a little while, keeping it will be a part of the daily routine, and when the arrangement has been made after careful consideration by the fellows involved it will prove no hardship but rather a source of pleasure. In an hour one can call the four stations, clear traffic, and be free to work other groups of "five-pointers" or to spend the time otherwise.

By referring to the sketch the idea may be seen at a glance. Five stars work together, five circles, five A's and so on, all over the country.

When there is no traffic, a few pleasantries are in order during the scheduled time of working. Several advantages of handling messages on schedule are evident from whatever angle the situation is approached. The use of several separate frequency bands for amateurs has more or less divided us. By arranging schedules and working in a business-like way we can make full use of all our frequencies.

WORD LIST FOR ACCURATE TRANSMISSION

When sending messages containing radio calls or initials that are likely to be confused and where errors must be avoided, the calls or initials should be thrown into the following code words:

A — ABLE	N — NAN
B — BOY	O — OBOE
C — CAST	P — PUP
D — DOG	Q — QUACK
E — EASY	R — ROT
F — FOX	S — SAIL
G — GEORGE	T — TARE

- | | |
|----------|-----------|
| H — HAVE | U — UNIT |
| I — ITEM | V — VICE |
| J — JIG | W — WATCH |
| K — KING | X — XRAY |
| L — LOVE | Y — YOKE |
| M — MIKE | Z — ZED |

Example: *W1BCG* is sent as *WATCH ONE BOY CAST GEORGE* but put back into the first form by the operator who delivers the message.

A somewhat different list can be obtained from the local Western Union telegraph office and posted beside the telephone to use when telephoning messages containing initials and difficult words. Such code words prevent errors due to phonetic similarity. Here is the Western Union word-list:

- | | |
|-------------|--------------|
| A — ADAMS | N — NEW YORK |
| B — BOSTON | O — OCEAN |
| C — CHICAGO | P — PETER |
| D — DENVER | Q — QUEEN |
| E — EDWARD | R — ROBERT |
| F — FRANK | S — SUGAR |
| G — GEORGE | T — THOMAS |
| H — HENRY | U — UNION |
| I — IDA | V — VICTOR |
| J — JOHN | W — WILLIAM |
| K — KING | X — X-RAY |
| L — LINCOLN | Y — YOUNG |
| M — MARY | Z — ZERO |

PHONE PROCEDURE

Amateur radiophone stations should use the international radiotelephone procedure which is part of the supplementary regulations to the International Radiotelegraph Convention.

For calling, the geographical name of the location must be used in addition to the assigned call. For spelling call signals, service abbreviations and words, the following internationally well-known names are specified and should be used.

- | | |
|----------------|----------------|
| A — AMSTERDAM | N — NEUFCHATEL |
| B — BALTIMORE | O — ONTARIO |
| C — CANADA | P — PORTUGAL |
| D — DENMARK | Q — QUEBEC |
| E — EDDYSTONE | R — RIVOLI |
| F — FRANCISCO | S — SANTIAGO |
| G — GIBRALTAR | T — TOKIO |
| H — HANOVER | U — URUGUAY |
| I — ITALY | V — VICTORIA |
| J — JERUSALEM | W — WASHINGTON |
| K — KIMBERLEY | X — XANTIPPE |
| L — LIVERPOOL | Y — YOKOHAMA |
| M — MADAGASCAR | Z — ZULULAND |

At the start of communication the calling formula is spoken twice by both the station called and the calling station. After contact is established it is spoken once only. Examples of procedure:

W5QL calls: "Hello W3JZ Philadelphia, hello W3JZ Philadelphia, W5QL Oklahoma City calling, W5QL Oklahoma City calling, message for you, message for you, come in please."

W3JZ replies: "Hello W5QL Oklahoma City, hello W5QL Oklahoma City, W3JZ Philadelphia answering, W3JZ Philadelphia answering, send

your message, send your message, come in please."

W5QL replies, "Hello W3JZ Philadelphia, W5QL Oklahoma City answering, the message begins, from Oklahoma City Oklahoma W5QL number [usual preamble, address, text, signature, etc.], message ends; I repeat, the message begins, from Oklahoma City Oklahoma W5QL number [repetition of preamble, address, text, signature etc.], message ends, come in please."

W3JZ replies: "Hello W5QL Oklahoma City, W3JZ Philadelphia answering, your message begins, from Oklahoma City Oklahoma W5QL number [repetition of complete message], end of your message, come in please."

W5QL replies: "Hello W3JZ Philadelphia, W5QL Oklahoma City answering, you have the message correctly, you have the message correctly, W5QL Oklahoma City signing off."

Note that in handling traffic by voice, messages are repeated twice for accuracy, using the word list to spell names and prevent misunderstandings. The receiving station must repeat the message back and only when the sender confirms the repetition as correct can the message be regarded as handled.

GETTING FILLS

Sometimes parts of a message are not received correctly or perhaps due to fading or interference there are gaps in the copy. The problem is to ask for "fills" or repeats in such a way as to complete the message quickly and with the minimum of transmission.

If the first part of a message is received but substantially all of the latter portions lost, the request for the missing parts is simply *RPT TXT AND SIG*, meaning "Repeat text and signature." *PBL* and *ADR* may be used similarly for the preamble and address of a message. *RPT AL* or *RPT MSG* should not be sent unless nearly all of the message is lost.

Each abbreviation used after a question mark (. . . — . . .) asks for a repetition of that particular part of a message.

When a few word-groups in conversation or message handling have been missed, a selection of one or more of the following abbreviations will enable you to ask for a repeat on the parts in doubt. Phone stations of course request fills by using the full wording specified, without attempt at abbreviation.

Abbreviation	Meaning
?AA	Repeat all after
?AB	Repeat all before
?AL	Repeat all that has been sent
?BN AND	Repeat all between and
?WA	Repeat the word after
?WB	Repeat the word before

The good operator will ask for only what fills are needed, separating different requests for repetition by using the break sign or double dash (— . . . —) between these parts. There is seldom any excuse for repeating a whole message just to get a few lost words.

Another interrogation method is sometimes used, the question signal (. . . — . . .) being sent between the last word received correctly and the

first word (or first few words) received after the interruption. *RPT FROM TO* is a long, clumsy way of asking for fills which we have heard used by beginners. These have the one redeeming virtue of being understandable.

The figure four (. . . -) is a time-saving abbreviation which deserves popularity with traffic men. It is another of those hybrid abbreviations whose original meaning, "Please start me, where?" has come to us from Morse practice. Of course *7AL* or *RPT AL* will serve the same purpose, where a request for a repetition of parts of a message have been missed. While these latter usages are approved, the earlier practice is still followed by some operators.

THE SERVICE MESSAGE

A service message is a message sent by one station to another station relating to the service which we are or are not able to give in message handling. The service message may refer to non-deliveries, to delayed transmission, or to any phase of message handling activity.

Whenever a message is received which has insufficient address for delivery and no information can be obtained from the telephone book or the city directory, a service message should be written asking for a better address. While it is not proper to abbreviate words in the texts of regular messages, it is quite desirable and correct to use abbreviations in these station-to-station messages relating to traffic-handling work.

The prefix "svc" is place of the usual "msg" shows the class of the message and indicates at once that a station-to-station message is coming through. Service messages should be handled with the same care and speed that are given other messages.

Suppose a regulation message is received by W3CA for someone in Roanoke, Va. Suppose that the message cannot be delivered because of insufficient address. The city and station of origin of the message are given as "Pasco Washn W7GE." In line with the practice outlined above W3CA makes up a service message asking W7GE to "give better address," of course obtaining the address from the party that gave him the message. W3CA will give the message to anyone in the west, of course trying to give it to the station nearest Pasco, Washington, and sending it over the greatest distance permitting reliable communication. The message looks something like this:

*HR SVC FM ROANOKE VA W3CA NR
291 AUG 19
To RADIO W7GE
LC MAYBEE
110 SOUTH SEVENTH AVE
PASCO WASHN — . . . —
UR NR 87 AUG 17 TO CUSHING SIG
GICK HELD HR UNDL D PSE GBA — . . . —
(sig) WOHLFORD W3CA*

OPERATING HINTS

Listen carefully for several minutes before you use the transmitter to get an idea of what stations are working. This will help in placing messages where they belong.

Use abbreviations in operating conversations.

This saves time and cuts down unnecessary interference.

Stand by (QRX) when asked to by another station who is having difficulty working through your interference. It is equally courteous to shift frequency (QSV) to a point where no interference will be caused. Sometimes a change in frequency will help the station you are working to get your message through interference. Accurate frequency meters at both stations will make this change speedy and the contact sure.

Report your messages to the local traffic official every month on time. Otherwise you cannot expect a report to reach *QST*. Reports sent to Headquarters are routed back to the local official; who make up the monthly report.

Don't tell a fellow his signals are *QSA5* when you can just hear him.

Don't say "QRM" or "QRN" when you mean "QRS."

Don't acknowledge any message until you have received it completely.

Don't CQ unless there is definite reason for so doing. When sending CQ, use judgment. Sign your call frequently, interspersed with calls, and at the end of all transmissions.

Abbreviated standard procedure deserves a word in the interest of brevity on the air. If you hear some old timers using it you will understand what is meant by reading the following paragraph. In handling lots of messages with a number of scheduled stations, most traffic can be cleared by holding all stations to 15-minute schedules. Several schedules should be arranged in consecutive order. To get several messages through in 15 minutes isn't an easy job but abbreviated practices help to cut down unnecessary transmission.

WIAUF DE WIBMS P, meaning paid, personal, or private message (adopted from commercial procedure) is much quicker than *HR MSG* added to a call. *N QSK* is shorter than *QRU CU NEXT SKED*. Instead of using the completely spelled out preamble *HR MSG FM AUGUSTA MAINE WIBIG NR 156 OCTOBER 13 CK 14 TO*, etc., transmission can be saved by using *RDO AUGUSTA ME WIBIG 156 OCT 13 14 TO*, etc. One more thing that conserves operating time is the cultivation of the operating practice of writing down "156 W1UE 615P 11 13 28" with the free hand during the sending of the next message. It is hard to do at first, but all these little points make the total time saved on a message mean something. Of course only stations handling many messages regularly need to think of abbreviations to this extent. If one follows standard practices, he is most sure of being understood and it is not necessary to waste time in explaining too-abbreviated messages in detail. Make it a rule not to abbreviate unnecessarily when working an altogether unknown station.

Be courteous over the air. Offer suggestions for improving the other fellow's note or operating methods. Expect and ask for similar suggestions without expecting any praise. Constructive things can be said without being disagreeable or setting one's self up as a paragon. Be truthful but tactful.

CALL BOOKS

One useful addition to every station is a good call book. When stations are heard or worked, the first thing that interests us is the location. If we have messages to be handled, it is necessary that we know the location of stations so that we may route our messages correctly.

Several call books are available for small sums of money. However, no call books are ever quite up-to-date because new stations are continually coming on the air and old stations occasionally drop out of existence and some changes have taken place in just the short time while an up-to-date list of calls is being set in type by the printer.

"Amateur Radio Stations of the United States" contains a list of the licensed amateur radio stations of this country. Experimental station or "X" calls are also listed. This may be obtained for 25 cents (not in stamps) from Superintendent of Documents, Government Printing Office, Washington, D. C. The yearly June edition is usually available about October 1st.

"Commercial and Government Radio Stations of the United States" gives lists of the various commercial stations, together with government calls. This publication may be obtained for 15 cents (not in stamps) from Superintendent of Documents, Government Printing Office, Washington, D. C.

A complete list of Canadian amateur station calls can be obtained for 25 cents from the Department of Marine and Fisheries, Ottawa, Canada.

The "Radio Amateur Call Book," listing amateur and commercial stations of the entire world, may be obtained from Radio Amateur Call Book, Inc., 508 S. Dearborn St., Chicago. Single copies, \$1.00 (foreign \$1.10). This call book now appears in March, June, September and December, with new calls added up to the date of issue. Yearly subscription, \$3.25 (foreign \$3.50).

AUDIBILITY

The International Radiotelegraph Convention has agreed upon a Q Code of abbreviations for all services. Audibility is indicated by sending a figure (1 to 5) after the appropriate Q signal, to show progressive signal strength. QSA means, "The strength of your signals is"

Thus one might say "QSA 3," the exact and literal meaning of which is "The strength of your signals is fairly good; readable, but with difficulty." The scale:

- 1 — Hardly perceptible; unreadable.
- 2 — Weak; readable now and then.
- 3 — Fairly good; readable, but with difficulty.
- 4 — Good; readable.
- 5 — Very good; perfectly readable.

INTERFERENCE COMMITTEES

The subject of public relations is important to us amateurs both individually and as an organization. No amateur can long afford to operate when he knowingly interferes widely with broadcast reception in his neighborhood and when there are simple remedies to be applied. Even the observance of the prescribed quiet hours, while

covering the situation legally, does not entirely suffice. Broadcast listeners do not look on interference with greater tolerance just because it is caused outside certain hours, and of course we want the good will which only a full understanding of the problem and contact with next-door residents can bring. Since all amateur operators are well qualified technically and most b.c.l.'s are not, the burden of responsibility falls on us in individually contacting any listeners who may be troubled. Patience in explaining, frankness, tolerance in listening to other viewpoints and other qualities of diplomacy are needed to give the full technical explanations required, to win confidence and permission to conduct necessary tests, install wave-traps, etc.

Most of our troubles are due to "proximity," choice of frequency, and the like, and sometimes simple adjustments or changes will cure the difficulty altogether. The A.R.R.L. Communications Department has a circular offering many helpful suggestions which is available to any amateur on request. For that matter you will find about all the information required right in this book.

We are glad to say that amateur interference is almost unknown to-day, the amount of interference from this source being altogether less than one percent of that caused by faulty electrical circuits and apparatus, troubles in receivers themselves, etc. In the past we organized A.R.R.L. "vigilance committees" in every community to take care of interference reports, but now this is no longer necessary since the trouble is reported in isolated cases, and each can be taken care of on its own merits direct or often through the existing A.R.R.L. field organization and the affiliated clubs. We do recommend and request that each A.R.R.L. affiliated club organization maintain an interference committee, to keep order, make investigations and recommendations locally, cooperate with the press, the public, and listeners who wish to file complaints of amateur interference. These committees can well be patterned after our older "vigilance" organizations and composed of representative broadcast listeners, amateurs and with one member from a local newspaper to assist in collecting and referring complaints. It is best not to attempt to handle all types of interference since this is a "large order," but a few leading questions will disclose the amateur cases and the other difficulties can be referred to local power and communications companies, etc.

The club interference committees investigate reports of amateur interference, put the interested parties in touch with each other, suggest ways of reducing or getting rid of the interference and see that the blame is placed where it belongs. When quiet hours are necessary, they are recommended. In cases where suggestions are disregarded, the interference is reported in detail to League Headquarters. In extreme cases the matter has to be turned over to the Radio Division, Department of Commerce. Ninety-eight percent of the interference experienced by broadcast listeners comes from power leaks and foreign ships who transmit in the broadcast band when near our shores. The Vigilance Committees did much to educate

the broadcast listener regarding the sources of interference and they have reduced what little amateur interference there was to a negligible quantity.

RADIO SHOW STATIONS

All will agree that the publicity is most valuable which comes from station exhibits and radio show stations where traffic is solicited. Headquarters is always ready to assist amateurs who put on such demonstrations. However, after some radio shows there are complaints of undelivered messages, or seriously delayed traffic, so perhaps a few suggestions are in order.

First of all let it be known that the percentage of deliveries, while always fair, is a variable depending on the season of the year — and on the traffic load. Show stations collect a lot of traffic, more than the normal amount handled in a few days by one station. If the traffic load gets so great that it becomes more work than fun for those amateurs outside the show-station city, the handling of messages and deliveries is bound to be poor. This may be remedied by building up a number of schedules to different points in advance and distributing the messages, in the proper directions, widely enough so that a few outside stations do not become seriously overburdened. Another factor is that the public frequently lacks imagination, filing too many "greeting by radio" rubber-stamp type messages. The "apparent importance" of a message exerts a psychological effect on operators handling messages just for the enjoyment in the work, and booth attendants taking messages from the public would do well to explain this point.

A large placard or suitable printed slips should be prepared, explaining in as few words as possible the conditions under which traffic is accepted. No traffic for "points all over the world" can possibly be accepted since there are not active amateurs in all countries, and since the Washington Convention prohibits the handling of important messages to many of the countries where there are amateurs. Messages to any point in the U. S. A., its territories and possessions, can be handled of course, and the points to which especially prompt service can be offered, due to schedules arranged and in operation, should be mentioned.

If the traffic is offered for local points where there are no amateurs, the condition should be frankly stated or admitted. The individual in charge of the station has full powers to refuse any traffic unsuitable for radio transmission, or addressed to points where prompt radio deliveries cannot be made. The disclaimer for liability for delivery should be mentioned briefly as set forth on the reverse of A.R.R.L. message blanks and the public made to understand that the relaying is subject to radio conditions and favorable opportunity for contacting. Also, suggest to the public the desirability of wording messages as telegrams would be worded instead of writing letters, pointing out that better service can be expected on 15-word texts of apparent importance.

The operators of the station must bear several points in mind. Most important is the fact that messages must be forwarded toward the destina-

tion and that the effort is not merely one to "clear the hook" but to route traffic properly. Advance schedules are essential to assist in the distribution of messages. It may be possible to schedule stations in cities to which you know quantities of messages will be filed. Stations worked should be informed of the amount of traffic you wish to clear through them *first*. There is no surer way to make traffic die on the hook than to give it to a fellow who does not want it and is not in a position to keep operating his station and handle it. Have the latest copies of *QST* at hand and study the traffic summaries at the end of sectional activity reports. Nearly all these stations are reliable Official Relay Stations interested in traffic handling. The lists of calls will help you to identify or distinguish reliable consistent operators to whom to entrust valuable messages. Operators must take their work seriously and remember that they are not there to "show off" to the public or other "hams" who may visit the booth. The full cooperation of all local stations should be requested. By dividing up the traffic filed with the other stations it may be sent more speedily on its way — but be sure that the operators undertaking to help are qualified and have good facilities for distributing messages. Remember that a station license is good for but one location, and start early to secure the necessary permission from the Supervisor of Radio for the booth-station.

KEEPING A LOG

Every operator of an amateur station must keep a log of the operating work that is done; it should cover, as well, the tests of an experimental nature that are carried out with the transmitter or receiver.

The well-kept log is invaluable in checking up reports of any nature concerning amateur station operation. It contains positive evidence of every transmission. It is a permanent record of the achievements of the station. The presence or absence of a log and the completeness of the entries at once mark the station and operation as either quite systematic or else haphazard and unreliable. The Federal Radio Commission obliges every amateur station to maintain an accurate log of the time of *each* transmission, the station called, the input power to the last stage of the transmitter, and the frequency band used. So, in addition to other excellent reasons for log-keeping, the regulations make a complete record of transmitting activity compulsory.

Amateurs keep a log because of the ready-reference value in proving records and because of the pleasant recollections and associations that come from reviewing the history of friendly radio contacts and from displaying the record of the accomplishments of the station to interested visitors and friends. Plan to start a log at the same time you start operating the station.

There are many different kinds of logs. Station owners all have opinions on the form that the log should take. The more elaborate it is, the more time, care, and pains are required in keeping it.

A loose-leaf notebook can be used. The sheets can be renewed each month and those used can be taken out and filed away with the cards and

station records. A stenographer's ordinary notebook costing from ten to thirty cents and about 4½" by 8½", takes little space on the operating table and also makes a good log book. If simplicity and low cost are the only considerations, such a modified notebook-log is recommended.

A dozen pages may be ruled in advance with vertical lines. In the first column the date and

distinguish between your use of c.w. telegraphy and radiophone operation; or *A1*, *A2*, or *A3* can be used, these official international designations representing c.w. telegraphy, c.w. telegraphy modulated at audible frequencies, and speech or music, respectively. The frequency band you use may be indicated in the next column but it is better to record the exact frequency. The next

Date	Time	Call	W H	My Power	My Freq.	His Freq.	His Note	My QSA	His QSA	Remarks
May 9	0310	G5BY	H	3820	Xtal	..	3	Cig CQ and W8AWJ
" 11	0120	W8DYH	W	275 w	3700	3525	Phone	5	4	Fast fading and poor mod.
" 11	0130	W6CZR	H	3780	RAC	..	5	Working KA1AF.
" 11	0137	W9FLG	W	275 w	3700	3900	Gud d.c.	5	5	QRM lighter now
" 11	0200	K6EWF	W	180 w	7200	7030	Xtal	3	3	On sked. Rec'd 2, sent 3

FIG. 1

time are noted. In the second column the calls of stations worked, heard, and called are put down. A circle, parentheses, or a line drawn under the call can indicate whether a station was worked, heard and called, or simply heard. A special designating sign or abbreviations before or after the call letters can show this information. Provision must be made for entering the power and the frequency band used.

Figure 1 shows a very detailed log which really gives a lot of information but which is somewhat harder to keep in good shape. *W*, *H*, and *C* are used for "worked," "heard" and "called." A bar under the "R" in "RAC" may show that the note is well-rectified and fairly smooth. A line under the "AC" can indicate that the ripple is pronounced. Plenty of information will be available for stations wanting information when such a log is kept, no matter how late the request for information is received.

Some amateurs' logs use an *X* to indicate when they call a station. If communication is established a circle is placed around the *X*. Power and frequency can be written across the page, new entries being made only when these are changed. The dial settings of receiver or frequency meter may be entered in logging stations so that we can come back to these same stations without difficulty when desired. *A*, *B*, *C*, and *D* are sometimes used to indicate the 1750-, 3500-, 7000-, or 14,000-kc. bands.

Figure 2 shows the official A.R.R.L. log sheet. The first entry for each watch is that for the date and time. Greenwich Civil Time is the logical reference standard but local standard time is easiest to use to avoid confusion and so this is used by most amateurs. *PST*, *MST*, *CST*, *EST*, *GCT*, etc., is entered in the heading of the first column in the A.R.R.L. log and then the date which corresponds to that brand of time is put in the first space below the heading, and time entries on the first vacant line below that, those to be entered progressively until a change in date makes it necessary to use a line for again entering the date.

CW and *F* can be used in the second column to

column is for the plate input power to the last stage of your amplifier.

If you hear G5BY calling W1UE, log W1UE in the fifth column and G5BY in the sixth column. If G5BY were calling CQ, then CQ should be entered in the fifth column. A letter in the C-W-H

FIG. 2

The official A.R.R.L. log is shown above, answering every government requirement in respect to station records. Bound logs made up in accord with the above form can be obtained from Headquarters for a nominal sum or you can prepare your own, in which case we offer this form as a suggestion, hoping that you find it worthy of adoption. Every station must keep some sort of a log.

column shows by a single appropriate letter whether a station was called, worked, or heard by you. *H* would indicate here that you heard G5BY. *C-W* might indicate that you called a station and completed the contact immediately afterward. Reports on the characteristics of G5BY's signal would be entered in the space provided for "station heard" or data on received signals. The signal strength, the tone (*P.D.C.*, *R.A.C.*, *Chirpy D.C.*, *Xtal*, *Voice*, quality or frequency of modulation, etc.) and the frequency or dial setting can be logged here, making it easy to return to this station, offer evidence on its frequency, or to fill out a report card.

Log users will quickly adopt certain convenient practises which simplify the keeping of a log such as use of ditto marks to record frequency and

power as long as these remain unchanged, and the use of an X for one's own call signal, to save time in making the entries in the fifth and sixth columns. When several stations answer a CQ, each

expeditions, for diagrams, records of tuning adjustments and ranges, experiments and changes in equipment, etc.

A log is of great value in a number of additional

DATE TIME		FREQ'Y KC	POWER	CALLED	CALLED BY	C.W. H.	STATION HEARD			MESSAGES, REMARKS, ETC.
DATE	TIME						MODE	TONES	RC OR DIAL	
9/28/50	7:50 AM	CW 3585	500	W3BWT	W6ARX	CW 5	1/2 dc	84°		Sent W8ON's #42, rec'd W3ZF's #201 + 202. QSA4 R6
	7:52	" "	" "	W1BXB	"	W3	d.c.	52°		Sent my #189. His sig QSB.
	8:00	-	-	QST	W1MK	H		3575		Copied two spec. ltr on new page, and QRM on 14440 kc. in addition to spec. ltr on WDDE. Off 10 mins to ans. phone.
	8:40			W9DFR	W9BCL	H3	rac	25°		Said rain there.
	45	CW 7240	280	CQ	W6ARX	C				N.D.
	50	" "	" "	W3AVI	W6AKU	X5				Berkeley Calif!
	55	" "	" "	W6AKU	W6ARX	W4	rac	44°		Good N.E. Sent my #170 for P.I.
	9:18			NS off - hook clear - QRM heavy now.						

should be listed in the sixth column following your own call signal in the fifth column. Any unusual data requiring explanation, such as an interrupted or incomplete contact due to power line failure, local interference, etc., should go in the "remarks" column. Also a detailed record of messages exchanged should be entered, thus: "Sent my No. 5 W1MK's No. 97, rec'd his No. 19, No. 20 and W8BAH's No. 61." Of course every message must show call signals and time handled too, and the message file itself is used for counting traffic for monthly reports. This last column should show everything from the "sine" of a new operator taking the key to reports on your own signals from other operators.

Left-hand pages in the log may be left blank to use for extensive remarks on emergencies or

ways through use of these left-hand pages. A comparison of the operating results obtained with different apparatus in use at different times is valuable. The "DX" or traffic-handling value of the various frequencies over varying distances may be readily found from the log. The effect of weather or time of day may be also quickly found. Every change made in either the transmitter or antenna system should be noted down in the log so that results may be compared for dates before and after the date when a change was made. No matter how trivial the change, put it down in the log. Remember that only one change at a time should be made if the changed results are to be attributed to one definite cause.

Keep an accurate and complete station log at all times!!!

Appendix

THE CONTINENTAL CODE

Letter or Figure Symbol	Phonetic
A	Dit darr
B	Darr dit dit dit
C	Darr dit darr dit
D	Darr dit dit
E	Dit
F	Dit dit darr dit
G	Darr darr dit
H	Dit dit dit dit
I	Dit dit
J	Dit darr darr darr
K	Darr dit darr
L	Dit darr dit dit
M	Darr darr
N	Darr dit
O	Darr darr darr
P	Dit darr darr dit
Q	Darr darr dit darr
R	Dit darr dit
S	Dit dit dit
T	Darr
U	Dit dit darr
V	Dit dit dit darr
W	Dit darr darr
X	Darr dit dit darr
Y	Darr dit darr darr
Z	Darr darr dit dit
1	Dit darr darr darr darr
2	Dit dit darr darr darr
3	Dit dit dit darr darr
4	Dit dit dit dit darr
5	Dit dit dit dit dit
6	Darr dit dit dit dit
7	Darr darr dit dit dit
8	Darr darr darr dit dit
9	Darr darr darr darr dit
0	Darr darr darr darr darr
Period (.)	Dit dit dit dit dit dit
Question (?)	Dit dit darr darr dit dit
Break (double dash) (=)	Darr dit dit dit darr
Exclamation (!)	Darr darr dit dit darr darr
Received (O.K.)	Dit darr dit
Bar Indicating Fraction (Oblique stroke)	Darr dit dit darr dit

Wait	Dit darr dit dit dit
Comma (,)	Dit darr dit darr dit darr
Colon (:)	Darr darr darr dit dit dit
Semicolon (;)	Darr dit darr dit darr dit
Quotes (" ")	Dit darr dit dit darr dit
Parenthesis ()	Darr dit darr darr dit darr
Attention Call to precede every transmission	Darr dit darr dit darr
End of each message (cross)	Dit darr dit darr dit
Transmission finished (end of work)	Dit dit dit darr dit darr
Invitation to transmit (go ahead)	Darr dit darr

A dash is equal to three dots.
 The space between parts of the same letter is equal to one dot.
 The space between two letters is equal to three dots.
 The space between two words is equal to five dots.

FOREIGN LETTERS

Ä (German)	Dit darr dit darr
Å or Å (Spanish-Scandinavian)	Dit darr darr dit darr
CH (German-Spanish)	Darr darr darr darr

THE "Q" CODE

- É (French) Dit dit darr dit dit
- Ñ (Spanish) Darr darr dit darr darr
- O (German) Darr darr darr dit
- U (German) Dit dit darr darr

In the regulations accompanying the existing International Radiotelegraph Convention there is a very useful internationally agreed code designed to meet major needs in international radio communication. This code follows. The abbreviations themselves have the meanings shown in the "Answer" column. When an abbreviation is followed by an interrogation mark (?) it assumes the meaning shown in the "question" column.

Abbreviation	Question	Answer
QRA	What is the name of your station?	The name of my station is
QRB	At what approximate distance are you from my station?	The approximate distance between our stations is nautical miles (or kilometers).
QRC	By what private company (or government administration) are the accounts for charges of your station liquidated?	The accounts for charges of my station are liquidated by the private company (or by the government administration of).
QRD	Where are you going?	I am going to
QRE	What is the nationality of your station?	The nationality of my station is
QRF	Where do you come from?	I come from
QRG	Will you indicate to me my exact wave length in meters (or frequency in kilocycles)?	Your exact wave length is meters (or kilocycles).
QRH	What is your exact wave length in meters (frequency in kilocycles)?	My exact wave length is meters (frequency kilocycles).
QRI	Is my tone bad?	Your tone is bad.
QRJ	Are you receiving me badly? Are my signals weak?	I can not receive you. Your signals are too weak.
QRK	Are you receiving me well? Are my signals good?	I receive you well. Your signals are good.
QRL	Are you busy?	I am busy. Or, (I am busy with). Please do not interfere.
QRM	Are you being interfered with?	I am being interfered with.
QRN	Are you troubled by atmospherics?	I am troubled by atmospherics.
QRO	Must I increase power?	Increase power.
QRP	Must I decrease power?	Decrease power.
QRQ	Must I send faster?	Send faster (. words per minute).
QRS	Must I send more slowly?	Send more slowly (. words per minute).
QRT	Must I stop sending?	Stop sending.
QRU	Have you anything for me?	I have nothing for you.
QRV	Must I send a series of V's?	Send a series of V's.
QRW	Must I advise that you are calling him?	Please advise that I am calling him.
QRX	Must I wait? When will you call me again?	Wait until I have finished communicating with I will call you immediately (or at o'clock).
QRY	Which is my turn?	Your turn is No. (or according to any other indication).
QRZ	By whom am I being called?	You are being called by
QSA	What is the strength of my signals (1 to 5)?	The strength of your signals is (1 to 5).
QSB	Does the strength of my signals vary?	The strength of your signals varies.
QSC	Do my signals disappear entirely at intervals?	Your signals disappear entirely at intervals.
QSD	Is my keying bad?	Your keying is bad. Your signals are unreadable.
QSE	Are my signals distinct?	Your signals run together.
QSF	Is my automatic transmission good?	Your automatic transmission fades out.

Abbreviation	Question	Answer
QSG	Must I transmit the telegrams by a series of 5, 10 (or according to any other indication)?	Transmit the telegrams by a series of 5, 10 (or according to any other indication).
QSH	Must I send one telegram at a time, repeating it twice?	Transmit one telegram at a time, repeating it twice.
QSI	Must I send the telegrams in alternate order without repetition?	Send the telegrams in alternate order without repetition.
QSJ	What is the charge to be collected per word for including your internal telegraph charge?	The charge to be collected per word for is francs, including my internal telegraph charge.
QSK	Must I suspend traffic? At what time will you call me again?	Suspend traffic. I will call you again at (o'clock).
QSL	Can you give me acknowledgment of receipt?	I give you acknowledgment of receipt.
QSM	Have you received my acknowledgment of receipt?	I have not received your acknowledgment of receipt.
QSN	Can you receive me now? Must I continue to listen?	I can not receive you now. Continue to listen.
QSO	Can you communicate with directly (or through the intermediary of)?	I can communicate with directly (or through the intermediary of).
QSP	Will you relay to free of charge?	I will relay to free of charge.
QSQ	Must I send each word or group once only?	Send each word or group once only.
QSR	Has the distress call received from been attended to?	The distress call received from has been attended to by
QSU	Must I send on meters (or kilocycles) waves of type A1, A2, A3, or B?*	Send on meters (or on kilocycles), waves of Type A1, A2, A3 or B.* I am listening for you.
QSV	Must I shift to the wave of meters (or of kilocycles), for the balance of our communications, and continue after having sent several V's?	Shift to wave of meters (or of ... kilocycles) for the balance of our communications and continue after having sent several V's.
QSW	Will you send on meters (or on ... kilocycles) waves of Type A1, A2, A3 or B?*	I will send on meters (or kilocycles) waves of Type A1, A2, A3 or B.* Continue to listen.
QSX	Does my wave length (frequency) vary?	Your wave length (frequency) varies.
QSY	Must I send on the wave of meters (or kilocycles) without changing the type of wave?	Send on the wave of meters (or kilocycles) without changing the type of wave.
QSZ	Must I send each word or group twice.	Send each word or group twice.
QTA	Must I cancel telegram No. as if it had not been sent?	Cancel telegram No. as if it had not been sent.
QTB	Do you agree with my word count?	I do not agree with your word count; I shall repeat the first letter of each word and the first figure of each number.
QTC	How many telegrams have you to send?	I have telegrams for you or for
QTD	Is the word-count which I am confirming to you accepted?	The word count which you confirm to me is accepted.
QTE	What is my true bearing? (or) What is my true bearing relative to?	Your true bearing is .. degrees (or) Your true bearing relative to degrees at (o'clock).
QTF	Will you give me the position of my station based on the bearings taken by the radiocompass stations which you control?	The position of your station based on the bearings taken by the radiocompass stations which control is latitude longitude.
QTG	Will you transmit your call signal for one minute on a wave length of meters (or kilocycles) in order that I may take your radiocompass bearing?	I am sending my call signal for one minute on the wave length of meters (or kilocycles) in order that you may take my radiocompass bearing.

<i>Abbreviation</i>	<i>Question</i>	<i>Answer</i>
QTH	What is your position in latitude and longitude (or according to any other indication)?	My position is latitude longitude (or according to any other indication).
QTI	What is your true course?	My true course is degrees.
QTJ	What is your speed?	My speed is knots, or kilometers per hour.
QTK	What is the true bearing of relative to you?	The true bearing of relative to me is degrees at (o'clock).
QTL	Send radio signals to enable me to determine my bearing with respect to the radio beacon.	I am sending radio signals to permit you to determine your bearing with respect to the radio beacon.
QTM	Send radio signals and submarine sound signals to enable me to determine my bearing and my distance.	I am sending radio signals and submarine sound signals to permit you to determine your bearing and your distance.
QTN	Can you take the bearing of my station (or of) relative to you?	I can not take the bearing of your station (or of) relative to my station.
QTP	Are you going to enter the dock (or the port)?	I am going to enter the dock (or the port).
QTR	What is the exact time?	The exact time is
QTS	What is the true bearing of your station relative to me?	The true bearing of my station relative to you is at (o'clock).
QTU	What are the hours during which your station is open?	My station is open from to

* Waves are classified as follows in Art. 4, General Regulations. A1: unmodulate | continuous waves, varied by telegraphic keying. A2: continuous waves modulated at audible frequency, with which is combined telegraphic keying. A3: continuous waves modulated by speech or by music. B: damped waves.

MISCELLANEOUS ABBREVIATIONS

The following miscellaneous abbreviations have universal agreement and should not be

employed in other than the meanings specified, nor should other than the specified abbreviation be employed to convey any meaning listed in this table.

<i>Abbreviation</i>	<i>Meaning</i>
C	Yes.
N	No.
P	Announcement of private telegram in the mobile service (to be used as a prefix).
W	Words or words.
AA	"All after " (to be used after a question mark to request a repetition).
AB	"All before " (to be used after a question mark to request a repetition).
AL	"All that has just been sent" (to be used after a question mark to request a repetition).
BN	"All between " (to be used after a question mark to request a repetition).
BQ	Announcement of reply to a request for rectification.
CL	"I am closing my station."
CS	Call signal (to be used to ask repetition of a call signal).
DB	"I can not give you a bearing, you are not in the calibrated sector of this station."
DC	"The minimum of your signal is suitable for the bearing."
DF	Your bearing at (o'clock) was degrees, in the doubtful sector of this station, with a possible error of two degrees.
DG	Please advise me if you note an error in the bearing given.
DI	Bearing doubtful in consequence of the bad quality of your signals.
DJ	Bearing doubtful because of interference.
DL	Your bearing at (o'clock) was degrees in the doubtful sector of this station.
DO	Bearing doubtful. Ask for another bearing later, or at (o'clock).
DP	Beyond 50 miles, possible error of bearing can attain two degrees.
DS	Adjust your transmitter, the minimum of your signal is too broad.
DT	I can not furnish you with a bearing; the minimum of your signal is too broad.
DY	This station is bilateral, what is your approximate direction in degrees relative to this station?
DZ	Your bearing is reciprocal (to be used only by the central station of a group of radio-compans stations when it is addressed to other stations of the same group).

Abbreviation	Meaning
ER	"Here" (to be used before the name of the mobile station in the sending of route indications).
GA	"Resume sending" (to be used more especially in the fixed service).
JM	"If I may send, make a series of dashes. To stop my transmission, make a series of dots" Not to be used on 600 meters (500 kilocycles).
MN	Minute or minutes (to be used to indicate the duration of a wait).
NW	"I resume transmission" (to be used more especially in the fixed service).
OK	"We are in agreement."
RQ	Announcement of a request for rectification.
SA	Announcement of the name of an aircraft station (to be used in the sending of indications of passage).
SF	Announcement of the name of an aeronautic station.
SN	Announcement of the name of a coast station.
SS	Announcement of the name of a ship station (to be used in the transmission of indications of passage).
TR	Announcement of the request or of the sending of indications concerning a mobile station.
UA	"Are we in agreement?"
WA	"Word after" (to be used after a question mark to request a repetition).
WB	"Word before" (to be used after a question mark to request a repetition).
XS	Atmospherics
YS	"See your service advice."
ABV	"Shorten the traffic by using the International Abbreviations." or "Repeat (or I repeat) the figures in abbreviation form."
ADR	Address (to be used after a question mark to request a repetition).
CFM	"Confirm" or "I confirm."
COL	"Collate" or "I collate."
ITP	"The punctuation counts."
MSG	Announcement of telegram concerning ship service only (to be used as a prefix).
PBL	Preamble (to be used after a question to request a repetition).
REF	"Referring to" or "Refer to"
RPT	"Repeat" or "I repeat" (to be used to ask or to give repetition of all or part of the traffic by making the corresponding indication after the abbreviation).
SIG	Signature (to be used after a question mark to request a repetition).
SVC	Announcement of service telegram concerning private traffic (to be used as a prefix).
TFC	Traffic.
TXT	Text (to be used after a question mark to request a repetition).

HAM ABBREVIATIONS

In amateur work the following abbreviations are also used, together with many other abbreviated words usually composed "on the spur of the moment." Study of abbreviations brings to light some methods that may be followed in coining abbreviations.

1. A method much used in short words is to give the first and last letters only, eliminating all intermediate letters in the word. Examples: Now, nw; check, ck; would, wd.

2. Another method uses consonants only, eliminating all vowels in the word. Examples: Letter, ltr; bound, bnd; message, msg; received, recd.

3. A third method consists of using phonetic spelling. Examples: Some, sum; good, gud; says, sez; night, nite.

4. Replacing parts of a word with the letter "X" is a method occasionally used in abbreviating. Examples: Transmitter, xmtr; weather, wx; distance, dx; press, px.

ABL	Able
ABT	About
AC	Alternating Current
ACCT	Account
ACCW	Alternating current C. W. (Not rectified before application to plate circuit of transmitting tubes)
ADR-ADS-ADSD	Address, addressed
AER	Aerial
AGN	Again
AHD	Ahead
AMP	Ampere
AMT	Ampere
ANI	Any
ANT	Antenna
ARL	Aerial
ART	All right
AST	Atlantic Standard Time (1 hour later than E.S.T.)
AUD	Audible, audibility
AUSSIE	Australian amateur
B	Be
B4	Before
BCL	Broadcast listener
BD	Bad
BI	By
BK	Break, back
BKG	Bookkeeping, breaking
BLV	Believe
BN	Been, all between
BND	Bound

BPL	Brass Pounders' League	MK	Make
BTR	Better	MO	Month, master oscillator
BUG	Vibroplex key, amateur radio "fever"	MST	Mountain Standard Time
C	See, correct, yes	MTR	Meter
CANS	Phones	N	Nil, nothing, no
CHGS	Charges	ND	Nothing doing
CK	Check	NG	No good
CKS	Chokes, circuits	NIL	Nothing
CKT	Circuit	NITE	Night
CL-CLG-CLD	Call, calling, called, closing (station)	NM	No more
CM	Communications Manager	NO	Know
CM	Can	NPR	Night Press Rate
CNT	Can't, cannot	NR	Number, near, no record
COND	Condenser, condition	NSA	No such address
CONGRATS	Congratulations	NT	Not
CP-CFSE	Counterpoise	NTG	Nothing
CRD	Card	NW	Now (I resume transmission)
CST	Central Standard Time	NZ	New Zealand
CUD-CD	Could	OB	Old Boy, Official Broadcast
CUL	See you later	OFS	Office
CUM	Come	OM	Old man
CW	Continuous wave	OO	Official Observer
CY	Copy	OPN	Operation
DA	Day	OP-OPR	Operator
DC	Direct current	ORS	Official Relay Station
DPS	Disregard former service	OSC	Oscillate, oscillations
DH	Dead head, service message	OT	Oscillation transformer, old timer, old top
DL-DLVD	Delivered	OW	Old woman
DLY	Delivery	PRI	Primary
DN	Done, down	PSE	Please
DNT	Do not, don't	PST	Pacific Standard Time
DPR	Day Press Rate	PT	Point
DSTN	Destination	PUNK	Poor operator, lid
DSTC	Delivered subject to correction	PUR	Poor
DUPE	Duplicate	PWR	Power
DX	Distance	PX	Press (news)
ER(E)	Here	R	Are, all right, O.K.
EM	Them	RAC	Rectified alternating current
ES	And	RCD	Received
EST	Eastern Standard Time	RCVR	Receiver
EVDI	Everybody	RDO	Radio
EVY	Every	RDS	Reads
EZ	Easy	RES	Resistance
FB	Fine business, excellent	RHEO	Rheostat
FIL	Filament	RI	Radio Inspector
FIL-D-FLT	Filed, filing time	RITE	Write, right
FM	From	RM	Route Manager
FONES	Telephones	RPT	Repeat, report
FR	For	RUF	Rough
FREQ	Frequency, frequently	SA	Say
GA	Go ahead (resume sending)	SCM	Section Communications Manager
GB	Good-bye	SEC	Second
GBA	Give better address	SED	Said
GE	Good evening	SEZ	Says
GEN	Generator	SHUD	Should
GES	Guess	SIG-SG	Signature
GG	Going	SIGS	Signals
GM	Good morning	SINE	Sign, personal initials, signature
GCT	Greenwich Civil Time	SINK	Synchronous
GN	Gone, good night	SITE	Sight
GND	Ground	SKED	Schedule
GCA	Get quick answer	SORRI-SRI	Sorry
GSA	Give some address	SPK	Spark, speak
GUD	Good	SUM	Some
GV-GVG	Give, giving	TC	Thermo couple
HA	Hurry answer	TDA	Today
HAM	Amateur, brass-pounder	TKS-TNX	Thanks
HD	Had, head	TNG	Thing
HI	Laughter, high	TMW	Tomorrow
HR	Here, hear	TR	There, their, position report
HRD	Heard	TRI	Try
HV	Have	TRUB	Trouble
HVY	Heavy	TS	This
HW	How, hot wire, herewith	T	The
HWM	Hot wire meter	TT	That
I	I understand	TU	Thank you
ICW	Interrupted continuous wave	U	You
INPT	Input	UNDL	Undelivered
IMPT	Important	UNKN	Unknown
KNW	Know	UR	Your, you're
LD-LID	"Lid," a poor operator, long distance	URS	Yours
LITE	Light	V	Volt
LTR	Later, letter	VAR	Variable
LW	Low	VC	Variable Condenser
MA	Milliampere	VT	Vacuum tube
MANI	Many	VY	Very
MG	Motor-generator	WD	Would, word
MGR	Manager	WDS	Words
MILS	Milliamperes	WN-WEN	When
MI	My	WI-WID	With
MIN	Minute	WK	Work, weak, week, well-known
MIM	Exclamation	WKD	Worked
MITY	Mighty		

WKG	Working
WL	Will
WN	When
WO	Who
WT	What, wait, watt
WUD	Would
WV-WL	Wave, wavelength
WX	Weather
XMITR	Transmitter
XCUSE	Excuse
XPLN	Explain
XTRA	Extra
YDA	Yesterday
YL	Young lady
YR	Your
ZEDDER	New Zealander
73	Best regards
88	Love and kisses
99	Keep out
2	Two, to, too
2DA	To-day
4	Please start me, where?, for, four
8	Eight, ate

D	Germany
EAA-EHZ	Spain
EIA-EIZ	Irish Free State
ELA-ELZ	Liberia
ESA-ESZ	Ethonia
ETA-ETZ	Ethiopia (Abyssinia)
F	France (including colonies)
G	French Indo-China
HAA-HAZ	Great Britain
HBA-HBZ	Great Britain except Ireland
HCA-HCZ	Northern Ireland
HHA-HHZ	Hungary
HIA-HIZ	Switzerland
HJA-HJZ	Ecuador
HRA-HRZ	Republic of Haiti
HSA-HSZ	Dominican Republic
I	Republic of Colombia
J	Republic of Honduras
K	Siam
KA	Italy and colonies
K4	Japan
K6	United States of America
K7	Philippine Ids.
LA	Porto Rico and Virgin Ids.
LU	Territory of Hawaii
LZ	Alaska
[G]	Norway
[W]	Argentina Republic
OA	Bulgaria
OH	Great Britain
OK	United States of America
ON	Peru
OZ	Finland
PA	Czechoslovakia
PB	Belgium and colonies
PC	Denmark
PJ	The Netherlands
PK	Curacao
PY	Dutch East Indies
PZ	Brazil
RA	Surinam
RV	U.S.S.R. ("Russia")
RX	Persia
RY	Republic of Panama
SM	Lithuania
SP	Sweden
SU	Poland
SV	Egypt
TA	Greece
TF	Turkey
TG	Iceland
TI	Guatemala
TS	Costa Rica
UH	Territory of the Saar Basin
PK	Hedjaz
UL	Dutch East Indies
UN	Luxemburg
UO	Yugoslavia
VE	Austria
VK	Canada
VO	Commonwealth of Australia
VP	Newfoundland
VQ	British colonies and protectorates
VS	Bermuda, Br. Guiana, Zanzibar
VT-VU	Northern Rhodesia, Kenya
W	Colony, Fanning Id.
X ²	Straits Settlements, Ceylon,
(AC) ²	Hong Kong, Malay States
YA	British India
YH	United States of America
YI	continental
YK	Mexico
YL	China
	Afghanistan
	New Hebrides
	Iraq
	Formosa
	Latvia

INTERNATIONAL PREFIXES

The nationality of a radio station is shown by the initial letter or letters of the call signal assigned it by its government. These assignments are based on an international allocation of the alphabet embraced in the International Radiotelegraph Convention.

Amateur calls commonly consist of one or two initial letters to indicate nationality, a digit, and two or three additional letters.

Nations are obliged to select some letter or letters from their assignment to use as a prefix to amateur calls. The remainder of the call commonly consists of a numeral and two or three letters.

In the list which follows, the first column shows the allocation of call signals made in the Washington Convention. Every call of a nation must be taken from the block of letters assigned it. Thus this list is useful in identifying the nationality of any call heard, whether amateur or not. In the second column the amateur prefixes, the beginning letters of amateur calls, are listed. In most cases we know these prefixes to have been officially designated by the government concerned, but in some cases we have listed, of our own initiative, the proper prefix when there can be no choice about it. For instance, Haiti is assigned the calls from HHA to HHZ and therefore every Haitian call must begin with the letters HH, whether that government so proclaims or not. In a few cases blanks are shown, where there is some choice and the government concerned has not acted. For instance, one does not know, until Colombia acts, whether Colombian amateur calls will commence with HJ or HK. Where a prefix is shown in brackets, it indicates that that government has more than one assignment of initial letters and that the indicated letter will be found assigned, in another part of the list, to that country.

The list:

CAA-CEZ	CE	Chile
CFA-CKZ	[VE]	Canada
CLA-CMZ	CM	Cuba
CNA-CNZ	CN	Morocco, Algeria, Tunisia
CPA-CFZ	CP	Bolivia
CQA-CQZ ¹	CR	Portuguese colonies
CRA-CRZ		
CSA-CUZ	CT	Portugal
CVA-CVZ	CV	Rumania
CWA-CXZ	CX	Uruguay
CZA-CZZ	CZ	Monaco

¹ Provisionally assigned by Berne Bureau.
² Improperly assigned by Mexico. Should have two letters to distinguish from China.
³ Unofficial prefix, heritage from I.A.R.U. "intermediates," still used by amateurs in China. They would be better advised to use XG, which would establish nationality.

YMA-YMZ	YM	Free City of Danzig
YNA-YNZ	YN ⁴	Nicaragua
YSA-YSZ	YS	Republic of El Salvador
YVA-YVZ	YV	Venezuela
ZAA-ZAZ	ZA	Albania
ZBA-ZHZ ¹		British colonies and protectorates
ZKA-ZMZ	ZL	New Zealand
	ZK	Cook Islands
	ZM	British Samoa
ZPA-ZPZ	ZP	Paraguay
ZSA-ZUZ	ZS }	Union of South Africa
	ZT }	

CIRCULAR TIME-AND-DATE CHART

A method of comparing different times with each other and with G.C.T. (Greenwich Civil Time) is necessary to get time, weather, and press schedules, announced in almost every case in local time. In the chart shown, the two discs A and B should be drawn carefully and mounted on cardboard. When centered and pinned together we have a convenient device to use in working international schedules and in checking QSL-cards. The chart is based on the fact that time changes an hour for each 15° of arc.

To find local time from a given G.C.T., simply set the G.C.T. mark on the given time and read the local time directly at its mark. Let us take an example. Set the G.C.T. mark at 00 G.C.T. Then by direct reading it is 6 p.m. Chicago time or 9 a.m. Tokio time. If we in Tokio wanted to find what time it was in New York at 6 p.m. Tokio time, we would set the Tokio pointer at 6 p.m. and read 4 a.m. for New York time.

Finding dates: Suppose an operator in Los Angeles works a station in Tokio at 11 p.m. P.S.T. on June 10. Then the slide rule shows that it will be 4 p.m. Tokio time. The next thing is to find whether it is *to-day* or *to-morrow* in Tokio,

MEASURING DISTANCES

Often it is interesting to know just how far away some station is located. In measuring distances it is customary to measure along the shortest path on the surface of the earth. This distance is along the arc of a Great Circle, and for very short distances is practically a straight line. Distances of a thousand miles or so may be measured with sufficient accuracy on an ordinary map with a ruler, using the "scale of miles" indicated on the map.

For longer distances where the curvature of the earth cannot be neglected, the simplest way of measuring distance is by means of a common globe of the type used in school-rooms. The globe

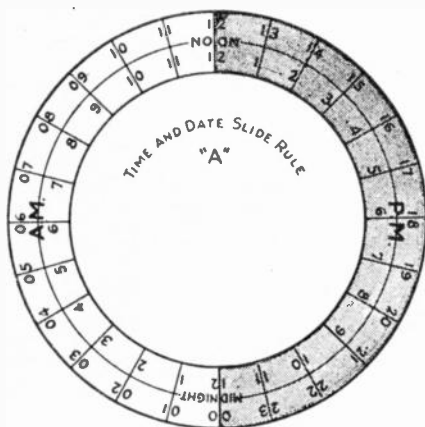

should be at least eight inches in diameter for good results. A piece of string should be stretched between the two points in question, and when pulled taut will automatically align itself along the Great Circle route between them. The length of the string between the two points when converted into miles according to the scale of the globe, will be the distance between the two points.

The globe will be found useful in other ways also, as for instance in determining the direction in which a distant spot lies from the station. Flat maps of the world (on Mercator's projection) give a wholly misleading impression of both distance and direction between points widely separated, especially if located in the extremes of latitude.

that is, June 10th or 11th. Now with the rule all set we run our eye around it in a *clockwise* direction from Los Angeles to Tokio. If at any point in that space the midnight mark on disc A is encountered it is *to-morrow* in Tokio, i.e. June 11th. If the midnight mark is not encountered in this space it is *to-day* in Tokio. For example: Suppose the Los Angeles station works the station in Tokio at 1 a.m. P.S.T. June 10th. Then the Los Angeles operator will know from the slide rule that it is 6 p.m. June 10th Tokio time.

Let us work from the Eastern Hemisphere back to the Western. Suppose the operator at the Tokio station is doing the figuring. He works the Los Angeles station, let us say, at 9 p.m. June 15th, Tokio time. He wants to know what time it is in Los Angeles and also what the date is. He sets the rule to 9 p.m. Tokio time and finds at once that it is 4 a.m. in Los Angeles. Now for the date. He reads around disc B from Tokio to Los

⁴ Most Nicaraguan amateurs apparently use NN, particularly certain amateur stations operated by U. S. Marines in Nicaragua. YN is preferable, as it indicate nationality.

Angeles in a *clockwise* direction. Notice that it is always clockwise from the local station to the distant station. If at any place in that path the midnight mark is encountered it is *to-day* in Los Angeles, in other words June 15th.

Suppose the Tokio station works the station in Los Angeles at 1 a.m. Tokio time. It would be 8 a.m. Los Angeles time, and since the midnight mark is not encountered between the two, in a clockwise direction from Tokio to Los Angeles, it is *yesterday* in Los Angeles, i.e. June 14th.

Now to find the difference in dates between two stations in the same hemisphere. Consider that half of the disc *B* and disregard the other half altogether. If the midnight mark does not come between them, within that semicircle, they are both *to-day*. If, however, the midnight mark comes in between them the one to the right is one day ahead of the one to the left, or inversely, the one to the left is a day behind the one to the right.

GOOD BOOKS

Every amateur should maintain a carefully selected bookshelf; a few good books, consistently read and consulted, will add immeasurably to the interest and knowledge of the owner. We suggest a selection among the following works, all of which have been gone over carefully and are recommended in their various fields.

Principles of Radio, by Keith Henney, is an excellent book for the amateur who wants to acquire a better understanding of the fundamentals of radio transmission and reception. The book is thoroughly modern and, generally speaking, is a "non-mathematical" treatment. Recommended to every amateur. Price, \$3.50.

Other excellent theoretical works, requiring, however, slightly more knowledge of mathematics (algebra, at least) are *Elements of Radio Communication*, by Prof. J. H. Morecroft, price \$3.00, and *Radio Engineering Principles*, by Lauer and Brown, price \$3.50. Both books are in the "first-year" student class. Probably the best-known of all theoretical works is *Principles of Radio Communication*, by Morecroft, priced at \$7.50, but a familiarity with mathematics is essential to anyone who expects to derive much benefit from this book.

For the amateur in the "experimenter" class there are two publications which are ideal: *Experimental Radio*, by Prof. R. R. Ramsey, \$2.75, describes in detail 128 experiments designed to bring out the principles of radio theory, instruments and measurements; *Radio Data Charts*, by R. T. Beatty, is an English publication available through the League's Book Department at \$1.50. It is a series of abacs (graphic charts) which enables most of the problems connected with radio design to be solved without recourse to mathematical calculations. Full instructions for use are appended to each chart. Another standard reference work for basic radio formulas, measurements, etc., is *Radio Instruments and Measurements*, Circular No. 74 of the Bureau of Standards, which can be obtained for sixty cents (no stamps or checks) from the Superintendent of Documents, Government Printing Office, Washington, D. C. This book requires a knowledge of mathematics.

For practical handbooks covering just about

the entire field of radio, we recommend either *Radio Theory and Operating*, by Loomis, price \$4.25, *The Radio Manual*, by Sterling, at \$6.00, or *Radio Telegraphy and Telephony*, by Duncan and Drew, at \$7.50. All of these are over 900 pages and are of the type used as texts in radio schools; while they contain a moderate amount of theory, they are essentially practical handbooks for commercial and broadcast operators. Any one of them is well worth having.

Amateurs who are interested in studying for commercial operator's licenses will be interested in the following, in conjunction with the volumes listed in the preceding paragraph: *How to Pass U. S. Government Radio License Examinations*, by Duncan and Drew, price \$2.00, which is written to supplement the other work by the same authors, mentioned above; and *Radio Operating Questions and Answers*, by Nilson and Hornung, \$2.00, which is intended to supplement *Practical Radio Telegraphy* (by the same authors, price \$3.00), in preparation for commercial licenses.

Van der Bijl's *Thermionic Vacuum Tube* still remains the best text available for the theory of operation of vacuum tubes. Beginners should steer clear of it, however; it is strictly an engineering work and requires a thorough knowledge of higher mathematics. The price is \$5.00.

Any of the above books (with the exception of Circular No. 74) may be obtained from the Book Department of the A.R.R.L. at the prices stated. Readers are referred to the Book Department's advertisement, in the advertising section of this Handbook, for a list which includes additional volumes of interest to amateurs.

QST is the official organ of the American Radio Relay League. It is published monthly, containing up-to-date information on amateur activities and describing the latest developments in amateur radio. It is a magazine devoted exclusively to the radio amateur. Written by and for the amateur, it contains knowledge supplementary to the books we have mentioned. *QST* is found on the bookshelves of earnest amateurs and experimenters everywhere. Good books are a worth-while investment. A subscription to *QST* is equally valuable.

STANDARD LETTER SYMBOLS FOR ELECTRICAL QUANTITIES

Admittance	Y, y
Angular velocity ($2\pi f$)	ω
Capacitance	C
Conductance	G, g
Current	I, i
Difference of potential	E, e
Dielectric constant	K or ϵ
Energy	W
Frequency	f
Impedance	Z, z
Inductance	L
Magnetic intensity	H
Magnetic flux	Φ
Magnetic flux density	B
Mutual inductance	M
Number of conductors or turns	N
Permeability	μ
Phase displacement	θ or ϕ
Power	P, p

Quantity of electricity	Q, q
Reactance	X, x
Resistance	R, r
Susceptance	b
Speed of rotation	n
Voltage	E, e
Work	W

METRIC PREFIXES OFTEN USED WITH RADIO QUANTITIES

	$\frac{1}{1,000,000}$	One millionth	micro-
μ	$\frac{1}{1,000,000}$		
	$\frac{1}{1,000}$	One-thousandth	milli-
m	$\frac{1}{1,000}$		
	$\frac{1}{100}$	One-hundredth	centi-
c	$\frac{1}{100}$		
	$\frac{1}{10}$	One-tenth	deci-
d	$\frac{1}{10}$		
	1	One	uni-
	10	Ten	deka-
dk	10		
	100	One hundred	hekto-
h	100		
	1,000	One thousand	kilo-
k	1,000		
	10,000	Ten thousand	myria-
	1,000,000	One million	mega-

LETTER SYMBOLS FOR VACUUM TUBE NOTATION

Grid potential	E_g, e_g
Grid current	I_g, i_g
Grid conductance	g_g
Grid resistance	r_g
Grid bias voltage	E_c
Plate potential	E_p, e_p
Plate current	I_p, i_p
Plate conductance	g_p
Plate resistance	r_p
Plate supply voltage	E_b
Emission current	I_a
Mutual conductance	g_m
Amplification factor	μ
Filament terminal voltage	E_f
Filament current	I_f
Filament supply voltage	E_a
Grid-plate capacity	C_{gp}
Grid-filament capacity	C_{gf}
Plate-filament capacity	C_{pf}
Grid capacity ($C_{gp} + C_{gf}$)	C_g
Plate capacity ($C_{gp} + C_{pf}$)	C_p
Filament capacity ($C_{gf} + C_{pf}$)	C_f

NOTE.— Small letters refer to instantaneous values.

FIGURING THE CAPACITANCE OF A CONDENSER

$$C' = \frac{kA(n-1)}{4\pi d \times 9 \times 10^9}$$

$$= .0088 \frac{kA}{d} (n-1) 10^9 \text{ mfd.}$$

where A = area of one side of one plate (sq. cm.)
 n = total number of plates
 d = separation of plates (cm.)
 k = specific inductive capacity of dielectric.

The Specific Inductive Capacity (k) is a property of the dielectric used in a condenser. It determines the quantity of charge which a given separation and area of plates will accumulate for

ABBREVIATIONS COMMONLY USED IN RADIO

Alternating current	a.c.
Antenna	ant.
Audio frequency	a.f.
Continuous waves	c.w.
Cycles per second	~
Decibel	db.
Direct current	d.c.
Electromotive force	e.m.f.
Frequency	f.
Ground	gnd.
Henry	h.
Intermediate frequency	i.f.
Interrupted continuous waves	i.c.w.
Kilocycles (per second)	kc.
Kilowatt	kw.
Megohm	M Ω
Microfarad	μ f.
Microhenry	μ h.
Micromicrofarad	$\mu\mu$ f.
Microvolt	μ v.
Microvolt per meter	μ v/m.
Milliampere	ma.
Milliwatt	mw.
Ohm	Ω
Power factor	p.f.
Radio frequency	r.f.
Volt	v.

TABLE OF DIELECTRIC CONSTANTS

Dielectric	"k"	Puncture voltage	
		Kilovolts per cm.	Kilovolts per inch.
Air (normal pressure)	1.00	7.8-9.0	19.8-22.8
Flint Glass	6.6 to 10	900	2280
Mica	4.6 to 8	1500	3810
Paraffin Wax (solid)	2.0 to 2.5	400	1017
Sulphur	3.9 to 4.2	—	—
Castor Oil	4.7	150	381
Porcelain	4.4	—	—
Quartz	4.5	—	—
Resin	2.5	—	—
Olive Oil	3.1	120	305
Gutta Percha	3.3 to 4.9	80-200	203-508
Shellac	3.1	—	—
Common Glass	3.1 to 4.0	300-1500	762-3810
Turpentine	2.23	110-160	280-406
Dry Oak Wood	2.5 to 6.8	—	—
Formica, Bakelite, etc.	5 to 6	—	—

a given applied voltage. The "inductivity" of the dielectric varies as in the above table. "k" is the ratio of the capacitance of a condenser with a given dielectric to the capacitance of the same instrument with air dielectric.

When the air dielectric in a variable condenser is replaced with some other fluid dielectric its maximum and minimum capacitance values are multiplied by "k" and the "sparking" potential is increased.

Fluid dielectrics repair themselves after a breakdown unless an arc is maintained that carbonizes the oil. Dry oil is a good dielectric with quite low losses. When solid dielectric is used it should be borne in mind that dielectric strength

(breakdown voltage) becomes lower as temperature rises. Breakdown is a function of time as well as voltage. A condenser that stands up under several thousand volts for a few seconds might break down when connected to a 2000-volt line for a half-hour.

Example of finding condenser capacitance: We have 3 plates, 3" x 5", in air. The plates are separated 1/8". $1'' = 2.54$ centimeters.

$$k = 1. A = 7.62 \times 12.70 = 96.8 \text{ sq. cm. } d = .3175 \text{ cm. } n - 1 = 2.$$

$$C' = .0088 \frac{1 \times 96.8}{.32} 2 \times 10^{-5} = .0005325 \mu\text{f. or } 53\frac{1}{4} \text{ micromicrofarads.}$$

The capacity formula becomes as follows, when A is the area of one side of one plate in square inches and d is the separation of the plates in inches.

$$C = .02235 \frac{kA}{d} (n-1) 10^{-5} \mu\text{fds.}$$

If we put the condenser of our example in castor oil the increase in capacitance, owing to the greater value of k , will make our condenser have a capacitance of

$$53\frac{1}{4} \times 4.7 = 250 \text{ micromicrofarads.}$$

The air condenser might spark over at about $7.8 \times .3175 \text{ cm.} = 2.475 \text{ kv. (2,475 volts).}$

In oil (castor oil) it would have $150/7.8$ (or $381/19.8$) times the breakdown voltage of air.

$$\frac{150}{7.8} = 19.25$$

$$19\frac{1}{4} \times 2475 = 47,600 \text{ volts}$$

We can find the same value directly:

$$150 \times .3175 \text{ cm.} = 47,600 \text{ volts (peak).}$$

Using the formulas for "reactance" we can find what the voltage drop across this condenser will be when carrying current at a specified high frequency.

$$E_x = X_c I \quad X_c = \frac{1}{2\pi f C}$$

where E_x is the reactance voltage drop, C is the capacitance of the condenser (farads),

f is the frequency (cycles per second), X_c is the reactance of the condenser in ohms.

Suppose we are using the 3-plate fixed air condenser in our antenna circuit, and that a radio-frequency ammeter is in series with it. We are operating on an 80-meter wavelength (3,750,000 cycles) and the meter right next the condenser reads 1.3 amperes. What is the voltage drop across the air condenser?

$$X_c = \frac{1}{2 (3.1416) (3,750,000) (53.25) 10^{-12}} \\ = \frac{1}{1257 \times 10^{-5}} = \frac{10^5}{1257} = 797 \text{ ohms}$$

$$E_x = (797) (1.3) = 1034 \text{ volts (root mean square value).}$$

If the wave is a sine wave, this value multiplied

by 1.414 will give the "peak" or maximum value. $1034 \times 1.414 = 1462$ volts (peak)

Our radio-frequency ammeter measures the heating effect of all the instantaneous values of current during the radio-frequency cycle. The direct current, the square of which equals the average of the squares of all the values of alternating current over a whole cycle, produces the same heat as the alternating current. Alternating current meters generally used for a.c. switchboard work read the effective or root mean square values which we mention above.

INDUCTANCE CALCULATION

The lumped inductance of coils for transmitting and receiving is fairly easy to calculate.

$$L = \frac{.0395 a^2 n^2}{b} K$$

(for single-layer solenoids)

Where L is the inductance in microhenries

n is the number of turns

a is the mean radius of the coil (cm.)

b is the length of coil (cm.) = nD

D is the distance between the centers of two adjacent turns

K is the coil shape factor depending on the ratio $2a/b$ (see chart).

Start with the given coil diameter. Using the overall length of the coil find a value for K . If the

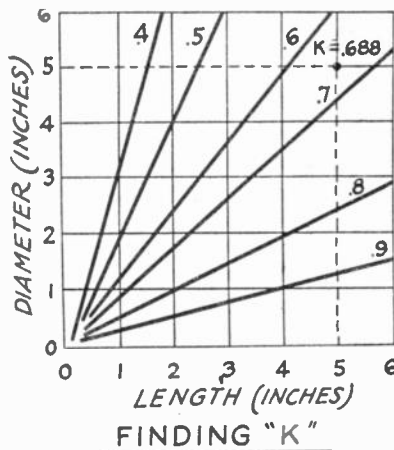

diameter is 5" and the length 5" go to the right from "5" on the diameter scale. At the same time go "up" from "5" on the length scale. Notice where the two lines meet. They meet at "X" between the lines "6" and "7." We estimate the value of K at .688 and proceed.

Assume a transmitting coil having 10 turns of 1/4" brass strip, flatwise wound, 5" diameter (6.35. radius), and spaced 1/4" between turns, making the overall length (nD) 12.7 cm.

$$a = 6.35 \quad 2a \\ n = 10. \quad \quad \quad = 1 \\ b = 12.7 \quad \quad \quad b$$

K is about .688 (from chart)

$$L = \frac{.0395 (6.35)^2 (10)^2}{12.7} .688 = 8.64 \text{ microhenries.}$$

COPPER WIRE TABLE

Gauge No. B. & S.	Diam. in Mils ¹	Circular Mil Area	Turns per Linear Inch ²				Turns per Square Inch ²			Feet per Lb.		Ohms per 1000 ft. 25° C.	Current- Carrying Capacity at 1500 C.M. per Amp. ³	Diam. in mm.	Nearest British S.W.G. No.
			Enamel	S.S.C.	D.S.C. or S.C.C.	D.C.C.	S.C.C.	Enamel S.C.C.	D.C.C.	Bare	D.C.C.				
1	289.3	83690	—	—	—	—	—	—	—	3.947	—	1264	55.7	7.348	1
2	257.6	66370	—	—	—	—	—	—	—	4.977	—	1593	44.1	6.544	3
3	229.4	52640	—	—	—	—	—	—	—	6.276	—	2009	35.0	5.827	4
4	204.3	41740	—	—	—	—	—	—	—	7.914	—	2533	27.7	5.189	5
5	181.9	33100	—	—	—	—	—	—	—	9.980	—	3195	22.0	4.621	7
6	162.0	28250	—	—	—	—	—	—	—	12.58	—	4028	17.5	4.115	8
7	144.3	20820	—	—	—	—	—	—	—	15.87	—	5080	13.8	3.665	9
8	128.5	18510	7.6	—	7.4	7.1	—	—	—	20.01	19.6	6405	11.0	3.264	10
9	114.4	13090	8.6	—	8.2	7.8	—	—	—	25.23	24.6	8077	8.7	2.906	11
10	101.9	10380	9.6	—	9.3	8.9	87.5	84.8	80.0	31.82	30.9	1.013	6.9	2.588	12
11	90.74	8234	10.7	—	10.3	9.8	110	105	97.5	40.12	38.8	1.284	5.5	2.305	13
12	80.81	6530	12.0	—	11.5	10.9	138	131	121	50.59	48.9	1.610	4.4	2.053	14
13	71.96	5178	13.5	—	12.5	12.0	170	162	150	63.80	61.5	2.042	3.5	1.828	15
14	64.08	4107	15.0	—	14.2	13.3	211	198	183	80.44	77.3	2.575	2.7	1.628	16
15	57.07	3257	16.8	—	15.8	14.7	262	250	223	101.4	97.3	3.247	2.2	1.450	17
16	50.82	2593	18.9	18.9	17.9	16.4	321	306	271	127.9	119	4.094	1.7	1.291	18
17	45.26	2048	21.2	21.2	19.9	18.1	397	372	329	161.3	150	5.163	1.3	1.150	18
18	40.30	1624	23.6	23.6	22.0	19.8	493	454	399	203.4	188	6.510	1.1	1.024	19
19	35.89	1288	26.4	26.4	24.4	21.8	592	553	479	256.5	237	8.210	.86	.9116	20
20	31.96	1022	29.4	29.4	27.0	23.8	775	725	625	323.4	298	10.35	.68	.8118	21
21	28.46	810.1	33.1	32.7	29.8	26.0	940	895	751	407.8	370	13.05	.54	.7230	22
22	25.35	642.4	37.0	36.5	34.1	30.0	1150	1070	910	514.2	461	16.46	.43	.6438	23
23	22.57	509.5	41.3	40.6	37.6	31.6	1400	1300	1080	648.4	584	20.76	.34	.5733	24
24	20.10	404.0	46.3	45.3	41.5	35.6	1700	1570	1260	817.7	745	26.17	.27	.5106	25
25	17.90	320.4	51.7	50.4	45.6	38.6	2060	1910	1510	1031	903	33.00	.21	.4547	26
26	15.94	254.1	58.0	55.6	50.2	41.8	2500	2300	1750	1300	1118	41.62	.17	.4049	27
27	14.20	201.5	64.9	61.5	55.0	45.0	3030	2780	2020	1639	1422	52.48	.13	.3606	29
28	12.64	169.8	72.7	68.6	60.2	48.5	3670	3350	2310	2067	1759	66.17	.11	.3211	30
29	11.26	126.7	81.6	74.8	65.4	51.8	4300	3900	2700	2607	2207	83.44	.084	.2859	31
30	10.03	100.5	90.5	83.3	71.5	55.5	5040	4660	3020	3287	2534	105.2	.067	.2546	33
31	8.928	79.70	101.	92.0	77.5	59.2	5920	5280	—	4145	2768	132.7	.053	.2268	34
32	7.950	63.21	113.	101.	83.6	62.6	7060	6250	—	5227	3137	167.3	.042	.2019	36
33	7.080	50.13	127.	110.	90.3	66.3	8120	7380	—	6591	4697	211.0	.033	.1798	37
34	6.305	39.75	143.	120.	97.0	70.0	9600	8310	—	8310	6168	266.0	.026	.1601	38
35	5.615	31.52	158.	132.	104.	73.5	10900	8700	—	10480	6737	335.0	.021	.1426	38-39
36	5.000	25.00	175.	143.	111.	77.0	12200	10700	—	13210	7877	423.0	.017	.1270	39-40
37	4.453	19.83	198.	154.	118.	80.3	—	—	—	16660	9309	533.4	.013	.1131	41
38	3.965	15.72	224.	166.	126	83.6	—	—	—	21010	10666	672.6	.010	.1007	42
39	3.531	12.47	248.	181.	133	86.6	—	—	—	26500	11907	848.1	.008	.0897	43
40	3.145	9.88	282.	194	140	89.7	—	—	—	33410	14222	1069	.006	.0799	44

¹ A mil is 1/1000 (one thousandth) of an inch.² The figures given are approximate only, since the thickness of the insulation varies with different manufacturers.³ The current-carrying capacity at 1000 C.M. per ampere is equal to the circular-mil area (Column 3) divided by 1000.

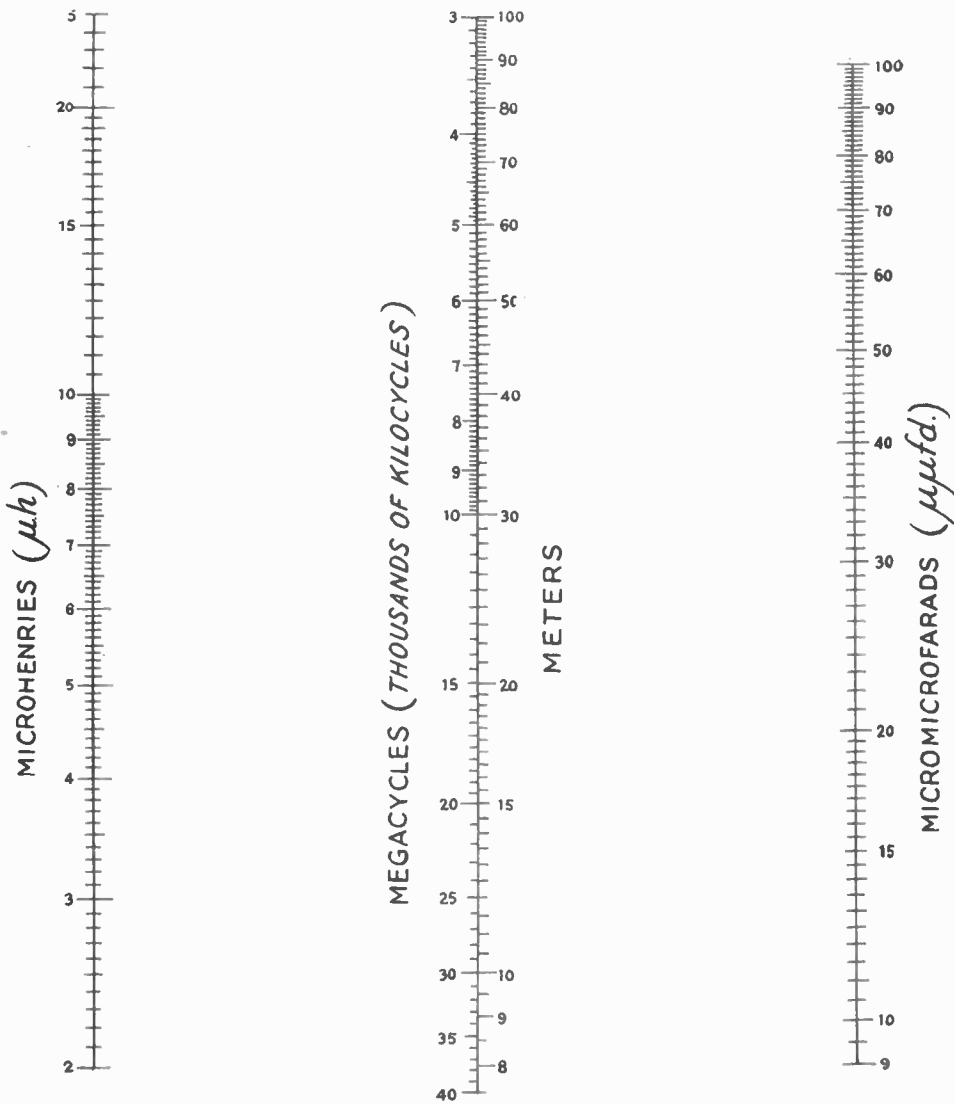

RELATION BETWEEN INDUCTANCE, CAPACITY AND FREQUENCY

With this chart and a straight-edge any of the above quantities can be determined if the other two are known. For example, if a condenser has a minimum capacity of 15 μμfd. and a maximum capacity of 50 μμfd., and it is to be used with a coil of 10 μh. inductance, what frequency range will be covered? The straight-edge is connected between 10 on the left-hand scale and 15 on the right, giving 13 mc. as the high-frequency limit. Keeping the straight-edge at 10 on the left-hand scale, the other end is swung to 50 on the right-hand scale, giving a low-frequency limit of 7.1 mc. The tuning range would, therefore, be from 7.1 mc. to 13 mc., or 7100 kc. to 13,000 kc. The center scale also serves to convert frequency to wavelength.

NUMBERED DRILL SIZES

Number	Diameter (mils)	Will Clear Screw	Drilled for Tapping Iron, Steel or Brass*
1	228.0	—	—
2	221.0	12-24	—
3	213.0	—	14-24
4	209.3	12-20	—
5	205.5	—	—
6	204.0	—	—
7	201.0	—	—
8	199.0	—	—
9	196.0	—	—
10	193.5	10-32	—
11	191.0	10-24	—
12	189.0	—	—
13	185.0	—	—
14	182.0	—	—
15	180.0	—	—
16	177.0	—	12-24
17	173.0	—	—
18	169.5	8-32	—
19	166.0	—	12-20
20	161.0	—	—
21	159.0	—	10-32
22	157.0	—	—
23	154.0	—	—
24	152.0	—	—
25	149.5	—	10-24
26	147.0	—	—
27	144.0	—	—
28	140.5	6-32	—
29	136.0	—	8-32
30	123.5	—	—
31	136.0	—	—
32	116.0	—	—
33	113.0	4-36 4-40	—
34	111.0	—	—
35	110.0	—	6-32
36	106.5	—	—
37	104.0	—	—
38	101.5	—	—
39	99.5	3-48	—
40	98.0	—	—
41	96.0	—	—
42	93.5	—	1-36 4-40
43	88.0	2-56	—
44	86.0	—	—
45	82.0	—	3-48
46	81.0	—	—
47	78.5	—	—
48	76.0	—	—
49	73.0	—	2-56
50	70.0	—	—
51	67.0	—	—
52	63.5	—	—
53	59.5	—	—
54	55.0	—	—

* Use one size larger drill for tapping bakelite and hard rubber.

EXTRACTS FROM THE RADIO LAW

The complete text of the Radio Act of February 23, 1927, would occupy many pages. Only those parts most applicable to amateur radio station licensing and regulation in this country (with which we should all be familiar) are given. Note particularly Secs. 26, 27, 28 and 29 and the penalties provided in Secs. 32 and 33.

Be it enacted by the Senate and House of Representatives of the United States of America in Congress assembled, That this Act is intended to regulate all forms of interstate and foreign radio transmissions and communications within the United States, its Territories and possessions; to maintain the control of the United States over all the channels of interstate and foreign radio transmission; and to provide for the use of such channels, but not the ownership thereof, by individuals, firms, or corporations, for limited periods of time, under licenses granted by Federal authority, and no such license shall be construed to create any right, beyond the terms, conditions, and periods of the license. That no person, firm, company, or corporation shall use or operate any apparatus for the transmission of energy or communications or signals by radio . . . except under and in accordance with this Act and with a license in that behalf granted under the provisions of this Act.

SEC. 3. That a commission is hereby created and estab-

GREEK ALPHABET

Since Greek letters are used to stand for many electrical and radio quantities, the names and symbols of the Greek alphabet with the equivalent English characters are given.

Greek Letter	Greek Name	English Equivalent
A α	Alpha	a
B β	Beta	b
Γ γ	Gamma	g
Δ δ	Delta	d
E ε	Epsilon	e
Z ζ	Zeta	z
H η	Eta	—
Θ θ	Theta	th
I ι	Iota	i
K κ	Kappa	k
Λ λ	Lambda	l
M μ	Mu	m
N ν	Nu	n
Ξ ξ	Xi	x
Ο ο	Omicron	ō
Π π	Pi	p
P ρ	Rho	r
Σ σ	Sigma	s
T τ	Tau	t
Υ υ	Upsilon	u
Φ φ	Phi	ph
X χ	Chi	ch
Ψ ψ	Psi	ps
Ω ω	Omega	ō

lished to be known as the Federal Radio Commission, hereinafter referred to as the commission, which shall be composed of five commissioners . . .

SEC. 4. Except as otherwise provided in this Act, the commission, from time to time, as public convenience, interest, or necessity requires, shall —

- (a) Classify radio stations;
- (b) Prescribe the nature of the service to be rendered by each class of licensed stations and each station within any class;
- (c) Assign bands of frequencies or wavelengths to the various classes of stations, and assign frequencies or wavelengths for each individual station and determine the power which each station shall use and the time during which it may operate;
- (d) Determine the location of classes of stations or individual stations;
- (e) Regulate the kind of apparatus to be used with respect to its external effects and the purity and sharpness of the emissions from each station and from the apparatus therein;
- (f) Make such regulations not inconsistent with law as it may deem necessary to prevent interference between stations and to carry out the provisions of this Act: *Provided, however, . . .*
- (i) Have authority to make general rules and regulations . . .

SEC. 5. From and after one year after the first meeting of the commission created by this Act (Mar. 15, 1927), all the powers and authority vested in the commission under the terms of this Act, except as to the revocation of licenses, shall be vested in and exercised by the Secretary of Commerce; except that thereafter the commission shall have power and jurisdiction to act upon and determine any and all matters brought before it under the terms of this section.

It shall also be the duty of the Secretary of Commerce —
 (A) For and during a period of one year from the first meeting of the commission created by this Act, to immediately refer to the commission all applications for station licenses or for the renewal or modification of existing station licenses.

(B) From and after one year from the first meeting of the commission created by this Act, to refer to the commission for its action any application for a station license or for the renewal or modification of any existing station license as to the granting of which dispute, controversy, or conflict

arises or against the granting of which protest is filed within ten days after the date of filing said application by any party in interest and any application as to which such reference is requested by the applicant at the time of filing said application.

(C) To prescribe the qualifications of station operators, to classify them according to the duties to be performed, to fix the forms of such licenses, and to issue them to such persons as he finds qualified.

(D) To suspend the license of any operator for a period not exceeding two years upon proof sufficient to satisfy him that the licensee (a) has violated any provision of any Act or treaty binding on the United States which the Secretary of Commerce or the commission is authorized by this Act to administer or by any regulation made by the commission or the Secretary of Commerce under any such Act or treaty; or (b) has failed to carry out the lawful orders of the master of the vessel on which he is employed; or (c) has willfully damaged or permitted radio apparatus to be damaged; or (d) has transmitted superfluous radio communications or signals or radio communications containing profane or obscene words or language; or (e) has willfully or maliciously interfered with any other radio communications or signals.

(E) To inspect all transmitting apparatus to ascertain whether in construction and operation it conforms to the requirements of this Act, the rules and regulations of the licensing authority, and the license under which it is constructed or operated.

(F) To report to the commission from time to time any violations of this Act, the rules, regulations, or orders of the commissions, or of the terms or conditions of any license.

(G) To designate call letters of all stations.

Sec. 14. Any station license shall be revocable by the commission for false statements either in the application or in the statement of fact which may be required by section 10 hereof, or because of conditions revealed by such statements of fact as may be required from time to time which would warrant the licensing authority in refusing to grant a license on an original application, or for failure to operate substantially as set forth in the license, for violation of or failure to observe any of the restrictions and conditions of this Act, or of any regulation of the licensing authority authorized by this Act or by a treaty ratified by the United States. . . .

Sec. 16. Any applicant for a construction permit, for a station license, or for the renewal or modification of an existing station license whose application is refused by the licensing authority shall have the right to appeal from said decision to the Court of Appeals of the District of Columbia; and any licensee whose license is revoked by the commission shall have the right to appeal from such decision of revocation to said Court of Appeals of the District of Columbia or to the district court of the United States in which the apparatus licensed is operated. . . .

Sec. 26. In all circumstances, except in case of radio communications or signals relating to vessels in distress, all radio stations, including those owned and operated by the United States, shall use the minimum amount of power necessary to carry out the communication desired.

Sec. 27. No person receiving or assisting in receiving any radio communication shall divulge or publish the contents, substance, purport, effect, or meaning thereof except through authorized channels of transmission or reception to any person other than the addressee, his agent, or attorney, or to a telephone, telegraph, cable, or radio station employed or authorized to forward such radio communication to its destination, or to proper accounting or distributing officers of the various communicating centers over which the radio communication may be passed, or to the master of a ship under whom he is serving, or in response to a subpoena issued by a court of competent jurisdiction, or on demand of other lawful authority; and no person not being authorized by the sender shall intercept any message and divulge or publish the contents, substance, purport, effect, or meaning of such intercepted message to any person; and no person not being entitled thereto shall receive or assist in receiving any radio communication and use the same or any information therein contained for his own benefit or for the benefit of another not entitled thereto; and no person having received such intercepted radio communication or having become acquainted with the contents, substance, purport, effect, or meaning of the same or any part thereof, knowing that such information was so obtained, shall divulge or publish the contents, substance, purport, effect, or meaning of the same or any part thereof, or use the same or any information therein contained for his own benefit or for the benefit of another not entitled thereto: *Provided*, That this section shall not apply to the receiving, divulging, publishing, or utilizing the contents of any radio communication broadcasted or transmitted by amateurs or others for the use of the general public or relating to ships in distress.

Sec. 28. No person, firm, company, or corporation within

the jurisdiction of the United States shall knowingly utter or transmit or cause to be uttered or transmitted, any false or fraudulent signal of distress, or communication relating thereto, nor shall any broadcasting station rebroadcast the program or any part thereof of another broadcasting station without the express authority of the originating station.

Sec. 29. Nothing in this Act shall be understood or construed to give the licensing authority the power of censorship over the radio communications or signals transmitted by any radio station, and no regulation or condition shall be promulgated or fixed by the licensing authority which shall interfere with the right of free speech by means of radio communications. No person within the jurisdiction of the United States shall utter any obscene, indecent, or profane language by means of radio communication.

Sec. 32. Any person, firm, company, or corporation failing or refusing to observe or violating any rule, regulation, restriction, or condition made or imposed by the licensing authority under the authority of this Act or of any international radio convention or treaty ratified or adhered to by the United States, in addition to any other penalties provided by law, upon conviction thereof by a court of competent jurisdiction, shall be punished by a fine of not more than \$500 for each and every offense.

Sec. 33. Any person, firm, company, or corporation who shall violate any provision of this Act, or shall knowingly make any false oath or affirmation in any affidavit required or authorized by this Act, or shall knowingly make any false oath or affirmation in any hearing authorized by this Act, upon conviction thereof in any court of competent jurisdiction, shall be punished by a fine of not more than \$5,000 or by imprisonment for a term of not more than five years or both for each and every such offense.

Sec. 34. The trial of any offense under this Act shall be in the district in which it is committed; or if the offense is committed upon the high seas or out of the jurisdiction of any particular State or district, the trial shall be in the district where the offender may be found or into which he shall be first brought.

Sec. 35. This Act shall not apply to the Philippine Islands or to the Canal Zone. In international radio matters the Philippine Islands and the Canal Zone shall be represented by the Secretary of State.

UNITED STATES AMATEUR REGULATIONS

Pursuant to the basic radio law, general regulations for amateurs have been drafted by the Federal Radio Commission. The text below is that of General Order No. 84 as amended, dated September 22, 1930. Every amateur should be thoroughly familiar with these regulations.

Under the provisions of Section 4 of the Radio Act of 1927, as amended, the Federal Radio Commission establishes the following regulations for amateur radio stations:

Section I. *Definitions:* As used in these regulations,

- (a) An amateur is a person interested in radio technique solely with a personal aim and without pecuniary interest;
- (b) An amateur operator is a person holding a valid license from the Secretary of Commerce as a radio operator who is authorized under the regulations of the Secretary of Commerce to operate amateur radio stations;
- (c) An amateur station is all the apparatus controlled from one location used for amateur radio communication;¹
- (d) Amateur radio communication is radio communication between amateur radio stations by telegraph, telephone, facsimile, or television solely with a personal aim and without pecuniary interest;
- (e) A fixed station is a station permanently located;
- (f) A mobile station is a station permanently located upon a mobile unit and ordinarily used while in motion.
- (g) A portable station is a station so constructed that it may conveniently be moved about from place to place for communication and is in fact so moved about from time to time, but not ordinarily used while in motion.

¹ As a matter of licensing procedure, in all cases of remotely-controlled transmitters the location of the station shall be assumed to be that of the control point, save that where such control point is more than five miles from the radiating antenna the location shall be assumed to be that of the radiating antenna.

Section II. *Classification of Amateur Stations:* The public interest, convenience and necessity will be served by the operation of amateur stations. Save as restricted by and subject to the provisions of, treaty, law or regulations of the Commission and with the exception of individual cases where the public interest, convenience or necessity requires otherwise, all applications from amateurs for amateur station licenses will be granted.

Section III. *Prescription of the Nature of Service to be Rendered:*

- (a) For the present, amateur mobile stations will not be licensed.
- (b) Amateur stations are to communicate only with similar stations.
In emergencies or for testing purposes they may communicate with commercial or government stations. They may also communicate with mobile craft and expeditions which do not have general public service licenses and which may have difficulty in establishing communication with commercial or government stations.
- (c) Amateur stations shall not broadcast news, music, lectures, sermons, or any form of entertainment to the general public.
- (d) Amateur stations shall not transmit or receive messages for hire nor engage in any communication for material compensation, direct or indirect, paid or promised.
- (e) Except as otherwise herein provided, amateur radio stations shall be used only for amateur radio communication, as defined in Section I, paragraph (d) above.

Section IV. *Assignment of Bands of Frequencies:*

- (a) The following bands of frequencies are assigned exclusively to amateur stations:

1,715 to 2,000 kilocycles
3,500 to 4,000 "
7,000 to 7,300 "
14,000 to 14,400 "
28,000 to 30,000 "
56,000 to 60,000 "
400,000 to 401,000 "
- (b) All bands of frequencies so assigned may be used for continuous wave telegraphy.
- (c) The following bands of frequencies may also be used for radio telephony:

1,715 to 2,000 kilocycles
3,500 to 3,550 "
56,000 to 60,000 "
- (d) Upon application, amateurs who hold operators' licenses from the Secretary of Commerce of the Extra First Class Amateur grade, or higher, or who show special technical qualifications, satisfactory to the licensing authority, will also be licensed for radio telephony in the band of frequencies:

14,100 to 14,300 kilocycles

- (e) The following bands of frequencies may also be used for television, facsimile and picture transmission:

1,715 to 2,000 kilocycles
56,000 to 60,000 "
- (f) Licenses to individual amateur stations shall permit the use of all frequencies within the service bands above assigned which the licensee may be entitled to use and shall not specify individual frequencies.

Section V. *Location:* An amateur radio station shall not be located upon premises controlled by an alien.

Section VI. *Regulations Concerning the Kind of Apparatus to be used with Reference to its External Effects:*

- (a) Amateur stations shall not use apparatus transmitting damped waves.
- (b) The frequency of the waves emitted by amateur stations must be as constant and as free from harmonics as the state of the art permits. For this purpose they must use circuits loosely coupled to the radiating system or devices that will produce equivalent effects to minimize keying impacts and harmonics. Conductive coupling to the radiating antenna, even though loose, is not permitted but this restriction does not apply against the employment of transmission-line feeder systems to Hertzian antennas.
- (c) Amateur stations must use adequately filtered direct current power supply or arrangements that produce equivalent effects to minimize frequency modulation and prevent the emission of broad signals.²
- (d) Amateur stations are authorized to use a maximum power input into the last stage of a transmitter of one kilowatt.

Section VII. *Regulations Deemed Necessary to Prevent Interference:*

- (a) In the event that the operation of an amateur station causes general interference with broadcast reception in receiving apparatus of modern design, that amateur station shall not operate during the hours from eight o'clock p.m. to ten-thirty p.m., and on Sundays from ten-thirty a.m. until one p.m., local time, upon such frequency or frequencies as cause such interference.
- (b) An amateur station shall transmit its assigned call at the end of each transmission but in any event at least once during each fifteen minutes of operation.

Section VIII. *Other Regulations:*

- (a) Amateur station licenses shall be issued only to persons who are amateurs, as defined in Section I, paragraph (a) above.
- (b) Amateur station licenses shall be issued only to persons who are amateur operators, as defined in Section I, paragraph (b) above, provided, however, that if an applicant is not such an operator, an amateur station license shall be issued him upon the presentation of affirmative evidence that the station, when licensed, will be operated by an amateur operator.
- (c) Amateur station licenses shall not be issued to corporations or associations, provided, however, that in the case of a bona fide amateur radio society, a license may be issued to an authorized official of such society as trustee therefor.
- (d) The licensee of a portable station shall give advance notice to the Supervisor of Radio in the district where application was made for said portable station license, of all locations at which the station will be operated.
- (e) The licensee of an amateur station shall keep an accurate log of station operation, in which shall be recorded the time of each transmission, the station called, the input power to the last stage of the transmitter, and the frequency band used.

Section IX. *Administration:* These regulations shall be administered in accordance with the Radio Act of 1927 as amended.

² E.g., the use of unrectified alternating current power supply will be considered satisfactory in the amplifier stages of an oscillator-amplifier transmitter so arranged that variations in plate voltage cannot affect the frequency of the oscillator.

INDEX

	PAGE		PAGE
Abbreviations, Amateur	201-203	Inductance-Capacity-Frequency Calculation	209
Abbreviations, International Standard	198-200, 200-201	International Prefixes	203
Abbreviations Used in Radio	206	Metric Prefixes	206
Accented Letters	197	Numbers and Drill Sizes	51
Accepting Messages	181, 187	Performance of Different Wavelengths	51
Acknowledging Messages	179, 187	Q Signals	198-200
Address Count	184	Rectifier Tubes and Filter Combinations	138
Adjusting the Transmitter	91-93, 95, 96, 101, 102, 104, 115	Sine Wave	31, 34-36
Alternating Current	31, 33-35	Time and Day Conversion	204
Alternator	31	Transformer Design	144
Amateur Bands	23, 24	Vacuum Tube Characteristics	88
Amateur Operator's and Station Licenses	20-22	Wire Table	208
Amateur Regulations	22, 23, 211-212	Word List for Amateur Transmission	190
Amateur Status	182	Zapp Feeder Lengths	184
American Radio Relay League	10	Checking Messages	75
Accomplishments	8	Checking Transmitter Frequency	75
Divisions	171	Chemical Rectifiers	134-136
Headquarters	10	Choke Coils (A. F.) (see "Power Supply")	
Headquarters Station W1MK (frontispiece)	11, 19	Chokes (R. F.)	94, 100, 104, 106, 110, 112-113
History	1-10	Circuits, Transmitting (see "Transmitters")	
Joining the League	11	Circuits, Receiving (see "Receivers")	
Traditions	11	Circuits, Tuned	41
Ampere	27, 28	Circular Mil	134
Ampere Turns	30	Circuitless Keying Methods	153-155
Application, Theory of in Vacuum Tube	45	Code (Continental) and Code Practise	14-17, 197
Amplifying Harmonics	108, 110, 112	Code Practice Stations (for Beginners)	18
Amplifier, Audio	57, 61, 64, 65, 67-69	Coded Messages	184
Amplifier, Peaked	68-69	Coils:	
Amplifier, Power	102-104, 108, 110-112	Inductance Formula	41, 207
Class A	119	Monitor-Frequency Meter	74, 82
Class B	120, 124-125	Receiving	57, 63, 65, 67, 69, 70
Class C	120, 124-125	Resistances	114
Amplifier, Push-Pull	105-106, 110-112	Transmitting	113
Amplifier, Radio Frequency (Receiver)	60	Tube Base	63, 74
Amplifying Transformers	45	Colpitts Circuit	96
Answering a Call	178	Communications Department, A. R. R. L.	
Antenna Systems:		Activities	170
Calculating Length	161	Appointments	174
Construction of	168-169	Official Broadcasting Station	174
Directional	42, 168-169	Official Relay Station	174-176
Doublet Receiving Antennas	159	Official Observers	173
Feed Systems:		Route Managers	173
General	161	Section Communications Manager	172
Current	162-163	Duties of S. C. M.	172
Voltage:		Organization	171
Zapp	163-165	Policies	170
Two-Wire Untuned	166-167	Territorial Limitations	171
Single-Wire Untuned	167	Condenser Breakdowns	206-207
Theory	159-161	Condenser Capacitance	37
Types	159	Condensers, definition of	32
Application for League Membership	217	Condensers, Electrolytic (Computing)	142
Application for Official Relay Station	218	Condenser Capacitance (Computing)	206-207
Appointment for Official Relay Station	174-175	Condensers, Current Through	38
Applying for a License	20	Condensers, Receiver Tuning	58, 62, 63, 65, 67, 68
Army-Amateur Work	9	Condensers, Transmitter Tuning	114
Audibility Rating	193	Constant-Current Modulation	50
Audio Howler for Code Practise	15	Continuous Waves	42
Audio Amplifier, Peaked	68-69	Contributions to QST	190
Autodyne Reception	47	Conversion, Day and Time Charts	204
Band Spreading and Tuning Arrangements	57	Conversion Factors	36
B Batteries for Power Supply	132	Conversion, Frequency-Wavelength	40
B Battery Eliminators for Power Supply	132	Counting Messages	188
Beat Notes	48	Counting Cites in Address and Text, Numbers:	
Beginner's Booklet	12, 14	Radio Calls, Telephone Numbers and Trade Marks	184-185
Beginner's Code Practice Stations	18	Coupling	42, 43, 60
Best Wavelength	24, 51	Coupling Tube, for S. W. Receiver	60, 63
Books Recommended	205	CQ, How to Use	178
Break-Down Voltage	37, 206-207	C. W. Reception	47, 48
Break-In Operation	157	Crystals:	
Using a Break-In System	180	Action	106, 107
Broadness of Tuning, How Resistance Affects	41-42	Grinding and Cutting	106, 107
Brute-Force Filter	141	Mounting	107
Buzzer Code Practice Set	15	Crystal-Control Transmitter Construction (see "Transmitters")	
By-Pass Condenser	63	Current Feed for Antennas	162, 163
C Bias	45, 85, 88, 104, 106, 110	Current Flow	27
Table of Receiving and Transmitting Tubes, including proper bias values (7th column)	88	Current in A. C. Circuits	33
C. W.	42	Current Lag and Lead	34
Cable Count Check Explained	183-184	Dead Spot in Receiver, How to Shift	71
Calculation of Inductance	207	Definition of Radio Terms	205-206
Calculation of Condenser Capacitance	206-207	Delivering Messages	187
Calibrating the Frequency Meter	76-80, 83	Designing the Receiver	85-87
Call Books	193	Designing the Transmitter	49, 44
Calling Practice	178, 179	Detection	43, 44
Canadian Regulations	25	Detectors, Screen Grid	61, 64
Canadian Traffic Agreement	185	Dials for Monitors and Frequency Meters	80, 81
Capacitance	32, 206-207	Diagrams, Reading	51
Capacitive-Reactance of Condensers	37	Dielectrics and Dielectric Constants	206
Caslin Grip, The	16	Direction of Current and Magnetic Field	42, 168-169
Center Tap for Filaments	91	Directional Antennas	178-179, 187
Characteristic Curves of Vacuum Tubes	44, 45	Distance Measurement	204
Characteristic of Vacuum Tubes (Table)	88	Distortion Transformers	61
Charts and Tables		Distributed Capacitance (Effect of)	46
Amateur Wavelength-Frequency Bands	24	Distributed Inductance, Capacitance and Resistance	33
Antenna and Feeder Lengths	167	Districts (Dept. of Commerce, Inspection)	20
Audibility	193	Divisions of A. R. R. L.	171
Continental Code	17, 197	Doublet Receiving Antennas	159
Dielectric Constants	206	Doubling Frequency in a Transmitter	110
Electrical Symbols	205-206	Drill Sizes	210
Filter Choke Design	149	Dry Cells as Plate Supply	132
Greek Alphabet	210	Dummy Antenna	125
Ham Abbreviations	201-203	Dynamotors	132

	PAGE		PAGE
Dynatron Frequency Meter:		Induction	32
Construction	82	Insufficient Address	184, 192
Calibration	76-80, 83	Insurance Rating Bureau	55
Effective Value (A.C. Sine Wave)	31	Interference Committees	193
Electrical Units and Symbols	36, 205-206	Interference, Elimination of:	
Electricity	26	Power-Line Suppressors (R.F.)	157
Chemical and Magnetic Effects	26	Quiet Hours	23, 155
Current Electricity	26	Re Broadcast Receivers	155
Electrolytic Condensers	142	Wavetrays	155-157
Electrolytic Rectifier (see "Power Supply")		(See also "Keying")	
Electromotive Force (E.M.F.)	27	International Prefixes	203
Electrons	27, 43	Keep-Alive Circuits for Mercury Arc Rectifier	139-140
Emergency Work	9, 180-181	Keeping a Log	194-196
Error Signal	179	Kennelly-Heaviside Layer	50
Extracts from Radio Law of 1927	210-211	Key, How to Grip	15, 16
Fading	50	Key Clicks	153-155
Feed-Back	47	Keying:	
Feeders and Feed Systems (see "Antenna Systems")		Methods	152-153, 156
Filament Supply	150	Key-Click Elimination	153-155
Filaments (Oxide Coated, Thoriated, Tungsten)	43	Key-Sparking Elimination	154
Fills and Repeats	179, 191	Keying Oscillator-Amplifier Transmitters	152, 153
Filters (see "Power Supply")		Lag Circuits, Use and Design	154-156
Filter Choke Inductance Chart	149	(See also "Interference Elimination, Break-in Operation" and "Relays")	
Five Point System, The	190	Kirchoff's Law	28
Flux	30	Laws Concerning Amateur Operation	22
Ford Coil for Peaked Amplifier	68	Lead and Lag	33-35
Foreign Traffic Restrictions	185	Lead-in Bushings	189
Canadian Agreement	185	Learning the Code	14-19
Forming Electrolytic Rectifier	135	License Examination, How to Pass	21
Formulas:		Licenses (Obtaining Amateur)	20-22
A.C. Average and Effective Value	31	Licenses Required for Operator and Station	14, 20
Breakdown Voltages of Condensers and Dielectrics	206-207	Lightning Arrestor	42, 56
Calculating Antenna Length	161	Lighting Hazard	126-127
Capacitive Reactance of Condensers	37, 206-207	Linear Amplifiers	126-127
Capacity of Condenser	206-207	Log Books	194-196
Current in A.C. Circuit	34	Magnetic Circuit	30
Current Through Condenser	206	Magnetic Field	30
Electrolytic Rectifier Solutions	135-136	Magnets	30-31
Great Circle Distances	204	Marker Stations, How to Calibrate the Monitor From	76
Impedance	34	Matching Internal and Load Impedances	30, 45, 86
Inductance Calculation	207	Maximum Power (Conditions for)	30, 45
Inductance of Choke Coil	149	Measurements:	
Magnetic Circuit	30	Distance	24
Ohms Law (A.C.)	34	Frequency	76, 83
Ohms Law (D.C.)	27	Mechanical Analysis of Electric and Radio Circuits	28, 40
Phase Difference	36	Membership Blank (A.R.R.L.)	217
Power (in A.C. Circuits)	35	Memorizing the Code	14
Power (in D.C. Circuit)	29	Mercury Arc Rectifiers	137-138
Power Factor	36	Mercury Vapor Rectifiers	182
Reactance	34, 35, 37	Message Component Parts of	183
Series, Parallel and Series-Parallel Capacities	33	Message Blanks	182-185
Series, Parallel and Series-Parallel Resistances	24	Message Form	181
Voltage Drops	28, 29	Message Traffic	181
Watts-Horse-Power Conversion	36	Meters	113
Wavelength Frequency Conversion	40	Meter, Frequency (see "Frequency Meters and Monitors")	
Frequencies, Amateur	24	Metric Prefixes	206
Frequencies for Best Operation	31	Microphones and Their Care	121-122
Frequency	31	Mil	139
Frequency, Checking Transmitter	75	Modulation and Modulation Methods	49, 50, 117-119
Frequency Doubling	108-112	Modulator Tubes	119-120
Frequency Meters and Monitors:		Modulator Tube Calculations	128
General Considerations	74, 80-82	Modulometer, Construction and Use	127-129
Frequency Meter Construction (Dynatron)	80-82	Monitor, Phone	125
Frequency Meter Calibration	76, 83	Monitor Box	55, 74
From Standard Frequency Transmissions	79-80	Monitor-Frequency Meter (see "Frequency Meters and Monitors")	
From "Marker" Stations	76	Motor-Generators	132
Monitor, Construction of	74	Mounting Crystals	107
Monitor, Calibration	76-80	Negative and Positive Terminals	27
Frequency-Wavelength Conversion	40, 209	Neon Tubes	94
Fringe Howl, How to Eliminate	71	Neutralizing the Power Amplifier	103-104, 109-112
Gaseous Conduction Rectifiers	137	Note Improvements (see "Adjusting the Transmitter")	
Greek Alphabet	210	Numbering Messages	186
Grid	43	Number Sheet	186
Grid Bias	45, 85, 88, 104, 106, 110	Official Broadcasting Stations	19, 174
How to Measure	37	Official Observers	173
Table of Receiving and Transmitting Tubes, Including proper bias values (7th column)	88	Official Relay Station:	
Grid Excitation, Control of (see "Grid Bias")		Appointment	175
Grid Leak (Value to Use)	60, 85, 115	Duties	174-176
Grid Milliammeter Connections and Use	113	Qualifications	174-176
Grid Potential	44	Ohm	27
Grid Voltage-Plate Current	44	Ohm's Law	27, 28, 33
Ground Connection	56	Ohm's Law for A.C.	33
Ground Switches	56	Operating a Station:	
Grounding Antennas for Lightning Protection	56	Accepting and tracing messages	187
Hand Capacity	62	Amateur Status	182
Harmonics	46, 160	Audibility Scale	193
Amplification of	108, 110, 112	Cable Count	183-184
Amplitude of	46	Callbooks	193
Effect of Grid Bias on	47	Canadian Traffic Agreement	185
Harmonic Operation of Antennas	160-161	Counting Messages	187
Hartley Transmitter	93-96	Diverging Messages	188
Heat in D.C. Circuits	29	Emergency Work	180-181
Helsing Modulation	50, 118	Five-Point System	190
Henry, The	32	Foreign Traffic Restrictions	185
Hertz Antenna	159	Interference Committees	194-196
Heterodyne reception	47	Keeping a Log	182-185
Horsepower-Watts Conversion	36	Message Form	183-184
Impedance	115	Message Traffic	181
Impregnating Coils	147	Numbering Messages	186
Incomplete Preambles	184	Operating Rules and Regulations	178-179
Inductance	32		
Inductance Calculation	207		
Inductance-Capacity-Frequency Calculation (Chart)	209		
Inductance of Choke Coils	149		

	PAGE		PAGE
Operating Notes and Hints	179, 180, 192	Radio Inspection Districts	20
Originating Traffic	185	Radiotelephony:	
Troubles to Avoid	186	Amplifiers:	
Phone Procedure	191	Class A	119
Relay Procedure	187	Class B	126
Reporting	189	Class C	120, 124-125
"Rubber-Stamp" Messages	189	Frequencies and Regulations	22
Schedule Operation	190	Holding Modulation	118
Service Messages	192	Linear Amplifiers	126-127
Tracing Messages	187	Microphones and Their Care	121-122
Using a Break-in System	180	Modulation and Modulation Methods	49, 117-119
Word List for Accurate Transmission	190	Modulator Construction	120-121, 123-124
Operating Hints	192	Modulator Tubes	119-120
Operating Notes	179, 180	Modulator Tube Calculations	128
Operating Procedure:		Modulometer, Construction and Use	127-129
Amateur (see "Operating a Station")		Monitor (for "Phone")	125
Commercial	18-19	Receiver Considerations	126
Government	19	Single-Tube Modulator Unit	123
Operating Receivers	71	Speech-Amplifier and Modulator Construction	120-121
Operating Rules and Regulations	178-179	Two-Stage Speech Amplifier and Modulator	124
Operator's License	20	Tube Combinations for "Phone Transmitters"	120, 127
Originating Traffic	185	(see also "Transmitters")	
Troubles to Avoid	186	Rating Power Tubes	87, 88
O.R.S. Application	218	Reactance	34
Oscillator, Audio	15	Reactance of Condensers	37
Oscillator Circuits	86	Readability	193
Oscillator, Crystal Controlled	105-108, 109-110	Reading Diagrams	151
Oscillator, Push-Pull	40, 42, 46, 48	Receivers:	
Oscillations	35	Antennas for	72
Parallel Alternating Current Circuit	35	Audio Amplifiers for	61
Parallel Capacities	33	Construction:	
Parallel Resistances	27	Two-Tube	62
Parasitic Oscillations	115	Three-Tube A.C. (with Screen Grid Detector)	64
Peaked Audio Amplifier	67, 68	Four-Tube (with Peak-to-Peak Audio Amplifier)	66
"Peak" Value for Sine Wave A.C.	207	Superheterodyne Converter	69
Permeability	30	Designing	57
Phase Difference	34-36	Operation of	71
Phone Procedure	191	Phone (General Considerations)	126
Phone Transmitters (see "Radiotelephony")		Radio Frequency Amplifiers for	60
Phone Wavelengths for Amateurs	22	Regeneration Control	59
Plate Current	43	Screen Grid Detectors	61, 64
Plate Impedance	115	Superheterodyne	69
Plate Modulation	50	Trouble Shooting	72
Plate Power Input, How to Calculate	37	Tuning Arrangements and Band-Spreading	57
Plate Transformer Design	143-148	Receiving Coils (see Coils)	
Plug-in Coils	57, 63, 65, 67, 69, 74, 92, 95, 105, 109	Reception, General	48
Plug-in Condensers (Receiving)	67, 68	Rectification	44
Polarization of Radio Waves	50	Rectifier-Filter Systems (see "Power Supply")	
Posting of Licenses	22	Rectifiers (see "Power Supply")	
Positive and Negative Terminals	37	Reducing Sparking in Keying Circuits	154
Power, Electrical vs. Mechanical	36	Regeneration	47
Power Amplifier	102, 105, 108-112	Regeneration Control Methods	59
Power Line R.F. Suppressors	157	Regulation, Voltage	131
Power Supply:		Regulations, Amateur	22, 211-212
Battery Substitutes and Eliminators	132	Regulations, Canadian	25
Dry-Cell ("B" Battery) Supply	132	Relays	157-158
Electrolytic Condensers	142	Relay Procedure	187
Electrolytic Rectifiers	134-136	Reluctance	30
Filament Supply	150	Remote Control	158
Filters:		Reports and Reporting	175, 189
Design	140-142	Resistance	27
Design Data Chart	149	Resistance, Effect of in Tuned Circuit	42
Filter Chokes	143, 148-150	Resistance Regeneration Control	60
Filter Condensers	142	Resonance, Current and Voltage	35
Motor Generators and Dynamos	132	Resonance Indicator	91-92
Plate Supply Considerations	131	Restrictions, Foreign Traffic	185
Rectifier and Filter Systems (Theory and General Considerations)	133	Retrysmitch	11
Rectifiers:		Right Hand Rule	31
Chemical	134-136	Route Manager	173
Mercury Arc	139	Root Mean Square Value	31
Tube: Table of Various Rectifier Tubes	138	Routing Messages	190
Thermionic	136	Rubber Stamp Messages	189
Gaseous Conduction	137	Rules and Regulations (Operating Practice)	178-179
Mercury Vapor	137-138	Schedules	190
Regulation	131	Screen Grid Detectors	61, 64
Storage Cells	132	Secrecy of Messages	18, 21, 23, 188
Transformer Design and Construction	143-148	Section Communications Manager	172
Voltage Doubling	150	Selectivity	57-58
Power Factor (Condition for Maximum)	30, 45	Sending Words Twice	179
Power Factor	35	Series Alternating Current Circuit	35
Power in A.C. Circuits	29	Series Capacities	33
Power in D.C. Circuits	29	Series Resistances	27
Practical Problems	37	Service Message, The	192
Plate Power Input	37	Shifting Dead Spot on Receiver	71
Resistance of Circuit	37	Short Wave Receivers (see "Receivers")	
Measuring Grid Bias	37	Signaling Off	178
Condenser Reactance	37	Skip Distance	50
Current Through a Reactance	38	Small Transformer Design and Construction	143-148
Size Resistor to Handle a Given Current	38	Solutions to Use in Aluminum-Lead Rectifier	134-136
Total Transformer Current	38	Soldering	54
Preamble	182	Speech Amplifier	120-121, 123, 124
Prefix, International	203	Speech Envelope	59
Prefixes, Metric	206	Speed, Best Sending	178
Privileges of Official Relay Stations	176	Stability, Transmitter (see "Adjusting the Transmitter")	
Protecting Coil Insulation from Radio Frequency Voltage (see "Condenser Reactance")		Standard Frequency System and Transmissions	10, 79
Push-Pull Oscillators	98	Standardized Log (see Log)	79, 80
Push-Pull Amplifiers	105-106, 110-112	Station Arrangement	55
Quartz Crystals	105-107	Station License	21
Qualifications of Good Operators	177	Status, Amateur	182
QST	V, 10, 190	Steady Signals (see Stability)	
Q Signals	198-200	Storage Cells	132
Quiet Hours (Regulations)	23, 155	Superfluous Signals	180
R.M.S.	31	Superheterodyne	69
Radiator (see "Antennas")		Superheterodyne Converter	69
Radio Act of 1927	210-211	Supervisors of Radio	20
		Symbols, Electrical	205-206
		Symbols Used in Radio Diagrams	51

	PAGE		PAGE
T.O.M. (The Old Man)	11	Tuning Arrangements and Band-Spreading	57
Tables and Charts (see Charts and Tables)		Ultraudion	97
Tank Circuit	86	Underwriters Rules	55
Tap Sizes	53, 210	Units, Electrical	36
Testing Filter Action	150	Unsteady Signals, Cause and Cure	115
Throttle-Condenser Regeneration Control	60	Using Break-in	180
Thump Filters	156	Vacuum Tubes:	
Time Conversion	204	General	43-48
Time Signals	19	Theory (Receiving):	
Tools	53	As Detector	44
Tracing Messages	187	As Amplifier	45
Traffic Restrictions, Foreign	185	As Oscillator	46
Canadian Agreement	185	Modulators	119-120
Transformer Design and Construction	143-148	Table of Data on All Types of American Tubes	88
Transmitters:		Transmitting:	
Adjustment and Tuning	91, 95, 101, 104, 108	General Considerations	87
Checking Frequency of	75	High Impedance (Special Considerations)	115
Chokes, Radio Frequency, Design and Construction	112-113	Amplifiers:	
Circuits and Construction:		Class A	119
Single-Control Transmitter	89-93	Class B	126
Low-Power Hartley Transmitter	93-96	Class C	120, 124-125
Colpitts (General Considerations)	96	Combinations for Use in Phones	120, 127
Ultraudion (General Considerations)	97	Vacuum Tube Rectifiers (see Rectifiers)	
Push-Pull (General Considerations)	98	Vacuum Tube Voltmeter	127-129
Push-Pull 150-watt Transmitter	99-102	Velocity of Radio Waves	40
Oscillator-Amplifier (General Considerations)	102	Vigilance Committees	172
Low-Power Oscillator-Amplifier Transmitter	102-105	Volt	27
Crystal-Control (General Considerations)	107, 108	Voltage Amplification	45
Crystal-Controlled Transmitter	109-110; 111, 112	Voltage Doubling	150
Power Amplifier (General Considerations)	108	Voltage Drop	28, 30
Power Amplifiers	110, 112	Voltage Feed for Antennas	163-167
Coil Construction	113	Voltage Regulation of Rectifiers (see "Rectifiers")	
Condensers	114	Volunteer Code Practice Stations (for Beginners)	18
Crystals, Cutting, Grinding and Mounting	106-108	WIMK, A.R.R.L. Hq. Station (frontispiece)	11, 19
Frequency Stability and Efficiency	86	W.A.C. Club	7
Grid Bias	85	Wave Motion	39, 40
How Transmitters Work	85	Wavelength Formula (L and C known)	41
Meters	113	Wavelength-Frequency Conversion	40, 209
Parasitic Oscillations	115	Wavelength Performance	24, 51
Phone (see "Radiotelephony")		Wavelengths, Amateur	23, 24
Planning the Transmitter	89	Wavemeter (see "Frequency Meters and Monitors")	
Power Supply (see "Power Supply" in General Index)		Wavetraps	155-157
Practical Oscillator Circuits (Explanation of Types)	86	Weather Bureau Code (footnote)	19
Transmitter Assembly	114	Weather Reports	198
Tubes (General Considerations)	87	Winding Jig for Transformer	146
Tubes (Table of Transmitting and Receiving Tube Characteristics)	88	Wire Table	208
Tubes, High Impedance (Precautions for Use)	115	Wiring Requirements	55
Unsteady Signals, Cause and Cure	115	Wiring the Receiver	54, 57
Trap Circuit for Interference Elimination	157	Wiring the Transmitter	55
Trouble Shooting (Receivers)	72	Wood Screw Sizes	54, 210
Tubes (see "Vacuum Tubes")		Word Lists for Accurate Code Transmission (and Voice Work)	190
Tube-Base Coils	63	Wouff-Hong	11
Tube Characteristics (Table)	88	Zeppelin Feed for Antennas	163-165
Tube Rectifiers (see "Rectifiers")			
Tuned Circuits	41		
Tuner, The Hoffman-Mix	59		
Tuning	40, 48		

To Handbook Readers Who Are Not A. R. R. L. Members

WOULDN'T you like to become a member of the American Radio Relay League? We need you in this big organization of radio amateurs, the only amateur association that does things. From your reading of this Handbook you have gained a knowledge of the nature of the League and what it does, and of its purposes. We would like to have you become a full-fledged member and add your strength to ours in the things we are undertaking for Amateur Radio, and incidentally you will have the membership edition of *QST* delivered at your door each month. A convenient application form is printed below — clip it out and mail it today.

.....19.....

AMERICAN RADIO RELAY LEAGUE

1711 Park Street

Hartford, Conn., U. S. A.

Being genuinely interested in Amateur Radio, I hereby apply for membership in the American Radio Relay League and enclose \$2.50 (foreign \$3.00) to cover one year's dues.*

It is understood that this entitles me to receive the league magazine "QST" for a similar period. Please begin my subscription with the..... issue.

Send "QST" and my certificate of membership to the address below.

Name.....
.....
.....

A bona fide interest in amateur radio is the only essential qualification; ownership of a transmitting station and knowledge of the code are desirable but not necessary

Station call, if any.....

Grade operator's license, if any.....

Radio clubs of which a member.....

Do you know a friend who is also interested in Amateur Radio, whose name you might give us so we may write him about the League?.....

.....Thanks!

*The dues are \$2.50 per year in the United States and Possessions, in Canada, and in all other countries in the American Postal Union; in foreign countries not in the American Postal Union, \$3.00.

To Handbook Readers Who Are Already A.R.R.L. Members:

FOR telegraphing members, who hold amateur licenses, and who are interested in Communications Department work, here is an application blank for an appointment as Official Relay Station. Copy this, or cut and fill it out, and send it to A.R.R.L. Headquarters for routing to the proper Section Communications Manager, if you are interested. The Communications Department operates only in the United States and its territories, Canada, Newfoundland, Labrador, Cuba, the Isle of Pines, and the Philippine Islands. Foreign applications from outside these areas cannot be handled.

AMERICAN RADIO RELAY LEAGUE, INC.

1711 Park Street, Hartford, Connecticut, U. S. A.

Application for Appointment as Official Relay Station

Name Call

Street and Number

City County

State

Transmitting frequencies: kc.

In making application for appointment as Official Relay Station, I agree:

- to obey the radio communication laws and regulations of the country under which this station is licensed, particularly with respect to quiet hours and observance of our frequency allocations.
- to send monthly reports of station activities to the Section Communications Manager under whose jurisdiction this station comes.
- to handle messages in accordance with good operating procedure, delivering messages within forty-eight (48) hours when possible, mailing to destination whenever impossible to relay to the next station in line within a 48-hour period.
- to participate in every A.R.R.L. communication activity to the best of my ability, always trying to live up to those ideals set forth in "The Amateur's Code."

My membership in the A.R.R.L. expires
month year

I understand that an appointment as Official Relay Station may be suspended or cancelled at the discretion of the Section Communications Manager for violation of the agreement set forth above.

Please send detailed forms to submit to my S.C.M. in connection with this application.

Signed

BARGAINS IN TRANSMITTING EQUIPMENT

TRANSFORMERS

THORDARSON 175 watt — 1150 volts center tapped, two 7.5 and one 3 v. windings \$4.25
THORDARSON 250 watt — 1200 volts center tapped, two 7.5 and one 3 v. windings \$5.75
THORDARSON 100 watt — 700 volts center tapped, one 5 and one 2.5 v. windings \$3.75
THORDARSON 100 watt — same as above but for use with 25 cycle A.C. current \$4.25
JEFFERSON step-down — gives 14 volts at 2.5 amperes from 110 v. A.C. \$1.25
AMERICAN step-down — gives 110 volts from 220 volts A.C. \$4.25
AMERTRAN step-down — three 2.5 volt windings at 3, 3, and 7 amps from 110 A.C. \$9.00
AMERTRAN 1200 volts center tapped with two 7.5 volt winding at 2.5 amps \$15.00
AMERICAN FILAMENT TRANSFORMER—110-120 V. primary—secondary—two windings—2.5 volts at 11 amps., and 2.5 volts at 3 amps. Mounted and cased \$3.75
THORDARSON Push Pull output transformer... \$2.75

TUBES

GENUINE R.C.A. UV-213 Rectifying Tubes, full wave, same voltages at 280 \$.95
GENUINE R.C.A. 216-B Rectifying Tubes, 7.5 volt filament, 550 plate volts \$2.35
KENOTRON Rectifying Tubes, filament voltage 8 to 10, plate 550 volts \$.50
WESTERN ELECTRIC VT-2 — 5 watt tubes — standard base \$2.50
GENUINE DE FOREST Transmitting Tubes shipped you direct from factory:
503-A, \$30.00; 511, \$30.00; 545, \$33.75 (50 watt oscillators, modulators, etc.)
552, \$24.25 (75 watt oscillator and R.F. amplifier, low internal capacity.)
566, \$9.00 (half wave mercury arc rectifier, filament 2.5 — plate 7500 volts.)

CHOKES

THORDARSON Filter Choke, 30 henri — 150 mls. 3000 volts insulation test \$3.25
THORDARSON Double Filter Choke, contains two 18 henri — 250 mil chokes \$6.25
AMERTRAN Filter Choke, 20 henri — 250 mls, D.C. resistance 110 ohms \$10.80
AMERTRAN Filter Choke, 20 henri — 120 mls, D.C. resistance 210 ohms \$3.60
PILOT Filter Choke, 32 henri — 145 mls. \$7.00
R.C.A. Double Filter Choke — contains two 30 henri — 100 mil chokes \$1.75

MICROPHONES

AMERICAN DOUBLE BUTTON, will respond to frequencies from 30 to 7000 cycles, low carbon hiss. 100 ohms per button \$31.50
UNIVERSAL AND GENERAL INDUSTRIES MICROPHONES, DESK STANDS AND MOUNTS — Write for special discounts.

CONDENSERS

FLECHTHEIM HIGH TENSION Filter Condensers, with porcelain insulators, guaranteed.
 1500 volts — 1 mfd. \$2.70
 2 mfd. 5.10
 4 mfd. 8.70
 2000 volts — 1 mfd. 6.00
 2 mfd. 9.00
 4 mfd. 15.60
 Write for special prices on 3000 volt condensers and type HS & HV.
DUBILIER Filter Condenser, 1.75 mfd., 1000 working voltage D.C. \$1.35
DUBILIER Filter Condenser, 7 mfd., 600 working voltage D.C. \$2.50
DUBILIER Filter Condenser, 4 mfd., 600 working voltage D.C. \$1.80
DUBILIER 11.75 mfd. condenser, 3 mfd. at 1000, 4 mfd. at 600 and 4, 5 and .25 mfd. at 160 working voltage D.C. \$3.75
STROMBERG-CARLSON Filter Condenser, 3.5 mfd. at 600 working voltage D.C. \$1.50
AEROVOX 7 mfd. Condenser, 2 mfd. at 1000, 2 mfd. at 800 and 3 mfd. at 400 working voltage D.C. \$3.00
DUBILIER Plate Stopping Condenser, .000125 mfd. at 1000 volts \$.35
DUBILIER 10 1/4 mfd. condenser, 3 mfd. at 800, 3 at 600, 3 1/4 at 400 and 1 mfd. at 200 working volts \$4.50

SPECIALS

BRADLEYSTAT, type E210, current capacity 10 amperes, for transmitters \$.95
WARD LEONARD—13600 ohm. heavy-duty resistor tapped at 6000, 6000 and 1600 \$1.50
R.C.A. Power Rheostats, (heavy duty) will carry 15 amps., for large tubes \$3.00
R.C.A. Rotary Grid Chopper Wheels, complete with bushing \$.75
CENTRALAB Gain Controls for lone transmitters, 0-250000 ohms \$.75
SAMSON 3000 Ohm double head set, sensitive on weak code signals \$2.25
ELECTRAD Transmitting Grid-Leaks, center tapped 5000 ohms — 141 mls. \$2.25
ELECTRAD Transmitting Grid-Leaks, center tapped 10,000 ohms — 100 mls. \$2.60
AMERICAN 50 watt transmitting sockets, made from heavy bakelite \$2.50
R.E.L. Frequency meters, separate unit for each band, accurate \$15.00
VIBROPLEX new and improved, direct from factory in red, green or blue base \$17.00
TELEPLEX with code learning tapes, shipped you from factory \$25.00
PILOT SUPER-WASP, D.C. kit, all parts complete for excellent receiver \$29.50
PILOT SUPER-WASP, A.C. kit, practically hum-less, for short waves \$34.50
PILOT Modulation Transformer No. 428, excellent for use with American mike \$5.00
PILOT Short Wave Plug in coils, set of five for all bands \$4.95

We also handle the products of the following nationally known companies and will be pleased to supply catalogs and prices on request: **VIBROPLEX, AMERTRAN, GENERAL INDUSTRIES MICROPHONES, ELECTRAD, JEWELL METERS, R.E.L., FLECHTHEIM, DE FOREST, UNIVERSAL MICROPHONES, TELEPLEX CODE LEARNER, PILOT, ESCO GENERATORS, SAMSON AMPLIFIERS, NEW HAVEN ELECTRIC CLOCKS, KEN-WEL SPORTING GOODS, GEORGE W. WALKER MULTI-UNITS** and many others.

We are pleased to announce the connection of Mr. Nat Pomeranz, W2WK, W2APD, formerly of the technical staff of Radio News with the American Sales Company. He will answer any of your technical questions free of charge.

AMERICAN SALES COMPANY

Dept. H, 19-21 Warren St.

NEW YORK CITY

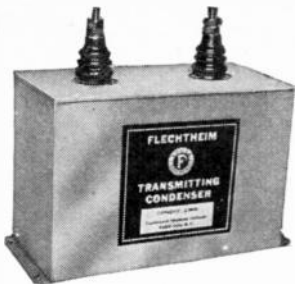

Type VM—5000V D.C.
(3500 rms RAC)

Condensers that are made of the finest quality materials and are very conservatively rated.

LEEDS

The Home of RADIO
45 VESEY STREET
NEW YORK

RECOMMEND AND
ENDORSE

FLECHTHEIM SUPERIOR CONDENSERS

"In Our Many Years' Experience, They Are, by Far, the Best!"



Type HV-800V D.C.
(340 rms RAC)

In catering to a highly discriminating class of Buyers, as are all Amateurs, we strive to offer them the very best that the market affords.

OVER 50% OF THE BROADCASTING STATIONS USE
FLECHTHEIM SUPERIOR CONDENSERS

Allay your condenser troubles by sending us your order, which we can fill immediately



Type HS-1000V D.C.
(660 rms RAC)

TYPE 558 G. R. AMATEUR BAND WAVEMETER



Type 558 Amateur-Band Wavemeter, a fixed air condenser is connected in parallel with the variable condenser. This arrangement spreads a narrow band of frequencies over the entire wavemeter scale which greatly increases the accuracy of reading. Five coils are used, covering the following amateur bands:

Coil A	4.6 to 5.4 Meters
Coil B	9.4 to 10.9 Meters
Coil C	18.5 to 21.5 Meters
Coil D	37.0 to 43.0 Meters
Coil E	75.0 to 86.0 Meters

The accuracy of calibration is to within 0.25%.

Type 558 Amateur-Band Wavemeter.....\$18.00

GENERAL RADIO TRANSMITTING CONDENSER

Type 334Z—.0005 cap., 3000 v.....	\$10.00
Type 334R—.00025 cap., 3000 v.....	5 50
334-T. .0001.....	2 75
334-V. .00005.....	2 50

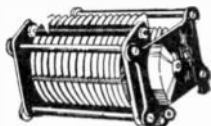

The 334-Z is same as illustrated above, but in 2 sections and has no counterweights.

We carry a complete line of G. R. products.



Hardwick, Hindle Bleeder Resistors

We recommend
HH RESISTORS
for the following
voltages:



500 to 600 volts — 50,000 ohms — 100 watt.....	\$2 75
500 to 600 volts — 50,000 ohms — 200 watt.....	3 25
1000 volts — 60,000 ohms — 100 watt.....	2 95
1000 volts — 100,000 ohms — 100 watt.....	2 95
1000 volts — 60,000 ohms — 200 watt.....	3 45
1500 volts — 80,000 ohms — 100 watt.....	3 60
1500 volts — 80,000 ohms — 200 watt — double unit.....	6 25
2000 volts — 100,000 ohms — 200 watt.....	6 50

(Double Unit)

100 watt resistors. Size 6 1/2" x 1 3/4"
200 watt resistors. Size 8 1/2" x 1 3/4"

All Above Complete with mounting brackets

200 Watt Centre Tapped Transmitting GRID LEAK



Size 8 1/2" x 1 1/4" complete with bracket mounting

5,000 ohm. Special.....	\$2.25
10,000 ohm. Special.....	2.70
15,000 ohm. Special.....	2.95
20,000 ohm. Special.....	3.25
30,000 ohm. Special.....	3.75
50,000 ohm. Special.....	4.50

PLEASE PRINT YOUR NAME AND
ADDRESS PLAINLY to AVOID DELAY

WRITE FOR
SPECIAL PRICE LIST

MAIL ORDERS FILLED SAME DAY
10% Cash Must Accompany All C. O. D. Orders

Leeds Listening MONITOR

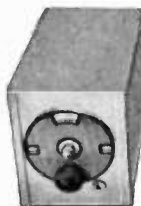

For checking your note, its stability and whether D.C. or not. **THE ONLY SURE CHECK.** Gives you an accurate idea as to what your signal sounds like to the other fellow. The Leeds Monitor is encased in an aluminum shield, 5" x 6" x 9" overall. Completely shielded, with batteries self contained. Supplied with A. & B. batteries, but without 1-UX. 199 tube.

Special **\$15.00**



The Home of RADIO
**45 VESEY STREET
 NEW YORK**

**New York's Headquarters
 for
 Transmitting Apparatus
 When in Town Visit Our Store**

Make your own transmitting and receiving coils. Copper tubing transmitting inductance.

Size of tubing			
Inside Dia.	3/16"	1/4"	5/16"
2 1/8"	9c	10c	12c
2 3/8"	9c	10c	15c
3 1/8"	10c	12c	17c

Prices per turn

WIRE

No. 14 Enamel	34c Foot
No. 12	1c "
No. 10	1 1/4c "

Any length up to 1000 feet

AEROVOX

**Cardwell
 NATIONAL
 VIBROPLEX
 JEWELL
 PYREX — BRADLEY**

*Complete line of the following
 Nationally advertised products*

**SIGNAL
 ELECTRAD
 THORDARSON
 RECTOBULB**

LEEDS RADIO LABORATORIES

Precision Custom Built Short Wave Receivers and Transmitters

This department under the supervision of the Short-Wave Specialist Jerome Gross. We design, construct and advise on any material for the "Ham" Broadcasting station or laboratory. Write Jerry Gross for advice on any of your problems.

**LEEDS Special 75 Watt Master
 OSCILLATOR— Power Amplifier
 TRANSMITTER**

The ultimate in a real transmitter of medium high power. Finest construction throughout. Angle aluminum framework, oscillator thoroughly shielded with heavy aluminum. Circuit perfectly balanced. Easily adjusted for full output. Size 11" x 19" x 26" overall. Extremely flexible, wavelength changes easily effected. Utilizes one UX210 as oscillator, one UX852 as power amplifier.

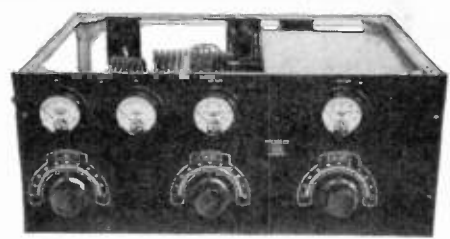

WRITE FOR OUR CIRCULARS ON OUR PRODUCTS. QUOTATIONS ON SPECIAL TRANSMITTERS, ETC., SUPPLIED UPON APPLICATION.

ACME
for transmission

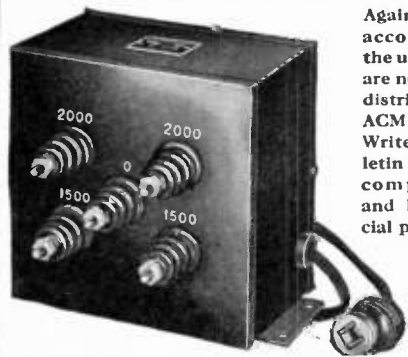

Again we have accomplished the unusual. We are now the only distributors of ACME products. Write for bulletin 110 giving complete line and latest special prices.

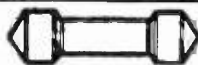

1 and 2 Watts Cartridge Type

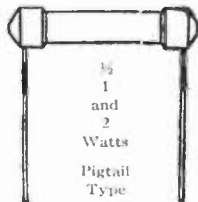

1/2
 1
 and
 2
 Watts
 Pigtail
 Type



Precision Wire Wound

USE
**LYNCH
 RESISTORS**

for your replacement work. They are accurate, dependable and guaranteed.

Send for new descriptive catalog showing new sizes and low prices.

PLEASE PRINT YOUR NAME AND ADDRESS PLAINLY to AVOID DELAY

WRITE FOR SPECIAL PRICE LIST

MAIL ORDERS FILLED SAME DAY
 10% Cash Must Accompany All C. O. D. Orders

NATIONAL CO. engineers designed this new High-Frequency Receiver in collaboration with Robert S. Kruse.

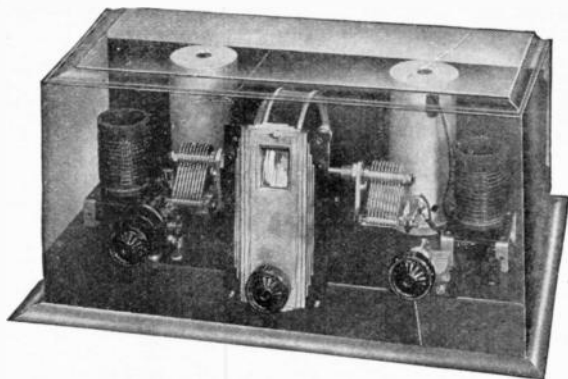

Write today for new Bulletin 143-A on NATIONAL Amateur-Equipment.

High Quality Phone Reception

Full A. C. Operation—No Hum—Push-Pull Audio

NATIONAL A.C. SW 5 THRILL-BOX

A true A.C. Amateur Instrument, tunes and logs as easily as a broadcast receiver. Actual single control; — set and forget the antenna trimmer. There are 1080 dial degrees available between 21.2 m.c. and 2.61 m.c. Easily adapted for still wider spreading of the amateur bands if desired. Very smooth control

of sensitivity either on c.w. or phone. No grunting or backlash — no hand capacity. Double screen-grid, with 224 grid-leak detection. Equipped with push-pull audio, and special phone-jack after first stage. Made also in new battery-model, using the new UX 230, 231 and 232 tubes.

Easily assembled with genuine NATIONAL Radio Parts



R. F. TRANSFORMERS

Standard set of four pairs covering from 21.2 to 2.61 m.c. Special coils also available for 33-21.2 m.c. and the 2.61-1.5 m.c. ranges. Forms are moulded

R-39, the new low loss coil material developed by Radio Frequency Laboratories. Blank forms also available for winding experimental coils.



SE AND ST VARIABLE CONDENSERS

Model SE, a special high-frequency design,

not a cut-down broadcast job. Insulated main bearing and constant impedance pigtail. 270 degree straight-line frequency plates. Model ST has 180 degree equitune plates. Either model available in capacities up to 150 mmf.



PRECISION VELVET-VERNIER DIALS, Type N

A four inch Solid German Silver Dial, for use in amateur and experimental equipment requiring maximum accuracy in logging. Equipped with real vernier, reading to $1/10$ division. Easy and simple to mount.

LEVER-TYPE INDICATOR Type J



For transmitter-panel use. Bakelite knob and handle. Nickel plated brass pointer. 6" diameter etched scale can also be furnished. Available for $1/4$ " and $3/8$ " shafts. Details on request.

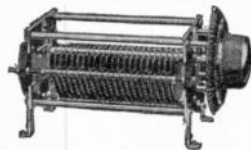

Transmitting CONDENSERS—Model TM

Widely used by the U. S. Government, Broadcasting Stations and amateur transmitters the world over. Made in 3000 and 6000 volt ratings and in capacities from .00035 to .0045 Mfd. Other voltages and capacities made to special order. Now supplied with Crolite insulation.

THE POWER UNIT



A separate unit with cable and soft rubber covered connecting plug, especially designed for humless operation of high-frequency receivers. 180 Volt B, 2.5 Volt filament supply. Licensed under R.C.A. Patents.

NATIONAL

Precision-Built RADIO—PARTS

NATIONAL COMPANY INC., SHERMAN, ABBOTT & JACKSON STS., MALDEN, MASS.

QUALITY CONDENSERS

GENERAL RADIO COMPANY has been designing and building amateur experimental and laboratory condensers for more than fifteen years. Why not avail yourself of our accumulated experience? Although our soldered plate condensers are built by precision instrument makers, they cost no more than others. The following are three representative instruments.

Type 557 Amateur-Band Condenser carries 4 rotor plates 2 of which are complete circles giving the high zero capacitance required in band-spanning condensers. Especially useful in frequency meters. Price \$3.25.



Type 247 Variable Air Condensers are furnished in 4 different models with a scale calibrated in micromicrofarads. Useful as an experimental capacitance standard.

Type 334 Variable Air Condensers are made in 4 different models for use on amateur transmitters. Maximum voltage 3500 volts, peak.

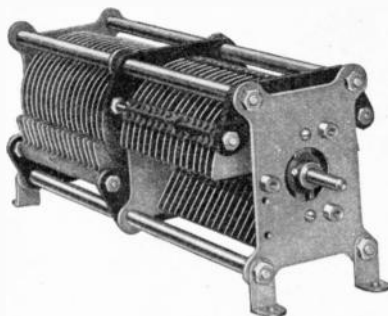

A bulletin describing our complete line of amateur equipment will be mailed on request.

GENERAL RADIO COMPANY

OFFICES

LABORATORIES

FACTORY

CAMBRIDGE A, MASSACHUSETTS

Pacific Coast Warehouse: 274 BRANNAN STREET, SAN FRANCISCO

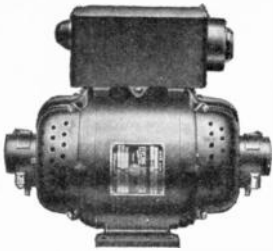

Dynamotor with
New Style Filter

NEW!

An improved line of dynamotors and motor-generators by "ESCO" to operate alternating current radios or other apparatus from direct current. Equipped with attachment plug receptacles and a new filter designed to iron out disturbances from the d.c. supply line, in addition to giving humless operation from the ESCO unit.

"ESCO" Dynamotors — small — compact — rugged and efficient. Commander Byrd had several in the Antarctic. Primary wound for 6 volts DC or higher. Secondary wound for high or low voltage AC or DC, 26 frame sizes to choose from.

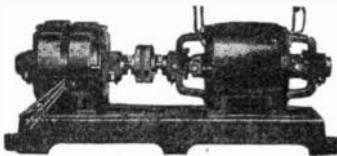
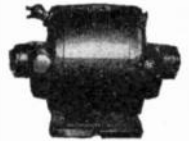

"ESCO" four bearing motor generators are the power pioneers of the Radio Art. ESCO bulletins list over 250 combinations. The "ESCO" four bearing set shown to the left is Item No. 37 with a polyphase AC motor. It was this item which was used by Carlos Braggio of Bernal, suburb of Buenos Aires in establishing the first amateur radio communication between North and South America.

"ESCO" 2 bearing motor generator sets are very practical and economical where a single voltage is required. The secondary end may be wound for any voltage between 6 and 750 volts. These machines are excellent for crystal control equipment, grid bias on large sets, Neon tube supply for television or for small transmitting sets.

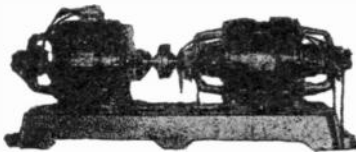
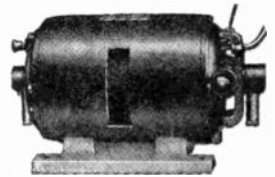

The cut on the left shows an "ESCO" 2 unit, 4 bearing motor-generator. The generator is double commutator high voltage, with a distributed and compensated field winding. This design permits greater overload, produces less ripple and gives more power output for a given frame size than the conventional type of generators. The MacMillan Arctic Expedition was equipped with four of this type.

Low wind resistance, light weight, non-corroding parts, ball bearings, tool steel shafts, steel shells, cast steel pole pieces, weather proof construction, many sizes to choose from, high voltage and low voltage windings to suit individual requirements, are a few of the many reasons for "ESCO" generators being the first choice.



ELECTRIC SPECIALTY COMPANY

333 South Street, Stamford, Conn., U.S.A.

Manufacturers of Motors, Generators, Dynamotors and Rotary Converters for all purposes

SM

Don't Throw the Old B. C. L. Set Away!

Don't throw it away—hook a 738 Converter on it and turn it into a *real* receiver—a short-wave super-heterodyne! There is no sweeter converter made. The only trouble is that it's too easy to hook onto the broadcast set. All you have to do is to remove the antenna lead from the b.c.l. set and connect it to the antenna post of the converter; then run a couple of leads from the 738 to the antenna and ground posts of the broadcast set. That's all. Your grandmother could do it. Of course, if you really want some fun, get Data Sheet No. 23 and take a look at the parts list—you'll be inspired to do some interesting building.

And what a set! Every bit of the sensitivity and selectivity possessed by the broadcast set contributes to the short-wave performance—giving results never before achieved.

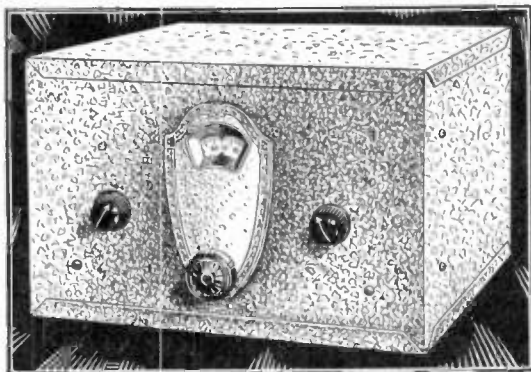

The 738 is tuned by a single dial which tunes the oscillator circuit and an auxiliary midjet condenser. And there's no critical regenerative control. It will give short-wave broadcasting as well as phone and i.c.w. where there is any carrier modulation at all. Included in the list price are eight plug-in coils (four pairs), covering a wave length range of from 18 to 206 meters. It uses one '24, one '26 and a '27 tube. The 738 Short-Wave Converter is complete as described above. Housed in a handsome black crystalline steel case (11"x11"x7½"), with hammered silver dial escutcheon. Completely factory-wired, tested and RCA licensed, \$69.50 List. For list of component parts in the 738 see Data Sheet No. 23 (as mentioned above). Individual part prices total \$56.50 List.

Also for 25 cycle. Wired price \$74.50 List.

New Superheterodynes

The 724 is a superheterodyne custom-built receiver that will make a DX bug of a commercial operator. It has *nine* tuned circuits—six (three dual pre-selector) circuits in the i.f. amplifier, preceded by two tuned r.f. circuits, plus the oscillator circuit. It has uniform selectivity and sensitivity over the entire broadcast band, with no trace of second "spot" or repeat points.

Tubes required (in the AC model): 5—'24, 1—'27, 2—'45, 1—'80.

Tubes required (in the DC battery model): 5—'32, 1—'30, 2—'31.

S-M 724AC Superhet receiver, completely factory-wired and RCA licensed, \$99.50 List. Parts total \$87.50 List.

S-M 724DC (for batteries) factory-wired, tested and licensed, \$82.50 List. Component parts total \$68.50 List.

The 714 Tuner—successor to the famous Sargent-Rayment 710 and the 712—accomplishes a perfection of design never before attempted: the building of a double pre-selector tuned-radio-frequency circuit into a single-dial screen-grid superheterodyne for all a.c. operation. Amazing sharpness of tuning is achieved through the use of *eleven* tuned circuits. The dual pre-selector circuits absolutely prevent the cross-modulation you've encountered in ultra-sensitive superhets, and insure complete suppression of the second resonance "spot." The 714 is unhesitatingly classed as the finest superhet tuner it is possible for modern engineering to produce.

Tubes required 4—'24, 2—'27.

S-M 714 Superhet Tuner (only), completely factory-wired, tested and RCA licensed, \$87.50 List. Component parts total \$76.50 List.

The Radiobuilder, Silver-Marshall's publication telling the very latest developments of the laboratories, is too valuable for any amateur to be without. Send the coupon for a free sample copy. If you want it regularly, enclose 50c for the next 12 issues.

4,000 Authorized S-M Service Stations are being operated. There's money in it. Write for information on the franchise.

SILVER-MARSHALL, Inc., 6433 WEST 65TH ST.
CHICAGO, U. S. A.

Silver-Marshall, Inc.
6433 West 65th St., Chicago, U. S. A.
... Send your New Fall Catalog with sample copy of the Radiobuilder.
... 6c enclosed; send Data Sheets giving complete information on the 738, 724 and 714.

Name

Address

Standard For Years

RCA Radiotron UX-250 Power Amplifier

RCA Radiotron UX-250 is the largest and most powerful amplifier RCA Radiotron for radio reception.

Due to the high plate current of the UX-250, some form of loud-speaker coupling must be used. Its characteristics are: Filament terminal voltage, 7.5 a. c. or d. c. Filament current, 1.25 amps. Plate voltage, 450. Grid bias, 80 with d. c. on filament—84 with a. c. Mutual conductance, 2100. Amplification factor, 3.8.

RCA Radiotron UX-852 Oscillator or R. F. Power Amplifier

RCA Radiotron UX-852 is a 75 watt transmitting tube designed for use as an oscillator or radio-frequency power amplifier, particularly at frequencies above 3000 kilocycles (wavelengths below 100 meters). It draws 3.25 amps. at 10 volts on the filament. Amplification factor, 12. Normal plate volts, 2000. Grid bias, 250.

RCA Radiotron UX-210 Power Amplifier

RCA Radiotron UX-210 is a high-power-amplifying tube. The high plate current of this RCA Radiotron makes a loudspeaker coupling device a necessity. Its characteristics are: Filament terminal voltage, 7.5 a. c. or d. c. Filament current, 1.25 amps. Plate voltage, 425. Grid bias, 35 with d. c. on filament—39 with a. c. Mutual conductance, 1600. Amplification factor, 8.

RCA Radiotron UX-865 Screen Grid R. F. Power Amplifier, Oscillator

RCA Radiotron UX-865 is a 7.5 watt, four electrode transmitting tube designed primarily for use as a power amplifier at radio frequencies. It is especially applicable to frequencies greater than 3000 kilocycles.

RCA Radiotron UX-865 is also very useful as a crystal-controlled oscillator. Its characteristics are: Filament terminal voltage, 7.5. Filament current, 2 amps. Plate voltage, 500. Grid bias, 85. Screen voltage, 125.

The recognized quality, uniformity and reliability of RCA Radiotrons are the result of the efforts of a group of able and experienced tube engineers backed by superior manufacturing facilities.

RCA Radiotron UY-227 Detector Amplifier

RCA Radiotron UY-227 is a general purpose tube containing a heater element which permits operation from alternating current. Its characteristics are: Filament terminal volts, 2.5 a. c. or d. c. Filament current, 1.75 amps. Plate Voltage, 180. Grid bias, 13.5. Mutual conductance, 1000. Amplification factor, 9.

RCA Radiotron UX-245 Power Amplifier

RCA Radiotron UX-245 is a powerful amplifier tube useful in the last audio stage for delivering large undistorted power to the loudspeaker. Its characteristics are: Filament terminal volts, 2.5 a. c. or d. c. Filament current, 1.5 amps. Plate voltage, 250. Grid bias, 48.5 with d. c. on filament or 50 using a. c. Mutual conductance, 2000. Amplification factor, 3.5.

RCA Radiotron UX-112-A Detector Amplifier, Power Amplifier

RCA Radiotron UX-112-A is an improved general purpose storage battery tube. While it was primarily designed as a power amplifier for use in the last audio stage, it may also be used for detection or amplification. It is extremely sensitive as a detector, and is an excellent radio-frequency or audio-frequency amplifier. Its characteristics are: Filament terminal voltage, 5 a. c. or d. c. Filament current, .25 amps. Plate voltage, 180. Grid bias, 13.5 with d. c. on filament, 16 with a. c. Mutual conductance, 1700. Amplification factor, 8.5.

RCA Radiotron UY-224 Radio-Frequency Amplifier

RCA Radiotron UY-224 is a uni-potential, screen-grid tube. It is recommended for use primarily as a radio-frequency amplifier in carefully shielded circuits especially designed for it, but may also be used in special circuits as a screen-grid detector. Its characteristics are: Filament terminal voltage, 2.5 a. c. or d. c. Filament current, 1.75 amps. Plate voltage, 180. Grid bias, 3. Mutual conductance, 1000. Amplification factor, 400.

RCA Radiotron UX-281 Half-Wave Rectifier

RCA Radiotron UX-281 is a half wave rectifier tube of the coated ribbon filament type. The filament of the UX-281 is very sturdy and gives unusually high emission.

Its maximum output capacity is 85 milliamperes. Two RCA Radiotrons UX-281 may be connected to give full wave rectification with an output of 170. Filament terminal voltage is 7.5 a. c. Filament current, 1.25 amps. Max. a. c. plate voltage, 700.

RCA Radiotron UX-280 Full-Wave Rectifier

RCA Radiotron UX-280 is an improved full wave rectifying tube that contains coated ribbon filaments.

The plates of this RCA Radiotron have specially treated surfaces (to be noted by their dark appearance) which cause rapid dissipation of heat. Its characteristics are: Filament terminal voltage, 5. Filament current, 2. Max. a. c. voltage per plate, 400. This gives a d. c. output current of 110 ma.

RCA Radiotron UX-866 Half-Wave Rectifier

RCA Radiotron UX-866 is a half wave, hot cathode, mercury vapor rectifier tube for use in suitable rectifying devices designed to supply d. c. power from a. c. supply lines. Full wave rectification is accomplished by using two of these RCA Radiotrons. Its characteristics are: Filament terminal voltage, 2.5. Filament current, 5 amps. Max. peak inverse voltage, 5000. Max. peak plate current, 16 amps. Approx. tube voltage drop, 15.

NEW TUBES OF SPECIAL INTEREST TO AMATEURS

These new battery operated RCA Radiotrons for short wave and portable sets and other amateur applications, represent an important step in the art of designing tubes for economical performance.

RCA Radiotron 230 Detector Amplifier

RCA Radiotron 230 is a new general purpose tube of the three electrode, high vacuum type. Its characteristics are: Filament terminal voltage, 2 d. c. Filament current, .06 amps. Plate voltage, 90. Grid bias, 4.5 volts. Mutual conductance, 700. Amplification factor, 8.8.

RCA Radiotron 231 Power Amplifier

RCA Radiotron 231 is a new power amplifier tube of the three electrode high vacuum type. Its characteristics are: Filament terminal voltage, 2 d. c. Filament current, .13 amps. Plate voltage, 135. Grid bias, 22.5 volts. Mutual conductance, 875. Amplification factor, 3.5.

RCA Radiotron 232 Radio-Frequency Amplifier

RCA Radiotron 232 is a new screen-grid tube recommended for use primarily as a radio-frequency amplifier. Its characteristics are: Filament terminal voltage, 2 d. c. Filament current, .06 amps. Plate voltage, 135. Grid bias, 3 volts. Mutual conductance, 550. Amplification factor, 440.

For additional information on the above and other receiving RCA Radiotrons address your inquiry to the Commercial Engineering Department, RCA Radiotron Co., 215 South 5th Street, Harrison, N. J.

RCA Radiotrons

THE HEART OF YOUR RADIO

THE

Amateur's Bookshelf

GOOD TEXTBOOKS and operating manuals should be on every amateur's bookshelf. We have reviewed practically all the books in which the amateur would be interested, and have arranged to handle through the *QST* Book Department at A.R.R.L. Headquarters those volumes which we believe to be the best of their kind. Take pride in a small but good radio library; buy a few good books and get into the habit of reading them.

- Principles of Radio**, by Keith Henney. This book is chock-full of meat for the experimenter. The subjects treated range from the fundamentals of electricity to the most modern concepts of modulation and detection. 477 pp., 306 illustrations. \$3.50
- Elements of Radio Communication**, by Prof. J. H. Morecroft. This is a new book by the author of the "Principles" listed below. It is about half the size of the larger work, and the subject is treated in more elementary fashion. Simple algebra is sufficient. An excellent book for the "first-year" student. 269 pp., 170 illustrations. \$3.00
- Principles of Radio Communication**, by Prof. J. H. Morecroft. An elaborate general textbook, and one of the recognized standards on theory for the engineering student. A working knowledge of mathematics is desirable for the reader who expects to get the greatest benefit from this work. 935 pp., 5¾ x 9. \$7.50
- Radio Engineering Principles**, by Lauer and Brown. While not as voluminous as "Morecroft" this excellent general textbook on radio principles is the favorite of many students. A moderate knowledge of mathematics is desirable. 300 pp., 5½ x 9. \$3.50
- Experimental Radio**, by Prof. R. R. Ramsey. Revised Edition. A splendid book for the experimenter. This is a laboratory manual, describing 128 excellent experiments designed to bring out the principles of radio theory, instruments and measurements. 150 illustrations, 229 pp., 5¼ x 7. \$2.75
- Radio Theory and Operating**, by Mary Texanna Loomis. Although giving a moderate amount of theory, it is essentially a practical handbook for commercial and broadcast operators, and as such ranks among the foremost publications of this sort. Used as a textbook by many radio schools. A good book for any amateur. 1000 pp., 800 illustrations. \$4.25
- The Radio Manual**, by George E. Sterling. Another excellent practical handbook, especially valuable to the commercial and broadcast operator, and covering the principles, methods and apparatus of all phases of radio activity. Over 900 pp. \$6.00
- Radio Telegraphy and Telephony**, by Duncan and Drew. Still another work along the lines of a general practical handbook. In size it is approximately the same as the two listed just previously, and the subject matter generally follows along the same lines. A good book in this class. 950 pp., 468 illustrations. \$7.50
- Practical Radio Telegraphy**, by Nilsen and Hornung. Written particularly for the student training for a commercial license, and covering theory and apparatus. A practical handbook. 380 pp., 223 illustrations. \$3.00
- Radio Data Charts**, by R. T. Beatty. A series of graphic charts for solving, without the use of mathematics, most of the problems involved in receiver design. 82 pp., 8½ x 11. \$1.50
- Thermionic Vacuum Tube**, by H. J. Van der Bijl. For many years this has stood out above all other works as a theoretical textbook and treatise on the vacuum tube and vacuum tube circuits. A knowledge of higher mathematics is required. Not a book for the beginner, but for the laboratorian and engineering student it is without a peer. \$5.00
- Radio Operating Questions and Answers**, by Nilsen and Hornung. Revised Edition. This is intended as a companion volume to "Practical Radio Telegraphy" by the same authors. In conjunction with that work it should leave the commercial license applicant well prepared for his examinations. There is a chapter on amateur license questions and answers, too. 267 pp., 5½ x 8. \$2.00
- How to Pass U. S. Government Radio License Examinations**, by Duncan and Drew. Intended as a companion volume to "Radio Telegraphy and Telephony" by the same authors, as a guide to the applicant for commercial licenses. It is not a text in itself. The chapter arrangement follows that of the sections of the commercial theoretical examination, each being made up of typical examination questions and their answers. 169 pp., 92 illustrations. \$2.00
- Theory of Radio Communication**, by Lt. John T. Filgate, S.C., U.S. Army. An excellent book on the theory of receivers, transmitters and associated equipment for those familiar with elementary electricity and magnetism. 250 pp., 180 illustrations. \$2.00
- Radio Traffic Manual and Operating Regulations**, by Duncan and Drew. A book for students, amateurs or radio operators who contemplate entering the commercial field; it will enable you to learn quickly and easily all the government and commercial traffic rules and operating regulations. 181 pp. \$2.00
- ABC of Television**, by Raymond F. Yates. A practical treatment of television with particularly complete chapters on photo-electric cells, amplifiers and scanning methods. 205 pp., 78 illustrations. \$3.00
- Manual of Radio Telegraphy and Telephony**, by Commander (now Admiral) S. S. Robison, U.S.N. Published by the Naval Institute. Covers both the theoretical and practical fields. 895 pp., 6¾ x 9. \$4.00

Prices include postage

Read 'em and learn!

AMERICAN RADIO RELAY LEAGUE, INC.
1711 Park Street, Hartford, Connecticut

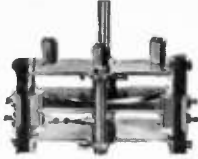

The 201-E (2 Plates). A taper plate condenser for short wave receivers. The stator plate is adjustable, affording maximum capacities of from 50 to 10 mfd. Constant min. 7 mfd. Price \$4.

IF YOU DO NOT WANT OR EXPECT

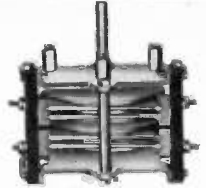

202-E (Split Stator) Taper Plate.—.000300 mfd. Sections in multiple.—.00075 mfd. Sections in series.—.000150 mfd. per section. Useful for tuning push-pull circuits.



147-B transmitting condenser. Capacity .00044 mfd. Voltage 3000.

Superlative Performance,
Mechanical Strength,
Long Life and Reliability
Under All Conditions

in a variable condenser—
then, less than

CARDWELL

quality may satisfy you

BUT—

The greatest concerns in the country
and the Government use CARDWELLS

The most useful condensers for
the amateur are illustrated. There
are many more. Send for literature.

The Allen D. Cardwell Mfg. Corp.
81 Prospect Street Brooklyn, N. Y.

CARDWELL CONDENSERS

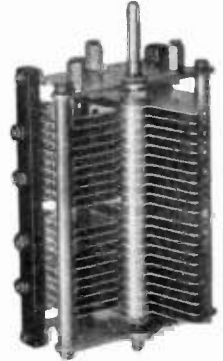

The 157-B transmitting condenser (Split Stator .00022 mfd. each section). Voltage 3000.



The T-183 transmitting condenser. Heavy polished and rounded plates. Capacity .00011 mfd. Voltage 6000.

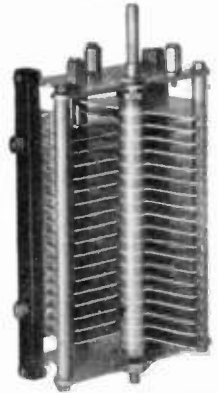

The T-199 transmitting condenser. Heavy polished and rounded plates. Capacity .00033 mfd. Voltage 3500.

"THE STANDARD OF COMPARISON"

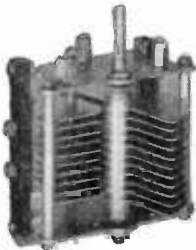

The 164-B transmitting condenser. Capacity .00022 mfd. Voltage 3000.



NEW!

613-A Balancing Condenser with mounting bracket and locking device (50 mmfd.) Made in 6 capacities, single and dual. This locking device will be supplied with any of our standard condensers at a cost of 60c additional or will be sold separately.

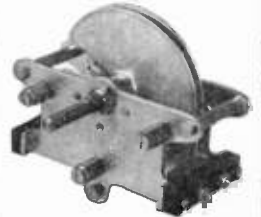

191-E (Taper Plate) .000075 mfd. One of five regular receiving sizes supplied. From .0005 mfd. to .00075 mfd.

Tips to Progressive Amateurs

FOR THOSE elusive DX signals, we suggest that you try a set of Eveready Raytheon 4-Pillar Radio Tubes in your receiver. They will make it more sensitive whether it be a broadcast receiver or a short wave set.

Plates 1 and 2 give a graphical comparison of the relative sensitivities of the most popular 224 and 227 tubes as used in a single shielded radio frequency stage tuned to 1000 KC. These comparisons were made by a well known radio laboratory on lots of tubes purchased in dealers' stores.

These tests show that the lot of Eveready Raytheon 224 tubes were the most uniformly sensitive tubes of the 7 makes of 224's tested. Likewise, the lot of Eveready Raytheon 227 tubes were also the most uniformly sensitive tubes of the 10 makes of 227's tested.

Eveready Raytheon 4-Pillar Radio Tubes

are more uniformly sensitive because of their painstaking manufacture and their patented 4-Pillar construction which securely maintains the accurate positioning of the filament, cathode, grid and plate elements regardless of the jars and vibration caused by shipment and use.

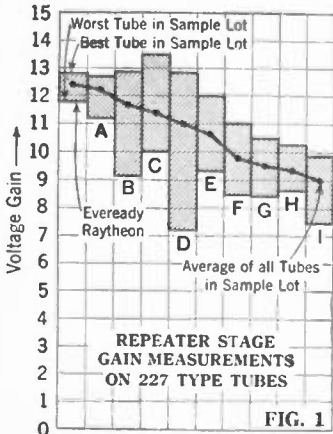

FIG. 1

The 224 and 227 A.C. type Eveready Raytheon tubes are also quick acting — which means signals in a few seconds, and humless — due to their patented non-inductive heater and thorough electrostatic shielding.

We have a Tube Chart giving complete electrical characteristics of all receiving tubes which we will be glad to mail to any amateur free of charge.

Ask for it.

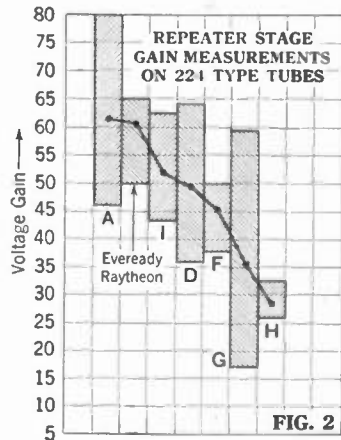

FIG. 2

NATIONAL CARBON CO., INC.

General Offices: NEW YORK, N. Y.

Branches: Chicago Kansas City New York San Francisco

UNIT OF UNION CARBIDE  AND CARBON CORPORATION

With a Vibroplex Sending Is Easy

Trade in your old
VIBROPLEX
as part payment

Great *New* Easy-working Genuine Martin No. 6 **VIBROPLEX**

Reg. Trade Marks: Vibroplex, Bug, Lightning Bug

In Colors
Blue
Green
Red

The Choice of
Good Operators
Everywhere

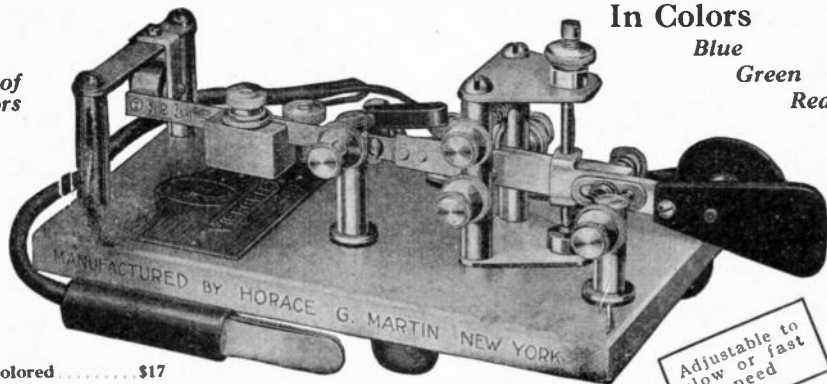

Black or Colored \$17
Nickel-Plated \$19
Slightly higher in Canada

Adjustable to
slow or fast
speed

Easy to Learn —

Simply Press Lever—Vibroplex Does the Rest

With a Vibroplex sending is easy. Anyone who can send on an ordinary key can send *better, faster and easier* with a Vibroplex. It saves the arm, prevents cramp and loss of grip and develops a smooth, clear, uniform style of sending.

Now is the time to get your Vibroplex. *The Great New, Easy-Working Genuine Martin Vibroplex.* This is the bug you want because it is the *smoothest, easiest-working* bug on the market. Experienced operators know this — that's why over 100,000 use and endorse only the Genuine Martin Vibroplex.

Don't deny yourself this New, Easy-Working Vibroplex any longer. Place your order NOW for immediate delivery. Shipped anywhere on receipt of price. Money order or registered mail.

Be sure the bug you buy is the Genuine Martin Vibroplex. Look for the Vibroplex Nameplate—that's your guaranty of complete satisfaction.

Write for Catalog

THE VIBROPLEX CO., Inc.
825 Broadway
New York

Telephone:
Algonquin 4828



J. E. Albright
President

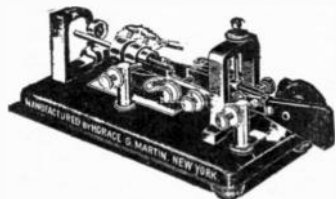

Famous Improved Genuine Martin Vibroplex

Used by tens of thousands of operators because of its *ease and perfection* of sending. Large contact points. Black or Colored, \$17. Nickel-Plated, \$19.

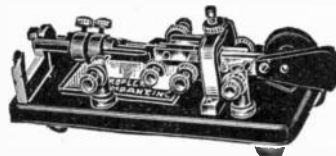

Famous Blue Racer Genuine Martin Vibroplex No. 4

A small model with all the advantages of the larger instrument.

Black or Colored, \$17
Nickel-Plated, \$19

Special Radio Model

This Special Radio Model is fitted with Extra Heavy, Specially Constructed Contact Points $\frac{3}{8}$ -inch in diameter to break high current without use of relay. Black or Colored, \$25.

Glorious Adventure awaits you in **RADIO**

RADIO needs men just like you. Thousands of opportunities are now open for fellows who already know something about radio . . . who "think" radio, who "play" with radio, men who are "radio-minded" . . . radio amateurs! You, too, can use the knowledge you already have as a stepping-stone to success in radio. All you need is a little commercial training in order to make good in this fascinating profession. Others have done it and so can you. RCA Institutes actually trains you for success. It gives you the practical as well as the theoretical knowledge . . . the "how" as well as the "why" of radio. You study under the direction of nationally known experts . . . men who have made good in radio and can show you how you, too, can make your mark in this, the fastest-growing industry in the world today.

Get a Commercial Radio License

Radio needs you. Never before has there been such an opportunity for rapid advancement. On ship or shore, the constant demand is for men . . . more men . . . trained men! Large broadcasting stations, manufacturers, dealers, as well as steamship companies are continually asking for men who have the knowledge and the confidence to hold a well-paid position in Radio. You, too, can now get that knowledge . . . You can be trained for a good paying radio job.

*This is the Only Course Sponsored by the
Radio Corporation of America*

RCA is the world's largest radio organization. It sets the standards for the entire radio industry.

Our book is yours free . . . SEND FOR IT TODAY!

Clip this Coupon NOW!

RCA INSTITUTES, INC.

A Division of Radio Corporation of America



And the RCA Institutes' home laboratory training course enables you to quickly learn the secrets of radio. It enables you to obtain a thorough, practical education in radio in your spare time . . . You get the inside information, too, because you study right at the source of radio achievement. You learn radio by actual experience with the remarkable outlay of apparatus given to every student.

*See for Yourself why RCA Graduates
Earn Good Money in Radio*

Clip this coupon now . . . send for this free book. Or, if you wish, step in at one of our resident schools and see for yourself how RCA Institutes actually prepares men for success in radio. Come in and get this free book or send for it by mail. Everything you want to know about radio. Each page packed with pictures and descriptions about the amazing opportunities in this vast, world-wide, money-making profession.

For the added convenience of students who prefer a Resident Study Course, RCA Institutes, Inc., has established Resident Schools in the following Cities:

New York . . . 75 Varick St.
Chicago . 222 North Bank Drive
Boston, Mass. . 899 Boylston St.
Philadelphia, Pa. 1211 Chestnut St.
Baltimore, Md. 1215 N. Charles St.
Newark, N. J. . . 560 Broad St.

Home study graduates may also attend any one of our resident schools for post-graduate instruction at no extra charge.

RCA INSTITUTES, Inc.
Dept. RHA, 75 Varick St.
New York, N. Y.

Gentlemen: Please send me your FREE 40-page book which illustrates the brilliant opportunities in Radio and describes your laboratory-method of instruction at home!

Name-----

Address-----

It Is EASY to Quickly Increase Your Speed in Sending Receiving and Typing Through The Candler System Courses

The only specialized courses for Radio and Morse Operators. Over 45,000 of the world's leading telegraphers owe their skill and speed to The Candler System Courses.

SKILL, SPEED and ACCURACY in handling key, bug, pen and typewriter have meant **SUCCESS and PROMOTION** for thousands. If you are ambitious to be a **TOP NOTCHER**, we can help you to quickly achieve your goal.

The *efficient Radio Operator* gives no thought to "letters" in sending and receiving. He thinks only of "words" and "groups of words" as in talking or listening to some one talk — this is why he is *faster, more accurate and more capable*.

We Have Thousands of Letters Similar to This One

"Since taking The Candler System I can copy 7 to 10 words behind as fast as they come without being the least bit nervous. I can send like a streak of lightning and my arm does not weaken or become tired. If many of those with whom I work would take your System life would be worth living." (Signed) A. C. Jerrett, Post Office Dept., Gambo, B. B. Newfoundland.

Original Methods Bring Remarkable Results

The Candler System shows you quickly how to copy far enough behind, without nervous or mental strain, so you can make a clean-cut, accurate copy. By our own original method of Radio-Touch Typing, no sender can "rush" you. We show you how to send with key or bug, rapidly and smoothly for any length of time without tiring.

Raymond Bell, Radioman, U. S. S. Idaho, San Pedro, Cal., writes:

"Already I've accomplished one thing I never thought possible, and that is to stay four or five words behind in copying and my sending is just about perfect. My friends remark about it. The Candler System in High-Speed Telegraphing, the course in Radio-Touch Typewriting, and Speedhand course which I use as a telegraph shorthand also for other purposes where shorthand is used — have certainly done wonders for me.

Rapid Promotion For Efficient Radio Operators

The sun never goes down on Candler System Radio Operators. They are on Ships at Sea, calling at far-flung ports; in large Broadcasting Stations, Commercial and Amateur Stations; in Airplanes and Ground Stations everywhere. They are doing their work efficiently and winning rapid promotion, while untrained, inefficient men are being shifted about in poorly paid, mediocre jobs with never a chance for advancement.

Let Us Help You To Realize YOUR Ambitions

If you are stuck anywhere between 5 and 30 wpm; if you have a weak arm; if you copy "close-up" making a poor copy with "mill" or pen; if you're nervous, excitable and easily rattled while sending and receiving; if you're despondent, discouraged and feel that skilled operators are born — not made; if you desire to obtain and hold the higher class position, the three Candler System Courses — **High-Speed Telegraphing, Radio-Touch Typewriting and Speedhand (Radio Shorthand)** — will do wonders for you. Write us, outlining your difficulties and ambitions. We will give you without obligation, our personal counsel as we have to thousands of others during the past 19 years, and give you further evidence of how The Candler System Courses will help you to realize your ambitions. Tell us your present code and typing speed. *Write NOW!*

The Secret
of
High Speed
Telegraphing

THE CANDLER SYSTEM CO.

Dept. H. B.

6343 South Kedzie Avenue

CHICAGO, ILLINOIS

xxii



WALTER H. CANDLER

Former World's Champion Operator and Originator and Director of The Candler System Courses—High Speed Telegraphing, Speedhand, and Radio Touch Typewriting will instruct you personally throughout these Courses.

THOUSANDS WRITE LIKE THIS

"I am pleased with your Course in every respect. My sending and receiving have improved to a very great extent. Am getting along fine with the Radio Touch Typewriting Course. It is the best course on typing and the easiest and quickest to learn." (J. W. Mularkey, RM3c, U. S. C. G. C. Wolcott.)

"I have taken the first lesson as directed and can see a difference already in a number of ways. My arm is getting better every day. Can make dots and dashes better and faster than I ever could. Never stick on dots like I did. Before I started the Course I would send awhile and my hand would get so cramped I had to stop. Am very glad I took your Course." (Pvt. Donald Kaake, Hdq. Battery 2nd C. A., Fort Sherman, Panama.)

"There is marked improvement in my sending and typing speed, and am rapidly acquiring receiving speed. Can copy as far as 3 to 4 words behind at a speed of 32 wpm on the "mill" and am confident that it will not be long before I can polish 40 on the "mill" with no exertion whatever." (Kendrick M. Martin, 2035 Webster St., Oakland, Calif.)



The Vitrohm Plaque Resistor, 507-111, is a non-inductive, non-capacitative unit having a standard resistance value of 5,000 ohms. Maximum current 80 m.a. \$2.00



The Amateur's standard grid leak, 507-51. Center-tapped, mounted resistor of 10,000 ohms total resistance. Maximum current 100 m.a. \$3.85



507-66 has a total resistance of 15,000 ohms in steps of 5,000, 5,000 and 5,000 ohms. Mounting brackets are supplied. Maximum current 75 m.a. \$4.25



Vitrohm Stabilizing Resistors when placed across the plate supply output protect condensers from high no-load voltages, steady the note, help eliminate keying chirps. Various sizes and prices.



These heavy duty Vitrohm Steel Rheostats are made in 3 sizes: 507-83, 12.5 ohms; 507-59, 20 ohms; 507-63, 50 ohms. Each is priced at \$5.50

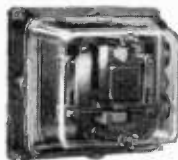

This key relay is a new and important addition to the W.L. line for amateurs. Operates directly from the 110 v.a.c. line and follows any key speed without missing or chattering.

Write for information.

VITROHM COMPONENTS

for radio transmitters

The Ward Leonard Electric Co. has served the cause of amateur radio since its inception. During this time, we have endeavored always to furnish VITROHM COMPONENTS to meet every requirement for resistors and rheostats at the lowest price consistent with a high standard of quality.

We want you as an amateur station operator to feel that your cause in radio is ours. If you believe that this company should make a new product, or improve an old one, write and tell us about it. If you have a question concerning the best use of resistors, rheostats, or relays, ask us about it. We'll do our level best to give you a prompt, satisfactory solution.

Below are listed three services which are of interest to you:

1. A new Bulletin on resistors and rheostats for radio transmitters.
2. QSL cards which are furnished without charge to all ARRL members. Write, giving your address and station call letters, and we will send you a supply.
3. Have your club secretary write us at once to learn the details of a money-saving plan for all radio club members.

WARD LEONARD ELECTRIC CO.

MOUNT VERNON, N. Y.

