

The RADIO AMATEUR'S HANDBOOK

A MANUAL OF AMATEUR
HIGH-FREQUENCY RADIO COMMUNICATION



Published by the

AMERICAN RADIO
RELAY LEAGUE

PRICE \$1.00



**The Radio Amateur's
HANDBOOK**

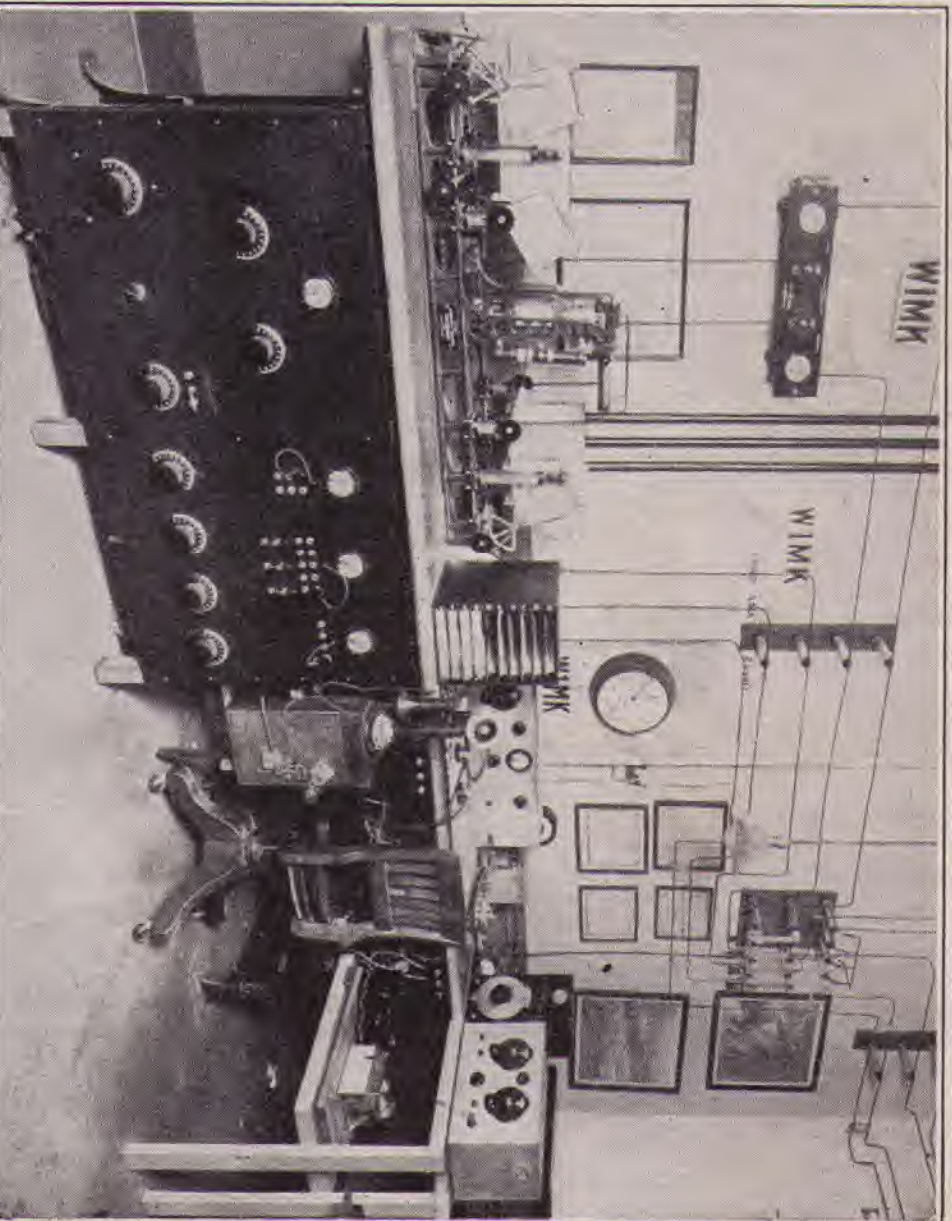
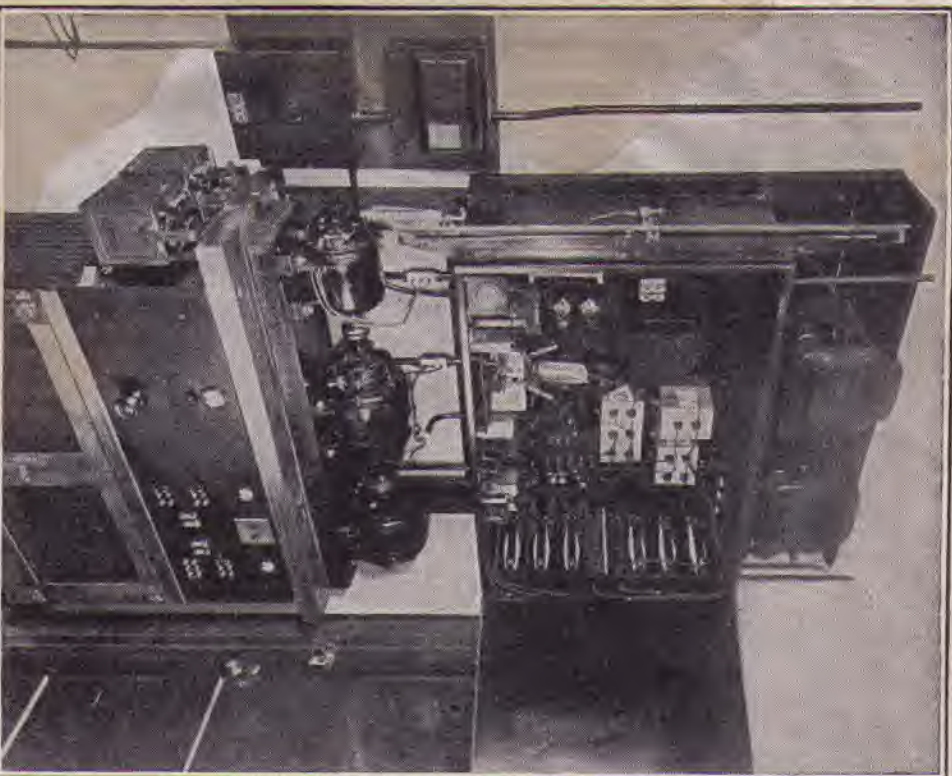

W1MK, THE HEADQUARTERS STATION OF THE A.R.R.L. AT HARTFORD, CONN.

These views of power supplies and operating position show good station arrangement. Note the neatness and accessibility of every piece of apparatus. High voltage d.c. is obtained from a motor-generator and a mercury-arc rectifier and filter, with facilities also available for using mercury-vapor rectifiers. Fuses, relays, batteries, and changing equipment are all in the power-supply room. The single-signal receiver is in front of the operator, key and controls at his right hand, message file box and telephone at his left. At his right side are monitor, electron-coupled frequency meter, and an automatic tape transmitter for sending Official Broadcasts to A.R.R.L. members. On

the table is the 3500-4000-kc. band transmitter using two Type 04-A tubes in a self-excited I.P.T.G. circuit. The panel transmitter below works on the 7-mc. and 14-mc. bands. This is a controlled-temperature crystal-excited set terminating in a Type 61 tube. Two-wire voltage (Zeppelin) feed is used to separate antennas for the two transmitters, and a separate receiving antenna facilitates "break-in" work. W1MK is a busy station but is always ready for a call from any "ham." See page 17 for the schedule of regular transmissions of addressed information to A.R.R.L. members.

The Radio Amateur's HANDBOOK

A Manual of Amateur High-
Frequency Radio Communication



BY THE HEADQUARTERS STAFF
of the
AMERICAN RADIO RELAY LEAGUE

Eleventh Edition

WEST HARTFORD, CONNECTICUT
THE AMERICAN RADIO
RELAY LEAGUE, INC.

1934

CONTENTS

Headquarters Station W1MK	<i>Frontispiece</i>
Foreword	v
The Amateur — His Code of Ethics	viii
Chapter One — The Story of Amateur Radio	1
Chapter Two — Getting Started	7
Chapter Three — Electrical Fundamentals	19
Chapter Four — Radio Fundamentals	31
Chapter Five — Receivers	43
Chapter Six — Monitors and Frequency Meters	67
Chapter Seven — Planning and Building Transmitters	77
Chapter Eight — Radiotelephony	113
Chapter Nine — The Ultra-High Frequencies	128
Chapter Ten — Power Supply	139
Chapter Eleven — Keying and Interference Elimination	159
Chapter Twelve — Antenna Systems	168
Chapter Thirteen — Assembling the Station	184
Chapter Fourteen — The A.R.R.L. Communications Department	189
Chapter Fifteen — Operating a Station	196
Chapter Sixteen — Message Handling	206
Appendix	217
Index	234

The Amateur's Code

- I *The Amateur is Gentlemanly.* He never knowingly uses the air for his own amusement in such a way as to lessen the pleasure of others. He abides by the pledges given by the A.R.R.L. in his behalf to the public and the Government.
- II *The Amateur is Loyal.* He owes his amateur radio to the American Radio Relay League, and he offers it his unswerving loyalty.
- III *The Amateur is Progressive.* He keeps his station abreast of science. It is built well and efficiently. His operating practice is clean and regular.
- IV *The Amateur is Friendly.* Slow and patient sending when requested, friendly advice and counsel to the beginner, kindly assistance and coöperation for the broadcast listener; these are marks of the amateur spirit.
- V *The Amateur is Balanced.* Radio is his hobby. He never allows it to interfere with any of the duties he owes to his home, his job, his school, or his community.
- VI *The Amateur is Patriotic.* His knowledge and his station are always ready for the service of his country and his community.

THE RADIO AMATEUR'S HANDBOOK

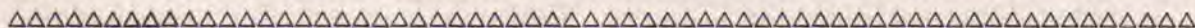

Chapter One

THE STORY OF AMATEUR RADIO

AMATEUR radio represents, to upwards of fifty thousand people, the most satisfying, most exciting of all hobbies. Forty thousand of these enthusiasts are located in the United States, for it is this country which gave birth to the movement and which, since the beginning, has represented its stronghold.

When radio broadcasting was first introduced to the public a few years ago it instantly caught the fancy of millions of people all over the world. Why? Because it fired their imagination — because it thrilled them to tune in a program direct from some distant point, to hear speech and music that was at that moment being transmitted from a city hundreds and even thousands of miles away. To be sure there was also a certain amount of entertainment value, and it is true that as the years have passed this phase has become uppermost in the minds of many listeners; yet the thrill of “dx” is still a major factor in the minds of hundreds of thousands of people, as witness the present growing popularity of international short-wave reception of foreign programs.

That keen satisfaction of hearing a distant station is basic with the radio amateur but it has long since been superseded by an even greater lure, and that is the thrill of *talking* with these distant points! On one side of your radio amateur's table is his short-wave receiver; on the other side is his private (and usually home-made) short-wave transmitter, ready at the throw of a switch to be used in calling and “working” other amateurs in the United States, in Canada, Europe, Australia, every corner of the globe! Even a low-power transmitter using nothing more ambitious than one or two receiving-type tubes makes it possible to develop friendships in every State in the Union, in dozens of countries abroad. Of course, it is not to be expected that the first contacts will necessarily be with foreign amateurs. Experience in adjusting the simple transmitter, in using the right frequency band at the right time of day when foreign stations are on the air, and practice in operating are necessary before communication will be enjoyed with amateurs of other nationalities. But patience and experience are the sole prerequisites to foreign contacts; neither high power nor expensive equipment is required.

Nor does the personal enjoyment that comes from amateur radio constitute its only benefit. There is the enduring satisfaction that comes from doing things with the apparatus put together by our own skill. The process of designing and constructing radio equipment develops real engineering ability. Operating an amateur station with even the simplest equipment likewise develops operating proficiency and skill. Many an engineer, operator or executive in the commercial radio field got his practical background and much of his training from his amateur work. So, in addition to the advantages of amateur radio as a hobby, the value of systematic amateur work to a student of almost every branch of radio cannot well be overlooked. An increasing number of radio services, each expanding in itself, require additional personnel, technicians, operators, inspectors, engineers and executives and in every field a background of amateur experience is regarded as valuable.

► How did amateur radio start? What developments have brought it to its present status of a highly-organized and widespread movement?

It started shortly after Marconi had astounded the world with his first experiments proving that telegraph messages actually could be sent between distant points without wires. Marconi was probably the first amateur — indeed, the distinguished inventor so likes to style himself even today. But amateur radio as we think of it was born when the first private citizen saw in the new marvel a means for personal communication with others and set about learning enough of the new art to build a home-made station, hoping that at least one of his friends would do the same so he could have someone to talk to. Object: the fun and enjoyment of “wireless” communication with a few friends. Urge: the thrill of DX (one to five miles — maybe!). That was thirty-odd years ago.

Amateur radio's subsequent development may be divided into two periods, the first before and the second after the World War.

Pre-war amateur radio bore little resemblance to the art as we know it today, except in principle. The equipment, both transmitting and receiving, was of a type now long obsolete. The range of

even the highest-powered transmitters, under the most favorable conditions, would be scoffed at by the rankest beginner today. No United States amateur had ever heard the signals of a foreign amateur, nor had any foreigner ever reported hearing an American. The oceans were a wall of silence, impenetrable, isolating us from every signal abroad. Even trans-continental DX had to be accomplished in relays. "Short waves" meant 200 meters; the entire wavelength spectrum below 200 meters was a vast silence — no signal ever disturbed it. Years were to pass before its phenomenal possibilities were to be suspected.

Yet the period was notable for a number of accomplishments. It saw the number of amateurs in the United States increase to approximately 4,000 by 1917. It witnessed the first appearance of radio laws, licensing, wavelength specifications for the various services. ("Amateurs? — oh yes — well, stick 'em on 200 meters; it's no good for anything; they'll never get out of their own back yards with it.") It saw an increase in the range of amateur stations to such unheard-of distances as 500 and, in some cases, even 1,000 miles, with U. S. amateurs beginning to wonder, just before the war, if there were amateurs in other countries across the seas and if — daring thought! — it might some day be possible to span the Atlantic with 200-meter equipment. Because all long-distance messages had to be relayed, it saw relaying developed to a fine art — and what a priceless accomplishment that ability turned out to be later when our government suddenly needed dozens and hundreds of skilled operators for war service! Most important of all, the pre-war period witnessed the birth of the American Radio Relay League, the amateur organization whose fame was to travel to all parts of the world and whose name was to be virtually synonymous with subsequent amateur progress and short-wave development. Conceived and formed by the famous inventor and amateur, Hiram Percy Maxim, it was formally launched in early 1914 and was just beginning to exert its full force in amateur activities when this country declared war on Germany and by that act sounded the knell for amateur radio for the next two and one-half years. By presidential direction every amateur station was dismantled. Within a few months three-fourths of the amateurs of the country were serving with the armed forces of the United States as operators and instructors.

► Few amateurs today realize that the war not only marked the close of the first phase of amateur development but came very near marking its end for all time. The fate of amateur radio was in the balance in the days immediately following declaration of the Armistice, in 1918. The government, having had a taste of supreme authority over all communications in wartime, was more than half inclined to keep it; indeed, the war had

not been ended a month before Congress was considering legislation that would have made it impossible for the amateur radio of old ever to be resumed. President Maxim rushed to Washington, pleaded, argued; the bill was defeated. But there was still no amateur radio; the war ban continued in effect. Repeated representations to Washington met only with silence; it was to be nearly a year before licenses were again to be issued.

In the meantime, however, there was much to be done. Three-fourths of the former amateurs had gone to France; many of them would never come back. What of those who had returned? Would they be interested, now, in such things as amateur radio; could they be brought back to help rebuild the League? Mr. Maxim determined to find out and called a meeting of such members of the old Board of Directors as he could locate. Eleven men, several still in uniform, met in New York and took stock of the situation. It wasn't very encouraging: amateur radio still banned by law, former members of the League scattered no one knew where, no League, no membership, no funds. But those eleven men financed the publication of a notice to all the former amateurs that could be located, hired Kenneth B. Warner as the League's first paid secretary, floated a bond issue among old League members to obtain money for immediate running expenses, bought the magazine *QST* to be the League's official organ and dunned officialdom until the wartime ban was lifted and amateur radio resumed again. Even before the ban was lifted in October, 1919, old-timers all over the country were flocking back to the League, renewing friendships, planning for the future. When licensing was resumed there was a head-long rush to get back on the air. No doubt about it now — interest in amateur radio was as great as ever!

From the start, however, it took on new aspects. The pressure of war had stimulated technical development in radio; there were new types of equipment, principally the vacuum tube, which was being used for both receivers and transmitters. Amateurs immediately adapted the new apparatus to 200-meter work. Ranges promptly increased; soon it was possible to bridge the continent with but one intermediate relay. Shortly thereafter stations on one coast were hearing those on the other direct!

These developments had an inevitable result. Watching DX come to represent 1,000 miles, then 1,500 and then 2,000, amateurs wondered about that ole debbil ocean. Could we get across? We knew now that there were amateurs abroad. We knew, too that their listening for our signals was still fruitless, but there was a justifiable suspicion that their unfamiliarity with 200-meter equipment had something to do with it. So in December, 1921, the A.R.R.L. sent abroad one of our most prominent amateurs, Paul Godley, with the

best amateur receiving equipment available. Tests were run, and thirty American amateur stations were heard in Europe! The news electrified the amateur world. In 1922 another trans-Atlantic test was carried out; this time 315 American calls were logged by European amateurs and, what was more, one French and two British stations were heard on this side.

Everything now was centered on one objective: two-way communication across the Atlantic by amateur radio! It *must* be possible — but somehow we couldn't quite make it. Further increases in power were out of the question; many amateurs already were using the legal maximum of one kilowatt. Better receivers? We already had the superheterodyne; it didn't seem possible to make any very great advance in that direction.

Well, how about trying another wavelength, then? We couldn't go up, but we could go down. What about those wavelengths below 200 meters? The engineering world said they were worthless — but then, they'd said that about 200 meters, too. There have been many wrong guesses in history. So in 1922 the technical editor of *QST* carried on some tests between Hartford and Boston on 130 meters. The results were encouraging. Early in 1923 the A.R.R.L. sponsored a series of organized tests on wavelengths down to 90 meters and it was noted that as the wavelength dropped the reported results were better. A growing excitement began to filter into the amateur ranks. It began to look as though we'd stumbled on something!

And indeed we had. For in November, 1923, after some months of careful preparation, two-way amateur communication across the Atlantic finally became an actuality when Schnell, 1MO, and Reinartz, 1XAM, worked for several hours with SAB, Deloy, in France, all three stations using a wavelength of about 110 meters!

There was the possibility, of course, that it was a "freak" performance, but any suspicions in that direction were quickly dispelled when additional stations dropped down to 100 meters and found that they, too, could easily work two-way across the Atlantic. The exodus from the 200-meter region started.

By 1924 the entire radio world was agog and dozens of commercial companies were rushing stations into the 100-meter region. Chaos threatened until the first of a series of radio conferences partitioned off various bands of frequencies for all the different services clamoring for assignments. Although thought was still centered on 100 meters, League officials at the first of these conferences, in 1924, came to the conclusion that the surface had probably only been scratched, and wisely obtained amateur bands not only at 80 meters, but at 40 and 20 and 10 and even 5 meters.

Many amateurs promptly jumped down to the 40-meter band. A pretty low wavelength, to be

sure, but you never could tell about these short waves. What had worked once might work again. Forty was given a whirl and responded by enabling two-way communication with Australia, New Zealand and South Africa.

How about 20? It was given a try-out and immediately showed entirely unexpected possibilities in enabling an east-coast amateur to communicate with another on the west coast, direct, at high noon. The dream of amateur radio — daylight DX!

► From that time to the present represents a period of unparalleled accomplishment. The short waves proved a veritable gold mine. Country after country came on the air, until the confusion became so great that it was necessary to devise a system of international intermediates in order to distinguish the nationality of calls. The League began issuing what are known as WAC certificates to those stations proving that they had worked all the continents. More than a thousand such certificates have been issued. Representatives of the A.R.R.L. went to Paris several years ago and deliberated with the amateur representatives of twenty-two other nations. On April 17, 1925, this conference formed the International Amateur Radio Union — a union of national amateur societies. We have discovered that the amateur as a type is the same the world over.

Nor has experimental development been lost sight of in the enthusiasm incident to international amateur communication. The experimentally-minded amateur is constantly at work conducting tests in new frequency bands, devising improved apparatus for amateur receiving and transmitting, learning how to operate two and three and even four stations where previously there was room enough for only one.

As investigation of the short-wave territory proceeded, commercial engineers finally came to the conclusion that the lowest wavelength that could be used particularly effectively for long-distance communication was in the neighborhood of 13 meters. Yet in November, 1928, an amateur station on Cape Cod was pouring steady and strong signals into New Zealand day after day — on ten meters! Sponsored by the A.R.R.L., these experimental directive transmissions were also reported in England, Canada, and many parts of the United States.

In 1924 first amateur experiments on five meters showed that band to be practically worthless for distance transmission; signals at such wavelengths could be heard only to "horizon range." But the amateur turns even these apparent disadvantages to use. If not suitable for long-distance work, at least it was ideal for "short-haul" communication. Beginning in 1931, then, we have witnessed tremendous activity in five-meter work by thousands of amateurs all over the country, and a complete new line of transmitters

and receivers has been developed to meet the special conditions incident to communicating at these ultra-high frequencies. The pioneer work of the amateur in this band is showing the way for police, airplane and other special types of service whose requirements make the territory around five meters ideal.

Most of the technical developments in amateur radio have come from the amateur ranks. Many of these developments represent valuable contributions to the art. At a time when only a few broadcast engineers in the country knew what was meant by "100% modulation" the technical staff of the A.R.R.L. was publishing articles in *QST* urging amateur 'phones to embrace it and showing them how to do it. It is interesting to know that these articles were read as widely in professional circles as by amateurs with the result that dozens of broadcast stations besieged the League for information on how this method of modulation could be adapted to their own installations. When interest quickened in five-meter work, and experiments showed that the ordinary regenerative receiver was practically worthless for such wavelengths, it was the A.R.R.L. that developed practical super-regenerative receivers as the solution to the receiver problem. From the League's laboratory, too, came, in 1932, the single-signal superheterodyne — the world's most advanced high-frequency radiotelegraph receiver. And in 1933 came another great contribution to transmitter practice in the form of the tri-tet crystal oscillator, simplifying the high-frequency crystal controlled transmitter by reducing the number of stages necessary and improving transmitter reliability, stability and efficiency.

▶ Amateur radio is one of the finest of hobbies, but this fact alone would hardly merit such whole-hearted support as was given it by the United States government at recent international conferences. There must be other reasons to justify such backing. There are. One of them is a thorough appreciation by the Army and Navy of the value of the amateur as a source of skilled radio personnel in time of war. The other is best described by the words "public service."

We have already seen 3500 amateurs contributing their skill and ability to the American cause in the Great War. After the war it was only natural that cordial relations should prevail between the Army and Navy and the amateur. Several things occurred in the next few years to strengthen these relations. In 1924, when the U. S. dirigible *Shenandoah* made a tour of the country, amateurs provided continuous contact between the big ship and the ground. In 1925 when the United States battle fleet made a cruise to Australia and the Navy wished to test out short-wave apparatus for future communication purposes, it was the League's Traffic Manager

who was in complete charge of an experimental high-frequency set on the U.S.S. *Seattle*.

Definite friendly relations between the amateur and the armed forces of the Government were cemented in 1925. In this year both the Army and the Navy came to the League with proposals for amateur coöperation. The radio Naval Reserve and the Army-Amateur Net are the outgrowth of these proposals.

The public service record of the amateur is a brilliant one. These services can be roughly divided into two classes: emergencies and expeditions. It is regrettable that space limitations preclude detailed mention of amateur work in both these classes, for the stories constitute some of the high-lights of amateur accomplishment. As it is, only a general outline can be given.

Since 1919, amateur radio has been the principal, and in many cases the only, means of outside communication in more than thirty storm and flood emergencies in this country. The most noteworthy were the Florida Hurricane of 1926, the Mississippi and New England floods of 1927, and the California dam break and second Florida hurricane in 1928. During 1931 there were the New Zealand and Nicaraguan earthquakes and the "Viking" explosion disaster in Labrador, and in 1932 the floods at Caliente, California and in the upper Guadalupe valley of Texas. Outstanding in 1933 was the southern California earthquake. In all of these amateur radio played a major rôle in the rescue work, and amateurs earned world-wide commendation for their resourcefulness in effecting communication where all other means failed.

It is interesting to note that one of the principal functions of the Army-Amateur network is to furnish organized and coördinated amateur assistance in the event of storm and other emergencies in this country. In addition, Red Cross centers in various parts of the United States are now furnished with lists of amateur stations in the vicinity as a regular part of their emergency measures program.

Amateur coöperation with expeditions started in 1923, when a League member, Don Mix, of Bristol, Conn., accompanied MacMillan to the Arctic on the schooner *Bowdoin* in charge of an amateur set. Amateurs in Canada and the United States provided the home contact. The success of this venture was such that MacMillan has never since made a trip without carrying short-wave equipment and an amateur to operate it.

Other explorers noted this success and made inquiries to the League regarding similar arrangements for their journeys. In 1924 another expedition secured amateur coöperation; in 1925 three benefited by amateur assistance, and by 1928 the figure had risen to nine for that year alone. Each year since then has seen League headquarters in receipt of more and more requests for such service, until now a total of approximately a hundred voyages and expeditions have been assisted.

To-day practically no exploring trip starts from this country to remote parts of the world without making arrangements to keep in contact through the medium of amateur radio.

Emergency relief, expeditionary contact, and countless instances of other forms of public service, rendered as they always have been and always will be, without hope or expectation of material reward, have made amateur radio one of the integral parts of our complex national life.

The American Radio Relay League

The American Radio Relay League is to-day not only the spokesman for amateur radio in this country but is the largest amateur organization in the world. It is strictly of, by and for amateurs, is non-commercial and has no stockholders. The members of the League are the owners of the A.R.R.L. and *QST*.

The League is organized to represent the amateur in legislative matters. It is pledged to promote interest in two-way amateur communication and experimentation. It is interested in the relaying of messages by amateur radio. It is concerned with the advancement of the radio art. It stands for the maintenance of fraternalism and a high standard of conduct. One of its principal purposes is to keep amateur activities so well conducted that the amateur will continue to justify his existence. As an example of this might be cited the action of the League in sponsoring the establishment of a number of Standard Frequency Stations throughout the United States; installations equipped with the most modern available type of precision measuring equipment, and transmitting "marker" signals on year-round schedules to enable amateurs everywhere to accurately calibrate their apparatus.

The operating territory of the League is divided into thirteen United States and six Canadian divisions. You can find out what division you are in by consulting *QST* or the *Handbook*. The affairs of the League are managed by a Board of Directors. One director is elected every two years by the membership of each United States division, and a Canadian General Manager is elected every two years by the Canadian membership. These directors then choose the president and vice-president, who are also directors, of course. No one commercially engaged in selling or manufacturing radio apparatus can be a member of the Board or an officer of the League.

The president, vice-president, secretary, treasurer and communications manager of the League are elected or appointed by the Board of Directors. These officers constitute an Executive Committee to act in handling matters that come up between meetings of the Board, their authority subject to certain restrictions.

The League owns and publishes the magazine *QST*. *QST* goes to all members of the League each month. It acts as a monthly bulletin of the

League's organized activities. It serves as a medium for the exchange of ideas. It fosters amateur spirit. Its technical articles are renowned. *QST* has grown to be the "amateur's bible" as well as one of the foremost radio magazines in the world. The profits *QST* makes are used in supporting League activities. Membership dues to the League include a subscription to *QST* for the same period.

The extensive field organization of the Communications Department coordinates practical station operation throughout North America.

Headquarters

From the humble beginnings recounted in the story of amateur radio, League headquarters has grown until now it occupies an entire floor in a new office building and employs more than two dozen people.

Members of the League are entitled to write to Headquarters for information of any kind, whether it concerns membership, legislation, or general questions on the construction or operation of amateur apparatus. If you don't find the information you want in *QST* or the *Handbook*, write to A.R.R.L. Headquarters, West Hartford, Connecticut, telling us your problem. All replies are directly by letter; no charge is made for the service.

If you come to Hartford, drop out to Headquarters at West Hartford. Visitors are always welcome.

W1MK

For many years it was the dream of the League's officers that some day Headquarters would be able to boast a real "he-station." In 1928 this dream became an actuality, and the League to-day owns and operates the station shown in the frontispiece, operating under the call W1MK.

The current operating schedules of W1MK may be obtained by writing the Communications Department at Headquarters or by consulting the current issue of *QST*. While much of the operating time is devoted to pre-arranged schedules, the station is always ready at other times for a call from any amateur.

Traditions

As the League has come down through the years, certain traditions have become a part of amateur radio.

The Old Man with his humorous stories on "rotten radio" has become one of amateur radio's principal figures. Since 1915 his pictures of radio and radio amateurs as revealed by stories in *QST* are characteristic and inimitable. There is much speculation in amateur circles concerning the identity of T.O.M., but in eighteen years of writing he has not once given a clue to his real name or call.

The *Wouff-Hong* is amateur radio's most sacred symbol and stands for the enforcement of law and order in amateur operation. It came into being originally in a story by T.O.M. For some time it was not known just what the *Wouff-Hong* looked like, but in 1919 The Old Man himself supplied the answer by sending in to League Headquarters



THE WOUFF-HONG

the one and only original *Wouff-Hong*, shown here. It is now framed and hangs on the wall of the Secretary's office at A.R.R.L. Headquarters.

Joining the League

The best way to get started in the amateur game is to join the League and start reading *QST*. Inquiries regarding membership should be addressed to the Secretary, or you can use the convenient application blank in the rear of this book. An interest in amateur radio is the only qualification necessary in becoming a member of

the A.R.R.L. Ownership of a station and knowledge of the code are *not* prerequisites. They can come later.

Learn to let the League help you. It is organized solely for that purpose, and its entire headquarter's personnel is trained to render the best assistance it can to you in solving your amateur problems. If, as a beginner, you should find it difficult to understand some of the matter contained in succeeding chapters of this book, do not hesitate to write the Information Service stating your trouble. Perhaps, in such a case, it would be profitable for you to send for a copy of a booklet published by the League especially for the beginner and entitled "How to Become a Radio Amateur." This is written in simple, straightforward language, and describes from start to finish the building of a single simple amateur installation. The price is 25 cents, postpaid.

Every amateur should read the League's magazine *QST* each month. It is filled with the latest amateur apparatus developments, "dope" on current expeditions which use short-wave radio for contact with this country, and the latest "ham" news from your particular section of the country. A sample copy will be sent you for 25c if you are unable to obtain one at your local newsstand.

Chapter Two

GETTING STARTED

HAVING related, briefly, the origin and development of amateur radio in this country, we can now go on to the more practical business of describing in detail how to get in on the amateur radio of today. Subsequent chapters will treat of receiver and transmitter construction and adjustment, station operation, etc. This chapter deals with the first two *bête noir's* of every beginning amateur — learning the code and getting your licenses.

A high-frequency (short-wave) receiver alone will bring you hours of pleasure and will repay the little effort necessary to assemble it. Sooner or later, however, it is probable that you will build yourself either a radiotelephone or radiotelegraph transmitter. While many amateurs build 'phone transmitters, the majority both in this country and abroad operate radiotelegraph sets. There are several reasons for this. First, the code must be learned regardless of whether you operate a 'phone or telegraph set; the United States government won't issue any kind of amateur license without a code test. Secondly, radiotelegraph apparatus is far less expensive to build and less complicated to adjust than radiophone apparatus; less equipment and power are required and fewer tubes used. And lastly, code signals will usually cover four or five times the distance possible from the same or more complicated radiophone equipment, and are less susceptible to interference, fading and distortion.

There is nothing particularly difficult incident to taking your place in the ranks of licensed amateurs. The necessary steps are first, to learn the code, second, to build a receiver and a transmitter and third to get your amateur licenses and go on the air. Don't let any of these worry you. Thousands of men and women between the ages of 15 and 60 have mastered the code without difficulty by the exercise of a little patience and perseverance; these same thousands have found that only a moderate amount of study is necessary to prepare for the examination required by the government of all applicants for the combination station-operator license which every amateur must have before actually going on the air. We will treat of both of these subjects in detail later in this chapter.

Nor should you doubt your ability to build short-wave receivers and transmitters. The simpler types of receiver and transmitter described further on in this *Handbook* can be assembled and put into operation by anyone capable of using a screwdriver, a soldering iron and a little common sense. Of course, there are advanced

forms of amateur equipment that are intricate, complicated to build, and more difficult to understand and adjust, but it is not necessary to resort to them to secure results in amateur radio, and it would be best to avoid them until the rudiments of the game have been learned.

Our Amateur Bands

Most people, because they have never heard anything else, are prone to think of broadcasting as the most important radio service. To such people a few nights listening in on the high frequencies (wavelengths below the broadcast band) will be a revelation. A horde of signals from dozens of different types of services tell their story to whoever will listen. Some stations send slowly and leisurely. Even the beginner can read them. Others race along furiously so that whole sentences become meaningless buzzes. There are both telegraph and telephone signals. Press messages, weather reports, transocean commercial radiotelephone and telegraph messages, high frequency international broadcasting of voice and music, transmissions from government and experimental stations including picture transmission and television services, airplane dispatching, police broadcasts, and signals from private yachts and expeditions exploring the remote parts of the earth jam the short wave spectrum from one end to the other.

Sandwiched in among all these services are the amateurs, thousands of whose signals may be heard every night in the various bands set apart by International Treaty for amateur operation. These bands are in approximate harmonic relation to each other; their position in the short wave spectrum and their relative widths are shown in the sketch.

Many factors have to be considered in picking a certain frequency band for a certain job, especially the distance and the time of day when communication is desired. But in addition to daily changes, there are seasonal changes, and in addition a long-time change in atmospheric conditions which seems to coincide closely with the cycle of sun-spot or solar activity which is completed approximately each eleven years. The reliability of communication on a given frequency at a given time of day, the suitability of a given band for traffic or DX, the desires of the individual amateur in choosing his circle of friends with whom he expects to make contact on schedule, the amount of interference to be expected at certain hours, and the time of day available for operating — all influence the choice of an operat-

ing frequency. Many amateurs can use any one of the several available frequency bands at will. Let us now discuss briefly the properties peculiar to each of them.

The 1715-kc. band, which carried all our activity before experimenters opened the way to each of the higher frequency bands in turn,

from South Africa, New Zealand and other remote points, and 'phone signals heard in Europe. As the winter evening advances, the well-known "skip effect" (explained in detail in Chap. Four) of the higher frequencies has made itself known, the increased range of the "sky wave" brings in signals from the other coast and the increased

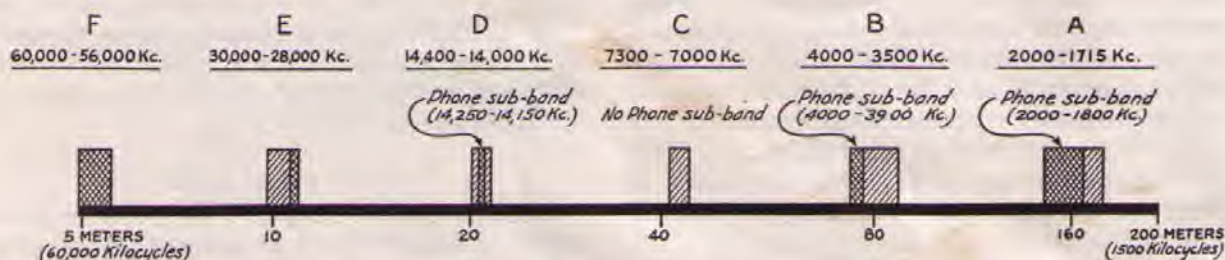

RELATIVE POSITION AND WIDTH OF THE AMATEUR BANDS IN THE HIGH-FREQUENCY SPECTRUM

(There is also a band from 400 to 401 Mc., not shown in this drawing)

always served amateurs well for general contact between points all over the country. There was a short period, during the height of development of the higher frequencies, when activity in this band dwindled, but it is again greatly on the increase.

The band is popular especially for radiotelephone work. The very fact that it is less congested and occupied makes it an extremely attractive band for the amateur operator who would communicate effectively and avoid interference. Code practice transmissions are made in this band for beginning amateurs and many beginners may be heard in this region making their first two-way contact with each other. The band is one of our "widest" from the standpoint of the number of stations that may be comfortably accommodated. In the next year or so, it may be expected to take more of the present properties of the 3500-kc. region, and its use by amateurs continue to increase. The band is open to amateur television and picture transmission. If you are just getting on the air, plan to use this band. If you have been working on higher frequencies, include this band in your plans for 1934 and 1935 — or you will be missing an important part of amateur radio.

The 3500-kc. band has, in recent years, been regarded as best for all consistent domestic communication. It is good for coast-to-coast work at night all the year except for a few summer months. It has been recommended for all amateur message-handling over medium distances (1,000 miles for example). Much of the friendly human contact between amateurs takes place in the 3500-kc. band. It is the band from which we have made excursions to the higher frequencies on occasions when foreign contacts were desired. During the last year or so this band has exhibited some of its former DX properties, signals from amateur stations in this country being reported

range also brings in more stations, so that the band appears busier.

The 7000-kc. band has been the most popular band for general amateur DX work for some years. It is useful mainly at night for contacts with the opposite coast, or with foreign countries. Power output does not limit the range of a station to the same extent as when working on the lower frequency bands discussed above. However, the band is more handicapped by congestion in the early evenings and more subject to the vagaries of skip-effect and uncertain transmission conditions than are the lower frequency bands, but not limited in usefulness by these things to the same extent as the 14-mc. band. The 7000-kc. band is satisfactory for working distances of several hundred miles in daylight. It is generally considered the most desirable night band for general DX work in spite of difficulties due to interference. This band may be expected to take on better daylight DX characteristics during 1934 if predictions based on the sun-spot cycle are correct, and at the same time, while great possibilities will exist for evening work, it is likely to be more inconsistent and unreliable during the late evenings.

The 14,000-kc. or 14-mc. band is the very best frequency to use to cover great distances in daylight. In fact it is the *only* band generally useful for daylight DX contacts (QSO's) over coast-to-coast and greater distances. Communication over long distances will usually remain good during the early evenings and surprising results can be obtained then, too. Using these higher frequencies there is often difficulty in talking with stations within three or four hundred miles, while greater distances than this (and very short distances within ten or twenty miles of a station) can be covered with ease. The reason that 14-mc. signals are less useful for general amateur DX late eve-

nings is because the "skip" increases during darkness until the "sky wave" covers greater than earthly distances. The band, while one of the very best for the amateur interested in working foreign stations without much difficulty from domestic interference, is sometimes subject to sudden fluctuations in transmitting conditions, and this characteristic will become more important perhaps as we return to the general conditions for radio communication that obtained back in 1923 and 1924, a condition now estimated to be due by 1934 or 1935.

The 28,000-kc. (28-mc.) band, opened for amateur work by the Federal Radio Commission in early 1928 at the request of the A.R.R.L. is principally an experimental band at the present time. It combines both the long-distance characteristics of the 14-mc. band and some of the local advantages of the 56-mc. band, but its long-distance characteristics are generally too "spotty" for reliable communication. The result is that only a few amateurs to-day operate in this territory, though it is probable that more attention will be given to its short-distance properties as the 56-mc. band fills up.

The 56,000-kc. or 56-mc. band, likewise made available for amateur experimentation at the request of the League, is strictly a local and short-distance band, but as such possesses many advantages. For distances of ten to thirty miles (and occasionally more, depending on the height of the apparatus) it is ideal; the apparatus is cheap, easily constructed, and extremely compact; operation is marked by freedom from interference and fading. The result has been a tremendous interest in this band by amateurs during the past two years and a half, and hundreds of stations are now operating there with keen enjoyment.

Memorizing the Code

The first job you should tackle is the business of *memorizing* the code. This can be done while you are building your receiver. Thus, by the time the receiver is finished, you will know all the characters for the alphabet, the most-used punctuation marks, and the numerals, and will be ready to practice receiving in order to acquire speed. Speed practice, either by means of a buzzer, or by listening in on your receiver, can be indulged in in odd moments while the transmitter, in turn, is being constructed. The net

result of such an organized program should be that by the time the transmitter is finished you will be able to receive the ten words a minute required by the government for your amateur operator license, and can immediately proceed to studying for the "theoretical" part of your license examination without loss of time.

Memorizing the code is no job at all if you simply make up your mind you are going to apply yourself to the job and get it over with as quickly as possible. The complete Continental alphabet, punctuation marks and numerals are shown in the table given here. The alphabet and all the numerals should be learned, but only the first eight of the punctuation marks shown need be memorized by the beginner. Start by memorizing the alphabet, forgetting the numerals and punctuation marks for the present. Various good systems for learning the code have been devised. They are of undoubted value but the job is a very simple one and usually can be accomplished easily by taking the first five letters, memorizing them, then the next five, and so on. As you progress you should review all the letters learned up to that time, of course. When you have memorized the alphabet you can go to the numerals, which will come very quickly since you can see that they follow a definite system. The punctuation marks wind up the schedule — and be sure to learn at least the first eight — the more commonly-used ones.

One suggestion: Learn to think of the letters in terms of *sound* rather than their appearance as they are printed. Don't think of *A* as "dot-dash" but think of it as the sound "dit-dah." *B*, of course, is "dah-dit-dit-dit," *C*, "dah-dit-dah-dit" and so on.

Don't think about speed yet. Your first job is simply to memorize all the characters and make sure you know them without hesitation. Good practice can be obtained, while building the receiver, if you try to spell out in code the names of the various parts you are working on at the time.

Acquiring Speed by Buzzer Practice

When the code is thoroughly memorized, you can start to develop speed in receiving code transmission. The most enjoyable way to do this is to have two people learn the code together and send to each other by means of a buzzer-and-key outfit. One advantage of this system is that it develops sending ability,

•••••	A
•••••	B
•••••	C
•••••	D
•••••	E
•••••	F
•••••	G
•••••	H
•••••	I
•••••	J
•••••	K
•••••	L
•••••	M
•••••	N
•••••	O
•••••	P
•••••	Q
•••••	R
•••••	S
•••••	T
•••••	U
•••••	V
•••••	W
•••••	X
•••••	Y
•••••	Z
•••••	1
•••••	2
•••••	3
•••••	4
•••••	5
•••••	6
•••••	7
•••••	8
•••••	9
•••••	0
•••••	PERIOD
•••••	INTERROGATION
•••••	BREAK (DOUBLE DASH)
•••••	WAIT
•••••	END OF MESSAGE
•••••	END OF TRANSMISSION
•••••	RECEIVED (O.K.)
•••••	INVITATION TO TRANSMIT
•••••	(GO AHEAD)
•••••	EXCLAMATION
•••••	BAR INDICATING FRACTION
•••••	(OBLIQUE STROKE)
•••••	COMMA
•••••	COLON
•••••	SEMICOLON
•••••	QUOTES
•••••	PARENTHESIS

THE CONTINENTAL CODE

too, for the person doing the receiving will be quick to criticize uneven or indistinct sending. If possible, it is a good idea to get the aid of an experienced operator for the first few sessions, so that you will know what well-sent characters sound like.

The diagram shows the connections for a buzzer-practice set. When buying the key for this

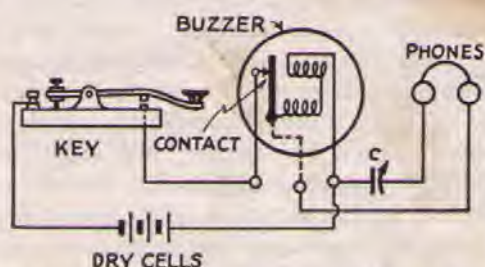

CONNECTIONS OF A BUZZER CODE PRACTICE SET WITH A TELEPHONE HEAD SET

The intensity of the signal can be varied by changing the setting of the variable condenser. The 'phone and condenser are connected either across the coils of the buzzer or across the vibrator contacts. The condenser may be omitted and the tone may be changed by changing the number of dry cells.

set it is a good idea to get one that will be suitable for use in the transmitter later; this will save you money.

Another good practice set for two people learning the code together is that using an old audio transformer, a type '30 tube, a pair of 'phones, key, two No. 6 dry cells, tube-socket, a 20-ohm filament rheostat, and a 22½-volt B battery. These are hooked up as shown in the diagram to form an audio oscillator. If nothing is heard in the 'phones when the key is depressed, reverse the leads going to the two binding posts at either transformer winding. Reversing both sets of leads will have no effect.

Either the buzzer set or this audio oscillator will give good results. The advantage of the audio oscillator over the buzzer set is that it gives a fine signal in the 'phones without making any noise in the room.

After the practice set has been built, and another operator's help secured, practice sending turn and turn about to each other. Send single letters at first, the listener learning to recognize each character quickly, without hesitation. Following this, start slow sending of complete words and sentences, always trying to have the material sent at just a little faster rate than you can copy easily; this speeds up your mind. Write down each letter you recognize. Do *not* try to write down the dots and dashes; write down the letters. Don't stop to compare the sounds of different letters, or think too long about a letter or word that has been missed. Go right on to the next one or each "miss" will cause you to lose several characters you might otherwise have gotten. If you exercise a little patience you will soon be getting every character, and in a sur-

prisingly short time will be receiving at a good rate of speed. When you think you can receive ten words a minute (50 letters a minute) have the sender transmit code groups rather than straight English text. This will prevent you from recognizing a word "on the way" and filling it in before you've really listened to the letters themselves.

Learning by Listening

While it is very nice to be able to get the help of another person in sending to you while you are acquiring code-speed, it is not always possible to be so fortunate, and some other method of acquiring speed must be resorted to. Under such circumstances, the time-honored system is to "learn by listening" on your short-wave receiver. Nor should you make the mistake of assuming that this is a more difficult and less-preferred method: it is probable that the *majority* of amateurs acquire their code speed by this method. After building a receiver and getting it in operation, the first step in "learning by listening" will be to hunt for a station sending slowly. With even the simplest short-wave receivers a number of high-power stations can be heard in every part of the world. It is usually possible to pick a station going at about the desired speed for code practice. Listen to see if you cannot recognize some individual letters. Use paper and

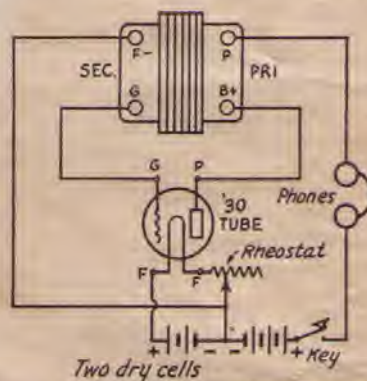

CONNECTING AN AUDIO OSCILLATOR (HARTLEY) FOR CODE PRACTICE WORK

pencil and write down the letters as you hear them. Try to copy as many letters as you can.

Whenever you hear a letter that you know, write it down. Keep everlastingly at it. *Twenty minutes or half an hour is long enough for one session.* This practice may be repeated several times a day. Don't become discouraged. Soon you will copy without missing so many letters. Then you will begin to get calls, which are repeated several times, and whole words like "and" and "the." After words will come sentences. You now know the code and your speed will improve slowly with practice. Learning by this method may seem harder to some folks than learning with the buzzer. It is the opinion of the writer, who learned in this way, that the practice

in copying actual signals and having real difficulties with interference, static, and fading, is far superior to that obtained by routine buzzer practice. Of course the use of a buzzer is of value at first in getting familiar with the alphabet.

In "learning by listening" try to pick stations sending slightly faster than your limit. In writing, try to make the separation between words definite. Try to "read" the whole of short words before starting to write them down. Do the writing while listening to the first part of the next word. Practice and patience will soon make it easy to listen and write at the same time. Good operators usually copy several words "behind" the incoming signals.

A word of caution: the U. S. radio communication laws prescribe heavy penalties for divulging the contents of any radiogram to other than the addressee. You may copy anything you hear for practice but you must preserve its secrecy.

Volunteer Code Practice Stations

Each fall and winter season the A.R.R.L. solicits volunteers, amateurs using code only, or often a combination of voice and code transmission, who will send transmissions especially calculated to assist beginners. These transmissions go on the air at specified hours on certain days of the week and may be picked up within a radius of several hundred miles under favorable conditions. Words and sentences are sent at different speeds and repeated by voice, or checked by mail for correctness if you write the stations making the transmissions and enclose a stamped addressed envelope for reply.

The schedules of the score or more volunteer code-practice stations are listed regularly in *QST* during the fall and winter. Information at other times may be secured by writing Headquarters. Some of the stations have been highly successful in reaching both coasts with code-practice transmissions from the central part of the country.

Interpreting What We Hear

As soon as we finish our receiver and hook it up we shall begin to pick up different high-frequency stations, some of them perhaps in the bands of frequency assigned to amateurs, others perhaps commercial stations belonging to different services. The loudest signals will not necessarily be those from near-by stations. Depending on transmitting conditions which vary with the frequency, the distance and the time of day, remote stations may or may not be louder than relatively near-by stations.

The first letters we identify probably will be the call signals identifying the stations called and the calling stations, if the stations are in the amateur bands. Station calls are assigned by the government, prefixed by a letter (W in the United States, VE in Canada, G in England,

etc.) indicating the country. In this country amateur calls will be made up of such combinations as W9GP, W8CMP, W3BZ, W1MK, etc., the number indicating the amateur call area (see map) and giving a general idea of the part of the country in which the station heard is



U. S. AMATEUR CALL AREAS

located. The reader is referred to the chapter on "Operating a Station" for complete information on the procedure amateurs use in calling, handling messages, and the like. Many abbreviations are used which will be made clear by reference to the tables of Q Code, miscellaneous abbreviations, and "ham" abbreviations included in the Appendix. The table of international prefixes, also in the back of the book, will help to identify the country where amateur and commercial stations are located.

The commercial stations use a procedure differing in some respects from amateur procedure, and to some extent the procedure of army, naval and government stations is different from this, each service having a modified procedure meeting its own requirements. On the other hand the International Radiotelegraph Convention has specified certain regulations, abbreviations and procedures which govern all services and insure basic uniformity of methods and wide understanding between stations of all nations, regardless of services.

"Tape" or "machine" transmission and reception is used to speed up traffic handling to the limit fixed by relays and atmospheric conditions. Most beginners are puzzled by certain abbreviations which are used. Many code groups are sent by different commercial organizations to shorten the messages and to reduce the expense of sending messages which often runs as high as 25 cents a word. Unless one has a code book it is impossible to interpret such messages. Five- and ten-letter cypher groups are quite common and make excellent practice signals. Occasionally, a blur of code will be heard which results when tape is speeded up to 100 words per minute and photographic means are used to record the signals.

League O.B.S. System

Official Broadcasting Stations of the A.R.R.L. send the latest Headquarters' information addressed to members *on amateur frequencies*. The messages are often interesting and many of them are sent slowly enough for code practice between 15 and 20 words a minute. Lists and schedules appear from time to time in the membership copies of *QST*.

The very latest *official and special information of general interest*, addressed to A.R.R.L. members, is broadcast twice nightly (except Tuesday, Wednesday and Saturday) simultaneously on two frequency bands from the Headquarters' amateur station, W1MK. The schedule for these transmissions is as follows:

Sun.	8:30 p.m. EST-13 w.p.m.	— 3825 and 7150 kcs.
Sun.	Midnight EST-22 w.p.m.	— 3825 and 7150 kcs.
Mon.	8:30 p.m. EST-22 w.p.m.	— 3575 and 7015 kcs.
Mon.	10:30 p.m. EST-13 w.p.m.	— 3575 and 7015 kcs.
Thurs.	8:30 p.m. EST-13 w.p.m.	— 3825 and 7015 kcs.
Thurs.	Midnight EST-22 w.p.m.	— 3825 and 7015 kcs.
Fri.	8:30 p.m. EST-22 w.p.m.	— 3825 and 7150 kcs.
Fri.	10:30 p.m. EST-13 w.p.m.	— 3825 and 7150 kcs.

As you can see from this schedule, W1MK sends these bulletins simultaneously on two different frequency bands, so if you are unable to hear the station on the 3500-kc. band you may be able to pick it up on the 7000-kc. band, and *vice versa*.

These transmissions are sent at a moderate rate of speed and are frequently used by advanced beginners for *code practice* work.

Using a Key

The correct way to grasp the key is important. The knob of the key should be about eighteen inches from the edge of the operating table and about on a line with the operator's right shoulder, allowing room for the elbow to rest on the table. A table about thirty inches in height is best. The spring tension of the key varies with different operators. A fairly heavy spring at the start is desirable. The back adjustment of the key should be changed until there is a vertical movement of about one-sixteenth inch at the knob. After an operator has mastered the use of the hand key the tension should be changed and can be reduced to the minimum spring tension that will cause the key to open immediately when the pressure is released. More spring tension than necessary causes the expenditure of unnecessary energy. The contacts should be spaced by the rear screw on the key only and not by allowing play in the side screws, which are provided merely for aligning the contact points. These side screws should be screwed up to a setting which prevents appreciable side play but not adjusted so tightly that binding is caused. The gap between the contacts should always be at least a thirty-second of an inch, since a too-finely spaced contact will cultivate a nervous style of sending which is

highly undesirable. On the other hand too-wide spacing (much over one-sixteenth inch) may result in unduly heavy or "muddy" sending.

Do not hold the key tightly. Let the hand rest lightly on the key. The thumb should be against the left side of the key. The first and second fingers should be bent a little. They should hold the middle and right sides of the knob, respectively. The fingers are partly on top and partly



ILLUSTRATING THE CORRECT POSITION OF THE HAND AND FINGERS FOR THE OPERATION OF A TELEGRAPH KEY

over the side of the knob. The other two fingers should be free of the key. The photograph shows the correct way to hold a key.

A wrist motion should be used in sending. The whole arm should not be used. One should not send "nervously" but with a steady flexing of the wrist. The grasp on the key should be firm, not tight, or jerky sending will result. None of the muscles should be tense but they should all be under control. The arm should rest lightly on the operating table with the wrist held above the table. An up-and-down motion without any sideways action is best. The fingers should never leave the key knob.

Sending

Good sending *seems* easier than receiving, but don't be deceived. A beginner shouldn't send fast. Keep your transmitting speed down to the receiving speed, and rather bend your effort to sending *well*.

When sending do not try to speed things up too soon. A slow, even rate of sending is the mark of a good operator. Speed will come with time alone. Leave special types of keys alone until you have mastered the knack of properly handling the standard-type telegraph key. Because radio transmissions are seldom free from interference a "heavier" style of sending is best to develop for radio work. A rugged key of heavy construction will help in this.

When signals can be copied "solid" at a rate of ten words a minute it is time to start practicing with a key in earnest. While learning to receive, you have become fairly familiar with good send-

ing. Try to imitate the machine or tape sending that you have heard. This gives a good example of proper spacing values.

When beginning to handle a key do not try to send more than six or seven words a minute. A dot results from a short depression of the key. A dash comes from the same motion but the contact is held three times as long as when making a dot. A common mistake of beginners is to make it several times too long. There is no great space between the parts of a letter. Particular care should be exercised when sending letters such as *c* to make them "all at once" like this (— — —) and *not* irregularly spaced like this (— - —).

Key practice should not be extended over too long periods at first. The control of the muscles in the wrist and forearm should be developed gradually for best results.

Individuality in sending should be suppressed rather than cultivated. Speed needs to be held in check. "Copiability" is what we want. Repeats waste valuable time. When you find that you are sending too fast for the other fellow, slow down to his speed.

A word may be said about the "Vibroplex" and "double-action" keys. The "Vibroplex" makes dots automatically. The rate of making dots is regulated by changing the position of a weight on a swinging armature. Dots are made by pressing a lever to the right. Dashes are made by holding it to the left for the proper interval. A side motion is used in both types of keys.

These keys are useful mainly for operators who have lots of traffic to handle in a short time and for operators who have ruined their sending arm. Such keys are motion savers. However, a great deal of practice is necessary before readable code can be sent. The average novice who uses a "bug" tries to send too fast and ruins his sending altogether. The beginner should keep away from such keys. After he has become very good at handling a regulation telegraph key, he may practice on a "bug" to advantage.

Obtaining Government Licenses

When you are able to copy ten words per minute, have studied basic transmitter theory and familiarized yourself with the radio law and the amateur regulations, you are ready to think about obtaining your combination amateur operator-station license. This is issued you, after examination, by the government, through the Federal Radio Commission.

No licenses are necessary to operate receivers in the United States, but you positively must have the required amateur licenses before doing sending of any kind with a transmitter. This license requirement applies for any kind of transmitter on any wavelength. There is no basis for the assumption that low-power transmitters, or transmitters operating on 5 meters or below, need no license. They do, most emphatically. Attempts to

engage in transmitting operation of any kind, without holding licenses, will inevitably result in arrest, and fine or imprisonment.

Amateur licenses are free, but are issued only to citizens of the United States; this applies both to the station license and the personal operator license. But the requirement of citizenship is the only limitation, and amateur licenses are issued without regard to age or physical condition to anyone who successfully completes the required examination. There are licensed amateurs as young as nine and as old as eighty. Many permanently bed-ridden persons find their amateur radio a priceless boon and have successfully qualified for their "tickets"; even blindness is no bar — several stations heard regularly on the air are operated by people so afflicted.

The amateur license now comes in the form of a small card, one side of which bears the station-license authorization, and the other the operator-license authorization. The station license is the station's registration; it licenses a particular collection of apparatus at a given address and specifies the call to be used. The operator authorization constitutes a person's personal license to operate not only his but all other licensed amateur stations. Persons who would like to operate at amateur stations, but do not have their own station as yet, may obtain an amateur operator license without being obliged to take out a station license. But no one may take out the station license alone; all those wishing station licenses must also take out operator licenses.

The Station License

The amateur station license is secured by filling in, satisfactorily, those parts of the combined application form which particularly concern the station license. A station license will not be issued if the property on which the set is to be located is controlled by an alien. We have already mentioned that neither station nor operator licenses are issued to aliens. In the case of the station license the government goes still further, and refuses to issue the license even to a citizen of the U. S. if the property on which the transmitter will be built is under alien control. This does not mean that a citizen must own the property on which he lives, or rent it from another citizen. Rental of property brings it under the control of the renter. From this it follows that a citizen renting a house or apartment is entitled to have a station there, regardless of the citizenship of the actual owner of the property. But this works two ways, and a citizen cannot put a station on alien-rented property even though the actual owner is a citizen; the alien's rental brings the property under alien control.

The station license, never issued except in conjunction with an operator license, runs concurrently with it and has the same term — three years. It may be renewed, as will be outlined later.

The Operator License

This, as has just been mentioned previously, may be obtained either by itself, or in conjunction with a station license. In either case the procedure is the same and involves filling in the proper portions of the application form and in successfully passing a ten-question examination on transmitter theory and practice, the U. S. radio law and the amateur regulations. We will take up the examination later.

There are three classes of amateur operator license, known as the Class A, Class B and Class C. Since the privileges and requirements of Class B and Class C are the same, it may be said that there are two grades of amateur operator license — the normal grade (Classes B and C) and the advanced grade (Class A). The difference between the two grades is that the holder of a Class A license, in addition to having the normal privileges authorized for the lower grade, is further entitled to operate 'phone in the two restricted 'phone bands, 3,900–4,000 kc. and 14,150–14,250 kc. This privilege of 'phone operation in these two particular bands is denied those who hold only the Class B or C license (although they may operate 'phone in the sub-bands in Band A and Band E and in the entire Band F). Since this difference in radiophone privileges is the only distinction between the Class A license and the other two types, the Class A is often referred to as the "unlimited 'phone" license.

The Class B and C licenses are identical so far as privileges are concerned and enable an amateur to do everything except engage in the restricted 'phone operation just noted. The reader may wonder why we have both Class B and Class C if their privileges and requirements are identical — as they are. The difference is that the Class B license is issued to persons who have personally appeared before a radio inspector and have passed their code test and written examination in his presence, while the Class C code test and exam are given by mail.

Class B (with its personal appearance for examination) is *compulsory* for all persons living within 125 miles *airline* of one of the 32 examining centers (see next section) designated by the F.R.C., the only exception being in the case of persons physically incapable of journeying to the examination office. Persons living more than 125 miles *airline* from an examining point are entitled to take the mail examination and get a Class C license. But it should be pointed out that if a Class C license holder violates the regulations, he may be called upon to appear at the nearest examining point for a personal examination, regardless of how far away that point may be, and that failing to make such an appearance or failing to pass the personally-administered exam after so appearing, his Class C license will be revoked. Thus it behooves every Class C licensee to be

particularly careful to avoid violation of the regulations.

Applying for Licenses

An applicant for amateur licenses who has never had previous amateur experience or certain forms of commercial license must of necessity start out with either the B or C license. First, then, let us outline the procedure necessary in applying for these.

The Class B license, as already mentioned, is compulsory for all persons living within 125 miles of the 32 designated examining centers. Of these, 20 are the regular inspection offices created by the Federal Radio Commission, and a list of them appears in the table at the end of the Appendix in the rear of this book. Examinations are given at these 20 district offices once or twice a week. In addition, the following cities have also been designated as examination cities: Schenectady, Winston-Salem, Nashville, San Antonio, Oklahoma City, Des Moines, St. Louis, Pittsburgh, Cleveland, Cincinnati, Columbus (Ohio) and Washington, D. C. In all these cities but Washington examinations are given every three months on a date and at an address designated in advance. A card to the office of the inspector in whose district is located the particular city in which you are interested will bring information on the date and place. In Washington examinations are held every Thursday at the offices of the Federal Radio Commission.

Now, if you live within 125 miles *airline* of one of the above 32 examining points you should write or visit the inspector of the district in which you live, asking for an application blank for amateur station and operator license and the date when examinations will be held in the city at which you wish to appear. Fill out the application form and mail it *back to the inspector's office*, and then appear at the specified time for personal examination. First the inspector gives you your code test; if you are successful in passing this you will be given the written exam. After the examination is completed you can go home; the inspector sends all the papers to Washington and if you were satisfactory your combination license comes direct to your home a couple of weeks later.

If you live more than 125 miles *airline* from any of the 32 examining points, write the inspector of the district in which you live, asking for a *Class C* amateur operator and station application blank, examination, etc. He will send you application blanks, a *sealed* envelope containing the examination questions, and instructions for handling the latter. Following these instructions, get someone of legal age to open the envelope and witness your writing of the examination. The witness must then make oath that he opened the envelope and that you gave yourself the examination without the assistance of any other person or without

recourse to notes or books. You must also get in touch with an already-licensed operator (who must be the holder of an amateur operator license of Class A or Class B or of the old First Class or Extra First Class, or of a higher grade of commercial license) and have him give you the code test, making oath afterwards that you can copy at least 10 words per minute. This licensed operator may also be your witness on the examination. All the papers being completed, forward them *direct to the Federal Radio Commission*, Washington, D. C. If you were successful in passing the examination and if your application is satisfactorily filled out, your combination license will be mailed to you.

The application form you will receive is self-explanatory and needs no treatment here except to say that you should not be concerned over that section which requires you to waive claim to the use of any particular frequency or of the ether as against the regulatory power of the United States. This is a form requirement under the law, and agreement is required of all licensees, whether amateur or commercial.

Shut-Ins

No physical infirmity is a bar to issuance of amateur operator and station licenses provided the applicant can qualify. Invalids and shut-ins who live more than 125 miles from the nearest examining point will, of course, follow the usual mail procedure specified for the Class C license. If, however, they live within the 125-mile limit but are genuinely incapable of traveling, they should write the Federal Radio Commission at Washington stating the circumstances. They will then be advised what procedure to follow. In all probability the distance requirement will be waived and the applicant permitted to apply for a Class C license. Needless to say, the infirmity must be one of a permanent or semi-permanent nature; temporary sickness does not entitle one to exemption.

Renewals

Since all new licenses run concurrently and for a period of three years, no amateur getting new licenses at this time will have to worry about renewals for some time. When the time does arrive, renewals should be applied for at least 60 days in advance; if the licensee can show he is eligible under the minimum-activity specification of Rule 402, by having worked at least 3 other stations in the preceding 90 days, he will not have to take another examination but will have his licenses renewed on application. If he has been inactive and cannot comply with Rule 402, he will not have his licenses renewed and must, in addition, wait until 90 days after expiration before he can again take the examination.

For fellows who are licensed now and are wondering what the renewal procedure will be

under the new regs: Since no existing amateur station license expires before January 6, 1935, any renewal applications will come about through operator expirations. If you are the holder of a Temporary operator license it will be necessary for you, when it expires, to take the Class-B or Class-C examination, depending upon where you live. You have to take the examination regardless of whether or not you comply with Rule 402 so far as the minimum-activity provision is concerned. If you are the holder of a First Class operator license and have been inactive, you will have to be reexamined for Class B or Class C, again depending on where you live. If you have met the minimum-activity specification of Rule 402 you do not have to take the examination; depending on where you live, you are eligible for Class B or Class C, without reexamination, simply filing the application forms. In any of these cases you get the new combination license which replaces your old station license as well as renews your operator authorization.

Modifications

The holder of a Class-C license is eligible for Class B (thereby eliminating the possibility of being called up for personal examination at an inconvenient time and distance) whenever and wherever he can arrange for personal appearance and examination before an inspector. If he has had a year's experience as a licensed amateur operator he is similarly eligible for Class A. The holder of a Class-B license is similarly eligible for Class A if he has had a year's experience. Passing any such higher grade license results in an endorsement "modifying" the operator license, without, however, changing its date of expiration. Rule 402, as to minimum activity, applies in all these cases. If you are interested in a higher class of license, communicate with the inspector of your district.

If you change your station's location by moving to another address in the same city, or to another part of the state, or into another state, you must apply for a "modification" to authorize the new address. The procedure for this is the same as in an original application except that of course you do not have to pass the operator examination again if you have been operating actively. Write your inspector for the usual amateur application form and fill it out as before except that it is now designated at the top as an application for modification. Mail it back to your inspector if you have a Class B license, or direct to the Commission if you are Class C. But Rule 402 of the F.R.C. applies the before-mentioned minimum-activity standard to modifications as well as renewals, since modifications of this type result in extensions. You must therefore be able to cite at least the minimum required activity or prepare to take the operator examination over. You will see the reason for this when you get your modi-

fication — it will be a new license running for a full three years additional.

Exemptions

Applicants who within the previous five years have held an operator license should carefully consult Commission Rules 405 and 406, printed in the amateur regulations towards the end of this booklet. If you now want Class B or Class C and within the past five years held an Amateur *Extra* First Class or certain specified grades of commercial radiotelegraph operator license, you are now exempt from the code test and from half of the examination. You escape that half relating to apparatus and adjustment and take only that half relating to laws, treaties and regulations affecting amateur licenses. Regardless of the class you now want, if within the past five years you held certain specified grades of commercial radiotelephone operator license or had an amateur license bearing endorsement for unlimited amateur radiotelephony, you are exempt from that portion of the examination relating to apparatus and adjustment. You have to demonstrate your code ability but your written examination is confined to laws, treaties and regulations affecting amateurs. This last exemption is particularly important to the Class-A applicant of previous "unlimited" experience, since he escapes not only half of the basic examination but all of the extra examination relating to radiotelephony.

Passing the Class B-C Exam

We are now ready to treat briefly of the examination itself. The examination for the Class B and C licenses concerns itself with two general subjects: transmitter theory and practice, and radio laws and regulations. No questions are asked relative to the theory or adjustment of receivers, nor are the questions on transmitting based on the particular transmitter which the applicant has assembled — all transmitter questions are general in nature.

Ten questions are asked in each exam. The Federal Radio Commission has prepared a list of several hundred questions from which ten will be selected at random for each individual examination. To facilitate selection, the Commission has established ten classes under the following general headings: Power Supply; Frequency Measurement; Transmitters — Theory; Transmitters — Practice; Radiotelephony; Treaty and Laws; F.R.C. Regulations, Part I; F.R.C. Regulations, Part II; F.R.C. Regulations, Part III; Penalties. All questions in the brackets covering the F.R.C. Regulations (Parts I, II and III) are based on the amateur regulations appearing in the Appendix. This Handbook contains all the technical and other information necessary to get an amateur license.

With the idea of indicating the type of questions asked and the general ground covered by the

government examinations and to aid the prospective amateur, the A.R.R.L. has prepared a booklet entitled "*The Radio Amateur's License Manual*," which may be obtained from the League for 25 cents postpaid. Every applicant for amateur license is urged to possess himself of a copy before taking his examination, whether he be applying for Class B, Class C or Class A. Supplementing a study of the material in this Handbook by a study of the questions listed in the License Manual (the correct answers are given in each case) will insure passing the examination.

Passing the Class A Exam

As has been mentioned, only those who have had at least one year's experience as licensed amateur operators are eligible for the Class A license, with the exception of holders of previous commercial license specified in Rule 405. The examination for Class A is never given by mail; in all cases the applicant must appear at one of the specified examining points. An applicant who has had the required year's experience, but at the moment does not possess a Class B license will have to take an examination that will consist of the 10 questions forming the normal Class B-C examination plus an additional 10 questions relating exclusively to amateur radiotelephony — the Class A examination itself being devoted solely to 'phone. To those already possessed of the lower form of license, the Class A exam consists only of the 10 questions relating to radiotelephony. As in the case of the Class B and Class C test, the telephony examination consists of one question under each of ten headings: Diagram of a modern 'phone installation; 'Phone Theory; Methods of Modulation; Frequency Stability; Classes of Amplifiers; Exciting Stages; Audio; Modulated Amplifier and Modulator; Frequency Modulation; Overmodulation. In preparing for this exam, it is again recommended that a study of the Handbook be supplemented by a study of the License Manual. In the License Manual representative questions,¹ with their correct answers, are listed for the Class A exam just as for the Classes B and C. As for these latter two classes, the applicant for Class A need have no fear of the examination if he can correctly answer the Class A examination questions listed in the License Manual.

Portable Operation

There was a time when an amateur wishing to operate a portable transmitter was obliged to take out a separate portable station license. This is no longer the case. Instead, the holder of a fixed amateur station license is entitled to operate portable equipment under that call whenever he pleases, so long as he complies with the provisions of Rule 384 of the Regulations concerning method of signing the call for a portable, and with Rule 387 regarding advance notification to the radio

inspector of the district or districts in which the portable will be operated.

Amateurs who contemplate operating a portable station should, however, be sure to provide themselves with a photostatic or photographic copy of the station authorization side of their combination operator-station license card. If the owner of the station remains at the fixed set he should keep his original combination license with him at the fixed location (since this is his only operator authorization) and send the photostatic copy of the station authorization along with whoever is running the outside portable outfit. On the other hand, if the station owner himself goes out with the portable, he should take his original license with him and leave the photostatic copy of the station authorization at home, with his fixed station.

Important: In sending your portable set out in charge of another operator, or when leaving your home set in charge of someone else, be sure that such other operator is a duly licensed amateur operator and that he has his operator's license with him. Permitting any of your equipment to be operated by a non-licensed person will get you in trouble as well as him.

Posting of Licenses

It is not required that your license be posted in the room where your transmitter is located, but it is required that your license be in your personal possession whenever you are operating. When it happens that your license has been sent in to the Federal Radio Commission for some change or modification, you are permitted to continue to operate for a period of not more than sixty days while the license is away, provided that such operation does not extend beyond the date of expiration.

Portable-Mobile Operation

By definition in the regulations of the Federal Radio Commission (see pars. 192 and 192 (a)) a portable station is one which may be conveniently moved about, but which is not used while in motion; in fact, a portable station may not be used while in motion without violating the regulations. When such a station is used while in motion, it is known as a portable-mobile station. Amateurs may operate portable stations. But they may not operate portable-mobile stations, except in the special case of such outfits on aircraft, and then only in the frequency bands 56,000-60,000 kc. and 400,000-401,000 kc. When such amateur high-frequency aircraft portable mobile stations are operated, the calling and signing procedure specified for portable operation in paragraph 384 of the regulations applies. Be sure to comply with paragraph 387, regarding notification to the radio inspectors concerned, too.

Amateur Regulations

Every reader of this book who contemplates becoming an amateur should spend such time as is necessary to turn back to the appendix and study both the extracts from the Radio Law and the U. S. amateur regulations which will be found there. In general the text is self-explanatory.

Particularly important sections of the Radio Law are as follows: Sec. 4, paragraph (D) which specifies for what reasons an operator's license may be suspended; Sec. 26, specifying the use of the minimum amount of power to carry out communication; Sec. 27, relating to the secrecy of messages; Sec. 28, prohibiting the transmission of false distress signals, and Sections 32 and 33, which specify the penalties for violation of the regulations and of the basic radio law.

In the amateur regulations all provisions should be studied. Some of the more important points are mentioned at this point.

An amateur is a person interested in radio technique solely with a personal aim and without pecuniary interest. The right to use the amateur frequencies is extended only to amateurs and then only for amateur purposes. This provision protects us from the attempts of commercial enterprises to make use of amateur frequencies. *Bona fide* amateur clubs or organizations will have no difficulty in obtaining station licenses, providing an official individually accepts full legal responsibility for operation of the station.

Amateur stations shall not transmit or receive messages for hire nor engage in communication for material compensation, direct or indirect, paid or promised. This proviso gives further protection against commercial enterprises masquerading as amateurs, and defines the test of commercial traffic as that involving any sort of "compensation" for the handling thereof. Accordingly, so far as practice within the U. S. is concerned, an amateur may handle any traffic he sees fit to handle, so long as he receives no compensation of any kind.

The licensee of an amateur station shall keep an accurate log of station operation, in which shall be recorded the time of each transmission, the station called, the input power to the last stage of the transmitter, the frequency band used and the personal "signature" or identification of the operator for each period of operation. Amateur stations are authorized to use a maximum power input into the last stage of a transmitter of one kilowatt. The Radio Act requires that the records of a station must be available to the radio authorities on demand. Such logs then assist the inspector in investigating interference cases, alleged off-frequency operation or other violations, determining when changes in frequency and power were made, which conditions interfere and which do not, etc. The A.R.R.L. has designed a log-book

especially to take care of this government requirement which will be described when we come to the discussion of "Operating a Station." An accurate and complete station log is compulsory.

Except on the 28-mc., 56-mc., and 400-mc. bands amateurs are obliged to use "pure d.c." throughout their transmitters; this is to minimize frequency modulation and prevent the emission of broad signals.

Whenever general interference with broadcast reception on receiving apparatus of modern design exists, the Commission regulations regarding quiet hours must be observed, and these will continue in effect until it can be shown that adjustments or alteration of the transmitting arrangement or methods of treatment of the receivers to do away with the trouble have eliminated the difficulty. The quiet hours shall be eight to ten thirty p. m. local time, daily, and, in addition, quiet hours shall be observed on Sunday morning from 10:30 a. m. until 1 p. m. It should be noted that if use of one frequency band causes local interference but another band does not, the station remains free to operate on the bands that do not give rise to this difficulty. Even operation on a different frequency in the same band may be used for operation if it can be shown that it overcomes the trouble.

Amateur stations are not permitted to communicate with commercial or government stations unless authorized by the licensing authority except in an emergency or for testing purposes. This restriction does not apply to communication

with small pleasure craft such as yachts and motor boats holding limited commercial station licenses which may have difficulty in establishing communication with commercial or government stations.

Amateur stations are not allowed to broadcast any form of entertainment.

Canadian Regulations

Canadian amateurs wishing operators' licenses must pass an examination before a radio inspector in transmission and reception at a speed of ten words per minute or more. They must also pass a verbal examination in the operation of amateur apparatus of usual types, must have a working knowledge of procedure, and must have a little operating ability prior to taking the examination. Nothing is likely to be asked which is not covered in this *Handbook*. The fee for examination as operator is 50 cents and is payable to the Radio Inspector who examines the candidate.

The form for application for station license may be obtained either from a local Radio Inspector's office or direct from the Department of Marine and Fisheries, Radio Branch, Ottawa. This consists of a blank form with spaces for details regarding the station equipment and the uses to which it is to be put. The applicant must also sign a declaration of secrecy which, as a matter of fact, is executed at the time of obtaining the operator's license. The annual fee for station licenses for amateur work in Canada is \$2.50.

ELECTRICAL FUNDAMENTALS

ALTHOUGH it is possible for the amateur unversed in electrical fundamentals to build and operate a station more or less successfully, better practical results and greater personal enjoyment of the game are in store for him who knows something of what it's all about. Amateur radio is really a part of the great field of electrical communication, both wire and radio, and hence has its foundations in the electrical fundamentals that have been in process of development for hundreds of years. To cover completely the basic principles involved is far beyond the scope of any one book, let alone a single chapter, so the aim here must be to present only those fundamentals that experience has shown to be of the greatest practical value to the amateur in the building and operating of his station. To the avid amateur whose appetite may be whetted for more, the books suggested in the Appendix are recommended for further study.

What Is Electricity?

In the not distant past the nature of electricity was considered something beyond understanding but in recent years much of the mystery has been removed. We know now that what we call electricity is the evidence of activity of electrons.

"Electrons in motion constitute an electric current."

But what is the electron and what is the source of those that constitute electric current? The accepted theory is that the electron does not ordinarily exist in an isolated state but normally has a sort of family life, in combination with other electrons, in the *atom*. Atoms make up *molecules* which, in turn, make up the substances familiar to us, copper, iron, aluminum, etc. Atoms differ from each other in the number and arrangement of the electrons that constitute them.

The atom has a nucleus which is considered to be composed of both positive and negative electrons, but with the positive predominating so that the nature of the nucleus is positive. For purposes of identification the positive electrons are referred to as *protons* and the negative electrons simply as *electrons*. The electrons and protons of the nucleus are intimately and closely bound together. But exterior to the nucleus are negative electrons which are more or less free agents that can leave home with little urging. Ordinarily the atom is electrically neutral, the outer negative electrons balancing the positive nucleus. It is when something happens to disturb this balance and when the foot-loose electrons begin to leave home that electrical activity becomes evident.

Electron Flow—Electric Current

It is considered likely that there is a continuous interchange of electrons between the atoms of a solid body, such as a piece of copper wire, but that the net effect under ordinary conditions is to make the average in any one direction zero. If, however, there is an electric field through the wire, as when the ends are connected to the terminals of a battery, there sets in a consistent drift of the negatively charged electrons, from

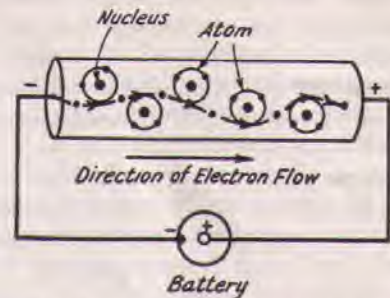

FIG. 301 — HOW CURRENT IS CONDUCTED IN A WIRE

Electrons are relayed from atom to atom, from the negative to the positive end of the conductor.

atom to atom, towards the end of the wire connected to the positive battery terminal, somewhat as shown in Fig. 301. This drift of electrons constitutes an electric current. The rate at which the current flows will be determined by the characteristics of the conductor, of course, and by the strength of the electric field.

Each electron, and they are all alike irrespective of the kind of atom from which they come, is unbelievably minute and a measure of electric current in terms of number of electrons would be impracticable. Therefore a larger unit is used, the *ampere*.

A current of 1 ampere represents nearly 10^{19} (ten million, million, million) electrons flowing past a point in 1 second; or a micro-ampere (millionth of an ampere) nearly 10 million electrons per micro-second (millionth of a second).

Conductors and Insulators

The ease with which electrons are able to be transferred from one atom to another is a measure of the conductivity of the material. When the electrons are able to flow readily, we say that the material is a good *conductor*. If they are not able to chase off to another atom quite so readily, we say that the substance has more *resistance*. Should it be almost impossible for the electrons to break from their normal path

around their own nucleus, the material is what we term an *insulator*. Copper, silver and most other metals are relatively good conductors of electricity; while such substances as glass, mica, rubber, dry wood, porcelain and shellac are relatively good insulators.

The resistance of most substances varies with changes in temperature. Sometimes the variation is so great that a body ordinarily considered an insulator becomes a conductor at high temperatures. The resistance of metals usually increases with an increase in temperature while the resistance of liquids and of carbon is decreased with increasing temperature.

Conduction in Liquids and Gases

Besides the case of conduction in the solid copper wire, in which there is electron drift from atom to atom but with the individual atoms remaining more or less stationary and each being but momentarily deficient in electron content, there are other forms of conduction important in radio communication. The general case of conduction in liquids is one.

For instance, take that of conduction in a solution of sodium chloride (common table salt) in water. In such a solution there are a number of *molecules* of salt that have separated into two parts, one of which has the nucleus of the sodium atom while the other has the nucleus of the chlorine atom. But the two parts are not truly atoms because the chlorine part has one excess electron and is *negative* in character while the sodium part is deficient by one electron and therefore is *positive* in character. No longer true atoms, they are now *ions* and the spontaneous process of *disassociation* in solution is one form of *ionization*. If plates connected to the terminals of a battery are now placed in the solution, the positive sodium ions travel to the negative plate where they acquire negative electrons; and the negative chlorine ions travel to the positive plate where they give up their excess electrons; and both again become neutral atoms. The energy supplied by the battery is used to move the ions through the liquid and to supply or remove electrons. Thus there is a flow of electric current through the liquid by *electrolytic conduction*. This kind of conduction plays a part in the operation of such radio equipment as electrolytic rectifiers.

Another type of conduction important in the operation of radio equipment is that which takes place in gases. This also involves ionization, although here the ionization is not spontaneous as in the electrolytic conduction just described but is produced by rapidly moving free electrons colliding with atoms, and hence, is called *ionization by collision*. Such conduction is illustrated by the ordinary neon lamp. The bulb contains a pair of plates and is filled with neon gas. In addition to the molecules of the gas, there will be a few free electrons. If a battery of sufficient voltage is con-

nected to the two plates, the initial free electrons will make a dive for the positively charged plate, their velocity being accelerated by the electric field. In their headlong dash they collide with neon atoms and knock off outer electrons of these atoms, converting the latter to positive ions. The additional free electrons produced by collision now join the procession, and ionize more atoms. As they are freed, the electrons travel towards the positive plate. In the meantime, the more sluggish positive ions have been traveling towards the negative plate, where they acquire electrons and again become neutral atoms. The net result is a flow of electrons, and hence of current, between the electrodes, from negative plate to positive plate. The light given off, it may be mentioned, is considered incidental to the recombination of ions and free electrons at the negative plate. This kind of *conduction by ionization* is utilized in the operation of the gaseous rectifiers used in radio power supplies.

Still another form of conduction very important in radio communication is pure *electronic conduction*. In the case of the copper wire we saw that the individual electrons did not make the complete trip from one end of the circuit to the other but that the flow was a sort of relay process. We also saw that the electrons could not leave the wire in random directions but, under the influence of the electric field, progressed only from the

negative towards the positive end. They were restrained from leaving the surfaces of the conductor. But they can be made to fly off from the conductor when properly stimulated to do so, as is illustrated by the familiar radio vacuum tube. Here we have electrons being freed from the *cathode*, a conductor that would nominally retain them, and actually traveling through vacuum to the plate that attracts them because it is connected to the positive terminal of a battery, as illustrated in Fig. 302. The reason that the electrons are freed from the cathode is that it has been heated to a temperature that activates them sufficiently to enable them to break away. This is known as *thermionic electron emission*, sometimes called simply *emission*. Once free, most of the emitted electrons make their way to the plate, although some return, repelled from traveling farther by the cloud of negative electrons immediately surrounding the cathode. This electron cloud about the emitting cathode constitutes

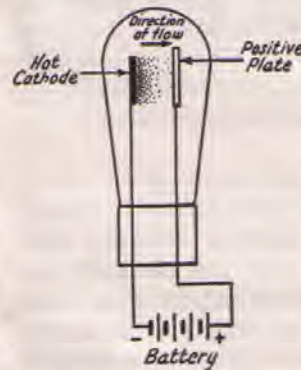

FIG. 302—ELECTRONIC CONDUCTION BY ELECTRON EMISSION IN THE VACUUM TUBE

Stimulated by heat, electrons fly off from the cathode or filament and are attracted to the positive plate.

illustrated in Fig. 302. The reason that the electrons are freed from the cathode is that it has been heated to a temperature that activates them sufficiently to enable them to break away. This is known as *thermionic electron emission*, sometimes called simply *emission*. Once free, most of the emitted electrons make their way to the plate, although some return, repelled from traveling farther by the cloud of negative electrons immediately surrounding the cathode. This electron cloud about the emitting cathode constitutes

what is known as the *space charge*. A few electrons that reach the plate may have sufficient velocity to dislodge one or more electrons already on the plate. This dislodging of electrons from the plate by other fast moving electrons constitutes *secondary emission*. When it occurs there is actually simultaneous electron flow in two directions. The various phenomena connected with electronic conduction, briefly outlined here, are of such extreme importance in the operation of vacuum tubes that they cannot be emphasized too greatly.

Direction of Flow

There is one point in connection with current flow which is likely to cause confusion in the reader's mind if particular attention is not paid to it. *The drift of electrons along a conductor (which constitutes a current flow) is always from the negative to the positive terminal.* On the other hand, the usual conception is that of electricity flowing from the positive to the negative terminal. The discrepancy results from the fact that the pioneer electrical experimenters, having no accurate understanding of the nature of electricity, assumed the direction to be from positive to negative. However, just so long as the facts are recognized clearly, no confusion need result.

Electromotive Force — Voltage

Just as soon as electrons are removed from one body and become attached to a second one, there is created a firm desire on the part of the estranged electrons to return to their normal position. For instance, the excess electrons on the negatively charged pole of a battery, attempting to return to the positively charged pole, create an *electrical pressure* between the two terminals. This pressure is termed *electromotive force* and the unit of measurement, widely used in our radio work, is the *volt*. In the ordinary dry cell (when fresh) the electromotive force between the two terminals is of the order of 1.5 or 1.6 volts. Should we have two such cells, and should we connect the negatively charged terminal of one to the positively charged terminal of the second cell we would then have twice the voltage of one cell between the remaining two free terminals. In this example we have connected the cells in *series* and the combination of the two cells becomes what we know as a *battery*. In the common "B" battery, so widely used with radio receivers, a great many small cells are so connected in series to provide a relatively high electromotive force or voltage between the outer terminals.

Another method of connecting a battery of cells together is to join all the positive terminals and all the negative terminals. The cells are then said to be connected in *parallel*. The voltage between the two sets of terminals will then be just the same as that of a single cell but it will be possible to take a greater amount of current from the

battery than would have been possible from the single cell.

In practical work we use meters to measure voltage and current. The *voltmeter* is connected across the points between which the unknown voltage exists while the *ammeter* is connected in series with the conductor in which the current flows. With this arrangement, the ammeter becomes a part of the conductor itself. In both cases, the reading in volts or amperes will be indicated directly on the calibrated scale of the instrument.

How Electricity Is Produced

The ordinary electric cell and the electric generator are the sources of current used in ordinary practice. The electric cell may take the form of a so-called dry cell, a wet cell or perhaps a storage cell. In any case, the current is derived by a chemical action within the cell. In the first two forms mentioned, the action of the fluid (there is a fluid even in a "dry" cell) tears down the structure of one of the elements or "poles" of the cell, producing an excess of electrons in one element and a deficiency in the other. Thus, when the elements are connected by a conductor, this unbalance of electrons results in a flow of electrons from one element to the other and the flow is what we know as an electric current. In the storage cell, the chemical change is reversible and the cell can be "recharged." The manner in which the electric generator produces a current is to be discussed at a later stage.

Direct and Alternating Current — Frequency

Of course, all electric currents do not flow continuously in the same direction along a conductor. The currents produced by batteries and by some generators flow in this manner, and therefore are termed *direct currents*. Should the current, for some reason or other, increase and decrease at periodic intervals or should it stop and start frequently it is still a direct current as long as the flow is always in the same direction, though it would be a fluctuating or intermittent one.

The type of current most generally used for the supply of power in our homes does not flow in one direction only, but *reverses* its direction many times each second. The electron drift or flow in a conductor carrying such a current first increases to a maximum, falls to zero, then reverses its direction, again rises to a maximum and again falls to zero — to reverse its direction again and continue the process. In most of the power circuits, the current flows in one direction for 1/120th of a second, reverses, flows in the opposite direction for another 1/120th of a second and so on. In other words, the complete *cycle* of reversal occupies 1/60th of a second. The number of complete cycles of flow in one second is termed the *frequency* of the current. In the instance under discussion we would say that the frequency

is 60 cycles per second. All currents which reverse their direction in this manner are known as *alternating currents*. We are to find that they are not by any means limited to the circuits which supply power to our homes. Telephone and radio circuits, for instance, are virtually riddled with alternating currents having a wide variety of frequencies. The currents which are produced by the voice in a telephone line may have frequencies between about 100 and 5,000 cycles per second while the alternating currents which we are to handle in the circuits of a radio transmitter may have a frequency as high as 60 million cycles per second. Because of the high frequencies used in radio work the practice of speaking in terms of cycles per second is an awkward one. It is customary, instead, to use *kilocycles per second* or, simply, *kilocycles* (kc.) — the kilocycle being one thousand cycles. Yet another widely used term is the *megacycle* (mc.) — a million cycles.

Alternating current, unlike direct current, cannot be generated by batteries. For the supply of commercial power it is almost always produced by rotating machines driven by steam turbines. In radio work we make use of this current for the power supply of our radio apparatus but the very high frequency alternating currents in the radio transmitter are almost invariably produced by vacuum tubes connected in appropriate circuits.

Resistance and Resistors — Ohm's Law

Now that we have some conception of what an electric current really is and of the different forms

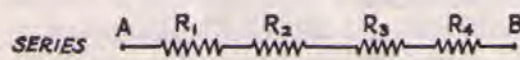

$$R_{total} = R_1 + R_2 + R_3 + R_4$$

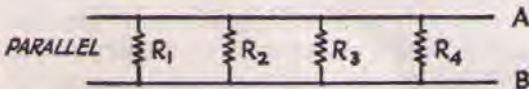

$$R_{total} = \frac{1}{\frac{1}{R_1} + \frac{1}{R_2} + \frac{1}{R_3} + \frac{1}{R_4}}$$

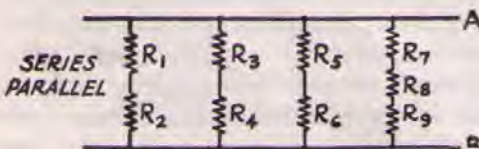

$$R_{total} = \frac{1}{\frac{1}{R_1 + R_2} + \frac{1}{R_3 + R_4} + \frac{1}{R_5 + R_6} + \frac{1}{R_7 + R_8 + R_9}}$$

FIG. 303 — RESISTANCES CONNECTED IN SERIES, PARALLEL, AND SERIES-PARALLEL

in which electricity is to be found, we may proceed to examine its effects in the apparatus which is to be used in radio work.

The most common equipment used in radio work is the conductor. We have already mentioned that any substance in which an electric current can flow is a conductor and we have also pointed out that some substances conduct more

readily than others — they have less resistance. Most of the conductors in radio apparatus — such as wiring, coils, etc. — are required to have the greatest conductivity or the least resistance possible. They are of metal, usually copper. But many of the conductors are actually placed in the circuit to offer some definite amount of resistance. They are known under the general term of *resistors* and the amount of resistance they (or any conductor) offer is measured in *ohms*.

When a current flows in any electric circuit, the magnitude of the current is determined by the electromotive force in the circuit and the resistance of the circuit, the resistance being dependent on the material, cross-section and length of the conductor. The relations which determine just what current flows are known as *Ohm's Law*. It is an utterly simple law but one of such great value that it should be studied with particular care. With its formula, carrying terms for current, electromotive force and resistance, we are able to find the actual conditions in many circuits, providing two of the three quantities are known. When I is the current in amperes, E is the electromotive force in volts and R is the circuit resistance in ohms, the formulas of Ohm's Law are:

$$R = \frac{E}{I} \quad I = \frac{E}{R} \quad E = IR$$

The *resistance* of the circuit can therefore be found by *dividing the voltage by the current*; the *current* can be found by *dividing the voltage by the resistance*; the *electromotive force or e.m.f.* is equal to the *product of the resistance and the current*. At a later stage it will be shown just how valuable may be the practical application of this law to the ordinary problems of our radio work.

Series and Parallel Connections

The resistors used in electrical circuits to introduce a known amount of resistance are made up in a variety of forms. One common type consists of wire, of some high resistance metal, wound on a porcelain former. To

obtain very high values of resistance the wire must be extremely fine. Because this introduces manufacturing difficulties, some of the high value resistors which are not required to carry heavy current are made up of some carbon compound or similar high resistance material. Resistors, like cells, may be connected in series, in parallel or in series-parallel. When two or more resistors are

connected in series, the total resistance of the group is higher than that of any of the units. Should two or more resistors be connected in parallel, the total resistance is decreased. Fig. 303 shows how the value of a bank of resistors in series, parallel or series-parallel may be computed.

Heating Effect and Power

The heating effect of the electric current is due to molecular friction in the wire caused by the flow of electricity through it. This effect depends on the resistance of the wire; for a given time (seconds) and current (amperes) the heat generated will be proportional to the resistance through which the current flows. The power used in heating or the heat dissipated in the circuit (which may be considered sometimes as an undesired power loss) can be determined by substitution in the following equations.

$$\begin{aligned} \text{Power (watts)} &= EI \\ \text{We already know that } E &= IR \\ \text{Therefore, } P &= IR \times I = I^2R \\ \text{Also, } P &= \frac{E^2}{R} \end{aligned}$$

It will be noted that if the current in a resistor and the resistance value are known, we can readily find the power. Or if the voltage across a resistance and the current through it are known or measured by a suitable voltmeter and ammeter, the product of volts and amperes will give the instantaneous power. Knowing the approximate value of a resistor (ohms) and the applied voltage across it, the power dissipated is given by the last formula.

Just as we can measure power dissipation in a resistance, we can determine the plate power input to a vacuum-tube transmitter, oscillator or amplifier, by the product of the measured plate voltage and plate current. Since the plate current is usually measured in milliamperes (thousandths of amperes), it is necessary to divide the product of plate volts and milliamperes by 1000 to give the result directly in watts.

Part C of the diagram, showing the variation of output of a generator with different resistance loads, suggests how a voltmeter and ammeter may be connected for measuring the power output of the generator or the power dissipated in the resistor. The power will be $E \times I$ in all cases, but this product will be zero in either A or B where either I or E is zero. As shown by the sketch the maximum power in the load (but not maximum efficiency) is obtained when the load resistance equals the internal resistance of the battery or generator.

Alternating Current Flow

In all of these examples we have been assuming that direct currents are being considered. When we impress an alternating voltage on circuits such

as those discussed we will cause an alternating current to flow, but this current may not be of the same value as it would be with direct current. In many instances, such as that of a vacuum tube filament connected to a source of alternating current by short wires, the behavior of the circuit would follow Ohm's Law as it has been given and if alternating current meters were used to read

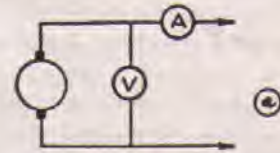

OPEN CIRCUIT

Full voltage at terminals but no current, therefore no output

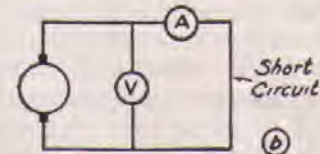

SHORT CIRCUIT

Very large current but no voltage at machine terminals therefore no output, although much power is being used up inside the machine

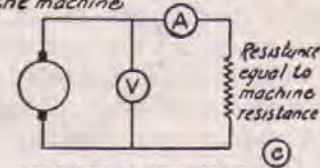

LOAD FOR MOST OUTPUT

Half the generated voltage at machine terminals, heavy current, large output.

NOTE: Conditions (b & c) shown above are impractical for generator operation, however for vacuum tubes we want largest possible output

FIG. 304 — SHOWING THE VARIATION OF OUTPUT AS LOAD RESISTANCE IS CHANGED

the current and voltage we could compute the resistance of the circuit with sufficient accuracy for all ordinary practical purposes. Should there be a coil of wire in the circuit, however, or any electrical apparatus which is not a pure resistance, it would not necessarily be possible to apply our simple formula with satisfactory results. An explanation of the reason for this involves an understanding of the characteristics of other electrical apparatus, particularly of coils and condensers, which have very important parts to play in all radio circuits.

Electromagnetism

When any electric current is passed through a conductor, magnetic effects are produced. *Moving electrons produce magnetic fields.* Little is known of the exact nature of the forces which

come into play but it is assumed that they are in the form of lines surrounding the wire; they are termed *lines of magnetic force*. It is known that these lines of force, in the form of concentric circles around the conductor, lie in planes at right angles to the axis of the conductor.

The magnetic field constituted by these lines of force exists only when current is flowing through the wire. When the current is started through the wire, we may think of the magnetic field as coming into being and sweeping outward from the axis of the wire. And on the cessation of the current flow, the field collapses toward the wire again and disappears. *Thus energy is alternately stored in the field and returned to the wire.* When a conductor is wound into the form of a coil of many turns, the magnetic field becomes stronger because there are more lines of force. The force is expressed in terms of *magneto-motive force (m.m.f.)* which depends on the number of turns of wire, the size of the coil and the amount of current flowing through it. The same magnetizing effect can be secured with a great many turns and a weak current or with fewer turns and a greater current. If ten amperes flow in one turn of wire, the magnetizing effect is 10 *ampere-turns*. Should one ampere flow in ten turns of wire, the magnetizing effect is also 10 *ampere-turns*.

The length of the magnetic circuit, the material of which it is made and the cross-sectional area, determine what *magnetic flux* (Φ) will be present. And just as the resistance of the wire determines what current will flow in the electric circuit, the *reluctance* (μ) of the magnetic circuit (depending on length, area and material) acts similarly in the magnetic circuit.

$$I = \frac{E}{R} \text{ in the electric circuit; so}$$

$$\Phi = \frac{m.m.f.}{\mu} \text{ in the magnetic circuit.}$$

The magnetic field about wires and coils may be traced with a compass needle or by sprinkling iron filings on a sheet of paper held about the coil through which current is passing. When there is an iron core the increased magnetic force and the concentration of the field about the iron are readily discernible.

Permeability is the ratio between the flux density produced in a material by a certain m.m.f. and the flux density that the same m.m.f. will produce in air. Iron and nickel have higher permeability than air. Iron has a permeability some 3000 times that of air, is of low cost, and is therefore very commonly used in magnetic circuits of electrical devices. The permeability of iron varies somewhat depending on the treatment it receives during manufacture. Soft iron has low *reluctivity*, another way of saying that its permeability is extremely high. The molecules of soft iron are readily turned end to end by bringing a current-

carrying wire or a permanent magnet near. When the influence is removed they just as quickly resume their former positions.

When current flows around a soft iron bar we have a *magnet*. When the circuit is broken so the current cannot flow, the molecules again assume their hit-or-miss positions. Little or no magnetic effect remains. When a steel bar is subjected to the same magneto-motive force in the same way, it has less magnetic effect. However, when the current is removed, the molecules tend to hold their end-to-end positions and we have produced a *permanent magnet*. Compass needles are made in this way. Permanent magnets lose their magnetism only when subjected to a reversed m.m.f., when heated very hot or when jarred violently.

Inductance

The thought to be kept constantly in mind is that whenever a current passes through a coil it sets up a magnetic field around the coil; that the strength of the field varies as the current varies; and that the direction of the field is reversed if the direction of current flow is reversed. It is of interest now to find that the converse holds true — that if a magnetic field passes through a coil, an electro-motive force is *induced* in the coil; that if the applied field varies, the induced voltage varies; and that if the direction of the field is reversed, the direction of the current produced by the induced voltage is reversed. This phenomenon provides us with an explanation of many electrical effects. It serves in the present instance to give us some understanding of that valuable property of coils — *self-inductance*. Should we pass an alternating current through a coil of many turns of wire, the field around the coil will increase and decrease, first in one direction and then in the other direction. The varying field around the coil, however, will induce a varying voltage in the coil and the current produced by this induced voltage will always be in the opposite direction to that of the current originally passed through the wire. The result, therefore, is that because of its property of self-induction, the coil tends constantly to prevent any change in the current flowing through it and hence to limit the amount of alternating current flowing. The effect can be considered as electrical inertia. The formula for computing the inductance of radio-frequency coils is given in the Appendix; and data for iron-core coils in Chapter Ten.

The Reactance of Coils

As we have said, a coil tends to limit the amount of current which an alternating voltage can send through it. A further very important fact is that a given coil with a fixed amount of inductance will impede the flow of a high frequency alternating current much more than a low frequency current. We know, then, that the characteristic of a coil in impeding an alternating

current flow depends both on the inductance of the coil and on the frequency of the current. This combined effect of frequency and inductance in coils is termed *reactance*, or *inductive reactance*.

The inductive reactance formula is:

$$X_1 = 2\pi fL$$

where: X_1 is the inductive reactance in ohms

π is 3.1416

f is the frequency in cycles per second

L is the inductance in henries

Transformers and Generators

We have stated that if a magnetic field passes through a coil, an electromotive force is induced in the coil. Not only does this phenomenon provide us with an explanation of self-inductance in coils but it permits an understanding of how transformers and generators operate. Transformers are very widely used in radio work — their essential purpose being to convert an alternating current supply of one voltage to one of higher or lower voltage. In transmitters, for instance, there will be one or more transformers serving to step down the 110-volt supply voltage to 7.5, 10 or 11 volts for the filaments of the transmitting tubes. Then there will be another transformer to step up the 110-volt supply to 500, 1000 or perhaps several thousand volts for the plate supply of the transmitting tubes. These transformers will consist of windings on a square *core* of thin iron strips. The 110-volt supply will flow through a primary winding and the magnetic field created by this current flow, because it is common to all windings on the core, will induce voltages in all the windings. Should one of the secondary windings have twice the number of turns on the primary winding, the secondary voltage developed will be approximately twice that of the primary voltage. Should one of the secondary windings have one third of the primary turns, the voltage developed across the secondary will be one third the primary voltage. Direct current flowing in the primary of such a transformer would build up a magnetic field as the current started to flow but the field would be a fixed one. So long as the primary current remained steady there would be no voltages developed in the secondaries. This is the reason why transformers cannot be operated from a source of continuous direct current.

A somewhat similar arrangement is to be found in the alternating current generator — a simplified diagram of which is shown in Fig. 305. In one common form of alternator, the magnetic field is fixed and voltages are induced in the coil by its rotation in the field. The result is exactly similar to that which would be obtained if the coil was fixed and the field rotated around it. As the coil turns at a uniform rate from the vertical position, it is cut by an increasing number of magnetic lines of force and the induced voltage increases until it becomes a maximum when the

coil is horizontal. As the coil continues to rotate towards the vertical position the induced voltage decreases until it becomes zero when the coil is again in the vertical plane. When the coil continues its rotation from this position, the direction of the field with respect to the turns of the coil has now been reversed and the voltage between the ends of the coil has therefore been reversed also. As the coil continues its rotation, the voltage again climbs to a maximum and falls to zero when the coil reaches its original vertical position. In the actual generator, of course, the rotation of the coil (the armature) is very rapid. The speed of rotation in the elementary machine shown in the diagram would directly govern the frequency of the alternating voltage produced.

In the practical alternator, of course, the arrangement is much more complex and the electro-magnet which produces the field may have many pairs of poles. A similar machine is used to generate direct current. The chief difference in it is that a commutator is provided on its shaft to rectify the output of the armature. This process involves changing the direction of every alternate half-cycle — so causing all the pulses of voltage generated to be in the same direction.

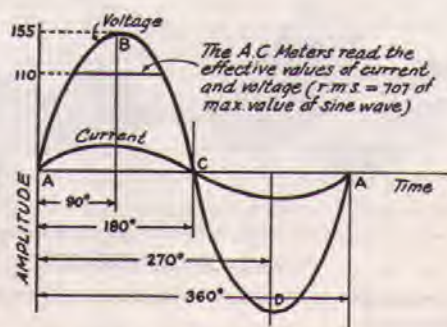
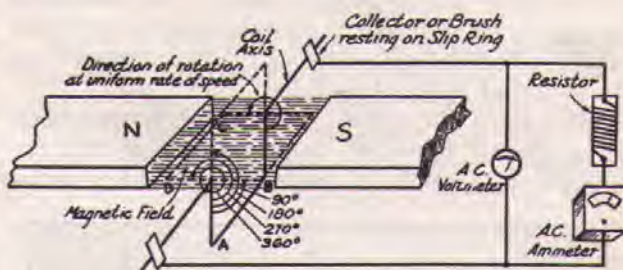

SIMPLE ALTERNATOR CIRCUIT

Diagram shows instantaneous values of current and voltage with electrical degrees of coil rotation — there are 360 electrical degrees for every pair of poles so that one complete mechanical revolution may correspond to more than one electrical revolution.

FIG. 305

Condensers — Capacitance

In radio circuits condensers play just as important a part as coils. Condensers and coils, in fact, are almost always used together. The condenser consists essentially of two or more metal plates separated by a thin layer of some

insulating medium from a second similar plate or set of plates. The insulating medium between the metal elements of the condenser is termed the *dielectric*. Unvarying direct current cannot flow through a condenser because of the insulation between the plates. But a steady voltage applied to the terminals of such a condenser will cause it to become charged. The effect, to return to a discussion of electrons, is simply that one element of the condenser is provided with an excess of electrons — thus becoming negatively charged — while the other plate suffers a deficiency of electrons and is therefore positively charged. Should the charging voltage be removed and the two elements of the condenser be joined with a conductor, a flow of electrons would take place from the negative to the positive plate. In other words, a current would flow.

The characteristic which permits a condenser to be charged in this manner is termed *capacity* or *capacitance*. The capacity of a condenser depends on the number of plates in each element, the area of the plates, the distance by which they are separated by the dielectric and the nature of the dielectric. Glass or mica as the dielectric in a condenser would give a greater capacity than air — other things being equal. The *dielectric constants* for different materials and the formula used for computing the capacity of condensers are to be found in the Appendix.

The unity of capacity is the *farad*. A condenser of one farad, however, would be so large that its construction would be impractical. A more com-



FORMS OF CONDENSERS

The variable condenser symbols are interchangeable. Both are widely used.

mon term in practical work is the *microfarad* (abbreviated $\mu\text{fd.}$) while another (used particularly for the small condensers in high-frequency apparatus) is the *micro-microfarad* (abbreviated $\mu\mu\text{fd.}$). The $\mu\text{fd.}$ is one millionth of a farad; the $\mu\mu\text{fd.}$ is one millionth of a microfarad.

A considerable variety of types of condensers is used in radio work. Perhaps the most commonly known type is the variable condenser — a unit comprising two sets of metal plates, one capable of being rotated and the other fixed and with the two groups of plates interleaving. In this case, the dielectric is almost invariably air. The fixed con-

denser is also widely used. One type consists of two sets of metal foil plates separated by thin sheets of mica, the whole unit being enclosed in molded bakelite. Yet another type — usually of high capacity — consists of two or more long strips of tin foil separated by thin waxed paper, the whole thing being rolled into compact form and enclosed in a metal can. Common units of this type have capacities of from one to four microfarads.

Alternating Current in a Condenser

We can readily understand how very different will be the performance of any condenser when direct or alternating voltages are applied to it. The direct voltages will cause a sudden charging current, but that is all. The alternating voltages will result in the condenser becoming charged first in one direction and then the other — this rapidly changing charging current actually being the equivalent of an alternating current through the condenser. Many of the condensers in radio circuits are used just because of this effect. They serve to allow an alternating current to flow through some portion of the circuit but at the same time prevent the flow of any direct current.

Capacitive Reactance

Of course, condensers do not permit alternating currents to flow through them with perfect ease. They impede an alternating current just as an inductance does. The term *capacitive reactance* is used to describe this effect in the case of condensers. Unlike inductances, condensers have a reactance which is *inversely* proportional to the condenser size and to the frequency of the applied voltage. The formula for capacitive reactance is

$$X_c = \frac{1}{2\pi f C_{fd}}$$

Where X_c is the capacitive reactance in ohms

π is 3.1416

f is the frequency in cycles per second

C_{fd} is the condenser capacitance in farads

Where the capacitance is in microfarads ($\mu\text{fd.}$), as it is in most practical cases, the formula becomes

$$X_c = \frac{10^6}{2\pi f C_{\mu\text{fd}}}$$

10^6 being 1,000,000.

Condenser Connections

Capacitances can be connected in series or in parallel like resistances or inductances. However, connecting condensers in parallel makes the total capacitance *greater* while in the case of resistance and inductance, the value is lessened by making a parallel connection.

The equivalent capacity of condensers con-

nected in parallel is the sum of the capacities of the several condensers so connected:

$$C = C_1 + C_2 + C_3$$

The equivalent capacity of condensers connected in series is expressed by the following formula which can be simplified as shown when but two condensers are considered:

$$\frac{1}{C} = \frac{1}{C_1} + \frac{1}{C_2} + \frac{1}{C_3}; \quad C = \frac{C_1 C_2}{C_1 + C_2}$$

It is sometimes necessary to connect filter condensers in series. This increases the break-down voltage of the combination although, of course, it decreases the capacity available. Condensers of identical capacitance are most effectively connected in series for this purpose. Voltage tends to divide across series condensers in inverse proportion to the capacity, so that the smaller of two series condensers will break down first if the condensers are of equal voltage rating. Before selecting filter condensers the operating conditions, voltage peaks and r.m.s. values should be carefully considered. For complete information on this matter the chapter on Power Supply should be consulted.

Distributed Inductance, Capacity and Resistance

So far we have considered three very important properties of electrical circuits and apparatus: Resistance, inductance and capacity. Resistors, coils and condensers are all built to have as much as possible of one of these properties with as little as possible of the other two. These "lumped" properties can then be utilized in a circuit to produce the required effect on the current and voltage distribution. In every sort of coil and condenser, however, we find not just the one property for which the instrument is used but a combination of all the electrical properties we have mentioned. And for this reason most design work is somewhat of a compromise. Every coil and transformer winding has resistance and distributed capacity between the turns in addition to the inductance that makes it a useful device. Then, every condenser has some resistance. Resistors, as another example, quite often have appreciable inductance and distributed capacity.

Ohm's Law for Alternating Current

We start to realize the importance of these characteristics just as soon as we endeavor to apply Ohm's Law to circuits in which alternating current flows. If inductances did not have any resistance we could assume that the current through the coil would be equal to the voltage divided by the reactance. But the coil will have resistance, and this resistance will act with the reactance in limiting the current flow. The combined effect of the resistance and reactance is termed *impedance* in the case of both coils and

condensers. The symbol for impedance is Z and it is computed from this formula:

$$Z = \sqrt{R^2 + X^2}$$

where R is the resistance of the coil and where X is the reactance of the coil. The terms Z , R and X are all expressed in ohms. Ohm's Law for alternating current circuits then becomes

$$I = \frac{E}{Z} \quad Z = \frac{E}{I} \quad E = IZ$$

In finding the current flow through a condenser in an alternating current circuit we can often assume that $I = \frac{E}{X_c}$ (X_c being the capacitive reactance of the condenser). The use of the term Z (impedance) is, in such cases, made unnecessary because the resistance of the usual good condenser is not high enough to warrant consideration. When there is a resistance in series with the condenser, however, it can be taken into account in exactly the same manner as was the resistance of the coil in the example just given. The impedance of the condenser-resistance combination is then computed and used as the Z term in the Ohm's Law formulas.

The Sine Wave

In Fig. 305, illustrating the action of the alternator in generating an alternating voltage, a curve indicating the voltage developed by the alternator during one complete cycle was shown. This curve, as obtained with a theoretically perfect alternator, is known as a *sine* curve. All the formulas given for alternating current circuits have been derived with the assumption that any alternating voltage under consideration would follow such a curve. It is evident that both the voltage and current are swinging continuously between their positive maximum and negative maximum values, and the beginner must wonder how one can speak of so many amperes of alternating current when the value is changing continuously. The problem is simplified in practical work by considering that an alternating current has a value of one ampere when it produces heat at the same average rate as one ampere of continuous direct current flowing through a given resistor. This *effective* value of an alternating current, if it truly follows a sine curve or has a *sinusoidal wave form*, is equal to the maximum or peak value divided by 1.41, the square root of 2. Similarly, the effective value of an alternating voltage is its peak value divided by 1.41.

Another important value, involved where alternating current is rectified to direct current, is the *average*. This is equal to .636 of the maximum (or peak) value of either current or voltage. The three terms *maximum* (or *peak*), *effective* (or *r.m.s.*) and *average* are so important and are encountered so frequently in radio work that they should be fixed firmly in mind right at the start.

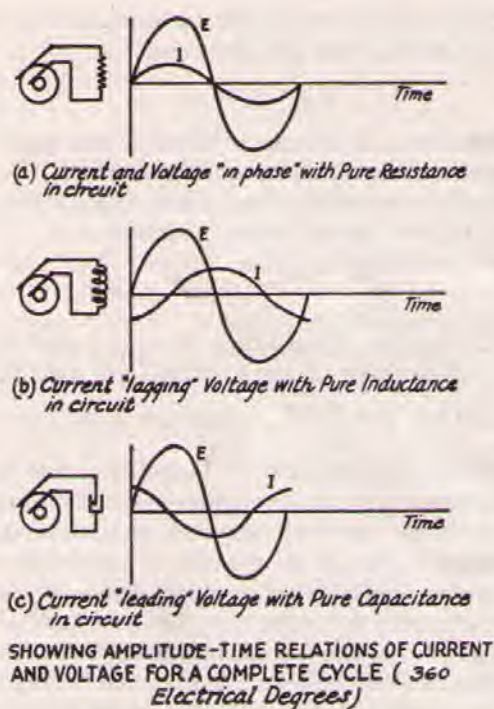

FIG. 306

They are related to each other as follows:

$$E_{\max} = E_{\text{eff}} \times 1.414 = E_{\text{ave}} \times 1.57$$

$$E_{\text{eff}} = E_{\max} \times .707 = E_{\text{ave}} \times 1.11$$

$$E_{\text{ave}} = E_{\max} \times .636 = E_{\text{eff}} \times .9$$

The relationships for current are the same as those given above for voltage. The usual alternating current ammeter or voltmeter gives a direct reading of the effective or r.m.s. (root mean square) value of current or voltage. A direct current ammeter in the plate circuit of a vacuum tube approximates the average value of rectified plate current. Maximum values can be measured by a peak vacuum-tube voltmeter such as is described in the chapter on Radiotelephony.

Phase Angle

It has been mentioned that in a circuit containing inductance, the rise of current is delayed by the effect of electrical inertia presented by the inductance. Both increases and decreases of current are similarly delayed. It is also true that a current must flow into a condenser before its elements can be charged and so provide a voltage difference between its terminals. Because of these facts, we say that a current "lags" behind the voltage in a circuit which has a preponderance of inductance and that the current "leads" the voltage in a circuit where capacity predominates. Fig. 306 shows three possible conditions in an alternating current circuit. In the first, when the load is a pure resistance, both voltage and current rise to the maximum values simultaneously. In this case the voltage and current are said to be *in phase*. In the second instance, the existence of inductance in the circuit has caused the current

to lag behind the voltage. In the diagram, the current is lagging one quarter cycle behind the voltage. The current is therefore said to be 90 degrees *out of phase* with the voltage (360 degrees being the complete cycle). In the third example, with a capacitive load, the voltage is lagging one quarter cycle behind the current. The *phase difference* is again 90 degrees. These, of course, are theoretical examples in which it is assumed that the inductance and the condenser have no resistance. Actually, the angle of lag or lead depends on the ratio of reactance to resistance in the circuit.

Power Factor

In a direct current circuit or in an alternating current circuit containing only resistance, the power can be computed readily by multiplying the voltage by the current. But it is obviously impossible to compute power in this fashion for an alternating current circuit in which the current may be maximum when the voltage is zero; or for any case in which the voltage and current are not exactly in phase. In computing the power in an a.c. circuit we must take into account any phase difference between current and voltage. This is made possible by the use of a figure representing the *power factor*.

The power factor is equal to the actual power in the circuit (watts) divided by the product of the current and voltage (volt amperes). In terms of a circuit property, it is equal to the resistance divided by the impedance in the circuit. In the case of a circuit containing resistance only, the ratio and, hence, the power factor, is 1 or 100% (unity). If there is reactance only in the circuit (zero resistance), then the power factor is zero. In circuits containing both resistance and reactance the power factor lies between these two values. As instances, a good condenser should have nearly zero power factor, as should a good choke coil. Resistors for use in a.c. circuits should, on the other hand, have a power factor approaching 100%.

Practical Problems

It is surprising how many practical uses may be found for the fundamental information and formulas set forth in this chapter. A brief study of the equations and explanations with the few examples that will now follow will enable you to apply Ohm's Law and other electrical relations to determining practical things that arise in planning, building and operating even the simplest amateur station equipment. The problems which follow will serve as examples of some of the different things taken up in this chapter.

Plate Power Input

A certain transmitter has an output stage in which a single 203-A tube is employed. A high-voltage voltmeter is connected across the plate

supply circuit and a milliammeter of suitable range used in the circuit so as to measure the current of this tube only. We have seen that $P = E \times I$. Therefore, assuming that the meters read 1125 volts and 125 milliamperes, the plate input

power will be $1125 \times \frac{125}{1000} = 140.6$ watts.

Resistance of a Grid Leak

It is necessary to determine whether a resistor has a resistance which would make it suitable for a grid leak for a Type 10 transmitter, either used separately or in connection with other resistors of the same type. A 90-volt B-battery and a 0-50 ma. scale milliammeter are available. The battery is connected to the unknown resistor through the meter which is observed to read 10 milliamperes. The resistance is next calculated from Ohm's Law: $R = E/I$. $90 \div .010 = 9000$ ohms.

Measuring Grid Bias Voltage

When the grid-leak resistance is known, the current through the grid leak measured by a milliammeter of suitable range enables us to calculate the voltage drop across the resistor, which is the same as the bias between grid and filament. For example, 9000-ohm resistor is used biasing a Type 10 tube in the r.f. amplifier stage of a small oscillator-amplifier transmitter. A milliammeter connected in series with the resistors reads 21 milliamperes. Calculating the voltage drop by Ohm's Law ($E = RI$) we have the bias as $9000 \times .021$, which equals 189 volts (a high value).

Resistance Value for Dropping Plate Voltage

The transformer output goes to a tube rectifier through a filter which has a 70-henry choke in one lead. After keying in the negative lead the current passes through a 3-henry "keying" filter choke to the plates of two Type 10 tubes. There is some voltage drop in the rectifier tubes and in the resistance of the two choke-coil windings. In addition to this, a resistor may be added in series with the keying choke winding to drop the voltage further so our tube will operate normally with about 400 volts d.c. on its plate. The proper size of this resistor is quickly found by using Ohm's Law. If it is desired to produce a *drop in voltage* of about 100 volts, divide this value by the estimated plate current, let us say 100 ma. or .1 ampere. ($R = E/I$)

$$\frac{100}{.1} = 1,000 \text{ ohms.}$$

Size Resistor to Handle a Given Current

In purchasing resistors, be sure they are of ample size to dissipate the heat that will be produced by the current they will have to carry. The power that must be dissipated in heating is $W = I^2R$ (watts).

$1000 \times 100^2 = 10$ watts, which must be dissipated by the resistor for dropping the plate voltage to two Type 10 tubes. Examining manufacturers' lists, this size can be used, but a 20-watt resistor is recommended to give long life and keep the maximum temperatures low. It is best to allow 40 per cent or 50 per cent factor of safety, since resistors are usually rated for their maximum allowable dissipation mounted in free space. Actually, the heat radiation is limited by mounting resistors near other apparatus. Heat also should be kept away from filter condensers or any other apparatus whose life varies inversely with temperature.

Transformer Output Current to Resistance Load

The transformer is rated at 100 watts (v.a.) which means that it will deliver

$$I = \frac{W}{E} = \frac{100}{1100} = 91.1 \text{ ma.}$$

Capacities

A fixed condenser of 250 $\mu\text{mfd.}$ is connected in parallel with two variable air condensers having a maximum capacitance of 140 $\mu\text{mfd.}$ and .0005 $\mu\text{mfd.}$, respectively. What is the total capacitance obtainable for any adjustment or setting of the condensers? First it is necessary to change the ratings to either microfarads or micro-microfarads to get the three units on the same basis. The answer will be either:

$$250 + 140 + 500 = 890 \mu\text{mfd. (micro-microfarads)}$$

or

$$.00025 + .00014 + .0005 = .00089 \mu\text{mfd. (micro-farads).}$$

Assume the three capacities to be connected in series. Let us determine the equivalent lumped capacity:

$$\frac{1}{C} = \frac{1}{C_1} + \frac{1}{C_2} + \frac{1}{C_3} = \frac{1}{250} + \frac{1}{140} + \frac{1}{500} =$$

$$.004 + .00715 + .002 = .01315$$

$$C = 76.1 \mu\text{mfd. (micro-microfarads).}$$

Condenser Reactance

A high-voltage power-supply transformer may, under certain conditions, require protection of the windings from voltages built up due to leakage of high-frequency currents back through r.f. chokes and the filter, or due to r.f. induced in power-supply leads located in the field of the high-power stage of a transmitter. The same circumstances can cause break-down of insulation in filament transformers. At any rate it will be assumed that we have a 7200-kc. transmitter and that it is desired to connect a small condenser across the high-voltage winding to bypass current of this radio frequency. Remembering that *the higher the frequency is, the lower the reactance of a condenser*, we judge that a small condenser

will sufficiently by-pass the radio-frequency current, preventing the undesired r.f. voltage from building up across our transformer winding (or a choke coil, milliammeter or other piece of apparatus could be protected similarly).

Finding a .02- μ fd. mica-insulated transmitting condenser available, rated to withstand 2000 volts, we decide to consider what may happen if we connect it across the transformer secondary.

First of all to see if it will be practical and accomplish the result we want, let's find (a) what the reactance of the condenser to the 7200-kc. (7,200,000-cycle) voltage which has strayed into the circuit will be; and (b) what the reactance will be to the 60-cycle source. In the formula the units are cycles and farads so we must remember to use the proper conversion factors.

$$\begin{aligned} \text{(a) } X_c &= 1 \div 2\pi fC \\ &= 1 \div 6.28 \times 7,200,000 \times .02 \times 10^{-6} \\ &= 1 \div 6.28 \times 7.2 \times .02 \\ &= 1/.905 \\ &= 1.105 \text{ ohms} \end{aligned}$$

reactance at this frequency. This is an extremely low value which will readily by-pass r.f. and prevent any harmful voltages building up across an inductance.

$$\begin{aligned} \text{(b) } X_c &= 1 \div 2\pi fC \\ &= 1 \div 6.28 \times 60 \times .02 \times 10^{-6} \\ &= 132,800 \text{ ohms} \end{aligned}$$

reactance at 60 cycles.

Current Through a Reactance

The transformer is a small one and so we cannot be sure until we figure it out whether the secondary current taken by the protective condenser and the set combined will be likely to overheat the transformer or not. The plate transformer we happen to have has a ratio of 10:1 and delivers 1100 volts (effective value) when run normally. The 60-cycle current through the condenser will be:

$$\begin{aligned} I &= \frac{E}{X_c} = \frac{1100}{132,800} = .0083 \text{ amperes} \\ &= 8.3 \text{ ma.} \end{aligned}$$

Reading Diagrams — Schematic Symbols

Schematic diagrams show the different parts of a circuit in skeleton form. Pictures show the apparatus as it actually appears in the station or laboratory. A little study of the symbols used in schematic diagrams will be helpful in understanding the circuits that appear in *QST* and in most radio books. The diagrams are easy to understand once we have rubbed shoulders with some real apparatus and read about it. Schematic

diagrams are used in all electrical work because they save so much space and time when discussing the various circuits. Photographs of apparatus show the actual arrangement used but the wiring is not as clear as in the schematic diagrams. In building most apparatus a schematic diagram and a photograph will make everything clear. It is suggested that the beginner carefully compare a few pictures and schematic diagrams if not entirely familiar with the latter.

The symbols used in schematic diagrams throughout this book will be easily understood by reference to the Fig. below. Most of the diagrams shown are plainly labelled or worded so that it is only necessary to know the general scheme which differentiates coils, condensers, and resistors to read the diagram. Reference to the text will help in understanding fully what is intended, since diagrams and text have been prepared to complement each other. In general, coils are indicated by a few loops of wire, resistances by a jagged line, and variable elements in the circuit by arrowheads. If a device has an iron core it is usually shown by a few parallel lines opposite the loops indicating coils or windings.

SCHEMATIC SYMBOLS USED IN CIRCUIT DIAGRAMS

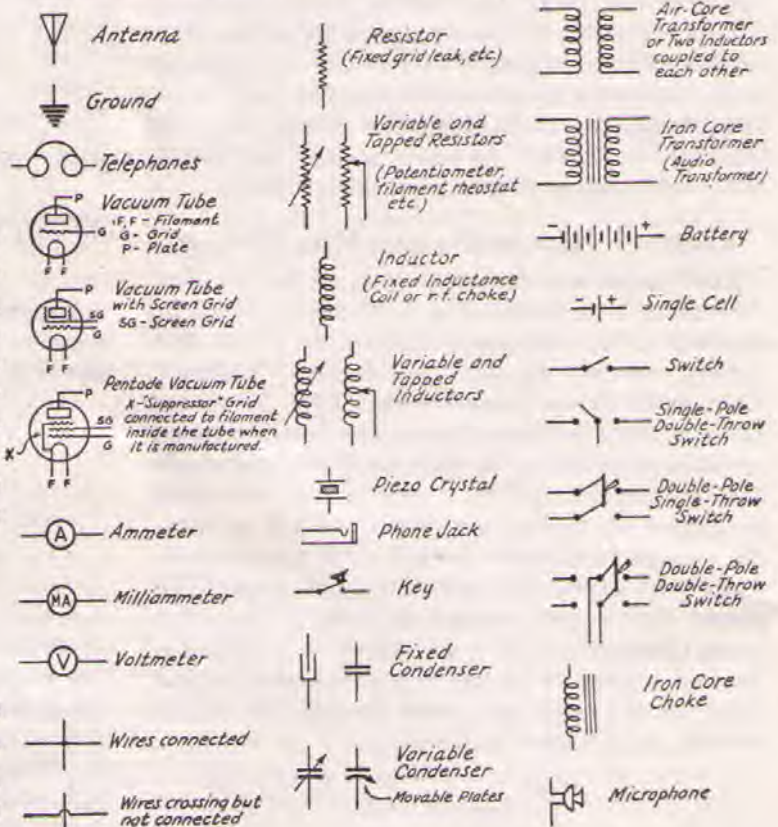

When you can draw and talk about circuits in terms of the various conventional symbols you are on what is familiar ground to every amateur and experimenter. Then you can meet the dyed-in-the-wool expert and understand what he talks about.

RADIO FUNDAMENTALS

IN OUR discussion of fundamental principles, we have seen how a flow of electrons through a wire constitutes an electric current, and how this current, under certain conditions, gives rise to electric and magnetic effects as changes in the current flow take place. In addition to the effect which resistance produces in direct and alternating current circuits, we have learned how an inductance or coil tends to prevent any change in the current flowing through it because of the existence, around the coil, of a magnetic field, which varies in strength with every variation in the current flow. We have also seen how this field around a coil can link with the turns of a second coil, so inducing voltages in it — voltages which vary in accordance with the changes in the original current flow. Further, we have seen how a condenser can be charged by an applied voltage and how the energy represented by this charge can cause a current to flow in any conductor which is connected across the condenser terminals. Lastly, we have learned that in an alternating current circuit, inductance causes the current to lag behind the voltage while capacity causes the current to lead the voltage.

Equipped with an understanding of these principles we are now ready to study inductance, capacitance and resistance as combined in the circuits of our radio transmitters, receivers and other equipment. Examination of the circuit diagram of almost any piece of radio equipment will reveal one or more combinations of coil and condenser (inductance and capacitance) and, hence, of inductive reactance and capacitive reactance. Let us now consider how they work together to form the *tuned circuit*.

The Tuned Circuit

Let us assume that a condenser *C* and coil *L* are connected as shown in Fig. 401, and that the condenser is initially charged as indicated in A, one plate having a surplus of electrons and therefore being negative while the other plate, being correspondingly deficient in electrons, is positive. The instant that the condenser plates are con-

nected together through the coil *L* there will start a flow of current as shown by the arrow in B. The rate of flow of current will be retarded by the inductive reactance of the coil and the discharge of the condenser will not be instantaneous even though the velocity of flow is constant. As the current continues to flow from the condenser into the coil, the energy initially stored in the condenser as an electrostatic field will become stored in the electromagnetic field of the coil. When substantially all the energy in the circuit has become stored in this field the lines of force about the coil begin to collapse, and thus cause

a continued flow of current through the circuit, the flow being in the same direction as the initial current. This again charges the condenser *but in opposite polarity to the initial charge*. Then, when all the energy again has been stored in the condenser, the sequence is repeated in the opposite direction. The process is one of *oscillation*. During one complete cycle the energy is alternately stored in the condenser and in the coil twice, and there is one reversal in the direction of current flow. This represents a complete cycle of alternating current. The process would continue indefinitely were there only inductance and capacitance in the circuit but, as has been pointed out in Chapter Three, all circuits contain some resistance. Therefore during each cycle a part of the energy will be dissipated in the resistance as heat, each cycle will be of lesser amplitude than the preceding one and the process will finally stop because there is no longer energy

to sustain it. This *damping* caused by resistance is overcome in practical circuits by continuously supplying energy to replace that dissipated in resistance of one form or another, as will be shown later.

Oscillation Frequency And Resonance

In such an oscillatory circuit, the larger the coil is made the greater will be its inductance and the longer will be the time required for the condenser to discharge through it. Likewise, the larger the

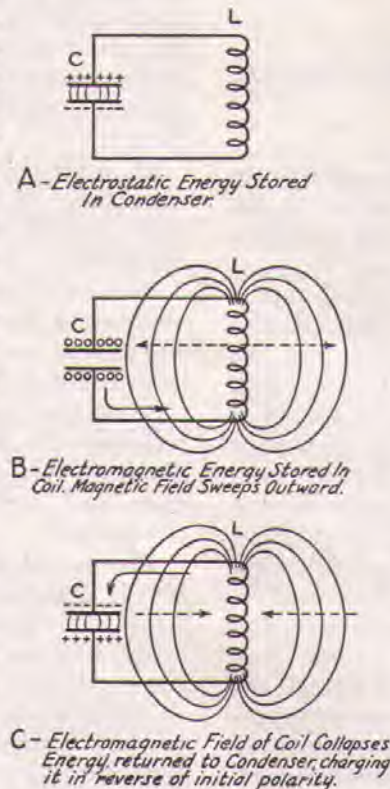

FIG. 401 — A HALF-CYCLE OF OSCILLATION IN A RESONANT CIRCUIT

condenser and the greater its capacitance, the longer it will take to charge or discharge it. Since the velocity of the current flow is substantially constant, it is clear that the circuit with the larger coil or condenser is going to take a longer period of time to go through a complete cycle of oscillation than will a circuit where the inductance and capacitance are small. Putting it differently, the number of cycles per second will

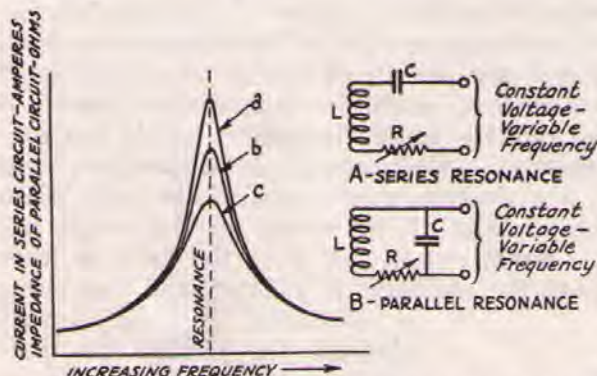

FIG. 402 — CHARACTERISTICS OF SERIES AND PARALLEL RESONANT CIRCUITS

be greater as the inductance and capacitance values become smaller. Hence the smaller the coil or condenser, or both, in the tuned circuit, the higher will be the frequency of oscillation.

The important practical aspect of all this is that in any circuit containing capacitance, inductance and not too much resistance, the introduction of a pulse of electrical energy will cause an alternating current oscillation of a frequency determined solely by the values of inductance and capacitance; and that for any combination of inductance and capacitance there is one particular frequency of applied voltage at which current will flow with the greatest ease. Recalling the explanations of inductive reactance and capacitive reactance given in Chapter Three, this becomes readily understandable. It has been shown that the inductive reactance of the coil and the capacitive reactance of the condenser are oppositely affected with frequency. Inductive reactance increases with frequency; capacitive reactance decreases as the frequency increases. In any combination of inductance and capacitance, therefore, there is one particular frequency for which the inductive and capacitive reactances are equal and, since these two reactances oppose each other, for which the net reactance becomes zero, leaving only the resistance of the circuit to impede the flow of current. The frequency at which this occurs is known as the *resonant frequency* of the circuit and the circuit is said to be *in resonance* at that frequency or *tuned* to that frequency.

In practical terms, since at resonance the inductive reactance must equal the capacitive reactance, then

$$X_L = X_C \text{ or } 2\pi fL = \frac{1}{2\pi fC}$$

The resonant frequency is, therefore,

$$f = \frac{1}{2\pi\sqrt{LC}} \times 10^6$$

Where

f is the frequency in kilocycles per second

2π is 6.28

L is the inductance in microhenries ($\mu\text{h.}$)

C is the capacitance in micromicrofarads ($\mu\mu\text{f.d.}$)

Series and Parallel Resonance — Effect of Resistance

In the simple tuned circuit just discussed the elements, inductance and capacitance, were considered with respect to each other but not in combination with other circuit elements as they are usually encountered in practical applications. In our radio transmitters, and in receivers as well, the tuned circuit is invariably associated with a source of electrical energy and also is usually coupled to still other circuits to which it transfers energy.

All practical tuned circuits can be treated as either one of two general types. One is the *series resonant* circuit in which the inductance, capacitance, resistance and source of voltage are in series with each other. With a constant-voltage alternating current applied as shown in A of Fig. 402 the current flowing through such a circuit will be maximum at resonant frequency. The magnitude of the current will be determined by the resistance in the circuit. The curves of Fig. 402 illustrate this, curve *a* being for minimum resistance and curves *b* and *c* being for greater resistances.

The second general case is the *parallel resonant* circuit illustrated in B of Fig. 402. This also contains inductance, capacitance and resistance in series, but the voltage is applied in parallel with the combination instead of in series with it as in A. Here we are not primarily interested in the current flowing through the circuit but in its characteristics as viewed from its terminals, especially in the *parallel impedance* it offers. The variation of parallel impedance of a parallel resonant circuit with frequency is illustrated by the same curves of Fig. 402 that show the variation in current with frequency for the series resonant circuit. The parallel impedance is maximum at resonance and increases with decreasing series resistance. Although both series and parallel resonant circuits are generally used in radio work, the parallel resonant circuit is most frequently found, as inspection of the diagrams of the equipment described in subsequent chapters will show.

High parallel impedance is generally desirable in the parallel resonant circuit and low series

impedance is to be sought in series resonant circuits. Hence low series resistance is desirable in both cases. At frequencies other than resonance frequency, the series resonant circuit has capacitive reactance for frequencies below resonance and inductive reactance for frequencies above resonance frequency, while the parallel resonant circuit offers inductive reactance at frequencies below resonance and capacitive reactance for frequencies above resonance.

It is to be noted that the curves become "flatter" for frequencies near resonance frequency as the resistance is increased, but are of the same shape for all resistances at frequencies further removed from resonance frequency. The relative sharpness of the resonance curve near resonance frequency is a measure of the sharpness of tuning or selectivity (ability to discriminate between voltages of different frequencies) in such circuits. This is an important consideration in tuned circuits used for radio work. Since the effective resistance is practically all in the coil, the condenser resistance being negligible, the efficiency of the coil is the important thing determining the "goodness" of a tuned circuit. A useful measure of coil efficiency, and hence of tuned circuit selectivity, is the ratio of the coil's reactance to its effective resistance. This ratio will be recognized as an approximation of the reciprocal of the circuit property of power factor discussed in Chapter Three, and is designated by Q .

$$Q = \frac{2\pi fL}{R}$$

A Q of 100 would be considered high for coils used at the lower amateur frequencies, while the Q of coils for still lower frequencies may run into the hundreds.

Coupled Circuits

Resonant circuits are not found in an isolated state in very many instances but are usually associated with other resonant circuits or are coupled to other circuits. It is by such coupling that energy is transferred from one circuit to another. Such coupling may be direct, as shown in A, B and C of Fig. 403, utilizing as the common coupling element, capacitance (A), resistance (B) or inductance (C). These three types of coupling are known as direct capacitive, direct resistive or direct inductive, respectively. Current circulating in the L_1C_1 branch flows through the common element (C , R or L) and the voltage developed across this element causes current flow in the C_2L_2 branch. Other types of coupling are the indirect capacitive and magnetic or inductive shown below the others. The coupling most common in high-frequency circuits is of the latter type. In such an arrangement the coupling value may be changed by changing the number of active turns in either coil or by changing the relative position

of the coils (distance or angle between them). The arrangement then performs in a manner similar to the transformer described in the previous chapter.

All of the above coupling schemes may be classified as either tight or loose. Coupling cannot, however, be measured simply in "inches" separation of coils. The separation between the coils (distance and angle between axes) and the inductance in each determine the coefficient of coupling. Many turns in two coils very close together give us tight coupling and a big transfer of power. Few turns at right angles or far apart give us loose coupling with little actual energy transfer. "Tight" coupling is not necessarily the best coupling, it should be kept in mind. Too-tight coupling will give a double-humped resonance effect and should be avoided.

Radio Frequency Resistance — Skin Effect

The effective resistance of conductors at radio frequencies may be hundreds of times the "ohmic" resistance of the same conductors as it would be measured for direct current or low frequency alternating current. This is largely due to the skin effect, so called because the current tends to concentrate on the outside of the conductor, leaving the inner portion carrying little or no current. It is for this reason that hollow copper tubing is widely used in the coils and connections of high-frequency circuits. However, the current may not be distributed uniformly over the surface. With flat conductors the current tends to concentrate at the edges and with square conductors it tends to concentrate at the corners. Hence the popularity of round copper tubing in radio transmitters. In addition to the skin effect,

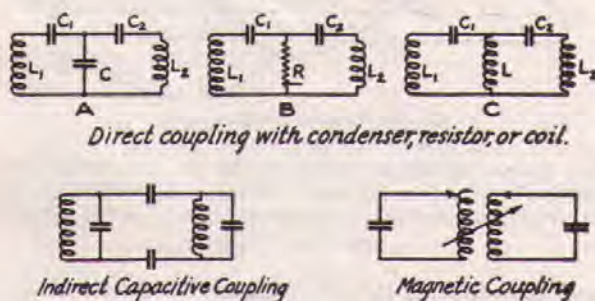

FIG. 403 — COMMON TYPES OF COUPLED CIRCUITS

dielectric losses due to insulators and resistance losses in other conductors in the field of the conductor contribute to its effective resistance. The effective resistance is measured as the power in the circuit divided by the square of the maximum effective radio-frequency current.

Circuits with Distributed Constants — The Antenna

In addition to resonant circuits containing lumped capacitance and inductance, there are important tuned circuits in which no condensers and coils are to be found. Such circuits utilize the

distributed capacitance and inductance that are inevitable even in a circuit consisting of a single straight conductor. Our transmitting and receiving antennas are such circuits and depend on their distributed capacitance and inductance for tuning. A peculiarity of such a "linear" circuit is that when it is excited at its resonant frequency the current or voltage, as measured throughout its length, will have different values at different points. For instance, if the wire happens to be one in "free space" with both ends open circuited (in other words, a Hertz antenna), when it is excited at its resonant frequency *the current will be maximum at the center and zero at the ends*. On the other hand, *the voltage will be maximum at the ends and zero at the center*. The explanation of this is that the traveling waves on the wire are reflected when they reach an end. Succeeding waves traveling toward the same end of the wire (the *incident waves*) meet the returning waves (*reflected waves*) and the consequence of this meeting is that currents add up at the center and voltages cancel at the center; while voltages add up at the ends and currents cancel at the ends. A continuous succession of such incident and reflected waves therefore gives the effect of a *standing wave* in the circuit.

Frequency and Wavelength — Harmonic Operation

Instead of specifying the properties of a linear circuit such as the antenna in terms of inductance

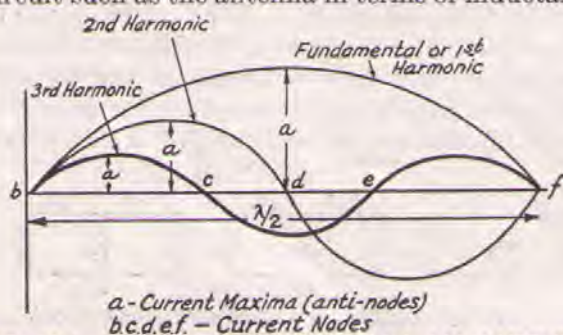

FIG. 404 — CURRENT DISTRIBUTION IN AN ANTENNA OPERATING AS A LINEAR OSCILLATORY CIRCUIT AT ITS FUNDAMENTAL, AND SECOND AND THIRD HARMONICS

and capacitance it is customary to do so simply in terms of length. This is possible because the length of such a circuit will be inversely proportional to its resonant frequency, since the velocity of the waves is practically identical for conductors of various materials, lengths and diameters. This velocity is given as three hundred million meters per second, corresponding to 186,000 miles per second. The *wavelength* is equal to the velocity divided by the frequency, and is usually expressed in meters and designated by the Greek letter λ . In practical terms,

$$\lambda = \frac{300,000}{f_{\text{kc.}}}$$

where $f_{\text{kc.}}$ is the frequency in kilocycles.

The length of an antenna is specified in terms of the wavelength corresponding to the lowest frequency at which it will be resonant. This is known as its *fundamental* frequency or wavelength. As will be shown in the chapter on Antennas, this length is (very nearly) a half-wavelength for an ungrounded (Hertz) antenna and a quarter-wavelength for a grounded (Marconi) antenna. Therefore it is common to describe antennas as *half-wave*, *quarter-wave*, etc., for a certain frequency ("half-wave 7000-kc. antenna," for instance).

Although a coil-condenser combination having lumped constants (capacitance and inductance) resonates at only one frequency, linear circuits such as antennas containing distributed constants resonate readily at frequencies which are integral multiples of the fundamental frequency (or wavelengths that are integral fractions of the fundamental wavelength). These frequencies are therefore in *harmonic* relationship to the fundamental frequency and, hence, are referred to as *harmonics*. In radio practice the fundamental itself is called the *first harmonic*, the frequency twice the fundamental is called the *second harmonic*, and so on. For example, a Hertz antenna having a fundamental of 1790 kc. (in the amateur 1750-kc. band) also will oscillate at the following harmonic frequencies: 3580 kc. (2nd), 5370 kc. (3rd), 7160 kc. (4th), 8950 kc. (5th), 10,740 kc. (6th), 12,530 kc. (7th) and 14,320 kc. (8th). Hence the one antenna can be used for four amateur bands, resonating at its first, second, fourth and eighth harmonics. A "free" antenna (Hertz) may be operated at the fundamental or any harmonic frequency, odd or even; a grounded (Marconi) type only at its fundamental or harmonics that are *odd* multiples of the fundamental frequency.

Fig. 404 illustrates the distribution of the standing waves on a Hertz antenna for its fundamental, second and third harmonics. There is one point of maximum current with fundamental operation, there are two when operation is at the second harmonic and three at the third harmonic; the number of current maxima corresponds to the order of the harmonic and the number of standing waves on the wire. As noted in the figure, the points of maximum current are called *anti-nodes* (also known as "loops") and the points of zero current are called *nodes*.

Because the velocity of the waves on the conductor (antenna) is essentially the same as that for the radio waves in space, wavelength is used interchangeably with frequency in describing not only antennas but also for tuned circuits, complete transmitters, receivers, etc. Thus the terms "high-frequency receiver" and "short-wave receiver", or "75-meter fundamental antenna" and "4000-kilocycle fundamental antenna" are synonymous. A chart showing the relationship between frequencies and wavelengths, including those of the amateur bands, is given in the Appen-

dix. The resonance equation of a tuned circuit, previously given for frequency, is expressed in terms of wavelength as follows:

$$\lambda = 1.885\sqrt{L_{\mu h}C_{\mu\mu fd}},$$

where

λ is the wavelength in meters

$L_{\mu h}$ is the inductance in microhenries

$C_{\mu\mu fd}$ is the capacitance in micromicrofarads.

Radiation By Antennas

So far we have discussed the antenna with respect to its ability to perform as a resonant circuit. We now come to the practical use that is made of the energy that oscillates in the antenna. It will be remembered that in the preceding chapter it was shown that current flow in a conductor was accompanied by a magnetic field about the conductor; and that with an alternating current the energy was alternately stored in the field in the form of lines of magnetic force and *returned to the wire*. Now this is quite true when the alternating current is of low frequency, such as the 60-cycle kind commonly used. But when the frequency becomes higher than 15,000 cycles or so (radio frequency) all the energy stored in the field is not returned to the conductor but some escapes in the form of electro-magnetic waves. In other words, energy is radiated. This we know. Just how radiation occurs is not clearly understood at the present time. But we know enough for practical purposes about what happens in the antenna and about how the waves behave after leaving the antenna.

Some radiation will occur with any conductor that has high-frequency current flowing in it but the radiation is greatest when the antenna is resonant to the frequency of the current. If the antenna is essentially "in free space" (isolated from other wires, pipes, trees, etc., that might absorb energy from it), nearly all the energy put into it will be radiated as radio waves. As was seen in the paragraph on "Radio-Frequency Resistance," *the radio-frequency resistance is equal to the actual power in the circuit divided by the square of the maximum current*. Energy radiated by an antenna is equivalent to energy dissipated in a resistor. The value of this equivalent resistance is known as *radiation resistance*. Its average value for a Hertz (ungrounded) antenna operating at its fundamental frequency is approximately 70 ohms; and for a Marconi (grounded) antenna operating at its fundamental is about half this value, or 35 ohms. Since it is impossible to measure radio-frequency power directly with ordinary instruments, the approximate value of the power in an antenna can be computed by multiplying its assumed radiation resistance by the square of the maximum current (the current at the center of a fundamental Hertz antenna).

$$\text{Antenna power (watts)} = \text{Radiation resistance (ohms)} \times \text{Current Squared (Amperes}^2\text{)}$$

The antenna must, of course, be coupled to the transmitting equipment that generates the radio-frequency power. Practical methods of doing this are described in Chapter Twelve, together with details of the antenna systems most useful in amateur transmission.

The receiving antenna is the reciprocal of the transmitting antenna in operation. Whereas radio-frequency current in the transmitting antenna causes the radiation of electro-magnetic waves, the receiving antenna intercepts such waves and has a voltage induced in it. This voltage causes a flow of radio-frequency current of identical frequency to the radio receiver and through its tuned circuits. Generation of radio-frequency power by the transmitter and reception of radio-frequency waves will now be discussed further.

The Vacuum Tube — Rectification

The most universally used device in radio communication is the vacuum tube. It works to change alternating to direct current in our power supplies, to amplify sound from a whisper to a roar, to generate the radio-frequency power used in transmission and to amplify and detect weak radio waves in our receiver. Vacuum tubes appear in many sizes and in a variety of structures. But all operate on the same principle. Most commonly, the vacuum tube has a glass bulb from which practically all air and other gas has been removed, and within which there are two or more elements, ranging from a filament (cathode) and plate on up to these two in combination with three, four and even more elements.

The simplest type of vacuum tube is that shown to illustrate electronic conduction in Chapter Three. It has but two elements, cathode and plate, and is therefore called a *diode*. As was explained, the hot cathode emits electrons which flow from cathode to plate within the tube *when the plate is positive with respect to the cathode*. The tube is a conductor in one direction only. If there should be a battery connected with its negative terminal to cathode and positive to plate, this flow of electrons would be continuous. But if a source of alternating current is connected between the cathode and plate, then electrons will flow only on the positive half-cycles of alternating voltage. There will be no electron flow, and hence no current flow, during the half cycle when the plate is negative. Thus the tube can be used as a *rectifier*, to change alternating current to pulsating direct current. This alternating current can be anything from the 60-cycle kind to the highest radio frequencies, making it possible to use the diode as a rectifier in power supplies furnishing direct current for our transmitters and receivers, as described in Chapter Ten, or even to

use it as a rectifier (detector) of radio-frequency current in receivers.

How Vacuum Tubes Amplify — Tube Characteristics

If a third element, called the *control grid* or simply the *grid*, is inserted between the cathode and plate of the diode, the tube becomes a *triode* (three-element tube) and acquires utility for more things than rectification. This grid is usually in the form of an open spiral or mesh of fine wire. With the grid connected externally to the cathode and with a steady voltage from a d.c. supply applied between the cathode and plate (the positive of the plate or "B" supply is always connected to the plate), there will be a constant flow of electrons from cathode to plate, through the openings of the grid, much as in the diode. But if a source of variable voltage is connected between the grid and cathode there will be a variation in the flow of electrons from cathode to plate (a variation in plate current) as the voltage on the grid changes about a mean value. When the grid is made less negative with respect to the cathode there will be an increase in plate current; when the grid is made more negative with respect to the cathode there will be a decrease in plate current. This occurs because the electron flow to the plate is encouraged when the grid swings positive, while electrons leaving the cathode are repelled from traveling to the plate when the grid swings negative. The important thing about this is that when a resistance or impedance is connected in the plate circuit, the variation in plate

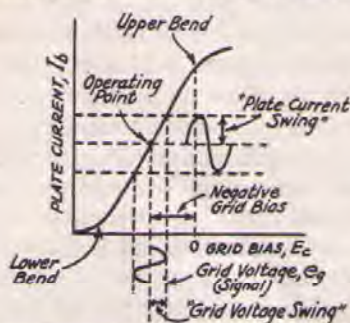

FIG. 405 — OPERATING CHARACTERISTICS OF A VACUUM TUBE AMPLIFIER

current will cause a variation in voltage across this load that will be a magnified version of the variation in grid voltage. In other words there is *amplification* and the tube is an *amplifier*.

The measure of the amplification of which a tube is capable is known as its *amplification factor*, designated by μ (mu), an important *tube characteristic*. Another important characteristic involving plate current change caused by grid voltage change over a very small range is a tube's *mutual conductance*, designated by g_m and expressed either in milliamperes plate current change per volt grid voltage change (ma. per volt), or as the current to voltage ratio in *mhos* (inverse of ohms). Since the plate current changes

involved are often very small, the mutual conductance is also expressed in *micromhos*, the ratio of amperes plate current change to volts grid voltage change, multiplied by one million. Still another important characteristic used in describing the properties of a tube is the *plate resistance*, designated r_p . This is the ratio of a small plate voltage change to the plate current change it effects. It is expressed in *ohms*. These tube characteristics are inter-related and are different with tubes of different types, being dependent primarily on the tube structure (spacing between elements, spacing and size of wires in grid, etc.).

Amplifier Operation

The operation of a vacuum tube amplifier is graphically represented in Fig. 405. The sloping line represents the variation in plate current obtained at a constant plate voltage with grid voltages from a value sufficiently negative to reduce the plate current to zero to a value slightly positive. It should be kept in mind that grid voltage is with reference to the cathode of filament. This is known as the *static grid-voltage plate-current characteristic*. Notable things about this curve are that it is essentially a straight line (is *linear*) over the middle section and that it bends towards the bottom (near *cut off*) and near the top (*saturation*). In other words, the variation in plate current is directly proportional to the variation in grid voltage over the region between the two bends. With a fixed grid voltage (*bias*) of proper value the plate current can be set at any value in the range of the curve.

With negative grid bias as shown in Fig. 405 this point (the *operating point*) comes in the middle of the linear region. If an alternating voltage (*signal*) is now applied to the grid in series with the grid bias, the grid voltage swings more and less negative about the mean bias voltage value and the plate current swings positive and negative about the mean plate current value. This is equivalent to an alternating current superimposed on the steady plate current. With this operating point it is evident that the plate current *wave shapes* are identical reproductions of the grid voltage wave shapes and will remain so as long as the grid voltage amplitude does not reach values sufficient to run into the lower- or upper-bend regions of the curve. If this occurs the output waves will be flattened or be *distorted*. If the operating point is set towards the bottom or towards the top of the curve there will also be distortion of the output wave shapes because part or all of the lower or upper half-cycles will be cut off. This kind of distortion may be undesirable or desirable, as will be shown later.

The major uses of vacuum tube amplifiers in radio work are to amplify at audio frequencies (approximately 100 to 10,000 cycles per second) and to amplify at radio frequencies (up to 60,000 kc. or higher). The audio-frequency amplifier is

generally used to amplify without discrimination at all frequencies in a considerable range (say from 100 to 3000 cycles for voice communication), and is therefore associated with non-resonant or untuned circuits. The radio-frequency amplifier, on the other hand, is generally used to amplify selectively at a single radio frequency, or over a small band of frequencies at most, and is therefore associated with resonant circuits tunable to the desired frequency.

The circuit arrangement of a typical audio-frequency amplifier using a triode is shown at A in Fig. 406. The alternating grid voltage is applied through the transformer T_1 to the grid circuit, in series with the grid bias furnished by a battery. The alternating current component in the plate circuit induces an alternating voltage in the secondary of the output transformer T_2 . This output might go on to another similar audio amplifier for further amplification. In lieu of the output transformer, a pair of 'phones could be connected in place of the primary in the plate circuit, in which case the alternating component in the plate current would be reproduced immediately as sound.

In B of Fig. 406 is shown the circuit arrangement of an amplifier for radio frequencies. In this case the tube is of the screen-grid type, the extra element being placed between the control grid and plate to prevent the feed-back and oscillation that will be discussed in the next section. Its operation, however, is similar to that shown in Fig. 405. The input and output circuits in this case are resonant circuits, tuned to the radio frequency that is to be amplified. The grid bias, instead of being furnished by a separate battery, is furnished by the voltage drop across the cathode resistor resulting from the steady plate current flowing through the plate circuit (which includes the "B" supply). Since this flow of current is from plate to cathode in the external circuit, the supply side of the cathode resistor will be negative with respect to the cathode and thus apply negative bias to the grid. Methods of obtaining grid bias are explained further in Chapter Five.

Generating Radio Frequency Power — Oscillators

Because of its ability to amplify, the vacuum tube can oscillate or generate alternating current power. To make it do this, it is only necessary to couple the plate (output) circuit to the grid (input) circuit so that the alternating voltage supplied to the grid of the tube is opposite in phase to the voltage on the plate. Typical circuits for this condition are shown in Fig. 407. In A the feedback coupling between the grid and plate circuits is inductive (by means of coils), while in B the coupling is capacitive (through a condenser). In the circuit of A the frequency of oscillation will be very nearly the resonant frequency of the tuned circuit L_1C_1 , while in B the frequency of oscillation will be determined jointly by L_1C_1 and

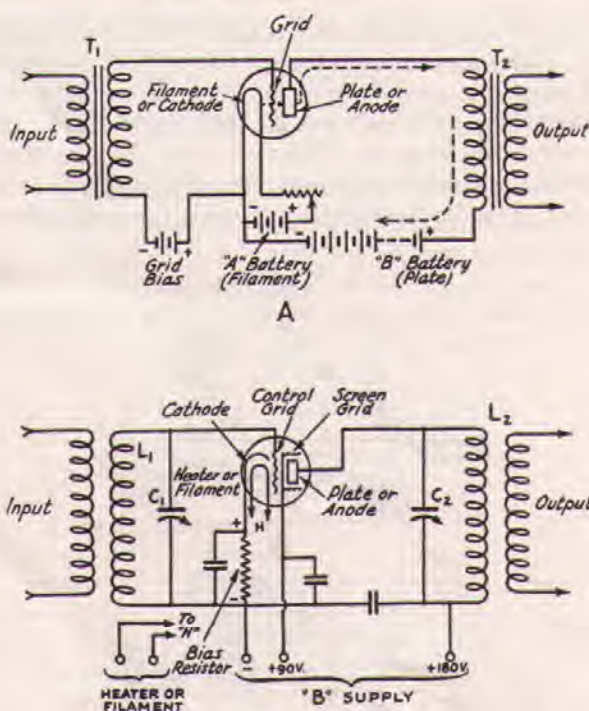

FIG. 406 — CIRCUITS OF TYPICAL VACUUM TUBE AMPLIFIERS

L_2C_2 . To insure the proper phase relationship between plate and grid voltage, with the inductive feed-back of A the grid and plate should be connected to the opposite ends of the plate and grid coils when these coils are wound in the same direction; while in the arrangement of B the plate circuit should be tuned to a slightly higher resonant frequency than the grid circuit. (Plate circuit reactance inductive with respect to the grid circuit.) At the high radio frequencies used in amateur work the inherent plate-grid capacitance of the usual triode tube is sufficient for feed-back in the tuned-grid tuned-plate type circuit of B and the feed-back condenser shown connected between grid and plate is not necessary.

There are many other arrangements of oscillator circuits but all utilize either the inductive or capacitive feed-back typified in the two shown here. Several of these other types are treated in Chapter Seven. A special type of oscillator of exceptional frequency stability that is becoming increasingly popular is the piezo-electric or crystal-controlled type. Most commonly it resembles the tuned-grid tuned-plate circuit of B with the exception that the tuned grid circuit is replaced by a plate of quartz crystal mounted between metal electrodes. This crystal acts like a tuned circuit, its electrical equivalent being that shown at B of Fig. 408. As shown, it consists of a very high inductance (L) in series with a very small capacitance (C) and resistance (R). The shunt capacitance C_1 is that of the electrodes between which the crystal is mounted, with the quartz as the dielectric. Its exceptional stability is attributable to its high ratio of inductive

reactance to resistance; in other words, to its high Q . This property also makes the crystal useful as a very selective tuned circuit or filter for radio reception, as it is used in the Single-Signal receivers outlined in Chapter Five. Power type oscillators and amplifiers are used in combination in radio transmitters, both for radioteleg-

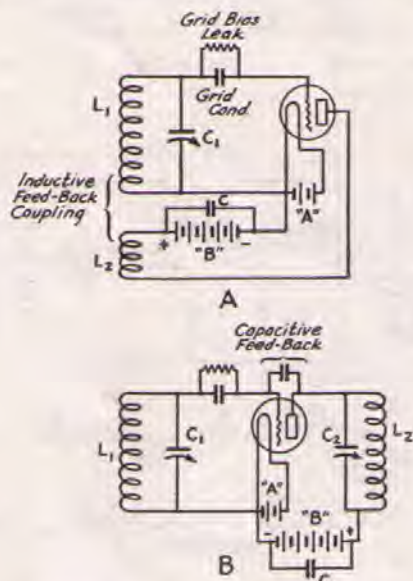

FIG. 407—TWO GENERAL TYPES OF OSCILLATOR CIRCUITS

raphy and radiotelephony, and later chapters will describe practical aspects of these applications.

Modulation

In addition to generating radio-frequency energy in the transmitter and radiating it from the antenna, it is necessary to do something to utilize this energy for communication of intelligence. This is accomplished by *modulating* the transmitter's output either to form the dots and dashes of the telegraph code (by keying) or by varying the amplitude of the radio-frequency current to conform with the variations in intensity of the voice. Radio-frequency currents modulated by these two methods are represented in Fig. 409, a wave modulated for telegraphy by keying the transmitter's output into dot and dash form being shown in A, and one modulated with a sine-wave of audio-frequency current being shown in B. The outline of the modulation is referred to as the *envelope* and it is to this that the useful output of the receiver must conform. Detailed descriptions of modulation methods for both telegraphy and telephony are given in later chapters.

Detection of Radio Signals

After the modulated radio-frequency current has made its way into the receiver and perhaps through one or more radio-frequency amplifiers, it must be *demodulated* or *detected* to bring out the

useful modulation envelope just described. To do this it is necessary to rectify the radio-frequency current. This might be done with the simple diode, as mentioned previously. However, the triode is more commonly used in amateur receivers because it gives much greater output in proportion to its radio-frequency input (is more *sensitive*) than the diode. Triode detectors are of two types, one giving what is known as *plate detection* and the other what is known as *grid detection*.

The circuit arrangement of a typical *plate detector* is shown in A of Fig. 410 and its operating characteristics are illustrated in A of Fig. 411. The circuit L_1C_1 is tuned to resonance with the radio frequency and the voltage developed across it is applied between the grid and cathode, in series with the grid bias battery. A telephone headset (or the primary of a transformer feeding an audio amplifier) is connected in the plate circuit, a small fixed condenser C being connected across the plate load circuit to by-pass radio frequency. As shown in A of Fig. 411, the negative grid bias voltage is such that the operating point is in the lower-bend region of the curve, near cut-off. Hence only the positive half-cycles of the signal voltage are completely effective in causing plate current change. With a modulated signal as shown there will be a variation in plate current conforming to the average value of the positive

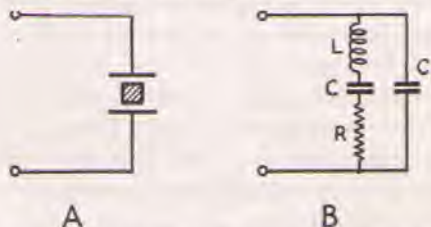

FIG. 408—EQUIVALENT CIRCUIT OF PIEZO-ELECTRIC QUARTZ CRYSTAL

half-cycles of radio frequency. This variation corresponds to the envelope, representing an audio-frequency current superimposed on the steady plate current of the tube, and constitutes the useful audio output of the detector. When this pulsating current flows through the 'phones their diaphragms vibrate in accordance with it to give a reproduction of the modulation put on the signal at the transmitter. This type of detection is called *plate detection* because the rectification takes place in the plate circuit after radio-frequency amplification from grid to plate.

The circuit arrangement of a triode used as a *grid detector* (also called *grid leak detector*) is shown in B of Fig. 410. Here again we have an input circuit tuned to the frequency of the radio wave and connected so that the r.f. voltage developed across it is applied between the grid and cathode. However, there is no fixed negative grid bias, as in the case of the plate detector, but instead a small fixed condenser (*grid condenser*) and resistor of

high value (*grid leak*) in parallel are connected between tuned circuit and grid. The plate circuit connections are the same as for the plate detector.

As shown in B of Fig. 411, the operating point is near the upper bend of the curve because the grid bias is near zero when there is no signal on the grid. A modulated radio-frequency voltage applied to the grid swings it alternately positive and negative about the operating point. The grid attracts electrons from the cathode, the consequent grid current increasing more during the positive half cycles than it decreases during the negative half cycles of grid swing. Hence there is a rectified grid current flow at modulation frequency whose average value develops a voltage across the grid leak. This audio-frequency variation in voltage across the grid leak causes corresponding variations in plate current which are reproduced in the 'phones. In contrast to plate detection, with grid detection the rectification takes place in the grid circuit and there is audio-frequency amplification to the plate circuit. Grid detection is generally used in amateur receivers of limited r.f. amplification because grid detectors are capable of greater sensitivity for small signals than plate detectors using similar tubes. Plate detection is more commonly used where detector sensitivity is of minor importance.

Regenerative Detectors

With both the grid and plate detectors just described it will be noted that a condenser is connected across the plate load circuit to bypass radio-frequency components in the output. This radio-frequency can be fed back into the grid circuit, as shown in C of Fig. 410, and re-amplified a number of times. This *regeneration* gives a tremendous increase in detector sensitivity and is used in most amateur receivers. If the regeneration is sufficiently great the circuit will break into oscillation, which would be expected since the circuit arrangement is almost identical with that of the oscillator shown in Fig. 407-A. Therefore a control is necessary so that the detector can be

operated either regenerating to give tremendous amplification without oscillation, or to oscillate and regenerate simultaneously. Methods of controlling regeneration are given in Chapter Five.

Heterodyne or Beat-Note Reception

In discussing the detection of signals it has been pointed out that the detector output is a replica of the modulation applied at the transmitter. In the case of radiotelephony this modulation is at

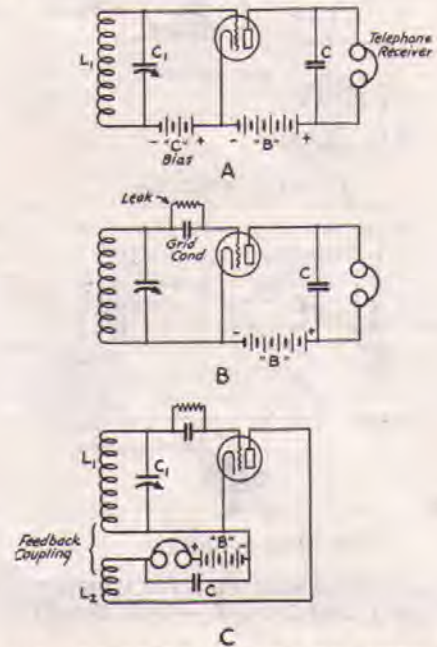

FIG. 410 — DETECTOR CIRCUITS OF THREE TYPES
 A — Plate detection, B — Grid detection, C — Regenerative grid detection.

audio frequency and the methods of detection that have been described will reproduce it satisfactorily. But in the case of c.w. radiotelegraphy the variations in detector plate current, while they correspond with the dots and dashes of the code, will not cause an audio-frequency tone in the 'phones unless they are actually modulated with a tone of audible frequency. The most satisfactory method of giving this tone to c.w. signals is by *heterodyne* action, a form of modulation. The idea is illustrated in Fig. 412. When two alternating voltages of different frequencies are simultaneously applied to a detector, there appear in the detector output circuit current variations of both the original frequencies, of their sum frequency and of their difference frequency. This difference frequency is the *beat note*, and if the difference between the two original frequencies is an audio frequency, the beat note will be of audio frequency. One of the original frequencies is, of course, that of the radio signal. The other is that of a local oscillator. This local oscillator may be separate from the detector or a separate heterodyne. In most cases, however, the detector itself also serves as the local oscillator to give the beat

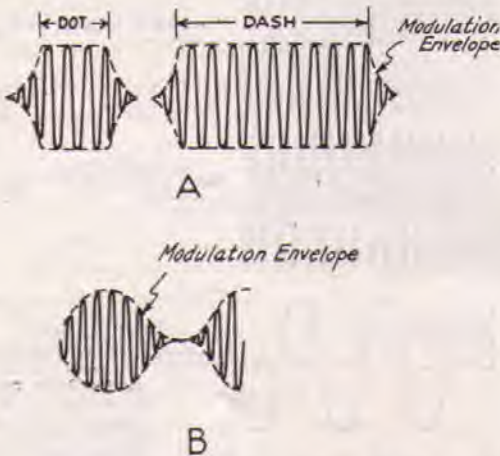

FIG. 409 — RADIO WAVES MODULATED FOR C. W. TELEGRAPHY AND TELEPHONY

note. When so used, such a detector is known as an *autodyne*. A regenerative detector circuit like that shown in Fig. 410-C, with the regeneration adjusted so that the detector oscillates, is commonly used for amateur c.w. reception.

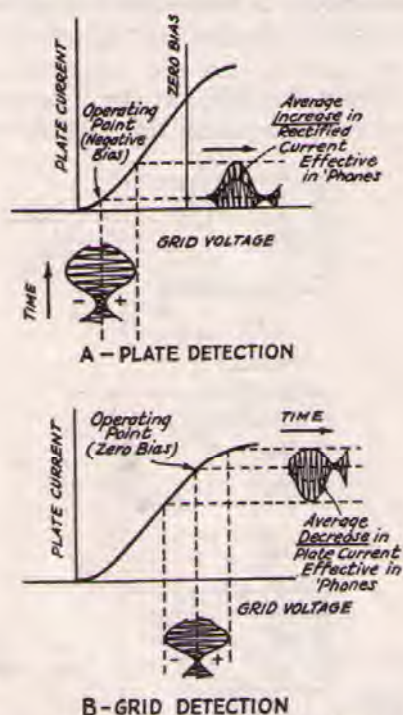

FIG. 411 — OPERATING CHARACTERISTICS OF, A — PLATE DETECTOR, B — GRID DETECTOR

Superheterodyne Reception

As was mentioned in the section on series and parallel resonance, the selectivity of tuned circuits is relatively poor at even the lower amateur frequencies. At the higher amateur frequencies it becomes worse. Therefore it is impracticable to obtain really high selectivity in tuned amplifiers resonant to frequencies in the amateur bands. On the other hand, both higher selectivity and greater amplifications per stage can be obtained in radio-frequency amplifiers operating at intermediate frequencies of 500-kc. or so. Such amplifiers can be utilized for amateur reception by converting the amateur frequency signals to the lower *intermediate frequency*. This also is possible by the heterodyne method.

Both the incoming signal and the local oscillator signal are introduced in a detector, with the local oscillator frequency either intermediate frequency higher or lower than the signal frequency. Since the difference between the two frequencies is quite great in this case, it is advisable to use a separate oscillator rather than to use the detector as an autodyne. The output of the detector is coupled to the i.f. amplifier stages by a radio-frequency transformer tuned to the intermediate frequency, thus selecting the difference frequency component in the detector output and eliminating the other components.

After amplification in the intermediate-frequency (i.f.) stages, the signal is detected in normal fashion by the *second detector*. If the incoming signal is modulated at audio frequency, the intermediate-frequency signal will be identically modulated and the audio-frequency output of the second detector will be normal. For c.w. reception it will be necessary to use a second heterodyne oscillator at the second detector or to operate this detector as an autodyne, as with the detector in the usual amateur receiver. A receiver operating in this fashion is a *superheterodyne*. Several types of modern superheterodyne receivers especially designed for high-frequency work are shown in Chapter Five.

Generation of Harmonic Frequencies

Distortion in vacuum tube amplifiers causes harmonics and we often purposely adjust vacuum tube circuits to give us maximum distortion when we desire output at a frequency that is a harmonic of the exciting frequency. High input voltage amplitude or grid swing and high negative bias are favorable for the production of harmonics. Because of curvature in the plate-current plate-voltage characteristic curves and because there is a different plate-voltage plate-current (static characteristic) for each value of impressed grid voltage, the current wave-form in the plate circuit becomes distorted, resulting in the generation of harmonic frequencies. A low plate-load (external) resistance or impedance will emphasize such distortion. Even with a high grid bias, large inputs to the grid circuit will also cause the grid to become positive during part of the input cycle, causing grid current to flow, thus decreasing the grid-filament resistance of the tube. This results in an uneven load and produces further distortion and harmonics. The way in which distortion in the output wave-form introduces a harmonic impulse or component is indicated in Fig. 413.

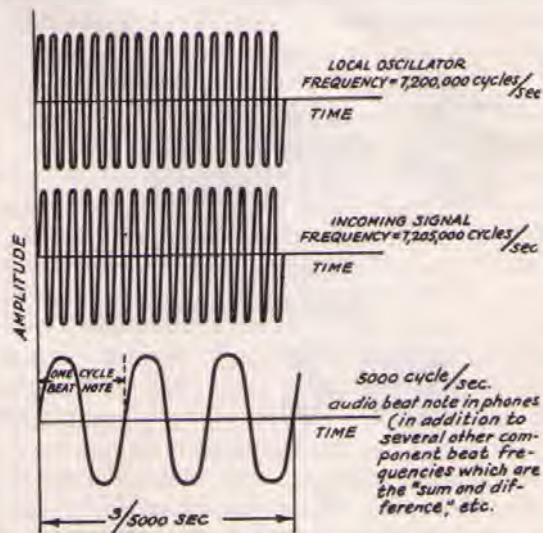

FIG. 412 — ILLUSTRATING HETERODYNE ACTION

Harmonics cannot be generated at frequencies below the fundamental but always occur at higher frequencies. When we pick up a radio signal with the receiver tuned to half the frequency of the transmitting station it is because our oscillating detector generates a harmonic in the receiver. In this case the harmonic is beating with the fundamental frequency of the transmitter.

By properly biasing tubes and tuning the output circuit to a desired harmonic frequency, a vacuum tube may be operated as a frequency doubler or frequency tripler, etc.

How Radio Waves Travel in Space — Fading and Skip Distance

No discussion of amateur radio or of high-frequency phenomena can be complete without something about the commonly accepted theory advanced in explanation of the things that have been observed in connection with high-frequency

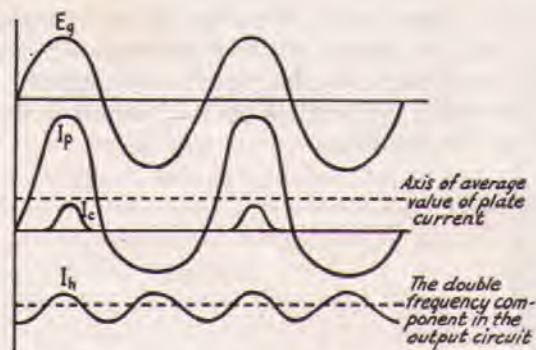

- E_g —Sine-wave input impressed on grid
- I_p —Distorted output plate current wave
- I_c —Grid current—when grid becomes positive occurring at right time intervals to set up second harmonic.
- I_h —The harmonic component of the output current

FIG. 413 — HOW DISTORTION CAUSES HARMONICS IN VACUUM TUBE OPERATION

transmission. It appears that just as light waves can be reflected and refracted so it is with radio waves. The behavior of radio waves is harder to understand because these waves are not visible or audible except by artificial means of detection. The frequency spectrum used for radio communication is a wide one and the determination of what happens is further complicated by the continuous variations taking place in the medium traversed by the radio waves. The bending or refraction of radio waves in the upper atmosphere is attributed to the presence of free electrons resulting from ionization of the earth's upper atmosphere, principally by radiation from the sun. The ionization passes through a daily and seasonal variation depending on sunlight and changes in the sun's radiation.

Changing reflecting and refracting properties of the Kennelly-Heaviside layer, so named for the two men who independently and almost simultaneously proposed the existence of an ionized

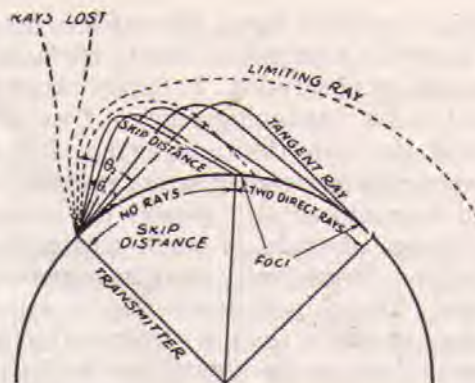

- θ_1 ANGLE AT TRANSMITTER CORRESPONDING TO THE FIRST CRITICAL ANGLE
- θ_2 ANGLE AT TRANSMITTER CORRESPONDING TO THE SECOND CRITICAL ANGLE

FIG. 414 — HOW RADIO WAVES TRAVEL FROM TRANSMITTER TO RECEIVER

The vertical and near-vertical rays penetrate the ionized layer and wander away. When one reaches the "limiting angle" the ray just does get bent enough to be kept from wandering away, but it continues to graze the layer and is after all worthless. Below this angle we have progressive reflection (or refraction) and the ray returns to earth. As the angle of departure from the transmitter is chosen flatter the energy strikes so far away as to miss the earth, possibly going out to the ionized layer again, and perhaps even being reflected down a second time if it has energy enough left.

region in the upper atmosphere, are presumed to account for the rapid variation in the intensity of received signals that is called *fading*.

Fig. 414 explains what is commonly referred to as the *skip distance*, that distance which sig-

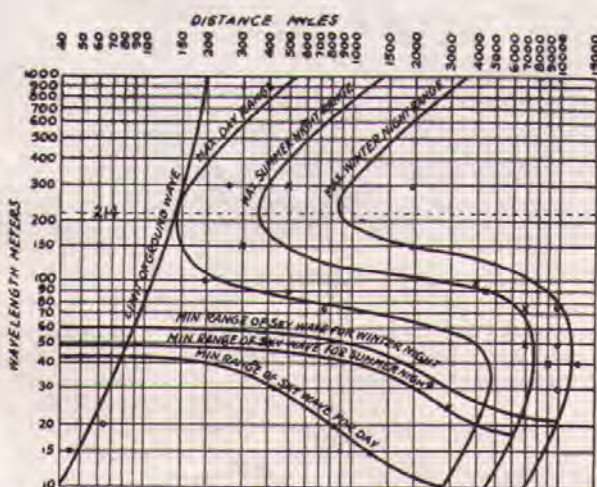

FIG. 415 — APPROXIMATE AVERAGE TRANSMISSION PERFORMANCE OF DIFFERENT WAVELENGTHS AT DIFFERENT DISTANCES

The received signal is assumed to have a field-strength of 10 microvolts per meter at the receiving point. The transmitter is assumed to have 5000 watts in the antenna. The chart is explained as follows. To the left of the line marked "limit of ground wave" it should be possible to receive at all times. After that, one must pick a pair of curves of the same sort (that is for the same time) and if the distance is between the curves one should hear the signal. Thus, a 30-meter wave should be reliable at all times to 70 miles for the conditions mentioned. From there to 400 miles its daylight performance will probably be uncertain while from 400 on it will gradually die down until at 4600 it will again be below 10 microvolts per meter. There are, of course, numerous exceptions where one does hear it when it should be absent. The curves are mainly from data by A. H. Taylor.

nals skip over. The signal decreases in intensity as we leave the transmitter due to spreading out and to energy absorption. It finally drops below a useful value, remaining out until we reach a great distance from the transmitter, after which it unexpectedly gets strong again, gradually dropping in intensity at still greater distances. The skip distance at night is much greater than in the daytime. It gradually increases up to about midnight. The skip distance also is known to be greater in winter than in summer which seems reasonable because the ionization should be less then, due to shorter periods of sunlight. It can be seen readily from the charts that the skip distance is very definitely influenced by the transmitted frequency.

Fading is usually less violent over long distances because the waves can arrive by many routes, thus averaging conditions and giving a fair signal in spite of fading along some paths. Right at the edge of the skip distance interference effects may occur with very severe fading, while beyond this point the rays of high-angle radiation die out, giving a better chance for a steady signal. In general high-frequency communication results go to prove that the skip dis-

tance for any given time decreases with decreasing frequency. While skip-distance effects are important on our high frequencies they are not as noticeable on the broadcast band and less important still on low frequencies.

There is nothing absolute about any of the rules that different investigators have devised for determining whether a signal from a certain transmitter can be heard at a given point. However, some charts and rules are useful when studying the subject of transmission phenomena, even though they are approximate. Such a chart is shown in Fig. 415 with an explanation of what it means. It shows roughly what may be expected of different frequencies or the corresponding wavelengths in radio communication.

Amateur experience seems to indicate that the power of a transmitter is one of the less important considerations in high-frequency work. Extreme distances are covered day and night with less than ten watts in the antenna using 14,000- and 7000-kc. frequencies, and the signal strength of high and low power stations is much the same. The conditions in the upper atmosphere are undoubtedly the most important factor in determining the results.

HIGH-FREQUENCY RECEIVERS

WHATEVER one's principal interest in amateur radio, be it operating a complete station or experimenting with a variety of circuits, the basic piece of apparatus is a good receiver. The building of the complete station is always a process of evolution. Most amateurs start out with a simple receiver, listening in on it until they become proficient in the art of tuning in high-frequency signals, and at the same time learning the code in preparation for obtaining a transmitting license. The amateur has the choice of building his own receiver or of purchasing one of the several amateur-band manufactured receivers now available at reasonable prices. Many amateurs prefer to build their own, not just for reasons of economy, but more for the experience and to acquire the intimate knowledge of operation that they obtain. Instructions for building chosen types of receivers of proved high performance and descriptions of representative manufactured receivers are contained in this chapter.

The first receiver need not be an elaborate one; in fact it is better to pick out a simple and inexpensive set for the initial attempt. It will be relatively easy to get such a set working and, even though it is built with the full knowledge that it will not be the permanent receiver of the finished station, the investment in the equipment for it will not be wasted. Most of the parts used in simple receivers can be used equally well in more intricate sets later on. In this chapter several types of receivers are described. All of them are thoroughly practical outfits, capable of giving excellent service if carefully built and correctly operated.

Receiver Characteristics

The three important general characteristics of a receiver are its selectivity, its sensitivity and its fidelity. These three are inter-dependent, with selectivity the controlling factor. The *selectivity* is the receiver's ability to discriminate between signals of different frequencies. The *sensitivity* is the minimum r.f. voltage input required to give useful output. The *fidelity* is the proportionate response through the audio-frequency range required for a given type of communication.

Sensitivity is fundamentally limited by the noise output, which in turn is directly related to

the selectivity, being less as the selectivity is greater. Only signals that are detectable above the noise background are useful; therefore, reducing the noise output by increasing the selectivity improves the effective sensitivity in proportion. Sensitivity is thus not solely dependent on the amplification in the receiver but on the combination of amplification and selectivity. The fidelity requirement in amateur receivers is essentially different from broadcast receiver requirements, although this is not generally realized, and is set by the minimum required for intelligibility. For c.w. telegraph reception of hand-keyed signals (say up to 30 words per minute) adequate fidelity for intelli-

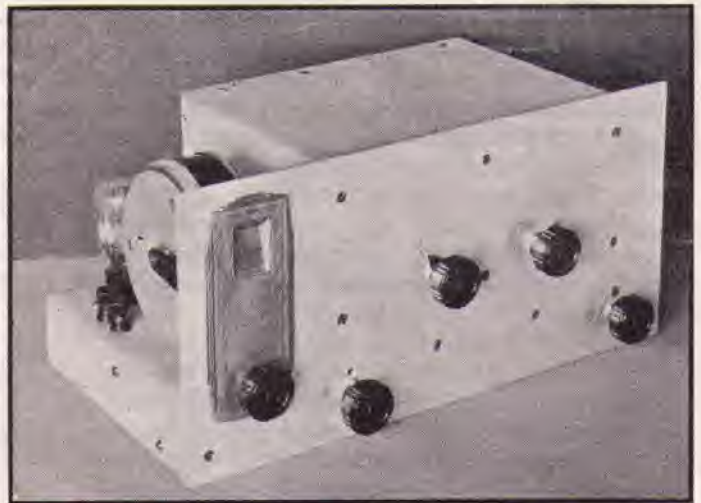

FIG. 501 — A MODERN THREE-TUBE TUNED R.F. AMATEUR-BAND RECEIVER DESCRIBED IN THIS CHAPTER

It comprises a stage of r.f. amplification with controlled sensitivity, a stable regenerative detector and one-stage audio. It uses heater-type tubes for a.c. or 6-volt d.c. operation and is adapted to conversion to a single-signal type superheterodyne, as shown later in the chapter.

The tuning dial is placed at the left so the receiver can be operated without getting in the way of papers, log books, etc. To the right and below the dial is the regeneration control. The two upper knobs are the band-setting condensers. The sensitivity control is in the lower right-hand corner. The audio tube and the 'phone binding posts can be glimpsed behind the drum dial on the sub-base.

gible reception can be obtained with selectivity such that the receiver's equivalent band width is but 20 cycles or less; for 'phone reception with usable intelligibility the equivalent band-width may be as little as 120 cycles, as has been determined by actual measurement of a highly-selective single-signal receiver. It is therefore evident that the most important receiver characteristic is the effective selectivity; for the higher the selectivity, the greater can be the amplification and the higher the effective sensitivity, to the

limits imposed by the requirement of intelligible output.

Types of Receivers

Two types of receivers meeting the requirements of general amateur work are the simple regenerative receiver (autodyne) and the superheterodyne. Special types for ultra-high frequency work are treated in Chapter Nine. In the regenerative receiver there is r.f. feedback in the detector circuit with the amount of this regeneration controllable to give either high amplification and selectivity without oscillation, or to give these together with oscillation to provide the heterodyne for beat-note c.w. reception, as has been explained in Chapter Four. The simplest form of receiver is just one tube in a regenerative detector circuit, although the output available from such an arrangement is so small as to be generally unsatisfactory. A single stage of audio amplification following the detector gives more satisfactory results. A still further improvement is a stage of tuned radio-frequency amplification preceding the detector. This increases sensitivity and gives somewhat greater selectivity, provides helpful isolation of the regenerative detector from the antenna circuit and allows sensitivity control ahead of the detector circuit.

Whereas the regenerative receiver's r.f. circuits handle the signal at incoming frequency, in the superheterodyne type receiver the incoming signal is converted to a lower radio frequency and then amplified in intermediate circuits prior to conversion to audio frequency in the second detector. As explained in Chapter Four, this method allows greater r.f. amplification and the attainment of higher selectivity, since both of these are more readily obtained in the intermediate-frequency (i.f.) amplifier. This applies particularly to the single-signal type superheterodyne, originally developed in the A.R.R.L. laboratory and described in this chapter, which obtains extremely high selectivity in the i.f. circuits either by means of a variable-selectivity quartz crystal filter or by controllable regeneration in an i.f. stage.

The simple regenerative type receiver is less complicated than the superheterodyne, of course, and is accordingly less expensive. Until one has gained experience it is advisable to work with the simpler receiver, progressing later to the superheterodyne type. In fact, a suitable regenerative receiver can be used as the foundation of the superhet, as will be illustrated by a typical example.

Tuning Arrangements and Band Spreading

Since the amateur frequency-bands comprise narrow slices of territory widely separated, it is not possible to cover them all effectively with one coil and condenser in the tuner. Many schemes have been evolved to provide suitable coils and

coil sockets. The use of a tube-base or a special form of larger size plugging into a tube socket is now almost universal. Coils of this type are pictured later on with the constructional details of the receivers in which they are used. Larger coils with a horizontal row of plugs fitting into a similarly-arranged row of sockets are also used in some cases. The important requirements are that the coils should be readily interchangeable; the contacts should be positive; the coils should be mechanically strong so they will not be deformed in handling; and they should be small in diameter in order to avoid the existence of an extensive magnetic field around them.

Tuning condensers used in high-frequency receivers are much smaller than those employed for the broadcast band and lower frequencies. A 350- or 250- μfd . condenser will, at high frequencies, cover so much territory that tuning becomes extremely difficult, because the amateur bands occupy only a few divisions on the usual 100-scale dial. Many amateurs remove plates from standard-sized condensers to reduce the maximum capacity, or else use midget condensers, which can be obtained in a variety of capacities. If the receiver is to cover all frequencies between 20,000 and 3000 kc., common practice is to use a tuning condenser rated at 150 μfd . with three plug-in coils, but even this arrangement crowds the amateur bands in a very small proportion of the dial scale. Most amateurs prefer to spread the bands over a large part of the dial.

The amateur bands are not entirely in harmonic

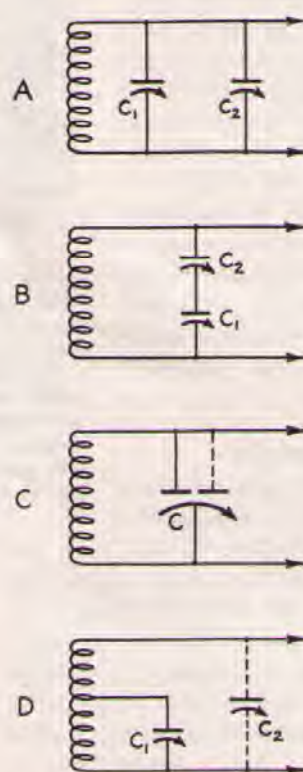

FIG. 502 — THE ESSENTIALS OF FOUR POPULAR BAND-SPREAD SYSTEMS

relation, and therefore a condenser which spreads one band satisfactorily will not give the same spread on others. In order to make each band cover a large number of dial divisions, the ratio of maximum to minimum capacity must be different for each band. One method is to use plug-in midget tuning condensers which are changed each time the coils are changed. The standard midget condensers will not always work satisfactorily, and plates must therefore be removed until each band is spread as much as desired. Since this method is somewhat cumbersome mechanically, its use is not very practical if the receiver has a tuned r.f. stage.

Several widely used band-spreading schemes are shown in Fig. 502. At A is the parallel-condenser method. C_1 is the tuning condenser, usually with a maximum capacity of about 25 μfd . C_2 is a "band-setting" condenser; its maximum capacity should be at least 100 μfd . and may be larger. The setting of C_2 will determine the minimum capacity of the circuit, and the maximum capacity will be the maximum capacity of C_1 plus the setting of C_2 . A different maximum-to-minimum capacity ratio can be chosen to give good band-spreading on each band.

The series-condenser method is shown at B. As explained in Chapter Three, the total capacity of two condensers in series is less than that of either. C_1 again is the tuning condenser. It should have 100 μfd . or more maximum capacity. C_2 is the band-setting condenser and is preferably small, perhaps 25 μfd . The maximum-minimum capacity ratio in the circuit will be determined by the setting of C_1 . The minimum capacity changes very little for any setting of C_2 , but the maximum capacity can be varied over quite a range, depending upon the ratios of the capacities of the two condensers.

At C is another arrangement which makes use of a "split-stator" tuning condenser — one with two separate stationary-plate sections and a single rotor. One of the stator sections is made small enough to give good band spreading on the 14- and 7-megacycle bands, and the second stator section, when connected in parallel with the small stator, will give good spread on 3500- and 1750-kc. The dotted connection for the two lower-frequency bands shown in C can be made by using a jumper in the low-frequency coil forms, the change being automatically made when the coils are plugged in. This method is used in the two-tube receiver described later in this chapter.

The tapped-coil system at D is used in several commercial amateur-band receivers and has also been adopted by a number of amateurs in home-built sets. Condenser C_1 may be fairly large — 100 μfd . or so — but will give good spread on any band if the right size of coil is chosen and the tap to which the stator plates of the condenser are connected is made at the right place. This system is a little more tricky to adjust than the first three. Condenser C_2 is not strictly necessary but will be found helpful in getting the spread just right, and its use will help eliminate some of the cut-and-try in winding the coils. It should have a maximum capacity of about 25 μfd .

Regeneration Control

Almost any arrangement of the tickler coil and feed-back control can be depended upon to give similarly loud signals, but some of them have the advantage of being more convenient and of permitting adjustment of regeneration without

detuning the signal. It is also a great advantage if the regeneration control is absolutely quiet in action; if it permits a gradual adjustment up to and past the point of oscillation; and if it permits the tube to oscillate gently all across the frequency band on which the receiver is working without the necessity of touching anything but the tuning control.

Fig. 503 shows two ways in which regeneration may be controlled with a screen-grid detector. At A the regeneration control is a variable condenser having a maximum capacity of 100 or 150 μfd . It acts as a variable by-pass between the low-potential end of the tickler coil and the cathode of the tube. If the by-pass capacity is too small the tube will not oscillate, while increasing the capacity will cause oscillations to start at a certain critical value of capacity. This method of regeneration control is very smooth in operation, causes relatively little detuning of the received signal and, since the voltage on the screen-grid of the tube is fixed, permits the detector to be worked at its most sensitive point. The sensitivity of a screen-grid detector depends a great deal upon maintaining the screen-grid voltage in the vicinity of 30 volts.

At B regeneration is controlled by varying the mutual conductance of the detector tube through varying its screen-grid voltage. The regeneration control is usually a voltage-divider — or so-called "potentiometer" — with a total resistance of 50,000 ohms or more. This circuit causes more detuning of the signal than A, and the resistor is likely to cause some noise unless by-passed by a large capacity (about 1 μfd .) at C. In A, condenser C may be .5 μfd . or larger. With circuit B it is necessary to adjust the number of turns on the tickler coil to make the tube just start oscillating with about 30 volts on the screen-grid if maximum sensitivity is desired.

Both the methods shown in Fig. 503 may be applied to three-electrode detectors, although these tubes have been largely superseded as detectors by the more sensitive screen-grid tubes. To use method B the regeneration-control resistor should be placed in series with the plate of the tube and it need not be used as a voltage-divider but simply as a series variable resistor. It can also be used as a series resistor when controlling a screen-grid tube. Another type of regeneration control, more suitable for lower radio frequencies, is shown in the five-tube superhet described later.

In all methods it is essential that the tickler be mounted or wound at the filament end and not the grid end of the tuning coil. In the interests of smooth control it will be found advisable to use just as few turns on the tickler as will allow the tube to oscillate easily all over the tuning range. If the tube starts oscillating with a sudden thump instead of a smooth rushing noise, a lower value of grid lead resistance should be used.

Radio-Frequency Amplifiers

A regenerative detector followed by a stage or two of audio-frequency amplification, when used for c.w. telegraphic work, will bring in amateur signals from all over the world on the higher

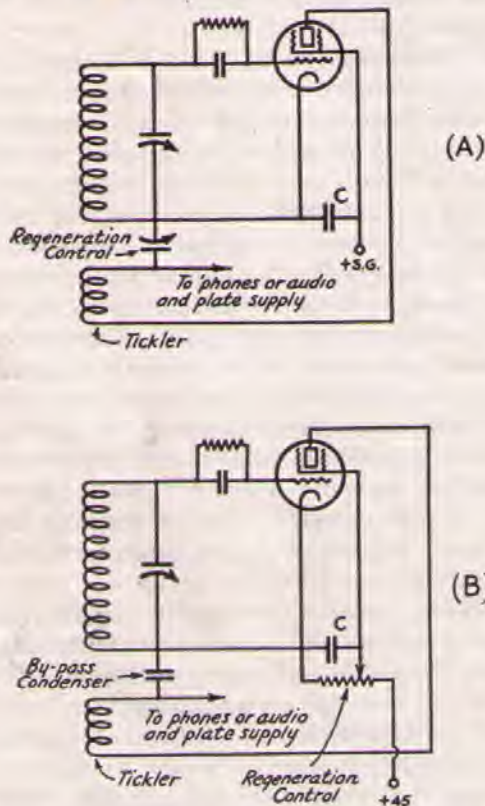

FIG. 503 — CONDENSER AND RESISTOR CONTROL OF REGENERATION

frequencies. For such work, the sensitivity of this type of receiver usually proves to be ample. At times, however, a radio-frequency amplifier ahead of the detector is very desirable. The increase in sensitivity and selectivity provided by it can be put to good use in the reception of amateur radiotelephone signals. A further advantage of such an amplifier is that it isolates the detector from the antenna, reducing the radiation from the detector in an oscillating condition and making it impossible for the antenna, swaying in a wind, to cause the received signal to waver. A radio-frequency amplifier is also of considerable service in the elimination of "dead-spots" — points on the tuning dial at which the antenna, coming into resonance, might otherwise stop the detector from oscillating.

The three-element tube is almost useless as a radio-frequency amplifier in the short-wave receiver. The modern screen-grid tube, however, is most effective providing the circuit in which it is used is a suitable one. One arrangement for the radio-frequency amplifier is that in which the grid circuit for the first tube comprises a resistor or choke connected directly between the antenna and ground. This so-called "untuned" radio-

frequency amplifier isolates the detector from the antenna and gives some amplification, but it does not improve the selectivity of the receiver. Rather, it makes the receiver susceptible to interference from any near-by powerful amateur or broadcast transmitters. Careful proportioning of the choke in the grid circuit makes it possible to avoid interference from broadcast stations, but not from other amateurs. If local interference is not likely to be troublesome an untuned r.f. stage will be found helpful. It is not hard to install because no shielding will be necessary.

Fig. 504 shows two methods of connecting an untuned r.f. amplifier to a regenerative receiver. That at A uses transformer coupling between the r.f. stage and detector, while at B impedance coupling is shown. Transformer coupling is preferable because the number of turns on the two coils can be proportioned to give the greatest amplification (usually the primary, P , should have about $\frac{2}{3}$ as many turns as the secondary, S), and because the plate voltage for the r.f. tube is kept away from the detector circuit. It requires coil forms with enough pins to take care of primary, secondary and tickler, however. With impedance coupling, as at B, the detector coil must be isolated from ground by means of the by-pass condenser C . The grid leak must be connected between grid and filament instead of across the grid condenser, since the latter blocks the positive plate voltage from getting to the

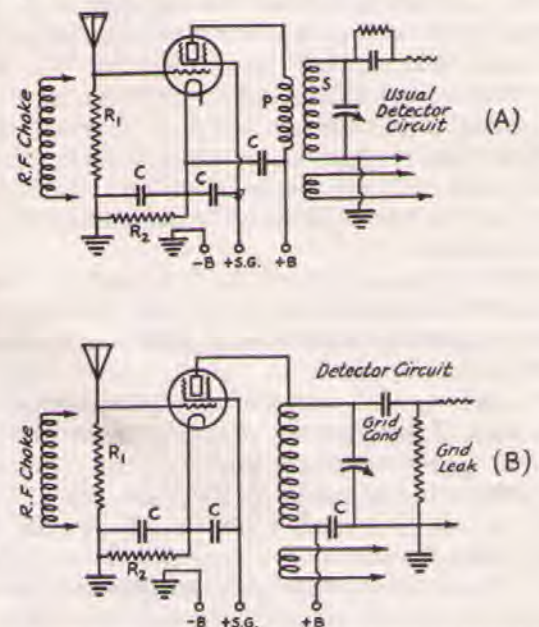

FIG. 504 — UNTUNED R. F. AMPLIFIER DIAGRAMS

A transformer coupling, B, impedance coupling to detector. A resistor, R_1 , having a resistance of 10,000 to 20,000 ohms is connected between the grid of the screen-grid amplifier tube and ground. An r.f. choke, consisting of perhaps 100 turns of small wire wound on a form about the size of a pencil, can be substituted for the resistor if interference is experienced from local broadcast stations. Resistor R_2 gives the tube the correct operating bias, as explained in a later section of the text. If the tube filament is directly heated a battery of the proper voltage should be substituted for the resistor, and the ground connection should be brought to the filament of the tube.

grid of the detector. Because of leakage across the grid condenser this circuit may be noisy unless a good mica condenser with extremely high insulation resistance is used.

Rather complete shielding is always required when the input circuit to the r.f. amplifier tube is tuned. For this reason the tuned r.f. type receiver is somewhat more costly and more difficult to build. In one form such a receiver has two separate tuning dials — one for the input circuit to the r.f. tube and one for the input circuit to the detector. The obvious difficulty in tuning these two controls has led to the development of receivers in which the two tuning condensers are "ganged." The construction of a receiver of this type is a work requiring a little more skill, and had best be attempted after experience has been gained with the simpler types.

Shielding

The purpose of shielding is to confine the magnetic and electrostatic fields about coils and condensers so that those fields cannot act on other apparatus, and to prevent external fields from acting upon them in turn. Chapter Three has explained the nature of these fields. They can be confined by enclosing the apparatus about which the field exists in a metal box. The effectiveness of the shield depends upon the metal of which it is made and upon the completeness of contact at the joints. At radio frequencies the best shield is one made of a low-resistance non-magnetic metal, such as copper or aluminum, because the losses in it will be low. The magnetic fields about the apparatus enclosed in the shield cause currents to flow in it, and since the flow of current is always accompanied by some loss of energy the shield in effect causes an increase in the resistance of the tuned circuit. The lower the resistance of the shielding material the lower will be the energy loss. At low frequencies, such as those in the audio range, copper and aluminum are ineffective for shielding and iron must be used.

The increase in resistance caused by shielding also depends upon the proximity of the apparatus inside the shield to the walls. Coils in particular should be spaced from the walls in all directions by at least a distance equal to the coil diameter. For this reason small coils are much to be preferred to large ones if the set is to be kept reasonably small. The losses in the shielding due to electrostatic fields are negligible in comparison to those caused by magnetic fields, so condensers can be mounted right on the walls of the shield if desired.

To be effective a shield must be grounded. Although an actual ground connection always will be best, it is sometimes sufficient to connect the shielding to a point in the receiver at zero r.f. potential, such as the negative side of the plate supply. Another point is that shields must be complete for each amplifier stage or group of appara-

tus shielded. Do not attempt to use a single sheet of metal to form a common wall for two shields as shown in Fig. 505; such a wall will actually couple the two shielded groups or pieces of apparatus together instead of shielding them from each other.

There are two general methods of shielding. One is to group all the apparatus forming a single stage of amplification and put it in a single shield. The three-tube receiver described in this chapter is an example of this type of shielding. The second method, exemplified by the manufactured receivers described later, is to use individual shields around each piece of apparatus, connecting them by shielded leads where necessary. Only those leads which are not at zero r.f. potential need be shielded. Each method will give good results, and the choice is usually dictated by mechanical considerations.

Although, as we pointed out in the previous section, shielding is not necessary if no tuned r.f. amplifiers are used, it is often helpful. A metal cabinet about a simple receiver will prevent direct pick-up of signals by the coils and wiring of the set, and it will also keep out "induction hums" from unshielded house wiring.

Amplifier Biasing

Practically all amplifiers, both audio and radio frequency, must be operated with a minimum negative voltage between the grid and cathode of the amplifier tube. This *bias* voltage may be obtained from a battery or from a suitable voltage drop through a resistor in the circuit. Fig. 506 shows these two methods in an elementary fashion.

In general, the battery-bias method should be used with tubes having directly-heated cathodes (*filament-type* tubes). In such cases one side of the filament is connected to ground. In order to connect the bias battery in series with the lower end of the transformer secondary or whatever may be in the grid circuit of the amplifier tube, it is necessary to insulate point X in Fig. 506-A from ground. Condenser C is used to provide a low-impedance path to the filament should the bias battery develop appreciable internal resistance. It should be about .01 μ fd. in r.f. circuits and 1 to 2 μ fd. in audio circuits.

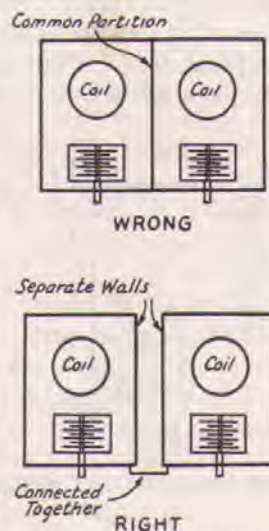

FIG. 505—SHIELDING ALWAYS SHOULD BE COMPLETE ABOUT EACH PIECE OR GROUP OF APPARATUS SHIELDED

Do not attempt to use a common partition between shielded stages, especially when one of them contains a regenerative detector or oscillating circuit.

The second method, known as *cathode resistor biasing*, is shown at B. This method does away with the extra bias battery, and is particularly adapted to tubes with indirectly-heated cathodes (*heater-type tubes*). With this method point X is grounded and the cathode is isolated from ground and negative "B" through the biasing resistor R. By-pass condenser C will have the same values

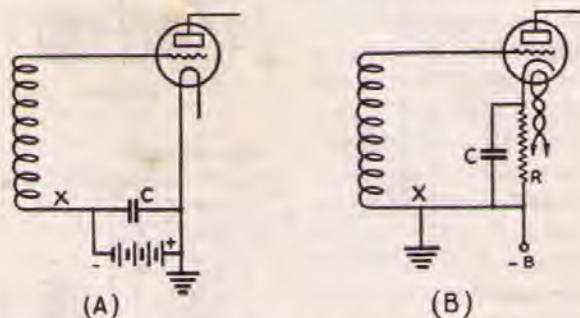

FIG. 506—BATTERY AND CATHODE-RESISTOR BIASING

as in A. When plate current flows through the tube there will be a voltage drop through R which makes the cathode more positive than the grid — in other words, puts negative bias on the grid. The right value for R can be calculated by Ohm's Law, knowing the bias voltage required and the total space current through the tube. The space current is the sum of the plate current and all currents that may be taken by auxiliary grids in the tube. For example, a certain pentode tube requires a bias of 10 volts with 150 volts on the plate and screen-grid; at this plate voltage the plate current will be 15 ma. and the screen-grid current 5. The bias resistance required will be:

$$R = \frac{10 \text{ volts}}{.02 \text{ amp.}} = 500 \text{ ohms.}$$

Cathode-resistor biasing can be used with tubes having directly-heated filaments provided a separate source of filament-heating is used with each stage so biased. This is often done in a.c.-operated receivers having an audio power output stage, the power tubes being heated by a separate filament winding on the power transformer.

Audio-Frequency Amplifiers

For reception of amateur signals, it is unnecessary and even undesirable to have the frequency-distortionless audio amplification which is the aim of designers of broadcast receivers. Audio transformers with "flat" frequency characteristics are therefore not required. In fact, a transformer which has a decided "hump" at some portion of its frequency curve is preferable for c.w. reception, particularly if the hump is in the neighborhood of 1000 cycles. Such a transformer will provide some audio-frequency selectivity, since it amplifies one frequency a great deal more than others.

For 'phone reception the same principles

should be applied as for ordinary amplification. Plate voltage and "C" bias on the amplifier tubes are important, and should be those recommended in the instruction sheets accompanying the tubes or may be taken from the table. Since, in amateur radiotelephony, we are concerned only with the transmission and reception of speech, it is unnecessary that the equipment be capable of handling frequencies higher than about 3000 cycles per second. Frequencies above this, indeed, may merely cause interference and can well be eliminated.

The receivers described in detail in this chapter are intended to be used with headphones, although they can operate a loud-speaker at low or moderate volume. For satisfactory loud-speaker

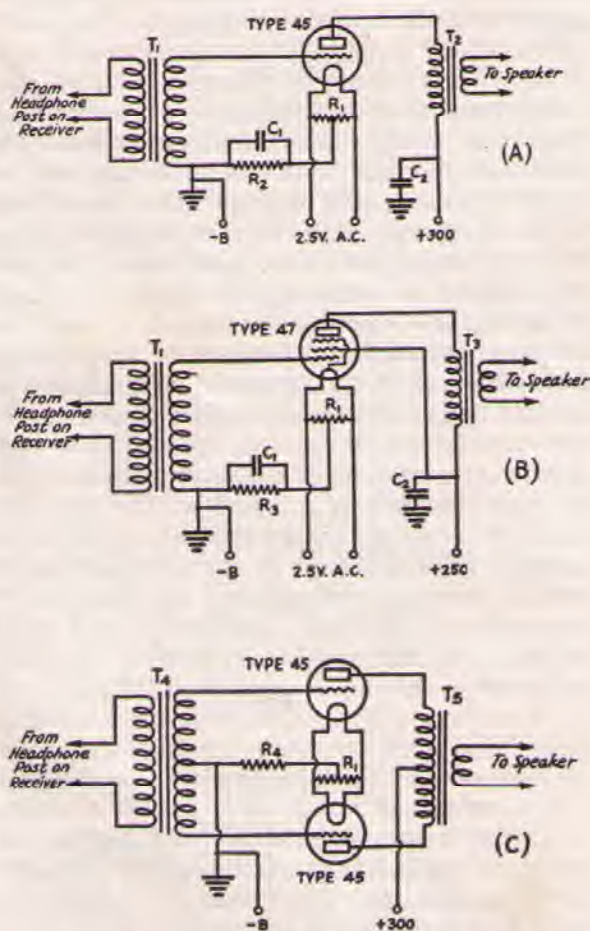

FIG. 507—AUDIO POWER AMPLIFIERS FOR LOUD-SPEAKER OPERATION

A — using a single Type 45 tube, B — a single 47 pentode, C — two 45's in push-pull. Transformer T₁ is an ordinary audio transformer having a turns ratio of 2:1 or 3:1. T₂ is an output transformer designed to couple a 45 tube to the loud-speaker being used. T₃ is for coupling a 47 to the speaker. T₄ is a push-pull input transformer and T₅ a push-pull output transformer for a pair of 45's. It is necessary to know the impedance of the loud-speaker in order to purchase the right type of output transformer in all three cases. R₁ is a 20-ohm resistor, tapped at the center. R₂ is 1500 ohms, rated to carry approximately 50 ma. R₃ is 450 ohms, also to carry about 50 ma. R₄ is 750 ohms, rated at 75 ma. or more. Both C₁ and C₂ should be 1 to 2 μfd. C₂, which must be rated to stand the full plate supply voltage, may not be needed if the plate voltage for the amplifier comes directly from a filter condenser in the power pack.

operation, however, a power audio stage should be used. A number of diagrams for this purpose are given in Fig. 507. These amplifiers had best be a.c.-operated, using power supplies of the type described in Chapter Ten. Other tubes than those shown can be used provided the voltages are changed to the recommendations in the tube table.

Receiving Tubes

The large number of types of receiving tubes available often causes considerable confusion to the beginning amateur because it seems difficult to choose the proper ones for the contemplated receiver. Many of them, indeed, have little application in amateur work. Modern receiving tubes are grouped into three classes, depending upon the type of service for which they are intended. One group is for dry-cell operation and is characterized by tubes with 2-volt directly heated filaments which take very small currents. The second group has filaments designed for use with a 6-volt storage battery. Most of the tubes in this group have indirectly-heated filaments. The third, or "a.c." group, has filaments which take rather heavy currents at 2.5 volts a.c. In this group the tubes used as r.f. amplifiers and detectors have indirectly-heated filaments while the power audio amplifiers have directly-heated filaments.

In each group will be found general-purpose three-element tubes which are useful as detectors, audio amplifiers and oscillators; screen-grid amplifiers (usually two types of these, one with the "variable- μ " feature, the other without); and various kinds of power amplifiers — triodes, pentodes and special tubes for Class B amplifiers (see Chapter Eight).

In addition to these groups, there are also several older types such as the 99 and 01-A which have been superseded by the newer and better tubes and are now only used for special purposes.

From the above it is obvious that the first question to be decided is that of filament supply. If a.c. is available it is undoubtedly best to use the heater-type tubes, not only because no batteries will be required but because, type for type, these tubes are better than the others. On the other hand, an all-d.c. set will have no "hum troubles."

Fig. 508 shows the socket connections for the tubes listed in the table. The symbol for each type of tube also is shown.

Receiver Construction

The receiver descriptions which follow are intended to illustrate the points just discussed. The various arrangements need not be followed slavishly by the constructor, providing principles of good design are not violated. For instance, any of the various band-spreading schemes already detailed may be substituted for the one in the particular set in which you are interested. If you prefer to use coils wound on forms other than those specified by all means do so, but at the same time remember that some modification of the coil sizes given will be necessary if the forms differ in diameter. Audio systems may be interchanged, likewise. A little common sense applied to most of the problems you may encounter will solve nearly all difficulties.

Tools

While it is possible to put a set together with the aid of only the proverbial jackknife, a few good tools of the proper sort will be found invaluable in saving time and helping to make a good job mechanically. The following list is typical of the tools which most amateurs consider adequate:

- Soldering iron (preferably electric)
- Large and small side-cutting pliers
- Large and small screwdrivers
- Hand drill stock with a few drills of different sizes (Nos. 11, 18 and 28 will be most useful)
- File (not too large)
- Knife (Boy-Scout kind)
- Hammer
- Vise (the small 4" size will do)
- Steel rule (6" or 12")

With these tools it is possible to construct practically any of the apparatus ordinarily built at home. Others will be found useful at times, however. A small tap-holder, a die-holder and three or four taps and dies covering the 6-32, 8-32 and 10-32 sizes can be obtained from a hardware store at reasonable cost. With the dies you can thread brass rod and run over threads that become "bunged-up" on machine screws. With the taps you can

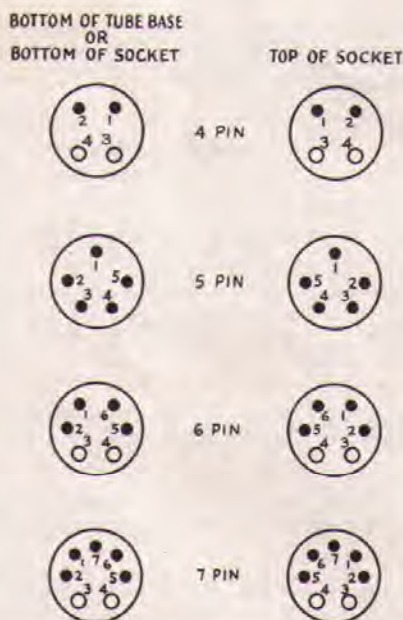

FIG. 508 — TUBE SOCKET CONNECTIONS FOR RECEIVING TUBES

The diagrams in the left-hand column are for the sockets as viewed from the bottom, those in the right-hand column as viewed from the top. The pin numbering is according to the system adopted by tube manufacturers (R.M.A. standard). The accompanying table indicates by number the tube element connected to each socket pin, also to the cap on top of the tube when there is one. It should be noted that some tubes have a larger base than most, in which case the pin arrangement is the same but of greater radius requiring a larger socket.

STANDARD RECEIVING TUBES

Type No.	Description	Filament or Heater		Plate Volts E_b	Neg. Grid Volts E_c	Screen Volts E_d	Screen Ma. I_d	Plate Ma. I_b	Plate Resistance r_p	Mutual Conductance Microhos	Amp. Factor μ	Load Resistance Ohms	Power Output Watts (Audio)	Base Connections ¹				
		Volts E_f	Amps. I_f											1	5	6	7	Cap
30	Triode Det., Amp.	2.0	0.06	180	13.5			3.1	10,300	900	9.3			G				
32	S.G. R.F. Amp., Det.	2.0	0.06	180	3.0	67.5	0.4	1.7	1,200,000	650	780			S				G
34	Var- μ S.G. Pentode	2.0	0.06	180	3.0	67.5	1.0	2.8	1,000,000	620	620			S				G
1A6	Pentagrid Converter ²	2.0	0.06	180	3.0	67.5	2.4	1.3	500,000					G ₂	G ₃	G ₄		G ₄
19	Twin Amp. (Class B)	2.0	0.26	135	0			10-35						G				
31	Triode Power Amp.	2.0	0.13	180	30.0			12.3	3,600	1050	3.8	5,700	0.375	G	P	G		
33	Pentode Power Amp.	2.0	0.26	135	13.5	135	3.0	14.5	50,000	1450	70	7,000	0.7	G	S			
49	Dual-Grid Power Amp. ³	2.0	0.12	180	0			4-35				12,000	3.5	G ₁	G ₂			
27	Triode Det., Amp.	2.5*	1.75	250	21.0			5.2	9,250	975	9.0			G	C			
56	Triode Det., Amp.	2.5*	1.0	250	13.5			5.0	9,500	1450	13.8			G	C			
24-A	S.G. R.F. Amp.	2.5*	1.75	250	3.0	90	1.7	4.0	600,000	1050	630			S	C			G
35	Var- μ S.G. R.F. Amp.	2.5*	1.75	250	3.0	90	2.5	6.5	400,000	1050	420			S	C			G
57	Pentode R.F. Amp.	2.5*	1.0	250	3.0	100	0.5	2.0	over 1.5 meg.	1225	1500			S	C	K		G
58	Var- μ Pentode R.F. Amp.	2.5*	1.0	250	3.0	100	2.0	8.2	80,000	1600	1280			S	C	K		G
2A7	Pentagrid Converter ²	2.5*	0.8	250	3.0	100	2.2	3.5	360,000					G ₂	C	G ₁	G ₂	G ₂
2A6	Duplex-Diode, High- μ Triode ⁴	2.5*	0.8	250	1.35			0.4						D	C	D		G
2B7	Duplex-Diode, Pentode ⁵	2.5*	0.8	250	3.0	125	2.3	9.0	650,000	1125	730			S	C	D	D	G
55	Duplex-Diode, Triode ⁴	2.5*	1.0	250	20.0			8.0	7,500	1100	8.3	20,000	0.35	D	C	D		G
2A3	Triode Power Amp.	2.5	2.5	250	45.0			60.0	800	5250	4.2	2,500	3.5	G				
2A5	Pentode Power Amp.	2.5*	1.75	250	16.6	250	6.5	34.0	100,000	2200	220	7,000	3.0	S	C	G		
45	Triode Power Amp.	2.5	1.5	275	56.0			36.0	1,700	2050	3.5	4,600	2.0	G				
46	Dual-Grid Power Amp. ⁶	2.5	1.75	250	33.0			22.0	2,380	2350	5.6	6,400	1.25	G ₁	G ₂			
47	Pentode Power Amp.	2.5	1.75	250	16.5	250	6.0	31.0	60,000	2500	150	7,000	2.7	G	S			
53	Twin Amp. (Class B)	2.5*	2.0	300	0			35-110				10,000	10.0	G	P	G		C
59	Triple-Grid Power Amp. ⁷	2.5*	2.0	250	28.0			26.0	2,400	2600	6.0	5,000	1.25	G ₂	C	G ₂		G ₁

Plate and screen ratings in this table are maximum.

¹ Indirectly-heated cathode. ² Plus 3 and 4 are always heater or filament connections; Pin 2 is always a plate. C, cathode; D, diode plate; G, control grid; G₁, G₂, G₃, G₄, grids in multi-grid multi-purpose tubes numbered in order from cathode; K, suppressor grid; P, plate; S, screen grid. ³ Ratings refer to screen-grid section only.

Type No.	Description	Filament or Heater		Plate Volts E_b	Neg. Grid Volts E_c	Screen Volts E_d	Screen Ma. I_d	Plate Ma. I_b	Plate Resistance r_p	Mutual Conductance Micromhos	Amp. Factor μ	Load Resistance Ohms	Power Output Watts (Audio)	Base Connections ¹				
		Volts E_f	Amps. I_f											1	5	6	7	Cap
37	Triode Det., Amp.	6.3*	0.3	250	18.0			7.5	8,400	1100	9.2			G	C			
38	S.G. R.F. Amp.	6.3*	0.3	250	3.0	90	1.7	3.2	550,000	1080	595			S	C			G
39-44	Var- μ Pentode R.F. Amp.	6.3*	0.3	250	3.0	90	1.4	5.8	1,000,000	1050	1050			S	C			G
77	S.G. R.F. Amp.	6.3*	0.3	250	3.0	100	0.6	2.3	1,500,000	1250	1500			S	C	K		G
78	Var- μ S.G. R.F. Amp.	6.3*	0.3	250	3.0	125	3.0	10.5	600,000	1650	990			S	C	K		G
75	Duplex-Diode, High- μ Triode ¹	6.3*	0.3	250	1.35			0.4						D	C	D		G
85	Duplex-Diode, Triode ¹	6.3*	0.3	250	20.0			8.0	7,500	1100	8.3	20,000	0.35	D	C	D		G
6B7	Duplex-Diode, Pentode ⁵	6.3*	0.3	250	3.0	125	2.3	9.0	650,000	1125	730			S	C	D	D	G
6F7	Triode, Pentode ⁸	6.3*	0.3	250	10.0	100	0.6	2.8						S	C	C	P	G
6A7	Pentagrid Converter ²	6.3*	0.3	250	3.0	100	2.2	3.5	360,000					G ₂	C	C	G ₁	G ₂
6A4	Pentode Power Amp. ⁹	6.3	0.3	180	12.0	180	3.9	22.0	45,500	2200	100	8,000	1.4	G	C	S		G
38	Pentode Power Amp.	6.3*	0.3	250	25.0	250	3.8	22.0	100,000	1200	120	10,000	2.5	S	C	C		G
41	Pentode Power Amp.	6.3*	0.4	250	18.0	250	5.5	32.0	68,000	2200	150	7,600	3.4	S	C	C	G	
42	Pentode Power Amp.	6.3*	0.7	250	16.5	250	6.5	34.0	100,000	2200	220	7,000	3.0	S	C	C	G	
79	Twin Amp. (Class B)	6.3*	0.6	250	0			10-60				14,000	8.0	G	C	P	C	G
89	Triple-Grid Power Amp. ¹⁰	6.3*	0.4	250	31.0			32.0	2,600	1800	4.7	5,500	0.9	G ₂	C	C	G ₂	G ₁
864	Triode Amp.	1.1	0.25	135	9.0			3.5	12,700	645	8.2			G				
20	Triode Power Amp.	3.3	0.13	135	22.5			6.5	6,300	525	3.3	6,500	0.11	G				
22	S.G. R.F. Amp.	3.3	0.13	135	1.5	67.5	1.3	3.7	325,000	500	160			S				G
01-A	Triode Amp., Det.	5.0	0.25	135	9.0			3.0	10,000	800	8.0			G				
40	Triode Amp.	5.0	0.25	180	3.0			0.2	150,000	200	30			G				
112-A	Triode Amp., Det.	5.0	0.25	180	13.5			7.7	4,700	1800	8.5			G				
71-A	Triode Power Amp.	5.0	0.25	180	43.0			20.0	1,750	1700	3.0	4,800	0.79	G				
43	Pentode Power Amp.	25.0*	0.3	135	20.0	135	7.0	34.0	35,000	2300	80	4,000	2.0	S	C	C	G	
48	Tetrode Power Amp.	30.0*	0.4	125	22.5	100	9.0	50.0	10,000	2800	28	2,000	2.5	S	C	C	G	

¹ Ratings are for two tubes in Class B. ² Triode ratings only. ³ Pentode ratings as screen-grid r.f. amplifier. ⁴ Class-A ratings. See Chapter Eight for Class-B ratings.
⁵ Class-A triode ratings. Class-B ratings approximately the same as those of 46; Class-A pentode ratings approximately the same as those of 2A5. ⁶ Pentode unit as mixer.
⁷ Also known as Type LA. ⁸ Class-A triode ratings. As pentode, maximum output is 3.4 watts; two 89's in Class B at 180 volts; 3.5 watts output.

thread the holes you drill so that they will take machine screws to hold the apparatus you wish to mount. A hacksaw, reamer, center-punch, scriber, tweezers, square and some other inexpensive tools are also desirable but not entirely necessary.

In building equipment for experimental purposes and for temporary use it is just as desirable



FIG. 509—GOOD TOOLS CONTRIBUTE TO GOOD CONSTRUCTION

All those illustrated, although convenient, are not entirely necessary. Those suggested in the text are recommended as the basis for the constructor's equipment.

to use system in laying out the apparatus and in wiring up as when the more permanent panel job is built. Some square "breadboards," a bunch of General Radio plugs and jacks, Fahnestock clips, some scrap bakelite pieces for building terminal boards, angles for supports and an assortment of different sized brass machine screws, wood screws, nuts, and washers will make it easy to build up and try out new circuits. It is a good idea to keep some bus wire on hand, and various sized spools of magnet wire will prove useful in doing temporary wiring if you are an experimenter.

A table of drill sizes giving the proper numbered drill to use for passing a screw through a panel or for tapping to take a certain size of machine screw is included in the Appendix. Only the sizes most used in radio constructional work are given. Wood screws also come in various sizes and lengths. Usually the numbers correspond to the drill-size numbers, the diameter given being that of the screw just below the head. Wood screws are stocked by most hardware stores in lengths to the nearest quarter inch of what you want.

Soldering and Wiring

In wiring different pieces of apparatus a neatly soldered job will repay the builder in good appearance and reliable operation. Good connections may be made without solder, but a well-soldered job has low contact resistances. A soldered outfit works quietly and uniformly over long periods of time. Soldering is decidedly worthwhile when properly done.

Making soldered joints is a quite simple matter. A few points should be kept in mind for best results. A hot well-tinned soldering iron, clean,

bright surfaces, and a *small* amount of rosin-core solder will do the trick. Tinning the parts to be soldered before completing a joint will be helpful.

Soldering flux keeps the clean surface from becoming oxidized when heat is applied. Acid fluxes or soldering pastes are especially to be avoided. They are good for mending tin pans and gutter pipes but cause corrosion of electrical connections. The melted "paste" can cause a set to operate poorly or to become inoperative by adding leakage paths across coils and condensers. Use lump or powdered rosin that can be obtained for a dime from any drug store, or buy "rosin-core" solder.

"Tinning" the soldering iron is done by filing the point bright and clean and rubbing it in hot solder with a little flux until the point is covered with clean solder. Scrape connections with a knife or file before soldering, to save time and make a joint good electrically and mechanically. The soldering iron must be re-tinned occasionally if it becomes overheated. It should always be used when very hot but not allowed to become red hot. A hot iron makes soldering easy.

Bus wiring is neat and effective. The wires are laid out in straight lines running straight back, horizontally and vertically. The corners are made square. Hold bus wires firmly with pliers while a little solder "runs" into the joint.

In receiver wiring, battery leads may be bunched to good advantage. Radio-frequency circuits should have the leads well spaced. Wires should cross at right angles when crossing is necessary. Connections between coils and condensers in radio-frequency circuits should be as short as possible. However, coils and condensers must not be jammed together too much as this increases the effective resistance and lowers the sensitivity. Leads a couple of inches long are permissible and will allow mounting the condenser out of the field of the coil.

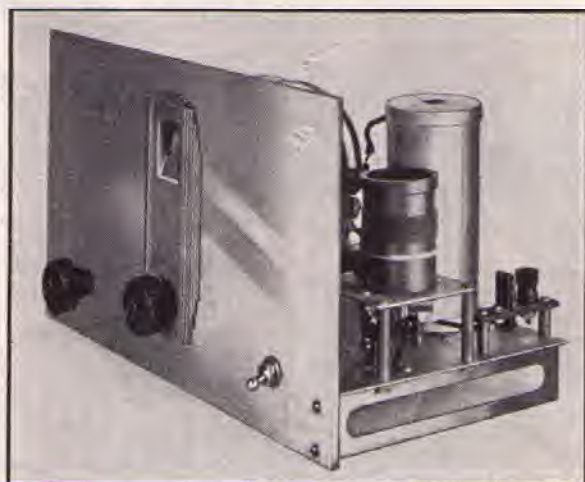

FIG. 510—THE FRONT PANEL AND PART OF THE "CHASSIS" OF THE TWO-TUBE D.C.-A.C. RECEIVER

This photograph shows the detail of the coil and antenna condenser mountings. The detector tube shield is also visible.

A Two-Tube A.C.-D.C. Receiver

A simple receiver of sturdy construction that incorporates modern features is illustrated in Fig. 510. It uses a screen-grid regenerative detector and one stage of audio amplification, being intended for headset output. The model pictured happens to be fitted for operation with 2½-volt a.c. filament supply but is also adaptable to operation from 6-volt a.c. or d.c., or 2-volt battery supply, as described in the circuit diagrams of Figs. 511 and 514. Somewhat better results will be obtained with the 2½- or 6-volt tubes than with the 2-volt types, however. Plug-in coils are used and the band-spread system of Fig. 503-C is

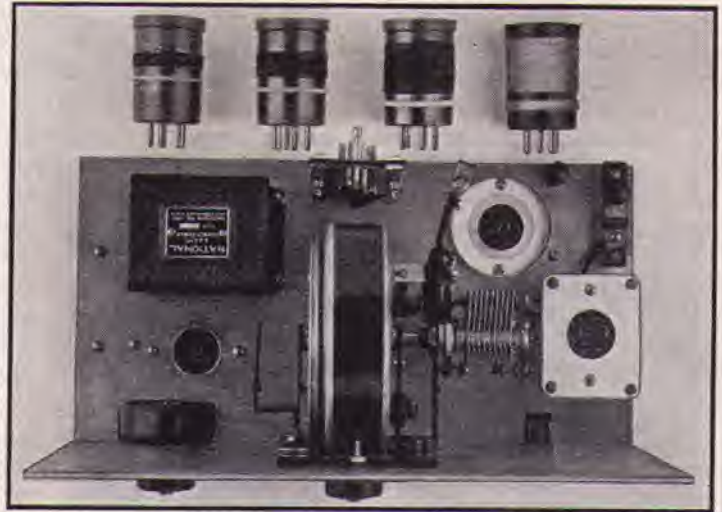

FIG. 512 — THE TOP OF THE SUB-PANEL

The audio coupler, audio amplifier tube socket and regeneration-control resistor are to the left of the drum dial. Connections are brought out to the cable socket to the rear of the dial. Tip-jacks for the 'phones are mounted on this socket. This photo also shows the method of mounting the tuning condenser, grid condenser and leak, and shows the coil socket and antenna condenser mountings from another angle. The ground binding post is mounted on the sub-panel between the detector tube socket and the antenna condenser.

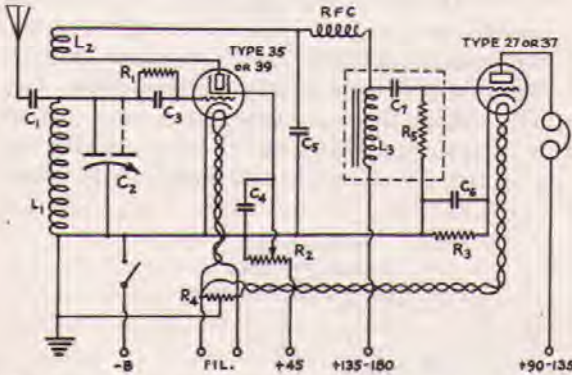

FIG. 511 — CIRCUIT OF THE TWO-TUBE RECEIVER FOR HEATER-TYPE TUBES

As alternatives to the tubes indicated, for 2.5-volt a.c. heater operation a Type 58 may be used for the detector, with a 6-prong socket replacing the 5-prong used for the 35 and with the suppressor of the 58 (No. 6 pin) connected to the cathode; also, a 56 may be used to replace the 27 without changing the socket. For 6-volt d.c. operation a Type 78, with a 6-prong socket connected as for the 58, can be used in the detector with a 37 in the audio stage. The filament center-tap resistor R₄ should be omitted for d.c. operation.

- C₁ — Antenna coupling condenser; see text for details.
- C₂ — Split stator condenser; see text.
- C₃ — 100 μfd.
- C₄ — .5 μfd.
- C₅ — 200 μfd.
- C₆ — 1.0 μfd.
- R₁ — 10 megohms.
- R₂ — 100,000-ohm variable resistor.
- R₃ — 2000 ohms.
- R₄ — 20-ohm center-tapped resistor (not required if d.c. tubes are used).
- RFC — Receiver-type r.f. choke.
- L₃, C₇, R₅ — National Screen-Grid Detector Coupler, Type S-101. If a home-made coupling is assembled, C₇ should be about .006 μfd. and R₅, 2-4 megohms. See text for details of L₃.

Coil Data

Band	L ₁	L ₂
1750	70 turns No. 32 s.c.c.	10 turns No. 32 s.c.c.
3500	37 " " " 22 s.c.c.	6 " " " 30 "
7000	19 " " " " "	4 " " " " "
14,000	8 " " " " "	4 " " " " "

All coils are close-wound except the 14,000-kc. grid coil. The spacing between turns on this coil is adjusted until the band is covered. Spacing is approximately half the diameter of the wire.

employed. The regeneration control is of the type illustrated in Fig. 504-B.

The panel is a piece of ⅛-inch sheet aluminum, 7 inches high and 12 inches wide. On it are mounted the drum dial which controls the tuning condenser, the regeneration control resistor, and the "B" cut-off switch, as shown in 510 and 512. The remaining apparatus is mounted on the shelf or "sub-panel," which is also sheet aluminum, 12 inches wide and 6 inches deep. The sub-panel mounting brackets are one inch high.

Three five-prong sockets are required, one for the plug-in coils and two for the tubes; the variety used in this particular set are sub-panel sockets of the type widely used by broadcast-receiver manufacturers. It is not necessary to use the same style, of course, although they lend themselves nicely to sub-panel wiring and are inconspicuous.

The tuning condenser is a National Type SE-100 with several plates removed for band-spreading. The drum dial is a National Type HS, which is the projector dial with special mounting brackets for the Type SE condenser. To the right of the condenser, as shown in the top view of the receiver, Fig. 512, is the mounting for the coil socket, and just behind the latter is the mounting for the antenna coupling condenser and the antenna binding post. The reason for these two special mountings is obvious when it is remembered that the sub-panel is metal. The mounting for the coil socket is made from a piece of ⅛th-inch aluminum 2 inches by 2½ inches, supported at each corner by brass sleeves 1⅜" long bolted to the sub-panel.

The antenna coupling condenser is mounted on a 2-inch strip of bakelite which is supported above the sub-panel by two spacers sufficiently long to give ample clearance for the screws holding the condenser and antenna binding post. The condenser itself consists of two strips of thin

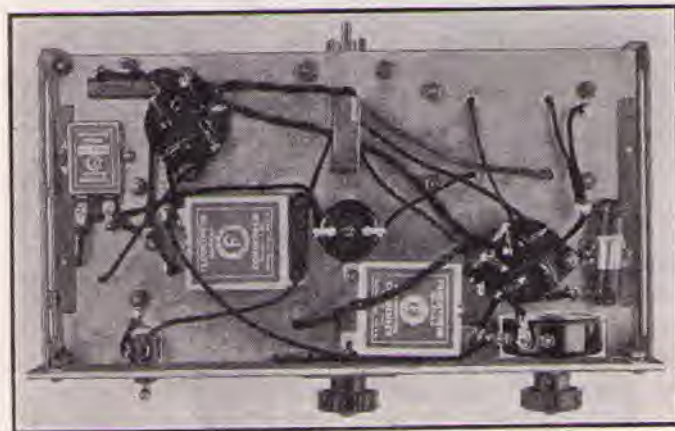

FIG. 513 — UNDER THE SUB-PANEL

The center-tapped resistor for the heater leads is mounted directly underneath the ground binding post. The small condenser to the left is the plate by-pass condenser, the one below the detector tube socket is the screen-grid by-pass condenser. The r.f. choke is in the center. The cathode resistor for the audio tube is at the extreme right, held in place by a home-made bracket. The by-pass condenser across the resistor is mounted between the r.f. choke and the front panel. The metal piece behind the r.f. choke is a bracket which rests on the table and serves as a mechanical support for the sub-panel.

brass about a half inch wide, bent to face each other about $\frac{1}{8}$ inch apart as shown in the photograph.

To spread the various bands satisfactorily the capacity ratio of the tuning condenser is changed for each band so that stations will not be unduly crowded.

The type of tuning condenser used is a particularly easy one to alter for band spreading, since the stationary plates can be removed without difficulty. The nuts holding the stationary

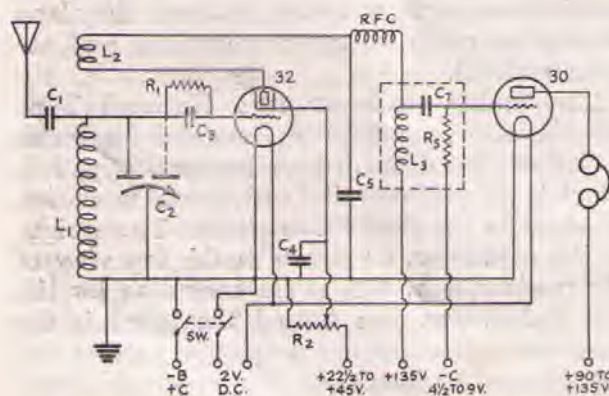

FIG. 514 — DIAGRAM OF TWO-TUBE RECEIVER FOR 2-VOLT D.C. OPERATION

The circuit is the same as in Fig. 511, except that 4-prong sockets are used and a d.p.s.t. switch is included to cut off the B-battery and filament supply circuits simultaneously. This is necessary to prevent B-battery drain when the receiver is inoperative.

plate assembly to the insulating strip on the front of the condenser should be removed; then the two screws holding the rear strip to the frame should be taken out and the stationary plates can be lifted out. The condenser as revamped for this receiver has two stationary sections insulated from each other. One consists of one plate and the other of two, each section being mounted on one of the insulating strips. Three-quarter inch 6-32 machine screws are used to hold the two stator sections in place. Fig. 516 shows clearly how these changes are made.

The connections between the condenser and the coil socket are made as shown in Fig. 515. The single plate alone may be used, or the two sections may be connected in parallel. With the single-plate stator only, the 7000- and 14,000-kc. bands will be amply spread on the dial scale, while with the two sections in parallel the 1750- and 3500-kc. bands will cover a goodly portion of the dial. The change from one condenser section alone to two in parallel is made automatically by a jumper between the coil-form prongs which

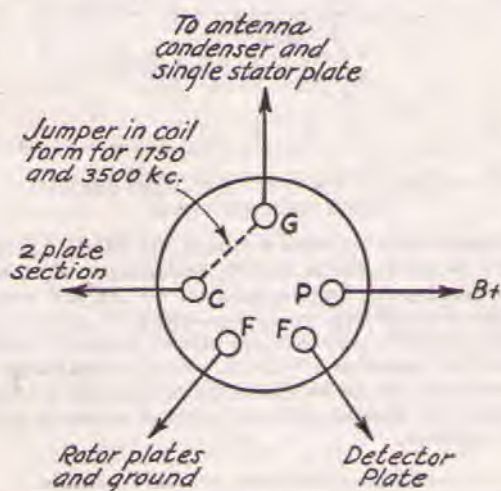

FIG. 515 — COIL FORM AND SOCKET CONNECTIONS FOR THE TWO-TUBE RECEIVER

connect to the two stator sections of the tuning condenser when the coil is placed in the socket.

Other details of the arrangement of the parts and of the wiring can be followed in an examination of the illustrations. It will be noted that a Yaxley cable socket is used in place of binding posts for external leads and that all wiring is made with flexible "hook-up" wire, the leads running directly from one point to another.

In this receiver the coils are wound on manufactured five-prong coil formers. Specifications for the windings are given, but it may be necessary to make slight changes in them in order to obtain the best possible performance. Since the antenna will have some effect on the tuning of the detector circuit, it may be found that the bands will not be centered on the tuning dial unless a

few turns are added to or subtracted from the numbers specified for the grid coils. It is particularly important that the tickler windings be adjusted so that the detector oscillates with approximately 22 volts on the screen-grid. To

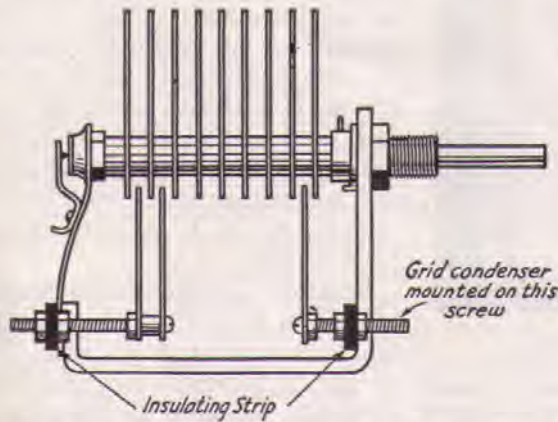

FIG. 516—HOW THE TUNING CONDENSER IS REMODELLED FOR THE TWO-TUBE RECEIVER

accomplish this it is helpful to connect the screen-grid lead temporarily to a 22½-volt tapping, then adjusting the ticklers until the detector just oscillates at the "high" setting of the regeneration control, R_2 . With the screen lead back on the 45-volt tapping there will be plenty of range for the regeneration control.

Instead of using an audio transformer with the primary and secondary connected in series as a coupling impedance in the detector plate circuit, as might be done, a special coupler made for the purpose is used in this set. The audio transformer stunt may be used instead, of course.

There should be no hum in the receiver with a.c. tubes and an a.c. filament supply. If filament hum is encountered make certain that the center-tap resistor, R_4 , is connected properly and that the receiver is connected to a good ground. A cold water pipe is best. If this does not cure it, try other tubes. An otherwise good tube may have a bad hum, especially when used as a regenerative detector. There will be no hum, of course, with d.c. tubes and a storage battery filament supply.

Either batteries or a power pack may be used for the plate and screen-grid voltages. Many "B" substitutes, while entirely adequate for broadcast receivers or audio amplifiers, are unsatisfactory on short-wave regenerative receivers because their output voltage is not constant, making the received signals sound unsteady or causing tunable hums.

Chapter Ten goes into this subject in more detail. If batteries are used the switch in the minus "B" lead should be opened when the receiver is not in operation, to cut off the current which otherwise would be drained through R_2 . This receiver will work well with 135 volts of "B" batteries, and since the total current is only about 5 or 6 milliamperes the batteries will last a long time.

A Three-Tube Receiver

The progressive amateur is rarely content to operate a receiver not fitted with at least one stage of radio-frequency amplification. The increase in sensitivity and the general improvement in performance made possible by a stage of r.f. amplification is usually well worth the additional apparatus and the added construction.

The three-tube receiver illustrated and diagrammed in Fig. 519 has a tuned r.f. stage with controllable sensitivity. The circuit arrangement differs a little from those previously described, but the operating principles are the same. The band-spreading system will be recognized as the first of those outlined early in this chapter. It is used in this set because it is one of the easiest systems to get working when the tuning of two stages is to be ganged, and because the relatively large capacity in the tuned circuits makes the detector oscillate more stably and thus prevents the signals from wavering should the "B" supply voltage change slightly.

The panel is of ½-inch aluminum and measures 7 by 14 inches. The sub-base is made of a single piece of ¾-inch aluminum with the corners cut

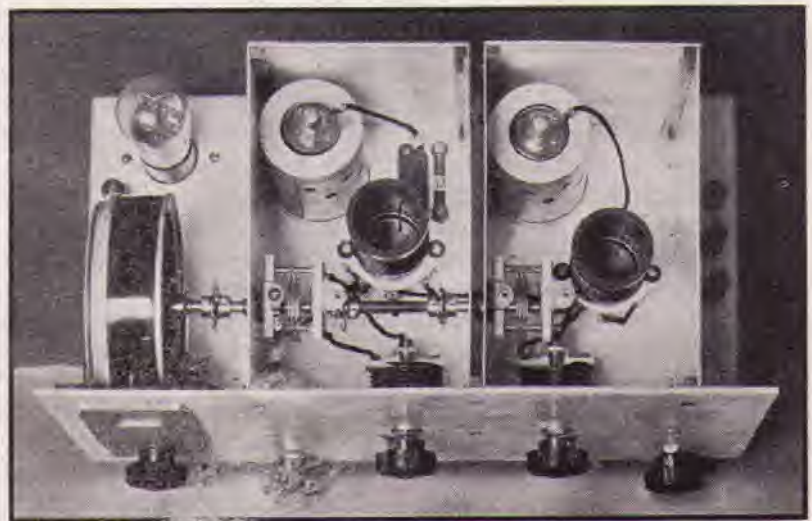

FIG. 517—PLAN VIEW OF THE THREE-TUBE AUTODYNE WITH SHIELD COVER REMOVED

The panel view of this receiver appears at the beginning of the chapter. The detector stage is next to the drum dial. The ganged tuning condensers are mounted on the left-hand wall of each shield. The Isolantite coil sockets are mounted on small pieces of brass tubing which lifts them far enough above the base to prevent grounding of the contacts. The detector grid condenser and leak are just behind the coil in the detector compartment. The tubes, also mounted in sub-panel sockets, have individual shields.

for the c.w. beat oscillator frequency adjustment. As shown in the bottom view, $\frac{1}{4}$ -inch Bakelite shafts with flexible couplings are used for C_6 and R_9 . The rear chassis extension measures $13\frac{1}{2}$ inches by $4\frac{1}{2}$ inches by 2 inches deep. It is fastened to the original base with pieces of the

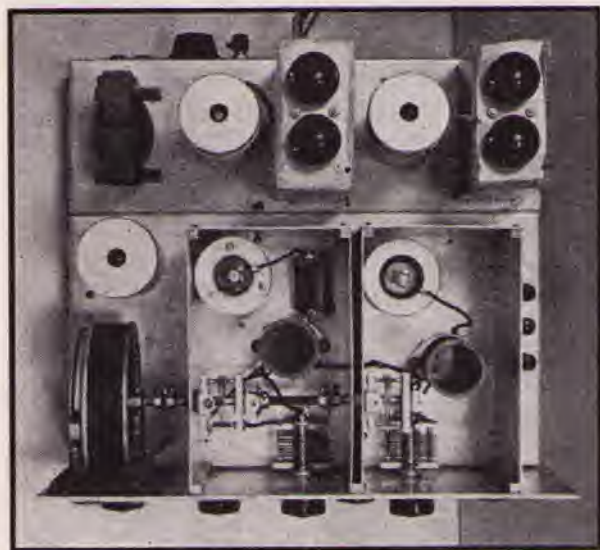

FIG. 520 — PLAN VIEW OF THE FIVE-TUBE SUPERHET AFTER CONVERSION OF THE T.R.F. RECEIVER

The panel arrangement is the same as shown in Fig. 501, except that the selectivity (regeneration) control has been inserted between the c.w. beat control (left) and gain control (right). The original mechanical arrangement is left intact and a $4\frac{1}{2}$ -inch back porch added for the additional equipment. The left front compartment contains the h.f. oscillator, the right the first detector. The regenerative r.f. stage is rear right, the beat oscillator rear left. The tube behind the drum dial is the pentode second detector.

quarter-inch square brass rod drilled and tapped for 6-32 screws, at the front corners and near the top-center. On the base are mounted the i.f. transformers, the i.f. and beat-oscillator sub-panel tube sockets, and the output transformer, as shown in the plan view of Fig. 520.

The i.f. transformers in this particular case are home-made. Air-type (midget) condensers are used for tuning in preference to less stable compression-type mica condensers. The i.f. transformer shields measure 4 inches by 2 inches by 4 inches high and are made of thin copper sheet, with the joints soldered. The inner assembly is as shown in the illustration of the second i.f. transformer, Fig. 523. The first i.f. transformer is similar except that it has, in addition, the tickler coil L_7 . The two 100- μ fd. Hammarlund midget condensers are mounted on a $3\frac{1}{2}$ - by $1\frac{3}{4}$ -inch strip of $\frac{3}{16}$ -inch bakelite which, in turn, is supported from the top of the can by 6-32 screws through spacing bushings that prevent the condenser bearings from shorting to the shield. Holes through the shield for the condenser shafts are large enough so that they do not short either. The transformer coils, on a 3-inch length of $\frac{1}{2}$ -inch wood dowel, are supported from the con-

densers by strips of $\frac{1}{16}$ - by $\frac{1}{2}$ -inch fiber screwed to the condenser frames and bent to hold the coil assembly clear of the other components and the base, as shown in Fig. 523. The universal-wound r.f. choke, RFC_2 , is mounted on one of these supports.

The primary and secondary i.f. coils are of the "diamond weave" (universal) type and are each of 1-millihenry inductance. They are mounted approximately 1 inch apart. The tickler coil of the first transformer is a 20-microhenry coil of the same type, mounted relative to the other coils and with leads brought out as shown in Fig. 524. The coils shown were obtained from the F. W. Sickles Co., Springfield, Mass. With the coils arranged as shown, the proper location of the tickler is determined by experiment, with the transformer connected in the tube circuit. The tickler is moved on the dowel form until a position is found where oscillation just starts with the regeneration control resistor at maximum and with the primary and secondary tuned to resonance at the intermediate frequency, which obtains when the condensers C_6 are at approximately half capacity. The tickler adjustment is made readily through the slot cut in the base immediately under the first i.f. transformer, as shown in Fig. 521. If it should be impossible to obtain oscillation, as indicated by the familiar "plop" when the i.f. tube's grid is touched, or if oscillation should occur but decrease as the tickler is moved toward the secondary, it is likely that the leads to the tickler coil have been reversed, and should be interchanged. If oscillation persists at any position of the tickler, it's turns should be

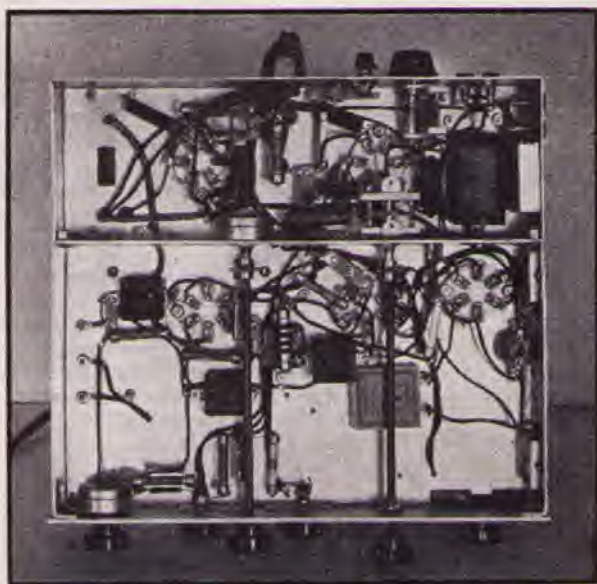

FIG. 521 — THE UNDERSIDE OF THE CHASSIS

Wiring and components are placed as convenient. A hole underneath the first i.f. transformer gives convenient access for adjusting the tickler position. The regeneration control resistor (near center) and beat-note control condenser are in the rear compartment, with $\frac{1}{4}$ -inch bakelite shaft extensions to the panel knobs.

reduced in number or provision made to place it further from the secondary, as by using a longer dowel form.

Although it was not found necessary to enclose the c.w. beat oscillator circuit in a shield in the model shown, it may be advisable to do so according to the dash-line indicated in Fig. 522, the circuit diagram of the receiver. The other shielding indicated in this diagram is used, including the shielding of certain leads. This shielding is flexible copper braid (Belden) over "spaghetti" tubing. The wiring of the receiver is

straightforward, the physical arrangement following closely the schematic arrangement of Fig. 522. The placement of bypass condensers, resistors and chokes is not especially critical but they should be located approximately in conformity with their positions in the schematic diagram, with connecting leads as short and direct as possible. All circuit connections indicated as "grounded" should be inter-connected by a copper wire soldered to each "ground" point, to eliminate possibility of poor connections through the aluminum shielding.

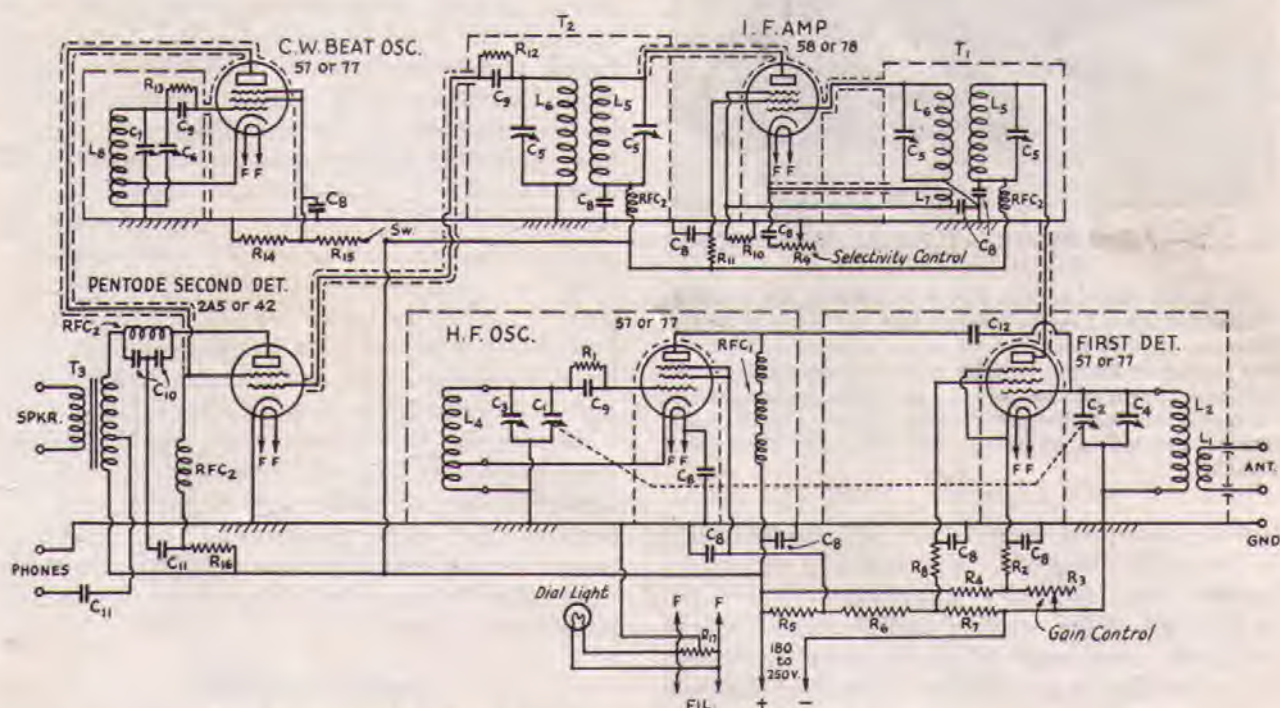

FIG. 522 — COMPLETE CIRCUIT OF THE FIVE-TUBE S. S. SUPERHET

Most of the components are unchanged from the three-tube receiver previously described, which should be studied for the additional constructional data. The original r.f. amplifier coils are used in the first detector and the original detector coils are used in the h.f. oscillator, with change in the cathode taps of the latter as noted below. See Fig. 519 for coil data.

L₁ and L₂ — Antenna and grid coils of first detector unchanged.
L₃ — Not used. Leave disconnected from circuit.
L₄ — Unchanged except that cathode tap is placed $\frac{1}{4}$ to $\frac{1}{3}$ of total turns from ground end. (Not critical.)
L₅ and L₆ — See text.

L₇ — See text.

L₈ — Beat oscillator inductor. 140 turns of No. 30 d.s.c. or equivalent on $1\frac{1}{2}$ -inch diameter form. Length of winding $1\frac{7}{8}$ in. Tapped 30 turns from ground end.

C₁ and C₂ — Ganged tuning condensers, 35- μ fd. midgets. (Unchanged.)

C₃, C₄ — Tank padding condensers, 100- μ fd. midgets. (Unchanged.)

C₅ — I.f. tuning condensers, 100- μ fd. midgets.

C₆ — Beat oscillator tuning condenser, 20- or 25- μ fd. midget.

C₇ — Beat oscillator tank padding condenser, 200- μ fd. midget variable or 100- μ fd. midget in parallel with 100- μ fd. fixed mica.

C₈ — Non-inductive r.f. by-pass condensers, 0.005- μ fd. or larger (paper or mica).

C₉ — 250- μ fd. mica grid condenser.

C₁₀ — 250- μ fd. plate by-pass condensers.

C₁₁ — 1- μ fd. audio by-pass and coupling condensers.

C₁₂ — H.f. oscillator coupling condenser, same as C₁ of Fig. 511.

R₁ — 50,000-ohm 1-watt oscillator grid leak.

R₂ — First detector cathode resistor, 5000-ohm 1-watt.

R₃ — 2000-ohm variable resistor, "left-hand" taper preferred.

R₄ — 100,000-ohm 1-watt.

R₅ — 10,000-ohm 5-watt.

R₆ — 7000-ohm 2-watt.

R₇ — 3000-ohm 2-watt.

R₈ — 50,000-ohm 1-watt.

R₉ — 2000-ohm variable resistor, preferably non-inductive type with "left-hand" taper.

R₁₀ — I.f. amplifier cathode resistor, 300-ohm 1-watt.

R₁₁ — 50,000-ohm 1-watt.

R₁₂ — Detector grid leak, 1-megohm $\frac{1}{2}$ -watt.

R₁₃ — Beat osc. leak, 50,000-ohm 1-watt.

R₁₄ — 2500-ohm 2-watt.

R₁₅ — 10,000-ohm 5-watt.

R₁₆ — 25,000-ohm 5-watt.

R₁₇ — 20-ohm center-tap resistor for 2.5-volt tubes, 100-ohm for 6-volt tubes. Omitted with d.c. filament supply.

T₁ and T₂ — 525-kc. i.f. transformers. See text.

T₃ — Audio output transformer, push-pull "replacement" type.
RFC₁ — Sectionalized type short-wave choke, 3-to 8-millihenry. One with universal-wound sections preferred. (National No. 100 or equivalent.)

RFC₂ — 40- to 60-millihenry broadcast-band type r.f. chokes. Single-section universal-wound type satisfactory.

Dash lines indicate shielding. Shading indicates chassis. "Ground" points are bonded with copper wire, in addition to connection through chassis.

Alignment and Checking of the Superhet

The tuning and checking of operation of the various sections of any superhet receiver is best accomplished by a logical procedure. With the audio circuits operating properly, as indicated by strong clicks in the output when the detector grid is touched, this procedure starts with the i.f.

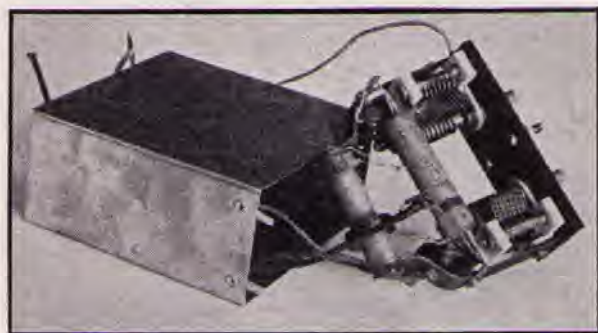

FIG. 523 — AIR-CONDENSER TUNED I.F. TRANSFORMER USED IN THE RECEIVER

The can is soldered copper, 4 by 4 by 2 inches. The assembly is supported from a bakelite strip that bolts to the top of the can. Pieces of $\frac{3}{16}$ -inch fiber screwed to the condenser frames are bent to support the coil form (wood dowel) and also carry the plate-feed choke, grid resistor, etc. A double-section .01- μ f. tubular by-pass serves for both plate and grid return circuits in this version. The tuning condensers are 100- μ f. Hammarlund midgets.

circuits and progresses to the h.f. circuits. The intermediate circuits are first tuned to the proper intermediate frequency, approximately 500 kc. in the case of the receiver just described. A test oscillator, operating at intermediate frequency, is used for this. A modulated oscillator of the type used for checking broadcast receivers can be used, or an unmodulated oscillator having exactly the same circuit as the c.w. beat oscillator of the receiver can be made up. With the unmodulated oscillator a d.c. milliammeter connected in a plate lead of the second detector is best as a visual resonance indicator. In the five-tube s.s. receiver a 0-50 milliammeter should be connected in the plus-B lead to the lower terminal of the output transformer primary. Since the detector is of the grid-leak type, the current will dip toward zero and minimum current will indicate resonance. For detectors having cathode-resistor self-bias, a 0-1 ma. meter can be used, which will indicate resonance by maximum current reading.

The frequency of the test oscillator can be checked by beating its second harmonic against the carrier of a broadcast station tuned in on a broadcast receiver set at 1000 kc. or thereabouts. In aligning the i.f. circuits, the test oscillator is first coupled loosely to the grid of the i.f. tube preceding the second detector (the second i.f. stage in a two-stage intermediate amplifier) by means of an insulated wire hooked around the grid cap. The primary and secondary of the *last* i.f. transformer are then adjusted to resonance. The

coupling is next transferred to the grid of the next preceding tube (the first detector, in the s.s. five-tuber, or the first i.f. in a two-stage i.f. amplifier), and the second-last i.f. transformer is adjusted. In the regenerative i.f. amplifier this adjustment should be made with the regeneration control near minimum. If there is a third i.f. transformer, the same procedure applies to it; the test oscillator is always coupled to the grid of the tube preceding the transformer under adjustment. The c.w. beat oscillator should be "off" while the i.f. circuits are being aligned.

The high-frequency circuits are adjusted in similar fashion, using an oscillator furnishing a signal in the band to which the h.f. circuits are tuned. The station heterodyne frequency meter or crystal oscillator of the transmitter can be used for this purpose. If the high-frequency circuits (h.f. oscillator and first detector) seem to be inoperative, check the operation of the h.f. oscillator by listening for it on an ordinary regenerative receiver. Remember that the h.f. (first) oscillator must be tuned intermediate-frequency different from the incoming signal frequency to which the first detector is tuned. In the five-tube set, it is intended that the first oscillator should be 500-ke. higher. For the 3500-ke. band the oscillator tank condenser will be near minimum and that of the first detector at about $\frac{1}{4}$ capacity; for 7000 kc., the oscillator at about half capacity and the first detector slightly greater than half; for 14 mc., the settings are slightly advanced over those for 7 mc. The settings for 1.75 mc. are nearly the same as for 3.5 mc.

Image Interference

The setting of the first detector tank (padding) condenser is especially important in the minimizing of high-frequency image interference, a type of interference peculiar to superhet receivers.

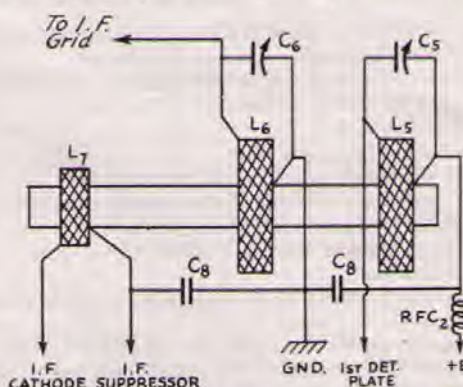

FIG. 524 — HOW THE COILS ARE ASSEMBLED IN THE REGENERATIVE I.F. TRANSFORMER

With all three wound in the same direction, the correct polarity of the tickler is obtained with the connections indicated. The 1-millihenry primary and secondary coils, L_5 and L_6 , are spaced approximately 1 inch between centers. The 20-micro-henry tickler, L_7 , is adjacent to the secondary and its proper position is determined by the procedure described in the text. All three coils are of the "universal" type made by the F. W. Sickles Co., Springfield, Mass. Coils of different size and type might necessitate modification of the tickler specifications.

This interference results when signals twice intermediate frequency removed from the desired signal get through to beat with the high-frequency oscillator signal in the first detector and occurs because there is insufficient selectivity ahead of the first detector to discriminate against them. It is aggravated when the first detector circuit is off-tune for the desired signal frequency. The first detector therefore should be tuned as precisely as possible to the desired-signal frequency. For further improvement in signal-image response ratio, a tuned r.f. stage, exactly like that shown earlier in the chapter and having a tuned circuit identical with that of the first detector, can be added ahead of the first detector. This also will improve the sensitivity of the receiver. Images also can be reduced by using a simple wave-trap, of the type described in Chapter Eleven, tuned to the image frequency (1000 kc. above signal frequency) and connected in the antenna lead as closely as possible to the receiver's antenna terminal. (*QST*, December, 1933).

Quartz Crystal I. F. Filters

As has been mentioned previously, high i.f. selectivity can be obtained by the use of a quartz crystal filter and such filters are used in a number of s.s. receivers, two commercially manufactured types of which are shown later in this chapter. When connected in a suitable series circuit, a quartz crystal having a resonant frequency corresponding to the receiver's intermediate frequency is capable of several hundred times the selectivity obtainable in the usual transformer-coupled i.f. amplifier. The selectivity obtainable is, in fact, considerably greater than is practicable for some types of communication, especially 'phone, unless means for modifying it are provided. Such provision is made in the variable-selectivity filter developed by J. J. Lamb and described in several *QST* articles (August, 1932; March, June and November, 1933).

As shown in the filter portion of the diagram of Fig. 530, the variable parallel impedance of the input transformer secondary in series with the crystal (which is equivalent to a high-Q electrical circuit) effects variation in the effective resistance in the crystal circuit, thereby varying the selectivity in accordance with the principles of resonant circuits discussed in Chapter Four. The applied voltage is proportional to the parallel impedance, increasing as the effective resistance increases, so that the effective sensitivity of the receiver for a single-frequency signal is but little affected over a selectivity (band-width) range of approximately 10 to 1. Minimum selectivity occurs, of course, with the parallel circuit tuned to resonance, when it is purely resistive, and maximum selectivity when the parallel circuit is tuned to be considerably reactive. The crystal is connected in a bridge circuit to provide counter voltage of controllable phase, through an adjustable

condenser, so as to modify the resonance curve and shift the anti-resonant frequency of the crystal, thus giving particular rejection for an unwanted signal (of a frequency from several kilocycles above to several kilocycles below the crystal's resonant frequency), in addition to the sharply peaked response given for the desired signal.

Automatic Gain Control

With the wide variation in signal strength and severe fading encountered in high-frequency reception there is considerable advantage in automatic gain (or volume) control in the receiver, with the receiver gain governed by the strength of the received signal. Such a system is applicable for 'phone reception, with a continuous carrier, but is not useful for amateur c.w. reception where the carrier is intermittent. Although there is a wide variety of a.g.c. systems, all operate on the same principle; namely, that rectified and filtered carrier voltage is used to provide inversely varying bias for the r.f. amplifier tubes of the receiver. This bias may be obtained from the detector circuit (*QST*, November, 1933), or from a separate tube having its grid excited by r.f. bled off from the second-detector input. Typical examples are shown in Figs. 528 and 530.

Manufactured Superhets

Because many amateurs now purchase manufactured amateur-type superhet receivers in preference to constructing their own, brief descriptions of three representative models are included in this chapter. Plan views and circuit diagrams are shown for reference in servicing and checking.

Fig. 525 illustrates the amateur-type National FB7A superheterodyne. Immediately behind the horizontal h.f. oscillator plug-in coil shield (left) is the oscillator tube; behind the first detector coil shield (right) is the first detector tube. Behind these, in line from right to left, are the first i.f. transformer, first i.f. tube, second i.f. transformer and second i.f. tube. The second detector tube is in the rear-left corner, with the c.w. oscillator's shielded tank circuit, c.w. oscillator tube and pentode audio output tube to its right. Immediately below the vernier tuning knob is the projecting edge of the horizontal volume control disc. Above the tuning control is the frequency calibration chart for the amateur bands. To the right of the oscillator-first detector tuning condenser gang (center) is the trimmer for the first detector tuning which is set once for all ranges. Individual trimmers are included in each coil assembly, with screw-driver adjustment through the front end of the coil forms.

Fig. 526 shows the circuit of the FB7A receiver. In this diagram, and in the two following, figures adjacent to condensers indicate capacitance in

$\mu\text{fd.}$, those next to resistors indicate resistance in ohms. Values are given for assistance in servicing and are not intended as specifications for construction. Lettered values are as follows: C_1 , 105- $\mu\text{fd.}$ variable condensers; C_2 , coil trimmers, varying with type of coil, between 2- $\mu\text{fd.}$ and 115- $\mu\text{fd.}$; C_3 , 2- $\mu\text{fd.}$ oscillator coupling condensers; C_4 , 70- $\mu\text{fd.}$ air-type i.f. tuning condensers. This receiver is intended for a.c. operation from a separate power pack furnishing 2.8 volts a.c. and 180 to 250 volts d.c., the latter being recommended for maximum sensitivity and loud-speaker output. The i.f. is 495 kc.

The Hammarlund Single-Signal type "Comet Pro" with quartz crystal i.f. filter and automatic gain control is shown in Fig. 527. The first-detector plug-in coil ("W.L.") is housed by the large shield immediately behind its tuning condenser, to the right of the drum dial; the h.f. oscillator coil ("Osc.") and tuning condenser are similarly located at the left. The respective tank padding condensers are on the front panel, right and left of the dial. The h.f. oscillator tube is to the left of this assembly, the first detector to the right near the panel. The i.f. filter crystal assembly is on a small panel behind the main panel (not visible) with its input and output transformers in the shield at the front-right corner. To the rear of this are, in order, the second and third i.f. transformers, and the c.w. oscillator tank circuit. To their left are the first and second i.f. tubes, and the second detector, with the c.w. oscillator tube at the extreme rear. Behind the plug-in coil shields are the a.g.c. tube and its

plate transformer. The receiver's power pack is at the left side, with the rectifier tube socket left of the a.g.c. transformer. The pentode output tube socket is the one remaining, near the antenna terminal strip (right) and speaker terminals (left) at the rear edge of the chassis. On the panel, in addition to the tuning controls, are (left to right) the tone control, 'phone jack, combined audio volume control and power switch, beat oscillator switch, manual gain control, the a.g.c. switch, filter switch and filter "elimination" control. A metal cabinet houses the chassis.



FIG. 525

Fig. 528 is the circuit of the "Comet Pro" with crystal filter and a.g.c. In the 465-kc. i.f. filter, step-down input and step-up output transformers provide practically constant low impedance in the crystal circuit. The crystal is shorted by the switch for straight superhet operation. The elimination-control condenser operates to shift the anti-resonant frequency of the crystal to reject an unwanted carrier, with the crystal in circuit.

Amplified automatic gain control for 'phone reception is provided by the 2B7 tube which acts as a combined r.f. amplifier and diode rectifier.

Its control grid is coupled to the output of the second i.f. stage. Amplified i.f. energy in its plate circuit is coupled to the diode circuit by the tuned-primary transformer. Rectified r.f. voltage developed across the resistor-condenser connected between the secondary of this transformer and ground is applied to the control grids of the i.f. amplifier tubes through their return circuits, varying i.f. gain inversely as the carrier strength. The manual gain control

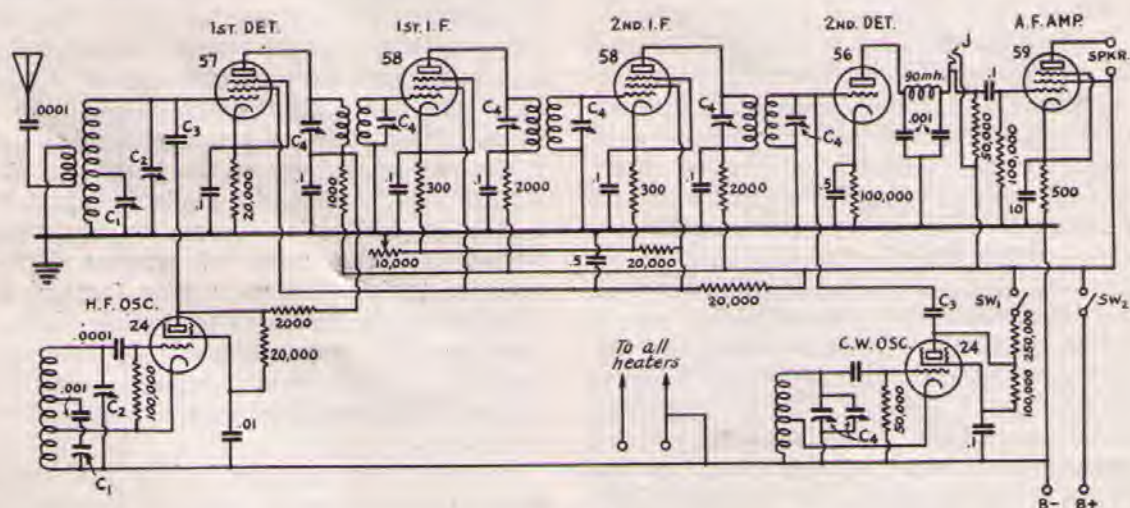

FIG. 526

is simultaneously operative to set the maximum sensitivity. The a.g.c. is cut off by the switch shorting the grid-return circuit to ground.

Fig. 529 is a rear view of the National AGSX single-signal type superhet with preselector, variable-selectivity i.f. filter and automatic gain

superhet operation), or connects it in parallel or in series, the latter for full single-signal operation. A panel control operates the double-section condenser to vary selectivity with the crystal in series. To align the i.f. transformers in this type receiver, the plug-in crystal is removed and connected in a

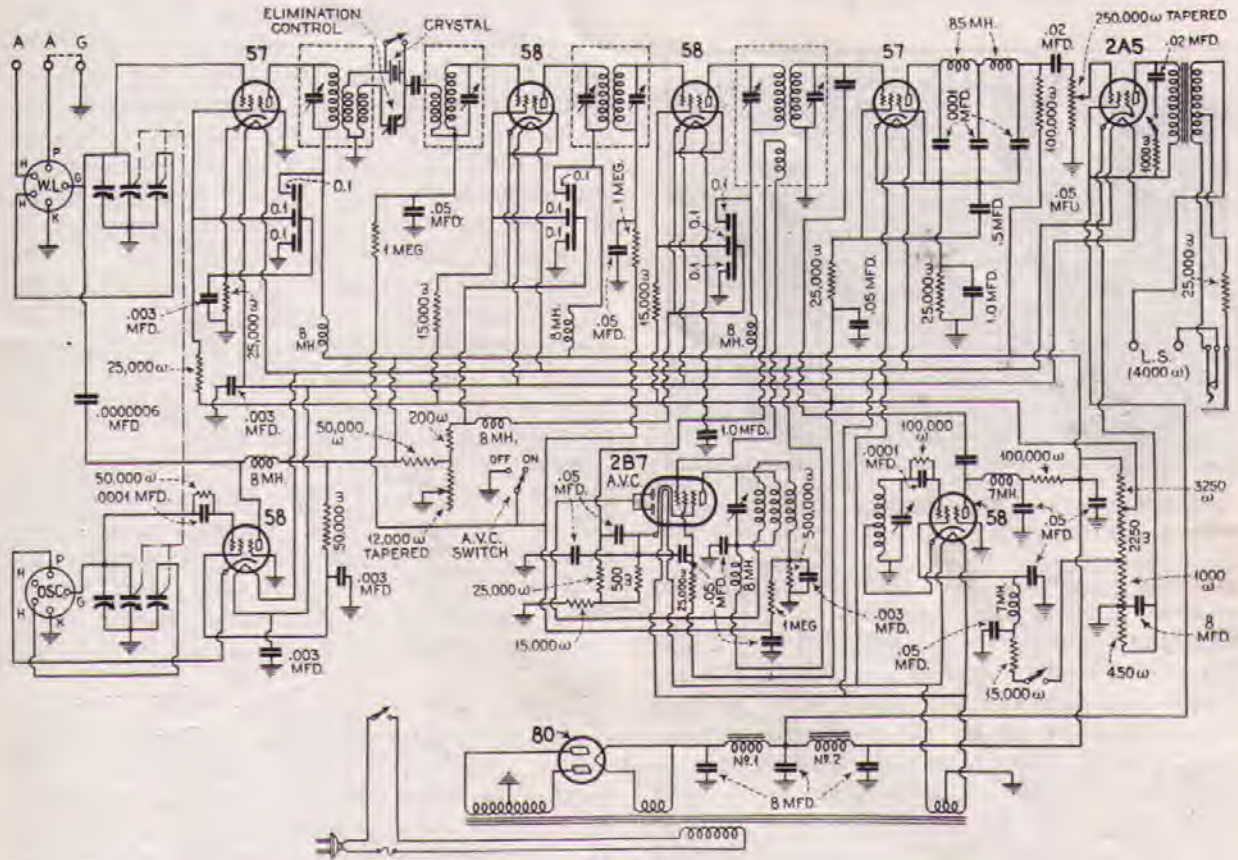

FIG. 527

control. The three variable tuning condensers of the h.f. circuits (r.f., first detector and oscillator) are contained in the shielded compartment and are driven by a rack-and-pinion mechanism operated by the main dial. The coils, which plug in from the panel front, are individually shielded in the horizontal cans. The pre-selector coil assembly is at the right, the oscillator in the center and the first detector at the left, the respective tubes being immediately below the coil shields. The i.f. filter circuit is at the left of the assembly, next to the panel. The i.f. circuits progress thence to the rear of the chassis and to the right, where are the c.w. beat oscillator and output stages. The beat-oscillator frequency control condenser is on the panel at the right. This model is intended for mounting on a standard 19-inch relay rack.

The circuit of the AGSX Receiver, Model F., is shown in Fig. 530. The circuit is generally conventional with the exception of the 495-kc. i.f. filter and a.g.c. circuits. H.f. circuit constants are as in Fig. 526. The filter is of the variable bandwidth type, operating as explained earlier in the chapter. A switch shorts the crystal (for straight

495-kc. crystal oscillator circuit of conventional type which serves as the test oscillator. The adjustments of i.f. transformer tuning are made with the filter switch in the "off" position, of course,

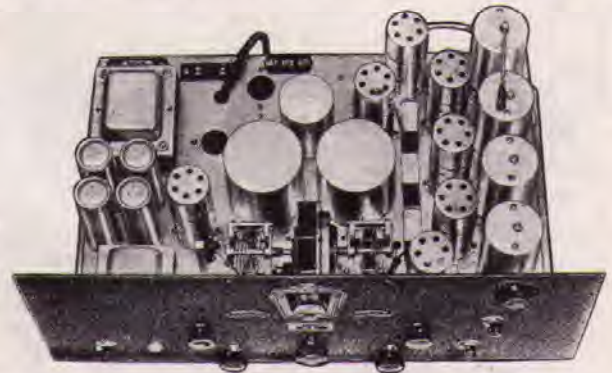

FIG. 528

the alignment procedure being the same as has been described for conventional superhets. With the crystal back in the filter circuit, a steady signal of local origin is tuned in precisely on resonance and the c.w. beat oscillator adjusted to a

frequency of about 1000 cycles above i.f. resonance, as indicated by the beat note. The receiver is then tuned "through zero beat" to a setting which gives an identical beat note "on the other side." The phasing condenser (rejection control), to the right of the filter in the rear view, is then adjusted to make this "audio image" signal of

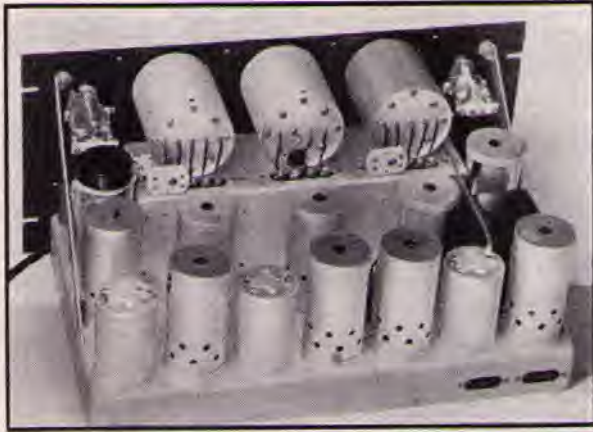

FIG. 529

minimum audibility. This procedure applies to any receiver using this type filter.

Automatic gain control is provided by the 236 tube whose control grid is coupled to the i.f. output. Variation in r.f. (carrier) signal voltage causes variation in its plate-cathode current which, flowing through its plate load resistor, in turn causes corresponding variation in the grid bias of the r.f. and i.f. tubes, thereby regulating their gain automatically. The manual control operates to set the bias on the a.g.c. tube, thus allowing adjustment for desired maximum sensitivity with the a.g.c. in operation; or giving complete manual control with the a.g.c. switch in the "M.V.C." position.

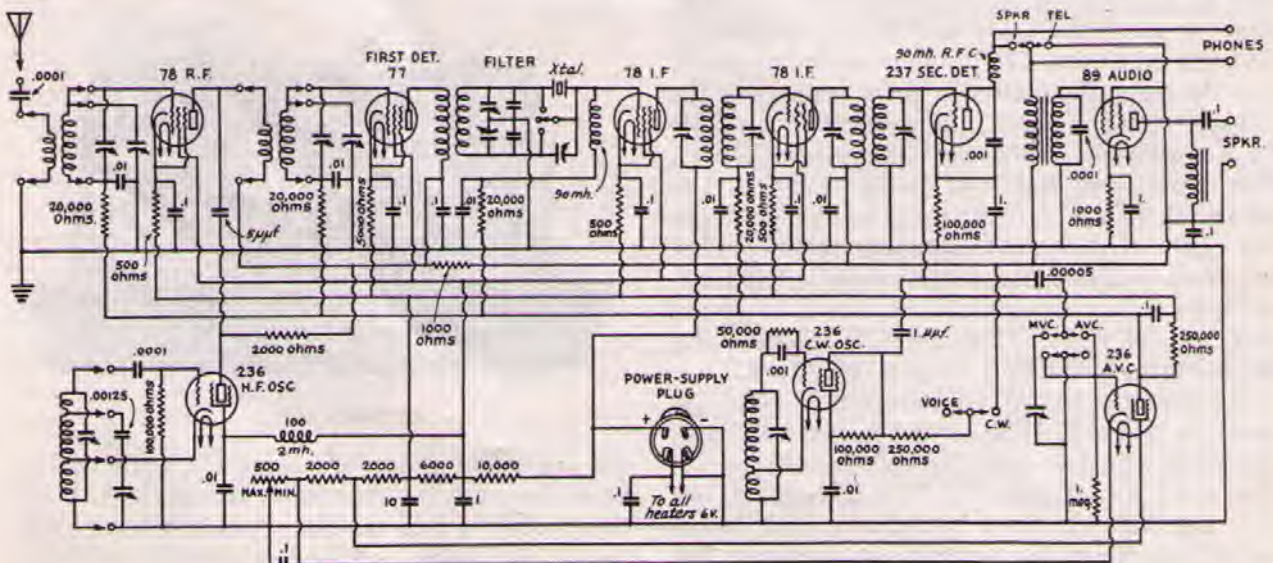

FIG. 530

Trouble Shooting

The most useful instruments for locating faults in a defective receiver are a multi-range ohmmeter and a high-resistance d.c. voltmeter. A simple combination ohmmeter and d.c. voltmeter suitable for general receiver testing is diagrammed in Fig. 531. As an ohmmeter it consists of the 0-1 d.c. milliammeter, 3-volt battery, fuse and 2800-ohm resistor in series. The ends of the leads are tapped across the circuit whose resistance is to be checked. It is essentially a 3-volt voltmeter, giving full-scale reading when the terminals are shorted with the 3-volt battery in series. It can be used for fairly accurate measurement of resistances between the values given in the calibration table, which calibration can be marked on the meter scale or plotted on graph paper. The ohmmeter should never be connected across a circuit in which current is flowing; that is, the receiver power should be turned off when resistance measurements are made.

As a four-range d.c. voltmeter it has a characteristic resistance of 1000 ohms per volt, with full-scale reading (1 ma.) on each range corresponding to the maximum voltage specified for that range, lesser voltages on each range being in direct proportion to the scale reading (80% maximum voltage at 0.8 ma., 50% at 0.5 ma., etc.).

Lacking such an instrument, rough checks for circuit continuity (indicated by audible clicks) can be made with a pair of 'phones and a "B"-battery in series, connected across the circuit under check; or with a low-range d.c. voltmeter and battery in series. An a.c. voltmeter should be used for checking the line and filament voltages in a.c. operated sets.

If the tubes do not light, check the filament supply (transformer or battery) and connections. Zero voltage across the primary will result with a

blown fuse in the primary of an a.c. supply. Check the voltage at the socket terminals of a single tube that fails to light when others come on. If voltage checks OK, the tube may be burned out or there may be a defective contact in the socket.

Unreasonable hum in an a.c. receiver usually indicates either an open filament center-tap resistor or a tube with low resistance (leakage) between heater and cathode. Such a tube should be replaced. Less likely causes of excessive hum are an open filter or by-pass condenser in the supply circuits, or a defective rectifier tube. An open receiving tube grid circuit also may cause bad hum, usually accompanied by low output and serious distortion. Periodic clicking accompanied by poor sensitivity in a regenerative receiver may indicate an open detector grid leak or one of excessively high resistance. Replace the leak, using one of lower resistance if necessary.

If the filaments light but there is no output (set "dead"), first check the B-supply voltage and connections to the output stage. Even with no signal coming through there should be strong clicks when the headset or speaker is connected and disconnected. If the output circuit checks OK, clip a pair of 'phones across the output of each preceding audio stage, including the detector, until the signal is picked up, thus locating the circuit in which the fault lies. Check the tube, resistors, bypass and coupling condensers, etc., in the defective stage, both for shorts and opens, using an ohmmeter or its equivalent.

If strong clicks result when the grid of the detector is touched, but there is no signal or only very weak signal output, it is likely that the fault is in a r.f. circuit ahead of the detector. Check the r.f. tube or tubes and the plate circuits of preceding stages for opens and shorts. An open secondary circuit or grid coil may cause periodic clicking like that resulting from a defective detector grid leak, in which case the grid circuit should be tested for open circuit with an ohmmeter or 'phones and battery. If a circuit should test neither shorted nor open but does not "tune," look for a defective connection between coil and tuning condenser.

Noticeably weak signal response will result with an open antenna coupling coil or open connection in the antenna-ground circuit. A shorted grid condenser, either in a detector circuit or a r.f. amplifier using capacitive coupling, will have the same effect. This may be checked by removing the grid resistor, which should cause the periodic clicking sound in the output. Shorts of this kind can be caused by a blown condenser or by soldering paste smeared between the terminals. Needless to say all soldered connections should be thoroughly wiped with a clean cloth to prevent such leakages.

A regenerative receiver may "howl" just as the detector starts to oscillate. This "fringe

howl" is most likely to result with transformer or impedance-coupled detector output and the best precaution against it is to use an audio transformer or choke of the better grade rather than one of the cheaper type with inadequate primary windings. If it does occur with the transformer that must be used, however, it can be reduced or

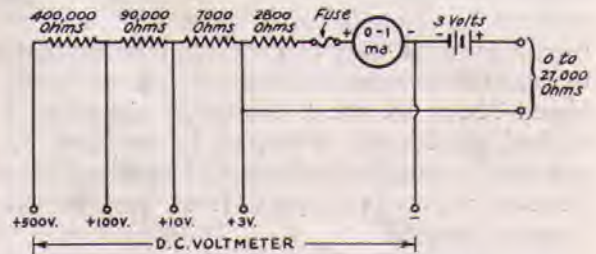

FIG. 531 — A COMBINATION OHMMETER AND D.C. VOLTMETER SUITABLE FOR RECEIVER TESTING

It may be assembled on a Bakelite panel in an instrument case. The 0-1 ma. d.c. milliammeter should be of the low-resistance type. Two flash-light cells in series serve as the battery. The resistors preferably should be "precision" type. A 1/100-amp. low-voltage type Littelfuse should be connected as shown. If it is omitted, the 2800-ohm resistor should be replaced by one of 3000-ohms. The approximate ohmmeter calibration is as follows:

Meter Scale (Ma.)	Ohms	Meter Scale (Ma.)	Ohms
1.0	0	.375	5000
.96	100	.30	7000
.85	500	.25	9000
.75	1000	.20	12,000
.60	2000	.15	17,000
.50	3000	.10	27,000

eliminated by connecting a resistor across the secondary of the audio transformer. In most cases a resistance of 100,000 ohms will be sufficiently low. A grid leak of lower value also may help in some cases. These expedients reduce the receiver output, of course, and must be considered as less desirable than the substitution of an audio coupler having better characteristics.

"Scratching" noises that persist when the receiver is untouched by the operator may have several sources. In a battery operated receiver they may result with A or B batteries in poor condition, either because of a defective (high-resistance) cell or cells, or because the batteries are nearly run down. The batteries should be checked with a voltmeter, while the receiver is turned on. Dry batteries should be replaced when the voltage becomes about 80% of normal rating. "Scratching" noise also can be caused by poorly soldered connections, loose lug terminals, a partially open resistor, a "leaky" condenser or defective tube socket contacts. Locate by moving the wiring with a piece of stick, by checking resistors and condensers with an ohmmeter and by "wobbling" the tubes in the sockets with the receiver turned on. In some cases noises of this type is caused, when the receiver controls are manipulated, by a metal shaft or dial rubbing against the panel or some other metal object. It also may result from dirt between the plates of a variable

condenser or a poor contact in a variable condenser or resistor. The latter types usually can be located by inspection.

If the "scratching" ceases when the antenna and ground are disconnected its source is probably outside the receiver, possibly in the antenna system (poor connections) or in other metallic objects touching or rubbing against the antenna conductors, or against each other without touching the antenna. Any two wires in poor contact in or near the antenna can cause serious noise when blown about by wind. Noises of the type described should not, of course, be confused with ordinary atmospheric static and electrical interference originating apart from receiver and antenna circuits.

"Stringy quality" or poor base-note response usually can be traced to an open or inadequate bypass capacitance in a detector or audio amplifier circuit. Too-small capacitance across a cathode resistor is a common source. An open or too-small grid condenser in a grid-leak detector also may be the cause of this trouble.

Servicing Superheterodyne Receivers

In addition to the general receiver servicing suggestions given in the preceding section, there are a few others for troubles peculiar to superhet type receivers. Generally poor performance, characterized by broad tuning and poor sensitivity, calls for checking of the circuit tuning and alignment as previously described in connection with the adjustment of the five-tube receiver. The procedure is to start with the receiver output (audio) and work back through the second detector, i.f., and high-frequency circuits, in the order named.

In case of oscillation in high-frequency amplifier and first detector circuits, as evidenced by squeals or "birdies" with varying of their tuning, look for poor connections in the common ground circuits, especially to the tuning condenser rotors. Inadequate or defective bypass condensers in cathode, plate and screen grid circuits also can cause such oscillation. In some cases it may be advisable to provide a baffle shield between the

stators of pre-r.f. amplifier and first detector ganged tuning condensers, in addition to the usual tube and inter-stage shielding. Improper screen-grid voltage, as might result with a shorted or too-low screen-grid series resistor, also could be responsible.

Oscillation in the i.f. circuits, independent of high-frequency tuning and indicated by a continuous squeal when the gain is advanced with the c.w. beat oscillator on, will result from similar defects in i.f. amplifier circuits. Inadequate cathode resistor bypass capacitance is a very common cause of such oscillation. Additional bypass capacitance, 0.1 to 0.25 μ fd., usually will remedy this type of oscillation. The same applies to screen-grid bypasses of i.f. tubes.

"Birdies" and "mush" occurring with tuning of the high-frequency oscillator may indicate that it is "squegging" or oscillating simultaneously at two frequencies. This may be caused by a defective tube, too-high oscillator plate or screen-grid voltage, excessive feed-back in the oscillator circuit or excessive gridleak resistance. If the latter, replace with a new resistor, using one of lower resistance if necessary.

Excessive "hiss" may be caused by a defective h.f. or i.f. tube, by an open grid circuit, or by too-large first oscillator r.f. input to the first detector circuit. The first oscillator plate (or screen) voltage should be no greater than that necessary for good signal response and the coupling between oscillator and first detector should be the minimum required. It may be helpful to reduce the oscillator screen voltage, in the case of an electron-coupled oscillator, or the plate voltage in the case of a triode. The same symptoms and remedies apply to the c.w. beat oscillator and its coupling to the second detector. There should be some increase in hiss when the latter is switched on, of course, as a result of the i.f. noise components beating with the carrier it furnishes in the second detector. The oscillator input to the second detector should be just enough to cause a noticeable change in second detector plate current. (About 0.05 ma. increase in the case of a self-biased triode second detector, for instance.)

Chapter Six

MONITORS AND FREQUENCY METERS

ONE might suppose that, having finished the receiver, the next piece of equipment to be built would be the transmitter. But before the job of adjusting a transmitter to maximum effectiveness can be tackled, the amateur must have some means of checking its performance — particularly, how it is going to *sound* to other amateurs — and of making certain that the frequency of the signals is inside the band in which the transmitter is supposed to be working. Without the facilities to determine definitely whether the frequency of his transmitter is within the limits of the band the amateur has no right in the world to send even a single dot.

It is fortunate that when the station has been equipped with a monitor — which is nothing but a simple shielded oscillator — it is also provided with what is without doubt the cheapest and most effective apparatus for setting the transmitter frequency within the band. More elaborate instruments, which we call frequency meters, can be constructed for precise frequency measurement, but an inexpensive monitor, intelligently used, will insure against committing the unforgivable sin of amateur radio — working “off-frequency.”

Building a Monitor

A monitor is a miniature receiver, usually having only a single tube, enclosed with its batteries in some sort of metal box which acts as a shield. It need not be a costly or elaborate affair. The example shown in Fig. 601 illustrates the simplicity of a typical monitor. The constructional work probably would not occupy more than an hour or two.

The requirements of a satisfactory monitor are not difficult to satisfy. It should oscillate steadily over the bands on which the station is to be active; the tuning should not be excessively critical, although the degree of band-spreading ordinarily considered desirable for receivers is not essential; the r.f. pick-up from the 'phone cord should be sufficiently nullified and the shielding complete enough to permit the monitor to be set near the transmitter and still give a good beat note when tuned to the fundamental frequency of the transmitter (this is usually impossible with the receiver be-

cause the pick-up from power supply leads is so great); and it should be constructed solidly enough so that it can be moved around the station without the necessity for retuning when listening to a fixed signal.

Almost any sort of metal can or box can be used as a shield for the monitor, provided it is large enough to contain the necessary components. The can shown in Fig. 601 is an ordinary cracker tin having a diameter of six inches; tins of this sort will be found in most homes or can be purchased in practically every grocery store. To disguise its origin and make it look like a piece of radio apparatus, the can has been given a coat of black lacquer. The circuit diagram of the monitor is given in Fig. 602. A Type 30 tube is used in a simple oscillating circuit; the number of parts required has been reduced to a minimum.

All parts except the “A” and “B” batteries are mounted on the under side of the lid. The data under the circuit diagram includes a complete list of the material needed. The placing of



FIG. 601 — AN INEXPENSIVE MONITOR BUILT IN A CRACKER TIN
The simple construction shown above is typical. The monitor, despite its simplicity and low cost, is an indispensable piece of station equipment.

the parts is not especially important; they should simply be mounted so there is no crowding. The tube sockets into which the coil and tube are plugged are held to the lid by means of machine screws. The tuning condenser, C_1 , the switch, S , and the pin jacks for the 'phones come provided with mounting nuts. The pin jack which connects to the negative terminal of the “B” battery must be insulated from the lid, as indicated in Fig. 602.

Care must be taken to see that other wiring which is not "grounded" or connected to the lid, does not inadvertently touch any metal part of the lid or can.

The "A" battery is a single 1.5-volt dry cell of the type that is used in tubular flashlights. The "B" battery is a small-size 22½-volt block, such as the Eveready No. 763. These two batteries are taped together and connected to the monitor proper with rubber-covered leads also taped

Many amateurs make a practice of continuously monitoring all their transmissions—a good idea not only because a constant check is kept on the frequency and the note, but because listening to one's own keying makes for accurate and clean-cut sending. When this is done, however, the monitor must operate without interruption over rather long periods, which increases the strain on the "A" battery. In such cases it is advisable to use a larger shield box or can so that a full-size No. 6 dry cell can be accommodated. A single No. 6 cell will operate a monitor of the type illustrated for a matter of months with ordinary use.

The data under the diagram should be used chiefly as a guide, because it may be found that slight changes in the number of turns on the plate coils will be required to maintain smooth oscillation over the entire tuning range, since the monitor has no regeneration control.

Installation and Adjustment

A monitor has two functions to perform, the first being that of providing a means of listening to the transmitter signal under conditions similar to those at distant receiving stations; that is, with the signal weak enough so that its tone and general characteristics can be distinguished readily. The second function is that of acting as a small transmitter radiating a weak signal which can be picked up in the regular receiver for the purpose of aiding in setting the transmitter frequency by the method described in a subsequent section.

In order to make full use of the monitor it must be placed carefully with respect to the receiver and transmitter so that the signal in it from the transmitter is not too loud and so that the signal produced by it in the receiver also is of reasonable strength. If the receiver is located several feet from the transmitter a satisfactory location for the monitor will be found alongside the receiver. If the receiver is across the room from the transmitter it will be necessary to move the monitor to a spot convenient to the transmitter whenever adjustments are to be made. Of course, the monitor can be placed alongside the receiver for frequency setting and monitoring of the transmitter during transmissions. It may be found that the pick-up with the lid of the shield closed is not enough to give a pleasantly loud signal. In such a case the lid can be opened until the required signal strength is obtained, and then left in that position for monitoring.

It is a very worthwhile plan to fit the receiver with a small double-pole double-throw switch so that the 'phones can be thrown from the receiver to the monitor. In this way it is possible to monitor all transmissions simply by flipping over the switch when a change is made from the transmitter to the receiver. Ordinarily the transmitter makes a tremendous and very uncomfortable thump in the receiver 'phones during operation.

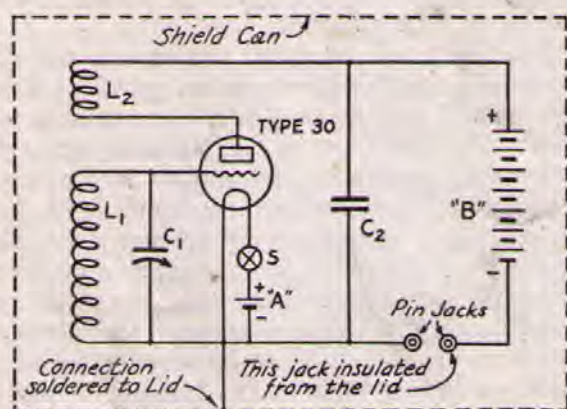

FIG. 602 — WIRING DIAGRAM OF THE MONITOR

The circuit components have the following values:
 C₁ — 50- μ fd. (.00005 μ fd.) midjet variable condenser.
 C₂ — .002- μ fd. fixed condenser.
 S — Single-pole toggle switch.

Band	L ₁	L ₂
1750 kc.	70	20
3500 kc.	35	10
7000 kc.	15	6
14,000 kc.	5	4

The coil forms are 1½ inches in diameter. All coils are wound with No. 30 d.s.c. wire.

Other materials required include two 4-prong tube sockets, a Type 30 tube, a pair of 'phone-tip jacks, a small-size 22½-volt "B" battery (Eveready No. 763 or equivalent), and a single-cell 1.5-volt flashlight battery. Two or even three of these cells can be connected in parallel for longer life.

The coils L₁ and L₂ are wound on the same plug-in coil form (4 prong) and are wound in the same direction, L₁ at the upper end of the form. The upper terminal of L₁ connects to the grid of the tube, the lower terminal to the filament of the tube, the terminal of L₂ nearest L₁ goes to the positive side of the "B" battery and the remaining terminal to the plate of the tube. The arrangement of the pins on the form may be anything convenient.

together. This is necessary to keep the battery leads from moving or vibrating after the monitor has been assembled, since movement or vibration of the leads will affect the frequency of oscillation and destroy the usefulness of the device in checking the quality of the transmitter signal. Cotton batting or wadded paper may be packed around the batteries when they are placed in the bottom of the container so that they will not move when the monitor is carried around. Any paint that may be on the upper lip of the can should be scraped off so the lid will make good electrical contact to the body of the can when the monitor is assembled. If the contact is poor the shielding will be impaired and the monitor is likely to be noisy and unstable in operation.

If it is possible to throw the 'phones over to the monitor this thump is then replaced by a moderate signal which will be almost a replica of the signal that the other fellow has to copy. This makes for much snappier and more readable sending and provides a continuous check on the signal. Should anything go wrong with the transmitter or antenna to cause the frequency to change, the trouble is immediately apparent.

Checking the Transmitter Frequency

In the absence of more elaborate frequency-measuring equipment, a monitor is an absolute necessity in the highly-important operation of setting the frequency of a self-excited transmitter (or oscillator-amplifier transmitter with a self-controlled oscillator) within an amateur band. While not wholly essential for this purpose when the transmitter is crystal-controlled—provided the crystal frequency is accurately known—the monitor is desirable for keeping watch on the quality and stability of the signal.

Before any frequency checking can be done, however, it is necessary to calibrate the receiver tuning dial in terms of frequency. After the receiver has been in use for a little time the locations of the amateur bands are pretty definitely known, because large numbers of amateur stations can be heard working on the more important bands at almost any hour. First get the receiver working on the band in which the transmitter is to be set and note the limits between which amateur stations are heard. Often high-power commercial stations will be heard working just outside these limits, and the frequencies of these stations can be looked up in lists such as the one in the *Radio Amateur Call Book*. Similar lists are also occasionally published in *QST*. These commercial stations generally are accurately set on their assigned frequencies and furnish a means for making an approximate calibration of the receiver. Amateurs call them, appropriately enough, "marker stations."

No specific examples will be given here because the frequency assignments are changed from time to time, and the latest call book should be consulted for accurate information. Suppose, however, that a station is heard whose frequency, as shown by the list, is 6980 kc. This is only 20 kc. outside the 7000-kc. band, and therefore serves as an approximate marker for the 7000-kc. end. On the high-frequency end of the band we might find a station listed at 7350 kc. which will help in locating the 7300-kc. limit. Obviously the transmitter cannot be tuned to all frequencies between these two markers because both are somewhat removed from the actual limits of the band, and it would easily be possible for the transmitter to be set to some frequency not assigned to amateurs. Due allowance must therefore be made for the fact that marker stations are never actual markers of

the band limits, but are outside the bands by an appreciable amount.

The receiver may be calibrated roughly by picking up a number of such marker stations at various frequencies near the amateur bands and plotting the tuning-dial readings for each frequency, in the fashion shown in Fig. 603. The regular transmissions of A.R.R.L. Standard Frequency Stations will provide calibration points at the edges of bands and at several intermediate points, as described later in this chapter. The general shape of the curve can be determined from the plotted points and drawn in. In the illustration shown the actual limits of the band would be at 44 and 83 on the tuning dial, although the nearest marker stations are outside these limits. A curve plotted in this way is not entirely accurate, but is good enough to show approximately where the band lies.

After the band limits have been determined to a fair degree of certainty, a suitable working spot should be picked within the band and the receiver left running at that setting. The monitor now should be put into operation. If an extra pair of 'phones is not available a spare plug with its contacts shorted by a piece of wire may be plugged into the monitor so that its plate circuit will be closed. Next tune the monitor con-

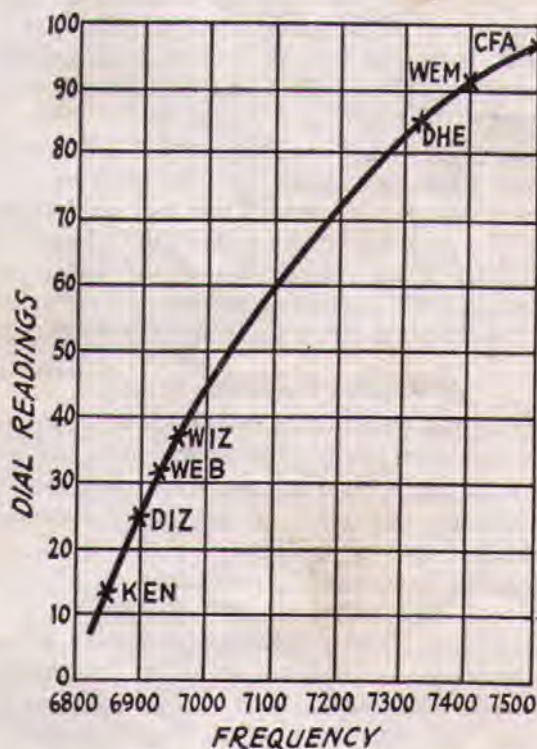

FIG. 603 — SAMPLE CALIBRATION CURVE

made from calibration points supplied by commercial "marker" stations. Such a curve may be made for the receiver or monitor, and will aid in determining the limits of the amateur bands. It is impossible to measure frequency exactly with this type of calibration, so the transmitter should be set well inside the indicated limits to be certain that all transmissions will be inside the band. Each of the above blocks represents a half-inch square on ordinary cross-section paper. The intermediate lines are not shown because of the difficulty of reproduction in printing.

denser slowly across the band, stopping when the signal from it is heard in the receiver. The monitor will now be set exactly on the frequency to which the transmitter is to be tuned. If no signal is heard, check the monitor to make sure it is oscillating (the same tests should be applied as were described for oscillating detectors in Chapter Five), move it closer to the receiver, or open the lid so that the shielding will not be so great. Make certain that the right coil is in the monitor.

With the monitor setting determined, transfer the headset from the receiver to the monitor, start up the transmitter, set its tuning controls at approximately the point where the band should be, and tune carefully until a signal from the transmitter is heard in the monitor. Set the transmitter frequency to "zero beat" — the silent space between the two beat notes — and the transmitter frequency will be exactly on the spot picked out. Since the calibration obtained as described above is only approximate, the frequency upon which the transmitter is set should be well inside the limits indicated by the calibration curve. Take no chance of operating outside the band.

This method does not provide the means for setting the transmitter on any definite frequency unless there is a known station there to mark it, but it does enable the transmitter to be tuned to, say, the center of the band, to a spot a quarter of the way from the top, or to any roughly estimated point. It is not often that the amateur finds it essential to tune his transmitter to within a few kilocycles of a given frequency but if such is the case there are means involving greater difficulties which can be used. They will be detailed later. The prime requisite usually is to have the transmitter within the limits of the band and perhaps in some particular section of it. For this work the simple monitor is all that is necessary.

Absorption Frequency Meters

Setting the transmitter frequency as described above is subject to a possible error which, particularly with high-power transmitters, may lead to off-frequency operation unless the approximate transmitter-control settings for the band are known. All vacuum-tube oscillators, in addition to generating oscillations at the frequency to which the coil and condenser tune, also set up *harmonics*, or oscillations at other frequencies which are integral multiples of the frequency set by the coil and condenser (the *fundamental frequency*). For example, a 1750-kc. oscillator will have harmonics at twice 1750 kc., or 3500 kc., at three times 1750 kc., or 5250 kc., at four times 1750 kc., or 7000 kc., and so on. If this oscillator is a monitor, it will pick up signals from a powerful transmitter set to any of this series of frequencies, although the signal will be weaker the farther it is in frequency from the fundamental.

This sometimes leads to off-frequency opera-

tion, because the total tuning range will be large in a transmitter circuit using a large variable condenser and a small inductance, as nearly all self-controlled oscillators do. As an illustration, suppose a self-controlled high-*C* oscillator such as one of those described in Chapter Seven is to be tuned to a frequency in the upper half of the 3500-kc. band; say, 3800 kc. The second harmonic is 7600 kc.; it is possible for the monitor to pick up signals on either of those frequencies if the transmitter power is high and the monitor is close to the transmitter. Unless the operator is thoroughly familiar with the tuning of his transmitter it would easily be possible for him to set the transmitter on 7600 kc. — which is not included in any amateur band — under the impression that he was putting it on 3800 kc.

An error of this sort can be discovered very readily by the use of an absorption frequency meter. This consists simply of a coil and condenser, often with a small flashlight lamp in series although the lamp is not strictly necessary. See Fig. 604. Such a frequency meter can be made from spare parts to be found in every amateur station and is well worth the few minutes' time involved in building it. Although it is not adapted to accurate frequency measuring nor to setting the transmitter frequency inside the band once the approximate settings of the transmitter controls are known, it can be useful in a variety of ways.

A series of coils should be provided for the absorption meter so that it will cover a continuous frequency range from about 1500 kc. up to the highest frequency likely to be needed — perhaps 20,000 kc. A rather large condenser should be used; a variable with 350 $\mu\text{fd.}$ maximum capacity is about right. Coils to cover the range with a condenser of this size may be made as shown in the table below. The frequency ranges are approximate only. The specifications are for coils wound on a two-inch form with No. 20 d.c.c. wire, no spacing between turns.

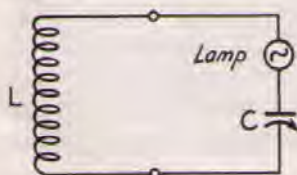

FIG. 604 — ABSORPTION FREQUENCY METER CIRCUIT

An absorption meter can be made in a few minutes from an old variable condenser, *C*, having a maximum capacity of about 350 $\mu\text{fd.}$, and a series of coils, *L*, to cover a large range of frequencies. The meter should be arranged so that the coils are readily interchangeable, although the construction need not be elaborate. The lamp acts as a resonance indicator when the absorption meter is used with a transmitter, its use is not essential, although it is a convenience. The absorption meter is not adapted to accurate measurement of frequency but is helpful in approximately locating an unknown frequency, as described in the text.

The frequency ranges are approximate only. The specifications are for coils wound on a two-inch form with No. 20 d.c.c. wire, no spacing between turns.

Range	Turns
1500-5000 kc.	25
3000-10,000 kc.	10
6000-20,000 kc.	5

It is not necessary to have calibration curves for these coils

nor even to have permanent calibration points. The use of the meter can best be explained by continuing the example already cited. To make sure that the transmitter is actually on 3800 kc. and not 7600 kc., the coil which covers the range from 3000 to 10,000 kc. should be connected to the condenser and coupled loosely to the tuning coil in the detector circuit of the receiver. Set the receiver to 3800 kc. with the detector oscillating gently and turn the dial on the absorption meter condenser. At some point toward the high-capacity end of the condenser the meter will absorb enough energy from the detector to cause it to stop oscillating. Move the meter a little farther away until this occurs at one very definite point on the meter dial. The meter will then be set approximately to 3800 kc.

Now turn on the transmitter and couple the meter, without changing its dial setting, to the transmitter tank coil. When the meter is equipped with a lamp indicator, the lamp will glow if the transmitter is tuned to 3800 kc. Always use the loosest possible coupling in making this kind of test; that is, keep far enough away from the tank coil so that the lamp shows only a faint glow at a definite point on the meter dial. A "broad" indication, or one in which the lamp lights over a considerable range of meter tuning, is not nearly so good. Should the meter be without a lamp indicator, the same effect can be obtained by watching the plate milliammeter on the transmitter. It will show a slight increase as the absorption meter is tuned through resonance with the transmitter.

Continuing the example, if no indication of resonance appears when the meter is coupled to the transmitter, the chances are that the transmitter is tuned to a harmonic of the monitor instead of to its fundamental frequency. This can be checked by decreasing the capacity of the condenser in the meter, upon which the indication should appear toward the low-capacity end of the scale. If the receiver can tune to 7600 kc. the order of the frequency to which the transmitter is tuned can be checked quite easily by following the method described in the paragraph second above, this time varying the detector tuning and holding the absorption meter condenser setting constant.

An absorption meter is also useful when, as sometimes happens, a doubling stage in a crystal-controlled transmitter is accidentally tuned to the third harmonic instead of the second. A few minutes spent in checking often will prevent off-frequency operation.

More Precise Methods

So far we have outlined the simple procedure necessary to determine definitely whether the transmitter frequency is within the limits of the band and roughly in what part of the band it is located. Many amateurs will be interested in

knowing how a transmitter can be tuned to within a few kilocycles of a given frequency. For this work some calibrated standard will be necessary against which to compare the frequency of the transmitter. Such a standard is the heterodyne frequency meter.

The heterodyne frequency meter somewhat resembles the monitor in that it is a small oscillator, completely shielded, but the refinement and care in construction is carried to a high degree so that the frequency meter can be accurately calibrated and will retain its calibration over long periods of time. The oscillator used in the frequency meter must be very stable; that is, the frequency of oscillation at a given dial setting must be practically the same under any conditions. No plug-in coils are used in the frequency-meter; one solidly built and firmly mounted coil is permanently installed in it, and the oscillator covers one band only. A low-frequency band is used for this purpose, and when the meter is to be used on the higher-frequency bands its harmonics instead of the fundamental oscillation are used. The single coil can be mounted in a much more solid fashion than could plug-in coils, and since it is not subject to continual handling such as plug-in coils receive, the turns will not be loosened or pulled out of place.

The frequency meter must possess a dial which can be read precisely to fractions of divisions. To obtain accuracy it is necessary to read the scale to at least one part in 500; ordinary dials such as are used for receivers are not capable of such precision. The National 4" Type N and 6" Type N and NW dials are provided with vernier scales for reading to a tenth of a scale division (one part in 1000), and are well suited to this work. The General Radio 704 and 706 series dials also are excellent. There are a few other good dials on the market. Care should be used to select one which has fine lines for division marks, and which has an indicator very close to the dial scale so that the readings will not be different when the dial is viewed from different angles.

The frequency meter also can be used as a monitor if desired with a resulting simplification in checking transmitter frequency. For maximum accuracy, however, the frequency meter should be left permanently in a fixed place on the operating table, since handling the meter may jar it enough to destroy its calibration unless it is very solidly constructed. A monitor, on the other hand, is a much handier instrument if it can be carried around when tests or adjustments are being made on the transmitter.

The Electron-Coupled Frequency Meter

One of the most stable oscillator circuits, electrically, that has been devised, is the electron-coupled oscillator circuit. In this circuit the oscillation frequency is practically independent of moderate variations in supply voltages, provided

the plate and screen voltages applied to the screen-grid tube used are properly proportioned. Variations in plate and filament supply voltages constitute probably the greatest source of frequency change attributable to electrical causes in vacuum tube oscillators. Furthermore, by using the grounded screen grid as the anode in the oscillatory circuit, the other elements in the tube are electrostatically shielded from the plate, just as they are in an ordinary receiving screen-grid amplifier, and it becomes possible to take output from the plate circuit with practically no reaction on the frequency of the oscillator. This is a feature of great value, because it means that the frequency meter can be coupled to the receiver with no danger of changing its calibration. A third feature of the electron-coupled oscillator which makes it ideally suited to use in frequency meters is that strong harmonics are generated in its plate circuit so that the meter is useful over an extremely wide range of frequencies.

Circuit diagrams for electron-coupled frequency meters are given in Figs. 605 and 606. The former is for use with tubes having indirectly-heated cathodes, such as the 24-A, 35, and 36. Fig. 606 is a circuit for filament-type tubes such as the 32. With these tubes it is necessary to provide an extra winding, L_2 , in series with one leg of the filament so that both filament terminals will be at the same r.f. potential. In general, the types of tubes just mentioned (all of them are four-element tubes, or tetrodes) will be better

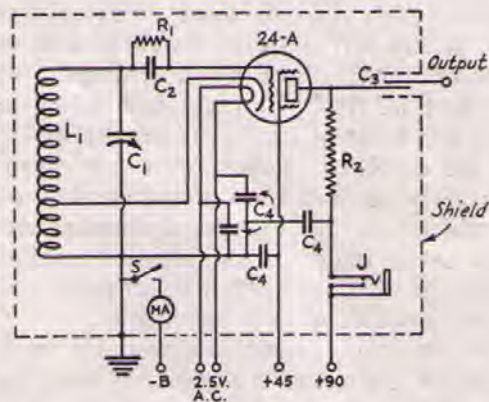

FIG. 605 — CIRCUIT OF THE ELECTRON-COUPLED FREQUENCY METER

This circuit is for use with indirectly heated tubes such as the 24-A and 36.

C_1 — Band-spread condenser, minimum capacity 53 $\mu\text{fd.}$, maximum capacity, 81 $\mu\text{fd.}$, approximately. (Such as General Radio Type 556.)

C_2 — 250- $\mu\text{fd.}$ mica condenser.

C_3 — Approximately 10 $\mu\text{fd.}$ See text for details.

C_4 — .01- $\mu\text{fd.}$ mica by-pass condenser.

R_1 — 100,000-ohm grid leak.

R_2 — 50,000-ohm 1-watt resistor, pigtail type, non-inductive.

J — Closed-circuit 'phone jack.

S — On-off switch, s.p.s.t.

L_1 — Approximately 90 turns of No. 30 d.s.c. wire close-wound on a 1-inch bakelite tube, tapped at the 30th turn from the grounded end. A few more or less turns may be needed to spread the 1750-kc. band over the dial scale to the best advantage.

suited for use as electron-coupled oscillators than the screen-grid pentode receiving types such as the 34, 39-44, and 78, because in these types the suppressor grid, connected to the cathode inside the tube, nullifies the shielding when the tube is used as an electron-coupled oscillator. The 77, 57 and 58 will be satisfactory, however, because the separate base connection of the suppressor grid makes it possible to tie this grid either to ground or to the regular screen grid.

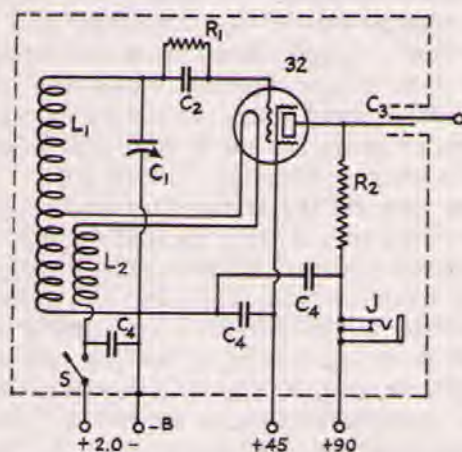

FIG. 606 — ELECTRON-COUPLED FREQUENCY METER CIRCUIT FOR USE WITH DIRECTLY-HEATED TUBES SUCH AS THE 32

The circuit is essentially the same as that of Fig. 605 except that both sides of the filament must be fed through coils to prevent grounding the filament. L_1 has the same specifications as in Fig. 605. L_2 has the same number of turns as the tapped portion of L_1 . It may be wound over the corresponding part of L_1 or directly on the coil form between the turns of the tapped portion of L_1 . The other components have the same values as in Fig. 605. In this circuit the filament switch as well as the output binding post and 'phone jack must be insulated from the shield.

Mechanical considerations are most important in the construction of a frequency meter. No matter how good the instrument may be electrically, its accuracy never will be good if it is flimsily built. Mount everything solidly; make connections with stiff wire and place all leads so they cannot be moved in the course of ordinary handling. Thoughtful care in the construction of the frequency meter makes the difference between the precise instrument and just an ordinary oscillator.

The construction of the two-tube frequency-meter monitor shown in Figs. 607 and 608 is illustrative of good practice in building a frequency meter. The same layout can, in fact, be followed in using the circuit diagrams of Figs. 605 and 606, even though the separate detector tube is not used.

It is desirable to design the frequency meter so that the oscillator operates in the 1715-2000-kc. band, with a "spread" such that almost the entire dial scale is used to cover the band. While the specifications for the oscillator inductance under Fig. 605 will be found to work out closely, it may be necessary to add or subtract a few turns to

get the band-spread just right. For the higher-frequency bands harmonics of the oscillator are used. Thus the second harmonic will cover the 3500–4000-kc. band, the fourth the 7000–7300-kc. band over part of the scale, and so on to the highest frequencies used by amateurs. Strong harmonics can be taken from the frequency meter even on the 56,000-kc. band, which is the highest-frequency band amateurs have used for practical communication.

The cathode tap on the coil L_1 usually will be set at about $\frac{1}{3}$ the length of the coil from the grounded end. The location of the tap is not critical, but if too many turns are used between cathode and ground it sometimes happens that a species of multiple oscillation will be set up, corresponding to the howl a regenerative detector will give if too much regeneration is used. This results in the production of an extended series of beats on either side of the desired one. Such a condition can easily be cured by moving the cathode tap toward the ground end of the coil or by using a grid leak, R_1 , having a lower value of resistance. When the coil has been completed and the tap correctly placed the winding should be coated with lacquer or collodion to hold the wires firmly in place.

The coupling condenser, C_3 , in Figs. 605 and 606 should have very small capacity—about 10 to 15 micromicrofarads. A midget variable condenser will do—both sides must be insulated from the shield—or a small “trimmer” condenser can be used. Alternatively, a suitable condenser can be made from two pieces of metal strip measuring approximately one-half by one inch, arranged to face each other with a space of about $\frac{1}{8}$ inch between their surfaces.

The signal from the frequency meter can be fed into the receiver by connecting a wire from the output post on the meter to the antenna post on the receiver. This will give strong signals on all harmonics; in fact the signals may be stronger than is deemed desirable. If this should be the case the wire from the output post can be disconnected from the receiver but left in the vicinity of the receiving lead-in. Satisfactorily loud signals from the frequency meter ordinarily can be obtained even with such loose coupling.

The frequency-meter can be used as a monitor by

connecting a pair of headphones in the screen circuit through the medium of the jack, J .

When the frequency meter is first turned on some little time is required for the tube to reach its final operating temperature, and during this period the frequency of oscillation will drift slightly. Although the drift will not amount to more than two or three kilocycles on the 3500-kc. band and proportionate amounts on the other bands, it is desirable to allow the frequency meter to “warm up” for about a half hour before calibrating, or before making measurements in which the utmost accuracy is desired. This applies particularly with indirectly-heated tubes. The directly-heated tubes, because of the smaller filament power required, warm up much more quickly. The on-off switch in Fig. 605 is a useful adjunct to the meter because the “B” supply can be cut off independently of the filament supply, permitting the operator to keep the frequency meter up to temperature without wasting “B” current when no measurements are being made.

With careful construction, a good readable dial, and an accurate calibration made as described in a later section, measurements made with the electron-coupled frequency meter can be depended upon to be accurate to within 1 part in 1000, or one-tenth of 1%, an accuracy more than sufficient for amateur work.

A Combined Frequency Meter-Monitor

Although an electron-coupled frequency meter constructed according to the diagrams, Figs. 605 or 606, can be used as a monitor as explained in the previous section, the monitoring function will be performed more satisfactorily if a separate detector tube is added to the unit. Installation of the extra tube will result in a stronger signal for monitoring purposes, and will eliminate such slight changes in oscillator frequency as may be occasioned by plugging the headphones into the plate lead of the oscillator. The separate detector adds little to the cost of the frequency meter.

A combined frequency meter-monitor of this type is illustrated in Figs. 607 and 608. The circuit diagram is given in Fig. 609. The circuit diagram of the oscillator is the same as that of Fig. 605 up to the “output” terminals, where condenser C_3 replaces C_2 in Fig. 605. The os-



FIG. 607—TYPICAL FREQUENCY METER CONSTRUCTION

This photograph is a panel view of the two-tube frequency-meter-monitor described in the text. Among the essentials in frequency-meter design are mechanical construction of high stability and the use of a dial having a true vernier scale.

illator output is fed into the grid circuit of a Type 56 tube connected as a plate or grid-bias detector. This tube operates both as an amplifier of the radio-frequency output of the oscillator and as a detector when the oscillator output or one of its harmonics is made to beat with the signal from the transmitter. A convenient method of switching the headphones from the receiver to the frequency-meter-monitor also is shown in Fig. 609.

The construction of the unit should be evident from the two photographs. The case is a sturdy aluminum box measuring 10 by 6 by 5 inches. An aluminum shelf bolted to the panel holds all the parts. The oscillator and detector tubes are at the right in Fig. 608; at the center are the two tuning condensers, C_1 and C_2 , C_2 being used as an adjustable fixed section to set the minimum capacity in the circuit to spread the 1750-kc. band over most of the dial scale. It need only be adjusted when the frequency meter is first built, and therefore is not controllable from the front of the panel. The grid condenser, C_3 , and grid leak, R_1 , are mounted by a small bracket on the upper stator-plate terminal of C_2 to make a short, direct connection to the grid of the 24-A oscillator tube. To the left of C_1 and C_2 , near the shelf, is the oscillator coil, L_1 . By-pass condensers and resistors are mounted underneath the shelf, together with a cable socket for the heater and plate-supply connections.

If desired, it is possible to include a power supply for the frequency meter-monitor in the same cabinet if the space for a small power transformer and a compact rectifier-filter is available. Since the plate current requirements of a unit of this type are very low — about two milliamperes at the most — a simple filter of the resistance-capacity type will be sufficient. The power transformer can be of the midget type. As a general rule, however, it is better to use a separate power supply because of the possibility of vibration and hum pickup from the power unit. Alternating current can be used on the tube heaters in conjunction with "B" batteries, or all the power can come from a receiver power unit — from the same unit used with the receiver, in fact.

Calibrating the Frequency Meter

When the frequency meter is finished it must be calibrated before it can be put into service.

After its tuning range has been checked to be certain that it covers the 1750-kc. band with a little overlap at each end, an approximate calibration may be made using marker stations. These markers may be near *any* of the amateur bands, not necessarily only in the vicinity of 1715 and 2000 kc. For example, stations in the vicinity of 4000 kc. can be used as markers, the actual frequency of the station being divided by 2 to get the calibration point since the second harmonic of the frequency meter is being used. Again, marker stations near 7000 kc. can furnish points for the low-frequency end of the scale, the calibration frequency being the marker station frequency divided by 4 because the checking will be done on the fourth harmonic of the frequency meter. A large number of points can be secured in this way for the purpose of making up a preliminary calibration.

The general procedure is to tune in the marker station on the receiver with the detector oscillating, then back off the regeneration control until the detector stops oscillating but is still giving a great deal of regenerative

amplification, just as if a 'phone station were being tuned in. With a superhet receiver the signal would first be tuned in with the beat oscillator on; after setting the receiver to zero beat with the incoming signal the beat oscillator should be shut off. The dial on the frequency meter should now be turned until the signal from the meter is heard to beat with the marker station signal. This amounts to using the frequency meter as a separate heterodyne. Adjust the frequency meter to give zero beat with the marker signal and note the dial reading. The calibration point will be the marker station frequency divided by whatever harmonic of the frequency meter is being used. A number of these points will give a complete-enough calibration to make possible the drawing of an approximate calibration curve on regular graph paper.

After this approximate curve has been constructed, the current issue of *QST* should be consulted for information as to the next transmission of standard frequencies for calibration purposes. These transmissions are given once or twice each week by the stations comprising the A.R.R.L. Standard Frequency System. A word about the A.R.R.L. Standard Frequency System is in order here because the service is unique in the radio world. The Standard Frequency System consists



FIG. 608 — AN INTERIOR VIEW OF THE TWO-TUBE E. C. FREQUENCY-METER-MONITOR

Careful attention to small details of construction is repaid by a high order of accuracy in the frequency meter.

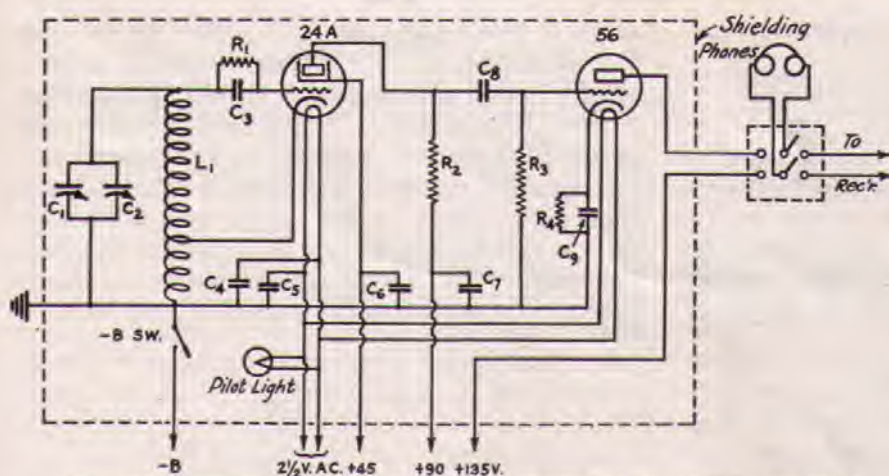

FIG. 609 — CIRCUIT OF THE TWO-TUBE FREQUENCY-METER-MONITOR

- C_1 — 3-plate Cardwell Midway Type 401-B, maximum capacity $26 \mu\text{fd.}$, minimum capacity $7 \mu\text{fd.}$ (See text.)
 C_2 — 5-plate Cardwell Midway Type 402-B, maximum capacity $50 \mu\text{fd.}$, minimum $8 \mu\text{fd.}$
 C_3 — .0001- $\mu\text{fd.}$ fixed condenser.
 C_4, C_5, C_6, C_7 — .01- $\mu\text{fd.}$ fixed by-pass condensers.
 C_8 — 40- $\mu\text{fd.}$ fixed coupling condenser.
 C_9 — .25- $\mu\text{fd.}$ fixed condenser.
 R_1 — 100,000-ohm $\frac{1}{2}$ -watt size.
 R_2 — 100,000-ohm 1-watt size.
 R_3 — 1-megohm 1-watt size.
 R_4 — 100,000-ohm 1-watt size.
 L_1 — 79 turns No. 30 d.s.c. wire on a 1-inch diameter tube. Cathode tap should be at 23rd turn from "ground" end. The heater and "B" supplies may be from the receiver power pack.

of three stations, especially licensed to transmit calibration signals for amateur use, located in different geographical sections of the United States. Each of the stations is equipped with a frequency standard which is accurate to better than one part in 10,000 or .01%. These individual standards have been calibrated directly against the national frequency standard located in the laboratory of the Bureau of Standards at Washington, and the calibration signals transmitted for amateurs are therefore based on the national frequency standard. Every amateur is urged to make the fullest possible use of the transmissions. In general the transmissions consist of signals which mark accurately the limits of the 3500-, 7000- and 14,000-kc. bands with intermediate points at 100 kc. intervals.

The date and exact form of each transmission are indicated in each issue of *QST*. The transmissions generally take the form of an eight-minute period for each frequency. The first part of each period is devoted to a QST — general call to all A.R.R.L. stations — then follows a series of long dashes and an announcement of the exact frequency, then a final short period in which the frequency of the transmission to follow in a few minutes is announced.

The same procedure should be followed in calibrating from Standard Frequency Transmissions as in calibrating from marker stations. The purpose of the marker station calibration is simply to serve as a guide in locating the Standard Frequency signals when the frequency meter is ready for its first calibration.

After the dial readings for various frequencies have been secured, they should be plotted carefully on a curve sheet. The curve should not be "cramped" — that is, the scale should not be so small that it is difficult to make accurate readings. Fig. 610 shows a satisfactory way of making up such a curve. The paper used is standard cross-section paper (20 lines to the inch); each of the blocks shown in the drawing represents a half-inch block on the paper. It may be necessary to use two sheets to draw the entire curve, one for the low-frequency half of the band and the other for the high-frequency half. The illustration shows calibrations only for the three bands on which Standard Frequency Transmissions are sent. For the 1750-kc. band the 3500-

kc. readings would be divided by two. The dial

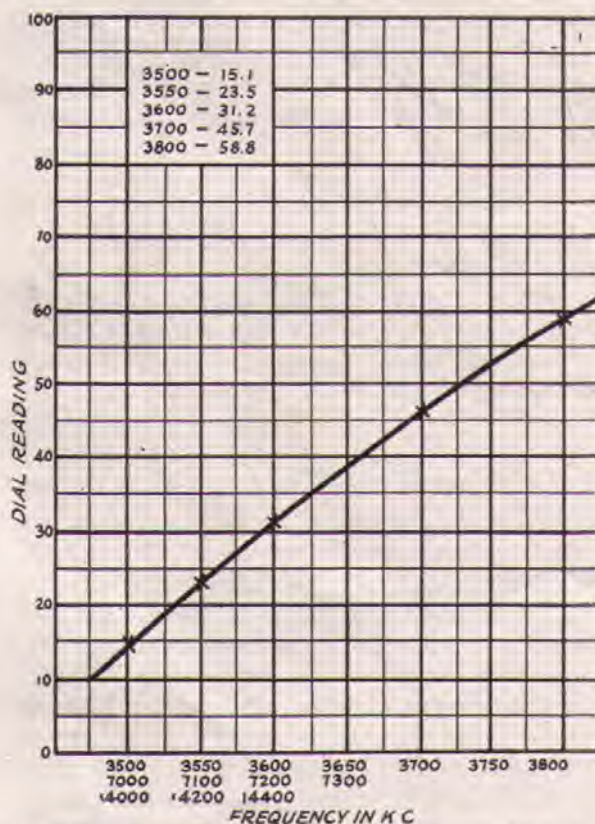

FIG. 610 — TYPICAL CALIBRATION CURVE FOR THE FREQUENCY METER

Each of the small blocks represents a half-inch block on ordinary cross-section paper. The chart must be large enough so that tenths of divisions can be read accurately on the dial reading scale, and the frequency scale must be spread out to facilitate making readings to within a few kilocycles.

settings are the same for all frequencies harmonically related.

Safety First!

Always play safe when setting the frequency of a transmitter having a self-controlled oscillator. Make allowance for all possible errors in frequency measurement and set the transmitter well inside the limits of the band. Take every opportunity to check the monitor or frequency

meter to make sure that nothing has happened to the calibration. *Know* whether you are in the band or not — that part is easy if no attempt is made to crowd the edges. Although accurate determination of frequency is becoming increasingly important, the amateur who follows the simple directions given earlier in this chapter can at least be certain that he is operating in his legally assigned territory, even though no elaborate methods are used for actual measurement of frequency.

PLANNING AND BUILDING TRANSMITTERS

IN ONE respect the transmitter is the most important piece of equipment in the amateur station — it is the mouthpiece through which the operator conveys his thoughts to other amateurs the world over. Distant amateurs must therefore judge the station by the quality of the transmitter's output and by the way it is operated. A steady signal with a clean "pure d.c." note is the finest testimonial an amateur station can have. It is well worth attaining, not only because it indicates possession of a good transmitter intelligently operated but also because it shows that the station's operator is not "hogging" more than his share of the amateur bands — as he would with a rough, wobbly, creeping signal.

The steady pure d.c. signal is acknowledged to be far superior to all other types for communicating under adverse conditions. Moreover, the importance of reducing interference by the production of really good signals is so great that the government regulations under which amateur stations operate require adequately-filtered direct-current plate supplies for transmitters operating on those frequency bands which carry the bulk of amateur communication — the 1.75-, 3.5-, 7- and 14-mc. bands. The amateur who follows the principles of transmitter design and adjustment laid down in this chapter and the corresponding instructions in the Power Supply chapter need have no fear of running afoul of the regulations.

Types of Transmitters

All amateur transmitters employ the vacuum tube as a generator of the high-frequency alternating current necessary for the production of radio signals. For this reason, it is quite impossible to have a good understanding of the operation of transmitters without first understanding the way in which vacuum tubes function. It is suggested that the beginner should make a careful study of the third and fourth chapters before attempting the construction or operation of any of the apparatus described in this chapter.

Present-day amateur transmitters are of two general types: those which employ "self-controlled" oscillators and those in which a crystal-controlled oscillator is used. The first of these types is called "self-controlled" because the frequency of the oscillations generated in the transmitter depends on the constants of the circuit (chiefly the size of the coil and condenser used in the plate circuit of the oscillator). The crystal-controlled transmitter, on the other hand, makes

use of a special type of crystal (usually quartz) in the oscillator. In this case, the crystal is the chief factor in determining the frequency on which the transmitter operates.

When an oscillator of either type is used to feed the antenna directly, the transmitter is said to be "self-excited." If the oscillator merely feeds one or more amplifier tubes which in turn feed the antenna, the arrangement is known as an "oscillator-amplifier" transmitter. One may have either a self-controlled or a crystal-controlled oscillator-amplifier transmitter.

Of all transmitters, the crystal-controlled type of set is by far the most satisfactory. In its usual form it is somewhat more complicated than the self-controlled self-excited transmitter but the advantages to be gained in its operation and in the signal it produces far outweigh the added cost. The crystal-controlled transmitter is fast becoming universal throughout the world. There is, of course, still a place for the low-powered self-excited self-controlled transmitter. Its simplicity and its low cost make it attractive to the beginner in amateur radio. Further, it must be admitted that such a transmitter, when built and operated very carefully, is capable of good performance.

Self-Controlled Oscillator Circuits

Fundamentally there are two general divisions of self-controlled oscillator circuits; those employing capacitive coupling (condensers) to feed back energy from the plate to the grid circuit, and those using inductive coupling (coils) for the same purpose. All circuits are modifications of these two general classes.

Before going into the details of the various oscillator circuits, however, it is desirable to have an understanding of basic oscillator operation. It is briefly as follows: When the tuned output circuit of a vacuum-tube is properly coupled to its input circuit, a variation of the output current will cause a voltage in the input circuit which, by virtue of the amplifying action of the tube, will cause a current variation of greater amplitude in the output circuit. In turn this augmented variation will be impressed on the input circuit, and so the oscillation builds itself up. The input circuit of the oscillator is the grid and the output is the plate circuit.

The maximum amplitude to which oscillations will build up depends upon the characteristics of the tube, the circuit constants, the grid bias and the plate voltage. The frequency of oscillation will be determined principally by the inductance

and capacity values in the tuned circuit, although other circuit constants such as the inter-electrode capacitances of the tube also will affect the frequency. For satisfactory oscillator operation the amplitude of the grid excitation voltage should be sufficient to cause large pulses of plate current to flow during a small part (the peak) of the excitation's positive half-cycle. Since no plate current flows during the negative half-cycle of the excitation voltage, the plate tuned circuit receives a pulse on alternate half-cycles only. These

timed impulses are sufficient to maintain oscillation in the plate tuned circuit — called the "tank" circuit because it acts as a reservoir for radio-frequency energy.

To meet the condition specified above — that plate current should flow only during a part of the positive excitation cycle — the oscillator must be operated with sufficient negative grid bias to prevent or "cut off" the flow of plate current during most of the excitation cycle. Grid bias is usually obtained by means of a grid leak. During the positive half-cycle of excitation voltage there is a considerable flow of electrons from the grid to the filament through the external circuit. If a blocking condenser is connected between the grid and its excitation circuit, this rectified current may be made to flow through a resistance connected across the blocking condenser or between the grid and filament. The voltage drop caused by the current flowing through the resistor will maintain the grid at a potential negative with respect to the filament and so provide the negative bias. The bias voltage so developed will be equal to the resistance of the grid leak in ohms multiplied by the average current (as read by a direct-current meter) expressed in amperes.

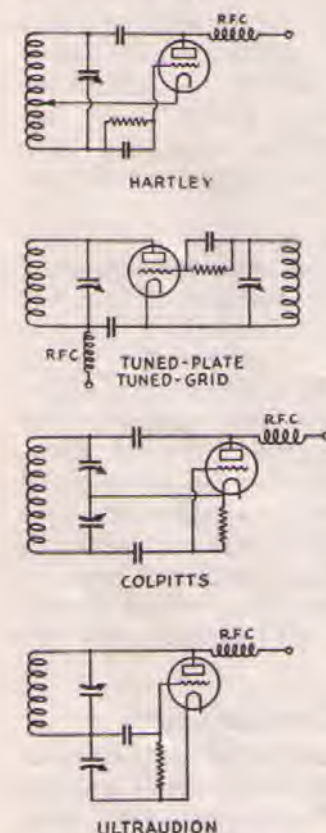

FIG. 701—FOUR COMMONLY-USED OSCILLATOR CIRCUITS

The Hartley and tuned-plate tuned-grid are the most popular among amateurs for frequencies up to 30,000 kc. On the ultra-high frequencies the Colpitts and ultraudion are popular with experimenters.

The choice of a circuit is not of great importance, for if the circuit is arranged to suit the particular tube or tubes used, and is adjusted prop-

erly, similar results can be obtained with any of them. In every oscillator provision is made to tune the condenser-coil circuits to the required frequency and to vary the amount of energy fed into the grid circuit from the plate circuit (the grid excitation). Other means are provided to adjust the grid bias and to adjust the load to that value which will allow the most efficient transfer of energy from the plate circuit. Some method of making all of these adjustments is to be found in every satisfactory circuit.

The circuits in most general use are the Hartley, Armstrong or tuned-grid tuned-plate, Colpitts and ultraudion.

In the Hartley oscillator the tank circuit has its ends connected to the grid and plate of the tube. The filament circuit of the tube is also connected to the coil at a point between the grid end of the coil and the plate end. In this way the coil is really divided into two sections, one in the grid circuit and one in the plate circuit. Oscillations are maintained because of the inductive coupling between these two sections.

In the tuned-grid tuned-plate circuit there are two tank circuits, one connected between the grid and the filament of the tube and the other between the plate and filament. In the high-frequency oscillator these two circuits are not coupled inductively and the capacity of the tube itself is utilized to provide the coupling between the grid and plate circuits which is necessary to cause oscillation.

The Colpitts circuit is arranged so that the filament is connected to the junction of two condensers which are in series across the coil. In this way the grid and plate circuits share the voltage drop across the condensers, and oscillation is produced in this manner.

A fourth circuit is the ultraudion. It belongs to the Colpitts family of circuits, and is used by only a comparatively small number of amateurs.

The Hartley and tuned-plate tuned-grid circuits are most popular, probably because the adjustments which regulate feed-back and frequency of oscillation are more independent in those two circuits, thus making them somewhat easier to handle.

Of the many possible variations on these four basic circuits, one general class is worthy of separate consideration — the push-pull oscillator. The push-pull self-controlled oscillator has certain advantages over the simpler single-tube circuits when operating at high frequencies, chiefly because a higher order of frequency stability is attainable. In the push-pull oscillator two tubes are connected across the tank circuit in such a way that the r.f. grid and plate voltages of one tube are 180 degrees out of phase with the corresponding voltages of the other tube. The plate current pulses flow alternately to the two tubes. Fundamental push-pull circuits are shown in Fig. 702. An attempt to devise a push-pull

ultraudion circuit results in either a push-pull Hartley or Colpitts.

A great many modifications of these fundamental circuits, both single-tube and push-pull, have been evolved and it is not surprising that the newcomer is often confused by them. It is well to remember that however complex or unusual the circuit may appear, it can without doubt be "boiled down" to one of the fundamental arrangements. And, what is more important, when it has been adjusted carefully it will provide almost an identical performance to that of any other circuit.

Frequency Stability and Efficiency

An oscillator incapable of maintaining a high degree of frequency stability is characterized by a broad, creeping signal and a mushy or rough note. Such a note indicates that the operator is inconsiderate of the rights of others in the operation of his station, because any amateur can construct a transmitter of good frequency stability.

The causes of frequency instability can be roughly divided into two groups, those which are "mechanical" in nature and those which are "dynamic." Mechanical instability results from variations in the circuit constants due to mechanical vibration and thermal effects. Mechanical vibration will cause rapid fluctuations in frequency by varying the spacing between condenser plates, the separation between coil turns or the distance between the tube elements. These are avoided largely by rigid construction and by reducing the vibration. Frequency fluctuation ("creeping") due to thermal effects results from variation in spacing of the tube elements (variation in inter-element capacity) with changes in temperature. Creeping can be minimized by keeping the power dissipated in the tube at or below its normal rating, by choosing tubes having internal construction particularly intended to reduce frequency-creeping, and by using circuits which have large capacities in parallel with the tube's input and output capacities. Such circuits are popularly known as "High-C" circuits. The use of a large shunting capacity in the plate circuit is particularly effective.

"Dynamic" instability is caused by anything which affects the tube's characteristics, especially its plate impedance, during operation. A variation in plate impedance will cause a change in frequency. The principal cause of dynamic frequency instability — sometimes called "frequency flutter" — is the variation in plate voltage which results when a poorly-filtered plate supply is used. To prevent dynamic instability it is essential that the plate supply be the best "pure d.c." obtainable and that the grid bias — or grid leak — be sufficiently high in value. Moreover, too much care cannot be exercised in adjusting the grid excitation. Dynamic instability can be

reduced by careful circuit design and here again the use of a High-C plate tank is very effective. Such a tank circuit is capable of reducing the amplitude of frequency fluctuations with variations in plate impedance.

The characteristics of the load circuit (which include the plate tank circuit and the antenna circuit or the input circuit of a succeeding tube amplifier) and the losses in the grid circuit affect the oscillator's plate efficiency. The plate efficiency is the ratio of radio-frequency power output to plate power input. The losses in the grid circuit are largely the power dissipated by the grid leak and the losses due to radio-frequency displacement currents between the grid and filament. The latter may be considerable at high frequencies with tubes having large grid-filament capacity.

There is no simple method of accurately determining the plate efficiency of a high-frequency oscillator. If the tube is operated at normal plate dissipation, usually indicated by dull red coloring of the plate, the power output will be approximately the difference between total plate input (d.c. plate voltage multiplied by the plate current in amperes) and the rated plate dissipation in watts. For a more exact determination, the power dissipated in the grid leak should be subtracted also. The power dissipated in the grid leak is the resistance of the leak in ohms multiplied by the square of the d.c. grid current in amperes.

Transmitting Tubes

An excellent variety of power tubes is available to the amateur contemplating the construction of a high-frequency transmitter. The large number of tubes is, in fact, often a source of confusion to the beginning amateur because it is difficult for him to decide upon the type best suited to his particular purpose. Broadly speaking, however, tubes may be classified according to the power output to be expected from them. Thus, a group of small tubes of the receiving type, adapted by amateurs to use in low-power transmitters, show power outputs of the order of 5 to 15 watts; a

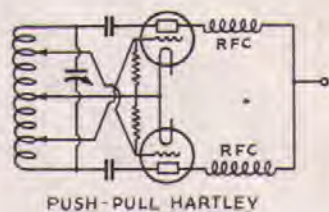

PUSH-PULL HARTLEY

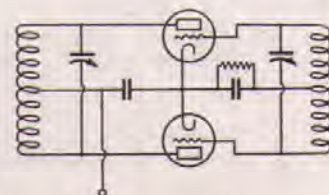

PUSH PULL T.P.T.G.

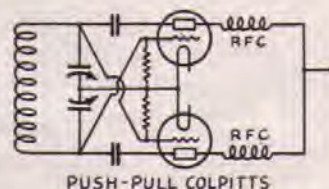

PUSH-PULL COLPITTS

FIG. 702 — FUNDAMENTAL PUSH-PULL CIRCUITS

Many practical variations are possible. Both the Hartley and Colpitts circuits can, with minor modifications, be arranged for series plate feed.

TRANSMITTING TUBES

TRIODES

Type	Nominal R.F. Output (watts) ¹	Fil. Volts (E _f)	Fil. Amps. (I _f)	Plate Volts ² (E _b)	Plate Ma. ³ (I _p)	Neg. Grid Bias Volts ⁴ (E _c)	Max. Grid Ma. (I _c)	Safe Plate Dissipation (watts)	Amp. Factor (μ)	Interelectrode Capacitances (μfd.)			Grid Leak ⁵ (ohms)
										Grid to Fil.	Grid to Plate	Plate to Fil.	
45	10	2.5	1.50	400	50	180			3.5				50,000
46	10	2.5	1.75	400	50	180 ⁴ 22 ⁷			5.6 30.0				50,000 1,000
59	10	2.5*	2.0	400	50	135 ⁶ 22 ⁷			6.0 30.0				25,000 1,000
205-D 205-E	10	4.5	1.60	400	50	90		14	7.3	5.2	4.8	3.3	10,000
271-A	10	5.0*	2.0	400	50	90		15	8.5	6.5	5.3	3.8	10,000
843	10	2.5*	2.5	425	40	90	7.5	15	7.7	5.0	6.0	5.0	10,000
10	15	7.5	1.25	500	60	135	15	15	8.0	4.0	7.0	3.0	10,000
841	15	7.5	1.25	500	60	30	20	15	30.0	5.0	8.0	3.0	2,000
800	50	7.5	3.25	1000	75	135	25	35	15.0	2.8	2.5	1.0	10,000
825	50	7.5	3.25	1000	75	180		40	10.0	2.0	3.0	1.0	10,000
830	50	10.0	2.15	750	110	180	18	40	8.0	4.9	9.9	2.2	10,000
RK-18	50	7.5	2.5	1000	85	135	15	40	18.0	3.8	5.0	2.0	10,000
203-A	100	10.0	3.25	1250	175	100	60	100	25.0	6.5	14.5	5.5	10,000
211	100	10.0	3.25	1250	175	200	50	100	12.0	8.0	15.0	7.0	15,000
242-A	100	10.0	3.25	1250	150	150	50	100	12.5	6.5	13.0	4.0	15,000
276-A	100	10.0	3.0	1250	125	150	50	100	12.0	6.0	9.0	4.0	15,000
852	100	10.0	3.25	3000	100	350	40	100	12.0	2.0	3.0	1.0	20,000
F-108-A	200	10.0	11.0	3000	200	350	50	175	12.0	3.0	7.0	2.0	15,000
204-A	350	11.0	3.85	2500	275	250	80	250	25.0	18.0	17.0	3.0	10,000
849	450	11.0	5.0	2500	350	300	125	300	19.0	17.0	33.5	3.0	10,000
831	500	11.0	10.0	3000	350	300	100	400	14.5	3.8	4.0	1.5	10,000
F-100*	500	11.0	25.0	2000	500	300		500	14.0	4.0	10.0	2.0	10,000

TETRODES AND PENTODES

Type	Nominal R.F. Output (watts) ¹	Fil. Volts (E _f)	Fil. Amps. (I _f)	Plate Volts ² (E _b)	Screen Volts (E _d)	Neg. Grid Bias Volts (E _c)	Plate Ma. ³ (I _p)	Max. Grid Ma. (I _c)	Safe Screen Dissipation (watts)	Safe Plate Dissipation (watts)	Interelectrode Capacitances (μfd.)			
											Grid to Cathode	Grid to Plate	Plate to Cathode	
41	5	6.3*	0.4	300	100	22	40							
42	10	6.3*	0.7	400	100	45	50							
47	10	2.5	1.75	400	100	45	50					8.6	1.2	13.0
2A5	10	2.5*	1.75	400	100	45	50							
59	10	2.5*	2.0	400	100	45	50							
844	5	2.5*	2.5	500	150	10	30	5	3	15	10.0	0.07	8.5	
865	15	7.5	2.0	750	150	75	60	15	3	15	10.0	0.05	7.5	
254-A	20	5.0	3.25	750	175	90	60		5	20	4.6	0.1	9.4	
254-B	25	7.5	3.25	750	150	135	75		5	25	11.2	0.085	5.4	
282-A	50	10.0	3.0	1000	250	150	100		5	70	12.2	0.2	6.8	
850	100	10.0	3.25	1250	150	150	175	40	10	100	17.0	0.2	26.0	
860	100	10.0	3.25	3000	250	200	100	40	10	100	8.5	0.05	9.0	
861	540	11.0	10.0	3500	500	200	350	100	35	400	17.0	0.1	13.0	

¹ Conservative rating based on normal plate input and operating conditions. The actual output will depend upon the efficiency and the power supplied to the tube plate.

² Maximum recommended values, unmodulated d.c. With modulation, d.c. plate voltage should be 25 to 30 per cent lower.

³ Recommended value for operation as oscillator or Class-C power amplifier.

⁴ With outer grid connected to plate.

⁵ With grids connected together.

⁶ Grids Nos. 2 and 3 connected to plate.

⁷ Grids Nos. 1 and 2 connected together; grid No. 3 connected to plate.

* Indirect y-heated cathode.

group of medium-power tubes is rated at 35 to 50 watts output; a third group carries a nominal rating of 100 watts, and so on. Obviously, then, the first decision the amateur has to make in the choice of a transmitting tube is that of the power output he wants. The table of transmitting tubes gives the important characteristics and operating ratings of the tubes most suitable for use as radio-frequency oscillators and power amplifiers.

The design of almost every item in the transmitter will be influenced by the tube with which it is to be operated. The rating of the transformers, the current-carrying capacity of the filter, the rating of the fixed condensers, the type of variable condensers and the design of the inductances, all will depend upon the power and voltage rating of the tube. The amateur usually uses a low-power tube for his first transmitter. This practice is a good one. The use of low power enables the transmitter to be built cheaply and yet provides full opportunity for the amateur to gain a knowledge of the operation and handling of a transmitter. Many of the most experienced amateurs actually prefer a low-power transmitter of this type, knowing that they can readily communicate over many thousands of miles under good conditions. The distance that can be covered by a transmitter is, in fact, not very much dependent upon the power output. Even a receiving tube in the hands of an experienced amateur can send across the world when conditions are very good. The higher-powered transmitters can send no farther than this but they have the advantage of being able to put signals into far distant countries with greater reliability and readability.

Planning the Simple Transmitter

Before going on to the considerations involved in the construction of the more complicated oscillator-amplifier transmitters, we shall show some examples of the type of construction which has been found most satisfactory for low-power self-controlled oscillators. The use of oscillator transmitters is, in fact, confined almost entirely to low-power work (50 watts output or less) in present-day amateur radio; almost without exception the transmitters using the larger varieties of tubes are of the oscillator-amplifier type, generally with crystal control. Because the oscillator transmitter is the simplest and therefore the easiest to build and operate, most beginners build a transmitter of this type for their first attempt at radio transmission.

There is a splendid field for the exercise of thought and originality in the arrangement of the apparatus of the transmitter. The shortness of leads and the placement of the coils and condensers with respect to the other apparatus are matters of such importance that the amateur will always be rewarded for time spent in consideration of the problem. In the pages that fol-

low some examples of satisfactory layouts will be given. These will serve to give a general idea of how the transmitter can be arranged. However, they are not the acme of perfection; neither are they applicable to all types of apparatus. The use of even a different variable condenser than that shown in any one of the examples — a condenser with its terminals in a different place — may make some entirely different lay-out preferable.

Most of the transmitters to be described are baseboard-mounted with all the apparatus exposed and readily accessible for adjustment or experiment. If desired, the apparatus can be mounted on a baseboard and a vertical panel in a manner somewhat similar to the receiver. Unless the apparatus is arranged with great care, however, this type of construction is likely to mean a sacrifice of convenience in making alterations and adjustments.

Building a Transmitter

The construction of a simple transmitter can be accomplished in the shortest time and with the least difficulty by mounting the apparatus on a baseboard in somewhat the manner shown in the illustrations. We will use this self-controlled self-excited transmitter as an example and describe it in detail. If the reader studies the circuit diagram, the photographs and the description carefully he will find that the transmitter is even simpler than it looks. If he understands just what it is all about he will find it easier to modify the arrangement to suit the particular apparatus at his disposal.

This transmitter is perhaps the simplest and most nearly fool-proof ever designed. It contains the very minimum of parts and is therefore extremely low in cost. The construction is in no way complex and the adjustment is easily accomplished by even the inexperienced operator. The circuit is a modification of the popular tuned-grid tuned-plate arrangement. Despite its simplicity, the set has excellent frequency stability and efficiency, comparing favorably with more complicated arrangements.

The frequency is determined by the tuning of the plate tank circuit and the excitation is dependent on the constants of the grid circuit. Since one excitation adjustment is satisfactory over a considerable range of plate-tank tuning, it is possible to use a fixed coil in the grid circuit for each amateur band. An antenna coupling coil is provided in the set but an external antenna tuning condenser (perhaps two of them) will usually be found necessary. The set is designed to use a Type 10 tube with a 500-volt d.c. plate supply and a 7.5-volt a.c. filament supply, a Type 45 tube with a 350-volt d.c. plate supply and a 2.5-volt a.c. filament supply, or a Type 01-A tube with a 135-volt d.c. plate supply and a 6-volt d.c. filament supply.

Construction of the Set

The schematic wiring diagram is given in Fig. 704, together with the constants, and the photographs show how the set looks when constructed. The layout chosen is one which allows short r.f. leads.

The baseboard is $12\frac{1}{2}$ inches long by 10 inches wide. Two porcelain stand-off insulators are mounted at one end, as shown in the photo-

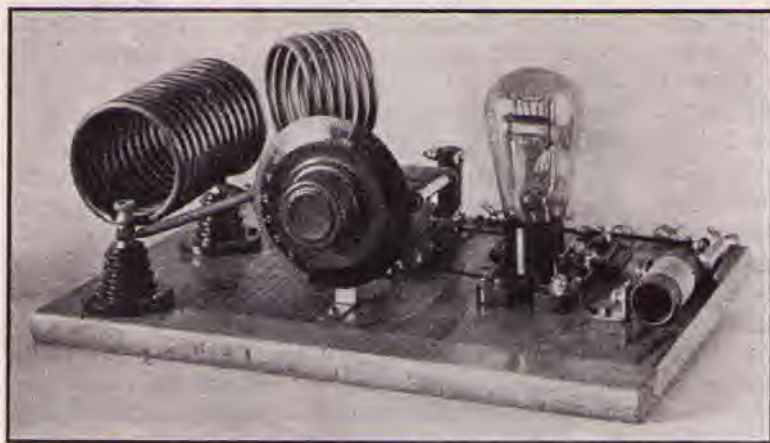

FIG. 703 — THE LOW-POWER SINGLE-TUBE TRANSMITTER

The plate tank circuit is at the left. The grid coil, leak and grid condenser are to the right of the Type 10 tube. The antenna coil is shown swung away from the plate coil to give loose antenna coupling.

graphs, to support the plate coil, L_1 . These insulators should be placed $4\frac{1}{2}$ inches apart between centers. This mounting is very solid mechanically, and allows easy changing of coils. The tuning condenser C_5 , in this case a 21-plate Cardwell, is mounted on small brass angles. Connections between the condenser and the coil are made by pieces of copper tubing, since the leads in the tank circuit must be as heavy as the inductance itself. The connection to the insulator at the rear of the baseboard should be from the rotary plates (the condenser frame); that to the front insulator goes to the stationary plates.

The plate by-pass condenser, C_2 , is mounted close to the tuning condenser on the baseboard. The radio-frequency choke, L_4 , is just behind it. The filament by-pass condensers, C_3 , are directly behind the tube socket. The purpose of these condensers is to provide an easy path for radio-frequency currents flowing to the filament of the tube, which would otherwise have to go through the resistor R_1 . When the filament of the tube is heated from alternating current the "center-tap" resistor is necessary to avoid having the alternating voltages on the filament reach the grid, for this would cause modulation or "ripple" on the transmitted signal. The voltage at the leads to the filament is constantly changing at the 60-cycle supply frequency but the voltage at the center point of the resistor R_1 is constant. Another method of accomplishing the same result is

to use a center tap in the filament-supply winding of the transformer. The center-tap resistor arrangement is sometimes preferable, however, since it permits the use of a filament rheostat in the secondary of the filament transformer instead of the primary. Rheostats for the secondary winding are more readily available than the other type.

The grid condenser, C_4 , and leak, R_2 , are to the right of the filament by-pass condensers. The condensers in this set are mounted flat by means of machine screws running up through the baseboard. The filament center-tap resistor, R_1 , is mounted directly on top of the filament by-pass condensers.

All connections are run to the rear of the board where they terminate in Fahnestock clips. From right to left in the photograph, the first pair of clips is for antenna or feeder connections, the second for "plus" and "minus" high voltage, the third for filament supply and the fourth pair for the key. The wiring of the whole set is quite simple, and in case it is to be duplicated no difficulty should be experienced in following the diagram and photographs.

The plate coils, L_1 , are $\frac{1}{4}$ -inch

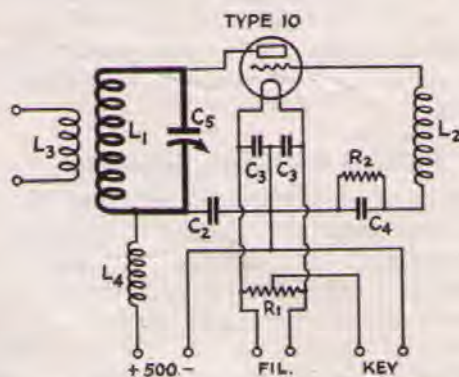

FIG. 704 — THE CIRCUIT OF THE TRANSMITTER

- L_1 , L_2 and L_3 —Plate, grid and antenna coils. The specifications are given under the illustration of the coils.
 L_4 —A commercial "short-wave" receiving-type radio-frequency choke will do or one can be made by winding a two-inch length of half-inch tubing or wooden dowel with No. 38 d.s.c. or d.c.c. wire.
 C_2 —2000- μ fd. (.002 μ fd.) mica fixed condenser, receiver type, if plate voltage does not exceed 500.
 C_3 —5000- μ fd. (.005 μ fd.) mica fixed condenser, receiver type.
 C_4 —250- μ fd. (.00025 μ fd.) mica fixed condenser, receiver type.
 C_5 —500- μ fd. (.0005 μ fd.) variable condenser. Any good receiving condenser will be satisfactory.
 R_1 —Center-tapped resistor, 75 to 100 ohms total resistance.
 R_2 —Grid-leak resistor, 10,000 ohms. Any small resistor rated at 5 watts or more will do.

Three General Radio or similar stand-off insulators will be necessary, as well as 8 Fahnestock clips, some miscellaneous small machine screws and nuts, and a few feet of bus wire.

soft copper tubing, wound around a pipe $2\frac{3}{8}$ inches outside diameter. The ends of the coils are flattened in a vise and drilled to fit over the machine screws in the mounting insulators. The 3500-kc. coil should have the turns so spaced that when finished it will just fit on the insulators without having the ends bent out, as is done on the coils for the higher-frequency bands. The spacing between turns on the 7000-kc. coil is about $\frac{3}{16}$ -inch, and on the 14,000-kc. coil about $\frac{1}{8}$ -inch.

The grid coils, L_2 , are wound with No. 30 d.c.c. wire on $2\frac{1}{2}$ -inch lengths of 1-inch tubing, which may be of Bakelite, paper, wood or any other of the common insulating materials. The coils should be given a coat of collodion or clear Duco varnish to maintain their characteristics. Two small brass angles serve both as connections and supports for these coils, the ends of the winding being brought out to small machine screws inserted at the ends of the coil forms.

The antenna coil, made in similar fashion to the tank coils, is mounted on an insulator immediately behind the tank condenser. Connection to the far end of this coil is made by means of a clip and a small piece of flexible wire. The coil may thus be swung away from the plate tank coil in order to vary the antenna coupling.

The 350-volt power supply described in Chapter Ten is an excellent one to use with this transmitter when the transmitter tube is a Type 45. This power supply may also be used to supply plate voltage for a Type 10 oscillator, in which case a separate 7.5-volt filament transformer for the 10 will be required. Alternatively, a 550-volt supply for a Type 10 tube may be built up from the information given in Chapter Ten. Most 550-volt power transformers intended for radio use have 7.5 volt filament-heating windings for the oscillator or amplifier and rectifier tubes, in addition to the plate windings. If a Type 01-A receiving tube is used, the plate supply can be a 135-volt "B" substitute or 135 volts of "B" batteries. Filament supply can be from a 6-volt battery, through a 6-ohm rheostat.

Tuning the Transmitter

The tuning of any transmitter is a matter of the greatest possible importance. The performance of even the best transmitter can be spoiled by the slightest misadjustment, and on the other hand almost any transmitter can be made to perform well by an amateur experienced in the work. Even the most experienced amateur, however, cannot tune the transmitter effectively unless he

is able to listen to it as he adjusts the controls. The use of some sort of monitor to listen to the signal as the transmitter is tuned is essential. A detailed description of a simple monitor will be found in Chapter Six. It should be studied and a

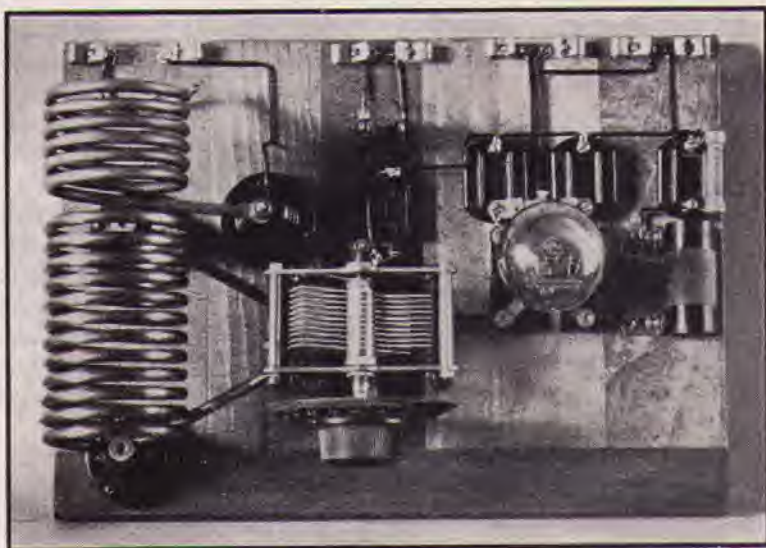

FIG. 705 — PLAN VIEW OF THE TRANSMITTER

The antenna coil, L_1 , is to the rear of the plate inductance. The fixed condenser, C_2 , and the radio-frequency choke are behind the tuning condenser, C_1 . The two fixed condensers behind the socket are the filament by-pass condensers C_3 . The filament center-tap resistor, R_1 , is mounted on top of these condensers. The grid condenser, C_4 , and grid-leak resistor, R_2 , are to the right of the socket. The grid inductance, L_2 , is in front of the grid condenser and leak. The connections to the Fahnestock terminals are explained in the text.

monitor built before any attempt is made to tune the transmitter.

In addition to the monitor, an extremely desirable aid to tuning is a "tuning lamp." This is nothing more than a flash-lamp bulb connected in series with a single turn of wire about two or three inches in diameter. In use, the turn of wire is coupled to the tank coil of the oscillator or amplifier and induced currents cause the lamp to glow. With practice, it soon becomes possible not only to detect the presence of r.f. current in the tank coil with such a lamp but also to gain a very useful idea of the amount of r.f. energy in the tank.

Before the transmitter can be tuned, it is obviously necessary to have available a suitable power supply, antenna and keying circuit. It will therefore be assumed that the reader will have studied the chapters on those matters and built the necessary equipment before attempting the all-important tuning process. It will be assumed, also, that the oscillator coils and leads have been made rigid; that the transmitter itself has been mounted in such a way as to escape vibration from keying and that the antenna and feeder wires have been made tight enough to avoid any swinging in the wind. We are ready to start tuning only after all these matters have been given attention.

Even then, we cannot expect to do a good job

of tuning the set unless we have one or more meters. Of greatest importance is a plate current meter in the positive high voltage lead to the transmitter. Without such a meter, we have no idea of the power input and so are in danger of wrecking the tube and possibly other equipment right at the start. For a single tube transmitter

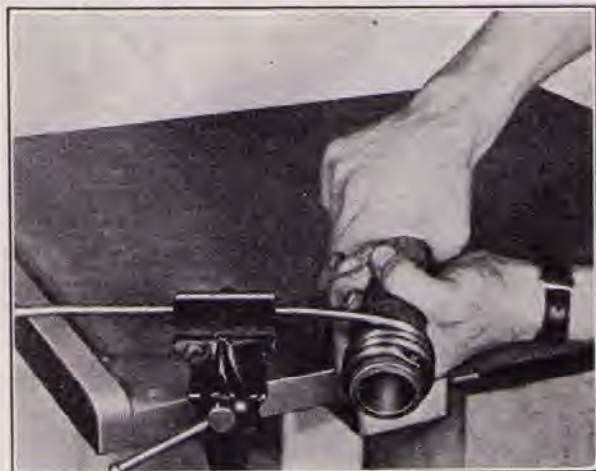

FIG. 706 — WINDING A COPPER-TUBING INDUCTANCE

One end of the tubing is held in the vise and the other is flattened out and bolted to the pipe used as a winding form. Pulling on the tubing and turning the pipe in the hands, the operator walks towards the vise. The turns should be wound as closely together as possible and spaced later.

like this one, the plate meter might well be a d.c. milliammeter reading to 100 ma. The other very desirable meter is a thermo-couple ammeter to be connected in the antenna or feeder circuit; its reading will give a good indication of *changes* of power in the antenna with changes in the transmitter adjustment. It is possible to dispense with the antenna meter and still tune the transmitter effectively if the operator is prepared to pay very careful attention to the plate meter and to make use of the tuning lamp.

Assuming that at least a plate meter is in the circuit, the first move is to switch on the filament supply, make certain that the tube lights, and then check the voltage at the filament terminals. Excessive filament voltage will soon ruin any tube. Then the antenna leads should be disconnected, the key opened and the plate tank tuning condenser set to approximately the correct position. If the constructional specifications have been followed closely, this setting will be with the rotor plates about four-fifths meshed for the 3500-kc. band; about three-quarters meshed for the 7000-kc. band; and about half meshed for the 14,000-kc. band. The antenna system should have been constructed to specifications for a frequency in one of the bands, preferably for about 3575 kc. in the 3500-kc. band.

Tuning for operation on the 3500-kc. band (with the 12-turn plate coil), set the condenser with the rotor plates four-fifths in, turn on the power supply and close the key. If the tuning lamp is now held near the front end of the plate

coil the bulb should glow, indicating that the set is oscillating. The loop should not be held too close to the coil, however, because the bulb is likely to burn out. The frequency should now be checked with the frequency meter following the method described in the preceding chapter. If the frequency is outside the band, the transmitter should be retuned to a frequency inside the band.

During this process the plate current milliammeter should be watched to make certain that the plate current falls to a minimum as the plate tank is tuned to the desired setting. Should this minimum point occur at a frequency much lower than that desired, it is an indication that the grid coil has too many turns. If the minimum point occurs at too high a frequency, it shows that the grid turns should be increased. This trouble is not likely to happen, however, if the constructional specifications are followed carefully.

Coupling the Antenna

With the oscillator operating on the desired frequency, the feeder or antenna may be con-

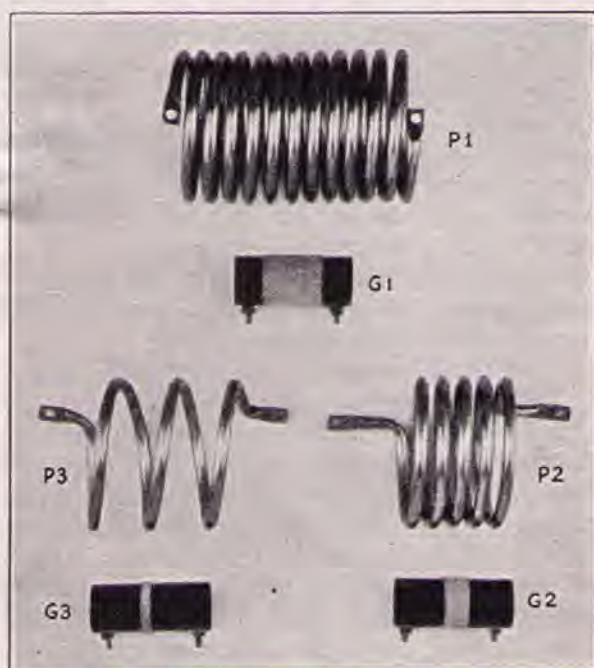

FIG. 707 — THE PLATE AND GRID COILS

A description of these coils is contained in the text, while the number of turns on each is given below.

Coil	Band	Turns
P-1	3500	12
P-2	7000	5
P-3	14,000	3
G-1	3500	60
G-2	7000	25
G-3	14,000	9

For the 1750-kc. band, a plate coil of 25 turns of No. 14 d.c.c. on a 3" diameter form with spacing between turns equal to the diameter of the wire; a grid coil of 150 turns on the same size form as the other grid coils. The number of turns on the grid coils may require some modification. Turns should be added or removed until the set operates stably and efficiently over the required frequency band.

The antenna coil is of 6 turns exactly similar to those used in coil P-1. A clip on this coil enables the best number of turns to be selected.

nected and the antenna coil swung at an angle of about 45 degrees to the plate coil. As the antenna or feeder condensers are tuned it will now be found that the plate current rises as the antenna comes into tune with the oscillator. Also it will be seen that while the tuning lamp bulb may glow brightly (when the loop is placed near the tank coil) with the antenna detuned, it will become dim as the antenna comes into tune and takes power from the tank. These effects of the rising plate current and the dimming tuning lamp are of the greatest assistance in tuning the antenna circuit when no antenna meter is available. With an antenna ammeter, of course, it is merely necessary to tune the antenna or feeder circuit for maximum meter reading in order to locate the point of resonance.

The next adjustment to be made is that of antenna coupling. It must be kept closely in mind that there is an optimum value of coupling which allows the greatest transfer of power from the tank circuit to the antenna. Closer coupling than this results in lowered efficiency and, in the case of the self-controlled self-excited transmitter, invariably destroys the quality of the transmitted signal. Excessive coupling usually can be detected by the existence of two settings of the feeder or antenna condensers at which the feeder or antenna current rises to a peak. In a transmitter of this type, the antenna coupling must always be less than the optimum value just mentioned. Experience has shown that it is a good plan first to get the optimum coupling for greatest output and then to reduce the coupling until the feeder or antenna current reads about 85 per cent of the first value. Then, the antenna or feeder circuit should be detuned until the current drops a further 10 or 15 per cent. These adjustments should only be made while listening to the signal on the monitor since the most unexpected things may happen to the quality of the signal and its frequency. The signal quality is usually better with the antenna circuit detuned on one side of resonance than on the other.

It is futile to give definite instructions with respect to the proper plate current since this depends so much on the plate voltage and on the manner in which the transmitter is adjusted. When the oscillator is operated at high efficiency, the input can be carried above the 350 volts and 60 ma. at which the Type 10 tube is rated. About the only practical procedure is to keep a careful watch for heating of the tube plate. Even a dull red plate is indication of excessive plate dissipation. The remedy is either decreased plate current or improved efficiency.

Using Two Tubes

If one wants more power output from the transmitter than one tube can give and yet does not wish to go to the expense of installing the next larger size of power tube, it is possible to use two

tubes in parallel or push-pull to double the power output. Tubes connected in parallel have their plates, grids and filaments respectively connected together; the oscillatory circuits used with them are otherwise exactly the same as for one tube. The push-pull oscillator circuits correspond to the push-pull amplifier circuits so common in present-day broadcast receivers; that is, the tubes are in effect connected in series in both input and output circuits. Although the total power output is the same with either method of connection, in actual practice the push-pull arrangement is preferable for oscillator circuits at the high frequencies used by amateurs.

A Push-Pull Transmitter

Although two tubes are used, the design and layout of a push-pull transmitter is little more difficult or intricate than that of a single-tube set, as the accompanying photograph shows. This transmitter is intended to be used with either Type 45 or Type 10 tubes.

The circuit of the two-tube transmitter is the push-pull Colpitts, which has been found to be particularly effective for high-frequency work. This circuit is in fact "double-barrelled" — not only is it a good high-frequency oscillator circuit, but it can, with minor modifications, readily be converted into a push-pull amplifier should it be considered desirable later on to change the transmitter to the oscillator-amplifier type. Since every serious amateur sooner or later graduates to the more complicated — but equally more satisfactory — oscillator-amplifier transmitter, the construction of a transmitter using this circuit is actually economical of time and apparatus.

The chief distinguishing features of the circuit are the use of a split-stator tuning condenser, variable grid condensers, and a split tank coil, to which the antenna coil is coupled at a point of low r.f. potential. These features result in good oscillator efficiency and frequency stability, and reduce the possibility of radiation of harmonics. (A later section in this chapter discusses harmonic radiation in detail.)

Front and below-baseboard views of the transmitter are shown in Figs. 708 and 710. The circuit diagram is given in Fig. 709. All parts are mounted on a 11½-inch by 14-inch baseboard, on the bottom of which are 1½-inch-high cross pieces which make room for parts fastened beneath the base. The tube sockets are placed at each side of the tuning condenser with the grid and plate terminals facing the condenser terminals; this permits short leads and at the same time crosses the filament wiring, a device which is helpful in preventing modulation from the filament supply.

The two variable grid condensers, C_1 , are mounted immediately in front of each tube. The grid leads are crossed, to give the push-pull connection, right at the terminals of the tuning condenser (terminals are available on both sides

of the condenser). This makes all wiring short and direct. The tank circuit is arranged symmetrically behind the tuning condenser and is wired to the condenser with 3/16-inch copper tubing.

The two stand-off insulators which hold the antenna coupling coil are mounted 1½ inches



FIG. 708 — A PUSH-PULL OSCILLATOR

The tuning condenser, *C*, in Fig. 709, occupies the central position at the front of the baseboard. On either side of it are the variable grid condensers, directly behind these condensers are the tubes. The split tank coil and hinged antenna coil are mounted on porcelain stand-off insulators to the rear of the variable condensers and tubes.

apart and are fitted with two brass "L" pieces to which the ends of the coupling coil are bolted. A piece of felt should be pulled between the turns of the coupling coil to prevent it from vibrating and thus modulating the note. Two pieces of Bakelite might also be fastened across the two leads of the coupling coil to give additional strength and prevent movement.

The stand-off insulators which carry each section of the tank coil are mounted 2½ inches apart, the two inside insulators being placed two inches apart to allow room for the coupling coil to fit between them. A short length of ½-inch copper strip is used to connect the two halves of the tank coil; a heavy connector should be used here because it is part of the tank circuit. The plate r.f. choke is mounted underneath this connecting strip. All by-pass condensers are under the base, as is most of the wiring. Since the wiring under the base is only a few inches from the tank coils, care should be taken not to run any long leads where they would be likely to pick up r.f. The wiring from the variable grid condensers should be as short and as direct as possible and should be kept clear of the a.c. filament wiring.

The tank coils must all be wound in the same direction, as otherwise their fields will buck each other. The direction of winding of the antenna coil does not matter.

Tuning the Push-Pull Transmitter

When the transmitter is ready to be used, the first necessity is to tune it inside the band. With

the particular tank capacity used and the coil sizes given, the 3.5-mc. band is covered with the condenser *C* almost at maximum capacity, the 7-mc. band with the condenser approximately three-quarters of the way in, and the 14-mc. band with the condenser set at one-third capacity. The variable grid condensers may then be adjusted to get the proper excitation. Scales made from white cardboard are fastened to the lock nuts on the condenser shafts and make it possible to return accurately to previous settings. The scales are marked from one to ten, with ten falling at the maximum-capacity end. About 5 on this scale gives the proper excitation for all of the bands. The grid-condenser adjustment should be made carefully with the aid of a monitor because correct adjustment makes the difference between a poor note or a good one.

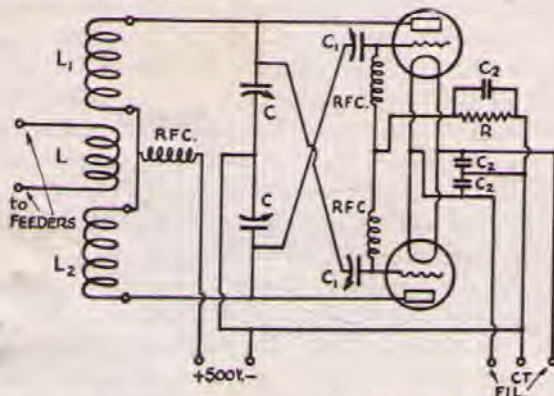

FIG. 709 — THE PUSH-PULL OSCILLATOR CIRCUIT

- C* — Split stator condenser, two 500 $\mu\text{fd.}$ sections in series making 250 $\mu\text{fd.}$ as used (Cardwell 156B).
*C*₁ — 50- $\mu\text{fd.}$ grid condensers (National SE-50).
*C*₂ — .01- $\mu\text{fd.}$ by-pass condensers.
L — Antenna coupling coil, 7 turns 3/16-inch copper tubing 2½ inches in diameter.
*L*₁ and *L*₂ — Tank coils, both identical and wound in the same direction. 3.5-mc. coils each 10 turns of 3/16-inch copper tubing, 7-mc. coils each 5 turns of ¼-inch tubing, 14-mc. coils each 3 turns of ¼-inch tubing. All tank coils are 2½ inches long and 2½ inches in diameter.
R — 7000-ohm grid leak, 25-watt size.

With a 550-volt power supply, slightly more than 30 watts output can be obtained on the 3.5- and 7-mc. bands and about 30 watts on the 14-mc. band, using Type 10 tubes. With 45's and a 350-volt supply the output should be approximately 15 watts.

The tuning instructions given for the single-tube transmitter — especially those covering antenna tuning — should be read carefully before the transmitter is put on the air. They apply with equal force to the adjustment of this transmitter.

Electron-Coupled Oscillators

A special type of oscillator circuit characterized by a higher order of frequency stability than the fundamental circuits previously described is the "electron-coupled" circuit, which has already been mentioned in connection with

frequency measurement in Chapter Six. A fundamental type of electron-coupled circuit is shown in Fig. 711. A screen-grid tube is required; the screen is used as the anode in a Hartley circuit with the control grid and cathode as the other two elements of a triode oscillator. The inductance L_1 and capacity C_1 form the tank circuit of the oscillator. Power is taken from the plate in the tank circuit L_2C_2 , which may be tuned to the same frequency as L_1C_1 or to a harmonic of that frequency. L_1C_1 usually is referred to as the "oscillator" circuit and L_2C_2 as the "output" circuit.

A major feature of the electron-coupled oscillator is that the coupling between the oscillator and output circuits should be entirely by variations in the electron stream from the cathode to the plate. To make the coupling wholly electronic, it is necessary to have the plate electrostatically shielded from the control grid and cathode, thereby eliminating unwanted capacity coupling between the plate and these elements. To get complete shielding the screen must be at ground potential, hence the cathode must take an r.f. potential above ground to fulfill the conditions for self-oscillation in the oscillator portion of the circuit. Because of the difficulty of eliminating r.f. leakage between the filament and ground in filament-type tubes, it is desirable to use a tube having an indirectly-heated cathode. In the power tubes, only the 844 has this type of cathode. Several receiving-tube types, notably the 24-A and 35, have the requisite type of construction, but their power output is extremely limited. They can be used to excite other small tubes in oscillator-amplifier transmitters, however. If filament-type power tubes are to be used,

the filament may get its power through suitable r.f. chokes — which are likely to be bulky because of the heavy current they must carry — or by use of a double tank-coil winding such as was described in Chapter Six in connection with the electron-coupled frequency meter using a Type 32 tube.

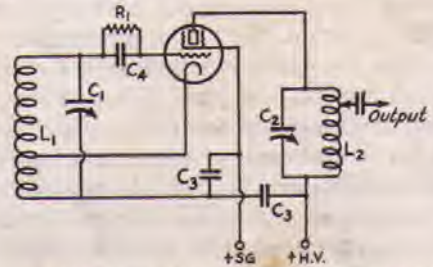

FIG. 711 — ESSENTIALS OF THE ELECTRON-COUPLED OSCILLATOR CIRCUIT

The oscillator tank circuit, L_1C_1 , should be High-C for the oscillation frequency. The grid condenser, C_4 , and leak, R_1 , may have normal values for the tube used; with receiving types such as the 24-A the grid leak should have a resistance of 25,000 to 50,000 ohms. The higher grid-leak values will give better output on harmonics. The output tank circuit, L_2C_2 , should be low-C. The plate and screen by-pass condensers, C_3 , should have low impedance at the operating frequency; .002 μ fd. or larger will be satisfactory in amateur transmitters. These condensers should be of the non-inductive mica type.

Excellent dynamic stability can be obtained with the electron-coupled oscillator by proper proportioning of the screen and plate voltages. Greatest stability usually results when the screen is operated at about half the voltage applied to the plate. The position of the cathode tap also affects the stability; usually it should be nearer the screen or "ground" end of the coil than the grid end.

In an electron-coupled oscillator using a well-screened tube, tuning the output circuit has very little effect on the frequency of the oscillator. The circuit therefore is an ideal arrangement for exciting a following amplifier or for feeding an antenna. It is unfortunate that the power screen-grid tubes are relatively expensive and that suitable receiving tubes have such low power output; these two factors have restricted the use of the electron-coupled oscillator. In the receiving types, the 59 has good output but its screening is not complete; the tube can, however, be used as an electron-coupled oscillator with good success if the output circuit is tuned to the second harmonic of the oscillator circuit, as we shall see later in the chapter.

Unsteady Signals

One of the chief problems in transmitters other than those of the crystal-control type is to maintain a steady frequency. First there is the frequency creep due to heating of the tube or other apparatus in the set. This can be reduced to a minimum by tuning the set for greatest efficiency. The greater the antenna power for a given input the less will be the heating of

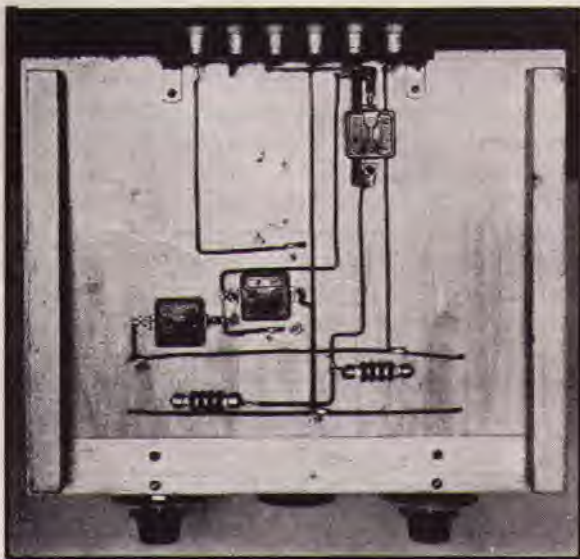

FIG. 710 — SUB-BASE WIRING OF THE PUSH-PULL TRANSMITTER, SHOWING THE FILAMENT BY-PASS CONDENSERS, GRID LEAK AND CONDENSER, AND THE GRID R.F. CHOKES

The power-supply and key terminals are at the back of the baseboard.

the tube. The aim is, therefore, to keep the input at or below the rated value and to tune the set until the tube operates with the least heating.

The detuning of the antenna circuit mentioned in the paragraphs on tuning does not result in appreciably lowered efficiency in the tube. When it is said that the greatest antenna current should be obtained for a given input to keep the tube coolest it is meant that the greatest antenna current *with the antenna detuned in the manner described* should be obtained. When the antenna is detuned the plate current drops. Detuning the antenna is unnecessary when an oscillator-amplifier transmitter is used because the frequency is then set by a separate tube which is isolated from the antenna. With such transmitters the antenna circuit may be tuned to take maximum power from the output tube.

Another common cause of frequency instability is vibration or swinging of the antenna or feeders. The effect of such vibration or swinging is reduced considerably by the detuning of the antenna circuit but it is essential that the antenna be supported in such a way that it is steady even in a high wind. This point will be given consideration in the chapter on antennas.

Leaky insulation also is often a serious offender. Not only can a leak destroy the character of the note but it can be responsible for a wobbly frequency. Trouble of this type often can be detected by removing the antenna circuit and listening to the transmitter in the monitor. Sometimes the leak is visible in the form of a thin arc. If the leak is through Bakelite a swelling on the surface of the insulation often will be noticed.

Perhaps the most common cause of all is vibration of the coils or wiring. A vibration which results in serious frequency instability often is too slight to be noticeable. The coils and wiring should be watched very carefully during operation to make sure that the movements of keying, the humming of a transformer or the vibration of a generator are not transmitted to the set. Mounting the set on rubber sponges often will aid in the elimination of the trouble.

It is only by careful and prolonged attention to such details that the performance of the transmitter can be maintained at a high standard.

The Crystal-Controlled Oscillator

In marked contrast to the self-controlled oscillators which we have just described is the family of crystal-controlled oscillators. In these circuits the frequency of oscillation is influenced hardly at all by the constants of the circuit or the load associated with it. The reason for this is that the frequency-controlling element is a small slab of crystal (usually quartz) which, because of its electro-mechanical properties, will oscillate at a frequency determined almost entirely by its dimensions. When it is properly connected in the controlling oscillator circuit, the line voltage can

vary, the antenna can swing, and the tubes may heat without seriously affecting the output frequency of the transmitter. A ripple in the plate-supply voltage will cause amplitude modulation of the output of such an oscillator but can cause practically no frequency flutter. For this reason, the note produced by a transmitter driven from a properly adjusted crystal-controlled oscillator is always of a piercing musical character. Such a note is unmistakable evidence of a good amateur station.

Before considering the circuits of crystal-controlled oscillators let us examine the crystals themselves.

Crystal Cuts and Grinding

A quartz crystal has three major axes, designated X, Y and Z. The Z axis is the optic axis. The Y axis is the mechanical axis. The X axis is the electric axis and is the one used as a reference in designating the cut of the plates used in oscillators. A plate cut with its major surfaces perpendicular to an X axis is known as an X-cut plate. This cut is also referred to as the "perpendicular" and "Curie" cut. Plates cut with their major surfaces parallel to an X axis are known as "Y," "parallel," and "30-degree" cuts. The most accepted terms for these two cuts are X-cut and parallel or 30-degree cut.

Each of these cuts has characteristics of its own and these characteristics determine its suitability for different services. For a given frequency, an X-cut plate is thicker than a 30-degree-cut plate. The X-cut plate has but one major frequency of oscillation which is a function of its thickness but a 30-degree cut plate sometimes has two, generally a kilocycle or so apart. The 30-degree cut plate is usually the more ready oscillator although properly ground and mounted plates of either cut oscillate quite persistently in well-designed power circuits. The X-cut plate is more generally used in power oscillators, although many amateurs have a preference for the 30-degree cut.

When a finished crystal or unground blank is purchased, a statement of the cut should be obtained from the seller. This is particularly important when a blank is purchased because the grinding cannot be done so easily if the ratio of thickness to frequency is not known. For X-cut plates $f \times t = 112.6$ and for 30-degree-cut plates $f \times t = 77.0$, where f is the frequency in kilocycles and t is the thickness in inches. From these relations the thickness for a desired frequency of a crystal of known cut can be determined quite accurately by measurement with a good micrometer such as the Starrett No. 218-C, $\frac{1}{2}$ inch. This tool also can be used to make sure that the crystal is the same thickness at all points and that bumps or hollows are not being ground in. The best crystals are about 1" square, perfectly flat, and the two major surfaces are parallel.

Since the thickness of an oscillating crystal is inversely proportional to its frequency, the plates become very thin and fragile at frequencies above those in the amateur 3500-kc. band. For this reason the most satisfactory amateur crystals are those ground for the 1750-kc. and 3500-kc. bands. If the transmitter is to be operated on the

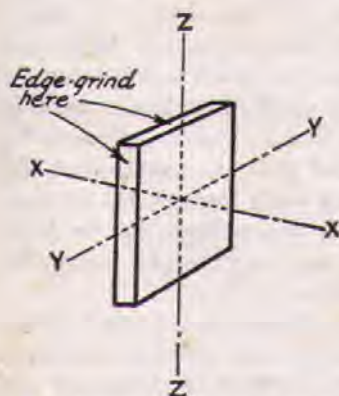

FIG. 712 — RELATION OF THE AXES OF AN X-CUT QUARTZ PLATE

3500-kc. and higher frequency bands only, a crystal having a suitable frequency in the 3500-kc. band will be best. The higher frequencies are obtained from such a crystal by means of the harmonic generators or frequency doublers to be described further on. Some carefully-ground 7000-kc. crystals are now being used in amateur

transmitters but they require careful handling. There are even instances of successful operation of 14,000-kc. crystals.

Grinding is usually done by rotating the crystal in irregular spirals on a piece of plate glass smeared with a mixture of No. 102 carborundum and water or kerosene. It is better to have the crystal stuck to a perfectly flat piece of thin brass or a glass microscope slide than to bear down on the surface of the crystal with the fingers. Even pressure over the whole area of the crystal is essential for flat grinding. The crystal will stick to the flat brass plate or slide if the top of the crystal is moistened with kerosene. The crystal should be frequently tested for oscillation in a test circuit such as one of those shown in Fig. 713. If the crystal should stop oscillating during the grinding process the edges should be ground as indicated in the illustration of an X-cut plate. The frequency also can be checked by listening to the signal in a receiver and measuring the frequency as described in Chapter Six. When the frequency is within a few kilocycles of the desired value it is well to use a finer grade of carborundum powder for finishing. The FF and FFF grades are suitable for the final grinding.

Crystal Oscillator Circuits

Power crystal oscillators operate as tuned-grid tuned-plate circuits, with the crystal replacing the grid tank circuit. Other fundamental circuit arrangements are possible, but have not met with much favor for power work. The simplest crystal oscillator circuit is shown in Fig. 713-A. It uses a triode tube, usually a Type 45 or 10. When the plate tank circuit is tuned to a frequency slightly higher than the natural frequency of the crystal,

the feed-back through the grid-plate capacity of the tube excites the grid circuit, and the crystal oscillates at approximately its natural frequency.

The power obtainable from the crystal oscillator will depend upon the type of tube used, the plate voltage, and the amplitude of vibration of the crystal, or more precisely, the amplitude of the r.f. voltage developed as a result of the mechanical vibration. If the feedback voltage is too great, the mechanical strain in the crystal as a result of vibration will cause the crystal to heat considerably and may eventually cause cracking, ruining the crystal. In simple oscillator circuits such as that in Fig. 713-A, the limit of plate voltage that can be used without endangering the crystal is about 250 volts. There is no exact rule for this, however; much depends upon the crystal itself, its mounting, and the type of tube used. Tubes with low amplification factors — the 45, for instance — should be operated at lower plate voltage than tubes with medium or high μ 's, because low- μ tubes require a relatively large exciting grid voltage for a given output.

Within limits, the power output that can safely be taken from the crystal oscillator can be increased by the use of special circuits or tubes having more suitable characteristics than the simple triodes. One such circuit is shown in Fig. 713-B. It differs from circuit A in having the lead to the tube plate tapped in on the tank inductance instead of being connected directly to the end. This practice decreases the r.f. voltage fed from the plate to the grid circuit and consequently reduces the strain on the crystal. The nearer the tap is to the filament end of the inductance (the end which connects back to the filament through the plate bypass condenser) the smaller will be the feedback voltage. Somewhat higher plate voltages can be used without danger of cracking the crystal, therefore. The efficiency is lower with this sort of circuit than with that at 713-A, but so long as the plate current limits of the tube are not exceeded this is not a highly important consideration.

The same result can be secured by using a tube having low grid-plate capacity (this will reduce the feedback) and which at the same time is capable of delivering fairly large power output with a small exciting grid voltage. The pentode tubes designed for audio power work, such as the 47, 2A5, 42, and 59 (with proper element connections), fulfill both these requirements and are excellent crystal oscillator tubes. For a given plate voltage the crystal heating will be less with a pentode than a triode as the oscillator tube; alternatively, for the same amplitude of crystal vibration, higher plate voltages can be used with the pentodes, resulting in greater power output. A typical pentode oscillator circuit is shown in Fig. 713-C. It has been found best to operate the screen grid of the tube at approximately 100

volts; plate voltages up to 500 may be used without danger to the crystal.

Crystal heating is not only undesirable from the standpoint of safe operation; the frequency of oscillation is dependent upon the temperature of the crystal, and when the crystal heats up the frequency will creep. The temperature coefficient of X-cut plates is negative, that is, the

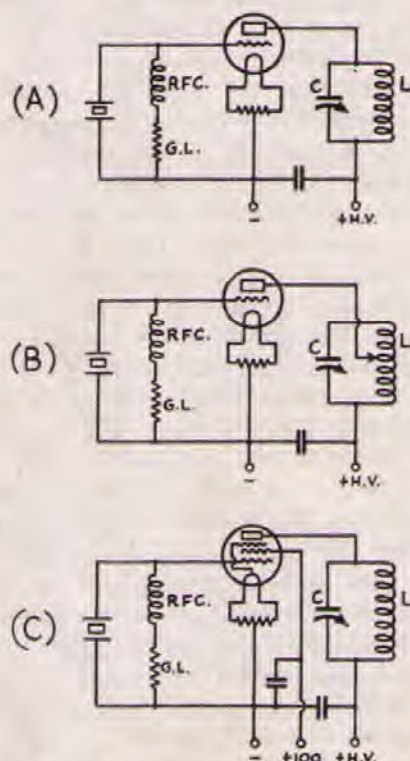

FIG. 713—TYPICAL CRYSTAL OSCILLATOR CIRCUITS

In each case the plate tank circuit, LC, must be so proportioned that it can be tuned to the natural frequency of the crystal, preferably with a low value of capacity. By-pass condensers and grid leaks have values similar to those used in ordinary oscillator circuits. If the grid leak resistor is non-inductive, the r.f. choke in series with it may be omitted.

frequency goes down with rising temperature. The temperature coefficient for 30-degree cut plates is positive, the frequency increasing with rising temperature.

Grid bias for the oscillator may be supplied through a choke from a dry "B" battery. The bias for a Type 10 or Type 47 tube is usually 22.5 volts. Bias for low-impedance tubes will be greater. The Type 45 will operate satisfactorily with negative bias of 67.5 or 90 volts. Grid-leak bias may be used also, the value of the grid-leak resistance being between 5000 and 50,000 ohms.

Grit or an oily film on the surface of a crystal will affect its operation and will sometimes prevent oscillation. The crystal should be cleaned whenever erratic behavior or stoppage of oscillation gives evidence of a dirty condition. Carbon tetrachloride (Carbona) or grain alcohol are the best cleaning fluids. Plain soap and water will do quite well, however. Handling of the crystal is

especially likely to give it an oily surface, and the crystal should always be cleaned after it has been touched by the hands.

Crystal Mountings

To make use of the piezo-electric oscillation of a quartz crystal, it must be mounted between two metal electrodes. There are two types of mountings, one in which there is an air-gap of about one-thousandth inch between the top plate and the crystal and the other in which both plates are in contact with the crystal. The latter type is simpler to construct and is generally used by amateurs. It is essential that the surfaces of the metal plates in contact with the crystal be perfectly flat. Satisfactory mountings can be purchased from most dealers in crystals or can be made up by the amateur.

The simplest way for the amateur to rig his own mounting is to make up two flat brass plates, the crystal being placed on one of them and the other being arranged to rest on the crystal with no more pressure than that provided by the weight of the brass. A crystal mounting of this type is illustrated. The plates preferably should be turned flat in a lathe and then ground to a fine finish. Successful plates can be made, however, by cutting them with a hack-saw from $\frac{1}{8}$ "-thick brass plate, then grinding them in much the same way as the crystal would be ground. A suitable size for the top plate is about 1" square. The bottom plate may be made large enough to accommodate the whole mounting, as shown.

Though it is possible to operate the crystal between such plates merely by arranging the plates and the crystal in the form of a sandwich on a piece of insulating material or on the table top, it is a very much better plan to make up some form of holder out of which the crystal or plates cannot be jarred. The arrangement illustrated in Fig. 714 is one suitable type. Connection to the upper plate can be made by means of a very light leaf of spring brass but a small spiral of very fine copper wire usually is more satisfactory. This wire can be soldered to the plate if care is taken to use an absolute minimum of heat in the soldering process to avoid warping the plate.

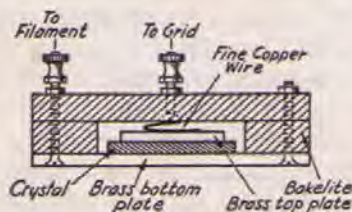

FIG. 714—SIMPLE FORM OF CRYSTAL HOLDER

The flat brass bottom plate may be round or square, whichever is more convenient. The center part of the inner piece of Bakelite is cut out to allow the crystal to rest upon the bottom plate. The top piece is solid and completely encloses the crystal and top plate. Three-sixteenths or quarter-inch Bakelite should be used for the inner piece. The brass plates should be $\frac{1}{16}$ - or $\frac{1}{8}$ -inch stock.

Oscillator-Amplifier Transmitters

The progressive amateur will not long be content with the simple self-controlled oscillator transmitters previously described. Notwithstanding the fact that transmitters of that type are capable of giving good results with proper handling, they are always subject to those ills discussed in the section on unsteady signals — particularly, the frequency stability is always at the mercy of a swinging antenna or feeders. Overcoming the factors which adversely affect the frequency stability always entails a sacrifice of power output in the simple oscillator; for this reason it is possible to get more power from a given tube used as a power amplifier than from the same tube operating as a self-controlled oscillator feeding the antenna. The power amplifier can be excited by a relatively low-power oscillator which has been designed particularly for frequency stability; then when the amplifier's output is fed to the antenna swinging feeders will have negligible effect on the frequency stability. Furthermore, the antenna coupling can be adjusted for maximum output only — it is not necessary to use the loose coupling and detuning required with the self-controlled oscillator transmitter to keep the signal steady.

The oscillator-amplifier type of transmitter is used almost universally for power output greater than that obtainable from a pair of Type 10 tubes. Frequently stability is of paramount importance in the high-power transmitter, because a strong signal can cause intolerable interference unless it is perfectly steady and pure d.c. Either of the self-controlled transmitters already described will make excellent drivers for a higher-power amplifier. The single-tube set, using a Type 10 tube with about 500 volts on the plate, would excite an amplifier using one of the 50- or 100-watt tubes, while the push-pull transmitter will do equally well to excite a pair of similar tubes in push-pull. Several different tube combinations for oscillator-amplifier transmitters with self-controlled oscillators will be given farther along in the chapter.

In the following discussion we shall go into the operation of different types of amplifiers at some length, with particular reference to the crystal-controlled transmitter. By far the greater number of oscillator-amplifier transmitters are crystal controlled, but it should be borne in mind that amplifier operation is the same whether or not a crystal is used as the frequency-determining element. The information given is therefore equally applicable with either type of frequency control.

To get the full benefit of crystal control it is necessary to amplify the radio-frequency output of the crystal oscillator and thus bring it up to the output power level desired. The output of the usual crystal oscillator is seldom more than five

watts or so, while ten watts is about the limit obtainable with available crystals and tubes. The crystal oscillator could be coupled to an antenna just as was done with the self-controlled oscillators previously described, provided the limited power output could be tolerated. But most amateurs prefer to use amplifiers.

A second consideration in the use of the crystal oscillator is the fact that the output frequency is set by the mechanical dimensions of the crystal. A single crystal is therefore good for only one frequency in one band. Having only a single frequency is no particular hardship if the operation is to be confined entirely to one amateur band, but many amateurs wish to change bands to utilize to the utmost the long-distance communication possibilities of all of them at different times of the day. For this reason it has become customary to use harmonic amplifiers to obtain output in different bands from a single low-frequency crystal.

Amplifiers which step up the power output on some harmonic of the fundamental crystal oscillator frequency are called "frequency multipliers." The plate tank, in a frequency multiplier, is tuned to a frequency which is a harmonic of the exciting frequency. If the output is tuned to twice the exciting frequency, the amplifier is known as a "doubler." The doubling action obtained is caused partly by excitation from the second harmonic output of the oscillator (or preceding amplifier) and partly by distortion in the amplifier itself. Although it is possible to triple frequency with frequency multipliers, doubling is most generally applicable to amateur transmitters because the amateur frequency bands are in even harmonic relation. In typical amateur crystal-controlled transmitters, to be described later, we find several "doublers" operated one after the other in order to obtain good power output on the higher frequency bands.

When an amplifier's output is tuned to the excitation frequency, the amplifier is known as a "straight" amplifier. This is the form of amplifier most commonly used in the self-controlled oscillator-amplifier transmitter and in the final stage of the more powerful crystal-controlled transmitters. Since both the grid and plate circuits are tuned to the same frequency in this form of amplifier, the arrangement becomes a type of tuned-grid tuned-plate circuit which would allow the amplifier to oscillate of its own accord unless special precautions were taken. The most common method of preventing oscillation is by neutralizing the circuit. Circuits of various forms of neutralized amplifiers are given in Fig. 715. If a screen-grid tube is used in the "straight" amplifier or if the amplifier is a "frequency multiplier," troubles from self-oscillation are not likely to occur. Unfortunately, the medium-size screen-grid tubes suitable for intermediate amplifiers in amateur transmitters are still relatively expensive.

Neutralizing is one of the very important necessities in most amateur transmitting equipment. For this reason, we will proceed to give detailed consideration to the circuits used for neutralizing and the manner in which they function.

Neutralizing

As we have already explained, a three-electrode tube used as a straight radio-frequency amplifier will itself oscillate because of radio-frequency feed-back through the grid-plate capacity of the tube unless that feed-back is nullified. The process of neutralization really amounts to taking some of the radio-frequency voltage from the output or input circuit of the amplifier and introducing it into the other circuit in such a way that it effectively "bucks" the voltage operating through the grid-plate capacity of the tube, thus rendering it impossible for the tube to supply its own excitation. There are several ways of doing this, the more common ones being shown in the drawings. Parts of the circuit which are not essential to the neutralizing scheme considered are not included in the diagrams; they will be quite conventional in nature.

In Circuits A and B the operation is the same; the choice between one or the other is simply a matter of preference or mechanical considerations. A point on the tank inductance (usually a third or half the way up toward the plate end) is made to assume the same r.f. potential as the filament by connecting it to the filament through a by-pass condenser. The voltage at the lower end of the coil is, therefore, opposite in phase to that at the plate end, and this voltage is fed back to the grid through a small condenser, C_n , to balance the voltage which appears across grid and plate. Exact balance is obtained by properly proportioning the number of turns between X and Y and by adjusting the capacity of C_n . If parallel plate supply feed is used the by-pass condenser between the point X and the filament is unnecessary, since there will be no d.c. voltage between the two points and a direct connection can be made.

In Circuit C the neutralizing or bucking voltage is obtained from the voltage drop across half the tuning condenser, which in this circuit must be a split-stator affair. Parallel plate feed is shown in this circuit, although series feed can be used by introducing the plate voltage at the center of the tank inductance through an r.f. choke. If series feed is used, the feed tap on the tank coil should not be connected to the filament through a by-pass condenser as is done in Circuits A and B; doing this places two grounds in the circuit and is likely to lead to circulating r.f. currents and undue losses. Circuit C is likely to be more stable at very high frequencies than Circuits A and B. A further advantage is that the neutralizing condenser setting will be the same for any tank coil that may be used, if the two sections of the

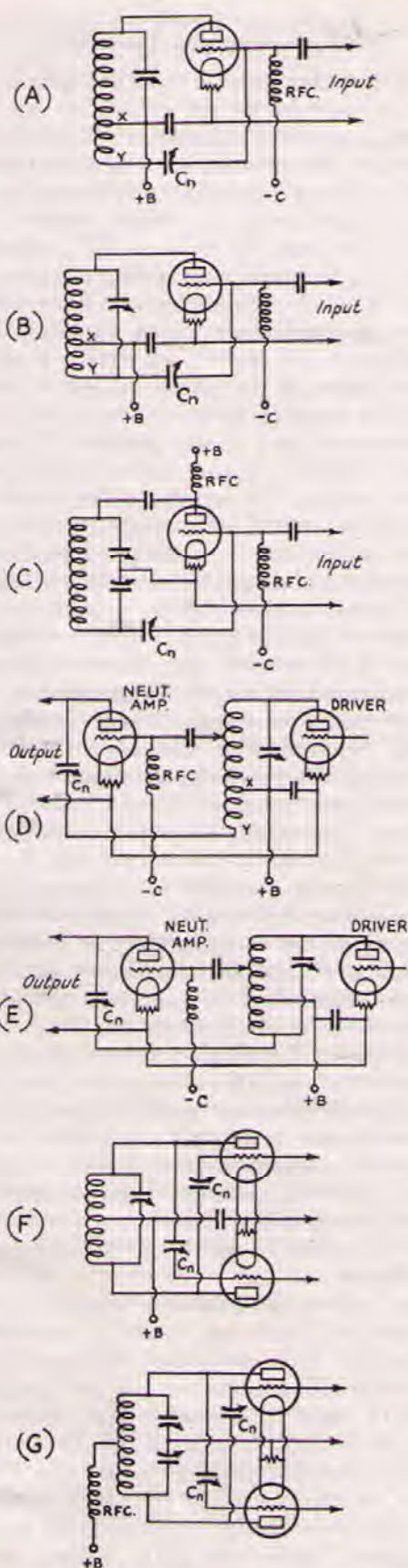

FIG. 715 — METHODS OF NEUTRALIZING AMPLIFIERS

The first five are for neutralizing the grid-plate capacity of single tubes or tubes in parallel. The push-pull neutralizing arrangements shown at F and G are known as "cross-neutralized" circuits because the neutralizing condensers form a cross-connection from the grid of one tube to the plate of the other.

tuning condenser are identical. This is a convenience when bands are changed frequently.

Circuits D and E also are equivalent. In these circuits the neutralizing or bucking voltage is obtained from the tank circuit of the preceding tube and is fed to the plate of the amplifier through the neutralizing condenser. The tank tuning condenser may be connected across part of the coil or all of it, whichever seems most desirable.

Two push-pull neutralizing circuits are shown in F and G. One has a tapped plate tank coil and the other a split-stator tuning condenser with the rotor grounded. The neutralizing condensers are simply connected from the grid of one tube to the plate of the other. Fig. 715-G is to be preferred for the higher frequencies, just as was the case with Circuit C. Both F and G will remain neutralized with different tank coils; in F, however, it is essential that the tap on the coil be placed accurately at the electrical center of the coil. Good balance between the two sections of the condenser in G will obviate this necessity.

In all these circuits, by-pass condensers and other parts not particularly a part of the neutralizing arrangement will have the usual values. The specific pieces of apparatus to be described later will illustrate ordinary practice in amateur transmitters. In most cases the neutralizing voltage will be equal to the r.f. voltage between the plate and grid of the tube (using one of the circuits involving the use of a split-stator condenser, or a tapped-coil circuit having the tap at the center of the inductance) so that for perfect balance the required capacity in the neutralizing condenser will be equal to the grid-plate capacity of the tube being neutralized. Reference to the grid-plate capacitance column of the tube table in this chapter will indicate the correct size of neutralizing condenser; a condenser which will give the requisite capacity at about half scale should be chosen. If, in the circuits having tapped tank coils, the tap is more than half the total number of turns from the plate end of the coil, the required neutralizing capacity will increase approximately in proportion to the relative number of turns in the two sections of the coil. As a general rule, however, an even division between "plate" and "neutralizing" turns is desirable.

The procedure necessary to make actual adjustments for neutralizing will be treated later in this chapter.

Interstage Coupling

For efficient operation, the grid circuits of tubes used as radio-frequency power amplifiers must be supplied with power from the oscillator or driver tube. To transfer with the least possible loss the power developed in the plate circuit of the driver to the grid circuit of the amplifier is the task of the interstage coupling arrangement. The type of

coupling best adapted to efficient power transfer depends upon the characteristics of the driver and amplifier tubes. Several satisfactory arrangements are shown in Fig. 716.

The circuit at A is known as capacity coupling, because the radio-frequency power is fed from the driver to the amplifier through the coupling condenser *C*. The purpose of the condenser is to prevent the driver plate voltage from being impressed upon the grid of the amplifier tube while providing a low-impedance path for r.f. current. This method of coupling is generally most satisfactory when the amplifier tube is one having a low or medium amplification factor (μ of 8 or less). The bias for the amplifier is fed to the grid through the r.f. choke, *RFC*, which keeps the excitation voltage from leaking off through the bias supply and being wasted. Since the negative side of the driver plate supply and the positive side of the amplifier bias supply meet at the common filament connection between the two tubes, the coupling condenser *C* must have insulation good enough to stand the sum of these two voltages without breakdown. The fact that the condenser also is carrying a considerable radio-frequency current makes it desirable that it have a voltage rating giving a factor of safety of at least 2 or 3.

Circuit B is practically equivalent to Circuit A; the coupling condenser has been moved to the plate circuit of the driver tube and the radio-frequency choke appears at the plate of the driver. This simply shifts the driver to parallel plate feed, and permits the use of series feed to the amplifier grid. In both circuits the excitation can be controlled by moving the tap on the tank coil; the nearer the tap is to the plate end of the coil the greater will be the excitation voltage up to the limit of the driver output. These circuits have the advantage of simplicity, but have the disadvantage that the interelectrode capacities of both the driver and amplifier tubes are connected across the tuned circuit, thus causing a reduction in the *L-C* ratio and reducing the efficiency at the very high frequencies. They operate quite satisfactorily with ordinary tubes at frequencies of 7 mc. and lower, and at 14 mc. with tubes having low interelectrode capacities, such as the 852, 800, 825, RK-18 and others with comparable capacities to be found in the tube table. The variable tap for regulating excitation is likewise sometimes responsible for parasitic oscillation in the amplifier, a condition which also is harmful to the efficiency.

Circuit C overcomes these two disadvantages, but requires two tuned circuits and a method for varying the coupling between the two coils. This circuit is particularly effective at 14 mc. and higher frequencies, where the increased complications are worth while in view of the greater efficiency. Circuit D is much the same as Circuit C, except that an untuned transmission line,

inductively coupled to the tank circuits at both ends, is substituted for the variable inductive coupling. This system is more convenient mechanically, because the power transfer is governed by the relative number of turns on each coupling coil, and because the transmission line can be any reasonable length—up to several feet. Ordinary twisted lampcord will do nicely for such a line. In practical operation, the number of turns on the coupling coils is adjusted to give maximum excitation to the amplifier. Three or four turns will be sufficient in most cases provided the coils are closely coupled to the tank coils with which they are associated.

The push-pull circuit at E corresponds to the simple capacity-coupled circuit at A, while F is the same thing as D but arranged for push-pull. It should be pointed out that in circuits using the untuned coupling line or "link," as it is sometimes called, the coupling coils should be coupled to the tank coils at a point of low r.f. potential. This is indicated in Circuits D and F.

The use of power amplifier tubes with relatively high voltage-amplification factors—15 and more—sometimes introduces complications in the coupling arrangement because such tubes generally operate best with a lower exciting voltage than is developed by the driver tube. In other words, the grid impedance of such tubes is lower than the value of impedance which, when connected across the whole driver tank circuit, is optimum for maximum driver power output. "Tapping down" on the driver tank coil will take care of this condition but as pointed out above sometimes leads to parasitic oscillation in the amplifier. For this reason the inductive coupling methods are more satisfactory with high- μ amplifier tubes. Parasitic oscillation can be avoided in condenser-coupled systems (which includes circuit B) by taking the excitation directly from the plate end of the coil and using a coupling condenser having low capacity to avoid overloading the driver. The coupling efficiency is reduced by this compromise, however. The optimum coupling capacity will depend upon the type of amplifier and driver tube used and the operating conditions; in general it had best be determined experimentally for the individual layout. Where this consideration is not a factor—i.e., when the amplifier is a medium- or low- μ tube—the size of the coupling condenser is not critical. Usual values are 100 to 250 μfd .

In Fig. 716 the coupling systems have been considered without reference to neutralizing or other circuit modifications. These will not, generally speaking, affect the operation of the coupling system. The neutralizing circuits of Fig. 715 can be introduced into the coupling arrangements of Fig. 716 with little difficulty. The one important practical effect of the addition of the neutralizing condenser is the fact that the capacity shunted across the tuned circuit is in-

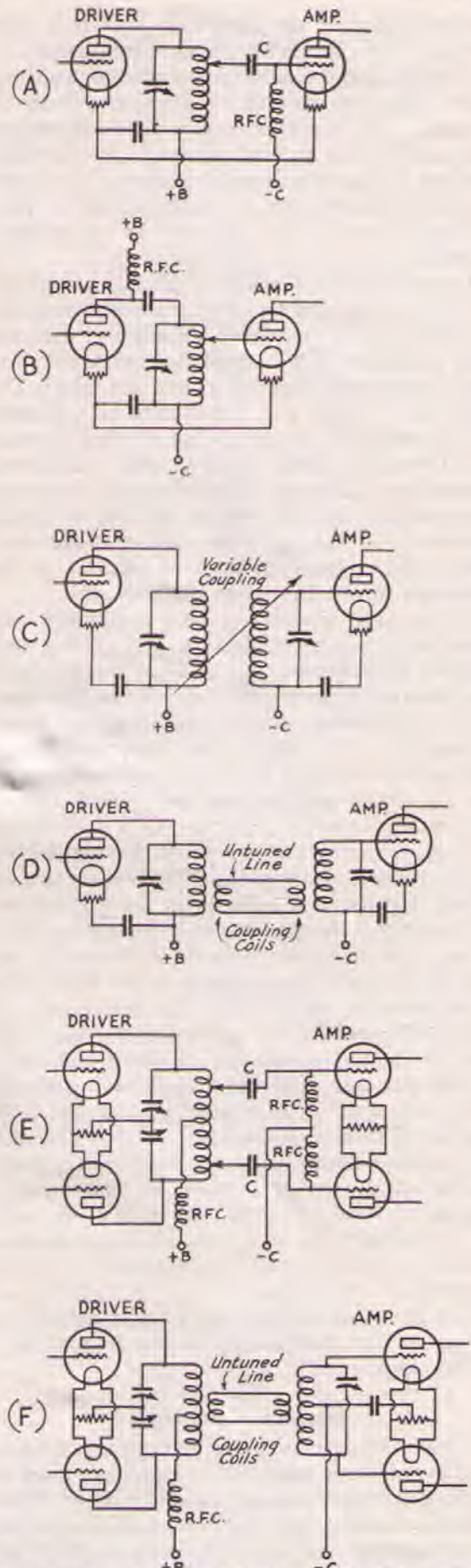

FIG. 716—SIX WAYS OF COUPLING AN OSCILLATOR OR DRIVER TUBE TO AN AMPLIFIER

creased thereby. This makes a further point in favor of inductive or transmission-line coupling systems, since they tend to reduce the capacities shunting the tuned circuits. Nevertheless, the condenser-coupled arrangements, because of greater simplicity, are widely used and are capable of giving excellent results, particularly at the lower amateur frequencies.

Single Tube to Push-Pull

One important coupling problem is that of connecting a single-ended oscillator or driver to a push-pull amplifier. Three methods of doing it are shown in Fig. 717. Circuit A shows the capacity-coupling scheme. The driver tank coil is tapped at the center; the end of the tank circuit opposite the plate of the tube is left free to assume an r.f. potential equal to that at the plate and opposite in sign, thus making the output voltage suitable for exciting a push-pull amplifier. The lower end of the driver tank circuit may be utilized for neutralizing the driver tube, if desired. In fact, the neutralizing circuits at Fig. 715-B and C are suitable for exciting a push-pull following amplifier with capacity coupling.

Inductive coupling is shown at Fig. 717-B and transmission line coupling in 717-C. Since all these methods have been discussed at length in the preceding section, we need not go into further detail here. The same advantages and disadvantages apply.

Frequency Multipliers

The frequency multiplier is the simplest kind of amplifier, since neutralization is not required; the tube is simply coupled to the preceding stage by one of the methods shown in Fig. 716 and a tank circuit tuned to the desired harmonic is inserted in its plate circuit. The efficiency of the frequency multiplier is always less than that of a straight amplifier, and decreases rapidly with harmonics higher than the second; for this reason it is rarely worth while to operate such an amplifier on harmonics higher than the second.

To obtain maximum output and efficiency from the doubler it is necessary to use high negative grid bias on the tube and excite it with a correspondingly high radio-frequency voltage. A low-*C* tank in the plate circuit is also desirable. In general, a tube having a relatively large amplification factor is best as a doubler; tubes such as the 46 and 59 with Class-B connections, the 841, RK-18, 800, 825 and 203-A are most suitable. Other types, such as the 10 and 830, will work satisfactorily but require higher bias and greater excitation voltage than the high- μ tubes. In practical work the bias may be supplied by batteries, through the voltage drop caused by the flow of d.c. grid current through a high-resistance grid leak, or from a combination of both.

The efficiency and output of a doubler can be increased by feeding some of the energy in the

plate circuit back to the grid to cause regeneration, provided the process is not carried so far that the tube breaks into self-oscillation. One of the most satisfactory ways of introducing regeneration is by neutralizing the frequency multiplier

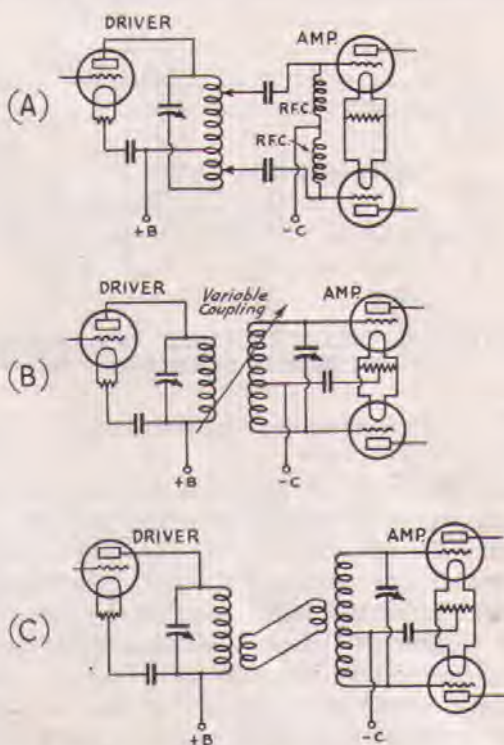

FIG. 717—TYPES OF COUPLING USED TO FEED A PUSH-PULL AMPLIFIER FROM A SINGLE-ENDED OSCILLATOR OR DRIVER

by one of the methods in which the neutralizing voltage is fed from the plate circuit to the grid. Circuits A, B and C in Fig. 715 are examples of this type of circuit. When the tube is properly neutralized it cannot oscillate, yet the feedback is sufficient to increase the output and efficiency of the doubler to a worth-while extent.

Push-pull amplifiers are unsatisfactory as doublers because the push-pull connection balances out the even harmonics. Push-pull amplifiers will work quite well as triplers, however.

A special type of doubler circuit which has given good results is shown in Fig. 718. The grids are fed in push-pull (excitation 180 degrees out of phase) while the plates of the two tubes are connected in parallel. Thus the output circuit receives two pulses for each r.f. cycle at the grids, resulting in all second-harmonic output.

Straight Amplifiers — Operating Considerations

High power output usually is the first consideration in the operation of an amplifier in the c.w. transmitter. The frequency stability of the transmitter is set by the characteristics of the oscillator; the amplifier's job is simply that of stepping up to the maximum possible value the power delivered to its grid. The power output that can be obtained from a given tube is limited by the

safe plate dissipation, the maximum safe plate voltage and the maximum permissible plate current. Since the power input is limited by the tube ratings, it is therefore desirable to obtain high efficiency in the plate circuit so that the largest possible proportion of the power input

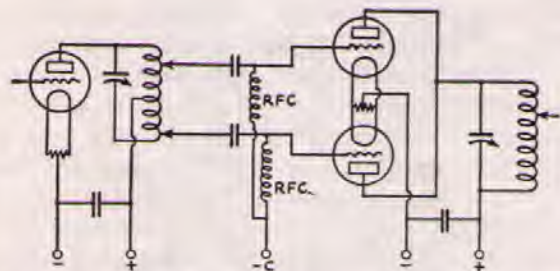

FIG. 718 — A CIRCUIT DESIGNED ESPECIALLY FOR FREQUENCY DOUBLING

will be converted to radio-frequency power output.

The efficiency of an amplifier is determined largely by the negative grid bias and the peak value of the excitation voltage applied to its grid. For maximum efficiency the grid bias should be at least twice the value required to cut off the plate current at the plate voltage used, and the excitation voltage must be such that the grid is driven positive during part of the excitation cycle, causing grid current to flow. Grid bias may be supplied by a suitable source of voltage, such as "B" batteries or a "B" eliminator (see Chapter Ten) or can result from the flow of grid current through a grid leak. The L - C ratio in the plate tank circuit should be high.

The problem usually confronting the amateur in the design of an oscillator-amplifier transmitter is that of providing adequate excitation for a pre-determined type of output tube operating on a given frequency. In the crystal-controlled transmitter, the power output of the crystal oscillator is usually five watts or less, and is ordinarily on a frequency in the 3500-kc. band. It then becomes necessary to decide upon the number of amplifier or doubler stages that will be necessary to give adequate excitation to the final amplifier on the final operating frequency. There are so many ways of arriving at the result that it is useless to give exact specifications. The tube table will be of value in the preliminary estimates, however. The power output ratings given are conservative when the tube is used as a straight amplifier; as a doubler, the output will usually be less — as a safe estimate, say fifty percent of the rated power output, assuming the recommended plate voltages and currents are applied. Then, by further assuming that the power amplification ratio in the tube will be approximately ten — that is, the power required by the grid will be one-tenth the rated output — for straight amplification, and not more than five for doubling, it is possible to choose a reasonable

tube line-up for the complete transmitter. These figures are not to be considered exact; a great deal depends upon the skill of the operator in adjusting the transmitter and upon the frequency. As a general rule, the efficiency will decrease as the frequency is raised, so that some allowance for unexpected losses should be made, especially on frequencies higher than 7 mc.

The specific examples of transmitters now to be discussed will illustrate different types of designs. They can be duplicated or can be used simply as a starting point by the amateur capable of working out his own design. The large variety of tubes available makes it impossible for us to do more than indicate a few possible layouts in this chapter.

A Crystal-Controlled Transmitter

A simple yet entirely satisfactory crystal-controlled set for operation on three bands is

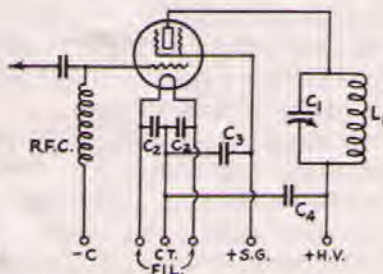

FIG. 719 — TYPICAL SCREEN-GRID AMPLIFIER CIRCUIT

For use with filament-type power tubes such as the 865, 860, 282-A, 850, 254-A and 254-B. Important points to observe in the operation of the screen-grid amplifier are that the screen by-pass condenser should have low impedance at the operating frequency (capacity of at least .002 μ fd. for amateur transmitters) and that the output tank circuit L_1C_1 must be isolated from the input circuit, either by shielding or by physical spacing great enough to prevent feedback. By-pass condensers C_2 and C_3 may be the usual values used in power-tube circuits; .002 μ fd. will be sufficient. Any type of input coupling shown in Fig. 716 may be used in place of the capacity coupling indicated.

For greatest efficiency the screen voltage should not be greater than the value recommended in the tube table for the type of tube used. Screen voltage is preferably supplied from a voltage divider across the plate supply.

shown in Fig. 720. It uses inexpensive tubes and parts and, when used in conjunction with a power supply giving 400 volts, will have a power output of approximately 25 watts on the 3.5- and 7-mc. bands, and 15 watts on 14 mc. The lower power output on the latter band results from the fact that in the interests of simplification the final stage is used as a doubler on that band. These outputs are adequate for practical work in all three bands; in addition, the set is well adapted to use as a three-band exciter for a higher-power amplifier.

The complete circuit diagram of the transmitter is given in Fig. 721. As nearly as possible this diagram follows the physical layout of the apparatus. It will be seen by inspection of the diagram that the crystal oscillator uses a 47 tube; that a 46 tube is used as a doubler; and that a pair of

46's operate in parallel in the final amplifier. A double-pole double-throw switch connects the amplifier to either the oscillator or the doubler, depending upon the frequency to be used. For 3.5-mc. work the doubler is omitted, the amplifier being connected directly to the oscillator. On 7 and 14 mc., however, the switch connects the doubler grid to the oscillator and the doubler plate to the amplifier grids, through the coupling condensers. It is necessary to change coils only in the amplifier plate circuit when changing bands.

On the horizontal baseboard, the oscillator tube with its tuning condenser, C_1 , and inductance, L_1 , are at the right-hand end. The doubler and its tuning condenser and coil are at the left; the changeover switch is between these two stages. The amplifier is built on a vertical baseboard which is fastened centrally to the horizontal board. The coupling condenser C_{10} can be glimpsed beneath the projecting shelf on which the amplifier tubes and the neutralizing condenser, C_8 , are mounted. The amplifier plate by-pass condenser, C_9 , is mounted flat on the vertical board just below the tank tuning condenser, C_7 , which projects from the board near the top. Condenser C_7 also holds a bakelite strip with five G.R. jacks into which the G.R. pins on the coil-mounting strip fit. The jack strip is fastened to C_7 by small fittings made from brass strip, held in place by the condenser terminals. Other parts not specifically mentioned above are mounted in convenient locations, some under-

neath the lower baseboard. All connections in the r.f. circuits should preferably be kept short. The crystal and its mounting, not visible in the photograph, are to the right of the oscillator tube near its grid and filament terminals. The filament center-tap resistors, R_1 , R_2 and R_6 , are mounted right at the filament terminals on the sockets of their respective tubes. Fahnestock clips fastened to the edges of the baseboards serve as terminals for the power supply and keying leads.

Tuning the Crystal Transmitter

After finishing the construction and checking over the wiring carefully to make certain that it is exactly as shown in Fig. 721, the first step in getting the transmitter on the air is to try out the oscillator. A d.c. milliammeter (0-200 scale) should be connected in the plate supply lead, and the doubler tube should be removed from its socket. With a random setting of the tuning condenser, C_1 , the plate and filament power should be applied. The milliammeter should read between 30 and 40 milliamperes if the recommended 250 volts are used on the plate of the oscillator tube. Now turn C_1 slowly over its whole scale; at one spot the plate current should drop suddenly, indicating that the tube is oscillating. As the condenser is turned farther, the plate current will rise again and finally reach the steady value which indicates the cessation of oscillation. If the crystal is normally active, the minimum value of plate current with C_1 set for oscillation will be between 15 and 20 milliamperes; the lower the plate current, the more active the crystal. If the tube does not oscillate, the wiring of the oscillator should be checked over and the crystal tried out in another set, if possible. In this connection, the grid leak resistor, R_3 , must be non-inductive. A wire-wound resistor is likely to prevent the oscillator from functioning; the best resistors for the purpose are the metallized or carbon-rod type.

When the oscillator is working as described above, the doubler tube should be placed in its socket and the switch Sw thrown so that the doubler grid is connected to the oscillator tank circuit (left-hand position in Fig. 721). The milliammeter will now read the plate currents of both tubes. Condenser C_1 should be readjusted for oscillation; then the doubler tuning condenser C_2 should be turned over its scale until the plate current takes a noticeable dip, indicating that the tank C_2L_2 is tuned to resonance on the second harmonic. If desired, separate plate supply leads may be brought out from the oscillator and doubler so that the milliammeter will read the plate current of only one tube at a time; this may make interpretation of the meter readings somewhat more simple. In first tuning the doubler stage the amplifier tubes should be out of their sockets and the amplifier neutralizing condenser, C_8 , should be set at about half scale; having these



FIG. 720 — A LOW-POWER CRYSTAL-CONTROLLED TRANSMITTER FOR OPERATION IN THREE AMATEUR BANDS

The set has three stages: a 47 crystal oscillator, a 46 doubler and a pair of 46's in parallel as a final amplifier.

tubes out of their sockets takes the load off the doubler and makes the plate current variations more pronounced. It is also helpful to have a neon lamp handy; one terminal of the lamp touched to the plate of either the oscillator or doubler will indicate the presence of oscillations by its characteristic glow. The strength of the oscillations also can be gauged roughly by the intensity of the glow. The tuning lamp described earlier in the chapter will do the same work.

Having finished the adjustments described above, it is time to neutralize the amplifier. Plug in the 7-mc. tank coil at L_4 , put the tubes in their sockets, and readjust C_1 and C_2 for resonance; do not as yet apply the amplifier plate voltage, however. The doubler plate current will not drop to as low a value as before when the amplifier tubes are receiving excitation because r.f. power is being taken from the doubler. With the neutralizing condenser, C_8 , at minimum, touch the neon bulb to the stator plates of C_7 , and turn C_7 until the bulb glows. This indicates that the amplifier plate circuit is tuned to resonance. Now increase the capacity of C_8 by small steps, readjusting C_2 and C_7 each time to resonance, and watch the neon bulb. As the capacity of C_8 is increased, the glow will become dimmer, and finally at one setting the bulb will not light even though both C_2 and C_7 are tuned to resonance. If the capacity of C_8 is increased still more, the bulb will glow again. The setting of C_8 at which the bulb will not light is the correct setting for neutralization. When the amplifier is properly neutralized C_7 can be tuned all over its scale without the slightest indication of glow in the lamp. Both C_2 and C_7 should be brought to resonance each time a change is made, since the setting of C_8 will affect the tuning of both stages.

When the neutralizing is completed, shift the milliammeter to the plate supply lead to the amplifier, apply the plate voltage and close the key or bridge the key terminals. The tank condenser C_7 should be set approximately at resonance as found during the neutralizing adjustment. Now tune C_7 slowly about resonance and watch the plate current. At exact resonance the plate current will dip to a very low value — 10 to 20 milliamperes — while on either side it should rise to 150 or so. Always keep C_7 at resonance; tuning off on either side is likely to ruin the filament emission of the tubes if done more than momentarily. After a final re-check of the tuning adjustments of C_1 , C_2 , and C_7 , the transmitter is all ready to deliver power to the antenna.

The operation of the set on the 3500-kc. band is similar to that just described except that the step involving the doubler tuning is omitted. The oscillator is coupled directly to the amplifier by throwing Sw to the right; the neutralizing procedure is exactly as described above. The remarks applying to the tuning of C_2 on 7 mc.

apply with equal force to the tuning of C_1 on 3.5 mc.

For 14-mc. work, the oscillator and doubler are

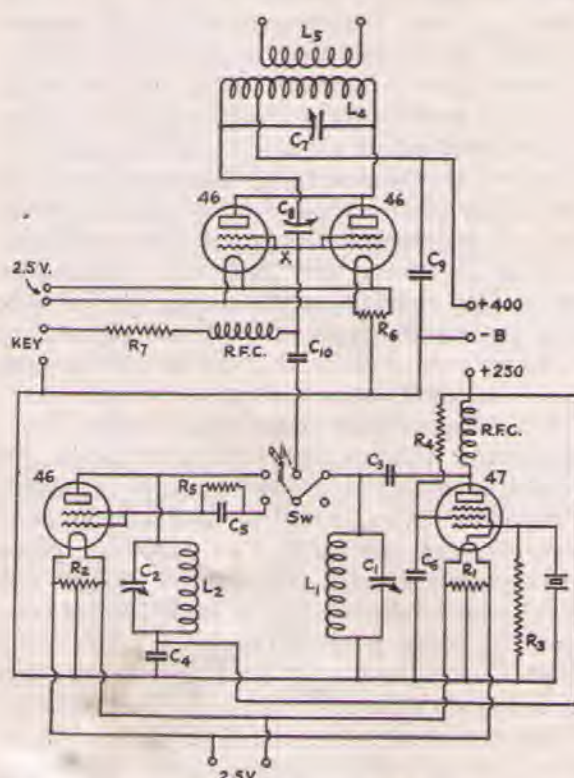

FIG. 721 — COMPLETE CIRCUIT DIAGRAM OF THE LOW-POWER CRYSTAL TRANSMITTER

- C_1 — Oscillator tuning condenser, 140- μ fd. midget condenser, Hammarlund.
 C_2 — Doubler tuning condenser, same as C_1 .
 C_3 — Oscillator plate blocking condenser, 500- μ fd. mica condenser.
 C_4 — Doubler plate by-pass condenser, same as C_3 .
 C_5 — Coupling condenser, 100- μ fd. mica condenser.
 C_6 — Screen by-pass condenser, .001- μ fd. mica condenser.
 C_7 — 150- μ fd. variable condenser (Cardwell 405-B).
 C_8 — 50- μ fd. midget condenser (Hammarlund MC-50-S).
 C_9 — .001- μ fd. mica condenser.
 C_{10} — 40- μ fd. mica condenser (see text).
 R_1, R_2 — Filament center-tap resistors, 20 ohms, center tapped.
 R_3 — Oscillator grid leak, 5000 ohms, 2 watt.
 R_4 — Screen dropping resistor, 50,000 ohms, 5 watt.
 R_5 — Doubler grid leak, 20,000 ohms, 2 watt.
 R_6 — 20-ohm center-tapped resistor.
 R_7 — 1000 ohms, 2-watt.
 Sw — D.P.D.T. Porcelain-Base Switch.
R.F.C. — Short-wave choke (National Type 100).
 X — Ultra-high-frequency choke to be inserted here, if necessary to prevent parasitic oscillation. A suitable coil can be made by winding 15 turns of No. 20 d.c.c. wire on a diameter of $\frac{1}{4}$ inch.
 L_1 — Oscillator tank coil, 21 turns of No. 14 enamelled wire on 2" bakelite tube, spaced to occupy 2 inches.
 L_2 — Buffer tank coil, 11 turns same construction as L_1 but spaced to occupy $1\frac{1}{2}$ inches.

AMPLIFIER COIL DATA

Band	L_1	L_2
3500 kc.	20 turns tapped at 12th	8
7000 kc.	11 turns tapped at 7th	5
14,000 kc.	7 turns tapped at 4th	5

Taps are from plate ends of coils. L_1 turns are spaced to make length of 3500-kc. coil 2", 7000-kc. coil $1\frac{1}{2}$ ", 14,000-kc. coil $\frac{3}{8}$ ". L_2 spacing between turns equal to approximately half the diameter of wire.

tuned as before. The 14-mc. tank coil is plugged in at L_4 . Tuning in this case is best done with the plate voltage applied to the amplifier. Begin with C_3 set at minimum capacity and tune C_7 for the dip in plate current which indicates resonance on the 14-mc. harmonic. Then, with the key closed and the amplifier plate voltage on, stop the crystal from oscillating by detuning C_1 and note the amplifier plate current. It should be in the vicinity of 10 to 15 milliamperes. Now increase C_3 in small steps, retuning both C_2 and C_7 for resonance each time, until C_3 is at about half scale. Again stop the crystal from oscillating and again note the amplifier plate current. If it is the same as during the first test, the capacity of C_3 can be increased a bit more; in fact, the object of this procedure is to use the largest capacity at C_3 which will still permit the amplifier plate current to drop to its original value when the crystal is prevented from oscillating. Manipulating C_3 in this fashion adds regeneration to the amplifier and increases its output on 14 mc. The adjustment must be made very carefully, however; the slightest increase in amplifier plate current over its original value (crystal non-oscillating in both cases) indicates that the amplifier is self-oscillating. This must not be allowed to occur; self-oscillation not only decreases the efficiency of the amplifier but also is likely to lead to off-frequency operation. Touching the neon bulb to the stator plates of C_7 also will give evidence of self-oscillation, but the plate current indication is best.

Output Coupling

With the adjustments described above completed, the transmitter is ready for coupling to the antenna.

No provision has been made in the amplifier for variable antenna coupling. The kind of coupling needed depends upon the type of antenna, the feeder length if feeders are used, and the method of tuning. Space does not permit specifying antenna coil sizes and spacings for all of the many methods of coupling in use. The specifications given in Fig. 721 probably will be about right for Zepp feeders with series tuning, but the right number of turns and the distance between the amplifier tank coil and the antenna coil must be determined by experiment in each individual case. Once found, however, the right-sized coil and right degree of coupling is automatically plugged in each time the transmitter is shifted to another band. If it should be thought more desirable to have a permanent antenna coil swung on a hinge so coupling can be varied, such a coil can easily be rigged up. It would be comparatively easy, also, to put the antenna coil on a piece of tubing slightly larger than the plate-coil form and slide it over the latter to vary the coupling.

The antenna coupling and tuning should be adjusted so that the antenna current is greatest, so long as the plate current is not more than

about 120 milliamperes. It is a little hard on the tubes to load them beyond this, even though a higher plate current will result in greater antenna current.

The output coils, L_5 , specified in Fig. 721 will have approximately the right number of turns if the transmitter is to be coupled to a more powerful amplifier by the method shown at Fig. 716-D. This is, in fact, the most satisfactory way of coupling the set to a following amplifier. In such case L_5 should be wound close to L_4 —with spacing between them of perhaps one-quarter to one-half inch. The power output of the transmitter is ample to excite an amplifier using one of the tubes in the "100-watt" classification in the tube table. The set can be used equally well, of course, to drive one of the 50-watt tubes, or a pair of them in push-pull or parallel.

Other Circuits — The Tri-Tet Oscillator

While the low-power transmitter just described is representative of usual amateur design in the construction of multi-band crystal transmitters, it must not be thought that other methods of achieving similar results are not equally satisfactory. The layout of the transmitter usually will be dictated by the type of tube to be used in the output stage. If the transmitter is to have one of the 50-watt tubes, such as the 800, 825, 830 and RK-18, or even one or two 10's, in the output stage, the final amplifier can be excited by several low-power tube combinations. The most important of recent developments along these lines is the combination of a special crystal-oscillator circuit and a doubler which although not neutralized as in the previous transmitter, nevertheless is regenerative and therefore operates at good efficiency.

The oscillator combines the features of a triode oscillator and high- μ tetrode frequency multiplier, hence the name "tri-tet." As in the electron-coupled oscillator, a screen-grid tube is operated with its screen as the plate of a triode oscillator; the screen is grounded and the power output is taken from the plate circuit. This necessitates operating the tube cathode at an r.f. potential above ground, which in turn makes the use of a tube having an indirectly-heated cathode desirable. The crystal is connected between the control grid and cathode, with the oscillator tank circuit between the cathode and the screen. Power is taken from the plate circuit in the regular way. Of the inexpensive tubes now available, the 59 is the most suitable type for the tri-tet oscillator, although its screen is not a perfect shield between the other elements and the plate. As used in the oscillator circuit, the screen grid and No. 3 grid (the suppressor when the 59 is used as a pentode) are connected together to act as a single element. The tri-tet oscillator will deliver sufficient power at the second harmonic to excite a second low-power tube, and will also give fairly good output at

the third and fourth harmonics. Thus a single tube is made to function both as oscillator and frequency multiplier, eliminating a frequency-multiplying stage in the transmitter.

We shall now describe an exciter unit which will furnish excitation for an amplifier of moderate power on five amateur bands. It employs only two Type 59 tubes: one a tri-tet oscillator and the other an amplifier or frequency doubler whose regenerative effects result from its tendency to act as an ultraudion oscillator at high frequencies.

A Five-Band Exciter Unit

The exciter unit is not in itself a complete transmitter, being intended for driving a power amplifier. The oscillator circuit is arranged so that it can be used either with crystal control or as an electron-coupled oscillator simply by plugging a coil into either of two sockets. Plug-in coils are used in three positions; for convenience, all the coils are wound on regular receiving-coil forms. The complete circuit diagram, showing alternative connections when the oscillator operates as a self-controlled electron-coupled oscillator, is given in Fig. 723. Using the self-controlled electron-coupled oscillator gives great flexibility in choosing harmonic combinations for output on different frequencies, and in addition permits operation in different parts of the same band at will. The character of the signal with electron-coupled control is very nearly as good as with crystal control.

The baseboard on which all the parts are mounted measures 7 by 20 inches. The two sockets at the left edge of the board are for the oscillator coil. The one toward the front is used for crystal control; that at the rear is for e.c. con-

trol. Immediately to the right of the coil sockets is the oscillator tuning condenser, C_1 , mounted edgewise so that the $2\frac{1}{4}$ by $3\frac{1}{2}$ -inch Bakelite platform holding the oscillator tube socket can be bridged between the stator-plate terminals of this and the similarly-mounted plate tuning condenser, C_2 . Suspended below the front edge of the platform by small metal angle-brackets is a bakelite strip equipped with two G.R. Type 274-J sockets spaced $\frac{3}{4}$ -inch between centers, standard spacing for the conventional type of plug-in crystal holder. The r.f. choke in the crystal grid circuit is mounted vertically between the baseboard and the platform, held at the baseboard end by a machine screw which goes through to make connection to the grid leak, R_1 , underneath. The connections to the oscillator tube socket are run directly to the socket terminals through small holes in the platform. The filament prongs face the rear edge of the board.

To the right of C_2 is the socket for the oscillator plate coil, L_2 . Beside it is the r.f. choke which serves as a coupling impedance on the low-frequency bands. The doubler tube socket (filament prongs to the rear) is on the other side, with the interstage coupling condenser, C_5 , between. The doubler plate tuning condenser, C_3 , the socket for L_3 , and the output terminals at the extreme right, complete the list of parts on the upper surface of the baseboard.

In the photograph of the under side of the baseboard, Fig. 724, the terminal strip at the lower left is a piece of bakelite measuring $\frac{5}{8}$ by 4 inches; at regular intervals G.R. Type 738-A screw terminals have been forced into it. Just above the terminal strip is the voltage-divider resistor, R_4 . The other voltage-divider resistor,

R_5 , is mounted somewhat to the right; beside it is the oscillator grid leak, R_1 . The oscillator screen and plate by-pass condensers, C_4 and C_6 , are fastened end-to-end to the board by means of a wood screw; the connection common to the two goes to the negative "B" while appropriate leads from the tube socket and C_2 drop through the board to the other terminals. The doubler cathode by-pass condenser, C_7 , is held in place by one of its tapped terminals, which is threaded on one of the machine screws which holds the L_2 coil socket to the board. The doubler cathode resistor, R_3 , is connected directly across the condenser terminals. Above

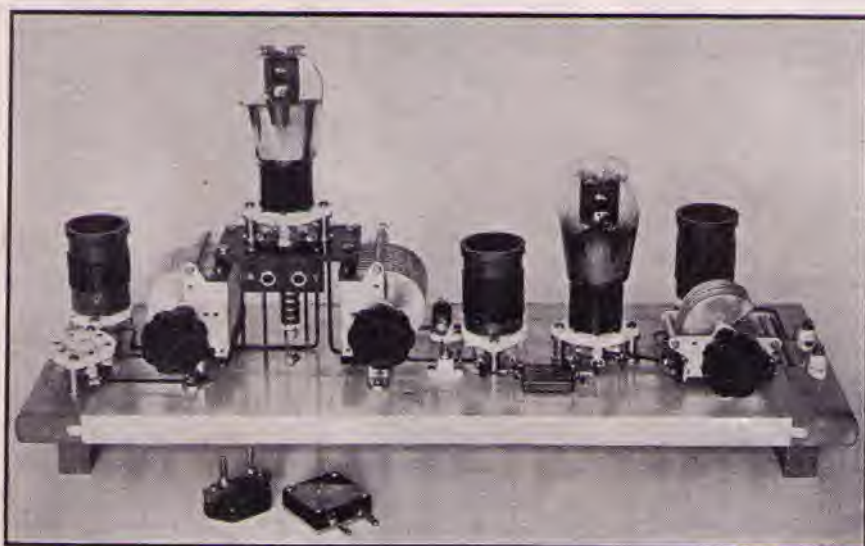

FIG. 722 — A BREADBOARD EXCITER UNIT

Two Type 59 tubes are used to give crystal or electron-coupled frequency control on five bands. This photograph shows the coils in place for 14-mc. operation with electron-coupled control. The grid condenser in the foreground, which plugs into the socket underneath the oscillator tube, has been removed so that the r.f. choke and wiring underneath the platform can be seen.

these toward the upper (front) edge of the board is the r.f. choke in the doubler grid circuit; it is mounted on a pair of miniature stand-offs like those used for the output terminals on top. Between the cold end of the choke and the ground end of C_7 is the doubler grid leak, R_2 . The two remaining condensers, one fastened to each of the two machine screws which hold the doubler tube socket in place, are the doubler screen and plate by-pass condensers, C_8 and C_9 .

The wiring of the oscillator coil sockets for crystal and e.c. control is shown in Fig. 725. Six-prong coil forms and sockets will be required for greatest economy of coils; four prongs are needed for the oscillator windings and two more for the output windings. Four-prong forms can be used throughout if crystal control is to be used exclusively.

When e.c. frequency control is to be used it is necessary to replace the crystal by a grid condenser. This condenser, which can be seen in one of the photographs, is supplied with a pair of G.R. plugs which fit the crystal mounting. This has been done by appropriately drilling and tapping small pieces of 1/4-inch square brass rod which are fastened to the condenser terminals.

Coil Requirements

The number of coils needed will depend upon the frequency coverage desired. A maximum of eight will be required for complete coverage from 1.75 to 28 mc. For ordinary operation, i.e., 3.5, 7 and 14 mc., only four coils need be used with crystal control; one additional coil will give the same coverage with e.c. control.

Complete coil specifications are given in Table I. Only six coils are indicated; the other two needed to finish off the set are duplicates of the B and C coils. If coil forms of different diameter are to be used, the number of turns should be increased or decreased accordingly. The oscillator coil, L_1 , always should be high- C for the fundamental frequency of the oscillator. Adjust the number of turns so that the desired frequency will be obtained with C_1 set at at least 75% of maximum capacity. The oscillator plate coil, L_2 should be low- C for the frequency to which it is to be tuned. Proportion it so that the plate tuning condenser, C_2 , is very nearly at minimum capacity at resonance. This is extremely important on the higher frequencies. In practice, it will be found that a plate coil properly adjusted will also work well in the L_1 position as a high- C coil in the next-lower-frequency band. It is also highly important to use very low C in the doubler plate coil, L_3 , and coils for this position also should be proportioned so that resonance is reached with the condenser C_3 near minimum capacity. Since 59 tubes of different makes have different inter-electrode

capacities, it may be necessary to add or subtract a turn or so from the specifications given for the higher-frequency coils to obtain resonance with C_3 or C_2 near minimum capacity.

Table II indicates the way in which the various coils are used in operating the exciter unit on dif-

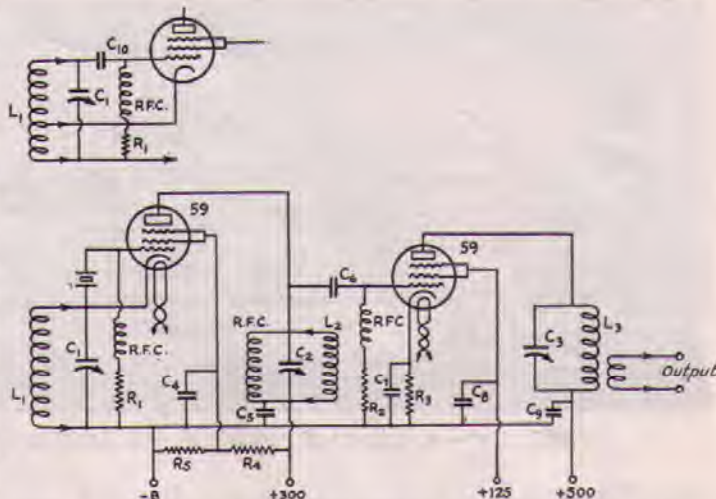

FIG. 723 — EXCITER UNIT WIRING DIAGRAM

The alternative crystal and e.c. control circuits are shown as separate diagrams, although the choice actually is made in the unit by plugging L_1 into either of two sockets and using a crystal or grid condenser as required. Wiring of the sockets is shown in Fig. 725.

- C_1 — 350- μ fd. variable condenser (Cardwell Midway Type 407-B).
- C_2 — 100- μ fd. variable condenser (Cardwell Type 412-B).
- C_3 — 50- μ fd. variable condenser (Cardwell Type 410-B).
- C_4, C_5 — .005- μ fd. mica condensers (Dubilier Type 3).
- C_6 — 100- μ fd. mica condenser (Dubilier Type 4).
- C_7 — 100- μ fd. mica condenser (Dubilier Type 9).
- C_8, C_9 — .005- μ fd. mica condensers (Dubilier Type 3).
- C_{10} — 250- μ fd. mica condenser (Dubilier Type 9).
- R_1, R_2 — 50,000-ohm, 2-watt resistors (I.R.C.).
- R_3 — 1000-ohm, 5-watt wire-wound resistor (I.R.C.).
- R_4 — 10,000-ohm, 10-watt wire-wound resistor (Electrad).
- R_5 — 5000-ohm, 10-watt wire-wound resistor (Electrad).
- RFC — Universal-wound high-frequency chokes (National Type 100).

Coil data are given in Tables I and II. All coils are wound on National six-prong receiving coil forms (diameter 1 1/2 inches).

Coil and tube sockets are Isolantite, made by National. The knobs are G.R. Type 637-G.

The heaters of the two tubes are wired in parallel. No center-tap resistor is used in the exciter unit itself; a 20-ohm c.t. resistor should be connected across the heater winding at the power supply. The center-tap should be connected to -B.

ferent bands. Since Type 59 tubes are not completely screened, oscillation will take place if the plate and grid circuits of the same tube are tuned to the same frequency; such a possibility naturally must be avoided and for this reason an untuned coupling arrangement is used on those bands where consecutive circuits might logically be expected to work on the same frequency. The untuned coupling consists of the r.f. choke shunted across C_2 together with the regular coupling condenser and choke in the grid circuit of the doubler. It is important to have good chokes if the coupling is to work at all well; the

small, inexpensive universal-wound chokes are satisfactory.

Tuning the Exciter Unit

The tuning procedure is quite simple. The easiest case is that of crystal control on 1.75 or

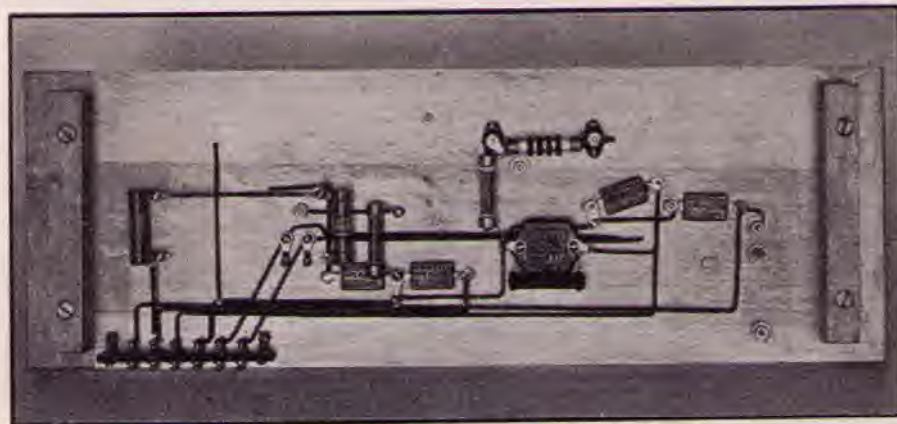

FIG. 724 — A SUB-BASE VIEW OF THE EXCITER UNIT

3.5 mc. On either band, using an appropriate crystal and the coils recommended in Table II, apply all voltages except that to the doubler plate. Set C_2 at minimum capacity and tune C_1 until the oscillator starts. Oscillation will be indicated by a dip in the oscillator plate current (a meter inserted in the plus 300 lead will read the voltage-divider and screen currents as well as the oscillator plate current, the first two taking between 20 and 25 ma.) or, if no meter is used, can be detected by the usual neon bulb or flashlight-lamp-loop. Set C_1 somewhat on the high-frequency side of resonance. Now apply the doubler plate voltage and adjust C_3 to resonance, which will be indicated by minimum plate current. The output terminals then can be connected to a following amplifier, the tuning of which will of course depend upon its design.

The procedure is just the same when e.c. control is to be used on either of these two bands, except that the oscillator coil, L_1 , is placed in the rear socket; C_1 must be adjusted so that the oscillator operates on the desired frequency. This should be done with the aid of a frequency meter.

To use crystal control on 7 mc., plug in the proper coils and apply all voltages except the doubler plate voltage. Make sure that the oscillator cathode circuit is closed by a jumper connecting the upper left and lower right prongs of the "xtal" socket together. If this is not done the oscillator cathode socket will be open. Turn C_2 down from maximum capacity; near the minimum-capacity end of the scale oscillations will start. Now apply plate voltage to the doubler and adjust for minimum plate current, and the tuning is complete.

For 7-mc. e.c. control, set the oscillator to one-fourth the desired output frequency, again having the doubler plate voltage off. Next, tune C_2 for

resonance at the second harmonic of the oscillation frequency; resonance will be indicated by a dip in oscillator plate current or by use of the neon bulb or lamp-and-loop. Either of the latter will affect the tuning, however, so the plate current indication is best. Now apply the doubler plate voltage, adjust C_3 for minimum plate current and, leaving C_3 set, readjust C_2 for maximum doubler output.

For 14-mc. crystal control, the general procedure is about the same as that just described. The oscillator condenser, C_1 , should be set well on the high-frequency side of the point at which oscillations start; C_2 should be set for the dip in oscillator plate current at the second harmonic (a 3.5-mc. crystal is assumed); and C_3 should be set for minimum doubler plate current. When this last adjustment is completed, both C_1 and C_2 should be readjusted for maximum doubler output. If e.c. control is to be used, the oscillator must be adjusted to a suitable frequency in the 3.5-mc. band with the aid of a frequency meter and thereafter let alone. The oscillator plate and doubler plate circuits are tuned just as with crystal control.

On 28 mc. the tuning is the same as for 14 mc. (with a 3.5-mc. crystal) except that the fourth harmonic instead of the second is picked off in the



COIL CONNECTIONS

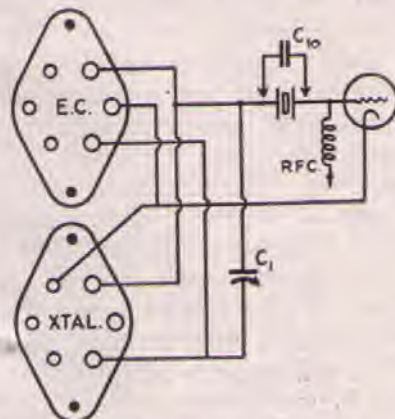

OSCILLATOR SOCKET CONNECTIONS

FIG. 725 — COIL AND SOCKET WIRING

The upper drawing shows the internal wiring of the coils, looking down into the coil form. The wiring of the two sockets into which L_1 may be plugged for either crystal or e.c. control is shown below.

oscillator plate circuit. The dips in both oscillator and doubler plate current as C_2 and C_3 are varied probably will not be as pronounced as on the lower frequencies. If a 7-mc. crystal is used the second harmonic of the oscillator will be taken off in the oscillator plate circuit.

With e.c. control on 28 mc., the oscillator grid will be tuned to a frequency between 7 and 7.5 mc., oscillator plate to the second harmonic, and doubler plate to the 28-mc. harmonic. The same tuning procedure is used.

The power output from the doubler, when the set is supplied the voltages indicated in Fig. 723, is approximately as follows: 1.75 mc., 3.5 watts; 3.5 mc., 3.5 watts; 7 mc., 8 watts; 14 mc., 5 watts. These outputs are sufficient to drive at good efficiency a push-pull amplifier having a pair of Type 10 tubes or a single-tube amplifier of the type now to be described.

An Intermediate-Power Amplifier

The amplifier shown in Fig. 726 is designed as a companion unit to the five-band exciter. A Type RK-18 tube is used in a neutralized circuit similar to that in Fig. 715-C; the input coupling is of the type shown in Fig. 716-D.

The physical layout follows the circuit diagram, Fig. 727, as nearly as possible. The socket into which the grid coil plugs is near the left-hand edge of the board, with a pair of miniature porcelain standoffs alongside to serve as input terminals. To the right of the coil socket is the grid tuning condenser, C_1 , mounted edgewise with the "bottom" of the condenser facing left. The socket for the tube is mounted vertically from this condenser by a pair of brackets made from pieces of 1/16-inch by 1/4-inch strip brass, the brackets being fastened to the condenser by the two screws which hold the insulating strip to the end frames. This type of mounting keeps the r.f. leads short, without at the same time having the grid and plate circuits too near each other. The plane of the tube filament should be vertical so that the filament will not sag and touch the grid. The stationary plates of C_1 are connected to the grid prong on the tube socket; the filament leads drop down behind C_1 to a pair of midget

by-pass condensers and thence through the board to the terminal strip on the rear lower edge.

The plate end of the tube is supported by a grid clip soldered to a piece of stiff bus wire which in turn is mounted firmly on the terminals of one set of stator plates of C_2 , the plate tuning condenser. Between C_1 and C_2 is the neutralizing condenser, C_5 . One terminal of this condenser connects to the second set of stator plates on C_2 , while the other goes to the stator plates of C_1 .

The plate coil, L_3 , and antenna coupling coil, L_4 , rest on the bakelite rods to the right of C_2 . These rods are mounted on midget standoffs to

TABLE II

Crystal Control			
Band, Mc.	Coil at L_1	Coil at L_2	Coil at L_3
1.75	B*	None	A
3.5	C	None	B
7	Jumper	B	C
14	C	C	D
28	C	E	E
	D**	E	F

E. C. Oscillator			
Band, Mc.	Coil at L_1	Coil at L_2	Coil at L_3
1.75	B	None	A
3.5	C	None	B
7	B	B	C
14	C	C	D
28	D	E	F

* 1.75-mc. crystal.

** 7-mc. crystal.

give the necessary clearance between the plate coils and the baseboard. The antenna tuning condensers, C_3 and C_4 , stand vertically at the right-hand edge of the board. The mounting pillars are underneath, and the machine screws holding the condensers in place run through the baseboard.

The grid by-pass condenser, C_8 , and the plate r.f. choke are fastened to the under side of the baseboard in convenient locations.

Operating the Amplifier

Complete specifications for five bands are given under Fig. 727. Bias may be supplied by a 90-volt battery or can come from the voltage drop through a grid leak. With 90 volts "C" or a 5000-ohm leak the grid current should be between 15 and 20 milliamperes. A combination of battery and leak bias can be used, if desired; in such case it is recommended that the leak be 2500 or 5000

TABLE I

Coil	Turns	Length of Winding	Tap*	Wire Size	Output Winding**
A	80		20	No. 28 d.s.c.	10
B	32	1 1/4"	8	No. 22 d.s.c.	5
C	15	1"	4	No. 22 d.s.c.	5
D	10	1"	3	No. 22 d.s.c.	3
E	7	1"		No. 22 d.s.c.	
F	4	1/2"		No. 22 d.s.c.	3

Coil diameter is 1 1/2 inches in all cases.

* Number of turns from ground end of coil.

** Turns close-wound.

ohms and that at least 45 volts of battery bias be used.

The amplifier should be neutralized by the same method that was employed with the low-power crystal transmitter previously described. In this case the grid condenser, C_1 , replaces the

only gives twice the power output of a single tube, but also has certain advantages on the higher frequencies. When two tubes are connected in push-pull their interelectrode capacitances are connected in series, so that the capacity shunting the input and output circuits is reduced. This is

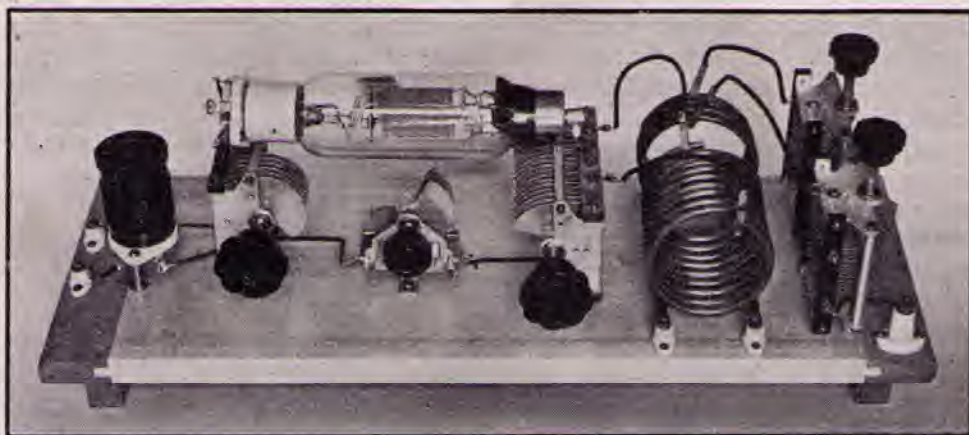

FIG. 726 — AN AMPLIFIER OF MODERATE POWER OUTPUT USING AN RK-18 TUBE

Although built particularly to go with the exciter unit, it can be used with any low-power transmitter. With adequate excitation — about five watts from the driver — an output of 50 watts can be obtained at the rated tube input of 1000 volts and 85 milliamperes.

driver stage tuning condenser. After having been neutralized on one band, the amplifier will also be neutralized for all the others provided the plate coil dimensions are such that resonance is reached with C_2 between half and full capacity. The antenna tuning and coupling are simply adjusted for maximum output; the instructions given for the low-power transmitter apply equally well.

Push-Pull Amplifiers

A great many amateurs use amplifiers in which two tubes are arranged in push-pull. This not

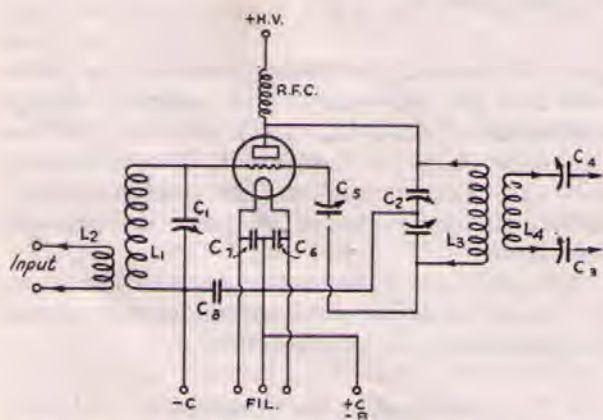

FIG. 727 — THE CIRCUIT OF THE HIGH-FREQUENCY AMPLIFIER

- C_1 — 50- μ fd. variable (Cardwell 410-B).
 C_2 — Split-stator condenser, 75 μ fd. each section (Cardwell 413-B).
 C_3, C_4 — 250- μ fd. variables (Cardwell 406-B).
 C_5 — 5- μ fd. variable (Cardwell 519).
 C_6, C_7 — .005- μ fd. mica condensers.
 C_8 — .002- μ fd. mica condenser.
 RFC — High-frequency r.f. choke (National Type 100).

especially important on 14 mc. and higher frequencies, where tube capacities represent an important part of the total capacity shunting the tank coils. A second feature of the push-pull amplifier is that fact that in its output circuit the even harmonics are cancelled out so that the danger of harmonic radiation on some frequency outside an amateur band is reduced.

The push-pull oscillator shown in Fig. 708

COIL DATA

Grid Coils

	L_1		L_2
	Turns	Coil length	
28 mc.	4	coil length $\frac{5}{8}$ inch	2 turns
14 mc.	10	" " 1 "	3 "
7 mc.	18	" " 1 "	4 "
3.5 mc.	30	" " $1\frac{1}{4}$ "	5 "
1.75 mc.	80	" " $1\frac{1}{2}$ "	10 "

No. 20 or 22 wire may be used for the first four coils listed; the 1.75-mc. coil will require No. 28 d.s.c. In each case L_2 is close-wound at the bottom of the coil form, tightly coupled to L_1 . Diameter of all coils is $1\frac{1}{2}$ inches.

Plate Coils, L_2

- 28 mc. 4 turns 3/16-inch copper tubing, inside diameter $2\frac{1}{2}$ inches
 14 mc. 10 turns 3/16-inch copper tubing, inside diameter $2\frac{1}{2}$ inches
 7 mc. 24 turns No. 12 wire double-spaced, inside diameter $2\frac{1}{2}$ inches*
 3.5 mc. 45 turns No. 12 s.c.c. wire, no spacing, i.d. of coil $2\frac{1}{2}$ inches
 1.75 mc. 68 turns No. 16 d.c.c. wire, no spacing, i.d. of coil $3\frac{1}{2}$ inches

* No. 12 enamelled wire, double-spaced, will run six turns to the inch.

Specifications for the 3.5- and 1.75-mc. bands call for plate coils of high inductance, since the plate tuning condenser has low maximum capacity. For 3.5- and 1.75-mc. work it may be more convenient to use a plate tank condenser, C_2 , of higher capacity, which will permit the use of smaller plate coils.

illustrates a suitable type of construction for a pair of Type 10 tubes. To use this unit as an amplifier, it is only necessary to add a pair of grid coupling condensers such as the condensers shown in Fig. 716-E; the grid condensers, C_1 in Fig. 709, are the right size for neutralizing and are properly connected to do so. A complete diagram is given in Fig. 728. Aside from the addition of the coupling condensers, the only change in the diagram is the provision for introducing fixed bias.

A popular type for amplifier for high-power consists of a pair of 852 tubes in push-pull. Fig. 729 is a photograph of a typical amplifier of this type; the circuit diagram is given in Fig. 730. The wiring is practically the same as that of the push-pull 10 amplifier; the chief differences are in the heavier construction and the use of apparatus capable of handling the high voltage applied to the plates of the 852's. The push-pull 10 amplifier would be suitable for driving this high-power amplifier.

The push-pull amplifier is neutralized and tuned in much the same way as the single-tube amplifier. With the plate supply disconnected



FIG. 729 — A TYPICAL EXAMPLE OF THE USE OF 852 TUBES IN A PUSH-PULL AMPLIFIER

Grid chokes and coupling condensers can be seen at the right of the tubes, supported on a strip of bakelite. The tank and antenna coils are supported on large G.R. stand-off insulators — the coils being fitted with the large size G.R. plugs. Heavy copper strip furnishes the connection between the tank coil and condenser.

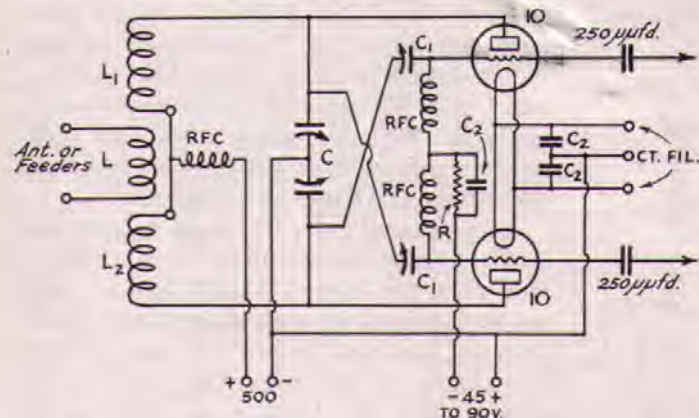

FIG. 728 — CIRCUIT DIAGRAM OF THE PUSH-PULL OSCILLATOR OF FIG. 708 ARRANGED TO OPERATE AS A NEUTRALIZED AMPLIFIER

Only minor changes in the wiring need be made. The physical layout is unchanged.

from the amplifier but with the driver running, the neutralizing condensers should be set at zero and the amplifier plate tank condenser rotated until maximum indication is obtained with the tuning lamp. At this stage the neutralizing condensers should be adjusted in small steps (both of them together) until no indication is obtained. At this time, the amplifier plate tank should be retuned carefully and it is probable that the lamp will show the presence of r.f. at some slightly different setting of the tank condenser. Now the neutralizing condensers should be adjusted again until the bulb goes out. The idea is to keep adjusting the neutralizing condensers until there is

no sign of r.f. at any setting of the plate tank condenser.

More accurate neutralizing can be obtained by connecting a small thermo-coupled galvanometer across a few turns of the amplifier plate coil and using it as an indicator of r.f. in the tank circuit. The method is the same as neutralizing with the lamp. Be sure to remove the meter before turning on the plate voltage. Otherwise, it is certain to be burnt out.

With neutralization of the amplifier completed, the plate voltage can be connected to the amplifier and the key closed. With the antenna disconnected, the amplifier tank circuit should be tuned until the plate milliammeter of the amplifier indicates *minimum* plate current. Then the antenna should be connected and the feeders or antenna circuit tuned to resonance. Adjust the coupling and antenna tuning for maximum current, not forgetting to make a final adjustment to the plate tank condenser to be sure the amplifier is still tuned to resonance when the antenna tuning is completed.

Other Oscillator-Amplifier Arrangements

The reader will appreciate that the oscillator-amplifier transmitters which have been described in detail represent only a very few of the many possible layouts. Endless tube and circuit combinations — all of them workable and having features of value for particular applications — could be devised. These could be built around self-controlled oscillators, screen-grid or neutralized amplifiers, arrangements with and without frequency multipliers, single-ended and push-

pull stages—in short, transmitter designs are almost as numerous as the amateurs using them. There are, however, a few fairly well-defined factors upon which effective transmitter designs are based.

Before deciding upon a tube and circuit combination a number of things should be given careful consideration: the output power desired, the number of amateur bands on which the transmitter is to work, the relative importance of convenient operation (few and simple adjustments and quick band-changing), and economy. Economy includes weighing the cost of power-supply apparatus against tube cost and the cost of r.f. circuit components. In the medium-power field, for instance, it is cheaper to get 100 watts of r.f. output from a tube like the 203-A, 211, 276-A or 242-A than from the similarly-rated

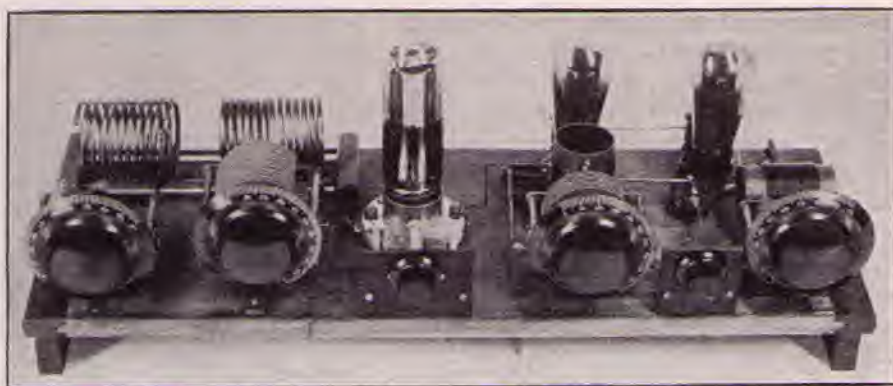

FIG. 731 — A THREE-TUBE CRYSTAL-CONTROL TRANSMITTER

It will operate in the 3.5-, 7- and 14-mc. bands with a single crystal. The crystal oscillator is at the right, followed by the Type 10 buffer-doubler and the 203-A output tube. The variable condensers, going from right to left, are the oscillator tank condenser, buffer neutralizing condenser, buffer tank condenser, 203-A neutralizing condenser, 203-A tank condenser, and antenna tuning condenser. The two neutralizing condensers are mounted on small bakelite panels to insulate them from the baseboard. The 203-A tank condenser is mounted on a strip of bakelite for insulation purposes, since both ends are at high r.f. potential. The longer leads in the transmitter are one-eighth inch copper tubing, used for the sake of rigidity, while the short leads are ordinary bus wire. The coils rest on glass rods. The filament by-pass condensers for the oscillator and doubler are mounted on short vertical pieces of copper tubing directly behind the tubes. The plate blocking condensers for the first two stages are located near the plate terminals on the sockets holding the tubes. All other fixed condensers and all r.f. chokes and bias resistors are mounted underneath the baseboard. Binding post strips at the back of the board furnish means of connecting to power and bias supplies.

852 or 860. The first-named tubes are less expensive, they give full output with a lower-voltage power supply, and the r.f. circuit parts need not have the high-voltage ratings required with the latter tubes. On the other hand, the 852 and 860 are designed especially for high-frequency work and ordinarily are capable of better operation than the others at 14 mc. and higher.

As a general rule, the most economical and convenient transmitter design will result when the largest possible power step-up is obtained in each stage and, consequently, the number of tubes and circuits is reduced to the minimum. With fewer stages, also, less trouble is likely to be encountered. The transmitter shown in Fig. 731, whose circuit diagram appears in Fig. 732, illustrates a design in which economy and convenient operation are the chief features. This three-tube outfit will deliver good output on the 3.5-, 7- and 14-mc. bands, yet it is necessary to change only the coil in the final amplifier stage for operation in any of the three. The simplification is secured by operating the 203-A final amplifier as a neutralized (regenerative) doubler on 14 mc.; while the output on this band (about 90 watts) is not as great as on the other two, the slight sacrifice of output power has been considered justifiable in view of the elimination of a 14-mc. driver stage and its attendant complications in shifting from one band to the other.

This transmitter also illustrates a some-

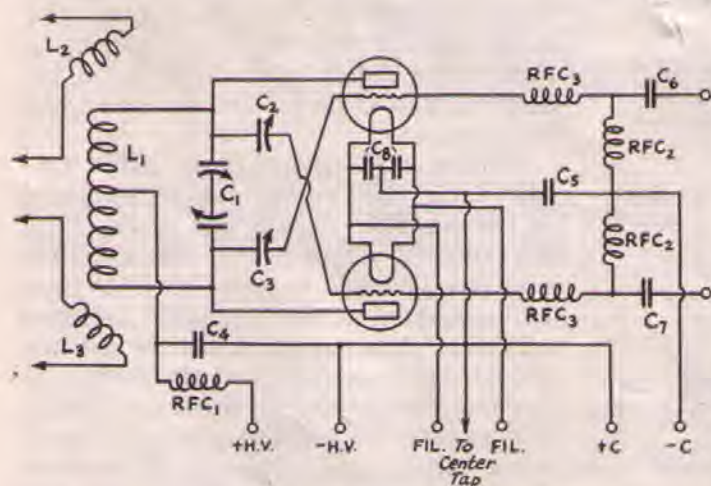

FIG. 730 — CIRCUIT OF THE HIGH-POWER PUSH-PULL AMPLIFIER

- L_1 — See coil chart. The coil shown in the illustration is for 7000 kc. It has 12 turns of $\frac{1}{4}$ -inch tuning with 3-inch inside diameter turns.
- L_2, L_3 — Six turns each, 3-inch diameter.
- C_1 — Cardwell special type 16-B split-stator condenser, 100 μ fd. effective capacity, with neutralizing condensers attached.
- C_2, C_3 — See above. Cardwell Type 519 condensers would serve as separate neutralizing condensers. The capacity required is approximately 5- μ fd., with about $\frac{1}{4}$ -inch spacing between plates.
- C_4, C_6 — 1000- μ fd., 5000 volt fixed condensers.
- C_5, C_7 — 100- μ fd. 5000 volt fixed condensers.
- C_3 — 1000- μ fd. receiving type fixed condensers.
- RFC_1 — Four-inch winding of No. 30 wire on a 1-inch tube.
- RFC_2 — Three-inch winding of No. 36 wire on $\frac{1}{2}$ -inch wooden or bakelite rod.
- RFC_3 — These are for the suppression of parasitic oscillations. They may not be found necessary. Ten turns of No. 14 wire wound on a pencil (the pencil being removed) will be suitable.

what different circuit arrangement than those previously described, although the circuit features will be recognized as having been covered in the general discussion on amplifiers and neutralizing. The plates of the first two tubes are parallel-fed to permit the use of series feed in the grid circuits of the following tubes. The crystal oscillator, a Type 10 tube, obtains its bias from a grid leak, R_1 , and grid leaks also are used to provide part of the bias on the second and third tubes. A 90-volt battery should also be used to provide some fixed bias to prevent the amplifier tubes from drawing excessive plate current if the excitation fails.

The second Type 10 tube in the set is used as a straight amplifier or "buffer amplifier" on 3500 kc. or as a 7000-kc. doubler. This is accomplished by proportioning the capacity of C_6 and the inductance of L_2 so that the 7000-kc. band is covered at the low-capacity end of the condenser scale and the 3500-kc. band at the other end. This tube is neutralized by means of C_6 and the lower portion of L_2 . It is neutralized in the regular way on 3500 kc. and the setting of the neutralizing condenser left untouched when C_6 is shifted to 7000 kc. The tap from L_2 to the grid of the 203-A should be placed so that the second Type 10 draws normal plate current on the 7000-kc. band when the 203-A is receiving excitation.

The plate circuit of the 203-A amplifier is similar to that of the amplifier in the low-power crystal transmitter, and the method of neutralizing and tuning is also the same. It should be neutralized on 14,000 kc. as well as on the other two bands, since this improves the efficiency. Usually there will be enough second-harmonic output from the second Type 10 tube to make it possible to neutralize the 203-A by regular methods on 14,000 kc.

The condensers marked C_2 shown in dotted lines on the plate-supply side of the first two tubes are necessary when a voltage divider across the 500-volt power supply provides the 250 volts for the crystal oscillator. Their purpose is to prevent r.f. leakage between stages, which may make it impossible to neutralize the second tube. They may be omitted if separate power supplies are used for all stages.

Other representative oscillator-amplifier circuits are given in Figs. 733 and 734, the former for use with self-controlled oscillators and the latter for crystal control. They are offered chiefly as suggestions; parts of one circuit can be combined with parts of another, different oscillator circuits can be substituted for those shown for feeding one type of amplifier if the same or a similar-power driver tube is retained, or different interstage coupling and neutralizing arrangements can be substituted in the amplifiers, and so on. The subject of oscillator-amplifier transmitter design is a fascinating one; much valuable experience can be gained by trying and comparing different circuit arrangements.

Harmonic Suppression

Operating a power oscillator or amplifier at high efficiency results in a plate output having a greatly-distorted wave form; in other words, harmonics are present in considerable strength in the output. Since the output tank circuit is resonant only for the fundamental frequency the harmonics are filtered out to a large extent, but despite the filtering action of the tuned circuit there may be enough harmonic content in the power delivered to the antenna to cause interference on the harmonic frequencies. Since harmonics often will fall outside the frequency bands assigned to amateurs, there is danger of off-frequency operation as well. The amateur regulations require that the transmissions shall be as free from harmonics as the state of the art permits.

The use of an output tank circuit having a relatively large capacity-to-inductance ratio (high- C) will reduce harmonics. While this is quite usual practice in self-controlled transmitters, the use of low- C tank circuits in oscillator-

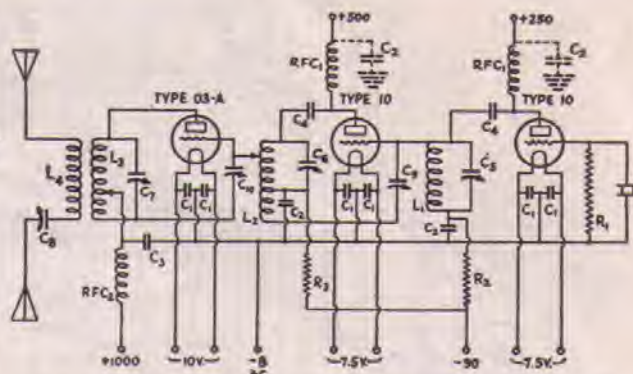

FIG. 732 — THE THREE-TUBE TRANSMITTER-CIRCUIT

- C_1 — .004- μ fd.
- C_2 — .002- μ fd.
- C_3 — .002- μ fd., 5000-volt rating.
- C_4 — 250- μ fd.
- C_5 — 250- μ fd. variable.
- C_6 — 350- μ fd. variable.
- C_7 — 250- μ fd. variable double-spaced. (The one shown in the photograph is a Cardwell 43-plate receiving condenser with alternate plates removed.)
- C_8 — 500- μ fd. variable.
- C_9 — 13-plate midget.
- C_{10} — 50- μ fd. double-spaced condenser (Cardwell 410-B).
- L_1 — 21 turns of No. 12 enamelled wire on 2-inch bakelite tube.
- L_2 — 10 turns of No. 12 enamelled wire on 2-inch bakelite tube with slight spacing between turns. Neutralizing coil consists of 6 additional turns, close-wound, 1/4-inch from tank coil.
- L_3 — 3500 kc. — 20 turns of 3/16-inch copper tubing, 2 1/2-inch dia.
7000 kc. — 12 turns of 3/16-inch copper tubing, 2 1/2-inch dia.
14,000 kc. — 7 turns of 3/16-inch copper tubing, 2 1/2-inch dia. Spacing between turns approximately equal to half the diameter of tubing.
- L_4 — 11 turns same.
- R_1 — 20,000 ohms, 2-watt rating.
- R_2 — 50,000 ohms, 2-watt rating.
- R_3 — 10,000 ohms, 5-watt rating.
- RFC_1 — 3-inch winding of No. 36 s.s.c. on 1/2-inch form.
- RFC_2 — 3-inch winding of No. 32 s.s.c. on 1/2-inch form.

amplifier transmitters is general because the efficiency is higher with low- C . Nevertheless, slightly lower efficiency with high- C is preferable to off-frequency operation. Loosening the antenna coupling also will reduce harmonic radiation.

In neutralized amplifier circuits, those neutralizing schemes in which the tube output is connected across a condenser — such as those in Fig. 715-C and 715-G — will discriminate against harmonics to a greater extent than the systems in which the grid and cathode are connected across part of a tapped coil, such as 715-B. This is because the condenser more effectively short-circuits the harmonics than the coil; in other words, the condenser impedance at the harmonic frequencies is smaller than the coil impedance at those same frequencies.

The push-pull amplifier possesses the characteristic of suppressing the even harmonics in its

output circuit, although odd harmonics will be present to the same degree as in single-tube amplifiers of equivalent power output. Since the second harmonic is the most serious offender, however, the use of push-pull will do much to eliminate harmonic radiation. Those circuits utilizing a grounded-rotor split-stator tuning condenser — see Fig. 715-G — are more effective in eliminating harmonics than the type shown in 715-F.

Aside from those steps which can be taken to reduce harmonics in the plate circuit of the final amplifier stage, beneficial results can be secured by using certain types of antenna coupling and feeder systems. Inductive coupling to the feeder is preferable to direct coupling, from the standpoint of harmonic elimination. Likewise, the coupling coil should be coupled to the tank at a point of low r.f. potential — at the filament end in

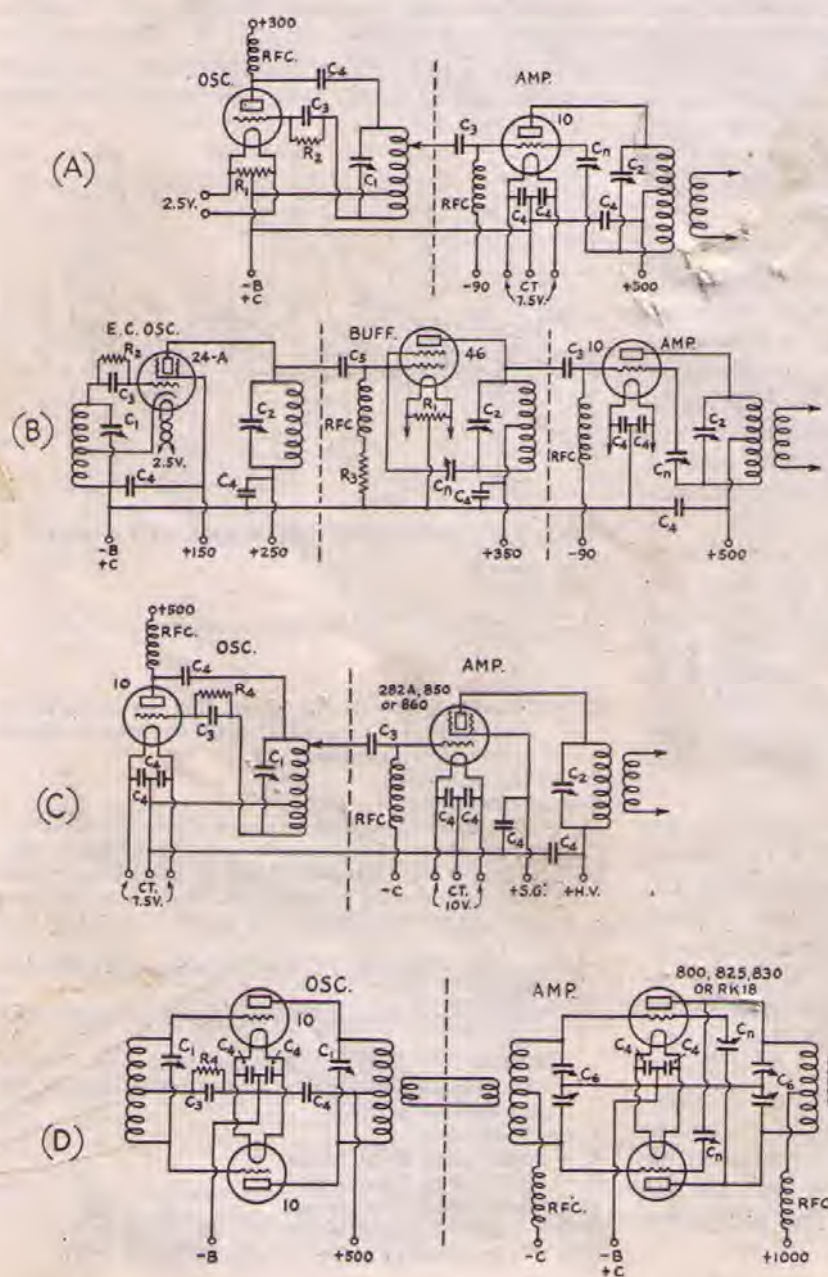

FIG. 733 — SUGGESTED OSCILLATOR-AMPLIFIER COMBINATIONS FOR USE WITH SELF-CONTROLLED OSCILLATORS

These are by no means the only possible arrangements, but are intended to show how the circuits and discussion already given can be applied to other transmitting arrangements than those described in detail in this chapter.

A simple form of self-controlled oscillator-amplifier is shown at A; it consists of a 45 Hartley oscillator and a neutralized 10 amplifier. The use of the electron-coupled oscillator with a buffer amplifier is shown at B; C illustrates the use of the screen-grid amplifier. A push-pull circuit is given at D. In all these circuits other tubes having equivalent power rating can be substituted for those shown; likewise, the circuits in each individual stage can be modified. In A, for instance, the t.p.t.g. circuit could be used instead of the Hartley; the push-pull amplifier of D could be coupled to the Hartley oscillator of C.

Approximate circuit values will be as follows:

- C_1 — 500- μ fd. variable condenser.
- C_2 — 250- μ fd. variable condenser.
- C_3 — 100- μ fd. fixed mica condenser.
- C_4 — .002- μ fd. fixed mica condenser.
- C_5 — 50- μ fd. fixed mica condenser.
- C_6 — 100- μ fd. (both sections in series) split-stator condenser.
- C_n — Neutralizing condenser; see Tube Table and section on "Neutralizing."
- R_1 — 20 ohms, center-tapped.
- R_2 — 50,000 ohms.
- R_3 — 5000 ohms. R_4 — 10,000 ohms.

Tank coil sizes will be found in the table of coil specifications. Select a coil which will tune to the desired frequency in conjunction with the variable condenser specified. In circuits A, C and D, both oscillator and amplifier work on the same frequency. In B, the grid circuit of the e.c. oscillator should be tuned to a frequency in the 3500-kc. or 1750-kc. band, the plate circuit to the same frequencies or 7000 kc.; the buffer may be used as a straight amplifier or as a frequency doubler.

output systems which are not balanced with respect to ground; at the center of the coil in balanced systems—to prevent electrostatic coupling between the tank and feeder circuits. Feeder systems having a current loop at the coupling apparatus will discriminate against even harmonics; a quarter-wave Zepp feeder is an example of this type of feeder system. Directly-coupled feeders will do little to prevent the radiation of harmonics; the directly-coupled single-wire fed antenna is practically as good a radiator at harmonics as at the fundamental frequency.

As for the antennas themselves, those systems which are center-fed through a low-impedance

untuned transmission line will discriminate against even harmonics; an end-fed antenna or one fed through a high-impedance line such as the single-wire system and the doublet with fanned feeders will not, practically speaking. Grounded antennas (Marconi type) and center-fed antennas without transmission lines (sometimes called antenna and counterpoise) also are poor radiators of even harmonics.

To check for harmonic radiation it is necessary to enlist the cooperation of another amateur station a few miles distant from the transmitter. Have the other operator listen for the harmonics to check their strength relative to that of the fundamental frequency. If a strong harmonic is

FIG. 734 — SOME CRYSTAL-CONTROL TRANSMITTING LAYOUTS

As with the self-controlled circuits of Fig. 733, substitutions or modifications can be made in any of these circuits.

The simple crystal oscillator and amplifier shown at A is good for operation in only one or at the most two bands with a single crystal; the amplifier can be used as a doubler for operation on the second harmonic of the crystal frequency. The arrangement at B will work on two bands. Circuit C illustrates the use of the tri-tet oscillator, neutralized buffer or doubler, and changing from a single-ended stage to push-pull. In D the power step-up in each stage is greater than in the first three circuits; this transmitter could be used with good results on three bands.

Circuit values should be approximately as follows:

- C₁ — 250- μ fd. variable condenser.
- C₂ — 100- μ fd. variable condenser.
- C₃ — 100- μ fd. fixed mica condenser.
- C₄ — .002- μ fd. or larger fixed mica condenser.
- C₅ — 50- μ fd. fixed mica condenser.
- C₆ — 350- μ fd. variable condenser.
- C₇ — 100- μ fd. (both sections in series) split-stator condenser.
- C_n — Neutralizing condenser; see Tube Table and section on "Neutralizing."
- R₁ — 20 ohms, center-tapped.
- R₂ — 10,000 ohms.
- R₃ — 50,000 ohms.
- R₄ — 100,000 ohms.
- R₅ — 5000 ohms.

Tank coil sizes will be found in the table of coil specifications; select a coil which will tune to the desired frequency in conjunction with the variable condenser recommended.

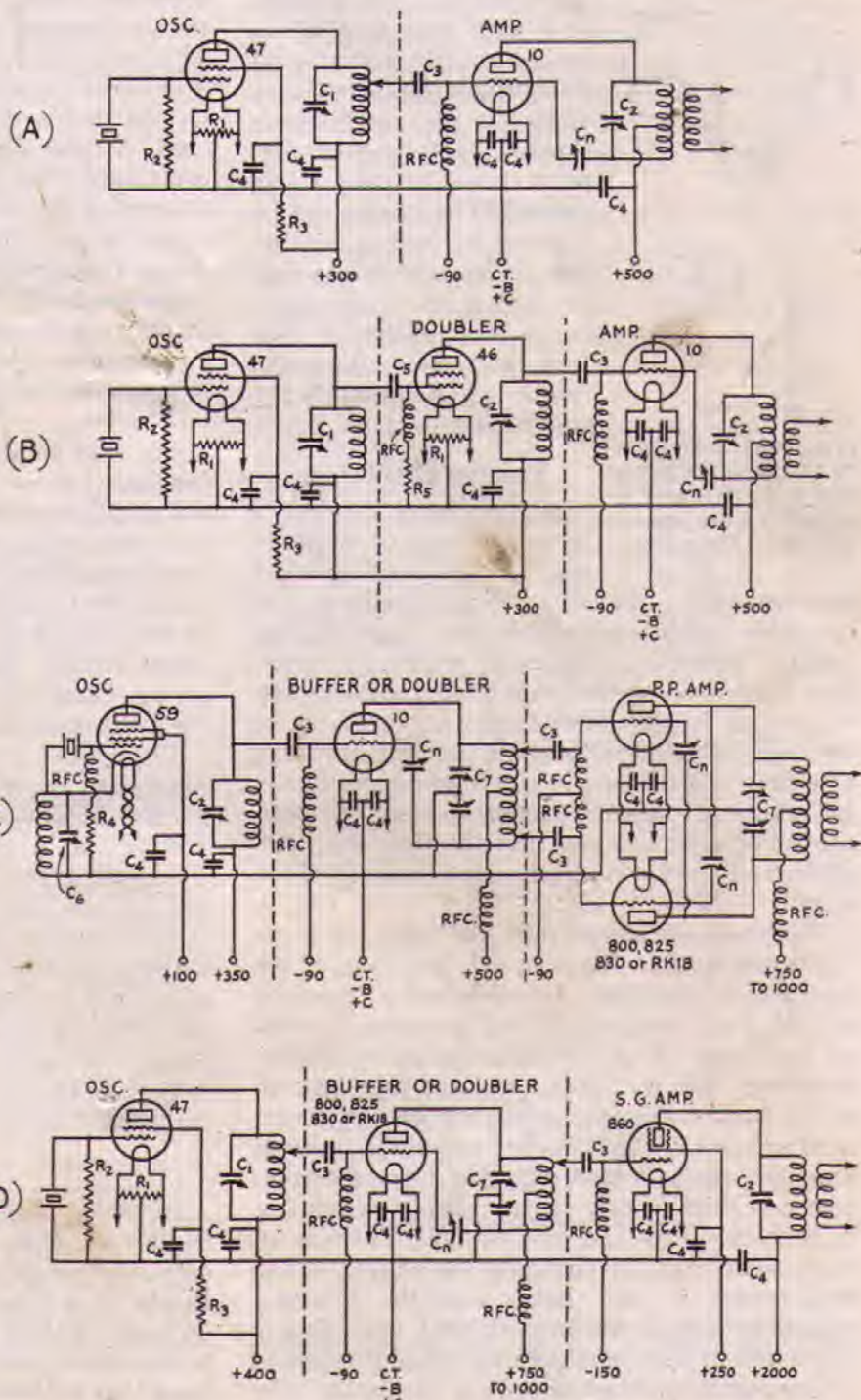

detected, steps should be taken to reduce its strength. The discussion above should be of assistance.

If it is inconvenient to make major changes to the apparatus or antenna and feeder system, harmonics often can be brought to satisfactorily-low strength by the use of tuned trap circuits.

One method which has proved successful in a number of cases is shown in Fig. 735. The trap circuits are tuned to the frequency of the harmonic to be eliminated; a simple unilateral connection is used between the trap and the antenna or feeder. Best results will be secured by listening to the harmonic in the monitor while the trap condenser is slowly varied; the minimum point should be quite clearly defined. The tuning can be checked by having another station listen while the trap is tuned. A low- C trap seems to be most effective. The trap will not affect the fundamental output of the transmitter.

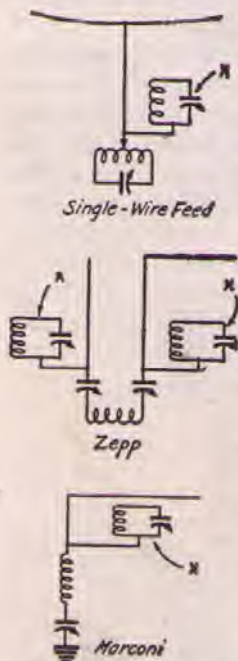

FIG. 735 — TUNED TRAP CIRCUITS OFTEN WILL REDUCE OR ELIMINATE HARMONIC RADIATION

Parasitic Oscillations

If the circuit conditions in an oscillator or amplifier are such that oscillations at some frequency other than that desired can and do exist, such oscillations are appropriately termed "parasitic." The energy required to maintain a parasitic oscillation is wasted so far as useful output is concerned, hence an oscillator or amplifier afflicted with parasitics will have low efficiency and frequently will operate erratically. In addition, parasitic oscillations in the self-controlled oscillator can ruin the frequency stability and spoil completely the character of the note.

Parasitic oscillations may be higher or lower in frequency than the nominal frequency of the oscillator or amplifier. Low-frequency parasitics are relatively uncommon, but occasionally exist as the result of unfortunate choice of by-pass condenser and r.f. choke values. One way in which such a parasitic oscillation can be generated is shown in Fig. 736. A driver and neutralized amplifier are indicated, but this type of oscillation can exist in any circuit having r.f. chokes in both the plate and grid circuits. There is always some capacity shunting the chokes; if the inductances of the chokes and the shunting capacities happen to be such that both chokes are tuned to approximately the same frequency, a tuned-grid tuned-plate type of oscillation may

be set up. The normal tank circuits will have but little effect on the oscillation. If oscillations of this type occur they can be avoided, usually, by changing the size of the plate by-pass condenser or by removing a choke in a series-feed circuit. In general, it is better to omit r.f. chokes with series feed and depend upon the by-pass condensers to keep the r.f. currents in the right path. If the by-pass condensers are large enough the chokes will not be necessary.

A type of parasitic oscillation peculiar to the neutralized amplifier is indicated in Fig. 737. It results from the use of a tapped plate tank coil for neutralizing and a similar tap on the driver tank coil for control of excitation. The parasitic circuit, again a t.p.t.g. type of oscillation, is through the shaded parts of the tank coils. This is a particularly vicious type of parasite; it is a persistent oscillator and usually requires a change in the design of the transmitter for its cure. A neutralizing circuit using a split-stator condenser (Fig. 715-C) will cure it; so also will discarding the tap on the driver tank, feeding the amplifier grid through a smaller coupling condenser connected directly to the plate end of the driver tank coil. The latter scheme does not result in particularly efficient coupling between driver and amplifier, however. A change to inductive or transmission-line interstage coupling also will be beneficial.

Fig. 738 shows one way in which ultra-high frequency parasitic oscillations can be set up in a neutralized amplifier; the same type of oscillation could exist in a Hartley oscillator with too-long leads. The leads to the tank circuit, if more than a few inches long, possess enough inductance to tune the shaded circuit in the three- to five-meter region; an ultraudion-type oscillation is set up. Changing the physical layout to shorten the leads should eliminate the parasitic.

Ultra-high frequency parasitic oscillations sometimes occur when tubes are connected in parallel because of the length of the leads connecting the grids and plates of the two tubes. The same type of oscillation can occur in push-pull circuits if the leads from the grids and plates of the two tubes to the tank circuits have approximately the same length. Such oscillations can be eliminated by putting small r.f. chokes in either the plate or grid leads, but not in both. The chokes can consist of a few turns of fairly heavy wire (No. 18 or larger) wound in a coil having a diameter of about a quarter inch.

Other Bands

In many of the transmitters described earlier in this chapter specifications have been given only for coils for the 3500-, 7000- and 14,000-kc. bands. It is true that the majority of amateurs do most of their work in these bands, but there is also much activity in the other bands, particularly that between 1715 and 2000 kc.

Specifications for coils for any band can be obtained from the table on page 112. In this table, coils are given for three sizes of tuning capacity. The highest capacity will generally be used in self-controlled oscillators, the other values being suitable for crystal oscillator and amplifier tank coils. Considerable tolerance is permitted in the specifications as given since the coils are designed to hit the various bands with the associated condenser set at about 75 per cent of its maximum capacity. A study of the table will soon enable the amateur to estimate the necessary coils for odd turn diameters, odd spacing and conductors other than those specified.

Transmitter Assemblies

As we have already mentioned, it is by no means necessary to arrange the apparatus in the transmitter in the manner shown in the illus-

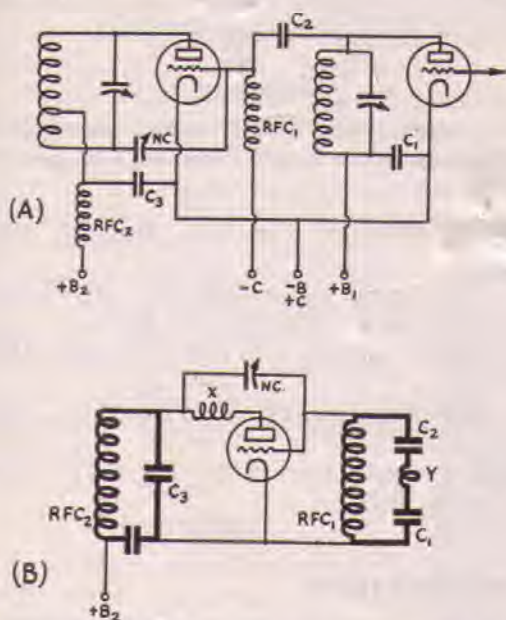

FIG. 736 — HOW LOW-FREQUENCY PARASITIC OSCILLATIONS CAN BE GENERATED

trations. Many other excellent schemes are possible. The board on which the apparatus is mounted can, for instance, be arranged in a vertical position, with the wiring, transformers, chokes, etc., behind it and the remaining apparatus in front. Alternatively, the apparatus can be mounted chiefly on a baseboard, with the meters and controls on a vertical panel in front of it. The panel could be of Bakelite or hard-rubber or may be made of well-dried wood. The important points to watch in arranging the apparatus are to make sure that the leads, particularly in the tuning circuits, are short; to see that the coils are well clear of the condensers or other large metal bodies; and to arrange the parts in such a way that the controls are convenient and all apparatus is accessible.

Transmitting Apparatus

The performance of the transmitter will be dependent to a considerable extent upon the quality and suitability of the individual pieces of apparatus which comprise the whole. The importance of using high-grade apparatus can not be over-estimated. Insulation is particularly important because of the high voltages used in the transmitter and the heavy radio-frequency currents which must be handled. Without any external indication there can be radio-frequency leaks through the insulation which will make it impossible to obtain a clean note from the transmitter; often the signal emitted under such conditions is a rough hash and no amount of careful tuning will improve it. It is therefore a wise plan to use only apparatus of reputable manufacture — the equipment advertised each month in *QST* can be depended upon, since all apparatus advertised is inspected and approved by the technical staff of the magazine before being permitted to appear in its pages.

The variable condensers for transmitters operating from a plate supply of 500 volts or less may be of high-grade receiver type. For transmitters operating from higher voltages than these, special transmitting condensers are desirable. They are available in many capacities and voltage ratings.

The fixed condensers in other parts of the set also are important. Mica or glass dielectric is satisfactory for these, and several types of suitable condensers are available. Receiver-type condensers, providing they are rated at not less than 500 volts, can be used in low-power transmitters but special high-voltage condensers will be necessary when higher plate voltages are used.

Resistors used in radio-frequency circuits

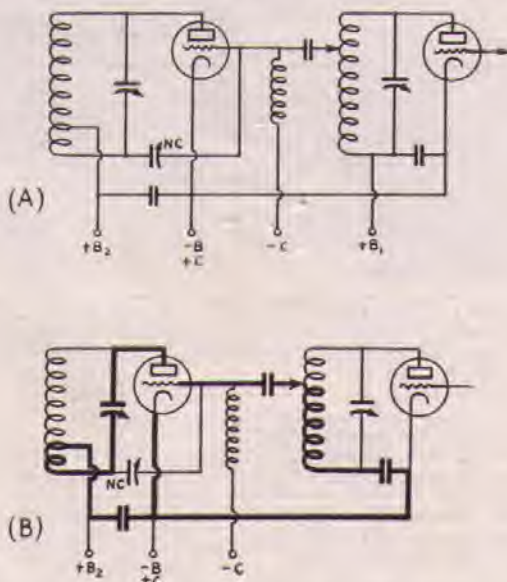

FIG. 737 — A HIGH-FREQUENCY PARASITIC CIRCUIT RESULTING FROM THE USE OF A TAPPED EXCITATION COIL

(grid leaks, etc.) always should be non-inductive to prevent tuning effects and erratic operation. In those crystal oscillator circuits in which the grid leak is connected directly from grid to cath-

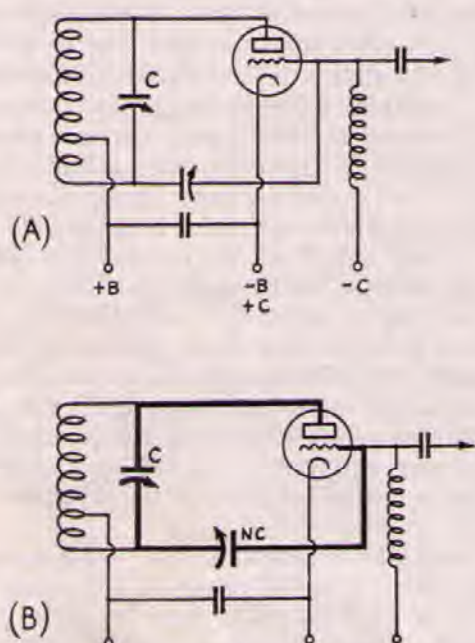

FIG. 738 — ULTRA-HIGH-FREQUENCY OSCILLATIONS CAN BE GENERATED IF THE LEADS FROM THE AMPLIFIER TUBE TO THE TANK CONDENSER ARE TOO LONG

ode, for instance, the circuit probably will not operate if the grid leak is of the wire-wound type. Non-inductive resistors of the graphite rod or metallized filament type can be obtained in power-dissipating ratings up to five watts and should be used wherever possible. If a resistor of

higher rating is needed, it should be by-passed by a mica condenser and placed in series with an r.f. choke whenever there is a possibility that radio-frequency current will flow through the resistor.

The most satisfactory radio-frequency chokes are those of the sectional type having several small honeycomb-wound coils connected in series. These can be obtained quite cheaply in the smaller sizes — continuous current-carrying capacity up to 100 milliamperes d.c. — and are recommended. Similar chokes can also be obtained for higher power. If chokes are to be made at home, a long winding of small diameter is to be preferred to windings having the shape of receiving or transmitting coils. The smallest wire size capable of carrying the required current should be used. Satisfactory chokes can be made by winding a half-inch diameter form with No. 30 to 34 wire to a length of three or four inches. The best length will depend upon the principal frequency at which the choke is to operate, and had best be determined experimentally.

Bibliography

The transmitters listed below have been described at greater length in the following issues of *QST*:

Push-pull oscillator, Fig. 708: January, 1934, *QST*.

Low-power crystal transmitter, Fig. 720: November, 1932, and February, 1933, *QST*'s.

Five-band exciter unit, Fig. 722: November, 1933, *QST*.

Single-tube amplifier, Fig. 726: December, 1933, *QST*.

Three-tube crystal transmitter, Fig. 731: November, 1931, *QST*.

SOME SUGGESTED COIL SPECIFICATIONS

Band →	1750			3500			7000			14,000		28,000	
	500	250	100	500	250	100	500	250	100	250	100	250	100
Max. condenser capacity — $\mu\text{mfd.}$	500	250	100	500	250	100	500	250	100	250	100	250	100
$\frac{1}{4}$ " c.t., i.d. $1\frac{1}{2}$ "	—	—	—	—	—	—	9	17	—	5	11	2	4
$\frac{1}{4}$ " c.t., i.d. 2"	—	—	—	18	—	—	6	10	22	4	7	—	3
$\frac{1}{4}$ " c.t., i.d. $2\frac{1}{2}$ "	—	—	—	12	—	—	5	7	15	3	6	—	2
$\frac{1}{4}$ " c.t., i.d. 3"	—	—	—	10	17	—	4	6	12	—	5	—	—
$\frac{1}{4}$ " c.t., i.d. 4"	20	—	—	7	11	24	—	—	8	—	—	—	—
$\frac{1}{4}$ " c.t., i.d. 6"	12	20	—	—	—	—	—	—	—	—	—	—	—
$\frac{3}{16}$ " c.t., i.d. $1\frac{1}{2}$ "	—	—	—	—	—	—	8	13	—	5	10	2	4
$\frac{3}{16}$ " c.t., i.d. 2"	—	—	—	16	—	—	5	9	20	4	7	—	3
$\frac{3}{16}$ " c.t., i.d. $2\frac{1}{2}$ "	—	—	—	11	20	—	4	6	14	3	5	—	2
$\frac{3}{16}$ " c.t., i.d. 3"	27	—	—	9	15	—	—	—	10	—	4	—	—
$\frac{3}{16}$ " c.t., i.d. 4"	18	32	—	—	10	22	—	—	—	—	—	—	—
No. 12 wire, spaced $1\frac{1}{2}$ "	—	—	—	16	28	—	6	9	19	4	7	—	3
No. 12 wire, spaced 2"	34	—	—	10	19	40	4	7	13	3	5	—	2
No. 12 wire, spaced $2\frac{1}{2}$ "	20	45	—	8	14	29	—	5	10	2	4	—	2
No. 14 wire, d.c.c. $1\frac{1}{2}$ "	30	53	—	10	17	35	—	7	11	3	6	—	2
No. 14 wire, d.c.c. 2"	20	35	75	8	12	24	—	5	9	2	4	—	—
No. 14 wire, d.c.c. $2\frac{1}{2}$ "	16	25	53	7	10	19	—	4	7	—	3	—	—

* Spacing between turns (not centers) is $\frac{1}{8}$ " for these coils. Abbreviations — Copper tubing, c.t.; inside diameter, i.d.
 † Spacing between turns, in this case, equals wire diameter.

Chapter Eight

RADIOTELEPHONY

ALTHOUGH radiotelephony is closely akin to c.w. telegraphy and the 'phone transmitter might be considered as simply a c.w. set with additional equipment to give voice modulation to its output, 'phone not only is much more complex than c.w. in point of apparatus involved but also demands a sharply different and more rigorous technic; for the 'phone transmitter not only must have radio-frequency equipment typical of the good c.w. set and audio-frequency equipment to accomplish voice modulation, but also there must be proper coördination of the r.f. and audio units to insure that the outfit's performance meets modern requirements. The carrier frequency must be stable; the modulation capability must be high; and there must be no detrimental distortion. Fortunately the satisfaction of these requirements can be realized by following the well-defined rules subsequently outlined and without resort to hit-or-miss guessing. Actual experience gained from the construction and operation of the exemplary amateur transmitters described in this chapter has tried these principles; and their widespread application in modern commercial transmitters is a further recommendation. The amateur can profit by following them closely.

Modulation

Amplitude modulation is the process by which the amplitude of the transmitted radio-frequency wave is varied in accordance with the sound waves actuating the microphone. When the wave is detected or demodulated in the receiver, as explained in Chapter Four, there should result a true reproduction of the original modulating signal.

By definition, *percentage modulation is the ratio of half the difference between the maximum and minimum amplitudes of a modulated wave to the average amplitude, expressed in percent.* When the variation in amplitude is symmetrical above and below the unmodulated carrier amplitude, as shown in "A" and "B" of Fig. 802, the average amplitude is the same as the carrier amplitude and the *percentage of modulation is the ratio of the difference between the maximum amplitude and the carrier amplitude to the carrier amplitude, multiplied by 100.* That is,

$$M = \frac{i_{\text{mod}} - i_{\text{car}}}{i_{\text{car}}} \times 100.$$

In case of unsymmetrical modulation (over-modulation) such as that suggested by "C," the average amplitude is no longer the same as the unmodulated amplitude and distortion results, even though the modulating signal is a pure tone. This effect is known as "carrier shift" because it is equivalent to a shift in average amplitude, sometimes being upward as in "C" and sometimes downward. The latter might occur in a transmitter which had less than 100-percent modulation capability. Either causes distortion, a broad signal and needless interference.

The process of modulation, involving combination of the carrier radio frequency and the modulating audio frequency, produces two additional frequencies coexistent in the output. These are the side-band frequencies, the carrier plus the modulating frequency (the upper side

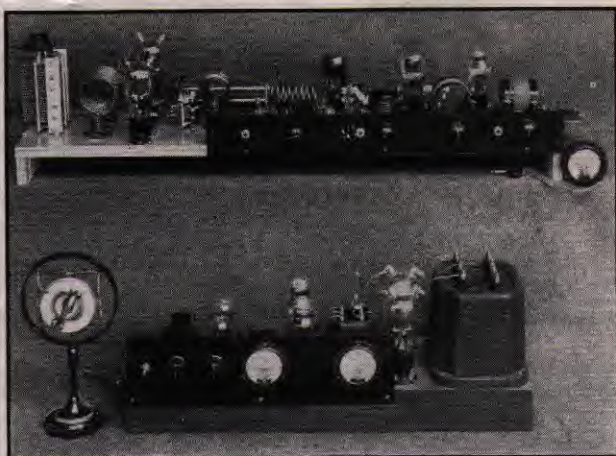

FIG. 801 — THE R.F. UNIT (ABOVE) AND THE AUDIO UNIT (BELOW) OF A MODERN AMATEUR 100-WATT RADIOTELEPHONE TRANSMITTER DESIGNED AND CONSTRUCTED BY W2BRO

band) and the carrier minus the modulating frequency (the lower side band). At amateur-band frequencies, present technic requires the transmission of the carrier and both side bands although it is theoretically possible to communicate with the carrier and only one side band transmitted, or even with the carrier suppressed, since the carrier is only useful for beating with the sideband frequencies to reproduce the original

signal in the receiver's detector output. A locally generated carrier might be used for this purpose.

The radiated power is considered to be divided between the carrier and the side bands. Considering the case of 100% modulation shown in A, Fig. 802, one-third of the total power is divided equally between the side bands, two-

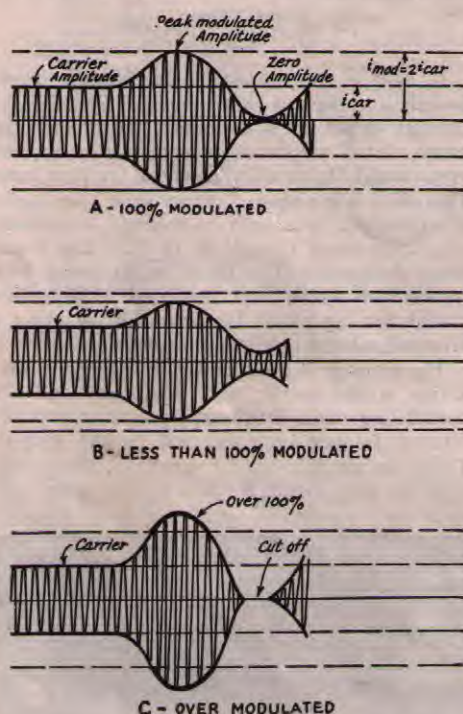

FIG. 802 — GRAPHICAL REPRESENTATION OF AN AMPLITUDE MODULATED WAVE

C illustrates the condition of overmodulation, the negative peak of the envelope being cut off. The outline of the r.f. peaks is called the envelope and should correspond to the wave shape of the modulating signal.

thirds being in the carrier. Since the maximum amplitude (peak current) is twice the carrier amplitude, the *instantaneous peak power* must be four times the carrier power because the antenna (load) resistance is constant and the power is therefore proportional to the square of the current. Using *effective current values*, the antenna power at 100% modulation, with a sustained sinusoidal signal, is 1.5 times the unmodulated carrier power. *The additional or side-band power in the antenna with 100% modulation is, therefore, 50% of the unmodulated carrier power.* The antenna current indicated by the r.f. ammeter will be the square root of 1.5 or 1.226 times the unmodulated value, *when the modulating signal is a pure tone (sinusoidal).*

It is apparent that the modulating system, whatever its type, must be able to effect a 50%

increase in the transmitter's output power if the set is to have a modulation capability of 100%. Since the effectiveness of a modulated wave as measured by receiver response depends on the *variation in amplitude*, it is desirable that the transmitter's modulation capability be high. As a specific instance, a 10-watt carrier modulated 100% (modulation factor 1.0) is practically as effective as a 40-watt carrier modulated 50% (modulation factor 0.5), the carrier power required for a given variation in wave amplitude being inversely proportional to the square of the modulation factor.

With transmitters of high-percentage modulation capability, particular care must be exercised to guard against frequency modulation as well as the over-modulation previously described. It has been shown that frequency "wobulation" is a serious defect in c.w. transmission and it must be realized that frequency modulation is far more objectionable in 'phone transmission. It not only causes unnecessary interference with other stations working on adjacent frequencies in the same band but also can cause interference with services operating on greatly different frequencies. An amateur 'phone working on the 3900-kc. band is even likely to cause interference on the broadcast band, as a result of frequency "wobulation" accompanying modulation and the consequent radiation of spurious frequencies over a band of hundreds of kilocycles. Frequency modulation is also a cause of distorted reception. Modulation of the oscillator in amateur transmitters is therefore prohibited except on the ultra-high frequency bands. Even when a radio-frequency amplifier following an oscillator is modulated, precautions are necessary to insure against affecting the oscillator's frequency. An extremely stable oscillator circuit is necessary, isolated from the modulated stage by at least one buffer amplifier.

Methods of Modulation

Modulation systems most generally used in modern transmitters are of two types. The most widely used is that in which the modulating signal is applied in the plate circuit of a radio-frequency power amplifier (*plate modulation*); and the other that in which the audio signal is applied to the control-grid circuit (*grid-bias modulation*). Other systems are occasionally used for special purposes but are not generally suitable for amateur work. Among these are screen-grid modulation in an amplifier using that type tube (limited to approximately 60 percent modulation capability), and suppressor-grid modulation of a pentode-type screen-grid tube (limited to small receiving tubes and hardly applicable to amateur transmission at this time). Practical arrangements illustrative of plate and grid-bias methods are diagrammed in Fig. 803.

In A of this figure is shown the circuit of what is

known as the Heising or constant-current system of plate modulation. The plate power for the modulator tube and modulated amplifier is furnished from a common source through the modulation choke, L , which has high impedance for audio frequencies. When the grid circuit of the modulator tube is excited at audio frequency, the modulator operates as a power amplifier with the plate circuit of the r.f. amplifier as its load, the audio output of the modulator being superimposed on the d.c. power supplied to the amplifier. The r.f. output of the amplifier is therefore identically modulated. For 100% modulation the modulator audio power output must be 50% as great as the d.c. power plate input of the r.f. stage and the audio voltage applied to the amplifier plate circuit across the choke, L , must have a peak value equal to the d.c. voltage on the modulated amplifier. To obtain this without distortion, the d.c. plate voltage on the amplifier must be dropped to a certain value that is less than the modulator plate voltage. The necessary drop in voltage is provided by the resistor R , which is by-passed for audio frequencies by the condenser C .

In Fig. 803B is shown another system of plate modulation in which a balanced (push-pull or Class-B) type modulator is transformer-coupled to the plate circuit of the modulated r.f. amplifier. When the grids of the modulator tubes are excited, the audio-frequency power generated in the plate circuit is combined with the d.c. power in the modulated-amplifier plate circuit by transfer through the coupling transformer, T . The power output of the modulated amplifier varies exactly with the power input to its plate, and the carrier power is therefore varied in accordance with the signal at the grids of the modulator tubes. For 100% modulation the audio-frequency power output of the modulator must be equal to 50% of the d.c. power input to the modulated amplifier, and the turns ratio of the coupling transformer must be such that the voltage at the plate of the modulated amplifier varies between zero and twice the d.c. operating plate voltage.

In C of the same figure is the diagram of a typical arrangement for grid-bias modulation. In this system of modulation, the secondary of an audio-frequency output transformer, whose primary is in the plate circuit of the modulator tube, is connected in series with the grid-bias supply for the modulated amplifier. When the grid bias and radio-frequency excitation to the modulated amplifier are properly adjusted, the power output will vary in accordance with the audio-frequency voltage variations set up in the grid circuit by the modulator tube. In this method of modulation the modulator tube furnishes little or no power to the modulated stage. The efficiency of the modulated stage is low because for 100% modulation it must have sufficient capacity to supply power peaks four times as great as the carrier power, and

therefore is working far below its capabilities when no modulation is taking place.

Classes of Amplifiers and Modulators

The modulator is simply an audio-frequency amplifier. In plate systems of modulation it must furnish power to the plate circuit of the modulated r.f. amplifier and, therefore, must be an audio-frequency power amplifier. The plate modulators generally used at the present time are of two types, Class-A and Class-B. The Class-A type may be coupled to the plate circuit of the modulated r.f. amplifier by the choke method shown in Fig. 803A or by the transformer method shown in B of the same figure. The choke method is generally used with a single tube or tubes in parallel, the transformer coupling being used for push-pull modulator systems. The transformer

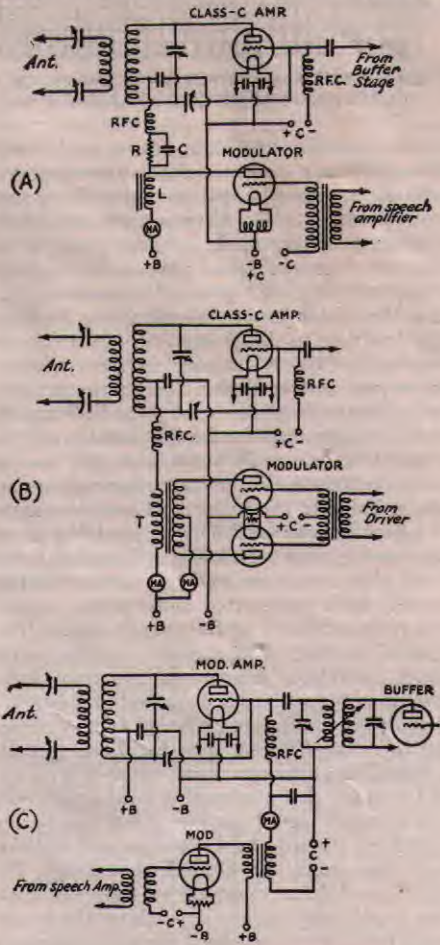

FIG. 803 — CIRCUITS FOR THREE METHODS OF MODULATION

A and B are for plate modulation, C for grid-bias modulation

coupling is always used with the Class-B type modulator, for the reasons given later.

The Class-A amplifier or modulator operates so that the plate output wave shapes are essentially the same as those of the exciting grid voltage, as shown in Fig. 804. It is operated with a negative

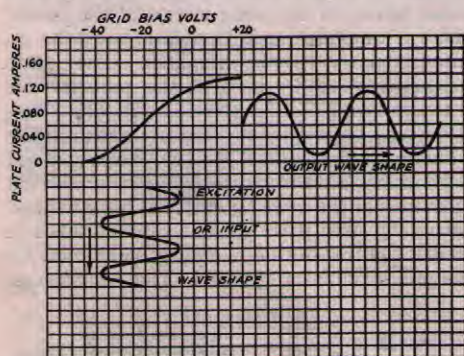

FIG. 804 — INPUT AND OUTPUT WAVE SHAPES OF A CLASS A AMPLIFIER OR MODULATOR

grid bias such that the plate current is the same with and without excitation, the alternating grid excitation voltage and load resistance being such as to make its dynamic characteristic essentially linear. As generally used, the grid must not go positive on the excitation peaks and the plate current must not fall so low on the more negative half-cycles of the excitation voltage as to cause distortion due to the lower curvature of the characteristic. Since the grid is always negative with respect to the filament under these conditions, it draws negligible power and allows the use of a voltage amplifier for its excitation. Typical operating ratings for tubes popularly used as Class-A modulators in amateur transmitters are given in Table I. The tubes most suitable for use as Class A power amplifiers or modulators are those having relatively low amplification factor (μ) and plate resistance, and are characterized by relatively high undistorted audio power output. Their plate efficiency at full output ranges from 20 to 35 percent. The method of determining Class-A modulator load conditions from audio power amplifier ratings is described further on.

A more economical and efficient type of modulator than the Class-A type has been recently developed. It is known as the Class-B type and uses two tubes in a push-pull or balanced circuit. With it much higher audio output can be obtained for a given plate dissipation and emission rating than with the Class-A modulator. The Class-B modulator operates so that the plate power input (and output) depends on the excitation. When there is no signal the plate current is nearly zero and when the excitation is maximum the efficiency and output are high, comparatively large output being obtainable without exceeding

the rated plate dissipation. The factors that limit the output are the excitation available, the filament emission and the plate dissipation on the output peaks. Its operation is shown by the mutual and grid characteristics of Fig. 805, these being for a pair of Type 46 tubes used in the unit described later. As shown in Fig. 806, plate current flows only during the positive half of the excitation cycle, the output wave shapes for each tube being essentially half cycles. It is necessary, therefore, to use two tubes in a balanced circuit with a special output transformer, the combined output wave shape being then the same as the excitation. The grids go positive on the excitation peaks, necessitating an exciting amplifier of the power type in contrast to the voltage amplifier used to excite the Class-A modulator. The operating conditions are determined from the curves shown, which are obtained by experiment. Because of the design of the Type 46 tubes no grid bias is required, although tubes of other types may require negative bias sufficient to bring the no-signal plate current down near zero value. The approximate value of this "cut-off" bias is the d.c. plate voltage divided by the tube's rated amplification factor (μ).

The tubes most suitable as Class-B audio power amplifiers or modulators are generally triodes having relatively high amplification factor, as contrasted to most types suitable as Class-A modulators. Class-B plate efficiencies at full output are considerably higher than in comparable Class-A modulators, running from 50 to 65 percent. Operating data for generally used Class-B modulator combinations are given in Table II, and the general method for determining modulating load conditions is described further on.

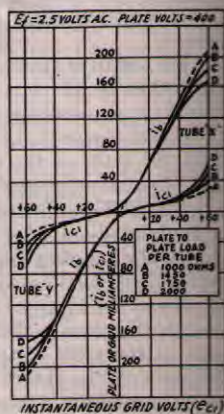

FIG. 805 — DYNAMIC CHARACTERISTIC OF TWO TYPE 46'S IN PUSH-PULL AS A CLASS-B AMPLIFIER WITH FOUR VALUES OF LOAD RESISTANCE

The Plate-Modulated R.F. Amplifier

For distortionless or linear plate modulation with 100-percent modulation capability, the modulated r.f. amplifier should operate with a steady d.c. power input equal to twice the modulator's maximum rated undistorted power output and should, simultaneously, present a load or *modulating impedance* to the modulator equal to the modulator's rated plate load impedance. To satisfy these conditions it is necessary that the modulated r.f. amplifier operate so

that its plate circuit presents a constant resistance of proper value as viewed from the modulator's output, the value of this load resistance in ohms being the r.f. amplifier d.c. plate voltage (volts) divided by its d.c. plate current (amperes).

This condition obtains when the modulated stage operates as what is known as a Class-C amplifier; that is, so that its power output is proportional to its plate power input, the plate current and output current varying as the plate voltage between the limits of zero plate voltage and twice the mean plate voltage. This is accomplished by operating with a negative grid bias more than sufficient to reduce the plate current to zero with no excitation (usually twice "cut-off" bias) and by supplying the grid with r.f. excitation sufficiently ample to cause plate current saturation. Grid bias may be obtained from a fixed-voltage source (batteries), or by means of a grid leak, or by a combination of fixed and leak bias in series, or by a dropping resistor in the negative (cathode) circuit. A combination of automatic grid-leak bias and fixed bias is desirable for full-range linear modulation. As shown in the graphical representation of this operating condition, Fig. 807, large amplitudes of plate current flow during positive excitation

energy and the tank receives a "kick" on both halves of the cycle, this action being analogous to that of a two-cylinder two-cycle engine in which an explosion occurs at every half-revolution of the crank. The radio-frequency harmonic content in the output, including the antenna circuit, is less with a push-pull Class-C amplifier than with a single-ended one, the even harmonics canceling, and push-pull output amplifiers are therefore advisable where the final stage is modulated.

When the amplifier's operation is truly Class-C, its plate circuit input resistance, as viewed from the modulator output, will be equal to the mean plate voltage divided by the plate current. Also, the product of the plate voltage and current is the unmodulated power input, equal to twice the modulator's maximum audio power output for 100% modulation. Regardless of the type, size or number of tubes used in the Class-C amplifier, its mean plate voltage and plate current will be the same for a given modulator.

The tubes most suitable for use in modulated Class-C amplifiers are those designated for r.f. power amplifier use, such as are listed in the transmitting tube table of Chapter Seven. Triodes are preferable, in a neutralized circuit, because they are capable of giving more linear modulation while making best use of the modulator audio power output. Screen-grid tubes are seldom used because linear modulation requires simultaneous modulation of both plate and screen voltages, with consequent loss of audio power in the screen-grid voltage dropping resistor that is necessary. Tubes chosen for Class-C amplifier operation should have plate voltage and current ratings that will not be exceeded in modulated service. Excessive plate voltage or plate current will not only shorten the life of the tube but also may cause non-linear modulation, distortion and interfering spurious radiation. This applies particularly to receiving-type tubes (such as the 46) when operated as modulated Class-C r.f. amplifiers.

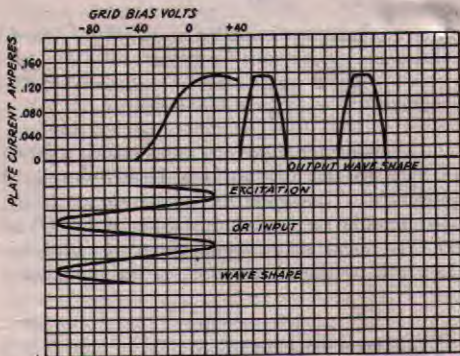

FIG. 806 — INPUT AND OUTPUT WAVE SHAPES FOR ONE TUBE AS A CLASS-B AMPLIFIER

In a Class-B modulator the grid excitation would be less than that giving flattening of the peaks. In the Class-B r.f. amplifier the fly-wheel effect of the resonant tank circuit would restore the missing half-waves of the plate current.

peaks. The plate output wave shapes are quite distorted and "kick" the tank circuit on alternate half-cycles only. But the wave form in the output circuit is nearly sinusoidal because of the tank circuit's "flywheel" effect. This action is analogous to that of a single-cylinder two cycle gas engine whose crank has nearly harmonic motion because of the smoothing effect of the flywheel, even though the impulses are delivered to the mechanism during but a small part of each revolution. In a push-pull Class-C amplifier (or oscillator) the two plates alternate in supplying

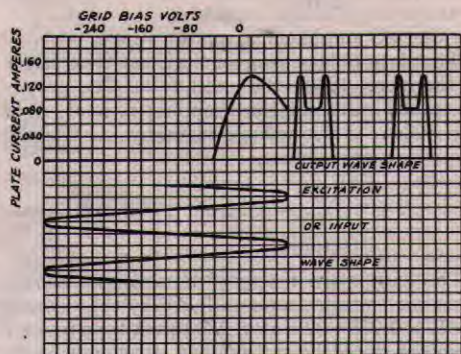

FIG. 807 — CLASS C AMPLIFIER INPUT AND OUTPUT WAVE SHAPES

Determining Operating Conditions For Plate Modulation

With a modulator of given power output and load resistance (or impedance) requirement (Tables I and II), calculation of the proper plate input to the Class-C amplifier and of coupling circuit values can be made quite easily. In the case of a Class-A modulator with choke coupling to the Class-C amplifier plate circuit, as shown in Fig. 803A, the procedure is as follows:

As has been stated, for 100 percent modulation the Class-C amplifier d.c. input power should be twice the modulator's rated maximum undistorted power output (u.p.o.). This input will be equal to the product of the Class-C amplifier's mean (d.c.) plate voltage and plate current. At the same time, the mean plate voltage divided by the plate current gives the *modulating impedance*, which in this case should equal the modulator's rated load impedance. By Ohm's law,

$$I_b = \sqrt{\frac{P_o}{R_p}} \text{ and } E_b = \frac{P_o}{I_b}$$

where P_o = unmodulated d.c. power input to r.f. stage = twice modulator power output, watts.

R_p = optimum load resistance for modulator, ohms.

I_b = mean current to r.f. amplifier plate, amperes d.c.

E_b = r.f. amplifier mean plate voltage, d.c.

For the case of a Type 845 tube operating as a Class-A modulator with plate supply of 1000 volts at 75 ma. (grid bias -147 volts), the rated power output with negligible distortion is 23 watts for a load resistance of 7500 ohms. Substituting in the above equations,

$$I_b = \sqrt{\frac{2 \times 23}{7500}} = 0.078 \text{ amp.} = 78 \text{ ma.},$$

the Class-C amplifier d.c. plate current.

$$E_b = \frac{2 \times 23}{0.078} = 590 \text{ volts,}$$

the Class-C amplifier d.c. plate voltage.

The plate voltage drop for the Class-C amplifier is, therefore, $1000 - 590 = 410$ volts. The proper resistance value for the dropping resistor, R of Fig. 803-A, is this value divided by the Class-C amplifier plate current,

$$R = \frac{410}{0.078} = 5256 \text{ ohms (5250 ohms satisfactory).}$$

The dissipation rating of this resistor should equal the voltage drop multiplied by the current, or $410 \times 0.078 = 32$ watts. A 50-watt type resistor therefore would be satisfactory. It should be by passed for audio frequencies by condenser C (2- μ f. or larger). A coupling choke, L , of 30-

henry *effective* inductance at 150-ma. d.c. will be suitable. Any one of several tubes capable of operating with 78 or 80 ma. input at 590 or 600 volts could be used in the Class-C amplifier; a Type 830, RK18 or 800 would be a likely choice.

In the case of transformer coupling between the modulator and Class-C amplifier, as shown in Fig. 803-B, the procedure is somewhat different. This method of calculation is generally applicable to any type of modulator, Class-A or Class-B, with transformer coupling. The purpose is to calculate the turns ratio of the transformer to match the modulating impedance of the Class-C amplifier to the required load impedance of the modulator. For illustration, take the case of a modulator using a pair of Type 800 tubes in Class-B, operating at a plate voltage of 1000 volts (Table II). The rated power output with negligible distortion is 100 watts and the plate-to-plate load impedance is specified as 12,500 ohms. The Class-C amplifier using two similar tubes is to operate at the same plate voltage, 1000 volts, with a mean (d.c.) Power input of twice the modulator's rated maximum output, or 200 watts. The Class-C amplifier plate current is, therefore,

$$I_b = \frac{P_o}{E_b} = \frac{2 \times 100}{1000} = 0.2 \text{ amp.} = 200 \text{ ma.}$$

The modulating impedance of the Class-C amplifier is

$$Z_m = \frac{E_b}{I_b} = \frac{1000}{.02} = 5000 \text{ ohms.}$$

The transformer therefore must match a 5000-ohm load to the modulator's 12,500-ohm load requirement. This calls for a step-down transformer having an impedance ratio of 12,500 to 5000. The turns ratio, *total primary to total secondary* will be the square root of the impedance ratio:

$$\text{Turns Ratio} = \sqrt{\frac{12,500}{5000}} = \sqrt{2.5} = 1.58 \text{ to } 1$$

(or 1 to 0.63).

In the case of Class-B output transformers it is customary to specify the turns ratio of $\frac{1}{2}$ *primary to total secondary*, which would be 1 to 1.26 in the example given. In the actual design of the transformer the secondary turns would be increased slightly over the theoretical calculated value, to allow for losses. Since the construction of such transformers is beyond the facilities of most amateurs it will not be described here. However, manufactured types having suitable characteristics for standard modulator combinations are widely available at reasonable prices. The transformer preferably should be designed to carry the Class-C amplifier d.c. plate current through its secondary without saturating the core. Otherwise it would be necessary to feed the amplifier plate d.c. through an audio-frequency choke and

couple the transformer, across the choke, through a large condenser.

Speech Input Equipment — Microphones

A microphone is the device used to convert the sound waves of speech into corresponding alternating currents or voltages which, after amplification, excite the modulator. Typical circuit arrangements of five types of microphones generally used in amateur transmitters are shown in Fig. 808. The arrangement of A is for a single-button carbon microphone; B is for a double-button carbon microphone; C is that of a condenser microphone; D is for a ribbon (velocity) type; and E is for a piezo-electric (crystal) type microphone.

Carbon-grain microphones, both single- and double-button, convert sound waves into pulsating electrical current by the variation in the resistance with pressure between carbon granules in contact with a metal or graphite diaphragm which is caused to vibrate by the sound waves striking it. In the single-button microphone, M_1 of A, one connection is made to the diaphragm and the other is made to the cup containing the carbon granules, called a button. The microphone terminals are connected in series with a variable resistor (to adjust microphone current), which is connected across a battery, and the primary winding of a transformer. The current through the primary is a pulsating direct current which induces alternating voltage in the secondary winding, which is applied to the grid circuit of the speech-amplifier tube. In the double-button microphone, M_2 of B, there is a carbon element on each side of the diaphragm. These "buttons" are connected to the two ends of the primary winding of the microphone transformer and the diaphragm is connected in series with a battery to the center of the winding, as shown in B. The granules in one button are compressed and their resistance is reduced while the granules on the other side loosen and their resistance is increased when the diaphragm is vibrated, with the result that there is an increase in current flow

between one button and the diaphragm while there is a decrease in current flow between the other button and the diaphragm. The current flow through the common circuit and the battery will remain constant if the buttons have been properly adjusted. The diaphragm of the "high-quality" double-button microphone is "stretched" to make its natural resonant frequency well up in the audio-frequency range. This makes the microphone's sensitivity comparatively low but improves its frequency characteristic. More sensitive double-button microphones have an "unstretched" carbon or graphite diaphragm.

The condenser microphone illustrated in B utilizes an entirely different principle — that the variation in electrostatic capacity between two plates causes a change in the potential difference between them. In the microphone one of the plates is thick and incapable of vibration but the other is of thin metal, tightly stretched, separated from the fixed plate by about a thousandth-inch. A high d.c. potential, which may be obtained from the amplifier "B" supply, is applied between the plates and the variation in the potential which results when the thin plate vibrates in response to a sound wave is applied across a high resistance (several megohms) in the grid circuit of an amplifying tube.

The dynamic ribbon type microphone, M_4 , operates on the principle of the electric generator. A corrugated ribbon of light conductive material, such as dural, is suspended with slight tension between the poles of an electromagnet so that its motion will be transverse the magnetic field. When vibrated by sound waves, the ribbon conductor cuts the magnetic lines of force and a corresponding alternating current flows through the ribbon and the primary of a transformer in its external circuit. The impedance of the ribbon is very small, a few ohms, permitting the use of a transformer with a small primary and large turns (voltage) step-up ratio for coupling to the grid of the first amplifier. The frequency response of this type microphone is very uniform over the audio range, since its

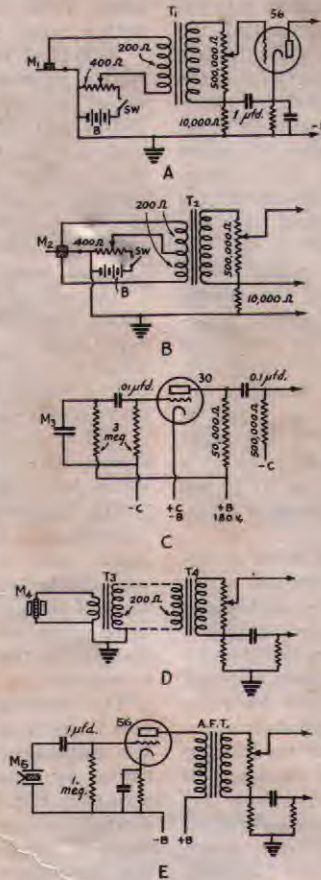

FIG. 808 — SPEECH INPUT CIRCUIT ARRANGEMENTS FOR FIVE GENERALLY USED TYPES OF MICROPHONES

M_1 , single-button carbon; M_2 , double-button carbon; M_3 condenser; M_4 , ribbon or velocity type; M_5 , crystal or piezo-electric type.

inherent characteristics are such that the voltage generated is proportional to the amplitude of the sound wave and nearly independent of frequency, the velocity of the ribbon being proportional to the sound-wave particles. For this reason this type of dynamic microphone is also known as the "velocity" microphone. A somewhat different type of dynamic microphone has a low-impedance coil mechanically coupled to a diaphragm, the electrical current being induced in the coil by motion caused by sound waves. The moving-coil type microphone is relatively more complex and expensive than the ribbon type and is not so widely used for amateur work.

The input circuit for a piezo-electric or crystal type microphone is shown in Fig. 208-E. This type consists of a piece of piezo-active material, usually Rochelle salts crystal, mounted between metal electrodes. In the form diagrammed, the crystal is mechanically coupled to a diaphragm. Sound waves actuating the diaphragm cause the crystal to vibrate mechanically and, by piezo-electric action, to generate a corresponding alternating voltage between the electrodes, which are connected across the grid circuit of a vacuum tube amplifier as shown. This electro-mechanical action is the reverse of that utilized with the quartz crystals used in transmitters and described in Chapters Four and Seven. Unlike the other microphones described, the crystal type requires no separate source of current, polarizing voltage or magnetic field. The diaphragm type illustrated has frequency characteristics entirely adequate for speech transmission. Another type, which has no diaphragm and in which the crystal itself is actuated by sound waves, has more uniform response over a wider range of audio frequencies (up to 10,000 cycles or more) as is required for program transmission.

Wide-frequency response speech input equipment is not required for voice transmission and is actually undesirable for amateur work because the band of radio frequencies radiated is thereby increased over the maximum required for intelligible reception. Uniform frequency response up to 2800 or 3000 cycles is adequate for voice transmission and it should be the amateur's aim to prevent higher frequencies from modulating the carrier. For this reason it is desirable to choose a microphone intended particularly for speech transmission, rather than one designed primarily for broadcast program use. Since the high r.f. selectivity of modern amateur 'phone receivers and the use of "tone controls" in receiver audio systems cut off the higher frequencies anyway, the modulation frequencies above 3000 cycles transmitted are largely wasted and serve only to cause interference to other transmissions on neighboring frequencies.

Microphone Output Levels

The sensitivity of the microphone, or electrical output obtainable with speech input, governs the amount of amplification required between the microphone and modulator. Typical approximate values of electrical output, in terms of equivalent a.c. voltage across the microphone for speech at a distance of 6 inches or so, are as follows:

Standard single-button carbon microphones give output ranging from 0.3 volt across 50 ohms (W. E. Type 337), to 0.1 volt across 50 ohms (W. E. Type 395). An intermediate value for s.-b. types is 0.15 volt across 50 to 75 ohms (W. E. Types 323 and 615-A). With the usual microphone input transformer, designed to work with a single-button microphone, a peak voltage of between 2 and 3 volts across 100,000 ohms or so can be assumed available at the grid of the first tube. These microphones should be operated with a button current of about 100 ma.

A typical rating for a high-quality double-button microphone is approximately 0.025 volt across 200 ohms (32 db below 1 volt, W. E. Types 387-W and 600-A). With this type microphone, and the usual push-pull input transformer, a peak voltage of 0.4 to 0.5 volt across 100,000 ohms or so can be assumed available at the first speech amplifier grid. The button current with this type microphone may be 50 ma. per button (100 ma. total).

The output of condenser microphones varies widely from one type to another, the high-quality type being about one-hundredth to one two-hundredth as sensitive as the standard double-button carbon type. Usually an additional two-stage resistance-coupled amplifier having a gain of approximately 100 (40 db) is satisfactory as a "pre-amplifier" for adapting a double-button set-up to condenser mike input.

The sensitivity of the dynamic ribbon-type microphone is between that of the standard d.-b. carbon and condenser types. With a suitable microphone coupling transformer, about one stage of pre-amplification having a tube gain of 10 or so will bring the level up to that obtained at the grid of the first tube with a standard d.-b. microphone.

The sensitivity of piezo-electric microphones also varies from type to type. A typical value for the diaphragm type (Astatic Type D-104) obtained by experiment in a circuit of the type shown in Fig. 808-E, is approximately 0.1 volt across 1 megohm at the grid of the first tube. Since this particular microphone has a characteristic impedance of approximately 80,000 ohms, it might be used with transformer instead of resistance input coupling, providing a sufficiently good transformer with a high-impedance primary was used — say a 1-to-3 step-up interstage-type audio transformer of high quality. This would give a proportionate voltage gain prior to amplification and bring the level up to approximately

that obtained at the first amplifier grid with a standard d.-b. microphone.

A microphone of any type is a piece of apparatus deserving careful handling. It should never be moved or even touched while current is flowing through it because the slightest jar will give the diaphragm a jolt far greater than that caused by a loud sound. The carbon microphone should

are operated as Class-A voltage amplifiers; that is, they are designed to give high undistorted voltage amplification and their output circuits are of high-impedance, as contrasted with audio power amplifiers. The tubes used are the smaller receiving types having medium to high amplification factors, resistance or transformer coupling being generally used with the medium- μ types and resistance coupling with the high- μ types.

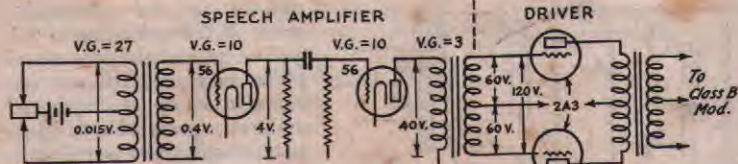

FIG. 809 — SKELETON DIAGRAM OF SPEECH-AMPLIFIER AND DRIVER STAGES, SHOWING APPROXIMATE VOLTAGE GAIN AND PEAK VOLTAGE PER STAGE

never be operated with excessive current through the buttons because the heat generated by high current may fuse the carbon granules together, causing "freezing." The current to each button of a double-button microphone should be of the same value and sometimes adjustment of the pressure on the buttons may be necessary to make it so. This adjustment must be made very carefully, preferably by an experienced microphone repairman.

If a carbon microphone should become "frozen" the granules may be loosened by lightly tapping the frame with one finger *after the microphone battery circuit has been opened*. The microphone should be suspended by springs in a frame or hung from the ceiling in preference to having it unprotected from shock and vibration on the operating table. A good shock-proof mounting will eliminate a lot of the "background" noise which afflicts many amateur outfits. A light cloth sack pulled over the microphone will keep out insects and dust as well as protect the diaphragm from corrosion by moisture condensed from the speaker's breath. An ordinary conversational tone should be used. Sometimes it is better to talk "across" rather than directly at the microphone because breath striking the diaphragm gives the speech a hissing characteristic.

Speech Amplifiers

The speech amplifier of the 'phone transmitter includes the audio stages between the microphone and the grid circuit of a Class-A modulator or the grid circuit of the Class-A power driver stage for a Class-B modulator. The speech amplifier stages

Knowing the approximate value of voltage output obtainable from the microphone and the voltage excitation requirement of the Class-A modulator or driver stage, the total voltage amplification necessary can be estimated. The

voltage swing required by the Class-A power stage will be approximately equal to its grid bias in the case of a single tube or tubes in parallel, and approximately twice the bias value for tubes in push-pull. The approximate voltage gain required of the speech amplifier therefore will be the ratio of this maximum grid swing to the peak voltage across the microphone. This gain will include amplification of the tubes and step-up in coupling devices such as transformers. The method illustrated by the skeleton diagram of Fig. 809, which is for the 100-watt modulator unit described later. The voltage step-up in a coupling transformer is assumed the same as its turns ratio while the approximate gain of a tube is taken as 75 or 80 percent of its rated amplification factor (μ) in the case of a triode, and about 10 percent in the case of a screen-grid tube. The combination chosen should show a calculated maximum gain of 50 to 100 percent greater than will actually be required, to allow for

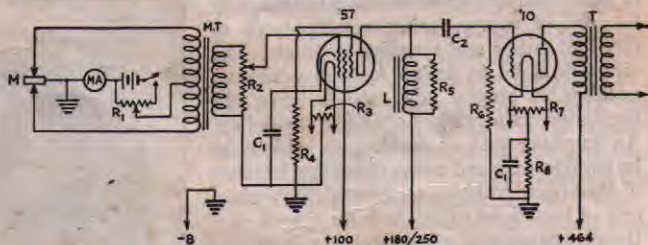

FIG. 810 — CIRCUIT USING A SCREEN-GRID TUBE AS A HIGH-GAIN SPEECH AMPLIFIER

- M — Double-button microphone.
 - MA — 0-100 milliammeter.
 - MT — Microphone input transformer.
 - T — Output transformer for Type '10 tube.
 - L — 300- to 500-henry choke.
 - C₁ — 4- μ fd. 200-volt.
 - C₂ — 0.1- μ fd. 500-volt.
 - R₁ — 400-ohm potentiometer.
 - R₂ — 100 000-ohm potentiometer.
 - R₃ — 50-ohm center-tapped resistor.
 - R₄ — 1000-ohm 1-watt resistor.
 - R₅ — 250,000-ohm carbon resistor.
 - R₆ — 0.5-megohm leak.
 - R₇ — 100-ohm center-tapped resistor.
 - R₈ — 2170-ohm 2-watt resistor.
- Filament supply for the '10 should be separate from that used on other tubes. An additional secondary winding on the filament transformer will serve.

reserve, the excess being compensated for in operation by adjustment of the volume or gain control.

The diagram of Fig. 810 gives the circuit of a high-gain speech amplifier stage using a screen-grid tube as an audio amplifier and having a voltage gain of approximately 100 (40 db) for the single stage. Fig. 811 gives the design of a typical

plification is used since the strong magnetic field about the choke is quite likely to induce feedback in nearby audio transformers. As a further precaution all transformer cases should be connected to the negative side of the plate supply and grounded. One lead of the microphone circuit should also be grounded and a shielded microphone cable is advantageous, particularly for

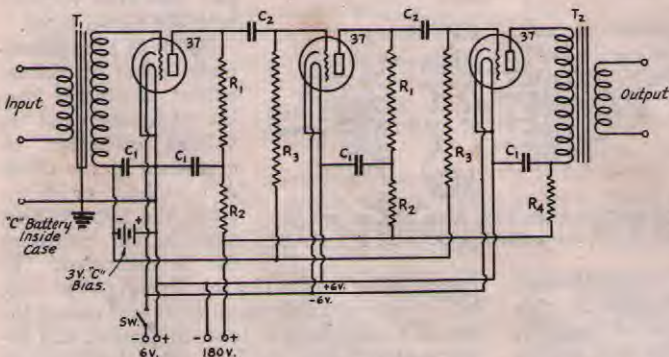

FIG. 811 — A THREE-STAGE RESISTANCE-COUPLED AMPLIFIER USING HEATER-TYPE TRIODES

- T₁ — 200- or 500-ohm line-to-grid input or microphone transformer.
- T₂ — Tube plate-to-line output transformer.
- C₁ — 4- μ fd. by-pass condensers.
- C₂ — 0.25- μ fd. coupling condensers.
- R₁ — 25,000-ohm 1-watt plate coupling resistors.
- R₂ — 9000-ohm 1-watt plate de-coupling resistors.
- R₃ — 1-megohm grid coupling resistors.
- R₄ — 25,000-ohm 1-watt plate de-coupling resistor.

Gain control is used in a subsequent amplifier, although it could be incorporated in the grid circuit of one of the three stages.

three-stage resistance-coupled amplifier using triodes. This amplifier is intended to work from a 200-ohm velocity or ribbon microphone transformer secondary and into a 200-ohm output. Its rated overall voltage gain is approximately 1000 (60 db). There is an almost infinite number of speech amplifier arrangements that may be used, of course, using combinations of different tubes and coupling methods. The aim should be to design for the minimum number of stages adequate to give the necessary gain with negligible distortion. An amplifier with excessive gain is likely to be troublesome and cause distortion because of feed-back troubles and instability, while one of insufficient gain will be forced and thereby cause distortion from overloading.

When two or more stages of speech amplification are used particular care must be taken to prevent "motor-boating" and distortion resulting from inter-stage feed-back. The coupling transformers should be isolated from each other and all supply circuits should be adequately by-passed. It is advisable to keep the modulation reactor well away from the other audio equipment when more than one stage of speech am-

eliminating radio-frequency pick-up in the microphone leads. R.f. overloading of the grid circuits of the speech amplifier and modulator is one common cause of "singing" and every precaution to eliminate it will prove worthwhile. Liberal use of radio-frequency chokes in the power and bias supply leads, particularly the high-voltage leads between the modulator and Class-C amplifier, together with removal of the audio-frequency equipment from the vicinity of the radio-frequency units, helps eliminate r.f. overloading. Complete shielding of the speech-amplifier unit is decidedly good practice.

D.c. plate and filament supply from batteries is recommended for the early stages in multistage high-gain amplifiers. A.c. filament supply and very well filtered rectified a.c.

plate supply can be used, of course, provided precautions are used to prevent hum from reaching grid circuits. Filtering or decoupling in individual plate and grid feed circuits should be employed in such amplifiers, as shown in the dia-

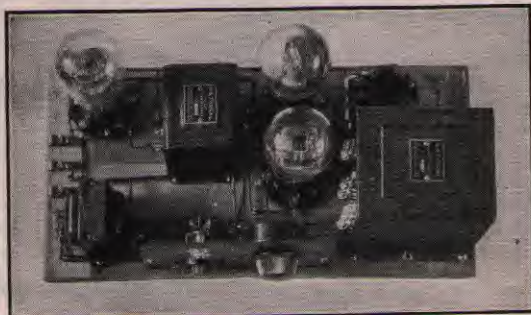

FIG. 812 — A TYPICAL LOW-POWER CLASS-B MODULATOR UNIT USING RECEIVING TYPE TUBES AND CAPABLE OF COMPLETELY MODULATING THE 40- OR 50-WATT INPUT OF A SMALL CLASS-C AMPLIFIER

Its circuit diagram is given in Fig. 813. The microphone switch and gain control are on the bakelite panel. The microphone input transformer and speech amplifier tube are at the left, with the Class-B input transformer, modulator tubes and output transformer to the right. The socket at the rear-right is for power supply connection.

grams of Figs. 811 and 815. In the latter figure, the decoupling resistors are R_4 , R_6 and R_{10} .

Transmitter Assembly and Adjustment

Typical examples of speech-amplifier and modulator construction are illustrated in Figs. 812 and 814, and diagrammed in Figs. 813 and 815. The first unit is for use with a sensitive single-button microphone, has an audio output rating of 20 watts and is intended for operation with a 40-watt plate input Class-C r.f. amplifier using one or two Type 46 or 10 tubes with plate voltage of 400 volts, such as has been described in the previous chapter. The second unit incorporates a speech amplifier suitable for double-button carbon microphone input, has an output rating of 100 watts and can be used to modulate the 200-watt plate input of a Class-C amplifier using 1000- or 2000-volt type tubes, the output transformer secondary being wound in two sections which can be connected in parallel for the former or in series for the latter. Fig. 801 shows this unit with a typical r.f. companion unit using a pair of Type 800 tubes in its Class-C final stage. The construction of the r.f. unit follows the design principles given in the previous chapter, while the audio circuits follow the design given in this chapter. This transmitter was described in detail in the December, 1933, and January, 1934, issues of *QST*.

The r.f. portion of the transmitter should be tuned up and adjusted as outlined in the previous chapter. For 'phone transmission it is especially important that the Class-C modulated stage, and any subsequent r.f. amplifiers, be completely neutralized. Even slight regeneration in a stage handling modulated r.f. will cause non-linear modulation and distortion. The modulated Class-C amplifier requires greater excitation than comparable amplifiers used for c.w. telegraph transmission. A conclusive test for adequacy of excitation would be to vary the d.c. plate voltage from zero to twice normal operating value while observing simultaneous values of plate current and r.f. load current, but this is usually impossible. A check on the d.c. grid current in the bias circuit is of more practical aid. When increase in excitation, which causes increase in grid current, is no longer accompanied by increase in r.f. amplifier output, the excitation may be considered adequate for Class-C operation. The excitation may be varied by adjusting the coupling to the preceding stage or by varying the plate voltage and grid bias of a preceding r.f.

stage. Definite figures for grid current with different types of tubes cannot be specified because there are wide variations with different operating conditions.

Checking Operation

Before connecting the audio unit to the r.f. circuit it should be tested separately for proper operation. A resistor equal to the intended modulating impedance into which the modulator is to work should be connected across the modulator

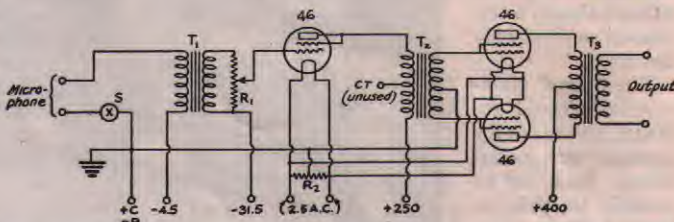

FIG. 813 — CIRCUIT DIAGRAM OF THE CLASS-B MODULATOR

- T₁ — Single-button microphone transformer.
- T₂ — Class B input transformer, turns ratio, total primary to total secondary, 1 to 1.
- T₃ — Class B output transformer; if secondary is not tapped the turns ratio from total primary to secondary should be 1 to 0.79. (National Type B1 and B0.)
- R₁ — 500,000-ohm potentiometer.
- R₂ — 20-ohm center-tapped resistor.
- S — Single-pole single-throw switch.

output circuit. In the case of the 100-watt unit described, whose output transformer secondary load should be 5000 ohms with the secondaries paralleled, a 5000-ohm 100-watt resistor should be used. A low-range thermo-couple meter in series with the resistor will show the a.c. load current, which will be approximately 0.14 amp. at 100 watts output. A pair of 'phones tapped across a hundred ohms or so of the load resistor may be used for listening checks. Electric phonograph input is convenient for testing; or microphone input may be used with an assistant doing the talking. If noticeable distortion or other defect is noticed, the preceding stages should be checked, the procedure being generally the same as described for receiver testing in Chapter Five. There should be no variation in plate current of Class-A speech amplifiers, of course, as indicated by a d.c. milliammeter. With the 100-watt Class-B modulator the plate current should "kick" to approximately 160 ma. at full output, while with the 46 unit it should kick to about 100 ma.

With the audio unit operation checked, it should be connected to the r.f. unit for modulation checks. The r.f. circuits should be tuned and neutralized as described in Chapter Seven. The testing should not be done with a radiating antenna connected to the transmitter. A dummy antenna should be used. The heating element of a 500-watt electric iron is convenient for this purpose. It can be clipped across a few turns of the plate tank circuit, or of an inductively coupled

tank, the proper number of turns being that which causes the Class-C amplifier to draw the correct plate current (200 ma. at 1000 volts for the Type 800 modulator shown). Do not adjust for maximum antenna current. The Class-C amplifier plate current value is the indicator of proper operating conditions, let antenna current be what it may. If the amplifier will not load up to the proper plate current, insufficient r.f. excitation is probable and the excitation should be increased as previously described.

The Class-C plate-current should remain practically constant with modulation. It should be possible to make it kick upward with modulation but the gain controls should be backed off so that the greatest plate current variation does not exceed 5 percent of the unmodulated value. This applies to any amplifier han-

dling modulated r.f. and with all systems of modulation. Variation, either upward or downward, indicates unsymmetrical modulation (overmodulation), distortion and generation of spurious frequencies which cause interference.

"Downward modulation," indicated by drop in plate current and even by drop in antenna current in extreme cases, is usually indicative of insufficient r.f. excitation or overloading of the r.f. stage, the latter calling for reducing the output coupling. R.F. circuits should not be detuned to vary loading because this also can cause distortion. All r.f. circuits should be tuned precisely to resonance.

A heterodyne monitor, of the type described in Chapter Six, should be used to check for frequency modulation. If the speech sounds "mushy" with the carrier tuned to zero beat but is clear

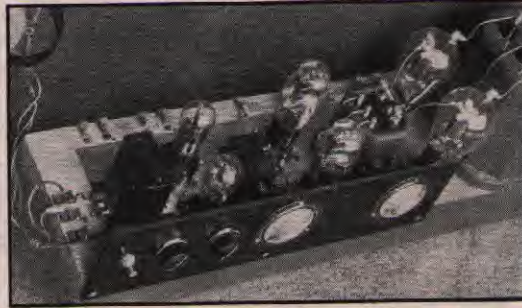

FIG. 814—PLAN VIEW OF THE 100-WATT MODULATOR AND SPEECH-AMPLIFIER UNIT DIAGRAMMED IN FIG. 815

Mounted on the baseboard, from left to right, are the microphone transformer, speech amplifier tubes, the driver-stage input transformer, 2A3 driver tubes, Class-B input transformer, Type 800 Class-B modulator tubes and the output transformer. On the front panel, left to right, are the microphone switch, microphone button-current resistor, volume control potentiometer, microphone current milliammeter, and Class-B plate current milliammeter. The parts are assembled on a copper sheet fastened to the baseboard. Common ground-side circuit connections are made to this sheet.

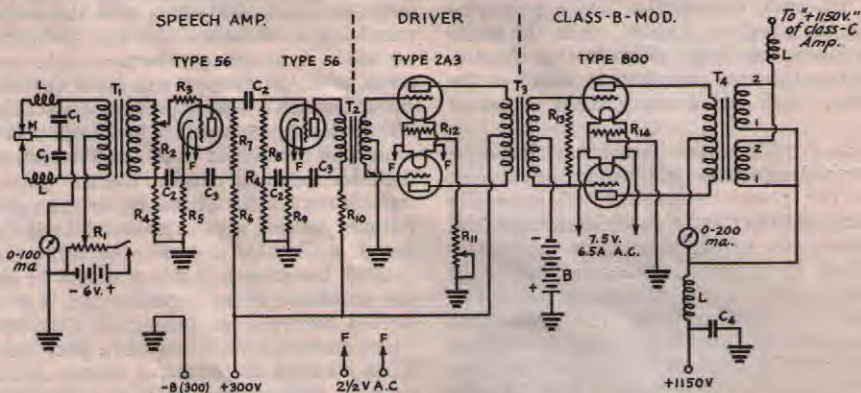

FIG. 815—CIRCUIT OF THE SPEECH AMPLIFIER AND MODULATOR UNIT

- T₁—Double-button microphone transformer (Thordarson Type T-3180).
 T₂—Push-pull input transformer.
 T₃—Class-B input transformer (Hilet Type IB-100).
 T₄—Class-B output transformer (Hilet Type OB-101).
 M—Type 600-A double-button microphone.
 B—Medium-size 63-volt "B" battery (45 and 18 volts in series).
 L—8-mh. r.f. choke (General Radio Type 379-T).
 R₁—400-ohm potentiometer, wire-wound.
 R₂—500,000-ohm potentiometer, volume control.
 R₃—75,000-ohm 1-watt resistor.
 R₄—200,000-ohm 1-watt resistor.
 R₅—2800-ohm 1-watt resistor.

- R₆—25,000-ohm 1-watt resistor.
 R₇—50,000-ohm 1-watt resistor.
 R₈—500,000-ohm 1-watt resistor.
 R₉—2700-ohm 1-watt resistor.
 R₁₀—7500-ohm 1-watt resistor.
 R₁₁—500-ohm 10-watt adjustable wire-wound resistor.
 R₁₂—20-ohm center-tapped wire-wound resistor.
 R₁₃—20,000-ohm 2-watt resistor.
 R₁₄—50-ohm center-tapped wire-wound resistor.
 C₁—0.002- μ fd. fixed mica.
 C₂—0.1- μ fd. 300-volt.
 C₃—2.0- μ fd. 400-volt.
 C₄—0.002- μ fd. 5000-volt.
 "Grounds" indicate connections soldered to copper base-sheet.

without the heterodyne oscillation, frequency modulation is present. There should be no frequency modulation in the 'phone transmitter, of course, and its presence indicates reaction on the oscillator, with r.f. feed-back from the modulated stage, variation in oscillator plate voltage with modulation or ineffective buffer action as likely causes.

Grid Bias Modulation

Grid bias modulation is less practicable than plate modulation in lower-powered transmitters because the carrier power obtainable at the same plate voltage is only a fraction of that obtainable with plate modulation of the same r.f. amplifier. It is practicable, however, in transmitters using 100-watt or larger tubes in the final stage. Carrier output of approximately 10 watts per tube, with 100-percent modulation capability, can be realized with tubes such as the Type 203-A and 852 operated at normal plate voltage. An amplifier of the type used as the Class-A driver in the 100-watt modulator unit can be used as the modulator, the circuit arrangement being that shown in Fig. 803-C. The output coupling transformer is the same one used as the Class-B input transformer in the unit illustrated.

The method of adjustment is as follows:

The negative bias on the modulated r.f. amplifier is set at approximately 50% beyond cut-off value and the amplifier is neutralized. With normal plate voltage applied, the r.f. grid excitation is adjusted so that grid current just begins to flow, as indicated by the grid meter, and the antenna current is noted. The grid excitation is then reduced until the antenna current becomes one-half the value at which grid current began to flow. Finally, the audio input is adjusted so that grid current barely shows on the modulation peaks.

Class B Linear R.F. Amplifiers

The power output of a low-power 'phone transmitter may be increased by adding a suitable linear r.f. amplifier operating on the same frequency as the modulated amplifier. One suitable unit for operation with the low-power transmitter just described is the high-power push-pull amplifier described in Chapter Seven. There would be little gain in adding a linear amplifier of lower power because the carrier power output of a tube used as a linear amplifier is but quarter the rated carrier power of the same tube used as a modulated Class-C amplifier.

The construction of a linear amplifier is much the same as that of any other power amplifier excepting the provisions for adjusting its grid excitation and for obtaining good r.f. grid voltage regulation. These are, respectively, adjustable input coupling and a resistor shunting the grids.

The Class-B linear amplifier operates so that its power output is proportional to the square of the

grid excitation voltage, and with 100% modulation the unmodulated carrier output is one-fourth the peak or rated maximum output. The Class-B output rating of a push-pull amplifier using a pair of 852 tubes is 60 watts carrier and 240 watts peak for plate voltage of 2000.

Fixed negative grid bias must be of cut-off value, approximately equal to the mean plate voltage divided by the amplification factor of the tube, or about 180 volts for the Type 852 at a plate voltage of 2000 volts d.c.

The procedure for putting a Class-B linear

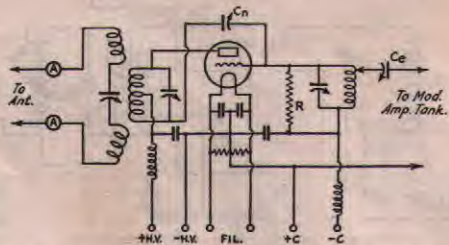

FIG. 816—CIRCUIT OF A SINGLE-ENDED CLASS B LINEAR R.F. AMPLIFIER

The non-inductive grid-regulation resistor, R, should be capable of dissipating 50% of the exciting amplifier's power output. The excitation can be regulated by the coupling condenser, C, or by adjustment of the regulating resistor or a tap on the exciting amplifier tank coil. The circuit values can be as usual for the frequency and power.

amplifier into operation is first to adjust its unmodulated excitation until the antenna current is the maximum obtainable and then to reduce the excitation until the antenna current becomes half that value. This adjustment is made by altering the coupling between its input circuit and the tank of the modulated amplifier (by means of a tap on the latter) or by varying the value of a resistor connected between the grids of the linear amplifier tubes, grid shunting resistance, or by varying both coupling and resistance. Since the primary function of the resistor is to stabilize the load across the output of the exciting amplifier, it is better as well as more convenient to keep the resistance fixed and make use of the coupling adjustment only. A variable resistor having a total resistance of 10,000 ohms will be satisfactory. It should be non-inductive and capable of dissipating 25 watts. Each change in coupling will necessitate retuning of the exciting amplifier's tank circuit and, possibly, the output tank and antenna circuits. *It is essential that all circuits be tuned to exact resonance.* If the carrier excitation is adequate, the total d.c. plate current at excitation coupling for maximum antenna current should be about 240 ma. (120 ma. per tube) and at half maximum antenna current the total d.c. plate current should be about 120 ma. (60 ma. per tube) with 2000 volts on the plates. The antenna current reading should increase with

modulation of the carrier, but the plate current should remain constant.

Percentage Modulation Measurement

A more accurate check on transmitter performance than that possible by the methods which have been described can be made with a simple adaptation of the peak vacuum-tube voltmeter which is known as the modulator, the circuit

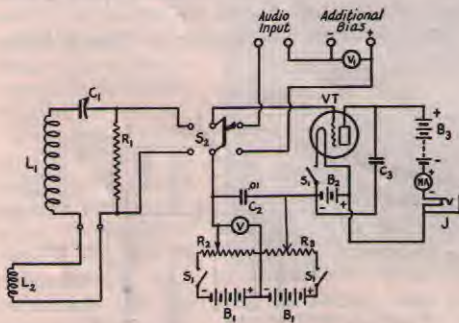

FIG. 817—SCHEMATIC CIRCUIT OF THE MODULATOR

- L₁**—For 3500 kc. use 40 turns of No. 28 d.c.c. wire on a Silver-Marshall plug-in coil form
L₂—Pick-up coil. 2 or 3 turns of lamp cord, any size convenient.
C₁—100- μ fd. midjet variable condenser. Any variable will do.
C₂—.01- μ fd. fixed condenser.
C₃—1000- μ fd. fixed condenser.
R₁—1500-ohm Ward-Leonard resistor No. 507-55. Any good "non-inductive" resistor of 1500 or 1000 ohms might be used.
R₂—200-ohm wire-wound potentiometer.
R₃—2000-ohm potentiometer.
B₁—9- and 4.5-volt "C" batteries.
B₂—2 dry cells in series (3 volts).
B₃—Small size 22.5-volt "B" battery.
S₁—Triple-pole single-throw switch.
S₂—Double-pole double-throw battery type switch.
V—0-10 d.c. voltmeter.
V₁—0-120 d.c. voltmeter.
MA—Weston Model 375 Student Type Galvanometer or 0-1 d.c. milliammeter.
J—Closed-circuit phone jack.
VT—Type '99 or '30 tube.

of which is shown in Fig. 817. The peak value of an a.c. voltage applied to the grid circuit of the tube is equal to the negative d.c. bias voltage required to balance it and bring the plate current milliammeter indication back to the same value as with no grid excitation. This reading of the plate milliammeter is known as the "false zero" and may be the first scale division above true zero. To obtain it the tube is operated at a set value of minimum bias determined by adjusting the potentiometer R_2 . The additional bias required to balance grid excitation voltage of 9-volt or less amplitude and bring the plate current back to false zero, is determined by adjustment of the potentiometer R_2 and is measured by the d.c. voltmeter V . Additional bias in series with that across R_2 is necessary for measurement of amplitudes of more than 9 volts. It is connected to the

"Additional Bias" terminals shunted by the voltmeter V_1 . The sum of the readings of V and V_1 then gives the value of the peak voltage being measured. The "Additional Bias" terminals should be shorted when no battery is connected.

Percentage modulation measurements are made with S_2 thrown to the left. The coil L_2 is coupled to the output circuit of the transmitter and the r.f. current through the circuit causes a voltage drop across R_1 which is directly proportional to the current through the resistor. Variations in the amplitude of the r.f. current will therefore cause proportionate variations in the r.f. voltage across R_1 . The amplitude of the positive half cycles of this voltage is measured by the peak voltmeter.

The transmitting antenna should be replaced by a dummy antenna, of course. The coupling should be adjusted so that the modulated amplitude of the voltage across R_1 measures 5 or 6 volts. The gain control is then set at zero, leaving the carrier unmodulated, and a second measurement is made. The percentage of modulation is the difference between the two voltages divided by the unmodulated carrier voltage, multiplied by 100:

$$M = \frac{E_{\text{mod}} - E_{\text{car}}}{E_{\text{car}}} \times 100$$

M is the percentage of modulation, E_{mod} is the voltage with modulation, and E_{car} is the voltage for the unmodulated carrier.

The gain of the speech amplifier is found by measuring the audio voltages on the grid of the first speech amplifier tube and on the grid of the modulator, the ratio of modulator grid voltage to the speech-amplifier grid voltage being the voltage gain of the amplifier. A performance curve for the transmitter can be made by plotting the percentage of modulation for various values of speech-amplifier signal voltage against the signal voltage values.

Audio-frequency feed-back in the speech amplifier is detected by making measurements of the signal voltage on the grid of one of the amplifier tubes with the modulator plate voltage "on" and "off." If the signal amplitude is greater with the modulator "on," there is feed-back. Radio-frequency pick-up is similarly detected, the r.f. excitation (oscillator) being switched on and off, an increased amplitude with the carrier "on" indicating r.f. in the audio circuits. Audio- and radio-frequency feed-back can be eliminated by following the suggestions given in earlier parts of this chapter.

Transmitter Power Supply

The filament supply for amateur transmitters is usually alternating current for the modulator and radio-frequency tubes, and either a.c. or d.c. for the speech amplifier tubes. The plate power for the speech amplifier may be from B batteries or a B substitute while that for the modulator and radio-frequency tubes is usually

from d.c. generators or a.c. rectifiers. The power supply for the oscillator and buffer amplifier stages should be separate from that used for the modulator and Class-C amplifier, particularly with a Class-B modulator, unless the plate supply has exceptionally good voltage regulation. The plate supplies described in Chapter Ten will be satisfactory if the particular features pointed

out therein as desirable for telephony are incorporated.

Fixed negative grid bias for low and medium power transmitters can be obtained from dry B batteries. Rectifiers are satisfactory for supplying grid bias to some r.f. and audio-frequency stages but, because of their poor regulation, are not so well suited to supplying bias for Class-B modulators.

TABLE I — TYPICAL CLASS-A AMPLIFIER AND MODULATOR OPERATING DATA

Type Tube	Fil. Volts, E_f	Plate Volts, E_b	Plate Ma., I_b	Neg. Grid Volts, ¹ E_c	Load Imp., ² Ohms	Audio Output, ³ Watts
50	7.5	500	50	100	7500	5.5
2A3 (P.P.) ⁴	2.5	300	80	62	3000	15.0
211, 242A, 276A	10.0	1000	65	52	7000	10.0
845	10.0	1000	75	150	7500	23.0
284A	10.0	1250	60	228	10,000	41.5
849	11.0	2000 2500 3000	125 110 100	75 104 132	12,000 12,000 20,000	42.5 81.0 100.0

With exception noted, ratings are for a single tube. For tubes in parallel multiply I_b and Output Watts by number used, and divide Load Impedance by number used. For 2 tubes in push-pull, multiply I_b , Load Impedance and Output Watts by 2, taking peak audio grid voltage twice bias value.

¹ Peak audio grid voltage equal to bias value for single tube or tubes in parallel.

^{2, 3} To be used in determining Class-C amplifier operating conditions by method described in text.

⁴ Two tubes in push-pull. Peak audio grid voltage twice bias value.

TABLE II — TYPICAL CLASS-B MODULATOR OPERATING DATA

Class-B Tubes (2)	Fil. Volts, E_f	Plate Volts, E_b	Plate Ma. (Max.), I_b	Neg. Grid Volts, E_c	Load Imp., Ohms ¹	Tube Output, Watts	Input Trans. Turns Ratio (Pri.:Sec.)	Driver Tubes (P.P.)	Driver Plate Volts
46	2.5	400	108	0	7000	25	3:1	45	225
59	2.5	400	124	0	6000	28	3:1	45	225
841	7.5	500	108	13.5	8000	29	5:1	45	250
210*	7.5	600	153	67	8000	57.5	1.6:1	45	250
800	7.5	1000	164	55	12,500	100	1:1	2A3	250
RK18	7.5	1000	164	45	12,000	100	2:1	45	250
830-B*	10.0	1000	280	33	10,000	190	1:1.4	2A3	250
203-A*	10.0	1000	366	40	5800	240	1.6:1	2A3	250

Ratings are for 2 tubes, Class-B.

* Graphite anode types.

¹ Plate-to-plate. Use this load impedance and Output Watts for determining Class-C stage coupling and operating conditions by method described in text.

Chapter Nine

THE ULTRA-HIGH FREQUENCIES

UNTIL the end of 1931, the amateur bands higher in frequency than 28,000 kc. were virtually unoccupied. Equipment and methods which were satisfactory on the lower frequency bands had proved entirely unsuitable for the 56-mc. and 400-mc. bands to which the amateur has access. Experimental work on the 56-mc. band had been in progress in League's laboratory for many years, but it was not until 1931 that the technique was sufficiently advanced to allow reliable and completely satisfactory communication. Upon the publication in *QST* of the designs for practical 56-mc. transmitters and receivers, amateurs throughout the world became active. At the present time, operation on the very high frequencies of this band is considered one of the most interesting activities in which the amateur can engage. Because the equipment necessary for this work differs considerably from that used on the lower frequency bands, we will devote this chapter to a description of it.

Operation on the 400-mc. band is still in the very early experimental stages. Activity in that territory is limited, at the moment, to the experimental work of scientifically inclined and technically qualified men who labor in the hope that 400 mc. may someday soon become a field for routine amateur communication. Reports of the work and data on equipment and methods appear from time to time in *QST*.

What to Expect

It is important that the amateur about to undertake 56-mc. work should understand that the band is suitable at present exclusively for short-distance communication. The lower frequency bands provide ample opportunity for long-distance working, and the amateur interested only in DX should restrict his endeavors to that territory. The particular value of the 56-mc. band to the amateur is that, in contrast to the other bands, it does not seem to permit communication over distances much greater than can be covered visually. It is this very characteristic of the band which has allowed groups of amateurs in various parts of the country to talk with each other night after night without interfering in any way with the next group 40 or 50 miles away from them. This means, of course, that amateurs located in a valley or in a heavily populated flat area will be limited to communication over just a few miles from their home station. Many such amateurs would have no use for 56-mc. apparatus. Others, however, either have stations located on high points or are interested in the operation of a

portable station on some hill top. To these amateurs, the band is of great value and interest.

56-mc. is also of great value to the amateur owning or having available an airplane. An airplane installation on the 56-mc. band is the only type of mobile amateur station permitted by the regulations.

As a guide to the approximate distance which can be covered reliably on 56 mc. we will cite a simple formula which is used to obtain the visibility over flat country for various heights above the surrounding terrain. It will not be generally applicable in amateur work because of the difficulty of allowing for the interference of smaller hills, but it will serve to give an approximate idea of the ranges to be expected. The formula is:

$$D = 1.32\sqrt{x}$$

D is the distance in miles; *x* is the height, in feet, of the observer above the surrounding country. Should we wish to find the visible range between two elevated points, we make a separate calculation for each point and add the result. Reliable 56-mc. communication often can be obtained over ranges slightly greater than this visible range. It is not usually to be expected, however.

One important feature of 56-mc. work is that very low power is satisfactory in the transmitter. If the two stations are within working range, extremely low power suffices to give a strong signal. An increase of power at the transmitter gives stronger signal in such cases, but it is not effective in extending the working range to any appreciable extent. Because of these facts, the usual amateur 56-mc. apparatus is low-powered and extremely simple. Powerful and complicated equipment could be used, but its cost would hardly be justified by the improvement in performance.

Suitable Apparatus

The conventional type of transmitting equipment, described in previous chapters, can be made to function on 56-mc. With anything other than a crystal-controlled transmitter, however, it is extremely difficult to obtain good frequency stability. Crystal control, of course, presents a great many problems. With the usual 3500- or 7000-ke. crystal, a whole row of doubler stages is necessary. The only alternative is to use a special tourmaline crystal ground to operate on 28 or 56 mc. Unfortunately, such crystals are very expensive. Oscillator-amplifier transmitters are satisfactory for the work, but even in this case the problems to be faced are quite formidable.

It is important to realize that the 56-mc. band has its particular value in permitting short-distance communication only. Most of the present activity is in "around-town" communication in experimental work from hill-tops and high buildings and in tests from airplanes in flight. Most of this valuable work would be quite impractical if crystal-controlled or other oscillator-amplifier type transmitters were essential. Fortunately, this is not the case. A multi-tube transmitter is extremely desirable in large cities, (where a stable transmitter is necessary to avoid producing serious interference) and such equipment is of value in a fixed station. For portable work, however, by far the most practical type of equipment is a simple self-controlled oscillator modulated by voice or tone. Apparatus of this type is prohibited on the lower frequency bands because of the drastic interference it is capable of producing. It is allowed on the ultra-high frequencies simply because it is still the only genuinely practical equipment for this type of service.

The same considerations apply to receiving equipment. Receivers of the usual type, when fitted with suitable coils, will operate on 56-mc. Their poor frequency stability and their "trickiness" in general, however, make it difficult to obtain a satisfactory performance. Autodyne reception of c.w. signals from amateur 56-mc. transmitters is not yet considered entirely practical.

All these factors have resulted in the adoption of a special technique for 56-mc. work. At present, modulated signals are used exclusively in transmission, the transmitter being an oscillator-amplifier when conditions permit or, for portable work, a simple modulated oscillator. For recep-

tion, the super-regenerative receiver is almost universally used. This type of receiver operates particularly well on the very high frequencies, is extremely sensitive to modulated signals and has the broad admittance characteristic necessary for the reception of signals which suffer from severe frequency modulation. Various types of super-heterodyne and special autodyne receivers

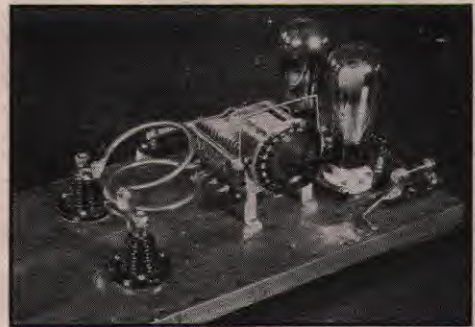

FIG. 902 — A TYPICAL 56-MC. EXPERIMENTAL OSCILLATOR

The various components can be located by reference to the circuit of Fig. 901. The antenna coil is a half turn mounted over the plate coil.

are also effective in fixed ground installations when the signals to be received have a high order of frequency stability. It is the opinion of many experienced experimenters, however, that such receivers exhibit no greater sensitivity than that of a well-adjusted super-regenerative receiver.

Transmitters for 56 mc.

The circuit of Fig. 901 will serve to illustrate what is probably the simplest arrangement of a 56-mc. transmitter. Built into a "bread-board" lay-out, it will resemble the transmitter shown in Fig. 902. The tuning and adjustment of such a unit will be carried out in the manner suggested for the lower frequencies with the difference that it will hardly be practical to make use of a monitor for checking the signal emitted. This type of oscillator, when modulated, will produce a frequency-modulated signal occupying a wide slice of the band. For this reason, we cannot recommend its use in large cities or in other localities where many 56-mc. transmitters are in operation.

A suitable modulator for this type of transmitter could readily be devised from the circuits and data given in Chapter Eight. The antenna problem will be given treatment later in this chapter.

An Oscillator-Amplifier Set

In order to illustrate the general arrangement of a simple oscillator-amplifier transmitter for 56 mc., Fig. 903 is given. Two important features

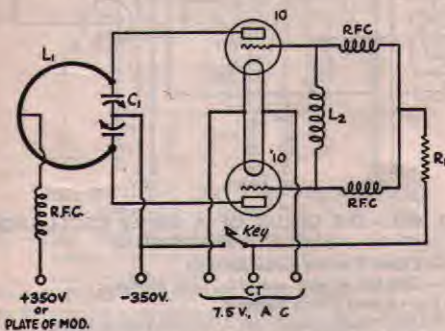

FIG. 901 — A 56-MC. OSCILLATOR CIRCUIT

- L1 — Single turn of 1/4-inch copper tubing, 4 inches in diameter, mounted on stator terminals of tank condenser.
- L2 — 4 turns No. 14 enameled antenna wire, 1" in diameter, and about 2" in length. Turns are squeezed together or separated until set oscillates with minimum plate current at the desired frequency of operation.
- C1 — National split-stator condenser, Type TMP-100. Net maximum capacity (sections in series) 100 μ fd.
- RFC — 18 turns of No. 24 d.c.c. on 1/2-inch wooden dowel, 1/16-inch spacing between turns.
- R1 — 10,000-ohm non-inductive grid-leak 5-watt size or larger.

distinguish it from the oscillator-amplifier circuits used on the lower frequencies: the use of an oscillator having comparable output to the amplifier and the employment of inductive coupling between oscillator and amplifier. Both of these are made desirable by the relatively poor efficiency of amplifiers on the very high frequencies and the consequent difficulty in providing sufficient excitation with the conventional low-powered oscillator and the conventional circuits. It will be seen that the oscillator circuit is similar to that of Fig. 901 and that its tank circuit is inductively coupled to the tuned grid circuit of the amplifier. In practice, this coupling is adjusted to the lowest possible value consistent with full excitation of the amplifier. The amplifier is neutralized in the normal fashion. Its adjustment in every respect will be similar to the process outlined for similar transmitters in Chapter Seven.

Suitable modulators for this type of transmitter are those suggested for the circuit of Fig. 901.

It should be remembered that while the signals from this type of transmitter will be more stable than those from the straight oscillator type of set and less subject to frequency modulation, the arrangement is still far from perfect. Advanced 56-mc. workers anxious to obtain the greatest possible freedom from frequency modulation will find it practical to excite a unit such as that shown in Fig. 903 from the output of the "Tri-tet" exciter described in Chapter Seven.

Finding the Band

If the transmitter is built according to the specifications and tuned to resonance with an antenna which has been carefully cut to the correct length, there is little danger that the transmitter frequency will not lie in the immediate vicinity of the amateur band. It is very desirable, however, to take further precautions to insure that the frequency is what it should be. This is one way to check the frequency:

Put the receiver on the 14-mc. band and tune it to a frequency between 14,000 and 15,000 kc. by beating the detector oscillation against the proper harmonic of your frequency meter. The detector should be oscillating vigorously. Now start up the 56-mc. oscillator and tune the tank circuit carefully, starting from maximum capacity and going up in frequency. Do this slowly and listen for signs of a fairly loud signal in the 'phones or speaker, disregarding any weaker ones. When you find it, tune the oscillator "right on the nose" and make a record of the dial setting. This should be near the maximum capacity setting of the tank

condenser (for a duplicate of the set illustrated). Of course it is possible that the oscillator frequency might be some harmonic other than the fourth of the oscillating detector, or that a harmonic of the oscillator might be beating with a harmonic of the receiver. The first possibility might be probable but the second is very remote providing the oscillator setting chosen was that for the loudest signal. The harmonics of the transmitter will be so weak in comparison to the fundamental that there is little danger of making this mistake.

Portable Transmitters

As we have already indicated, it is possible to build a highly stable 56-mc. transmitter for a fixed station in which a multiplicity of tubes and power supplies can be provided. For the portable transmitter, of course, any such procedure is almost completely impractical. It is not surprising that the general practice is to use the simplest possible circuit arrangements in the portable transmitter — single tube or push-pull oscillators modulated directly.

A typical circuit suitable for the portable transmitter is that given in Fig. 904. In this instance, a pair of pentode tubes serve as the modulator and are built into the same unit as the oscillator. Fig. 905 shows one example of the way in which the apparatus of this circuit may be

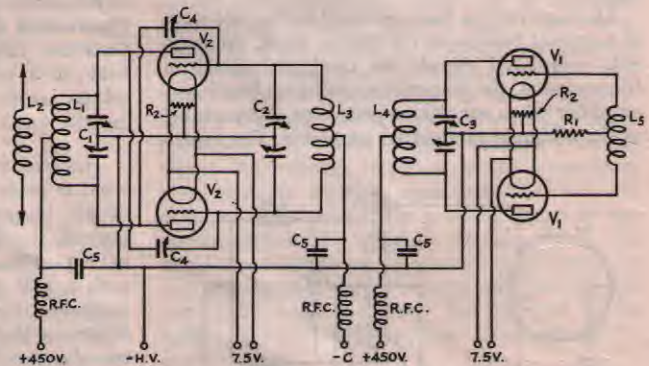

FIG. 903 — THE CIRCUIT OF A SIMPLE OSCILLATOR-AMPLIFIER TRANSMITTER

- L₁ — 2 turns 2 inches inside diameter.
- L₂ — One turn at each end of L₁, same diameter.
- L₃, L₄ — 2 turns 1-inch diameter.
- All above coils wound with 3/16-inch copper tubing.
- L₅ — See L₂ of Fig. 901.
- C₁ — Double-section midget condenser, 35 μ fd. per section, double spaced.
- C₂ — Double-section midget condenser, 100 μ fd. per section.
- C₃ — Same, 140 μ fd. per section.
- C₄ — Single 35 μ fd. midget condensers double spaced.
- C₅ — R.f. by-pass condensers, about 100 μ fd.
- R₁ — 10,000-ohm 5-watt resistor.
- R₂ — 75-ohm center-tapped resistors.
- RFC — See ditto of Fig. 901. Any other r.f. chokes suitable for 56-mc. may obviously be used.
- V₁, V₂ — Type 10 tubes. Other UX-type tubes may be used with reduced voltages.

assembled. For portable operation, Type 01-A tubes could be used for the oscillators and Type 33 tubes for the modulator. A plate voltage between 135 and 200 volts would then be suitable. For operation at a "home" station or in other cases where higher voltage is available, Type 71-A and Type 47 tubes could be used with a plate voltage between 200 and 300. In the illustration it will be seen that the two tubes of the oscillator are immediately behind the panel and mounted in ordinary tube sockets. Behind them is the split-stator condenser made up from a Type 406B Cardwell. As modified, it has five stator plates and four rotor plates in each section. It is so mounted in aluminum angles that the shaft runs laterally. A slot in the end of the shaft and a hole in the "can" allow the condenser to be set with a screwdriver. Behind the condenser and mounted directly on its terminals with lugs is the tank inductance. The feeders or antenna are coupled to it inductively with the aid of a split two-turn coil mounted on insulators. The particular insulators used were of Isolantite. G. R. sockets, through brass angles mounted on these

insulators, serve as receptacles for plugs on the feeder or antenna leads. Two three-quarter-inch holes in the "can" allow for their passage. Because of their height and the limited space, the modulator tubes fit in sub-panel sockets of the type used on broadcast receivers. The radio frequency choke is mounted under the tank condenser — above the base. The only remaining apparatus on top of the base is the fixed-tune grid coil. It is wound on a piece of 1/2-inch bakelite tubing supported with machine screws.

On the underside of the base there are located the supply cable connector plate, the microphone transformer (between the two modulator sockets), the speech choke and the grid leak. The three control switches serve to open or close the filament, microphone and plate circuits. The remainder of the panel, as can be seen in other

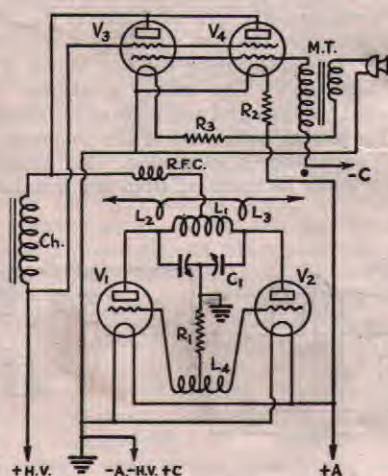

FIG. 904 — THE CIRCUIT OF THE PORTABLE TRANSMITTER ILLUSTRATED IN FIG. 905

C₁ — Type 406B 25-plate Cardwell receiving condenser with stator split and plates removed to give 5 stator and 4 rotor plates in each section.

R₁ — 50,000-ohm Electrodr wire-wound resistor.

R₂ R₃ — 2-ohm fixed filament resistors for Type 47 modulators; 12-ohm resistors for Type 33 modulators.

L₁ — 5 turns 1 inch inside diameter of 1/8-inch diameter copper tubing or wire.

L₂ L₃ — One turn each 3/4-inch diameter of similar conductor.

L₄ — 7 turns spaced 1/8 inch of 22 d.s.c. wire on 1/2-inch bakelite tube. Adjustment of turns and spacing may be necessary.

R.F.C. — 35 turns of 30 gauge d.s.c. wire on former 5/16-inch diameter. Turns spaced approximately twice diameter of wire.

M.T. — Microphone transformer made from old audio transformer with primary removed. New primary of 300 turns of 30-gauge d.s.c. wire.

CH. — Choke rated at 150 ma., 10 to 30 henrys.

V₁ to V₄ — See text.

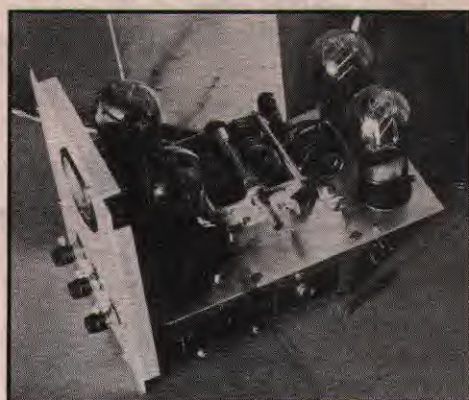

FIG. 905 — THE PORTABLE TRANSMITTER WITH THE OUTSIDE CASE REMOVED

In operation the unit is enclosed in an aluminum box, holes being provided for access to the tuning condenser and the feeder terminals.

photographs, is devoted exclusively to the small 0- to 200-ma. meter which reads the total plate current of the four tubes.

Fig. 906 shows how Class B modulation may be employed in a transmitter of this type. This arrangement is a particularly desirable one in cases where appreciable power output is required at low plate voltages and with the lowest possible plate current drain. At a plate voltage of 180, for instance, the static plate current of the modulator of Fig. 906 will be of the order of 15 ma. — the output rating approximately 5 watts. The adjustment of the modulator and oscillator will, of course, follow the principles laid down in Chapter Eight. At 180 volts on the plates of the oscillator tubes, the plate current should be approximately 35 ma.

Receivers for 56-mc. Work

Of the possible types of receivers for 56-mc. operation, the super-regenerative is by far the

most popular. Though possibly more sensitive than the super-regenerative receiver, the super-heterodyne has not yet been widely accepted. The probable reason is that its complexity and cost appear to be out of all proportion with its performance. The autodyne type of set, sometimes fitted with a radio frequency amplifier, has

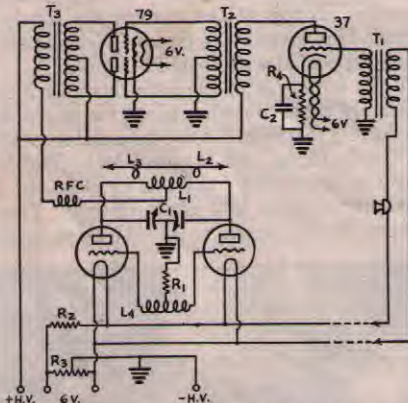

FIG. 906 — THE CIRCUIT FOR A PORTABLE TRANSMITTER WITH CLASS-B MODULATION

Constants other than those given here are identical with the equivalent items in Fig. 904.

C_1 — 2- μ fd. fixed condenser.

R_1 — 2 ohms.

R_2 — 75-ohm center tapped.

R_3 — 2500 ohm, 1 watt.

T_1 — Standard microphone transformer.

T_2, T_3 — Special Class-B transformers (such as the Collins Tinytrans), designed for operation with the tubes specified.

been used successfully by some workers. Like the super-heterodyne, it is of value in the reception of stable signals in instances where high selectivity is called for. The super-regenerator, however, remains the ideal for most work. It is simple, inexpensive, sensitive, and reliable. It is, of course, capable of accepting the broad wave emitted by a modulated-oscillator type 56-mc. transmitter.

Since super-regeneration plays such an important part in this work, it might be well to outline its principle of operation. We all know that the sensitivity of a regenerative receiver increases very rapidly as the point of oscillation is approached, but that the point of oscillation constitutes the limit to which this amplification may be carried in the usual receiver. In the super-regenerative system the application of an auxiliary super-audible frequency voltage on the grid or plate of the regenerative tube allows relatively terrific regeneration without the paralyzing self-oscillation which would ordinarily occur. In the first receiver to be described, the regenerative detector is "plate modulated" by the long-wave oscillator and the detector plate voltage is therefore swinging back and forth at the frequency of that oscillator. On the positive peaks the voltage

is of an order which would ordinarily make the detector oscillate violently. Such oscillation has no time to develop, however, before the plate voltage swings down on the next half-cycle of the auxiliary oscillator. Strictly speaking, an oscillation may develop during the positive half cycles but its amplitude is of such a low order as to be of little consequence. Operated in this condition, a regenerative detector may provide amplification many million times greater than that of the simple regenerative detector operated just below oscillation.

In other receivers described, the low interruption frequency is generated by the same tube that does the regenerating and detecting on the signal frequency. This arrangement is particularly desirable in small receivers where weight, size and battery consumption are important factors. Practice indicates that the elimination of the separate interruption frequency oscillator tube usually results in a slight loss of sensitivity in the receiver.

Figs. 907 and 908 illustrate a typical two-tube super-regenerative receiver in which a separate tube is used for providing the interruption frequency voltage. The left-hand tube in the circuit is the detector. Its own circuit is a series-feed Hartley, L_1 and L_2 being the two halves of the tank inductance. The tuning condenser C_1 is connected between grid and plate of the detector. For this reason, both sides of the condenser are "hot" with respect to ground. The condenser must not only be insulated from any metal chas-

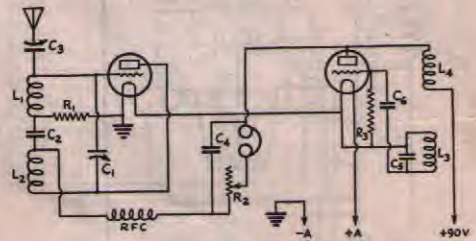

FIG. 907 — THE WIRING OF THE TWO-TUBE 56-MC. RECEIVER

C_1 — 20- μ fd. three-plate Hammarlund midget variable.

C_2 — 150- μ fd. fixed condenser.

C_3 — Trimmer condenser (mica dielectric) set near zero.

C_4 — .001- μ fd. fixed condenser.

C_5 — .002- μ fd. fixed condenser.

C_6 — .0005- μ fd. fixed condenser.

R_1 — 1-megohm fixed resistor.

R_2 — 50,000-ohm variable resistor.

R_3 — 50,000-ohm fixed resistor.

RFC — 30 turns of No. 26 wire on $\frac{1}{4}$ " rod.

L_1, L_2 — Each three turns of No. 16 enamelled antenna wire $\frac{1}{2}$ " inside diameter.

L_3, L_4 — 1400 and 900 turns, respectively, of No. 34 silk-covered wire wound on a $\frac{3}{8}$ " dowel between cardboard disks spaced $\frac{1}{4}$ ". A "Sickles" interruption-frequency coil unit may be used instead.

The tubes are Type 30 with a 4-volt "C" battery serving as filament supply.

An insulating coupling between the dial and tuning condenser is essential if "hand-capacity" effects are to be avoided.

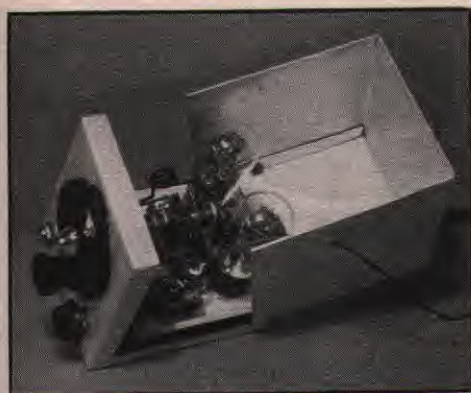

FIG. 908 — WITH THE COVER OPEN: A VIEW INSIDE THE TWO-TUBE SET

sis in the set but it must also be provided with an insulated coupling and an extension shaft. If the knob or dial were attached directly to the shaft of the condenser, serious hand-capacity effects would result. In the plate circuit of the tube we have the usual radio frequency choke and the phones (by-passed by a large fixed condenser). The regeneration control resistor R_1 usually will not be noisy if connected in the manner shown. It is possible, however, that with some type of resistors a by-pass condenser of $1 \mu\text{fd.}$ will be required to prevent noisy operation.

The low-frequency oscillator comprises the tube at the right side of the circuit diagram, the inductances L_3 , L_4 and the associated condensers. Examination of the wiring will reveal that this tube is connected to the detector unit in just the same way as a modulator would be connected to a modulated amplifier for plate modulation — L_4 being the equivalent of the speech choke.

Fig. 908 shows one possible arrangement of the parts of a receiver of this type. The two tubes and associated apparatus fit comfortably in an aluminum box measuring 5 by 5 by 4 inches. The outer shell is made in two sections, the rear one swinging back to allow ready access to the set's insides. Most of the components are mounted on a shelf supported $1\frac{1}{4}$ inches above the bottom of the shell. The exact location of the parts is not of much consequence except in the r.f. portion of the circuit, kept above the shelf. The tuning condenser is poised rigidly on a Bakelite strip about $\frac{3}{4}$ inch above the shelf and the inductances are attached directly to the condenser frame and stator. No plug is provided for the battery cable. Instead, the cable leads run directly to the various points of contact within the set.

When a receiver of this type is operating correctly, there will be a continuous and quite loud rushing noise when signals are not being received. This noise will disappear just as soon as a carrier is tuned in.

A Single-Tube Receiver

Fig. 909 is the circuit of a midget single-tube receiver which has proved very effective for portable work. Examination will show that the signal-frequency portion of the circuit is exactly similar to that used in our previous super-regenerative sets. The interruption-frequency coils L_4 and L_5 , instead of being connected to a separate interruption-frequency oscillator tube, are inserted in the plate and grid circuits of the detector tube, so permitting it to do the double job of oscillating at the interruption frequency and super-regenerating at the signal frequency.

The receiver in its final form is illustrated in Figs. 910 and 911. In its planning, consideration

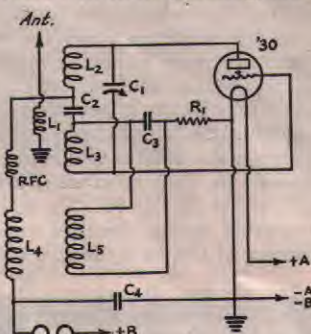

FIG. 909 — THE CIRCUIT OF THE MIDGET RECEIVER

- C_1 — Five-plate Cardwell Special Balanct (see text).
- C_2 — 100- $\mu\text{fd.}$ midget fixed condenser.
- C_3 — 0.002- $\mu\text{fd.}$ midget fixed condenser.
- C_4 — 0.004- $\mu\text{fd.}$ midget fixed condenser (two 0.002's in parallel).
- R_1 — 1-megohm half-watt fixed resistor.
- L_1 — Two turns of No. 22 wire $\frac{1}{4}$ " diameter mounted between L_2 and L_3 .
- L_2, L_3 — Five turns each of No. 20 wire $\frac{3}{8}$ " diameter and spaced to occupy $\frac{1}{2}$ " for 56 Mc. Ten turns of No. 24 wire same diameter and spaced for 28 Mc. The coils are made solid with "dope" in the latter case.
- L_4, L_5 — Sickles interruption-frequency coil unit.
- RFC — No. 30 gauge wire wound unspaced for a length of $\frac{3}{4}$ " on 5/16" bakelite rod.

was given not only to size but to the accessibility of every component and connection; hence the "U" shaped frame. Measuring $3\frac{1}{4}$ by $4\frac{1}{4}$ by $1\frac{1}{16}$ inches, this frame is bent from a strip of $\frac{1}{16}$ -inch aluminum. Sharp bends at the corners result from scoring the aluminum deeply at those points. The entire assembly is mounted on the frame, permitting the receiver to be adjusted or serviced after slipping off the "U" shaped cover. In Fig. 910, the Type 30 tube can be seen at the top. Immediately below the tube socket are to be seen the inductances L_1 , L_2 , L_3 and the condensers C_1 , C_2 , C_3 . The tuning condenser, C_1 , is a Cardwell 13-plate "Balanct," cut down to 5 plates by removing plates from the rear. It is therefore a more compact unit than the normal 5-plate midget of this type in which the plates are set

back from the frame. A special compact "Bal-ancet" condenser of this type is, we understand, now available from Cardwell. In the receiver, this tuning condenser is mounted to and insulated from the frame by a small piece of bakelite. It is placed at the end of the set opposite the knob so as to allow space for the essential insulated coupling. Straddling the $\frac{1}{4}$ -inch bakelite shaft is the interruption frequency coil unit. Under the latter, and under the drive shaft, are the two 0.002- μ fd. midget fixed condensers connected in parallel to form C_4 . The two "tip-jacks" for connection of the 'phones can be seen close under the knob. They are mounted in a strip of bakelite bolted to the frame. Remaining items are the gridleak, placed between the interruption frequency coils and the tuning condenser, and the insulated antenna terminal in the frame above the tuning coils.

The cover for the set is bent from $\frac{1}{16}$ -inch thick aluminum. It is drilled to accommodate the tuning condenser shaft and is held in place by one long machine screw, the head of which can be seen at the rear of the set in Fig. 911. The inside of the cover is protected against electrical contact with the components of the set by having its surfaces

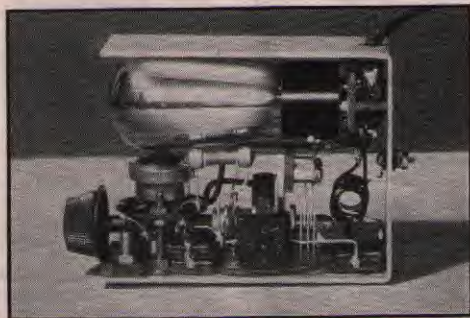

FIG. 910 — UPON SLIPPING THE COVER OFF THE MIDGET RECEIVER, ALL COMPONENTS AND WIRES ARE IMMEDIATELY REVEALED

This type of construction is therefore particularly valuable when service and adjustment become necessary — and when is it that they don't?

covered with ordinary writing paper and lacquered. All the aluminum, incidentally, was given a bath in strong lye solution, washed in water and then lacquered with clear Duco.

The operation of the receiver should present no problem other than the adjustment of coils to give the desired band coverage. The lack of the characteristic rushing noise which accompanies normal functioning will indicate either a faulty component or incorrect wiring. There are no half measures in these receivers; they either work well or not at all. This particular circuit operates satisfactorily with just 45 volts of plate supply. For filament supply, two ordinary flashlight cells are used with a 16-ohm fixed resistor in series.

A Three-Tube Set for A.C. Operation

A typical a.c. operated receiver for the ultra-high frequencies is illustrated in Figs. 912 and 913. It will be seen from the circuit diagram that the detector is arranged in the electron-coupled circuit already discussed in Chapters Five and Seven. The screen grid acts as the plate of the r.f. oscillator while the audio is taken out in the plate circuit. The long-wave modulator was connected into the screen grid, thereby modulating the r.f. oscillator by varying the screen-grid voltage. It would appear that both the coils comprising the long-wave oscillator transformer are untuned. However, they are arranged in a tuned-plate circuit with the grid coil acting as a tickler. The condenser C_4 acts not only as a ground for the screen grid but also as the tuning condenser across the long-wave plate coil L_4 . If the grid coil is not large enough, a small condenser may be required to tune it also. L_4 must be a good long-wave choke but care must be taken that C_4 is not of such a value as to tune the filter to the frequency of the long-wave oscillator.

In other respects, the circuit of this set follows the usual practice.

The mechanical arrangement of the parts is made clear in Fig. 913. The interruption frequency oscillator tube is at the left. Its associated coils are in the shield can immediately in front of it. The detector, its coils and condenser occupy the center of the base while the audio tube and coupling choke are at the right. Needless to say, a quiet plate supply system is needed for a.c. operation of the set.

A Regenerative Receiver with R.F. Amplifier

While the super-regenerative receiver is generally admitted to be the only practical one for portable operation, it is true that the plain regenerative receiver is capable of good service at fixed stations — where critical tuning can be tolerated. Some amateurs have found that effective reception with the type of sets just described can be had by removing the interruption frequency



FIG. 911 — THE SMALL SUPER-REGENERATIVE RECEIVER

Containing but one tube, the set is, nevertheless, capable of producing strong 'phone signals.

voltage. The advantage claimed is a reduction in the background noise. Other workers have developed special regenerative receivers for the work. This chapter would not be complete without mention of a representative receiver of the normal regenerative type.

Probably the most promising of the receivers in this group is that developed by Richard Hilferty, W1AFC, and shown in Fig. 914. It employs an unusual circuit in the detector—a circuit peculiarly adapted to ultra-high frequency work. Unlike the normal regenerative circuits, this one has no tickler or other obvious means of feedback. The important element in the circuit is the radio frequency choke in the cathode circuit of the detector. This choke provides an impedance common to both plate and grid circuits and makes the arrangement highly regenerative. Regeneration is controlled by a variable screen-grid voltage obtained by means of the potentiometer *R*. To avoid the problem of “dead-spots” invariably associated with a regenerative detector coupled directly to the antenna, a radio frequency amplifier is provided. Its use is justified even though it results in little if any amplification. The audio system on the receiver is a conventional pentode amplifier. It will be seen that alternative inductive

or capacitive antenna coupling is indicated by the broken lines. With either type of circuit, the coupling should be adjusted so that the antenna loads the grid circuit of the r.f. amplifier heavily.

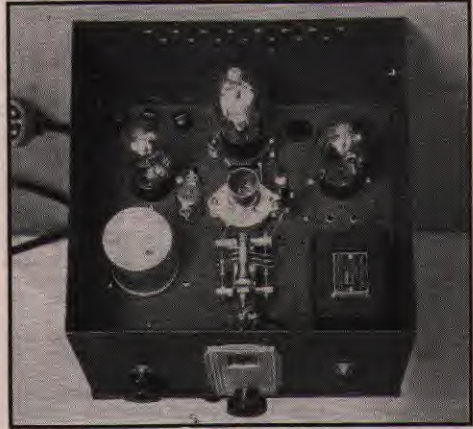

FIG. 913 — THE THREE-TUBE 56-MC. RECEIVER

In this way, the tendency towards self-oscillation in the circuit is minimized.

The mechanical arrangement of the set could well be similar to that of the receiver shown in Fig. 517 of Chapter Five. In operation, the set should behave in similar fashion to the regenerative receivers used on the lower frequencies. Tuning, of course, will be quite critical and some difficulty may be had in receiving 56-mc. stations suffering from particularly bad frequency modulation.

Transceivers for 56-mc. Operation

Amateurs who have had any experience with 56-mc. recognize as its most important advantage the possibility of completely effective 'phone operation with extraordinarily simple equipment. It is no wonder that, for most portable work and much home-station operation, the transceiver is becoming increasingly popular. In such a unit the same tubes, power supply and other components are used both for transmission and reception, with the obvious result of a still greater reduction in the cost, size and weight of the apparatus required.

Of the many possible circuit arrangements for the transceiver, that shown in Fig. 915 is probably the most popular. In it, the first tube is operated as a self-quenching detector for reception and a normal oscillator for transmission. The second tube serves as an audio frequency amplifier for reception and a modulator for transmission. The two transformers of the circuit likewise do double duty. *T*₁ serves as both inter-tube audio transformer and microphone transformer.

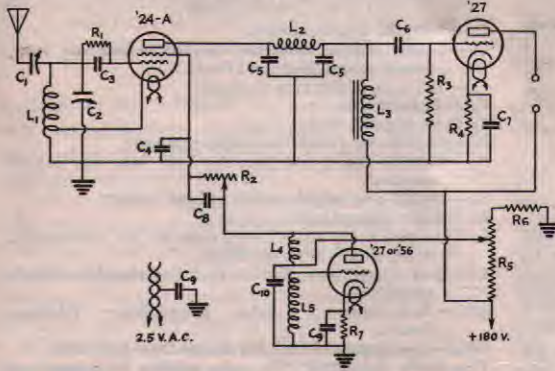

FIG. 912

- C₁ — Very small compression type mica trimmer condenser.
- C₂ — 12- μ fd. variable condenser (same as on r.f. detector and r.f. tuning condensers).
- C₃ — Small mica .0001- μ fd. condenser.
- C₄ — .001- to .002- μ fd. mica condenser.
- C₅ — .001- μ fd. condenser.
- C₆ — .5- μ fd. or more.
- C₇ — .5- μ fd. or more.
- C₈ — .01- μ fd. or more.
- C₉ — .5- μ fd. or more.
- C₁₀ — .5- μ fd. or more.
- R₁ — $\frac{1}{2}$ watt, 5 megohm.
- R₂ — 50,000 ohm rheostat.
- R₃ — 2,000 ohm, 1 watt.
- R₄ — 12,000-ohm voltage divider.
- R₅ — Additional resistors to fix reg. point.
- R₇ — 2,000-ohm, 1 watt.
- L₁ — Detector coil. Two turns, 1-inch diameter. Tap one-quarter turn from grounded end.
- L₂ — 250 millihenry r.f. choke.
- L₃, C₆, R₄ — Parts of National S101.
- L₄ — 600 turn, 175-kc. i.f. coil.
- L₅ — Three or four times larger than L₄.

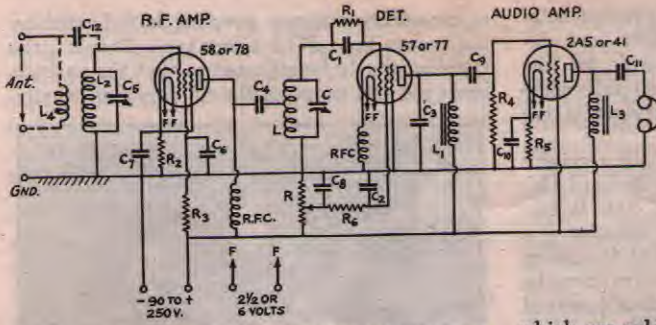

FIG. 914 — COMPLETE CIRCUIT OF THE 56-MC. RECEIVER USING A STRAIGHT REGENERATIVE DETECTOR CIRCUIT

Type 58, 57 and 2A5 tubes should be used for 2.5-volt a.c. filament supply; Type 78, 77 and 41 tubes for 6-volt a.c. or d.c. supply. Batteries or a power pack may be used for the "B" supply.

- L — 8 turns No. 16 enameled, 3/8-inch diameter form, turns spaced diameter of wire.
- L₁ — 500-henry audio-frequency choke.
- L₂ — 10 turns No. 16 enameled, same diameter and spacing as L.
- L₃ — 30-henry output choke or a pentode output transformer.
- L₄ — Few turns coupled to L. Varies with antenna and should be adjusted for best operation.
- RFC — National Type 100-R radio-frequency chokes (2.5-mh).
- C and C₃ — 4-plate midget variable condensers.
- C₁, C₂, C₄, C₅ and C₆ — 100- μ fd. or larger mica condensers.
- C₃ and C₁₁ — 0.5- μ fd. paper condensers.
- C₈ — 0.05- μ fd. mica condenser.
- C₁₀ — 2 μ fd. or larger paper condenser.
- C₁₂ — 1 or 2 μ fd., overlapped insulated wires (used or capacitive antenna coupling).
- R — 100,000- or 200,000-ohm potentiometer.
- R₁ — 2 to 10 megohms, preferably the higher resistance.
- R₂ — 300- or 400-ohm 1-watt resistor.
- R₃ — 50,000-ohm (or thereabouts) 1-watt resistor.
- R₄ — 0.5-megohm.
- R₅ — 750-ohm 2-watt resistor.
- R₆ — 500-ohm 1-watt (decoupling) resistor.

T₂ operates as output transformer and as the modulation choke. Switching from receiver to transmitter is accomplished by a four-pole double-throw switch indicated on the diagram as four separate switches for the sake of clearness. SW₁ changes the receiver gridleak to one suitable for transmission. SW₂ switches the plate lead of the detector to the audio transformer for reception and to the modulator plate for transmission. SW₃ connects the microphone to the microphone transformer primary for transmission while SW₄ simultaneously disconnects the head 'phone.

Fig. 916 illustrates one possible mechanical arrangement of such a circuit. The two transformers are mounted one on each side of a fourpole switch occupying the lower center of the panel. Two Isolantite sockets are used for the

Type 230 and 233 tubes, this type of socket having more grip on the tube prongs than fiber, which seems to "give." There is consequently less danger of the tubes falling out during transit, since the tubes are mounted upside down.

Between the tubes is a tuning condenser which is just large enough to cover the band. Mounted on the condenser are two double-terminal lugs on

which are soldered the two tuning coils. In the middle of the set can be seen the two grid leaks and the r.f. choke, connected between the coils and the switch. Five fixed condensers complete the circuit, C₁ being a midget mica condenser mounted directly on the terminal lugs between the two coils. The dial is connected to the tuning condenser with a flexible coupling and a bakelite shaft to eliminate body capacity. The aluminum panel in this model is only 5 1/2 by 6 3/4 inches.

The transformers can be purchased, or adapted in the following manner: T₁ is any ordinary interstage audio transformer with the addition

FIG. 915 — CIRCUIT AND SPECIFICATIONS OF THE TRANSCEIVER

- C₁ — .001- μ fd. mica condenser.
- C₂ — 3-plate midget condenser, two stator and one rotor, double-spaced (National STN-6).
- C₃ — 100- μ fd. midget mica condenser.
- C₄ — .004- μ fd. mica.
- C₅, C₆ — .002- μ fd. mica.
- R₁ — 10,000-ohm 1-watt (transmitting grid leak).
- R₂ — 100,000-ohm 1-watt (receiving grid leak; may require variation).
- R₃ — 10,000-ohm variable resistor (volume control).
- R₄ — 2-ohm filament supply resistor.
- L₁, L₂ — each 5 turns about 5/8-inch diameter, No. 14 enameled wire (adjust to cover the band).
- L₃ — 2 or 3 turns, same diameter (coupling should be slightly adjustable).
- RFC — Radio-frequency choke, 2 1/2-millihenry (National R-100).
- SW₁₋₂₋₃₋₄ — Sections of four-pole double-throw jack switch.
- T₁ — Audio transformer with extra winding for microphone (see text).
- T₂ — Output transformer (to match telephone receiver).

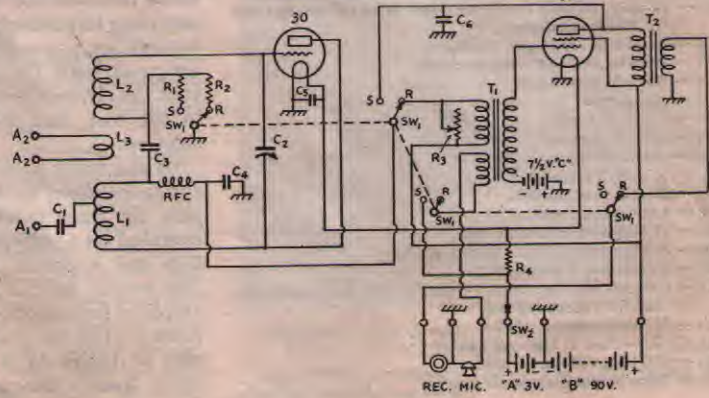

of a 300-turn microphone winding; T_2 is a 7000-ohm-to-15-ohm speaker output transformer (for use with the low-resistance telephone receiver). It should be a high-resistance output type, of course, if high-resistance 'phones are to be used. Alternatively, a conventional choke-condenser output circuit could be used for the operation of high-resistance 'phones.

Fig. 917 is the circuit arrangement for a similar

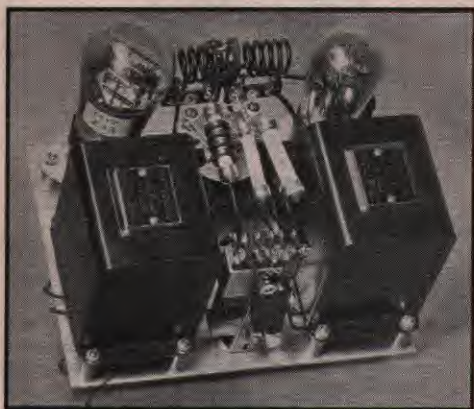

FIG. 916—ILLUSTRATING THE ASSEMBLY OF EQUIPMENT ON THE BACK OF THE PANEL

Details of the arrangement are given in the text

transceiver but adapted for operation from a 6-volt storage battery. Units of this type have been used with complete success in several experimental airplane installations.

The circuit of Fig. 918 is included to illustrate one other possible arrangement of a transceiver. This particular arrangement was devised to permit the lowest possible battery consumption and because of its low power is obviously suited only for work over very short distances.

The circuit is based on the knowledge that the interruption frequency oscillator of a super-regenerative receiver is functioning as a modulator for reception and that it might readily be switched to operate as a modulator for transmission. Study of the wiring will show that L_4 and $Ch.$ are really two plate chokes in series—one functioning at the interruption frequency, the other at speech frequencies. The grid circuit of the modulator, containing both the tuned circuit L_5, C_4 and the modulation transformer secondary, is also capable of operation at both interruption and speech frequencies. Changing from reception to transmission involves shorting the 'phones, reducing the oscillator gridleak resistance and shorting the interruption oscillator plate coil.

With 90 plate volts, the total plate current is of the order of 7 ma. with the oscillator loaded. This, with only 60 ma. of filament current, permits the set to be operated economically from very small batteries.

It need hardly be said that there is a great variety of possible mechanical arrangements for units of this type. Many amateurs build such equipment into small carrying cases or metal tool-boxes, providing space for the batteries, 'phones and microphone. Others prefer to make the transceiver a separate unit available for connection to any power supplies that may be found desirable.

Suitable Antenna Systems

The same principles are involved in planning antennas for 56-mc. work as for operation on the lower frequency bands. For this reason, the ultra-high frequency enthusiast should be quite familiar with the contents of Chapter Twelve.

Practice has shown that, in general, a vertical antenna performs more satisfactorily than any other. Since height is such an important factor in all ultra-high frequency work, it is not surprising that the other important fundamental requirement is an antenna well elevated above the surrounding terrain. In portable installations, of course, this is not always possible. One can only remember that every foot of antenna height will result in some increase in the range of the station.

A feature which has been shown to be extremely desirable for 56-mc. reception is a tuned antenna. In receivers having a small condenser for coupling between the antenna and input circuit, it is invariably advantageous to make the total length of the antenna (including lead-in) one or more half-waves long (8 feet or some multiple of 8 feet). When inductive coupling is employed, it is possible to use a half-wave doublet with a twisted-pair feeder (see Chapter Twelve), or merely two quarter-wave (4-foot) wires or rods. Alternatively, one side of the antenna coil may be grounded and the other connected to a long vertical wire having a length equal to some odd multiple of four feet. A still further possibility

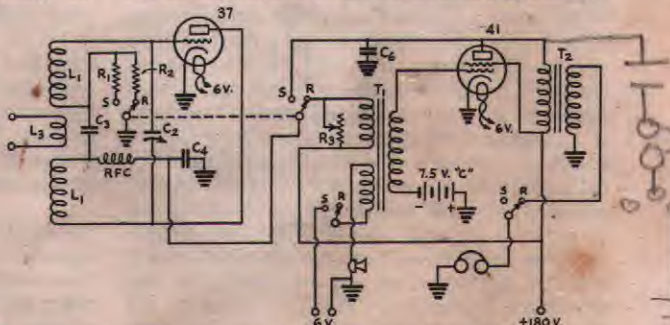

FIG. 917—A TRANSCEIVER WITH A.C. TYPE TUBES

Constants are similar to those given in Fig. 915

is merely to ground one side of the antenna coil, attaching the other to some well elevated antenna (such as that used for transmission on the lower frequencies), then tuning the system, with a five- or seven-plate midget condenser across the antenna coil.

Any of the systems are effective for transmission — particularly those in which the entire radiator is vertical.

Experiment Necessary

In describing these odd pieces of representative 56-mc. equipment, the idea has been to sketch the requirements for effective working. None of the apparatus can be considered as the ultimate. Ultra-high frequency work is a relatively new field and it seems certain that many present ideas will be drastically revised in the early future. It is possible that the super-heterodyne will displace the super-regenerator and that oscillator-amplifier transmitters will become essential in all stations. Time will tell. It is certain that because the 56-mc. band has not been explored in the same thorough manner as the lower frequency bands have been, it is a field of particular interest to the experimentally inclined amateur. We make a special plea for careful observation of all phenomena experienced in working on the band and would ask that amateurs experiencing unusual effects or obtaining ranges greatly in excess of the visible range should immediately report their results to League Headquarters.

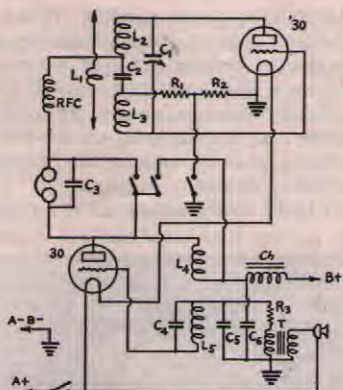

FIG. 918 — THE CIRCUIT OF A LOW-POWERED TRANSCEIVER

- C₁ — Five-plate midget variable condenser.
- C₂ — 100- μ fd. midget fixed condenser.
- C₃ — 0.002- μ fd. midget fixed condenser.
- C₄ — 0.002- μ fd. midget fixed condenser.
- R₁ — 50,000-ohm half-watt fixed resistor.
- R₂ — 2-megohm half-watt fixed resistor.
- R₃ — 25,000-ohm half-watt fixed resistor (found necessary to prevent "howling" of the modulator as a result of proximity of Ch. and T).
- L₁ — Two turns of No. 16 wire $\frac{1}{2}$ " diameter mounted between L₂ and L₃.
- L₂, L₃ — Each 4 turns of No. 16 wire $\frac{3}{8}$ " diameter with turns spaced $\frac{1}{8}$ ".
- L₄, L₅ — Sickles interruption frequency coil unit.
- RFC — Similar to choke specified for midget receiver.
- Ch., T — Similar to those specified under Fig. 5.

Chapter Ten

POWER SUPPLY

FULLY as important as the transmitter itself is the apparatus which supplies the power to the tube filaments and plates. The operation of a well-designed transmitter can be spoiled by a poor power supply. Although the power supply involves only the use of simple apparatus in most cases, good design and adjustment will be well rewarded by improvement in the signal and in the over-all effectiveness of the transmitter.

In this chapter we shall consider various types of power supplies for both transmitters and receivers. It is the function of both to provide steady power for the tube filaments and direct current for the plates. Filament supply with modern transmitting and receiving tubes is relatively simple; the design of the plate supply, however, depends to a considerable extent upon the type of service to which it is to be put and is therefore worthy of careful consideration. We shall discuss first the plate supply for the transmitter.

The Plate Supply

Under the regulations governing amateur stations the plate supply must deliver adequately-filtered direct current to the plates of all tubes in transmitters operating on frequencies below 14,400 kc. This requirement is designed to ensure that the emitted signal will be "pure d.c." on the four most important amateur bands, and to prevent transmitters having poor frequency stability from producing broad signals.

High-voltage direct current for the transmitting tubes can be obtained in a number of ways. These include banks of dry or storage cells connected in series to give the required voltage, dynamotors and motor-generators, and transformer-rectifier-filter systems. The latter are by far the most generally used.

The output of dry-cell or storage batteries is ideal for the transmitter because it is steady, pure direct current. Except for very low-power transmitters, however, the battery cost is a great deal more than the cost of other power supply apparatus of the same voltage output; furthermore, the current that can be taken from the

batteries is extremely limited if reasonable battery life is to be secured. Not more than 30 milliamperes should be taken continuously from standard-size "B" batteries; at this discharge rate the life of the battery should be approximately 200 hours. The heavy-duty batteries can stand higher discharge rates and will last longer. Because of their cost and relatively short life, batteries are used chiefly for portable transmitters — particularly with ultra-high frequency equipment — and in locations where no other source of power is available, such as on farms.

A direct-current motor-generator set is an excellent source of plate power. It is relatively costly, however, and its output is not as pure as that from batteries because of the ripple caused by commutation. The commutator ripple can be filtered out with little difficulty; a 1- or 2- μ fd. condenser shunting the output usually will be sufficient.

A dynamotor is a double-armature machine; one winding drives it as a motor while the other delivers a few hundred volts d.c. for the transmitting tubes. The motor winding usually operates from a six- or twelve-volt storage battery. The dynamotor also has commutator ripple, which must be filtered out just as with the motor-generator set.

The Rectifier-Filter Systems

Assuming that alternating-current power is available at 110 or 220 volts, a very effective high-voltage supply system can be built up from a high-voltage transformer, a rectifier system and a filter. The details of the transformer and the filter are to be given complete treatment later in the chapter and for the moment we will limit the discussion to the rectifier.

An understanding of how a rectifier functions may be obtained by studying Fig. 1001. At (1) is a typical a.c. wave, in which the polarity of the current and voltage goes through a complete reversal once each cycle. The object of rectification is to transform this wave into one in which the polarity is always the same, although the amplitude of the current and voltage may vary continually. At (2) we have the secondary of a power transformer connected to a single rectifier

DANGER—HIGH VOLTAGE!

It must be realized that the plate supply equipment of even a low-powered transmitter is a potential lethal machine. It is ever ready to deal out sudden death to the careless operator. A number of amateurs, indeed, have been killed by the output of their power supplies during the last few years. Many more have suffered severe injury. We cannot urge too strongly the observance of extreme care in the handling of power supplies and transmitters.

element, represented by the arrow and dash enclosed in the circle. The rectifier is assumed to be "perfect," that is, current can only flow through it in one direction, from the arrow to the plate. Its resistance to flow of current in that direction is zero, but for current of opposite polarity its resistance is infinite. Then during the period while

that direction. The circuit is completed through the transformer center-tap. At the same time the lower end of the winding is negative and no current can flow through rectifier No. 2. When the current reverses, however, the upper end of the winding is negative and no current can flow through rectifier No. 1, while the lower end is positive and therefore rectifier No. 2 passes current to the load, the return connection again being the center-tap. The resulting wave shape is again shown at the right. All of the wave has been utilized, and the amount of power which can be realized at the load is doubled. In order to maintain the same output voltage (instantaneous, not average) as at (2), however, each half of the transformer secondary must be wound for the same voltage as that furnished by the whole winding in (2); or, conversely, the total transformer voltage with the connections shown in (3) must be twice the desired output voltage.

If the transformer has no center-tap, or if the total voltage it furnishes is the same as the desired output voltage, scheme (4), known as the "bridge" rectifier, may be used to obtain full-wave rectification. Its operation is as follows: When the upper end of the winding is positive, current can flow through No. 2 to the load, but not through No. 1. On the return circuit, current flows through No. 3 back to the lower end of the transformer winding. When the wave reverses and the lower end of the winding becomes positive, current flows through No. 4 to the load and returns through No. 1 to the upper side of the transformer. The output wave shape is shown at the right. Although this system does not require a center-tapped transformer, and the voltage of the winding need only be the same as that desired for the load, four rectifier elements are required, so that the center-tap may actually prove to be more economical, all things considered.

Although the rectifier output is direct current in the sense that the polarity is always the same, the amplitude is not uniform but varies continually as shown in Fig. 1001. Before the power can be supplied to the transmitting-tube plates the "humps" must be smoothed out by a filter. Filters will be considered in detail in a later section.

Types of Rectifiers

Practically all rectifiers in use today by amateurs are of the vacuum-tube type; in former years when suitable tube rectifiers were not available many other types, including chemical, rotating (synchronous), and mercury-arc were in general use. These are now of relatively little importance in amateur transmitters, and since they have no particular advantages over the widely-used tube rectifiers will not be treated in this chapter.

There are two types of tube rectifiers: those having a high vacuum, in which the conduction

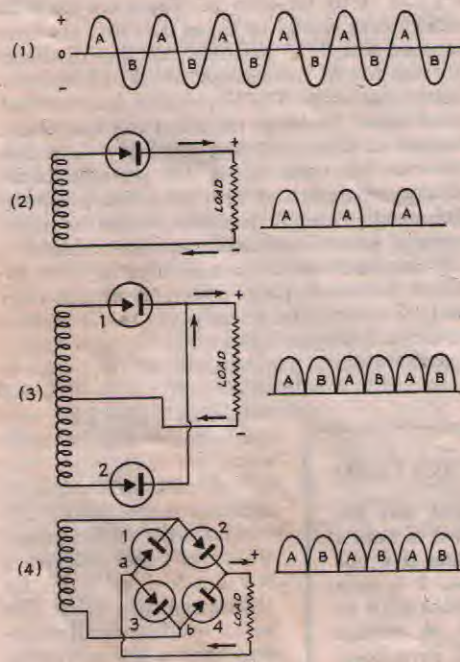

FIG. 1001 — FUNDAMENTAL RECTIFIER CIRCUITS

At (1) is the conventional representation of the a.c. wave; (2) shows a half-wave rectifier, at (3) is the full-wave center-tap system, and (4) is the "bridge" rectifier. The output wave form with each type of rectifier is shown at the right.

the upper end of the transformer winding is positive, corresponding to A in (1), current can flow to the load unimpeded. When the current reverses, however, as at (1) B, it cannot pass through the rectifier, and consequently nothing flows to the load. The drawing shows how the output from the transformer and rectifier looks. Only one-half of each cycle is useful in furnishing power to the load, so this arrangement is known as a "half-wave" rectifier system.

In order to utilize the remaining half of the wave, two schemes have been devised. At (3) is shown the "full-wave center-tap" rectifier, so called because the transformer secondary winding must consist of two equal parts with a connection brought out from the center. In (3), when the upper end of the winding is positive, current can flow through rectifier No. 1 to the load; this current cannot pass through rectifier No. 2 because its resistance is infinite to current coming from

is purely by means of the electronic stream from the cathode to the plate; and those in which a small quantity of mercury has been introduced after the tube has been evacuated. In the latter type, part of the mercury vaporizes when the cathode reaches its operating temperature, and during the part of the cycle in which the rectifier is passing current the mercury vapor is broken down into positive and negative ions; the positive ions decrease the normal resistance of the plate-cathode circuit so that the voltage drop in the tube is less than with high-vacuum types. As a result of the lower voltage drop the power lost in the rectifier is decreased, and the efficiency of the mercury-vapor rectifier is therefore greater than that of the high-vacuum type.

Operating Limits of Rectifiers

Two factors determine the safe operating limits of tube rectifiers. These are the maximum inverse peak voltage and the maximum peak current.

The inverse peak voltage is the maximum voltage which appears between the plate and cathode of the rectifier tube during the part of the cycle in which the tube is not conducting. Referring again to Fig. 1001, in (2) it is apparent that during the "B" part of the cycle when the half-wave rectifier does not conduct, the inverse potential between the plate and cathode will be equal to the full transformer voltage; the peak value of this voltage is 1.4 times the r.m.s. or effective output voltage. In the full-wave center-tap rectifier of (3), during the part of the cycle when rectifier No. 1 is non-conducting the inverse potential across its elements is equal to the sum of the potentials of both halves of the secondary of the transformer; the peak inverse voltage is again 1.4 times the full transformer voltage. Inspection will show that this is similarly the case with the bridge rectifier, circuit (4). It is well to remember that, no matter what the type of rectifier, the inverse peak voltage is always 1.4 times the *total* transformer voltage. Strictly

RECTIFIER TUBES

Type No.	Fil. Volts	Fil. Amps.	Max. Voltage per plate (a.c. r.m.s.)	Max. Inverse Peak Voltage	Max. D.C. Output Current (ma.)	Max. Peak Current (ma.)	Type
1	6.3*	0.3	350	1000	50	400	Half-wave M.V.
1-V	6.3*	0.3	350		50		Half-wave H.V.
84	6.3*	0.5	225		50		Full-wave H.V.
12Z3	12.6*	0.3	250		60		Half-wave H.V.
25Z5	25.0*	0.3	125		100		H.V. Voltage-Doubler ¹
80	5.0	2.0	350 400 550 ²		125 110 135		Full-wave H.V.
82	2.5	3.0	500	1400	125	400	Full-wave M.V.
5Z3	5.0	3.0	500		250		Full-wave H.V.
83	5.0	3.0	500	1400	250	800	Full-wave M.V.
81	7.5	1.25	700		85		Half-wave H.V.
RK19	7.5*	2.5	1250	3500		600	Full-wave H.V.
866	2.5	5.0		7500		600	Half-wave M.V.
866-A	2.5	5.0		10,000		600	Half-wave M.V.
872	5.0	10.0		7500		2500	Half-wave M.V.

H.V. — High Vacuum. M.V. — Mercury Vapor.
* Indirectly-heated cathode.

¹ Two independent rectifiers in one bulb.

² Only with input choke of at least 20 henrys to filter.

speaking, the voltage drop in one rectifier tube should be subtracted from the figure so calculated, but since the rectifier drop usually is negligible in comparison with the transformer voltage, no practical error results from neglecting it. Because it is always the total transformer voltage which must be considered, we find that for a given inverse peak voltage rating the permissible output voltage with the bridge rectifier circuit is twice that with the center-tap circuit, because in the latter circuit only half the total transformer voltage is available for the load. The bridge circuit, however, requires twice as many rectifier elements.

The peak current through the rectifier tube is chiefly a function of the load and the type of filter circuit used. We shall have more to say on this point in the section on filters.

While inverse peak voltage and peak current ratings apply to both high-vacuum and mercury-vapor rectifiers, they have more significance with the mercury-vapor types than with the vacuum types. In the vacuum-type rectifiers the inverse voltage which the tube will handle safely is limited chiefly by the spacing between the plate and cathode and the insulation between the leads from these elements in the glass press and in the base. In the mercury-vapor rectifier, however, the inverse peak voltage is a function of the design of the tube and the operating temperature; for a given tube type there is a critical voltage above which an "arc-back" will occur, ruining the tube. The higher the temperature of the mercury vapor the lower the voltage at which arc-back will take place; for this reason mercury-vapor rectifier tubes should always be located so that there is free circulation of air around them for cooling. The tubes are usually rated at a peak inverse voltage which will permit safe operation at normal current in a room of average temperature.

The peak current rating is based on an electron flow from the filament which will give a filament life of 1000 hours or more. In the high-vacuum types the tube voltage drop depends upon the current; the higher the current the greater the voltage drop. High-vacuum tubes therefore tend to protect themselves under overload, because excessive current causes a larger voltage drop which in turn reduces the voltage across the load circuit, thus limiting the current flow. In mercury-vapor rectifiers, however, the voltage drop is substantially constant for all values of current, hence the rectifier cannot protect itself from overloads. A heavy overload on a mercury-vapor rectifier, even though instantaneous, is likely to destroy the filament or cathode of the tube, because under such conditions the positive ions of the mercury vapor are attracted to the cathode with such force as actually to tear off the emitting material with which the cathode is coated. A less drastic overload applied over a longer period of

time will have the same effect. Mercury-vapor rectifiers should always be worked within the peak current ratings if normal tube life is to be expected.

Standard types of rectifier tubes are listed in the table, together with their ratings and a brief description of each type. In the smaller sizes, the tubes are generally manufactured as full-wave rectifiers; that is, a cathode and two plates are provided in one bulb so that full-wave rectification can be obtained with a center-tapped transformer. Tubes for high voltages are always half-wave rectifiers; two of them are needed for the center-tap system.

The principal advantages of the mercury-vapor rectifiers over the high-vacuum type are the lower voltage drop and the fact that this drop is independent of the load current. In all the mercury-vapor tubes the voltage drop can for practical purposes be considered to be 15 volts regardless of load current. This low, constant drop results in a power supply having better voltage regulation — discussed in a later section — than one using high-vacuum rectifiers, and is responsible for the wide use of mercury-vapor rectifiers in amateur transmitting equipment. The most popular rectifier tubes are the 82, 83, and 866. Occasionally high-power transmitters will be found with 872 rectifiers.

Mercury-vapor rectifiers always should be operated with the rated voltage applied to the filament. If the filament voltage is low (filament or cathode temperature too low) the effect is exactly the same as though the tube was heavily overloaded, and the cathode will rapidly lose its emission. For this reason, in operating high-voltage mercury-vapor rectifiers the filament power always should be applied for at least 30 seconds before the plate voltage is turned on so that the filament will be certain to reach its correct operating temperature. If the rectifiers have been out of service for some time it is also advisable to heat the filaments for 10 or 15 minutes before applying plate voltage so that all the mercury that may have condensed on the filament will be vaporized.

Rectifier Circuits

The elementary rectifier circuits of Fig. 1001 are shown in practical form in Figs. 1002 and 1003. Fig. 1002 is the center-tap circuit for use with a full-wave rectifier tube, and is used only for low-voltage power supplies — 500 volts or less. Both center-tap and bridge circuits are given in Fig. 1003, half-wave rectifier tubes being used in both cases. In the practical circuits, it can be seen that while a single filament transformer will suffice for both tubes in the center-tap circuit, the bridge circuit requires the use of three separate filament transformers; the filaments of one pair of tubes can be connected together, but the filaments of the other two tubes are at different

potentials and must have separate sources of filament-heating power.

Reference to the table of rectifier tubes will show that the smaller mercury-vapor tubes are rated for a given output current and a maximum r.m.s. applied transformer voltage, while the ratings on the larger tubes are exclusively in terms of inverse peak voltage and peak current.

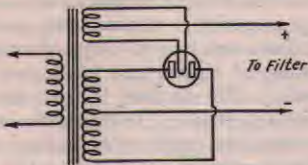

FIG. 1002 — HOW FULL-WAVE TUBE RECTIFIERS ARE CONNECTED

This diagram can be used with Type 80, 82 and 83 rectifier tubes.

Because of the low voltage at which the small tubes are operated, the ratings for them will hold regardless of the type of filter into which the rectifier works. The 866 and 872, on the other hand, are high-voltage tubes and must be handled with more care; the peak current, which must not exceed the rated value, will depend largely on the type of filter used, while the inverse peak voltage is a function of the transformer voltage and the rectifier circuit. With rectifier tubes having an inverse peak voltage rating of 7500 volts the transformer voltage, in the center-tap circuit, should not exceed 2600 volts each side of the center tap. If the bridge circuit is to be used, the total transformer voltage should not exceed 5200 volts. The corresponding voltages with 10,000-volt tubes are 3500 and 7000 volts. Few amateurs use plate voltages exceeding 3000 volts; the average for high-power amateur transmitters is 2000 to 2500 volts. The high-voltage rectifiers in the table are therefore sufficient for practically all amateur needs.

Voltage Regulation

The term "voltage regulation" is used to indicate the change in terminal voltage of a plate-supply system with different load currents. The windings of transformers and filter chokes used in plate supplies all have some resistance; as the current drawn from the power supply is increased the voltage drop in the transformer and chokes also increases with the result that the terminal voltage drops. Besides these ohmic effects, there may be other causes contributing to the decrease in terminal

voltage with load, such as the behavior of the filter.

As ordinarily used in electrical engineering, the term "voltage regulation" refers to the increase in voltage resulting when the load current is decreased from the rated value to zero, expressed as a percentage of the terminal voltage at full-load current. It is often more convenient in speaking of plate-supply systems, however, to use the terminal voltage at no load as a base, in which case the percent. regulation will be the decrease in terminal voltage from the no-load value to the value of load at which the power supply is to be worked. Amateur plate supplies are seldom used at a definitely-fixed load current, hence the greater convenience of expressing voltage regulation as a percentage of the no-load terminal voltage.

As an illustration, suppose the measured terminal voltage of a power supply is 1200 volts at no load — i. e., no current being drawn by the transmitting tubes. Then with the transmitter in operation the voltage is measured and found to be 900 volts. The voltage regulation will be

$$\frac{1200 - 900}{1200} = .25 \text{ or } 25\%$$

The voltage regulation will be found to vary with the load and with the type of filter used. Good plate supplies will have a regulation of the order of 10% or less; poorly-designed power supplies often have regulation as high as 50% — in other words, the voltage at full load drops to half its no-load value. Good voltage regulation is highly desirable with the self-controlled transmitter because in such a transmitter the frequency depends upon the plate voltage; if the

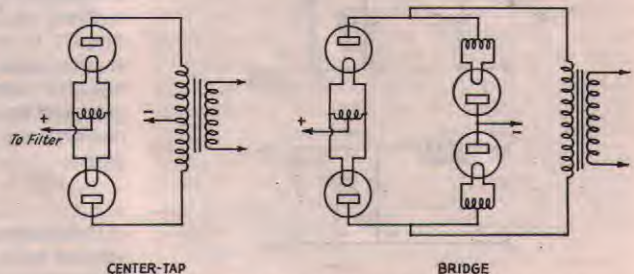

FIG. 1003 — CENTER-TAP AND BRIDGE RECTIFIER CIRCUITS

In both circuits, the peak inverse voltage is equal to the total secondary voltage of the transformer multiplied by 1.4. Therefore, twice as much voltage can be obtained from the bridge as from the center-tap rectifier without exceeding the tube ratings. The tubes will pass the same load current in both cases.

plate voltage dives suddenly every time the key is pressed the note will have a chirpy or "yooping" character and be hard to read. While this consideration is not as important in the amplifier stages of oscillator-amplifier transmitters, good voltage regulation is still desirable because it tends to reduce key thumps.

The Filter

It is not an exaggeration to say that the filter is worthy of more careful attention than any other section of the power supply. Primarily its purpose is to take the electrical pulses from the rectifier (see Fig. 1001) and smooth them out so that the power delivered to the plates of the transmitting tubes is perfectly continuous and unvarying in just the same way that the current from a battery is continuous and unvarying. But in addition to this, the design of the filter will greatly affect the voltage regulation of the power supply and the peak current through the rectifier tubes.

In analyzing the output of a rectifier-filter system, it is customary to consider the output voltage to consist of two components, one a steady "pure d.c." voltage and the other a superimposed a.c. voltage—the ripple voltage—which when combined with the assumed unvarying voltage gives the same effect as the actual rapid variations in the output of an incompletely-filtered power supply. When the r.m.s. or effective value of the ripple voltage is divided by the d.c. voltage the result, expressed as a percentage, gives a "figure of merit" (percent. ripple) for

comparing the performance of various filter circuits; furthermore, the amount of filter needed for various transmitter applications is dependent upon the ripple percentage that can be tolerated. Experience has shown that a ripple of 5% or less will give "pure d.c." for c.w. telegraphy if the transmitter has high frequency stability; for radiotelephony the ripple should be .25% or less to reduce hum to a satisfactory level.

Filters are made up of combinations of inductance and capacity—chokes and condensers. Although there are several ways of considering the operation of chokes and condensers in the filter, possibly the simplest is from the standpoint of energy storage. Both chokes and condensers possess the property of storing electrical energy, the former in the form of the electromagnetic field, the latter in the dielectric field. While the amplitude of the rectified a.c. wave is increasing, energy is stored in both the inductance and capacity; after the peak has been reached and the amplitude of the rectified wave begins to decrease, the stored-up energy is released and fills in the valleys between the rectified humps. A little consideration of the action will make it evident that the energy storage required will depend upon the rate of occurrence of the rectified waves; the closer they are together the less will be the energy storage required. In other words, the amount of inductance and capacity needed will be inversely proportional to the frequency of the a.c. supply. A supply frequency of 60 cycles with full-wave rectification gives 120 rectified waves per second, corresponding to a frequency of 120 cycles. Similarly, full-wave rectification with 50-cycle supply gives a frequency of 100 cycles, and with 25-cycle supply a frequency of 50 cycles. The discussion to follow is based on full-wave rectification with 60-cycle supply; to maintain a given ripple percentage at the lower frequencies both inductance and capacity must be increased over the 60-cycle values. The required increases will be directly proportional to 60 divided by the supply frequency.

Types of Filters

Inductance and capacity can be combined in various ways to act as a filter. Four representative arrangements are given in Fig. 1004. The single condenser at A is not a complete filter, but will give considerable smoothing. This type of filter will not, generally speaking, be sufficient to meet the requirement that the plate supply for an amateur transmitter must be adequately filtered. The arrangement at B has been extremely popular in the past; with suitable values of L and C the smoothing will be adequate for most amateur purposes. This is known as a condenser-input filter because a condenser is connected directly across the output of the rectifier. The condenser-input filter is characterized by

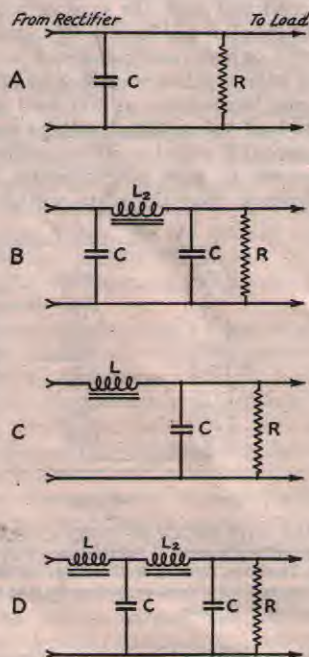

FIG. 1004—FILTERS

At A is the simplest type of filter—a single condenser of high capacity connected across the rectifier output. With the addition of a filter choke and a second condenser this becomes the "brute force" circuit of B. C is a single-section choke-input filter. The two-section filter at D is recommended when the ripple voltage in the output must be low.

high output voltage, poor voltage regulation and high rectifier peak current.

A third type of filter is shown at *C*. It consists of a single choke and condenser, and because the rectifier output goes to the choke, is known as a choke-input filter. Chief characteristics of the choke-input filter are good voltage regulation and low rectifier-tube peak current; for a given transformer voltage the output voltage will be lower than from the condenser-input filter over most of the load range, however. The choke-input filter is the only type whose performance can be calculated accurately; there is no simple method of predetermining the performance of a condenser-input filter. The filter at *D* consists of two filters of the *C* type connected in series; this more elaborate arrangement is known as a two-section filter and is used to obtain greater smoothing than can be gotten economically with the single-section filter. Because of the many advantages of choke-input filters, they will be given detailed consideration in this chapter.

Designing the Plate Supply

There are two ways to go about building a plate supply. One is the hit-or-miss method, in which the amateur procures a transformer which has an output voltage somewhere near the d.c. plate voltage desired and proceeds to add a rectifier and such filter as he can afford, hoping that the smoothing will be good enough and the output voltage not too far from expectations. The other method is that in which the d.c. plate voltage, load current and permissible ripple voltage are first decided upon, and, working from this point, the correct ratings for all parts of the plate supply system are accurately determined by calculation. Needless to say, the latter method is more likely to be productive of good results than the former.

As suggested before, the ripple voltage tolerable in the output of the power supply will depend upon the type of service. We can take .25% or less as standard for radiotelephony. The percent. ripple allowable for c.w. telegraphy will, however, depend upon the design of the transmitter itself. If the dynamic stability of the transmitter is high — that is, if changes in plate voltage cause no noticeable change in the transmitter frequency — a larger ripple voltage can be tolerated without seriously affecting the tone of the transmitter than would be the case with transmitters in which a small change in plate voltage produces an audible change in frequency. As a working rule, we can say that the plate supplies for all oscillators — and especially self-controlled oscillators — should have not more than 1% ripple in the d.c. output. Since filter apparatus for low-power stages — oscillators and buffers in almost all transmitters are low-power — is inexpensive, plate supplies for all low-power stages should conform to the rule of not

more than 1% ripple. For amplifier stages in which frequency modulation is not a factor, the figure of 5% or less ripple will be satisfactory for c.w. telegraphy.

To illustrate the method of designing a plate supply, let us go through a specific problem. Suppose that two 203-A tubes are to be supplied 1000 volts at 350 milliamperes; the tubes are to be used in the final amplifier stage of a crystal-controlled transmitter and a ripple of 5% or less will be satisfactory. As a rough working rule, it can be assumed that for ripple percentages of this order a single section filter such as that in Fig. 1004-C will represent the most economical design; for 1% or less ripple two sections, Fig. 1004-D, should be used. For our particular problem, then, a single-section filter will suffice. The percent. ripple will depend upon the product of the choke inductance and condenser capacity; the following formula gives the ripple percentage directly:

$$\% \text{ ripple} = \frac{100}{LC}$$

where L is in henrys and C in microfarads. Transposing, we find that the product of LC must be 20 or more to result in 5% or less ripple.

The most economical filter design will be that in which choke cost is balanced against filter-condenser cost to give the required total of inductance and capacity. There are other considerations, however, which must be taken into account before the constants of the filter can be determined upon. These have to do with the functions of the input choke in the filter system.

The Input Choke

Upon the input choke falls the burden of improving voltage regulation and reducing rectifier peak current as well as contributing to the smoothing. The inductance required in the input choke to maintain a constant output voltage and a reasonably-low peak current depends upon the load to be placed on the power-supply system; i. e., the amount of current to be drawn. The load on the system can be expressed in ohms, and is equal to the output voltage divided by the total load current in amperes. The optimum value of input-choke inductance is equal to

$$L_{opt.} = \frac{\text{Full-load resistance in ohms}}{500}$$

With an input choke having optimum inductance, the rectifier peak current will not exceed the d.c. output current by more than 10%; in other words, the current from the plate-supply system can approach 90% of the peak-current rating of one tube in the full-wave rectifier without danger to the tubes.

To maintain the output voltage at a constant value, it is necessary to have some load on the plate-supply system at all times. If there is no

load at all on the system, the filter condensers will charge up to the peak value of the rectified a.c. wave; the peak of this wave is approximately 1.4 times the r.m.s. or rated transformer voltage. To keep some load on the system at all times a bleeder resistor, R in Fig. 1004, is used. Since it is desirable to keep down the amount of power dissipated in the bleeder, a fairly high resistance is ordinarily used; usual practice is to make the bleeder take 10% or less of the full load current. The bleeder resistance will therefore be much higher than the resistance of the total load, which includes the load represented by the transmitting tubes and that of the bleeder itself. The critical value of input choke inductance which will prevent the d.c. output voltage from rising to the peak of the rectified wave is equal to

$$L_{crit.} = \frac{\text{Resistance of bleeder in ohms}}{1000}$$

With this value of input choke the rectifier-tube peak current will be greater than with optimum choke inductance, but with only the bleeder as a load the current will be low and no harm will be done to the tubes.

Since the no load-current (bleeder only) will usually be only one-tenth the full-load current, it is evident that these two formulas will give widely-different values for input choke inductance; in fact, the critical value of inductance will be about five times that of the optimum value. It should be pointed out that both these values represent the *minimum* input choke inductance that should be used; some improvement will result if the inductance is increased, although the improvement will be slight in comparison to the extra cost. A choke having the critical inductance value can therefore be used with entirely satisfactory results, but it is more economical to use a "swinging" choke whose inductance varies from the critical value at no load to the optimum value at full load; such chokes are available from manufacturers.

Returning now to the specific problem in hand, it will be found after consultation of manufacturers' catalogs that swinging chokes capable of carrying the desired load current can be obtained with an inductance swing of 5 to 25 henrys. Based on the critical value of 25 henrys, the bleeder resistance should be 25×1000 , or 25,000 ohms; the bleeder therefore will take 25 milliamperes. The power dissipated in the bleeder will be $1000 \times .025$, or 25 watts; a resistor having this or larger power-dissipation rating should be used. The full-load inductance value of 5 henrys should be used in the calculation for percent ripple. We have previously determined that the product of inductance and capacity must be at least 20 for 5% or less ripple, so that the required condenser capacity will be $20/5$, or 4 microfarads. A greater capacity will give a correspondingly smaller ripple voltage.

After the size of the filter condenser and choke have been determined, it is necessary to ascertain whether the particular combination chosen will be such as to resonate at or near the ripple frequency. If the combination should through accident be resonant, the operation of the plate supply system is likely to be unstable and the smoothing will be impaired. The resonance frequency will be equal to

$$f_{res.} = \frac{159}{\sqrt{LC}}$$

where L is in henrys and C in microfarads, and should be well below the supply-line frequency. In our example, the resonance frequency by the formula above is approximately 35 cycles, so the filter design is satisfactory from this standpoint.

Calculating the Required Transformer Voltage

After the filter has been decided upon, the next step in the design of the power supply system is to select suitable rectifier tubes and determine the necessary ratings of the power transformer. For a plate supply of the type we have been considering, the logical rectifier tube is the 866; a pair of them can be used in the center-tap circuit, or four of them can be connected in bridge. Since the voltage is well below the inverse peak ratings of the tubes, it is probably more economical to use the center-tap circuit. The transformer must be capable of handling the same amount of power with either type of rectifier, so that the cost of the power transformer will not be a deciding factor in the choice of the rectifier circuit. Assuming that the center-tap circuit is to be used, we are now ready to determine the secondary voltage required to ensure having 1000 volts at the power supply terminals under full-load current.

To find the secondary voltage needed, the voltage drops in the system at full-load current must be calculated. To do this it is necessary to know the resistance of the filter choke. The type of choke we have been considering probably will have a resistance of about 50 ohms; the voltage drop in it at full load will therefore be $50 \times .375$, or approximately 18 volts. There will be an additional drop in the rectifier tubes; we have only to consider one tube, however, since only one works at a time. This drop is approximately 15 volts. The total is therefore 33 volts, which added to 1000 gives 1033 volts as the average value of the a.c. voltage from one side of the transformer secondary. Transformers are rated in effective or r.m.s. voltages, however, so to find the required voltage in r.m.s. values it is necessary to divide the average value by .9. The required secondary voltage therefore will be $1033/.9$ or 1150 volts. The general formula for determining transformer voltage is

$$\text{Sec. } E_{rms} = \frac{E_o + IR_o + E_t}{.9}$$

where E_o is the d.c. output voltage of the power supply, I is the full-load current, including the bleeder current, R_c is the resistance of the choke or chokes in the filter, and E_t is the voltage drop in one rectifier tube in the center-tap circuit, or the sum of the drops of two tubes in the bridge circuit.

If the design principles given in the preceding discussion have been followed through, the required secondary volt-amperes will be

$$\text{Sec. VA} = \text{Total } E_{rms} \times I \times .75$$

where I is the d.c. output current, and E_{rms} is the total secondary voltage (both sides of center-tap). In our illustration, the secondary VA capacity required therefore will be $2300 \times .375 \times .75$, or 650 VA. The actual watts drawn from the transformer will be less than this figure, but a somewhat higher VA capacity is required because the rectifier-filter system distorts the secondary-voltage wave-form, and it is necessary to take this into account in computing the heating effect of the current in the secondary winding. Because the heating effect is greater than in ordinary transformer applications, additional VA capacity must be built into the transformer.

In purchasing a transformer, it should be borne in mind that standard designs do not always fit exactly an individual problem. It therefore becomes necessary to select a transformer with ratings which fit the desired ones as closely as possible.

Greater Smoothing

In the specific design problem just used as an illustration, the permissible ripple voltage was assumed to be 5%. As we have pointed out previously, this will be satisfactory when the plate supply is to be used on the amplifier stages of an oscillator-amplifier transmitter used exclusively for c.w., but the ripple voltage must be smaller for self-controlled transmitters and radio-telephone sets. The most satisfactory way to get the additional smoothing is to use the two-section filter shown at Fig. 1004-D. The percent. ripple for a two-section filter is found by the following formula:

$$\% \text{ Ripple} = \frac{650}{L_1 L_2 (C_1 + C_2)^2}$$

For 1% ripple, satisfactory for oscillators, the numerical value of the denominator must therefore be at least 650; for .25% ripple, satisfactory for radiotelephony, the denominator must be at least 2600. The ripple in the power supply design previously discussed can be reduced considerably simply by the addition of a smoothing choke (not the swinging type) having an inductance of about 8 henrys, and a second 4- μ fd. condenser at the filter output terminals. Substituting these values in the formula above will give a ripple of approximately .25%. The two-section filter will

have better voltage regulation and will require less inductance and capacity than a single-section filter having equivalent smoothing. The voltage drop in the second choke should be included in the calculation for determining the required transformer secondary voltage. If the design data given above is followed carefully, the voltage regulation of the power supply will be less than 10% — a very good figure.

Condenser-Input Filters

The great advantages of the choke-input filter in reducing rectifier-tube peak current and in making possible good voltage regulation have been pointed out in the preceding discussion. These two points are of utmost importance in high-voltage plate-supply systems. The life of the rectifier tube is determined by the peak current it has to pass, while poor voltage regulation makes it necessary to buy filter condensers rated for the maximum voltage that is likely to appear across the condenser terminals. The cost of filter condensers goes up at a rapid rate as the voltage increases.

For low-voltage plate supplies — 500 volts or less — these considerations are of less economic importance. The smaller rectifier tubes, besides being inexpensive, are rated to work into either choke- or condenser-input filters; low-voltage filter condensers also are inexpensive. Plate supplies for low-power transmitters are often built around a power transformer of fixed design (transformers giving 350 and 550 volts each side of the center-tap are legion) and in such cases the requisite smoothing is often obtained most economically by using a condenser-input filter. No simple formulas are available for computing the percent. ripple with a condenser-input filter, but experience has shown that a filter of the type shown in Fig. 1004-B will have excellent smoothing if each condenser is 2 to 8 μ fd. and if the choke has an inductance (commercial rating) of 20 to 30 henrys. With the condenser-input filter, the d.c. output voltage tends to be greater than the r.m.s. output voltage of the transformer secondary; at very light loads the output voltage will be approximately 1.4 times the secondary voltage (approaching the peak value of the rectified a.c. wave) gradually decreasing with load until at the nominal output rating of the transformer the d.c. output voltage will be approximately equal to the secondary r.m.s. voltage. This characteristic is of value in low-power sets where the highest output voltage consistent with the power-supply apparatus used is wanted.

The large change in voltage with load represents poor voltage regulation and possibly may result in a chirpy signal from the low-power self-controlled oscillator. It has no such effect with the oscillator-amplifier transmitter, and therefore can be tolerated. The filter condensers, however, must be rated to stand continuously the

peak value of the voltage — 1.4 times the rated secondary voltage of the transformer. This means that the filter condensers for a 350-volt transformer must be rated at at least 500 volts; those for a 550-volt transformer at at least 800 volts. With condenser-input filters the chief function of the bleeder resistor is to discharge the filter condensers when the power is turned off and thus prevent accidental shocks, because filter condensers will hold a charge for a long while. A resistor of 15,000 to 30,000 ohms is customary for low-voltage plate supplies, the higher resistances being used for the higher voltages.

25- and 50-Cycle Supply

The filter design data just given is, as previously mentioned, applicable only to full-wave rectifiers working from a 60-cycle supply line. For lower frequencies, both inductance and capacity must be increased in proportion to the decrease in frequency to maintain the same reduction in ripple. After following through the design for 60 cycles, the inductance and capacity values obtained should both be multiplied by 2.4 to obtain the values necessary for 25 cycles; for 50 cycles the multiplying factor is 1.2. In practice, the 60-cycle design usually will be found to be adequate for 50 cycles as well.

Filter Chokes

The purchase of a filter choke can be a hazardous business unless the choke is obtained from a reputable manufacturer. The difficulty in the past has been that apparently no two manufacturers have used the same method of rating their chokes. The inductance of a choke will vary with the current through it and with the value of the ripple voltage impressed on it in the practical filter; inductance decreases with increasing direct current and with decreasing ripple voltage. In purchasing a choke information should be obtained as to its actual smoothing inductance at full d.c. load current and at the ripple voltage at which it is to work. The latter requirement can be expressed more simply by determining whether the choke is to be used as an input choke or as a smoothing choke (second choke) in a two-section filter. Input chokes usually are of the swinging variety.

Most of the small chokes obtainable from radio dealers are given a commercial rating of 20 or 30 henrys. This rating is meaningless unless the conditions under which the choke's inductance was measured are stated. Fortunately the smaller chokes are inexpensive and usually have enough inductance to work quite well in condenser-input filters; it is better, however, to buy a choke of good make than to trust to luck with a cheap, but unknown, product.

Filter chokes for high voltages should in every case be purchased from a reputable manufacturer. It must be realized that the design formulas given

previously are based on *actual* inductance under load conditions; an over-rated choke will nullify the calculations and probably lead to an entirely different order of performance.

Specifications for building chokes at home are given in a table at the end of this chapter. The design data apply particularly to smoothing chokes; if a choke having an inductance equal to the critical value is chosen for the input choke the results will be satisfactory, although such a choke will not be as economical of materials as a properly-designed swinging choke. The design of swinging chokes to fulfill predetermined conditions is a difficult problem and is beyond the scope of this *Handbook*.

A filter choke should be made with an air-gap in the core to prevent magnetic saturation of the iron at the rated d.c. current. The size of the air-gap is extremely important if the choke is to have high inductance at full-load current. Careful attention should be paid to the air-gap if chokes are to be built according to specifications in the table at the end of the chapter.

Filter Condensers

Two types of filter condensers are commonly available: electrolytic condensers, and condensers using paper as the dielectric. In electrolytic condensers, the dielectric is an extremely thin film of oxide which forms on aluminum foil when the foil is immersed in a suitable electrolyte and is subjected to a d.c. voltage of the proper polarity. Electrolytic condensers are characterized by high capacity for a given size and cost, but cannot be made in single units for very high voltages, 500 volts being about the limit under present conditions. Electrolytic condensers are made in two types, "wet" and "dry." The "wet" condensers are provided with a liquid electrolyte in a sealed container; in the "dry" type the electrolyte is mixed with a filler to form a paste which is then placed between strips of aluminum foil. In neither type is the dielectric a perfect insulator; there is always an appreciable current flow between the electrodes, although it is only of the order of a few milliamperes. This leakage current is greater with the wet than with the dry types; the wet condensers, however, can stand voltage overloads better than the dry types because excessive voltage will simply increase the leakage current. Excessive voltage applied to the dry type will result in a "blown" condenser which must be replaced. Either type of electrolytic condenser will be satisfactory for condenser-input filters used with transformers delivering 350 volts each side of the center tap. Electrolytic condensers can be obtained in various capacities; 8 μ fd. is a popular size.

If the maximum voltage of the power supply is greater than the rating of a single electrolytic condenser, two or more units may be placed in series to handle the higher voltage. When con-

densers are connected in series all the units of the string should have the same capacity so the voltage will divide equally between them. As a further assurance that each condenser in the string will take a proportionate share of the voltage, resistors may be connected across the individual units as shown in Fig. 1005. Each of the resistors should be 500,000 ohms, and should be rated to dissipate one or two watts.

Electrolytic condensers are suitable for use only in d.c. circuits, and must be connected correctly. In the types having a metal container, the container usually is the negative terminal while the stud terminal is positive. In any event the polarities are always plainly marked. Reversing the polarity will ruin the condenser.

If electrolytic condensers are allowed to stand idle for a time, the dielectric film will gradually disappear and the condenser must be "reformed." To prevent damage to the condensers and other power-supply components, the voltage always should be lowered before application to a power supply equipped with electrolytic condensers after it has been out of service for a few weeks. The film will re-form after a few minutes of low-voltage operation.

Paper condensers also are made in two types, with and without oil impregnation of the paper dielectric. The oil-impregnated condensers generally are suitable for higher voltages than the plain types. Condensers having a working-voltage rating equal to the highest output voltage of the power-supply system (see discussion on condenser-input filters) always should be purchased. Paper condensers can be purchased with voltage ratings up to 3000 volts and more. High-voltage condensers always should be purchased from reputable manufacturers; it does not pay to "economize" by buying a cheap high-voltage condenser. Although the first cost of a good condenser may be higher, it will last indefinitely if not abused. Poor condensers may work for a time, but eventually will "blow" and have to be replaced. Failure of a high-voltage condenser may also mean the destruction of the rectifier tubes.

The Filament Supply

The second division of the power supply for the transmitter is the supply to the filaments of the tubes used. Though batteries are sometimes used for this supply, alternating current obtained from the house current through a step-down transformer usually is more practical and more satisfactory. In some cases the filament-supply winding is wound over the core of the high-voltage transformer, thus eliminating the necessity for a separate filament transformer. This practice, however, is not always to be recommended. The filament supply must be constant if the transmitter is to operate effectively, and with both filament and high-voltage supplies coming from

one transformer this constancy is obtained only with great difficulty, since changes in the load taken from the high-voltage winding cause serious changes in the voltage obtained from the filament winding—unless the transformer is operating well under its rating or unless special compensating apparatus is employed. Wherever possible the high-voltage and filament transformers should be separate units operating, if it

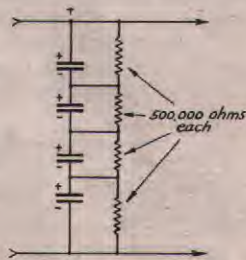

FIG. 1005 — HOW EQUALIZING RESISTORS ARE USED WITH FILTER CONDENSERS CONNECTED IN SERIES FOR HIGH VOLTAGES

can be arranged, from different power outlets, particularly with transmitters using tubes larger than the Type 10.

Examination of any of the power-supply circuits will make it obvious that the filaments of the rectifier tubes must be well insulated from the filaments of the oscillator tubes. The filaments of the rectifiers provide the positive output lead from the plate-supply system while the filaments of the transmitter tubes are connected to the negative side of the high-voltage supply. The fact that the two filament supplies must be insulated does not, however, mean that two transformers are required. The two windings can be on the same core, the necessary insulation being provided between them. Should the filament transformer be bought and should it have no windings suitable for the filaments of the rectifiers, an extra winding usually can be fitted without difficulty. For Type 66 rectifiers two No. 12 gauge wires in parallel should be used for the winding, the number of turns being determined by the "out and try" method. With most transformers only a few turns will be necessary to give the required voltage. The rectifier-filament winding can be center-tapped or a center-tapped resistor can be used across it in the manner described for the transmitter filaments. The center-tap is not an absolute necessity, however; the positive high-voltage lead can be taken from either side of the rectifier filament winding instead.

Practical Power Supplies

The wide varieties of rectifying and filtering equipment available to amateurs, together with the different classes of service for which power

supplies may be used, make it almost impossible for us to show complete constructional details of such equipment for any but the simplest of transmitters. The foregoing information should enable the amateur to choose the type of rectifier and filter best suited to his needs. As a guide in construction, however, Fig. 1006 shows a number of rectifier-filter combinations to give various output voltages and currents. All will give adequately-filtered direct current to the transmitting tubes, and in the cases where mercury-vapor rectifier tubes are shown the necessary protection is afforded them by the use of an input choke to the filter. In all circuits except that at C the volt-

age regulation will be good so that the voltage at no load will not be very much higher than at the load currents indicated. In these cases the filter condensers need be rated to stand only the voltage delivered by one-half of the high-voltage secondary; for example, a condenser with a working-voltage rating of 1250 volts d. c. will be ample for the 1000-volt power supply shown at D. This assumes, of course, that the bleeder resistance is used. Without this resistor, the condensers should be rated to stand 50% more voltage than half the secondary voltage of the transformer. In the arrangement at C the condensers should have the higher rating whether the bleeder is used or not.

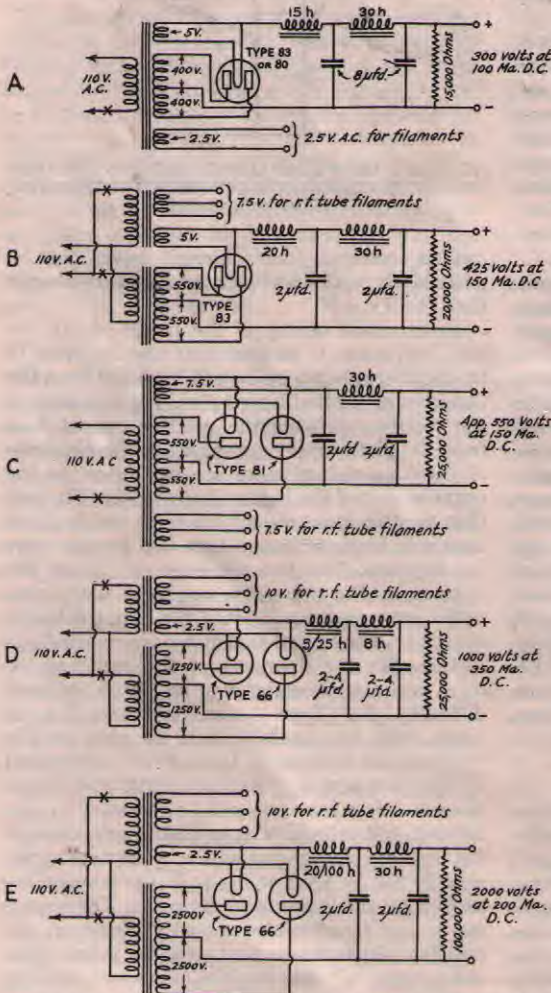

FIG. 1006 — REPRESENTATIVE POWER-SUPPLY ARRANGEMENTS FOR DIFFERENT TYPES OF TRANSMITTING TUBES

All these diagrams will give adequately-filtered d.c. output for the different classes of service. They are explained more fully in the text. Many other arrangements are possible. Control switches should be inserted in the transformer primaries at the points marked "X" to permit the filament supplies to be turned on before the plate supply.

The input choke may be omitted in diagram A even though the small mercury-vapor rectifiers are used because the tubes are built to stand working into a condenser-input filter. Should this be done, however, the filter condensers must be rated at 600 volts working, which means that electrolytic condensers cannot be used unless two of them are put in series to replace the single condensers shown. The condensers need not have 8 µfd. capacity each, but this is a standard size with electrolytic condensers and is recommended.

The rectifier-filter system at A will handle any of the small transmitters using receiving-type tubes shown in Chapter Seven. The ripple will be ¼% or less, depending upon how well the choke inductance holds up under load. Diagram B will take care of a pair of Type 10 tubes with ease; the ripple should be about the same as in A. The rectifier-filter at C does not use mercury-vapor rectifiers and hence can dispense with the input choke. Its output voltage will be variable between approximately 750 and 550 volts, however, depending upon the load current. It will be suitable for a pair of Type 10 tubes if it should be thought desirable to run them at more voltage than can be obtained with Diagram B. At D is shown a power supply for one or two tubes of the 203-A, 211 or 845 type. It is practically the same thing as the illustrative problem previously discussed. The arrangement at E is suitable for use with one or two 852 or 860 tubes. With the filter values shown the ripple will be .25% or less. Other combinations can be worked out without much difficulty. It is not absolutely necessary to follow the specifications in the filter section of the diagrams absolutely; for example 1-µfd. condensers or smaller chokes can be substituted in the filter of the high-power plate supply if the big tubes are amplifiers used for c.w. work in a crystal-controlled or oscillator-amplifier transmitter. For 'phone it is better to have as much filter as possible to keep the carrier free from hum.

In all these diagrams it is of course necessary to use power transformers of adequate capacity and chokes of high-enough current rating to carry the load currents indicated. In *D* and *E* the plate transformers should be rated at about 650 and 850 VA, respectively, to give the necessary output.

Fig. 1007 is a photograph of a power supply suitable for use with a low-power transmitter. Its circuit diagram, Fig. 1008, will be seen to be similar to *A* in Fig. 1006 with the exception of the fact that the input choke to the filter is omitted and that no bleeder resistance is used. The filter condensers are electrolytics having a capacity of 8 μ fd. each. The power transformer should deliver not more than 350 volts each side of the center tap to avoid damaging the condenser.

Electrolytic condensers have inherent leakage and the charge accumulated on them will dissi-

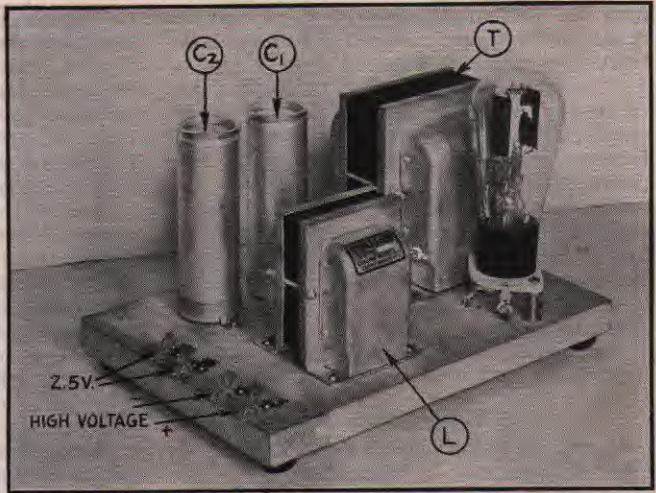

FIG. 1007 — A 350-VOLT POWER SUPPLY, OF INEXPENSIVE CONSTRUCTION, SUITABLE FOR THE LOW-POWER TRANSMITTER

the heat generated by them can be radiated into the surrounding air, and have all wires, particularly those carrying high voltage, well insulated. In other respects the layout can be made anything convenient.

A Duplex Plate Supply for the Medium-Power Transmitter

To illustrate one of the many modifications that can be made to straightforward power-supply design, a diagram of a two-voltage power supply suitable for operating a complete transmitter of medium power is given in Fig. 1009. Inexpensive Type 83 tubes are used in the bridge circuit to give a high voltage of 1000 volts; simultaneously one pair of the tubes acts as a center-tap rectifier in conjunction with the center-tap on the power transformer to furnish 500 volts for the low-power stages of the transmitter. A total of 250 milliamperes (or slightly more, since both filters have choke input) may be taken from the power supply without exceeding the rectifier-tube ratings; a representative current division would be 100 ma. for the small tubes and 150 ma. for the final

amplifier stage. Such a power supply will operate either the exciter unit and RK-18 amplifier or the three-tube transmitter described in the chapter on transmitters.

With the filter values indicated in Fig. 1009, the ripple in the 500-volt output will be less than .1% and in the 1000-volt output approximately .25%, so the power-supply will be well suited to use with the r.f. end of a 'phone transmitter. For c.w., the second filter section may be omitted

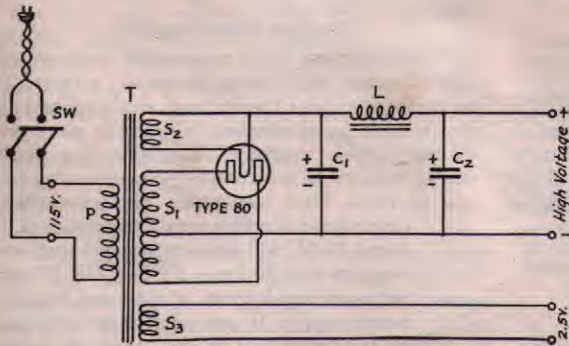

FIG. 1008 — WIRING DIAGRAM OF THE POWER SUPPLY SHOWN IN FIG. 1007

T — Power transformer; high-voltage winding, S_1 , 350 volts each side of center tap; rectifier filament windings, S_2 , 5 volts; transmitting-tube filament windings, S_3 , 2.5 volts. Transformers of this type are sold for broadcast-receiver purposes.

L — Filter choke, commercial inductance rating 20 to 30 henrys, current-carrying capacity 100 ma.

C₁, C₂ — 8- μ fd. electrolytic filter condensers rated at 500 volts peak.

pate itself in a short time, which is the reason why the bleeder can be dispensed with. If paper condensers are used a bleeder of about 20,000 to 30,000 ohms should be connected across the output of the filter. This power supply will deliver approximately 350 volts with a load of 100 milliamperes.

The location of parts in a power supply system is not of great importance. Make certain that the transformer and rectifier tubes are placed so that

from the 1000-volt section, in which case the ripple will be approximately 6%; increasing the remaining condenser capacity from 2 μ fd. to 4 μ fd. will bring the ripple down to 3%. It is best to use the two-section filter on the low-voltage output; the condensers and chokes are relatively inexpensive and low ripple is desirable on low-power stages.

An input choke having fixed inductance is recommended for the 500-volt output because the load on this section usually is continuous. If the load is to be variable, a swinging choke should be used, together with a bleeder of suitable value across the output. The bleeder may be used as a voltage divider to obtain still lower voltage—for instance, for a crystal oscillator.

Voltage Dividers

In addition to the voltages shown in Fig. 1006, lower voltages may be taken from any of the power supplies diagrammed by using the bleeder resistor as a *voltage divider*. If the resistor is tapped at some point the voltage appearing between the negative side of the power supply and the tap will be proportional to the position of the tap. Thus in *D* if the 25,000-ohm resistor is tapped at 10,000 ohms from the negative side the voltage between the negative post and the tap will be

$$\frac{10,000}{25,000} \times 1000 \text{ volts} = 400 \text{ volts.}$$

This is true, however, only when no current is taken from the tap, because when current is drawn there will be an additional voltage drop in the part of the resistor between the tap and the positive terminal which will make the voltage at

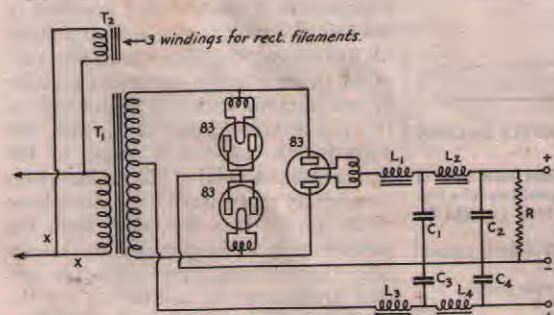

FIG. 1009—A DUPLEX PLATE SUPPLY CIRCUIT

This plate supply will deliver 500 and 1000 volts at a total of 250 milliamperes (sum of currents from both taps).

T_1 —Power Transformer, 600 volts each side center tap; 350 VA.

T_2 —Rectifier filament transformer, three 5-volt 3-amp. windings.

C_1 —2 μ fd., 1250-volt rating.

C_2 —4 μ fd., 1250-volt rating.

C_3, C_4 —2 μ fd., 800-volt rating.

L_1 —Swinging choke, 8/40 henrys, 275 ma.

L_2 —Smoothing choke, 12 henrys, 275 ma.

L_3, L_4 —10 henrys, 200 ma.

R —40,000 ohms, 25-watt rating.

the tap lower. To get the tap at the right place under load conditions it is necessary to know the current that will be drawn at the low voltage required. This current can be added to the normal bleeder current and the resistance required between the positive terminal and the tap for the desired voltage drop can be determined. For example, to get 400 volts at 50 ma. from *D*, the 50 ma. load should be added to the normal bleeder current, 40 ma., making a total of 90 ma. to flow through that part of the resistor between the positive terminal and the tap. The drop required is 600 volts, so the resistance between the positive terminal and the tap should be

$$\frac{600}{.09} = 6700 \text{ ohms, approximately.}$$

This method of calculation is not entirely accurate because the current through the lower part of the bleeder will not remain 40 milliamperes when current is drawn from the tap, and the actual voltage will be somewhat higher than calculated. Slightly more resistance between the positive terminal and the tap can be used to compensate for this effect. If the tap voltage must be accurately set it is better to use a variable resistor or one with a large number of taps so the proper one can be chosen.

Receiver Power Supplies

Power supplies for a.c.-operated receivers do not differ materially from those used with transmitters except that the voltages are lower and all ripple must be eliminated. Nothing is more annoying than a "hummy" B supply. The ripple can be reduced to satisfactory proportions by the use of three filter condensers (a three-section electrolytic condenser with capacities of 2, 4 and 8 μ fd. will be satisfactory) and two receiver-type 30-henry chokes. Fig. 1010-A is the wiring diagram of a typical receiver power supply. It uses a power transformer, of the type used in broadcast receivers, delivering approximately 350 volts each side of the center-tap on the high-voltage winding. This type of power supply will take care of an ordinary amateur receiver and in addition will easily handle an audio power amplifier stage using a 47 pentode or a pair of 45's in push-pull. The output voltage will be rather higher than is required for the receiver itself, however, so the filter may be rearranged somewhat to use choke input, which will reduce the voltage and give better regulation. This is shown in Fig. 1010-B.

Special care must be taken with power packs for autodyne receivers to make certain that the voltage output will be constant and that "tunable hums" do not appear. A varying output voltage will make the detector oscillation frequency change and hence make signals sound

wavering and unsteady. The choke-input filter of Fig. 1010-B is recommended on this score; it will be especially valuable if the receiver volume control operates on the bias on the r.f. amplifiers. Tunable hums are hums which appear only at certain frequencies to which the receiver is set and only with the detector oscillating. It may be that no hum can be heard with the detector out of oscillation but a strong hum is noticed as soon as the detector is made to oscillate. This is a tunable hum and cannot be eliminated by the addition of more filter condensers or chokes since it is caused by r.f. getting into the power supply and picking up modulation. Small condensers connected across the plates and filament of the rectifier tube as shown in both diagrams usually will eliminate this type of hum. A grounded electrostatic shield between the primary and secondaries of the power transformer also will help. Not all transformers have such a shield, however. Of course the power leads coming from the receiver itself should be well by-passed to prevent r.f. from getting into the power supply.

For some applications where the current to be taken from the power supply is not more than a few milliamperes — a separate power supply for a frequency meter, for example — resistors can be substituted for the filter chokes to make a compact power supply. Resistors of 10,000 to 50,000 ohms should be satisfactory, depending upon the voltage drop that is permissible. With a midget power transformer and a low-voltage high-capacity electrolytic condenser, together with one of the smaller rectifier tubes listed in the table, a physically small but adequate power supply can be built.

Vibrator-Transformers

The increasing use of automobile radio receivers has brought about a revival of the "buzzer" type of transformer to obtain power at a voltage suitable for the plates of tubes from a low-voltage d.c. source such as a storage battery. In its modern form the vibrator-transformer consists of a specially-designed transformer combined with a vibrating interrupter; when the unit is connected

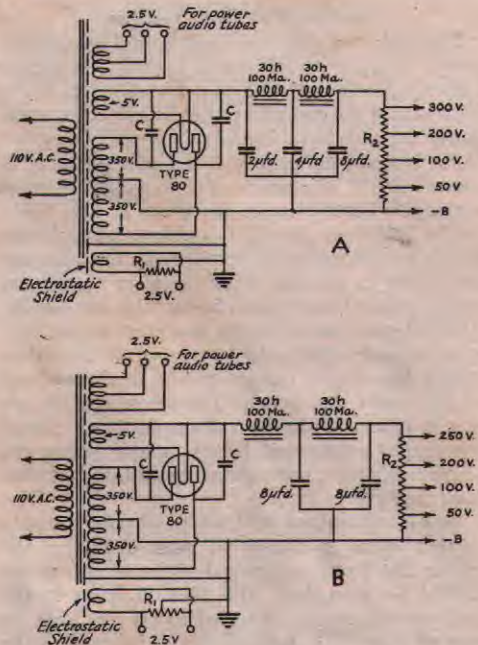
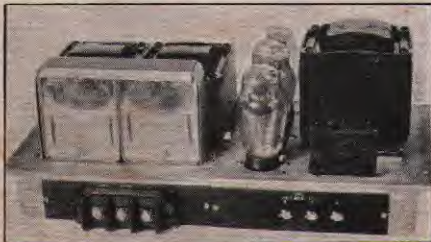

FIG. 1010—WIRING DIAGRAMS FOR RECEIVER POWER SUPPLIES

Condenser C should be a mica condenser of about .002 μf . capacity, its size is not critical and it will be required only if tunable hums are present, as explained in the text. Resistor R_1 is 20 ohms total, tapped at the center. R_2 is the voltage divider for obtaining different voltages from the power supply. If the receiver itself is equipped with a divider (the preferable method) R_2 will be a simple bleeder of about 15,000 ohms. Otherwise it may be any of the regular voltage dividers sold commercially for this use, or may be a 15,000 ohm resistor tapped at every 3000 ohms. The resistance needed between taps will depend upon the currents to be drawn at each of the taps. It is not usually necessary to have the voltages nearer rated values than within 20%, with modern receiving tubes.

to a 6-volt battery the circuit is made and broken rapidly by the vibrator contacts and the pulsating d.c. which flows in the primary of the transformer causes an alternating voltage to be developed in the secondary. The transformer is usually so designed that the direct-current output of the plate supply unit, after having been rectified and filtered, is in the vicinity of 200 volts. Rectifier tube types 1, 1-V, and 84 are commonly used in this type of plate supply.

Power supplies of this type can be obtained at reasonable cost and will be suitable for transmitters of very low power. Amateurs who have no a.c. have occasionally built higher-voltage power supplies operating on the same principle. A system using 6-volt batteries and Ford spark coils was described in the June, 1932, issue of *QST*. A home-made transformer for use with 32-volt farm-lighting plants was described in the June, 1933, issue.



A COMMERCIAL PLATE POWER SUPPLY

using the duplex circuit of Fig. 1009, although without the filter on the low-voltage section. It is rated at 1000 and 500 volts at a total output current of 250 ma. This plate supply is a product of the Delta Manufacturing Company.

Transformerless Plate Supplies

The 25Z5 rectifier tube can be used in receiver power supplies which work directly from the 110-volt power line without a transformer. Aside from saving the cost of a power transformer, such power supplies have few advantages for amateur work, but will do quite well if a power supply is needed in an emergency and no transformer is available. Three circuits are given in Fig. 1011. In the half-wave circuit, the plates and cathodes of the two independent rectifiers in the tube are connected in parallel; with the filter shown the ripple will be inaudible on 50- or 60-cycle supply. The full-wave circuit shows how a bridge rectifier can be made with only two tubes. With either circuit the output voltage will be in the vicinity of 135 volts d.c. provided the receiver has no power tubes. With the voltage-doubling circuit the output voltage will be 200 or more under the same conditions; the voltage regulation is rather poor, however.

One disadvantage of this type of power supply is that there is danger of short-circuiting the power line if either terminal of the power supply should be grounded. The 25-watt lamp in the half-wave circuit is intended to prevent this. In any case no direct ground should be used on the receiver; the ground connection should be made

through a mica condenser having a capacity of about .002 μ fd.

Tunable hums can be eliminated by the same methods used with the other receiver power supplies described.

Building Small Transformers

Power transformers for both filament heating and plate supply for all the transmitting and rectifying tubes used by amateurs are available commercially at reasonable prices, but occasionally the amateur wishes to build a transformer for some special purpose or has a core from a burned out transformer on which he wishes to put new windings.

Most transformers that amateurs build are for use on 110-volt 60-cycle supply. The number of turns necessary on the 110-volt winding depends on the kind of iron used in the core and on the cross-sectional area of the core. Silicon steel is best, and a flux density of about 50,000 lines per square inch can be used. This is the basis of the table of cross-sections given.

The size wire used depends on the current expected. This will vary with the load on the transformer. A circular mil is the area of the cross-section of a wire one thousandth of an inch in diameter. When a small transformer is built to handle a continuous load, the copper wire in the windings should have an area of 1500 circular mils for each ampere to be carried. (See Wire Table in Appendix.) For intermittent use, 1000 circular mils per ampere is permissible.

The transformer uses a little energy to supply losses in the core and windings. Because of the resistance of the windings and the magnetic leakage paths, the voltage of the secondary may drop materially under load. In filament-heating and plate-supply transformers we can arrange the windings compactly, make good solid joints in the core, use large low-resistance wire in the windings, and keep the length of the magnetic path fairly short and of good cross-section. This will keep the secondary voltage nearly constant under load.

A table is given showing the best size wire and core to use for particular transformers. The figures in the table refer to 60-cycle transformers. The design of 25-cycle transformers is similar but a slightly higher flux density is permissible. Because the frequency is much lower the cross-sectional area of the iron must be greater (or the number of turns per volt correspondingly larger). Otherwise the inductance of a certain number of turns will be too low to give the required "reactance" at the reduced frequency. If one builds the core so that its cross-section is 2.1 to 2.2 times the value of area worked out from the table, the same number turns of wire may be used in a primary coil for 25-cycle operation. If the same core and more turns of wire are used a larger "window" will be needed for the extra wire and

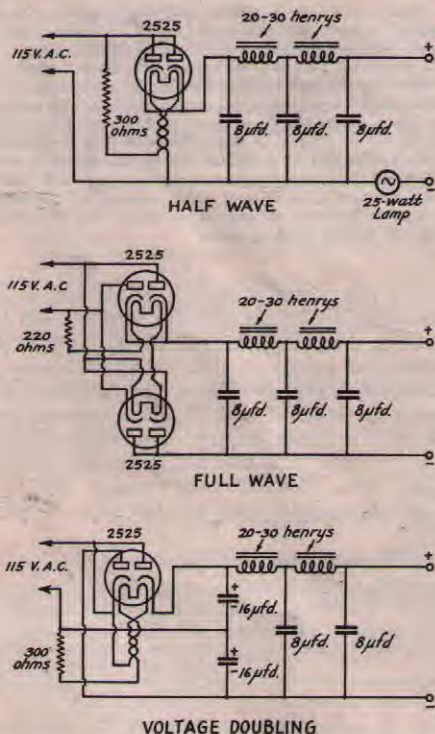

FIG. 1011 — CIRCUITS FOR TRANSFORMERLESS PLATE SUPPLIES FOR RECEIVERS

insulation. Increasing both the number of turns per volt and the cross-section of the core gives the best-balanced design.

Most 60-cycle transformers will behave nicely on a 25-cycle supply if the applied voltage is sufficiently reduced. Up to 52 volts at 25 cycles may be applied to a 110-volt 60-cycle winding without harm. Knowing the transformer voltage ratio, the output voltage will be known. The current-

to try a different value for the length of the winding, figuring the size of the window all over again. A transformer with a large core and a relatively small amount of wire is best from the standpoint of the amateur builder because wire in smaller sizes is expensive while transformer iron is cheap. It is hard for most amateurs to wind many turns by hand unless a convenient winding jig is available.

Input (Watts)	Full-load Efficiency	Size of Primary Wire	No. of Primary Turns	Turns Per Volt	Cross-Section Through Core
50	75%	23	528	4.80	1 $\frac{1}{4}$ "x1 $\frac{1}{4}$ "
75	85%	21	437	3.95	1 $\frac{3}{8}$ "x1 $\frac{3}{8}$ "
100	90%	20	367	3.33	1 $\frac{1}{2}$ "x1 $\frac{1}{2}$ "
150	90%	18	313	2.84	1 $\frac{5}{8}$ "x1 $\frac{5}{8}$ "
200	90%	17	270	2.45	1 $\frac{3}{4}$ "x1 $\frac{3}{4}$ "
250	90%	16	248	2.25	1 $\frac{7}{8}$ "x1 $\frac{7}{8}$ "
300	90%	15	248	2.25	1 $\frac{7}{8}$ "x1 $\frac{7}{8}$ "
400	90%	14	206	1.87	2"x2"
500	95%	13	183	1.66	2 $\frac{1}{8}$ "x2 $\frac{1}{8}$ "
750	95%	11	146	1.33	2 $\frac{3}{8}$ "x2 $\frac{3}{8}$ "
1000	95%	10	132	1.20	2 $\frac{1}{2}$ "x2 $\frac{1}{2}$ "
1500	95%	9	109	.99	2 $\frac{3}{4}$ "x2 $\frac{3}{4}$ "

carrying capacity will be the same as at 60 cycles. The KVA (kilovolt-ampere) rating will be about half the 60-cycle value.

Before going ahead with the construction it is necessary to figure out the opening or window size that will be necessary in the core to just get the windings on without wasting any space. The best thing to do is to decide on a tentative length of winding, making a full-size drawing of the transformer on a sheet of paper. From the wire table find out how many turns of wire per layer can be put in the primary winding. Leave at least $\frac{1}{4}$ " between the end of the winding and the adjacent leg of the core. Divide the total number of turns that will be needed in the winding by the number of turns per layer to find out how many layers will be needed. The depth of the winding can next be ascertained. Be sure to allow $\frac{1}{8}$ " between the core and the inside layer of wire for insulation. Allow for insulation between layers if there is to be any, too. Having finished these computations, draw in the outline of the winding, just as it will look when finished. The depth of the secondary winding can be figured in the same way, using the same length of winding as in the primary. If enameled wire is used, allow for a layer of thin paper between each layer of wire. Although enamel-insulated wire has the best space factor, single-cotton-covered enamel is best to use. Double-cotton covered wire can be used but is not so economical of space.

When the depth of both primary and secondary windings has been computed, their sum plus $\frac{1}{4}$ " (for a factor of safety) will give the width of the window in the core. If the drawing begins to look like *D* instead of *E*, Fig. 1012, it will be necessary

After a little juggling with pencil and paper, the design of the transformer will be complete. The next step will be to obtain the materials and start the process of construction.

Any kind of transformer iron or silicon steel will make a good core. Sometimes an old power transformer from the local junk yard or from the electric light company can be torn down to get good and cheap core materials. It is not worth while to try to cut out core materials yourself or to use ordinary stove-pipe iron, as it will not lie flat. Laminations of about 28-gauge thickness should be used, as thicker iron pieces will give a large loss from eddy currents in the core and the heating will be objectionable. The iron must be carefully cut so that good joints can be made if the transformer is to have passably good regulation. L-shaped laminations are convenient to use in building a transformer but separate pieces for the four sides can be used if they are more readily obtained. The method of assembling a core is shown in Fig. 1013. Three sides can be built up, the windings put on, and then the fourth leg put in place, one lamination at a time. All laminations should be insulated from each other to prevent eddy currents from flowing. If there is iron rust or a scale on the core material, that will serve the purpose very well — otherwise one side of each piece can be coated with thin shellac. It is essential that the joints in the core be well made and be square and even. After the transformer is assembled, the joints can be hammered up tight using a block of wood between the hammer and the core to prevent damaging the laminations. A cigar box with two adjacent sides knocked out and the cover removed will be helpful in building

up the core evenly. When three legs are completed, the whole can be tied with string, clamped in a vise, and the legs on which the windings are to be slipped wound with friction tape to hold them firmly in place and to keep the iron from damaging windings and insulation.

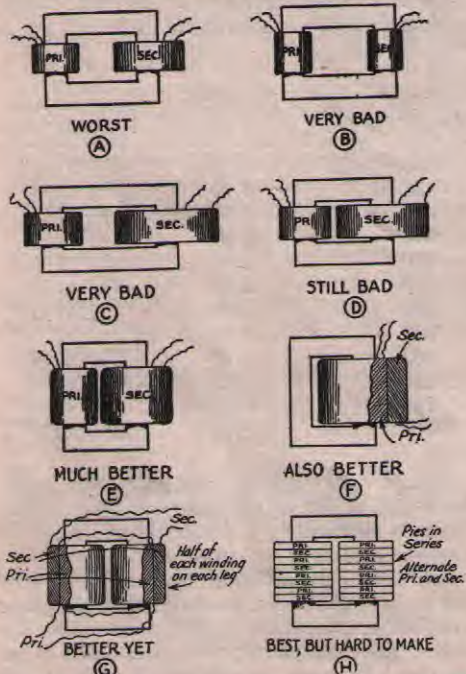

FIG. 1012 — HOW THE ARRANGEMENT OF THE CORE AND WINDINGS AFFECTS THE VOLTAGE REGULATION OF CORE-TYPE TRANSFORMERS

It is convenient to wind the coils on varnished cardboard. At any rate the coils should be wound on a wooden form and if some pliable cardboard can be put over this it will make it easy to slip the finished coils from the form to the core without mechanical injury. The wires cannot get out of place when so wound and they are well insulated from the core besides. The wooden block should be slightly larger than the leg of the core on which the winding is to be put and it should be a few inches longer than the winding. The block must be smooth and of just the right size. Several pieces fastened with small screws at the ends will make a form which can be easily taken apart when the winding is finished.

The winding itself is quite simple. The wire is wound on in layers as it takes least space when wound that way. Strips of paper between layers of small enameled wire are necessary to keep each layer even and to give added insulation. Thick paper must be avoided as it keeps in the heat generated in the winding so that the temperature may become dangerously high.

Transformers built by the amateur can be

painted with insulating varnish or waxed to make them rigid and moisture proof. A mixture of melted beeswax and rosin makes a good impregnating mixture. Melted paraffin should not be used because it has too low a melting point. Double-cotton-covered wire can be coated with shellac as each layer is put on. However, enameled wire should never be treated with shellac as it may dissolve the enamel and hurt the insulation, and it will not dry because the moisture in the shellac will not be absorbed by the insulation. Small transformers can be treated with battery-compound after they are wound and assembled.

Keep watch for shorted turns and layers. If just one turn should become shorted in the entire winding, the voltage set up in it would cause a heavy current to flow which would burn it up, making the whole transformer useless.

Taps can be taken off as the windings are made if it is desired to have a transformer giving several voltages. The more taps there are, the more difficult becomes the problem of avoiding weakened insulation at the points where they are made. Taps should be arranged whenever possible so that they come at the ends of the layers. If the wire of which the winding is made is very small, the ends of the winding and any taps that are made should be of heavier wire to provide stronger leads.

High-voltage coils should be taped with varnished cambric tape. Low-voltage coils can be taped with friction tape or with untreated cotton tape and varnished later. Always lay the tape on smoothly so that each turn advances half the width of the preceding one. Pull the tape tight but not so tight as to pull the winding out of shape.

The leads should be well insulated. High-voltage leads can be run through varnished cambric tubing or "spaghetti." Pieces of flat tubular shoe lacing are good enough to cover the low-voltage leads.

When slipping the coils on the partially-assembled core, be sure that the leads do not touch the

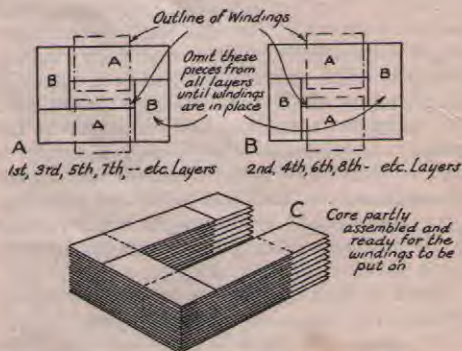

FIG. 1013 — HOW TO PUT A TRANSFORMER CORE TOGETHER

DESIGN DATA FOR INDUCTANCE COILS WITH IRON CORES. Weight of Steel taken as 480 $\frac{lbs}{cu.ft.} = 0.28$ pounds cubic inches

CORE SIZE	INDUCTANCE HENRYS	EQUIV GAP (G)	* ACTUAL GAP		NO TURNS (N)	FLUX DENS (B) Lines/inch	WINDING FORM			MEAN TURN INCHES	FEET OF WIRE (D.C.)	RESISTANCE COPPER	WEIGHT OF COPPER	CORE DIMENSIONS		POUNDS STEEL
			Decimals	Nearest Fraction			b	c	Long Piece					Short Piece		
1/2 x 1/2	0.5	.040"	.017"	1/64"	1600	6500	0.42"	0.28"	3.0	4.00	82.5	1.00Z	1/2 x 1.6"	1/2 x .50	0.30	
	1.0	.041	.019		2300	9000	0.50	0.33	3.2	6.15	127.0	1.5 "	1/2 x 1.7	1/2 x .55	0.31	
	5.0	.043	.023		5200	20000	0.75	0.50	3.8	1670	345.0	4.0 "	1/2 x 1.92	1/2 x .75	0.37	
	10.0	.046	.030	1/32"	7600	27000	0.90	0.60	4.2	2640	545.0	6.5 "	1/2 x 2.1	1/2 x .85	0.41	
	15.0	.048	.035		9500	32000	1.00	0.68	4.5	3510	725.0	8.5 "	1/2 x 2.2	1/2 x .85	0.43	
3/4 x 3/4	5.0	.043"	.023		3500	13000	0.62"	0.42"	4.5	1310	271	3.25oz	3/4 x 2.4	3/4 x .75	1.0	
	10.0	.046	.030		5000	18000	0.73	0.49	4.75	2000	411	5.0 "	3/4 x 2.5	3/4 x .75	1.0	
	15.0	.048	.035		6300	21000	0.82	0.55	5.0	2630	544	6.5 "	3/4 x 2.6	3/4 x .75	1.05	
	20.0	.052	.044	3/64"	7600	24000	0.91	0.60	5.2	3290	678	8.0 "	3/4 x 2.7	3/4 x .85	1.1	
	50.0	.070	.100	7/64"	14000	33000	1.25	0.83	6.0	7000	1445	1lb 1 "	3/4 x 3.0	3/4 x 1.0	1.25	
1 x 1	10.0	.046"	.030	1/32"	3800	14000	0.64"	0.43"	5.6	1760	364	4.25oz	1 x 3.0	1 x .75	2.1	
	15.0	.048	.035		4800	16000	0.69	0.49	5.8	2310	478	5.5 "	1 x 3.0	1 x .75	2.1	
	20.0	.052	.044	3/64"	5700	18000	0.78	0.52	5.9	2800	580	6.75 "	1 x 3.1	1 x .75	2.2	
	50.0	.070	.100	7/64"	11000	25000	1.10	0.75	6.7	6130	1270	15.0 "	1 x 3.5	1 x 1.0	2.5	
	100.0	.100	.250	1/4"	18000	29000	1.40	0.93	7.4	11000	2280	1lb 10 "	1 x 3.8	1 x 1.1	2.75	
2 x 2	100.0	.100"	.250	1/4"	8900	14000	0.97"	0.65"	10.4	7700	1590	1lb 3oz	2 x 5.5	2 x 1.0	14.5	
	1/2 x 1/2	0.5	.040"	.017	1/64"	1600	13000	0.55"	0.38"	3.4	4.50	46	2.2oz	1/2 x 1.6	1/2 x 0.63	0.31
		1.0	.041	.019		2300	18000	0.66	0.45	3.6	700	72	3.5 "	1/2 x 1.75	1/2 x 0.70	0.35
		5.0	.043	.023		5200	39000	1.00	0.68	4.5	1950	200	9.5 "	1/2 x 2.10	1/2 x 0.95	0.43
		3/4 x 3/4	1.0	.041"	.019		1500	12000	0.53"	0.37"	4.3	54.0	56	2.7oz	3/4 x 2.10	3/4 x 0.63
5.0			.043	.023		3500	26000	0.83	0.56	5.0	1470	151	7.2 "	3/4 x 2.5	3/4 x 0.80	1.05
10.0	.046		.030	1/32"	5000	35000	1.00	0.67	5.4	2250	230	11.0 "	3/4 x 2.6	3/4 x 0.95	1.12	
1 x 1	5.0	.043"	.023		2600	20000	0.71"	0.49"	5.8	1250	130	6.1oz	1 x 2.8	1 x 0.75	2.0	
	10.0	.046	.030	1/32"	3800	27000	0.86	0.58	6.1	1940	200	9.5 "	1 x 3.0	1 x 0.85	2.2	
	15.0	.048	.035		4800	32000	0.96	0.65	6.4	2550	260	12.5 "	1 x 3.1	1 x 0.90	2.25	
	2 x 2	10.0	.046"	.030	1/32"	1900	13000	0.60"	0.42"	9.5	1500	160	7.5oz	2 x 4.66	2 x 0.60	11.5
		15.0	.048	.035		2400	16000	0.68	0.46	9.7	1900	200	9.5 "	2 x 4.75	2 x 0.66	12.3
20.0		.052	.044	3/64"	2900	18000	0.75	0.51	9.8	2400	250	11.5 "	2 x 4.85	2 x 0.75	12.5	
100.0	50.0	.070	.100	7/64"	5300	24000	1.00	0.70	10.5	4600	480	1lb 8.5 "	2 x 5.50	2 x 0.95	14.0	
	100.0	.100	.250	1/4"	8900	28000	1.33	0.90	11.2	8300	860	2lb 8 "	2 x 5.90	2 x 1.15	16.0	
	1/2 x 1/2	0.5	.040"	.017	1/64"	1600	32000	0.90"	0.60"	4.2	550	22.5	7oz	1/2 x 2	1/2 x .85	0.40
1.0		.082	.120	1/8"	3200	32000	1.30	0.85	5.1	1350	55	1lb 1 "	1/2 x 2.5	1/2 x 1.10	0.50	
3/4 x 3/4		0.5	.040"	.017	1/64"	1000	21000	0.72"	0.46"	4.7	390	16	5oz	3/4 x 2.3	3/4 x 0.71	0.96
		1.0	.041	.019		1500	30000	0.90	0.58	5.1	640	26	8 "	3/4 x 2.5	3/4 x 0.83	1.05
		1 x 1	1.0	.041"	.019		1100	22000	0.75"	0.50"	5.8	530	22	6.5oz	1 x 2.9	1 x 0.75
5.0	.086		.170	1/64"	3700	35000	1.40	0.92	7.3	2260	92	1lb 12 "	1 x 3.6	1 x 1.20	2.7	
2 x 2	5.0		.043"	.023	1/8"	1300	23000	0.82"	0.53"	9.7	1050	43	13oz	2 x 4.9	2 x 0.80	12.7
	10.0	.050	.040	1/64"	2000	32000	1.05	0.68	10.5	1750	71	1lb 6 "	2 x 5.2	2 x 1.0	13.8	
	15.0	.056	.200	13/64"	3300	28000	1.35	0.86	11.1	3060	125	2 " 6 "	2 x 5.5	2 x 1.1	14.7	
20.0	10.0	.104	.280	9/32"	4000	32000	1.43	0.95	11.5	3820	156	2 " 15 "	2 x 5.6	2 x 1.2	15.2	
	3 x 3	10.0	.046"	.030		1300	22000	0.81"	0.53"	14.0	1510	62	1lb 3oz	3 x 6.9	3 x 0.8	39
		15.0	.048	.035		1600	26000	0.90	0.60	14.2	1900	77	1 " 7 "	3 x 7.0	3 x 0.85	40
		20.0	.052	.044	3/64"	1900	30000	1.00	0.65	14.4	2300	93	1 " 12 "	3 x 7.1	3 x 0.9	41
	50.0	10.0	.140	.330	1/2"	5000	28000	1.60	1.10	15.9	6600	270	5 " 2 "	3 x 7.8	3 x 1.35	46
100.0		.200	.600	19/32"	8400	34000	2.10	1.40	17.0	12000	485	9 " 3 "	3 x 8.3	3 x 1.65	50	
1/2 x 1/2	0.5	.016"	.35	11/32"	3200	32000	1.80"	1.20"	6.4	1700	35	2lb 10oz	1/2 x 3	1/2 x 1.45	0.62	
	3/4 x 3/4	0.5	.008"	.170	11/64"	1480	30000	1.25"	.83"	6.0	735	15	1lb 2oz	3/4 x 2.9	3/4 x 1.1	1.26
		1.0	.016	.35	11/32"	3000	30000	1.75	1.20	7.2	1800	37	2 " 13 "	3/4 x 3.5	3/4 x 1.5	1.6
		1 x 1	0.5	.004"	.02	1/64"	800	32000	0.90"	0.60"	6.2	410	8.5	0lb 10oz	1 x 3.0	1 x 0.85
	1.0		.008	.17	1/64"	1600	31000	1.30	0.85	7.1	945	19	1 " 8 "	1 x 3.5	1 x 1.0	2.5
5.0	.0387		.75	3/4"	7800	32000	2.90	1.90	11.0	7000	143	10 " 14 "	1 x 5.2	1 x 2.2	4.2	
2 x 2	1.0	.044"	.019		560	22000	0.75"	0.50"	9.8	460	9.4	0lb 12oz	2 x 4.9	2 x 0.75	12.7	
	5.0	.086	.17	1/64"	1800	32000	1.35	0.90	11.3	1700	35	2 " 10 "	2 x 5.5	2 x 1.15	15.0	
	10.0	.184	.40	13/32"	3800	33000	2.00	1.30	12.8	4100	83	6 " 6 "	2 x 6.2	2 x 1.5	17.3	
	3 x 3	5.0	.043"	.023		860	30000	1.00"	0.60"	14.2	1000	21	1lb 10oz	3 x 7.1	3 x 0.85	40.0
		10.0	.092	.20	13/64"	1840	31500	1.40	0.92	15.3	2350	48	3 " 10 "	3 x 7.5	3 x 1.15	43.5
15.0		.130	.30	19/64"	2620	32000	1.65	1.10	16.0	3500	71	5 " 7 "	3 x 7.8	3 x 1.4	46.0	
50.0	20.0	.175	.38	3/8"	3500	32000	1.90	1.25	16.6	4850	99	7 " 8 "	3 x 8.1	3 x 1.5	48.0	
	50.0	.432	.80	13/16"	8700	32000	3.00	2.00	19.2	14000	282	21 " 8 "	3 x 9.3	3 x 2.3	58.0	
	100.0	.900	1.50	1/2"	16700	31500	4.10	2.80	22.0	31000	620	47 " 5 "	3 x 10.5	3 x 3.1	68.0	

* The Actual Gap can only be an approximation owing to the many factors which may effect fringing of flux, permeability of core, etc. It must be adjusted by trial until the proper value of inductance is obtained or better yet, until the set up operates at the best point.
 ** The values of (B), the flux density, are those obtained with all D.C. & 60 A.C., or the effective B if all A.C. The maximum value in the latter case will be 1.4 x B as given. In the case of rectified A.C. applied to coil with no previous smoothing the maximum B may be 1.57 times the values given.

core. If the windings fit loosely some small wooden wedges should be driven in place at each end. Last of all, the other leg of the core is put in place and driven up tight. If the coils are wedged firmly and wound tightly and the core is taped, clamped or bolted between some strips of wood or bakelite, the transformer will not hum.

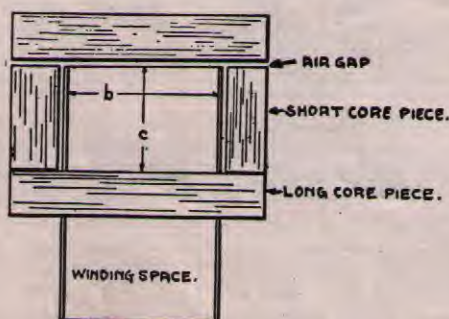

FIG. 1014 — CORE ARRANGEMENT FOR FILTER CHOKE COILS

The dimensions b and c refer to the full-page table.

After leaving the primary winding connected to the line for several hours it should be only slightly warm. If it draws much current or gets hot there is something wrong. Some short-circuited turns are probably responsible and will continue to cause overheating and possibly fireworks later.

Designing and Building Choke Coils for the Filter

The design and construction of choke coils to use in filtering the plate supply can be carried out in the same way that the building of a transformer was developed. The basic design principles are the same and the building of a choke coil is even simpler because no taps are necessary and only one coil is required on the core.

The full-page chart shows the dimensions for chokes that will meet most needs of the amateur in filter systems. Chokes of inductances between the values given in the table can be made by using less turns of wire in the winding. Inductance varies about as the square of the number of turns so that using half the number of turns specified gives one-fourth the inductance. More turns than those specified must not be used as the core will become saturated. Dimensions b and c given in the table can be understood by reference to Fig. 1014. The arrangement of core and winding is supposed to be that of the diagram, also.

The best core material is the same as that specified for building transformers — silicon steel sheet. The laminations should be .014" (or less) thick, covered with shellac or rust to reduce eddy-current losses. Fine iron wire is excellent as a core material, also. While interleaved corners are

almost a necessity for a good transformer core, the core of the choke coil should be made with butt joints. An air-gap is needed in any case to prevent saturation of the core and to offer a means for adjustment of the inductance. After the gap is adjusted the core should be clamped firmly so that the magnetic pull will not change the adjustment and to insure quiet operation. Besides clamping the core, a substantial brass "air" gap can be used or a wooden or cloth wedge inserted in the gap to prevent vibration and make the adjustment permanent. The total air-gap, if there is more than one, will of course be the sum of the length of the separate air-gaps.

Wire with thin insulation should be used to make an economical design. Large wire uses a great deal of space without giving much inductance. It is best to wind directly on the core with just a single layer of tape between. More insulation will be required for chokes that are to be placed in high-voltage plate-supply lines but this should not be any thicker than is necessary. Before starting the winding on the core, put some cotton strips along it and fasten some heavy cardboard or thin micarta end flanges in place. After winding the coil, the tape can be tied over it to keep the wire from spreading. Too much tape should not be put on or the choke will not keep cool under load conditions. The wire sizes in the table are conservative and 10% more current can be carried continuously and even more than this intermittently. If the winding is very deep, the cooling will be better if the coil is split into two sections to slip onto each long core piece. 10% more turns will then need to be added to each coil to make up for the magnetic leakage between coils which is increased by splitting the winding. Heavy flexible leads should be soldered to the ends of the coil and taped down to prevent their breaking off.

The simplest way to adjust the air-gap is to connect the filter to the load with which it is to work, changing the gap until the best filter action is observed when listening to the output of the transmitter in the monitor. A too-large air-gap will reduce the inductance and the choke will be ineffective. A too-small gap will allow the core to become saturated, and the choke will be just as ineffective.

The right value for the air-gap is one that uses up about nine-tenths of the ampere-turns of the coil to maintain flux in the gap. The rest of the magnetomotive force magnetizes the core. As the permeability of air is unity and that for sheet steel is about 3,000 (average), the ratio of air to iron can be determined approximately but the iron varies so much that the exact value must always be decided by trial. For a core of 10" total length, an air-gap of about .05" or a little less will meet average requirements.

Chapter Eleven

KEYING AND INTERFERENCE ELIMINATION

TO UTILIZE the transmitter for telegraphic communication, it is necessary to break up its output into long and short pieces which, at the receiving end, will constitute the desired dots and dashes. There are many simple ways of so breaking up the output of the transmitter, but careful adjustment both of the transmitter and of the keying system usually is necessary to avoid the production of key-thumps, which may interfere with broadcast reception.

Methods of Keying

Keying can be accomplished by any arrangement which reduces the output of the transmitter to zero when the key is "open" and permits full output when the key is "closed." Perhaps the most obvious way of doing this is to put the key in series with one of the plate-supply leads to the tube, as shown in Fig. 1101-A. When the key is open the plate power is completely cut off so that there is no output. The keying method shown at (B) is known as "center-tap" keying, because the key is connected between the filament center-tap (which may be the midpoint of a resistor or a center-tap on the filament transformer) and the point where the negative side of the power supply and the grid return circuit are connected together. This system differs from (A) because in addition to breaking the plate supply from the tube, the key also breaks the d.c. return circuit from the grid and thus also prevents the flow of grid current.

In (C) the key breaks only the d.c. grid return circuit, leaving the plate supply connected to the tube at all times. Since the plate power has not been disconnected, the explanation of this method has to be found in the operation of the tube itself, and is as follows: In all oscillators and radio-frequency power amplifiers, the excitation is such that the grid is positive during a part of the r.f. cycle so that electrons are attracted to the grid from the filament. Normally a path is provided for these electrons to flow back to the filament (this electron flow constitutes the d.c. grid current) but if the key is inserted in this return path, the resistance of the path is practically infinite when the key is open. Under these conditions the electrons cannot flow back to the filament and therefore collect on the grid. The electrons trapped on the grid give the grid a negative charge, and in the space of a few r.f. cycles enough of them accumulate to make the grid so negative that plate current cannot flow, thus preventing the tube from oscillating. The success of this method depends upon good insulation in the re-

turn path when the key is open, because if there is leakage in the key itself, in the tube socket or in the baseboard to which the parts are fastened, enough electrons can leak off the grid to allow the tube to deliver some output — greatly diminished, perhaps, but still enough to cause an objectionable "back-wave," which means that the transmitter can be heard at reduced strength when the key is open.

Keying through biasing the grid so far negative that plate current cannot flow can also be done by other methods which do not depend upon lack of leakage in the grid circuit. Fig. 1101-D shows one system of this type. The grid-blocking voltage necessary to cut off plate-current flow is here supplied by a battery or "B" eliminator. When the key is open the full blocking voltage is applied to the grid through the resistor R ; when the key is closed the blocking voltage is short-circuited, so far as the grid of the tube is concerned. Resistor R is in the circuit simply to prevent actual short-circuiting of the blocking-voltage source. It should be of such value as to limit the current flow to a few milliamperes when the key is closed — roughly 5,000 ohms for each 50 volts of bias. The extra bias or blocking-voltage required in this keying method will depend upon the type of tube, the plate voltage, and the excitation. In normal oscillator or amplifier stages a first approximation would be a blocking voltage equal to the plate voltage divided by $\frac{1}{2}$ the amplification factor, or μ , of the tube. The actual value of bias required may be somewhat more or less than this, and had best be determined by experiment.

The system shown at (E) is similar to that at (D), but in this method the blocking bias is obtained from the plate supply through a voltage divider. The center-tap of the filament and the grid return to the negative side of the power supply are connected to the junction of R_1 and R_2 , so that when the key is open the voltage drop across R_2 is applied as bias to the grid of the tube. With the key closed, R_2 is short-circuited. R_1 may be the regular power-supply bleeder. R_2 should have about half the resistance of R_1 in practically all cases.

In any of these diagrams the center-tapped resistor across the filament supply may be omitted if the filament transformer winding is center-tapped. Simply connect the center-tap of the winding to the wire which in these diagrams goes to the midpoint of the resistor. If a storage battery is used to light the transmitting-tube filament, the center-tapped resistor may be

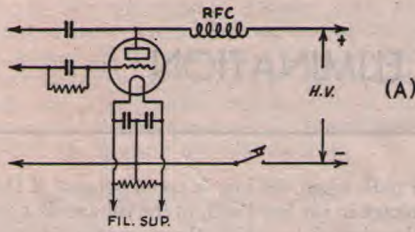

(A)

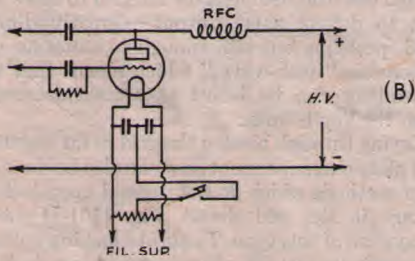

(B)

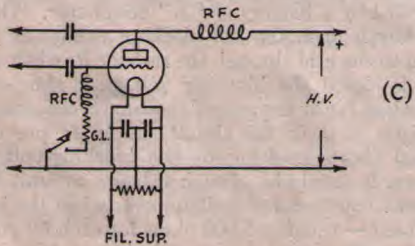

(C)

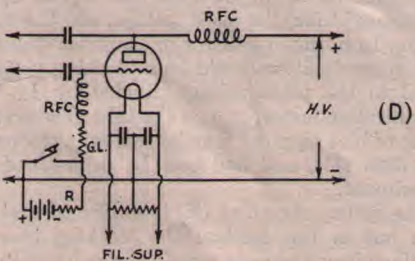

(D)

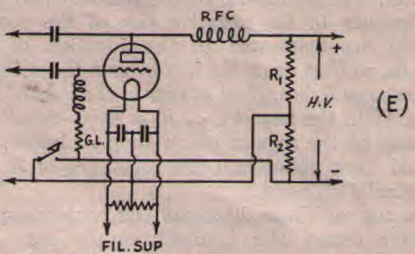

(E)

FIG. 1101 — FIVE METHODS OF KEYING AN OSCILLATOR OR AMPLIFIER

(A) Plate keying; (B) Center-tap keying; (C) Grid-leak keying; (D) Blocked-grid keying with additional bias supplied by batteries; (E) Blocked-grid keying with additional bias supplied by voltage divider in plate supply.

omitted and the connection which goes to its midpoint should be connected to the negative terminal of the filament. The by-pass condensers across the filament will not be necessary.

Although the foregoing keying methods or adaptations of them are almost universally used by amateurs, other arrangements occasionally are encountered. Generally these operate on the r.f. circuits in such a way as to detune the circuit when the key is open, thus reducing the output, or by actually breaking a radio-frequency lead. Such arrangements have several disadvantages which have prevented their being adopted to any extent.

Keying Multi-Stage Transmitters

With an oscillator-amplifier transmitter it is generally preferable to allow the oscillator to run continuously and key the amplifier. If the amplifier has more than one stage, it is good practice to key in one of the low-power stages before the final amplifier is reached, since this lessens the possibility of emitting a back-wave and is not so productive of key-clicks as keying the final tube. In a multi-stage crystal-controlled transmitter with doubling amplifiers, one or more of the doubler tubes should be keyed.

The keying methods shown in Fig. 1101 may be applied to any tube in a multi-stage transmitter, but in certain cases a slight rearrangement of the connections may be necessary. For instance, negative high-voltage keying, Fig. 1101-A, cannot be used on a single stage if a common plate and filament supply is used for all stages, because the plate voltage would be removed from all stages simultaneously. The key should be placed in the positive lead to the tube which is to be keyed (a bad thing to do unless a keying relay is used, because of danger from shocks) or, better, a separate filament transformer can be installed for the keyed tube. A separate filament transformer or winding also is necessary with center-tap keying, *B*, and the blocked-grid arrangement at *E*. The methods shown at *C* and *D* do not require separate plate or filament supplies for the keyed stage.

Key Clicks

While for communication purposes keying methods which break up the output of the transmitter are all that is required, it is unfortunate that some highly undesirable effects can accompany the use of simple keying systems such as are shown in Fig. 1101. Chief of these is the phenomenon of key clicks. Sudden starting of oscillations produces transient side-bands which theoretically will extend over the entire frequency spectrum if the oscillations rise to their full value in an infinitesimally small space of time. The amplitude of these side-bands can be quite large, but they are of very short duration — so short, in fact, that they can be heard only as a click. Because the energy is spread over an extremely wide range of

frequencies, the clicks generally are not heard at appreciable distances, but in nearby receivers their effect may be quite pronounced. A somewhat similar phenomenon takes place when oscillations are stopped, as when the key is opened, but the key-click from opening the key usually is much weaker than the click at closing. Clicks not only cause interference with amateurs whose receivers are tuned near the frequency of the transmitter causing them, but also with broadcast reception in the immediate neighborhood. The clicks will be strongest near the transmitter frequency, gradually losing their amplitude at frequencies farther removed.

The problem of key-click elimination is that of preventing the undesired side-bands from being produced. To do this it is necessary to cause the oscillations to build up gradually from zero to full amplitude. This may be done by applying various types of electrical filters, the simplest of which is an inductance in series with the key. Inductance has the property of opposing the sudden rise of current. In all of the keying methods described in the foregoing paragraphs it is necessary for direct current to flow through the key circuit before oscillations can build up; an inductance of a few henrys will oppose the sudden rise of current to a sufficient extent to prevent oscillations from starting too rapidly.

Key clicks can be reduced in transmitters with several amplifier stages by keying one of the low-power tubes. The side-bands will be filtered off to a considerable extent in passing through the tuned circuits in the succeeding amplifier stages — the same effect that occurs in broadcast receivers in which freedom from interference is obtained by passing the signal through a number of tuned amplifier stages. In transmitters with large power output, however, this type of filtering may not be sufficient, and additional elimination methods must be applied to the keyed stage.

Key-Thump Filters

Arrangements which prevent the sudden building up of oscillations have become known as "lag" circuits — a term quite descriptive of their operation. The use of an inductance in series with the key has already been mentioned. It is not necessary to put it directly in the key circuit, however; it may be placed in any part of the circuit in which direct current flows, as in series with the plate supply or in series with the grid leak or bias battery, even though the key is in some other part of the circuit. Exact values for the inductance usually have to be determined by experiment. It should be large enough to prevent clicks, but should not be so large that the oscillations will build up too slowly to permit clean keying. Values between 5 and 50 henrys usually will be found satisfactory. Small transformers, such as those used for bell-ringing, often will work nicely with transmitters using one or two 10's.

A variable resistor can be connected across the inductance to enable the operator to adjust the impedance to the best operating value.

Arcing at the key contacts is quite common, since the direct current flowing through the key tends to "hang on" at the instant of breaking contact, and is not only bothersome but sometimes a source of interference. Arcing is likely to be more pronounced when an inductance is used in series with the key to introduce a lag, because the sudden collapse of the magnetic field about the inductance when the current is broken generates a voltage high enough to jump the small gap between the key contacts at the instant of opening. If a condenser is connected across the key contacts, the voltage will charge the condenser instead of causing an arc between the key contacts. The condenser capacity required will depend on the amount of energy to be absorbed, values between .5 and 1.0 μ f. usually being sufficient. The charge accumulated on the condenser when the key is opened will cause an arc to form when the key is closed, unless a resistor of suitable value is connected in series with the condenser. The resistance must be low enough to allow the condenser to charge up quickly and absorb the spark when the key is opened, and yet large enough to dissipate most of the energy in the condenser when the key is closed so no spark will appear at the contacts. A 500- or 1000-ohm variable resistor will usually suffice.

Practical ways of introducing lag circuits are shown in Fig. 1102. Many variations of these circuits are possible, of course.

Clicks will be much more serious if the plate supply has poor regulation — characteristic of all plate supplies with condenser input filters. The reason for this is that with no load on the plate-supply apparatus the condensers of the filter system become charged to the peak voltage of the transformer. Then, when the plate voltage is applied, the tube not only starts oscillating suddenly but starts oscillating with abnormal force because of the peak voltage which accumulated in the filter. This peak voltage is soon reduced to normal, but the result will have been a heavy key-thump.

A plate supply with good regulation will minimize this effect. A drain or "bleeder" resistor connected across the output of the plate supply and having a value such that it imposes a continuous load of about 25% of the normal transmitter load will be found helpful in cutting down the peak voltage if the regulation is poor. A more satisfactory solution is to use a choke-input filter with a suitable bleeder, a combination which results in very good regulation. This subject is covered in detail in Chapter Ten.

Another keying method which has attained a good deal of popularity is shown in Fig. 1103. In this system a vacuum tube is placed with its plate-filament circuit in the center-tap of the

tube to be keyed, while the key itself is in the grid circuit of the auxiliary or "keyer" tube. When the key is open, high negative bias is placed on the grid of the keyer tube so that the plate current is completely cut off; when the key is closed the grid of the keyer tube is connected to its filament and the tube acts like a resistance of low value, thus permitting plate current to flow to the oscillator or amplifier being keyed. The mechanism by which the lag is introduced in this circuit is not apparent, but tube keyers have been markedly successful, especially in low-power transmitters. The keyer tube has some resistance even though the grid is connected to the filament, so the plate voltage on the oscillator or amplifier will be lower than with other keying systems. To overcome this several tubes may be connected in parallel. Tubes of the 45 type are excellent for

The blocking bias is obtained by utilizing the drop in a resistor in series with the high-voltage supply.

It is impossible to cover in this *Handbook* all the methods of key-click elimination which have been proposed from time to time, but suggestions are regularly published in *QST* which often may be successfully applied to the particular conditions existing in one's own transmitter.

Interference with Broadcast Reception

The wide distribution of broadcast receivers makes it unlikely that any amateur, unless in an isolated location, can ignore the possibility that his transmitter will cause interference with broadcast reception in his vicinity. This, while serious enough not only because most of us desire to live on good terms with our neighbors but because

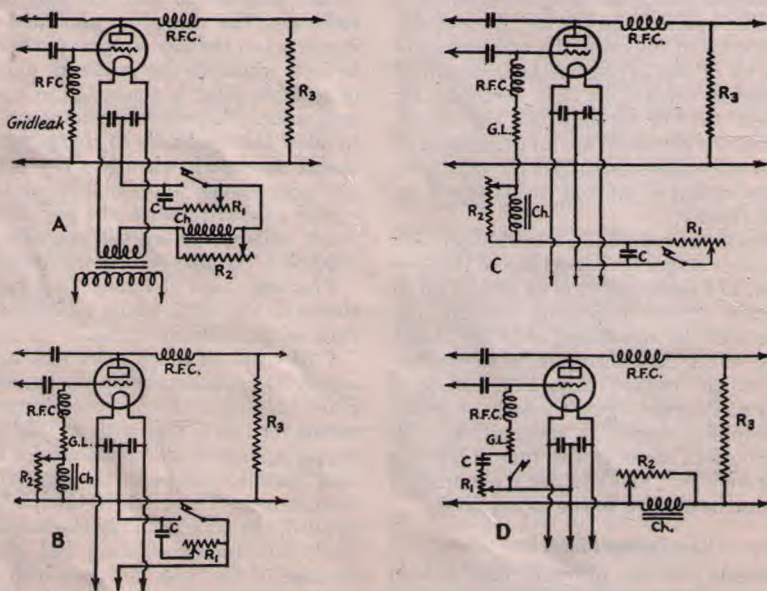

FIG. 1102 — HOW LAG CIRCUITS MAY BE ADDED TO SOME REPRESENTATIVE KEYING METHODS

In all circuits the condenser-resistor is connected across the key, as shown in the other diagram. In "A" the inductance-resistor is in series with the key, which in this case (center-tap keying) breaks the full plate current. The choke must therefore be capable of carrying this current. In "B" (also center-tap keying) the choke is placed in series with the grid leak, and should be capable of carrying about 10% of the plate current. In "C" the lag circuit is applied to grid-leak keying. The choke should have the same current-carrying capacity as "B." Grid-leak keying is also used at "D," but the choke is in the negative high-voltage lead, and therefore must carry the full plate current. The actual values of capacity, inductance and resistance must be determined by experiment, as explained in the text. These are by no means all the combinations which could be worked out, but simply illustrate the principles involved.

low-power transmitters because their plate resistance is low. One 45 should be used for each 50 ma. of plate current required by the tube being keyed. The filament transformer for the keyer tubes need not be center-tapped; in fact, the filaments may be connected in series if desired.

It can cause a great many people to take an antagonistic attitude toward amateur radio, is fortunately not impossible of solution. Should interference be caused, an understanding of the several types that exist will make it easier to apply the proper corrective measures.

Interference with broadcast reception usually falls into three separate classes. The first, and most common, is that of key clicks, which already have been treated in this chapter. This type of interference is usually heard over the whole tuning range of the broadcast receiver, or if not over the whole range will be more intense at the high-frequency end of the broadcast band. Key clicks are not *tunable*, that is, they are not heard at definite frequencies with interference-free areas between. The key-thump filters described previously should eliminate this type of interference.

The second type of interference is that known as "blocking," or "blanketing." This is not so common now as it was when broadcast receivers were generally unselective, but occasionally will be encountered if the receiver is old or if the broadcast antenna is too close to the transmitting antenna. It can be readily recognized because the program disappears or is much reduced in strength when the key is closed, and is the result of overloading of the tubes in the receiver by the energy picked up from the transmitting antenna. This type of interference can be minimized by moving the broadcast antenna away from the transmitting antenna or by

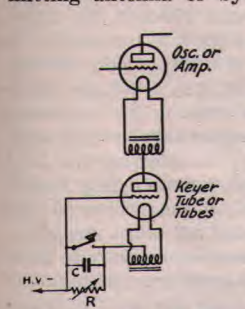

FIG. 1103 — A VACUUM-TUBE KEYING METHOD TO PREVENT CLICKS

One or more keyer tubes may be used; the larger the number the greater the plate current that can be safely passed. Condenser C may be between .25 and 1.0 μfd . Resistor R should be adjusted to cause the plate current to drop to zero when the key is open. A variable resistor of about 50,000 ohms should give enough range.

Frequency of Interfering Signal	Coil (3" dia.)
1,715–2,000 kc.	20 turns
3,500–4,000 kc.	8–10 "
7,000–7,300 kc.	4–5 "
14,000–14,400 kc.	3 "

Bell wire (No. 18) or a size near to it may be used. When the trap is installed the transmitter should

be started up and the condenser in the trap adjusted to the point where the interference is eliminated. This trap will not affect the operation of the broadcast receiver.

Blanketing may be and generally is accompanied by key clicks. The wave trap may help

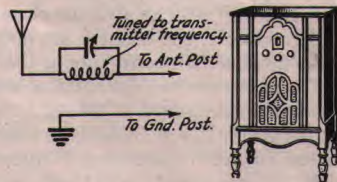

FIG. 1104 — HOW A WAVE-TRAP CAN BE INSTALLED TO PREVENT CERTAIN TYPES OF INTERFERENCE

to eliminate the clicks but usually a key-click filter will be needed as well. A key-click filter alone cannot eliminate or even alleviate the blanketing effect.

The third type of interference is peculiar to superheterodyne broadcast receivers, and is never encountered with tuned r.f. sets. A strong signal from the transmitter will be heard at three or four points on the dial, while over the rest of the tuning range there may be no sign of interference. The explanation is not difficult to follow if one understands the operation of the superheterodyne receiver as outlined in Chapter Four. The superheterodyne oscillator, the output of which is mixed with the incoming signal to form the intermediate frequency signal, generates harmonics just as does any other vacuum tube oscillator. These harmonics, at some setting of the broadcast receiver dial, will fall near the amateur bands, and if an oscillator harmonic happens to be just far enough removed from the transmitter frequency to give a beat equal to the intermediate frequency, a signal from the transmitter will be heard in just the same way as an ordinary broadcast signal. If the receiver is properly shielded and the oscillator is isolated from the antenna circuit, the signal from the transmitter cannot get into the oscillator circuit to be mixed with its harmonics and this type of interference cannot occur. When it *does* occur the fault does not lie with the transmitter but with the broadcast receiver, and nothing can be done to the transmitter to prevent such interference. It is unfortunate that the recent craze for cheap superhets of the midget variety has caused manufacturers to cut down costs to such an extent that this type of interference is quite likely to be encountered. These receivers cannot be called "modern" in the right sense of the word, and the amateur operator is entirely blameless if interference is caused. A wave-trap may help if the transmitter signal is brought into the receiver through the antenna, but in some cases the pick-up is direct because of lack of oscillator shielding, and the interference is just as

strong whether the antenna is connected to the receiver or not.

One's own broadcast receiver, if of modern design, is a good "subject" for experimenting with key-click filters and other interference-prevention methods. If interference can be eliminated in a receiver in the same house, operating from the same power line and with an antenna close to the transmitting antenna, the chances are good that there will be no general interference in the neighborhood. The amateur should ascertain, however, whether or not interference is caused in nearby broadcast receivers. If your neighbors appreciate that you are as much interested in preventing interference to their enjoyment of broadcast programs as they are, much more can be accomplished than by acrimonious disputes. It is better to settle the interference problem right at the beginning than to trust to luck with the possibility of an unfavorable reaction towards amateur radio in general and yourself in particular on the part of nearby broadcast listeners.

In searching for causes of interference, it is a good idea to have someone operate your transmitter while you listen on the affected receiver. Remove the antenna from the receiver, and if the interference disappears it is certain that it is coming into the set through the antenna, which simplifies the problem. The various types of interference prevention already described should work under these conditions. If the interference persists when the antenna is removed, however, it is probably getting into the receiver through the power lines. This happens occasionally with a.c. operated broadcast receivers.

House wiring may pick up r.f. either directly from the antenna or through the power-supply system of the transmitter. If the 110-volt line is found to be picking up energy directly from the antenna it is advisable to change the location of the antenna, if possible, or run it in a different direction, not only because of interference to broadcast reception but because energy so picked

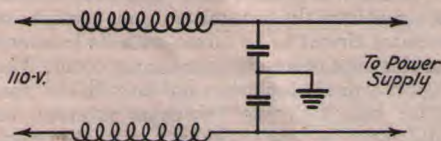

FIG. 1105 — R.F. SUPPRESSORS FOR THE POWER LINE

A combination of choke coils and condensers, the construction of which is described in the text, may be connected in the power line before the plate-supply equipment is reached, to prevent r.f. from feeding back from the transmitter to the line and thus causing interference with broadcast listeners.

up is useless for radiation and decreases the effective range of the transmitter. This is particularly important when, as often happens, electric lamps in different parts of the house are found to glow when the key is pressed. The energy used in lighting the lamps is wasted.

If the r.f. is getting back through the transmitter power-supply system radio frequency choke coils should be connected between the 110-volt outlet and the power transformer, at the transmitter. The wire of which the chokes are wound must be heavy enough to carry the current taken by the power-supply system. No. 14 or No. 16 will be sufficient in most cases. Mailing tubes make good winding forms for these chokes. Between 100 and 300 turns will be required, depending on the transmitter frequency. Tuned traps of the construction described previously may be used instead of the chokes. A pair of condensers connected in series across the line with the mid-connection grounded will often improve the results. Paper by-pass condensers such as are used in receivers (about 0.1 μ fd.) rated at 200 volts or more will serve. Fig. 1105 shows how the chokes and condensers should be connected.

Power transformers with electrostatic shields between the primary and secondary windings are helpful in preventing r.f. from getting into the supply lines, provided the shield is connected to a good ground, and often will make extra chokes and condensers unnecessary.

When an a.c. broadcast receiver and the transmitter are on the same 110-volt line interference may be caused when the transmitter is keyed because the load is being rapidly thrown on and off the tube, resulting in a voltage variation which appears as a noise in the broadcast receiver. Such interference can only be eliminated by reducing power or by transferring the load to a part of the line which is more lightly loaded and sufficiently removed from the receiver so that the fluctuations in load will not affect reception. If the load is heavy it may be necessary to have a separate line installed for the transmitter.

Interference usually decreases as the transmitter frequency is raised. In many cases where bad interference is caused on the 1750- and 3500-ke. bands, changing to 7000 or 14,000 ke. will cure it. If none of the usual methods is wholly effective a reduction in power often will allow the station to be worked during quiet hours without bothering the neighbors. It is a little unreasonable to expect that interference can be entirely eliminated when it is caused by a high-power transmitter whose antenna is only a few feet from broadcast receiving antennas. With the average amateur transmitter using a Type 10 or even a Type 52 tube a satisfactory solution to the interference problem can in most cases be reached by the intelligent application of one or more of the methods described above.

Rectifier Noise

Mercury-vapor rectifiers often are the source of a peculiar and easily identifiable type of interference, taking the form of a raspy buzz with a characteristic 120-cycle tone (100 cycles on 50-cycle power lines and 50 cycles on 25-cycle lines)

which is usually broadly tunable in spots on the broadcast receiver dial. The cause lies in the fact that at the instant the mercury vapor ignites on each half cycle of the power frequency a small oscillation is set up, the frequency depending upon the characteristics of the power supply apparatus. Unless suitable precautions are taken the oscillations will travel back over the power line and be detected in receivers connected to the line.

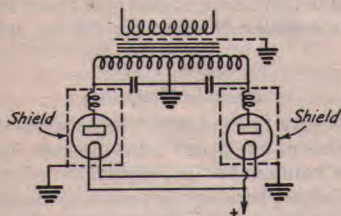

FIG. 1106 — DEVICES FOR ELIMINATING NOISE FROM MERCURY-VAPOR RECTIFIER TUBES

The r.f. chokes in series with each plate should be placed inside the shields enclosing the rectifiers. The chokes should have an inductance of about 10 millihenrys each. Small honeycomb-type windings are suitable.

The line filter shown in Fig. 1105 usually will suppress this type of noise without difficulty. Sometimes the condensers alone will do it, no chokes being necessary. Transformers with electrostatic shields between primary and secondary are not likely to transmit the oscillations to the line. Other ways of curing this type of interference are shown in Fig. 1106. They include shielding of the rectifier tubes, connecting a radio-frequency choke between each plate and the transformer winding, and shunting fixed condensers of about .002- μ f. capacity between the outside ends of the transformer winding and the center-tap. The condensers should be rated to stand at least 50% more voltage than the r.m.s. voltage delivered by half of the secondary winding.

Radiophone Interference

Key-click filters are naturally of no value on transmitters used exclusively for 'phone transmission, since clicks do not occur. A phenomenon similar to key clicks can take place if the transmitter suffers from frequency modulation or from over-modulation because both these defects cause the radiation of side-bands often far removed from the band of frequencies normally required for the transmission of speech. These abnormal side-bands can and frequently do cause interference in the broadcast band, often just as a series of unintelligible noises when the transmitter is modulated. The obvious remedy is to use a radio frequency system in the transmitter whose frequency does not vary when modulation is taking place, and to adjust the transmitter so that over-modulation or "lop-sided" modulation does not occur. Chapter Eight covers this subject thoroughly.

Blanketing and other forms of interference caused by r.f. pickup can be treated in exactly the same way as described previously. Wave-traps in the receiving antenna lead-in and r.f. filters in the power lines will prove effective in eliminating this type of interference.

Miscellaneous Interference

Amateurs are often unjustly blamed for code interference. Foreign ships and commercial radiotelegraph services sometimes cause bad interference to radio broadcasting. This may be cured in many cases by long-wave traps similar to those already described for short-wave work. Power leaks from electrical distribution systems, disturbances from thermostats in heating pads, flatirons and oil heaters; interference from street car lines, dial telephones, loose electric lamps, ignition systems, vibrating battery chargers, mechanical rectifiers, and violet-ray apparatus are other possible sources of interference, not to mention the neighbor who operates a "blooper" (an oscillating receiver which itself is a miniature transmitter without a license). Many of the broadcast receivers sold to-day are still not properly selective. All this points to the conclusion that the broadcast listeners as well as the amateur concerned must approach the interference problem with an open mind and a cooperative attitude.

Quiet Hours

In most cases interference can be prevented by the use of key-click filters or some of the other simple devices described. If the amateur is unable to solve the problem, quiet hours must be observed from 8:00 p.m. to 10:30 p.m. (local time) and on Sunday mornings between 10:30 a.m. and 1:00 p.m. upon the frequencies which cause such interference. The regulations state that the station must "cause general interference with broadcast reception on receiving apparatus of modern design" before quiet hours are obligatory. In effect, if a good many receivers are in the vicinity and only one or two of them experience interference, the inference is that the broadcast receiver is at fault, and not the transmitter. Likewise interference with a non-selective broadcast receiver is not sufficient cause for compulsory observance of quiet hours. The amateur should cooperate with such listeners to the fullest possible extent, however, and his aim should be to eliminate interference at all hours of the day with reasonably good broadcast receivers.

Keying Chirps

The importance of frequency stability in transmitters — that is, the ability to hold to one frequency in spite of changes in plate voltage — has been stressed in Chapter Seven. Since most key thump filters in effect vary the voltage applied to the tube from zero to full voltage rather

slowly, an unstable transmitter will exhibit a considerable change in frequency in the fraction of a second during which the voltage is increasing. This rapid change in frequency gives the signal a "yooping" sound or chirp which makes it annoying to listen to and difficult to copy. Self-controlled oscillators are especially subject to keying chirps unless carefully adjusted. High-C circuits such as those described in Chapter Seven are beneficial. Chirps are rarely present in well-designed oscillator-amplifier and crystal-controlled transmitters.

Keying Relays

When the key is so placed in the circuit that the current through it is more than 150 milliamperes or so, or in systems such as those shown in Fig. 1101 at (A), (B) and (E) with plate voltages of 1000 or over, the use of a keying relay is recommended both for the sake of the key contacts and to avoid accidental shocks. When a relay is used the key is placed in a low-voltage circuit which is incapable of causing damage either to the key or to the operator.

A keying relay can be made easily from an old telegraph sounder. The magnets should be carefully insulated from the frame, and two additional binding posts should be added to the device to make it easy to connect to the contacts. Flat silver slugs measuring $\frac{1}{4}$ " x $\frac{1}{4}$ " x $\frac{1}{16}$ " thick make dependable contacts, and will be heavy enough to key any amateur transmitter. These can be fitted into notches filed in the armature and frame of the sounder and soldered in place. The armature and frame must be insulated from each other; if the sounder has a metal base it should be removed and a new one made of bakelite or a similar substance substituted. A piece of copper braid or a thin brass spring should be connected between the U-shaped part of the frame and the armature so that the pivots do not carry any current. In addition it will be necessary to fasten a bit of insulation between the armature and the back-stop screw to keep the armature from closing the circuit when the key is open. This can be threaded and glued to the back-stop screw itself or may be part of the armature. The relay may be operated from a storage battery or a few dry cells. It can be adjusted to work well at almost any desired speed without bad sparking or sticking.

Automobile generator cut-outs can also be transformed into keying relays for low-power transmitters. They can be obtained for a dollar or so from any automobile supply house. A connection should be brought out from each of the contacts to take the place of the key in the transmitter, care being taken to see that the windings on the cut-out do not connect to either of the contacts. There are two windings on the magnet, one of which has only a few turns of coarse wire, the other having many turns of fine

wire. The latter winding will usually operate the armature satisfactorily from a 6-volt battery, but if not both windings can be removed and a new one put on, using as much No. 30 d.c.c. wire as can be put in the space. Such a relay is very fast in operation and will follow a "bug" key at high speeds.

Ready-made keying relays can be obtained from several concerns advertising in this *Handbook* and in *QST*. Several different types, designed to operate under different conditions, are available.

Break-In Operation

The ability to "listen in" in between the dots and dashes of one's own transmissions makes for speedier communication, especially when interference is bad, because the receiving operator can indicate to the transmitting operator, by holding down his key for a few seconds, that he wants to "break" or interrupt the transmissions. Break-in operation is comparatively easy if the transmitter is a simple self-controlled oscillator. A separate antenna should be used for receiving, and although in most cases it will be impossible to hear signals when the transmitter key is closed the receiver will be in operating condition within a fraction of a second after the key is up. The only objection to this method is the heavy thump in the headphones which results from listening to the transmitter. To minimize pick-up from the transmitter the receiving antenna should be short and should be run at right-angles to the transmitting antenna. If a keying relay is used, it may be equipped with an extra set of contacts which will short-circuit the receiving antenna to ground when the transmitter is keyed, although this may not prove of very great benefit unless the receiver is well shielded. A separate relay connected in the key circuit will serve the same purpose.

Oscillator-amplifier or crystal-controlled transmitters in which the oscillator is allowed to run continuously during a transmission do not permit break-in operation so easily as self-controlled sets. Satisfactory break-in can be secured, however, if a time-delay circuit is used in conjunction with the key so that the oscillator plate voltage is applied the instant the key is pressed but is

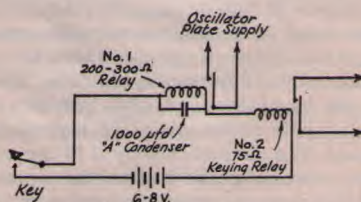

FIG. 1107 — BREAK-IN SYSTEM FOR OSCILLATOR-AMPLIFIER OR CRYSTAL-CONTROLLED TRANSMITTERS

Two relays are required, one for keying and one for controlling the oscillator plate voltage. Time-delay action is secured by using a high-capacity condenser in shunt with the plate relay.

not released until after the key has been open for one or two seconds. This will keep the oscillator running during the normal pauses between dots and dashes or words and sentences, but a slightly greater than normal pause will shut off the oscillator so that signals can be heard. Fig. 1107 shows a simple method of accomplishing this, using parts which are not difficult to obtain.

Two relays are used, one with low resistance for the regular keying and the other with high resistance for the time-delay circuit. The condenser across the latter relay is a 1000 μ fd. electrolytic condenser of the type used in "A" eliminators. The two relays are connected in series. When the key is pressed both relays close instantaneously, and the condenser charges to a potential equal to the voltage drop across the oscillator relay. When the key is opened the keying relay opens immediately, but the other relay will stay closed for a second or so because the charge on the condenser keeps the coil magnetized. A suitable relay for this purpose can easily be made from a high-resistance telegraph relay or sounder, re-wound if necessary to the desired resistance.

Remote Control

If the location is such as to allow the transmitter to be installed some distance from the receiver, the transmitter may be remotely controlled. This will make it easy to use break-in and save worrying about losses in poor dielectrics which are certain to be in the field of the lead-in or feeders if brought right down to the operating room.

In a remotely-controlled installation, relays can be used in one of several ways depending on the distance and the individual application. The problem is merely one of turning the filament-heating and plate-supply power on and off and keying the transmitter, using a minimum number of relays and as small an amount of wire as possible.

One simple method of using two relays, requir-

ing the use of only three wires, is shown in Fig. 1108. With this arrangement the filaments of the rectifier tubes can be lighted before the plate transformer is connected and can be allowed to

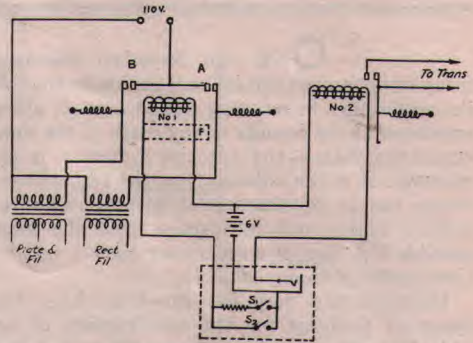

FIG. 1108 — A SUCCESSFUL REMOTE-CONTROL SYSTEM

Only three wires need be used between the operating table and the transmitter. The part of the circuit enclosed in the dotted rectangle is the only part within reach of the operator. In practice, Relay No. 1, which has two sets of contacts, is adjusted so that the contacts at "A" will close when S_1 is closed, the contacts at "B" remaining open. The latter contacts close when S_2 is closed. Such a relay may be home-constructed with two separate armatures, the spacing between the armatures and the pole pieces and the tension on the springs being adjusted for proper operation. Relay No. 2 is the keying relay. This arrangement permits the filaments of the rectifier tubes to be lighted before the plate load is thrown on. S_1 may be left closed during a period of communication, thus keeping the rectifier tubes ready for instant operation.

remain lighted during an entire period of communication, which is good practice.

All relay contacts should be large enough to avoid the possibility of sticking if the set is remote-controlled. The outfit also must be built substantially and adjusted to operate stably. If a motor-generator is used an automatic starting compensator operated by a suitable relay will be necessary for starting up the set.

Chapter Twelve

ANTENNA SYSTEMS

ONE can have an excellent array of apparatus and still not realize to the full its possibilities in reaching out to contact other amateurs at far corners of the earth if the final connecting link — the antenna system — is ineffective. It is the antenna, not the transmitter, which has to do the job of getting radio-frequency energy out into space with the least possible loss and in such a way that it will be most usefully employed.

Unfortunately very few amateurs have the space or facilities for the construction of an "ideal" antenna system. Nevertheless if a few general principles of antenna design are understood and applied, much more can be accomplished than by the haphazard stringing of wires here and there about the landscape. There is plenty of latitude in antenna-system design for adapting the antenna to existing local conditions; no one antenna system is "best" any more than one specific transmitter layout is better than all others. The measure of the goodness of an antenna system is its ability to radiate effectively the power supplied to it by the transmitter; if it does this well its type is unimportant.

Types of Antennas

Notwithstanding the great variety of antenna systems to be seen in operation, the antennas themselves are of but two distinct types. Those in which the ground is an essential part are known as Marconi antennas. The second type is the Hertz antenna, which operates independently of the ground. In its purest form the Hertz antenna consists of a single wire suspended sufficiently high above the earth or earthed objects to have an inconsequential capacity to ground. The Hertz antenna is now used almost to the exclusion of all other types for short-wave transmission.

An antenna is an oscillatory circuit having a natural frequency in much the same way that the tuned circuits in a receiver or transmitter have natural or resonant frequencies. The chief difference is that in the antenna the inductance, capacity and resistance are distributed throughout its length, whereas in the tuned circuits of the transmitter or receiver these properties are concentrated or lumped. The tuned circuits made up of coils and condensers known as closed oscillatory circuits and have very limited radiating abilities; the antenna is an open oscillator circuit and is an effective radiator of radio-frequency energy.

The distribution of current and voltage in

various parts of the open oscillatory circuit differs widely from that in closed circuits. In circuits having lumped constants the current is the same in all parts of a simple circuit or in all parts of a branch of more complex circuits; the voltage varies directly as the reactance across which it is measured. Thus if we have a number of coils and condensers connected in series with a source of radio-frequency power, ammeters inserted in different parts of the circuit will give identical readings. This is not true of the antenna; current readings taken a few feet apart along the wire may differ appreciably.

Contrary to usual practice throughout this *Handbook*, in this chapter we shall find it more convenient to speak in terms of wavelength than in terms of frequency. The reason for this will be evident from the discussion to follow. At the same time, however, the relationship between frequency and wavelength should be kept in mind continually.

Current and Voltage Distribution

If we start an electrical impulse travelling along a wire it will proceed at uniform speed and intensity (assuming the losses are negligible) until it reaches the open end. At this point it can go no farther and therefore starts back again; the impulse is said to be reflected. Reflection gives rise to the phenomenon of "standing waves" on wires; when the wire is excited by a source of alternating potential the reflected impulses either add to or subtract from the later impulses travelling along toward the open end of the wire. The net result of the addition or subtraction at any point depends upon the distance along the wire from the open end and the rate at which the impulses are fed to the wire (the frequency of the alternating potential). At the open end of the wire the resultant potential will be the sum of the outgoing and reflected pulses; at a distance from the open end equal to one-fourth the speed of travel — velocity — divided by the frequency, the outgoing and reflected impulses will cancel each other and the resultant potential or voltage will be zero. The velocity is approximately 300,000,000 meters per second; the frequency will be that generated by the transmitter. Since the wavelength in meters is equal to 300,000,000 divided by the frequency in cycles (300,000/frequency in kc.) it is evident that the potentials of the outgoing and reflected impulses will cancel at a distance from the open end of the wire equal to one-quarter wavelength. At a distance of one-half wavelength the potentials will add once

more just as they did at the open end, but the sign is reversed.

If ammeters are inserted along the wire at various points it will be found that the current also will vary with distance from the open end, but in opposite fashion to the potential or voltage. Obviously the current must be zero at the end of the wire; there is no place for it to flow. Away from the open end the current will increase until the quarter-wavelength point is reached, after which it will decrease until at the half-wavelength point, where the potential is maximum, the current again will be zero. At intermediate points along the wire both current and voltage will be found to vary approximately according to the sine law. These relationships are shown in Fig. 1201.

The distance along the wire corresponding to one wavelength is dependent upon the distributed inductance and capacity of the wire; for ordinary wires not too close to the earth the wavelength is almost exactly the same as that of a wave in space; i.e., 300,000,000 divided by the frequency in cycles per second. Such departures from this figure as may be necessary will be considered later on.

From Fig. 1201 it is evident that the shortest length of wire which will accommodate one complete rise and fall of current is equal to one-half wavelength; the wire could be cut at this point without changing the distribution of current or voltage. Any other length would result in an impossible current distribution since the current at the ends would have to be zero and some finite value simultaneously. A wire having a length equal to one-half wavelength will be resonant to the supply frequency. An antenna

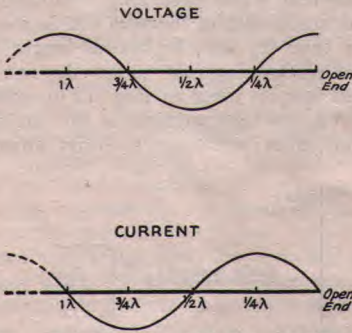

FIG. 1201 — STANDING WAVES ON AN OPEN-ENDED WIRE EXCITED BY HIGH-FREQUENCY ALTERNATING POWER

having this length is said to be a "half-wave" antenna, and is the shortest "free" (both ends open) antenna which will be resonant at the desired frequency. The open-ended or free antenna also can be one wave-length long, in which case it is known as a full-wave antenna; it can, in fact, be any number of half-waves long.

Effect of Ground—Images

The earth acts as though it were a perfectly-conducting surface and because of this gives much the same effect as a huge mirror; that is, an electrical image of the antenna can be considered

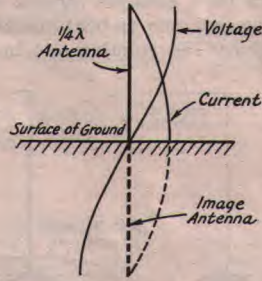

FIG. 1202 — THE SIMPLEST FORM OF GROUNDED ANTENNA

The actual antenna need be only a quarter wave long. Reflection from the earth gives the effect of an image antenna which supplies the missing quarter wave.

to exist in the ground at a distance below the surface approximately equal to the height of the antenna. In the case of the Hertz antenna, the image effect tends to concentrate the radiation of the antenna at certain definite angles with the horizontal, a characteristic which sometimes is found useful. But the chief practical use made of the image is in its application to the grounded antenna.

As we have seen in the preceding section, the shortest possible resonant length of wire for the free antenna is that equal to one-half wavelength. But since the ground acts as though it produced an image of the antenna, it is possible to take a wire a quarter-wave long, connect it to ground, and depend upon the image for the other necessary quarter wave. This is the grounded antenna. The drawing of Fig. 1202 shows a quarter-wave grounded antenna and its image. The current and voltage distribution along the actual antenna are equivalent to the corresponding distributions along a quarter wavelength of the open-ended wires of Fig. 1201; the current is maximum at the ground connection and the voltage is minimum at the same point. It should be understood that the electrical image has no more real existence than an image in a mirror, however; both are merely simplified and understandable ways of explaining the observed effects of reflection, in one case of electrical waves, in the other of light.

Although of less importance in amateur work than the Hertz antenna, we shall give first consideration to the grounded antenna and later go into the details of designing and building antenna systems for high frequencies.

The Grounded Antenna

Fundamental forms of grounded or Marconi-type antennas are shown in Fig. 1203. They are of interest because many amateurs find it necessary to use the grounded antenna for 1715-kc. work on account of limited space. The grounded antenna can be a straight vertical wire or, as usually is the case, can be bent into the shape of an inverted L. The counterpoise in the right-

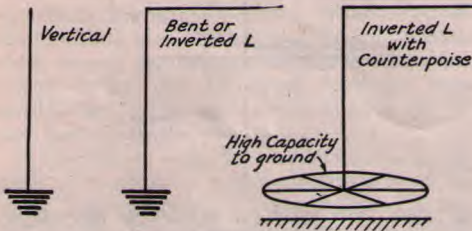

FIG. 1203 — THREE TYPES OF GROUNDED ANTENNAS

The bent form, with or without counterpoise, is most generally used.

hand drawing of Fig. 1203 consists of several wires, all joined together and strung over a fairly large area a few feet above and parallel to the surface of the ground. This type of construction is adopted so that the counterpoise will act as one plate of a high-capacity condenser of which the ground itself is the other plate. The counterpoise is a useful substitute for a direct ground connection when such a connection cannot be made to naturally-moist soil. Dry soil usually results in a ground connection of rather high resistance, which causes a loss of power.

If a grounded antenna is to be used for transmitting, the ground should preferably be one with conductors buried deep enough to reach natural moisture. In urban locations, good grounds can be made to water mains where they enter the house; the pipe should be scraped clean and a low-resistance connection made with a tightly-fastened ground clamp. If no water-pipes are available several pipes, six to eight feet long, may be driven into the ground at intervals of six or eight feet, all being connected together. The use of a counterpoise will obviate the necessity for a buried ground and probably will give better results than the direct ground connection if made large enough. The length of the counterpoise wires bears no particular relation to the length of the antenna, except that the wires in the counterpoise should be at least as long as the antenna itself. The shape of the counterpoise is not of great moment; it may be made in the form of a circle as in Fig. 1203 or may be square, rectangular, etc.

The natural wavelength of a bent grounded antenna is approximately 4.2 times its actual length. It is not necessary to make a highly-accurate cal-

ulation when figuring the length of a grounded antenna because the tuning apparatus inserted at the base will compensate for discrepancies between the natural wavelength and the transmitter wavelength or frequency. For example, an antenna for 1900 kc. (158 meters wavelength) should be $158/4.2$ or 37.6 meters long, corresponding to a length of 124 feet. This length, it should be noted, is the *total* length from the open end of the antenna to the ground connection or counterpoise. If the transmitter is located on a floor several stories above the ground and the ground connection is made to a cold-water pipe on the same floor, it becomes a bit difficult to determine the actual length of the ground lead. The water piping of the building will tend, however, to act as a counterpoise so that the effective length of the ground lead will not usually be equal to the actual distance along the pipe to the point where it enters the ground. In such cases it is as well to consider the length of the ground lead to be the length of the wire going to the water piping; if, on this basis, the antenna length turns out to be too long for convenient tuning when actually installed, the antenna easily can be shortened.

Hertz Antennas

The Hertz antenna in three forms is shown in Fig. 1204. It is a single-wire antenna the natural wavelength of which depends primarily upon its length and secondarily upon such factors as may operate to change the distributed constants of the wire from those it would have in free space. The natural wavelength of a free wire is, as we have pointed out previously, twice the actual length of the wire, since the wire will be resonant when it is one-half wavelength long. Practically, the natural wavelength of the wire will be somewhat greater than its actual physical length, partly because electromagnetic waves do not travel quite as fast on wires as they do in space, and partly because the antenna is not an isolated wire but is in proximity to other objects, in-

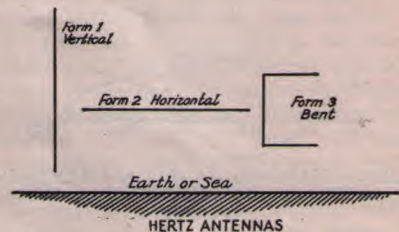

FIG. 1204 — THREE FORMS OF HERTZ ANTENNAS

cluding the antenna poles, guy wires and insulators, all of which increase the distributed capacity and thereby increase the wavelength of the antenna. Because of the varying nature of these extraneous effects, the natural period of a

given length of wire will differ with different surroundings. If the antenna is reasonably clear of other objects and is well off the ground, its natural wavelength will be between 2.07 and 2.1 times its actual length. In calculating the antenna length required for a given wavelength or frequency, the fact that local conditions will have some influence on the natural wavelength must be kept in mind.

In figuring antenna length it is convenient to be able to work directly from feet to wavelength in meters, or from feet to natural frequency in kilocycles. The following formulas will give direct results without the necessity for conversion from feet to meters and from meters to kilocycles:

Length in feet = $1.56 \times$ desired natural wavelength in meters; or

Length in meters = $0.475 \times$ desired natural wavelength in meters.

In terms of frequency:

$$\text{Length (feet)} = \frac{468,000}{\text{Freq. (kc.)}} = \frac{468}{\text{Freq. (mc.)}}; \text{ or}$$

$$\text{Length (meters)} = \frac{142,500}{\text{Freq. (kc.)}} = \frac{142.5}{\text{Freq. (mc.)}}$$

These formulas are based on a 2.1/1 ratio of natural wavelength to actual length. Expressed another way, the actual length is approximately 95% of one-half the natural wavelength. The length should be measured off accurately, of course, preferably with a good steel tape, yard stick or meter rule. Cloth measuring tapes are unreliable.

A Hertz antenna is not necessarily cut to a length equal to half the desired operating wavelength. As already stated, the antenna length can be a half wavelength multiplied by any whole number. If more than one half wave exists on the antenna, the antenna is said to be operating on a harmonic. The number of the harmonic will be the same as the number of half waves on the antenna. The current and voltage distribution on Hertz antennas working on the fundamental, second and third harmonics (one, two and three half waves, respectively) are shown in Fig. 1205. The antenna must *always* be cut for a definite number of half waves; there can be no odd quarter or eighth waves left over. It is often convenient and desirable to operate an antenna on harmonics; since the amateur bands are in even-harmonic relationship an antenna can be designed for a low-frequency band (where its length is greatest) and operated on the second, fourth, or even eighth and sixteenth harmonics when the transmitter is to work on a higher-frequency band.

Resistance of Antennas

In common with other electrical apparatus, antennas possess resistance. The resistance of an antenna usually is considered to consist of two components, the loss resistance and radiation

resistance. Both loss and radiation resistance are based on power dissipation; when we say that an antenna has a radiation resistance of 70 ohms we mean that the power radiated by the antenna in the form of electromagnetic waves is equiva-

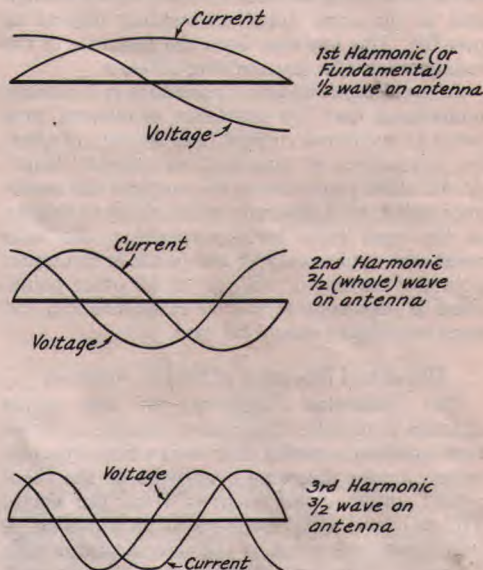

FIG. 1205 — VOLTAGE AND CURRENT DISTRIBUTION OF ANTENNAS OPERATING AT HARMONICS

lent to the power that would be dissipated in a 70-ohm resistor at the same current. Radiation resistance therefore is a measure of the radiating properties of the antenna.

Loss resistance is also an equivalent resistance representing the unradiated part of the power supplied to the antenna. Included in the loss component are the losses in the antenna wire, and, of most importance, losses in objects directly associated with the antenna such as trees, houses, nearby wires, and the ground. If the antenna is to be an efficient radiator, the loss resistance must be kept low, which means that the antenna should be strung in a clear space well away from everything likely to absorb energy.

The radiation resistance of a half-wave antenna in space is 72.4 ohms. The actual radiation resistance will depend upon the height of the antenna; radiation resistance decreases with low height. The efficiency of the antenna also increases with the height, because while increasing the height increases the radiation resistance, it has little or no effect on the loss resistance. Radiation efficiency also varies with the ratio of antenna height to wavelength, so that if the height is constant the efficiency will increase as the wavelength is decreased. This, in part, explains why low-power transmitters can cover such long distances on high frequencies; not only is the

frequency better suited to long-distance communication, but a higher proportion of the power delivered to the antenna is radiated than is the case at lower frequencies.

These considerations all point to the fact that the transmitting antenna should be built as high and as far away from surrounding objects as possible. This has ever been the first rule in the construction of a transmitting antenna.

In speaking of antenna resistance it is usually understood that the resistance is referred to a point of maximum current (odd number of quarter waves from an open end) or current "loop." At all other points along the antenna the resistance will have a different value, rising to infinity at the open ends. Strictly speaking, the term resistance applies only at maximum or minimum points of current or voltage; at all other points there is reactance as well as resistance and the term impedance should be used.

Directional Properties of Simple Antennas

The theoretical directivity of the simple antenna is of little importance because no practical amateur antenna ever works even approximately under the same conditions as the theoretical antenna far removed from the earth. The radiation characteristics of an antenna invariably are distorted by the objects surrounding it, particularly by reflection from the ground, guy wires, from nearby power or telephone lines, buildings, etc. In most cases the final effect of local conditions is such that most amateur antennas possess no appreciable directional effect in the horizontal plane.

It is useful to know, however, the effect of the antenna in producing directivity in the vertical plane — i.e., the angle with the horizon at which the radiation is concentrated, because the angle of radiation is intimately concerned with the effectiveness of the antenna for long-distance transmission. In the discussion on the transmission of radio waves through space at the end of Chapter Four mention was made of the Heaviside layer and the effect of the angle at which radio waves strike the layer. At the very high frequencies it is necessary for the waves to strike the layer at a low angle (nearly horizontal) to be returned to earth. It is therefore desirable for the antenna to be one that will radiate most of the energy at an angle not far from the horizontal — commonly called low-angle radiation.

Vertical antennas are very effective low-angle radiators, since most of the radiation is concentrated in the plane at right-angles to the line of the antenna. Vertical antennas are rather difficult to build, however, because of the height required. The lower end of the antenna should be well removed from ground, so that few amateurs find it practical to build vertical antennas for frequencies below 14 mc.

The vertical-plane radiation characteristic of

a horizontal antenna will depend upon its height above the ground. The radiation from a horizontal half-wave antenna at a height of $\frac{1}{4}$ wave above ground will in the absence of local reflections be concentrated vertically, with practically no radiation at the low angles. As the height is increased, the antenna becomes a better radiator at the lower angles. It is quite a good low-angle radiator at a height equal to one-half wavelength and there is little use in increasing the height beyond one wavelength. It is advantageous to have the horizontal Hertz antenna at least 50 or 60 feet above the ground; most amateurs can get their antennas up to this height with relatively little expense or difficulty. The antenna can be built for the 3500-kc. band and worked on harmonics on 7000 and 14,000 kc.; the harmonic operation on the higher frequencies probably will help lower the angle of radiation and increase the effectiveness of the antenna. As a matter of fact, just this sort of antenna is used by many of the amateur stations who most consistently put signals into odd corners of the world.

If this discussion should seem discouraging to the amateur who has neither the space nor facilities for constructing such an antenna, it must be remembered that these suggestions are not to be taken as hard-and-fast rules. Because of local topography the antenna is always the unknown quantity in the amateur station; it is almost impossible to predict how it will behave when

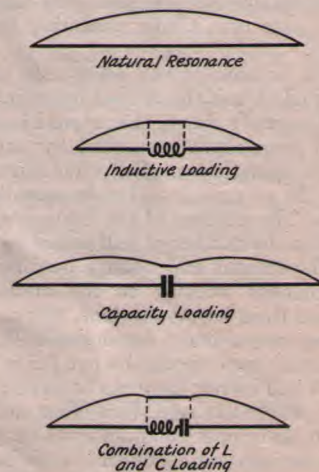

FIG. 1206 — HOW LOADING AFFECTS THE CURRENT DISTRIBUTION IN AN ANTENNA

The exciting frequency is the same in each case

actually installed. Fortunately it nearly always performs in better fashion than purely theoretical considerations would indicate.

Loaded Antennas

Often it will happen that an antenna is not exactly the right length to be resonant at the

desired frequency. In such cases it can be brought into resonance by *loading*, which simply means the insertion of a coil or condenser in the antenna to permit tuning it to the desired frequency. When inductance is inserted in the antenna the wavelength is increased (frequency is lowered). If capacity is inserted the wavelength is decreased (frequency is raised). The amount of inductance or capacity that must be inserted to bring the antenna to resonance depends upon the actual length of the wire in relation to the required length. It is possible, by the insertion of enough inductance, to raise the wavelength of the antenna to any reasonable limit, although the radiation efficiency will drop if too much loading is used. With capacity loading at the center of the antenna, however, the limit of decrease in wavelength is one-half the original natural wavelength of the antenna; at this limit the inserted capacity will be zero and the antenna will simply be cut in two parts. In practice it is not possible to carry the decrease in wavelength this far and still utilize the antenna as a radiator.

Fig. 1206 shows how the current distribution is changed by the insertion of inductance or capacity in the antenna. This distribution is based on the assumption that the inserted constants are actually lumped; that is, that the coil has no distributed capacity and that the condenser has no inductance, and that the capacity between them and other objects is negligible. In practice the coil, at least, will have distributed capacity and to that extent will not have uniform current throughout its length. With small coils the difference between the theoretical and actual current distribution will not be great.

A combination of inductance and capacity can be inserted in the antenna, in which case the net result will be either an increase or decrease in the resonant wavelength, depending upon whether the inductive or capacity reactance is larger. Combination loading is useful when power is to be coupled into the antenna at the center; to get the power into the antenna it is necessary to insert a coil which can be coupled to the transmitter, and since adding inductance raises the wavelength, the condenser is connected in series to reduce it again to the natural wavelength of the antenna. The condenser can be variable, thus providing an easy means of tuning the antenna to the transmitter.

Inspection of Fig. 1206 will show that loading does not change the shape of the current-distribution curve along the antenna wires themselves. In other words, if the frequency is fixed it is impossible to move the current loop or antinode up and down along the antenna by the insertion of coils or condensers. The current loop will invariably occur at a point one-quarter wavelength from an open end of the antenna.

Feeding the Antenna

Before the antenna can do any radiating it must be supplied with power from the transmitter. This process is commonly termed "feeding" or "exciting" the antenna. Antennas are ordi-

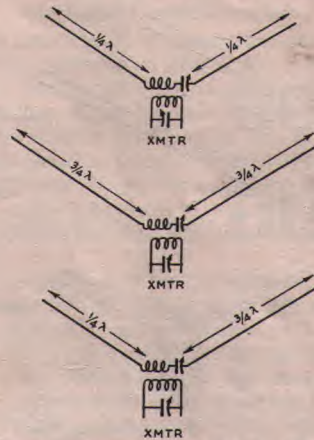

FIG. 1207 — CURRENT-FED HERTZ ANTENNAS

The coupling apparatus, which is series-tuned, should be inserted at a point an odd number of quarter waves from the open ends. There must be an even number of quarter waves on the whole system. Radio-frequency ammeters may be connected in the antenna at the coupling apparatus. With this type of feed the coupling coil usually consists of five or six turns of the same type of winding as the transmitter tank coil, the tuning condenser will have a maximum capacity of 250 to 500 μfd . Two tuning condensers may be used, one on each side of the coil, as suggested for the feeder systems described later in the chapter.

narily either "current" or "voltage" fed; these labels simply mean that the power is introduced into the antenna either at a point of maximum current — a current loop — or a point of maximum voltage — a voltage loop or current node.

A number of current-feed arrangements are shown in Fig. 1207. The antenna is split into two parts; its total length always must be a multiple of a half-wave, but the power must be introduced at a point an *odd number of quarter waves* from the open ends. Many other arrangements than those shown are possible so long as this rule is observed. Current-feed systems do not work on even harmonics because of the requirement that the coupling apparatus must be inserted at a point an odd number of quarter waves from the open ends; on the second harmonic, for instance, the antenna length which represents a quarter-wave at the fundamental frequency becomes a half wave, so the coupling coil would have to be moved to bring it back to a current loop. To work such antennas on even harmonics, it is necessary either to add more wire to the system to bring a current loop to the coupling point; to move the coupling apparatus to a current loop; or to change to voltage feed.

The practical dimensions of the systems shown in Fig. 1207 can be found by using the formulas for antenna length previously given, remembering that the length so obtained is a half wavelength and must be divided by two to give a quarter wave. For example, in the third system shown, for operation at 7000 kc. the

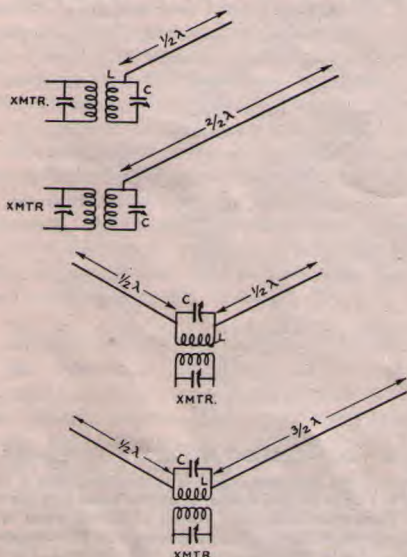

FIG. 1208 — VOLTAGE-FED HERTZ ANTENNAS

The coupling coil and condensers, which must be connected in parallel, are connected to the antenna at a voltage loop; this requires that the coupling be made at a point an even number of quarter waves (any whole number of half waves) from the open ends of the antenna. The coupling coil and condenser, LC , will be tuned to the transmitter frequency if the antenna sections are exactly half waves; if the antenna length is not an exact number of half waves the coupling circuit will be tuned to a higher or lower frequency, depending upon whether the antenna is too long or too short.

quarter-wave section would be approximately 33 feet long, while the $\frac{3}{4}$ -wave section would be 99 feet long. The wires should preferably be run in opposite directions outside the station, and should of course be as high and clear as possible, just as with any other antenna.

Voltage Feed Systems

Some of the most practical and popular amateur antenna systems are of the voltage-feed type, which differ from the current-feed types in that the energy is fed to the antenna at one of its voltage loops (current nodes) instead of at a current loop (voltage node) as in the current-feed type. Several forms of voltage feed are shown in Fig. 1208. In the two upper drawings one end of the antenna is brought into the station and attached to a tank circuit which is coupled to the output of the transmitter. The antenna length, which must be one or more half-waves, is determined by the general formula previously

given. The antenna can be operated at its harmonics as well as at its fundamental frequency. Moreover, this system is readily convertible to operation as a grounded antenna for operation at half the natural frequency (twice the natural wavelength) which it has as a Hertz antenna; this is accomplished by connecting the antenna to ground through the coupling coil and antenna condenser in series. Fig. 1209 shows one arrangement which a number of amateurs have found useful, since it can be used for operation in all amateur bands.

The two lower drawings in Fig. 1208 illustrate the method used for tuning the first and third systems of Fig. 1207 when they are to be operated on the second and fourth harmonics. In such a case each fundamental quarter wave becomes a half wave at the second harmonic and two half waves at the fourth harmonic, bringing voltage loops at the station ends of the wires. This calls for voltage feed, in which a coil and condenser are connected in parallel instead of in series as with the current-feed system.

The coil and condenser, LC , must be such that they will tune to the frequency of the transmitter without the antenna connected. Then if the antenna wire or wires have the correct length they may be attached to the circuit LC without affecting its tuning. Best results will be secured when L is very large and C very small for the frequency involved; that is, the antenna coupling or tank circuit should be very low- C . The coupling between the antenna tank circuit and the transmitter also should be loose.

Tuning the system is not difficult, although

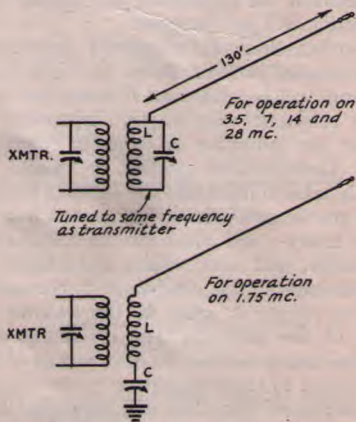

FIG. 1209 — A SIMPLE ANTENNA SYSTEM FOR FIVE AMATEUR BANDS

The antenna is voltage fed on 3.5, 7, 14 and 28 mc., working on the fundamental, second, fourth and eighth harmonics, respectively. For 1.75 mc. the system is a quarter-wave grounded antenna, in which case series tuning must be used. The antenna wire should be kept well in the clear and should be as high as possible.

If the length of the antenna is approximately 260 feet, voltage feed can be used on all five bands.

misleading results are likely to be secured if the right method is not followed. Since the antenna is being fed at a point of high voltage the current will be very low, hence an ammeter inserted in the antenna at the coupling coil will give no indication. The tuning procedure should be as follows: With the antenna disconnected from the circuit LC , start the transmitter and tune LC to resonance as indicated by a sharp increase in the transmitting-tube plate current. Now loosen the coupling until the plate current gives only a small kick as LC is tuned through resonance. Next, connect the antenna and retune LC for the plate-current kick; the resonance indication will be broader with the antenna connected, but should still come at the same setting of C if the antenna length is correct. Now increase the coupling in small steps, simultaneously readjusting C and the transmitter tank condenser to resonance each time the coupling is changed, until the transmitter is drawing normal plate current. *Always use the loosest coupling that will give normal transmitter plate current with both the transmitter tank and coupling tank adjusted to resonance.* A neon bulb touched to the end of the antenna will give, by the brightness of its glow, some indication of the r.f. voltage at the coupling point.

In using the antenna arrangement of Fig. 1209 as a grounded antenna, tuning is simply a question of adjusting the size of L and the setting of C to give resonance with the transmitter frequency. An ammeter may be inserted in the antenna at the point where it is connected to the upper end of L and the tuning adjusted for maximum current, subject of course to those limitations pointed out in Chapter Seven in the discussion on antenna tuning. The ground lead with this antenna system should preferably be short, otherwise it will make the antenna length a great deal more than that of a quarter wave and necessitate a change in the tuning system.

Feeder Systems

The methods of feeding the antenna just described all involve bringing part of the antenna into the station. Because this puts the radiating system in close proximity to the building and wiring, which can absorb energy, and also because it often requires that the height of at least part of the antenna be reduced, most amateurs prefer to put the whole antenna out in the clear and feed it through a radio-frequency transmission line. The transmission line does not radiate, but serves simply as a link between the transmitter and the antenna. The efficiency of lines used by amateurs is quite high when they are adjusted properly; the losses are small even though the line is carried through locations where the losses in a radiating antenna would be high.

R. F. transmission lines are of two general types: those on which standing waves similar to the standing waves on the antenna appear

(tuned or resonant lines), and those having uniform current distribution along the line (untuned or aperiodic lines). Because of their greater flexibility and simpler adjusting procedure the tuned lines are in more general use in amateur stations than the untuned lines. For this reason we shall describe them first.

Tuned Transmission Lines

It is not difficult to understand the operation of tuned transmission lines if the preceding discussion on antennas, particularly with reference to standing waves, has been followed closely. In fact, a resonant transmission line is simply an antenna that has been folded so that the currents flowing in the two parts are opposite in phase but of the same magnitude. Because of the folding the radiation from one wire cancels that from the other.

Two variations of the tuned transmission line are shown in Fig. 1210. At A is the simple half-wave antenna; it has been folded at the center in B so that it consists of two quarter-wave wires. Folding the wires has made the currents flowing in each oppose each other, resulting in cancellation of the fields about the wires. This is known as a quarter-wave line or feeder. The coupling coil and condenser are inserted at the junction X of the two wires; they will have no effect on the current distribution. Because the power is coupled into the line at a point of maximum current this becomes a case of current feed just as with the antennas previously discussed, and the coil and condenser are therefore connected in series.

The antenna at C has three half waves on it; in D the two outer half-waves have been folded back on themselves and the middle half-wave is replaced by a tuned circuit which acts as a phase reverser to bring the currents in the two wires into phase opposition. This circuit, consisting of a coil and condenser in parallel, is tuned to the fundamental wavelength represented by one of the half waves. Since the power is introduced at a point of high voltage (a current node) this is a case of voltage feed to the transmission line.

It is apparent from the figures that open-ended lines an odd number of quarter waves long (length of one wire) will require current feed, in which the coupling coil and condenser are connected in series—called series tuning; lines an even number of quarter waves long require voltage feed, with the coil and condenser connected in parallel—parallel tuning. Series tuning has no effect in the phase of the currents in the wires; parallel tuning reverses the phase in one wire.

In practice the two wires of the tuned transmission line should both have exactly the same length, and they are usually spaced from three to twelve inches apart. The spacing is not critical at most frequencies, since even a foot separation represents but a very small fraction of a wave-

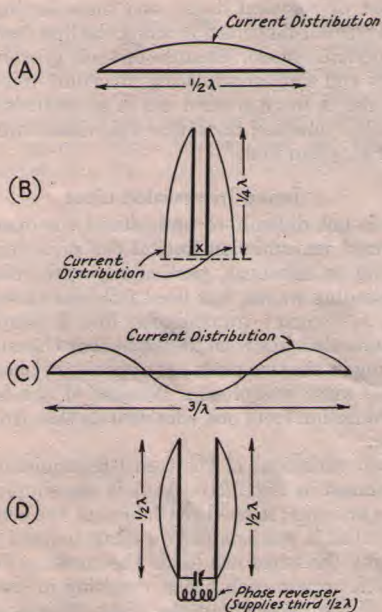

FIG. 1210 — CURRENT DISTRIBUTION ON TUNED FEEDERS

Tuned feeders can be considered simply to be an antenna folded so that the fields about the wires oppose each other, thus cancelling the radiation.

length and the cancellation is practically complete. It is preferable to make the length of the line an exact multiple of a quarter wavelength, although this is not strictly necessary because the tuning apparatus can serve the double purpose of coupling in the power from the transmitter and of loading the feeders to compensate for differences between a quarter wavelength and the actual length of the wires.

We have discussed above the means of coupling power into the feed line. This is quite distinct from the method of coupling the line to the antenna, which we shall now take up. The antenna itself may be either current- or voltage-fed, depending upon how the transmission line is connected to it. The voltage-fed system, known as the "Zeppelin" — or simply "Zepp" — because it was first used on Zeppelin airships, is probably the most popular amateur antenna.

The Zepp

In the Zepp antenna one wire of the feeder is attached to one end of a Hertz antenna. Since there is always a voltage loop at the end of the antenna, the antenna is therefore voltage-fed from the transmission line. The antenna itself may be any number of half waves long, the length of a half wave being computed by the formula previously given. The feeder is usually an odd multiple of a quarter wavelength long, although other lengths may be used. Fig. 1211 shows a

half-wave antenna fed by tuned feeders having different lengths, together with the current distribution in each case. Series tuning can be used with feeders having a length between one-quarter and three-eighths of a wavelength; for feeders much less than a quarter wave long, or for lengths from approximately three-eighths up to one-half wavelength, parallel tuning will be required. Some lengths are more easily handled than others; recommended lengths for various frequencies and the tuning method required in each case are given in Fig. 1212. Fig. 1213 shows larger-scale diagrams of series and parallel feeder

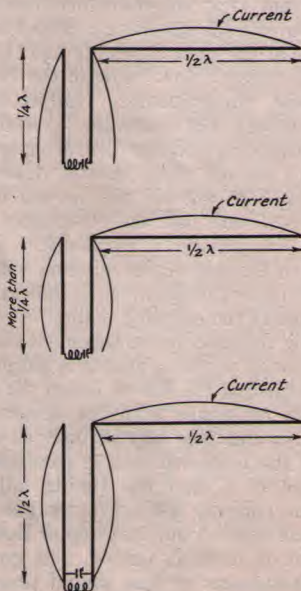

FIG. 1211 — TYPICAL ILLUSTRATIONS OF VOLTAGE FEED WITH TUNED FEEDERS (THE ZEPPE ANTEENNA)

Although usually designed to be a number of quarter waves long, the feeders can be loaded to resonance in just the same way as the simple antenna if their length is not exactly a multiple of a quarter wave. Zepp feeders are ordinarily made approximately an odd multiple of a quarter wavelength long so r.f. ammeters inserted in the feeders at the coupling apparatus will give fairly large readings and thus facilitate adjustment.

tuning, and also shows how r.f. ammeters may be connected in the feeders to indicate resonance. The use of two ammeters is not actually necessary; a single ammeter may be switched from one feeder to the other during the tuning process. If the antenna length is correct and the two feeder wires have the same length, both ammeters should give the same reading. If the readings differ by more than 10% or so when the antenna system is tuned exactly to resonance with the transmitter, the system is not properly balanced. Care should be taken to see that both feeders have the same length and that the leads inside the station from the coupling apparatus to the feeders are symmetrical. The length of the an-

tenna itself also must be correct if the feeder currents are to be balanced.

In the series-tuning arrangement it is not necessary to have two tuning condensers, but they are often used because with two condensers it is possible to shift the voltage node to a desirable point on the coupling coil, *L*, and to compensate for the effect of stray capacities at the tuning apparatus. The current distribution at resonance will be the same with either one or two condensers provided distributed and stray capacities in the tuning apparatus are negligible. Since stray capacities cannot always be neglected, however, the use of two condensers is often preferable.

The actual value of the feeder current indicated by the antenna ammeter or ammeters is not the true indication of how well the system is operating. If the meters happen to be connected at or near current nodes (voltage loops) they will indicate very little current. This is particularly likely to happen when parallel tuning is used and the feeders are nearly multiples of 1/2-wave long for the frequency being used.

A Zepp antenna system suitable for operation in several amateur bands is shown in Fig. 1214.

Current-fed Antennas

It is also possible to feed an antenna at the center through a tuned transmission line. When a half-wave antenna is fed at the center there must be a current loop at the end of the trans-

mission line; the radiating properties of the antenna are not affected by the method of feeding it.

An antenna fed at the center by a tuned transmission line is not necessarily a current-fed antenna. For example the antenna system shown in Fig. 1216 is current-fed on 7000 kc., where the antenna is a half-wave long, but is voltage fed on 14,000 kc. and higher even harmonics; in these cases the antenna is really two Zeppelin-type antennas placed end-to-end. For 3500-kc. operation there is actually only half an antenna, because the radiating portion measures only one-quarter wave at this frequency. The other quarter-wave is made up in the feeders. Although not as effective as a full-size 3500-kc. antenna, this arrangement is useful in that it will permit operation on the low-frequency band when space for a 130-foot antenna is not available.

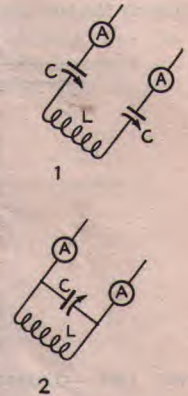

FIG. 1213—SERIES AND PARALLEL FEEDER TUNING

Series tuning is used when there is a current loop on the feeders at the coupling point; parallel tuning when a voltage loop appears at the coupling point. The feeders are operating properly when the currents indicated by the two ammeters are identical.

Tuning

The tuning of voltage- and current-feed systems is quite similar and the tuning practices recommended in Chapter Seven should be observed to obtain the maximum output compatible with good frequency stability. When series

APPROXIMATE LENGTH OF EACH WIRE, FEET	TUNING ARRANGEMENT FOR VARIOUS BANDS					
	1750 kc (160m)	3500 kc (80m)	7000 kc (40m)	14000 kc (20m)	28000 kc (10m)	
120	SER.	PAR.	PAR.	PAR.	SER. OR PAR.	
90	PAR.	SER.	SER.	PAR.	SER. OR PAR.	
60	PAR.	SER.	PAR.	PAR.	SER. OR PAR.	
40	(--)	PAR.	SER.	PAR.	PAR.	
30	(--)	(--)	SER.	PAR.	SER. OR PAR.	
15	(--)	(--)	PAR.	SER.	PAR.	
8	(--)	(--)	(--)	PAR.	SER.	

SER - Series Tuning PAR - Parallel Tuning (--) - Not Recommended

FIG. 1212—SOME SUGGESTED ZEPPELIN FEEDER LENGTHS AND RECOMMENDED TUNING METHODS FOR THE VARIOUS AMATEUR BANDS

mission line; the antenna itself is cut in the center, and each of the wires is connected to one of the feeder wires. A current-fed system, with the distribution of current shown, is given in Fig. 1215. There must be three half waves on the entire system to have the currents in the two halves of the radiating antenna in the proper phase relationship. In Fig. 1215 this is done by making each wire in the feeder one-half wavelength long. If the feeders are each one-quarter wave long it would be necessary to insert a phase-reverser at the point X; in other words, parallel tuning would be used with quarter-wave feeders in this system, just the reverse of the case of the Zepp antenna. The current-fed arrangement may be

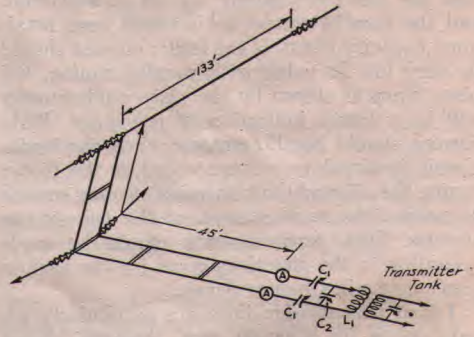

FIG. 1214—A ZEPPELIN (VOLTAGE FEED) ANTENNA FOR SEVERAL BANDS

The antenna has a fundamental frequency of 3550 kc. but could be of any fundamental frequency between 3500 and 3600 kc. Since the feeders are less than a quarter-wave long for 3550 kc., parallel tuning should be used for this band. Series tuning will be best on the 7000- and 14,000-kc. bands and probably for the 28,000-kc. band. The condensers C₁ and C₂ may be of 250- or 350-μfd. capacity.

tuning is used with either of the typical antenna systems shown in Figs. 1214 and 1216, the parallel tuning condenser should be set at minimum capacity and the series condensers at maximum. After the transmitter has been set on the desired frequency the antenna coupling coil should be coupled

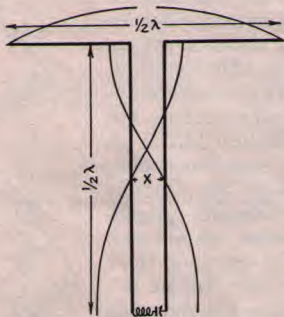

FIG. 1215 — CURRENT-FED ANTENNA WITH TUNED FEEDERS

The antenna is cut in the center and one feeder wire connected to each of the two halves. To bring a current loop at the coupling point, the feeders must be a half wavelength long.

to the transmitter tank and the series condensers tuned simultaneously, from maximum capacity down, until the radio-frequency ammeter shows maximum feeder current and the plate milliammeter shows normal plate current. If the meters should show two points of maximum current, the coupling should be loosened. After tuning for maximum current the capacity of the feeder series condensers should be increased until the current drops about 15%, if the transmitter is a self-excited rig. With an oscillator-amplifier set the best tuning adjustment is the one which gives maximum balanced feeder current. The procedure with parallel feeder tuning is similar except that the series condensers are set at maximum and the parallel condenser is tuned from maximum capacity down. If the feeder current should be very low in value with parallel tuning, the plate input as shown by the plate milliammeter will be a better indication of resonance. Plate current should be the greatest when the feeder circuit is tuned to resonance unless the feeder tuning has affected the transmitter tuning enough to necessitate readjustment of the transmitter circuits. Such readjustments should be made according to the directions given for the various transmitters in Chapter Seven.

Tuned transmission lines are particularly advantageous for amateur work because all the adjustments can be made inside the station. The dimensions of the antenna system also are less critical than when the antenna is fed by an untuned line. Inspection of the figures will show that should the length of the antenna be slightly incorrect for the operating frequency the only result will be a corresponding lack of balance in

the feeder currents. While this may cause the feeders to radiate a small portion of the energy supplied to them, nevertheless the whole system can still be tuned to resonance and will operate at good efficiency.

Untuned Transmission Lines

The tuned transmission lines just described operate with standing waves on them and therefore their length is an important consideration. The untuned transmission line, on the other hand, operates without standing waves and can be made any random length; that is, the line is aperiodic or non-resonant. To operate without standing waves, the line must be properly coupled to the antenna.

Any transmission line has distributed inductance and capacity, just as has the antenna. The inductance and capacity per unit length determine the characteristic or surge impedance of the line; inductance and capacity in turn depend upon the size of the wire used and the spacing between the wires, if the line consists of two parallel wires. The surge impedance will be

$$Z = 276 \log \frac{b}{a}$$

where Z is the surge impedance, b is the wire spacing, and a is the radius of the wire. Now it is a characteristic of a transmission line that if it is terminated in an impedance equal to its surge impedance, reflection cannot occur and standing waves will not be present. It is the object, therefore, in adjusting the untuned transmission line to terminate it at the antenna in an impedance

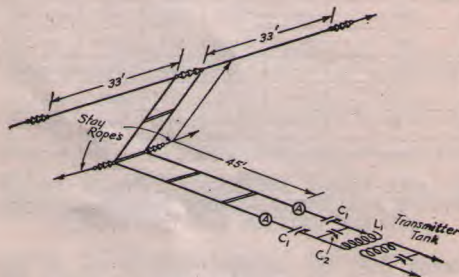

FIG. 1216 — A CURRENT-FEED SYSTEM FOR SEVERAL BANDS

The antenna has a fundamental frequency of 7100 kc. and is operated on its second and fourth harmonics for 14,200 and 28,400 kc., respectively. Parallel tuning is used on 7100 kc. and series tuning for 14,200 kc., parallel tuning again being used for 28,400 kc. The system operates as two voltage-fed Hertz antennas in parallel on the two higher frequencies. The arrangement will also work quite well on the 3500-kc. band with parallel tuning of the tank circuit, the whole system being approximately a half-wave antenna with all but the two end eighth-waves "folded back on itself." With a fundamental 3500-kc. antenna (total length about 133 feet) better all-band operation could be obtained with feeders of the length given. The condensers C_1 and C_2 can be of 250- or 350- μ fd. capacity. The feeders can be pulled back as shown if the distance between the antenna and the station is less than 45 feet.

equal to its surge impedance. When this is done the line can be any convenient length, radiation will be eliminated, and practically all the power fed into the line will be delivered to the antenna.

We have mentioned previously that the impedance of an antenna depends upon the point at which the measurement is made. It varies from an extremely high value at the open ends to a very low value at the center, assuming it is a half-wave long; if the length is a number of half waves the impedance will vary in much the same way in each half wavelength. Practically all r.f. transmission lines have fairly low impedance — 600 ohms or less — so that the line usually is terminated near the center of the antenna where the antenna impedance also is low. The termination can be made by inserting a coil at the center of the antenna (in series with a condenser so the loading effect of the coil can be cancelled) and using inductive coupling to the line, which is also provided with a coupling coil. Then by adjusting the coupling and the number of turns in each coil — while power is being supplied by the transmitter to the sending end of the line — for maximum current in the antenna and uniform current along the transmission line, the antenna impedance can be properly matched to that of the line. An untuned line is properly terminated only when the current shows no variations with distance along the line. On very long lines there may be a gradual but uniform decrease in current, but there will be no standing waves.

Terminating a line by the method just described requires that tuning apparatus be inserted in the antenna, which is inconvenient. Simpler methods make use of the fact that the impedance of an antenna varies through nearly all possible values along its length, and depend for the impedance match upon connecting the line to the proper point along the antenna. We shall now describe some of these.

The "Doublet" Antenna

The construction of the doublet antenna is shown in Fig. 1217. The transmission line is usually made to have an impedance of 600 ohms. Since it is impossible to connect a 600-ohm line directly to any part of the antenna and have the proper termination, the section *E* is "fanned" to have a gradually increasing impedance so that its impedance at the antenna end will be equal to the impedance of the antenna section *C*.

The antenna length *L*, the feeder clearance *E*, the spacing between centers of the feeder wires *D*, and the coupling length *C* are the important dimensions of this system. The system must be designed for exact impedance values as well as frequency values and the dimensions are therefore more critical than those of tuned feeder systems.

The length of the antenna is figured as follows:

$$L \text{ (feet)} = \frac{492,000}{F} \times K; \text{ or}$$

$$L \text{ (meters)} = \frac{150,000}{F} \times K$$

where *L* is the antenna length in feet or meters for a desired fundamental frequency *F*, and *K* is a constant depending on the frequency. For frequencies below 3000 kc. (wavelengths above 100 meters) *K* is 0.96; for frequencies between 3000

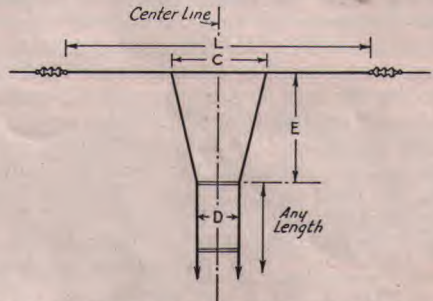

FIG. 1217 — TWO-WIRE MATCHED-IMPEDANCE ANTENNA SYSTEM

and 28,000 kc., *K* is 0.95; and for frequencies above 28,000 kc., *K* is 0.94. *F* is the frequency in kc.

The length of the antenna section *C* is computed by the formula:

$$C \text{ (feet)} = \frac{492,000}{F} \times K_1; \text{ or}$$

$$C \text{ (meters)} = \frac{150,000}{F} \times K_1$$

*K*₁ is 0.25 for frequencies below 3000 kc., 0.24 for frequencies between 300 and 28,000 kc., and 0.23 for frequencies above 28,000 kc.

The feeder clearance *E* is worked out from the equation:

$$E \text{ (feet)} = \frac{147,600}{F}; \text{ or}$$

$$E \text{ (meters)} = \frac{45,000}{F}$$

The above equations are for feeders having a characteristic impedance of 600 ohms and will not apply to feeders of any other impedance. The proper feeder spacing for a 600-ohm transmission line is computed to a sufficiently close approximation by the following formula:

$$D = 75 \times d$$

where *D* is the distance between the centers of the feeder wires and *d* is the diameter of the wire. If the wire diameter is in inches the spacing will be in inches and if the wire diameter is in millimeters the spacing will be in millimeters.

Since the feeder spacing is the critical dimension in determining the line impedance, the wires should be kept taut and the spacing should be kept constant. The feeders may be run around

corners if suitably insulated and rigidly supported, but sharp right-angle bends in the wires must be avoided. Particular care should be taken to run the feeder clearance portion *E* straight away from the antenna. Each side of *E* should be of exactly the same length and the feeder wires should tap the antenna an equal distance on either side of its exact center.

Two methods of coupling the transmission line to the transmitter output circuit are shown in Fig. 1218. The feeders should be clipped on the inductance an equal number of turns on either side of its center. The correct places for the taps can be found by starting at the center and moving the taps farther along the coil until the tubes are drawing their proper input power. The fixed condensers *C* in the direct-coupled circuit are used as a precaution to prevent short-circuiting the plate supply in case the feeders should become grounded. Since the feeder current is very small the plate current milliammeter reading will

be the most satisfactory indication of loading.

The feeder tank circuit in the inductively-coupled arrangement will be similar in construction to the usual transmitter tank circuit. This system involves an additional adjustment—that of tuning the feeder tank circuit to resonance with the transmitter and finding the optimum coupling between the two.

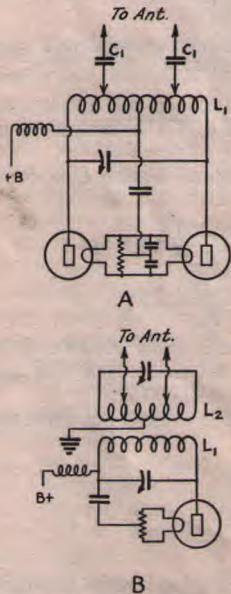

FIG. 1218—TWO WAYS OF COUPLING THE TWO-WIRE UNTUNED TRANSMISSION LINE TO THE TRANSMITTER

A is for coupling a push-pull oscillator or amplifier. The condensers marked C_1 are blocking condensers of about .002 μfd . to keep the d.c. plates supply voltage from being applied to the feeders. The inductively-coupled arrangement at B is for use with single-ended oscillators or amplifiers. It can also be used with push-pull, thus making unnecessary the blocking condensers C_1 .

fundamental frequency in any of the amateur bands. Although the dimensions shown in the chart are for the 3500-kc. band, the dimensions for the 7000-kc. band can be obtained by multiplying the frequency by 2 and dividing the lengths by 2; and

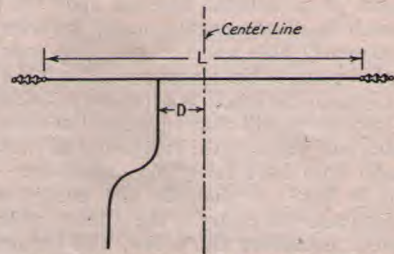

FIG. 1219—SINGLE-WIRE FEED SYSTEM

The length L and coupling D are determined from the chart

for the 14,000-kc. band by multiplying the frequency by 4 and dividing the lengths by 4. When the antenna is to be operated on harmonic frequencies the length must be such that the harmonics of the antenna's fundamental frequency fall inside the higher frequency bands. Suppose that the antenna is to be used for the 3500-, 7000- and 14,000-kc. bands. Since the limits of the 14,000-kc. band are 14,000 and 14,400 kc., the fundamental frequency of the antenna must lie between 3500 and 3600 kc. The antenna length should be, therefore, somewhere between 132 and 135.5 feet. The feeder should be tapped on the antenna at a distance from the antenna center of 18' 11" for operation with an antenna of 135.5' length, or at 18' 5" for an antenna of 132' length.

In constructing an antenna system of this type the feeder must run straight away from the antenna (at a right angle) for a distance of at least $\frac{1}{3}$ the length of the antenna. Otherwise the field of the antenna will affect the feeder and cause faulty operation of the system. There should be no sharp bends in the feeder wire at any point.

Twisted-Pair Feeders

It is evident from the formula for characteristic impedance previously given that the closer the spacing and the larger the wires, the lower will be the impedance. It happens that the impedance of a two-wire line composed of ordinary twisted lampcord or twisted No. 14 rubber-covered wire of the type used in house wiring will be approximately that of the center of the antenna itself, thus simplifying the method of connecting the line to the antenna. Such discrepancy as may exist between line and antenna impedance can be compensated for by a slight fanning of the line where it connects to the two halves of the antenna, as shown in Fig. 1221.

The twisted line is often a convenient type to use, since it is easy to install and the r.f. voltage on it is low because of the low impedance. This

Single-Wire Feed

The single-wire matched-impedance feed system operates on the same principle as the two-wire feed: there will be no standing waves on the feeder and consequently no radiation from it when its characteristic impedance is matched by the impedance at its terminal. The principal dimensions are the length of the antenna L , Fig. 1219, and the distance D from the exact center of the antenna to the point at which the feeder is attached. These dimensions can be obtained from Fig. 1220 for an antenna system having a

makes insulation an easy matter. The losses are slightly higher than those in spaced lines, however, although in lengths up to 100 feet or so the difference is negligible.

Operating Considerations With Untuned Lines

If the untuned line is to operate properly, great care must be used in making the terminating adjustment and in determining the proper antenna length. It should be realized that the foregoing formulas are based on average conditions and that the presence of guy wires, nearby power wires, etc., can upset things to a considerable extent. The antenna length, for example, is much more critical with untuned than tuned lines, because if the antenna is not the right length it will be impossible to get an exact impedance match and standing waves will appear on the line. There

the antenna. In such cases the feeder tends to act as part of the antenna; standing waves are present and often a voltage loop appears at the transmitter. When this happens, large r.f. voltages appear in the power-supply apparatus and in other points in the transmitter which should be at zero r.f. potential, if the feeder is directly-coupled to the transmitter tank inductance. This will introduce losses and often make it impossible to adjust the transmitter for efficient operation. The antenna length and feeder position should be such that the feeder current is uniform as determined by measurements made at intervals of a quarter wavelength.

Directional Antennas

By combining a number of half-wave antennas in various space relationships and exciting them in the proper phase, it is possible to concentrate the radiation in a desired direction. Few amateurs are interested, however, in working only in one particular direction, since communication is held with stations at widely varied locations. For general amateur work the ideal antenna would be one that would radiate equally well in all directions.

The construction of a directive antenna requires plenty of height and space, and usually is impractical for anything but the ultra-high frequencies — 28 and 56 mc. At lower frequencies, the radiation pattern of the antenna usually is so greatly distorted by nearby objects that the directivity obtained is small and does not justify the trouble and cost of building the antenna.

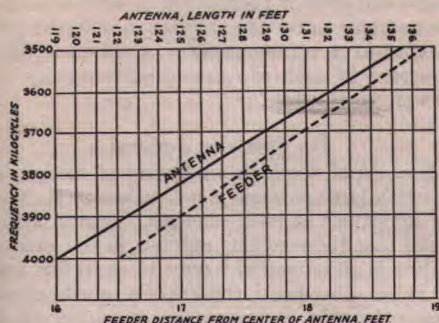

FIG. 1220 — SINGLE-WIRE FEED DATA CHART FOR NO. 14 WIRE FEEDER

will also be a circulating current in the line which represents a loss of power. The same thing will be true if the antenna length is correct but the terminating adjustment is incorrectly made. If possible, the operation of the line should be checked after installation by measuring the current in the line at two points a quarter wavelength apart. If the current at both points is substantially the same the line will be operating properly.

Lines depending upon correct impedance match at the antenna are not ordinarily very efficient if the antenna is to operate at a harmonic because the impedance distribution along the antenna changes with harmonic operation while the line impedance remains constant. Thus harmonic operation always results in an incorrect termination. Usually the systems matched at relatively high impedance, such as the doublet and the single-wire feeder, will operate fairly well on harmonics, however, although not as efficiently as on the fundamental. The twisted-pair line is inefficient at even harmonics, but will operate quite well on odd harmonics.

The single-wire feeder, especially, is critical in adjustment. Quite unorthodox behavior will result if the antenna length is incorrect or if the feeder is not connected at the right point along

Antenna Construction

For the purpose of this discussion let us divide the antenna system into two parts — the con-

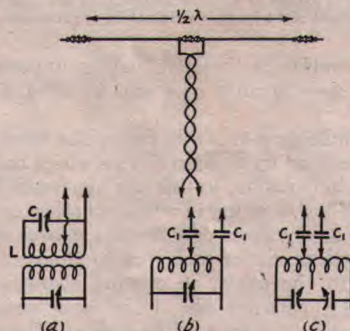

FIG. 1221 — A HALF-WAVE ANTENNA CENTER-FED BY A TWISTED PAIR LINE

An improved impedance match often will result if the antenna end of the line is fanned out in the shape of a "V" for the last 18 inches or so of its length. Two insulators also should be used at the center of the antenna so the open end of the "V" will be approximately 18 inches wide.

Three methods of coupling the line to the transmitter also are shown. The two direct-coupled methods require the use of blocking condensers, C_1 , of about .002 μfd . each, if the d.c. plate voltage appears on the transmitter tank coil. Tuning adjustments are similar to those with the two-wire untuned line or doublet.

ductors and the insulators. If the system is to operate most effectively the conductors must be of low resistance. On the other hand the insulators must be of the highest possible resistance. For low- or medium-powered transmitters an entirely satisfactory conductor is No. 14 gauge hard-drawn enamelled copper wire. For higher-powered transmitters No. 12 gauge is preferable. Every effort should be made to make the wires in one piece so that the only joints are at the output terminals of the transmitter. Where joints cannot



FIG. 1222 — WHEN HEAVY GLASS SPACERS ARE USED

in the feeder construction there is a tendency for the wires to vibrate as shown, so causing a wobbly frequency from the transmitter, if self-excited.

be avoided they should be thoroughly soldered. It should always be possible to make the Hertz antenna portion in one piece.

If the feeder system is of the tuned type the currents in it will be of the same order as those in the antenna and the same care in avoiding joints is necessary. In the untuned feeder system, however, the currents are relatively low and this

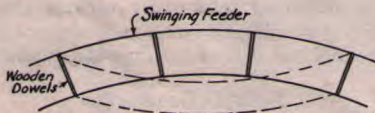

FIG. 1223 — THE USE OF LIGHT WOODEN DOWELS IN THE FEEDER

permits the system as a whole to swing. In this case the effect of movement of the feeder would not be as noticeable.

consideration is therefore not as important. In these cases smaller wire can be used if necessary.

In building a two-wire feeder the wires should be separated by wooden dowels which have been boiled in paraffine. In this way the feeder is given a tendency to swing in windy weather as a unit. When heavy glass or porcelain spacers are used the tendency is for each wire to vibrate with respect to the other, so causing changes in the capacity between the wires and consequent changes in the emitted frequency. The wooden dowels can be attached to the feeder wires by drilling a small hole in the dowels, then binding them to the feeders with wire.

A good insulation to use throughout the antenna system is Pyrex electrical-resistant glass. Glazed porcelain also is very good. It should be kept in mind that the ends of tuned feeders or the ends of the antenna are points of maximum voltage. It is at these points that the insulation is most important. A 12" Pyrex insulator is quite

satisfactory for amateur transmitters of any power. For the low-powered transmitters one of the smaller sizes, or two in series, would be satisfactory.

It is hardly possible to give practical instructions for the suspension of the antenna since the methods used will vary so widely in individual instances. In most cases poles are desirable to lift the antenna clear of surrounding buildings but in some locations the antenna is in the clear when strung from one chimney to another or from a chimney to a tree. Small trees are not usually satisfactory as points of suspension for the antenna on account of their movements in windy weather. If the antenna is strung from a point near the center of the trunk of a large tree this difficulty is not as serious.

In most locations a variety of possible arrangements will present themselves. It will be well for the amateur to try the antenna in different positions or to try different types of antennas. Time expended in such experiment undoubtedly will be well worth while.

The Receiving Antenna

Because of the high sensitivity of modern receivers a large antenna is not necessary for picking up signals at good strength. Often it will be found that the receiving antenna in the amateur station is an indoor wire only 15 or 20 feet long.

On the other hand, the use of a tuned antenna unquestionably improves the operation of the receiver because the signal strength is greater in proportion to the stray noises picked up by the antenna than is the case with the antenna of random length. Likewise, it is advantageous to have the receiving antenna well out in the clear, away from power wiring which radiates the noises resulting from the use of electrical household appliances, and to bring the signal in to the receiver over a radio-frequency transmission line. A non-radiating transmission line is inefficient

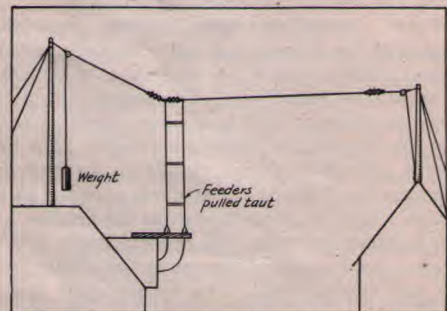

FIG. 1224 — A TYPICAL EXAMPLE OF GOOD ANTENNA CONSTRUCTION

One halyard is tied fast while the other has a heavy weight on its lower end. The weight keeps the tension on the antenna constant and compensates for stretching and shrinkage of the rope.

at intercepting signals, hence it can pass through locations where noise is great without picking up much interference. The transmission-line fed antennas used for transmitting will make excellent receiving antennas; a switch can be fitted in the feeders inside the station so that the antenna

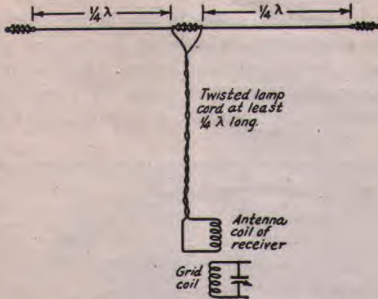

FIG. 1225 — DOUBLET RECEIVING ANTENNA

can be connected to either the transmitter or receiver.

If a separate receiving antenna is preferred, a doublet antenna of the type shown in Fig. 1225 will give very good results. The length of the lampcord transmission line may be anything convenient. The antenna itself should be a half wave long for the frequency band most used; despite the fact that the antenna is resonant for only one band, it will give good results on others as well. A popular length is 65 feet or so, designed to resonate in the 7000-ke. band.

Dummy Antennas

The absolute value of current in an antenna or feeder system is practically meaningless so far as indicating actual power is concerned, because the resistance of the antenna or feeder at the point where the current is measured is rarely known. In tuning the antenna system to the transmitter the antenna ammeter's chief function is that of providing a means for comparing the effects of different adjustments. The actual power output must be measured by adopting a different method. The simplest of these is that involving the use of a non-radiating or "dummy" antenna.

The dummy antenna is a resistance of suitable value capable of dissipating in the form of heat all the output power of the transmitter. One of the most satisfactory types of resistors for amateur work is the ordinary incandescent electric lamp. Other non-inductive resistors of suffi-

cient power-dissipating capacity can be used, however.

Three circuits for use with dummy antennas are given in Fig. 1226. The first of these is for use with a low-resistance dummy — say 25 ohms or less. The resistor is connected in series with a tank circuit which tunes to the same frequency as the transmitter and is coupled inductively to it. If the value of the resistance is known accurately — measurement is difficult, however, because of skin effect at high frequencies — the power may be determined by measuring the radio-frequency current in the resistor and applying Ohm's Law ($W = I^2R$). The resistor must be non-inductive.

Incandescent bulbs, which in the 115-volt sizes have a resistance of 75 ohms or more at operating temperature for ratings or 150 watts or less, will work more satisfactorily in either of the other two circuits. The lamp should be equipped with a pair of leads, preferably soldered right to the terminals on the lamp base, so that the number of turns on the inductance across which the lamp is connected can be varied. The tank circuit again tunes to the same frequency as the transmitter, and should be low-C. The system is adjusted in the same way as the coupling for the untuned transmission lines described previously. The number of turns across which the lamp is connected should be varied, together with the tuning and the coupling between the dummy circuit and the transmitter, until the greatest output is obtained for a given plate input.

In using lamps as dummy antennas, a size corresponding to the expected power output should be selected so that the lamp will operate near its normal brilliancy. Then when the adjustments have been completed an approximation of the power output can be obtained by comparing

the brightness of the lamp with the brightness of one of similar power rating in a 115-volt socket. For more accurate measurement of power output, a lamp can be calibrated by measuring the illumination it delivers with different power inputs. The Weston Photronic cell is useful for this sort of work, as are also the various photo-electric cells. In most cases, however, the rough determination of power by visual methods will be sufficient.

A dummy antenna always should be used in making transmitter adjustments which require power output measurements or comparisons but do not require actual radiation of power. This gives a more accurate indication of the power output and avoids putting the transmitter on the air.

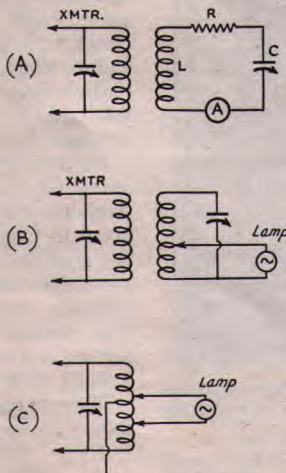

FIG. 1226—DUMMY ANTENNA CIRCUITS

Chapter Thirteen

ASSEMBLING THE AMATEUR STATION

IN THE preceding chapters we have seen how all the component parts of an amateur station may be designed and built, and we have come to know that a complete station consists of a receiver, a transmitter with power supply, a monitor or frequency meter or both, and suitable antennas for transmission and reception. Many amateurs, on completion of the necessary units for their station, are so anxious to put the outfit into operation that they merely toss the apparatus on a table, connect it up in some haphazard fashion and begin operating. This procedure frequently results in danger to the operator and his family from exposed wiring. Also it invariably leads to unreliable and unsatisfactory operation of the equipment. The sincere amateur not only takes pride in the quality of signal his transmitter emits but also in the appearance of his station. One does not need a powerful transmitter or an elaborate receiver to have a fine amateur station.

Finding a Location

The first problem encountered in building a station is usually the selec-

tion of a suitable space in the house. Some fortunate amateurs are able to provide a special "shack" away from the house. Others are able to monopolize an entire room for their station. Most amateurs, however, are obliged to content

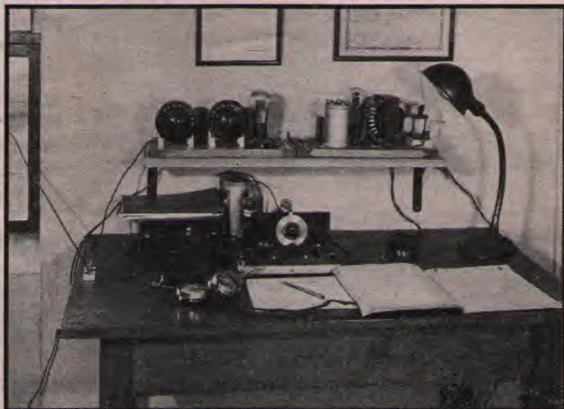

AN IDEAL ARRANGEMENT FOR THE LOW-POWERED STATION

The transmitter and power supply are placed on a shelf supported above the operating table. The key is at the right, well back on the table so that the operator's elbow will be supported. Ample space is available on the front of the table for writing. The small switch at the left is the antenna change-over switch. It is unnecessary if a separate antenna is used for reception.



A CORNER OF THE ROOM CAN ACCOMMODATE AN AMATEUR STATION OF MODERATE PROPORTIONS

Originally started on spark and following all the improvements this station emerges in its present-day form. W8HD, described in June, 1933, QST, shows a practical design for the average station owner.

themselves with a corner of the basement, their bedroom or the attic. Some fellows, living in apartments, have even been restricted to the space under the kitchen stove, or in a small closet. Still others, for the sake of convenience and comfort, have built their transmitter and receiver into a small cabinet located in the living room, the heavier power supply apparatus being arranged in the basement.

Further schemes for the amateur limited in space are made available by remote control methods—some typical examples of which are given in Chapter Eleven. With remote control, the transmitter and its power supply may be located in the attic, in the basement or in a specially built "dog-house" in the back yard. The receiver and control switches may then be located in a small cabinet in the living room or on a small table in any other room available.

There is certainly room for an amateur station in any house or apartment.

The Operating Position

Convenient operation of a station calls for ample space around the receiver and key. There

must be room for the log book, call book, message blanks and miscellaneous papers. For this reason, it is almost universal practice to use a table or desk as the operating position.

The items which are handled most frequently are the receiver, power switches, key, frequency meter and monitor. It is well, therefore, to group all of these on the table or desk selected. Perhaps the most popular practice is to place the receiver towards the left of the table. The monitor is then located alongside the receiver on the right (where it is near enough to give a good signal in the receiver) and the key is screwed to the table slightly to the right of this and far enough back to give a good support for the operator's arm.

Since the filaments of the transmitting tubes should be lighted before the high voltage is applied, two switches should also be fitted on the table — one for the primary of the filament transformer and one in the supply circuit to the plate supply apparatus. These switches can be mounted under the front edge of the table in a position convenient for right-hand operation. With low-power transmitters, the filament and plate power are often sup-

plied by one transformer; in such a case only one power-line switch will be necessary.

It is usually inadvisable to mount the transmitter or power supply on the operating table. In the case of the self-controlled transmitter, indeed, it is extremely bad practice. All such transmitters are susceptible to vibration and to the effects of "body capacity." Consequently, they cannot be expected to deliver an output of constant frequency when subject to the vibration of keying and the movements of the operator. It is very much better, even in the case of a crystal controlled set, to mount the transmitter itself on a shelf supported from the wall, on a separate table, or in a special frame. In any case, the transmitter should be conveniently placed with respect to the feeder or antenna leads.

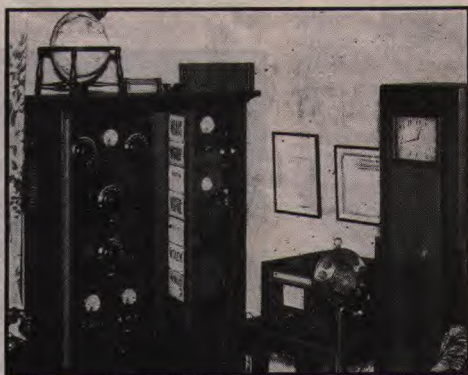

AN AMATEUR STATION SUITED FOR THE LIVING ROOM

This station when not in operation poses as another piece of furniture. Nonetheless, W6IBK is capable of excellent amateur work. This equipment was originally described in August, 1933, *QST*.

The power supply equipment of even a low powered transmitter requires careful placement because of the danger involved. It should not be on the operating table nor should it be under the

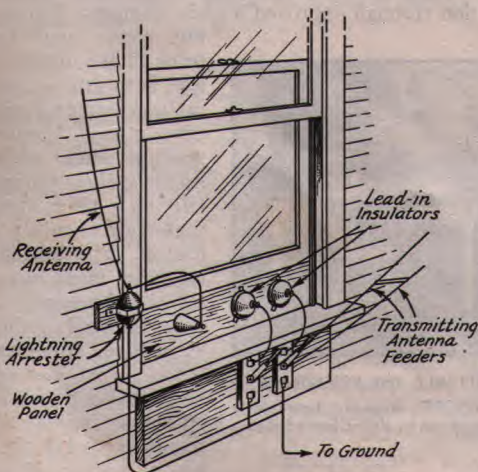

ANTENNA AND FEEDER GROUNDING METHODS FOR LIGHTNING PROTECTION

Lightning switches are used on the transmitting antenna lead-in or feeders. A lightning arrester is satisfactory for the receiving antenna.

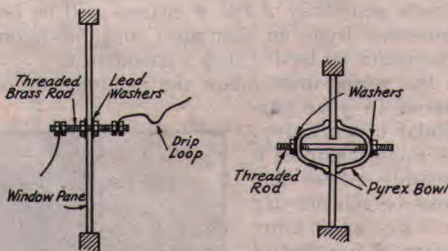

TWO GOOD METHODS OF BRINGING THE TRANSMITTING ANTENNA LEAD-IN THROUGH A WINDOW

table in a position where the operator's feet could come in contact with it. Often it is placed on a shelf under the transmitter table or frame. Alternatively, it could be in a large and well ventilated box under the operating table and off to one side.

It is futile, of course, to attempt to outline every possible arrangement of the components of the station. It is better that the amateur should make a study of the stations he visits (and of those illustrated in this chapter and in *QST*) with the idea of improving on them or at least adapting them to his particular needs.

Underwriters' Rules

Before actually starting on the installation and wiring of the complete station, the amateur should certainly make a study of the Underwriters' requirements.

The specific rules covering radio equipment are given in Article 37 of the National Electric Code, under the heading of "Radio Equipment." Some states have adopted this code or a more strict version of it. Certain cities have adopted it, too, and they enforce their regulations through municipal inspectors. Before making an installation it is well to find out if the apparatus and wiring are subject to a state and city inspection as well as to inspection by insurance interests.

"Approved" refers to devices designed for the purpose used in accordance with recognized practice. The device must be acceptable to the inspection department having jurisdiction (there may be a city or state inspector in addition to the insurance rating or inspection bureau). When there is no inspector for the city or state, insurance interests inspect through their rating organizations, one of which covers each part of the United States. Your local insurance agent can advise you in whose territory you are located so you can get in touch with the proper authority.

A conference with the inspection department *before* making an installation or change will save inconvenience and expense later. Your own interests and those of fellow citizens will be best protected from an insurance and fire-hazard standpoint by having such a conference.

The wiring must follow the requirements observed in your particular community. In some instances a separate power line must be run directly to the watt-hour meter. A few feet of "BX" from the nearest outlet to a "Square-D" switch box, properly fused at the switch, will usually be satisfactory. The installation of high-voltage apparatus and wiring must be done in approved fashion. High-tension cable, supported on porcelain pillar insulators, keeping the high voltage away from all woodwork and neighboring conductors, is a safe type of construction.

A receiving antenna can be connected to ground before it gets to the set through either the

in-door or out-door type of lightning arrester. Several approved types are sold by local dealers with complete instructions for installation. These arresters usually are simply spark-gaps sealed in a vacuum to lower the voltage break-down. The ground can be made by scraping a water pipe or ground rod clean and bright with a file. A 10-cent



AN ELABORATE PHONE AND C. W. STATION

As shown in May, 1933, *QST*, W8AFM is a station which is entirely flexible from the standpoint of being capable of operation with a minimum of effort on all amateur communication frequencies.

ground-clamp will make a good connection to the pipe. A yearly inspection will insure a good ground. An approved lightning arrester operating at a potential of 500 volts or less is required for each lead-in conductor of a receiving station. There are no requirements for indoor antennas, however.

The lead-in wires must be brought into the station through approved lead-in bushings. A good but cheap way to bring in the antenna lead is to drill a hole in the center of a large window pane. A brass machine screw with rubber gaskets will go through this and make an excellent lead-in. The lead-in insulator must have a 3-inch clearance beyond the wall of the structure. Antenna leads must never come within 5 inches of supply wires. A wooden board at the top or bottom of a window will make a good support for lead-in bushings under most circumstances.

Everyone who owns an amateur station or who plans to have one should send ten cents (not in stamps) to the Superintendent of Documents,



A PRACTICAL LAYOUT WITH ALL THE ESSENTIALS

This medium-powered station of W8DED, originally described in Feb., 1933, *QST*, shows how a spare room can be altered into a first-class amateur relay and DX station.

Government Printing Office, Washington, D. C., for the booklet *Safety Rules for Radio Installations*, Handbook of the Bureau of Standards No. 9.

The Antenna

In addition to the problems of installing the apparatus inside the house, the amateur must also concern himself with the problems of the outdoor equipment — the antenna and its support. In this connection it is very difficult to offer suggestions because of the widely different requirements in different locations. It is certain that any amateur having the patience and application necessary for the completion of the transmitter, receiver and accessories is not to be stumped by the selection and provision of suitable supports for the antenna. In some cases the lack of yard space presents a *real* problem. Usually the owner of the adjoining property will consent to the antenna being extended into his domain. Failing that, about the only alternative is to restrict one's activity to one of the higher frequency bands on which a sufficiently short antenna can be used.

Building a Mast

It is very rarely that an effective antenna can be erected without putting up some form of mast. And in many cases the mast must be erected and guyed in a restricted space. With the idea of providing some suggestions for the prospective mast-builder, we will present the description of a typical mast. The example selected is a 40-foot mast of simple construction and low cost. The only lumber used is 2-by-2 straight-grained pine (which many lumber yards know as hemlock) or even fir stock. The uprights can be each as long as 22 feet (for a mast slightly over 40 feet high) and the cross-pieces are cut to fit. Four pieces of 2-by-2 22 feet long will provide enough and to spare. The only other materials required are five ¼-inch carriage bolts 5½ inches long, a few spikes, about 300 feet of No. 12 galvanized iron wire for the guys or stays, enough No. 500 ("egg") glazed porcelain strain insulators to break up the guys into sections and the usual pulley and halyard rope. If the strain insulators are put in every 5 feet approximately 30 of them will be enough.

After selecting and purchasing the lumber — which should be straight-grained and knot-free — three sawhorses or boxes should be set up and the mast assembled in the manner indicated in the diagrams. At this stage it is a good plan to give the mast two coats of "outside white" house paint.

After the second coat of paint is dry, attach the guys and rig the pulley for the antenna halyard. The pulley anchorage should be at the point where the top stays are attached so that the back

stay will assume the greater part of the load tension. It is better to use wire wrapping around the stick, with a small through-bolt to prevent sliding down, than to use eye bolts. The latter weaken the mast.

If the mast is to stand on the ground, a couple of stakes should be driven to keep the bottom from slipping. At this point the mast may be "walked up" by a pair of helpers. If it is to go on a roof, first stand it up against the side of the building

and then hoist it, from the roof, keeping it vertical. The whole assembly is light enough for two men to perform the complete operation — lifting the mast, carrying it to its permanent berth and fastening the guys — with the mast vertical all the while. It is therefore entirely practicable to put up this kind of mast on a small flat area of roof that would prohibit the erection of one that had to be raised vertical in its final location.

Once the base has been placed on its spot and made level right-and-left, the front and back guys from the mid-section are anchored so that the mast stands vertical fore-and-aft. The last step is to anchor the top guys so that the upper section lines up vertical. This can be done quite accurately by sighting up from the bottom, while a helper tightens and loosens guys as commanded.

Transmitting antennas or feeders must be grounded by means of lightning switches. The switch should be of the single-pole double-throw type having a minimum break distance of 4 inches and a blade of at least .0625 square inch cross-section. The switch should be in the most direct line between lead-in and ground but can be located either outside or inside the station. Live parts of the switch must clear the wall (or other conductors) by 3 inches. The switch must

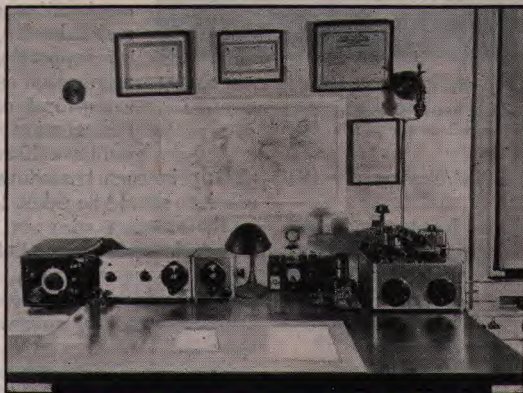

NEATNESS AND ACCESSIBILITY FEATURE THIS MODERN STATION

Described in March, 1933, *QST*, W3NR is complete upon a table top, allowing plenty of room for the operator.



EVERYTHING AT HAND FOR ENJOYABLE AMATEUR OPERATION

Experience in amateur radio of many years standing was an important factor in the most recent W3QP, as described in December, 1933, QST.

be connected to the ground wire whenever the station is not in operation.

Antennas for receiving and low-power transmitting stations should be supported and insulated similarly to public service communication lines, while for medium- and high-power stations

the requirements for constructing supply lines for transmitting electrical energy in like situations must be met. Antennas should not cross over or under supply lines or telephone and telegraph wires nor should they run above and parallel to them in such a way that a falling antenna might come in contact with a live wire. Antennas should not cross railroad tracks or public thoroughfares. They should not be attached to poles owned and maintained by local public utilities for supporting power lines or communication cables or wires. In most cases local ordinances forbid such construction as a menace to the public welfare. When antennas are

put up in such hazardous locations special precautions should be taken to have ample strength in the antenna wire and its supports, as well as ample clearances. Antennas should not be supported on chimneys. When a tree is used there should be some provision for keeping the antenna from snapping when the tree sways in the wind.

Any size of wire can be used for a receiving antenna. Probably No. 14 B. & S. (American Wire Gauge) hard-drawn copper wire, enameled to

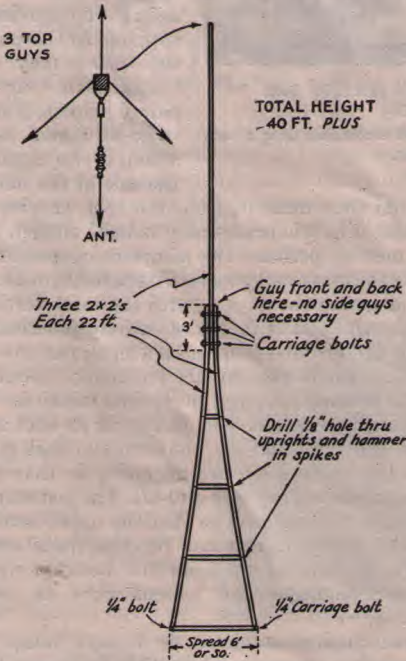

DETAILS OF A 40-FOOT MAST SUITABLE FOR ERECTION IN LOCATIONS WHERE SPACE IS LIMITED

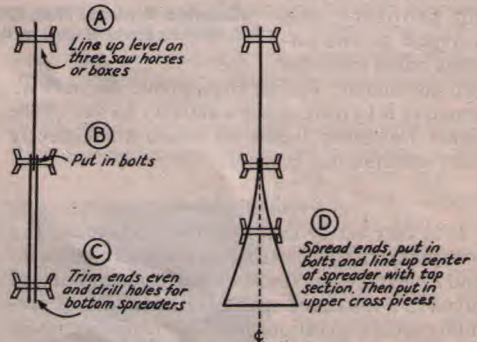

ILLUSTRATING THE METHOD OF ASSEMBLY

prevent corrosion, will have the best balance of electrical conductivity and mechanical strength for that purpose. Transmitting antenna wires for medium or high power amateur stations should have a strength not less than that of No. 10 hard-drawn copper wire and should be insulated with insulators having a minimum creepage distance of 10 inches.

Chapter Fourteen

THE A.R.R.L. COMMUNICATIONS DEPARTMENT

THE Communications Department is concerned with the practical operation of the stations of League members. Its work includes arranging amateur operating activities, establishing standard operating procedure, encouraging good operation, improving message relaying, and concluding tests to these ends.

The aim of the Communications Department is to keep in existence an active organization of League stations made entirely of privately-owned radio stations covering the entire continent of North America. One of its objectives is to create a body of skilled operators whose services and abilities will further the general knowledge of the art of radio communication. The relaying of friendly messages between different parts of the country without charge is one of the most important phases of the work coming under the supervision of the Communications Department. Amateur operators have also always been of great assistance to our country in times of emergency in which quick communication has been a factor, especially when other methods of communication have failed.

These objects of our organization must be kept in mind at the same time we, as individuals, are getting enjoyment from our chosen hobby. Only by operating our stations with some useful end in view can we improve the service which we give others and increase the pleasure we get, at the same time justifying our existence.

The activities of the Communications Department are arranged and recorded through *QST* and by special correspondence. Tests and relays are arranged from time to time to develop new routes for traffic handling, to prepare ourselves to render emergency service in time of need, and to bring to light additional general radio information. In this way all members of the League benefit from the experience of certain individuals who excel along specified lines of work.

The policies of the Communications Department are those urging members to adopt uniform operating procedure and to use system in their station operating. The Communications Department constantly works to make our communication system as efficient as a non-commercial message-handling organization can be. Compliance with government regulations, orderly operating, and cooperation with each other and with outside interests for the advancement of the art, are a part of its policies. The first duty of the department to member-stations is to supervise operating work so well that the amateur will continue to justify his existence in the eyes of his

Government. Then he will be allowed a continuance of the privileges which he has received as his due in the past.

Records of worth-while traffic handling, of message routing, and of specific tests conducted between the different stations are kept in the files of the Communications Department and recorded in the Official Organ of the League, *QST*.

It is obviously impossible to distribute up-to-the-minute information in a monthly periodical. Therefore mimeographed circular letters are used on special occasions. The active stations are thus kept informed of the developments in such a rapidly progressing system. Through such letters, through *QST* and through a large volume of routine correspondence with individual members, the contact is kept good and the activities we have outlined are effectively carried out by the interested member-stations.

Official Broadcasting Stations have been appointed to improve on even the arrangement we have just outlined. These stations regularly transmit addressed information to all amateurs by voice and in telegraphic code. This service of sending addressed messages to A.R.R.L. members on current matters of general interest is supplemented by official and special transmissions on timely subjects from Headquarters Station W1MK (schedule given on page 12).

In these pages we are going to explain the organization of the Communications Department, the proper message forms to use, and some special practices which experience has proved best. We urge that you help strengthen amateur radio by studying the operating practice suggested and by adopting uniform operating procedure.

Everyone at League Headquarters welcomes criticism that is accompanied by constructive suggestions. The fullest benefits of organization are realized only when every member participates freely in his organization and gives brother amateurs and his organization the benefit of his advice, suggestions, criticism, participation and cooperation in the common cause, amateur radio. In individual operating work as well, advancement comes as we learn to exchange constructive suggestions in the true amateur spirit.

In some department of the A.R.R.L.'s field organization there is a place for every active amateur who has a station. It makes no particular difference whether your interest lies in getting started and learning the code, traffic handling, DX, friendly contacts by 'phone, or other aspects of amateur radio. Whatever your qualifications, we suggest that you get into the game

and cooperate with your Section Manager by sending him a monthly report of the particular work you are doing. As you become experienced in amateur work of different kinds it is likely that you will qualify for appointment as O.R.S. or O.P.S. or that you can accept other important responsibilities in connection with the conduct of A.R.R.L. work in the different sections. Operating work and the different official appointments will be explained in detail in this and the following chapter. We want to make it clear right at the start that the Communications Department organization exists to increase individual enjoyment in amateur radio work, and we extend a cordial invitation to every amateur and reader of this book to participate fully in the different enterprises undertaken by and for amateur operators.

Organization

The affairs of the Communications Department in each Division are supervised by one or more Section Communications Managers, each of whom has jurisdiction over his section of a Division.

For the purpose of organization the A.R.R.L. divides the United States and Possessions (plus Cuba and the Isles of Pines) and Canada (plus Newfoundland and Labrador) into divisions as follows:

ATLANTIC DIVISION: Delaware, District of Columbia, Maryland, Pennsylvania, that section of New Jersey within the Third Federal Inspection District, and that section of New York within the Eighth Federal Inspection District.

CENTRAL DIVISION: Illinois, Indiana, Kentucky, Michigan, Ohio and Wisconsin.

DAKOTA DIVISION: Minnesota, North Dakota and South Dakota.

DELTA DIVISION: Arkansas, Louisiana, Mississippi and Tennessee.

HUDSON DIVISION: The entire Second Federal Inspection District, consisting of certain counties of New Jersey and New York States.

MIDWEST DIVISION: Iowa, Kansas, Missouri and Nebraska.

NEW ENGLAND DIVISION: Connecticut, Maine, Massachusetts, New Hampshire, Rhode Island and Vermont.

NORTHWESTERN DIVISION: Idaho, Montana, Oregon, Washington and the Territory of Alaska.

PACIFIC DIVISION: Arizona, California, Nevada, the Territory of Hawaii and the Philippine Islands.

ROANOKE DIVISION: North Carolina, Virginia and West Virginia.

ROCKY MOUNTAIN DIVISION: Colorado, Utah and Wyoming.

SOUTHEASTERN DIVISION: Alabama, Florida, Georgia, South Carolina and the Island of Porto Rico. (*The Republic of Cuba and the Isle of Pines are attached to this Division for Communications Department activities.*)

WEST GULF DIVISION: New Mexico, Oklahoma and Texas.

MARITIME DIVISION: The provinces of New Brunswick, Nova Scotia and Prince Edward Island. (*Newfoundland and Labrador are attached to this Division for Communications Department activities.*)

ONTARIO DIVISION: Province of Ontario.

QUEBEC DIVISION: Province of Quebec.

VALALTA DIVISION: Provinces of Alberta and British Columbia and Yukon Territory.

PRAIRIE DIVISION: Provinces of Manitoba and Saskatchewan and the Northwest Territories.

Each United States Division elects a Director to represent it on the A.R.R.L. Board of Directors and the Canadian Divisions elect a Canadian General Manager who is also a Director. The Board determines the policies of the League which are carried out by paid officers at League Headquarters. When the Board is not in session, the officers of the League, constituting an Executive Committee, can act for the Board, subject to certain limitations.

The Communications Department has a field organization made up of officials selected by the membership in a way similar to the Directors. Each Director and the Communications Manager at League Headquarters decide the proper sectionalizing of each Division. A.R.R.L. operating territory is further sub-divided into Sections to facilitate the collection of reports, and more important, the efficient supervision of activities and appointments in the field organization.

These field officials (S.C.M.s) are listed on page 5, while the names and addresses of the Directors are printed on page 6, of each *QST*.

In each Section there is a Section Communications Manager who, under the direction of the Communications Manager, has authority over the Communications Department within his Section. He is responsible to, and reports to the Communications Manager, except in Canada, where he reports to the Canadian General Manager.

Whenever a vacancy occurs in the position of Section Communications Manager in any section of the United States, its island possessions or territories, or the Republic of Cuba, the Communications Manager announces such vacancy through *QST* or by mail notice to all members of the Section, and calls for nominating petitions signed by five or more members of the Section in which the vacancy exists, naming a member of the Section as candidate for Section Communications Manager. The closing date for receipt of such petitions is announced.

After the closing date, the Communications Manager arranges for an election by mail or declares any eligible candidate elected if but one candidate has been nominated. Ballots are sent to every member of the League residing in the Section concerned, listing candidates in the

order of the number of nominations received. The closing date for receiving ballots is announced. Immediately after this date, the Communications Manager counts the votes. The

section over the activities indicated by their titles. They will report and be responsible to the Section Communications Manager for their work. With the consent of the Communications Manager the Section Manager may, if necessary, designate a competent League member to act for him in a particular matter in any part of his territory. He shall be careful to instruct such an appointee properly in the duties he is to execute while acting for the S.C.M.

2. His territorial limitations are determined by the Division Director (or C.G.M.) and the Communications Manager.

3. The Section Manager is responsible to the Communications Manager at League Headquarters for maintenance of records of all his appointments, and cancellations of such appointments either for violations of the regulations under which these are issued, or for violations of the F.R.C.'s amateur regulations. The Form 4 (appointment) and Form 4C (cancellation) cards provided, must be sent to Headquarters that A.R.R.L. mailing lists and records may be kept exactly in accordance with those of the S.C.M. office. Annual endorsement of O.R.S. and O.P.S. certificates (and S.C.M. notification-to-Headquarters by Form 4) is required to keep these appointments in effect.

4. The Section Manager is responsible for the cooperation of active station-owners in A.R.R.L. activities, contests, traffic work, etc. and is authorized to devise and develop special plans in the furtherance of Section interest and esprit de corps.

5. The Section Manager is the Section executive. His leadership must take into consideration the proper distribution of basic and key appointments to those best qualified in the different cities and in each radio club in the Section. Such



candidate receiving a plurality of votes becomes Section Communications Manager. The Canadian General Manager similarly manages such an election for a Section Communications Manager whenever a vacancy occurs in any section of the Dominion of Canada, Newfoundland or Labrador. Section Communications Managers are elected for a two-year term of office.

The office of any Section Communications Manager may be declared vacant by the Executive Committee upon recommendation of the Communications Manager, with the advice and consent of the Director, whenever it appears to them to be in the best interests of the membership, and they may thereupon cause the election of a new Section Communications Manager.

Communications Department Officials and Appointments

These S.C.M.s elected in each Section by the A.R.R.L. members in that Section, appoint active qualified amateur stations for special types of radio work in the A.R.R.L. field organization. Whether your activity is directed toward DX, experimenting, 'phone or traffic, there is a place for you in League work. Your S.C.M. welcomes a monthly report from every active ham. The following regulations will explain the duties of the S.C.M. and the specialized radio work of all stations honored by holding A.R.R.L. appointments.

Section Communications Manager

1. The Section Manager shall appoint Route Managers, Official Observers, Official Broadcasting Stations, Official Relay Stations, Official 'Phone Stations, and individuals and/or stations for specific work in accordance with the qualifications and rules for such appointments. He shall likewise make cancellations of appointments whenever necessary.

Appointees shall have full authority within the

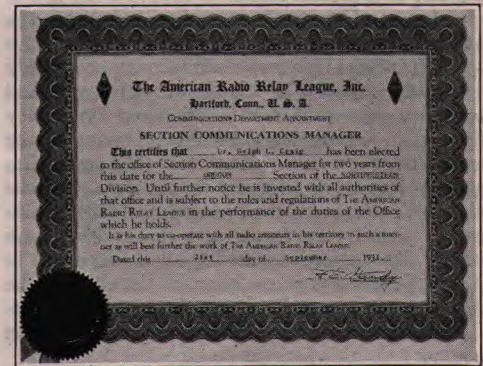

problems as the geographical distribution and coverage of stations (OBS) sending addressed information to members, the distribution of appointments in the different frequency bands for effective Section activities require careful study. The S.C.M. must in his decisions try to grant

recognition to the best qualified operators and stations, and endeavor to insure A.R.R.L. representation and activity in each amateur group.

6. The S.C.M. may appoint *only League members* to any A.R.R.L. office. He must see that each O.R.S. and O.P.S. appointed has the proper qualifications, as indicated by actual operating radio tests and/or station inspection made by him or under his direction. The S.C.M. shall also conduct investigations of radio organizations and interference cases whenever such cases are referred to him by Headquarters or the Division Director. It is his duty to demonstrate Section leadership and coordinate all types of amateur operating work to make his Section as effective and active as possible.

7. The S.C.M. may requisition necessary Communications Department supplies provided for making appointments and supervising the work in his section. He may render an itemized postage expense account at intervals, for reimbursement. Section Managers are entitled to wear the distinctive A.R.R.L. pin with red background, similar in other respects to the regular black-and-gold A.R.R.L. membership pin.

8. The S.C.M. shall render a monthly report or activity summary to Headquarters. It shall be made up from all reports from all active stations, whether members or not, and include comprehensive information on each appointee. Reports shall be mailed to Headquarters by S.C.M.s on or before the 20th for the reporting month (16th to the 15th inclusive) in the mainland U. S. A. and Canada.

Official Observers

Each S.C.M. recommends for appointment one or more Observers who report regularly to the S.C.M. on off-frequency operation noticed, sending out notification forms (provided from Headquarters) to help amateurs in keeping within the assigned bands.

Each Official Observer shall have an accurately calibrated monitor or frequency meter, checked regularly against A.R.R.L. Standard Frequency Station transmissions and by government or commercial "marker" stations of known frequency operating adjacent to our own amateur channels. Observers shall be supplied with notification postal card forms and report blanks on which the stations notified shall be reported to A.R.R.L. Headquarters (through the office of the S.C.M.) just as rapidly as the blanks are filled out. Radio contacts with off-band stations shall be made by O.O.s wherever possible.

Observers also shall report harmonic or parasitic radiations and other operation of commercial or government telegraph services or broadcasting stations causing interference in the amateur bands, these being reported direct to Headquarters as promptly as possible so that remedial action may be taken.

The notification service to amateurs is designed as a friendly move to protect amateur privileges from official government restrictions. These are invited by careless or intentional disregard of regulations by individuals who may thus jeopardize the enjoyment of all amateurs. Observers also report flagrant violations of good amateur practice, including improper procedure, poor spacing, "a.c." notes, etc.; all to the end that these things may be brought before the operators concerned, the effectiveness of stations improved, and high standards of amateur operating maintained. Observers also make annual station-distribution surveys showing actual density of stations and operating conditions in our different amateur bands.

Route Managers

The Route Manager is the authority on schedules and routes and his station must be active in traffic and organization work. Section Managers



generally appoint one Route Manager to every twenty or twenty-five Official Relay Stations. The Route Manager's duty is to line up routes, coordinate schedules, bring together stations needing schedules and to cooperate with all active stations in his district.

The Route Manager must keep posted on schedules already in operation within the Section, on the between-Section schedules and those kept with foreign points by stations within his jurisdiction (territory determined by the S.C.M.). The R.M. reports these data monthly (at the same time O.R.S. report).

Route Managers may wear the League emblem with the distinctive deep-green background.

Official Broadcasting Station

The Official Broadcasting Station transmits information on timely subjects addressed to radio amateurs and A.R.R.L. members. This must be sent at scheduled times during the week following receipt of the information from A.R.R.L. Headquarters.

Applicants for this appointment must submit

their qualifications to the Section Manager with the proposed dates, times and frequencies for transmission of the broadcasts. In deciding on the times of transmission schedules, preference should be given to those times when the largest number of amateurs are listening, that is, the hours between 6:00 p.m. and midnight. Station power, geographical location, frequent transmissions, ability to copy messages direct from WIMK in advance of mail, should all receive consideration by S.C.M.s in making appointments. Section Managers are instructed to cancel the appointments of stations not adhering to the schedules agreed upon, and the appointments of stations not returning information on current or revised schedules when periodic surveys of the broadcasting system are made.

Basic A.R.R.L. Appointments

Both Official Relay Station and Official Phone Station appointees receive an appointment certificate to be displayed in the station, a quarterly bulletin from Headquarters, and Form 1 reporting cards on which to turn in the monthly reports to the Section Communications Manager.

Appointment certificates (O.R.S. and/or O.P.S.) must be returned to Section Managers annually for proper endorsement to keep these in effect more than one year. Any applicant who fails to qualify may again apply for appointment after three months have elapsed. In making application, forms indicating knowledge of recommended procedure must be filed with the S.C.M. on blanks available from each S.C.M. office. New applicants must communicate by radio with a Section official and receive approval of this official or his representative. Operators with personal responsibility and high standards of operating are recognized as O.R.S. and O.P.S., and appointed to these important basic posts in A.R.R.L. organization because they have the qualifications. As a result of operating appointments carefully supervised and given only to active men with demonstrated ability in technical and operating matters, the present effective field organization, in successful operation for many years is maintained.

It is the duty of Official Relay Station and Official Phone Station appointees (a) to report activities monthly to the S.C.M., whether or not a special reporting form is available; (b) to keep stations always on the air, i.e., in readiness for operation and in actual service; (c) to follow A.R.R.L. operating practices; (d) to take part in the activities of the League whenever possible; (e) to hold message files three months ready for any call by the S.C.M. or licensing authority. Reports are due on the 16th of each month for mainland United States stations.

O.R.S. and O.P.S. appointments are not transferable from one station-owner to another. When an appointee moves they may be trans-

ferred from one Section to another by arrangement with the S.C.M.s concerned who notify Hq. of cancellation and re-appointment. Appointments may be cancelled by S.C.M.s whenever three consecutive reports are missed, and evidence of regular work and reports for three months must be submitted before such a station may be reinstated. "Earned reinstatements" may be made within one year without filing new application papers. After this the filing of new application papers is desirable, and discretionary with the Section Manager.

The Official Phone Station Appointment

This appointment is for every qualified ham who normally uses his "mike" more than his key in his amateur station, and who takes a pride in the manner of signal he puts on the air, and aims to have his station really accomplish worthwhile



communication work. Official Phone Station appointees must endeavor to live up to the Amateur's Code of good fraternalism and operating equality. The appointment gives phone operators the advantages of organization for systematic coöperation in emergencies, quarterly bulletin news, and operating tests. O.P.S. appointment does not stress traffic handling by voice, but aids phone operating enjoyment by helping to formulate good voice operating practices, not overlooking the emergency organization aspect. The operating standards established make voice work more enjoyable and systematic.

1. O.P.S. use circuit precautions that avoid frequency modulation and overmodulation, and employ indicators in their transmitters to detect maladjustments.

2. O.P.S. coöperate with each other, and with all amateurs, regardless of power, or frequency. No "monopolization" of a frequency channel by an individual operator is permissible, excepting such a situation is demanded by emergency conditions at a station in an isolated area.

3. Major adjustment of transmitters is completed outside of heavy operating hours.

(No needless music playing under the guise of legitimate testing to increase QRM and constitute an exhibition of selfishness. Such tests should be performed using dummy antennas, and radiating antennas connected only for bona fide voice communication.)

4. O.P.S. endeavor at all times to make the operation of their stations an example to be looked up to by other amateurs; they will stand ready to assist other amateurs in observing frequency bands, in complying with F.R.C. regulations, in adopting and furthering common sense, effective, voice operating procedure as formulated and codified by the group of O.P.S. for the benefit of all, and the furtherance of radiotelephone work.

All operators who use voice should use the suggestions codified to improve operating conditions in the phone bands. Official Phone Station appointment differs from O.R.S. appointment in that the operators are *not appointed specifically to handle traffic*. Of course when traffic is handled these stations observe the same high standards of responsible operating work; they will therefore at all times cooperate with S.C.M.s and R.M.s by prompt dispatch or delivery of any traffic that may be sent via the phone bands. Stations holding O.P.S. appointment will, of course, insist on complete addresses, and give city of origin and number each message carefully in accordance with A.R.R.L. procedure.

The application for O.P.S. appointment does not require a 15-w.p.m. code speed such as prescribed in the test for O.R.S. applicants. Applicants must have had at least one year of amateur operating experience. A description of the station for which appointment is sought must be given the S.C.M. If the arrangement meets modern technique, if the operating experience is adequate, and if the adjustment of the station checked by inspection, or test over the air, is also approved, the A.R.R.L.-O.P.S. appointment may be granted by the S.C.M. and Headquarters so notified at the same time the appointee receives his certificate. The station signal, and its operation too, must meet satisfactory standards. Appointments may be cancelled for inactivity, or failure to meet prescribed qualifications (like all other A.R.R.L. appointments) to make the O.P.S. appointment really stand for something worth while to all voice-operated amateur stations.

A Phone Route Manager or Activities Manager may assist the S.C.M. in necessary station inspection or test-over-the-air for O.P.S. applicants.

This appointment is for every live-wire operator of a first class phone, working any phone band. Like all other C.D. appointments, one makes application to the Section Communications Manager for O.P.S. appointment, and receives the necessary application forms. A certificate of appointment is issued by the S.C.M. if and when an appointment is granted. Appoint-

ments are issued good for one year, but must be kept in effect by activity and annual endorsement by the S.C.M.

If you have a year or more of radiotelephone operating experience behind you, and a well adjusted voice station of modern technique on the air, this is a cordial invitation to you to get in touch with your Section Manager. Tell him you are interested in the Official Phone Station appointment; ask him for application forms.

The Official Relay Station Appointment

Every radio telegraphing amateur interested in traffic work and worthwhile operating organization activities who can meet the qualifications is eligible for appointment of his station as



A.R.R.L. Official Relay Station. Brasspounders handle traffic because they enjoy such work. There is fun in efficient operation; pride in accomplishing something; opportunity to demonstrate operating proficiency at the same time this is maintained and increased. The potential value of the operator who handles traffic to his community and country is enhanced by his ability, and the readiness of his station and schedules to function in the community interest in case of emergency. Operators with good signals and personal responsibility toward the communications they handle, seek and hold Official Relay Station appointment. Traffic-awareness is often the sign by which mature and experienced amateurs may be distinguished from newcomers to the ranks of hamdon.

1. O.R.S. must be able to transmit and receive at least 15 words per minute.

2. O.R.S. cooperate with each other, and with all amateurs. They must make their stations and operating an example to other amateurs. They must follow standard A.R.R.L. operating practices (use proper message form, finish signals, misc. abbreviations, etc., as set forth in the next Chapter).

3. Appointees must keep a transmitter and receiver in operative condition at all times. Consistent activity is required to keep appointments

in effect and must be demonstrated by regular reports to the S.C.M.

4. O.R.S. must display a high degree of interest in relay traffic activities, nets, schedules, trunk lines, and such.

O.R.S. are the "minute men" of amateur radio — always organized, reporting, active, and holding their equipment in tip-top condition ready for instant service on any communicating problem, large or small. Official Relay Stations are, as the name implies, stations that can be depended on absolutely to see a hard job through. They are ready for every opportunity of service to the public or amateur radio that may come their way, whether a special emergency, test, experiment, or just in the line of ordinary operation. They deliver and relay promptly all traffic that comes their way. O.R.S. appointment is highly significant since it puts the station owner in a special position as respects the opportunities of service. The appointment certificate also has come to be known as the badge that shows an amateur station has "arrived" in the dependable class.

O.R.S. appointees are entitled to wear the distinctive blue A.R.R.L. pin which is similar to the regular membership pin except that it has a blue instead of a black background.

To secure an appointment as Official Relay Station is quite a simple matter if you have the qualifications and a little experience. After building the station, gaining some code speed, and reporting your activities to the S.C.M. as suggested, ask the S.C.M. to furnish you with an application for appointment as Official Relay Station (or use the one printed for your convenience in the rear of this book). The S.C.M. will be glad to send you the necessary forms to be filled out and returned to him, and to give you advice on the application as may be necessary. But you must be willing to accept a certain amount of "personal responsibility" in regard to regular reporting each month, and absolute reliability in forwarding and delivering a number of messages regularly through your station. The appointment is one made with advantage to yourself. Fill out the application form as soon as you can qualify!

An Invitation

Any A.R.R.L. member who has a station and operator's license and wants to "do things" with his equipment will find it easy and very much

worth while to earn an appointment in the Communications Department organization. As has been explained, knowledge and use of certain fundamentals of operating procedure are prerequisite to appointment to the important basic posts in our field organization. Study procedure. Put into practice the things that you read. Originate and relay some traffic regularly. Keep a few schedules with other amateurs. Report all your activities on time (the 16th) each month to your S.C.M. whose address is given on page 5, any *QST*, to prove your qualifications and interest. Regardless of whether you have yet applied for appointment, a postal to the S.C.M. will give him information to use in his report for *QST* and boost the standing of your station and Section.

"Being active" in amateur work should not mean sacrificing all the varied interests we have as individuals. A few hours daily spent in *planned* radio work, a postal to our S.C.M. once each month about our activities, and including traffic handled, gives us credit for all we attempt, contact with and news from fellow hams through *QST*, and adds the touch that makes the difference between organized ham radio and merely haphazard unchronicled work. All reports summed up, make the record for Section and Division. There are many kinds of amateur work; each has its benefits and its leaders. Friendships, DX, technical knowledge, proficiency in construction, ability to operate or communicate, all are important. Interest in a special phase of amateur work is all right if moderation is observed.

The well-balanced amateur will not only know how to handle a message, but will have extended the principles of neatness and efficiency to his other station activities. The complete amateur station includes attention to traffic matters as part of its regular routine; it is one essential in building a reputation for "reliability" in amateur work. Communication (general) involves an exchange of thoughts. "Traffic" is merely the exchange of thoughts for ourselves or others using messages as a simple medium to get the thought "exact and concise." The development of systematic habits of work is beneficial and may extend to fields other than amateur radio with profit also. To get full value from amateur organization work you must take part in such work. The different appointments have been explained. If your station is active you are invited to qualify and take part fully in A.R.R.L. work.

Chapter Fifteen

OPERATING A STATION

THE enjoyment of our hobby comes from the operation of our station once we have finished its construction. Upon the *station* and its *operation* depend the traffic reports, DX, and communication records that are made. We have taken every bit of care that was possible in constructing our transmitter, our receiver, frequency measuring and monitoring equipment and in erecting a suitable antenna system. Unless we make ourselves familiar with uniform standard operating procedure, unless we use good judgment and care in operating our stations, we shall fall far short of realizing the utmost in results achieved. More than this, we may make ourselves notorious unless we do the right thing, because we may interfere with other stations or delay their work.

After some listening-in experience you will hear both kinds of operators and realize the contrast that exists between the operation of the good men and that of "lids" and "punks" who have never taken the trouble to familiarize themselves with good practice. Occasionally you will pick up an amateur whose operating is so clean-cut, so devoid of useless efforts, so snappy and systematic, that your respect is gained. It is a pleasure to listen and work with him. On the other hand the operator who sends forty or more CQ's and signs two or three times in a slipshod manner gains the respect of no one. His call may be impossible to identify. His lack of operating judgment seriously impairs and handicaps *his own success and enjoyment* in addition to causing other amateurs to form an unfavorable opinion of his work and the uncalled-for interference he creates. By *proper* procedure the number of two-way contacts (QSO's) and the enjoyment and profit in each will be a maximum.

For most efficient operation, the transmitter should be adjusted for satisfactory, stable, operation *on one frequency* in the amateur band. Use of quartz crystal control helps to insure close adherence to one frequency and gets results when once a dependable arrangement has been installed. With self-controlled sets known condenser settings to approximate certain frequencies will make it possible to change location in the band slightly to get around interference if necessary. But when such a change is made take no chances; always check frequency with care for there is *no* good excuse for off-band operation. Calibrations of the station frequency standard should be checked at least once a month by A.R.R.L. standard frequency transmissions to guard against variations, and daily comparison

with dependable stations assigned channels adjacent to our bands is desirable. Do not try to work too near the edge of an amateur band. Keep well *within* the estimated accuracy of your frequency measuring equipment and means of measurement. Check frequency often.

The operator and his methods have much to do with limiting the range of the station. The operator must have a good "fist." He must have patience and judgment. Some of these qualities in operating will make more station records than many kilowatts of power. Engineering or applied common sense are as essential to the radio operator as to the experimenter. Do not make several changes in the set hoping for better results. Make one change at a time until the basic trouble or the best adjustment is found.

An operator with a clean-cut, slow, steady method of sending has a big advantage over the poor operator. Good sending is partly a matter of practice but patience and judgment are just as important qualities of an operator as a good "fist."

The good operator sends signals which are not of the "ten words per minute" variety, but they are slow enough so that there is no mistaking what he says. The *good* operator does not sit down and send a long call when he wants to work someone. He puts on the 'phones and *listens in*. He goes over the dial thoroughly for some time. The fellow that is admired for his good operating is the one who is always calling some particular station instead of using the "inquiry signal." Because he *listens* until he hears someone to work and *then* goes after him, our good operator gets his man nearly every time. A good operator chooses the proper time to call, he makes plain signals, and he does not call too long. A short call is sufficient because if a station does not get the call it is likely that he is listening to another station. A long call makes the receiving operator lose patience and look for someone else.

The adjustment of the receiver has much to do with successful operation, too. The good receiving operator notes the dial setting and when he has completed calling in proper fashion, he waits a moment and then tunes above or below the logged dial setting just in case something has shifted slightly in the receiver or transmitter. The best operator has patience and waits a few minutes in case of delay at the transmitter or in case fading signals make a second answer necessary.

Communication

After all, communication has as its object the exchange of thought between two minds.

Sometimes those minds are near each other and it is possible for the individuals concerned to converse at length and exchange their thoughts freely. At other times, and this when radio communication is involved, the individuals are miles apart and the thoughts to be transmitted must be condensed to just a few words. Then these words must be relayed or passed on from operator to operator. When they reach their ultimate destination someone can interpret them fully if they have been properly and carefully handled by the intermediate operators.

Time is involved in making any exchange of thought. Because every man's life and experience is measured by time, this factor becomes important in everything we do or say. The number of messages handled, the number of distant stations worked, the number of records made at our station, all depend in some degree on the time available for our hobby. The more time we spend at the set, the more well known our station becomes and the more extensive will be the sum total of our results in amateur radio.

As time is a factor, uniform practices in operating have become necessary to insure a ready understanding of what is going on in the minds of each operator. "Q" signals and abbreviations of various sorts have been devised and are in general use to-day just because of the time element involved, to enable every operator to exchange intelligible thoughts with as little waste effort as possible. So proficiency in the commonly-used abbreviations and in knowledge of uniform operating practices is to be desired. Proficiency comes with practice. In the Appendix are the "Q signals" and some abbreviations used by amateur operators.

Accuracy is of first importance. Then *speed* in transmission and handling of radiograms must be considered. Very often, transmission at moderate speeds moves traffic more quickly than fast sending. A great deal depends on the proficiency and good judgment of the two operators concerned. Fast sending is helpful only when two fast operators work together.

Procedure

Official Relay Stations and Official Phone Stations conform in their operating procedure to definite high standards which are mentioned on the appointment certificate. Some specific rules and regulations have been made to raise the standard of amateur operating. Official A.R.R.L. Stations observe the rules regarded as "standard practice" carefully.

Any actively-operating stations will do well to copy these rules, to post them conspicuously in the station, and to follow them when operating.

1. The calling station shall make the call by transmitting not more than three times the call signal of the station called and the word DE, followed by its own call signal sent not more than

three times, thus: VE9AL VE9AL VE9AL DE W1MK W1MK W1MK. In amateur practice this procedure may be expanded somewhat as may be necessary to establish communication. The call signal of the calling station *must* be inserted at frequent intervals for identification purposes. Repeating the call signal of the called station five times and signing not more than twice (this repeated not more than five times) has proved excellent practice in connection with break-in operation (the receiver being kept tuned to the frequency of the called station). The use of a break-in system is highly recommended to save time and reduce unnecessary interference.

Stations desiring communication, without, however, knowing the calls of the operating stations within range, may use the signal of inquiry CQ, in place of the call signal of the station called in the calling formula. The A.R.R.L. method of using the general inquiry call (CQ) is that of calling three times, signing three times, and repeating three times. CQ is not to be used when testing or when the sender is not expected or looking for an answer. After a CQ, the dial should be covered thoroughly for two or three minutes looking for replies.

The directional CQ: To reduce the number of useless answers and lessen needless QRM, every CQ call shall be made informative when possible. Stations desiring communication shall follow each three-times-sent CQ by an indication of direction, district, state, continent, country or the like. Stations desiring communication with amateur stations in a particular country shall include the official prefix letters designating that country after each CQ. To differentiate domestic from foreign calls in which the directional CQ is used, the city, state, point of the compass, etc., is mentioned only after the third CQ just before the word DE and the thrice-repeated station call. Examples follow. A United States station looking for any Canadian amateur calls: CQ VE CQ VE CQ VE DE W1MK W1MK W1MK K. A western station with traffic for the east coast when looking for an intermediate relay station calls: CQ CQ CQ EAST DE W6CIS W6CIS W6CIS K. A station with messages for points in Massachusetts calls: CQ CQ CQ MASS DE W3QP W3QP W3QP K. In each example indicated it is understood that the combination used is repeated three times.

2. Answering a call: Call three times (or less); send DE; sign three times (or less); and after contact is established decrease the use of the call signals of both stations to once or twice. Example. W1BIG DE W1MK GE OM GA K (meaning, "Good evening, old man, I am ready to take your message, go ahead").

3. Ending signals and sign off: The proper use of AR, K and SK ending signals is as follows: AR (end of transmission) shall be used at the end of messages during communication and also at the end of a call, *indicating when so used that com-*

munication is not yet established. K (invitation to transmit) shall be used at the end of each transmission when answering or working another station, carrying the significance of "go ahead." SK (or VA) shall be used by each station only when signing off, this followed by your own call sent once for identification purposes. SK (end of work) sent alone, or for clarification followed by a single (never more) "CQ DE ---", indicates to others that you are through with the station which you have been working and will listen for whomever wishes to call. Examples:

(AR) G2OD DE W1AQD AR (showing that W1AQD has not yet gotten in touch with G2OD but has called and is now listening for his reply). Used after the signature between messages, it indicates the end of one message. There may be a slight pause before starting the second of the series of messages. The courteous and thoughtful operator allows time for the receiving operator to enter the time on the message and put another blank in readiness for the traffic to come. If K is added it means that the operator wishes his first message acknowledged before going on with the second message. If no K is heard, preparations should be made to continue copying.

(K) ZL2AC DE W6AJM R K. (This arrangement is very often used for the acknowledgment of a transmission. When anyone overhears this he at once knows that the two stations are in touch, communicating with each other, that ZL2AC's transmission was all understood by W6AJM, and that W6AJM is telling ZL2AC to go ahead with more of what he has to say.) W9APY DE W3ZF NR 23 R K. (Evidently W9APY is sending messages to W3ZF. The contact is good. The message was all received correctly. W3ZF tells W9APY to "go ahead" with more.)

(SK) R NM NW CUL VY 73 AR SK W7NT. (W7NT says "I understand OK, no more now, see you later, very best regards, I am through with you for now and will listen for whomever wishes to call W7NT signing off.")

4. If a station sends test signals to adjust the transmitter or at the request of another station to permit the latter to adjust its receiving apparatus, the signals must be composed of a series of V's in which the call signal of the transmitting station shall appear at frequent intervals.

5. When a station receives a call without being certain that the call is intended for it, it shall not reply until the call has been repeated and is understood. If it receives the call but is uncertain of the call signal of the sending station, it shall answer using the signal --- (?) instead of the call signal of this latter station. QRZ? (see Appendix) is the appropriate signal to use, followed by your call to ask who is calling and get this station to call again.

6. Several radiograms may be transmitted

in series (QSG) with the consent of the station which is to receive them. As a general rule, long radiograms shall be transmitted in sections of approximately fifty words each, ending with --- (?) meaning, "Have you received the message correctly thus far?"

7. A file of messages handled shall be kept, this file subject to call by the Section Manager at any time at his discretion. Only messages which can be produced shall be counted in the monthly reports, and these under the A.R.R.L. provisions for message-counting.

Above all, the operator will *never make changes or alterations in the texts or other portions of messages passing through his hands*. However slight or however desirable such changes may seem, the changing of a message without proper authority or without the knowledge of the originator of the message may be considered the "unpardonable sin." The proper thing to do of course is to notify the party filing the message or the originating station of your observations, secure permission from the proper source for making the change by sending a "service message" or other means. If the case seems urgent, the traffic should not be delayed but should be delivered or forwarded with appropriate notation or service accompanying it.

In acknowledging messages or conversation: Never send a single acknowledgment until the transmission has been successfully received. "R" means "All right, OK, I understand *completely*." When a poor operator, commonly called a "lid," has only received part of a message, he answers, "R R R R R R R R R R, sorry, missed address and text, pse repeat" and every good operator who hears, raves inwardly. The string of acknowledgments leads one to believe that the message has been correctly received and that it can be duly filed away. By the time this much is clear it is discovered that most of the message did not get through at all, but must be repeated. The part after the string of R's may be lost due to fading or interference. It may be assumed the message was correctly received. (The message then filed never arrives at its destination.) Be clear and understandable. Use R *only* when *all* is received correctly.

Here is the proper procedure to follow when a message has been sent and an acknowledgment is requested. When all the message has been received correctly a short call followed by "NR 155 R K" or simply "155 K" is sufficient. When most of the message was lost the call should be followed by the correct abbreviations (see Appendix) from the international list, asking for a repetition of the address, text, etc. (RPT ADR AND TXT K). When but a few words were lost the last word received correctly is given after ?AA, meaning that "all after" this should be repeated. ?AB for "all before" a stated word should be used if most of the first part of the

copy is missing. ?BM AND (two stated words) asks for a fill "between" certain sections. If only a word or two is lost this is the quickest method to get it repeated.

Do not send words twice (QSZ) unless it is requested. Send single unless otherwise instructed by the receiving operator. When reception is very poor, a QSZ can be requested to help make better copy. When conditions are even moderately fair, a QSZ is unnecessary. Few things are as aggravating as perfect transmission with every word coming twice. Develop self-confidence by not asking others to "QSZ" unless conditions are rather impossible. Do not fall into the bad habit of sending double without a request from fellows you work.

Do not accept or start incomplete messages. Omission of the fundamental parts of a message may keep a message from getting through to its destination. Official Relay Station appointments are subject to cancellation for failure to make messages complete enough.

Operating Notes

A sensitive receiver is often more important than the power input in working foreigners. There is not much difference in results with the different powers used, though a 250-watt will probably give 10% better signal strength at the distant point than a Type '52, 800 or 10's, other factors being the same. It will not do much better than this because the field strength drops so rapidly as we get away from the antenna. In working foreign countries and DX stations you should be able to hear ten or a dozen stations before expecting that one of them will hear your call.

Hams who do not raise DX stations readily may find that (a) their sending is poor, (b) their calls ill-timed or judgement in error. It is usually *wasted* effort for W/VE stations to send CQ DX. When conditions are right to bring in the DX, and the receiver sensitive enough to bring in several stations from the desired locality, the way to raise DX is to use the appropriate frequency and to *call these stations*. Reasonably *short* calls, with appropriate and brief breaks to listen will raise stations with minimum time and trouble. The reason W/VE CQs do *not* raise DX is that the number of U. S. A. and Canadian hams is so great that it is always possible for a foreign station to find a large number of W/VE's calling, without wasting time on stations not definitely looking for this station.

The signal "V" is sometimes sent for two to five minutes for the purpose of testing. When one station has trouble in receiving, the operator asks the transmitting station to "QSV" while he tries to adjust his receiving set for better reception. A decimal point is often sent by the letter "R." Example: 2.30 PM is sent "2R30 PM." A long dash for "zero" and the Morse C (. . .) for "clear" are in common use. An operator who misses directions for a repeat will send "4,"

meaning, "Please start me, where?" These latter abbreviations, like others in our present day practice, are hybrids, originating in wire practices and Morse usages.

Improper calling is a hindrance to the rapid dispatch of traffic. Long calls after communication has been established are unnecessary and inexcusable. Some stations are slow to reply to a call. However, the day of the station with dozens of switches to throw is past. Controls for both receivers and transmitters are simpler, fewer in number, and more effective. The up-to-date amateur station uses a "break-in" system of operation and just one switch controlling the power supply to the transmitter.

Poor sending takes the joy out of operating. There are stations whose operators are not able to send better and those who can send better but do not. The latter class believe that their "swing" is pretty. Some use a key with which they are not familiar.

Beginners deserve help and sympathetic understanding. Practice will develop them into good operators. The best sending speed is a medium speed with the letters quickly formed and sent evenly with proper spacing. The standard type telegraph key is best for all-round use. Before any freak keys are used a few months should be spent listening-in and practicing with a buzzer. Regular daily practice periods, two or three half hour periods a day, are best to acquire real familiarity and proficiency with code.

No excuse can be made for a "garbled" text. Operators should copy what is sent and refuse to acknowledge messages until every word has been received correctly. *Good operators never guess* at anything. When not sure of part of a message they ask for a repeat. The "lid" operator can be told very quickly when he makes a mistake. He does not use a definite "error" signal and go on with his message but he usually betrays himself by sending a long string of dots and nervously increasing his rate of sending. The good operator sends "?" after his mistakes and starts sending again with the last word sent correctly. Unusual words are sent twice; "?" is sent and then the word repeated for verification.

The law concerning superfluous signals should be noted carefully by every amateur. Some operators hold the key down for long periods of time when testing or thinking of something to send. Whenever this is done during operating hours, someone is bothered. Unnecessary interference prevents someone from getting in contact with (QSO) someone else, and if messages are being handled the copy is ruined. If you must test, disconnect the antenna system and use an equivalent "dummy" antenna (made of lumped resistance, capacity and inductance). Always send your call frequently when operating with the antenna. Pick a time for adjusting the station apparatus when few stations will be bothered.

Using a Break-in System

A break-in system of operation makes it possible for us to interrupt the other fellow if we miss a word or do not understand him. With a telephone we stop talking as soon as the distant party speaks and interrupts us. In a telegraph office the operator who misses a word opens his key so that the sending is interrupted and cannot go on until the receiving operator has had his say and again closed the circuit. In a radio system using break-in the receiving operator presses the key and makes some long dashes for the transmitting operator to hear. As soon as he gets the signal he stops transmitting and listens to what the receiving operator says, before resuming sending.

A separate receiving antenna makes it possible to listen to most stations while the transmitting tubes are lighted. It is only necessary with break-in to pause just a moment occasionally when the key is up (or to cut the carrier momentarily and pause in a 'phone conversation) to listen for the other station. Appreciation of the many advantages should make the use of break-in wide-spread for both voice and code work.

Useless calling and unnecessary transmission during periods of heavy QRM can be prevented through intelligent use of break-in. Long calls, for example, are inexcusable, inconsiderate and unnecessary. Every transmitter can be so arranged that by lifting the key (and connecting 'phones to the receiver if these are cut off during transmission) the operator can ascertain if the station called is replying. Brief calls with frequent short pauses to listen for replies constitute intelligent operating, devoid of useless effort. During c.w. transmissions insert a "BK" and pause briefly at intervals. This makes it possible for the other operator to stop you, or get fills, if necessary. If not, transmission may be resumed. If you find that the station you are calling has, in the meantime, connected with another amateur instead of answering your call you will have at least saved yourself some wasted effort. QRM will also be lessened thereby. If the operators understand that break-in is being used, a "bk" and "g.a." will be of greatest value to interrupt transmission and direct when it shall be resumed. Where voice is being used similarly, conversations resemble wire telephone communication, and flow smoothly from subject to subject, and the "click" noted when the carrier is cut off momentarily can be as effective as the word "break" (so this can be eliminated) when two operators experienced in this mode of operating use this improved system of operation.

The faster the change from transmitting to receiving can be engineered the better. A Morse-wire type key with a switch on the side, in series with either the filament center-tap (cathode) of the oscillator stage, or in the negative high voltage supply can be used for voice break-in. (There

must be enough fixed bias on amplifier stages to keep the plate current low when r.f. excitation is nil, and h.v. on, of course.) If there is audio feedback from speaker to microphone, head-phones should solve the problem, or if desired a relay can be used to short the microphone transformer. A push button to put the carrier on the air only while talking is a completely practical device, and amateur 'phone operators would do well to emulate the push-to-talk efficiency of the Airways operators to improve conditions in the 'phone bands.

C.w. telegraph break-in is usually simple to arrange. With break-in, ideas and messages to be transmitted can be pulled right through the holes in the QRM. Snappy, effective, efficient, enjoyable amateur work really requires but a simple switching arrangement in your station to cut off the power and switch 'phones from monitor to receiver. If trouble occurs the sending station can "stand by," (QRX) or it can take traffic until the reception conditions at the distant point are again good.

In calling, the transmitting operator sends the letters "BK," "BK IN," or "BK ME" at frequent intervals during his call so that stations hearing the call may know that a break-in is in use and take advantage of the fact. He pauses at intervals during his call, to listen for a moment for a reply from the station being called. If the station being called does not answer, the call can be continued. If the station called answers someone else, he will be heard and the calling can be broken off. When two stations are using break-in, they can interrupt each other at any time when something goes wrong or a letter is dropped, and traffic can be handled in half the usual time. There is a real "kick" from working a break-in arrangement.

Keeping a Log

Every operator of an amateur station must keep a log of the operating work that is done; it should cover, as well, the tests of an experimental nature that are carried out with the transmitter or receiver.

The well-kept log is invaluable in checking up reports of any nature concerning amateur station operation. It contains positive evidence of every transmission. It is a permanent record of the achievements of the station. The Federal Radio Commission obliges every amateur station to maintain an accurate log of the time of each transmission, the station called, the input power to the last stage of the transmitter, the frequency band used and the operator's personal "sine" for each session of operating. So, in addition to other excellent reasons for log-keeping, the regulations make a complete record of transmitting activity compulsory.

Amateurs keep a log because of the ready-reference value in proving records and because of

the pleasant recollections and associations that come from reviewing the history of friendly radio contacts and from displaying the record of the accomplishments of the station to interested visitors and friends.

A loose-leaf notebook can be used. The sheets can be renewed each month and those used can be taken out and filed away with the cards and station records. A stenographer's ordinary notebook costing from ten to thirty cents and about 4½" by 8½", takes little space on the operating table and also makes a good log book. If simplicity and low cost are the only considerations, such a modified notebook-log is recommended.

A dozen pages may be ruled in advance with vertical lines. In the first column the date and times are noted. In the second column the calls of stations worked, heard, and called are put down. A circle, parentheses, or a line drawn under the call can indicate whether a station was worked, heard and called, or simply heard. A special designating sign or abbreviations before or after the call letters can show this information. Provision must be made for entering the power and the frequency band used.

Figure 1 shows a very detailed log which really gives a lot of information but which is somewhat harder to keep in good shape. *W*, *H*, and *C* are used for "worked," "heard" and "called." A bar under the "R" in "RAC" may show that the note is well-rectified and fairly smooth. A line under the "AC" can indicate that the ripple is pronounced. Plenty of information will be available for stations wanting information when such a log is kept, no matter how late the request for information is received.

Some amateurs' logs use an *X* to indicate when they call a station. If communication is established a circle is placed around the *X*. Power and frequency can be written across the page, new entries being made only when these are changed.

and time. Greenwich Civil Time is the logical reference standard but local standard time is easiest to use to avoid confusion and so this is used by most amateurs, *PST*, *MST*, *CST*, *EST*, *GCT*, etc., is entered in the heading of the first column in the A.R.R.L. log and then the date which corresponds to that kind of time is put in the first space below the heading, and time entries on the first vacant line below that, those to be entered progressively until a change in date.

CW and *F* can be used in the second column to distinguish between your use of c.w. telegraphy and radiophone operation; or *A1*, *A2*, or *A3* standing for c.w. telegraphy, c.w. telegraphy modulated at audible frequencies, and speech or music, respectively. The frequency band you use may be indicated in the next column but it is better to record the exact frequency. The next column is for the plate input power to the last stage of your amplifier.

If you hear G5BY calling W1UE, log W1UE in the first column and G5BY in the sixth column. If G5BY were calling CQ, then CQ should be entered in the fifth column. A letter in the C-W-H column shows by a single appropriate letter whether a station was called, worked, or heard by you. *H* would indicate here that you heard G5BY. *C-W* might indicate that you called a station and completed the contact immediately afterward. Reports on the characteristics of G5BY's signal would be entered in the space provided for "station heard" or data on received signals. The signal strength, the tone (*P.D.C.*, *R.A.C.*, *Chirpy D.C.*, *Xtal*, *Voice*, quality or frequency of modulation, etc.) and the frequency or dial setting can be logged here, making it easy to retune to this station, offer evidence on its frequency, or to fill out a report card.

Log users will quickly adopt certain convenient practises which simplify the keeping of a log such

Date	Time	Call	W H	My Power	My Freq.	His Freq.	His Note	My QSA	His QSA	Remarks
May 9	0310	G5BY	H	3820	Xtal	..	3	Clg CQ and W8AWJ Fast fading and poor mod.
" 11	0120	WSDYH	W	275 w	3700	3525	Phone	5	4	
" 11	0130	W6CZR	H	3780	RAC	..	5	Working KA1AF
" 11	0137	W9FLG	W	275 w	3700	3900	Gud d.c.	5	5	QRM lighter now
" 11	0200	K6EWB	W	180 w	7200	7030	Xtal	3	3	On sked. Rec'd 2, sent 3

FIG. 1

The dial settings of receiver or frequency meter may be entered in logging stations so that we can come back to these same stations without difficulty when desired. *A*, *B*, *C*, and *D* are sometimes used to indicate the 1750-, 3500-, 7000- or 14-,000-ke. bands.

Figure 2 shows the official A.R.R.L. log. The first entry for each watch is that for the date

as use of ditto marks to record frequency and power as long as these remain unchanged, and the use of an *X* for one's own call signal, to save time in making the entries in the fifth and sixth columns. When several stations answer a CQ, each should be listed in the sixth column following your own call signal in the fifth column. Any unusual data requiring explanation, such as an

interrupted or incomplete contact due to power line failure, local interference, etc., should go in the "remarks" column. Also a detailed record of messages exchanged should be entered. This last

- A — ABLE
- B — BOY
- C — CAST
- D — DOG
- E — EASY
- F — FOX
- G — GEORGE
- H — HAVE
- I — ITEM
- J — JIG
- K — KING
- L — LOVE
- M — MIKE
- N — NAN
- O — OBOE
- P — PUP
- Q — QUACK
- R — ROT
- S — SAIL
- T — TARE
- U — UNIT
- V — VICE
- W — WATCH
- X — X-RAY
- Y — YOKE
- Z — ZED

Example: *W1BCG* is sent as *WATCH ONE BOY CAST GEORGE*.

A somewhat different list can be obtained from the local Western Union telegraph office and posted beside the telephone to use when telephoning messages containing initials and difficult words. Such code words prevent errors due to phonetic similarity. Here is the Western Union word-list:

- A — ADAMS
- B — BOSTON
- C — CHICAGO
- D — DENVER
- E — EDWARD
- F — FRANK
- G — GEORGE
- H — HENRY
- I — IDA
- J — JOHN
- K — KING
- L — LINCOLN
- M — MARY
- N — NEW YORK
- O — OCEAN
- P — PETER
- Q — QUEEN
- R — ROBERT
- S — SUGAR
- T — THOMAS
- U — UNION
- V — VICTOR
- W — WILLIAM
- X — X-RAY
- Y — YOUNG
- Z — ZERO

AMATEUR RADIO STATION LOG									
DATE	TIME	FREQ	MODE	CALLER	CALLING	STATION HEARD		MESSAGES, REMARKS, ETC.	
						W	T		
7/20/35	7:40	3575	5B	W3BWT	W4AD	5	11/6	8 th	sent W3BWT's 942, read W3BWT's 2341 + 2402, 2344 66
7/20	"	"	"	W1B1B	"	W5	1c	5:20	sent W1B1B's 1149, the sig. 45B. Copied time signal 45B on message card, 8:28 AM, 11/456 in addition to file on W1BDE
8/10				W4DFR	W4OCL	H3	nae	2:5	off 10 mins to one hour. Send train times
8/15	7:40	3720	2B	W4PAX	W4PAX	C			N/D
8/15	"	"	"	W4APL	W4APL	W5	nae	4:4	teaching calls!
9/18				NS	off - hard clean				Send 25, starting 9:20 forth

FIG. 2

KEEP AN ACCURATE AND COMPLETE STATION LOG AT ALL TIMES! THE F.R.C. REQUIRES IT

The official A.R.R.L. log is shown above, answering every government requirement in respect to station records. Bound logs made up in accord with the above form can be obtained from Headquarters for a nominal sum or you can prepare your own, in which case we offer this form as a suggestion, hoping that you find it worthy of adoption. Every station must keep some sort of a log.

column should show everything from the "sine" of a new operator taking the key to reports on your own signals from other operators.

Left-hand pages in the log may be left blank to use for extensive remarks on emergencies or expeditions, for diagrams, records of tuning adjustments and ranges, or changes in equipment.

A log is of great value in a number of additional ways through use of these left-hand pages. A comparison of the operating results obtained with different apparatus in use at different times is valuable. The "DX" or traffic-handling value of the various frequencies over varying distances may be readily found from the log. The effect of weather or time of day may be also quickly found. Every change made in either the transmitter or antenna system should be noted down in the log so that results may be compared for dates before and after the date when a change was made. No matter how trivial the change, put it down in the log. Remember that only one change at a time should be made if the changed results are to be attributed to one definite cause.

Word List for Accurate Transmission

When sending messages containing radio calls or initials likely to be confused and where errors must be avoided, the calls or initials should be thrown into short code words:

'Phone Procedure

Amateur radiophone stations should use the international radiotelephone procedure which is part of the supplementary regulations to the International Radiotelegraph Convention.

For spelling call signals, service abbreviations and words, such lists as just given should be used.

At the start of communication the calling formula is spoken twice by both the station called and the calling station. After contact is established it is spoken once only. Examples of 'phone procedure in accordance with the International Radiotelegraph Convention:

W5QL calls: "Hello W3JZ Philadelphia, hello W3JZ Philadelphia, W5QL Oklahoma City calling, W5QL Oklahoma City calling, message for you, message for you, come in please."

W3JZ replies: "Hello W5QL Oklahoma City, hello W5QL Oklahoma City, W3JZ Philadelphia answering, W3JZ Philadelphia answering, send your message, send your message, come in please."

W5QL replies, "Hello W3JZ Philadelphia, W5QL Oklahoma City answering, the message begins, from Oklahoma City Oklahoma W5QL number [usual preamble, address, test, signature, etc.], message ends; I repeat, the message begins, from Oklahoma City Oklahoma W5QL number [repetition of preamble, address, text, signature, etc.], message ends, come in please."

W3JZ replies: "Hello W5QL Oklahoma City, W3JZ Philadelphia answering, your message begins, from Oklahoma City Oklahoma W5QL number [repetition of complete message], end of your message, come in please."

W5QL replies: "Hello W3JZ Philadelphia, W5QL Oklahoma City answering, you have the message correctly, you have the message correctly, W5QL Oklahoma City signing off."

Note that in handling traffic by voice, messages are repeated *twice* for accuracy, using the word list to spell names and prevent misunderstandings. The receiving station must repeat the message back *in addition*. Only when the sender *confirms* the repetition as correct can the message be regarded as handled.

Amateur Status

It is most important that individually and as an organization we be most careful to preserve our standing as amateurs by doing nothing to harm that most precious possession, our amateur status.

No brief can be held for the amateur who accepts direct or indirect compensation for handling specific messages. This is in direct violation of the terms of the amateur station license and the regulations of the Federal Radio Commission.

It is the purpose of these paragraphs to warn amateurs to avoid being "used" by commercial interests in unethical ways. An amateur asked our advice recently on accepting a whole set of fine station equipment from a business house — the only string being that he should consistently try to handle some traffic with a certain foreign point. A hotel on the Pacific Coast offered an amateur radio club a fine meeting place with free light, power and heat — provided the amateurs would establish an amateur station and relay messages for guests of the hotel. A certain newspaper planned to "organize an amateur radio club" and establish a "net" for the collecting of amateur news for the paper. It offered the amateurs a club room and the facilities of a powerful station that it would install as "net control station" in return for the things it could gain by making amateurs violate their amateur status!

There are plenty of legitimate activities in which amateurs may participate. The League approves amateur cooperation with worthy enterprises, sponsors tests to show the utility of short-wave communication, encourages worth-while service to expeditions in getting their messages from the far parts of the earth. Be assured that there is nothing wrong in accepting trophies and prizes of any sort for legitimate amateur competition in communication contests. Watch carefully and refuse to enter into any agreement or alliances through which you accept anything in the nature of a consideration for services rendered in connection with your amateur radio station. There is no question of the good intentions of the amateurs involved in the several cases cited. Very great damage can be done unless there is strict observance of both the spirit and letter of the regulations involving amateur status. Avoid sugar-coated promises and opportunities which

might be construed as direct or indirect compensation and a violation of amateur status. Seek competent advice before you jump at chances to get something for nothing. Preserve your most valued possession, your status as an amateur.

Our right to handle friendly communications of worth-while character and to engage in valuable work of all kinds in emergencies and with expeditions remains unquestioned. A "consideration" of any nature whatsoever absolutely establishes the "commercial" nature of any traffic.

Emergency Work—QRR

Amateurs have always given an excellent account of themselves in many emergencies of local and national character. In every instance, the amateurs who have considered the possibilities of an emergency arising *before* the trouble actually came to pass were the ones who must be credited with doing the most important work. They were ready, prepared for the crisis when it came.

Considerations of an emergency power supply are of first importance in many cases where radio is destined to play a part. If local electric service mains are crippled one may have recourse to B batteries, dynamotors driven from storage batteries, and the like. By consulting with other amateurs and putting all the available facilities together in the most favorable location a station can be made operative in short order. An order from some competent authority will make supplies of batteries or temporary service from a public utilities company available for emergency stations. It is sometimes as easy to move the amateur station to a power supply as to collect a power supply together and bring it to the amateur station. This is especially true if the transmitter and receiver are built as independent units. In some emergencies B batteries have been provided from local electrical supply stores.

During emergencies it is often possible to send press addressed to U.P., A.P., N.A., A.N., etc. between the transmissions of relief priority traffic. Invariably such messages are correctly delivered to local member-newspapers in such associations, the public kept informed, and amateur radio credited. Such broadcasts should be sent at regular intervals if possible. They have sometimes been overlooked in the rush.

Be ready for the emergency call, QRR, when it comes. Jump into the breach with your station if feasible or stand by and avoid interference to those handling emergency traffic if this seems to be the right thing to do. "Standing by" is sometimes the harder but wise course if the important communications are being handled satisfactorily by others and your traffic is "public correspondence" for individuals.

Make note of the address of railroads, of Red Cross headquarters, of local military units, police departments, representatives of press associa-

tions and the like, if possible putting your station on record with such organizations and other competent authorities so that you will be called upon to assist when emergency communication is necessary. When storms approach or disaster threatens it is best to keep in touch with the situa-

situation by telegram to facilitate traffic movement and for the information of the press.

BEFORE EMERGENCIES

Be ready, with really portable sets, and emergency power supply.

Overhaul and test periodically.

Give local officials and agencies your address; explain the availability of amateur radio facilities through your station in emergencies.

IN EMERGENCY

CHECK station operating facilities; offer your services to all who may be able to use them; inform A.R.R.L. an emergency exists, if possible.

QRR is the official A.R.R.L. "land SOS," a distress call for emergency use only . . . for use only by station asking assistance.

THE KEY STATION in emergency zone is the first and the supreme authority for priority and traffic routing in the early stages of emergency relief communications.

PRIORITY must be given messages in the general public interest (relief plans, re food, medicine, necessities). Press reports and personal assurance messages can then be handled if practicable.

COÖPERATION is required of all amateurs. Don't clutter the air with useless CQs. The majority of amateurs must listen in; QRX; avoid QRMing. Be ready to help; operate as intelligently as possible; cooperate by staying off the air while vital first information and relief measures are handled, if stations able to help as well as yours are on the job. (CQ STORM AREA is nothing but "more QRM.")

AFTER EMERGENCIES

REPORT to A.R.R.L. as soon as possible and as fully as possible so amateur radio can receive full credit. Amateur radio communication in 33 major disasters since 1919 has won glowing public tribute. Maintain this record.

tion by radio and again to offer service to these agencies well in advance of the actual emergency. Emergency work reaps big returns in public esteem and personal satisfaction.

After emergency communications are completed, report in detail direct to A.R.R.L. just what part you and fellow amateurs played in the situation. On such reports *QST* articles are written. *From analysis of all reports an Award Committee of A.R.R.L. Headquarters officials, base their recommendations for awards granted for notable "public service" work.* Certificates are given individual amateur operators from time to time in recognition of meritorious work contributing substantially to the service record of the amateur through noteworthy achievement in emergencies, and regular work with expeditions. Report your work!

Stations outside an "emergency zone" in communication with relief stations in that zone are requested to inform A.R.R.L. Headquarters of this

Interference Problems

The subject of public relations is important to us amateurs both individually and as an organization. No amateur can long afford to operate when he knowingly interferes widely with broadcast reception in his neighborhood and when there are simple remedies to be applied. Even the observance of prescribed quiet hours, while covering the situation legally, does not entirely suffice. Patience in explaining, frankness, tolerance in listening to other viewpoints and other qualities of diplomacy are needed to give the full technical explanations required. Evidence of fair dealing, and coöperation with listeners is always given weight when F.R.C. representatives find it necessary to investigate facts in an interference case.

Actually most interference is traceable to faulty electrical equipment, inadequate shielding or poor design of receivers, and less than one percent of the interference reported is traceable to amateur sources.

It is necessary for both parties to an interference problem to understand that *both the transmitter and the receiver* are part of the problem — improved adjustment of the former — improved design of the latter to increase its selectivity, may be necessary. Where "proximity" is part of the problem special measures should be considered to isolate circuits and equipment by installation of suitable "traps," to aid selectivity, or by chokes and condensers to prevent "coupling" through common supply line wires. Each individual must accept responsibility for his equipment. Coöperation is the only policy that will help either party — a full measure of coöperation and understanding must be brought about in every interference case.

Club Interference Work

We recommend and request that each A.R.R.L. affiliated club organization maintain an interference committee, to keep order, make investigations and recommendations locally, coöperate with the press, the public, and listeners who wish to file complains of amateur interference. These committees can be composed of representative broadcast listeners, amateurs and with one member from a local newspaper to assist in collecting and referring complaints. A few leading questions will disclose the amateur cases and other difficulties can be referred to local power and communications companies.

The club interference committees investigate reports of amateur interference, put the interested parties in touch with each other and suggest ways of reducing or getting rid of the interference. When quiet hours are necessary, they are recommended.

Call Books

The "Radio Amateur Call Book Magazine," listing amateur and many high-frequency commercial stations of the entire world, may be obtained from A.R.R.L. Headquarters, 38 La Salle Road, West Hartford, Conn., single copies, \$1.10 (foreign \$1.20). This call book now appears in March, June, September and December, with new calls added up to the date of issue. Yearly subscription, \$3.25 (foreign \$3.50). This publication is the most up to date of all such books, since it is issued and revised quarterly. An up-to-date call book is a practical necessity and convenience in just about every ham station.

A complete list of Canadian amateur station calls can be obtained for 25 cents from the Department of Marine and Fisheries, Ottawa, Canada.

Readability and Audibility

The International Radiotelegraph Convention has agreed upon a Q Code of abbreviations for all services. Readability is indicated by sending a figure (1 to 5) after the appropriate Q signal, to show progressive signal strength. QSA means, "The strength of your signals is"

Thus one may say "QSA 3," the exact and literal meaning of which is "The strength of your signals is fairly good; readable, but with difficulty." The scale:

- 1 — Hardly perceptible; unreadable.
- 2 — Weak; readable now and then.
- 3 — Fairly good; readable; but with difficulty.
- 4 — Good; readable.
- 5 — Very good; perfectly readable.

The R-system of indicating *audibility* is widely used by amateurs to supplement a report on the more important consideration of *readability*. The readability, indicated by the above scale, may be handicapped by local interference (QRM), atmospherics (QRN), receiver background, or a noisy operating room to such an extent that signals are uncopiable, even though strong. The report on audibility is one concerned entirely with the *strength of the signal* without regard to other sounds in the 'phones or room. Introduced in May, 1925, QST, the R-system of audibility came into use in a very short time. The meanings of the several R signals are as follows:

- R1 — Faint signals, just audible.
- R2 — Weak signals, barely audible.
- R3 — Weak signals, copiable (in absence of any difficulty).
- R4 — Fair signals, readable.
- R5 — Moderately strong signals.
- R6 — Strong signals.
- R7 — Good strong signals (such as copiable through interference).
- R8 — Very strong signals; can be heard several feet from phones.
- R9 — Extremely strong signals.

Operating Hints

Listen carefully for several minutes before you use the transmitter to get an idea of what stations

are working. This will help in placing messages where they belong.

Use abbreviations in operating conversations. This saves time and cuts down unnecessary interference.

Stand by (QRX) when asked to by another station who is having difficulty working through your interference. It is equally courteous to shift frequency to a point where no interference will be caused. Sometimes a change in frequency will help the station you are working to get your message through interference. Accurate frequency meters at both stations will make this change speedy and the contact sure.

Report your messages to the local traffic official every month on time. Otherwise you cannot expect your report to reach QST. Reports sent to Headquarters are routed back to the local officials who make up the monthly report.

Don't say "QRM" or "QRN" when you mean "QRS."

Don't acknowledge any message until you have received it completely.

Don't CQ unless there is definite reason for so doing. When sending CQ, use judgment. Sign your call frequently, interspersed with calls, and at the end of all transmissions.

Abbreviated standard procedure deserves a word in the interest of brevity on the air. Abbreviated practices help to cut down unnecessary transmission. However, make it a rule not to abbreviate unnecessarily when working an operator of unknown experience.

WIAUF DE W1BMS P, meaning paid, personal, or private message (adopted from commercial procedure) is much quicker than HR MSG added to a call. NIL is shorter than QRU CU NEXT SKED. Instead of using the completely spelled out preamble HR MSG FM AUGUSTA MAINE W1BIG NR 156 OCTOBER 13 CK 14 TO, etc., transmission can be saved by using AUGUSTA ME W1BIG 156 OCT 13 14 TO, etc. One more thing that conserves operating time is the cultivation of the operating practice of writing down "156 W1UE 615P 11/13/33" with the free hand during the sending of the next message.

"Handling" a message always includes the transmission and receipt of radio acknowledgment (QSL) of same, and entry of date, time and station call on the traffic, as handled, for purposes of record.

All messages should be handled in standard A.R.R.L. form.

Be courteous over the air. Offer suggestions for improving the other fellow's note or operating methods. Expect and ask for similar suggestions without expecting any praise. Constructive things can be said without being disagreeable or setting one's self up as a paragon. *Be truthful but tactful.*

Chapter Sixteen

MESSAGE HANDLING

ONE activity of the League that is quite important is the accepting and relaying of messages. Station owners may originate traffic of *any kind* going to any part of the United States, Hawaii, Porto Rico, Alaska, or the Philippines. Canadian messages may be handled under certain restrictions. Important traffic in emergencies or messages from expeditions for delivery in Canada must be put on a land wire by the U. S. amateur station handling. International regulations prohibit the handling of third party messages to the majority of foreign countries. Messages relating to experiments and personal remarks of such unimportance that recourse to the public telegraph service would be out of the question may be handled; but third party messages only under special arrangements between U. S. A. and other governments, and only to the extent agreed upon by the contracting governments.

Messages may be accepted from friends or acquaintances for sending by amateur radio. Such messages should be put in as complete form as possible before transmitting them. *Incomplete messages should not be accepted.* As messages are often relayed through several stations before arriving at their destination, *no abbreviations should be used in the text* as mistakes are bound to happen when the text is shortened in this manner. To people not acquainted with radio abbreviations, messages written in shortened form are meaningless. Delivering stations must be careful to see that messages are written out fully.

In handling messages we are doing something really worth-while. We want to start only good worth-while messages from our stations. Our efforts should be directed to making the quality of our message service high. The number of messages we handle is of secondary importance. The *kind of messages* we originate or start from our stations and the *speed* with which the messages pass through our station and the *reliability or accuracy* with which the messages are handled are the things of paramount importance.

Message Form

Each message originated and handled should contain the following component parts in the order given:

- (a) City of origin
- (b) Station of origin
- (c) Number
- (d) Date
- (e) Check (optional)

- (f) Address
- (g) Text
- (h) Signature

(a) The "city of origin" refers to the name of the city from which the message was started. If a message is filed at League Headquarters by someone in Hartford, Conn., the preamble reads *Hr msg fm Hartford Conn W1MK Nr 457 April 9, etc.*

If a message is sent to your radio station by mail the preamble reads a little differently to show where the message came from and from what city and station it originated as well. If a message was filed at A.R.R.L. Headquarters and if it came by mail from Wiscasset, Maine, the preamble would run like this to avoid confusion: *Hr msg fm Wiscasset Maine via Hartford Conn W1MK Nr 457 April 9, etc.*

(b) The "station of origin" refers to the call of the station at which the message was filed and this should always be included so that a "service" message may be sent back to the originating station if something interferes with the prompt handling or delivery of a message. In the example of preambles just given W1MK is the station of origin, that call being the one assigned the League Headquarters Station.

(c) Every message transmitted should bear a "number." Beginning on the first day of each calendar year, each transmitting station establishes a new series of numbers, beginning at Nr. 1. Keep a sheet with a consecutive list of numbers handy; file all messages without numbers; and when you send the messages, assign numbers to them from the "number sheet," scratching off the numbers on that list as you do so, making a notation on the number sheet of the station to which the message was sent and the date. Such a system is convenient for reference to the number of messages originated each month.

(d) Every message shall bear a "date" and this date is transmitted by each station handling the message. The date is the "day filed" at the originating station unless otherwise specified by the sender.

(e) Every word in the address text and signature of a message counts in the check using radio cable-count. Words and abbreviations in the preamble are not counted.

(f) The "address" refers to the name, street and number, city, state, and telephone number of the party to whom the message is being sent. A *very complete address* should always be given to insure delivery. When accepting messages this point should be stressed. In transmitting the

message the address is followed by a double dash or break sign (—...—) and it always precedes the text.

(g) The "text" consists of the words in the body of the message. No abbreviations should ever be substituted for the words in the text of the message. The text follows the address and is set off from the signature by another break (—...—).

(h) The "signature" is usually the name of the person sending the message. When no signature is given it is customary to include the words "no sig" at the end of the message to avoid confusion and misunderstanding. When there is a signature, it follows the break; *the abbreviation "sig" is not transmitted.*

The presence of unnecessary capital letters, periods, commas or other marks of punctuation may alter the meaning of a text. For this reason commercial communication companies use a shiftless typewriter (capitals only). The texts of messages are typed in block letters (all capitals) *devoid of punctuation, underlining and paragraphing except where expressed in words.* In all communication work, accuracy is of first importance.

Numbering Messages

Use of a "number sheet" or consecutive list of numbers enables any operator to tell quickly just what number is "next." Such a record may be kept in the log, or with the message file, or posted on the wall of the station. Numbers may be crossed off as the messages are filed for origination. Another method of use consists of filing messages in complete form *except for the number.* Then the list of numbers is consulted and numbers assigned as each message is sent. As the operator you work acknowledges (QSLs) each message cross off the number used and note the call of the station and the date opposite this number.

A "number sheet" is quite essential to help in keeping records straight, and to avoid possible duplication of numbers on messages. It is of assistance in checking the count of originated messages in a given month. With each amateur station log book A.R.R.L. provides C.D. Form 3, a *number sheet of originated messages* — or you can start a consecutive list of numbers in January of each year on a blank sheet, adding numbers as needed.

The original number supplied each message by the operator at the originating station is transmitted by each station handling the message. No new numbers are given the message by intermediate stations. If a message is filed at WIMK on April 9 and when sent is given the number "nr 458," this same call, date and number are used by all stations handling this message. The number and date become a part of the city-and-station-of-origin identification used for the purpose of tracing. Only at stations where a message

originates or is filed can a number be assigned to a message. Intermediate relaying stations neither change numbers nor supply new ones to messages.

Checking Messages — Cable Count

All radiograms are counted by the "cable" system, that is, all words in the *address, text, and signature* are counted and added together in determining the "check" of the message. Checking messages is very easy. The following paragraphs classify the types of messages to be counted, and go beyond this fundamental statement to help solve special problems of word counting.

Messages may be worded in *clear language* or in *secret language*. Secret language may be either code or cipher language. A clear language message gives an intelligible meaning in one of the languages authorized for international telegraph work. Each word in a plain-language message has its regular dictionary meaning.

All ordinary messages are plain-language messages. Every 15 characters or fraction thereof counts as one word. 5 figures or groups of five (or less) numerals also count as one word in an ordinary plain-language message. (A fraction bar or decimal point counts as one character or figure.)

Examples (plain language):

USS.....	1 word	91¾.....	1 word
ARRANGEMENT....	1 word	396¾.....	2 words
UNCONSTITUTIONAL	2 words	2961.....	1 word
X-RAY.....	2 words	85772.....	1 word
(the hyphen is not transmitted)		171186.....	2 words

COUNTING SPECIAL WORDS

Any character, letter, isolated figure, any punctuation marks, apostrophe (JN), hyphen (BA), fraction bar (DN), colon (OS), quotes (AF), underline (UK) (regardless of its length), or parenthesis (KK) (both signs used to form it), counts as *one word* in checking messages. In the text or signature, periods, commas, colons, dashes and fraction bars shall be counted as one character in the group in which they appear.

Mixed letters and figure combinations count a word to each character. *R4TG* counts as four words unless it is an established trade mark or trade name. Radio calls are always counted as cipher. *WIMK* counts as four words in the text or signature of a message (though but one word if sent "en groupe" in the address). For accuracy it should be written in texts as *watch one mike king*. A misspelled word with missing letters takes the same count as though it were correctly spelled.

In the address the names of cities, states, countries or other divisions of territory each count as one word regardless of the number of letters they contain. Proper names in the address and signature are counted at the rate of one word for each 15 letters or fraction thereof. The words "street," "avenue," "square" or "road" are always to be counted each as one word separately from the

name of the street, etc., whether written with it or separately. The fraction bar is not counted as a character in the group of figures (or figures and letters) indicating a house number. Names of ships, telegraph offices, or land stations are counted as one word *in the address* irrespective of the number of letters they contain. When there are two ships of the same name, the name and the call letters of the ship are together counted as one word. The name of the state is always counted as one word in addition to the name of the city. Initials in the address are counted each as one word. Each group of house or street numbers is allowed to pass as one word, however.

It is customary to omit the count of the name of a state in the check when it is written and sent in parentheses in the address.

If a telephone number is included in the address, the word "telephone" or "phone" counts as one word. The name of the exchange is an additional word in the check. Each group of five figures or fraction thereof counts as one word. Mixed letter and figure combinations are counted as a word to each character. A house number followed by a letter counts as but one word, however. *Fifth Avenue* counts as two words. *Hyde Park* counts two words, *Hydepark* as one word.

Radio calls are often included in the address to make proper routing easy. *W5XAY* counts as one word in the address but as five words in the body or signature of the message.

In the text, words are counted for every fifteen characters or fraction thereof if the message is a plain language message. A word containing from 16 to 30 letters counts 2 in the check.

Names of cities in the address count always as one word, while in the text they may count as more than one word depending on how written in official telegraph nomenclature. *New York City* counts as one word in the address but three words wherever it appears in the body (or signature) of the message. *New York City* is counted as one word when written and sent *without spacing between the parts*.

Isolated characters each count as one word. Five figures or less in a group count as one word. Words joined by a hyphen or apostrophe count as separate words. Such words are sent as two words, without the hyphen. A hyphen or apostrophe each counts as one word. However, they are seldom transmitted. Two quotation marks or parenthesis signs count as one word. Punctuation is never sent in radio messages except at the express command of the sender. *Even then it is spelled out*. In the text of messages, the names of ships are counted at the rate of 15 letters to a word if the names are written out separately. *Two hundred and forty* counts as four words. *Written twohundredandforty* (18 characters) it counts as only two words.

When the letters "ch" come together in the

make-up of a dictionary word, they are counted as one letter.

Either whole or fractional numbers spelled out so each group forms a continuous word may be checked at the 15-letter rate. *FOB, COD, SS, ARRL, QST*, standard terminology of commerce, trademarks, and such expressions in current use, are counted five letters to a word wherever they appear. Each group must of course be sent and counted separately to indicate separate words. Groups of letters are not acceptable in the address but must be separated and checked as one word each. Roman figures shall be sent as arabic figures. The word "roman" may be added after such a numeral if necessary to so identify it. The multiplication sign (X) can be transmitted X. When so sent it counts as one word.

Here is an example of a plain-language message in correct A.R.R.L. form and carrying the "cable-count" check:

(HR MSG FM HARTFORD CONN W1MK NR 83—
217p MAY 3 CK 50)
H B ALLEN
416 MOUNTAINVIEW AVE
MOUNTHOLLY NEWJERSEY.
PLEASE COMMENT ON PROPOSED OLD TIMERS
WEEK USING 3500 KILOCYCLES STOP BACK
NUMBER OF QST WAS FORWARDED MONDAY
STOP WHAT FREQUENCY IS MOST IN USE AT
W3ATJ QUESTION 73 TO YOU AND NEW JERSEY
GANG.

ARRL COMMUNICATIONS MANAGER

The count on each part of the message is added to give the "check" shown. Address, 8; text, 39; signature 3. The check is the sum of these three or 50 words. The first parts of the message in parenthesis are always transmitted but do not count in the check. "Sig" is not transmitted.

The following words that give most trouble in counting this message add into the "check" as follows:

H.....	1	QST.....	1
B.....	1	W3ATJ.....	5
416.....	1	73.....	1
AVE.....	1	NEW JERSEY.....	2
NEWJERSEY.....	1	ARRL.....	1
3500.....	1		

The use of a check on amateur messages is optional. Where employed, however, it is a matter of courtesy to see that the check is correct and is handed on along with the rest of the message. Very important messages should be checked carefully to insure accuracy, and if an important message is received with no check, a check should be added.

Request originators of messages to *spell all punctuation marks out that must appear in delivered copies. Likewise, never abbreviate in texts, or use ham abbreviations except in operator conversations.*

CHECKING CODE AND CIPHER

In coded secret messages the words do not have the normal dictionary meanings, but are

given artificial or special meanings. Real words with artificial meanings, and also artificial or synthetic words are used. These words do not normally form intelligible sentences. The preamble of coded messages starts with CDE (just as SVC is used to indicate a service message). Several selected words or word groups express more extensive thoughts. Every *five* characters or less count as one word. Words containing 6 to 10 letters count "2" in the check. When one has a copy of the simple and commonly used codes the business of coding and decoding is easy.

In cipher messages, groups or series of arabic figures (or words, names, expressions, or letter combinations, *not* conforming to clear language) having a secret meaning, are used. Cipher also is counted at the rate of 5 (or fraction thereof) characters per word. Groups of letters are checked at the same rate as groups of figures.

Examples (cipher count):

XYPPQ.....	1 word
D6W.....	3 words
CXQFWL.....	2 words

If a message is written partly in plain language, partly in cipher, and partly coded, the words are all checked at the 5-letter rate. When messages are written in plain language and part in cipher, the whole dispatch takes the 5-letter count. Likewise messages part in plain language and part in code take the 5-letter count throughout.

Foreign Traffic Restrictions

Any and all kinds of traffic may be handled between amateur stations in different parts of the United States, Hawaii, Alaska, and Porto Rico. There is no qualification or restriction except that amateur status must be observed and no material considerations become involved in the communications. Radio amateurs in all U. S. possessions except the Philippines (which has its own radio administration) are licensed by the U. S. Federal Radio Commission. The F. R. C. permits U. S. amateurs to handle with P. I. all types of communication permitted internally in the U. S. as with the other possessions. But the Philippine Island administration, since part of the inter-island communications system is government owned, leans toward the incorporation of certain additional restrictions on its amateurs relating to the handling of messages of "business importance."

Internationally the general regulations attached to the international communications treaty state the limitations to which work between amateur stations in different foreign countries is subject. In practically every country outside our own country and its possessions, the government owns or controls the public communications systems. Since these systems are maintained as a state monopoly, foreign amateurs have been prohibited by their governments from

exchanging traffic which might be regarded as "competition" with state owned telegraphs. The international treaty regulations reflect this condition and the domestic traffic restrictions (internal policy) of the majority of foreign countries. Any country ratifying the Madrid (1932) Convention is, however, permitted to make its domestic arrangement as liberal as it likes; in addition it may conclude special agreements with other governments for amateur communication that are *more liberal* than the quoted terms of the treaty itself. If no specific formal negotiations have been concluded, however, amateurs must observe the following (treaty) regulation in conducting international amateur work. Article 8:

The exchange of communications between amateur stations and between private experimental stations of different countries shall be forbidden if the Administration of one of the interested countries has given notice of its opposition to this exchange.

When this exchange is permitted the communications must be conducted in plain language and be limited to remarks of a personal nature, for which, by reason of their lack of importance, recourse to the public telegraph service would not be warranted. It shall be absolutely forbidden to licensees of amateur stations to transmit international communications emanating from third parties. The above provisions may be modified by special arrangements between the interested countries.

Referring to the first paragraph above, in the years since the Washington Convention (1927) no prohibition on amateur communication (international QSOs) has been filed by *any* country with the Berne Bureau. In some countries, principally European, amateurs are restricted by regulation to privileges much *less* than made available by international agreement. The use of some amateur bands is withheld, or the width of certain bands severely restricted by proclamation of "buffer bands," power is restricted, absurd time regulations restricting operation to two hours per day, fifteen minutes per hour, etc., enacted, and "third party" messages absolutely forbidden *domestically* as well as internationally. In the U. S. A. it is the policy, and of course necessary to take care of our greater numbers of amateurs, to give amateurs the fullest frequency allocations and rights possible under international treaty provisions, and to permit free exchange of domestic non-commercial traffic addition. This policy has justified itself, giving the public amateur radio traffic service, and developing highly skilled operators and technicians who have the ability to keep the U. S. A. in the lead in radio communications facilities. Many countries have the false notion that their security or revenue might be endangered by giving citizens any such freedom of action.

The second paragraph of Article 8 prohibits *international* handling of third party traffic, except where two governments have a special arrangement for such exchange (we have such agreement with Canada and are negotiating similar agreements with other countries). In *any*

event, traffic relating to experimental work, and personal remarks which would not be sent by commercial communications channels may be sent, when in communication with foreign amateurs.

As always, the major opportunity for outstanding message-handling work exists right at home. There are chances to render a real service to local communities everywhere that an amateur puts up a station and gets on the air, and especially in time of emergencies. Excellent work in traffic handling is so very common that it takes almost exceptional emergency and expedition work, or work with unusual characteristics, to "rate" special mention. Many expeditions and exploring parties go to the far parts of the earth—and now they always take high-frequency equipment along for contact work.

The Canadian Agreement

The special reciprocal agreement concluded between our country and the Dominion of Canada at the behest of the A.R.R.L. permits Canadian and U. S. amateurs to exchange messages of importance under certain restrictions. This agreement is an expansion of the international regulations to permit the handling of important traffic.

The authorized traffic is described as follows:

"1. Messages that would not normally be sent by any existing means of electrical communication and on which no tolls must be charged.

"2. Messages from other radio stations in isolated points not connected by any regular means of electrical communications; such messages to be handed to the local office of the telegraph company by the amateur receiving station for transmission to final destination, e.g., messages from expeditions in remote points such as the Arctic, etc.

"3. Messages handled by amateur stations in cases of emergency, e.g., floods, etc., where the regular electrical communication systems become interrupted; such messages to be handed to the nearest point on the established commercial telegraph system remaining in operation."

The arrangement applies to the United States and its territories and possessions including Alaska, the Hawaiian Islands, Porto Rico, the Virgin Islands, the Panama Canal Zone and the Philippine Islands.

Originating Traffic

Every message has to start from some place and unless some of us solicit some good traffic from friends and acquaintances there will be no messages to relay. Of course the simplest way to get messages is to offer to send a few for friends, reminding them that the message service is free and no one can be held responsible for delay or non-delivery. A number of the amateur fraternity have distributed pads of message blanks to local stores and business houses to assist in getting good traffic to originate regularly. A neatly typed

card is displayed near-by explaining the workings of our A.R.R.L. traffic organization, and *listing the points to which the best possible service can be given.*

The time of collecting messages and the list of schedules kept may also be posted for the benefit of those interested. Wide-awake amateurs have distributed message blanks to the nearest tourist camps during the summer seasons of recent years and lots of good traffic has been collected through a system of message-collection boxes placed in public buildings and hospitals. A sign prominently displayed outside the radio station has in some instances proved a good source of obtaining worth-while messages. Messages from broadcast listeners to the stations where programs originate have helped in the search of the traffic-minded amateur to be of service to the public at the same time he enjoys his hobby.

Messages that are not complete in every respect *should not be accepted* for relaying. The city of origin, station of origin, number, date, address, text, and signature constitute a complete message. All these parts are necessary to make a message of value to the recipient, to make it possible to deliver the message and to route an answer back to the sender. A very *complete* address on every message is important.

To properly represent amateur radio, placards when used should avoid any possible confusion with telegraph and cable services. Any posters should refer to **AMATEUR RADIOGRAMS**, and explain that messages are sent through **AMATEUR RADIO STATIONS**, as a **HOBBY, FREE**, without cost (since amateurs can't and will not accept compensation). The exact conditions of the service should be stated or explained as completely as possible, including the fact that there is **NO GUARANTEE OF DELIVERY**. The individual in charge of the station has full powers to refuse any traffic unsuitable for radio transmission, or addressed to points where deliveries cannot be made. Relaying is subject to radio conditions and favorable opportunity for contacting. Also, it is desirable to word messages as telegrams would be worded instead of writing letters. Better service can be expected on 15-word texts of apparent importance than on extremely long messages. Traffic should *not* be accepted for "all over the world" since there are not active amateurs in all countries, and more important, since the majority of countries outside the U. S. A. and Canada prohibit the handling of third party traffic altogether, by a restriction written into the station licenses of foreign amateur stations.

Careful planning and organized schedules are necessary if a *real* job of handling traffic is to be done. Advance schedules are essential to assist in the distribution of messages. It may be possible to schedule stations in cities to which you know quantities of messages will be filed. Distribute

messages, in the proper directions, widely enough so that a few outside stations do not become seriously overburdened. Have the latest copies of *QST* at hand and study the traffic summaries at the end of sectional activity reports. Nearly all these stations are reliable Official Relay Stations interested in traffic handling. The list of calls will help you to identify or distinguish reliable consistent operators to whom to entrust valuable messages.

Operators must route traffic properly — not merely aim to “clear the hook.” New stations worked should be informed of the amount of traffic you wish to clear and agree to handle the messages, *before* they are sent. Delays and non-deliveries result from giving an operator more than he can handle efficiently. Operators should *not* accept traffic when not in a position to continue operating their stations to give it proper handling.

It is better to handle a small or moderate volume of traffic *well*, than to attempt to break records in a manner that results in delayed messages, non-deliveries, and the like which certainly cannot help in creating any public good-will for amateur radio.

Tracing Messages

Tracing messages is sometimes necessary when it is desired to follow the route of a message or to find where it was held up or delayed. Tracing is usually accomplished by sending a copy of the message and a letter requesting that the time, date, and station calls of the stations from whom the message was received and to whom the message was given, be noted in the proper place on an enclosed sheet. The letter asks that the sheet and message be forwarded in rotation to all the stations handling the message until it has overtaken the message, when the tracer is mailed back to its starting point with the information collected from all the logs along the route.

Amateur Stations at Exhibits and Fairs

Where installation of an amateur radio station in a booth is planned, a *portable* amateur station can be installed. The station must operate under F. R. C. license of course. Since every amateur station owner can use his regular authorization for portable work under certain regulations, a local amateur already licensed, can accept responsibility for the station. Of course the proper F. R. C. office must be notified of the location from which the equipment will be operated, and the dates of such operation, in advance, as provided in the regulations. No license for station equipment is required if the exhibit will not include a transmitter in actual operation. Whatever type of exhibit is planned, write A.R.R.L. in advance, in order to receive sample material to make your amateur-booth more complete.

If the time is short and there is no opportunity

for special organization of schedules to insure reliable routing and delivery, quite likely exhibit work, to be most productive of good-will results, had best *not* include message handling plans — at least not from the booth-station itself where subject to noise, electrical interference, and other handicaps. To handle such traffic as offered with *real efficiency*, it should be distributed for origination via existing schedules of the *several most reliable local amateur stations*. By *dividing the traffic filed with other stations it may be sent more speedily on its way*. The full cooperation of all local stations should be requested. However, be sure that the operators undertaking to help are qualified and have good schedules for distributing messages.

“Show stations” must avoid origination of “poor traffic” by rigid supervision and elimination of meaningless messages with guessed-at inaccurate and incomplete addresses right at the source. Misaddressed and rubber-stamp-type traffic will always be subject to serious delays and non-delivery, and especially so when the traffic load is so great that handling such messages becomes irksome and work instead of fun. What good is any message if it cannot be delivered?

The “Apparent Importance”

The “apparent importance” of a dispatch has been proved to have a very direct bearing on the speed of relaying a message and the likelihood of its delivery, especially if the relaying is to be attempted through several unknown stations instead of between one or two known reliable stations keeping regular schedules. It may seem a strange commentary on amateur relaying that such is the case, but examination of delivery results proves the statement; and the very fact that amateur radio is a hobby, and that it is “human nature” to devote most time and effort to doing what seems most worthwhile, will afford sufficient explanation. In successful relaying work *all* factors must be taken into account.

Troubles to Avoid in Originating Traffic

Incomplete preambles seem to be the most common fault in message handling. The city of origin, the station of origin, the number, the date, and the check are all a part of the preamble which goes at the beginning of every message. The *city* and *station of origin* are most essential. Without them it is impossible to notify the sender that his message could not be delivered and without this information it is not possible to route the reply speedily. The number and date are essential in servicing and tracing radiograms. All Official Relay Stations are instructed to refuse to accept messages without this necessary information. Every station should demand an “office of origin” from stations who have messages, and traffic may be rightly cancelled (QTA) on failure to

include it. Thus messages will never get on the air without a starting place.

Many messages carry an insufficient address and cannot be delivered. Originating stations should refuse to accept messages to transmit when it is apparent that the address is too meagre.

Some stations lose track of the messages which they accept for delivery or transmission. They use scratch pads to copy signals on and they never clean up the operating table or have a place for things. The remedy is to adopt a few of the principles of neatness and to spend about two minutes each time you are through operating to put things in order. Write messages on message blanks of a uniform size when they arrive at the station. Keep together the messages to be sent. A good system to use is to mark the state of destination in the upper right hand corner of each message, arranging the messages in a heavy clip so that the names of the states are in easy view. A file box may be similarly arranged. A simple log book, a good filing system, an accurate frequency meter and an equally accurate clock, are sure signs of a well-operated station. The apparatus on the operating table will tell a story without words.

Volume vs. Deliveries

In passing we should add that starting traffic in volume always results in lowering percentage deliveries simply because "operating enjoyment" becomes "work" and amateur operators with limited time are able to cope with only definite quantities of messages. While in emergencies traffic could and would be willingly moved at any sacrifice of time, thus giving great credit to the amateur, the transmission of less important material, especially in volume, meets resistance, due to the characteristics of human nature and the fundamental aspects of amateur radio as a hobby (not a job). This of course does not excuse any amateur from accepting messages he knows he cannot handle. *It is best to refuse traffic when not in a position to handle it, and especially if unwilling to accept proper responsibility for doing your best to see it on its way — or delivered — speedily.*

Relay Procedure

Messages shall be relayed to the station nearest the location of the addressee and over the greatest distance permitting reliable communication.

No abbreviations shall be substituted for the words in the text of a message with the exception of "service messages," to be explained. Delivering stations must be careful that no confusing abbreviations are written into delivered messages.

Sending "words twice" is a practice to avoid. Use it only when expressly called for by the receiving operator when receiving conditions are poor.

Messages shall be transmitted as many as three times at the request of the receiving opera-

tor. Failing to make a complete copy after three attempts, the receiving operator shall cancel the message (QTA).

Agreement to handle (relay or deliver) a message properly and promptly is always tacitly implied in accepting traffic. When temporarily *not* in a position to so handle, it is a service to amateur radio and your fellow ham to courteously *refuse* a message.

Let us assume that a station in Hartford, Conn., receives a message whose destination is Dallas, Texas. The message is at once written out on a message blank, filling in the city and station of origin, leaving only the "number," "rec'd," and "sent" spaces vacant.

The operator does not hear any western stations so he decides to give a directional "CQ" as per A.R.R.L. practice. He calls, *CQ CQ CQ TEXAS DE W1MK W1MK W1MK*, repeating the combination three times.

He listens and hears W9CXX in Cedar Rapids calling him, *W1MK W1MK W1MK DE W9CXX W9CXX W9CXX AR*.

Then he answers W9CXX indicating that he wishes him to take the message for Dallas. W1MK says *W9CXX W9CXX DE W1MK R QSP DALLAS? K*.

After W9CXX has given him the signal to go ahead, the message is transmitted, inserting the "number" in its proper place, and assigning the next number indicated on the "number sheet." The message is sent in A.R.R.L. sequence.

"HR MSG FM HARTFORD CONN W1MK NR247 NOV 11 CK31 TO FRANK M CORLETT W5ZS 2515 CATHERINE STREET DALLAS TEXAS —...— COMMUNICATIONS DEPARTMENT SUPPLIES AND MEMBERSHIP LIST ARE GOING FORWARD TODAY PLEASE SEND YOUR REACTION TO GENERAL NUMBER 372 OUR ARMY FILE —...— SIG HOUGHTON AR W1MK K.

W9CXX acknowledges the message like this: *W1MK DE W9CXX NR 247 R K*. Not a single *R* should be sent unless the whole message has been correctly received.

The operator at W1MK writes in the number of the message, scratches off number 247 on the "number sheet," putting *W9CXX* after the number. In the "sent" space at the bottom of the message blank he notes *the call of the Cedar Rapids station, the date, time, and his own personal "sine."* At the same time he concludes with *W9CXX* something like this: *R QRU 73 GB SK W1MK*, meaning, "All received OK, I have nothing more for you, see you again, no more now, best regards, good-bye, I am through with you and shall at once listen for other stations who may wish to call me. W1MK is now signing off."

W9CXX will come back with *I R GB AR SK W9CXX*, meaning "I understand, received you OK, good-bye, I am through." Then he will listen a few minutes to see if anyone is calling him. He will listen particularly for Texas stations

and try to put the message through W5ZC or a neighboring station. If he does not hear someone calling him, he will listen for Texas stations and call them.

Getting Fills

Sometimes parts of a message are not received correctly or perhaps due to fading or interference there are gaps in the copy. The problem is to ask for "fills" or repeats in such a way as to complete the message quickly and with the minimum of transmission.

If the first part of a message is received but substantially all of the latter portions lost, the request for the missing parts is simply *RPT TXT AND SIG*, meaning "Repeat text and signature." *PBL* and *ADR* may be used similarly for the preamble and address of a message. *RPT AL* or *RPT MSG* should not be sent unless nearly all of the message is lost.

Each abbreviation used after a question mark (..—..) asks for a repetition of that particular part of a message.

When a few word-groups in conversation or message handling have been missed, a selection of one or more of the following abbreviations will enable you to ask for a repeat on the parts in doubt. Phone stations of course request fills by using the full wording specified, without attempt at abbreviation.

Abbreviation	Meaning
?AA.....	Repeat all after.....
?AB.....	Repeat all before.....
?AL.....	Repeat all that has been sent...
?BN...AND.....	Repeat all between...and.....
?WA.....	Repeat the word after.....
?WB.....	Repeat the word before.....

The good operator will ask for only what fills are needed, separating different requests for repetition by using the break sign or double dash (—...—) between these parts. There is seldom any excuse for repeating a whole message just to get a few lost words.

Another interrogation method is sometimes used, the question signal (..—..) being sent between the last word received correctly and the first word (or first few words) received after the interruption. *RPT FROM TO* is a long, clumsy way of asking for fills which we have heard used by beginners. These have the one redeeming virtue of being understandable.

The figure four (...—) is a time-saving abbreviation which deserves popularity with traffic men. It is another of those hybrid abbreviations whose original meaning, "Please start me, where?" has come to us from Morse practice. Of course *?AL* or *RPT AL* will serve the same purpose, where a request for a repetition of parts of a message have been missed. While these latter usages are approved, the earlier practice is still followed by some operators.

Delivering Messages

The only service that we can render anyone by handling a message comes through "delivery." Every action of ours in sending and relaying messages leads up to this most important duty. Unless a message is delivered, it might as well never have been sent.

There is no reason for anyone to accept a message if he has no intention of relaying it or delivering it promptly. It is not at all discourteous to refuse politely to handle a message when it will be impossible for you to forward it to its destination.

Occasionally message delivery can be made through a third party not able to acknowledge the radiogram he overhears. When a third party happens to be in direct contact with the person addressed in the message he is able to hand him an unofficial confirmation copy and thus to make a delivery much sooner than a delivery could be made otherwise. It is *not* good radio etiquette to deliver such messages without explaining the circumstances under which they were copied, as a direct delivery discredits the operator who acknowledged the message but who through no fault of his own was not able to deliver so promptly. With a suitable note of explanation, such deliveries can often improve A.R.R.L. service and win public commendation.

Provisions of the Radio Act of 1927 make it a misdemeanor to give out information of any sort to any person except the addressee of a message. It is in no manner unethical to deliver an unofficial copy of a radiogram, if you do it to improve the speed of handling a message or to insure certain and prompt delivery. Do not forget that there are heavy fines prescribed by Federal laws for divulging the contents of messages to anyone except the person addressed in a message.

When it is possible to deliver messages in person, that is usually the most effective way. When the telephone does not prove instrumental in locating the party addressed in the message it is usually quickest to mail the message.

To help in securing deliveries, here are some good rules to follow:

Messages received by stations shall be delivered immediately.

Every domestic message shall be relayed within forty-eight (48) hours after receipt or if it cannot be relayed within this time shall be mailed to the addressee.

Messages for points outside North America must not be held longer than half the length of time required for them to reach their destination by mail.

We are primarily a radio organization, and the bulk of our messages should go by radio, not by mail. The point is that messages should not be allowed to fall by the way, and that they should be sent on or delivered just as quickly as possible. When a message cannot be delivered, or if it is

unduly delayed, a "service" message should be written and started back to the "office of origin."

Each operator who reads these pages is asked to assume *personal responsibility* for the accuracy and speed of each message handled so that we can each have reason to take personal pride in our operating work and so that we will have just cause for pride in our League as a whole. Do *your* part that we may approach a 100% delivery figure.

The Service Message

A service message is a message sent by one station to another station relating to the service which we are or are not able to give in message handling. The service message may refer to non-deliveries, to delayed transmission, errors, or to any phase of message handling activity.

Whenever a message is received which has insufficient address for delivery and no information can be obtained from the telephone book or the city directory, a service message should be written asking for a better address. While it is not proper to abbreviate words in the texts of regular messages, it is quite desirable and correct to use abbreviations in these station-to-station messages relating to traffic-handling work.

The prefix "svc" in place of the usual "msg" shows the class of the message and indicates at once that a station-to-station message is coming through. Service messages should be handled with the same care and speed that are given other messages.

Suppose a regulation message is received by W3CA for some one in Roanoke, Va. Suppose that the message cannot be delivered because of insufficient address. The city and station of origin of the message are given as "Pasco Washn W7GE." In line with the practice outlined above W3CA makes up a service message asking W7GE to "give better address":

HR SVC FM ROANOKE VA W3CA NR 291 AUG 19
 To RADIO W7GE
 L C MAYBEE
 110 SOUTH SEVENTH AVE
 PASCO WASHN —...—
 UR NR 87 AUG 17 TO CUSHING SIG BOB HELD
 HR UNDDL PSE GBA —...—
 (sig) WOHLFORD W3CA

Counting Messages

So that we can readily keep run of our messages and compare the number originated and delivered each month to learn some facts about the "efficiency" of our work in handling messages, a method of counting is used. Each time a message is *handled by radio* it counts one in the total.

A message received in person, by telephone, by telegraph, or by mail, *filed at the station and transmitted by radio* in proper form, counts as *one originated*.

A message received by radio and delivered in

person, by telephone, telegraph, or mail, counts as *one delivered*.

A message received by radio and sent forward by radio counts as two messages relayed (one when received and again one when sent forward).

All messages counted under one of the three classes mentioned must be handled within a 48-hour (maximum) delay period to count as "messages handled" with but one exception. Messages for all continents except North America may be held one-half the length of time it would take them to reach their destination by mail. A "service" message counts the same as any other type of message.

The message total shall be the *sum* of the messages originated, delivered and relayed. Each station's message file and log shall be used to determine the report submitted by that particular station. Messages with identical texts (so-called rubber-stamp messages) shall count once only for each time the complete text, preamble and signature are sent by radio.

By following the above rules, the messages handled during the "message month" may be counted readily. A monthly report should be sent to the local traffic official of the A.R.R.L. as mentioned under the subject of "Reporting." The closing date of the "message month" is the 15th of each month (the last of the month in Hawaii and the Philippines). Reports must go forward the next day.

Let us assume that on the 15th of the month one operator of a large amateur station receives several messages from another station. (a) Some of these messages are for relaying by radio. (b) Some of them are for local delivery. (c) There are still other messages the disposal of which cannot be accurately predicted. They are for the immediate neighborhood but either can be mailed or forwarded to another amateur by radio. A short-haul toll telephone call will deliver them but the chances of landing them nearer the destination by radio are pretty good. This operator's "trick" ends at midnight on the 15th and he must make out the report with some messages "on the hook" to be carried over for the next month's report.

(a) The messages on the hook that are to be relayed have been received and are to be sent. They count as "1 relayed" in the report that is made out now, and they will also count as "1 relayed" in the next month's report (the month during which they were forwarded by radio).

(b) By mailing the messages or phoning them at once, they can count as "1 delivered" for the current month's report. By holding them until the next day they will count in the next report as "1 delivered."

(c) The messages in this class should be carried forward into the next month. If they have to be

mailed they will count in the next report as "1 delivered." If they are relayed, we count them as "2 relayed"; "1 received" in the preceding month being carried forward and added to "1 sent" makes the "2 relayed." If the operator wishes to count this message at once (for the current month) it must be mailed promptly and counted as "1 delivered."

Some examples of counting:

The operator of Station A gets a message by radio from Station B addressed to himself. This counts as "1 delivered" by himself and by Station A.

The operator of Station A takes a verbal message from a friend for relaying. He gives it to Station B over the telephone. Operator A does not handle the message by radio. Station B and operator B count the message as "1 originated." A cannot count the message in any manner.

The operator and owner of Station A visits Station B and while operating there takes a message for relaying. The operator and owner of B cannot operate for a day or two so the message is carried back to Station A by operator A who relays it along within a few hours. The traffic report of both Station A and Station B shows "1 relayed" for this work.

Please note that "handling" a message always includes the transmission and receipt of radio acknowledgment (QSL) of same, and the entry of date, time, and station call on the traffic, as handled, for purposes of record. Only messages properly handled, shall be counted in A.R.R.L. totals.

"Rubber-Stamp" Messages

Because, now and again, our stations fall into the habit of originating quantities of so-called "rubber-stamp" messages with such texts as "Your card received will QSL"; "Greetings by radio" and the like, the identical text being addressed to a large number of addressees, it becomes necessary to reaffirm our policy with respect to such messages. The history of our organization shows the demoralizing effect of an influx of such stereotyped messages in quantity. The net effect is to clog the hooks of traffic-handling stations until they can no longer function. This must be prevented by stopping uncalled for messages right at their source. The handling of traffic must be either fun or constructive, interesting, work. Because such multiple-address messages mean much drudgery for little accomplished they cannot be handled effectively in a hobby like amateur radio.

Obviously, a station in handling a rubber-stamp message has to exert only a small amount of effort in receiving the text and signature once. Then by handling the address to different points *en groupe* a large number of messages (?) can be received and transmitted with little time and effort. The League's system for crediting points for messages handled is based on giving one credit

each time a *complete* message is handled by amateur radio, i.e., one credit for each originated message, one credit for each delivered message and two credits for each relayed message (one credit for the work in receiving it and one for the work in transmitting it). *Only* every message handled by radio with a *complete preamble, address, text, and signature* shall be counted, except in the case of *deliveries*, each mailed, telephoned or otherwise delivered message shall count "one delivered" regardless of handling in "book" form (with text sent once only).

Example (showing a claimed and revised count on R.S. messages): A certain station takes an R.S. message to 10 addresses and relays it onward to another station, claiming "relayed 20" for his work. This station shall be credited with "relayed 2"; one for receiving a complete preamble, address, text, and signature, one for sending a complete message on its way. For receiving and relaying to three stations (requiring the complete message to be sent three times) a total of four might be justly claimed in the relayed column. (This should not be construed to mean that any message to a single address should be given to more than a single reliable station.) For receiving and *delivering* to three addresses this work should be credited as "three delivered."

Reporting

Whether the principal accomplishments of the station are in traffic handling or other lines, what you are doing is always of interest to A.R.R.L. headquarters. Our magazine, *QST*, covers the entire amateur field, keeping a record of the messages handled in different sections of the country, giving mention of the outstanding work that is done in communicating over great distances using small amounts of power, and summarizing all types of activities in monthly reports.

We have mentioned the Official Relay Stations and the Communications Department organization. A section of *QST* is devoted to Communications Department reports. Form postals are sent the active stations in the relay system for reporting purposes. There is space to tell about the traffic handled, the frequency used during the reporting month, the "DX" worked, and other station records and activities, together with a list of the stations with which schedules are kept. Items of general interest, changes in the set, and addresses of new amateurs also come in on this card.

Every operator of an active amateur station in the United States and Canada is cordially invited to report. Each month on the 16th (the 1st in Hawaii and the Philippines) the active stations send reports to their local officials. These officials forward condensed reports to Headquarters. Representative space is given each section of the country depending on the number reporting. Reports must have the dead material edited out

of them to allow room for as much active and interesting news as can be gotten in. The more worth while a report is, the more of it gets in print. Traffic figures and calls of active stations always get full space. Readers of this Handbook are invited to send in their reports to the local traffic official just as soon as they have a station in operation. Write the nearest traffic official whose name appears on page 5 of each *QST*. Make your report as informative and interesting as possible.

Especially important work having a high news value should be reported direct to League Headquarters at Hartford.

Contributions to *QST* are welcomed by the Editors! Authors must remember that only a small percent of the received material can be printed and that it is impossible for an organization like ours to pay for articles. Ours is a "family" organization supported by and for the amateur. By carefully selecting material the members get the best magazine that can be made. *QST* is noted for its technical accuracy. "Breaking into print" in *QST* is an honor worth working for.

Operating on Schedules

Traffic handling work can be most advantageously carried on by arranging and keeping a few schedules. By arranging schedules and operating the station in a business-like way, using an accurate frequency meter and a clock, it has been proven many times that a maximum amount of business can be moved in a minimum of time and effort. The message "hook" can be cleared in a few minutes of work on schedule and the station will be free for DX or experimental work.

Every brass-pounder is urged to write letters to some of the reliable and regular stations heard, asking if some schedules cannot be kept a few times a week especially for traffic handling. The Route Manager is very frequently able to help in arranging schedules. Write your S.C.M. (see page 5, *QST*) and through him get lined up with your R.M. With reliable schedules in operation it is possible to advertise the fact that messages for certain points can be put through with speed and accuracy, and the traffic problem will take care of itself.

The Five-Point System

To make our relaying more systematic the "five-point system" of arranging schedules was proposed and has worked out very nicely on many cases. After getting the station in good operating condition, each station's operator arranges to work four stations, one north, one east, one south, and one west. These directions are not exact but general. The distances are not too great but they must be distances that can be worked with absolute certainty under any conditions.

A good way to select the four stations is to

listen in and to pick out the stations heard most regularly, operating most consistently, and in the right direction. It is a good scheme to work these stations a few times. Write them letters and get acquainted; then try to arrange some schedules. Short schedules are the best. A half or quarter hour each day is enough. In an hour one can call four stations, clear traffic, and be free to work other groups of "five-pointers."

When there is no traffic, a few pleasantries are in order during the scheduled time of working. Several advantages of handling messages on schedule are evident from whatever angle the situation is approached.

Traffic Handling Develops Skill

The dispatch of messages makes operators keen and alert. The better the individual operator, the better the whole organization. Proper form in handling traffic, getting fills, and in general operating procedure develops operators who excel in "getting results." Station performance depends 90% on operating ability, and 10% on the equipment involved, granting of course that station and operator are always inter-dependent. Experience in message handling develops a high degree of operating "intelligence."

Interest in relaying amateur radiograms has always been the important basic activity around which A.R.R.L. organization revolved. There are several good reasons why. Message handling leads to organization naturally, through the need for schedules and coöperation between operators. It offers systematic training in "real" operating. It leads to planned, useful, unselfish, constructive, work for others at the same time it represents the highest form of operating "skill" and enjoyment to its devotees. Emphasis should be placed on the importance of traffic handling in training operators in the use of procedure — and in general operating reliability. The value of the amateur (as a group), in cases of local or national emergency, depends to a great extent on the *operating ability* of individual operators. This ability is largely developed in message handling work.

Practise in handling traffic familiarizes one with detailed time-saving procedure, and develops general skill and accuracy to a higher extent than obtains in "just rag-chewing" or haphazard work. This work provides a definite aim. Message handling is a vital link in guiding the interest of operators to the point where many accept additional responsibilities in the Signal Corps organization (A.A.R.S.), or the Volunteer Communication Reserve (U.S.N.R.). The interest amateurs show in these services is directly reflected by a full measure of appreciation and important backing by Uncle Sam whenever amateur rights are threatened with encroachment of any kind. Message handling work represents an advanced form of amateur operating activity in which all amateurs sooner or later become interested.

APPENDIX

The "Q" Code

In the regulations accompanying the existing International Radiotelegraph Convention there is a very useful internationally agreed code designed to meet major needs in international radio communication. This code follows. The abbreviations themselves have the meanings shown in the "Answer" column. When an abbreviation is followed by an interrogation mark (?) it assumes the meaning shown in the "question" column.

<i>Abbreviation</i>	<i>Question</i>	<i>Answer</i>
QRA	What is the name of your station?	The name of my station is
QRB	How far approximately are you from my station?	The approximate distance between our stations is nautical miles (or kilometres).
QRC	What company (or Government Administration) settles the accounts for your station?	The accounts for my station are settled by the company (or by the Government Administration of).
QRD	Where are you bound and where are you from?	I am bound for from
QRG	Will you tell me my exact frequency (wave-length) in kc/s (or m)?	Your exact frequency (wave-length) is kc/s (or m).
QRH	Does my frequency (wave-length) vary?	Your frequency (wave-length) varies.
QRI	Is my note good?	Your note varies.
QRJ	Do you receive me badly? Are my signals weak?	I cannot receive you. Your signals are too weak.
QRK	Do you receive me well? Are my signals good?	I receive you well. Your signals are good.
QRL	Are you busy?	I am busy (or I am busy with). Please do not interfere.
QRM	Are you being interfered with?	I am being interfered with.
QRN	Are you troubled by atmospherics?	I am troubled by atmospherics.
QRO	Shall I increase power?	Increase power.
QRP	Shall I decrease power?	Decrease power.
QRQ	Shall I send faster?	Send faster (..... words per minute).
QRS	Shall I send more slowly?	Send more slowly (..... words per minute).
QRT	Shall I stop sending?	Stop sending.
QRU	Have you anything for me?	I have nothing for you.
QRV	Are you ready?	I am ready.
QRW	Shall I tell that you are calling him on kc/s (or m)?	Please tell that I am calling him on kc/s (or m).
QRX	Shall I wait? When will you call me again?	Wait (or wait until I have finished communicating with). I will call you at o'clock (or immediately).
QRY	What is my turn?	Your turn is No. (or according to any other method of arranging it).
QRZ	Who is calling me?	You are being called by
QSA	What is the strength of my signals (1 to 5)?	The strength of your signals is (1 to 5).
QSB	Does the strength of my signals vary?	The strength of your signals varies.
QSD	Is my keying correct; are my signals distinct?	Your keying is incorrect; your signals are bad.
QSG	Shall I send telegrams (or one telegram) at a time?	Send telegrams (or one telegram) at a time.
QSI	What is the charge per word for including your internal telegraph charge?	The charge per word for is francs, including my internal telegraph charge.
QSK	Shall I continue with the transmission of all my traffic, I can hear you through my signals?	Continue with the transmission of all your traffic, I will interrupt you if necessary.

Abbreviation	Question	Answer
QSL	Can you give me acknowledgement of receipt?	I give you acknowledgement of receipt.
QSM	Shall I repeat the last telegram I sent you?	Repeat the last telegram you have sent me.
QSO	Can you communicate with direct (or through the medium of)?	I can communicate with direct (or through the medium of).
QSP	Will you retransmit to free of charge?	I will retransmit to free of charge.
QSR	Has the distress call received from been cleared?	The distress call received from has been cleared by
QSU	Shall I send (or reply) on kc/s (or m) and/or on waves of Type A1, A2, A3, or B?	Send (or reply) on kc/s (or m) and/or on waves of Type A1, A2, A3, or B.
QSV	Shall I send a series of VVV	Send a series of VVV
QSW	Will you send on kc/s (or m) and/or on waves of Type A1, A2, A3 or B?	I am going to send (or I will send) on kc/s (or m) and/or on waves of Type A1, A2, A3 or B.
QSX	Will you listen for (call sign) on kc/s (or m)	I am listening for (call sign) on kc/s (or m).
QSY	Shall I change to transmission on kc/s (or m) without changing the type of wave? or Shall I change to transmission on another wave?	Change to transmission on kc/s (or m) without changing the type of wave or Change to transmission on another wave.
QSZ	Shall I send each word or group twice?	Send each word or group twice.
QTA	Shall I cancel telegram No. as if it had not been sent?	Cancel telegram No. as if it had not been sent.
QTB	Do you agree with my number of words?	I do not agree with your number of words; I will repeat the first letter of each word and the first figure of each number.
QTC	How many telegrams have you to send?	I have telegrams for you (or for).
QTE	What is my true bearing in relation to you? or What is my true bearing in relation to (call sign)? or What is the true bearing of (call sign) in relation to (call sign)?	Your true bearing in relation to me is degrees or Your true bearing in relation to (call sign) is degrees at (time) or The true bearing of (call sign) in relation to (call sign) is degrees at (time).
QTF	Will you give me the position of my station according to the bearings taken by the direction-finding stations which you control?	The position of your station according to the bearings taken by the direction-finding stations which I control is latitude longitude.
QTG	Will you send your call sign for fifty seconds followed by a dash of ten seconds on kc/s (or m) in order that I may take your bearing?	I will send my call sign for fifty seconds followed by a dash of ten seconds on kc/s (or m) in order that you may take my bearing.
QTH	What is your position in latitude and longitude (or by any other way of showing it)?	My position is latitude longitude (or by any other way of showing it).
QTI	What is your true course?	My true course is degrees.
QTJ	What is your speed?	My speed is knots (or kilometres) per hour.
QTM	Send radioelectric signals and submarine sound signals to enable me to fix my bearing and my distance.	I will send radioelectric signals and submarine sound signals to enable you to fix your bearing and your distance.
QTO	Have you left dock (or port)?	I have just left dock (or port).

<i>Abbreviation</i>	<i>Question</i>	<i>Answer</i>
QTP	Are you going to enter dock (or port)?	I am going to enter dock (or port).
QTQ	Can you communicate with my station by means of the International Code of Signals?	I am going to communicate with your station by means of the International Code of Signals.
QTR	What is the exact time?	The exact time is
QTU	What are the hours during which your station is open?	My station is open from to
QUA	Have you news of (call sign of the mobile station)?	Here is news of (call sign of the mobile station).
QUB	Can you give me in this order, information concerning: visibility, height of clouds, ground wind for (place of observation)?	Here is the information requested
QUC	What is the last message received by you from (call sign of the mobile station)?	The last message received by me from (call sign of the mobile station) is
QUD	Have you received the urgency signal sent by (call sign of the mobile station)?	I have received the urgency signal sent by (call sign of the mobile station) at (time).
QUF	Have you received the distress signal sent by (call sign of the mobile station)?	I have received the distress signal sent by (call sign of the mobile station) at (time).
QUG	Are you being forced to alight in the sea (or to land)?	I am forced to alight (or land) at (place).
QUH	Will you indicate the present barometric pressure at sea level?	The present barometric pressure at sea level is (units).
QUJ	Will you indicate the true course for me to follow, with no wind, to make for you?	The true course for you to follow, with no wind, to make for me is degrees at (time).

Special abbreviations adopted by the A.R.R.L.:

QST General call preceding a message addressed to all amateurs and A.R.R.L. Members. This is in effect "CQ ARRL."
 QRR Official A.R.R.L. "land SOS." A distress call for emergency use only.

Miscellaneous Abbreviations

<i>Abbreviation</i>	<i>Meaning</i>
C	Yes.
N	No.
P	Indicator of private telegram in the mobile service (to be used as a prefix).
W	Word or words.
AA	All after (to be used after a note of interrogation to ask for a repetition).
AB	All before (to be used after a note of interrogation to ask for a repetition).
AL	All that has just been sent (to be used after a note of interrogation to ask for a repetition).
BN	All between (to be used after a note of interrogation to ask for a repetition).
BQ	A reply to an RQ.
CL	I am closing my station.
CS	Call sign (to be used to ask for a call sign or to have one repeated).
DB	I cannot give you a bearing, you are not in the calibrated sector of this station.
DC	The minimum of your signal is suitable for the bearing.
DF	Your bearing at (time) was degrees, in the doubtful sector of this station, with a possible error of two degrees.
DG	Please advise me if you note an error in the bearing given.
DI	Bearing doubtful in consequence of the bad quality of your signal.
DJ	Bearing doubtful because of interference.
DL	Your bearing at (time) was degrees in the doubtful sector of this station.
DO	Bearing doubtful. Ask for another bearing later, or at (time).
DP	Beyond 50 miles, the possible error of bearing may amount to two degrees.
DS	Adjust your transmitter, the minimum of your signal is too broad.

<i>Abbreviation</i>	<i>Meaning</i>
DT	I cannot furnish you with a bearing; the minimum of your signal is too broad.
DY	This station is two-way, what is your approximate direction in degrees in relation to this station?
DZ	Your bearing is reciprocal (to be used only by the control station of a group of direction-finding stations when it is addressing other stations of the same group).
ER	Here (to be used before the name of the mobile station in the sending of route indications).
GA	Resume sending (to be used more specially in the fixed service).
JM	If I may transmit, send a series of dashes. To stop my transmission, send a series of dots [not to be used on 500 kc/s (600 m)].
MN	Minute or minutes (to be used to indicate the duration of a wait).
NW	I resume transmission (to be used more especially in the fixed service).
OK	Agreed.
RQ	Designation of a request.
SA	Indicator preceding the name of an aircraft station (to be used in the sending of particulars of flight).
SF	Indicator preceding the name of an aeronautical station.
SN	Indicator preceding the name of a coast station.
SS	Indicator preceding the name of a ship station (to be used in sending particulars of voyage).
TR	Indicator used in sending particulars concerning a mobile station.
UA	Are we agreed?
WA	Word after (to be used after a note of interrogation to request a repetition).
WB	Word before (to be used after a note of interrogation to request a repetition).
XS	Atmospherics.
YS	Your service message.
ABV	Repeat (or I repeat) the figures in abbreviated form.
ADR	Address (to be used after a note of interrogation to request a repetition).
CFM	Confirm (or I confirm).
COL	Collate (or I collate).
ITP	Stops (punctuation) count.
MSG	Telegram concerning the service of the ship (to be used as a prefix).
NIL	I have nothing for you (to be used after an abbreviation of the Q code to mean that the answer to the question put is negative).
PBL	Preamble (to be used after a note of interrogation to request a repetition).
REF	Referring to (or Refer to).
RPT	Repeat (or I repeat) (to be used to ask for or to give repetition of all or part of the traffic the relative particulars being sent after the abbreviation).
SIG	Signature (to be used after a note of interrogation to request a repetition).
SVC	Indicator of service telegram concerning private traffic (to be used as a prefix).
TFC	Traffic.
TXT	Text (to be used after a note of interrogation to request a repetition).

Ham Abbreviations

In amateur work many of the most commonly used radio and ordinary English words are frequently abbreviated, either by certain generally recognized methods or, as often occurs, on the spur of the moment according to the ideas of the individual operator. Beginning amateurs are likely to be confused by these "ham abbreviations" at first, but will probably pick them up quickly enough in the case of the more or less standard ones, and get the general idea governing the construction of the unusual ones occasionally encountered.

A method much used in short words is to give the first and last letters only, eliminating all intermediate letters. Examples: Now, nw; check, ck; would, wd.

Another method often used in short words employs phonetic spelling. Examples: Some, sum; good, gud; says, sez; night, nite.

A third method uses consonants only, eliminating all vowels. Examples: Letter, ltr; received, rcd; message, msg.

Replacing parts of a word with the letter "x" is a system occasionally used in abbreviating certain words. Examples: Transmitter, xmtr; weather, wx; distance, dx; press, px.

In listing below a short list of some of the more frequently encountered amateur abbreviations, we want to caution the beginner against making too great an effort to abbreviate or to scatter abbreviations wholesale throughout his radio conversation. A judicious use of certain of the short-cut words is permissible and saves time — the only legitimate object of abbreviations, of course. To abbreviate everything one sends, and to do so in many cases to extremes, is merely ridiculous.

ABT	About
ACCT	Account
AGN	Again

AHD Ahead
 AMP Ampere
 AMT Amount
 ANI Any
 AUSSIE Australian amateur
 BCL Broadcast listener
 BD Bad
 BI By
 BKG Breaking
 BLV Believe
 BN Been, all between
 BPL Brass Pounders' League
 BUG Vibroplex key
 CANS Phones
 CK Check
 CKT Circuit
 CL-CLD Closing station; call; called
 CM Communications Manager
 CONGRATS Congratulations
 CRD Card
 CUD Could
 CUL See you later
 CW Continuous wave
 DH Dead head
 DLD-DLVD Delivered
 DLY Delivery
 DX Distance
 ES And
 FB Fine business, excellent
 FIL Filament
 FM From
 FONES Telephones
 FR For
 FREQ Frequency
 GA Go ahead (resume sending)
 GB Good-bye
 GBA Give better address
 GE Good evening
 GG Going
 GM Good morning
 GN Gone, good night
 GND Ground
 GSA Give some address
 HAM Amateur, brass-pounder
 HI Laughter, high
 HR Here, hear
 HRD Heard
 HV Have
 ICW Interrupted continuous wave
 LID "Lid," a poor operator
 LTR Later, letter
 MA Milliampere
 MG Motor-generator
 MILS Milliamperes
 MO Master oscillator
 ND Nothing doing
 NIL Nothing
 NM No more
 NR Number, near
 NSA No such address
 NW Now
 OB Old Boy, Official Broadcast
 OM Old man
 OO Official Observer
 OPN Operation
 OP-OPR Operator
 ORS Official Relay Station
 OT Old timer, old top
 OW Old woman
 PSE Please
 PUNK Poor operator
 R Are, all right, O.K.
 RAC Rectified alternating current
 RCD Received
 RCVR Receiver
 RI Radio Inspector
 RM Route Manager
 SA Say
 SCM Section Communications Manager
 SED Said
 SEZ Says
 SIG-SG Signature
 SIGS Signals
 SINE Sign, personal initials, signature
 SKED Schedule
 TC Thermocouple
 TKS-TNX Thanks
 TNG Thing
 TMW Tomorrow
 TT That
 U You
 UR Your, you're
 URS Yours

VT Vacuum tube
 VY Very
 WD Would, word
 WDS Words
 WKD Worked
 WKG Working
 WL Will
 WT What, wait, watt
 WUD Would
 WV-WL Wave, wavelength
 WX Weather
 XMTR Transmitter
 YL Young lady
 YR Your
 ZEDDER New Zealander
 73 Best regards
 88 Love and kisses

International Prefixes

The nationality of a radio station is shown by the initial letter or letters of its call signal. The International Radiotelegraph Convention, supplemented by provisional action of the Berne Bureau, allocates the alphabet amongst the nations of the world for that purpose. Every station call of a nation must be taken from the block of letters thus assigned it. The amateur station call commonly consists of one or two initial letters thus chosen (to indicate nationality), a digit (assigned by the local government to indicate the subdivision of the nation in which the station is located), and two or three additional letters (to identify the individual station).

In the list which follows, the first column shows the international allocation of blocks of call signals. This list is useful in identifying the nationality of any call heard, whether amateur or not. In the second column appears the area to which the calls are assigned. In the third column the amateur prefixes, the beginning letters of amateur calls, are listed. In most cases we know these prefixes to have been officially designated by the government concerned, but in some cases we have listed, of our own initiative, the proper prefix when there can be no choice about it. For instance, Haiti is assigned the calls from HHA to HHZ and therefore every Haitian amateur call must begin with the letters HH, whether that government so proclaims or not. Where a prefix is shown in brackets, it indicates that that government has more than one assignment of initial letters and that the indicated letter will be found assigned, in another part of the list, to that country. The list:

Block	Assigned to	Amateur Prefix
CAA-CEZ	Chile	CE
CFA-CKZ	Canada	[VE]
CLA-CMZ	Cuba	CM
CNA-CNZ	Morocco	[F]1
COA-COZ	Cuba	[CM]
CPA-CPZ	Bolivia	CP
CQA-CRZ	Portuguese colonies:	
	Cape Verde Islands	CR4
	Portuguese Guinea	CR5
	Angola	CR6
	Mozambique	CR7
	Portuguese India	CR8
	Macao	CR9
	Timor	CR10
CSA-CUZ	Portugal:	
	Portugal proper	CT1
	Azores Islands	CT2
	Madeira Islands	CT3
CVA-CXZ	Uruguay	CX
CYA-CZZ	Canada	[VE]
D	Germany	D
EAA-EHZ	Spain	EA

EIA-EIZ	Irish Free State	EI	YIA-YIZ	Iraq	YI
ELA-ELZ	Liberia	EL	YJA-YJZ	New Hebrides	YJ
EPA-EQZ	Persia	EP	YLA-YLZ	Latvia	YL
ESA-ESZ	Estonia	ES	YMA-YMZ	Lanzig	YM
ETA-ETZ	Ethiopia (Abyssinia)	ET	YNA-YNZ	Nicaragua	YN
EZA-EZZ	Territory of the Saar	EZ	YOA-YRZ	Roumania	(CV) ²
F	France	FF	YSA-YSZ	El Salvador	YS
	France, Algeria, Martinique, Morocco and Tahiti	F3, F8	YTA-YUZ	Jugo-Slavia	(UN) ²
	Tunisia	F4	YVA-YVZ	Venezuela	YV
	French Indo-China	FI	ZAA-ZAZ	Albania	ZA
G	United Kingdom:		ZBA-ZJZ	British colonies and protectorates:	
	Great Britain except Ireland	G		Transjordan	ZC1
	Northern Ireland	GI		Palestine	ZC6
HAA-HAZ	Hungary	HA		Nigeria	ZD
HBA-HBZ	Switzerland	HB	ZKA-ZMZ	Southern Rhodesia	ZE1
HCA-HCZ	Ecuador	HC		New Zealand:	
HHA-HHZ	Haiti	HH		Cook Islands	ZK
HIA-HIZ	Dominican Republic	HI		New Zealand proper	ZL
HJA-HKZ	Colombia	HJ-HK		British Samoa	ZM
HPA-HPZ	Republic of Panama	HP	ZPA-ZPZ	Paraguay	ZP
HRA-HRZ	Honduras	HR	ZSA-ZUZ	Union of South Africa	ZS-ZT-ZU
HSA-HSZ	Siam	HS			
HVA-HVZ	Vatican City	HV			
HZA-HZZ	Hedjaz	HZ			
I	Italy and colonies	I			
J	Japan	J			
K	United States of America:				
	Continental United States	[W]			
	Philippine Islands	KA			
	Porto Rico and Virgin Islands	K4			
	Canal Zone	K5			
	Territory of Hawaii, Guam, Samoa	K6			
	Territory of Alaska	K7			
LA	Norway	LA			
LOA-LWZ	Argentina	LU			
LXA-LXZ	Luxembourg	LX			
LYA-LYZ	Lithuania	LY			
LZA-LZZ	Bulgaria	LZ			
M	Great Britain	[G]			
N	United States of America	[W]			
OAA-OCZ	Peru	OA			
OEA-OEZ	Austria	OE			
OFA-OFZ	Finland	OH			
OKA-OKZ	Czechoslovakia	OK			
ONA-OTZ	Belgium	ON			
OUA-OZZ	Denmark	OZ			
PAA-PIZ	Netherlands	PA			
PJA-PIZ	Curacao	PJ			
PKA-POZ	Dutch East Indies	PK			
PPA-PYZ	Brazil	PY			
PZA-PZZ	Surinam	PZ			
R	Union of Soviet Socialist Republics	(AU-EU) ²			
SAA-SMZ	Sweden	SM			
SOA-SRZ	Poland	SP			
STA-SUZ	Egypt	ST			
SVA-SZZ	Greece	SV			
TAA-TCZ	Turkey	TA			
TFA-TFZ	Iceland	TF			
TGA-TGZ	Guatemala	TG			
TIA-TIZ	Costa Rica	TI			
TKA-TKZ	France and colonies and protectorates	[F]			
U	Union of Soviet Socialist Republics	(AU-EU) ²			
VAA-VGZ	Canada	VE			
VHA-VMZ	Australia	VK			
VOA-VOZ	Newfoundland	VO			
VPA-VSZ	British colonies and protectorates:				
	Fiji, Ellice Islands, Zanzibar	VP1			
	Bahamas	VP7			
	British Honduras, Trinidad	VP4			
	Jamaica	VP5			
	Barbados	VP6			
	Bermuda	VP9			
	Fanning Island	VQ1			
	Northern Rhodesia	VQ2			
	Tanganyika	VQ3			
	Kenya Colony	VQ4			
	Uganda	VQ5			
	British Guiana	VR			
	Malaya (Straits Settlements)	VS1-2-3			
	Hongkong	VS6			
	Ceylon	VS7			
VTA-VWZ	British India	VU			
W	United States of America:				
	Continental United States	W			
	(For others, see under K)				
XAA-XFZ	Mexico	X3			
XGA-XUZ	China	XT-XU ⁴			
XYA-XZZ	British India	[VU]			
YAA-YAZ	Afghanistan	YA			
YBA-YHZ	Dutch East Indies	[PK]			

¹ A number of Moroccan amateurs use the unofficial prefix CN, although the French government has decreed that F8 must be used by licensed stations.

² Changes in the Table of Distribution of Call Signs made at the Madrid convention, and incorporated in this list, will cause changes in the prefixes used by amateurs of several countries. At the time of going to press no official information concerning these changes, which have not in all cases been ratified by the governments concerned, is available. For this reason, the old prefixes used under the Washington convention are shown.

³ Improperly assigned by Mexico; it should have two letters to distinguish it from China.

⁴ Few Chinese amateurs, on the contrary, use the X prefix; most of them still use AC, an heritage from the old I.A.R.U. intermediates.

Measuring Distances

Often it is interesting to know just how far away some station is located. In measuring distances it is customary to measure along the shortest path on the surface of the earth. This distance is along the arc of a Great Circle, and for very short distances is practically a straight line. Distances of a thousand miles or so may be measured with sufficient accuracy on an ordinary map with a ruler, using the "scale of miles" indicated on the map.

For longer distances where the curvature of the earth cannot be neglected, the simplest way of measuring distance is by means of a common globe of the type used in school-rooms. The globe should be at least eight inches in diameter for good results. A piece of string should be stretched between the two points in question, and when pulled taut will automatically align itself along the Great Circle route between them. The length of the string between the two points when converted into miles according to the scale of the globe, will be the distance between the two points.

The globe will be found useful in other ways also, as for instance in determining the direction in which a distant spot lies from the station. Flat maps of the world (on Mercator's projection) give a wholly misleading impression of both distance and direction between points widely separated, especially if located in the extremes of latitude.

Circular Time-and-Date Chart

A method of comparing different times with each other and with G.C.T. (Greenwich Civil Time) is necessary to get time, weather, and press schedules, announced in almost every case in local time. In the chart shown, the two discs A and B should be drawn carefully and mounted on cardboard. When centered and pinned to-

gether we have a convenient device to use in working international schedules and in checking QSL-cards. The chart is based on the fact that time changes an hour for each 15° of arc.

To find local time from a given G.C.T., simply set the G.C.T. mark on the given time and read the local time directly at its mark. Let us take an example. Set the G.C.T. mark at 00 G.C.T. Then by direct reading it is 6 p.m. Chicago time or 9 a.m. Tokio time. If we in Tokio wanted to find what time it was in New York at 6 p.m. Tokio time, we would set the Tokio pointer at 6 p.m. and read 4 a.m. for New York time.



Finding dates: Suppose an operator in Los Angeles works a station in Tokio at 11 p.m. P.S.T. on June 10. Then the slide rule shows that it will be 4 p.m. Tokio time. The next thing is to find whether it is *to-day* or *to-morrow* in Tokio, that is, June 10th or 11th. Now with the rule all set we run our eye around it in a *clockwise* direction from Los Angeles to Tokio. If at any point in that space the midnight mark is encountered it is *to-morrow* in Tokio, i.e. June 11th. If the midnight mark is not encountered in this space it is *to-day* in Tokio. For example: Suppose the Los Angeles station works the station in Tokio at 1 a.m. P.S.T. June 10th. Then the Los Angeles operator will know from the slide rule that it is 6 p.m. June 10th Tokio time.

Let us work from the Eastern Hemisphere back to the Western. Suppose the operator at the

Tokio station is doing the figuring. He works the Los Angeles station, let us say, at 9 p.m. June 15th, Tokio time. He wants to know what time it is in Los Angeles and also what the date is. He sets the rule to 9 p.m. Tokio time and finds at once that it is 4 a.m. in Los Angeles. Now for the date. He reads around disc *B* from Tokio to Los Angeles in a *clockwise* direction. Notice that it is always clockwise from the local station to the distant station. If at any place in that path the midnight mark is encountered it is *to-day* in Los Angeles, in other words, June 15th.

Suppose the Tokio station works the station in Los Angeles at 1 a.m. Tokio time. It would be 8 a.m. Los Angeles time, and since the midnight mark is not encountered between the two, in a clockwise direction from Tokio to Los Angeles, it is *yesterday* in Los Angeles, i.e. June 14th.

Now to find the difference in dates between two stations in the same hemisphere. Consider that half of the disc *B* and disregard the other half altogether. If the midnight mark does not come between them, within that semicircle, they are both *to-day*. If, however, the midnight mark comes in between them the one to the right is one day ahead of the one to the left, or inversely, the one to the left is a day behind the one to the right.

Good Books

Every amateur should maintain a carefully selected bookshelf; a few good books, consistently read and consulted, will add immeasurably to the interest and knowledge of the owner. We suggest a selection among the following works, all of which have been gone over carefully and are recommended in their various fields.

Principles of Radio, by Keith Henney, is an excellent book for the amateur who wants to acquire a better understanding of the fundamentals of radio transmission and reception. The book is thoroughly modern and, generally speaking, is a "non-mathematical" treatment. Recommended to every amateur. Price, \$3.50.

Radio Engineering, by Prof. F. E. Terman, is written from the viewpoint of the practical engineer engaged in design and experimental work on modern transmitters and receivers, and covers all phases of radio communication with the thoroughness of a complete reference book. A knowledge of advanced mathematics is helpful, but not necessary. Price, \$5.00.

An excellent theoretical work, requiring some knowledge of mathematics (algebra, at least) is *Elements of Radio Communication*, by Prof. J. H. Morecroft, price \$3.00. This is in the "first-year" student class. Perhaps the best known of all theoretical works is *Principles of Radio Communication*, by Morecroft, priced at \$7.50, but a familiarity with mathematics is essential to anyone who expects to derive much benefit from this book. The *Manual of Radio Telegraphy and Telephony*, by Admiral S. S. Robison, U.S.N., and published by the Naval Institute, covers both the theoretical and practical fields.

A monumental work on vacuum tubes has been made available recently in Dr. E. L. Chaffee's *Theory of Thermionic Vacuum Tubes*, based on his research and study at Harvard University. This book is of an advanced nature, but is partic-

ularly recommended because of its exhaustive and competent presentation.

Two valuable books cover the general field of electricity and communications, with fitting emphasis on the radio aspects. *Electricity — What It Is and How It Acts*, by A. W. Kramer, is an easily understood treatment of modern electrical theory, including comprehensive discussions of vacuum-tube and electro-magnetic wave phenomena. It is written in two volumes, price \$2.00 each. *Communication Engineering*, by Prof. W. L. Everitt, is a thorough treatment of all types of communications networks. A certain amount of training in d.c. and a.c. current theory as well as mathematics through calculus is needed for fullest appreciation of this work. The price is \$5.00.

For the experimenter, there is Prof. R. R. Ramsey's *Experimental Radio*, price \$2.75, which describes in detail 128 experiments designed to bring out the principles of radio theory, instruments and measurements. There are two excellent books on high frequency measurements, intended primarily for serious experimenters and engineers. *Radio Frequency Electrical Measurements*, by H. A. Brown, is priced at \$4.00, while *High Frequency Measurements* by August Hund costs \$5.00.

Radio Data Charts, an English publication by R. T. Beatty, is a series of abacs (graphic charts) which enables most of the problems connected with radio design to be solved easily without recourse to mathematical calculations.

For practical handbooks covering just about the entire field of radio, we recommend either *Radio Theory and Operating*, by Loomis, price \$4.25, *The Radio Manual*, by Sterling, at \$6.00, or *Radio Telegraphy and Telephony*, by Duncan and Drew, at \$7.50. All of these are over 900 pages and are of the type used as texts in radio schools; while they contain a moderate amount of theory, they are essentially practical handbooks for commercial and broadcast operators. Any one of them is well worth having.

Amateurs who are interested in studying for commercial operators' licenses will be interested in the following, in conjunction with the volumes listed in the preceding paragraph: *How to Pass U. S. Government Radio License Examinations*, by Duncan and Drew, price \$2.00, which is written to supplement the other work by the same authors, mentioned above; and *Radio Operating Questions and Answers*, by Nilson and Hornung, \$2.50, which is intended to supplement *Practical Radio Telegraphy* (by the same authors, price \$3.00) in preparation for commercial licenses. There is also the *Radio Traffic Manual and Operating Regulations*, by Duncan and Drew, which carries the new commercial licensee right into the practical operating field.

Any of the above books (with the exception of Circular No. 74) may be obtained from the Book Department of the A.R.R.L. at the prices stated. Readers are referred to the Book Department's advertisement, in the advertising section of this Handbook, for a list which includes additional volumes of interest to amateurs.

QST is the official organ of the American Radio Relay League. It is published monthly, containing up-to-date information on amateur activities and describing the latest developments in ama-

teur radio. It is a magazine devoted exclusively to the radio amateur. Written by and for the amateur, it contains knowledge supplementary to the books we have mentioned. *QST* is found on the bookshelves of earnest amateurs and experimenters everywhere. Good books are a worth-while investment. A subscription to *QST* is equally valuable.

The Decibel

The decibel (abbreviated *db*) is a convenient unit for the measurement of electrical or acoustic power ratios on a logarithmic scale. The number of decibels equivalent to the ratio between two amounts of power is

$$db = 10 \log_{10} \frac{P_1}{P_2}$$

Since the decibel is a logarithmic unit, successive gains and losses expressed in *db* can be added algebraically. If the ratio of the two power values is greater than 1 there is a power gain; if the ratio is less than 1 there is a loss of power. A gain is expressed in "plus *db*"; a loss in "minus *db*."

The decibel also can be used to express ratios between voltages and currents provided the circuit conditions are the same for the two quantities whose magnitudes are being compared; i.e., if the impedances and power factors of the circuits are the same.

The decibel is primarily a unit which specifies gains or losses with reference to the power value at some point in a system regardless of the actual value of the reference power. In telephone and radio work, however, it is convenient to assume a reference power level and express the power at a point in a circuit in terms of "plus *db*" or "minus *db*" above or below this reference level. A standard reference level in radio work is .006 watts, or 6 milliwatts.

Standard Letter Symbols for Electrical Quantities

Admittance	Y, y
Angular velocity ($2\pi f$)	ω
Capacitance	C
Conductance	G, g
Current	I, i
Difference of potential	E, e
Dielectric constant	K or ϵ
Energy	W
Frequency	f
Impedance	Z, z
Inductance	L
Magnetic intensity	H
Magnetic flux	Φ
Magnetic flux density	B
Mutual inductance	M
Number of conductors or turns	N
Permeability	μ
Phase displacement	θ or ϕ
Power	P, p
Quantity of electricity	Q, q
Reactance	X, x
Resistance	R, r
Susceptance	b
Speed of rotation	n
Voltage	E, e
Work	W

Letter Symbols for Vacuum Tube Notation

Grid potential	E_g, e_g
Grid current	I_g, i_g
Grid conductance	g_g
Grid resistance	r_g
Grid bias voltage	E_c
Plate potential	E_p, e_p
Plate current	I_p, i_p
Plate conductance	g_p
Plate resistance	r_p
Plate supply voltage	E_b
Emission current	I_s
Mutual conductance	g_m
Amplification factor	μ
Filament terminal voltage	E_f
Filament current	I_f
Filament supply voltage	E_a
Grid-plate capacity	C_{gp}
Grid-filament capacity	C_{gf}
Plate-filament capacity	C_{pf}
Grid capacity ($C_{gp} + C_{gf}$)	C_g
Plate capacity ($C_{gp} + C_{pf}$)	C_p
Filament capacity ($C_{gf} + C_{pf}$)	C_f

NOTE.—Small letters refer to instantaneous values.

Abbreviations Commonly Used in Radio

Alternating current	a.c.
Antenna	ant.
Audio frequency	a.f.
Continuous waves	c.w.
Cycles per second	~
Decibel	db.
Direct current	d.c.
Electromotive force	e.m.f.
Frequency	f.
Ground	gnd.
Henry	h.
Intermediate frequency	i.f.
Interrupted continuous waves	i.c.w.
Kilocycles (per second)	kc.
Kilowatt	kw.
Megohm	MΩ
Microfarad	μfd.
Microhenry	μh.
Micromicrofarad	μμfd.
Microvolt	μv.
Microvolt per meter	μv/m.
Milliampere	ma.
Milliwatt	mw.
Ohm	Ω
Power factor	p.f.
Radio frequency	r.f.
Volt	v.

Metric Prefixes Often Used with Radio Quantities

μ	$\frac{1}{1,000,000}$	One-millionth	micro-
m	$\frac{1}{1,000}$	One-thousandth	milli-
c	$\frac{1}{100}$	One hundredth	centi-
d	$\frac{1}{10}$	One-tenth	deci-
	1	One	uni-
dk	10	Ten	deka-

h	100	One hundred	hekto-
k	1,000	One thousand	kilo-
	10,000	Ten thousand	myria-
	1,000,000	One million	mega-

Greek Alphabet

Since Greek letters are used to stand for many electrical and radio quantities, the names and symbols of the Greek alphabet with the equivalent English characters are given.

Greek Letter	Greek Name	English Equivalent
Α α	Alpha	a
Β β	Beta	b
Γ γ	Gamma	g
Δ δ	Delta	d
Ε ε	Epsilon	e
Ζ ζ	Zeta	z
Η η	Eta	e
Θ θ	Theta	th
Ι ι	Iota	i
Κ κ	Kappa	k
Λ λ	Lambda	l
Μ μ	Mu	m
Ν ν	Nu	n
Ξ ξ	Xi	x
Ο ο	Omicron	ø
Π π	Pi	p
Ρ ρ	Rho	r
Σ σ	Sigma	s
Τ τ	Tau	t
Υ υ	Upsilon	u
Φ φ	Phi	ph
Χ χ	Chi	ch
Ψ ψ	Psi	ps
Ω ω	Omega	o

Inductance Calculation

The lumped inductance of coils for transmitting and receiving is fairly easy to calculate:

$$L = \frac{0.2 A^2 N^2}{3A + 9B + 10C}$$

where L is the inductance in microhenrys

A is the mean diameter of the coil in inches

B is the length of winding in inches

C is the radial depth of winding in inches

N is the number of turns.

The quantity C may be neglected if the coil is a single-layer solenoid, as is nearly always the case with coils for high frequencies.

For example, assume a coil having 35 turns of No. 30 d.s.c. wire on a receiving coil form having a diameter of 1.5 inches. Consulting the wire table, we find that 35 turns of No. 30 d.s.c. will occupy a length of one-half inch. Therefore,

$$A = 1.5$$

$$B = .5$$

$$N = 35$$

and

$$L = \frac{0.2 \times (1.5)^2 \times (35)^2}{(3 \times 1.5) + (9 \times .5)}$$

or 61.25 microhenrys.

Figuring the Capacitance of a Condenser

$$C = \frac{kA(n-1)}{4\pi d \times 9 \times 10^5}$$

$$= .0088 \frac{kA}{d} (n-1) 10^{-5} \mu\text{fds.}$$

where A = area of one side of one plate (sq. cm.)
 n = total number of plates
 d = separation of plates (cm.)
 k = specific inductive capacity of dielectric.

The Specific Inductive Capacity (k) is a property of the dielectric used in a condenser. It determines the quantity of charge which a given separation and area of plates will accumulate for

Table of Dielectric Constants

Dielectric	"k"	Puncture voltage	
		Kilovolts per cm.	Kilovolts per inch.
Air (normal pressure)	1.00	7.8-9.0	19.8-22.8
Flint Glass	6.6 to 10	900	2280
Mica	4.6 to 8	1500	3810
Paraffin Wax (solid)	2.0 to 2.5	400	1017
Sulphur	3.9 to 4.2	—	—
Castor Oil	4.7	150	381
Porcelain	4.4	—	—
Quartz	4.5	—	—
Resin	2.5	—	—
Olive Oil	3.1	120	305
Gutta Percha	3.3 to 4.9	80-200	203-508
Shellac	3.1	—	—
Common Glass	3.1 to 4.0	300-1500	762-3810
Turpentine	2.23	110-160	280-406
Dry Oak Wood	2.5 to 6.8	—	—
Formica, Bakelite, etc.	5 to 6	—	—

a given applied voltage. The "inductivity" of the dielectric varies as in the above table. "k" is the ratio of the capacitance of a condenser with a given dielectric to the capacitance of the same instrument with air dielectric.

When the air dielectric in a variable condenser is replaced with some other fluid dielectric its maximum and minimum capacitance values are multiplied by "k" and the "sparking" potential is increased.

Fluid dielectrics repair themselves after a breakdown unless an arc is maintained that carbonizes the oil. Dry oil is a good dielectric with quite low losses. When solid dielectric is used it should be borne in mind that dielectric strength (breakdown voltage) becomes lower as temperature rises. Breakdown is a function of time as well as voltage. A condenser that stands up under several thousand volts for a few seconds might break down when connected to a 2000-volt line for a half-hour.

Example of finding condenser capacitance: We have 3 plates, 3" x 5", in air. The plates are separated $\frac{1}{8}$ ". $1'' = 2.54$ centimeters.

$$k = 1.A = 7.62 \times 12.70 = 96.8 \text{ sq. cm. } d = .3175 \text{ cm. } n - 1 = 2.$$

$$C = .0088 \frac{1 \times 96.8}{.32} 2 \times 10^{-5} = .00005325 \mu\text{fd. or } 53\frac{1}{4} \text{ micromicrofarads.}$$

The capacity formula becomes as follows, when A is the area of one side of one plate in square inches and d is the separation of the plates in inches.

$$C = .02235 \frac{kA}{d} (n-1) 10^{-5} \mu\text{fd.}$$

If we put the condenser of our example in castor oil the increase in capacitance, owing to the greater value of k , will make our condenser have a capacitance of

$$53\frac{1}{4} \times 4.7 = 250 \text{ micromicrofarads.}$$

The air condenser might spark over at about $7.8 \times .3175 \text{ cm.} = 2.475 \text{ kv. (2,475 volts).}$

In oil (castor oil) it would have $150/7.8$ (or $381/19.8$) times the breakdown voltage of air.

$$\frac{150}{7.8} = 19.25$$

$$19\frac{1}{4} \times 2475 = 47,600 \text{ volts}$$

We can find the same value directly:
 $150 \times .3175 \text{ cm.} = 47,600 \text{ volts (peak).}$

Using the formulas for "reactance" we can find what the voltage drop across this condenser will be when carrying current at a specified high frequency.

$$E_x = X_c I \quad X_c = \frac{1}{2\pi f C}$$

where E_x is the reactance voltage drop, C is the capacitance of the condenser (farads),

f is the frequency (cycles per second), X_c is the reactance of the condenser in ohms.

Suppose we are using the 3-plate fixed air condenser in our antenna circuit, and that a radio-frequency ammeter is in series with it. We are operating on an 80-meter wavelength (3,750,000 cycles) and the meter right next the condenser reads 1.3 amperes. What is the voltage drop across the air condenser?

$$X_c = \frac{1}{2 (3.1416) (3,750,000) (53.25) 10^{-12}}$$

$$= \frac{1}{1257 \times 10^{-6}} = \frac{10^6}{1257} = 797 \text{ ohms}$$

$$E_x = (797) (1.3) = 1034 \text{ volts (root mean square value).}$$

If the wave is a sine wave, this value multiplied by 1.414 will give the "peak" or maximum value
 $1034 \times 1.414 = 1462 \text{ volts (peak)}$

Our radio-frequency ammeter measures the heating effect of all the instantaneous values of current during the radio-frequency cycle. The direct current, the square of which equals the average of the squares of all the values of alternating current over a whole cycle, produces the same heat as the alternating current. Alternating current meters generally used for a.c. switchboard work read the effective or root mean square values which we mention above.

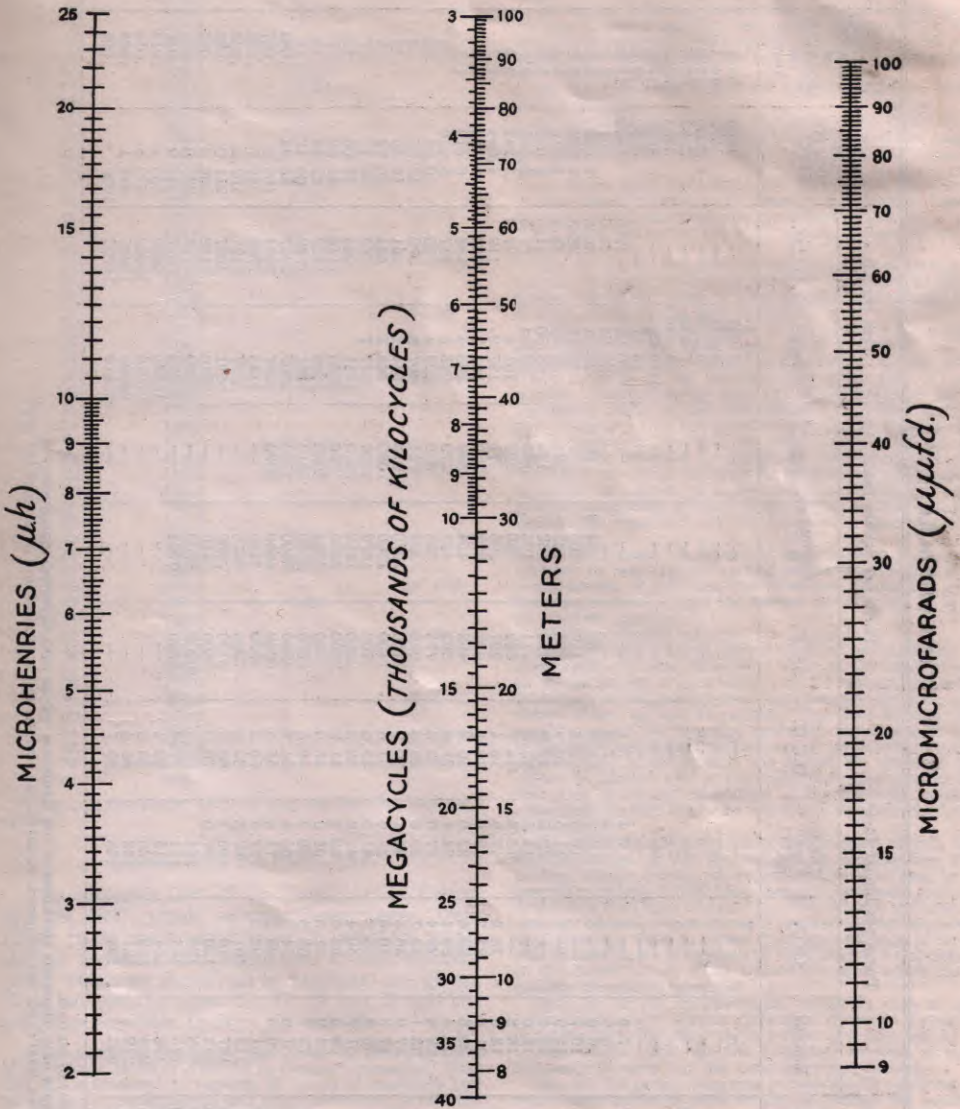

RELATION BETWEEN INDUCTANCE, CAPACITY AND FREQUENCY

With this chart and a straight-edge any of the above quantities can be determined if the other two are known. For example, if a condenser has a minimum capacity of 15 μμfd. and a maximum capacity of 50 μμfd., and it is to be used with a coil of 10 μh. inductance, what frequency range will be covered? The straight-edge is connected between 10 on the left-hand scale and 15 on the right, giving 13 mc. as the high-frequency limit. Keeping the straight-edge at 10 on the left-hand scale, the other end is swung to 50 on the right-hand scale, giving a low-frequency limit of 7.1 mc. The tuning range would, therefore, be from 7.1 mc. to 13 mc., or 7100 kc. to 13,000 kc. The center scale also serves to convert frequency to wavelength.

COPPER WIRE TABLE

Gauge No. B. & S.	Diam. in Mils.	Circular Mil Area	Turns per Linear Inch ²			Turns per Square Inch ²		Feet per Lb.		Ohms per 1000 ft. 250 C.	Current-Carrying Capacity at 1500 C.M. per Amp. ¹	Diam. in mm.	Nearest British S.W.G. No.
			Enamel	S.S.C.	D.S.C. or S.C.C.	D.C.C.	S.C.C.	Enamel S.C.C.	D.C.C.				
1	289.3	82890	—	—	—	—	—	3.947	1.264	55.7	7.348	1	
2	257.0	66370	—	—	—	—	—	4.977	.1593	44.1	6.654	3	
3	229.4	52940	—	—	—	—	—	6.276	.2009	35.0	5.827	4	
4	204.3	41740	—	—	—	—	—	7.914	.2533	27.7	5.189	5	
5	181.9	33100	—	—	—	—	—	9.980	.3193	22.0	4.621	7	
6	162.0	26260	—	—	—	—	—	12.587	.4028	17.5	4.119	8	
7	144.3	20820	—	—	—	—	—	16.011	.5080	13.8	3.665	9	
8	128.5	16510	—	—	—	—	—	20.51	.6405	11.0	3.264	10	
9	114.4	13090	—	—	—	—	—	25.23	.8077	8.7	2.908	11	
10	101.9	10380	—	—	—	—	—	31.52	1.018	6.9	2.598	12	
11	90.74	8284	—	—	—	—	—	40.12	1.284	5.5	2.309	13	
12	80.81	6530	—	—	—	—	—	50.59	1.619	4.4	2.053	14	
13	71.96	5178	—	—	—	—	—	63.80	2.042	3.5	1.828	15	
14	64.08	4107	—	—	—	—	—	80.44	2.575	2.7	1.628	16	
15	57.07	3257	—	—	—	—	—	101.4	3.247	2.1	1.450	17	
16	50.82	2583	18.9	—	—	—	—	127.9	4.084	1.7	1.291	18	
17	45.26	2045	21.2	—	—	—	—	161.3	5.063	1.3	1.150	19	
18	40.30	1624	23.0	—	—	—	—	203.4	6.210	1.0	1.034	20	
19	35.89	1285	26.4	—	—	—	—	256.5	7.537	.8	.9118	21	
20	31.96	1022	29.4	—	—	—	—	323.4	9.058	.6	.8118	22	
21	28.46	810.1	32.7	—	—	—	—	407.8	10.80	.5	.7239	23	
22	25.35	642.4	37.0	—	—	—	—	514.2	12.8	.4	.6438	24	
23	22.57	509.5	41.3	—	—	—	—	645.7	15.0	.3	.5733	25	
24	20.10	404.0	46.3	—	—	—	—	801.7	17.5	.2	.5107	26	
25	17.90	320.4	51.7	—	—	—	—	1031	20.2	.1	.4547	27	
26	15.94	254.1	58.0	—	—	—	—	1300	23.0	.1	.4049	28	
27	14.20	201.5	64.7	—	—	—	—	1639	26.0	.1	.3600	29	
28	12.66	159.5	72.7	—	—	—	—	2067	29.2	.1	.3200	30	
29	11.26	126.7	81.9	—	—	—	—	2597	32.7	.1	.2849	31	
30	10.08	100.5	93.3	—	—	—	—	3287	36.4	.1	.2548	32	
31	8.928	79.70	101	—	—	—	—	4245	40.2	.084	.2298	33	
32	7.950	63.71	115	—	—	—	—	5455	44.2	.067	.2098	34	
33	7.089	50.45	127	—	—	—	—	6991	48.5	.055	.1901	35	
34	6.305	39.45	145	—	—	—	—	8991	53.0	.042	.1718	36	
35	5.615	31.52	158	—	—	—	—	11580	57.7	.032	.1548	37	
36	5.000	25.00	178	—	—	—	—	14850	62.7	.026	.1391	38	
37	4.453	19.52	198	—	—	—	—	18960	68.0	.021	.1241	39	
38	3.969	15.27	224	—	—	—	—	24100	73.5	.017	.1101	40	
39	3.551	12.57	258	—	—	—	—	30500	79.3	.013	.0977	41	
40	3.185	9.88	282	—	—	—	—	38410	85.1	.008	.0879	42	
									1069	.008	.0799	43	
									14222	.008	.0799	44	

¹A mil is 1/1000 (one thousandth) of an inch.
²The figures given are approximate only, since the thickness of the insulation varies with different manufacturers.
³The current-carrying capacity at 1000 C.M. per ampere is equal to the circular-mil area (Column 3) divided by 1000

Numbered Drill Sizes

Number	Diameter (mils)	Will Clear Screw	Drilled for Tapping Iron, Steel or Brass*
1	228.0	—	—
2	221.0	12-24	—
3	213.0	—	14-24
4	209.0	12-20	—
5	205.5	—	—
6	204.0	—	—
7	201.0	—	—
8	199.0	—	—
9	196.0	—	—
10	193.5	10-32	—
11	191.0	10-24	—
12	189.0	—	—
13	185.0	—	—
14	182.0	—	—
15	180.0	—	—
16	177.0	—	12-24
17	173.0	—	—
18	169.5	8-32	—
19	166.0	—	12-20
20	161.0	—	—
21	159.0	—	10-32
22	157.0	—	—
23	154.0	—	—
24	152.0	—	—
25	149.5	—	10-24
26	147.0	—	—
27	144.0	—	—
28	140.5	6-32	—
29	136.0	—	8-32
30	128.5	—	—
31	120.0	—	—
32	116.0	—	—
33	113.0	4-36 4-40	—
34	111.0	—	—
35	110.0	—	6-32
36	106.5	—	—
37	104.0	—	—
38	101.5	—	—
39	99.5	3-48	—
40	98.0	—	—
41	96.0	—	—
42	93.5	—	4-36 4-40
43	98.0	2-56	—
44	98.6	—	—
45	98.2	—	3-48
46	98.1	—	—
47	97.8.5	—	—
48	97.6	—	—
49	97.3	—	2-56
50	97.0	—	—
51	96.7	—	—
52	96.3.5	—	—
53	95.9.5	—	—
54	95.5	—	—

* Use one size larger drill for tapping bakelite and hard rubber.

Extracts from the Radio Law

The complete text of the Radio Act of February 23, 1927, would occupy many pages. Only those parts most applicable to amateur radio station licensing and regulation in this country (with which we should all be familiar) are given. Note particularly Secs. 26, 27, 28 and 29 and the penalties provided in Secs. 32 and 33.

Be it enacted by the Senate and House of Representatives of the United States of America in Congress assembled, That this Act is intended to regulate all forms of interstate and foreign radio transmissions and communications within the United States, its Territories and possessions; to maintain the control of the United States over all the channels of interstate and foreign radio transmission; and to provide for the use of such channels, but not the ownership thereof, by individuals, firms, or corporations, for limited periods of time, under licenses granted by Federal authority, and no such license shall be construed to create any right, beyond the terms, conditions, and periods of the license. That no person, firm, company, or corporation shall use or operate any apparatus for the transmission of energy or communications or signals by radio . . . except under and in accordance with this Act and with a license in that behalf granted under the provisions of this Act.

Sec. 3. That a commission is hereby created and established to be known as the Federal Radio Commission, hereinafter referred to as the commission, which shall be composed of five commissioners . . .

Sec. 4. Except as otherwise provided in this Act, the commission, from time to time, as public convenience, interest, or necessity requires, shall —

- (a) Classify radio stations;
- (b) Prescribe the nature of the service to be rendered by each class of licensed stations and each station within any class;
- (c) Assign bands of frequencies or wavelengths to the various classes of stations, and assign frequencies or wavelengths for each individual station and determine the power which each station shall use and the time during which it may operate;
- (d) Determine the location of classes of stations or individual stations;
- (e) Regulate the kind of apparatus to be used with respect to its external effects and the purity and sharpness of the emissions from each station and from the apparatus therein;
- (f) Make such regulations not inconsistent with law as it may deem necessary to prevent interference between stations and to carry out the provisions of this Act . . .
- (i) Have authority to make general rules and regulations . . .

Sec. 5. (C) To prescribe the qualifications of station operators, to classify them according to the duties to be performed, to fix the forms of such licenses, and to issue them to such persons as he finds qualified.

(D) To suspend the license of any operator for a period not exceeding two years upon proof sufficient . . . that the licensee (a) has violated any provision of any Act or treaty binding on the United States which the . . . commission is authorized by this Act to administer or by any regulation made by the commission . . . under any such Act or treaty; or (b) has failed to carry out the lawful orders of the master of the vessel on which he is employed; or (c) has wilfully damaged or permitted radio apparatus to be damaged; or (d) has transmitted superfluous radio communications or signals or radio communications containing profane or obscene words or language; or (e) has wilfully or maliciously interfered with any other radio communications or signals.

(E) To inspect all transmitting apparatus to ascertain whether in construction and operation it conforms to the requirements of this Act, the rules and regulations of the licensing authority, and the license under which it is constructed or operated.

(G) To designate call letters of all stations.

Sec. 14. Any station license shall be revocable by the commission for false statements either in the application or in the statement of fact which may be required by section 10 hereof, or because of conditions revealed by such statements of fact as may be required from time to time which would warrant the licensing authority in refusing to grant a license on an original application, or for failure to operate substantially as set forth in the license, for violation of or failure to observe any of the restrictions and conditions of this Act, or of any regulation of the licensing authority authorized by this Act or by a treaty ratified by the United States . . .

Sec. 16. Any applicant for a construction permit, for a station license, or for the renewal or modification of an existing station license whose application is refused by the licensing authority shall have the right to appeal from said decision to the Court of Appeals of the District of Columbia; and any licensee whose license is revoked by the commission shall have the right to appeal from such decision of revocation to said Court of Appeals of the District of Columbia or to the district court of the United States in which the apparatus licensed is operated. . . .

Sec. 26. In all circumstances, except in case of radio communications or signals relating to vessels in distress, all radio stations, including those owned and operated by the United States, shall use the minimum amount of power necessary to carry out the communication desired.

Sec. 27. No person receiving or assisting in receiving any radio communication shall divulge or publish the contents, substance, purport, effect, or meaning thereof except through authorized channels of transmission or reception to any person other than the addressee, his agent, or attorney, or to a telephone, telegraph, cable, or radio station employed or authorized to forward such radio communication to its destination, or to proper accounting or distributing officers of the various communicating centers over which the radio communication may be passed, or to the master of a ship under whom he is serving, or in response to a subpoena issued by a court of competent jurisdiction, or on demand of other lawful authority; and no person not being authorized by the sender shall intercept any message and divulge or publish the contents, substance, purport, effect, or mean-

ing of such intercepted message to any person; and no person not being entitled thereto shall receive or assist in receiving any radio communication and use the same or any information therein contained for his own benefit or for the benefit of another not entitled thereto; and no person having received such intercepted radio communication or having become acquainted with the contents, substance, purport, effect, or meaning of the same or any part thereof, knowing that such information was so obtained, shall divulge or publish the contents, substance, purport, effect, or meaning of the same or any part thereof, or use the same or any information therein contained for his own benefit or for the benefit of another not entitled thereto: *Provided*, That this section shall not apply to the receiving, divulging, publishing, or utilizing the contents of any radio communication broadcasted or transmitted by amateurs or others for the use of the general public or relating to ships in distress.

Sec. 28. No person, firm, company, or corporation within the jurisdiction of the United States shall knowingly utter or transmit or cause to be uttered or transmitted, any false or fraudulent signal of distress, or communication relating thereto, nor shall any broadcasting station rebroadcast the program or any part thereof of another broadcasting station without the express authority of the originating station.

Sec. 29. Nothing in this Act shall be understood or construed to give the licensing authority the power of censorship over the radio communications or signals transmitted by any radio station, and no regulation or condition shall be promulgated or fixed by the licensing authority which shall interfere with the right of free speech by means of radio communications. No person within the jurisdiction of the United States shall utter any obscene, indecent, or profane language by means of radio communication.

Sec. 32. Any person, firm, company, or corporation failing or refusing to observe or violating any rule, regulation, restriction, or condition made or imposed by the licensing authority under the authority of this Act or of any international radio convention or treaty ratified or adhered to by the United States, in addition to any other penalties provided by law, upon conviction thereof by a court of competent jurisdiction, shall be punished by a fine of not more than \$500 for each and every offense.

Sec. 33. Any person, firm, company, or corporation who shall violate any provision of this Act, or shall knowingly make any false oath or affirmation in any affidavit required or authorized by this Act, or shall knowingly make any false oath or affirmation in any hearing authorized by this Act, upon conviction thereof in any court of competent jurisdiction, shall be punished by a fine of not more than \$5,000 or by imprisonment for a term of not more than five years or both for each and every such offense.

Sec. 34. The trial of any offense under this Act shall be in the district in which it is committed; or if the offense is committed upon the high seas, or out of the jurisdiction of any particular State or district, the trial shall be in the district where the offender may be found or into which he shall be first brought.

Sec. 35. This Act shall not apply to the Philippine Islands or to the Canal Zone. In international radio matters the Philippine Islands and the Canal Zone shall be represented by the Secretary of State.

United States Amateur Regulations

Pursuant to the basic radio law, general regulations for amateurs have been drafted by the Federal Radio Commission. The regulations here listed are effective as of October 1, 1933. The number before each regulation is its official number in the complete book of regulations for all classes of radio stations as issued by the Commission; since the amateur regulations are not all in one group, the numbers are not necessarily consecutive. The number of each regulation is of no consequence to the amateur, except as a means of reference.

Every amateur should be *thoroughly familiar* with these regulations and their effect, although, of course, it is not necessary to know the exact wording from memory.

RULES AND REGULATIONS GOVERNING AMATEUR RADIO STATIONS

1. Each application for an instrument of authorization shall be made in writing on the appropriate form prescribed by the Commission for the purpose. Separate application shall be filed for each instrument of authorization. The

required forms except as provided in paragraph 408 for amateur applicants, may be obtained from the Commission or from the office of any inspector. For a list of such offices and related geographical districts, see paragraph 30.

* * *

2. (h) Each application for amateur facilities shall be filed in accordance with the following instructions:

(1) Applications for amateur station and/or operators' licenses from applicants residing within 125 miles of Washington, D. C., a radio district office of the Commission, or an examining city (see par. 30): One copy to the Inspector-in-Charge of the Radio District in which the applicant resides.

(2) Applications for amateur station and/or operators' licenses from applicants residing more than 125 miles from Washington, D. C., a radio district office of the Commission, or an examining city (see par. 30): One copy direct to the Federal Radio Commission, Washington, D. C., in accordance with the instructions specifically set forth on the application form.

* * *

14. Each application for new license, where a construction permit is not prerequisite thereto, shall be filed at least 60 days prior to the contemplated operation of the station.

* * *

16. Unless otherwise directed by the Commission, each application for renewal of license shall be filed at least 60 days prior to the expiration date of the license sought to be renewed.

* * *

20. The transfer of a radio station license, or the rights granted thereunder, without consent of the Commission shall be sufficient ground for the revocation of such license or denial of any application for its renewal. Amateur station licenses and call signals are not transferable.

* * *

22. The Commission may grant special authority to the licensee of an existing station authorizing the operation of such station for a limited time in a manner, to an extent, or for a service other or beyond that authorized in the license.

* * *

24. Any licensee receiving official notice of a violation of Federal laws, the Commission's rules and regulations, or the terms and conditions of a license, shall within three days from such receipt send a written reply direct to the Federal Radio Commission at Washington, D. C. The answer to each notice shall be complete in itself and shall not be abbreviated by reference to other communications or answers to other notices. If the notice relates to some violation that may be due to the physical or electrical characteristics of the transmitting apparatus, the answer shall state fully what steps, if any, are taken to prevent future violations, and if any new apparatus is to be installed, the date such apparatus was ordered, the name of the manufacturer, and promised date of delivery.

* * *

26. If the notice of violation relates to some lack of attention or improper operation of the transmitter, the name and license number of the operator in charge shall be given.

27. All station licenses will be issued so as to expire at the hour of 3 a. m., eastern standard time.

(e) The licenses for amateur stations will be issued for a normal license period of three years from the date of expiration of old license or the date of granting a new license or modification of a license.

28. In so far as practicable, call signals of radio stations will be designated in alphabetical order from groups available for assignment, depending upon the class of station to be licensed. Because of the large number of amateur stations, calls will be assigned thereto in regular order and requests for particular calls will not be considered.

29. Call signals of stations will be deleted in each of the following cases:

(a) Where an existing instrument of authorization has expired and no application for renewal or extension thereof has been filed.

(b) Where a license has been revoked.

(c) Where a license is surrendered or cancelled.

(d) Other cause, such as death, loss of citizenship, or adjudged insanity of the station licensee. Such occurrences coming to notice should be reported to the Commission, preferably accompanied by the station license for cancellation, if available.

* * *

30. The following list of the radio districts gives the address of each field office of the Federal Radio Commission and the territory embraced in each district. [This list is reproduced on the last page of this booklet. — Ed.]

(a) The following is a list of the cities where examinations

will be held for radio operators' licenses in addition to Washington, D. C., and the radio district offices of the Commission. Other cities may also be designated from time to time for the purpose of conducting commercial operators' examinations only: (See pars. 2, 404, and 408.)

- | | |
|----------------------|------------------|
| Schenectady, N. Y. | St. Louis, Mo. |
| Winston-Salem, N. C. | Pittsburgh, Pa. |
| Nashville, Tenn. | Cleveland, Ohio |
| San Antonio, Tex. | Cincinnati, Ohio |
| Oklahoma City, Okla. | Columbus, Ohio |
| Des Moines, Iowa | |

188. The term "station" means all of the radio-transmitting apparatus used at a particular location for one class of service and operated under a single instrument of authorization. In the case of every station other than broadcast, the location of the station shall be considered as that of the radiating antenna.

192. The term "portable station" means a station so constructed that it may conveniently be moved about from place to place for communication and that is in fact so moved about from time to time, but not used while in motion.

(a) The term "portable-mobile station" means a station so constructed that it may conveniently be moved from one mobile unit to another for communication, and that is, in fact, so moved about from time to time and ordinarily used while in motion.

204. Allocations of bands of frequencies to services, such as mobile, fixed, broadcast, amateur, etc., are set forth in Article 5 of the General Regulations annexed to the International Radiotelegraph Convention and in the North American Radio Agreement. These allocations will be adhered to in all assignments to stations capable of causing international interference.

207. Licensees shall use radio transmitters, the emissions of which do not cause interference, outside the authorized band, that is detrimental to traffic and programs of other authorized stations.

210. Radio communications or signals relating to ships or aircraft in distress shall be given absolute priority. Upon notice from any station, Government or commercial, all other transmission shall cease on such frequencies and for such time as may, in any way, interfere with the reception of distress signals or related traffic.

213. One or more licensed operators, of grade specified by these regulations, shall be on duty at the place where the transmitting apparatus of each station is located and whenever it is being operated; provided, however, that for a station licensed for service other than broadcasting, if remote control is used, the Commission may modify the foregoing requirement upon proper application and showing being made so that such operator or operators may be on duty at the control station in lieu of the place where the transmitting apparatus is located. Such modification shall be subject to the following conditions:

(a) The transmitter shall be capable of operation and shall be operated in accordance with the terms of the station license.

(b) The transmitter shall be monitored from the control station with apparatus that will permit placing the transmitter in an inoperative condition in the event there is a deviation from the terms of the license, in which case the radiation of the transmitter shall be suspended immediately until corrective measures are effectively applied to place the transmitter in proper condition for operation in accordance with the terms of the station license.

(c) The transmitter shall be so located or housed that it is not accessible to other than duly authorized persons.

214. The person manipulating the transmitting key of a manually operated radiotelegraph mobile or amateur transmitting station shall be a regularly licensed operator. The licenses of other stations operated under the constant supervision of duly licensed operators may permit any person or persons, whether licensed or not, to transmit by voice or otherwise, in accordance with the types of emission specified by the respective licenses.

220. Licensees of stations other than broadcast stations are authorized to carry on such routine tests as may be required for the proper maintenance of the stations, provided, however, that these tests shall be so conducted as not to cause interference with the service of other stations.

221. The original of each station license, except amateur, portable and portable-mobile stations shall be posted by the licensee in a conspicuous place in the room in which the transmitter is located. In the case of amateur, portable, and portable-mobile stations the original license, or a photostat copy thereof, shall be similarly posted or kept in the personal possession of the operator on duty.

(a) The original license of each station operator, except amateur and aircraft radio station operators, and operators of portable and portable-mobile stations, shall be posted in a conspicuous place in the room occupied by such operator while on duty. In the case of an amateur or aircraft radio operator, and operators of portable or portable-mobile stations, the original operator's license shall be similarly posted or kept in his personal possession and available for inspection at all times while the operator is on duty.

(b) When an operator's license cannot be posted because it has been mailed to an office of the Federal Radio Commission for endorsement or other change, such operator may continue to operate stations in accordance with the class of license held, for a period not to exceed sixty days, but in no case beyond the date of expiration of the license.

361. The term "amateur service" means a radio service carried on by amateur stations.

362. The term "amateur station" means a station used by an "amateur," that is, a duly authorized person interested in radio technique solely with a personal aim and without pecuniary interest.

364. The term "amateur radio operator" means a person holding a valid license issued by the Federal Radio Commission who is authorized under the regulations to operate amateur radio stations.

365. The term "amateur radiocommunication" means radiocommunication between amateur radio stations solely with a personal aim and without pecuniary interest.

366. An amateur station license may be issued only to a licensed amateur radio operator who has made a satisfactory showing of ownership or control of proper transmitting apparatus; provided, however, that in the case of a military or naval reserve radio station located in approved public quarters and established for training purposes, but not operated by the United States Government, a station license may be issued to the person in charge of such station who may not possess an amateur operator's license.

(a) An amateur operator's license may be granted to a person who does not desire an amateur station license, provided such applicant waives his right to apply for an amateur station license for ninety days subsequent to the date of application for operator's license.

367. Amateur radio station licenses shall not be issued to corporations, associations, or other organizations; provided, however, that in the case of a bona fide amateur radio society, a station license may be issued to a licensed amateur radio operator as trustee for such society.

368. Licenses for amateur mobile stations and portable-mobile stations will not be granted, except for portable-mobile stations located aboard aircraft (see pars. 384 and 387) and capable of operating in the band of frequencies 56,000-60,000 kilocycles and 400,000-401,000 kilocycles only.

370. Amateur stations shall be used only for amateur service, except that in emergencies or for testing purposes they may be used also for communication with commercial or Government radio stations. In addition, amateur stations may communicate with any mobile radio station which is licensed by the Commission to communicate with amateur stations, and with stations of expeditions which may also be authorized to communicate with amateur stations.

371. Amateur stations shall not be used for broadcasting any form of entertainment.

372. Amateur stations may be used for the transmission of music for test purposes of short duration in connection with the development of experimental radiotelephone equipment.

373. Amateur radio stations shall not be used to transmit or receive messages for hire, nor for communication for material compensation, direct or indirect, paid or promised.

374. The following bands of frequencies are allocated exclusively for use by amateur stations:

1,715 to 2,000 kc.	28,000 to 30,000 kc.
3,500 to 4,000 "	56,000 to 60,000 "
7,000 to 7,300 "	400,000 to 401,000 "
14,000 to 14,400 "	

375. All bands of frequencies so assigned may be used for radiotelegraphy, type A-1 emission. Type A-2 emission may be used in the following bands of frequencies only:

28,000 to 30,000 kc.
56,000 to 60,000 "
400,000 to 401,000 "

376. The following bands of frequencies are allocated for use by amateur stations using radiotelephony, type A-3 emission:

1,800 to 2,000 kc.	56,000 to 60,000 kc.
28,000 to 28,500 "	400,000 to 401,000 "

377. Provided the stations shall be operated by a person who holds an amateur operator's license endorsed for class A privileges, an amateur radio station may use radiotelephony, type A-3 emission, in the following additional bands of frequencies:

3,900 to 4,000 kc.	14,150 to 14,250 kc.
--------------------	----------------------

378. The following bands of frequencies are allocated for use by amateur stations for television, facsimile, and picture transmission:

1,715 to 2,000 kilocycles
56,000 to 60,000 kilocycles

379. Transmissions by an amateur station may be on any frequency within an amateur band above assigned.

380. An amateur radio station shall not be located upon premises controlled by an alien.

381. The frequency of the waves emitted by amateur radio stations shall be as constant and as free from harmonics as the state of the art permits. For this purpose, amateur transmitters shall employ circuits loosely coupled to the radiating system or devices that will produce equivalent effects to minimize keying impacts and harmonics. Conductive coupling to the radiating antenna, even though loose, is not permitted, but this restriction does not prohibit the use of transmission-line feeder systems.

382. Licensees of amateur stations using frequencies below 14,400 kilocycles, shall use adequately filtered direct-current power supply for the transmitting equipment, to minimize frequency modulation and to prevent the emission of broad signals.

383. Licensees of amateur stations are authorized to use a maximum power input of one kilowatt to the plate circuit of the final amplifier stage of an oscillator-amplifier transmitter or to the plate circuit of an oscillator transmitter.

384. An operator of an amateur station shall transmit its assigned call at least once during each fifteen minutes of operation and at the end of each transmission. In addition, an operator of an amateur portable radiotelegraph station shall transmit immediately after the call of the station, the Break Sign (BT) followed by the number of the amateur call area in which the portable amateur station is operating; as for example:

Example 1. Portable amateur station operating in the third amateur call area calls a fixed amateur station: WIABC WIABC WIABC DE W2DEF W2DEF W2DEF BT3 BT3 BT3 K

Example 2. Fixed amateur station answers the portable amateur station: W2DEF W2DEF W2DEF DE WIABC WIABC WIABC K

Example 3. Portable amateur station calls a portable amateur station: W3GHI W3GHI W3GHI DE W4JKL W4JKL W4JKL BT4 BT4 BT4 K

If telephony is used the call sign of the station shall be followed by an announcement of the amateur call area in which the portable station is operating.

385. In the event that the operation of an amateur radio station causes general interference to the reception of broadcast programs with receivers of modern design, that amateur station shall not operate during the hours from 8 o'clock p.m. to 10:30 p.m., local time, and on Sundays from 10:30 a.m. until 1 p.m., local time, upon such frequency or frequencies as cause such interference.

386. Each licensee of an amateur station shall keep an accurate log of station operation, in which shall be recorded:

- The date and time of each transmission.
- The name of the person manipulating the transmitting key of a radiotelegraph transmitter or the name of the person operating a transmitter of any other type with statement as to nature of transmission.
- The station called.
- The input power to the oscillator, or to the final amplifier stage where an oscillator-amplifier transmitter is employed.
- The frequency band used.
- The location of each transmission by a portable station.

This information shall be made available upon request by authorized Government representatives.

387. The licensee of an amateur station may operate a portable amateur station, or a portable-mobile station located aboard an aircraft in accordance with Rule 368, provided advance notice of all locations in which the station will be operated is given to the Inspector-in-Charge of the district in which the station is to be operated. Such notices shall be made by letter or other means prior to any operation contemplated and shall state the station call, name of licensee, the dates of proposed operation and the approximate

locations, as by city, town or county. An amateur station operating under this rule shall not be operated during any period exceeding 30 days without giving further notice to the Inspector-in-Charge of the radio inspection district in which the station will be operated.

* * *

400. An amateur station may be operated only by a person holding a valid amateur operator's license, and then only to the extent provided for by the class of privileges for which the operator's license is endorsed.

401. Amateur operators' licenses are valid only for the operation of licensed amateur stations, provided, however, any person holding a valid radio operator's license of any class may operate stations in the experimental service licensed for, and operating on, frequencies above 30,000 kilocycles.

402. Amateur station licenses and/or amateur operator licenses may, upon proper application, be modified or renewed provided: (1) the applicant has used his station to communicate by radio, with at least three other amateur stations during the three-month period prior to the date of submitting the application, or (2) in the case of an applicant possessing only an operator's license, that he has similarly communicated with amateur stations during the same period. Proof of such communication must be included in the application by stating the call letters of the stations with which communication was carried on and the time and date of each communication. Lacking such proof, the applicant will be ineligible for a license for a period of ninety days.

403. There shall be but one main class of amateur operator's license to be known as "amateur class" but each such license shall be limited in scope by the signature of the examining officer opposite the particular class or classes of privileges which apply, as follows:

Class A. Unlimited privileges.

Class B. Unlimited radiotelegraph privileges. Limited in the operation of radiotelephone amateur stations to the following bands of frequencies: 1800 to 2000 kilocycles; 28,000 to 28,500 kilocycles; 56,000 to 60,000 kilocycles; 400,000 to 401,000 kilocycles.

Class C. Same as Class B privileges, except that the Commission may require the licensee to appear at an examining point for a supervisory written examination and practical code test during the license term. Failing to appear for examination when directed to do so, or failing to pass the supervisory examination, the license held will be cancelled and the holder thereof will not be issued another license of the Class C privileges.

404. The scope of examinations for amateur operators' licenses shall be based on the class of privileges the applicant desires, as follows:

Class A. To be eligible for examination for the Class A amateur operator's privileges, the applicant must have been a licensed amateur operator for at least one year and must personally appear at one of the Commission's examining offices, and take the supervisory written examination and code test. (See Rules 2 (2) a, 30 and 408.) Examinations will be conducted at Washington, D. C., on Thursday of each week, and at each radio district office of the Commission on the days designated by the Inspector-in-Charge of such offices. In addition, examinations will be held quarterly in the examining cities listed in Rule 30 on the dates to be designated by the Inspector-in-Charge of the radio district in which the examining city is situated. The examination will include the following:

- Applicant's ability to send and receive in plain language messages in the Continental Morse Code (5 characters to the word) at a speed of not less than 10 words per minute.
- Technical knowledge of amateur radio apparatus, both telegraph and telephone.
- Knowledge of the provisions of the Radio Act of 1927 as amended, subsequent acts, treaties, and rules and regulations of the Federal Radio Commission, affecting amateur licensees.

Class B. The requirements for Class B amateur operator's privileges are similar to those for the Class A, except that no experience is required and the questions on radio-telephone apparatus are not so comprehensive in scope.

Class C. The requirements for Class C amateur operator's privileges shall be the same as for the Class B except the examination will be given by mail. To be eligible for this class of privileges, an applicant must reside more than 125 miles (airline) from Washington, D. C., a radio district office of the Commission, or an examining city. (See pars. 2 h (2), 30, and 408.)

405. An applicant for any class of amateur operator's privileges who has held a radiotelephone second class operator's license or higher, or an equivalent commercial grade license, or who has been accorded unlimited amateur radiotelephone privileges, within five years of the date of application may only be required to submit additional

proof as to code ability and/or knowledge of the laws, treaties, and regulations affecting amateur licensees.

406. An applicant for the Class B or C amateur operator's privileges who has held a radiotelegraph third class operator's license or higher, or an equivalent commercial grade license, or who has held an amateur extra first class license within five years of the date of application may be accorded a license by passing an examination in laws, treaties, and regulations affecting amateur licensees.

407. An applicant for the Class C amateur operator's privileges must have his application signed in the presence of a notary public by a licensed radiotelegraph operator other than an amateur operator possessing only the third class privileges or former temporary amateur class license, attesting to the applicant's ability to send and receive messages in plain language in the Continental Morse Code (5 characters to the word) at a speed of not less than ten words per minute. The code certification may be omitted if the applicant can show proof of code ability in accordance with the preceding rule.

408. Forms for amateur station and/or operator license shall be obtained by calling or writing to the Inspector-in-Charge of the radio inspection district in which the applicant resides. Upon completion of the forms they shall be sent back to the same office where the final arrangements will be made for the examination: *Provided*, however, in the case of applicants for the Class C amateur operator's privileges, the forms and examination papers when completed shall be mailed direct to the Federal Radio Commission, Washington, D. C.

409. The percentage that must be obtained as a passing mark in each examination is 75 out of a possible 100. No credit will be given in the grading of papers for experience or knowledge of the code. If an applicant answers only the questions relating to laws, treaties, and regulations by reason

of his right to omit other subjects because of having held a recognized class of license, a percentage of 75 out of a possible 100 must be obtained on the questions answered.

410. An amateur station license shall be issued so as to run concurrently with the amateur operator's license and both licenses shall run for three years from the date of issuance. If either the station license or the operator's license is modified during the license term, both licenses shall be reissued for the full three-year term, provided, however, if an operator's license is modified only with respect to the class of operator's privileges, the old license may be endorsed in which case the expiration date will not change.

411. No applicant who fails to qualify for an operator's license will be reexamined within ninety days from the date of the previous examination.

412. Any attempt to obtain an operator's license by fraudulent means or by attempting to impersonate another, or copying or divulging questions used in examinations, will constitute a violation of the regulations for which the licensee may suffer suspension of license or debarment from further examination for a period not exceeding two years at the discretion of the licensing authority.

413. Any licensee applying for a duplicate license to replace an original which has been lost, mutilated, or destroyed, shall submit an affidavit to the Commission attesting to the facts regarding the manner in which the original was lost. Duplicates will be issued in exact conformity with the original, and will be marked "duplicate" on the face of the license.

414. Licenses are not valid until the oath of secrecy has been executed and the signature of the licensee affixed thereto.

415. All examinations, including the code test, must be written in longhand by the applicant.

U. S. INSPECTION DISTRICTS

<i>District</i>	<i>Territory</i>	<i>Address, Radio Inspector</i>
No. 1	States of Maine, New Hampshire, Vermont, Massachusetts, Connecticut, and Rhode Island.	Customhouse, Boston, Mass.
No. 2	City of Greater New York and the Counties of Suffolk, Nassau, Westchester, Rockland, Putnam, Orange, Dutchess, Ulster, Sullivan, Delaware, Greene, Columbia, Albany, Schenectady and Rensselaer of the State of New York, and the Counties of Bergen, Hudson, Passaic, Sussex, Warren, Morris, Essex, Union, Somerset, Middlesex, Monmouth, Mercer, Hunterdon of the State of New Jersey.	U. S. Subtreasury Building, New York, N. Y.
No. 3	City of Philadelphia and the Counties of Bucks, Montgomery, Philadelphia, Delaware, Chester, Lancaster, York, Adams, Cumberland, Perry, Dauphin, Lebanon, Berks, Schuylkill, Lehigh, Northampton, Carbon and Monroe of the State of Pennsylvania, and the Counties of Ocean, Burlington, Atlantic, Cape May, Cumberland, Salem, Gloucester and Camden of the State of New Jersey; and the County of Newcastle of the State of Delaware.	Gimbel Building, 32 South Ninth St., Philadelphia, Pa.
No. 4	State of Maryland, the District of Columbia, and the Counties of Arlington, Loudoun, Fairfax, Prince William, Fauquier, Rappahannock, Page, Warren, Shenandoah, Frederick and Clark, of the State of Virginia, and the State of Delaware except the County of Newcastle.	Fort McHenry, Baltimore, Md.
No. 5	State of Virginia, except the Counties of Arlington, Loudoun, Fairfax, Prince William, Fauquier, Rappahannock, Page, Warren, Shenandoah, Frederick and Clark, and the State of North Carolina, except the Counties of Ashe, Watauga, Caldwell, Avery, Burke, McDowell, Yancey, Mitchell, Madison, Buncombe, Haywood, Swain, Graham, Cherokee, Clay, Macon, Jackson, Transylvania, Henderson, Polk, Rutherford and Cleveland.	Customhouse, Norfolk, Va.
No. 6	States of Alabama, Georgia, South Carolina, Tennessee, and the Counties of Ashe, Watauga, Caldwell, Avery, Burke, McDowell, Yancey, Mitchell, Madison, Buncombe, Haywood, Swain, Graham, Cherokee, Clay, Macon, Jackson, Transylvania, Henderson, Polk, Rutherford, and Cleveland of the State of North Carolina.	528 Postoffice Building, Atlanta, Ga
No. 7	The State of Florida, Puerto Rico, and Virgin Isles.	1424 Dade County Building, Miami, Fla.
No. 8	The States of Louisiana, Mississippi and Arkansas, and the city of Texarkana.	Customhouse, New Orleans, La.
No. 9	Counties of Jefferson, Chambers, Harris, Galveston, Fort Bend, Brazoria, Wharton, Matagorda, Jackson, Victoria, Calhoun, Goliad, Refugio, Aransas, San Patricio, Nueces, Jim Wells, Kleberg, Brooks, Kenedy, Willacy, Hidalgo, and Cameron of the State of Texas.	209 Prudential Bldg., Galveston, Texas
No. 10	State of Texas, except the Counties of Jefferson, Chambers, Harris, Galveston, Fort Bend, Brazoria, Wharton, Matagorda, Jackson, Victoria, Calhoun, Goliad, Refugio, Aransas, San Patricio, Nueces, Jim Wells, Kleberg, Brooks, Kenedy, Willacy, Hidalgo and Cameron and the city of Texarkana; and the States of Oklahoma and New Mexico.	464 Federal Building, Dallas, Texas
No. 11	Counties of Monterey, Kings, Tulare, San Luis Obispo, Kern, Santa Barbara, Ventura, Los Angeles, Orange, San Diego, Imperial, Riverside, and San Bernardino of the State of California; the County of Clark of the State of Nevada, and the State of Arizona.	1105 Rives-Strong Building, Los Angeles, Calif.

- No. 12 State of California, except the Counties of Monterey, Kings, Tulare, San Luis Obispo, Kern, Santa Barbara, Ventura, Los Angeles, Orange, San Diego, Imperial, Riverside and San Bernardino; the State of Nevada, except the County of Clark; and the Hawaiian Islands. Customhouse, San Francisco, Calif.
- No. 13 State of Oregon and the State of Idaho, except the Counties of Boundary, Bonner, Kootenai, Shoshone, Benewah, Latah, Clearwater, Nez Perce, Lewis and Idaho. 227 Postoffice Building, Portland, Ore.
- No. 14 State of Washington, the Counties of Boundary, Bonner, Kootenai, Shoshone, Benewah, Latah, Clearwater, Nez Perce, Lewis and Idaho of the State of Idaho; and the Counties of Lincoln, Flathead, Glacier, Toole, Pondera, Teton, Lake, Sanders, Mineral, Missoula, Powell, Lewis and Clarke, Cascade, Meagher, Broadwater, Jefferson, Granite, Ravalli, Deerlodge, Silver Bow, Beaverhead, Madison, Gallatin of the State of Montana, and Territory of Alaska. 808 Federal Office Building, Seattle, Wash.
- No. 15 States of Colorado, Utah, Wyoming, and Montana except the Counties of Lincoln, Flathead, Glacier, Toole, Pondera, Teton, Lake, Sanders, Mineral, Missoula, Powell, Lewis and Clarke, Cascade, Meagher, Broadwater, Jefferson, Granite, Ravalli, Deerlodge, Silver Bow, Beaverhead, Madison and Gallatin. 538 Customhouse, Denver, Colo.
- No. 16 States of South Dakota, North Dakota, Minnesota, the northern peninsula of Michigan, and the State of Wisconsin, except the Counties of Crawford, Richland, Sauk, Columbia, Dodge, Washington, Ozaukee, Milwaukee, Waukesha, Jefferson, Dane, Iowa, Grant, Lafayette, Green Rock, Walworth, Racine and Kenosha. 413 Federal Building, St. Paul, Minn.
- No. 17 States of Nebraska, Kansas, Missouri and Iowa, except the Counties of Winnesiek, Allamakee, Fayette, Clayton, Buchanan, Delaware, Dubuque, Linn, Jones, Jackson, Clinton, Cedar, Johnson, Washington, Muscatine, Scott, Louisa, Des Moines, Henry and Lee. 231 Federal Building, Kansas City, Mo.
- No. 18 States of Indiana, Illinois and the Counties of Winnesiek, Allamakee, Fayette, Clayton, Buchanan, Delaware, Dubuque, Linn, Jones, Jackson, Clinton, Cedar, Johnson, Washington, Muscatine, Scott, Louisa, Des Moines, Henry and Lee of the State of Iowa; and the Counties of Crawford, Richland, Sauk, Columbia, Dodge, Washington, Ozaukee, Milwaukee, Waukesha, Jefferson, Dane, Iowa, Grant, Lafayette, Green Rock, Walworth, Racine and Kenosha of the State of Wisconsin. 2022 Engineering Building, Chicago, Ill.
- No. 19 State of Michigan, except the northern peninsula and the States of Ohio, Kentucky and West Virginia. 2909 David Stott Building, Detroit, Mich.
- No. 20 State of New York, except the City of Greater New York and the Counties of Suffolk, Nassau, Westchester, Rockland, Putnam, Orange, Dutchess, Ulster, Sullivan, Delaware, Greene, Columbia, Albany, Schenectady and Rensselaer; the State of Pennsylvania, except the City of Philadelphia, and the Counties of Bucks, Montgomery, Philadelphia, Chester, Delaware, Lancaster, York, Adams, Cumberland, Perry, Dauphin, Lebanon, Berks, Schuylkill, Lehigh, Northampton, Carbon and Monroe. 514 Federal Building, Buffalo, N. Y.
- Hawaii is attached to District No. 12.
Porto Rico and the Virgin Ids. are attached to District No. 7.

INDEX

	PAGE		PAGE
Abbreviations, Amateur	220-221	Modulator Data	127
Abbreviations, International Standard	217-220	Numbered Drill Sizes	229
Abbreviations Used in Radio	225	Q Signals	217-219
Absorption Frequency Meters	70-71	Rectifier Tube Characteristics	141
Acknowledging Messages	198-199	Socket Connections	49
Address Count	207-208	Time and Day Conversion	223
Alternating Current	21-22, 23, 27-28	Transformer Design	155
Amateur Bands	7-9	Vacuum Tube Characteristics	50-51, 80
Amateur Operator's and Station Licenses	13-14	Wire Table	228
Amateur Regulations	17-18, 230-233	Word List for Amateur Transmission	202
Amateur Status	203-204	Checking Messages	207-209
American Radio Relay League	5	Checking Transmitter Frequency	69-70
Divisions	190	Choke Design	156-158
Headquarters	5	Circuits, Transmitting (see "Transmitters")	
Headquarters Station WIMK (frontispiece)	5	Circuits, Receiving (see "Receivers")	
Joining the League	6	Circuits, Tuned	31
Traditions	5	Circular Mil	154
Ampere	19	Clickless Keying Methods	160-162
Ampere Turns	24	Code (Continental) and Code Practice	9-13
Application, Theory of in Vacuum Tube	36	Code Practice Stations (for Beginners)	11
Amplifier, Audio	36-37, 48-49	Coded Messages	208-209
Amplifier, Push-Pull	104-105	Colpitts Circuit	78
Amplifiers, Radio Frequency (Receiver)	46-47	Communications Department, A.R.R.L.	
Antenna Systems:		Activities	189-190
Construction of	181-182	Appointments:	
Current and Voltage Distribution	168-169	Official Broadcasting Station	192-193
Directional	172, 181	Official Relay Station	194-195
Feed Systems:		Official 'Phone Station	193-194
General	173-174	Official Observers	192
Current	177	Route Managers	192
Voltage	174-175	Section Communications Manager	191-192
Zepp	176-177	Organization	190-191
Tuned	175-176	Condenser Breakdowns	226
Two-Wire Untuned	178-180	Condenser Series and Parallel Connections	26-27
Single-Wire Untuned	180	Condenser Reactance	26
Grounded	169-170	Condensers	25-26
Hertz	170-171	Condensers, Electrolytic	148-149
Loading	172-173	Condenser Capacitance (Computing)	226
Receiving	182-183	Condensers, Current Through	26
Resistance	171-172	Conductors	19-21
Theory	33-35	Conversion, Day and Time Charts	222-223
Twisted-Pair Feeders	180-181	Counting Messages	214-215
Types	168	Counting Cities in Address and Text, Numbers, Radio	
Ultra High Frequency	137-138	Calls, Telephone Numbers and Trade Marks	207-208
Appointment for Official Relay Station	194-195	Coupled Circuits	33
Army-Amateur Net	4	Coupling, Interstage	93-95
Audibility Rating	205	CQ, How to Use	197
Autodyne Reception	39-40	Crystals:	
Band Spreading and Tuning Arrangements	44-45	Action	37-38
Beat Notes	39-40	Grinding and Cutting	88-89
Beginner's Booklet	6	Mounting	90
Beginner's Code Practice Stations	11	Crystal-Control Transmitter Construction (see "Transmitters")	
Best Wavelength	7-9	Current Feed for Antennas	177
Bias	47-48	Current Flow	21
Books Recommended	223-224	Current in A.C. Circuits	21-22, 23
Break-In	166-167, 200	Current Lag and Lead	28
Breadth of Tuning, How Resistance Affects	32-33	Decibel	224
Buzzer Code Practice Set	10-11	Delivering Messages	213-214
Cable Count Check Explained	207-209	Detection	38-40
Calculation of Inductance	225-226	Diagrams, Reading	30
Calculation of Condenser Capacitance	226	Dials for Monitors and Frequency Meters	71
Calibrating the Frequency Meter	74-76	Dielectrics and Dielectric Constants	226
Call Books	205	Direct Current	21-22
Canadian Regulations	18	Directional Antennas	172, 181
Canadian Traffic Agreement	210	Directional CQ	197
Capacitance	25-26, 226	Distance Measurement	222
Capacitive-Reactance of Condensers	26	Distributed Inductance, Capacitance and Resistance	27
Characteristics of Vacuum Tubes (Table)	50-51, 80, 141	Districts Inspection	234-234
Charts and Tables:		Divisions of A.R.R.L.	190
Amateur Wavelength-Frequency Bands	8	Doubling Frequency in a Transmitter	95
Antenna and Feeder Lengths	177, 181	Drill Sizes	229
Audibility	205	Duplex Plate Supply	151-152
Class A Amplifier and Modulator Data	127	Effective Value (A.C. Sine Wave)	27
Class B Amplifier and Modulator Data	127	Electrical Units and Symbols	224-225
Coil Specifications	106	Electricity	19, 21
Continental Code	9	Electrolytic Condensers	148-149
Dielectric Constants	226	Electrolytic Rectifier (see "Power Supply")	
Electrical Symbols	224	Electromagnetism	23-24
Filter Choke Design	157	Electromotive Force (E. M. F.)	21
Greek Alphabet	225	Electron-Coupled Frequency Meter	71-73
Ham Abbreviations	220-221	Electron Flow	19
Inductance-Capacity-Frequency Calculation	227	Emergency Work	203-204
International Prefixes	221-222	Exciter Unit	100-103
Metric Prefixes	225		

	PAGE		PAGE
Exhibition and Fair Stations	211	Keeping a Log	200-202
Extracts from Radio Law of 1927	229-230	Kennelly-Heaviside Layer	41
Fading	41-42	Key, How to Grip	12
Feed-Back	39	Key Clicks	160-161
Feeders and Feed Systems (see "Antenna Systems")		Keying:	
Filament Supply	149	Methods	159-160
Fills and Repeats	213	Keying Chirps	165-166
Filters (see "Power Supply")		Key-Click Elimination	160-162
Filter Choke Inductance Design Chart	157	Keying Oscillator-Amplifier Transmitters	160
Five-Band Exciter Unit	100-103	Lag Circuits, Use and Design	161-162
Five Meters (see "Ultra-High Frequencies")		(See also "Interference Elimination," "Break-in Operation" and "Relays")	
Five Point System, The	216	Laws Concerning Amateur Operation	17-18, 229-230
Flux	24	Lead and Lag	28
Foreign Traffic Restrictions	209-210	Lead-in Bushings	187
Canadian Agreement	210	Learning the Code	9-11
Formulas:		License Examination, How to Pass	16
A.C. Average and Effective Value	27-28	Licenses (Obtaining Amateur)	13, 14-15
Antenna Coupling	179	Licenses Required for Operator and Station	13-14
Antenna Length	171	Lightning Arrester	186
Capacitive Reactance of Condensers	26	Linear Amplifiers	125, 126
Capacity of Condenser	226	Log Books	200-202
Current in A.C. Circuit	27	Magnetism	23-24
Current Through Condenser	226	Manufactured Receivers	61-64
Impedance	27	Marker Stations, How to Calibrate the Monitor from	69
Inductance Calculation	225-226	Masts	187-188
Input Choke	145, 146	Maximum Powers (Conditions for)	23
Magnetic Circuit	24	Measurements:	
Modulation Percentage	113	Distance	222
Ohms Law (A.C.)	27	Frequency	69-71
Ohms Law (D.C.)	22	Memorizing the Code	9-11
Plate Modulation Conditions	118	Mercury Vapor Rectifiers	141-142
Power (In A.C. Circuit)	28	Message, Component Parts of	206-207
Power (In D.C. Circuit)	23	Message Form	206
Power Factor	28	Message Traffic	206
Q	33	Messages, "Rubber Stamp"	215
Reactance	25, 26	Meter, Frequency (see "Frequency Meters and Monitors")	
Resonance	32, 35	Metric Prefixes	225
Ripple	145, 147	Microphones and Their Care	119-121
Series, Parallel and Series-Parallel Capacities	27	Mil	154
Series, Parallel and Series-Parallel Resistances	22	Modulation	38
Surge Impedance	178	Modulator Tubes and Calculations	127
Transformer Voltage	146, 147	Modulometer, Construction and Use	126
Visibility	128	Monitor (see "Frequency Meters and Monitors")	
Wavelength Frequency Conversion	34	Mounting Crystals	90-91
Frequencies, Amateur	8	Multipliers, Frequency	95
Frequencies for Best Operation	7-9	Negative and Positive Terminals	21
Frequency	21-22	Neutralizing	92-93
Frequency, Checking Transmitter	70	Note Improvements (see "Adjusting the Transmitter")	
Frequency Doubling	95	Numbering Messages	207
Frequency Meters and Monitors:		Number Sheet	207
Absorption Frequency Meters	70-71	Official Broadcasting Stations	12
Combined Frequency Meter-Monitor	73-74	Official Observers	192
Electron-Coupled Frequency Meter	71-73	Official Relay Stations	194-195
Frequency Meter Calibration	74-76	Ohm	22
Monitor, Construction of	67-69	Ohm's Law	22
Generators	25	Ohm's Law for A.C.	27
Greek Alphabet	225	Operating a Station:	
Grid	36	Amateur Status	203
Grid Bias	47-48	Audibility Scale	205
Grid Excitation, Control of (see "Grid Bias")		Cable Count	207-209
Grid Voltage-Plate Current	36	Call Books	205
Grounding Antennas for Lightning Protection	187	Canadian Traffic Agreement	210
Harmonics	40-41, 107-110	Counting Messages	214-215
Harmonic Operation of Antennas	171	Delivering Messages	213-214
Hartley Circuit	78	Emergency Work	203-204
Heat in D.C. Circuits	23	Five-Point System	216
Hertz Antenna	170-171	Foreign Traffic Restrictions	209-210
Heterodyne Reception	39-40	Interference Committees	204
Impedance	27	Keeping a Log	200-202
Impregnating Coils	156	Message Form	206-207
Incomplete Preambles	211-212	Numbering Messages	207
Inductance	24	Operating Hints	205
Inductance Calculation	225-226	Originating Traffic	210-211
Inductance-Capacity-Frequency Calculation (Chart)	227	Phone Procedure	202-203
Inductance of Choke Coils	157	Procedure	197-199
Inspection Districts	233-234	Readability	205
Insufficient Address	211-212	Reporting	215-216
Insulators	19-20	"Rubber-Stamp" Messages	215
Insurance Rating Bureau	186	Schedule Operation	196-197
Interference Committees	204-205	Service Messages	240
Interference, Elimination of:		Tracing Messages	211
Power-Line Suppressors (R.F.)	164	Using a Break-in System	200
Quiet Hours	165	Word List for Accurate Transmission	202
Radiophone Interference	165	Operating Hints	205
Re Broadcast Receivers	162-164	Operating Notes	199
Rectifier Noise	164-165	Operator's License	14
Wavetraps	163		
(See also "Keying")			
International Prefixes	221-222		

	PAGE		PAGE
Originating Traffic	210-211	Modulation and Modulation Methods	113-115
Troubles to Avoid	211-212	Modulator Construction	123
Oscillation Frequency	31-32	Modulator Tube Calculations (Class A)	127
Oscillator, Audio	10	Modulometer Construction and Use	126
Oscillator Circuits	37	Percentage Modulation	113, 126
Oscillator, Crystal Controlled	88	Performance Measurement of Phone Transmitters	123-125
Oscillator, Push-pull	85-86	Procedure	202-203
Parallel Capacities	26-27	Speech Amplifier Construction	121-123
Parallel Resistances	22-23	Transmitter Construction and Adjustment	123
Parallel Resonance	32-33	Reactance	24-25
Parasitic Oscillations	110	Reactance of Condensers	26
Percentage Modulation (definition)	113	Readability Scale	205
Permeability	24	Receivers:	
Phase Angle	28	Antennas for	182-183
Phone Procedure	202-203	Audio Amplifiers for	43-49
Phone Transmitters (see "Radiotelephony")		Characteristics	43-44
Phone Wavelengths for Amateurs	8-9	Construction:	
Plate Current	36	Two-Tube	53-55
Plate Modulation	114-115	Three-Tube	55-56
Plate Transformer Design	146-147, 154-156	Superheterodyne	56-59
Posting of Licenses	17	Radio Frequency Amplifiers for	46-47
Portable Operation	16-17	Regeneration Control	45
Positive and Negative Terminals	21	Shielding	47
Power Amplifier	103-104	Superheterodyne	40, 56-64
Power Line R.F. Suppressors	164	Trouble Shooting	64-66
Power Supply:		Tuning Arrangements and Band-Spreading	44-45
Choke Design	156-158	Ultra High Frequency	131-135
Duplex Plate Supply	151-152	Receiving Coils (see Coils)	
Electrolytic Condensers	148-149	Rectification	35-36
Filament Supply	149	Rectifier-Filter Systems (see "Power Supply")	
Filters	144-145	Rectifiers (see "Power Supply")	
Design	147-148	Regeneration Control Methods	45
Filter Chokes	148-149	Regenerative Detectors	39
Filter Condensers	148-149	Regulation Voltage	143
Input Choke	145-146	Regulations, Amateur	230-233
Plate Supply Considerations	139-145	Regulations, Canadian	18
Practical Power Supply	149-151	Relays	166-167
Receiver Power Supplies	152-153	Relay Procedure	212-213
Rectifier and Filter Systems (Theory and General Considerations)	139-140	Reluctance	24
Rectifier Circuits	142-143	Remote Control	167
Rectifiers	140-142	Reports and Reporting	215-216
Table of Rectifier Tube Characteristics	141	Resistance	22
Regulation	143	Resistance, Effect of in Tuned Circuit	33
Transformer Design and Construction	146-147, 154-156	Resistance, R. F.	33
Transformerless Plate Supplies	153-154	Resistance Regeneration Control	45
Vibrator-Transformers	153	Resonance	31-32
Voltage Dividers	152	Restrictions, Foreign Traffic	209-210
Voltage Doubling	153-154	Route Manager	192
Power (Condition for Maximum)	23	Root Mean Square Value	27-28
Power Factor	28	Rubber Stamp Messages	215
Power in A.C. Circuits	28	Schedules	216
Power in D.C. Circuits	23	Schematic Diagrams	30
Practical Problems:		Secrecy of Messages	213
Plate Power Input	28-29	Section Communications Manager	191-192
Resistance of Grid Leak	29	Selectivity	32-33
Measuring Grid Bias Voltage	29	Series Capacities	27
Resistance Value for Dropping Plate Voltage	29	Series Resistances	22-23
Size Resistor to Handle a Given Current	29	Series Resonance	32-33
Transformer Output Current to Resistance Load	29	Service Message, The	214
Capacities	29	Shielding	47
Condenser Reactance	29-30	Short Wave Receivers (see "Receivers")	
Current Through a Reactance	30	Signing Off	197-198
Preamble	206-207	Sine Wave	27-28
Prefixes, International	221-222	Single-Signal	56-57
Prefixes, Metric	225	Skin Effect	33
Push-Pull Oscillator	85-86	Skip Distance	41-42
Push-Pull Amplifiers	104-105	Small Transformer Design and Construction	146-147, 154-156
Quartz Crystals	37-38, 88-90	Soldering	52
Qualifications of Good Operators	196-197	Symbols	30
Q.R.R.	203-204	Speech Amplifier	121-123
Q.S.T.	6, 224	Speech Envelope	38, 113-114
Q Signals	217-219	Speed, Best Sending	12-13
Quiet Hours (Regulations)	165	Stability, Transmitter (see "Adjusting the Transmitter")	
R.M.S.	27-28	Standard Frequency System and Transmissions	74-75
Radiator (see "Antennas")		Standardized Log (see Log)	
Radio Act of 1927	220-230	Station Arrangement	184-185
Radio Frequency Resistance	33	Station License	13
Radio Inspection Districts	233-234	Status, Amateur	203-204
Radiotelephony:		Superfluous Signals	199
Amplifiers:		Superheterodyne	40, 56-64
Class A	116	Symbols, Electrical	224-225
Class B (Modulator)	116	T. O. M. (The Old Man)	5
Circuit Diagram	123	Tables and Charts (see Charts and Tables)	
Class B (Linear R.F. Amplifier)	125-126	Tap Sizes	49-50, 228
Class C	116-117	Throttle-Condenser Regeneration Control	45
Decibel	224	Thump Filters	161-162
Frequencies and Regulations	8-9, 230-233	Time Conversion	221-223
Interference	165	Tools	49-52
Microphones and Their Care	119-121		

	PAGE
Tracing Messages	211
Traffic Restrictions, Foreign	209-210
Canadian Agreement	210
Transceivers	135-137
Transformer Design and Construction	146-147, 154-156
Transformers	25
Transformerless Plate Supplies	153-154
Transmitters:	
Adjustment and Tuning	83-84, 86, 97-99, 162-164
Checking Frequency of	69-70
Circuits and Construction:	
Simple Transmitter	81-85
Push-Pull	85-86
Oscillator-Amplifier (General Considerations)	91-92, 95-96
Crystal-Control (General Considerations)	88
Crystal Circuits	89-90
Five-Band Exciter Unit	100-103
Low-Power Crystal-Controlled Transmitter	96-99
Tritet Oscillator	99-100
Electron-Coupled Oscillators	86-87
Frequency Multipliers	95
Interstage Coupling	93-95
Power Amplifiers	103-107
Condenser	101
Crystals, Cutting, Grinding	88-89
Frequency Stability and Efficiency	79
Grid Bias	47-48
Neutralizing	92-93
Oscillator Circuits (Explanation of Types)	71-73
Phone (see "Radiotelephony")	
Planning the Transmitter	81
Power Supply (see "Power Supply" in General Index)	
Transmitter Assembly	111
Tubes (General Considerations)	79-81
Tubes (Table of Transmitting and Receiving Tube Characteristics)	80
Ultra High Frequency	129-131
Unsteady Signals	87-88
Trap Circuit for Interference Elimination	149
Tritet Oscillator	99-100
Trouble Shooting (Receivers)	64-66
Tubes (see "Vacuum Tubes")	
Tube Characteristics (Table)	50-51, 80, 141
Tube Rectifiers (see "Rectifiers")	
Tuned Circuits (see "Rectifiers")	
Tuning Arrangements and Band-Spreading	44-45

	PAGE
Ultra-High Frequencies:	
Antenna Systems	137-138
General Considerations	128-129
Transmitters	129-131
Receivers	131-135
Transceivers	135-137
Ultraudion	78
Underwriters Rules	186-187
Unsteady Signals, Cause and Cure	87-88
Using Break-in	166-167, 200
Vacuum Tubes:	
General	35-38, 49
Theory (Receiving):	
As Detector	35-36, 38-40
As Amplifier	36-37
As Oscillator	37-38
Modulators	105-107
Symbols	225
Table of Data on All Types of American Tubes	50-51, 80, 141
Vacuum Tube Rectifiers (see Rectifiers)	
Vacuum Tube Voltmeter	126
Velocity of Radio Waves	34
Vibrator-Transformers	153
Volt	21
Voltage Amplification	36
Voltage Dividers	152
Voltage Doubling	153-154
Voltage Feed for Antennas	174-180
Voltage Regulation of Rectifiers (see "Rectifiers")	
Volunteer Code Practice Stations (for Beginners)	11
WIMK, A.R.R.L. Hq. Station (frontispiece)	5
Broadcasting schedule	12
W.A.C. Club	3
Wave Propagation	41-42
Wavelength-Frequency Conversion	34
Wavelength Performance	7-9
Wavelengths, Amateur	7-9
Wavemeter (see "Frequency Meters and Monitors")	
Wavetraps	163
Wire Table	228
Wiring	52
Word Lists for Accurate Code Transmission (and Voice Work)	202
Wouff-Hong	6
Zeppelin Feed for Antennas	176-177

To Handbook Readers Who Are Not A.R.R.L. Members

WOULDN'T you like to become a member of the American Radio Relay League? We need you in this big organization of radio amateurs, the only amateur association that does things. From your reading of this Handbook you have gained a knowledge of the nature of the League and what it does, and of its purposes. We would like to have you become a full-fledged member and add your strength to ours in the things we are undertaking for Amateur Radio, and incidentally you will have the membership edition of *QST* delivered at your door each month.

JOIN THE LEAGUE

To:

- ▶ Save yourself 50c a year (newsstand copies of *QST* cost \$3).
- ▶ Be sure of getting your copy of *QST* first.
- ▶ Be sure of getting your copy of *QST* (newsstands are often sold out).
- ▶ Be eligible for appointment or election to A.R.R.L. offices.
- ▶ Be eligible to sign petitions for your Director, your representative on the A.R.R.L. Board.
- ▶ Be eligible to vote for Director and Section Comm. Manager (only A.R.R.L. members receive ballots).
- ▶ Lend the strength of your support to the organization which represents YOU at Madrid, at Washington — at all important radio conferences.
- ▶ Have YOUR part in the A.R.R.L., which has at heart the welfare of all amateurs.

— Application Blank —

.....19....

American Radio Relay League
38 La Salle Rd., West Hartford, Conn.

Being genuinely interested in Amateur Radio, I hereby apply for membership in the American Radio Relay League and enclose \$2.50 (foreign \$3.00) to cover one year's dues. ★

It is understood that this entitles me to receive the League magazine *QST* for a similar period. Please begin my subscription with the..... issue.

Send *QST* and my certificate of membership to the address below.

Name.....
.....
.....

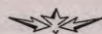

A bona fide interest in amateur radio is the only essential qualification; ownership of a transmitting station and knowledge of the code are desirable but not necessary

★ The dues are \$2.50 per year in the United States and Possessions, and Canada. All other countries \$3.00 per year.

NATIONAL COMPANY, INC. • ENGINEERS AND MANUFACTURERS

NATIONAL RADIO PRODUCTS



The AC SW-58 • See page 10



ESTABLISHED 1914

61 SHERMAN STREET • MALDEN, MASSACHUSETTS

FOR STATION EFFICIENCY



THE LOG

Bound with heavy paper covers. 8½ x 10¾. Contains 39 log pages, and same number of blank pages for miscellaneous notes. Also list of Q sigs, message number sheet and sheet of cross-section paper. 40c each or 3 for \$1.00. Postpaid.

- VERNIER DIALS & LEVER DIALS
- TRANSMITTING CONDENSERS
- NEUTRALIZING CONDENSERS
- RECEIVING CONDENSERS
- PADDING CONDENSERS
- AIR DIELECTRIC TUNED I.F. TRANSFORMERS
- COIL SHIELDS & TUBE SHIELDS
- COIL SOCKETS & TUBE SOCKETS
- PLUG-IN COILS
- TRANSMITTER COIL FORMS
- FIFTY-WATT SOCKETS
- GRID GRIPS
- R.F. CHOKES
- FILTER CHOKES
- SW-3 RECEIVERS
- SRR RECEIVERS
- HFC CONVERTERS
- FB-7A and FBXA RECEIVERS
- AGS and AGSX RECEIVERS
- RECEIVER POWER PACKS
- POWER TRANSFORMERS
- STAND-OFF INSULATORS
- ANTENNA & LEAD-IN INSULATORS
- HIGH VOLTAGE SHAFT COUPLING
- GENERAL PURPOSE INSULATORS

Our general catalogue No. 220 describes National Products in detail. If you desire a copy, send your name and address, enclosing six cents in stamps, and mention the HANDBOOK.

MESSAGE BLANKS

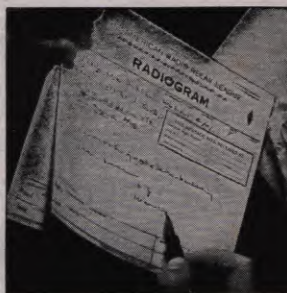

Most convenient form. Designed by the Communications Department of the A.R.R.L. Well printed on good bond paper. Size 8½ x 7¼. Put up in pads of 100 sheets. One pad postpaid for 35c or 3 pads for \$1.00.

American Radio Relay League
West Hartford, Connecticut



Collins Standardized Equipment Opens New Fields for Amateurs

UNTIL a few years ago amateurs were forced to build their own equipment from whatever parts were available. Many an old time amateur now finds that he has accumulated a lot of obsolete radio gear which originally cost several hundred dollars but now has little value. This picture is rapidly changing because the Collins Radio Co. is building a standardized line of transmitters which gives the amateur exactly what he wants at a price within his reach.

The present day radio hobbyist wants the very best equipment obtainable so that he can get real results whenever he has time to go on the air. Makeshift equipment just won't do. Every Collins transmitter is designed and built with the assistance of precision equipment and laboratory standards. Assembling and wiring is done by real craftsmen and every unit must pass a rigid series of tests, including exact determination of power output and actual measurement of audio fidelity. A record is made of dial settings and meter readings observed under actual operation. Each transmitter is operated under full load for several hours. All the data obtained by these measurements accompanies the operating manual. This painstaking care in building the transmitters and the continued assistance given the purchaser has proved its value by the wide spread acceptance of Collins equipment by the amateur and other discriminating users, such as, the Byrd Antarctic Expedition.

Your letter of inquiry will receive personal attention

The 4A and 32B transmitters are low priced, but both have sufficient power to give real results. These units are easily adapted to the addition of higher power at a later date, because of their standard rack type construction.



COLLINS RADIO COMPANY

CEDAR RAPIDS  IOWA, U. S. A.

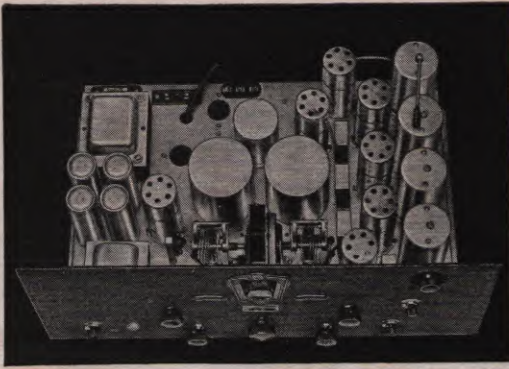

RADIO INSURANCE

That Costs Nothing

WHEN you buy the Hammarlund COMET "PRO" Receiver, or any Hammarlund Precision Part, you get not just an instrument that works but also definite insurance of superior performance.

That is the all-important consideration, not always seen but it is always present in every Hammarlund Product. And it costs you nothing extra.

Write Hammarlund Mfg. Co., Dept. HB-34, 424 W. 33rd Street, New York, for New Catalog "34," describing Condensers, Coils, Chokes, Sockets and other Short-wave Essentials.

Air-Tuned

I. F. TRANSFORMERS

Where 100% efficiency and stability are essential requirements, these new laboratory type "air-tuned" units are an absolute necessity.

The coils are Litz-wound and are tuned by AIR-DIELECTRIC, Isolantite-insulated condensers. This feature assures peak I. F. selectivity and a gain of 200 per stage. Unaffected by temperature, humidity or other atmospheric conditions.



I. F. TUNING CONDENSERS



Sensitivity and selectivity of superheterodynes depend on accurate tuning of the I. F. Transformers. These condensers are especially designed to maintain uniform capacity under varying conditions of temperature, humidity and vibration.



BACK
COPIES of

QST

WITH INDEXES

Listed below for the convenience
of HANDBOOK readers

HERE THEY ARE

- 1923 — Only May and November issues \$1.50
- 1924 — Only November and December issues50
- 1925 copies (except January, March, May and July) 2.00
- 1926 copies — complete 2.50
- 1927 copies (except January) 2.50
- 1928 copies (except January, February and August) 2.25
- 1929 copies (except February, March, April and May) 2.00
- 1930 copies (except January, February and July) 2.25
- 1931 copies — complete 2.50
- 1932 copies — complete 2.50
- 1933 copies — complete 2.50
- 1934 copies — as published 25c ea.

Complete Set of Copies as Listed

\$15.00

SINGLE COPIES 25c EACH

ALL PRICES INCLUDE POSTAGE

New binders to keep these files in order are \$1.50 each, postpaid. Each binder holds 12 issues of QST and index, and does not mutilate the copies.

**AMERICAN RADIO
RELAY LEAGUE**

West Hartford

Connecticut

EXCLUSIVELY FOR AMATEURS ..

de Forest AMATEUR RADIO DIVISION

OF THE

RCA RADIOTRON CO., INC.

COMBINING the resources of two of the best known organizations in radio, the DeForest Amateur Radio Division of the RCA Radiotron Co., Inc., offers a complete sales and engineering service to the radio amateur.

Having at its command the entire resources of the RCA Radiotron Laboratories, the DeForest Amateur Radio Division offers the amateur a comprehensive line of transmitting tubes designed to meet every amateur requirement. RCA Radiotron engineers are devoting a considerable portion of their time to the development and improvement of tubes designed for high-frequency radio communication.

The De Forest Amateur Radio Division of the RCA Radiotron Co. solicits your inquiries regarding the solution of your technical problems. For complete information on transmitting tubes or receiving Radiotrons, write to

de Forest AMATEUR RADIO DIVISION

RCA RADIOTRON CO., INC., CAMDEN, N. J.

A Radio Corporation of America Subsidiary

Eveready "Layerbilts" pack "B" Energy into every cubic inch

No other "B" battery is built like this! Flat cells in Eveready Layerbilts. Save space, hold more energy-creating ingredients, more power. The most economical "B" battery your money can buy.



Gone are the spaces that have to be . . . when old-fashioned round cells are used. Gone, too, are the 60 internal wire connections . . . those fruitful sources of battery breakdown. Layerbilts' flat cells insure free-flowing

power . . . and nothing else but. As for price . . . the lowest in Eveready History . . . only \$1.95 (medium size 45 volt) \$2.95 for larger size 45 volt. Get a Layerbilt and you get more power . . . nothing else but.

EVEREADY BATTERIES...packaged electricity at its best

HINTS AND KINKS FOR THE RADIO AMATEUR

(No. 10 in the A.R.R.L. series entitled *The Radio Amateur's Library*)

Amateurs are noted for their ingenuity in overcoming by clever means the minor and major obstacles they meet in their pursuit of their chosen hobby. An amateur must be resourceful and a good tinkerer. He must be able to make a small amount of money do a great deal for him. He must frequently be able to utilize the contents of the junk box

rather than buy new equipment. This book is a compilation of hundreds of good ideas which amateurs have found helpful. It will return its cost many times in money savings—and it will save hours of time. Why try to figure these things out for yourself? You might just as well profit by the experience of others. Order your copy today.



PRICE

80 pages in attractive paper covers. **50** (no stamps, please), postpaid anywhere

CENTS

AMERICAN RADIO RELAY LEAGUE, INC., WEST HARTFORD, CONN.