

**ELECTRONICS  
ILLUSTRATED**

# HI-FI Handbook

By DONALD C. HOEFLER



Preamps



Cartridges



Changers



Tuners



Turntables

Sound Waves and Electrons • AM, FM, Records, Tape, TV  
Stereo Conversion, Multiplex • Review of Best Records  
Tone Arms, Compensators, Amplifiers • Speakers, Networks  
Building from Kits • Your Complete System

# ANY

## STEREOPHONIC

if you join the Club now — and agree to purchase as few as 5 selections from



1. Night and Day, plus 11 more hits



15. Broadway's newest smash hit



5. 16 favorites — Sweet Violets, etc.



8. What'll I Do, Warm, 10 more



7. Three brilliant hi-fi showpieces



24. 16 classical and pop selections



49. That's All Over, One More Ride, etc.



40. "Hallelujah", "Finlandia", etc.



9. Always, Please, Speak Low, 9 more



25. Two very popular piano works



13. Don't Blame Me, Lucky Day, etc.



6. Newly recorded for stereo sound



A wonderful way to acquire a fine stereophonic record library — at a 40% savings!

If you own a stereophonic phonograph, or plan to purchase one in the future—here's a unique opportunity to obtain SIX brand-new stereo records for only \$5.98.

We make this unusual offer to demonstrate the tremendous savings you will enjoy as a Columbia  Record Club member. Read below how the Club operates; then mail the coupon to receive the six records of your choice for only \$5.98.

### HOW THE CLUB OPERATES:

- ★ You enroll in either one of the Club's two Stereo Divisions: Classical OR Popular — whichever one best suits your musical taste
- ★ Each month the Club's staff of music experts selects outstanding recordings that deserve a place in your new stereophonic record library. These selections are described in the Club's entertaining Music Magazine, which you receive free each month
- ★ You may accept the selection for your Division, take any of the other records offered, or take NO record in any particular month
- ★ Your only obligation as a member is to purchase five selections from the more than 100 Columbia and Epic stereo records to be offered in the coming 12

months . . . and you may discontinue membership any time thereafter

★ After purchasing only five records you receive a 12" Columbia or Epic stereo Bonus record of your choice free for every two additional selections you buy

★ The records you want are mailed and billed to you at the regular list price of \$4.98 (Classical Selections, \$5.98) — plus a small mailing charge

★ Here, indeed, is the most convenient method ever devised to build, systematically and with expert guidance, a well-balanced stereophonic record library of the music you enjoy most — at truly substantial savings! So mail the coupon today to receive your SIX stereophonic records for only \$5.98



19. No Other Love, Our Love, 10 more



21. Four dashing, fiery rhapsodies



42. Body and Soul, I Got It Bad, 10 more



41. Strauss' loveliest tone poems

**NOTE:** Stereophonic records must be played only on a stereophonic record player

**MAIL THIS**

# SIX

## RECORDS

for only **\$5.98** RETAIL VALUE UP TO \$35.88

the more than 100 to be made available during the coming 12 months



2. A beloved American classic



50. Where or When, Manhattan, 10 more



27. Granada, La Paloma, 11 more



30. A "must" for any record library



10. Be My Love, Where or When, etc.



37. Lovely "musical portrait of nature"



12. Let's Dance, Jubilee, 7 more



11. Berlioz' most popular work



22. Organist Cole plays 11 hit tunes



17. Rain, Bidn' My Time, 10 more



29. High-spirited, gay symphonies



20. Come to Me, Long Ago, 10 more



3. Didn't It Rain, God Is Real, etc.



39. Also: Sylvia, Coppella, etc.



33. 11 beautiful, immortal melodies



18. Two electrifying tone poems



45. Tico-Tico, Brazil, 10 others



36. The ballet that "rocked the world"



28. Brahms' most beloved symphony



44. 12 songs from famous movies



31. Solitude, Autumn Leaves, etc.



16. Two colorful, exciting scores

SEND NO MONEY — Mail coupon to receive 6 records for \$5.98

COLUMBIA <sup>®</sup> RECORD CLUB, Dept. 282-1  
Stereophonic Section  
Terre Haute, Indiana

I accept your offer and have circled at the right the numbers of the six records I wish to receive for \$5.98, plus small mailing charge. Enroll me in the following Division of the Club:

(check one box only)

Stereo Classical  Stereo Popular

I agree to purchase five selections from the more than 100 to be offered during the coming 12 months, at regular list price plus small mailing charge. For every two additional selections I accept, I am to receive a 12" Columbia or Epic stereo Bonus record of my choice FREE.

Name.....  
(Please Print)

Address.....

City.....ZONE.....State.....

ALASKA and HAWAII: write for special membership plan  
CANADA: address 11-13 Soho Street, Toronto 2B

If you wish to have this membership credited to an established Columbia or Epic record dealer, authorized to accept subscriptions, fill in below:

Dealer's Name.....

Dealer's Address..... 271-1

CIRCLE 6  
NUMBERS:

- 1 22
- 2 24
- 3 25
- 5 27
- 6 28
- 7 29
- 8 30
- 9 31
- 10 33
- 11 36
- 12 37
- 13 39
- 15 40
- 16 41
- 17 42
- 18 44
- 19 45
- 20 49
- 21 50

**COUPON NOW**

© "Columbia," "Epic," "Epic" Marcas Reg.  
© Columbia Records Sales Corp., 1959

F-87

ELECTRONICS ILLUSTRATED

# HI-FI HANDBOOK

A FAWCETT BOOK

NUMBER 424

LARRY EISINGER • EDITOR-IN-CHIEF  
GEORGE TILTON • MANAGING EDITOR  
SILVIO LEMBO • ART EDITOR

W. H. Fawcett, Jr. . . . . President  
Roger Fawcett . . . . . General Manager  
Gordon Fawcett . . . . . Secretary-Treasurer  
Roscoe Fawcett . . . . . Circulation Director  
Ralph Daigh . . . . . Editorial Director  
James B. Boynton . . . . . Advertising Director  
Al Allard . . . . . Art Director  
Ralph Mattison . . . . . Associate Art Director  
George H. Carl . . . . . Production Director

FRED HONIG . . . . . EDITOR  
Lois Bianchi . . . . . Editorial Assistant

Staff Artists

NICK CARLUCCI . . . . . ASSOCIATE ART EDITOR  
Harold E. Price • Michael Gaynor  
Larry Flanagan • Stanley Moskowitz  
John S. Selvaggio • Bob Vatter  
Mike Eastman • Frank Bermudez

Phyllis J. Bendremer . . . . . Production Editor  
Nancy Kay . . . . . Assistant Production Editor

HI-FI HANDBOOK, Fawcett Book 424, is published by Fawcett Publications, Inc., Greenwich, Connecticut. Editorial and Advertising Offices: 67 West 44th Street, New York 36, New York. General Offices: Fawcett Building, Greenwich, Connecticut. Printed in U.S.A. Copyright 1959 by Fawcett Publications, Inc.

On the cover: Stereo Preamplifier by Marantz. Stereo Cartridge M3D by Shure. Record Changer by Garrard. Turntable by Rek-O-Kut. Stereo AM-FM Tuner by H. H. Scott. Speaker by Audax.

Cover photos by Mike Bonvino—FAWCETT Studios

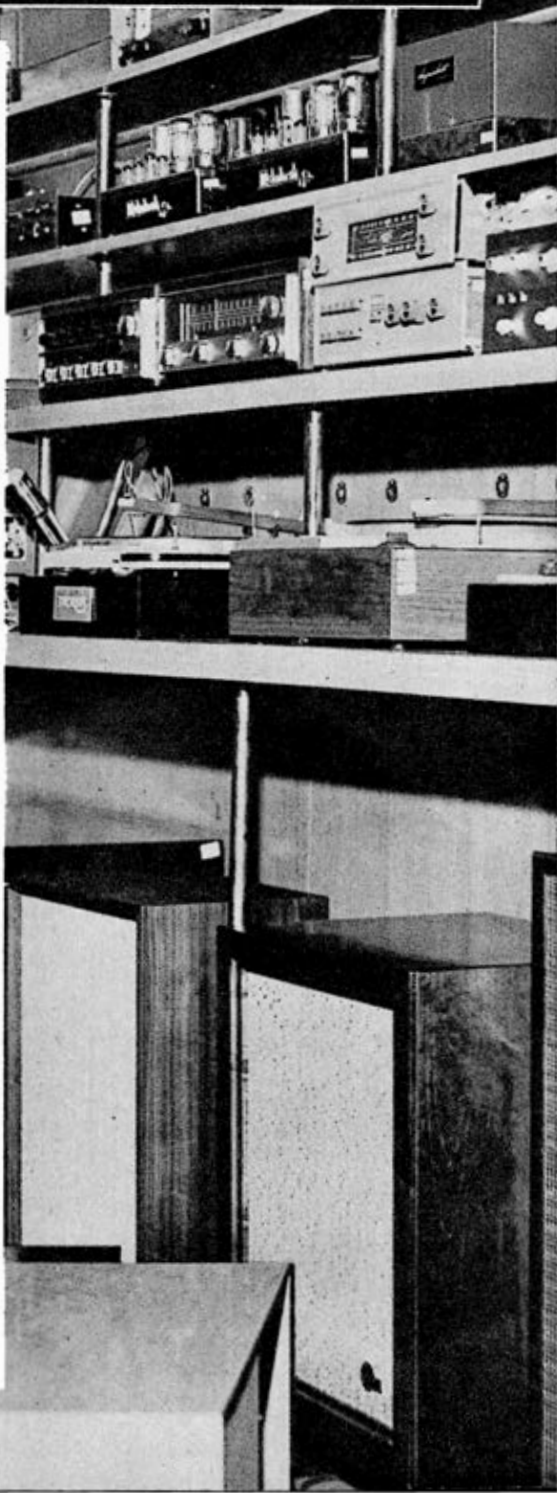

# How to pass a genius



All of us can't be geniuses. But any ordinarily talented mortal can be a success—and that's more than some geniuses are.

Now, as in Æsop's time, the race doesn't always go to the one who potentially is the swiftest. The *trained* man has no trouble in passing the genius who hasn't improved his talents.

In good times and bad times, in every technical and business field, the *trained* man is worth a dozen untrained ones, no matter how gifted.

The International Correspondence Schools can't make you into a genius. For more than 67 years, however, I. C. S. has been helping its students to become *trained, successful leaders*—and it can do the same for you.

Mark your special interest on the coupon. Don't be like the unsuccessful genius who wastes his life in dreaming of what he intends to do. **Act now!**

For Real Job Security—Get an I. C. S. Diploma! I. C. S., Scranton 15, Penna.

Accredited Member,  
National Home Study Council

## INTERNATIONAL CORRESPONDENCE SCHOOLS



BOX 59541K, SCRANTON 15, PENNA.

(Partial list of 258 courses)

Without cost or obligation, send me "HOW TO SUCCEED" and the opportunity booklet about the field BEFORE which I have marked X (plus sample lesson):

- |  |   |  |  |   |
|--|---|--|--|---|
| <p><b>ARCHITECTURE and BUILDING CONSTRUCTION</b></p> <ul style="list-style-type: none"> <li><input type="checkbox"/> Air Conditioning</li> <li><input type="checkbox"/> Architecture</li> <li><input type="checkbox"/> Arch. Drawing and Designing</li> <li><input type="checkbox"/> Building Contractor</li> <li><input type="checkbox"/> Building Estimator</li> <li><input type="checkbox"/> Carpenter Builder</li> <li><input type="checkbox"/> Carpentry and Millwork</li> <li><input type="checkbox"/> Carpenter Foreman</li> <li><input type="checkbox"/> Heating</li> <li><input type="checkbox"/> Painting Contractor</li> <li><input type="checkbox"/> Plumbing</li> <li><input type="checkbox"/> Reading Arch. Blueprints</li> </ul> <p><b>ART</b></p> <ul style="list-style-type: none"> <li><input type="checkbox"/> Commercial Art</li> <li><input type="checkbox"/> Magazine Illus.</li> <li><input type="checkbox"/> Show Card and Sign Lettering</li> <li><input type="checkbox"/> Sketching and Painting</li> </ul> <p><b>AUTOMOTIVE</b></p> <ul style="list-style-type: none"> <li><input type="checkbox"/> Automobile</li> <li><input type="checkbox"/> Auto Body Rebuilding and Refinishing</li> <li><input type="checkbox"/> Auto Engine Tuneup</li> <li><input type="checkbox"/> Auto Technician</li> </ul> | <p><b>AVIATION</b></p> <ul style="list-style-type: none"> <li><input type="checkbox"/> Aero-Engineering Technology</li> <li><input type="checkbox"/> Aircraft &amp; Engine Mechanic</li> </ul> <p><b>BUSINESS</b></p> <ul style="list-style-type: none"> <li><input type="checkbox"/> Accounting</li> <li><input type="checkbox"/> Advertising</li> <li><input type="checkbox"/> Business Administration</li> <li><input type="checkbox"/> Business Management</li> <li><input type="checkbox"/> Cost Accounting</li> <li><input type="checkbox"/> Creative Salesmanship</li> <li><input type="checkbox"/> Managing a Small Business</li> <li><input type="checkbox"/> Professional Secretary</li> <li><input type="checkbox"/> Public Accounting</li> <li><input type="checkbox"/> Purchasing Agent</li> <li><input type="checkbox"/> Salesmanship</li> <li><input type="checkbox"/> Salesmanship and Management</li> <li><input type="checkbox"/> Traffic Management</li> </ul> <p><b>CHEMICAL</b></p> <ul style="list-style-type: none"> <li><input type="checkbox"/> Analytical Chemistry</li> <li><input type="checkbox"/> Chemical Engineering</li> <li><input type="checkbox"/> Chem. Lab. Technician</li> <li><input type="checkbox"/> Elements of Nuclear Energy</li> <li><input type="checkbox"/> General Chemistry</li> <li><input type="checkbox"/> Natural Gas Prod. and Trans.</li> <li><input type="checkbox"/> Petroleum Prod. and Engr.</li> <li><input type="checkbox"/> Professional Engineer (Chem.)</li> <li><input type="checkbox"/> Pulp and Paper Making</li> </ul> | <p><b>CIVIL ENGINEERING</b></p> <ul style="list-style-type: none"> <li><input type="checkbox"/> Civil Engineering</li> <li><input type="checkbox"/> Construction Engineering</li> <li><input type="checkbox"/> Highway Engineering</li> <li><input type="checkbox"/> Professional Engineer (Civil)</li> <li><input type="checkbox"/> Reading Struc. Blueprints</li> <li><input type="checkbox"/> Sanitary Engineering</li> <li><input type="checkbox"/> Structural Engineering</li> <li><input type="checkbox"/> Surveying and Mapping</li> </ul> <p><b>DRAFTING</b></p> <ul style="list-style-type: none"> <li><input type="checkbox"/> Aircraft Drafting</li> <li><input type="checkbox"/> Architectural Drafting</li> <li><input type="checkbox"/> Drafting &amp; Machine Design</li> <li><input type="checkbox"/> Electrical Drafting</li> <li><input type="checkbox"/> Mechanical Drafting</li> <li><input type="checkbox"/> Sheet Metal Drafting</li> <li><input type="checkbox"/> Structural Drafting</li> </ul> <p><b>ELECTRICAL</b></p> <ul style="list-style-type: none"> <li><input type="checkbox"/> Electrical Engineering</li> <li><input type="checkbox"/> Elec. Engr. Technician</li> <li><input type="checkbox"/> Elec. Light and Power</li> <li><input type="checkbox"/> Practical Electrician</li> <li><input type="checkbox"/> Practical Lineman</li> <li><input type="checkbox"/> Professional Engineer (Elec.)</li> </ul> <p><b>HIGH SCHOOL</b></p> <ul style="list-style-type: none"> <li><input type="checkbox"/> High School Diploma</li> </ul> | <ul style="list-style-type: none"> <li><input type="checkbox"/> Good English</li> <li><input type="checkbox"/> High School Mathematics</li> <li><input type="checkbox"/> High School Science</li> <li><input type="checkbox"/> Short Story Writing</li> </ul> <p><b>LEADERSHIP</b></p> <ul style="list-style-type: none"> <li><input type="checkbox"/> Industrial Foremanship</li> <li><input type="checkbox"/> Industrial Supervision</li> <li><input type="checkbox"/> Personnel-Labor Relations</li> <li><input type="checkbox"/> Supervision</li> </ul> <p><b>MECHANICAL and SHOP</b></p> <ul style="list-style-type: none"> <li><input type="checkbox"/> Diesel Engines</li> <li><input type="checkbox"/> Gas-Elec. Welding</li> <li><input type="checkbox"/> Industrial Engineering</li> <li><input type="checkbox"/> Industrial Instrumentation</li> <li><input type="checkbox"/> Industrial Metallurgy</li> <li><input type="checkbox"/> Industrial Safety</li> <li><input type="checkbox"/> Machine Shop Practice</li> <li><input type="checkbox"/> Mechanical Engineering</li> <li><input type="checkbox"/> Professional Engineer (Mech.)</li> <li><input type="checkbox"/> Quality Control</li> <li><input type="checkbox"/> Reading Shop Blueprints</li> <li><input type="checkbox"/> Refrigeration and Air Conditioning</li> <li><input type="checkbox"/> Tool Design</li> <li><input type="checkbox"/> Tool Making</li> </ul> <p><b>RADIO, TELEVISION</b></p> <ul style="list-style-type: none"> <li><input type="checkbox"/> General Electronics Tech.</li> </ul> | <ul style="list-style-type: none"> <li><input type="checkbox"/> Industrial Electronics</li> <li><input type="checkbox"/> Practical Radio-TV Eng'g</li> <li><input type="checkbox"/> Practical Telephony</li> <li><input type="checkbox"/> Radio-TV Servicing</li> </ul> <p><b>RAILROAD</b></p> <ul style="list-style-type: none"> <li><input type="checkbox"/> Car Inspector and Air Brake</li> <li><input type="checkbox"/> Diesel Electrician</li> <li><input type="checkbox"/> Diesel Engr. and Fireman</li> <li><input type="checkbox"/> Diesel Locomotive</li> </ul> <p><b>STEAM and DIESEL POWER</b></p> <ul style="list-style-type: none"> <li><input type="checkbox"/> Combustion Engineering</li> <li><input type="checkbox"/> Power Plant Engineer</li> <li><input type="checkbox"/> Stationary Diesel Engr.</li> <li><input type="checkbox"/> Stationary Fireman</li> </ul> <p><b>TEXTILE</b></p> <ul style="list-style-type: none"> <li><input type="checkbox"/> Carding and Spinning</li> <li><input type="checkbox"/> Cotton Manufacture</li> <li><input type="checkbox"/> Cotton Warping and Weaving</li> <li><input type="checkbox"/> Loom Fixing Technician</li> <li><input type="checkbox"/> Textile Designing</li> <li><input type="checkbox"/> Textile Finishing &amp; Dyeing</li> <li><input type="checkbox"/> Throwing</li> <li><input type="checkbox"/> Warping and Weaving</li> <li><input type="checkbox"/> Worsted Manufacturing</li> </ul> |
|--|---|--|--|---|

Name \_\_\_\_\_ Age \_\_\_\_\_ Home Address \_\_\_\_\_  
 City \_\_\_\_\_ Zone \_\_\_\_\_ State \_\_\_\_\_ Working Hours \_\_\_\_\_ A.M. to P.M.  
 Occupation \_\_\_\_\_

Canadian residents send coupon to International Correspondence Schools, Canadian, Ltd., Montreal, Canada. . . . Special low monthly tuition rates to members of the U. S. Armed Forces.

# CONTENTS

<b>Chapter 1</b>	The How and Why of Hi-Fi. . . . .	6
<b>Chapter 2</b>	Sound Waves and Electrons. . . . .	18
<b>Chapter 3</b>	Audio Sources—AM, FM, TV, Records and Tape. . . . .	28
<b>Chapter 4</b>	Turntables and Changers. . . . .	38
<b>Chapter 5</b>	Stylus, Cartridge and Arm. . . . .	46
<b>Chapter 6</b>	Preamps and Compensators. . . . .	56
<b>Chapter 7</b>	Tuners and Receivers. . . . .	64
<b>Chapter 8</b>	Power Amplifiers . . . . .	72
<b>Chapter 9</b>	The Speaker System. . . . .	82
<b>Chapter 10</b>	Tape Recording . . . . .	94
<b>Chapter 11</b>	Building from Kits. . . . .	102
<b>Chapter 12</b>	Your Complete System. . . . .	112
<b>Chapter 13</b>	Review of Best Recordings. . . . .	126
<b>Chapter 14</b>	The Hi-Fi Language. . . . .	136

Electro-Voice



new  
**RECORDS AMPEX STEREO**

and plays  
both  
2-track  
and  
4-track  
tapes



**Record stereo off the air; copy stereo tapes and discs**

Here's stereo recording of full professional quality. The Ampex Universal Series 950 recorder/reproducer enables you to build a stereo tape library of highest quality at lowest cost. Records monaurally, too, from radio, tv sound, phonograph records, and "live" from microphone.

**Benefit from traditionally fine Ampex engineering features**

With the Universal's instant-acting head switch, you can shift from 2-track to 4-track operation at will, and play back as long as 4 hours and 16 minutes of stereo music on a single reel of tape (2400.ft.). Automatic stop at end of reel.

**Enjoy years of flawless, trouble-free operation**

The Universal's performance will be within specifications the day you install it and for years afterwards. Its three precision dual head stacks (one each for record, playback and erase) are built to tolerances as close as 10 millionths of an inch. Twin pre-amplifiers provide output to match either your own amplifier-speakers or Ampex units.

**MAIL COUPON TODAY FOR COMPLETE SPECIFICATIONS AND DETAILS**

**AMPEX  
STEREO**

SIGNATURE OF PERFECTION IN SOUND

AMPEX AUDIO, INC. • 1058-F KIFER ROAD • SUNNYVALE, CALIFORNIA

Please mail me full information on the  
UNIVERSAL "A" (900 series):

Name \_\_\_\_\_

Address \_\_\_\_\_

City \_\_\_\_\_ Zone \_\_\_\_\_ State \_\_\_\_\_

## Chapter 1

# The How and Why of Hi-Fi



Columbia Records

**H**IGH FIDELITY has become a magic name in this most recent decade of its long and colorful life. But to many people it is still as mysterious as it is magical. What does it really mean?

To the musical artist it is another means of communicating with his listeners. To the sound engineer it is the best known means of collecting, storing, and reproducing audio. To the record and component equipment manufacturers, it spells new markets and new opportunities for profit.

But what about you and me? Mr. Average Joe Consumer. What does high fidelity really mean to us?

For you and me, high fidelity should be the means of erasing the barriers of time and space between a fine musical performance—or any other sound source if our taste happens to run that way—between the original production of this sound and our own private listening enjoyment of it.

This is quite a wonderful proposition. And because it is so wonderful, quite a

few snake-oil merchants have attempted to befuddle us with curves, charts, ten-dollar words, and other weird incantations and mumbo-jumbo.

Pay them no heed. The road to hi-fi is wide, easy to follow and well mapped out. Our objective is simple enough: *we want the best possible sound reproduction we can get without at the same time going into bankruptcy.* To achieve this we need only know the various possible approaches to our objective, choose the one which best appeals to us, plan our system with the aid of this approach, and then execute the plan.

We can save ourselves a lot of useless argument later if we agree at the outset just what hi-fi is. To begin with, the very term *high fidelity* can have only a relative meaning. It's like the old childhood conundrum, how high is up? This sort of question simply can't be answered with numbers or other specifics.

Hi-fi is constantly shifting upward with the state of the art. What was hi-fi yester-





The photo at left shows some of the members of the Cleveland Orchestra taking a short breather during recording session.

One of the top "good music" stations in this country is WQXR in New York. Below, the control room, equipped to play stereo records and tapes. Its services five studios.

day may be low-fi tomorrow. So don't think we are dodging the issue when we define hi-fi simply as *the nearest approach presently possible to true or perfect sound reproduction.*

This may seem to be answering the question with another question, but we can go on and positively identify true fidelity as the exact psychological impression of actual presence at the original performance. The smaller the difference between hi-fi and true-fi, the higher the fidelity goes.

While you are still considering that there is a difference between hi-fi and true-fi, this may be as good a time as any for you to be let down easy, if you happen to be riding a fur-lined pink cloud over this whole hi-fi business. Because the fact is that hi-fi still has a long way to go.

Every now and then, some zealot stages a comparison demonstration between live and recorded performances, purporting to prove that the two are now indistinguishable. We could go on at some length to discuss why and how audiences are fooled by this kind of hanky-panky, but in this connection there is really only one important thing for you to remember: this sort of thing has been going on ever since the early days of broadcasting, and even before the record industry shifted from

The New York Times



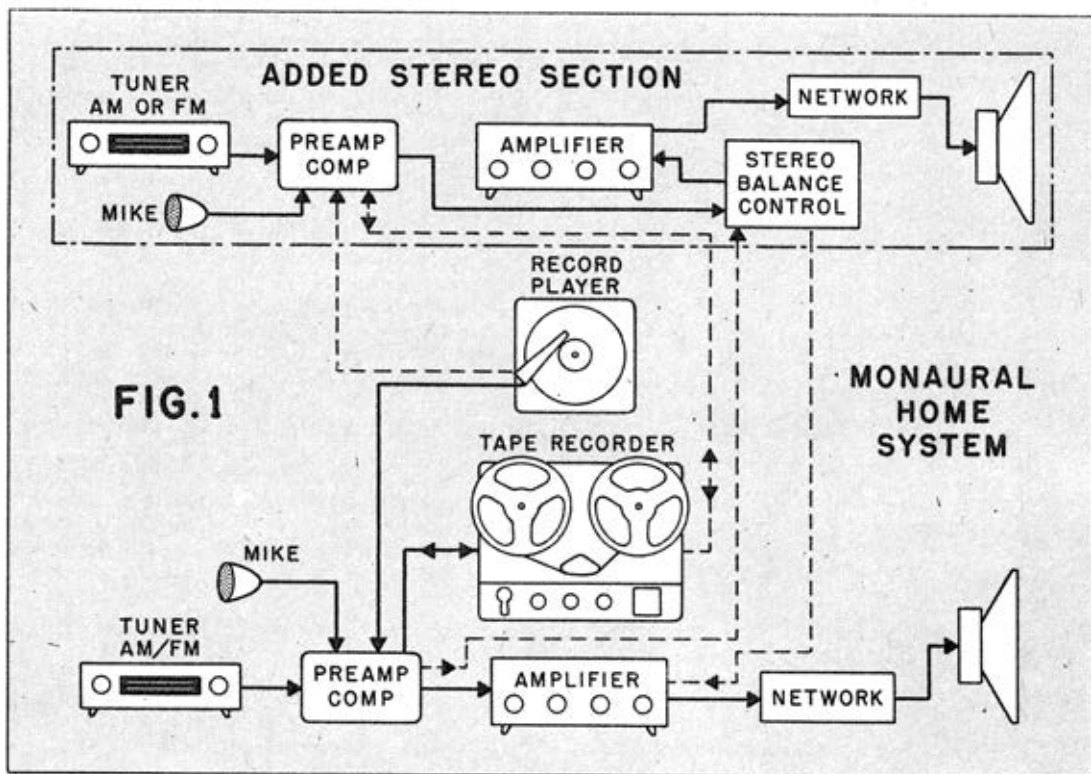

FIG. 1

the acoustical to the electrical method. Now everybody knows we didn't have perfect fidelity way back then, or anything even remotely approaching it. But you could have found plenty of people at the time who believed that the ultimate had been reached.

Don't be fooled. Just as your old Atwater Kent has been obsoleted by today's modern hi-fi tuner, so will today's equipment be obsoleted by even greater advances in hi-fi tomorrow. But this is no reason to hold back from buying hi-fi "until they perfect it," any more than it's a good reason not to buy a new car, an air conditioner or color TV. Sure, hi-fi and all these other things will improve. But hi-fi today is the best we've ever had, by a wide, wide margin.

Another important thing to remember about hi-fi is that you have control *only* over the last link in the chain. Before the sound signals ever reach your system, they may already have gone through microphones, mixers, amplifiers, filters, equalizers, telephone lines, transmitters, recorders, and "the luminiferous ether." And if any of these pieces of equipment, or the

personnel operating them, happen to have been a little sloppy, then your fidelity isn't going to be quite as high as it might have been, no matter how good your equipment is or how smartly you operate it.

This idea is illustrated by the drawing of Fig. 1, where we see that only a relatively small group of blocks comprises the monaural home system. The entire chain of events (not shown in the drawing) from original performance to recreated performance is at least three times as long.

The system shown here has three different sources of sound: radio, tape and disc. We should begin by examining these three types of transmission, finding out their similarities and their differences.

Whichever method is used, we see that the beginning element is the microphone. This is known as a *transducer*, because it converts the varying air pressures we call sound waves into a varying electrical signal. Thus the microphone is an electromechanical device, converting mechanical energy into similar electrical energy. This conversion is basic, and common to all types of audio systems presently known.

Now suppose that the entire purpose of

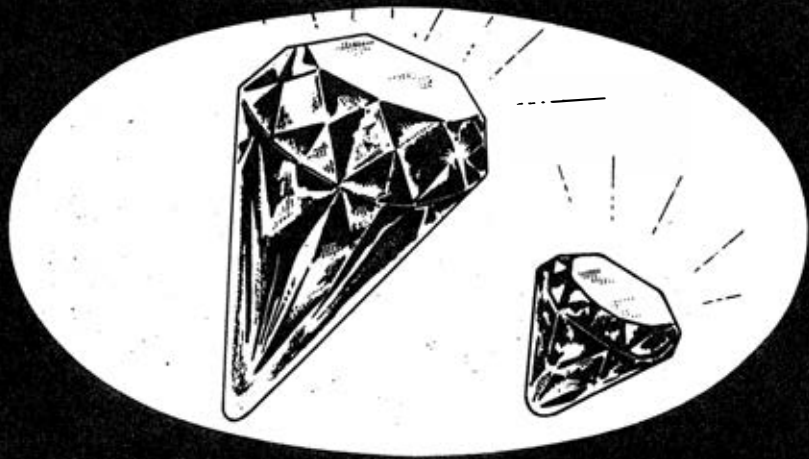

**WHICH  
WOULD  
YOU  
CHOOSE?**

**DUOTONE GUARANTEES THE WHOLE DIAMOND NEEDLE FOR EITHER MONOPHONIC OR STEREOHONIC REPRODUCTION, AT NO EXTRA COST**

What do we mean by the *whole* diamond needle?

There are two kinds of diamond needles now on the market. One is the *whole* diamond; the other is a diamond chip welded on a steel shaft. The overall length of both is the same. With the welded chip diamond the entire amount of diamond is visible on top of the steel shaft, and should there be a bubble resulting from heat or gas during the welding, the slightest jar can result in instant loss of the diamond. With the *whole* diamond needle, only  $\frac{1}{3}$  of the total diamond is visible and the remaining  $\frac{2}{3}$  is deeply embedded, crimped and cemented into the metal holder — thus making it impossible to shear off the point by any jarring or dropping of the tone arm.

What are the additional advantages of a Duotone Diamond Needle?

All Duotone diamond tips are hand ground and polished to a mirror finish, hand radiused to the exact required specifications, and hand set in perfect alignment to the record grooves. None of these delicate hand operations can weaken a weld that does not exist in a *whole* diamond. The constant observance under microscopic inspection plus Duotone's exacting quality standards eliminate every possibility of imperfection — permitting Duotone's 100% guarantee of the diamond needle itself, better reproduction and longest life possible for the needle.

One more important feature of your Duotone Diamond Needle. No diamond needle will last forever. Only Duotone Diamond Needles give you the "needle that remembers" service and warns you when the Company Technicians know that needle wear is getting dangerous for your record collection.

All this at no extra cost over ordinary diamond needles.

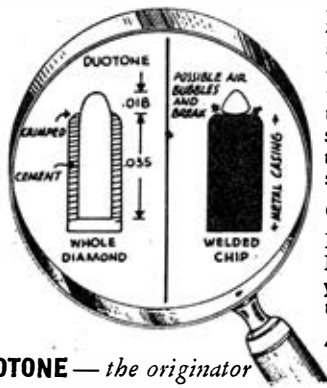

**DUOTONE** — *the originator of the commercial diamond needle*

**DUOTONE**

**KEYPORT, NEW JERSEY**

*In Canada: Charles W. Pointon, Ltd., Toronto*



Columbia Broadcasting System

Many popular entertainers, such as Bing Crosby, above, participate frequently in live broadcasts. Good hi-fi tuners make it possible to have these famous names perform right in your living room.

this conversion is to make the sound louder, and then to reproduce it again immediately. This can be done readily using the setup of Fig. 2. Here the feeble electrical signals coming from the microphone are strengthened many times over by the amplifier, and then fed into a loudspeaker.

This speaker is another electromechanical device, or transducer, with a purpose exactly the opposite from that of the microphone. Its function is to receive electrical signals and reconvert them into varying air pressures which impress the human ear as sound.

A system no more complex than this is all that is needed for public address, in which the sound of a speaking voice or musical performance is amplified and played to a large audience. This basic idea could be carried right into your home, in which case you would have your own private *closed-circuit* hi-fi system. But if there were any considerable distance between the original performance and your listening room, you would have to install rather extensive wire line facilities, or else lease those of your local telephone company. And that would be rather expensive.

This leads us to one of the problems of the simple live closed-circuit system of Fig. 2. Over long distances, the expense is prohibitive. The other objection is that the performances cannot be stored. All you can hear from the speaker is whatever is happening at the microphone right now. Ideally, then, our hi-fi system must exhibit two other characteristics: it must be able to transmit the sound over long distances at low cost, and it should be capable of preserving sound indefinitely.

The first requirement is met by the system of Fig. 3. Here we have a double conversion, in which the electrical signal from the microphone and amplifier is combined with a second electrical signal known as a *radio* wave. This composite signal is sent out into space by a transmitting antenna.

When a part of this radio signal is inter-

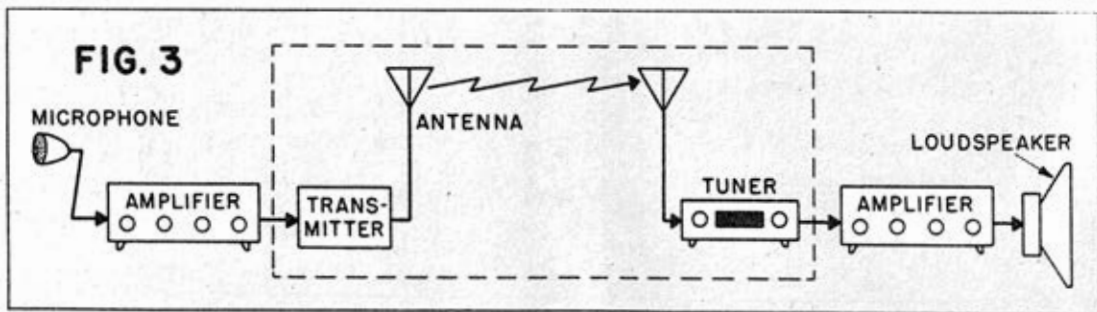
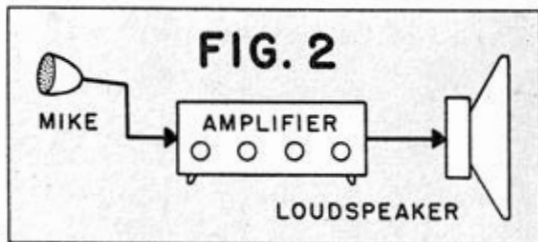

**WHERE  
THERE'S  
A FINE  
TAPE  
RECORDER... THERE'S**

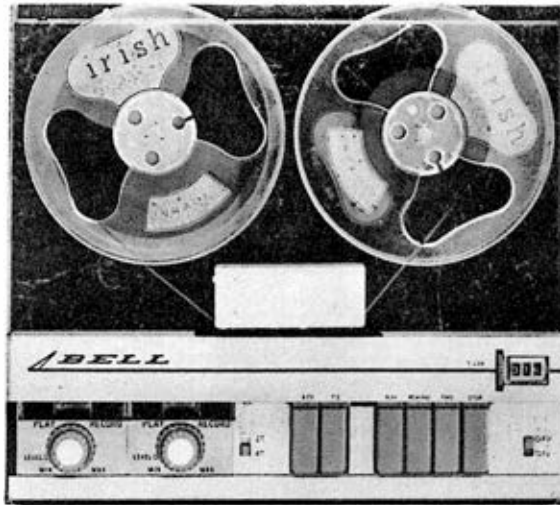

**irish**  
ferro-sheen tape  
BRAND

*note to **BELL** owners*

*To insure optimum recording quality  
with your excellent machine, the  
recommended tape is **irish** #211...  
and for uninterrupted recording,  
**irish** #724 with its 6 lb. tensile strength  
gives you one full hour at 7½ i.p.s.  
Send for technical bulletin.*

**ORR INDUSTRIES INC.**  
Opelika, Alabama

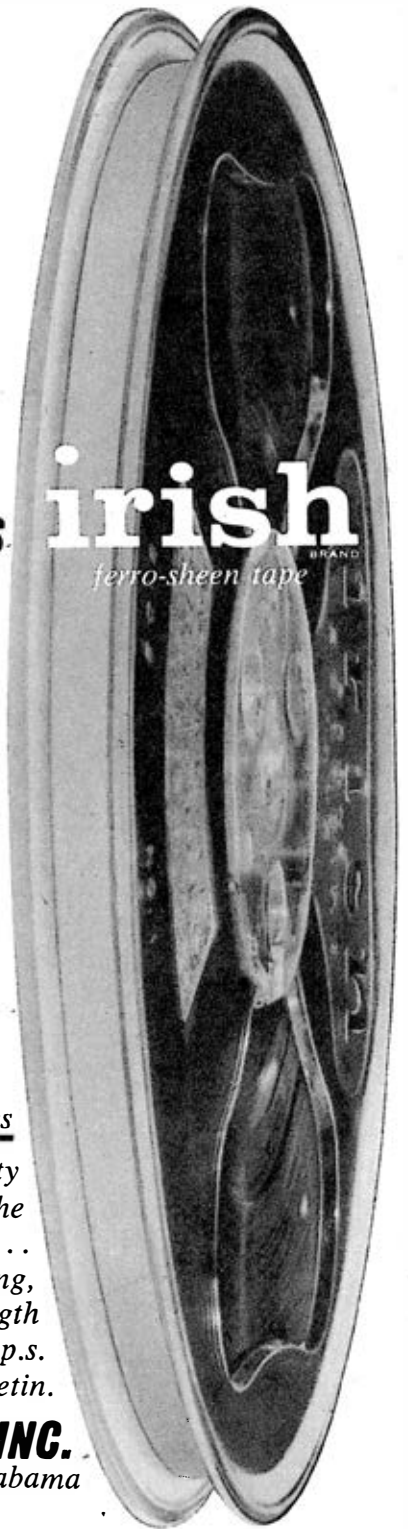



NBC-TV

Television spectaculars, productions of musicals and operas, offer today's TV audience the best in FM sound, another inducement for hi-fi equipment purchase. Photo shows set of "The Great Waltz."

cepted by your receiving antenna, it is fed into the tuner of your hi-fi system, where the audio signal is separated from the radio wave. At this point the audio should be nearly identical to the signal at the output of the microphone amplifier at the left of Fig. 3. In other words, the radio system of Fig. 3 is essentially the same as the closed-circuit system of Fig. 2, with the addition of the broadcast equipment enclosed by the broken lines.

Since radio transmission is quite cheap, we now have at least one system for getting the sound from source to you at very reasonable cost. But we don't yet know how to tune in radio broadcasts made last week or thirty years ago, so we still must find some means of storage.

Light rays are fleeting images, but a photograph is not. Taking a cue from this analogy, we can surmise that for the storage of sound waves, we must convert them to yet another form. This form could be any

of dozens proposed or actually in use, but there are only two which are of any importance in home hi-fi systems. One of these is shown in Fig. 4.

This is the basic phonograph system, in which two more types of transducers are introduced. In this case the electrical signals out of the amplifier are converted to mechanical motion by a disc recorder or cutter. This motion is permanently recorded by an engraving tool on a rotating disc.

When the wavy groove is later traced by a stylus, the mechanical motion generated causes the development of a new electrical signal which is substantially the same as the one fed into the cutter. The second transducer, which converts mechanical motion into electrical signals, is often called a phono reproducer, cartridge or pickup.

Once again we see that our basic closed-circuit system of Fig. 2 remains, with just the addition of an electromechanical system

# New H. H. Scott 222 Stereo Amplifier puts top quality within your budget!

A high fidelity system is a long term investment, so it is essential that your amplifier . . . the heart of your system . . . be the very best you can afford. The new H.H. Scott 222 offers you features, versatility, and advanced engineering to meet your needs now, and in the future. Its conservatively designed output stages will drive even inefficient speaker systems. Examine the features below to see why you should plan your system around the new H.H. Scott 222 24 watt stereophonic amplifier.

**\$139<sup>95</sup>\***

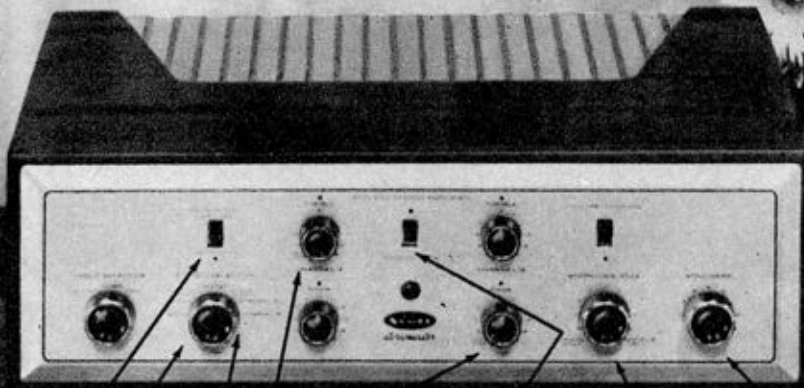

Equalization switch lets you choose between RIAA compensation for monophonic and stereo records; NARTB, for tape heads.

Special switch positions for accurate balancing, for playing stereo, reverse stereo and for using monophonic records with your stereo pickup.

Separate Bass and Treble controls on each channel let you adjust for differences in room acoustics and different speaker systems.

This position lets you play a monophonic source such as an FM tuner or a tape recorder through both power stages and speakers.

Effective scratch filter improves performance on older worn records and improves reception on noisy radio broadcasts.

Exclusive center-channel output lets you use your present amplifier for 3-channel stereo or for driving extension speakers. Separate stereo tape-recorder outputs.

Channel balance control adjusts for different speaker efficiencies and brings channel volumes into balance quickly and easily.

Master volume control adjusts volume of both channels simultaneously. Also functions as automatic loudness control whenever desired.

**SPECIFICATIONS:** Dual 12 watt channels; 0.3% 1M distortion; 0.8% harmonic distortion; frequency response 20 to 30,000 cps; extremely low hum level (-80db); DC operated preamplifier heaters; Inputs for stereo or monophonic recorders, tuners, phono cartridges and tape heads. Phono sensitivity 3 mv. Sub-sonic rumble filter prevents overload from noisy changers or turntables.

Price \$139.95\*

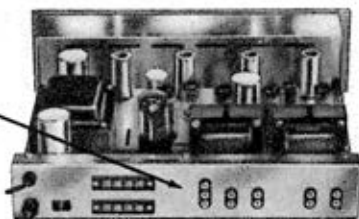

\*West of Rockies \$143.25. Accessory case extra.



SEND NOW FOR FREE  
HI-FI GUIDE AND CATALOG

H.H. SCOTT INC. Dept. HFG, 111 Powdermill Road, Maynard, Mass.  
Export: Telesco International Corp., 36 W. 40th St., N.Y.C.

Rush me complete details on your new Model 222  
and your complete 1960 Hi-Fi Guide and Catalog.

Name \_\_\_\_\_

Address \_\_\_\_\_

City \_\_\_\_\_ State \_\_\_\_\_



The New York Times

slipped into the middle. As a practical matter, the disc actually cut on the recorder is not the one you play on your reproducer at home, but a near-exact duplicate of it. As we shall see in a later chapter, there is a rather intricate process of duplication and manufacturing between the recorder and the reproducer, but the basic elements of the system are those shown in Fig. 4.

Another method of recording, which is enjoying increasing popularity, is that shown in Fig. 5. In this case the electrical

audio signals are used to magnetize millions of tiny grains of material on a moving plastic tape. Once again we see that the system is essentially that of Fig. 2, this time with a magnetic circuit slipped into the middle.

You can buy recorded tapes just as you buy recorded discs, in which case your system need only contain the three elements shown to the right in Fig. 5. Recorded tapes will be discussed in more detail on page 28. But it is also possible to make your own tapes, in which case your

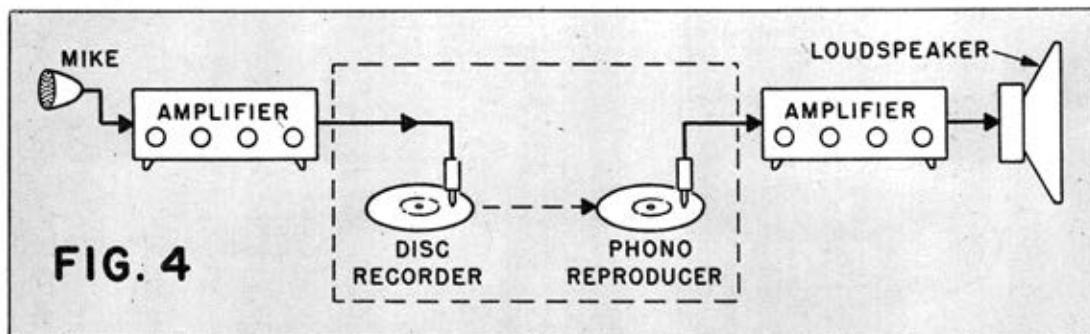



Some 65,000 recordings and 500 tapes, the largest collection of classical music owned by a radio station, are housed in WQXR's record library.

Shopping for hi-fi components can be confusing with today's wealth of items available; however, being able to compare units with instant back and forth switching lessens the chore. Below, Jimmy Carroll of Harvey, Inc., New York, explains intricacies of the switch panel to your editor.

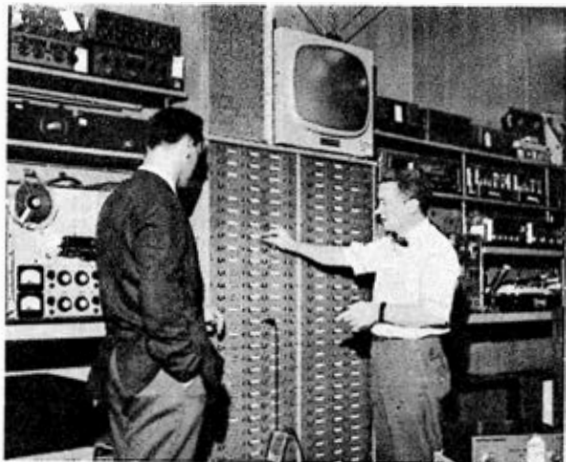

Mike Bonvino—FAWCETT Studios

system will contain all of those shown in Fig. 5. A thorough discussion of tape recorders will be found in Chapter 10.

Now if we consider Figs. 3, 4 and 5 together, we see that our concern is solely with the right-hand half of each drawing, this being the part having to do with reproduction in the home. Furthermore, we see that the two right-hand elements are common to all of the drawings. That is, whatever the means of transmission or recording, we still must have an amplifier and a loudspeaker for reproduction.

All that remains, then, is the input transducer. This may be a phono reproducer, tape player, tuner, TV, film projector, microphone, or some other translating device. Now since the amplifier and speaker are common to all, only one of each of these is needed (except for stereo sound, which we shall come to presently).

Now we come to the point where we can recognize the distinguishing characteristics of any hi-fi system. First, it has an amplifier and a loudspeaker. Second, it has as many input transducers as may be desired. Third, it has suitable selector switching and control equipment between the transducers and the amplifier-speaker system.

That's all there is to it. All of the other hi-fi component names you may have heard will upon closer examination be found to fall into one of these basic areas. With this simple fact in mind, the block diagram of the home system in Fig. 1 doesn't look quite so complex.

The several connections to the tape machine are required simply so that we may not only play recorded tapes, but also may record from the microphone, from discs, or off-the-air. The COMP and PRE-AMP blocks refer to refinements in the phono channel which will be discussed on page 56. Similarly, the CROSSOVER NETWORK is a refinement in the speaker system and is fully explained in Chapter 9.

### The Stereo Story

This would complete our discussion of the basic hi-fi system, if a new factor hadn't come on the scene a few seasons ago. This is called *stereophonic* transmission, and while it requires more equipment than the *monophonic* system we have just discussed, its basic principles can be developed in the same way we have just done. But first, we need some idea of its purpose.

Stereo sound is intended to give a roundness and depth to hi-fi reproduction which

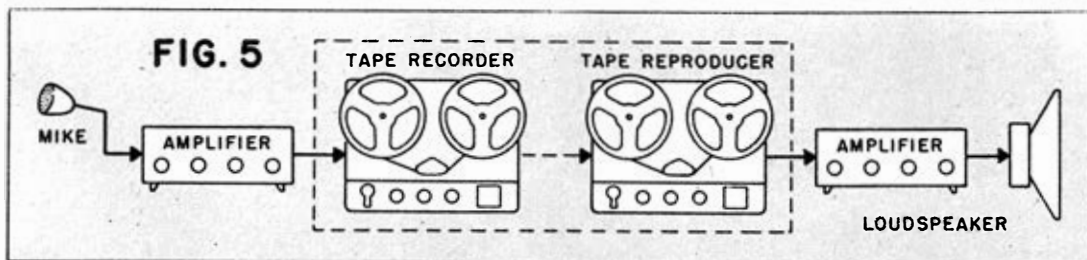

Program of concert given to show how little difference there is between live and recorded music. Although remarkable, some difference was noted, especially by those sitting near front.

CONCERTAPES DYNAKIT ACOUSTIC RESEARCH

present

## THE FINE ARTS QUARTET

Leonard Sorkin, *violin*  
 Abraham Loft, *violin*  
 Irving Ilmer, *viola*  
 George Sopkin, *cello*



in a

## LIVE vs. RECORDED

concert at CARNEGIE RECITAL HALL

Saturday, January 10, 1959

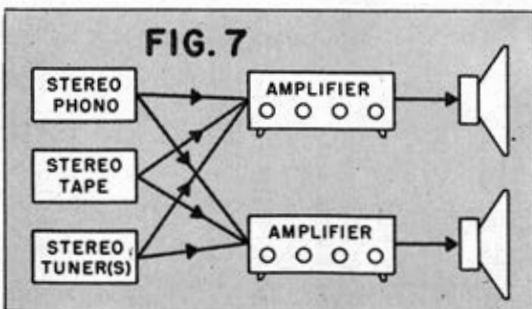
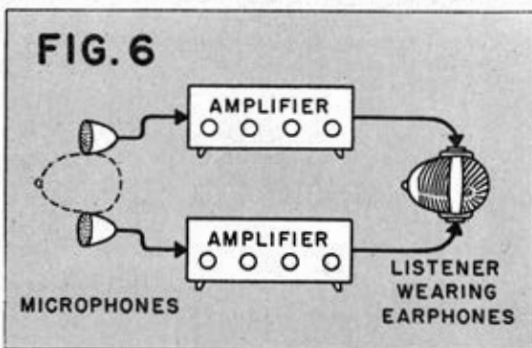

The concert during one of the live portions. A previously recorded tape would be played, then the orchestra, then back to tape. Switchover from live to tape was often exceedingly smooth.



## The How and Why of Hi-Fi



is not possible with a monophonic system. Furthermore, it is more directional. That is, in stereo reproduction the listener has a more accurate idea from which direction a given sound originally came.

And just as stereo photography uses two "information channels," so does stereo sound. In stereo photography, two pictures are taken by a dual-lens camera, with two optical systems side by side. In stereo hi-fi, two sound signals are carried by two separate audio systems.

Compare Fig. 6 with Fig. 2. Except for replacing the loudspeaker with a pair of headphones, we have simply doubled the monophonic equipment to obtain the stereo type. With this setup the listener readily imagines himself to be transported to the location of the original sound.

Although the system of Fig. 6 is the most accurate means of achieving realism in sound reproduction, it has several serious disadvantages:

1. Continuous use of the earphones is tiring.
2. Group listening is difficult and awkward.
3. When the listener turns his head, the performance follows, swinging around in an arc before him.

Because of these drawbacks, most people prefer to replace the headphones of Fig. 6 with two loudspeakers. Since the sound from the two speakers blends somewhat in the room before it reaches the listener's ears, it is not as accurate or realistic as the true binaural system shown in Fig. 6. Still it does have more excitement than the ordinary monophonic system, and all but the most die-hard purists seem willing to settle for that.

Faced with the choice of mono or stereo, the beginner often doesn't know which way to turn when beginning to build up his system. To reach a decision, let's look at the building blocks which comprise a stereo system, and compare them with the monophonic elements. The basic stereo units are shown in Fig. 7.

The amplifier-speaker combination in the stereo system is just exactly double that in a monophonic system. While stereo

amplifiers specifically designed for that use usually comprise two identical amplifiers on a common chassis, there is no reason other than convenience why this need be so. In other words, it is entirely practical to buy one amplifier and speaker now, and another amplifier and speaker later, to convert to stereo.

As far as the record player is concerned, the turntable or changer as well as the tone arm remain the same. Stereo and mono cartridges are not the same, however. If you start out with a mono cartridge, you will have to replace it with a stereo type for your conversion. But since the stereo cartridge will also reproduce the mono type records, it is possible to install the stereo type in the first place. Before deciding to do that, however, you had better read Chapter 5.

In the tape department, the situation is much the same as for disc. The transport mechanism and other mechanical features remain the same. To convert a monophonic tape machine to stereo requires the replacement of one or two heads, plus some additional electronics. This is entirely practical although it does entail some rebuilding.

For stereo broadcasts, conventional AM and FM tuners will receive the most common type without any modification. For "multiplex" FM stereo, an adapter is required.

Obviously, then, it is quite feasible to build a solid hi-fi foundation with a good monophonic system, and later add on to build up to stereo. This is the method recommended in this book. Most of each chapter will be devoted to one of the basic components of the monophonic hi-fi system. The concluding section of each chapter will tell you how this information ties in with stereo, and what modifications must be made for your stereo conversion.

This is the simple, logical way to "go stereo" if you really want to. While the total cost may prove to be a little more, the initial cost, especially if you already own a monaural system, will be much less. And it just may be that you'll be content not to go stereo at all. •



## Chapter 2

# Sound Waves and Electrons



**S**OUND is vibration, and this is true whether it be hi-fi, low-fi, or medium well done fi. The physicist would add that the vibration takes place in an elastic medium, which means that sound can travel through metal, wood or water, for example. But for hi-fi purposes we are primarily concerned with sound that travels through the air.

Sound can also be defined as the sensation produced in the brain by these vibrations. When we hear live sound, several things are happening. First, some object is vibrating and causing rapid changes in the atmospheric pressure surrounding us. The ear drums detect these vibrations, and through a rather complex process pass a message along to the brain.

In the case of hi-fi, we are adding other elements into the middle of this chain of events. As we noted in Chapter 1, the sound originally produced is converted to an electrical signal, and then converted once again into still another form for transmission or storage. Then in reproduction it is converted back to electricity, and then finally back to sound, which is transmitted through the air from the loudspeaker system to our ears.

This then is the complete hi-fi system, from the original production of sound all

the way through to the auditory sensation in the brain of the listener. As a high fidelity enthusiast, you should know something about the hearing apparatus which enables you to enjoy high quality sound reproduction.

The ear is regarded as having three parts, known as the outer ear, middle ear, and the inner ear. The outer ear is the part normally visible at either side of the head, along with the canal which directs the sound inside. Stretched across the inner end of this canal is the membrane known as the ear drum, which marks the beginning of the middle ear.

When the ear drum is set in motion by sound in air, it transmits this vibration to a mechanical lever system of three bones in the middle ear known as the hammer, anvil and stirrup. At the end of the stirrup is a second and much smaller membrane, known as the oval window, which is the entrance to the inner ear.

Because of the lever action of the bones in the middle ear, and the relative sizes of the two membranes, the pressure exerted upon the inner ear is 30 to 60 times as great as that of the outer air striking the ear drum. The inner ear is a snail-shaped cavity in the skull, which is filled with a liquid. The vibrations set up in the inner



Columbia Records

Above, Bruno Walter conducting Beethoven's 9th Symphony with full orchestra and chorus. This work is one of the most demanding; only the best equipment is recommended for its reproduction.

Right. Simplified drawing of the human ear shows the intricate design that makes hearing possible. Sound waves striking eardrum are magnified 60 times by small bone levers before reaching brain.

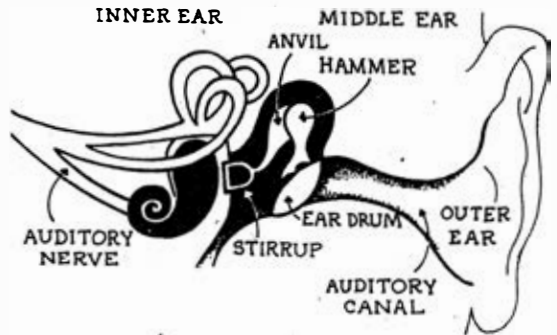

ear are transmitted through this liquid to the brain over a network of tiny nerve fibers.

There have been many theories concerning the precise way in which the nervous system converts sound waves in air into an auditory sensation in the brain. But nobody knows for certain even yet just how it happens. The important thing to us is that this rather wonderful thing does happen, and that it is an integral part of the overall hi-fi process.

There are many sounds in the air right now which you are unable to hear. The footsteps of a fly, for example, have been picked up and amplified by sensitive mi-

crophones and sound equipment, but no human ear has ever heard them without the aid of these artificial devices.

Sounds such as these, which are not loud enough to be heard, are said to be below the threshold of audibility. Above this threshold, the ear responds to a wide range of sound intensities, but they can ultimately become loud enough to cause pain. The point at which this happens is called the threshold of feeling.

There are essentially three classes of sound, known as noise, speech and music. The rumble of a subway train, the clatter of horses' hoofs, the clap of thunder, the crash of breaking glass: all of these are

Below, soprano Eileen Farrell and conductor Max Rudolph. The human voice is just another musical instrument and has similar overtones, vibrations.

Columbia Records



Fine string instruments, such as the violin Zino Francescatti plays, reach a frequency of 18,000 cps. Bass viols go down to about 40 cycles.

Columbia Records

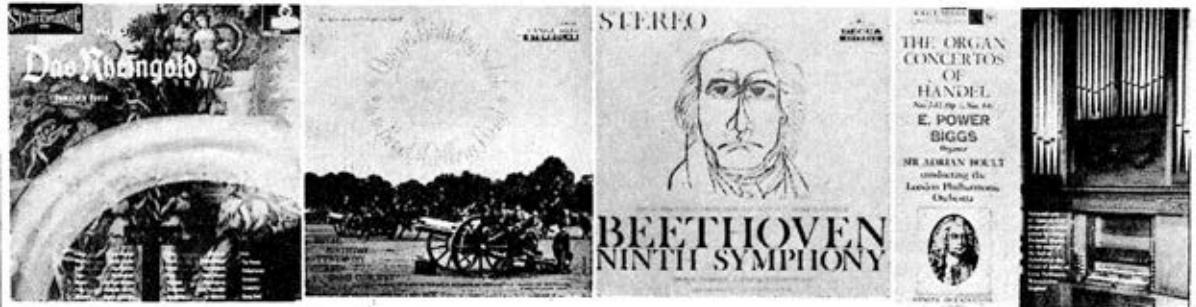

Today's modern recording techniques capture every audible note in the sound spectrum. The records above, *Das Rheingold*, London; *Queen's Birthday Salute*, Vanguard; *Beethoven's Ninth*, Decca; and *Organ Concertos of Handel*, Columbia, are especially fine examples of the record maker's art in high-fidelity sound.

sounds which have no definite pitch. We can tell whether they are high or low, but cannot assign them a comparable note which might be struck on the piano.

Any such unpitched sound is called noise. Noises are actually mixtures of great numbers of tones, with no single one predominant enough to establish a definite pitch. Many noises therefore encompass practically the entire audible range. For this reason, various types of noises are often used to test the response of hi-fi systems.

Speech sounds are those produced by the human vocal organs. The pitch of speech is more or less definite, with the average female voice being about an octave above that of the average male.

The vowel sounds, which are the most powerful in speech, are produced by em-

ploying the lungs as a bellows to produce an air stream, which in turn is set into vibration by the vocal cords. The unvoiced sounds, such as *f*, *k*, *p*, *ch*, *sh* and *th*, don't involve the vocal cords at all, but are produced by directing the air stream through small openings or over sharp edges of the teeth, lips and tongue. The voiced consonants, such as *h*, *w* and *y*, are really only special ways of beginning the vowel sounds, and are produced by a combination of the vowel and consonant processes.

Musical sounds are those in which the rate of vibration is uniform. Thus they have a definite pitch. Because the instruments of the orchestra have a greater overall tonal range than does human speech, and because speech is still intelligible over a low-fi telephone circuit, it is often thought that music alone provides the acid

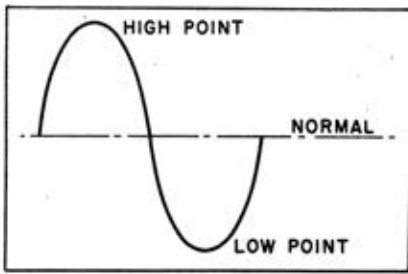

Left. Drawing of one cycle as shown on oscilloscope. Number of cycles per second gives frequency. Below. Illustration of theory that the louder a sound the wider the range of frequencies audible to the human ear. At low volume only a small area between 2,000 and 4,000 cps is clearly discernible..At loud volume, broader band is covered.

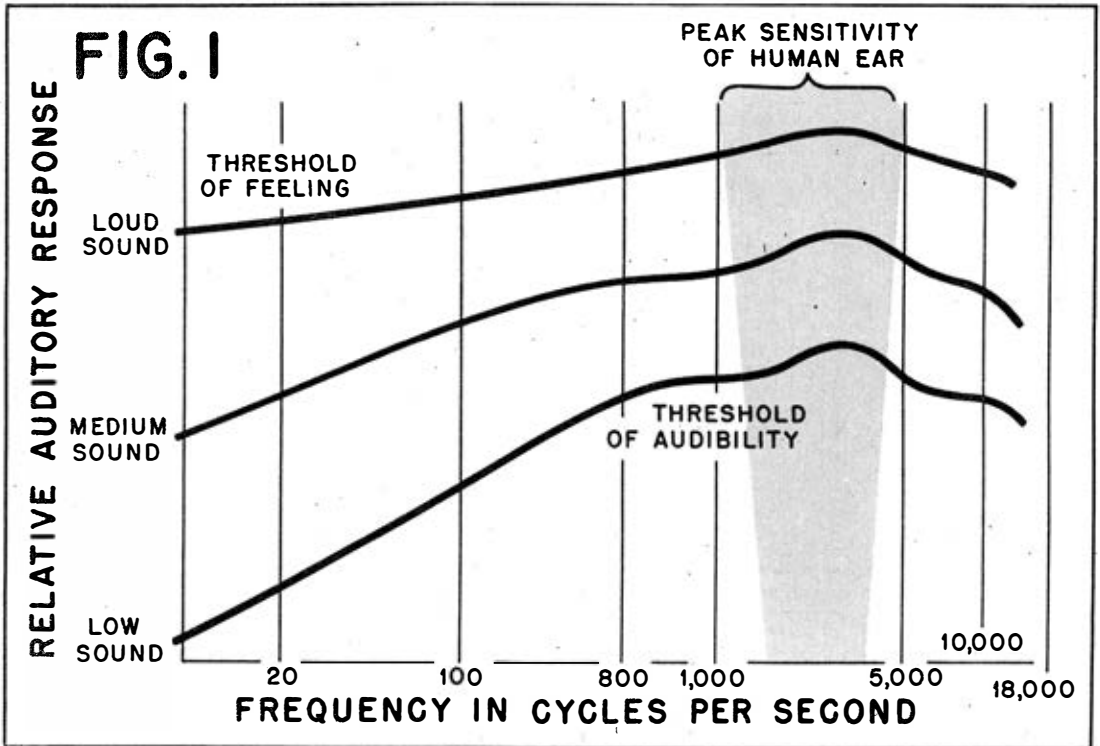

test of hi-fi system performance. This is not true, however, for speech and noise make equally stringent demands on the system.

When we speak of pitch, we refer to the relative position of a tone on the musical scale. In hi-fi work we often use a closely related term called *frequency*. This is the rate of the vibrations of which all sound is comprised.

Sound vibrations in air are actually variations in air pressure, both above and below normal atmospheric pressure. Each full movement of the pressure, from normal to the highest peak and back to normal, and then from normal to the lowest peak and back again, is called a *cycle*.

The number of cycles a sound wave goes through in a given period of time is known as the *frequency*. Since one second is

usually the period of time used, frequency is normally measured in terms of cycles per second, abbreviated cps. It is important to remember that, whenever you hear an audiophile speak of cycles, it's almost certain that he really means *cycles per second*.

The higher the musical pitch, then, the greater will be its number of vibrations in cycles per second. Middle A, for example, is 440 cps, while the low E string on the bass viol is pitched at about 41 cps, and the highest C on the piano is tuned to 4186 cps.

The differences in pitch between musical tones is known as an *interval*. While musicians often speak of intervals of thirds, fifths, ninths and such, a fairly important relationship to remember for hi-fi purposes is the *octave*.

This is the two-to-one ratio between

(TONES IN THE SCALE OF EQUAL TEMPERAMENT)

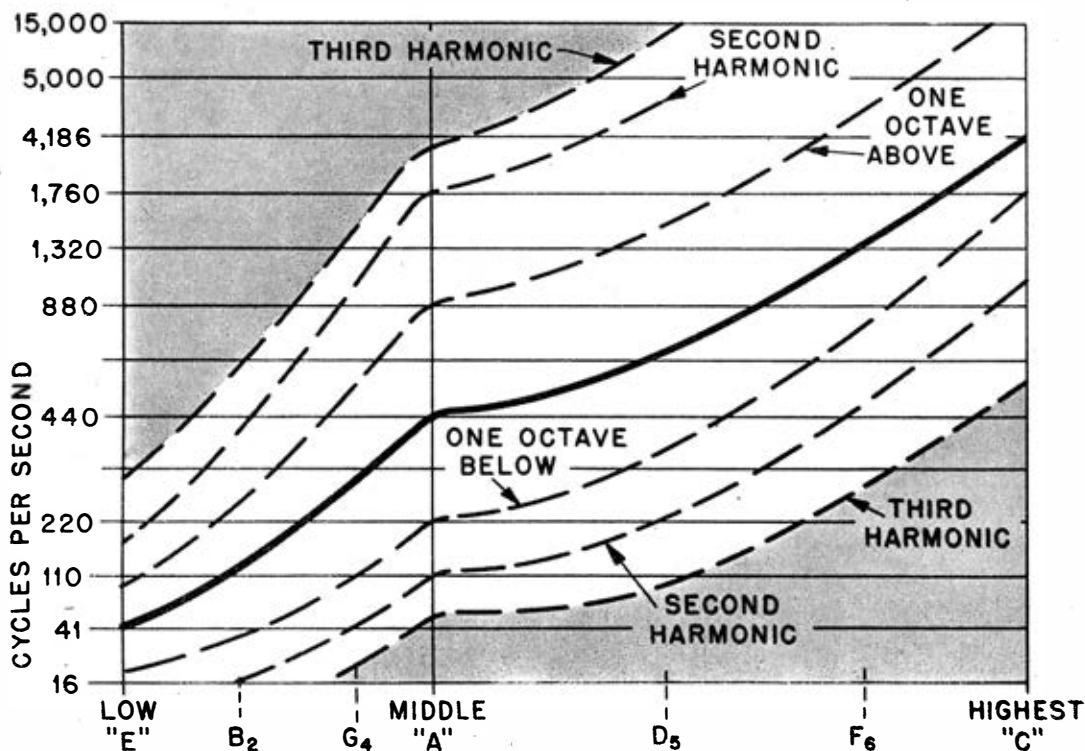

As shown above, although middle A, for instance, has frequency of 440 cps, the harmonics go three times as high and three times as low. See text for fuller explanation how this affects hi-fi equipment.

tones. Thus with middle A pitched at 440 cps, going up the scale to just twice the frequency, 880 cps, we find another A, this one said to be an octave above the first. Similarly, going down the scale to 220, we find another A below middle A. Each note on the scale, in fact, is separated from those of the same name adjacent to it by exactly twice the frequency, or one octave.

The lowest tone produced by any musical instrument is about 16 cps, while the highest is in the neighborhood of 5,000 cps. This is a span of about eight octaves. It would seem at first glance that a system capable of reproducing all of this eight-octave range should be quite adequate for sound reproduction. But the fact is that such a system would not be very high fidelity at all, as we shall see.

We all know that there is considerable difference in the sounds produced by the various instruments in an orchestra, even if all of them are playing the same note. If this were not so, there would be no point in having all those different voices.

But if G below middle C, for example,

is always 196 cps, then there must be still another factor determining the differences in the sound *timbre* or *tone quality*. The reason for this is that no instrument produces an absolutely pure tone. That is, when G is struck on the piano, there are several frequencies produced in addition to 196 cps, the *fundamental* frequency.

These extra vibrations are known as *overtones* or *harmonics*, and their frequencies are normally multiples of the fundamental. In other words, the important harmonics are two, three and more times the fundamental.

Now the main difference in the timbres of the instruments of the orchestra lies in the harmonics these instruments produce, and the relative strengths of each as compared to the fundamental. These characteristics will also often vary with even the same instrument. When the G string of the violin is bowed, for example, all of its harmonics up to the thirteenth are stronger than the 196-cps fundamental. The E string, on the other hand, has third, fifth and eighth harmonics about equal to



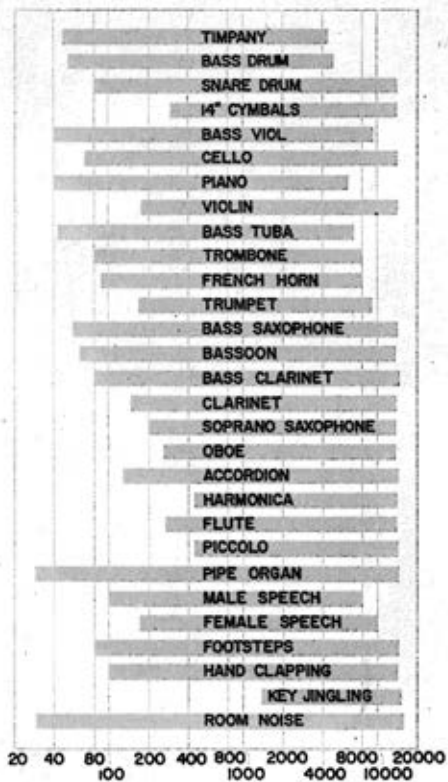

Frequency range of various instruments, human speech, etc. At right is drawing of piano scale.

the fundamental, while the others are less.

These facts are very important to us in hi-fi listening, for it is by these harmonics that we distinguish the characteristics of the various instruments. It has been shown experimentally, in fact, that the human ear must be able to hear at least up to the third harmonic of a tone to be able to identify the instrument producing it.

If we hear an instrument playing a middle A at 440 cps, for example, we will be unable to tell what instrument it is unless we can hear all the way to the third harmonic, or 1,320 cps. And this fact gives us a major clue to one of the important benchmarks of hi-fi system performance.

We have already noted that the highest fundamental frequency of any present musical instrument is about 5,000 cps. Then in order to hear the third harmonic of this tone, we require a system which is able to pass three times that figure, or up to around 15,000 cps.

So there we have it. A good hi-fi system must be able to pass the lowest musical note, about 16 cps, and the third har-

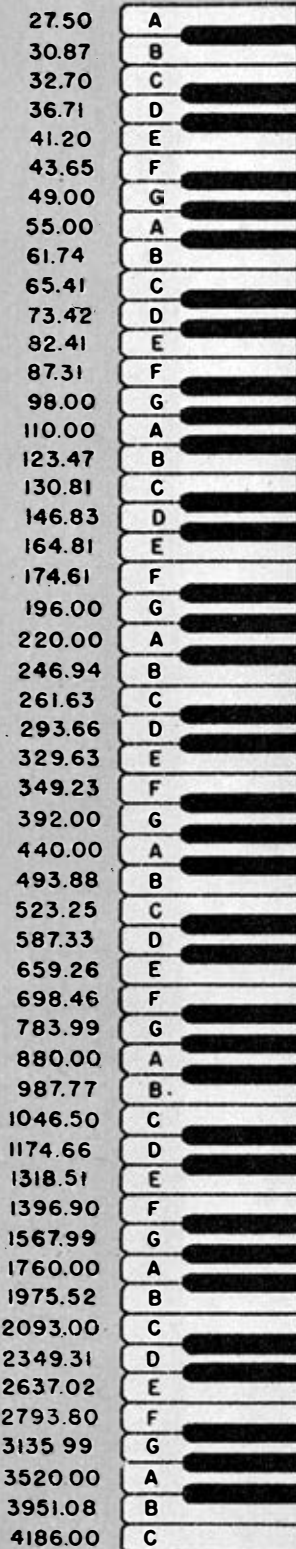

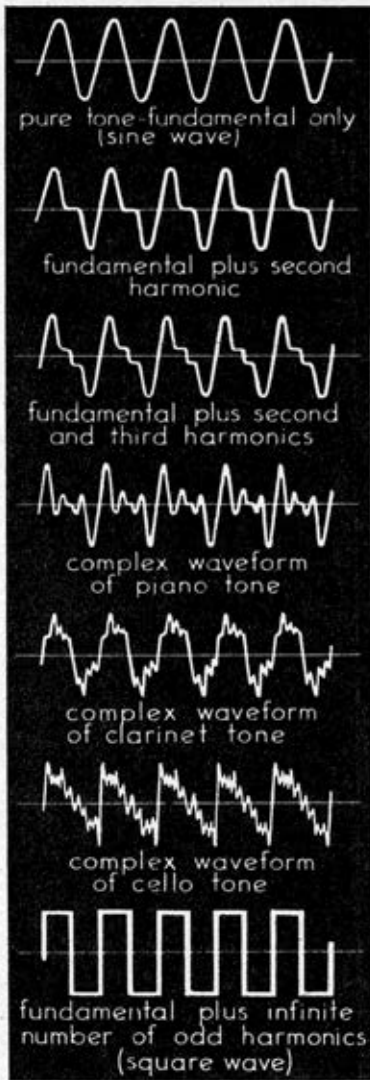

These vertical patterns are made by sound on the screen of an oscilloscope. Harmonic components of a tone give the quality of the individual instrument.



Modern jazz, trombones, trumpets, drums, etc., demands a full-range system for true fidelity.

monic of the highest musical note, or around 15,000 cps. And it also must be able to pass everything in between as well. The actual frequency range encompassed by the hi-fi system is known as its *frequency response*.

When the frequency response of a hi-fi system is spoken of as *flat*, this means that it does not alter the relative loudness of any of the tones within its range. If it does so, it, of course, changes the delicate relationship between harmonics and fundamentals of the instruments, and thus *distorts their quality*.

The loudness of a sound is its relatively high intensity as perceived by the human ear. Loudness is expressed in *decibels*, and is essentially a ratio of two acoustic powers. Thus we might say that the maximum loudness of a bass saxophone is about 8 decibels (*abbreviated db*) above that of a clarinet. Similarly, we might say

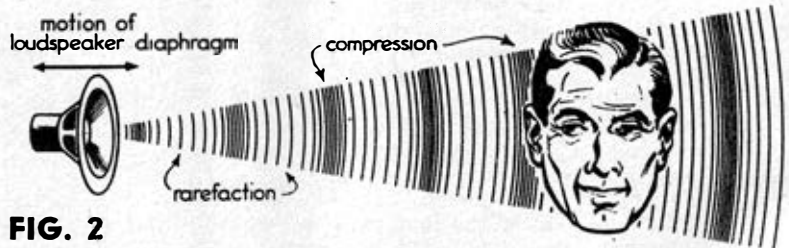
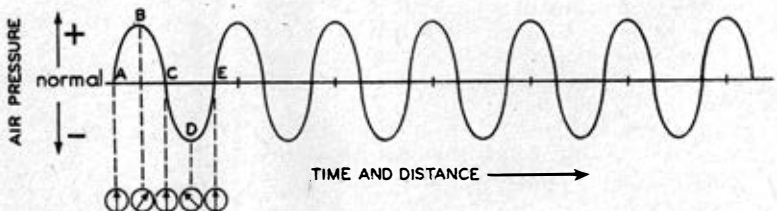

FIG. 2

Sound is caused by changes in air pressure. One ear in drawing is shown in compression area, and one ear in the air's rarefaction region.





that turning up the volume control on our hi-fi system has increased the output by, say, 5 db.

There is good reason for expressing loudness as a ratio rather than an absolute value. Suppose, for example, that by turning up the gain on a given amplifier we increase the output from 2 to 5 watts. This 3-watt increase is in a ratio of 2.5 to 1, or 4 db.

But if another amplifier is increased from 10 to 13 watts, the same 3-watt increase is in a ratio of 1.3 to 1, or barely over 1 db. The 4-db increase would be quite significant to the ear, while 1 db would probably be entirely unnoticed. It is therefore essential that we know our starting point before we can analyze intelligently any change in sound level.

The frequency range from 16 to 15,000 cps, which we established as minimum for hi-fi requirements, is also just about the

range of the average human ear. But oddly enough, the ear is nowhere nearly flat in its response. It is markedly more sensitive in the region around 3,500 cps, and much less so in the extreme bass and treble regions.

Furthermore, this response varies with the loudness of the sound. When the sound is extremely loud, for example, the midrange peak and the droops at either end are much less pronounced. This is shown in Fig. 1. Since the ear itself distorts in this fashion, it is sometimes difficult to understand the necessity for a perfectly "flat" hi-fi system.

The reason is that the system must do nothing to alter the relationship between the original sound and its effect on the ear. The fact that human hearing is not "flat" is of no serious consequence, so long as the sound reaching the ear is identical to that originally produced.

We don't actually have such perfection in hi-fi yet, as we observed in the previous chapter, but at least we have identified the target. From our knowledge of human hearing, we can conclude that the perfect hi-fi system would exhibit the four following basic characteristics:

1. The full frequency range of the human ear
2. The full loudness (dynamic) range of a symphony orchestra
3. Absolute freedom from distortion of any sort
4. Absolute freedom from extraneous noise

Point 1 is quite adequately fulfilled by today's systems. For the most part, this is also true of point 2. Point 3 still has a few percentage points to go yet before distortion reaches zero, while the noise condition, point 4, is reasonably good.

This graph shows how each ear responds if a sound of constant intensity is moved from front to back around the right side of listener's head.

FIG. 3

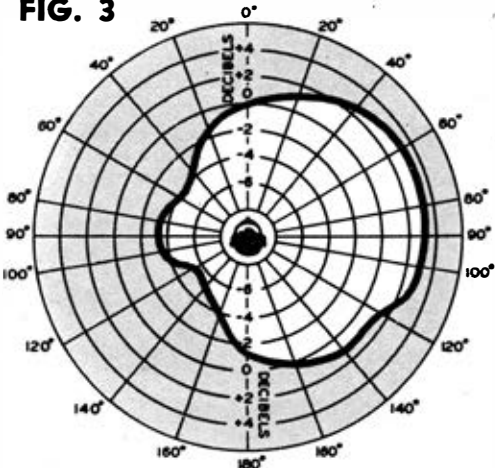

Photo below shows members of the Budapest String Quartet recording with guest artist Walter Trampler. Inset, Alexander Schneider, Boris Kroyt, and Joseph Roisman, listen to a playback of the tape. Performers are often among the most critical listeners.

Columbia Records



### The Stereo Story

Up to here in this chapter we have been referring to the human "ear," in the singular. Although this might be taken in the literary sense to mean the human hearing system collectively, in this case it would be better to take the term literally.

For the human hearing system actually comprises two ears, and the combination gives us still another characteristic known as *directivity*. Because we have two ears, we can tell the direction from which a sound is coming. This can be understood rather readily by reference to Fig. 2.

Now let's see what happens to you when you're within earshot of that speaker. The varying air pressures set up by the vibration of the speaker cone will push and pull against each of your ear drums. These vibrations in turn set in motion the complicated process of hearing which ends with your brain receiving the sensation of sound. Since your ear drums are separated by the width of your head, the sound must

travel different paths between the source and each ear.

In Fig. 2 you see that your right ear is closer to the speaker. Thus the sound will get to it before it reaches the left ear. This is so because your head is turned at an angle relative to the speaker.

Now remembering that distance traveled equals (rate  $\times$  time), let's see how that applies to the sound from the single speaker striking your ears. The rate—in this case the velocity of sound—will be constant. The distances will be different. Therefore the *times* will not be the same. In fact, we can generalize and say that, except for those circumstances when the sound is directly in front of or directly behind you, the arrival times of the sounds at the ears will *never* be the same.

This time differential is in turn responsible for a difference in *phase* of the sounds reaching each ear. Notice in the drawing that while the right ear is in a high pressure area, the left ear is in a low pressure trough. Since sound is a wave motion

## Sound Waves and Electrons



Baritone Leonard Warren is another exacting listener, one of the many artists who have hi-fi equipment. Stereo is his choice because it best captures the full range of voice and orchestra.

University Loudspeakers, Inc.



moving constantly outward from the source, in another instant the compression part of that wave will have moved on to your left ear, while your right ear will be in a rarefied area.

These differences in time and phase between sounds striking each ear will give your hearing system the clues it needs to estimate both the distance and direction of the sound source. You can get some idea of the ability of your ears to sense direction by referring to Fig. 3. This shows how each of your ears would respond if a sound of constant intensity were moved from front to back around the *right* side of your head.

The ear on the same side as the source—in this case the right—of course hears more. But the loudness of the sound does seem to vary as the sound moves around. The response of the ear is almost heart-shaped, with greatest sensitivity to sounds arriving from a little ahead of abeam, or about 75 degrees.

The opposite ear, naturally, hears most

when the sound is closest to it, which would be directly forward or behind.

These differences in directional responses of the ears are evidently due to the physical construction of the external parts of the ear and of the head. When combined with the differences in time and phase of sounds arriving at each ear, there is sufficient information for the brain to discern distance and direction.

This is strictly true, however, only at the higher frequencies. As we have already noted, the differences in time and phase becomes scarcely noticeable at the longer wavelengths around 300 cps and lower. Just what this fact means in terms of a hi-fi stereo system is still a matter of some controversy. One school of thought argues that two wide-range channels are not necessary, that the bass can all come from one loudspeaker since it is basically non-directional in character. Others say that it's a nice theory which doesn't prove out in practice. We'll examine both sides of this argument in Chapter 9. •

## Chapter 3

# Audio Sources . . . . . AM, FM, TV,



IT has become rather stylish in the past few years to have "a hi-fi" in the home, by which most people mean simply a souped-up version of a record player. But as we saw in Fig. 1 of Chapter 1, this notion is no more than 25 per cent accurate. Today the phonograph record is but one part of the group of hi-fi sources, the others being tape and radio, plus an additional bonus of TV audio.

Records still offer the greatest variety of music, of course, with the well-advertised advantage of "music you want when you want it." With an automatic changer you can stack up a dozen 45-rpm for a half-hour of continuous playing time, while ten 12-inch LP's will provide better than three hours of listening.

With the plain turntable, without a changer, you will have to manually change after each record. Since the playing time of a 12-inch 33-rpm disc runs from 20 to 30 minutes, this is no great chore. We'll

explore the relative merits of turntables and changers in the next chapter, so we'll hold that question open for the moment.

Music on tape can be either recorded by you, or purchased on prerecorded tape. Recorded tapes are usually copies of the same master tapes used for duplication of disc recordings. Since magnetic recording is inherently a better system, recorded tapes should theoretically be higher in quality than discs. But since the tape duplicating processes sometimes leave something to be desired, this advantage isn't always obtained.

The same general observation holds for the two types of radio broadcasting. Theoretically FM is the superior system. But with any broad statement of this sort, we have to qualify it with "all other things being equal." And they are not a ways that.

Far too often we find an entrenched AM operator running a little FM station as a

## Records and Tape



The greatest international performers, conductors and soloists, orchestras and singers, ranging from Bach to Sinatra, are today readily available to the hi-fi listener. Record and tape manufacturers, radio and TV programs, bring you these musical treasures—and you can enjoy them while sitting in your easy chair.

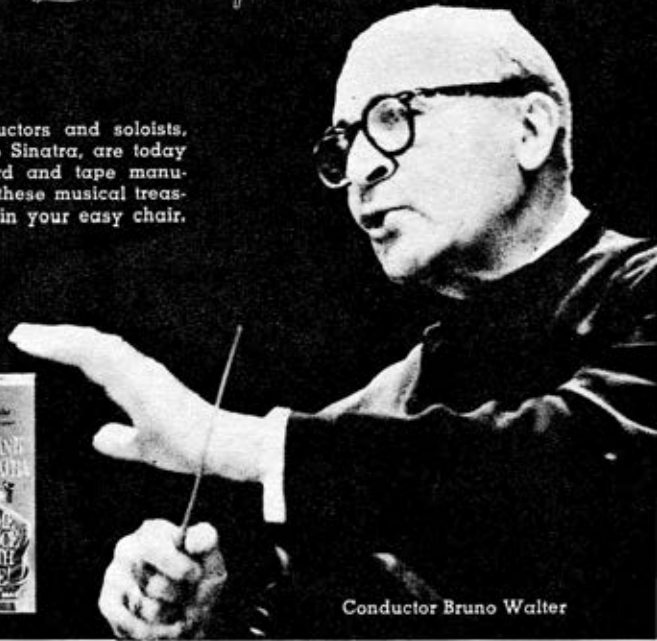

Conductor Bruno Walter

sideline, merely to maintain a franchise. And when a flea-power FM rig has to run in competition with an AM powerhouse, we needn't tell you who comes out on top. But FM at its best will still run rings around AM.

The audio portion of television broadcasts is also FM. This is not to say that you can pick up the TV audio with an ordinary FM broadcast receiver, but rather that the same general method of transmission is used. For certain technical reasons, the FM used for TV audio is not as high in quality as that in FM broadcasting, but it is certainly very much better than one would think from listening to the average TV set.

Most of the manufacturing cost of a TV receiver is assigned to the video portion, and the audio takes the leftovers, with skimpy circuitry and cheap speakers. If you haven't heard the audio part of the better TV shows reproduced through a hi-fi

system instead of the junky little TV audio system, you don't know what you're missing.

The transmission of sound over radio waves, whether they be AM, FM or TV, involves the superimposition of an audio wave, called the *modulation*, on the radio *carrier wave*. This modulated wave is transmitted through the air to the antenna of a radio or TV receiver.

In the tuner section of the radio or TV set the audio component of the signal is recovered by a process called *detection* or *demodulation*. The carrier wave's mission is now completed and it is discarded. The audio which remains is an electrical signal, very little different from that of a microphone, phono pickup or tape head. In other words, at this point it can be treated just as any other signal which is fed into the input of a hi-fi system.

The original modulation method employed by Dr. Lee DeForest is still the most



Making a record is an exact science. Elaborate mike setups are tested and re-tested. Photo, left, shows pianist Glenn Gould during recording session at the Columbia Record studios.



Left and below: Conductor George Szell, members of the Cleveland Orchestra, and violin soloist Zino Francescatti, making a record. Keeping in constant touch with control room, piece is rehearsed until conductor, soloist and producer are satisfied with results. Then taping begins for final recording.

Columbia Records photos







Full orchestra recording here is the New York Philharmonic, with Leonard Bernstein as piano soloist and conductor. Note novel seating plan.



Main console of Columbia Records' New York 30th Street studio control room. All sound is fed through here before going onto the tape machines.

widely used today. This is AM, the abbreviation for *amplitude modulation*. In this system the power output of the broadcast transmitter is alternately increased and decreased as the audio level varies. The power thus swings above and below its normal unmodulated value, the amount of these swings being determined by the intensity of the audio signal.

We must realize that, while it is theoretically possible for AM radio to meet hi-fi standards just as well as any other method, the fact is that in today's commercial broadcasting setup it doesn't do so. There are several reasons for this, some of them physical and some economic, but it was another characteristic of AM that Major Armstrong hoped to improve on when he advanced the idea of FM broadcasting.

Experimenters before him believed that "static" noise was inseparable from radio signals because the two are identical in character. It was this noise that Armstrong wanted to eliminate, and he devoted many years to the problem. His first efforts were concerned with receiver circuits, and while the famous superheterodyne circuit was among those which came out of these researches, the noise problem was still present.

Concluding that nothing more could be accomplished by working on the receiver alone, Armstrong then decided to consider the system as a whole, including both transmission and reception. If AM radio and static noise are so similar in character, he thought, perhaps some other method of modulation could be used which was *not* like static. From this line of reasoning came the system of FM radio broadcasting as we know it today.

It is easy to infer from its name that in FM the frequency is varied, rather than the amplitude or power of the carrier wave. The power, on the other hand, remains perfectly constant, regardless of the modulation. With a receiver which is insensitive to variations in amplitude—and this is essential—the FM system will provide substantially noise-free reception.

Since freedom from noise is one of the criteria for hi-fi, as we noted in the preceding chapter, this characteristic is certainly useful. And since dynamic range, another of our criteria, is also closely related to noise level, we are still another step closer to hi-fi radio broadcasting.

Frequency response and distortion, the other two objectives mentioned in Chapter 2, can be excellent with the FM system, as they can with AM. But in the case of FM, very high standards were legislated into



Columbia Records

Two tape machines are used to simultaneously record the program material. Tapes are then edited and spliced, giving one final master tape which becomes the basis of the commercial recording.

the system by the Federal Communications Commission, including a frequency range of 30 to 15,000 cps. With the exception of the bottom octave, this is about all we expect out of the best hi-fi systems today. But with FM we had this nearly a quarter-century ago.

The recording art was comparatively in the dark ages in those days, although it has recovered a lot of lost ground since then. Magnetic recording was still in the early experimental stages then, although it is, of course, now widely used, even in disc recording.

Today all original recordings, regardless of the ultimate form they are to take, are first made on magnetic tape or film. At the studio session, performances are recorded not just once, but many times over, and perhaps not completely, but in many short segments. The best complete tapes may be picked as the masters to be rerecorded to disc, but more often there are a couple of intermediate steps.

The first of these is editing of the tapes. The best parts of the many recorded tapes are physically cut out of the originals and spliced together to make a new composite master. Thus the performance on the final record is likely better than a live one, even by a gifted performer, because it is really a synthesis of the best of many of his performances.

The composite master, too, could serve as the original for the disc, but more and more often there is still another step: re-recording from tape to tape. The copy tape is not an exact duplicate, but instead a revised version of the original. The signal from the edited original is fed through special filters, equalizers and other control equipment. This permits changes in balance, timbre, dynamics, even changes in pitch. When all of the settings have been established and thoroughly rehearsed, a second tape recorder is started to take down the sound as revised.

When a finished tape is approved for mastering, it is then rerecorded onto a blank disc. A record cutting machine, along with its associated amplifying equipment, receives the sound from a tape reproducing machine and converts it into mechanical motion in an engraving stylus.

The blank recording disc is a plate of thin aluminum covered with a very smooth coating of black lacquer. One of the basic ingredients of this lacquer is cellulose nitrate, which is highly inflammable. For this reason cellulose acetate is usually used for non-professional applications, and from this all instantaneous disc recordings have come to be known as "acetates."

To record the maximum information in the smallest possible groove area, the frequency characteristics of the recording

From master tape, music is recorded onto lacquer disc. Photo shows sound grooves being cut into the lacquer master with help of special lathe.

Here is the "stamper" which presses the records. See drawing at bottom of page for the various steps involved to make a phono disc from tape.



RCA Victor



RCA Victor

ONE-STEP PROCESSING

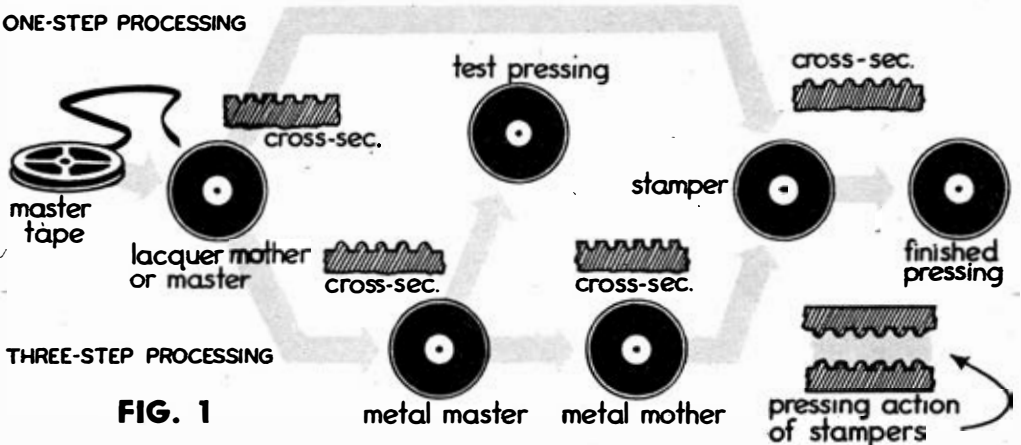

FIG. 1

Two methods, as explained in text, may be used for making a phonograph record.

system are deliberately misshapened by a process called "pre-equalization." This consists basically of two techniques. First, the high end of the audio range is increased in level with respect to the midrange, so that there will be a better ratio of recorded sound to high-frequency surface noise. Second, the powerful bass sounds are dropped down in level relative to the midrange, so they won't cause overcutting into adjacent grooves. Just how this is done in recording, and undone in reproduction, is described in Chapter 6.

An "acetate" which is intended for mass reproduction is known either as a lacquer

master or mother, depending upon the processing method. In either case an exact reproduction of it will appear on the finished record.

When the record arrives at the processing plant from the studios, it is removed from its special shipping container with all the gentle care accorded a newborn baby. It is first given a mild bath followed by a spray rinse. Next, the grooved side is coated with a thin film of silver by chemical means, in a process very similar to the silvering of glass for mirrors. The silver makes the record electrically conductive, and it can now be electroplated



NBC Television

Multiplex adaptor recovers 41,000 cps frequency which is superimposed on main FM channel in multiplex broadcasting. Drawings below show typical setup.

MULTIPLEXED FM SIGNAL

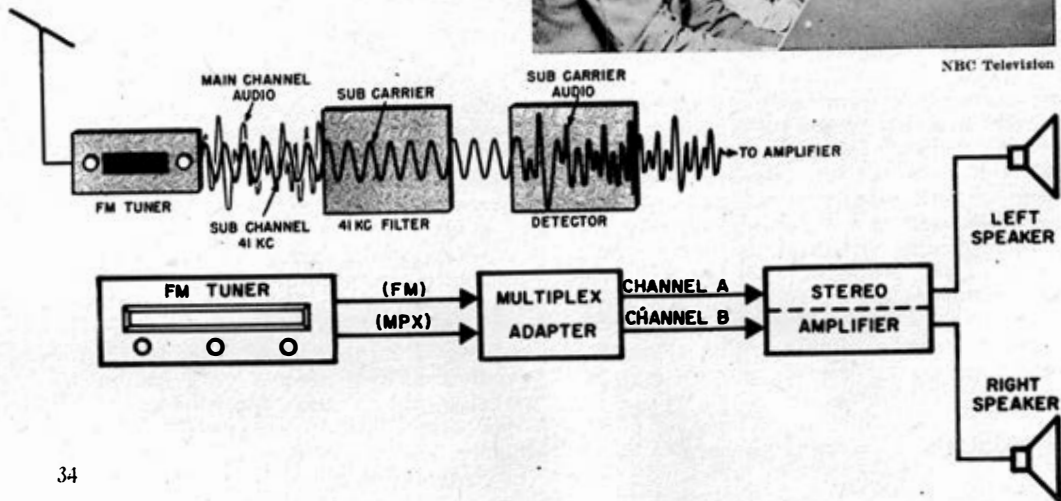



Radio Station WQXR

An announcer sits before two microphones in studio as the sound engineer prepares stereo tape for broadcasting. AM and FM is used here.

Left: Many audio problems had to be solved in the elaborate TV production of *Naughty Marietta*. Inset shows video, as well as sound engineers, keeping constant control of program's quality.



Columbia Records

Leonard Bernstein's TV musical programs have been largely responsible for the general public's growing acceptance of good classical music.

with a heavy layer of copper composition.

When the plating builds up to adequate thickness, it is stripped away from the lacquer, and what remains on the silver side is an exact negative impression of the original record, with ridges corresponding to the grooves in the lacquer. With a thin coating of chromium over the silver for durability, this metal negative may be used to press out finished records. When this is done the procedure is called one-step processing, as shown in Fig. 1, and the metal negative is known as a stamper.

In the older three-step processing method, this first metal part is called a master, and it is used as the source of a number of metal positive parts, called mothers. These second-generation parts are once again electroplated to form negative stampers.

The advantage of three-step processing obviously is the ability to get a large number of stampers out of an original recording. In the old days, when the original was cut on wax—and the wax destroyed in the process—the three-step method was an absolute necessity. Today, with the originals on tape, it is just as easy and about as cheap to cut a new lacquer from the tape. Since this cuts down the number of generations between original and pressing from five to three, obviously the quality is better in the one-step method. Although the three-step method is traditional and still widely used, the demands of hi-fi are rapidly forcing a conversion to one-step processing exclusively.

Home tape recordings are still rather more expensive than their disc counterparts, but the price gap, in terms of cents-per-minute of playing time, is constantly growing smaller. It is unlikely, however, that it will ever be possible to manufacture raw tape as cheaply as the few cents worth of plastic used in a disc, so there will have to be further economies in the more efficient utilization of the tape itself.

There are two ways of doing this. One is to use a slower tape speed, and the other is to put more separate tracks of music on the same width of tape. As we note in Chapter 10, the speed of tape has been dropping steadily from the original speed of 30 inches per second. Although passable recordings have been made at speeds as slow as 15/16 ips, today's hi-fi standard is 7½ ips.

While it was once customary to use all of the tape width for a single recording, improvements in tape formulations and in equipment have made it possible to record first two, then four separate tracks on a

View of typical broadcast studio, designed for the finest of sound reproduction. Today's radio listener gets concert-hall realism and fidelity from the many frequency modulation stations throughout the U.S.

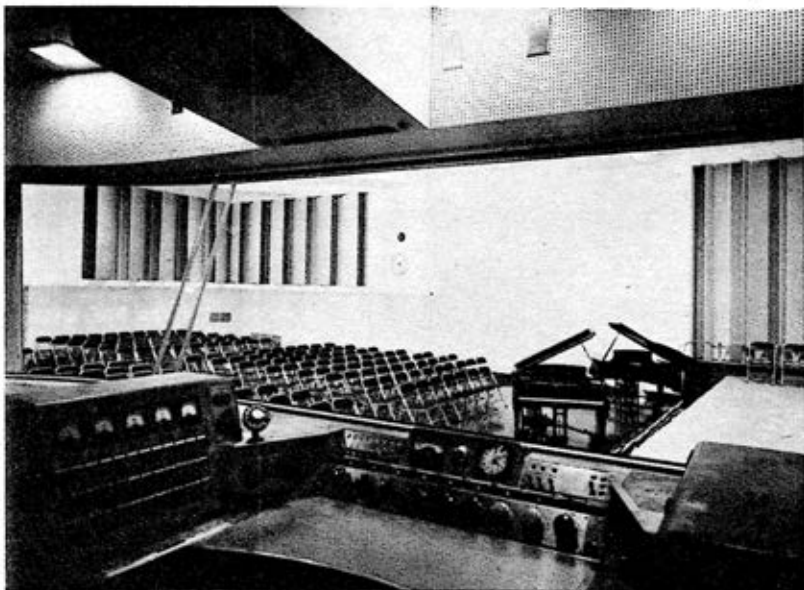

CBS Radio

single quarter-inch ribbon of tape. Four-track tape at  $7\frac{1}{2}$  ips has now been adopted by Magnetic Recording Industry Association as standard for stereo, about which we'll have more to say presently.

The final source of professional sound for your hi-fi system is television. It took a long time, but television producers have finally come to realize that the audio part of the TV show is just as important as the video, and they are paying a little more attention to getting decent sound on their shows. They aren't wholly to blame for the previous horrible condition of TV audio, because TV sets being what they are, any good sounds broadcast largely go to waste anyhow.

You can get around this shortcoming by taking the TV audio out of its straight-jacket in your TV set and feeding it into your hi-fi system. This is unfortunately easier said than done, as very few TV sets are connected with audio output jacks. Thus you'll have to do a little rewiring work yourself, or else have a service technician do it for you. The audio signal should be picked up at the output of the sound detector, and from there fed into the hi-fi input. With this arrangement, you'll be surprised at the results. It even makes the small screen picture look bigger!

### The Stereo Story

All of your hi-fi sources are now capable of stereo, and three out of the four are

delivering it rather regularly. Although TV is as capable of stereo as AM or FM, it is seldom done. And with the problems the television industry is having in getting color off the ground, it isn't likely we'll be hearing much TV stereo for awhile.

The simplest means of accomplishing 2-channel stereo transmission by means of radio waves is simply to use two separate stations, one for the right channel, the other for the left. Whether the two stations use the same system of transmission or not is of no importance. If they are the same, we could have any of three combinations: AM-AM, FM-FM, or TV-TV. In any case, we would need two separate tuners of the same type, one for each channel.

Not many of us are so equipped, but most of us have at least one each of the AM, FM and TV types. Then we could easily listen to stereocasts which were AM-FM, AM-TV, or FM-TV. All of these combinations have been tried, but the only one presently being used to any extent is AM-FM. Many cities have broadcasters airing stereocasts by this method on a regular schedule.

The newest method of stereocasting, which shows great promise, uses only one station in a system known as *multiplex*. In this arrangement, a conventional modulator at the transmitter superimposes an audio signal on the carrier in the usual way. At the same time, a supersonic frequency is imposed on the carrier, and audio in turn superimposed on that as well. Thus

## Audio Sources . . . . AM, FM, TV, Records and Tape



the supersonic signal acts as a sub-carrier for the second audio signal.

An FM version of this multiplex system has been known for quite a few years, and quite recently a similar AM system was developed. Some of the better hi-fi FM tuners have a multiplex detection circuit included, and as more becomes known about AM multiplex, presumably there will be equipment available for that, too. Multiplex adapters are also on the market, which are simply plugged into any existing FM tuner, and permit immediate reception of stereocasts.

As we have already noted, magnetic tape is ideally suited to stereo recording, because it can readily accommodate two or more channels. With dual-track monophonic tape, as shown in Fig. 2(A), the tape is first recorded along half of its width in one direction, and then along the other half in the other direction. This gives just double the playing time for the same length of tape.

With two-channel stereo, those same two tracks are recorded simultaneously, with each track getting one of the stereo channels. This is shown in Fig. 2(B), where we see that one-way stereo is nearly identical to two-way monophonic, with only a slight difference in the dimensions of the

tracks to gain better channel separation.

The trouble with the one-way stereo system is that it wipes out the double-time advantage of two-way monophonic. And the only way to get it back is either to cut the tape speed in half, or record two tracks in *each* direction, for a total of four separate tracks. Two such four-track systems are in use today, and their arrangement is shown in Fig. 2(C) and (D). The arrangement at (D) has now been adopted as standard by Magnetic Recording Industry Association, and most of the major recorder companies now make machines of this type. These manufacturers include Ampex, Bell, Viking, Pentron, Magnecord and Revere.

The stereo disc is now firmly entrenched, to complete our list of stereo sources. Since the record groove is in the shape of a V, it has two sides or walls. The two-channel stereo disc thus has essentially one channel of information engraved on each groove wall. Just how this is accomplished, and what demands it places on the reproducing equipment will be explained in Chapters 5 and 6.

But neither tape nor disc can be played until it is set into motion. A discussion of the devices which accomplish this is next on the agenda. •

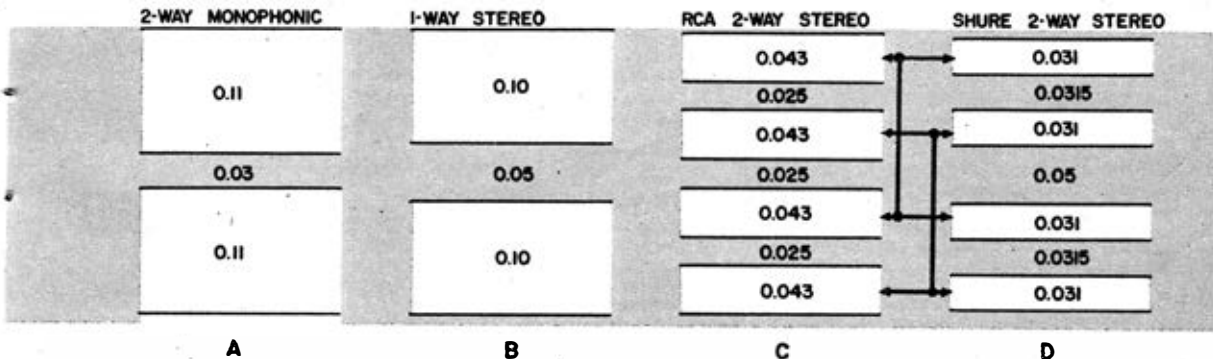

FIG. 2, above, shows in schematic form one piece of tape and what happens to it when exposed to the various head configurations of the different systems. See text for fuller explanation of this subject.

# Chapter 4

## Turntables and Changers



Garrard 4-speed turntable has 12" steel disc, push buttons for automatic trip mechanism. Price: from \$60 to \$90, depending on cartridge used.



MK II, by Garrard, table and arm, comes with interchangeable plug-in heads, 45-rpm adaptor, 4-pole motor. Arm is aluminum, turntable is made of steel.

**T**HE wiggles in a record groove, or the millions of tiny magnets on a piece of tape, will leap to life and provide sound for our loudspeakers only after they have been set in motion. In the original recording of both discs and tapes, there is mechanical movement of the recording medium. This movement must be recreated in the home before these records will speak back to us.

Because of their primary requirement of very close speed regulation, phono drive mechanisms have developed closely along the lines first established for clocks and timepieces. Even today, clocks are driven by either of three types of mechanisms: weights, springs, or electric motors. And all of these have been used in recording. The newest method of telling time, the atomic clock, is still confined to advanced research laboratories, but perhaps in time to come that, too, will find its way into home hi-fi systems. Who knows?

In the early days of acoustical disc

recording, when the record groove was engraved in a thick slab of wax, the mechanism which kept that wax rotating was a heavy, slowly descending weight, similar in principle to those in a grandfather's clock. In the home, the earliest machines were simply hand cranked, but soon the spring-wound motor took over, again much like those in clocks.

Later, clocks were introduced using the *telechron* principle, in which a self-starting AC motor runs in exact synchronism with a central-station generator. This principle is used in all electric clocks today—and in all turntables, record changers and tape transports as well.

Thus the speed of rotation of an electric power generator, at a central station possibly many miles away from your home, is the sole determining factor of the rotational speed of the motors in your hi-fi equipment. Electric motors which follow in step with generators are called *synchronous*, and it is nothing more than a happy





Garrard 301 "Professional" has cast aluminum turntable, variable speed control, resistor-condenser network to eliminate motor shutoff noise.

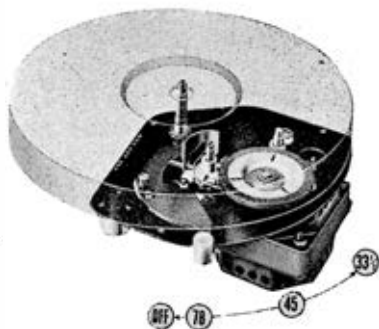

General Industries' DSS, shown here in cutaway view, has 10-inch turntable, 45-rpm adaptor, radially operated shift lever, oilless bearings.

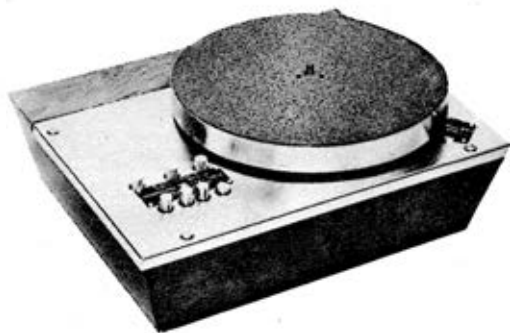

H. H. Scott comes with push-button speed selector, built-in stroboscope, aluminum-cast turntable. Rumble, wow and flutter are well below audability.



Rek-O-Kut B-12GH, hysteresis-motor turntable, has lathe-turned cast aluminum table, built-in strobe disc, sells for \$99.95, without tone arm or base.

coincidence that we are able to use them in hi-fi equipment.

For the speed of the generator determines the frequency of the AC voltage on a power line, and the electric power companies maintain this frequency exceedingly constant, for reasons which have nothing to do with hi-fi. It just happens that the generation and transmission of electric power is most economical when the frequency is held constant, and the power plants maintain this constancy through the use of exceedingly accurate master clocks. So once again we see what a debt the hi-fi art owes the science of horology.

Although all electric motors used in hi-fi applications are of the synchronous type, there are several categories within this type with which the audiophile should be familiar. (See Fig. 1). The first of these is the two-pole type, and the most important thing for the hi-fi fan to remember is NOT to use it. But since the other motors

evolved from it, we'll spend a little time in an analogy which will show the two-pole disadvantages, and the advantages of the more refined types.

To understand something of the operation of the two-pole motor, think of a seesaw, the fancier type which will rotate on a central pivot as well as go up and down. Now suppose that you and I stand on the ground at opposite ends of the board, giving it a push to swing it around in a circle. Every time either end moves past us, we each give it another push to keep up the motion. Then the board gets a new push every half revolution, while its own momentum carries it the rest of the way. Such a motion would obviously be one of spurts and slowing down, which in hi-fi language spells *wow*.

Suppose now that we add a second board at right angles to the first to form a cross, or a huge + sign. And suppose we have two companions at the ends of that board to help us with the spinning. Now the



N-33H by Rek-O-Kut comes with hysteresis motor, aluminum deck, belt drive 33 $\frac{1}{3}$  rpm speed. Noise is 53 db below recording level. Sells for \$69.95.



A synchronous hysteresis motor is featured in the Rek-O-Kut B-12H. Noise level is 57 db below recording level; \$129.95, less arm and base.

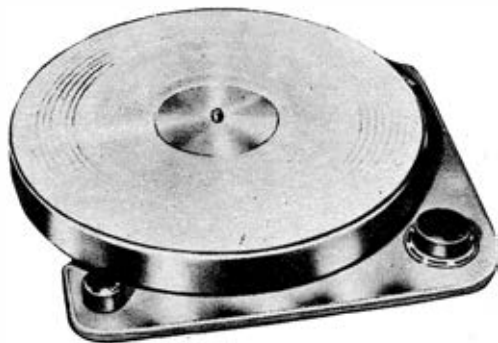

Lafayette 4-speed turntable sells for \$37.50, has 3 lb. aluminum table, 4-pole motor. Noise and rumble is 50 db below average recorded level.

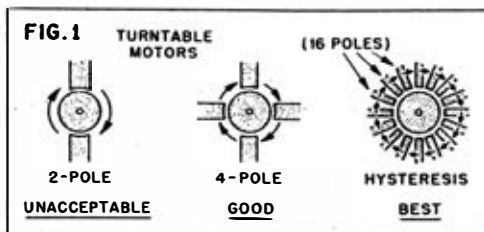

boards get a new push every quarter turn, as each one of us applies new force to each end as it comes by. The motion will now be very much smoother, just as it will in the four-pole turntable motor as compared with the two-pole variety. The four-pole motor is standard equipment on all medium-priced hi-fi equipment, and you shouldn't settle for less.

We can add even more poles to the motor, ultimately coming to the hysteresis synchronous type, which may have 16 poles. Although the four-pole type is probably the most widely used motor in hi-fi, it does generate some noise in the 30-60 cps range, the important second octave in the bass region. This low-frequency noise, known as *rumble*, is measurably reduced by the use of a hysteresis motor in place of the four-pole type.

In the Rek-O-Kut Rondine line, for example, tables which are otherwise identical show that the hysteresis model has 7 db less noise than the comparable four-pole type. It should also be noted, however, that the use of the hysteresis motor also involves an increase of about 50 per cent in initial cost. The hi-fi fan must therefore

Drawing below shows one big disadvantage of record changer as compared to manual turntable. For best results arm should be parallel to disc.

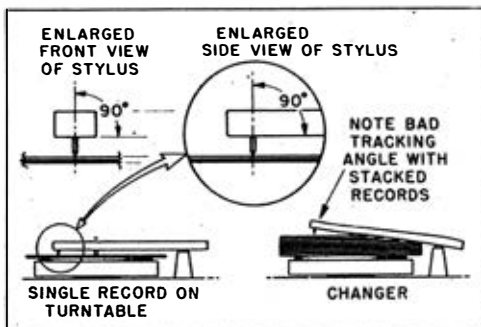

decide whether 7 db less noise is worth half again as much money.

The speed of the motors used for hi-fi often is in the vicinity of 1,800 rpm. This represents about the best compromise for efficiency, smoothness of operation, and adequate cooling. For turntables operating at two, three or four different speeds, it is obvious that changing speeds of the motor would involve even further compromises. Such a motor might be subject to overheating, vibration or poor speed regulation. The better approach to multispeed turntable operation is one where the motor speed is kept constant, while the turntable speed is varied by adjusting the power linkage between motor and table.

Thus there must be some sort of intermediate power linkage between the motor and table, rather than a direct connection between the motor shaft and the turntable spindle. Even the so-called direct-drive turntables are not actually that, as they have a set of step-down gears and mechanical vibration filters between the motor shaft and the table shaft.

Direct-drive systems used to be popular in commercial practice. They are quite good, provided their components are machined throughout to an exceedingly high degree of precision. The primary advantage of such a system, if any, is that it is probably better able to withstand the wear and tear of heavy-duty service, as in broadcast stations, film studios and wire music services. But you will never be subjecting your equipment to such abuse, and so the expense of such a system is unwarranted.

The problem of an inexpensive power linkage, which at the same time meets the requirements of smoothness and quietness, is neatly solved by the friction drive system. This is the one used most extensively in present hi-fi systems. It is a completely gearless method, in which a smooth motor pulley turns against a smooth rubber idler wheel, or idler, which in turn bears against the turntable rim, on either the inside or the outside.

When properly designed and built, this system will perform every bit as well as the most expensive direct-drive assemblies. And it can be purchased at a much more reasonable price, simply because there are fewer precision parts. The rubber idler may in time acquire flat spots, or generally become worn, but it can be replaced easily and inexpensively.

The table itself, if properly designed, can assist in the smooth rotational movement, by acting as a flywheel and opposing any



**Argonne Model AR-340 is a single-speed 33½ rpm turntable with hysteresis motor, has die-cast aluminum turntable, comes with a rubber disc mat.**



**Miraphon XMS-210 4-speed player costs \$47.50, has 4-pole motor, plug-in cartridge heads and automatic shutoff at the end of photo record.**



**Bogen-Presto T-3 operates at 33½ rpm with endless belt drive system. It has a built-in strobe disc for checking of speed. Price, less arm, \$59.95.**



Lafayette 4-speed hysteresis turntable with 16-pole motor. The 12-inch aluminum table weighs 4 lbs.; rumble and noise is 50 db below average.

tendency toward speed fluctuation. A cheap turntable is simply a flanged disc stamped out of a piece of sheet metal. But a really good table is made of a heavy casting, precisely machined for perfect balance and smooth fit of its moving parts.

Since many hi-fi phono pickups operate on magnetic principles, the table should be made of nonmagnetic material such as aluminum or brass. When the pickup tracks a record, it is separated from the metal table only by the thickness of the mat, the record, and the length of the stylus, a fraction of an inch at best. Laying this close to the metal table, the magnetic pickup operation would be very seriously affected by magnetic fields in the table. Furthermore, the magnetism of the cartridge is attracted by a steel table to such an extent that the stylus pressure is increased markedly and the record wear correspondingly increased.

The record changer is a turntable which changes its own records. Only it isn't that simple. The record changer is actually a very complicated piece of machinery, the underside of which looks like one of Rube Goldberg's wildest inventions.

Juke box designers have concocted a wide assortment of changer mechanisms, but nearly all of the changers for home use are some version of the drop mechanism type, in which a stack of records is supported several inches directly above the turntable, and the records dealt one by one off the bottom and onto the table. The drop mechanism is usually some variation of the pusher platform, with the stack supported at two points, by a fixed platform at the edge and by an offset in the

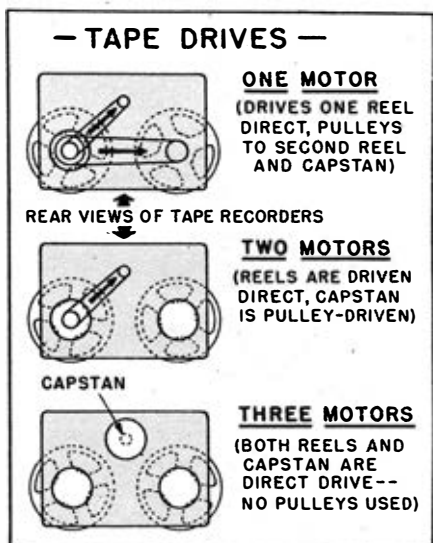

Drawings above show typical arrangements of motors on tape recorders. As can be seen, the 3-motor recorder is best, but most expensive.

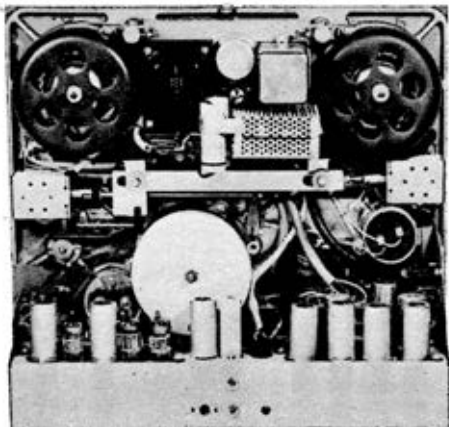

Strobe disc made by Irish Tapes is used to check on speed of your recorder when viewed under 60-cycle lamp. Strobe wheel is held against tape.

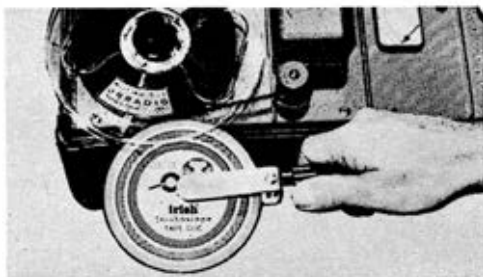

Left: Rear view of American Concertone Series 60 model with direct hysteresis-motor tape drive for great timing accuracy. No belts or gears are used.

center spindle. When the next record is called for, a small arm in the outer platform pushes the edge of the bottom record sideways until it, like Humpty Dumpty, falls off the edge and slides down the spindle.

Some changers provide such additional features as a muting which kills the audio during the changing process, and an automatic stop switch which turns off the changer power after the last record has finished playing. These automatic conveniences are very handy, but they must be paid for in terms of increased record wear, perhaps even record damage. All changers have at least some of the following disadvantages:

1. Abrasion between grooved surfaces when records are dealt off the stack.
2. Nicks in the center holes or edges, caused by the platforms.
3. Wear on the center hole, since the spindle remains stationary during playing.
4. Change of stylus angle with respect to the record groove as the stack of records on the table varies in height.
5. Possible sacrifice of motor smoothness in favor of power to operate changer mechanism.
6. Slippage of the record when on a stack rather than on a mat.
7. Slowing down of turntable as weight of stack increases.
8. Excessive groove wear at inner section of record, as sub-chassis extension of tone arm bears against pawl and ratchet mechanism.
9. Exceedingly difficult maintenance and adjustment.

The big advantage of the record changer is, of course, its great convenience. This is undeniable, and many hi-fi afficiandos feel that this one advantage outweighs all the disadvantages. Whether or not you

agree is strictly a matter of personal choice.

Unlike the turntable, but more like the changer, the transport mechanism in a tape machine is fairly complex. This is true because of the several functions which the mechanism must perform. Not only must the tape be moved past the heads at a constant speed, but it must also bear against those heads accurately, must play out of the supply reel smoothly, and must be reeled in on the takeup side after passing the heads. And when playing or recording is finished, it must be rewound from the takeup reel back to the supply reel.

These functions are best performed by three separate motors, one on each reel and a third on the transport itself. Although this is the best arrangement, and invariably found on professional equipment, it is all too seldom found in home hi-fi gear. But when one or two motors are required to do the job which should logically be assigned to three, the sub-chassis of the tape machine is a mechanical nightmare, and performance will be less than the best.

The types of motors used are the same as those found in turntables, hysteresis synchronous being the best, and four-pole motors being used more commonly because they are cheaper. Both idle-wheel and belt drives are used, with belts probably in the majority.

In a turntable the motion is imparted to the disc by friction. The disc and table move as one, while the cartridge moves across the face of the record in scanning the grooves. But in a tape machine the head does the scanning, and the head remains stationary. Thus fresh tape must be pulled continuously across the head.

The special tape pulling mechanism is known as capstan drive. The tape winds partly around the revolving capstan, while a pressure roller squeezes the tape against

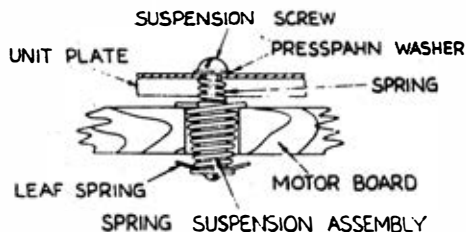

Careful engineering is extremely important to obtain good performance from automatic changers. Above, left, is template included with Garrard changers for checking accuracy of critical spindle angle. Right, spring suspension method used to isolate the Garrard and similar units from shock and vibration.



Shown on this page are: 1 and 2, Garrard RC 98 changer, \$67.50, minus cartridge, and underside view of mechanism. Automatic changers are very complicated pieces of machinery, must be precision-engineered to perform their many functions smoothly and without impeding the sound reproduction; 3. Garrard RC 88, 4-speed automatic and manual player is wired for stereo, sells at \$54.50, without cartridge, incorporates accurate speed control; 4. Garrard RC 121 automatic 4-speed changer is this company's economy model; 5. Voice of Music player comes with ceramic stereo cartridge, plays four speeds, will handle records of all sizes. Magnetic stereo pickup is also available; 6. Miracord XS-200 is priced at \$67.50, has 10-inch table, push-button control, plays all four speeds, comes with 4-pole motor; 7. Glaser-Steers GS-77 features stereo wiring, permits stacked records of various speeds and size. It comes with 4-pole motor, sells for \$59.50; cartridge is extra; 8. United Audio Dual-1006 changer intermixes records, has four speeds with push-button control. The unit is wired for stereo cartridges and comes with a built-in gauge for measuring of stylus pressure. Prices of all models shown do not include base.



the capstan to ensure adequate traction. The capstan is usually a precisely machined metal shaft and the roller is a rubber puck which very much resembles the idle wheel on a turntable. Rubber has been used for the capstan, too, but the wow and flutter are too great for hi-fi reproduction.

While the phono turntable itself acts as a flywheel to damp out speed irregularities, the tape capstan is so small that the addition of a flywheel is essential. This is made a part of the capstan shaft, out of view below the mechanism chassis.

The speed of both turntables and tape mechanism is checked by making use of the stroboscopic effect, in which a flickering light can make a moving object appear to be standing still. Once again we use the steady frequency of the AC power line as our reference. With conventional 60-cycle mains, electric lights actually flick on and off 120 times each second, once for each alternation of the current.

This flicker rate is too fast for the eye to see normally, but it shows up in the case of rapidly moving objects. Ordinary light bulbs, which are incandescent, actually

## Turntables and Changers

only grow brighter and dimmer, because of a thermal lag. But gas tubes, such as fluorescent or neon, do actually extinguish twice each cycle. Thus these types are best for speed checking.

The basic idea of the stroboscopic effect is simply this: if a moving object happens always to be in the same place when it is illuminated by a rapidly flickering light, then it will appear to be there constantly. We don't actually see it when it is anywhere else, because the light is off. With the proper flicker rate, we can even make the treacherously spinning teeth of the buzz saw look like they are standing still. But just put a piece of wood against them and see what happens!

In speed checking on discs and tape, we use the motion of alternate black and white segments, or of black dots, as an indicator. Many turntables now have stroboscopes built in. For those that don't, it is a simple matter to get a separate disc and place it on the turntable, just like a record. When the segments or dots appear to be standing still when under the proper neon illumination, then the table is operating at correct speed. But if they appear to be creeping forward or back, then the table is off speed.

Since there are several power frequencies still in use in this country, including 25, 50 and 60 cycles, and since there are at least four record speeds, the stroboscope disc which allows for all of these eventualities may have up to a dozen different bands of segments on it. But since any given record has only one speed, and since it is the speed of the record itself in which we're interested anyway, one wonders why the record manufacturers don't all imprint stroboscopic patterns right on their labels.

This principle is followed in the stroboscope tape, in which the segments are imprinted right on the tape backing. The "tiger tape" used by amateur cinematographers for synchronizing movie projectors to tape recorders can't be used for accurate speed checking, however, because its segments are geared to the flickers set up by the projector shutter, which are not the same as those from an AC power line.



Another means of checking tape speed is the stroboscopic disc, which is held against the moving tape or capstan. Irish Tape makes such a gadget, which is segmented for the three most popular tape speeds. The idea was first used at RCA Victor in 1950, and it really works.

### The Stereo Story

Stereo imposes no new requirements on the tape transport, and any mechanism which is good for monophonic tapes will be just as good for stereo. But this is not necessarily true for the turntable or changer. The biggest difference is in the new limitations on noise or rumble.

Previously the phono cartridge was not required to respond to motion in the vertical direction. In fact, it was purposely made insensitive to vertical movement. But as we shall see in the next chapter, the stereo cartridge must respond to both vertical and lateral movement.

Now suddenly vertical rumble, which has been virtually ignored in the past, becomes a serious factor. This means that, when considering purchase of a turntable, one must be sure that the noise figures claimed by the manufacturer are for stereo conditions. The signal-to-noise figure as registered by a conventional lateral pickup may be quite different from that with a stereo pickup.

Since a lot of idle-wheel tables can't measure up, there has been renewed interest in belt drive as the linkage between motor and table. In this case an endless belt wraps around the motor shaft and the outer rim of the turntable, or a sub-chassis drum attached to the turntable shaft. Although the belt drive is often less attractive in appearance than the idler type, all things being equal, the belt in many cases is the quieter of the two. •



## Chapter 5

# Stylus, Cartridge and Arm



Careful attention to manufacturer's instruction must be paid when installing cartridge in head. Hum and noise in a system are often due to error in grounding and wrong wiring of cartridge.

**W**HEN disc or tape recordings have been properly set into motion, the next step is reconverting the wiggles in a groove or the magnetism on a tape, first into electrical voltages, and ultimately into hi-fi sound. Part of the electrical job is accomplished in disc reproduction through the combination of the stylus, cartridge and tone arm. With tape, it is done by one element, the reproduce head.

All hi-fi styli today are made of some sort of precious or semiprecious stone. The diamond has for some years been promoted as the ideal stylus material because of its hardness. It should wear longer than sapphire, its leading competitor, and it is almost impossible to break under normal use. But the advantages of diamond styli are not so overwhelming as popularly supposed.

Because of its hardness, the smooth ball tip which the diamond stylus must have is not always very easy to achieve. The purchase of a diamond stylus is no guaran-

tee of perfection, as there have been such styli marketed with needle-sharp points which cut their own grooves in records. Others are so badly polished that they give the groove walls a rough scraping at every pass.

With the stylus forces commonly used today—upward of 6 grams—a high-quality diamond is the only stylus to use. But any diamond has a crystalline structure which, no matter how it is cut, will show some end grain, just like the roughness at the end of a wooden board. This grain can be seen clearly under a microscope.

A sapphire tip, on the other hand, can be given a mirror sheen, much smoother than anything possible with a diamond. This is accomplished by flame-polishing, where heat causes the surface of the jewel to glaze. The problem now is the practical matter of taking advantage of this tip smoothness.

The only way this can be done safely is through the use of a very low stylus force,



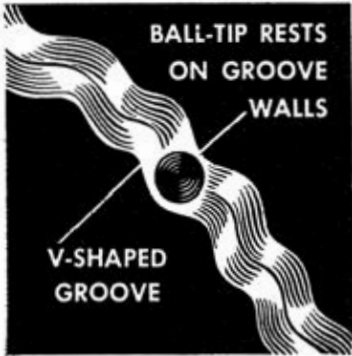

A GOOD NEEDLE FUNCTIONS SMOOTHLY

Graphic demonstration is given in these two drawings of what happens when a stylus tip is worn and how a new, smooth diamond tip rests on the groove walls of record.

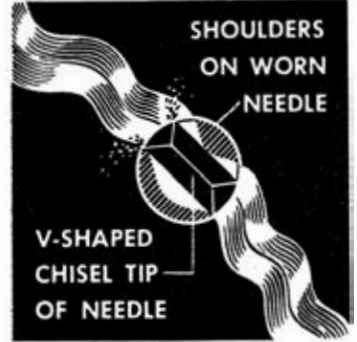

A WORN NEEDLE SHOULD BE REPLACED

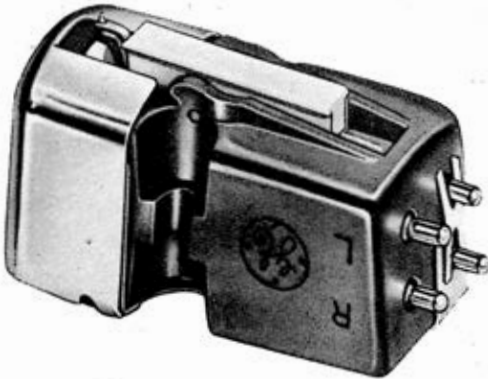

General Electric stereo-magnetic cartridge has .5 or .7 mil diamond stylus. Response is 20-20,000 cps  $\pm$  3 db for the .5 mil; pressure: 2 to 4 grams.

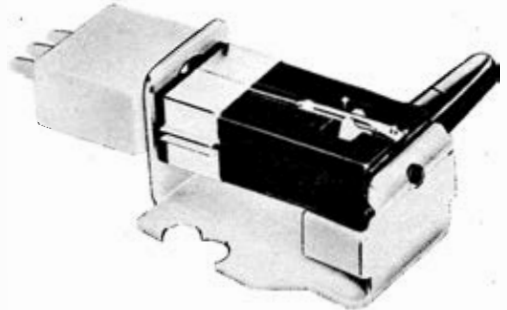

Electro-Voice Series 20 stereo model is priced at \$15 for the single-diamond stylus cartridge. Diamond stylus replacement is \$7.50; sapphire, \$2.50.

of two grams or less. We were very close to such forces with commercial pickups, when stereo came along and kicked them upstairs again. As we will see, stereo tracking forces are considerably greater than those for monophonic cartridges, but when the time comes—if ever—that we get consistently good tracking at less than two grams, then perhaps the sapphire will come into its own.

If sapphire can be polished much more smoothly than diamond, then the only question remaining concerns wear. And exhaustive tests at Electro-Sonic laboratories over thousands of hours at these low tracking forces have shown *no sapphire wear at all*.

Even the hard diamond can't make such a claim under today's usual operating conditions, and so your stylus should be inspected periodically for wear. Rather strong claims have been made for diamond wear, with the safe period varying from 500 all the way up to 2,000 hours. Since

Audiogersh monaural model is turnover type, has 30-19,500 cps  $\pm$  4 db response, 55 mv output at 1,000 cps.

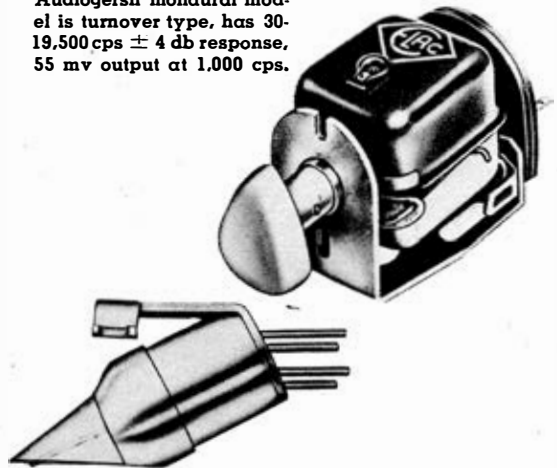

Stereodyne cartridge made by Dynaco Inc., is designed to fit into tone arm developed by this company.

Audiogersh Corporation makes the two Stereotwin cartridges shown below. Both have .7 mil diamond styli, 30-18,500 cps  $\pm$  2 db response, 25 mv output at 1,000 cycles. Cross talk is below -20 db.

Shure Custom stereo Dynetic has 20-15,000 response, .7 mil stylus tip, tracks at 4 grams.

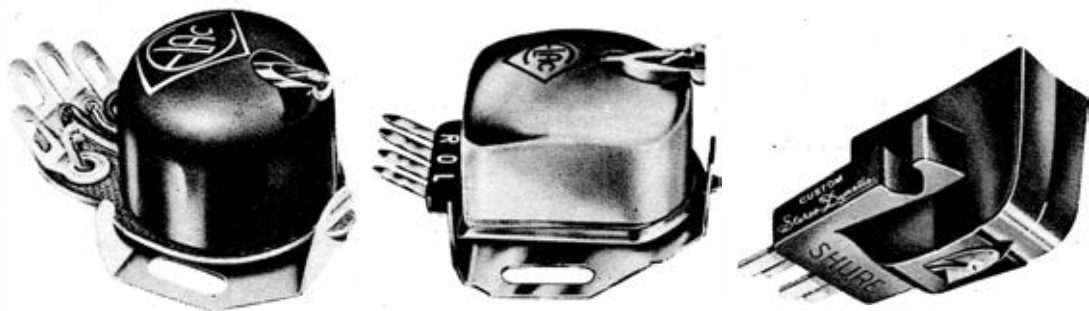

Duotone stereo turnover cartridge is British import, has 40-15,000 cps response, 1 v output. Tracking force is 2 to 4 grams; it has four terminals.

Electro-Voice ceramic stereo model can be used on magnetic phono inputs. Response is 20-20,000 cps  $\pm$  2 db. Channel isolation is 28 db at 1 Kc.

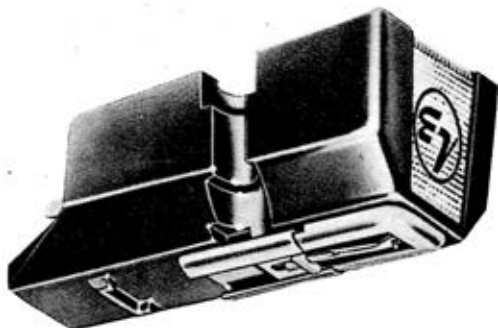
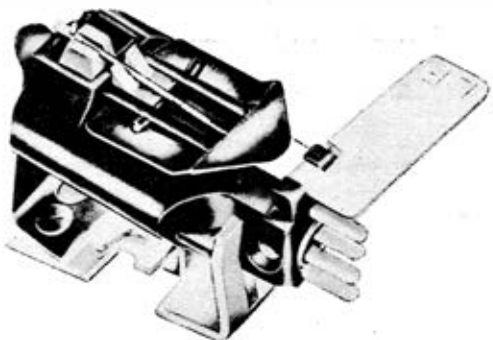

the actual safe period of diamond use will depend largely upon the equipment with which it is used, the wise procedure is to start giving it fairly frequent microscopic inspections after the first 300 hours.

This should be done on a regular schedule, for when a worn stylus becomes apparent in the reproduction, permanent damage has already been done to the record. The only way to be certain of stylus condition is to examine it under a microscope of 50 or 100 power. As soon as the length of the worn flat exceeds the tip radius, the stylus is due for replacement or repolishing.

With the stylus tracing the winding path of the groove, the next item in the chain is the pickup, or cartridge, which must

translate this mechanical motion into an audio voltage. Phono pickups are classified either in terms of their method of generating a signal, or of the characteristics of that signal. On the latter basis, pickups are described as either amplitude responsive or velocity responsive. These terms are explained in Chapter 6, where we will see that the characteristic of the record cutter is a composite of both these types, and either type of pickup must therefore have its own inherent characteristic modified somewhat.

Any pickup is known technically as a *transducer*, because it converts mechanical motion into electrical signals. Transducers are widely used in electronic instrumentation, and just about every type of trans-

Below, left. Electromagnetic induction is caused by metal bar moving through magnetic force lines; meter registers current. Below, right, simplified drawing of variable reluctance magnetic cartridge components.

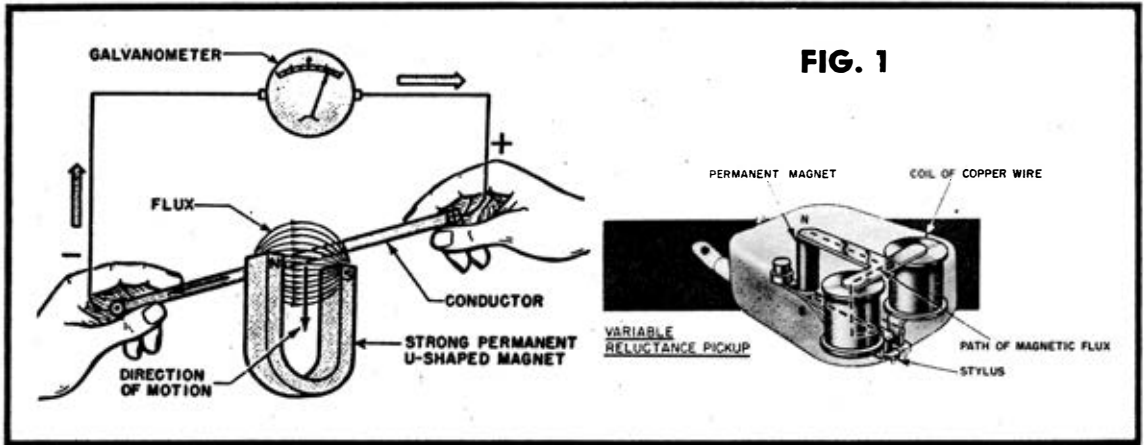

ducer known has at one time or another been tried for record reproduction. But of all the principles employed, only two account for the great majority of phono pickup designs today.

Nearly all present pickups are either magnetic or piezoelectric in principle. The magnetic types are in effect miniature electric generators, and they obey the same laws of physics as do the huge dynamos in electric power stations. The principle in each case is that of electromagnetic induction, which is illustrated in Fig. 1.

As the metal bar is moved through the magnetic lines of force, there will be a voltage induced in it as indicated on the meter. If the bar is twisted into a coil, more voltage will be generated because more lines of force will be cut. This is basically all there is to the magnetic phono pickup: a magnet, a coil, and a linkage which permits the stylus to move one or the other of them.

Since a moving coil and a stationary magnet will induce a voltage, as will a moving magnet and a stationary coil, we have both moving-iron and moving-coil type pickups. The mass of a magnet is too great to be moved readily by a tiny stylus, however, and so in the moving-iron types there is usually a third element, called an armature, in the magnet gap.

In this case both the magnet and the coil remain stationary, while the moving armature attached to the stylus varies the reluctance of the magnetic path and thereby induces a voltage in the coil. Hence

the name "variable reluctance," by which this type is usually known. In the electrodynamic cartridge, on the other hand, the coil itself actually does move within the field of the magnet. In either type, a pair of flexible wires attached to the ends of the coil carries off the signal to the compensator and preamplifier.

The voltage output of magnetic cartridges is considerably less than that of the piezo types, and it varies considerably among available models. Some types put out as little as 0.01 volt, while others deliver up to 0.2 volt. The output of the moving coil types is usually considerably less than that of the moving iron variety, and a step-up transformer is therefore usually required between the pickup and the amplifier input. Both of the magnetic types are essentially velocity responsive.

The other basic type of pickup operates on one of the several piezoelectric effects, in this case the generation of a voltage when the material is mechanically strained, the amount of voltage being directly proportional to the amount of the strain. The material is either a slab cut from a natural crystal of sodium potassium tartrate, commonly called Rochelle salt, or a synthetic ceramic material, usually barium titanate or lead zirconium titanate.

Recent developments in crystal technology have resulted in pickups of quite high fidelity, although Rochelle salt crystals are still rather sensitive to excessive heat and humidity, as well as mechanical shock. The ceramic cartridge, however, is fairly impervious to these weaknesses.

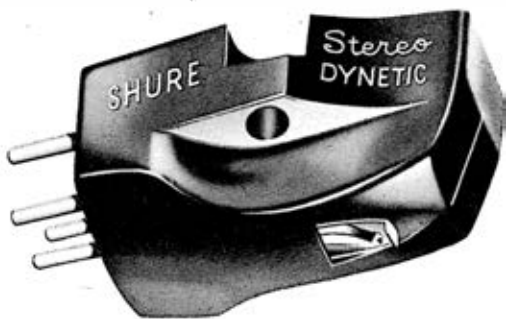

Shure stereo Professional Dynetic cartridge has 5 mv output per channel, 3-6 grams tracking force. Response: 20-15,000 cps  $\pm$  3 db; four terminals.

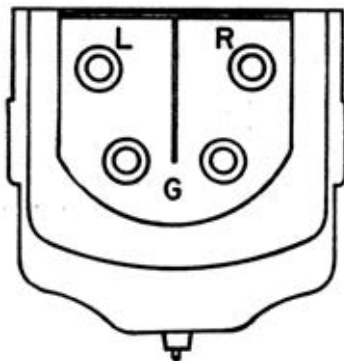

Diagram of Shure connection to tone arm wires. Left and right channels and both grounds are marked; 3-lead types need single wire to ground.



Above are some of the stylus pressure gauges available. At left is one by Cleveite Walco, at right is a Garrard. The Walco gauge is unusual in that it has no springs; it uses movable counterweight.

The best piezo cartridges, both crystal and ceramic, closely approach the average magnetic pickup in fidelity. Their outputs range between 0.5 and 1.0 volt, with most hi-fi types running about midway between at 0.75 volt. This is much higher than the typical magnetic output, and a preamplifier is therefore unnecessary. Other advantages of piezo pickups are freedom from hum pickup, and relatively low cost. They are essentially amplitude responsive.

The primary purpose of the tone arm is transporting of the pickup, while maintaining the stylus in proper relationship to the groove. It also carries the electrical wiring which connects the pickup to the amplifying system. Since the arm must not in any way impede the motion of the stylus and pickup, it must have low mass and stiffness, and high compliance, both in the vertical and lateral directions. A really good arm is therefore a very finely designed and machined piece of precision equipment.

The design and adjustment of the tone arm also largely determine the stylus force, usually by means of sliding counterweights or springs. With present stylus forces being on the order of only a few grams, a change of merely a gram or two can make a whale of a difference in track-

ing ability and record wear. For this reason, the force should be checked periodically, and adjusted if necessary.

The cutting stylus on a commercial recording machine is mounted in a lathe mechanism which moves the cutter across the face of the disc in a straight line. The tone arm, on the other hand, is mounted on a pivot which causes the pickup to move in an arc. The difference between the straight-line movement of the cutting stylus and the curved movement of the reproducing stylus is called *tracking error*, and is illustrated in Fig. 2.

Tracking error causes distortion and record wear, and should therefore be held to a minimum. Any good arm will minimize tracking error, provided it is properly installed. The distance of the pivot point from the center spindle is critical with any given arm design, and it is therefore essential to follow manufacturers' directions.

When the stylus is correctly mounted in the pickup, the pickup in the tone arm, and the arm on the motor board, the stylus as it rides in the record groove should be perfectly vertical to prevent uneven wear on the groove walls. But since the stylus is rather well concealed when the record is playing, it is often difficult to determine its angle visually.



Garrard transcription pickup arm is adjustable for length, height, stylus angle and pressure. The Model TPA 10, as shown, is a monaural type.



London Records and H. H. Scott have cooperated in designing this arm with its integral stereo cartridge. Tracking force is 3.5 grams, the diamond stylus is 0.5 mil; \$89.95.



Lafayette stereo PK-270 arm is made of lightweight, die-cast aluminum, comes in 12- and 16-inch lengths. It sells for \$17.50 and \$19.50. Plug-in heads take monaural and stereo.

Drawing at right shows the difference in motion between the original cutting stylus and your tone arm. This is called the tracking error.

The best way is to use a small mirror, preferably about the thickness of a record. The mirror is placed on the turntable, and the pickup placed gently on the mirror. The stylus and its reflection should then be perfectly in line when viewed from any angle. If there appears to be any bending between the two, then there is need for adjustment. Since this angle will vary with the height of the stack on record changers, the best compromise is simply to adjust the stylus to vertical with a stack thickness half that of the number of records you usually play.

A tape reproduce head operates on the same principles as the moving-iron phono pickup. A recorded tape is really a series of tiny magnets, which in reproduction are drawn rapidly past the coil in the tape head. Voltages are then induced in the coil in accordance with the magnetic pattern on the tape. In the tape head this coil has a metal core, but the principle is still that of the moving iron transducer.

The purpose of the core is to conduct the magnetic flux away from the tape and into the coil, for greater signal strength, better frequency response and less distortion. The core is bent around in the shape of a ring, with the ends of the ring closed so tightly that the gap is barely discernible.

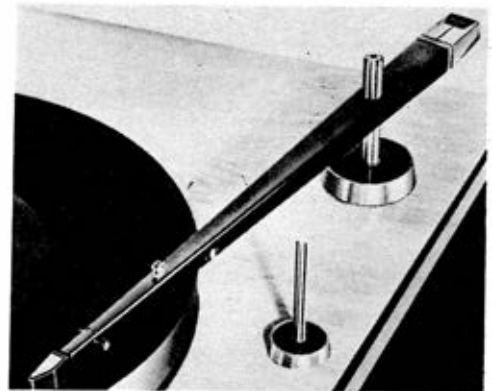
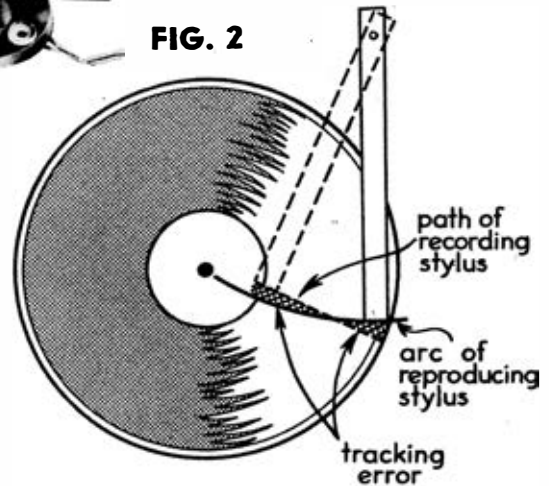

Shure integral stereo arm and cartridge has a 20-20,000 cps response,  $\pm 2.5$  db, with a more than 20 db at 1,000 cycles channel separation.

# NEEDLE REMOVAL INSTRUCTIONS

## SPRING-HELD (G.E. "slide-in" needle assembly)



**TO REMOVE:**  
Push red button down and turn so that needle assembly will be at a right angle to cartridge. Slide needle forward, out of assembly.



**TO REPLACE:**  
Hold red button down. Slide new needle in. Make sure LP tip corresponds to "arrow" or LP position on red button.



**TO REMOVE:**  
Slightly lift retaining spring with fingernail. Grasping needle by "handle" carefully lift out of position.



**TO REPLACE:**  
Slightly lift retaining spring; hold needle by "handle"—place in position with arm resting on small forked post.



**TO REMOVE:**  
Grasping needle by "handle" pull it sideways out from under spring.



**TO REPLACE:**  
Holding needle as before, push squared portion under spring.

## HORIZONTAL PUSH-IN NEEDLES (friction-held)



**TO REMOVE:**  
Grasp shank of needle with tweezers—pull straight out, horizontally from front of cartridge.



**TO REPLACE:**  
Push shank in gently with fingers or tweezers until seated.



**TO REMOVE:**  
Grasp wide flat portion of needle with flat tweezers—pull straight out, horizontally from front of cartridge.

**TO REPLACE:**  
Grasp as above and insert needle into cartridge slot until firmly seated.

## CLIP-HELD NEEDLES



**TO REMOVE:**  
Insert fingernail under front edge of silver colored clip of needle—pull needle assembly from cartridge.

**TO REPLACE:**  
Place rear leg of needle clip into rear cartridge slot and snap needle into place. Make sure needle shaft is in fork of needle guide.

## SCREW-HELD NEEDLES



**TO REMOVE:**  
With small screwdriver, remove screw holding the needle.



**TO REPLACE:**  
Insert screw in hole in needle's base—align needle in cartridge recess and tighten screw.

## FRICTION-HELD NEEDLES



**TO REMOVE:**  
Raise needle tip with fingernail and move it to side as shown. Holding needle at shank, lift from socket.



**TO REPLACE:**  
Press shank of needle into socket until seated. Rotate needle into forward position. Make sure needle is in fork of needle guide.

## HEX-NUT-HELD NEEDLES



**STEP 1**  
Remove cartridge from tone arm by removing the two retaining screws.



**STEP 2**  
Carefully slide wire lugs from the terminals on cartridge.



**STEP 3**  
Using small pliers or hex-nut wrench (supplied with each Walco needle) remove nut from top of cartridge. Needle may now be removed.



**STEP 4**  
To replace: Insert needle shaft upward in hole, with tip between guard arms. Holding needle in position, place washer, then nut, on shaft—tighten with hex-nut wrench.



**TWIN NEEDLE TYPE**  
LP (red) needle must be removed first, as in Steps 1-4 above. If 78 rpm needle is to be replaced, too, its own hex nut is now exposed under LP needle position.



**CAUTION:**  
LP needle goes between forked guards of cartridge; guards for the 78 rpm needle are part of the assembly which holds cartridge in place.

### VERTICAL PUSH-IN NEEDLES (friction-held)



**TO REMOVE:**  
Place knife blade under small projecting heel of needle shank, pry up gently.



**TO REPLACE:**  
With shank of needle held by fingers, push needle in gently until set.



**TO REMOVE:**  
Place knife blade under needle shank, pry up gently.



**TO REPLACE:**  
With shank of needle held by fingers, push needle in gently until seated. Make certain key on needle aligns with slot in cartridge chuck.



**TO REMOVE:**  
Place knife blade under needle shank, pry up gently.

**TO REPLACE:**  
With shank of needle held by fingers, push needle in gently until seated. Make certain key on needle aligns with slot in cartridge chuck.

### KNURLED-NUT-HELD NEEDLES



**TO REMOVE:**  
Loosen knurled nut one or two turns, but don't remove. Pull needle from hole in stud.

**TO REPLACE:**  
Insert needle shank in hole, center it, and tighten knurled nut.



**TO REMOVE:**  
Loosen knurled nut, slide needle assembly forward.

**TO REPLACE:**  
Slide slotted portion of needle assembly under nut, flanking the screw. Tighten nut.

### SET-SCREW-HELD NEEDLES



**TO REMOVE:**  
Remove turn-over knob. Unscrew cartridge from tone arm. Carefully slide wire lugs from cartridge terminals. With small screwdriver loosen set screw holding both needles.



**TO REPLACE:**  
Insert needle shanks with tips forward) from opposite sides of cartridge. Hold them in place with fingers and tighten set screw. Replace cartridge in tone arm, connect wires and replace turn-over knob. Make sure its LP position corresponds to LP (red) needle.

### FRICION-HELD NEEDLES (G.E.)

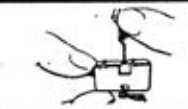

**TO REMOVE:**  
Remove cartridge from tone arm as shown in instruction K. Insert a paper clip or other small tool into the hole in the top of the cartridge and push needle assembly out.



**TO REPLACE:**  
Replace cartridge in tone arm. Grasp needle shank between thumb and forefinger, insert firmly in hole.

### CONVENTIONAL SHANK NEEDLES



**THUMBSCREW HELD** **TO REMOVE:**  
Unscrew counter-clockwise and remove needle.



**TO REMOVE:**  
Insert small screwdriver in tone arm hole. Turn screw counter-clockwise until needle is loose.

**TO REPLACE:**  
Keep flat side of shaft toward screw. Be sure needle is firmly up in hole. Tighten screw.

Chart by Cleveite-Walco

The size and shape of the gap in this ring is very important in determining the fidelity of the head response. If we want to be able to handle up to 15,000 cps, for example, then the tape would have up to 15,000 complete magnetic reversals on whatever length of tape passes the head in one second.

At the standard speed of  $7\frac{1}{2}$  inches per second, for example, the length of one wave on the tape would be  $(7.5 \div 15,000)$ , or 0.0005 inch. The wavelength of 15,000 cps at 7.5 ips is therefore only one half mil (a mil is  $1/1,000$  inch). But the head gap must be even smaller than that, for experiment has shown that the output is almost zero when the gap length is the same as the recorded wavelength. But when the gap length is half the wavelength, then the induced signal is maximum.

We can infer from this that to reproduce frequencies up to 15,000 cps with  $7\frac{1}{2}$ -ips tape, we must have a head gap of one quarter-mil.

Better equipment today has quarter-mil heads, which are a far cry from those which once limited the frequency response of 7.5-ips tape to 7,500 cps. We now have that additional octave of response, but since the gap is almost a short circuit, it isn't likely that we will see the day that it will be cut in half again, to permit full fidelity at 3.75 ips.

### The Stereo Story

The first important difference in stereo disc reproduction begins right at the stylus. Whereas a tip radius of 1 mil was considered standard for monophonic micro-grooves, we now often find stereo car-

tridges equipped with 0.7 or even 0.5 mil tips.

To understand how stereo cartridges differ from the monophonic varieties discussed earlier in this chapter, we must remember that in a monophonic groove, all of the information is contained in a side-to-side wiggling of the engraving stylus, in a system known as *lateral* recording. The reproduction motion involved in lateral recording is shown in Fig. 3(A).

It is also possible for the engraving stylus to have an up-and-down motion, to make a record known as vertical or hill-and-dale. The first serious attempts at stereo recording therefore naturally used a combination of vertical and lateral recording, with one channel assigned to each of the two types of movements. The basic principle of reproduction in such a system is shown in Fig. 3(B).

Note that the stereo cartridge has two generators driven by the common stylus, as opposed to the monophonic type which has only one. Thus the stereo cartridge is inevitably heavier and stiffer than its monophonic counterpart.

In the vertical-lateral stereo system shown in Fig. 3(B), one channel of information is presented by the lateral displacement of the groove, while the other

channel is represented by a varying depth of the groove. A more symmetrical system is the 45-45 arrangement, which has now been adopted as standard in the United States, and many other parts of the world as well. The reproducer system is shown in Fig. 3(C), and might be thought of as the vertical-lateral system tipped at a 45-degree angle.

Now the signal information is contained in the diagonal displacement of each groove wall. One set of stylus motions, affecting generator A, is along a line of 45 degrees to the record surface, and moving between northwest and southeast. The effect of one half-cycle of a heavy A signal is shown in Fig. 3(D). A second set of motions, between northeast and southwest, similarly affects generator B.

As shown in Fig. 3(D), the groove deepens under modulation, but only the left wall moves with an A signal, and only the right wall moves with a B signal. Thus in effect each wall of the groove is modulated separately, and each wall represents one channel of the 2-channel stereo system.

In a true stereo signal, however, both channels will be active. In this case both groove walls will have a tendency to move, and there will be a resultant motion in two

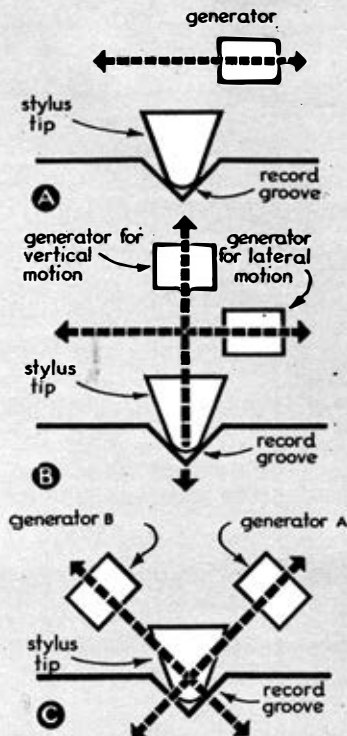
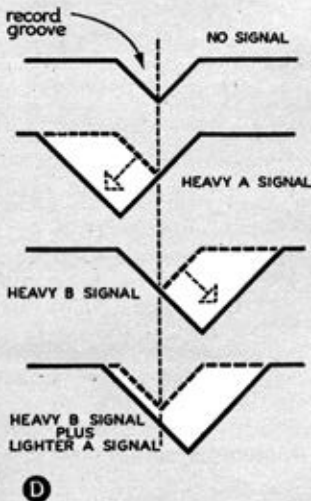

FIG. 3

See text for explanation of stylus movements





## Stylus, Cartridge and Arm

directions. The effect of a heavy *B* signal plus a lighter *A* signal is shown in Fig. 3(D).

The stereo pickup may be either of the magnetic or piezo type, but in either case each of the generators should respond only to its own component of the complex groove motion. The more accurately they do this, the greater will be the isolation between channels, and the more realistic the stereo effect will be. The best stereo cartridges will have a channel separation of upward of 20 decibels.

If you are beginning in hi-fi, and definitely intend to go stereo after starting with an expandable monophonic system, you should get a stereo cartridge at the outset. Since the stereo pickup will play both stereo and monophonic records, while the monophonic pickup will severely damage stereo records, the monophonic type is a total loss when making the conversion.



Most good monophonic tone arms will track stereo all right, but their connectors and wiring must be modified. Stereo cartridges, since they have two separate generators, require 3- or 4-wire connections, while the monophonic variety uses only two. Conversion kits are available for this modification for many arms, and the changeover is quite a simple job.

The stereo tape head is in effect two half-track heads stacked atop each other. With stereo heads the tape system is completely compatible, in that it will not only handle stereo, but can also record and play monophonic half-track tapes as always. Thus converting an existing tape recorder to stereo is a fairly simple process of replacing heads.

Of course, the conversion of either tape or disc to stereo also involves additional electronics, the discussion of which begins on the next page. •

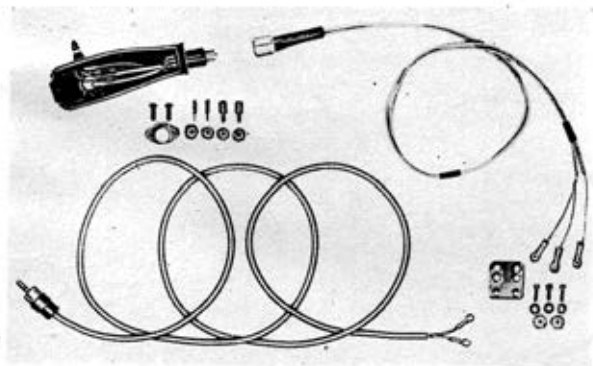

Left: Garrard stereo conversion kit consists of new head with a three-wire connection, cable for the arm, terminals, shielded-lead phono plug.

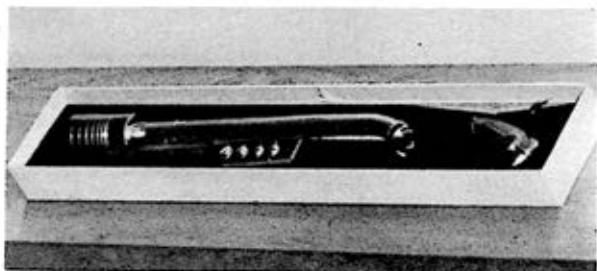

Above: Stereodyne phono cartridge is combined in novel tone arm assembly which mounts in a single mounting pole. Price: \$50.

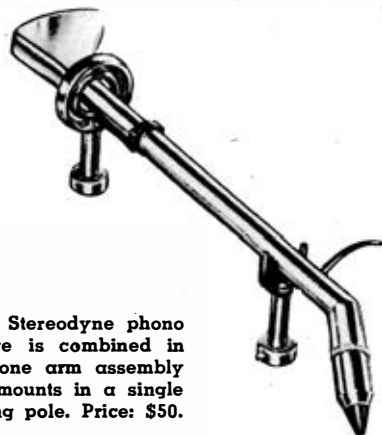

Stereo conversion kit by Rek-O-Kut is designed to convert company's monaural arms to stereo. It includes head, arm, terminal; 4-wire type.

## Chapter 6

# Preamps and Compensators

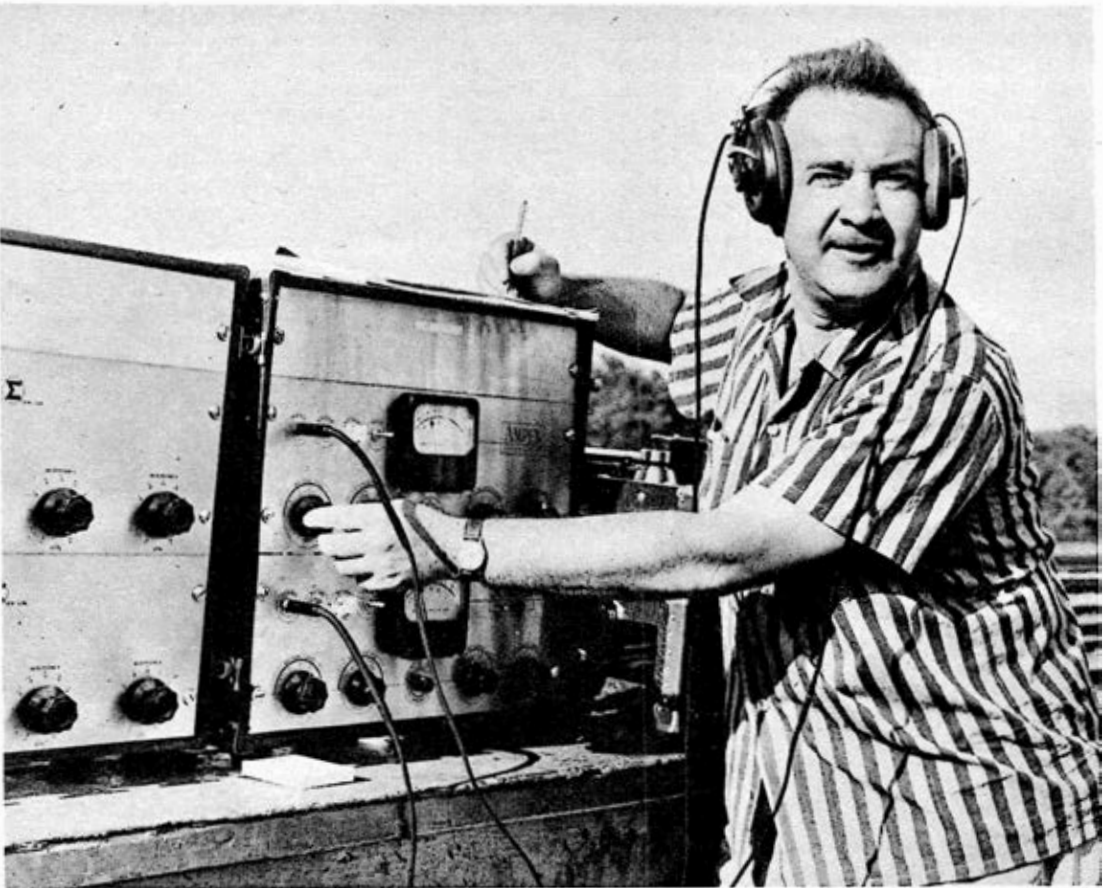

HI-FI Systems magazine

Above is Audio Fidelity records' president, Sidney Frey, juggling the controls on an Ampex stereo tape preamplifier during one of this company's on-the-spot recordings. Note impressive monitor headset.

Sherwood S-4400 stereo preamp and 36-watt basic amplifier, \$159.50. This unit, when added to single basic amplifier, gives a complete stereo system.

Marantz stereo console has 18 inputs, 3 pairs of outputs, 6 AC outlets, tone, volume and balance controls, tape and record equalizers; \$249.00.

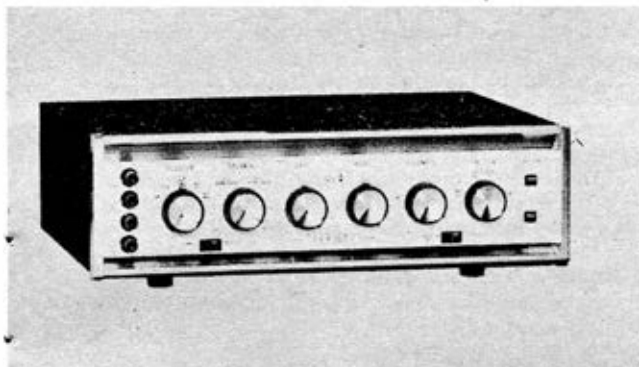

AS soon as an audio voltage emerges from a phono cartridge, or tape head, or FM radio detector, it next goes into a gadget where it is *distorted*. Or perhaps it would be more accurate to say it is *undistorted*. For all of these signals were deliberately twisted out of shape during recording or transmission, and now they must be restored to their original condition. It's something like the toys which are knocked-down for ease in shipping, and which Dad has to sweat over in reassembly on Christmas Eve. Only the knocked-down hi-fi signal doesn't put as much wear and tear on old Dad, because reassembly is automatically taken care of for him by the little gadget called the equalizer or *compensator*.

You will remember that in the last chapter we spoke of phono pickups being either *velocity* or *amplitude* responsive. To understand what *this* means, we have to consider that there are two main types of record-cutting mechanisms. One is called *constant amplitude*, and the other is *constant velocity*.

In the constant amplitude system, the *displacement* of the cutting stylus, the distance it swings from side to side in cutting the groove will depend upon the loudness of the sound. In the constant velocity system, the *speed* with which the stylus moves will depend on the loudness. Some of the important characteristics of the two types are shown in Fig. 1.

The constant amplitude type is shown in Fig. 1(A). Note that for a signal of a given loudness, the groove displacement (or excursion) is the same at all frequencies. This means that at the higher frequencies the

stylus must move much faster to cover the same ground. Hence in the constant amplitude system; the velocity or speed of the stylus goes up with increasing frequency.

Compare this with the constant velocity condition in Fig. 1(B). Since the velocity is constant for a given loudness, the stylus simply cannot cover as much distance at the higher frequencies. Hence the groove displacement and therefore the amplitude go down as the frequency goes up.

Here we see the inherent weakness in the constant velocity system. Since the groove displacement diminishes at high frequencies, it can become so slight that it is overcome by the inherent surface noise on the disc. Also, since displacement increases at the bass end, the powerful low frequencies can send the stylus right over into the next groove, to cause *overcutting*.

It would seem from this that the constant amplitude system is by far the better of the two, and there are some authorities who contend just that. But here is just one more case where the theory hasn't been proved in practice. Up until now, at least, nobody has been able to build a constant amplitude cutter which will do what it theoretically should be able to do.

All cutters in commercial use today are of the magnetic variety, which means they are constant velocity. Like a DC motor, their speed (velocity) depends on the amount of voltage fed into their coils. But this still leaves us with the anemic high end and over-powerful bass characteristic of the constant-velocity system. So in practice we use a *modified* constant-velocity system, as shown in Fig. 1(C), which is actually constant velocity only in the mid-

range, but constant amplitude at both extremes of the audio range.

This is the typical *recording characteristic*, in which there is less bass than normal, and more highs. Now the job of the compensator at the reproducer end is to boost the bass and attenuate the highs by exactly the same amounts as the opposite was done in recording. To do this, it is necessary to know the *turnover frequencies*, which are the points at which the characteristic goes from amplitude to velocity, or the reverse. This is shown in Fig. 2, in which we see the reproducing characteristics most commonly used today.

The RIAA curve is the one commonly used in the United States, while the CCIR curve is generally used in Europe. Note that in both cases the curve is constant

velocity throughout the midrange. But note also that the CCIR curve turns over at 353 cps, while the RIAA curve doesn't turn over until 500 cps, nearly a musical fifth higher. Similarly at the upper end, the RIAA curve turns over at 2120 cps, while the CCIR turnover occurs at 3180 cps, again an interval of about a musical fifth.

The simplest compensators today are fixed at the RIAA characteristic, and let it go at that. This is fine, as long as your record library contains nothing but American records, all made within recent years. But if you have many European recordings, or older American material (time was when there were seemingly more recording characteristics than record companies), then you must have an adjustable compensator.

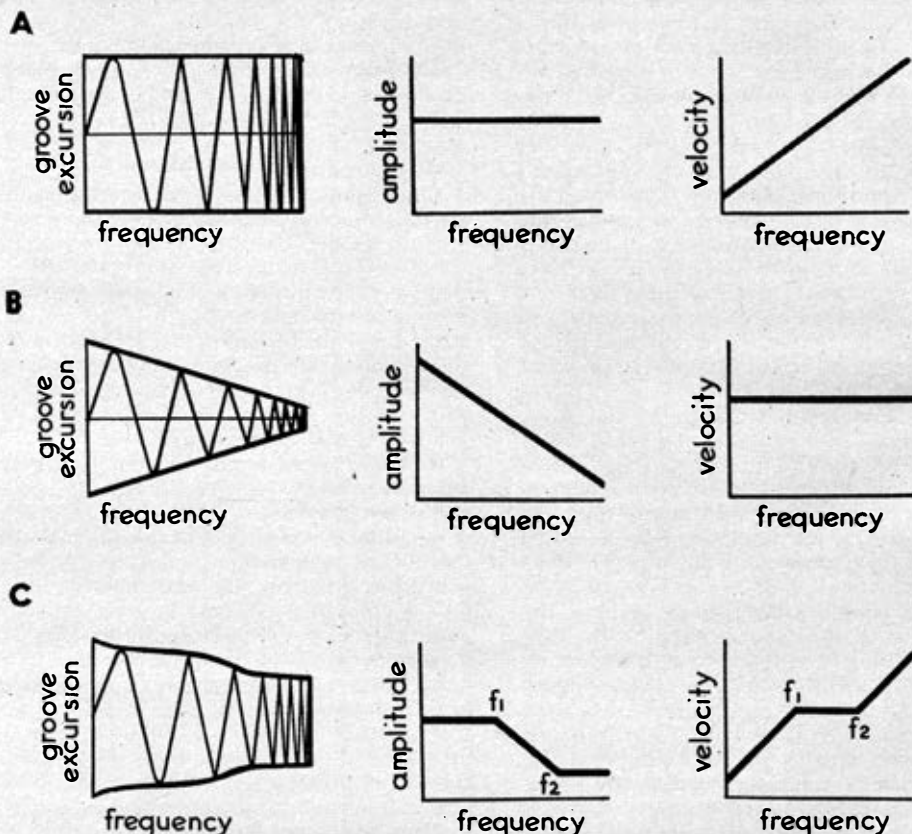

FIG. 1

The next most elaborate compensators cover the most used curves, with selector switch positions having such markings as RIAA, EUR (CCIR) and AES (old Audio Engineering Society). These types take care of both turnover frequencies in one flick of the switch.

The most elaborate compensators of all, and those with the greatest flexibility, permit separate adjustment of the two turnover frequencies. These, too, may have designations such as RIAA and CCIR, or they may have numerical designations instead. And here is where the going gets a little tricky.

Going back once again to Fig. 2, remember that the low-frequency turnover is 353 cps for CCIR and 500 cps for RIAA. To adjust correctly for either of these record



McIntosh C20 stereo compensator has 2.5-v main output, record and tape equalizers, rumble filter, stereo balance, phase switch, 600-watt outlets.

Below, left: H. H. Scott 130 provides stereo balance, has provision for 3rd channel, 10 inputs, tape and record equalization. Response: 19-35,000 cps.

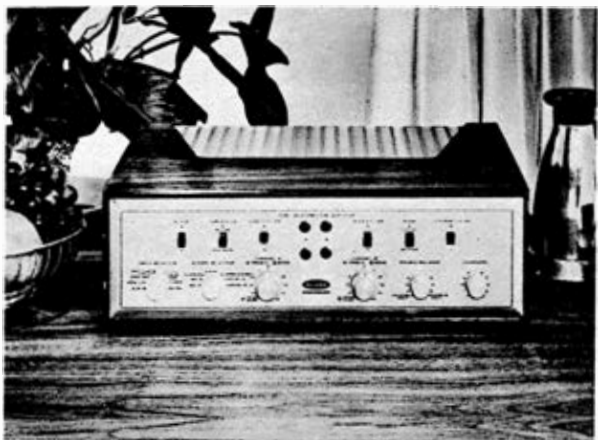

Fisher 400-C Master control has 16 inputs, 11 controls, ganged bass and treble knobs. Push buttons operate tuner, phono and auxiliaries.

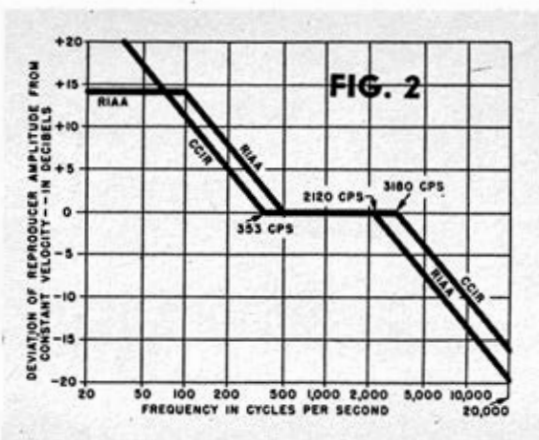

Pilot 216-A, \$199.50, has two VU meters for balancing each channel or tape output level. Unit has 4 outputs, 14 inputs, internal cathode follower.

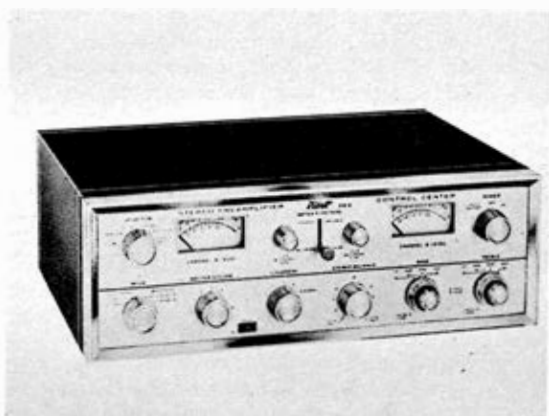



Eico stereo preamp is sold assembled, \$64.95, or in kit form, \$39.95. It has ganged controls, tape and record equalizer, channel reverse, hum balance.

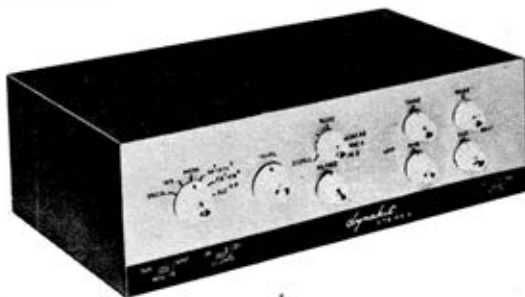

Dynakit stereo preamp sells for \$59.95 in kit form, with portions preassembled on printed circuit board. Controls include a channel blend.

Grommes 209 Premier stereo preamp comes with 12 inputs, is self-powered, has a 10-20,000 cps frequency response at  $\pm 0.25$  db, four outputs.

Marantz Model 3 electronic crossover for stereo programs has independent on-off and level control for each channel, low and high frequency knobs.

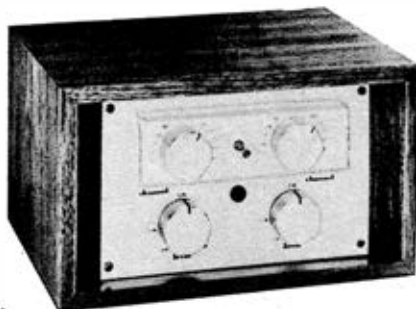

types, it is simply necessary to set the L-F TURNOVER control to either 353 or 500. Or if some other frequency is called for, merely set the switch to that.

So far so good. But to adjust for the other knee in the curve, you won't find the compensator marked "h-f turnover," but instead it will most likely be indicated as H-F ROLLOFF. Although it still is actually a turnover point, it isn't expressed in terms of frequency. To follow this, we'll have to go back once more to Fig. 2.

Follow the sloping legs at the far right of each curve until the line crosses the 10,000 cps point. Note that at this frequency the CCIR curve is at the horizontal level of -10. At the same time the RIAA curve is at about -13. These are the decibels of roll-off at that frequency.

In other words, when a record is cut at the CCIR characteristic, the upper turnover is such that the treble boost is 10 decibels at 10,000 cps. Similarly, an RIAA record has a turnover with a treble boost of 13db at 10,000 cps. Now the reproducing compensator must do just the opposite of what the recording equalizer has done. That is, where the record is boosted, the compensator must roll off, and where the

record is rolled off, the compensator must boost.

For reasons which are hidden deep in the antiquity of recording practice, the high-frequency compensator will be labeled in terms of roll-off, either in decibels, or by letter designations such as RIAA, CCIR or AES. But it is *never* spoken of as "high frequency turnover." Since there are in fact two turnovers, perhaps this was done to avoid confusion. But I daresay, gentle reader, that at this point it has done just the opposite for you.

Just to make matters even more confusing, the RIAA curve has still a *third* turnover. You may have noticed in Fig. 2 that the RIAA curve flattens off again below about 100 cps. Recording engineers call this plateau the low frequency *shelf*, and what it amounts to is a little bass boost in recording to get a better advantage over inherent bass noise such as hum and rumble.

Theoretically, in your playback compensator the **bass boost** should stop at around 100 cps and flatten off to accommodate this shelf. As a practical matter, the odds are very great that this is simply overlooked. The bass boost is there, and it stays there.

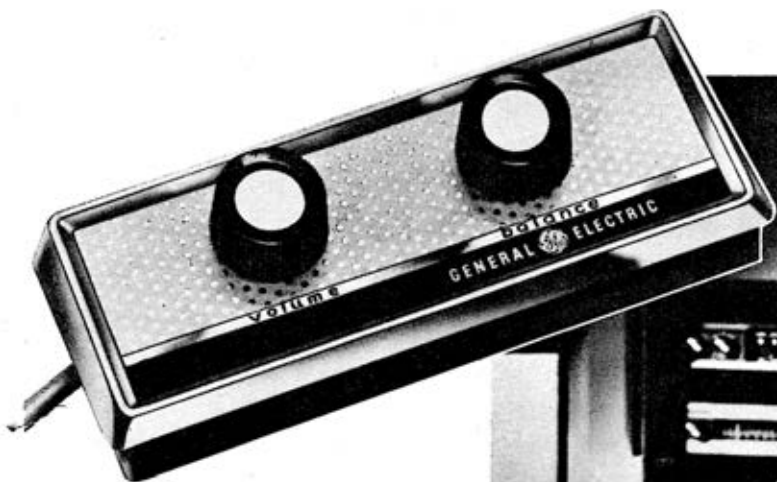

Remote control for stereo amplifiers by General Electric, has channel balance and volume controls, sells for \$14.95. It can also be used with monaural source. Its weight is 12 ounces.



So you won't have to concern yourself with this one, unless the records sound too bassy to you, in which case you'll just have to adjust your tone control.

Equalization is necessary in tape recorders also, and for reasons similar to those for disc recording. There is the problem of hiss and other high frequency noise at the treble end, plus hum and rumble at the bass end. In addition to these factors there is the peculiar nonlinearity of the tape recorder itself.

Without equalization, the output of a tape recorder will double each time the frequency is doubled. If the output were 2 volts at 1,000 cps, for example, it would be 4 volts at 2,000 cps, 8 volts at 4,000 cps, and so forth. This will go on up to a critical frequency, above which the output will begin to droop again. The unequalized playback below this critical frequency is therefore described as having a normal rise of 6 decibels per octave.

The recording and reproducing characteristics for tape are a combination of the inherent peculiarities of the magnetic process, plus electronic equalization where needed. During recording, the electronic system is flat up to the critical frequency,

permitting the 6 db/octave rise to go directly onto the tape. Then where the magnetic system begins to droop, electronic equalization continues with a tip-up of about 6 db/octave.

In playback the reverse holds true. A roll-off of 6 db/octave is inserted electronically up to the critical frequency, but the electronics becomes flat where the inherent magnetic roll-off takes over.

This equalization is normally taken care of automatically in the tape preamplifier, and no adjustment is necessary. In fact, none is possible on most American machines, which makes for difficulties when playing imported tapes.

In tape and disc reproducers, the compensation circuit is usually inserted immediately following the transducer and ahead of any amplification. In FM tuners, it appears between the detector and the first audio stage. In FM parlance, the compensation or equalization circuit is known as *de-emphasis*.

The reason for the name is simply the fact that at the transmitter we have *pre-emphasis* of the high audio frequencies, to provide a better ratio of signal to noise. This takes the form of a 6 db/octave rise

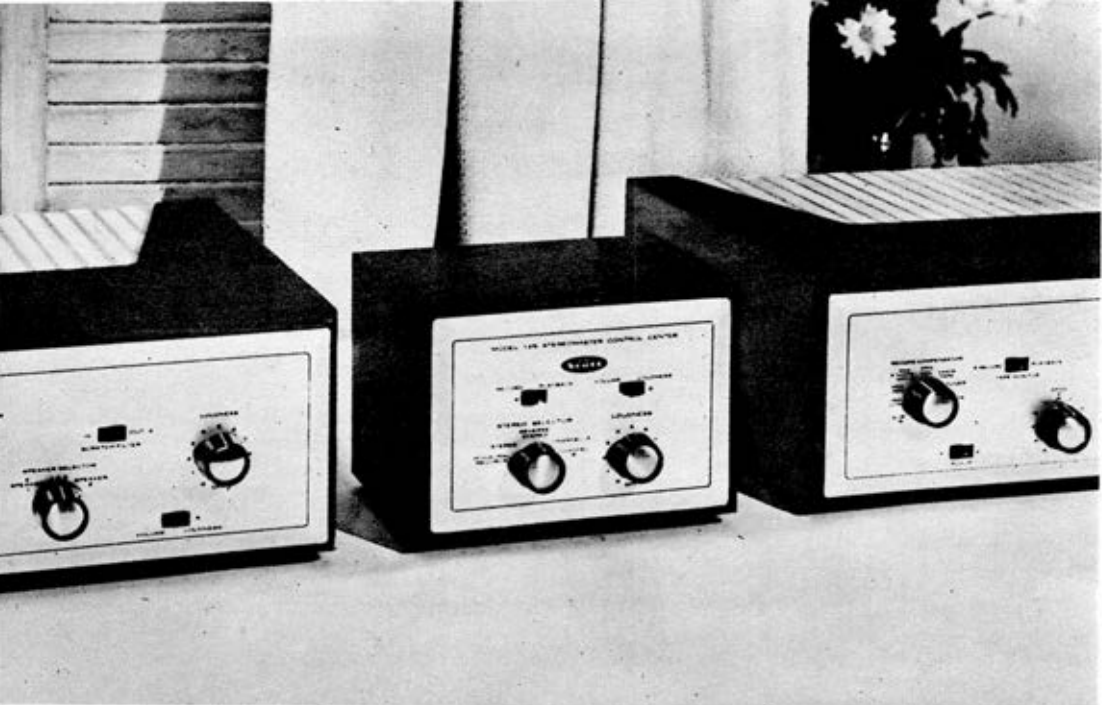

H. H. Scott stereo adaptor sells for \$24.95, is used to convert two separate monaural systems to stereo. The drawing below, right, shows how this unit controls and mixes both channels of a stereo program.

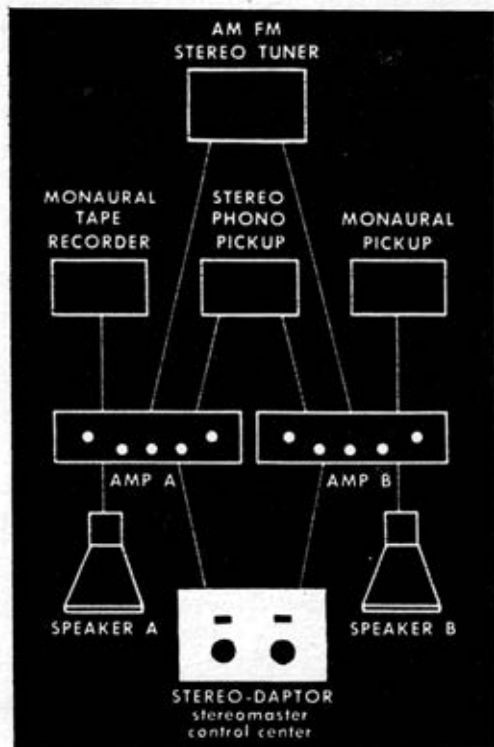
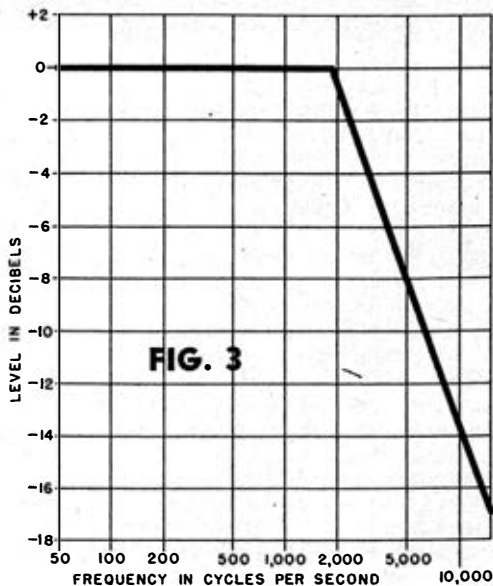

Left: Lafayette stereo control is self-powered, sells for \$27.50 in kit form. It has provision for a third channel, plus a phase and channel reverse switch.



## Preamps and Compensators

above 2,000 cps. Similarly, the de-emphasis is simply a roll-off of 6 db/octave beginning around 2,000 cps.

This is shown in idealized form in Fig. 3. We say "idealized" because none of these characteristics actually have such straight lines or well-defined bends as shown in these graphs. But if it were possible to build equalizers as sharp as these, that is the way their characteristics would look.

Of all the source devices in the hi-fi system, only the magnetic phono cartridge and the tape reproduce head require any preamplification. The reason for this is the great difference in output voltage between the two types of devices. Tuners, piezo pickups and piezo microphones, all are relatively *high-level* devices, with outputs on the order of a volt or so. Magnetic pickups, tape heads, and most magnetic type microphones have much smaller outputs, on the order of millivolts. The preamplifier is therefore a special accommodation for these magnetic devices only, to amplify their signals and bring them up to a level comparable with the piezo devices.

Although preamplifiers have been known in professional practice for years, they only came into vogue for home use following the introduction of the G.E. Variable Reluctance pickup in the late 1940's. This cartridge was relatively low in price, high in quality, and it represented a major breakthrough at the time in the quest for home hi-fi at reasonable cost. But it also had much lower output than the crystal cartridges which were then standard in home phono systems.

The first preamp for use with this cartridge was a simple little 1-tube amplifier, with fixed compensation. Since record manufacturers of the time liked to keep an aura of mystery surrounding their recording characteristics, there wasn't much point in adjustable compensation anyway.

The simplest preamplifier of this type is essentially a fixed-gain device, without volume control or other adjustments. Its sole function is to increase the feeble output of the pickup-compensator combination to a value which is comparable to that of other common signal sources. The requirements of the preamplifier are very exacting, for any noises which might get into the system at this point would become exceedingly serious after the tremendous amplification which follows.

It is much easier from a design standpoint to keep the preamplifier completely isolated from the main amplifier, rather than take the additional precautions neces-



sary to avoid noise induction from associated equipment. A separate preamplifier, then, is usually to be preferred over one which is part of the main amplifier.

Very often, however, the preamplifier and compensator are constructed as a single unit, and this is an entirely logical and useful combination. The unit may have a self-contained power supply, or it may obtain its necessary operating voltages from the same supply as the main amplifier. The self-contained unit is naturally more expensive, but it avoids possible troubles in obtaining satisfactory isolation between preamp and the main unit.

Now that piezo type cartridges are so much improved in quality, you may be wondering if it isn't possible once again to dispense with the preamp altogether. The answer is yes, provided you never have need to handle any low-level signals.

### The Stereo Story

There isn't a great deal to say about stereo compensators and preamplifiers, except that stereo requires two of everything. Although the stereo cartridge uses a single stylus in a single groove, remember that it actually has two separate generators, and each of them must be separately compensated and separately amplified. The same is true of two-track stereo tape heads, and of stereo tuners, except for the AM-FM variety. There will be more on this, however, in the next chapter.

None of the old comp-preamp equipment used with monophonic equipment need be obsoleted by stereo. But it will have to be augmented by a duplicate set for the second channel, preferably identical to the first.

Some persons like to add a third piece of equipment here, called a stereo adapter or control center. Essentially this contains no more than a ganged set of controls connected to the two channels and affords somewhat greater convenience in balancing the outputs of the two loudspeakers.

Most of the technical specifications for preamplifiers are the same as for power amplifiers. These and amplifier controls are discussed in Chapter 8. •

## Chapter 7

# Tuners and Receivers



**T**HE RADIO broadcast signal, as was pointed out in Chapter 3, is a complex combination of radio and audio waves. The complete unit which receives and tunes such signals, and retrieves and recreates the sound portion, is known as a *receiver*.

The ordinary home radio for broadcast reception comprises five basic elements. The first is the antenna, which collects the radio signals. The antenna is usually not tuned, which means that it feeds into the receiver all of those signals which strike it. At the front end of the receiver is the radio-frequency section, which selects the desired signal out of the many thousands striking the antenna, and builds it up to usable strength.

The third unit in the receiver is the detector, which picks the sound off the radio carrier, discards the radio-frequency portion, and sends the remainder along in the form of an electrical audio signal. Following the detector we have the final two units, the audio amplifier and loudspeaker.

Now a hi-fi audio system usually begins with a separate high quality audio amplifier and speaker, so there is no need for

the radio system to include these elements. If we have a radio receiver without the audio components, the remaining part is called a *tuner*.

There are two schools of thought on hi-fi radio systems today, one involving the use of a tuner, and the other a complete receiver. Tuners are probably the more popular of the two, but the receiver has much to recommend it.

The so-called hi-fi receiver is really a complete set of hi-fi electronics, including not only a tuner and amplifier, but also a preamplifier, compensator, and all necessary controls. Since best hi-fi practice requires that the speaker and its enclosure always be isolated from the electronics, the reproducer system is not included as a part of the receiver.

But the differences between a hi-fi receiver (or tuner) and an ordinary home model radio are more than functional. To understand both the similarities and differences, let's begin with the tuner antenna. All of the signal voltages induced in it from impinging radio waves are fed into the radio-frequency amplifier or preselect-

**AM-FM stereo tuner-preamplifier by Bogen sells for \$159.95. Frequency response: 20-20,000  $\pm$  1 db. Noise and hum for FM is -58 db, for AM -48 db.**

**McIntosh MR-55 AM-FM tuner has FM hum of -75 db, AM -50 db; Multiplex output, phono input. 300 and 72 ohm antenna. 20-20,000 cps  $\pm$  3 db.**

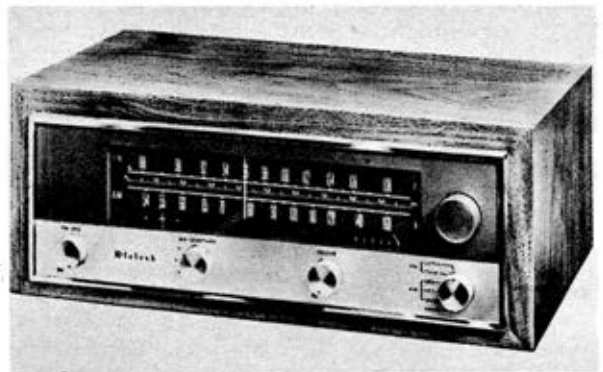
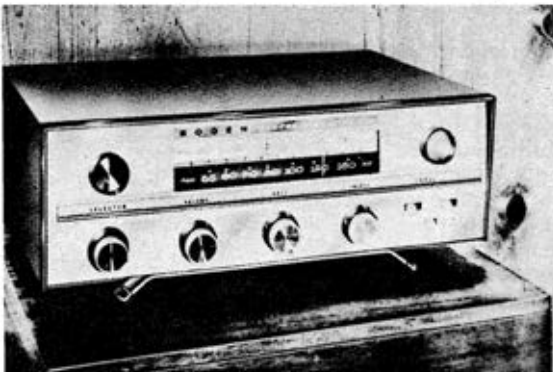



Allied Radio

tor. This amplifier tunes and amplifies the desired signal, rejecting all others. Thus it must be both *sensitive* and *selective*.

It's a fairly simple design problem to achieve both sensitivity and selectivity in a tuner—provided fidelity is not a serious consideration. But to get all three requires considerably more skill, more and better components, and consequently more expense. Thus in the ordinary home instrument, quality begins to fall off right here, before the signal gets to the audio stage.

The elements following the r-f amplifier are typical of the superheterodyne receiver which is the type used almost exclusively today. The first detector receives not only the r-f signal just discussed, but also a signal from a local oscillator within the set. This locally generated signal is also a radio frequency, usually higher than that of the carrier arriving from the preselector.

When those two signals combine in the first detector, the output is a new and lower carrier frequency, which still carries the

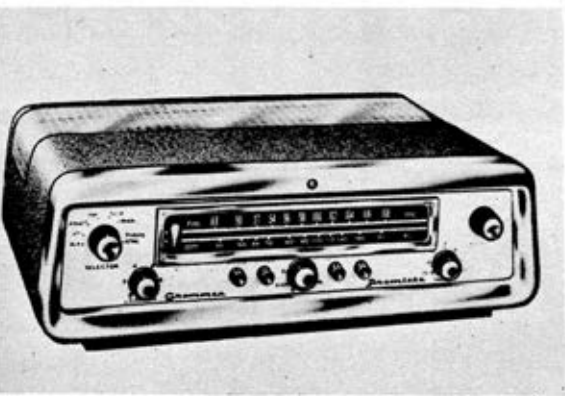

Stereo AM-FM tuner by Grommes has FM response of 20-20,000 cps  $\pm$  0.5 db, AM 20-7,500  $\pm$  3 db. It features push-button controls, tuning meter.

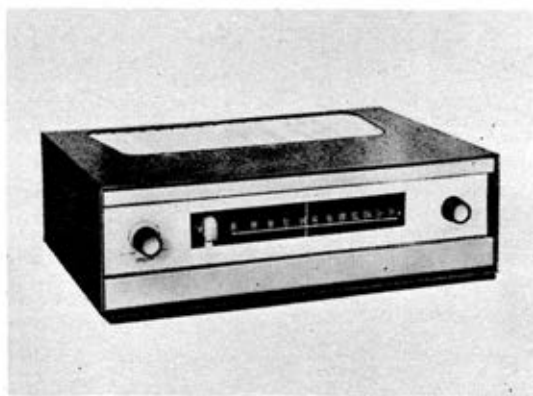

FM-only tuner by Grommes has center-of-channel tuning eye, 1 mv for 20 db sensitivity, 88-108 Mc tuning range. Frequency response: 20-20,000.



AM-FM stereo tuner, Carillon, by Bell comes with AFC switch, 88-108 Mc FM band; sensitivity is 1 mv for 20 db quieting. Price with cabinet is \$189.95.

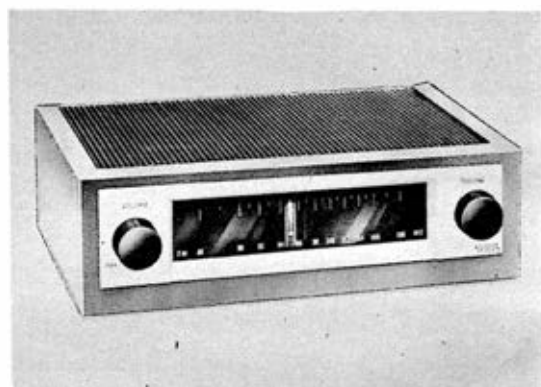

Eico FM tuner is available in kit form or assembled. Response is 20-20,000  $\pm$  1 db. It has Multiplex adaptor output, cathode follower tube.

same modulation which arrived at the input. When the preselector is tuned to the incoming signal, the local oscillator is simultaneously varied in frequency, usually by the setting of the same tuning knob on the front panel of the set.

The local oscillator is varied in such a way that there is a constant difference between the frequency of the local oscillator and that of the incoming signal. The result is that the two "beat" together and emerge as a modulated carrier of fixed frequency known as the *intermediate frequency* and abbreviated *i-f*. In most AM broadcast tuners the *i-f* is about 455 kilocycles, and in FM sets it is usually 10.7 megacycles.

The advantage of this arrangement is

that the *i-f* amplifiers can be fixed rather than variable, specifically designed to operate only at the intermediate frequency. This not only simplifies the design, but also enables greater selectivity. When the *i-f* amplifier is over-selective, however, it cuts off some of the audio modulation and hence severely limits the fidelity. The components used in *i-f* circuits of hi-fi tuners are therefore quite different (and more expensive) than ordinary types.

The detector in AM sets may be either a grid, plate or diode type, depending upon the tube and circuitry used. The first two are much more sensitive, and are therefore often found in low-priced sets. They also exhibit considerable distortion, how-

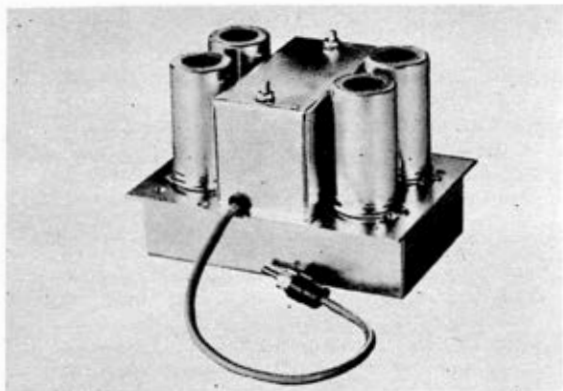

Fisher Radio Corp. makes this plug-in Multiplex adaptor, priced at \$49.50. The unit is designed with single phono plug for FM tuner insertion.

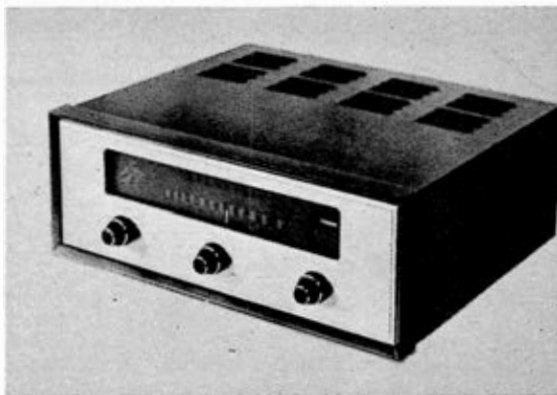

Fisher FM-100 tuner has main channel and Multiplex channel switch, four wide-band IF stages with limiters, bridge-connected mixer and oscillator.

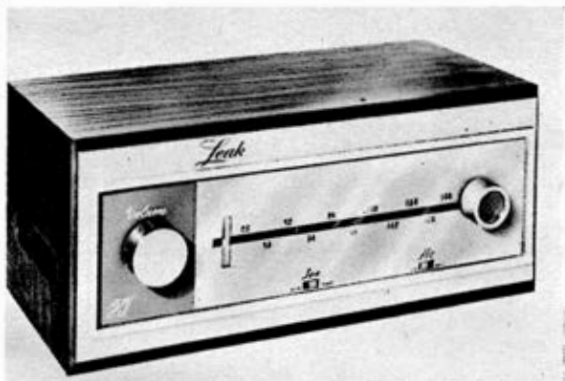

A British import is the Leak "Through Line II" FM tuner. Sensitivity is 1.5 mv for 20 db quieting. It has Multiplex output, 9 tubes; price: \$129.90.



Precise makes the "Perfecta" AM-FM tuner with variable AFC. It has inputs for TV and phono, cathode-follower output, AM-FM output meter.

ever, and the *diode* type detector is the one to be preferred for AM hi-fi tuners.

There are two basic types of FM detectors, one known as a phase discriminator, or Armstrong circuit; the other is called a ratio detector. Both of these circuits are actually discriminators and operate on similar principles. The ratio detector was originally devised to avoid the necessity for limiting amplifiers, and also to get around the Armstrong patents. It was not too successful in either attempt.

Limiting is a process occurring in one or more i-f amplifiers immediately preceding the discriminator, in which any AM noise is rejected. Without it the full signal-to-noise capabilities of FM cannot be realized.

But since many *ersatz* FM sets were built without limiters, using ratio detectors which are inadequate to do a good limiting job, the ratio detector rather than bad design was held to blame. The fact is, there is nothing wrong with ratio detection which proper limiter design won't cure, but since the circuit now has such a bad name, it is seldom to be found in hi-fi FM tuners.

Radio tuners for hi-fi are available in FM-only, AM-only, AM-FM and AM-plus-FM types. The first two are self-explanatory, but the latter two are not as similar as they might seem. The difference is that the either-or type can receive only one *type* of signal at a time, since many of

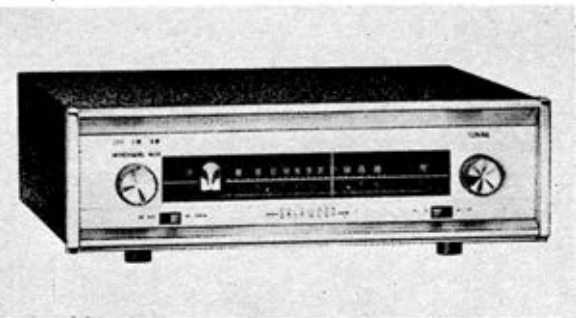

Sherwood FM-AM model has AFC switch; FM response: 20-20,000 cps  $\pm$  .5 db, AM: 20-7,000 cps  $\pm$  6 db. FM hum and noise: -60 db, AM: -55 db.



De Wald stereo tuner has 3 mv sensitivity for 20 db quieting. Output jacks include AM, AM-FM, FM stereo, AM tape and FM tape, Multiplex adaptor.

H. H. Scott AM-FM tuner sells for \$139.95, has 3 mv for 20 db quieting sensitivity, FM Multiplex output, logging scale and electron-eye tuning.



the tubes and circuits in the set are shared by both the AM and FM functions. The AM-plus-FM or stereo type, on the other hand, is really two complete tuners in one, and if desired it can feed two separate programs to two different hi-fi systems simultaneously. Since such tuners can also handle AM-FM stereocasts, this type unit is often described as a stereo tuner.

The antenna for an AM tuner is no serious problem. Local signals are so strong that almost any sort of antenna will suffice, and the broadcast spectrum is now so crowded that long distance (DX) reception is hardly worth the trouble. Tuners usually have some sort of small antenna built in, often a ferrite loopstick. If this isn't sufficient, a section of ordinary wire, ten feet long or so, will usually do the job.

An external antenna is normally required for FM, but an indoor type is plenty adequate for all except fringe reception. The usual TV "rabbit ears," for example, make an excellent indoor FM antenna.

There are many good FM outdoor antennas commercially available. They look very much like TV antennas, which is not surprising, since the FM band is right in the middle of the TV allocations, between channels 6 and 7. Many, but not all, outdoor TV antennas will work well on FM. Those which do not are purposely designed to have poor response in the FM band, so as to avoid interference from FM in the adjacent TV channels.

An excellent do-it-yourself FM antenna can be constructed by yourself. The only

Pilot stereo FM-AM tuner and dual preamp costs \$289.50, has AM and FM meter, 2 mv sensitivity for AM, 1 mv for 20 db FM, dual cathode output.

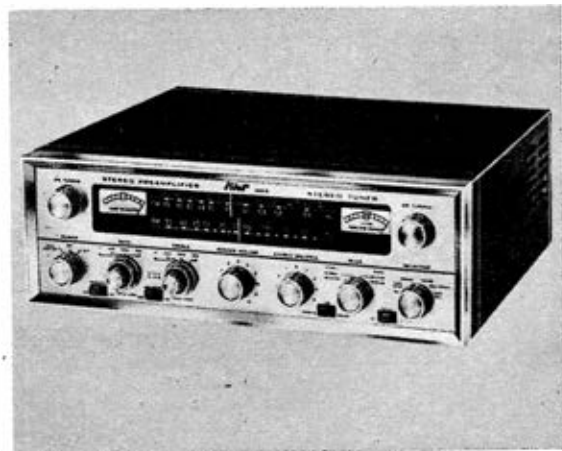

materials are some ordinary antenna wire, ribbon-type transmission line, and three strain insulators. This antenna can be strung from garage to house, between trees, or with supporting posts or towers. To get a fairly good impedance match between the antenna  $V$  and the transmission line, the ribbon insulation should be split for a length of two feet, so the wires can fan out to a four-inch spacing where they join the antenna.

Ribbon-type transmission line of 300 ohms impedance, commonly used in television installations, is also widely used for FM, although there are some exceptions. In noisy areas it may be necessary to use shielded 300-ohm line. Some antennas have a characteristic impedance which is closer to 72 ohms, in which case 72-ohm line should be used. This is available in both ribbon and coaxial types. Many of the better tuners have antenna input terminals for both 72 and 300 ohms to accommodate these varying conditions.

Tuning indicators are useful with AM tuners and essential in FM operation. They can be either of the electron-ray "magic eye" variety, or an electric meter. In AM sets they usually indicate the condition of maximum signal, while in FM sets they normally indicate the correct tuning to the center of the channel. Although the tuning eye is more difficult to read, it is every bit as accurate, and not as expensive, as the meter.

Sensitivity specifications for tuners are best given in terms of the amount of input

signal required to produce a certain signal-to-noise ratio. Although this method is quite generally used for FM, it is unfortunately not often used for AM in the United States, although that method of testing is rather widespread in England.

In this country the usual AM sensitivity specification gives the number of signal microvolts (mv or  $\mu v$ ) necessary to be fed into a standard antenna to obtain the rated output of the tuner or receiver. This is too nebulous a figure to enable valid comparisons between tuners of different manufacture, although it may be useful in evaluating those in a given line. With these reservations, it can generally be said that the fewer the microvolts required, the more sensitive is the receiver.

There are several types of sensitivity measurements which can be made on FM tuners, but the one usually mentioned in manufacturers' literature is the quieting-signal sensitivity. This in effect tells the minimum amount of radio signal required to produce a certain signal-to-noise ratio in the output. Although good engineering practice calls for this quantity to be expressed in terms of 30 db (decibels) of quieting, some manufacturers, with apparent malice aforethought, have adopted their own standard.

These people have arbitrarily decided that, since a sensitivity figure based on only 20 db of quieting looks a lot prettier, they will use that instead. This certainly makes for confusion in the mind of the consumer, which no doubt was the whole

**Scott AM-FM stereo tuner, 330-C, has 2 mv for 20 db quieting FM sensitivity, Multiplex output, AM-FM tuning meter, includes two tape outputs.**

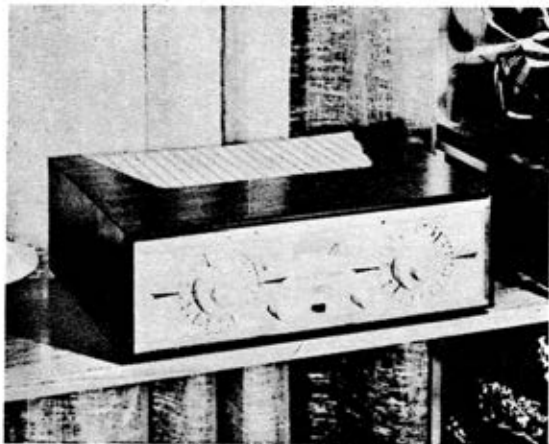

**FM-only tuner by H. H. Scott features automatic gain control, interstation noise suppressor, a signal strength and tuning meter, Multiplex jack.**

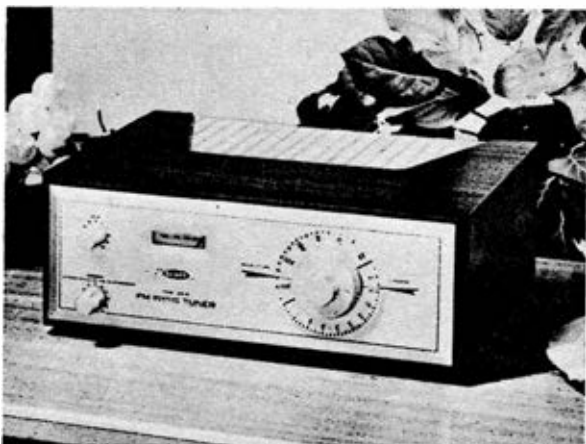

The "Duet" stereo tuner by Harman-Kardon sells for \$114.95, has FM sensitivity of 3.5 mv for 20 db quieting, 30-15,000 cps response,  $\pm 0.75$  db.

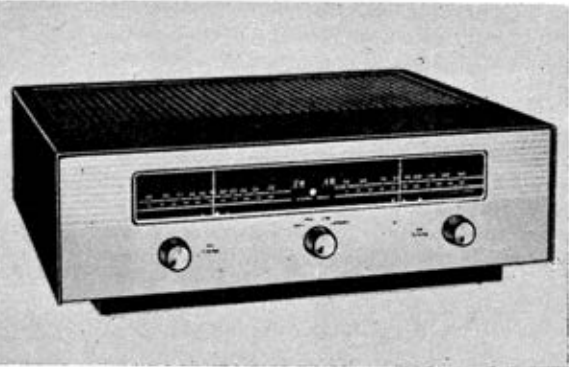

Harman-Kardon "Madrigal" ST350 stereophonic AM-FM tuner has push-button controls for Multiplex, AM noise filter, FM-AFC, FM, AM and stereo.



Heathkit FM tuner comes in kit form, has 2.5 mv sensitivity, AFC, flywheel dial tuning and Multiplex adaptor output. Price of kit, below, \$34.95.



idea of this flummery. But you still can't add oranges and apples, and you can't compare sensitivity statistics having two different bases.

Just remember this: it's a lot harder to get 30 db of quieting than it is 20 db. Obviously then, a tuner which requires 2 mv for 20 db of quieting is less sensitive than one which will deliver 30 db of quieting for the same 2 mv input signal. To summarize, then:

1. If the microvolts are the same, the set with more decibels of quieting is the more sensitive.

2. If the decibels are the same, the set requiring less microvolts of signal is the more sensitive.

A feature of most of the better tuners, both AM and FM, is automatic volume control (AVC). This is a circuit which automatically varies the gain of the tuner to compensate for changes in received signal level. This is not so important when the set is tuned to local stations, except when for some reason the station changes power. But AVC has its greatest usefulness when tuned to more remote signals, which have a tendency to fade.

Another refinement is quiet AVC, which automatically kills the noise ordinarily heard when tuning between stations. Such circuits are also sometimes referred to as muting, squelch or interstation noise suppression. Since noise can be a real annoyance when attempting to find a weak signal from a distant station, it is most important that the tuner be provided with a switch for defeating this circuit when desired.

Since broadcast transmissions are held to their assigned channels within very close tolerances, the tuner, too, should have

Sargent-Raymont AM-FM stereo tuner is priced at \$184.50, has Multiplex adaptor switch, a 10 Kc whistle filter, gold-plated frame grid cascade.

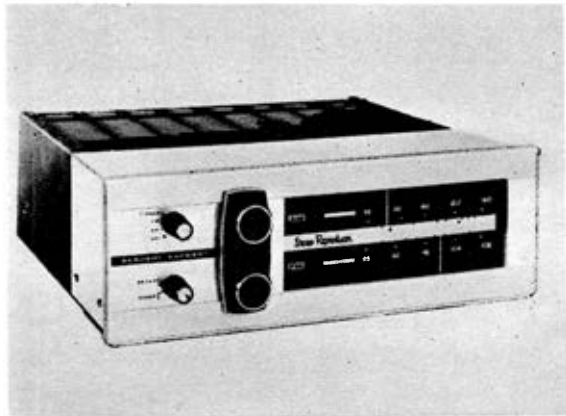



## Tuners and Receivers

some means of keeping itself locked in on frequency. But there is a tendency for tuners to drift, and this is especially noticeable at the high frequencies employed for FM. The means used to compensate for this is automatic frequency control (AFC). This circuit usually controls the local oscillator, to correct its frequency so that the required i-f is always produced. An AFC circuit is indispensable for FM, and it is very useful for AM as well.

Another factor sometimes mentioned in tuner specifications is the FCC radiation specifications. Since every superheterodyne circuit has a local radio-frequency oscillator, it is in effect a miniature radio station itself. The Federal Communications Commission has laid down specifications concerning the amount of external radiation permissible from these circuits, so as to minimize interference with other receivers. All tuners, both AM and FM, must meet or exceed these specifications.

Sometimes the term "capture ratio" is found in sales literature. This refers to the ability of an FM tuner to accept the stronger of two signals on the same channel, while rejecting the weaker. It apparently evolved as a sales point from the tendency of an FM set to flip-flop back and forth between two signals of approximately equal strength, as they vary slightly with atmospheric conditions. There are no accepted standards for this particular figure, so the laudatory adjectives found in promotion material are next to meaningless.

**Pilot 580 Stereophonic AM-FM tuner has center-of-channel AM and FM indicators. Multiplex outlet, on-off switch, logging scale, 88-108 Mc FM.**



### The Stereo Story

The simplest means of broadcasting two-channel transmissions for stereo is to use two separate stations. Since a broadcaster may be licensed to operate an AM, an FM and a TV station in the same city, he could use any two of these for two-channel stereo. Thus we have the possibility of AM-FM, AM-TV or FM-TV stereocasts. All of these combinations have been used for stereo, but only the AM-FM type is today used with any regularity. To receive such stereocasts you need an AM-plus-FM tuner, as we have already discussed.

The newest method of stereocasting uses only one FM station in a system known as *Multiplex*. In this arrangement a conventional modulator superimposes an audio signal on the FM carrier in the usual way. But in addition a supersonic frequency is imposed on the FM carrier, and then audio is also imposed on this supersonic sub-carrier as well. (See drawing on page 34.)

Ordinarily an FM tuner will detect only the audio on the main carrier. But with the aid of a Multiplex adapter the tuner can detect and separate the second audio signal as well. Very few tuners are as yet featuring multiplex circuits built in, but they are readily available as an accessory. As stereo increases in popularity, this method of stereocasting is destined for great future importance. •

**Model 680 Stereophonic FM-AM tuner by Pilot is equipped with two tuning meters, separate on-off switches for AM and FM, Multiplex outlet.**



## Chapter 8

# Power Amplifiers



Rear view of Bell stereo amplifier showing speaker connections, input and output jacks.

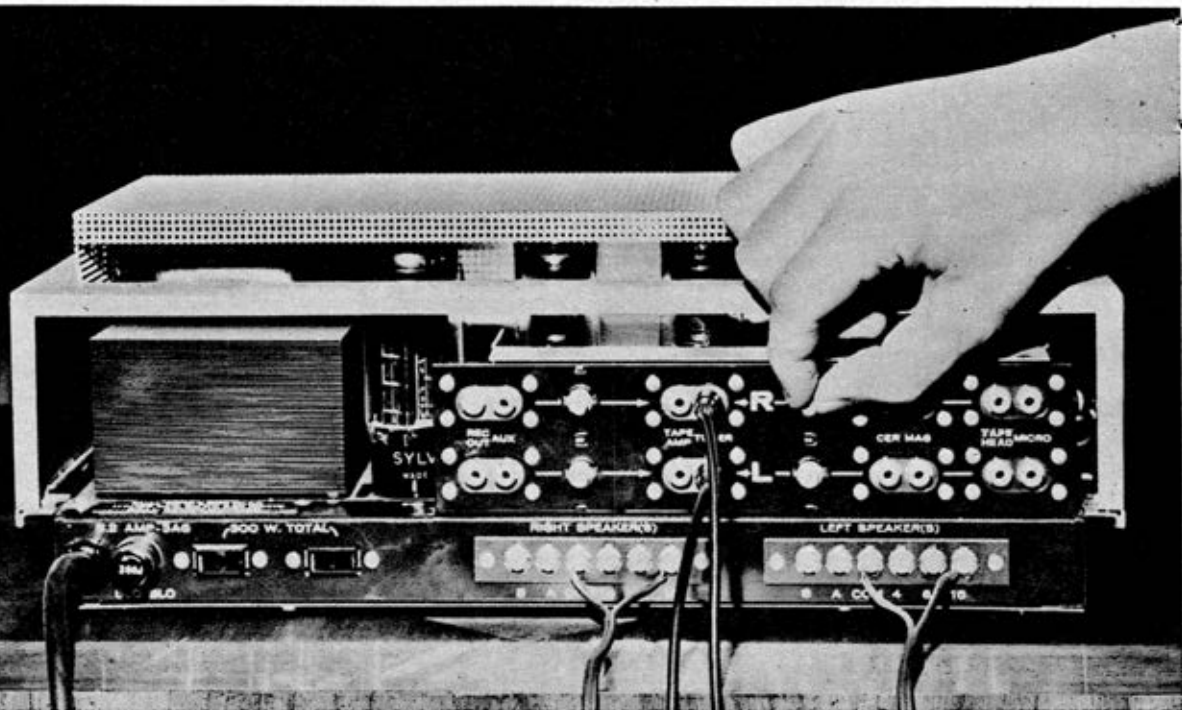

At the end of the electronic chain in the hi-fi system is the power amplifier, which builds up the tiny voltages from the program sources or preamplifier and sends them as powerful signals into the loud-speaker, where they are to be reconverted to sound. The complexity of the power amplifier will depend upon the number of functions it must perform, and whether any functions are handled by a preamplifier or control amplifier preceding it. The simplest basic amplifier is a fixed-gain device, which sends through in enlarged form whatever signals are fed into it by a control amplifier, the signals being other-

wise unchanged. At the other extreme, the hi-fi amplifier may include preamplification, switching and other controls, all within a single unit.

The controls may therefore be an integral part of the main amplifier, or they may precede it. In either event their function is the same, so we will discuss them here, even though they may not always be found as a part of the main power amplifier.

The first control, without which all the others are useless, is the electric power switch. This may be a rotary, toggle, or slide type, but it's still a two-position



Marantz 40-watt power amplifier has hum level of  $-90$  db at 40 watts. Damping is more than 20; 20-20,000 cps; 4, 8, 16 ohm terminals. Price: \$219.



Stromberg-Carlson stereo control amp provides 12 watts for each channel, with individual controls for both channels, plus a master gain adjust.



Bell 2-channel stereo unit has a rating of 30 watts for each of its channels, continuously variable loudness control, speaker function lever switch, stereo balance. Response is 15-30,000 cps  $\pm 1$  db, hum is  $-71$  db; price: \$219.95.



switch, which is turned either on or off. Sometimes it is ganged with the volume or tone control, while in other cases it is entirely separate.

A different type of switch, a selector or function switch, is found at the amplifier input. Since a number of devices from various program sources may be fed to the input, a rotary switch or series of push buttons is necessary for selection of the desired one at any given time. In many cases this switch will also select the phono compensation.

Bear in mind, however, that most compensator design is based on magnetic pick-

ups. When such an equalizer is used with piezo type cartridges, an adapter is required. But since crystal and ceramic cartridges are reasonably well equalized internally to the RIAA characteristic, they may be connected directly to any high-level unequalized input jack, such as TV, TUNER, TAPE or AUX. A jack which is specifically designated for the piezo type cartridge may have a little additional equalization and it should certainly be used if available.

There are usually at least two tone controls on the amplifier; one for bass and one for treble. Unlike the simple treble roll-off

control found in home instruments, hi-fi tone controls provide either accentuation or attenuation at both ends of the spectrum. They will thus accommodate almost any personal taste, as well as any acoustical peculiarities of the listening area.

The midrange is not usually controllable, although some amplifiers do feature a "presence" control. Since the human ear is most sensitive in the region between 3,000 and 5,000 cps, it has been found that boosting this range will make solo voices stand out and improve articulation. The change in quality possible with such a control is quite dramatic, but since this form of equalization is now widely used at the source in broadcasting and recording, more fooling around with this range at home is usually overdoing it a bit.

Another form of control over the frequency response is the fixed filter, which may be switched in and out as required. At the low end is the rumble filter, which is used to cut out low frequency noise generated by the turntable, or present in the program source. This filter can't help cutting some bass as well, but it is made as selective as possible.

At the other end of the spectrum are scratch and hiss filters, which are intended to reduce those types of noise to a comfortable volume. There may be several of these each cutting off everything above a specified frequency. They may start as low as 3,000 or 5,000 cps, and go up as high as 10,000 or 12,000 cps.

There are two types of sound level con-

trol, one of them actually being a form of tone control as well. The ordinary volume control adjusts the level of all parts of the spectrum equally, but the more elaborate loudness control does not. Since flat response is generally a desirable hi-fi objective, the deliberate distortion introduced by this control must be justified.

The design of the loudness control is tied in with the peculiar characteristics of the ear already described. The increased sensitivity in the 3,000-5,000 cps range is true at all volume levels, but more so at lower intensities. In other words, the ear is always less sensitive in the bass and treble regions than in the midrange, but as the volume is lowered, the droop at each end becomes even more pronounced. That is, the bass and treble drop even faster than does the middle.

Since most of the time we listen to a hi-fi system at a much lower level than that of the original sound, we are also hearing less treble and bass than originally produced. This can be corrected in a haphazard way simply by tipping up both tone controls, but that is strictly a guesswork method. The loudness control, however, has a characteristic which is just the inverse of the ear, and thus provides the correct aural balance at all listening levels.

The power rating of an amplifier is supposed to tell the maximum watts it develops in its output load with only a reasonable amount of distortion. But there are dozens of different types of distortion, almost as many ways of measuring it, and



Leak, British 50-watt monaural amp can be used with speakers having impedance of 3 to 20 ohms. Response is 20-20,000 cps  $\pm$  .5 db; price is \$149.

At right are two models by Leak, the 50-watt stereo amplifier and the "Point One" stereo preamp. The power amplifier is rated at 25 watts for each of its two channels, sells for \$189; the preamp is \$129.

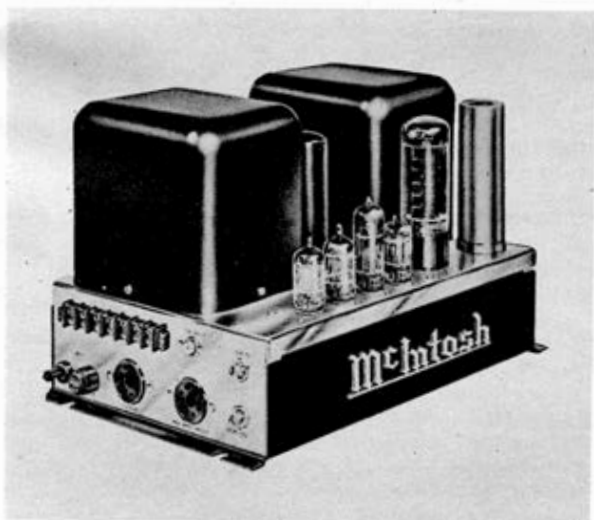
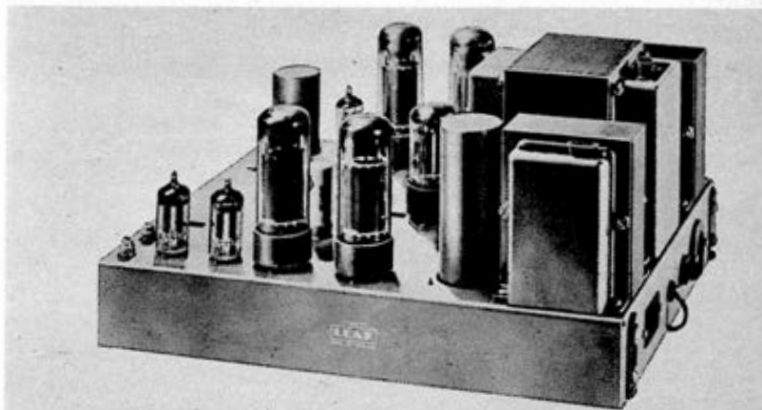

McIntosh 30-watt basic amplifier has frequency range of 15-50,000 cps  $\pm$  .5 db at 30 watts. The damping factor is 12 for 4, 8, 16 ohms; \$143.30.

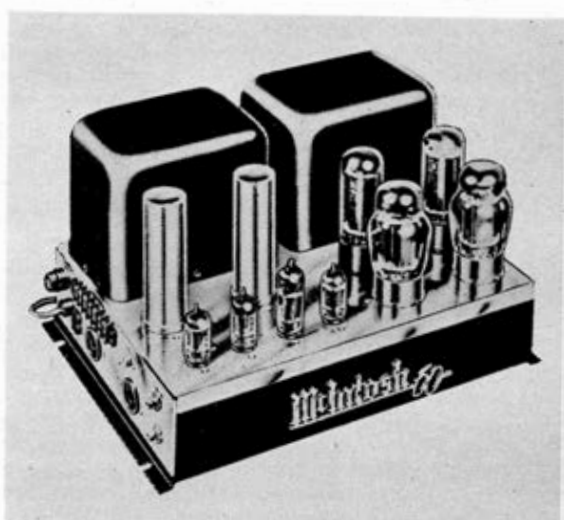

Continuous 60 watts are obtainable with the MC-60 by McIntosh. Noise and hum: -90 db at 60 watt. Distortion is less than .3% at full power; \$198.



Grommes stereo amplifier gives 20 watts for each channel, has ganged controls. The unit is also a complete preamplifier and compensator for tape and phonograph discs.

Basic 60-watt amplifier made by Grommes has 5-50,000 cps  $\pm$  .5 db frequency response. The power response is 20-20,000 cps  $\pm$  .5 db at 30 watts. Damping is continuously variable. Hum and noise: -95 db.



some disagreement as to what constitutes a reasonable amount. This all adds up to the fact that the amplifier power rating is not a very useful concept in judging equipment performance.

Since distortion is such an important factor in rating amplifier power, however, it follows that distortion will be less when the system is operated well below its maximum rating. This is the basis of the argument for using amplifiers of upward of fifty watts in home installations when the program content usually is only a fraction of a watt. When a low efficiency loudspeaker is used, of course, the argument takes on even more validity.

The most serious forms of distortion are those which occur when more than a single pure tone is fed into the amplifier simultaneously. Since most hi-fi programs comprise music as the audio signal, and since most music is made up of chords of tones, plus their harmonics, the resultant waveform which must pass through the system is highly complex. A type of distortion which often occurs under these conditions is called *intermodulation*. This occurs when two or more audio frequencies in the amplifier combine to form sum-and-difference tones in the output.

A similar phenomenon actually occurs within the human hearing mechanism, in which case the resultant combinations are

called *subjective tones*. But the amplifier is supposed to be completely objective, not subjective. It should not add any coloration of its own at all. As a practical matter, no amplifier is this perfect. All amplifiers will generate some intermodulation, and most listeners are not offended by it, as long as it remains under 5 per cent. Under these conditions, harmonic distortion is no more than 1 or 2 per cent, a negligible amount.

Another important index of amplifier performance is *transient response*. This is the reaction of the system to steep waveforms, attacks and releases. In the case of music, tonguing a mouthpiece, depressing a key, or striking a drumhead or cymbal, all produce sharp sounds which have only a brief instant between the initial impact and the maximum amplitude. At the end of the tone there is a decay period, although the cut-off is less sharp. The system which can accurately reproduce these steep waves is said to have low transient distortion. This distortion is sometimes expressed in terms of the manner in which the shape of a square wave is altered as it passes through the system, the distortion being observed on an oscilloscope.

The human ear is still the best measuring instrument of all, however, and in evaluating any amplifying system you should rate it strictly in terms of what your own ears tell you. Listen carefully to the han-



Dual stereo amp-preamp by Bogen-Presto provides 30 watts for each channel, has phase and channel reverse switch and two hi-lo filter switches.

Harman-Kardon A250 stereo amplifier, 25 watts each channel, has frequency response at 20 w of 20-20,000  $\pm$  1 db, local and remote speaker switch.



ding of program material containing many sharp attacks: staccato, pizzicato and sforzando passages. These should all be perfectly clear, without any "hash" or "ringing."

Any audio power amplifier is really a series of smaller amplifiers in cascade, each of these sub-units being known as a *stage* of amplification. The number of stages in an amplifier indicates the number of multiplication processes the signal goes through between the source and the output.

The means by which the signal is transferred from the output of one stage to the input of the next is known as the *coupling*.

Most audio amplifiers are called resistance-coupled, having an arrangement of resistors and capacitors between the plate circuit of the previous stage and the grid circuit of the following tube.

A rather special type of coupling is the *cathode follower*, in which the output signal is taken from the cathode of a tube rather than its plate. When a tube is connected in this way, it isn't really an amplifier at all, but actually a loss device in which the output signal is smaller than the input. The cathode follower is very low in distortion, and an excellent device for coupling a high-impedance source to a low-impedance load. It is therefore some-



A220 stereo amp by Harman-Kardon gives 10 watts at each channel, has 8 and 16 ohm outputs. Inputs include phonograph, tuner and auxiliary. Crosstalk is below 50 db, hum is -70 db at low volume.

Fisher stereo master audio control and 40-watt two-channel amplifier has 8-position input selector, frequency response of 20-20,000 cps; hum and noise are 80 db below rated output; 50 db channel separation.



times used to couple the amplifier output to the loudspeaker, thus eliminating the output transformer.

When more than one tube is used in a single amplifier stage, the connection of the tubes is usually in an arrangement called *push-pull*. In this case the signal is fed simultaneously into both tubes, in such a way that a positive peak at the output of one tube coincides with a negative peak at the output of the other. The principle is therefore somewhat analogous to the increased smoothness found in an alternating-fire twin outboard motor. In amplifiers, the advantages are less hum and distortion, and the ability to use smaller and cheaper output transformers.

Between the output of the single-ended

amplifier and the push-pull input, there must be a device which can produce, from the single waveform, two output waveforms which are exactly opposite in polarity. The device which does this is called a *phase inverter*. This may be either a center-tapped transformer, or the job may be done electronically by a paraphase (phase-splitting) amplifier. Although the transformer is every bit as much a phase inverter as the paraphase, the term is usually applied only to electronic phase inversion. Paraphase amplifiers have the same advantages as any resistance-coupled amplifiers, namely, better frequency response and the elimination of expensive transformers.

The operation of audio amplifiers often



Three units by H. H. Scott are shown on this page. Right is 99-D monaural 22-watt pre amplifier with 20-30,000 cps  $\pm .5$  db frequency response.



Dual 12-watt amplifier and stereo preamp, Model 222, has noise and hum of 80 db below full power output; harmonic distortion is .8%. It has a third channel amplifier jack.



Type 229 stereo dual 20-watt amplifier and preamplifier is rated at 17 watt of continuous power for each channel, has a phase reverse and stereo balance control. Outputs include tape and 4, 8 and 16 ohm.

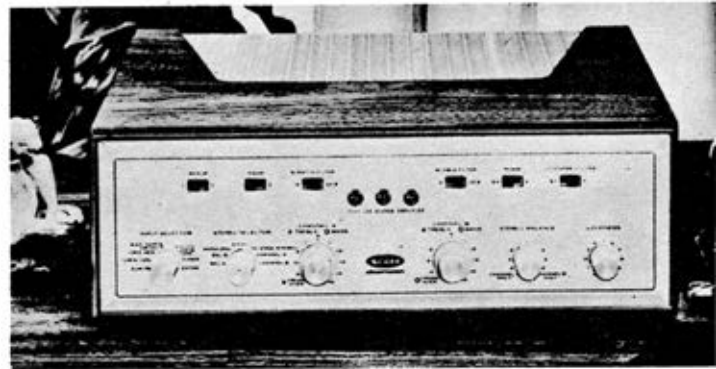

is described as Class A, AB, or B. These designations refer to operating conditions within the tube, which depend upon its basic characteristics and the voltages applied to it. Class A is the least efficient, but it also exhibits the least distortion. All sorts of trick circuitry have been developed for canceling out distortion in the more efficient Class AB and B systems, but the serious audiophile should steer clear of this sort of thing. The best amplifier always has a good, clean Class A design throughout.

In some audio amplifiers, a portion of the output signal is fed back into the input in such a way as to oppose, and therefore reduce, the incoming signal. This action is known as *degeneration*, and the system is called negative—or inverse—feedback.

Negative feedback causes some loss in signal level, but it also causes an even greater **reduction** in noise and distortion. It should be understood, however, that the feedback only reduces the distortion which is generated within the stages where feedback is used. Any distortion already present in the input signal before the feedback will pass right through unmolested. Generally speaking, negative feedback is desirable in limited amounts, although excessive degeneration will result in instability on peaks and high distortion on overloads.

There are two basic types of vacuum tubes used in audio amplifiers. One of these is the three-element tube known as the triode. The other is the five-element type,

called the pentode. The beam-power tube such as the 6L6, which is often used in the output stages of audio amplifiers, is really a member of the pentode family, although its physical construction is somewhat different from others in the five-electrode group.

Because pentodes as a group are much more efficient than triodes, they are much more commonly used for audio. But the purist knows that the triode amplifier is still the cleaner of the two. Design engineers may argue that it is theoretically possible to build a pentode amplifier with no more measurable distortion than the triode, but that best measuring instrument of all, the human ear, tells us that the best all-triode amplifier will beat the best pentode rig.

## The Stereo Story

The basic power amplifier setup for stereo involves essentially two identical monophonic amplifiers. If you already have a good monophonic system, simply duplicating the power amplifier will take care of that part of the stereo chain. The so-called stereo amplifier is actually two separate amplifiers in one, mounted on a common chassis.

The system which is tailor-made for stereo, however, will have a few convenience features, especially in the way of controls. Since it is fairly difficult to maintain the proper balance between the two stereo channels when volume adjustment of each channel is made separately, most stereo controls have both volume-loudness controls ganged together, so that the out-



H. H. Scott basic 40-watt power amplifier has flat frequency response from 12-40,000 cps. Speaker outputs available are 4, 8, 16 ohms.

Precise stereo amplifier delivers 20 watts for each channel, has Multiplex adaptor built in, includes a speaker phase, and a channel reverse switch.

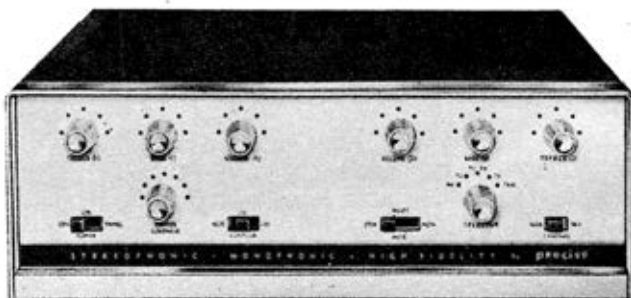

Pilot 30-watt stereo preamp-amplifier sells for \$129.50, has frequency response of 20-20,000 cps  $\pm$  1 db. Full output phono sensitivity is 3 mv. Hum and noise is below 80 db.



## Power Amplifiers

puts of both channels are affected by exactly the same amount.

This is only useful, however, when the two channel outputs have previously been balanced. Ideally, the outputs of the two loudspeakers would be just the same in volume. But differences in recording technique, listening room acoustics, and the location of the listener require some flexibility in this rule. For this reason, stereo systems usually have a *balance control*, which has nothing to do with tonal balance, but merely varies the relative outputs of the two channels.

Most stereo systems also have a *reverse switch*, which corrects for any anomaly in the system whereby the left signal appears out of the right speaker, and vice versa. This makes for a rather topsy-turvy



orchestra, but it can be simply corrected by adjustment of the reverse switch. This switch should not be confused with the stereo loudspeaker phasing switch, which will be discussed in the next chapter.

Other switches permit listening to either channel alone for checking purposes, without disturbing the balance, and feeding monophonic program material into either or both loudspeakers. •

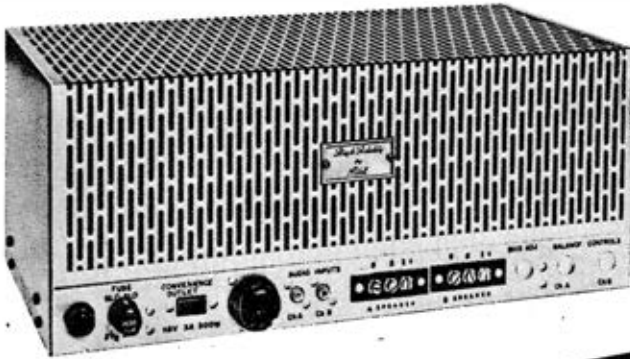

Basic 80-watt stereo amp by Pilot gives 40 watts per channel. Hum level is 90 db below full output. Harmonic distortion is .5% at 70 watts. Outputs are 8 and 16 ohms; \$139.50.

Lafayette stereo audio output level indicator is used to balance stereo channels. Meter responds to average values of music and speech, lets you compare levels in channels.

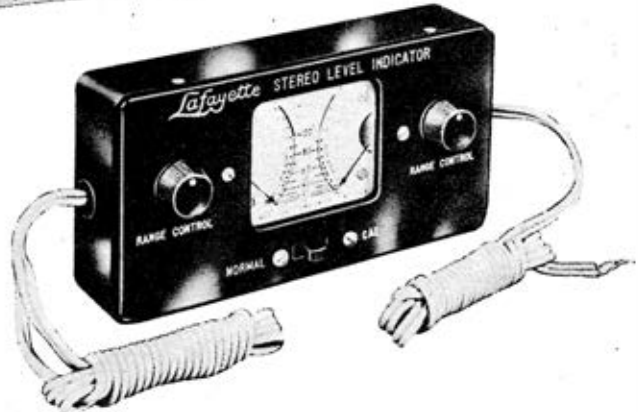

Among the many hi-fi units made by Sherwood is this stereo dual preamp-amplifier which gives 20 watts for each channel. It has pushbutton filter and level controls, function indicator lights and phase reverse. Interchannel crosstalk is -50 db at 1 Kc. Frequency response: 20-20,000 cps  $\pm$  .5 db. Price, less case, \$189.

## Chapter 9

# The Speaker System



Above, J. B. Lansing "Ranger Paragon" stereo reproducer weighs 850 lbs., uses two 15-inch woofers, two midrange, two tweeters, two networks.

Janszen electrostatic speaker has frequency response of 700-30,000 cps, 8-ohm impedance, uses two radiators with power supply in the cabinet.

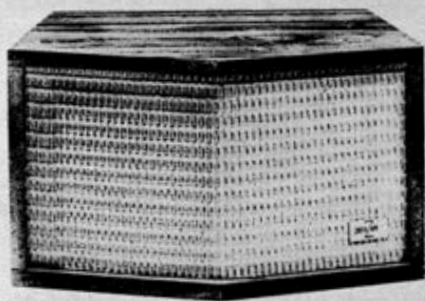

**W**HEN the electrons in an electric current cause the molecules in air to vibrate and produce sound, the device that produces this transformation is called the loudspeaker. These are the terminal facilities of the hi-fi system, the end of the line. If the sound isn't right when it leaves the speaker diaphragm, nothing can be done to save it. The hi-fi system has done its job, for better or for worse.

The vast majority of loudspeakers are of the dynamic type, and any such speaker must have two essential elements. One of these is the *driving motor*, which is basically an electric vibrator whose movements coincide with the variations in audio current producing them. This motor is attached to the *acoustic radiator*, the element which actually radiates the sound.

In many speakers the acoustic radiator is the *cone*, made of special paper. Add to this a supporting framework and suspensions for the cone, and you have the basic speaker, the kind most commonly found in ordinary home instruments and auto radios.

Even the most inexpensive hi-fi speaker, however, has refinements beyond this point. Because the high frequencies are produced only in the area near the apex of the cone, there is often some sort of de-

coupler which permits the apex to vibrate independently of the overall motion of the cone.

The simplest way of building in decoupling is to mold an annular ridge into the cone, which forms a springy joint between the two sections of the cone. Another method is to build the cone in two sections, with a viscous cement joining the two. In any case, the stiffness of the paper usually changes at this point, with the cone being softer in the outer area than in the center. Finally, a small dome of convex metal or plastic is usually attached over the apex. This not only serves to provide dust protection for the motor, but also tends to disperse the higher frequencies, which otherwise travel in rather narrow beams.

A speaker of this sort comprises the basic extended-range hi-fi unit, and it is reasonably good for a start. But it has long been known that no single speaker is capable of reproducing the entire audible spectrum, any more than a tuba can be made to sound like a piccolo. Only two or more speakers, each specifically designed to reproduce a part of the spectrum, can do the full job.

The first two-way systems were designed for motion-picture theaters, where

**JansZen 200 system comprises 12-inch woofer and 4-radiator electrostatic tweeter, power supply. Range: 30-30,000 cps; 16-ohm impedance; 2.5 cu. ft.**

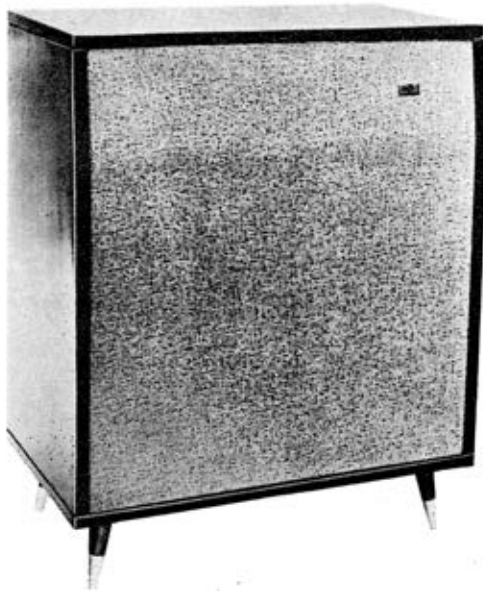

**Z-300 JansZen system has 8-ohm impedance, a 2-radiator electrostatic tweeter, 11-inch woofer. Power handling capacity is up to 100 watts peak.**

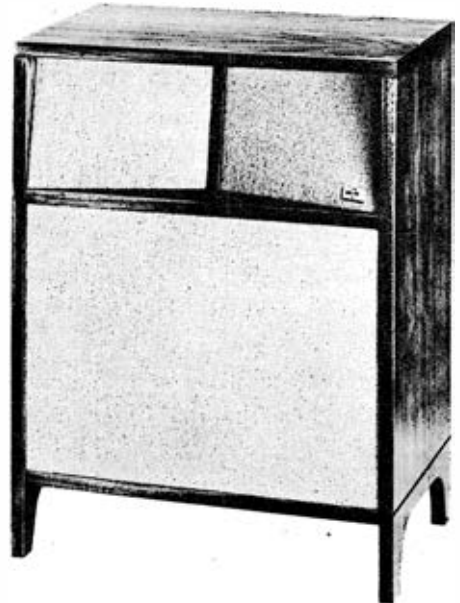



Bel-Aire by J. B. Lansing has 8-inch woofer and 2,500-cycle crossover tweeter, plus network. Two units give stereo system. Single cabinet: \$166.

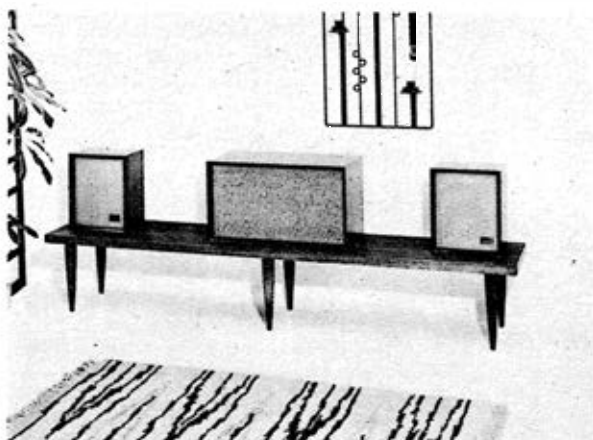

Electro-Voice stereo system comprises one full-range system and two (above 300 cps) add-on units. Complete price, with mixer, is \$223.50.



James B. Lansing kit units shown are (clockwise from bottom) dividing network, two 15-inch woofers, exponential horn with midrange-high driver.

Rear-loaded horn by J. B. Lansing has 15-inch extended range speaker, h-f tweeter and network. Can also be adapted for 12-inch speaker.

the low-frequency speaker is called a *woofer*, and the treble speaker a *tweeter*. But with present hi-fi speaker systems often cutting the spectrum three or four ways, these names no longer have such definite meaning. But those who are fond of nicknames seem to go along with calling the midrange unit a *squawker*, and the very-high-frequency unit a *super-tweeter*.

These several speakers may be entirely independent of one another, or they may be constructed coaxially. If you use the add-on method of building up your speaker system, you will probably have the several elements spaced out on a common mounting panel. The coaxial types are usually of integrated construction which doesn't lend itself to the add-on system.

There is widespread confusion concerning the many coaxial speaker types, with many audiophiles thinking they have a better unit than they actually possess. This is such an important subject that we should spend some time in discussing just what the facts are.

The simplest coaxial speaker is just a small jump above the ordinary extended-

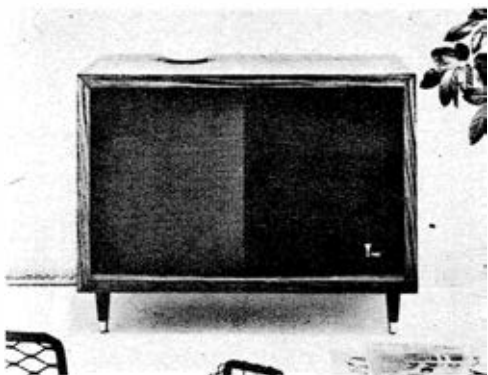

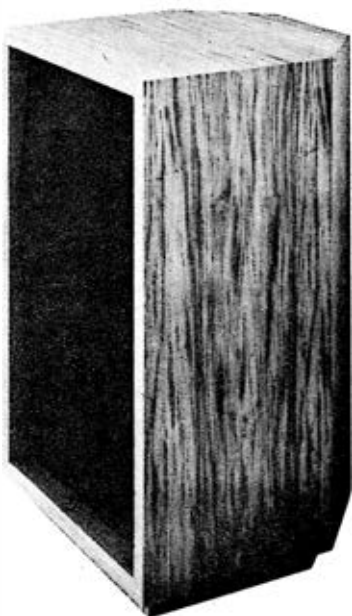

Lansing Model 34 has exponential folded horn with an effective 6-foot length, accepts either one full-range speaker or a 2-unit, 2-way system.

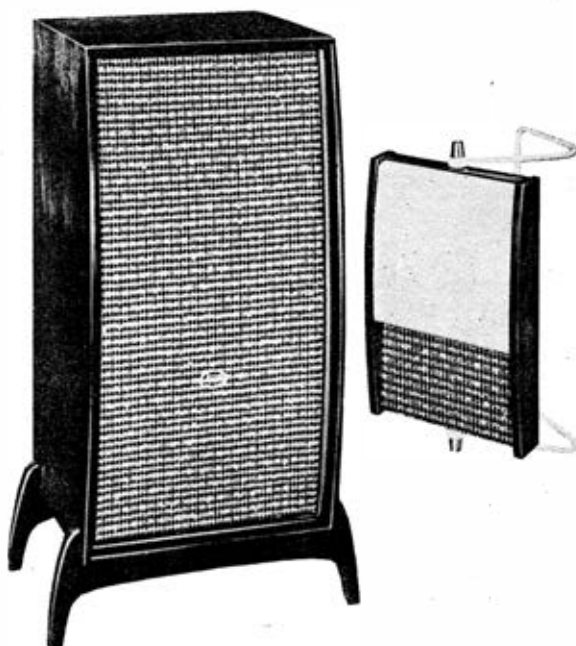

Jensen "Galaxy" stereo system has one bass center unit and two add-on satellites. One woofer gives below-350 cps response, has two voice coils.

range type. The difference is that it has two cones instead of one, the conventional full-sized cone acting as the woofer, while a smaller, stiffer cone inside it acts as the tweeter. But note carefully that while this speaker has two acoustic radiators, they are both driven by one and the same motor. This is not a true two-way coaxial speaker, although many people owning this type think that it is.

A speaker of this type is sometimes said to have a "mechanical crossover," which is the key expression to look for in the sales literature. It means that while the voice coil in the driving motor may vibrate at all frequencies, each cone will vibrate only in the range for which it was designed. This separation is determined solely by the physical size and shape of the two cones.

A true two-way speaker operates quite differently. In the first place, the splitting of the spectrum into two bands is done *electrically*, by a filter device known as a *crossover* network. Then each group of signals is fed to its own separate and complete driving motor. Only then, when two

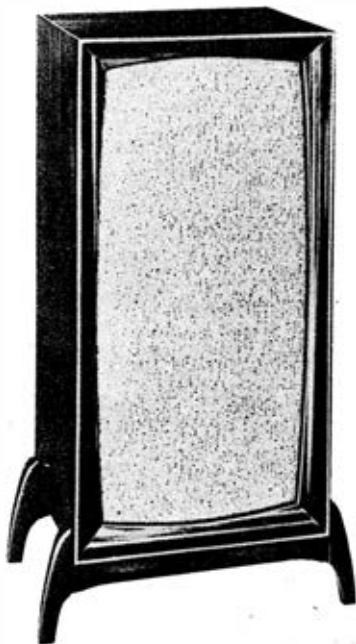

Two-way speaker by Jensen has 16-ohm impedance, 36-14,000 cps frequency response, costs \$79.50. Unit is available as cabinet kit only, \$29.75.



University "Debonaire" system with two add-on "Stereoflex I" units for stereo reproduction. A 12-inch dual voice coil woofer is used here.

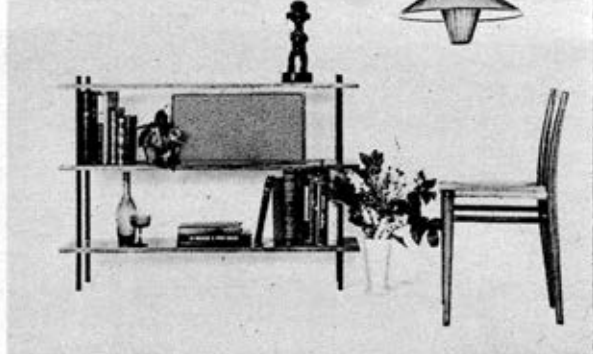

Several types of two-way speaker systems are made by University. Above is the Model S-80 for limited space installation; 8-ohm impedance.

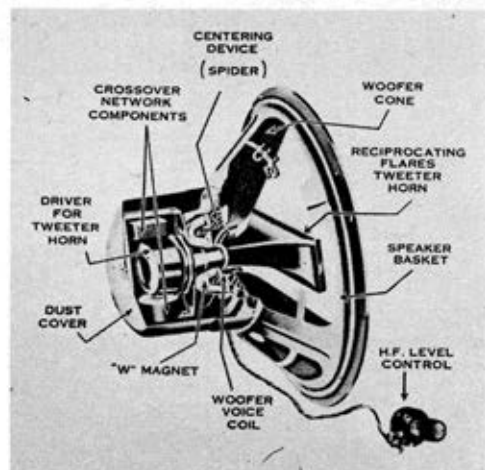

Cutaway drawing of University dual range coaxial 12-inch speaker. Tweeter with driver is mounted through center axis; built-in network, control.

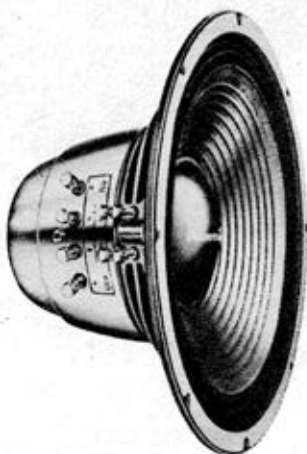

Dual voice coil 12-inch University woofer can be adjusted for 700, 2,500 or 5,000 cps high-end cutoff to suit requirement of the tweeter.

University makes the "Stereoflex II," comprising a 150-cycle horn and driver, tweeter, and balance control. Unit can be used as second channel of stereo system in which main channel utilizes a wide range speaker, or two units may be combined with single woofer. Response: 150 cps to inaudibility.

Photos by Fred Honig

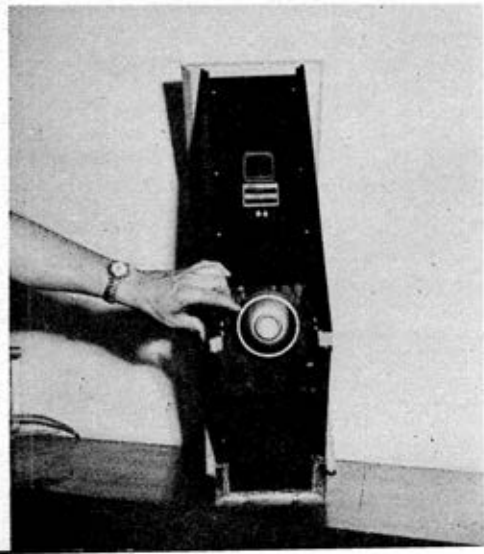
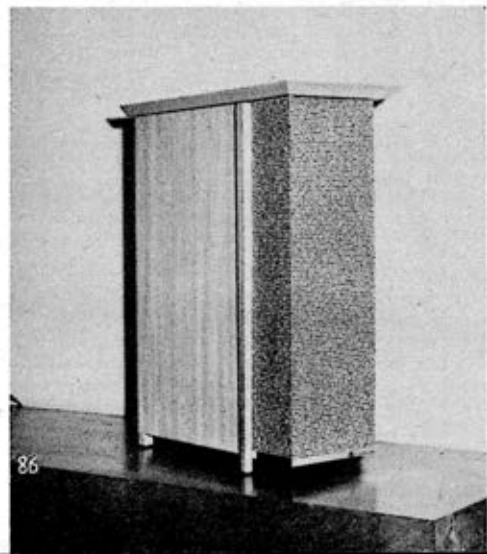



completely separate speaker systems are mounted coaxially, can the speaker system be truly called two-way.

The next speaker type is really a composite of the two types just discussed. It has three acoustic radiators with but two driving motors. In this case the large main cone acts as the woofer, a smaller parasitic cone attached to it is the squawker, and an independently driven small element is the tweeter.

This unit, with three radiators and two drivers, was for quite some time sold as a "triaxial," and is still incorrectly thought of as that by many poorly-informed audiophiles. There is only one truly triaxial speaker, and it happens to be one of the best ever made. This is the Jensen Triaxial, which at this writing is the only one having coaxial mounting of three complete loudspeakers, with three separate driving motors and three separate acoustic radiators.

Until now, we have assumed the acoustic radiator in every case to be a cone, but this needn't always be the case. Tweeters of the cone type send out high-frequency waves in rather sharp beams, with the result that the reproduction at any distance off the center line of the speaker is rather deficient in highs. This condition may be partially rectified by using two or more tweeters arranged around in an arc, but it is usually better to use a *horn* at these frequencies.

The driving motor in the horn is essentially the same as in other types of speakers, but the acoustic radiator is a small diaphragm instead of a cone. The

diaphragm is in turn surrounded by a sound chamber, which opens out onto a small opening at the throat of the horn. This arrangement gives broader high frequency coverage, and greater efficiency.

With advantages like these, it would seem that the horn should be used for all frequencies. It's a great idea which has been used successfully, but there's a hidden joker. While any loudspeaker must be big and husky to do justice to the low frequencies, this is several times more true in the case of the horn, which is a very effective high-pass filter. While its high-frequency response is practically limitless, it cuts off rather sharply below a certain point which is determined by its geometry. And to handle all of the bass properly, the horn must be huge. Just to get down to 30 cps, for example, it must have a mouth diameter of over eleven feet, and its length would have to be even greater than that. So while some people have built horns in their attics, with the mouth of the horn covering the entire grillwork ceiling, or in an attached garage, with the mouth of the horn covering a whole wall, this is a little too esoteric for most of us, who must be content with the mundane cone-type woofer.

However the sound is produced, the vibrating element will set up two groups of opposing sound waves simultaneously, one from its front surface and another from the rear. If these two waves combine, they can either add together and sound boomy, or try to cancel each other out, with a resulting sound which is weak and thin. As a third alternative, they can combine

Using the University "Stereoflex" unit with a full range system containing a dual voice coil woofer gives complete stereo reproduction. Diagram, below, right, shows how connections are made. Below, left, are components of stereo conversion kit which attach to terminals of the woofer; hardware included.

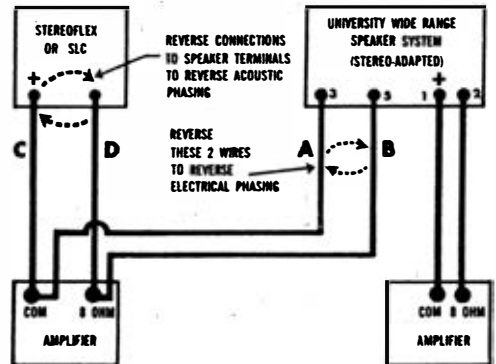
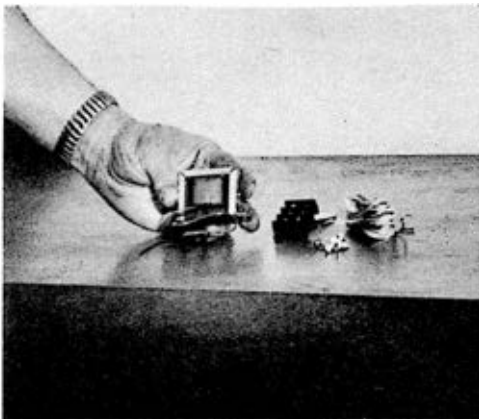

CONNECTION FOR STEREOFLEX OR SLC AND WIDE RANGE SYSTEM HAVING DUAL VOICE COIL WOOFER

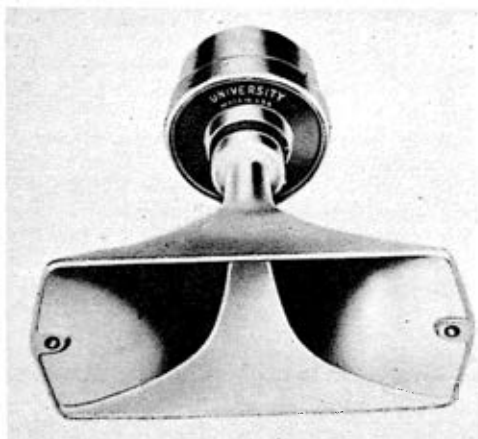

University 4401 tweeter has compression loaded driver, reciprocating-flare horn. Frequency response is 2,000-15,000 cps; 25-50 watt power.



Balance control by University regulates speakers of different efficiencies, balances sound to room acoustics. For midrange speakers and tweeters.

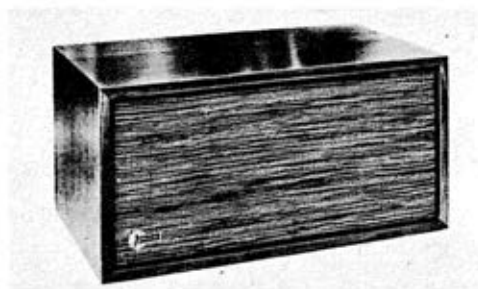

Wharfedale full range two-way system has 12- and 5-inch speaker, 1,000 cps network; impedance is 15 ohms; includes treble control. From \$159.

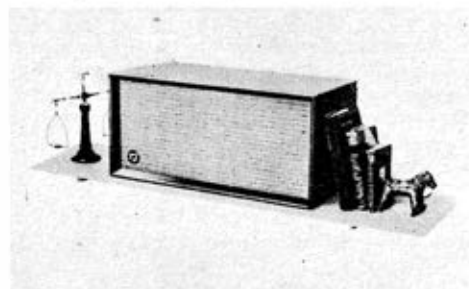

R-J enclosure with Wharfedale speaker has 8-inch full range reproducer, fits into bookcase. Also available in floor models with 15-inches.

Bradford enclosure with British Bakers 12-inch speaker has totally enclosed baffle, can be used with any speaker from 8 to 15 inches in size.

Briggs sand-filled 3-speaker corner system with imported Wharfedale speakers has bass chamber of plywood frame and panels, filled with sand.

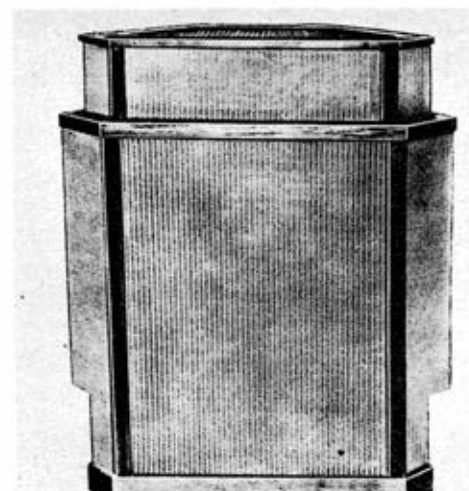
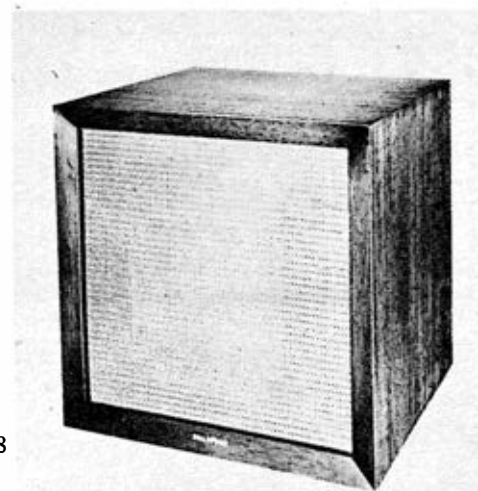

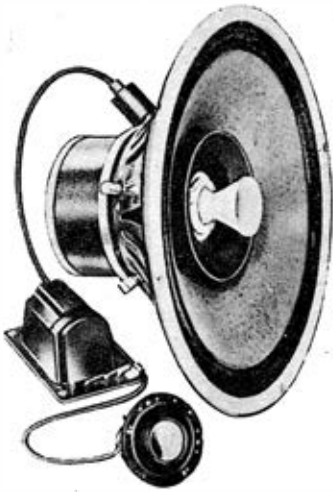

Lafayette 3-way coaxial is built by Goodmans of England, comes in 12- and 15-inch size with 45- and 50-watt capacity. Response: 30-20,000.

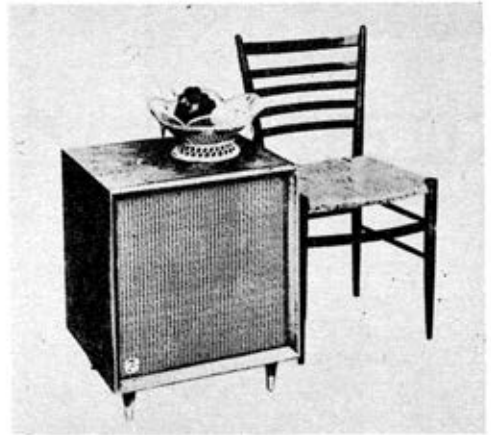

Floor model RJ enclosure for 12-inch speakers extends the bass range to 50 cps without resonant peaks. Enclosure is slightly larger than speaker.

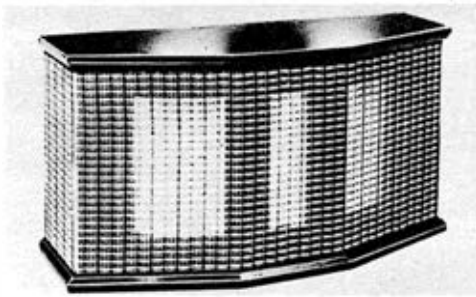

Electrostatic tweeter by Lafayette Radio has a 3-element high-frequency tweeter unit, can be used as part of stereo or monaural system.

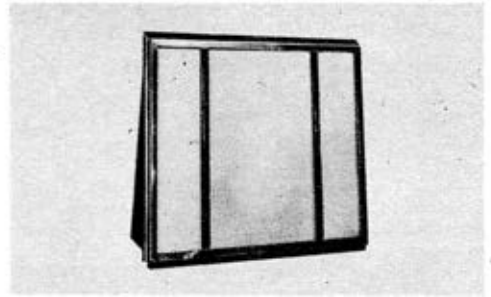

Wharfedale sand-filled baffle designed by Briggs, has frequency bass response down to 30-35 cps, 15 ohms impedance, does not need a wall behind it.

additively to compensate for an inherent deficiency.

Whether or not these waves combine at all will be determined by the loudspeaker enclosure. If they do, the enclosure has the further important function of determining that they do so under properly controlled conditions. Of all the wide variety of enclosures designed to do this job, each will fall into one of only three categories:

1. The *direct radiator*, in which the back wave is never permitted to join the forward wave.
2. The *resonator*, in which the back wave joins the forward wave under controlled conditions.
3. The *horn*, which is a direct radiator with the addition of a flared opening at the front, presenting a partially enclosed volume of air for the diaphragm or cone to push against.

The direct radiator mounting is often called a *baffle*, and in its simplest form is nothing more than a plane surface with a hole in it, through which the speaker is mounted. The back wave cannot join the forward wave until it travels out to the end of the baffle and then into the area of the cone. To prevent the back wave from ever catching up with the forward wave, the baffle would have to be infinitely large, or an *infinite baffle*.

A reasonable approximation of this is the wall of a room, where the front of the speaker generates sound in the listening room, while the back wave escapes into the room adjacent. Now if we continue to reduce the size of this infinite baffle even further, soon the room has shrunk to closet size. This is a fairly popular arrangement, in fact, having the speaker mounted in the closet door.

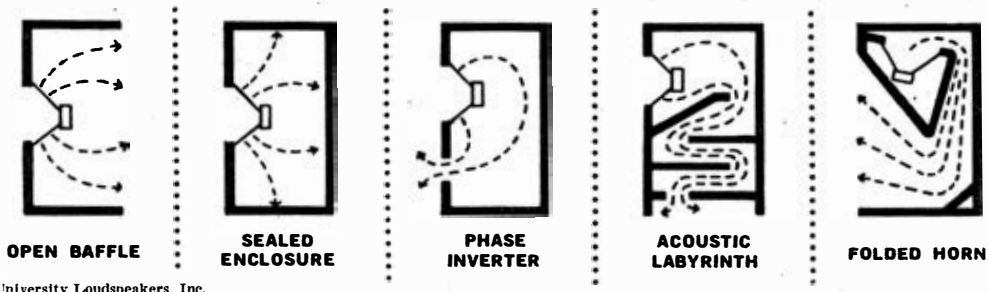

**OPEN BAFFLE**

**SEALED ENCLOSURE**

**PHASE INVERTER**

**ACOUSTIC LABYRINTH**

**FOLDED HORN**

University Loudspeakers, Inc.

Above are sound-path diagrams of some of the most popular types of speaker enclosures.



Kingdom Products, Ltd., make the "Compass," an omni-directional enclosure, with the speaker mounted to face the top baffle board, as shown.

Wide-range system by Kingdom is the "Audette," with 30-18,000 cps response, 20-watt peak power, 8-ohm impedance. Contains 8-inch Lorenz woofer.

**CONSTRUCTION OF A BASS REFLEX ENCLOSURE**

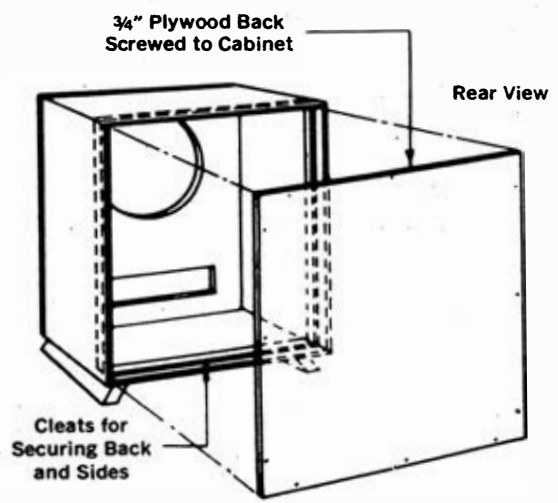
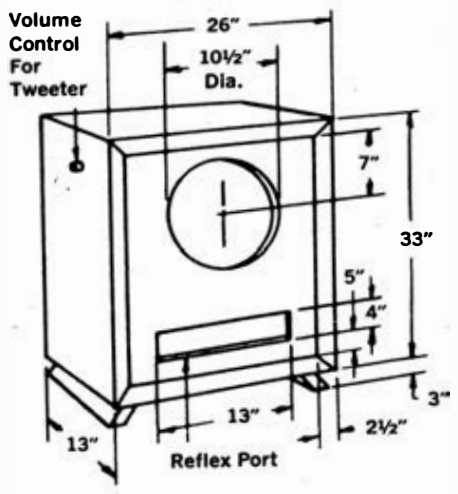

**NOTE:** Install sound insulation material on interior surfaces. Cover back completely and approximately 50% of remaining surfaces

University Loudspeakers, Inc.

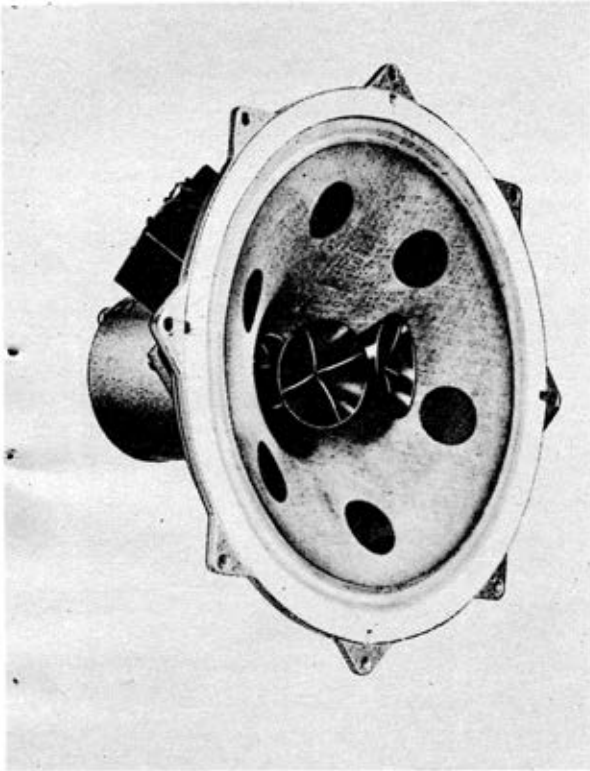

Stentorian 15-inch Duplex weighs 16 lbs., has low-frequency flux density gauss of 14,000; h-f gauss is 17,000; Alnico V magnet. Price: \$159.



Klipsch patented corner horn enclosure uses a bass exponential horn for the reproduction of the lowest note of a pipe organ without any distortion.

Continuing to decrease the size, we finally get down to a small box, completely enclosed. This is often the form of the bookshelf enclosures. These boxes seem to have astounding bass for their size, until we examine them more closely. Then we find that the bass response has a very big peak in it, with almost complete cut-off below that peak.

So take your time and listen carefully before buying any small enclosure. It is still axiomatic in speaker design that to get big sound you must have a big system. If your budget won't stand that, then you must be very careful to avoid ending up with gimmicked sound which will soon wear out its welcome.

The basic idea in all of the resonator types is phase inversion. This, incidentally, is not the same as that discussed for paraphase push-pull in the preceding chapter. Whereas in the push-pull amplifier we need a single wave to be converted to two waves of opposite polarity, in the resonator loudspeaker enclosure we want just the

opposite. The back wave, which is normally exactly opposite in polarity from the front wave, is shifted in such a manner that when it joins the forward wave it adds to and reinforces it. Since adequate bass is always the big problem in speaker systems, especially the smaller types, the treble end of the spectrum is normally absorbed by padding within the enclosure, so that only the bass part of the back wave emerges from the front, to provide in effect a bass boost.

One example of the resonant phase inverter is the acoustic labyrinth, which has a serpentine pathway for the back wave, much like the mystic maze in an amusement park. The labyrinth performs quite well, but its structural intricacy, and consequent high cost, have limited its popularity.

The most popular enclosure by far is still the bass reflex, another member of the resonator family. This was developed by Jensen back in the days when hi-fi was the interest of only a handful of hardy

Audax makes this double 8-inch extended range speaker with a slot-loaded cabinet. Three-dimensional "acoustic screen" is said to help frequency response.

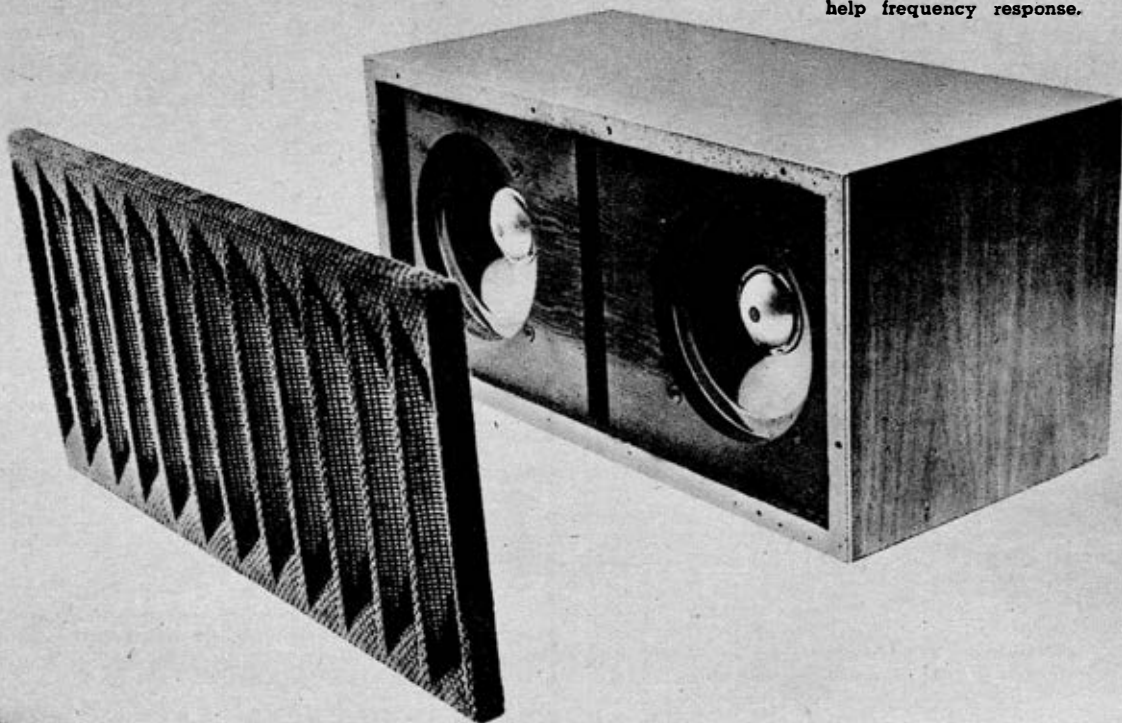

pioneers. It has since withstood the onslaughts of dozens of trick variations, each claiming to be the ultimate in hi-fi reproduction. But most speaker design engineers, as well as your own listening tests, will tell you that the bass reflex is still the best thing yet in small enclosures.

In construction it is nothing more than a padded box with two holes in it, one for the speaker and another for a vent or port, to emit the back wave. Whether buying or building a bass reflex enclosure, however, it is important to have a cabinet specifically designed for the speaker with which it is to be used. The size and shape of the box, the size and location of the port, and the resonant frequency of the loudspeaker, all must be properly integrated for optimum performance. This is not a difficult problem, but it does mean that you should follow the recommendations of the manufacturer of your speaker when considering

what to do about enclosures. He will gladly advise you on what to buy or how to build a bass reflex which will get the most out of your speaker.

The true horn, as we've noted, employs a small diaphragm driver which sets air into motion in the narrow neck of a straight flaring trumpet. But as we have also seen, the huge size required for adequate bass response makes it prohibitive for most home hi-fi applications.

The cone-type radiator may also be used with a horn, in which case the enclosure is really a directional baffle. Ideally, the flare of the baffle should follow a mathematical formula, which brings us right back to the same space problem encountered with the true horn. This is circumvented in the so-called horn used in some hi-fi systems by twisting the pathway for the air into a *folded horn*.

The great size required for the mouth

## The Speaker System

opening of the horn is taken care of after a fashion by placing the folded horn in the corner of the room. The walls, floor and ceiling thus act somewhat as extensions of the sides of the horn, with the listener in effect seated right inside it.

Since most of the highs would be lost in traversing the intricate bends of the enclosure, the folded horn is usually a bass unit only, and requires one or more additional speakers for the middle and upper ranges. An exception to this may be found in the back-loaded folded horn, where the cone radiates a forward wave directly, while the back wave escapes through the folded path of the horn. This is not a true horn, obviously, but is more properly classified with the resonators.

### The Stereo Story

The biggest problem in stereo is the loudspeaker system, for audiophiles and manufacturers alike. Ideally you should have two top grade speakers, preferably of the same make and model. And right here is where the problems begin:

1. Expense
2. Decor

The loudspeaker represents one of the largest expenditures in the entire hi-fi



system. Doubling that expenditure can put a crimp in anybody's budget. Then the placement of these speakers is fairly critical, and no respecter of interior decoration.

Designers have attacked both problems simultaneously by bringing into play the popular theory that the ears perceive no directivity effect below 300 cps. Therefore, it is said, a single low-frequency speaker in the middle plus a pair of small tweeters at either side will do the job. The **only** way to determine if this arrangement will suffice for you is to listen to the many such systems available.

Stereo speakers, and in fact any multiple loudspeaker setup, must be so connected that all radiators are simultaneously pushing air in the same direction. If they do not, there will be some partial cancellation, especially noticeable by a thinness of bass quality. The phase switch in stereo controls will take care of this, although reversing the wire leads to one speaker only will also usually take care of the problem. •

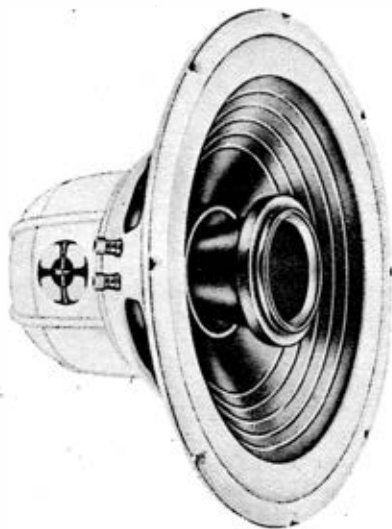

Tri-cone 15-inch by Audax covers range from 20-20,000 cps, uses coaxially mounted tweeter. Impedance: 8 ohms; 24 cps resonant frequency.

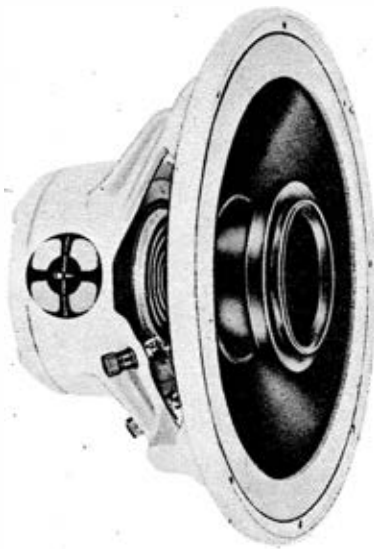

Audax A-120X has 40 cps resonant frequency, is priced at \$59.95. Impedance is 8 ohms, power handling capacity, 20 watt. Flux: 12,500 gauss.

## Chapter 10

# Tape Recording



An Ampex 960 tape recorder is being used above to tape a stereo broadcast from AM-FM tuner. Units shown are the Ampex stereo tuner and amplifier. Similar setup lets you record monaural sources.



**J**UST about one third of all the dollars spent for hi-fi equipment this year will go for tape recorders, tape, microphones and related tape equipment. Obviously hi-fi tape recording has come of age. It may seem odd that tape, the highest form of the recording art, lagged so badly in the home hi-fi field. The reasons are many and complex, but that is all history now. The important thing is that home hi-fi tape is here, and you should have it.

One of the first questions you will want answered in the choice of a hi-fi tape recorder is the same as for any other piece of hi-fi equipment: What is the frequency response? Although many hi-fi amplifiers exceed the audible range of 15 to 15,000 cps—as do instrumentation and video tape recorders—most audio tape recorders do not. Even among the most expensive professional machines, very few lay claim to a response exceeding 30 to 15,000 cps. Most recorders in the medium price range (\$200 to \$400) have an advertised response of 40 to 12,000 cps.

Equally important as the response limits, however, is the flatness within that range. Large peaks or valleys in the reproduction are as annoying as the roll-offs at the ends. Few people can discern a variation in sound level of less than 2 decibels, so a better standard of frequency response is the region in which the recorder is flat plus-or-minus 2 db. Using this reference, we find that the range of the average medium-price recorder is actually about 50 to 10,000 cps.

This is where we should draw the hi-fi line. Good clean response within this range is really quite adequate for all except the most exacting hi-fi requirements, but anything less than this can't truly be considered hi-fi. Understand, of course, that pub-

lished figures such as these almost always refer to the magnetic and electronic systems only, and not to the built-in speaker, if any. The nondescript little speaker to be found as standard equipment with most tape recorders is totally useless for hi-fi. The built-in speaker may come in handy for portable use, but if your recorder is built in as part of your hi-fi system, then use only your own regular speaker.

Next we come to the problems which have been most vexatious to audiophiles who have had to wait for the quality of home tape recorders to come up to that of the rest of the hi-fi system. These all have to do with the mechanical tape transport system and its smoothness of movement. They are speed accuracy, wow and flutter.

Speed accuracy isn't very important so long as you play only those tapes recorded on your own machine. If a machine is running a little fast—say around 8 inches per second—it won't matter much as long as tapes are both recorded and reproduced at that speed. But tapes made on that machine and reproduced on another operating at the standard speed of 7.5 ips will be flat in pitch. Similarly, tapes recorded at 7.5 ips will sound sharp when played on the faster machine.

Wow and flutter in tape recorders are the same bugaboos as in disc reproduction, as we noted in Chapter 4. The best professional tape equipment usually has an overall wow-and-flutter figure of 0.1 per cent or less. In semiprofessional and home hi-fi types it ranges from 0.2 to 0.3 per cent. The cheap equipment goes on up from there. The quality of your equipment will be in direct ratio to your investment, but there is no reason for you to settle for worse than 0.3 per cent wow and flutter. As mentioned in Chapter 4, the motor types used in tape

**Fun at home is possible with tape recorder and two-microphone arrangement for stereo production on a do-it-yourself basis. Note mike positions.**

Amibex Audio, Inc.



**Another use for tape is learning of a foreign language. Student is wearing headphones for monitoring. The tape recorder is the Ampex 960.**





Slide-rule type "Stereo-Graph" is available to consumers, shows basic settings required for the various functions of the Ampex 960 tape recorder.



Amplifier Corp., of America makes this portable recorder. It has VU meter, rechargeable dry batteries, 125 hour operating life, various speeds.

machines are similar to those used for turntables, but tape machines should have three motors for best performance.

Distortion figures, as in amplifiers, can be more confusing than useful. There are a baker's dozen varieties of distortion, and unless you fully understand the significance of each as well as the method of measurement, the resulting figures are not very useful. Furthermore, you seldom know whether the figures refer to the record function, or playback, or both. As far as distortion in tape recorders is concerned, let your ears be the judge.

Somewhat the same objection may be raised for signal-to-noise ratio figures, although this factor is probably a little more reliable for comparison purposes. It refers to the difference in volume level between the loudest program material and the noise generated by the system. This includes tube hiss, hum, tape hiss, rumble and the like. The higher the signal-to-noise ratio, the less internal noise is generated. About 60 db is the best figure achieved in professional recorders to date. Most home hi-fi tape systems have a ratio of around 40-50 db, which is adequate for most purposes.

When making a tape recording, both distortion and signal-to-noise ratio will depend in part on your own techniques. The setting of the volume level recorded on the tape must be high enough to override the noise at all times, but never so high as to cause overload distortion. It is usually possible to find a good average setting and leave it fixed. But if the program has a very wide dynamic range, from less than pianissimo to more than fortissimo, then it may be necessary to compress the level by "riding gain." This means increasing the setting above the average during the softest passages, and decreasing below average

during peaks. This can be done by yourself.

Correct volume level is indicated by either of several methods. Those most commonly used in recorders include one or more neon bulbs, a magic-eye tube, or a volume-indicating meter. The neon bulb simply indicates that the volume has exceeded a predetermined level. Two bulbs, adjusted to trigger at different levels, provide greater accuracy. The volume is then set so that one bulb is flickering most of the time, while the other one lights infrequently. There is nothing wrong with the neon-bulb idea, provided enough lamps are used. With a bank of 15, covering a range of 45 db in 3-db steps, as once used in Hollywood film recording, one could get along just fine. But two neon lamps are simply not enough.

The magic-eye tube, sometimes used as a tuning indicator on radio tuners and receivers, is a very accurate monitor of volume levels. When used for sound level indications, the width of the wedge-shaped shadow will depend upon the signal level. With no signal the angle of shadow is greatest, and as signal increases the angle narrows down.

Although this little tube is highly accurate, it has two major shortcomings. First, the screen is so small that even the recordist with 20/20 vision has difficulty following the rapidly-changing audio peaks. Furthermore, the volume must be adjusted so that the peaks just barely close down the beam angle, but when signals go above this point and into the distortion zone, there is no way of knowing of this for certain. That is, when the eye closes down for a peak signal level which is just right, it just stays that way if the signal is strong enough to cause serious overmodulation.

The best method of volume indication is the electric meter, which when designed

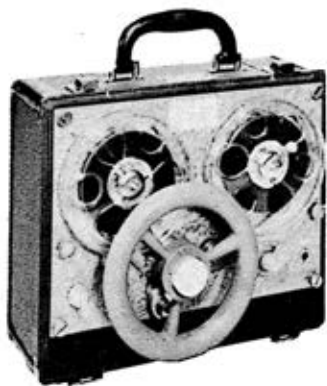

Magnemite recorder is similar to model shown at left, has no meter. It employs flywheel, weighs 15 lbs., operates for 1½ hours at 1½ ips.

for audio applications is called a VI (volume indicator). This meter indicates in volume units (VU), a quantity very similar to the decibel. It gives an accurate indication of signal level at all times, including as much as 3 db of overmodulation.

Tape cost can be cut in half by the method of dual-track recording, with only a slight sacrifice in signal-to-noise ratio and in inconvenience. This is the system most popular in home hi-fi equipment, although the four-track system for stereo is making rapid inroads. In the dual-track system, a signal is recorded on only half the width of the tape. After the full length of the tape has been recorded along one track, another recording can be made on the adjacent track. Playing time is doubled.

There is a 3-db increase in noise level in this arrangement, but that is not usually very important. If you intend much extensive editing, however, the full-track system is your best bet. Noiseless splicing is somewhat trickier in twin-track tape, and any cutting will, of course, also interrupt the unrelated signal on the adjacent track.

Playing time will also depend on the maximum reel size—and hence tape length—that the machine can handle. Most home machines use the 7-inch reel, although some can accommodate only the 4- or 5-inch size, while more and more are using the professional size of 10½ inches. The serious hi-fi hobbyist should consider nothing less than a 7-inch reel capacity.

Tape machines will have either two or three electromagnetic head structures. The two-head machine has a separate erase head, plus a combination record-reproduce head. The three-head machine has separate heads for each of these three functions. Since the design requirements for recording and reproduction are somewhat dissimilar, the combination head is of neces-



Newcomb stereo model SM-310 has 7½ and 3¾ ips speeds, two record level meters, synchronous motor, weighs 34 lbs. Response at 7½ ips is 30-15,000 cps ± 2 db. signal to noise: 50 db. It has two input jacks (rear view, below) for mike, two high level inputs and three output jacks.

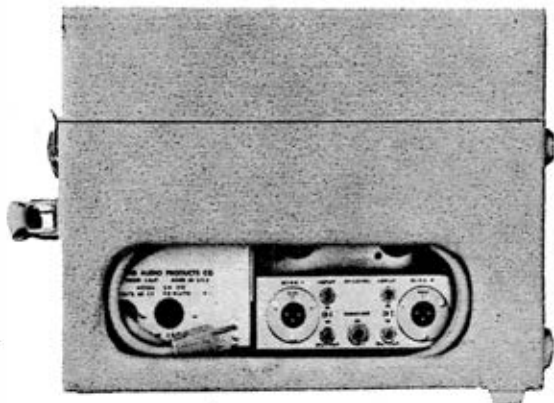

Tandberg recorder has 4-track in-line record/playback head, erases any of the four tracks, has playback amplifier, one built-in speaker.



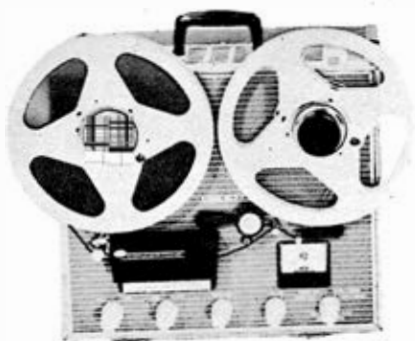

Concertone VII has frequency response of 30-17,000 cps  $\pm$  2 db at 7½ ips, plays two- or four-track stereo, has 3-motor drive, weighs 39 lbs.



Bell "overture" has 3¾ ips speed, plays tape stereo cartridge. It uses 9 transistors, weighs 25 lbs., has volume-level meter, 3 inputs.

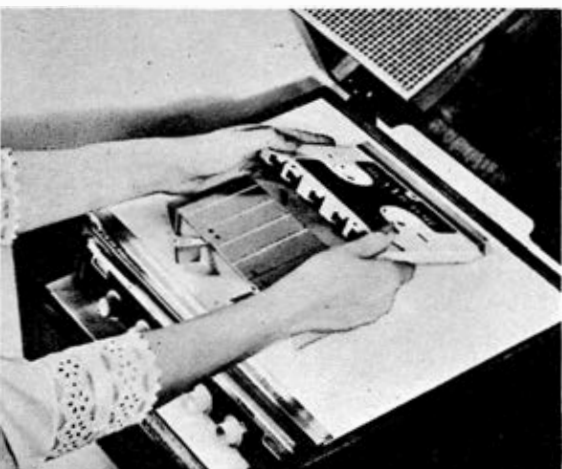

Bell uses RCA tape cartridge. Units have stereo amplifier and built-in preamps for playback and record, include automatic stop and off switch.



Model 404 by Bell with 3¾ ips speed has 7-watt power output at each channel, 10 tubes, a dual 8-ohm output for each of two stereo speakers.

sity somewhat of a makeshift compromise.

Another advantage of separate heads is the possibility of checking the quality of the recording on the tape even as it is being made. Although most two-head machines provide for listening to the signal through speaker or headphones as it is being recorded, this is not the same thing as monitoring from the tape.

In the one case the signal is heard as it is fed into the machine. In the other case the sound is actually a reproduction of the signal being played back from the tape at the output of the machine. The latter is an accurate indication of the way the tape will sound every time it is played.

The erase system may be either permanent-magnetic or electronic. For hi-fi

there is no choice. Permanent-magnet erase is simply too noisy, and electronic erase with a supersonic oscillator must always be used.

The hi-fi recorder must have at least two separate input circuits. One of these should be high-impedance and low-sensitivity, for use with tuners, phono preamps or mixers. The other should be low-impedance, high-sensitivity, for use with a high-quality microphone.

Good microphones, which are seldom if ever furnished as standard equipment with tape machines, are almost always of the low-impedance type. This is desirable to minimize hum pickup and high-frequency losses in long cable runs. The output of such a microphone is invariably low in



Irish recording tape, "Green Band" is made on 1½-mil acetate base, comes in 2,400 ft. length. Price: \$9.27.



View of Soundcraft factory tape quality control room where tapes are tested against magnetic specs.

level. Thus it is essential that the gain of the recorder input circuit be adequate to handle such a mike.

Many home recorders have built-in loudspeakers and power amplifiers. These two elements are ordinarily superfluous to the hi-fi system. Thus it is now possible to obtain tape decks, which include only the mechanical facilities, plus low-level electronics for erase, bias and preamplification.

The recorder should have provision for a high-level, low-impedance output to permit the internal amplifier to drive an external loudspeaker. Even more important, there should also be a low-level, high-impedance output to feed directly into the input of your own hi-fi amplifier.

The playing time available from a tape

depends not only on the recorder speed, but also on the length of the tape, which for a given reel is in turn determined by the tape thickness. There are three tape thicknesses: standard (1.5 mil), thin (1.0 mil), and very thin (0.5 mil). On the standard 7-inch reel, standard tape can be wound up to 1,200 feet. The same reel can accommodate up to 1,800 feet of the thin tape, and as much as 2,400 feet of the very thin type.

The thickness refers only to that of the base, the thin plastic ribbon on which the oxide recording medium is coated. For a given base material, the thinner tape types will, of course, be weaker.

The most used material is cellulose acetate, and tapes of this material are avail-



Argonne makes this tape head demagnetizer with three sets of interchangeable pole pieces for head demagnetizing without removal of tape heads.

able in regular and thin sizes. Both the stretching and breaking characteristics of this material are too poor to permit its being practical in the half-mil size. For this application there is used a polyester film, usually referred to by its Dupont trade name, Mylar. Polyester has greater mechanical strength, but it is also more expensive.

Furthermore, polyester is much more resistant to breaking than it is to stretching. As any professional recordist will tell you, he would much prefer to have a tape break in case of trouble. It's a fairly simple matter to splice a break, but there is no known way of shrinking a stretch, and the resulting wow is in the tape permanently.

Polyester-base tape is available in all three thicknesses. But at a half-mil, the polyester is a little weaker than 1-mil acetate, which at least one tape manufacturer thought too weak for practicality. Consequently there was developed a new, tougher film, called tensilized polyester, which is used only in the half-mil size, and has characteristics similar to those of the standard thickness acetate.

Left. Amplifier Corp., of America, bulk eraser for magnetic tape, weighs 2½ lbs., works on AC current. Can be used on ¼- or ½-inch tape reels.



VU recording-playback meter is made by Argonne Electronics Mfg. Corp. Calibration is from -20 to plus 3, can be installed in any type player.

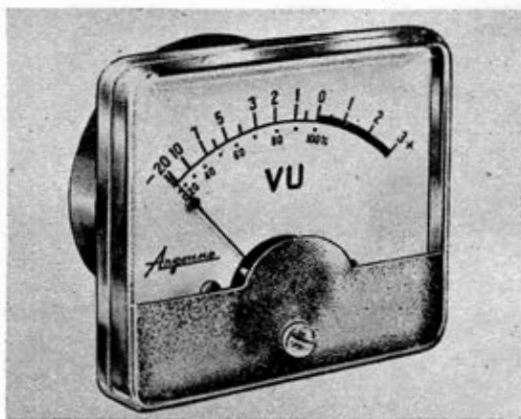

## Tape Recording

### The Stereo Story

Without tape, stereo would be well-nigh impossible. It was the first means of carrying stereo reproduction to the home, and until recently stereo recordings on tape offered by far the most extensive selection. And stereo tapes at their best are still of vastly superior quality than any other form of recording.

Conversion of an existing tape recorder to stereo is not terribly complicated, nor is it very expensive. The transport mechanism is the same for both types, so no changes need be made here. For a present full-track machine, the erase head may be retained. For half-track machines, all heads must be replaced. None of the present electronics need be replaced or modified, but some additions will be necessary. A second record-bias preamplifier, plus a playback preamplifier if the recorder is of the three-head type, are all that is required. Conversion kits containing all these elements are available from many recorder manufacturers and independent suppliers.

When selecting a new stereo recorder, be absolutely sure what you are getting. One



so-called stereo machine is simply a conventional monophonic type, with a two-track playback head in place of the usual half-track monophonic one. Even to play stereo tapes on such a machine would require an equalized playback preamplifier plus a complete hi-fi channel, and to record stereo would require all of the conversion steps just described.

Another machine is for stereo playback only, and in addition to its stereo playback head and transport mechanism, the electronics includes two playback preamplifiers, one power amplifier and a loudspeaker. The remaining part of the second channel would be supplied by the conventional monophonic hi-fi system. •

Dynaco stereo spacer, right, with microphone brackets, has built-in swivel for 360° rotation. The acoustical separator eliminates "ping-pong" effect which is often found in poor stereocasts.

Microtran Co., 145 E. Mineola Ave., Valley Stream, N.Y., makes a pick-up coil for transcribing telephone conversations or for making these conversations audible with the help of an amplifier.

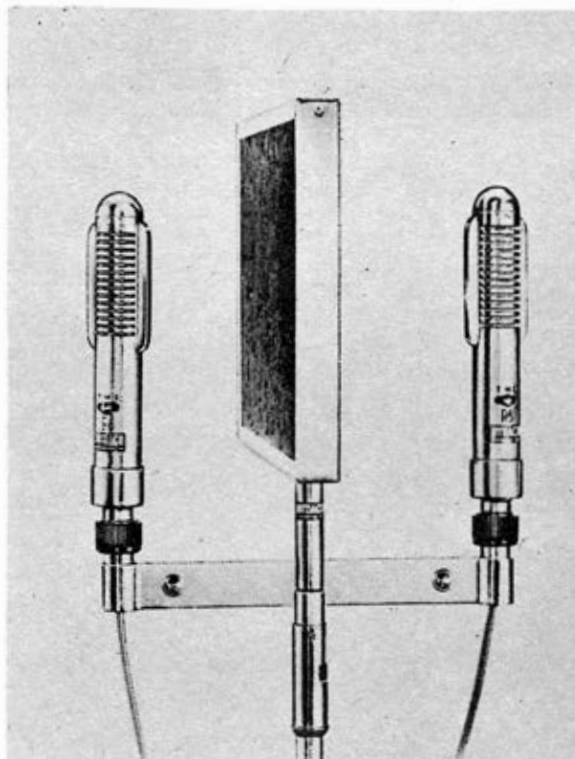
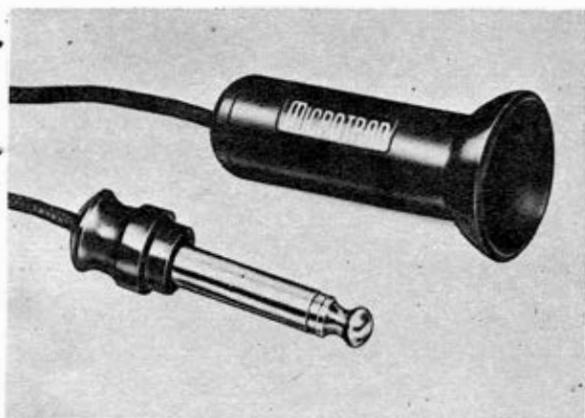

# Chapter 11

## Building from Kits

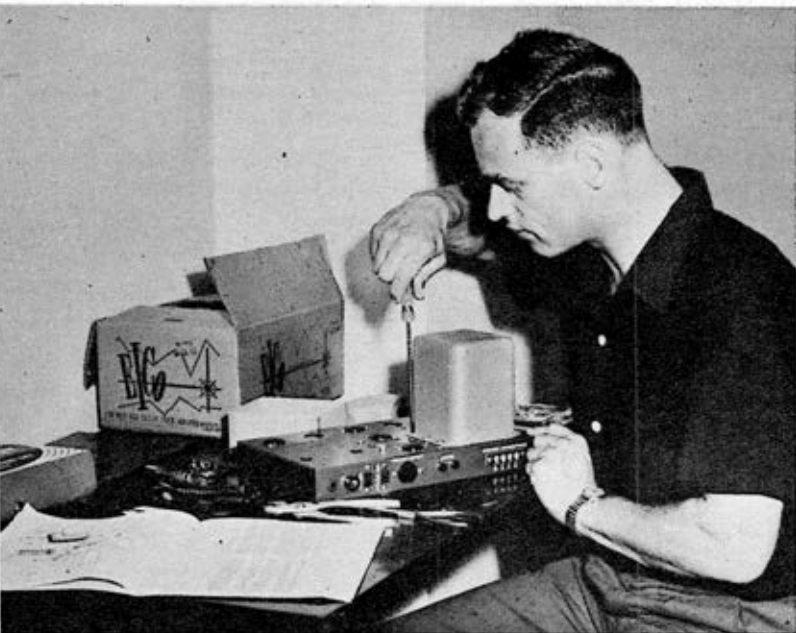

Assembling the Eico HF-50, 50-watt basic amplifier. After mounting external jacks and tube sockets, the heavy output transformer is installed on the chassis. Explicit step-by-step instructions are included with the kit and must be followed at all times for best results.

Photos by Fred Honig

Gun-type soldering iron made by Weller is used here to solder connections on underside of the chassis. Always employ good rosin core solder.

Tubes are last item inserted in the finished kit. Before operating amplifier, the two EL34 output pentodes should be balanced with a test meter.

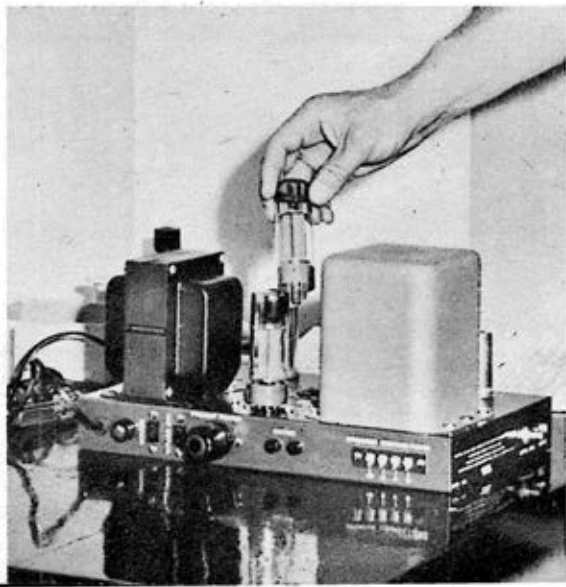



**S**AVING money and having fun are the two best reasons known for building your hi-fi system from kits. The cost is about half what you would pay for factory-assembled components, and there is a considerable feeling of accomplishment when you have taken a boxful of static, unrelated component parts, assembled them with loving care, and then, at the flick of a switch, they come to life and reward your efforts with full, rich hi-fi sound. This is a thrill of which you never tire, no matter how many kits you have built.

Today, absolutely everything the serious audio hobbyist could require is available in kit form. Preamplifiers, power amps, tuners, tone arms, turntables and changers, and tape recorders. The only exceptions are the transducers at either end, for pickups and speakers are a little too exacting in their mechanical specifications to permit building by the home handy man.

Not only is the electronic line complete, but so is the selection of audio furniture. No matter what kind of cabinetry or speaker enclosure you require, you can find it in a kit. And the quality can be anything you wish, from ruggedly simple "laboratory" models, to beautifully finished pieces worthy of the finest cabinetmaker.

Not to be overlooked are the many fine test instruments available for maintenance and repair of hi-fi systems. Everything from the simple multimeter, through tube checkers, to audio analyzers, all are ready to be assembled from kits. Other kits include audio generators, voltmeters, watt-

meters and signal tracers. Not a complete audio laboratory, perhaps, but more than the average hi-fi enthusiast could use.

When one considers this wide assortment of audio goodies, it is difficult to realize that the modern electronic kit business is not much more than ten years old. It began in earnest with the television boom just after World War II, but building and aligning a TV set proved to be a little too formidable a task for most home hobbyists. The biggest factor in this business, the Heath Company, wisely eschewed the TV business and have since seen most of their early competitors fall by the wayside.

Since component parts are component parts—no matter who assembles them into a box and calls the combination a kit—the fabricators of kits long ago learned some important lessons which have enabled them to stay on top. First of all, they know all there is to know about electronics purchasing. You can take most kit parts lists, go to your nearest parts jobber, and have him fill the order. When you have finished, you will find that, even at 40 per cent off list prices, you will spend more than if you had bought the kit in the first place.

Second, nearly all of the circuitry to be found even in the best hi-fi amplifiers is not patented or patentable. What then is there to prevent a kit maker from copying the designs of the most popular kits and issuing a kit version of it? The answer is, nothing at all. It happens every day.

There are those who say that the imitations are not very accurate, that they are

Wiring diagram of Eico HF-85 stereo preamplifier is studied before assembly. Note selector switch which was wired up before chassis installation.

View of top of unit. Pencil points to molded-in resistor-capacitor assembly. Previously wired selector switch is shown here installed in position.

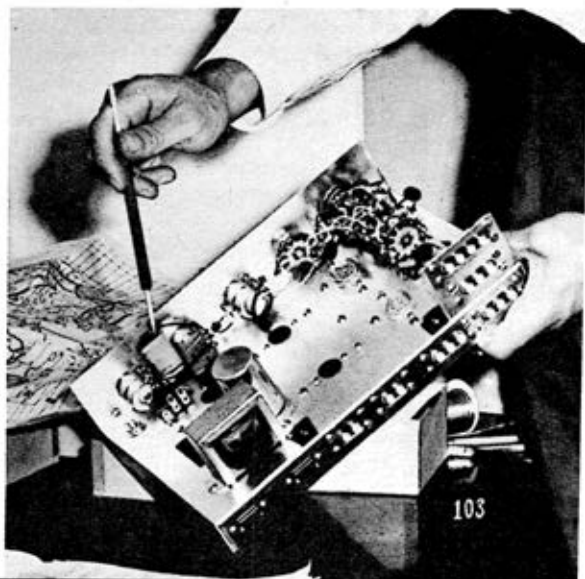
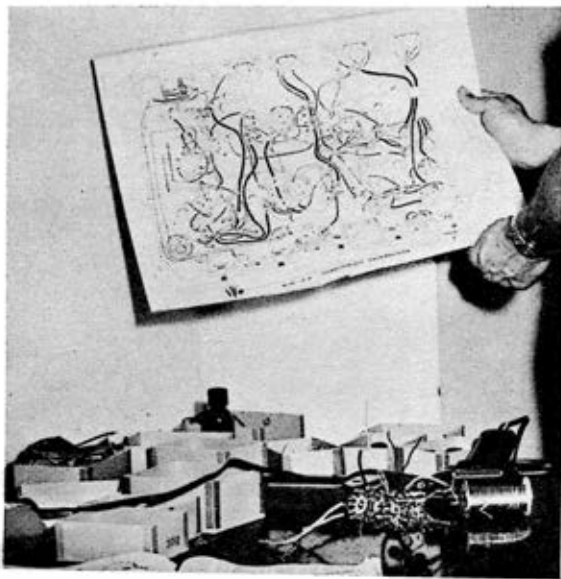

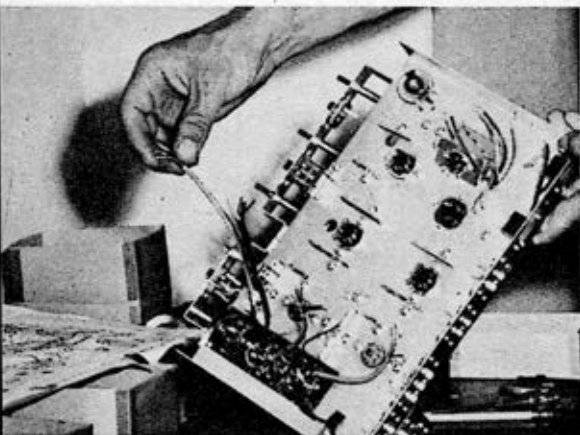

Selector switch leads are brought through the chassis opening at bottom, connect to input and output terminals of the Eico stereo preamp.

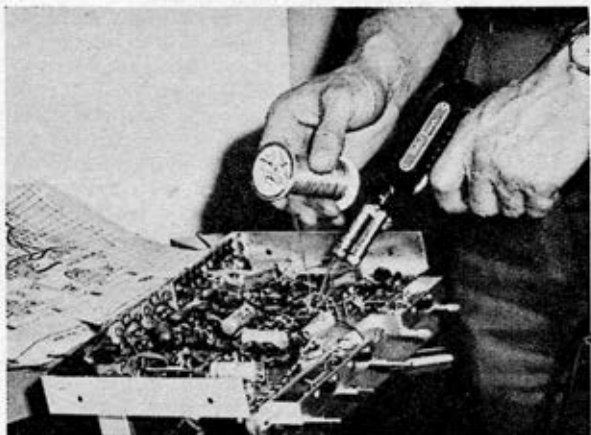

Bottom view of chassis. Gun and rosin core solder are used to wire up resistors, capacitors and condensers. Always follow manufacturer's instruction.

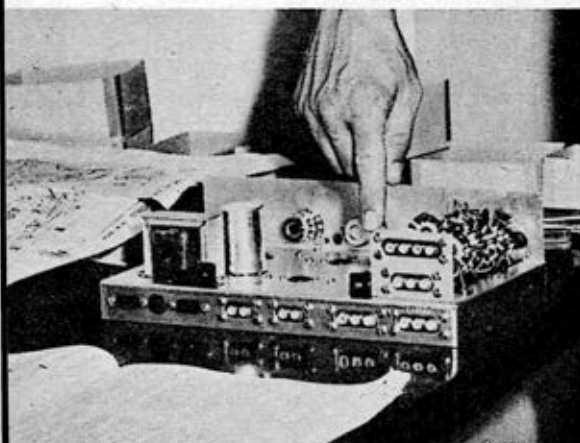

Rear output-input panel holds jacks and the AC convenience outlets. The stereo preamp unit is self-powered, comes with perforated brass cover.

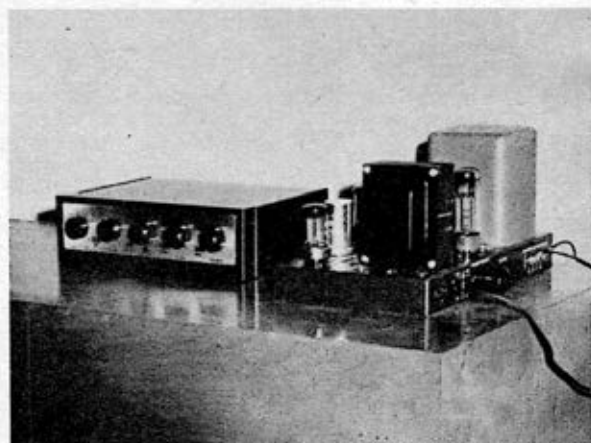

Assembled HF-85 preamp and HF-50 50-watt basic amplifier. An additional amplifier gives complete stereo setup. Preamp has ganged control knobs.

really only "Chinese copies." And there is some merit to that argument. The kit industry is intensely price conscious, as we have seen, and they are not always the most particular in the choice of components. Sometimes the cheapest, rather than the best, gets the nod.

This is not to say that it is impossible to get premium quality in kits. On the contrary, some kits are every bit as good as anything available factory-made. But in these cases, it will be seen that the price break isn't quite as good.

Perhaps most important of all, kit producers are well aware that hi-fi fans whose

only workbench is the kitchen table are not electronics experts. And they turn out instruction manuals which are masterpieces of lucidity. Any long-suffering father who has spent all of Christmas Eve sweating over a bunch of knocked-down toys, with nothing to guide him but a few pieces of mimeographed scrap paper, will marvel at the slick production of a Heath-kit, Knight-Kit or Eico construction manual.

The most important thing to learn in advance, before attempting to assemble any electronic kit, is to master the knack of soldering. The technique is not very dif-

ful, but if it isn't done right in the first place, you can run into all sorts of grief later.

Soldering is a process of uniting two or more metals by first heating their junction, and then applying to the joint a fusible alloy called solder. The entire procedure can thus be broken down into three simple elements:

1. Joining the metals.
2. Heating the joint.
3. Applying the solder.

Nearly all of your soldering will involve attaching a piece of hookup wire or a component wire to some fixed point, such as a tube socket, control, tie point or terminal strip. In any case, the wire is first cut to length, stripped and cleaned, and then attached to the terminal so that it is mechanically secure.

The physical strength of the joint should not depend upon the solder. The wire is

therefore doubled back on itself for about  $\frac{1}{8}$  inch at the end, and crimped with long-nose pliers, so that it is clamped to the terminal. Before soldering, of course, make certain that the wire is going to the correct point and only to that point. When working in confined quarters on miniaturized components, it is quite easy to have the bare end of the wire brushing against some point where it doesn't belong.

Now that the metals are properly joined, the next question is how to heat them preparatory to soldering. The heat is usually applied by contact with a hot piece of copper, which itself is usually heated by electricity. The chunk of copper is the tip end of a tool misnamed a soldering iron.

Old-time radiomen have always liked an iron in the 75- or 100-watt size, with about a  $\frac{3}{8}$ -inch tip. But in these days of miniaturized components and etched circuitry, that size is a little large. Now something on the order of 30 or 40 watts is more com-



Dynakit Mark IV power amplifier is rated at 40 watts, has frequency response of 10-40,000 cps  $\pm .5$  db; damping factor is 15; outputs are 4, 8 and 16 ohms. Price, with cover: \$59.95.



Mark III Dynakit 60-watt basic amplifier has 4, 8 and 16 ohm speaker terminals, outlet for powering a preamplifier. IM distortion is less than 1% at 60 watts. Price of kit: \$84.95.

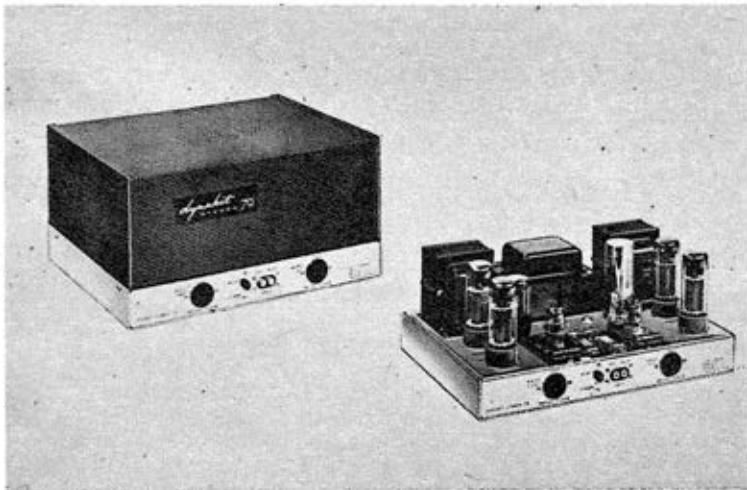

Stereo amplifier kit by the Dynakit makers has 35 watts power for each channel, with IM distortion less than 1% at 35 watts. Frequency response is 10-40,000  $\pm .5$  db; it comes with a printed circuit. Price of kit, with cover, \$99.95.



Grommes kit for 60-watt amplifier has damping factor of 15; 4, 8 and 16 ohm outputs. Hum and noise: 90 db below rated power. Feedback: 25 db.

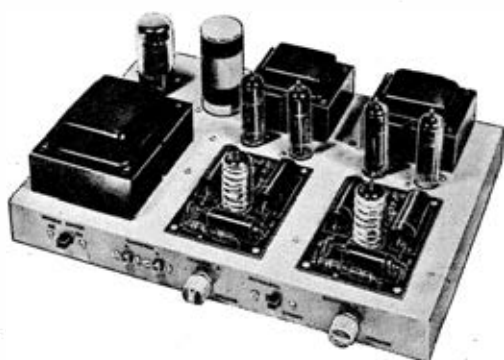

Lafayette stereo amplifier kit costs \$44.50, has two 18-watt stereo channels. Speaker terminals are 4, 8, 16 and 32 ohms. IM distortion is below 1%.

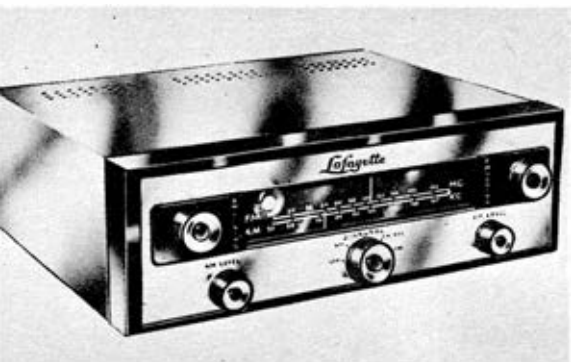

Stereo tuner kit by Lafayette costs \$74.50, has Armstrong FM circuit with 5 Kc maximum drift. It comes with prealigned IF's, plus printed circuits.

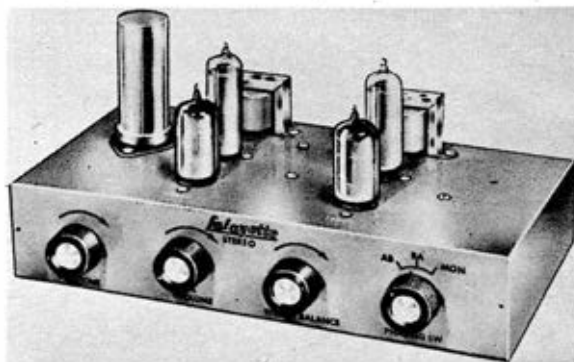

Stereo phonograph preamplifier kit by Lafayette sells for \$17.95, has 2-watt power for each of its two channels, ganged tone control, phase knob.

patible with audio do-it-yourself work.

One trouble with soldering irons has been the wide range of uncontrolled tip heat, which, when the iron is "idling," can go so high as to deteriorate the copper tip, and when applied to the work can go so low as to be unable to melt solder. The answer to this problem is the new *Magnastat* temperature-controlled soldering iron by Weller, which keeps the temperature well within bounds.

Many electronics workers prefer to use the soldering gun, another Weller innovation. This is really a step-down transformer with a switch, forcing a high current at a low voltage through a copper-wire tip. The tip is therefore directly heated by the current passing through it. It heats instantaneously, and therefore the trigger is pulled to apply heat only as it is needed.

Before attempting to solder with an iron, the part of the bit which comes into contact with the joint must be covered with a coating of solder, or tinned. With a brand new iron you will begin by plugging in the power and rubbing solder against the tip every few moments. The iron won't be hot enough to melt the solder at first, but continue the operation so that solder begins to flow the instant the temperature reaches the melting point. The reason for this is having the *tinning* accomplished before the copper tip gets a chance to oxidize. With molten solder flowing freely over both faces of the tip of the iron, wipe off the excess with a rag rolled up into a ball, thus exposing a thin, shiny layer of metal covering the tip. Because of the wide heat range of irons which are not temperature controlled, the tinning will become dull

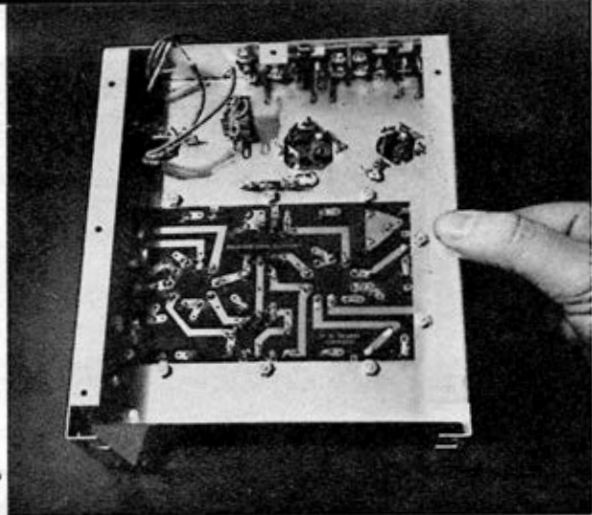

Stereo adapter kit by Lafayette, KT-315, sells for \$27.50, has printed circuit board, with cross-channel rejection of better than 50 db. Unit is used to adapt two monaural systems to stereo reproduction.

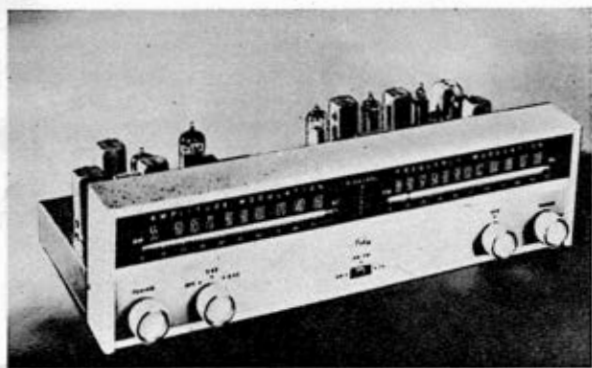
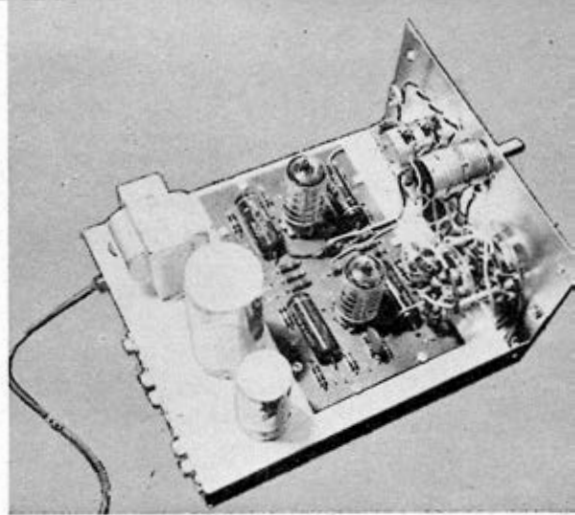

Arkay AM-FM stereo tuner kit costs \$49.95, or \$74.50 assembled. FM sensitivity is 4 mv for 20 db quieting. It features AFC control, logging.

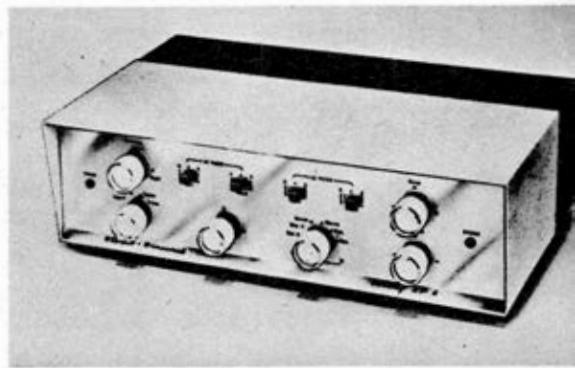

Arkay SP-6 stereo control center has individual output adjust with one control, channel reverse switch, hi-lo filters. Price of kit: \$39.95, less cover.

and flaked after some hours of use, and the tip may even become pitted. When this occurs, it is necessary to dress down the tip faces to the bare copper, using a file, and then to repeat the tinning procedure.

The solder used in electronics work is an alloy of two metals, lead and tin, and it usually has a flux built into its hollow core. The purpose of the flux is to prevent rapid oxidation of the metals as they are heated.

All fluxes are somewhat corrosive when heated to the melting point of solder, but some types go right on corroding after the joint has cooled. This is not particularly important in many types of work, but where the flow of electric current is involved, corrosive acid flux cannot be tolerated. Corrosion will cause noise and high-resistance joints, perhaps even ultimately eating through the joint and open-

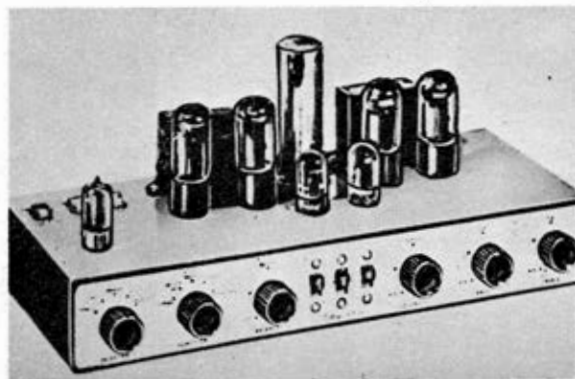

Arkay stereo preamp-amp combination kit sells for \$36.95, has 12 watts total output. Frequency response is 20-20,000 cps  $\pm$  1 db; 20-watt peak.

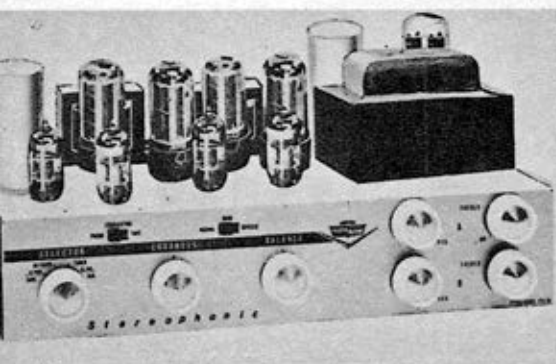

Quality Electronics stereo control center and dual 12-watt amplifier sells for \$39.95, has a tape NARTB compensator, 4 dual inputs, —80 db hum.



Eico stereo amplifier-preamp sells for \$69.95 as kit, or \$109.95 assembled. It has two 14-watt channels. Harmonic distortion: —1% 30-10,000 cps.



University makes a variety of high-quality speaker kits, including the 3-way KEN-15 model shown here which holds a 15-inch woofer. Plywood veneer gives professional look. All hardware, plastic grille cloth, etc., included.

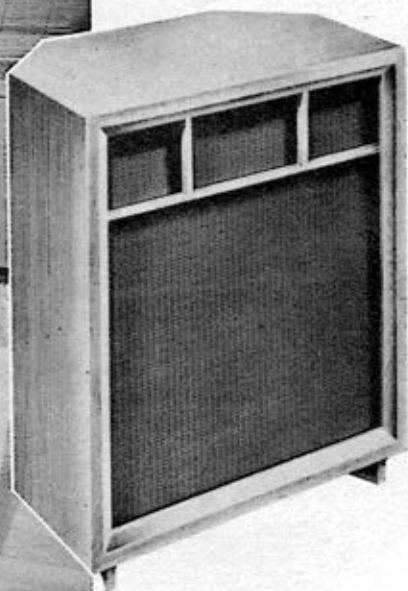

ing the circuit with disastrous results.

This is such an important consideration that the use of acid flux in kit construction will automatically void your guarantee. Kit producers want satisfied customers and they are most co-operative in helping out if you should strike a snag during assembly, or if the unit should fail to operate after you've finished. But if you have used acid-core solder in the construction, all bets are off.

The flux commonly used for electronic work is rosin. If it is inserted in the solder during manufacture, that solder is usually referred to as *rosin core radio solder*. This is the type you *must* use for kit construction. Although flux is also available in paste, liquid and powdered form, the flux-core solder is most convenient and is now used almost universally.

Solder used in audio work is known as soft solder, as contrasted against silver and aluminum solders, which have much higher melting points. The best flowing solder, and therefore the easiest for the beginner, comprises 60 per cent tin and 40 per cent lead. The 50-50 alloy is a little better for electronic work, but it has a higher melting point and is more difficult to use. You might therefore try building a small kit using the 60-40 type, and when you feel that you have the soldering technique well in hand, switch to 50-50.

Having the joint securely crimped and mechanically solid, hold the heated iron in such a way that the tip heats the joint and the joint melts the solder. Unless the joint gets hot enough to fuse the solder itself, a

cold solder joint will result. This is mechanically weak, and electrically a poor conductor. For electronic work, you should use the minimum amount of solder possible. Since the electrical conductivity of solder is only one seventh that of the copper wiring, there should be a minimum of solder separating the conductors.

It is also essential that the joint not be disturbed as the solder is hardening. All solders have what is known as a "plastic range," which is the range of temperatures in which the metal is in a pasty condition, neither solid nor liquid. After you remove heat from the joint, the solder must go through this plastic range before it hardens. If any strain is put on the joint, or the parts of the joint are moved while the solder is in this plastic state, the solder will crumble and the joint is worthless. If this should happen inadvertently, the whole procedure must be repeated, with the solder once again raised to free-flowing temperature.

In addition to good soldering equipment, you, of course, need an assortment of screw drivers and wrenches. But the two tools you will probably use most of all are the pliers, the diagonals and the long-nose. Probably first in importance is the long-nose variety, which is used primarily for light holding operations, particularly in confined areas. They are also used for shaping the bare ends of wire into loops for screw-terminal mountings, or for crimping wire ends onto solder terminals.

The most important thing to remember about long-nose pliers is that it is a light-

Schober Organ Corp. sells electronic organ kits in a variety of models. Diagram, below left, shows how a reverberation effect is incorporated in a hi-fi sound system to accommodate an electric organ.

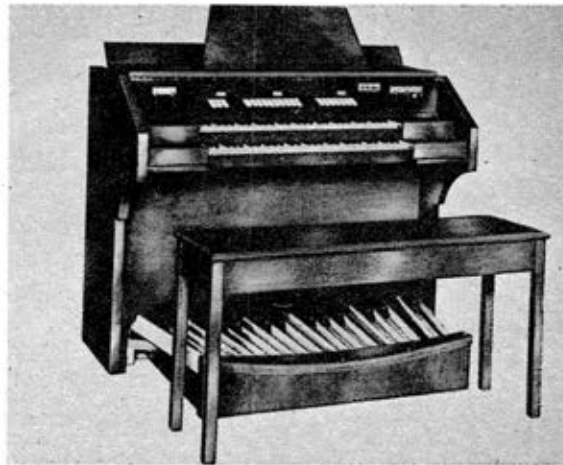
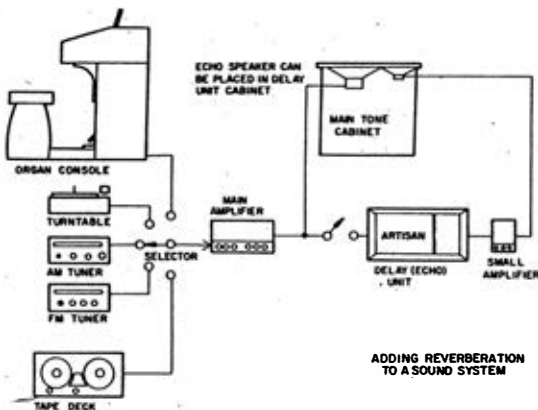



Rek-O-Kut turntable kit costs \$39.95, has 33½ rpm speed, endless-belt drive. Noise level is -47 db at average recording level; 4-pole motor.



Heathkit AM-FM tuner comes with prewired and prealigned FM front end, built-in AM antenna, tuning meter, AFC, individually tuned AM and FM.

Below is the "Stereo Center" Lafayette cabinet kit. It has room for AM-FM tuner, tape deck, stereo preamp and amplifiers, record changer, record storage and speakers. Heath makes components to fit.





## Building From Kits

duty tool. It is often misused by being forced to do jobs too heavy for it.

Similar to the long-nose is the needle-nose pliers, which has circular instead of semicircular jaws. This is not a holding tool at all, but is used only for wire shaping, such as forming loops for attachment to a binding post. Since the ordinary long-nose will do the job almost as readily, this tool is really unnecessary for the budget-conscious audiophile.

Since the long-nose pliers often have side cutters behind the gripping surfaces of their jaws, they can also substitute in a pinch for the next most important tool. This is the diagonal-cutting pliers, often shortened to "diagonals" or "dikes."

The diagonal jaws are two cutting edges set at an angle of 15° to 20° with the length of the tool, which construction permits them to cut off a wire end very close to its point of attachment. The chief misuses of this tool are trying to cut sheet metal with it, cutting wire of too heavy a gauge, or skinning insulation off a wire. The 5- to 6-inch size is adequately husky for all audio work, while a knife is the tool for wire-skinning, and snips or a hack saw should be used for cutting metal.

While some kits have the wire leads pre-cut to length and the ends properly stripped of insulation, this is more likely a job you will have to do yourself. A wire stripper is the best tool for this job, but you can also use an ordinary pocket knife.

If you are right-handed, begin by holding the insulated wire in your left hand, with the end to be stripped pointing toward your right. With the knife in your right hand, place the blade against the side of the wire away from your body, at the point where the insulation is to be cut away. The hands should be against the body and



just below the chest, so that the lower arms are in line with each other, and the thumbs grasp the wire at a point opposite the blade.

Hold the knife blade almost parallel to the wire with the sharp edge pointing toward the end to be stripped. Then, while rotating the wire with the left hand, move the knife in a paring motion and peel the insulation away. This gives the insulation a tapered appearance, like a sharpened pencil, and it perhaps isn't as good looking as a right angle cut. But it almost eliminates the possibility of nicking the wire, with resultant mechanical weakening, and lowering of conductivity.

For the best solderability, and highest conductivity, the wire must be cleaned right down to the bare metal. All varnish, lacquer, wax or pitch must be removed. The best way to do this is with the dull edge of the knife blade, to avoid nicking or cutting the wire.

### The Stereo Story

Here is one place where stereo makes no difference in your plans at all, except in the kind of kits you buy. An exceptionally wide assortment of stereo kits are available, so there is no problem there. But whether stereo or monophonic, the construction methods are identical, so go to it, and have fun. •

**Heathkit tape recorder kit for stereo use has 7.5 and 3.75 ips speeds. Frequency response at 3.75 is  $\pm 2.5$  db, 30-12,000 cps. Heads are: erase, record, in-line stereo. Output: 2-volt max.**



## Chapter 12

# Your Complete System

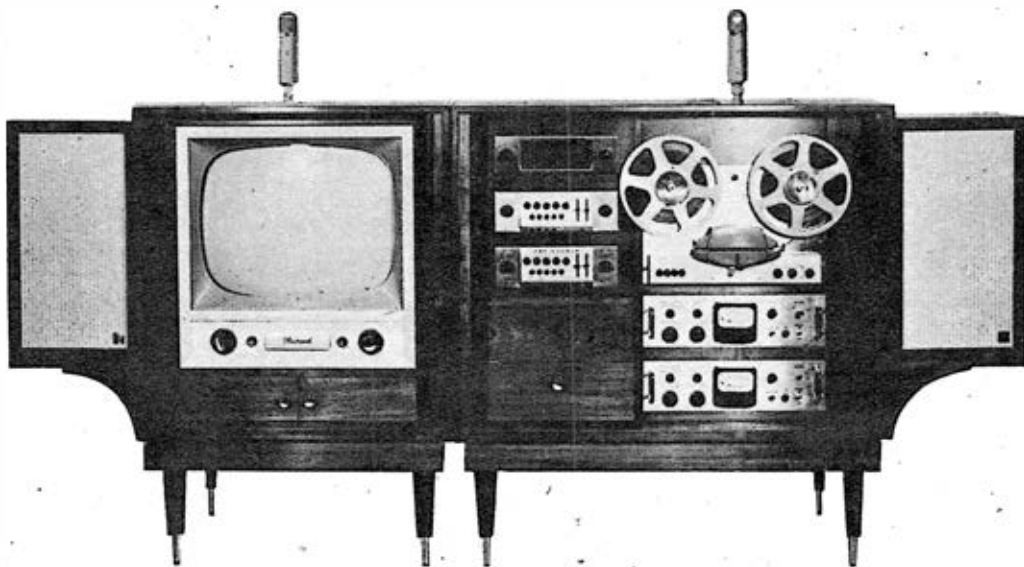

Complete stereo system shown here includes Fisher AM-FM tuner, two Fisher control-preamps, Magnecord tape recorder with two preamplifiers, a Fleetwood TV set, two AR speaker enclosures, two mikes.

**A**S we enter the home stretch, with you perhaps champing at the bit, eager to step out and acquire your new hi-fi system, let's just see where we've been, and recall the useful information you now have at hand to guide you in the selection of your equipment.

To begin with, we discussed just what hi-fi is all about, as an art, a science and a hobby. Then we discussed the various sources of hi-fi sound, and how they fit into the overall scheme of things. After that we talked about each individual component in the hi-fi system, one by one, to discover its

relationship to the complete installation. And, of course, we couldn't overlook the real do-it-yourself endeavor, the hi-fi kit.

Throughout this book we have been talking about the only hi-fi systems we believe in, those based on *components*. Early hi-fi components were intended for professional applications, and for use by professionals. They were complex in design and—to be charitable—spartan in appearance. But as more and more hobbyists became interested in the field, audio manufacturers realized that they had their jobs cut out for them.

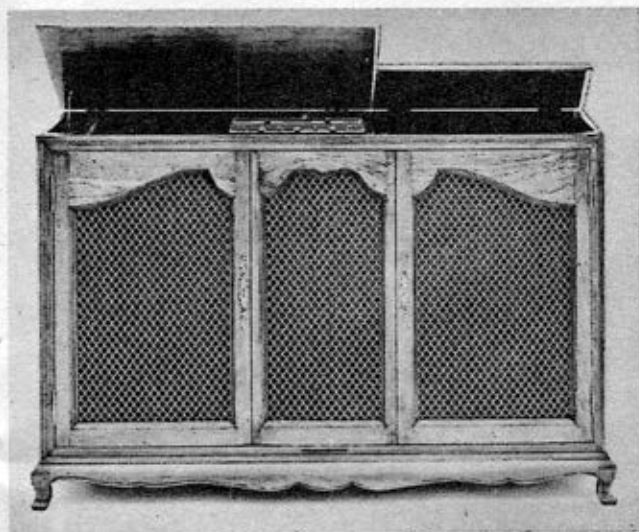

**Above:** Stromberg-Carlson SP-963 sells for \$1,095, has AM FM tuner, Garrard RC-88 changer, 60-watt amp., acoustic labyrinth stereo speakers. Isolated cabinet eliminates feedback.

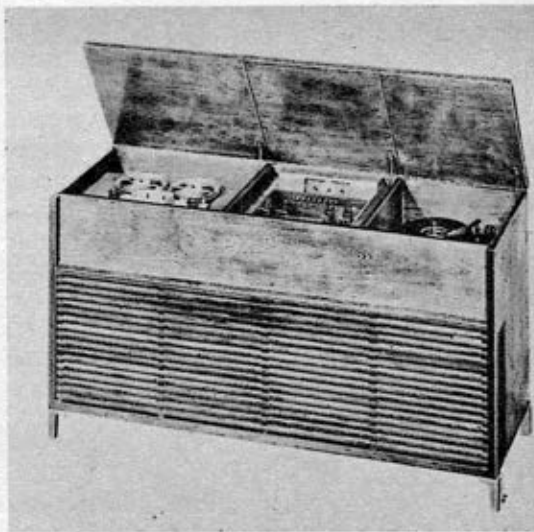

**Above, right:** Voice of Music Model 1000 "Stereo Fidelis," incorporates AM-FM tuner, record changer and a tape recorder with program timer.

**Right:** Stromberg-Carlson "Oriental" includes the components listed in the model shown at top left of this page, sells for the same price. A "stereo choice switch" enables the listener to choose degree of stereo separation for any program material.

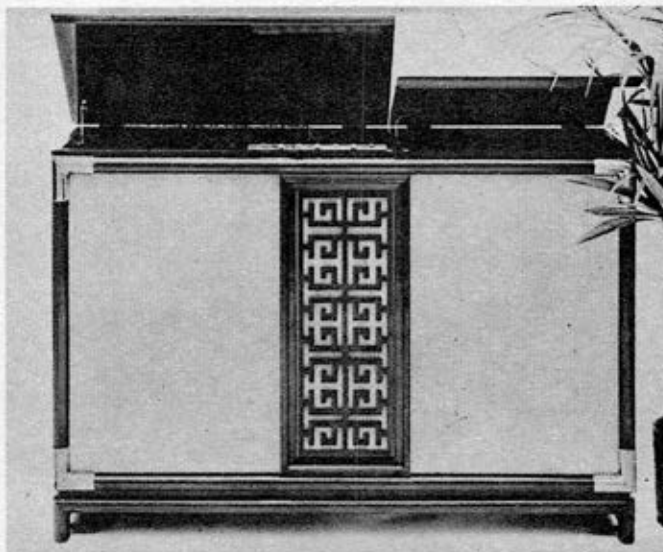

Hobbyists were not interested in getting an engineering degree, just so they could listen to good sound. And no homemaker who takes pride in her decor will permit sound, no matter how beautiful, to come out of equipment which makes her living room look like a haywired radio shack.

Happily, these primitive situations are now history. Today's components are not only simpler in design and in means of interconnection, but they have been reduced in size and placed in well-styled enclosures. Even so, you might argue, "Why should I go to all that bother? Why not simply go

out to an appliance store and buy a hi-fi set, with looks that suit my wife, and that I can plug in and play as soon as I get it home?"

Well, dear friend, there are many reasons why not. Let's begin with the simple flat statement that any system which has both the loudspeaker, the record player, and the electronic components all in one box, is not—repeat *not*—hi-fi! It is a physical impossibility to have a strongly vibrating system delivering full-range sound in such close proximity to sensitive tubes and pickups, without causing all sorts of havoc

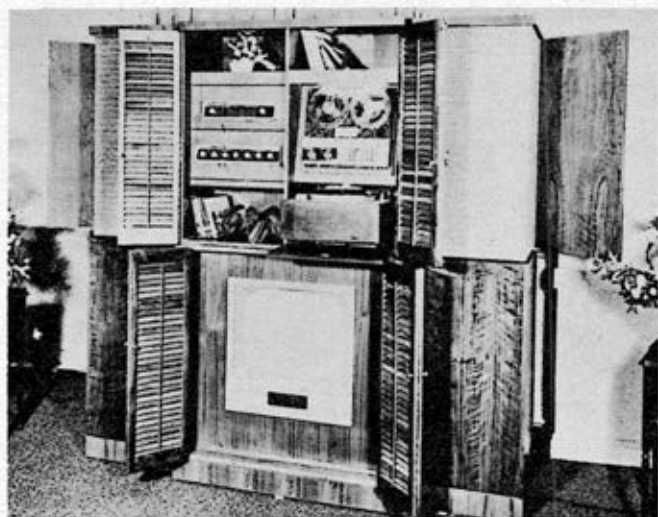

Installation below boasts Concertone tape recorder with preamp, a slide-out turntable with two tone arms, Jensen speaker enclosure and an AR.

Bell home music center is equipped with Bell stereo components. Featured are the 2-channel stereo amp and the tape transport for stereo record and playback.





Built-in stereo system includes a Fisher AM-FM tuner and 400-C stereo preamp, two Fisher amps (not shown), Garrard changer, Model RC-88, a JBL 001 speaker system and Ampex 910 stereo deck.



Professional Ampex 350 (\$1,284) is featured in this installation. Below is a D&R turntable with a Pickering 190D arm. A Fisher 80C preamp and AM-FM tuner are at bottom above disc storage.

in feedback, rumble, motorboating and distortion.

But the home instrument makers are doing it every day, you say. How? The answer is that the system is deliberately and necessarily designed to be deficient in bass response. If the loudspeakers are capable of complete bass response, which is unlikely, then the amplifying system is purposely emasculated by filtering out some of the bass. If that seems hard to believe, make a direct comparison of a home instrument, any home instrument, against a true hi-fi system. You will quickly detect the phony bass in the pretty box when you compare it against the real thing.

For another thing, when you buy a home instrument, the most important consideration—the sound—becomes secondary. Your selection will almost invariably be based on the cabinetry, its design, size, shape and finish.

Of course, you want something which is pleasing to the eye as well as the ear. So why not buy an equipment cabinet which suits your decor, and put in it whatever tailor-made components you want? This is the sensible way.

If you are budget conscious, then the component system wins hands down. When you buy a home instrument, a wholly disproportionate part of your hi-fi dollar goes for fancy cabinetry and middleman profits. Components are now attractive enough in appearance so that no cabinets are needed at all, and the profit markup on components is definitely less. Unquestionably, components are your best buy. And you can shave costs even further if you build your own from kits.

As for quality, the differences are astonishing. Even apart from the gimmicking necessary in the bass response because of the unitized construction, it simply is not possible to find, even in the most expensive home instruments, the quality of design, construction and performance to be regularly found in hi-fi components.

There is also greater convenience in a component system. Since cabinetry is not really necessary, it can be dispensed with if desired, and there is therefore no decorating problem. Equally important, small and inconspicuous components can be placed where they will be most convenient to use.

Say you want the controls near your favorite chair, within easy reach. If you use that arrangement with a home instrument, then the speaker has to be right beside you as well. This is no good for hi-fi listening. So you put the speaker down at



Allied Radio Corp.

the end of the room where it belongs. But with a home instrument, then you would have to get up every time you wanted to adjust the controls, change a record, or tune another station. With components, you can put each one right where it will do the most good.

As for flexibility in the home instrument, there is none. When you buy the factory-built job, that's it. You can't change it or improve it, and you probably can't add to it. When you have lived with it for a while, and find out how bad it really does sound, there isn't a thing you can do about it, except throw the whole works out and start over again.

With a component installation, you can make additions, changes, improvements, even deletions, at any time. The entire system can be kept completely up-to-date, at the very minimum of expense.

There's also the personal angle. Anything has more value and importance to you when it is the result of your own crea-

tive efforts. When you have done all the planning, and have come up with a system which is truly tailor-made to your own special requirements, then you can honestly say, "There's a part of me built into that job!" This strikes home even more when you have spilled sweat, blood and tears over a kit system.

To summarize, the scale is tipped heavily in favor of components. Because the home instrument is an inseparable combination of electronic equipment and furniture, any selection is inevitably a compromise between appearance, performance and convenience. There is no protection whatever against obsolescence. The cost is high and the quality is low.

Components, on the other hand, eliminate any compromise because of furniture. They provide maximum flexibility and protection against obsolescence. And they add that very important element of personal accomplishment, while giving you better sound at lower cost.



The Altec Lansing component cabinet and speaker enclosure, above, contain an automatic changer, AM-FM tuner, amplifier and preamp. This company makes many similar structures.

Photo left: Stretching along a whole wall is this stereo installation, which includes a Fisher 90R AM-FM tuner, two McIntosh C4P preamplifiers, two Fisher 100 power amps, a Garrard RC-88 changer with Shure stereo cartridge, Zenith TV, Ampex 902, Tannoy speakers.

A stereophonic room divider is used in a small apartment to great advantage. Hi-fi components installed here include a Bell stereo tape transport with Bell stereo amplifier and tuner-amp. Speakers are AR and Electro-Voice; Rek-O-Kut turntable, Garrard changer.



With the wide variety available in components of every type, the only accurate way for you to make a selection is to hear with your own two ears the various units you have under consideration. Since no set of test instruments and no one else's ears can determine precisely what you like to hear, it would be very desirable for you to run your own series of listening tests before you finally make up your mind.

Most of the electronic distributors in the larger cities have high fidelity salons which provide facilities for A-B testing of a wide variety of components. Connections to and from all of the units terminate at a master control panel, which permits interconnection of any combination of components which you select. And while this method cannot duplicate the acoustic environment of your own listening room, and even though you will often be subjected to various distractions, it nevertheless affords an opportunity for a better direct comparison between units than almost any other items you normally buy. Have you ever had the chance to A-B test a series of automobiles, for example, or power tools, or cans of beans, trying first one and then the other?

Despite the fact that hearing is largely a subjective process, you can nevertheless approach your listening tests with logic and objectivity. Perhaps we can offer a few hints which will enable you to get the most out of them.

You should bear in mind at the outset that this sort of testing (and consumer ratings as well) fall into the category which the statistician describes as "sampling." That is, a single unit of given manufacture is placed under test, and it is inferred from the results that all such units coming off the same production line are identical. But this is not always the case, as many of the companies engaged in high fidelity manufacturing are small, young organizations, and their quality controls are not always held to as narrow tolerances as would be desirable. Consequently, there occasionally rolls off the line an exceptionally good unit, and now and then there appears a "lemon" or two.

This is not true of all manufacturers, of course, but you can hedge against it by being sure that you can hear the identical unit which you will carry out of the store. Normally you will not hear the same unit which is to be delivered to you, since those on the shelves are more or less permanently installed. But once your decision is made, it is not unreasonable for you to ask that the fresh unit which you receive be connected up for an on-the-spot test

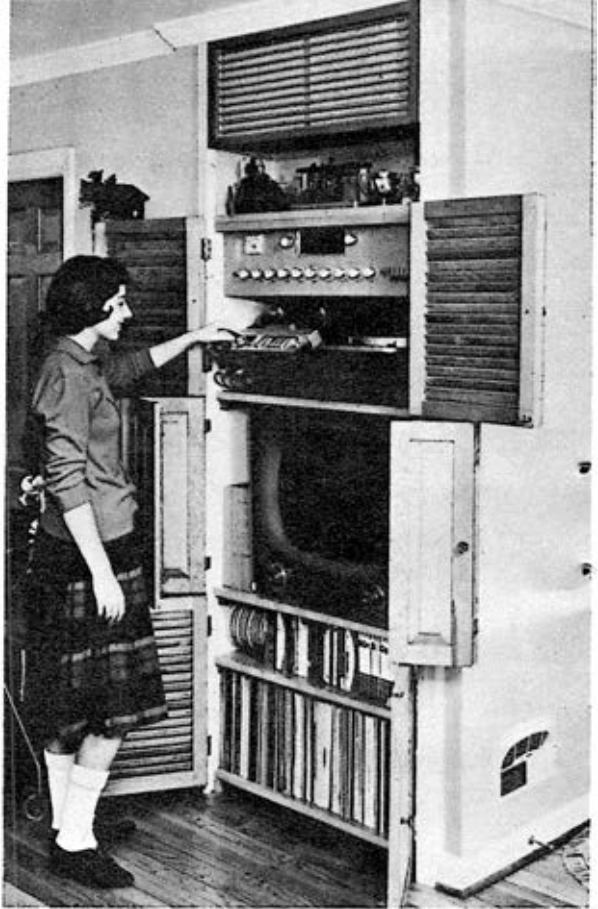

Three feet of wall space contain AR-2 enclosure, Bell 3030 stereo amplifier, Bell 2520 AM-FM tuner, Bell stereo tape deck, Garrard 301 turntable, custom auxiliary switches and VU meter.

Custom cabinet holds Sargent-Raymont AM-FM tuner with stereo preamp, controls, S-R 70-watt and Acrosound 60-watt power amps, Miracord changer, Ampex 950, RCA color TV, Stephens speakers.





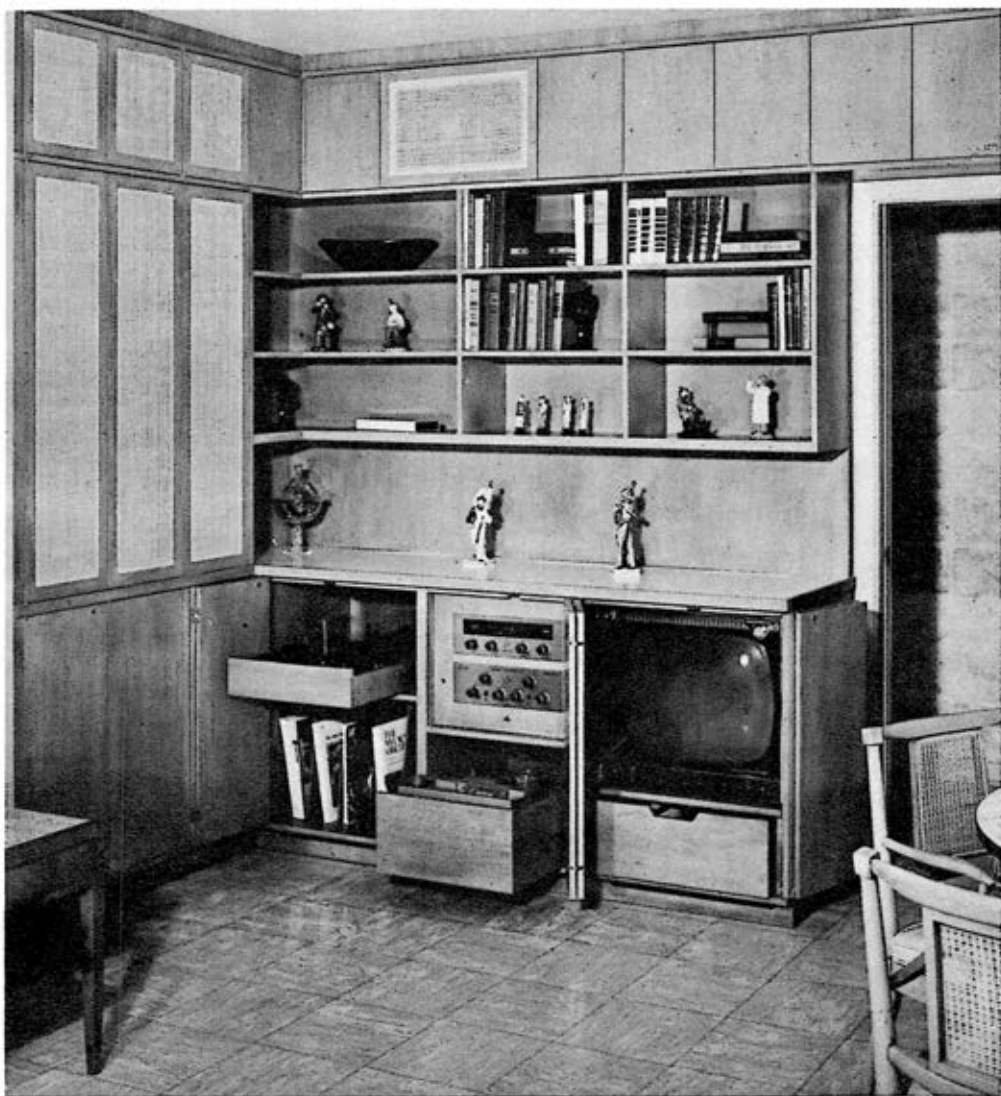

Well-planned installation takes up little room, fits in with rest of decor. Fisher AM-FM tuner sits above preamp. A Zenith TV set is at bottom right. Slide drawers hold tape recorder and a record changer.

Elegant "music wall" contains Ampex A-122 tape deck, two Fisher 90R AM-FM tuners, two Bogen 35-watt amps, Thorens turntable and Rek-O-Kut arm, Garrard changer. Speakers at each end are James B. Lansing.

Bakersfield Audio



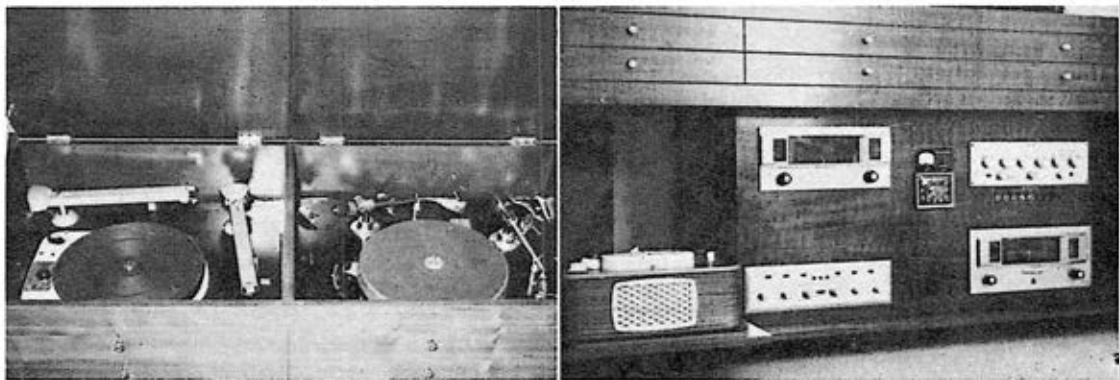

Components of system shown above include a Fisher AM-FM tuner, H. H. Scott 299 stereo amplifier, Fisher 90X FM tuner, Marantz preamplifier, VU meter and program clock, Tandberg stereo tape recorder. Closeup view of turn table setup shows, left, stereo arrangement with Garrard 301 turntable and two Pickering arms. At right is a Presto K-10 turntable with two Rek-O-Kut 120 arms. Total cost of system: \$4,855.40.

Compact installation in cabinet, front and rear view, includes two McIntosh MR-55 AM-FM tuners, two McIntosh preamplifiers, Magnadette tape recorder and stereo preamp with two VU meters. Turntable is a Miracord XS-200 automatic. Rear view shows two 60-watt McIntosh basic amplifiers installed vertically. Note ample area provided for good circulation of cooling air currents.

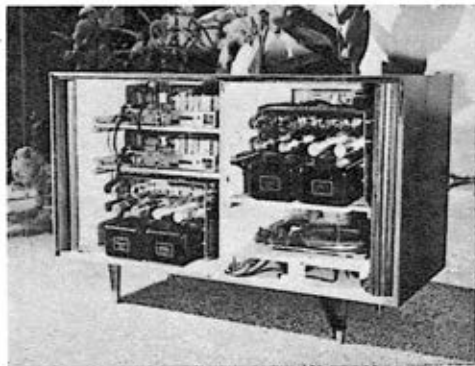

before you accept it. If you are buying by mail-order and are unable to hear your system in advance, then you should make doubly sure of the reliability of the distributors and manufacturers, and of their guarantees. All of the reputable houses bend over backwards to insure your satisfaction, and will readily make good on defective merchandise.

Since the loudspeaker and its enclosure are so susceptible to variation, it is a good plan to select them first. If you intend to make your own enclosure or console cabinet, see to it that the speaker is mounted in an enclosure which is very similar to the one which you intend using. Ask that the speakers which you are considering be connected to a high quality amplifier and program source, preferably records or tape with which you are quite familiar. Listen at various loudness levels for frequency response, freedom from distortion, and transient response. Play some material having a lot of high frequency sounds, such as triangle and cymbal, and walk back and forth in front of the speaker to test the angle of radiation. The speaker should be able to disperse the high frequencies well enough for you to hear them in full when you are 45 degrees away from the center axis. Then having finally decided on a speaker system, continue to use it for the remainder of your tests.

Next try out various amplifiers, again listening at several loudness levels. Notice the performance of the controls at all levels. Does the equipment have a loudness control, or can the deficiency of the ear at

low levels be compensated by the tone controls? You should test this with several records of different manufacture, as practice varies between companies. Note particularly the bass boost, and determine whether the lowest bass range is being increased, or whether the control is actually operating only over the lower midrange. If the bass response is smooth, there will be no "one-note" bass, an indication of low-frequency resonance.

The male voice is a good test for hi-fi systems, affording an examination of the smoothness with which the system reproduces the low frequencies, while at the same time providing sibilant sounds which require a clean treble response, free from thinness or harshness. Even if you haven't attended many concerts in your lifetime, you do hear human voices every day, and you will quickly spot any unnaturalness of reproduction.

Selection of the pickup, compensator and preamplifier follows the same general procedures. Note particularly the action of the compensator. Does it really make a difference in the quality of reproduction when it is varied while playing the same record? And does the position which is recommended for a given make of record actually provide unmistakably the best results? Although the recording industry has agreed on a standard characteristic curve, if your record library is already extensive and varied, you will do well to select this component with great care, for inaccurate compensation can easily ruin otherwise flawless reproduction.

Simple, well-designed cabinet holds a Sherwood AM-FM tuner and a Sherwood stereo preamplifier-amplifier combination. The turntable is a 2-speed Rek-O-Kut with 120 arm, Shure stereo cartridge.

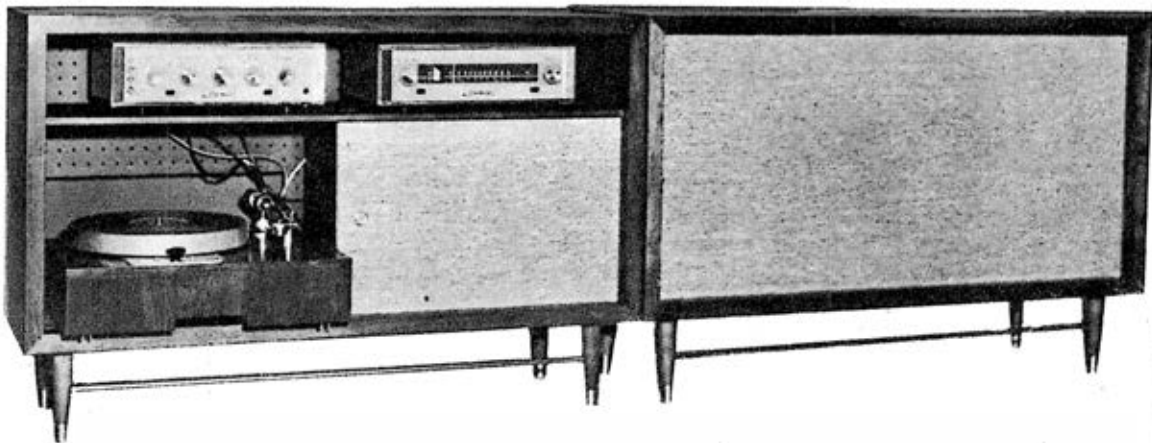

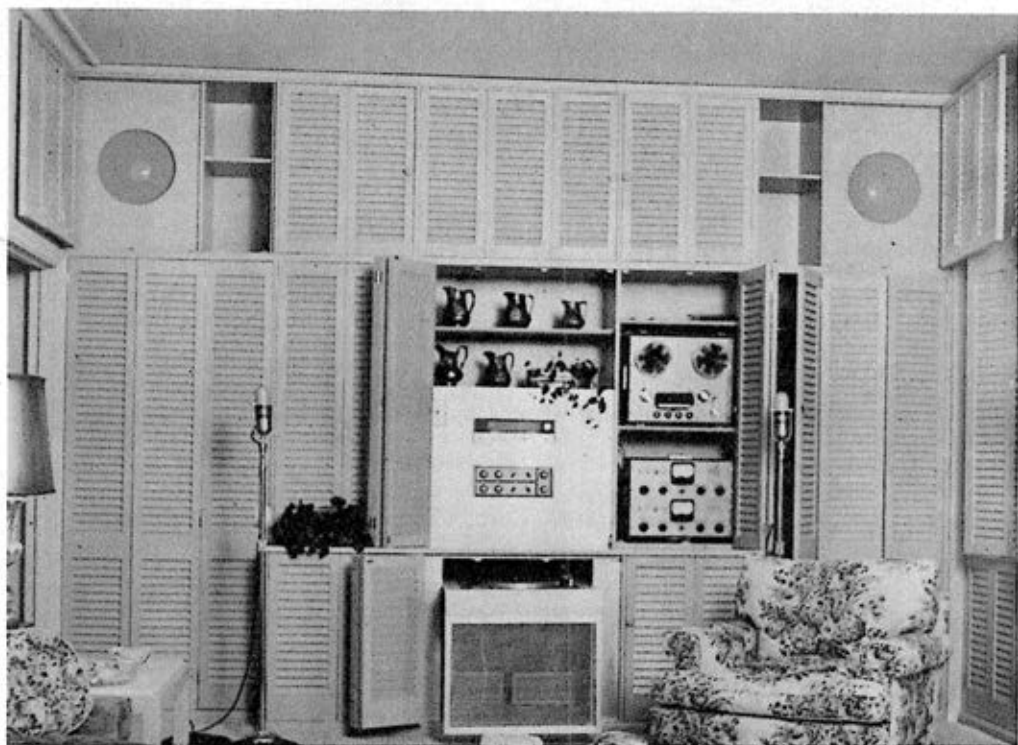

Hi-Fi Systems magazine

Combination bar and music room contains two 40-watt Marantz amplifiers, McIntosh MR-55 tuner, Ampex 351-D tape recorder, Rek-O-Kut B-16H turntable, Fairchild 248 stereo preamp, two JBL D-130 speakers.

Professional looking installation includes RCA color TV, three McIntosh preamps and three 60-watt amplifiers, two Viking tape decks and preamps, Thorens turntable, Electro-Voice speakers.

Installation of your components is now simplicity itself. The electrical connections are mostly by means of phono plugs, which makes the procedure just about as difficult as plugging a lamp into a wall socket. Mounting is likewise a small problem. If any drilling or cutting of cabinets or shelves is necessary, templates are supplied with the various components.

The variety, flexibility and operating simplicity of high fidelity components today is something undreamed of even five years ago. But you no longer have to dream. You know now how it's done.

### The Stereo Story

The ideal stereo system is basically two monophonic systems side by side. Although all sorts of gimmick circuits and short-cut speaker systems are now being offered the public as true stereo systems,



WITH THE NEW  
**TICONAL<sup>®</sup> VIII**

**MAGNETS**

(30% more powerful  
than alnico)

**T-7**

**Norelco<sup>®</sup>**

**LOUDSPEAKERS**

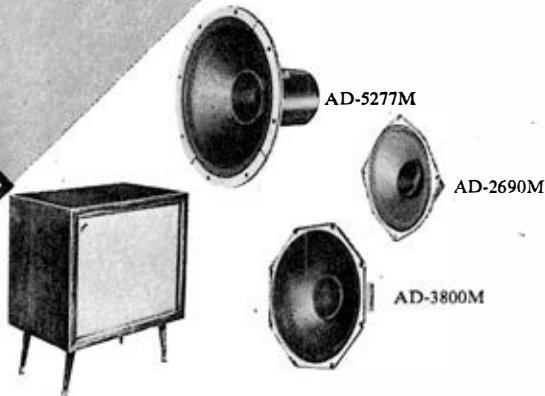
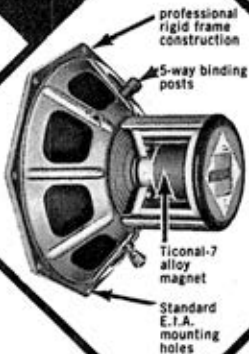

**DEVELOPED  
AND  
GUILD-CRAFTED  
BY  
PHILIPS  
OF THE  
NETHERLANDS**



for further descriptive literature write to:  
**NORTH AMERICAN PHILIPS CO., INC.**  
High Fidelity Products Division, Dept. 3U  
230 Duffy Ave., Hicksville, L. I., N. Y.

**FROM THE AUDIO RESEARCH CENTER  
OF THE WORLD...**

This new line of 5" to 12" loudspeakers is designed to match the quality requirements of the discriminating music lover... at a surprisingly moderate price. The world's greatest buys on the basis of listening quality, the T-7 series incorporates voice coil magnets of Ticonal-7 steel, the most powerful of modern magnet alloys, for maximum efficiency and damping... dual cones for wide frequency response... constant impedance resulting in an extremely straight response curve... longer effective air-gaps and extra high flux density to provide exceptional transient response and to eliminate ringing and overshoot.

model	size	power (watts) cont.	peak	impedance (ohms)	efficiency at 400 cps (maxwells)	total flux	flux density (gauss)	frequency response (cps)	audiophile net
AD-5277M	12"	20	30	8	14%	134,000	11,000	35-18,000	\$72.50
AD-4277M	12"	20	30	8	7%	98,000	8,000	35-18,000	39.00
AD-4877M	8"	6	10	4-6	10%	58,300	13,000	50-20,000	26.00
AD-3800M	8"	6	10	4-6	6%	26,200	11,000	76-19,000	9.90
AD-3500M	5"	3	5	4-6	4%	26,200	11,000	130-19,000	8.34
AD-3690M	6x9"	6	8	4-6	5.5%	26,200	11,000	70-18,000	7.95
AD-2690M	6x9"	6	8	4-6	2.5%	15,200	8,500	70-16,000	6.75

**Norelco SPEAKER ENCLOSURES**

Available in three sizes in hand-rubbed Mahogany, Walnut, Blond or Cherry finishes. The "REMBRANDT" for AD-5277M, AD-4277M, and most full range 12" speakers (26" x 21½" x 17¼" deep) Walnut or Cherry \$99.50; Blond \$94.95; Mahogany \$91.00. The "VAN GOGH" for AD-4877M or most other full range 8" speakers (23¾" x 13¾" x 11¾" deep\*) Walnut or Cherry \$59.95; Blond \$55.50; Mahogany \$51.00. The "VERMEER" for AD-3800M or most other full range 8" speakers (18½" x 12" x 8-15/16" deep\*) Walnut or Cherry \$35.00; Blond \$33.25; Mahogany \$31.00.

\*May be placed horizontally or vertically.  
**The "Hague":** Completely integrated quality speaker system. Two high-efficiency T-7 loudspeakers in an acoustically matched enclosure. Designed for optimum dispersion... maximum efficiency... extremely wide-range, flat response. 26" x 21½" x 17¼" deep. Walnut or Cherry \$159.95; Blond \$154.95; Mahogany \$149.95.

## Your Complete System

the fact is that every one of them is a compromise of sorts, and performance in some cases can only be described as pseudo stereo.

The hi-fi neophyte should start out with the very best monophonic system he can afford, and then build up his stereo system on that solid foundation. For while the aural effect of stereo is revolutionary, the equipment which produces it is not. The entire system is simply a logical extension of monophonic techniques.

This means that very little of an existing monophonic system must be thrown into the discard. Some must be modified, it is true, and there must be additions for the second channel. But the conversion to stereo from a solid monophonic basis is primarily a process of building up, not tearing down.

If you are definitely committed to the idea of having stereo ultimately, then your phono pickup initially should be of the stereo type. Remember that, although stereo discs cannot be played on monophonic cartridges without severe damage to the record, a stereo cartridge can reproduce either type of recording, even through a monophonic system. With a stereo car-



tridge, then, you can begin building up your library of stereo records, playing them monophonically until your stereo system is complete.

Your first addition should definitely be a second loudspeaker, and if at all possible it should be identical to the first. Your single power amplifier will easily drive two speakers, and very likely has output connections for this very purpose. Then the only problem is phasing of the two speakers, and this is a simple matter. You could install a phase switch at this time, but it isn't necessary. All you need do is experiment with reversing the leads to one of the speakers only. Whichever arrangement gives the better bass reproduction is the in-phase condition. •

Two JBL 001 speaker systems give stereo sound to this installation. It holds a Fisher AM-FM tuner, Garrard changer, Ampex A-124 stereo tape deck, two Fisher 30-watt amplifiers, Pickering cartridge.





# RCA INSTITUTES



# OFFERS YOU THE FINEST OF HOME STUDY TRAINING

**COURSE I  
ELECTRONIC FUNDAMENTALS**  
**COURSE II-T  
TV SERVICING**  
**COURSE II-EA  
ELECTRONICS FOR AUTOMATION**  
**COURSE III-T  
COLOR TV**

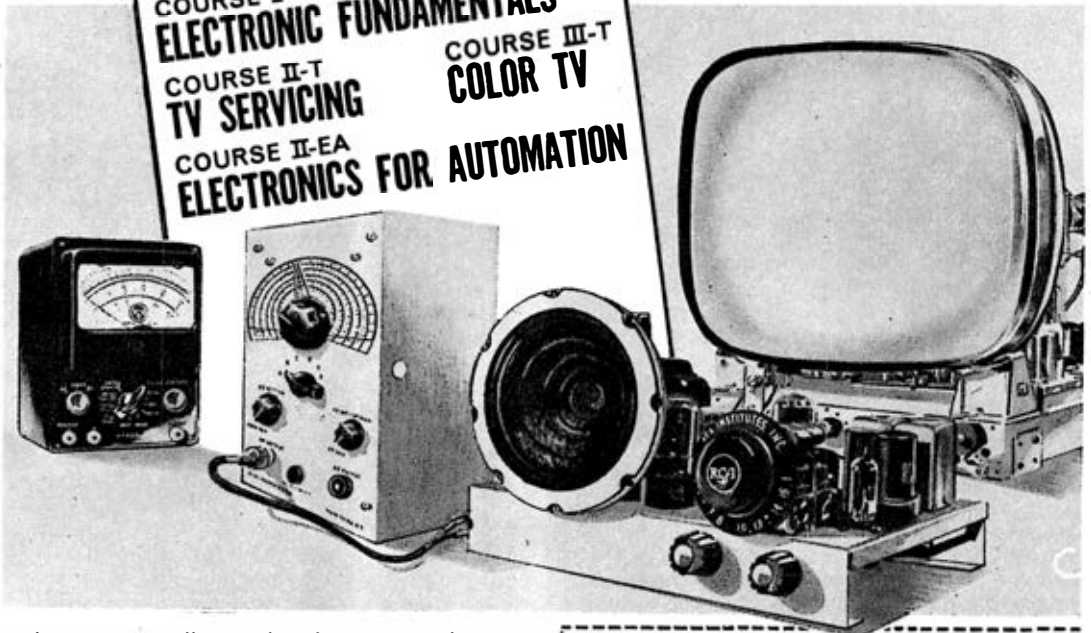

The equipment illustrated and text material you get with each course is yours to keep. Practical work with very first lesson. Courses for the beginner and the advanced student. Pay-as-you-learn. You need pay for only one study group at a time.

## RCA INSTITUTES, Inc. Home Study School HF-59

A Service of Radio Corporation of America  
 350 West Fourth Street, New York 14, N. Y.  
 Without obligation, send me FREE 64-page CATALOG on Home Study Courses. No salesman will call.



**SEND FOR THIS  
FREE BOOK NOW**

Resident School courses in New York City offer comprehensive training in Television and Electronics. Day and evening classes start four times each year. Detailed information on request.

ANOTHER WAY RCA SERVES EDUCATION THROUGH ELECTRONICS

Name.....  
 Please print

Address.....

City.....Zone.....State.....

Korean Vets! Enter discharge date.....

**CANADIANS** - Take advantage of these same RCA courses at no additional cost. No postage, no customs, no delay. Send coupon to:

**RCA VICTOR COMPANY, LTD.**  
 5001 Cote de Liesse Rd., Montreal 9, Que.

To save time, paste coupon on postcard

## Chapter 13

# Review of Best Recordings



By Fred Honig

**T**ODAY'S music lover is faced with the fortunate problem of overabundance. The supply of fine recordings by famous soloists, conductors and orchestras, has never been greater, especially since the advent of stereo, where many discs are duplicated in that version. But the picture is not all bright. There are many recordings that are very inferior in sound and performance. And even the technical production of many records, although this seems hard to believe with today's fine recording equipment, leaves a lot to be desired. Overwhelmed by an avalanche of music, dazzled by ads and publicity, the buyer often finds that he has purchased a dud, has paid good money for an album that will do nothing but gather dust and

will take up valuable record storage space.

This is why reviews are so important. They tell the buyer what is good, what is better, why to buy a particular disc, and why another album is best left alone. With this in mind we approached the major recording companies to send us records **THEY** consider among their best recent releases—classical, popular, jazz, etc.—in sound and performance. From this list we discarded many, picked the ones most worthy of note, and reviewed them for the reader's information. Due to limited space, unfortunately only very brief comments could be made, but with an attempt to emphasize the most outstanding point of each recording—good or bad. The records listed below are reviewed by the editor.

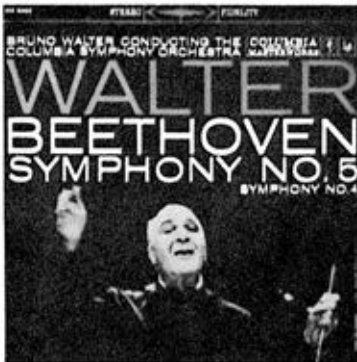



**BEETHOVEN:** *Symphony No. 5 in C minor/Symphony No. 4 in B-flat major.* Walter, Columbia Symphony Orch. Columbia MS 6055 Stereo

The two works above are part of the Beethoven series Bruno Walter is presently recording for Columbia in stereo. As good or better than ever, the maestro leads the orchestra in a spirited and knowledgeable performance of the 5th, perhaps Beethoven's most popular work. Sound is excellent on both the 4th and 5th, with good stereo separation. The only sour note is some sloppy editing of the master tape; probably due to a rush to get this disc on the market.

**BEETHOVEN:** *Symphony No. 7 in A major/Coriolan Overture.* Bohm, Berlin Philharmonic Orch. Deutsche Grammophon Gesellschaft DGS 712006 Stereo

Adequate performance of a symphony which has had many great interpretations. Excellent audio.

**BEETHOVEN:** *Symphony No. 9 in D minor (Choral)/Lenore Overture No. 3/Egmont Overture.* Seefried, Forrester, Haeflinger, Fisher-Dieskau, Fricsay, Berlin Philharmonic Orch. Choir of St. Hedwig's Cathedral. Decca DXB 7157 Stereo

No matter how much you may like any previous recording of this monumental work, it is not until you hear this stereo version that you can fully appreciate its subtleties and splendors. Fricsay conducts with vigor; the choir and soloists are excellent, except for Fisher-Dieskau, whose fine, though rather weak, voice is often overshadowed by the rest of the ensemble. Best audio of any Ninth available.

**BERLIOZ:** *Symphonie Fantastique.* Wallenstein, Virtuoso Symphony of London. Audio Fidelity FCS 50,003 Stereo  
Excellent sound, spirited performance.



**BOB AND RAY:** *Stereo Spectacular.* With Julie Andrews, Belafonte Singers, Skitch Henderson, Lena Horne, Abbe Lane, etc. RCA LSP-1773 Stereo

Lovers of this zany twosome, and there must be millions of us, will regret that the entire disc is not devoted to Bob and Ray alone. But what there is of them is worth its weight in laughs. Outstandingly excellent stereo with weird sound effects.

**BRAHMS:** *Piano Concerto No. 2 Op. 83.* Vladimir Ashkenazy, piano. Leopold Ludwig, Berlin Opera Orch. Angel 35649

Of the many recordings available of this piece, Ashkenazy's must rank among the finest.

**COPLAND:** *Billy The Kid/Rodeo.* Morton Gould and his Orch. RCA Victor LSC-2195 Stereo

Although many good recordings of these two ballet pieces are in the catalog, Mr. Gould's, especially in this stereo version, is among the best.

**DAKOTA STATON:** *Crazy He Calls Me.* With Nelson Riddle, Sid Feller and Howard Biggs orchestras. Capitol T1170  
The best of Dakota, mean and lowdown.





**DUKES OF DIXIELAND:** *Up the Mississippi, Vol. 9.* Frank Assunto, trumpet; Fred Assunto, trombone; Jac Assunto, banjo; Stanley Mendelsohn, piano; Jack Maheu, clarinet; Red Hawley, drums; Lowell Miller, string bass. Audio Fidelity AFLP 1892

Another volume in the series recorded by the Dixie group. Some of their other albums are *On Campus*, *Mardi Gras Time*, *Circus Time*, *Marching Along*, *On Bourbon Street*, etc. *Up the Mississippi* Volume No. 9, is as good if not better than the previous, swinging, crazy, New Orleans renditions.



**ERICH KUNZ:** *German University Songs.* Erich Kunz; Litschauer, chorus and orch. of Vienna Volksoper. Vanguard VRS-477  
The fine, strong voice of Erich Kunz is especially suited for these "Wenching and Wining" songs, old favorites of Heidelberg and other German universities. The album also contains the original German text, with rather poor English translations. The Vienna Volksoper male chorus and orchestra, a group mainly devoted to operettas and light opera, accompanying Mr. Kunz in vigorous, lusty style.

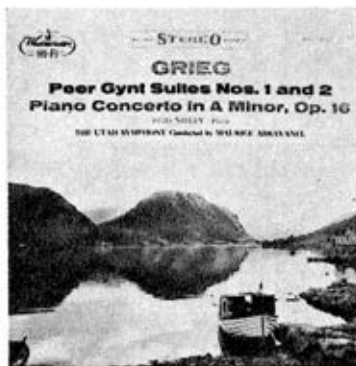

**GRIEG:** *Peer Gynt Suites Nos. 1 and 2/Piano Concerto in A minor, Op. 16.* Nibley, piano; Abravanel, Utah Symphony. Westminster WST 14057 Stereo

Beautiful rendition of the Peer Gynt suites by the excellent Utah orchestra. Reid Nibley's piano is brilliant in the concerto. Excellent audio.



**GROFÉ:** *Grand Canyon Suite.* Abravanel, Utah Symphony. Westminster WST 14065 Stereo

This fast rising American orchestra, under its excellent conductor, gives a superb performance of this popular work.

**HANDEL:** *Concertos, Nos. 7-12 (Op. 7, Nos. 1-6).* E. Power Biggs, organ. Boult, London Philharmonic Orch. Columbia M2L 261  
Great music, performed by a great organist, using one of Handel's original organs. Excellent sonic balance.

**HAYDN:** *Symphony No. 104 in D major (London)* **MENDELSSOHN:** *Symphony No. 4 in A major (Italian).* Bernstein, New York Philharmonic. Columbia MS 6050 Stereo  
Superb, spirited reading by Mr. Bernstein of both works. The Haydn is light, gay and captures the meaning of the composer. The Italian, one of Mendelssohn's favorites, shows off the conductor and orchestra at their most brilliant in what is probably the best performance of the Mendelssohn 4th available to date.

# Here's all you need to build a HEATHKIT®...

... these tools and NO EXPERIENCE

We say "NO ELECTRONIC EXPERIENCE NEEDED" . . . and we mean it.

Recognized by leading consumer research organizations as the best in the field of kit construction manuals, the Heathkit step at a time instructions leave absolutely nothing to question. Giant size pictorial diagrams and everyday, non-technical language make every Heathkit easy for anyone to build. No electronic or soldering experience is required; the Heathkit manuals teach you the right way to do a professional job the first time.

No matter what your field of interest, building a Heathkit will be one of your most exciting, rewarding experiences.

And you'll save 50% or more on the world's finest electronic equipment. Send today for your *free* Heathkit catalog—or see your nearest authorized Heathkit dealer.

#### EVERYTHING FOR HI-FI

HIGH FIDELITY  
AMPLIFIERS



TUNERS



TAPE DECKS



CHANGERS



Mail the coupon Today!



#### HEATH COMPANY

a subsidiary of Daystrom, Inc.  
Benton Harbor 7, Michigan

Please send the latest Free Heathkit Catalog.

NAME \_\_\_\_\_

ADDRESS \_\_\_\_\_

CITY \_\_\_\_\_ ZONE \_\_\_\_\_ STATE \_\_\_\_\_

**HAYDN:** *Sinfonia Concertante in B flat major, Op. 84.* **MOZART:** *Sinfonia Concertante in E flat major, K. 297b.* Ormandy, Philadelphia Orch. Columbia ML 5374

Both works are gems of the musical repertoire and are given a spirited performance in this recording. Superb sound.

**KIRSTEN FLAGSTAD:** *Kirsten Flagstad Sings Sibelius Songs.* Oiven Fjeldstad, London Symphony Orch. London OS 25005 Stereo

Miss Flagstad is in fine voice in this recital of Sibelius songs. Her native understanding of his music gives us a sensitive picture of bleak landscapes, wild mountains, rippling streams—images which are the essence of the Scandinavian composer's works.

**JENNIE TOUREL:** *A French-Italian Program,* with Paul Ulanowsky, piano. Berlioz, Bizet, Ravel, Poulenc, Liszt, Rossini, Vivaldi, Gluck, Stradella. Decca DL 710013 Stereo

Miss Tourel, among the best of the rapidly vanishing concert singers, is in excellent voice in this recital of some lesser known songs. This is a recording where stereo does not seem to add anything, although it does not detract.

**MENDELSSOHN:** *Symphony No. 4 (Italian)/Symphony No. 5 (Reformation).* Munch, Boston Symphony Orch. RCA LSC-2221 Stereo

The above works, which have so often been abused by many conductors, are given a sound interpretation here by Charles Munch and his fine Boston group.

**OFFENBACH:** *Gaite Parisienne.* Slatkin, Hollywood Bowl Symphony Orch. Capitol PAO 8405

The best sounding version available of this happy composition.

**ORFF:** *Carmina Burana.* Stokowski, Houston Symphony Orch. Houston Chorale, Houston Symphony Boy's Choir. Capitol PAR 8470

Stokowski's interpretation of this exciting work seems to lack the understanding given to it in a previous recording by Jochum under the Decca label, but this new disc has perhaps the best and clearest audio.



**QUEEN'S BIRTHDAY SALUTE:** *Band Concert, Royal Birthday Celebration and 21 Gun Salute.* Herald Trumpeters and Band of Royal Regiment of Artillery. Vanguard VSD-2011 Stereo

A pageant in sound, drums, guns, pipes and brass band.



You should know there is something better . . .

New HI-FI STEREO

# GALAXY\*II

SATELLITE SPEAKER SYSTEM

by Jensen

The ultimate space-solving  
speaker system for panoramic  
stereo sound in the home

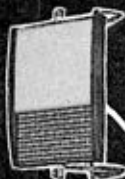

Shown against a background  
of the Andromeda Galaxy



You've never seen a stereo speaker system like this . . . an inspired merging of function with decor . . . takes less than a square foot of floor space . . . yet gives big speaker dual 3-way panoramic stereo sound. For any room . . . Jensen Galaxy is the most livable stereo speaker system ever! Only \$169.50 Complete. For more about GALAXY . . . Brochure GY is free on request.



Jensen

Division of The Muter Company

MANUFACTURING COMPANY

6601 South Laramie Avenue, Chicago 38, Illinois

In Canada: J.R. Longstaffe Co., Ltd., Toronto

In Mexico: Radios Y Television, S.A., Mexico, D. F.

\*T.M.

**RAVEL: Concerto in G. D'INDY: Symphony on a French Mountain Air.** Nicole Henriot-Schweitzer, piano. Munch, Boston Symphony Orch. RCA Victor LSC-2271 Stereo

There is perhaps no better interpreter of French music today than Charles Munch, and he proves this again by his conducting of these two pieces. Henriot-Schweitzer's solo in the Ravel concerto is admirably performed.

**REDHEAD: Original Cast Recording.** Gwen Verdon, Richard Kiley, Herbert and Dorothy Fields, Sidney Sheldon, David Shaw. RCA Victor LSC-1048 Stereo  
Buying this album is the next best thing to seeing the original Broadway show. Gwen Verdon is as great as ever in this stereo disc.

**SCHUBERT: Quintet in A Major, Op. 114 (Trout).** Dennis Mathews, piano, with members of Vienna Konzerthaus Quartet. Vanguard VSD-2019 Stereo

After hearing this splendid recording you can stop wondering why stereo is necessary for such a small ensemble as a quintet. You will know. Stereo gives this beautiful piece a new "dimension," a new clarity and brilliance, never before heard on any monaural disc.

**SCHUMANN: Piano Concerto in A minor Op. 54.** Rubinstein, piano. Krips, RCA Victor Symphony Orch. RCA Victor LSC-2256 Stereo

Arthur Rubinstein's piano is especially suited for this work. Joseph Krips conducts with spirit and feeling.

**SEGOVIA: Golden Jubilee.** Andres Segovia, guitar; Enrique Jorda, Symphony of the Air. Decca DXJ-148

Three records make up this special album, which also contains as part of the program notes a poem by Carl Sandburg, an essay by Castelnuovo-Tedesco, excerpts from Segovia's autobiography and photos of the master. Each of the more than twenty pieces in this album is a study in the art of the guitar by the greatest living exponent of that instrument. The sound is undistorted and true, and the fifteen composers represented in this performance, mostly modern, are given a loving and knowledgeable interpretation. The only regret is that Bach is absent in this album.



Discover for yourself why Sherwood is the most honored line of high fidelity components in the field. Sherwood Tuners (the first ever to achieve sensitivity under 0.95 microvolts) feature: Inter-Channel Hush, a noise muting system which makes FM tuning easier than ever • FM Multiplex Output • "Feather-Ray" Tuning Eye • Automatic Frequency Control • Flywheel Tuning. Combine these tuners with either of Sherwood's "mated" stereo amplifier choices; 20+20 watts or 36+36 watts. And only Sherwood offers all these features: Single/Dual Bass & Treble Controls • Mid-Range Presence Rise • Stereo-Mono Function Indicator Lights • Phase-Reverse Switch • Damping Factor selection. Sherwood also offers either 36 or 60 watt monaural amplifiers, FM Multiplex Adapters and a complete decorator-styled line of cabinetry and 3-way speaker systems —The Finest in High Fidelity, Sherwood Electronic Laboratories, Inc., 4300 N. California Avenue. Chicago 18, Illinois.

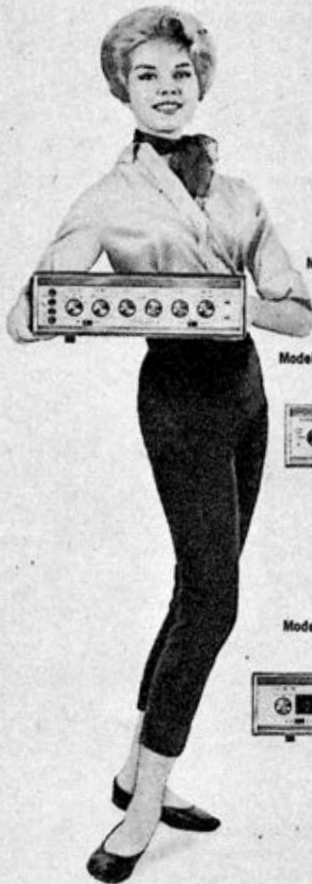

Model S-4400, Stereo Preamp. + 36W Amp. —\$159.50

Model S-5000, 20 + 20W Stereo Dual Amplifier —\$189.50



Model S-3000 II, FM Tuner —\$105.50



Model S-1000 II, 36W Monaural Amplifier —\$109.50



Model S-2000 II, FM-AM Tuner —\$145.50

only for those who want the ultimate

# SHERWOOD HIGH FIDELITY

For complete technical details write Dept. FHF-10

**STOKOWSKI:** *Music for Strings*. Bach, Gluck, Borodin, Paganini, Rachmaninoff. Leopold Stokowski Symphony Orch. Capitol PAO 8415.

Few conductors have equaled Mr. Stokowski's understanding of the string orchestra, and this record is an excellent example of his mastery of this medium. The rich, vibrant tones, especially in the Bach *Prelude* give us a new insight into this work. Although some may quarrel with Mr. Stokowski's "personalized" version of this and other pieces, no one can dispute the force and understanding he brings to it in his interpretation. Excellent sound throughout.

**VICTORY AT SEA:** *Volume 2, Suite from the score composed by Richard Rogers*. Robert Russel Bennet, RCA Victor Symphony Orch. RCA Victor LSC-2226 Stereo. Originally composed for the NBC TV production of the same name, the music of this disc is an adventure in sound and fury, "blood, sweat and tears." Superb stereo.

**VIVALDI:** *The Four Seasons*. Krotzinger, violin; Munchinger, Stuttgart Chamber Orch. London OSA 1309 Stereo

This stereo version is every bit as good as Munchinger's previous monaural one, which is still among the finest available. Stereo has added clarity and direction to this charming and popular work by the great Italian master.

**WAGNER:** *Das Rheingold*. Flagstad, London, Madeira, Svanholm, Wachter, Neidlinger, Boehme. Solti, Vienna Philharmonic Orch. London OSA 1309 Stereo

As a *tour de force* in stereo "sound" this recording stands alone, and it is hard to imagine that it can be matched even in an actual live performance, except under ideal conditions. A "must" for Wagner lovers, it is the best sounding and the only complete version of this opera and by far the best recorded of any of the composer's works available. Even for non-Wagner fans it will be a revelation and education in the capabilities of well-recorded stereo.

**TCHAIKOWSKY:** *Concerto No. 1 in B-flat minor*. Leonard Pennario, piano. Leinsdorf, Los Angeles Philharmonic Orch. Capitol PAO 8417

The sensitive playing of Pennario is complemented by Erich Leinsdorf's forceful conducting of the fine Los Angeles group, to give us a brilliant addition to an all-time favorite of the musical literature.



**THE WEAVERS:** *At Carnegie Hall*. Seeger, Gilbert, Hayes, Hellerman. Vanguard VRS-9010

Recording of actual Carnegie Hall concert—applause included—by this superb quartet, which ranks among the all-time greats of folk singing groups. Among the old favorites performed in this album are, *Goodnight Irene*, *Kisses Sweeter Than Wine*, *When the Saints Go Marching In*, and *Greensleeves*. Lesser known numbers, such as *Woody's Rag* and *Follow the Drinkin' Gourd* are included in this recital of international folk music. A "must" for Pete Seeger fans.





# TONIGHT'S PROGRAM

## Concerto for Static Electricity and Dust or POP GOES THE NEEDLE

Eliminate those annoying crackles, clicks, and pops by removing their causes . . . latent static electricity charges and build-ups of microscopic dust. Most record shops feature these fine Clevite "Walco" products that help you restore your recordings to original brilliance . . . and protect against recurrence of record chewing, needle wearing, sound destroying static electricity and dust.



**CLEVITE Walco**  
ANTI-STATIC/HI-FI  
DISCLEANER KIT

Most effective anti-static cleaning solution together with velvet-piled applicators that reach deep between groove walls.



**CLEVITE Walco**  
DISCOVERS

Contoured polyethylene sleeves for 10" and 12" discs — protect against dust, finger-marks, and groove abrasion.



**CLEVITE Walco**  
STATI-CLEAN

Push-button static and dust removal. Aerosol-spray a disc, wipe with special cloth, and records stay static-free for months. Non-gumming.



**CLEVITE Walco MICROGRAM**  
STYLUS PRESSURE GAUGE

Foolproof balance scale accurately measures stylus pressure from 1 to 10 grams, never requires adjustment or recalibration.

# PEAKING MID-FREQUENCIES

## . . . WEAK HIGHS AND LOWS?

*Before Shuffling Your Components,  
Try Installing*

## A NEW Clevite 'Walco' DIAMOND NEEDLE

Did you know that a *badly assembled* or *poorly made* needle can wreak havoc on your sound, even when the needle is new? See the two response curves from the same

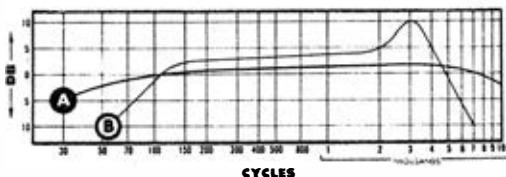

cartridge . . . a GE RPX-052. Line A shows the nearly flat frequency response throughout the audio range achieved with a proper Clevite "Walco" replacement diamond needle. Line B, the response curve of a "bargain" diamond stylus assembly, displays an abnormal peak in the 2000-4000 cps range with severe losses in the highs and lows.

Because Clevite "Walco" makes hundreds of models of needles for installation in *original* factory assembled equipment, the name Clevite "Walco" on a *replacement* needle is your assurance of rigid adherence to the specifications of the audio engineers who designed your equipment.

Play it safe. Play it with a Clevite "Walco" diamond needle and get the response that your equipment was designed to give. At better record stores everywhere.

# CLEVITE Walco

60 Franklin Street • East Orange, New Jersey

# trading?

audio exchange  
makes the **BEST**  
Trades!\*

\*See HI-FI Magazine, May 1959, page 39

We have the franchise for these exclusive  
manufacturers



• PROMPT SERVICE • LARGEST SELECTION  
of guaranteed used equipment

• TRADE BACK PLAN — write for details

Write Dept. FG59 for our unique Trade-Back plan



## audio exchange

Registered Component Dealers



The Hi Fi Trading Organization  
153-21 Hillside Ave., Jamaica 32, N.Y.  
Closed Mondays • Parking at all stores  
Brooklyn . . . . . 836 Flatbush Avenue  
White Plains . 367 Mamaroneck Avenue  
Manhasset . . . . . 451 Plandome Road

## Chapter 14

# The Hi-Fi Language

**A-B Test**—Direct comparison of sound of two tape recorders made by simultaneously playing identical recorded selections on both machines and successively turning on the speaker of first one, then the other.

**AES**—Audio Engineering Society.

**AF**—Abbreviation for audio frequency.

**AFC**—Abbreviation for automatic frequency control; an electronic circuit used in tuners to correct inaccuracy in tuning a station.

**AM**—Abbreviation for amplitude modulation; the type of transmission utilized by the standard broadcast stations.

**Amplification**—Magnification (see Gain).

**Amplifier**—An electronic circuit which increases the amplitude of an electric voltage or power.

**Arm (phonograph)**—A movable bracket which holds the pickup in proper position over the record (also Tone Arm).

**Attenuation**—Reduction of an electric voltage or current; the opposite of amplification.

**Audio**—The range of frequencies from approximately 30 to 15,000 cps. Also an adjective used in reference to the electronic and acoustical equipment concerned with the reproduction of sound.

**Audiophile**—A person who is interested in improving musical reproduction for his own personal listening, by use of the latest audio equipment and techniques.

**Background Noise**—The total system noise, regardless of whether or not a signal is present.

**Baffle**—A barrier or partition designed to separate the sound waves generated by the front and back of a loud-speaker cone.

**Bas s Reflex Speaker Enclosure**—Type of extension loud-speaker cabinet frequently available as accessory item for tape recorders. Design employs a "port" or opening which greatly reinforces the bass, yet requires but a relatively small cabinet.

**Capstan**—The spindle or shaft (often the motor shaft itself) which rotates against the tape, pulling it along at a constant speed on recording and playback.

**Cartridge**—Another name for the phonograph "pickup"; the device which converts the mechanical

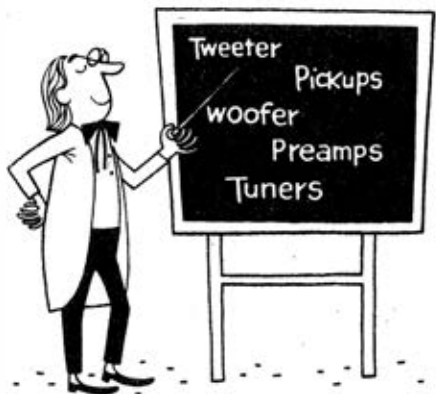

energy stored in the record grooves into electrical energy.

**Chassis**—The metal box, framework or other support to which the components of a tuner or amplifier or other device are attached. The term is also used to designate the entire equipment (less cabinet) when assembled.

**Compensator**—An electronic circuit for altering the frequency response of the amplifier system to achieve a specified result. In general this refers to such things as record equalization or loudness correction.

**Constant Amplitude**—The disc recording characteristic wherein the groove displacement is directly proportional to the signal amplitude.

**Constant Velocity**—The disc recording characteristic wherein the groove displacement is inversely proportional to the signal frequency.

**Crossover Network**—A filtering circuit used on multiple speaker systems which separates the high frequencies from the low frequencies and channels them respectively to the tweeter and woofer speaker units.

**Crystal**—Used in reference to a phonograph cartridge, it is a small slab of piezoelectric material used to convert mechanical motion to an electrical voltage.

**Crystal Microphone**—Inexpensive piezoelectric type microphone supplied with many tape recorders which employs a natural crystal, usually Rochelle salt, as its element. As the diaphragm moves it causes the crystal to generate electrical voltages. Should be handled with care, however, and never exposed to heat. Provides best quality of all inexpensive microphones.

**Cycles Per Second**—The unit for measuring the frequency or pitch of any musical sound. Abbreviated cps.

**Decibel**—

(1) A logarithmic measure of the acoustical level of sound intensity. 0 db is the threshold of human hearing while 130 db is the threshold of pain, i.e. the intensity level at which physical pain is felt.

(2) A logarithmic unit of measure used to express

# The DUAL-1006 satisfies every need

...as both a professional  
single play turntable and  
superior record changer

Tracks—and operates automatically  
—with stylus pressure as low as 1½  
grams! Minimizes *all* wear.

## DUAL-1006

*Built-in* direct reading stylus pressure gauge. Easy to use, weight adjustment conveniently located.

## DUAL-1006

Big, heavy 10<sup>5</sup>/<sub>8</sub>" turntable is laminated and concentrically girded. Can't warp or become eccentric.

## DUAL-1006

Rumble-free motor is so powerful turntable reaches full RPM from *dead start* in less than ¼ turn!

## DUAL-1006

All drive gears disengage *automatically*—no "neutral" position to remember, no flat spot thump.

## DUAL-1006

Obsolescence-proof intermix for all present or *future* record sizes. Stack in *any* sequence.

## DUAL-1006

Elevator Action changer-spindle prevents damage to record grooves and center holes. Truly gentle!

For the full story, write . . .

**united Audio**

PRODUCTS OF DISTINCTION  
202-4 East 19th St., N.Y. 3, N.Y.

## The Hi-Fi Language

the voltage or power gain of an amplifier. With a minus sign it is also used to express the loss in attenuating circuits.

Because the ear measures differences in sound level logarithmically rather than arithmetically (if sound A is twice as loud as sound B, it will appear to the ear to be only slightly louder), and because decibel numbers can be used to represent large figures in a convenient manner (60 db equals a power ratio of 1,000,000 to 1), the decibel system is universally used by electronic engineers.

**De-Emphasis**—A form of equalization complementary to pre-emphasis.

**Distortion**—The modification of the input signal by the discrimination against some frequencies, or by the introduction of additional frequencies not present in the original.

**Dual Track Recorder**—Usually a tape recorder with a recording head that covers about half of the tape width, making it possible to record one track on the tape, then turn the reels over and record a second track in the opposite direction. Sometimes called a half-track recorder.

**Dynamic Microphone**—High quality electromagnetic microphone which employs a moving coil in a magnetic field to produce varying voltages.

**Dynamic Range**—The ratio between softest and loudest sounds a tape recorder or other device can reproduce without undesirable distortion. Usually measured in db.

**Editing**—Selecting certain sections of a tape recording, or of a number of different tape recordings, then splicing them together in the desired sequence.

**Equalization**—Either boosting or decreasing the intensity of the low, middle or high tones of a recording during recording or playback or both. This compensation serves to correct any deficiencies in the recording system and to increase the signal-to-noise ratio.

**Erase**—Neutralizing the magnetic pattern on tape by placing it in a strong magnetic field, thereby removing the recorded sound from the tape.

**Feedback**—The combining of a portion of the output signal with the input signal.

- (a) Degenerative (Inverse or Negative) Feedback is the type which reduces the distortion caused by vacuum tubes and improves the frequency response characteristic.
- (b) Regenerative (Acoustic) Feedback is the type which causes distortion or sustained "howling" —as between the loud-speaker and cartridge.

**Feed Reel**—Reel on the recorder which supplies the magnetic tape.

**Fidelity**—A measure of the exactness with which any sound is duplicated or reproduced.

**Flat Response**—The ability of a sound system to reproduce all audible tones in their proper proportion. A hi-fi sound system might be specified as having a flat response, plus or minus 1 db, from 30 to 15,000 cycles per second.

**Flutter**—Very short, rapid variations in tape or turntable speed causing similar variations in sound volume and pitch, not present in the original sound. A form of distortion.



**save on everything in hi-fi**

**SEND FOR THE 1960 ALLIED CATALOG**

**free** SAVE MOST! Here's your complete no ey-saving guide to Hi-Fi. See how you save on ALLIED-recommended complete Stereo systems. Choose from the world's largest stocks of famous name components (amplifiers, tuners, changers, speakers, enclosures, accessories); save most with KNIGHT deluxe components. Build your own—save even more with our exclusive Hi-Fi KNIGHT-KITS. Easy terms available. For everything in Hi-Fi and Electronics, get the 1960 ALLIED Catalog!

**ALLIED RADIO**

**FREE Catalog**

ALLIED RADIO, Dept. 128-KO  
100 N. Western Ave., Chicago 80, Ill.

Send FREE 1960 ALLIED Catalog

Name \_\_\_\_\_  
Address \_\_\_\_\_  
City \_\_\_\_\_ Zone \_\_\_\_\_ State \_\_\_\_\_



take a tip from

**wigo**  
PRONOUNCE IT WEEGO

Not every speaker that looks good sounds good. Though Wigo may not be the best looking speaker in the world, it is one of the best sounding, now...and for years to come. Hear it at your dealer...then tip off your friends. For literature, write...

**united audio**  
PRODUCTS OF DISTINCTION  
202-4 East 19th Street, N. Y. 3, N. Y.

**FM**—Abbreviation for frequency modulation; the type of radio transmission which can provide truly high fidelity with practically no static or background noise.

**Frequency Range**—The range between the highest and lowest pitched sounds which a tape recorder or other sound system can reproduce at a usable output or volume level.

**Frequency Response**—The output level of a recorder or sound system over a given range of frequencies. A more specific term than *frequency range*. Usually in the form of a curve plotted on a chart.

**Gain**—The ratio between the input and output levels of a piece of sound equipment. Gain is increased by means of an amplifier.

**Gap**—The tiny distance between the poles of the recording head, measured in mils. The head gap of most home recorders may range from 1 mil down to  $\frac{1}{4}$  mil. The smaller the gap, the higher the frequency range of the tape recorder can be.

**Head**—The ring-shaped electromagnet across which the tape is drawn and which magnetizes the iron oxide-coated tape in a series of patterns. Most tape recorders employ a combination record-playback head and also an erase head. Some professional machines also employ a monitor head for listening to the recorded sound a split second after it has been put on the tape.

**Head Alignment**—Positioning of the record-playback head on a tape recorder so that its gap is exactly perpendicular to the path of travel of the tape.

**Head Demagnetizer**—Device to eliminate any magnetism built up and retained in a recording head.

**Hum**—The extraneous portion of the output signal deriving from unwanted introduction of the power line frequency and its harmonics into the audio circuit.

**Impedance**—A rating in ohms of the input and output of any electrical component, referred to in a general way either as high or low impedance. Importance is that, in connecting any two components, the output and input impedances must match. Most home tape recorders use a high-impedance microphone and require a relatively short-shielded connecting cable. Low-impedance microphones used on professional recorders can use much longer cables with no loss in high frequencies.

**In-Line Heads**—Arrangement of stereophonic heads on a tape recorder so that gaps are directly in line. One head is mounted directly above the other. Also called stacked heads.

**Input**—The terminals or connections to which wires carrying the electrical current are attached. Also refers to the electrical energy which is being fed into an amplifier, etc.

**Inverter**—Device to change one type of electrical current to another type. Frequently used to change 6-volt or 12-volt direct current to 110-volt alternating current for operation of a tape recorder in an automobile.

**IPS**—Abbreviation for tape speed in inches-per-second.

ALL  
NEW!



1960 Edition of Constantine's

## WOODWORKING CATALOG & MANUAL

Since 1812—World's Largest Source For Rare Woods and Woodworking Supplies, Tools, Hardware, Plans, Projects!

Whether you work with wood for fun or profit—get your copy of this biggest Constantine Catalog & Manual! Hobbyists and professionals say it's the world's one truly complete source for fine rare imported and domestic woods, cabinet wood lumber, turning blocks & squares, veneers, plywoods, bandings, inlays, mouldings, carvings—plus hard-to-find hardware, lamp parts, wood finishing and upholstery supplies, patterns, tools, wood-working materials—at bargain prices! See unusual Hi-Fi hardware and cabinet items. Also exclusive Inlaid-Wood-Picture Kits. Includes natural-color Identification Chart of 60 rare woods . . . pages of practical articles on wood-finishing, veneering, making inlays and other projects. Complete with instructions. *We ship same day.* Send 25¢ with coupon for postage and handling (refunded on first order).

### FREE!

When you send for the Catalog & Manual, you also get a year's subscription to "Chips & Chats"—FREE! It's Constantine's newswy periodical, filled with exciting ideas for woodworkers and bargains in supplies.

Albert Constantine and Son, Inc.  
2050 Eastchester Rd., Dept. P16, New York 61, N. Y.

Enclosed 25¢ (refunded on first order) for new 1960 Constantine Catalog & Manual. Also send FREE a year's subscription to "Chips & Chats."

Name .....

Address .....

City..... State.....

See **HI-FI**  
HARDWARE & CABINET ITEMS

130 Pages—Many Full Color! 3,500+ Items! Rare Woods, Veneers, Carvings, Inlays, Mouldings, Hard-to-Find Hardware, Wood-finishing and Upholstery Supplies, Lamp Parts, Inlaid Wood Picture Kits, Solid brass hardware, Plans, Projects, etc.



## SPEAKER...

when it's in an enclosure. So why make it with fancy frills that may look good, but costs more and adds nothing to the performance?

**wigo**  
PRONOUNCE IT WEEGO

**SPEAKERS** put the emphasis on quality, which is on the inside where you can't see it, but can sure hear it. See what we mean? For literature, write...

**united audio**

PRODUCTS OF DISTINCTION  
202-4 East 19th Street, N. Y. 3. N. Y.

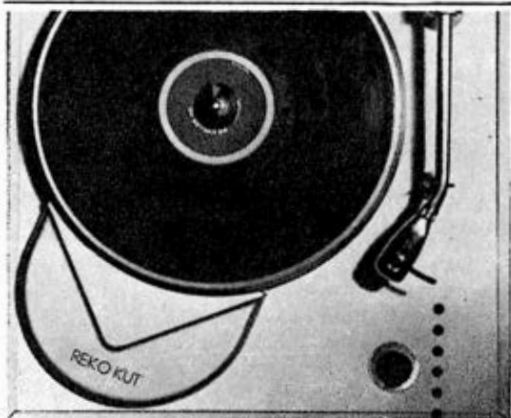

### WHY PAY MORE?

Assemble your own stereo phono system and SAVE! Pictured above is the REK-O-KUT K33-H turntable kit (33 1/3 rpm) with hysteresis motor, matching REK-O-KUT S-120 12" arm, and unfinished base kit. Total assembly time is less than one hour. Only \$92.85. With your purchase of the above, you will receive the Shure M7D magnetic stereo cartridge FREE.

All units in factory sealed cartons. Full mfg'r's warranty. Shipments f.o.b., N.Y.C. Ask for audio discount catalog A-10.

**KEY ELECTRONICS COMPANY**  
120 LIBERTY ST., N. Y. 6, N. Y.



**SHURE**  
**M7D**  
REG. NET VALUE  
\$24.<sup>00</sup>

## The Hi-Fi Language

**Jack**—Receptacle for a plug connector leading to the input or output circuit of a tape recorder or other piece of equipment.

**Lateral Recording**—The common form of disc recording in which the groove modulation is perpendicular to the motion of the disc and parallel to its surface.

**LCS**—Abbreviation for loudness contour selector. A circuit for altering the frequency response of an amplifier so that with various levels of loudness the characteristics of the amplifier will more closely match the requirements of the human ear.

**Level Indicator**—A device on the tape recorder to indicate the level at which the recording is being made, and which serves as a warning against under-recording or over-recording. It may be a neon bulb, a magic eye or a VU meter.

**Load**—The component or device which is being supplied with electrical energy from a source such as an amplifier.

**Loud-speaker**—The electro-acoustical device which converts electrical current to mechanical motion, which in turn creates sound waves.

**Matching**—The technique of selecting and connecting equipment so that each unit works at its peak performance capabilities.

**Magnetic Tape**—A high-quality plastic or paper tape which has been precision-coated with a layer of magnetizable iron-oxide particles.

**Micro**—One one-millionth (prefix).

**Milli**—One one-thousandth (prefix).

**Mixer**—Device by which signals from two or more microphones can be fed simultaneously into a tape recorder at the proper level and balance.

**Monaural Recorder**—Standard type tape recorder which uses a single-channel system consisting of one microphone, amplifier and recording head, as opposed to a binaural or stereophonic recorder.

**Monitor Head**—Additional playback head featured on some tape recorders making it possible to listen to the material off the tape while the recording is being made.

**Motor Board**—Also called tape transport mechanism. The platform or assembly of a tape recorder on which the motor(s), reels; heads and controls are mounted. It includes those parts of the recorder other than the amplifier, pre-amplifier, loud-speaker and case.

**NARTB Curve**—Standard tape recording and playback equalization curve set by National Association of Radio and Television Broadcasters. The NARTB disc curve is the same as RIAA.

**Noise Suppressor**—An electronic circuit which reduces high frequency hiss or noise. It is utilized primarily with old records.

**Ohm**—The fundamental unit of measure of electrical resistance and impedance.

**Output**—The terminals or connection to which the load is connected. Also refers to the electrical energy being supplied from the device.

**Oxide**—Microscopically small particles of ferric oxide dispersed in a liquid binder and coated on a tape backing. Red oxide is most common, although High Output tape employs a dark green oxide. These oxides are magnetically hard, that is, once magnetized they remain magnetized permanently.

unless they are demagnetized by exposure to another strong magnetic field.

**Patch Cord**—Sometimes called attachment cord. A short cord or cable with a plug on either end, or with a pair of clips on one end, for conveniently connecting two pieces of sound equipment such as a phonograph and tape recorder, or an amplifier and speaker. Not used for 110-volt current.

**Peak**—A point in the frequency range where a component delivers excessive energy, i.e., departs from a "flat" characteristic. Also used to denote the maximum instantaneous output of a device.

**Pickup**—The device which converts the vibrations of the stylus or needle to an electrical current which can be amplified. (Cartridge)

**Playback Head**—Magnetic head used to pick up signal off a tape. Often same head as used for recording, but with circuitry changed by means of switch.

**PM**—Permanent magnet. Used as an adjective to differentiate from previous designs of speakers which required an electrical current for magnetization.

**Polyester Backing**—Plastic film backing for magnetic tape used for special purposes where strength and resistance to humidity change are important. Often referred to by the DuPont trade name Mylar.

**Power Amplifier**—An amplifier designed to operate a loud-speaker.

**Power Cord**—Cord for connecting any hi-fi equipment to 110-volt AC current.

**Preamplifier**—An amplifier that raises extremely weak signal levels such as those from a microphone, magnetic playback head, or a phonograph pickup to a level usable by the power amplifier.

**Pre-Emphasis**—The introduction of additional amplification over a limited range of frequencies. FM stations introduce pre-emphasis in the treble range to override atmospheric noise.

**Pressing**—A disc recording produced in a record-molding press from a master or stamper.

**Pressure Pads**—Felt pads mounted on spring brass arms which hold the magnetic tape in close contact with the heads on some machines.

**Pressure Roller**—Also called capstan idler or puck. A rubber-tired roller which holds the magnetic tape tight against the capstan by means of spring pressure to insure constant tape speed and prevent slippage.

**Print-Through**—Transfer of the magnetic field from layer to layer of tape on the reel.

**Quieting**—Denotes (in rating FM tuners) the degree to which noise in the receiver is reduced below the signal.

**RF**—Abbreviation for radio frequency. This refers to that range beyond the limit of hearing which is suitable for transmission through the air by means of broadcasting.

**Recorded Tape**—Usually a recording on tape that is commercially available. Also called a pre-recorded tape. Not to be confused with Recording Tape, which is the unrecorded magnetic tape often called raw tape, virgin or blank tape.



## "BUCK STRETCHER" HI-FI VALUES!

Expand the buying power of your Hi-Fi dollar at Sun Radio with substantial savings on new and fully guaranteed name brand Hi-Fi components!

Dept. G9, **SUN** Radio & Electronics Co., Inc.  
650 6th Ave., New York 11, N. Y. Phone: ORegon 5-8600

*I am interested in your special price quotations and your Hi-Fi package specials! Please send data at once.*

Name \_\_\_\_\_

Address \_\_\_\_\_

City \_\_\_\_\_ Zone \_\_\_\_\_ State \_\_\_\_\_



**wigo**  
PRONOUNCE IT WEEDO

## SPEAKER FOR LOOKS!

Wigo's true beauty is on the inside, where you can't see it, but where you can sure hear it!... And with Wigo it's not done with mirrors! For literature, write...

**united Audio**

PRODUCTS OF DISTINCTION  
202-4 East 19th Street, N. Y. 3, N. Y.

## PURCHASING A HI-FI SYSTEM?

**Send Us  
Your List of  
Components  
For A  
Package  
Quotation**

**WE WON'T BE  
UNDERSOLD**

All merchandise is brand new, factory fresh and guaranteed.

**AIREX  
RADIO  
CORPORATION**

### PARTIAL LIST OF BRANDS

Altec Lansing  
Electrovoice  
Jensen • Hartley  
University  
Acoustic Research  
Janszen  
Wharfedale  
Karlson  
Viking  
Concertone  
Bell • G.E.  
Weathers  
Harman-Kardon  
Elco • Pilot  
Sherwood  
Acrosound  
Fisher • Ferrograph  
Bogen • Leak  
Dynakit • Tandberg  
H. H. Scott  
Pentron  
Ampro • VM  
Revere • Challenger  
Wollensack  
Garrard  
Miracord  
Glaser-Steers  
Components  
Rek-O-Kut  
Norelco  
Fairchild  
Pickering • Gray  
Audio Tape • Conrac  
Wellcor Cabinets

64-FG Cortlandt St., N. Y. 7.

CO 7-2137

## The Hi-Fi Language

**Recording Noise**—Noise induced by the amplifier and other components of the recorder. High quality magnetic tape itself is inherently noise-free.

**Reluctance Microphone**—Inexpensive electromagnetic type microphone supplied with many tape recorders which is extremely rugged and durable but generally not as high quality as crystal or ceramic types. Employs a metal "wand" which moves in a magnetic field to produce varying voltages.

**RIAA Curve**—Standard disc recording and playback equalization set by the Record Industry Association of America.

**Response**—A contraction of "frequency response" which is the reaction of an amplifying system to a range of signal frequencies. See also Peak.

**Reverberation**—The persistence of sound in a room due to repeated reflections from walls, ceiling, floor, furniture and occupants.

**Roll-Off**—A term used in connection with recording to describe a reduction in the intensity of the high bands of frequencies to provide a specified deviation in the frequency response. It is used when playing phonograph records which have been recorded with pre-emphasis, and also in FM receivers.

**Rumble**—A low frequency vibration mechanically transmitted to the turntable and appearing in the reproduction as noise.

**Selectivity**—The ability of a tuner to select and separate between two broadcasting stations which are close together on the dial.

**Sensitivity**—A measure of a tuner's ability to receive weak signals.

**Signal**—The designation given to those impulses generated by a pickup, a microphone, or received from a broadcasting station via the antenna. These signals are the electrical energy corresponding to the music or speech.

### Signal-Noise Ratio

- (1) The basis for rating sensitivity in an FM tuner. The ratio between the signal and background noise, expressed in decibels, at a stated input signal.
- (2) The ratio in an audio system between the rated output power and the noise and hum content—usually expressed in decibels.

**Single-Track Recorder**—A tape recorder which records only one track on the tape. Usually a full-track recording head is used which covers the full width of the 1/4-inch tape, although some machines use a narrower half-track recording head which records a single track down the middle of the tape.

**Splicing Tape**—A pressure-sensitive non-magnetic tape used for splicing magnetic tape. Its hard adhesive will not ooze and consequently will not gum up the recording head, or cause adjacent layers of tape on the reel to stick together.

**Stacked Heads**—Arrangement of recording heads used for stereophonic sound where the two heads are located directly in line, one above the other.

**Staggered Heads**—Arrangement of recording heads used for stereophonic sound where the heads are located 1-7/32" apart. Stereo tapes recorded using staggered heads cannot be played on



recorders using stacked heads, or vice versa.

**Stereophonic Sound**—Dimensional or directional sound reproduction achieved through use of two or more sound tracks, or channels, heard simultaneously through loud-speakers arranged in the same relative positions as were the microphones during the recording. In tape two channels are used, one on each track of a standard tape, with a recording head for each channel. On phonograph discs, a 45°-45° groove is cut in the record, with the stereo pickup riding in this groove. The left side of the groove plays one stereo channel, the right side plays the other channel. A special stereo cartridge must be used to play these stereo records.

**Stroboscope Disc**—A device for measuring the speed of a rotating object such as a phonograph turntable.

**Stylus**—The correct name for "needle." A rounded point of specified radius which is inserted into a pickup and rides a record groove.

**Take-up Reel**—Reel on the tape recorder which accumulates the tape as it is recorded or played.

**Tape Deck**—Tape recorder designed for use in a hi-fi music system. Usually consists only of motor-board mechanism and does not include preamplifier, power amplifier, speaker or case.

**Tape Speed**—Speed at which tape moves past the recording head. Standard tape speeds for home use are 3¾ and 7½ ips. Faster speeds are 15 ips and 30 ips. Slower speeds sometimes used

are 1⅞ and 15/16 ips. Faster speed makes possible improved high-frequency response, while slower speed means greater tape economy. If a tape is recorded at 3¾ ips, then played back at 7½ ips, all sound will be raised one octave in pitch and the tempo doubled. Cutting the speed in half lowers a tone one octave.

**Tone Control**—Control knob on preamp or amplifier used to vary bass and treble response to achieve most desirable balance of tone.

**Triode**—A type of tube used in amplifiers. It is characterized by very low distortion.

**Turnover**—A specified point in the lower frequencies where the recording signal is decreased in amplitude. In order to obtain proper fidelity on playback, equalization or increase of the lower frequencies is introduced in the amplifier.

**Volume**—An acoustical, rather than electrical, measurement which refers to the pressure of the sound waves in terms of dynes per square centimeter. The louder the sound, the greater the pressure. Most technicians prefer to talk in terms of decibels.

**VU Meter**—A volume-unit meter which indicates the relative levels of the various sounds being recorded by measuring the electrical voltages.

**Woofer**—A loud-speaker designed to reproduce the lower range of frequencies.

**Wow**—Slow variations in tape or disc speed causing similar variations in sound volume and pitch not present in original sound. A form of distortion.



The last  
preamp-  
amplifier  
you'll ever  
have  
to buy!

a 40-watt stereo  
preamp-amplifier  
in kit form  
for only  
\$79.95  
by

**PACO** also  
available  
factory wired  
for \$129.95

COMING SOON!



Model ST-45  
AM/FM Stereo Tuner Kit  
matching companion  
for the SA-40

**PACO** is the kit division of **PRECISION** Apparatus Co., Inc., world famous manufacturers of laboratory electronic instruments for over a quarter century.

The new PACO Model SA-40 offers you greater reserve power capacity than any other preamp-amplifier in its category. Its exceptional circuit design assures highly stable performance with extremely low distortion. And...the SA-40 provides maximum flexibility in any stereophonic high fidelity system present or contemplated.

*outstanding specifications:*

**POWER OUTPUT:** 20 watts per channel, 40 watts total

**RESPONSE:** 30 cps to 90 Kc ± 1 db

**DISTORTION:**

**Harmonic** — less than .2% at 20 watts per channel  
less than .1% at 10 watts per channel

**Intermodulation** — less than 1% at full rated output

**FRONT PANEL CONTROLS:** 14 controls including  
separate bass and treble controls

**POWER SUPPLY:** Silicon diode, low impedance for  
minimum distortion

**EXTERNAL DESIGN:** gold and satin black hooded case  
with panel illumination and satin gold panel

At leading electronic parts distributors and wherever  
good sound is sold.

For complete information, write to:

**PACO** ELECTRONICS COMPANY, INC.  
70-31 84th Street, Glendale 27, Long Island, New York  
Export: Morhan Exporting Corp., 458 B'way, N. Y. 13, N. Y.  
Canada: Atlas Radio Corp., 50 Wingold Ave., Toronto 19, Ont.

# NEW from University

*three  
elegantly  
styled  
ultra  
compact  
speaker  
systems  
of superb  
quality at  
modest cost*

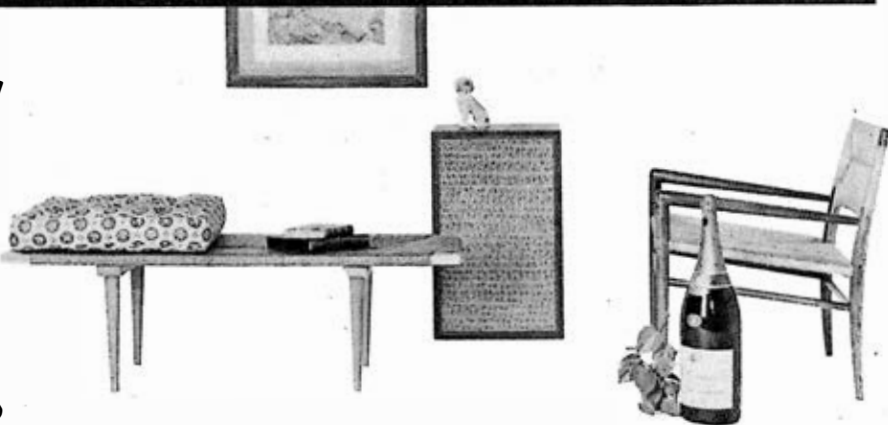

*Model RRL-12 12" 3-Speaker RRL System*

**MODEL RRL-12**  
*Features the sensational new Sphericon Super Tweeter for sweet, smooth high frequency response to inaudibility. 25" x 15 $\frac{5}{8}$ " x 12 $\frac{1}{2}$ " deep. From \$114.95 unfinished.*

**MODEL RRL-8**  
*The impossible becomes reality! An 8" system with full bass response down to below 40 cps! 22 $\frac{1}{4}$ " x 12 $\frac{1}{4}$ " x 10 $\frac{3}{8}$ " deep. From \$95.50 unfinished.*



*Furniture courtesy of Smilow-Thielle Corp.*

*Model RRL-8 8" 3-Speaker RRL System*

**MODEL S-80**  
*Excellent wide-range response from a system measuring only 21 $\frac{1}{4}$ " x 11 $\frac{1}{2}$ " x 9 $\frac{1}{4}$ " deep. From \$56.95 unfinished.*

**ALL THREE MODELS**  
*finished on four sides for use as highboy or lowboy. Beautiful oiled walnut finish for RRL-12 and RRL-8 in addition to mahogany, walnut and limed oak; S-80 in mahogany, walnut and fruitwood.*

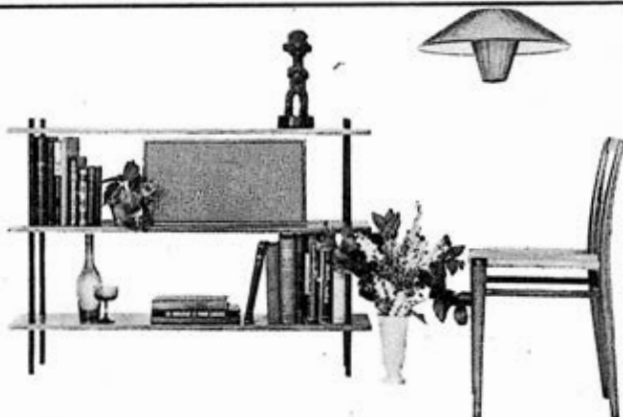

*Model S-80 8" 2-Way High Efficiency System*

WRITE FOR LITERATURE, DESK W-10 UNIVERSITY LOUDSPEAKERS, INC. WHITE PLAINS, N. Y.





**Special  
Introductory  
Offer to**

# ELECTRONICS ILLUSTRATED

**12 Monthly Issues  
Only \$2.00**

Regular Price 25¢ per Copy

America's newest and fastest growing how-to electronics magazine.

**ELECTRONICS ILLUSTRATED** shows you how to buy, how to use and how to build: hi-fi, short wave and ham equipment, transistor radios and projects for your home and hobby. First with exclusive reports on stereo, satellites, death ray, electronic driving, sun power, etc.

**ORDER NOW • SAVE 33½%**

Mail this card today →



**Send me the special subscription offer  
to Electronics Illustrated. I want 12  
issues for \$2.00.**

(this saves me \$1.00)

# Yes!

**ELECTRONICS  
ILLUSTRATED**

**Accept This Great  
Bargain Today!**

**12 Issues  
Only \$2.00**  
Saving You 33½%

**MAIL THIS CARD  
TODAY**

I enclose \$2.00

Bill me later

Name .....  
please print

Address .....

City..... Zone... State.....

**BUSINESS REPLY MAIL**

No Postage Stamp Necessary if Mailed in the United States

**FIRST CLASS**

PERMIT No. 80

Greenwich, Conn.

POSTAGE WILL BE PAID BY

# **ELECTRONICS ILLUSTRATED**

**FAWCETT BUILDING  
GREENWICH, CONN.**



# HOW TO GET A GOOD PAYING JOB IN RADIO-TELEVISION



Build this equipment while learning... it's yours to keep!

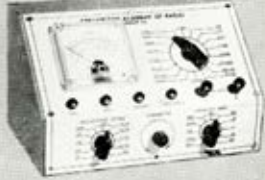

## EARN WHILE YOU LEARN AT HOME IN SPARE TIME

I'll prove to you that I can prepare you to become a trained Radio and Television Serviceman in a few months' time... ready to step into a good paying job with a real future!



MASON R. WARNER, PRESIDENT

**Only \$6 starts you** "Learn by Doing" Training Plan

Men by the thousands... trained Radio-Television Service Technicians... are needed at once! Perhaps you've thought about entering this interesting, top paying field, but lack of ready money held you back. Now—just \$6 enrolls you for America's finest, most up-to-date home study training in Radio-Television! This offer is made because Radio-Television must have the additional men it needs as quickly as possible. We are willing to do our part by making Sprayberry Training available for less money down and on easier terms than ever before. This is your big opportunity to get the training you need... to step into a fine job or your own Radio-Television Service Business.

### Get Practical Experience with 25 Kits of Radio-TV Parts

In addition to modern lessons, you train with actual parts and equipment. Build the famous Sprayberry Training Television Set, Multi-Range Tester, 2-Band Radio, other Test Equipment—all yours to keep. Get latest training on Color TV, Transistors, Hi-Fi and UHF Conversions... included to make your training more valuable.

### Radio-TV Needs You Now!

Get all the facts... FREE!

Radio-Television needs you! See how and why Sprayberry Radio-Television home training offers you *more*. Three training plans to suit your exact needs. Low payment... only \$6 starts you. Backed by over 27 years of distinguished training experience. Rush special postcard—reply coupon for catalog and free sample lesson. No stamp needed. No obligation. No salesman will bother you. Let us prove the opportunity in store for you!

The Radio-Television industry is begging for trained men for interesting, profitable service work... get set now!

✂ WRITE NAME AND ADDRESS — Cut out card and mail. ✂

**FREE**

new 60 page catalog and actual sample lesson



This coupon needs no stamp or envelope. Just write name in upper left corner, cut out along dotted line and drop in any mail box. Pay no attention to printing on back of the card. By return mail you'll receive our big 60 page catalog and free sample lesson.

**SPRAYBERRY**

Academy of Radio-Television  
Dept. 22-C

1512 Jarvis, Chicago 26, Ill.

YOUR NAME \_\_\_\_\_  
ADDRESS \_\_\_\_\_  
TOWN \_\_\_\_\_ STATE \_\_\_\_\_



**BUSINESS REPLY MAIL**

First Class Permit No. 34316, Chicago, Ill.

**SPRAYBERRY**

Academy of Radio-Television

Dept. 22-C

1512 Jarvis, Chicago 26, Ill.



# HEAR

## BASS NOTES DOWN TO 35 CPS... BUILD THE ELECTRO-VOICE ARISTOCRAT



**DRAMATIC PERFORMANCE** has made the Electro-Voice Aristocrat the world's most popular enclosure for 12" loudspeakers. The Aristocrat will make an exciting difference in the performance of your loudspeaker—hear deep, extended bass response without annoying boom; sharp, well-defined low frequency transients, and all with greatly increased power handling capacity.

**ASSEMBLE THE ARISTOCRAT YOURSELF AND SAVE 50%.** When completed, the KD6 Aristocrat Kit interior construction is identical to E-V's factory-assembled Aristocrat enclosure, but with this difference: you save 50% and have an evening's fun.

**AS EASY AS ONE... TWO... THREE.** The KD6 Aristocrat Kit can be assembled in only one evening with E-V's exclusive sub-assembled parts and exploded view, step-by-step instructions. All you need is a screw driver; the rest is in the box. And E-V's accurately milled, furniture grade woods and veneers plus a choice of six finishing kits create an enclosure that will match your finest furniture.

Model KD6 Aristocrat Kit

Audiophile Net. \$39.00

Model FK Finishing Kits, each

Audiophile Net. 5.00

Factory Finished Aristocrat Enclosure, Mahogany

Audiophile Net. 72.00

Limed Oak or Walnut

Audiophile Net. 79.00

Mail this coupon for free illustrated literature... see why more E-V Enclosure Kits have been built than all others combined.



2



3

**E-V** *Electro-Voice*® , INC.

BUCHANAN, MICHIGAN

**Superb New Products Through Research:**

Microphones—Phono Cartridges—  
High Fidelity Loudspeakers and Enclosures—  
Public Address Speakers—  
Marine Instruments—Communication Equipment—  
Electronic Test Instruments and  
Material for Defense.

Electro-Voice, Inc.  
Buchanan, Michigan

Dept. HH-59

Gentlemen: Please send me free illustrated literature on E-V kits, enclosures and speakers.

NAME \_\_\_\_\_

ADDRESS \_\_\_\_\_

CITY \_\_\_\_\_ ZONE \_\_\_\_\_ STATE \_\_\_\_\_