

PERSONAL RECEIVERS



**DEALING PROGRESSIVELY WITH THE
DESIGN, CONSTRUCTION AND DETAILED
ALIGNMENT OF ALL MODERN RECEIVERS
IN THE PORTABLE AND PERSONAL CLASS**

E. N. Bradley

Describes and explains the functions of the various circuits used in portable receivers; shows how the constructor may design his own set to suit his purpose; and how to improve the performance of an existing set that fails to give satisfaction.

LONDON : NORMAN PRICE (PUBLISHERS) LTD.

Three shillings and sixpence net

PERSONAL RECEIVERS

By the same author—

PERSONAL PORTABLES

(published by the author)

THE OSCILLOSCOPE BOOK

PERSONAL RECEIVERS

E. N. BRADLEY

NORMAN PRICE (Publishers) LTD.

283, CITY ROAD, LONDON, E.C.1

First published 1952

PREFACE

THE modern type of personal and portable receiver is well to the fore in popularity compared with other types of receiving set, but many amateur constructors avoid it. The chief reason is apparently that the majority of these receivers are superhets., so home constructors without signal generators fear there will be insuperable difficulties in lining-up the tuned circuits. The problem of winding and adjusting frame aerials is also a deterrent. For these reasons both the alignment of superhet. circuits and the adjustment of frame aerials, using only the simplest apparatus, are dealt with quite fully in this book.

Personal and portable receivers are rather like televisions in that the constructor must be prepared for a little "trouble-shooting" on the completed set if best results are to be obtained. Not every set will give trouble, but when "trouble-shooting" is necessary it is usually a simple matter when the various stages and circuit operations in the receiver are thoroughly understood. The chief purpose of this book is to describe and explain the functions of the various circuits used in portable receivers, and to show how the constructor may either design his own set to suit his purpose and pocket, or improve the performance of an existing set that fails to give satisfaction.

For all complete receiver circuits given, the reception areas where the receiver will perform well is indicated, and advice is given as to whether the set is suitable for construction by the beginner or novice.

E. N. BRADLEY.

CONTENTS

| | <i>page</i> |
|--|-------------|
| PREFACE | v |
| 1. AERIALS | 13 |
| 2. T.R.F. RECEIVERS | 26 |
| 3. SUPERHETS: THE FREQUENCY CHANGER | 32 |
| 4. SUPERHETS: I.F. AND DETECTOR STAGES | 38 |
| 5. SUPERHET. ALIGNMENT | 44 |
| 6. THE OUTPUT STAGE | 50 |
| 7. A.C./D.C./BATTERY POWER SUPPLIES | 54 |
| INDEX | 61 |

ILLUSTRATIONS

| | <i>page</i> |
|--|-------------|
| 1. Untuned loop aerial | 13 |
| 2. Alternative couplings for untuned aerials | 14 |
| 3. Frame aerial wound on a card | 15 |
| 4. Frame aerial to go round receiver chassis | 16 |
| 5. Frame aerial with reduced losses | 16 |
| 6. Circuit utilising low impedance loop aerial | 17 |
| 7. Basic tuned circuits of a t.r.f. receiver | 18 |
| 8. A simple multivibrator | 21 |
| 9. Complete circuit for simple t.r.f. single wave-band receiver | 26 |
| 10. Complete t.r.f. circuit for double wave-band | 27 |
| 11. Basic layout for personal receiver | 28 |
| 12. Simple reflex circuit | 29 |
| 13. Reflex circuit using both stages for both r.f. and a.f. | 31 |
| 14. Showing how tapping into coils can be employed to reduce circuit damping | 32 |
| 15. Conventional frequency changer circuit | 33 |
| 16. Double wave-band frequency changer | 34 |
| 17. All-wave frequency changer, using DK91 | 35 |
| 18. Aladdin coil former for booster coil and filament choke | 35 |
| 19. All-wave frequency changer, using DK92 | 36 |
| 20. Typical DK92 frequency changer for 30 mc/s operation | 37 |
| 21. Double triode frequency changer, all-wave, using DCC90 | 37 |
| 22. Typical i.f., detector and a.f. amplifier | 39 |
| 23. Common oscillator—i.f. screen feed | 40 |
| 24. Two valve reflex superhet | 42 |
| 25. Layout and drilling for Fig. 24 | 42 |
| 26. Superhet. alignment—the tuned circuits | 44 |
| 27. A simple signal generator | 48 |
| 28. Oscillograms of typical output stage form | 50 |
| 29. An economy output stage | 51 |
| 30. Complete audio section, with negative feedback | 52 |
| 31. Typical series filament chain | 54 |
| 32. Typical American series filament chain | 55 |
| 33. The a.c./d.c. mains unit | 56 |
| 34. How to obtain a d.c. supply to adjust the unit | 57 |
| 35. An a.c. mains unit for series filament operation | 58 |
| 36. An a.c. mains unit for parallel filament operation | 59 |

PERSONAL RECEIVERS

Chapter 1

AERIALS

TO be really portable a receiver must contain not only its own voltage supplies, but also a whole signal pick-up system completely independent of a normal aerial and earth. The design of all portable receivers is, therefore, influenced by the greater sensitivity required to deal with small inputs.

The higher and longer the aerial is made for normal reception, the more effective its interception of the wave-front, and so greater are the signal voltages set up. In a portable receiver the aerial must either be an untuned sheet of metal or an open wire loop, or else a tuned, and thus closed, wire loop having small effective dimensions. As a result it is essential to use as large a sheet or loop as can be accommodated within the receiver cabinet. In a wire loop similar voltages are induced in opposite sides of the loop which tend to cancel out each other, so the resultant signal is very small. The loop must be aligned in the direction of the transmitter for best reception. When a tuned loop is used, the "Q" or goodness of the loop serving for the first tuned circuit of the receiver in place of a normal coil, must be made as high as possible to produce a strong signal. Also, the receiver should be readily rotatable in order that the loop may be positioned correctly. This last requirement, however, is no drawback, for it can also aid the receiver in rejecting unwanted stations from other directions.

UNTUNED AERIALS

A simple untuned aerial is generally as that shown in Fig. 1. It is a spiral winding arranged on the back of the receiver case so that it takes up

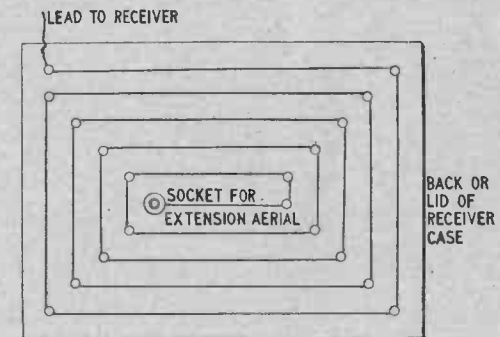

FIG. 1. UNTUNED LOOP AERIAL

very little space. The winding, which should be of well-insulated wire, is supported on brads or panel pins, and should be as large as possible: the number of turns is not important. One end of the wire goes to the first tuned circuit of the receiver; the other end of the open loop can be anchored without further connection, or taken to an extension aerial socket. An external aerial can then be plugged into this socket when convenient.

A metal plate aerial can be arranged in the same way. Sheet metal or metal foil can be mounted on the back panel of the receiver case and

connected in to the first tuned circuit of the set. Again, a further lead from the metal plate to a socket on the case will allow an external aerial to be coupled in.

An untuned loop or metal plate aerial should be coupled to the receiver by trial, various methods being shown in Fig. 2. The tuned circuit shown

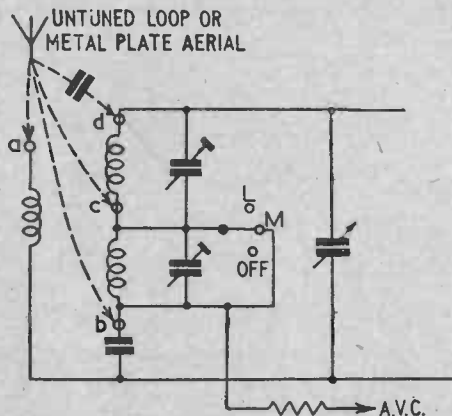

FIG. 2. ALTERNATIVE COUPLINGS FOR UNTUNED AERIALS

is suitable for all types of superhet. (an untuned loop or plate aerial cannot be recommended for t.r.f. receivers), and consists of a normal aerial coil either single or, as shown, double wave-range type, with an aerial coupling winding. In good reception areas the aerial may first be tried connected to the aerial coupling winding (Fig. 2 (a)); this will provide selectivity, but relatively poor signal transfer. In medium reception areas bottom coupling (b) can be tested; but in some cases where long wave coverage as well as medium wave reception is required this may be found to give poor results on the long wave band. The effect of connection (c) may be tried; this gives bottom coupling on the medium wave band, but a tapped-in direct aerial connection on the long waves. For normal open loop and plate aerials this should cause no trouble in the alignment of the long wave range.

Finally, in poor reception areas the "top end" (d) coupling from the aerial through a capacitor to the grid side of the tuning coil should be tested. This provides good signal transfer, but reduces selectivity because the aerial damps the tuned circuit; the value of the coupling capacitor must be found by trial to allow good tracking between the signal and oscillator circuits.

Another type of open or untuned loop which can be tried with both t.r.f. and superhet. receivers is the open "sling" aerial. This aerial consists of a short length of wire contained within a shoulder strap or sling of leather or fabric, by which the receiver is carried. When the receiver is to operate at rest it may be hung up by the sling, which is thus extended for best signal pick up. A loose coupling between an open sling aerial and the first tuned circuit is desirable, because the aerial characteristics are subject to considerable changes due to body capacitance, etc., which would cause detuning through a tight coupling. Connections (a) and (b) of Fig. 2 are most suitable, for preliminary tests at any rate. This type of open sling aerial is not suitable for poor reception areas.

A convenient form of construction for a sling aerial is a length of rubber covered flex threaded through a shoulder strap made by sewing the

edges together of a strip of leather-cloth or suitable fabric, so making the strap tubular in shape. The wire can be sweated on a spring clip at one end of the strap (a similar clip at the other end being insulated from the wire), and the aerial connection from the first tuned circuit of the receiver brought out to a metal eye or loop into which the aerial clip is connected. The other end of the sling may also clip on the opposite side of the receiver case. A second socket can provide for an earth connection to the receiver chassis, so the set can readily be coupled to a conventional earth and aerial system used in the home. Some means of identification should be provided so that the strap will only be fixed in the correct way round, *i.e.*, connecting with the aerial socket.

A further and uncommon type of untuned aerial, applied effectively in the small reflex receiver designed for use with headphones (described in a later chapter) uses the headphone lead, the receiver resting on the ground, or being directly earthed in some other way. When the receiver is totally supported above the ground the metal case combines with the headphone lead to serve as an efficient aerial.

TUNED AERIALS

By far the most common type of aerial used in portable and personal receivers is the tuned medium wave loop, which is a coil of wire as large as the receiver case will allow and which, when tuned by one of the ganged tuning capacitors, will cover the normal medium wave range. For long wave coverage a further loop may be wound on the same former. It is, however, more usual to switch a coil in series, so the loop and coil combine to give the required long wave inductance.

The type most used is shown in Fig. 3, where the winding is a spiral held in slots cut from a card or fibre former. This provides a thin yet

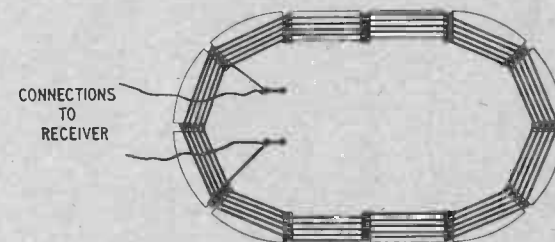

FIG. 3. FRAME AERIAL WOUND ON A CARD, IN THE LID OF THE RECEIVER

rigid coil which can easily be mounted in the lid of the receiver. This mounting has the advantages that, in use, the aerial is swung clear of unavoidable metal (transformers, etc.) within the chassis, and that it is supported in the vertical plane for easy alignment on the required station.

In larger portable receivers the tuned loop is usually as shown in Fig. 4—the "frame aerial," so called because the loop is wound on a light frame. This form of tuned loop is probably the most efficient and, when combined with any reasonably efficient superhet. circuit, should give good results at almost any point of the country. An efficient short wave loop can be added (provided the frame is not too large and, therefore, a single loop does not have too much inductance), so that an "all wave" portable may be built.

The frame aerial can be slightly improved by constructing it as shown in Fig. 5, where the turns of the winding do not lie along a former but are supported only at the corners of a rectangle. A suitable former can be

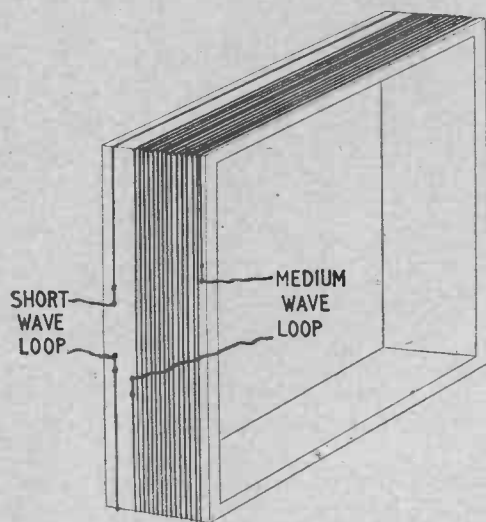

FIG. 4. FRAME AERIAL TO GO ROUND RECEIVER CHASSIS, INSIDE CASE

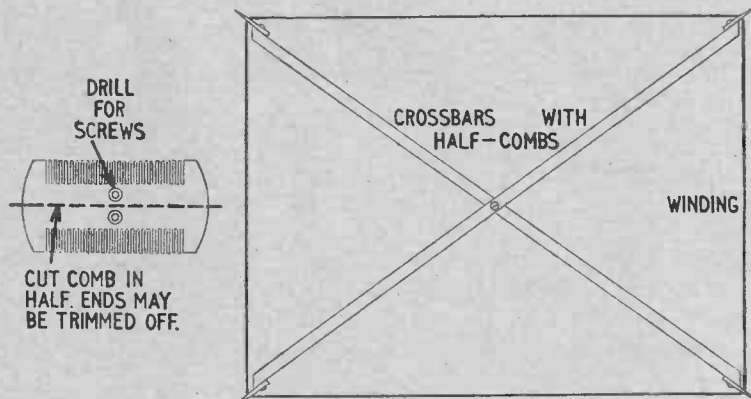

FIG. 5. FRAME AERIAL WITH REDUCED LOSSES, BY USING CROSS-STRUT CONSTRUCTION

made from wooden strips, with insulated spacers and supports fitted at the ends, made from fine tooth-combs. Such spacers provide uniform and rigid spacing of the turns. Double sided tooth-combs are purchasable, each comb providing two spacers when cut in half along the centre line. This type of aerial must be mounted clear of the chassis (generally at the rear); the open frame of Fig 4 is readily fixed within the receiver case and can surround both the receiver and batteries.

Whichever type of aerial used it must be ganged with the tuned circuits in the rest of the receiver (whether t.r.f. or superhet.). It is this

matching that bothers the home constructor, particularly in a set of his own design where data about the aerial winding are not available. Obviously, it is impossible to list aerial sizes and windings; the frame or former size must depend on the cabinet dimensions, and the number of turns must depend on the dimensions of the former used. As a general guide, and as a basis for tests, on a former as illustrated in Fig. 3 7" long and 4" wide, with semi-circular ends of a radius of 2", 20 turns of wire should be close-wound in slots $\frac{1}{2}$ " deep. On a frame type of former 11" high by 8 $\frac{1}{4}$ " wide, with sides 1" deep, 15 turns of wire matches in very well with the Weymouth HO3 medium oscillator coil.

Wire gauge is not of great importance. Enamelled copper wire 24 s.w.g. is satisfactory for the loop shown in Fig. 3. For the winding in Fig. 4, 32 s.w.g. enamelled wire, with space between the turns equal to the diameter of the wire, is suitable. In some cases the spacing between the turns provided by the type of former shown in Fig. 5, together with the low self-capacitance of the winding, allow an extra turn to be used, with slight improvement.

These windings are for medium wave coverage; for long wave tuning it is suggested that a coil be switched in series with the loop. For use in the home an auxiliary winding of four or five turns of wire can be placed on the former, $\frac{1}{4}$ " or so from the main winding, to serve as a coupling between a normal aerial and earth system and the loop. This small coupling winding also provides a simple means of injecting a test signal from a signal generator into the receiver.

LOW IMPEDANCE LOOPS

The tuned loops so far described may be termed high impedance loops for, in conjunction with the tuning capacitor, they provide the high impedance to signal currents normal to parallel tuned circuits. It is also possible, for medium wave coverage, to employ a small loop of only two or three turns of wire, connecting it in series with a coil to bring up the inductance of the complete tuned circuit to the required amount, as shown in Fig. 6. The system, apparently

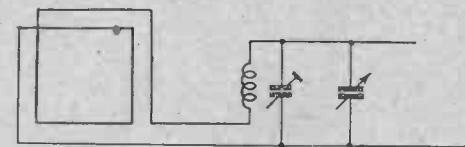

FIG. 6. CIRCUIT UTILIZING LOW IMPEDANCE LOOP AERIAL

more popular in America than here, has the advantage that a quite large loop could be used (e.g. in the form of a sling aerial) whose fluctuations of self-capacitance and inductance under different operating conditions would be substantially swamped out by the fixed coil; but experiments in a poor reception area appear to show that signal pick-up with a low impedance loop is decidedly inferior to that of a full frame aerial. It is probable, too, that a low impedance loop could be tapped across part of a normal tuning coil in the first tuned circuit, but since this would call for a specially wound coil (unobtainable commercially) no experiments have been made, the majority of constructors preferring to employ commercial coils.

THROW-OUT AND TELESCOPIC AERIALS

Although it may at first appear that throw-out and telescopic aerials should be dealt with under the heading of untuned aerials, these are generally used with short wave portable receivers where the aerial, if not tuned, can, with

advantage, bear a definite relationship to the frequency in use. The throw-out aerial, commonly rubber covered flex, can be in a "long wire" or in dipole form, coupled to the receiver directly, or through feeders. The telescopic aerial, used on the high frequencies, can be used on an all-wave receiver of the more ambitious type, where a wide coverage is provided (modern miniature frequency changers can be made to work up to frequencies of 30 mc/s). These aerials are not common and are generally required only for amateur operation. Constructors intending to employ such aerials will certainly have sufficient experience to require no further details here.

TUNED AERIAL ALIGNMENT

Rather more care is necessary in aligning the tuned circuits of a portable receiver than in the equivalent home receiver, because the first and second tuned circuits (in either t.r.f. or superhet. sets) are of different forms. In a simple home t.r.f. receiver with two tuned circuits, the two tuning coils are wound by the manufacturer to have identical characteristics; but in a portable t.r.f. receiver the first coil is in the form of a large loop, and the second is a normal r.f. coil. Even if the inductances were matched exactly, almost certainly there would be a difference in self-capacitances.

The same is true for superhets, although here the first and second tuned circuits are variable over different frequency ranges. It is still necessary, however, for the tuning ranges to "track" (a statement which means that the difference in frequency between the aerial tuned circuit and the oscillator tuned circuit must be constant and equal to the chosen intermediate frequency).

It is suggested that any type of personal or portable set should be trimmed by trial and error, adding or subtracting turns from the loop aerial winding, until it comes into line with the other tuned circuits. The following notes are intended to cover all types of t.r.f. and superhet. receivers, and to serve as alignment instructions for the complete circuits in later chapters.

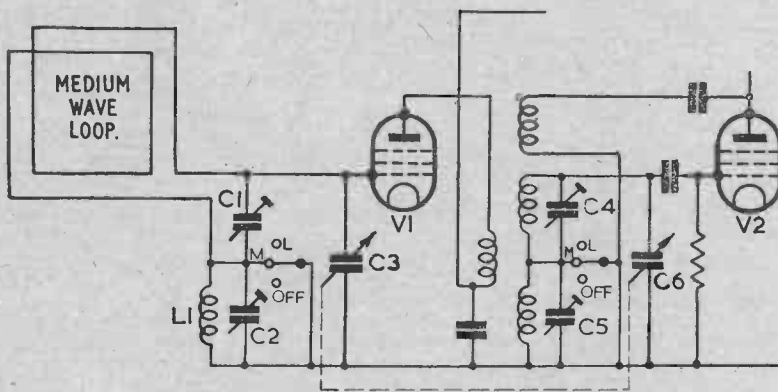

FIG. 7. BASIC TUNED CIRCUITS OF A T.R.F. RECEIVER

T.R.F. RECEIVER ALIGNMENT

A source of signal is essential for aligning any type of receiver. Broadcast stations may be used if nothing better is available, but a signal generator is much to be preferred. For loop aerial alignment, however, even the signal generator can be bettered by a simple multivibrator, the circuit of which is shown in Fig. 8.

ALIGNMENT, USING BROADCAST STATIONS

The basic circuit of a t.r.f. receiver's tuned stages is shown in Fig. 7 where the loop aerial is switched in circuit with an additional long wave coil for low frequency coverage, a two band coil such as the Weymouth CT2W2 being employed in the detector stage of the receiver. Reaction will almost certainly be incorporated in the circuit and the detector should be operated at its most sensitive point throughout the tests. It is assumed that the loop has been wound to a suitable starting point, such as the windings already indicated.

Until the loop is brought reasonably into tune, an external aerial and earth should be coupled in, preferably through a small extra winding as already described; the tests should be conducted in the evening, when plenty of signals round the tuning range are available. Switch to the medium wave band, set C4 at approximately half capacitance, and search with the main tuner, C3, C6, for the Light Programme at 247 metres. Probably nothing will be heard on the first trial: reaction may temporarily be increased so that even faint carriers may be heard as heterodyne whistles.

Continue to search the high frequency end of the tuning range while increasing the capacitance of C1, which should be screwed in from its minimum position. If signals weaken as the capacitance of C1 is increased the loop is too large, and a turn should be removed.

If signals increase in strength as C1 is increased to full capacitance, add another turn to the loop. The object is to obtain an increase in signal strength as C1 is increased to about half capacitance, the signal strength then falling off again with further increase in C1.

When the number of turns on the loop have been adjusted to give this effect, back off reaction and check for reception on the Light Programme. If the receiver is fitted with a tuning dial, the next step is to bring the signal to its correct marked point on the dial by adjusting C4, this capacitance being increased if the Light Programme is found above the correct point, and *vice versa*. C1 is then retrimmed for volume.

If a tuning dial is not fitted it will be found convenient, by trimming, to bring the Light Programme to a point along the semi-circular arc described by the tuning pointer, at a distance of approximately one-seventh of the arc length from the low wavelength end.

In some areas the medium wave Light Programme is not well received and in these circumstances a check can be made on, say, Luxemburg. Make the reception check with the external aerial and earth connections removed, to obtain an indication of the sensitivity of the receiver. If all is well, tune over the range towards the lower frequencies, checking reception on all signals received. If reception falls off, try increasing and decreasing the capacitance of C1 in an endeavour to improve volume, keeping the reaction control at its most sensitive point.

If the loop aerial and the second tuned circuit are matching well it should not be necessary to adjust C1 to obtain good results over the whole tuning range. If, however, the loop has more self-capacitance it will be necessary to slacken off C1 to maintain good reception, and *vice versa* if the self-capacitance of the loop is low. As a general rule it will be found that the loop will match in sufficiently well once it is trimmed to the Light Programme frequency; but if results fall off badly over the rest of the medium wave band some small adjustments will be necessary. If it is found that the loop has too much self-capacitance it will be necessary to space the turns further apart, adding a turn if necessary to maintain inductance. If the self-capacitance of the loop is low the turns should be rewound more closely, a turn being subtracted if this increases the inductance too much.

In receivers where a frame aerial of the Fig. 5 type is employed, and where the spacing between turns cannot be varied, it will be necessary to try the effect of adding a turn instead of closing up existing turns; or of subtracting a turn instead of spacing existing turns further apart. After each adjustment it will

be necessary to re-align the receiver at 247 metres before checking for improved reception over the band.

With the medium wave tuning finally adjusted, switch the receiver to the long wave band and again couple in the external aerial and earth for the preliminary tests. The choice of a suitable coil for L1 is not always easy, and this must be borne in mind when trimming the long wave band. Commercial long wave coils have rather too much inductance to match in well with the loop when connected in series, while a medium wave coil obviously does not introduce sufficient additional inductance to bring the circuit in gang for long wave tuning. The effect of using a long wave oscillator coil can be tried (though generally these have too little inductance to bring up the total sufficiently); but the simplest method of providing the necessary inductance is to employ an iron cored long wave coil with the core removed, and to trim on the Light Programme. Alternatively, an air cored coil (such as the Wearite PA1) can be used with turns removed until the total inductance with the loop in series is correct. Correct alignment over the whole wave band is not important especially that, as a general rule, it is now only required to bring in the Light Programme in areas where the 247 metres Light Programme is poorly received. Accordingly, the receiver need only be tuned to the Light Programme, using reaction if necessary to find the carrier, trimming C5, then C2, for best results. Under some conditions extra capacitance in the C2 position will be found necessary, and the trimmer can then be removed entirely from the circuit.

If good long wave coverage is required for any purpose it will be essential to use a coil such as the Wearite PA1 in the L1 position, and to adjust the number of turns against standard signals from a signal generator, in the way to be now described.

ALIGNMENT BY SIGNAL GENERATOR

The use of a signal generator provides more precise trimming between the tuned circuits. Couple the generator into the receiver by connecting the auxiliary coupling loop into the artificial aerial and earth sockets of the generator. If an auxiliary loop has not been wound beside the main loop, the generator may be coupled in by two or three turns of wire wound loosely over the frame aerial. Switch the receiver to the medium waves, set C4 to mid capacitance, tune the generator to 250 metres (1,200 kc/s) and, using reactance if necessary, bring in the signal on the receiver. Adjust C1 for best volume (reducing the signal generator output to the lowest practical point as the receiver is brought into alignment) and, as already described, adjust the loop winding until it peaks at the required frequency with C1 at about half capacitance.

Now tune both receiver and generator to 500 metres (600 kc/s) and compare the output with that obtained at the 1,200 kc/s tuning point, using an output meter if available for a definite indication. A slight drop in output is probable at the lower frequencies, but any large drop should be investigated by adjusting C1 for best volume. A low self-capacitance in the loop is indicated if C1 has to be increased. Wind the turns of the loop closer together, or add a turn, to increase; and to reduce, try spacing the loop turns farther apart, or take away a turn. Continue with tests at 1,200 and 600 kc/s until reasonable balance over the tuning is reached. Check for straightforward reception with the generator disconnected from the auxiliary coupling winding.

To align the long wave band, use for L1 a coil from which turns may easily be removed. A suitable coil is the Wearite PA1 from which, for a start, strip off about 40 turns. (The main tuned winding on this coil is that connected to the two upright tags, one of which is coded in red). Switch the receiver to the long wave band, tune the generator to 1,000 metres (300 kc/s) and couple it into the auxiliary loop. With the modified L1 in circuit bring in the generator signal, using reaction if necessary. Set C5 to about mid capacitance and adjust C2 for maximum volume, backing off reaction until the signal is well received if the detector was previously made to oscillate.

Now tune both generator and receiver towards 150 kc/s step by step, moving about 25 kc/s at a time, bringing in the signal on the receiver at each step. Keep the reaction at the most sensitive point. In all probability the signal strength will commence to fall off rapidly. As soon as this is detected, by ear or by an output meter, reduce the setting of C2 to find whether L1 still has too high an inductance, which will be indicated by an increase in volume. If so, further turns may be removed.

Should the signal strength weaken further as C2 is reduced in capacitance the indication is that too many turns have already been removed from L1, and it will be necessary to restore some of them.

Continue with the test, removing or adding turns in steps of about 10 turns at a time after the original 40 turns have been removed, until the generator signal can be followed from 300 to 150 kc/s, without serious falling off. The receiver should then be in alignment over the long wave band, and can be tested for direct reception on the Light, and other programmes available.

ALIGNMENT BY MULTIVIBRATOR

The tests so far described have in effect tested the alignment of the tuned circuits one with another at certain selected points—either the tuning points of suitable broadcast stations or suitable signal generator check points. It is obvious that if, by some means, a continuous signal stretching right over the broadcast band could be injected into the receiver, and the tuning capacitor rotated, a very close check indeed could be made of the receiver alignment. At points where the alignment between the tuned circuits was lost the signal would temporarily fade as the tuner was turned. If the circuits became progressively out of alignment towards the low frequency end of the range the signal would progressively weaken. Such a check would be worth while on t.r.f. receivers, but even more valuable in the alignment of superhets.

It is easily possible to set up such a "continuous" signal, stretching right across the broadcast bands, by means of a multivibrator, such as that shown in Fig. 8. A multivibrator is an oscillator with an output having a square waveform, which possesses a wide range of harmonics. A multivibrator working on a fundamental frequency of 10 kc/s (an audible note), supplies a chain of harmonics stretching up into the megacycle frequencies; and if such a signal is fed into a receiver the effect is to give a series of signals each modulated by a 10 kc/s note and all 10 kc/s apart. As the receiver tuner is rotated, therefore, one signal comes in immediately after another giving the effect of a "continuous" signal, and the response to successive "carriers" should be reasonably level, allowing for a slow falling off towards the higher frequencies. A normal receiver has a slow falling off in sensitivity towards the low frequencies, however, so that the two effects tend to cancel out and give a level signal over the medium wave band, at least.

Strictly speaking, a vibrator working at 10 kc/s with a perfectly balanced

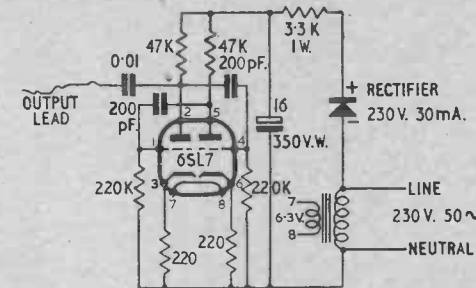

FIG. 8. A SIMPLE MULTIVIBRATOR

waveform, will possess only odd harmonics, *i.e.* at 20 kc/s intervals: but, in practice, very little out of balance is necessary for quite useful even harmonics to appear. But odd and even harmonics will differ in amplitude somewhat, so alternate 10 kc/s whistles may vary in intensity somewhat, depending also on the selectivity of the circuits. If alternate "carriers" maintain a reasonable level, the drop at the intervening ones can be ignored as due to the reduced level of even harmonics.

The circuit of Fig. 8 requires little explanation. The unit need not be screened (though to prevent interference with other receivers it is as well to group all the small components round the valve holder and to use a small four-sided chassis), and the circuit has no critical points. The constants are chosen to give approximately a 10 kc/s note; if for any reason it is required to control the fundamental frequency within limits one of the 220,000 ohms grid leaks can be made variable and placed in series with a fixed 68,000 ohms resistor. Double triodes other than the 6SL7 may be used and a battery version of the multivibrator can be constructed round a Mullard DCC90, if desired.

The mains lead as shown in the unit should be terminated for safety in a three-pin mains plug, so that the polarity cannot be reversed and the chassis thus made "live." If a switch is fitted it should be of the double-pole type for preference. Only a single output lead is required, and the chassis of the multivibrator must *not* be connected to the chassis of the receiver under test.

To align a t.r.f. receiver with the multivibrator proceed as follows, using the circuit of Fig. 7 as an example.

First, to set the tuned circuits on frequency when a tuning dial is fitted, tune the receiver to the 247 metres Light Programme (coupling in an external aerial and earth if necessary), and, with the wavechange switch in the medium wave position, set C4 so that the station is tuned in at the correct point on the dial, roughly trimming C1 for best results. Throughout the subsequent adjustments do not vary the setting of C4.

Disconnect the external aerial and earth if used, and couple in the multivibrator by running the output lead beside the loop aerial with the multivibrator switched on. If the receiver is insensitive the output lead can be wrapped round the loop for one or two turns, keeping the coupling as loose as possible. Tune the receiver to the high frequency end of the medium wave band—to 220 metres approximately. Adjust C1 for best volume, starting at the mid position. If increasing the value of C1 up to maximum steadily increases volume add a turn or more to the loop if necessary; if decreasing the value of C1 down to the minimum gives a steady increase of volume, remove a turn or more from the loop, until C1 peaks the signal up to maximum volume at about its midway position.

Now tune over the medium wave range, noting any falling off in the volume of the audio signal from the multivibrator. If the volume is reasonably steady no further tests need be made, but if it falls off, check by adjusting C1 to see whether an increase or decrease in its capacitance increases the volume. If an increase in C1 is required try the effect of rewinding the loop with the turns closer together or adding a turn, and *vice versa*.

On the long wave range the multivibrator can assist very considerably in matching in L1 (Fig. 7). Remove about 40 turns for a preliminary trial, set C5 to the midway position and inject a multivibrator signal. Adjust C2 for maximum volume; if C2 needs to be right open for any signal at all, or only a weak signal, remove more turns from L1 until reasonable volume is obtained. Now tune over the long wave range, investigating any drop in volume by varying C2. If C2 has to be reduced in capacitance to bring up volume, remove a few more turns from L1 and retrim at the high frequency end of the band before tuning over the range for a further trial. If C2 has to be increased in capacitance, too many turns have been removed from L1 and some should be replaced. If only a few of the turns are removed at a time, it will not be necessary to replace turns, a considerably more awkward undertaking than removing them.

When a reasonably steady multivibrator signal can be received over the

entire medium and long wave bands, the receiver is ready for normal reception trials on broadcast signals.

As usual, all these tests should be made with the reaction control at its most sensitive setting. When the receiver is fitted with a tuning dial, C5 is adjusted to bring in the Light Programme at the correct point, C2 being trimmed for best volume.

SUPERHET. RECEIVER ALIGNMENT

The aerial and oscillator tuned circuits in a superhet. must always "track," *i.e.* must always have a difference in frequency equal to the i.f.—generally 465 kc/s or thereabouts, the oscillator tuning being 465 kc/s or so higher than the aerial circuit. With an untuned aerial, either loop or metal plate, the alignment takes no longer than for any other type of superhet.; but a tuned loop must be adjusted to give good tracking throughout the tuning range. This may call for careful adjustment of the number of turns on the loop, as well as the spacing of the turns. These adjustments are by no means difficult, but certainly a little patience is needed. Once the i.f. transformers and oscillator are aligned the loop can be adjusted on broadcast signals.

The best way of aligning a receiver using a tuned loop aerial is to ignore the loop completely at first, and to align the i.f. stage and the oscillator against an aerial coil temporarily connected in, in place of the loop. An aerial coil known to match in with the oscillator is, of course, ideal (*e.g.* a PA2 to match in with a PO2 oscillator, or an HA3 to match in with an HO3 oscillator); but almost any normal aerial coil will suit for the purpose.

The preliminary steps must be the same whatever input signal is used for the adjustment. First the i.f. transformers must be aligned on the correct intermediate frequency; and the oscillator coil trimmed and padded against the aerial coil. (These steps will be explained and described in Chapter 5).

Nothing more is necessary in a superhet. using an untuned aerial, as the aerial coil is permanently a part of the receiver and there is no tuned loop to be adjusted.

SUPERHET. ALIGNMENT ON BROADCAST SIGNALS

With the i.f. and oscillator stages in order, disconnect the temporary aerial coil and connect in the loop aerial. Couple in an external aerial and earth to the auxiliary loop if fitted, or make a temporary coupling loop round the loop aerial by two or three turns of insulated wire and connect the external aerial and earth to that. Set the receiver tuning capacitor to the 247 metres Light Programme tuning point and adjust the loop trimmer capacitor for best results. If the capacitor has to be increased to maximum add a turn or more to the loop, and *vice versa*. Aim at tuning the Light Programme up to maximum volume with the loop trimmer at its mid capacitance point.

Now tune over the medium wave band and endeavour to pick up the North Home Service on 434 metres, again adjusting the loop trimmer when the signal is tuned in, for best volume. If no improvement, or only a slight improvement, in volume can be obtained the loop aerial is satisfactory as it stands; adjust the trimmer once more on the Light Programme, or set it to give a balance between the two test signals, and proceed to the long wave test.

If a considerable improvement can be made in the reception of the North station by increasing the loop trimmer capacitance try adding another turn to the loop, or winding its turns closer together. If the volume is increased when the loop trimmer is opened out for minimum capacitance, try removing a turn from the loop or spacing its turns further apart. When an adjustment is made to the loop aerial, check the effect of the operation by trimming again on the Light Programme before rechecking the effect on the 434 metres tuning point. Adjust the loop until the setting of the loop trimmer serves equally well (or approximately so) for both the Light and North Home Service Programmes.

On the long waves, as in the case of the t.r.f. receiver, the alignment of the

superhet. will depend to a considerable extent on the series connected coil used with the loop (L1 of Fig. 7, ignoring the rest of the circuit). Undoubtedly the simplest course to take is to align the long waveband on the Light Programme only, using small iron cored coils such as the Weymouth H series (HA1 for the loading coil and HO1 for the oscillator).

Connect in the long wave coil as an aerial coil during the preliminary i.f. and oscillator alignments, and trim and pad the circuits so that the Light Programme is received at the correct point on the dial. Then connect in the loop aerial, and, by running the core of the coil out as far as possible, the Light Programme should be received at its correct point on the tuning dial.

If better tracking between the aerial and oscillator circuits is needed the adjustments must be made using a signal generator or multivibrator.

SUPERHET. ALIGNMENT BY SIGNAL GENERATOR

With the preliminary steps completed and the i.f. and oscillator coils correctly adjusted, connect in the loop aerial. Switch the receiver to the medium wave band and couple in the signal generator to the auxiliary coupling loop, or to a turn or two of wire round the loop aerial. Set the generator to 250 metres (1,200 kc/s) and tune the receiver to this point on the dial; the signal should be audible; by adjusting the loop trimmer bring the volume up to maximum. If the trimmer has to be at full capacitance add a turn or more to the loop; if the trimmer has to be completely unscrewed for good reception remove a turn or more from the loop and, as before, aim at best volume with the loop trimmer near its mid capacitance point.

Tune the generator to 500 metres (600 kc/s) and bring in the signal on the receiver. As already described adjust the loop trimmer to improve volume if possible; if only a small improvement can be made the loop aerial is satisfactory and long wave adjustments can be commenced.

If a considerable improvement at 500 metres is possible by increasing capacitance, add a turn to the loop, or wind the existing turns more closely together. If the loop trimmer has to be unscrewed, remove a turn or space out the existing loop turns. After each adjustment to the loop retrim at 250 metres before rechecking results at 500 metres, and continue until good results are obtained at both ends of the tuning range.

With a signal generator the long wave aerial circuit can be correctly matched with the oscillator circuit to give a properly tuned range. As described in a later chapter, the long wave oscillator coil will already be trimmed and padded, and it remains only to remove turns from the series coil in series with the loop aerial until the tracking is correct. Commence by stripping 40 turns from the coil (an air cored coil such as the Wearite PA1 is best for this purpose); connect it in circuit, and switch the receiver to the long wave band. The aerial circuit will then be similar to that shown in Fig. 7 (the loop and coil with C1 and C2, ignoring the rest of the diagram). Tune the signal generator to 1,000 metres (300 kc/s), couple it into the loop aerial as before and tune in the signal on the receiver; then trim the series coil by its trimmer. Probably the trimmer will have to be at minimum capacitance for a signal to be heard, in which case remove more turns from the coil and continue with the test until the 1,000 metres signal can be peaked with the trimmer across the loading coil.

During these tests the medium wave trimmer across the loop (C1 of Fig. 7), should not be touched.

Now tune both generator and receiver to 1,500 metres, (200 kc/s) and check for response, which should be satisfactory. If necessary, give a slight adjustment to the padding of the oscillator to improve the volume, followed by a retrimming of both aerial and oscillator circuits at 1,000 metres. Only slight adjustments should be made if the tuning scale is to read correctly. If the tuning scale is to be drawn to suit the circuit then more extensive adjustments may, of course, be made.

SUPERHET ALIGNMENT BY MULTIVIBRATOR

To align the superhet. by means of the multivibrator commence, as already described, by adjusting the number of turns on the loop aerial so that the medium wave trimmer gives good response at about 250 metres when set to mid-capacitance. Then rotate the receiver tuning capacitor to investigate the tracking between the aerial and oscillator circuits. If response falls off steadily towards the low frequency end of the tuning range make the trimmer tests to ascertain whether the loop requires more or fewer turns or whether the spacing requires altering. After each adjustment retrim at about 250 metres, not touching the oscillator settings and trimming only the loop trimmer. Tune over the whole medium wave range, and listen for dips or peaks in the response. When response is fairly level over the band, further improvements may be attempted if desired or warranted by small local dips in the response. Small adjustments can be made to the loop and to the spacing of the turns and, finally, to the trimming and padding of the oscillator coil. Again, if a tuning scale has still to be drawn these adjustments can be more extensive in scope.

The long wave range is adjusted as explained for alignment with a signal generator, although it is again possible to keep a closer check on the tracking between the aerial and oscillator circuits over all frequencies in the band.

SHORT WAVE ALIGNMENTS

Usually, short wave ranges are found only in larger portable receivers. In personal sets there is little space to spare for the extra oscillator components necessary, nor is the size sufficient for a really effective short wave loop.

The tracking between the aerial and oscillator circuits depends chiefly on the size of the aerial frame or former, a single turn of wire usually making up the whole short wave loop. On large formers even this single turn can have too high an inductance, and for good results it is very desirable to use a signal generator by which the oscillator can be set, and the loop aerial pruned or trimmed as required. The form of the aerial circuit on the short wave band, makes it unselective and coupling between the generator and receiver should be loose. It is generally sufficient to run the output lead from the generator beside the receiver aerial.

The short wave oscillator coil should first be trimmed and padded in the way to be described in a later chapter. Suitable frequencies for a coil, such as the Wearite PO3, are 15 mc/s for trimming with a check at 7 mc/s. Most short wave oscillator coils have large value fixed padding capacitors, that for the PO3 coil being specified by the manufacturer as 0.005 mfd, so there are no padding adjustments.

The aerial loop may now be trimmed at 15 mc/s, and the size of the loop varied, if necessary, to obtain good tracking with the oscillator. If the loop is found to be too small (because the aerial trimmer has to be large), a part of a turn can be put on if a solid frame former is used. If an open former similar to that in Fig. 5 is used, the smallest possible variation is limited to a quarter of a turn. If even a single turn is found to give too great an inductance (a very small trimmer, or none at all, being required across the loop), part of the turn can be removed.

It is important to realize that the path taken by connecting leads will have considerable effect on timing at these frequencies. So half a loop may not have much less inductance than a whole one, unless care is taken to shorten connections.

Frequent checks should be made on actual short wave signals during the adjustments, since it is possible to tune in harmonics and images of the signal generator output, even if this is kept to as low a level as will give satisfactory indications. With a little patience, however, surprisingly good short wave results can be obtained if a modern frequency changer is used. If response to the generator appears to be good, but signal strength on actual reception tests is poor, check conditions first by tuning the appropriate short wave band on a receiver of known performance, because conditions can vary widely and quickly on these frequencies.

T. R. F. RECEIVERS

THE use of t.r.f. receivers for personal and portable operation should be limited to reasonably good reception areas if simple and inexpensive circuits are to be used. The high gain necessary in a poor reception area makes r.f. stability difficult to obtain and, as at least as many stages are required as for a superhet., the t.r.f. receiver will be no cheaper to build and offers no saving in battery power.

Many constructors are attracted by the t.r.f. circuit because it is easily aligned without a signal generator. But a straight circuit can be just as "tricky" as a superhet. and can, in fact, show more instability unless considerable care is taken over the layout.

In general, a t.r.f. circuit consists of at least one stage of r.f. amplification, fed from a tuned loop aerial for preference, and a reacting detector which can give a considerable measure of useful gain. Thus, a minimum of three stages is required: r.f., detector, and output stage. There are t.r.f. circuits which include two r.f. stages, the first being sometimes fed from what may be termed a "semi-tuned" loop, wound to resonate approximately at the frequency of the medium wave Light Programme, or any other required station.

A two stage receiver consisting of a reacting detector, fed from a tuned loop, and followed by an audio amplifier and an output stage can give good results in the best reception areas. It is not suitable in other areas without the assistance of an external aerial and a direct earth connection.

Fig. 9 shows a t.r.f. circuit for medium wave reception only. It is suitable for construction by the beginner, and is for use in reasonably good reception areas. The aerial input circuit contains only the tuned loop; the amplified r.f. signal is passed on to the detector grid circuit by the capacitor C4, the best value for which may be found by experiment. A further experiment is to replace

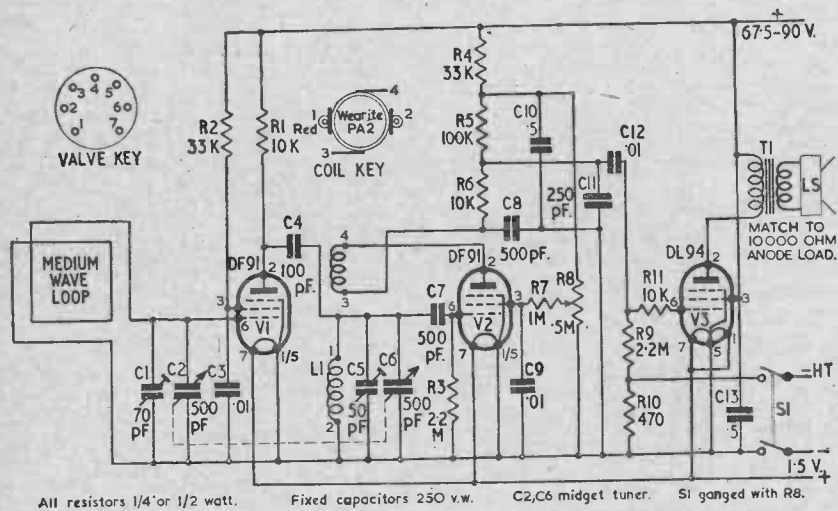

FIG. 9. COMPLETE CIRCUIT FOR SIMPLE T.R.F. SINGLE WAVE-BAND RECEIVER

the anode load resistor R1 of V1 by a small r.f. choke, the screen grid of V1 then being connected directly to the h.t. line, and R2 omitted.

The coil L1 should be of the Wearite PA2 type to suit the circuit as shown, and it should be connected as denoted in the coil key. The reaction control is by screen voltage control of V2, which is smooth and effective. C8, R6 and C11 filter r.f. from the audio output, and the detector is decoupled completely from the other valves by R4 and C10. Further filtering is achieved by the grid stopper R11. Stoppers in grid circuits must be connected directly at the valve holder pin by as short a lead as possible.

R10 provides grid bias for the output valve; the total current from the h.t. battery flows through this resistor from the common earth line, setting up a voltage making its junction with P negative to earth. C13 provides a low impedance path for l.f. and h.f. h.t. positive and earth, and so, in effect, by-passes R10. A capacitor across R10 itself would be as effective a by-pass, but would not by-pass the h.t. battery as well (as the battery ages and its internal impedance rises); C13, in the position shown, carries out both functions.

The valves specified for V1 and V2 (Mullard DF91: American equivalent, IT4) are normal types for such a circuit; but the specified output valve (Mullard DL94: American equivalent, 3V4) is not used so often as a Mullard DL92 (American equivalent, 3S4). The beginner is advised to use a DL94 because this valve can have 90 volts h.t. on both anode and screen (the DL92 screen voltage being limited to 67.5 volts, necessitating a dropper when a 90 volts battery is used). Also, the DL94 is more sensitive and better suited to the various experimental reflex circuits to be described.

Note that the valve connection key relates to the underside of the valve holder, viewed in the wiring-up position.

Fig. 10 shows a slightly more comprehensive three valve circuit, developed from that of Fig. 9. This receiver tunes over both medium and long waves, and is suitable for reasonably good reception areas. The circuit is recommended for general construction. To simplify alignment of the tuned circuits, particularly over the long waves, the circuit specifies a matched pair of tuning coils, such as the Weymouth CT2W2 components. The long wave winding of the aerial coil is used as L1, the series coil for long wave reception. The long

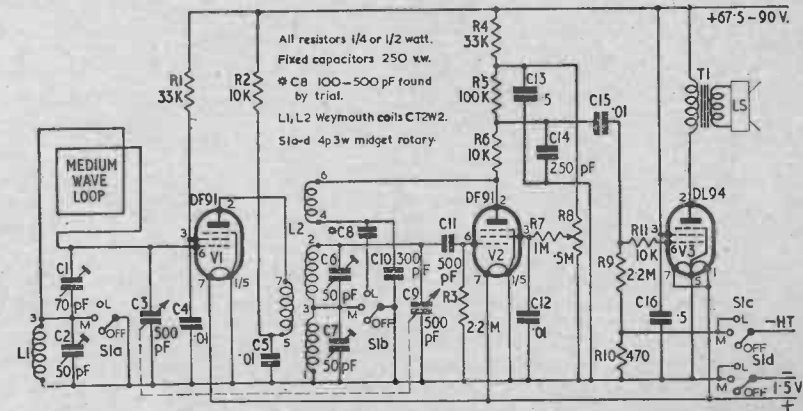

FIG. 10. COMPLETE T.R.F. CIRCUIT FOR DOUBLE WAVE-BAND

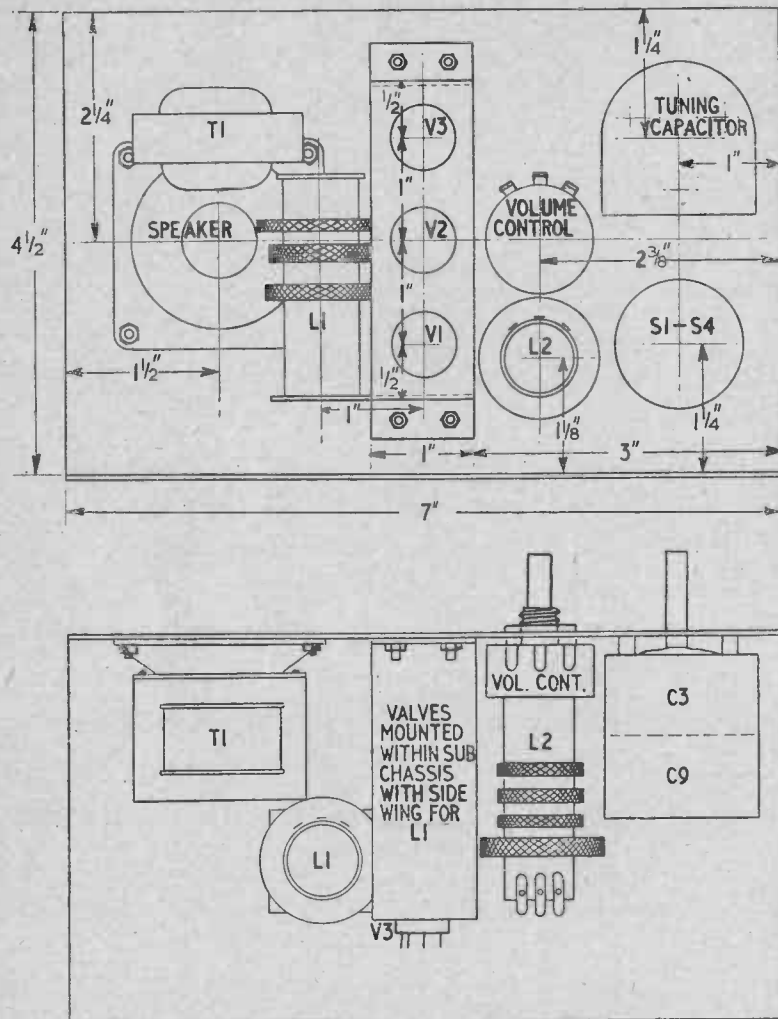

FIG. 11. BASIC LAYOUT FOR PERSONAL RECEIVER, USING CIRCUIT OF FIG. 10

wave coil in both aerial and detector circuits is in series with the medium wave coil, so there is no need to adjust L1, apart from trimming by C2.

In this receiver the amplified r.f. signal is passed on from V1 to the grid circuit of V2 by an inductive coupling; and, instead of the series connected reaction coil of Fig. 9, the reaction winding in this circuit is shunt fed. This may lead to weak reaction over the long wave range, in which case C8 can be connected in circuit as an extra feedback capacitance, effective on long waves only. The exact form of construction will control, to some extent, whether C8

will be needed, also its value; tests should be made to obtain the best results.

The two tuned circuits of Fig. 9 contain very dissimilar inductances (as far as shape is concerned), and instability should be unlikely. In the new circuit of Fig. 10, however, the two long wave coils are similar, and they should, therefore, be spaced apart. The r.f. leads to the wavechange switch should also be kept apart, and as short as possible. A typical layout for a personal portable is shown in Fig. 11.

In all circuits where reaction is employed there is a slight chance that correct connections for regeneration will not be made at first. In some cases the coil connections are coded differently from coil manufacturers' codings. All the circuits given have been tested, and the codings shown are those found to work by trial.

If reaction is weak or non-existent, the effect of reversing the connections to the reaction winding should be tried.

REFLEX CIRCUITS

The present high cost of valves has discouraged the construction of multi-stage receivers, and, as a result, circuits including reflex stages are being revived—in a modern form—after several years neglect. As the name suggests, a reflex stage is one through which the signal passes a second time.

In a t.r.f. receiver a reflex stage is one which serves first as an r.f. amplifier, and later as an audio amplifier. The use of a reflex stage enables the effective number of stages of a receiver to be increased without increasing the number of actual valves; or, alternatively, the number of valves may be reduced with no reduction in the number of stages. A t.r.f. portable is chiefly suitable for use in good reception areas, so there is little point in adding further stages to the receiver which will increase its useful range only slightly. Saving a valve and saving in l.t. and h.t. current drain without affecting the receiver's functioning are more worth-while advantages.

A reflex receiver circuit is shown in Fig. 12, where the output valve, V1, is also the r.f. amplifying stage—two valves thus doing the work of three. It

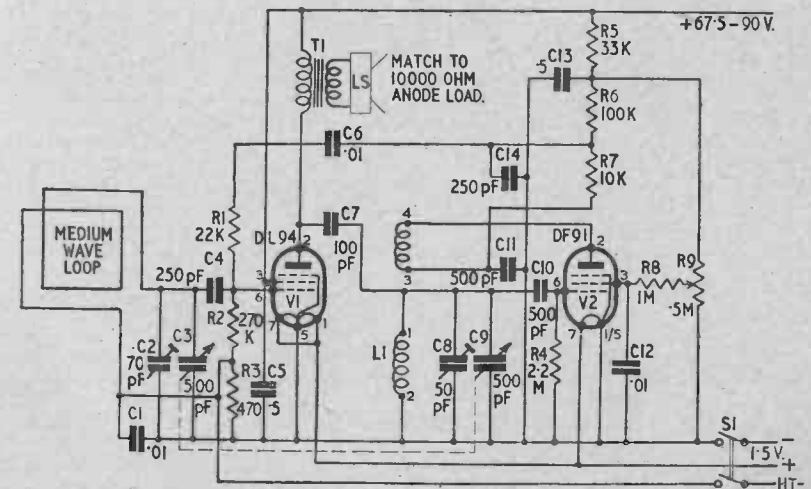

FIG. 12. SIMPLE REFLEX CIRCUIT USING V1 AS R.F. AND A.F. AMPLIFIER

will be understood that V1 cannot perform its dual functions with the same efficiency as when it is used solely as an output valve. It is found, however, that the advantages considerably outweigh the slight losses; a good measure of r.f. amplification is obtained if the grid impedance of the valve is not made too high. R2 must therefore have a relatively low value and, consequently, a slightly lower audio voltage is developed across R2 as input to the "output stage"; but the receiver still gives plenty of output when used in good reception areas. It is suitable for construction by all experimenters, but a novice should not attempt a reflex circuit until experience has been gained with more conventional and straightforward receivers.

The circuit shown covers the medium wave band only. Coverage for the long wave band can, of course, be added very easily; but it is preferable to keep the circuit as simple as possible for its first tests, which will show whether it is suitable for a particular reception area. The loop aerial feeds into V1 via C4, which is a grid blocking capacitor of fairly low value and which passes r.f. to the grid of V1, while preventing the loop from short circuiting the audio frequencies that are also being fed to the valve.

The DL94, like any other normal output valve, must be biased to a suitable working level to give a reasonably linear audio output. The very small r.f. input from the loop aerial would be insufficient to run the valve into grid current were it applied to the unbiased grid, and so is made to appear directly across the grid resistor, R2, by connecting the earthy end of the loop to the junction of R2 and R3. With this arrangement, R3 must be by-passed by C1. If reception from a local station is very good and there are signs of distortion due to overloading, the earthy end of the loop may be connected direct to the chassis, and C1 omitted from the circuit.

C5 by-passes both R3 and the h.t. battery impedance for r.f. and audio signals, as before.

The amplified r.f. signal passes from the anode of V1 to the grid circuit of V2 via a capacitance coupling, the primary of the output transformer proving to be a satisfactory r.f. choke, so that no extra anode load is required. The detector, V2, is made regenerative with a reaction control in the screen circuit, and so gives r.f. and audio gain. The audio signal is taken from the junction of R6 and R7 (C11, R7 and C14 providing an r.f. filter), and is passed via the d.c. blocking capacitor, C6, and R1 to the grid of V1. R1 prevents the small r.f. signals supplied to the grid from the loop, from being lost to earth through C6 and C14.

The experimenter more interested in economy than in portable operation will find this circuit useful. If a normal tuning coil is substituted for the loop aerial and coupled to a good external aerial and earth, very reasonable results can be obtained in the poorer reception areas. The circuit suffers, of course, from a lack of selectivity which is an inherent defect in t.r.f. receivers; but with careful trimming and a judicious use of the reaction control, the local stations should be receivable clear of interference (except in such areas as the West Country where B.B.C. coverage is notoriously poor).

When used in this way a Wearite PA2 coil should be used, both for L1 in Fig. 12 and in place of the loop. The upright tags (Nos. 1 and 2) are connected to C4 and the junction of C1, R3; and the side tags (Nos. 3 and 4) are connected one to the aerial and the other direct to the receiver chassis, to which, also, a direct earth connection is made.

It is possible that different valves in either the 2 volt battery or the mains ranges might serve. This has not been checked as the main concern here is the use of midget valves for portable operation. The chief requirement is that V1 should be an output valve with inter-electrode capacitances as low as possible.

A different reflex circuit using the same valve types as in Fig. 12 in another sequence, and with a separate detector, is shown in Fig. 13. This receiver is more selective because a further tuned stage is employed. It is not, however, suitable for a personal receiver because, so far at least, it has not been possible

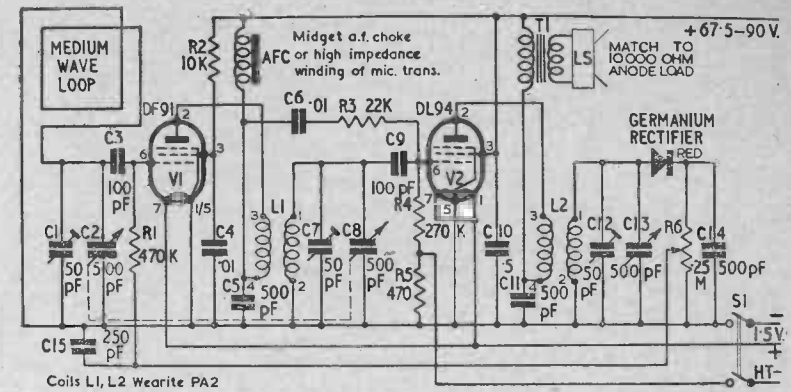

FIG. 13. REFLEX CIRCUIT USING BOTH STAGES FOR BOTH R.F. AND A.F.

to obtain three-gang miniature tuning capacitors. All the circuits shown use two-gang tuners, miniature components being used when the selected circuit is to be made into a personal receiver, and either miniature or normal tuners being used for larger portables. The circuit of Fig. 13 is, therefore, suitable only for portables or experimental home receivers.

The use of a separate detector provides no extra sensitivity as a germanium detector is used which, of course, precludes the detector being of the regenerative type. Consequently the receiver is suitable for good reception areas only, and it is designed for the more experienced constructor. Only the medium waves are covered; long wave tuning can be added if required.

The loop aerial feeds into a DF91 (IT) r.f. pentode through a blocking capacitor, C3, the r.f. signal being amplified and passed inductively to the tuned grid circuit of V2, which is a DL94 acting as an r.f. amplifier and output stage. V1 gives good r.f. gain being connected as a choke-loaded audio stage, allowing high voltages on both anode and screen. A resistance-loaded circuit would serve here on the audio frequencies, but would be less effective as an r.f. stage.

From V2 the r.f. signal, further amplified, is again passed through an inductive coupling to the germanium detector stage. Selenium and copper-oxide detectors will work here, but they cannot be recommended; the germanium type rectifier is far superior for this method of operation. The audio signal is developed across the volume control, R6, and fed back from the slider and via R1 to the grid of V1 for audio amplification. The audio grid return for V1 is through R1 and R6, R1 also serving as a block to r.f. on the grid of V1. After amplification the audio signal is passed from the earthy side of the V1 anode coupling coil via C6 and R3 to the grid of V2, and is eventually delivered to the output transformer and loudspeaker.

In this circuit both valves act as reflex amplifiers, as each handles r.f. and audio at the same time. Some care in building and laying out the circuit is essential to avoid instability, with thoughtful placing of coils and using really short leads.

Instability in t.r.f. circuits, already mentioned, is more likely to occur in a reflex receiver (such as that of Fig. 13) than in a straight-forward circuit. Some experimental shifting and placing of components may be found necessary; also, coil screens may be necessary. One way of improving stability which is not commonly used at broadcast frequencies is to tap the tuned circuit as shown in Fig. 14(a). While reducing the voltage input in the valve or following circuit,

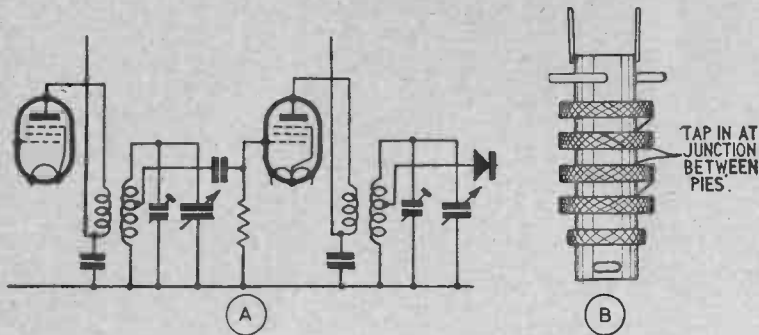

FIG. 14. SHOWING HOW TAPPING INTO COILS CAN BE EMPLOYED TO REDUCE CIRCUIT DAMPING

this reduces loading on the tuned circuit and gives operating conditions intended to reduce the possibility of undesired feedback. The coils specified (Wearite PA2's) are well adapted to this tapped connection. The tap may be made at the junction between pies of the winding at approximately the centre of the coil. For full efficiency it is essential to make the joint to all strands of the Litz wire, and *Enamaclean* can be used for stripping a short length of wire.

Chapter 3

SUPERHETS: THE FREQUENCY CHANGER

The superhet., as already indicated, is the type of receiver most suitable for portable and personal use. Compared with a t.r.f. receiver, a superhet. has much greater range and selectivity, and costs only a little more to build.

Those intending to construct a portable set are strongly advised to disregard any apprehension they may have regarding the superhet., particularly in relation to alignment. This chapter, and the one following, offer a solution of the two major problems likely to be encountered—namely, tuning the i.f. transformers and aligning the oscillator circuits without using elaborate or costly apparatus.

The frequency changer is the "trickiest" stage of any superhet., and is especially so to the beginner. This stage accepts the r.f. signals from the aerial (of whatever type) with tuning to the required signal, and proceeds to "beat" the signal against a plain and unmodulated signal provided by a local oscillator, which is almost always a part of the frequency changer valve and circuit itself. The oscillator tuning must be higher in frequency than the required signal by exactly the intermediate frequency—generally 465 kc/s; so, for example, the medium wave Light Programme where the station carrier is on 1,214 kc/s, the local oscillator must be tuned to 1,679 kc/s for an i.f. of 465 kc/s.

A frequency changer valve is so constructed that the two signals are combined in such a way that one of the outputs (there are several others) is a signal of 465 kc/s carrying the modulation of the original r.f. broadcast signal. This is the i.f. signal and it is tuned and accepted by the primary winding of the

first i.f. transformer; the other output signals coming from the frequency changer are automatically discarded, because the transformer does not tune to their frequencies.

A typical frequency changer circuit as used in many personal and portable receivers is shown in Fig. 15(a) which uses a Mullard DK91 valve (American equivalent, IR5). The first grid of this valve serves as the oscillator grid, the

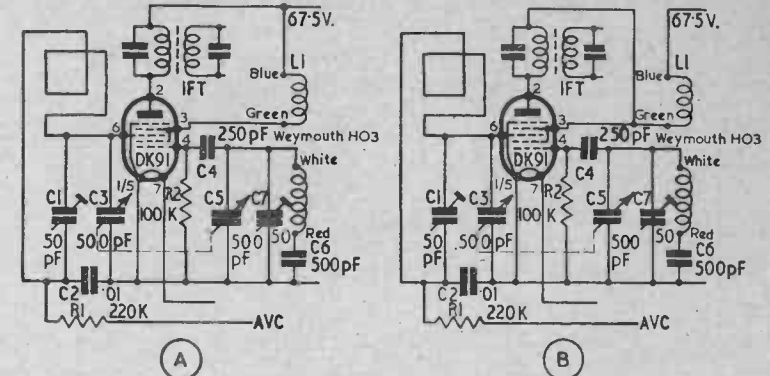

FIG. 15. CONVENTIONAL FREQUENCY CHANGER CIRCUIT, AND AN IMPROVEMENT TO GIVE BETTER OSCILLATION

oscillator "anode" being provided by the second grid, which has a common connection with the fourth grid. The broadcast signal is supplied from the aerial circuit to the third grid, the i.f. output being drawn finally from the anode.

By using an iron cored coil (Weymouth HO3 is recommended) the oscillator section of the frequency changer is made compact and simple to adjust. This coil is very small, the adjusting core making it possible to use a small fixed padder capacitor, padding being done by moving the core position. Most variable padders are rather large for a personal receiver, so the fixed padder, C6, offers a considerable advantage. The function of the padder capacitor is to correct the tuning coverage of the coil as the main tuning capacitor, C3, C5, is rotated, thereby tracking the circuit and maintaining the correct frequency difference between broadcast signal and oscillator carrier.

The value of the oscillator grid leak, R2, is specified as 100,000 ohms for the DK91. (Remember that the oscillator is self-biasing, grid current flowing through R2 to set up the correct grid voltage). This oscillator grid current provides a valuable means of investigating and testing the oscillator performance, if the receiver is working poorly, or not at all. By disconnecting R2 from the earth line and inserting a 0.1 mA meter with the positive terminal taken to earth, the grid current can be measured over the tuning range. The grid current will vary with the h.t. battery voltage; but, on average, using a 67.5 volt battery a grid current of between 150 and 200 microamps (0.15-0.2 mA) is ideal. An inefficient coil for the oscillator may mean difficulty in obtaining such a grid current; or oscillation may actually cease before the tuning capacitor is at full capacitance. In these circumstances the oscillator circuit must be improved before good reception can be obtained. One method of doing so is to increase the h.t. on the oscillator anode; but this cannot be done if it already has its maximum voltage applied. The maximum voltage on the second grid of DK91 must not rise above 67.5 volts; therefore, when a 90 volts battery is used, a series dropping resistor is needed. Another method of improving oscillator performance is shown in Fig. 15(b), where the anode current of the frequency changer valve, as well as the screen and oscillator current, is drawn

through the feedback winding of the coil. The method may not be academically ideal; but it does work, and apparently causes no instability or other bad effects.

When the oscillator fails to work, the likeliest reason is an incorrectly phased winding. A possible remedy is reversing the connections to one of the windings of the coil.

Fig. 16 shows the frequency changer circuit of Fig. 15 expanded to cover medium and long wave tuning. The series coil for long waves is shown as

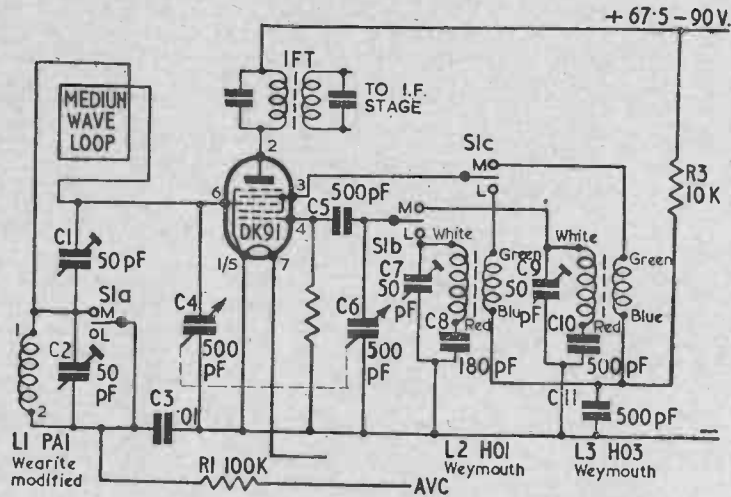

FIG. 16. DOUBLE WAVE-BAND FREQUENCY CHANGER

an air cored type from which turns can be removed for good tracking over the long wave band. The long wave oscillator coil is iron cored, the Weymouth HO1 type being recommended for the reasons previously given.

Unless special precautions are taken DK91 and IR5 operate poorly on the short wave band, and it is difficult to make a conventional short wave coil (such as the Wearite PO3) oscillate efficiently or consistently. For short wave coverage a circuit designed and recommended by Mullards should be used (Fig. 17). It will be seen that the oscillator arrangements for medium and long wave bands are conventional and are as already described; but a single-wound oscillator coil is used for the short waves, the valve becoming an electron-coupled oscillator with a choke in the filament positive lead. A booster coil (L2) is required. The tuning capacitor must be switched to maintain correct connections over the wave bands.

The choke and booster coil can be home-made quite simply. The booster coil should consist of 40 turns of 32 s.w.g. enamelled copper wire close-wound on a half-inch diameter former. An Aladdin former of the type illustrated in Fig. 18 should be used and the winding made at one end. If the turns are carefully put on, the winding length should be approximately a half-inch. The former specified has an iron core and, for the first trials, this should be run completely out of the winding (i.e. to the opposite end of the former). The effect of the booster should be checked by a grid current measurement at the earthed end of R2. The core can then be run into the booster coil if necessary, and adjusted to give the most constant grid current readings, as the tuning capacitor is rotated over the band.

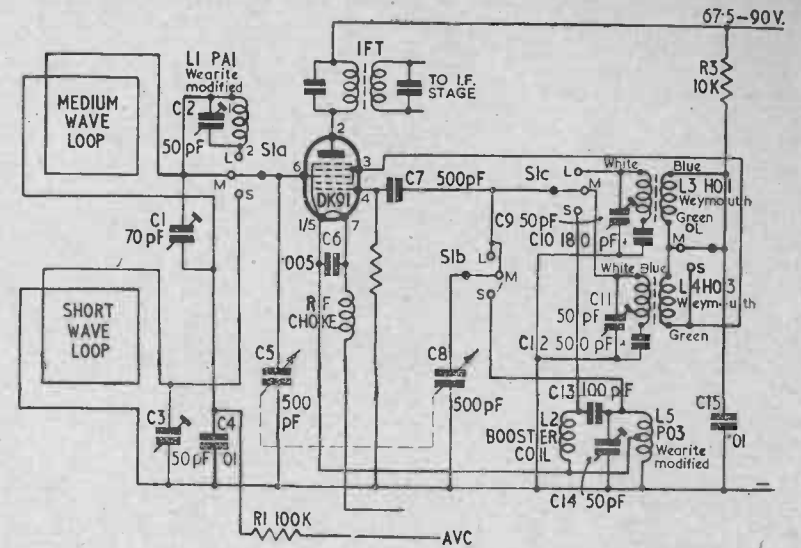

FIG. 17. ALL-WAVE FREQUENCY CHANGER, USING 'DK91

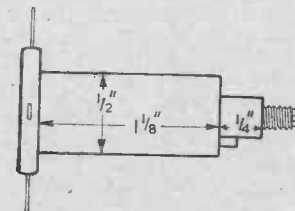

FIG. 18. ALADDIN COIL FORMER FOR BOOSTER COIL AND FILAMENT CHOKE

The filament choke is wound with 26 s.w.g. enamelled copper wire (thinner wire should not be used, as the resistance of the choke must be below 0.5 ohm). The choke may also be wound on a similar Aladdin former, with the iron core completely removed.

Some experiment with the short wave coil itself will be necessary, using as a good starting point a PO3 tapped at the centre turn. The PO3 coil will be found to have a winding with quite a wide spacing between turns, and tappings can easily be made by soldering the lead directly to the appropriate turn of the coil. Use a clean iron with a narrow bit and little solder—a solder gun is best.

Before using the PO3 coil in this circuit it is an advantage to remove the thin wire secondary which will be found towards the bottom of the main coil.

Different tappings along the oscillator coil, and different settings of the booster core, should be tried until the best results are obtained, using the oscillator grid current as a guide.

A new frequency changer valve, the DK92, recently introduced by Mullard, has a considerably improved performance which makes it usable in conventional circuits at frequencies up to 30 mc/s, the only special precaution required at

SUPERHETS: I.F. AND DETECTOR STAGES

NOTWITHSTANDING its simplicity the i.f. stage probably gives more trouble than the rest of the receiver. Frequently it takes the form of instability that is often not obvious, and when traced may not be easy to remedy.

Instability in the i.f. amplifier can range from a tendency to regenerate on signal peaks, which causes distortion on loud passages, to a completely oscillating i.f. stage which blocks the whole receiver. In the latter case the loudspeaker gives no indication of the trouble: the set appears to be "alive": the on-off and wavechange switches click when operated: and altogether a great deal of time can be wasted in looking for faults and poor components in the wrong places.

Such severe instability is generally caused by placing modern high gain i.f. transformers close to one another; even when the transformer screening cans prevent feedback between windings, the external wiring is sufficiently close together to produce regenerative conditions. Tests were made with extra screening between the components themselves, but with little apparent effect. But screening the grid and anode leads can be most beneficial, and in a superhet. exhibiting i.f. instability, the first remedy to be tried should be the complete screening of the grid lead from the secondary of the first i.f. transformer to the i.f. amplifier valve. Transformers such as the Weymouth P4J are strongly recommended for small receivers, because they have all connections brought out at the base, and the B7G based valves are also single-ended without top-cap connections.

When octal-based valves are used in the larger portable receivers, i.f. transformers with flying grid leads should be used, of course. Larger valves necessitate larger chassis and greater spacing between components, so reducing the likelihood of instability.

Insulated screened sleeving should be used to screen i.f. leads, and should cover their entire length, including the connecting pins at the base of the transformer. Also, the sleeving should be carried as near as possible to the grid pin on the valve holder, with only sufficient spacing for good insulation. The screening mesh at each end of the lead should be carefully trimmed, leaving no wires protruding, and then bonded to the nearest earthed point, such as a soldering tag under the valve holder or a transformer fixing bolt. Slight i.f. instability can usually be cured by screening the grid lead, but more stubborn cases may require screening the anode lead to the second i.f. transformer. Transformers will need a slight re-alignment to correct for the effect of extra capacitance of the screening.

Serious i.f. stage instability may at first prove difficult to trace because the whole receiver is blocked. One check is to inject a fairly strong signal into the receiver by coupling a signal generator or external aerial into the loop, and tuning the set over the signal or local station frequency, when a faint whistle will indicate that the i.f. carrier is being heterodyned in the i.f. stage. A further check is to introduce a signal in the same way and to detune one i.f. winding right off its correct frequency; the primary of the second i.f. transformer may be used for this check. Regeneration will probably be heard to stop with a "plop"; but even slight detuning should permit the heterodyne whistle due to the injected signal to be heard.

Several remedies may be tried to cure such serious instability. The grid and anode leads to the i.f. amplifier valve should be screened, and, if convenient, one of the transformers should be rotated through 90° to break down, or at least reduce, any magnetic coupling which might be present. Increasing the spacing between the transformers may help, but may not be simple owing

to the existing chassis layout. Screening the valve may also help, although this has little effect as a rule.

After each experimental change re-align the transformer tuning and check that all windings are on the correct i.f. Another experiment is to increase the intermediate frequency from, say, 465 kc/s to 470 or 475 kc/s. (In coastal locations it is advantageous, in any case, to use a high i.f., to avoid interference from C.W. stations).

The use of one or more of these measures may reduce the instability without curing it entirely, in which case the gain of the whole i.f. stage must be reduced. This can be achieved by reducing the screen grid voltage on the i.f. valve, or by other voltage adjustments. A simple and convenient method is to connect a damping resistor across the secondary of the first i.f. transformer, as shown in Fig. 22. The resistor is connected directly between the transformer output terminals, and not from the grid of the valve to earth, where it would shunt AVC voltages.

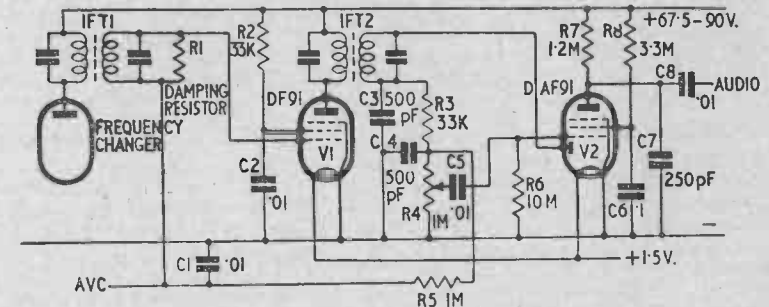

FIG. 22. TYPICAL I.F., DETECTOR AND A.F. AMPLIFIER

The value of the damping resistor must be found by trial, a suitable starting value being 82,000 ohms and a common final value 47,000 ohms. The objective is to use the highest possible value giving good operation, because the shunting effect of the resistor reduces the gain and selectivity of the stage.

It may have been noticed that decoupling of the i.f. stage from the h.t. line has not been mentioned as a remedy for i.f. instability. The reason is that tests have shown that decoupling is not effective. In a rare case it might be found to cure regeneration; but stray couplings between transformer windings, and between external leads, are the more usual cause of instability. Decoupling requires more components in the circuit, one of which, the capacitor, is bulky. In a personal receiver one's aim is to reduce rather than to increase the number of components. Nor is there much space to spare in a modern portable.

A popular method of reducing the number of components is shown in Fig. 23, where the frequency changer oscillator section is fed through a common connection to the i.f. stage screen grid, a single resistor and decoupling capacitor then being used. The main precaution when using this circuit is to ensure that neither the oscillator anode nor the i.f. stage screen is at too high a potential. When a 67.5 volts h.t. battery is used this is impossible, as valves DK91, DK92 and the Mullard DF91 are used in the i.f. stage; but where a 90 volts battery is used the value of the oscillator/screen feed resistor should be checked by Ohm's law. A voltmeter check is often misleading because the valves draw only small currents, and unless a really sensitive meter is used the meter current can swamp the valve screen current. Assume that the screen grid voltage of Fig. 23 is measured with a voltmeter. The current taken by the meter is drawn through the resistor R3 and so increases the voltage drop across it, making the voltage lower than the true voltage with the meter disconnected. (Some may

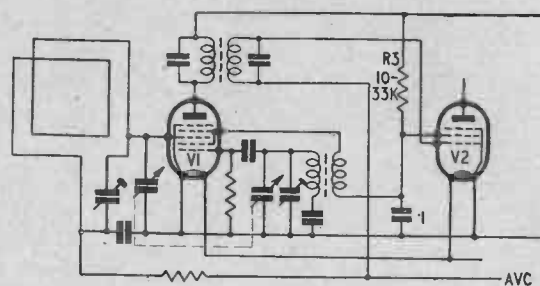

FIG. 23. COMMON OSCILLATOR—I.F. SCREEN FEED

feel that this point has been laboured; but the necessity for emphasising it is demonstrated by correspondence reaching the author, complaining that voltage measurements on personal receivers seem very low). Since common resistor values in the audio stage are as high as 1 megohm for the anode load, and 3.3 megohms for the screen fed resistor, it is clear that voltmeter readings in this stage are meaningless, unless a valve voltmeter is used.

After amplification the i.f. signal is passed to a detector, or demodulator, from which the audio content can be coupled into the final stages of the receiver. In superhet. receivers the detector is almost invariably a diode, which is very conveniently placed within the envelope of the first audio amplifier. An example of such a diode/pentode is the Mullard DAF91 (American equivalent, 1S5).

Fig. 22 shows the circuit for the detector and audio amplifier of a typical superhet. following the i.f. stage, where one side of the second i.f. transformer secondary is taken to the diode anode, the rectified audio signal appearing across the resistor chain R3, R4. In many circuits, especially in personal sets where space is limited, the resistor R3, and its associated capacitor, C4, are omitted, leaving only R4 shunted by C3 in circuit. R3 and C4 form a filter to remove residual i.f. carrier from R4; any residual carrier here would be amplified in the pentode section of V3 and could then cause instability and feedback. These components can be omitted without serious consequences if the anode of the pentode is by-passed. This is done by C7 in Fig. 22. To avoid over-biasing V2, the grid is isolated from the volume control, R4, by capacitor C5, the audio signal then appearing across R6. A common value for R6 is 10 megohms, at which value the valve is correctly self-biasing. Although the current through R6 on positive peaks is very small it maintains a charge on C5, depending on the signal strength, so providing a negative bias for the pentode grid. C5 discharges very slowly through R6 and the charge is maintained by successive positive peaks in the signal.

This form of grid biasing on the audio amplifier is not always used. Various grid circuits and component values will be found in published circuits and commercial receivers. The constructor making a receiver or modifying a design will be wise to experiment with the grid leak of V2 in the circuit of Fig. 22, choosing the value of R6 by trial for the most pleasing results. As a general rule R6 should not be reduced below 2.2 megohms, or increased to more than 20 megohms.

The amplified audio signal is coupled by the capacitor, C8, to the output stage. The voltage output at this capacitor, however, is more than ample for headphone operation, and a small receiver built for only one listener may omit the output stage, coupling high impedance headphones between C8 and earth. Even when an output stage is fitted to the set to feed a normal loudspeaker, it is recommended that alignment be carried out with the output valve removed and headphones inserted between C8 and earth, or clipped across the grid leak

of the output stage. Not only is a faint signal much more readily heard as the set is brought into alignment, but battery consumption is greatly reduced during the tests.

The a.v.c. line, which usually controls the frequency changer and i.f. stage, is also operated from the detector circuit. Good a.v.c. control is desirable in any type of portable receiver because it is often used in areas where some fading is to be experienced. In Fig. 22 the a.v.c. line is shown connected to the junction of R3 and R4. When the filter, R3, is omitted from the circuit the a.v.c. line is connected directly to the i.f. transformer secondary, together with R4.

R5 and C1 form a filter which smoothes out the audio component from the rectified signal producing a d.c. voltage varying with the strength of the i.f. carrier, and depending, of course, on the amplitude of the received broadcast signal. This d.c. voltage is negative to earth, and is used to bias the signal grid of the frequency changer and the control grid of the i.f. stage. As received signal strength rises, so does the bias rise, thus reducing the amplification of these two stages.

C1 in Fig. 22 also serves to complete the i.f. circuit to earth for the secondary of the first i.f. transformer. In many circuits the same capacitor also completes the r.f. circuit to earth for the loop aerial. It is better, however, to isolate the aerial and i.f. transformer circuits by using a resistance of about 100,000 ohms with a separate by-pass capacitor. These components are shown in Fig. 15(a) as C2 and R1.

REFLEX I.F.—A.F. CIRCUITS

The ordinary portable and personal superhet. receivers have six stages contained in four valves, with approximate power consumption of 1.5 volts at 0.25 amp. and 67.5 volts at 10-15 mAs, depending on the valve types. The six stages are: Frequency changer, oscillator, i.f. amplifier, detector, audio amplifier, and output stage. It is clear that both construction and upkeep would be very substantially cut if one or two valves could be omitted, without materially affecting the number of stages in the receiver. A great saving is possible by making the i.f. stage of the reflex type so that it affords both i.f. and audio gain, as well as acting as the detector. By dispensing with the loud-speaker and using headphones it is possible to make a two valve superhet. receiver capable of reception in all areas, which is suitable for the constructor with only slight experience. The circuit of such a receiver is shown in Fig. 24, with constructional details in Fig. 25. The consumption of the original two valve receiver was 1.5 volts at 0.1 amp. and 67.5 volts at 4 mAs, so it was found that by using small l.t. cells and h.t. batteries of the "deaf-aid" type (three 22.5 volt units connected in series) a small and quite cheap long-life h.t. battery was made up.

The receiver was designed for personal use on camping holidays for which it proved ideal as it can be hung from the ridge pole of a tent. When the receiver is suspended the case and headphones serve as the aerial; when placed directly on the ground the case is earthed and the headphone lead acts as the aerial. A large hook of heavy gauge copper wire was fitted to the case of the original receiver which enabled it to be suspended from any convenient point such as wire fences, guy ropes, etc. Provided the headphone lead does not touch the ground the receiver will work satisfactorily whether the point of suspension is earthed or not. The receiver will also operate when being carried in the hand but it should be held a foot or so away from the body. When used in this way an insulating handle is necessary.

Fig. 24 shows that a conventional frequency changer with a normal aerial coil input circuit feeds into the reflex circuit built around a DAF91 diode-pentode. The secondary of the first i.f. transformer is connected to the grid circuit. A damping resistor of 47,000 ohms is usually required across the transformer secondary. The transformer winding is isolated from earth by the resistor R2, by-passed

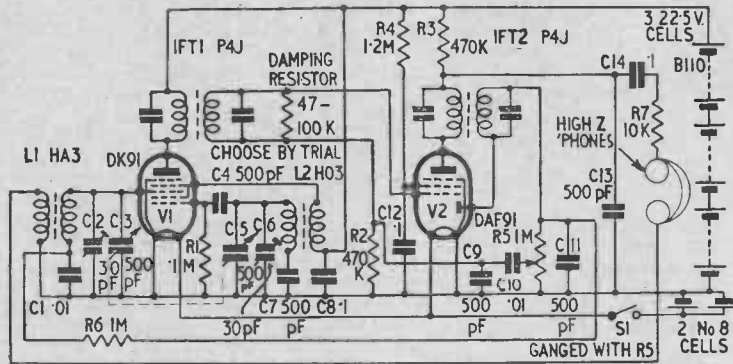

FIG. 24. TWO VALVE REFLEX SUPERHET.

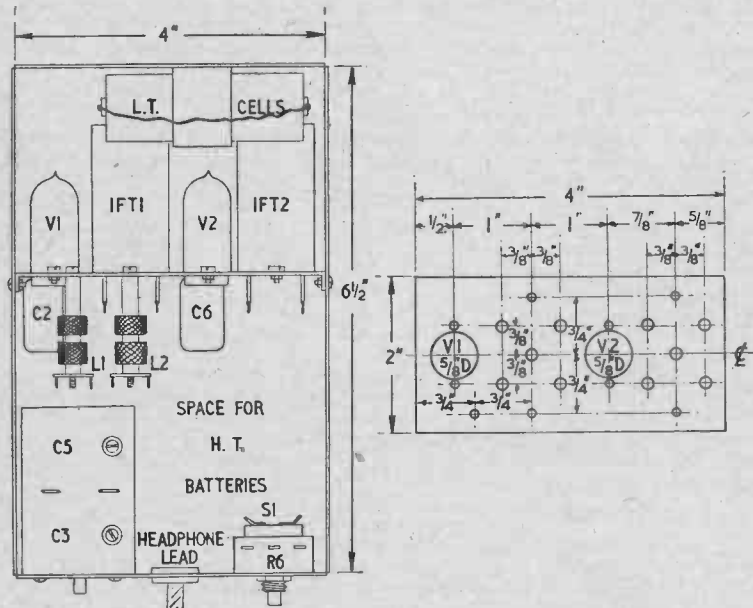

FIG. 25. LAYOUT AND DRILLING FOR THE TWO VALVE REFLEX SUPERHET. OF FIG. 24.

by C9 which provides a path for i.f. signals. A capacitance of more than 500 pfd's must not be used, as audio signals are set up across the resistor.

The pentode section of the valve is arranged and fed as an audio amplifier, although the anode load resistor is separated from the anode of the second i.f. transformer, the junction of the transformer and load resistor, R3, also being by-passed to earth by 500 pfd's. The secondary of the second i.f. transformer is connected in a normal detector circuit to the diode section of V2. Audio signals are set up across the volume control, R5, with a.v.c. voltages

supplied through R6 to the aerial input circuit. In this receiver a.v.c. is not supplied to the i.f. amplifier, as this stage is also the audio amplifier and so must work at fixed gain.

Audio signal from the volume control slider is fed to the pentode grid via the blocking capacitor, C10, to the top of R2, and thus through the secondary of IFT1 to the valve, which draws its amplified output from the junction of IFT2 with R3. High impedance headphones are connected to this point through a blocking capacitor, C14 and R7, the resistor serving to isolate radio frequencies picked up on the headphone leads. The headphones are returned to earth through the coupling coil of L1, r.f. signals picked up on the leads thus being coupled inductively into the frequency changer.

The layout of the original receiver is shown in Fig. 25; this can be adapted to suit any small metal case that may be available. A midget two-gang tuner and midget volume control/on-off switch are mounted on the end of the case, leaving a well large enough to take the three h.t. batteries wired together and compactly held by a binding of adhesive tape, which should cover the soldered battery contacts. The l.t. supply is from two U8 or No. 8 cells in parallel, mounted in a clamp at the upper end of the receiver case with a rubber covered lead soldered to both central brass caps. The negative connection is made directly to the case through the clamp, the cardboard cell cases being removed.

In the prototype, the headphone lead was carried through a rubber grommet between the tuner and volume control and anchored to a small two-way tag board. Direct drive tuning was used. Many stations were received at excellent strength (particularly after dark) and the fitting of a slow motion drive might well be worth while—if the case size allows.

Alignment should be carried out as described in the following chapter. To suit a coastal location near a powerful local station, the i.f. transformers of the prototype were tuned to 470 kc/s, and the coils were trimmed and padded at 250 and 500 metres respectively. When the lid is fitted the added capacitance causes some slight variation to the trimming, which is readily corrected by experimenting with the adjustment of C2.

Little constructional experience is required to make this receiver into an excellent three valve loudspeaker set by adding a normal output stage, fed from C14 in place of the headphones, and replacing the aerial coil input circuit by a tuned loop aerial.

SUPERHET. ALIGNMENT

IT is, of course, usual and advisable to complete the whole receiver before any alignment is attempted. But, as already suggested, the output valve may be removed and the signal heard in the headphones, so it is convenient to describe the alignment procedure now, before passing to a discussion of the output stage.

For quick and successful alignment of a superhet, a signal generator is desirable but not essential, as it is possible to use broadcast signals for the tuning of all stages. The multivibrator could be used for some of the operations; but, because it gives a broad signal with no identifiable standard frequency, it can be misleading. The constructor is advised to retain it for aerial alignment.

Whether a signal generator is being used or broadcast signals, the preliminary step to prepare the superhet, is the same—namely, disconnect the frame or loop aerial and in its place connect a suitable aerial coil, one made to match the oscillator coil in use, if possible. For example, with the Weymouth HO3 medium wave oscillator an HA3 aerial coil is preferred; and an HA1 aerial coil is the best match for an HO1 long wave oscillator coil.

Always start by tuning the i.f. transformers to the selected intermediate frequency (or as near as possible if a signal generator is not being used); then align the medium wave band. Next, remove the temporary aerial coil, and, if a tuned aerial is to be used, match in the loop aerial as in Chapter 1. If the aerial is an untuned loop or plate, the temporary coil is not required as there will already be a suitable aerial coil fitted.

ALIGNMENT ON BROADCAST SIGNALS

When relying on broadcast signals for alignment do not disturb the settings of the adjustable cores of i.f. transformers, as they have been tested by the manufacturer and they will be tuned, or nearly so, to the correct i.f. For a small extra charge some manufacturers will supply pre-aligned components which require only a slight extra trim when the receiver is first tested and aligned.

The tuned circuits of the receiver will be similar to those shown in Fig. 26.

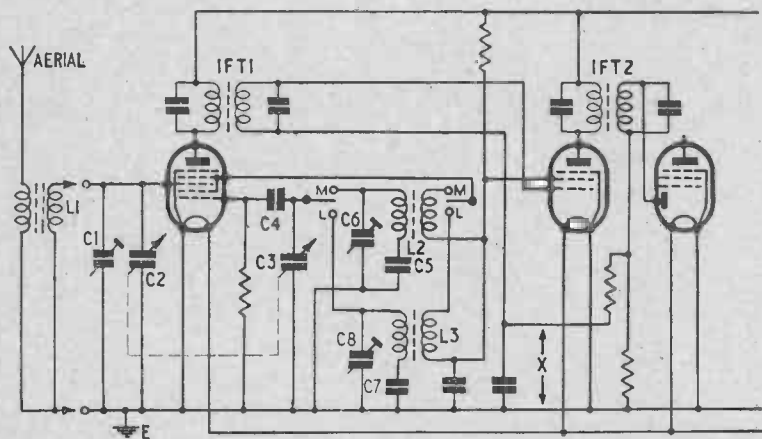

FIG. 26. SUPERHET. ALIGNMENT—THE TUNED CIRCUITS

To commence, connect in the temporary aerial coil, and couple in a good external aerial and earth to provide signals of reasonable strength. Switch the receiver to the medium wave band; set C1 and C6 to about mid capacitance point; and then set the core adjusting screws of L1 and L2 to about half-way point. To obtain the half-way point on either trimmer or core fully turn in the adjusting screw; then, counting the number of turns, run it completely out. At both extreme positions care must be taken not to force the screws—particularly in the case of coils. If these are of the type where the iron dust cores are adjusted directly by means of a slot on the top of the core (as in Osmor or similar types) a screwdriver with a metal shaft should not be used. A proper plastic trimming tool should be used, or a simple trimmer may be made by shaping the end of a plastic knitting needle with a file.

When the trimmers and coil cores are centred, switch on the receiver and endeavour to pick up a signal by tuning around the band with the main tuner, C2, C3. It is advantageous to use headphones as the local station should be tuned in with little difficulty if the i.f. transformers are reasonably near tune. If no signals can be heard, temporarily tap the aerial on to the signal grid of the frequency changer through 100 pfd's, and try again.

If there are still no signals at any tuning point it must be assumed that the i.f. transformers are right off tune, and their cores or trimmers must be centred. When this has been done, retune over the band; if there is still no result alter the cores of the second i.f. transformer a little at a time, until a station is brought in. (Normally, a signal is obtained without this trouble).

When a signal is heard trim the i.f. transformers for greatest volume, commencing with the secondary of IFT2 and working forward to the primary of IFT1. When the signal is brought up to maximum volume short-circuit the a.v.c. line as at X in Fig. 26, and recheck the trimming of the i.f. transformers. Leave the i.f. transformers as set, and do not readjust their cores throughout the following procedures.

Identify the station tuned in—probably the local Home Service—and, if a calibrated dial is fitted, note whether its tuning point on the dial is higher or lower than it should be. If the station is tuning higher (*i.e.* towards the high wave-length end), screw in C6 and retune until the tuning point is approximately correct. If the station is tuning lower, slacken off C6 and retune C2, C3 until the point is approximately correct. C1 should then be trimmed for best volume.

It should now be possible to receive the Light Programme on 247 metres at reasonable strength. Tune in this station and repeat the procedure just described, trimming with C6 until the correct point is reached on the dial. Again, trim C1 for best volume.

Now tune up the dial until an identifiable high wave-length station can be received—the North Home Service on 434 metres is suitable. The signal will most probably be found off its proper tuning point. To correct this adjust the core of L2, at the same time “rocking” C2, C3. By “rocking” is meant slightly turning the main tuner first one way and then the other so that at each movement it tunes through the signal, thus allowing the exact tuning point to be easily recognised. When the correct position on the dial has been reached return to the Light Programme which will no longer be received at the correct dial reading; so C6 must be readjusted to bring it in at the 247 metres position.

Retune of the 434 metres signal, or to that selected on the high wave-length of the dial. The variation of C6 will have upset the high wave-length tuning and, to bring it to the correct point on the dial, adjust the core of L2 and rock the main tuner.

Continue to trim with C6 and the core of L2 alternately until both the selected “marker” stations are received at proper dial settings. The medium wave band is then in alignment, and it is only necessary to make a final adjustment to the aerial coil if it is a permanent fixture, or to match in the loop aerial as in Chapter 1. If the aerial coil is to be left in circuit and the receiver is to

operate with an untuned loop or similar aerial, disconnect the external aerial and connect in the one to be used. Trim C1 on the Light Programme and, if a cored coil is used for L1, adjust the core on the signal used during the trimming of the oscillator, the 434 metres Home Programme, for instance. Again, make one operation after the other, continuing until both are correct at once. In these operations, of course, the adjustments are judged by volume and not by dial settings, the object being to obtain good reception at both ends of the tuning range.

To align the long wave band, switch the receiver to the long waves and connect a long wave coil in the frequency changer grid circuit. This coil will be switched in automatically if an untuned aerial is to be used with the receiver.

The original aerial circuit trimmer, C1, will be used to trim the loop aerial, so, for the long wave alignment, this capacitor (which must not have its setting disturbed) will be left connected across the loop aerial when the loop is temporarily disconnected, and the long wave coil connected in its place. A new trimmer must be placed across the long wave aerial coil; this, also, will be referred to as C1 in the following instructions.

Couple in a good external aerial and earth, just as for the medium wave alignment, and centralise C1 (or the permanent long wave aerial trimmer if a permanent aerial coil is fitted); also centralise C8 and the core of the long wave oscillator coil L3. The i.f. transformers must not be touched. Tune in the Light Programme and bring its tuning point to the correct dial setting of 1,500 metres, by adjusting C8 and the core of L3, trimming C1 if necessary to maintain volume. If the Czechoslovakia signal at 1,103 metres can be picked up, trim C8 on this programme, and the core of L3 on the Light Programme, trimming each until both stations are received at their correct tuning points on the dial.

If a permanent aerial coil is fitted, trim it on the Czechoslovakia signal and adjust the core on the Light Programme until both stations are at the best possible volume. If a loop aerial and series coil are used, the loop will already have been brought into alignment: adjust the series coil as described in Chapter 1.

Finally, remove the short-circuit across the a.v.c. line and test the receiver thoroughly over both wave-bands. A final check may be given to the i.f. transformers provided that only very slight adjustments are made.

The foregoing refers to receivers with a calibrated tuning scale. If a scale is not fitted some reference points must be made to which the main tuning control can be repeatedly set during the trimming operations.

Glue or pin a plain card scale under the tuning pointer, the card having a pencilled arc over which the pointer swings, with the ends of the pointer travel marked. Along this arc roughly measure a distance corresponding to about one-seventh of a full rotation of the pointer, and mark the distance with a dot; this may be taken as the tuning point to which the Light Programme may be brought by trimming. From the opposite end of the arc, measure off roughly two-sevenths of a full rotation and mark the position; this will indicate the point at which the North Home Programme should be received when correctly tuned. The blank scale can be calibrated with station names when alignment has been completed. In personal receivers where space is limited it is sometimes more convenient to mark the tuning positions of the major medium wave stations in dots of one colour, and the long wave tuning positions in another.

ALIGNMENT BY SIGNAL GENERATOR

To align a portable superhet, commence, as previously, by substituting a suitable medium wave coil for the loop aerial, unless a coil aerial circuit is already fitted. Short out the a.v.c. line as at X in Fig. 26, and couple the signal generator output lead direct to the signal grid of the frequency changer VI, i.e. on pin 6 of either DK91 or DK92. Take the earth lead of the signal generator to point E in Fig. 26 (a direct physical earth connection is not needed). Switch the receiver to the medium wave range and set the main tuner to about half capacitance. Switch on both generator and receiver and tune the former to the selected i.f.—generally 465 kc/s, or a little higher for a coastal location.

Unless the i.f. transformers are badly off tune, at least a faint signal should be heard; but it should be a simple matter to bring the signal through. Turn up the generator output to the full position and tune the secondary of IFT2 until the signal is found. Tune the primary of IFT2 to peak up the signal, then turn down the generator output control to the lowest point that will give clear audibility. Tune both windings of IFT1 to peak up the signal to the best possible volume, and reduce generator output as the transformers come into line. Finally, give a last trim to all windings, working from the secondary of IFT2 back to the primary of IFT1. The i.f. transformers are then set and their adjustments must not be touched again.

Transfer the signal generator output lead from the grid of V1 to the aerial terminal in Fig. 26 to give normal signal injection into the tuned circuit, and tune the generator to 250 metres (1,200 kc/s). If a calibrated scale has been fitted the pointer should be set at this reading; mark a plain card as before if a scale has not been fitted. Tune the generator signal to the correct dial reading by adjusting C6; if required use a high output at first, and reduce it as much as possible. With C6 adjusted, trim C1 for maximum volume.

Now tune the generator to 500 metres (600 kc/s) and bring the signal to the correct point on the scale by adjusting the core of L2 while rocking the main tuner. If a plain card is fitted the correct tuning point for 500 metres (assuming a tuning range of 200-250 metres) will be about one-seventh of the full arc from the high wave-length end.

Retune the receiver and the generator to 250 metres and retrim C6 which will now be off setting; retune to 500 metres and readjust the core of L2. Continue to trim these alternately until one adjustment makes no difference to the setting of the other. The medium wave range is then correctly adjusted.

Where a loop aerial is to be used it should now be connected in place of the temporary aerial coil and aligned with the oscillator, as in Chapter 1.

When the loop aerial is correctly set up, disconnect it and its trimmer and, without disturbing the aerial turns or the trimmer setting, place on one side. Substitute a temporary long wave aerial coil and trimmer, which is again referred to as C1 in Fig. 26.

Switch the receiver to the long wave band, tune the generator to 1,000 metres (300 kc/s), and find the signal on the receiver. By adjusting the long wave oscillator coil trimmer, C8, bring the signal to the correct point on the dial, increasing the value of C8 if the signal reading is high, and *vice versa*. Trim C1 for best volume.

If a calibrated scale is not fitted draw a new arc on a blank card and divide it into twelfths over the sweep of the tuning pointer. The 1,000 metres point (assuming a normal long wave range of 800-2,000 metres) is about two-twelfths of the arc from the 800 metres end.

Now tune the generator to 1,750 metres (171.4 kc/s) and, while gently rocking the main tuner, bring the signal to the correct tuning point on the scale by adjusting the core of L3. If the scale is not calibrated the correct point is about midway between the nine- and ten-twelfths divisions of the full arc.

Retune the generator and the receiver to 1,000 metres and retrim C8 which will now be out of tune; then retrim at 1,750 metres. Continue trimming alternately until one adjustment has no effect on the other. The long wave oscillator coil is then correctly aligned.

Next, align the long wave aerial circuit, adjusting the coil in series with the loop aerial for this type of circuit. No adjustment is necessary to an untuned aerial with normal aerial coils. Adjust the series coil as in Chapter 1. The short across the a.v.c. circuit is then removed, and the receiver tested on signals in the normal way, the aerial trimmers being given a final touch on weak signals at the low wave-length ends of the tuning bands.

CONSTRUCTING A SIMPLE SIGNAL GENERATOR

Many constructors, while fully appreciating the advantages in possessing a signal generator, are unable to afford such a relatively expensive instrument,

and they are chary of constructing a unit which often seems difficult to screen, to make stable, and to calibrate. It is reasonable to be cautious about constructing a generator of standard type: considerable experience is required to make results worth while; but there is no difficulty at all in making a simple oscillator such as that shown in Fig. 27.

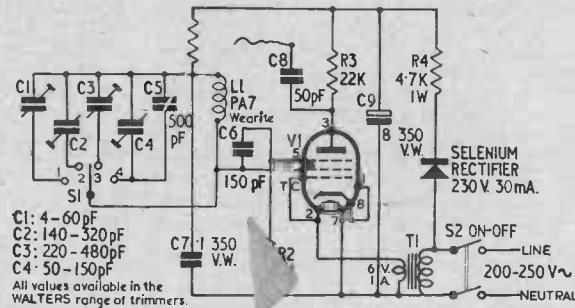

FIG. 27. A SIMPLE SIGNAL GENERATOR. V1 CAN BE EF50, SP61, 6J7, EF36, OR SIMILAR TYPE VALVE

The circuit operates as a transitron oscillator with the tuned circuit between the screen and suppressor grids of a simple r.f. pentode. If a variable capacitor were used it would need to be insulated from earth; preset tuning is recommended for this unit, with four semi-variable capacitors switched across the single coil. These capacitors are so adjusted that the switch gives frequencies of: 1,200 kc/s (250 metres); 600 kc/s (500 metres); 465 or 470 kc/s i.f.; and 300 kc/s (1,000 metres) across the switch points 1 to 4.

Almost any r.f. pentode may be used for the valve. The value of C6 may be increased if oscillation is poor. The valve actually used was an old 6J7, and good results were obtained with an EF37. The h.t. voltage is far from critical, and there is no reason why the oscillator should not be included on the multivibrator chassis and powered from the same source.

The carrier is modulated by a hum signal, the grid being returned to the "live" side of the heater instead of directly to earth. This saves an extra valve, and is just as useful as any other modulation frequency for testing battery operated receivers. It would not be so suitable for testing mains operated receivers, as cancellation or addition effects, with hum sources in the receiver itself, might give spurious results. If the oscillator is to be used for mains operated receivers as well, a single valve modulation oscillator working at about 400 c/s could be added with the signal injected into the grid of the h.f. oscillator, instead of returning it to the "live" heater.

To save expense no attenuator or output control is fitted. (In any case it would be valueless unless the oscillator is fully screened). Simple unscreened construction is used; direct connection between the oscillator and the receiver under test is not necessary, unless the set is so far out of alignment that a very strong input is required. Usually it is sufficient to drape the output on or beside the frame aerial, or the aerial coil of the receiver. The output lead should be kept short to avoid possible interference with neighbouring receivers, and, for the same reason, the oscillator should be switched off when not in use.

To calibrate the oscillator it is necessary to compare it with broadcast signals, using a good superhet. receiver as an indicator. Switch on the receiver and the oscillator; place the output lead fairly close to the receiver aerial: if the oscillator signal swamps the receiver move the output lead farther away.

Tune the receiver to the medium Light Programme and by careful inspection of the scale, ensure that the signal is being heard at the correct point for 247

metres. If the scale reading is high or low, estimate the necessary allowance and set the receiver to 250 metres. Switch the oscillator to position 1 and adjust C1 until the hum signal is tuned correctly by the receiver. The output from the oscillator is then on 250 metres (1,200 kc/s) fairly accurately—quite sufficient for portable receiver alignment.

Tune the receiver to 500 metres, checking the accuracy of the scale reading against nearby stations. A choice of signals for this purpose is provided by the Third Programme on 464 metres; Athlone on 530 metres; Lyons on 498 metres; and Sundsvall on 506 metres. Allow for any discrepancy and tune the receiver as near as possible to 500 metres; switch the generator to position 2, and tune in the hum modulated carrier, using C2. The two medium wave check points are then set up.

The third frequency can be adjusted by reference to the intermediate frequency of the receiver. Leave the receiver switched to the medium wave band; tune the oscillator switched to position 3, and vary C3 until the hum modulated carrier is heard. By tuning the receiver, check that the carrier is not tuned to the medium wave setting. If the carrier is on the i.f., rotating the main tuner of the receiver will only make the hum slowly increase or diminish in strength; the signal will tune out and in sharply if it is set to the medium wave tuning point of the receiver. Another check is to switch to the long waves and, if the oscillator is correctly tuned to the receiver's i.f., the signal will still be heard, though possibly at a different strength.

This method of setting up the 465 kc/s tuning point on the oscillator assumes that the receiver in use is fairly modern and that it has a 465 kc/s intermediate frequency. However, very few receivers are found (apart from communications receivers) which have i.f.'s widely different from 465 kc/s, and the final frequency of the oscillator is not of great importance provided it is in the correct range.

Before setting up the 300 kc/s tuning point on the oscillator, the receiver must be checked for accuracy on the long wave band. In many reception areas this is a less simple matter, and the nearest check points provided by broadcast stations are: Minsk on 1,068 metres; and Czechoslovakia on 1,103 metres. Set the receiver as near as possible to 1,000 metres; switch the oscillator to position 4 and, adjusting C4, bring in the hum signal, which will be found to tune rather broadly.

The oscillator can now supply fixed frequencies on the medium wave band at 250 and 500 metres; an i.f. signal; and one trimming frequency on the long wave band. The tuned circuit cannot be made to embrace a lower frequency for a second long wave trimming point without switching in a different coil. However, the long wave Light Programme can be used quite conveniently as a long wave check frequency. When adjusting a receiver over this wave band an aerial should be coupled into the first tuned circuit, and the oscillator loosely coupled to the aerial. Long wave trimming is carried out at 1,000 metres on the hum signal, and at 1,500 metres on the Light Programme. Fig. 27 shows the correct way of connecting the unit to the mains supply; do not connect the oscillator chassis to the receiver or to earth.

Chapter 6 THE OUTPUT STAGE

AFTER the coupling capacitor there is nothing to distinguish between the output stages of a superhet. and a t.r.f. receiver, so this chapter applies equally to either type.

Because it consumes by far the greatest amount of power from the batteries, the output stage should receive as much attention in the portable or personal receiver as any other stage; yet often it is fitted and forgotten, though it may be working indifferently. Frequently, even in commercial receivers, tone is distorted as soon as reasonable output is achieved. Sometimes the volume of sound is poor, even taking into consideration that the ordinary valve does give no more than 200-250 milliwatts.

If good efficiency is to be realised, a really fine quality loudspeaker must be obtained, when possible using a 5" model at least. In personal receivers a 2½"—or at best a 3"—speaker is the largest possible; of course, only reputable makes should be used. In low level reproduction the difference between good and indifferent speaker sensitivities will be equivalent to reducing the power output by at least half.

Even a good speaker will not give best results if the voice coil is not correctly matched into the anode circuit. Small transformers can be used, as the standing d.c. through the primary is relatively small, and the core is not likely to be saturated; but the matching ratio must be correct if output is not to suffer in volume or distortion. Perhaps the latter is of even greater importance in a circuit where harmonic distortion is already rather high. For example, the DL92 has a total distortion rating of 13% for an output of 235 milliwatts; the DL94 is better with a rating of 7% for an output of 270 milliwatts.

Oscillographic inspection shows that the deterioration of tone noted with some personal receivers is due almost entirely to harmonic distortion. The oscillograms shown in Fig. 28 are the results of experiments made under various conditions of feed, transformer matching and power supply. Harmonic

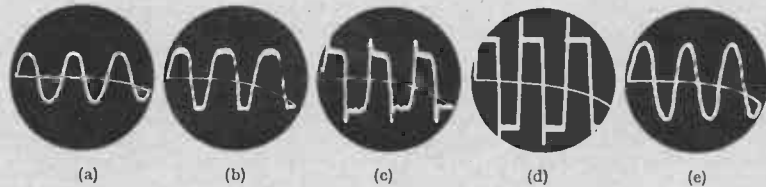

FIG. 28. OSCILLOGRAMS OF TYPICAL OUTPUT STAGE WAVEFORM

- (a) Sine wave input, and output at low medium levels.
- (b) Output advanced.
- (c) Output further advanced.
- (d) Full output.
- (e) Conditions of (c) with negative feedback added.

distortion of this type cannot be improved by bias adjustment (as some constructors appear to think). As a rule the output from the audio amplifying stage is remarkably pure, and it is safe to say that (in personal portables at least) the weakest link is the B7G type of output valve. There is, therefore, much to be said for the inclusion of a larger 1.4 volts filament valve where space allows.

The main cause of trouble when using the small output valve would appear to be the reluctance on the part of the user to set the volume control correctly. The ear is accustomed to the far greater outputs from normal mains receivers,

and too much is demanded from the small valve. Consequently, the volume control is fully advanced under practically all conditions. This results in considerable overloading on strong signals, and it should be realised that the control must be held back on the more powerful stations.

However, many constructors are more concerned with the possibility of economising on battery consumption in the output stage. This is especially so in personal portables where the small layer-type h.t. batteries are hardly suited to supply 10 mAs, and upwards; also where a fairly small l.t. cell has to supply 0.1 amp. to the output valve alone. One way to economise is to use only one side of the output valve filament. The majority of small output valves have double filaments which are normally connected in parallel for 1.4 volts battery operation. By supplying only one side of the filament the consumption of l.t. and h.t. is halved, and the output is almost halved. This will not give a corresponding reduction of volume detectable by the ear; when the input power to a loudspeaker is halved the impression is that volume has dropped by about one-fifth. In addition to being economical this method of feed may be regarded as extending the life of the valve; when emission from one half drops, the other half may be brought into operation. This, however, does not apply when the working half breaks, as the broken half will almost inevitably short across other electrodes.

Different matching ratios are required in the output transformer when half-filament operation is employed. With a DL92 the speaker must be matched into a load of 12,000 ohms instead of the usual 8,000 ohms for normal operation, necessitating a higher transformer ratio (approximately 64 : 1 for a 3 ohms speech coil). The constructor may have a microphone transformer which will serve as a suitable output transformer.

Connections to the output valve for half-filament operation are the same as for normal working, except for the link between pins 1 and 7, which parallels the two halves of the filament. This link is omitted and the positive filament feed is taken to either pin 1 or 7. The negative feed, as usual, is taken to pin 5. Slightly less grid bias is required; but, in view of the fact that the h.t. current is less, the normal bias resistor must be increased. The resistor should be of the order of 680 ohms for a DL92 with 67.5 volts h.t. supply and a typical superhet. circuit.

Another way of economising on the output stage is shown in Fig. 29 where an r.f. pentode is in a circuit suitable for loudspeaker operation. Filament

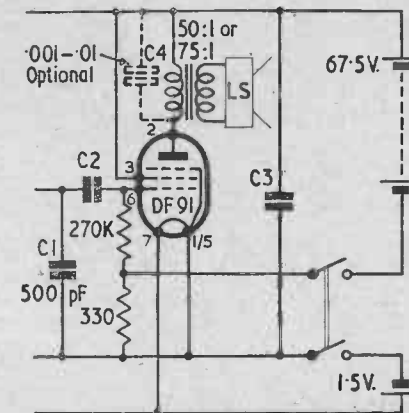

FIG. 29. AN ECONOMY OUTPUT STAGE

consumption is halved, and the h.t. consumption is reduced by about 30 per cent. If a good loudspeaker is used and is carefully matched to the valve, the sound output is only a little less than that of an ordinary output stage. A requirement of the circuit is that a fairly low grid leak should be used. For a normal four valve superhet. circuit the value of the leak should be 270,000 ohms and that for the bias resistor 330 ohms. As it might be expected, the stage is rather easily overloaded; but this can be prevented, and operation improved, by the provision of negative feedback, which will be described later.

The output transformer ratio must depend on the speaker used and a rather higher ratio is required; here, also, a small microphone transformer might be tried. An oscilloscope provides an excellent method of checking the matching of any speaker to any output stage. The input to the oscilloscope is taken direct from the speaker speech coil terminals and different transformer ratios tried.

A constant sine wave or square wave (which is preferable) input is applied to the grid of the output valve. Both amplitude or transient response and distortion can be seen clearly, and the optimum ratio of the output transformer can be chosen with exactitude. (For sine wave and square wave testing see *The Oscilloscope Book*, from the same publishers).

Two simple methods are available to relieve distortion in all types of output stage, including existing receivers where it is not desired to change the valve type, or make extensive alterations. One is to reduce the value of the coupling capacitor between the first audio amplifier and the grid of the output stage to 0.001 mfd, or even 500 pfd. This often cleans up the tone of a distorting receiver. Naturally, there is a slight drop in volume, because the presence of distortion indicates there is more input to the final stage than it can handle. The second method is to apply negative feedback and, as only a single resistor need be added, the improvement can be carried out on the most compact personal portable. The resistor, of a value of 1 or 2 megohms, is connected between the anodes of the audio amplifier and output stages, as shown in Fig. 30.

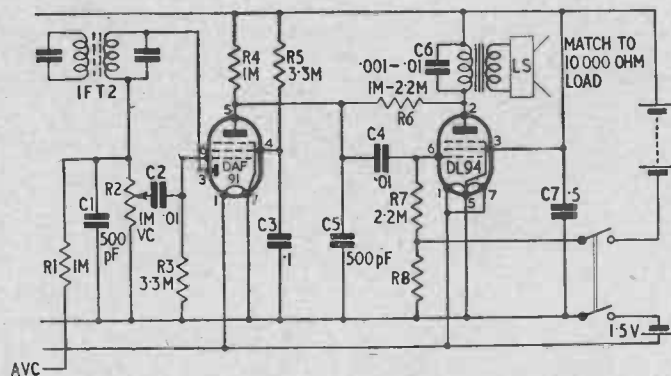

FIG. 30. COMPLETE AUDIO SECTION, WITH NEGATIVE FEEDBACK

A difficulty often encountered in the design of a portable receiver is adequate amplification for weak signals without producing distortion on strong local signals.

A particularly acute instance of this is in all-wave portables where several of the short wave signals will be received at far lower levels than those over the medium wave band. Short wave signals need all the amplification possible throughout the receiver, including a sensitive output stage; on the other hand

local signals would overload such an output stage. To resolve the difficulty a sensitive output valve (e.g. Mullard DL94) may be used, and negative feedback applied to it over the medium and long wave bands only. A three-pole three-way switch to handle the wave change circuits is used in the all-wave frequency changer circuit of Fig. 19. It is just as simple to fit a four-pole three-way switch. The fourth pole brings negative feedback into play on the medium and long wave ranges, and breaks the connection between the feedback resistor and one of the anodes in Fig. 30 on the short wave switch position.

BATTERY BY-PASSING

Throughout the diagrams of both t.r.f. and superhet. circuits the value of the capacitor by-passing the positive h.t. line to earth (e.g. C13 of Fig. 9 and C7 of Fig. 30) is shown as 0.5 mfd. Experiment shows that, apparently, this capacitance is adequate; but, should instability arise in a receiver as the h.t. battery ages, it may be necessary to increase it.

A 150 volt working 8 mfd electrolytic capacitor takes up little more space, and may be substituted for the 0.5 mfd paper type if necessary.

A.C./D.C./BATTERY POWER SUPPLIES

RECEIVERS designed for alternative power supplies, known variously as A.C./D.C./BATTERY, THREE-WAY or ABC receivers, are now commonly available commercially among portable receivers, and mains units for supplying personal portables are also very widely obtainable both complete and in kit form. Judging from many letters received by the author, however, the basic requirements of these circuits are still not understood at all clearly by some home constructors.

Fig. 31 shows a basic receiver, with supply connections suitable for mains

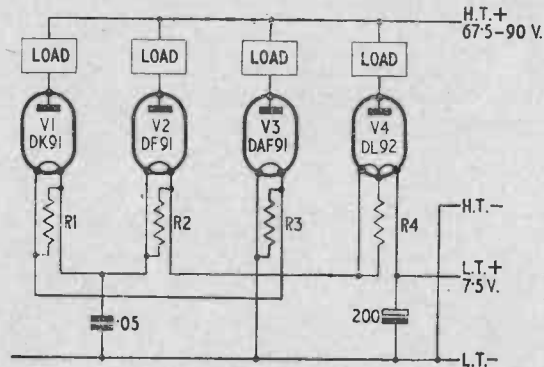

FIG. 31. TYPICAL SERIES FILAMENT CHAIN

or battery, and it will be immediately apparent that the filament circuit involves the greatest rearrangement. Deriving an h.t. supply of 67.5 to 90 volts at 10 to 15 mA from any mains supply is a simple matter; but obtaining a filament supply is more difficult to arrange. Two methods of connecting the filaments are possible. The first, with all filaments in parallel, is ideal for battery operation because only a low voltage is needed, and the current required can be delivered from a single cell of good capacity. However, parallel operation from a mains source is awkward without a transformer. In a.c. operation only, a transformer can be used to supply the 1.4 volts at 250 mA called for by the average four valve receiver; but if this has to be supplied from d.c. mains through a dropper resistor the high current will result in unnecessary power dissipation, requiring very high wattage resistors and presenting the problem of ventilation.

This disadvantage is overcome by the second method in which all filaments are connected in series; but some fresh problems are set. In the normal four valve receiver the filament chain, including an output valve with a centre-tapped 3 volts filament, requires 50 mA at 7.5 volts when series connected; so battery operation is still a simple matter—a 7.5 volts battery being used. The relatively low current demand permits the use of smaller cells, and the battery need be little larger than a high capacity 1.5 volts cell. For mains operation the voltage drop from a 230 volts line is almost equal to the drop required for the operation of a 1.5 volts line; but the current is only one-fifth of that formerly considered, with consequent saving in resistor power ratings and dissipated heat.

When filaments are connected in series there are several items for consideration. The filament chain carries the h.t. current as well as the l.t. current; therefore, without some form of compensation, this extra current will overrun

some of the filaments. When 1.4 volts filaments are operated from a mains source the voltage drop across each 1.4 volts section should have a value of 1.3 volts nominally, and the voltage should be maintained between 1.25 and 1.4 volts at normal line voltages. To observe this, and to obtain correct operation, it is often necessary to shunt some or all of the filament, or filament sections. Generally, the value of these shunts is of the order of 200 ohms, and the best method of adjusting them for correct working is to take a selection of 20% tolerance 180, 220 and 330 ohms resistors, placing various resistance values across the filaments. Check the voltage drop across each until the whole chain is supplied correctly, measuring voltages with a reliable voltmeter. These tests should be carried out, of course, using a fresh 7.5 volts battery, the mains dropper afterwards being adjusted to give 7.5 volts across the chain. Obviously the receiver must be working fully with the normal h.t. voltage supplied during the test.

The sequence of filament connections is important as each filament, or section, will be 1.4 volts more positive to earth than that preceding it, and so will bias its valve relative to the earth line. This also means that if the output valve is made the last in the chain its filament at the centre point will be 6 volts positive to earth, which is practically correct operating conditions for a DL92 without any other provision for supplying bias. In an experimental receiver using the connections as in Fig. 31, the necessary shunting resistors (all $\frac{1}{2}$ watt rating) were found to be: R1, 180 ohms; R2, 220 ohms; R3, 120 ohms; and R4, 330 ohms.

A rather different filament arrangement is shown in Fig. 32, which is used

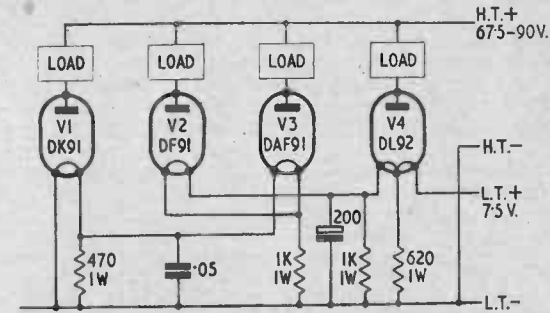

FIG. 32. TYPICAL AMERICAN SERIES FILAMENT CHAIN

in several commercial receivers, especially those of American origin. Individual filament shunting is replaced by what may be called "group" shunting; but again the voltage drop across each filament, or section, should be checked by a good voltmeter, and corrected if necessary. It will be noted that the frequency changer, in this case, has one side of its filament earthed, the detector/audio amplifier stage being next in the chain. This lifts the detector filament above earth and the a.v.c. is, therefore, delayed by about 1.5 volts. Grid bias for the output valve is still derived from the voltage drop across the filament chain. It will be noted, also, that in this circuit the smoothing capacitor across the filament chain is the other side of the output valve.

This essential capacitor needs placing with some care in circuits where the receiver can be switched from battery to mains supplies. A capacitance of some hundreds of microfarads is required to provide a really smooth supply to the filaments after rectification; and, since the working voltage need be little higher than that of the filament chain (7.5 volts), it must never be in a position where it is connected across a higher potential source. Should the mains unit

be accidentally switched on when the set is running from batteries, the filament supply voltage will rise almost to the mains voltage without the filament load; so a low voltage capacitor left connected across the mains filament supply would be ruined.

If the capacitor were to be of a high working voltage to prevent this, it would then charge up to a high potential if the mains unit was accidentally switched on, and could discharge through the filament chain with consequent filament ruptures. Leaving the capacitor connected direct across the filament chain, as in Figs 31 and 32, offers the simplest solution. Even this, however, can be improved upon in view of the fact that high capacitance/low voltage components are liable to show some leakage, which would act as a slight, but unnecessary, additional drain on the l.t. battery during battery operation. It is not generally possible, in a switched receiver, to spare a switch bank to couple in the filament smoothing capacitor on mains operation; but where a separate mains unit is used, as in personal receivers, the receiver plug can usually be so arranged that two of the pins act as a "jumper," or link, to connect in the capacitor only when the receiver and the mains unit are coupled together. In these circumstances both filaments and capacitor are protected; accidental connection to the mains will have no deleterious effects, provided there are suitable capacitor ratings in the high voltage circuits.

There is an important point in connection with using the mains unit on both a.c. and d.c. supplies. The normal mains unit uses a selenium half-wave rectifier; from a 230 volts a.c. line this will supply a d.c. potential of more than 230 volts. On no load the output from the rectifier and reservoir capacitor will be almost 320 volts, and, even when the load is imposed on the power pack, the voltage supplied from the circuit will be as great as, or greater than, the input voltage (r.m.s.). On d.c. mains, however, the rectifier merely acts as a resistance, so the output from the rectifier and reservoir capacitor is, inevitably, rather less than the input voltage. Clearly, some method of compensation is necessary to make the output from the power pack substantially equal when either a.c. or d.c. inputs are used; for, without such compensation, the filament chain will be underrun or overrun in some supply conditions. Compensation can be made by placing resistance between the output side of the rectifier and the reservoir capacitor. This will affect the efficiency of the rectifier and will limit the peak voltage to which the reservoir can charge; thus the effect of the resistance will be greater on a.c. operation than on d.c.

Fig. 33 shows a mains supply unit suitable for both a.c. and d.c. The

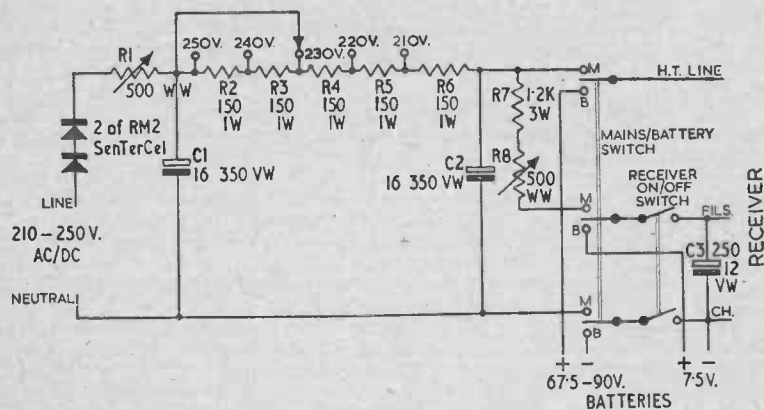

FIG. 33. THE A.C./D.C. MAINS UNIT

rectifier should be rated to carry 80 mA at 250 volts, the most convenient arrangement being to use two SenTerCel RM2 units in series. (The smaller units, RM1, should not be used, as they will be overloaded). Avoid using too small a reservoir capacitor as this will be carrying a fairly heavy ripple current. A capacitor rated at 100 mAs a.c. is recommended.

In order that the unit may be adjusted to all operating conditions the a.c. compensating resistor is a 500 ohms wire wound rheostat, which feeds into the reservoir capacitor. Different supply voltages are dealt with following this circuit by providing a set of tappings for the usual range of 210 to 250 volts, after which the main smoothing/h.t. dropping resistor is connected, feeding into the smoothing capacitor. An output voltage of approximately 80 volts at 15 mAs may be drawn from this point.

The filament supply, drawn through a further resistance chain, must, finally, depend not only on the filament current but, also, on the h.t. current drawn by the receiver. Therefore, it is thought advisable to allow for some adjustment by including a variable and a fixed resistor in the chain. Before the unit is connected to a receiver the variable controls must be set as closely as possible by feeding the unit into fixed loads. An accurate 150 ohms 1 watt resistor should be connected across the filament supply terminals, and a resistance equal to the h.t. load of the receiver should be connected across the h.t. terminals.

The h.t. load of the receiver may be found by measuring the current drawn by it from an h.t. battery of known voltage. For instance, if the receiver requires a current of 15 mA at 90 volts, the equivalent resistance would be 6,000 ohms, 2 watts. As current will vary non-linearly with voltage, the method is not exact; but it is sufficiently so for preliminary settings.

When the two load resistors are connected to the unit the mains voltage tapping should be chosen to suit the supply. If both a.c. and d.c. are available R1 should be set to give an equal voltage reading across C2 for either input, and, if necessary, the mains voltage adjustment should be corrected for each input. Generally, both a.c. and d.c. mains will not be available, so it is necessary to simulate a d.c. supply by drawing 230 volts or so from a suitable power pack, using a circuit based on that in Fig. 34. When doing so it will be most

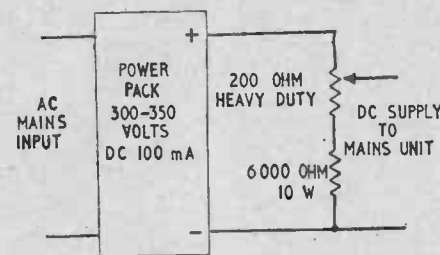

FIG. 34. HOW TO OBTAIN A D.C. SUPPLY TO ADJUST THE UNIT

convenient to set the d.c. input at a voltage equal to the a.c. mains r.m.s. input, so that the same mains voltage tapping will serve for both supply conditions.

With a set voltage across C2 for either a.c. or d.c. inputs the voltmeter should be connected across the 150 ohms load, representing the filament chain. The filament smoothing capacitor also should be connected across the load. The 500 ohms resistor, R8, is now adjusted to give exactly 7.5 volts across the 150 ohms load; if a milliammeter is available the current should also be checked at 50 mAs.

If components are varied from the specifications in Fig. 33 it is possible that the output from the power unit will be lower than that expected for an

a.c. input. Indeed, under some conditions it would be possible for the output from a.c. mains to be lower than that from a d.c. source. In these circumstances, for an a.c. input, the output volts can be increased by reducing the setting of resistor R1.

When the two variables, R1 and R8, are set using the resistor loads, the unit may be connected to the receiver. It is important to remember that the filament supply must never be used without the h.t. being connected also. Recheck the filament voltage and current under working conditions, inserting the millimeter in the positive 7.5 volts line. Finally, check the voltage drop across each filament as described. (It is understood that this, and the adjustment of the filament voltages, have already been done; but a second check under mains operating conditions is a prudent precaution).

When the mains unit is required to operate from a.c. only, it is possible to modify the circuit of Fig. 33 for more economical construction by omitting the reservoir capacitor; the output from the rectifier will then fall to practically half the input voltage. A fairly low resistance choke (200-400 ohms) is necessary. The final output voltage depends on the rectifier characteristic, so it is necessary to make careful checks across resistance loads, in the way previously given, before connecting the unit to a receiver. If the choke reduces the final h.t. too much a small reservoir capacitor (of about 0.5 mfd.) connected directly between the rectifier output terminal and earth will give a voltage rise sufficient to offset this. Fig. 35 gives the circuit of the power pack for a.c. operation only, with series connected filaments.

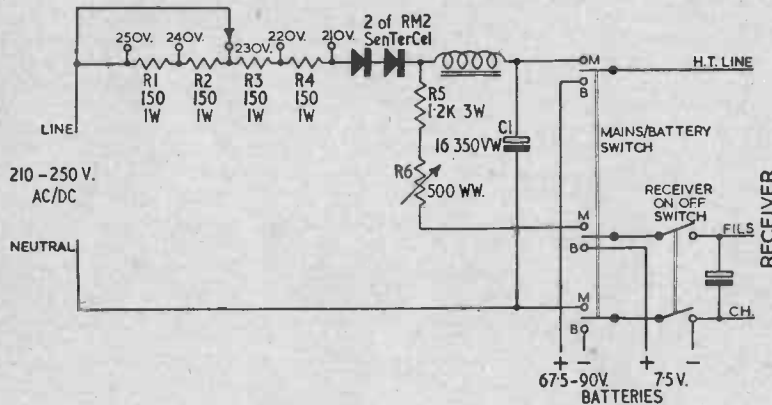

FIG. 35. AN A.C. MAINS UNIT FOR SERIES FILAMENT OPERATION

The same type of circuit can also be used with parallel filament connections if the h.t. is supplied from a small transformer. This component could be specially wound to deliver the correct 1.4 volts at 250 mAs after rectification, but the constructor may perhaps prefer to use one of the small heater transformers freely obtainable at present, together with a small bridge rectifier of the 6V. $\frac{1}{2}$ amp. variety. Filament voltage control is effected by a semi-variable resistor. A heavy duty component with a tapping band is more suitable in this circuit than a rheostat or potentiometer. A Bulgin P.R.147 4 watt 25 ohms wire wound resistor, ordered with tapping band, is ideal. This is only 1" long and so it is easily fitted into a small unit. The circuit of this type of a.c. power is shown in Fig. 36.

Compensation for mains voltage variations in this unit is made by connect-

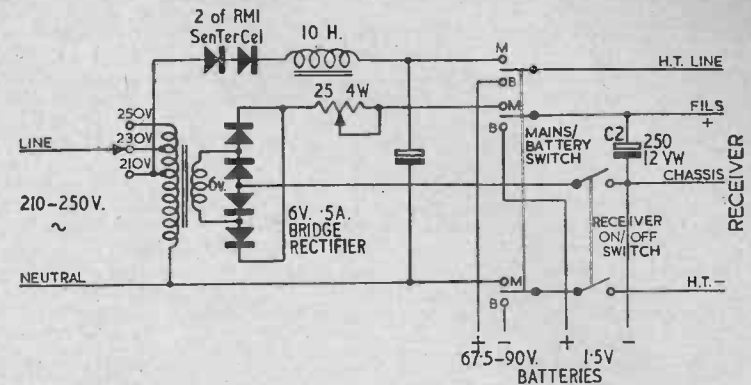

FIG. 36. AN A.C. MAINS UNIT FOR PARALLEL FILAMENT OPERATION

ing the rectifiers (which can now be SenTerCel RM1 types) to the 210 volts tap on the transformer (assuming it has a tapped primary). The output h.t. voltage may readily be adjusted in this circuit by using different tapings on the transformer primary, in addition to the resistance adjustments already described.

The adjustment of the filament voltage output from the unit must be carried out as carefully as in the other power supplies. First trials should be across a resistance load, using a 5 ohms 1 watt component (made up of two accurate 10 ohms resistors in parallel), and adjusting the voltage across this resistance to 1.25 volts. This will give a safe working setting and the unit may be connected across the filament line of the receiver, adjusted finally to give 1.4 volts across the line.

It must be mentioned that the values quoted are for a normal four valve receiver with a parallel-connected output valve. Output valves with provision for series/parallel filament connection give slightly larger output with parallel connection, so this is the best arrangement to use when a.c. supply only has to be used. For other filament arrangements corresponding changes will be needed in the series dropping and test load resistors.

It is safe to connect the transformer unit into the filament line without connecting up the h.t. supply, as no variation in filament voltage is caused by h.t. current. There is no internal connection between h.t. and h.t. in the unit and, because biasing is not automatic with parallel connected filaments, a bias resistor must still be included in the output stage of the receiver. The filament supply smoothing capacitor should still be connected across the filament line on the filament side of the on-off switch. Although it cannot charge to a voltage higher than 6 volts or so in this circuit, nevertheless this would still be a dangerous voltage on discharge of the capacitor across the filament line, should the unit be accidentally switched on with no load connected.

FILAMENT BY-PASSING

When filaments are connected in a series chain there is always a possibility of feedback from stage to stage through the filament wiring. Should such instability arise it can be checked by capacitors connected as the 0.05 mfd. component shown in Figs. 31 and 32, the number and connections of the capacitors being found by trial.

CAUTION

All the power packs shown connect the receiver directly to the mains supply. The usual precautions for A.C./D.C. receivers are essential, in particular the mains unit must always be connected up as indicated in the diagrams.

IN NO CIRCUMSTANCES MUST THE RECEIVER BE DIRECTLY CONNECTED TO EARTH WHEN IT IS DRAWING POWER FROM A MAINS UNIT. If an earth connection seems desirable it must be made through 0.01 mfd. using a 1,000 v.w. component; but a separate earth is not usually required as the receiver chassis is already earthed through the mains neutral or earth line.

If an external aerial is connected to the receiver this must also be isolated by a 1,000 v.w. 0.01 mfd. capacitor.

Battery economy may be effected by supplying the receiver from a mains unit during the alignment processes (in which case, obviously, the output valve must be left in circuit); but it must be remembered that this will give misleading results on the final tests. When the receiver is aligned switch over to battery operation for the final aerial alignments and reception tests, because the mains unit provides another signal input to the receiver. This input will be absent when the receiver is used in its true portable applications, and it should be adjusted for best results under the more arduous conditions.

INDEX

| | | | |
|--------------------------|----------------|-----------------------------|----------------|
| A.C./D.C. EQUALISATION | 56 | HEADPHONE LEAD AERIAL | 41 |
| ADJUSTING | | INSTABILITY | 26, 29, 31, 38 |
| Oscillator | 33 | LOCAL RECEPTION | 26, 27, 29 |
| Supply unit | 57 | LOOP AERIALS | 15 |
| AERIAL | | Low impedance | 17 |
| Alignment | 18 | MAINS UNITS | 54 |
| Coupling | 14 | MULTIVIBRATOR | 21 |
| Headphone lead | 41 | NEGATIVE FEEDBACK | 52 |
| Loop | 15 | OSCILLATOR | |
| Plate | 13 | Adjustment | 33 |
| Positioning | 16 | Padding | 33 |
| Sling | 14 | Short wave | 34 |
| Winding data | 17 | PLATE AERIAL | 13 |
| ALIGNMENT | | PULLING | 37 |
| Aerial | 18 | REACTION PHASING | 29, 34 |
| Dial settings | 19 | RECEPTION | |
| Short waves | 25 | All area | 41 |
| Superhet. | 44 | Local | 26, 27, 29 |
| Using multivibrator | 21 | REFLEX CIRCUITS | 29, 41 |
| ALL AREA RECEPTION | 41 | R.F. FILTERING | 27, 41 |
| AUTOMATIC VOLUME CONTROL | 41 | ROCKING | 45 |
| BATTERY | | SCREENED LEADS | 38 |
| Decoupling | 53 | SELF BIASING | 40 |
| Economy | 30, 41, 50, 60 | SERIES FILAMENT OPERATION | 54 |
| BEGINNERS' DESIGNS | 26, 27, 41 | SHORT WAVE | |
| BLOCKING | 38 | Alignment | 25 |
| BURN-OUT OF FILAMENTS | 55 | Oscillator | 34 |
| CHOICE OF I.F. | 43 | SIGNAL GENERATOR | 48 |
| DAMPING RESISTORS | 39 | SUPERHET. | |
| DIAL SETTING ALIGNMENT | 19 | Alignment | 44 |
| DISTORTION | 50 | Tracking | 23 |
| ECONOMY | 30, 41, 50, 60 | SUPPLY UNIT ADJUSTMENT | 57 |
| FRAME CONSTRUCTION | 15 | TRANSITRON SIGNAL GENERATOR | 48 |
| FILAMENT | | VOLTAGE MEASUREMENTS | 39 |
| Burn-out | 55 | VOLUME SETTING | 50 |
| Decoupling | 56, 59 | | |
| Series operation | 54 | | |

FROM THE SAME PUBLISHERS

Audio Handbooks

A new series specially written by N. H. CROWHURST, A.M.I.E.E.

No. 1. AMPLIFIERS. 64 pages. Demy 8vo. 3/6

The scope and purpose of this book is admirably expressed in a review in *ELECTRONIC ENGINEERING*. "This book is neither a theoretical treatise on the design of amplifiers, nor yet a constructional manual. It is, in fact, intended as a guide to 'trouble shooting' for the constructor who has built an amplifier, but then finds it doesn't work. To this end a TROUBLE TRACING GUIDE has been included which refers the reader to the appropriate chapter in the book. In the various chapters the most common causes of trouble (e.g., Distortion, Instability and Intermodulation, etc.) are dealt with in some detail, and sufficient basic theory is given to enable the constructor to locate the trouble and apply an intelligent remedy."

With 38 diagrams drawn by the Author.

No. 2. FEEDBACK. 64 pages. Demy 8vo. 3/6

An essentially practical work, explaining clearly what feedback can do, where and how, and what its limitations are. The theory of closed loops is presented in a simple form, progressively developed without involved mathematics.

There are design charts, developed specially for this book, which use a new and simplified approach to the problem. Examples are given, illustrating the practical application to actual circuits, and showing how the methods can be applied to a wide range of problems and circuits.

With 40 diagrams drawn by the Author.

Titles to follow in this series are: AUDIO TRANSFORMERS: THEIR USE and THEIR DESIGN; PUBLIC ADDRESS; and THE QUEST FOR QUALITY.

Television Faults

by N. STEVENS

72 pages and supplement. Demy 8vo. 5/-

Containing a quick reference fault guide giving more than 60 faults, with test procedure. Probable faults in all sections of the receiver are explained in detail and are arranged in logical sequence. Diagrams of the various sections are included, together with fault tables to aid quick location.

There are 31 illustrations including half-tones showing typical defects in picture with designation of faults responsible.

The supplement comprises circuit diagrams and specifications of the following British televisions: BAIRD "EVERYMAN," ENGLISH ELECTRIC, MARCONIPHONE, MURPHY, PHILIPS PROJECTION and ULTRA.

The Oscilloscope Book

by E. N. BRADLEY

88 pages. Demy 8vo. 5/-

Full constructional details of a comprehensive but inexpensive oscilloscope, together with several auxiliary units: Timebase, wobulator, a.f. generator, square wave unit—some or all of which may be built as required by any home constructor. An explanation is given of a wide range of tests using this (or any other) oscilloscope, with complete instructions for setting up, aided by copious illustrations, of typical circuits for testing; of the traces obtained under correct operation, and with various faults. An explanation is also given of the use of the oscilloscope for precision calibration of an a.f. generator, illustrated with a complete set of necessary traces. There are instructions for aligning both A.M. and F.M. receivers. The circuit diagram of the complete instrument measures 15 ins. by 8 ins.; and there are 43 other illustrations.

Television Receiver Practice

by ROY HOLLAND

(Chief Development Engineer, Scophony-Baird Ltd.)

80 pages. Demy 8vo. 5/-

This book is devoted to practical descriptions of the circuit techniques in current use, and covers the following: Power Supplies; Cathode Ray Tubes and Associated Circuits; Timebase Oscillators; Electromagnetic Deflection; Signal Amplifier Circuits; Detectors and Video Amplifiers; and Separation of the Synchronising Pulses. The majority of the 80 illustrations are circuit diagrams with explanatory waveforms and typical component values. Operation is explained in non-mathematical terms easily followed by any reader familiar with the elementary principles of radio.

Magnetic Recording

by M. L. QUARTERMAINE

72 pages. Demy 8vo. 4/6

This deals with theory, construction and use of both types, including variety of design to suit applications individually desired.

Commencing with a simplified explanation of the functions of h.f. bias in providing high quality recording, this is applied to the practical aspects of adjustment and setting up an actual recorder for the various recording materials available. It gives mechanical details of construction and layout, including fabrication of heads that can be undertaken by any experimenter, and layout to secure smooth and stable operation, free from hum pick-up; and details of electrical design, amplifier, oscillator switching, control arrangements and correction. The book is copiously illustrated with over 70 drawings.

Radiocharts

In a permanent folder.

2/6 each

A new series of constructional charts which will cover a wide field in radio and electronic equipment. Each issue is a tested design of high performance based upon the latest engineering practice.

No. 1. A MODERN SUPERHETERODYNE FOR A.C.-D.C. MAINS

Using four of the latest B8A valves and embodying modern circuit technique this receiver is capable of excellent performance. Designed for use with A.C.-D.C. supplies and covering 200-500 metres, the receiver will provide a small and attractive installation.

No. 2. A HIGH-FIDELITY PUSH-PULL AMPLIFIER FOR A.C. OPERATION

With radio and pickup inputs, and with a comprehensive tone control circuit incorporated. Up to 14 db of negative feedback may be applied, improving both stability and frequency response, while power supplies are available for an external tuning unit.

No. 3. A T.R.F. TUNING UNIT and A SUPERHETERODYNE TUNING UNIT

The first is a 2-valve unit comprising an R.F. stage followed by an infinite impedance detector. The second is a variable-selectivity unit with a novel system of bandwidth control. These were specially designed for use with RADIOCHART No. 2; but they can also be used with similar high-fidelity audio equipment.

