

# MODEL RADIO-CONTROL

ARD L. SAFFORD, Jr.

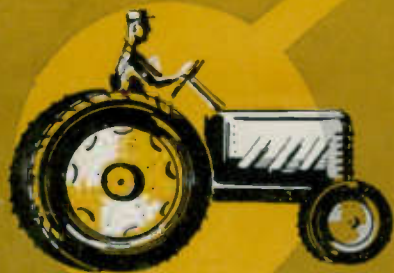

\$2.65



GERNSBACK LIBRARY BOOK NO. 74

3

1871  
1872  
1873  
1874  
1875  
1876  
1877  
1878  
1879  
1880  
1881  
1882  
1883  
1884  
1885  
1886  
1887  
1888  
1889  
1890  
1891  
1892  
1893  
1894  
1895  
1896  
1897  
1898  
1899  
1900

1901  
1902  
1903  
1904  
1905  
1906  
1907  
1908  
1909  
1910  
1911  
1912  
1913  
1914  
1915  
1916  
1917  
1918  
1919  
1920  
1921  
1922  
1923  
1924  
1925  
1926  
1927  
1928  
1929  
1930  
1931  
1932  
1933  
1934  
1935  
1936  
1937  
1938  
1939  
1940  
1941  
1942  
1943  
1944  
1945  
1946  
1947  
1948  
1949  
1950  
1951  
1952  
1953  
1954  
1955  
1956  
1957  
1958  
1959  
1960  
1961  
1962  
1963  
1964  
1965  
1966  
1967  
1968  
1969  
1970  
1971  
1972  
1973  
1974  
1975  
1976  
1977  
1978  
1979  
1980  
1981  
1982  
1983  
1984  
1985  
1986  
1987  
1988  
1989  
1990  
1991  
1992  
1993  
1994  
1995  
1996  
1997  
1998  
1999  
2000



*model  
radio-  
control*

edward l. safford, jr.

instructor, guided missile electronics  
fort bliss, texas

GERNSBACK LIBRARY, INC.

NEW YORK, N. Y. 10011

First Printing—May, 1959  
Second Printing—October, 1959  
Third Printing—July, 1960  
Fourth Printing—June, 1962  
Fifth Printing—May, 1964  
Sixth Printing—February, 1966



© 1959 Gernsback Library, Inc.  
All rights reserved under Universal  
International, and Pan-American  
Copyright Conventions.

Library of Congress Catalog Card No. 57-9011

# contents

## Model Radio-Control

<b>Chapter 1 . . . . .</b>	<b>Basic Concepts . . . . .</b>	<b>5</b>
	Eliminating the wires. Coding. Decoding. How many channels? Slow and quick control. Commercial equipment.	
<b>Chapter 2 . . . . .</b>	<b>Coding and Coders . . . . .</b>	<b>13</b>
	Pulse codes. Numerical pulse sequences. Pulse width variations—spacing constant. Pulse spacing variations—width constant. Pulse sequences (pulse-presence—pulse omission). Pulse-rate variations. Pulse amplitudes.	
<b>Chapter 3 . . . . .</b>	<b>Transmission . . . . .</b>	<b>21</b>
	Radio transmission. Sound-wave transmission. Light-beam transmission. Infra-red wave transmission. Wired transmission. Radio transmitters. Performance indicators. Crystal oscillator. Self-excited oscillator. Amplifier stage. Transmitter keying. Tone oscillators. Methods of modulation. Transmitting antennas. Field-strength indicators.	
<b>Chapter 4 . . . . .</b>	<b>Receivers . . . . .</b>	<b>31</b>
	Superregenerative receiver. Relay stage. Receiver antennas. Batteries. Relays.	
<b>Chapter 5 . . . . .</b>	<b>Decoders . . . . .</b>	<b>41</b>
	Resonant relays and resonant reeds. Single relays. Polarized relays. Delay relays. Relays as amplitude detectors. Relay chains. Steppers. Motor-driven commutators. Bandpass filters. Band-rejection filters. Broad bandpass filters. Discriminators. Separate receivers. Delay lines and coincidence circuits. Generation of microsecond pulses. Counting circuits. Amplitude-detecting circuits. Gating circuits. Pulse-rate discriminators.	
<b>Chapter 6 . . . . .</b>	<b>Power Control Circuits . . . . .</b>	<b>71</b>
	Latching relays. Reversing relays. Babcock speed control and reversing relay. Electronic power control. Resonant reed and relay power control unit.	
<b>Chapter 7 . . . . .</b>	<b>Servo Motors . . . . .</b>	<b>79</b>
	Limit switches. Neutralizing switches. Commercial servo motors. Proportional control. Pulse-width—pulse-space control. True proportional control. Simultaneous proportional control.	
<b>Chapter 8 . . . . .</b>	<b>Transistors . . . . .</b>	<b>89</b>
	Fundamentals. Transistor relay stages. Transistor audio stages. Transistor oscillator circuits. Miscellaneous transistor circuits. Transistor receivers.	
<b>Chapter 9 . . . . .</b>	<b>Practical Receivers . . . . .</b>	<b>105</b>
	Construction hints. One-tube receivers. Hard-tube receivers for 27.255 or 50—54 mc. Two-tube receivers. Voltage doublers, triplers and quadruplers. Three-tube tone-operated receivers. Four-tube tone receivers.	
<b>Chapter 10 . . . . .</b>	<b>Practical Transmitters . . . . .</b>	<b>131</b>
	Checking frequency. Checking transmitter antennas. Unmodulated transmitters. Tone transmitters.	
<b>Chapter 11 . . . . .</b>	<b>Construction of Coders and Decoders . . . . .</b>	<b>155</b>
	Simple escapements. Additional functions for the simple escapement. The Babcock super-compound escapement. Eight-position escapement. Homing type escapement switch. Escapement-controlled steerable tail wheel. Coders for use with escapements. A motorless beep box. Motor-driven coders. Pulse-width—space-space and pulse-rate decoders. Pulse-width—space-rate coder. Second-function control. Decoder for fixed pulse width. Resonant-reed decoder. Numerical-sequence coder and decoder.	

# introduction

**T**HIS book, a complete revision of a previous work first published in 1951, reflects the multitude of new ideas and concepts which have developed since that time. It still retains the basic information of the first edition.

An effort has been made to start at the very beginning, to show what is required to obtain radio control and to present this information in simple everyday language and terms.

This is followed by a discussion of the basic theory and methods of conveying intelligence, a general discussion of the elements in a control system and then a detailed discussion of the various types of receivers, transmitters and complete systems.

It is suggested that you browse through this volume carefully, noting the various items and concepts covered in each chapter. Many questions which might arise from a study of one section may be answered either earlier or later in the pages of the text. It is also suggested that you pay particular attention to the methods of construction of any of the circuits. All too often the cause of malfunction is hasty construction or improper layout of equipment. Neatness, good mechanical and electrical connections, proper adjustment and patience in making the proper connections will result in a piece of equipment of which you can be justly proud.

The author wishes to express his sincere appreciation to those readers whose acceptance of the first book made this revision possible. It is hoped that you will also find this second work worth while. The author is indebted to the following manufacturers, publishers and individuals who have allowed their material to be used in this volume: Aero Modeler; Babcock Radio, Inc.; CG Electronics Corp.; Electronic Model Engineering; Essco Co.; Walter Goode; Vernon C. Macnabb Co.; Minimac; *Model Airplane News*; *Popular Electronics*; *QST*; Ra-Con Mfg. Co.; *Radio & TV News*; RADIO-ELECTRONICS.

Last, but certainly not least, let me express my appreciation to some who worked behind the scenes in the preparation of this book. To Thelma, Eddie and Thomas, thanks! Your faith and spirit make all things possible.

E. L. SAFFORD, JR.

# basic concepts

**I**N this chapter we will begin at the beginning and as we progress we will build a radio-control system, item by item. We will learn why each component is necessary and where it fits into the overall scheme of operation. We will also examine some terms and definitions used in radio control.

The basic idea behind radio control is to send a command or series of commands from a control point to the model being con-

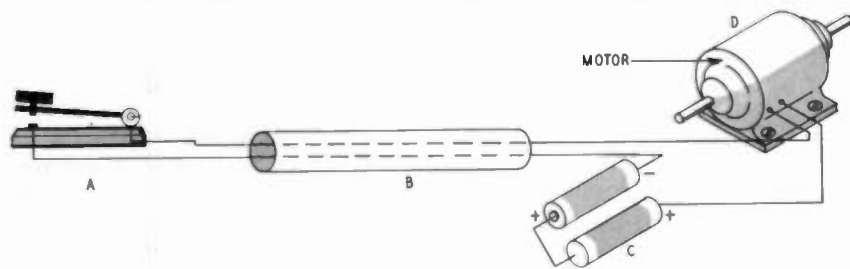

Fig. 101. A basic system to control simple motor functions.

trolled and to have the model follow the commands exactly as directed. The person sending the commands will be referred to as the controller.

Suppose a controller wants to start and stop an electric motor located some distance away. Fig. 101 shows that four items are necessary: a switch the controller may turn off and on (A); connecting wires that link switch, motor and battery (B); a battery which causes the motor to run when the switch is closed (C); the motor itself (D). The control operation is simple: when the switch is closed, the motor turns in one direction. When the switch is opened, the motor stops.

## Eliminating the wires

Assume it is still desired to make the motor run, but now the problem is to eliminate the wires (B) and substitute a radio link to furnish the connection between controller and motor. Fig. 102 shows the solution as far as the receiving end is concerned. Note that the motor, battery and switch are now in the output circuit of a receiver. The switch has changed its physical form and has become a device known as a relay. A relay functions as a switch but, instead of being physically closed by the controller, it is made to close by having an electric current pass through a coil. When the current stops, a small spring causes the relay to open, opening the circuit. This relay is generally an integral part of the radio receiver.

The radio receiver needs batteries for its operation and to supply current to magnetize the relay coil, thus operating the relay. Two

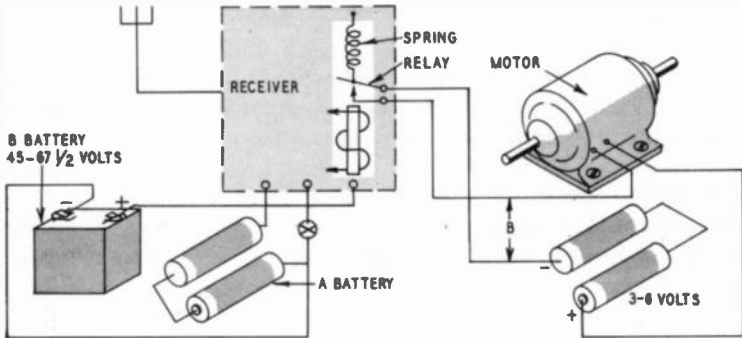

Fig. 102. Components needed to provide radio control of the motor.

types are needed; an A battery (generally flashlight cells) which supplies filament current and a B battery which has a higher voltage (22.5 to 67.5). The B battery furnishes the power for the tubes and the relay. Small electric motors operated by flashlight cells are commonly used. This fulfills the battery requirements at the receiving end of the control system.

What has happened at the control point? A glance at Fig. 103 will reveal that the controller still has the same control switch (A) used when the motor was wire-connected. Now, however, instead of interrupting the flow of current to the motor itself, this switch controls the flow of current from a battery to a radio transmitter. The transmitter uses the same types of batteries as the receiver, but these are generally much larger and of the heavy-duty kind. The transmitter may also use a power supply similar to that of a car radio. The controller's switch interrupts the B-supply only.

When the controller closes the switch, the transmitter sends out a signal which is picked up by the receiver in the model. The receiver



then closes its relay, letting current flow to the motor. When the controller opens the switch, the signal stops, the relay opens and the motor stops. Radio control has been achieved to the extent of starting and stopping the motor.

### Coding

Some means must be used to make the motor move a rudder or steering wheel right, left and straight ahead (neutral) in response to particular commands. It is desirable to do this with the single-channel<sup>1</sup> system described thus far instead of a more elaborate multi-channel system.

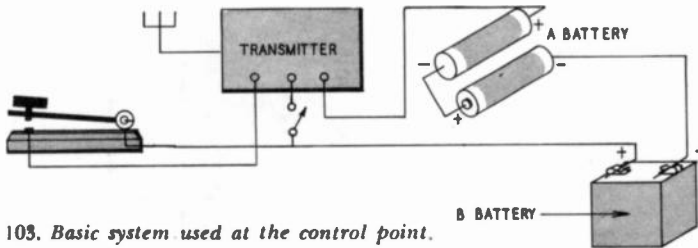

Fig. 103. Basic system used at the control point.

Fig. 104 illustrates two types of multichannel groups. Combinations of two multichannel systems are possible and feasible and are sometimes used in elaborate control systems.

Now back to the basic system. Examination of switch A shows that it can do only two things: turn the transmitter on and turn it off. This can be repeated as many times as desired. Let us consider this OFF-ON operation in groups and we have a clue as to how our commands may be stated in code.

Signal OFF—always neutral  
Signal ON and hold—always left  
Signal ON-OFF-ON and hold—always right

When a transmitter is turned on and off quickly, it is said to have sent a *pulse*. If the transmitter is always on but a tone is sent over it for a short period, this is also considered as a pulse. Three pulses,

<sup>1</sup>A channel is the route a command takes going through a receiver or the route the signals take in going from the controller to the controlled object (motor). If one receiver is used and it sends all commands to one relay switch, the system is called single-channel. If, however, one receiver is used but the individual commands are separated in the receiver and sent to individual relays, it is a multichannel system. If more than one receiver is used, one for each command, it is also a multichannel system. Generally, a multichannel system is denoted by the number of relays operated in response to commands: two relays, two-channel; three relays, three-channel; etc.

either carrier or tone would be ON-OFF-ON-OFF-ON-OFF in quick succession.

Now that we have defined our commands it is necessary to do something to the motor so that it will know how to interpret them. The motor must also be connected to the steering element in such a manner that the mechanical operation of steering will be performed.

### Decoding

It is possible to arrange a set of contacts around the motor shaft and wire the motor through these contacts to the relay so that the motor is able to interpret or decode the commands. See Fig. 105. Before examining the operation, note the fiber disc and the shafts

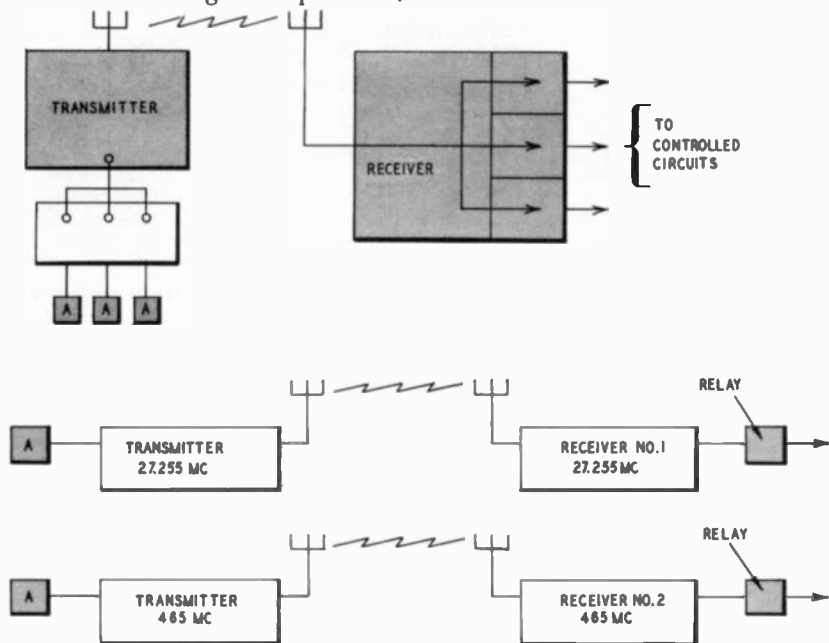

Fig. 104. In elaborate systems several control channels are often used.

N (neutral), R (right) and L (left). In the neutral position shown, shaft N is depressing contact switch 2, opening its connection to D. This shaft does not open switch 1 since this switch is not as high as switch 2 and N is nearer to the center of the fiber disc than L or R. Notice also how the mechanical output of the motor, the rotation of the fiber disc, is coupled to the control surface through yoke Z. As the disc turns, the yoke loop will be moved left and right from the neutral position causing the elevator to move up and down.

Assume that signal ON and HOLD is transmitted. The armature for the relay is pulled down to make contact with G. This lets power

flow from the motor battery through the relay to B of switch 1. At this moment, B is in contact with A and so the power goes to one lead of the motor. Since the other motor lead is directly connected to the opposite side of the battery, the motor begins to run, turning the fiber disc in a clockwise direction. It will continue to run until shaft R opens switch 1, breaking the circuit. At this point, loop Z has been moved to the right and, through the linkage, the elevator is moved to the full down position. As long as the signal is held

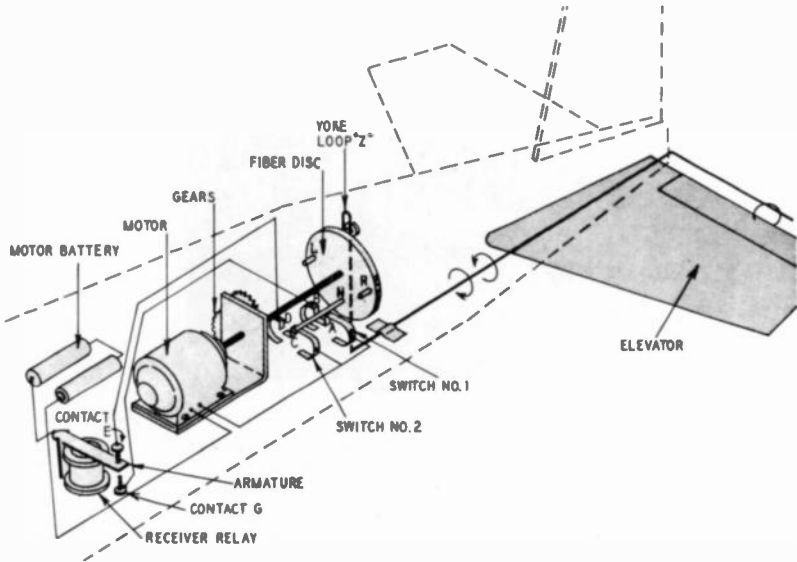

Fig. 105. Using a motor as a decoder and power unit.

ON, the steering element will be thus deflected; but since the circuit to the motor is open, the motor consumes no power from its battery. This is an important consideration in operation over long periods of time.

Now assume that the signal for neutral is sent. According to the code set up, this simply means that no signal at all is transmitted. The relay armature is pulled up by the spring opening the circuit to G, but closing the circuit to E. The battery is now connected to the motor through switch 2 and so the motor runs again. It will continue to turn the fiber disc until shaft N again opens the circuit by opening switch 2. In this position, the loop Z and the elevator are again at neutral.

The third command of ON-OFF-ON and HOLD causes the following action: The first ON signal causes the motor to turn as before, to the right. It moves rapidly enough so that when the OFF part of the signal comes it is just in time to keep the circuit closed and cause

the fiber disc to keep turning. Now the second ON arrives at the receiver. The relay is energized again, and the circuit is completed through switch 1. Shaft L is turning toward the switch and now opens the circuit by breaking the contact through switch 1. Loop Z is now held in the right position and through the linkage produces up-elevator. It will hold it there as long as the signal is kept on. When another neutral or no signal command is sent, the motor again turns around to the neutral position.

Fig. 106 illustrates the DeBolt servo, a commercial item with the switches as described. Thus by modifying the motor, it can be made to

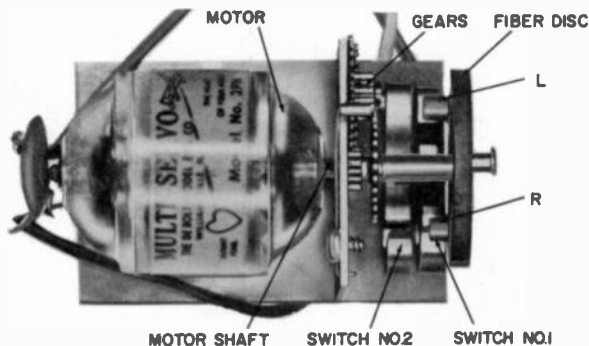

Fig. 106. The DeBolt servo, a commercial unit which not only supplies control power but also acts as a decoder.

interpret the commands transmitted as well as place them in physical effect. In other systems, the decoder and servo or power device may be separated, but they must be present in some form. The switch used by the controller also may take a more elaborate form, depending upon the code to be transmitted.

### How many channels?

The newcomer often asks, "How many channels do I need? How many things can I do with one channel?" One may perform an almost unlimited number of operations using a single-channel system by selection of the proper code and use of a decoder that can interpret these commands. Although the idea of a single channel suggests simplicity, it does not necessarily mean that the system will not become complex. The controller would want to have a ground coder so designed that all he has to do is to push levers, turn wheels or close switches. He does not want to have to remember the particular code necessary for each command. This means complexity.

### Slow and quick control

Another point to be considered is that, in most cases, when one

attempts to achieve a large number of controls with a single-channel system, there will be delays incurred while the system methodically analyzes each command and then performs the operation. The longer the command, in the sense of a sequence, the greater the delay. This can be costly, particularly if this idea is used in a model plane. For a model airplane, the controller would want the command followed with as little delay as possible to prevent disaster. In multichannel systems one can have many commands and the time for execution of each is, not only the same, but short. Of course, trying to get enough channels for all commands that one can think of again means that the equipment becomes complex.

The solution is to analyze the model to be controlled, decide on how many commands one would need executed quickly and how many could be performed slowly without causing trouble. For example:

### Quick Control

Car	Plane	Boat
Steering	Steering (rudder)	Steering
Stop	Steering (elevator)	Stop
	Bomb drop	

### Slow Control

Lights	Landing gear	Lights
Door open	Motor speed	Winches
Change speed		Change speed
Motor start		Motor start
Motor reverse		Motor reverse

This table is not complete and is intended to serve only as a guide in determining requirements. One can see, however, that perhaps three channels would be adequate; two for fast controls and one for all slow-control functions. This assumes that one can get left-right from one channel and up-down from the second. A controller might want five channels for aircraft control—an individual channel for left, right, up and down, and a multifunction channel.

### Commercial equipment

After learning the basic concepts there is usually an additional question or two: "How much do I need to know about electronics?" "Do I need a license?" "What about manufactured equipment?" In practice, if one is able to solder a joint and handle a screwdriver and pliers, he will be able to put together a control system. Manufacturers have designed all types of reliable equipment both in completed and kit form. The kits have easy-to-follow pictorial diagrams and complete instructions for assembly and operation.

To operate radio control it will be necessary to fill out a form, available at hobby dealers. Send it to the nearest FCC office for model control on the radio-control spot frequency of 27.255 mc or the Citizens' band of 465 mc. No examination is required.<sup>2</sup>

---

<sup>2</sup>Complete information on how to fill out this form is described in the companion volume "Radio-Control Handbook" by Howard G. McEntee. Gernsback Library Book No. 53.

# coding and coders

**I**N the first category, an example of coding would be to let one frequency, say 465 mc, represent one command, a frequency of 52 mc a second and 27.255 mc a third.

Another form of coding with constant frequencies is to modulate a constant carrier with the desired command, represented by tones or subfrequencies. Each tone or subfrequency then represents a different command. Amplitude modulation is perhaps the most commonly used coding in radio control.

The second general type of coding refers to systems in which pulses represent the commands. Pulses may be used with carrier only or tone transmitters. They may also be used with light beams.

Pulses may be further broken down into two groups, the first of which is called pulse codes and the second variations of the pulse rates. Pulse transmission is controlled by the coder at the transmitter.

## **Pulse codes**

Pulse codes can exist in six distinct groups distinguished by: (1) numerical sequences; (2) width variations (spacing constant); (3) spacing variations (width constant); (4) sequences of pulse-presence-pulse-omission; (5) rate variations; (6) pulse amplitudes. This, however, does not mean that a code will consist of just one of these six methods. It may be a combination of them, depending upon the application.

## **Numerical pulse sequences**

A numerical pulse-sequence method of coding is one in which the number of pulses transmitted conveys a command. For example, this arrangement might be used in connection with a simple electric motor.

Motor on	1 pulse
Motor off	2 pulses
Motor full speed	3 pulses
Motor half speed	4 pulses

If a great number of commands are to be given, the number of pulses in the last sequence will require a comparatively large amount of time. We must consider the relative spacing between the pulses in each numerical sequence and the spacing between sequences. The interval between all pulses in a command or sequence should be the

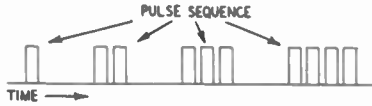

Fig. 201. Each group of pulses represents a separate command. The entire sequence might be used to key four separate functions.

same; the spacing between each sequence should be much longer or at least long enough so that the decoder, in the receiver knows that a command has been given and thus is able to distinguish it from the others following. If four commands were sent, one after another, they would appear as shown in Fig. 201.

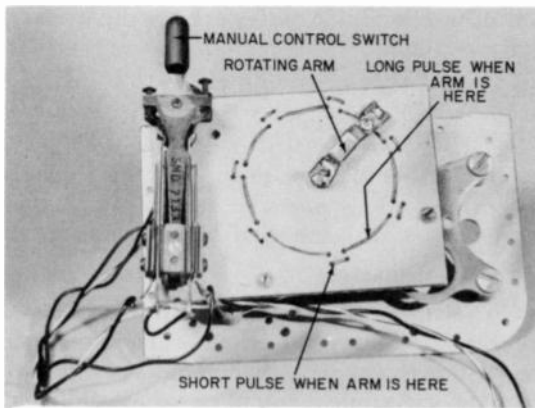

Fig. 202. A motor-driven coder.

One of the best examples of a coder which puts commands into a numerical sequence form is the telephone dial. In this case the dial performs the dual function of coder and control device. This unit has a cam on the underside which closes a set of contacts a given number of times when a number is called. It is spring-powered and has a friction governor so that, when the dial is pulled back and



released, the pulses come at a uniform rate and with uniform spacing and duration. The time it takes to dial a second number is so much longer than the interval between pulses that each command is well separated even though one might dial as fast as the unit will allow. A sequence of up to 10 pulses is possible.

### Pulse width variations—spacing constant

The second form of pulse coding is that in which the pulse width varies but the spacing between the pulses remains constant. An excellent example of this is the code used in radio telegraphy. As far as

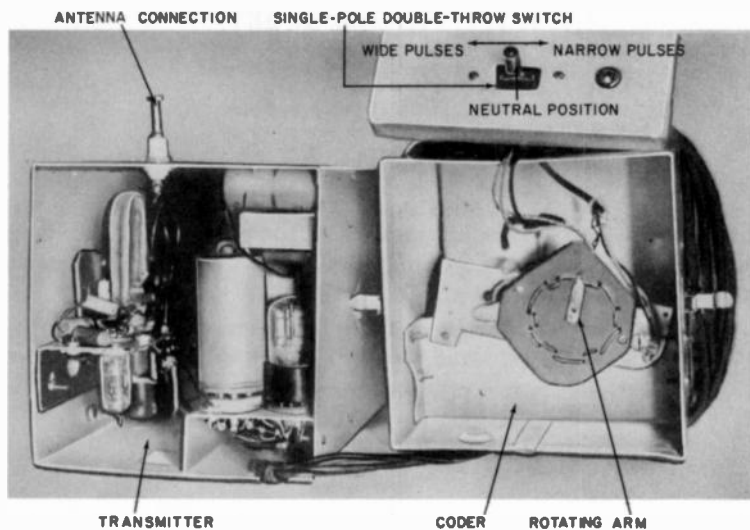

Fig. 203. A motor-driven coder which produces wide or narrow pulses. In this unit the spacing between pulses is constant.

model application is concerned, a series of short pulses might represent one command and a series of long pulses a second.

A simple coder suitable for transmitting this arrangement might be a motor-driven arm (see Fig. 202) made of some conducting material such as copper, aluminum or brass. The arm rides over concentric contacts, one set giving narrow (or short) pulses and the other set wide (or long) ones. By closing the circuit to the proper set at the right time, the correct command would be transmitted. The coder is just a means of keying a transmitter. A manual control switch is used in conjunction with the coder. The position of the control switch determines whether the transmitter will send out a series of wide or narrow pulses.

Fig. 203 shows a small transmitter designed for radio control on 144 mc. Note the single-pole double-throw manual-lever switch immediately above the coder. This is our control switch. When, for

example, the control switch is pushed toward the left, the coder opens and closes either the transmitter B-plus bus or the tone modulator circuit, resulting in a succession of wide pulses. Narrow pulses are produced when the control switch is pushed toward the right. When the control switch is in the center or neutral position, the transmitter is open-circuited and does not send out carrier or tone pulses.

### Pulse spacing variations—width constant

In this coding system the pulse width is constant but the spacing varies. To illustrate the use of such a sequence we should first visu-

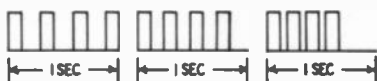

Fig. 204. A series of pulses of equal duration. Notice the variation in spacing.

alize a unit of time, say 1 second. All commands will use this length of time. If only four pulses are needed to convey the commands, then the spacing between them in this 1-second period would determine which command is transmitted. See Fig. 204.

With this system, since the spacing between the pulses varies, it might be advisable to use some means other than a long time interval

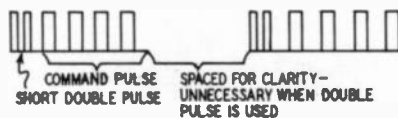

Fig. 205. The short double pulse preceding the command pulses separates the commands from each other.

between commands to allow the decoder to distinguish one command from another. Each command might be started with a double pulse of some fixed duration. This would signal the fact that a command is coming, and each time it is received it would inform the decoder that a new command was on the way or that the previous command was going to be repeated. These identifying pulses serve to separate the commands, however used. A sequence of this type for two commands is represented in Fig. 205.

A second means to denote commands by using pulses of constant width, spacing variable, is to cause each of the pulses following the identifying marker to shift independently back and forth, timewise, about a rest position. This is a method of handling a large number of commands in a short period of time. The rate at which the 'intelligence' pulses are shifted about the rest position can be made to represent various audio tones. For example, a shift rate of 1,000 times per

second would be a tone of 1,000 cycles when decoded. In decoding equipment using this method, the decoder knows the rest time of each pulse following the marker. Through a circuit like a discriminator, it produces the positive and negative alternations of a sine wave as

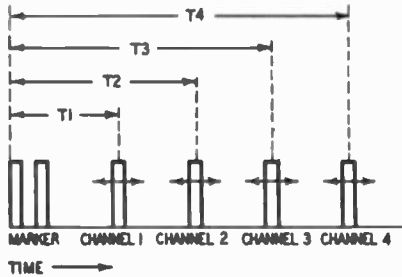

Fig. 206. Time modulation of the pulses is often used when a great many commands are to be sent in a short period.

each pulse is received early or late with respect to its rest interval. This idea is illustrated in Fig. 206.

A coder which will provide a variation in either the pulse width or spacing is shown in Fig. 207. When the tube conducts, the flow of current closes the relay in the plate circuit, connecting (through the bottom contacts of the relay) the grid circuit to a source of B-minus voltage. This voltage is sufficiently high to drive the tube to

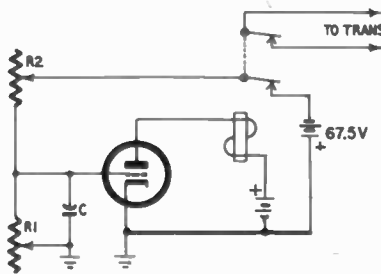

Fig. 207. A simple coder which will vary pulse width or spacing.

plate current cutoff. The relay then opens. However, during the time the relay is closed, capacitor C in the grid circuit has an opportunity to become charged. This holds the tube cut off until the capacitor can discharge through the resistance across it; then the action repeats. By having a variable resistance R2 in series with capacitor C, the time it takes for the capacitor to charge will be controlled, thus regulating the length of time the upper contacts of the relay cause the signal to

be transmitted. Under such circumstances we are actually governing the width of the transmitted signal or pulse.

When tube current flows, the relay, being in the down position, closes a transmitter circuit and puts the transmitter on the air. The size of resistor R1 determines the time it takes the capacitor to discharge, governs the time the signal is *off* the air and thereby controls the pulse spacing.

### **Pulse sequences (pulse-presence—pulse-omission)**

Codes dependent on pulse sequences, other than numerical, are generally of the pulse-presence—pulse-omission type. Consider a sequence of 5 pulses within each command block. The pulses all have the same width and spacing. The commands result from the fact that they may be transmitted or omitted:

Command 1:	Pulse	Pulse	Pulse	Pulse	Pulse
Command 2:			Pulse	Pulse	Pulse
Command 3:				Pulse	Pulse
Command 4:					Pulse
Command 5:	Pulse			Pulse	Pulse

Each pulse has a definite time to be transmitted, and the particular command results from whether it is transmitted or not. With this group of 5 pulses, it is possible to get 32 combinations, no two of which are identical. If more operations are desired, the block may be raised to 6 or higher, and the possible combinations are astonishing.

The coder for this particular arrangement might again, in a mechanical sense, be a motor-driven arm which sweeps over a set of contacts. The line from each contact to the transmitter energizing circuit might then run through a switch and, depending upon how many switches were thrown, the functions would be performed.

In one system using this sequence, the motor-driven arm passed over a number of contacts every revolution. Four of these contacts were the command contacts; a fifth caused the receiving motor to slow down and a sixth notified the receiving motor to speed up. (The receiving motor was in the decoder and caused a similar arm to pass over a set of contacts duplicating the coder. The two arms had to be in synchronization so that a contact in the coder would represent a circuit in the decoder.) A seventh contact of the coder was used to energize the circuit set up by the command pulses.

### **Pulse-rate variations**

Pulse-rate variations is another means of coding commands in a pulse system and is very popular. To vary the pulse rate means that the number of pulses transmitted per second will be changed according to the command. For example:

- Command 1: 20 pulses per second
- Command 2: 30 pulses per second
- Command 3: 40 pulses per second

A coder might present this arrangement of pulses to a transmission system in several ways. One would be to use a thyratron, such as an 884 gas tube connected as a sawtooth oscillator. The firing rate of

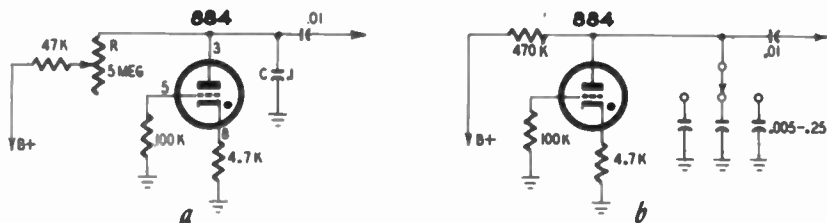

Fig. 208. Thyratrons are easily adapted to electronic coder circuits: a) the firing of the gas tube is varied by resistor  $R$ ; b) in this circuit various values of fixed capacitance are switched into the circuit to control the firing of the tube.

the tube is controlled by the size of resistance and capacitance in the plate circuit and by the amount of grid and plate voltage on the tube. See Fig. 208-a. If we hold the grid and plate voltages at a constant value and vary  $R$ , we can change the firing time, either increasing or decreasing the number of firings per second. We can also hold the resistance constant and get the same effect by using several capacitors attached to a rotary switch so that they could be inserted in the circuit one at a time. See Fig. 208-b.

It is also possible to vary the pulse rate mechanically by changing the speed of a motor which is driving an arm over a set of contacts.

### Pulse amplitudes

Coding by variation of pulse amplitudes means increasing or decreasing the amount of power the transmitter puts out with each pulse or pulse train. This method is not recommended because of the tendency of the receiver to become confused, the normal signal varying as the controlled body moves. This makes it almost impossible to distinguish between a transmitted command or a fading signal. This coding method is useful in a wired transmission system. For example, at the receiving end a group of relays might be so arranged that some of the relays respond to pulses of low voltage; others to higher voltages, etc. A change in polarity of the signal (if dc) might also be part of the command method. The coder would simply be a contact selector which would choose the contact having the proper amount of voltage and/or polarity for the command to be transmitted.

Mechanical-electrical arrangements in some forms of coding are

quite elaborate. The ability to control, aside from the electronic standpoint, depends upon the controller's ability to transmit the commands easily and at the proper time.

# transmission

**T**HE choice of transmission system depends upon the type of coding used and the particular application of the control system. Conversely, it is possible that the type of coding will be second choice and the transmission system will govern its selection.

There are five general means of getting information from one point to another: (1) radio or electromagnetic waves; (2) sound waves; (3) light beams; (4) heat waves (infra-red) and (5) wires.

## **Radio transmission**

This is the most common type of transmission used by the radio-control enthusiast. Since it has such an important role it will be discussed in detail.

## **Sound-wave transmission**

This might, at first, be thought a method with limited application. However, it can be the solution to a control problem. Radio-control systems operating on other than the radio-control spot frequency or the Citizens' band require a license; a sound system does not. A sound system might be merely a public-address setup which propagates a pressure wave in the direction of the controlled body. The receiver could be an audio amplifier with a microphone input. Coding could be by different tones or a single pulsed tone.

To answer immediately the question of the disturbing effect of transmitting pulses over a sound system: if the input to the sound system were from an audio oscillator tuned to 15,000 cycles, few people could even hear the transmitted tone. By use of a selective filter in the receiving audio amplifier, the model would respond only to this particular tone and thus give satisfactory operation. Practi-

cally all the aspects of radio control would be present except that the transmitting range would be limited.

### **Light-beam transmission**

Light beams are generally used with garage-door openers, etc. The light beam can be modulated or unmodulated. In the latter case, the beam would be interrupted to send pulses. Of course, the receiver phototube or a cell from a light-exposure meter (which is light sensitive) must be oriented so that it can always see the light source. This can be done by rotating the light-sensitive unit, using slip rings to convey its output to an amplifier. The cell does not respond to ordinary light if it is hooded and the sensitivity control properly adjusted. Another thought would be to arrange three light-sensitive cells in a fixed triangle so that no matter what the position of the model, one or more of the cells would always be able to receive the light signal from the controller. The model then could be controlled with an ordinary flashlight.

### **Infra-red wave transmission**

Infra-red waves, like light beams, can transmit intelligence. They also require that the infra-red receiving source be able to see the transmitter. These waves are generated by high-temperature arcs; the receiver consists of a bolometer connected into a special temperature-sensitive resistance circuit. This type of transmission system is seldom used.

### **Wired transmission**

This is perhaps the most common method used between fixed transmitting and receiving points. It is possible to attach a pair of flexible wires to a model car or boat and investigate the control technique easily and simply. One or a multiple pair of wires can be used. This is an electric, not an electronic, technique.

### **Radio transmitters**

The power and size of radio transmitters are generally determined by the range to be covered and by the coding used. A modulated transmitter might be larger than a nonmodulated unit. The size of the transmitting antenna is also a factor. For example, a transmitter using an antenna which beams energy toward the model might be smaller for a given application since it is required to generate less power than one using an antenna which just fills the atmosphere with energy. In the latter case, the model actually receives but a small portion of the total transmitted output. The physical size of the antenna is also determined by the operating frequency. Generally, the higher the frequency, the smaller the components and the shorter the connections required for any efficiency of operation. As the frequency increases, it is more difficult to obtain high efficiencies.



The power output is determined by the primary power supply. It may or may not be an integral part of the transmitter. Dry batteries cannot supply high voltage and current requirements for extended periods of time, so for higher-powered transmitters, vibrator supplies or small motor generators powered from wet-cell storage batteries are used. In planning the overall system, consider the primary supply,

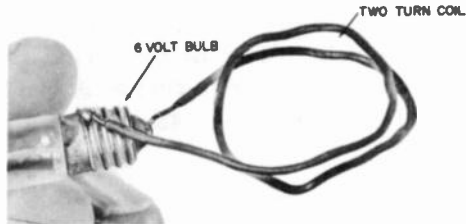

Fig. 301. A simple transmitter performance indicator.

thinking in terms of whether the carrier will be constantly transmitted during operation and modulated to send intelligence, or transmitted only when the intelligence (tone, for example) is transmitted. The former would require a heavy-duty, long-life primary supply while dry cells may be adequate for the latter.

Almost any transmitter can use a vibrator-type supply if the voltage is adjusted to the required value. The wet cells can be recharged easily and the expense of operation is greatly reduced.

### Performance indicators

Every well-designed radio-control transmitter will have as an integral part some device which will indicate that the unit is performing properly. A meter, or even a small light bulb (6 volt, brown bead) connected to a small loop placed near the final tank coil will indicate that the required energy is being generated. See Fig. 301. When a meter is used, it is possible to connect it through a switch so that the A and B voltages can be monitored, as well as the currents to the various stages. If trouble should develop in the unit, this built-in metering system allows a quick determination of its source.

### Crystal oscillator

The allocation of a spot frequency (27.255 mc) for control operation means that the transmitter must have a crystal-controlled radio frequency (rf) generating circuit. The crystal prevents operation on any but the assigned spot. A typical crystal circuit is illustrated in Fig. 302.

When the voltage is applied and the tube draws current, the magnetic lines of force that develop around the tank coil (L) cause a signal to be impressed on the grid of the tube through the crystal. Now the crystal will not pass any signal unless it is 27.255 mc (the frequency for which the crystal is ground). This means that the cir-

cuit will not operate unless the tank circuit is properly tuned. If the tank is correctly adjusted, the signal passes to the grid and the tube operates to generate rf energy in a continuous manner.

### Self-excited oscillator

It becomes difficult to use crystals as the frequency of operation increases since the crystal, a quartz plate, must be so thin that it fractures if ground to a high frequency. One solution is to use several tubes in a circuit which will allow the crystal to operate at a low frequency and to multiply this frequency as it goes through each tube.

In the region of 50–54 mc, 144–148 mc, etc., the allocation is not

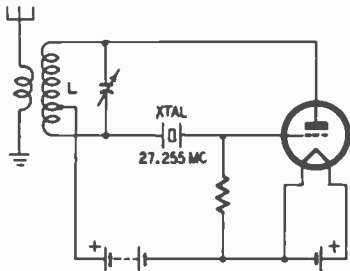

Fig. 302. A typical crystal oscillator circuit.

a spot but a band, hence self-excited rf generating devices can be used. A typical circuit is shown in Fig. 303. This is almost identical to the crystal circuit except that *any signal* developed by the tank circuit may pass to the grid, causing oscillation. Thus it may generate energy throughout the tuning range of the L-C tank circuit. Of course some means must be used to make sure that the transmitter is not tuned outside the allocated band. Devices such as wavemeters, receivers with calibrated dials, frequency meters and grid-dip meters can be used.

On 465 mc the band is so narrow that the FCC must approve any transmitter used. Do not try to build a transmitter for this frequency. It is possible to construct transmitters operating on 420 to 450 mc or 220 to 225 mc. These do not require approval. The setting of the frequency of operation requires great care however, to keep inside legal operating frequencies.

### Amplifier stage

Some radio transmitters send the signal from the oscillator tube into an amplifier. This, as its name implies, builds the signal to a larger value. The amplifier also provides isolation between the antenna and the oscillator. This helps the stability of self-excited types of transmitters. It allows a crystal-type oscillator to operate into a constant load, ensuring good, reliable operation. In model control, however, most transmitters are of the single-stage variety, since the power-developing capabilities of the tube employed is adequate.

## Transmitter keying

If the transmitter is to convey intelligence by having its carrier pulsed and if the unit is a single-tube type using a relatively low voltage (135 to 150) it is common to break the B minus with the

Fig. 303. *A simplified self-excited oscillator.*

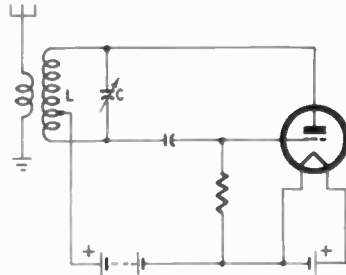

coder switch. If high voltage is employed, a keying relay is inserted so that the voltage handled by the coder is only about 6 volts. This prevents accidental shock.

When a filament-type tube is used, it is almost always necessary to key the B-minus lead. With heater-cathode types it is common to key the transmitter by opening and closing the cathode-to-ground lead through the coder. Again, however, a keying relay should be used in this circuit if the B voltages are high.

When using a two-stage unmodulated transmitter to operate carrier-type receivers it is always wise to key the oscillator section *and* the amplifier stage. Otherwise the radiation from the oscillator can operate the receiver at close range even though the key or coder is open. With a modulated transmitter, it is necessary to open only the circuit to the tone oscillator. This can be done by opening and closing the grid circuit of the tone oscillator. The voltage here is very low. Of course, the tube or tubes in the modulator may also be keyed in the same way as for the transmitter rf section.

The modulator may be an integral part of the transmitter or a separate unit. One method is to have a carrier type of transmitter and then, by providing suitable plug and jack connections, add a modulator unit capable of transmitting tones merely by connecting the two units.

## Tone oscillators

There are three tone oscillators most commonly used: (1) relaxation type: (2) plate feedback and (3) the well-known tapped-coil Hartley. A relaxation oscillator is shown in Fig. 304. In this circuit a small neon bulb is connected across the tuned primary of an audio transformer. The 100-volt source is applied to the circuit through a resistance R1. When the circuit to the battery is completed by pressing down on the key, the voltage across C1 builds slowly due to R1. When this voltage reaches a high enough value, the neon bulb fires, discharging the

capacitor. This action repeats continually. The frequency of oscillation is governed by the amount of resistance in the circuit and the size of C1. In effect, C2 is shorted by the low-resistance transformer

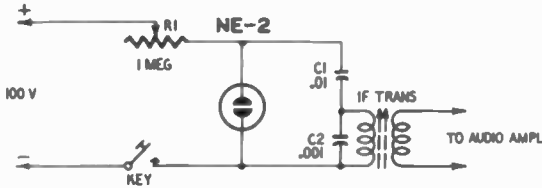

Fig. 304. Neon-bulb relaxation tone oscillator.

winding. The purpose of the transformer and C2 is to smooth out the sawtooth waveform and couple it as a sine wave to the next stage.

The plate-feedback type of oscillator is shown in Fig. 305. In this circuit a small interstage audio transformer is connected so that the current to the tube plate passes through the primary winding, inducing a voltage in the secondary. The secondary is connected to the grid through a grid resistance R and grid capacitor C1. Since the induced voltage is large, the tube grid draws current, charging the grid capaci-

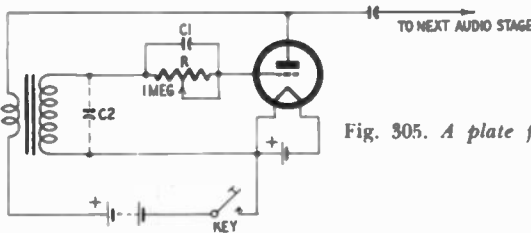

Fig. 305. A plate feedback tone oscillator.

tor negative until it cuts the tube off. The tube is held cut off until the capacitor can discharge through the grid resistance, then the cycle repeats. The frequency of oscillation is governed by the values of R, C1 and the inductance of the secondary winding. This oscillator is capacitor coupled to the next stage. A tuning capacitor C2 may be added across the transformer secondary. This gives smoother operation and allows lower frequencies to be attained than are possible by use of just the windings alone.

The tapped-coil Hartley in Fig. 306 works in the same manner as the plate-feedback type. A small output-type audio transformer can be used.

## Methods of modulation

A radio-control transmitter can be modulated in any one of three basic ways: (1) plate modulation; (2) screen modulation and (3) grid modulation. Plate modulation requires that the output of the modulator be coupled into the B-plus lead of the final stage of the transmitter. The final stage is the output. If this stage uses a screen grid type of tube, then both the plate and screen leads may be connected to the

modulation transformer or just the plate lead alone. If both screen and plate are modulated, there should be no large rf bypass capacitors

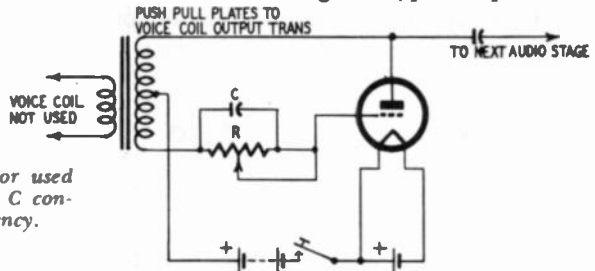

Fig. 306. Hartley oscillator used to produce tones. R and C control the audio frequency.

to shunt the audio signal. Values of  $0.0005 \mu\text{f}$  are adequate for rf and will not cause a loss of the audio signal. Fig. 307-a illustrates the mod-

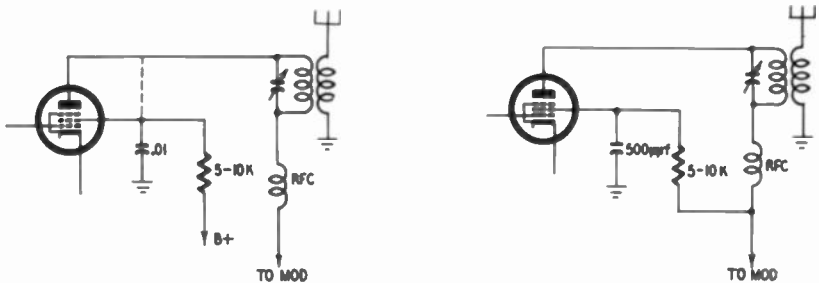

Fig. 307. Methods of using plate and screen modulation: a) if plate modulation only is used, connect as shown by the dashed lines; b) when plate and screen modulation are required, use a small value screen bypass capacitor.

ulator connections to such a stage. Fig. 307-b shows connections for plate and screen modulation.

Modulation of the screen grid alone, as shown in Fig. 308, is sometimes used since this requires less audio modulation voltage. No modulation transformer is required, although one can be used.

Grid modulation can be used only when the transmitter is a two-stage type. In this case, the audio signal is applied to the grid of the final stage. Much less audio power is required than for the other methods. However, this method does not allow the final output efficiency obtainable with plate or screen modulation. In the previously described methods, the audio signal adds power to the transmitted signal; grid modulation does not. The method of connecting a modulator into the grid circuit is shown in Fig. 309.

## Transmitting antennas

The importance of the transmitting antenna system cannot be over-emphasized. With manufactured units, the antennas are designed for optimum performance and should not be changed in any way. It is possible to design an output circuit for the transmitter which will allow any wire of reasonable length to be used but, unless this is done,

exercise great care in getting the antenna exact. The resulting care-free performance will justify the time and effort.

Three types of antennas are commonly used: (1) half-wave doublet; (2) quarter-wave rod and (3) beam type. The doublet consists of a

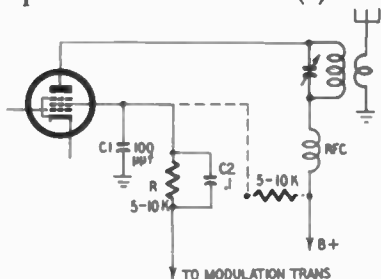

Fig. 308. Normally, the screen is connected as shown by the dotted line. To screen modulate, connect R and C2 to the modulation transformer or the plate of the modulator tube.

half-wave antenna divided in the center and connected to the feed line at this point. Either a single wire or folded dipole can be used. This latter is constructed from TV lead-in wire (300-ohm line) cut to the

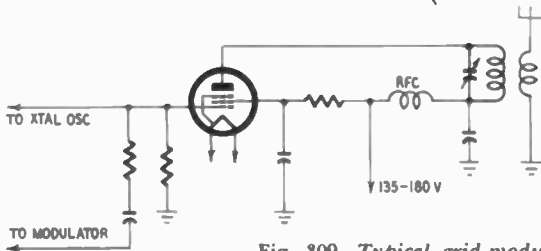

Fig. 309. Typical grid-modulated circuit.

specified length. The ends are soldered together. One conductor is cut at the exact center, the two cut portions being connected to another piece of transmission line. Fig. 310 shows the two methods. Ordinary twisted lamp cord can be used with the single-wire antenna.

The radiation pattern of a dipole is a doughnut which is curled around the antenna. Minimum radiation is off the ends. For model aircraft flying overhead, this pattern is ideal. Horizontal range is not affected if the antenna is turned so that it is generally broadside to the model. There are no stringent requirements for a ground system, although the height above the earth does affect the radiation pattern. It is best to have the antenna at least a half-wave length above the earth.

The only requirement in tuning the transmitter to the antenna is to adjust the coupling link for the desired output or loading as indicated on a plate-current meter. Never make this coupling so tight that it takes all the energy out of the tank as this will cause unreliable operation.

The quarter-wave or one-eighth-wave rod is the type most commonly used on 27.255 mc since it is physically small and allows efficient radiation for practical purposes. The length of a quarter-wave

antenna is half that of the doublet, and the one-eighth-wave antenna is half the size of the quarter-wave antenna. This antenna can be so

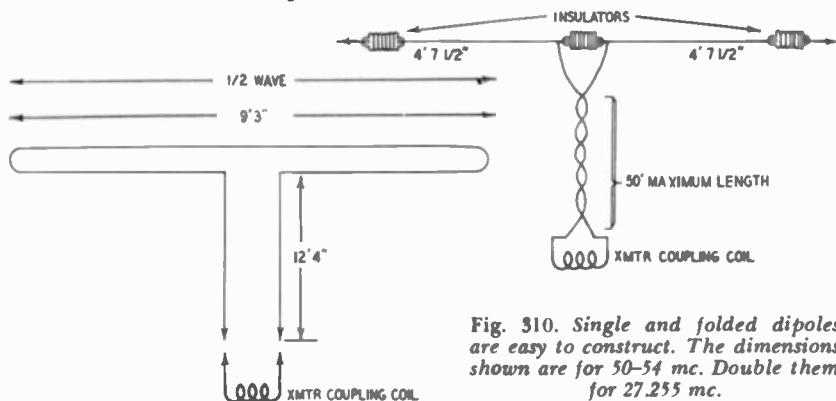

Fig. 310. Single and folded dipoles are easy to construct. The dimensions shown are for 50-54 mc. Double them for 27.255 mc.

made that it plugs into the transmitter case directly whether the transmitter is a hand-held unit or larger size. Again, the radiation pattern curls around the antenna and so, if the model aircraft is directly overhead, it is in a zone of minimum radiation if the antenna is also vertical. The antenna may be tilted slightly to provide a good signal overhead. Normally the transmitted output and the receiver sensitivity are so great that there is little danger of losing control even if the model is in the minimum radiation zone, unless it is being operated at extreme distances.

These types of antennas work best when operating against some type of ground system—a stake driven into the earth; connecting the transmitter case to an automobile body through a wire, or the body of the controller himself may serve. A ground system is needed since the antenna has a mirror image in the ground; it is like a dipole then with

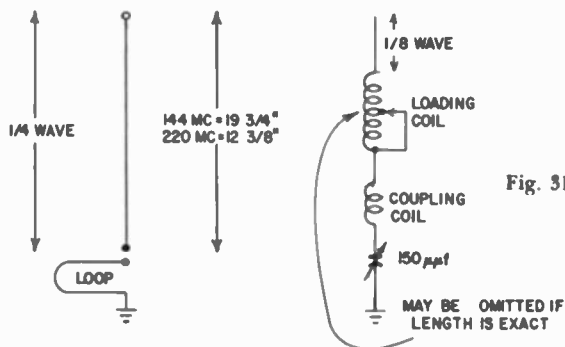

Fig. 311. Whip antennas are often used in R-C work.

but one half radiating into space. Looking at it this way indicates the coupling method needed. See Fig. 311. The coupling loop or coil is adjusted for the required output. If it is wound close about the tank, the coupling is tight; if spaced about the tank, the coupling is loose.

One side connects to the transmitter ground and the opposite end to the antenna. A relatively long transmission line can be used but it should be a special type known as coaxial cable.

Only a few beam antennas will be considered here although there are others. When the transmitter operates on a high frequency, the size of the antenna becomes small and generally the power output is reduced somewhat due to lowered transmitter efficiency. This makes a beam antenna desirable.

A rod, metal tube or wire of specified length placed a certain distance in front of a dipole and parallel to it tends to draw the radiated output from the dipole toward it. This is called a director. A rod, metal tube or wire of specified length placed a certain distance behind the antenna will tend to reflect radiation back to the dipole. This is called a reflector. By using directors and reflectors the radiated energy can be beamed, the sharpness of the beam being determined by the number of elements making up the director and reflector.

A beam-type<sup>3</sup> antenna should be pointed in the general direction of the model. Exactness is not necessary as the beam is broad. The method of coupling this antenna to the transmitter is the same as for the dipole since the directors and reflectors have no physical connection to the transmitter.

### **Field-strength indicators**

A field-strength meter is useful as a final check in determining the transmitter's operation. Once the transmitter has been adjusted, this device will indicate whether the transmitter is radiating properly. A field-strength meter is essentially a tuned circuit connected to a small antenna and through a diode rectifier to a sensitive meter. The unit is placed some distance away from the transmitter, tuned to the transmitted frequency and the reading noted. From then on, if it is placed the same distance each time and the transmitter keyed, the reading should be approximately the same, indicating correct transmitter operation.

---

<sup>3</sup>Detailed information on beam antennas can be obtained from the Radio Amateur's Handbook, published by ARRL, West Hartford, Conn.



# receivers

**T**HE receiver is the second half of the communications system between controller and model. The requirements placed on it are stringent: it must be reliable, lightweight, rugged; consume little power; be small in size, yet sensitive; operate for long periods under unusual conditions of vibration and shock, yet maintain tuning and adjustments as perfectly as possible.

There are many types—autodyne or regenerative, superheterodyne, reflex and superregenerative. Tuned rf receivers are not used because of low sensitivity. The superheterodyne has not been considered for model applications due to its size and complexity, although its sensitivity and selectivity are desirable. Using transistors, however, the superheterodyne now comes within the requirements of model control.

The choice will be determined entirely by the particular application. The autodyne is not popular due to its inability to maintain adjustments. Reflex circuits are not as good as the commonly used superregenerative receiver.

## **Superregenerative receiver**

The basic receiver uses a detector which is allowed to build up to an oscillatory condition and then is *quenched* or stopped from oscillating. This oscillation-quench cycle takes place thousands of times per second. When the detector oscillates, it means that energy is fed from the plate into the grid circuit in such manner that it is amplified again. If this process continues, the tube reaches its limit of amplification (a condition known as saturation) and it will not amplify further. The quench is important since it results in a continuous amplification of the signal.

The small signal voltage on the antenna is coupled to the grid of

a superregenerative detector through a tuning coil and is amplified by normal tube action. The amplified signal, appearing in the plate circuit, is then fed back into the grid circuit of the detector and is amplified again. This process is repeated over and over again. The tremendous amplification and its broad tuning (it does not lose signals easily) are reasons for its popularity.

Four basic circuits are used to get superregenerative action: (1) hard-tube self-quench; (2) thyatron or gas-tube self-quench; (3) dual-frequency self-quench and (4) separate quench.

A hard tube is a vacuum type, and has no gas inside the envelope. In this circuit (Fig. 401) a grid voltage builds up across R1 shunted by C1. This grid voltage, produced when the grid draws current,

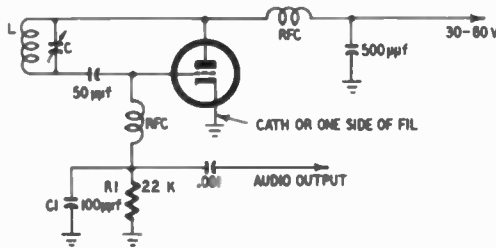

Fig. 401. A self-quenched superregenerative detector using a hard-vacuum tube.

makes the grid negative with respect to the cathode. The grid voltage builds up and finally is strong enough to cut off the flow of plate current. C1, which has become charged, discharges through R1, thus holding the tube in a condition of plate current cutoff for a small



Fig. 402. Output of the superregenerative detector with and without signal. The spacing of the bursts depends upon the signal strength.

time. When the capacitor discharges to such a value that the grid voltage is small, the tube goes again into a regenerative state, into oscillation and the entire cycle is repeated.

In a self-quenching circuit, the output of the tube consists of bursts of rf energy (Fig. 402) which are fairly evenly distributed. When a received signal is present in the tank circuit (L-C in Fig. 401) it causes these bursts of rf to come closer together, the amount depending upon the signal strength. If the signal is modulated (that is, the strength is

varied) the spacing between the bursts varies. When these signals are converted into currents, they flow strong and weak, reproducing the modulated signal. The important point in connection with this type of circuit is that the oscillations build up and reach a saturation value. Thus the detector is good only for the reception of modulated signals.

A similar superregenerative circuit (Fig. 403) uses a thyratron gas tube (soft tube) as the detector. The tube, an RK-61 or British XFG-1, is especially designed for radio control.

RK-61 or XFG-1

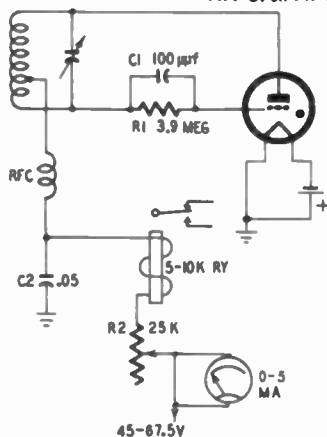

Fig. 403. A thyratron detector can be used as a single-tube receiver.

inert gas which gives it the ability to change from low to high plate current with a weak signal when used in the proper circuit. This current change is sufficient to operate a relay directly, making possible a one-tube radio-control receiver. Vacuum-tube type one-tube receivers are also used.

The gas tube detects the signal and, like the previous circuit, causes a buildup of negative grid voltage across R1 and C1. The grid has no control over the plate current in gas tubes unless the plate voltage is lowered, causing a sharp reduction in plate current. To make this possible, R2 and C2 are added to the plate circuit. The plate voltage charges C2 through the relay resistance and R2. If there is no negative voltage across C1, the tube fires (conducts) when the voltage across C2 reaches a large value. The result is a pulse of plate current as C2 is discharged through the tube. The charge and discharge cycle takes place continuously, causing enough average plate current to operate the relay. When a signal is present, a negative bias voltage develops across R1 and C1 and the grid gains control of the electron flow, preventing such a flow even though C2 might charge to full value.

With this detector, then, a large plate current of 1 to 1.5 ma flows without signal and drops to 0.2 to 0.5 ma with signal.

The circuit of Fig. 404 is sometimes called a dual-frequency type since there are two tank circuits connected to the tube elements. The quench tuned circuit governs the tube's action, while the receiving tuned circuit determines the frequency the set will pick up.

The tube oscillates readily at the quench frequency of 50 to 80 kc. Feedback is controlled, so that the grid is made alternately positive

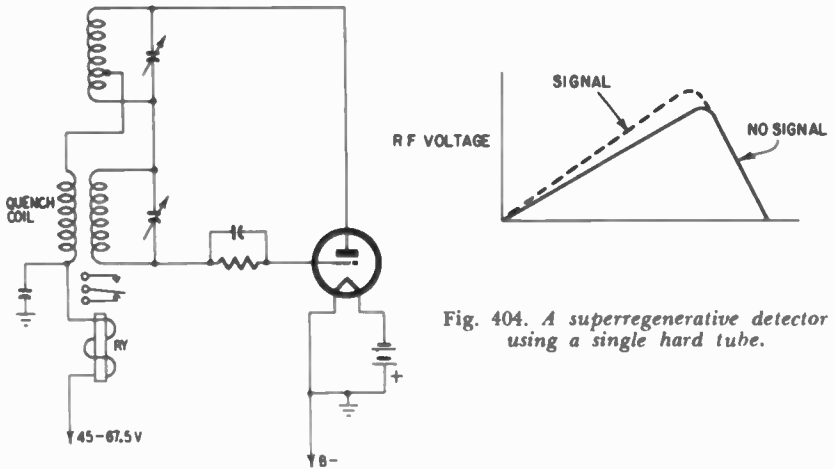

Fig. 404. A superregenerative detector using a single hard tube.

and negative as the quench cycle repeats. When the grid voltage approaches zero, the receiving tuned circuit goes through a regenerative and then oscillatory action. This causes some negative voltage to ap-

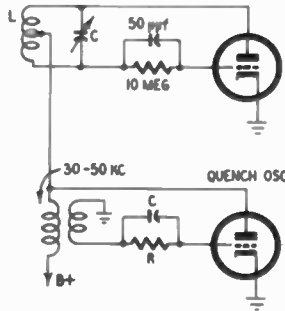

Fig. 405. This superregenerative detector uses a separate quench oscillator.

pear on the grid capacitor, but not enough to cut the tube off. Then the much slower quench-cycle voltage reverses direction and it too adds a negative voltage to the grid capacitor. Finally, the tube finds

it impossible to maintain the oscillations of the receiving tuned circuit, so these stop. This cycle repeats continuously.

When the receiving tuned circuit goes through its cycle of regeneration—oscillation—stop, it is functioning as a normal superregenerative detector. By proper proportioning of the quench voltage and frequency to the received frequency, it is possible to make this circuit perform like the soft-tube detector; that is, to cause an abrupt change in plate current. In this circuit, however, the change may be from a high state to a low state or the reverse.

In Fig. 405 a separate tube is used to furnish the sinusoidal quench voltage. The presence of a signal causes an increase in the amplitude of the rf burst (or plate current increase) from the tube. This circuit can be used for detection of modulated or unmodulated signals.

### Relay stage

In that part of the receiver where we normally find a speaker, the radio-control receiver has one or more relays. The output tube also has a particular circuit associated with its grid. Its purpose is to make the tube draw current, closing the relay when a signal is present, or to stop plate current flow, opening the relay with a signal. Fig. 406 illustrates the basic method of connecting the relay tube so it will cause the relay to close with signal.

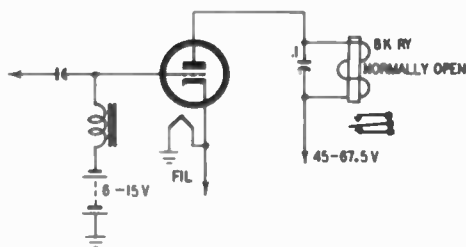

Fig. 406. This type of circuit is used to close a relay when a signal is received.

A small battery supplies a negative voltage to the grid through a choke coil, used so that the resistance in the grid circuit will be as low as possible (and the impedance to the signal high) so that all the signal will be presented to the grid. In operation, no current is drawn from the bias battery. When the grid receives a signal of sufficient amplitude, the positive alternation will cancel the effect of the battery bias and tube current will flow. During the next half-cycle, the negative alternation adds to the battery voltage and the tube is cut off. Thus the plate current flows in pulses through the relay. These repeat fast enough so that the relay closes. It is common practice to put a .01 to 2  $\mu\text{f}$  capacitor across the relay to smooth the pulses and provide a steady current through the relay windings. The capacitor charges when plate

current flows and discharges through the relay during cutoff. Thus the relay has a steady current all the time a signal is present.

It is possible to use a grid resistor if one additional element is added. In Fig. 407 a diode conducts when a negative voltage is present on the grid. The bias voltage is impressed on the grid through the re-

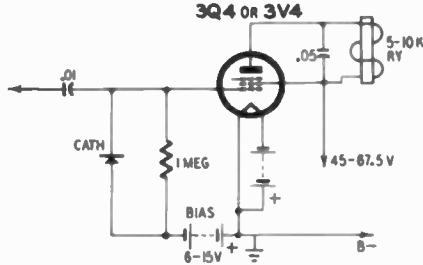

Fig. 407. By adding a diode to the grid circuit of a tube a grid resistor can be used in place of a grid choke.

sistance to hold the plate current cutoff. A positive alternation of the signal sees a large grid resistance and causes the tube to conduct. The negative alternation of the signal sees a low resistance (diode conducts) and its effect on the grid is negligible. Again the tube conducts in pulses and the relay closes.

The second method (see Fig. 408) of working the relay is to have the circuit arranged so that the relay is normally closed by the relay tube plate current. The signal is rectified by the grid-to-filament diode

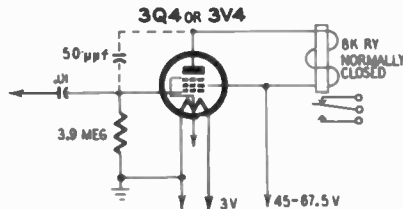

Fig. 408. A simple circuit which can be used to open the relay on signal. To prevent quench feedthrough from reducing plate current a 50  $\mu\text{f}$  capacitor can be added as shown in dashed lines.

action. If there is a large grid resistance, this voltage builds up across it and biases the tube to cutoff. The relay then opens.

Let us examine the advantages and disadvantages of the two methods. In the first, the relay tube draws no current unless a signal is present and the B-battery drain is small. It is also fail-safe. If the re-

ceiver should fail, there is no relay action, causing an undesired signal to control surfaces.

In the latter, the B-battery drain is higher by one or two ma. If the receiver should fail, the relay becomes de-energized, causing a signal to be sent to the control elements. In model planes this can cause abrupt turns, dives, and a crash. The possibility of failure is small if control equipment is constructed carefully. The advantage that the plate current can be adjusted for good relay closure is not to be disregarded. This type of operation is satisfactory and extensively used.

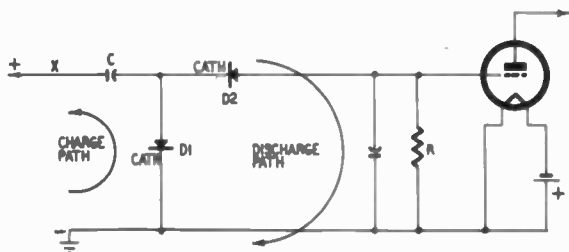

Fig. 409. A voltage doubler which applies a negative voltage to the grid of the tube when a signal is received.

In both cases it is advisable (if possible) to cover the relay armature with thin tissue paper. This keeps the armature from sticking to the pole piece. The soft iron of the relay core becomes magnetized in operation and does not lose its magnetism completely during brief intervals between signals. The result is unreliable operation of the armature unless the signals are slow and of long duration. In the second case mentioned, the signal may not completely cut off tube current if the model is some distance away. If the armature is touch-

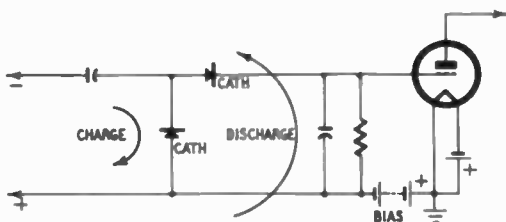

Fig. 410. This voltage doubler applies a positive voltage to the tube. Note the position of the bias battery.

ing the pole piece it may stick and not release at all unless the tissue paper or small gap between armature and pole piece is always present. Model control relays close on a current of 0.8 to 2 ma. They have adjustments so they can be set to work in any type receiver.

It is possible to use a circuit in the grid of the relay tube which will

multiply the size of the signal acting on the tube. When a signal is applied to the voltage-doubler in Fig. 409, the positive alternation at X allows current to flow through diode D1 to charge C. This charge is practically equal to the magnitude of the alternation. When point X becomes negative on the second half of the cycle, current flows through D2 and resistance R, developing a voltage across R which is negative with respect to ground but with a value twice the amplitude of one alternation. In a sense, this has the effect of adding the voltage from the preceding amplifier tube to the voltage stored in the capacitor to obtain this high value. Fig. 410 shows a circuit which puts a positive voltage on the grid with signal.

A voltage quadrupler, modified for R-C use, is shown in Fig. 411. This is similar to the doubler circuit, except that it consists of two such circuits in series. C3 is charged to the peak-to-peak value of the signal by D1 and D2 and C4 by diodes D3 and D4. Since C3 and C4 are in series, their voltages add, and a value nearly four times the half-wave magnitude is presented to the grid. No load resistance is shown since the capacitors will discharge through the back resistance of the diodes and the size of the capacitors is small enough (.01  $\mu$ f) so that the charge will not remain when the signal stops.

### Receiver antennas

Unlike the transmitting antenna, this is not a critical item. It should not be a resonant length (quarter- or half-wavelength) as this causes the antenna to pull rf energy from the detector tank, preventing it from working as a superregenerative detector. For a receiver on 27.255 or 50-54 mc, an 18 to 24-inch piece of flexible wire is satisfactory. A solid antenna can be used, such as a length of piano wire or aluminum tubing.

With higher radio frequencies, the physical size and shape of the antenna changes. At 144 mc, the length reduces to 19½ to 20 inches; for 220 mc between 11½ and 12 inches. When one approaches 465 mc, the antenna can be a square loop mounted parallel to the receiver chassis but in close proximity to it. There is no physical connection between this antenna and the detector tuning circuit. When a signal is present it excites the loop which resonates as a tuned circuit, reinforcing the radiation so that it is easily picked up by the tuning circuit. Generally, the higher the frequency the less coupling required between antenna and tuning circuit.

When using higher frequencies make certain that the model wiring or metal sides are kept as far from the antenna as possible. Connect the receiver ground to all metal parts of the model and such of the installation wiring that can be grounded without interfering with circuit operation. This keeps electrical noise from affecting the receiver and supplies more pickup than possible with the antenna alone.



The mirror image of the antenna will be found in the ground system for antennas close to a quarter-wavelength.

## Batteries

Receiver batteries are usually hearing-aid types. B-batteries can be 22.5 or 30-volt sizes, capable of long life at current drains of 3 to 5 ma. The filament batteries can be penlight cells or medium-size flashlight units.

Hearing-aid batteries can have their life reduced quickly if subjected to heat for long periods. Remove the batteries from the model and place in the refrigerator during non-operating periods. A cool spot, away from the freezing unit, will do nicely. Wrap the batteries in some moisture-proof covering, such as cellophane.

When replacing the batteries, allow a 10- to 15-minute warmup at room temperature. Put the batteries in the model and measure the

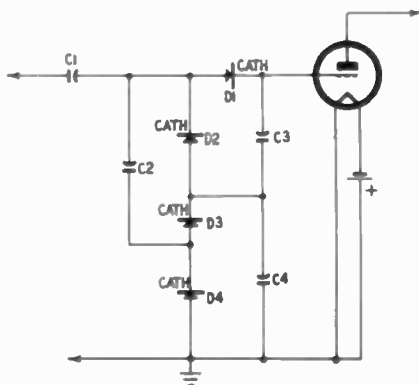

Fig. 411. A voltage quadrupler will provide usable voltage from weak signals.

voltage under load. Transmit a signal so that the receiver relays operate. The voltage check should be about 1 minute. If the batteries are weak the voltage will start to drop and replacement is indicated. Charging these batteries gives increased life. This is considered dangerous by the author. The investment in the model is usually enough so that it is more economical to replace batteries than to take a chance.

The same idea of testing under load applies also to the filament batteries. These have the shortest life of any in the system. Check them frequently and replace when they become erratic. To determine this point put new batteries in the model and run a life test. Turn the receiver on and send signals. If possible, connect a voltmeter to the filament batteries so they can be constantly observed. Time the start of the operation and again when you notice operation getting erratic. This is the constant drain condition and, in practice, the life

will be somewhat longer because models are operated intermittently. *Always replace batteries at the first sign of weakness.* It's worth it in reliable, trouble-free operation.

A final word about batteries. If using battery boxes, use the type which has a screw-down cap that holds spring contacts firmly against the battery terminals and cannot come loose. Or, use soldered connections to the batteries. Receiver connections can be through phono plugs and jacks or good, lightweight, small-size commercial plugs and jacks which have a tight fit and a large contact area.

## **Relays**

There are many reliable types suitable for use in a model receiver. Generally, the unit should be capable of three adjustments: spring tension; de-energized distance from armature to core; and again (in the closed condition) the distance from armature to core. Once set, relays need little attention, unless the model has been subjected to some large shock.

Exposed contacts may be covered with dust and spray. A careful relay check prior to operation prevents trouble. This consists of visual inspection followed by operation of the receiver by the transmitter until you are sure it is working correctly.

# decoders

**O**NCE the command, in code form, has been transmitted from the control point and received at the remote location by the receiver in the model, it is fed into the decoding section. This is the section which causes power to move to the circuit or device designated by the coded signal.

The two basic decoder types are: 1) electromechanical and 2) electronic. Each type may consist of methods which are frequency or pulse selective.

Electromechanical decoders can be:

1. Frequency selective types
  - (a) resonant relays
  - (b) resonant reeds
2. Pulse selective types
  - (a) relays (single, delay, and relay chains)
  - (b) steppers (relay or motor driven, cyclic or reset)
  - (c) motor-driven commutators

Electronic decoders can be:

1. Frequency selective types
  - (a) bandpass, band elimination (rejection) filters
  - (b) discriminators
  - (c) separate receivers
2. Pulse selective types
  - (a) delay lines and coincidence circuits
  - (b) counting circuits
  - (c) amplitude detecting circuits
  - (d) gating circuits
  - (e) pulse-rate discriminators

Although this is not a complete list, it contains most methods of decoding used at the present time.

The decoder used will depend on the choice of coding, allowable size, weight requirements and amount of power available. (The decoder and the unit it controls must have power to operate.) The type of decoder also depends on the imagination and ability of the constructor. The decoder can be part of the receiver or a separate unit.

### **Resonant relays and resonant reeds**

A metal bar, when displaced and released will oscillate at a frequency determined by its length, thickness, width and type of metal from which it is constructed. A tuning fork is the simplest example. Another method of making a metal bar vibrate is to suspend it on or over a coil so that one end of the bar is rigid and the other end free. The coil is then energized with ac. As the frequency of the current approaches that at which the bar is resonant, the bar will vibrate with a large amplitude. Devices which use this principle are the frequency meters in power stations and in aircraft. The reeds are thin spring-steel pieces of metal of various lengths suspended over the magnetic coil. Each reed vibrates when the applied frequency is within 10 to 15 cycles (audio) of its resonant frequency, the amplitude becoming maximum at resonance. A series of these reeds can be used to indicate the frequency of the ac applied within this narrow tolerance.

This characteristic of the reed makes it an ideal decoder for separating commands when these are different audio tones. Three commands can be separated by only 25 to 50 cycles (i.e., 475, 500 and 550 cycles) and the reed decoder will cause different circuits to be operated as these tone commands are received.

The vibrating reed armature is adjusted to hit a set of nonmovable contacts at its maximum swing, caused by feeding a particular frequency into the coil. As it does so, it can make a power control relay close. If this relay is of the delay type which will hold closed during the small breaks caused when the armature is away from the contacts, it allows power to go into the desired control circuit. Because the armatures of resonant relays and reeds can be made of different dimensions, they will respond to various frequencies.

### **Single relays**

Among pulse-selective electromechanical devices the ordinary single-pole double-throw relay can be used to discriminate between some code sequences. For example, suppose a sequence such as

Neutral—Even pulse and spacing time

Command 1—Short pulses, wide spacing

Command 2—wide pulses, short spacing

were transmitted. Because of the even spacing and pulse duration in the neutral command position, the relay armature will spend exactly the same time on the make contact as on the break. If each of these contacts were wired to a small PM motor so that closing the make

contact would cause the motor to turn one way and closing the break contact would make it rotate in the opposite direction (the command calls for the same amount of rotation in each direction), the motor just would not move. Instead it would vibrate slightly back and forth around its neutral position at a rate proportional to the frequency of the pulse and space repetition. Fig. 501 illustrates such a circuit.

With command 1, the short pulses will cause the relay armature to spend a lesser amount of time on the make contact and a longer time

Fig. 501. A standard relay and a motor connected to form a decoder.

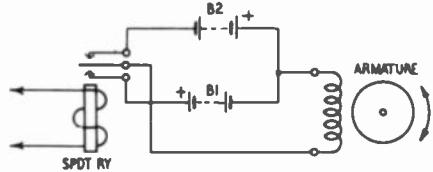

on the break. The motor then turns in one direction—call it reverse—with the first command. The second command causes the opposite action and the relay armature spends more time on the make contact

Fig. 502. True proportional control results when the motor armature is equipped with springs.

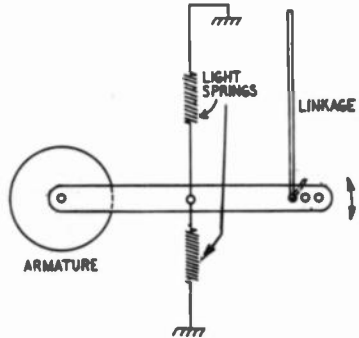

than on the break. This causes the motor to rotate forward. The speed of motor rotation will be directly proportional to the difference, time-wise, between the pulses and spacings. Thus, this idea becomes applicable to proportional control.

In proportional control, not only is the speed of rotation of the motor directly proportional to the differences in pulses and spacings, but the power exerted by the motor in trying to rotate is proportional also to this difference. If the motor armature is equipped with two springs (Fig. 502) then the deflection of the armature shaft will be proportional to the time-duration difference between pulses and spacings. No signal will cause maximum deflection one way; full signal maximum deflection in the opposite direction. When the pulses and spacings are equal in time, the springs furnish the force necessary to cause the motor armature to return to neutral.

In many applications, the motor is replaced by a circular magnet

which is free to turn within a coil. See Fig. 503. The relay contacts can cause current to flow through the coil in both directions and, since the magnet will try to align itself with the magnetic lines of force, it rotates like the motor. By means of a lever attached to the magnet shaft, the motion of the magnet can be translated into physical steering.

A commercial device (Fig. 504) known as a Fly Ball actuator uses the centrifugal force developed by the motor's rotation to affect the

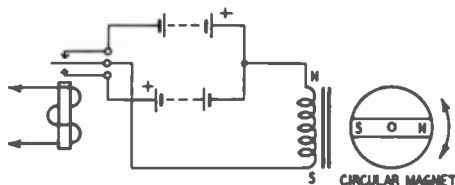

Fig. 503. A magnet is used as a decoder in this simple circuit.

mechanical output. When the motor turns, centrifugal force causes the diamond-shaped linkage to pull in. The amount that it pulls depends on the motor speed and this in turn is dependent upon the pulse and spacing time. The linkage is attached to a shaft and a single

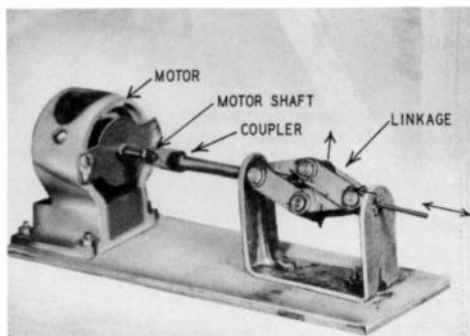

Fig. 504. A Fly Ball actuator. Centrifugal force is used for control.

spring. Equal pulses and spacings cause the shaft to be pulled in about halfway; pulses longer than spacing cause the shaft to be pulled in more while spaces longer than pulses let the spring pull the shaft out from the neutral position. The linkage to the shaft from the steering element allows control.

### Polarized relays

A polarized relay is one which has a small permanent magnet forming part of the armature. The armature is placed inside a coil which has no magnetic core and is centered by a small spring.

This type of relay can be used to distinguish between a positive or negative signal, such as that from a discriminator. It may be used in a bridge so that if even pulses and spaces are received by the tube,

the bridge can be balanced for 'no contact.' If longer spaces are received, the relay energizes one contact; if longer pulses are received, it energizes a second. Fig. 505 illustrates the bridge circuit and general relay construction.

It is possible to make a normal relay polarity-sensitive by placing a diode in series with the windings. In Fig. 506 the relay closes when

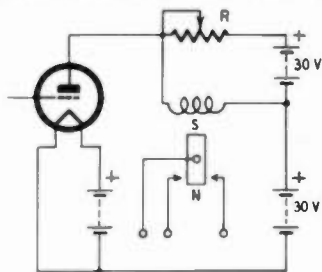

Fig. 505. A polarized relay in a bridge circuit which is balanced so that no contact is made when equal pulses and spaces are received.

the polarity is correct but remains de-energized if the polarity is incorrect. Thus only one contact can be used. Of course, the relay requires direct current otherwise the polarization is not effective. The diodes will rectify any ac applied.

### Delay relays

Delay relays may be of two basic types: those which delay in closing and those which delay in opening but close instantly with a signal. A

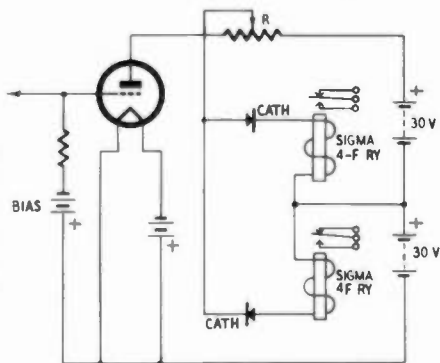
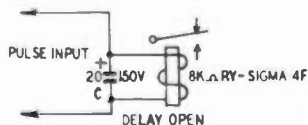

Fig. 506. Polarizing a standard relay with diodes. R is adjusted so that the relays are normally open.

delay relay can be made using a resistance and capacitance, or both, in the relay circuit. A delay relay also can be made which is entirely

Fig. 507. A delayed-opening relay. When in the closed position, the relay does not immediately respond to a drop in current.



mechanical by attaching a dashpot to the armature. Figs. 507 and 508 illustrate electronic methods of obtaining delay characteristics.

When a pulse is applied to the circuit of Fig. 507, the relay closes and at the same time the capacitor becomes charged. At the end of the pulse, the capacitor discharges through the relay windings, holding it closed for a period of time determined by the resistance of the relay and the size of the capacitor. This is a delay-in-opening type.

A delay-in-closing type (Fig. 508) has a resistance in series with the applied voltage, the relay and capacitor. When a pulse is applied, the capacitor, acting like a short circuit at the other end of the resistance, causes a large voltage drop across the resistance and does not allow the current to reach the relay to close it. However, the capacitor finally becomes charged and the current does pass on through the relay, closing it, but only after an interval of charging time. It is possible to calculate the delay by multiplying the value of the capacitor in farads by the resistance in ohms. This gives the time in seconds. The time is *one time constant* and it takes at least three of these to allow the capacitor to build up a large enough charge to let the relay operate. For the values illustrated in Fig. 508:  $0.00002 \times 22,000 = 0.4$  second for one time constant. The relay will close after approximately  $3 \times 0.4$  or 1.2 seconds.

The mechanical method of achieving a delay in closing and opening a relay is illustrated in Fig. 509. Here the piston of the dashpot is connected to the armature. When the relay tries to close, air is compressed in the chamber, preventing sudden closure. As the vent is adjusted, the air can be pushed out slowly, thus regulating closure time. This type of delay relay can be used to obtain operation of a function by holding a signal on for the necessary length of time. As an example, the unit illustrated in Fig. 509 was used in a model aircraft, wired in parallel with a motor-control relay. A pulse was all that was required to change the motor speed. If the pulse was held, not only was the motor speed changed, but a bomb was dropped as the delay relay was actuated.

It is possible to use the two delay relays of Figs. 507 and 508 wired in parallel to decode a pulse sequence for steering. The complete circuit is illustrated in Fig. 510. Upon receipt of short pulses with long spacing, the first relay will close. The second relay will not close since the pulse does not exist for a long enough time to charge the capacitor through the resistor. However, when signals consisting of long pulses with short spacing are received, both relays are closed. The circuit is so wired that the function battery voltage will be routed out through either one of the two contacts of the second relay to the controlled devices, depending upon which command is transmitted. When no command is sent, the armature of the first relay goes to the no-pulse-command contact, breaking the battery circuit to both controlled devices.

## Resonant relays

Resonant relays are so designed that the armature will close (in a vibrating motion) to a set of contacts when a particular audio fre-



quency is impressed on the windings. Commercial relays of this type are available on the market. The Frahm 3304-4, for example, operates

Fig. 508. This delayed-action relay does not close until the capacitor is charged.

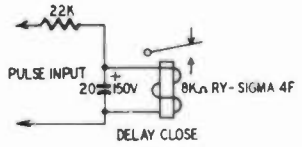

when a tone of 416 cps is applied. It is possible to wire these relays in series or parallel to achieve simultaneous operation of more than one relay when combinations of tones are transmitted.

### Relays as amplitude detectors

It is possible to use conventional relays as amplitude detectors. If a series of relays are all wired parallel to the same pair of control lines and the spring tensions are adjusted progressively tighter, the first will

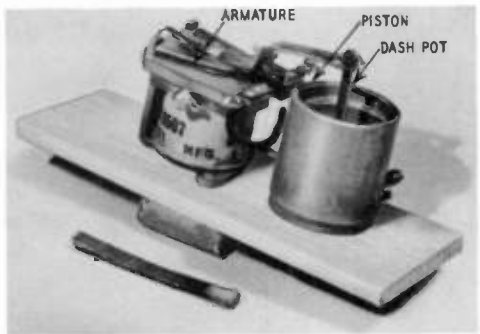

Fig. 509. By making the relay work against air pressure the dashpot delays opening and closing action.

operate with minimum voltage, the first and second with a slightly higher voltage and so on until all are operated.

### Relay chains

Relay chains are of varied and assorted types. They can count pulses

Fig. 510. A variety of responses to coded signals are obtained by wiring delay relays in parallel.

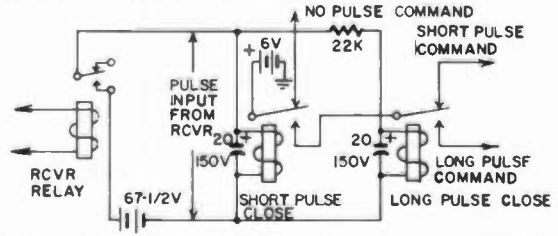

and distinguish between long and short pulses or between pulses of

different amplitudes. The use of relay chains for the modeler has the same application that the more complex delay lines and gating circuits have for the control engineer.

Sometimes, in a control application, it is desired to have a circuit which will energize some control function with the application of a signal. After the signal stops, a second function will be energized automatically a short time later. Such a circuit is illustrated in Fig. 511.

When switch SW (which might be the contacts of the receiver relay) is closed, RY1 is energized. Since capacitor C2 is shunted across this relay, it will become charged. Now, if SW is opened, C2 will discharge through the relay winding holding it closed for a period of time governed by the resistance of the winding and the size of the capacitor. During the time that this relay is energized, the bottom armature of the relay has moved down and touches contact 4. This could close the first circuit it is desired to operate.

Now examine the top contacts of this relay (upper armature and contact points 1 and 2). C1 is connected to the upper armature and the negative side of the battery. When the relay is energized, the upper armature touches contact 2 of the relay, placing C1 across the battery.

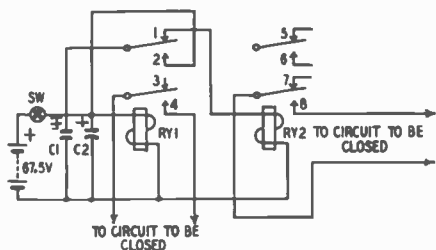

Fig. 511. The second relay in this chain closes automatically after the first is energized. C1 and C2 are 25-50  $\mu\text{f}$ .

As a result, C1 becomes charged. As long as the first relay is closed, C1 is shunted across the battery and does no useful work. When SW is opened, RY1 will be held closed by the discharging action of C2. When this discharging action is completed, the relay will open. The upper armature will then move to touch contact 1. This has the effect of removing C1 from across the battery and at the same time placing it in shunt across RY2. C1 will now discharge through RY2, energizing it. The time that RY2 remains closed is again governed by the resistance of the coil and the size of the capacitor. As RY2 closes, the lower armature will touch contact 8, which closes the second circuit to be operated. Observe that RY2 will not close until RY1 has opened.

It is possible to add as many relays as desired to the basic chain wired in the same manner to form a "modeler's delay line." If the receiver has two channels, it becomes possible to accomplish many functions since, not only is the numerical sequence type of code applicable, but also the pulse-presence-pulse-omission code.

A four-relay delay line, with a two-channel receiver input is illus-

trated in Fig. 512. In this circuit, RY1 is closed by a signal through channel 1 of the receiver. This starts the chain action. If, when the channel-1 signal stops, a quick pulse follows in channel 2, power will be applied to control circuit 1. If the channel-2 pulse does not arrive until after RY2 has opened but before RY3 opens, then power is routed to control circuit 3, etc. Thus, by pulsing the second receiver channel at the right time after channel 1 has sent a signal, any one or all or any combination of the four relays in the chain can have power routed through their bottom contacts to the four control circuits.

If each control circuit is connected to a series of multipole relays as in Fig. 513, then it is possible to obtain 16 control functions.

To use this circuit in model applications, such as a model ship, probably half of the 16 contacts would cause latching relays to lock

$C = 25-50 \mu\text{f}$ ; all relays are 8-10k; B1, B2 and B3 are 45-67.5 volts; all circuits operate 6-volt devices.

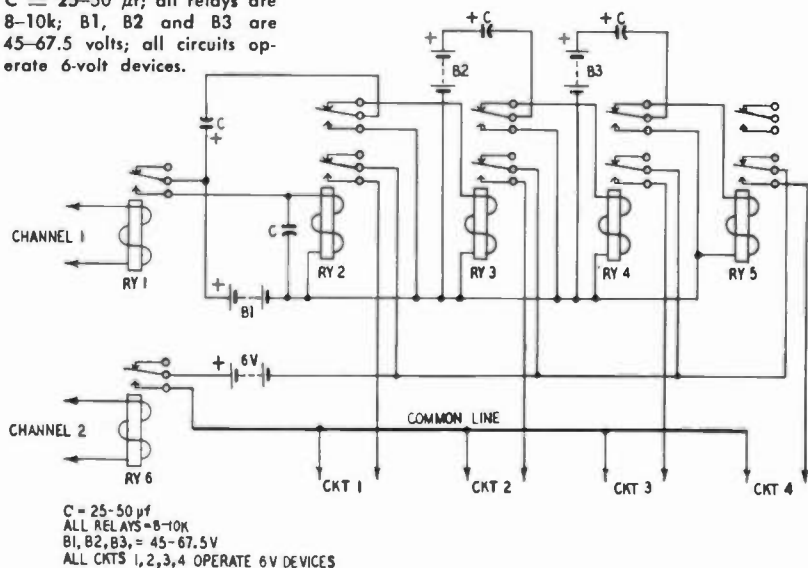

Fig. 512. A four-relay delay line with a two-channel input.

up; the other half of the 16 contacts would be the release controls. The only requirement for use is that the pulse from channel 2 of the receiver follow at the right time after the signal from channel 1 stops. The capacitors (as shown in Fig. 512) can be made large enough (20 to 80  $\mu\text{f}$ ) and the relays sensitive enough (Sigma 4F, 8,000-ohm coil or others of this type) to close at about 1 ma. The action should be slow enough so that hand pulsing is feasible. To achieve the best control, however, use a motor-driven arm riding over a set of contacts at some controlled speed. Then if the motor starts by closing channel 1 and the control box is provided with switches which can close the other contacts to channel 2 at the right time, absolute synchronism can be achieved.

## Steppers

A stepper, as the word suggests, consists of an arm or arms moved to any of a number of contacts, usually arranged in a circle or semicircle. The arm can be turned by relay power, rubber bands (as in model aircraft), by clock-work springs or an electric motor.

One of the simplest steppers can be constructed from an escapement. This can be a relay and a rotating arm so arranged that the relay catches the arm every 90° of rotation (Fig. 514). To make this unit into a stepper add a contact wiper to the shaft connected to the bar and then arrange a series of four contacts 90° apart so that the wiper will touch one of the contacts in each of its four positions. Two of these contacts will be closed with on signals, and two with off signals. This stepper is known as a cyclic type, the wiper continuing to

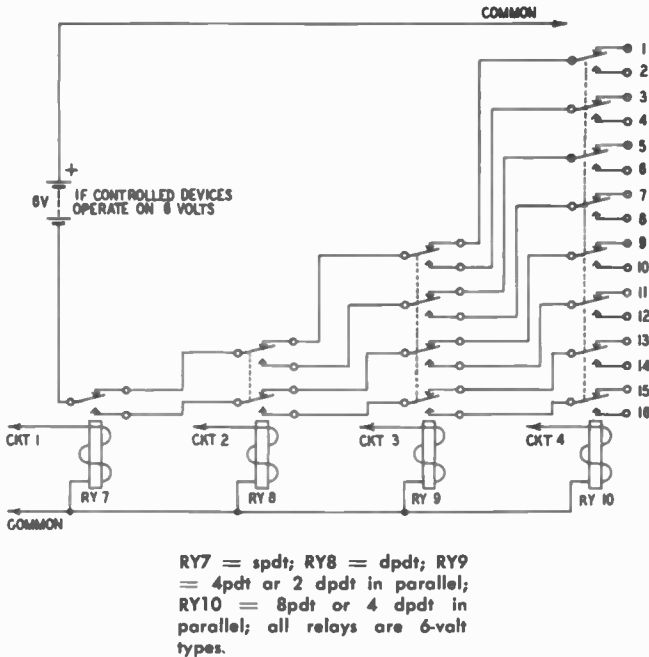

Fig. 513. By connecting each control section to a multipole relay, 16 control functions are possible.

move around and around in a circle over the contacts if the relay is pulsed over a long period of time.

It is possible to obtain more contacts by using an escapement with three or four fingers and adjusting the catch points so that they stop the rotation every 45° instead of 90°. It is also possible to use a single contact finger and gear the output shaft so that, for every revolution of the finger, the output shaft moves only a fraction of a revolution

and will remain there until another on-off signal moves the wiper to the next position.

Contacts can be kept 'cold' or unenergized while the wiper is moving over them. This can be done by using a quick-close-delay-in-opening relay (a relay with a capacitor across its windings) which is initially energized with the first pulse. The contacts of this relay can break the common line from the stepper shaft to the control circuits when

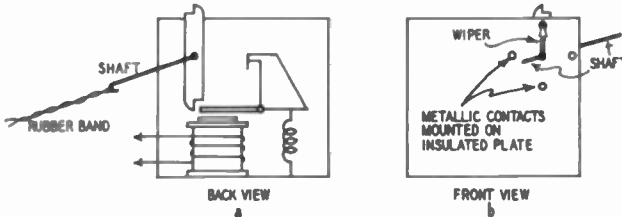

Fig. 514. An escapement can be easily converted into a stepper: a) back view; b) front view.

it is energized. When the wiper is being pulsed (or stepped around), this relay is energized and no control circuit power is applied. As soon as the wiper reaches the desired position and the pulsing stops, the delay relay will open, closing the control circuit. It is advisable to insert a small resistance in series with this relay's winding to isolate it

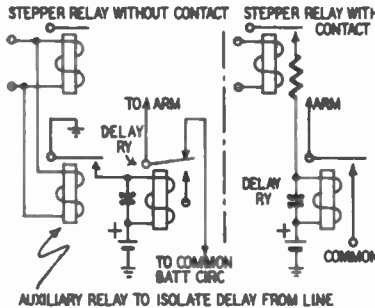

Fig. 515. Circuit for keeping the stepper and contacts electrically isolated.

from the escapement or receiver plate relay. Otherwise the delay action of the capacitor will affect these and interfere with the ability to pulse the circuit properly. A suggested circuit is illustrated in Fig. 515.

Relay-driven steppers (Fig. 516) are those in which the relay itself forces the arm to move, generally by driving a ratcheted wheel when the armature is pulled in. In this case the multinotched wheel allows a greater number of contacts to be passed over by the wiper. This arrangement has a pawl which prevents the armature from pulling the notched wheel off the contact once it has been pulled down and released by the opening of the circuit to the relay. Notice the arrange-

ment of the pawl. It will allow the notched wheel to move clockwise but not counterclockwise. There is a reason for this. When the relay armature pulls down, it moves the wheel a small amount. Then, when the armature is pulled back by the spring (due to the breaking of the relay circuit) it will not tend to pull the wheel back with it. This stepper wheel does not rotate except in small jerks every time the relay is energized and then only in a clockwise direction. It is possible to obtain steppers of this type with two relays. One is the stepping relay and the second a reset relay. In this case, the wiper may be stepped around to any one of the contact positions, left there as long as desired and then, by energizing the reset relay, the wiper is made to spring back to the original starting position.

A motor-driven stepper is one in which a motor causes rotation of the stepper arm, but the amount that the arm moves is still controlled by a relay.

### Motor-driven commutators

The word commutator is familiar to anyone who has ever seen an electric motor or generator of the brush type. A commutator has a number of segments of conducting material, grouped together in a circular manner and insulated from one another. The brush makes con-

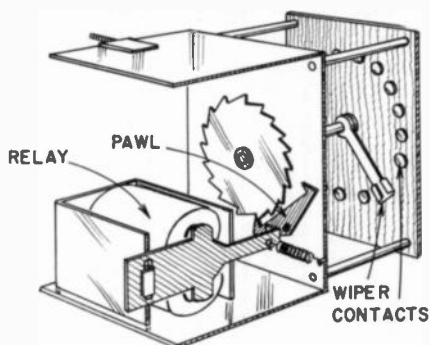

Fig. 516. A relay-driven stepper.

tact with each segment as the commutator rotates. The segments may also be arranged in a circle (Fig. 517) and a rotating arm can sweep over them. This arm, driven by a motor, sweeps over each contact in succession. If the transmitting location has a commutator identical to the one used at the receiving location and the two arms move in exact synchronism, then a pulse code of the presence-omission type may be sent and decoded.

The decoding arm will fall on contacts 1, 2, 3, 4, 5 and 6 in succession and then the action will be repeated. If at the same time the transmitting arm makes connection to contacts to the transmitter through switches, then, when the switch is closed for contact 1, a pulse will be transmitted every time the rotating arm passes over it. The transmitted pulse will arrive at the receiver and be sent along to the decoder. The circuit connected to contact 1 will then be energized.

If a relay chain (with latching and release relays) such as that illustrated in Fig. 513 were connected to four of the decoder commutator contacts, this chain could be operated. A fifth contact could be used to energize the combination which was set up by the previous four contacts. A difficulty with this decoder is to maintain absolute synchronism between the two arms when they are separated. Governors or extra contacts may be used for this synchronization. If, for example, two extra contacts were provided, they could be arranged so that, if the receiving arm of the decoder were slow, it would be on contact 5

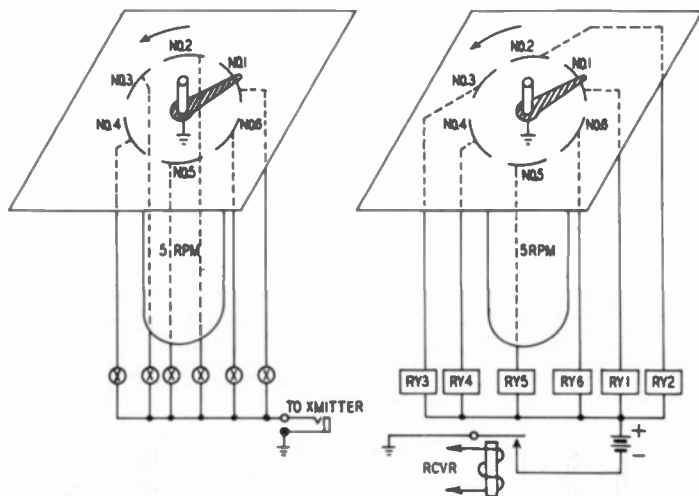

Fig. 517. Motor-driven commutator-type coder and decoder.

while the transmitting arm was on contact 6. This would cause a signal to be received in a motor speed-up circuit, closing a relay and momentarily feeding the receiving motor a larger voltage. If the transmitting arm were slow and the receiving arm fast, then the transmitting arm would be on contact 5 while the receiving arm was on contact 6. This could cause a relay to open momentarily, breaking the supply voltage to the receiving arm motor and thus slowing it. This method would cause the two arms to be synchronized every revolution. The problem of synchronization becomes more difficult as the speed of the motors is increased and becomes easier as the speed is reduced. It is often possible to tolerate a small delay in getting particular commands performed.

### Bandpass filters

Frequency-selective decoders of the electronic type are those which use circuit elements in connection with vacuum tubes or transistors to decode signals consisting of tones or frequencies. In most cases each

tube or transistor in the output of the decoding section operates a relay which controls the power to a particular circuit.

The bandpass filter is one of the most common forms of decoders when the code consists of audio tones. The device permits a restricted band of frequencies to pass and rejects all others. There are two general arrangements for doing this: one is to use a choke and capacitor; the second is to use capacitors and resistors arranged in a frequency-bridge circuit.

A choke and capacitor connected in series form a resonant circuit at some particular frequency. At resonance, the impedance of the circuit is a minimum, resulting in a maximum flow of current. However, each unit—the choke and the capacitor—have separate impedances. Thus the circuit current passing through them creates a high-voltage drop across each. These voltages are out of phase and cancel when looking at the unit as a whole. Taking only one unit of this combination, we find a large voltage suitable for tubes or transistors. When the tube or transistor conducts, it can cause a relay to operate.

Although the series circuit has a minimum impedance at the frequency of resonance, the impedance increases above or below resonance. The farther the frequency is away from the resonant frequency, the greater will be the impedance of the series circuit.

A method for determining the resonant frequency of a coil  $L$  and a capacitor  $C$  in series is to apply the output from an audio signal

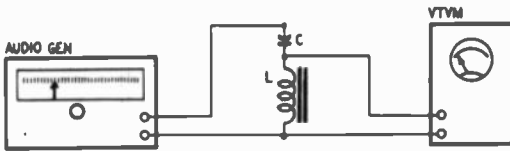

Fig. 518. Determining the resonant frequency of series tuned circuits.

generator to one end of the coil and one end of the capacitor, connecting a vacuum-tube voltmeter (or other high-resistance voltmeter) across one element as shown in Fig. 518.

If the audio generator's frequency is changed from the low to the high end of the range, there will be an abrupt rise of voltage shown on the meter as the resonant frequency is reached. At the point of maximum output, the reading on the generator dial will give the frequency at which the combination is resonant. The voltmeter should be of a type which reads ac. An oscilloscope may also be used in the same manner. The highest amplitude of the signal on the scope tube will be noted at resonance. It is assumed that the coil and capacitor combination will resonate in the audio range. The same idea may be used in the rf range to determine the resonant frequency. However, the use of a grid dip meter for rf is more practical.



Where a parallel-resonant circuit is desired (for example, in a transmitter tone oscillator which uses a tuned circuit to control the tone frequency) this same method of determining resonance may be used. The series and parallel-resonant frequency of any coil and capacitor are the same.

Series bandpass filters lend themselves quite well to control applica-

Fig. 519. The voltage across  $L$  or  $C$  is maximum at resonance.

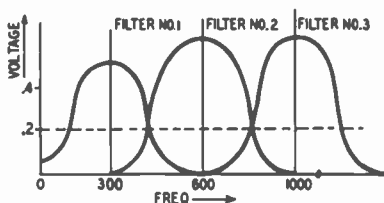

tions. If a number of these resonant circuits are fed from the last audio tube (or transistor) of a receiver and if each has a different resonant frequency, meters connected across the coils alternately peak as the signal generator is varied throughout its range. If the readings are plotted against frequency, a chart such as that shown in Fig. 519 results. This chart indicates that frequency separation of the tones is taking place.

If vacuum tubes (or transistors) were connected (instead of the meters) to each coil and if each required a signal of at least 0.3 volt to cause it to conduct, then each tube or transistor would conduct only when its particular tone was being transmitted and received. When one of the tubes conducts, it closes a relay in its plate circuit. Closing of the receiver plate circuit relay might permit delivery of power to

Fig. 520. Twin-T band-rejection filter.

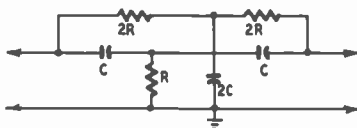

some device which in turn would cause some desired command to be performed.

This is, at the present time, perhaps the most popular and most reliable form of decoder used in radio-control applications. Its principal disadvantage is that it is somewhat larger and heavier than other methods if a number of tones are used. If a simple filter is used, the separation of tones should be reasonably large (for example: 300, 700, 1,000, 1,200, 3,000 and perhaps 5,000 cps) since these filters are relatively broad in their frequency discrimination. In multitone systems make sure that no filter is tuned to the harmonic (second) of some other tone. If more than six or eight tones are to be used, elaborate filters must be constructed. These filters consist essentially of several simple sections which operate in series or combinations of band-rejec-

tion and bandpass filters. (A band-rejection filter of the L-C variety is a parallel-tuned circuit so placed that the signal must pass through it.) With a complex filter of this type the selectivity becomes sharp enough so that closely associated tones may be used for commands without adverse effects.

### Band-rejection filters

Another frequency-selective decoder of the bandpass variety and one more desirable in some applications because of its reduction in weight is the null-bridge type of filter. It can be constructed from capacitors and resistors and, when inserted in an amplifier so that it controls the feedback, makes the amplifier frequency-selective. It does so by allowing those tones or signals to which it is not tuned to degenerate more than the one at which it has its null.

This filter is not really a bandpass unit but a band rejection type. One of the more popular filters is the twin-T illustrated in Fig. 520. The determination of the frequency at which the circuit has its null is easy, using the following formula:

$$F = \frac{1}{6.28 \times 2R \times C}$$

Where F is in cycles per second, R in ohms, and C in farads.

The following sample problem illustrates the use of the formula:

*Find:* Values of capacitance so that null occurs at 1,000 cps.

Let R = 1 megohm.

*Solution:* If R is 1 megohm, then 2R becomes 2 megohms

$$C = \frac{1}{6.28 \times F \times 2R} = \frac{1}{(6.28)(1,000)(2,000,000)}$$

$$C = 80 \mu\mu\text{f} \text{ and so } 2C \text{ becomes } 160 \mu\mu\text{f}$$

When using this type of filter, a signal loss occurs so generally an

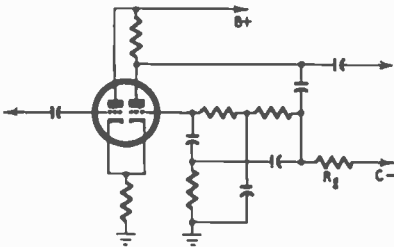

Fig. 521. Twin-T filter used in the grid circuit of one section of a duo-triode.

additional tube is added in the circuit to overcome it. One method (Fig. 521) is to put the network in the grid circuit of the second half of a duo-triode, the second half of the tube being connected to the input half of the tube through the cathode resistor. This prevents any load on the filter itself, an important consideration as far as its selec-

tivity is concerned. Resistor  $R_g$  can be tied to a bias voltage if required.

This filter is usually connected around the input or high-gain stages of an amplifier and should be followed with the tube or tubes necessary to build up the desired frequency voltage to a value large enough to operate a relay tube. A group of tubes which have the twin-T as a feedback system can be fed from the audio section of the receiver, and from there the decoding is the same as for the L-C filter. The reason for the choice of the twin-T over other types is that it has a common ground for input and output and is more adaptable than units which must operate above ground potential. Another reason is that the selec-

Fig. 522. A typical twin-T filter as used in an amplifier stage.

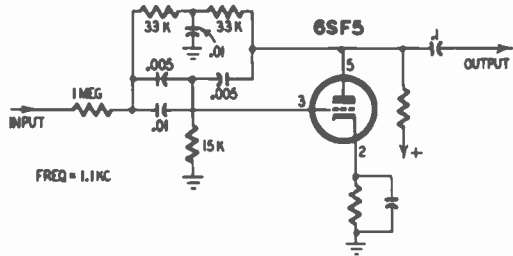

tivity is very sharp and thus more command channels can be obtained throughout the audio range than are possible with the simple L-C filter. A representative circuit employing the twin-T appears in Fig. 522.

### Broad bandpass filters

It is possible through the use of relatively simple networks to separate the audio spectrum into two or three broad bands. This means

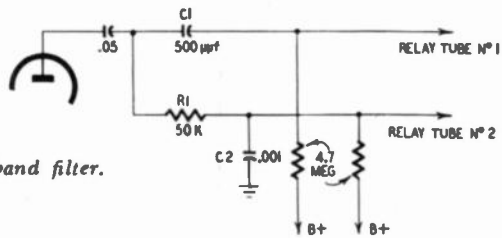

Fig. 523. A two-channel broad-band filter.

that the modeler can select low, intermediate and high audio tones which do not have to be of an exact frequency and have multichannel operation. In the first circuit (Fig. 523) a simple resistance network divides the audio spectrum into two areas. The frequencies below approximately 1,200 cycles will be channeled to one relay tube and those above this frequency to a second. When high frequencies are impressed on the filter, they pass through the small capacitor  $C_1$  readily and so go to the grid of relay tube 1. These same frequencies find

difficulty in passing through the series resistance R1 and those that do are bypassed to ground at the grid of relay tube 2 through capacitor C2.

Low frequencies find it very difficult to pass through the small capacitor C1 to the grid of relay tube 1, so this tube does not operate. They can pass quite readily through the series resistor and again have difficulty in trying to go to ground through the shunt capacitor C2 and

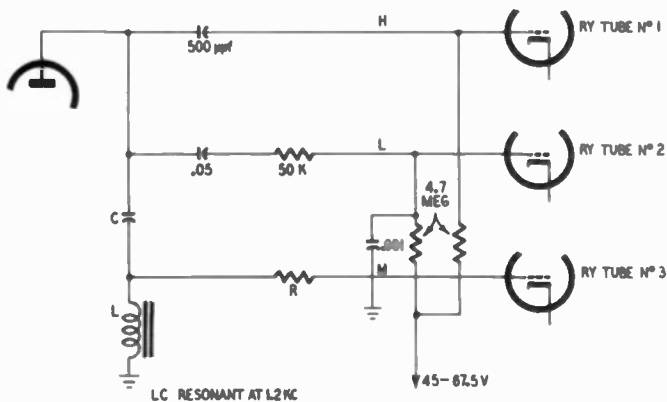

Fig. 524. A combination filter which separates the audio spectrum into three bands.

so are impressed on the grid of relay tube 2, causing it to operate. The values shown are representative for proper circuit operation. Here again, however, there is some signal loss and so an additional stage of audio amplification may be required.

It is possible to combine L-C and R-C units to obtain a filter which will separate the audio spectrum into three broad bands. See Fig. 524. This circuit is identical to the one previously described except that a series L-C filter has been added. This filter should be resonant to the 1,200-cycle mid- or crossover point. If one were to connect an audio signal generator to the input of this filter and monitor the outputs at points H and L, a frequency will be noted where the two outputs are identical. This should occur somewhere in the middle of the range of the generator. The L-C filter should then be resonated at this frequency.

When the two elements are combined, a sharp drop will be noted at this mid-point frequency at points H and L and at the same time a sharp rise at point M. The series resistance at M should be adjusted so that signal amplitude at 1,200 cycles is the same as, for example, 3,000 and 600 cps and these would then represent the operating frequencies. Considerable latitude can be tolerated for the low and high tones.

## Discriminators

Another widely employed method in the decoding of signals where the tones or frequencies represent commands is the use of a discriminator. There is no output from a discriminator when the resting frequency is transmitted; a positive (polarity is assumed here) dc output when the frequency is lower than the resting frequency and a negative dc output when it is higher.

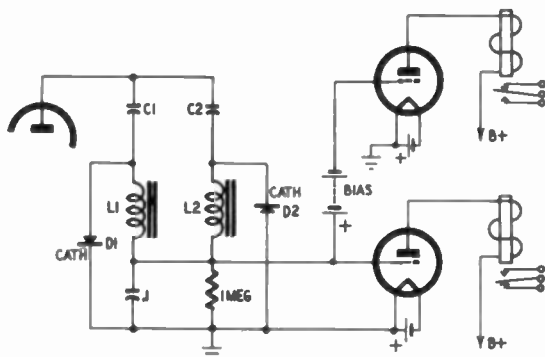

Fig. 525. Discriminator used as a decoder.

The value of dc output is proportional to the deviation from the resting frequency, within the limits of the circuits involved. Thus, a small dc signal can be produced with a small frequency deviation or

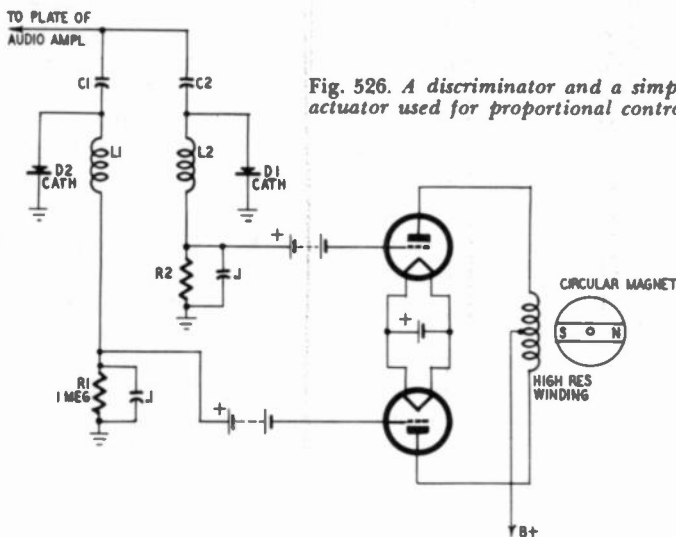

Fig. 526. A discriminator and a simple actuator used for proportional control.

a large output for a large deviation. This circuit, then, becomes especially adaptable for proportional control. A circuit which can be

used with audio or radio frequencies is illustrated in Fig. 525. Two vacuum tubes are connected to the output of the discriminator so that one operates a relay in its plate circuit with a positive signal and another with a negative signal.

L1-C1 is tuned higher than the chosen resting frequency. Both L1-C1 and L2-C2 have their resonant frequencies equally removed from the center or resting frequency. L2-C2 then is tuned lower than the resting frequency. The two diodes are connected across one half of the series-resonant circuit so that one diode rectifier produces a positive voltage and the other a negative voltage, across the common 1 megohm load resistor R1.

When the resting frequency is received, it is exactly midway between the frequencies of the two tuned circuits. The equal positive and negative voltages cancel, and the output is zero. When the deviation is above or below the resting frequency, that L-C circuit whose resonant frequency is nearest the deviation produces a larger voltage than its opposite and thus governs the polarity and magnitude of the output.

Note that one tube (Fig. 525) is biased by a small battery. Normally the relay in the plate circuit of this tube is open. A plus voltage on the grid of this tube would overcome the bias, the tube would conduct and the plate circuit relay would close.

The second relay tube is normally conducting and so requires a negative signal voltage applied to its control grid to cut off the flow of tube current. This in turn would make the relay drop out on the back or normally closed contact. Thus, the plus or minus voltages from the discriminator cause one or the other of the plate relays to function.

Why use this circuit when the result is simply two channels? This is true in the operational circuit just discussed. To understand fully the advantages of a discriminator type of decoder, the circuit of Fig. 526 is added. The plate relays of the two tubes are replaced with an actuator which consists of a magnet surrounded by a split winding coil.

The resting frequency is adjusted so that the currents in the two halves are equal and, since they flow in opposite directions, the magnetic field of the coil does not attract or repel the armature. If the input frequency is raised a small amount, one current predominates. The coil establishes a magnetic field, pulling the armature in one direction. If the armature is fastened to a rudder, for example, a small force will move it a small amount in this direction. A larger deviation from the resting frequency causes more force and a larger motion. This same principle applies to the situation where the frequency is lower than the resting value, but here the rudder is moved in the opposite direction.

In practice, it is necessary either to use tubes capable of controlling reasonably large currents or direct-couple a second stage to each of

the discriminator-fed amplifier tubes to get sufficient current flow to produce the power required for rudder movement.

### Separate receivers

The final method of frequency decoding is that of using separate receivers operating on radio frequencies separated far enough so that the receivers do not interfere with one another. A two-channel arrangement would be 27.255 and 465 mc.

### Delay lines and coincidence circuits

Electronic pulse-selective methods, among which are included delay lines and coincidence circuits, are generally complex. Basically they

Fig. 527. This simple series-parallel circuit forms a fundamental delay line.

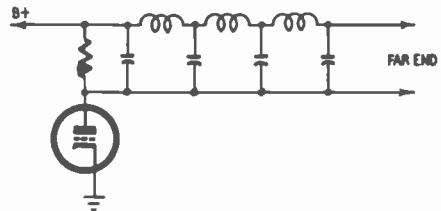

consist of an arrangement of vacuum tubes, delay lines and special circuits which form gates through which the desired pulses are channeled. This method of decoding is most applicable when applied to pulses whose duration and spacing can be measured in millionths of a second, generally too fast for the hobbyist's purpose.

A delay line consists of an arrangement of coils and capacitors in a series-parallel circuit. See Fig. 527. A line of this type possesses some unique properties. When the far end is short-circuited and the impedance of the line is equal to the impedance of the driving source, no reflection occurs. However, it does take a definite time for the current and voltage waves to pass through the coils and charge the capacitors. Thus, this type of line delays the arrival of the signal or



Fig. 528. A transmitted command consisting of a series of paired pulses is used with a delay line.

pulse. The length of the delay is proportional to the size and number of coils and capacitors.

A line may also be used to reflect a pulse from the far end if the impedance of the line is not matched to the impedance of driving source. If the two impedances are unequal and the line is open-circuited at the far end, a reflected signal will come back in phase with the one impressed on the line. If the far end of the line is short-cir-

cued and the impedances are unequal, the reflected wave will be  $180^\circ$  out of phase with the impressed signal.

With these points in mind let the code be such that the spacing between the pulses represents different commands. See Fig. 528. Each command consists of a pulse pair, with varying spacing between them. The receiver will pick up a 1-microsecond pulse. This will be followed by a second rf pulse, also 1 microsecond, but separated in time from the first pulse by an interval of 2 microseconds. This particular pulse pair repeats at intervals of 50 microseconds as long as the command is desired or until a latching relay in the receiver has had time to close and lock. We can use this varying-space pulse-pair command in connection with the delay line circuit shown in Fig. 529.

The rf pulses are passed through the if section of the receiver by V1, half of a diode. From the if transformer end of the 220,000-ohm diode load resistor, these pulses have a *negative* polarity to ground. The negative pulses are fed through the .0001  $\mu$ f coupling capacitor to the control grids of V2-V3. The common grids of the 6SN7-GTA are returned to ground through a 560,000-ohm grid return resistor. Note that the plate load resistor for V2 is actually the terminating or load resistor for the delay line. Ordinarily, the plate current for V2 would flow from the plate of V2 through the 22,000-ohm load resistor, back to the power supply. The IR drop across the load resistor would also charge capacitors C1, C2, C3, C4 and C5 of the delay-line network since these are shunted across the load resistance. When the grid of V2 receives a negative pulse, V2 becomes biased to plate current cut-off. When V2 stops conducting, the capacitors of the delay line discharge through the load resistor. It is interesting to note that these capacitors do not all discharge in the same time. C1, being farthest away from the load resistor, discharges first since it will try to charge the other capacitors as they start to discharge. C1 is followed by C2, C3, C4 and finally C5.

Because C1 discharges first, it removes the bucking voltage it presented between point W and the supply voltage. Point W is the first to reach the supply voltage potential after the plate itself does. In this case point W reaches the supply voltage potential 2 microseconds after the plate; point X, 4 microseconds; point Y, 6 microseconds; and point Z, 8 microseconds later.

V4 is so biased that both its grids (control and injector) must be positive at the same time before it will draw enough current to operate the relay in its plate circuit. With this in mind, consider V3, the second half of the 6SN7-GTA. The first pulse causing V2 to cease conducting also forces V3 to behave in the same way. This results in a rise in voltage at the plate of V3. This voltage rise is transferred to the control grid of V4, making it positive; but since the injector grid of V4 is not positive, the tube does not close the relay.

The second of the two pulses now arrives at the grids of V2 and V3.



The effect on V3, as we have seen, results in a positive voltage being placed on the control grid of V4. Meanwhile the line, which started discharging with the first pulse, becomes equal at this instant to the supply potential at point W. This is equivalent to placing a positive pulse on the injector grid of V4. Since both grids are now positive at the same instant, the tube conducts and the relay closes. The plate relay, in turn, can close a circuit to a latching relay energizing it, forcing it to close and hold.

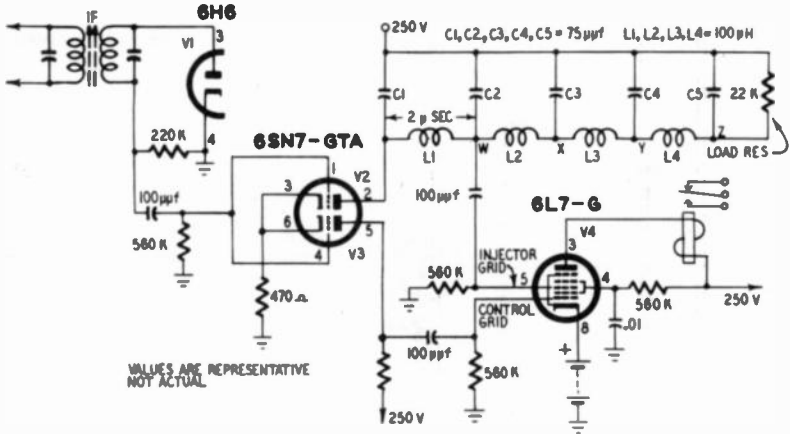

Fig. 529. The action of this delay-line decoder depends upon the pulse timing.

A second relay tube similar to V4 connected to point X on the line would require pulses with a 4-microsecond spacing to give a similar

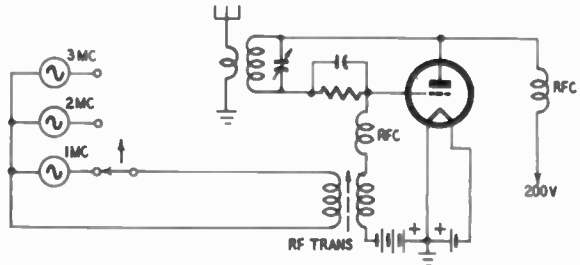

Fig. 530. Rf oscillator pulsed in microseconds.

response. It might be thought that our original relay tube V4 might conflict with additional relay tubes added to the circuit. Remember, however, that relay tube V4 will conduct only upon reception of pulses 2 microseconds apart.

In general, when V2 conducts, it starts a pulse down the delay line so that it arrives at points W, X, Y and Z at 2, 4, 6 and 8 microseconds, respectively, after starting. To effect a command, a series of, say, 2 microsecond pulses would be transmitted continuously as long as the command were desired. This could hold a relay closed as long as

the pulses were received. Then there would be a break of 50 microseconds or longer before another command would be started.

### Generation of microsecond pulses

A simple circuit for generating these microsecond pulses is illustrated in Fig. 530. The rf portion of the circuit is a simple one-tube self-excited oscillator. The grid return, however, is connected through a transformer to a battery bias supply large enough to prevent the tube from oscillating. The primary of the transformer is connected to a signal source which will supply any of three sine-wave signals

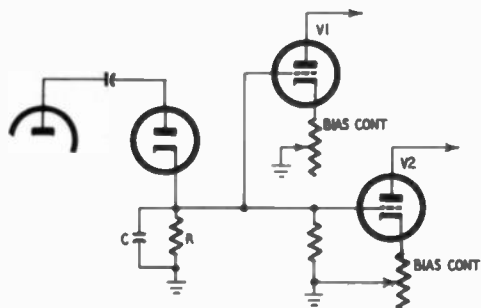

Fig. 531. This counting circuit decoder can distinguish between a variety of codes.

of, for example, 1- 2- and 3-mc. It is possible to select which one is fed to the transformer by a selector switch.

When the positive alternation of the signal is present on the secondary of the transformer so that it opposes the bias voltage, the rf portion of the circuit oscillates in a normal manner, producing an rf pulse. Thus, by selecting the proper frequency input, proper pulse spacings can be transmitted. A 500-kc input frequency would produce pulses spaced 2 microseconds apart, etc.

### Counting circuits

It is possible to decode codes of the numerical sequence type by electronic means. With a circuit such as illustrated in Fig. 531, several numerical commands can be distinguished. In this circuit, each pulse is rectified by the diode and stored in capacitor C as a certain value of voltage. Each tube, connected to the top portion of the capacitor, has a value of bias which differs from the bias of the other tubes. When two pulses are transmitted, V1 will have its bias raised above the cutoff point and the tube will conduct. This flow of plate current could operate a relay in the plate circuit of the tube. Since the bias on V2 could be made greater than the bias on V1, it might be necessary to have three pulses to make V2 conduct. Additional tubes could be added as required.

After a command (of two pulses, for example) has been transmitted, a pause is required long enough for the capacitor to discharge through its load resistor to allow the circuit to return to its static condition

and be ready for the next command. Otherwise, if two pulses were followed quickly by two more, the circuit could not tell whether it was a two- or four-pulse command. In this type of circuit latching relays should be used since the tube will not hold its relay closed continuously. The number of relays that close is directly proportional to the number of pulses transmitted. This circuit can also decode pulses whose width varies, as the width of the pulse would govern the amount of charge on the capacitor.

Fig. 532. This decoder, because of the short R-C time constant, is sensitive to pulse amplitude.

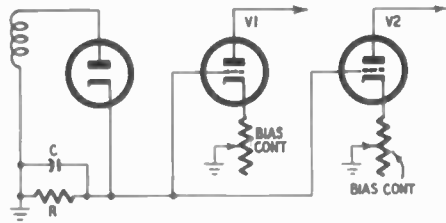

### Amplitude-detecting circuits

It is feasible to use pulse amplitudes to convey information just as it is possible to amplitude-modulate any radio signal. A decoder

Fig. 533. The heart of many gating circuits is a simple integrating network.



which decodes the amplitude of a pulse into a command function is illustrated in Fig. 532. It consists of several biased detectors V1 and V2. Since each tube has a relatively large amount of bias, it would take a pulse of greater amplitude to cause each succeeding stage to operate. Here, as in the decoder for numerical sequences, one, two or more tubes may be made to conduct but we cannot have tube 4, for example, operating without having tubes 1, 2 and 3 working also.

Fig. 534. In this simple gating circuit, V2 is equivalent to R1 of Fig. 533. R2 and C2 form the remainder of the integrating network.

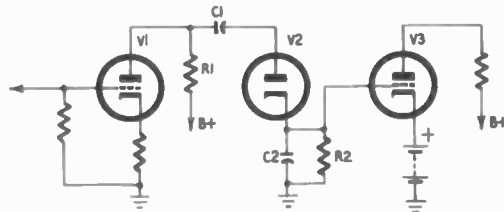

The circuits of Figs. 531 and 532 are the same. In Fig. 531 the time constant of the R-C combination ( $T = R \times C$ ) is very large. This means that this circuit will hold a voltage level due to a given pulse long enough so that a second pulse may be added to it. Thus the voltage level increases according to the number of pulses transmitted.

Resistor R and capacitor C in Fig. 532, however, have such a very short time constant that it is the instantaneous amplitude of the pulse that determines the magnitude of the voltage across R and C, instead of the number of pulses applied.

### Gating circuits

A gating circuit is used to decode signals of the pulse-presence-pulse-omission type. It may also be used to decode time-modulated or pulse-spacing codes. An essential feature of a gating circuit is an integrator network. Basically, the integrator consists of a resistor and capacitor in series, with a second resistor shunted across the capacitor as illustrated in Fig. 533.

When the switch is closed, the battery charges the capacitor and, since the current must flow through R1, it takes a definite time to do so. This length of time depends directly upon the size of the resistor and the amount of capacitance.

If the switch is opened at the moment that the capacitor is charged, C1 will begin to discharge through R2. It takes a definite time for the capacitor to discharge. We can use this simple circuit to distinguish between a pulse which has a long time or which is wide and a short time or a narrow pulse by combining our integrator network with a diode. See Fig. 534.

V3 has sufficient bias on its cathode to be normally cut off. The tube can be made to conduct, however, by placing on its grid a positive pulse having an amplitude sufficient to overcome the bias. Whenever the input triode V1 receives a negative pulse on its control grid, the decrease in plate current means less of a voltage drop across its plate load resistor R1. Consequently the potential on the plate of V1 increases. The result is a positive charge placed on the diode plate, through C1. The positive plate of the diode will attract electrons from its cathode. Since the cathode is returned to ground through R2, there is a flow of current up through R2 from ground. The effect of this current flow is to charge C2. Since C2 acts like a short circuit until it does get some charge, it takes some time before a voltage appears across R2. If V1 produced only a short pulse, there would be no voltage drop across R2 and, as far as V3 is concerned, the short pulse produced by V1 would have no effect.

Let V1 produce a pulse much longer in time. Capacitor C2 does get a charge which builds up until the full possible voltage exists across it and R2. This voltage is positive with respect to ground and is of sufficient magnitude to override the bias on V3, causing it to conduct. In this manner V3 will recognize only long pulses and not short ones. Our diode acts just like R1 in the circuit shown in Fig. 533. C1 prevents the application of the B-plus supply to the plate of the diode.

There is one more important fact to consider. Because of the slow

charging and discharging action of C2, the rectangular pulses fed into the integrator system appear triangular at the output.

Before we study a complete gating circuit making use of an integrator, let's go over another subsidiary gating circuit network known as a differentiator. It is quite possible to have a circuit which produces a voltage only when the applied voltage is *changing*. If the voltage produced is in proportion to the *rate of change* of the applied voltage, the circuit is said to be a differentiator. See Fig. 535.

If the switch is suddenly closed, current flows through R to charge the capacitor. As soon as the capacitor has taken a charge, the flow of current stops. Naturally, a voltage appears across the resistor only so long as there is current flowing. The voltage across R is propor-

Fig. 535. The output of a differentiating network is proportional to the rate of change of the input signal.

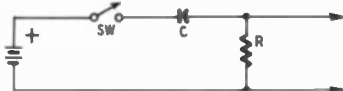

tional to the *rate* at which the voltage across C changes. Such a circuit can be used to produce sharp trigger pulses for control purposes. Let's examine Fig. 536 to see how a differentiator is used in conjunction with a vacuum tube.

Fig. 536. The differentiator in this circuit converts a rectangular pulse into a sharply peaked waveform.

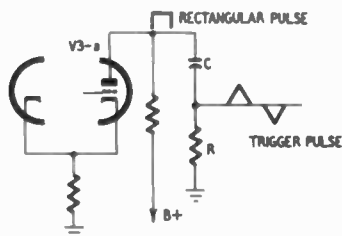

When a pulse appears in the output of V3-a, due to a rise in voltage at the plate of the tube, it tries to charge capacitor C through R. C cannot be charged instantaneously and so, while current is flowing into it (this may take a millionth of a second), a voltage is built up across it which is positive with respect to ground. As soon as the capacitor is charged, the current flow through R stops. No voltage will appear across R even though the plate potential of V3-a will have risen to a higher value. Although not shown, V3-a is actually part of a multivibrator circuit. The job of the multivibrator is to make V3-a conduct, cut off and then conduct again. While C was becoming charged, V3-a was not conducting. When V3-a begins to conduct once again, it short-circuits C and R and the capacitor discharges through the tube. This time, however, the flow of current is from the capacitor *down* through R instead of from the power supply *up* through R. Once again a voltage is produced across R but this time the polarity with respect to ground is reversed. By this action, then, two trigger

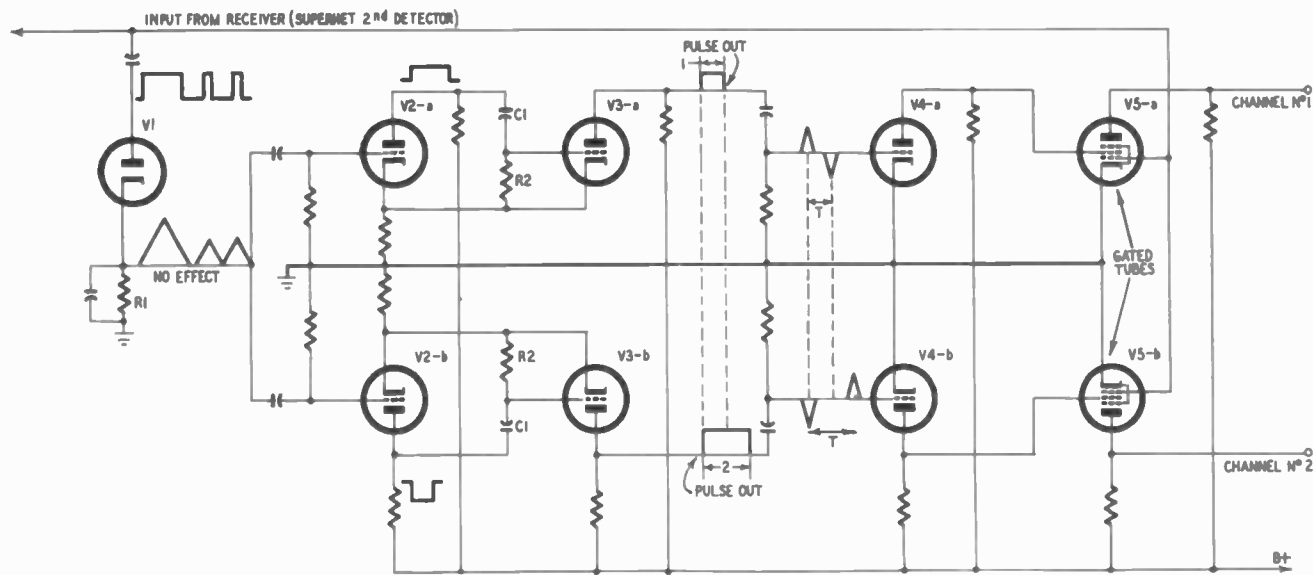

Fig. 537. A complete gating circuit including an integrating and a pulse-shaping differentiating network. The circuit arrangement of the upper channel is identical with that of the lower channel, the sole difference being in the value of the time-constant components. The control grids of V4-a and V4-b are connected to a differentiating circuit. The output of the gated tubes, V5-a and V5-b, supplies two-channel operation. Refer to Fig. 538 for details of the timing.

pulses are produced, one at the beginning and one at the end of the rectangular pulse when the voltage at the plate of V3-a is changing. We can use either the positive or the negative trigger to control the operation of a succeeding tube.

The complete gating circuit, including an integrating and differentiating network, is shown in Fig. 537. The command pulse is always preceded by a marker pulse designated as number 1 in Fig. 538. This is followed by a series of short pulses representing the code. When these pulses are received and sent to the decoder, V1 in the integrating network of Fig. 537 separates the wide marker pulse from the others. In this case, the marker is the only pulse that will cause a large voltage to appear across R1. When this voltage appears, it compels

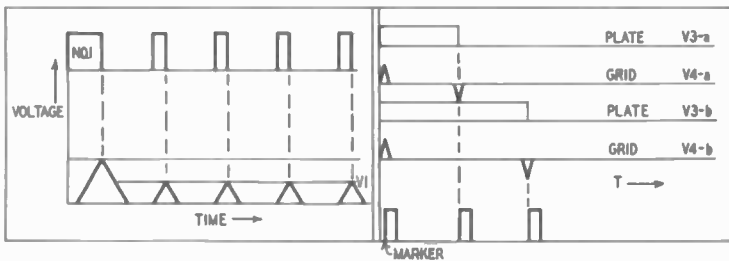

Fig. 538. Timing of the marker and pulses produced at various stages of the gating circuit shown in Fig. 537.

V2-a to conduct, changing the charge on capacitor C1. Current then flows through R2 in such a direction that a negative voltage appears at the top of R2. The voltage drop across R2 forms a bias voltage for V3-a having a value sufficient to cut off the flow of plate current through that tube. V3-a will remain cut off until the capacitor can recharge. Because of this action, a square pulse is generated at the output of V3-a. This pulse has a width proportional to the time constant of C1 and R2. This pulse is then differentiated to produce the triggers shown in Figs. 537 and 538.

The triggers, positive and negative, are fed to V4-a. The negative pulse forces V4-a to cease conduction; the positive pulse has no effect. As the plate voltage on V4-a rises, it also increases the screen voltage of V5-a, to which it is directly connected. If a signal pulse is transmitted now, V5-a will conduct, passing the command on to channel 1. Since V5-a is in the conducting state only while its screen is at a high positive potential, the code pulse must come at that particular time if it is to be channelized. This is a definite time interval after the arrival of the marker signal.

The lower channel operates in the same manner. Since the length of the rectangular pulse from the plate of V3-b is longer, V5-b will become operative *after* V5-a, the length of the time difference be-

tween them being determined by the difference in the time constants of the two circuits.

If a pulse code of the presence-omission type is sent, the pulses are channeled to the proper tubes in the output in sequence. If output tubes V5-a and V5-b have self-locking relays in their plate circuits, a particular combination of pulses would cause either channel 1 or 2 to be placed in operation.

### **Pulse-rate discriminators**

The final decoder which we will consider is the discriminator which can choose between different pulse rates. If a discriminator of the type mentioned earlier for decoding frequency commands is placed in the output of a receiver picking up pulses corresponding to the frequency of the L-C units, such a discriminator will produce an output in the same manner as for variations in pulse rates. When an L-C circuit is pulsed, the pulse is converted into a cycle through the charging and discharging of the capacitor and the buildup and decay of the magnetic field around the coil. Thus a pulse rate of 1,000 pulses per second becomes, in effect, a frequency of 1,000 cycles per second.

It is possible to use this idea of a pulse rate being converted into cycles to operate a tone receiver which has tuned filters preceding the relay tube. If the receiver is capable of amplifying the pulses without losing their rate, the effect on the tuned bandpass filter is the same as a tone and different pulse rates can produce different actions of the model, corresponding to different commands.

Once the choice of a decoder has been made, the next step is to decide upon the type of power control circuit to operate the actual motors or devices which furnish the physical response in the model in accordance with the transmitted commands.



# power control circuits

**P**OWER control circuits are those which are operated by the decoder. They handle the power from the primary supply and govern its flow to motors or devices to be operated by the given commands.

Sometimes the decoder performs this function and sometimes not. Where a simple pulse sequence is used, as in control of model aircraft in which an escapement moves the fin directly, no power circuits are needed. In the use of tone-coded commands such as those for steering (one tone for left and one for right), additional power circuits also may not be needed. However, with pulse codes in which one transmission channel is used to send a variety of commands, it might be desirable to give a command for one motor to start operating and continue to operate while other commands are being transmitted.

## Latching relays

One of the most common types of power control circuits for such an operation is the latching relay. This relay is designed to lock in the closed position when it receives a flow of power through its windings from the decoder. It remains locked until the next signal (release signal) is sent to a second relay or winding in close proximity to the first, either electrically or physically, and which releases the first, either electrically or mechanically.

Latching relays may be electrical and mechanical. A mechanical latching relay is shown in Fig. 601. The armature of RY1 is equipped with contacts. RY2 is used for latching only. When contact relay RY1 is energized, its armature is held down by the armature of the second relay. While RY1 is in this locked position, latching relay RY2 is not energized. When the latching-relay coil is energized, its

armature moves far enough so that it releases the contact-relay armature.

Fig. 602 shows a relay that latches electrically. This merely requires a relay which has two poles and makes two contacts when energized. One set of these contacts completes the circuit to the power source,

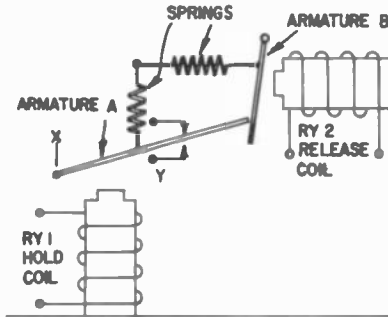

Fig. 601. In this mechanical latching relay, when A is pulled down by the hold coil RY1, B is pushed back by the tip of the armature. Armature A is then held down by the tip of B because RY2 is not energized. Contacts X and Y are closed in the latched position. When RY2, the release coil, is activated, A is free to move, opening contacts X and Y.

keeping the power flowing through the windings when the coded command ceases. The second set of contacts is used to have power flow to the motor or other device that is to be made operational.

The second relay is always connected to the first in such a manner that the power to the latching relay's coil flows through the normally closed contact of the release relay. When RY2 is energized, it breaks the circuit to the latching relay and allows it to release.

The mechanical latching relay requires no power from a power source to hold it shut; the electrical does. However, if a high-resistance relay is used for this function, the battery or supply drain may be small and within reason.

It is also possible to use steppers directly to control the flow of power to various devices. With these, the contacts can be wired to

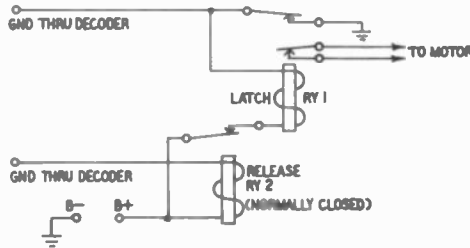

Fig. 602. Unlike the relay in Fig. 601 this latching mechanism does not rely on mechanical devices. Its action is electrical.

the activated device. The only circuit that is needed is one which prevents the passed-over contacts from becoming energized as the stepper arm moves. This circuit can be a relay which holds the

common line open while the arm is in motion and closes it when the pulses cease (a delay-in-releasing relay).

### Reversing relays

Reversing relays which can be used to control the flow of power are illustrated for different types of motors in Fig. 603. To reverse the rotation of a permanent-magnet motor (Fig. 603-a) it is necessary to change the polarity of the voltage to the motor terminals. A double-pole double-throw relay can do this.

The armatures are connected to each end of the battery. When the armatures are against the normally closed (up) contacts, the top terminal of the motor has a plus polarity and the bottom a minus

Fig. 603. Reversing relays of several types are used to control the direction of motor rotation: a) permanent-magnet type; b) split-field type; c) shunt type; d) series type.

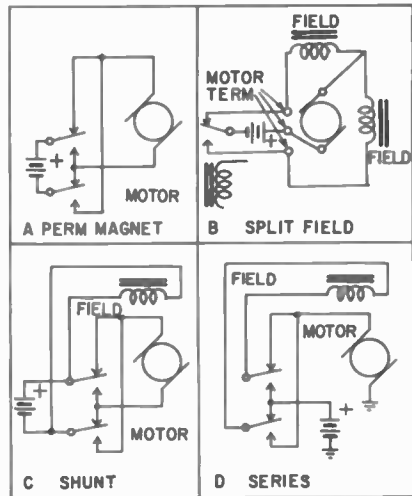

one. When the relay is energized, the armatures pull down. Now the top motor terminal is negative and the bottom positive. The motor reverses direction.

To reverse the direction of rotation of a split-field motor (Fig. 603-b) it is necessary only to energize the opposite half of the field winding. This type of motor usually has three out leads: one common, one for rotation one way and the other for rotation in the opposite direction. A single relay as shown connects the armature through the normally closed contact of the relay to one half of the field winding. The armature is connected through a common lead to one end of the battery. The other end of the battery is connected to the center tap of the field. With the armature open or resting against the normally closed contact, one half of the field is energized. When the armature is closed, it energizes the second half of the field, reversing the rotation of the motor.

To reverse the rotation of any dc shunt motor (Fig. 603-c) either the field or armature leads must be reversed. In the diagram shown,

the armature leads are transposed by a double-pole double-throw relay while the field remains constantly attached to the same battery terminals. With the relay not energized, the motor armature has plus on top and minus on the bottom. When the armatures of the relay pull down, the top terminal of the motor becomes attached to the negative side of the battery and the bottom to the plus side. The field, connected to the armature, does not have the direction of current flow through itself changed.

The series motor (Fig. 603-d), like a shunt motor, must have *either* the field leads *or* the armature leads reversed if a change of rotation is desired. In this diagram the field leads are reversed while the armature remains the same. With the relay in the normally open position, current flows through the armature of the motor to the top contact (normally closed) of the relay, the relay armature, then through the field, back to the relay bottom armature and up to the plus side of the battery. When the relay is energized, the relay upper armature connects its side of the field to the battery plus while the relay bottom armature connects its side of the field to the motor armature and through it to the battery minus. The direction of current flow through the field reverses and the motor changes its direction of rotation.

### **Babcock speed control and reversing relay**

This relay-operated stepper is designed to provide complete control of the propelling motor in radio-controlled boats and cars when it is an electric type. A small relay, when energized, provides the power to step the printed circuit contact disc to any one of eight positions in sequence. When connected as illustrated in Fig. 604, the sequence is: slow reverse, stop, slow forward, stop, slow reverse, stop, full speed forward, stop. The disc is caused to move up one position for each pulse received by the radio receiver. After completing one cycle of the eight positions mentioned, the cycle repeats.

In addition to the normal function of controlling the propelling motor, this device also has a single contact (No. 6) on the top of the case which is closed with each pulse received. This can be used for control of some auxiliary device, such as ringing a bell, etc.

The small relay (not shown in Fig. 604) which furnishes the stepping power does not have a spring return to pull the stepping armature away from the magnet. The unit is so designed that the armature hangs down and thus gravity pulls the armature away from the magnet. This eliminates any requirement for spring adjustment. Normal rocking or listing of a model boat will not affect this operation.

To understand the operation, refer to Fig. 604. Notice that the PM type motor leads A and B are connected to contacts 2 and 7, the battery minus terminal to contact 3 and its plus terminal to contact 1 directly and to contact 8 through the two 1.5-ohm resistors. The pur-

pose of the resistors is to reduce the amount of voltage which will be fed to the motor through the disc when it is in the half-speed positions.

The position shown in the diagram is stop. The finger of contact 2 rests upon an insulated area, as does the finger of contact 7. Assume that the disc rotates 45° clockwise. Now the finger of contact 2 would make contact with the inner ring, which is also touching the finger of contact 3. This causes lead A of the motor to be connected to the minus terminal of the battery.

In the meantime the finger of contact 7 is now touching the outer ring and thus is connected to the finger of contact 8. This causes the B-lead of the motor to be connected to the plus side of the battery through the two 1.5-ohm resistors.

Assume that another pulse is received which moves the disc another 45°. Again the fingers of contact 7 and contact 2 will be on an insulated portion of the disc. This is another stop position.

The third pulse moves the disc another 45°. Now the finger of contact 7 will touch the inner ring. Since the finger of contact 3 is

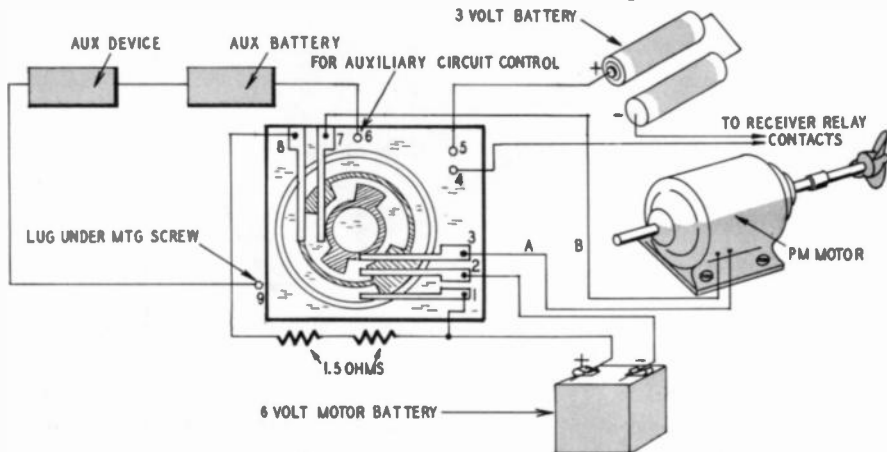

Fig. 604. The Babcock speed control and reversing relay is a fairly complex mechanism. The heart of the unit is a special switch. (The coded terminals correspond to those shown in Fig. 605.)

still touching this ring, lead B of the motor is now connected to the minus terminal of the battery. Also, since the finger of contact 2 is now touching the outer ring, lead A of the motor is connected to the plus terminal of the battery. The direction of the current flow through the motor has been reversed and so the motor will now change direction. It is still at half-speed, however.

The fourth pulse and 45° rotation will break the circuit. The fifth pulse will again give forward rotation of the motor as the fingers will be positioned as they were after the first 45° of rotation.

Assume that the sixth pulse (a stop position) and the seventh pulse are transmitted, giving the disc 90° of rotation from the fifth pulse

position. Now the fingers associated with contacts 8, 7 and 1 are all connected to the outer ring. Since this shorts the two 1.5-ohm resistors (by connecting contacts 8 and 1 together) lead B of the motor is tied directly to the plus side of the battery. The fingers of contacts 2 and 3 are connected together through the inner ring and so lead A of the motor is now connected to the minus side of the battery. Since the voltage-dropping resistors have been removed from the circuit (by shorting them), the drive motor now runs at full speed.

To operate the auxiliary circuit, the auxiliary device is connected in series with its actuating battery and then to the frame, contact 9.

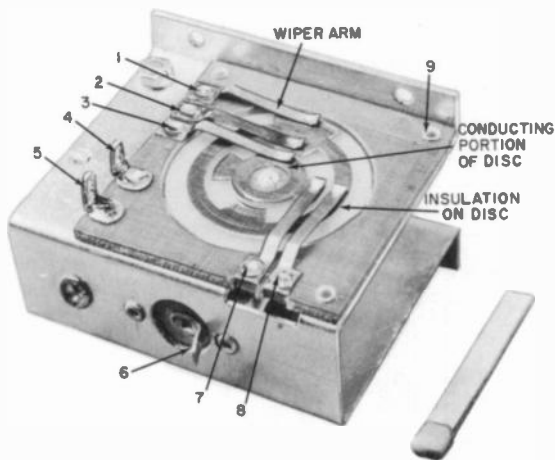

*Fig. 605. Size and construction of Babcock motor speed control and sequence reversing relay.*

The opposite end of the auxiliary battery connects to contact 6 which is closed internally by the relay action. Fig. 605 illustrates the size and construction of the unit.

The maximum rating of the motor-control contacts is 10 amperes at 6 volts; the auxiliary contact rating 5 amperes. The actuating coil requires 3 volts at 1 ampere, which means that the relay operating batteries should not be smaller than size D to secure satisfactory operation.

### **Electronic power control**

One of the electronic methods of handling a relatively large amount of current is to use a thyatron type tube such as 2D21 or 884. The presence of gas in the tube allows the passage of a large amount of current when the tube is in the conducting state.

The current passed by these tubes is large enough to operate a motor directly. (The introduction of small motors which require 40

to 50 ma of current for operation leads to the interesting thought that perhaps small motors of this type operating with a slightly larger voltage than 3 or 6 volts—say,  $22\frac{1}{2}$  or 45—and requiring perhaps 3 to 5 ma to operate might be forthcoming.) However, such tubes have one very distinct disadvantage: when the tube starts conducting, the grid loses control of the electron stream. The only way that the current can be stopped is to cut off the plate supply or make it negative, while the grid supply is negative. One way in which the plate can be made

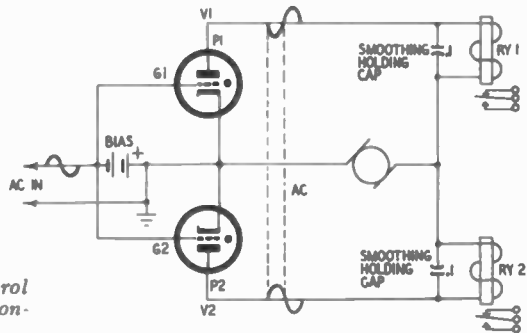

Fig. 606. This power control makes use of thyatron-controlled relays.

positive for conduction purposes and negative so that the grid can get control is to apply ac to the plates. Thus the plates are positive half of the time and negative during the other half. In this manner, the conduction of the tubes can be controlled by an ac signal on the control grids. It is also possible that the plate supply to each tube could

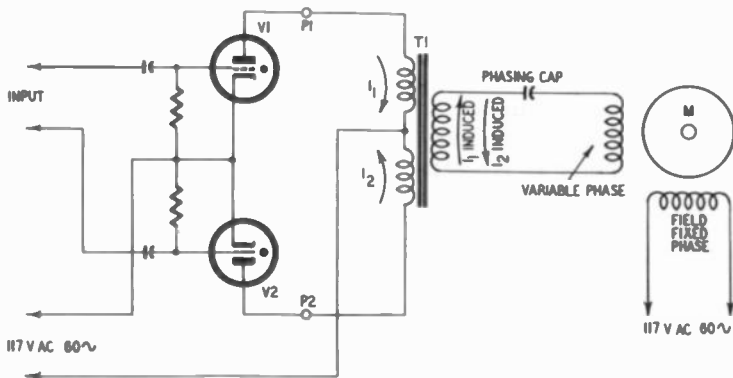

Fig. 607. Bidirectional and speed control of an ac motor. The gas tubes are wired in push-pull.

be in series with a resistor, and a plate capacitor to ground could be used as in the case of the RK-62 when used as a superregenerative detector. The charge and discharge of the capacitor would cause a reduction in plate voltage, thus allowing the grid to gain control. In

this case, the circuit is so designed that it will convert a received signal into a positive voltage. Applying it to the grid would cause pulsating conduction as long as the signal was present. In the absence of the signal, a negative bias would be placed on the thyatron grid to stop conduction.

If gas tubes have relays in their plate circuits (Fig. 606), these can be closed by changing the phase of an ac input signal. In this circuit, with no ac input to the grids, the grids are biased to cutoff by means of the bias battery. If an input signal is applied which has a magnitude on the positive alternation large enough to overcome the bias then the grids of both tubes will be made positive simultaneously. If the phase of the ac input is such that it is the same as that applied to the plate by the ac supply, then the plate of V1 can be positive when its grid is positive; hence this tube will conduct. The phase is negative on the plate of V2; therefore this tube will not conduct.

As long as the input phase and magnitude are maintained, V1 continues to conduct in pulses, or each time that its plate is positive. V2

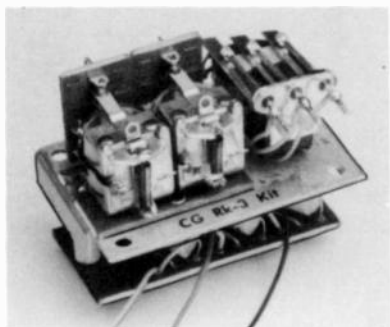

Fig. 608. Reeds and relays forming a power control unit.

can never conduct while V1 is conducting since both grids are *simultaneously* made either positive or more negative by the input signal. Reversing the phase of the input signal makes the grid of V2 positive when its plate is positive, and the plate of V1 positive when its grid is negative. The key here is that the grids are tied together, the plates are not. Depending upon the phasing of the input signal and the ac plate voltage, either RY1 or RY2 can be made to function. This situation is also applicable for ordinary tubes supplied with ac. With gas tubes, however, due to their ability to pass a large amount of current, we have the advantage of a bidirectional dc motor without the use of relays. A typical circuit is shown in Fig. 607.

### Resonant reed and relay power control unit

Fig. 608 shows a typical power control unit found in most model applications. Here the resonant-reed decoder causes the operation of small high-resistance relays which in turn operate the model motors and other devices.



# servo motors

**A** SERVO motor (servo from the Latin, meaning slave) is a motor which responds to some command and is usually the final unit in radio or electronic control systems. It can be an electric motor, with or without gears, which merely moves clockwise and counter-clockwise like a meter hand as its input polarity is changed. This type does not revolve. It may be a relay and an escapement which furnishes mechanical power or it may be a plunger-type solenoid. It might also be a pneumatic or hydraulic cylinder in which the flow of air or oil on each side of the plunger governs the direction and force applied by the arm. Whatever form the servo takes, its movement or that of the device it actuates must be limited by one means or another to provide control.

## Limit switches

A limit switch is, as the name implies, a switch which limits the motion of some mechanism moved by an electric motor or device. If the arm in Fig. 701 tries to move too far in either direction, it physically opens a switch, interrupting the circuit which originally caused the arm to move.

Limit switches are made of spring metal and are normally closed due to spring tension. When the arm moves or pushes against a limit switch, the switch is placed in the open position. When the arm moves away from the switch, it closes automatically. This allows the circuit to be completed once again so that the arm can be made to move back if so desired.

There are other means for opening a circuit when the limit of rotation or movement of a wheel or arm is reached. The limiting mechanism might be a cam of some insulating material mounted on the shaft which holds the switch closed and allows the circuit to open

when the limit of travel is reached. It might also be a physical stop if a solenoid, a pneumatic or a hydraulic cylinder is used.

One method of employing a limit switch to govern the rotation

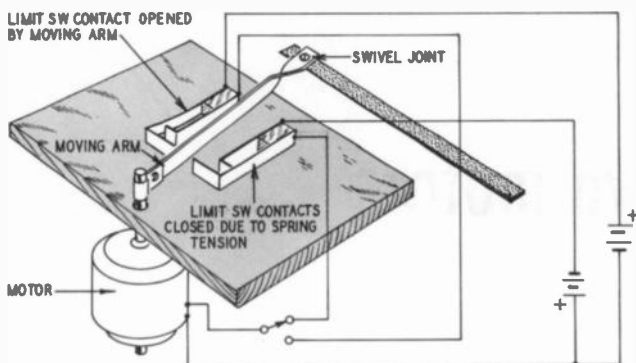

Fig. 701. Limit switches can be arranged to operate through a moving arm attached to the motor shaft.

of a wheel is illustrated in Fig. 702. Here the limit switch is activated by a cam mounted on a gear shaft which in turn is geared to the wheel shaft. The rotation of the cam depends upon the gear ratio; it might be arranged to move, let us say,  $180^\circ$  when the wheel turns 10 times—a 20:1 reduction. Note that this particular limit switch is normally open and is closed only upon contact with the cam.

### Neutralizing switches

A neutralizing or normalizing switch is found physically mounted on some types of servo motors. Its job is to cause the servo motor output shaft to return to some predetermined position (usually neutral) when the commands have ceased. For model purposes, a neutralizing switch can be similar to the limit switch in construction except that its contacts are normally open. The contacts are closed when the output arm moves from the neutral position and pushes against the insulated portion of the neutralizing switch.

In this circuit (Fig. 703) RY1 is closed by a left command and RY2 by a right command. Two small batteries in series are used with the center point connected to one side of the PM motor, eliminating the need for a reversing relay. The second motor lead is connected to both relay armatures. The armatures of the relays are connected through contacts 2 and 3 to the neutralizing switches which, with the arm in the neutral position, are open. Thus, no power is being applied to the motor.

Consider that RY1 closes in response to a left command. The armature drops down and touches contact 1. Now the motor lead B is connected directly to the minus side of B1. Since lead A is con-

nected to the plus side of this battery, the motor turns, moving the arm to the left. As the arm moves, it closes neutralizing switch 6, As the arm moves, it closes neutralizing switch 6,

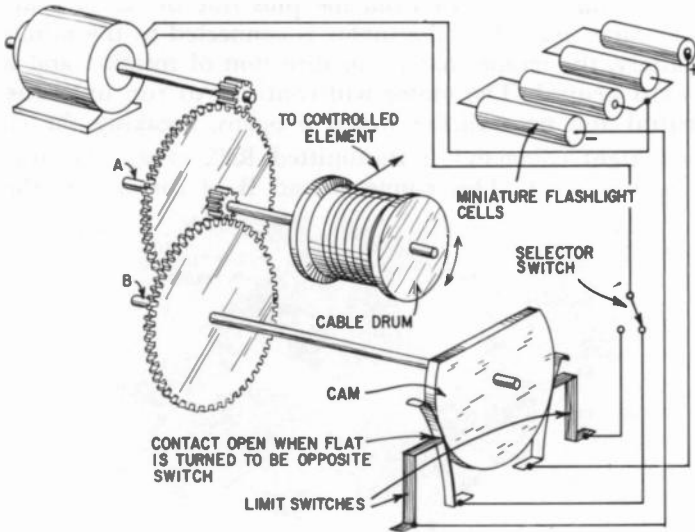

Fig. 702. A more complex arrangement operates the limit switch through a cam and gear arrangement. Shaft A rotates 20 times for each rotation of B. Gears with other than a 20:1 ratio may be used to produce different numbers of revolutions of the drum.

but there is no effect from the closure at this time since the circuit through the neutralizing switch is open at contact 2 of RY1. The arm

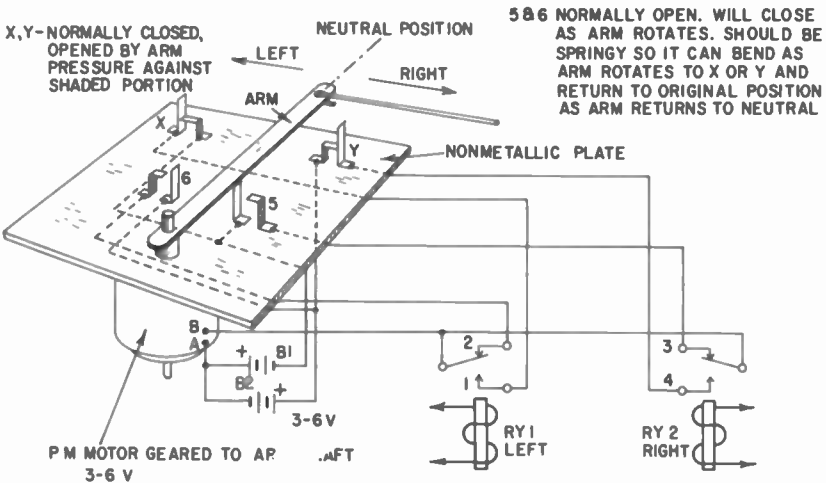

Fig. 703. A simple neutralizing switch arrangement. Note the position of the limit switch included in this system.

will continue to move to the left until it opens a limit switch (X). This stops the rotation of the motor.

When the command ceases, the armature of RY1 moves up against contact 2, closing the circuit from the plus side of B2 to lead B of the motor. Since lead A of the motor is connected to the minus side of the battery, the motor changes its direction of rotation and moves back toward neutral. The motor will continue to run until the arm is at neutral and neutralizing switch 6 opens, breaking the circuit.

When a right command is transmitted RY2 closes, the armature moving to contact 4. This connects lead B of the motor, through

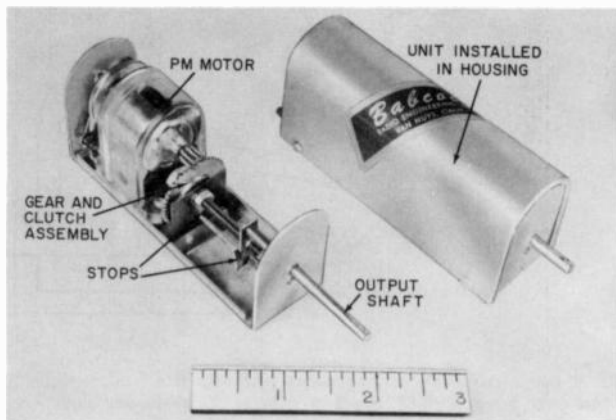

Fig 704. *Non-neutralizing Babcock servo.*

contact 4 and the limit switch Y to the plus side of B2. The motor runs since lead A is connected to the minus terminal of this battery. This time the arm moves to the right, closing neutralizing switch 5 and continuing to move until it opens limit switch Y. Its movement then stops.

When the right command ceases, the armature of RY2 moves up and touches contact 3. Again the circuit is complete from lead B of the motor to the battery—this time to the minus terminal of B1. Lead A of the motor is in contact with the plus terminal of this battery so the motor reverses. When the arm reaches the neutral position, neutralizing switch 5 opens and the motor stops running.

It is possible to have either a "tight" or a "sloppy" neutral, depending upon how close the neutralizing switches are placed to the arm and the spacing between their contact points. If such a system is used to control the rudder of a model aircraft, one might desire a tight neutral which would always result in straight flight. If it were used for elevator control, a sloppy neutral might be desired. Thus one might signal for up and then, since the arm would not quite reach the absolute neutral position, a slight up-elevator would remain after

the command stopped. The same would apply to down. This allows the controller to trim the model in flight.

A combination limit and neutralizing switch can be constructed, provided the contacts of each switch are well insulated from each other. However, it is common practice to use units that are physically separated so that individual adjustments (especially positioning in relationship to the arm) can be made to fit the builder's needs.

One usually finds that the neutralizing servo is used for steering.

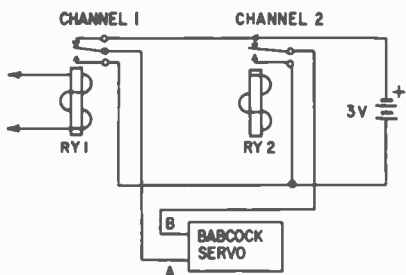
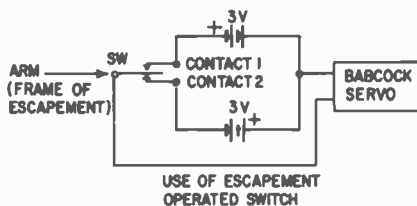

Fig. 705. Wiring diagram for the Babcock servo shown in Fig. 704.



The non-self-neutralizing servo is used for elevator control in model planes where more control of trim is desired—for flaps or other control functions where it is desirable to position an element for a period of time.

### Commercial servo motors

Servo motors have been developed especially for use in the model field. Lightweight, they employ a minimum of parts and are rugged and reliable. The Babcock servo motor is shown in Fig. 704.

To prevent overtravel, the lead screw is provided with mechanical stops instead of an electrical limit switch. These stops are designed to eliminate sticking or binding. To prevent stalling the motor, which would result in very high battery drain, a small friction clutch connects the motor to the lead screw through a small gear train.

The motor is a PM type so a reversal of battery polarity is required to change the direction of travel. The output shaft has a full  $\frac{3}{4}$ -inch movement. The wiring diagram is shown in Fig. 705. Either a two-channel receiver or a single-channel receiver operating a simple two-arm escapement switch may be used.

Another type of commercial servo is the Debolt unit. Its particular advantage is that it will move the output shaft to a given position, hold this position as long as desired *without power consumption* and, when the signal stops, will return the shaft to neutral. This is a self-neutralizing type of servo. It is possible with this unit to use a single channel and select two or more positions. There are some types of Debolt servo's which can be pulsed (using a single channel) to a given position and they will remain there until a new command is received which causes it to move to a new position or back to neutral.

## Proportional control

Proportional control means that the device which furnishes mechanical power does not have to move the steering element completely to the left or right. It means that the steering element may be deflected any amount— $1^\circ$ ,  $2^\circ$  or  $3^\circ$  etc., as desired. In the case of a motor, the speed may be any value from full stop to full speed.

However, proportional control is not absolutely necessary to effect *gradual steering* of the model. The steering system can be so designed that the rudder has only three positions (full left, full right and

Fig. 706. A partial or complete turn is accomplished by controlling the amount of time that the rudder is deflected in one direction. Neutral rudder is used for most of the time.

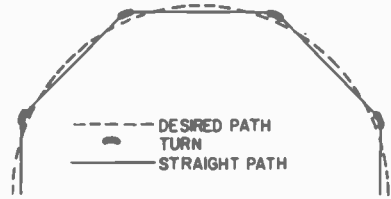

neutral) yet the model can be made to execute gradual turns if the controller limits the time that the rudder is in the deflected position. The shorter the time, the wider the turn, etc.

Suppose, in a model aircraft, it is desired to make a wider turn than would normally be executed if the rudder were held to its maximum position. The procedure would be somewhat as follows: First, the command for a turn is given; the rudder moves to its maximum position and stops; the plane starts to turn. The controller observes the amount of this turn and when a small fraction of the turn is completed sends a command for neutral rudder causing the plane to straighten. This neutral command is actually no signal at all. The next command would make the rudder deflect in the same direction and again the plane would turn slightly before the signal stopped. This process is continued until the desired turn has been executed as shown in Fig. 706.

## Pulse-width—pulse-space control

When the pulse-width—pulse-space method of coding is used varying the pulse width and spacing causes the rudder to stay in one position longer than in another. If the time difference is small due to almost equal pulses and spaces the turn is gradual. If, however, there is a large difference in the pulse width and spacing, the length of time the rudder spends on one side is greater, so the turn is sharp.

In model control, this system is most commonly used since it is one of the simplest to construct. It is also reliable and light in weight. Although it causes the model to exhibit the characteristic flight of real proportional control (from the controller's standpoint) it is not true proportional control, for in that system the rudder moves a few or a large number of degrees in response to command.

## True proportional control

A servo motor can be controlled by relays in the plate circuits of vacuum tubes, one for each direction of rotation (Fig. 707). Both relay tubes have their grids tied together and these are then connected to a direct-coupled amplifier which has as its input the dc output of a discriminator. When the discriminator output is positive the servo motor rotates in one direction; when the output is negative it rotates in the opposite direction.

When the resting frequency is being transmitted, the output of the discriminator is zero and no movement of the servo motor results. If this frequency is raised slightly, by turning a potentiometer connected into the audio circuit of the ground station, the discriminator produces a negative output. This negative potential, acting as a bias

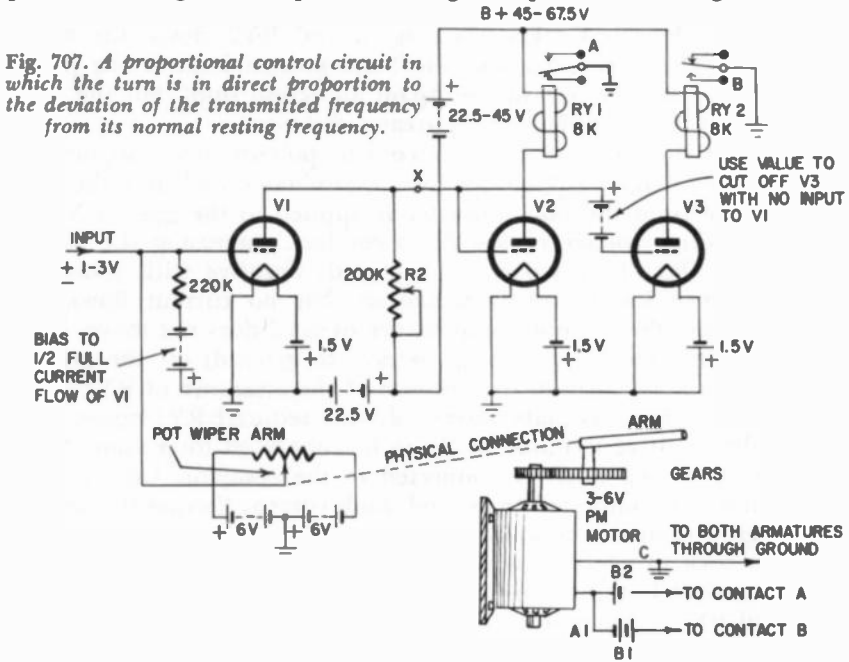

voltage would cause the plate voltage of V1 to become more positive making the control grids of V2 and V3 more positive. V3 is normally biased so that no plate current flows while V2 conducts continuously keeping RY1 closed. When the two grids are made more positive due to the increased plate voltage of V1 RY1 is not affected. However RY2 closes since no current was flowing through its windings before the signal was present. When RY2 closes, it connects the plus terminal of B1 to ground. Since the motor has one lead (A1) connected to a common battery junction and the other (C) to ground, current flows through the motor causing the output shaft to move. When

the shaft moves it deflects the steering element and at the same time moves the potentiometer wiper from neutral.

When the wiper moves from neutral a voltage is developed between it and ground, which is proportional to the distance moved. (This assumes that a linear potentiometer is used). When the wiper has moved far enough so that this voltage is equal to, and opposite in polarity from the discriminator output, the voltage on the grid of V1 is cancelled. Thus V1 is restored to its normal condition and RY2 opens, stopping the movement of the motor when the steering element has been partially deflected.

If more deflection is required, then the audio frequency being transmitted is raised higher above the resting frequency. This produces a more negative voltage which is applied to the grid of V1. Assume that this is 1 volt more negative than the previous voltage. The action described takes place again and RY2 closes, the motor rotates (in the same direction) until the potential across the potentiometer is 1 volt more positive. Again all action stops, but the steering element has been deflected a greater distance.

Now the controller returns his control potentiometer to neutral, there is no voltage output from the discriminator and only the positive voltage from the potentiometer is applied to the grid of V1.

This positive voltage causes V1 to conduct, increasing the voltage drop across R2. This makes the two grids negative with respect to ground. Since V3 is already biased so that no current flows, this circuit is not affected and the armature of RY2 does not move. However, the negative voltage (with respect to ground) on the grid of V2 does cause a change in the position of the armature of RY1. Since this tube will have its plate current sharply reduced RY1 opens. This causes the negative terminal of B2 to be connected to ground. Again the motor, having lead A1 connected to the common battery junction and lead C connected to ground, finds current flowing through its windings, but in the opposite direction. The motor turns, bringing the arm back to neutral. As the arm moves, it also moves the potentiometer wiper back toward its neutral position and finally, at neutral, the feedback voltage is zero. The grid of V1 has no voltage applied to it and all action stops.

This same analysis can be applied to movement of the arm in the opposite direction where the output of the discriminator is positive due to a change of the audio signal to a frequency *below* the resting frequency, and the feedback is negative since the wiper of the potentiometer moves in the opposite half of its circuit.

The circuit of Fig. 707 is unique in that it is a direct-coupled amplifier. This means that the plate of the first tube is directly connected to the grid of the second. Note that the minus side of the 22.5-volt battery connects to ground and that the plus side is tied to the variable load resistor R2. The amount of plate current drawn



by V1 can be determined by regulating the fixed bias voltage and the plate load resistor R2. The voltage drop across the plate load resistor is opposite in polarity to that of the battery.

If the drop across the load resistor is almost equal to the battery voltage, then the voltage measured from point X to ground with a vtvm will be some small value. In this way V3 can be cut off by using a small bias battery. In adjusting a circuit of this type, the voltage at point X to ground must be measured at the time that the plate load resistance and the amount of bias voltage of V1 are adjusted. With half of the permissible current flow possible through V1, this voltage should be small. A test application of 1 volt to the grid of V1 with a negative polarity to ground should raise the voltage at X and the test voltage when positive with respect to ground should reduce the voltage at point X, causing the relays to operate.

It is desirable that 45 to 67.5 volts be used as a plate supply for the relay tubes. As far as the plate circuits of the relay tubes are concerned, both the 22.5-volt battery which furnishes the plate voltage for V1 and the second 22.5 or 45-volt battery are in series from the bottom end of the relays to ground. This makes possible a high enough battery voltage for proper relay operation.

One method of obtaining fairly adequate proportional control of an elevator in a model airplane and which also fulfills the fail-safe requirement is to use a flyball actuator. However, since the model is normally trimmed to climb, this device can be connected to the elevator so that its operation results in down elevator only. The elevator can be spring-loaded to return to neutral. In operation, no-signal through the channel controlling the flyball actuator allows the model to climb normally. If a signal is sent which causes the flyball motor to run at full speed, full down elevator results and the model will go into a sharp dive. As the model dives, air pressure builds up on the elevator and this increased force causes it to move back toward neutral, even though the flyball is running at full speed. This means that the model can never overdrive or tuck under. If the dive is held long enough the plane will actually pull itself out. Its increased speed produces more lift and the increased air pressure forces the elevator toward neutral. If the controller stops the signal, the spring return snaps the elevator back to neutral and the model will loop, etc., due to the additional lift produced by its increased speed.

If the flyball channel is pulsed, then the model will dive at a much shallower angle, as determined by the pulse rate. Overall, the action of this device is fast and reliable.

### **Simultaneous proportional control**

The dream of every radio-control enthusiast, particularly those interested in the model aircraft field, is to have a system which will

allow simultaneous and proportional control of, at least, the rudder and elevator. The ground control station would consist of a joy stick which could be moved away from center in any direction. There are two basic methods for obtaining this type of control. In both, two signals must be sent almost simultaneously and perhaps continuously:

- (a) Commutation of signals (time sharing)
- (b) Combined signals (modulation sharing)

If one considers commutation of signals there comes to mind a coder which has an arm which sweeps over two separate sets of contacts, each contact covering slightly less than  $180^\circ$  of the arc. One contact causes one tone to be transmitted, the second another. If the controller closes a switch connected to both channels, then, as the arm sweeps, first one tone then the other is transmitted. This could cause a relay in the rudder channel, and also a relay in the elevator channel to close. If the speed of commutation is fast enough simultaneous control would result. To obtain the proportional feature a pulser could feed each of the two halves of the commutator. Full control of a channel would have to be obtained with half-time transmission. Actually the commutation speed could be greater than the pulser speed and so no detrimental effect would occur.

The advantage of this method is that each time a tone is sent it will fully modulate the carrier, producing a powerful signal. It can also be used with two separate rf receivers and transmitters.

The second method, combined signals, means that both tones are transmitted simultaneously. Just as one can hear a flute and a piano together on a normal broadcast receiver, so the control receiver gets both tones together. However, if two tones are used the amount of modulation must be divided between them—each will modulate the carrier only 50% at most. This results in a weaker tone signal. Also a more elaborate tone filter must be used to insure separation of the tones. It is possible that in some radio-control applications the added complexity is not detrimental and the receiver can be made sensitive enough so that it will operate satisfactorily with 50% modulation. Proportional control could be obtained by pulsing each tone or by using a discriminator in the receiver. If the discriminator is used the filters must be designed to pass a band rather than a single frequency.

# transistors

**T**HE transistor has certain advantages of intense interest to the model-control hobbyist. The transistor requires no filament voltage, the B-drain is small and the amount of voltage required for its operation is usually lower than that required for vacuum tubes. The life span of transistors is very long. This means that they can be built into equipment. They are lightweight, small in size.

The transistor, a rugged device as far as physical shock is concerned, is very sensitive to heat. This means that extreme care must be used when soldering transistor leads into a circuit. A heat sink (Fig. 801)

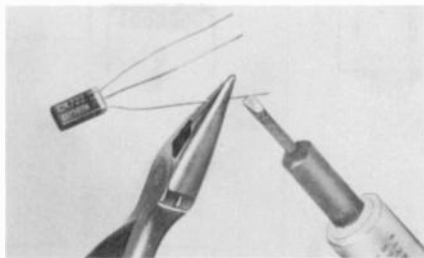

Fig. 801. Always use a heat sink when soldering or unsoldering transistor leads.

should always be used. This can be a pair of pliers holding the lead on the transistor side so that heat is absorbed in the metal of the pliers instead of going to the transistor itself.

Of course, the leads can be clipped and the transistor plugged into a small five or seven-pin socket like a vacuum tube provided you make certain that the leads make firm contact with the socket pins and cannot be jarred loose by vibration.

In constructing circuits using transistors the applied voltage must

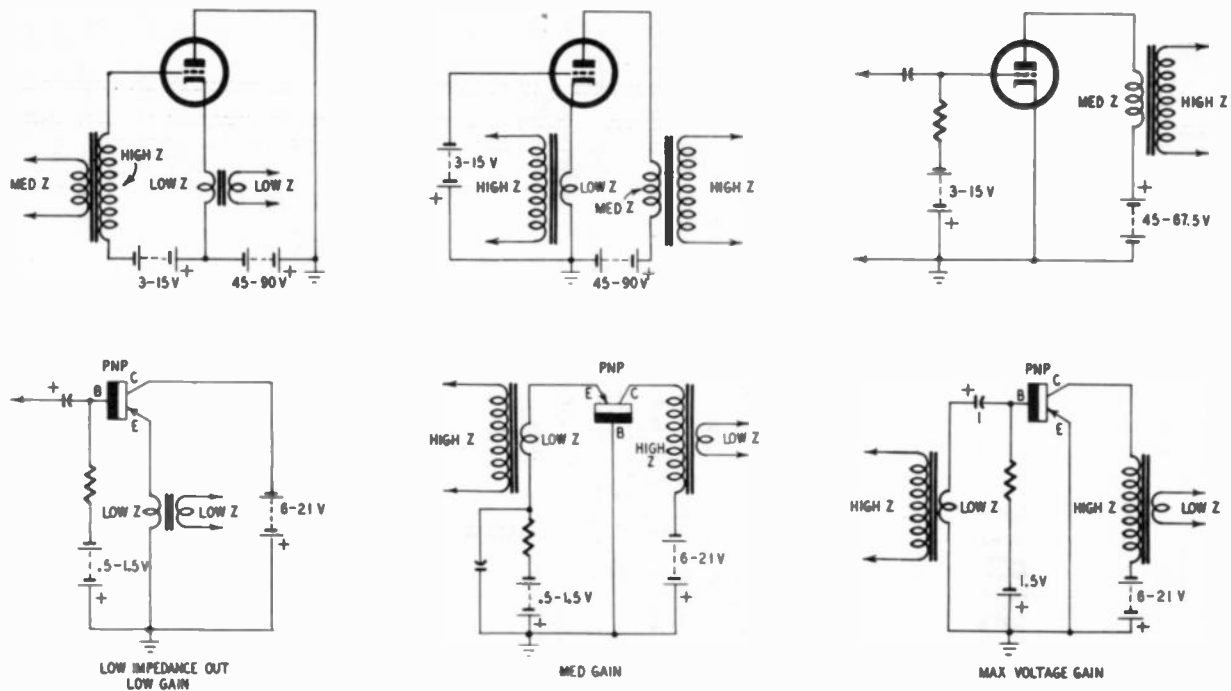

Fig. 802. Transistor and vacuum-tube equivalent circuits.

be of the proper polarity. A transistor can be damaged by having an improper potential applied to its elements.

## Fundamentals

A triode transistor such as the Raytheon CK722 can be thought of as a special type of vacuum tube. In the diagram of Fig. 802, the arrow on the transistor symbol designates the type. It points toward

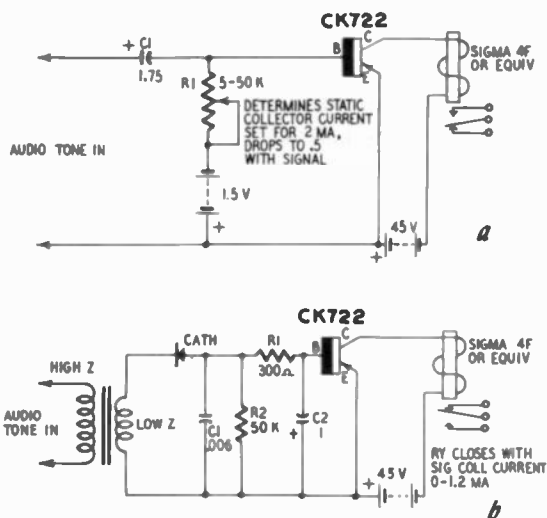

Fig. 803. Relays can be opened or closed on signal with these transistor circuits: a) relay opens; b) relay closes.

the base when the unit is a p-n-p type. A p-n-p transistor requires the application of a negative voltage on its collector.

If the arrow of the emitter points away from the base, the transistor is an n-p-n type. This transistor requires a positive voltage on its collector.

To identify the leads of a typical transistor such as the CK722, look for the red dot on the side of the device. This identifies the collector lead. The center connection is the base and the remaining lead is the emitter. If you have some doubt as to the connections for a particular transistor, obtain the base diagram.

## Transistor relay stages

A transistor (the CK722 will be used as the example, although other equivalent junction triodes can be used) can operate a relay in the same manner as a vacuum tube. See Figs. 803-a, b. The relay can be any of the standard types used in model applications. Such relays have resistances of 5,000 to 8,000 ohms and operate on 1 to 3 ma.

When the collector-emitter circuit (Fig. 803-a) is completed through the relay and battery, the relay will not operate until there is a small bias current flowing between the base and the emitter. This is accomplished by inserting the small 1.5-volt bias battery in series with a variable resistor R1. The polarity of this battery should be as illustrated. A current flows through the base-emitter circuit. This also causes a flow of current in the collector-emitter circuit through the relay. If R1 is about 5,000 ohms, a current flow of about 2 ma will result in the collector circuit closing the relay tightly.

The audio signal is applied to the relay circuit through the 1.75- $\mu$ f, 25-volt miniature tantalum electrolytic capacitor. When an audio signal is impressed on the base-emitter circuit, the negative alternations effectively meet a short circuit and go right through the transistor to ground. The positive alternations however, cannot pass through the transistor and thus a positive voltage is produced across R1. The polarity of this voltage drop is such that it opposes the bias voltage. When the top of R1 becomes more positive the bias voltage is reduced. Since the transistor required negative bias to cause collector conduction, the collector current flow stops and the relay opens.

When the signal stops, the opposing voltage is removed from the bias circuit and the relay closes again. To use this circuit, then, the controlled device would be wired to the normally closed contacts of the relay.

This type of circuit requires a flow of current from the bias battery. This current flow is small and the capacity of the smallest penlight cell is adequate. However, the bias battery must be checked so that you do not try to operate the model when the circuit is inoperative due to low bias voltage. It is also advisable to incorporate a switch between the relay and the controlled device so that when the receiver is off, the controlled device will not run down its battery supply.

From this explanation, it becomes obvious that some modification must be made if the relay is to close with signal. This means that the positive alternation of the audio signal must be removed before it reaches the transistor. This can be accomplished by using a small diode in series with the signal source as illustrated in Fig. 803-b. This diode is connected so that it will pass only the negative alternation of the signal.

The transistor (unless a negative bias is applied) will not have a flow of current of any significant magnitude through the collector circuit. Although the circuit is complete from the collector, through the relay, to the battery and then to the emitter, a relay connected in this way does not close.

When using a diode as a rectifier the output will be a series of negative pulses. This does not cause enough current to flow through

the base-emitter circuit to close the relay. To build up this voltage, a small filter consisting of C1, R1, R2 and C2 is added. The diode output is developed across R2 when a signal is applied. This voltage charges C1. This capacitor, in turn, charges C2 through series resistor R1. When C2 receives a charge, it has the same effect as placing the negative bias battery in the base-emitter circuit of Fig. 803-a. The transistor conducts and the relay closes. The function of series resistor R1 is to prevent the transistor from completely discharging C1 when conduction takes place in the base-emitter circuit.

R2 can be adjusted experimentally to get the best voltage output. It should have a large value. C2 should be large—say 1  $\mu$ f at 15 volts—but if it is made too large, it tends to form a delay circuit and thus

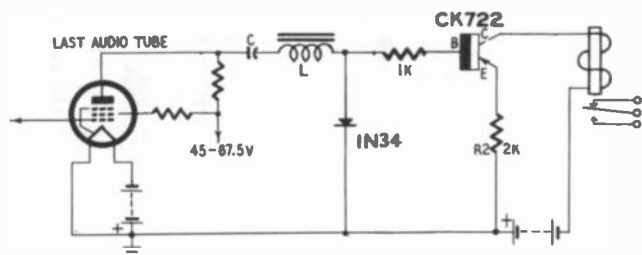

Fig. 804. A transistor-operated relay stage. Note the position of the audio filter.

holds the relay closed after the signal stops. The delay would make it impossible for the relay to respond to fast pulses.

The magnitude of the collector battery voltage is determined primarily by the resistance of the relay. The lower the relay resistance, the smaller this battery can be. The relay should be capable of operating within the 1-3-ma range.

It is possible to operate a transistor relay stage by using an audio filter to obtain tone selection. See Fig. 804. Since the transistor is a current-operated device, the filter must be placed in series with the transistor input. A series-resonant filter produces maximum current flow through its elements when the resonant frequency is applied. The output of the filter terminates in a relatively low value of resistance, R1. The value indicated can be varied for best results. Bias resistor R2 is used in the emitter circuit and can be from 200 to 2,000 ohms. The values of the tuned circuit are selected as usual.

When other than the resonant frequency is applied to the input, the tuned circuit presents a high impedance and thus too small a current flows to operate the relay. When the resonant frequency is applied, the current flow increases and the transistor operates the relay. It is possible with this type of circuit to obtain a current change of from 4 to 6 ma, depending upon the collector battery voltage, the resistance of the relay and the type of transistor used.

A transistor output stage capable of operating a reed unit is illustrated in Fig. 805. The requirement here is that the transistor function like a high-gain audio amplifier. The emitter has a large bias resistor which is bypassed by a capacitor to allow the audio to be amplified properly. A form of bias is applied to the base by resistor R1 to stabilize the transistor and provide smooth audio amplification.

With any given transistor, the bias resistors may have to be adjusted experimentally for optimum performance. One should examine the waveform across the reed winding and adjust the resistors until the waveform is a good sine wave of the proper amplitude.

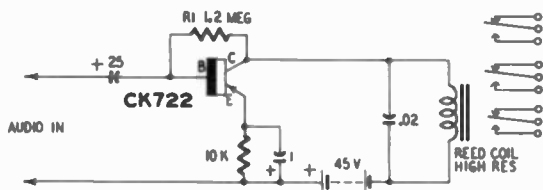

Fig. 805. Transistor-operated reed relay.

The use of a transistor as a power detector in the relay stage is shown in Fig. 806. Some variation of the supply voltage and resistors R1 and R2 might be needed for a particular relay.

### Transistor audio stages

The big difference between transistor and vacuum-tube audio stages is that transistors require small values of resistance and large size capacitors, while the reverse is generally true with tubes. Transistors,

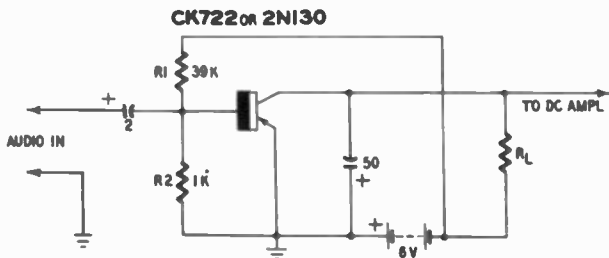

Fig. 806. This transistor power detector converts audio to dc. If the signal input is high enough, a relay may be substituted for  $R_L$ .

when used with special audio transformers designed for them, are capable of excellent operation with low voltages. The transformer fulfills the requirement for low dc resistors and yet gives efficient signal transfer.

The transistor, like the tube, requires bias. This may be supplied



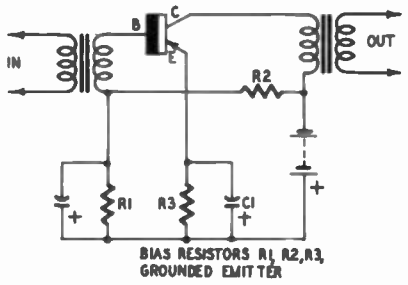
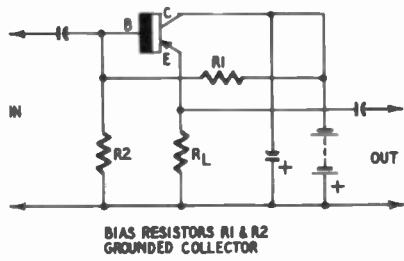
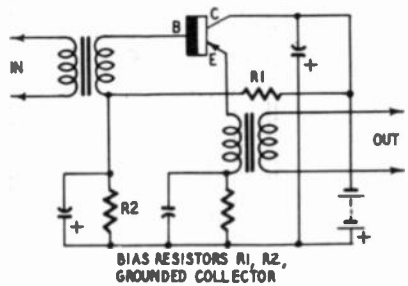
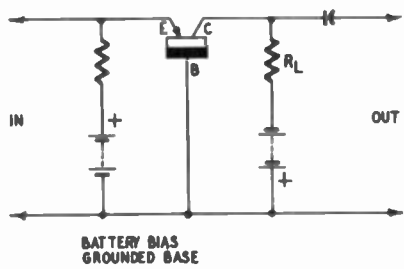
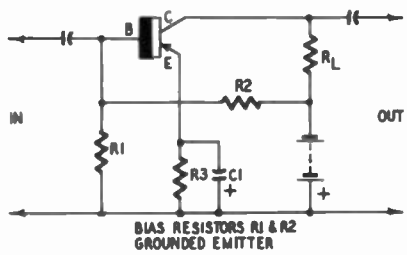
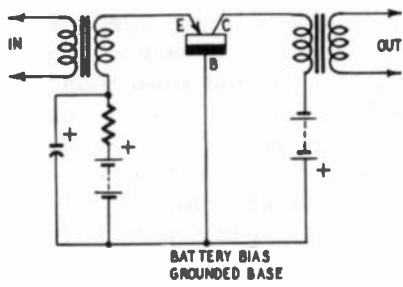

Fig. 807. Various methods of supplying transistor bias.

in the two forms used with vacuum tubes—battery bias or self bias. Some practical bias circuits are illustrated in Fig. 807.

Fig. 808-a is an example of a transistor audio stage which is stabilized, while Fig. 808-b shows the same stage without stabilization. In model applications, bias stabilization is generally unnecessary.

One of the most critical items to consider when thinking of transistor audio amplifiers is that there must be correct impedance matching between transistors or between the transistor and the load, otherwise the output will be low and distorted. For greatest efficiency, the transistor and load must be matched.

When several audio stages are used, decoupling circuits are needed just as with vacuum tubes. These become quite critical in transistor circuits because, as soon as the battery voltage begins to drop, an internal resistance is built up inside the battery across which signals are developed. Some of these signals will have the proper phase to feed back into input circuits and cause audio howl. Decoupling

circuits can consist of resistors and large capacitors. Alternatively, separate batteries can be used, say one battery for every two stages.

It is possible to use a combination of n-p-n and p-n-p transistors and reduce the decoupling requirement. The result is an unusual circuit but one which requires a minimum number of parts. Before examining the circuit itself, a note concerning the high values of coupling capacitors: If these are tantalum electrolytic types, one terminal is marked with a plus sign. This must be connected to the

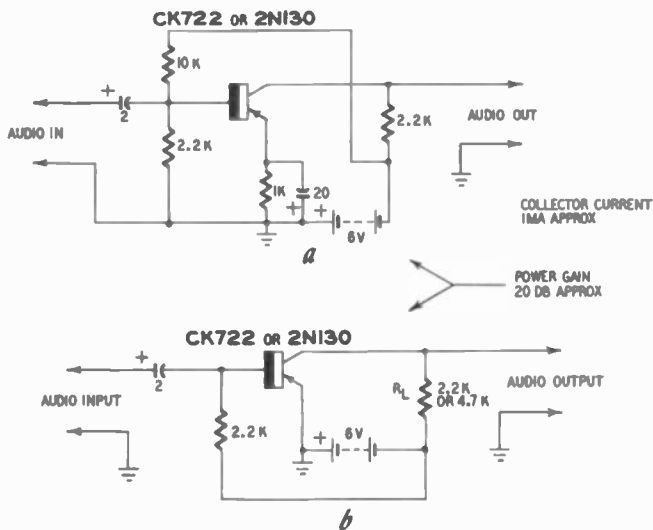

Fig. 808. Two useful transistor audio amplifiers: a) stabilized amplifier; b) amplifier without stabilization,  $R_L$  is adjusted to produce 0.5-1 ma collector current.

plus side of the circuit. Immediate shorting will result if the polarity of the capacitor is reversed. It is wise to place a standard paper capacitor in the circuit first, measure the voltage drop across it with a high-resistance meter and determine from this which is the plus and which is the negative voltage circuit.

Fig. 809 illustrates a receiver using a high-frequency transistor (requiring a negative collector voltage) as a regenerative detector; a 2N214 junction transistor requiring a positive collector voltage and a CK722 second audio stage requiring a negative collector voltage. The connections to the single battery are such that the proper polarity is obtained for each transistor. The tuned circuit resonates in the broadcast band. Although this is not a radio-control receiver, it does illustrate the method that might be used if low-cost transistors, capable of operation on radio-control frequencies with suitable stability, are developed. The detector is a superregenerative type with the regeneration controlled by the amount of resistance in the detector emitter circuit.

## Transistor oscillator circuits

Using transistors as small low-powered transmitters in connection with radio control is attractive. This would be especially true in connection with a model car, where the operating distance is quite small. A transistor oscillator would be almost ideal as the local oscillator of a superheterodyne radio-control receiver. Of course, in the latter case, one would want the oscillator crystal-controlled to prevent any possible drift.

Fig. 810-a illustrates an oscillator capable of producing a radio frequency at 1890 kc. The value of the  $.001\text{-}\mu\text{f}$  capacitor may have to be reduced to produce oscillation. A resistance of 500 ohms may have to be inserted between the tuned circuit and ground.

Three types of crystal-controlled oscillators are indicated in Figs. 810-b-d. In the circuit of Fig. 810-c, adjust the collector voltage to about 10 and rotate R1 for oscillation. In the circuit of Fig. 810-d, C1 and C2 must be adjusted to obtain oscillation. The final circuit

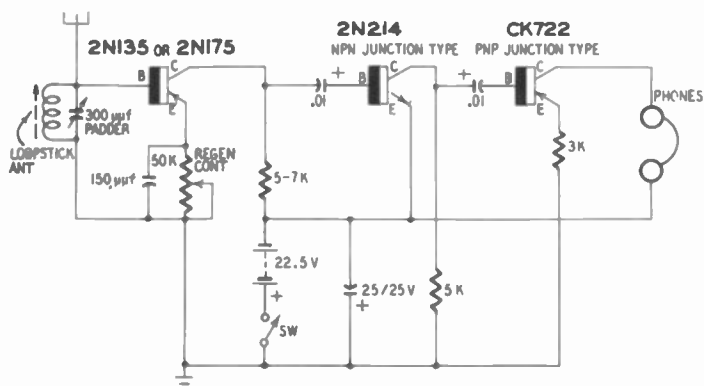

Fig. 809. Transistor receiver using a superregenerative detector and two stages of audio amplification.

is a Clapp type oscillator. The emitter bias is developed across the 15,000-ohm resistor. C2 is the critical capacitor as far as sustained oscillations are concerned and its size may have to be varied.

It is possible to modulate a transistor oscillator by feeding the output of a tone oscillator through a transformer to the base or collector circuit. In Figs. 810-a, b, the modulation transformer secondary could be connected in place of the 1,000-ohm resistor in the collector circuit, if its dc resistance is near this value.

In the other circuits, the secondary of the modulation transformer would be connected in series with the B-plus lead.

In all of these circuits various transistors may be used, especially if higher frequencies are required. The 2N137, 2N168A, AO-1 and SB100 can be successfully substituted. However, when adapting these circuits for use with various transistors it is important to keep the

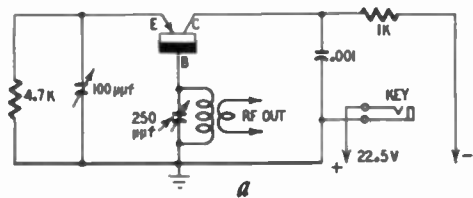

a

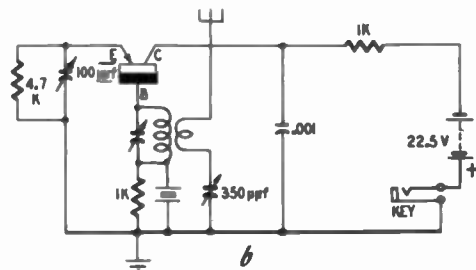

b

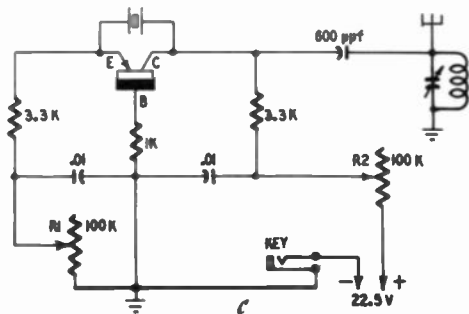

c

TRANSISTORS  
 2N137 - 7 MC  
 5B100 - 80 MC  
 2N168A - 8 MC  
 AO-1 - 30 MC

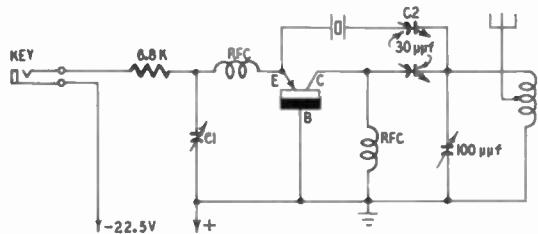

d

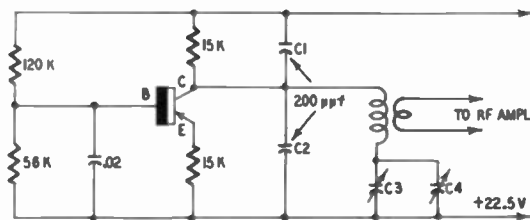

e

Fig. 810. Transistors make excellent oscillators in a variety of circuit configurations. The tuned circuits have the same values as those used in tube oscillators at any given frequency.

collector current from exceeding that specified by the manufacturer. If necessary, resistance must be added in series with the B-supply lead. Voltage polarity must be observed when using these types, since it may differ from that indicated on the schematics. When in doubt refer to the specifications.

**Miscellaneous transistor circuits**

A transistor can be used as a tone oscillator to drive a modulator in a tone type transmitter. The output of a transistor oscillator is low unless special power transistors are used. Without special compensating circuitry this type of oscillator is not capable of producing

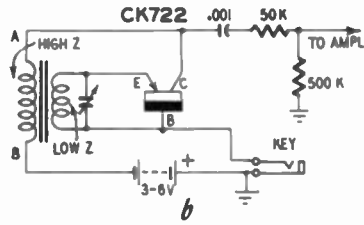
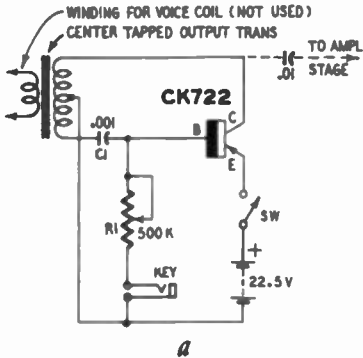

Fig. 811. Transistor tone oscillators: a) Hartley type; b) transformer used to provide feedback.

the exact and consistent tones which might be required by receivers using filters or reed decoders. The circuits illustrated in Figs. 811-a,b could be used with receivers requiring a tone, but not a particular tone.

Fig. 811-a illustrates a Hartley type tone oscillator while Fig. 811-b uses the plate-feedback method of obtaining oscillation. The frequency

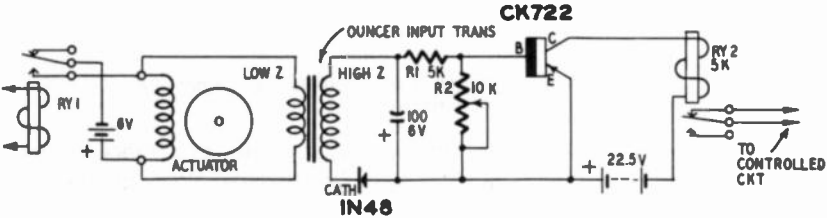

Fig. 812. A transistor circuit used to decode a pulse-rate signal. As the rate increases, collector current decreases.

of the Hartley is governed by the inductance of the transformer winding and the values of C1 and R1. Some latitude in the frequency of the output is obtained by adjustment of R1.

The frequency of the plate feedback type is more difficult to control. It is possible to use different values of capacitance to change the

frequency of output. Reverse the connections at A and B if this circuit does not oscillate.

A transistor can be used to provide decoding of a signal in which the pulse repetition rate increases and decreases. See Fig. 812.

A control system which uses an actuator for control of the steering element (this is a permanent magnet within a coil of wire) can be

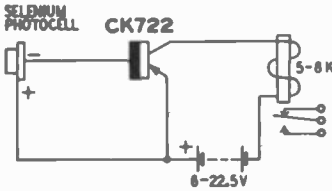

Fig. 813. A light-controlled transistor-operated relay.

arranged so that an increase in the pulse spacing produces a left turn and an increase in the pulse spacing produces a right turn. Adding the circuit shown makes possible an additional control by simply increasing the rate at which the pulses are transmitted. The transistor in the circuit draws current without signal, causing RY2 to close. R2 controls the amount of base current, which should be about 0.5 ma. When the pulse rate increases, the diode rectifies the

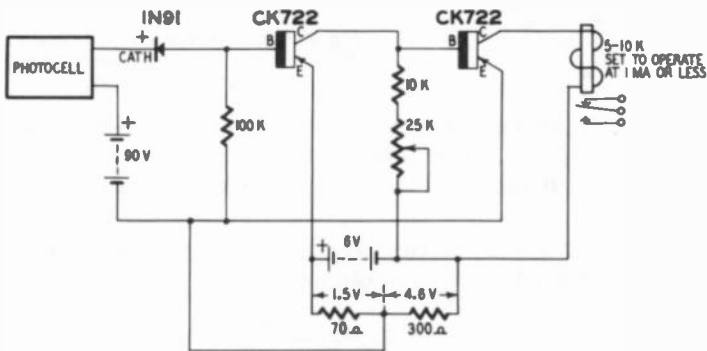

Fig. 814. A two-stage direct-coupled transistor amplifier for relay operation.

signal which comes from the transformer and applies a more positive bias to the transistor, causing it to stop conducting. This causes relay RY2 to open. As noted, the circuit to be controlled should be connected to the armature and the normally closed contact of RY2. RY1 is the receiver relay.

A transistor receiver which closes a relay when a beam of light is flashed at its selenium photocell is illustrated in Fig. 813. Such a circuit could be used to control a model car in the living room. By using three photocells arranged in a triangle on the roof of the model it will be possible to activate the relay with a light no

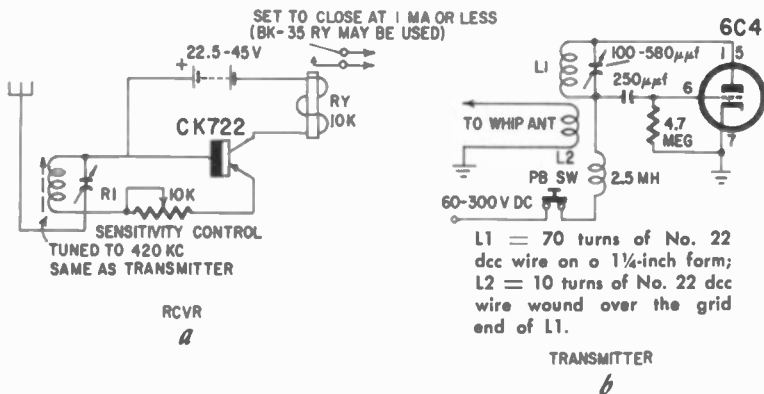

Fig. 815. A low-frequency control system: a) single-stage transistor receiver; b) low-power 420-kc transmitter.

matter which way the model turns. The springs of the relay should be adjusted so that the relay does not close in normal light.

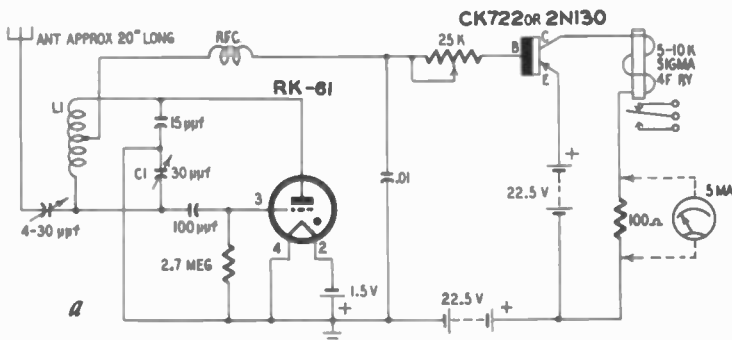

Fig. 816. Two very successful receivers using gas tube detectors and transistor relay stages: a) the RK-61 idles at 0.5 ma, transistor at 4.8 ma;

In some applications an additional stage of transistor current amplification may be desirable. Such a circuit is shown in Fig. 814.

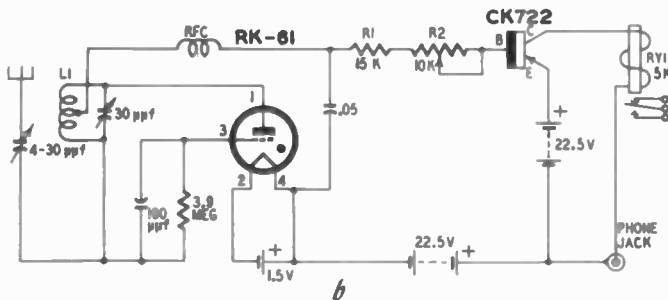

Fig. 816. (continued). b) the RK-61 idles at 0.2 to 0.6 ma, transistor at 0.1 ma.

This dc amplifier could have additional applications in model control. The input signal might be obtained from other than a photocell source—a small diode detector connected to a tuned circuit or the rectified output from a superregenerative detector could be used.

It is possible to construct a simple transistor control system which can be used for model operation over limited distances. Such a circuit is shown in Figs. 815-a,b. Sensitivity control R1 can be adjusted so that the collector current will not exceed that specified by the manufacturer for the CK722.

### Transistor receivers

To operate a model at distances of a quarter to a half-mile away using transistors, try the circuits of Figs. 816-a,b. These are almost identical. Both use the RK-61 as a superregenerative detector to provide adequate sensitivity and stability. Both use a transistor in the relay stage. Fig. 816-a allows slightly finer adjustment of the detector by having an additional capacitor in the tuning circuit.

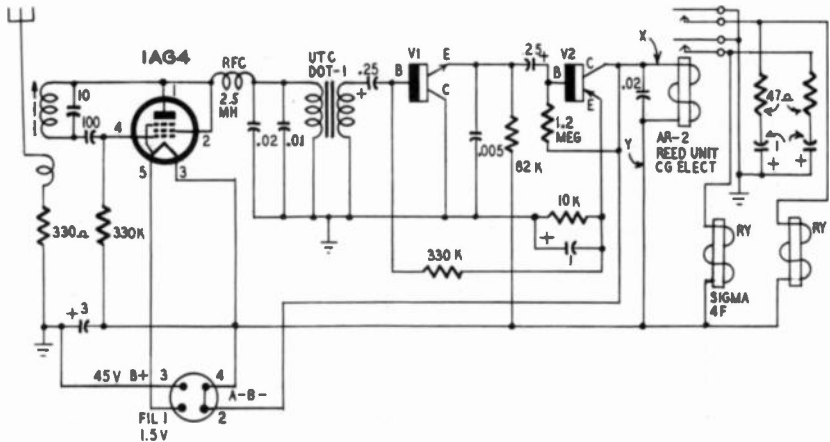

Fig. 817. A tone receiver using a tube detector and transistors for the audio and relay stages. Connect earphones across X and Y for testing.

It is possible to construct a tone type receiver which uses a tube detector and has transistors for the audio and relay sections. Such a receiver is shown in Fig. 817. Two transistors are used in a transformer-coupled circuit to drive the coil of a reed unit. This receiver is not critical and affords low current drain. It can be very compact.

It is especially important to observe the correct polarity of the small electrolytic capacitors. Clip a pair of earphones across the reed coil during the initial testing and tune in the signal to determine that the unit is operating correctly. The earphones should then be removed to obtain reed operation.

Note that the transistors used must have certain characteristics. Beta is the current amplification rating when the transistor is used



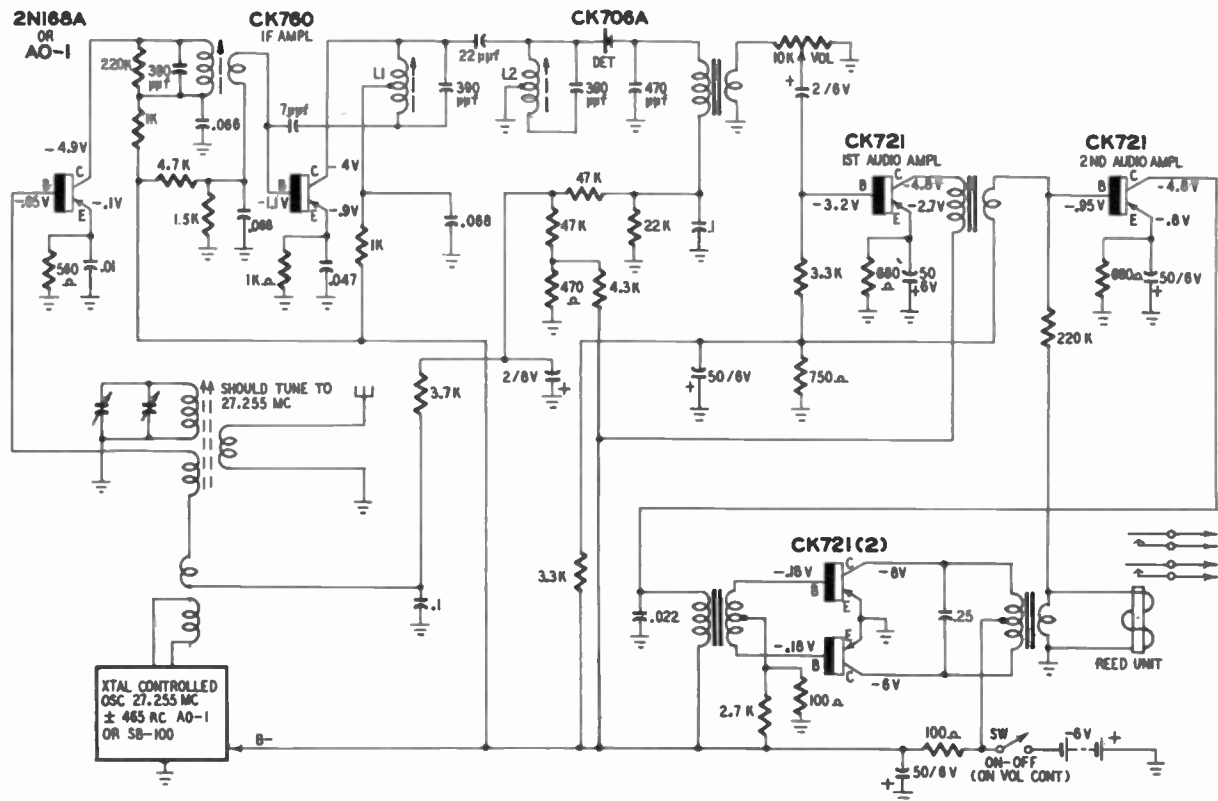

Fig. 818. A five-transistor broadcast receiver modified for control purposes.

in a grounded emitter circuit.  $I_{co}$  is the saturation current; it is the current which flows in the collector circuit when the emitter current is zero.

A five-transistor superheterodyne type receiver which drives a reed type tone-selection device is illustrated in Fig. 818. While the basic circuit is for a broadcast type receiver, it is shown here with the addition of a reed unit to illustrate the possibility of using a receiver of this kind in model applications. Transistors have been developed which make the idea of constructing a superheterodyne type receiver for control applications at 27.255 or 50-54 mc realistic. The if stages would require no change nor would the audio and detector sections.

Thus, this type of circuit, with a transistor converter capable of receiving signals at the two frequencies mentioned, and an oscillator capable of operating within 455 kc of the desired input signal, make an ideal R-C receiver with high gain and excellent selectivity. The overall power supply requirement of four 1.5-volt cells is indeed attractive. The push-pull amplifier stage could be used with its output coupled through a suitable transformer to a reed unit. This would provide excellent signal amplification.

# practical receivers

**T**HE receivers presented in this section have been carefully selected. They include single-tube single-channel types as well as more complex units. Operating frequencies include 27.255, 50–54, 144–148, 220, 420–450 and 465 mc. The receivers are grouped by complexity rather than frequency, since many of them can operate on bands other than those for which coil data are given. Appropriate modifications must be made to operate these units on any but the specified frequencies.

## Construction hints

Where tube sockets are required, use those which afford maximum contact area to the tube pins. For high frequencies (50 mc and above), use high-frequency sockets in the detector stages.

Coils and other electronic components are generally available from the manufacturers of model equipment and parts supply houses.

When constructing a receiver, planning layout prior to actual mounting and soldering of components will help locate them in the most advantageous positions. Tuning coils and rf chokes must have a free air space around their windings of at least the diameter of the coil. In all stages short leads help make the unit rigid. They also help prevent undesirable coupling between stages. One good technique is to keep all components associated with a particular tube as close to its base as possible.

Always try to use an in-line type of construction, keeping the output stage farthest from the detector. Many troubles can be traced to a looping-back type of layout in which signals spill over from the output stage into the detector.

One way to approach the problem of layout is to place the major parts on a piece of cardboard and then arrange each until the best

layout is obtained. Mark the cardboard and use it as a template for a linen board, which is one of the best bases that can be used. Drill the socket and coil holes and mount these units first, then the other major components. Wire the filament connections and install lugs for the B-plus connections and anchoring points for resistors and capacitors. Eyelets may be used in place of lug tie points if desired.

Complete the circuitry for the detector stage first and then, in the case of tone receivers, the first audio stage. Couple a pair of ear-phones through a .01- $\mu$ f capacitor and apply filament and B-plus voltages. A hiss should be heard in the absence of signal. Wire in the second stage (with power removed) and test, etc. This method permits the builder to check the receiver while it is being constructed and can save subsequent troubleshooting time. The photographs included in this chapter illustrate many possible layout arrangements. Table 9-1 gives construction data for the tank coils.

**Table 9-1. Construction Data for Receiver Tank Coils**

<i>frequency (mc)</i>	<i>diameter</i>	<i>form</i>	<i>turns</i>	<i>wire size (enam.)</i>
27.255	¼"	LSM	34	# 32
50-54	¼"	LSM	22	# 26
144-148	¾"	LSM	5	# 26
220		same as transmitter (¾" U-shaped loop)		
420-450		same as transmitter (aluminum loop)		

All slugs should be connected to ground or B minus. All coils are slug-tuned except those working above 220 mc. If coils are center-tapped double the number of turns. Tuning capacitors have not been indicated since they will vary considerably depending on the tube used. The circuits illustrated in this chapter will give you some idea of variable capacitance values.

### **One-tube receivers**

The simplest receivers, from a construction standpoint, are the gas- or soft-tube (Figs. 901 and 902) and the single-hard-tube types. These are designed to operate a single relay when they receive a non-modulated rf signal. They fall into the single-channel category.

The heart of the gas-tube receiver is the thyratron (RK-61). Designed especially for radio-control, this tube is filled with a small amount of inert gas. It can amplify as a normal tube and has the ability to change abruptly from a state of high plate current (1.2 to 1.3 ma) to low plate current (0.2 to 0.5 ma). This current change is more than sufficient to operate a sensitive relay.

When a thyratron is in a state of high conduction, the grid loses control and cannot cause the tube to return to a state of minimum conduction unless the plate voltage is made to drop at the same time that the grid is made more negative.

To detect a signal, the tube is operated as a superregenerative detector. An input signal is amplified in the plate circuit and is fed back to the grid in such a manner that it is built up. This action re-

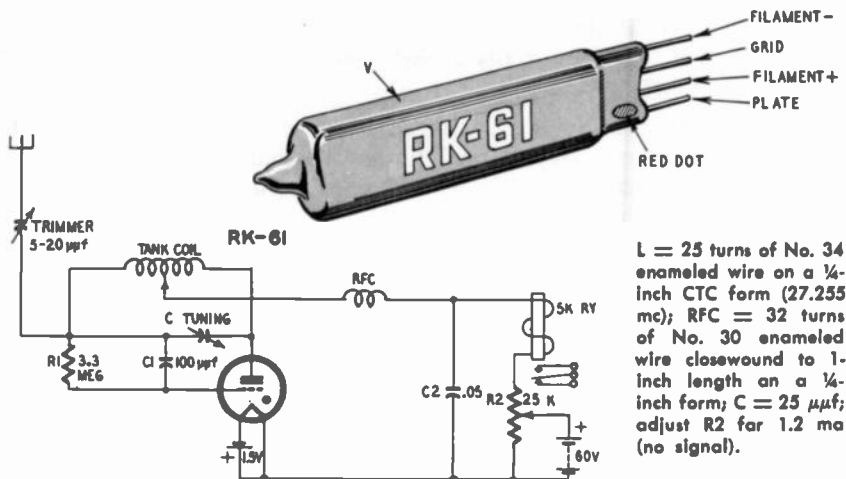

Fig. 901. A typical gas-tube receiver. The leads of the gas tube can be identified by the red dot on the side.

peats until the signal is so strong that it develops a negative voltage large enough to cause the plate to cut off. This negative voltage is stored in C1.

If the plate voltage is reduced at this time, even for a moment, the grid gains control of the electron stream and holds the tube in a low conduction state as long as the signal is present.

To reduce the plate voltage periodically, C2 is coupled from the plate of the tube to ground. The plate voltage, which appears across C2, must build up as current flows through R2 and the resistance of the relay winding. When C2 charges to full B-plus, and when the voltage on the grid of the tube approaches zero due to the discharge of C1 through R1, the tube will conduct, discharging C2.

C2 cannot assume a charge again immediately due to the resistance of the relay and R2, and so, for a moment, the voltage at the plate of the tube is low. Thus, as long as a negative voltage is present at the grid, the tube is held in a state of low conduction. As soon as the signal stops, the grid voltage stored across C1 will discharge through R1, the grid will approach zero and the tube will conduct.

In the absence of signal, the tube will conduct with a series of pulses of plate current as C2 charges and discharges. It is the average of these that represents the high-current state of 1.2 to 1.5 ma.

The magnitude of the charge stored across C1 due to the signal will be a function of the signal strength. The stronger the signal, the greater the charge. Thus, the plate current drop will be less with a weak signal than with a strong one.

This type of receiver will close the relay when it is turned on and will allow it to open when a signal is received. This could be a dis-

advantage since, if the receiver fails for any reason, the control circuit connected to the normally closed contact would be energized.

When using the RK-61:

1. To obtain the lowest possible loss use an L-C ratio which will produce the highest possible Q. This means that the coil should be large and constructed of fairly wide diameter wire. The value of the tuning capacitor should be low.

2. A high-value quench control capacitor (C2) results in high peak currents which shorten tube life. Receiver sensitivity is not greatly affected by the frequency of the quench. However, this frequency should be in the region of 20 to 30 kc. This is obtained with the value of capacitors shown.

Once constructed, the receiver must be adjusted to operate correctly.

1. Connect the batteries and attach a wire approximately 18 inches long to the antenna capacitor. Turn the capacitor so that the plates are completely unmeshed or the metal dot on the rotor is farthest from the mounting holes, indicating minimum capacitance.

2. Set the potentiometer so the *maximum* amount of resistance is in the circuit.

3. Plug a 3-5-ma meter of good quality in the jack if provided or connect the meter in series with a B-plus lead.

4. Check the battery connections again to make sure that they are correct. If they are, *turn on the receiver switch*. The meter should read 0.3 to 0.5 ma.

5. Carefully decrease the amount of resistance of the potentiometer until the meter indicates 1.1 to 1.3 ma.

6. Check the relay to see if it closes at just under 1.1 ma. If it does not, adjust the spring tension and decrease the armature gap until it does.

7. Turn the potentiometer to increase the resistance in the circuit and lower the plate current. The relay should open at about 0.6 ma.

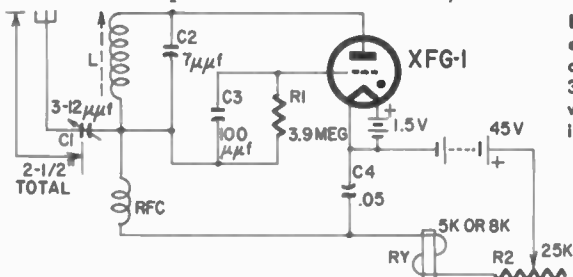

L=20 turns of No. 24 enameled wire centered on a CTC LS3 form; RFC=No. 34 enameled wire jumble wound on a 1-inch long 1/4-inch form.

Fig. 902. This gas-tube receiver uses an XFG-1 thyratron.

If it does not, adjust the points and spring until it does. Once set, the relay should open and close at the current values specified.

8. Close the antenna tuning capacitor about one-quarter turn. Place

a transmitter 4 to 6 feet away. Do not insert or connect the transmitter antenna. Turn the transmitter on and key it.

9. If the receiver tuning coil has a metal slug for tuning, a non-metallic screwdriver will be required. Adjust the receiver potentiometer R2 until the plate current is about 1.2 ma. Screw the tuning slug (or adjust the tuning capacitor) until a spot is reached where the plate current suddenly changes. Tune carefully for the lowest possible current reading.

10. Release the transmit button. The plate current should rise. Pulse the button and the relay should click with each closure of the keying switch.

11. If the meter needle seems jumpy without signal, increase the antenna coupling by closing the antenna capacitor and retune by adjusting the coil slug or tuning capacitor. It may be necessary to adjust R2 to keep the plate current around 1.3 ma. Tube life will be shortened if more than 1.5 ma is drawn for any length of time.

12. Connect the antenna to the transmitter and conduct a field test by placing the receiver and batteries on a small board and walking away from the transmitter. An assistant should be present to send signals. At a distance of 100 to 200 yards the plate current may not drop

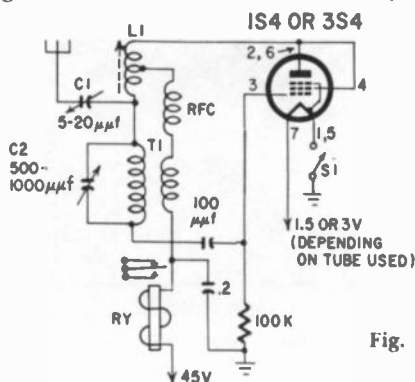

T1 = National OSR or equivalent; L1 = 32 turns of No. 28 enameled wire on a 1/4-inch CTC form; RFC = No. 32 enameled wire closewound to 1-inch length on a 1/4-inch form. (L1 coil data is for 27.255 mc.)

Fig. 903. Hard-tube superregenerative receiver.

low enough to de-energize the relay. Readjust the antenna capacitor, the tuning coil and possibly R2. If the receiver operates satisfactorily at 200 yards, it is ready for installation in the model.

13. After removing the meter it may be necessary to readjust the tuning. When the receiver is installed in the model and connected to the antenna which will be permanently used, some additional touching up may be required.

14. The final check is to operate the receiver with the model motor running. This is especially true for model aircraft. If the relay chatters, remount the receiver in a rubber-band web or on soft sponge-rubber pads. Bad solder joints and loose battery connections may also contribute to chatter.

With some types of relays it may be necessary to place a small piece

of tissue paper on the relay pole piece to prevent sticking. Finally, if a distance check with the receiver in the model indicates that there is sufficient range and the vibration check shows no malfunction, the model is ready to be radio-controlled.

### Hard-tube receivers for 27.255 or 50-54 mc

It is possible to operate a hard-tube receiver in a manner somewhat similar to the gas-tube. (See Fig. 903.) This circuit operates on the principle that a vacuum tube can oscillate on two frequencies simultaneously. The lower of the two governs the length of time that oscillation will occur at the higher frequency. L1 is the tuning coil which is set to 27.255 or 50-54 mc (depending on the number of turns). The frequency to which it is tuned is that which the trans-

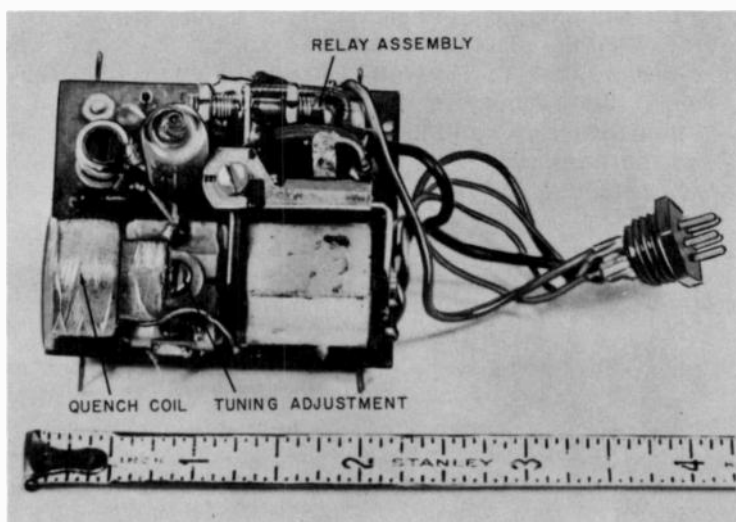

Fig. 904. This compact hard-tube receiver uses a Sigma 4F relay.

mitter must send to cause relay operation. L1 with its distributed capacitance (and also the plate-to-ground and grid-to-ground capacitance of the tube across it) forms a resonant circuit. When the grid voltage is of the proper value to cause oscillation, the circuit goes through the normal regenerative-superregenerative action required of a superregenerative detector. The tube capacitance across the tank makes the circuit a Colpitts oscillator.

An additional tank circuit is formed by T1, with its tuning capacitor in the grid circuit, and a feedback winding, which is the transformer secondary. Much more feedback is required for the tube to oscillate at low frequencies which is why a transformer is used. The high-frequency component also has a direct path to the grid of the tube through C2. Fig. 904 illustrates a method of construction using a Sigma 4F relay. It also shows the relative size of this type of receiver.



When the receiver is completed and the wiring checked for accuracy, align it to obtain proper operation.

1. Connect an 18–24-inch antenna to C1.
2. Connect a 0–3 or a 0–5-ma meter in series with the B-plus lead.
3. Apply filament and plate voltages to the receiver by closing S1.
4. Adjust C2 for minimum capacitance (turn screw counterclockwise). Note the meter reading. The current should be about 2 ma.
5. Turn C2 clockwise, increasing capacitance. A point should be reached where the current suddenly drops to 0.2 to 0.5 ma.
6. If the plate current remains at a low value regardless of the adjustment of C2, then *either* the primary or the secondary winding of the quench coil must be biphased. *Do not reverse both.*
7. When a sudden change in plate current occurs, note the amount of this change.
8. Adjust the relay spring tension and contact settings until the relay will pull in just below the maximum current and drop out at a value slightly above the minimum value observed.
9. If no *sudden* change of plate current occurs but a gradual increase or decrease is observed, the tube is probably bad and should be replaced.
10. Turn C2 clockwise until the plates are tightly meshed. Begin backing off by rotating the screw counterclockwise, to reduce the capacitance in the circuit. Watch the meter for a sudden rise in

Fig. 905. This simple one-tube receiver uses one section of a dual triode.

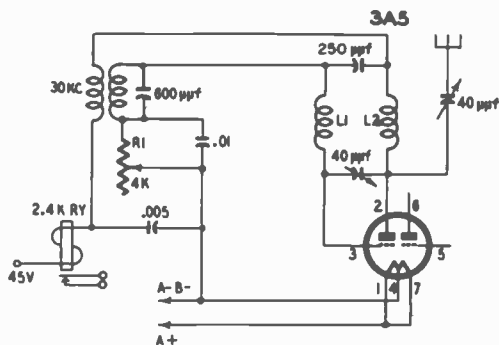

plate current. When this point is reached, turn the screw about a half-turn more. The quench is now adjusted and the plate current should be 1.5 to 2 ma.

11. Remove the antenna from the transmitter and turn on the unit. Tune the receiver tuning slug with a nonmetallic screwdriver and observe the meter for a dip in plate current. It should drop to about 0.1 to 0.2 ma. Move the transmitter farther away and repeat the tuning process.

12. Insert the transmitter antenna for distance and vibration tests. The circuit of Fig. 905 illustrates a method of producing high-

frequency feedback by splitting the tuning coil. With this circuit the adjustment of the bias for correct operation is made possible through variable grid resistor R1.

When a pair of earphones is connected across the relay coil, a loud hiss will be heard if the receiver is functioning. Adjust the grid resistor until a point is reached where the plate current makes an abrupt change, either from a high to a low or a low to a high value. The resistor value should be such that the plate current is high, but

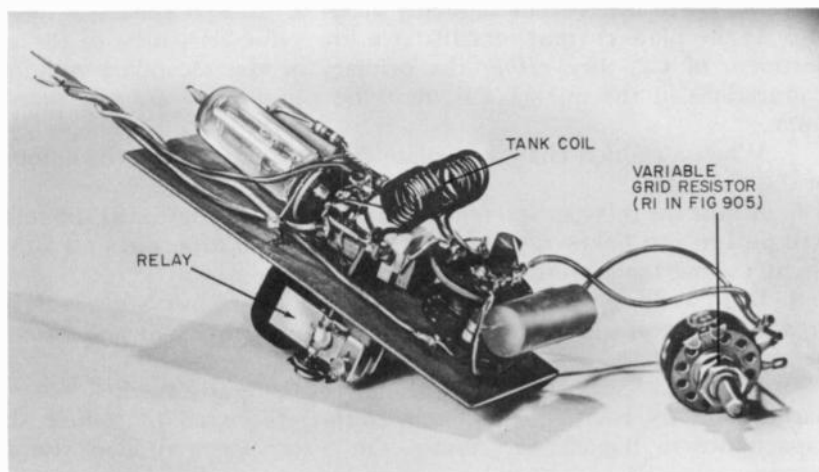

Fig. 906. Complete unit built from the schematic of Fig. 905.

also that a small increase in resistance will cause the current to drop. The hiss should still be present after this adjustment has been made.

Fig. 906 illustrates a method for constructing this receiver. Note that the two halves of the tank coil are close together. If the receiver does not regenerate, move the halves closer together. On occasion may be necessary to reverse the connection to *one* of the windings.

Fig. 907 shows how the Colpitts idea can be used in both the low- and the high-frequency roles. The tank circuit is effectively tied to the plate through the  $.001\text{-}\mu\text{f}$  capacitor and to the grid through the  $.003\text{-}$  and  $.002\text{-}\mu\text{f}$  capacitors. If one considers the tube's internal capacitances, the high-frequency Colpitts circuit can be visualized.

The inductance of the tuning coil L1 is insignificant at the low quench frequency. So the low-frequency tuning circuit consisting of the 2.5-mh coil and the  $.003\text{-}$  and  $.002\text{-}\mu\text{f}$  capacitors across it has one end connected to the plate of the tube through the  $.001\text{-}\mu\text{f}$  capacitor and the other to the grid through the  $100\text{-}\mu\text{f}$  grid capacitor.

At the low quench frequency the inductance of the  $100\text{-}\mu\text{h}$  choke is also insignificant and so the junction of the two capacitors can be considered to be connected to the filament. In a Colpitts circuit the voltage on the grid is developed across one of two capacitors con-

nected in series across a coil. This circuit is of that type and the tube will oscillate at the low quench frequency.

In the plate circuit of the tube, there is a 100- $\mu$ h choke, to prevent the loss of the high (27.255-mc) radio frequency, and a variable

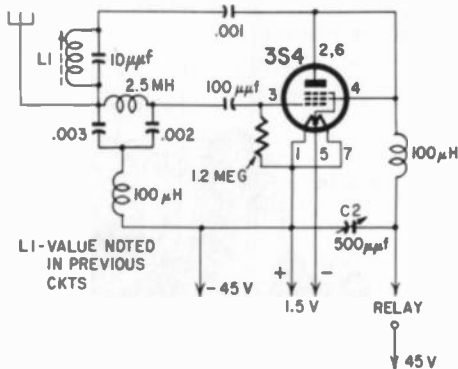

Fig. 907. This CG Electronics Corp. 4-A receiver is an example of a popular commercial one-tube unit.

capacitor C2. The choke does not impede the low quench frequency, but the relay coil with its relatively large inductance does. The variable capacitor provides a means of adjusting the magnitude of the

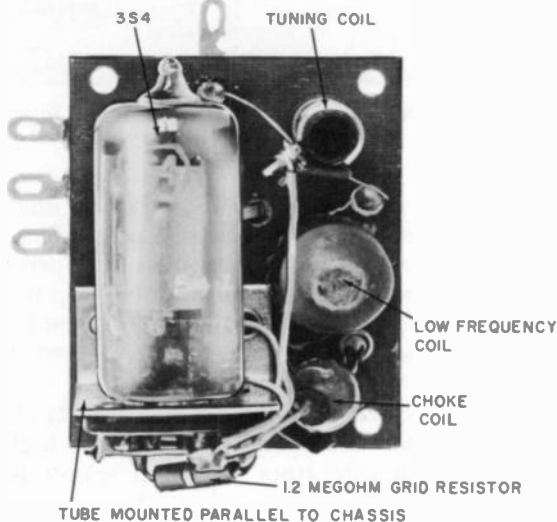

Fig. 908. Internal view of the receiver in Fig. 907.

quench oscillation. The capacitor is set for the critical plate-current change point, as previously noted for other circuits of this type. Fig. 908 illustrates the compact arrangement of parts. The relay is not present for it would be mounted separately.

An example of a receiver which falls into the one-tube category but

operates on a much higher frequency (465 mc) is the one shown in Figs. 909 and 910. Some unusual construction features are required because of the high operating frequency. Also, the relay in this receiver closes with signal instead of opening. Note the antenna used (the aluminum loop below the base) and the tuning circuit at the left of the photograph.

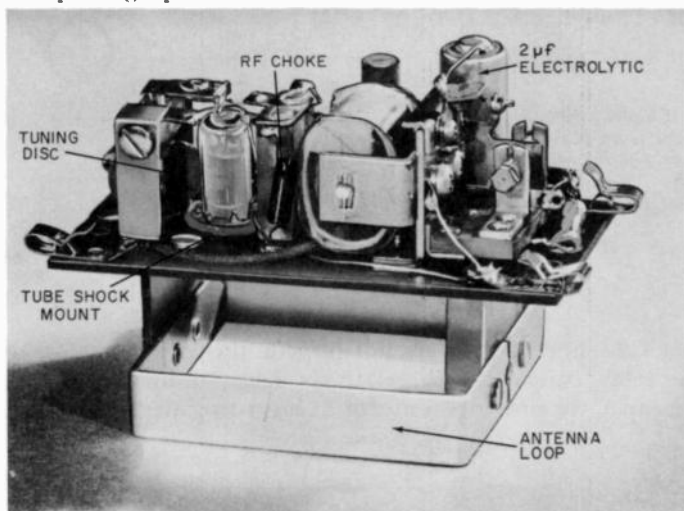

Fig. 909. A 465-mc receiver. The strip of metal at the bottom is the antenna. There is no electrical connection between it and the receiver.

There is no physical connection between the antenna loop and the tuning circuit. The loop is open at one end and, when a small screw is screwed into the mounting bracket between the open ends, it forms a variable capacitance which is used to tune the loop to the operating frequency. (The screw is omitted in the photograph.) The antenna is excited by the transmitted signal and, in a sense, reradiates the signal, which is picked up by the tuning circuit.

The circuit of the receiver is shown in Fig. 910. Rf chokes are used in the filament leads for decoupling purposes. At high frequencies, complete isolation of the tube from the power supply is necessary.

The receiver is tuned by a small copper disc in the center of the tuning loop. When this disc is parallel to the plane of the loop its effect is the same as if a turn of a conventional coil were shorted—it raises the resonant frequency. When the disc is perpendicular to the plane of the loop, its effect is small, the frequency being that of the loop and associated capacitance. The physical size and shape of the loop are the primary determining factors of the frequency at which the receiver can function.

When installing this receiver in a model, keep the wiring as far

from the antenna loop as possible. A receiver of this type cannot be mounted in the metal hull of a model ship where the antenna would be completely shielded.

To adjust the receiver for proper operation:

1. Mount the receiver in a small jig, using rubber bands through the mounting clips so that the antenna does not contact the bench or any other object.

2. Connect the B-plus lead from the receiver to a 0-1.5- or 0-3-ma meter.

3. Make sure that the receiver is turned *off*. Then connect the filament batteries to the receiver, the B-minus battery lead to the receiver and the B-plus battery lead to the meter.

4. Soften with ordinary lacquer thinner the glue that holds the slug in the quench coil. Make sure it is soft before attempting to turn the core.

5. To adjust the receiver, a 465-mc transmitter will be required. Turn on the receiver and the transmitter, making certain that the

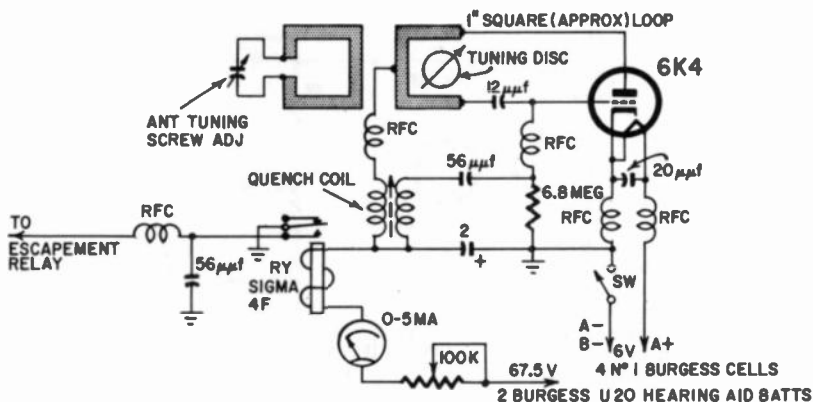

Fig. 910. Circuit of the 465-mc receiver.

transmitter antenna is disconnected. Press the transmitter button and slowly turn the core of the quench coil with a *nonmetallic* tool, while observing the meter. A position of the slug will be found where the plate current will suddenly jump to about 1 ma. Move the transmitter away and keep adjusting the core until the most sensitive (highest-current reading) point is found. This position of the quench core should result in the highest no signal current too. This should not exceed 0.2 ma. If it does, readjust the core.

6. Adjust the antenna tuning screw for maximum no signal current. Use caution. The loop must not be shorted by turning the screw in too far. If this adjustment raises the plate current above 0.2 ma, reset the quench core. If it is impossible to obtain an increase in current,

move the transmitter away, key it and adjust the screw for a maximum reading.

7. The transmitter should now operate the receiver relay with a current change of about 1 ma at a distance of at least 6 feet without an antenna. It may be necessary to readjust the core of the quench coil, the tuning vane and the antenna tuning screw.

8. When adjusting the tuning vane, the transmitter should be moved as far from the receiver as possible but still produce a reading on the meter. The vane should be moved only slightly from its original position, first in one direction then the other, always tuning for maximum current.

9. Touch up the quench core and the antenna screw for maximum reading. Insert the transmitter antenna and conduct a range check. The receiver should be operated by the transmitter for at least 200 to 300 yards.

If the plate current fluctuates and the relay operates erratically, a new tube is generally needed. When the installation is made, cut the tube leads to exactly the same length as the old ones and duplicate

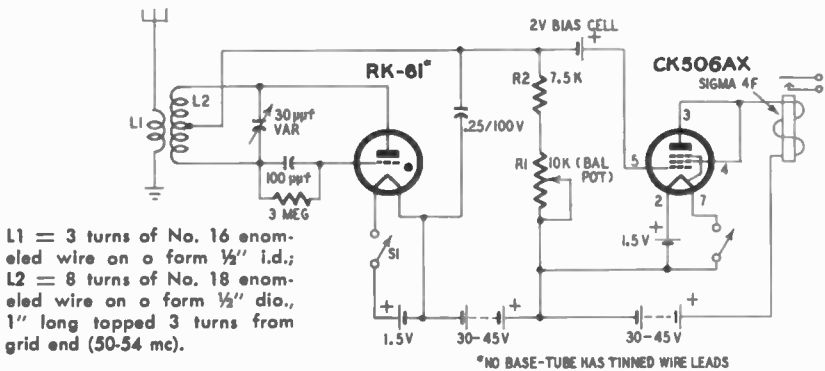

Fig. 911. This receiver uses an RK-61 detector with a direct-coupled stage.

the old tube installation as accurately as possible. Of course, the set will have to be retuned after any such procedure.

The filament and plate batteries require attention and should be checked frequently. Always test the batteries with the receiver turned on.

## Two-tube receivers

There are at least two reasons for using an additional stage in a receiver: The first is to gain greater reliability and sensitivity. The second is to be able to close the relay with a signal instead of having it open as with some of the single-tube receivers.

Greater sensitivity is obtained by the added amplification of two tubes; greater reliability by being able to control a larger current flow

through the relay (2 to 4 ma). And there is a definite reason for wanting the relay to close with signal. If receiver failure occurs while the model is in operation, there will be no sustained control circuit (generally steering) operation which could result in disaster.

Fig. 911 illustrates a method by which a second tube may be direct-coupled to an RK-61 detector stage. Although a 1Q5-GT tube is shown, almost any other miniature power amplifier filament type can

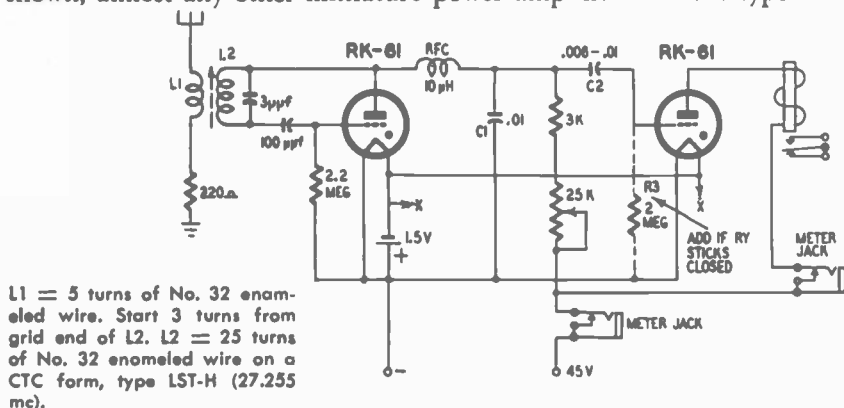

Fig. 912. Two-tube receiver using a gas tube in the relay stage.

be used. Battery bias may have to be increased or decreased and the balance potentiometer R1 will have to be adjusted if a substitution is made.

The tuning of the first stage is performed exactly as in a single-tube receiver. Adjust R1 so that the voltage drop across R1 and R2 is greater than the positive bias voltage. This will bias the relay tube to cutoff and the relay will open. When a signal is received, the drop across R1 and R2 decreases. The positive battery bias overcomes the negative drop and the relay tube conducts, closing the relay.

The advantage of this circuit is that in the absence of signal very little (0.2 to 0.5 ma) plate current is drawn. A disadvantage might be the need for two filament and B-batteries.

It is possible to add a second stage to a detector which will cause a relay to close with signal and at the same time eliminate the need for two battery supplies. Fig. 912 illustrates a circuit of this kind.

The second stage in this circuit is held at cutoff by pulses produced by the charging and discharging of C1. This results in a negative voltage stored in C2. When a signal is received, the pulsing action of the detector stops, the charge leaks off C2 and the relay stage conducts, closing the relay.

The pulses, essentially alternating current when first produced, pass through C2 readily and proceed to the grid of the relay stage. The grid, made positive on the positive alternation, acts like a short circuit, passing the positive pulses. The negative pulses remain however, and

the grid side of C2 becomes charged. This action continues even though the relay tube is not conducting, since its grid and filament act like a diode.

In some circuits of this type, the relay-stage grid resistor R3 is omitted. Then the charge across C2 is dissipated (when a signal is received) through normal capacitor leakage. The capacitor used,

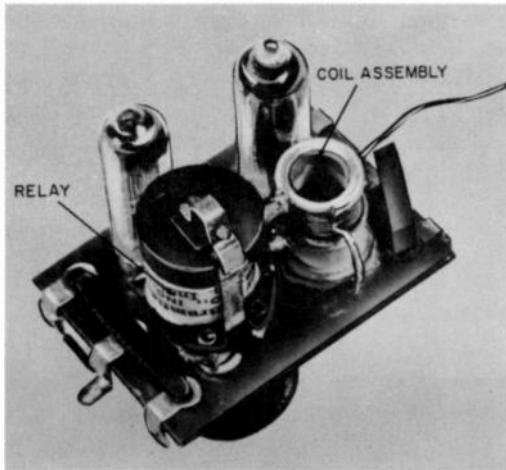

Fig. 913. Construction of the receiver shown in Fig. 912.

therefore, must be a high-quality type with a mica or ceramic dielectric. A paper capacitor may have too much leakage to develop the voltage needed to cut off the relay tube. If too large a value of capacitance is used, the receiver will not respond to rapid pulses. Too small a value will allow the relay to be energized constantly. Some experimentation will be necessary to obtain the best value for a particular receiver.

Spraying the relay tube socket and all associated wiring with an insulating compound (acrylic sprays are readily available) will help minimize the detrimental effects of moisture.

Fig. 913 illustrates one manner of construction using a small Potter-Brumfield relay.

### **Voltage doublers, triplers and quadruplers**

To obtain still better performance from a two-tube receiver, model enthusiasts and manufacturers have made use of voltage-doubling, -tripling and -quadrupling circuits. These circuits, when installed between the first and second stages, tend to increase the signal voltage, achieving still more reliability and greater sensitivity since the receiver can operate the relay when even a weak signal is received.

Fig. 914 illustrates the various methods of using these circuits. The quadrupler (Fig. 914-a) consists of two half-wave doubler circuits in



series. In the doubler circuit (Fig. 914-b) each half of the sine-wave alternation is separated. The two alternations are then added, pro-

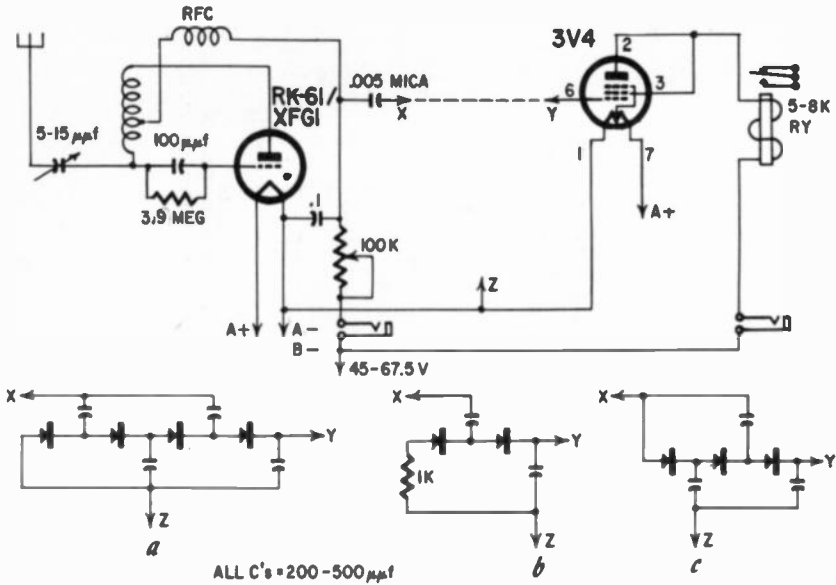

Fig. 914. The signal to the relay stage in a receiver can be increased by the use of: a) voltage quadrupler; b) voltage doubler; c) voltage tripler.

ducing a voltage equal to the peak-to-peak value of the sine wave. The voltage-tripler circuit (Fig. 914-c) is effectively a full-wave doubler and a half-wave rectifier in series.

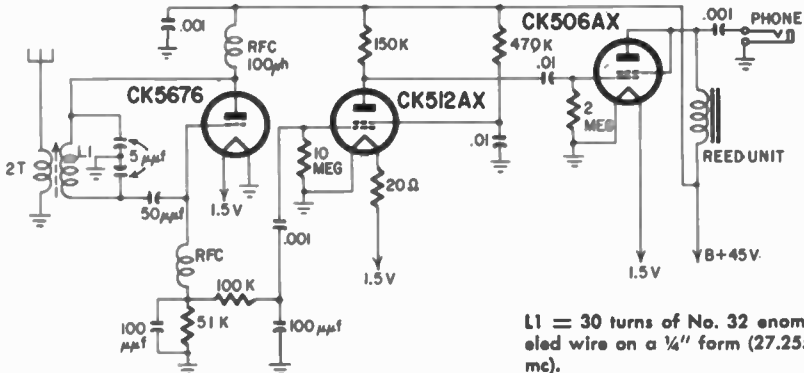

Fig. 915. Three-tube receiver using a reed decoder.

Any one of these circuits may be used by connecting it into the basic receiver circuit at points X, Y and Z as indicated.

To adjust, use two meters: 0-1-ma meter in the first stage and 0-5-

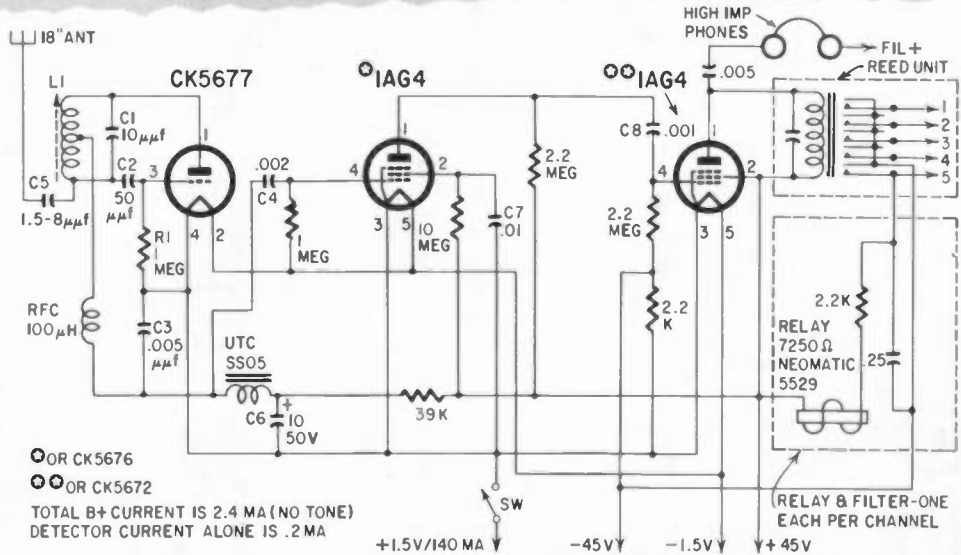

Fig. 916.

ma meter in the second. The 100,000-ohm first-stage potentiometer should be set to a point where the second-stage meter reads zero. This is done by slowly rotating the potentiometer so that its resistance decreases. The second-stage meter will begin to rise with a flutter when the resistance approaches too low a value. When the flutter is noted, increase the resistance of the potentiometer to a point where the flutter stops.

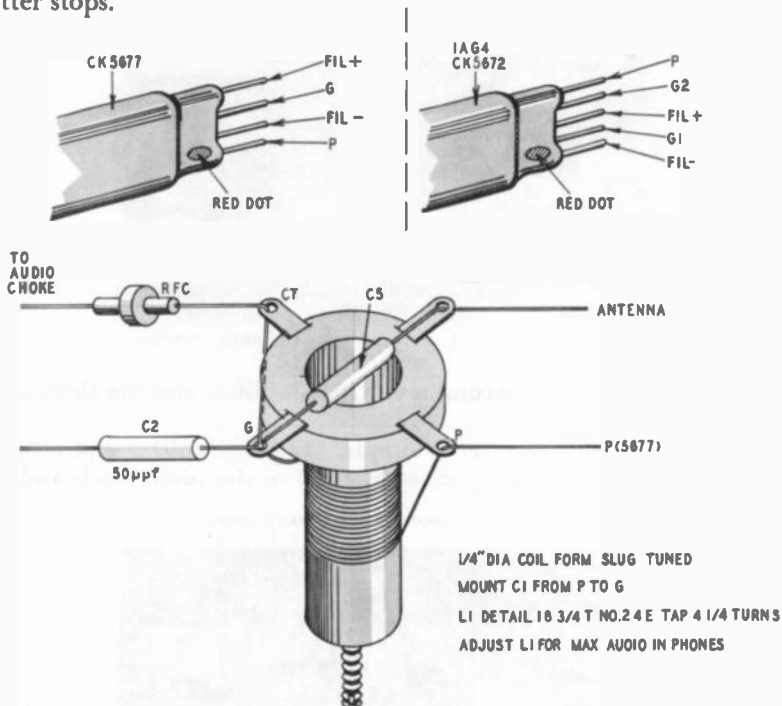

Fig. 916. Five-channel tone receiver using reed decoders is shown on the facing page. Tube and coil details are shown in the illustration above.

Connect the 18–24-inch receiver antenna, adjust the tuning slug with the transmitter ON until the first stage-drop is noted and tune for a maximum reading of the second-stage meter. This should be from 1 to 4 ma, depending upon the tube used. The first-stage current should drop to about 0.5 to 0.1 ma.

If loop coupling is used between the antenna and the tuning circuit, the antenna loop may be adjusted during the range test for maximum sensitivity by sliding it back and forth on the tuning coil. It should be located about seven to eight turns from the plate end of the tuning coil. The other tests and checks are the same as previously described.

### Three-tube tone-operated receivers

Tone receivers are generally more complex in construction than

carrier-operated types, since more parts must be used. Fig. 915 shows a three-tube receiver designed to operate a reed type decoder. The first

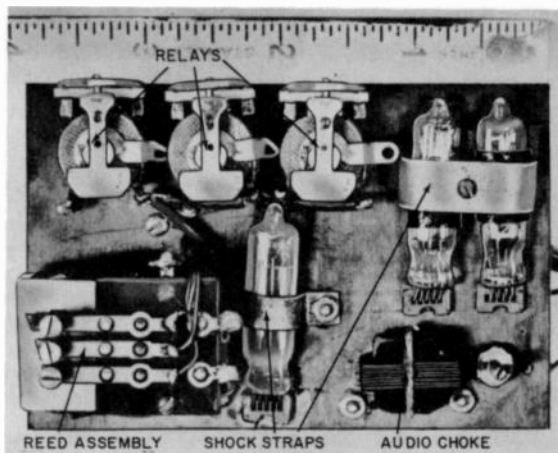

Fig. 917. Top view of chassis of three-channel receiver.

stage is the detector, the second a voltage amplifier and the third stage a power amplifier.

Adjustment of this receiver is simple. The transmitter and receiver are turned on, a pair of earphones inserted in the phone jack and the

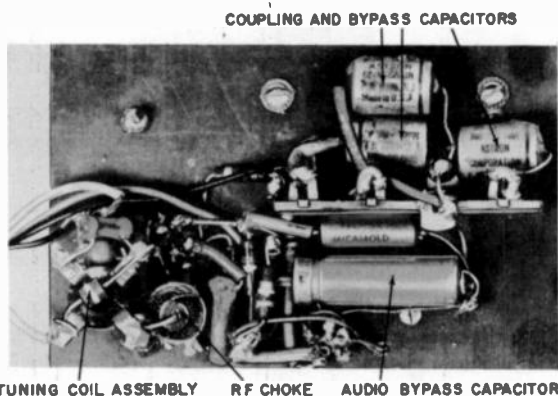

Fig. 918. Bottom view of three-channel receiver.

receiver tuned until the transmitted tone is the loudest. A high-resistance ac voltmeter or vtvm can be connected across the reed coil and the receiver tuned for maximum if so desired.

If the tones transmitted correspond to the frequencies at which the reeds resonate, they will vibrate when the phone or meter is removed from the circuit. The reed contacts must be set so that the circuit

is closed to the relays and the relays set so they will pull in when the reeds vibrate and drop out when they stop. After range and vibration checks have been made, the unit is ready to operate in the model.

In all tone type receivers there are two critical points which must be considered to obtain best performance:

1. The tones transmitted must be correct and must not *change* during the operating time.
2. The modulation percentage of the transmitted carrier must be high, 85 to 100%.

Certain tolerances are allowable for particular receiver types:

1. When the receiver uses reeds, tones must be accurate within 5 to 10 cycles and the frequencies used must be such that normal operational vibration cannot mechanically activate them.

2. When using L-C filters, tones must be accurate within 10% of the filter frequency.

3. When using receivers which do not contain frequency-selecting elements, the wiring and associated circuitry will establish a best tone

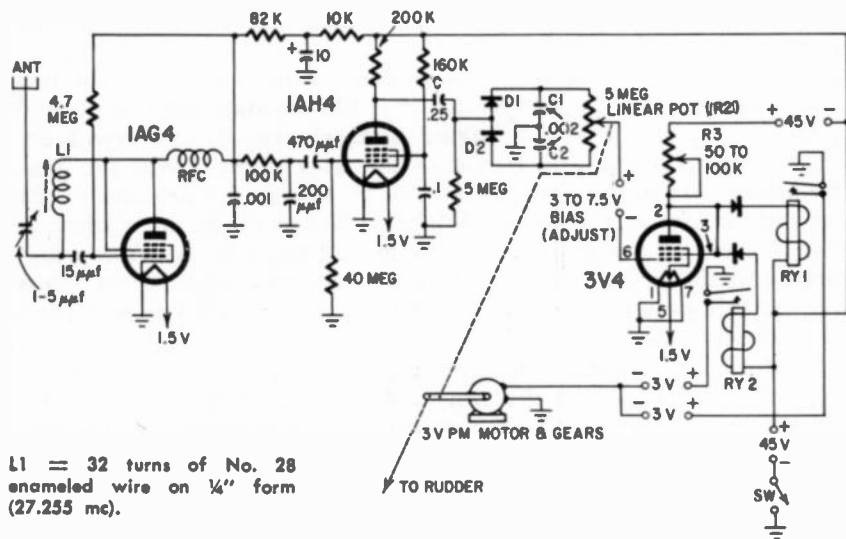

Fig. 919. Proportional control receiver. The linkage to the pot should be such that the pot arm moves to restore electrical balance when uneven pulse-spaces are transmitted. For a small difference in pulse-space the motor moves a small amount; for a large difference the motor moves a large amount. The receiver requires a pulsed carrier. The bias battery voltage must be adjusted as described in the text.

frequency. This can be determined by connecting an audio generator to the input of the audio section and reducing the output until the relay just operates. Run through the frequency range of the generator until a frequency is found which will require the *least* output to operate the relay. This is the tone which should be used.

4. The output of a superregenerative detector is logarithmic. If 30–50% modulation is used, the output of the detector will be very low. However, if the normal modulation is 85%, and is increased to 90%, the output of the detector goes up tremendously. A relative check of modulation can be made using an oscilloscope.

Figs. 916-a,b illustrate another type of tone receiver (using sub-miniature tubes) suitable for three-channel operation.

In this circuit the detector uses a Hartley oscillator to obtain super-regeneration. Maximum amplification is obtained from the power output tube by tapping B-minus into the grid resistance to develop proper bias. Figs. 917 and 918 illustrate parts layout.

A receiver which falls into the three-tube category and is designed for proportional control is shown in Fig. 919. It operates on the pulse-width–pulse-space principle. An unusual feature is that the transmitter need not be modulated in the usual sense with an audio tone. The rf carrier is turned off and on at some predetermined rate, when properly coded and is interpreted by the receiver as the equivalent of an audio signal and can be amplified in a standard audio stage. Therefore, although the receiver is of the tone type, no tone is actually transmitted.

When a signal is received, it is coupled to the junction of the two diodes through the .25- $\mu$ f capacitor (C). The resistance R1 to ground is the load across which the signal is developed. It also forms the ground return of the grid circuit of the relay stage. When the positive alternation of the signal is present, D1 charges C1 negative at the top and positive at the ground junction. When the negative alternation of the signal is present, D2 charges C2 negative at the top and positive at the junction. Since the two capacitors are in series across R2, the full peak-to-peak rectified voltage of the signal is impressed across the potentiometer.

C1 and C2 can be considered as voltage sources which produce current through R2. When the arm of the potentiometer is at its electrical center, no voltage can be measured from it to ground. If the arm is moved up, the voltage drop across the top half would be less than that across the bottom and a voltage would appear whose magnitude is proportional to the ratio of the resistance of the top half of the potentiometer to the bottom. This voltage would be negative with respect to ground. If the arm were moved in the opposite direction, the voltage would be positive. The result is a voltage which varies with the signal and is in series with the bias voltage. Since the tube must be operated near the center of its current rating, a bias battery is placed between the potentiometer arm and its grid. The arm is adjusted so that, when pulses with equal width and spacing are received, there is a slight negative voltage on the grid of the relay stage with respect to ground.

The two relays in the plate circuit form a bridge which can be adjusted by R3. One relay closes when the bridge is unbalanced in one

direction by, for example, a signal in which the pulses are longer than the spaces, and the second relay closes when the bridge is unbalanced in the opposite direction by pulses shorter than the spaces. A single polarized relay can be used if it will operate on about 1 ma.

When equal pulses and spaces are transmitted, both relays remain open. When the pulse width is made larger than the spacing and one relay closes, the steering motor operates, moving the steering element and the arm of the potentiometer so that the voltage to the grid of

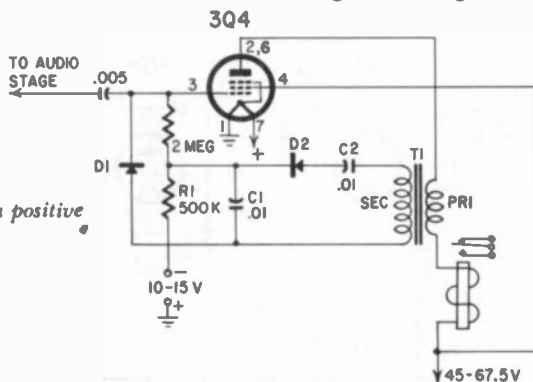

Fig. 920. Output stage using a positive feedback circuit.

the relay tube returns to its no-signal value. The relay opens and the motor stops. The steering element will remain deflected as long as the signal is present.

If the controller now causes equal pulses and spaces to be sent, the voltage across the grid circuit changes again—this time in the opposite direction. The other relay closes and the steering motor rotates in the opposite direction, returning both the steering element and the potentiometer wiper to the original point.

To adjust the circuit for operation, rotate R3 until both relays open. Apply 1.5 volts, from a flashlight cell, to the arm of the potentiometer, with the arm mechanically centered. One relay should close with one polarity applied; reverse the battery and the second should close. Adjust the clearances and tension if necessary. Best operation will result if the relays are adjusted to operate when less than a 0.2-volt change occurs at the grid of the tube.

When using only three tubes in a receiver, it is possible to increase performance by adding a positive feedback circuit (Fig. 920.).

The relay tube is normally biased to cutoff by the bias battery. When an audio signal is received, the positive alternations tend to cause the tube to conduct, producing a current of from 1 to 3 ma through the relay, depending on signal strength. D2 prevents negative bias from forming at the grid.

The signal at the grid is not completely smoothed out and some audio appears at the plate of the tube. This is coupled back through a small transformer T1 into D1. It is rectified and appears as a posi-

tive voltage across R1 and C1. The effect is to increase the positive bias on the grid of the relay tube, causing it to draw more current.

C2 in the transformer lead is necessary to prevent short-circuiting R1. The dc resistance of the transformer's primary winding should be small since it is in series with the plate and relay, and its high-resistance secondary should be connected to D1.

The feedback must not be too great, otherwise the relay will ener-

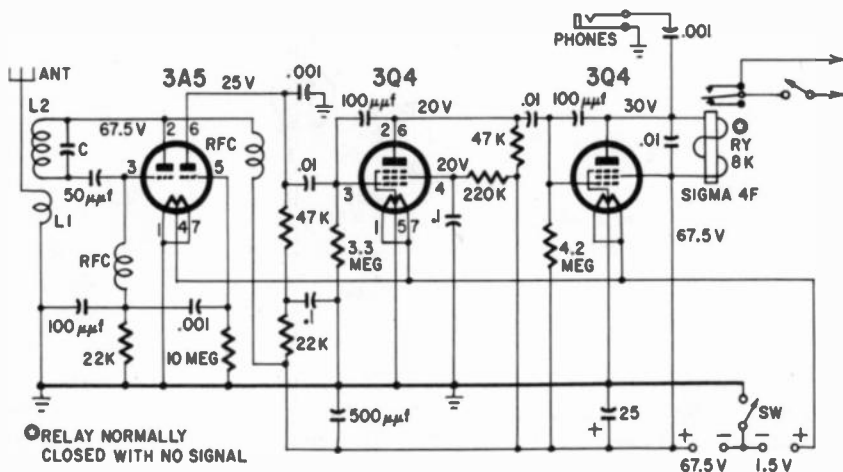

Fig. 921. Tone operated receiver. The relay closes with signal. No critical tone is necessary.

gize on normal hiss. When properly adjusted, this circuit can increase the performance of tone receivers, using a minimum number of tubes.

### Four-tube tone receivers

The addition of more audio stages in the tone type receiver increases reliability. Fig. 921 illustrates a receiver in which the added stage furnishes enough current to operate a relay directly. This last stage takes the place of the reed unit used in previous circuits.

Much more current (1 to 5 ma) is available to operate the relay, depending upon the supply voltage and the size of the grid resistance of the last stage. This resistance is returned to the B-plus side of the B-battery to obtain a positive bias on the relay tube without signal and to effect a quick recovery after a signal has been transmitted.

When the receiver is turned on, the relay should close. If it does not, increase the size of capacitor C. When a signal is transmitted, it is rectified by the grid and filament of the relay tube and produces a negative voltage on the grid, opening the relay.

This type of receiver is not fail-safe but, like the previous types, has been used with complete success. It is possible to adjust the plate current of the relay stage so that the relay will close positively but, in adjusting the relay, make sure that the armature does not touch the



pole piece. The relay spring tension should be as tight as allowable.

When the model is some distance away, the signal it receives is weaker. Therefore, there will be less negative voltage developed at the grid of the relay tube and there may not be complete cutoff of the

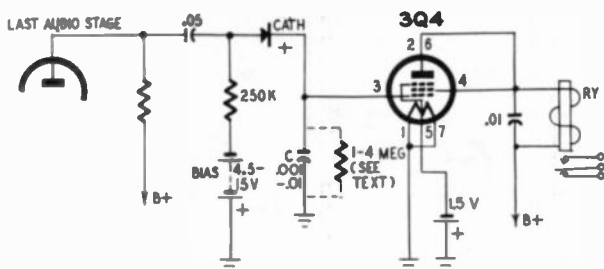

Fig. 922. In this arrangement the relay closes on signal.

current passing through the relay. If the armature touches the pole piece or the spring tension is too loose, enough residual magnetism may be developed to hold the armature pulled in even though a signal is present. It takes much less magnetism to hold an armature in place

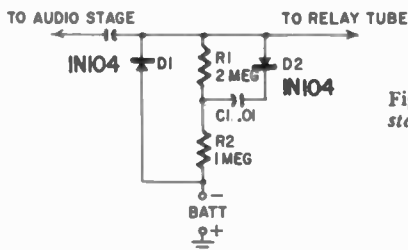

Fig. 923. By adding diodes between the audio stage and the relay of a tone receiver, the relay can be made to close on signal.

than to pull it in. This receiver, like the others which close the relay without signal, has been safely operated over distances of  $\frac{1}{2}$  mile.

There is one possible source of trouble with this or any receiver which uses a 3A5 tube as a superregenerative detector. This tube, often microphonic due to vibration of the model, can cause relay chatter when the motor is running. One cure is to place a small wide rubber band around the tube so that it is held tightly in place. Also try different tubes of the same type—some are less microphonic than others. Proper suspension of the receiver by rubber bands or foam-rubber padding helps minimize this trouble.

To test for microphonics, turn the receiver on and tap the detector tube with a pencil. If the relay operates with a light tap, check the filament and plate voltages. Low voltages, especially filament voltages, can cause this condition.

Fig. 922 illustrates a method of modifying this circuit so the relay will close with signal. A bias battery applies a negative potential to the grid of the relay tube through a small diode. This bias can be

adjusted to the correct value to cut off the plate current. When a tone signal is received, the diode develops a voltage drop across itself, positive to the grid and negative to the bias battery, opposing the applied bias. If the signal is strong enough it will overcome the bias

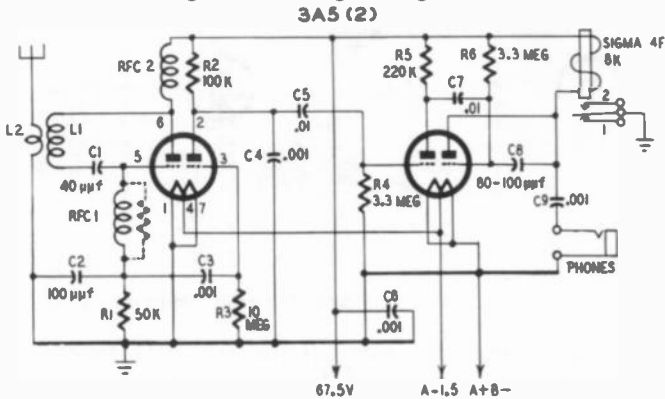

L1 = 13 turns of No. 18 enameled wire, 1/2" i.d., closewound (50-54 mc); L2 = 3 turns of No. 18 enameled wire, 1/2" i.d., closewound; RFC1 = 25 turns of No. 28 wire scramble wound on a 10 megohm, 1/2-watt resistor; RFC2 = 2 meter radio-frequency choke or 25 turns of No. 28 wire wound on form 1/4" dia.

Fig. 924. Superregenerative receiver using a pair of 3A5's. If the set does not superregenerate, increase C2 and substitute a 2.5 mh choke for RFC1. For model plane use, increase R2 and R5 to 470,000 ohms for greater sensitivity.

voltage and the tube will conduct, closing the relay. The value of C, which holds the positive voltage, must be adjusted experimentally for the receiver used. It may be advisable to place a fixed 1 to 4-megohm resistor across this capacitor if the relay does not follow fast pulses.

Another method of using diodes to close the relay with signal is shown in Fig. 923. D1 and D2 short R1 when the negative alternation of the signal is present or when a negative voltage tries to develop across R1. However, they allow a positive pulse to be impressed upon the grid and thus the relay tube conducts when a signal is present.

Bias voltage on the grid (in the absence of signal) is through R1 and R2. D1 conducts when the positive alternation is present, discharging C1 (charged to the bias potential) and then charging it with a positive voltage sufficient to oppose the bias. The relay tube now conducts. When the negative alternation of the signal is present at the junction of the diodes, D2 conducts and this alternation is passed to ground through the battery.

If the antenna were cut to resonate at the operating frequency, it would pull rf energy from the tank circuit, stopping the detector. R1 helps prevent this.

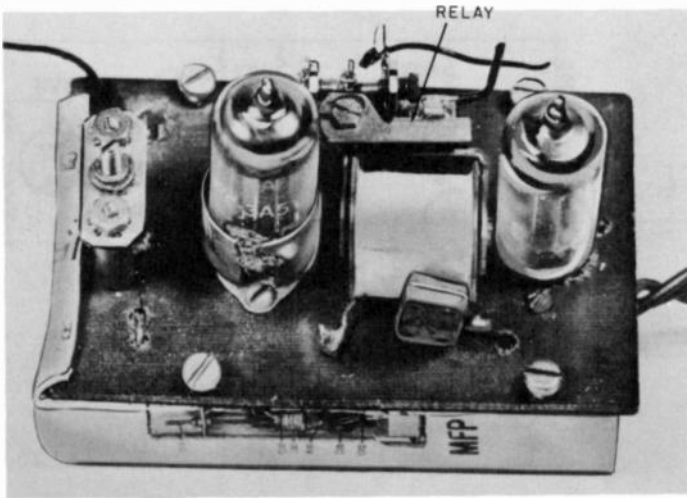

Fig. 925. Above chassis view of the receiver in Fig. 924.

Fig. 924 is similar to that in which the relay opens when a tone signal is received. To improve performance two audio stages have been incorporated. Figs. 925 and 926 illustrate the component layout.

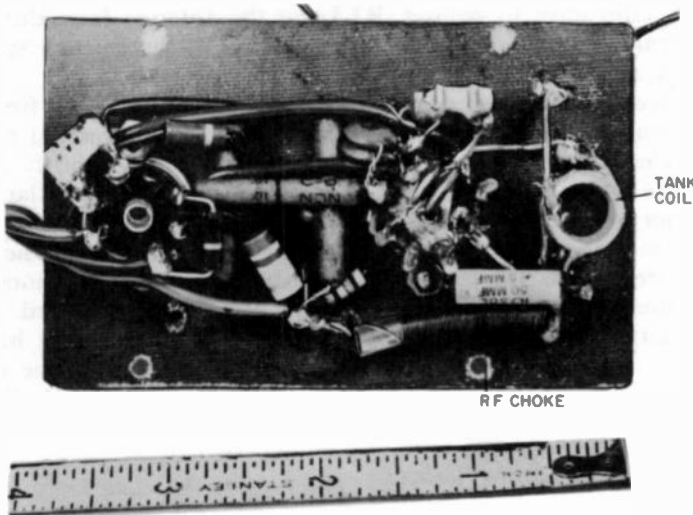

Fig. 926. Below chassis view of the receiver in Fig. 924.

A four-tube tone-operated receiver in which the relay closes with signal is illustrated in Fig. 927. A diode is used across the grid resistor of the relay tube to prevent the negative voltage, due to rectification of the signal between grid and cathode, from building up at the grid. This results in a large relay current with signal.

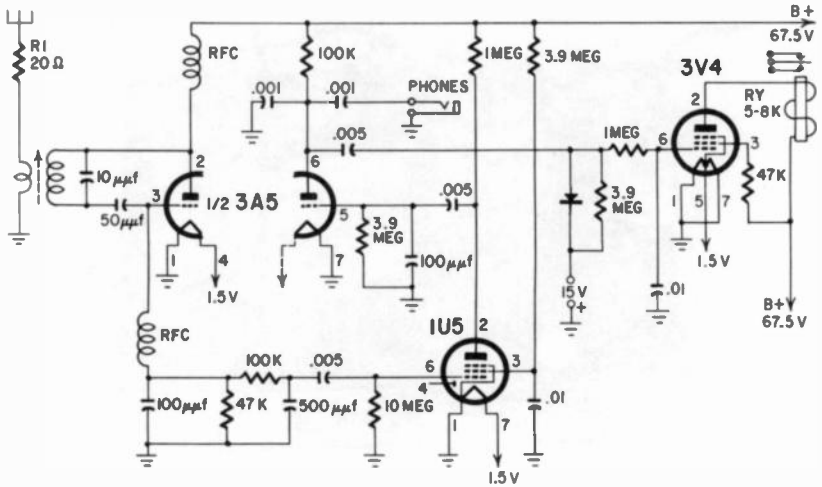

Fig. 927. Four-tube tone-operated receiver. The relay closes with signal.

The circuit differs from previous ones in that an R-C quench and impedance-matching filter are used between the detector and first audio stage. A quench filter capacitor is placed from the grid of the second audio stage to ground. R1 keeps the antenna from disturbing the operation of the detector. The rf chokes in the detector stage are resonant at 27 mc.

The receiver operates on an audio tone. However, the frequency of the tone is not critical and can vary without detrimental effect.

A sealed relay may be used to eliminate the possibility of dirt getting into the contacts. Since the current swing is quite large, the relay does not have to be adjusted.

The only adjustment needed is to tune the receiver to the transmitted frequency. Insert a pair of earphones into the phone jack. When the receiver is turned on, a loud hiss should be heard. As the tuning circuit is adjusted to the transmitter frequency, the hiss will diminish until it is almost inaudible, and a transmitted tone will be loud and clear. Tuning is adjusted for the loudest signal. Remove the phones and the relay will operate.

# practical transmitters

**T**HE various transmitters in this chapter consist of carrier-only, single-tube modulated and multistage types.

To operate a transmitter on the radio-control frequency of 27.255 mc or the Citizens' band of 465 mc, one does not need to take a licensing examination. (All 465-mc Citizens' band transmitters have to be commercial units whose design and construction are FCC-approved.) A form, available at most hobby dealers, must be filled out and mailed to the nearest FCC office before operating on these frequencies.

A comprehensive examination on theory and code must be passed before a license to operate on any of the amateur bands is granted.<sup>4</sup>

## Checking frequency

Before using a transmitter, especially one that has been constructed, check the output to make certain that it is operating at the correct frequency. Crystal controlled transmitters operating on the 27.255-mc spot frequency can be checked simply by removing the crystal. If the output stops, then the transmitter was crystal controlled. If not, then it is likely that the output was deviating from that required.

There are four useful methods of checking the frequency of self-excited transmitters:

1. A wavemeter (obtainable at most radio parts dealers) consists of a variable capacitor rigidly attached to a calibrated dial, and a socket into which various coils can be plugged to cover different frequencies. The indicating device is a built-in pilot light connected to a loop which forms part of each coil. See Fig. 1001.

To use the wavemeter the coil covering the proper range is inserted

---

<sup>4</sup>A technician license, requiring a code speed of only five words per minute, allows operation on 50-54 mc, 144-148 mc, 220-225 mc and 420-450 mc.

into its socket. The transmitter is turned on and the coil of the wavemeter is held close to the transmitter tank coil. The wavemeter is tuned until its pilot light glows. The instrument is then moved farther from

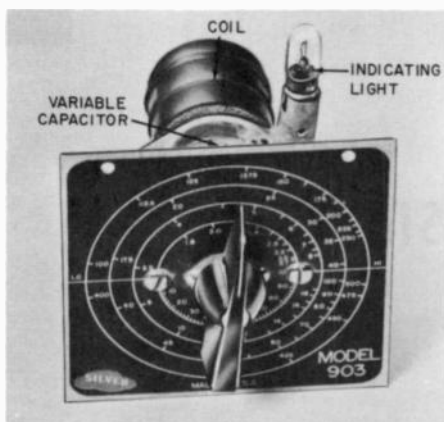

Fig. 1001. A wavemeter can be used to check the frequency of a transmitter.

the tank coil and retuned. This process is repeated until the maximum distance at which an indication can be achieved is reached. The tuning at this point should be extremely sharp. It is now possible to read the output frequency on the calibrated dial.

To use the wavemeter to check a receiver, turn the receiver on and connect a pair of earphones across the relay (if no other provision is made for the phones). You should hear a loud hiss. Place the wavemeter coil over or very close to the receiver tuning coil so that the turns of both are in the same plane. The wavemeter capacitor is varied and, at the frequency to which the receiver is tuned, a distinct plop will be heard. As before, the wavemeter is moved away until a fine tuning point is required to obtain indication. The frequency can then be read on the dial.

2. By means of a grid-dip meter (Fig. 1002) (an elaboration of the wavemeter and a more sensitive indicating device) you can determine the frequency that a coil and capacitor are tuned to without having to have the transmitter or receiver turned on.

The grid-dip meter uses a standard meter as an indicating device. In addition to the calibrated dial and socket of the wavemeter, it has a vacuum tube which forms part of an oscillator circuit. When energy is removed from the tank circuit of an oscillator, the grid voltage decreases; therefore this circuit can be used as a frequency-determining device.

The coil of the grid-dip meter is held close to the tuning coil of the transmitter or receiver. However, these units do not need to be turned on. As the dial of the grid-dipper is tuned, a spot will be found where the meter reading will drop sharply. When the unit is carefully tuned

for the *lowest* reading, the dial will indicate the frequency. Of course, the grid-dip meter should first be calibrated against some standard such as an accurate signal generator.

The frequency of the transmitter can be checked by two methods while it is turned on. First, the grid-dipper can be turned off so that

Fig. 1002. The grid-dip meter is a sensitive device which can be used to check the resonant frequency of "cold" tuned circuits. (Photo courtesy Allied Radio Corp.)

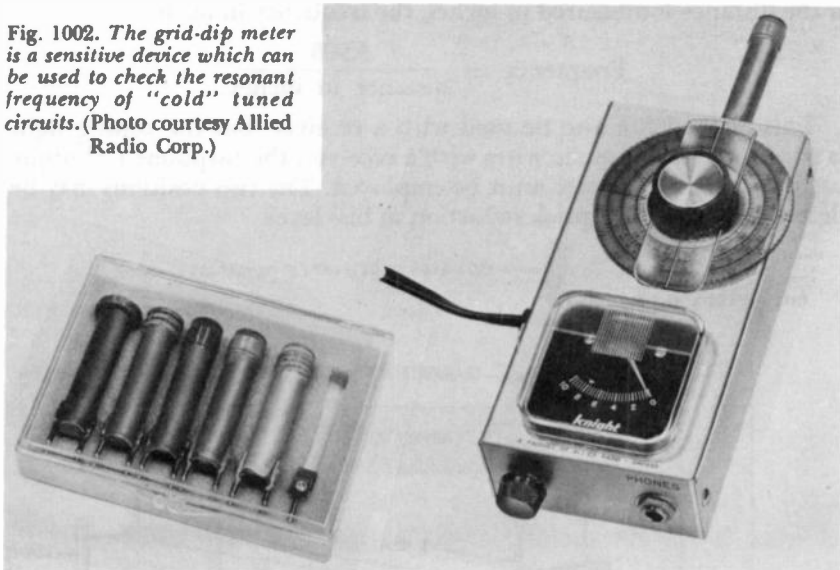

its oscillator is inactive. It is then used exactly like a wavemeter. The tube will act as a simple diode rectifier to provide a voltage to the meter. When used in this manner, the grid-dipper must be tuned for the *highest* meter reading. Second, a pair of earphones can be connected to the grid-dipper as an indicating device. The meter and the transmitter are turned on and the dial is tuned until an audible tone or beat can be heard. The dial is then carefully rotated until the note vanishes and a movement in either direction causes it to reappear. At this null point, the dial will indicate the frequency being transmitted. This second method can also be used with a receiver since it radiates a certain amount of rf energy during a portion of its operating cycle.

3. Frequency checks can be made by means of Lecher wires (Fig. 1003)—an application of the wavemeter idea but, instead of a variable capacitor and a coil, two wires are used.

The wires, at least a wavelength long at the expected frequency, are mounted about 3 inches apart on a board. A twisted lead connects the ends to the antenna coupling loop of the transmitter. A second loop of wire attached to a 150-ma 6-volt pilot light is placed over the transmitter coil.

When the transmitter is turned on, the pilot light should glow brightly. A metal bar is placed across the two wires and, starting at

the twisted-pair end, is slowly pushed down their length. At some point (A) the light will dim. If the bar contact is narrow (almost a knife edge), the light can be made to lose almost all its brilliance. Mark this point carefully. Again move the bar down the wires until a second such position (B) is found. The distance between the two positions then represents a half-wavelength of the frequency being transmitted. If the distance is measured in inches, the frequency in mc is

$$\text{Frequency} = \frac{5,905}{\text{distance in inches}}$$

This method can also be used with a receiver, but the tuning light is of no value. To use the wires with a receiver, the earphone technique used with the wavemeter must be employed. The two positions may be determined from the quick reduction in hiss level.

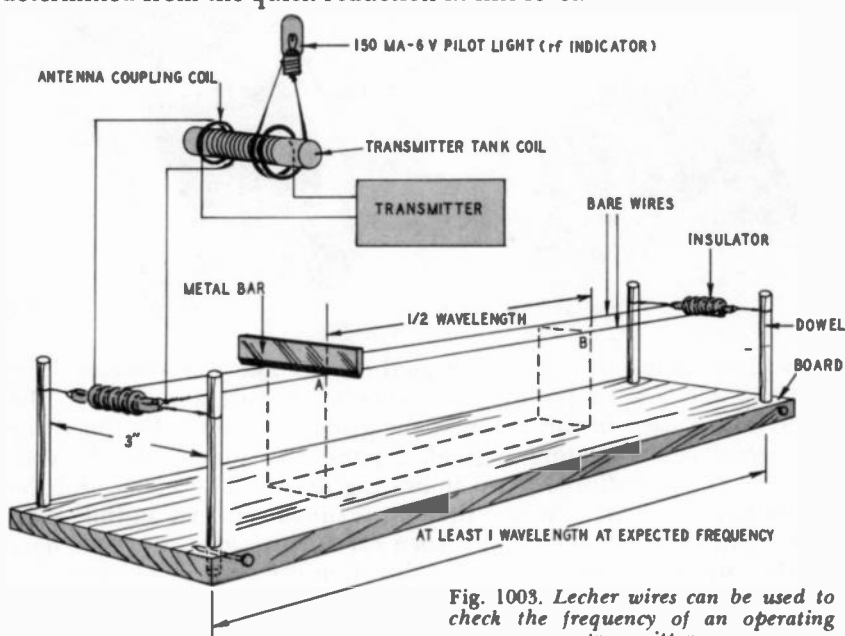

Fig. 1003. Lecher wires can be used to check the frequency of an operating transmitter.

4. A calibrated radio-control receiver tuned to the correct frequency or a commercial receiver known to have accurate calibration can be used. The transmitter is turned on and adjusted until it operates the radio-control receiver or transmits a signal within the proper band, as indicated by the commercial unit. One cannot use this method for determining the tuning of a receiver as easily or as accurately as the other methods described.

### Checking transmitter antennas

One of the most critical components of the transmitting system is the antenna. It must be the correct length (unless the transmitter has



an antenna compensating network), or the transmitter will not radiate efficiently. Antennas supplied with commercial transmitters are carefully adjusted to exactly the right length for optimum operation and should not be altered.

If you use a center-fed half-wave antenna, the length as found with Lecher wires is satisfactory. However, it is generally necessary to shorten a quarter-wave antenna slightly to compensate for the coupling loop or connecting wires. The problem is to determine the length required for optimum operation.

One way to approach the problem is to make the antenna 6 to 8 inches longer than a quarter-wave. The length is then trimmed 1/16

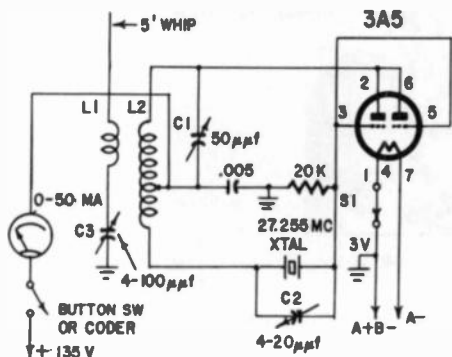

L1 = 1 or more turns of No. 18 enameled wire wound around L2; L2 = 21 turns of No. 18 enameled wire air-wound to 1/2-inch diam., top 3 turns from crystal end.

Fig. 1004. A one-tube transmitter for use on 27.255 mc.

or 1/8 inch at a time while observing some indicating device which can detect radiated power, such as a field-strength meter. It is necessary, during this pruning process, to snip and then stand away, then snip and step back again so that the presence of the human body will not cause an inaccurate indication.

It is possible, in the absence of a field-strength meter, to use a freshly sharpened pencil to indicate the presence of rf energy. If the tip of a soft lead pencil is lightly touched against the tip of a quarter-wave antenna and if the antenna is the correct length, a tiny spark will be discernible. Of course, this method should not be attempted in bright daylight.<sup>5</sup>

Suitable antennas can be made from aluminum or copper tubing or large-diameter copper wire fastened against a wooden rod for support. Generally, the larger the diameter of the tubing, the better the performance.

Never couple the antenna too tightly to the tank. If many turns are required in the coupling link and it has to be tightly wound around the transmitter coil, the antenna is probably the wrong length. Gen-

<sup>5</sup> This method of determining the presence of rf power can be dangerous and is not recommended. Avoid contact with the metal cap of the lead pencil. If it is touched, an rf burn can result.

erally, at frequencies of 50 mc and above, a single turn is all that is necessary; at 27.255 mc, two turns should be adequate.

### Unmodulated transmitters

A single-tube transmitter operating on 27.255 mc and using a 6AG7 tube is shown in Fig. 1004. This circuit is typical of transmitters of this type. If feedback capacitor C2 is too large, the circuit will oscillate with the crystal removed and thus may be off frequency.

Once the transmitter has been constructed, a 0-50-ma meter is con-

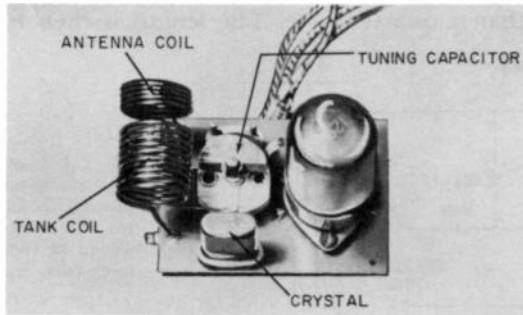

Fig. 1005. One-tube crystal-controlled transmitter is a compact unit.

nected in the B-plus lead as indicated. C2 is adjusted to a half-open setting and the antenna is removed. The filament and B-minus con-

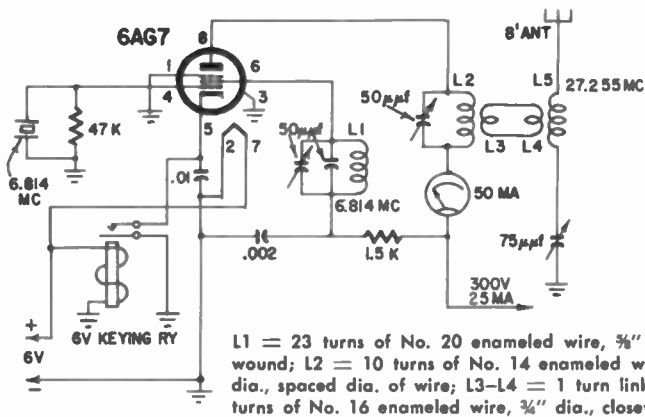

Fig. 1006. A low-frequency crystal is used in this one-tube transmitter.

nections are completed. The switch is turned on and C1 is adjusted quickly to obtain a dip in plate current. This should be about 10 ma. If no dip results when C1 is tuned through its range, turn the switch off and increase the value of C2. This can be done by shunting a small ceramic capacitor across it. Hold the button switch closed during the tuning process.

When the dip is found and C1 is adjusted to obtain the lowest possible reading, the switch is turned off and the crystal is removed from its socket. An indicating pilot light attached to a small two- or three-turn loop is placed over the tank coil and the switch is turned on.

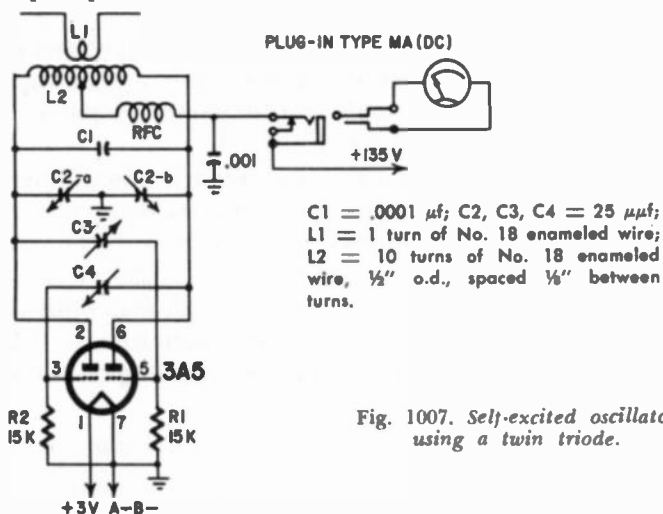

Fig. 1007. Self-excited oscillator using a twin triode.

Watch the pilot light. If it glows, decrease the capacitance of C2; if it does not, turn the transmitter off, replace the crystal, insert the antenna and remove the loop.

When the transmitter is turned on with the antenna connected, the plate current will increase. Adjust C1 again for a dip. If this dip is very near that obtained without the antenna, adjust C3 for an increase. Now rotate C1 for a dip. Repeat this process until the dip is obtained with a reading of from 15–20 ma. The transmitter is now ready for use.

Table 10–1 gives construction data for tank coils. The number of turns is determined by the shunting capacitor (if any), the size, spacing, diameter and overall winding length of the coil. The specifications given in the table do not necessarily need to agree with values given in the circuit diagrams.

Table 10–1. Construction Data for Transmitter Tank Coils

frequency (mc)	diameter	winding length	turns	wire size (enam.)	capacitor ( $\mu$ f)
27.255	1"	1½"	10	# 12	3–30
50–54	1"	1"	5	# 12	3–30
144–148	½"	½"	1¼	# 12	3–30
220	¾"	1½"	U-shape	¼" copper tube	1–3
420–450	Butterfly-tuned circuits or parallel lines one-quarter wavelength long shorted at end of one-quarter wavelength.				none

All coils air core.

Check the batteries frequently with the transmitter on and the button depressed. Replace the B-batteries when the voltage falls to approximately 95 and the A-batteries when they drop to about 2.3. Fig. 1005 illustrates a commercial radio-control transmitter of this general type.

The transmitter of Fig. 1006 is designed to operate at 27.255 mc but uses a standard 6-volt filament tube which requires a plate supply of 300 volts. This circuit is quite stable and the power output is higher than that of the previous transmitter.

The circuit is a combined oscillator and frequency multiplier. The screen grid of the tube is used as the plate of a triode oscillator. It is tuned to the fundamental frequency of the crystal, 6.814 mc. The plate circuit is tuned to the fourth harmonic or 27.255 mc.

When adjusting this circuit, tune the screen tank first while observing the plate meter for a dip. When the lowest indication is obtained, tune the plate tank, watching for a still lower reading on the meter.

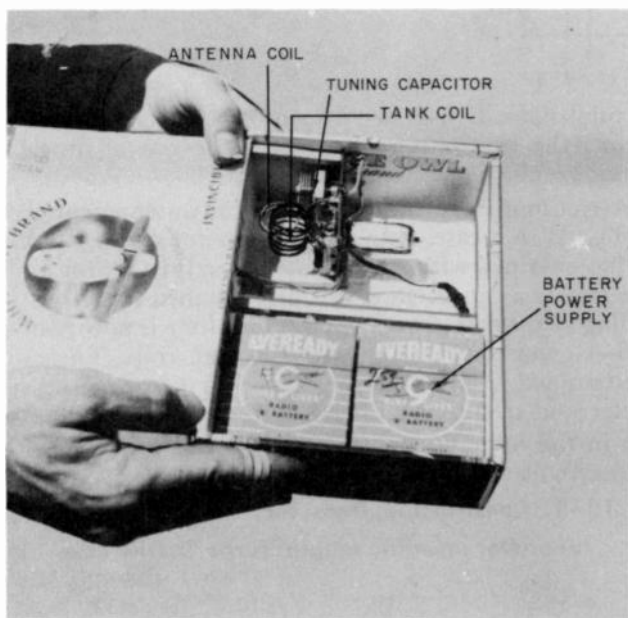

Fig. 1008. The twin-triode transmitter and power pack fit into a cigar box with room to spare.

Do not tune the plate circuit to the second harmonic, 13.628 mc. This can be checked with a wavemeter.

A keying relay is used to prevent accidental shock. Since the voltage

is high, it can be dangerous. Therefore, the cathode or the B-plus circuit should not be keyed directly using a button switch.

The method of loading the antenna is exactly as described for the previous circuit. When the plate meter rises to 15 ma after juggling adjustments between the antenna and the plate tuning capacitors, the input to the antenna is 4.5 watts.

The circuit of Fig. 1007 illustrates how a twin-triode can be used as a self-excited oscillator to provide an efficient transmitter. The 3A5 tube shown is adaptable for battery operation; however, other types

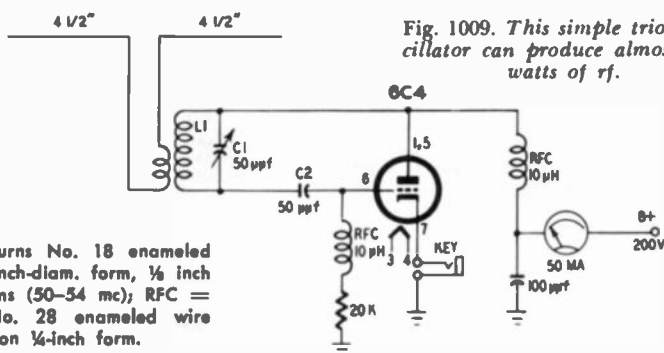

L1 = 10 turns No. 18 enameled wire on  $\frac{1}{4}$ -inch-diam. form,  $\frac{1}{8}$  inch between turns (50–54 mc); RFC = 50 turns No. 28 enameled wire closewound on  $\frac{1}{4}$ -inch form.

can be used which will allow higher voltages, thus making a higher output possible.

C2-a and C2-b are the sections of a split-stator tuning capacitor and are used to tune to the desired frequency. C3 and C4 control the feedback and should be rotated until the dc milliammeter in the plate circuit reads its lowest value with the antenna disconnected. The settings of these capacitors do not have to be changed unless a new tube is used.

The tank coil (L2) is made from 10 turns of No. 18 enameled wire, wound  $\frac{1}{2}$  inch in diameter, spaced  $\frac{1}{16}$  inch between turns. There is a tap at the 5th turn. The antenna coil is a single-turn loop of the same wire placed at the mid-point of the coil and spaced about  $\frac{1}{8}$  inch from it. The antenna coil loops over the B-plus tap. (The coil data are for the 50–54-mc band). Fig. 1008 shows one method of construction.

A simple triode oscillator circuit which uses a 6C4 and provides an output of about 2 watts is illustrated in the circuit of Fig. 1009.

Although a keying jack is shown in the cathode circuit, a relay could be used to prevent possible shock. With this circuit, tune C1 to the desired frequency and then adjust the number of turns and tightness of the antenna-coupling loop for the proper plate current. It should be about 10 ma without the antenna and 25 ma with it connected.

A 465-mc transmitter is shown in Fig. 1010. It illustrates the type of circuit used when operating on the higher radio frequencies. Note the use of rf chokes in the filament leads; also the voltage-indicating circuit using an NE21 neon glow lamp in the cathode circuit. This

voltage indicator operates on the principle that sufficient voltage is needed to light the neon tube. When the B-supply is high enough, there is enough current flowing through R1 and R2 so that the voltage drop across R2 causes the bulb to glow. As long as it lights, the B-

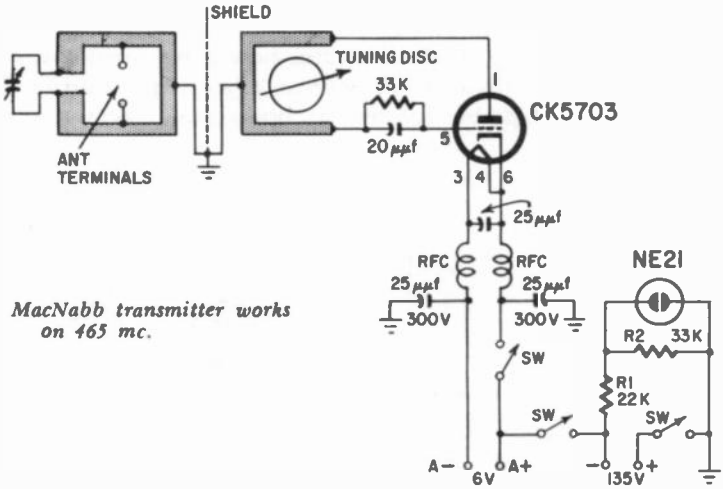

Fig. 1010. MacNabb transmitter works on 465 mc.

voltage is adequate. When the voltage drops below the safe value for proper stability and output, the bulb extinguishes.

Another characteristic of this circuit is the use of a grounded plate. The center tap of the loop tank and the B-plus battery terminal are grounded. This configuration can be used whenever it is desirable to have the tank coil at chassis potential or a metallic connection for mounting purposes is needed between the coil and chassis.

A single-tube transmitter (for operation on 27.255 mc) which uses a 3A4 tube and employs a feedback loop to provide stability of operation is shown in Fig. 1011. This circuit connects the crystal between the grid of the tube and C1 which is connected to ground. At the junction of the crystal and C1 is a lead which is also connected to the bottom end of the tuning circuit. Thus, energy which is present in the tank circuit appears across C1. If this feedback voltage is in phase with the crystal voltage, it adds to the resultant signal at the grid of the tube, helping to produce the desired oscillation. C2 helps prevent the circuit from breaking into self-oscillation.

In addition to the normal coupling coil L2, there is a second coil (L1) in series with the antenna which allows it to be shorter than a quarter-wave length. The number of turns on L1 are determined by the amount of compensation needed for an antenna of a particular length. If antennas of various lengths are to be used, L1 might be tapped so that the effective inductances in series with the antenna could be varied. The indication of proper length would be an increase in plate current.

Tuning is the same as for other crystal oscillators. Adjust C3 for a minimum reading on a 0-50-ma meter with the antenna disconnected. It is trimmed slightly for minimum when the antenna is connected.

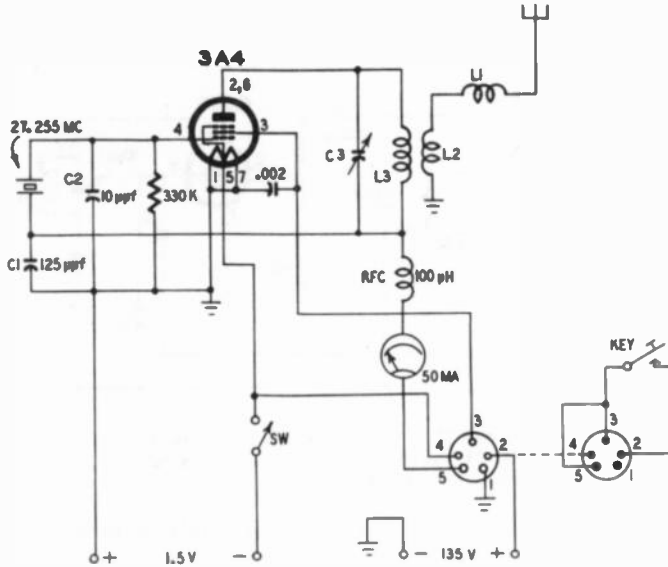

Fig. 1011. The CG Electronics Corp. T-15 transmitter features a feedback network to stabilize the oscillator. Coil data is similar to that of other 27.255-mc units.

The desire to have the full 5-watt input allowed at 27.255 mc and yet have a hand-held transmitter which can make use of the power available in a normal car radio brought about the design of the transmitter of Fig. 1012.

Power is obtained from the automobile radio through a three-con-

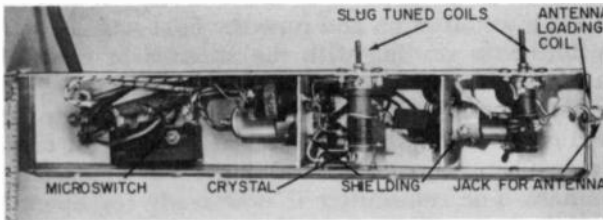
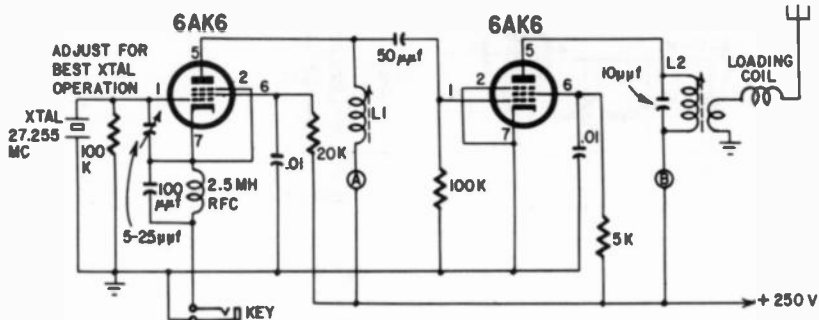

Fig. 1012. Transmitter, powered by a car battery, can deliver five watts.

ductor cable which provides B-plus, B-minus and one side of the filaments; the third lead connects the second side of the filaments to the car battery. The automobile radio was modified to provide a socket for the connections.

The transmitter is constructed in a 2 x 2 x 12-inch aluminum case. A microswitch is used for sending commands. The small antenna loading coil and jack for the antenna can be seen in the photo.

One unique feature of this transmitter (see Fig. 1013) is that the tuning capacitors are either fixed values or omitted. Tuning is accom-



L1 and L2 = approximately 20 turns of No. 28 enameled wire closewound on  $\frac{1}{4}$ " form (National XR91).

Fig. 1013. This transmitter is tuned by variable inductors.

plished by varying the position of the metal slug in the coils. In this particular transmitter, the crystal was soldered into the circuit. This is not recommended. A crystal socket should always be used. To tune the circuit:

1. Disconnect the B-plus lead to the final stage.
2. Insert a 0-50-ma meter in the crystal B-plus lead at A.
3. Turn the transmitter on and tune, by adjusting the crystal coil slug, until the meter is just above the minimum reading.
4. Turn the transmitter off and place a jumper across the oscillator B-plus lead. Connect the meter into the final-stage B-plus lead at B.
5. Turn the transmitter on and tune the final stage by adjusting the slug for a minimum reading with the antenna in place. The meter should read from 15 to 20 ma. If necessary, the number of turns on the coupling coil can be increased to obtain this reading or the loading coil adjusted by increasing or decreasing its number of turns.
6. The meter can be removed and a jumper connected across the meter terminals. The transmitter is now ready for operation.

This transmitter is particularly adaptable for chasing down runaway model aircraft which have gone out of range.

A two-tube transmitter using battery type tubes and employing a pi-network antenna loading system is shown in Fig. 1014.

One unusual feature of this transmitter is the use of a 2- $\mu$ h rf choke in series with the crystal to ground. This helps keep the grid of the oscillator tube at a high potential above ground as far as rf is concerned. The result is an easy-to-start well-stabilized oscillator. The



3A4 is connected as a triode since maximum power is not required from this stage.

The 3D6 output stage has its plate voltage applied through a 1-mh rf choke and is coupled to the combination tank and antenna circuit

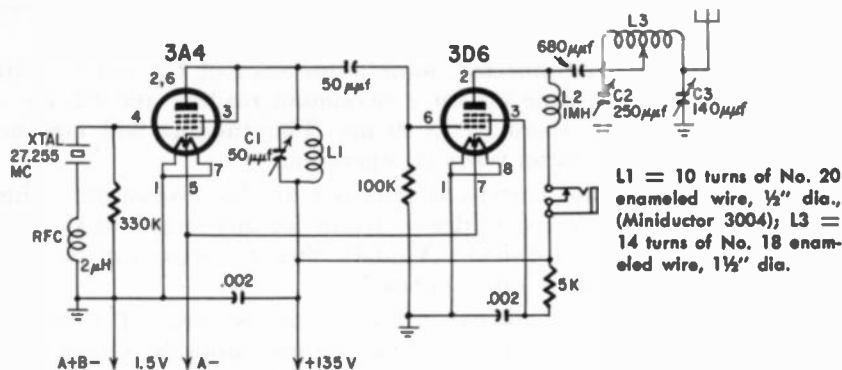

Fig. 1014. The oscillator is connected as a triode in this 27.255-mc transmitter. Note the pi network used to load the antenna.

through a large (680- $\mu$ f) capacitor. When the antenna circuit is properly tuned it will cause any length antenna to radiate effectively. L3 could have more turns and be provided with taps so that a portion

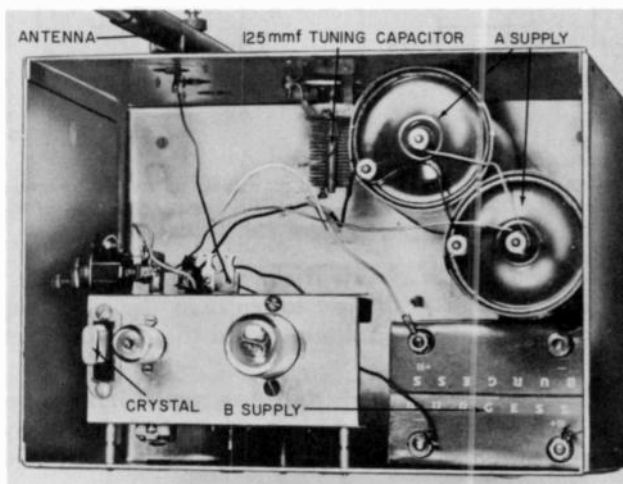

Fig. 1015. The Lorenz transmitter of Fig. 1014 is a portable unit.

of the coil could be shorted to provide a proper load for antennas of various lengths. Fig. 1015 illustrates how one transmitter using this circuit was constructed.

Tuning the transmitter is accomplished by first disconnecting the

B-plus lead from the 3D6 plate and screen at the battery. Insert a 0-50-ma meter in the B-plus lead of the 3A4. Tune C1 for a point just above minimum dip. Reconnect the B-plus lead to the 3D6 and plug the meter into the jack provided. The transmitter should be turned off while changing connections. With the transmitter turned on, tune C2 for a dip reading. It should be near maximum capacitance.

With the antenna connected, some adjustment of C2 and C3 will be required. Always tune C3 for a maximum reading and C2 for a dip until the dip is about 30 to 40 ma. The antenna will now be excited and the transmitter ready for operation.

A rather high plate current is required by this transmitter. This means that if it is allowed to draw current for any length of time, it will drain the batteries quickly. A small vibrator supply can be used to eliminate this possible source of trouble.

Some 3D6's are not as efficient in this circuit as others. Try various tubes if the circuit does not seem to perform properly. Other tube

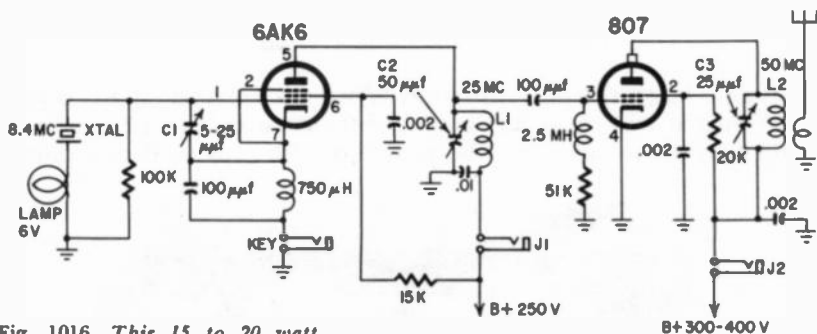

Fig. 1016. This 15 to 20 watt transmitter provides ample power for use on the 50-54 mc band.

L1 = 6 turns of No. 20 enameled wire,  $\frac{3}{8}$ " dia.,  $\frac{3}{8}$ " long; L2 = 5 turns of No. 18 enameled wire,  $\frac{3}{8}$ " dia.,  $\frac{1}{2}$ " long.

types can be used in the circuit if the screen resistors are chosen so that the screen voltage is slightly lower than the plate supply. The value of the plate supply should not exceed that specified for the tube used.

In some applications of model control—a model boat to be sailed on a large lake or a model aircraft of large size which might fly long distances—more power will be desired to insure reliability and give the range required.

A long-range transmitter circuit for operation on the 50-54-mc band is shown in Fig. 1016. Remember that this type of transmitter cannot be used on the 27.255-mc band due to the power limitation of 5 watts imposed by the FCC.

The power supply required is much larger than for lower-power transmitters. It might be obtained from a vibrator power supply de-

delivering 300 to 400 volts at 100 ma or from a dynamotor of equivalent rating.

To tune the transmitter, C1 is set at maximum capacitance and a 0-100-ma meter is inserted in J1. A dummy plug is placed in J2 to prevent voltage from being applied to the 807. The transmitter is

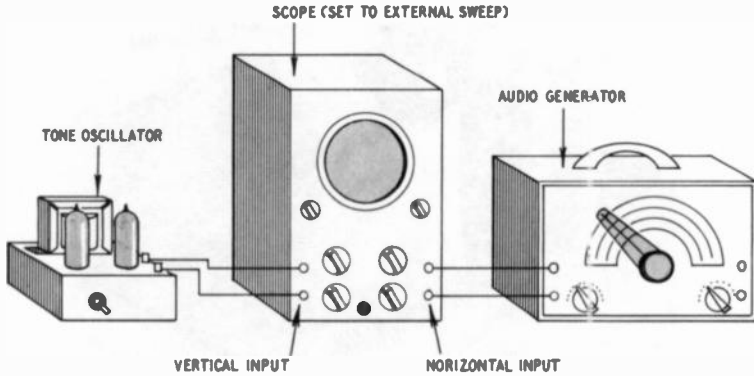

Fig. 1017. Because tone frequencies must be accurate, a test setup such as that shown above, must be used.

turned on and C2 is adjusted for the off-dip point, as previously described. The light in the crystal circuit should not glow. (This is a safety fuse to protect the crystal from excessive current.) Now, C1 can be adjusted for a lower dip. Then touch up C2 again. These two capacitors should be juggled for a minimum reading.

With the transmitter off, the meter is moved to J2 and power is applied again. C3 is adjusted quickly for a minimum reading with the

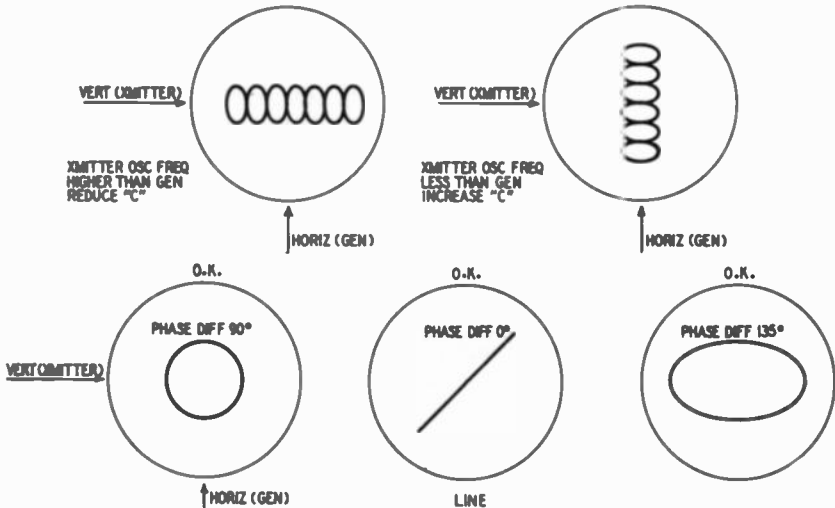

Fig. 1018. Lissajous figures obtained with the test setup of Fig. 1017.

antenna removed. When this is obtained, the antenna may be connected and the coupling loop moved near or over the plate coil until the desired loading is obtained. This is shown by a reading of from 50 to 60 ma. There should be a dip point and, whenever the coupling loop is moved, C3 should be adjusted for minimum reading.

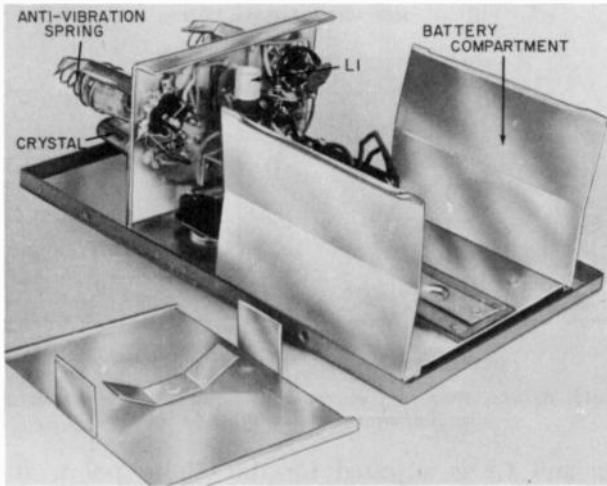

Fig. 1019. A commercial tone transmitter, the Babcock BCT-2 combines simplicity with portability.

When constructing any transmitter using two or more stages, the coils of each stage should be kept at right angles to each other and separated by 3 to 6 inches, depending upon the power generated. It is also advisable to use a shield over the coils. The shield should allow a minimum clearance of at least the coil diameter completely around and at each end of the coil.

The circuit can be keyed by breaking the B-minus lead through a keying relay. Note: this transmitter uses voltages which can be dangerous.

### Tone transmitters

Before going into detail concerning the various types of tone transmitters, it is advisable to know the method used to determine just what tone is generated by the tone modulator section. The tones must be *exact* or the control system will not function properly.

Two items of test equipment are needed—an oscilloscope and a good audio oscillator. (The circuit connections are illustrated in Fig. 1017.) The output of the tone oscillator is connected to the vertical input of the scope and the output of the audio generator to the horizontal input. The horizontal sweep switch on the scope is placed in the external position and the amplitude of the signal from the audio generator is adjusted so that a line appears across the face of the scope.

Now the tone section is turned on and the gain controls of the scope are adjusted until there is an almost square area filled with the trace. The dial of the audio generator is slowly turned through its range while observing the scope. At some point the picture on the face of the scope will resolve into some sort of circle. It may be irregular or appear to be on its side, but it will definitely be circular. The dial of the audio generator will then indicate the frequency of the tone.

If the frequency of the tone oscillator is too high or too low, capacitors or coils in the circuit may be changed until the circle appears when the audio generator is set at the desired frequency. Fig. 1018

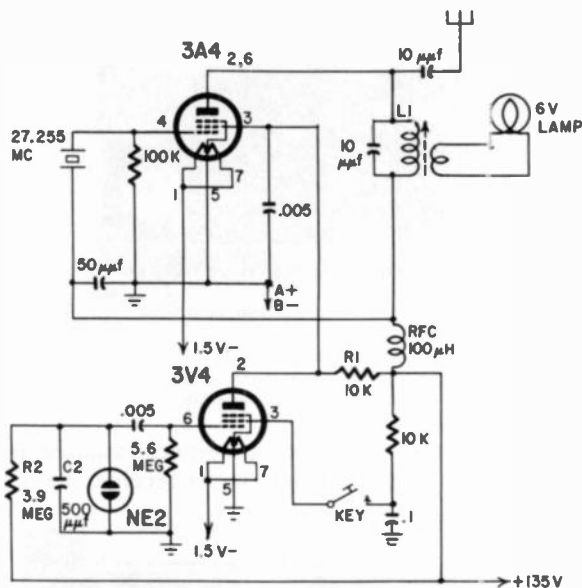

R2 and C2 control tone frequency. Decreasing R2 increases frequency. For L1 see previous data on 27.255-mc transmitters or Table 10-1 on page 137.

Fig. 1020. Because the power radiated by the Babcock BCT-2 is greater when the signal is unmodulated, the rf lamp will dim when the modulator is keyed.

shows some of the traces which might appear and indicates the meaning of the patterns in terms of frequency differences between the generator and tone unit.

A simple but reliable tone transmitter which uses battery type tubes, has a self-contained power supply and a performance indicator in the form of a small pilot light which shows the presence of rf energy, is the Babcock BCT-2 unit. The internal wiring and battery compartment are shown in Fig. 1019.

The transmitter uses a 3A4 crystal-controlled oscillator stage, with

the regeneration tap between the lower end of the tuning coil and the rf choke. The antenna is coupled to the tank circuit through a  $10\text{-}\mu\text{f}$  capacitor which provides the proper impedance match for the

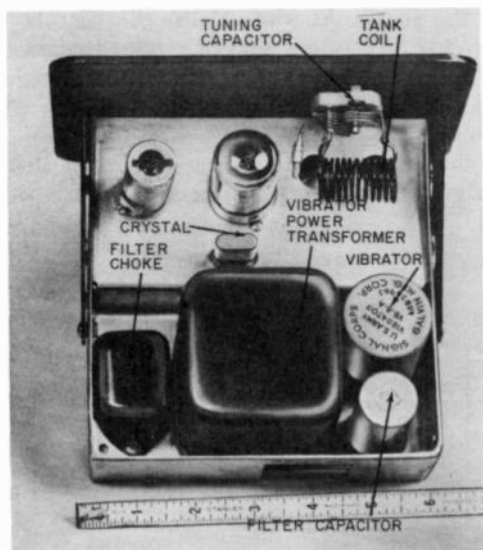

Fig. 1021. Transmitters of the type shown in Fig. 1020 can be built with a self-contained vibrator-power supply.

$1/12$ -wavelength antenna. The effective power radiated is about  $1/10$  watt, but this is more than adequate for a receiver with a  $4\text{-}\mu\text{v}$  sensitivity.

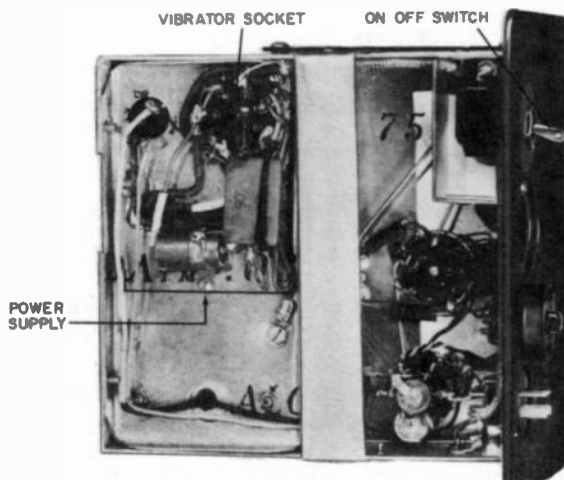

Fig. 1022. Below-chassis view of the unit shown in Fig. 1021.

The modulator is a 3V4 connected as a clamp tube modulator. In the circuit of Fig. 1020 B-plus is fed to both the screen of the oscillator and the plate of the modulator through R1, a 10,000-ohm resistor. When the 3V4 draws more current, due to the voltage applied to its grid by the neon-tube tone section, the voltage drop across R1 is greater. This means that the screen voltage of the rf tube drops. Con-

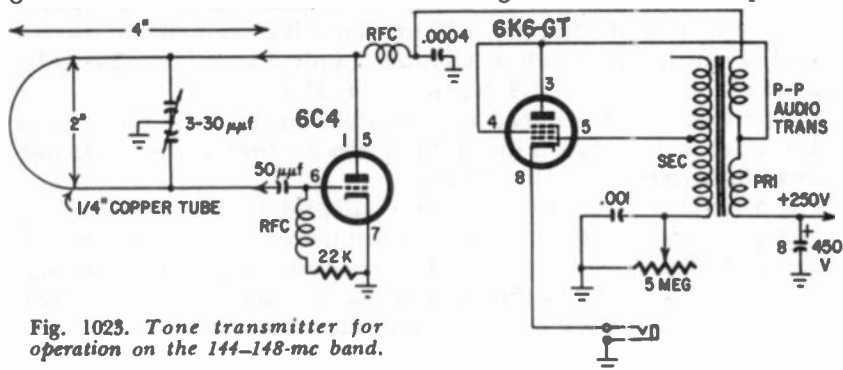
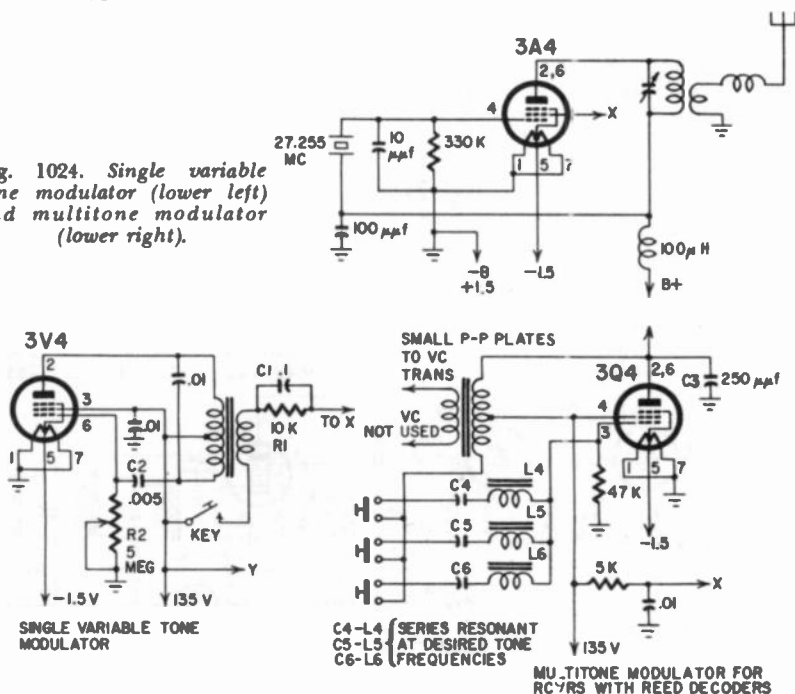

Fig. 1023. Tone transmitter for operation on the 144-148-mc band.

versely, when the modulator tube draws less current, the screen potential of the rf oscillator goes up. This means that the screen voltage is varied with the tone signal and the carrier is modulated.

In this type of transmitter the radiated power without modulation

Fig. 1024. Single variable tone modulator (lower left) and multitone modulator (lower right).



is greater than when modulation is applied and, in practice, the rf indicator will dim when the tone button is pushed.

The frequency of the tone generated with the constants shown is about 900 cycles. The end voltages are 1.1 for the A-supply and 110 for the B-supply, measured with the transmitter on and the tone button (or key) depressed.

A vibrator supply can be used with this transmitter if it is capable of producing at least 135 volts at 20 ma. Figs. 1021 and 1022 illustrate a good layout using a built-in vibrator supply and a 3D6/1299 tube in place of the 3A4 and a 3Q4 in place of the 3V4.

A tone transmitter designed for operation on the 144–148-mc band is illustrated in Fig. 1023. This unit requires a vibrator supply capable of furnishing 250 volts at 50 to 75 ma.

The modulation transformer, a push-pull-grid-push-pull-plate inter-stage type, is connected in an unusual manner to get a high degree of modulation. B-plus is connected to one end of the primary winding, while the opposite end of the winding leads to the rf oscillator. The 6K6-GT modulator plate is connected to the center tap.

One half of the grid winding is used as the grid-circuit tuning coil with the tone controlled by the grid resistor and capacitor. In construction, it may be necessary to reverse the grid winding leads if no tone is generated. The jack in the cathode lead of the 6K6-GT is for keying purposes.

The antenna-coupling coil is a loop constructed to the same dimen-

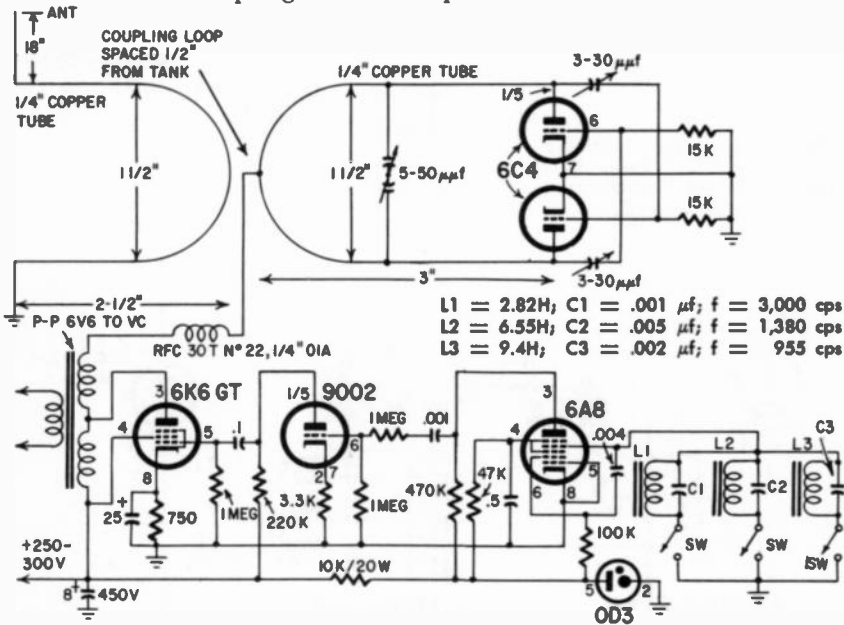

Fig. 1025. Tone-modulated transmitter using 6C4's in push-pull. The modulator is a transitron oscillator.



sions as the tank coil, L1. It is mounted parallel to it. The spacing between the two is about  $\frac{1}{2}$  inch. When a quarter-wave antenna is used, one end of the antenna loop is grounded. When using a half-

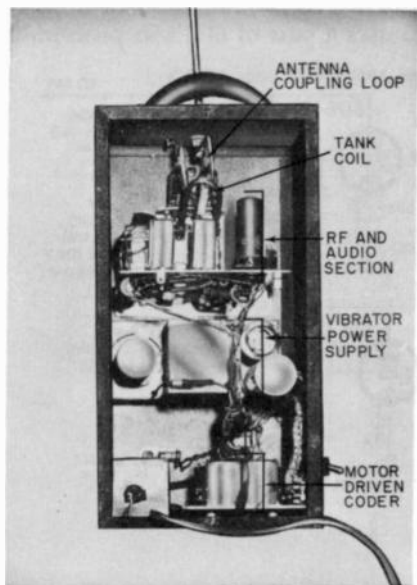

Fig. 1026. Pulse-width-pulse-space transmitter.

wave antenna, the loop is not grounded but has both ends connected to the transmission line.

A battery-operated tone transmitter which uses a standard interstage transformer in the tone circuit is shown in Fig. 1024. The rf section is similar to those previously described using feedback and an antenna loading coil. The screen of the 3A4 is modulated.

R1 and C1 are used to reduce the screen voltage to a value which

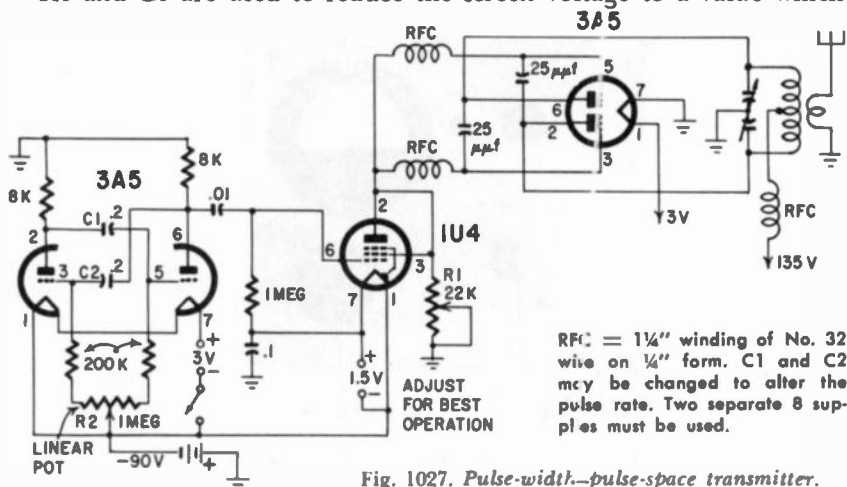

Fig. 1027. Pulse-width-pulse-space transmitter.

can be fully modulated. The capacitor passes the audio to the screen. The frequency-controlling elements in the tone section are R2, C2 and the inductance of the transformer in the grid of the tone section. C3 also affects the tone frequency transmitted.

The transmitter shown in Fig. 1025 uses a pair of 6C4's in push-pull

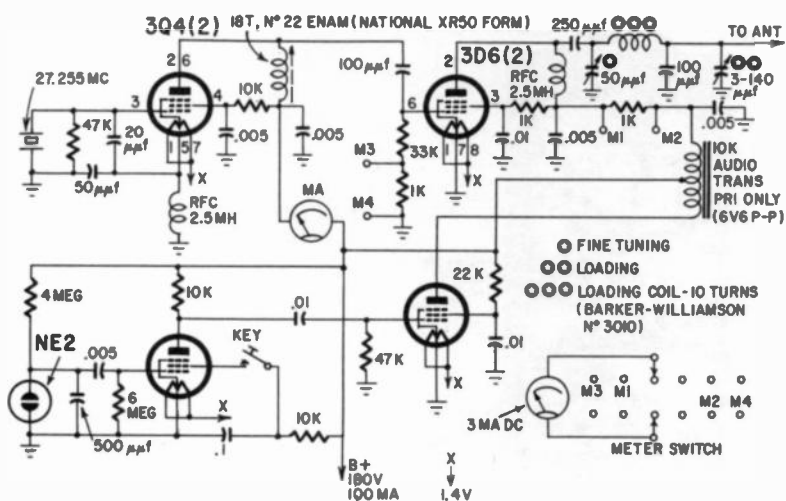

Fig. 1028. Single-tone transmitter with meter switching arrangement.

to give a 5-watt output in the 144–148-mc band when powered with a 300-volt 100-ma vibrator supply or equivalent dynamotor.

Each audio tone is generated by the 6A8 pentagrid tube, using a resonant circuit tuned to the desired frequency. This type of oscillator,

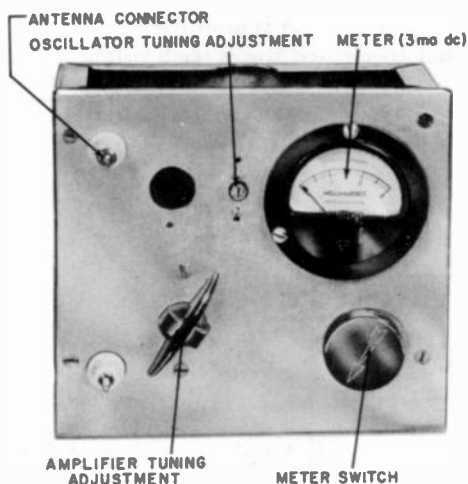

Fig. 1029. Front view of the single-tone transmitter whose circuit is shown in Fig. 1028.

when voltage-regulated (in this case by the OD3), is very stable, an important consideration when reed and tuned-filter decoders are used.

The circuit to any particular tone tank is completed by closing a

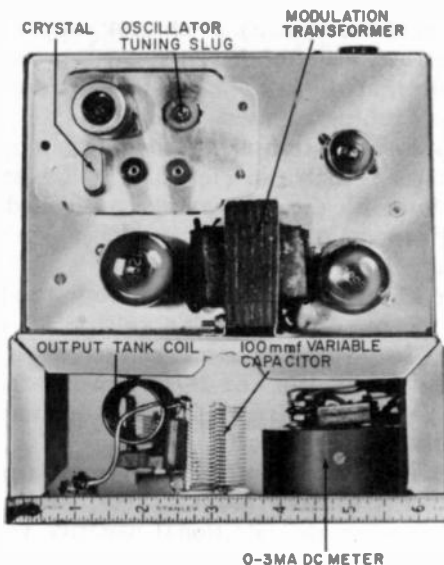

Fig. 1030. This is an inside view looking down at the top of the single-tone transmitter.

switch which connects the lower end of the coil and capacitor to ground.

To get a high degree of modulation, a conventional push-pull audio

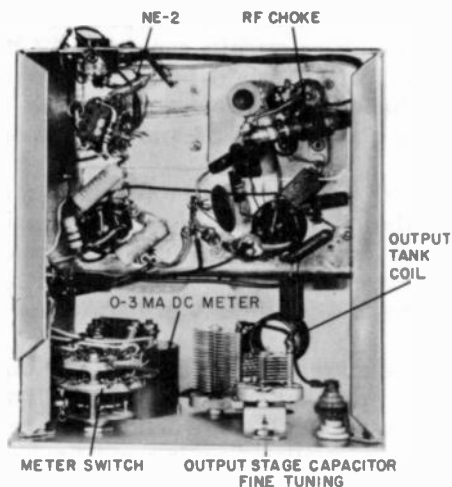

Fig. 1031. Under-chassis view of the single-tone transmitter.

output transformer is connected in an autotransformer circuit. This drops the voltage to the rf section slightly, but provides the correct match for a single modulator tube.

Fig. 1026 illustrates one method of construction using a two-tone bank (to the left on the rf chassis), a vibrator supply (center) and, at the bottom of the case, a motor-driven coder powered by a separate 6-volt battery. Note that the coupling loop is inverted and that different sizes of copper tubing are used.

A pulse-width-pulse-space transmitter designed to operate a proportional control receiver is shown in Fig. 1027. It consists of a push-pull self-excited rf section with the grid voltage controlled by the pulsing section so that the proportional signals are developed without using a mechanical pulser.

The plate of the 1U4 is tied to ground through the 22,000-ohm grid resistor of the rf section. The operating voltage for this tube comes from B1 which has its positive terminal connected to ground and its negative end to the filament of the 1U4. Thus, as far as the tube is concerned, it has a positive voltage applied to its plate in relation to its cathode and will operate normally.

When the multivibrator section (the 3A5) sends a pulse to the grid of the 1U4, it forces it to draw more current. As the rf section also uses R1 as a grid resistor, the additional negative voltage developed across it causes the bias to become so negative that the rf section will not oscillate. The result is that the carrier is cut off while a pulse from the multivibrator is present and is transmitted when the pulse is absent. The width of the pulse with respect to the spacing can be varied by moving the linear control potentiometer R2 to the right or left. When the potentiometer is centered, equal pulses and spaces will be transmitted.

Although 3A5 tubes are used in this particular circuit, other types may be substituted. In fact, the idea of pulsing the carrier may be used with other transmitter circuits such as a 27.255-mc crystal-controlled oscillator. R1, which would be the grid resistor, might have to be a different value and an rf choke, say 2.5 mh, might have to be inserted between the plate of the 1U4 and the grid of the crystal oscillator tube.

Fig. 1028 illustrates a small single-tone transmitter which uses a slug-tuned coil in the crystal stage. Note that provision is made for metering the grid of the final stage (thus determining that the crystal stage is operating properly). The meter can be switched to the output stage to check tuning and loading. A pi network is used for antenna tuning.

The transmitter is powered with a vibrator supply which uses a 2-volt wet cell as its primary source. Figs. 1029, 1030 and 1031 illustrate the general layout and construction of the unit. Note the separation between the oscillator tuning and final stage coils as well as the shielding provided between these stages.

# construction of coders and decoders

**A** CODER is a device which causes the proper commands to be transmitted when the controller moves a lever, turns a dial or closes a switch. It makes possible quick and accurate control of the model since it relieves the controller of the task of remembering all of

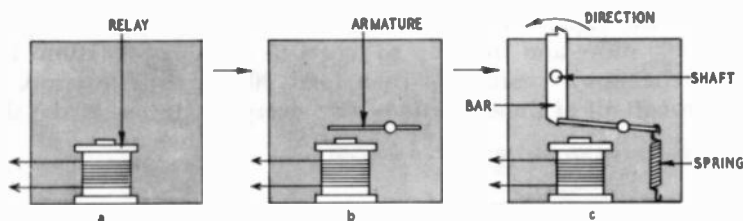

Fig. 1101. Steps in building a simple escapement: a) electromagnet mounted on plate; b) pivoted armature added; c) position of stop bar.

the codes for various commands. The decoder is the companion unit which receives the signals and turns them into physical movement as desired.

## Simple escapements

The escapement is one of the simplest decoders. If an electromagnet is mounted on a small plate (Fig. 1101-a) and an arm is fastened to it which is free to pivot like a relay armature (Fig. 1101-b), it can be used to stop the rotation of a bar when the magnet is not energized (Fig. 1101-c). The bar is fastened to a shaft and runs through a bearing on the base plate which prevents it from wobbling when it rotates.

A means of power is necessary to make the bar turn. It is obtained by forming a hook on the end of the shaft through the bar, attaching

a rubber band to the hook and twisting it until it has enough torque to rotate the bar (Fig. 1102).

If the magnet and bar are to be used as a decoder, some further refinement is necessary or the rubber band will unwind when the

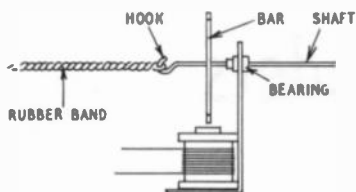

Fig. 1102. Method of powering a simple escapement.

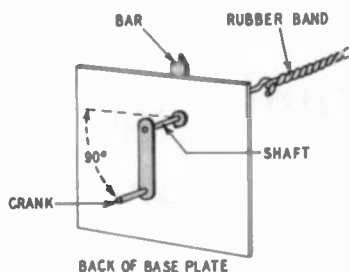

Fig. 1103. Modifying the escapement by adding a crank to the shaft.

magnet is energized and will not be able to supply power for any length of time.

Fig. 1103 shows the first modification of the basic escapement. The base plate is drawn so that the side from which the shaft protrudes from the bearing is seen. If this end of the shaft is bent into the form of a small crank in the same plane as the bar, it will rotate from the vertical to the right with a 90° turn of the shaft, from the right to up with 90° more and from up to left with the third rotation. It returns to the down position with a final 90° turn. The crank will move through all of these positions with every revolution of the shaft.

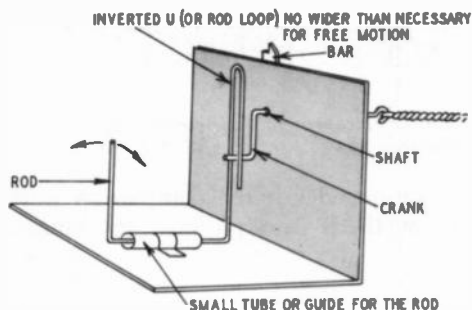

Fig. 1104. The simple escapement can be used to control one function of a model by attaching a small rod as shown.

In Fig. 1104 an inverted U bent at the end of a long shaft has been added to the assembly, using 1/16- to 1/32-inch piano wire. As the crank turns, the rod moves from the rest position to the right, back to the rest position, then left and back to the rest position once again. The rotating movement of the crank is transformed into a back-and-forth movement of the rod. If the opposite end of the rod is bent as shown, it can be attached to the rudder of a plane or boat to produce left, right or neutral rudder. The only way we can obtain this

positioning of the rudder is to provide some means of stopping the rotation of the crank every 90°. This is done by providing a second catch point on the magnet armature (Fig. 1105).

The bar of the escapement catches on the upraised portion of the

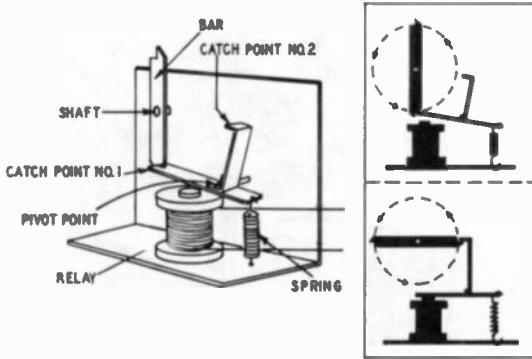
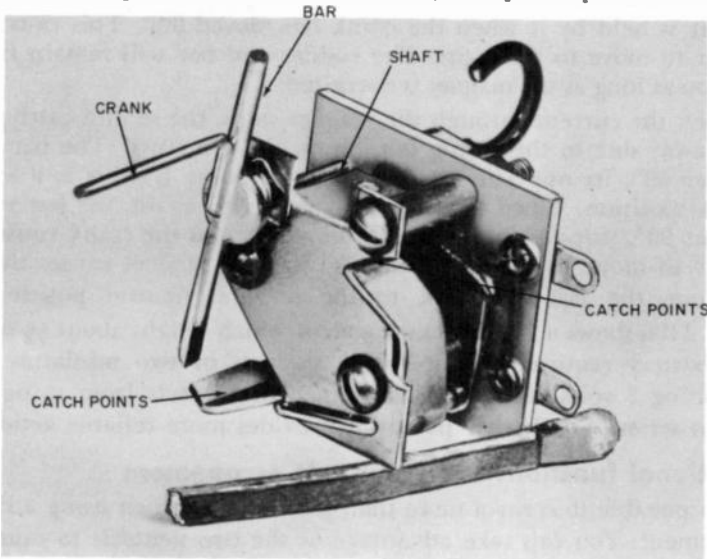

Fig. 1105. Adding another catch point to the armature allows the controlled element to be locked in several positions.

magnet armature and holds. The crank on the back of the plate is oriented so that the rudder is at neutral in this position. When the magnet is energized catch point 1 is pulled down and lets the bar

Fig. 1106. The Bonner standard escapement is a commercial unit which performs all of the functions of a simple escapement.



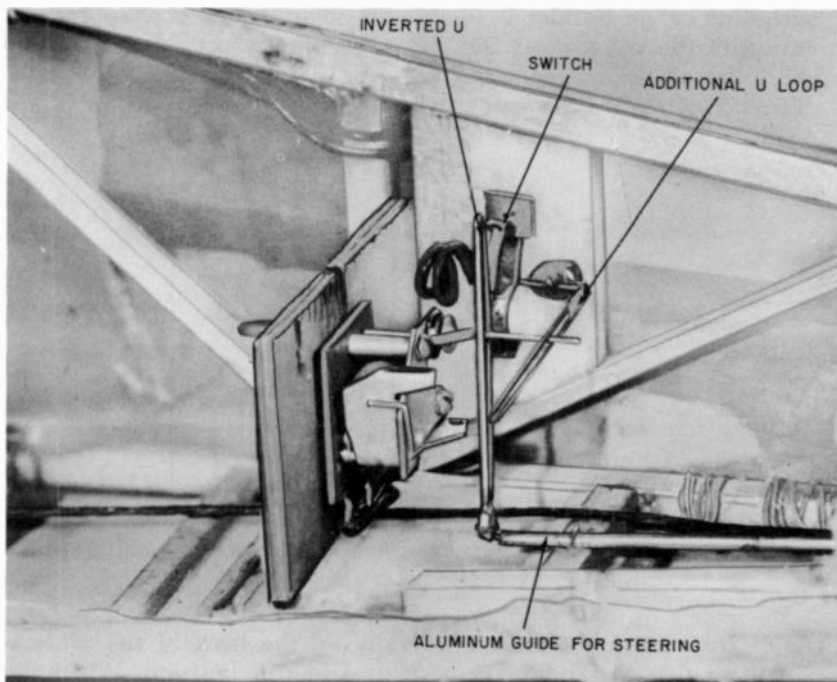

Fig. 1107. By using two loop and rod arrangements the simple escapement can control an additional function.

rotate. Since catch point 2 is moved into position by the armature, the bar is held by it when the crank has moved 90°. This causes the rudder to move to the right. The rudder and bar will remain in this position as long as the magnet is energized.

When the current through the magnet stops, the second catch point pulls away due to the spring tension on the armature. The bar turns another 90°, its opposite end catching on point 1. This is a second neutral position. When the magnet is energized again, the bar rotates another 90°, stops as catch point 2 moves in, and the crank causes the rudder to move to the left. De-energizing the magnet causes the bar to rotate the last 90° back to the original neutral position.

Fig. 1106 shows a standard escapement which weighs about 1/2 ounce. The battery required for operation consists of two miniature cells furnishing 3 volts. There are no detrimental effects from using four cells in series. The higher potential provides more reliable action.

### **Additional functions for the simple escapement**

It is possible to control more than just steering when using a simple escapement. You can take advantage of the two neutrals to cause circuits to close or to move other elements. Fig. 1107 shows how a second



yoke would be attached. In this it operates a single-pole double-throw switch made from light brass strips.

The link from the second loop could also, for example, extend forward to the motor where the up-and-down motion would insert or remove a small piece of sponge rubber from the venturi of the motor

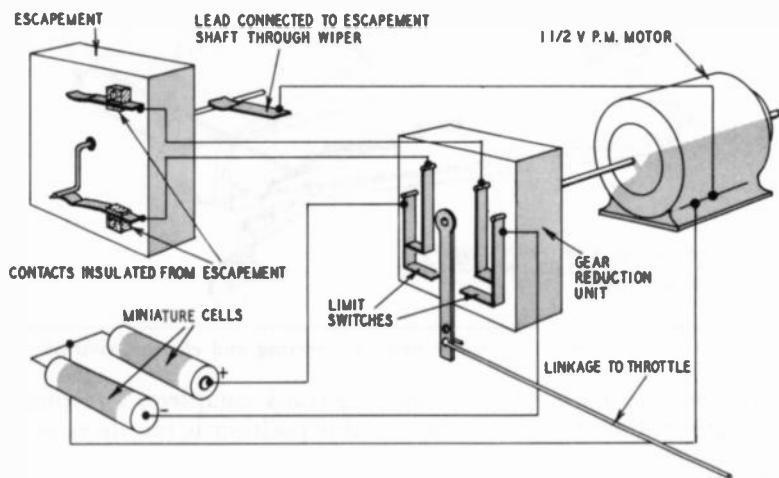

Fig. 1108. The addition of electrical contacts to an escapement permits motor control.

to control its speed. One neutral would be used for high speed, the other for low.

Note that the rod from the steering loop passes through a small aluminum tube. This prevents play and vibration of the rod when the model is in operation.

The two neutral positions can also be used by adding contacts to the escapement itself and letting the crank form a part of the electrical circuit (Fig. 1108). In this case more power was needed to operate the motor throttle than was available from the escapement itself. Therefore the switch arrangement was used to operate a small PM motor which operated the throttle through a gear train.

One advantage of this type of motor control is that the motor speed does not change instantly. Because of the time required to move the output shaft through the gear-reduction unit, the motion of the crank past the undesired neutral contact cannot cause the throttle position to change. In practice, one has to signal for the change in motor speed by sending a single pulse. After a second or so, the command will be executed. The amount of movement required to open and close the throttle is regulated by adjusting the position of the limit switches.

Fig. 1109 illustrates how the neutral positions can be used for elevator control of a model plane. The elevator loop will be moved only when the crank is in the down-neutral position. Although the

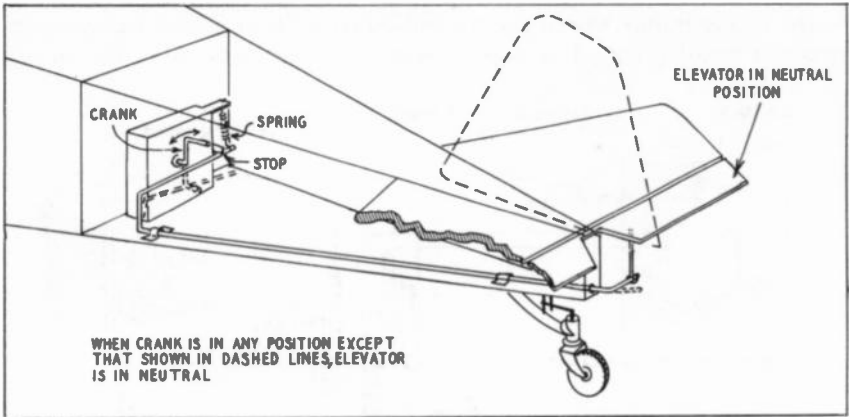

Fig. 1109. Using a simple escapement for steering and elevator control.

elevator will be deflected every time the crank completes a revolution, the length of time that it remains in this position is too short to produce a noticeable effect.

The down-elevator position is used since the model is normally trimmed to climb with the elevator in neutral. Full down can be used for dives and loops after the model gains altitude.

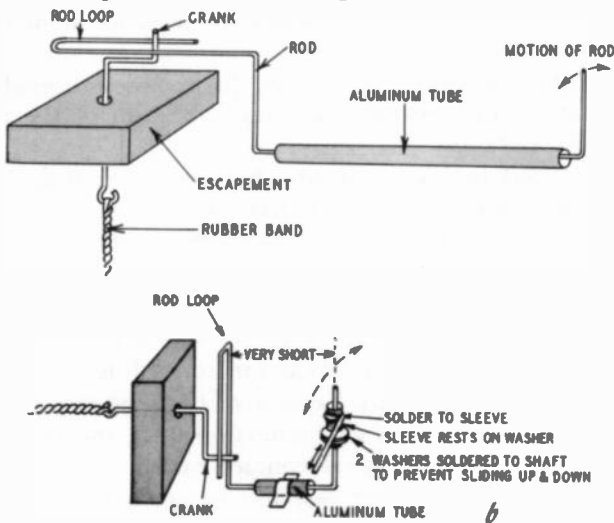
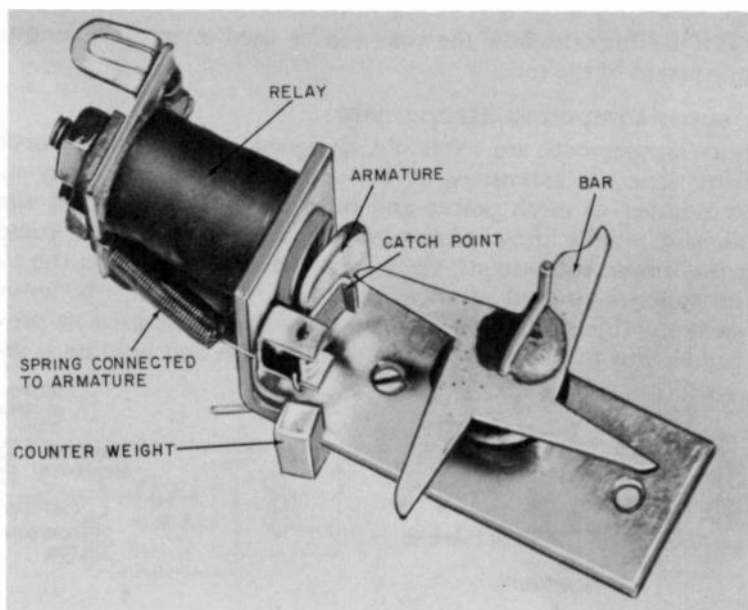
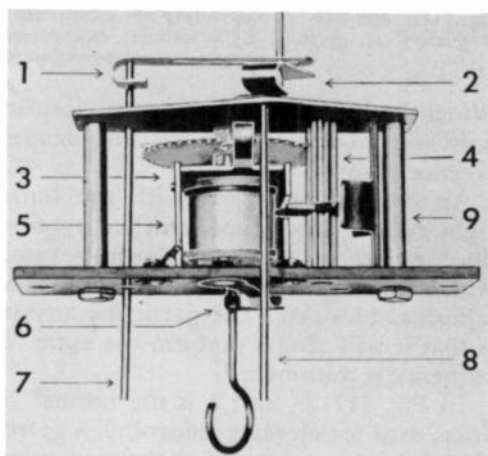

Fig. 1110. Tailoring a simple escapement to meet specific needs: a) escapement positioned so that rubber band is vertical; b) configuration used to produce longitudinal movement.



a

Fig. 1111. Two types of escapements: a) 4-arm multiposition escapement; b) Babcock Mark II super-compound escapement. This unit has provisions for rudder, elevator and motor control.



b

If the rubber-band motor powering the escapement is long and can function for a period of time, it is possible to obtain various degrees of down elevator. The elevator will spend more time in the down position if short rapid pulses are transmitted. It will spend less time with slow pulses. Since the rudder will spend as much time to the left as to the right, its only effect would be to slow the model slightly.

Fig. 1110-a shows how the rod loop may be formed so that the rubber band powering the escapement will be at right angles to the yoke shaft. This is a useful arrangement when the model is small.

Fig. 1110-b illustrates how the yoke can be used to produce longitudinal movement of the rod.

### The super-compound escapement

Many escapements are available, designed for multiple functions. Most of these are extensions of the simple escapement. They use a larger number of catch points and have more arms than the simple escapement. While these compound escapements are more complex than the simple escapement, their principle of operation is the same.

The super-compound escapement shown in Fig. 1111-b, however, has some notable differences of operation. It may be used to provide left rudder just by depressing the control button and holding it down.

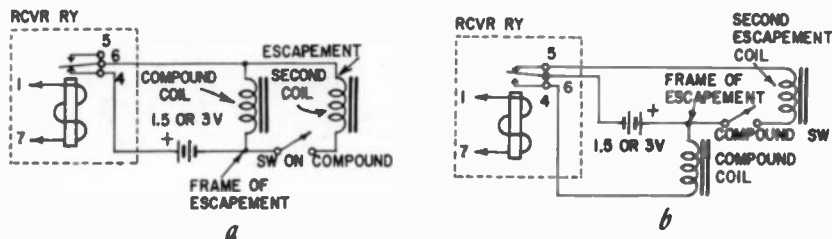

Fig. 1112. Methods of connecting an additional escapement to a compound unit: a) parallel connection; b) additional escapement operated by receiver relay and compound unit.

When the button is released, the escapement self-neutralizes. There is only *one* neutral, to which the escapement always returns in the absence of signal.

An ON-OFF-ON signal with the button held down will produce right rudder every time, and an ON-OFF-ON-OFF-ON signal will produce either up elevator, down elevator or close a set of contacts which may operate a circuit to release a bomb, cause lights to flash, a horn to blow, etc. The particular advantage of using this escapement is that it will always perform the same function when the same signal sequence is transmitted.

In Fig. 1111-b, unit 1 is the normal steering yoke; 2, the auxiliary yoke, used for elevator control; 3, a geared wheel attached to the hook shaft and designed so that the armature catch points will hold when the magnet is energized; 4 is a driven gear which has a star wheel as an integral part. This star causes a free-running clocklike escapement (9) to oscillate back and forth, engaging and disengaging the points of the star. This governs the speed of rotation of the hook shaft. The contact switch points are 6, while 7 and 8 are the two yoke shafts, and 5 indicates the frame of the relay.

The contact switch of this escapement can be used to operate a second escapement. The method of connecting the two to the receiver relay is shown in Fig. 1112-a. It is possible to have rudder, one position of elevator (in addition to neutral) and also motor control,

with this type of escapement. First, the wire portion of contact 6 is adjusted so that, when the unit is in the initial on position, the wire is moved to close and then open again just before the right position is reached. The circuit is then wired as shown in Fig. 1112-b.

When the position of the wire contact is properly adjusted, transmission of a very short blip type pulse will cause the secondary escapement to shift from one neutral to the other. One pulse and hold will give right; two pulses and hold left; three pulses and hold produces up or down elevator. The secondary escapement is a simple type operating a throttle control through a special linkage.

Wire torque rods have been suggested for use with escapements. Some experts prefer to use a balsa-wood rod with a yoke attached to

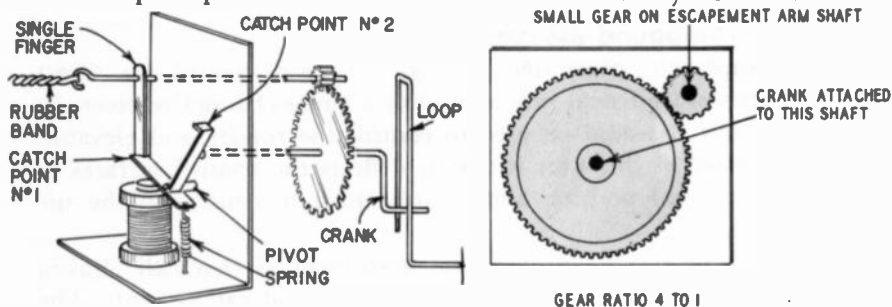

Fig. 1113. Additional power is obtained by driving the armature of this simple escapement with a gear train.

one end and a wire at the other. This arrangement provides a rigid linkage. On the other hand, fairly long piano-wire rods have a certain amount of springiness and will allow the controlled element to move toward neutral under propeller blast. However, during a glide phase it will deflect fully. Since the speed of the model is greatest under power, less deflection is needed for a given amount of control. Therefore, the spring action of a wire torque bar, in a sense, automatically compensates for this difference.

In some control applications it is desirable to have an escapement that will provide four no-signal positions plus the four signal positions as well as more power than is normally available from the average escapement. This additional power is available with a geared escapement (Fig. 1113). Essentially it is a simple escapement with one of the fingers removed from the rotating bar. The shaft terminates in a small gear which drives a larger gear. The ratio of the two is 4 to 1. The two catch points of the relay armature are still necessary to allow accurate pulsing and positioning of the output shaft.

When a pulse is received, the finger rotates to the first catch point and stops as long as the signal is present. When the pulse stops, the finger completes the balance of the 270° rotation, back to the original starting position.

The finger shaft has completed a full 360° turn but, since the out-

put shaft is moved through the gears, the crank moves only 90°. There is also a power stepup due to the gear ratio.

This arrangement can be used to move the elevator of a model plane operating from the second channel of a two-tone receiver. Power is adequate for this application and the speed of operation is fast. The elevator may be left in the four positions of the escapement output: neutral, up, neutral, or down. If one signals for up and gets down, through some loss of synchronization, one more quick pulse returns the element to neutral.

Constructing the bearings to eliminate play and unnecessary friction in the gears, makes the unit not only light but powerful and reliable.

### A type II compound escapement

The escapement illustrated in Fig. 1114 was created for direct control over two physical functions with a single-channel receiver. In model aircraft it would be used to control the rudder and elevator. One advantage of this unit is that it deflects the control surfaces in only the on-signal position and returns them to neutral in the no-signal position.

It consists of a standard one-arm escapement mechanically linked to a second unit consisting of two single bars and catch points. The catch points are moved on the secondary unit by a small pin extension

Fig. 1114. This cam-operated unit is activated by a one-arm primary escapement.

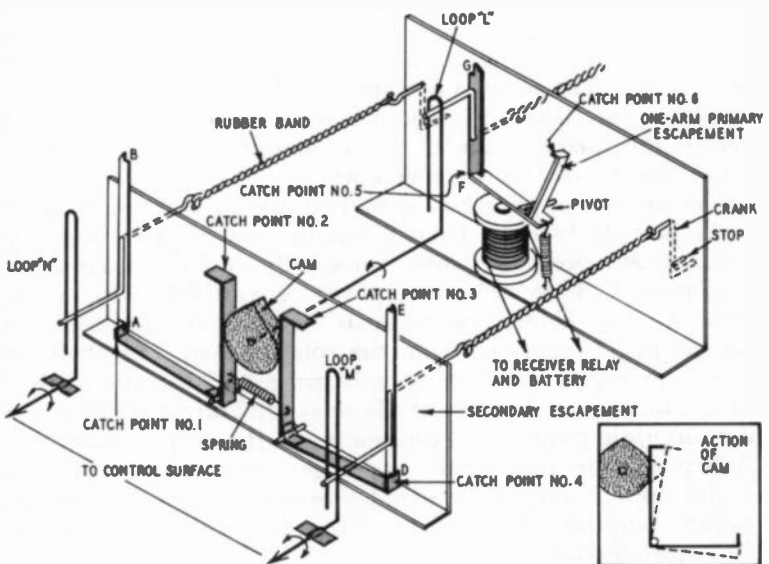

on the centrally located cam. A spring holds them firmly against the cam. The position shown in Fig. 1114 is neutral.

If a signal is sent, causing the standard escapement to move finger F to position 6, the cam rotates 90° counterclockwise, pushing catch point 2 forward and causing catch point 1 to move down. This releases A. As A moves clockwise, finger B is intercepted by catch point 2 and held. Loop N is then deflected to the left.

When the signal stops, the arm on the standard escapement turns another 90° until G is intercepted by catch point 5. The cam moves another 90° through loop L, allowing catch point 2 to be pulled back by the spring and forcing catch point 1 up to intercept B. Loop N is again at neutral.

Another ON signal brings G to catch point 6 and turns the cam another 90° so that the pin pushes against the second catch point arm, forcing catch point 3 forward and releasing D at catch point 4. Loop

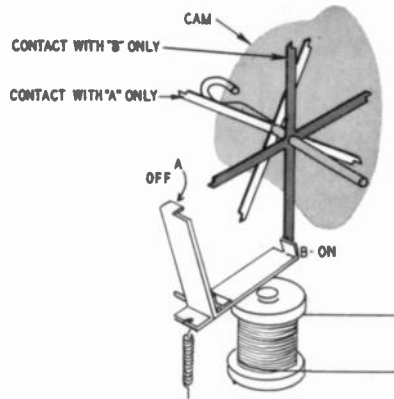

Fig. 1115. Basic movement of the Ecco eight-position escapement.

M is now deflected to the left. An OFF signal returns the standard escapement arm to its original starting position and releases E from catch point 3 to be intercepted by catch point 4. Loop M is now at neutral again.

The same sequence, if continued for another revolution of the standard escapement arm, will deflect loop N as well as loop M, to the right and then neutral. It takes two complete cycles of the primary unit to complete one cycle of the secondary escapement.

### Eight-position escapement

To use an escapement as a multiposition switch, more positions than specified thus far may be required in a smaller, more compact unit. The basic movement of the Ecco compound escapement. (Fig. 1115) is a solution to this problem.

The unit consists of two sets of four fingers which are mounted on the shaft so that one set intercepts catch point A for all no-signal (OFF) positions and the other intercepts catch point B for all signal (ON)

positions. The two catch points are offset from one another. This arrangement can be used to position a wiper, attached to the output shaft, to any one of eight contacts. Four of these contacts would be touched when the signal stops, and four would require that the signal be held to establish the circuit. It is doubtful that this arrangement would be used for control of both auxiliary functions and steering. It would be used for one or the other.

A delay relay circuit can be incorporated into the common lead to all of the off-signal positions. This relay would be energized with the

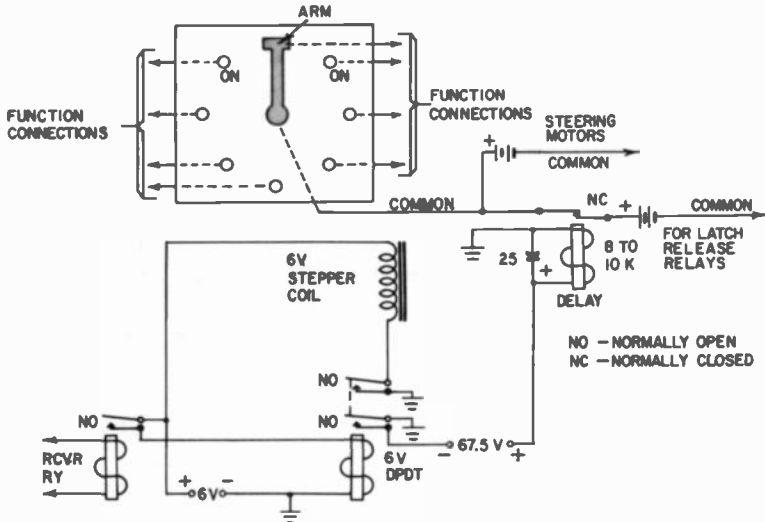

Fig. 1116. An eight-position wiper arrangement which can be used with a compound escapement.

first signal and would hold the common lead open for a longer time than that required to pulse the wiper from one position to another. In this case, one would not energize any of the off-signal contacts unless the wiper were positioned on one and left there.

You could then use the off-signal contacts to energize latching relays to control the forward, reverse, start and stop functions of a drive motor, and the signal-on contacts for steering using a motor-driven servo. The motor type servo should be self-neutralizing. Thus, the momentary connection made to the nondesired position would not have a detrimental effect on steering. The wiper would remain on either the left or right ON contact and cause sufficient movement to turn the model (Fig. 1116). The receiver relay would energize a 6-volt, double-pole double-throw relay which would, in turn, activate the escapement coil and delay relay. This is necessary to isolate the delay and escapement circuits from each other.



## Homing type escapement switch

An escapement which will always return to starting neutral when the signal stops prevents confusion since, in this case, one pulse held on would always mean the same command; two pulses, the second held on, would mean a second command, etc. Such an escapement, used as a switch, is shown in Fig. 1117.

The armature is equipped with a contact which is closed whenever it is in the no-signal position. This contact is connected to three of

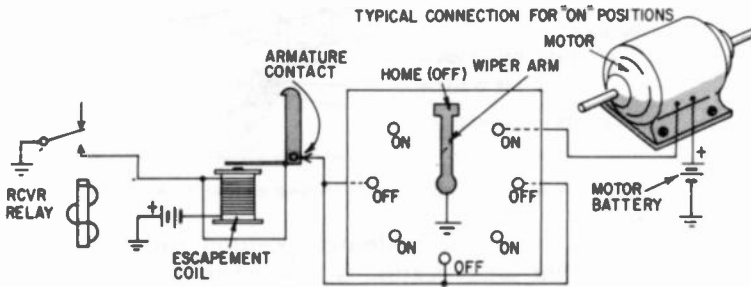

Fig. 1117. A multiposition homing switch.

four neutral positions. When a single pulse is transmitted and held, the wiper steps to the first ON contact and remains there as long as the signal is present. When the signal stops, the wiper steps to the first OFF contact position and completes the circuit to the escapement

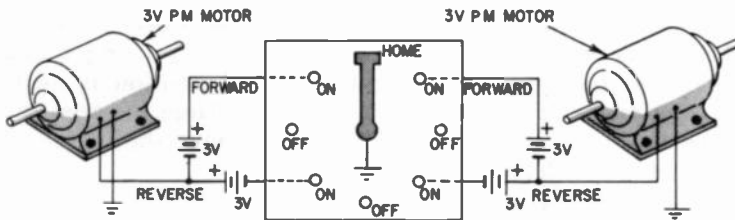

Fig. 1118. Self-neutralizing arrangement uses servo motors.

coil which pulls down the armature. The wiper moves to the second ON position, but now the escapement coil is energized again and the wiper moves again. In this manner it steps around to the original neutral where it stops since all of the circuits are open.

When using this type of switch the controller must release and depress the keyer quickly to obtain a given ON position.

Two self-neutralizing servos could be used with this circuit so that the momentary connection as the wiper passes a contact will not have a detrimental effect. Fig. 1118 illustrates one method which can be used.

If the output is connected via a crank and linkage to a rudder and

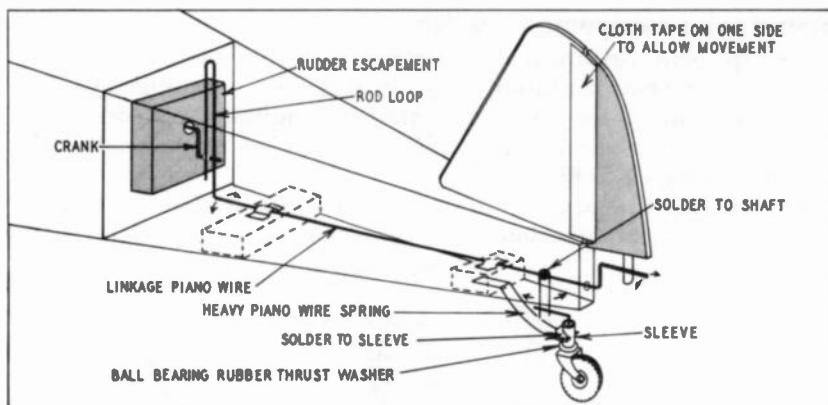

Fig. 1119. Using an escapement to provide ground control of a model plane.

elevator, the dwell time in the undesired position will be too short to affect the model. The safety feature is that, when in doubt, one can stop signaling and all the controls will return to neutral. Then one can send the proper number of signals to produce a particular response. Make sure that the wiper makes positive contact and is not affected by vibration.

### Escapement-controlled steerable tail wheel

In many model aircraft applications it is desirable have control while the model is still on the ground and moving very slowly. To accomplish this some form of steerable tail or nose wheel is necessary. Fig. 1119 shows one method of ground control using a simple escapement. With a compound escapement the third position is used for high or low motor speed. When the model is large, a servo motor should be used to provide enough power to move the wheel while the weight of the model is on it.

### Coders for use with escapements

The problem of remembering the proper sequence of signals when using escapement decoders can be hazardous. Therefore, the next step in a good control system is to design or build a coder which will automatically send the proper sequence of signals, thereby reducing the control operation to the simple task of pushing a lever, turning a wheel or closing a switch to obtain any particular response. One of the simplest types of coders for simple or multi-arm escapements is that shown in Fig. 1120.

Three cams can be used, corresponding to the escapement in the model. The microswitch is used to obtain the initial synchronization so that, with the control crank at OFF, the escapement will be positioned at a starting neutral. Always remember to turn the crank in the same direction, moving it around to the desired function and then

continuing the rotation back to the starting point when the command is no longer desired.

Also remember what the last command position is, as far as model response is concerned. If the coder and decoder get out of synchronization while the model is in operation, the coder crank can be put in the starting position and the microswitch button used to pulse the escape-

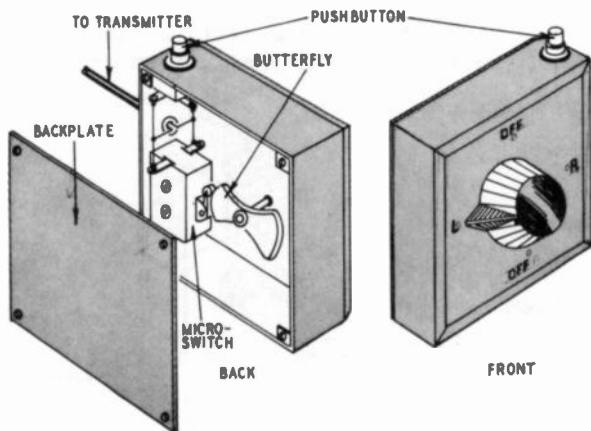

Fig. 1120. A simple coder for use with multiposition or simple escapements: (above) construction; (below) various cams used in the unit.



ment to the last command position. This will usually be an on-signal position, so releasing the button at this point re-establishes synchronization.

The details of another ground coder are shown in Figs. 1121-a,b,c. The direction of rotation of the steering wheel on the coder is not critical. The controller merely turns it to the desired operation as often as necessary. A second advantage is that the rate at which the sequences are transmitted is always the same. This allows the speed of the sequence transmission to be set for the most reliable operation.

The coder consists of a drum which has solid pins set into its surface and a set of tabs at one end to activate a microswitch as the drum rotates. The shaft through the drum is driven by a small electric motor, geared down to about 1 revolution every 3 or 4 seconds, or a small spring-wound motor and gear section. The motor used may slightly alter the mechanical construction of the unit.

When using a spring-wound motor, the drum should be rigidly at-

tached to the shaft. When an electric motor is used, the drum can be loose on the shaft so that it can continue to rotate when the drum is stopped by the slide finger and pins. This prevents a stalled motor and subsequent high current drain which shortens battery life.

When the slide finger is moved, the drum should rotate with the shaft and have enough power to move the tabs against the microswitch. This is accomplished by a small friction clutch which can be attached to one end of the shaft (Fig. 1121-b). The drum is mounted between a fixed washer soldered to the shaft on one side and a free

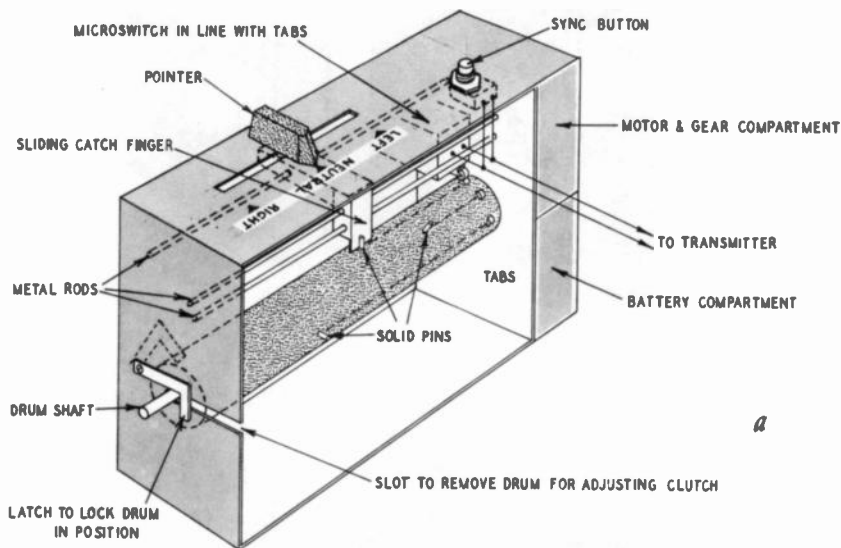
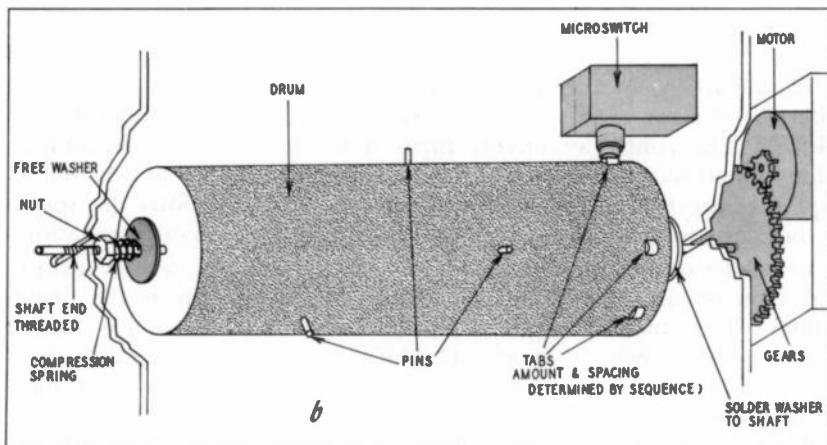

Fig. 1121. A motor-driven coder makes the control of complex functions easy:  
 a) exploded view of the unit; b) details of the clutch mechanism;



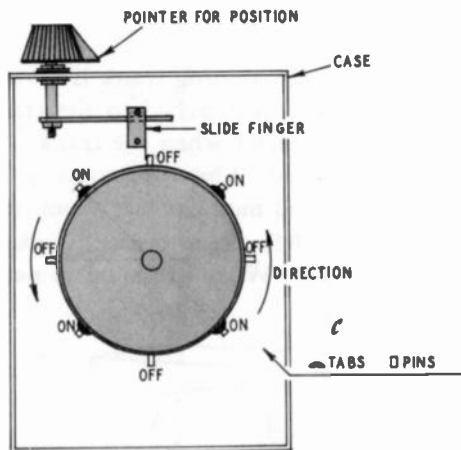

Fig. 1121 (continued). *c* end view of the roller showing alignment of the pins and tabs.

washer, made of a material such as hard rubber, on the other side. The free washer is tightened against the drum by a nut and a small compression spring.

Above the drum and across the box are two small metal rods (Fig. 1121-a). A small U-shaped catch finger is mounted on the rods so that it can slide back and forth as the steering wheel is rotated from left to right. The microswitch is located at the tab end of the drum.

The pins on the surface of the drum are positioned in relation to the tabs so that the drum may be stopped after any signal sequence. The simplest would be a sequence for a standard escapement where the code is OFF for neutral, ON for left, OFF for neutral and ON for right. This would require two tabs and three pins. The center pin (neutral position of the steering wheel) would not have a tab in line with it. Left would have a pin in line with a tab. After a space, there would be another tab with a pin in line with it for right.

Any sequence can be set up by locating the proper number of pins on the left or right half of the drum to correspond to left or right steering positions. An example of a drum set up for a complicated signal sequence is shown in cross-section in Fig. 1121-c.

If the coder is used for other than steering functions, then the selection wheel would normally start at one end and be moved to the opposite extreme of rotation, selecting functions as it was moved.

The pointer of the selection wheel should have a small spring-loaded pin set into it so that it will click into small indentations on the box surface as the various command positions are reached. This allows accurate positioning of the slider and selection by feel.

## A motorless beep box

A modified arrangement of the rotating crank is shown in Fig. 1122. The finger, a piano wire pluck, is attached to the crankshaft on the inside of the case. It closes contact 1 when the crank is rotated to the extreme right and holds it closed. When the crank is moved back to neutral, it breaks this contact and momentarily closes contact 2.

Rotating the crank to the left closes contact 3 momentarily and then closes and holds contact 4. When returned to neutral from this

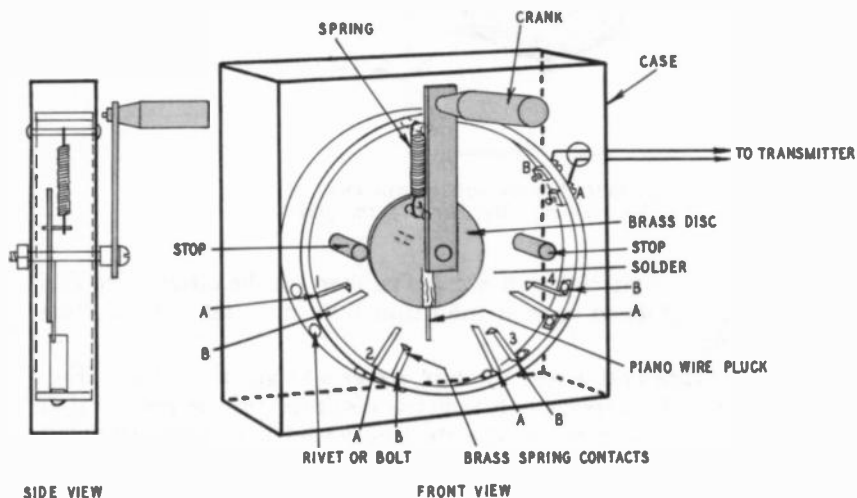

Fig. 1122. A motorless beep box for use with simple or compound escapements.

position, it opens contact 4 and no further contacts are closed. The spring helps return the crank to neutral.

This is the correct sequence for operating a standard simple escapement. It is necessary to synchronize the escapement with the beep before using it. A microswitch connected across terminals A and B to the transmitter will allow this to be done before the model is in operation.

Bend contacts 2 and 3 of Fig. 1122 slightly to the left so the finger can ride over them easily without catching or bouncing. A spot of silver can be soldered to the contacts at the point where the movable and fixed portions touch.

This unit can be used to operate a compound escapement of the one-, two- and three-pulse variety by eliminating the set of contacts marked 2. Only the one- and two-pulse code can be transmitted with the crank but a left or right rotation of the crank will correspond to the direction of steering. The three-pulse code would have to be transmitted by the synchronizing microswitch.

## Motor-driven coders

A motor-driven coder which will produce the correct pulse sequence when a lever switch is moved to the left or right is illustrated in Fig. 1123. This coder uses cams to close a microswitch when a small PM motor drives the shaft through a stepdown gear train.

When the lever switch is in neutral, the circuit to cam contact switch 1 is closed. However, since the cam is in the rest position with the flat side presented to the contact switch, the switch is open and the relay is not energized so the motor does not run. The butterfly cam which operates the microswitch is open and no signal is transmitted.

If the lever switch is moved to the left, the circuit to the relay is completed through contact 1 and cam switch 3. Since the cam closes its contact switch, the relay is activated and power is applied to the motor. The output shaft is turned until the circuit is broken by the flat of cam 3. This constitutes a 90° rotation and the butterfly cam, now closing the microswitch, causes a signal to be transmitted. Consequently, a simple escapement in the model would move to the first position.

When the lever switch is returned to neutral, the circuit to cam

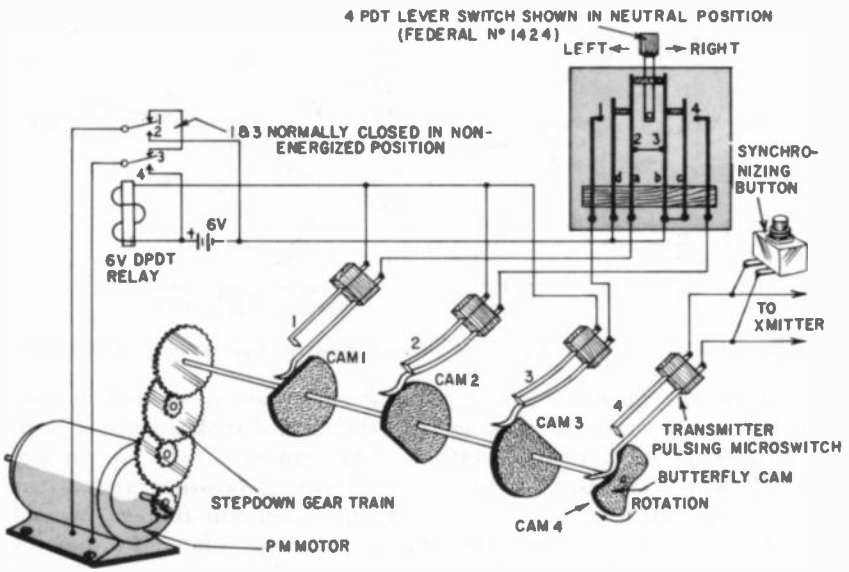

Fig. 1123. Motor-driven pulse-sequence coder.

switch 3 is opened but the circuit to cam switch 1 is closed. This switch, in turn, is closed by the round of the cam and the motor runs until the flat side allows the switch to open. The butterfly, when this action takes place, will have turned through 270°, opening, then clos-

ing, then opening the circuit to the transmitter. This action causes the simple escapement to return to its original neutral.

Another arrangement which shows the multiswitch control and a cam suitable for controlling an eight-position escapement selector switch is shown in Fig. 1124.

This unit uses a different method of construction but its basic operation is similar. The normal or resting position of the coder arm Z is at point O. The neutral positions of the single-pole double-throw switches are located so that the common line A is connected to each of contacts 1, 2, 3, 4, 5, 6 and 7.

When contact 3 is pushed over against common line B, the motor turns in a forward direction, since the circuit is now complete through

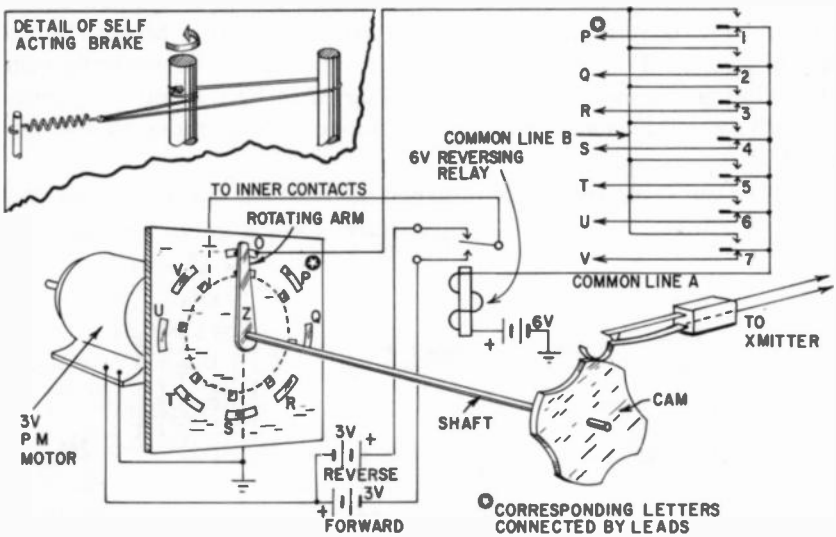

Fig. 1124. Multiswitch coder which can be used with an eight-position escapement.

O and ground. Since the bar segments P and Q are connected to common line A, the arm, in passing over them, still makes contact with the battery, giving forward rotation. The arm now rides up on segment R, which corresponds to the third switch position and is the desired stop point. If key 3 is held against common line B, contact R is not connected to any point except ground. The motor-battery circuit is broken and the motor is no longer driven forward. While the motor moves, the relay energizes and holds open the battery connection to the motor-reversing contacts. As soon as the forward rotation of the motor stops, the relay de-energizes and, when the circuit is completed by arm Z, the motor reverses. The segments are small and, as the arm hits, it reverses and backs off far enough to break the contact although, due to the self-acting brake, it cannot get back to



the small segment located near forward bar Q. Thus the arm rapidly travels around to R, reverses and stops, still in contact with R, whose circuit is broken by switch 3.

If contact 3 is closed by allowing the switch to return to its normal position, the circuit is again completed through segment R. The

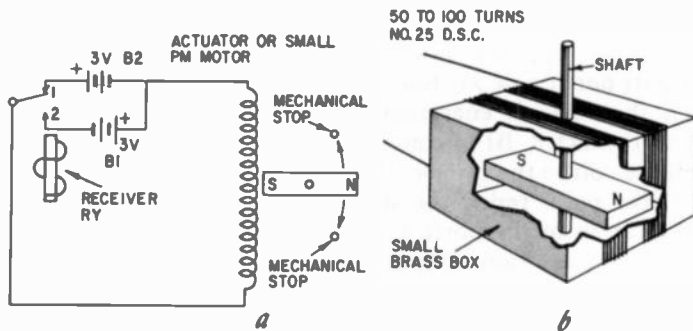

Fig. 1125. *A pulse-width-pulse-space decoder; a) relay, coil and bar magnet form the complete unit; b) construction details of the actuator.*

motor will run in a forward direction and the relay breaks all reversing connections. When the arm finally comes around to O (this contact is connected to common line B), all of the switches are disconnected from common line B. The forward circuit of the motor is broken, the relay is de-energized, the reverse segments became "hot" and the arm stops on segment O. It is then ready to move from this position when another switch is depressed.

The rotating arm Z is geared to the motor. The shaft which is attached to the rotating arm is also attached to a pulsing disc. Thus, as the arm rotates, the disc rotates, triggering the right number of pulses to make the stepper decoder move (in the case illustrated) to its No. 3 contact. When contact 3 of the coder is returned to normal, the right sequence is transmitted to make the wiper arm return to its starting position.

The self-acting brake consists of a string wrapped around the shaft so that, when it turns in the reverse direction, the string tightens. The increased friction acts like a brake. When the shaft moves in the forward direction, it tends to unwind the string and can move easily. The spring can be adjusted to produce the correct amount of tension for proper braking action.

### **Pulse-width-pulse-space and pulse-rate decoders**

The following two units make use of the pulse-width-pulse-space code for steering purposes and a variation of the pulse-rate code to effect secondary control.

In the schematic of Fig. 1125 a coil of wire is placed at right angles to and around a permanent bar magnet which is free to pivot about its center. The ends of the coil are connected to the junction of two small batteries and to the relay armature.

With the bar magnet positioned as shown, when the relay armature is in contact with 1, current flows through the coil so that the magnetic field about it is polarized with north at the top and south at the bottom. Since opposite poles attract, the bar magnet will rotate, bringing its north pole as close to the coil's south pole as possible.

When the relay is energized so that the armature completes the circuit to contact 2, B1 is connected across the coil and current flows through the coil in the reverse direction.

Since like poles repel, the north pole of the bar magnet will be pushed away from the north pole of the coil. The bar magnet rotates to the neutral position. But the pull of the coil's south pole on its north pole makes it continue to rotate another  $90^\circ$  so that it is aligned as near the poles as possible. The rotation of the bar magnet has been from one extreme to another, a full  $180^\circ$ .

When the pulse width and spacing are equal, the relay armature vibrates rapidly from one contact to another. Since the bar magnet cannot follow this rapid movement, it remains at the center position, swinging just slightly from one side to the other.

If the pulses were made longer, the armature would, let us say, spend more time on contact 1 than on 2. The magnet, then, would be pulled slightly more in the down direction than the up and would gradually drift toward the full down position. The direction of the bar magnet would be reversed if the spacing were made longer than the width.

If the shaft through the pivot point of the bar magnet were rigidly attached to the bar magnet, a small lever attached to one end, and this lever connected through a linkage to the rudder of a model, the rudder would move as the magnet rotated. This is the basic principle of the pulse-width-pulse-space decoder.

A combination decoder using pulse-width spacing and rate is illustrated in Fig. 1126. One end of the actuator coil is connected to the battery junction through the voice coil of a small push-pull plates-to-voice-coil transformer. (Any small transformer may be used which has a 2-6-ohm secondary and a high-resistance primary. The primary is connected through a bridge-rectifier circuit to the second relay and its shunt capacitor.)

When slow pulses are transmitted, regardless of the width or spacing they pass through the secondary of the transformer, are stepped up in the primary, rectified and applied to the relay and capacitor. However, the average current available through the relay windings is too small, because of the low pulse rate, to energize the relay. Thus the width and spacing of the pulses may be varied to effect steering by the actuator, and no secondary function will be performed.

When the *pulse rate* increases, the average current to RY2 increases and this relay closes, activating the second function, which might be motor control. Steering is accomplished in the same manner as before although the rate has been increased.

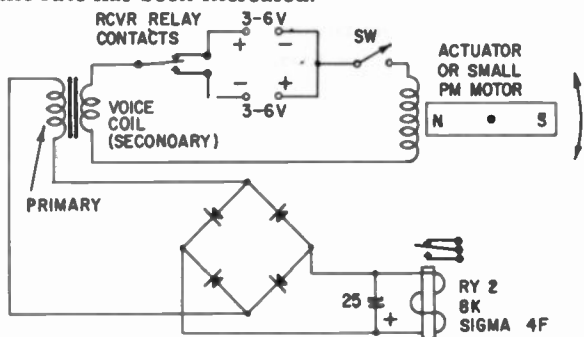

Fig. 1126. An increased pulse rate activates the secondary circuit of this decoder.

With this circuit, then, a low pulse rate means no secondary function and a high pulse rate will cause the secondary function to operate.

If a slow pulse rate is used, the rudder will move quite a distance from side to side. This means that in a model plane there will be

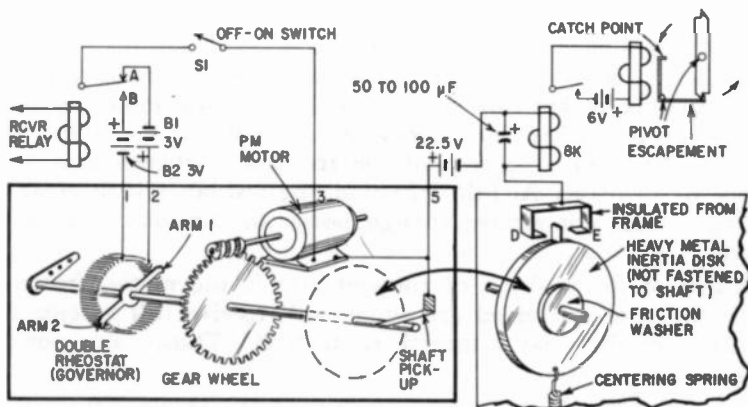

Fig. 1127. A motor-activated decoder in which a decreased pulse rate triggers the secondary circuit. If shaft A moves fast, the inertia of wheel 1 is too great to allow rotation to make contact at D or E in spite of friction of wheel 2. If shaft A moves slowly, the friction is great enough and acceleration slow enough to cause wheel 1 to oscillate, moving contact to D or E. Since wheels 1 and 2 are metal, the circuit is complete through wheel 1, the shaft and the wiper to the battery.

excessive drag, making it necessary to use more power. Also, when using this simple actuator you cannot move the control stick slightly to one side, causing a slight variation of pulse width and spacing, and expect the model to turn gently. Because the actuator drifts, it will continue to move toward one extreme, increasing the amount of turn.

In actual steering, then, deflect the control lever until the desired amount of turn is obtained and then restore the lever to neutral. The actuator will try to hold this gentle-turn position.

Some degree of proportional control results because of aerodynamic compensation. Deflecting the rudder more in one direction than the other requires a little more force than when it spends an equal amount of time on each side.

Another pulse-width-pulse-rate decoder compensates for drift and is so designed that the secondary function will be operated when the pulse rate is *reduced* instead of increased.

The Fenners-Pike servo unit (Fig. 1127) uses an electric motor for steering and an inertia ring for secondary control. A double rheostat reduces the current to the motor as rotation approaches either extreme, thus greatly reducing or eliminating the drift effect.

The connections to the two batteries and the relay armature are similar to the previous circuit except that the battery terminals connect to the double rheostat and the circuit is completed to one side of the motor winding through the metal shaft which is fastened to the rheostat arms, the reduction gear and the inertia contact.

The motor, a small PM type, operates exactly like the actuator except that it has more power. Slight oscillations of the armature are damped by the gear reduction unit, which also increases the amount of power available to the output linkage.

If switch S1 is turned on but the receiver is not receiving pulses, the relay armature makes contact with A, causing the motor to rotate, turning the gear wheel in a clockwise direction. As the wheel turns, it moves the rheostat arms and the resistance between arm 1 and battery B1 increases. At full deflection, the resistance is so great that the motor does not receive enough power to continue turning and it stops.

Because of the position of rheostat arm 2, the motor (when the pulses and spaces received are equal) will receive full voltage from B2 whenever the relay armature contacts B. Thus, more power is

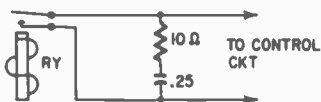

Fig. 1128. The spark-suppression filter increases relay life and helps prevent chatter.

supplied to the motor when it rotates in a direction opposite to that caused when the switch is closed. The motor continues to turn, bringing the linkage toward neutral, moving rheostat arm 2 down and arm 1 up. When the two arms are positioned so that the resistances between each and its battery are the same, the motor will try to turn in one direction as well as the other. Because of the gear-reduction unit, no movement of the output linkage will take place.

If the pulse width is made greater than the spacing, the motor

drifts and the gear wheel rotates counterclockwise, moving rheostat arm 2 down, increasing the resistance between B2 and ground until this difference is compensated. The motor then oscillates about this position as long as the particular width-space code is maintained. When equal pulses and spaces are transmitted again, the motor rotates to cause the linkage to seek neutral.

If the pulse rate is fast, the inertia contact cannot follow the pulses and so does not touch the silver contacts. But if the pulse rate is slowed, the inertia wheel begins to swing and touches first one and then the other ring contact. If a delayed-opening relay is connected to terminals 4 and 5 as shown, the capacitor will hold the relay closed

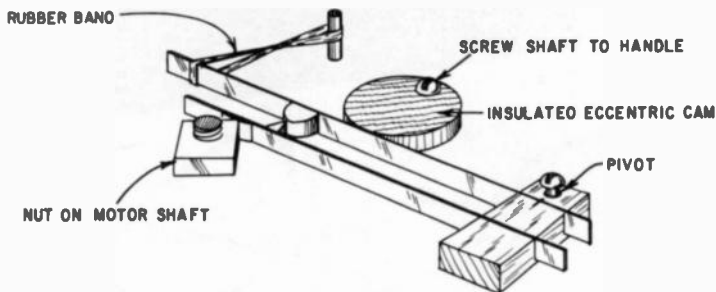

Fig. 1129. This pulse-variation coder produces long pulses (short spaces) or short pulses (long spaces). The eccentric cam controls pulse duration.

during the break time as the inertia contact swings back and forth. Thus, the secondary circuit is operated continuously as long as the code is maintained.

Proportional control is obtained since a small deflection of the control lever causes a slight deflection of the linkage and therefore the steering element.

The fast rate for normal steering means less oscillation of the output member and thus less drag. High power capability results from the use of the motor and gear train.

When using these decoders, the fact that the relay must make and break a relatively high current source many times a second causes arcing across the relay point. One solution to this problem is the use of a spark suppression filter (Fig. 1128). It is a good idea to examine the relay frequently and keep the contacts clean and smooth for trouble-free operation.

### Pulse-width-space-rate coder

When a decoder is available for use with this type of code, the next step is to acquire the coder which (when connected to the transmitter) will send out the required code. Such a unit is illustrated in Fig. 1129. It is simply a small PM motor geared down so that it turns

an output shaft about 15 revolutions per minute with normal battery voltage. A small four-point metal contact (a large square nut with rounded corners) is placed on the shaft.

On the motor frame and pivoted so that it can be closed by moving it against the nut is a set of contacts. These are arranged so that by turning a screw or moving a lever the contacts are moved down or away from the nut corners. When the nut is rotating, if the contacts are moved closer, they are closed sooner and remain closed longer; thus a long pulse with short spacing results. If they are moved away, just the tip of the nut closes them and a series of short pulses with

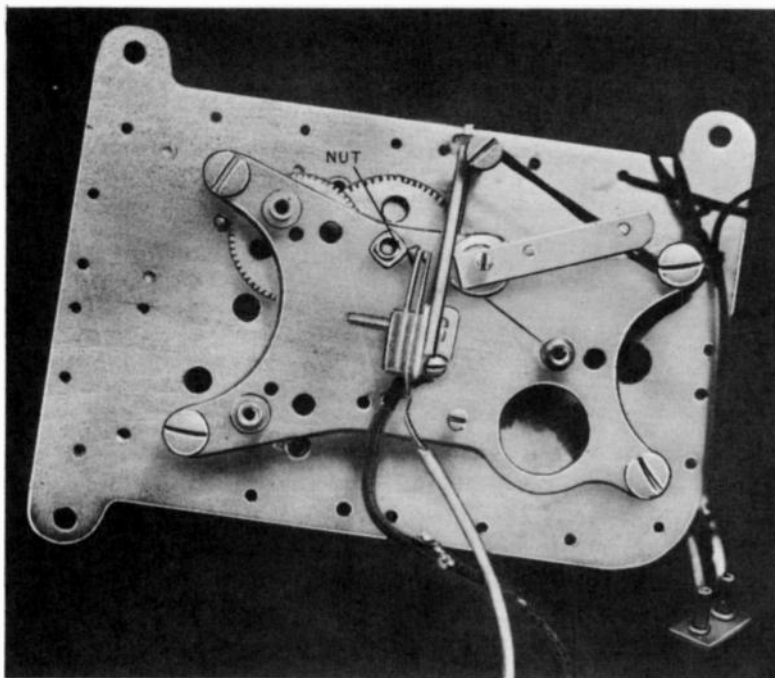

*Fig. 1130. The tip of the nut closes the switch contacts of this pulse-variation unit.*

long spacing results. There will be a point between these two extremes where equal pulses and spaces will be transmitted.

If a small battery is connected so that it can be placed in series with the motor battery by a switch, then closing this switch will increase the pulse rate. Conversely, opening the switch will decrease the pulse rate. This switch could be used to control a secondary function.

A single battery could be used with a low-value variable resistance in series with it to the motor. The resistance could be set for the pulse rate desired, and a switch could be wired to short the resistance when closed. Fig. 1130 pictures one method of constructing this coder.

## Second-function control

In some applications—a model boat or car—it is desirable to have a means of starting or stopping the drive motor without having to change the pulse rate. A circuit which will close the drive motor circuit whenever pulses are present and which will allow steering is shown in Fig. 1131.

The receiver relay contacts are connected to the pulse-width steering circuit and the delay relay which starts and stops the drive motor. With pulses coming into the receiver, the receiver relay armature is on contact 2. The delay relay is closed but it is also held closed during the time that the receiver is de-energized (during the pulse space) by the 20- $\mu$ f capacitor. When the delay relay closes, it connects the drive motor to the battery (through contact 3) and also closes the steering

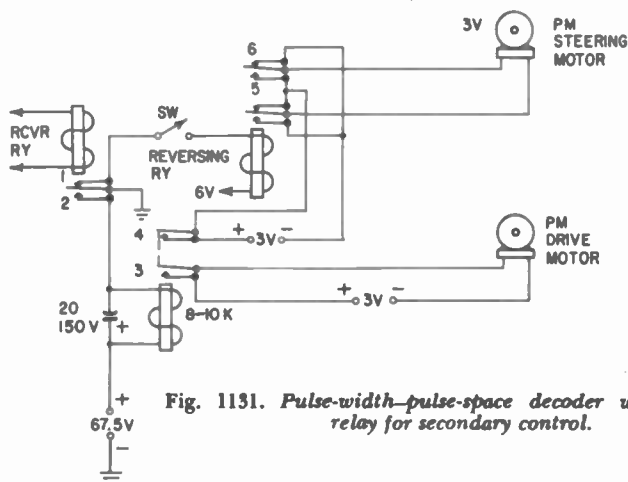

Fig. 1131. Pulse-width-pulse-space decoder with a delay relay for secondary control.

circuit through contact 4 and also through the armature of the small reversing relay (contact 6) connected to the steering motor.

The reversing relay closes every time the receiver relay armature completes its circuit through contact 1. When this happens, the direction of current flow through the steering motor is reversed. Thus, the action of decoding pulse width and spacing is accomplished.

If the pulsing action is stopped by opening a switch in the transmitter lead to the coder, the delay relay will open after a momentary pause and the drive motor will stop. Although the delay relay opens the circuit to the steering motor, the battery will still be connected to the reversing relay since the receiver relay armature will rest on contact 1. It is therefore necessary that the controller open switch SW to prevent the battery from running down if the model is stopped for any length of time.

Fig. 1132 illustrates the mechanics of connecting a decoder to the steering wheels of a model car and the electrical connections necessary

for steering and control of the drive motor. A model boat rudder could be substituted for the steering wheels.

### Decoder for fixed pulse width

A pulse-width decoder which will operate one function when a fixed-length wide pulse is received and another when a fixed-value narrow pulse is received is illustrated in Fig. 1133.

The decoder consists of three 5,000–10,000-ohm relays and capacitors. When any type of continuous pulse is received, the receiver relay closes, energizing RY1. This starts the drive motor and connects the steering circuit to ground. These connections remain closed as long as pulses are received.

If only short pulses are transmitted, delay relay RY2 will close and

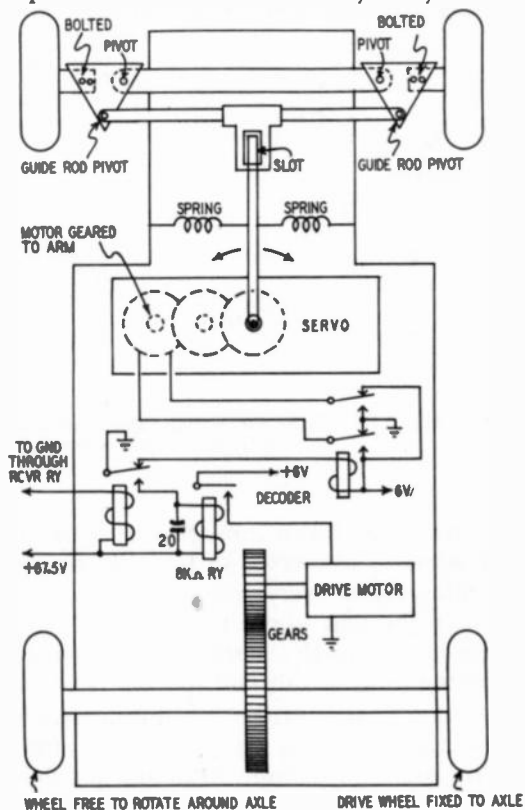

Fig. 1132. Delay decoder used in a model car.

hold closed, energizing the steering motor so that it turns in one direction. RY3 will not close with short pulses since the capacitor across it cannot charge in a short length of time. If long spaces are transmitted, the receiver relay armature spends a long enough time on the



upper, or back, contact (contact 1) so that both RY2 and RY3 are activated. This connects the second battery (B2) into the motor circuit so that the steering motor reverses direction.

If a continuous signal is received, the receiver relay, when energized, makes contact only to the drive motor relay. Thus, after a short time interval, RY2 and RY3 will be de-activated, completing the neutral connection to the steering servo and causing it to move the rudder or steering wheels to the neutral position.

The sequence of operation for control of the model is: Turn on the transmitter carrier (or tone) to start the drive motor. Pulse the

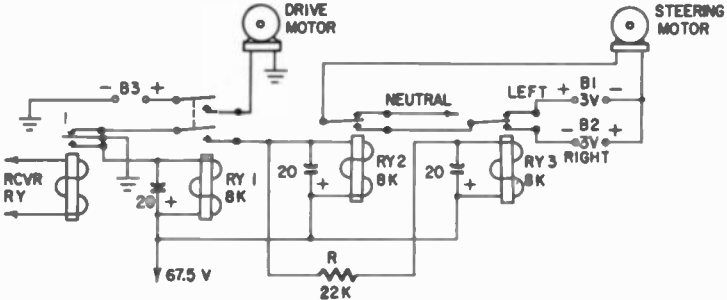

Fig. 1133. Fixed pulse-width decoder.

carrier (or tone) by a coder which causes short pulses to be transmitted for steering in one direction and long pulses for steering in the op-

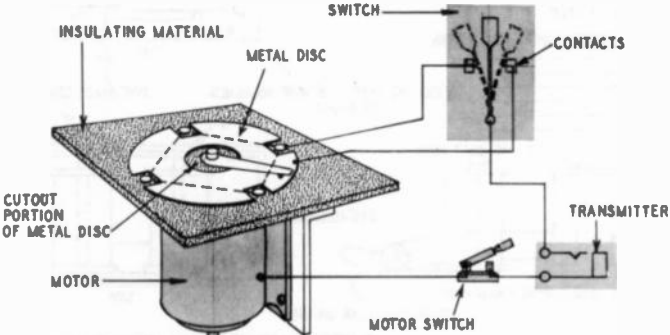

Fig. 1134. Fixed pulse-width coder for use with the type of system shown in Fig. 1133.

posite direction. A self-neutralizing servo with limit switches should be used in the steering section.

The coder for this system consists of a small dc motor geared down so that it will turn a contact arm at about 12 rpm. A set of contacts is arranged on the motor frame as in Fig. 1134.

When one set of contacts is opened by moving the control switch in

one direction, short pulses are transmitted. When the control switch is moved in the opposite direction, long pulses are sent. With the

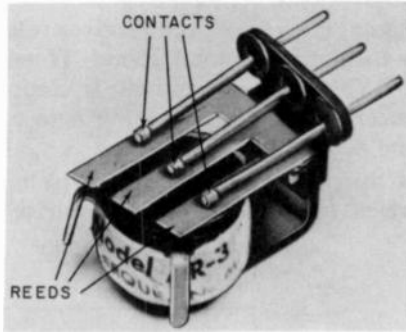

Fig. 1135. A commercial resonant reed decoder.

switch in neutral, a continuous carrier (or tone) is transmitted which may be cut off by opening the motor switch.

### Resonant-reed decoder

Specifically designed for use in model aircraft, this decoder is a

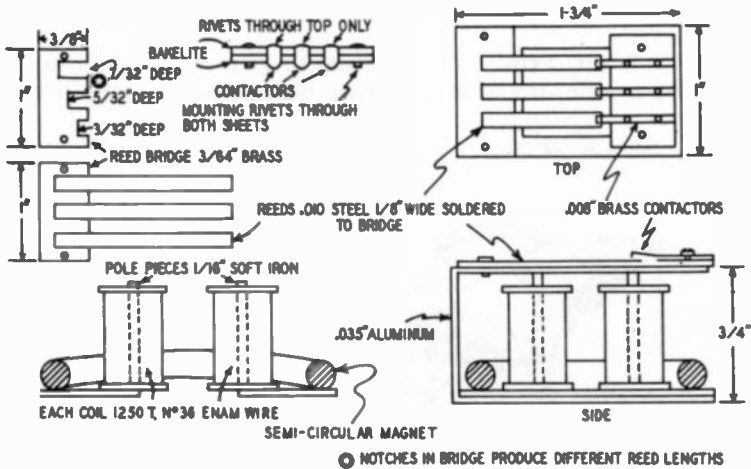

Fig. 1136. Construction details of a typical reed unit.

resonant-reed frequency-selective device. Fig. 1135 shows a commercial unit using three reeds.

Fig. 1136 illustrates the construction of such a device. The three reeds are secured at one end to a bridge. Although the reeds shown are identical, notches in the bridge give the effect of different reed lengths. Only one particular tone can make a reed vibrate sufficiently

to touch the contactor located above it. The vibration rapidly opens and closes a circuit through the reed and contactor, and can be made to hold a sensitive relay closed as long as the vibration continues.

As each tone is transmitted, the reed corresponding to that tone vibrates, closing the sensitive delay relay connected to it. Either servomotors or relays may be connected to the sensitive relay.

One way to adjust a resonant reed unit is to use an audio oscillator. The output of the oscillator is connected to the coil of the decoder. A connection is then made from each reed to one side of a flashlight bulb. The other side of each bulb is connected to a battery and the other side of the battery to the terminal contact which the reed strikes when it vibrates.

The amplitude of the audio oscillator is set rather high and the frequency slowly varied. As the resonant frequency of each reed is approached, it will vibrate, causing the light to glow. The amplitude of the output is reduced until only a very exact frequency will cause

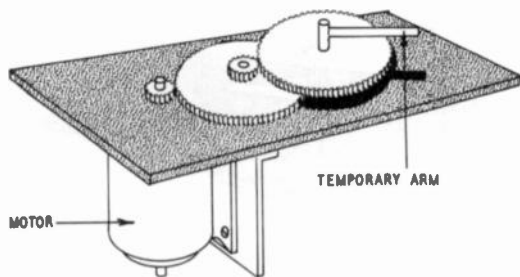

*Fig. 1137. First step in constructing a numerical-sequence decoder is to mount a small motor and gears on a plate.*

the light to glow. The frequency of each reed can be determined in this manner.

### **Numerical-sequence coder and decoder**

When controlling a model car or boat where weight is not one of the limiting factors, the more functions that can be performed, the greater the pleasure of operation. The numerical coder and decoder to be described will permit control of 16 operations and, although designed for use in a model boat, it can be used in other models.

Steering, because it must be instantaneous and absolutely reliable, will be controlled by two separate tone channels, one for left and one for right rudder. The rudder servo will be self-neutralizing. All other functions will be controlled through a third tone channel pulsed with a numerical-sequence code.

Steering functions will not be discussed here; they can be determined from other parts of the text. We will consider only the third

channel and the coder and decoder necessary to perform the following functions:

1. Motor on, cruising.
2. Full speed.
3. Reverse, full or half-speed.
4. Stop.
5. From full to half-speed.
6. Lifeboat down.
7. Lifeboat up.
8. Cabin and searchlights on.
9. Cabin and searchlight off, running and below-deck lights on.
10. Anchor winch down.
11. Anchor winch up.

The numbers preceding the actions listed do not indicate the number of pulses required to cause the particular command to be performed.

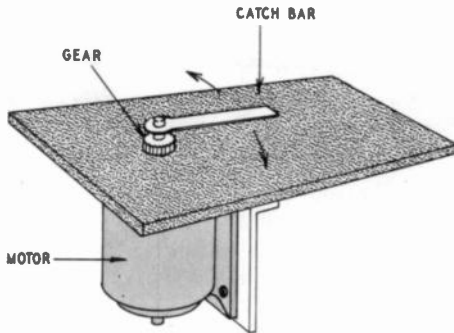

Fig. 1138. Mounting a catch bar on the motor shaft.

The decoder must have some sort of arm which can be stepped over a set of 10 contacts when the pulses are received. It must not energize any contact except that pertaining to a particular command and, after it does energize a circuit connected to this contact, it must automatically return to the starting position. The coder must be a device capable of transmitting at least a 10-pulse sequence, with equal spacing between pulses of equal length.

The coder used is a simple telephone dial. It is spring-powered, has a governor and a cam which can be made to close a set of contacts. (Normally the dial will open a set of contacts.) It also provides a simple and reliable way of determining the number of pulses to be transmitted by selecting the finger hole corresponding to the command sequence.

A telephone dial, as procured, will produce two pulses for the first position, three for the second, etc., hence it must be modified to produce the proper sequence.

The first step is to change the contacts on the back of the dial so that they close instead of open when operated by the cam. Drill a large finger hole below the No. 1 hole, halfway between it and the stop. This will correct the sequence so that pulses are transmitted in proper order. The dial can be used for transmitting an 11-pulse

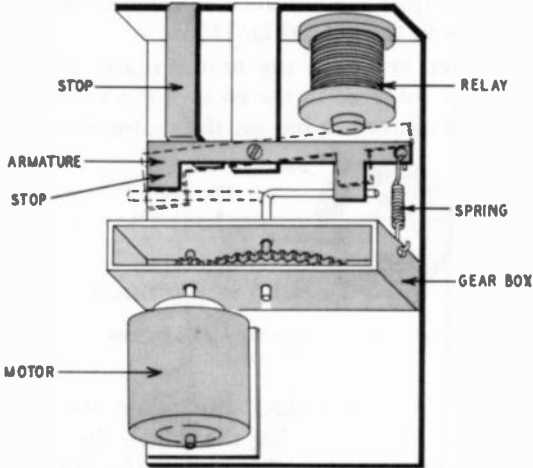

Fig. 1139. A relay is mounted above the motor to check rotation by engaging the catch bar.

sequence, one pulse more than is necessary. The speed may be adjusted by bending the springs of the centrifugal governor if transmission is too fast or slow.

With this system a decoder is necessary. If a commercial unit cannot

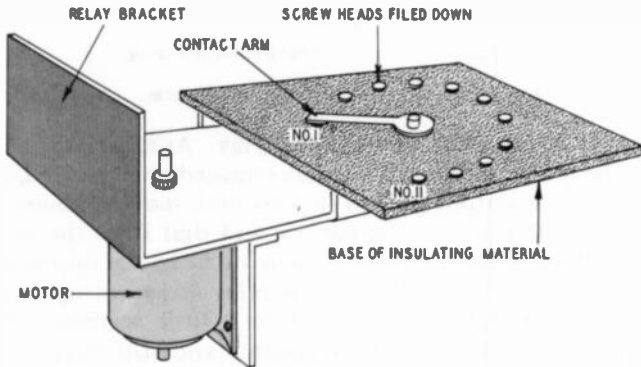

Fig. 1140. Insulated contact-plate mounting.

be purchased that will meet the requirements, a power-driven stepper can be easily constructed.

Procure a *small* 6-volt PM motor and mount it on a plate (Fig.

1137). Add small gears so that the output shaft will turn at about 30 rpm with enough torque to move a pointer over a set of contacts. Attach an arm 2 inches long to the shaft by soldering a piece of wire to it. Turn the drive motor 1 revolution and measure the distance the arm moves at its tip. It should move at least  $\frac{3}{8}$  inch. Lengthen or shorten the arm to adjust the distance it travels. Solder a small bar to the motor shaft above the gear (Fig. 1138).

On a small bracket just over the motor place a Sigma 8,000-ohm relay with small stops soldered to the ends of the armature (Fig. 1139). The relay is adjusted above the bar on the motor shaft so that the bar

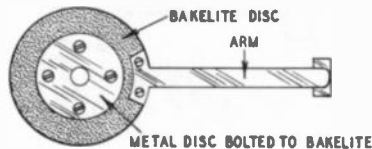

Fig. 1141. Construction of the contact arm.

catches on the low side and holds. But when the low side of the armature is pulled up (by energizing the relay), the bar can then pass beneath it and will catch on the other end of the armature. The relay armature should have at least  $\frac{1}{16}$ -inch travel at each end so that positive engagement of the bar is obtained.

To test, energize the motor in the forward direction and connect the

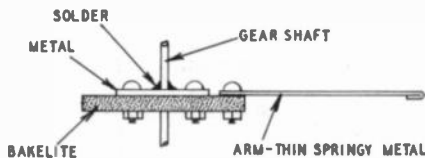

Fig. 1142. Side view of the contact arm.

dial through a battery (67.5 volts) to the relay. As the dial is operated, the arm on the motor shaft is alternately engaged and released, causing the wire arm on the output gear to step around, moving about  $\frac{3}{8}$ -inch with each pulse. Disconnect the battery and dial from the relay and reverse the battery to the motor so that it turns in the opposite direction. It should spin around, forcing the relay armature up as the bar on its shaft hits the slanted portion of each little segment. Tighten the relay spring tension as much as possible and still have it operate with every pulse.

Mount a piece of Bakelite or other insulating material on the gear housing so a series of contacts may be arranged on it which an arm driven by the last gear shaft can contact (Fig. 1140). Drill a hole in this insulated block and run the last gear shaft through it. Mount

the block in place with screws and spacers so that, when the contacts are fastened to it, they will not be shorted to the gear frame.

After the contact plate has been mounted, the best way to locate the contacts is to set the soldered arm at some starting position by rotating it backward and then pulling it forward until the bar on the motor shaft rests against the de-energized armature stop. Mark this point with a scribe or pencil. Connect the battery and dial to the relay and attach the motor battery so that the motor tries to turn in the forward position. Step the soldered arm on the output shaft around one step at a time by repeatedly dialing 1. Mark each point where the arm comes to rest.

Drill a small hole through each of these marks. Insert 6/32 screws and bolt them tightly over solder lugs placed on the underside of the plate. The plate may now have to be raised on spacers to insure that the contacts and lugs will not short out against the frame.

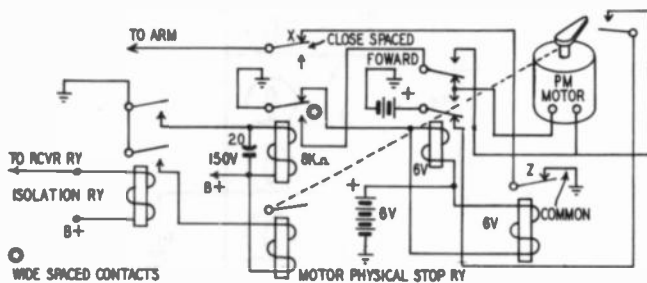

Fig. 1143. Relay system for use with the numerical-sequence decoder.

File down the heads of the screws until they present a flat contact area slightly above the plate level. Connect the dial and battery and motor battery and step the arm on the output gear around. It should stop over each contact.

The contact arm is made from three pieces of material (Fig. 1141). One is a circular metal disc, the second a disc of Bakelite or other insulating material larger than the metal disc and the third a T-shaped strip of some springy material (brass or thin steel) which is to be the arm itself. When these are bolted together as shown in Fig. 1142, the arm is complete and the unit may be slipped over the shaft of the output gear. The T portion should be bent down slightly so that, when the arm is soldered in place, the end of the T-arm rides firmly over the contacts. A small U-shaped strip of brass should be soldered to the end so the tip of the arm will ride up on the screw contacts easily. When the relay is dialed now, the arm should step to each contact and stop. The end of the arm must not short-circuit between any two contacts as it moves.

It is necessary to make two mechanical stops. These are simply

bolts passed through the last gear about 180° apart and so arranged that they make contact with another bolt attached to the frame. One is set so that the arm is stopped in the starting position (which should have no contact) and the second so that the arm is stopped when it is on the No. 10 contact. There are now 11 positions for the arm: No. 1 has no contact and the other 10 have contacts in the form of screw heads.

The arm can now be stepped around to any of the contacts, but an automatic reverse and a means whereby only the desired contact will be energized must be provided.

If the motor is activated through a delay relay, this relay will allow continuous rotation in the forward direction as long as pulses come

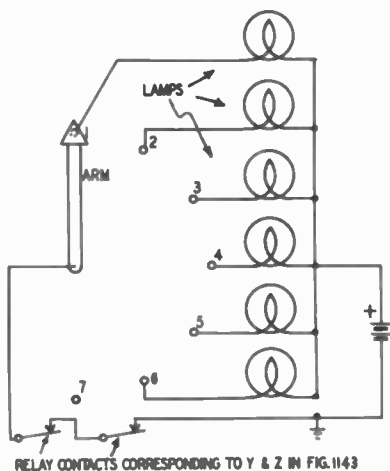

RELAY CONTACTS CORRESPONDING TO Y & Z IN FIG. 1143

Fig. 1144. Test unit for the numerical-sequence decoder.

without too great spacing and, when a long break exists, it drops out and energizes the reversing relay.

This same delay relay can also be used to prevent any but the desired circuit from being activated by opening a common line when it is energized and closing the line for an instant *before* it causes the motor-reversing relay to activate. Then a second relay in parallel with the reversing relay can hold this common line open during the reverse rotation of the motor.

Five relays are necessary: two 6-volt relays, one of which is a double-pole double-throw type; two 5,000–10,000-ohm dpdt relays capable of being operated at about 3 ma; a single Sigma 4F motor physical-stop relay. (It is possible to use two small high-resistance R–C relays wired in parallel to replace the dpdt high-resistance types.) Adjust the spacing of one set of contacts of one of the high-resistance double-pole



double-throw relays so that it closes *before* the other. The wiring diagram of the decoder is illustrated in Fig. 1143.

When pulses are transmitted, they cause both the motor physical-stop relay and the 8,000-ohm dpdt delay relay to become energized. As the delay relay is activated, it closes the circuit to the motor, which rotates in the forward direction. This same delay relay opens the common line through its second set of contacts. The arm is then stepped around to the desired position over cold contacts.

At the end of the pulse train, the dpdt delay relay de-energizes, the upper armature touches contact Y and closes the battery circuit to the common line while the contact arm is held stationary on a particular contact. A fraction of a second later the wide-spaced contacts of the relay (lower armature of the delay relay) close, activating both the motor-reversing relay and the 6-volt common-line relay. The motor relay makes the arm rotate back to the starting position, and the second 6-volt common-line relay breaks the common line again so that the contacts remain cold as the arm passes over them.

An electrical limit switch is placed at the starting point of the arm so that when the arm moves back to the starting position, this switch is opened by a second bar soldered to the output shaft. The switch

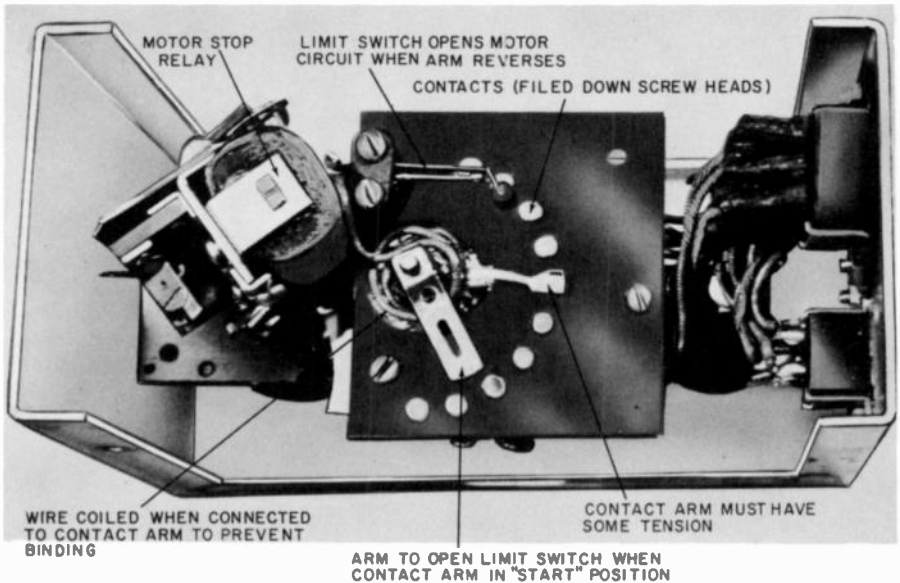

Fig. 1145. Top view of the decoder. Note the construction of the switch plate.

opens the circuit to the reversing and second common-line 6-volt relay so that the battery will not run down during the periods of no pulse transmission.

The limit switch is located near the starting position of the arm

and above it. The stepper arm is set in the starting position and the second bar is set against the limit contact to open it and is soldered to the shaft.

As a final test a series of flashlight bulbs may be connected to the contacts (Fig. 1144). Dialing various numbers causes the arm to step around, lighting the bulbs. The two relay contacts shown in series with the stepper correspond to those labeled Y and Z in Fig. 1143. They illustrate how the arm is kept from making contact with the battery when it is in motion. Fig. 1145 is a top view of the numerical-sequence decoder, showing the contact arm, motor-stop relay and the limit switch which is operated by the secondary bar attached to the top of the stepper-arm shaft. The electrical connection is made through the insulated wire coiled about the shaft, to prevent friction and possible breakage. Contact and battery connections are brought out of the case through the plugs at the right.



# Other GERNSBACK LIBRARY Books

## MODEL RADIO-CONTROL - PRICE \$2.65

- 59—SERVICING RECORD CHANGERS. Detailed drawings show how to make repairs. Full servicing information. 224 pages. \$2.90
- 60—RAPID TV REPAIR. Alphabetical listing of hundreds of TV troubles—symptoms and specific information on repair. 224 pages. \$2.90
- 61—TRANSISTOR TECHNIQUES. How to work with and test transistors; measurements; practical building projects. 96 pages. \$1.50
- 65—SERVICING COLOR TV. How to repair color receivers. Illustrated with photos, drawings and troubleshooting charts. 224 pages. \$2.90
- 70—ELECTRONIC PUZZLES AND GAMES. Build and design them. Dozens of projects which need no special parts or tools. 128 pages. \$1.95
- 75—TRANSISTORS—THEORY and PRACTICE. Theory equivalent circuits, amplifiers, oscillators, tests and procedures. 224 pages. \$2.90
- 76—SERVICING TRANSISTOR RADIOS. Fundamentals, types of construction, testing, stage-by-stage servicing procedures. 224 pages. \$2.90
- 78—RAPID RADIO REPAIR. Fix radios quickly and easily. Separate sections deal with receiver types, servicing techniques, troubles. 224 pages. \$2.90
- 79—DESIGNING & BUILDING HI-FI FURNITURE. Fundamentals of design, woods, tools, finishing, polishing and retouching, styling. 224 pages. \$2.90
- 81—PRINTED CIRCUITS. Designing and making printed circuits, repairs, subminiaturization, applications. 224 pages. \$2.90
- 93—RADIO CONTROL HANDBOOK (revised). Build-it-actuators, servos and radio devices to remote control model boats, planes, vehicles. 304 pages. \$4.95
- 95—NEW SHORTCUTS TO TV SERVICING. (2 vols.) No theory — no math tests. Check list and symptom analysis repair methods. 320 pages. \$5.90
- 96—HOW TO FIX TRANSISTOR RADIOS & PRINTED CIRCUITS. Two volumes of theory, and service hints for transistor radios. 320 pages. \$5.90
- 99—INDUSTRIAL ELECTRONICS MADE EASY. Operation, maintenance and application of electromechanical control systems and transducers. 288 pages. \$3.95
- 102—PRACTICAL TV TROUBLESHOOTING. Useful repair techniques based on actual servicing experience. An easy guide for tough repair jobs. 128 pages. \$2.35
- 103—HINTS and KINKS for TV, RADIO, AUDIO. The latest technician-tested work-savers for service shop and home experimenter. 128 pages. \$2.35
- 104—BASIC RADIO COURSE (enlarged & revised). Vacuum tube and transistor theory for radio circuits in easy-reading style. 224 pages. \$4.10
- 105—BASIC TV COURSE. A practical discussion of TV receivers—tube and transistor. Theory presented in a light, easy-to-follow style. 224 pages. \$4.10
- 106—FUN WITH RADIO CONTROLLED MODELS. Build basic relay and actuator. Install devices to control steering, speed and accessories. 160 pages. \$3.20
- 107—RADIO SERVICING MADE EASY. (2 vols.) Originally a school course, sold at many times this price. Latest data on servicing AM, FM, Citizens Band, marine, transistor, communications and auto receivers. 384 pages. \$7.20
- 108—THE OSCILLOSCOPE. Master the scope. Learn latest uses and techniques. 224 pages. \$3.65
- 109—BASIC INDUSTRIAL ELECTRONICS COURSE. All about transducers, electronic systems, automatic inspection, sorting, counting, control, electronic heating, welding, machining, power conversion, safety devices. 224 pages. \$4.10
- 111—BASIC TRANSISTOR COURSE. Describes transistor characteristics, audio amplifiers, detectors, semiconductor lattice structure, agc and i.f. amplifiers, mixers, oscillators, choppers, inverters, multivibrators and switches. 224 pages. \$4.10
- 112—LEARN ELECTRONICS BY BUILDING. Easy-to-build projects for the experimenter. Two- and four-transistor amplifiers, short-wave receiver, pocket radio, stereo amplifier, building crystal sets. Plus useful, practical information for constructors. 208 pages. \$3.85
- 113—ELEMENTS OF ELECTRON PHYSICS. Covers beginning of electronics, electron theory, electrical properties, solid-state semiconductors, tubes for electronics, electronic circuits. 192 pages. \$3.95
- 115—HORIZONTAL SWEEP SERVICING HANDBOOK. Written by a technician for technicians. Analysis of the horizontal oscillator and horizontal output with testing information. Separate chapter on dogs and intermittents. 224 pages. \$4.10
- 116—GETTING STARTED WITH TRANSISTORS. How transistors began; learning to read electronic diagrams; how transistors work; amplifiers; oscillators; transistor types; diodes; phototransistors; rectifiers; transistor ratings; testing transistors. 160 pages. \$3.95
- 117—HOW TO BUILD TINY ELECTRONIC CIRCUITS. All the details of subminiaturization, microminiaturization, molecular electronics. How to build tiny meter amplifiers, tone generators, preamplifiers, pocket radios. All the techniques of "building small." 192 pages. \$4.15
- 118—ELECTRONICS DATA HANDBOOK. A book of facts supplying the data most needed and used by electronics technicians and engineers. Supplies formulas and explanations. Includes ac, dc, vacuum tubes and vacuum-tube circuits, transistors, antennas and transmission lines, measurements. Separate section on tables and data. 160 pages. \$2.95
- 119—TV SWEEP OSCILLATORS. Practically an encyclopedia of relaxation oscillators, pulse techniques, transistorized oscillators, sawtooth generators, synchronization, afc, multivibrators and blocking oscillators. Gives full information on tv sweep failure and sweep servicing. 256 pages. \$3.95
- 120—HI-FI TROUBLES. How you can avoid them. How you can cure them. Explains why we have audio troubles, hum and noise problems, bass and treble problems, distortion, stereo problems, how to get the most out of kit building. 160 pages. \$3.95
- 122—ADVANCED RADIO CONTROL. Information most needed by radio-control hobbyists—pulse decoders, control problems, frequency decoders, design of proportional control, superregen and superhet control receivers, robots, model rocket design and construction. 192 pages. \$3.50
- 123—COLOR TV REPAIR. How to pinpoint the defective color section fast. Troubleshooting with a color bar generator; unexpected causes of tv color failure; replacing the color picture tube; servicing the chroma circuits; abc's of color tv servicing; antennas and boosters; color circuits and color servicing hints. 160 pages. \$2.95
- 125—THE HANDBOOK OF ELECTRONIC TABLES. Easiest way to solve problems in electronics. Tables supply answers to hundreds of possible problems. Quick—accurate. 160 pages. \$2.95
- 126—SERVICING AGC CIRCUITS. Tells exactly what agc circuits are, shows clearly how agc circuits work, pinpoints what can go wrong, demonstrates step-by-step how to fix circuits, spotlights where to find agc circuits in sets and gives special help on tv troubleshooting. 224 pages. \$3.95