

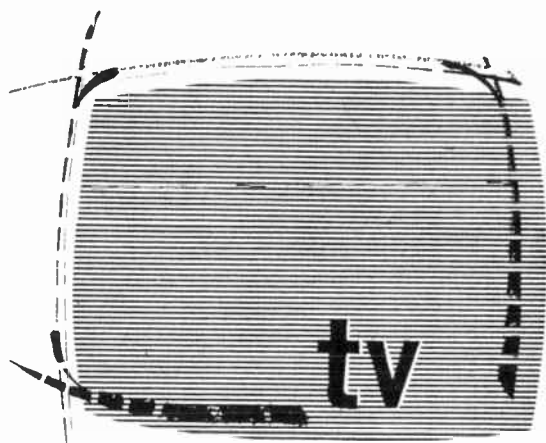

tv  
trouble  
analysis

harry miller

\$1.95



# **trouble analysis**

**harry mileaf**

Gernsback Library, Inc. New York 11, New York

FOR  
DAVE and KEN

© 1961 Gernsback Library, Inc.  
All rights reserved under Universal  
International, and Pan-American  
Copyright Conventions.

Library of Congress Catalog Card No. 61-9879

# contents

chapter

1

## Waveform analysis

7

Major sections of the tv receiver. The tuner. Rf signal. Local-oscillator signal. If signals. Video signals. Amplitude levels. Frequency response. Audio if signal. Sync signals. Sync-pulse characteristics. Vertical and horizontal sync pulses. Vertical sweep section. Vertical oscillator signal. Horizontal sweep section. Afc signal. Horizontal oscillator signal. High-voltage section. Picture tube and related circuits. Agc section.

2

## Component failure—tubes, rectifiers, diodes and transistors

37

Component analysis. Electron tubes. Construction of the miniature pentode. Causes of tube failure. Tube failure effects. Octal tubes. Construction of the cathode-ray picture tube. Picture tube failure. Effects of picture tube failure. Semiconductors. Construction of semiconductors. Germanium and silicon diodes. Types of transistors. Causes of semiconductor failure. Semiconductor failure effects.

3

## Component failure — capacitors and resistors

51

Types of capacitors. Construction of paper capacitors. Mica capacitors. Ceramics. Dielectric insulators. Electrolytics. Trimmers. Positive, negative and zero temperature coefficients. Causes of capacitor failure. Capacitor failure effects. Composition and film resistors. Resistor construction. Wirewound and movable-tab types. High-voltage resistors. Causes of resistor failure. Resistor failure effects. Potentiometers. Potentiometer failures.

4

## Component failure — coils and transformers

65

High-frequency coil and transformer construction. High frequency coil and transformer failures. Effects of coil and transformer failure. Series peaking coil construction and failure. Low-frequency coil and transformer failures. Focus-coil construction. Focus-coil failures and their effects. Construction of the yoke. Yoke failure and its effects. Construction of the horizontal output transformer. Horizontal-output transformer types and troubles.

5

## Component failure — speakers and tuners

77

Typical speaker construction. Causes of speaker failure. Voice-coil troubles. Buzz and distortion. Loss of sound. Types of front-end tuners. Construction of the drum tuner. Channel strips. Channel-selector mechanism. The fine-tuning control. Defects in the fine-tuning assembly. Other failures in the drum tuner. Effects of failure of the drum-tuner. The wafer-switch tuner and its construction. Wafer-switch tuner failures and their effects.

**Circuit failure analysis, tuner—if—video****85**

Cascode, neutrode and guided-grid tuners. Functions of the rf stage. Loss of high frequencies. Interference. Rf stage detuning. Other troubles in the rf stage. The mixer stage. Operation of the mixer. Heterodyning failures. The local-oscillator stage. Analysis of the local oscillator and causes of trouble. Tuning and drift failures. Amplitude failures. The if section. The detector stage. Video amplifier and output stages.

**Circuit failure analysis, audio and agc****127**

Audio if amplifier. The audio if limiter. Limiting failures. Audio detector. Types of detectors. The discriminator. Phase discriminator. Ratio detector. Gated-beam detector. Analysis of the audio detector stage. Audio amplifier and output stages. Basic agc circuits. Delayed agc. Amplified agc. Keyed agc. Analysis of agc circuits. Agc sluggishness. Agc cutoff failures. Noise and interference failures.

**Circuit failure analysis, sync and vertical sweep****159**

Sync clipper. Noise suppression. Gated sync clipper. Sync amplifier. Sync inverter. Sync phase splitter. Sync separation. Sync amplitude failures. Sync pulse distortion. High-frequency distortion. Low-frequency distortion. Waveshape distortion. Causes of sync-pulse distortion. Vertical section. Blocking oscillator. Vertical discharge stage. Output-driven oscillator. Vertical output stage. Vertical frequency troubles.

**Circuit failure analysis,  
horizontal sweep and high voltage****191**

Horizontal oscillator and afc stage. Synchrolock and Synchroguide circuits. Multivibrator and sync discriminator. Horizontal output and damper stages. High-voltage section. Failure analysis of the horizontal sweep and high-voltage section. Horizontal sync trouble. Hook. Hunting. Tearing. Horizontal frequency troubles. Phasing trouble. Width trouble. Horizontal linearity. High-voltage trouble. Horizontal interference.

**Index****221**

# introduction

OPERATING a successful television servicing business does not depend only on the ability to repair television sets. Inexperienced service technicians can repair most of them provided they are given enough time and a large stock of replacement parts. However, if the less-qualified service technician did his billing on the basis of the actual time spent in making repairs, his high prices would drive away most customers. And, if he made his prices competitive, his income would be so low his business eventually would become bankrupt. Therefore, success in the television service business depends on the ability of the service technician to make *rapid*, reliable repairs. This ability is the principal distinction between the experienced and inexperienced man. A slow technician might spend hours for each repair and thus can handle only a very limited number of sets a day. Because of this, he must work a 60-hour week to earn an average salary. On the other hand, a fast service technician can repair two to three times as many sets a day and work an average 40 hours for a reasonably good income.

The first few years in any trade can be considered apprenticeship, because the novice constantly encounters things still unfamiliar to him. In most trades the novice is fortunate because the principles and methods of the trade are stable and experiences repeat themselves often. Although this is also partly true in the television service business, it more often is the exception than the rule. Television design, methods and techniques are changing constantly. There are many manufacturers, each producing a number of different models that change each year. Electron tubes alone are an example of this. Some tubes used today did not exist a few years ago, and the tubes used then are now looked upon as obsolescent. Experiences and receiver characteristics that were

familiar not too long ago are often not encountered today. Because of these changes, new information is required constantly. The service technician attempts to keep abreast of the times by reading as much published material as possible but, unfortunately, he first becomes aware of most of the changes when they are presented to him in a defective set. As a result, most technicians soon realize that rapid servicing cannot depend solely on a good memory.

One of the first lessons of experience on the part of the technician is the realization that repairs are taking too long because he is dealing with something unfamiliar to him. He understands how a television set is supposed to work, but he does not understand fully how it actually works when trouble is present. And since he is always handling sets that are not working properly, that lack of understanding becomes a great problem.

Therefore, in the course of gaining practical experience, the service technician develops an analytical technique of evaluating symptoms that allows him to understand how the set actually works to produce the abnormal symptoms. This positive approach to servicing is based on a complete understanding of the theory of troubles.

This book explains the theory of troubles and its relationship to logical symptom analysis. First, a summary of television receiver theory is given, together with an analysis of waveforms showing the characteristics required for normal operation. Then, the pattern of failure development is described. This covers the construction of all component parts, and how and why they fail. It also discusses the theory of all television circuits, first giving the theory of normal operation and then the "trouble" theory of operation which results from the various types of component failures. The effects that various circuit troubles have on television waveforms are included together with a description of how these waveform changes cause the symptoms which are seen and heard.

HARRY MILEAF

# waveform analysis

**B**EFORE the theory of television troubles can be explained, the characteristics of the waveforms used by a television receiver must be understood thoroughly. There are many basic waveforms, each playing a specific part in producing the television picture and sound. Each waveform has specific characteristics which bring about the required end result. An understanding of these characteristics will afford a better comprehension of how and why various troubles affect the picture and sound the way they do.

## TV receiver block diagram

A block diagram of a typical television receiver is shown in Fig. 101. There are 12 major sections: (1) antenna; (2) tuner; (3) if (intermediate frequency); (4) video; (5) audio; (6) sync; (7) vertical sweep; (8) horizontal sweep; (9) high voltage; (10) picture tube and its circuits; (11) agc and (12) low-voltage power supply.

The television rf (radio frequency) signals from the stations are picked up by the antenna and fed to the tuner. The tuner selects the signal of the desired station, amplifies it and then converts it to an if signal. The if signal is passed on to the if section, where it is amplified and sent to the video section. In the video section the if signal is detected (or demodulated<sup>1</sup>). The detected signal is a combined video and a sound if signal. The sound if signal is applied to the audio section, where it is amplified and converted to an audio signal which drives the speaker to produce sound.

---

<sup>1</sup> The demodulator (or second detector) considered here as part of the video section is a link between the if and video amplifiers. The demodulator can be regarded as being part of or belonging to both circuits.



The video output signal from the video section is fed to the picture tube. In the picture tube, the video signal modulates the electron beam that produces the raster on the face of the picture tube. The video-modulated beam produces the picture on the screen.

The raster is produced by the sweep currents generated by the vertical and horizontal sweep sections. The composite video signal from the video section is also sent to the sync section, where the video is stripped from the sync pulses. These are then separated into horizontal and vertical sync signals, which, in turn, synchronize the operation of both sweep sections.

The horizontal sweep (as a sort of by-product) produces the high voltage required by the picture tube for its electron beam.

In addition to all these sections, there is an agc (automatic gain control) section that samples the video signal to produce an agc voltage. This dc voltage controls the gain of the if section and tuner. If the video signal going to the agc section becomes stronger, the agc voltage reduces the gain of the if amplifier and tuner; the opposite happens if the video signal becomes weaker. As a result, even though the signal from the station varies in strength, the video signal going to the picture tube is kept relatively constant, minimizing picture flutter or fading.

The agc section shown in Fig. 101 is called "keyed" agc because it uses an agc keying signal taken from the horizontal sweep section. The use of this signal will be explained in a later chapter. However, not all agc circuits need this signal.

The last section, the low-voltage power supply, provides the voltages and currents needed by the other sections of the receiver.

The receiver shown in Fig. 101 uses an intercarrier type of sound system. The audio and video components of the if signal are amplified jointly until they reach the detector. There, the audio and video components of the if signal are heterodyned to produce the sound if signal.

In older sound systems, the audio and video if signals were produced separately in the tuner and the audio if was taken off at the tuner or after the first or second stage of the if section. Such split-sound systems are found only in older television receivers. Intercarrier sound is more popular because it simplifies the audio section.

## **Tuner**

In ordinary vhf TV reception, there are 12 station channels each operating within a specifically-assigned frequency bandwidth. The 12 channels are broken down into 2 main bands; a high and a low.

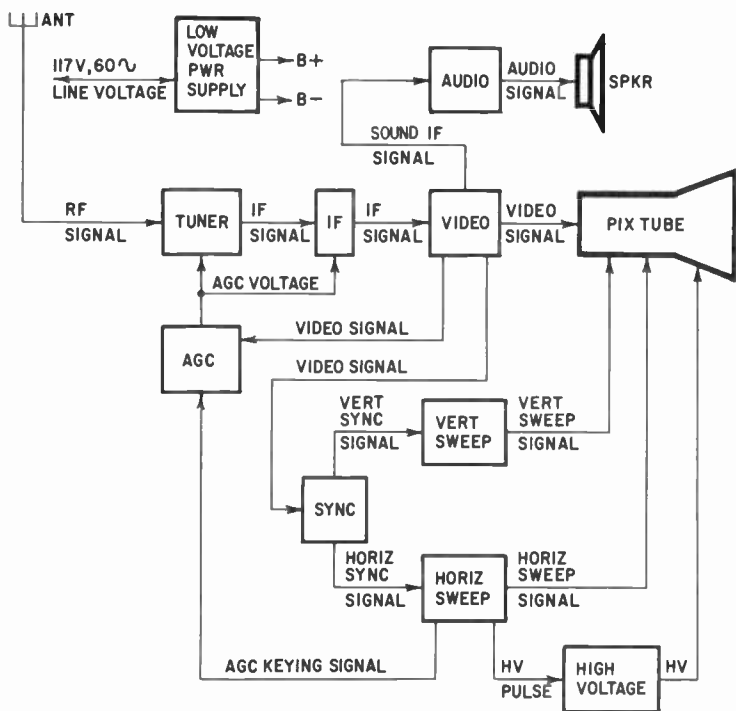

Fig. 101. Block diagram of a typical television receiver. Only the major sections are shown.

The low band consists of channels 2 through 6 broadcasting between 54 and 88 megacycles. The high band, channels 7 through 13, occupies the space from 174 to 216 mc. There are also uhf stations, channels 14 through 83, which operate between 470 and 890 mc. Stations using these channels are found in some areas only. Special uhf converters must be used with ordinary vhf tuners to pick up their signals.

The rf signals of all the channels are picked up by the antenna and fed to the tuner. The first purpose of the tuner, then, is to choose the one desired and to reject all the others. This is done by a complex switching arrangement that will be explained in a later chapter. Also, since the signal picked up by the antenna is relatively weak — often less than 30 — microvolts — the tuner must supply some gain. The final purpose of the tuner is to convert the rf to the if of the receiver.

The tuner, shown in block diagram form in Fig. 102, consists of three basic divisions: (1) an rf; (2) a mixer; and (3) a local

oscillator stage. The selected signal from the antenna is built up in the rf amplifier and applied to the mixer. A voltage from the local oscillator is also applied to the mixer. These two signals are

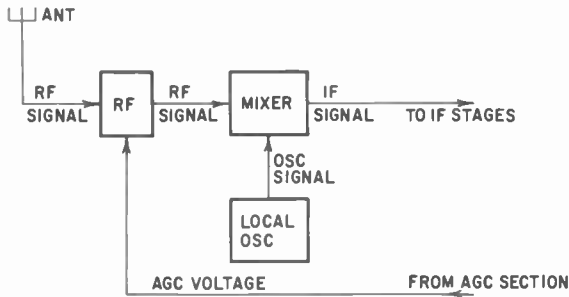

Fig. 102. Block diagram of an rf tuner. In most sets, the mixer and local oscillator stages are contained in one dual tube.

heterodyned in the mixer to produce the if signal. The if signal is the difference frequency between the rf and oscillator signals. Each time a new channel frequency is selected, the tuner changes the oscillator frequency so that the difference or intermediate frequency remains the same.

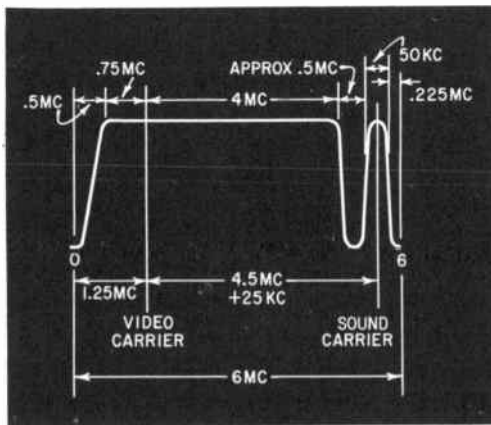

Fig. 103. Rf signal characteristics. It is a vestigial-sideband signal, and two individual carriers are used for the video and sound, separated by 4.5 mc.

The voltage from the agc section is applied to the rf amplifier to change its gain whenever the strength of the input signal changes.

### RF signal

The rf signal broadcast from the station is a complex one.

Picture and sound are transmitted on separate carriers within the standard 6-mc bandwidth. The response characteristics are shown in Fig. 103. This response curve applies to every TV channel. By applying the upper and the lower frequency limits of any chan-

Fig. 104. *The rf sound carrier signal is frequency-modulated and has a constant amplitude.*

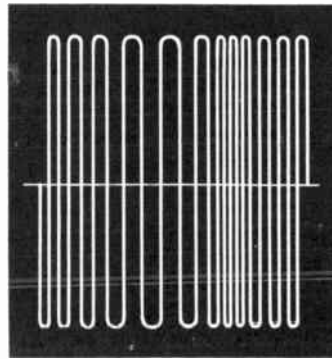

nel, the actual frequency of any point on the curve can be determined. For example, the video carrier frequency, which is 1.25 mc above the lower limit, is 55.25 mc for channel 2. The sound carrier, 4.5 mc higher than the video carrier, is frequency-modu-



Fig. 105. *The rf video carrier signal is amplitude-modulated and also carries the blanking and sync pulses.*

lated (Fig. 104) and has a 50-kc bandwidth. A 0.225-mc guard band above the sound signal separates it from the next higher channel.

The video portion of the composite video signal (Fig. 105) is amplitude-modulated. As the response characteristic shows (Fig. 103), what we have here is a vestigial-sideband signal, which is a compromise between a single- and double-sideband signal. Only

a part, or *vestige*, of the lower sideband is transmitted. Up to 0.75 mc of the lower sideband is transmitted without attenuation. Below this, or the first 0.5 mc of the channel, the response is attenu-

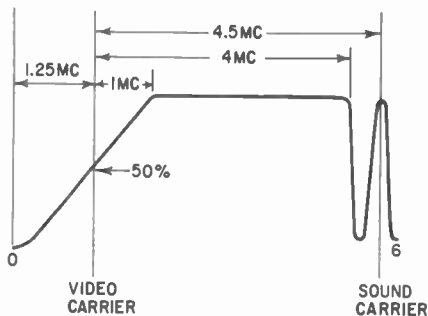

Fig. 106. Overall TV set response curve. The reduced response around the video carrier frequency results in a single-sideband effect.

ated linearly. The upper sideband has a flat response up to 4 mc. The video signal is attenuated sharply above that point to prevent the video from interfering with the audio.

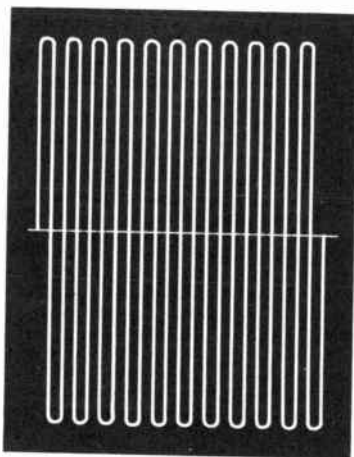

Fig. 107. The local oscillator signal is a continuous series of sine waves at a constant frequency and amplitude.

As shown in Fig. 103, the low-frequency video modulation of 0.75 mc or less is contained in both the lower and upper sidebands, and so this part is actually double-sideband transmission

Video modulation higher than 0.75 mc, however, represents single-sideband transmission. The lower video modulation frequencies, therefore, have twice the power level of the higher ones. If the receiver had the same response, the low video frequencies would be too strong compared to the higher video frequencies. To compensate for this, the response of the receiver is made to be as shown in Fig. 106. There is only a 50% response at the carrier frequency, and the response from 1 mc above the carrier is linearly attenuated to zero at 1.25 mc below the carrier. This response curve, when combined with the transmission response curve shown in Fig. 103, produces a single-sideband effect, with a flat video response from the carrier to 4 mc above it.

### Local-oscillator signal

The local-oscillator signal is shown in Fig. 107. A steady, unmodulated signal, it is separated from the rf signal by an amount equal to the if of the receiver. The oscillator frequency can be above or below that of the rf signal (but is usually above in most receivers) and is generally tuned somewhere between 25.75 and 45.75 mc above the rf signal. The lower intermediate frequencies are found in older receivers. The if can be higher than 45.75 mc, but this is limited by the maximum frequency at which the local-oscillator tube can be operated efficiently. For an if of 45.75 mc, the oscillator must work at 257 mc for channel 13.

### IF Section

The input to the if section is often less than 5 millivolts while

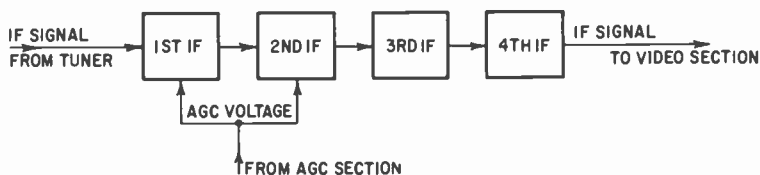

Fig. 108. Block diagram of an if section. The number of if stages used may vary from one set to another.

the output is in the area of 5 volts. The if section shown in Fig. 108 contains four if stages that are almost identical. Each performs the same function—amplification. Most receivers use only 3 (or just 2) stages of if amplification. But to do this and still obtain enough overall gain, some frequency response is sacrificed.

As shown in Fig. 108, the agc voltage is applied to the first two stages to make their gain inversely proportional to the strength

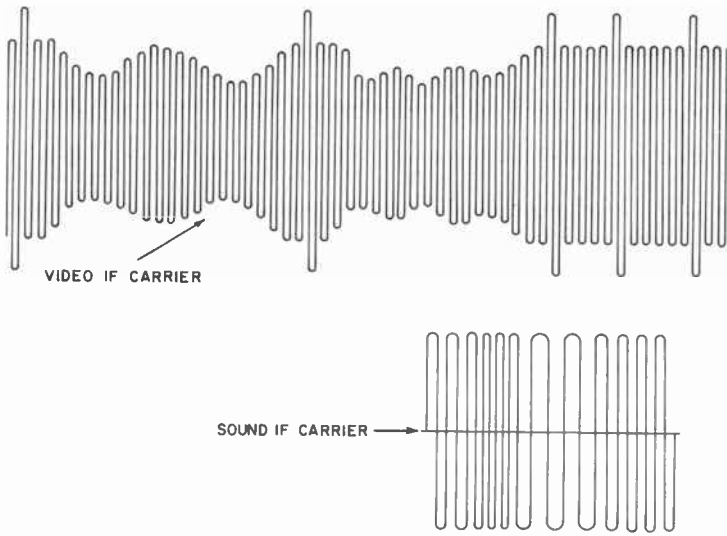

Fig. 109. The if signals are similar to the rf signals, except that they are stronger and are lower in frequency.

of the input signal. In some receivers, the agc voltage is applied only to the first stage, and in others to the first three.

### IF signals

The if signals are shown in Fig. 109. They are exactly the same as the rf signals except that the carriers are now intermediate frequencies. Also, the modulating frequency position of the if signal is opposite to that of the rf signal, as shown by the if response curve of Fig. 110. The video-modulation and sound-carrier frequencies are separated from the video carrier by the same

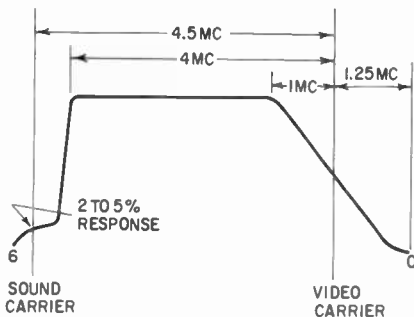

Fig. 110. If signal characteristics. The video and sound carrier positions are reversed, and the audio carrier is greatly attenuated.

amounts, but are below the video carrier instead of above it. This is because the if's generated are the difference frequencies between the rf and local oscillator signals. And, since the oscillator

frequency is above that of the rf, the higher rf's produce lower difference (intermediate) frequencies.

To make sure that all the video-frequencies are amplified, the bandwidth of the if section is approximately 4 mc. In older split-sound receivers, the response was cut off sharply at 4 mc below the video carrier. But in present-day intercarrier receivers, the cutoff is not as sharp, and the if section gives between 2% and 5% response to the sound carrier at 4.5 mc below the video carrier.

### Video section

The video section detects the video signal and produces the sound if. It consists of a detector, a video amplifier and a video output stage (Fig. 111).

The detector rectifies the video if signal and filters the if carrier frequency. The resultant video signal is built up by one or two video stages<sup>2</sup> and applied to the picture tube. In addition to de-

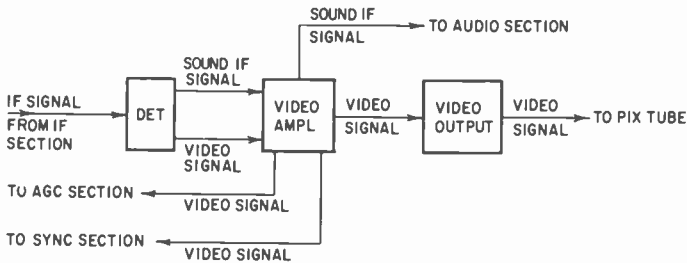

Fig. 111. Block diagram of a video section. The signal takeoff points can be from any stage, and vary from one set to another.

modulating the video signal, the detector stage also beats the video carrier of the if signal with the sound carrier to produce a 4.5-mc sound if signal. Since the sound carrier is a fixed 4.5 mc from the video carrier, the heterodyning of these two signals always produces a 4.5-mc difference frequency. This new sound if signal is then amplified in the video amplifier stage and sent to the audio section. However, the sound takeoff point need not always be after the video amplifier stage. It can be right after the detector or the video output stage. The sound portion of the if signal must have an amplitude of 2% to 5% of the video part of the if signal for proper heterodyning to take place in the video detector.

Besides the sound if signal and the video signal that is sent to the picture tube, video signals are picked off for the agc and sync

<sup>2</sup> Many receivers have a single video amplifier following the detector.



circuits. Fig. 111 shows these being taken from the output of the video amplifier stage. These signals, too, can be removed after the detector or video output stage. Where the takeoff points for the sound if and video signals appear to be optional, they are actually determined by how strong and by what polarity the video signals must be. With the sound if signal, gain is the dominant factor. The nearer to the picture tube the audio if signal is removed, the stronger it will be, allowing a simpler audio section. However, the closer the sound takeoff point is to the picture tube, the more easily it is affected by intercarrier buzz. This is explained in later chapters.

Gain is also an important factor in the takeoff of the agc and sync video signals but, with these, the polarity of the takeoff signal is often more important.

### Video signals

The rectified video signal is shown in Fig. 112. It is the same as the rf and if signals, except that the carrier is removed. The

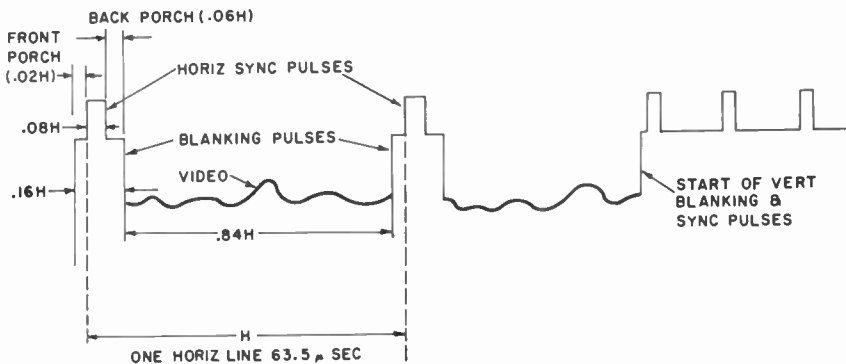

Fig. 112. The composite video signal is similar to the rf and if video signals, except that the carrier frequencies have been removed.

diagram shows the portion of the signal that contains video information for the last two horizontal lines of a frame and the first part of the vertical sync pulse. Basically, the video signal contains:

- (1) Video information
- (2) Blanking pulses
- (3) Sync pulses

The time for one horizontal line (H) of data is measured from the leading edge of one horizontal sync pulse to the leading edge of the following one. This (H) is 1/15,750 second, or 63.5 microseconds. Each sync pulse is 0.08H wide and is located on top of a blanking pulse. The top of the blanking pulse in front of the sync

pulse is known as the front porch and is  $0.02H$ . The area behind the sync pulse is the back porch, which is  $0.06H$ . The blanking

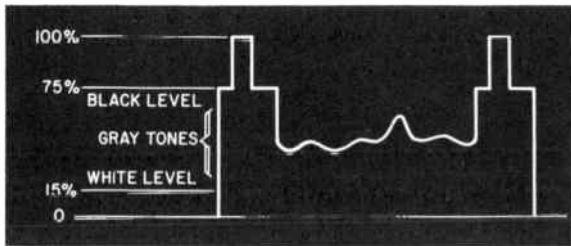

Fig. 113. *Video amplitude levels. The picture gets darker as the amplitude goes up.*

pulse itself is approximately  $0.16H$  wide. The time between the blanking pulses is where the video information is carried. This time interval is  $0.84 H$  and is the picture data for each line.

The blanking pulse cuts off the electron beam in the picture tube from the end of each line through the horizontal retrace to the beginning of the next line. The blanking pulse, therefore, keeps the retrace lines from being visible in the picture.<sup>3</sup>

At the bottom of each frame, the nature of the signal changes somewhat as shown in the vertical sync part of Fig. 112. The video portions of the signal are dropped out as the vertical sync pulses

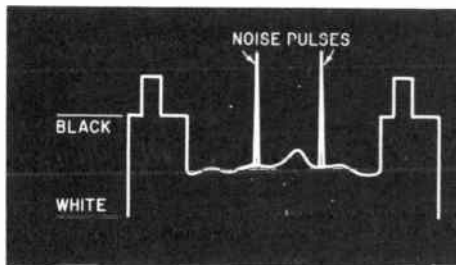

Fig. 114. *Noise pulses, being positive-going, drive the video signal into the black area.*

take over. The vertical pulses ride on one long blanking pulse during vertical retrace time. These sync pulses will be described more fully later.

<sup>3</sup> The presence of retrace lines can be the result of misadjusted contrast or brightness controls. In extreme fringe areas the appearance of snow can often be appreciably reduced by decreasing the contrast setting and increasing the brightness. Unfortunately, the price for this is generally visible retrace lines. Furthermore, it is normal to see these lines during camera changes and station breaks. Retrace elimination circuits can be used in the receiver to suppress the appearance of the lines.

## Amplitude levels

As shown in Fig. 113, the horizontal sync pulse occupies the top 25% of the signal amplitude. The top of the blanking pulse, which is the 75% point, is the black level of video information. This is the point at which the picture tube is cut off. At the lower part

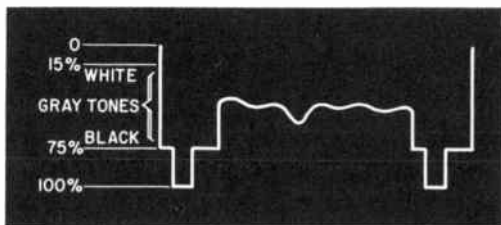

Fig. 115. The video signal applied to the control grid of the CRT is negative-going, with the black regions being most negative.

of the signal, about 15% of the amplitude, the maximum white level is produced. As the video signal varies between the 15% to 75% levels, gray tones are produced which get darker as the video amplitude increases. The white level can be anywhere between 0% and 15% but an attempt is made to keep it near the 15% point.

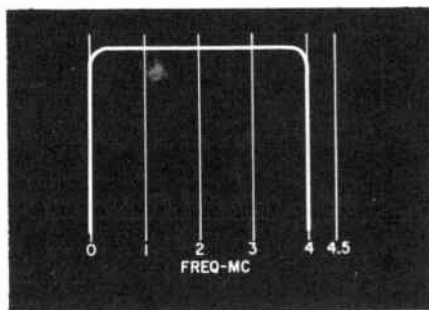

Fig. 116. The video-section response curve. Amplification goes up to 4 mc. followed by sharp cut off.

Since the whiteness of the video signal increases as the video amplitude goes down, the signal is known as negative transmission. It reduces the effects of noise pickup. Noise pickup is mostly positive-going in nature, as shown in Fig. 114. This means that noise interference appears as black dots or dashes, which are not nearly as objectionable as white ones.

Since the video information is a negative transmission, a negative signal (Fig. 115) must be applied to the control grid of the picture tube. The white level is at the more positive point of this signal, so the picture-tube beam current increases as the video signal varies from the black to the white level. On the other hand,

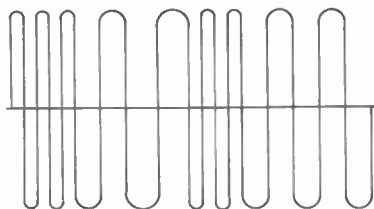

Fig. 117. The intercarrier sound if signal has a 4.5-mc carrier.

if the video signal is applied to the cathode of the picture tube, the polarity of the video signal shown in Fig. 113 can be used.

### Frequency response

The frequency response of the video section is shown in Fig. 116. It provides for amplification up to 4 mc, after which the section is sharply cut off to prevent the 4.5-mc sound if signal from reaching the picture tube. Fig. 116 shows the overall response of the video section. Actually, since part of the video section must pass the sound if signal, the response of that part of the section must drop off gradually after 4 mc and offer some gain to 4.5 mc. After the sound if signal is taken off, the remaining part of the video section must then reject any 4.5-mc sound if signals that might get by, so that the overall response of the video section will be as shown in Fig. 116.

### Sound if signal

The intercarrier sound if signal (Fig. 117) is the same as the rf and if sound signals except that the carrier frequency is now 4.5 mc.



Fig 118. Block diagram of an audio section. In some sets, more than one sound if stage may be used.

### Sound section

The sound section (Fig. 118) contains four stages: (1) sound if amplifier; (2) sound detector; (3) audio amplifier; and (4) audio

output. The output of the detector is the audio signal, which is built up in the audio amplifier and sent to the audio output stage. The audio output stage (including the output transformer) converts the audio signal to an audio current that drives the speaker to produce the sound.

The sound section shown in Fig. 118 uses only one sound if amplifier. Not all sets use the arrangement shown in Fig. 118, however. In some receivers the audio section is simplified through the



Fig. 119. A typical audio signal.

use of a gated beam tube acting as combined limiter, discriminator and af voltage amplifier.

### Audio signal

The audio current that flows through the voice coil of the speaker consists of amplitude variations as shown in Fig. 119. It is the FM detector that enables us to make the transition from the type of waveform shown in Fig. 117.

### Sync section

The sync section (Fig. 120) separates the sync pulses from the composite video signal and then amplifies the pulses. The sync section must also separate horizontal and vertical pulses.

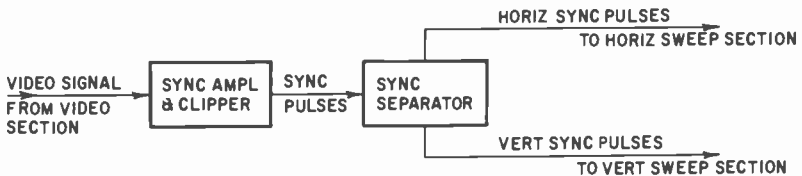

Fig. 120. Block diagram of a sync section. Sometimes, additional stages are needed to get the proper phase and gain.

The sync section contains a sync amplifier, a clipper stage and a sync separator. The signal from the video section is applied to the sync amplifier and clipper. Since the video signal is positive, the amplifier and clipper stage is biased beyond cutoff to the point where only the sync pulses are at an amplitude to make the tube conduct. Also, the amplitude of the pulses is large enough so that the pulses drive the stage into saturation. This causes all varying amplitude pulses to come out at one level. The video information

and blanking pulses are thus rejected, and the clipped sync pulses are amplified and fed to the sync separator.

The sync separator builds up the sync pulses further, and then separates the horizontal sync pulses from the vertical ones in its output circuit. The vertical and horizontal sync signals are then applied to their respective sweep sections.

Sync circuits vary considerably from one set to another, depending on the gain required and polarity. Sometimes, only one stage is needed. However, regardless of how it is done, the phase of the input signal to the sync section and the number of sync stages must be arranged so that the sync output pulses are positive.

### Sync signals

As shown in Fig. 112, the sync pulses all ride on the blanking pulses. In the sync amplifier and clipper, the sync pulses are removed from the composite video signal (Fig. 121).

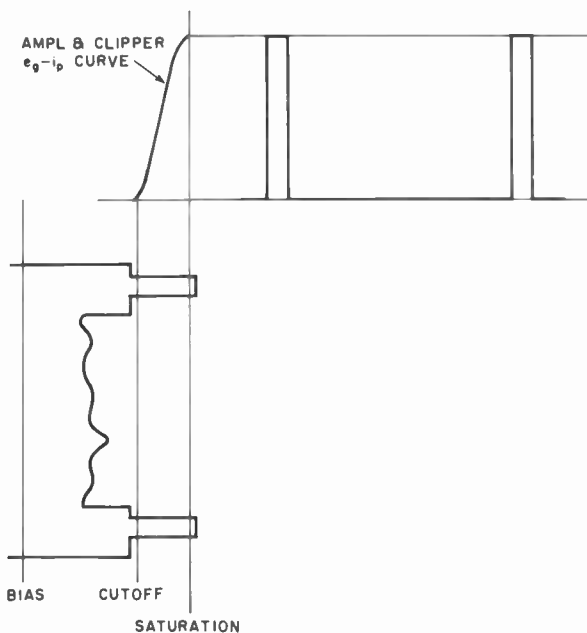

Fig. 121. The sync amplifier and clipper stage produces steady sync pulses by extracting them from the composite video signal.

The sync pulses actually represent a complex array of three types, rather than individual horizontal and vertical sync signals:

- (1) Horizontal sync
- (2) Equalizing sync

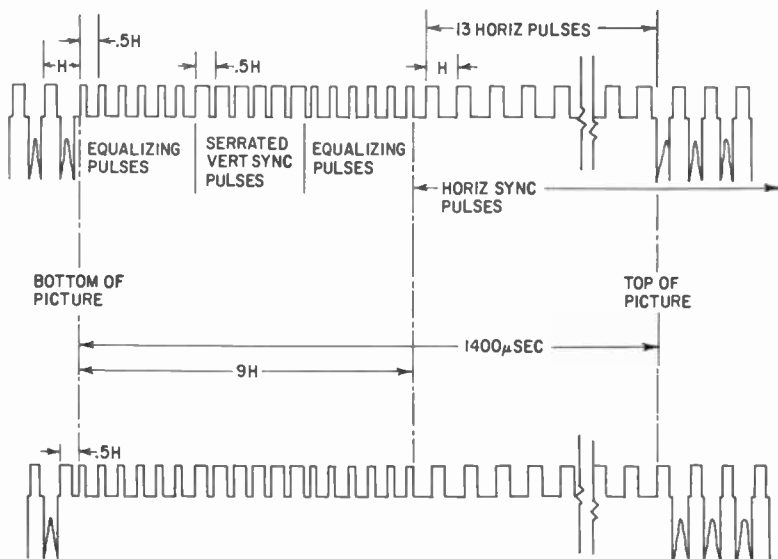

Fig. 122. Horizontal, equalizing and serrated vertical pulses are used. The upper diagram synchronizes one vertical frame, and the lower diagram synchronizes the next, or interlaced, frame.

### (3) Serrated vertical sync pulses

The horizontal sync pulses serve only one function: to synchronize the operation of the horizontal sweep section. The equalizing and serrated vertical sync pulses, however, are needed for both horizontal and vertical synchronization.

Serrated vertical sync pulses are required because, if one long vertical pulse were used, there would be no horizontal sync pulses during that time and the horizontal sweep section would not be synchronized. With the serrated pulse, however, the leading edge of each pulse is timed so that it can be used for horizontal synchronization. Also, the serrated pulses can be changed to one pulse for vertical synchronization. This will be explained more fully later.

The equalizing sync pulses are necessary because the serrated vertical sync pulses are used for both horizontal and vertical synchronization. This presents a problem because the horizontal scanning frequency of 15,750 cycles is  $262\frac{1}{2}$  times the 60-cycle vertical scanning frequency. Because the horizontal frequency is not an even multiple of the vertical frequency, the vertical sweep starts halfway between two horizontal pulses every other time. This can be seen by comparing the upper and lower diagrams of Fig. 122.

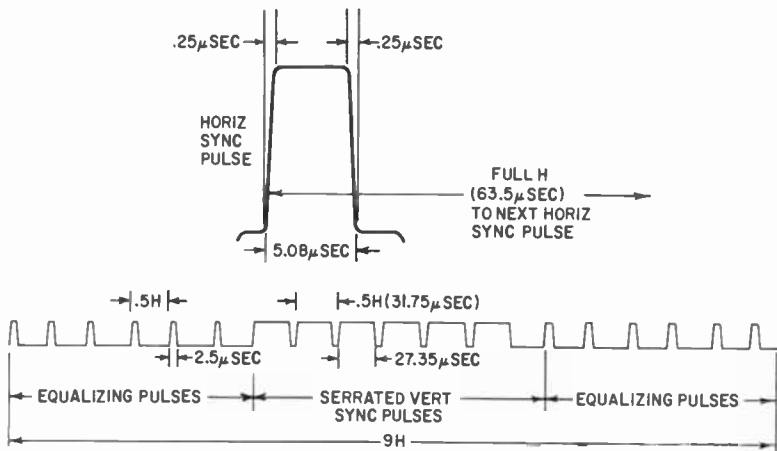

Fig. 123. Sync pulse characteristics. The pulse in the upper diagram is for horizontal synchronization, and the pulses in the lower diagram are for vertical synchronization. All of the sync pulses have the same amplitude.

The equalizing and serrated sync pulses start a full H away from the last horizontal sync pulse in the upper diagram, but they start only 0.5H away in the lower diagram, which represents the following vertical sweep.

To compensate for this, the equalizing sync pulses occur at twice

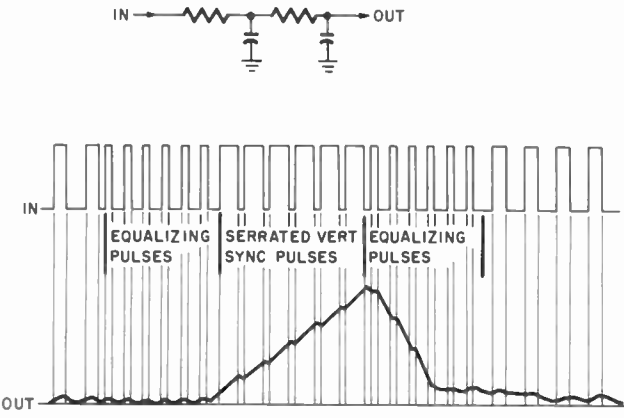

Fig. 124. The equalizing and serrated vertical sync pulses are used to produce an integrated vertical sync pulse.

the frequency of the horizontal sync pulses so that alternate 0.5H pulses will be available for the alternate vertical sweeps. In the upper diagram, where the equalizing sync pulses start a full H after the last horizontal pulse, the first, third and fifth equalizing pulses



act as horizontal sync pulses. In the lower waveform, though, where the first equalizing sync pulse occurs only  $0.5H$  after the last horizontal sync pulse, the second, fourth and sixth equalizing pulses act as horizontal sync pulses. The alternate serrated vertical sync pulses are used for horizontal synchronization in the same way.

### Sync-pulse characteristics

The characteristics of the sync pulses are shown in Fig. 123. The

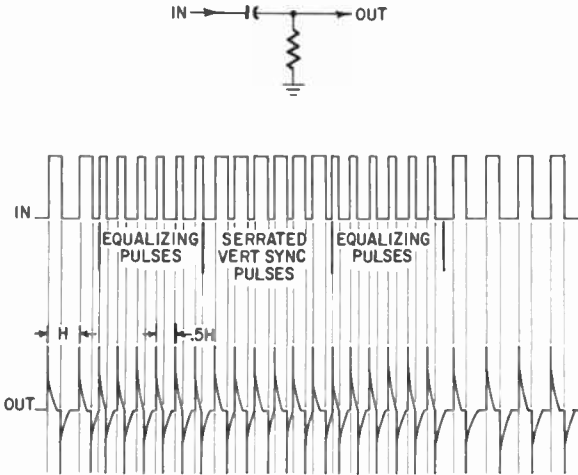

Fig. 125. The equalizing and serrated vertical sync pulses are also differentiated for use as horizontal sync pulses.

horizontal sync pulse is repeated every full  $H$ , or  $63.5$  microseconds. Each horizontal pulse is  $5.08$  microseconds wide, and the rise and fall times of the pulse are each  $0.25$  microsecond. There are six serrated vertical sync pulses with six equalizing sync pulses on each side. The equalizing and serrated pulses occur every  $0.5H$ , or  $31.75$  microseconds. The equalizing pulses are each  $0.04H$ , or  $2.5$  microseconds wide, but the serrated pulses are each  $0.43H$ , or  $27.35$  microseconds wide. The rise and fall times of these pulses are each approximately  $0.005H$ . The equalizing and serrated vertical sync pulses combined take about  $9H$ ; after these pulses approximately another  $13$  horizontal pulses appear during vertical blanking time before the video is resumed. Therefore, the complete vertical blanking pulse takes about  $1,400$  microseconds, and blanks out  $22$  horizontal lines.

### Vertical sync pulses

The serrated vertical sync pulses shown in Fig. 123 cannot be used directly as vertical sync pulses because they are actually indi-

vidual 0.5H pulses. However, the time of each serrated pulse is made long so that all six can be converted into one vertical sync pulse.

One output of the sync separator stage feeds the sync pulses into a long R-C time constant vertical integrator circuit (Fig. 124).



Fig. 126. Block diagram of a vertical sweep section.

The time constant is chosen so that the capacitors store a negligible charge during the small pulse width of the horizontal and equalizing sync pulses, and there is a sufficiently large time be-

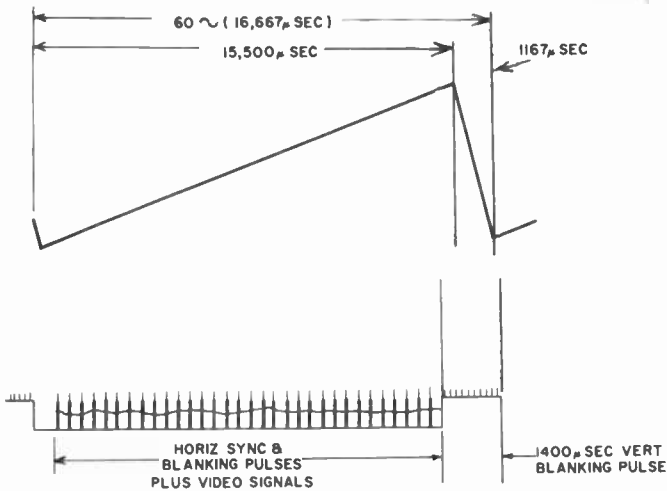

Fig. 127. Vertical sweep signal. Note the comparison of vertical sweep time to the composite video signals.

tween these pulses for the capacitors to discharge. The serrated vertical pulses, on the other hand, are much wider and the time between pulses is greatly reduced. Therefore, the capacitors build up a charge during the pulses and do not have time to do more than slightly discharge between them. This continues until the charge equals the maximum height of the serrated pulses. After the serrated pulses, when the equalizing pulses again appear, the charge drains off. The vertical sync pulse shown in the lower part of Fig. 124 is the waveform generated. Note the step-like characteristic of the waveform.

### Horizontal sync pulses

The leading edges of the pulses shown in Fig. 123 are used for horizontal synchronization. However, since the serrated vertical sync pulses are very wide compared to the time between pulses, the horizontal output of the sync separator stage must not allow a pulse buildup during that time. To prevent this the horizontal separator is made up of a short R-C time constant differentiator

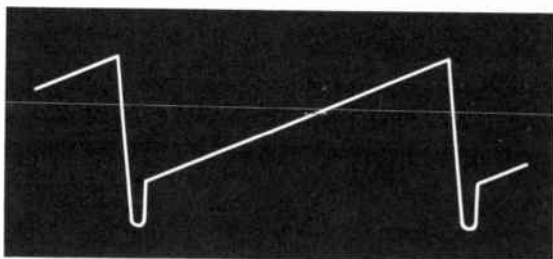

Fig. 128. Vertical oscillator signal. The negative-going spike is not always needed.

circuit (Fig. 125). The differentiator circuit produces the horizontal sync signals shown in the lower part of the diagram.

### Vertical sweep section

The vertical sweep section (Fig. 126) contains a vertical oscillator and a vertical output stage. The oscillator stage generates a voltage whose frequency is synchronized by the vertical sync signal. (When the receiver is not tuned to a station, no sync pulses are received and the oscillator is free running.) The oscillator output is applied to the vertical output tube, which produces a vertical sweep current in the vertical deflection yoke.

### Vertical sweep signal

The vertical sweep signal is shown in Fig. 127. Essentially it is a linear sawtooth current wave that occurs at a 60-cycle rate or every 16,667 microseconds. The linear rise of current sweeps the beam in the picture tube from top to bottom in 15,500 microseconds; the rapid fall of current retraces the beam to the top of the picture tube in 1,167 microseconds. The retrace time of the sweep signal is triggered by the vertical sync signal and finishes just after retrace ends. Vertical blanking time takes about 1,400 microseconds.

### Vertical oscillator signal

Fig. 128 shows a typical vertical oscillator signal. It is essentially a sawtooth voltage wave riding on a dc component, with a nega-

tive spike of voltage occurring after retrace time. The complete signal is known as a trapezoidal waveform, but its frequency and rise and fall times are the same as for the vertical sweep signal.

The dc component and spike voltage of the trapezoidal wave are necessary to overcome the inductive reactance of the vertical output stage to obtain the linear vertical sweep signal. For output stages with a high inductive reactance, a high dc component and spike are needed and vice versa. In general, triode output stages have more inductance to overcome, whereas pentode and beam power output stages have lower inductance because the high plate resistance of the tube makes the inductance of the output circuit almost negligible. Therefore, with pentodes and beam power output stages, very little or even no dc component and spike voltage are needed, and the vertical oscillator signal looks just like the vertical sweep signal.

### Horizontal sweep section

The horizontal sweep section (Fig. 129) contains, basically, automatic frequency control (afc), horizontal output and damper stages.

The frequency of the oscillator signal is stabilized by the horizontal afc signal. The afc stage receives two signals — a horizontal

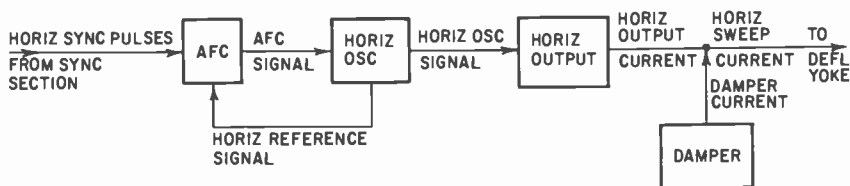

Fig. 129. Block diagram of a horizontal sweep section.

reference voltage from the oscillator and a horizontal sync signal from the sync section. The afc stage compares the two to see if the oscillator is working at the right frequency and sends a corresponding afc signal to the oscillator. If the reference signal shows that the oscillator is drifting from the proper frequency, the afc stage changes the afc signal, causing the oscillator frequency to return to normal. Fig. 129 shows the reference signal coming from the oscillator, but it can also be supplied by the output stage depending on the type of afc circuit used.

The horizontal oscillator signal is amplified in the horizontal output stage. The output current is sent to the horizontal windings in the yoke around the neck of the picture tube. This output

current produces only approximately the last two-thirds of the horizontal sweep on the right side of the raster. The horizontal output signal, though, also initiates the action of the damper

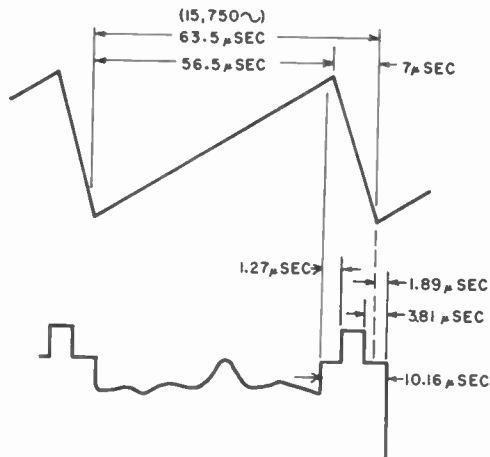

Fig. 130. Horizontal oscillator signal. Retrace should occur completely within blanking pulse time.

stage. This stage sends a damped current to the yoke to produce approximately the first third of the horizontal sweep on the left

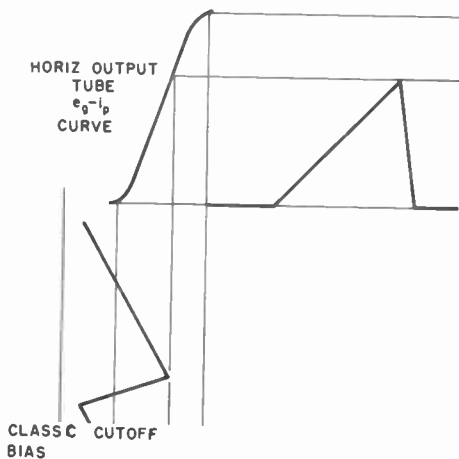

Fig. 131. Horizontal output current. Because the output stage is operated class-C, only the upper part of the sawtooth waveform causes conduction.

side of the raster. The output and damped currents combined make up the horizontal sweep signal to sweep the beam in the picture tube the full width of the raster.

### Afc signal

The afc signal applied to the horizontal oscillator stage is a dc control voltage that varies according to the results of the com-

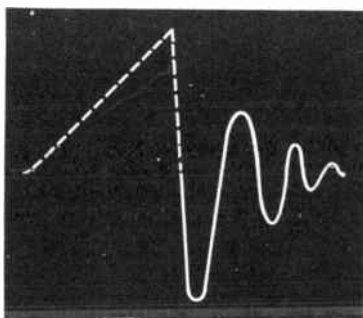

Fig. 132. *Without damping, the horizontal output would oscillate after retrace.*

parison of the horizontal sync signal with the horizontal reference signal. However, an intermediate afc signal is also considered to exist at the input to the afc stage. This is the ac waveform that results from combining the sync and reference signals. The form this signal takes differs considerably depending on the type of afc circuit used.

### Horizontal oscillator signal

The horizontal oscillator signal is shown in Fig. 130. In general,

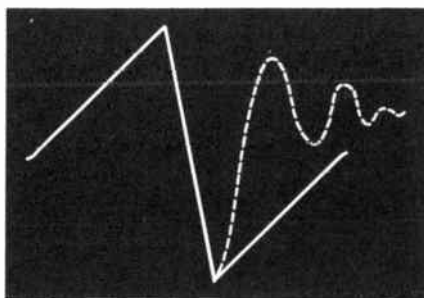

Fig. 133. *The damped oscillation results in a linear current rise.*

it is the same type of sawtooth waveform as used for the vertical sweep signal (Fig. 127) except that it occurs at a 15,750-cycle rate or every 63.5 microseconds. It has a linear voltage rise during a sweep time that takes 56.5 microseconds, and a fast fall time during retrace that takes 7 microseconds. Fig. 130 also compares the oscil-

lator signal with the composite video signal. Retrace starts with the leading edge of the horizontal sync pulse. The blanking pulse starts 1.27 microseconds prior to retrace, and continues to 1.89 microseconds after the start of the next sweep rise.

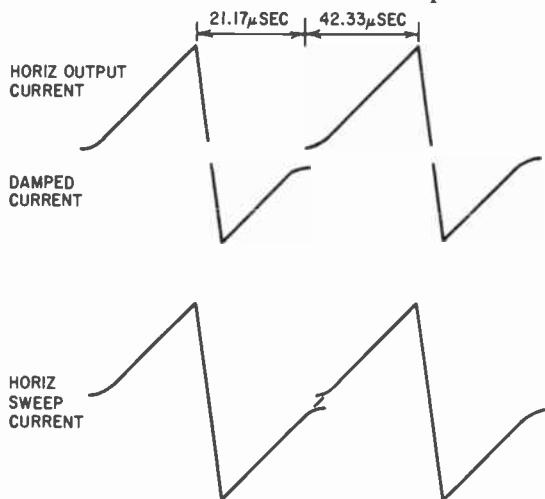

Fig. 134. The combination of the horizontal output and damped currents produces the linear horizontal sweep current.

### Horizontal sweep signal

The horizontal sweep signal is produced by the combined currents of the horizontal output signal and the damper signal. The time available for sweeping each horizontal line is only 63.5 micro-

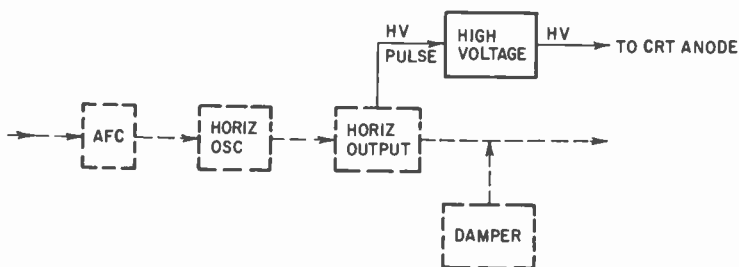
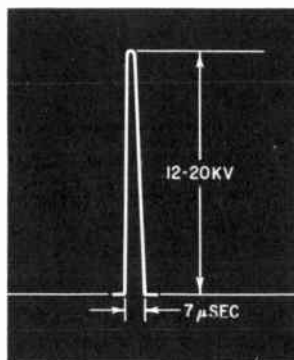

Fig. 135. The high-voltage section is triggered by the horizontal sweep section.

seconds. During this short time, there must be a wide change in sweep current, and producing this change in a short time is difficult. Therefore, two separate smaller signal currents are generated and then combined to produce the wider current change.

The horizontal output tube is operated class C. As a result, the entire oscillator signal cannot be amplified in the output stage. Only its more positive portions which overcome the cutoff bias of the tube produce the horizontal sawtooth output current pulses

Fig. 136. High-voltage pulse.



(Fig. 131). This current is sent through the horizontal output circuit to the yoke.

The horizontal output circuit is highly inductive. Therefore,

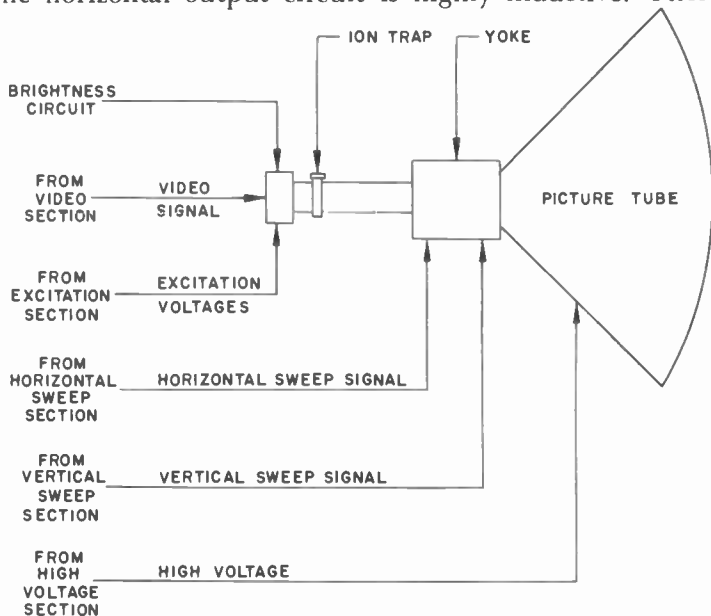

Fig. 137. Block diagram of typical picture-tube circuits.

during the rapid fall of the output current, an inductive kickback tends to make the circuit oscillate for a few cycles. Without the damper, oscillations would occur as shown in Fig. 132. The initial



oscillation, a highly negative pulse, is allowed to occur because it aids retrace. But as the oscillations start going positive, the damper tube conducts and damps them producing a linear current rise

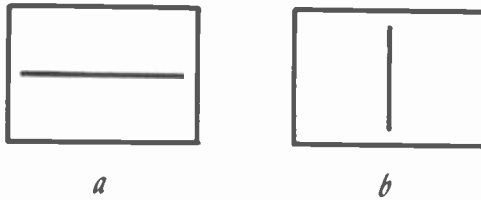

Fig. 138. The horizontal sweep current alone would produce a thin white line across the screen (a); the vertical sweep current, a line down the screen (b).

instead (Fig. 133). This waveform occurs in the time between the sawtooth pulses of the horizontal output signal. The damped current is then combined with the output current (Fig. 134) to produce a linear horizontal sweep current.

The output current portion of the sweep signal covers two-thirds

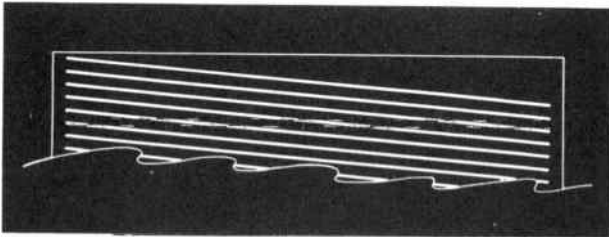

Fig. 139. Together, the horizontal and vertical sweep currents produce a number of horizontal lines swept downward.

of the screen on the right side, while the damped current sweeps the first third of the raster. The horizontal output sawtooth pulse is therefore approximately 42.33 microseconds wide, and the damped sawtooth pulse about 21.17 microseconds. The one-third and two-third sharing of the raster is nominal and depends on the circuit design. It may well vary up to half and half.

### High-voltage section

The high-voltage section can be considered part of the horizontal sweep section because it is directly triggered by it. As shown in Fig. 135, only the high-voltage stage is added to the horizontal section to produce the high anode voltage for the picture tube.

High voltage operation depends on the high inductive kick-

back that takes place during retrace time in the horizontal output circuit. As will be shown in a later chapter, the horizontal output circuit has a transformer with a stepup winding for the

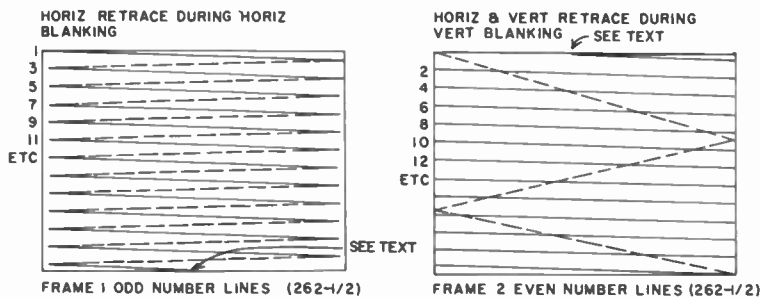
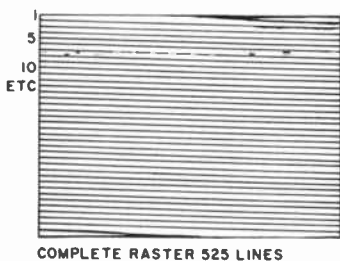

Fig. 140. Two vertical frames are used to complete one picture. The odd-number frame and the even-number frame are interlaced to create the complete 525-line raster.



high-voltage section. As the horizontal output current drops off suddenly during retrace, the inductive kickback in the output transformer produces a positive high-voltage pulse. The transformer then steps this up to between 12 and 20 kv, depending on the size of the screen. The high positive pulse is rectified then by

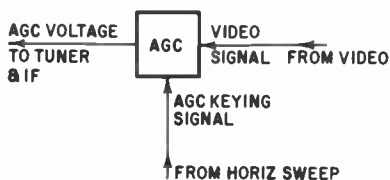

Fig. 141. Block diagram of an agc section. The keying signal is not always used.

the high-voltage section, filtered and sent to the anode cap of the picture tube.

### High-voltage pulse

The high-voltage pulse is simple, as shown in Fig. 136. It is very high and narrow. Since it is produced during horizontal retrace

time, the pulse is approximately only 7 microseconds wide.

### Picture tube and related circuits

As shown in Fig. 137, to work properly, the picture tube needs low voltage dc for the electron gun (including brightness and, possibly, the focus element) a high dc anode voltage, horizontal and vertical sweep signals and a video signal input.

With the application of the low and the high anode dc voltages, an electron beam is produced within the picture tube.

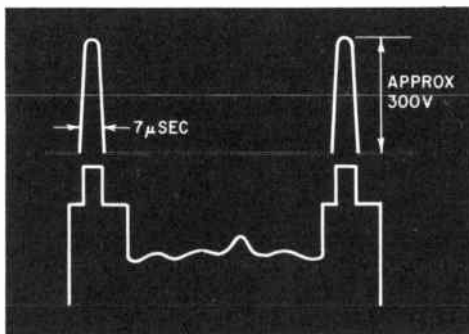

Fig. 142. The agc keying pulse occurs during horizontal blanking time and is similar to the flyback pulse.

The horizontal and vertical sweep signals applied to the yoke sweep the beam from side to side and up and down to produce the raster. The brightness circuit provides an adjustable voltage that allows the raster to be set at a pleasing level. The video signal applied to the picture tube modulates the electron beam to create the picture on the raster.

### Raster

The electron beam by itself produces a small spot in the center of the picture tube screen. If only the horizontal sweep signal were applied, the spot would be swept from left to right to produce a white line (Fig. 138-a). If we could have only the vertical sweep signal, the spot would be swept from top to bottom (Fig. 138-b). With both sweep signals, the spot moves both horizontally and vertically at the same time. However, since the horizontal sweep frequency of 15,750 cycles is much faster than the vertical sweep frequency of 60 cycles, full horizontal lines are produced during very small vertical movements. In effect, the horizontal lines slope downward slightly because of the vertical sweep, and each successive horizontal line starts just beneath the previous line (Fig. 139).

The raster for one complete picture contains 525 lines. For a horizontal sweep frequency of 15,750 cycles, this would require a 30-cycle vertical sweep. This low vertical sweep frequency, however, would produce flicker. To offset this, each picture raster is made up of two frames of  $262\frac{1}{2}$  lines each. As shown in Fig. 140, the vertical sweep first produces all the odd-numbered lines. The following vertical sweep then produces the even-numbered lines. The even-numbered lines are created in the space between the

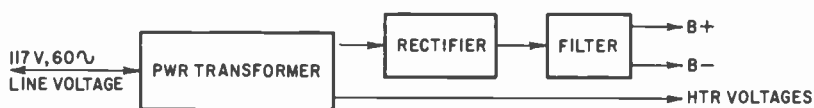

Fig. 143. Block diagram of a power supply section. This section varies little from one set to another.

odd-numbered ones so that, for every two vertical sweeps, 525 horizontal lines are created. This is known as interlaced scanning and, since the picture at the studio is broken down the same way, the complete original picture is reproduced. As a result of interlaced scanning, a complete picture can be sent every  $1/30$  second, but the raster frames are produced every  $1/60$  second, so flicker is eliminated.

Since each frame contains  $262\frac{1}{2}$  lines, it cannot contain all whole lines. The last line of the first frame and the first line of the second are each half lines. Also, since the horizontal scanning time is fast compared to the vertical retrace time, some horizontal lines are lost during vertical retrace time. These lines cannot be seen on a normal raster because the vertical blanking pulse blanks the picture tube during vertical retrace time. The dotted lines shown with the horizontal scanning lines are horizontal retrace lines. These also cannot be seen on a normal raster because the horizontal blanking pulse blanks the picture tube during horizontal retrace time.

### Agc section

The agc circuit is generally a simple stage as shown in Fig. 141. It must change the gain of the tuner and if amplifier whenever the rf signal varies in amplitude, so that the video signal going to the picture tube will be kept relatively constant.

The agc stage accomplishes its function by measuring the video signal output of the detector or first video amplifier. It then sends an agc bias voltage to the rf stage in the tuner and to one or more if stages.

The agc stage actually measures the peak amplitude of the video signal, represented by the sync pulses. However, when noise pulses are present, they may control the agc bias voltage regardless of any composite video signal amplitude. As a result, many receivers use a system called keyed agc, which measures only the strength of the sync pulses. This is accomplished with an agc keying signal from the horizontal output stage. The agc stage cannot measure the video signal until it receives the agc keying signal. This keying signal is a pulse that occurs during horizontal retrace time, which is the same time that the horizontal sync pulse (and blanking pulse) occur.

Fig. 141 shows the video signal being taken from the video amplifier. It could be obtained from any part of the video section, depending on the amplitude required. Also, the agc keying signal is not always used. Other types of agc systems will be explained in a later chapter.

### **Keying pulse**

The keying pulse is a small version or a sampling of the inductive kickback voltage generated in the horizontal output stage during horizontal retrace time. As shown in Fig. 142, the pulse is about 7 microseconds wide and approximately 300 volts high. Its timing in relation to the composite video signal is also shown in the diagram.

### **Power supply section**

The low-voltage power supply section (Fig. 143) provides the voltages and currents used by all the circuits of the television receiver. The low-voltage power supply steps up the line voltage, as required, then rectifies and filters it. The resulting dc voltage is sent to the receiver's circuits at the required B-plus and B-minus levels. Filament voltages for all of the receiver's tubes are also made available, except for the high voltage rectifier tube.

# component failure— tubes, rectifiers, diodes and transistors

**T**HIS and chapters 3 through 5 analyze all of the component parts used in a television receiver. First, the construction of the parts is given; then, how the parts become defective; and finally, how the various defects change the characteristics of the components.

## **Electron tubes**

About 90% of all television problems result from electron-tube failures. There are many types of tubes: diodes, triodes, tetrodes, pentodes, miniature, metal, etc. The construction points of interest in all of them, however, are more or less similar. This detailed discussion will concentrate on the miniature pentode; much of the data applies to the other types.

## **Tube construction**

The miniature pentode is basically constructed as shown in Fig. 201. It contains six functional elements: heater, cathode, control, screen and suppressor grids and a plate or anode. These parts are located physically as shown in the diagram. Besides these basic functional elements, the tube also contains a number of structural and connecting parts.

Insulating spacers are located at the top and bottom of the assembly to hold the elements in place. The cathode and plate are supported directly by the spacers, but the three grids (which are fragile) are each held in place by two vertical support insulators. In addition, spacer shields are placed above and below the insulating spacers. The getter is welded in place over the top spacer

shield. Wire leads connect the tube elements to the stem assembly, which supplies the pins to the outside circuits through individual glass seals. The wire leads connecting the elements to the stem pins are welded in place. The tube envelope is sealed to the stem assembly to complete the tube.

For the tube to function properly: (1) The heater must heat the cathode; (2) The cathode must emit sufficient quantities of electrons; (3) The grids and the plate must control the electron flow according to the tube's characteristics.

### **Tube failure**

Electrically, the tube fails most often because the heater opens. This happens in the normal course of events because the filament has reached the end of its useful life. The filament goes through a normal process of deterioration due to the high heat it develops.

The next most common reason for electrical failure is the loss or reduction of cathode emission. The cathode is coated with a material that emits electrons when it is heated. After a time, the electron supply of the emitting material is depleted. Because of the high heat, the control grid sometimes undergoes a chemical change and emits electrons instead of just controlling the flow of electrons from the cathode.

Mechanically, the tube can fail in many ways. The wire leads that connect the tube elements to the pins can break from their welds or loosen to form a high-resistance connection. The supporting parts, such as the insulating spacers, shields and support insulators can become loose and allow the elements to move and perhaps short. The getter, too, which is also welded in place, can become loose.

The seal between the tube envelope and stem assembly or around the individual pins can develop a leak. A microscopic crack in the envelope and stem assembly also can cause a leak.

Fatigue of the parts is another cause of trouble. After a time, structural strength is diminished. The heater and grid wires sag, move, and perhaps short to other elements.

### **Tube failure effects**

If the tube filament opens, of course, the tube will go dead. If cathode emission is reduced, however, the effects are more subtle, depending on how much the emission is lowered. For only slight reductions in emission, waveform distortion might result—there might not be enough peak-load electrons available for the control grid to have linear control of the current. When the emission is considerably reduced, the tube will saturate easily and clamp the

positive peaks of waveforms. The power output of current amplifiers will also be reduced.

When control-grid emission develops in a tube, the bias of the tube is upset because the flow of electrons in the grid circuit drives the grid positive. This usually causes considerable distortion and waveform clamping. The tube will also run much too hot and fail more rapidly.

If the weld on any wire lead fails, the element with which it is

Fig. 201. *Miniature pentode construction. The tube is evacuated and sealed. The plate, which completely surrounds the inner section, is cut away to show the heater, cathode and grid structures.*

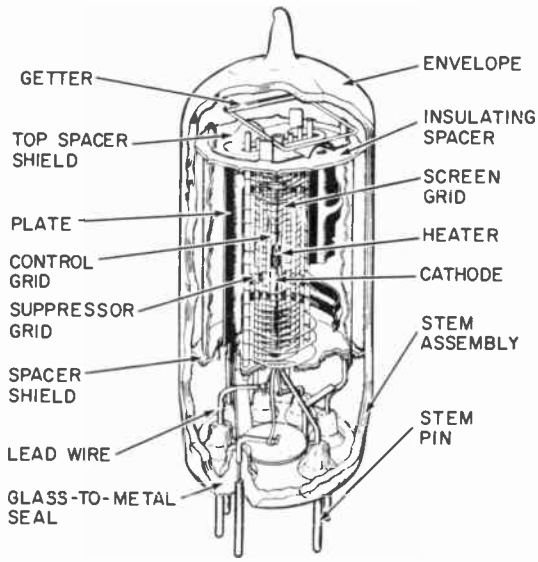

associated will become an open circuit. If a weld develops into a high-resistance connection, the tube characteristics will be affected. The filament may run cooler, causing low cathode emission. The defective weld can put an effective resistance in the cathode circuit, causing too much bias. Grids, too, can lose part, if not all of their effectiveness. Plate voltage can drop and the plate might run too hot because of increased  $I^2R$  (power) losses.

If the supporting structure becomes loose or the elements loosen because of fatigue, the parts will respond to the slightest vibration – someone walking across the room, or the vibration of the tube envelope or chassis due to the television sound. When the elements move or vibrate, they change the interelectrode capacitances of the tube; specifically, any motion of the control grid wires will



modulate the electron flow accordingly. This will inject microphonic noise in the signal which may appear as a howl in the sound, interference bars in the picture, or erratic sweep or synchronization.

If structural fatigue is severe, more serious trouble can develop. If the heater touches the cathode, the ac filament voltage will be impressed on the cathode to create hum problems. If a high-voltage element such as the screen grid moves enough to short a low-voltage element such as the control grid, the tube can become completely inoperative, and the current flow from such a short can burn out some circuit parts.

The getter dissipates the gases that develop in the tube during normal usage. Because of heat, chemical reactions take place that produce gas. The anode voltage is applied to the getter which, in effect, reacts with these gases to dissipate them. If the getter loosens from its weld, it will not function. Gas will build up in the tube and the control grid will be unable to control the electron flow. Also, the tube will operate too hot and eventually destroy itself. If the getter breaks loose from its support altogether, it might fall and short the tube elements.

If a microscopic crack occurs in the envelope or stem assembly, or if a leak develops in the stem seals, air will seep into the tube and oxidation will probably burn out the heater.

Tubes are designed so that the structural members give good support only when the tube is positioned in a specific way. Television manufacturers keep this in mind when they locate the tubes on the chassis, and the service technician should also keep it in mind when he stores tubes on the shelf. Tube manuals generally give this information.

### **Octal tubes**

All of this information also applies to octal tubes. Octal tubes do differ in one respect, however. As shown in Fig. 202, a bakelite base is added to the stem assembly. The stem pins then are soldered into the base pins and the base is held in place with cement. At times, the solder in the base pins makes a bad connection and causes intermittent operation. When this occurs, it can usually be remedied by heating the base pins and adding solder to them.

### **Cathode-ray tubes**

The supporting structures and connecting methods of the electron gun in a cathode-ray tube (CRT) are essentially similar to

those of ordinary electron tubes. As shown in Fig. 203, two ceramic insulators hold the gun elements in place. A support with four spring spacers holds the end of the gun assembly firmly in place within the neck of the tube. The spring spacers, which are metallic, also serve as contacts; they connect the accelerator electrode electrically to the Aquadag coating which covers the inside surface of the picture tube. The Aquadag serves as the high-voltage anode for the tube and is connected to the metal anode socket provided on the outside of the CRT bulb.

On many tubes, an Aquadag coating is also used on the outside of the glass shell. The inner and outer coatings form a capacitance of from 500 to 2,000  $\mu\text{f}$ . Spring clips from the yoke mounting are used on these tubes to ground the outer Aquadag coating to form an automatic high-voltage filter capacitor from the CRT anode to ground.

Fig. 202. *The octal tube, although larger, is constructed similar to the miniature tube, and then is placed on a bakelite base.*

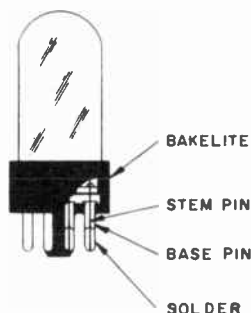

Welded leads connect the gun elements to the stem pins, which are soldered to pins in a bakelite base similar to octal tubes.

The CRT screen is a phosphor coating on the inside faceplate of the tube. The phosphor screen glows when it is struck by the electron beam. On some types of CRT's, an aluminum film is used over the screen to prevent ions from reaching it.

### **CRT failure**

Electrically and mechanically, the CRT can fail in much the same manner as ordinary electron tubes: The filament can open. The cathode can lose emission and welds on the wire leads can become defective. Solder connections in the base pins can become bad. Supporting parts and the getter can become loose. The heater can loosen from fatigue. Microscopic cracks in the glass or the seals can cause leaks.

In addition, because of its construction features, some other

unusual problems can develop. The Aquadag coating inside the tube sometimes flakes off and the particles may fall into the gun elements and cause short circuits. The Aquadag on the outside can flake off, too, particularly at the grounding-clip connections.

There is a small limiting aperture in the end of the accelerator electrode through which the electron beam passes. If the ion trap around the neck of the tube is not properly adjusted, the beam strikes the sides of the aperture and slowly burns it away. This distorts the aperture opening, which in turn distorts the shape of the beam.

### **CRT failure effects**

Although CRT failures are similar to those of ordinary tubes, their effects are considerably different.

If the filament opens, of course, the CRT will go dead, as do ordinary tubes. When cathode emission is reduced, the brightness of the raster will be decreased. Generally, an adjustment of the brightness control will compensate for a slight loss of emission. But, if there is a serious loss of emission and the brightness control is adjusted to compensate for it, the change in the operating point on the CRT characteristic curve will cause too much beam current. The white areas on the phosphor screen are over-driven and take on a silvery hue. In this condition, the higher the brightness control is turned, the more silvery the picture. Yet at a low brightness level, the picture appears normal. Generally, the brightness and contrast of the picture are set at a compromise level.

If the welds on the wire leads become totally defective, the associated circuits will fail. If the welds develop a high-resistance connection, the characteristics of the CRT will be affected. The filament can run cooler and cause decreased cathode emission. An added resistance can be placed in the cathode circuit, increasing the bias and causing a corresponding loss in brightness control.

Similar resistances in series within the other tube elements can cause them to lose part or all of their control over the electron beam, possibly reducing picture clarity.

Effects similar to those due to poor wire-lead welds can be caused by bad solder connections in the base pins.

If the supporting elements loosen, vibration of the gun parts will modulate the beam. If the cathode or control grid is loose, vibration will modulate the intensity of the beam and cause microphoniclike bars in the picture. If the CRT uses electrostatic focusing, vibration of the accelerating or focusing electrode will cause a microphonic focusing effect.

If the spring spacers that hold the gun assembly aligned become weakened, the entire gun may shift its position. This will cause picture centering to be erratic. And, if the gun alignment goes out far enough, the electron beam may strike the inside shoulder of the CRT to produce neck shadow which causes some edge of the raster to be lost. (This is similar to neck shadow caused by the yoke being set too far back from the shoulder of the tube.)

If the getter becomes loose or falls off, it will no longer function

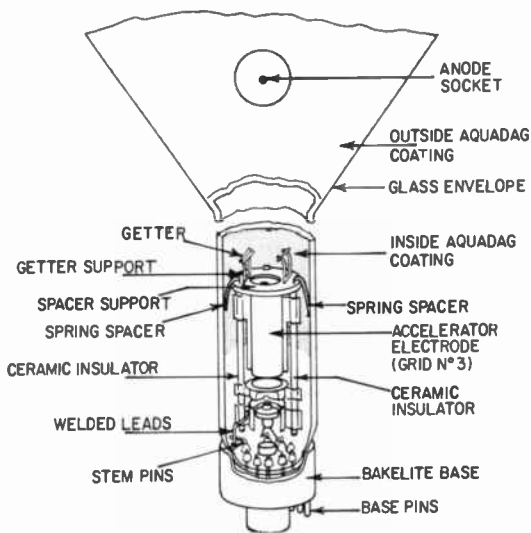

Fig. 203. Cutaway view of CRT, showing electron-gun and other construction details.

as a gas eliminator. Gas will form inside the tube and cause the silvery effect mentioned previously. Should the getter fall into the gun structure, it might short the gun elements. Loss of focus occurs if it falls between the focus and accelerating electrodes. If it shorts the cathode to the control grid, there will be loss of brightness control and, depending on the video circuit arrangement, the picture may also be lost. If the brightness circuit employs a bias control in the CRT's cathode, a short from the cathode to a grounded wire lead will also cause loss of brightness control. If the getter shorts a high-voltage electrode to a low-voltage electrode, an external circuit part might be damaged in addition to the CRT being made inoperative. Usually, the getter can be tapped loose easily to clear the short.

If the heater loosens due to fatigue, it can lean against the

cathode. If the cathode is being operated close to ground potential, the ac heater voltage will be placed on the cathode to produce a hum bar in the picture. If, however, the cathode is operated at a high potential, the filament probably will burn out.

Leakage at the seals or in the glass will allow some air to seep into the CRT and eventually destroy it.

If the Aquadag coating inside the CRT flakes off and falls into the gun assembly to cause shorts between the various gun elements, the effects will be the same as for the getter. Aquadag flakes are quite small sometimes and therefore cannot span the distance between elements. However, their position after they fall may decrease the distance between some of the elements. With high-voltage elements, this can cause arcing that will tear the picture. This type of arcing is usually quite audible and is also visible inside the neck of the tube. Aquadag flaking shorts can usually be “burned” out by the sudden momentary application of a voltage between the base pins going to the affected elements.

If the Aquadag coating on the outside of the tube flakes off at the grounding-clip connections, it will tend to charge to the CRT anode voltage. But as the charge builds up, the coating will discharge to the clips and cause intermittent arcing. This will tear the picture slightly, and will also be audible. This type of arcing is easily visible at the grounding clips. If the coating flakes to such a degree that it is completely separated from ground, its filter-capacitance effect will be lost. In many television receivers, since the Aquadag capacitance is the only filter capacitor used in the high-voltage circuit, regulation will become poor and the high voltage will go down as the brightness goes up. And, since the sweep is directly dependent on the amount of high voltage, the raster will get larger on all sides when brightness is increased (this is known as blooming).

If the aperture shape in the accelerator electrode is distorted by the electron beam, the beam spot will become distorted, too, and good focus of the raster might not be obtainable.

## **Semiconductors**

Semiconductors are nonlinear solid-state devices whose characteristics change in accordance with circuit conditions. This definition includes many components. This paragraph, however, is concerned only with those parts used for rectification, detection and amplification—selenium, silicon and germanium rectifiers, and diodes, and transistors.

## Semiconductor construction

The semiconductor rectifier has, to a great extent, replaced the 5U4-G as a low-voltage power supply rectifier. The semiconductor rectifier can be made of selenium or silicon. Selenium was the

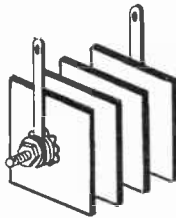
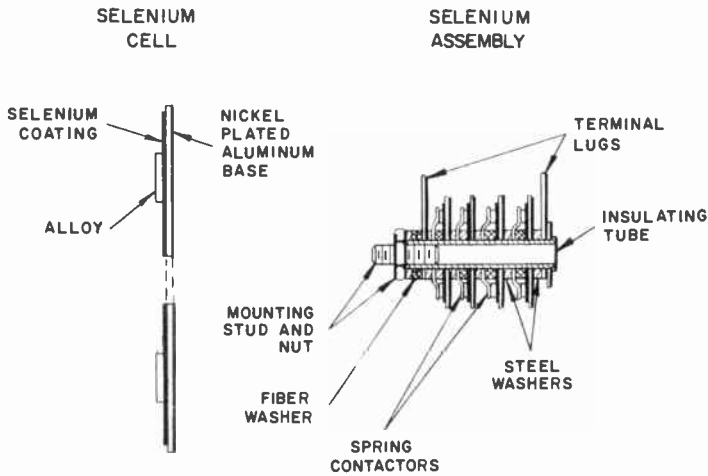

Fig. 204. Selenium rectifiers are made by stacking the basic selenium cells. In most sets, semiconductors have replaced the power supply rectifier tube.

first material used, and has been popular for a number of years. Silicon, although a relative newcomer on the semiconductor scene, has been gaining greatly in popularity, and might soon dominate in use. Selenium and silicon rectifiers can be stacked in the same way, but silicon can also be constructed as a small unit similar to the germanium or silicon diodes, covered later. The selenium rectifier will be described first.

The construction of a typical selenium rectifier is shown in Fig.

204. The basic selenium element is a nickel-plated aluminum base which is coated with selenium. A low-temperature alloy is sprayed over the selenium. The base is the negative electrode and the alloy the positive one. When current flows in one direction, the resistance of the unit is low, but its resistance increases about 100 times when the current goes in the opposite direction. The single selenium cell can only handle a limited voltage, so several cells are connected in series for use in a power supply. The cells are all mounted on an insulating tube with spring contactors and steel washers connecting the cells in series. Fiber washers are also strategically placed to prevent shorts within the cells. Terminal lugs at the ends of the stack make a pressure contact with steel washers. A mounting stud and nut hold the unit compactly.

The silicon rectifier is shown in Fig. 205. It uses a p-n junction to get its rectifying action, which is explained later for the diode. Generally, three different types of junctions are used: alloy, diffus-

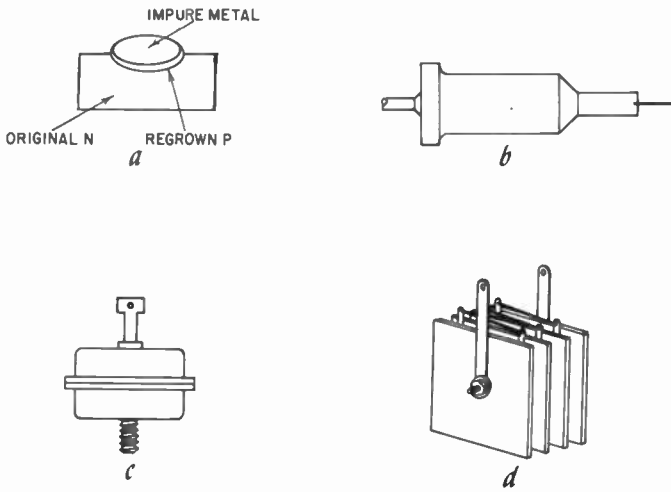

Fig. 205. Silicon rectifier construction (a). The unit can be lead-mounted (b), stud-mounted (c), or stacked like the selenium rectifier (d).

ed and grown. Fig. 205-a shows how an alloy junction is formed. A metal with the proper impurities, usually an aluminum alloy, is fused *onto* n-type silicon to produce a regrown p-type interface.

For the diffused junction, impurity atoms are diffused *into* a silicon wafer to produce a layer that forms a junction with the wafer. A grown junction is produced during the processing of silicon by the controlling of impurity concentrations in the unit.

The silicon rectifier is usually packaged as shown in Figs. 205-b, -c and -d. One type provides for mounting by its leads, and another type provides a stud for chassis mounting. These are usually single units sealed in a case. Wafer units are stacked to get the proper voltage rating in much the same manner as the selenium rectifier.

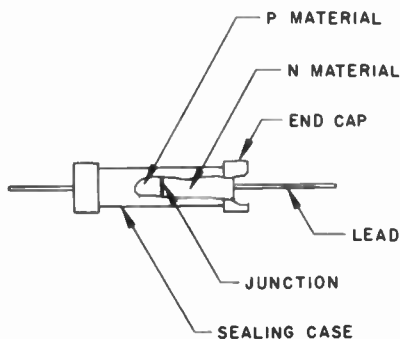

Fig. 206. Semiconductor diodes use p- and n-material joined together to obtain semiconductor action. These units must be completely sealed since they are affected greatly by moisture. Silicon or germanium can be used.

The semiconductor diode (Fig. 206) is made for small-signal rectification, such as in the video detector or horizontal phase discriminator. It, too, offers a low resistance to current flowing in one direction and a high resistance to current flowing in the opposite direction. Silicon and germanium are used in diode construction.

The semiconductor diode is a simple device. It uses a p-n junction to get the rectifying action. The p part of the diode has an excess of "holes," and the n portion an excess of electrons.<sup>1</sup> The opposite energy levels of the two materials sets up a barrier field at the junction that opposes current flow in one direction. The external leads are fused to the material so that they make exceptionally good contact. The entire unit is sealed to exclude moisture, and end caps are generally used to give added support to the leads.

For matched diodes, two are paired off at the factory to have

<sup>1</sup> For a more detailed discussion on hole theory, Rufus P. Turner, "Transistors — Theory and Practice," (Gernsback Library).



exactly the same resistance characteristics. This is necessary in special phase-detector circuits. Any two diodes, although they may be of the same type, almost always will be different enough not to work in a phase-detector circuit, unless they are specially matched.

The transistor (Fig. 207) is built similarly to the diode except that either a p-n-p or n-p-n semiconductor combination is used. The p-n-p type is discussed here.

Some types of transistors are the point contact, junction, and surface barrier. In the point-contact variety, now largely obsolete,

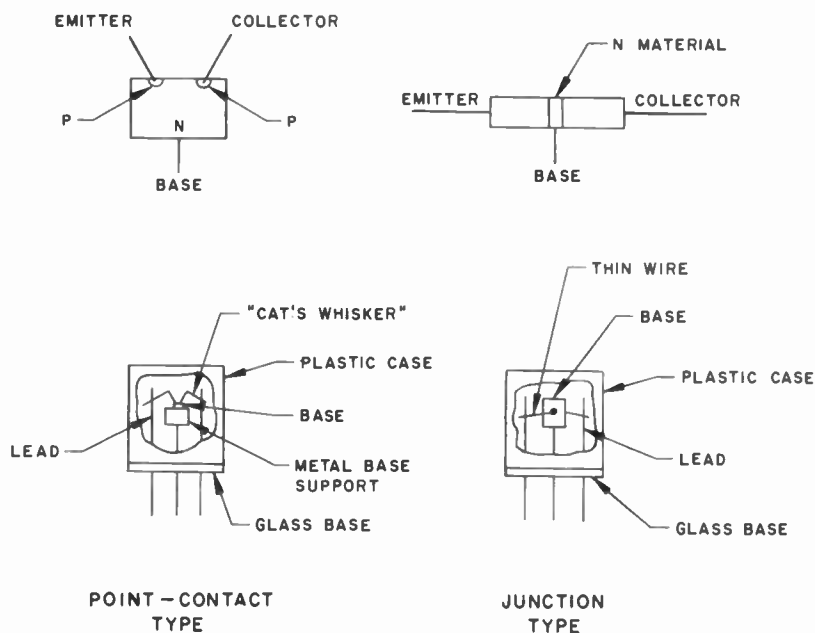

Fig. 207. Transistors can use either a p-n-p or n-p-n combination of materials. Some units plug into sockets and others must be soldered into place. The junction type of transistor is most common.

emitter and collector "cat's whiskers" are fused in the n-base material about .002 inch apart, and p material is produced around the end of each whisker wire. The whiskers are tack-welded to the leads running through a glass base. The n-base material is supported by metal, which also is attached to an external lead. The entire unit is imbedded in plastic.

The more widely used junction transistor is made in a similar manner except that the n-base material separates the p-type emitter

and collector materials. The base is about .001 inch thick. Thin wire leads imbedded in the materials are tack-welded to the external connecting leads, except for the base, which makes a pressure connection.

Since three layers are used, there are two junctions, each with a barrier field. Stated very simply, these barrier fields interact so that, when current changes in the emitter circuit, the impedance of the collector circuit will change accordingly.

### **Semiconductor failures**

Semiconductors fail mostly from heat and moisture. The heat can be ambient or due to an overload. It can cause chemical changes in the selenium-alloy junction in the selenium rectifier, or the p-n junction in the silicon rectifier, so that its forward, or low resistance is increased. Also, the back, or high resistance can be reduced. The series stack of cells can loosen, or the contacting surfaces on the steel washers, terminal lugs and spring contactors can corrode. Moisture settling in the cells can reduce the breakdown voltage.

In the germanium or silicon diode, the p-n charges can become reduced because of heat or age. This can also happen if the unit is overloaded with current. The resulting stress will change the molecular nature of the material to reduce the p-n charges. The wire leads can make poor contact and, if the seal is bad, moisture will settle in the unit. These same defects can occur in transistors.

Diodes and transistors are highly sensitive to temperature, so take care when soldering the units in place. Also, even a momentary current overload can cause a permanent characteristic change.

### **Semiconductor failure effects**

If the forward resistance of a semiconductor rectifier goes up, the unit acts more like a normal resistance, reducing its rectifying action. This causes the dc output voltage of the rectifier to go down. The output voltage will also decrease with a reduction in back resistance, but generally, since this also causes increased ac, the resulting overload might cause hum and probably will destroy the unit. With selenium, this back-current overload causes a chemical reaction that produces a foul-smelling poisonous smoke. If the stack becomes loose, the electrical pressure contacts will become poor and the added resistance will reduce the output voltage. If the contacts are poor enough, arcing will result or the unit will open. The same thing will occur if the contacting parts become corroded. If moisture settles in any cell, arcing will occur. This

can cause heat, changed resistances and the results explained previously.

If the p-n charges in a diode go down, the barrier field will follow it. The ratio of the forward-to-back resistance will be reduced so that the diode will become a poor rectifier. The detected output voltage will be lowered accordingly. If the wire leads make poor contact, the added resistance will also affect the forward-to-back resistance ratio, depending upon how bad the contact is. The diode can also open at the lead contacts. Moisture in the diode will change the semiconductor characteristics as well.

Small changes in most circuits have negligible effects, except when a matched pair is used. Even a very small change in one unit of a matched pair will unbalance the circuit enough to make it defective.

Any change in emitter—base—collector resistances of a transistor can have detrimental effects. How bad the effects will be, however, will vary a great deal depending on the amount of change and the type of circuit.

# component failure— capacitors and resistors

**C**APACITORS are the second most common troublemakers. There are many types used for many different applications. Capacitors

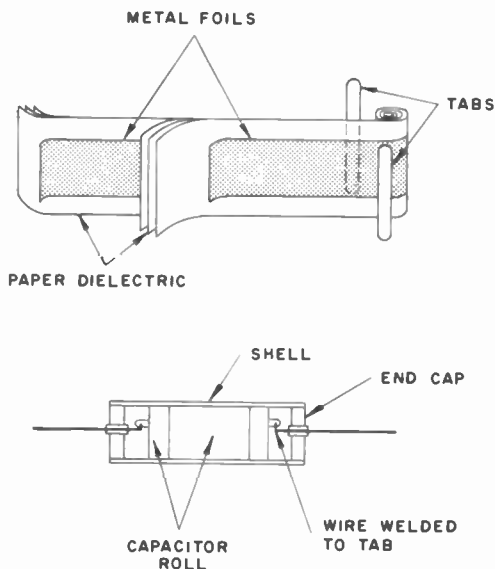

*Fig. 301. Roll construction of paper capacitors. The wires are welded to the tabs to provide for external connections, and the end caps and shell are sealed for protection against moisture.*

fall into numerous categories based on construction or use: paper, mica, ceramic, glass, electrolytic, trimmer, miniature and subminiature, tantalum, tubular, variable, bathtub, buffer, etc.

## Capacitor construction

As shown in Fig. 301, paper capacitors are made with two metal-foil electrodes (conductors) separated by a paper dielectric (insulator). The foils and paper are rolled to produce large elec-

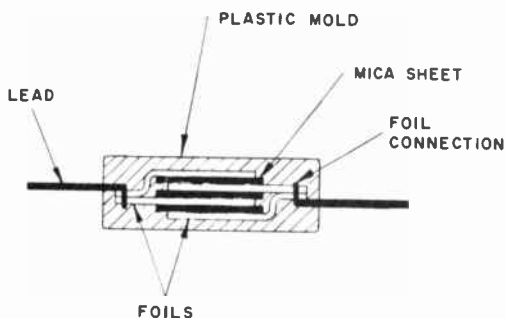

Fig. 302. Mica capacitors use a stack construction with mica sheets acting as the dielectric. Note that the alternate foils are connected together to form two plates. The entire stack can be encased in plastic or a similar material.

trode areas in a small space. The larger the length and width of the foils, the larger the capacitance. Usually, three sheets of paper separate the two foils. The number and thickness of the dielectric

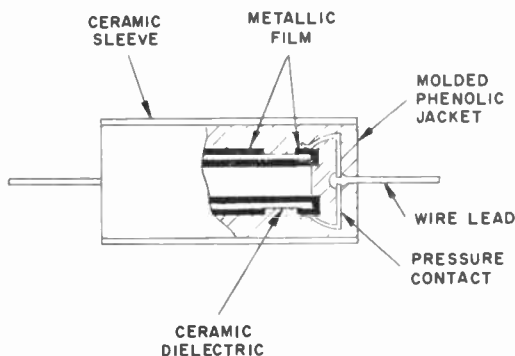

Fig. 303. One type of ceramic capacitor uses a cylindrical construction with metallic films deposited on the inner and outer surfaces. The wire leads can be connected to the films with pressure contacts that are held firmly when the jacket is molded in place.

sheets determine the breakdown voltage of the capacitor. The paper generally is impregnated chemically to raise the voltage-breakdown point.

Electrical connections to the foils are usually made with two tabs inserted in the roll, each in contact with a foil, or else a wire is soldered to each foil. The roll is inserted in a shell and insulator caps are placed at the ends. The shell can be metal, paper or a plastic mold. Many varieties of the basic paper capacitor exist. The dielectric can be a plastic film, or metallized paper can be used for both foils and dielectric.

The basic method of using dielectric insulators to separate conducting sheets is also used for all the other types of capacitors, except that stacks might be used instead of rolls.

Mica-foil capacitors (Fig. 302) use a stack of foils, with adjacent foils separated by a sheet of mica. The alternate foils are connected to form two effective plates. The leads are attached by pressure or soldering and the unit then is molded in plastic or ceramic. Silver-mica capacitors are made by coating silver onto the surfaces of the mica sheets; the silver then takes the place of separate foils.

Fig. 303 shows the construction of ceramic capacitors. Made by firing metallic films (generally silver), on ceramic dielectrics, they can be in tubular or disc form. Wire leads are attached by pressure

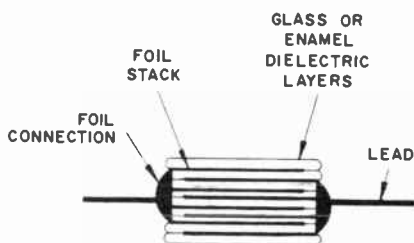

Fig. 304. Glass or vitreous-enamel capacitors are made similar to micas, except no molded jacket is needed.

or soldering. The entire unit is molded in a phenolic jacket or inserted into a ceramic sleeve. Sometimes, it is coated with varnish or plastic.

Glass or vitreous-enamel capacitors (Fig. 304) are made much like micas, except that alternate layers of glass or enamel are used in place of mica sheets. The leads are either welded or soldered to the plates.

Electrolytics are made in almost the same way as paper capacitors (Fig. 305) except that the paper is impregnated with an electrolyte and an oxide film is coated on one foil. This film acts like a rectifier. The foil containing it is the anode (plus) side of the electrolytic capacitor.

Trimmer capacitors (Fig. 306) are actually the same as other capacitors except that they are not sealed, and provision is made for changing the effective plate area or dielectric thickness. The most common type is that using mica sheets to separate metallic

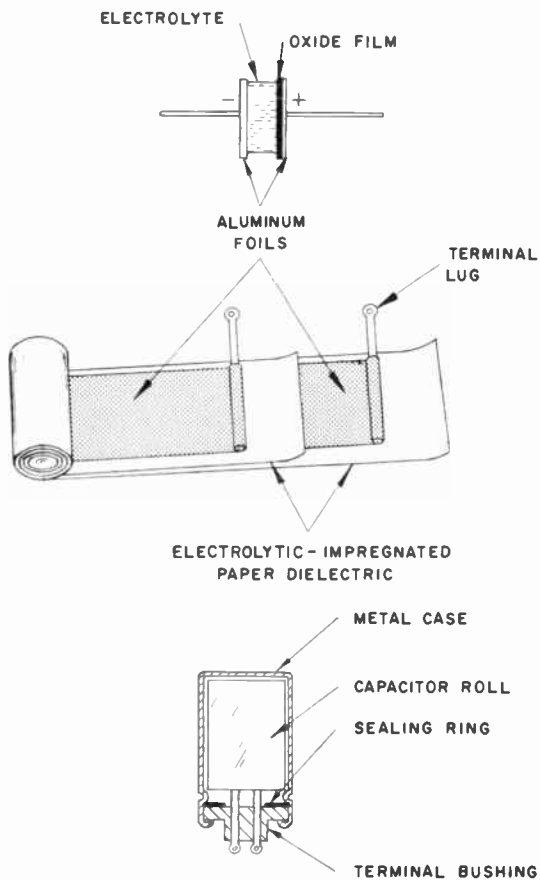

Fig. 305. *Electrolytic-capacitor construction. The oxide film is deposited on the anode foil, and the roll is enclosed in a rugged case.*

plates. A screw passing through the unit pulls the plates together to increase capacitance, or vice versa. Another type is ceramic coated with silver. These can be in disc or plunger form arranged so that only portions of the plate area are used as adjusted.

All normally-made capacitors possess a characteristic known as a positive temperature coefficient; their capacitance value goes up as temperature increases. In some critical circuits, this can present a

problem. In oscillators, for example, frequency will drift with the capacitance change.

With ceramic capacitors, the molecular construction of the ceramic dielectric can be made to produce varied temperature coefficients. It can be made to have a zero-temperature coefficient so that capacitance will remain constant regardless of temperature.

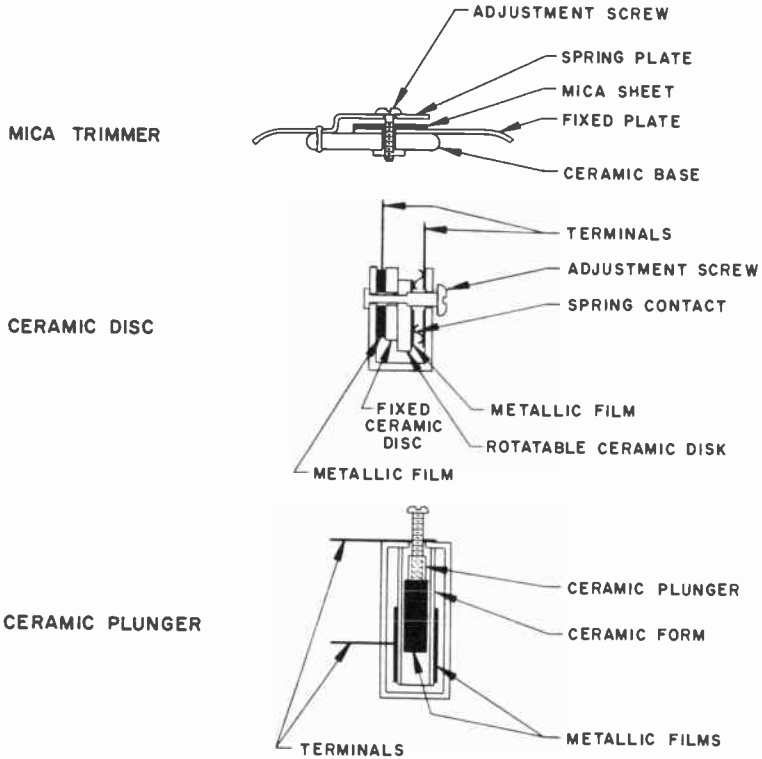

Fig. 306. Trimmers are not sealed and the distance or area between plates is adjustable. Spring plates are used for compressible trimmers; discs are used for the rotatable type, and cylinders for the plunger variety.

Or, it can have a negative-temperature coefficient so that capacitance goes down as temperature goes up. This negative-coefficient capacitor is used to compensate for the positive coefficients of the other parts in a circuit. Because they effectively neutralize the positive change by introducing an equal negative change, these ceramics are known as temperature-compensating capacitors. Except for the molecular structure of the ceramic dielectric, compensating capacitors are made the same as ordinary ceramics.



## **Capacitor failure**

Capacitors fail most often at the point where the leads make contact with the plates, particularly where only a pressure contact is used. After a while, the parts may warp, possibly from temperature, and make a poor connection. This can also occur if the capacitor is not sealed properly; the contact surfaces may become corroded. The contact can also become poor from abuse by bending the leads too close to the capacitor or soldering near the capacitor with too hot an iron.

Another common cause of failure is dielectric breakdown under the stress of voltage. Impurities in dielectric materials, particularly paper, may cause more ac conduction at one point. Too much heat develops at that point, reducing the insulation resistance of the dielectric and increasing its conductivity. This cycle continues until breakdown occurs and an arc between the plates is generated. In time, chemical changes also can reduce the dielectric strength to the point where it will fail. This will be accelerated if the capacitor is sealed poorly and moisture finds its way inside.

The dimensions inside the capacitor can change with time, mostly from the accumulated expansive effects of temperature. Usually warping of the plates occurs, increasing the space between them and reducing capacitance.

If arcing or corona tends to take place through the dielectric, carbon can form in its path to short the plates. In capacitors using silver film, a special type of failure known as silver migration can develop. The voltage across the capacitor causes a transfer of silver particles that eventually forms a short-circuit path across the dielectric. This tends to happen more often in high-voltage applications, and especially when moisture seeps into the capacitor.

Electrolytics can develop all of these troubles and, in addition, their electrolyte can become dry.

## **Capacitor failure effects**

If the wire contact inside the capacitor becomes bad, it can introduce a resistance at that point or open completely. If it opens, the capacitor will lose its function in the circuit; it will no longer couple, bypass, filter, shape waves or do whatever it is supposed to do. If the connection merely develops resistance, the effectiveness of the unit will be reduced. Lower effective capacitance will result because it is now more of an R-C network. It will not bypass or couple the lower frequencies and possibly may cause distortion, particularly in wave-shaping networks. In oscillator circuits it will

cause frequency shift or, if it is used as a feedback capacitor, oscillation may stop.

If the dielectric breaks down, arcing within the capacitor will take place. If the arcing is just momentary, noise will be generated and radiated; it will be heard in the sound and seen in the picture and will upset synchronization. When arcing takes place, carbonization usually follows, producing a short circuit. The capacitor

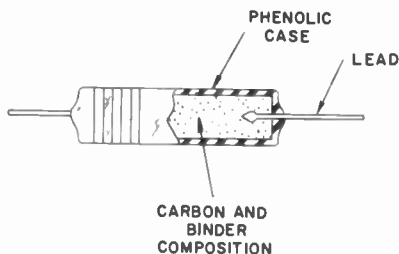

Fig. 307. The composition resistor is a solid casting of a resistive compound. Note that the wire lead is anchored within the composition body.

will then act just like a wire and will burn out other parts in circuits where it is connected between high and low voltages. Often, the conducting path between plates is not a complete short but a resistance. In such a case, the capacitor will act like a resistor. It will pass dc voltages instead of blocking them and will couple instead of decouple. The actual effect, of course, will be determined by the amount of resistance added to the capacitor. Silver migration produces the same effects as a carbonized path.

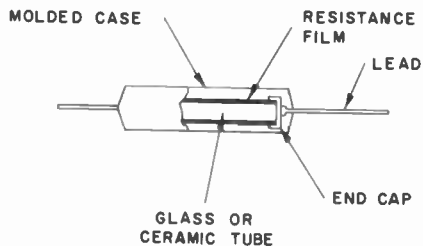

Fig. 308. The film resistor is made with a thin resistance material deposited on an insulator.

When capacitance values change because of internal plate warping, the capacitance almost always goes down, producing the effects on the circuit that were explained previously.

When the electrolyte in an electrolytic capacitor dries out, the capacitance goes down proportionately. Since electrolytics are mostly used in power supply filter circuits, hum will develop.

Chemical changes in the dielectric material of a temperature-compensating capacitor will change the capacitance-drift characteristics — the capacitor will no longer neutralize the positive drift of the other parts. Since these capacitors are used mostly in oscillator circuits, frequency drift will occur.

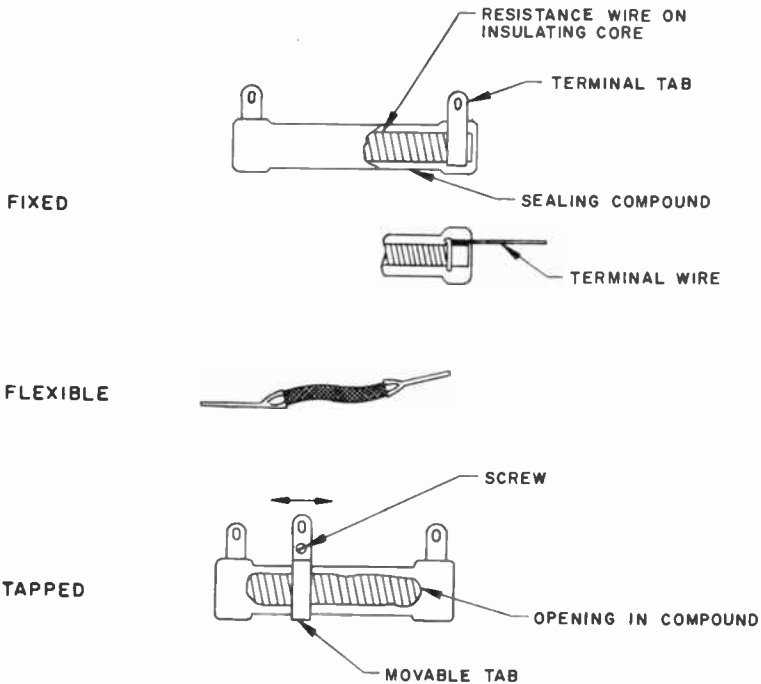

Fig. 309. Wirewound resistors. Either tabs or wires can be used for terminals. The movable-tab type shown is used only where infrequent adjustments are needed.

## Resistors

The most common types of resistors used fall into various categories: variable, fixed, composition, film, fuse-resistors, surge resistors, wirewound, tapped, chassis-mounted, high voltage, etc.

### Resistor construction

The composition-type resistor shown in Fig. 307 is the most common. Basically, it is a solid unit composed of a carbon resistance material molded within a phenolic case. The leads are imbedded in the composition material during the molding opera-

tion. The resistance of the unit is determined by the percentage of carbon material and the amount used in the composition.

The film resistor (Fig. 308) is made by depositing a film of resistance material on an insulating form, usually a glass or ceramic tube. At each end of the glass or ceramic form is an end cap and lead which contact the resistance film. An insulating tube is molded around the unit. The resistance film can be a carbon composition, evaporated metal or metal oxide. The resistance of the unit is determined by the material used in the film and the amount of film deposited on the tube.

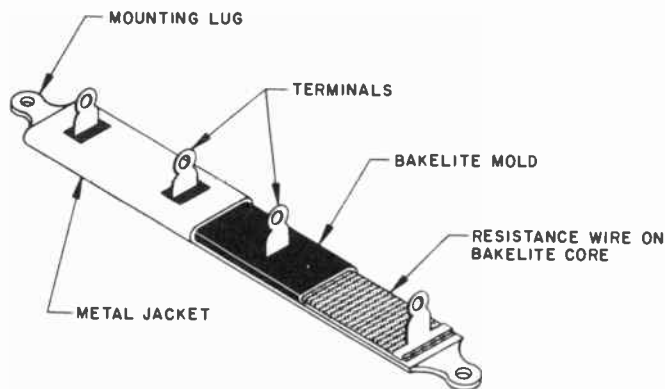

Fig. 310. The chassis-mounted wirewound resistor is encased in a metal jacket that is kept relatively cool by the chassis.

Wirewound resistors (Fig. 309) are very simple devices. They are made by winding resistance wire (usually Nichrome) on an insulating core (generally ceramic). The core can be flat or round, and the resistor is coated with a sealing compound. The ends of the resistance wire make pressure contact with either metal tabs or wires for external connections. The resistance of the unit is determined by the diameter, length and type of resistance wire used.

Wirewound resistors can also be made in a flexible form by winding the wire around an asbestos form and covering the unit with a braided material.

The ordinary wirewound resistor can be tapped merely by adding another tab or wire terminal along the length of the resistance wire.

As shown in Fig. 310, chassis-mounted resistors are specially made wire-wound units that have a much higher power rating than ordinary wirewound resistors, which are mounted in air. The resistance wire is wound on a bakelite core which then is molded

within bakelite. The entire unit then is encased in a metal jacket. The resistor terminals connect through holes in the metal jacket, and the jacket has mounting lugs for attaching the unit to the chassis with rivets or nuts and screws. Since this resistor is directly attached to a metal chassis, its heat is dissipated by the chassis. It operates cooler than an air-mounted resistor of the same size, thus, can have a higher power rating. Therefore, when a chassis-mounted unit is replaced by an air-mounted unit, the latter will probably be twice as large as the chassis-mounted unit.

High-voltage resistors (Fig. 311) are specially made film resistors designed for high-voltage doubler circuits. High-voltage doubler resistors need high resistances. Therefore, the resistance film is made thin, narrow and long so that it offers more resistance to the current flow. To keep the length within reason, the resistance film is deposited spirally around the ceramic form.

### **Resistor failures**

Resistors fail in four principal ways: they open, change value, become noisy and form arcs. Unlike the capacitor, a bad resistor is usually easy to spot. It fails mostly from too much heat. When this happens, it smokes and becomes charred and discolored; it might even crack or break. Generally, resistors do not fail by themselves. They usually break down because some other part in the circuit has become defective, allowing too much current to flow through the resistor. Most of the time, a shorted capacitor is at fault.

Resistors can open at the terminals, but usually do so in the body. In all types of wirewound resistors, the wire inside the unit merely breaks to open the circuit. Since composition or film resistors are more or less solid units, the body of the resistor cracks or breaks apart. Aside from abuse, this results from too much heat.

Open resistors due to bad terminal connections often result because the resistor leads have been bent too close to the resistor body; this strains and cracks the resistor core. It is quite common with units that have leads imbedded in place. With wirewound units, where a pressure contact is used, a bad connection can develop from warping of the terminal due to heat, or from corrosion due to poor sealing against moisture.

Carbon-composition and film resistors can change in value due to a change in the chemical nature of the resistance material. This can take place in the normal course of time, but it can be accelerated if the resistor is operating hot or if moisture seeps into the unit. When a resistor changes value, its resistance can go either

up or down; most of the time, it goes up. The resistance also can increase at the terminal, where a poor connection can effectively place another resistance in series with the unit. In addition, microscopic cracks in the resistor body can eliminate some of the available current paths and thus increase the effective resistance in that manner.

Reduced resistance occurs mostly in carbon-composition resistors. As a result of heat, or perhaps internal corona, the composition breaks down and the unit carbonizes. A separate carbon

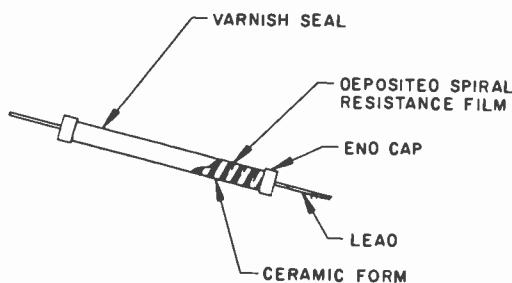

Fig. 311. *The high-voltage resistor is a specially made film resistor.*

path is formed that has less resistance than the composition of carbon with a binder material. The carbon path shunts the composition to reduce the resistor value. Generally, this takes place in high-current circuits, and the reduced resistance starts a cycle of more current, greater heat and increased carbonizing, which reduces the resistance still further. This process continues until the resistor effectively can become shorted. Wirewound resistors do not have the carbonizing problem — reduced resistance in them is due to shorted turns.

One peculiarity of the carbon-composition material is that it normally generates noise as current flows. This is why resistors using these materials are limited in use in sensitive and relatively high-current circuits. The noise-generating tendency can increase due to chemical changes in the presence of too much heat. This often precedes or accompanies the open- or changing-value types of failures. In high-voltage or high-current applications, minute cracks or voids in the composition can cause internal corona which results in noise. A poor terminal connection also can cause noise.

Arcing in resistors can be considered an advanced form of corona and can result from wider cracks in the body of the resistor and from deteriorated terminal connections. Arcing has more of

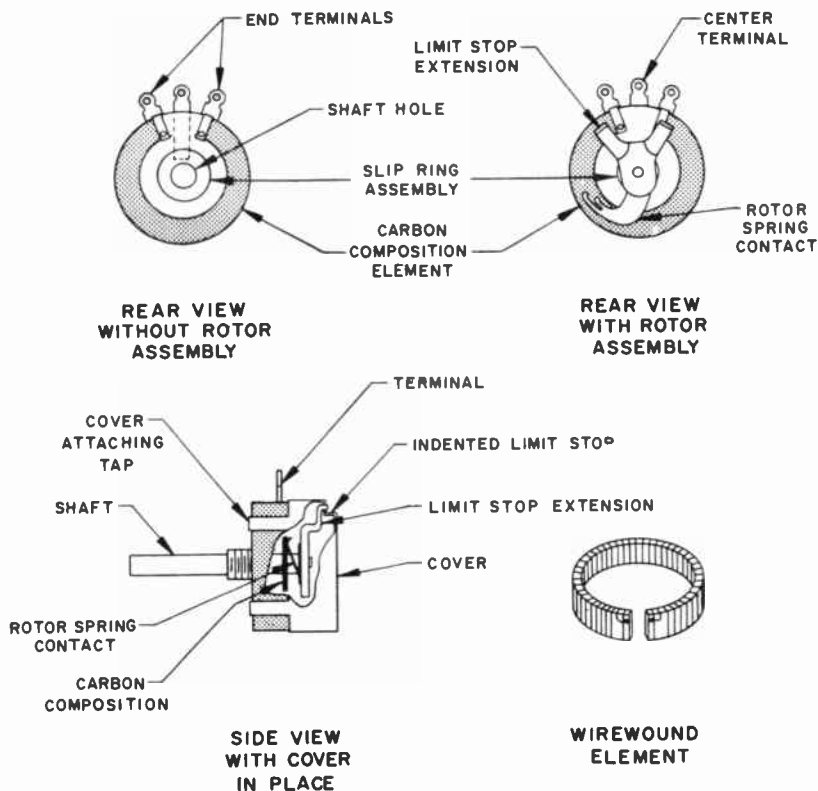

Fig. 312. Potentiometers use a composition film or wirewound element that can be tapped by a sliding contact connected to the center terminal.

a tendency to develop in high-voltage or high-current applications. Chassis-mounted resistors tend to develop arcing because of the grounded metal jacket that surrounds them. Under pressure of voltage, the bakelite insulation can break down and become carbonized, providing a shorter path for the voltage to arc over. Any arcs formed will increase carbonizing and accentuate the trouble. Often, the trouble starts with a slight corona where the terminal lugs pass through the holes in the metal mounting jacket. Excessive moisture also can reduce the breakdown voltage of the insulation and cause arcing.

### Resistor failure effects

If the resistor opens, of course, its function will be lost to the circuit. It will completely disable the circuit in which it is used; it no longer will develop signals, voltage waveforms or pass currents.

Resistors that change in value react differently in different circuits depending on the direction and amount of change. They bring about changes in gain and frequency response, and introduce distortion according to the circuits they are used in.

Noisy resistors inject noise signals into their circuits. In audio circuits, a background hiss results; in video circuits, an ignition-type interference becomes evident; and in sync and sweep circuits, an erratic raster.

An arcing resistor can bring about a momentary disabling of the circuit that will last as long as the arc and occur as often. It produces the same effects as noise but is much more pronounced, and usually brings about serious damage. The arc, accompanied by a definite audible crackling, can often be seen.

## **Potentiometers**

Potentiometers are nothing more than variable resistors. They have an extra terminal connected to a wiper arm that can move effectively along the resistance element between the two end terminals to tap off the desired resistance.

### **Potentiometer construction**

Potentiometers work much in the same manner as fixed resistors but have some physical differences to provide for the movable tap. Two typical potentiometers shown in Fig. 312 use carbon-composition and wirewound resistance elements. The resistance form is almost a complete circle, with the end terminals riveted in contact with the ends of the resistance element. The center terminal is riveted to a slip-ring assembly that is within, but isolated from the resistor body. A rotor spring contact connects this slip ring to any point on the resistance element. As the rotor is turned, the spring contact moves from one end of the element to the other to tap off any desired portion of resistance. The potentiometer cover has limit stops inside of it to prevent the rotor from being turned beyond the ends of the resistor body. Extensions on the rotor hit the limit stops. The rotor is attached to the shaft with an insulator, and is used to adjust the position of the rotor contact.

The tapped resistor shown in Fig. 309 can be considered a variable resistor, but the movable terminal must be tightened in place after it is set; it is not designed for frequent or continuously variable settings.

Dual potentiometers are made the same as single units except that the forward potentiometer has a hollow shaft that allows the



thin shaft of the rear potentiometer to pass through. The rear potentiometer is attached to the forward one by extended tabs on its cover.

### **Potentiometer failures**

Potentiometers develop the same defects in the same ways as regular resistors: they open, change value, become noisy and form arcs. However, more often than not, trouble develops in the area of the rotor contact because of the friction involved. The contact can wear out the carbon-composition material and cause intermittent contact. Or, if the wear is great enough, an open center contact will result at the point of wear. With wirewound units, this problem is uncommon. However, on both types, the spring contact on the rotor can lose tension and make poor or no contact.

Sometimes, the stop tabs on the rotor become bent so that they are not obstructed by the limit stops on the cover.

The most common trouble that develops with potentiometers is dirty contacts, because the unit is not sealed. With time, dust, dirt and other foreign particles generally settle inside the potentiometer and fall on the resistance element. Then, the rotor contact makes poor connections as it slides across the resistance element. A good cleaning fluid injected inside the unit can cure this problem.

### **Potentiometer failure effects**

Potentiometer failures can alter circuit performance the same as resistor failures. However, since potentiometers are used generally in more critical parts of the circuits, noisy potentiometers have a much more noticeable effect on operation. This is true especially if the resistance element is worn or dirt finds its way into the unit. Adjustment of the potentiometer will cause loud scratchy noises in the sound, tearing in the picture, etc., depending upon the circuit it is used in.

If the limit stops do not work, the movable contact might be turned past the ends to short both ends together. This will short the potentiometer completely. However, the part will work satisfactorily if the shaft is turned away from that position.

# component failure— coils and transformers

**C**OILS provide inductive reactance, and transformers an inductive transfer of signals. The only actual difference between them is that a transformer is made of two or more coils (or a tapped single coil) that are inductively coupled.

## High-frequency coil and transformer construction

High-frequency units include rf and if coils and transformers, horizontal oscillator coils and transformers, as well as horizontal size, linearity and keyed agc coils. All these are constructed similarly except that the inductances differ to provide for the various frequencies involved. Some examples are shown in Fig. 401.

The coils are wound with fine wire covered with enamel or other non-conducting material to insulate the tightly-wound windings from one another.

Coils are wound on an insulating form which can be mounted on a platform that contains the terminal lugs, riveted in place. The coil wires are wrapped around and soldered to these lugs, which provide external connections. A metal can may be used to isolate the unit from stray magnetic fields. Mounting studs on the can hold the unit in place (not all units are mounted in cans). If the coil form must support itself, it is generally made stronger, and the mounting lugs and terminals are riveted to the form. This is for above-the-chassis mounting. For below-the-chassis mounting, a spring-clip arrangement is attached to the top of the coil form, which snaps into a hole in the chassis.

For the coils and transformers to be tunable, either powdered-iron cores or trimmer capacitors are used. The trimmers are placed

inside the cans and connected in parallel with the coils. Holes in the top of the can give access to the trimmer adjustment screws. Powdered-iron cores are located inside the coil form and can be moved up and down, to or from the vicinity of the coils. The cores can be adjusted in two ways: One common method is to have a threaded screw imbedded in the core. The screw threads through a metal cap on the form. A slot in the end of the screw allows an alignment tool to turn the screw in or out to tune the unit. Another method is to use a threaded core and a threaded form.

Often, a gimmick is employed to loosely couple the two windings capacitively. This is a short wire connected to the terminal of one winding and looped around the other winding.

### **High-frequency coil and transformer failures**

The most common type of failure in these units is an open coil. This results generally from a current overload which breaks a wire.

Many times, the wire insulation deteriorates and causes adjacent wires to short, producing a shorted turn. Where two coils are wound together, one can become shorted to the other.

The coil winding can become loose on the core either because the adhesive agent has dried out or thermal expansion has enlarged the coil. When this happens, the coil may move and change the coupling between windings.

The wires going from the coils to the terminals are often near or touching one another. If the wire insulation is poor, one winding can short or become shorted to the other. If a can is used, a wire touching it might become shorted to the chassis.

The wire connection to the terminal is soldered. If a solder connection is poor, an effective resistance might be inserted in series with the associated winding. A very poor connection at the terminal will open the winding circuit.

Powdered-iron tuning cores are brittle, and can break if they are abused or get too hot. If the core uses an imbedded adjustment screw, the screw can loosen in the core. Also, the metal cap can become distorted so that it won't thread properly. With the threaded core, the slot can become worn from being forced. Also, the threads on the core and form have very little body and can wear out.

The gimmick, simply an incompleting turn (or turns) of wire, can become loose from the winding it couples or make a bad connection at its terminal.

### **High-frequency coil and transformer failure effects**

When a coil or transformer winding opens, or a bad terminal

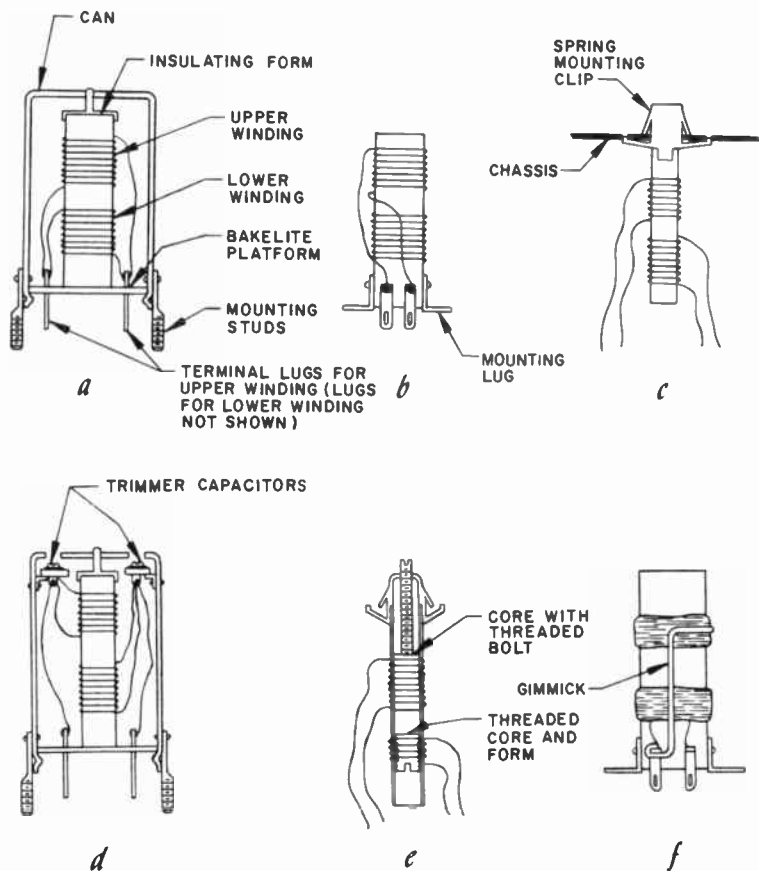

Fig. 401. High-frequency coils are constructed in many ways. They can be stud-, lug- or clip-mounted, and cans are used when shielding is necessary. Note the gimmick in f, which is sometimes used to increase coupling.

connection has developed, the circuit in which the part is used will fail. The open winding will not pass current nor can a voltage develop; signals reaching that point will go no farther.

If a shorted turn develops in a coil and the coil does not have many turns, the inductance can be changed enough to detune it. In a transformer, the shorted turn will act like a shorted winding and an excess amount of current will be induced in the turn. Often, the current will be high enough to burn out the winding; or, it might only cause an effective shorting of the winding so that the transformer either will work no longer or will give very little gain.

If one winding shorts to another, other damage probably will result besides the signal being shorted. The primary of the transformer generally is connected to a B-plus voltage, and the secondary winding to ground or a low voltage. A short between the two windings will cause a high current flow that will burn out some other parts, if not the transformer itself.

When a coil becomes loose on its form, its movement causes detuning if a tuning core is used. In a transformer, coil movement also can change the inductive coupling between windings. This will not only detune the transformer but will change its bandpass response. Some frequencies might be lost or some unwanted signals might get through, depending on how the bandpass is changed.

If the leads from the coils short to each other, the effects will be the same as if the windings themselves were shorted. If a lead shorts to the can, that winding also will become shorted and if the winding has a high voltage on it, other damage also might result.

A poor connection at the terminal causes an effective resistance to be inserted in the circuit. The  $Q$  of the coil will go down, causing a correspondingly reduced gain and widened bandpass. The widened bandpass will allow unwanted signals to pass through.

Tuning cores that cannot be moved up or down result in transformers or coils that cannot be tuned. This will also happen if a part of the core breaks off.

If the gimmick develops a bad connection or becomes loose, it will change the bandpass of the transformer. In some oscillating circuits, the gimmick is the principal source of feedback; in these circuits, erratic or no oscillation can result.

### **Series peaking coil construction**

A series peaking coil (Fig. 402) is a special R-L network, an inductive winding wrapped around a resistor. The ends of the coil are soldered to the resistor leads, and the entire unit is often impregnated to keep out moisture.

### **Series peaking coil failures**

The resistor and coil parts of the series peaking coil can develop any of the troubles afflicting ordinary coils and resistors. The resistor can open, change value or become noisy. The coil can open, short or develop a resistance connection where it is soldered to the resistor leads.

### **Series peaking coil failure effects**

Series peaking coils are used only in video amplifier circuits as high-frequency compensating units. The coil increases the gain

of the high-frequency signals; the resistor shunts the coil to prevent it from ringing. Any trouble in the resistor (such as its becoming open) will cause high-frequency peaking. If the coil decreases in inductance, the high video frequencies will be reduced. If it opens, only the resistor will remain in the circuit, reducing the overall video gain. If there is a short in the coil or resistor, the high video frequencies will be reduced in amplitude. These effects will be illustrated in a later chapter.

### Low-frequency coil and transformer construction

The category of low-frequency coils and transformers includes: power, audio, blocking oscillator and vertical deflection transform-

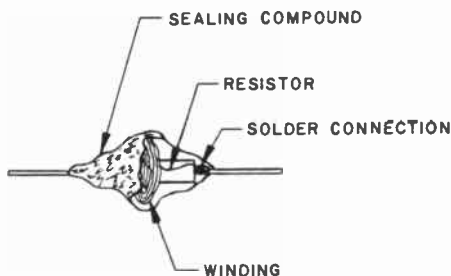

Fig. 402. Peaking-coil construction. Cut-away section shows coil wire soldered to resistor lead.

ers, as well as filter chokes. All these components are made in the same way. The size of the wire, number of windings, number of turns, size of the core, etc., will differ, though, since different frequencies, waveshapes, and currents are involved for the various functions.

A typical low-frequency transformer is shown in Fig. 403. The coils are wound around the center bar of an iron core. As the coil is wound, insulating paper is interleaved between the coil layers to insulate one from another. The wire is usually coated with enamel or other insulation to insulate one turn from another. The ends of the coil wires are soldered to the wires that go out of the transformer; an outer paper cover completes the winding assembly.

The iron core is made of laminated strips to reduce eddy-current loss. The laminations usually are impregnated with shellac and bolted to prevent vibration. Shims sometimes are used between the inner coil form and the core to prevent the coil from vibrating. A mounting clamp strapped around the core provides mounting holes for the unit.

The transformer just described has an open type of construction because the coil assemblies are in clear view. On high-power units that create strong magnetic fields, metal shell covers are used to enclose the unit.

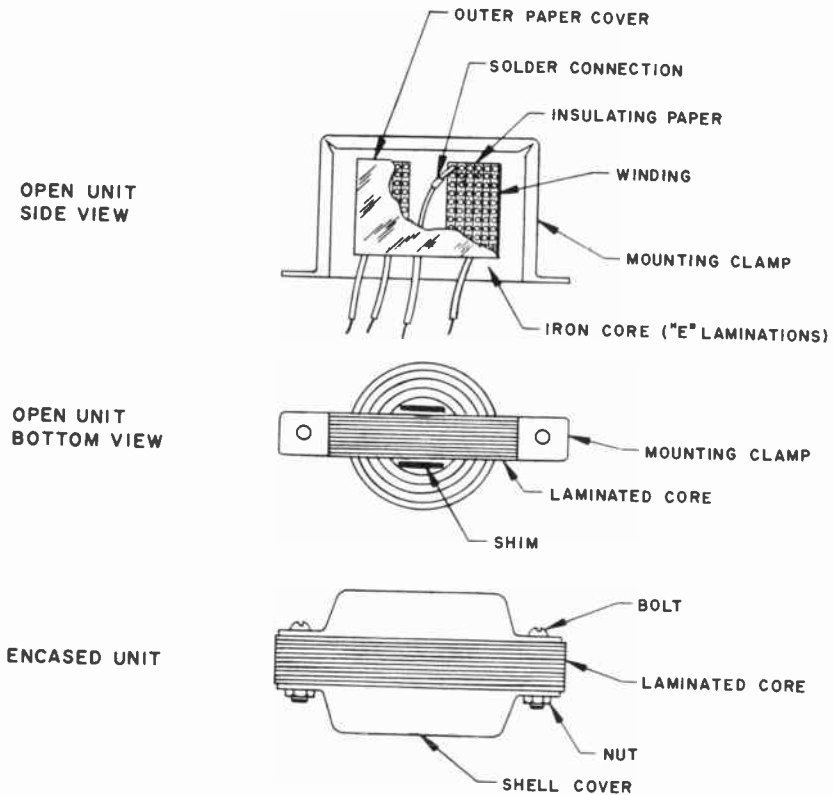

Fig. 403. Low-frequency coils and transformers are constructed on laminated cores. Note the shim, in the bottom view (center picture), used to keep the coil from vibrating.

Laminated-core forms come in many shapes, but the E, I and C are most popular. These laminated shapes are generally used in a face-to-face fashion. For example, Fig. 403 shows a transformer using two horizontal E-forms. The laminations at the connecting ends are interleaved to make a strong bond for a good magnetic circuit. Also, the secondary coil can be wound over the primary. A third or fourth coil can then be wound over the secondary, or they can be wound over some other part of the core.

#### Low-frequency coil and transformer failures

The low-frequency transformer can develop the same defects as

high-frequency units. However, because these transformers use laminated cores and heavier windings, other peculiar troubles can develop. The laminations can become loose when the shellac dries out or when the nuts and bolts become loose. And the coils can become loose if the shims fall out. The windings can also become shorted to the core.

### Low-frequency coil and transformer failure effects

When the low-frequency transformer develops the same defects as the high-frequency units, the results will be much the same.

Due to the strong magnetic fields developed by these transformers, loose laminations or coils will vibrate and produce a loud buzz. This can generally be cured by shellacking the laminations and tightening the nuts and bolts. Reinserting the shims or adding new ones usually will tighten a loose coil sufficiently.

Loose metal shell covers also vibrate. In addition, if they become loose enough not to make a good metal-to-metal contact, the escaping magnetic field might interfere with a nearby circuit. With power transformers, this will cause 60-cycle hum.

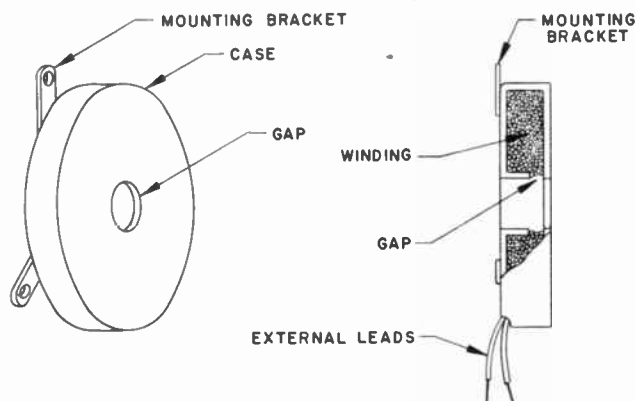

Fig. 404. Focus coils, used with the older magnetic-focus type picture tubes, are completely shielded except for the gap, which allows the concentrated field to encircle the neck of the CRT.

### Focus-coil construction

Focus coils generally are constructed as shown in Fig. 404. Insulated wires are wound inside a metal case to form a compact coil. The two ends of the coil are brought out through a hole in the bottom of the case. The only other opening in the case is a thin gap around its inner circle. This is the only area where the magnetic field can get out; it is directed into the neck of the pic-



ture tube. Mounting brackets are welded to the coil case for mounting the unit firmly in place.

Besides the coil shown in Fig. 404, there are two other popular types. One adds a permanent magnet to the unit to work together with a coil; in this way, the coil develops only a small field for adjustment purposes, and the permanent magnet supplies the rest of the focusing field.

The third type is merely a permanent magnet and has no winding. The focus magnet, as it is called, has an adjustable metal bolt that can be screwed in or out to change the strength of the field to adjust the focus. Sometimes, two or three adjustments are provided.

### **Focus-coil failures**

Focus coils develop the same defects as the parts previously discussed. The winding can become open or shorted or short to the metal case. Also, the magnetic field of permanent magnets can weaken. In addition, mounting brackets and bolts can loosen.

### **Focus-coil failure effects**

If the coil becomes open or shorted, the beam cannot be focused. If only a few shorted turns develop or, if the coil increases in resistance, beam focus may be only slightly off. The same will be true if the permanent-magnet unit becomes weak. In many receivers, the position of the focus coil is used to center the picture. Therefore, loose or broken mountings will interfere with proper centering.

### **Yoke construction**

A yoke is shown in Fig. 405. The four basic yoke coils appear in the upper part of the drawing. The upper and lower ones are the horizontal coils; the two on the sides are the vertical coils. The coils are installed this way because a magnetic field acts at right angles to the electron beam. The side coils will therefore move the beam up and down. Each coil is wound with enamel-covered wire in a somewhat rectangular shape with the forward and rear sides flared out. The flare of the coils follows the flare of the picture tube so that they can fit closely together.

The lower part of the diagram shows a side view of the yoke assembly (the side coils are not shown). The four coils are fitted together to form a long ring around the neck of the picture tube. A soft plastic tube is inserted in the neck opening to keep the yoke from sticking to the neck. Plastic sheets also insulate the horizontal

coils from the vertical. The four coils are held in place by an insulating bracket which is the main structure of the assembly and is often made of hard plastic. A powdered-iron ring core encircles the recessed part of the bracket around the coils. An insulating cover band then encloses the core.

The leads from the coils are soldered to terminals on an insulating disc at the rear of the unit. The two vertical coils are connected in series, as are the horizontal coils. An end cover protects the rear of the assembly. A wing-nut mounting on top of the yoke holds the assembly in place around the neck of the tube and provides for adjustment.

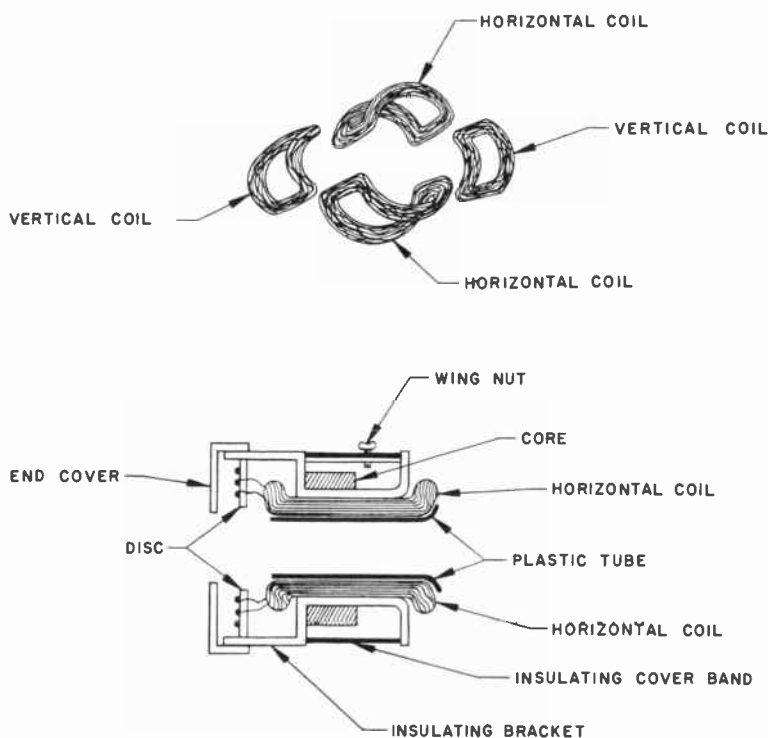

Fig. 405. The yoke is constructed with four coils surrounded by a core. It slides snugly around the CRT neck up to the CRT shoulder.

Another type of yoke assembly has its output terminals on the insulator cover band instead of the disc. In this case, a hard-paper body cover encloses the entire unit. The terminals, for external

connections, also hold the resistors and capacitor that shunt the coils.

### **Yoke failures**

The yoke can develop all of the troubles mentioned previously. A problem peculiar to the yoke assembly is that sometimes, because of heat, the thin plastic sheet that separates the yoke from the CRT melts. Also, the yoke coils can expand after a period of time.

### **Yoke failure effects**

If any one of the coils opens, the sweep associated with that coil will be lost. The same will happen if an entire set of coils is shorted. However, if only one coil of a set is shorted, the sweep associated with that coil will be keystoneed (this will be illustrated later). If one coil increases in resistance or gets some shorted turns, keystoneing will also result but to a lesser degree. If any of the coils shorts to any metal mounting, a B-plus-to-ground short will result.

If the plastic sheet around the picture-tube neck melts or if the yoke coils expand, the yoke will be locked in place. It becomes difficult to adjust or remove the yoke without breaking the neck of the tube. If the trouble is due to a melted plastic, it is best to run the set to heat the area and soften the plastic. Then, by slowly turning the yoke slightly from side to side, it can be worked loose for an expanded yoke, a very thin lubricant is used before trying the side-to-side movement. Generally, a yoke that is tight when the set is off will loosen slightly while it is on because of the slight coil movements that result from the varying magnetic field.

### **Horizontal output-transformer construction**

The typical horizontal output transformer shown in Fig. 406 uses a rectangular ferrite core. The primary and the secondary windings are wound around an insulating form on the upper arm of the core. The high-voltage rectifier filament winding is wound with one or two turns around the form on the lower arm of the core. These leads go directly (or through a small resistor) to the high-voltage rectifier socket. The leads from the upper coils go to terminals on a bakelite front plate. A rear plate is used for mounting. Two bolts pass from the front to the back plate to tighten the unit.

Since very high voltages are present, the coils are generally coated with a sealing dope to prevent corona and arcing. Litz wires are used in the upper coils. These are thin, insulated stranded

wires coated with enamel and soldered at their ends to form a single conductor. Generally, three-stranded Litz wire is used, because this type of wire reduces eddy-current losses.

Another popular type of high-voltage transformer is shown in Fig. 407 (this is an air-core type). Everything is contained on an insulating form.

### Horizontal output-transformer failures

Aside from the ordinary transformer failures, the high-voltage transformer can develop corona, a loose, cracked or broken core and one or more broken strands of Litz wire.

### Horizontal output-transformer failure effects

If any of the main windings become open or shorted, the transformer will be disabled. The transformer is resonant between 60 and 100 kc and, if shorted turns develop, this resonance will change. Also, regulation will be poor and the horizontal sweep

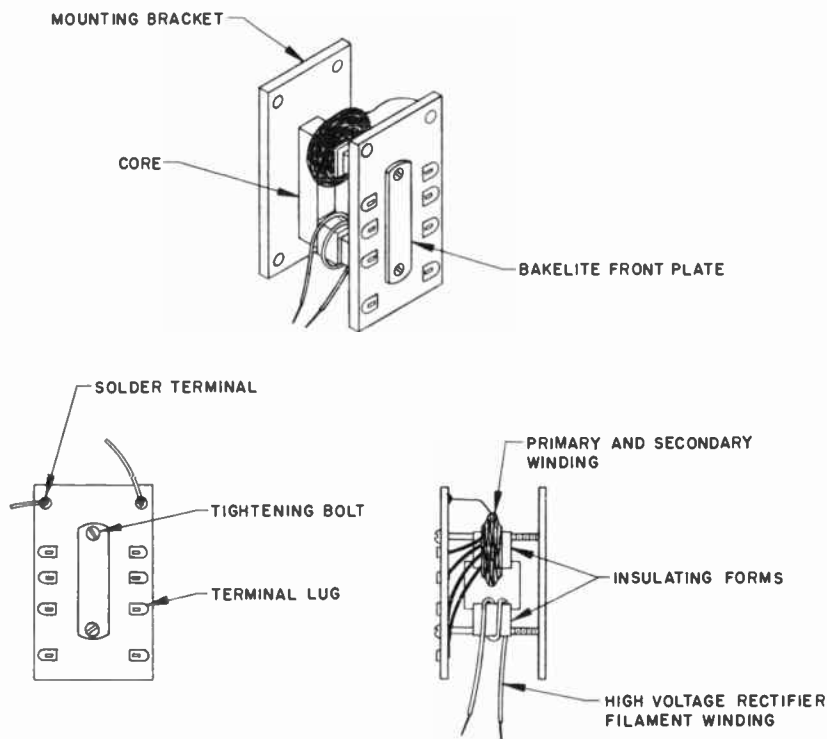

Fig. 406. The horizontal output transformer is actually a high-frequency unit specially made to withstand high voltages. The core is ferrite.

and high voltage will go down, depending on how many turns are shortened. Since the transformer is designed with a very high  $Q$ , the resultant shorted-turn current often loads it enough to make it useless. If any winding shorts to the core, the high-voltage short to ground will burn out the transformer.

Litz wires are used to reduce ac resistance. If a Litz strand opens, the ac resistance goes up and the  $Q$  goes down. This results in lowered sweep and reduced high voltage, as well as poor transformer regulation. Under this condition, the dc resistance of the coil will appear normal. A high-resistance solder connection at the terminals can also cause this symptom.

Because of the very high voltages present, sharp points on the terminals or wire ends will produce corona. This can be cured by

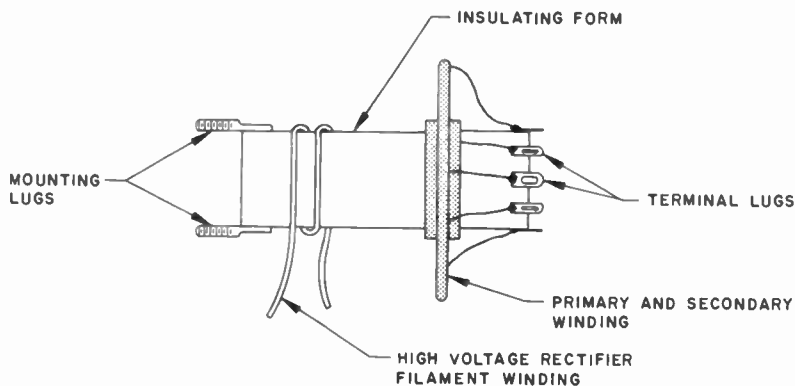

Fig. 407. Another type of horizontal output transformer which uses an air core.

making rounded solder connections or encasing the area with corona dope.

If the core becomes loose, it will vibrate and produce a high-pitched whistle because of the horizontal frequency of the magnetic field. This usually can be stopped by turning in the tightening bolts to lock the core in place. However, since the core is made of ceramic ferrite and is brittle, the core itself can become structurally loose. In this case, tightening will not help.

# component failure— speakers and tuners

**T**HE speaker is the weakest link in the television sound system. Although the television signal and circuits may provide for up to a 15,000-cycle response, speakers in TV sets are not designed mechanically to vibrate up to that frequency without introducing distortion.

## Speaker construction

Typical speaker construction is shown in Fig. 501. The frame is the main supporting part. The cone is cut from a sheet of special paper and the edges glued to the frame. Glued to the inner circle of the cone is a cylindrical form that holds the voice coil. The coil enters a thin gap in the rear of the frame, where the permanent magnet is located. The magnetic fields of the magnet and voice coil interact, causing the voice coil to move in and out of the gap. The spider, a fiber ring used to center the voice coil of the speaker, gives a flexible support to the voice coil so that it does not touch the sides of the gap. In some speakers, the spider is glued in place; in others, it is bolted to the frame. When bolts are used, the spider is adjustable. The paper cone follows the motion of the voice coil to produce the sound. The cone is corrugated to give it the right flexibility to follow the audio signal.

A felt dust cover generally protects the cone opening to the voice coil. The voice coil wires go to terminals on a bakelite strip mounted on the frame.

## Speaker failures

The speaker cone is glued in three places: at the outer rim;

along the seam; and at its inner circle to the voice coil form. If glue dries out, the cone will loosen. The cone also can be torn, get stiff or develop a soft spot. The spider can become loose or torn, and the voice-coil form also can become loose. The voice coil itself can develop the same troubles as any other coil. Although it is very rare, the permanent magnet could lose its magnetism. If the dust cover falls off, dust (or metallic particles) will get into the gap.

### Speaker failure effects

When the speaker cone becomes loose at any point, it vibrates and produces a buzzing sound. This also happens when the speaker cone tears. If the cone stiffens, it will not be able to move fast or far enough, reducing the sound and causing distortion. A soft spot in the cone will not follow the cone's motion faithfully, and the sound will become garbled.

If the spider becomes loose or torn, the voice coil no longer will ride free in the gap. It will rub against the gap sides to reduce

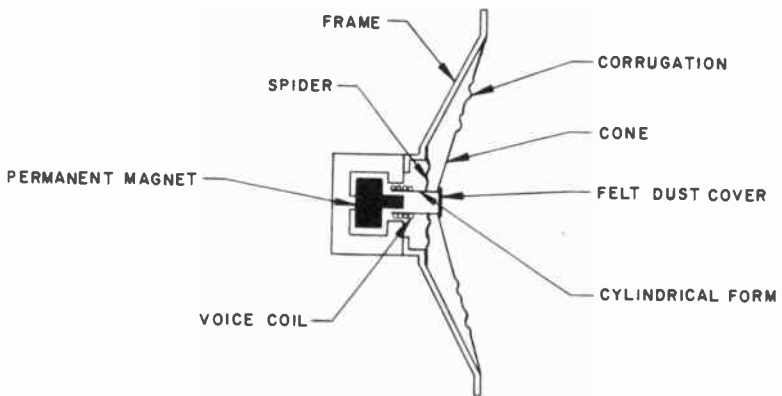

Fig. 501. *Speaker construction. The cone is corrugated for flexibility.*

and distort the sound. If the voice coil should become open or shorted, there will be no sound. If the magnet becomes weak, the sound will become correspondingly weak. Dust in the air gap will interfere with the freedom of the voice coil, as does a loose spider.

Dust in the gap can be blown clean and loose parts on the cone reglued. Torn parts on the cone can be repaired with speaker cement. For a soft spot on the cone, insert a wad of cotton between the frame and cone behind the spot to support it temporarily.

Spiders that are bolted in place can be adjusted after the bolts are loosened to recenter the voice coil.

## Tuners

The tuner is the most important unit that processes the TV signal. Ordinary VHF tuners are designed to handle 12 channels: 2-13. In addition, UHF tuners can add channels 14-83. These channels and their frequencies are listed in Table 1.

**Table 1. Television Frequency Bands**

channel	band (mc)	channel	band (mc)	channel	band (mc)	channel	band (mc)
2	54-60	22	518-524	42	638-644	62	758-764
3	60-66	23	524-530	43	644-650	63	764-770
4	66-72	24	530-536	44	650-656	64	770-776
5	76-82	25	536-542	45	656-662	65	776-782
6	82-88	26	542-548	46	662-668	66	782-788
7	174-180	27	548-554	47	668-674	67	788-794
8	180-186	28	554-560	48	674-680	68	794-800
9	186-192	29	560-566	49	680-686	69	800-806
10	192-198	30	566-572	50	686-692	70	806-812
11	198-204	31	572-578	51	692-698	71	812-818
12	204-210	32	578-584	52	698-704	72	818-824
13	210-216	33	584-590	53	704-710	73	724-830
14	470-476	34	590-596	54	710-716	74	830-836
15	476-482	35	596-602	55	716-722	75	836-842
16	482-488	36	602-608	56	722-728	76	842-848
17	488-494	37	608-614	57	728-734	77	848-854
18	494-500	38	614-620	58	734-740	78	854-860
19	500-506	39	620-626	59	740-746	79	860-866
20	506-512	40	626-632	60	746-752	80	866-872
21	512-518	41	632-638	61	752-758	81	872-878
						82	878-884
						83	884-900

Most tuners fall into these categories: drum, wafer, variable inductor and variable capacitor. The variable-inductor and capacitor-types were used on some older sets; the drum and wafer types are by far the most popular currently.

### Drum-tuner construction

The drum type tuner (Fig. 502) is so called because the tuning circuits all are contained on a drum assembly. The circuits are held on 12 pairs of strips, one pair for each station channel, with locking springs at the front and rear of the drum assembly to hold the strips in place. The channel-selector shaft is an integral part of the drum assembly. The drum is held inside the tuner chassis with retaining springs at the front and rear of the tuner. Springs



on the side of the tuner make contact with a pair of strips. When the drum is turned, a different set of strips makes contact to change the channel. A detent roller-and-spring assembly on the tuner chassis engages the detent around the drum to hold the drum steady in each channel position. The detent spring is bolted in place.

The fine-tuning control is on a concentric shaft around the drum shaft. A cam-shaped fiber disc at the end of the shaft is the variable dielectric between a capacitor button and the bolted retaining bracket. The button and bracket form the capacitor plates and, as the tuning shaft turns, it varies the dielectric with the fiber disc; and the resultant capacitance change tunes in the channel. A tension spring and fiber washer between the disc and tuner chassis hold the disc firmly in any position it is set in.

The forward strips around the drum assembly are the oscillator strips. Within each strip is a tuning slug that can be reached with a screwdriver through a hole in the front of the tuner chassis.

#### **Drum-tuner failures**

The most common parts to fail in the drum tuner are the contact springs. These get dirty or tarnished. They also can become compressed or bent back. In addition the contact points on the drum strips become dirty or tarnished, or the locking springs that secure the strips lose their tension.

The drum retaining springs can become weak or loose, as well as the detent roller spring. Also, the detent roller can fall out.

The fine-tuning assembly can develop a number of defects. The retaining bracket can loosen, the tension spring become weak, and the fiber disc loosen on the fine-tuning shaft.

Within a strip, the tuning slug can become loose or fall out of position.

#### **Drum-tuner failure effects**

If the contact springs or the strip contacts get dirty or tarnished, they will make poor connections. This can cause the associated station to be lost or weak, or, the position of the channel selector might be very critical and sensitive to the slightest vibration. Dirty or tarnished contact springs and strips contacts usually can be cleaned bright with a good cleaning fluid.

The same symptoms will result if the retaining, locking, detent or contact springs lose their tension or become loose. These springs usually can be bent back to shape or tightened. If the contact-spring tension is reduced considerably, the trouble will recur soon

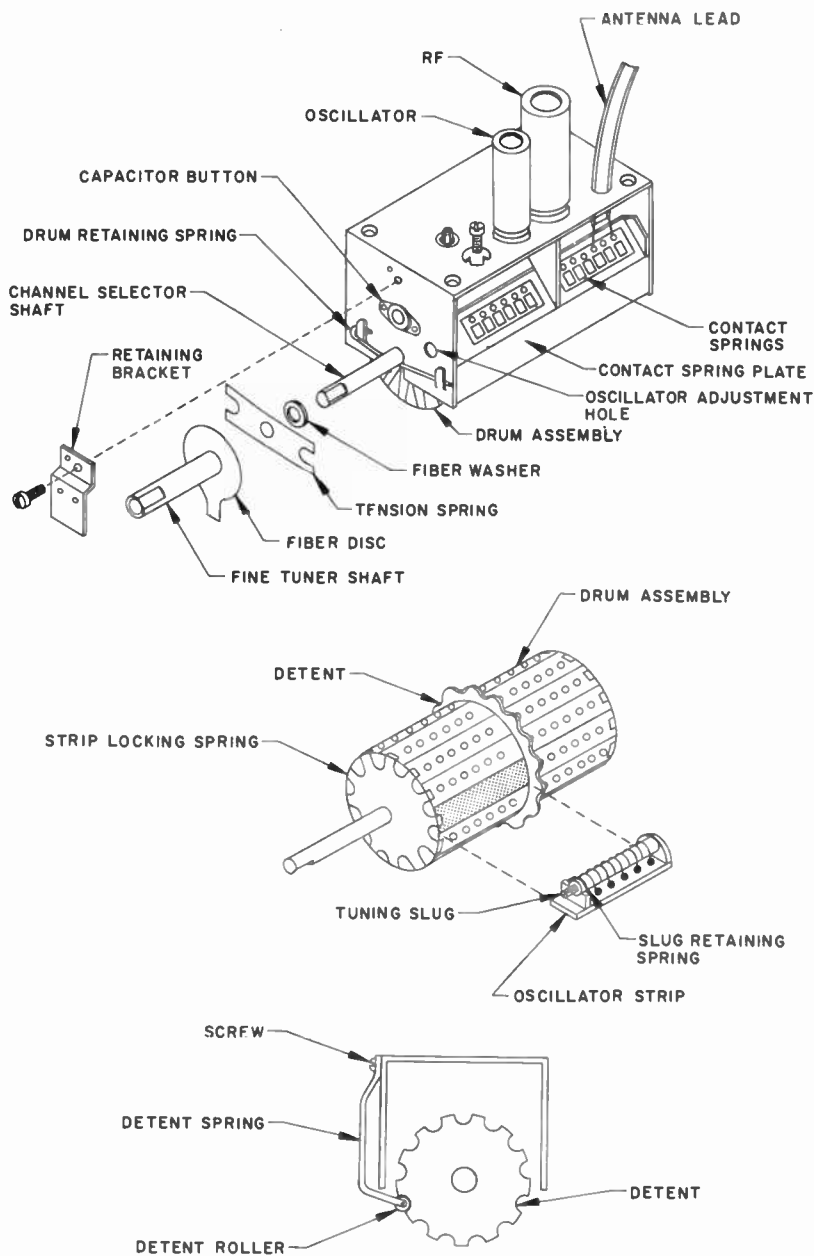

Fig. 502. The drum tuner is constructed for easy removal of the channel strips and the drum. Each channel strip is independent of the others. Note that the contact spring plate can also be removed.

after the repair. Since the side plate that holds the contact springs is removable, a new plate with contact springs can be installed. Also, if the contacts on the strips are worn flat, the strips can be replaced.

If the detent roller falls out, the drum no longer will turn with a positive locking action, and the position of the drum will be critical.

Fine tuning will become critical if the retaining bracket becomes loose, the tension spring weakens or the disc becomes loose on the fine-tuning shaft. If the disc is so loose as to turn freely, fine tuning will be lost.

If the tuning slug in a strip becomes loose, fine tuning for this channel also will be erratic; But if the slug is out of position — pushed back, for example — tuning will be so far out that either the picture or sound, or both, for that channel will be lost.

### **Wafer-switch tuner construction**

As shown in Fig. 503, the wafer type tuner uses wafer-switch sections for switching channels. The coils for the different channels are soldered between wafer terminals to form a series chain. As the channel-selector shaft is turned, the movable section of each wafer switch turns and either shorts or inserts channel coils. The front wafer section contains slug-tuned oscillator coils. These slugs are accessible for adjustment through holes in the front of the tuner chassis.

The channel selector shaft has a detent spring that moves a ball bearing in detents on a plate to provide a positive locking action in each channel position. Fine tuning generally is accomplished with a concentric fine-tuning shaft that drives a trimmer capacitor through friction pulley discs. Cam and lever drives also are used for fine tuning in some wafer tuners.

### **Wafer-tuner failures**

Wafer tuners fail most often because the wafer switch contacts become dirty, tarnished or loose. Tuning slugs also loosen and fall out of their coils. Quite frequently, the detent spring breaks or the fine-tuning drive makes poor contact and slips.

### **Wafer-tuner failure effects**

When the wafer-switch contacts become dirty, tarnished or loose, they make poor connections and cause the stations to be lost or weak. Or, as with the drum tuner, the position of the channel selector is very critical and sensitive to the slightest vibration. These contacts can be cleaned with a suitable cleaning fluid. How-

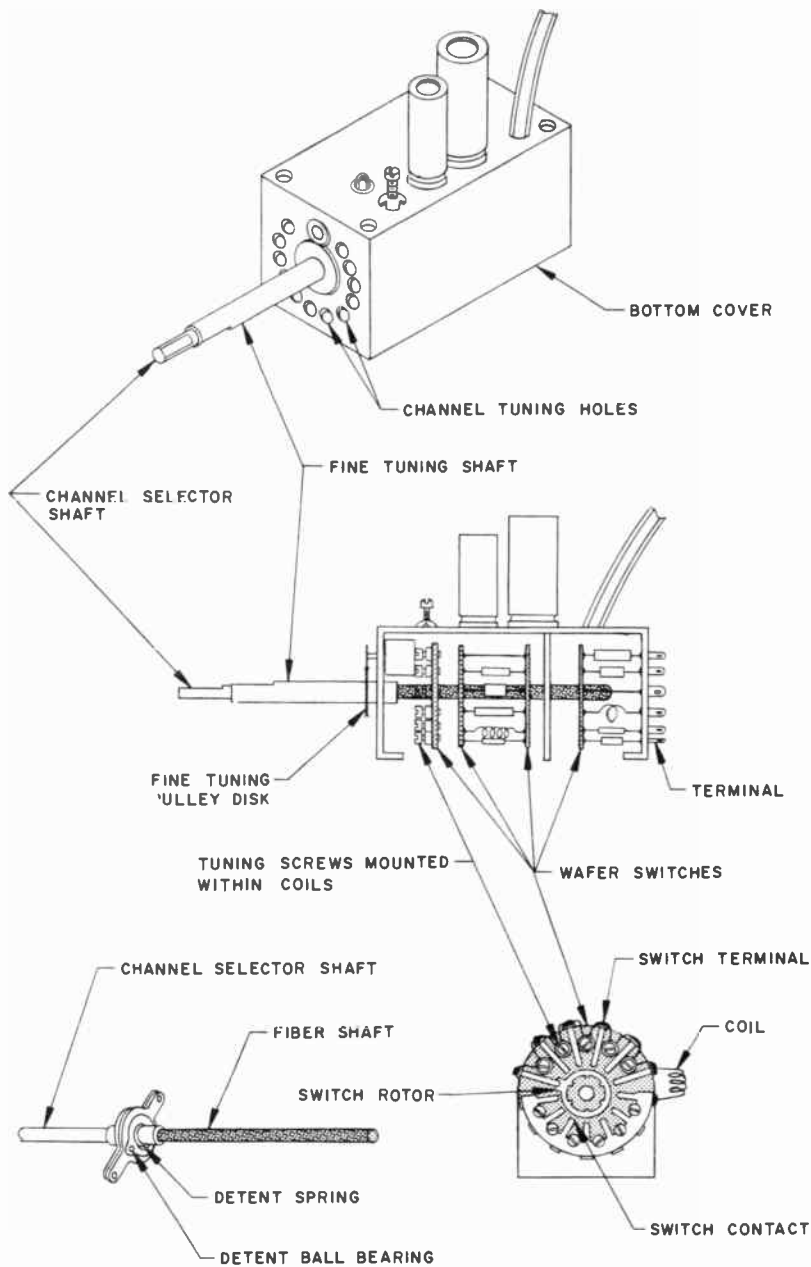

Fig. 503. In the wafer-switch tuner, all channel coils are interacting. The detent spring is a common cause of failure.

ever, the contacts often are held to the wafers with rivets and, if these rivets become loose, the tuner will have to be replaced.

Fine tuning will become erratic if any of the tuning slugs become loose. If a slug falls out, channel tuning will be far out of range. Unlike the drum tuner, this trouble will affect most or all of the lower channels.

If the detent spring breaks, the channel selector no longer will lock firmly in position and the tuner will operate critically or erratically. On many types of wafer tuners, the entire selector shaft with detent assembly can be replaced.

If the fine-tuning drive becomes loose or slips, fine tuning will be lost.

# circuit failure analysis, tuner-if-video

**T**HE previous chapters give information on the analysis of television waveforms and the failure of important component parts. This chapter and the remaining ones cover the failure analysis of circuits; each chapter covers a specific group of circuits. First, theory is given for normal operation of some popular types of circuits used for a given function, and then various types of circuit failures are discussed. The circuit failures are based on component malfunctions discussed in the earlier chapters.

## **Tuner circuits**

A typical tuner circuit is shown in Fig. 601. As explained in Chapter 1, the tuner contains an rf, mixer and local-oscillator stage. The rf stage chooses the desired rf signal from the antenna according to its channel-selector setting. This signal is amplified and applied to the mixer stage together with an oscillator signal from the local-oscillator stage. The rf and local-oscillator signals are heterodyned to produce an if signal.

## **Rf stage**

Two basic types of rf stages are shown in Fig. 602. The circuit of Fig. 602-a is known as a pentode grounded-cathode amplifier. The input signal is applied to the control grid of the rf stage through input transformer T1. The signal is amplified in the tube and passed on to the mixer stage through output transformer T2. The primary and secondary windings of the input and output transformers resonate with the interwinding and interelectrode capacitances of the circuit at the frequency of the desired station.

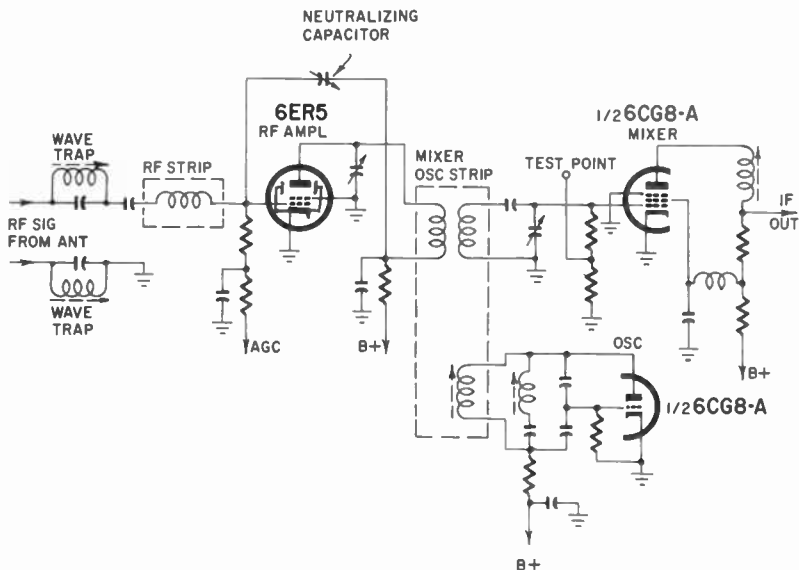

Fig. 601. Schematic diagram of a tuner circuit using a neutralized triode rf amplifier with a "guided grid" tube. In some sets, an ordinary high gain triode is used instead. With such tubes, the tuner is called the "neutrode." With the guided-grid tube, the front end is called the guided-grid tuner. The neutralizing capacitor provides degenerative feedback to prevent oscillation.

The windings generally are slug-tuned for fine adjustments. Trimmer capacitor C2 provides a coarse adjustment for the plate circuit. Resistor R1 shunts the secondary winding of the input transformer to provide the necessary bandwidth.

The gain of the rf stage is determined by an agc voltage applied to its control grid. The networks R2-C1 in the agc line and R4-C4 in the B-plus line provide ac decoupling. This prevents the signal in the grid and plate circuits from interfering with other stages in the set. R3 is the screen dropping resistor; C3 the screen decoupling capacitor.

Although pentode grounded-cathode amplifiers have the advantage of providing high gain, they also have the disadvantage of producing high noise voltages. The grounded-grid triode circuit shown in Fig. 602-b produces low noise voltages. The antenna input signal is applied to the cathode across inductance L1, amplified in the tube and applied to the mixer stage through output transformer T1. The plate circuit of the triode grounded-grid amplifier is similar to that of the grounded-cathode amplifier.

Since the grounded-grid amplifier shown is a triode, the high interelectrode capacitances of the tube produce regenerative feedback. This tends to cause the stage to oscillate. Capacitor C1 is used to couple the plate signal to the cathode to neutralize the regenerative feedback.

Although the grounded-grid triode amplifier produces less noise than the grounded-cathode pentode amplifier, it also has the disadvantage of having less gain. However, better, higher-gain triodes have been developed so that grounded cathode triodes are also popular. The neutrode and guided-grid tuners (Fig. 601) use such tubes. The guided-grid tube has beam-forming plates to achieve more plate current concentration and control. Tetrodes are also used sometimes.

### Cascode circuits

The cascode circuit, found in many television sets, provides the high gain of the pentode amplifier with the low noise figure of a triode. The cascode circuit comprises two triode stages: a grounded-cathode; and a grounded-grid. These two stages can be either direct-coupled or capacitor-coupled (Fig. 603). The circuit shown in Fig. 603-a is the directly coupled type. The plate of tube V1a is directly coupled through load inductance L1 to the cathode of V1b. The plate interelectrode capacitance of V1a and the cathode interelectrode capacitance of V1b form a pi resonant circuit with inductor L1, which is broadly tuned to the vhf television spectrum.

The signal from the antenna is applied through input transformer T1 to the control grid of V1a. The signal is amplified in the tube and the builtup signal voltage is developed across inductor

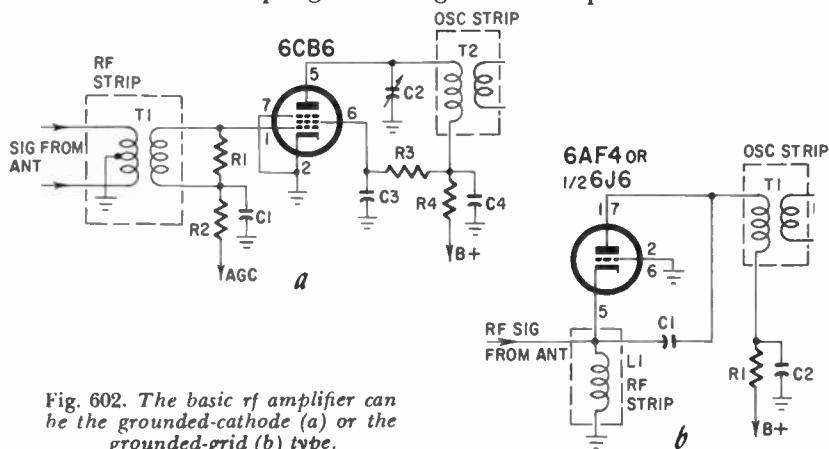

Fig. 602. The basic rf amplifier can be the grounded-cathode (a) or the grounded-grid (b) type.



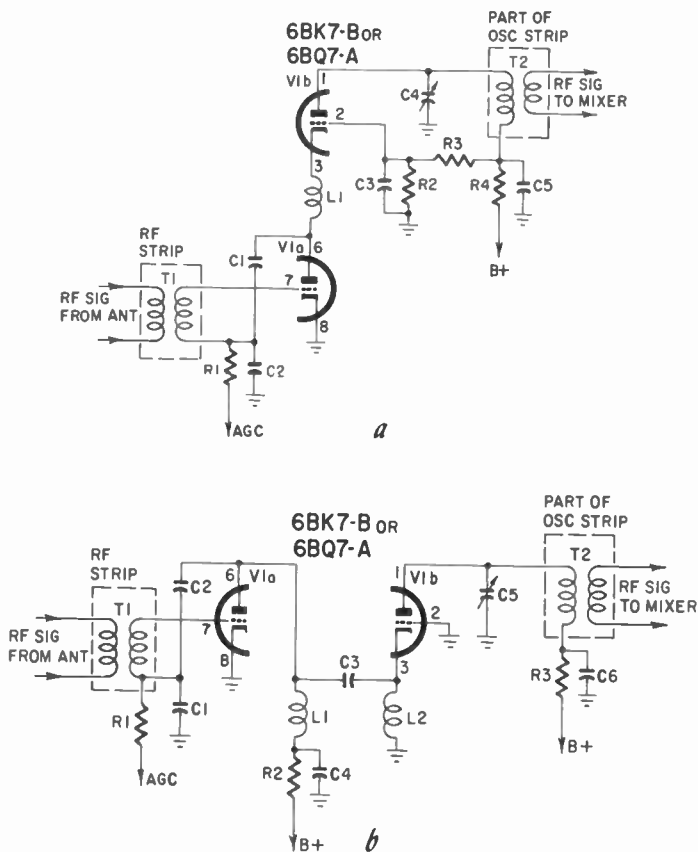

Fig. 603. The cascode type rf amplifier gives high gain with low noise. The two stages can be directly coupled (a) or capacitively coupled (b).

L1 and applied to the cathode of tube V1b, the grounded-grid amplifier. V1b's control grid is kept at ac ground by capacitor C3. The signal is further amplified in V1b and sent to the mixer stage through transformer T2.

The B-plus voltage applied to the V1b's plate circuit is generally about 300 volts dc. Since V1a and V1b form a voltage divider between B-plus and ground, approximately 150 volts dc exists at the cathode of V1b. For the tube to work properly, its control grid must be at nearly the same dc potential. The dc control-grid voltage is developed by divider resistors R2 and R3.

V1a's gain is controlled by the agc voltage applied through decoupling network R1-C2. R4 and C5 in the plate circuit of V1b

form the plate decoupling network; C1 is the neutralizing capacitor. Trimmer C4 provides coarse tuning for the plate circuit of V1b, while the windings of T1 and T2 are slug-tuned for fine adjustment of each channel.

The cascode circuit shown in Fig. 603-b is capacitor-coupled. The circuit works exactly the same as the direct-coupled one except that the output of V1a is coupled by C3 to cathode load L2. Since V1b's cathode does not have a high dc potential applied to it, the control grid is connected directly to ground.

Cascode circuits use dual-triode tubes specially designed to give efficient cascode operation. These include: 6BK7, 6BQ7, 6BZ7, etc., and their series filament counterparts.

### **Rf stage analysis**

Since the circuit shown in Fig. 603-a is the one most often found in receivers, it will be the one used for failure analysis.

To function properly, the rf stage must:

- (1) Choose the desired signal and reject all others, yet provide the proper bandpass for all of the low- and high-frequency components of the rf signal.
- (2) Amplify the desired rf signal faithfully.
- (3) Prevent noise and other forms of interference from modulating the rf carrier.

### **Tuning and bandpass failures**

Selection of the desired signal and the rejection of all others is primarily the function of the tuned windings of input and output transformers T1 and T2, as well as trimmer capacitor C4 (Fig. 603-a). L1 and the interelectrode capacitances of V1a and V1b also may affect the tuning but they do to a lesser extent. T1 and T2 are tuned to give gain at all frequencies within the desired channel, and little or no gain for frequencies that fall outside its bandwidth.

To provide this bandpass, the primary winding of each transformer generally is tuned below the center frequency of the channel, and the secondary winding above the center frequency. This produces the combined response curve shown in Fig. 604. Although new transformer coils are switched into the circuit for each channel, this same response curve should exist for each channel band. C4 is used to coarse-tune the plate circuit of V1b, and each set of coils is slug-tuned to align each channel.

If the grid and plate transformers T1 and T2 are not properly

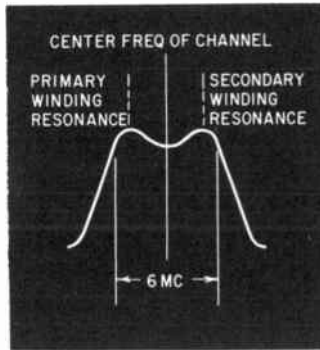

Fig. 604. The rf stage responds to 3 mc on each side of the center frequency of the channel.

aligned (Fig. 605), the rf signal selection, rejection and bandpass functions may be affected (Fig. 606).

When the primary winding of either transformer is tuned too close to the center frequency of the channel (Fig. 605-a), the bandwidth may be reduced sufficiently to lose the low-frequency modulation (Fig. 606-b). This will have the effect of reducing the contrast of the broad picture areas only, and will cause the outlines of people and objects (which are high frequencies) to predominate. Also, since the sync pulses are low frequencies, they may be affected as well. Because the vertical sync pulses are the lowest modulating frequencies, vertical synchronization would probably become critical, or lost before horizontal synchronization.

However, if both windings are tuned too high (Fig. 605-b), not only will the low frequencies be lost but interfering signal frequencies from above the channel band will be accepted (Fig. 606-c) rather than rejected. These interfering signals may be video frequencies from the adjacent high channel.

If the primary winding is tuned properly but the secondary winding is tuned too low (Fig. 605-c), the bandwidth may be reduced sufficiently to lose the high modulating frequencies (Fig. 606-d). Although the audio carrier amplitude may be reduced considerably, this may not have a noticeable effect. In intercarrier receivers, the audio if amplitude is required to be only a fraction of the video amplitude. However, the loss of the high video frequencies will have a very definite effect on the picture. Since all sharp details such as outlines of people and objects have high-frequency components, these outlines will not be sharp and the picture will lose detail and appear fuzzy.

Not only will the high frequencies be lost, but interference

CENTER FREQUENCY OF CHANNEL

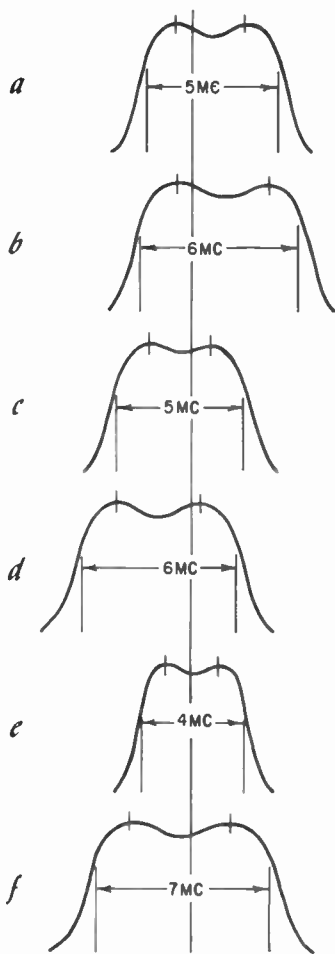
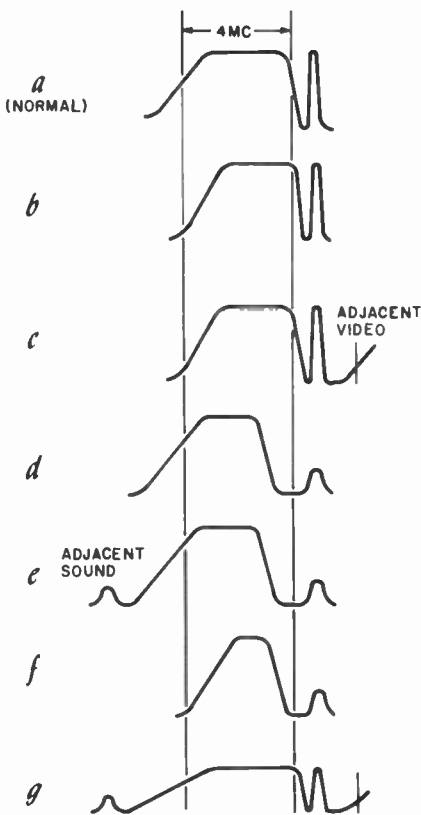

Fig. 605. Improper rf alignment will cause more or less than a 6-mc band-pass or an off-center response curve.

Fig. 606. Effect of rf detuning on the receiver's characteristics. The top curve (a) is normal.



frequencies from below the channel will be accepted (Fig. 606-e) rather than rejected if both the primary and secondary windings of the transformers are tuned too low (Fig. 605-d). These interference frequencies may come from the audio carrier of the low adjacent channel.

When both the primary and secondary windings are tuned too close to the channel center frequency, the over-all bandpass of the rf stage is reduced (Fig. 605-e). This causes the loss of both the high and low modulating frequencies (Fig. 606-f). As a result, the broad picture areas lose contrast and the outlines and details are

prominent but not sharp, and the sync may be affected. But, if both windings are tuned too far from the center frequency (Fig. 605-f), the bandpass will be too wide and the interference frequencies of both the high and low adjacent channels will be accepted (Fig. 606-g) rather than rejected. The bandpass shown in Fig. 605-f can also result if a transformer coil develops a high resistance, resulting in a lower  $Q$  and a wider bandpass.

If the detuning is merely due to misadjustment, alignment will correct the fault. But if this does not help, then a transformer coil has probably changed its inductance in one of the ways explained in Chapter 4. In a turret type tuner, if only one channel is affected, then the coil strips for that channel are causing the trouble. In a wafer-switch tuner, however, where all of the coils are switched in series, if one coil goes bad, then that channel and all lower ones will be affected.

In both types of tuners, if the response of all of the channels is affected, then the coarse trimmer capacitor C4 (Fig. 603-a), C5 (Fig. 603-b) has probably undergone a capacitance change (Chapter 3). However, a defective channel 13 coil in a wafer-switch tuner will also affect all channels.

Rf stage detuning can also be caused by the interelectrode capacitances of V1a and V1b and L1. V1a's grid-to-cathode capacitance is across the secondary winding of T1. The plate capacitance of V1b similarly affects the primary winding of T2. Also, the plate-to-ground capacitance of V1a and the cathode-to-ground capacitance of V1b form a pi network with L1. If any of these tube interelectrode capacitances should vary (Chapter 2), the detuning effects described earlier may occur. Although this tends to affect all the channels, it will be more noticeable on the high band because of the low interelectrode capacitances involved.

L1 and the interelectrode capacitance form a tuned circuit that has a broad bandpass which covers the entire vhf television spectrum (Fig. 607-a). If the inductance of L1 decreases, the gain of the lowermost channels will be reduced (Fig. 607-b) and vice versa, as shown in Fig. 607-c. However, since the tuning is so broad and inductor L1 offers only minor gain to signals, the inductance change would have to be large before it would have a noticeable effect.

The various capacitors shown in Fig. 603-a also tend to affect circuit tuning since they form a part of various ac paths to the coil circuits. Generally, however, when these capacitors develop trouble, they usually affect some other circuit function first. But they

can fail and have a noticeable effect on the bandpass. C3, for example, may decrease in capacitance. Since it must maintain the grid of V1b at ac ground, a reduced capacitance may cause it to act as an impedance at the higher frequency channels. This will cause reduced gain for the high-band channels. If neutralizing capacitor C1 increases in capacitance, too much signal voltage at the plate of V1a will be coupled back, also reducing the gain of the high chan-

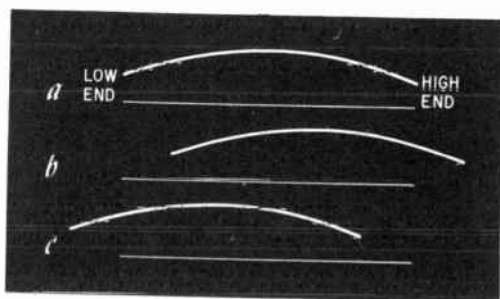

Fig. 607. The bandpass of the inductor is very broad, covering the frequencies from channels 2 through 13.

nels. The extent to which the high channels are affected will be determined by the amount the capacitances change.

In the circuit of Fig. 603-b, coupling capacitor C3 can decrease in value and offer impedance to the lower-channel bands.

### Gain failures

The gain of the rf stage is primarily a function of the inherent gain of the tube and of the circuit voltages, particularly the agc voltage. Gain failure is described as complete stage failure, too little gain and too much gain. The gain of a typical rf stage is about 5 to 10.

Of course, almost any part in the stage can cause complete failure so that the rf signal is not passed to the mixer stage. The tube can develop an open filament or other elements (Chapter 2). Either winding on T1 and T2 can become opened or shorted, and the same can happen with L1. If R4 in the plate circuit opens, it will prevent plate voltage from being applied to V1b and will cause a dead circuit. If divider resistor R3 opens, positive voltage will be removed from V1b's grid. Since the cathode is highly positive, the tube will be cut off. If R2 opens, too high a positive voltage will be applied to the grid. Current flow in the tube will become saturated and block the signal and the tube itself will probably burn out in a short time. Since V1b is a grounded-grid amplifier and

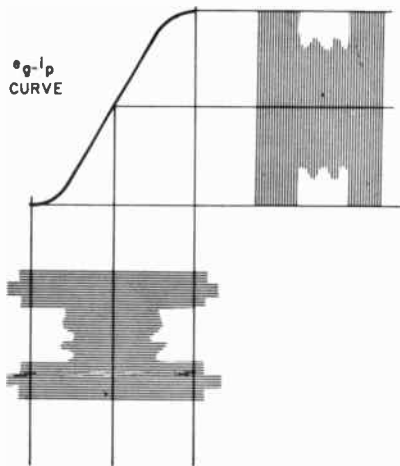

Fig. 608. Overdriven rf stage. The signal is driven into saturation and cutoff, causing the sync pulses to be clipped.

C3 keeps the grid at ac ground, the stage will not work if C3 opens. This will also occur if C3 develops a high-resistance leakage.

If C3 develops a low-resistance leakage or a short, the grid will have little or no positive voltage and the tube will be cut off. A short like this, though, will cause excessive current to flow through resistors R3 and R4, which may burn out. If capacitors C4 and C5 in the plate circuit are shorted, plate voltage will be removed from V1b. However, a shorted C4 probably will burn out the primary winding of T2. A shorted C5 most likely will burn out R4. If C1 becomes leaky or shorted, V1a will become disabled. And since this will apply a positive voltage to V1a's grid, the tube will fail soon.

If trouble develops in the rf stage so that not enough gain can be obtained, then the signal fed to the mixer stage will be weak and the picture will most likely be snowy. Actually, the troubles that cause complete stage failure also are those that cause reduced gain. For reduced gain, though, the parts change characteristics much less severely. The most common cause of insufficient gain is reduced emission in the tube. An increase in the resistance of R4 in the plate circuit may lower the plate voltage of V1b, resulting in insufficient gain.

If R3 increases in resistance or R2 decreases, the voltage on the grid of V1b will become less positive and cause increased bias. Although the bias may not become great enough to cut the tube off,

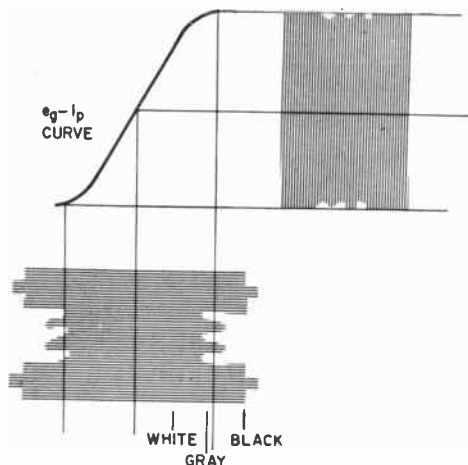

Fig. 609. In an overloaded rf stage, most of the blanking pulses and part of the video as well are lost.

its increase may reduce tube current to the point where insufficient gain will result.

Too much gain in the rf stage will cause the rf signal to build up too much. The signal can then overdrive one of the following stages (Fig. 608). Since the peak-to-peak amplitude of the signal is greater than the capability of the  $e_g - i_p$  curve, the tube is driven into saturation and cutoff. As shown in the illustration, the sync pulses are lost, with a resultant loss of picture synchronization. If the signal were a little smaller, only part of the sync pulses would be lost and the effect would merely be unstable sync.

If the signal became much too large ( Fig. 609), it would cause video overloading. Not only would the sync pulses be lost, but so would most of the blanking pulses and the black and dark gray tones of the picture. An overloaded picture is grayish white and unstable. The retrace lines may show, and the picture may even be barely recognizable. The amount of overload depends on the size of the signal. Sometimes the overload is slight and only the deep black tones are lost, and the clipped sync causes a wiggly or hooked picture; the retrace lines may also be difficult to eliminate. On the other hand, the overload can become great enough to cause the complete loss of a picture.

An overdriven or overloaded condition will also cause sound trouble. Intercarrier heterodyning in the video detector requires that both the video and audio carriers be present at all times for the intercarrier audio to be developed. Because of this, when the



rf signal is clipped, it is blocked at that instant and intercarrier heterodyning cannot take place. Therefore, the sound is also lost at that instant. If the rf clipping occurs periodically at an audio rate, the repeated interruption of the sound will cause what is known as intercarrier buzz.

The gain of the stage is controlled primarily by the grid voltage. If the rf tube develops grid-to-cathode leakage or its grid starts emitting, bias will be lost, causing very high gain and clipping of the signal. This will also happen if C2 in the agc line shorts the agc voltage to ground. If divider resistors R2 and R3 change value and increase the positive voltage slightly on the grid, the resulting reduction in bias will cause greater gain.

### **Noise and interference failures**

Interfering rf signals, such as fm signals, ham broadcasts or ignition interference picked up by the antenna, are difficult to cope with since they or their harmonics are generally within or close to the desired channel. The resonant circuits of the rf stage must be tuned properly for acceptance and rejection of the right signals. Therefore, many of the causes of tuning and bandpass failures may also permit outside interference to get through. Generally, if interfering frequencies are too close to or within the channel band, not much can be done except to reorient the antenna in a direction in which the interference pickup is weak.

Within the rf stage, just about any part can cause noise or various types of interference. The most common problem is 60-cycle hum in the picture because of a filament-to-cathode or filament-to-grid short within the tube. The 60-cycle filament voltage then modulates the video carrier.

The next most common trouble is a microphonic tube. Loose elements within the tube become sensitive to various disturbances, such as the receiver sound itself. The elements vibrate and modulate the video carrier to produce interference bars in the picture.

Arcing within the tube will cause momentary interruptions in the signal. If the arcs are heavy, the video interruptions will cause flashes in the picture with associated crackling in the audio. If the arcing interferes with the sync pulses, the picture will also tear.

If the arcing is only slight and of short duration, such as spitting corona, ignition type noise will be produced in the picture. Ordinarily, the repetition rate of this minor arcing is high enough not to tear the picture or be heard in the sound, but on occasion it does interfere with the audio.

Arcing troubles are also quite frequently caused by the parts in

the circuit that carry relatively high currents or are connected across B-plus voltages. R2, R3 and R4 in the plate circuit, for example, can carbonize or develop cracks that arc, or they can develop loose leads (as explained in Chapter 3). The dielectrics of C1, C4 and C5 may break down and cause arcing, and poor connections in L1 and T2 will arc over.

Interference may also result if the rf signal finds its way into the other stages of the set through the agc and B-plus lines. These circuits are common to many stages. The R1-C2, R4-C5 decoupling networks prevent this. However, if either capacitor opens or either resistor becomes shorted, the rf signal will not be decoupled to ground. The signal will then tend to be fed to the other stages in the set. In the majority of cases, this may not cause a problem. The rf frequency is high enough to be filtered by the decoupling networks in the other stages, and the other stages do not respond to the relatively high rf frequencies.

However, if the rf signal is strong enough, it may cause regenerative feedback with resulting oscillation. An oscillating stage in the rf and if line will block the video and audio signals and will cause erratic diagonal lines on the raster. Since the function of neutralizing capacitor C1 is to prevent the rf stage from oscillating, the stage may break into oscillation, perhaps only intermittently, if C1 opens.

### **Mixer stage**

Fig. 610 shows a typical mixer stage. The circuit is fairly standard and does not change much from one set to another. Some sets may use a pentode but the basic circuit, except for the screen grid, is the same. As with rf amplifiers, pentode mixers give more gain but also more noise.

The circuit receives two input signals: the signal from the rf stage and an oscillator signal from the local-oscillator. The two signals are heterodyned in the tube; the tube amplifies both signals plus their sum and difference frequencies. The modulation on the rf carrier signal is also placed on the sum and difference frequencies by the heterodyning action. The difference frequency is the one used for the if signal. It is sent through T2 to the if section.

The local oscillator signal can be applied to the mixer stage in two ways: One (which is fairly common), is to couple the oscillator coil inductively to the secondary coil of T1; and two, to use C4 to couple the oscillator signal directly to the mixer grid.

Bias for the mixer is obtained with C1 and grid-leaks R1 and R2. The junction between R1 and R2 provides a point for

alignment and test purposes. When the test point is used, R1 prevents the grid circuit from being loaded. C2 tunes the grid circuit over the broad vhf television range in conjunction with the various transformers that are switched into the circuit for each channel.

L2 in the mixer plate is an rf peaking coil that offers impedance to the plate signals above the if frequency. C5 resonates at the intermediate frequency with the primary winding of T2. As a result,

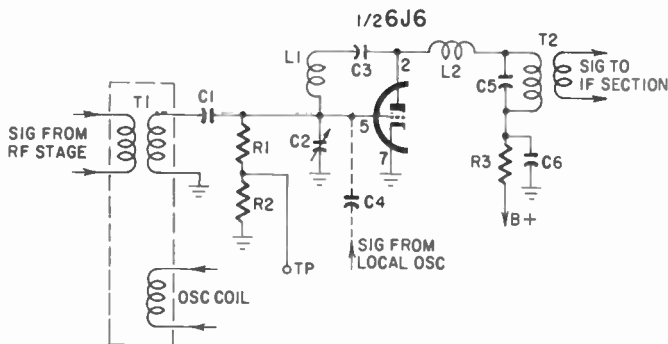

Fig. 610. Schematic diagram of a typical mixer stage. Capacitor C4 is not used if the oscillator coil is inductively coupled to T1.

although a number of frequencies exist in the mixer plate circuit, L2 and T2 allow only the if signals to be sent to the if section. R3 and C6 form a plate decoupling network.

L1 and C3 form a feedback network that prevents the stage from oscillating by neutralizing the plate-to-grid feedback within the tube. Pentode mixers, which have low interelectrode capacitances, generally do not require this network.

### Mixer-stage analysis

To function properly, the mixer stage must: (1) Provide sufficient bandpass for all of the rf and if; (2) Heterodyne the rf and local oscillator signals without distortion; (3) Provide sufficient if gain; (4.) Prevent noise and other forms of interference from modulating the if carrier.

### Tuning and bandpass failures

The tuning and bandpass characteristics of the mixer stage are primarily the function of T1 and T2 and C2 and C5. These tune the circuit in the same manner as their counterparts in the rf stage. If the bandpass characteristics of the mixer stage are changed, the results will be the same as in the rf stage.

## Heterodyning failures

Heterodyning is a function of the amplitude of the rf and oscillator signals, the mixer grid-bias voltage and the characteristics of the mixer tube. The amplitude of the rf signal should be only a fraction of the oscillator signal amplitude.

The oscillator signal must be large enough to swing the mixer tube from cutoff to saturation (Fig. 611). The rf signal must be small enough to operate completely in the nonlinear portion of the  $e_x - i_p$  curve. This is important because heterodyning can take place only under nonlinear conditions. However, the rf signal should be large enough to assure sufficient if amplitude. Only the if signal output is shown in Fig. 611, but a multitude of frequencies is generated. Although the rf signal is rectified to produce an if signal, the if signal becomes full ac after it is passed through the mixer if output transformer.

The cutoff bias is produced by the grid-leak action of C1 and R1 and R2 (Fig. 610) when the oscillator signal drives the mixer grid positive. The oscillator signal amplitude is therefore the most important factor determining mixer bias. The oscillator amplitude and the value of the grid-leak network are chosen to produce a bias in the area of 3 volts negative.

If the bias developed is too high and drives the mixer stage slightly beyond cutoff (Fig. 612), the white portions of the rf carrier are clipped. The picture then loses contrast and takes on a dark gray tone. In addition, since the video carrier is partially lost intermittently in each frame, an intercarrier buzz develops in the sound. Too large a bias voltage could result from: (1) increased oscillator signal amplitude; (2) increased capacitance of coupling

Fig. 611. *Mixing action. The rf signal operates on the nonlinear part of the curve, and its modulation is transferred to the if beat frequency.*

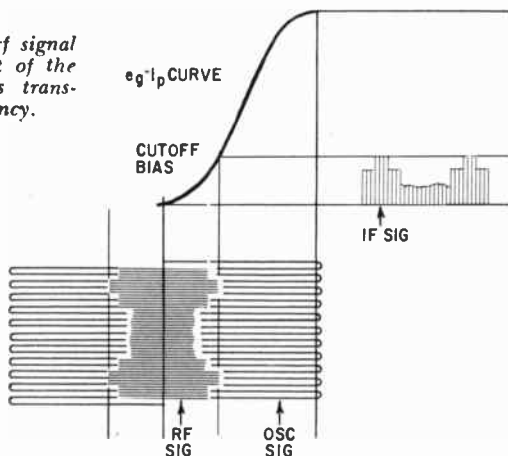

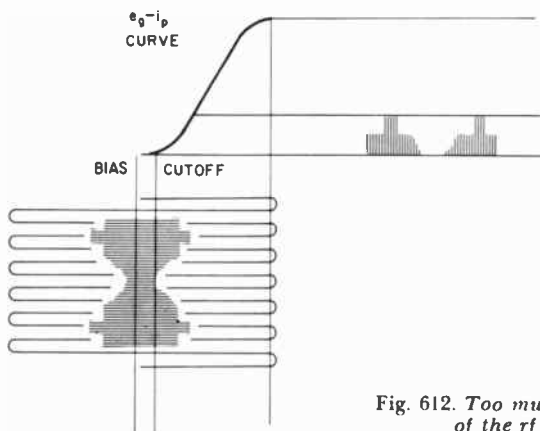

Fig. 612. Too much mixer bias results in part of the rf signal being clipped.

capacitors C4 or C1; and (3) increased resistance of R1 or R2.

If the value of C1 or R1 and R2 increases a great deal, the time constant of this grid-leak network becomes great enough to produce a large bias that completely cuts off the tube, allowing no signal passage. This bias would drain off slowly until conduction would again be allowed, but then the bias would build up rapidly as before and the operation would be repeated. The circuit, therefore, acts like a blocking oscillator, except that it needs an input signal for the bias to be developed. The blocking frequency will depend on the R-C time constant. This intermittent blocking will cause the picture and sound to go on and off at the blocking rate.

If insufficient bias is developed (Fig. 613), a portion of the rf signal operates on the more linear part of the  $e_g - i_p$  curve. As a result, that part would not heterodyne properly and would be weakened or lost. The exact components of the video carrier that would be affected would depend on the amount the bias is reduced. The sync pulses would be affected first (Fig. 613) and then the black levels of the signal, including the blanking pulse. This would cause poor sync, a poor picture, and perhaps retrace lines difficult to eliminate.

If most of the bias is lost, the entire rf signal may operate on the linear portion of the  $e_g - i_p$  curve and no heterodyning will take place. All of the video and audio will be lost. Reduced bias can be caused by: (1) grid-to-cathode leakage in the mixer tube; (2) an emitting grid in the mixer tube; (3) reduced oscillator signal amplitude; (4) reduced capacitance of coupling capacitors C1 or C4; and reduced resistance of R1 or R2. C1, C3 or C4 can also reduce the bias if they develop leakage.

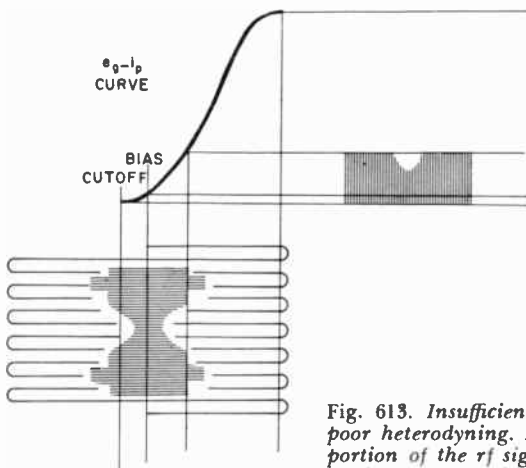

Fig. 613. *Insufficient mixer bias may cause poor heterodyning. Note that the sync pulse portion of the rf signal is on the linear part of the curve, resulting in poor sync on the if signal.*

If the bias remains at the proper value, heterodyning can also be affected by a changing  $e_g - i_p$  curve (Fig. 614). The effects are the same as the bias being increased or reduced. The  $e_g - i_p$  curve will vary if the emission of the mixer tube changes appreciably, or if the plate voltage of the stage is reduced. Reduced plate voltage occurs because of increased resistance of R3 or leakage in C6.

### Gain failures

The gain of the mixer stage is primarily a function of the inherent gain of the tube and also the circuit voltages. As in the rf stage, gain failure is described as complete stage failure, too little gain or too much gain. Since the input to the mixer stage is an rf signal and the output is an if signal, the ratio of output to input is known as the conversion gain. This is about 2 for a triode mixer.

As with the rf stage, almost any part can cause complete failure of the mixer stage so that an if signal is not passed to the if section. The tube (Fig. 610) can develop an open filament or other element, complete loss of emission or shorted elements. Either winding on T1 and T2 can become opened or shorted, and the same can happen with L2. R3 may open and remove plate voltage from the mixer tube. If R1 or R2 opens, the grid circuit of the mixer stage will be opened. The resultant floating grid will build up a bias that will completely cut off the tube.

If C5 becomes shorted, the if signal will bypass T2. A shorted C6 will ground the mixer plate voltage and burn out R3. If trimmer C2 becomes shorted, the mixer grid will be grounded, shorting the input signals. If C3 becomes shorted, positive voltage will be applied to the mixer grid. This will cause a saturated current

to flow, disabling the circuit. Because of the excessive current flow, the tube will probably burn out quickly.

Component parts that cause too little or too much gain will also affect the heterodyning action of the mixer stage. Therefore, the information given under "Heterodyning failures" also applies here.

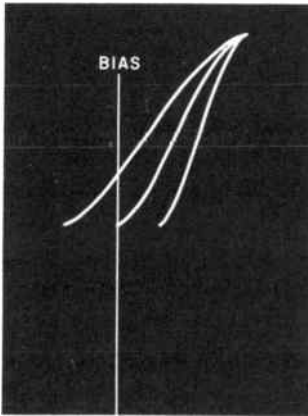

Fig. 614. Changing  $e_g-i_p$  characteristics is similar to varying bias levels.

### Noise and interference failures

Most of the normal video noise developed in the television set itself is generated in the mixer stage because of the nonlinear operation that is used. This noise causes what is known as snow. Because of this, it is important that the gain of the mixer stage be sufficient to maintain a high signal-to-noise ratio.

To reject the interference frequencies that originate at the antenna, the resonant circuits of the mixer stage must be properly tuned (as was explained in the discussion of the rf stage).

Noise and interference troubles generated within the mixer stage itself can be caused by almost any part. Filament-to-grid leakage within the mixer tube will modulate the if signal and cause a 60-cycle hum in the picture. A microphonic tube will cause sound bars in the picture (as explained for the rf stage). Arcing within the tube will produce momentary interruptions in the signal. If the arcing is heavy, the interruptions will cause flashes in the picture, with associated crackling in the audio. If the arcing interferes with the sync, the picture will also tear. If the arcing is slight and of short duration, such as spitting corona, ignition type noise will appear in the picture. Ordinarily, the repetition rate of

this minor arcing is high enough not to tear the picture or be heard in the sound but, on occasion, it may.

Arcing problems may also be caused by the parts in the circuits that carry high currents or are connected across B-plus voltages. R3, for example, can carbonize or develop cracks that arc, or it can develop loose leads. The dielectrics of C3 and C6 may break down and cause arcing, and poor connections in L2 and T2 will arc over.

Interference may also be caused if the if signal finds its way to the if stages through the B-plus lines. This may happen if decoupling capacitor C6 opens or if decoupling resistor R3 becomes shorted.

If either C3 or L1 of the neutralizing network opens, the mixer stage may oscillate. This will block the video and audio signals and cause erratic diagonal lines on the raster.

### Local-oscillator stage

A typical local oscillator stage is shown in Fig. 615. Most Hartley and Colpitts circuits would function well as a local oscillator. However, the circuit in Fig. 615-a is the one most commonly used. It is a modified Colpitts oscillator known as an ultra-audion. It uses the interelectrode capacitances of the tube (Fig. 615-b) for tuning and feedback. Fig. 615-b shows these capacitances connected in the circuit by dashed lines.

The grid-to-plate capacitance of the tube  $C_{gp}$  (Fig. 615-b), is essentially across oscillator coil L1. Plate-to-cathode capacitance  $C_{pk}$  and grid-to-cathode capacitance  $C_{gk}$  form a capacitive divider that is also across the coil. These interelectrode capacitances resonate with the coil at the desired frequency. The divider network R1- $C_{gk}$  and C1- $C_{pk}$  center tap is connected to the cathode at ground. Regenerative feedback from plate to grid is tapped down across the divider network and applied between grid and cathode across  $C_{kg}$ , causing the circuit to oscillate. The basic ac oscillator voltage is developed across plate load resistor R2. C2 and R1 form a grid-leak network that develops bias for the stage. A fine-tuning capacitor, C1, connected from plate to ground, is effectively across the  $C_{pk}$  part of the divider network. When the fine tuner is adjusted, it changes the resonance of the tuned circuit within a small band, normally about 1 mc. This adjustment is made for a clear picture and sound after the channel is chosen. When a new channel is chosen, a new oscillator coil, L1, is switched into the circuit. Each coil is slug-tuned for coarse adjustment.



## Local-oscillator stage analysis

To function properly, the local oscillator stage must:

- (1) Oscillate at the proper, steady frequency.
- (2) Oscillate at the proper, steady amplitude.

### Tuning and drift failures

Tuning trouble is defined as a permanent change in the tuning characteristics of the circuit, whereas drift may allow the circuit to start with normal operation but then cause changes during operation.

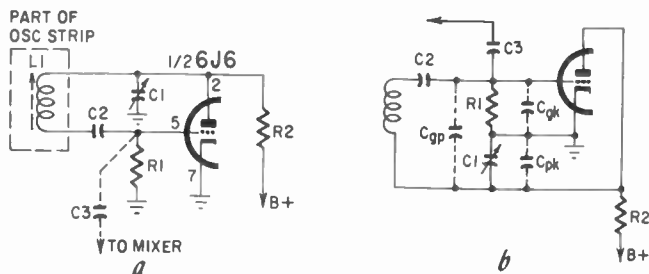

Fig. 615. Schematic diagram of a typical local-oscillator circuit (a). Diagram (b) is a simplified version.

Almost any part in the local-oscillator circuit can cause tuning failure. If the elements within the tube shift position, the interelectrode capacitances will be different. If  $C2$  or  $R1$  change value, the amount of grid-leak bias will change and, because of Miller effect,  $C_{gk}$  will change too. A variation in the value of  $R2$  will produce a different level of feedback voltage, and will also affect the bias and grid-to-cathode capacitance  $C_{gk}$ . Any of these variations will detune the resonant circuit, causing a change in frequency. If the change is only slight, however, adjustment of the coil or fine tuner will probably compensate for it. The changes in circuit values would have to be fairly severe before the adjustments would not work. Generally speaking, the high-frequency channels will be affected first since they are most susceptible to circuit changes.

In a turret tuner, if only one channel cannot be tuned in, then the coil for that channel has probably changed inductance or lost its slug. In a wafer tuner, if an oscillator coil develops trouble, the channel of that coil and all lower channels will be affected. If  $C1$  opens, fine tuning will be lost.

Drift in the local-oscillator circuit has always been a big prob-

lem because of the high frequencies and low capacitances involved. Any capacitance change, no matter how small, represents a substantial percentage of the normal capacitances of the circuit. Therefore, quality parts are generally used in the circuit because they are less affected by temperature or are temperature-compensating types. If the parts change value with temperature and cause tuner drift, the fine tuner will have to be readjusted to compensate for the change. The amount of drift and the time it takes depend on how easily the parts are affected by heat. The drift may be only one short change in frequency or a steady continuous one that may require repeated fine-tuning adjustments. The drift may continue till the oscillator goes out of range.

Any part (including the tube) can cause tuner drift. In an inter-carrier set, since the sound signal is a fixed 4.5 mc from the video carrier, the fine-tuning adjustment is made for the sharpest picture. As drift occurs, the oscillator frequency is set apart from the rf video carrier by more or less than the if difference frequency, depending on the direction of drift. The high or low video frequencies are lost, causing an unclear picture. As drift increases, adjacent-channel frequencies interfere with the picture. The condition may become severe enough to produce unstable sync. Throughout the initial drift period, sound is generally not affected. But as the drift becomes severe enough to make the picture very poor, the sound will become distorted and low, and inter-carrier buzz will develop.

### **Amplitude failures**

The output of the oscillator circuit is generally between 3 and 5 volts. If any part in the circuit opens or shorts completely, or if the tube becomes defective, the circuit will not oscillate at all. If any of the parts change value to cause either increased or reduced amplitude, the tuning and drift characteristics will also be affected. However, it is remotely possible for this to happen and have the tuner adjustments compensate for the shift in frequency yet still allow an improper oscillator signal amplitude. As with the other troubles, any part in the circuit may cause this by changing value. Low emission in the tube is the biggest offender. If the oscillator signal amplitude changes, it may produce an improper bias at the mixer grid and cause heterodyning troubles (as explained previously).

The biggest problem with the oscillator signal amplitude is keeping it steady and unmodulated. A high-resistance grid-to-filament leakage in the oscillator tube will modulate the oscillator

signal with a 60-cycle signal. This will be transferred to the if signal in the mixer stage through heterodyning action, causing a 60-cycle hum in the picture. Any arcing in the tube, R2 or C1 will cause momentary interruptions in the oscillator signal. These, in turn, will cause interrupted heterodyning action in the mixer stage and will affect the picture and sound the same as arcing in the mixer stage.

If either C2 or R1 increases greatly in value, their time constant will become high enough to make the oscillator self-quenching. While the tube is oscillating, the large – time – constant grid-leak circuit will build up a bias great enough to completely cut the tube off and stop oscillation. The tube will then remain cut off until the bias drains enough to again permit conduction and oscillation, and then, the quenching will again occur. The quenching frequency will depend on the R-C time constant. This intermittent oscillation will cause intermittent heterodyning – the picture and sound will go off and on in step with the quench frequency.

### **If section**

Fig. 616 is a schematic diagram of a typical if section. The section shown uses four if stages but most sets have only three. Four stages makes it easier to obtain enough gain with the required bandwidth.

In some sets, stacked if stages are being used, where the plate of one stage is in series with the cathode of the next, similar to the cascode rf stage (Fig. 603). However, the grid of the second stage is not at ac ground; it is fed by an if transformer in place of the load inductor used by the cascode circuit. The cathode of the second if is at ac ground.

The stacked if stages are sometimes referred to as cascode stages, but they are actually not. They are two grounded cathode amplifiers in series. Since they use the same dc plate current, there is less drain on the power supply, and the second stage regulates the plate voltage of the first stage.

The if input signal from the mixer stage is amplified in each if stage and sent to the video detector. The if section must amplify a bandwidth approximately 4 mc wide; to obtain this bandwidth, stagger tuning is used. Each tuned circuit is adjusted to a different frequency within the if band to give the over-all response shown in Fig. 617-a. For the circuit of Fig. 616, the frequencies shown for each tank circuit are used in a set that has a 45.75-mc video if carrier. The coils are generally slug-tuned, and they resonate with

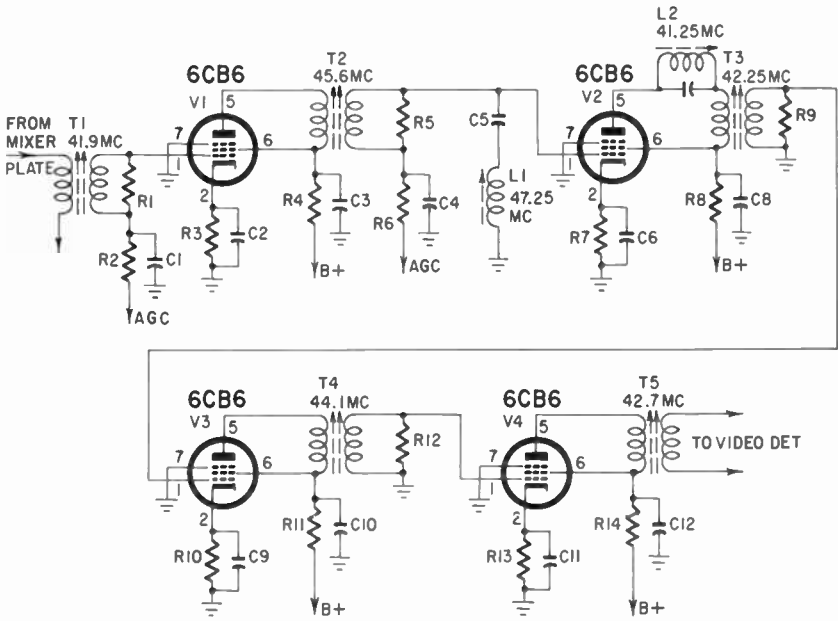

Fig. 616. Schematic diagram of a four-stage video if section. Except for the trap circuits, the stages are almost identical.

the tube interelectrode capacitances to form tank circuits.

The first two if stages are controlled by the agc bias line. In some receivers, only the first stage may use agc; and in some others, agc may be applied to the first three stages. Interference traps are added to some parts of the circuits to eliminate any interference signals not fully rejected by the tuner. These traps can be series-resonant bypass or parallel-resonant blocking types. The circuit shown in Fig. 616 uses if transformers for stage-to-stage coupling. Many sets have impedance coupling instead, or a combination of both. Other than these agc, wavetrap and coupling variations, all if stages are more or less identical.

The circuit in Fig. 618 is a composite video if stage that represents almost any if stage that may be encountered. T1 inductively couples the if signal from the plate of the previous stage to the control grid. R2 shunts the secondary winding of the transformer to widen its bandwidth. The series resonant trap C2 - L1, connected from grid to ground, is tuned to bypass the 41.25-mc sound if carrier of the channel being viewed. The sound signal is not shunted out entirely, but is reduced so that it will reach the video detector stage at the proper amplitude.

After being amplified in the tube, the if signal is developed across plate load inductance L3 and coupled by C7 to the control grid of the next stage. The parallel-resonant tank circuit C4 - L2 is tuned to block the 47.25-mc adjacent-channel sound signal from going any farther. Often, the sound if signal of the channel being viewed is strong enough to require attenuation by an additional 41.25-mc trap. This trap could be a series-resonant type in the grid of another if stage or it may be a parallel-resonant blocking circuit in series with coupling capacitor C7 (Fig. 618).

R1 and C1 and R4 and C5 form decoupling networks in the grid and plate circuits.

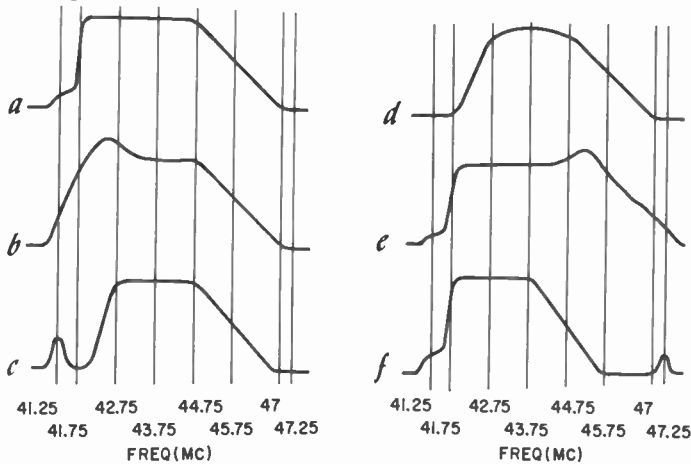

Fig. 617. Effects of detuning of the response of the if section. The normal curve is shown in (a).

For very weak signals picked up by the antenna, the agc section develops little or no bias. Consequently, if the if stage relied on agc alone for bias, the tube would run without bias on weak signals. To prevent this, R3 in the cathode develops a nominal amount of bias. C3 is the cathode bypass capacitor. Screen-grid voltage for the stage is obtained through plate decoupling network R4-C5.

### If stage analysis

To function properly, the if stage must:

- (1) Provide the proper bandpass for all of the high and low frequency components of the if signal.
- (2) Amplify the if signal faithfully.
- (3) Prevent noise and other forms of interference from being developed.

## Tuning and bandpass failures

As with the rf and mixer stages, the frequency response of the if stages is primarily a function of the tuned windings of the if transformers and coils. Also, since these transformers resonate with the circuit and tube capacitances, they also affect the frequency response, but to a lesser extent. As shown in Fig. 616, each circuit is tuned to a definite frequency so that, combined, the if section provides the response shown in Fig. 617-a. The lower response curves in the diagram indicate how the response can change when trouble develops in the various coils. If the 41.25-mc trap in the plate circuit of tube V2 is tuned too low, the sound carrier would not be attenuated to the proper level and the high-frequency video modulations would increase in amplitude (Fig. 617-b). This would cause an intercarrier buzz in the sound; and if the sound carrier were strong enough, it might reach the picture tube and impress a minor herringbone pattern on the picture similar to rf interference. If the sound carrier is very strong, it will produce sound bars in the picture which will occur in rhythm with the sound of the same channel.

If the high-frequency video amplitudes are great enough, they will overload the video. This generally results in a white outline around objects and at all other points where the contrast tone changes sharply. However, since the low video frequencies are hardly affected, the broad picture areas will appear normal. The response shown in Fig. 617-b can also result from the 42.25-mc transformer in the plate circuit of V2 being tuned too low.

If the 41.25-mc trap were tuned too high. (Fig. 617-c), not only would there be an audio interference in the picture and a buzz in the sound, but the high video frequencies would also be attenuated, causing a loss of video detail and a washed-out picture.

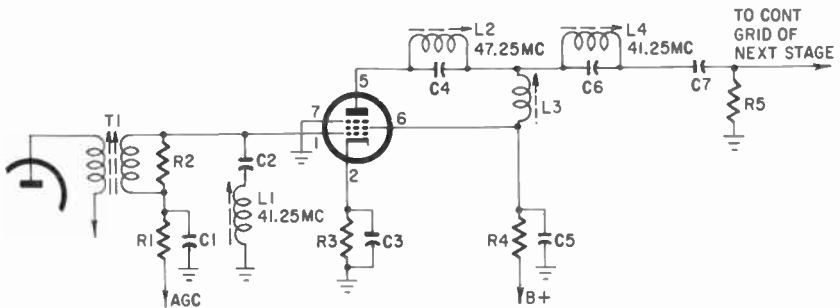

Fig. 618. Schematic diagram of a composite video if stage.

If the 41.9-mc transformer feeding V1 were tuned too high, the curve shown in Fig. 617-d could result. This will cause a reduction in amplitude of the high video frequencies and the audio carrier. Video definition might go down then, causing an unclear, washed-out picture. The sound would be weakened or even lost, depending upon how bad the detuning was.

If the 47.25-mc adjacent-channel sound trap in the grid circuit of V2 is tuned too high, the response curve shown in Fig. 617-e will be produced. The adjacent-channel sound will then be amplified, causing sound bars in the picture.

Adjacent-channel sound bars differ from same-channel sound bars, however, in that they do not occur in rhythm with the sound that is heard. If the 47.25-mc trap were tuned too low (Fig. 617-f), it would cause reduced low video frequencies, as well as allowing the adjacent sound to be built up. Therefore, in addition to sound bars, the broad picture areas would lose contrast, causing the outlines of objects to appear prominent. Also, since the sync pulses are low in frequency, the horizontal and vertical sync may become unstable. The vertical sync will tend to be affected first.

If any of the previous detuning is due merely to misadjustment, an alignment procedure will correct the fault. If alignment does not help, any one of numerous parts may be defective. If any tube becomes weak, it will, of course, weaken all frequencies but, because of stagger tuning, some frequencies will be affected most. For example, since V2's plate circuit is tuned to 42.25 mc, that frequency will suffer most if V2 loses gain, since the other frequencies are built up by the other stages. This type of trouble can also result if stage gain is reduced because of a faulty part. It is important to note, however, that a drop in gain most often weakens the signal to such an extent that low contrast and low sound become more noticeable than poor response. This is especially true for the stages controlled by agc. But if the stages that are not controlled by agc become weak, the response can be affected more because the agc-controlled stages will make up for the gain at their frequencies.

As explained for the tuner circuits, detuning can also occur if any transformer coil undergoes a change in inductance or if any tube interelectrode capacitance or circuit capacitor happens to change value.

The resistors that shunt the grid coils in each stage will also affect the frequency response if they open, but this is highly unlikely because they carry little or no current.

## Gain failures

Since the circuit of Fig. 618 represents what will most often be encountered, it will be the one used for gain failure analysis.

As with the other circuits, the gain of any if stage is primarily a function of the inherent gain of the tube and the circuit voltages, particularly the *agc* voltage. Gain failure is described as complete stage failure, too little gain and too much gain. The gain of a typical if stage is up to about 20. The gain of the entire if section is generally designed to be between 2,000 and 20,000, depending on the *agc* bias.

Almost any part in an if stage can cause complete failure so the signal is not passed to the video section. The tube can develop an open filament or other element, complete loss of emission or shorted elements. The windings of T1 or L1, L2, L3 or L4 can become opened or shorted. Shorted coils L2 or L4, however, will cause improper response to their associated frequencies. If R4 in the plate circuit opens, it will prevent plate voltage from being applied to the tube, causing a dead circuit. This will also happen if C5 in the plate circuit becomes shorted. However, a shorted C5 will probably burn out resistor R4. An open R3 will also cause a dead stage since it will open the cathode circuit of the stage, and an open C7 will not couple the signal to the next stage. If R1 in the grid circuit opens, the floating grid will probably cut off the tube; this however, will rarely happen since little or no current flows in the grid circuit.

If trouble develops in an if stage so that not enough gain is obtained, then the signal fed to the video section will be weak, the picture will lose contrast and the sound will be low. Actually, the troubles that cause complete stage failure are also those that reduce gain. For reduced gain, though, the parts change characteristics much less severely. The most common cause of reduced if gain is less emission in the tube. If R4 in the plate circuit increases in resistance, it will lower the plate voltage of the tube, causing insufficient gain. The plate voltage will also be lowered if C5 in the plate circuit develops a high-resistance leakage. This will tend to overload R4, which eventually may burn out.

If resistor R3 increases in value, the resulting higher cathode-voltage drop will cause increased bias that will also lower the gain. An open C3 will cause degenerative feedback. This will result in a minor decrease in gain that will probably not be noticed for normal-strength signals, but may have an effect on very weak signals. If coupling capacitor C7 decreases in value, it will couple a



smaller signal to the next stage; if the reduction is minor, agc will probably make up for the gain. If C7 increases in value, the RC time constant of the grid circuit might cause grid-leak bias to be developed, which will reduce the gain. If grid-leak resistor R5 increases in value, the same will result.

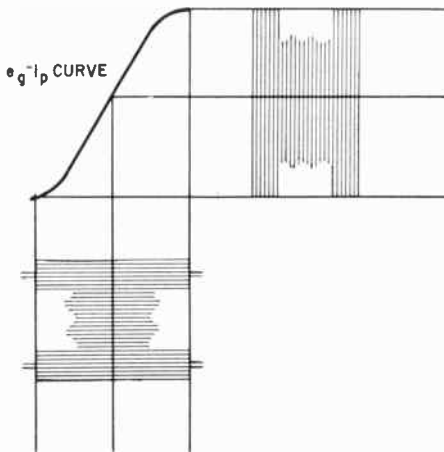

Fig. 619. An overdriven if stage results in sync clipping.

Excessive gain in an if stage will cause the if signal to be built up too much. The signal can then overdrive one of the following stages (Fig. 619). Since the peak-to-peak amplitude of the signal is greater than the full range of the  $e_g - i_p$  curve, the tube is driven into saturation and cutoff. The sync pulses are lost, causing a loss of picture synchronization. If the signal were a little smaller, only part of the sync would be lost, causing only unstable sync. If the signal became much too large (Fig. 620), it would cause video overloading. Not only would the sync pulses be lost, but so would most of the blanking pulses and the black and dark gray tones of the picture. An overloaded picture would be grayish white and unstable, and the retrace lines may show. The picture may also be barely recognizable. The amount of overload depends on the size of the signal. Sometimes, the overload is slight — only the deep black tones are lost and the clipped sync causes a wiggly or hooked picture. The retrace lines may be difficult to eliminate. If the overload is great enough, though, it can cause complete loss of the picture.

An overdriven or overloaded condition will also cause sound trouble. This is because intercarrier heterodyning in the video

detector requires that both the video and sound carriers be present at all times for the intercarrier sound if to be developed. As a result, when the if signal is clipped, it is blocked out at that instant and intercarrier heterodyning cannot take place. Therefore, the sound is also lost at that instant. If the if clipping occurs periodically at an audio rate, the repeated interruption of the sound will cause what is known as intercarrier buzz.

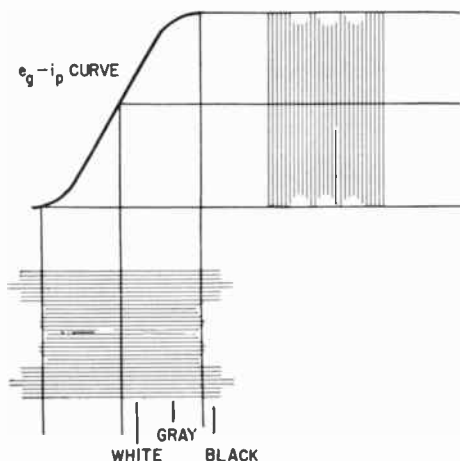

Fig. 620. An overloaded if stage results in loss of blanking and video information as well.

cally at an audio rate, the repeated interruption of the sound will cause what is known as intercarrier buzz.

The gain of the stage is controlled primarily by the tube's grid voltage. If an if tube develops grid-to-cathode leakage or its grid starts emitting, bias will be lost, causing very high gain and clipping of the signal. This will also occur if C1 in the grid circuit shorts the agc voltage to ground.

A positive grid can also develop if the primary winding of T1 becomes shorted to the secondary winding. Also, a leaky coupling capacitor C7 will apply a positive voltage to the grid of the next stage.

### Noise and interference failures

The resonant circuits of the if stages must be properly tuned for acceptance and rejection of the right signals. Therefore, many of the troubles covered previously for tuning and bandpass failures may also permit outside interference to get through.

Within an if stage, almost any part can cause noise or various types of interference. The most common symptom is 60-cycle hum in the picture, because of filament-to-cathode or filament-to-

grid leakage within the tube. The 60-cycle voltage modulates the video carrier.

The next most common trouble is a microphonic tube. Loose elements within the tube become sensitive to various disturbances, such as the receiver sound itself. The elements vibrate and modulate the video carrier to produce interference bars in the picture. Arcing within the tube will cause momentary interruptions in the signal. If the arcs are heavy, the video interruptions will cause flashes in the picture, with associated crackling in the audio. If the arcing interferes with the sync pulses, the picture will tear. If the arcing is only slight and of short duration (such as spitting corona), ignition type noise will be produced in the picture. Ordinarily, the repetition rate of this minor arcing is high enough not to tear the picture or be heard in the sound, but on occasion it does.

Arcing troubles are quite frequently caused by the parts in the circuit that carry relatively high currents or are connected across B-plus voltages. R4 in the plate circuit or R3, for example, can carbonize or get cracks that arc, or they can develop loose leads. The dielectric in C5 in the plate circuit or coupling capacitor C7 may break down and cause arcing. Poor connections in transformers and coils will arc over.

Interference may also be caused if the if signal finds its way to the other stages of the set through the agc or B-plus lines. The decoupling networks R1, C1 and R4, C5 in the grid and plate circuits are used to prevent this. But, if either capacitor C1 or C5 opens or if either R1 or R4 become shorted, the if signal will not be decoupled to ground. If the if signal is strong enough, it may cause regenerative feedback, particularly if it is fed in phase to an earlier if stage. This may result in oscillation in the video line which will block the video and audio signals and produce erratic diagonal lines on the raster.

## **Video section**

A schematic diagram of a typical video section is shown in Fig. 621. It uses a detector, video amplifier and video output stage. Many television sets, however, do not use the video amplifier stage, relying on the output stage to produce enough gain. With an amplifier and output stage, though, it is easier to get the gain and frequency response.

The if signal from the if section is applied to detector tube V1, which produces the 4.5-mc audio if signal and the video signal. These are amplified in V2. The 4.5-mc audio if signal is taken off

at the tube V2's plate and fed to the audio if section. The video signal is sent through video output stage V3 to the cathode-ray tube to produce the picture. V2's video signal output is also sent to the sync and agc sections.

### Detector stage

Typical detector stages are illustrated in Fig. 622. As the illustrations show, they vary little from one another. They can be connected as in Fig. 622-a for negative output or as in Fig. 622-b for positive output. As shown in Fig. 622-b, triodes are sometimes con-

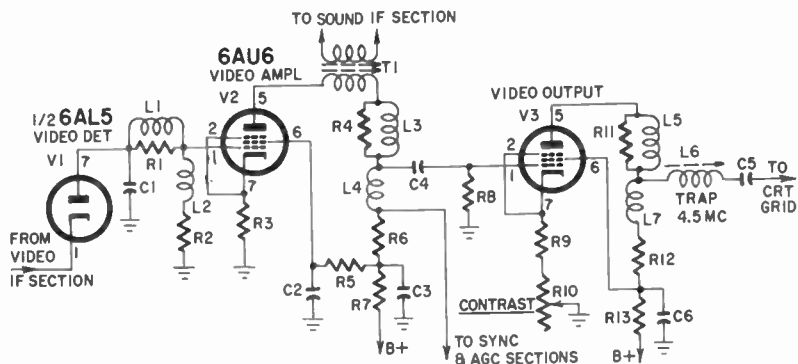

Fig. 621. Schematic diagram of a typical video section.

nected and used as diodes. Many sets (Fig. 622-c) use semiconductor diodes in place of the electron tube. The 4.5-mc audio if signal can also be taken off at the detector.

The audio and video components of the if signal are rectified and heterodyned in tube V1. In the output of the detector circuit, filter capacitor C1 bypasses the if to ground, and the remaining video signal and 4.5-mc sound if signal are passed through L1 and developed across L2 and R2. R2 is the main output load of the circuit, and L1 and L2 increase the high-frequency response of the circuit. L1 is a series peaking coil which resonates in series with the tube's interelectrode and circuit wiring capacitances to prevent the higher video frequencies and 4.5-mc sound if signal from being bypassed. R1, which shunts L1, lowers the Q of the coil to prevent a sharp tuning peak. L2 is a shunt peaking coil which resonates in parallel with the tube and circuit capacitances to extend the frequency response of the circuit.

### Detector-stage analysis

To function properly, the detector stage must:

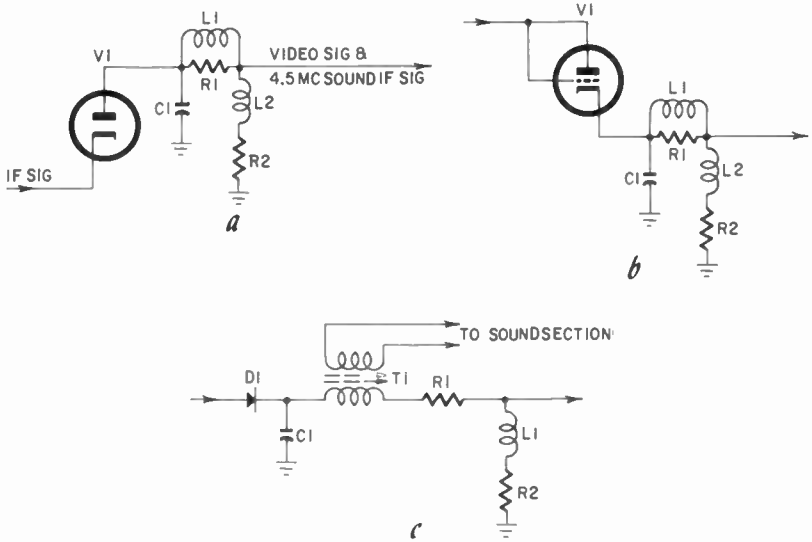

Fig. 622. Some typical detector circuits. Note in (c) how the sound if signal can be taken off in the detector stage.

- (1) Provide the proper bandpass for all the video and for the sound intermediate frequencies.
- (2) Prevent noise and other forms of interference from modulating the video or sound signals.

### Bandpass failures

The bandpass of the detector stage (Fig. 622-a) is determined by all the parts in the output circuit of the diode, including the stage's interelectrode and interwiring capacitances. Since the detected frequencies are relatively low, however, variations in these capacitances have little effect, particularly if the peaking coils are functioning properly.

The normal frequency response for the detector stage is as shown in Fig. 623-a for the entire video section. Actually, the over-all response of the video section goes to the dotted line at the 4 mc point. This is important because the 4.5-mc sound if carrier must not reach the picture tube. But since it is developed in the detector stage, the detector response follows the solid line.

The curve has a relatively flat response from zero to about 4 mc, and drops off to just beyond the 4.5-mc sound if signal. The sound if amplitude is chosen large enough to be built up in the audio section yet small enough to be trapped before the picture tube.

The low-frequency response of the circuit is determined mostly by load resistor R2 (Fig. 622-a). If it decreases in value, the low-frequency response will drop as shown by the solid line curve in Fig. 623-b. This will cause the broad picture tone areas to lose contrast and the outlines of objects to be accentuated. Also, since the sync signals are low frequencies, synchronization will become erratic or lost, depending on how bad the low-frequency response is. Vertical synchronization will be affected first. If R2 becomes very low in value or shorted, the low frequencies will be lost (dotted line in Fig. 623-b). When this happens, synchronization will be lost and the picture, if it could be viewed, would be composed entirely of outlines. However, since little current flows in the detector circuit, R2 does not decrease in value often.

If R2 should increase in value, the low frequencies will increase in amplitude (Fig. 623-c). This can cause overloaded sync and low-frequency video signals in the later stages, resulting in unstable sync and an overcontrasted picture. Often, in such cases, lowering the contrast control brings about normal tones, but this results in low-amplitude high frequencies. Sharp video outlines will then smear, causing an unclear picture.

Poor high-frequency response (Fig. 623-c) will also result if either peaking coil L1 or L2 (Fig. 622-a) decreases in inductance or becomes shorted. When this happens, the defective coil no longer neutralizes the circuit capacitances, which then bypass the high video frequencies. If the loss of high frequencies is bad enough, it may cause weak sound in addition to an unclear picture. Generally, however, the gain of the sound if section is great enough to make up for a weak 4.5-mc sound if signal.

If R1 increases in value, L1 will tend to resonate with the stage's interelectrode and interwiring capacitances, offering a greater response to some of the higher video frequencies (Fig. 623-d). L1, then, tends to oscillate whenever high video frequencies are detected. When this happens, the sharp picture outlines are repeated with alternate black-and-white lines. This is known as video ringing. There are many ringing lines if R1 is open but, if it just increases in resistance, there may be only a slight negative outline, which is similar to the familiar ghost.

### **Noise and interference failures**

One of the most common troubles to occur in the detector stage is intercarrier buzz. This is because the ratio of the audio and video if carriers is critical for proper heterodyning to take place. However, although the trouble shows up in the detector, it is

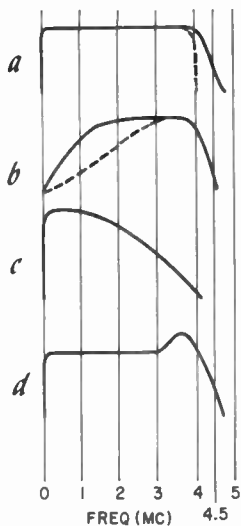

Fig. 623. Video-section response curves. The normal curve is shown in (a) with the dotted line showing the high end for the entire section and the solid line for the detector stage.

usually caused by improper bandpass in earlier circuits. On the other hand, when detector V1 becomes weak from loss of emission, the audio and video components may not beat properly causing intercarrier buzz. When germanium diodes are used, this trouble can result if the forward resistance increases somewhat or the back resistance drops. A great increase of forward resistance or drop in back resistance will, of course, prevent any detection at all.

Within the detector tube, noise and interference signals can be generated as explained for the if stages (hum, microphonics, arcing), with the associated picture, sound and synchronization effects.

### Video amplifier and output stages

Typical video amplifier and output stages are shown in Fig. 624. Basically, like the detector, they differ little from one set to the next. Variations generally occur where the agc, sync or audio if signals are taken off, or whether pentodes or triodes are used. Pentodes are used for higher gain and triodes for lower noise.

The stages are R-C-coupled circuits. The plate loads in both stages are made up of shunt peaking coils L2 and L4 and load resistors R3 and R10. L1 and L3 and shunt resistors R2 and R9 in each plate form series peaking circuits, as in the detector stage. R5 and R11 and C2 and C4 in the plate supply of each stage form decoupling networks. R4 and C1 form the screen decoupling network for amplifier stage V1. R1 and R7 in each

stage develop cathode bias. The contrast control in the video output cathode circuit allows the bias for that stage to be varied, so that the gain of the stage can be adjusted for a picture with the best contrast.

C3 and C5 in the output circuit of each stage couple the video signal from stage to stage. R6 is the grid-leak resistor for the control grid of V2.

Sound takeoff transformer T1 takes the audio if signal out of the plate circuit of V1 and sends it to the audio if section. Trap L5-, in the output circuit of V2, blocks any remaining 4.5-mc frequencies from reaching the picture tube. The video signals dropped across resistor R3 in V1 feed the sync and agc sections. Actually, the sync, agc and sound-takeoff points can be anywhere in either of the circuits, depending on the gain and phase desired.

### **Video amplifier and output stage analysis**

To function properly, the video amplifier and output stages must:

- (1) Provide the proper bandpass for the video and audio if signals.
- (2) Amplify the signals faithfully.
- (3) Prevent noise and other forms of interference from being developed.

### **Bandpass failures**

The bandpass of the video amplifier and output stages can be affected by most of the parts in the circuit. The frequency response of the circuit is the same as described for the detector stage (Fig. 623-a). Amplifier stage V1, which must pass the audio if signals, has a response curve that tapers down just beyond 4.5 mc. Output stage V2, on the other hand, which must reject the sound signal, passes only up to 4 mc.

As with the detector stage, resistors R3 and R10 and peaking coils L2 and L4 in both plate circuits have the greatest effect on frequency response. If they become defective, the effects will be the same as described for the detector circuit. However, in the plate circuit of the video output stage (Fig. 624-a), the peaking coils and load resistor will affect only the video, since the sound, sync and agc signals were taken off the previous stage.

The low-frequency response of the circuit can also be affected by coupling capacitors C3 and C5 and decoupling capacitors C2 and C4 in both stages. If either C3 or C5 decrease in capacitance, low-frequency response will be lost (Fig. 623-b), with the usual



effects on the picture. However, since the sync signal is taken off prior to the first coupling capacitor, synchronization would not be affected. However, many receivers do take the sync signal off the video output stage, so a defective capacitor C3 feeding tube V2 may cause synchronization, particularly vertical synchronization, to become critical or even lost.

Either C2 or C4 decreasing in value will cause an increase in low-frequency response (Fig. 623-c), with associated picture and sync troubles.

### **Gain failures**

As with the IF and tuner circuits, the gain of the video stages is primarily a function of the inherent gain of the tube and circuit voltages. Gain failure is considered complete stage failure, too little gain and too much gain. The gain of a typical video amplifier is between 10 and 50, and the output of the video section is generally up to 70 volts peak-to-peak.

Almost any component in the circuit shown in Fig. 624 can cause complete failure so that the signals do not reach the CRT and the audio, sync and agc sections. However, if complete failure occurs in the output stage, only the video will be lost; the sound will be good and the raster synchronized.

For complete failure, the tube can develop an open filament or other open element, loss of emission or shorted elements. If any resistor or coil winding in either stage opens, the signal path will be broken. If either decoupling capacitor or screen-grid capacitor becomes shorted, plate or screen voltage will be grounded, disabling the circuit. The associated resistors will probably be burned open because of the short. If either C3 or C5 opens, the signal will not be coupled to the following circuit.

If trouble develops in the video amplifier stage so that not enough gain can be developed, then the signals fed to the other stages will be weak. The picture will have low contrast, the sound will be low and the sync unstable. Often, however, the audio does not appear to be affected because of the high gain of the audio IF section. If the gain in the video output stage goes down, only the video will be affected. Contrast will be low, but sound and synchronization will be normal.

The most common cause of reduced gain is reduced emission in either tube. If either R5 or R11 in the plate circuits increase in resistance, they will lower the associated plate voltage. The plate voltage will also be lowered if either C2 or C4 develop high-resistance leakage. This will tend to overload the associated decou-

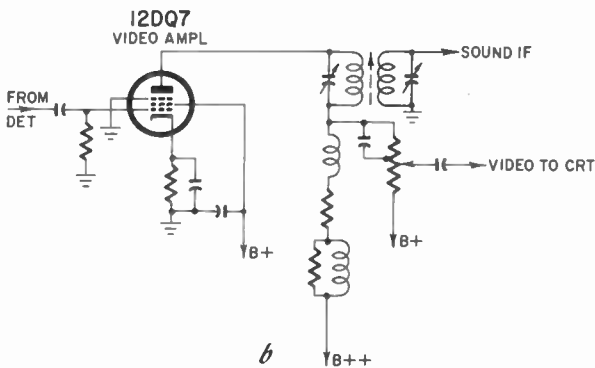
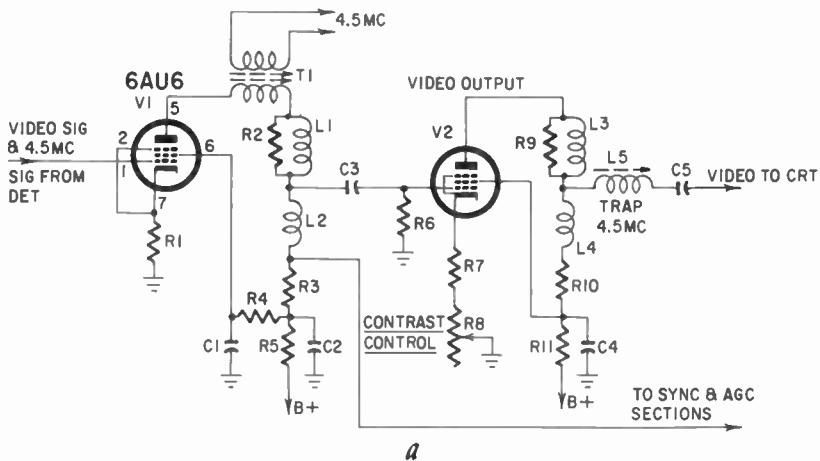

Fig. 624. Schematic diagram of a video section. Some sets use two stages (a), and others use one (b). Two stages give more gain and bandwidth.

pling resistor, which in all probability, will burn out eventually.

If either cathode resistor increases in resistance, the resulting higher cathode-voltage drop will cause increased bias, which will also lower the gain. A minor drop in gain in the output stage will probably not be noticed because an adjustment of the contrast control can make up for it.

Too much bias in a video stage can also cause the stage to be driven into cutoff when the signal fed to the control grid is strong enough. The exact effects, however, depend on the polarity of the video signal applied to the grid. If the video signal is negative (Fig. 625), the sync pulses would be driven into cutoff, causing a

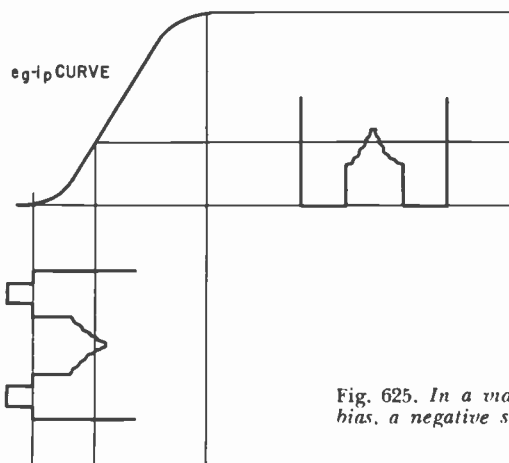

Fig. 625. In a video stage with too much bias, a negative signal could lose its sync pulses.

loss of picture synchronization. If the bias were not too high, only part of the sync pulses would be lost, causing unstable sync.

On the other hand, if the bias were very high, it also would cause the video to be driven into cutoff. Not only would the sync pulses be lost but so would most of the blanking pulses and the black and dark gray tones of the picture. The resulting picture would be grayish white and unstable and the retrace lines would show. The picture may become unrecognizable, depending on how great the bias is. Sometimes the cutoff is slight, and only the deep black tones are lost and the clipped sync causes a wiggly or hooked picture. The retrace lines may also be difficult to eliminate. If the tube is completely cut off, though, the picture can be lost altogether.

If the video signal is positive (Fig. 626), only the white picture tones will be lost, causing a dark picture. The sync and blanking pulses will not be affected.

A cut off stage will also cause sound trouble. When the tube is not conducting, it cannot pass audio signals. If cutoff occurs intermittently at an audio rate, the audio will be clipped at this rate, producing a sound similar to intercarrier buzz. If the bias is too high in the video output stage, however, only the video will be affected.

If trouble develops in the video circuits so that too much gain results, then the signals fed to the following stages will be too strong, causing an overloaded stage.

Although load resistors R3 or R10 can cause increased gain by rising in value, this will have a more noticeable effect on the

bandpass of the circuit, as explained earlier. Actually, the gain of the stage is determined primarily by the tube's control-grid voltage. If a video tube develops grid-to-cathode leakage or its grid starts emitting, bias will be lost, causing very high gain. This will also happen if coupling capacitor C3 or C5 develop a high-resistance leakage and applies some positive voltage to the control grid.

A decrease in bias or a positive grid can also cause the stage to be driven to saturation if the video signal is strong enough. The exact effects of such a trouble depend on the polarity of the video signal. If the video signal is positive (Fig. 627), the sync pulses would be driven into saturation. If the video signal is negative (Fig. 628), the white tones would be driven into saturation. The effects on the video, sync and audio for a saturated signal are similar to those explained earlier for signals driven into cutoff.

### Noise and interference failures

The most common symptom in the video section is 60-cycle hum in the picture, because of a filament-to-cathode or filament-to-grid leakage within either tube. In the video amplifier stage, the 60-cycle hum will modulate the video, audio, sync and agc signals. This will cause a hum bar to appear in the picture.

The 60-cycle signal is also sent to the sync section; the resulting poor synchronization will cause the picture to hook in a 60-cycle fashion. Since the 4.5-mc sound if signal is frequency-modulated, it may not be affected unless the hum tends to cut the video amplifier stage off, or the hum in the agc line tends to cause an overload at a 60-cycle rate. This, however, depends on how much hum is generated.

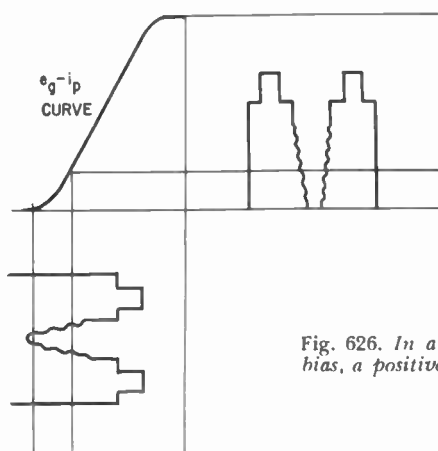

Fig. 626. In a video stage with too much bias, a positive signal can lose white video information.

The next most common trouble is a microphonic tube. Loose elements within the tube modulate the video to produce bars in the picture and erratic synchronization.

Heavy arcing within the tube will cause momentary interruptions in the signals, producing flashes in the picture and crackling in the sound. The arcing may also affect the sync pulses resulting in picture tearing. If the arcing is only slight and of short dura-

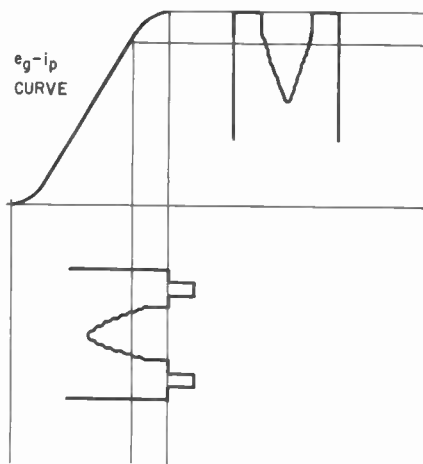

Fig. 627. With too little bias, a video stage can clamp the sync pulses out of a positive signal.

tion, ignition-type noise will appear in the picture. Ordinarily, the repetition rate of this minor arcing is high enough not to tear the picture or be heard in the sound, but often, it does interfere with the audio.

Arcing troubles are quite frequently caused by the parts in the circuit that carry relatively high currents or are connected across B-plus voltages. R3, R5, R10, and R11 in the plate circuits, or R1, R7 or contrast control R8 in the cathodes, or the screen-dropping resistor R4 can carbonize or develop cracks that arc, or they can develop loose leads. The dielectrics of C1, C2, C3, C4 or C5 may break down and cause arcing. Poor connections in the coil windings also produce this symptom.

Interference can also be caused if capacitor C1 opens. If this happens, the screen-grid voltage will vary with the signal. Sometimes, this has a degenerative effect that reduces the gain, but often, it has a regenerative effect that causes the stage to oscillate.

This will result in a loss of picture and sound. The oscillating stage will cause rf diagonal lines on the raster.

Of course, if trap L5 becomes detuned and the sound if signal is strong, sound bars will appear in the picture.

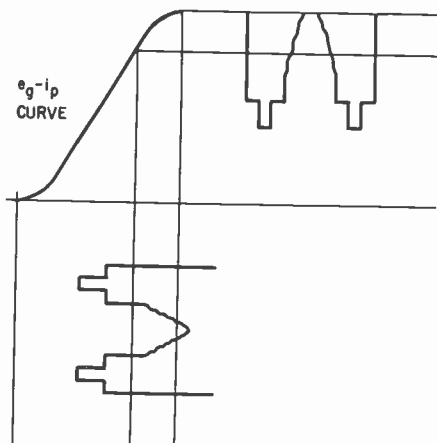

Fig. 628. With a negative signal, too little bias in a video stage could result in the loss of white picture details.

A dirty or worn contrast control will make poor connections while it is being adjusted, and flashes will appear in the picture.

### CRT circuits

The output of the video section is applied to the CRT grid as shown in Fig. 629. In many sets, however, it can be fed to the cathode, depending on the phase. In addition, horizontal and vertical blanking pulses can be applied to the cathode to cut the CRT beam off during retrace time. Some sets do not use either or both of the retrace pulses. The brightness control sets the cathode bias to adjust the brightness of the raster. Resistor R8 sets the voltage on the focus electrode for proper electrostatic focus.

### CRT circuit troubles

The CRT circuits can become defective to cause no raster, low brightness, no brightness control, no video or poor video, and poor focus. The CRT itself can cause the troubles described in Chapter 2. The raster will be lost if the cathode circuit becomes opened, because of an open R5 or brightness control, or loss of high voltage. Also, if C2 shorts, B-plus from the horizontal section will be put on the cathode to cut the CRT off. Low brightness will result if R5 increases in value or C2 becomes leaky. Loss of brightness

control, where the raster brightness cannot be turned down or off, will result if R7 opens or C4 shorts, removing cathode bias.

In addition, a shorted C1 would put video B-plus on the CRT

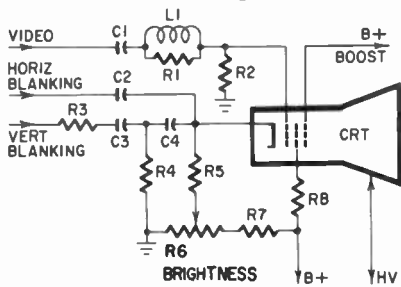

Fig. 629. CRT circuits showing retrace elimination circuits.

control grid to cancel the cathode bias. An open C1 would cause loss of video, and an open R2 would cause a floating grid. This could cut the CRT off to cause no raster, or it could cause a smeared picture. An open or arcing R8 would cause loss of focus. Arcing in any of the parts or a worn brightness control would cause flashes in the picture.

## circuit failure analysis, audio and agc

A TYPICAL audio section is shown in Fig. 701. Basically, it contains: (1) a sound if stage; (2) a detector; (3) an audio amplifier; and (4), an audio output stage. The 4.5-mc sound if signal from the video amplifier is built up in sound if amplifier V1 and applied to audio detector V2. V2 converts the FM if signal to an audio voltage that is amplified by V3 and forwarded to audio output stage V4. This stage drives the speaker to produce the sound.

This circuit is fairly standard for most intercarrier TV's. Some sets, though, use two sound if amplifiers for additional gain or a limiter stage following the if. The use of a limiter, however, is determined by the type of detector used (which will be explained later). Also, in some console sets such as the three-way models that have phonographs, the sound section may be more elaborate. It may for example, have push-pull output.

A few of the better audio sections are designed to give a frequency response from 50 to 15,000 cycles with a minimum of distortion, so that maximum advantage can be taken of the FM sound signal. In most sets, however, the high-frequency response may not reach even 8,000 cycles, due mostly to the use of an inexpensive speaker and output transformer.

### Sound if amplifier

A typical sound if amplifier is shown in Fig. 702. A comparison of Fig. 702 and Fig. 616 will show that the sound if amplifier is similar to the main if amplifiers. T1 is the slug-tuned sound takeoff transformer that feeds the control grid of the stage. R1 develops



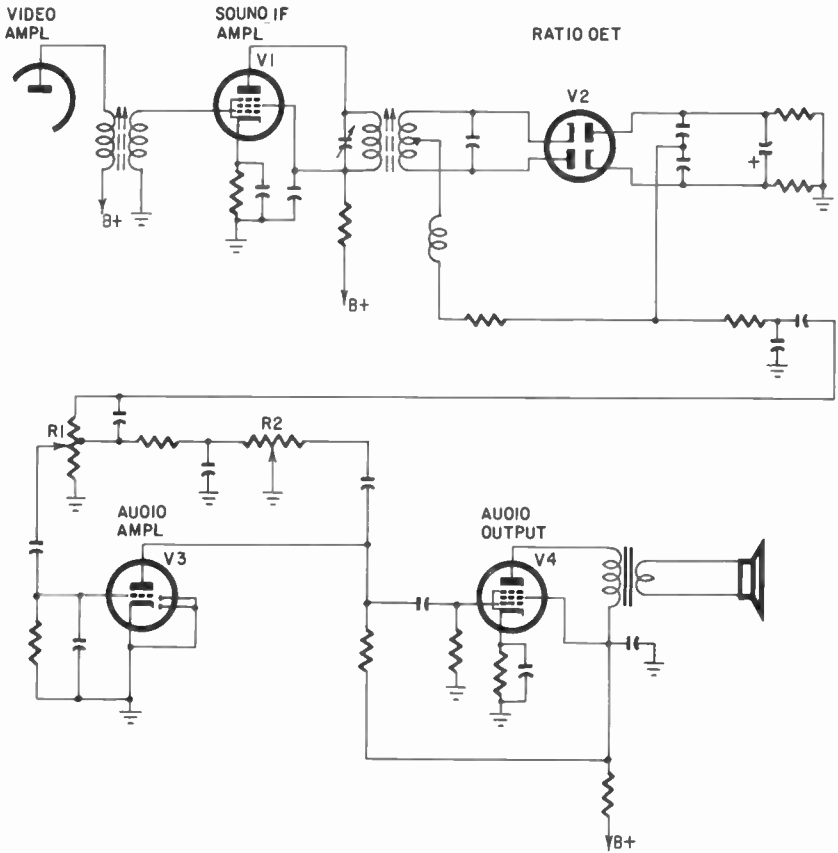

Fig. 701. Schematic diagram of a typical audio section.

cathode bias and C1 bypasses the cathode to prevent degenerative feedback. The amplifier signal is coupled to the detector through T2. The primary winding of the transformer resonates at the audio if frequency with C2. R2 and C3 form a plate decoupling network.

### Sound if amplifier stage analysis

To function properly, the sound if amplifier must:

- (1) Provide the proper bandwidth for the 4.5-mc if signal.
- (2) Amplify the desired signal.
- (3) Prevent noise and other forms of interference from modulating the sound if signal.

### Tuning and bandpass failures

The frequency response of the stage is primarily a function of

the tuned windings of input and output transformers T1 and T2, as well as C2. In addition, since the coils also resonate with the circuit and tube capacitances, these, too, affect the frequency response, but to a lesser extent.

T1 and T2 are tuned sharply to 4.5 mc and provide a 50-kc bandwidth (Fig. 703-a). This sharp bandpass enables the transformers to reject the video frequencies.

If the transformer tuning were too high (Fig. 703-b), audio gain would go down and the sound if frequencies below the carrier

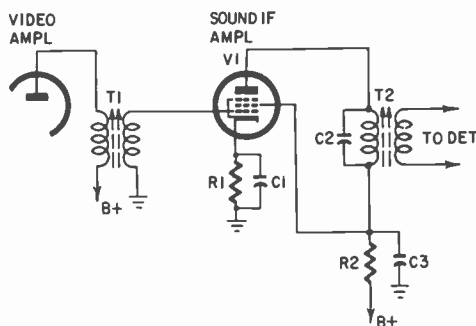

Fig. 702. Schematic diagram of a typical sound if stage.

would be weakened or lost. And, since the frequency shift in an FM signal determines audio amplitude, loss of the lower sound if frequencies would cause amplitude distortion. (This will be explained more fully under the audio detector discussion.) If the high tuning were due to the primary winding of T1, sound bars would get into the picture. This is because T1's primary winding also acts as a sound trap to keep the audio out of the picture.

If the transformers were tuned so that the response was too low (Fig. 703-c), low sound and audio amplitude distortion would again result. If the tuning were far enough off to give response to the higher video frequencies, those frequencies would also be amplified to interfere with the sound. Video in the audio often sounds like intercarrier buzz. If this low tuning were due to the primary winding of T1, then the winding would tend to block the higher video frequencies out of the picture (as explained for the video section).

If any of the detuning is due merely to misadjustment, then following an alignment procedure will correct the fault. If alignment does not help, however, any one of T1 or T2's coils (Fig. 702) may have changed inductance, C2 may have opened or the

tube's interelectrode capacitances may have varied. In addition, the transformer tuned circuit must have high  $Q$ 's for a sharp

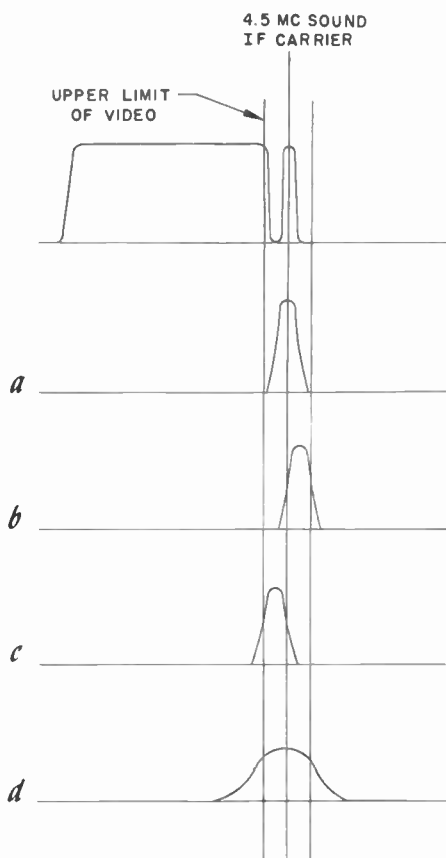

Fig. 703. Effects of detuning on the sound if response curve.

response. Therefore, if any coil develops additional resistance, it will broaden the response curve (Fig. 703-d). This will cause reduced sound, and the higher video frequencies will interfere with the audio.

### Gain failures

As with any stage, gain is a function of the inherent gain of the tube and the circuit voltages. Gain failure is considered complete stage failure, too little gain or too much gain. The gain of a typical sound if amplifier (Fig. 702) is up to approximately 20.

Total stage failure, which results in the complete loss of sound, can be caused by almost any component. The tube can have an open filament or other element, loss of emission or shorted elements. The windings in T1 or T2 can open or become shorted. An open or shorted primary winding of T1, however will also affect the video section. If R2 in the plate circuit opens, plate voltage will be removed, causing a dead stage. This will also happen if C3 becomes shorted, but this will most likely burn out R2 also. An open R1 also will cause a dead stage since it will open the cathode circuit.

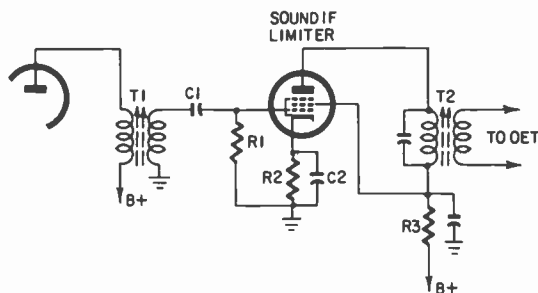

Fig. 704. *The limiter stage is actually an if stage that is easily cut off and saturated.*

If not enough gain can be obtained in the audio if stage, then the signal fed to the next stage will be correspondingly weak, with low sound output. Actually, the types of troubles that cause complete stage failure are also those that reduce gain. For reduced gain, though, the parts change characteristics much less severely. The most common cause of lowered sound if gain is insufficient emission in the tube. If R2 increases in resistance, it will lower the plate and screen voltages of the tube, causing insufficient gain. The plate voltage will also be lowered if C3 develops a high-resistance leakage; but this will also tend to overload R2, which will probably burn out eventually. If R1 increases in resistance, the resulting higher cathode voltage drop will produce increased bias which will also lower the gain. An open C1 will cause degenerative feedback and will lower the gain slightly, but this effect will probably not be noticed except for very weak signals.

Too much gain in the sound if stage can result from reduced bias, which can happen if the tube develops grid-to-cathode leakage or grid emission, C1 becomes shorted or R1 decreases in value. However, increased gain in a sound if amplifier prob-

ably will not be noticed because the stage might act somewhat like a limiter (as will be explained later), unless the reduced bias causes additional trouble (such as a burned-out tube).

### **Noise and interference failures**

Practically any component can cause noise or various types of interference. The most common type of trouble is 60-cycle hum in the sound because of filament – to – cathode or filament – to – grid leakage. Unlike the other stages, however, the 60-cycle signal modulating the audio if signal as a result of leakage does not present a problem, because the limiter or detector stage will remove any such amplitude modulations. But if the leakage within the tube is great enough, the 60-cycle signal will drive the stage into saturation and cutoff during its positive and negative swings. The audio if signal will then be blocked during those periods (twice per cycle), producing a 120-cycle hum in the sound.

Arcing within the tube will also cause momentary interruptions in the signal. If the arcing occurs at an audio rate, it will be heard as crackling. This arcing type trouble can also be caused by other parts in the circuit that carry heavy currents or are across B-plus voltages. R1 or R2 can carbonize, produce cracks that arc or develop loose leads. The dielectric in C3 can break down and cause arcing, and poor connections in the transformers will arc over.

Interference may also be caused if the audio if signal finds its way to the other stages of the set through the B-plus lines. Decoupling network R2 – C3 prevents this. But if C3 opens or R2 becomes shorted, the audio if signal will not be shunted to ground. If the signal finds its way to the video section, it may appear in the picture as a small herringbone pattern. If it finds its way to the other audio stages, regenerative feedback may result and cause oscillation in the audio line. This will block the audio signal completely – only the oscillating squeal will be heard.

### **Sound if limiter**

As will be explained later, the limiter stage is required only with certain audio detectors. The sound if limiter stage (Fig. 704), is very similar to the ordinary sound if amplifier (Fig. 702). The main differences are: (1) the limiter stage is operated at very low plate and screen voltages; and (2), grid-leak network C1 – R1 is used in the control-grid circuit to develop cutoff bias.

Because of the cutoff bias, the tube conducts only on the positive half-cycles, and, because of the stage's low operating voltages, the tube saturates on each positive peak (as shown in Fig. 705).

Therefore, although signal inputs may vary in amplitude, the current in the plate circuit consists of constant amplitude pulses. The plate tank circuit changes the pulses back to ac sine waves. Fig. 705

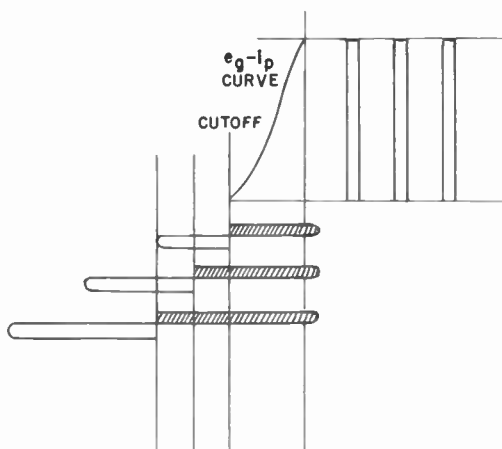

Fig. 705. Limiting action. Note how the bias increases with stronger signals.

also shows how the cutoff bias changes for different amplitude signals, so that the stage is not overdriven in the saturated portion and the plate current is kept at a steady average level. The limiting action removes all interfering amplitude modulations and often prevents any gain variations in the audio if amplifier from having any adverse effects.

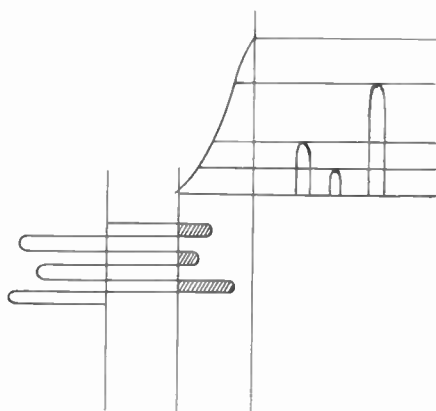

Fig. 706. Too much bias could result in the loss of saturation.

### Sound if limiter stage analysis

To function properly, the limiter stage must provide the same bandpass, gain and interference-free operation as the sound if amplifier. Troubles developing in the limiter stage are the same as described for the sound if amplifier except, of course, for limiting action.

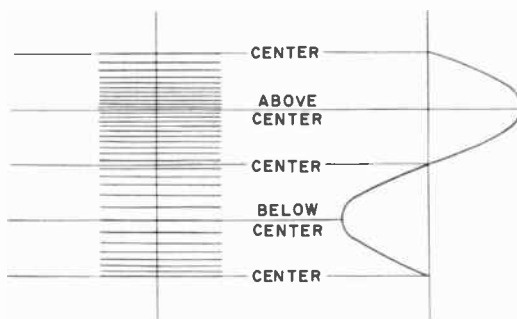

Fig. 707. *The FM signal increases in frequency for positive audio swings, and vice versa.*

### Limiter failures

The limiting properties of the stage are controlled by the bias and the plate and screen-grid voltages. If the plate and screen-grid voltages go up, the tube may not be driven into saturation. The positive peaks of the signal will not be clipped, and any amplitude variations that may exist will remain as part of the signal. The plate and screen-grid voltages are dropped to the proper values by R3. If this resistor decreases in value sufficiently, the plate voltage will go up.

If the grid bias is too large (Fig. 706), saturation will again be prevented. This can come about from R2 increasing in value for greater cathode bias, or from either C1 or R1 increasing in value for greater grid-leak bias (Fig. 704). If R1 or C1 increases in value greatly, the resulting long RC time constant will tend to cut the tube off completely periodically, causing a corresponding break in the sound that will produce a buzz or intermittent loss of audio.

If the grid bias goes down or is lost, the tube would no longer be operated in cutoff, and the negative signal swings may not be clipped. This would have the same effect as the positive swings not being clamped by saturation. Insufficient bias can result from R2 being reduced in value or C2 shorting to reduce the cathode bias. C1 can become shorted or R1 can decrease in value to reduce

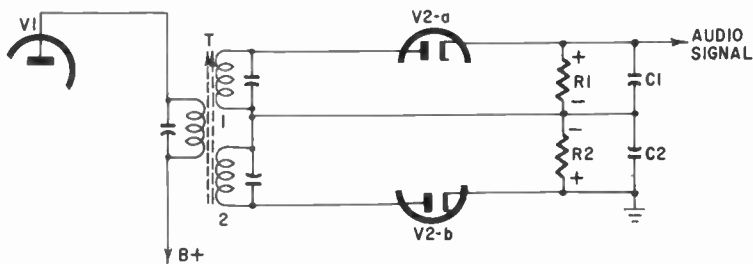

Fig. 708. Typical frequency discriminator circuit. Note that three tuned circuits are used.

grid-leak bias. Reduced bias will also result if the tube develops grid-to-cathode leakage or an emitting grid.

### Audio detector

The audio detector converts the sound if FM signal to the audio signal. To do this, the stage must change the frequency variations of the if signal to amplitude variations. Any increase in intermediate frequency above 4.5 mc must be reproduced as a relative positive voltage swing; any decrease below 4.5 mc must be reproduced as a relative negative swing (Fig. 707).

There are four basic types of FM detectors: (1) the frequency

Fig. 709. The discriminator response forms an S-curve.

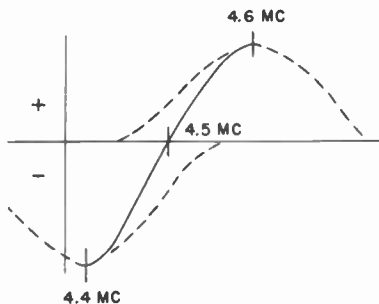

discriminator; (2) the phase discriminator; (3) the ratio detector; and (4) the gated beam detector. The frequency and phase discriminators are no longer used, but are discussed here for reference purposes.

### Frequency discriminator

As the name implies, the frequency discriminator is sensitive to frequency shifts in the audio signal. A typical frequency discriminator is shown in Fig. 708. The circuit is triple-tuned. The primary winding of (T) is tuned to the audio if carrier frequency. The upper secondary winding (1) is tuned above the carrier fre-



quency and the lower winding (2) is tuned below it. Both secondary windings are connected to identical rectifier circuits whose outputs are connected series-opposing. The combined response curves of both secondary windings produce the S-curve shown in Fig. 709.

When a 4.5-mc signal is applied to the circuit, the signals induced in each secondary winding are equal, and both diodes conduct equally. Since both diode outputs are connected series-opposing, the voltages they develop cancel each other for zero output. However, when the sound if signal goes up in frequency, more

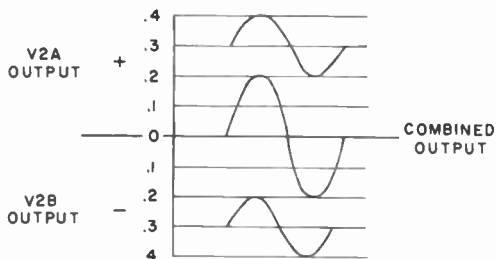

Fig. 710. Both diode outputs are combined for greater amplitude.

voltage is induced in secondary winding 1 and less in 2. Upper diode V2-a conducts more than diode V2-b, so the drop across R1 is greater than that across R2. The two opposing output voltages combine and the larger positive difference voltage is fed off the audio if output. When the audio if signal drops to a frequency lower than 4.5 mc, a larger voltage is induced in winding 2, so that a greater voltage drop appears across load resistor R2. Since the larger voltage drop is now negative with respect to ground, a negative difference voltage is supplied to the audio output.

The action of adding the opposing audio voltages across load resistors R1 and R2 to produce the audio output is shown in Fig. 710. Although the audio output polarities are opposing, the ac swings are in the same direction, so that both ac outputs are added for a greater output. If the diodes were connected to rectify the negative swings, the ac output would be inverted.

Both of the rectifier circuits are balanced. Thus, if any amplitude modulation exists on the FM input signal, it would cancel in the output circuit at 4.5 mc. But at any other if swing, the circuit voltages in both detectors are unbalanced, and so the diode producing the most output would also show a greater response to amplitude modulation. Therefore, a limiter circuit is required

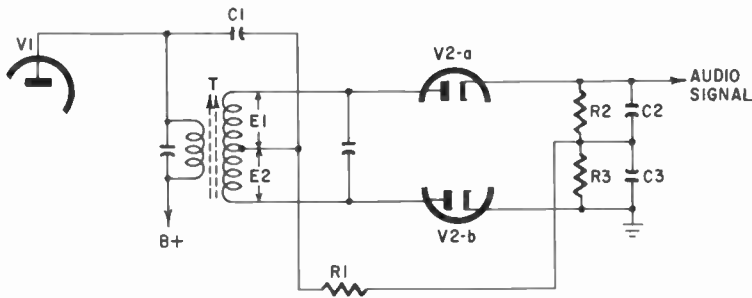

Fig. 711. Phase discriminator circuit.

to precede the frequency discriminator to eliminate any amplitude modulations that may exist.

Capacitors C1 and C2 across the diode load resistors filter the intermediate frequencies so that only audio frequencies appear at the output.

### Phase discriminator

The phase discriminator (Fig. 711), also known as the Foster-Seeley discriminator, is similar to the frequency discriminator.

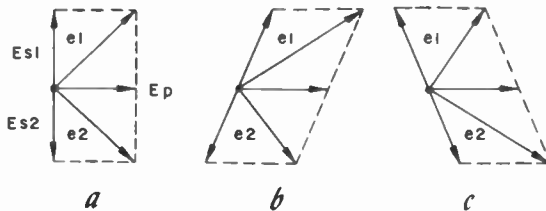

Fig. 712. Phase detection vectors. The relative phase angles change the frequency.

However, as the name implies, the frequency shifts of the FM signal are converted to phase shifts. By doing this, the phase discriminator allows the use of one less tuned circuit.

The phase discriminator makes use of the fact that input and output phase relationships in tuned transformers are a function of the input frequencies. In untuned transformers, the secondary voltage is either in phase or  $180^\circ$  out of phase with the primary voltage, depending on how the coils are wound.

But in tuned transformers, the secondary voltage is only  $90^\circ$  out of phase with the primary voltage at resonance, and more and less than  $90^\circ$  above and below resonance. The phase discriminator, then, causes one diode to conduct more when the phase shifts

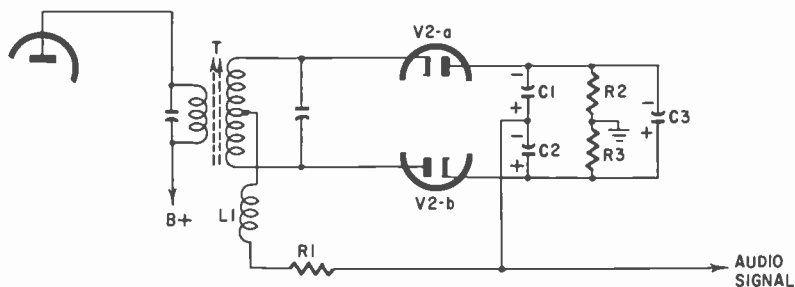

Fig. 713. Ratio detector circuit. Coil  $L1$  inductively couples the reference phase.

in one direction and the other diode to conduct more when the phase shifts in the other direction.

To do this, a reference phase must first be applied to both diode circuits. This is accomplished with  $C1$  and  $R1$ .  $C1$  couples the primary, or zero phase voltage, across  $R1$ . And since  $R1$  is connected between the center taps of the secondary winding and both output load resistors, this primary reference phase is applied to both diodes. The conduction in each diode will now be determined by the phase relationship of the secondary and reference voltages (Fig. 712).

Since the secondary winding is center-tapped, it essentially produces two equal but opposite secondary voltages,  $E_{s1}$  and  $E_{s2}$ . At resonance (4.5 mc), both  $E_{s1}$  and  $E_{s2}$  are displaced  $90^\circ$  from the reference phase,  $E_p$  (Fig. 712-a). The secondary voltages are added vectorially to the primary reference voltage to produce equal effective voltages  $e1$  and  $e2$ . Since these voltages are equal in amplitude, however, both diodes conduct equally. And since the diode output circuits are connected in series-opposing, as in the frequency discriminator, the net output is zero.

When the input frequency shifts above 4.5 mc, the secondary voltage phase-shifts away from  $90^\circ$  (Fig. 712-b). When the secondary and reference voltages are added vectorially, the resultant voltages now have different amplitudes. Since  $e1$  is greater,  $V2-a$  conducts more to produce a positive output (Fig. 710). When the input frequency drops below 4.5 mc, the secondary phase shifts as shown in Fig. 712-c, so that  $V2-b$  conducts more to produce a negative output.

Like the frequency discriminator, the phase discriminator is sensitive to amplitude modulations away from resonance; thus, a prior limiting stage is required.

In the circuit of Fig. 711, an inductance can be used in place

of R1. Also a tertiary inductive winding can be used instead of C1 to develop the reference phase voltage.

### Ratio detector

A typical ratio detector is shown in Fig. 713. It functions in the same manner as the phase detector in that conduction is deter-

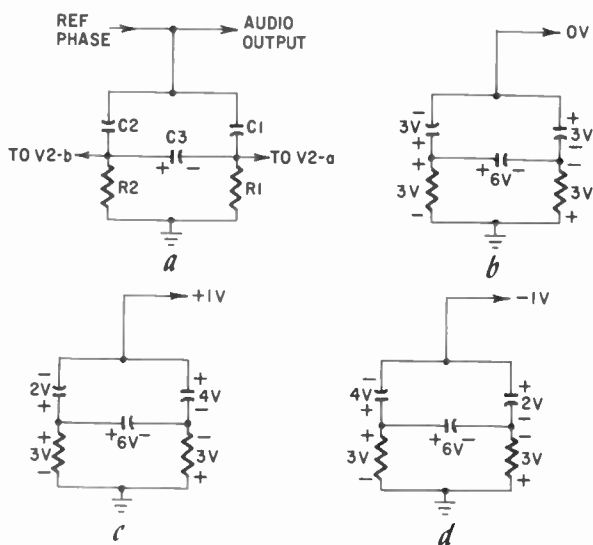

Fig. 714. The ratio detector output is the change in voltage across C1 or C2. Note the voltages across R1 and R2 are kept constant by C3.

mined by the secondary voltage phases. However, in the ratio detector, the diodes are connected to conduct on the same half-cycle and their outputs are connected series-aiding. In addition, stabilizing capacitor C3 is used across the output loads to make the detector circuit insensitive to amplitude modulation (this will be explained later).

Although the output circuits are actually connected in series-aiding, the circuits actually function in parallel-opposing (Fig. 714). Diode load capacitors C1 and C2 charge on the conduction cycle according to the amount of current conducted by diodes V2-a and V2-b. During the nonconducting cycle, these capacitors tend to discharge through R1 and R2 or maintain the charge on C3. During circuit operation, C3 builds up a total charge to the peak value of the audio carrier and tends to maintain this voltage constant. During the nonconducting cycles, C3 tends to discharge through R1 and R2 but, since their R-C time constant is very

long, the discharge is only a trickle which is generally replenished by the discharge of C1 and C2 during the nonconducting cycle.

The stabilizing voltage developed by C3 is applied in equal halves across R1 and R2. These voltages remain stable throughout the operation, regardless of diode conduction. As shown in Fig. 714-a, the output of the circuit is either the voltage across C1 in series with the voltage across R1, or the voltage across C2 in series with the voltage across R2. Actually, the sum voltages of each R-C branch are always the same regardless of diode conduction.

Fig. 714-b shows the output circuit operation at resonance. Both diodes conduct equally and so both load capacitors build up equal charges, assumed to be 3 volts. The stabilizing capacitor charges to the full 6 volts and applies 3 volts across each load resistor. Since the polarity of the voltage across each resistor is equal and opposite to the charge across its respective load capacitor, the net voltage across each R-C branch is zero.

When the input frequency goes above 4.5 mc, V2-a conducts more heavily and charges C1 to 4 volts (Fig 714-c). Conduction in V2-b is lowered and so C2 charges to only 2 volts. The voltages across C3 and R1 and R2 remain constant. As a result, since the voltage across C1 is now 1 volt more positive than that across R1, the sum voltage of the R-C branch is 1 volt plus. Also, since the voltage across R2 is 1 volt more positive than that across C2, the output of that R-C branch is 1 volt plus. This 1 volt is applied to the output.

When the if signal drops below 4.5 mc, V2-b conducts more heavily to charge C2 to 4 volts. Conduction in V2-a drops and the charge on C1 reaches only 2 volts (Fig. 714-d). As before, the voltages across C3 and R1 and R2 remain constant. The voltage drop across C2 is now 1 volt more negative than that across R2, producing a net voltage of minus 1. In the same way, the voltage drop across R1 is 1 volt more negative than the charge across C1, resulting in a minus 1 volt total. Therefore minus 1 volt is applied to the output.

Thus, the ac output of the circuit is not equal to the sum of both diodes' ac outputs, as in the previous discriminator circuits. It is equal to only one diode's output, or one half the other discriminators' value.

The operation of the stabilizing capacitor in making the ratio detector insensitive to amplitude modulations is rather complex. It makes use of the fact that the output of each diode is determined primarily by the phase sensitivity of the transformer secondary

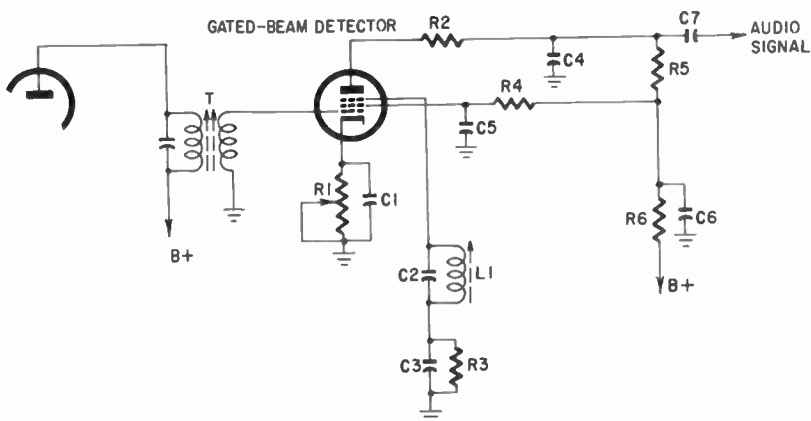
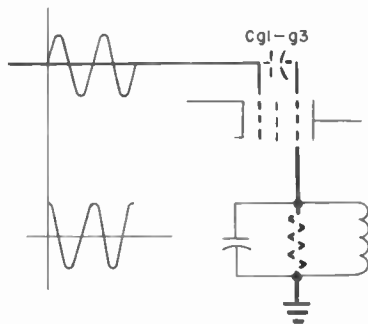

Fig. 715. Gated-beam detector circuit. This one circuit also limits and amplifies the signal.

winding. The greater the phase shift with frequency, the greater the output, and vice versa. The stabilizing capacitor, then, decreases phase sensitivity when amplitude goes up and increases it when amplitude goes down. This neutralizes the effects of amplitude modulation.

The stabilizing capacitor governs the phase sensitivity of the transformer winding by controlling its  $Q$  which is the major factor determining phase sensitivity. The larger the  $Q$ , the more the phase shift. And  $Q$  varies inversely with the average static current through the winding. This average static current is determined by the charge to be maintained on  $C3$ . When the amplitude of the

Fig. 716. The quadrature voltage is developed across the quadrature tank through interelectrode coupling. The dotted resistor indicates that the tank circuit is a resistive load at resonance.



FM signal remains constant, a nominal value of current through the diodes is needed to maintain the charge. If the signal carrier amplitude increases, the static charging current increases, lowering the  $Q$  of the winding. This reduces the phase sensitivity to lower

the output voltage, cancelling the amplitude effects. The opposite happens when the signal carrier amplitude decreases.

Because the ratio detector does not respond effectively to carrier amplitude, no limiter stage is needed when this type of detector is used.

### Gated-beam detector

A typical gated-beam detector is shown in Fig. 715. This type of circuit is used in place of the ratio detector because, in addition to the detection and limiting action, it also provides amplification.

The stage uses a tube specially designed for gated-beam operation. In place of the usual control, screen and suppressor grids, the

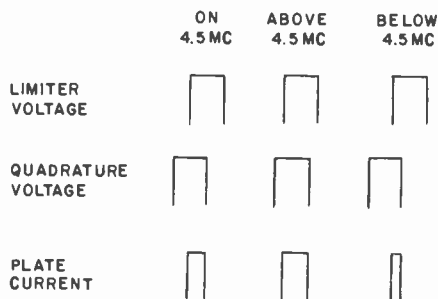

Fig. 717. Phase gating action. Plate current flows only when the limiter and quadrature pulses overlap in time.

tube has a limiter grid (grid No. 1), an accelerator grid (grid No. 2) and a quadrature grid (grid No. 3). The internal structure is designed to produce a beam of current.

The circuit relies on phase sensitivity to detect the audio signal. The signal applied to the limiter grid establishes the reference phase of the signal, and the signal developed at the quadrature grid varies in phase as the if shifts. The signal on the limiter grid is applied directly by transformer T. But the signal on the quadrature grid is developed across the parallel-resonant circuit L1 - C2 by interelectrode capacitive coupling from the limiter grid. This is shown in Fig. 716. The parallel-resonant tank circuit resonates at 4.5 mc and so, when the input frequency is at 4.5 mc, the tank circuit is actually a resistive load. The interelectrode capacitance  $C_{r1-r3}$  and the resistive load, then actually comprise an R-C coupling network. However, since  $C_{r1-r3}$  is usually only about .004  $\mu\text{f}$ , and the resistive impedance of the tank is generally only a few thousand ohms, their R-C time constant is extremely short

in relation to the 4.5-mc signal. As a result, the R-C coupling network acts as a differentiator. The current in the circuit is largely capacitive; thus, it leads the input signal voltage by  $90^\circ$ . The 4.5-mc voltage developed across the tank resistance, therefore, leads the limiter voltage by  $90^\circ$ . This is how the quadrature grid derives its name.

Fig. 718. The plate current pulses are integrated to produce the audio signal.

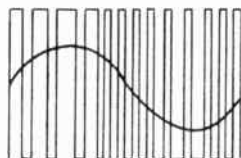

When the audio if input signal becomes higher than 4.5 mc, however, the tank circuit is no longer purely resistive. Instead, it exhibits a slight inductive reactance that tends to cancel some of the effects of the differentiator circuit capacitive current. Because of this, the resulting current leads the voltage by slightly less than  $90^\circ$ . When the input frequency goes below 4.5 mc, the tank circuit becomes capacitive, adds to the differentiator current, and makes the resultant current lead by slightly more than  $90^\circ$ .

To sum up, when the limiter grid signal is at 4.5 mc, the quadrature grid signal leads it in phase by  $90^\circ$ . Above 4.5 mc, this quadrature phase lead shifts to slightly less than  $90^\circ$ . Below 4.5 mc, the phase leads by slightly more than  $90^\circ$ .

To make the tube perform its functions, both the limiter and quadrature grids were designed to have very sharp  $e_g-i_p$  curves. As a result, the tube is easily driven into saturation and cutoff (Fig. 705). This provides the limiting action that removes any amplitude modulation which may exist.

Because of the limiting action, the plate current tends to flow as pulses. However, plate current cannot flow unless the limiting and quadrature grid voltages are both above cutoff. And since the voltages are displaced in phase, plate current can flow only when both voltages overlap in time (Fig. 717). As shown, the plate current pulse width becomes wider above and narrower below 4.5 mc. Integrator circuit R2 - C4 (Fig. 715) in the plate circuit averages the current pulses to produce the audio waveform (Fig. 718).

The audio signal is developed across load resistor R5 and is coupled to the next stage by C7. R6 and C6 form a B-plus decoupling network, and R4 - C5 an accelerator grid-decoupling network. Operating bias for the quadrature grid is developed by the grid-



leak network R3-C3. The basic bias level for both control grids is set by cathode potentiometer R1, which is adjusted for optimum operation. Usually, it is adjusted for a minimum level of buzz. C1 is the cathode bypass capacitor.

### **Audio detector stage analysis**

To function properly, the audio detector stage must:

- (1) Reproduce the audio signal with a minimum of distortion or interference.
- (2) Provide enough audio signal amplitude.

### **Audio distortion and interference**

In any type of detector, the primary source of distortion is improper tuning of the resonant circuits. As shown in Fig. 709, the S-response curve of these detectors is made 200 kc wide, although the FM signal uses only a 50-kc bandwidth. This is done to make sure that the signal operates on a linear portion of the curve at all times, so that the audio amplitudes will be reproduced faithfully. If the tuned circuits become misaligned to produce an improper bandpass (Fig. 719-a), the extreme high and low FM frequencies that determine the audio amplitude peaks will operate on the nonlinear portions of the curve. The peaks, then, would become compressed, producing sound amplitude distortion. Amplitude distortion will also occur if the center frequency of the FM signal operates on the high or low end of the curve (Fig. 719-b).

If the detuning is merely due to a misadjustment, then following an alignment procedure should correct the fault. But if the alignment procedure does not work, then a capacitor or inductor in a tuned circuit has probably changed value.

In the gated-beam detector (Fig. 715), frequency distortion can result from the parts in the plate circuit. If R5 increases in value, the higher plate circuit impedance will allow the interelectrode and interwiring capacitances to have more effect in bypassing the higher audio frequencies to ground. The high-frequency response of the circuit will therefore go down and the low-frequency sounds will predominate. If C6 decreases in value, it will have the same effect. With less capacitance, it will not be as effective in decoupling the low audio frequencies. R6 will then act as an additional load at the low frequencies, emphasizing the lows.

Since the ratio detector and gated-beam detector do not use a prior limiter stage, these circuits are most susceptible to interference from any amplitude modulation that may exist on the FM signal. In the ratio detector (Fig. 713), stabilizing capacitor C3

is most likely to cause trouble. If this capacitor opens, the entire limiting action of the circuit will be lost and amplitude modulations will be reproduced as interference. Intercarrier buzz, sometimes caused by the video being cross-modulated onto the audio signal in the video detector, is likely to be heard.

If, on the other hand, the capacitor only decreases in value, it will still be effective for minor amplitude modulations but ineffective for larger ones. Buzz will be heard only on strong signals. This can also be caused if the secondary winding of transformer T develops increased resistance. This will lower its Q so that it will not be properly matched to the characteristic action of the stabilizing capacitor.

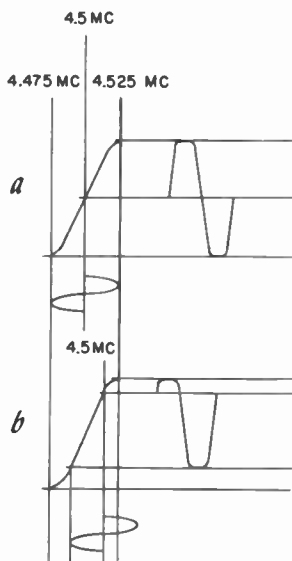

Fig. 719. Discriminator detuning can cause amplitude distortion.

In the gated-beam detector (Fig. 715), the bias settings of the limiter and quadrature grids critically affect the elimination of amplitude modulation. Since the signals must drive both grids to cutoff and saturation, the tube should be operated at the center of its  $e_k-i_p$  curve so that different-amplitude signals will be clipped at both ends. (This assumes that the signal received is strong enough to allow at least about a 3-volt signal to be applied to the stage). If R1 produces too much bias, the signal may not be driven to saturation. If it produces too little bias, the signal may not be driven to cutoff. If C1 opens, the resulting degenerative feedback in the cathode may prevent some signals from being clipped. If either C3 or R3 increase or decrease in value, improper quadrature grid-

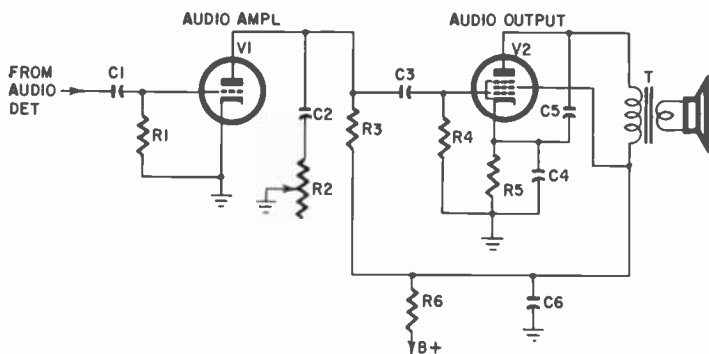

Fig. 720. Schematic diagram of typical audio amplifier and output stages.

leak bias will be developed which may interfere with proper limiting. In addition, the tube's characteristics may change with use so that its cutoff and saturation levels vary.

Sound interference can also occur in any of the detector types due to tube or component failures. As with the other stages, 60-cycle hum caused by a cathode-to-filament short in a tube will be injected into the signal to be heard at the speaker. In the frequency, phase and ratio detectors, arcing is likely to occur only in transformer T and capacitor C1 (Fig. 711) since these are the only parts exposed to considerable voltages. On the other hand, in the gated-beam detector (Fig. 715), any of the parts in the plate or accelerator grid circuits can develop internal arcing.

### Low-amplitude troubles

The primary reason for a detector stage causing reduced audio amplitude is reduced emission in the tube.

In the frequency and phase detectors (Figs. 708 and 711), where the audio output is the sum of the audio ac outputs of both diode sections, the output of the detector will be cut in half if a defective part causes one of the diode circuits to become opened. When this occurs, though, the detector stage will act like a simple slope detector and the frequency response will probably be reduced. In the ratio detector (Fig. 713), since the ac outputs are not added, the entire audio signal amplitude will not be reduced if one diode circuit becomes opened; instead, the limiting action of C3 will be impaired.

The gated-beam detector (Fig. 715) is most susceptible to gain trouble. The audio amplitude will go down if the plate or screen voltage goes down appreciably. These voltages will be reduced if

R2, R4 or R6 increase in resistance, or C4, C5 or C6 become leaky. If load resistor R5 decreases in value, the gain of the stage will be reduced accordingly.

Although it occurs rarely, the secondary winding of transformer T (Figs. 708, 711, 713, and 715) can develop increased resistance. This results in a lower Q and reduced induced signal voltage.

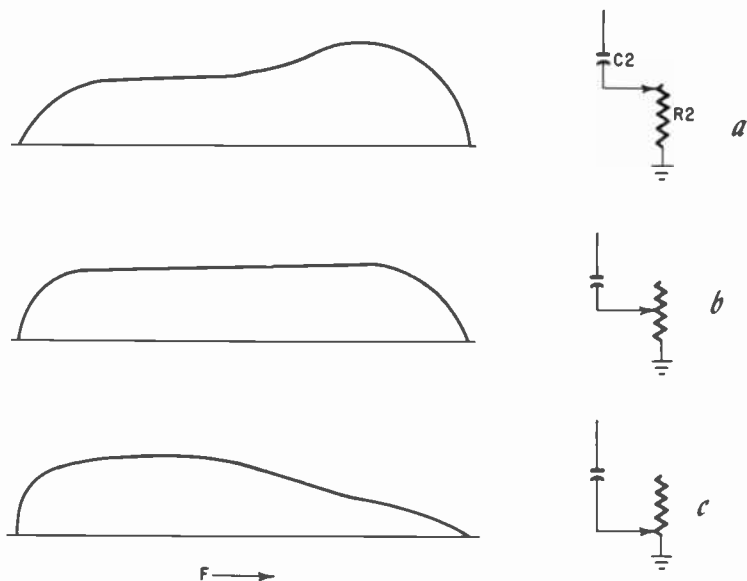

Fig. 721. Effects of tone-control network on audio response curve.

## Audio amplifier and output stages

Typical audio amplifier and output stages are shown in Fig. 720. Audio amplifier V1 builds up the audio signal voltage and output stage V2 converts the voltage to a current which is required to drive the speaker. Both circuits are fairly standard and used in most table-model sets.

C1 couples the audio signal and R1 develops contact bias for the audio amplifier stage. R3 is the stage's plate load resistor. C3 is a coupling capacitor and R4 is the grid-leak resistor for audio output stage V2. R5 develops cathode bias and C4 bypasses the cathode. Transformer T couples the audio output current to the speaker and matches the output stage impedance to that of the speaker. R6 and capacitor C6 decouple the B-plus for both stages. Bypass capacitor C5 shunts the output transformer primary winding to reduce its high-frequency response so that a relatively flat response can be obtained when the tone control is properly adjusted.

Potentiometer R2 and capacitor C2 form the tone control circuit which bypasses the plate circuit of stage V1. The over-all response of the two stages actually is arranged so that the highs predominate. Therefore, when the tone control is set for high resistance (Fig. 721-a), it reduces the bypassing action of C2 and the high frequencies are accentuated. When the control is set at half its resistance, the capacitor can bypass enough highs to provide a relatively flat response (Fig. 721-b). When the control is set at zero resistance, most of the high frequencies are bypassed (Fig. 721-c), so that the lows predominate.

As can be seen from Fig. 721, the simple tone control also has a great effect on the signal amplitude as it is adjusted. Because of this, some designs use rather complex tone control circuits that compensate the volume as the tone is set. For example, in the over-all circuit shown in Fig. 701, when R2 is varied, it also rearranges the values of a circuit that shunts part of volume control R1.

### **Audio amplifier and output stage analysis**

As with most other amplifier stages, to function properly, the audio amplifier and output stages must:

- (1) Provide the proper audio frequency response.
- (2) Amplify the desired signals faithfully.
- (3) Prevent noise and other forms of interference from being developed.

### **Frequency response failures**

The frequency response of the audio amplifier and output stages can be affected by most of the components in the circuit (Fig. 720). The low frequencies are affected most by C1, C3, C4, C5 and C6. If coupling capacitors C1 or C3 become reduced in capacitance, their low-frequency impedance will rise, reducing the low-frequency amplitudes. Reduced capacitance in cathode capacitor C4 will cause the cathode bias to vary with low-frequency signals, resulting in degenerative feedback. If bypass capacitor C5 decreases in capacitance, it will not bypass the highs effectively. The highs will predominate, which is the same as poor low-frequency response. A low value decoupling capacitor C6 will cause the drop across R6 to vary with low audio-frequency signals. Since the output stage is a high-current stage, the voltage across R6 will rise and fall with the output stage plate current at low frequencies, degenerating the signal voltage in the audio amplifier plate circuit.

The high-frequency response of the audio amplifier and output stages is controlled mostly by load resistor R3 and bypass capacitor

C5. If R3 increases in value, the impedance of the interelectrode and interwiring capacitances at the higher audio frequencies will shunt the load resistor to reduce the high-frequency signal voltages. If the value of C5 increases, it will shunt a greater portion of the high-frequency signal amplitudes.

The tone control circuit C2–R2, transformer T and the speaker can affect both the high and low frequencies. If C2 increases in value or R2 decreases, more highs will be bypassed and vice versa. If the change in value is small, adjustment of tone control R2 will compensate for it. If the inductance of transformer T increases, low-frequency response will go down; if the inductance decreases, high-frequency response will be reduced. Actually, any change in inductance will cause an impedance mismatch between the transformer and the speaker voice coil, which will change the over-all response. The speaker itself can develop the defects described in Chapter 5 to alter frequency response, particularly the highs.

#### **Gain and distortion failures**

Almost any component in the circuit shown in Fig. 720 could cause complete failure so that the signal would not reach the speaker. Either tube can develop an open filament or other element, complete loss of emission or shorted elements. If any resistor (except R2) or the transformer opens, the audio signal path will be broken. If coupling capacitors, C1 or C3 open, the audio signal will not be applied to the following stage. If C2, C5 or C6 become shorted, the associated plate voltage will be shorted, disabling the stage. The associated resistors or transformer will also probably be burned out because of the short.

The most common cause of reduced gain is insufficient emission in either tube. If R6 increases in value, plate voltage to both stages will be reduced, lowering the gain. The same thing will occur if C6 develops high-resistance leakage. This will tend to overload R6, which will eventually burn out. If load resistor R3 decreases in value, it will develop less signal voltage. Most cases of reduced sound will be easily compensated for with the volume control.

Any trouble that develops in the audio amplifier or output stage to increase gain will probably not be noticed unless the trouble also causes audio distortion. Distortion occurs most often when either stage is driven into saturation or cutoff. This is determined largely by the bias and plate voltages. When a stage is driven into saturation or cutoff, the signal peaks will be clipped, causing the sound to be garbled.

The grid voltage in V1 is developed by contact bias, the result of electrons that accumulate on the grid and flow through grid-leak resistor R1. Because this trickle of electrons is very small, the value of R1 is often made between 5 and 10 megohms so that enough bias voltage can be developed. If R1 increases in value, the resultant increased bias may cause the negative signal peaks to be clipped.

If the resistance value goes very high, the contact bias developed normally will cut off the tube and only the positive signal peaks will get through. The sound in this case may be unintelligible. If the value of R1 goes down, the reduced bias will cause the stage to be saturated easily.

If C1 develops a short, R1 will be shunted by the detector circuit, reducing the contact bias. Reduced or lost contact bias also will occur if the amplifier tube develops grid-to-cathode leakage or grid emission.

Ordinarily, C1 is kept low so that there is no grid-leak bias. If, however, C1 increases in value sufficiently, grid-leak bias will be developed, causing the over-all bias to be too large.

Bias for the audio output stage is obtained across the cathode resistor R5. If the value of R5 increases, there will be too much bias and vice versa. If C4 becomes shorted, bias will be lost. In many sets, C4 is an electrolytic. Therefore, if R5 opens, C4 will provide a high-resistance path that will permit the stage to continue functioning, but the resulting high bias will clip the signal. If C5 develops a high-resistance leak, the positive cathode voltage will increase, raising the bias. The amount the bias rises will depend on the leakage resistance of C5. A low-resistance short will probably burn out the cathode resistor.

The grid circuit of the output stage is not designed to develop bias of its own. If, though, the value of C3 or R4 increases, grid-leak bias will be developed, causing the over-all bias to rise. Ordinarily, the increased bias will only clip the signals, but if the value of the grid-leak network goes very high, the large amount of grid-leak bias developed will block the stage periodically. The period that the sound will become blocked depends on the resultant grid-leak R-C time constant.

Bias in the output stage will be lost if the tube develops grid-to-cathode leakage or grid emission, or if C3 develops high-resistance leakage.

If either R3 or R6 increase greatly in resistance, plate voltage may become so low that the signal grid voltage will easily drive

the stages into cutoff and saturation. A leaky C2 can also bring this about.

As explained in Chapter 5, the speaker cone can go bad in various ways to reduce the sound and cause distortion.

### Noise and interference failures

As with the previous amplifiers, the most common trouble in the audio amplifier and output stages is 60-cycle hum, resulting from a filament – to – cathode or filament – to – grid short. In the

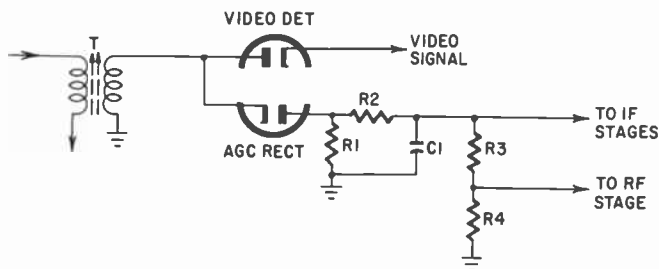

Fig. 722. Basic agc circuit. Note the tapped-down voltage to the rf stage.

output tube, hum also will develop when the filament tends to emit electrons, which becomes more noticeable as the tube ages.

The next most common trouble is a microphonic tube. Loose elements within the tube vibrate, causing a howl in the sound. Arcing can be caused by the parts in the circuits that carry relatively high currents or voltages. R3, R5 or R6 can carbonize or develop cracks or loose leads that arc. The dielectric of C1, C2, C5 or C6 can break down and cause arcing. Also, poor connections or dielectric breakdown in transformer T will cause this trouble.

Often, an open C6 will produce interference coupling through the B-plus lines. This may allow video or sync signals to enter the sound, or audio signals to go to other stages in the set.

### Agc circuits

The agc circuits keep the picture steady and more or less at the adjusted contrast level for a wide variation of antenna signal strengths. This allows the station to be changed without, in most cases, the adjustment of the other receiver controls. Some agc circuits keep to a minimum the rapid picture flutter which a passing aircraft tends to cause. The agc circuit accomplishes its purpose by monitoring the signal in the video section, and adjusting the gain of the tuner and if sections to keep the output of the video detector relatively constant. The agc circuit can be



a basic filter circuit similar to the avc circuits used in ordinary radios, or it can be more complex, such as the amplified- or keyed-agc types.

### Basic agc circuits

A typical basic agc circuit is shown in Fig. 722. It actually takes the composite video signal, rectifies it and filters it to a steady negative dc level. In cases where the output of the video detector is negative, a separate agc rectifier may not be needed.

R1 is the rectifier load resistor. R2 and C1 form a long-time-constant filter circuit that converts the rectified video signal to a steady dc level. The filter circuit generally has a time constant up

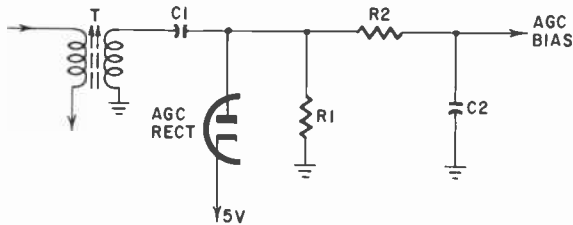

Fig. 723. Basic delayed-agc circuit. A shunt rectifier is used.

to a few tenths of a second. This is long enough to prevent the circuit from responding to the normal contrast variations in the signal, yet short enough to allow it to compensate partly for signal variations that cause flutter. R3 and R4 form a voltage-divider network which steps down the agc bias sent to the rf stage. This isn't always done, but is preferable since some rf signals may not be very strong. The signal output of the rf stage is the major factor determining the amount of snow in the picture. Thus, it is not desirable to make the gain of that stage too low and to rely principally on the if stages for most of the gain control.

### Delayed agc

When a signal is present, the agc bias reduces receiver gain because of the negative voltage it applies to the grids of other circuits. For weak rf signals, this is not good because all the gain possible is needed. Therefore, many receivers use a delayed-agc circuit that does not work until the input signal is strong enough to make agc worth while.

The delayed-agc circuit shown in Fig. 723 uses a shunt detector to remove if positive swings, leaving the negative ones to be filtered for the agc line. If the agc rectifier did not conduct, the positive

and negative swings would average to zero on the agc line. To make use of this fact, a positive voltage is applied to the cathode of the agc rectifier to keep it from conducting. Therefore, when the received signal is weak, the if signal applied to the rectifier is not great enough to overcome the positive cathode. The diode does not conduct, no agc bias is developed and the weak signal gets maximum receiver gain. When a stronger signal is received, the posi-

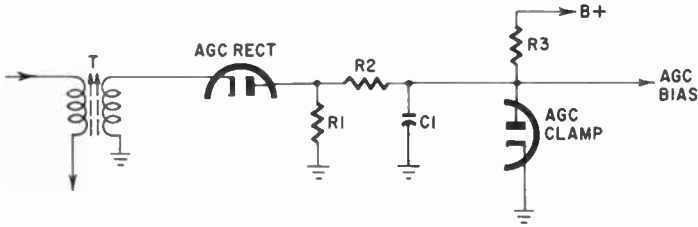

Fig. 724. Basic clamp-delay circuit. An additional diode is needed.

tive cathode is overcome, the diode conducts and a corresponding bias is produced.

Another more positive-acting delayed-agc circuit, shown in Fig. 724, uses a clamping circuit. R3 is added to the circuit to form a

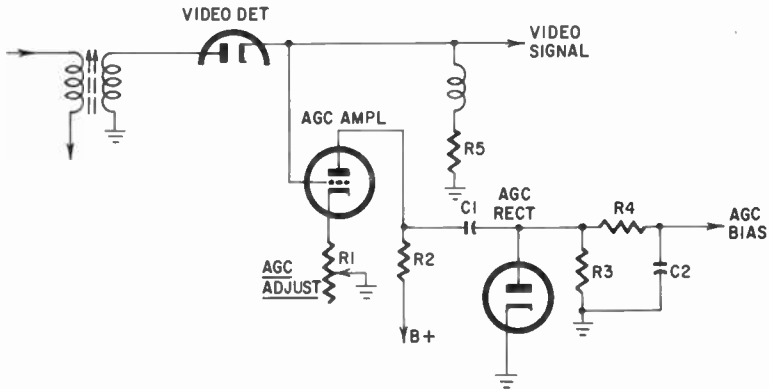

Fig. 725. For amplified agc, an extra stage first builds up the video signal.

voltage divider with R1 and R2 between B-plus and ground. The resistor values are such that a slight positive voltage is applied to the plate of the clamping diode when no signal input is present. As a result of this voltage, the clamping diode conducts, shunting the agc bias line to ground. As long as the rf signal received is weak, the negative output of the agc rectifier is too small to overcome the small positive voltage applied by R3 to the agc clamping

diode. However, when the rf signal received is strong enough, the negative output of the agc rectifier becomes greater than the small positive voltage developed by R3. With a negative voltage on its plate, then, the agc clamp cannot conduct. The agc bias line is removed from ground and applies the negative bias to the other circuits.

### **Amplified agc**

For minor variations in signal strength, the normal changes in agc bias level are sufficient but when very large variations in signal strength take place, the changing agc levels are not big enough to give full compensation. As a result, some contrast fluctuations and flutter still result.

To make an agc circuit fully compensating even for large signal variations, the agc bias change must therefore be greater. Some receivers accomplish this by using an amplified-agc circuit. Basically, there are two ways of obtaining an amplified agc bias: One is to use another if amplifier to build up a separated if signal before agc rectification; the other is merely to amplify the detected video signal before agc rectification. The former method was used occasionally in the past, but it was found that more agc stability is obtained by working with the video detector output rather than with the if signal.

The more-accepted basic amplified-agc circuit is shown in Fig. 725. The detected video signal is first built up in the agc amplifier and developed across plate load resistor R2. The amplified signal is then coupled by C1 to a typical shunt type agc rectifier and filter circuit. A variable resistor in the cathode circuit of the agc amplifier is used to set the gain of the stage so that the most effective agc level can be chosen for the best agc action.

### **Keyed agc**

The R-C time constant of the ordinary agc filter circuit deliberately is made long enough so that the agc circuit will not respond to the normal contrast variations that take place within a picture. Because of this, ordinary agc circuits are slow-acting, and cannot allow for rapid, sudden variations in signal strength. The keyed-agc system solves this problem by using a circuit that is unresponsive to the video portions of the composite signal. The circuit does this by being cut off during video time and keyed to conduct during blanking time. Therefore, the circuit monitors only the amplitude of the blanking pulses, which are relatively constant for any given signal. As a result, shorter time constants can be used to make this type of system faster acting.

A typical keyed-agc circuit is shown in Fig. 726. A composite signal from one of the video amplifier stages is fed to the grid of the keyed agc stage but, since no plate voltage is ordinarily applied during video time, the tube is cut off. However, when retrace time occurs in the horizontal sweep section, a keying signal pulse of a few hundred volts is capacitively coupled to the plate of the

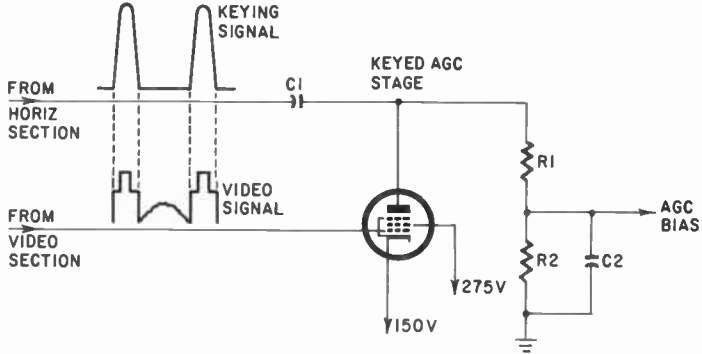

Fig. 726. Keyed agc circuit. The tube conducts only during blanking time.

stage by C1. This keying signal is actually derived from the horizontal flyback pulse. The keying signal occurs during the same time interval as the horizontal blanking pulse, so a current flows

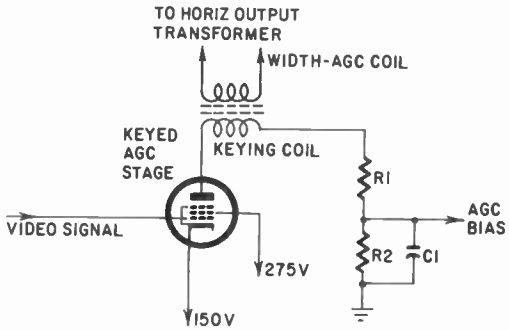

Fig. 727. A keyed agc circuit with width coil keying.

through the tube in proportion to the blanking signal amplitude. This produces a voltage drop across plate load resistors R1 and R2, which divide the voltage to the most effective bias level. C2 filters the voltage pulses to a steady dc level. Since the keying signal amplitude is always at a constant level, the current through the tube and the resulting bias will change only when the blanking signal amplitude varies.

Another popular type of keyed-agc circuit is shown in Fig. 727. This circuit is identical to that in Fig. 726 except for the manner of applying the keying pulses. Fig. 727 shows the use of a width-agc coil. A keying coil winding is added to the ordinary width coil to inductively couple the flyback pulse to the agc stage to key it into operation.

### **Agc circuit analysis**

To function properly, the agc circuit must:

- (1) React fast enough.
- (2) Provide the proper bias level for enough (but not too much) gain.
- (3) Prevent noise and other forms of interference from being applied to the tuner and if stages.

### **Agc sluggishness**

A sluggish agc circuit will not act fast enough to cope with sudden changes in signal strength, so that the picture and sound of the receiver will probably fluctuate. This condition becomes most noticeable when an airplane is passing overhead. Often, if the airplane is large and close and the station signal is not very strong, the resultant flutter can become severe enough to tear the picture.

It is important to realize that many receivers, particularly those using the basic agc circuit, do not provide a wide enough variation in agc bias levels, so sometimes the picture will flutter although no trouble actually exists. However, with agc circuits that do provide good control, sluggish agc action will result if the R-C time constant of the circuit becomes too long. The time constant is determined for the most part by filter network R2-C1 (Fig. 722), although R3 and R4 can also cause trouble. If any of these parts increases in value, the time constant will be made larger.

It is important to remember that there are other filter networks in the agc line to the tuner and if stages. These parts, which serve to isolate the amplifier stages from one another, can also lengthen the time constant if they increase in value. These resistor-capacitor combinations are shown in the grid circuits of Figs. 602, 603, 616 and 618.

Discriminatory sluggishness can also occur with delayed-agc circuits, since, for the weaker signals, the agc does not work. If the delaying voltage applied to the rectifier (Fig. 723) increases, the agc will not function for some of the stronger signals as well; flutter will become evident. In the circuit shown in Fig. 724, this will occur if R3 decreases in value.

## Gain failures

A failure can develop in the agc circuit that can cause either too much or too little if and tuner gain. Too much gain results when the bias level output of the agc circuit is too low. Depending on how low is, the composite signal will either be overdriven to affect the sync and audio or overloaded to affect the picture as well. The detailed effects of an overdriven or overloaded signal will be the same as explained for the tuner, if and video stages.

The primary cause of too low a bias level is reduced emission in the agc rectifier or amplifier tube. A reduced value of R1 (Figs. 722, 723 and 724) decreased value of R2 (Fig. 727) or a leaky or shorted filter capacitor will also reduce the bias voltage. When a divider network is used, this trouble will result from increased resistance in R3 or decreased resistance in R4 (Fig. 722). With delayed agc systems (Fig. 723 and 724), if the delaying voltage becomes too great, agc action will not take place even with strong signals, so that the gain of the receiver will be much too high for strong signals. For example, if R3 (Fig. 724) shorted, the positive voltage on the agc bias line will keep the line clamped to ground all the time.

With amplified agc systems (Fig. 725) the bias level will be reduced if the gain of the stage is reduced. Other than the tube, this will be caused by a reduced value of R2 or increased value of the agc adjustment control.

With keyed agc systems, more subtle troubles in other stages can occur to cause improper agc operation. For example, if the keying signal (Fig. 726) decreased in amplitude, bias would go down. Therefore since the keying signal is derived from the horizontal retrace pulse, the agc circuit could cause an overloaded picture and sound if the raster had insufficient width. Similarly, if the composite video signal applied to the agc stage were reduced, bias would drop off. Paradoxically, then, a weak video amplifier can cause an overloaded tuner and if section.

Similarly, since the keying and blanking pulses must occur at the same time for keyed agc to function, loss of horizontal sync would cause a drifting keying pulse that would disable the agc circuit to cause overload. Any defect in C1 (Fig. 726) or the width-agc coil (Fig. 727) will cause insufficient agc bias.

Too little receiver gain will cause weak pictures or insufficient contrast. This will occur when the agc circuit puts out too much bias in proportion to the antenna signal. This trouble is rare, but can occur if R3 (Fig. 722) decreases or R4 increases in value. With

delaying circuits, too much bias will be developed for weak stations if the delaying voltage is lost; the agc clamp (Fig. 724) can lose emission or R3 can increase in value or become open. In amplified agc circuits (Fig. 725), if R2 goes up in value or the agc adjustment control goes down, too much bias will result. With keyed agc circuits (Fig. 726) too much bias will occur if the static potentials on the cathode and grid of the keyer tube change to cause too much current to flow.

### **Agc cutoff failures**

Although this trouble occurs infrequently, the agc section can become defective and cut off the tuner and if stages. This can occur in two ways: (1) it can open the tuner and if section grid circuits, and (2) it can produce an abnormally large bias voltage.

In many receivers, the rf and if stages that are agc-controlled have their grid circuits returned to ground through a common resistor in the agc sections. For example: R4 and R1 in Fig. 722. R2 in Fig. 726, R1 in Fig. 723 and R3 in Fig. 725. If these resistors open, the respective grid circuits will float and build up a high negative potential that can cut the tube off. With the type of delay circuit shown in Fig. 724, however, this trouble could not occur since the clamping diode would then operate all the time to return the grids to ground. Instead, there would be no agc bias, and overload will take place.

An abnormally large bias can be developed in the circuit shown in Fig. 726 if the tube develops a grid-to-cathode short, the cathode voltage is reduced or lost, or if the grid voltage rises to too great a positive value.

### **Noise and interference failures**

The agc system can cause noise and interference failures in much the same way that these failures occur in the tuner, if and video circuits. Intermittent shorts and poor connections in any of the agc parts will cause momentary interruption or fluctuation of the bias. Depending on the time duration and the interval of the trouble, this could result in momentary overloads, tearing in the picture, ignition type noise, poor sync, or crackling or buzzing in the sound.

A cathode-to-filament short in the agc tube will inject 60-cycle hum in the picture and sound. In the delay circuit shown in Fig. 723, since the tube is inoperative for weak signals, the hum will only occur with the stronger signals. But with the circuit shown in Fig. 724, the tube is inoperative with strong signals, so that the hum will take place only with weaker signals.

# circuit failure analysis, sync and vertical sweep

A TYPICAL sync section is shown in Fig. 801. Basically, it contains: (1) a sync clipper, (2) a sync amplifier, and (3) a sync separator stage. Sync clipper stage V1 removes the sync from the composite video signal. The sync signals are then built up in sync amplifier V2, and separated into the horizontal and vertical sync pulses in separator stage V3. The sync signals are sent to their respective sections to synchronize the raster sweep voltages.

The composite video signal that is applied to the sync clipper can be obtained from any point in the video amplifier section. In many sets, the signal is taken from the video output stage so that less gain is required in the sync section for the sync pulses. Regardless of where the video signal is obtained, its polarity and the stages in the sync section must be arranged to provide positive sync signals to both sweep sections.

Although the circuit shown in Fig. 801 is typical, sync circuits vary a great deal from one set to another. This is because variations in the tuner, if and video circuits of the receiver, and the different requirements of individual sweep circuits require the sync section to be more of a custom design to process the sync signals. Often, additional amplifying and clipping is needed, and sometimes an amplifier precedes the clipper stage.

## Sync clipper

Basically, a clipper stage is an amplitude discriminator. It will respond only to amplitudes above a certain point so that the remainder is eliminated from its output. The clipper stage is kept biased beyond cutoff so that current does not flow during the



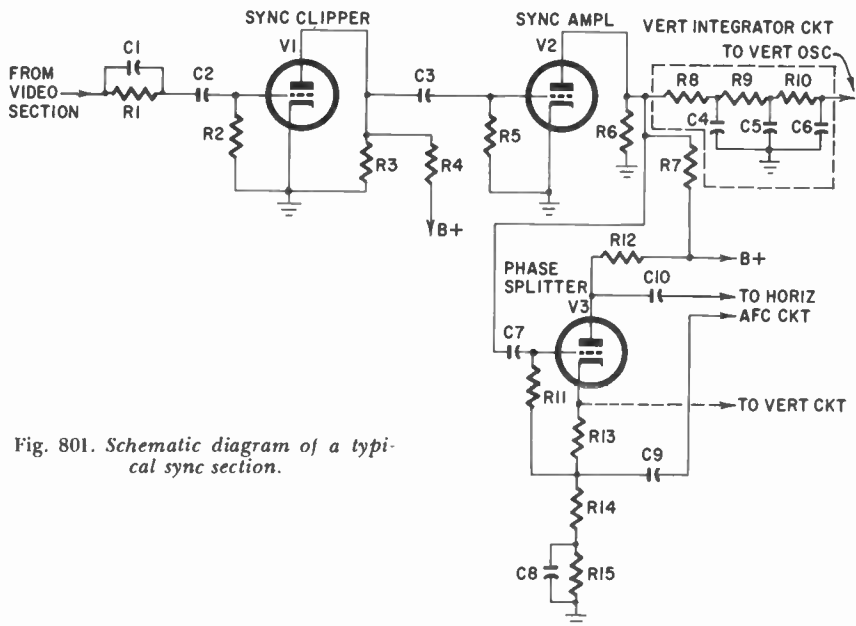

Fig. 801. Schematic diagram of a typical sync section.

video and blanking times. But since the sync pulses ride on the blanking pulses and have a high amplitude, they overcome the bias and are reproduced in the output circuit.

Two basic grid-leak sync clippers are shown in Fig. 802. The composite video amplitude is high, and the tops of the sync pulses not only take the tube out of cutoff, but drive it into saturation. When the grid goes slightly positive, it draws current, allowing C1 to charge (Fig. 802-a). When the signal goes negative again, C1 must discharge through grid-leak resistor R1. Their R-C time constant for the blanking and video signals is high, and so discharge is slow, producing a grid bias that keeps the tube well into cutoff.

The signal amplitude and the R-C network are so chosen that the sync pulse is well established before it starts conduction. This prevents the top of a blanking pulse causing conduction in case of amplitude variations. In addition, R2, from plate to ground, maintains a lower-than-usual plate voltage so that the stage is easily driven into saturation. As a result, the sync pulses developed across load resistor R3 remain constant, regardless of normal signal variations.

The circuit shown in Fig. 802-b works in the same manner, except that it is a cathode follower. It is used when a positive out-

put phase is needed or the sync pulses must be coupled clear across the chassis. In the latter case, a long length of ordinary wire will pick up interfering noise signals. The low impedance output of the cathode follower will then allow the use of shielded cable. The disadvantage of the cathode follower is that it offers less than unity gain, while the ordinary grid-leak clipper allows a gain of approximately 10.

In many receivers, where gain in the clipper stage is not too important, diode clippers are used (Fig. 803). The diode clipper

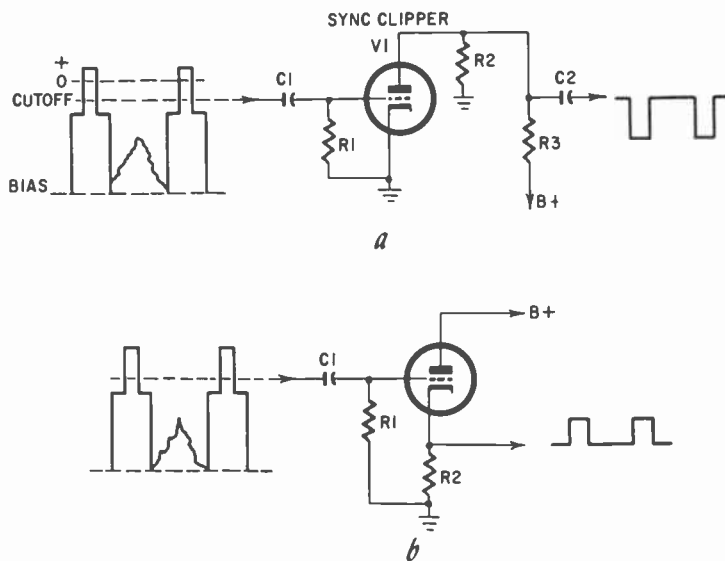

Fig. 802. Grid-leak sync clippers (a and b). The sync pulses drive the stages into conduction. The lower circuit (b) is a cathode follower.

of Fig. 803-a works in a manner similar to the grid-leak clipper. A cathode bias network, R1-C1, has a long time constant for the blanking and video signals, so that the charge built up on C1 maintains the cathode of the diode positive. The diode will not conduct until the sync pulse drives the plate more positive than the cathode. When the tube conducts, the bias charge on C1 is replenished, and the pulse appears across load resistor R2. With ordinary composite signal amplitudes, the diode clipper offers no limiting action, and so the output pulses tend to vary in amplitude with signal variations.

The circuit shown in Fig. 803-b makes use of dc restorer action to clip the sync pulses. The dc restorer was used in the past to reinsert the dc level into the video signal applied to the picture tube

to prevent varying video amplitudes from changing the average brightness level of the picture.<sup>1</sup> This can be done by making the

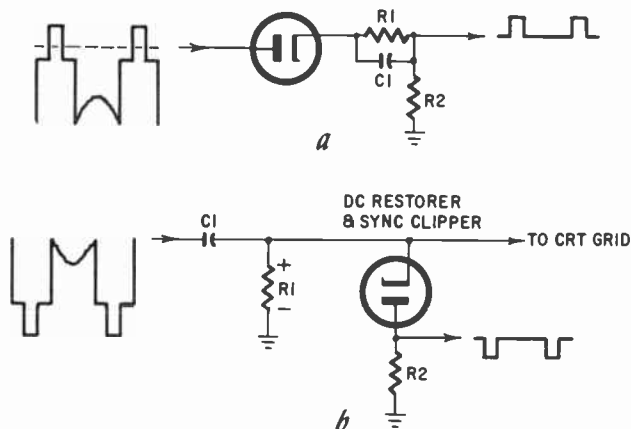

Fig. 803. Diode sync clippers. Bias is developed by  $R1$  and  $C1$ .

CRT grid-leak network,  $C1$ – $R1$ , have a long time constant that builds up a steady positive bias level. (The cathode of the CRT is more positive, so that a negative grid is still maintained.) The dc restorer cathode is positive, then, as in the other diode clipper, so that the tube does not conduct for blanking and video signals. The high negative sync pulse, however, drives the diode to conduction, and the sync pulse output is taken off load resistor  $R2$ .

### Noise suppression

Since the composite signal is amplitude-modulated, noise pickup generally finds its way into the signal. The noise pulses are usually high in amplitude, and can trigger the sweep sections if they pass through. Every attempt is made, therefore, to suppress any noises that occur.

Noise suppression can be accomplished in various ways, some simple and some complex. A few special circuits are sometimes used. Since noise pulses are generally higher in amplitude than the sync signal, a noise inverter circuit can clip off the noise pulse, amplify it, invert it and feed it back to the sync clipper stage to cancel the noise pulse. Another circuit, the diode noise gate, allows all signals to pass through it unless a high-amplitude noise pulse is present. In this event, the tube stops conduction. This circuit operates on the premise that a sync section is better off momentarily disabled during heavy noise interference. Even more

<sup>1</sup> In this book we are concerned with monochrome receivers only. While such sets no longer use dc restorers, the circuit is found in color TV receivers.

elaborate is the dual clipping stage, which discriminates against the noise frequencies. This circuit first separates the vertical and horizontal sync pulses with R-C filter circuits before clipping them.

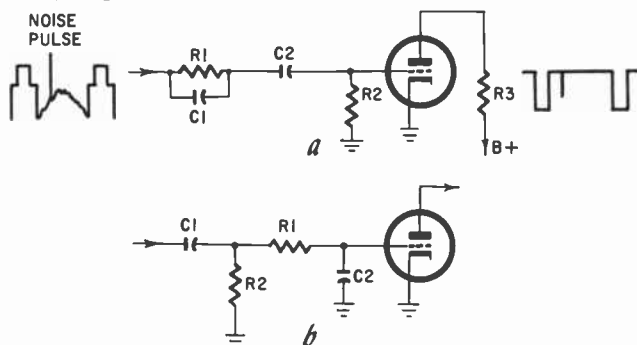

Fig. 804. Noise suppression. Note how the noise pulse is reduced in the output.

Consequently, many of the noise frequencies are bypassed because of the filtering action.

Most TV's use more basic, simple suppression circuits since the complex ones are expensive and critical. Two typical methods are shown in Fig. 804.

In Fig. 804-a, a parallel R-C network C1-R1 is placed in series with the grid coupling capacitor, C2. The time constant is long for the sync pulses as well as the blanking and video signals and so presents just a slight bias during those signals. But since the bias is on the ac side of the coupling capacitor, it does not affect the signals. However, the R-C time constant is short for noise-pulse frequencies, and so C1 becomes active for noise frequencies. C1 is then effectively in series with C2, and the overall coupling capacitance is reduced, causing less of a signal to be coupled to the grid. The noise pulse is then diminished so that it is not as much of a threat. Similar networks used in the following sync circuits will reduce the noise still further.

Fig. 804-b shows another variation of the noise-suppression circuit in which the network R1-C2 serves to bypass the higher noise frequencies to ground.

### Gated sync clipper

The gated sync clipper (Fig. 805) offers good noise suppression with an inexpensive, simple circuit that also provides the clipping and amplifying action. The circuit can use a pentagrid converter tube as shown, or a gated beam tube such as the 6BN6. The circuit uses two composite video inputs. A low-amplitude negative signal,

usually taken from the video detector, is applied to grid 1. A high-amplitude positive signal, generally taken from one of the video amplifiers, is applied to grid 3 through a grid-leak network, R1-C1. The network has a long time constant for the blanking and

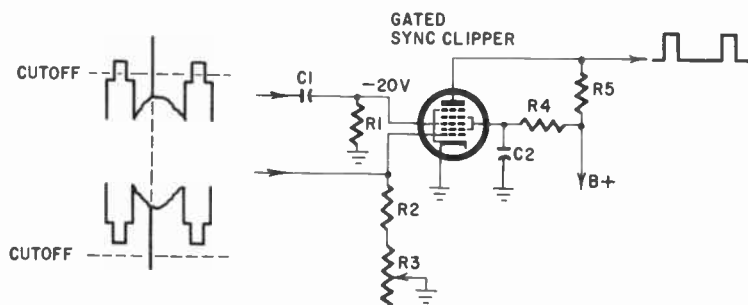

Fig. 805. Gated sync clipper circuit. A noise pulse can cut off the control grid to eliminate noise in the output.

video signals, and so builds up a large bias that keeps the stage cut off during those times regardless of the signal on grid 1. During sync-pulse time, on the other hand, the high amplitude on grid 3 drives the stage into conduction so that the negative-going sync pulse on grid 1 is amplified and produced in the plate circuit.

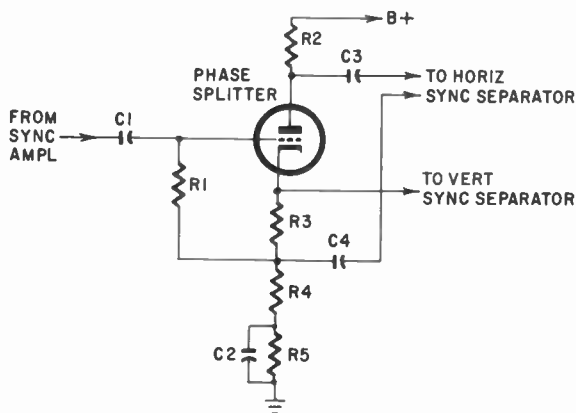

Fig. 806. The sync phase splitter is used when two equal but opposite horizontal sync pulses are required.

If a high-amplitude noise pulse occurs and drives grid 3 out of cutoff, the negative-going noise pulse on grid 1 generally drives the stage back into cutoff so that the noise does not get through. Control R3 in the grid 1 return is set for best noise rejection.

## Sync amplifier

Since the sync amplifier is needed only to give additional gain to the clipped sync pulses, it is basically a very simple stage. In many receivers, the sync amplifier stage is very similar to the clipper stage, so that it also provides additional clipping, limiting and noise suppression.

## Sync inverter

Since the sync pulses sent to the sweep sections must be positive, an inverter stage is used only when the output of the amplifier stage is negative. The inverter stage is usually just another amplifier that repeats again the clipping, limiting and noise-suppression actions.

## Sync phase splitter

Sync phase splitters are used only in receivers that have a horizontal sweep section that requires the use of two opposite-polarity horizontal sync pulses. The phase splitter (Fig. 806) produces two horizontal sync outputs by using a load resistor, R2, in the plate

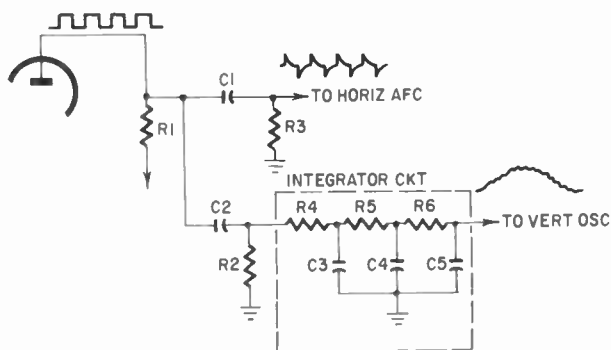

Fig. 807. Sync separation circuits. The integrator is often a printed-circuit unit.

circuit to develop sync  $180^\circ$  out of phase with the input, and another load resistor, R4, in the cathode for sync pulses in phase with the input. Both load resistors have the same value so that equal and opposite pulses are sent to the horizontal separator circuit.

Vertical sync can be taken off anywhere in the circuit where the polarity is correct. In the circuit shown in Fig. 806, R3 serves as an additional load for the vertical pulses and provides cathode bias for the stage. R5 and C2 set the current level for efficient stage operation.

## Sync separation

The horizontal and vertical sync pulses are processed together through the section, but must be separated from one another before being applied to the horizontal and vertical sweep sections. This is accomplished as shown in Fig. 807. A short-time-constant R-C network, R3-C1, differentiates all sync pulses going to the horizontal section. A long-time-constant integrator circuit builds up the equalizing and serrated pulses into the vertical sync pulse for the vertical section. This was explained in Chapter 1.

## Sync section analysis

To function properly, the sync section must:

1. Produce a stable, strong sync pulse.
2. Maintain the proper pulse shapes.
3. Prevent noise and other forms of interference from passing through the sync section.

Described earlier in Chapter 6, the sync pulses can be affected by the tuner, if and video sections. Therefore, sync trouble does not necessarily indicate trouble in the sync section. However, when sync trouble does develop on the video line, other parts of the picture operation are also usually affected, resulting in overload, buzz, poor retrace blanking, etc. These other symptoms, though, may only be slight. And, because the picture is at best unstable with poor sync, close scrutiny may be required to see the other symptoms. On the other hand, the other symptoms can be more evident, depending on how severe the trouble is.

## Sync amplitude failures

Since most television sets now use efficient agc systems and the sync amplifiers both clip and clamp the sync pulses, the output of the sync section is generally fairly constant over a wide range of rf signals. Even on some weak signals, where a low-amplitude pulse is fed to the section, the gain of the stages is great enough that clipping and clamping will take place in the final sync amplifier to standardize the pulse height. Of course, with the weaker signals that do not overdrive the stages at both ends, the output pulse amplitude will be small and will vary. For such weak signals, the horizontal and vertical hold adjustments will be critical, permitting picture lock-in over a very small portion of the controls.

Because the horizontal section uses an afc circuit, this ordinarily becomes evident with the vertical adjustment first. Also, since the agc section is not very effective for weak antenna signals, their varying amplitudes will likewise cause the pulse height to vary and

lose control of the picture for momentary intervals. The picture may tend to "skip-a-frame" and roll vertically now and then, or shimmy or even tear horizontally on occasion. This condition will be most evident when an aircraft passes close by. It is therefore important that the gain of the section be kept high to maintain a constant amplitude.

As with any other stage, both sync pulses will be lost completely if any stage's signal path is interrupted because of a defective tube or open or shorted load resistor or coupling capacitor. If, however, the parts go bad, but do not change characteristics drastically, they may only reduce the pulse amplitude and cause critical synchronization. The tubes are naturally most likely to cause this because of reduced emission or an emitting grid; or a tube's

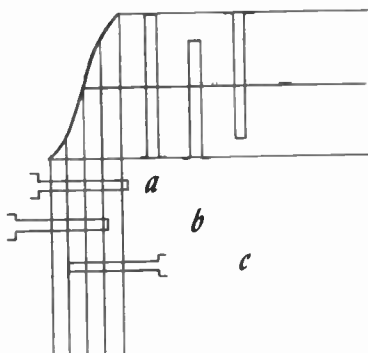

Fig. 808. *Effects of improper clipping bias. The one shown in (a) is normal.*

changing  $e_g - i_p$  characteristics may produce early cutoff or saturation to reduce the amplitude. In stage V1 (Fig. 801) coupling capacitor C2 or grid-leak resistor R2 may increase in value to produce too great a bias. Too much bias (Fig. 808-b) will keep the positive peaks of the pulses from being clamped by tube saturation and will cause too much of the pulse to be lost from clipping. As a result, a reduced unsteady pulse is obtained. In stage V2, however, where the input pulse is negative, weak and unsteady sync amplitude will result from R5 or C3 reducing in value. The resultant low bias (Fig. 808-c) will prevent clipping and cause oversaturation.

If plate load resistor R4 or R7 (Fig. 801) in stage V1 or V2 reduces in value, the gain of the stage will go down accordingly. If plate load resistor R12 in stage V3 reduces in value, however, it



will cause only one horizontal pulse to be reduced in amplitude. A decrease of R14 will affect the other horizontal pulse. This will upset the operation of the horizontal afc circuit. (This will be covered later.) Vertical sync, though, will still be normal. If the vertical sync is taken off before V3, trouble in V3 will affect only horizontal operation.

If any resistor or capacitor in the vertical integrator circuit increases in value, the increased R-C time constant will prevent proper vertical sync buildup (Fig. 809-b).

If R3 or R6 in either stage V1 or V2 decreases in resistance, the



Fig. 809. Correct vertical integration (a). Poor vertical integration will produce a weak vertical sync pulse (b).

lower plate voltage will cause early saturation and lower gain, reducing the amplitude of the sync pulses. If these resistors become too low in value, the resultant high current will probably eventually burn out the associated plate load resistor.

### Sync pulse distortion

For stable vertical and horizontal synchronization, the sync pulses must maintain their square-wave characteristics, which were described in Chapter 1. The relatively fast rise and fall times are necessary to assure positive synchronization, and the flat duration time is needed to prevent critical synchronization.

### High-frequency distortion

Square-wave pulses comprise a very wide range of frequencies. The higher frequencies make up the rise and fall times of the pulses, and the lower frequencies produce the duration of the pulses. Fig. 810-a shows a proper sync pulse. If the higher frequencies of the pulse are lost, the rise and fall times will take

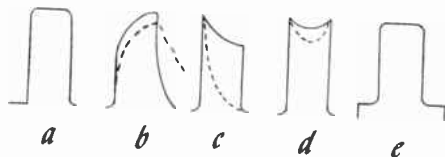

Fig. 810. Sync pulse distortion. The first curve (a) is normal.

longer and the pulse's leading and trailing edges will slope (Fig. 810-b). The more high frequencies lost, the worse the slopes would

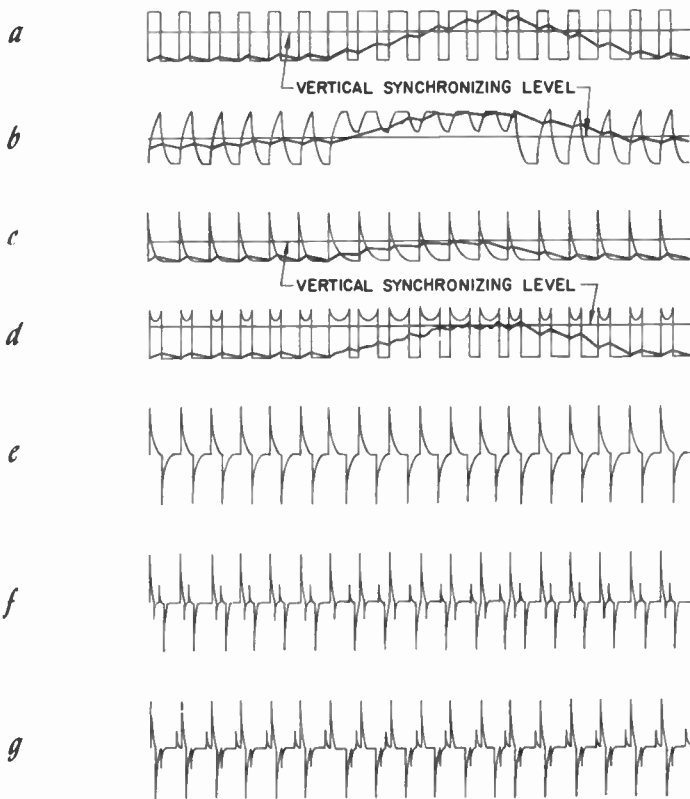

Fig. 811. *Effects of distortion on the horizontal and vertical sync pulses.*

be, as shown by the dotted lines. Generally, this would make the effective pulse width narrower, since the pulses ordinarily operate at their upper amplitudes. Also, the average amplitude of the pulses would be decreased, making them weaker.

Specifically, the slow rise and fall times would affect vertical synchronization as shown in Fig. 811-b. As explained in Chapter 1, the vertical sync pulse is produced by integrating the equalizing and serrated pulses (Fig. 811-a). Ordinarily, this will allow the integrated pulse to lock in the vertical oscillator about half to two-thirds of the way up. When the equalizing and serrated pulses shift  $1/2 H$  (Chapter 1) on alternate vertical frames, the integrated pulse will shift accordingly so that the vertical oscillator will start  $1/2 H$  earlier to interlace the vertical frames properly.

However, the integrated pulse shown in Fig. 811-b builds up much too fast because the slow fall times of the pulses do not allow

the integration capacitors to discharge properly. As a result, the integrated pulse tends not to follow the 1/2-H shift properly, and both frames of a picture are poorly interlaced. This causes an annoying vertical jitter in the picture as the vertical position of the horizontal lines is slightly different each frame.

In addition, since the resultant integrated pulse is comparatively coarse, it sometimes tends to lock in the picture at two different H-points. This makes vertical sync critical and causes the picture to hop up and down slightly with minor amplitude variations. Also, this may cause the vertical section to lock in too early to produce an off-frame picture with the vertical blanking bar showing at the bottom of the picture.

The effect of the waveshape shown in Fig. 810-b on the horizontal section is somewhat less complicated since the sync pulses are differentiated before being applied to the horizontal section. Differentiation is merely the extraction of the higher frequencies of the pulses to produce sharp pulses (Fig. 811-e). Therefore, when the higher frequencies of the original pulses are missing, the differentiated sync pulses are weakened, and the horizontal sync becomes critical. However, since the horizontal section uses an afc circuit, a large amount of high frequencies would have to be lost before poor synchronization would be noticed.

#### **Low-frequency distortion**

If the lower frequencies of the sync pulses were lost, the flat duration of the pulse could not be maintained (Fig. 810-c). If all the low frequencies were lost, the pulse would be almost differentiated, as shown by the dotted lines. The loss of low frequencies would affect the integrated vertical pulse as shown in Fig. 811-c. Since the pulses do not maintain their amplitude, the integrating capacitors charge more slowly and produce a low-amplitude vertical pulse that may only allow critical synchronization. The amount that the amplitude is reduced will depend on how poor the low-frequency response is. The amplitude may be kept low enough to lose vertical synchronization, or only high enough barely to bring about synchronization. In the latter case, minor variations in amplitude will cause synchronization to be lost momentarily and the picture will roll ("skip a frame") now and then.

Since differentiation is used to produce the horizontal sync pulses, the loss of low frequencies will have little effect on horizontal synchronization.

#### **Waveshape distortion**

Aside from frequency distortion, the sync pulse can be distorted

as shown in Figs. 810-d and -e. The shape shown in Fig. 810-d is caused by the sync pulse being overdriven into saturation. The grid voltage goes too highly positive and starts to draw current. This current, flowing in the grid circuit, causes a negative drop. This produces a degenerative action that reduces the positive pulse amplitude during pulse time. The more the overdrive, the greater the degenerative feedback, as shown by the dotted line. As shown in Fig. 811-d, this would prevent the vertical integrating capacitors from charging properly, producing an irregular low-amplitude vertical pulse. Points of synchronization and interlace will be poor. If the sync pulses are degenerated severely, the vertical pulse may not get a chance to build up and vertical synchronization will be lost entirely.

The oversaturated pulse shown in Fig. 810-d affects the horizontal sync pulses in a very unique way (Fig. 811-f). Since the oversaturated pulse actually has two rise and fall times, horizontal differentiation produces two sets of positive and negative pulses

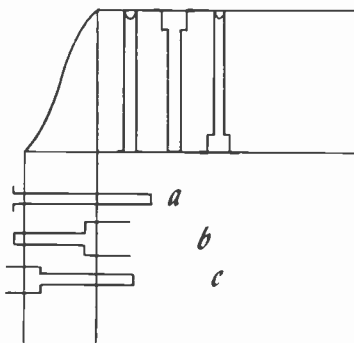

*Fig. 812. Causes of oversaturated and improperly clipped sync pulses.*

for each sync pulse. The amplitude of the extra pulses depends on how badly the sync pulse is degenerated. However, since the usual differentiated horizontal pulses are still present, synchronization will not be lost, but the extra pulses will "confuse" the horizontal afc circuit and may cause poor horizontal phasing.

The sync pulse shown in Fig. 810-e is brought about by improper clipping and clamping action which permits part of the blanking pulse to get through. Vertical integration, then, will build up much faster, and may cause critical vertical sync similar

to that caused by the loss of high frequencies.

Horizontal differentiation will be affected as shown in Fig. 811-g. The blanking pulse, as well as the sync pulse, will be differentiated to produce an extra set of pulses, similar to that of the oversaturated pulse. The over-all effect on synchronization will depend on how much of the blanking pulse gets through.

### **Causes of sync-pulse distortion**

Frequency distortion is determined largely by the bandpass characteristics of the sync section. In the typical sync circuit shown in Fig. 801, the low frequencies will be lost if coupling capacitors C2, C3 or C7 decreases in capacitance value, or if any grid-leak resistor drops in resistance. The high frequencies will be lost if any plate load resistor increases in resistance.

An oversaturated pulse can occur if the signal applied to stage V1 is much too large (Fig. 812-a) or if the plate voltage on V1 becomes much too low so that it saturates easily. A reduced value of R3 or increased value of R4 in the plate circuit will cause this. A large signal and too little bias, because of a decrease in R2 or C2, will also cause this. As shown in Fig. 812-b, too much bias on the grid of stage V2 will allow the blanking pulse to get through. And too little bias with a normal signal on the grid of stage V1 will produce the waveshape shown in Fig. 812-c.

### **Sync noise and interference failures**

As shown in Fig. 804, the R1-C1 filter network is used in grid circuits to minimize the effects of composite video noise pulses. Therefore, if C1 shorts, opens or changes value drastically, the noise pulses will be effective and may trigger the sweep section too early. They affect mostly the vertical section, since horizontal afc is used. Generally, vertical jitter, hopping and intermittent rolling occur.

A common but subtle form of sync interference is 60-cycle hum caused by filament-to-cathode or filament-to-grid leakage within a tube. When hum exists, the sync-pulse amplitudes will vary

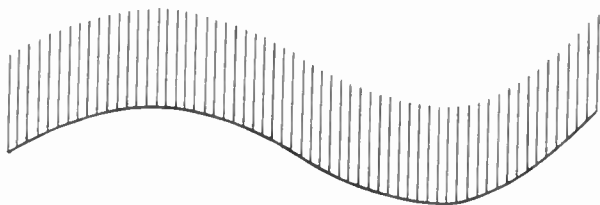

Fig. 813. Hum in the sync section, causing the sync pulse amplitudes to vary.

with the hum (Fig. 813). This will tend to synchronize each horizontal line at a slightly different point in time in relation to the video information. The distance of the edges of the picture, then, will vary at a 60-cycle rate with the edges of the raster as shown in

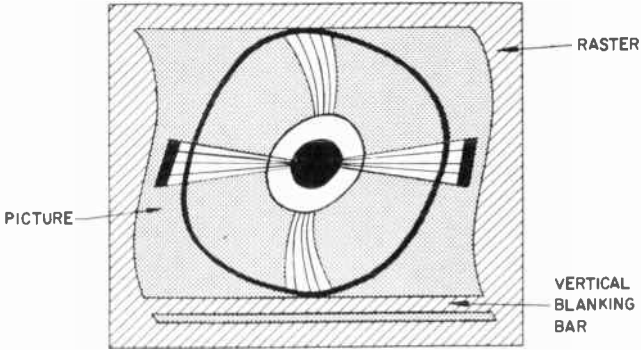

Fig. 814. Effect of sync hum on the picture. The picture hooks and blanking bar can show up.

Fig. 814. If the hum is produced by a tube in the sync section, the picture will otherwise be good. But if the hum comes from a video, if or tuner tube, either the upper or lower half of the picture will be darker.

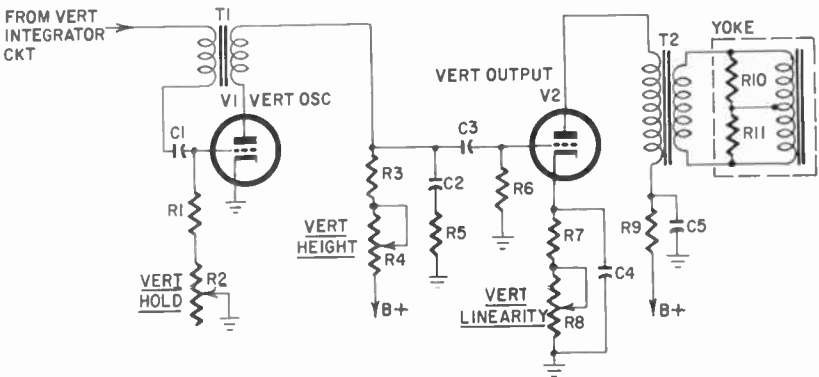
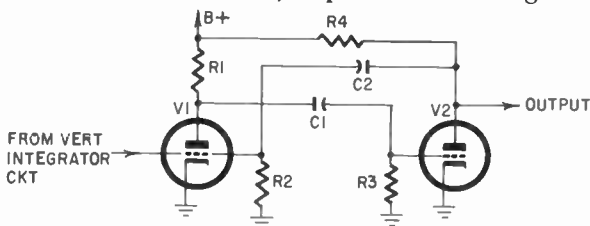

Fig. 815. Schematic diagram of a typical vertical sweep section.

The effect that sync hum has on the vertical section depends mostly on the phase relationship between the hum and the vertical sync pulses. This is because the vertical sync pulses occur during a very small portion of the hum cycle. If the vertical sync occurs around the 0-volt hum point, very little effect will be noticed.

But on the more positive parts of the hum cycle, integration will take place too soon and the picture may hop and jump or lock in out of phase. This will cause the vertical blanking bar to show (Fig. 814). If the sync occurs on the negative parts of the hum cycle, the vertical pulse amplitude will be reduced, and sync will be critical or even lost.

It is important to note that if the hum amplitude is very great, the amplitude of the horizontal sync pulses on the negative portion



a

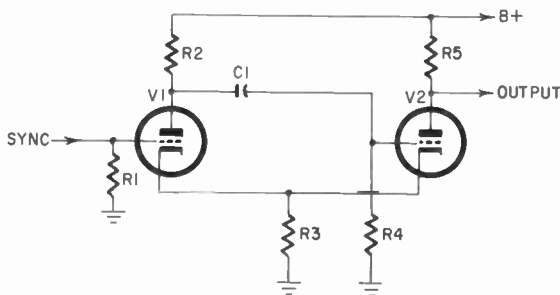

b

Fig. 816. Basic plate-coupled (a) and cathode-coupled (b) multivibrator circuits.

of the cycle can be so reduced that sync will be critical or even lost during that time. The raster will tend to tear or go out of sync completely. This will occur on either the upper or lower half of the picture, depending on the hum phase.

### Vertical section

A typical vertical sweep section is shown in Fig. 815. Basically, it contains a vertical oscillator stage that generates the vertical oscillator signal, and an output stage that produces a vertical sweep current that is transformer-fed to the vertical coils in the yoke to sweep the raster. The integrated vertical sync signal from

the sync section synchronizes the frequency of the vertical oscillator so that the vertical sweep of the raster is locked on the picture.

### Vertical oscillator stage

The vertical oscillator stages in most television sets are fairly similar. Generally, these circuits use multivibrators or blocking oscillators. These are known as relaxation oscillators because they alternately go on and off. The two most common types of multivibrators used are shown in Fig. 816. Fig. 816-a is a plate-coupled

Fig. 817. Multivibrator square waves.  
The waveform in (b) is the output of  
an unsymmetrical circuit.



multivibrator that uses two triodes generally enclosed in one tube. The plate of each tube is capacitively coupled to the grid of the other so that a ring of regenerative feedback is accomplished. When one tube, such as V1, conducts, its dropping plate voltage is coupled as a high negative bias to the grid of the other tube, V2. This cuts off V2, whose plate voltage rises. This rise in plate voltage is coupled as a high positive voltage to the grid of V1, to keep it conducting heavily for the regenerative action. The R-C time constants in the grid circuits are made long so that coupling capacitors C1 and C2 have to charge and discharge slowly. As a result, while C1 discharges because of the low V1 plate voltage, the high cutoff bias is maintained across R3. However, after a period, the discharge rate of C1 decreases and the bias voltage across R3 diminishes accordingly. When the bias is sufficiently reduced, V2 conducts and its plate voltage drops. This drop in voltage is then coupled by C2 to the grid of V1 to cut that tube off. The subsequent rise in the plate voltage of V1 is now coupled by C1 to drive V2 even further into conduction, and so on. The tubes will stay in this state until the discharge rate of C2 decreases enough to allow V1 to conduct again. The cycle is then repeated to produce free-running oscillations.

The frequency of oscillation is determined by how often each tube is cut off. And this is controlled by the R-C time constants in the grid circuits. Changing the value of any resistor or capacitor will change frequency. The frequency of oscillation of a free-running multivibrator will continuously go through slight up and down changes, though, because of slight varying characteristics in the circuit. To keep the oscillator locked at the 60-cycle frequency of the picture, the positive sync pulse is applied to the



grid of V1. The pulse overcomes the bias on V1 at the same point in time every cycle so that the tubes become cut off and conduct at a fixed rate.

The output of a multivibrator is taken from the plate of one of the stages, generally V2. Since the plate voltage goes through sudden rises and drops, the output ordinarily is a square wave (Fig. 817). The waveform shown in Fig. 817-a is that of a symmetrical

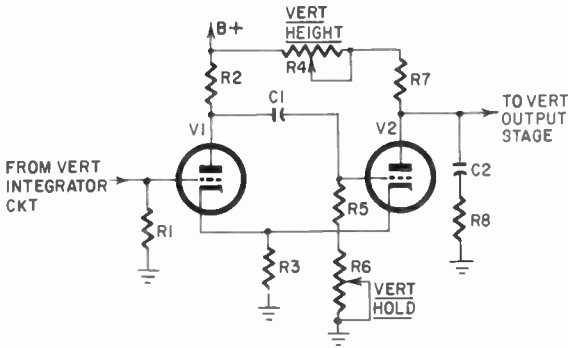

Fig. 818. Typical multivibrator used as a vertical oscillator. C2 produces the sawtooth wave.

multivibrator, where both tubes are on and off for the same times: the R-C grid circuits in both stages are identical. For television, however, since the positive part of the square wave is used for the sweep and the negative part is used for retrace, an unsymmetrical circuit is needed to produce the waveform shown in Fig. 817-b. This is obtained by having V2 remain in cutoff for a much longer period than V1 accomplished by making the R-C time constant in the grid of V2 much longer than that of V1.

Since the vertical oscillator signal must be closer to that of a sawtooth waveform than a square wave, and the frequency and amplitude of the waveform must be adjustable, the circuit shown in Fig. 818 is actually used. This circuit is a refinement of the one shown in Fig. 816-b, a cathode-coupled multivibrator. This circuit is similar to the plate-coupled type, except that feedback from V2 to V1 is across common cathode resistor R3. A control is added in series with R5 so that the R-C time constant can be adjusted to make changes in the frequency so that the sweep can be locked-in to the picture. This control is known as the vertical *hold, lock, or freq* control. Another control is generally added in series with load resistor R7 so that the output amplitude can be varied to make the

raster fill the screen. This adjustment is called the vertical *size* or *height* control.

To make the output of the circuit have a sawtooth waveform, a charging network is connected across the output of V2. In Fig. 818, this network is C2 and R8. If only a sawtooth signal were

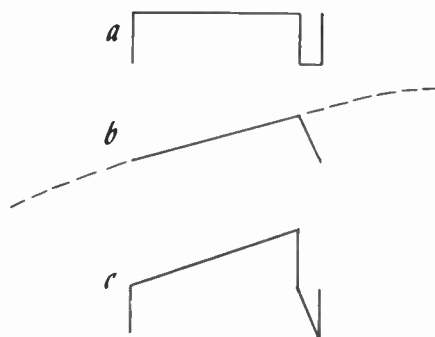

Fig. 819. Vertical oscillator signal. It is a combination of a square wave (a) and sawtooth wave (b). The spike is shown in (c).

needed, just C2 would be used. But, for a trapezoidal wave, R8 is also required. With this R-C network across the output, the voltage from the plate circuit can vary only as fast as C2 can charge and discharge. When V2 is cut off and its plate voltage tends to

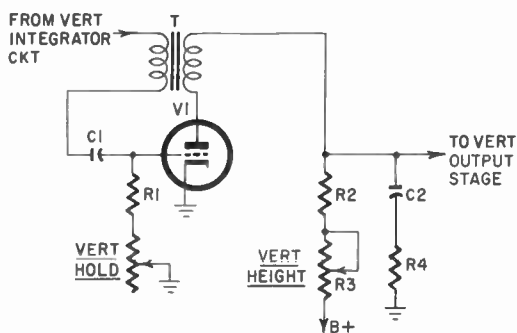

Fig. 820. Basic vertical blocking oscillator circuit. Transformer T supplies the regenerative feed back.

rise, C2 charges slowly (Fig. 819-b). The rate of charge is determined by the resistance in its path, which consists of R7 and the vertical height control. R8 is generally too small to affect charging time. C2 is given time to charge through only a relatively small

range of available plate voltage, so that the sweeping sawtooth waveform is fairly linear.

As the vertical height control is reduced in resistance, C2 can charge faster and reach a higher voltage to produce a large amplitude sweep. When V2 conducts, C2 is allowed to discharge rapidly through V2, which is a low-resistance path. The effect of R8 is to produce a small spike of voltage on discharge, which is added in series with the sawtooth waveform across C2 (Fig. 819-c). Larger spikes will be produced by higher R8 resistances. This spike on the waveform is necessary to overcome the inductance of the output stage, supplied by the output transformer and yoke. Inductance tends to retard a changing current, and in so doing, would make

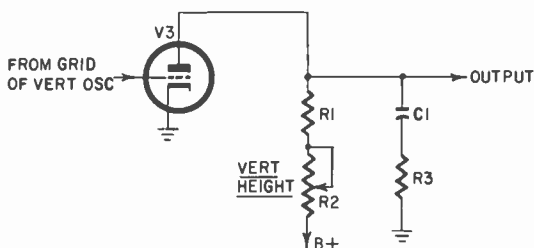

Fig. 821. Vertical discharge-tube circuit. This circuit is rarely used.

the beginning of the sweep nonlinear. The spike, though, overcomes this inductance so that the sawtooth wave is relatively unhampered. The spike is needed most with triode output stages, which have low plate resistances. When pentodes or beam power output tubes are used, which have high plate resistances, spikes are generally not required because the output circuit becomes resistive.

### Blocking oscillator

The blocking oscillator (Fig. 820), is used often because it requires only one stage. It uses transformer coupling for regenerative feedback from plate to grid, but functions similarly to the multivibrator.

When the set is first turned on, the tube starts to conduct, sending plate current through the primary winding of blocking transformer T. The transformer windings are so connected that it applies a positive voltage to the grid of V1. The grid draws current and charges grid capacitor C1. The capacitor can charge fast because of the low-resistance charging path through the tube. The

positive voltage on the grid causes the tube to conduct even more, which causes a higher positive voltage to be fed back to the grid, which again causes more current, and so on. This continues only until the transformer becomes saturated. At this point, the current through the blocking transformer primary winding is dc, and so no voltage is coupled to the grid circuit. The grid leak capacitor, then, starts to discharge through grid-leak resistor R1 and the vertical hold control. Since this is a high-resistance path, C1 dis-

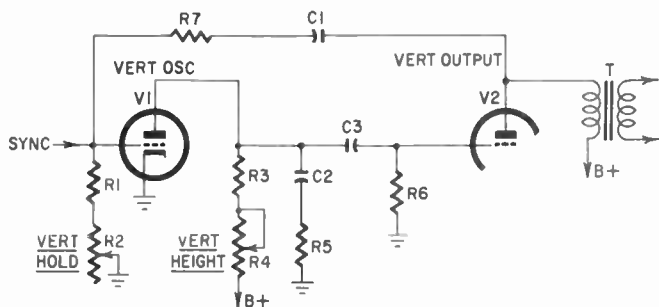

Fig. 822. Basic output-driven oscillator circuit. The oscillator and output stages actually form a multivibrator.

charges slowly. A high bias is dropped across the grid resistors, which cuts the tube off. The bias, however, slowly decreases as C1 continues to discharge. When the bias drops to the point where the tube is no longer cut off, current flows and the cycle is repeated. The sync, vertical hold, vertical height and charging network, C2–R4, work the same as for the multivibrators.

### Vertical discharge stage

This stage is used infrequently. It acts as a buffer between the oscillator and output stages, and allows the vertical adjustments in each stage to be made without affecting the other. When the discharge stage is used (Fig. 821), the output of the oscillator stage is a square wave which turns the discharge tube on and off. The plate of the discharge circuit then produces the sawtooth wave and spike as required.

### Output-driven oscillator

The output-driven oscillator circuit is sometimes used because it is economical. It needs only one triode for the oscillator stage, and no blocking transformer. In actuality, this circuit has the entire vertical section connected as a multivibrator. Oscillator stage V1 alone is not an oscillator, but forms one with the output

stage V2 (Fig. 822). When the vertical output stage conducts, a negative voltage is coupled back by feedback capacitor C1 to cut off V1. Capacitor C2 and resistor R5 in the output circuit of V1 then produce the sweep signal that drives the output stage. The oscillator stage is driven on and off as in an ordinary multivibrator.

This type of circuit is very critical to adjust because all controls are interacting. Anything that changes the output current slightly also changes the feedback, hence the oscillating frequency.

### **Vertical output stage**

The vertical output stage is a relatively straightforward current amplifier. It can be a triode or a pentode. A pentode gives more gain but poorer linearity. A triode gives less gain with better linearity, but needs a trapezoidal input signal because of its inductive plate circuit. The output stage (Fig. 823) uses power-amplifier tubes. The oscillator input voltage is changed to a vertical sweep current that is stepped up to a greater current in output transformer T and applied to the vertical windings in the yoke. The vertical sweep current in the yoke produces a corresponding magnetic field that sweeps the horizontal lines from top to bottom to form the raster. The vertical yoke windings are actually in two halves, one on each side of the CRT. This provides equal magnetic deflection to the electron beam on either side of the raster.

Bias for the stage is developed in the cathode circuit primarily across R2. The vertical linearity control modifies the bias slightly to adjust the sweep waveform. Bypass capacitor C2 provides cathode decoupling to prevent degenerative feedback. The decoupling network, R4-C3, in the plate circuit prevents the vertical sweep signal from reaching the other stages of the set through the B-plus lines. Figure 823-b shows the use of an autotransformer in the output circuit, and Fig. 823-c shows a directly coupled yoke. Transformer T and the yoke in the latter circuit make an autotransformer.

### **Vertical section analysis**

To function properly, the vertical section must:

1. Provide the proper vertical frequency.
2. Provide sufficient raster height.
3. Provide proper vertical sweep linearity.
4. Prevent the vertical sweep from interfering with the other sections of the receiver.

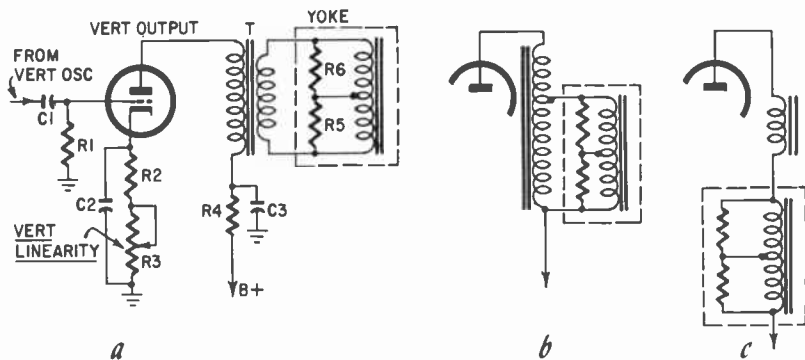

Fig. 823. A typical vertical output stage, showing transformer (a), autotransformer (b) and direct coupling (c).

### Vertical frequency troubles

The frequency of oscillation of the oscillator stage should be very close to 60 cycles so that the vertical sync signal can lock it in. The vertical hold control can adjust the frequency to a number of cycles above and below 60. If the oscillation is a couple of cycles off 60, the picture will roll since it is too far off for the sync pulse to take hold. By adjusting the hold control, the picture is set so that it rolls very slowly and the sync will take over. If the picture cannot be stopped, then there is trouble with the sync pulse. If, however, the control cannot bring the frequency close enough to be locked in, then circuit characteristics have changed enough for the frequency of oscillation to be too high or too low. If the rolling is so fast that the picture cannot be made out, then the oscillating frequency is way off. When the frequency is much too high, the raster will also shrink vertically, since the short sweep time prevents a high enough sweep amplitude from building up. On the other hand, too low a frequency stretches the raster vertically.

Almost any part in the oscillator circuit can cause a shift in frequency. If the tube emission drops off, feedback voltage will drop, causing less bias voltage to be produced. Tube on-and-off time, then, would go down, causing a higher frequency. If any plate load, R2 or R7 decreases in value, feedback voltage will also drop off for a higher frequency (Figs. 818 and 820). If the plate load increases in resistance, though, there will be a greater feedback voltage and a lower frequency. The lower frequency will also occur if the R-C time constant in the grid circuits became longer because C1 or R1 increased in value. This will cause C1 to take longer to discharge, which would keep the tube cut off longer.

The same is true if the cathode resistance in a cathode-coupled multivibrator increases in value for greater bias and feedback. If, on the other hand, R1, C1 or R3 (Fig. 818) decrease in value, the frequency will go up.

In the blocking oscillator circuit, shorted turns or increased resistance in the blocking transformer will reduce feedback to bring about a higher frequency.

In the output-driven oscillator (Fig. 822) any trouble reducing the gain of the output stage, such as a weak output tube, will reduce feedback and increase the frequency.

If the oscillator tube develops a filament-to-grid short, the hum signal develops a peculiar problem. The hum acts as the sync signal and locks the oscillator on the power-line frequency. The hold control may be able to change the frequency, but lock-in would always take place at power frequency. One might think, then, that if the power and vertical frequencies were both 60 cycles, it would make no difference. However, although the power frequency is considered to be 60 cycles, it is rarely exactly that. It is generally a few cycles off. At best, then, the picture would continually go through a slow roll.

### **Height troubles**

As explained earlier, the vertical oscillator and sweep signals must reach the proper amplitude if the raster is to be large enough vertically. Naturally, any trouble such as a dead tube or open resistor, capacitor or transformer in the signal or feedback path will cause a complete loss of vertical sweep. This will produce a horizontal line across the center of the screen. But, if the gain of the output stage goes down or if the oscillator produces too small a signal, the resulting weak sweep current will cause a short raster.

In the vertical oscillator, most troubles that affect the signal amplitude also affect the frequency. But, in some receivers, the range of the vertical hold control is made very large so that a trouble causing a shift in frequency may not show except as amplitude trouble after the adjustment is made. Therefore, many of the troubles, such as a weak tube, that were described earlier for frequency shift can also cause low amplitude. However, the parts most likely to cause amplitude trouble with a minimum effect on frequency are the charging capacitor, C2, plate load resistor, R3, and vertical height control R4 (Fig. 822).

If C2 (Fig. 822) or R3 increase in value, the capacitor will charge more slowly and not have enough time to reach the proper amplitude. Ordinarily, the vertical height control can be set for a

lower resistance to compensate for such a change. But the control's range is limited and may not be capable of compensating for extreme changes in R3 or C2. Also, if the center terminal circuit of the height control opened, the control would present its full resistance to decrease charging. By the same token, if C2 or R3 decrease greatly in value, C2 will charge too fast and may produce too much amplitude for excessive vertical sweep. This would drive the top and bottom of the picture off the face of the screen. This could also happen if the vertical height control shorted or jammed at too low a resistance setting.

In the output stage, a weak tube is the trouble that most often causes a small picture. If cathode resistor R2 (Fig. 823) increases in value, the resulting increased bias would also lower the gain of the stage. For minor changes in bias or tube gain, an adjustment of the vertical linearity control will provide compensation. But, if

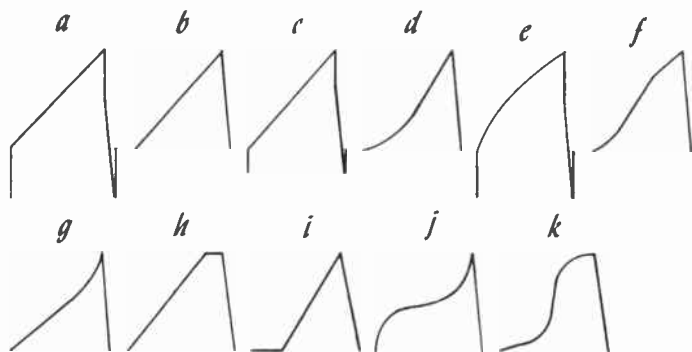

Fig. 824. Effects of poor linearity on the vertical sweep signal. Good waveforms, with and without the spike, are shown in (a) and (b).

the center terminal circuit of this control is open, the control would present its full resistance for high bias and low gain. If C2 is open, the cathode voltage would follow the grid voltage and degenerate the signal to reduce the output sweep current.

If either winding in transformer T develops a shorted turn or increased resistance, it would become inefficient and decrease the sweep current. Increased resistance or a shorted turn or two could also occur in a vertical winding of the yoke. This would not only produce a small picture but keystoneing as well (to be covered later).

Troubles can also occur in the vertical output stage to cause increased gain, but this would have more of an effect on vertical linearity rather than size. As a matter of fact, most of the troubles



in the output stage, even those causing reduced gain, will affect linearity. And, in many cases, the poor linearity may be more noticeable than the height trouble.

### Linearity troubles

Good linearity is obtained when the sweep voltage or current rises linearly, or at a steady rate, so that the horizontal lines of the raster are distributed equally from the top to the bottom of the raster. If the horizontal lines are closer together in some parts of the raster, those parts of the picture will appear compressed or squashed; and if the lines are too far apart, the picture will look stretched. The waveforms in Fig. 824 show some forms of poor vertical linearity. Figs. 824-a and -b show the desirable sawtooth waveform with and without a spike.

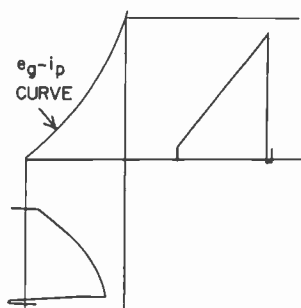

Fig. 825. The nonlinearity of the oscillator signal is counteracted by the nonlinearity of the output tube  $e_g - i_p$  curve to produce a linear vertical sweep current.

One cause of poor linearity would be the reduction or loss of the spike when one is needed to overcome the inductance of the output circuit so that the start of the sweep current would not be retarded. If the spike were reduced or lost (Fig. 824-c), the start of the sweep current would be retarded (Fig. 824-d). Since the raster is swept from top to bottom, this would cause the raster to be swept down slowly at first and then at a normal rate as it proceeded downward. The top of the picture would then be compressed. Since the only part involved in producing the spike is R8 (Fig. 818) in series with the charging capacitor, the spike would be reduced or lost if R8 dropped in resistance or became shorted.

Another form of nonlinearity, which is inherent in the way a capacitor charges, is shown in Fig. 824-e. A capacitor normally charges exponentially this way. Therefore to minimize the exponential effect, the capacitor is given time enough to charge to only a portion of the available B-plus voltage (Fig. 819-b) to produce a minimum of nonlinearity. However, if the vertical height control is set for a lower resistance to allow the capacitor

to charge to a greater amplitude (for example, to compensate for a weak output tube), the exponential charge will become more prominent; and, although the raster is made to fill the screen, the slower top of the sawtooth current will compress the bottom of the picture. In many receivers, the design is such that a slight exponential curve is planned on the sawtooth current since the  $e_g-i_p$  curve of the output tube provides an opposite nonlinearity at close to zero signal volts, as shown in Fig. 825. The net effect of the two opposing curves at the top of the waveform and the top of the

Fig. 826. *Waveform distortions causing different types of vertical foldover. The waveform phases are compared to the composite video signal (a).*

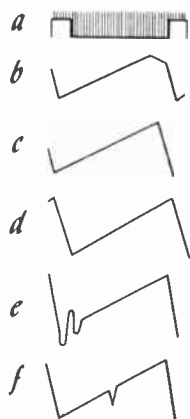

$e_g-i_p$  curve is a linear output, as shown. If, however, the bias were increased in such a case, the sweep waveform would operate at a lower point on the curve and the compensation of the  $e_g-i_p$  curve would not take place.

In effect, this is how the vertical linearity control works. It sets the bias for the best linearity compensation. In actuality, the height control sets the amount of nonlinearity, and the linearity control sets the amount of  $e_g-i_p$  compensation. These controls are highly interacting and must be adjusted together for both height and linearity. If R2 (Fig. 823) increased in resistance to the point where the linearity control would not have enough effect, the bias would go up and move the top of the sweep signal off the non-linear part of the  $e_g-i_p$  curve to allow the nonlinearity to continue. If the increase of resistor R2 were even greater, the bias might be such that the spikes were completely cut off (Fig. 825) and the beginning of the sweep voltage would be on the non-linear part of the  $e_g-i_p$  curve near cutoff. This would produce the sweep current shown in Fig. 824-f. Both the top and bottom of the raster

would be compressed and the central part would be linear.

If R2 decreased in value or capacitor C2 became leaky, and the bias were reduced, the sawtooth waveform would operate too high on the  $e_g-i_p$  curve and would be overcompensated. The amplitude of the upper part of the sweep current would increase faster (Fig. 824-g), causing the bottom of the raster to stretch. This could also occur if C1 developed a high-resistance leakage or the grid emitted slightly so as to cancel some of the cathode bias. If, of course, the bias were reduced too much, the sweep voltage would drive the grid positive and into saturation to clamp the top of the sweep current as shown in Fig. 824-h. The bottom of the raster would then be grouped into one thick bright white line. On the same order, if the bias became much too great, part of the start of the sweep would be cut off to produce the bright white line at the top of the raster (Fig. 824-i).

Vertical hum, resulting from a filament-to-cathode or filament-to-grid short in the output tube, produces another form of non-linearity. The 60-cycle filament voltage combines with the sweep voltage to produce the waveform shown in Fig. 824-j. The top and bottom parts of the raster are stretched, while the center of the raster is compressed. Actually, this depends on the phase of the 60-cycle voltage. The top and bottom could be compressed while the center is stretched (Fig. 824-k).

### **Vertical foldover troubles**

Foldover is a condition in which the raster stops and reverses direction to go back over itself, making the picture on that part of the raster appear folded. The most common cause of this is when a tube grid is driven too positive. The grid draws current at the top of the sweep voltage and degenerates that part of the wave so that it drops off instead of continuing to rise (Fig. 826-b). Since the top of the sweep current is the bottom of the raster, the raster would then reverse direction near the bottom of the picture and start sweeping the picture up again. The bottom of the raster would be folded over. The most common cause of this is that the height control has been adjusted to produce too great a sweep signal in an attempt to make up for a weak output tube that eventually becomes easily saturated.

However, foldover would also occur if the bias dropped off because of a shorted C2, decreased resistance of R2 or high-resistance leakage in C1 (Fig. 823). Also, if R4 increased greatly in resistance, the resulting low plate voltage would bring about easy saturation.

Another form of foldover occurs because of vertical retrace time

(Fig. 826-c). Compared with the composite video signal of Fig. 826-a, the retrace time starts early. Video that should continue down the raster is placed on the vertical retrace lines as they return to the top of the screen. This does not appear like ordinary fold-over since the retrace lines are generally far apart. However, if the retrace time degenerates to the point where it is much too slow, the retrace lines will be compressed and many of the ending lines of the raster will be caught in retrace time. This will show as a definite foldover of the bottom of the picture.

Fig. 827. *Retrace time can change although the frequency does not.*

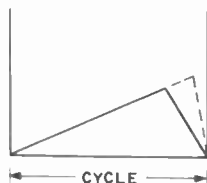

This type of lengthened retrace time can only be brought about by increased “on” time of the oscillator stage. In the multivibrator (Fig. 818), since the sync signal triggers V1 into conduction, thereby cutting off V2 to allow C2 to charge, the sync signal actually starts the sweep rise. When the sweep ends depends entirely on the C1-R5 time constant. If either C1 or R5 decreases in value, bias on V2 will be reduced faster and V2’s conduction will start sooner, allowing more time for C2 to discharge.

Ordinarily, this would tend to increase the frequency because the charging R-C time constant would also be reduced. However, since the sync pulse is used, the full discharging time of C1-R5 is not used because the sync arrives a little early to drive V1 into conduction. Therefore, since the on and off times of V1 and V2 occur at the same rate, the frequency is the same, but the ratio of on time to off time has changed. This is shown in Fig. 827.

A similar type of foldover caused by increased retrace time is shown in Fig. 826-d. This occurs with the blocking oscillator (Fig. 820). Here, the sync signal actually starts the retrace time by driving V1 into conduction and allowing C2 to discharge. But the end of retrace time is determined by the characteristics of the blocking transformer, which can change to cause this trouble. When the retrace time lengthens here, it continues into the next video frame so that the retrace lines of the top of the raster show up.

Another form of foldover known as ringing can produce ripples at the start of the sweep, as shown in Fig. 826-e. This happens because retrace current tends to shock-excite the yoke coils into oscil-

lation at their resonant frequency. R5 and R6 are used across the yoke windings (Fig. 823) to damp these oscillations. If either of these resistors opened, ringing occurs and sweeps the raster lines up and down a few times at the start of the sweep. Therefore, many lines would be folded over at the top of the raster. Resistors R5 and R6 (Fig. 823) are equal value units and are always found shunted across the vertical sweep coils in the yoke.

A foldover action during the vertical sweep can occur because of the momentary breakdown of a part in the vertical section at an almost repetitive rate. This is shown in Fig. 826-f. As the sweep

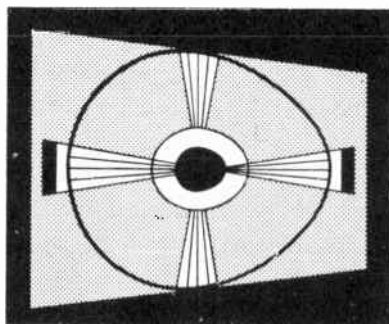

Fig. 828. *Vertical keystoneing.*  
*This is caused by a shorted vertical winding in the yoke.*

current is generated, a part breaks down momentarily and the current drops off, but the trouble corrects itself and the current returns to normal and proceeds again. This causes the sweeping raster to stop suddenly and back up over itself and then go down over itself again. This produces a white line or bar where the break in current occurred, depending on the extent and time duration of the break.

The trouble can exist every few frames or every now and then, and may occur at a different place in the raster each time or even a few places in the raster. The top and bottom of the raster will jitter and tend to collapse. This is generally due to a tube or part that has a bad connection, a resistor that is slightly carbonized, or a capacitor or coil winding that is arcing over. Often it is due to one of the tubes, most probably the output tube since it carries a heavy current. The output transformer is the next most probable part; but any other component that carries a heavy current or is across B-plus voltages is suspect.

## Vertical keystoning

Two vertical windings are used in the yoke. If only one were used, it would produce more sweep for a given current when the CRT electron beam is closer to it. Therefore, since the vertical winding must be at the sides of the picture-tube neck for its magnetic field to drive the beam up and down, it would lose effectiveness if the beam were swept horizontally away from the vertical winding. One side of the raster, then, would be larger

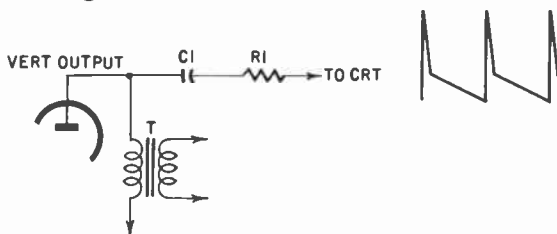

Fig. 829. To eliminate retrace lines, the inductive retrace pulse can be taken from the vertical output stage to cut off the CRT during vertical blanking time.

vertically than the other (Fig. 828). To prevent this, the yoke has two windings, placed opposite one another so that both sides of the raster will be swept equally. If, however, one winding becomes shorted, the raster will be keystoneed. If a winding develops only a shorted turn or two, the keystoneing effect may be barely noticeable.

## Vertical interference troubles

The vertical section can develop troubles that may not have apparent effects on the vertical sweep, but can interfere with other parts of the set. One such is either R4 (Fig. 823) shorting or C3 opening. These parts form the decoupling network that prevents the vertical sweep signal from reaching the other sections. If these parts go bad, the vertical sweep signal enters the B-plus lines. Where it would go from there would depend on how those lines were filtered. If it entered the sound section, it would introduce a 60-cycle buzz. In the video, it would act like hum, causing either the upper or lower half of the picture to be darker than the other half, depending on the phase. If it enters the sync section, it would have the same effect as 60-cycle hum. If it enters the horizontal section, it could cause the width to change gradually down the raster, and will resemble horizontal keystoneing.

Another common cause of vertical interference is the vertical output transformer. Its laminations often become loose and vi-

brate at 60-cycles to cause an annoying mechanical buzz. In addition, the output-transformer windings sometimes tend to arc over during vertical retrace time when a high inductive kickback takes place. This arcing radiates rf energy that is picked up by the if stages to produce ignition type noise in the picture and a 60-cycle cracking sound in the audio. Since the arcing occurs just during retrace, it only causes broken vertical retrace lines, which normally cannot be seen.

Still another form of vertical interference can develop in sets that use a vertical blanking circuit similar to that shown in Fig. 829. This circuit sends the positive vertical flyback pulse to the cathode of the CRT to cut it off during blanking time. This eliminates the retrace lines, regardless of the brightness setting. A negative pulse of the yoke is sometimes sent to the CRT control grid instead. Because of the high voltages present, arcing or intermittent breakdown of R1 or C1 causes flashes in the picture. And if C1 becomes shorted, the CRT voltages will be upset and can cause loss of brightness or the control of it.

Another more subtle form of interference comes from the fact that some sets obtain B-plus for the vertical section from the B-plus boost in the horizontal section. Therefore, when a trouble occurs in the vertical section to cause too much current to flow, the B-plus boost in the horizontal section can be so loaded that horizontal width, and even the high voltage, drops off.

# circuit failure analysis, horizontal sweep and high voltage

**A** TYPICAL horizontal sweep and high voltage circuit is shown in Fig. 901. The horizontal sweep section contains a horizontal oscillator stage and afc circuit, a horizontal output stage and a damper stage. The horizontal oscillator stage generates the horizontal sawtooth frequency, and the afc circuit compares that frequency with the horizontal sync pulses. As a result of this comparison, the afc circuit provides a control voltage to keep the oscillator locked on the proper frequency.

The output of the oscillator stage is a sawtooth wave that drives the output stage. The output stage is a class-C current amplifier that conducts only for the top half to two-thirds of the oscillator sawtooth. That current is applied by the output transformer to the horizontal windings of the yoke to sweep the right side of the raster.

At the end of the sawtooth current, during retrace time, inductive kickback in the transformer and yoke circuit produces a flyback current that retraces the scanning beam to the left side of the raster. After retrace, the damper stage conducts, permitting the flyback current to decay slowly toward zero. This decay sweeps from the left side of the raster toward the center, where the output stage current will occur again to continue the sweep. This process is repeated so that the horizontal output-stage current produces the right side of the raster, and the transformer and yoke produce the retrace and the left side of the raster, which is controlled by the damper stage.

## **Horizontal oscillator and afc stage**

Actually, the horizontal oscillator stage can be made very similar



to the vertical oscillator, and could also be synchronized directly by sync pulses. In fact, this is the way it was done in the early days of television. However, because of the higher operating frequency of the horizontal oscillator, it is more unstable and susceptible to sync noise interference, and shows more noticeable effects of noise. Individual raster lines tend to shift and tear, causing a ragged and jittery picture. The afc circuit is used to make horizontal synchronization more stable and immune to noise.

### **Synchrolock circuit**

The Synchrolock circuit was one of the first horizontal oscillator circuits using afc. It dropped out of use in the early 1950's, and then started showing up again, first as the color burst sync control in color sets of the late 1950's and then in a modified version, as the horizontal oscillator again in some sets of the early 1960's. The circuit (Fig. 902) contains a Hartley oscillator. V2 is a standard electron-coupled sine-wave oscillator that feeds a discharge tube to produce the sawtooth wave. The oscillator feedback coil is the primary winding of transformer T, which also feeds the oscillator signal to the sync discriminator. A center-tapped secondary winding applies equal amplitude sine waves to each diode, 180° out of phase. The sync pulse input is applied to the center tap so that identical pulses drive each diode (Fig. 903).

When the oscillator is on frequency, the phases of the sync pulses and sine waves are as shown in Fig. 903-a. Both diodes conduct equally. Since diode loads R1 and R2 are connected in series-opposing, the outputs cancel. When the horizontal output frequency decreases, the sync pulses occur on different positions of the sine waves (Fig. 903-b). Diode V1-a will conduct more heavily to produce a positive discriminator output. The opposite will occur when the oscillator frequency increases (Fig. 903-c).

The diode loads are connected in series with 2 volts minus, so that the actual output of the discriminator adds to or subtracts from this negative voltage. This control voltage is fed through R-C networks R4-C2 and R5-C4 to the grid of the reactance tube.

The reactance tube is an ordinary pentode amplifier connected in parallel with the oscillator tuned circuit. C6 and C7, in series with R10, resonate with the primary winding of T. R10 is small enough (around 10 ohms) so that it does not seriously affect the Q of the tuned circuit. Since R10 is also the cathode-bias resistor for the reactance stage, a small portion of the oscillator signal is amplified in the stage. The signal is coupled from the plate circuit and shifted in phase 90° by C5 through C6 and C7 back to

Fig. 901. Schematic diagram of a typical horizontal and high-voltage section. A Synchronomatic type of afc and oscillator is shown.

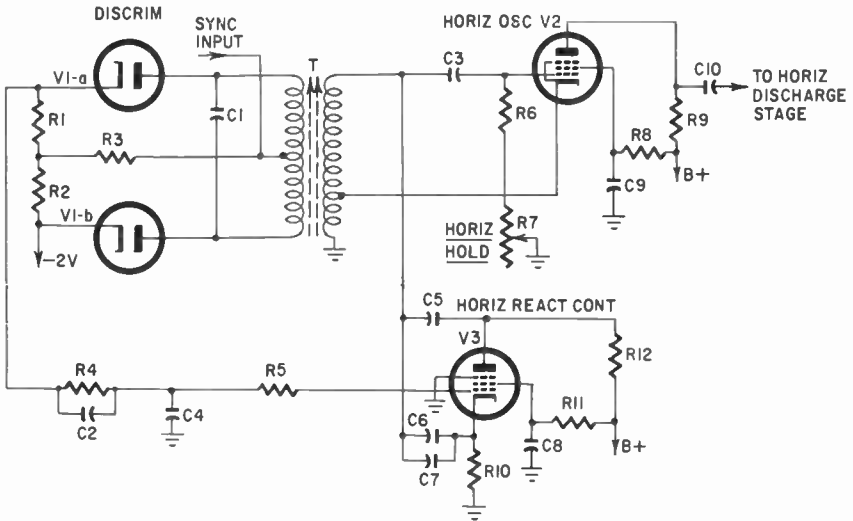
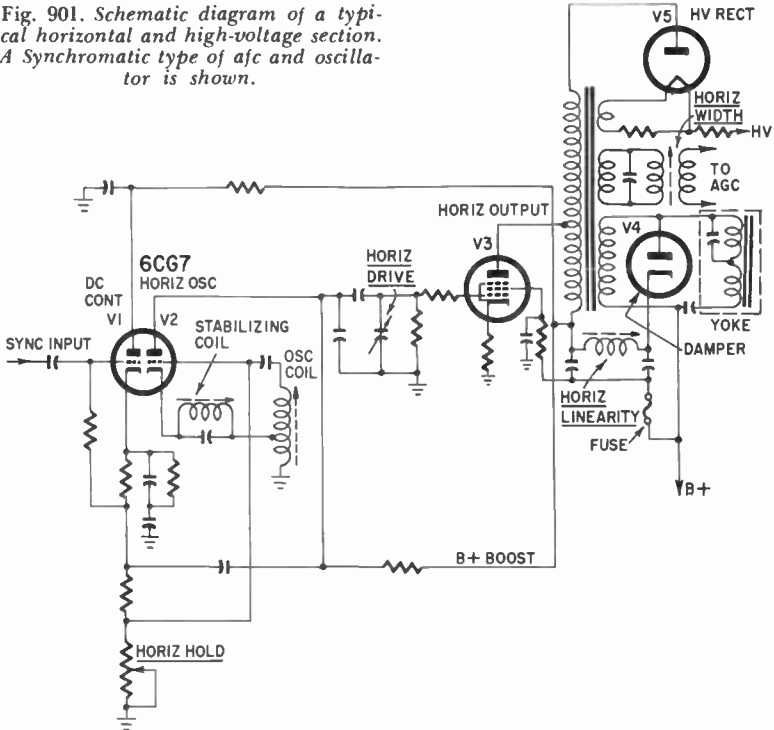

Fig. 902. Basic Synchrolock circuit. The reactance tube controls the horizontal oscillator frequency. In the later versions, semiconductor diodes are used in a sync discriminator circuit. The reactance tube is a triode, and the sawtooth voltage is developed in the plate of the oscillator.

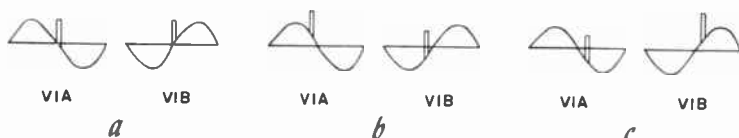

Fig. 903. Synchronolock waveforms. The sync pulse and oscillator frequency phase relationships determine the control voltage.

the cathode. This phase-shifted voltage produces a reactive current that is applied to the tuned circuit to affect its resonance. When the control-grid voltage on the reactance tube varies above or below 2 volts minus, the reactive current is increased or decreased to raise or lower the oscillator frequency.

### Multivibrator and sync discriminator

The multivibrator and sync discriminator is shown in Fig. 904. The multivibrator is a cathode-coupled type similar to the one

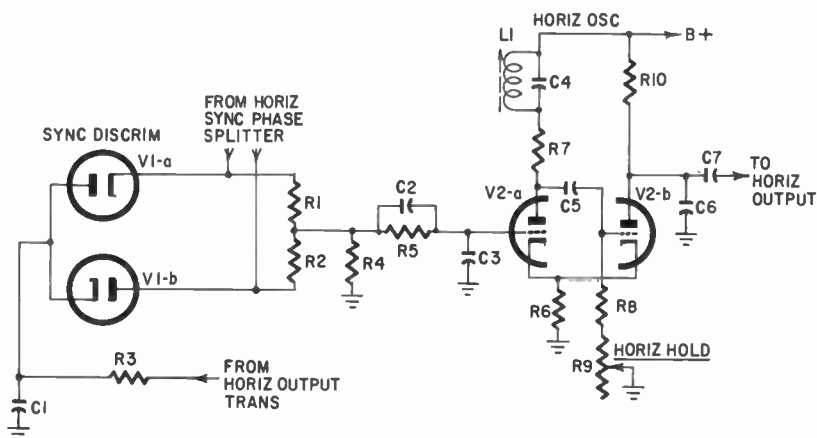

Fig. 904. A typical multivibrator and diode sync discriminator. The discriminator output is applied as bias to the multivibrator to control its frequency.

described for the vertical oscillator. The main difference is that a tuned circuit, L1-C4, is used in the plate of the first stage for stabilization. This will be explained in the discussion for the Synchronolock circuit.

The sync discriminator is similar to the ratio detector used in the sound section. It has two diodes connected to a common load resistor, R4. Since the current through R4 is opposite for each diode, there is a cancellation effect. R1 and R2 serve as sync-pulse input resistors. An equal but opposite-phase sync pulse from a sync-phase splitter is applied to each diode circuit. In addition, a negative-going sawtooth wave from the horizontal output circuit

is applied to the input junction of the two diodes. These waveforms control the current of both diodes (Fig. 905). The sync pulses occur during retrace so that the sharp slope produces large current changes for relatively small changes in phase relationships. Discounting the sync pulses, both diodes would conduct equally, because of the sawtooth wave, to produce a net output of zero volts.

When the horizontal oscillator is right on frequency, the phase

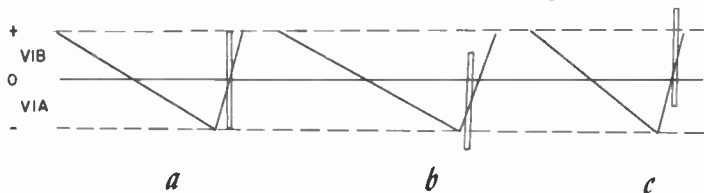

Fig. 905. Sync discriminator waveforms. The sync pulses arrive during retrace time and should be centered (a) for lock-in.

relationships are as shown in Fig. 905-a. Both sync pulses occur midway on the retrace, which is right at zero volts. Since the pulses are equal in amplitude, the diode outputs cancel. When the horizontal oscillator decreases in frequency, the pulses occur on a more negative part of the retrace (Fig. 905-b). Diode V1-a conducts

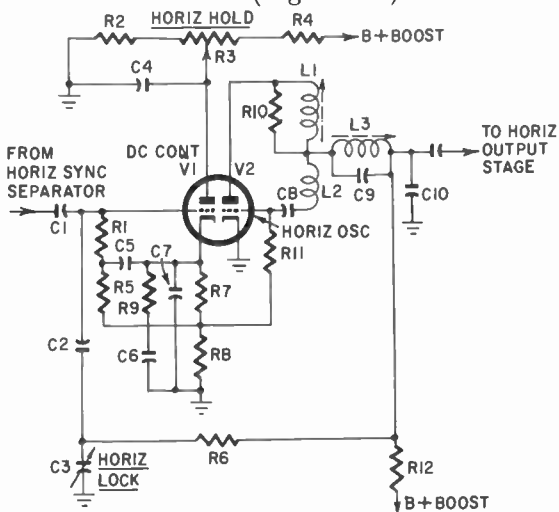

Fig. 906. A typical Synchroguide circuit. The dc control stage adjusts the oscillator grid bias for drift action.

more heavily, then, to produce a positive control voltage across R4. Heavier conduction in V1-b would produce a negative control voltage across R4 for the higher-frequency sawtooth shown in Fig.

905-c. The control voltage is filtered by C2 and C3 and R5 before being applied to the control grid of the multivibrator. A positive control voltage raises the frequency and a negative voltage lowers it.

### Synchroguide

The Synchroguide circuit (Fig. 906) uses a modified blocking oscillator and dc control tube. V2 is the blocking oscillator. L1 and L2 form an autotransformer for inductive feedback from plate to grid. C8 and R11 and R8 form the grid-leak blocking network.

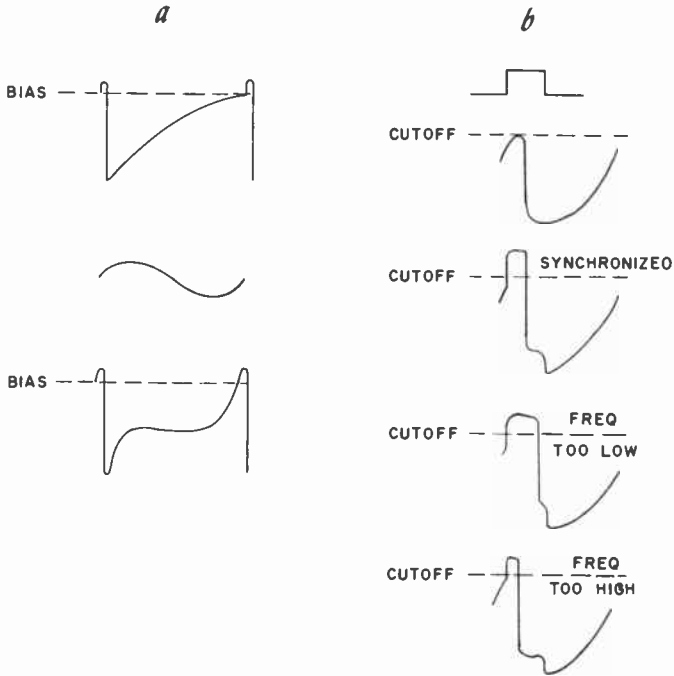

Fig. 907. Synchroguide waveforms. The action of the stabilizing tank is shown in (a), and the combined waveforms applied to the control stage are shown in (b).

C10 is the sawtooth charging capacitor, and R12 limits charging current to produce the linear sweep. L3 and C9 have been added to the output circuit to form a resonant stabilizing tank circuit that produces a damped oscillation at the horizontal frequency while the tube is cut off. This sine wave is fed back to the grid of the oscillator to modify the grid voltage (Fig. 907-a). This produces a sharp slope at the time the tube is triggered into conduction so that the frequency of oscillation is more stable. Also, L3 is adjustable, and can shift the phase of the fed-back sine wave to

change the phase of the horizontal oscillator. Since the phasing circuit is not in the charging path of C10, it does not affect the output waveform.

The afc control voltage is developed by the dc control stage V1. This circuit is in series with resistor R8. As a result, any current flowing through V1 will modify the negative voltage existing across R8 from the grid-leak action of the blocking oscillator.

V1 is normally kept at cutoff by the grid-leak action of C1 and

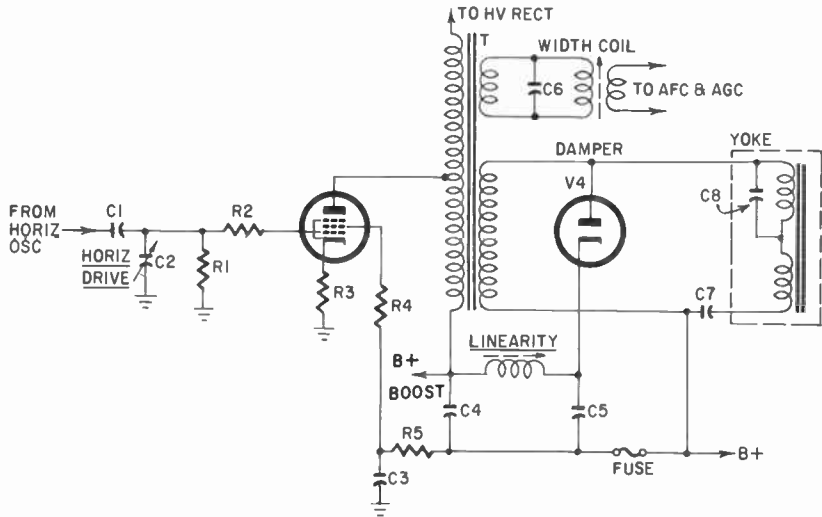

Fig. 908. Typical horizontal output and damper circuits. Note the fuse in the B-plus line and the horizontal drive trimmer in the grid circuit of the output stage.

R1. The waveforms applied to the grid are shown in Fig. 907-b. The sawtooth voltage from the plate of the oscillator tube is integrated by R6 and the horizontal lock capacitor C3 to produce a parabolic type waveform. This waveform, with a sharper retrace slope for better control, has only sufficient amplitude to drive V1 close to conduction. The sync pulse arrives during the start of retrace and is added to the oscillator signal. The sync pulse, riding atop the other waveform, drives the tube into conduction. However, the tube will conduct only during the width of the sync pulse that is astride the oscillator signal. When the oscillator is right on frequency, approximately half of the sync pulse width drives the tube. The other half, which is added to the retrace slope, is below cutoff. When the oscillator frequency is too low, more of the sync pulse drives the tube to produce a higher average current. The opposite happens when the oscillator frequency is too low.

When more current flows through V1, the resulting positive voltage drop across R8 cancels some of the negative grid-leak bias across it. This decreases the bias on the oscillator tube to increase its oscillating frequency. Less current through V1 increases the oscillator bias to reduce its frequency.

R7 produces cathode bias for the control tube, and R5-C5 form a decoupling network that keeps the control-tube grid signals out of the oscillator circuit. C7 and C6 and R9 bypass the cathode so that an average current flows through R8 and R7. The plate of the control tube is connected to a horizontal hold control that is part of a voltage divider in the B-plus line. The hold control is then used to adjust the plate voltage and, therefore, the normal plate current of the stage to set the frequency of oscillation. A coarse setting of oscillator frequency is made by slug-tuning L1.

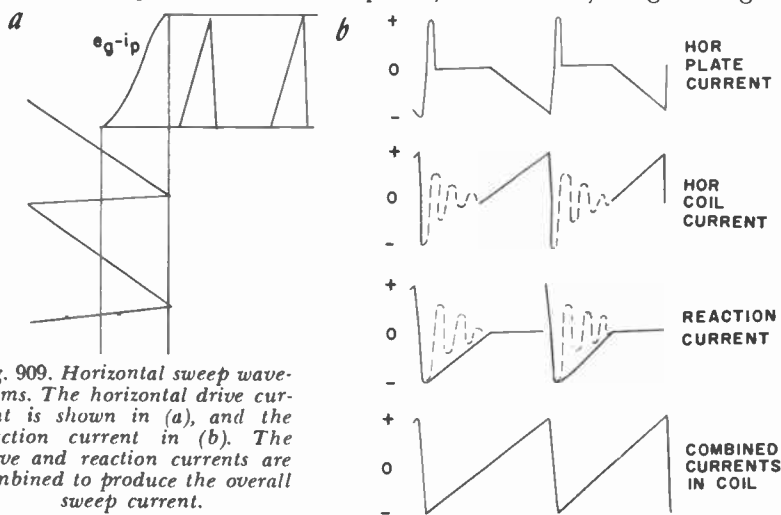

Fig. 909. Horizontal sweep waveforms. The horizontal drive current is shown in (a), and the reaction current in (b). The drive and reaction currents are combined to produce the overall sweep current.

The horizontal-lock trimmer capacitor is used to adjust the integration of the horizontal oscillator signal applied to the control tube. It therefore sets the waveshape and amplitude of that signal to adjust the range of control that the control tube has over the oscillator.

### Synchromatic

The Synchromatic circuit (Fig. 901) is the successor to the Synchroguide. Both work similarly, except the Synchromatic uses a Hartley oscillator.

### Horizontal output and damper stages

Typical horizontal output and damper stages are shown in Fig.

908. The output stage uses a high-current beam power pentode to amplify the sawtooth input. The sawtooth plate current is passed through the primary winding of the horizontal output transformer T, induced in the secondary windings, and sent to the horizontal coils of the yoke.

The horizontal output stage is a class-C amplifier. Grid-leak bias, developed by C1 and R1, keeps the tube cut off except for the top half to two-thirds of the horizontal oscillator signal, as shown in Fig. 909-a.

The output current, then, is a clipped portion of the sawtooth to drive only approximately the right half of the raster. The horizontal drive trimmer capacitor across the grid-leak resistor bypasses part of the sawtooth input in proportion to its capacitance

Fig. 910. Another method of drive control.

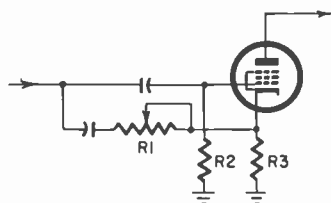

setting. The drive adjustment controls the amount of the sawtooth that causes tube conduction, and subsequently the quantity of grid leak bias. Another method of controlling the horizontal drive is shown in Fig. 910. The sawtooth voltage is also coupled to the cathode to produce an amount of degeneration that is determined by the potentiometer setting.

R3 in the cathode is small and is used to develop a nominal amount of bias to protect the tube in the event that grid-leak bias is lost. R2 (Fig. 908) limits grid-current flow during grid-leak action, and R4 suppresses parasitic oscillations.

When the output tube is put into conduction, a negative-going sawtooth current starts in the plate circuit as shown in the first diagram of Fig. 909-b. This causes a positive sawtooth current to start in the secondary circuit of the transformer, as shown in the second diagram of Fig. 909-b. This current starts about zero and rises to peak to drive the CRT beam from about the center of the raster to the right-hand edge. At the end of the sweep, the retrace starts and the current drops to zero. This causes the transformer's magnetic field to collapse, producing a sharp positive inductive kickback voltage in the primary circuit, and a sharp negative inductive kickback voltage in the secondary circuit. This flyback voltage causes a heavy negative current in the transformer and



yoke-winding circuit, which retraces the CRT spot to the extreme left of the raster.

If the damper stage were not in the circuit, the flyback pulse would cause oscillations, since the transformer output circuit resonates with interelectrode capacitances somewhere between 70 and 100 kc. This is shown by the dotted lines in Fig. 909-b. But the damper stage prevents this from happening. As shown in Fig. 911, since the secondary circuit is acting like a resonant tank during retrace, the flyback voltage leads the current by  $90^\circ$ . Consequently, just as the negative flyback current tends to decay rapidly, the flyback voltage starts going positive. This causes the damper

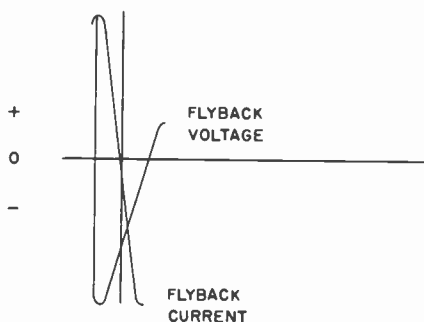

Fig. 911. Flyback voltage and current relationship in the secondary circuit. After flyback the voltage leads by  $90^\circ$  due to circuit resonance.

tube to conduct. The damper tube current is resistive and flows through the secondary circuit. This loads the secondary circuit, greatly reducing its Q and damping the oscillations. As a result, the high negative flyback current in the circuit cannot drop rapidly. Instead, the current decays only slowly toward zero, sweeping the CRT spot from the extreme left to about the center of the raster. Since this current results from a reaction to the flyback pulse, it is called reaction current, and the entire sweep system is known as reaction scanning.

The development of the reaction current is shown in the third diagram of Fig. 909-b. Just as the reaction current approaches zero, the horizontal output current resumes to continue the sweep and repeat the cycle. Combined, the reaction and horizontal output currents produce the fourth waveform shown in Fig. 909-b. C7 (Fig. 908) in series with the yoke allows only ac through the yoke coils. This is necessary because there is an average dc component in the circuit that would make centering of the raster difficult.

The current through the damper tube is made resistive by the linearity coil and C4 and C5 in the damper cathode (Fig. 908). As shown in Fig. 912, the linearity coil allows an inductive current and the capacitors allow a capacitive current to flow. Together, these average to produce a steady resistive damping current.

The linearity coil's inductance can be adjusted with a slug to increase or lower the inductive component of current. This puts a reactive component in the damper current to change the reactance-current decay characteristics. The coil is adjusted to produce a linear reactance-current decay, and therefore controls the linearity of the left side of the raster. The horizontal drive control determines the size and linearity of the right side of the raster; and together the controls set the linearity of the center of the raster.

The linearity coil and capacitors C4 and C5 are connected to form a pi network that filters the damper current. The capacitors charge to the B-plus value of the secondary circuit plus the value

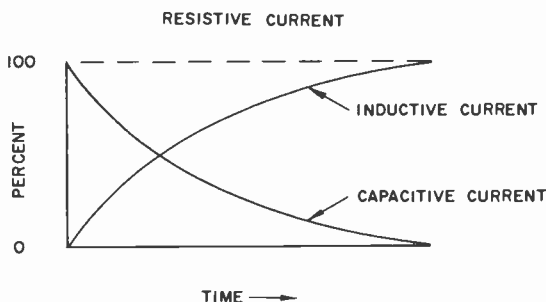

Fig. 912. *Damper current. The combined inductive and capacitive currents produce a steady resistive current.*

of the reactance voltage. Since the capacitor charge is greater than B-plus, it forms a B-plus boost circuit that is used to drive the plate of the horizontal output tube, and sometimes the horizontal oscillator as well as the vertical output stage. Often, the negative end of the B-plus boost capacitors are connected to ground rather than to B-plus. But the charged value is the same.

In addition to the drive and linearity controls, the output circuit sometimes uses a horizontal width control. This is a coil connected across some part of the secondary circuit or across a separate secondary winding (Fig. 908). The width coil draws current in accordance with its inductance, and thus loads the transformer to lower its Q and efficiency slightly. Decreasing its inductance causes more of a current load and less efficiency. This reduction in effi-

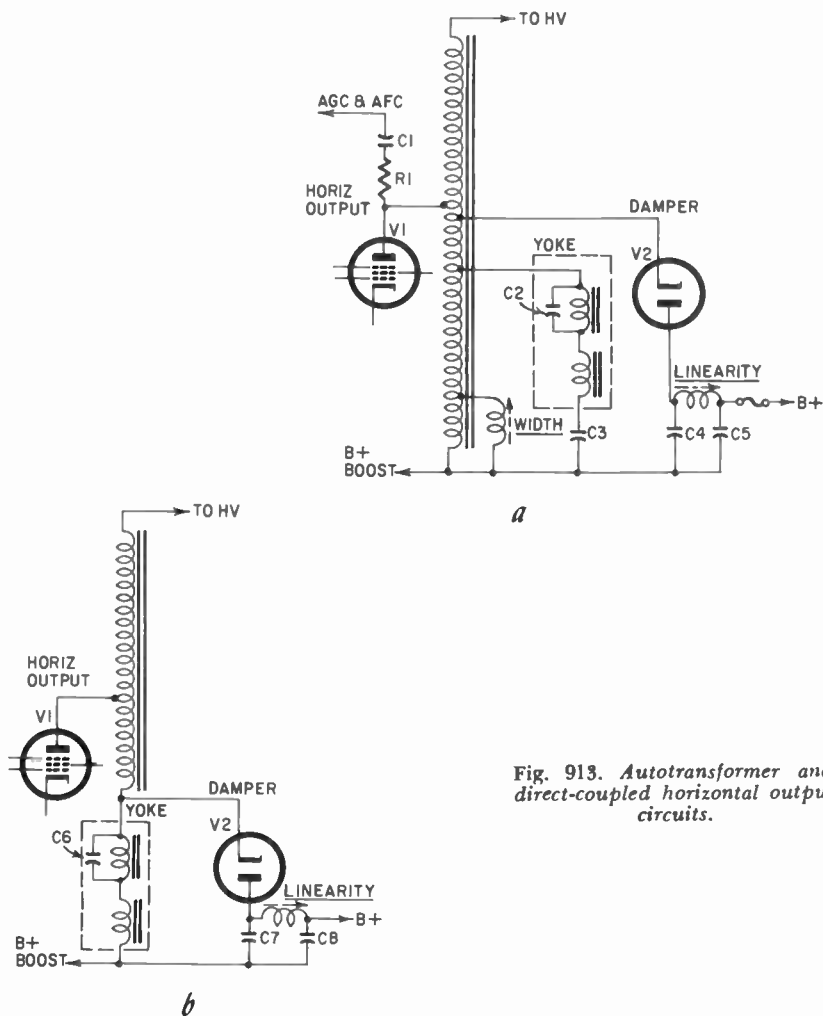

Fig. 913. Autotransformer and direct-coupled horizontal output circuits.

ency reduces the flyback pulse applied to the high-voltage section. The high voltage then goes down to increase the width of the raster. Increasing the width-coil inductance increases the transformer efficiency for more high voltage and a smaller sweep. Although the width coil tends to affect the output and reaction currents also, there is a greater change in high voltage. In some a width capacitor, C6, is also used to load the transformer.

Since the width-coil current follows that of the output transformer, a secondary winding is sometimes added to the width coil to couple the sawtooth and flyback waveform inductively to the

agc or afc circuit. However, these signals can also be obtained by capacitive coupling from the output tube's plate circuit or secondary and yoke circuits.

It is important to note that occasionally a set uses a small-value capacitor across the transformer secondary winding or from the output tube plate circuit to ground for width loading.

Shown in Fig. 913 are two variations of the horizontal output circuit and damper stage. Fig. 913-a shows the use of an autotransformer output circuit, in which various taps on the transformer feed the damper and yoke circuits. The circuit functions the same as the transformer with separate windings except that the current polarities in the damper tube and yoke are reversed since no transformer inversion takes place. The horizontal output tube current is a negative-going sawtooth, and during retrace a positive flyback pulse occurs. As the flyback pulse drops down again, the negative-going voltage causes the damper tube to conduct. This damps oscillations in the transformer-yoke circuit, and linear retrace scanning takes place.

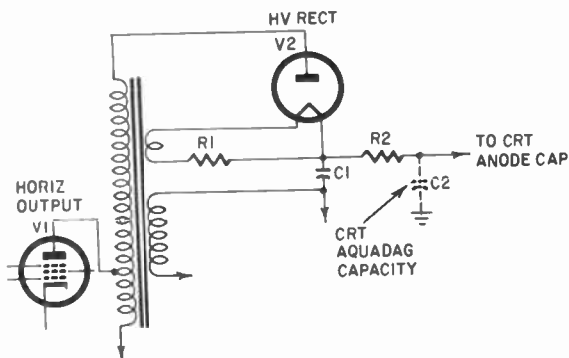

Fig. 914. High-voltage rectifier circuit.

The circuit shown in Fig. 913-b is direct-coupled. The horizontal coils in the yoke are in series with the horizontal output transformer. Their impedances are so matched that together they form an autotransformer circuit that operates the same as the one shown in Fig. 913-a.

### High-voltage section

The high-voltage circuit is shown in Fig. 914. It is basically a simple rectifier that works in conjunction with the horizontal output circuit. The primary winding of the horizontal output transformer is an autotransformer that steps up the ac voltage at the

plate of the output stage. When the flyback pulse occurs, the transformer steps up the pulse amplitude to between 12KV and 20 KV volts. This high, positive pulse causes the high-voltage rectifier to conduct, charging C1 in its heater circuit to the peak value of the pulse. This rectified dc voltage is applied through R2 to the high-voltage anode of the CRT.

In many sets, the Aquadag coatings on the inside and outside of the CRT form another filter capacitor that together with C1 and R2 form an R-C pi filter network that maintains a steady dc high-voltage output. Since the CRT draws a maximum of only about 1 milliampere, the value of R2 is high, about 1 megohm. This resistor, as a result, acts to cause a sharp drop in high voltage whenever excessive current is drawn. This protects the high-voltage rectifier and output transformer, and also any person who happens to contact the high-voltage line.

Filament voltage for the rectifier is obtained from a one-turn winding on the transformer. Since the ac voltages in the circuit are high, even the one-turn winding induces too much voltage. So a series dropping resistor R1 is placed in the filament circuit to limit the current to a safe value. This resistor is usually only about 3 ohms. Although Fig. 914 shows the high-voltage capacitor, C1, connected to the transformer secondary circuit, it is often wired to ground. The circuit shown in Fig. 914, though, will add about 300 volts to the high voltage because of the dc B-plus potential existing in the secondary circuit.

### **Horizontal sweep and high-voltage section failure analysis**

To function properly, the horizontal sweep and high-voltage sections must:

1. Produce a locked-in picture.
2. Generate a full-width raster.
3. Develop a linear sweep.
4. Give a bright, clear picture.
5. Give interference-free operation.

Failure in the horizontal sweep and high-voltage sections differs from other sections in that all of the stages are closely dependent on one another for proper operation. If either the horizontal oscillator signal or output current is lost, high voltage will also fail since those signals basically drive the high-voltage rectifier. In addition, since the B-plus boost voltage energizes the output stage and sometimes the horizontal oscillator, sweep and high voltage will also be lost if the damping circuit opens. As shown in Fig. 908, a fuse is used in the output circuit's B-plus line. This fuse will

open any time excessive current flows through the output transformer. This protects the transformer whenever the horizontal oscillator fails, since this will cause a loss of grid-leak bias on the output tube to produce too much current in its plate circuit.

Any complete tube failure, loss of tube voltages, or open or shorted signal path will cause loss of high voltage and, as a result, no raster.

### **Horizontal sync trouble**

Horizontal sync trouble in the horizontal section can be caused only by the afc stage, assuming that the sync section is supplying good pulses. If only the horizontal sync has failed, the picture will be locked in vertically and the horizontal oscillator will drift around off frequency to produce running diagonal bars. This will occur if one of the sync discriminator or control tubes (Figs. 902, 904 and 906) goes dead or loses considerable emission. Any open or shorted resistor or capacitor in the afc tube's B-plus, signal or control voltage lines will kill synchronization. Synchronization will also be lost if the horizontal sweep reference voltage taken from the oscillator or output circuit is lost. This can happen if the secondary winding of T (Fig. 902) opens, R3 (Fig. 904) or R6 (Fig. 906) opens, or if the associated capacitors short the signal. With the circuit shown in Fig. 904, it is important to remember that the width coil or a winding on the output transformer can become defective to lose the reference voltage.

The horizontal sync can become critical if the discriminator or the control tubes lose only enough emission to reduce their outputs somewhat. Then the afc control signals they develop will not vary enough to compensate fully for horizontal frequency drifts. The picture will be difficult to adjust and will tend to ripple or tear. This will also occur if R3 (Fig. 904) or R6 (Fig. 906) increases in value to reduce the reference voltage or if C3 (Fig. 904) or the horizontal lock control become leaky. Any of the coupling capacitors such as C1 in Fig. 906 decreasing in value will also cause this trouble.

In the Synchroguide circuit shown in Fig. 906, if R7 or R4 increase sufficiently in value, or if R2 reduces in value or C4 becomes leaky, the reduced tube current will cause critical sync. When this happens, though, the initial effect will be to drive the oscillator off frequency because of the increased bias on the oscillator. But often, when L1 is reset to bring in the picture, the critical sync will be evident. A leaky C7 or C6 will bypass some of the control current around R8 to make the sync critical. An

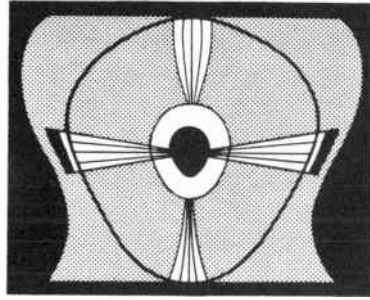

60 CPS HUM

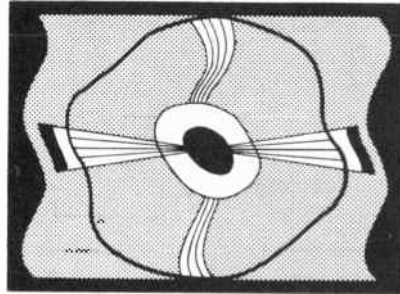

120 CPS HUM

Fig. 915. *Effects of hum in the horizontal oscillator and output stages. Both the raster and picture are affected.*

open C4 will allow the plate voltage to fluctuate and degenerate the tube current, causing critical afc action. With the circuit shown in Fig. 904, since the reference signal comes from the output stage, a weak output or damper tube, or other trouble that can reduce the width of the picture, will also reduce the reference signal amplitude and may produce critical sync.

Poor horizontal sync can also take the form of the picture hooking, hunting or tearing. Or the side edges of the picture can become ragged.

### Hook

Hook is a condition that causes parts of the picture lines to be synchronized earlier or later, and is somewhat similar to that caused by hum in the sync, as shown in Fig. 814. This will happen if the sync discriminator or control tube develops grid-to-filament or cathode-to-filament leakage. This will not affect the raster. On the other hand, hum developed in the oscillator or output tubes would bend the raster too, as shown in Fig. 915. The 60-cycle hum is filament-to-cathode or -grid leakage, and 120-cycle hum comes from a poorly filtered full-wave power supply. An interesting hum

trouble develops from heater-to-cathode leakage in the damper stage. The left side of the raster is more greatly affected than the right. A common cause of hook is overload in the tuner, if and video circuits, which clips the sync pulse and causes the video to appear in the sync areas. Hook will also develop in the circuit shown in Fig. 904 if C3 decreases sufficiently in value for poor filtering. Then when the emissions of diodes V1-a and V1-b become considerably unequal with age, a slight integrated sawtooth or parabolic waveform will be applied to the oscillator to cause different starting times up and down the raster.

### Hunting

Hunting is a condition in which the afc circuit tends to over-

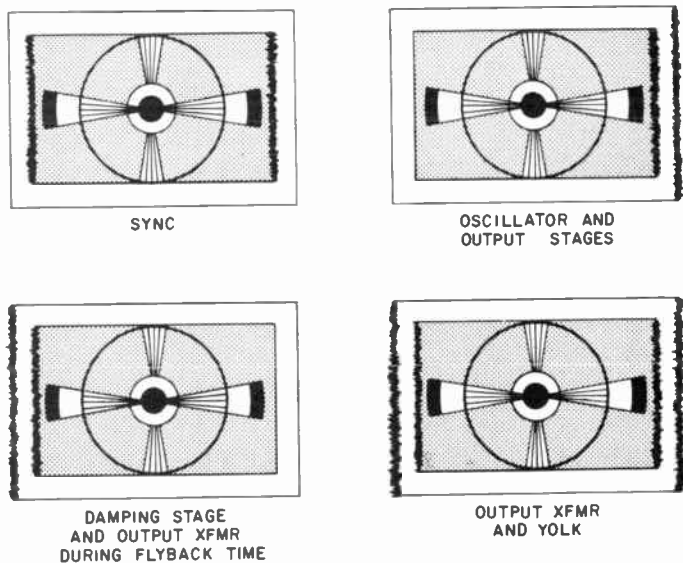

Fig. 916. *Effects of corona and arcing on the raster and picture.*

compensate for a change in horizontal oscillator frequency by driving the oscillator beyond the hold point. This can result in a hook in the picture or a fluctuating ripple at the sides. This condition is supposed to be prevented by the anti-hunt circuits (C3 and R5 in Fig. 904, and C6 and R9 in Fig 906). These parts filter the control signal to keep it steady and bypass spurious noise pulses, yet allow the control signal to reduce fast enough as the oscillator approaches locking frequency. If the R-C time constant of this circuit became too long, the control signal will change too slowly and will still be applying a driving afc signal when the



oscillator reaches the right frequency. The afc circuit will overdrive the oscillator slightly and then start bringing it back. This can continue for a few cycles, causing the oscillator to shift frequency slightly in each direction to hook or ripple the picture. In the circuit shown in Fig. 904, C3 or R5 can increase in value to cause too long an R-C time constant. In Fig. 906, an increase in the value of C6 or reduction in the value of R9 will cause hunting.

It is important to consider also that the normally long R-C time constant of the anti-hunt networks tend to make the afc circuit work too slowly when the oscillator first drifts. This too tends to cause a poorly synchronized picture similar to hunting. C7 (Fig. 906) and series capacitor C2 (Fig. 904) normally provide a short time constant to allow rapid variations in afc to occur. An increase in value of these components will cause their time constants to be too long.

### **Tearing**

Tearing occurs when a number of horizontal lines tend to go considerably off frequency, so that most of the picture is synchronized while these few lines are torn out of synchronization. Often this trouble occurs as an aggravated form of other critical sync troubles. In the circuits shown in Fig. 904, it can occur if a very large hum trouble develops in the sync or afc circuits. The larger hum voltage can swamp the sync on half its cycle to cause only the upper or lower half of the picture to tear. This can also happen if an overly large hum develops in the tuner, if or video sections, but this hum also shows up in the picture and sound. If the vertical sweep signal finds its way into the sync or afc circuits, it can drive the oscillator out of sync on its peaks.

Tearing also tends to occur if any parts in the afc circuits arc or produce corona. Mainly, resistors in relatively high-current paths cause this by carbonizing, or capacitors across B-plus voltages by dielectric breakdown. The resulting momentary interruptions in afc cause a few lines to tear. The number of lines that tear out of each frame and how badly they tear depend on the frequency and duration of the arcs. If they occur for a short duration at a high frequency, they may produce only ragged edges on the picture. The raster will not be affected (Fig. 916) if the arcing takes place in the sync or afc circuits since only picture timing is affected. But if the arcing occurs in the oscillator or output stages, the right side of the raster and the picture will be ragged since these stages produce the right-hand sweep. Slight arcing or corona in the damping tube or the output transformer only during flyback time will affect the

left side of the raster and sweep. At times other than retrace, arcing and corona in the output transformer or yoke affect both sides of the raster and picture.

The high-voltage rectifier and filter capacitor (Fig. 914) develop arcing easily because of the high voltage present. This arcing mostly causes tearing, although a slight corona can develop to cause a ragged raster. The high-voltage resistor R2 carbonizes to produce minute arcs to cause ragged edges. A frequent trouble develops at the grounding spring clip on the Aquadag coating on the CRT, which forms a high-voltage filter connection. This spring clip, usually at the yoke mounting, wears off the Aquadag to form a bad connection that arcs. The CRT, too, can arc internally, particularly if Aquadag flakes fall into the gun structure.

### Horizontal frequency troubles

Horizontal frequency trouble differs from horizontal sync trouble in that the horizontal frequency can be off but still be locked in. When the frequency is off, the picture is broken into diagonal segments, producing black diagonal bars on the raster, with a diagonal, distorted, indistinguishable picture between each



Fig. 917. *Effect of detuned stabilizer circuit on horizontal frequency.*

pair of diagonal bars. Because of the relationship between the horizontal and vertical sweeps, a black diagonal bar appears for each 60 cycles that the horizontal oscillator is off 15,750 cycles.

When the horizontal frequency goes off, it could be because of loss of horizontal sync or a drifting oscillator. But if the diagonal bars can be locked in place, then the afc section is working. If it were not, the diagonal bars would continue running. On the other hand, trouble in the afc section can cause the oscillator to go way off frequency if it applies an improper control signal. For example, if only one diode shown in Fig. 904 became defective or lost sufficient emission, the voltage-cancelling action in its output circuit would be lost, and the resulting high afc voltage would drive the oscillator far off frequency.

In Fig. 906, any trouble causing a loss of or insufficient bias on the control tube will cause too much current through resistor R8 to drive the oscillator off. This will happen if C1 becomes leaky or decreases in value, the tube's grid emits, C5 shorts, R6 opens or the horizontal lock trimmer shorts. Also, if R2 in the plate circuit

opens, too much plate voltage will be applied to cause high current.

In the oscillator circuit, as with any oscillator, almost any part can upset the frequency. The oscillator tube can lose emission or develop an emitting grid, or the parts in the grid circuit can increase or decrease in value. Shorted turns in the tuned coil or increased internal resistance will shift the frequency.

Minor changes in frequency, of course, can be compensated by an adjustment of the hold or frequency control.

It is important to remember that since coil resonance is involved in the oscillations of the circuit, the oscillator may show a tendency to stop oscillating if the frequency is too far off 15,750 cycles. This will produce a critical horizontal sweep over portions of the raster, where there will be a tendency for the raster to collapse. This could result from a severely detuned phasing circuit (Fig. 917). The sine wave fed back to the grid for stabilizing purposes could overcome the effects of the R-C time constant to cause a great increase or decrease in frequency. Either L1 or C4 in Fig. 904 or L3 or C9 in Fig. 906 could change value to bring this about.

#### **Horizontal phasing trouble**

Horizontal phasing trouble occurs when the horizontal retrace does not occur entirely during horizontal blanking time (Fig. 918). If retrace starts too late, the end of the retrace will run into the video of the next line, and the retrace will become visible on the left side of the picture. If the retrace starts too soon, the beginning of the retrace will occur during the video of the same line, and the retrace will show on the right side of the picture. If retrace time takes too long, it may occur before and after the blanking pulse to show on both sides of the raster. Since retrace time is very fast, the picture at those times will be greatly stretched and appear filmy over the picture created during trace time.

Since the horizontal oscillator is not triggered directly by the sync pulses, the actual position of the sweep in time can vary more easily with the horizontal oscillator than with the vertical oscillator. The adjustment of the stabilizer coil (L1, Fig. 904 and L3, Fig. 906) is used to set the precise time that the oscillator tube conducts for retrace, so that proper phasing can be accomplished. If these coils or their shunt capacitors change value somewhat, phasing will be off.

The range of the stabilizer coil effect is somewhat limited and so may tend to make oscillation erratic if it drives the oscillator too far off frequency in an attempt to compensate for a phasing trouble

caused by the afc circuit. In the circuit shown in Fig. 904, good phasing occurs when the oscillator is locked on frequency while the control voltage applied to V2-a is close to zero. This is because at that time, the sync pulses cancel at close to the center of retrace (Fig. 905-a). But if the discriminator or diode circuits become unbalanced, because of one slightly weak diode or an increased value of R1 or R2, the sync pulses may have to occur considerably away from the retrace center for the average currents in each diode circuit to cancel. This is shown in Fig. 919. Unbalanced diode conduction will also take place if R3 or C1 in the sawtooth reference line increases greatly in value to integrate the sawtooth waveform, thereby producing a parabola-type waveform.

With the circuit shown Fig. 906, if R6 decreases in value or C2 becomes leaky, the lock-in value of current through the control

Fig. 918. *Horizontal phasing trouble. Note the phase relationships between the retrace slopes and the blanking pulse.*

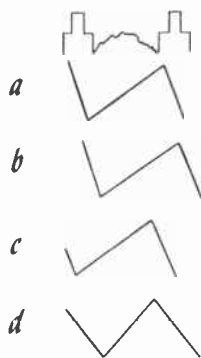

tube may change greatly to affect phasing. A large increase or decrease in resistor R7 or a substantial reduction in tube emission can do the same.

Too long a retrace time with the horizontal multivibrator and

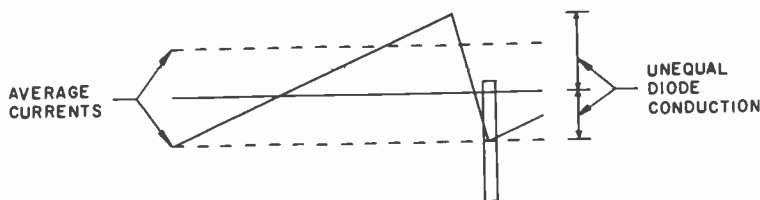

Fig. 919. *Effect of unequal diode conduction on horizontal phasing. The sync pulses must be away from the center of retrace to bring about equal average currents.*

blocking oscillator circuits can be caused by the same reasons given in Chapter 8 for the corresponding vertical circuits. In addition, the overall discharge time of the actual sweep signal is

determined primarily by the resonance of the output transformer and yoke circuit, since they develop the flyback pulse. That circuit generally resonates at about 70 kc to produce a half-cycle flyback pulse about 7 microseconds wide. Increased resistance in the transformer or yoke, or a change in inductance may lower the resonance to produce a lower-frequency flyback pulse and an extended retrace time.

### **Width trouble**

Although the horizontal output tube supplies the current to sweep the right side of the raster, and the damper tube damps the reactance current to sweep the left side of the raster, either of these circuits (Fig. 908) can develop trouble to affect the overall width of the picture. This stems from the fact that when the output tube current drops off, the flyback pulse and, therefore, the reactance current will also be decreased. And since the damper stage develops the B-plus boost voltage that powers the output tube, the drive current will go down if damper current is reduced. However, an extremely nonlinear sweep generally accompanies damper trouble, whereas the output stage can cause reduced width without bringing about too much nonlinearity. Mostly, width trouble is caused by a weak horizontal output tube.

Narrow width will also result if C1 (Fig. 908) is reduced in value to couple a weaker drive voltage to the output tube. An increase in resistance of screen dropping resistor R5 will lower the screen voltage, and may cause less output current to flow. Too much of a decrease in screen voltage, however, may cause excessive current to flow to the plate circuit. This may have some saturation effects on the output transformer, reducing its efficiency and lowering the width. A gassy output tube, which generates too much plate current due to gas ionization causes the same trouble. This high plate current generally causes the plate of the tube to run red hot. A shorted turn in the transformer plate primary winding, which reduces the plate load resistance of the output stage, will also cause excessive current to flow.

A marked increase in resistance of the plate load portion of the primary winding can reduce the efficiency of the transformer to cause decreased width. Often, this type of trouble develops only slightly so that the raster is not affected with normal pictures. However, since the current carried by the high-voltage rectifier also passes through this winding, the width can be reduced as the brightness is turned up.

If the width coil decreased in inductance or developed shorted

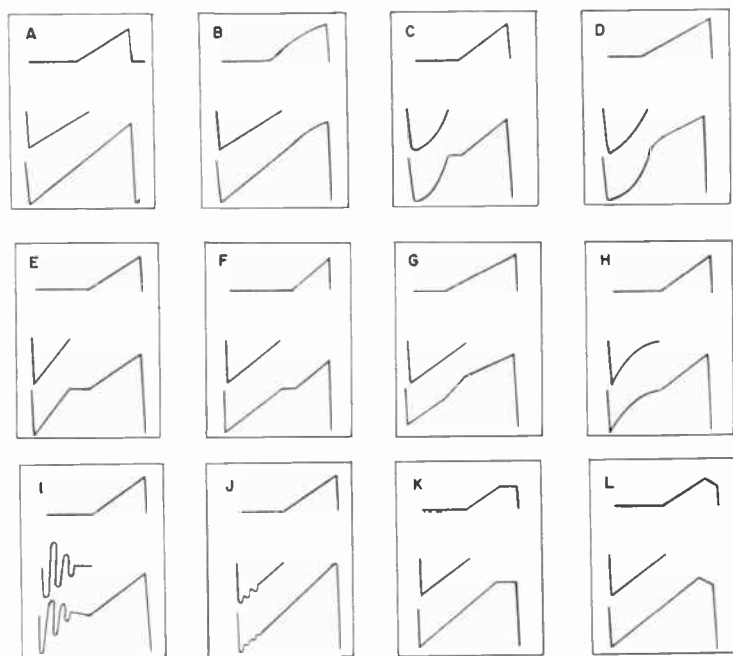

Fig. 920. Horizontal sweep waveforms for various types of linearity troubles.

turns, or C6 (Fig. 908) increased in value or became leaky, the output transformer would again be loaded down by excessive current, but this would tend to reduce the high voltage more than the sweep current, and so the picture would get too wide (and the brightness of the picture would decrease). On the other hand, with an increase in the width-coil inductance or resistance, or an open width coil or if C6 decreased in value or opened, there would be less loading on the transformer and the high voltage would go up reducing the width of the raster. It is important to note that high-voltage changes affect not only the horizontal sweep but the vertical as well. The raster would change size on all four sides with a change in high voltage.

Since C7 passes all of the sweep current, the sweep would go down if its value went down.

In the oscillator circuits if C6 (Fig. 904) or C10 (Fig. 906) or the plate load resistor R10 (Fig. 904) or R12 (Fig. 906) increased in value, charging would slow up proportionately, and the charging capacitor would build up less of a charge within the allotted time. The amplitude of the sawtooth wave will be smaller, and so will the width.

### Horizontal linearity trouble

As explained earlier, the damper stage controls the linearity of the left side of the raster, the oscillator and output stages determine the linearity of the right side, and all three govern the linearity of the center of the raster. The various ways in which the horizontal sweep currents can become nonlinear are shown in Fig. 920. Fig. 920-a shows a normal sweep current that will produce a full, linear raster. The waveform shown in Fig. 920-b becomes nonlinear near its peak. As the current on the top increases at a slower rate, the raster near the right edge is swept slower and is compressed there. Reaction current is normal and so the left side of the raster is linear. This type of nonlinearity results because the sawtooth wave from the oscillator is nonlinear. If the charging capacitor C6 (Fig. 904) or C10 (Fig. 906) increases in value and the current limiting resistor decreases in value, charging will be much faster and will follow an exponential curve rather than a linear one.

The sweep waveform shown in Fig. 920-c shows the drive current normal, but the reaction current falls nonlinearly and too soon. The raster is normal at the left edge and then is swept too fast to stretch the remainder of the left side of the picture. And since the reaction sweep finishes too soon, the CRT beam must wait at the center of the screen for the drive current to start. A brighter area appears at that spot on each horizontal sweep line to form a vertical white line down the raster. To compensate for this, the drive control is often adjusted for more drive time (Fig. 920-d). This eliminates the white line, but stretches the center of the raster as well as the left side. The nonlinear, rapidly decaying reaction current is caused by an unsteady damper current. The damper current falls off as shown in Fig. 921-a.

The reaction current decay, then, goes faster as the damper current reduces, producing the stretched part of the reaction sweep. This is caused by insufficient inductive current, as shown in Fig. 921-a. Either the linearity coil (Fig. 908) is improperly adjusted, or it has increased in resistance. If either B-plus boost capacitor increased in value, the damping current would also fall off, but in this case, since it starts at a higher level, the reaction time is not reduced. The left sweep will not end early to produce a white line. Instead, a waveform similar to that shown in Fig. 920-d will be produced.

If the damper tube lost emission, the damper current would be reduced, but it will still be steady. This would cause the reaction

current to fall off faster, but at a linear rate (Fig. 920-e). This would give a nonlinear picture similar to that caused by the waveform shown in Fig. 920-c, except that the entire left side would be stretched; the left edge would not be normal. Again, the white line could be eliminated by increasing the drive to stretch the center of the raster.

The waveform in Fig. 920-f shows a normal reaction current with a short but linear drive current. Both sides of the raster are linear but, since the drive current starts too late, the CRT beam must wait at the center of the screen for a time. This causes a thin white "drive" line down the center of the screen, similar to that caused by the waveforms shown in Fig. 920-c and -e. The drive line is often caused because the drive control is set for much too great a drive. This produces too much grid-leak bias on the output tube so that a smaller portion of the drive voltage allows the tube

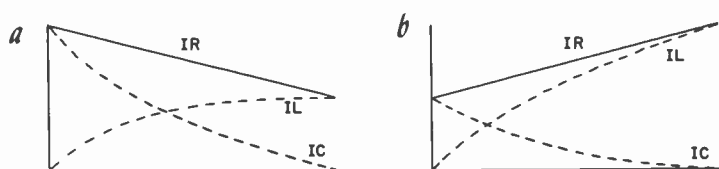

Fig. 921. Improper damping current.

to conduct. Therefore, while the drive control is being adjusted, the raster will first start getting wider, but then, when too much grid-leak bias is developed, the right side of the raster will get a little narrower and the white line will appear. This will also happen if the grid bias increased because C1 or R1 (Fig. 908) increased in value, or R3 went up in resistance. Similarly, the drive line will occur if the tube itself went into cutoff much sooner, either because of a bad tube or an increased R5 or a leaky C3 lowered its screen voltage.

If the horizontal drive voltage were not high enough to cause too much bias, yet still too high in relation to the reaction current, the waveform shown in Fig. 920-g will occur. Both sides of the raster will be linear, but the center will be stretched. In fact, as the drive control is adjusted, this center stretching generally precedes the drive line.

The waveform shown in Fig. 920-h is another form of poor damping. It results from insufficient capacitive current through the damper, which results in an initially low, but rising damper current, as shown in Fig. 921-b. Consequently, the reaction current drops off rapidly at first, then slows up as the damping current



increases. This stretches the left edge of the raster and compresses the remainder of the left side and, since the reaction current stops before the drive current starts, a white line appears down the center. As before, additional drive may eliminate the white line to stretch the center of the raster if the reaction current is not too nonlinear. The diminished capacitive current is caused by reduced capacitance values of the B-plus boost capacitors. If the values of the B-plus boost capacitors drop off radically or either capacitor opens, there will be no damping current right after retrace, and the transformer and yoke circuit will oscillate (Fig. 920-i). The CRT beam will be swept back and forth fast around the center of the screen to produce a raster that has a radically stretched left side, and a wide white bar at the center where the beam swept back and forth over itself. The right side of the raster would be normal as the oscillations stopped and the drive current started. The brightness of the white bar would depend on the number of oscillations that take place, which in turn would depend on how much capacitive current was lost to the circuit.

Fig. 920-j illustrates a waveform that shows another form of oscillation—yoke ringing. The horizontal windings in the yoke itself tend to oscillate when they are shock-excited by the flyback pulse. C8 (Fig. 908) is placed across one of the yoke windings to damp these oscillations. If this capacitor opened, the reaction current through the yoke would ripple with these oscillations to cause the CRT beam to shift back and forth as it swept the left side of raster. As a result, the left side of the picture would have a number of vertical white lines on it.

The waveforms shown in Figs. 920-k and -l illustrate types of non-linearity known as foldover. The tops of the drive voltage are clipped by saturation in the output tube. Since the waveform shown in Fig. 920-k is merely flattened, the raster will just go so far to the right and then stop. The rest of the picture will then be compressed into a white line down the edge of the raster. With the waveform shown in Fig. 920-l the grid draws enough current to degenerate the signal. After the raster reaches its peak, it will fold back over itself as the drive current reduces. This will produce a white bar at the right edge of the raster with a folded picture. These troubles are generally caused by the drive signal making the control grid of the output tube positive. Too large a drive signal will cause this, but most often, the white drive line will come first. In most cases, the trouble is from reduced bias caused by an emitting grid, a leaky coupling capacitor C1, or high resistance leakage in the drive control.

Horizontal keystoneing (Fig. 922) is also a form of nonlinearity. As with vertical keystoneing, this trouble results from a shorted winding in the yoke. If only a few turns in any one winding are shorted, the keystoneing will be much less severe and the width less affected. A shorted capacitor C8 (Fig. 908) will also short one yoke winding.

### High-voltage trouble

The high-voltage section is actually a simple half-wave rectifier circuit but, since it is dependent for its power on the horizontal sweep section, its troubles can be misleading.

Loss of high voltage does not necessarily mean high-voltage trouble, since the high voltage will also be lost when the horizontal oscillator or output circuit fails. Therefore, when there is no high voltage, the first test to make is to determine whether the horizontal sweep section is functioning properly. One method is to listen for the "singing" of the horizontal output transformer. The

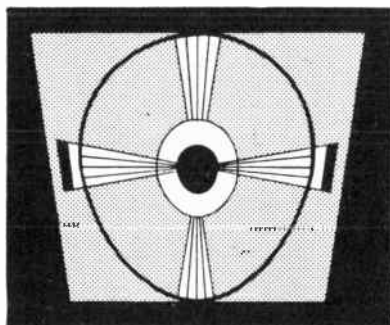

Fig. 922. *Horizontal keystoneing caused by one yoke winding being completely or partially shorted.*

output transformer core will vibrate at 15,750 cycles when it conducts the horizontal sweep current, and thereby produces the high pitched singing. Unfortunately, not all service technicians can hear this high frequency, so a better test is to hold a screwdriver tip near the plate of the rectifier tube. If the horizontal sweep section is functioning, about 12KV to 20 KV volts of ac energy is supplied to the rectifier plate, and so the screwdriver tip will draw an arc about  $\frac{1}{4}$  to  $\frac{1}{2}$  inch long. A smaller arc can also be drawn from the plate cap of the output tube.

Actually, for the arc test to be reliable, the high-voltage transformer rectifier plate lead should be taken off the rectifier and the arc should be drawn from the disconnected rectifier plate lead.

If there were a short in the tube or if the filter capacitor (Fig. 914) were shorted, the current would load down the transformer so that no high voltage would be produced.

When the proper high ac voltage is supplied to the rectifier, the output should be a steady, high dc voltage. If the output is much lower, it would become evident in the picture. The picture would get darker and out of focus, tending to get larger on all four sides, depending on how low the high voltage became. This could be caused by a weak rectifier tube or resistor R2 increasing in value.

Also, if C1 (Fig. 914) opens, the filter circuit will be a resistor-input instead of a capacitor-input type, causing the output to drop off considerably.

In addition, some sets use the CRT Aquadag coating as an additional filter capacitance. Therefore, if the spring clip that connects the Aquadag coating to ground makes a poor connection, the filter capacitance will be lost. The circuit voltages will be poorly regulated because of the drop across R2, and the high voltage will get lower. Under these reduced high voltage conditions, the high voltage will tend to drop still lower as the brightness level is raised, since this causes more current to flow in the circuit, dropping additional voltage. As the high voltage starts downward, the overall size of the picture gets larger.

This condition of the picture getting darker and larger as the brightness is turned up is known as blooming. In severe cases, the picture will disappear completely. Blooming will also take place if high resistance develops in the high-voltage segment of the horizontal output transformer primary winding. In contrast to this, higher resistance in the sweep segment of the primary winding makes the picture get narrower and darker as the brightness is turned up. Too much resistance in any part of the primary winding will cause all high voltage to be lost.

Blooming will also be produced if the width capacitor, C6, becomes leaky or the width coil (Fig. 908) develops shorted turns to load the transformer. If either of these parts shorts, loading will be so severe that all high voltage will be lost.

A less frequent cause of low high voltage is R1 (Fig. 914) increasing in value. This will reduce filament voltage and therefore tube current.

Some arcing troubles that develop in the high-voltage section cause interrelated brightness effects when the high voltage is poorly regulated. For example, R2 may become slightly carbonized and have a tendency to arc. But at a low brightness level, the

current is insufficient to trigger the arcing. When the brightness is turned up, the carbonized paths in the resistor “flare” up and tear the picture. C1, on the other hand, may develop a tendency to arc but, when the brightness is high, the high voltage drops enough to inhibit the arcing. Reducing the brightness increases the high voltage, and C1 arcs to tear the picture. This same condition can hold true for any point in the high voltage that tends to develop corona.

### Horizontal interference

The horizontal sweep section can interfere with the other receiver sections in various ways. One of the most common is known as Barkhausen oscillation. It results from the horizontal output tube tending to oscillate right after it is driven into cutoff. Right

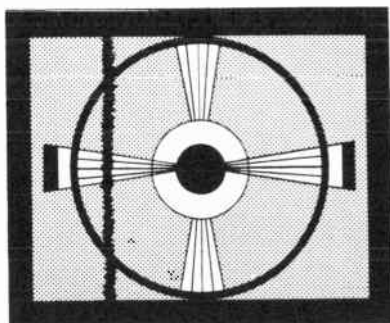

Fig. 923. Ragged line due to Barkhausen oscillations in the horizontal output tube.

after retrace, the plate voltage drops considerably, and so electrons previously attracted to the plate are turned back to the screen grid. This oscillatory effect of the electrons radiates rf energy that can be picked up by the tuner and passed through to the picture tube to cause a thin ragged black line down the left side of the screen (Fig. 923). Often, a drive adjustment can eliminate this, but many times the tendency toward Barkhausen oscillation is inherent in an output tube. A magnet such as an ion trap can be used on the output tube to retard the oscillations.

Since keyed agc systems are triggered by the flyback pulse, some troubles in the horizontal sweep section will also disable the agc section. Narrow width, for instance, will cause a weak flyback pulse to trigger the agc section. Little or no agc voltage will be developed, and the picture may overload. Also, loss of horizontal synchronization will cause this since the flyback pulse will not occur at the proper time to key the agc tube.

Since in many sets the B-plus boost circuit also powers the vertical sweep section, width and damping troubles will also reduce the vertical sweep size because of the lower B-plus boost voltage.

Some sets use a fixed negative voltage developed in the power supply to bias the horizontal output tube as well as some of the video circuits. If the filter capacitors in this bias line open, the horizontal drive voltage can get into the video and cause one side of the raster to be darker than the other. The same can happen if the main B-plus line to the horizontal sweep section is not properly filtered.

- A**
- Afc Signal ..... 29
  - Afc Stage ..... 191
  - Agc:
    - Amplified ..... 154
    - Circuit Analysis ..... 156
    - Circuits ..... 151
    - Circuits, Basic ..... 152
    - Cutoff Failures ..... 158
    - Delayed ..... 152
    - Gain Failures ..... 157
    - Interference Failures ..... 158
    - Keyed ..... 154
    - Noise Failures ..... 158
    - Section ..... 35
    - Sluggishness ..... 156
    - Amplified Agc ..... 154
  - Amplifier:
    - Audio If ..... 127
    - Stage Analysis, Audio ..... 148
    - Stage Analysis, Audio If ..... 128
    - Stage, Audio ..... 147
  - Amplitude Levels ..... 18
  - Analysis, Waveform ..... 7
  - Anti-Hunt ..... 208
  - Aquadag as Filter Capacitor ..... 218
  - Aquadag Coating ..... 41
  - Arcing ..... 96
  - Arcing in Resistors ..... 61
  - Arcing in the Damper Tube ..... 208
  - Audio:
    - Amplifier Stage ..... 147
    - Amplifier Stage Analysis ..... 148
    - Detector ..... 135
    - Detector Stage Analysis ..... 144
    - Distortion ..... 144
    - Distortion Failures ..... 149
    - Gain Failures ..... 149
    - If Amplifier ..... 127
    - If Amplifier Stage Analysis ..... 128
    - If Limiter ..... 132
    - If Limiter Stage Analysis ..... 134
    - If Signal ..... 19
    - Interference ..... 144
    - Low-Amplitude Troubles in ..... 146
    - Output Stage ..... 147
    - Output Stage Analysis ..... 148
    - Section ..... 19
    - Signal ..... 20
  - Automatic Frequency Control ..... 191
  - Automatic Gain Control (see Agc)
- B**
- Bandpass:
    - and Tuning Failures ..... 128
    - Failures ..... 116
    - of Rf Stage, Reduced ..... 91
  - Barkhausen Oscillation ..... 219
  - Bent Raster ..... 206
  - Black Diagonal Bars on the Raster ..... 209
  - Blocking Oscillator ..... 175, 178
  - Blooming ..... 44, 218
  - Boost, B-Plus ..... 220
  - Buzz ..... 144, 145
  - Buzz, Intercarrier ..... 113
- C**
- Capacitor Construction ..... 52
  - Capacitor Failure ..... 56
  - Capacitors:
    - Ceramic ..... 52
    - Electrolytic ..... 53
    - Glass ..... 53
    - Mica ..... 52
    - Paper ..... 51
    - Temperature Coefficient of ..... 54
    - Trimmer ..... 54
    - Vitreous-Enamel ..... 53
  - Carrier Signal, Rf Audio ..... 11
  - Carrier Signal, Rf Video ..... 11
  - Cascade Circuits ..... 87
  - Cathode-Coupled Multivibrator ..... 176, 194
  - Cathode-Ray Tubes ..... 40
  - Center of Raster Stretched ..... 215
  - Ceramic Capacitors ..... 52
  - Channel, Loss of ..... 104
  - Circuit Failure Analysis ..... 85, 127, 159, 191
  - Clamp-Delay Circuit ..... 153
  - Clipper, Sync ..... 159
  - Clipping of Rf Signal ..... 100
  - Coil:
    - and Transformer Construction ..... 69
    - and Transformer Failures ..... 66
    - Construction ..... 65
  - Coils ..... 65
  - Component Failure ..... 37, 51, 65, 77
  - Composite Video Signal ..... 16
  - Composition Resistor ..... 57
  - Construction:
    - Capacitor ..... 52
    - High-Frequency Coil ..... 65
    - Potentiometer ..... 63
    - Resistor ..... 58
    - Transformer ..... 65
  - Control, Fine-Tuning ..... 80
  - Control, Horizontal Width ..... 201
  - Core Vibration ..... 69
  - Cores, Tuning ..... 66
  - Corona ..... 208
  - Crackling in Audio ..... 96
  - Crt ..... 34, 40
  - Crt Failure ..... 41
  - Crt Failure Effects ..... 42
  - Current, Reaction ..... 200
  - Cutoff Failures, Agc ..... 158
- D**
- Damper:
    - Current ..... 28
    - Stages ..... 198
    - Tube Current ..... 201
  - Damping Tube Arcing ..... 208
  - Delayed Agc ..... 152
  - Detector:
    - Audio ..... 135
    - Gated-Beam ..... 142
    - Ratio ..... 319
    - Stage ..... 115
    - Stage Analysis ..... 115
    - Stage Analysis, Audio ..... 144
  - Diode, Silicon ..... 47
  - Diode Sync Clippers ..... 162

Diodes, Germanium .....	47
Discharge Stage, Vertical .....	179
Discriminator, Frequency .....	135
Discriminator, Phase .....	137
Distortion:	
Audio .....	144
High-Frequency .....	168
Low-Frequency .....	170
Sync Pulse .....	168
Waveshape .....	170
Drift .....	104, 105
Drive Control .....	201
Drive Control, Horizontal .....	199
Drum-Tuner Construction .....	79
Drum-Tuner Failures .....	80
Dual Potentiometers .....	63
<b>E</b>	
Electrolytics .....	53
Electron Gun .....	43
Electron Tubes .....	37
Eliminating Retrace Lines .....	189
Equalizing Pulses .....	23
Erratic Diagonal Lines on the Raster .....	97
<b>F</b>	
Failure, Capacitor .....	56
Failure, Component .....	51, 65, 77
Failures:	
Potentiometer .....	64
Resistor .....	60
Sync Amplitude .....	166
Feedback, Regenerative .....	86
Filament, High-Voltage Rectifier .....	204
Film Resistor .....	57
Fine-Tuning Control .....	80
Fine Tuning, Erratic .....	84
Flashes in the Picture .....	96, 125
Fluctuating Ripple at Side of Picture .....	207
Focus-Coil Construction .....	71
Focus-Coil Failures .....	72
Foldover .....	186, 216
Foldover Troubles .....	186
Forward-to-Back Resistance .....	48
Frames .....	35
Frequency:	
Bands, Television .....	79
Discriminator .....	135
Response Failures, Audio .....	148
Response of Video Section .....	19
Frozen Yoke .....	74
<b>G</b>	
Gain:	
Control, Automatic .....	127
Failure in Mixer Stage .....	101
Failures .....	130
Failures, Audio .....	149
Failures in the If .....	111
Failures in the Rf Stage .....	93
in If Stage, Excessive .....	112
Gas in Picture Tube .....	43
Gated-beam Detector .....	142
Gated Sync Clipper .....	163
Germanium Diodes .....	47
Gimmick .....	66
Glass Capacitors .....	53
Gray, Whittish Picture .....	95
Grid-Leak Sync Clippers .....	161
Grounded-Cathode Amplifier .....	85
Guided-grid tuner .....	86
<b>H</b>	
Height Control, Vertical .....	177
Height Troubles .....	182
Heterodyning Failures .....	99
High-Frequency:	
Coil and Transformer Failures .....	66
Coil Construction .....	65
Distortion .....	168
Response, Poor .....	117
High Voltage:	
Filter .....	44
Loss of .....	217
Pulse .....	33
Resistor .....	61
Section, Poor Regulation in .....	32, 203
Supply, Poor Regulation in .....	218
Testing for .....	217
Hold Control, Vertical .....	176
Hook .....	95, 173, 206
Horizontal:	
Drive Control .....	199
Frequency Troubles .....	209
Interference .....	219
Linearity Trouble .....	214
Oscillator .....	191
Oscillator Signal .....	29
Horizontal Output:	
and Damper Stages .....	198
Current .....	28
Transformer Construction .....	75
Transformer Failures .....	76
Horizontal Phasing Trouble .....	210
Horizontal Sweep:	
and High-voltage Section Failure .....	204
Analysis .....	27
Section .....	27
Signal .....	30
Horizontal Sync Pulses .....	22, 26
Horizontal Sync Trouble .....	205
Horizontal Width Control .....	201
Hum:	
in the Picture .....	123
Sync .....	173
Vertical .....	186
Hunting .....	207
<b>I</b>	
If:	
Amplifier, Audio .....	127
Limiter, Audio .....	132
Section .....	13, 106
Signal, Audio .....	19
Signal Characteristics .....	14
Stage Analysis .....	108
Stage, Excessive Gain in .....	112
Intercarrier Buzz .....	113
Interference:	
and Noise Failures, Audio .....	151
Audio .....	144
Failures and Sync Noise .....	172
Horizontal .....	219
Troubles, Vertical .....	189
Iron Cores .....	69
<b>J</b>	
Junction Transistor .....	46
<b>K</b>	
Keyed Agc .....	154
Keying Pulse .....	36
Keystoning .....	74
Keystoning, Vertical .....	188, 189
<b>L</b>	
Leakage in Picture Tube .....	44
Levels, Amplitude .....	18
Limiter, Audio If .....	132
Limiter Failures .....	134
Limiting Action .....	133
Linearity:	
Control .....	201
Trouble, Horizontal .....	214
Troubles .....	184
Lines on the Raster, Erratic Diagonal .....	97
Lines, Retrace .....	17
Local-Oscillator:	
Signal .....	13
Stage .....	103
Stage Analysis .....	104
Lock Control, Vertical .....	176



Loss of Channel .....	104	Power Supply Section .....	36
Loss of Sync .....	95	Pulses, Loss of Sync .....	167
Low-Amplitude Troubles in Audio .....	146	Pulses, Noise .....	17
Low-Frequency:		<b>R</b>	
Coil and Transformer Construction .....	69	Ragged Line Down Left Side of Screen	219
Coil Failures .....	70	Raster:	
Distortion .....	170	Bending in the .....	206
<b>M</b>		Black Diagonal Bars on the .....	209
Mica Capacitors .....	52	Center Stretched .....	215
Microphonic Tube .....	114	Erratic Diagonal Lines on the .....	97
Mixer Stage:		White Bar at Right Edge of .....	216
Analysis .....	98	White Line Down Edge of .....	216
Gain Failure in the .....	101	Ratio Detector .....	139
Oscillation .....	103	Reaction Current .....	200
Multivibrator:		Rectifier Filament, High Voltage .....	204
and Sync Discriminator .....	194	Rectifiers, Selenium and Silicon .....	45
Cathode-Coupled .....	176, 194	Regenerative Feedback .....	86, 97
Plate-Coupled .....	175	Relaxation Oscillator .....	175
<b>N</b>		Resistor:	
Narrow Width .....	212	Composition .....	57
Neck Shadow .....	43	Construction .....	58
Negative-Temperature Coefficient .....	55	Failure Effects .....	62
Negative Transmission .....	18	Failures .....	60
Neutrode tuner .....	86	Film .....	57
Noise .....	61	High-Voltage .....	61
Noise and Interference Failures:		Noise .....	61
Audio .....	151	Resistors:	
Due to Age .....	158	Arcing in .....	61
Sync .....	172	Variable .....	62
Noise Pulses .....	17	Wirewound .....	58
Noise Suppression .....	162	Response Curve .....	12
N-P-N Transistors .....	48	Retrace:	
<b>O</b>		Lines .....	17
Octal Tubes .....	40	Lines, Difficult to Eliminate .....	95
Oscillator:		Lines, Eliminating .....	189
Blocking .....	175, 178	Time .....	187
Horizontal .....	191	<b>Rf:</b>	
Output-Driven .....	179	Amplifier, Triode .....	87
Relaxation .....	175	Audio Carrier Signal .....	11
Signal, Vertical .....	26	Detuning, Effects of .....	91
Output:		Signal .....	10
Driven Oscillator .....	179	Signal Clipping .....	100
Stage Analysis, Audio .....	148	Stage .....	85
Stage, Audio .....	147	Stage Analysis .....	89
Stage, Vertical .....	180	Stage, Gain Failures in .....	93
Transformer Failures, Horizontal .....	76	Tuner .....	10
Overloaded Picture .....	112	Video Carrier Signal .....	11
Over saturated Sync Pulses .....	171	Ringing .....	187
<b>P</b>		Ringing, Video .....	117
Paper Capacitors .....	51	Ringing, Yoke .....	216
Peaking Coil Construction, Series .....	68	Ripple at Side of Picture, Fluctuating	207
Peaking Coil Failures, Series .....	68	<b>S</b>	
Pentodes .....	37	Screen, Ragged Line Down Left Side	219
Phase Discriminator .....	137	of .....	180
Phase Splitter, Sync .....	165	Section, Sync .....	174
Phasing Trouble, Horizontal .....	210	Section, Vertical .....	174
Picture:		Selenium Rectifiers .....	45
Detail, Loss of .....	91	Semiconductor:	
Flashes in the .....	125	Construction .....	45
Hook .....	173	Failure Effects .....	47
Hum in the .....	123	Failures .....	47
Overloaded .....	112	Semiconductors .....	44
Tube and Related Circuits .....	34	Separation, Sync .....	166
Tube, Leakage in .....	44	Series Peaking Coil Construction .....	68
Unstable .....	112	Series Peaking Coil Failures .....	68
Plate-Coupled Multivibrator .....	175	Serrated Vertical Pulses .....	23
P-N Junction .....	46	Shadow, Neck .....	43
P-N-P Transistors .....	48	Shorted Turns .....	67
Poor High-Frequency Response .....	117	Sideband, Upper .....	12
Poor Regulation in High-Voltage		Signal:	
Supply .....	218	Afc .....	29
Positive Temperature Coefficient .....	54	Audio .....	20
Potentiometer:		Audio If .....	19
Construction .....	63	Horizontal Oscillator .....	29
Failure Effects .....	64	Local-oscillator .....	13
Failures .....	64	Rf .....	10
Potentiometers .....	62, 63	Vestigial-sideband .....	11
Potentiometers, Dual .....	63	Signals, Sync .....	21
		Signals, Video .....	16
		Silicon Diode and Rectifier .....	46, 47
		Silvery Effect .....	42, 43
		Size Control .....	177



Sluggishness, Agc	156	Tuners	77, 79
Smear	117	Tuning:	
Sound Takeoff Point	15	and Bandpass Failures	89, 98, 109, 128
Speaker Failures	77	and Drift Failures	104
Speakers	77	Cores	66
Splitter, Sync Phase	165	Turns, Shorted	67
Square-Wave Pulses	168		
Suppression, Noise	162		
Sweep:		<b>U</b>	
Horizontal	191	Unstable Picture	112
Section, Horizontal	27	Unsteady Sync Pulse	167
Section, Vertical	26	Upper Sideband	12
Signal, Horizontal	30		
Signal, Vertical	26		
Sync-Vertical	159	<b>V</b>	
Sync:		Variable Resistors	62
Amplitude Failures	166	Vertical:	
Clipper	159	Discharge Stage	179
Clipper, Gated	163	Foldover Troubles	186
Clippers, Diode	162	Frequency Troubles	181
Clippers, Grid-Leak	161	Height Control	177
Clipping	112	Hold Control	176
Discriminator and Multivibrator	194	Hum	186
Discriminator Waveforms	195	Interference Troubles	189
Hum	173	Keystoning	188, 189
Loss of	95	Lock Control	176
Noise and Interference Failures	172	Oscillator Signal	26
Phase Splitter	165	Oscillator Stage	175
Section	20, 160	Output Stage	180
Section Analysis	166	Section	174
Separation	166	Section Analysis	180
Signals	21	Size Control	177
Trouble	205	Sweep Section	26
Vertical Sweep	159	Sweep Signal	26
Sync Pulse:		Sync Pulses	23
Characteristics	23, 24	Vertical Sync Pulses	23, 24
Distortion	168	Vestigial-Sideband Signal	11
Distortion, Causes of	172	Video:	
Horizontal	22, 26	Amplifier and Output Stage	
Loss of	167	Analysis	119
Oversaturated	171	Amplifier and Output Stages	118
Unsteady	167	Amplitude Levels	17
Vertical	24	Noise	102
Synchroguide	196	Ringing	117
Synchroguide Waveforms	196	Section	15, 114
Synchrolock	192	Section, Frequency Response of	19
Synchromatic	193	Signals	16
		Vitreous-Enamel Capacitors	53
<b>T</b>		Voltage, High	191
Tearing	208		
Tearing Picture	96	<b>W</b>	
Television Frequency Bands	79	Wafer-Switch Tuner Construction	82
Temperature Coefficient of Capacitors	54	Wafer-Tuner Failures	82
Transformer:		Waveform Analysis	7
and Coil Failures	66	Waveforms, Sync Discriminator	195
and Low-Frequency Coil		Waveshape Distortion	170
Construction	69	White Bar at Right Edge of Raster	216
Construction	65	White Line Down Edge of Raster	216
Failures	70	Whitish, Gray Picture	95
Transformers	65	Width, Narrow	212
Transistor Types	46	Width Trouble	212
Transistors	37	Wiggly Picture	95
Transistors, N-P-N	48	Wirewound Resistors	58
Transistors, P-N-P	48		
Transmission, Negative	18	<b>Y</b>	
Trimmer Capacitors	54	Yoke:	
Triode Rf Amplifier	87	Construction	73
Tube:		Failures	74
Construction	37	Locked in Place	74
Failure	38	Ringing	216
Failure Effects	38		
Microphonic	114	<b>Z</b>	
Tubes	37	Zero-Temperature Coefficient	55
Tubes, Octal	40		
Tuner:			
Circuits	85		
Construction, Drum	79		
Construction, Wafer-Switch	82		

PRINTED IN THE UNITED STATES OF AMERICA



