

RADIO-CRAFT LIBRARY N°27

Albert Models R.T.
MODERN

Coyne Electric School

1944 **RADIO** *1945*

SERVICING TECHNIQUE

An Aid to Quicker, More Profitable

Servicing Through the Application

of Modern Methods



PUBLISHED BY
RADCRAFT PUBLICATIONS, INC.
25 WEST 8'WAY.-NEW YORK

0000

NO
25

RADIO CRAFT LIBRARY No. 25
**HOME-MADE
RADIO TEST
INSTRUMENTS**

NO
26

RADIO CRAFT LIBRARY No. 26
**MODERN
BATTERY
RADIO SETS**

ONLY
50¢
EACH
3 BOOKS \$1.25
4 BOOKS \$1.50

RADIO CRAFT LIBRARY No. 27
**MODERN
RADIO
SERVICING
TECHNIQUE**

An Aid to Checker, Tester,
and Servicing Through
the
of Modern

NO
28

RADIO CRAFT LIBRARY No. 28
**ALL ABOUT
FREQUENCY
MODULATION**

COMPILED
BY THE EDITORS OF
Radio Craft

RADIO-CRAFT'S LIBRARY

presents

4 BEST SELLERS

HERE are four of the handiest, most informative books that this popular technical library ever turned out. They hardly need an introduction. Their usefulness is already an established fact, proven on the best "proving ground" in the world: "The field of practical application."

Yes, indeed, thousands upon thousands of technicians, servicemen, experimenters, trainees use these books daily. They are just the right size to slip in the pocket so you can read them when traveling.

The knowledge gained from these self-help books can be used in countless ways; for example, in building a home-set, when servicing an outside job; or when preparing for an examination. Many men in the armed service who are aiming toward a higher rating are making excellent use of these books. The price, only 50¢ each, and less when you buy more than one at a time, is trifling when you consider that the first application of the knowledge gained will likely pay the cost of all four books.

No. 25—Home-Made Radio Test Instruments

Outline of Contents: A Low-Cost Signal Chaser—Simple Tracer Test Unit—Simplified Practical Signal Tracer—A Home-Made Infinite Resistance Tube Checker—Build This Direct-Reading V.T. Voltmeter—How to Make a Modern V.T. Voltmeter—Measuring High Values of A.C. Voltage and Current with a Low-Range Meter—How to Make a Meter-Range Extender—How to Build a Practical Tube Tester and Set-Analyzer Adapter—The Beckliners' Simple Volt-Milliammeter—How to Make and Use a Frequency Wobbler—Double Tracing Your Oscilloscope—Home-Made Frequency Modulator.

No. 26—Modern Battery Radio Sets

Outline of Contents: Beginner's 1-Tube High-Gain All-Wave Receiver—Beginners-Build This 1-Tube Loop Receiver—A "3-in-1" Battery Portable—An Easily-Built "Pie-willing Superregenerative" 2-in-1 "Card File" Battery Set—A 2-Tube Superhet. With Pentagrid Regenerative 2nd-Detector—The 4-Tube Superhet. Vacation Portable—"Lunchbox 5" Battery Portable—"The Sealers" Loop-Type Boat Radio Set—4-Tube Permeability Portable—An All-Purpose Boat A Typical Commercial 3-Way Portable (Pilot Model X-1452 and X-1453)—Switch for Varying "C" Bias on Battery Radio Sets—Making a Simple Portable Aerial—Making a Pilot-Light Fuse—Old Auto Sets for New Cars—Using a Loop Portable in Cars—Quasi-Electric Soldering Iron—Lamp Bulbs as Resistors.

No. 27—Modern Radio Servicing Technique

Outline of Contents: Elementary Servicing Technique—Correct Procedure for the Servicing Beginner—Elementary Procedure for Servicing Radio Sets—A.F.C. Alignment Made Easy—Dynamic Servicing—Dynamic Testing Simplifies Servicing—Modern Receiver Test Requirements—Servicing Universal A.C.D.C. Receivers—Servicing "Orphans" and Private-Brand Sets—Emergency Servicing Without Test Meters—Servicing Coils—Servicing R.F. Coils—Servicing Oscillator Coils—General Information—RMA Transformer Color Code—What Causes Echo, Fading?—Radio Service Puzzlers.

No. 28—All About Frequency Modulation

Outline of Contents: The ABC of F.M.—Frequency vs. Amplitude Modulation—Basic Facts About F.M. Broadening—Construction—Build This Practical F.M. Adapter—Audio Amplification—F.M. Audio Amplifier, Part 1—F.M. Audio Amplifier, Part 2—F.M. Audio Amplifier, Part 3—F.M. Service—Part 1. Antenna Installation and Service for F.M. Servicing, Engineering—Part 2. The How and Why of F.M.—Part 2. The How and Why of F.M.—Theory and Design Considerations of R.F. and I.F. Coils in F.M. Receivers.

YOU NEED SEND NO MONEY

It is not necessary that you send money with an order for two or more books. If you wish to take advantage of our C.O.D. plan, either cut out the coupon or mail us the necessary information on a post card. Books will be sent to you immediately. All books are listed uniformly at 50¢ each. Do not fail to send order today!

RADCRAFT PUBLICATIONS, INC.
25 West Broadway, New York 7, N. Y.

RADCRAFT PUBLICATIONS, INC.

25 West Broadway,
New York 7, N. Y.
Gentlemen:

Rush to me by return mail, as per your C.O.D. Plan, the following books: (Check books selected.)

No. 25 No. 26 No. 27 No. 28

I will pay postman \$1.00 (if two books are ordered.) \$1.50 for three books. \$2.00 for four books, plus a few cents postage and charges.

WE CANNOT SEND A SINGLE 50¢ BOOK C.O.D.

NAME _____

PLEASE PRINT CLEARLY

ADDRESS _____

CITY _____

STATE _____

Save shipping and C.O.D. charges! Check here if you send cash with order. (Cash, U.S. new postage stamps, money order, check.) Foreign countries no C.O.D. Add 20% to all prices quoted.

MODERN RADIO SERVICING TECHNIQUE



COMPILED
BY THE EDITORS OF

Radio-Craft



RADCRAFT PUBLICATIONS, Inc.
PUBLISHERS

NEW YORK, N. Y.

NEW YORK, N. Y.

TABLE OF CONTENTS

CHAPTER 1

Elementary Servicing Technique	3
Correct Procedure for the Servicing Beginner	
Elementary Procedure for Servicing Radio Sets	
A.F.C. Alignment Made Easy	

CHAPTER 2

Dynamic Servicing	9
Dynamic Testing Simplifies Servicing	
Modern Receiver Test Requirements	

CHAPTER 3

Servicing Universal A.C. - D.C. Receivers	15
---	----

CHAPTER 4

Servicing "Orphans" and Private-Brand Sets	22
--	----

CHAPTER 5

Emergency Servicing Without Test Meters	36
---	----

CHAPTER 6

Servicing Coils	49
Servicing R.F. Coils	
Servicing Oscillator Coils	

CHAPTER 7

General Information	60
RMA Transformer Color Code	
What Causes Echo, Fading?	
Radio Service Puzzlers	

CHAPTER 1

Elementary Servicing Technique

CORRECT PROCEDURE for the SERVICING BEGINNER

HAVING been in a position to observe the professional actions of many Radio Service Men for a number of years, the writer believes that the following information will greatly benefit those who feel they are not reaping as much of the harvest as they deserve.

To the busy Service Man, doing the job correctly in the least possible time means money in his pocket. Putting in 2 hours on one job when it normally should be done in 30 minutes, most decidedly represents a cash loss. On the other hand, a completed job that is not 100 per cent correct may mean a dissatisfied customer and a future loss of business. It all adds up, so let's take a few jottings from our notebook and see if we can give some of you fellows a lift. Remember, if you only find one useful idea in this whole article, it will

probably mean future dollars in your pocket.

ALIGNING PROCEDURE

First a word on aligning procedure. There is a right way and a wrong way and in case of doubt always use the set manufacturer's instructions—he designed the set and knows how it should be done. One thing many men do incorrectly is to align the I.F. in the wrong sequence. Always start with the I.F. transformer next to the 2nd-detector and adjust the condensers, in order, back toward the signal. And always work with the weakest possible output from the signal generator. This is the secret of a sensitive and selective aligning job. (A few manufacturers specify procedure that differs from the above.—*Editor*)

Those sets using tertiary (a third) windings on the I.F. transformers are usually designed to be aligned with the high-fidelity control in the "normal" position. The response, curve is then broadened the proper amount on switching over to the high-fidelity side. If you have trouble

MODERN RADIO SERVICING TECHNIQUE



Fig. A. Two views of industrious students of radio servicing at work in the shops of a large radio school.

in aligning some I.F. transformers, try shorting out the oscillator section of the gang condenser. Many times reaction between the set oscillator and the generator (that is, service oscillator) signal puts you on the wrong track and you may be aligning the I.F. to some beat-note harmonic.

Now a word to you new men—all troubles in a set cannot be found by analyzing, although a good many can. The trouble must be such that it affects some of the voltage readings we normally take. If it doesn't, our voltages won't show where the trouble lies. For example: an open antenna coil may cause weak reception, but it will not affect any of the set's voltages. Or perhaps we have an open voice coil—no voltage changes will take place, yet the set is "dead." Many more examples could be given, but we believe you get the idea by now.

Always check the tubes before you start looking for trouble in the set itself. Quite a large percentage of service work is simply replacing defective tubes. Present-day tubes require a pretty good tester if all the bad tubes are to be weeded out. A simple *emission-type* tester will catch most of them, but to get the real stubborn ones, use a *power output type* checker.

A.V.C. CIRCUITS

Those A.V.C. circuits seem to be one big stumbling block for many men, when it comes to checking the action other than by a listening test. Since the bias on the I.F. tubes is generally controlled or varied by the A.V.C. voltage a check of the plate current of one of these tubes

will give us a picture of the A.V.C. action. Normal plate current will exist with no signal, dropping to a lower value when a strong signal is applied. If you do not wish to use a meter for checking, an alternate method is to hook-in a "tuning eye" and observe its action. These "eyes" can be purchased complete with socket and leads ready to connect to any set having A.V.C., simple directions for attaching this unit being provided. If the set already has some form of tuning indicator, this will give us a direct check on the A.V.C. action. Many cases of failure can be traced to defective bypass condensers in this circuit, so give them a thorough check, especially for leakage.

ADDITIONAL TESTS

A good condenser tester, one using a sensitive meter for indications, is a very good investment for any Service Man. Coupling condensers should always be checked if the set seems less sensitive than normally, assuming everything else to be OK. Be as fussy as Aunt Matilda when it comes to checking these units for leakage, as the least little bit can upset a circuit and prevent normal action. Do not rely too much on the neon lamp method of testing these smaller capacities.

How many of you fellows have a good pair of headphones? They don't have to be expensive, as the ordinary 2,000 ohms-per-pair type constitute a very handy as well as a *very sensitive* indicator for testing. For aligning sets, using a weak signal from the test-signal generator, they are just the ticket. In fact many factory pro-

MODERN RADIO SERVICING TECHNIQUE

duction lines use this method. For a quick check of A.F. stages use a 0.25-mf. condenser in series with the phones and connect from chassis to any control-grid or plate terminal of the audio tubes. It's surprising how many different uses you will find for headphones in checking various circuits.

This next is perhaps familiar to the old timers, but will bear repeating. When replacing defective screen-grid bypass condensers, use ones having a 450-V. rating even though the service manual calls for one of 200 V. at this point. The reason is this: when the set is first turned on, the type 80 tube heats up quickly and starts delivering voltage before the heater tubes are drawing current and consequently for the first few seconds the "B plus" voltages are abnormally high. That is probably what caused the original bypass condensers to break down, so put in the higher-voltage ones and keep your customer.

And now for that general pain in the neck, the lowly midget. Many Service Men will not even work on them, due to the usual difficulty of convincing the customer that even if he did only pay \$9.85 for the set new, the service charge is still \$3.50 and should be paid. For those of you who will be doing this work, here are 3 common causes of trouble in midgets.

(1) Dried-out electrolytic filter condensers. If the plate voltage is 25 per cent or more below normal, chances are new filter condensers will put the set back on its feet. (2) The rectifier tube is another regular trouble maker and I believe the remedy is self-evident. (3) And last, watch those coupling condensers.

A quick way to check the oscillator of a super-het. to see if this portion of the circuit is oscillating, is to measure the rectified grid current. Disconnect the lower end of the oscillator gridleak resistor (the end opposite to the control-grid end) and insert a low-range milliammeter to read the current passing through this resistor. Normally it should be about 50 to 75 microamps, dropping to zero if oscillations cease.

WHAT ABOUT SERVICE PRICES?

So much for the technical hints and if all the above checks on your list of everyday events, then you are really up near the top. But how do you check on prices? How many of Uncle Sam's \$1 bills do you collect for a call to the other side of town? You may be an expert but are you cashing-in on it? As yet there is no standardization of service rates for the radio industry and it's high time there was.

All indications point to a charge of \$2.50 for a call and that is for the call only, parts, labor, etc., being extra. Many of the better Service Men only carry a tube tester and voltmeter into the customer's home. After all, a person's living-room is not a workshop so take the set back to your own shop for repairs, where you have the facilities to work on it properly. Charge a fair price for your work, at least \$2.00 an hour on straight labor with a minimum charge of 1 hour's work. Naturally exorbitant prices are out of the question so keep your rates in the professional class, because after all good radio servicing is a profession.

Now let's take a look at "you." How do you keep up-to-date with all the new changes and improvements continually being made? A very excellent method is to subscribe to 2 or 3 monthly radio magazines and trade journals. Look them over carefully, read the ads., see what is taking place and learn as much as you can about new ideas before they get on the market so you'll be ready for them when they do arrive.

Also pay some attention to your personal appearance. Never call at a customer's house in dirty or sloppy clothes. Neat appearance and a pleasant smile, along with prompt and courteous service at a fair price will get you a lot of business that the sloppy, surly, stalling competitor loses.

Coyne Electrical School

ELEMENTARY PROCEDURE for SERVICING RADIO SETS

IN THE PAST it has been the practice of manufacturers to issue a service manual each time a new model was brought out. Due to similarity of circuits this has resulted in much unnecessary repetition. It is believed that information can be compiled, general enough, to cover all the important phases of servicing past, present and future models.

THE PROCESS OF ELIMINATION

While the trouble is immediately apparent on some service jobs, in the majority of cases it is necessary to locate the defects by the process of elimination. In comparison with the production problems, the Service Man has a relatively simple problem to face as he knows the radio was operating properly when shipped from the factory

and failure must be due to breakdown of one or more parts in the radio set. In the case of a set which is completely inoperative the tracing should always commence at the rectifier-filter circuit and work back through the audio circuits, through the I.F., R.F., etc., to the antenna circuit.

"A" AND "B" CIRCUITS

First study the circuit diagram. Notice whether filaments are wired in series or parallel. In series filament circuits as used in A.C.-D.C. sets, the burn-out of one tube or the opening of the filament series resistor will make all tubes fall to light. In parallel filament circuits a burned-out tube will show up at once as the other tubes remain lighted.

Absence of "B" voltage may indicate a defec-

MODERN RADIO SERVICING TECHNIQUE

1
2
3
tube, open filter choke or speaker field (if such is used in place of a filter choke), short-circuit or poor connection. A short-circuited filter condenser may have caused the rectifier tube to become inoperative.

Low "B" voltage may indicate a worn out rectifier tube, partial short-circuit at some location in the set (usually through a resistance or leaky condenser), open filter condenser or incorrect bias caused by faulty resistor.

OTHER TESTS WHEN SET IS "DEAD"

If "A" and "B" voltages seem correct but set is "dead," test for open speaker winding, defective tubes, defective bypass condensers, open connections or wiring shorts. It is advisable to keep a set of "master" tubes which are known to be in good condition, for comparative purposes.

WEAK OR POOR SENSITIVITY

These conditions are generally caused by weak tubes, leaky or open bypass condensers, resistors whose values may have changed (may also cause overload), damaged coils, or incorrect adjustment of tunable circuits either R.F. or I.F. methods of testing condensers and resistors and of adjusting tunable circuits will be given subsequently.

RESISTOR AND CONDENSER TESTS

A continuity meter consisting of a voltmeter and battery may be used for testing resistors. Its usefulness is limited however, to the operator's familiarity with the drop to be expected through various resistances. A simple ohmmeter of the type put out by the better known meter manufacturers is highly recommended. It is one of the most useful pieces of equipment in any service department.

If you want a very simple and useful condenser test, purchase a 2-watt neon lamp from any radio mail order house. Connect this as you would a voltmeter for continuity test using approximately 90 volts of "B" battery. An "A-B" eliminator may be used in place of the batteries if it is filtered sufficiently so the A.C. component is practically nil.

Condensers should be disconnected before being tested. There should be an instantaneous flash in the neon lamp as the circuit is completed across the condenser being tested. On small condensers this flash will be very small and of short duration. The brilliancy and duration of the flash are a rough indication of the capacity. The test should be maintained over a period of possibly $\frac{1}{2}$ -minute. When testing paper or mica condensers there should be no light in the neon lamp other than the initial flash. No flash indicates an open condenser. Sustained or fluttering illumination indicates a leaky condenser which should be replaced. A good electrolytic condenser, due to the leakage through it, will allow a rhythmic flutter.

The duration, rapidity and brilliancy of the flashes are governed by the capacity of the condenser.

OSCILLATORS AND OUTPUT METERS

While it is possible to do a certain amount of balancing and aligning without the aid of a signal generator and output meter it is not easy to approach the accuracy that can be obtained with their use. The well-equipped service department should have an oscillator that will generate modulated signals of frequencies suitable for ad-

justing the I.F. transformer assemblies in super-het. models and frequencies useful in aligning the tuning condensers on broadcast and short-wave bands. The harmonics of signals in the broadcast band may often be used in checking and adjusting the short-wave bands if the test oscillator does not cover the whole spectrum desired.

The standard type of A.C. output meter is satisfactory on all models not using A.V.C. When A.V.C. is incorporated in the radio set a microammeter with any convenient range up to 500 microamperes with a 1-megohm variable resistance in series should be used in place of the usual output meter. The variable resistance acts not only to protect the meter but allows adjustment to the most convenient portion of the scale. In practice, this assembly is connected across the manual volume control and reads A.V.C. voltage developed. Adjustments are made for maximum reading.

An alternative method, though not as satisfactory, is to connect a 0-10 ma. D.C. milliammeter in the "B"-plus lead to the primary of the last I.F. transformer to read plate current. Adjustments are made for minimum reading.

ALIGNING AND BALANCING

When it is necessary to rebalance or realign the tuning circuits due to damage, tampering or coil changes the procedure will be found similar on all models.

T.R.F. CIRCUITS

Set the signal generator at a frequency near 1,500 kc. Tune the radio set to resonance with this signal and adjust the small trimmer condensers on the tuning condenser for maximum output.

Next set the signal generator at 1,000 kc. Insert a thin bakelite, celluloid or mica feeler strip between the plates of the variable condensers to determine whether the circuits are properly matched. The action is this—the dielectric constant of the celluloid feeler strip being higher than that of the air it displaces, results in an increase of capacity.

Open the variable condenser just enough to indicate 2 or 3 points below maximum signal. As the feeler is inserted the meter reading should indicate increasing signal and then decreasing as the feeler is inserted farther. This procedure should be followed on all sections. Should the meter fail to show an increase in signal as the strip is inserted in one section this indicates too great a capacity for that section. This may be corrected by bending the outside rotor plates out at the point where they mesh with the stator.

After checking the alignment at 1,000 kc., repeat the process at 550 kc.

SUPERHETERODYNE CIRCUITS

It is customary to check the adjustment of the I.F. units before aligning the variable condenser. When doing this, the oscillator section of the variable condenser should be shorted-out so no oscillation will be generated in the radio set. The signal generator should be set at the proper intermediate frequency and its output connected to the antenna connection of the radio receiver. The valuable adjustments on the I.F. units should then be checked for exact resonance as indicated on the output meter. It is well to go over these adjustments more than once.

When the I.F.'s are properly adjusted, the variable condenser may be balanced and aligned

MODERN RADIO SERVICING TECHNIQUE

following the directions given for T.R.F. circuits. It is not advisable to bend plates on the oscillator section unless absolutely necessary. The other sections should be aligned to the oscillator section if possible.

In sets having an adjustable oscillator pad it is customary to first adjust trimmer condensers at 1,500 kc. and then go to 550 kc., and adjust the pad. While the condenser is rocked slowly back and forth across the signal the pad is adjusted for maximum output.

In sets incorporating a short-wave band, a vernier tuning condenser is provided so it is not necessary to worry about alignment after the set has been properly aligned on the broadcast band. Where needed, extra trimmer condensers are provided which are to be adjusted at the high-frequency end of the short-wave bands. Instead of bending condenser plates at the low-frequency end, alignment is accomplished by spreading or crowding turns on the short-wave antenna coil.

I.F. INTERFERENCE

In some few sections of the country there are airport or other commercial transmitters operating on or near the intermediate frequency used in the radio receiver. This may result in interference from this station being present at all dial settings of the radio. To overcome this condition it is only necessary to shift the intermediate frequency up or down about 10 kc. This necessitates readjusting the I.F. units and re-balancing and realigning the R.F. circuits.

ALL-WAVE ANTENNA SYSTEMS

There are available, on the market, many so called all-wave antenna systems. These are particularly helpful in locations where there is a great deal of "man made" interference in that the lead-in of such a "balanced" system picks up neither signal nor interference, all pick-up being from the top portion of the antenna. This then, can be placed far enough from the sources of interference to greatly improve results.

International Kadette

A. F. C. ALIGNMENT MADE EASY

THE automatic tuning devices now being used in radio receivers are subject to inaccuracies and many times do not tune the receivers correctly. Therefore, it becomes necessary to use an *automatic frequency control* system to insure perfect tuning.

These A.F.C. circuits normally consist of a *discriminator* tube and "oscillator" or *control* tube. A typical circuit is shown above.

As a signal passes through the I.F. section of the set, if the oscillator is not tuned to the exact frequency, a voltage is developed across the cathodes of the 6H6 discriminator tube. If the oscillator is tuned to one side of the I.F., a *positive* voltage will result; if it is tuned to the other side of resonance, the voltage will be *negative*. Whatever voltage is developed is, in turn, impressed on the grid of the oscillator control tube varying its mutual conductance; and in turn, adding or subtracting from the inductance in the oscillator tube circuit,—thereby correcting the tuning and assuring absolute resonance. The entire action of such A.F.C. circuits depends upon perfect adjustment of the discriminator transformer.

ALIGNING I.F. AND R.F.

In attempting to align a receiver using A.F.C., the set should be first adjusted in the conventional manner entirely neglecting the A.F.C. circuit. A good stable oscillator should be connected to the grid of the 1st-detector and ground. An output meter should be connected across the speaker terminals or from plate-to-plate on the output transformer. The I.F. trimmers should then be adjusted for maximum output reading. This procedure should be checked a second time in order to insure maximum accuracy.

After the adjustment of the I.F. transformers, the oscillators should be connected to the antenna and ground terminals and the R.F. section carefully adjusted. In making all of the above adjustments, the A.F.C. switch should be in OFF position so that there is no controlling action in the oscillator circuit. If, in some cases, the manufacturer does not supply a switch for eliminating the A.F.C. circuit, a short-circuiting switch should be inserted across the cathodes of the discriminator tube, or the control-grid on the oscillator control tube may be grounded to the

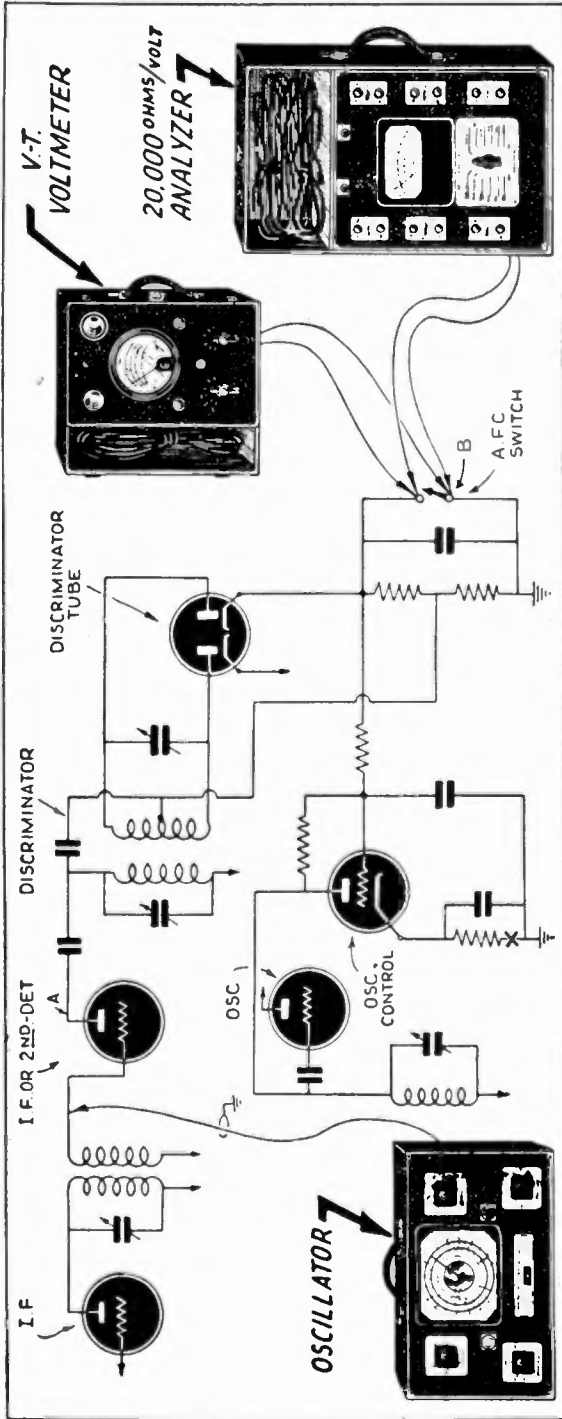

chassis. Care should also be used in the adjustment of the I.F. and R.F. sections so that the oscillator signal voltage is kept as low as possible, and the volume of the receiver turned up as high as possible in order to prevent any action of the automatic volume control circuit.

ALIGNING A.F.C.

With the completion of the above procedure, the set is perfectly aligned with the exception of the A.F.C. circuit. The

signal generator should then be set to the exact I.F. at which the set is now adjusted. The signal should be fed into the grid of the 2nd-detector or I.F. stage from which the discriminator transformer is coupled as shown at A above. A vacuum-tube voltmeter should be connected across the A.F.C. switch or discriminator tube cathodes with the switch open as shown at B in diagram. The trimmer on the secondary of the discriminator transformer should

then be detuned slightly. The trimmer on the primary should next be adjusted for maximum voltage reading on the vacuum tube voltmeter. Next, the secondary trimmer should be adjusted until an absolute zero voltage condition exists. Extreme care is required in this adjustment since a positive voltage can be obtained on one side of resonance and the negative voltage will be obtained on the other side of resonance. When this zero-voltage condition is

MODERN RADIO SERVICING TECHNIQUE

obtained, the discriminator transformer has been tuned to resonance and all adjustments have been made. If a vacuum-tube voltmeter is not available, a 20,000 ohms/volt analyzer can be used in its stead. Under no conditions should any attempts be made to measure the discriminator voltage with a 1,000 ohms/volt instrument. Such readings would only be a small portion of the actual circuit potential and the absolute zero adjustment necessary, will be much too difficult to read accurately.

FINAL CHECK

As a final check on the alignment, the

10-milliamperere range of an analyzer should be inserted in series with the cathode of the oscillator control tube as shown at point X above. One model of Weston socket selector unit provides a quick, easy method of breaking into all such tube circuits in making current measurements. With the meter inserted in this manner, the A.F.C. switch should be thrown "ON" and "OFF"; *if the discriminator circuit has been properly adjusted, there will be no change in the meter indication.*

We hope that this pictorial type of presentation will help Servicemen to visualize the procedure.

Weston Electrical Instrument Corp.

CHAPTER 2

Dynamic Servicing

DYNAMIC TESTING SIMPLIFIES SERVICING

THE Dynamic Tester, being the only real development in the radio testing field, is an instrument the Serviceman should give careful consideration before he brands it as just another gadget.

The dynamic tester is new—in principle as well as appearance, and it is strange indeed that an instrument so simple had to make its advent in a day when complicated video circuits are the main topic of discussion. There is not a thing in the dynamic tester that could not have been given the Serviceman a decade ago, yet this new instrument is so powerful it gives him complete mastery over a radio circuit.

Dynamic testing means checking the radio set under actual operating conditions. It is concerned with the signal itself, and not with the condi-



The use of the Dynalyzer (this is the instrument in the photo to which the test cord is connected).

tion that should make the signal correct and just as often does not. When the signal becomes affected by a defective condition, the dynamic tester permits the operator to put his finger on the defective circuit. It also permits him to eliminate those circuits which are not defective, thereby narrowing down the search.

TYPES

There are 2 general types of dynamic testers on the market: (1) those of the multi-channel variety which use the electronic eye for signal indicators; and (2) those of the single-channel, 1-probe type which have a built-in loudspeaker to permit constant monitoring of the signal, or "listening-in" at any point in the circuit. (Both types have been illustrated and described, and their uses analyzed in past issues of *Radio-Craft*.—*Editor*)

Because it was the privilege of the writer to help develop the Rimco Dynalyzer, it is around this instrument that this article is being written.

In designing the Dynalyzer, it was with the idea of producing an instrument with which the Serviceman could make every desired check on a radio receiver, using 1 instrument, 1 probe, and without jumping test leads around and throwing a multitude of switches.

The Dynalyzer consists of a 2-stage, high-gain, R.F. amplifier, having a tuning range of R.F. from 95 kc. to 15 mc., which is used to amplify R.F. signals and for use as a frequency meter. This is followed by a diode detector and a 2-stage audio amplifier driving a dynamic speaker. It has a no-current electronic voltmeter whose input resistance is never less than 10 meg.; and an ohmmeter which reads up to 10 meg. in 4 scales.

The meter is so designed that it may be thrown into the circuit to indicate R.F. or A.F. signal strength, or used individually with the probe or a pair of test leads. So much for the actual equipment. Now let's see how best to use it.

SIGNAL TRACING

To trace a signal through a superheterodyne, it is only necessary that the operator know the functions of the various tubes and their base socket connections.

R.F. and I.F.—Tune-in a station or a signal generator on the radio set under test and place the R.F. probe (which contains a small condenser) on the antenna post of the set. Tune-in the tester and observe volume. Jump the probe to the grid of the converter tube (1st-detector) or the grid of the R.F. tube should the set have an R.F. stage. The signal should increase considerably in volume if the set is of common design. If a decided loss in signal volume is found, the circuit is defective or out of tune.

Without attempting to realign the set, as yet, next jump the probe to the plate of the R.F. or converter tube as the case may be. If an R.F. stage is used the gain through the tube should drive the meter off-scale on the 5-volt range. (Don't worry about the meter. It will stand 100 times overload.) If the tube is a converter, it will be necessary to tune the dynamic tester to the intermediate frequency of the set to get the gain, because it is in this tube that the frequency is converted to the I.F. setting. A signal at the signal (station) frequency will be available, but it will be weak because the circuit is tuned to the I.F.

Comparing the reading on the plate of the converter to the reading at the grid of the I.F. tube gives the condition of the I.F. transformer. A slight loss here is not uncommon, but a decided loss indicates a defective circuit or misalignment.

Gain through the I.F. tube may be had by comparing the plate to the grid reading; it should be approximately the same as the R.F. or converter. A weak tube or defective circuit is easily identified after a little experience.

OSCILLOSCOPIC SERVICING

This article does not discuss the use of any more intricate electronic testing device than an "eye" indicator. However the general test procedures it describes are applicable (in general) to the use of oscilloscopes where this more advanced type of test equipment is available.

Detailed test procedure using C.-R. equipment and generally supplied by the manufacturer, is more involved and extensive than space here permits for discussion; nevertheless some of the elements of servicing with cathode-ray equipment are contained in the article "Modern Receiver Test Requirements" on Page 13.

A signal at the signal (station) frequency will be available, but it will be weak because the circuit is tuned to the I.F.

Comparing the reading on the plate of the converter to the reading at the grid of the I.F. tube gives the condition of the I.F. transformer. A slight loss here is not uncommon, but a decided loss indicates a defective circuit or misalignment.

Gain through the I.F. tube may be had by comparing the plate to the grid reading; it should be approximately the same as the R.F. or converter. A weak tube or defective circuit is easily identified after a little experience.

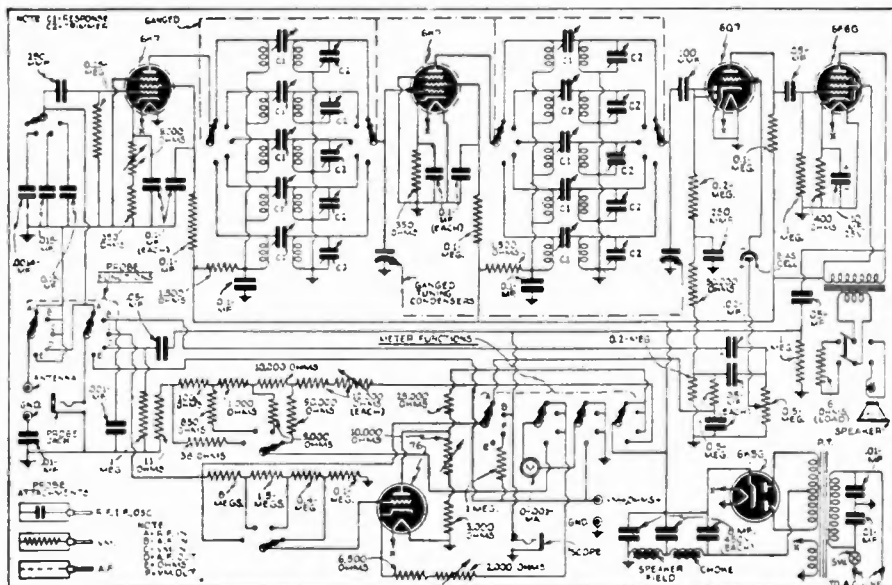

The interesting features in the "Dynamizer" described in the accompanying article are here diagrammed.

The last R.F. point is the 2nd-detector, usually a diode. The signal here should be approximately the same strength as at the plate of the I.F. tube. Decided loss would be caused by the same things previously mentioned. At the diode, 2 things happen.

(1) The R.F. component or carrier, is filtered out and becomes A.V.C., to be applied to grids of R.F. and I.F. tubes. This is done through a network of high-value resistors and low-value condensers. This action may be checked by measuring along this network with the electronic meter.

(2) The 2nd thing that happens is that the audio component is separated and fed onto the grid of the 1st audio tube. To continue tracing the signal, the dynamic tester must be set to receive audio signals.

A.F.—The audio signal may be traced through the volume control to the grid of the 1st audio tube. The increase in signal strength through the 1st audio stage is sufficient to require using the 25-volt range.

The loss or gain between the plate of the 1st audio tube and the grid of the output tube depends on the type of coupling. If resistance-capacity coupling is used there will be no gain. If transformer coupling, there will be a gain depending on the ratio of the transformer. However, watch out for drivers in class B outputs. Drivers are step-down transformers and will show a loss even though they are normal.

The gain through the output tube or tubes will be slightly less than through the 1st audio, due to the amplification factor of the tube, and across the output transformer there will be a decided loss due to the difference in impedance between the plate winding and the voice coil winding.

CHECKING ALIGNMENT

While the dynamic tester may be used to align a radio receiver using a station for a signal, it is of far more service as an out-of-alignment detector.

To check alignment, tune-in a station on the high-frequency end of the band (around

1,400 kc.). Add to this frequency the frequency of the I.F. (1,400 kc. plus 460 kc., for example) and set the tester at this frequency (in this case, 1,860 kc.). This should be the oscillator frequency when the set is tuned to 1,400 kc. To check this, place the R.F. probe on or near the oscillator tuning

MODERN RADIO SERVICING TECHNIQUE

condenser. If the oscillator signal is off-resonance, it will not peak at this point, but instead, will tune to resonance at some other point on the tester dial. Peaking is indicated by the meter in the "R.F." position. Nothing will be heard in the tester speaker because the oscillator signal is unmodulated at this point.

To check alignment of the R.F. circuit, place the R.F. probe of the tester on the R.F. plate, or in case of no R.F. stage, the converter plate. If retuning the set increases the signal in the tester, the alignment is not correct. A slight variation here may be tolerated, but appreciable variation means that the set needs realignment. Disregard the signal in the speaker of the radio set when making this test, as the signal will disappear completely, of course, as the set is returned.

To check I.F. alignment, place the R.F. probe on the plate of the I.F. tube and tune tester to maximum signal, which should be somewhere near the I.F. of the radio receiver. Next jump the probe to the diode, or to the plate of the 2nd I.F. tube. If the 2 I.F.'s do not peak exactly on the same frequency, the I.F.'s need re-aligning.

ALIGNMENT

To make adjustments to the R.F. and oscillator circuits, place the R.F. probe on the plate of the converter tube. Short the oscillator section of the tuning condenser (which stops oscillator), and tune the tester to the frequency of the station or signal being received. This must be a station near the alignment frequency specified by the manufacturer (usually, around 1,400 kc.). Adjust the antenna and R.F. trimmers for maximum intensity in the tester. The electronic meter, thrown to the "R.F." position, will serve perfectly as an output meter.

After the R.F. adjustments have been made, remove the short from the oscillator, and adjust the oscillator high-frequency trimmer to maximum signal in the tester with the tester set at the I.F.

Now tune set to a station or signal around 600 kc. and adjust the low-frequency paddler in the same manner. Rocking the condenser gang will not be necessary. For careful alignment, repeat the procedure.

Adjustments to the I.F. circuits may be made by leaving the tester tuned to the I.F. and jumping the probe to the last I.F. point (usually, the diode). It will not be necessary to make actual contact at this point because the signal is now strong enough to be picked-up in the tester with the probe clipped to an insulated wire in the circuit. This is called "loosely coupling" to the circuit and its advantage is that it does not detune the I.F. With the tester coupled in this manner, adjust the trimmer to maximum reading on the meter, remem-

bering to always use minimum signal in the radio set being aligned.

FINDING TRIMMERS

The dynamic tester is very useful in finding trimmers when alignment data is not available. To do this, tune-in a station or signal around 1,400 kc. Set the tester on the same frequency, and touch the R.F. probe to the various trimmers until the signal is found. The R.F. signals will be heard on the R.F. trimmers. As all the R.F. trimmers are adjusted to the same frequency, in most sets, it is not necessary to distinguish them; however in case of R.F. stages the various trimmers can be identified by their signal level. (The 2nd R.F. stage will be louder than the 1st, etc.)

Oscillator trimmers are easily found. Add to the frequency of the signal being received on the radio set the I.F. of the receiver. Tune the tester to this frequency, and watch the meter for indication. (Nothing will be heard in the tester speaker, as previously explained.) Usually the low-frequency paddler will indicate less signal than the trimmer when the set is tuned to 1,400 kc, or thereabout.

Trimmers for the shortwave bands may be located similarly by using signals in the respective bands, but misleading harmonics must be watched-out for.

INTERMITTENTS

Intermittent operation is the bugaboo of radio servicing, yet with the dynamic tester, even this condition is simplified.

Intermittents can be quickly localized to either the R.F. or A.F. end by tying the R.F. probe into the radio set at the last R.F. point. (Usually, the diode of the 2nd detector.) Monitor both the speaker in the radio and the one in the tester. An interruption in the radio speaker that does not affect the tester, means that the trouble is in the audio section. Interruption to both, means that the signal is being affected in the R.F. end as well as the audio. The electronic voltmeter may be tied into the high-voltage line to see if the interruption affects the voltage.

After the trouble has been localized to either the A.F. or R.F. end, the tester may be moved, 1 stage at a time until the defective stage is located.

MAKING ESTIMATES

The dynamic tester enables the Serviceman to give quicker and more accurate estimates. If there is more than one defect in a radio receiver, it is not necessary for him to repair one thing before he can find another. Cases where the oscillator, one of the I.F.'s, the 2nd-detector and the output transformer were out of commission have been found without making any temporary repairs. Servicemen are constantly getting in-

MODERN RADIO SERVICING TECHNIQUE

to trouble by making estimates which do not include some unforeseen defect.

The Rimco Dynalyzer has a feature which permits a station to be tuned-in on the tester, and the audio output then fed out through the probe. This A.F. signal may be fed into the radio set under test at the 1st audio stage, and the entire A.F. end of the set tested within a single operation.

Intermediate frequencies may be checked by feeding an I.F. signal into the set and picking it off at any point with the tester.

ELIMINATE "CLIPPING"

With a little head work, the Serviceman can locate many defective parts without the usual clipping-out and resoldering into circuit. Bypass condensers are in a radio set for 2 purposes: (1) to pass A.C. and (2) to block D.C./Resistors are used to drop voltages and furnish return paths. The electronic voltmeter, because it draws absolutely no current from the circuit, may be used to

big advantage to analyze these conditions. Direct-current drops across defective condensers point out these defects. The amount of voltage dropped across certain resistors will often lead the Serviceman to the defective part.

FOR HAM RIGS

The dynamic tester is a handy gadget to have around the ham rig. Percentage of modulation and field strength measurements may be made with it. It will provide a very efficient means of neutralizing, and it is a good frequency meter and monitor.

As in servicing receivers, it may be used to trace signal failure and out-of-tune transmitter conditions. Standing waves on the lead-in and antenna may be observed, and distortion localized. On the Dynalyzer a plug has been provided for connecting an oscilloscope. This permits the operator to look at the waveform at any point. The electronic meter ranges may be extended to read high voltages.

MODERN RECEIVER TEST REQUIREMENTS

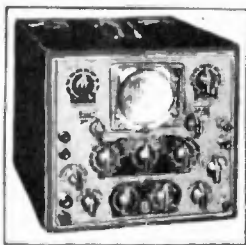

Fig. A. Oscilloscope.

IN order to meet the approval of an increasingly critical public, it has been necessary for receiver design engineers to develop radio sets of increasing complex-

ity, to meet the following specifications:

- (1) High sensitivity;
- (2) Sharp selectivity;

- (3) High selectivity;

- (4) A low noise-to-signal ratio.

Investigating these attributes separately, it is found that a receiver must have *high sensitivity* to bring in distant stations at a satisfactory volume level, especially the low-power stations.

The receiver must have *sharp selectivity* to discriminate distinctly between stations on adjacent channels and to prevent interference of one station with the other. This interference appears as cross talk, or hearing both stations at the same time.

The better-grade receivers are ex-

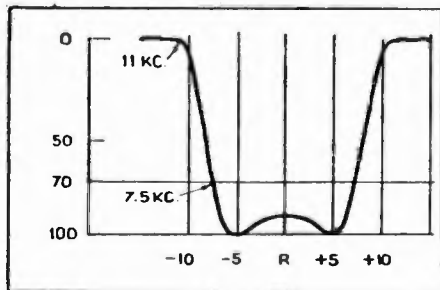

Fig. 1. Typical selectivity curve for a high-fidelity receiver.

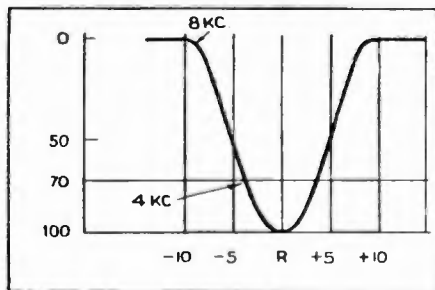

Fig. 2. Typical selectivity curve for an ordinary receiver.

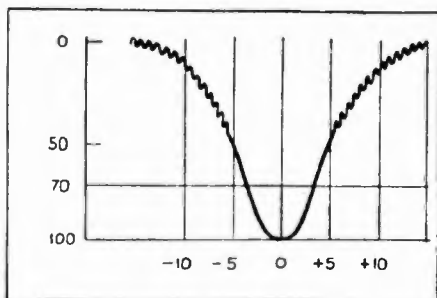

Fig. 3. Selectivity curve showing signal-to-noise ratio "ripple".

pected to give *high-fidelity* reproduction. This means that the R.F. sections of the receiver must pass, without appreciable attenuations, audio sidebands with a width of 5 to 7 thousand cycles per second, also that the audio amplifier in the receiver must be capable of amplifying, with equal response, frequencies between approximately 50 and 7,000 cycles per second.

To produce a satisfactory volume level with freedom from extraneous noise—i.e., to have *low noise signal ratio*—is probably one of the most vital points to the receiver owner.

CURRENT RECEIVER DESIGN

To manufacture receivers of this quality and meet the specifications pointed out, the design engineer has developed iron-core I.F. coils, over-coupled I.F. coils, automatic volume control, automatic frequency control, rejection filters, high-fidelity audio channels, and other complicated circuits.

Eventually there comes a day when the modern receiver will not operate correctly. The owner goes to a radio service laboratory to have the receiver restored to its original condition. This means that the Serviceman must be conversant with current receiver design, and possess the proper equipment to service the instrument. In order to assure himself ample profit from the work, the technician must be able not only to complete the work rapidly, but know that every circuit in the receiver is functioning properly when he is finished, so as to forestall subsequent failure and customer dissatisfaction.

ANALYSIS

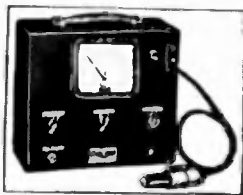

Fig. B. V-T. Voltmeter.

All of the modern performance requirements above enumerated may be rapidly checked by the selectivity response curve of receivers as

depicted on the cathode-ray oscilloscope. The mechanical method of obtaining this response curve is to adjust the receiver to resonance with a signal generator. An output meter is connected to the receiver output stage. By moving the signal generator off-resonance approximately 2 kc. at a time, and observing the output reading, it is possible to plot the output voltage against frequency off-resonance and obtain a selectivity or response curve.

Typical curve for a high-fidelity receiver is shown in Fig. 1, while the typical curve for the ordinary receiver is shown in Fig. 2.

Sensitivity is represented by the height of the selectivity curve, while selectivity is determined by the width of the curve at the zero voltage line. Fidelity of the receiver is judged from the width of the curve at approximately 70% of maximum voltage. If the signal generator is operated at low output voltage, the noise-to-signal ratio can be judged very closely. Experience with previous receivers will allow the technician accurately to determine this value. A high noise-to-signal ratio will appear usually along the base of the curve, as shown in Fig. 3.

After the curve for ordinary receivers illustrated in Fig. 2 is adjusted for maximum height and symmetry, it may then be analyzed for selectivity. The point at which the curve reaches zero voltage is 8 kc. off-resonance. In this instance, there would be no cross-talk from the station operating in the adjacent channel, which is 10 kc. off-resonance. Checking at 70% of maximum voltage, the curve intersection appears at 4 kc. This means that the R.F. section of the receiver will pass only

MODERN RADIO SERVICING TECHNIQUE

4,000 cycles of audio frequency as a maximum. If the audio section of the receiver is flat to 4,000 cycles or more, audio frequency which can appear at normal volume in the speaker will be 4,000 cycles per second. The base of the curve is relatively smooth, and it can be assumed that the noise-to-signal ratio is sufficiently low.

If a similar analysis is made of the high-fidelity response curve shown in Fig. 1, it will be found that the curve comes to the base line at 11 kc. The amount of cross-modulation from the station in the adjacent channel would undoubtedly be negligible in this instance. The 70% line intersects the curve at 7,500 cycles, which can be considered very good fidelity.

WHISTLES

Many superheterodyne receivers employ an I.F. rejection filter, which must be accurately adjusted with a signal generator and a suitable indicating instrument to prevent ex-

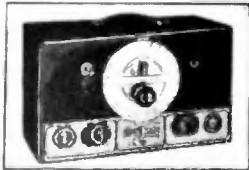

Fig. C. Signal Generator.

traneous whistles over a certain portion of the dial.

These heterodyne whistles are produced by commercial signals, outside of the broadcast band, feeding directly through the I.F. channel.

In many of the better-grade receivers, a 10,000-cycle cut-off filter will be found. This filter must be adjusted with a variable audio oscillator, and is for the purpose of removing heterodyne whistles which frequently occur when 2 relatively equal powered stations are operating on adjacent channels.

The cathode-ray oscilloscope (see Fig. A), or a vacuum-tube voltmeter (see Fig. B), should be used properly to adjust automatic frequency control receivers, as this adjustment is very critical, and only the most sensitive instruments may be used. Receivers having normal I.F. amplifiers may be aligned with an oscillator, as shown in Fig. C, and an output meter. High-fidelity receivers having over-coupled I.F. amplifiers must be adjusted on the cathode-ray oscilloscope if their fidelity is to be maintained.

Clough-Brenkle Co.

CHAPTER 3

Servicing Universal A.C.-D.C. Receivers

ONE of the most common types of receivers brought in for servicing is the "cigar box" type universal A.C.-D.C. receiver using a T.R.F. circuit with 4 or 5 tubes. Sets like these have been widely distributed over the entire country and have been sold at extremely low prices. Since manufacturing costs must obviously be kept down when a receiver complete with tubes is to sell for less than \$10, low-grade parts are often employed. Break-downs are frequent, and Service Men are expected to make prompt repairs.

Unfortunately for the customer, it costs very nearly as much to repair one of these small receivers as a larger set. When a customer hears the estimate of service costs, he generally exclaims:

"Why, I can buy a new radio for less than that!"

This is true, sad to say, but the business-like Service Man will point out that the parts in the new receiver will be no better than those in the old one, and the same trouble will undoubtedly develop in a short time. On the other hand, if the old receiver is repaired, using first-class parts which the manufacturer could not afford to employ, excellent results may be expected. The cost of service work on one of these sets should really be considered a part of the purchase price, for the value of the receiver will be increased in exact proportion to the value of the new high-grade parts. Such a line of reasoning seldom fails to bring in the job at a

MODERN RADIO SERVICING TECHNIQUE

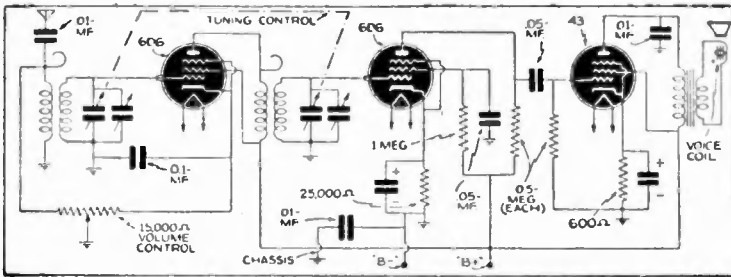

Fig. 1. Typical circuit of a midget A.C.-D.C. receiver.

high enough price to give the Service Man a fair profit.

Although this article deals primarily with the servicing of "universal"-type (or A.C.-D.C.) T.R.F. receivers for which circuit diagrams are not obtainable anywhere, the procedures described apply equally well to these T.R.F. receivers when circuit diagrams are at hand, and will also prove of value in servicing universal A.C.-D.C. superheterodyne receivers.

The signal circuits of a midget T.R.F. radio set are extremely simple. Generally there is one stage of radio-frequency amplification using a 6.3-volt super-control pentode tube such as the 78, 6D6 or 6K7. The former two types have the same base and are interchangeable, while the latter uses an octal base.

The R.F. amplifier feeds into the detector, which uses a pentode tube having a sharp plate-current cut-off characteristic. Interchangeable, type 6C6 or 77 tubes, or the octal-base 6J7 tube will generally be found in the detector stage.

The audio output of the detector is fed by means of resistance-capacity coupling into the power output tube, which is generally a type 43 pentode. This tube in turn feeds the loudspeaker; although a dynamic loudspeaker is more often used, you will occasionally encounter a magnetic speaker.

In some sets one or more *dummy* tubes will be found, with only the filaments connected into the circuit. As long as the filament circuit is not open, the condition of a dummy tube is immaterial; in fact, defective tubes are often used originally by the manufacturer to keep costs down while making the customer think he is getting a larger receiver.

TYPICAL "UNIVERSAL" CIRCUIT

In Fig. 1 is shown the typical signal circuit arrangement of an A.C.-D.C. T.R.F. receiver. There are several peculiarities which should be noted; these are: (1) the chassis may not be an electrical part of the circuit, in which case the ground symbols simply indicate that the parts so marked are connected together; (2) the screen-grid of the R.F. tube gets the same potential as the plate; (3) an external ground connection is not used because one side of the power line (which connects to the receiver circuits) is grounded; (4) the small coils connected to the primary R.F. coil windings provide capacitive coupling in addition to the usual inductive, primary/secondary coupling.

The aerial for a midget set is usually of flexible wire, permanently attached to the set and connected to the receiver input circuit through a small tubular or mica condenser. This aerial wire may

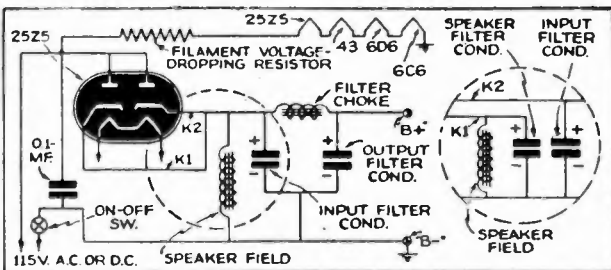

Fig. 2. Typical power-supply circuits of A.C.-D.C. sets.

MODERN RADIO SERVICING TECHNIQUE

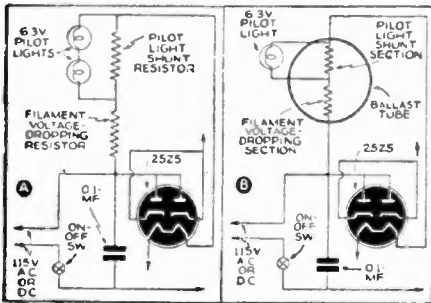

Fig. 3. A and B are different pilot light hookups.

be grounded to a water pipe or other external ground, in which case the R.F. signals picked up by the ungrounded side of the power line will flow through the primary of the 1st R.F. transformer, then through the antenna condenser and the aerial wire to ground. The R.F. signals passing through the primary induce a signal voltage in the secondary in the usual way.

If the chassis is an electrical part of the circuit and the line cord plug is inserted in such a way that the chassis connects to the hot (ungrounded) side of the power line, you may get a shock when you touch the chassis if some part of your body is grounded. If you get a shock, reverse the line plug if the source is A.C.; this will connect the chassis to the grounded side of the power line. In the case of D.C. power you cannot reverse the plug, for that would make polarity incorrect; you will simply have to avoid standing on a concrete floor (a good ground), and avoid touching any grounded object while working on the set with power on. With either A.C. or D.C. power, never make a direct connection from the chassis to an external ground, for this may short-circuit the power line and blow the line fuse.

TYPICAL A.C.-D.C. POWER SUPPLY

Figure 2 shows a typical power supply circuit used for both T.R.F. and superheterodyne universal A.C.-D.C. sets. A 25Z5 tube is connected as a single half-wave rectifier, but where the loudspeaker field coil is energized independently of the receiver circuit, there will be a separate connection to each cathode and an extra filter condenser connected directly across the loudspeaker field, as indicated in the dotted circle at the right in Fig. 2.

The tube filaments in a universal re-

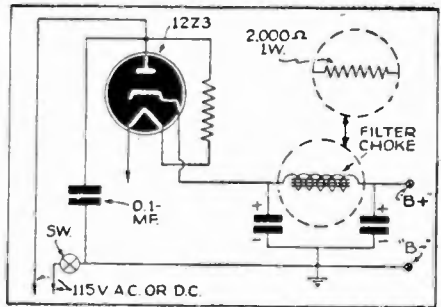

Fig. 4. The rectifier and filter circuit.

ceiver are wired in series, with each filament requiring 0.3-ampere. The filaments of the type 25Z5 and 43 tubes require 25 volts each, while the 6D6 and 6C6 tubes each require 6.3 volts. This makes a total of approximately 63 volts, and means that the filament voltage-dropping resistor must drop 115 - 63, or approximately 52 volts. Since 0.3-ampere flows through this resistor, it will have an ohm value of $52 \div 0.3$, or approximately 175 ohms.

If pilot lamps are used, they are usually placed in series with the voltage-limiting resistor. Each lamp is operated at about 4.25 volts, and hence the required voltage drop across the limiting resistor is reduced by this amount. Two pilot lamps connected as in Fig. 3A reduce this required voltage drop by 8.5 volts. (Although the lamps are rated at 6.3 volts, they are operated at 4.25 volts to prevent burn-out on surges.)

Pilot lamps are always shunted by resistors, for these lamps do not draw as much current as the tube filaments. The shunt resistance will be equal to the shunt current (the difference between the 0.3-ampere filament current and the pilot lamp current) divided into the voltage across the lamp or lamps.

Pilot Lamp Color Code. On A.C.-D.C. sets, only 2 types of pilot lamps are ordinarily used; these can be identified by the color of the glass bead through which the filament-supporting wires pass. A mazda No. 40 lamp with a miniature screw base draws 0.15-ampere and has a brown-colored bead. A mazda No. 46 lamp with a miniature screw base draws 0.25-ampere and has a blue bead, while a mazda No. 44 lamp with a bayonet base also draws 0.25-ampere and has a blue bead. A third type of lamp, having a white bead and drawing 0.20-ampere, is infrequently encoun-

MODERN RADIO SERVICING TECHNIQUE

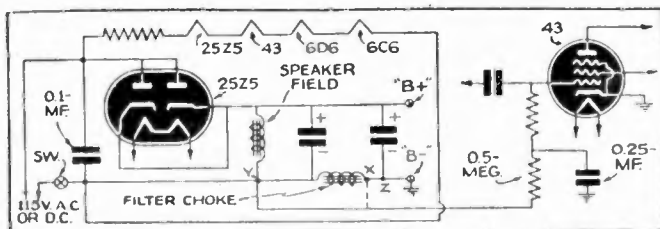

Fig. 5. Another power-supply circuit with the filter choke in the negative-supply lead.

tered. Replace burned-out lamps with new lamps having the same bead color and voltage rating (6.3 volts).

You will occasionally find 2 pilot lamps connected in series directly across the 110-volt line, with no shunt resistor across them. These will be 110-volt Japanese lamps similar to those used on Christmas trees. They are connected in series to operate at half-voltage, thereby having longer life while still giving sufficient light to illuminate the tuning dial.

Types of Filament Resistors. Various types of filament voltage-dropping resistors are used in universal A.C.-D.C. sets. Many of the earlier models use ordinary wire-wound resistors mounted under the receiver chassis. The chief disadvantage of these is that the heat which they radiate causes deterioration of nearby receiver components, chiefly the electrolytic condensers.

Line cord resistors, having the resistance wire embedded in asbestos and placed in the line cord along with the usual 2 copper wires, are now widely used because they keep the dissipated heat entirely out of the chassis. Line cords are easily identified by the fact that they have 3 leads instead of 2; the resistance wire is connected to one of the line wires, the connection being made directly to one of the prongs on the line cord plug. The line wire which connects to this same prong may be identified with an ohmmeter, and always goes to the rectifier plates. The other line wire will go to the ON-OFF switch which is mounted on the volume control of the receiver.

When a receiver which uses a line-cord resistor is in operation, the line cord becomes quite hot, but this is natural and is no cause for worry. Never attempt to shorten the line cord when it has a built-in resistance, for this would reduce the resistance value and affect the operation of the receiver.

Ballast tubes are even more satisfac-

tory than line cord resistors for filament voltage-dropping purposes. These tubes can now be secured with either glass or metal envelopes, the metal envelope being the more popular. The resistance element is mounted inside the envelope and connected to prongs on the tube base. Oftentimes taps are provided, with connections to tube prongs, to eliminate need for separate pilot lamp shunt resistors; an example of a ballast tube having one tap for this purpose is shown in Fig. 3B.

When a ballast tube burns out, always replace it with another having exactly the same number. This is necessary because the tubes are made with many different ohmic values and with many different arrangements of prong connections. Ballast tubes become very hot while in use, but as the heat is above the chassis, critical parts in the receiver are not damaged.

Service Men are sometimes asked to replace line cord resistors with ballast tubes; space limitations make it inadvisable to attempt this, for midget receivers are quite compactly constructed. Incidentally, an ohmmeter provides the quickest way of identifying the various prongs on a ballast tube.

Rectifier Circuit Variations. A single 12Z3 rectifier tube or even a type 37 triode with grid and plate connected together may be found in a circuit arrangement like that in Fig. 4. Since supplying field excitation to a dynamic speaker would place too heavy a drain on the rectifier, you may expect to find a magnetic loudspeaker in a receiver

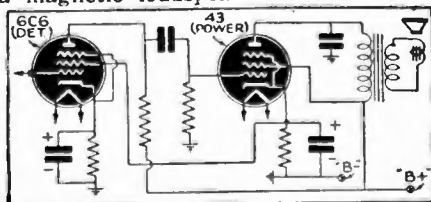

Fig. 6. The detector screen-grid obtains its bias from the cathode of the power tube.

having this power pack circuit. The 0.1-mf. condenser connected across the power line tends to prevent interference from entering the receiver by way of the power line. Oftentimes a 2,000-ohm, 1-watt resistor is used in place of the more efficient but bulkier and more costly filter choke, as indicated inside the dotted circle in Fig. 4.

Sometimes you will find a circuit which uses two 12Z3 tubes connected in place of a single 25Z5; the circuit will be the same as that in Fig. 2 except that the 2 diode sections of the rectifier tube will be in separate envelopes. The filaments of the two 12Z3 tubes will be in series and will together be electrically equivalent to the filament of a single 25Z5 tube. This gives the set an extra tube and is therefore an advantage from a sales standpoint. The 2 tubes supply sufficient power for loudspeaker field coil excitation, and hence a dynamic loudspeaker will usually be found. A single 12Z3 tube cannot, however, supply enough current for both the loudspeaker field coil and the receiver circuits and last a normal length of time.

Another power pack circuit using a 25Z5 rectifier tube is shown in Fig. 5. Here the filter choke is placed in the negative plate supply lead, and the voltage drop across the choke is used as C bias for the control grid of the power tube. When the voltage drop across this choke is not correct for biasing purposes, a resistor is inserted between points *x* and *z* in Fig. 5, and the control-grid return lead of the power tube is run to point *x*, as indicated by the dotted line, instead of point *y*. The ohms value of the inserted resistor is so chosen that the voltage drop across the resistor equals the correct bias voltage for the tube. Notice that the cathode of the power tube is grounded, eliminating the need for a cathode bypass condenser and resistor. A decoupling resistor and condenser are required in the control-grid circuit of this tube, however.

A rather unique method sometimes used to secure a positive screen-grid voltage for the detector tube is shown in Fig. 6. Observe that here the detector screen-grid is connected directly to the cathode of the power tube, which is sufficiently positive with respect to the detector tube cathode for this purpose.

FILTER CONDENSERS

Filter Condenser Connections. When the filter choke is in the positive side of the power pack circuit, all electrolytic condensers will have a common negative lead. When the filter choke is in the negative side of the circuit, however, the negative side of the input filter condenser does not connect to ground (chassis) and consequently requires a separate lead. In this case the 2 filter condensers may have a common positive lead, as is the case in Fig. 5.

Failure of filter condensers is quite a common occurrence in universal A.C.-D.C. receivers. Oftentimes there will be no markings whatsoever on the old condenser block to serve as a guide in ordering a new unit; in a case like this, the following method of reasoning will allow you to order a satisfactory replacement.

Make a sketch of the old condenser block, showing all leads which come out from it. Now trace each condenser lead and determine where it goes in the circuit. By this time you will be able to recognize the type of power pack circuit used. Label each lead on your sketch according to the point to which it connects, and indicate its polarity. Once you recognize the type of circuit used, you will have no difficulty in determining the polarity of any point with respect to the "B—" lead and in drawing the internal connections for the condenser sections. Condenser block sketches for the power pack circuits given previously in this article are shown in Fig. 7.

Here are a few tips towards identifying the various leads. If the filter choke is in the positive side of the power pack circuit, as evidenced by a direct connection from one of the choke terminals to the cathode or cathodes of the rectifier tube, then all of the filter condensers in the block will have a common negative lead. You can identify this common lead by the fact that it connects to the receiver side of the ON-OFF power switch either through the chassis or through a common lead. Once this is done, you can draw in the internal connections of the condenser block just as has been done in Fig. 7.

If the choke is in the negative side of the power pack circuit, as evidenced by the rectifier tube cathode tracing directly to the screen grid of the power tube without encountering any current-limiting or choking devices, you can locate the negative lead for the input filter condenser by the fact that it will be the only filter condenser lead connected to the switch side of the filter choke. Where the loudspeaker field coil gets its current from a separate section of the 25Z5 rectifier tube, there will be a condenser across the loudspeaker field coil with its negative lead also connected to the switch. In most cases a single common negative lead is used for both condensers. The positive leads for these condensers are easily identified; the positive lead of the loudspeaker filter condenser will go to that 25Z5 cathode to which the speaker field is also connected, while the positive lead of the input filter condenser will go to the other cathode of the rectifier tube.

Having located the leads and determined the functions of the various sections of the electrolytic filter condenser block, you are ready to place on your sketch the approximate capacity values for each section. Use the following general rules as your guide:

Input Filter Condenser—any value between 10 mf. and 20 mf., rated at 200 volts D.C. working voltage; **Output Filter Condenser**—any value between 8 mf. and 16 mf., rated at 200 volts D.C. working voltage; **Loudspeaker Field Coil Filter Condenser**—between 4 mf. and 8 mf., rated at 200 volts D.C. working voltage; **Cathode Bypass Condensers**—5 mf., rated at 25 or 35 volts D.C. working voltage.

While condensers smaller than the minimum values given should not be used, the maximum values may be exceeded without impairing the operating qualities of the receiver. The voltage ratings can likewise be higher than the minimum values given.

Your electrolytic condenser block sketch now gives you the necessary data for ordering a replacement unit. If a unit having the desired internal connections and desired capacities is not available, the next best thing is to order a condenser block having the desired capacities and separate leads for each section. If even this is not available, make up your condenser block

MODERN RADIO SERVICING TECHNIQUE

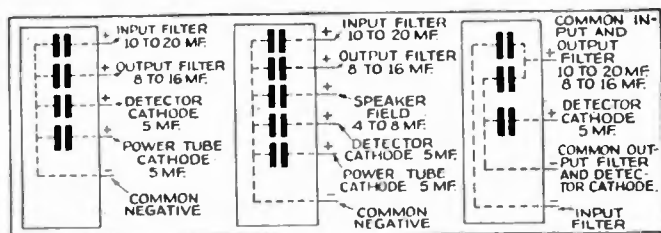

Fig. 7. Typical connections for the electrolytic condenser blocks used in midget A.C.-D.C. sets.

from two or more separate electrolytic condenser units having the desired capacity and voltage ratings. When ordering separate units in this way, be sure to check the available space and choose units which are small enough to fit this space.

JUSTIFIED COMPLAINTS

Is the Customer's Complaint Justified? The operating characteristics of a universal A.C.-D.C. or "cigar box" receiver of the T.R.F. variety must be carefully considered before attempting service work, in order to make sure that the customer's complaint is justified. These little receivers are designed primarily for reception of powerful local stations which are spaced well apart in the broadcast band. The receivers have little selectivity, so that local stations which are separated by less than 100 kc. may be expected to interfere with each other. The receivers likewise have poor sensitivity, and the reception of distant or even semi-distant stations will therefore be unreliable. Where the complaint of the customer simply involves one of these factors, no service problem exists. Likewise, good fidelity and freedom from blasting at full volume should not be expected from these receivers, particularly if they employ a magnetic-type loudspeaker. *The customer making complaints which involve these factors is asking too much of his receiver and requires a better receiver to meet his needs.*

Common Troubles. The simplicity of the circuits used in universal T.R.F. receivers greatly limits the variety of troubles which may develop. The complaints which will most often be encountered are: *Set is dead; local signals are weak; hum is excessive; set distorts; oscillation (squealing) exists; set operates intermittently.*

Servicing "Dead" Receivers. When the receiver is "dead," determine first of all if the tubes light or warm up. An open-circuit somewhere in the series filament circuit is indicated if they do not. Take out each tube in turn and check its filament prongs with an ohmmeter for continuity or test the tube in a conventional tube tester. If tubes are OK, check the filament voltage-dropping resistor with an ohmmeter. If a ballast tube is used for this purpose, inspect its socket connections in order to determine between which prongs there should be continuity. If a line cord resistor is used, check with an ohmmeter between the line cord resistor lead and each prong on the wall socket plug in turn (the plug being removed from its outlet); with the power switch open, or one tube removed, there should be continuity between one of the prongs on the wall plug and the receiver end of the line cord resistor if this resistor is OK. If there is a shunt resistor across the pilot lamp or lamps, check this with the ohmmeter for continuity. Check pilot lamps also for continuity.

If the set is dead but all tubes light up and test OK, use the D.C. voltmeter section of your multimeter to measure the voltage between the

common rectifier-tube cathode connection and the tuning condenser frame (this always being at "B—" potential and convenient to reach with a test probe). With the set plugged into an A.C. outlet, you should measure between 90 and 120 volts, while with the set plugged into a D.C. outlet, this voltage may be as low as 85 volts. If no voltage is measured here on D.C., try reversing the position of the line plug; proper polarity must always be observed on D.C.

A low rectifier-tube output voltage on A.C. operation is an indication of defective filter condensers. Check each condenser or condenser section in turn, by disconnecting one of its leads and then checking the condenser for leakage with an ohmmeter. If leakage resistance is lower than the normal value for a condenser of similar size, the condenser is defective and requires replacement. Even if leakage resistance is normal (check the leakage resistance of a new condenser, of about the same size for comparison if you are uncertain), the condenser may still have deteriorated through drying out of the electrolyte, with a resultant lowering of its capacity. Try a new filter condenser at each position in turn, while the old unit is disconnected. Separate 8-mf., 475-volt test condensers should be kept on hand for tests like this on any receiver. If the rectifier-tube output voltage comes up to normal when a new condenser is inserted, this is a sign that the old condenser was defective.

Even when only one section of the old electrolytic filter condenser is bad, a new block should be installed, for there is a good possibility that the other sections of the block will soon fail in a similar manner if left in the receiver. When using a test electrolytic condenser in this manner, you must, of course, observe polarity very carefully, for connecting an electrolytic condenser to a voltage source with improper polarity will in most cases ruin it.

If the rectifier tube output voltage of the "dead" receiver is normal, check the D.C. voltages between the "B—" point in the circuit and each plate and screen-grid prong of each tube. Repeat this test for the corresponding tube socket lug; failure of the two readings for any one tube electrode to correspond indicates a break between the lug and the tube socket prong connection, making the installation of a new socket necessary.

Improper voltages on any tube electrode will point to the source of trouble, just as in the case of an ordinary A.C. receiver. The circuit diagrams in this article will give you an idea as to what voltages to expect; obviously the detector tube plate voltage and the control-grid voltage on the power tube will be quite low due to the high values of resistance in these circuits.

Simple continuity checks of various receiver circuits often prove the speediest way of locating trouble in a "dead" receiver. There should be continuity between the rectifier-tube cathode and

MODERN RADIO SERVICING TECHNIQUE

the plates, as well as screen-grids, of all other tubes in the receiver, with the exact ohmmeter reading depending upon the sizes of the resistors in the various circuits. There should be continuity from the receiver side of the ON-OFF power switch to the control-grids, as well as the cathodes, of all tubes in signal circuits.

Rotor and stator plates of tuning condensers are sometimes shorted together; inspection will often reveal such a short, but if doubt exists, disconnect the coil lead from the stator of each section and check each section individually with an ohmmeter. There should be no continuity between rotor and stator plates of a section.

To check the bias resistors in the cathode leads of the detector tube and the power tube, first disconnect the electrolytic cathode bypass condensers and then check the resistor with an ohmmeter. These condensers often have sufficient leakage to mask the effect of an open resistor. While making this test, check the leakage resistance of the bypass condenser with the ohmmeter.

Circuit disturbance tests on these receivers are limited to touching the control-grid caps with the finger or removing the caps, for pulling out a tube opens all filament circuits and masks the effect of the test. The above tests should result in location of the trouble in any "dead" universal-type receiver which uses a conventional T.R.F. circuit.

ADDITIONAL DATA

Servicing Weak Receivers. Essentially the same tests are made on a weak receiver as on a dead receiver. In addition, the dynamic loudspeaker field coil and its supply should be checked by applying a screwdriver to a pole piece; absence of pull indicates a defective field coil or no supply voltage to it. The continuity of the aerial should be checked with an ohmmeter, and the trimmer condensers should be readjusted for maximum output. Weak reception can often be cured by moving the control-grid leads around enough to secure a small amount of regeneration.

It is a good idea to check the line voltage in the customer's home when weak reception is the complaint; if this voltage is below normal, report the matter to the local power company. Ordinarily there is nothing you can do to a receiver of this type to offset low line voltage. Excessively high line voltage is not serious in these small receivers, for the tube filaments and the pilot lamps are designed to stand up under all normal fluctuations in line voltage. With D.C. power lines particularly, the line voltage on peak loads may drop to a point where no reception is obtained, and again the trouble is not the fault of the receiver.

Servicing Receivers for Hum. A certain amount of hum is to be expected in any receiver operating from an A.C. line. Many Service Men forget this fundamental fact and spend hours trying to eliminate perfectly normal hum which they observe after correcting the original defect in the receiver. Hum should never be so loud, however, that it becomes annoying when listening to the program from a local station. Excessive hum is often caused by a reduction in capacity of filter condensers, by a heater-to-cathode short in some tube, by an improper connection of a filter condenser, or by an open control-grid return.

Curing Distortion. Improper centering of the loudspeaker voice coil is a common cause of distortion; the usual corrective methods apply here just as in larger receivers. Always try a new output tube when distortion is the complaint, for the great amount of heat dissipated by the heater in this tube often affects other electrodes in the tube.

A leaky coupling condenser between the detector and the grid of the output tube is another likely cause of distortion. If you can measure a D.C. voltage across the grid resistor of the output tube when the positive voltmeter probe is connected to the grid end of this resistor, a leaky coupling condenser is indicated; replace with a 0.05-mf., 600-volt cartridge condenser if you cannot determine the value of the original part. Check the ohms values of the cathode bias resistors, and check cathode bypass condensers for leakage in the manner already described, for these are also possible causes of distortion.

Distortion often occurs when the volume control is turned up too high when tuned to a strong local station; this is a normal condition due to overloading of the receiver stages or of the loudspeaker, and the remedy obviously is for the customer to keep the volume level below the point at which distortion begins.

Curing Oscillation. A certain amount of oscillation is to be expected in these midget receivers when the volume control is advanced to its maximum setting, for the designers of these sets depend to a certain extent upon regeneration for high gain. Oscillation at low volume control settings can be due to open bypass or filter condensers, as well as to failure to use tube shields if they were originally provided. Shielding of the control-grid leads of the R.F. and detector tubes, if these leads are over-exposed, or changing the positions of these leads are likely cures. Connecting the aerial to an external ground is sometimes effective in eliminating oscillations. Cramming the aerial into a small space will often cause circuit oscillation; keep this wire stretched out to its extreme length. As a last resort, when oscillation cannot be cured in any other way, detune the trimmer condensers until it ceases.

Intermittent Reception. Any of the usual causes of intermittent reception in radio receivers are to be expected in these midgets, but my experience has shown that in most cases either a defective type 43 output tube or a defective coupling condenser between this tube and the detector stage will cause intermittent trouble. Try a new output tube first of all, then try a new coupling condenser. If the trouble persists, wiggle each of the tubular condensers in the receiver in turn with your hand in an attempt to make the trouble appear. If this is not successful, resolder all connections in the receiver. If the volume control is noisy in its action, install a new control. Check the aerial with an ohmmeter while bending it slowly back and forth through its entire length, for this will sometimes reveal a break.

General Suggestions. Unless you are thoroughly familiar with the socket connections of the tubes used in these midget receivers, always have tube base layouts at hand for ready reference. These layouts are particularly helpful when making point-to-point voltage or resistance tests and when locating various parts in the receiver.

National Radio Institute

CHAPTER 4

Servicing "Orphans" and Private-Brand Sets

PART 1

PRESENT-DAY radio receiver service practice calls for the use of *service manuals* to locate the exact wiring diagram of the set involved. Provided with a wiring diagram and a reasonable amount of service equipment, the average radio technician has little difficulty restoring a standard receiver to its original operating condition. In following this practice day in and day out the Serviceman finds that the inevitable schematic becomes a necessity and unless it is available the proper service procedure is not instantly apparent.

For example there are receivers manufactured by major companies but marketed under private brands; also so-called "loft" receivers manufactured by smaller companies on contract; also numerous custom-built or special receivers, any one of which may be brought in for service and the service manual or wiring diagram not immediately available.

To service such receivers, the Serviceman needs a fair knowledge of the fundamentals common to all radio receivers regardless of type or manufacture. Standard service practice calls for restoring the circuit to its original condition and little thought given to the possibility of simple changes that will add improved operation and eliminate frequent disability. With few exceptions broadcast receivers are manufactured to a certain minimum cost and that calls for low safety factors of critical parts and sacrifice of desirable features in many instances. The Serviceman coming in close contact with his customers can often point out the advisability of changes or improvements versus simple repair of one defective part, a procedure that will add profits to the till.

The purpose of this article is two-fold, first it gives full information regarding the proper method of servicing "odd" receivers, or as a matter of fact any receiver, without the use of a diagram or service manual. Secondly, the same information will be found useful in improving radio receivers during the servicing operations.

EQUIPMENT

The following minimum service equipment should be available:

- (1) Tube-Tester.
- (2) Combination A.C.-D.C. Voltmeter, D.C. Milliammeter and Ohmmeter (the latter feature is also available for continuity tests).
- (3) Pair of Headphones.

The following additional equipment is desirable, and given in the order of importance:

- (1) Signal Generator.
- (2) Condenser Tester.
- (3) Vacuum-Tube Voltmeter.

BASIC CIRCUITS

Basically, all radio broadcast receivers and their circuits are essentially the same in that they employ (1) radio-frequency amplification; (2) rectification; (3) audio-frequency amplification; (4) a loudspeaker; and, (5) a power supply. Factors 1, 2, 3 and 4 are common to both tuned-radio-frequency and super-heterodyne receivers, and the latter also calls for additional radio-frequency amplification at an intermediate frequency in conjunction with 1 of 3 oscillator-mixer methods, viz:

- (1) A Mixer tube, either a triode, tetrode or pentode, and an Oscillator tube; the oscillator and signal voltages are applied to the same grid. The 2

MODERN RADIO SERVICING TECHNIQUE

circuits may be coupled by a condenser (capacity-coupled, through C4) as shown in Fig. 1A; or they may be inductively-coupled by suitable mechanical relation of the inductances L1 and L2, L3. This method was very common prior to the introduction of special tubes for this application.

(2) A Pentagrid Converter Tube may be used, wherein the oscillator tube and mixer tube are combined in 1 shell and the 2 circuits electron-coupled, as shown in Fig. 1B.

(3) A Pentagrid Mixer (especially designed for shortwave or all-wave circuits), having 2 separate control-grids, 1 for the R.F. signal and 1 grid for the oscillator voltage, and used with a separate oscillator tube, as shown in Fig. 1C.

While on the subject of *oscillators*, it is well to point out there are practically only 2 types of oscillator-coils used, one without a tickler winding and the other with a tickler winding, these are shown in Figs. 1D and 1E. The circuit in Fig. 1D, without the tickler, oscillates due to capacity feedback across the padding condenser C1, and is used principally for the broadcast band or lower frequencies. For the shortwave bands, the tickler method (Fig. 1E) gives more stable operation, especially on the higher frequencies and is preferred and used for that reason. Tests and adjustment to mixer-oscillator circuits will be described further on in this article.

CIRCUIT FEATURES

Aside from the fundamental circuit divisions previously mentioned, various receivers include one or more features developed in recent years including automatic volume control; automatic frequency control; noise limiters; signal (gain) limiters; volume expansion for record reproduction; devices to regulate selectivity, sensitivity, audio volume and audio characteristics, etc. Initial discussions will be confined to basic circuit factors.

HOW TO START?

There are 2 approaches in starting on a defective receiver, the proper one depends entirely on how thoroughly the customer wants the receiver serviced and his willingness to pay accordingly. If the repairs and repair costs are to be

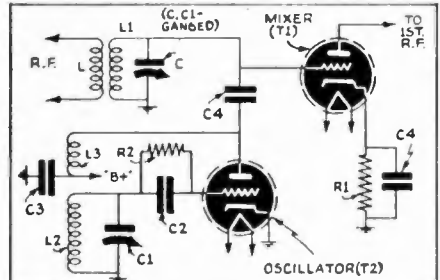

FIG 1A ~INDIVIDUAL OSCILLATOR-MIXER CIRCUIT~

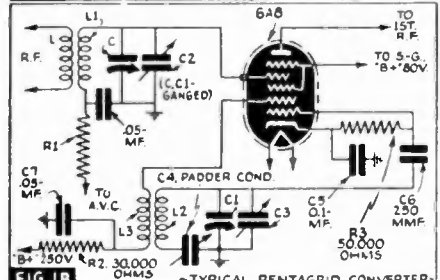

FIG 1B ~TYPICAL PENTAGRID CONVERTER~

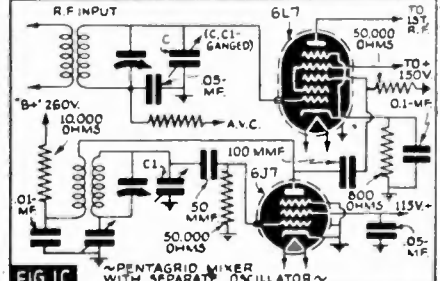

FIG 1C ~PENTAGRID MIXER WITH SEPARATE OSCILLATOR~

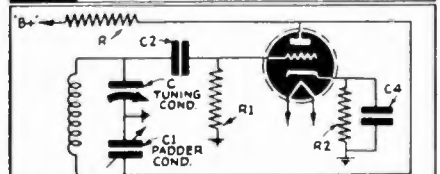

FIG 1D ~OSCILLATOR COIL WITHOUT TICKLER~

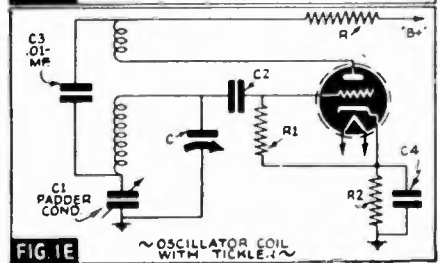

FIG 1E ~OSCILLATOR COIL WITH TICKLER~

confined to the single defect involved, the difficulty may be located promptly in many instances without elaborate

MODERN RADIO SERVICING TECHNIQUE

meter tests. The tubes are checked, replaced where necessary and the set placed in operation. Under these circumstances experience is often useful in quickly determining the source of trouble.

The second approach, where the owner requires a 1st-class repair job, and will pay a fair price accordingly, calls for a systematic check of the complete receiver. An efficient procedure is as follows:

1. Check and test all tubes, making replacements where necessary.
2. Test loudspeaker circuit; resistance and continuity of the electrodynamic speaker field; the resistance and continuity of the speaker voice coil, and the output transformer voice winding, individually, by disconnecting one from the other. Test for grounds or high-resistance leakage between the speaker field, voice coil and transformer voice coil winding to ground. While testing the continuity of the voice coil, the coil itself should be moved back and forth vigorously to determine that the flexible leads to the voice coil are not partially broken. Check the mechanical clearance between the voice coil and pole piece.
3. Check the power supply, which may utilize one of the following systems:
 - (a) Transformer, and either full-wave or half-wave rectifier tubes, as shown in Fig. 2A.
 - (b) Transformerless, A.C.-D.C. system, with series filaments and a rectifier; see Fig. 2B.
 - (c) A Voltage-Doubler Rectifier Circuit, per Fig. 2C.
 - (d) A Vibrator Power Pack, per Fig. 2D.
 - (e) Batteries.
 - (f) A Motor-Generator, Dynamotor or Rotary Converter.

POWER SUPPLIES

A large majority of all transformer power supplies use a full-wave rectifier tube. Occasionally a power pack will have a single half-wave rectifier, and for practical purposes, it can be considered either half of a full-wave circuit. In some high-voltage power supplies, we find 2 half-wave rectifiers used to make a full-wave circuit; for example, two 281 tubes as shown in diagram 2A.

The principal difference between transformer rectifier circuits is the matter of either choke or condenser input

to the filter. The *choke input* has the advantage of better regulation, tending to keep plate current constant and preventing distortion in R.F. or A.F. tubes due to current fluctuations. It also has the advantage of less voltage strain on the 1st filter condenser, C1, as shown in the Choke Input circuit.

The condenser, C, in the *condenser input* type of circuit must be capable of withstanding the instantaneous peak A.C. input voltages (1.4 times the r.m.s. value indicated on an A.C. voltmeter), and consequently, this is a common point of failure due to insufficient rating. To correct this condition when a sufficiently high-rating condenser is not available, 2 lower-voltage condensers may be connected in series to get the desired result, viz., two 16-mf., 400-working-volts condensers in series in place of one 8-mf., 475-working-volts condenser. When using series condensers for this purpose, they should be shunted by equal, high resistances to equally divide the total strain across the 2 condensers; this is shown by dotted lines in Fig. 2A. For the above case, equal resistors of about 50,000 to 100,000 ohms would be satisfactory.

To properly check a power supply, the "B plus" lead to the receiver should be disconnected and a dummy load substituted in the form of a resistor having a value which will duplicate the receiver plate load. The proper resistor can be calculated from Ohm's law, estimating the receiver's total plate load in milliamperes and the estimated plate voltage.

$$R = \frac{E_p}{I_p}$$

This is resistor R in Fig.

2A. Under this condition, tests on the power supply are independent of any influence from possible defects in the other parts of the receiver circuit.

The power supply tests then consist of the following (under load):

- (1) Line voltage across primary of transformer
- (2) Rectifier filament voltage.
- (3) Filament voltage to receiver tubes.
- (4) A.C. voltage input to rectifier plates (Y to ground).
- (5) Unfiltered D.C. (X-1 to ground).
- (6) Voltage drop across filter choke or chokes. Knowing the total

MODERN RADIO SERVICING TECHNIQUE

choke resistance and voltage drop across same, the total D.C. flowing can be calculated from Ohm's law.

Tests on the above circuit will not indicate an open filter condenser and these condensers should be tested separately for capacity if possible. Abnormally high A.C. voltages to the rectifier plates and also to the tube and rectifier filaments indicates shorted turns in the primary of the transformer. Lack of A.C. at any secondary point of the transformer of course indicates an open transformer winding. The voltage drop across the filter chokes having been checked, the proper D.C. voltages can be expected between X2 and X3 to ground. Shorted filter condensers are invariably instantly detected by the smoke emitted from the unit! A worn out tube will prevent obtaining proper D.C. voltage at X1, however it was previously stated that all tubes should first be tested.

The simpler rectifier circuits, for example the 25Z6 (Fig. 2B) commonly used in A.C.-D.C. sets with series filaments and half-wave rectification, or the 25Z6 used as a voltage doubler (Fig. 2C), are treated in the same manner. The D.C. voltages available from the doubler circuit are approximately twice that obtained from the same tube in the half-wave circuit. In the doubler circuit, the maximum voltage obtainable and the degree of regulation can usually be improved substantially by increasing the values of C and C1, up to about 32 mf., each.

OTHER POWER SUPPLIES

Secondary circuits of Vibrator Power Supplies are also treated in the same manner, an examination of Fig. 2D indicating that the circuit from the secondary of the transformer is practically the same as that of a transformer-rectifier circuit.

Battery Power Supplies need little mention other than caution that all voltage tests, to be of any value, must be made under full load conditions.

In checking output voltages available from Motor-Generators, Dynamotors or Rotary Converters, here again the tests must be made under full load operating conditions and while making these measurements, an examination of the commutators and collector rings should be made to see that they are free from any abnormal sparking. A check should be made to see that the machine frames are well grounded. Repairs to motor-generators, dynamotors and rotary converters should be carried out by repair shops specially equipped for this kind of work.

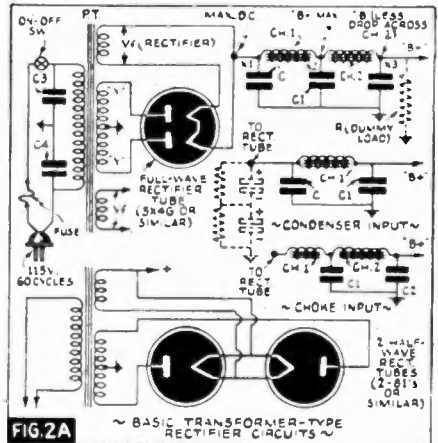

FIG. 2A ~ BASIC TRANSFORMER-TYPE RECTIFIER CIRCUITS ~

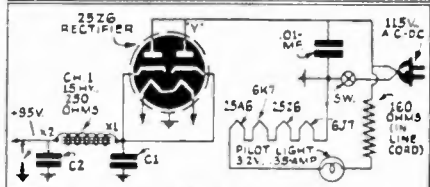

FIG. 2B ~ HALF-WAVE RECTIFIER-TYPICAL CIRCUIT FOR AC-DC ~

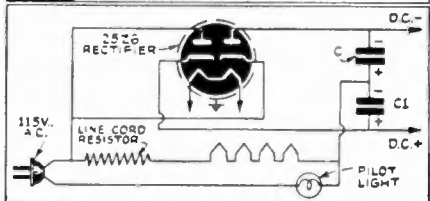

FIG. 2C ~ VOLTAGE-DOUBLER RECTIFIER-TYPICAL CIRCUIT FOR "TRANSFORMERLESS" SET ~

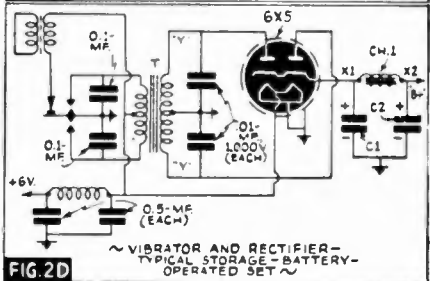

FIG. 2D ~ VIBRATOR AND RECTIFIER-TYPICAL STORAGE-BATTERY-OPERATED SET ~

Knowing that the receiver tubes are in perfect condition, that the power pack is functioning properly and that the loud-speaker circuit is in order, the technician is now in a position to proceed, confident that existing defects in remaining sections of the circuit can be located quickly and efficiently.

Servicing "Orphans" and Private-Brand Sets

PART 2

IN Part I, the discussion covered methods of checking the power supply and loudspeaker circuits. Knowing definitely that these 2 portions of the circuit are in order, greatly simplifies locating defects in other sections of the receiver.

In extreme cases the receiver involved may come into the shop without tubes and without marked sockets, or wrong type tubes may be found in one or more sockets. Accordingly, without a diagram, the Serviceman is not only called upon to find defects but also to determine the proper tube complement.

DETERMINING TUBE COMPLEMENT

Measurement of the transformer filament winding will determine the series—2½-, 6.3-, 7-volt, etc. Absence of external shields for the R.F. tubes will ordinarily indicate metal tubes were originally used. The type and number of socket connections will be of further assistance in this direction. For example in examining a resistance-coupled audio amplifier stage, by checking the plate,

grid and bias resistors used, against tube manual tables, one can determine if an ordinary triode or a hi-mu triode circuit is intended, for a 5-contact socket.

Possibly less than 50% of all Servicemen are completely equipped with modern test equipment. Accordingly in a discussion of this type, while the procedure calls for the use of test instruments, information is given covering satisfactory workable substitutes, therefore making the subject interesting to the largest possible number of readers.

After having checked the power supply and speaker circuits, the balance of the set may be checked by starting at either the antenna or audio end. Preference is given to approaching the audio end first, because here again knowing the audio section is in order facilitates the remaining tests.

THE A.F. CHANNEL

Before subjecting the audio amplifier to signal tests, it is well to check the voltages appearing at each tube, that is the plate voltage, screen-grid voltage (if used), and

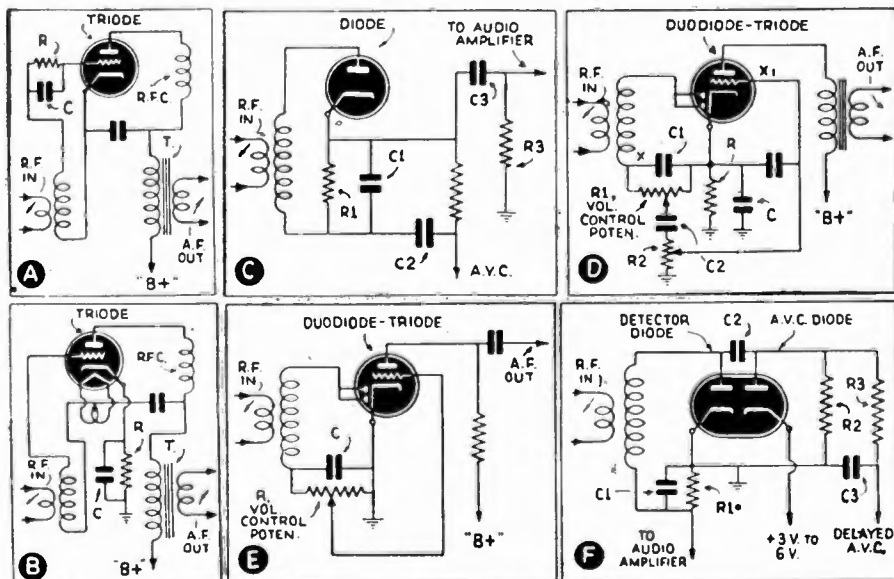

Fig. 7. Basic detection circuits. (A) Triode gridleak-and-condenser detector. (B) Triode grid-bias detector. (C) Diode detection and A.V.C.

(D) Duplex duodiodetriode tube (detector, and A.F. amplifier). (E) Diode-biased detector, using duplex duodiodetriode. (F) Dual diode detector and delayed A.V.C.

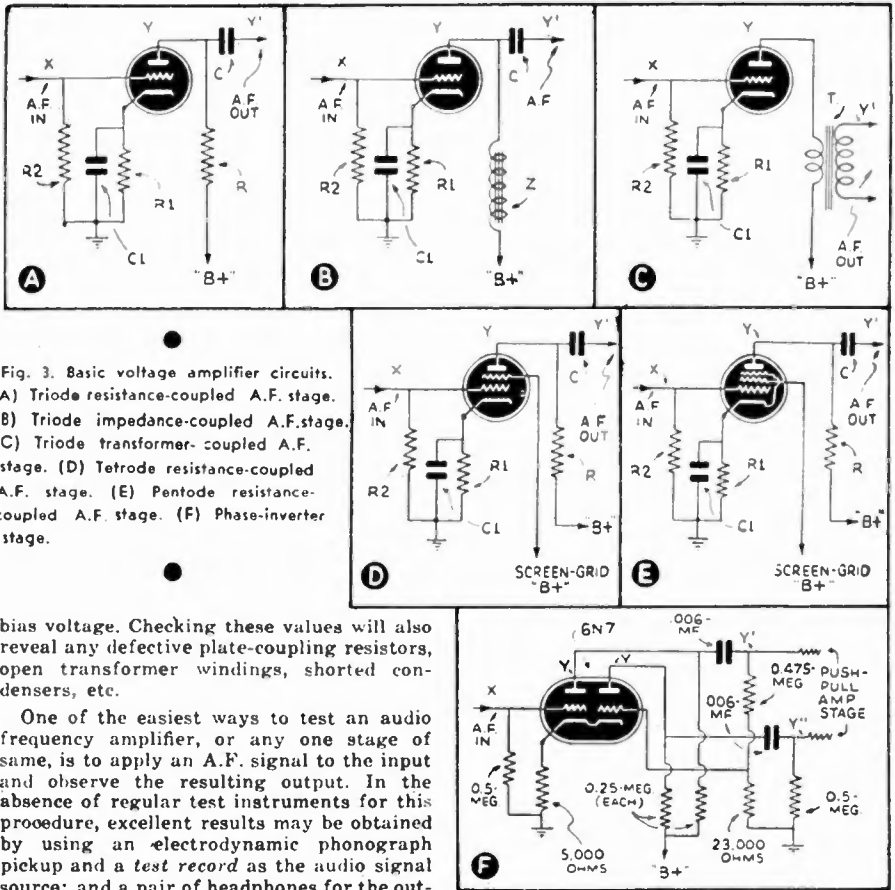

Fig. 3. Basic voltage amplifier circuits. (A) Triode resistance-coupled A.F. stage. (B) Triode impedance-coupled A.F. stage. (C) Triode transformer-coupled A.F. stage. (D) Tetrode resistance-coupled A.F. stage. (E) Pentode resistance-coupled A.F. stage. (F) Phase-inverter stage.

bias voltage. Checking these values will also reveal any defective plate-coupling resistors, open transformer windings, shorted condensers, etc.

One of the easiest ways to test an audio frequency amplifier, or any one stage of same, is to apply an A.F. signal to the input and observe the resulting output. In the absence of regular test instruments for this procedure, excellent results may be obtained by using an electrodynamic phonograph pickup and a test record as the audio signal source; and a pair of headphones for the output circuit, as per Fig. 5. This not only gives an indication of gain-per-stage, but by using high-grade wide-range phones, also gives a direct aural indication of quality and frequency coverage.

By connecting the phones directly across the phono pickup coil the direct response, for comparison, is obtained. This method is useful in testing 1 or 2 stages; where more amplification is present, the output should be observed at the loudspeaker. In testing an audio stage for quality and frequency coverage in this manner, the selection of the test record is very important. The recording should include musical instruments that jointly cover the entire musical scale. For example, vibraharp, bass violins and drums are excellent tests for the low frequencies; while flutes, piccolos, triangles and bells are excellent tests for the higher frequencies.

BASIC A.F. CIRCUITS

In using this signal-test method exclusively the technician may come to a stage giving distortion but also finding that all the electrical components appear to be in

order. The trouble may be due to insertion of the wrong type tube and in this case a fair knowledge of the basic amplifier circuits and related tubes is valuable.

VOLTAGE AMPLIFIERS. Figure 3A is a standard triode resistance-coupled stage. Figure 3B is a similar amplifier but using an impedance plate load.

Figure 3C shows the standard transformer-coupled stage, the gain depending upon the tube used and transformer ratio; the frequency coverage depending upon the design of the transformer. It must be remembered that regardless of the fidelity obtained by preamplifiers which may be resistance-coupled, the overall fidelity is limited by the performance of either the driver transformer or output transformer, accordingly for exceptional results these last 2 mentioned units should be of high-quality design.

Figure 3D shows a tetrode resistance-coupled amplifier; and Fig. 3E, a pentode resistance-coupled amplifier, the latter used

MODERN RADIO SERVICING TECHNIQUE

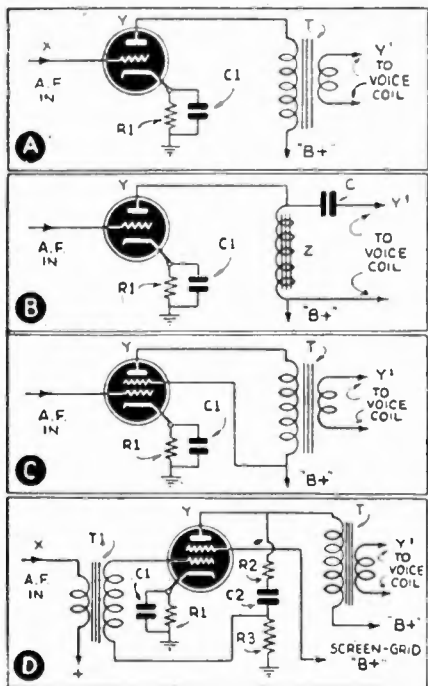

Fig. 4. Basic power amplifier circuits. (A) Triode output A.F. stage, transformer-coupled. (B) Triode output A.F. stage, impedance- (or resistance-) coupled. (C) Tetrode (beam power) output A.F. stage transformer-coupled. (D) Ditto, but with inverse audio feedback.

for high gain-per-stage (with the sacrifice of possible distortion). All interstage audio amplifiers are primarily *voltage amplifiers*.

Audio stages can be quickly serviced by first determining that the associated resistors and condensers are of the proper value and in perfect condition; 2nd, determine that the proper tube is being used and that the rated cathode bias voltage, plate voltage and screen-grid voltage (if used) are being applied. A signal test can then be made and the grid and plate resistors changed to higher values for increased amplification, if required; or to lower values for reduced amplification, reduced distortion and greater stability.

Figure 3F shows the basic phase-inverter circuit. Signal balance on the grids of the push-pull output of the phase inverter circuit can be checked with a V-T.Vm., from points Y' to ground and Y'' to ground; these readings should be equal and the reading across Y' to Y'' should be double either of the single readings. Unless this condition is fulfilled, the voltages are not in phase.

At low frequencies the phase shift is usually very small, but the error may become great at high frequencies, therefore

distortion may be introduced that will vary with frequency. Unequal capacities, grid to ground, will cause both unbalance of voltage and different phase positions for the grid voltage.

POWER AMPLIFIERS. Possible unbalance in the associated push-pull stage (see Fig. 6), can be checked by connecting the V-T.Vm. across the cathode bias resistor R1, but with C1 disconnected. With perfect balance, no A.C. voltage should appear. The phonograph pickup test is also applicable to any phase-inverter circuit.

The output amplifier stages must produce power, and accordingly, gain is usually a secondary consideration although some of the pentode output tubes do have a fairly high amplification factor.

Figure 1A shows the standard transformer-coupled output stage; Fig. 4B, the same circuit impedance-coupled, in both cases for a triode. Figure 4C is a pentode output stage transformer-coupled; and 4D, a beam power tube output stage, transformer-coupled and with inverse-feedback applied. For push-pull operation, the circuit may be considered as 2 circuits exactly the same as the one shown. All the above-mentioned amplifiers are shown self-biased. For fixed-bias, especially in the case of the larger tubes, the bias is taken from a separate small power supply.

A frequent complaint pertaining to resistance-coupled audio amplifiers is *motorboating*. It is invariably due to the use of excessively high grid leak or plate-load resistors and can be readily corrected by lowering the value of these units, otherwise the fault must be due to unstable plate "B" supply.

In most audio amplifier designs, a high value of cathode bias resistor bypass capacity is desirable but may be a source of increasing A.C. hum. Every effort should be made to eliminate the hum at its source and not sacrifice quality by reducing the bias resistor bypass value.

Figure 6 gives the points for aural test of a complete A.F. amplifier, overall, or for any 1 or 2 stages. The push-pull output stage, in its original condition, may be arranged for any one of the different classes of power audio amplification. By noting the value of the self-bias resistor, plate-load impedance, and driver transformer characteristics, and referring to a tube manual, the intended class of operation can be determined.

GAIN

The complete family of audio circuits is here given to bring out the similarity between the different variations. In absence of manufacturer's circuit specifications, reference should be made to a standard tube-manual which will invariably give all the

data required such as amplification factor, power output, proper bias values, plate load requirements, etc.

Generally speaking, it is well to remember that minimum gain, minimum distortion and maximum stability are obtained using low-gain triodes. Where more gain is essential per stage, a hi-mu triode may be substituted in resistance- or impedance-coupled circuits, and changing the associated resistors and condensers accordingly. If still more gain is required, and insertion of an extra stage is impractical, a pentode resistance-coupled or triode transformer-coupled circuit can be adopted to get the desired result. In a similar manner, if the existing arrangement gives excessive gain and distortion, a pentode stage can be changed down to a hi-mu, or a hi-mu changed down to a triode.

The radio technician should find audio amplifiers relatively easy to service. When a set comes in with 1 or 2 defective condensers an effort should be made to sell the customer on the idea of a complete new set of higher grade replacements. In a similar manner if the set-up uses cheap carbon resistors, it can be pointed out to the customer that the resistance value of carbon resistors varies with load and with temperature, and to insure permanent, stable operation the entire circuit should be changed to use higher-grade resistors with molded covering (so-called metallized resistors are one example). Provided the technician is a fair judge of music aurally, more reliance should be made on the "ear value," rather than on electrical measurements only. A "sour" audio amplifier is unacceptable even if accompanied by an impressive performance curve.

Referring again to the phono pickup test (or using a signal generator), the input is connected in each case from X to ground as per the family diagrams. The output indicator—phones or equivalent—is connected from Y to ground for the tube alone. Connecting the output indicator from Y' to ground brings condenser C into action, also the succeeding grid resistor, and the effect of these parts in-circuit is then noted. Under these conditions, necessary alterations may be made to the cathode bias resistor, the bias bypass, grid resistors, or plate load; or a change in type of tube, in accordance with proscribed values, or experimentally, to get the desired results.

DETECTOR CHANNEL—INCLUDING A.V.C.

Figure 7A shows the well-known *gridleak-and-condenser detector circuit* which is usually found where high sensitivity is essential, for example in 1-, 2- or 3-tube sets. Maximum sensitivity and selectivity in the circuit are obtained by using a high value of grid leak, 2 megohms or more, but with a

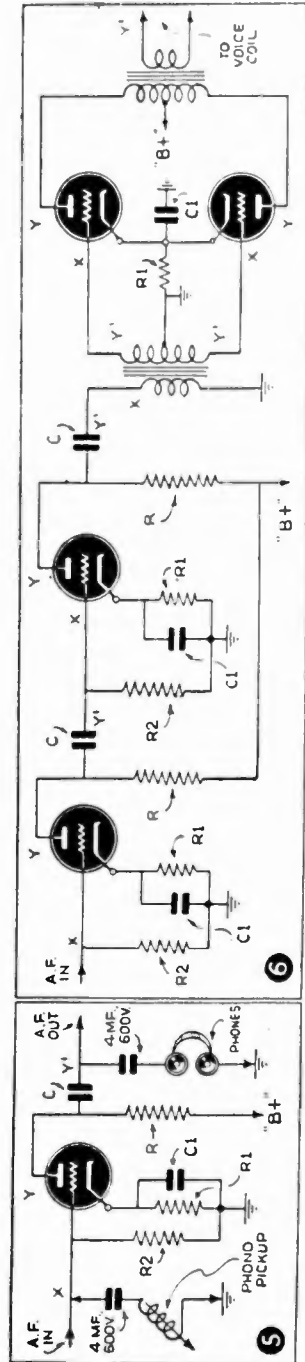

Fig. 5. Use of phono pickup for aural examination of A.F. amplifier stages. Fig. 6. Basic cascade (multi-stage) A.F. amplifier circuit with push-pull audio-output stage.

MODERN RADIO SERVICING TECHNIQUE

sacrifice of stability and audio quality. Stability and improved audio frequency response may be obtained by reducing the value of R, but at a sacrifice of selectivity. In this circuit there is no negative D.C. bias applied to the grid.

In Fig. 7B, the grid is biased practically to the cut-off point. In this diagram the bias is shown obtained from a cathode bias resistor, however it may also be obtained from a "C"-battery, a bias-cell or from a bleeder tap. This circuit has the advantage of amplifying the signal in addition to detection. Furthermore, this method does not draw current from the input circuit and does not lower the selectivity of the input circuit.

Typical diode detector circuits are shown in Figs. 7C, 7D and 7E. The diode method of detection (incidentally, invented in 1904), is subject to less distortion than most other systems, as the characteristics can be made fairly linear. However, diode detectors do not amplify the signal and furthermore as they draw current from the input circuit, a reduction in selectivity is inherent. The diode detector is widely used in spite of its disadvantage because of its 2 good features: (1) a linear characteristic; and, (2) ready adaptability to simple A.V.C. circuits.

The adjustments to these circuits are relatively simple, but steps should be taken to insure linearity and lowest possible distortion with high-percentage modulation. For standard diode tubes, such as the 6H6, the R.F. signal applied to the diode should be approximately 10 volts. The ratio of the A.C. impedance to the D.C. resistance of the diode circuit should be high. This means the grid-leak and A.V.C. filter resistors should be high as possible in the grid circuits of the R.F. and A.F. tube and the diode load resistor not excessive. An R.F. bypass condenser of too-high value across the load resistor will cause both loss of gain, and distortion, at the higher audio frequencies.

DELAYED A.V.C. Some circuit designers prefer *delayed A.V.C.*; a typical circuit of this type is shown in Fig. 7F. The advantage of this method is that the receiver may respond to weak signals with maximum sensitivity. In this arrangement, one diode is used exclusively for detection, the other diode supplies delayed A.V.C.

The amount of delay depends upon the voltage of the cathode of the second diode circuit. With, say 3 volts applied to the cathode of the control diode, no current can flow until the signal strength increases sufficiently to cause more than 3 volts to be applied across the resistor R3. Accordingly the A.V.C. action is delayed until the signal strength attains a peak value of about 3 volts.

Performance of detectors should be checked and adjusted using a V.-T.Vm. and for sustained signal input, measuring the

ratio of the rectified voltage across the diode load resistor to the R.F. voltage applied, from diode to cathode. With correct adjustment, the diode current should be directly proportional to the R.F. input voltage. Any variation in this proportion, upon changing the R.F. input voltage in value or frequency indicates that the detector circuit is improperly adjusted, and the associated capacities and resistors should be checked, altered or replaced as required.

Improper filtering of the R.F. from the grid of the triode or pentode associated with the diode will also cause distortion. This can be checked by using a V.-T.Vm. with a series condenser of 100 mmf. (.0001-mf.) in series with the grid lead of the V.-T.Vm. No R.F. voltage should appear between X and X', Fig. 7D; if found, additional shielding or filtering must be applied to eliminate all R.F. from the circuit.

Where an A.V.C. receiver circuit "blocks", determine first if the A.V.C. is actually working; if an A.V.C. tube is used, check the tube. The A.V.C. motorboating means a defective tube, defective load resistor or defective or no bypass capacity. Another source of R.F. motorboating is usually due to oscillator instability and is best corrected by the addition of a voltage regulating tube to the "B" circuit.

R.F. AND I.F. CHANNELS

A simple and quick method of testing R.F. circuits, at either direct (signal) or intermediate frequencies is shown in Fig. 8A. The device consists of a pair of phones, a crystal rectifier and a bypass condenser (not critical—about 0.005-mf.). A microammeter may be used in place of the phones for visual observation.

The input signal may be obtained from a signal generator (modulated) or a received signal. The prod leads are applied to points X and Y. Testing the secondary of the antenna coupler is the equivalent of a simple crystal receiver. Testing at the output of the mixer tube (with oscillator tube removed) covers the 1st R.F. and 1st-detector. In any case the test covers preceding tubes, from the point where the test is made.

Figure 8A is the conventional R.F. circuit used for either the antenna input or for direct R.F. amplification. For the broadcast band the coupler or transformer is usually of high-impedance, inductive-coupled type; and for the high-frequency bands, usually low-impedance, inductive-coupled. Quite often a small amount of capacity coupling is combined with the inductive coupling (indicated by dotted lines) and this capacity may be found within or external to the transformer case.

Figure 8B shows a standard I.F. stage as double-tuned and also for triple-tuned; and the latter may be designed for either

MODERN RADIO SERVICING TECHNIQUE

band-pass or for peak selectivity. Figure 8C is a double-tuned I.F. unit with the desirable feature of *adjustable selectivity*, permitting a setting for high fidelity under conditions where extreme selectivity is not required (no adjacent-channel interference prevailing).

Figure 8D shows a direct (signal-frequency) radio-frequency amplifier with band-pass tuning circuits, a system that will become more and more common with the demand for high-fidelity reception.

Screen-grid voltage for R.F. amplifiers is usually obtained in either of 2 methods, a series resistor from the main "B" plus (Fig. 8A) or from the main or an auxiliary voltage divider (Fig. 8B).

When available, a V.-T.Vm. should be used to check the gain of the R.F. and I.F. amplifiers.

The response of I.F. transformers or their proper peak value can readily be determined by a V.-T.Vm. and varying the input frequency.

ALIGNMENT

There is nothing complicated in servicing R.F. stages. First-hand, the individual components can be checked; the average cathode bias, screen-grid and plate voltages used for various tubes are then found in the tube manuals. Having checked the components, voltages and the tubes, the remaining step is alignment which can be accomplished using a signal generator or received signals.

Poor intermediate frequency selectivity, if no improvement is made by correct alignment, can be improved by inserting triple-tuned I.F. transformers in place of the universal double-tuned type.

Poor image-frequency conditions can be improved by inserting a band-pass 1st R.F. stage (Fig. 8D), adjusted for a sharp peak, in place of the usual single inductive coupler.

Improvement of overall audio response (assuming the audio amplifier is true) can be secured by replacing standard I.F. transformers with improved I.F. units having the modern feature of adjustable coupling as per Fig. 8C.

Unstable operation or oscillation in R.F. amplifiers may invariably be traced to defective or insufficient bypass capacity around cathode bias resistors, to screen-grids or plate-returns.

OSCILLATORS—VOLTAGE DIVIDERS—MANUAL CONTROLS

The principal oscillator circuits were described in Part I. By connecting a V.-T.Vm. (through a 100 mmf. mica condenser) to the plate of the oscillator circuit under test, the oscillator output voltage can be checked over the tuning scale for each band. The output voltage should drop off

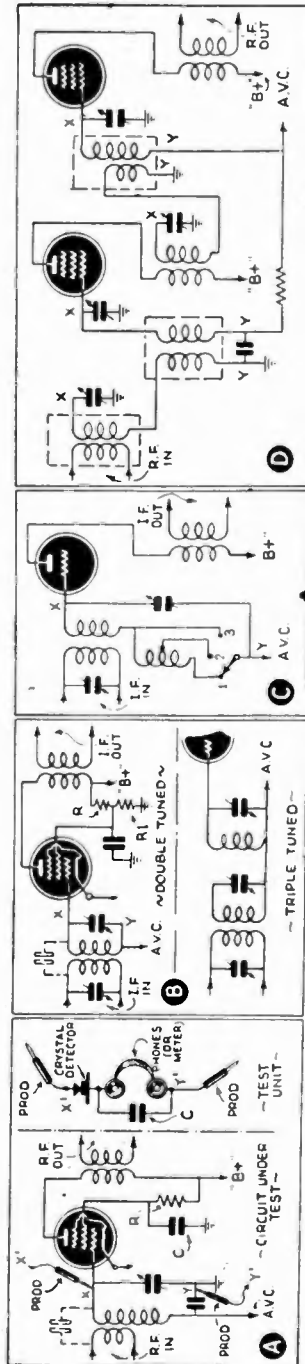

Fig. 8. Basic R.F. and I.F. circuits. (A) Basic R.F. pentode amplifier. (B) Basic I.F. amplifier. (C) I.F. amplifier with adjustable transformer coupling. Position 1 = minimum selectivity; position 3 = maximum selectivity. (D) Bandpass I.R.F. amplifier.

MODERN RADIO SERVICING TECHNIQUE

gradually as the tuning pointer is moved toward the low-frequency end of each band. The voltage should not drop off abruptly or to zero under any circumstances. Abnormally low voltage for any point on any band indicates either insufficient oscillator grid-plate coupling or defective padding condensers.

The discussion so far has covered all essential parts of receiver circuits with the exception of *voltage dividers* and *manual controls*.

The checking and adjustment or replacement of voltage dividers requires an accurate working knowledge of Ohm's law as related to multiple circuits. In regard to volume and tone controls, some technicians go to a lot of expense to secure the exact factory unit specified. This is not always necessary as there are several reliable replacement lines wherein a satisfactory unit can be conveniently obtained. In the case of a variable cathode bias type of volume control, care must simply be taken that the maximum value is not too large, otherwise all the effective action will be confined to a small portion of the pointer rotation. In the case of audio volume controls, use of high maximum values means the connected grid

is practically floating free and very sensitive to hum pick-up.

STABILITY

In general service practice, electrical and mechanical *stability tests* are often neglected. With the set in operation, the chassis should be jarred vigorously and the panel rocked, to bring out any loose or imperfectly soldered joints. The electrical stability is checked by tuning-in one of the major broadcast stations having a constant carrier and beating against this with a stable oscillator. With the beat note constant, the R.F. gain control should be moved quickly from minimum to maximum. With perfect stability there should be little change in the beat note under this test.

The Serviceman who finds it necessary to make repeated reference to wiring diagrams during repairs, will find it advantageous to memorize the basic family circuits given in this article, so that they can be instantly pictured or drawn. It will be then found during the examination of strange sets that the function of the different tubes and associated parts is usually instantly apparent, little trick variations will then be no obstacle.

Servicing "Orphans" and Private-Brand Sets

PART 3

In this concluding Part III will be discussed the problems which arise in connection with the replacement of volume and tone controls, and the correction of circuit-oscillation after rewiring, in those "alley cat" radio sets, for which there never were any published diagrams, which every Serviceman encounters from time-to-time; and those other, better-parented sets which once rated well but which Time has obsoleted both as to style and service diagram.

MANUAL VOLUME CONTROLS

For *standard* sets, specifications for replacement volume controls are available both from the set manufacturer's service sheets and from the volume control manufacturer's catalogs. For *odd* sets, the matter of correct replacement values becomes a bit

complicated. The defective unit can be measured to determine the taper and value originally used. However, if the set has been serviced before, there is a possibility that a volume control of incorrect specifications has been installed.

Accordingly in making volume control replacements, no mistake will be made if the new unit is selected to suit the tube and circuit requirements rather than simply inserting an identical substitute.

Outside of the overall physical size permissible, the correct shaft diameter and length, the important considerations are, (1) type of resistance element, (2) maximum value and (3) the characteristic or taper. Wire-wound elements are generally used for values up to about 7,500 ohms and

MODERN RADIO SERVICING TECHNIQUE

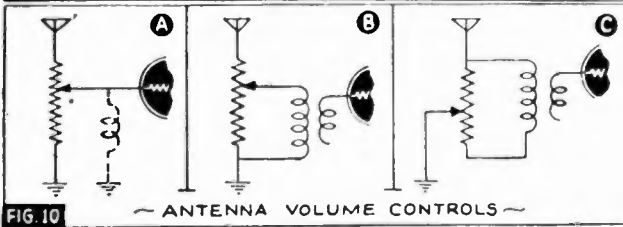
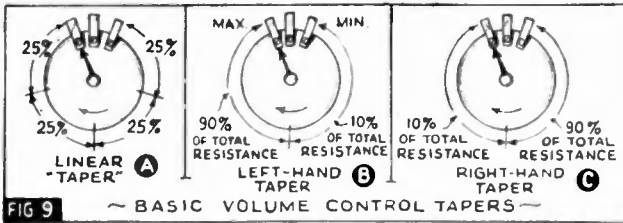

usually for bias control, antenna shunt (or a combination of both) and for voltage dividing applications. Carbon element controls are invariably used for service where a total resistance above 7,500 ohms is required.

The maximum value of resistance of a broken or burned-out control can be determined by measuring the value of resistance each side of the break and adding the 2 values.

TAPERS

The characteristic of any control can be determined by making resistance measurements of the control, from the rotating contact to either end terminal, for different angular positions of the control knob. For example if the measurements indicate equal resistance values, say 1,250 ohms at 25% rotation, 2,500 ohms at 50% rotation, 3,750 ohms at 75% rotation and 5,000 ohms at full rotation, the total resistance or maximum value is 5,000 ohms and the control has a *linear* characteristic (no taper) as per Fig. 9A.

Measurements indicating approximately 10% of the total resistance, for the first 50% of rotation (counterclockwise) and the balance of the total resistance concentrated in the second-half of rotation, points to a *left-hand taper* as per Fig. 9B. With the same rotation, but the above resistance values reversed, the taper is *right-hand* as per Fig. 9C. Variations of these basic characteristics exist, but one of the above 3 types will usually satisfactorily fill most replacement requirements.

R.F. & A.F. CONTROLS

Typical antenna volume controls, formerly used quite extensively, are shown in Fig. 10, wherein a potentiometer is used as a signal voltage divider. The full antenna voltage or any part thereof can be fed to the 1st tube grid, depending upon the control adjustment. Values of 3,000 to 7,500 ohms and a linear characteristic are commonly used for this application in the rather old sets and may or may not be combined with bias control.

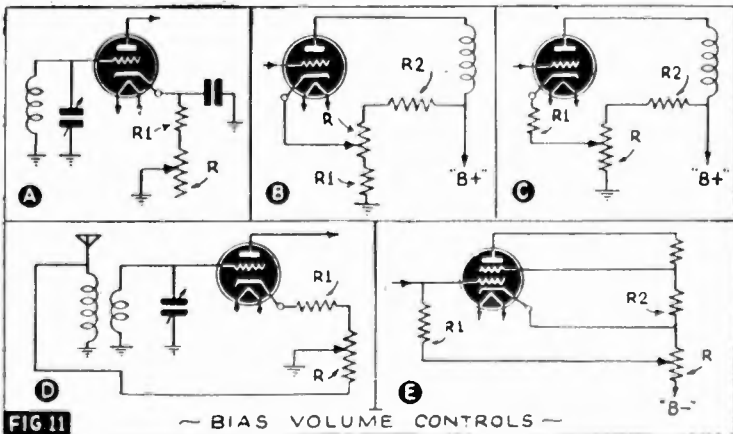

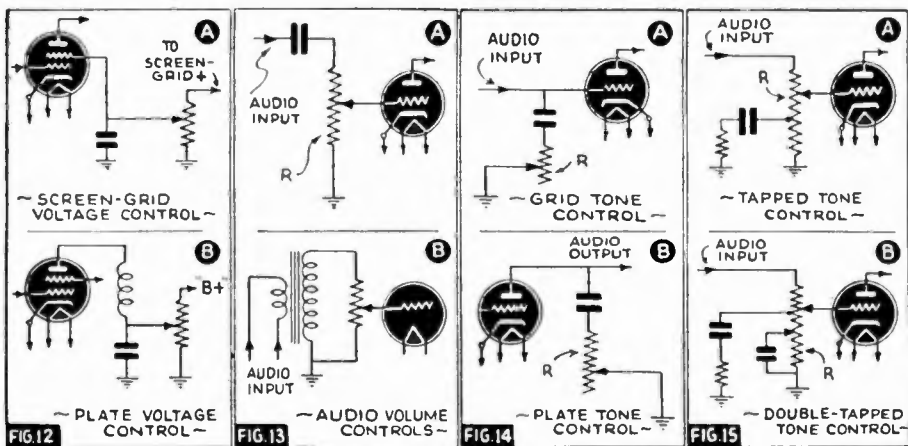

Variation of the cathode resistor value to obtain control of R.F. gain is used in numerous different circuits, all essentially identical.

Figure 11 shows bias volume controls, wherein R_1 represents the minimum bias resistance to produce the minimum bias voltage age permissible, R represents the adjustable cathode resistor to regulate the bias voltage and R_2 is the bleeder resistor. In circuits using old-type tubes with a sharp cut-off, the variation from minimum bias for maximum gain to maximum bias for cut-off represents only a few volts and the available regulation is restricted. Accordingly in the older A.C. sets, a combined cathode-bias regulator and antenna potentiometer (or a dual unit) is usually found and gives combined attenuation of input signal and amplifier gain, as per Fig. 11D.

Modern remote cut-off (variable μ) tubes have a much higher control range and the R.F. gain can be regulated at the tubes without any antenna potentiometer. However, bleeder resistors (R_2) are used ex-

tensively from either the "B" supply or screen-grid supply to R , to hasten increasing the bias values.

The diagrams are shown for 1 tube but the same considerations hold true for 2 or more tubes in cascade having a common bias control and whether the tubes are triodes, tetrodes or pentodes.

Figure 11E is another variation of bias control, the grid-return connecting to the cathode resistor R , the latter being in series with the negative "B" line, the voltage drop across R and the amount of this drop used, providing the bias. This is also a common method of obtaining bias in battery sets.

Varying the screen-grid voltage to control R.F. tubes is practically obsolete but the circuit is shown in Fig. 12A. Likewise it is unusual to find broadcast receivers with controls to vary plate voltage, as shown in Fig. 12B. For the above applications the controls must be capable of carrying definite power with noiseless operation. Where control circuits of this type are found, it is well to change the circuit to a more modern method of regulation.

Figure 13A is a typical audio volume control, with the output from the preceding tube shunt-coupled to a potentiometer, the latter also acting as a grid resistor, and in addition must be considered as reflecting on the plate load of the preceding tube. The values may vary from 100,000 ohms (0.1-meg.) to 1 megohm, or more, depending upon the tube type. Figure 13B is the same audio control application, where R is shunt-connected across the secondary of an A.F. transformer or choke. For push-pull secondaries, resistor R becomes a twin or dual unit, controlled by 1 shaft. Depending upon the characteristics of the transformer, the value of control across the secondary winding will vary from 0.1-meg. to 0.5-meg., maximum. Figure 13B is also occasionally found arranged to control an R.F. circuit, in which case the values for R across a

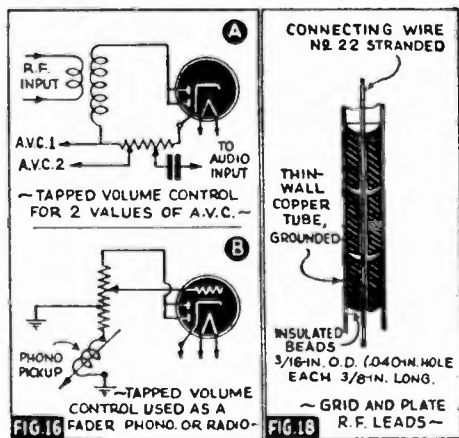

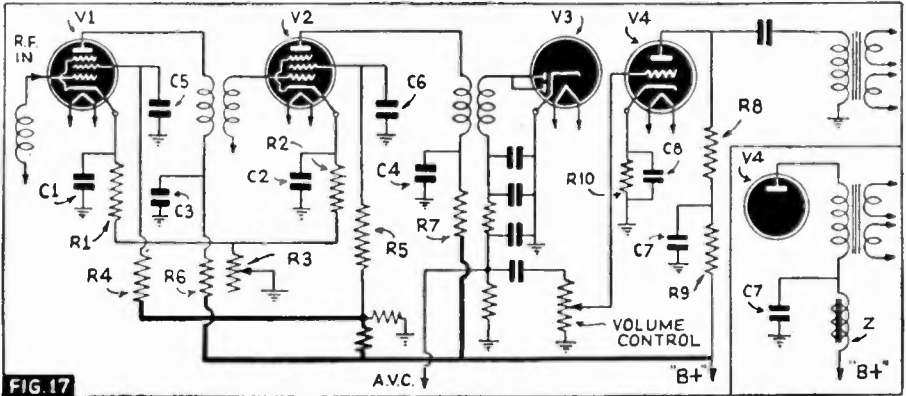

FIG. 17

tuned circuit may vary from about 0.1-meg. to possibly 0.25-meg., maximum.

TONE CONTROLS

Most tone controls are simply a means to bypass or attenuate the higher audio frequencies, leaving the lower frequencies or bass apparently more prominent. This bypass control can be accomplished at the A.F. tube grid input per Fig. 14A, or at the plate circuit, per Fig. 14B. The grid-circuit method is preferred as there are no power considerations. Using the grid control circuit, the values of R may vary from 50,000 ohms to ½-megohm. For the plate-type control the value of R may be from 5,000 to 0.1-meg., maximum. The exact values depend entirely upon the total or degree of high-frequency attenuation required.

Tapped tone controls are in common use to hasten the high-frequency cut-off at 1 or more points on the control scale. Figure 15A shows the single-tapped type and Fig. 15B the double-tapped type; in the latter case, a very decided or abrupt attenuation of the high frequencies occurs upon passing the 2nd tap.

Tapped controls are also found in diode detector circuits to provide more than 1 value of A.V.C. as shown in Fig. 16A, and also used as a fader to change from phonograph to radio as per Fig. 16B.

In order to properly replace tapped resistors, one must be guided by careful measurements made on the defective unit to determine the total value, value of resistance at the taps and the taper, in some cases the taper may be left-hand on one side of the tap and right-hand on the opposite side of the tap!

R.F. WIRING

In relatively compact receivers, it is not unusual to find tests indicate poor sensitivity and gain due to inherent feedback coupling which has been inefficiently decreased. One common method to eliminate feedback is the excessive use of shielded

braid R.F. plate and grid connecting leads. Ordinary R.F. shielded hookup wire has a very high capacity and when used for long grid leads may prevent proper alignment of the circuit with the trimmer provided. Furthermore, due to the poor dielectric of the insulation the loss is always high and can increase to tremendous amounts with moisture absorption.

This common defect can be corrected by running all R.F. plate and grid leads as shown in Fig. 18, wherein the connecting lead is run through insulating beads which in turn are housed in a grounded copper tube. By using beads made of low-loss insulating material and also free from moisture absorption, for example Polystyrene or Amphenol No. 912B, a connecting lead is provided having low capacity, low loss and free from effects of humidity.

After having replaced ordinary shielded leads with efficient connectors, as described above, the gain and sensitivity are invariably substantially improved, in fact the receiver may now be unstable or actually oscillate in the R.F. stages. Such oscillations can be traced to coupling between stages using a common voltage supply. Isolation of this coupling will eliminate the feedback, preserve the high gain and restore stability.

FILTERS & DECOUPLERS

Figure 17 illustrates the method of applying the type of filters known as *decouplers*. The circuit under consideration may have 2 or 3 R.F. screen-grids connected together and served by a common bypass condenser. By providing each screen-grid with a filter resistor (R4, R5, of about 10,000 ohms each) and an individual bypass condenser (C5, C6, each about 0.1-mf.), the 2 (or 3) screen-grids are isolated. In compact sets, the R.F. plate-return leads of 2 or more R.F. stages may also be connected directly together to the power supply and bypassed by a common condenser. Filter resistors (R6, R7, about 10,000 ohms each) are inserted in these plate-return leads, together with separate bypass condensers (C3, C4,

about 0.1-mf. each). Chokes may be used in place of resistors to avoid high D.C. voltage loss. However in limited space, the use of chokes means a possibility of stray coupling between the chokes if they are not carefully shielded from each other.

In the applications described above, the bypass condensers form a low-impedance path for the R.F. to ground while the resistors offer a high-impedance path for the R.F. to the power supply. High-quality paper condensers must be used and for high-frequency applications low-loss mica condensers become necessary.

In the cathode circuit, the situation is a little different. If the cathode bias resistor is large, it offers impedance to R.F. signal currents and accordingly is bypassed by a

condenser. Where 2 or more cathodes are connected directly together, it can be a source of common coupling between stages. This is best eliminated by using individual minimum-bias resistors (R1, R2) and separate cathode bypass condensers (C1, C2) as shown in Fig. 17.

Multiple audio-frequency stages can be isolated in the same manner, by a resistor and condenser (R9, about 5,000 ohms; C7, about 4 mf. or more) or by an iron-core choke and condenser Z and C7, respectively. In filtering A.F. circuits the bypass condensers need to be of sufficient size to offer a low-impedance path for the very lowest audio frequencies to be passed. Accordingly the condensers must be of relatively large size, 4 to 8 mf. or more, and of good quality.

CHAPTER 5

Emergency Servicing Without Test Meters

PART 1

THERE are occasions—sometimes emergencies—when the radio technician is called upon to make repairs and for one reason or another, wiring diagrams, service instruments and spare parts are not available. Under these unusual circumstances, the real ability of the radio Serviceman is instantly demonstrated.

Under such conditions the qualified expert not only locates the difficulty but also proves resourceful enough to make the necessary substitute parts out of any limited material that may be available.

The little fundamentals pointed out in this article are of course instantly obvious when called to one's attention. Whether or not the average Serviceman would think of these ideas while working under stress, and without meters, is another question.

LAMP-BULB "VOLTMETER"

A means to measure voltage without a voltmeter is frequently useful. Of course if the line being measured can supply ample current, electric light bulbs in series can be used and will give an accurate indication. Thus with 2, 3, 4 or more 110-volt bulbs in series, we can measure 220, 330, 440 or more volts, depending upon the number of bulbs in series; a couple desk lamps or floor lamps may conveniently supply the required sockets, wiring, etc., for series hookups. It is well to try a 110-volt, 60-watt lamp sometime when applied to voltages of 50 and 25 volts and make

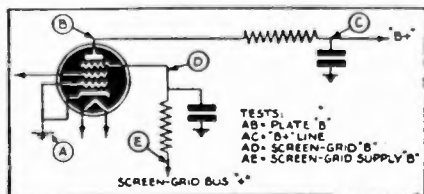

Fig. 1. Voltage tests.

a mental note of the relative brilliancy, for some future occasion.

When limited current is involved the electric lamp-test is impractical. By using a paper condenser, for example one of about 1 mf. capacity and rated at 600 volts, this can be charged and discharged from voltages of 25, 50, 100, 250, 450 and 600 volts. Naturally the condenser will absorb the largest charge when charged by the highest voltage. Accordingly the highest charge, when discharged (condenser terminals shorted), will create the greatest spark. A mental note is made of the corresponding discharge intensities for the different voltages tried; and experience will dictate the allowance to be made for leakage (particularly if an electrolytic condenser is being used). Using a condenser of 4 or 8 mf. capacity, the difference in discharges for the different voltages is very marked.

Using a condenser in this manner one can readily test for plate, screen-grid or cathode voltages for most receivers. The same test can be applied to amplifier or the smaller transmitting tubes. Likewise voltages being delivered by power packs, across bias resistors or to speaker fields may be estimated.

Indications that resistors associated with the plate and screen-grid tube terminals are in working order, is automatically determined in these tests, see Fig. 1.

"WIND YOUR OWN" CONDENSERS

In case an extra paper condenser is not available, often one can be removed temporarily from the piece of apparatus being tested, without impairing the circuit's operation. Or, one can be obtained from an old telephone box or automobile ignition suppressor circuit. A good substitute or emergency receiving condenser can be quickly made by winding 2 pieces of enameled wire on a spool. The wires are wound parallel to each other. The starting ends are separated and insulated from each other. At the finish the two ends become the condenser terminals. Using a small-gauge wire, any reasonable capacity can be obtained, increased capacity being obtained through the use of longer pieces of wire. A fairly-sized condenser can be made in a relatively small space as the condenser dielectric (the enamel film) is very thin. A paper or mica condenser can be

Fig. 2.
A—Testing condensers; and testing voltages at low current.

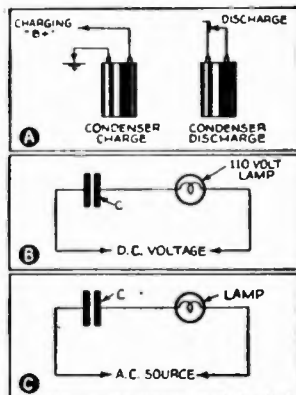

B—Lamp-test of D.C. voltage.

C—Lamp-test of A.C. supplies.

readily tested for capacity, an open, or a short by trying to charge and discharge across a direct-current source, as shown in Fig. 2A. However if the condenser is of a type which will not hold a charge, it can be tested by connecting in series with a lamp of low watts rating and across a direct-current source. In this case a perfect condenser will pass no current to the lamp. See Fig. 2B.

Another indication of a condenser's capacity can be obtained by connecting same across an alternating-current source, with a small lamp in series, as per Fig. 2C. The larger the capacity of the condenser, the greater the brilliancy the lamp will show. For relatively small condensers, the lamp should preferably be a 110-volt neon test type or a small flashlight bulb.

CONTINUITY TESTS

Continuity of coils or resistors can be readily tested by discharging a charged condenser across the coil or resistor terminals. The resulting discharge spark will be less than a direct short and this also gives some indication of the resistance involved.

Even before removing a chassis from a cabinet, the source of trouble can sometimes be instantly located by cautiously feeling the tubes after the apparatus has been turned on for a short period. A cold tube indicates that the tube or parts associated with it are inoperative. A tube which experience indicates is abnormally warm may indicate a short-circuit (of the tube elements or, possibly, the filter circuit).

In a cascade amplifier, whether a direct tuned radio frequency, an intermediate radio frequency or audio fre-

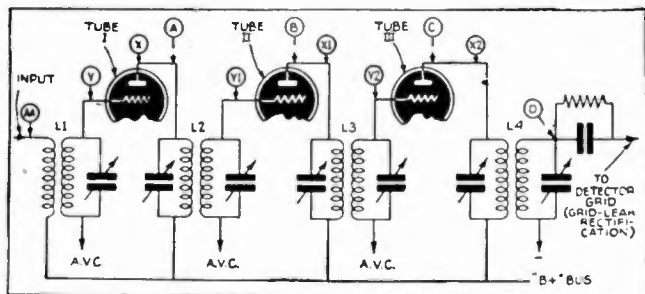

Fig. 3. Checking the R.F. and detector circuits.

quency, a defective stage can invariably be located by "jumping-out" one stage of the amplifier at a time. This procedure is very useful as the difficulty may be a defective tube and no spare available.

For example in Fig. 3, suppose tube II is "dead"; by connecting a jumper from X to X1, the set becomes operative. However, under this same condition the trouble might be in the R.F. transformer connected to the plate circuit of tube I. But by exchanging tubes I and II it is determined that tube II will not work in place of tube I.

EXAMPLE: "NO SOUND"

Suppose we start with a receiver or audio amplifier connected to an electrodynamic speaker, wherein all the tubes light or heat, but no sound of any kind is audible from the speaker. See Fig. 4.

To determine if the speaker is receiving field current, it is simply necessary to cautiously approach the speaker pole piece with a screwdriver, or other piece of iron, to test for magnetism. Lack of vigorous magnetism indicates the field coil is open, shorted or not receiving any voltage.

Let us say the field voltage is tested and found OK, it is also found that "B" voltage is going to the plates of the push-pull output tubes, IV and V. Now if the tubes IV and V are working, if either one or the other is moved out and in the tube socket quickly, a decided click should be heard in the speaker, due to the plate current being broken. Otherwise the trouble is in the voice coil circuit and may be an open or shorted voice coil or secondary of the output transformer.

Suppose an imperfect connection to the voice coil and repair same, then at least some hum is heard at the speaker, which is correct. Now upon removing

and inserting either of the power output tubes we get a healthy click in the speaker, indicating that the output circuit, from the plates on, anyway, is in order.

Knowing that the output stage and the speaker are in order, it is simple to locate any difficulty in the balance of the audio circuit back to the detector plate.

First by tapping tube I by hand, if the audio circuit is working, a microphonic rattle is heard in the speaker. Or the same effect can be obtained by removing and reinserting tube I, to temporarily break the plate current. Assume there is no click, we then apply the same test to tube II and also receive no click. However upon making this test on tube III, there is a strong click in the speaker. Now we know the trouble is somewhere between tubes I and II.

By connecting a jumper between point X and X1, we have eliminated the 1st audio stage and now find upon tapping tube I the microphonic rattle sounds in the speaker. The trouble may be in the 1st A.F. transformer, T1, or it may be tube II. With connections left just as they are, tube II is substituted for tube III and the circuit is again dead. We then know tube II is dead and the seat of the trouble.

This procedure of jumping-out part of a circuit is extremely useful in many ways. Suppose the secondary of transformer T2 was open. A jumper connected from Y to Y1 makes the circuit operative, with one less stage.

In a push-pull audio output stage, often 1 tube or half the circuit is inoperative and not noticed. One tube, say IV, should be removed. Then try the apparatus using tube V alone, and then move tube V to the socket formerly used for tube IV. If tube V is good and both sides of the circuit are in order, the apparatus will work under both of the

Fig. 4. Checking the detector and A.F. circuits.

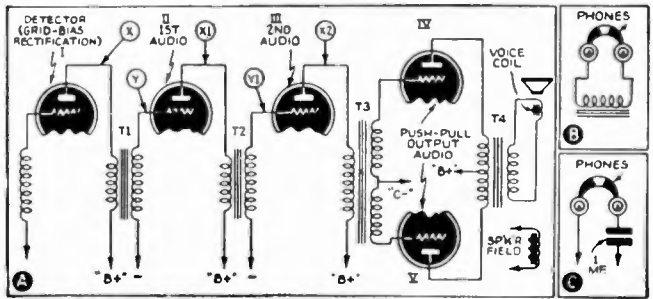

above conditions. Then tube IV can be tested in the same manner.

EXPLORING UNITS

An audio "feeler" or exploring coil can be made by connecting an iron core choke or primary of a transformer to a pair of head telephones, as shown in Fig. 4B. This "feeler" can be inductively coupled to audio transformers or chokes while they are in operation to instantly locate any units which are not excited or in order.

Or, the head telephones can be connected (through a condenser) to the primaries or secondaries of the various audio transformers, as shown in Fig. 4C. Extreme care should be taken in making this test at the primary of the output push-pull circuit if high voltages are involved. This is also a good test across audio plate coupling inductances or resistors as the blocking condenser prevents the phones from temporarily substituting a workable plate coupling unit.

FAULTY R.F. SECTION

Referring again to Fig. 3, assume it represents a straight tuned-radio-frequency receiver, working satisfactorily from the detector on, as previously covered; I, II and III being identical R.F. amplifier tubes.

By connecting the antenna directly to point D, and turning the tuning condenser to its lowest-capacity position, some signal should be heard; especially, if the receiver is within 20 miles of a broadcast transmitter. The receiver will not tune properly as the antenna capacity is directly in parallel with the detector grid circuit.

By connecting the antenna to point C the antenna is inductively coupled to the detector input transformer and the receiver tuning condenser will tune more normally.

Strong local broadcast signals can be heard fairly well under these conditions. In a similar manner the antenna lead-in can be transferred to point B and then to point A. In each case an increased signal response should be obtained, if the amplifier circuits are working.

However suppose upon moving the antenna from point B to A that the signal stops instead of being amplified. A jumper is connected from X to X1, with the antenna at A, and the signal is again heard. Tube II is now out of the circuit. Tube II is tried in place of III and works perfectly. The trouble is therefore not with the tube but some other part of the circuit associated with tube II. The primary of R.F. transformer L2 is easily checked for continuity by the voltage test at the plate of tube I. The secondary of R.F. transformer L2 is suspected and examination shows it is shorted or open. Or in a similar manner a jumper can be connected from Y to Y1, or Y1 to Y2 to check secondaries of the R.F. transformers.

SUPERHET. CIRCUITS

Where intermediate-frequency or I.F. transformers are involved, the same procedure can be followed. The signals picked up will not be from broadcast stations but from commercial radio telegraph transmitters working on frequencies close to the intermediate frequency of the amplifier. The signals may be I.C.W. or C.W. To receive the latter the amplifier can be arranged to oscillate (autodyne) during tests by connecting a small midget condenser from X back to Y.

Turning to the antenna end of a receiver, Fig. 5 illustrates a typical multi-band superheterodyne circuit consisting of 1 direct radio-frequency stage, a mixer, and an oscillator. For sake of simplicity band switches are omitted and only 1 band shown.

Assume the balance of the receiver is in working order as determined by the tests previously described. The first step is to make sure the R.F., mixer and oscillator tubes are receiving plate and screen-grid voltages by the "charged condenser" test.

A 1-TUBE SET!

Now by connecting the antenna leading to point X, removing the oscillator tube and connecting a pair of head telephones to points X1 and X2, we have a 1-tube receiver. The receiver simply consists of the mixer tube, acting as a non-regenerative detector.

On the broadcast band, it is now possible to tune and receive local broadcast stations faintly. Then by inserting the oscillator tube, the received signal will now be garbled, indicating that the oscillator tube is working; otherwise the oscillator tube is dead or some part associated with it defective.

By moving the antenna from X to the receiver antenna post A, the signals previously received should be amplified by the R.F. tube and accordingly come in stronger. Otherwise the R.F. tube is dead or some part associated with it defective.

In checking the oscillator tube, it may be necessary to temporarily readjust the oscillator condenser trimmer to get "beats" or to garble the signals for tests.

CHECKING COMPONENTS

The matter of checking principal circuit resistors is very simple. For example suppose we know the 250-volt supply is coming into this section of the receiver, as determined with a charged condenser. If resistor R5 (Fig. 5) is open the oscillator tube will not receive any screen-grid voltage. If R6 is open, the oscillator screen-grid voltage will be too high. Unit R4 open prevents the mixer from receiving screen-grid voltage. Likewise with R7 open, the R.F. tube has no screen-grid voltage.

Unit R1 open prevents the oscillator from receiving plate voltage. In the above mentioned cases, the lack of voltage might also be due to a shorted bypass condenser; however that is usually followed by the associated resistor discoloring from excessive heat or burning out.

Temporary substitute resistors can be

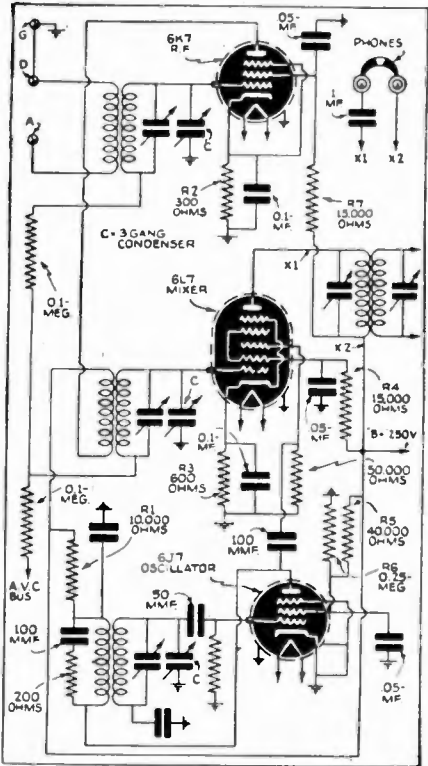

Fig. 5. Checking superhet. circuit elements; and testing components.

made from "lead"-pencil graphite, using one long piece or several short pieces in parallel depending upon the resistance required.

Upon removing a chassis for repairs, before any tests are made it is well to make a careful visual examination. Parts which are burned-out usually show discoloration; give off a peculiar "burnt" odor; or may have dripped molten wax. Such an examination often enables locating the trouble immediately and same can quickly be verified by tests.

Emergency Servicing Without Test Meters

PART 2

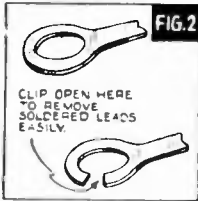

IN the preceding service article most attention was given to various service difficulties caused principally by the failure of circuit parts

It should be mentioned that audio frequency (A.F.) or intermediate frequency (I.F.) transformers found to have either an open primary or secondary, can be arranged to continue in service by making alterations as shown in Fig. 1.

Figure 1A shows an audio frequency stage with the primary of the transformer open. The resistor R1, of about 50,000 ohms, is connected as a plate load, together with the coupling condenser C1 having a capacity of about 0.05-mf. On the other hand, if the secondary winding is open, the proper connections are given in Fig. 1B. In the latter case the resistor R1 can have a higher value with some tubes, allowing increased amplification if required. Defective intermediate frequency transformers can be treated in a similar manner, for example in Fig. 1C the primary is open; accordingly the secondary circuit alone is used as a single-circuit plate coupling load. Condenser C2 should have a capacity of about 100 mmf. and the grid leak can have a value of from ¼-megohm to 1 megohm. With an open secondary, the primary is then used as the load as shown in Fig. 1D.

Incidentally it is often desirable to remove certain component parts with the connecting leads intact. If the leads have been threaded through a closed eye lug, removal is simplified by cutting an opening in the lug (see Fig. 2) with a pair of sharp side-cutting pliers.

The alignment of radio receivers without using a signal oscillator and output meter is not difficult, especially if the receiver is in such condition that at least some signals come through.

R.F. ALIGNMENT

Using a signal oscillator, T.R.F. receivers are usually aligned at 1,400 kc., but when using a received signal a more accurate alignment is obtained at about 1,500 kc., especially if the minimum tuning range extends to 1,550 kc., or more. Assuming a signal can be brought through at about 1,500 kc. the first attempt for readjustments should be made at that point.

Often true alignment cannot be obtained with the set of trimmers alone, due to one or more of the R.F. transformer secondaries being too large. In that case it is better to remove one or more turns from the large inductances and then completely align the tuner properly, even if the dial settings fall offscale a higher percentage than standard.

Lacking an output meter and provided the receiver has automatic volume control, a "tuning eye" tube can be connected in circuit temporarily as an indicator of maximum response, while making alignment adjustments. With an accurate alignment at 1500 kc. and provided the multiple tuning condenser has not been damaged, the receiver can be expected to perform satisfactorily over the entire scale.

I.F. ALIGNMENT

Intermediate frequency amplifiers are somewhat more difficult to align especially if the trimmers have been thrown all out of adjustment for one reason or another; however a satisfactory readjustment can be made without a signal oscillator. Assuming the superheterodyne does operate, even though unsatisfactorily, first attention should be directed to the I.F. amplifier. The tuning controls should be adjusted to bring in a broadcast signal around 1,500 kc., or if it is a multiple-band receiver, it can be adjusted to bring in an interrupted continuous wave (I.C.W.) signal at the high-frequency end of one of the short-

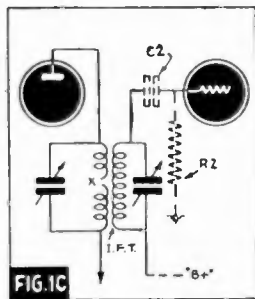
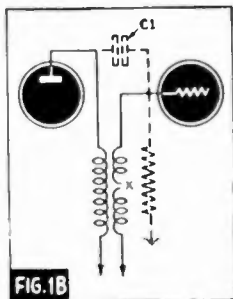
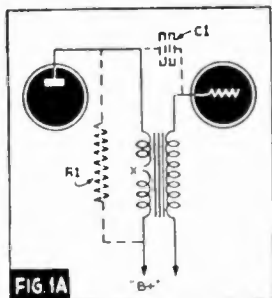

wave bands. The I.C.W. signal provides a source of oscillation of uniform amplitude.

Before making any trimmer adjustments, make a sketch of the I.F. transformer trimmer adjusting screws and position of the slots. All changes of trimmer adjustments should be recorded on this sketch, so many turns clockwise or counterclockwise as the case may be during the operation. Following this procedure the settings can be returned to the starting point if necessary.

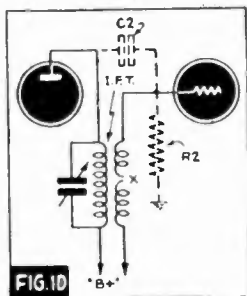

as per Fig. 4. If the received signal is 1,500 kc. and the dial indicator at 1,500 kc., maximum response will be obtained with transformer I.F.T.3 adjusted to 465 kc.; accordingly the trimmers on I.F.T.3 can be adjusted simultaneously until that condition is fulfilled. Thereafter, I.F.T.1 and I.F.T.2 can be brought into alignment (after removing the jumper) and finally a close overall adjustment made to all 3 transformers. A tuning eye tube, if available, can be connected into the circuit temporarily for an indicating device during these operations, the adjustments being made for minimum-shadow angle, see Fig. 4.

After the I.F. amplifier has been adjusted satisfactorily, attention can be directed to the radio-frequency amplifier, mixer and oscillator circuits. On all bands, trimmers are adjusted with the gang condenser set toward the high-frequency end of the scales and the padding adjustments (if provided) made at the low-frequency end of the scales.

If a factory-adjusted 465 kc. I.F. transformer is available, or can be borrowed from a good set, it can be substituted for one stage (Fig. 3) of the receiver under test. It is then known that stage is adjusted to 465 kc. and it can be used as a standard to readjust the other, preceding stages. Then the standard is removed again, the original transformer replaced and is adjusted to resonance with the balance of the entire amplifier, this is shown schematically in Fig. 3.

Another method of alignment can be used if the receiver was properly aligned and calibrated originally. This method consists of tuning-in a radio signal at about 1,500 kc. and running a jumper from the mixer plate to the plate terminal of the detector input transformer, A to A', removing tube 3,

OSCILLATOR ALIGNMENT

In checking the broadcast band, a received signal of 1,500 kc. is ideal. Even if the signal is of irregular amplitude, by making the trimmer adjustments very slowly, definite maximum response is readily discernible. With the dial set at 1,500 kc. and a 1,500 kc. sig-

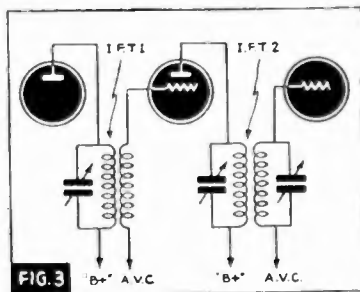

MODERN RADIO SERVICING TECHNIQUE

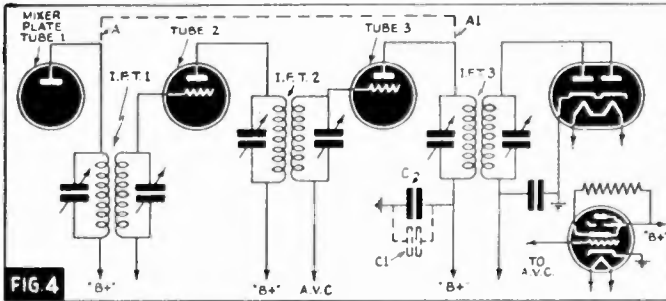

nal coming through (even though not in exact resonance), the oscillator trimmer can then be adjusted for maximum response. After obtaining a satisfactory oscillator adjustment, the R.F. and antenna trimmers can be brought into alignment. The main tuning control is then changed to a lower frequency toward the opposite end of the dial and the padding condenser adjusted. In case signals are not available at lower frequencies, the padder can be adjusted for maximum "hiss" if the receiver has sufficient sensitivity. In making this padding adjustment, the gang condenser should be "rocked" (turned back and forth) to keep the circuits tuned. Finally, the dial setting should be returned to 1,500 kc. and the trimmer settings rechecked.

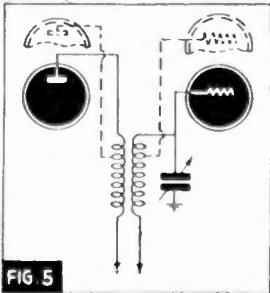

The other bands can be aligned in the same manner, trimmer adjustments being made at the high-frequency end of the dials and padding condensers, if included, adjusted at the low-frequency end of the dials on each band.

The received signals used for alignment should be kept at low levels; instead of connecting the antenna directly to the receiver, the antenna lead-in can be loosely coupled to a short wire connected to the receiver antenna post.

When the antenna is indirectly coupled to the receiver, a "dummy ar-

tenna" must be connected to the antenna and ground posts; for the broadcast band a condenser of 200 mmf. and for the shortwave bands a resistor of about 350 to 450 ohms will serve as a "dummy antenna."

OSCILLATION

Oscillation in an I.F. amplifier is a common difficulty; the entire amplifier may be in an oscillating condition or the oscillations may be confined to one stage. In looking for the cause of oscillations, attention should be directed to parts which may change with service or age, viz., carbon resistors, electrolytic condensers, variable condenser bearings and joints, and even paper condensers. Worn variable condenser bearings or moving contacts often fill up with oily grit and develop high resistance, causing overall oscillation in the circuit. The remedy is to dismantle the condenser, thoroughly clean the bearings or joints, and preferably install new pig-tail connectors from each baffle plate to the shaft at each rotor.

The most common cause of overall oscillation is due to electrolytic condensers deteriorating with age and developing high resistance, especially in bypass circuits. The performance of questionable electrolytic bypass condensers can be instantly checked by shunting a good paper condenser in parallel with the condenser under test, while the receiver is in an oscillating condition. The new paper condenser will stop the oscillations if the electrolytic condenser is at fault; this is shown schematically in Fig. 4, C being the imperfect condenser, and C1 being the supplementary paper condenser.

Oscillations confined to one stage may be due to a number of different conditions. A change of tubes may cure the fault if the original tube has a high

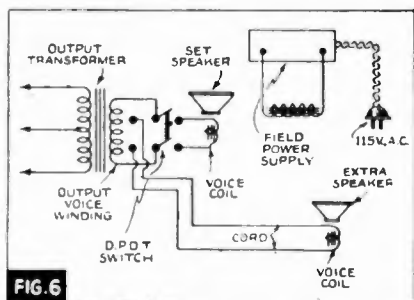

interelectrode capacity for some reason. Severe cases of single-stage oscillation can be corrected in tuned-radio-frequency circuits by either reducing the number of plate turns in the R.F. transformer or tapping the grid connection to a lower point on the secondary; also by inserting a series resistor of about 400 to 1,000 ohms in series with the grid, these alterations being shown in Fig. 5. The above changes should not be made until a fair effort has been made to correct the difficulty with rearrangement of grid and plate leads, better bypass condensers or reasonable readjustment of bias voltage.

A.F. DISTORTION

Often an audio-frequency amplifier which gives good reproduction with a phonograph pickup input, appears to

distort radio reception when adjusted to high levels. This distortion obviously is not in the audio circuit, but due to the last I.F. tube being unable to supply sufficient power to the diode detector for complete excitation. An immediate check can be made by temporarily disconnecting the A.V.C. from the last I.F. tube and providing same with a normal fixed bias. If the distortion is eliminated under the above situation, it is well to leave the last I.F. with a fixed bias independent of the A.V.C. circuit.

DX fans experimenting with long-range shortwave reception are often discouraged by audio feedback "howls" when the receiver is adjusted to approach maximum sensitivity for weak signals. Endless time can be spent on experiments to correct this condition, without much success. Some tubes are less microphonic than others and accordingly a change of detector or audio tubes may reduce the disturbance. Suspending both the receiver chassis and the speaker on soft sponge-rubber will reduce the effect, but the best solution consists of using a second loudspeaker removed from the set cabinet. With that arrangement, preliminary tuning is accomplished using headphones and then switching to the external speaker after the desired signal is properly tuned-in; see Fig. 6.

Emergency Servicing Without Test Meters

PART 3

PART I of this series of radio service articles referred to radio receivers wholly out of commission due to one or more defective parts or tubes.

Part II of this series pertained to receivers in fair operating condition but not properly aligned. The discussion so far has excluded the use of any indicating or measuring meters or instruments.

It is conceded that in modern radio servicing practice the technician should have the best possible assortment of testing instruments and accessories. The

possession of good test apparatus alone however does not guarantee a 1st-class repair job, no more than a set of expensive surgical instruments insures a successful operation. An experienced technician, knowing all fundamentals, can often locate trouble quicker by observation than the novice can by test! A good knowledge of radio fundamentals supplemented by adequate test instruments places the progressive technician in an enviable position and guarantees profitable operation.

It was previously mentioned that un-

MODERN RADIO SERVICING TECHNIQUE

der some circumstances the necessary test equipment may not be immediately available, for one reason or another, and, it is the purpose of this 3rd article, in the series, to suggest possible alternatives to meet such situations.

SUBSTITUTE R.F.-I.F. OSCILLATOR

Most radio technicians are trained to use a signal generator, accordingly it may be in order to describe a makeshift substitute to use in an emergency. Plate and filament voltages for the oscillator tube can be taken from the receiver under test, if necessary.

Figure 1A shows one or many oscillator circuits suitable for a temporary signal generator. The coupler L-L1 can be a broadcast-band, tuned radio frequency transformer together with a variable condenser of about 365 mmf., both of which may be taken from an old receiver. Winding L is the secondary of the transformer and L1 the primary or plate winding. Any triode may be used such as a 6C5 or one-half of a 6N7 as shown, in Fig. 1A, schematically. This oscillator will cover a frequency range of about 530 to 1,600 kilocycles, and can be used as a signal generator for that range.

Harmonics of the oscillator can be used to obtain additional coverage. This same oscillator can be adjusted for any desired intermediate radio frequency. First it is necessary to make a rough calibration of the generator. With the receiver under test in operation, 3 or more broadcast signals of known frequency are tuned-in and in each case the local oscillator condenser C varied until the local oscillator beats with the incoming carrier; the final adjustment being "zero beat" (incoming carrier and local oscillator at same frequency).

A graph is drawn as per Fig. 2, allowing 10 equal vertical separations for each 100 kilocycles, from 1,600 to 600 kc. The 180° dial movement of condenser C (0-100 scale), is divided into 10 equal horizontal divisions. Following the above procedure assume that 1,300 kc. appears at 22 on the condenser C dial, 1,000 kc. at 40, 800 kc. at 57 and 600 kc. at 82. These points are located on the graph and a curve drawn through same giving a rough approximation of the remaining calibrations in kilocycles. The accuracy of the entire calibration is only limited by the number of different

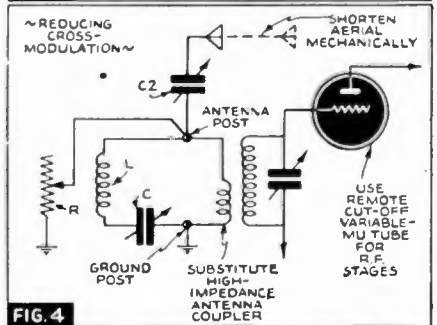
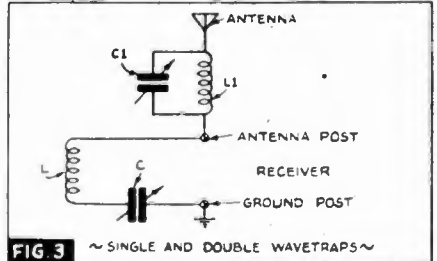
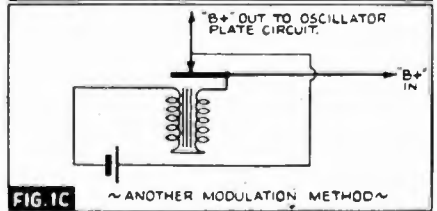
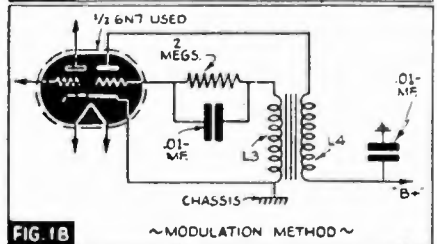
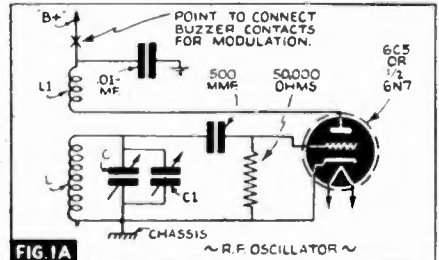

carriers checked and located on the graph.

CHECKING I.F.'S

Suppose it is desired to check intermediate frequency (I.F.) amplifiers and

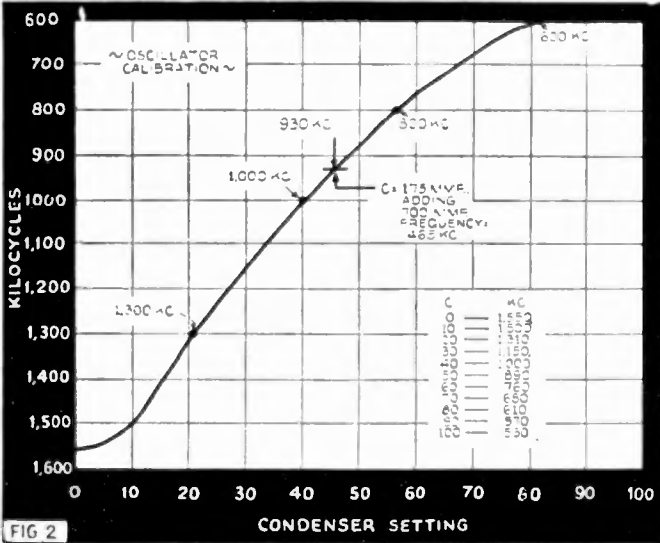

FIG 2

the frequency involved is 465 kc. Now, 930 kc. is double 465 kc. At 930 kc. on the above oscillator, the tuning condenser C (if 365 mmf., max.), will have a capacity of about 170 mmf. By adding a capacity of 4 times that value, or 680 mmf., the wavelength of the oscillator at that point is doubled and the frequency halved. A capacity of 700 mmf. is near enough and made up of available smaller condensers in parallel, viz, 2—250 mmf. and 2—100 mmf., or 1—500 mmf. and 2—100 mmf.

Now with the receiver tuned to the incoming carrier of 930 kc. and the oscillator set at approximately 465 kc., the condenser C is varied until the oscillator harmonic beats with the incoming carrier (adjusted for zero beat), and the exact dial setting for 465 kc. is readily obtained. In case a carrier of 930 kc. is not in range, carriers of 920 and 940 kc. can be used to locate 460 and 470 kc., respectively, on the oscillator dial;

then 465 kc. will fall equally distant between these 2 dial points. Other intermediate frequencies are readily located following the same procedure.

AUDIO OSCILLATOR

To use the signal generator some means of observing the output is necessary; if the receiver has a tuning eye (visual indicator) tube, that can be used as an indicator. Otherwise it is necessary for the signal generator to be modulated, so that an indication of relative output can be determined by headphones or the loud-speaker. Figure 1B shows one method of modulating the R.F. oscillator by adding an A.F. oscillator circuit to the 2nd-half of the 6N7 tube. Coil L3 is the primary of a low-ratio A.F. transformer and L4 the secondary; or L3 and L4 can be 2 iron-core chokes or filters laid parallel to each other. An alternative method is shown in Fig. 1C wherein the R.F. oscillator tube plate

CHEAP RESISTANCE STANDARDS

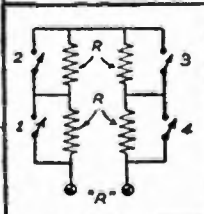

OPEN	CLOSE	R
1	2, 3, 4	1,000 Ω
2	1, 3, 4	2,000 Ω
3	1, 2, 4	3,000 Ω
4	1, 2, 3	4,000 Ω
1, 4	2, 3	5,000 Ω
2, 4	1, 3	6,000 Ω
3, 4	1, 2	7,000 Ω
1, 3, 4	2	8,000 Ω
2, 3, 4	1	9,000 Ω
1, 2, 3, 4	-	10,000 Ω

PRECISION resistors cost money, switches are cheap. By switching, as shown, a considerable amount may be saved in constructing decade resistance boxes. Where, for a series of tens, hundreds, thousands, ten-thousands, there would be required under ordinary circumstances a total of 40 resistors, by this method of switching only a total of only 16 resistors would be needed.

WILLARD MOODY,
New York City

circuit is interrupted by vibrating buzzer contacts; the contact adjustment determining the frequency of modulation.

For rough audio frequency coverage tests, the audio oscillator (Fig. 1B) can be varied over a limited range by adding a small variable condenser in parallel to the grid winding L3. Test signal generators are usually modulated at a frequency of 400 cycles. The musical pitch A above middle C is 440 cycles per second.

Incidentally this 440-cycle standard musical pitch is broadcast practically 24 hours a day by the Bureau of Standards radio station WWV at Beltsville, Md., on a frequency of 5 megacycles.

EMERGENCY A.F. "OSCILLATOR"

The receiver's audio amplifier frequency range can also be tested by another simple method.

First the receiver is placed in an oscillating condition, if a tuned radio frequency set, the radio frequency amplifier is made to oscillate; if a superheterodyne, the intermediate radio frequency amplifier is adjusted to produce oscillations.

The amplifier tubes can be adjusted for oscillation by decreasing the bias resistors or adding an external feedback in the form of a small variable condenser connected from the 1st R.F. amplifier grid to the last R.F. amplifier plate. Assume a superheterodyne is involved and the I.F. amplifier is adjusted to an oscillating condition at 465 kc.

Now by coupling the signal generator, also set at 465 kc. to the I.F. amplifier, beat audio oscillations are obtained and automatically pass through the receiver's audio amplifier and loudspeaker. By varying condenser C of the local oscillator, the frequency of these beat oscillations can be varied from zero beat to 10,000 c.p.s. or more. It is a rough test of course, but useful to locate "dead spots" or "resonant points".

COUPLING DEVICES

The matter of coupling this temporary oscillator to a receiver under test does not lend itself to adjustments for definite or constant input values. With the oscillator operat-

ing at carrier frequencies, the receiver under test should be fitted with a *dummy antenna*, viz., a 200 mmf. condenser or 350-ohm resistor connected from the receiver antenna post to receiver ground post. In addition, a small wire, 1 foot long or so, should be connected to the antenna post of the receiver. By varying the distance between this wire and the local oscillator, a suitable input value can be obtained. Any further reduction in local oscillator signal strength required is obtained by reducing the oscillator tube plate voltage.

At intermediate frequencies (I.F.'s), the oscillator is coupled to the mixer plate circuit. Where the mixer plate lead is shielded, a small external wire can be connected to the mixer socket plate contact and the local oscillator brought into inductive relation with same. In the last mentioned procedure the mixer tube is removed from its socket.

For direct audio frequency tests, for example on an audio amplifier alone, the iron-core chokes L3, L4, can be moved into inductive relation to audio transformers, viz., at the input transformer to test the entire amplifier or at the output transformer to test the speaker.

There are many service problems pertaining to radio receivers wherein all component parts, circuits, tubes and alignments apparently test perfectly but unsatisfactory performance still prevails due to inherent design defects or other conditions internal or external to the instrument.

TESTING FOR NOISE

One of the most annoying service problems is the so-called "stewing" or "crackling" noises, either steady or intermittent, and which may be originating within the receiver or externally. Before wasting any time in locating such disturbances, an immediate test should be made to determine if the source is internal or external to the receiver. By connecting the receiver antenna and ground posts together, right at the terminals, if the noise stops it is definitely proven that the interference is being picked-up by the aerial. On the other hand, if the noise persists, there is no doubt about

MODERN RADIO SERVICING TECHNIQUE

it originating within the receiver. An exception might be caused by a power line pick-up but with present-day transformer design such cases are most unusual.

Assuming the tests show the source of trouble to be within the receiver, by removing tubes one at a time, starting at the antenna end, the seat of the disturbance can be localized. Suppose all the tubes are removed down to the 1st audio stage and upon removing the 1st audio tube the noise ceases. We know that with the detector (T.R.F. set) or 2nd-detector (superhet. set) tube removed the noise continued, accordingly it cannot possibly be due to part of the detector grid or plate circuits.

Upon reinserting the 1st audio tube the noise starts again and therefore the difficulty probably originates in the 1st audio grid circuit and is amplified by that tube; or it might possibly be located in the 1st audio plate circuit but only when plate current is flowing to that tube, for example a poor plate socket contact or partially defective plate coupling resistor or bypass condenser. Substitution of parts at this point will locate the defective part by elimination.

CODE INTERFERENCE

The complaint of radio-telegraph interference at intermediate frequencies (I.F.'s) is common, especially where the receiver is located close to a seaboard. This type of signal interference is best eliminated by installing either a single trap L, C, or a double trap adding L1, C1, as per Fig. 3, adjusting same to attenuate the interfering frequency involved.

Traps for this purpose can be readily made from an old I.F. transformer. The coil support can be cut in half and the 2 windings placed at right-angles to each other, or a copper

shield baffle plate can be placed between the 2 windings. The trimmers are adjusted to eliminate the interfering signal. Standard, manufactured-type traps are usually more satisfactory due to having the proper L/C ratio for maximum cut-off. Additional traps may be used to eliminate severe interference from some particular nearby station, for example a broadcast station. In the latter case the trap inductance and trimmer will have to be proportionately smaller for the higher frequency involved. A better method of eliminating such interference is thru the use of a loop antenna or adjustable directional antenna.

CROSS-MODULATION

Tuned radio frequency receivers are commonly used in connection with public address systems. Earlier models are often subject to severe cross-modulation interference.

The first place to look is in the antenna circuit or 1st radio frequency stage, which is the point where cross-modulation starts. The successful elimination of cross-modulation involves securing increased signal strength of the desired frequency and decreased signal input from the undesired signals or frequencies. Here again a loop or directional antenna may provide a simple solution.

Otherwise a single wavetrap as per Fig. 4 may be of some value, L and C being tuned to the frequency involved. Decreasing the size of the antenna, mechanically or electrically may benefit, in the latter case a variable antenna series condenser is added (C'). Another alternative is to insert an antenna potentiometer (R) of about 5,000 ohms. If the tuner is quite old the R.F. tubes may be of the abrupt cut-off type, in which case they should be changed to the remote cut-off variable- μ type of tube, such as the types 34, 35, 39/44, 6D6, 6K7, 7A7, etc. A tuner subject to severe cross-modulation invariably will be found to have a low-impedance antenna coupler. A change to a high-impedance antenna coupler, preferably "iron core", will often work wonders in eliminating this difficulty.

INTERMITTENTS

An incalculable amount of service time has been wasted tracking down defects which cause an abrupt change of loudspeaker volume or which cause periodical interruptions to reception. The logical procedure is to first make sure the receiver is at fault. By removing the regular antenna and ground and substituting a small indoor antenna a few feet long, elimination of the dif-

difficulty means the antenna is at fault, possibly a loose antenna connection or part of the aerial system grounding periodically. On the other hand if the difficulty persists, tests should be made to localize the source of the trouble. Where the receiver includes a record player, records can be played to determine if the trouble exists in the audio and speaker circuits. Connecting a pair of phones at the last audio stage will provide a check on the speaker. Provided the above tests are

OK, it is then known that the trouble is confined to the detector or R.F. stages. By "jumping out" 1 R.F. stage at a time, as previously described, the defect can be tracked down to a definite R.F. stage or the detector circuit. After that the exact fault, such as a poor socket contact, partially defective condenser or resistor, loose internal tube element, loose connection, stray piece of loose wire or solder, etc., is more easily located.

CHAPTER 6

Servicing Coils

SERVICING R. F. COILS

THE question of replacements for defective radio-frequency coils has long been a nightmare to Servicemen. Many of these technicians, realizing the amount of design-work embodied in such coils, have insisted upon exact duplicate replacements or that the defective coil be repaired by a coil company. In either case, considerable delay often resulted.

Most Servicemen apparently have not realized that the part of the coil that fails in normal service is the part which was manufactured to rather broad tolerances of inductance, and that this part (the primary) can easily be replaced since it has only a minor influence on the "tracking" of the receiver circuits. *Therefore, if the defective primary is replaced, the original coil with its accurately-controlled secondary inductances can be salvaged.*

The Serviceman can give best service to his customers, when R.F. coils fail, if he is familiar with replacement primary windings and knows how to use them, and repairs the coil himself.

REPAIRS—IN DETAIL

The advantages of being able to repair radio frequency coils are obvious to every Serviceman. It remains only for him to convince himself that he, personally, can do the job.

Many Servicemen, who are well able to correct trouble in any make or type of receiver, hesitate to tackle the repair of an R.F.

maries usually consist of only a few turns of wire which can be replaced with an equal number of turns of No. 36 S.S.E.

The question of ability to handle the fine wire of which broadcast primaries are made can easily be settled after a few minutes practice with a piece of sandpaper and a piece of No. 36 S.S.E. or No. 38 S.S.E. wire, or the *outside* lead of one of the replacement primary windings. (If the outside lead should break off too short, a few turns can always be peeled off the coil to give the required lead length without materially altering the performance of the coil. This, of course, positively is *not* true in the case of secondaries, which must be held to close tolerance of inductance.)

It has been found that if a piece of No. 00 sandpaper is folded and cut in accordance with the sketch in Fig. 1 and is held between the thumb and forefinger the insulation—first the fabric, then the enamel—can easily be stripped off of the wire no matter how fine the wire, if appropriate pressure is used on the sandpaper while sanding the wire. Much too little pressure will require a long time to strip the insulation, while too great a pressure will break the wire. A few moments' experiment will quickly inform the Serviceman of the proper pressure to use. There is one point that should be stressed, and that is, that in his determination not to break the lead, the Serviceman should not make the mistake of failing to properly clean off the enamel. If the latter insulation is merely scratched through in a few places, it is not possible to make a good connection. The solder will not stick to the few bright scratches so made. The wire must be thoroughly cleaned.

A few trials at cleaning size 38 enameled wire will soon convince the Serviceman that he can do just as good a job of cleaning the wire without breaking it as can the trained fingers of feminine coil operators, although undoubtedly he will be somewhat slower. A trick that may help to avoid breaking the wire, is to rub the 2 surfaces of the sandpaper together before attempting to remove any insulation. This action removes the high spots on the sandpaper which tend to grab the conductor, and makes the action of the sandpaper smoother and much easier to control.

REPLACEMENTS—STEP-BY-STEP

The following section is a step-by-step set of directions for replacing a defective primary on a radio-frequency coil. A typical group of replacement Primary Windings is shown in Fig. 2. Some sections of the directions may seem obvious when read, but may

coil because of inadequate knowledge about the design constants of such coils, or because they believe that only trained feminine hands can properly handle the fine wire used. The first objection has been overcome by studies made by the Meissner Mfg. Co. which has determined that for any Broadcast-band Antenna or R.F. coil, one of 3 values of inductance will serve admirably, and as far as replacements for Shortwave primaries are concerned, these pri-

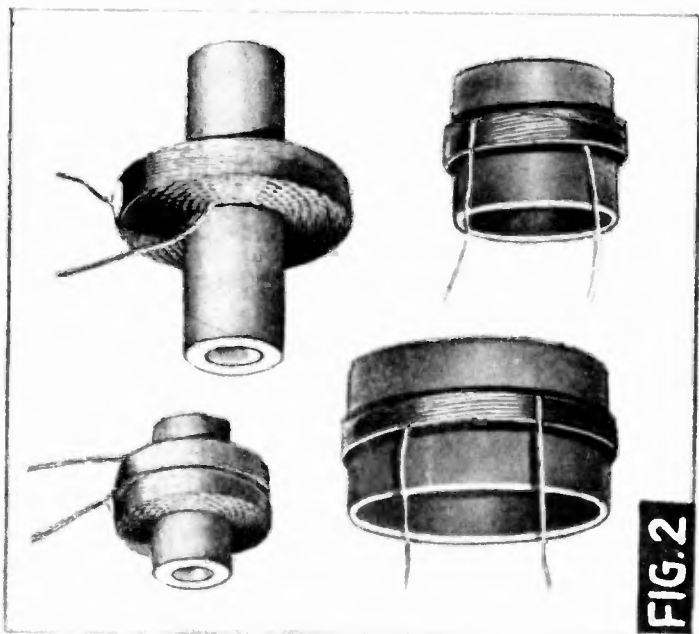
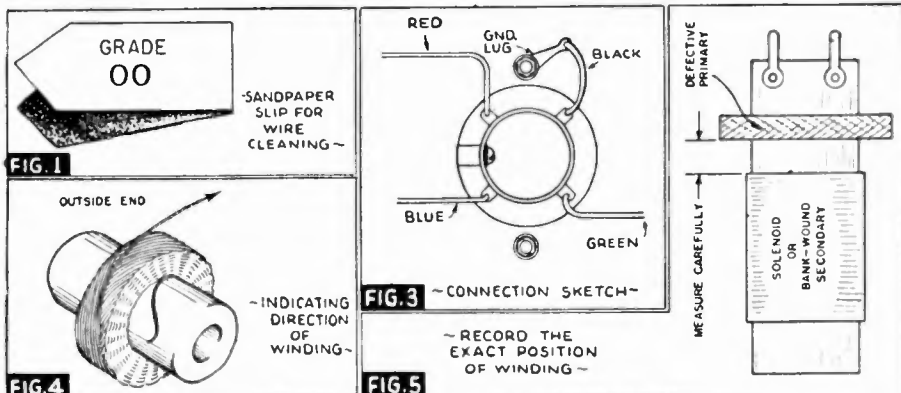

FIG. 2

Typical replacement of primary windings.

MODERN RADIO SERVICING TECHNIQUE



easily be overlooked until too late if the task of replacing a defective primary is started without careful consideration of each step, in sequence, because once a coil has been torn apart it may be too late to observe certain details, that it may be necessary to know, in order to properly complete the job.

(1) Make a clear diagram of all leads connecting to the coil terminals, marking the color of each wire and the position that the coil occupied in the receiver. This should be done carefully and rechecked before, or as, the wires are removed. (See Fig. 3.)

(2) In removing the leads from the coil, take care to put no unnecessary strain on the coil terminals lest the lugs move and perhaps break off some lead from a good winding attached to the lug. If the hook-up wires are hooked through and twisted around the coil terminal so that it is difficult to get them loose, it is best to cut the wires, close to the lug. After being cut, the short pieces of wire are usually easy to remove or, if such is not the case, the ends had best be left attached to the lugs and the hook-up wire merely soldered to the lugs without going through or around them when the coil is re-installed.

(3) Carefully examine the defective winding, which is to be replaced, in order to determine the winding direction and the lugs to which the ends of the winding connect. This information should be carefully recorded. A convenient method of designating winding direction is to use an arrow pointing as if its shaft were the outside end of the coil, and the head of the arrow were the end of the wire. (See Fig. 4.)

(4) The exact location of the winding on the form in relation to the other windings should be recorded, and the defective winding removed carefully to avoid damage to other windings or connections. (See Fig. 5.)

(5) If the defective winding consists of only a few turns of wire wound adjacent to, over, or between the turns of a secondary, this winding can be replaced with an equal number of turns of No. 36 S.S.E. or 36 D.S.C. wire.

(6) If the defective winding was of the "Universal" or honey-comb type, a (Meissner) *replacement primary* should be chosen as near the physical size of the original winding as possible, and yet be able to slip into place. In some cases, unfortunately, lugs or other windings interfere with slipping onto the coil form a new winding close to the size of the defective winding. In such cases a new primary just large enough to slip over the obstruction should be selected and fastened in place by means of small hard-wood wedges held in place by wax, or "radio cement." (See Fig. 6.) (Make certain that the winding direction is correct.)

The inductance of the replacement winding selected is determined by the type of coil being repaired. A Broadcast R.F. coil

MODERN RADIO SERVICING TECHNIQUE

takes the highest inductance, approximately 7.5 millihenries; an antenna coil for use with an outside antenna takes the lowest inductance, approximately 1.7 millihenries; while an antenna coil for an inside or "hank" antenna takes a value between the other 2, approximately 2.25 millihenries. Since these divisions have been so clearly drawn after a study of the replacement problems by the Meissner Manufacturing Company, there should be no doubt in the Serviceman's mind as to which value to select.

(7) Connect the replacement winding leads in accordance with the notes previously made concerning winding direction and connections.

(8) Check the coil for continuity on all windings and re-install it in the receiver in accordance with the notes made in section 1.

(9) Align the receiver, and adjust the coupling if necessary as described in the following paragraphs.

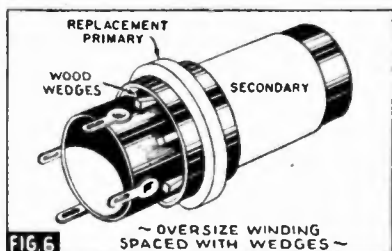

WINDING DIRECTION

When a Serviceman is called upon to repair a radio-frequency coil from which the defective winding has already been removed, or has been so badly damaged that the winding direction can not be discovered, there are 4 questions that must be answered:

(1) Which lug was the antenna or plate connection?

(2) What was the probable inductance of the coil?

(3) Where was the winding located?

(4) Which way was the outside end of the winding pointing?

If there is no data to show which lug was connected to the antenna or plate, the question must be answered from an inspection of the coil, or an answer must be

assumed and the coil repaired and rewired accordingly

If there is any kind of a coupling condenser used it will be found connected from the grid end of the secondary to the plate or antenna end of the primary, which immediately establishes a certain lug as the plate or antenna connection. The coupling condenser may take the form of 2 metal plates separated by a piece of mica and attached to the coil form by means of rivets or lugs (Fig. 7A). It may be a loop of heavy wire circling the secondary near the grid end (Fig. 7B). (This form is used only with solenoid or bank-wound coils.) It may be a few turns of insulated wire wrapped closely round another insulated wire forming what is commonly known as a "Gimmic" (Fig. 7C). In any case, the purpose of the capacity coupling is to transfer energy from the primary to the secondary.

In the case of "choke coupling," used frequently in R.F. coils, the choke is either at right-angles to the secondary, or at a considerable distance from it, and the coupling condenser constitutes the sole means of coupling between primary and secondary. Unless the coupling condenser is properly wired to the coil and into the receiver, practically no coupling would exist in the coil concerned. The winding direction of the primary in this type of coupling has practically no effect on the gain of the coil, and it may accordingly be connected either way.

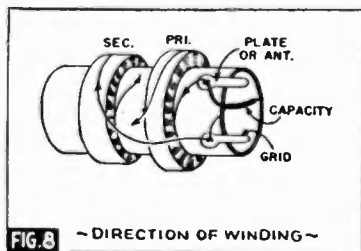

In the case where both magnetic and capacity coupling are employed, the purpose of the capacity is to hold up the gain at the high-frequency end of the band. The capacity coupling aids the magnetic coupling in such cases. Should a primary be connected reversed, the capacity coupling would oppose the magnetic coupling and would

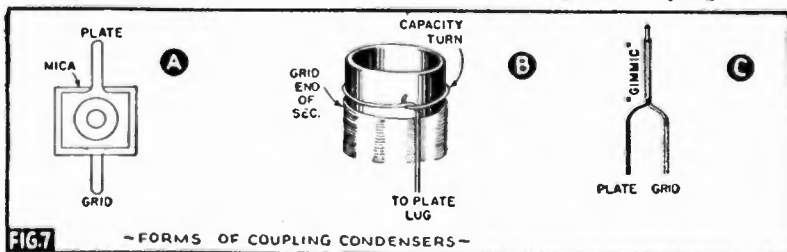

MODERN RADIO SERVICING TECHNIQUE

produce inferior performance at all frequencies and approximately zero amplification at some one frequency resulting in decreased sensitivity at all frequencies but especially poor sensitivity at the one frequency where the magnetic and capacity coupling cancelled.

In some antenna coils, especially in sets with only 2 sections in the tuning condenser, the stray capacity between the "hot" end of the primary and the "hot" end of the secondary is used to buck out the magnetic coupling at some frequency *above the band* (in frequency) for the purpose of improving the rejection of interfering signals in that frequency range. In superheterodyne receivers this improves the "Image Ratio" of the set. With the exception of this case, which is by no means universal, the rule for capacity coupling on radio-frequency coils is that *THE WIRES LEADING AWAY FROM THE COUPLING CONDENSER MUST GO AROUND THE COIL FORM IN OPPOSITE DIRECTIONS.*

In the event that no physical coupling condenser exists, and no data is available to tell which were the "hot" and "cold" ends of the primary, the corresponding lugs *should be chosen arbitrarily* and the primary connected "capacity aiding," that is with the wires from the grid of the secondary and the "hot" end of the primary going around the coil form in opposite directions. (See Fig. 8.)

ALIGNMENT

After repairing a coil and re-installing it in the receiver, the circuits should, of course, be aligned. The normal practice should be followed, using some form of service oscillator for a signal source, connected through a satisfactory dummy antenna to the radio set. The usual values of dummy antenna are 200 mmf. for the broadcast band of sets intended for use with an outside antenna, 85 mmf. for the broadcast band of sets using a "hank" antenna and 400 ohms of resistance for shortwave bands.

If the repaired coil is used on the broadcast band, the circuits should be aligned at 1,400 kc. and then "tracking" checked at 600 kc. If the set originally "tracked" well and the coil has been repaired as directed above, it will "track" well after the repair. Of course, there is usually no chance to find out how well the set "tracked" before the repair, but in the case of multiband sets, it is reasonable to assume that if all of the other bands track well, that the band having the defective coil also tracked well.

When tracking is poor at the low-frequency end of the repaired coil and is good on all other bands, the coupling on the repaired coil probably needs adjustment, but *if tracking is poor in the same direction on all bands* it is probable that the gang condenser is off its normal value by a small amount.

An experienced Serviceman sometimes bends the plates of the condenser to improve tracking but *this remedy should not be attempted by some one not thoroughly familiar with the work.* If the plates are bent to improve tracking, the adjustment should be made on a band that has not had a primary replaced, and then the primary adjusted on the broadcast band to obtain good tracking at 600 kc.

If the circuit appears to require more capacity at 600 kc. than the gang condenser supplies, the coupling is too tight and should be loosened by moving the primary farther away from the secondary; while if the condenser seems to be supplying too much capacity, the coupling is too loose and should be tightened by moving the primary closer to the secondary or, in the case of solenoid windings, closer to the center of the secondary. The latter case is likely to occur when the replacement primary had to be larger than the original in order to slip over some obstruction.

A convenient method of checking tuning capacity at 600 kc. is to insert between the plates of the tuning condenser a thin piece of celluloid while watching the output meter. This adds a little capacity to 1 section of the tuning condenser without changing the tuning of the other circuits. **If the meter reading increases** when the celluloid is inserted the capacity is too low or the coupling is too tight. **If the meter reading decreases**, the capacity may be correct or high. Coupling should then be tightened until the celluloid slip test just shows too little capacity, and then loosened slightly.

CONCLUSION

If care is taken to see that the replacement winding is properly placed (coupling adjusted if necessary) and proper attention is given to the winding direction and connections, there should be no difficulty whatsoever to prevent the Serviceman from giving his customer a satisfactory job in much less time than would be required to obtain an exact duplicate replacement coil or to return the defective coil to a coil manufacturer to be repaired or duplicated.

SERVICING OSCILLATOR COILS

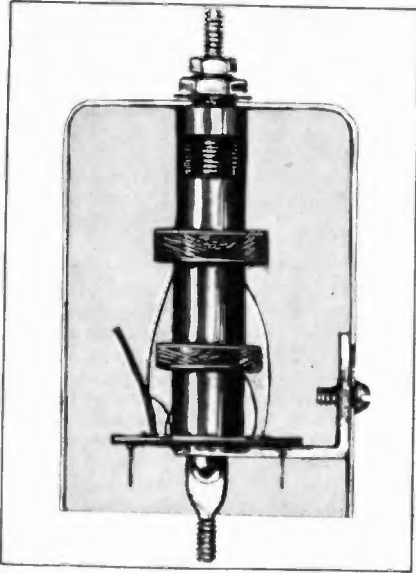

Fig. A. Cut-away view of Universal-type Adjustable-Inductance coil. Movable iron core is exposed inside coil form; adjusting screw and lock nut at top of shield can.

WHEN an oscillator coil fails in service, it is usually the Serviceman's inclination to look for a factory-made exact duplicate replacement coil or to return the defective part to a coil manufacturer for repair rather than to attempt to repair or replace the defective coil himself.

This is probably because he has long "been told" of the many conflicting considerations involved in the design of oscillator coils and he therefore believes it an impossible task to attempt any repair other than the installation of an exact duplicate replacement coil. In most instances such an attitude results in long delays before the set can be returned to the customer, whereas if the Serviceman is sufficiently well-informed, in many cases the defective coil can be quickly repaired or replaced with entire satisfaction from a performance standpoint and a customer's good will obtained through speedy service. It is the purpose of this article to discuss oscillator coils, their characteristics, their repair and their replacement.

OSCILLATOR FAILURES

Oscillators in superheterodyne receivers may fail to work properly for any one of

a number of reasons, the most important of which are listed below:

- (1) Oscillator tube worn out or defective.
- (2) Low oscillator plate voltage resulting from abnormal current consumption by some other part of the receiver.
- (3) Abnormally low plate voltage caused by worn-out rectifier tube.
- (4) Poor contacts on range switch.
- (5) Short-circuit in the oscillator coil or associated circuit.
- (6) Open-circuit in the oscillator coil or associated circuit.

Of the above listed causes for oscillator failure, all but the last are ordinary service problems easily solved by any good Serviceman. It is the last problem, an open-circuit in the oscillator coil, that has been so difficult for many Servicemen to handle with dispatch. The solution of the problem is discussed in the following paragraphs.

OSCILLATOR FREQUENCY RELATIONS

Before attempting to describe ways and means of repairing defective oscillator coils or of making satisfactory substitutions, it would probably be wise to review some of the basic ideas connected with oscillators in Superheterodyne receivers.

The purpose of the oscillator is to beat with the incoming signal to convert it to a new frequency for the purpose of cheaply obtaining more sensitivity and selectivity than could be obtained by simple R.F. amplification.

The new frequency, normally called the *intermediate frequency* (or I.F.), can be either the sum of the signal frequency and the oscillator frequency; or it may be the difference between the two.

THE "SUM" PRINCIPLE.—Either system will work, and both systems have been used, although sets working on the "Sum" principle—the oscillator frequency plus the signal frequency—are very rare since they present 2 distinct disadvantages, 1st, the I.F. is higher than the highest frequency it is desired to receive, which means that the circuits will not have the degree of selectivity available from circuits that operate at frequencies lower than the signal frequency; and the 2nd disadvantage is the difficulty of making the oscillator and the antenna circuit track together since the *tuning condensers must work in opposite directions* in order to maintain a constant sum, the intermediate frequency. In other words, as the signal frequency increases the oscillator frequency must decrease in order to maintain a constant sum.

THE "DIFFERENCE" PRINCIPLE.—Practically all superheterodyne receivers work on the "Difference" principle, that is, the intermediate frequency is the difference between the oscillator frequency minus the signal frequency. This does not necessarily mean, however, that the intermediate frequency must be below the frequency of the lowest signal received, although that is usually the case. Sets of the "All-Wave" type having an intermediate frequency of approximately 456 kc. and having a longwave band—150 to 375 kc. or thereabouts, are a good example of sets having an intermediate frequency above the signal frequency. Some of the more recent amateur receivers have 1,600-kc. I.F. systems. These are additional examples of sets working on the "Difference" principle, yet having intermediate frequencies above the signal frequency.

There is one more frequency arrangement sometimes used on receivers tuning to very high frequencies and that arrangement has the oscillator frequency below the signal frequency. The principal reason for the oscillator being operated below the signal frequency is that the oscillator then does not have to tune to as high a frequency as when it operates on the "high side" of the signal, and since there frequently is difficulty in getting an oscillator to function properly at the extremely high frequencies, especially in multi-band sets, operating the oscillator below the signal frequency gives some help in the problem of maintaining proper oscillation. The number of sets employing this procedure, however, are comparatively few.

TRACKING

When 2 identical inductances are tuned by 2 identical sections of a gang condenser, both circuits are simultaneously tuned to the same frequency. These circuits are said to "track" together. Such is the goal for which engineers strive in the design of T.R.F. (tuned radio frequency) receivers.

In a superheterodyne receiver, the problem is a little more complicated. There, the problem is to make 2 different values of inductances simultaneously tune to 2 frequencies having a fixed difference, the intermediate frequency.

Examining the most common arrangement of circuits, the oscillator frequency higher than the signal frequency, and selecting for an example a broadcast receiver tuning from 550 kc. to 1,650 kc. and having an intermediate frequency of 456 kc., it can be seen that the oscillator must operate from 1,006 kc. to 2,106 kc.

The antenna frequency ratio is $1,650 \text{ kc.} \div 550 \text{ kc.}$, or 3 which requires a capacity ratio of 9 to 1 since frequency ratio is proportional to the square of capacity ratio. The oscillator frequency range is only $2,106 \text{ kc.} \div 1,006 \text{ kc.}$, which equals 2.09, and

requires a capacity ratio of only 4.37 to 1. This reduced capacity ratio can be obtained in any one of the following ways:

- (1) Increase the fixed capacity in the circuit by the use of a high-capacity trimmer condenser.
- (2) Decrease the maximum capacity by the use of a condenser in series with the tuning condenser.
- (3) Combination of 1 and 2, decreasing the maximum by means of the series (padding) condenser and increasing the minimum circuit capacity.
- (4) Use fewer plates in the oscillator section of the gang condenser to reduce the maximum capacity.
- (5) Use plates of special shape in the oscillator section of the tuning condenser.

Actually, in practice, method No. 5 (specially-shaped oscillator plates), is used on most single-band sets of modern design, while method No. 3 (combined series and shunt condensers) is used on some single-band sets (usually of older design) and on dual-band or multi-wave receivers.

PADDING CONDENSER.—If method No. 1, high minimum capacity, No. 2, low maximum capacity, or No. 4, reduced number of plates of the same shape as the antenna tuning condenser plates, is used, the circuits will be "in-track" over 2 narrow regions on the tuning curve, one near each end, but the "tracking" would not be good at other points.

Method No. 3, combined series and shunt condensers, and method No. 5, specially-shaped plates in the oscillator tuning condenser, can give excellent tracking over the entire tuning range when the coils are properly designed.

SHAPED-PLATE OSCILLATOR CONDENSER.—Condensers having specially-shaped oscillator plates are frequently called "cut-plate" condensers or "tracking-section" condensers. A moment's thought should bring forth the realization that a "cut-plate" condenser can be correctly shaped for only 1 frequency range and 1 intermediate frequency (or any other set of frequencies, maximum, minimum and intermediate frequency that bears a fixed relation to the original figures). For example, if a given gang condenser tracks perfectly from 550 to 1,650 kc. with an intermediate frequency of 450 kc., it will also cover the range 1,100 to 3,300 kc. perfectly when using an I.F. of 900 kc. In this example all values were multiplied by 2. They could, of course, be divided by 2 giving perfect tracking from 275 kc. to 825 kc. with an I.F. of 225 kc., or any other multiplier or divisor could be used.

When one type of gang condenser is used in different sets to cover slightly different frequency ranges with the same intermediate frequency, or used to cover identical tuning ranges with different inter-

MODERN RADIO SERVICING TECHNIQUE

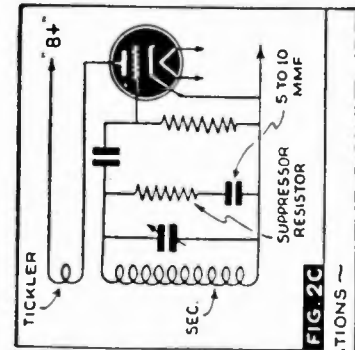

FIG. 2C

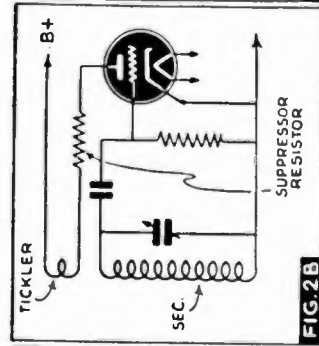

FIG. 2B

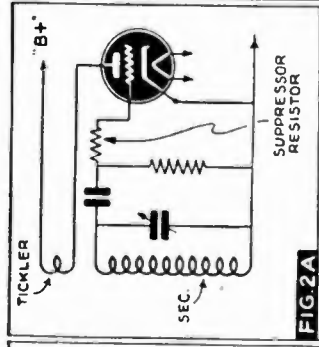

FIG. 2A

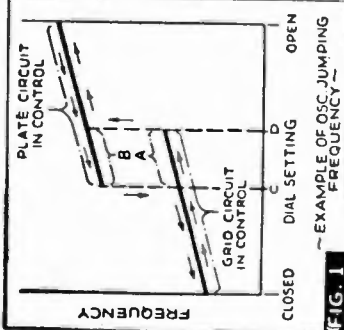

FIG. 1

mediate frequencies, the "tracking" under the ideal conditions (for which the plate shapes were worked out) can be perfect; while, for any other condition the set can be expected to run slightly out-of-track at several points, usually 3—the middle and the 2 extremes—while being perfectly tracked in the 2 places between. The maximum amount of mistracking, however, is usually small in any well-designed set.

It also follows from the above discussion that sets using intermediate frequencies that differ materially from each other and that use "cut-plate" gang condensers must use oscillator plates of different shape for one intermediate frequency than for another. There are, accordingly, "cut-plate" gang condensers for the broadcast band of sets with 175-ke., 252-ke., 370-ke. and 456-ke. I.F. systems.

THE TICKLER COIL.—Having considered, at some length, the frequency requirements of oscillators in superheterodyne receivers, it now remains to look into the operating characteristics of oscillators.

The vast majority of oscillator circuits consist of a tuned secondary to which is coupled a low-impedance winding commonly called the "tickler," whose duty it is to feed back from the plate circuit enough energy into the grid circuit to make the tube circuit oscillate strongly and continuously.

REFLECTED CAPACITY

It is unfortunately true that in feeding voltage from the plate circuit back into the grid circuit, *the tickler also reflects capacity and resistance from the plate circuit into the grid circuit.* The amount of capacity reflected depends upon, among other things, the tube, the ratio of tickler inductance to secondary inductance, and the degree of coupling.

In shortwave oscillator coils there frequently is considerable trouble during the initial design to make the circuit oscillate with sufficient strength at the low-frequency end without at the same time reflecting so much capacity across the secondary that the oscillator fails to reach as high a frequency as desired. When the design has been worked out satisfactorily from an electrical standpoint but with a coil construction that has not been chosen for maximum uniformity in production, there sometimes is enough variation in the characteristics of the coil due to the position of the tickler (on shortwave coils especially) to prevent the circuit from reaching its proper top frequency in the case that the coupling is unusually tight, or to permit oscillation to stop at the low-frequency end of the tuning range if the coupling is too loose. Sets with either of these defects seldom get out of the factory of a reputable manufacturer, but these tendencies are pointed out so that any Service-

man replacing the tickler on a shortwave coil will have a proper appreciation of the importance of the position of the tickler and will govern himself accordingly.

EXCESSIVE FEEDBACK

Sometimes during the initial design of shortwave oscillator circuits with tubes of low mutual conductance or with tuned circuits of poor quality, a large number of tickler turns may be used to obtain satisfactory oscillator strength at the low-frequency end of the tuning range. Then when the condenser is turned toward the high-frequency end of the scale, either of 2 undesirable results may occur: (1) the oscillator frequency may jump suddenly to some frequency much higher than it should be; or (2) the oscillator may start to work at a number of frequencies spaced close together giving rise to multiple responses from a single signal.

OSCILLATOR JUMPS FREQUENCY

In the case of the oscillator jumping frequency, Fig. 1 is representative of what occurs. Starting with the gang closed, and following the arrows in the diagram, the frequency of the oscillator is seen to increase smoothly for a considerable portion of the condenser rotation, then suddenly oscillation jumps to a much higher frequency. As the condenser is turned further in the same direction, the frequency increases further, as might be expected. On the return trip, increasing capacity, the frequency will be found to decrease smoothly to a point considerably past the setting at which the first jump in frequency occurred, and then suddenly the frequency will jump down to its proper value.

Frequencies in the range marked A can only be reached when the gang condenser starts from a position to the left of point C and frequencies in the region B can only be obtained when the condenser starts from a position to the right of D. The diagram has been clearly marked showing the region in which the grid circuit controls the frequency, and the region in which the plate circuit assumes control of the frequency.

There are several remedies to such a fault which, in all probability, no Serviceman will be called upon to repair unless the set is built by an experimenter, but they are listed here for the sake of the knowledge they impart:

- (1) Decrease the number of tickler turns.
- (2) If the oscillator gets too weak or stops at the low-frequency end of the tuning range before the jump in frequency is completely removed, connect a carbon resistor between the plate of the tube and the tickler. The value will have to be determined by

experiment. It may be 10, 25, 50 or 100 ohms. It is hardly likely that the value would have to go higher.

- (3) Make the oscillator coil enough more efficient that fewer tickler turns will give satisfactory strength of oscillation at the low-frequency end of the tuning range.

PARASITIC R.F. AND A.F. OSCILLATIONS (INCLUDING WHISTLES)

When the set suddenly breaks into multiple responses or multiple tweets and whistles near the high-frequency end of the tuning range, the oscillator is said to be "parasitic."

This trouble is usually remedied by reducing the number of tickler turns, if that can be done and yet maintain adequate oscillator strength at the low-frequency end of the tuning range, or carbon oscillation-suppressor resistors may be added in accordance with Figs. 2A, 2B or 2C. The values are not critical but should not be much larger than just enough for the job after testing a group of tubes while the set is operated at high line voltage. The high line voltage test condition is recommended because parasitic oscillation is usually aggravated by high voltage.

TICKLER FAILURES

Returning to a consideration previously brought out in the 3 preceding articles of this series, it is usually the winding at positive potential, in this case the tickler, that fails spontaneously in the presence of moisture and direct current. If one winding must fail it is, indeed, fortunate that the one which fails is manufactured to broad tolerances of inductances while the secondary, which determines tracking and dial calibration, and consequently is held to close tolerance, is undamaged.

On some broadcast and practically all shortwave oscillator coils the secondary is wound in a single layer while the tickler is wound in another single layer adjacent to, or over, or between the turns of the secondary. It should, therefore, be a simple matter to remove the defective tickler without disturbing the secondary and to replace it with a new winding.

REPAIRING SOLENOID OSCILLATOR COILS

The first step in replacing a defective tickler winding is to carefully make a diagram of the connections from the coil to the remainder of the receiver, and another sketch of the position of the winding, its winding direction, the lugs to which each end of the winding is connected and then to count the number of turns in it.

Should the winding direction be omitted or the terminals become confused, there is a universal rule for connecting oscillator

MODERN RADIO SERVICING TECHNIQUE

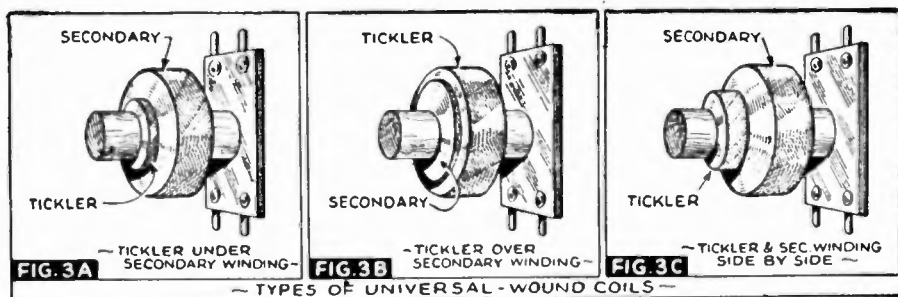

coils that is always correct, whereas no such universal rule can be given for R.F. or Antenna coils. The rule is as follows:

If one starts at the grid end of the secondary and follows around the turns of the tickler in the same direction, one enters the tickler at the low-potential end and ends at the plate.

The position and number of turns in the tickler is of great importance. Measurements should be made to the nearest 64th of an inch before the old tickler is removed, and then the new one of the same number of turns of approximately the same size wire should be installed in as nearly the same place as possible. Sometimes when the tickler is removed the marks from the cement or wax holding the tickler are a convenient guide to the location of the new tickler.

As pointed out in the preceding discussion of oscillator characteristics, the location of the tickler is important because if it is too far away from the center of the secondary coil the oscillator may fail to work at the low-frequency end of the tuning range, especially when operating at low line voltage, or if the tickler is too close to the center of the secondary, it may not be possible to reach the proper top frequency even with the trimmer condenser wide open.

When the tickler repair is finished the coil should be reinstalled in the set and then a complete alignment given to the receiver. If the repair has been properly made the trimmer and padder condensers should require only the most minor adjustments.

REPAIRING UNIVERSAL-WOUND OSCILLATOR COILS

Universal-wound oscillator coils are of 2 major types—(1) the completely universal-wound type in which both windings are the universal type; and, (2) the combination type in which the tickler is wound as a single-layer solenoid covered by a layer of insulating material with the secondary universal-wound on top of it.

The completely universal-wound type is divided into 3 general types: (1) tickler

under the secondary, shown in Fig. 3A; (2) tickler over the secondary, shown in Fig. 3B; (3) side-by-side construction shown in Fig. 3C.

Universal-wound oscillator coils present so much more difficult a repair problem than single-layer solenoid coils that their repair usually can be justified only by some very powerful argument. It is usually much more economical to install a new coil, either adjusting it to the proper inductance on some sort of a coil matching device, pulling off turns until the proper inductance is reached, or by employing a Universal adjustable-inductance oscillator coil which can be adjusted either on a coil matching device or in the set. It is possible, however, to make satisfactory repairs on certain types of coils if the tickler does not have too many turns, was wound where it was possible to work on the tickler, and if the Serviceman has sufficient patience.

TICKLER COIL UNDER SECONDARY.—A coil having its tickler wound under the secondary is a very difficult type of coil on which to attempt to replace the tickler, but in extremely urgent cases it can be done although involving some experiment to determine the proper number of tickler turns. With too-many turns, the oscillation may become parasitic, and with too-few it will fail to oscillate at the high-capacity end of the gang condenser. (With the tickler wound backwards or connected backwards the circuit will not oscillate at any setting of the tuning condenser. See rule above for proper polarity of connections to produce oscillation.)

A reasonable procedure in repairing a broadcast oscillator coil with tickler under the secondary is to wind about 30 turns of No. 36 D.C.C. wire (or some other wire of approximately the same size with reasonable insulation such as S.S.E., D.S.E. or D.S.C.) in the form of a doughnut just large enough to slip on the coil form, tie it with thread in several places to hold it together, and place this on the oscillator coil form close to the original winding holding it in place with wax or cement. The coil leads should then be connected to the lugs which terminated the original tickler wind-

MODERN RADIO SERVICING TECHNIQUE

ing (making sure of the winding direction and connection according to the rule previously set down), and the coil placed in the receiver for test.

If the set plays, and the oscillator can be trimmed to calibrate properly at 1,400 kc., and if it does not stop working with the gang condenser closed at low line voltage (about 105 volts on a nominal 110-volt line), and if it does not break into parasitic oscillations at the full-open position of the gang condenser, the repair can be considered a success.

If the circuit fails to oscillate at the low-frequency end of the dial, more tickler turns are needed. If the circuit becomes parasitic at the high-frequency end, fewer tickler turns are needed and adjustments on the number of tickler turns should be made accordingly until satisfactory results are obtained. Note that in all cases the bunched tickler should be as close to the secondary as possible.

TICKLER COIL OVER SECONDARY.—In the event that the tickler is wound over the secondary or beside the secondary as in Figs. 3B and 3C, the experimental work to determine the proper number of tickler turns need not be performed since it is very simple to remove the defective winding without disturbing the secondary, count the number of turns, and random wind a new coil to take the place of the defective one.

UNIVERSAL ADJUSTABLE - INDUCTANCE OSCILLATOR COIL

It has been pointed out in preceding articles of this series that where acceptable factory-made replacement coils are available at reasonable prices, it is usually an economy to use these replacement parts in preference to attempting a repair. Oscillator coil failures are no exception.

Where an oscillator tickler has corroded open, leaving the secondary intact, the Universal Replacement Coil is a great convenience, but in the unusual case where the secondary is open, giving no clue to the proper value of inductance to use, the Universal Adjustable-Inductance Oscillator Coil is practically a necessity. A coil of this type is shown in the heading illustration of this article. With its adjustable-inductance feature, the coil can be quickly adjusted in the receiver to match the dial calibration.

In the failure of an oscillator secondary, the greatest aid to rapid repair is an undisturbed setting of the oscillator trimming and padding condenser, especially the latter.

TRIMMERS AND PADDERS UNDISTURBED; SERVICE-OSCILLATOR ALIGNMENT.—If this adjustment has not been disturbed and the adjustable-inductance oscillator coil has been installed, the set should be connected to a signal generator or service oscillator in the normal manner with the service oscil-

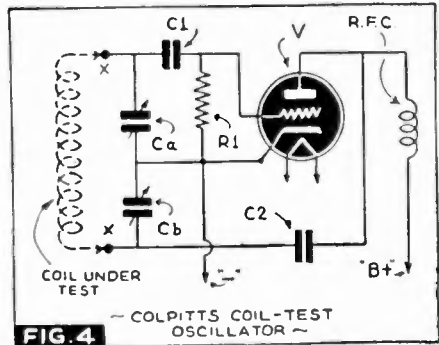

Suggested component values: C1, 100 mmf.; C2, grid excitation condenser, about 0.002-mf.; gridleak, R1, 50,000 ohms.

lator frequency set at 600 kc. and then the adjustment screw on the oscillator rotated slowly while the gang condenser is rocked—as if padding, watching for maximum response. When maximum response is obtained at 600 kc., the generator and set should be set to 1,400 kc. and the oscillator trimmed to calibrate properly. The 600 kc. point should be readjusted, if necessary using the inductance adjuster—not the padding condenser, and the trimming at 1,400 kc. touched-up.

TRIMMERS AND PADDERS DISTURBED; TRIAL-AND-ERROR ALIGNMENT.—In the event that the secondary of the original coil has been damaged, and the padding condenser has been thrown out of adjustment, it becomes necessary to track the oscillator coil to the dial calibration by the trial-and-error method. The simplest procedure is to align the set at 600 kc. and 1,400 kc. and then check to see how far the set runs “out-of-track” at the middle. The oscillator inductance is then changed and the set aligned at both ends and checked in the middle again. This process of adjusting, trimming, padding, and checking is continued until proper tracking over the entire tuning range results.

The procedure is as follows: Set the inductance adjuster at some point, tune the generator to 600 kc. and adjust the receiver dial to indicate the same frequency, then adjust the padding condenser until the set responds to the signal. Then tune generator and set to 1,400 kc. and trim the oscillator to respond at that frequency. Shift to 1,000 kc. and check the point on the dial at which the signal is heard. Shift the oscillator inductance adjuster 1 turn and repeat the process. If the dial calibration at 1,000 kc. becomes more nearly correct, proceed with the above-outlined plan until the accuracy is good at 1,000 kc. and the sensitivity is also good over most of the tuning range.

If the calibration at 1,000 kc. gets worse, it is obvious that the first shift in inductance was in the wrong direction and sub-

MODERN RADIO SERVICING TECHNIQUE

sequent shifts should be in the opposite direction until good alignment and calibration is obtained. It must be remembered, of course, that there is some variation from exact accuracy in practically all commercial sets, and therefore complete agreement with the indicated frequencies on the dial is not to be expected.

If the set is of the cut-plate type employing no padding condenser the problem is much simpler; simply use the oscillator inductance adjuster as if it were a padding condenser and adjust for maximum response at 600 kc., then trim at 1,400 kc.; repeat the process once more and the job is finished.

COIL-MATCHING DEVICE

Probably the simplest possible coil-matching device is a *Colpitts oscillator* such as shown in Fig. 4 used in combination with a receiving set and a signal from a broadcast (or shortwave) station. The tube, V, can be almost any triode, and the voltage about 90. The choke, R.F.C., shown in the schematic is not critical as to constants but should have reasonably low distributed capacity and reasonably high inductance. (A Meissner No. 19-2330, 30-millihy. choke or equivalent is recommended.)

The tuning condenser may be any high-capacity gang condenser. If possible, it should be a 4-gang condenser with the 2 gangs at one end connected together (in shunt) and the 2 at the opposite end also connected in parallel. This arrangement is

recommended because in the circuit shown, the 2 tuning condensers, Ca, Cb, in series across the coil under test, only equal a single section as normally used in the set.

With this device, the good secondary of the defective coil (shown dotted) is connected to the points marked X, the set tuned to a station of appropriate frequency and the test oscillator tuned to zero beat with the station, and the dial setting noted. (Remember that a broadcast oscillator for a set with 456 kc. I.F. normally tunes from about 1,000 to 2,000 kc. and shortwave oscillators correspondingly tune higher than the dial calibrations by an amount equal to the I.F.)

The new coil is now substituted for the old one, the test rig tuned for zero beat, and the dial setting noted. If the tuning capacity for zero beat is higher than when the original coil was connected, the new coil is too low in inductance and turns must be added until the desired inductance is obtained, or a new coil of higher inductance must be obtained so that it may be pulled down to the correct inductance. When turns have been pulled off until the inductance is only a fraction of a turn too high (or too low), the last adjustment can often be conveniently made by radially pressing in on the periphery of the coil which spreads the turns slightly and decreases the inductance a few per cent (or by squeezing the coil in the axial direction which will raise the inductance a little).

CHAPTER 7

General Information

THE FIRST 10 STEPS IN RADIO SERVICING

How do you go about servicing a set? One well-known radio engineer submits the following as the first 10 steps.

- (1) See that power supply to receiver is satisfactory. Check loudspeaker leads, antenna and ground connections.
- (2) Operate the set if possible. If trouble is not obvious, remove tubes and check them.
- (3) Touch the grid cap of I.F. tube or tubes with metal object, such as a screwdriver, and listen for click in speaker.
- (4) Check speaker transformer, voice coil and field, and make certain they are satisfactory.
- (5) Remove chassis and check power supply completely.
- (6) If power supply is OK, next measure all filament voltages, plate and screen-grid voltages, and bias voltages—compare with specified values in circuit diagram or tube data book. If voltages on individual tubes are high or low, test components in the feed circuit.
- (7) Make certain that the audio circuit is functioning satisfactorily, then proceed to work from the detector to the antenna, one tube at a time, until the fault is located.
- (8) If no apparent troubles can be found, examine carefully all wiring, grounds, switch contacts, socket contacts and controls.
- (9) Use meters and check values of all components in inoperative section.
- (10) Check, clean and adjust all wave-change switches, and if necessary, clean dirty tie points which would otherwise cause low insulation resistance to ground. Clean insulation on gang condensers and resolder all weak connections in set. Replace noisy controls. Adjust alignment of receiver.

RMA TRANSFORMER COLOR CODE

THE following information should be on file in every radio service shop as being the color codes recommended by RMA (see illustration).

In cases of use of single primary and/or single secondary, the top portion of the diagrammed windings should be used to indicate the color coding. Where polarity of primary and/or secondary is not a factor, both outside leads may be the same color as indicated. Where polarity must be indicated, the Brown and Yellow leads shall indicate the start of the primary winding and the start of the secondary winding respectively. In the case of an output transformer, the Black lead shall be the start of the secondary. (Note: Many output transformers have solder lugs for the secondary, rather than leads. In this case the primary leads only are marked according to RMA coding.)

- Red—Plate leads of High-Voltage secondary.
- Red and Yellow—50/50 stripes—H.V. Center-tap.
- Yellow—Rectifier filament leads.
- Yellow and Blue—50/50 stripes—Rectifier Center-tap.
- Green—Filament winding No. 1.
- Green and Yellow—50/50 stripes—Fil. Center-tap.
- Brown—Filament winding No. 2.
- Brown and Yellow—50/50 stripes—Fil. Center-tap.
- Slate—Filament winding No. 3.
- Slate and Yellow—50/50 stripes—Fil. Center-tap.

Color Coding of Power Radio Transformers

- Black—Primary leads.
- Black—Common of tapped primary.
- Black and Yellow—50/50 stripes—tap of primary.
- Black and Red—50/50 stripes—finish of primary.

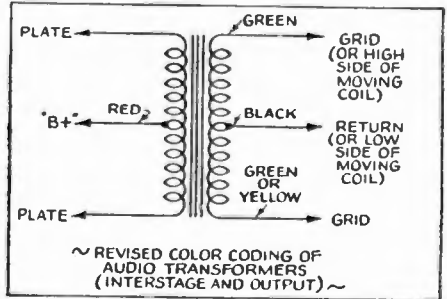

WHAT CAUSES ECHO, FADING?

NEXT time your customer waxes irate at the results he gets on his allwave radio receiver, let him see this item, which tells in the words of the Engineering Division of the British Broadcasting Corp. some of the reasons why listeners may sometimes experience echo, fading, distortion and other effects when listening to, let us say, one of the B.B.C.'s Overseas Stations.

"Echo" effect is rarely to be observed on waves longer than those in the 19-meter (15 megacycles) band, which means, usually, that on transmissions from one of the B.B.C.'s Overseas Stations the effect is most likely to be observed by listeners in India, Malaya, and Australia—and possibly the West Indies—during Transmissions 2 and 3. (The same principles apply in receiving short-wave programs in America, of course.—Ed.)

All the aerials used at the B.B.C. short-wave station for wavelengths below 20

meters are fitted with reflectors, the effect of which is to concentrate the radiated energy in one direction when it leaves the aerial. When propagation conditions are particularly favorable, it may happen that a frequency in, say, the 13-meter band, such as GSJ, may provide strong signals in India, and still be of sufficient strength to travel onward, until, having completely encircled the globe, it provides a second signal at the same point of reception.

When such "round-the-world" or "forward" echo takes place, the interval between successive signals is of the order of 1/7-second—there are authentic accounts on record of as many as 5 or 6 separate repetitions of a single signal. It will be seen that if a news bulletin, for example, is being read, and conditions bring about the echo effect described, then the distortion produced may make the program practically unintelligible. Although, as is shown below,

MODERN RADIO SERVICING TECHNIQUE

certain types of echo may be overcome by the use of reflectors at the *receiving* end, the type referred to here cannot be suppressed in this way.

A 2nd form of echo, sometimes called "backward echo," takes place when the transmitting aerial used is not equipped with a reflector. From such aeriels energy is radiated in equal amounts in opposite directions. If the point of reception is not equi-distant from the transmitter over both paths, and if conditions are well suited to the frequency concerned, then signals may be received from both directions. Since the 2 paths are of unequal length, the time taken for the signal to arrive will not be the same from both directions, and echo may again be produced, the time interval being determined by the difference in the 2 path lengths.

This effect can also be produced even when the radiating aeriels are equipped with reflectors, for it would be both difficult and costly so to design them that the whole of the energy radiated would be concentrated in the one direction. With the

arrays actually used by the B.B.C., a small amount of energy escapes in the direction opposite to the line of maximum radiation.

When conditions are suitable, as, for instance, on 13 meters and 16 meters in Transmissions 2 and 3, serving India, this small amount of escaping energy is sufficient to provide useful signals at relatively great distances from the transmitters. The "Great-Circle" route from Britain to the West Indies happens to be almost exactly in the opposite direction to the route to India, and listeners in the West Indies will, no doubt, be well aware that frequencies GSJ and GSG often provide useful signals there when primarily intended to serve India.

It may be possible, when propagation conditions are particularly suited to those frequencies, for listeners in the West Indies to observe the effect of echo due to the signals' arriving by the shorter route direct from Britain, and also by the long path across India and so round the globe. This type of echo may be reduced by the use of reflectors on the receiving aeriels.

RADIO SERVICE PUZZLERS

Interference in New Installation. A new receiver, a Motorola 65, was installed for a rural mail carrier whose complete route was along a high line. The complaint was made however that even on stronger stations the interference level was high enough to spoil reception.

The set was realigned with an output meter and oscillator. The 1st and 2nd I.F. transformers were staggered so that the final result was a nearly flat-topped curve for 3 kc. on either side of the resonance. After carefully realigning the R.F. and padder trimmers, the result was somewhat less sensitivity and selectivity, but greater fidelity so that the local interference was completely blocked out.

Edward S. Courter.

Inoperation over Part of Dial. Many General Motors auto-radio sets, operating on a short pole-type aerial, are inoperative between 68 and 55 on the dial, although the rest of the dial works all right.

By feeding a signal from an oscillator, it was noted that no signal would go through the mixer tube, indicating that this tube was not oscillating at this part

of the dial. The problem was solved by stepping the cathode resistor of the 6A7 tube to a value 1,000 ohms smaller. In some of these sets, the resistor has to be as much as 2,000 ohms smaller than the value originally used.

The set then brought in stations around 540 kc. perfectly when used on the short pole aerial. This trouble is apt to be misleading, since it might seem that the variable condenser plates are shorting, or that there is something wrong with some of the coils. Testing the resistance of the coils; testing for a short in the tuning condenser, and so on, however, will show these to be OK.

Monty Glass.

Distortion in Phono-Radio Set. Distortion, sounding as if the speaker was off-center, was the effect produced in a "combo." Routine check revealed that alignment was OK. Tubes were checked and found OK, so the set was brought into the shop.

By inducing an audio signal to the final stages and following it through to the speaker, trouble was established at the speaker. Examination showed that a phono needle had gotten on the outside of the voice coil and when the set

MODERN RADIO SERVICING TECHNIQUE

was turned on the needle was pulled down against the speaker core, causing distortion.

R. S. Wheeler.

Hum in Intercall Systems. Severe hum trouble was experienced in small custom-built intercall systems, which were of the A.C.-D.C. type. Condensers were rated at the usual 16-16 mf. ratings as were specified, so no trouble was expected there. An oscilloscope check showed up only 60 cycles A.C.

Condensers were checked with a Weston 20,000 ohms/volt meter. On rechecking, it was found that electrolytic condensers (of the type which contains 4 separate capacities) were too tightly packed into the containers, and after a few hours of operation would leak through to cause hum,

Paul C. Mangan.

Low Volume in a Standard Receiver. Low volume in a late-model 7-tube radio set was encountered. Tubes were checked on a portable checker. The tubes testing OK, the set was brought to the shop.

Routine analysis revealed the following: All voltages checked good, I.F. and R.F. values were perfect, signal strength to 1st audio stage good, all coupling condensers and resistors checked OK; with an output meter across the voice coil of the speaker, the signal received from the oscillator read about half-scale. One lead from the voice coil was clipped to the output transformer. When the meter was placed across the secondary of output transformer, and without any adjustment to the oscillator, the signal drove the needle of output meter off-scale. The resistance of the bank-wound voice coil of the speaker was next measured, and found to be shorted between windings to about half of its original resistance. A new speaker cone restored the set to its original volume.

W. R. Newman.

Low Volume in Sets with A.V.C. and 2nd-Detector Combined. A number of late model sets, having the customary system of A.V.C. and 2nd-detector combined, and with the audio volume control as the A.V.C. divider, were serviced for lack of snap and volume. After routine checking of alignment, voltages and quality of circuit constants, all were found to be in good condition until con-

tinuity checking was attempted with a high-sensitivity ohmmeter.

Analysis revealed a high-resistance leakage path and sometimes a near short from the rotor contact of the volume control to ground, which would to some degree short out a portion of the audio signal to ground and also reduce the quantity of A.V.C. developed. In many cases, the causes of these symptoms could not be detected without the use of high-range, sensitive, continuity meters or microammeters such as the Weston 20,000 ohms/volt meter.

Stephen Furedy.

Loss of Volume. A defect in a Grunow model 11G receiver caused a loss of volume. The customer had taken a screwdriver and turned down tight all the adjusting screws of both I.F. and R.F. stages, on all 3 bands of the receiver. No signal came through the I.F., but a signal generator put through an audio signal at normal volume from either plate of the 2nd-detector.

A voltmeter showed no screen-grid voltage on R.F. and I.F. amplifier tubes, showing up a shorted 0.1-mf. condenser to chassis. Being unable to get a signal through from the antenna post of the set, the signal generator was connected to the control-grid of the 2nd I.F. tube. A weak signal was indicated on the output meter connected across the primary of the output transformer. The trimmers of the 3rd I.F. transformer were adjusted; a signal generator connected to the control-grid of 1st I.F. tube, and the trimmers of the 2nd I.F. transformer adjusted; and, leads from the signal generator were connected to the control-grid of the det.-oscillator, and the 1st I.F. transformer trimmers adjusted. With a signal now being obtained through the antenna binding post (modulated R.F.), the broadcast trimmers and padders were adjusted. No signal was apparent on the foreign band, but voltages on the R.F. tube were OK. Resistance measurement between grid of R.F. and grid of 1st I.F. tube showed no continuity. Resoldering the contacts for this band on the wave-change switch terminals restored continuity and re-established normal operation on this band. Equipment high-resistance ohmmeter, a signal generator, and an output meter.

Dwight L. Cooley.

MODERN RADIO SERVICING TECHNIQUE

Fading in Car-Radio Set. In the car, a Stewart-Warner model R-1131 receiver faded out and gradually faded back to normal. Perfect performance was obtained on the test rack. Routine test in the car disclosed that fading was caused by oscillator failure, and that voltage at the set with the motor running was rather high, 7.5 volts.

On test bench, high battery voltage produced fading. Further tests indicated that the oscillator coil was causing the trouble, in spite of the fact that the D.C. resistance of the coil was exactly as specified by the manufacturer. Checking the coil further by signal generator and V.-T.V.M. disclosed an intermittent shorting of turns. Replacement of the coil cured the trouble. Later, a microscopic examination disclosed that the enamel wire insulation would break down at radio frequencies but not on the D.C. from the ohmmeter.

Raymond W. Tackett.

Frequency Shift on Broadcast Band. Trouble in the oscillator circuit of a Philco Model 116X showed up in no reception on short waves and frequency shift on broadcast band, both while set was playing; or having station come in at different point on dial from previous time of play. Usually high-resistance joints prevent oscillation or cause frequency shift. Sometimes rivets holding stator sections of condenser gang loosen, allowing spacing to change and thus cause a frequency change.

We installed a new padder condenser, all new resistors in the oscillator circuit, new grid condenser, soldered all joints on coil. Still had trouble, so just about ready for new condenser gang. Our ohmmeter reads to $7\frac{1}{2}$ megs. with a $22\frac{1}{2}$ -volt battery. As a last resort, we hooked up a power pack and extended the range to 75 megohms. A definite high-resistance short showed up in the grid circuit. Trouble was traced to condenser gang and found to be a small deposit of soldering flux from stator to frame of condenser. Careful scraping with knife, and cleaning with carbon tetrachloride and toothbrush, took care of the trouble.

The short was on the order of 10 to 15 megohms, but varied, getting to quite a low value as the set warmed up, and raising to a high value when cool. Effect was more pronounced, of course, on short waves.

GEORGE D. DAY

No Signal on "Shortwave Broadcast" Band. The regular broadcast band of a Stromberg-Carlson Model 240M was perfect, but there was no signal on the shortwave broadcast band.

A Weston Model 669 V.-T. VM. was connected across the oscillator circuit with the set on the broadcast band and the oscillator voltage was within 70 per cent across the dial. We then changed the band-switch to shortwave and our V.-T. VM. went down to zero. When turned back to broadcast, the oscillator started again, the voltage registering on the meter. We turned it back to shortwave and again there was a zero voltage. A new 6C5 oscillator tube put this set back in shape. By having a high-grade V.-T. VM. which could be shunted across the oscillator circuit tuning condenser, we were able to localize this trouble in about 5 minutes and correct it without using a soldering iron.

RICHARD J. DOYLE

Distortion of Audio Output. Set requiring servicing was an Atwater Kent model 89. Distortion occurred at intervals of time as much as an hour apart. Testing with a Weston model 566, all voltages and currents seemed correct.

After repeated testing of all circuits to enable a reading to be taken during distortion, it was found that there was a rise in the plate current of the 1st audio tube, a type 27. The bias voltage across the cathode bias resistor was then observed during distortion while set was in operation. During normal operation voltage was correct but it disappeared when distortion occurred. This disappearance was accompanied by some fluctuation of the voltage. The cathode bypass condenser was suspected, and when cut out and replaced, the trouble was corrected.

CHARLES E. DIEHL

RADIO CIRCUIT MANUAL 1942

UP-TO-DATE OF
GOVERNMENT
SHUT-DOWN
APRIL,
'42

Complete, Correct, Compact

**The Set You are
Looking For Is Here!**



This Radio Circuit Manual has more listings than any other publication of its kind. Check for yourself on such makes as Lafayette, Emerson, Pilot, Philco, RCA, Stewart Warner. If time really means money to you then this *completeness* will save you many times the cost of the book. It is the greatest time-saver you can buy today.

No fumbling around! No turning over to another page! The big roomy pages of the Radio Circuit Manual contain everything on a single page. You will see not only schematics, but quick reference IF spot, parts lists, dial stringing, diagrams, tuning range and data, tube locations, voltage charts, trimmer locations, push button, set-ups, alignment notes, and procedures, record changer details, etc.

THE ONLY EDITED MANUAL PUBLISHED!

The diagrams are perfect. Every one was checked and rechecked to make sure of it. The printing is clear and distinct. It's a pleasure to use this manual.

The index is another feature you'll like. At a glance you can tell whether a model is the same as another. No hunting back and forth . . . it's right there. Big readable type numbers and model numbers help to spot quickly what you want.

Special charts on tube and battery interchangeability, lights, ohms law, color codes; also a special article on "The Methods of Substitution" by F. L. Sprayberry, to make your wartime service job easier.

If you like your service manual in handy form—so shaped that you can grab hold of it easily and store in small space . . . if you like a book that lies open flat so you don't constantly lose the place . . . then you will certainly appreciate the Radio Circuit Manual.

Everything relating to a model is on a single page. Mighty handy!

700 fact-packed pages. The actual page size is 10 x 12 3/4 inches.

**\$10
EACH**

Use this simple coupon for ordering the 1941 and 1942 Radio Circuit Manuals.

RADCRAFT PUBLICATIONS, INC.
25 West Broadway, New York 7, N. Y.

Gentlemen: Rush to me by return mail, the RADIO CIRCUIT MANUAL ordered below, which I understand are priced at \$10 each.

1941 Edition 1942 Edition
 I enclose remittance to the amount of \$.....
 Kindly send C.O.D.

Name
(PLEASE PRINT CLEARLY)

Address

City Dist. No., if any State

(If remittance is enclosed, send in form of check or money order; register your letter if you send cash).

LIMITED NUMBER OF 1941 MANUALS LEFT

Our 1941 RADIO CIRCUIT MANUAL—the first we ever issued—proved so popular that we cleared out most of them in a short time notwithstanding a large printing. However, during a recent inventory, we discovered a small number still on hand which we are disposing of quickly. This should be good news to anyone who failed to get the 1941 edition. After all, many 1941 models must be served today, and the 1942 edition won't help at all for the earlier models. The price of the 1941 edition is the same as 1942 . . .
only \$10 each

What's new in electronics?



supplies the answer!

Every issue contains news galore of epoch-making radio-electronic developments. This news is not just glamour but carries a message to every man or woman who is or will be making radio and electronics his career. Each issue is teeming with workable ideas you can use immediately.

RADIO-CRAFT is a practical magazine published for the constructor, the experimenter, the serviceman and other technicians. By reading it regularly you will learn which of the new inventions are likely to survive. You will make good use of the "how-to-do-it" illustrations, radio hook-ups, servicing tips, shortwave station listings, etc. And you will become familiar with a host of subjects you never before encountered.

The list of contributors shown at the right represent the finest array of authorities on the staff of any publication. These writers are continually working for your benefit. Get a copy of the current issue — read it from cover to cover. Then judge for yourself if it is not the finest magazine in the field published today.

We will send you RADIO-CRAFT for One Year at the Special Rate of \$2.50; or \$4.50 for Two Years. (Canadian and Foreign 5c extra per copy). Send remittance in the form of check, stamp or money order to

•
Editors of

RADIO-CRAFT

HUGO GERNSBACK

Editor-in-Chief

FRED SHUNAMAN

Associate Editor

•
Contributors to

RADIO-CRAFT

DR. LEE DeFOREST

RAYMOND F. YATES

A. A. GHIRARDI

A. C. SHANEY

F. L. SPRAYBERRY

R. E. ALTOMARE

TED POWELL
•

RADCRAFT' PUBLICATIONS, Inc.

25 WEST BROADWAY

NEW YORK 7, N. Y.