

RADIO-CRAFT LIBRARY N°8

1163

# RADIO QUESTIONS AND ANSWERS

A Selection of the Most Important of 5,000 Questions

Submitted by Radio Men During the

Course of One Year

by R. D. Washburne

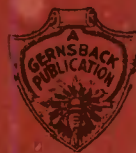

PUBLISHED BY  
GERNSBACK PUBLICATIONS, Inc.  
98 PARK PLACE - NEW YORK

**FREE**

Supplements are mailed every 60 days to owners of the Manual

*Free Questions and Answers Service*

Schematic Diagrams of All Latest Midget Receivers

OVER 1,000 PAGES

Over 2,000 Charts  
Hook-ups and  
Illustrations

Flexible Loose-Leaf  
Binder

9 x 12 Inches

Complete Directory of All 1931-  
1932 Radio Receivers,  
Full Radio Service Guide  
For Radio Service Men, Dealers,  
Jobbers, Manufacturers  
and Set Builders.

**\$5.00** The  
Copy



**E**XPERT servicing or installation of radio receivers requires experienced in handling sets of any manufacture. Need that the dealer, service man or radiobrician be thoroughly less to mention how important are modern methods of servicing, and how easy it is to complete any service job when the OFFICIAL RADIO SERVICE MANUAL is on hand. The 1932 MANUAL contains a Full Radio Service Guide and a most Complete Directory of all 1931-1932 Radio Receivers as well as models of older design. Everyone employed in the Radio Industry should have a copy available for his own use.

Here is a resumé of the 1932 Manual:

A step-by-step analysis in servicing a receiver which embodies in its design every possible combination of modern radio practice; it is fully illustrated and thoroughly explained. It is the greatest contribution to the radio service field.

Charts showing the operation of all types of vacuum tubes, whether new, old or obsolete. An exclusive resumé of the uses of the Pentode and Variable Mu Tubes and their characteristics. Complete discussion of the superheterodyne and its inherent peculiarities. Also a special chapter on tools used on superheterodyne circuits.

Schematic diagrams and circuits complete with color codings.

Important chapters on commercial aircraft radio equipment; new data on commercial short wave receivers and converters.

Servicing and installation of public address systems and talking machine equipment.

Standardized color coding for resistors. Operation of old and new testing equipment; tube voltmeters, output meters, oscillators and aligning tools.

A full section on Midget radios—their design, circuits and types. How to service them most economically.

Hundreds of schematic diagrams of older radio receivers which have never been published.

Blank pages for recording notes, diagrams and sketches; these pages are transferable to any part of the book.

GERNSBACK PUBLICATIONS, Inc.

98RQ Park Place, New York, N. Y.

# RADIO QUESTIONS and ANSWERS

*A Selection of the Most Important of  
5,000 Questions Submitted by Radio  
Men During the Course  
of One Year*

by

R. D. Washburne

**GERNSBACK PUBLICATIONS, Inc.**

**Publishers**

**98 PARK PLACE**

**NEW YORK, N. Y.**

# Contents

	Pages
Chapter 1—Definitions .....	5
Chapter 2—Vacuum Tubes .....	9
Chapter 3—The Antenna System .....	11
Chapter 4—Radio Frequency Circuits .....	13
Chapter 5—Audio Frequency Circuits .....	17
Chapter 6—Reproducers .....	19
Chapter 7—The Power Supply .....	22
Chapter 8—Superheterodynes .....	25
Chapter 9—Short Waves .....	28
Chapter 10—Automotive-Radio Data .....	33
Chapter 11—Sound Equipment .....	36
Chapter 12—Home Recording .....	39
Chapter 13—Test Apparatus .....	42
Chapter 14—General Inquiries .....	46
Chapter 15—Experimental Circuits .....	48
Chapter 16—Service Problems .....	50
Chapter 17—Handy Reference Data .....	56

Printed in U. S. A.

Copyright 1932 by G. P. Inc.

## *Preface*

Into the field of radio to tackle its tantalizing problems have come some of the foremost minds in the country. In consequence of their combined effort, coordinated through the medium of national and international societies and numerous technical journals, the "teasers" which formerly existed in profusion are being rapidly reduced in number.

Over night, literally, our radio receiver has changed, as a result of the attention which has been given to it, from a relatively simple mechanism to a complicated maze of heterogeneous units — each with a particular purpose in life.

To be sure, the fundamental steps which are necessary for the reception of radio programs follow a worn path; however, the auxiliary processes which we now find in the modern radio set have served to dress our primitive instrument in a manner calculated to please the most exacting person.

To list each of these "features" would require more space than is available; in consequence, we mention only a few of the most interesting subjects: Automatic volume control, phono-radio operation, remote control, home recording, short-wave reception, tone control, band-selection, automotive-radio receiver design, improved vacuum tubes, push-pull and push-push audio frequency amplification, multiple reproducers.

In consequence of this rapid and chameleon-like transition the average individual is left without any conception whatsoever of just *why* these changes were made; and *how* they were affected.

It remains to be seen, however, in what measure the writer may have succeeded in meeting this condition by compiling in convenient form some of the most informative answers to questions submitted by Radio-Craft magazine readers located throughout the world.

R. D. W.

July, 1932

## General Radio Abbreviations

A.C. Alternating current	"B" Plate or high-voltage circuit
A. or Amp. Ampere	"C" Grid or medium-voltage circuit
Ant. Antenna	P.E. cell Photoelectric cell
A.F. Audio frequency	I Current
C.W. Continuous waves	R Resistance
~ Cycle	E Electromotive force (potential)
c.p.s. Cycle per second	L Inductance
db. Decibel	T Transformer
D.C. Direct current	Poten. Potentiometer
hy. Henry	Ch. Choke
H.F. High frequency	V.C. Voice coil
I.F. Intermediate frequency	P. Primary
I.C.W. Interrupted continuous wave	S. Secondary
kc. Kilocycle	D.C.C. Double cotton covered
kw. Kilowatt	E.S.C. Enamel silk covered
L.F. Low frequency	S.S.C. Single silk covered
M $\Omega$ One thousand ohms	R <sub>p</sub> Plate resistance
mf. or $\mu$ f Microfarad	G <sub>p</sub> Grid resistance
$\mu$ hy. Microhenry	S-G Screen-grid
$\mu$ mf. Micromicrofarad	C-G Control-grid
$\mu$ v. Microvolt	F Filament
$\mu$ v/m Microvolt-per-meter	H Heater
$\Omega$ Ohm	P Plate
R.F. Radio Frequency	G Grid
r.p.m. Revolution per minute	K Cathode
R.M.S. Root mean square	Sup.-G Suppressor-grid
V. Volt	"B—" High-voltage negative
W. Watt	"B+" High-voltage positive
mw. milliwatt	Sw. Switch
"A" Filament or low-voltage circuit	P.T. Power transformer
	V Vacuum tube

## Metric Prefixes

c centi	k kilo
d deci	M mega
dk deka	u micro
h hecto	m milli

# CHAPTER I

## Definitions

### Permalloy

(Q.) What is Permalloy?

(A.) Permalloy is an alloy consisting of 73½% nickel and 21½% iron. It is annealed and heat treated in such a way that the resultant material in addition to being magnetic has a permeability greater than that of any other grade of iron known. It loses its magnetism more quickly and more completely than any other iron.

It is used mostly by the Western Electric Company and certain cable companies.

When used in cables it is a ribbon wrapped around the bundles of wires. This ribbon measures one-half inch in width and is one-six-thousandth of an inch thick.

In radio, its application is different. It forms the core of audio frequency transformers working over the entire audio frequency band. More "brilliant" reproduction results.

### AEO Light

(Q.) What is an "AEO" light?

(A.) The "AEO" ("alkaline earth oxides") light, a development of the Case Research Laboratory, was specially designed for recording sound in Fox "Movietone" productions. This tube, with a gas content mostly helium, is about 1½ in. in diameter and 6 in. long. Within the tube, at one end, are mounted the sheet nickel anode, about ⅛-in. wide and ¼-in. long, and a U-shaped cathode of platinum coated with oxides which ionize at 350 volts and 10 milliamps. The resulting intense blue glow at the cathode is capable of affecting photographic film; the anode, at this time, shows a less actinic pale pink glow. Sounds picked up by the microphones in the recording studio cause the blue light to vary in intensity, at audio frequencies. This light of varying intensity is focused on the margin of the film and photographed;

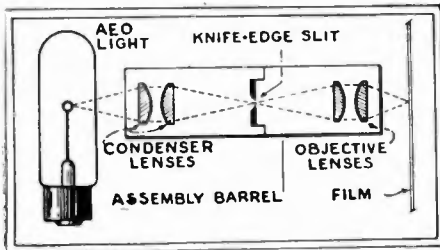

Fig. 1

producing the "sound track," illustrated in the articles on "Modern Sound Projection" in past issues of Radio-Craft. The optical arrangement is Fig. 1.

### Anti-Mobo

(Q.) What does "anti-mobo" mean?

(A.) It means anti-motor boating, the peculiar putt-putt or throbbing sound caused by circuit oscillation at low or sub-audio frequencies. We find use for this expression as we continue to develop amplifiers reproducing the very lowest notes.

### De-Coupling Resistors

(Q.) Is there any convenient method of preventing the circuit oscillation caused by common coupling in the "B" circuit?

(A.) The usual remedy for this condition is the use of bypass condensers of large capacity. However, improved operation will be obtained if a "de-coupling" or circuit-isolating resistor is inserted in the "B+" lead. It is shown in Fig. 2 as R; and has a resistance of 25,000 ohms when used in the plate circuit of a detector tube. If used in an amplifier's plate circuit, it may have a value as low as 600 ohms. It is bypassed by a fixed condenser C2, the value of which is between 0.25-mf. and 2.0-mf.; the latter value being required where the amplifier is designed for good low-note reproduction.

Condenser C1 is the usual .006-mf. capacity bypassing the detector's plate choke Ch. A somewhat similar arrangement for obtaining the desired result, in which an inductance is used instead of a resistance, was described in the September, 1929, issue of Radio-Craft Magazine, on page 122.

This idea may be used irrespective of whether the "B" voltages are obtained from a battery or an eliminator. Vary the "B" potential to make up the voltage drop through R.

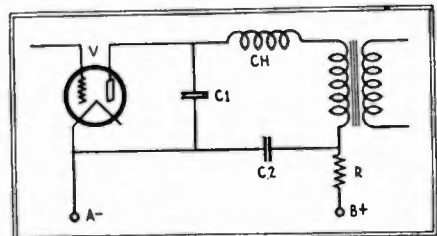

Fig. 2

Complete data on this subject is given in the article, "The Effective Use of Bypass Condensers and Resistors," by P. H. Greeley. This story appeared in the August, 1930 issue of Radio-Craft magazine.

### Celotex

(Q.) What is the composition of Celotex?

(A.) "Celotex," the material of which thousands of dynamic and magnetic speaker baffles are made, is constituted of sugar cane stalks compressed to four times the former density, resulting in a solid board with almost negligible acoustic resonance. The boards average one and one-half inches in thickness.

### IR Drop

(Q.) What is the "IR drop" occasionally referred to in articles?

(A.) This is the more familiar "voltage drop," or, the potential difference between two points in a circuit, the value being determined by multiplying R (the resistance in the circuit) by I (the current in the circuit).

### Zero Beat Tuning

(Q.) What is "zero beat" tuning?

(A.) With an oscillator or oscillating detector circuit, it means tuning exactly to the center of a stations' carrier (wave). Adjusting the tuning dial a hair's breadth left or right will start a howl, heard in the reproducer first as a growl and then, as the dial motion is continued, as a note rising in intensity and pitch to a powerful shriek, in most cases, going finally beyond the limits of hearing. Figure 3 illustrates this in exaggerated form. See also, "The Radio Encyclopedia," by S. Gernsback.

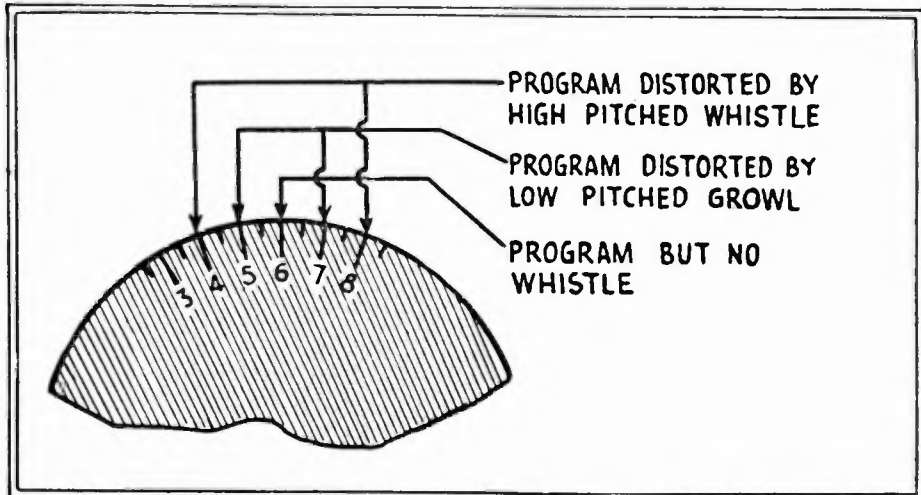

Fig. 3

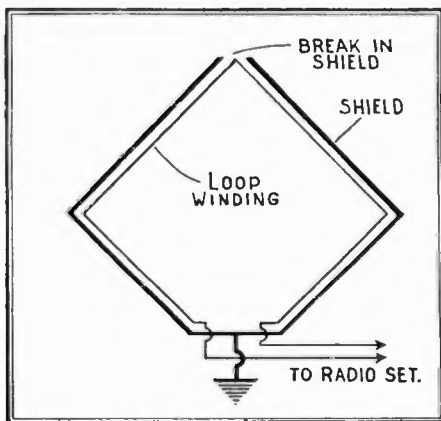

Fig. 4

### Shielded Loop

(Q.) Is the enclosed symbol the correct one to indicate a von Ardenne shielded loop?

(A.) The correct figure appears in these columns as Fig. 4. Shielding the loop reduces its pickup somewhat but this sacrifice in sensitivity is well worth the advantage gained by reduced response to local fields.

### Microphonic Howl

(Q.) What is a "microphonic howl"?

(A.) We thought everyone knew the answer to that.

It is a loud noise due to motion of the elements within one or more vacuum tubes in the set. The detector tube is the greatest offender; although any tube in the set may be the source of this trouble.



The generation of this noise is caused by sound waves (usually from the reproducer) setting the tube elements in motion. The resulting A. F. potential is amplified by the succeeding tubes in the set. Placing the reproducer elsewhere may eliminate the trouble. Padding (with paper, cloth or cotton), or loading (with lead, rubber or spring devices), may stop the noise. Both are makeshifts; the correct solution is to replace the tube (or tubes) with a tube in which the elements are supported more rigidly.

**Linear Power Detection**

(Q.) What is meant by "linear power detection"?

(A.) The older methods of detector connection resulted in distortion on high power, due to the fact that the signal input exceeded the grid-bias potential. By raising the grid bias to a value not exceeded by the signal, operation on the "straight (linear) portion" of the tube's "characteristic" curve resulted; this point is covered in Radio-Craft magazine by Mr. Palmer in his articles, "Vacuum Tubes for Radio Reception."

See also the book, "Fundamental Principles of Radio," by Louis Martin.

**Oscillator Coupler**

(Q.) What is an "oscillator coupler"?

(A.) This term is applied to the oscillator coil of a superheterodyne receiver and usually comprises a grid winding, a plate (feed-back or tickler) winding, and a coupling or pick-up winding of but a few turns. The grid and plate inductance are coupled to produce circuit oscillation, and the pick-up coil transfers a small portion of this high-frequency current to the frequency-changer. The rest of the action has been fully discussed in past issues of Radio-Craft.

**Screen-Grid Neurodyne**

(Q.) What is the meaning of the term "screen-grid neurodyne"? It is my understanding that a screen-grid circuit does not require neutralization. Please clarify this point. This term has been used in referring to the Crosley "Buddy" and "Chum" radio sets.

(A.) The "screen-grid neurodyne" circuit is a development of the laboratories of the Crosley Radio Corp. and the Hazeltine Service Corp., the latter concern being the patent-holding organization for the Hazeltine interests. The feature of the development centers around the R.F. transformers. As shown in the accompanying diagram, Fig. 5, of the receiver models mentioned, there is a small open-end winding L in the primary of each R.F. transformer. This adds a capacity coupling at the grid end of each secondary, which makes the tuning more uniform throughout the range. This desirable effect is improved by the method of winding the concentrated primary outside the secondary.

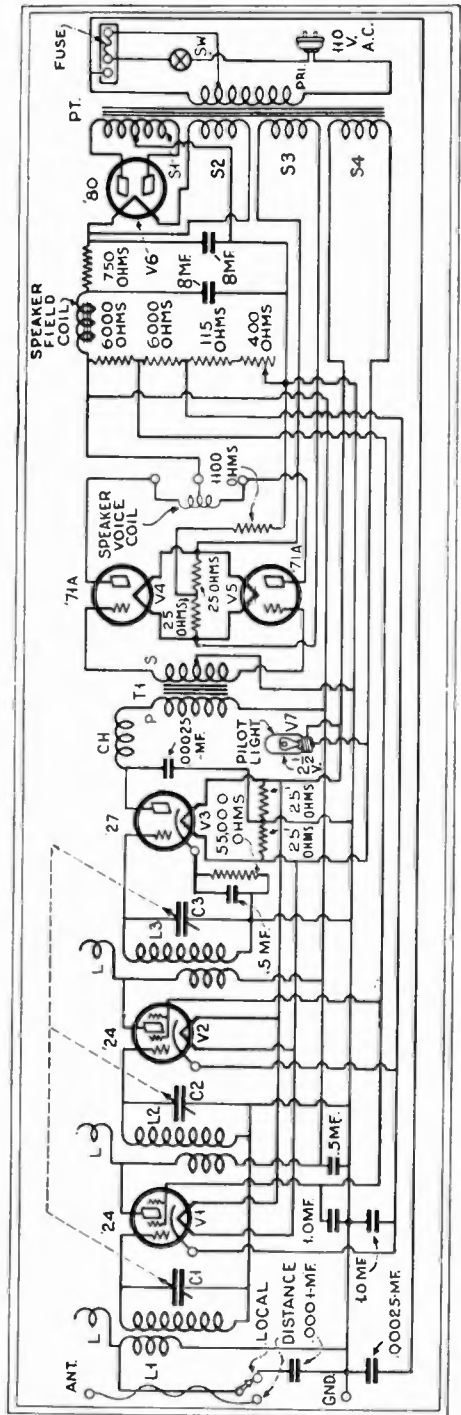

Fig. 5

**Computing the Decibel**

(Q.) What is the "decibel"; and how is the term used in connection with radio equipment?

(A.) Since the decibel indicates a geometric relation between two figures, it may be used to indicate a rate of change either in sound energy or in electrical units.

The ear, for instance, responds not in linear but in logarithmic proportion to changes in sound intensity. For example, although the energy ratio of a band playing soft or loud is 1,000,000/1, the ear appreciates it only as about 60/1; the figure 60 also is the "db" value.

The decibel, so often used in the work of audio amplification, transmission and reproduction, is simply the ratio between the strengths of any two signals, or the ratio of change in the energy of a signal when it is amplified or attenuated.

Ten decibels "up" on a signal means that the power has been increased tenfold; ten decibels down, that it has been divided by ten. The steps are unequal, but the peculiarities of this method of rating are based on physiological and engineering reasons. The decibel, as a mathematician would instantly see from the table given here, is a logarithmic unit (the number of decibels is represented by ten times the "common" logarithm of the ratio of change).

Since the sound energy of the reproducer should be, approximately, in proportion to the electrical output power; and since electric power is measured by "voltage times current," the power varies as the square of the voltage (or current). Therefore, the ratio of energy change corresponding to ten decibels is as much as the ratio or voltage (or current) change, corresponding to twenty decibels.

Any signal strength may be taken as the base (or zero) in computing relative intensities. However, for voice-transmission measurements, six milli-watts (1.73 volts across a 500-ohm line) is a standard used by engineers.

The ratio of change in power, and in voltage (or current) corresponding to any number of decibels, may be quickly found from the following table. Multiply the signal strength, or voltage, which is taken

as the base, by the factor given in the proper column, opposite the appropriate number of decibels.

"UP"		DECIBELS			"DOWN"	
Energy	Voltage	Number	Energy	Voltage		
1.26	1.12	1	0.794	0.891		
1.59	1.26	2	.631	.794		
2.00	1.41	3	.501	.708		
2.51	1.59	4	.398	.631		
3.16	1.79	5	.316	.562		
3.98	2.00	6	0.251	0.501		
5.01	2.24	7	.199	.447		
6.31	2.51	8	.158	.398		
7.94	2.82	9	.126	.356		

"UP"		DECIBELS			"DOWN"	
Energy	Voltage	Number	Energy	Voltage		
10.00	3.16	10	.100	.316		
12.59	3.55	11	.079	0.282		
15.85	3.98	12	.063	.251		
19.98	4.47	13	.050	.224		
25.12	5.01	14	.040	.200		
31.62	5.62	15	.032	.178		
39.81	6.31	16	.026	0.158		
50.12	7.08	17	.020	.141		
63.10	7.94	18	.016	.126		
79.45	8.91	19	.013	.112		
100.00	10.00	20	.010	.100		
125.9	11.22	22	.0079	.089		
158.5	12.69	22	.0063	.079		
199.6	14.13	23	.0050	.071		
251.2	15.85	24	.0040	.063		
316.2	17.78	25	.0032	.056		
398.1	19.96	26	.0026	.050		
501.2	22.39	27	.0020	.047		
631.0	25.12	28	.0016	.040		
794.3	28.18	29	.0013	.036		
1,000.0	31.62	30	.0010	.032		
1,259	35.48	31	.0008	.028		
1,585	39.81	32	.0006	.026		
1,996	44.67	33	.0005	.022		
2,512	50.12	34	.0004	.020		
3,162	56.23	35	.00032	.018		
3,981	63.10	36	.00026	.016		
5,012	70.80	37	.00020	.014		
6,310	79.43	38	.00016	.013		
7,943	89.13	39	.00013	.011		
10,000	100.00	40	.00010	.010		
12,590	112.2	41	.00008	.0089		
15,850	125.9	42	.00006	.0079		
19,960	141.3	43	.00005	.0071		
25,120	158.5	44	.00004	.0063		
31,620	177.8	45	.000032	.0056		
39,810	199.6	46	.000026	.0050		
50,120	223.9	47	.000020	.0047		
63,100	251.2	48	.000016	.0040		
79,430	282.0	49	.000013	.0036		
100,000	316.0	50	.000010	.0032		
1,000,000	1,000	60	.000001	.001		
10,000,000	3,162	70	.0000001	.0008		
100,000,000	10,000	80	.00000001	.00001		
1,000,000,000	31,620	90	.000000001	.000008		
10,000,000,000	100,000	100	.0000000001	.000001		

# CHAPTER II

## Vacuum Tubes

### Component Materials

(Q.) Mention has recently been made that there are 57 elements which enter into the construction of vacuum tubes. Is there any record of the names of these elements?

(A.) While the statement as to the number of elements is essentially true, the actual count varies from time to time, as the designs are modified; while the elements are, in the main, representative of most vacuum tubes. A late list of these elements is given below, by courtesy of the R.C.A. Radiotron Co.

Hydrogen	Mercury	Aluminum
Sodium	Boron	Neon
Potassium	Chromium	Phosphorus
Caesium	Yttrium	Argon
Copper	Carbon	Molybdenum
Silver	Silicon	Iron
Titanium	Tin	Cobalt
Calcium	Lead	Nickel
Strontium	Oxygen	Iridium
Barium	Tungsten	Platinum
Magnesium	Chlorine	Thorium
Zinc	Helium	Nitrogen
Tantalum	14 Rare Earths*	

\* (The "rare earths" include the metallic elements cerium, lanthanum, praseodymium, neodymium, illinum, samarium, europium, gadolinium, terbium, dysprosium, holmium, erbium, thulium, ytterbium and lutecium which occur together and are hard to separate. They are used for coating filaments.—Author.)

The different elements and materials are used as follows in different parts of the tubes:

#### GLASS

Silica	Borax
Sodium carbonate	Zinc oxide
Calcium oxide	Cobalt oxide
Sodium nitrate	Potassium carbonate
Lead oxide	

#### BASES

Bakelite	Copper
Porcelain	Nickel
Glass	Tin
Wood fiber	Marble flour
Zinc	Ethyl alcohol

#### FILAMENTS

Tungsten	Silicon
Thorium nitrate	Barium carbonate
Carbon	Strontium carbonate
Nickel	Calcium
Cobalt	Barium nitrate
Iron	Strontium
Titanium	

#### GRIDS

Nickel	Copper
Monel	Chromium
Molybdenum	

#### PLATES

Iron  
Tantalum

#### LEADS

Zinc  
Borax

#### SUPPORTS

Nickel  
Molybdenum  
Monel

#### GETTERS

Caesium  
Phosphorus  
Carbon  
Tantalum  
Miscmetal

#### GASES

Argon  
Nitrogen  
Oxygen

Nickel  
Monel  
Molybdenum

Iron  
Nickel  
Copper

Glass  
Mica  
Lava  
Isolantite

Magnesium  
Calcium  
Strontium  
Barium  
Sodium  
Potassium

Hydrogen  
Helium  
Neon

### Internal Construction

(Q.) In what manner does the construction of the type '35 "super-control" tube differ from the regular '24 screen-grid tube, which it replaces, in circuits designed for its use?

(A.) As stated in the article, "Recent Advances in Radio Tube Design," in the April, 1931, issue of Radio-Craft (page 599), the variable-mu tube may take any of a great number of different forms, in the design of the elements, to obtain the

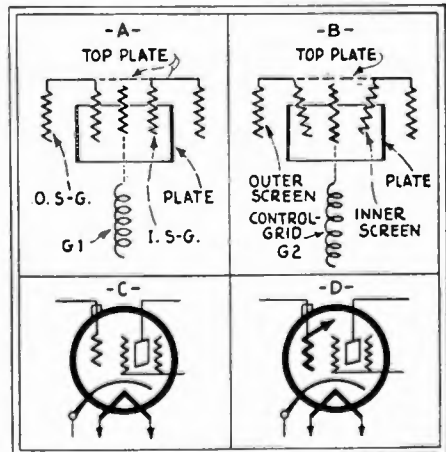

Fig. 6

"automatic variation of the mutual conductance" of the tube, which prevents "cross-talk," due to the proximity of a powerful local station.

The construction of the regular type '24 screen-grid tube is shown at A in Fig. 6. The control-grid G1 is placed symmetrically, and the screen-grid has two cylindrical meshes: an outer screen-grid O. S.-G., and an inner screen-grid I. S.-G.

The design of the elements of a well-known brand of the new variable-mu screen-grid type '35 "super-control" tube, is shown at B. The control-grid G2 is wound with uneven spacing; and the inner screen-grid is made conical, one end coming closer to the control-grid, and the other to the plate.

The symbol of a type '24 tube is shown at C; and a proposed symbol for the '35, at D.

A table of tube symbols, and more extensive information, appears in the book, "Modern Vacuum Tubes, and How They Work," by Robert H. Hertzberg.

**Internal Connections**

(Q.) Is the cap on a screen-grid tube connected to the screen-grid?

(A.) No, it is connected to the control-grid. The screen-grid connects to the tube prong connecting with the "G" or grid post of the tube socket.

**Gas Content**

(Q.) A type 200-A tube, when inserted in a certain radio set, lights but does not function. Please explain why this tube is "dead" in a regular radio receiver, and yet tests satisfactory on a meter.

(A.) This type of tube is extremely critical because of its very high "gas content." It is probable that the grid-return circuit is wrong; or the voltages used are not just right for this particular tube. If the set was designed for type '01A tubes the grid return is probably to "A+"; this should be changed to "A—" for the type '00A tube, as illustrated in Fig. 7.

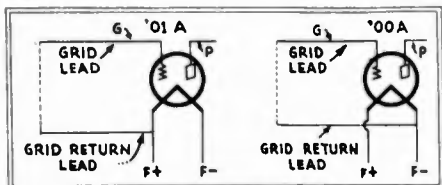

Fig. 7

**Blocking Tube**

(Q.) Does a "blocking" tube amplify?

(A.) Ordinarily, yes; but the input and output coupling circuits may be so poorly matched as to amplify and pass only a small portion of the signal current; and the effect of a reduction in volume may in fact be obtained.

By using the new pentode-type tubes and correct resistors it is possible to obtain very effective amplification from one of these connected as a blocking tube.

**Internal Resistance**

(Q.) In a table of tube characteristics, is the plate resistance an A.C. or a D.C. value?

(A.) The values are the A.C. resistances of the tubes. For three-element tubes this may be considered approximately the same for D.C. measurements. Four-element (screen-grid) tubes do not come within this class; their plate circuits' resistances (in ohms) are A.C. values, and are above the D.C. value.

**Multi-Element Tube**

(Q.) It is believed that the "multi-element" tube developed some time ago by Loewe has been marketed in Europe. If this is the case, please show a diagram of the connections of such a tube as used in a practical receiver.

(A.) The tube referred to is a product of the Loewe Radio Co., Ltd., and bears the designation of Triple Valve Type 3-NFB; which is really three tubes in one envelope, each stage being resistance-capacity coupled within the tube. A compact receiver, the Type OE-333, has been built around this tube (which is not available in America), and the schematic circuit is shown in Fig. 8; and at B, the general arrangement of the receiver and tube.

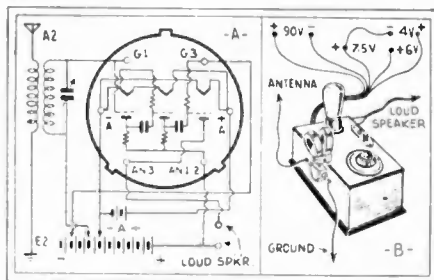

Fig. 8



# CHAPTER III

## The Antenna System

### Antenna Absorption

(Q.) Does each radio set in operation take its share of the energy broadcast by a radio station and dissipate it; thereby making the signal weaker for the next receiving station? If this were the case, perhaps it would be desirable if every one left his set ungrounded (removed the lead-in from the antenna post on the set) when not using it.

(A.) This question has been answered, partially at least, on page 393 of the February, 1930 issue of Radio-Craft. The dissipation of energy picked up by receiving sets is not important in comparison with other losses in the field of a transmitter, as a matter of fact.

It is inadvisable to disconnect an aerial and leave the lead-in ungrounded, as suggested. It was once customary to use a switch to cut out the receiver, and short the aerial to ground, when not using it. In Europe today, some broadcast stations make a rule of advising the listener to ground his aerial, just before they sign off. However, the use of a good lightning arrester serves the same purpose. This acts as an automatic switch and bypasses charges of static from the receiving set.

### High-Resistance Joints

(Q.) What is meant by a "high-resistance" joint in the aerial or ground wires?

(A.) An aerial (or ground) wire may often consist of several sections of wire. The junction points should be soldered, but seldom are. Due to atmospheric action, these junctures become corroded and an imperfect (high-resistance) contact is the result. The degree of "high" depends upon the degree of contact; and this may be determined in the laboratory by the use of a delicate voltmeter and a source of current (as illustrated in Fig. 9; where c is the point of contact;

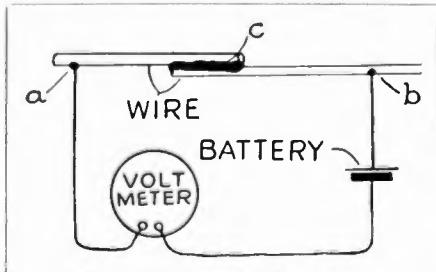

Fig. 9

a, one wire; b, the other; a voltmeter is depicted. If, having made contact on each side of the joint, the meter indicates the full battery voltage, there has been no current loss due to resistance in the joint; if the meter voltage reading is even one-tenth less than the known battery voltage, we know that there is a high resistance in the circuit and that this must be at the joint, c.

### De-Tuning Effects

(Q.) Varying the antenna coil coupling throws off the tuning dial readings considerably, which makes logging difficult. How can this be prevented?

(A.) It cannot easily be prevented. However, to minimize this effect it may be well to:

1. Try using a very compact antenna coil in relation to the filament end of the tuned circuit;
2. Grounding the filaments may help;
3. Antenna and grid coils should be wound in the same direction;
4. Antenna end of primary and grid end of secondary should be at the extremes of separation.

### Loop vs. Interference

(Q.) Will a loop antenna completely eliminate interference from power lines?

(A.) The efficacy of a loop in this respect is dependent upon the particular conditions that exist in its locality. This is illustrated in Fig. 10. The directional properties of a loop are often a successful means of balancing out interference of various kinds. In many cases, however, the effect of balancing is particularly evident in only one position; and in all others the interference again become fully evident. It may be pointed out that, in numerous instances, persistent trouble from line noise pick-up can be successfully balanced out with an outdoor aerial properly located, as explained on page 16 of the July, 1930, issue of Radio-Craft.

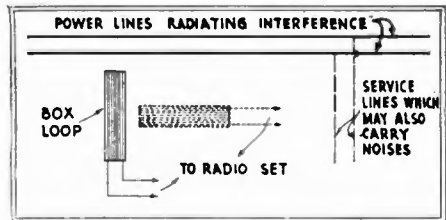

Fig. 10

### Tree Antenna

(Q.) Is there a "correct" way of "hanging" an antenna between a house and a tree? It seems those installed without due regard for the swaying of the tree do not stay up very long.

(A.) A propos of this subject we are privileged to quote some interesting information gleaned from the Davey Tree Expert Co., as follows:

"Where radio antennas are attached to trees, the manner in which the attachment is made may determine whether the tree or part of it will be killed. Too often the antenna is fastened by means of a wire that encircles a branch or perhaps the main trunk. In those cases where the encircling wire is used, no immediate harm will result aside from a certain amount of chafing which may or may not damage the living bark tissue. But, as the trunk or branch grows in diameter, the wire begins to press against the bark. In a relatively short time it becomes deeply imbedded and strangulation results, for the sap that flows in the inner bark is cut off by the wire barrier. The death of the branch or trunk quickly follows.

"To avoid the possibility of injury, the safe method is to use either a lag hook or a pulley with a screw end. These should be attached in the manner shown in the illustration." (Reproduced here as Fig. 11), "using first a bit to make the holes in which threaded attachments are to be turned. The hole bored by the bit should, of course, be a little smaller than the diameter of the lag or screw, in order that the threads will hold firmly.

"The system suggested will not interfere with the life functions or normal growth of trees. It will prevent much of the needless injury that has often been done to fine shade trees in the past."

Certainly this is valuable data for the Service Man who wants his installation to be as good as possible. We might add that it is well to keep the aerial itself about ten feet from the leaves of the trees; this may necessitate the use of an insulator at this distance from the tree end of the antenna. Of the two methods illustrated above, the weight seems preferable; as most springs, through the action of strong winds, gradually lose their elasticity and become inefficient.

### Protective Condensers

(Q.) What size condenser do you recommend for insulating aerial and ground against causing D.C. line fuses to blow?

(A.) About 0.1-mf. will be quite large enough. We recommend that the "operating voltage" rating be at least 250 volts and preferably higher.

### "Compensating" the Antenna Coil

(Q.) Is it possible to balance the antenna circuit of a receiver by taking turns from the antenna coil only?

(A.) It is best to balance all the inductances first.

It is preferable to balance a coil by removing or adding turns until resonance at a particular frequency is obtained when a given value of tuning capacity is used in shunt; a small "trimmer" condenser may then be placed in shunt with the tuning condenser and coil when assembled as a unit, and the minimum capacity of the circuit matched to the minimum of the other circuits. If the placement and design of the parts have been correct, the circuits should tune correctly throughout the tuning range. If they do not, the origin of the fault should be determined.

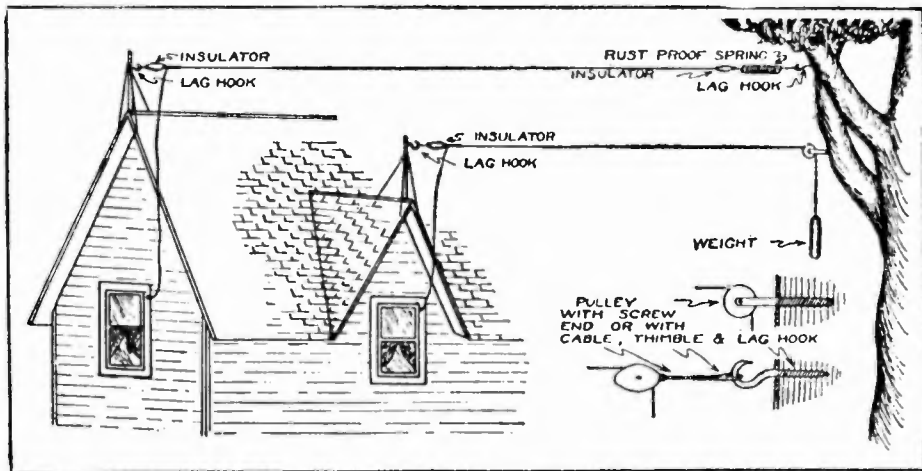

Fig. 11



# CHAPTER IV

## Radio Frequency Circuits

### Hand-Capacity Effect

(Q.) I cannot seem to eliminate "hand capacity" effect in a receiver I have. I can tune stations in and out by moving my hands in relation to the tuning dials (metal). Have grounded everything in sight, including condenser rotors and the dials.

(A.) Probably high ground lead resistance.

1. Ground lead may be too long;
2. Ground wire may have a high resistance or be open;
3. Earth to which grounding conductors lead may be dry;
4. Defective ground clamp;
5. Open at the set "ground" binding post;

6. If house piping is used, this may have several high-resistance joints. (In many gas or electric piping systems, remember that "insulating couplings" are used.)

### Dusting of Condensers

(Q.) Isn't it carrying things to extremes, to dust between the plates of variable condensers?

(A.) Not at all. During dry weather the dust may not cause much trouble but as soon as the air becomes damp, the dust absorbs moisture and becomes very conductive. These hundreds of conductive paths from rotor to stator form a resistance network of very low value. The observable results are broad tuning, crackling sounds and loss of sensitivity. Modern radio sets are well shielded instruments and are seldom effected by dust.

### Blocking-Tube Usage

(Q.) What is the reason for using a "blocking" tube?

(A.) The inductance and capacity values of the aerial, and the primary of the input transformer form a circuit having frequency-discrimination characteristics, resulting in uneven operation over the tuning band. "Dead spots," these are called. (This effect is particularly pronounced on the waves below 200 meters.) The use of a blocking tube greatly reduces this effect; and it accomplishes two other results.

It makes "ganging" of the tuned stages a more convenient and satisfactory proposition; and it greatly reduces the radiation of interfering signals when circuit oscillation results due to a "spill-over" of a regenerative circuit.

### Standard R.F. Choke

(Q.) What size and kind of wire and number of turns should be used in winding an 85-millihenry choke coil of small dimensions for use in a radio-frequency circuit?

(A.) An R.F. choke of this rating may be made by winding three "pies" of number 34 S.C.C. wire on a form  $\frac{3}{16}$ -in. in diameter; each section should be  $\frac{3}{16}$ -in. wide. (A wooden rod with three grooves turned in it will be a convenient method of obtaining this form.) In one end section, wind 550 turns; next, 700; and last, 800. The end of the 800-turn section should be connected to the plate (or high-potential) side of the circuit for best results; as this construction results in a "polarized" unit having greater choking action in one direction.

### T.R.F. Regeneration

(Q.) Would the sensitivity of a tuned-radio-frequency receiver be increased by adding regeneration to the R.F. stage, as per marked diagram?

(A.) This circuit, which we reproduce as Fig. 12, is quite practical, if the operator does not object to the difficulty of tuning. This arrangement is only for those who have infinite patience, and due appreciation of what happens in a neighbor's radio set when circuits such as this are adjusted.

As to the sensitivity; it is no greater than would be that of the standard circuit if the number of turns in L4 were increased to the point of oscillation, and some oscillation control incorporated in the set. As the rotors L3 and L6 unbalance the tuning of circuits L2 and L5, a critical condition obtains; varying L3 or L6 disturbs the stability of the system again, and causes everything to go out of adjustment.

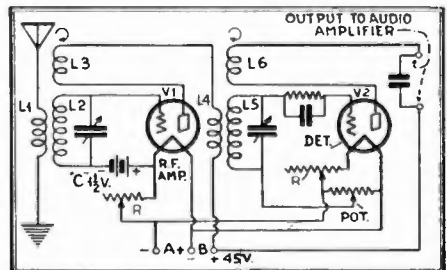

Fig. 12

Screen-Grid "Ambassador"

(Q.) If it is possible, I would like a circuit diagram of the "Ambassador Four" receiver altered to use a screen-grid tube in the position of the first stage of R.F. I have assembled about eleven of these sets and every one of them is working very well; and, with a screen-grid tube properly incorporated in the circuit, the results should be even better.

(A.) "Before" and "after" diagrams of the "Ambassador Four" showing the manner of connecting into circuit a screen-grid tube, are shown in this department. (Fig. 13.)

The electrical values of the parts used in this set are as follows: C1, C2, .0005-mf.; C3, .001-mf.; C4, .00025-mf.; C5, 2 mf.; C6, .01-mf.; C7, C8, 0.25-mf.; R1, 30 ohms; R2, R3, R4, filament ballasts of the "one-tube" type; R5, 2 megs.; R6, 15 ohms tapped at 10 ohms. Units T1, T2, the A.F. choke, and C5 are the usual audio components.

The constants for L1 and L2 are as follows: L1, 6 turns of No. 26 D.S.C. wire on a tube 2 3/4 in. in diameter, for the primary, and 55 turns of the same size wire for the secondary. Coil L2 has a 6-turn primary, center-tapped, wound on a 2 3/4 in. form; a 55-turn secondary; and a 14-turn tickler, the latter wound on a rotor 1 1/2 in. in diameter. The distance between primary and secondary should be about 5/16-in. It is recommended that, if convenient, the primary of L2, when used with a screen-grid tube, be increased to 15 or 20 turns; the best value depending upon the selectivity required by local reception conditions.

The only changes required in the circuit connections of the old receiver are indicated at the left of the larger schematic; the part of the latter to which the smaller diagram relates is set off by a dotted outline.

Comparing notes, it will be seen that the center-tap on the primary of L2 is not used and C6 is no longer required. An added "B" tap is shown, supplying the screen-grid with its required potential of about 45 volts (of course, if the detector works well with the plate held at this same potential, only one "B" tap is required). The bypass condensers C7 and C8 are absolute requirements; the low-voltage filament requirements of V1 are met by adding R6 to the circuit which provides also a small "C" bias for the control-grid through the voltage drop across it.

Whether shielding is required for the circuits of V1 must be determined by experiment. Because of the rather large dimensions of the Ambassador coils, really good shields must be of such large proportions that they are inconvenient to install in most sets; but a compromise, in size, may be secured by careful attention to the fundamentals of shielding. It is possible that the limited degree of shielding afforded by a vertical

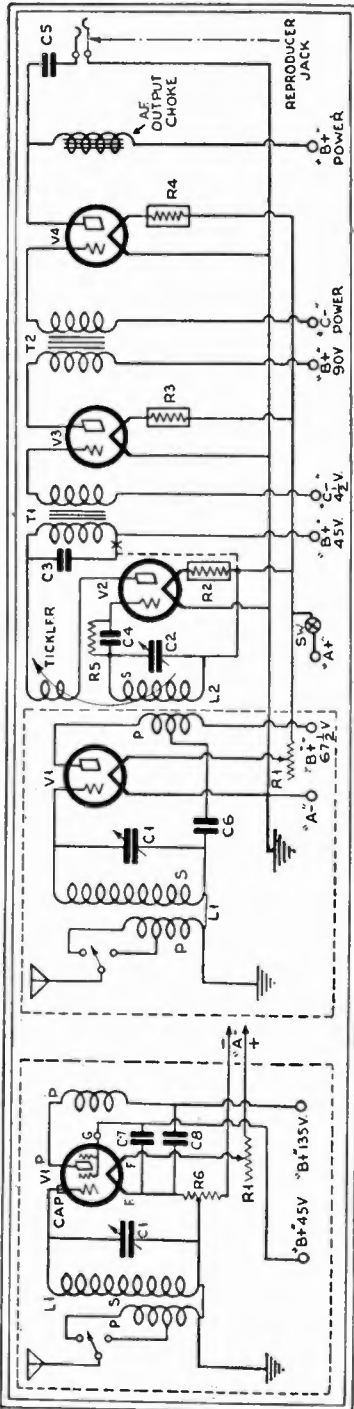

FIG. 13



aluminum or copper plate, between components of the first and second stages would be sufficient to prevent circuit oscillation due to over-all feed-back.

### Background Interference

(Q.) Does shielding a set help to reduce the pickup of "background" reception?

(A.) If a sensitive radio set is located in a district in which one or more stations are operating, shielding is usually necessary to prevent the coils and wiring of the set from picking up energy from one of these powerful locals, when tuned to a different station. This pickup gives the effect of the local "riding in" on the signals of the desired station. Open bypass condensers will cause the same effect; particularly, at resonance.

### Shielding Effects

(Q.) Why does removing a stage-shield cover result sometimes in increased volume; while at other times the same operation may result in a reduction of volume?

(A.) This is readily understood when we consider that pieces of metal in the "field" of a coil change its inductance. Going one step further, we find that where there are several tuned stages and a shield cover is removed, the removal may either cause that stage to come into tune with the others or, perhaps, throw the "gang" out of tune. The first condition would cause an increase of volume and the latter would cause a reduction.

### Suppression Resistor

(Q.) While recently repairing a radio set, I found a fixed resistor connected across the secondary of one of the radio-frequency transformers. What was the purpose of this resistor?

(A.) This resistor was used as one of several optional means of controlling circuit oscillation. This is a very effective method and does not possess as many disadvantages as some other systems. It cannot be called purely a "losser" method; for it does not cause a reduction of the signals in the same proportion as the parasitic circuit oscillation is reduced. Many Service Men apply this oscillation control means to balky receivers, as it is very convenient; it does not necessitate the breaking of any leads.

### Neutralizing Adapter

(Q.) In balancing a neutrodyne circuit by use of a tube with a shortened filament prong, as described in the November, 1929 issue of Radio-Craft (page 239), what is wrong when no reception results when this tube is used? The tube is OK, for the sets works when the tube is pushed all the way in; but, as soon as the filament circuit is broken by partial removal of the tube, the set goes dead and no amount of "trimming" will bring reception through. This applies to all stages in the set. In fact, I have tried

several times to apply this idea in both D.C. and A.C. neutrodyne, but have never yet succeeded in getting reception from any set as soon as the filament circuit is opened via the shortened prong.

(A.) We are inclined to believe that total lack of reception, when using the shortened tube partly removed from the tube socket, is due to insufficient signal strength. If the circuit is partly neutralized, and this tube is partly removed from the socket, the signal strength is insufficient to actuate the following stage through the capacity coupling afforded by the tube. To apply this method, it is necessary to tune in a very loud station. For this reason, it is common practice to use for this purpose a special audio-modulated R.F. oscillator. Such an oscillator usually has only three wavelength adjustments: one, at the lower end of the tuning scale; one at about the middle; and a third adjustment near the upper limit of the tuning scale. (An oscillator of the continuously-adjustable type was described on page 152 of the October, 1929 issue of Radio-Craft Magazine; see also the August, 1932 issue.)

### Screen-Grid-Tube Coils

(Q.) What are the general rules to be observed in making screen-grid coils?

(A.) The number of turns on the secondary is governed mainly by the capacity of the variable tuning condenser. For good selectivity, wind the primary so that it has approximately two-thirds the inductance (about two-thirds the number of turns) of the secondary. The primary should be wound with very fine wire; No. 36 or 38 is usually used. Wind both coils in the same direction, with the primary on a paper tube that will just slip inside the secondary; space-wind the primary so that it extends the length of the secondary. The end of the primary, nearest to the grid end of the secondary, is the plate connection.

### D.C. Coils—A.C. Tubes

(Q.) Can D.C. screen-grid coils be used with A.C. tubes? Can coils designed for type '26, '27 and '24 tubes be used with equivalent battery tubes?

(A.) Coils designed for A.C. operation may be used in battery sets; but coils designed for battery operation may cause circuit oscillation when used in conjunction with A.C. tubes, because of the higher amplification and the higher inter-element capacity of the latter.

### Multi-Stage T.R.F.

(Q.) Is it possible to build a receiver with six or seven stages of tuned R.F.?

(A.) Receivers having this number of stages have been built. They are impractical for ordinary commercial production; because it is too difficult to maintain circuit resonance and selectivity throughout the tuning band, with one-dial control, except as a laboratory job.

### Neurodyne Hiss

(Q.) With the correct tubes in all sockets, what causes a neurodyne to hiss on high wavelengths? I have a receiver the circuit of which is out of balance and oscillates on the low wavelengths. By adjusting the neutralizing condenser I stop oscillation on the low waves, but start a pronounced hiss at high wavelengths.

(A.) The hiss mentioned is due to too much circuit regeneration. The only remedy is to neutralize at the high wavelengths as well as the low. Detailed information on neutralizing a radio set appears in Radio Service Data Sheet No. 8, in the December, 1929 issue of Radio-Craft Magazine.

If the radio-frequency coils have changed their positions, this would explain the lack of balance on the higher wavelengths. Also, any change in the wiring might account for this. A loudspeaker cord brought too close to the tuning inductances of a set will often cause the effects described.

It may be necessary to install an "over-all" neutralizing capacity, to overcome the tendency to long-wave instability. Such a condenser arrangement is shown in Radio Service Data Sheet No. 5, in the November, 1929 issue of Radio-Craft Magazine. Condensers NC3 and C20 are the two to which reference is made.

### Screen-Grid vs. Neurodyne

(Q.) I have a six-tube neurodyne receiver the first stage of which is untuned. This set tunes very broadly. Will results be improved if the circuit is re-wired to include a screen-grid tube?

(A.) It is impossible to give more than a general answer to this question, without further information about the exact circuit of the original wiring.

An ordinary commercial circuit detail is shown in Fig. 14 A and, modified, as B. In the latter circuit are shown three recommended fixed bypass condensers C3, C4, C5, each having a capacity of about  $\frac{1}{4}$ -mf.

Fixed condenser C1 is recommended as a means of reducing the apparent broadness of tuning which results when the screen-grid tube is used. This condenser may be of an adjustable type, if desired, with a maximum capacity of about .00025-mf.

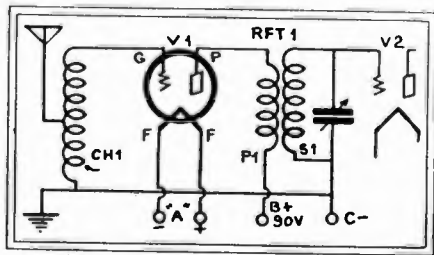

Fig. 14A

A choke-coil input is unusual in neutralized circuits. Unless a regular R.F. transformer and tuning condenser are substituted for CH1, it will not be possible to obtain maximum amplification throughout the tuning band from the screen-grid tube V1, shown in B. Unless the number of turns in primary P2 is also increased two or three times, and wound closely over the filament end of S2, it will not be possible to obtain very satisfactory results from the use of a screen-grid tube.

It is doubtful whether shielding will be needed; at best, however, this job of changing over a neurodyne circuit is "tricky."

Unit R is a 30-ohm rheostat; it should be adjusted while a voltmeter VM is shunted across the filament, to indicate when a voltage not exceeding the filament rating has been obtained.

### Coil Alignment

(Q.) Is it harmful practice to compensate, for capacity between turns in an R.F. coil that has been space-wound, by forcing together a few turns at one end in order to increase or decrease the turn-to-turn capacity? Will this practice result in a change in the over-all capacity and prove detrimental to the operation of a radio receiver?

(A.) It is presumed that operation of a gang condenser is the objective; otherwise, such accurate balancing of coil characteristics would not be necessary. The first point to be considered is that each tuned circuit should have its inductance and capacity distributed in the same proportions. For best results, the self (turn-to-turn) capacity of the coil should be evenly distributed along the length of the winding; however, if it is "lumped" at one end or the other of one coil, it should be similarly lumped in the other coils. If the turns are forced out of their original positions the wire is usually loosened slightly, and then the entire coil becomes loose in a fairly short time; since temperature variations cause expansion and contraction of the tube on which the wire is wound.

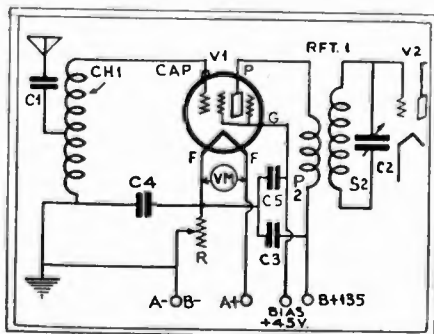

Fig. 14B

# CHAPTER V

## Audio Frequency Circuits

### Direct-Coupled-Amplifier Volume

(Q.) Having built a direct-coupled amplifier, I have observed the characteristic lack of volume when a two-tube amplifier is coupled directly to the antenna; as Mr. Sterns pointed out in his article on direct-coupled amplifiers, in the September, 1930, issue of Radio-Craft. Then, too, I have found a regenerative detector and single-stage audio (using type '99 tubes) to be superior in volume and selectivity. Is this a natural condition for such a set-up?

However, there is a much greater trouble than this in the set I constructed; it hums very much. Would increasing the size of the filter system take care of this? It is desired to apply this amplifier to a special audio system, also, for amplifying very small sounds, but the present amount of hum precludes this. Grounding the set has not remedied the trouble; and neither has coupling the amplifier through a good transformer to a separate detector.

(A.) This matter received the personal attention of the author of the article mentioned; and here is what Mr. Sterns replied:

"I am a firm believer in resistance-coupled amplifiers and have yet to find anything to beat them; but it has been hard to get sufficient volume in the output, because of the last tube's overloading. The Loftin-White amplifier solves the difficulty with the last tube and, combined with the straight resistance coupling, makes the ideal amplifier.

"Several amplifiers delivering 15 watts output have been built by the writer and would completely cover the audio range of 10 to 30,000 cycles without noticeable variation in output; the maximum variation within these frequency limits was two db (a value taken as a practical figure for a perfect amplifier).

"When using the regulation Loftin-White amplifier, you will find a marked diminution in the high frequencies which are required to give brilliancy to music and intelligibility to speech.

"In its present form the L-W is not easily connected to a radio set, owing to the ingenious differential input circuit which requires a very high input impedance. This situation is best met with resistance coupling to the detector.

"Regarding hum, it may be remarked that this is one condition that has never caused the writer any serious concern; because the 'bucking-out' condenser, C1 in the original diagram (Fig. 2 page 156, September, 1930 Radio-Craft) certainly does eliminate the hum; and there is no

necessity to increase the filter. A little experimenting with various values of fixed condensers (perhaps one or two of those now in the set are open-circuited) will probably result in eliminating the hum. This procedure is considered preferable to increasing the impedance values in the filter circuit.

"In passing it might be of interest to mention that the writer once constructed at the Bell Telephone Laboratories a 19-stage amplifier so sensitive that, when a fly walked across the resonator of a tuning fork to which was attached a microphone button, a 100-watt lamp in the output would flash. In a clinic room that amplifier, with a good dynamic speaker, would have made heart beats sound like sledge-hammer blows!"

### A.F. Amplifiers

(Q.) Please print several diagrams of amplifiers that can be used as separate units, apart from the radio set; and adaptable to operation on dry cells.

(A.) We are showing two circuits, in Fig. 15, which may be what you desire.

In A, transformers T1 and T2 are of the standard type. If high ratio ones are used, high volume will result at the expense of quality; using relatively low-ratio units will result in relatively better quality. The voltages are as indicated. This is the arrangement for a single stage of audio amplification. It may be desirable to shunt the input, or primary winding, of the first A.F. transformer with a fixed condenser of .001-mf. capacity, as indicated in dotted lines;

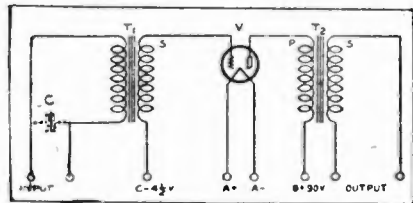

Fig. 15A

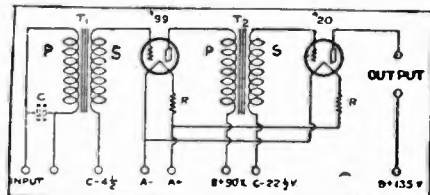

Fig. 15B

the output of the tube may connect to a pair of headphones or to the primary of a matching transformer, T2.

A two-tube circuit is illustrated in B. A power tube in the last stage is recommended and illustrated; it is of the dry-cell type. Resistors are ballasts designed for the particular tubes in the filament circuits of which they are shown.

In lieu of 3.3-volt tubes, the 2-volt or 6.3-volt type may be used, the "A" supply being changed accordingly.

### A.F. Transformer Reactivation

(Q.) I have an Amertran first-stage DeLuxe audio transformer which has a Permalloy core, I understand. The quality did not sound good so I changed it for another of the same type and immediately the beautiful tones I had originally were duplicated. Is it possible for transformers to change with age?

(A.) Yes, it is possible and occurs more often than is realized. Age, tube plate current and mechanical shocks can cause it. Particularly, transformers having a special nickel-iron core material are the only ones subject to this condition, so far as we know. It is our guess, that, perhaps unknown to you, the primary of the transformer was shunted across the direct current plate supply.

If, due to a fault in the tube, or to an accidental contact of some tool, the plate contact of the audio tube should be momentarily connected to the "A" circuit, this would result.

To reactivate your DeLuxe transformer, connect only the primary winding to the 110 volt A.C. lighting circuit for one minute, with the secondary entirely disconnected. This will rearrange the molecular structure of the special iron which, incidentally, is not Permalloy.

### Transformer Defects

(Q.) In a set having low volume, I found that placing my fingers across the first A.F. primary brought the volume up to normal. Continuity tests, etc., failed

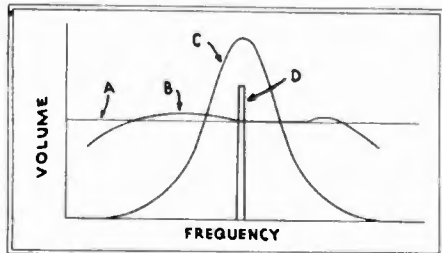

Fig. 16

to indicate any defect in the transformer. Condensers and resistors across the primary failed to be of any use. Could you explain such a case?

(A.) It is probable that the correct voltages were not being supplied to the tubes. Whenever a signal of even moderate amplitude reached the grid of the first A.F. tube it overloaded the grid which, operating at the wrong point on the characteristic (for lack of sufficient "B" or "C" potential) choked up. Reducing the input by shunting the primary with a resistance kept the input to the tube within the working limits of the first stage of A.F.

Also, a defective transformer might cause such a condition, by leakage between primary and secondary, whereby the signal energy transferred is in inverse proportion to the amount of energy in the input circuit. A similar effect is sometimes caused by a defective socket. It is assumed that the tube has been tested, or replaced, to see that it is not the source of trouble.

Connect an R.F. choke coil in the detector plate lead and bypass it to ground with a condenser; this unit may have a (fixed) capacity of about .0005-mf. or .001-mf. The purpose is to prevent R.F. energy getting into the A.F. circuits.

Another cause of trouble may be an open circuit, in the primary, that is partially closed through a high resistance. Testing for continuity with a high-resistance voltmeter would give an indication that might seem to indicate a perfect winding; while under the load of the tube the current passed through the circuit would be too little. Of course, a simple "cut-and-try" method of proving the case is to substitute another transformer for the questionable one. If this remedies the trouble, the defective unit may be sent to the makers for test and report by their laboratories.

### Tuned A.F. Amplification

(Q.) Is it possible to tune the secondary of an audio transformer to receive only one audio frequency from the primary?

(A.) This is common practice in selective, or multiplex, commercial code transmissions; and amateurs have used "peaked" transformers, which respond to only a few frequencies, for a long time (for amateur code transmission; this renders it possible to select one station from several others on the same wavelength). It is a laboratory feat to select a particular frequency to the almost total exclusion of all others (thus obtaining a "flat-top" characteristic). These degrees of selectivity are illustrated in Fig. 16.



# CHAPTER VI

## Reproducers

### Inductor-Dynamic Reproducer

(Q.) Is there an outstanding reason for the use of an "Inductor-dynamic" type of reproducer in radio sets of the 2-volt-tube type? It seems that manufacturers favor this type of speaker, rather than the more usual magnetics and electro-dynamics, for use with battery and electric sets?

(A.) The use of an electrodynamic reproducer, requiring a considerable exciting current for its field coils, would dissipate much of the economy obtained by the use of a 2-volt receiver for battery operation. This consideration was sufficient to rule out this type of speaker, except where there is a source of excess voltage which cannot be utilized in the receiver proper (as in D.C. line operation).

The inductor-dynamic unit has been selected by many designers of 2-volt sets because of the high "sensitivity," or high volume output at low levels of input power, of this type of reproducer.

Those who wish to look up references on the theory and design of the inductor-dynamic type of reproducer, will find the desired data in the articles, "A Novel Dynamic Reproducer," by Clyde J. Fitch, in the July, 1929, issue, and; "The Inductor-Dynamic Speaker," in the September, 1929, issue of Radio-Craft.

It is purely a "magnetic" reproducer. It does not have a field coil; and the "voice coils" correspond to the usual two (or four) magnet windings of the ordinary magnetic reproducer. However, in the latter instrument electromagnets are in permanently fixed relation to the armature, and operate to vary the strength of the field of permanent magnets. In the inductor-dynamic construction, the voice-coils, or electromagnets, are mounted on the moving armature. In addition, the armature does not approach and recede from the permanent

magnets; instead, it swings past them. Thus, the armature is not limited in its swing (as when reproducing a low note) by the pole-tips of the permanent magnets. This mechanical action is clearly shown in Fig. 17; (A, magnetic; B, inductor).

For the sake of simplicity the permanent magnet system of this type reproducer has not been shown. Although experiments have been conducted, to use an electromagnet, mechanical difficulties have prevented this design.

### Coupling Condenser

(Q.) Is there any advantage in placing one condenser in each lead of a speaker, instead of only one condenser in the entire circuit, to insulate the speaker from the supply?

(A.) There are several advantages to the idea.

Sets operating on D.C. lighting lines usually require insulation from the ground; placing the reproducer on grounded metal might cause a short circuit. Also, there is the danger of getting a shock if the reproducer and certain parts of the set were touched at the same time. This would apply to any type of set.

Then again the single condenser might become leaky or break down altogether, unless of the best and more expensive type. The heavy "B" current shunted through the reproducer would probably burn out the windings.

If, for instance, each condenser has a capacity of 1. mf., the effective capacity will be only 0.5-mf. (since the two condensers thus connected are in series).

### "100A" Connections

(Q.) What are the connections within the R.C.A. "100A" magnetic reproducer?

(A.) The connections inside this reproducer are shown in Fig. 18, it will be noticed that an audio filter system has been included in the design of this reproducer.

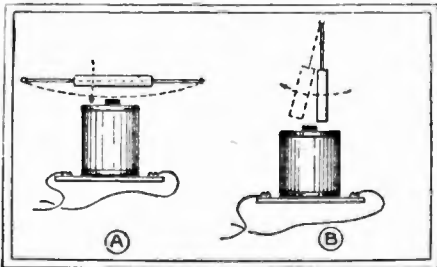

Fig. 17

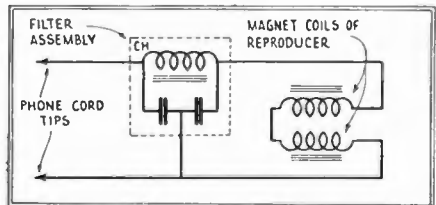

Fig. 18

### Binaural Reception

(Q.) How can two loud speakers at opposite ends of a room be wired and operated to produce a "binaural" effect? I have had the pleasure of listening to two reproducers, at a friend's house, connected this way. There did not seem to be any directional effect and, consequently, a realism resulted which seems quite unattainable with any other arrangement.

(A.) The circuits of Fig. 19 may be followed to create the illusion of binaural reception. In A a 100,000-ohm potentiometer is shown; other sizes may be used for experiment. If lower resistance is used, there will be a proportionate drop in the output volume. The setting of the potentiometer arm will depend upon the reproducers and the location of the listener; the listener should, preferably, be about half-way between the two reproducers. These units may have similar, or dissimilar characteristics, as desired.

The resistors indicated in B as R1 and R2 may have a value of about 100,000 ohms each. As shown, these need not be of the potentiometer type. This circuit has the advantages that one may obtain a variation in quality and volume, in addition to the binaural effect desired. Unit T is the usual output device.

In circuit A, it is necessary to use the radio set controls for volume, after the two speaker outputs have been balanced against each other. The indicated variation of the output connections employs an output impedance L; and C, the usual fixed condenser.

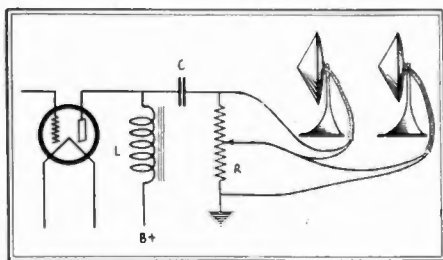

Fig. 19A

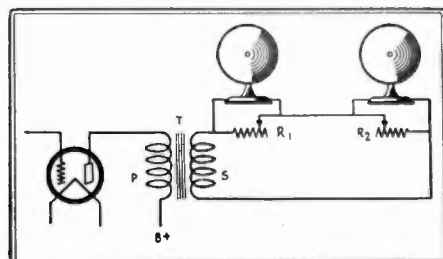

Fig. 19B

### Dynamic Reproducer Distortion

(Q.) What is the cause of low-note distortion in dynamic reproducers when the high notes can be heard without distortion?

(A.) We take this opportunity to present a few observations, by the engineers of the Kolster Radio Corp.; which, although particularly applicable to the Kolster dynamic reproducer used in the "Models K-23" and "K-24" combinations, apply to most dynamic units.

If the leather backing is loose, the reproducer will rattle on the lower audio range. If the voice coil goes off-center, the rattling will be noted on the over-tones. Most reproducers are equipped with a central "spider" which is fastened at its rim to the voice coil and at its center to the core of the pot-magnet. If this spider cracks—a not unusual occurrence—high-note distortion will usually result. This distortion will be most evident when certain single high notes are being sounded, as during a solo; when the tone will "go sour."

Lack of good low-note reproduction is sometimes traced to hardening of the leather ring. This ring, in a dynamic reproducer of poor workmanship, is cut from a cheap grade of leather, and often loses its flexibility. A person with a well-trained "radio" ear can detect the distortion this causes; for extremely low notes will lack fullness, or "depth," and the harmonics of the low fundamentals will be unduly emphasized.

Distortion caused by the voice coil touching the walls of the channel in which it should ride freely, is almost always a very pronounced and loud "rattle;" although an even louder rattle will result if the screw in the center of the spider should loosen.

Another source of distortion, and one usually blamed unjustly on the reproducer, is loose parts within the acousti-dynamic range of the loud speaker. In other words, little, unsuspected things like picture frames, screws in the radio cabinet, bric-a-brac on mantel or piano, two pieces of furniture which barely touch each other, a loose grille in the radio cabinet, and loose window panes, may suddenly start to vibrate audibly when their resonant frequency is sounded by the reproducer; and, the higher the pitch of this resonant frequency, the more difficult it is to localize its origin. In fact, it sometimes has taken hours to find the source of an annoying buzz which the trained Service Man would know, by past experience and listening close to the reproducer, did not originate in the loud speaker. It will be understood why this form of distortion is almost always confined to a single note or two in the audio scale.

Still another form of distortion is the annoying buzz that appears over the greater portion of the high-frequency end of the band. This fault, usually, is due to foreign particles in the air gap

between moving coil and fixed pole-piece. If the Service Man has a "lucky break," he may succeed in blowing them out; then again, he may need to "operate." (The latter procedure should not be attempted on a customer's reproducer until the technician has thoroughly familiarized himself with dynamic-reproducer assembly and adjustment, by study and practice on his own experimental equipment.)

A damaged cone will sound very much like the "dusty air-gap" just described. Only experience enables the Service Man to recognize its characteristic sound.

If the primary of the output transformer is not accurately matched to the plate circuit of the power tube; or, if the secondary does not accurately match the voice-coil winding, very pronounced distortion may result. This may take the form of insufficient bass reproduction, or "fuzzy" high-register notes.

### Bass Emphasis

(Q.) What causes a dynamic reproducer to "boom out" on the bass notes?

(A.) The first question to be settled is, whether the defect causing this form of low-note distortion is in the reproducer or in the receiver.

If the radio set has "mellow" reproduction when a magnetic reproducer is used, it probably is the receiver that is

at fault. Many radio sets are designed to operate with a particular loud speaker; and if this reproducer is deficient at the lower end of the audio "spectrum," fixed condensers are so placed by the manufacturer as to "boost" the low-note output of the set.

The dynamic reproducer works particularly well on the lower end of the audio band and, if it is connected to a radio set having an audio system that over-emphasizes the bass notes, this over-emphasis will then become very evident.

If the fault lies in the reproducer, it is probably due to resonance in the reproducer mounting or to loose parts. If the leather mounting ring loosens, "booming" may result. Should the reproducer be defective in design, it may "boom out" when certain low notes are played; because of resonance of the moving parts to notes of those particular frequencies.

If there is a "matching transformer" in the chassis of the reproducer, it is possible that this transformer is not properly matched to the output transformer or impedance in the receiver; this will cause poor reproduction of the low notes.

Incorrect "C" bias or other faults in power pack design may be the reason.

From a consideration of these causes of distorted reception, the line of procedure becomes evident.



# CHAPTER VII

## The Power Supply

### Increasing "B" Voltage

(Q.) What is necessary to rebuild a "B" eliminator to deliver 250 volts instead of 180?

(A.) The solution of that problem is to buy another eliminator. A shiftless and inadvisable scheme sometimes employed to increase voltage (and the writer admits having tried it) is to change the rectifier for one of higher output rating. However, this puts an added strain on the transformer, granting that the condenser pack has been changed for one having a higher break-down rating; and a burned-out transformer may result. These are only a few of many reasons why "B" eliminators should be operated only as designed.

### Receiver Operation Cost

(Q.) What is the cost of current per month for operating a 75-watt radio set?

(A.) Find the total wattage required to operate the set for an average month, and find the relation this figure bears to 1,000 watts—the usual basis on which the current cost is rated.

For example: the receiver is operated on an average of four hours every day, requiring a total current of approximately 9,000 watt-hours per month. This is nine times 1,000 watt-hours. In some localities the charge is "ten cents per kilo-watt-hour (1,000 watt-hours)" and this would make the cost of operation 90 cents per month.

### 25 or 60 Cycles?

(Q.) Can an electric set be used on 25- or 60-cycle supply, optionally? If not why not?

(A.) A radio set designed to be used with 60-cycle supply cannot, except by special design, be used with 25-cycle current supply.

The 25-cycle supply changes polarity very slowly, as compared to 60-cycle supply and the lower impedance at this frequency permits a much greater current flow in power transformer windings which causes them to heat to a high degree. In fact, the primary would probably burn out.

It is easier to filter properly 60-cycle current than 25-cycle current. For the latter, it will be necessary to double or triple the capacity values of the units in the filter condenser bank; and perhaps to increase the inductance of the choke coils.

A power transformer designed for 25-cycle supply must need to be substituted

for the 60-cycle transformer. If a current-regulating line ballast is used, this must be changed for one having the correct value.

Ordinarily, a 25-cycle set will work very well, and usually with less hum than a 60-cycle receiver, when connected to a 60-cycle current supply of the same voltage rating.

### "A-B-C" Eliminator

(Q.) I have an "ABC" eliminator, from which the leads have been removed. The power transformer is not marked, and I find it almost impossible to determine the original connections in this unit. Please show a standard wiring diagram, and any additional available data on the connections.

(A.) The schematic circuit of a representative "ABC" eliminator is shown in Fig. 20 at A, and the connections of the Earl power transformer, used in this unit, in the same figure at B.

It will be noted that the "A" portion of this eliminator will operate the filaments of the average all-electric set. Of

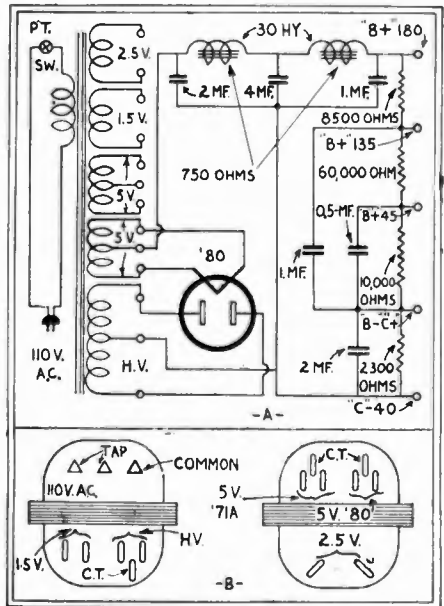

Fig. 20



course, the indicated voltages are alternating and not direct-current.

If any further difficulty is encountered in connecting up this eliminator, the trouble should readily be located by testing the circuits with an accurate voltmeter.

### Power Line Potential

(Q.) How could the range in voltage effect the practicability of design of an electric receiver?

(A.) By "electric receiver" it is presumed that what is meant is a radio receiver using A.C. tubes. Such a set would work well in the majority of cases if it was designed for a line supply of 112 volts, the average potential of so-called "110 volt" A.C. lines (D.C. lines run more nearly 115 to 120 volts).

However, the voltage range is so great in many instances it would be wise to incorporate some compensation arrangement.

First, there is the situation of a fairly steady supply at potentials other than 112 volts.

Then, we have the condition of a swinging potential with a mean value that is probably about 112 volts.

The remedy for the first condition is a limiting device which will prevent the supply exceeding 112 volts; we know of no unit to increase the voltage should it be low, other than the device mentioned below, which is of entirely different character to the fixed-limit compensating unit mentioned above.

In the case of a swinging potential, it is necessary to introduce a boosting voltage at one time and remove it at another.

Or, to express it more simply, the swinging voltage applied to a "balancing box" must have become a relatively steady 112-volt potential upon leaving the "box." The box's steady output becomes the steady 112 volt supply for the electric receiver. All this voltage equalizing depends upon the supply being A.C.

Such balancing units are already obtainable. Each one must be correctly designed for the job in hand, as the individual demands of amperage and voltage must be satisfied.

A few more words may complete this answer. It is probably obvious that the entire electric machine will work best at some steady voltage for which it is designed. Therefore, change of the line supply potential will cause an unbalance of the receiver voltages and in consequence affect the receiver performance.

Insufficient line potential usually results in distorted, weak reception, as the units comprising the voltage supply are not able to deliver the potential for which the set was designed. Thus, the tubes will operate on an entirely different part of their "characteristic curve". These two foremost effects are sufficient to cause entirely different operation of the circuit. When it is realized that, in ad-

dition, the electrical circuit of the tubes, the coupling circuits, will react very differently to these changed characteristics, it becomes evident that a low line potential is not desirable.

Too great a line voltage carries its disadvantages, which are usually broad tuning, short tube life, condenser breakdowns, and perhaps transformer burn-outs; circuit oscillation may also result and whether tuning is broad or sharp with such a condition will depend upon the couplings which result between the radio frequency tube input and output circuits (broad tuning may be caused by inductive feed-back, although circuit oscillation may result at the same time; tube-element capacitative feed-back can also cause circuit oscillation but it is not likely to cause broad tuning).

For many reasons it is desirable to incorporate some device for equalizing A.C. line voltages to a standard value.

### Sulphated Batteries

(Q.) In the July 1929 issue of Radio-Craft is an article on page 34 entitled "Reclaiming Sulphated Storage Batteries." My storage battery was sulphated to quite an extent and took a long time to charge. I obtained the articles specified and proceeded as per instructions. After getting the job completed, and leaving the battery on charge for the periods specified, I cleaned it out, rinsing it with several lots of water and charging it after the last filling for about twelve hours. I put in the new acid solution, which then had a specific gravity of 1300. After letting it stand several hours, the specific gravity dropped quite low; then, after putting the battery on charge for several hours, it seemed to rise quite rapidly to 1200, but nearly a week's steady charge has failed to raise it much over 1225. What is the matter and how can I remedy it?

When I looked in the battery, before I started putting in the new acid solution, the sulphate seemed to have disappeared; but, upon inspecting it today, I notice quite a lot more has formed; also, there is some down in between the plates, which seems to have never been removed. I am anxious to get it fully charged, as the radio set does not work up to par with the battery in the condition that it now is. Do you think I should have left the battery on charge longer, considering the charging rate?

(A.) The author of the article in question states that there is no reason why the battery referred to should remain sulphated, after receiving the treatment described in his article. Sometimes, however, with a large battery container, enough acid may remain so that it will not be completely neutralized by the alkali used to clean it before desulphation. In this case, a second treatment with the alkali should be given; then charge the battery as described. The complete elimination of the sulphate from the plates

should be indicated by the voltmeter's registering the ability of the battery to stand a full charge.

Then the cleansing operation should commence, and be carried out thoroughly. After this, the usual sulphuric acid solution is poured into the cells, and the charging continued until the battery is fully charged. Its ability to retain its charge is the best indication of its condition, and this is largely due to the skill with which it has been handled. The size of the containing cells and the active metal surface of the plates govern the best specific gravity for the solution to be used.

Our correspondent is recommended to disregard the hydrometer test, for the present; charge the battery at a greater rate—say three amperes—and, when each cell shows 2.5 volts while charging, remove the battery. Discharge it slowly—that is, through a suitable load, equivalent to a radio receiver. When the voltage drops to 1.5 per cell, recharge it without losing any time; so that it will have no opportunity to sulphate. Repeat this until the battery is as nearly normal to all indications, as may be judged from its working condition. Then, when it is fully charged, if it gives an incorrect hydrometer reading, pour out all the acid electrolyte and refill with a standard acid solution. It will be best to watch the voltage indicator until the battery begins to work normally.

#### "C" From "B" Unit

(Q.) Please advise me as to whether a "B" eliminator can be wired to supply the "C" bias for a '71A power tube and also a 4½-volt bias. An eliminator in question supplies 60 milliamperes at 180 volts.

(A.) A 2000-ohm resistor, connected between the center-tap of the power transformer secondary and the negative terminal of the power unit, will supply the required bias for a '71A tube. The center-tap is now "C" minus and the regular "B" minus post is now also the "C" plus connection. If the resistor is equipped with a sliding contact, the bias may be varied and, if two contacts are provided, the 4½ volts negative required as the bias potential for '01A-type tubes may also be obtained.

When securing a bias voltage in this manner, the "C" voltage is obtained at the expense of the "B" voltage; and causes a corresponding reduction in the total "B" available.

#### Connecting Two "B" Units

(Q.) Can two "B" eliminators, each delivering 180 volts, be hooked up to deliver 360 volts?

(Q.) Yes, the highest positive lead of the first unit being joined to the negative lead of the second.

Before connecting the increased output to a receiver, the latter should be examined to determine whether the bypass condensers within the set, from "B+ Max" to "B—" are capable of operating at the increased potential.

#### Trickle Charger "A"

(Q.) I have a trickle charger and a Kuprox replacement unit, "Type A-110." Can I connect this combination in such a way as to make an "A" eliminator?

(A.) As this unit is designed to pass not more than 0.8-amp., it cannot be used in an "A" unit requiring more than this amount of current. In addition to this, filtering would be required.

#### Gaseous-Rectifier "B" Unit

(Q.) I have a "B" eliminator of the type shown in Fig. 21. Please advise the range of the two variable resistors.

(A.) Two "universal range" resistors are used in this "B" eliminator, in the positions shown in the schematic diagram (Fig. 21). The rectifier is a "BH" or gaseous-type tube. The power-line resistor may be set to take care of differences in line-voltage. Resistor R1 measures 200 ohms.

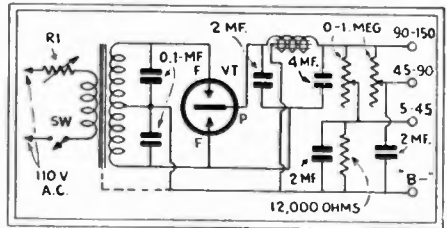

Fig. 21



# CHAPTER VIII

## Superheterodynes

### Intermittent Operation

(Q.) What might cause a "Radiola Superheterodyne" ("Second - Harmonic" semi-portable) to appear "dead" at times, operate well for a time, then suddenly go dead?

(A.) This is probably due to loose contact at the "cat" (catacomb). Closely examine all connections on the aluminum "cat"; this is grounded, and voltage tests may be made with one side of the meter grounded against it. A milliammeter in the "B—" lead will fluctuate if there is a break in the "B" circuit, during the process of shaking the leads of the set; a similar meter in the "A" circuit would check defective "A" connections.

There is a loop built into the rear of this receiver, and it occasionally happens that its connections to the set work loose. Another cause of trouble in this receiver is poor tube-prong contact. Clean the tube-socket springs with sandpaper, similarly clean the tube prongs; and bend up the socket springs, carefully, by placing below them a piece of cord and pulling it up. Whether the latter performance is necessary may be determined by gently wiggling each tube; if the receiver suddenly stops operating, this is due to an open circuit which will be remedied by restoring good contact.

### Antenna Coupler

(Q.) Please furnish construction details for an antenna coupler to be used with a superheterodyne. The I.F. coils are peaked at 4,300 meters.

(A.) An essential value, the capacity of the loop tuning condenser, is lacking. However, no difficulty should be found in making an antenna coupler. There is nothing to it but a primary and secondary winding. The exact number of secondary turns is to be determined by experiment; try 110 turns of No. 28 D. C.C. wire on a tube  $1\frac{1}{2}$  in. in diameter. Over this coil, at the filament end, bunch 30 turns of the same (or smaller) wire; taking taps at the 10th and 20th turns. This antenna coupler should be shielded, with a minimum of 1 inch between coil and can.

Connect the antenna coupler in an ordinary detector circuit, with antenna and ground connected to the primary, to determine whether turns should be added to, or removed from, the secondary to cover the broadcast band properly. The peak of the I.F. transformers has no bearing on the design of the antenna coupler.

### Matching I.F. Transformers

(Q.) How can a set of home-made intermediates be matched?

(A.) It is presupposed that the design is approximately correct for the desired frequency. The problem, then, is not to match the coils exactly to a given frequency, but to match one set of coils to the other. The best method involves the use of a calibrated, A.F.-Modulated, R. F. oscillator. Its output is transferred to a detector tube, the intermediate-frequency transformer being introduced between the two units. Maximum deflection on a milliammeter indicates resonance; which is obtained by varying the number of turns on the secondary. Varying the adjustment of the long-wave oscillator until the meter indicates a current will show whether there are too many or too few secondary turns.

A more simple method is to connect antenna and ground to the primary winding, and a detector tube to the secondary; one side of the coil connecting to the grid-condenser and leak, and the other side to "A+." A pair of headphones, shunted by a .001-mf. fixed condenser, are connected in the plate circuit of the detector tube. A .0005-mf. variable condenser is connected across the secondary coil and varied until a spark signal is heard; if there is no spark signal within this long-wavelength range a .0005-mf. variable condenser may be connected from detector plate to antenna, and varied until there is circuit oscillation (to obtain this condition it may be necessary to reduce the capacity of the fixed condenser in shunt with the headphones).

When a whistle is heard, as the beat-frequency between a CW signal and the circuit under test becomes audible, the reading of the variable condenser in shunt to the secondary is noted, and the second intermediate-frequency transformer is substituted for the first. The shunt condenser is again varied until the same sig-

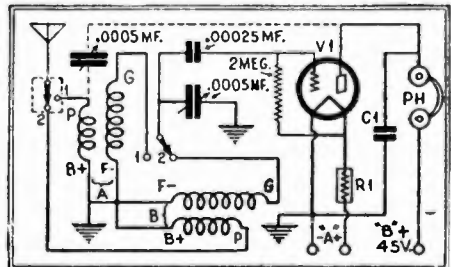

Fig. 22

nal is recognized. Then, turns are removed from (or added to) the secondary coil until the variable condenser's reading is exactly the same as it was when the same signal was heard with the first transformer in circuit.

This is a very accurate method; the only requirements are care and common sense in applying it. In this arrangement, a code station is commandeered to supply the A.F.-modulated R.F. long-wave signal (the spark signal); or the R.F. signal may be the code transmissions of the C.W. station (the A.F. modulation being obtained by the heterodyne method as mentioned above).

To facilitate rapid comparison, a circuit, shown at Fig. 22, has been developed.

Although 1, 2 and the antenna may all be connected together a refinement, an antenna switch, is indicated in the dotted enclosure.

### Aperiodic Amplification

(Q.) After reading the description of the "1930 Electric" receiver in the November, 1929 issue of Radio-Craft, the question arose in my mind, whether the idea of untuned stages could be applied to other receivers. Please answer whether a superheterodyne, for example, could be improved by this circuit arrangement?

(A.) The superheterodyne incorporates an amplifier which is tuned (at least at its input and output) in such a manner that its stages are called on to handle only one frequency range; this is brought about by "changing the frequency" of the signal. On the other hand, the "untuned" R.F. amplifier is designed to accept, and amplify with as little discrimination as possible, any frequency in the broadcast band. This subject was discussed quite thoroughly by Mr. Grimes in the Co-operative Radio Laboratory section of Radio-Craft (page 458 of the March, 1930 issue, with illustrative diagrams).

The "untuned" R.F. amplifier (as a matter of fact, every circuit containing resistance, capacity and inductance is tuned to some frequency; and the "untuned" or "aperiodic" circuit, ordinarily, is one that is working a long way from its natural frequency) was in favor in the early days. The need for selectivity led to tuning the R.F. stages; and now we have tuning devices—such as a band-selector circuit—separated from the amplifying stages.

In some designs of superheterodyne, the "intermediate-frequency" output of the frequency-changer is at high R.F. frequency, such as that of the broadcast band; and the "untuned R.F. amplifiers" suggested could be used. The only advantage is that, under varying conditions, met with in different locations, the operator could choose the intermediate frequency best adapted to avoid station interference. It is necessary that the intermediate frequency, whatever it may be, shall be evenly amplified over a band of ten kilocycles, or so, and that the undesired station frequencies be kept out of this amplifier.

### Loop Dimensions

(Q.) Can a loop of the "box" type be made for the "Radiola 25?"

(A.) A satisfactory loop for this receiver may be made by winding 12 turns of wire on a frame 12 x 24 inches, spacing the turns about 1/4-in.

### I.F. Tuning Capacity

(Q.) What is the recommended capacity for a variable condenser to be used as a shunt capacity to balance the secondaries of intermediate-frequency transformers?

(A.) A small unit (100-mmf. rating) is usually suitable. However, a larger capacity may be required if the transformers were not carefully constructed to close limits. This is usually evident by pronounced lack of resonance in one I.F. stage.

### Service Data

(Q.) A "super," wired exactly as specified by the manufacturers and using specified parts, with the exception of the audio transformers, has decided to develop a loud howl. When two stages of audio are used the set starts to howl, not at a high pitch, but with a low, deep whistle like a steamboat in the distance, growing louder until it turns to a deafening roar. This action does not occur when only a single audio stage is used. The fault is not due to microphonic tubes.

I am using a 6-volt "A" battery, "B" eliminator, and "C" batteries, and have tried different audio transformers the same and different ratios (they work well in other sets). A resistance in shunt with the secondary of the first audio transformer reduces the howl, but also reduces the signal volume. An R.F. choke and a bypass condenser in the second-detector plate circuit do not change the operation. Inserting an audio choke coil in the "B" lead to the detector and bypassing it to "A—" does not stop the howl.

Changing the resonant period of the transformers by shunting the secondaries with fixed condensers has been tried. I have grounded the transformer shells, changed sockets, tried different tubes, and even removed the entire audio unit to a distance, connecting the circuit with lengthened leads. The "A" and "B" potentials test O.K. with the set in operation.

(A.) Although the "B" potential may seem to be correct by meter test, we believe that the trouble lies in the output of the particular "B" eliminator you are using. One designed to deliver a heavier current should enable you to operate the "super" without trouble.

The entire trouble is due to audio regeneration; there is a feed-back coupling in some part of the set which is "common" to both the grid and plate circuits.

The "C" battery may have sufficient "internal resistance" to cause this; a 2- to 4-mf. condenser around this battery is recommended here.

However, we believe it is the "internal resistance" of the "B" unit that is causing the trouble. Although the meters indicate a steady current supply to the tubes, there is a rapid fluctuation of the potential at an audio-frequency rate, too rapid for the meter to indicate. Very large bypass condensers across the several voltage-output posts of the eliminator will stop the howl; but it will probably be impractical to use the high capacities called for. Exchanging the eliminator for one having a heavier current-output capacity (lower internal resistance) is the better plan.

Changing the reproducer is sometimes a convenient remedy. Another expedient is the use of low-ratio A.F.T.'s—not exceeding 2-to-1.

### I.F. Transformer Design

(Q.) Numerous issues of Radio-Craft have contained descriptions of service oscillators, designed for use in aligning superheterodynes in which the intermediate frequency is in the neighborhood of 175 or 180 kc. However, I never have seen a description of an I.F. transformer operating in this range. While this may not be a service request, at least it should be of interest to a large number of set builders; and even, perhaps, to a few Service Men who sometime might be stuck with a badly burned I.F. transformer and have no immediate repair unit on hand for replacement. Please publish construction details for an I.F. transformer of the shielded type, similar to average I.F. transformers. This should be a good item for use in modernizing old superhets.

(A.) In Fig. 23 is illustrated a suitable design for an I.F. transformer which by

adjustment of variable condensers C will operate over the frequency band of 160 to 200 kc. (one type of small-space unit is shown on page 22 of the July 1931 issue). The copper plate is required only when exceptional selectivity is required—as when a limited number of stages are to be used. Selectivity and volume are controlled also by the spacing of coils L. Brass supports may be used, bent as shown. The formers, or spools, may be lathe-turned bakelite or wood, or a job built up of insulating washers and rods. Scramble-wind the coils.

Extensive data on this subject appears in "The Superheterodyne Book," by Clyde J. Pritch.

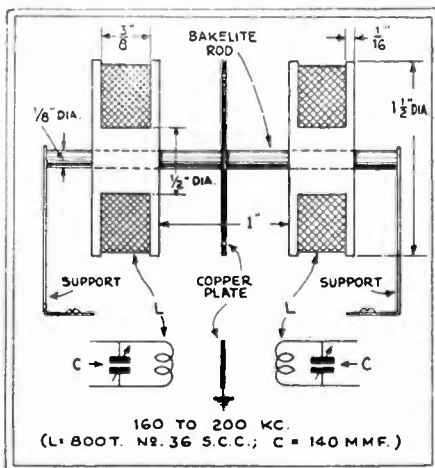

Fig. 23



# CHAPTER IX

## Short Waves

### Servicing Short-Wave Receivers

(Q.) If the difficulties I am experiencing in getting to operate the "Composite Short-Wave Receiver" described by Mr. Robert N. Auble in the February, 1930 issue of Radio-Craft are described to you, perhaps a remedy can be suggested; ideas which would be applicable in the repair of any set of this general type. The set was laid out and wired in accordance with the instructions; all voltages are as specified. Only local broadcast stations can be heard, and the detector circuit cannot be made to oscillate. What can be the cause of the trouble?

(A.) Mr. Auble points out that a not uncommon cause of trouble in home-built radio sets is the inclusion of defective parts. It is suggested that every part used in the set be carefully tested, individually, for its rated characteristics.

If grounded shielding braid is used, the trouble may be due to a strand of the braid touching a lead from which it should be insulated.

Since it is reported that only local stations can be received, Mr. Auble suggests this procedure: disconnect the R.F. stage by removing the '22 (first R.F.) tube, VI in Fig. 24 and the R.F. choke R.F.3 in its plate circuit. Next, connect the antenna to the stator of the tuning condenser C1, through a 3-plate "midget" variable condenser, and connect a ground connection to the "P" terminal of the tuning coil socket. This results in a standard three-tube short-wave receiver circuit.

Short-wave stations should now be received; and, if short-wave code stations

cannot be heard, the detector circuit must be carefully checked to determine why this circuit does not oscillate. Now, by shorting the midget condenser, it will be possible to receive broadcast stations on any coil (try it). If the reception obtained in this manner seems to be the same as before, this would indicate that the original wiring included a short-circuit of equivalent effect, which should be located and eliminated.

Although a few more turns in the tickler winding may cause the circuit to oscillate, there is probably some other cause for the lack of circuit oscillation, which should be found and corrected. For instance, the tubes may need changing. The '22 is a delicate tube and should be handled like a precision instrument; its filament circuit should include resistors which will prevent the potential exceeding 3.3 V., as checked by an accurate meter. An increase in plate voltages may be desired; and a grid condenser of .0001-mf. may work better. The "C" bias battery, also, may be connected backwards; check for correct polarity.

A source of trouble, which often escapes the attention of inexperienced constructors, is found in leaky insulators. Condenser insulation is sometimes poor; and the strips of insulation (particularly fiber) used to support instruments carrying R.F. currents, may leak to a great extent and cause what is popularly termed a "high-resistance short." A pair of headphones and a 45-volt battery in series ordinarily are suitable test equipment for locating faults of this sort.

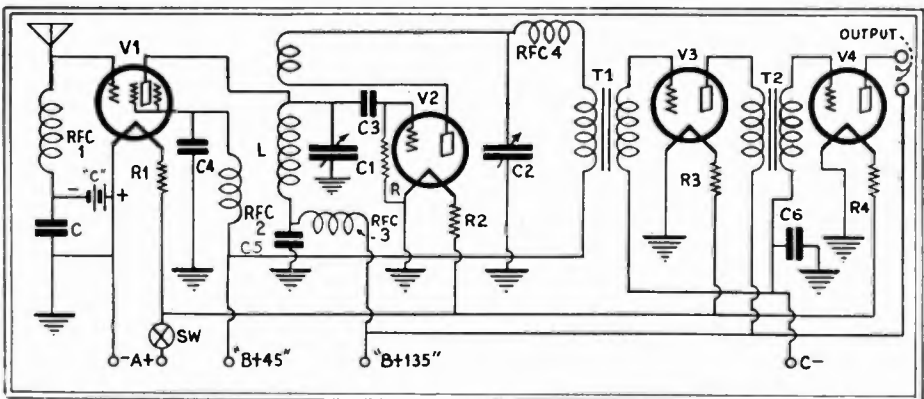

Fig. 24

More complete information will be found in the book, "How to Build and Operate Short-Wave Receivers," by the Editorial Staff of Short Wave Craft magazine.

### Lack of Oscillation

(Q.) I have a short-wave receiver, the circuit of which will not oscillate at any point, on five coils ranging from 20 to 200 meters. How can this be remedied?

(A.) You do not enclose your circuit, so we can give you only a general answer. Granting the circuit is correct, check off the following points:

1. Defective tube.
2. Shorted antenna coupling condenser (antenna coupling too close).
3. Defective detector plate circuit choke.
4. Low "A" or "B" potentials.
5. Reversed tickler leads.
6. Defective R.F. coil secondary (or primary).
7. Leaky tuning condenser insulation.
8. Corroded connections.

### Shielding

(Q.) What is the recommended distance between tuning inductances and shields, for short-wave operation?

(A.) This depends considerably upon the operating wavelength. For very short waves, it has been suggested that special wire screening be used to overcome certain losses which result when even the best of solid shields are used at very short wavelengths.

In general, copper shielding may be placed not closer than one to one and one-half inches from the sides of coils, and not closer than two to three inches from the ends. However, such figures are a matter of discussion, as many factors enter into the situation. For example, certain coil shapes produce magnetic and electrostatic "fields" with different arrangements of the lines of "flux"; and each type of coil, therefore, is best used with shields of a certain pattern.

### R.F. Choke Desirability

(Q.) How is it possible to tell whether a choke coil is needed in a short-wave receiver?

(A.) The purpose of a choke coil is to prevent the passage of alternating current. Its location in a receiver depends upon the design of the receiver. Some sets call for the use of choke coils in dozens of places, while other sets entirely dispense with their use.

The usual place for at least one choke coil, in a short-wave receiver, is in the plate circuit of the detector. In one position, it makes regeneration a possibility; without it, no regeneration or circuit oscillation is possible. This is probably the use you have in mind.

Another action of the choke coil, also in the plate circuit of the detector, is to prevent R.F. currents getting into the A.F. amplifier. In this position it will be found in a majority of the better commercial broadcast receivers.

These same receivers, as well as the short-wave receivers, use choke coils in the leads which supply plate potential to R.F. stages, as well as bias potentials for the screen-grid of screen-grid tubes. When used to prevent R.F. currents passing into the current supply units, these choke coils are almost always bypassed with fixed condensers, as is seen upon inspection of most any schematic circuit; the R.F. is "led" from the "high potential end" of the R.F. choke, to a point at low potential. This is ordinarily the ground or the "A" circuit.

When it is desired to use the choke as a "load impedance" or coupling unit between stages, the fixed condenser connecting to the high potential end of the choke "leads" the R.F. to the stage which follows, instead of to ground.

Erratic regeneration will result if a choke coil is not used in certain circuits. Without choke coils, a tuned R.F. receiver may operate with only one-half the volume it should. Radio frequency choke coils often prevent R.F. circuits from going into uncontrollable oscillation. In screen-grid circuits they are almost a necessity.

If a choke coil is poorly made, "holes" in tuning result; there will be points at which the short-wave receiver circuit goes out of regeneration or oscillation; or, it may go into oscillation with an uncontrollable "thump."

More detailed information appeared in the August, 1929 issue of Radio-Craft magazine under the title, "Some Notes on Short-Wave Operation," by Robert Hertzberg.

### A.C. Short-Wave Adapter

(Q.) Please show, as a matter of interest, the schematic circuit of a short-wave adapter to be used with A.C. sets.

(A.) A circuit arrangement of a short-wave adapter using the type '27 tube is depicted, in Fig. 25, in answer to this query.

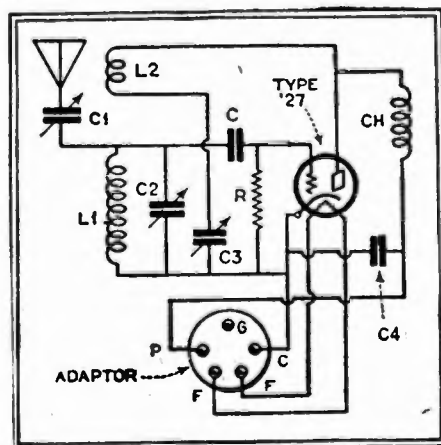

Fig. 25

It must be mentioned, this is a throw-back to the old 3-circuit regenerative set of some time ago; and the comparison of results obtained on this arrangement with those of the regular radio set, at the broadcast wavelengths, will not be a good recommendation for the adapter. At the short wavelengths, however, good code reception should be obtained and the few phone stations broadcasting should be heard. Squeals and whistles and distorted reception generally will result when trying to tune in the harmonics of broadcast stations. This is quite natural, as the harmonics cannot be expected to reproduce as clearly as the fundamental frequencies.

Inductances L1 and L2 are the standard windings, which constitute one of the units of a short-wave kit. The 5-prong plug is a standard tube base. Resistor R is a grid leak with a value of about 3 megohms or more. Condenser C4 is of .00025-mf. capacity. Condensers C2 and C3 are the usual tuning and regeneration units, the capacities of which are determined by the particular set of short-wave coils decided upon. The antenna coupling condenser, C1, is very necessary and has a value of about .0001-mf. The grid condenser, C, is .00015-mf.

### Coil Design

(Q.) Where is it possible to obtain specifications for winding short-wave coils, using various sizes of wire, for various condenser tuning capacities?

(A.) It is impossible to obtain such systematized information; for the simple reason that there would be no end to the data. It would consume the space of many large volumes; for it is true that tubes, aeriels, condensers, coil placement, associated apparatus, shielding, winding forms, methods of winding and other factors vary critically at high frequencies. The only reliable method is that of winding a set of coils to suit the conditions in a receiver, following a general idea of the values; and varying the coils until

exactly the desired tuning band is obtained.

This general idea of values may be obtained from published data; including the detailed specifications which have appeared in past issues of Radio-Craft and Short Wave Craft magazines for coils covering the entire short-wave range.

### Receiver Constants

(Q.) I would like to have a schematic circuit and any other available data on a good short-wave receiver using a screen-grid "blocking" tube; and, preferably, of commercial design.

(A.) The schematic circuit of an excellent 4-tube battery-model short-wave receiver, the Radiola Model AR-1145 is shown in Fig. 26, together with all available constants. The tube (average) characteristics are as follows: filament potentials, V1, 3.2 volts; V2, V3, C4, 5 volts. Plate potentials: V1, V4, 130 volts; V2, 30 to 60 volts (depending upon the position of the volume control); V3, 65 volts. Control-grid potentials: V1, 1.5 volts; V2, zero; V3, 3 volts; V4, 9 volts. Screen-grid potentials: V1, 67.5 volts. Plate currents: V1, 3.5 ma; V2, 0.65 to 1.5-ma; V4, 4 ma. Screen-grid current, V1, 0.5-ma.

Readings of V1 will vary with individual test instruments; those of a Weston "Model 537" test set being given above.

The color code of the 6-wire battery cable is as follows: Red, "B+135"; maroon, "B+67½"; black-green, "C-3"; black, green tracer, "C-9"; yellow, "A+" (6 volts); black, yellow tracer, "A-". To the lug on the last is connected a green, red-tracer lead which terminates in a "B-" lug from which runs a short green, red-tracer lead which terminates in a "C+" lead.

The wavelength range of the standard "Model AR-1145" receiver is approximately 15 to 75 meters, covered by three coils; though two additional coils are available for the 200- to 545-meter range of the instrument.

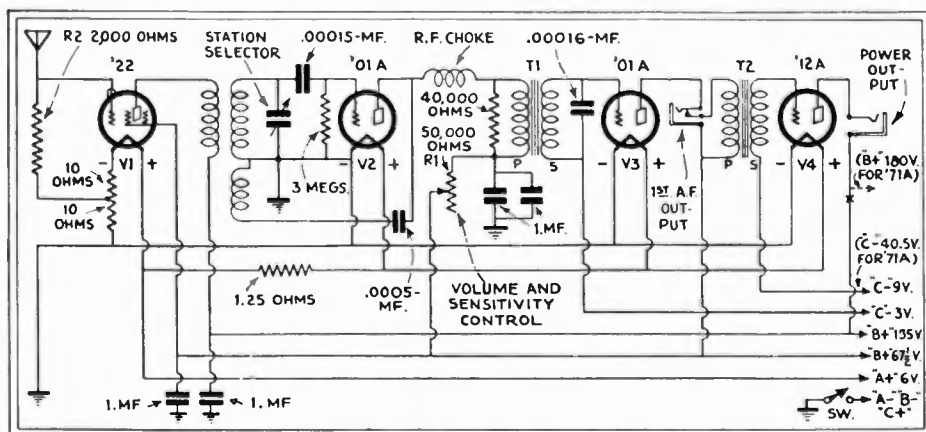

Fig. 26



In lieu of the resistor R2, some models incorporate an R.F. choke coil. It is recommended that a 5-amp. fuse be placed between the yellow, positive filament lead and the battery.

The antenna may be to 25 to 100 feet long. Station interference may be reduced by using a short antenna, or connecting in series with the aerial a condenser of .00025-mf. capacity. In some instances, it may be necessary to use a wavetrap in the antenna lead. A supplementary volume control is a 200-ohm variable resistor connected in series with the antenna.

### Amateur Licenses

(Q.) What is the fee and what are the requirements for operating an amateur short-wave station transmitting voice?

(A.) The required forms may be obtained from the office of the Supervisor of Radio in the Inspection District where the applicant resides; the correct address may be determined from the following list:

First District: Maine, New Hampshire, Vermont, Massachusetts, Rhode Island and Connecticut. (Supervisor of Radio, Custom House, Boston, Mass.)

Second District: New York (New York City, Long Island, and the counties on the Hudson River to and including Schenectady, Albany, and Rensselaer) and New Jersey (counties of Bergen, Passaic, Essex, Union, Middlesex, Monmouth, Hudson and Ocean).

(Supervisor of Radio, U. S. Sub-Treasury Building, Wall, Pine and Nassau Sts., N. Y. C.)

Third District: New Jersey (all counties not included in Second District), Pennsylvania (counties of Philadelphia, Delaware, all counties south of the Blue Mountains, and Franklin County), Delaware, Maryland, Virginia, and the District of Columbia. (Supervisor of Radio, Room 13, Custom House, Baltimore, Md.)

Fourth District: Alabama, Tennessee, North Carolina, South Carolina, Georgia, Florida and the Territory of Porto Rico. (Supervisor of Radio, Room 524, Post Office Bldg., Atlanta, Ga.)

Fifth District: Mississippi, Louisiana, Texas, Arkansas, Oklahoma, and New Mexico. (Supervisor of Radio, Custom House, New Orleans, La.)

Sixth District: California, Nevada, Utah, Arizona and the Territory of Hawaii. (Supervisor of Radio, Custom House, San Francisco, Calif.)

Seventh District: Oregon, Washington, Idaho, Montana, Wyoming and the Territory of Alaska. (Supervisor of Radio, 2116 L. C. Smith Building, Seattle, Wash.)

Eighth District: New York State (all counties not included in the Second District), Pennsylvania (all counties not included in the Third District), West Virginia, Ohio and Lower Peninsula of Michigan. (Supervisor of Radio, 504 Commerce Building, Detroit, Mich.)

Ninth District: Indiana, Illinois, Wisconsin, Michigan (Upper Peninsula), Minnesota, Kentucky, Missouri, Kansas, Colorado, Iowa, Nebraska, North Dakota and

South Dakota. (Supervisor of Radio, 2022 Engineering Building, Chicago, Ill.)

This subject is thoroughly covered in the chapter, "Getting Started," in "The Radio Amateur's Handbook," obtainable from The American Radio Relay League, Hartford, Conn. The prospective "ham" should write to the Government Printing Office, Washington, D. C., for a copy of "Regulations Governing Radio Communication," (10c per copy); and "The Radio Law of 1927," (5c per copy).

(Further procedure is explained on the forms, which are obtainable gratis.)

Amateur transmitting stations licensed to operate in any of these districts may be permitted to use any or all of the available amateur frequency bands; amateur phone stations must transmit only on the 1715-2000 and 56000-60000 kc. (150-175, and 5-5.36 meter) bands; and, by special permission only, on the 3,500-4,000 kc. and 14,150-14,250 kc. (75-85.7 and 21.05-21.20 meter) bands. Transmission is prohibited, in the United States, between the hours of 8:30 and 10:30 p.m., local standard time; and also, from 10:30 A.M. to 1:30 P.M. on Sundays if interference to other services exists.

### Servicing Short-Wave Converters

(Q.) After carefully following the directions appearing in the September, 1930, issue of Radio-Craft in the article, "Short-Waves on Your Broadcast Receiver," by Watson Brown, I still have been unable to get the smoking-stand converter to operate on the lower wavelengths; that is, those below 60 meters or so, using Zenith "Model 52" broadcast receiver. What can be the trouble?

(A.) Mr. Brown has done some more work on this interesting and effective converter, which may be considered representative of other converters, and his remarks are worth noting: "Apparently you have failed to connect the set up quite right. I would suggest that you use a separate filament transformer and an Arcturus or Pilot '27 tube. It is most important too, that you have your power supply and switch not over twelve inches from the 'A' and 'G' posts on the Zenith '52.' Also two condensers C5 (of 0.5-mf. capacity) should be mounted, one on each side of the filament transformer, and the connections run direct.

"Have you tried 45 volts on the plate? The shorter the cable that leads from your set to the smoking stand, the easier it is to cut out locals. (I have no trouble like this—even when lightning is bad on the broadcast band.) A metal chassis should be used, by all means. Try a 15-foot aerial.

"Since this article was published I have had a lot of fun with the very instrument pictured. Using it in conjunction with an Atwater Kent 'Model 60' receiver, I have picked up the transmissions from London, Sydney (Australia), Bolinas and Oakland (Calif.), Mexico City, and a 'raft' of closer stations; all of them daytime reception at loud-speaker strength."

It is possible that some of the parts in the completed converter are defective. The "Model 52" Zenith has an unusual input arrangement; the secondary of the first R.F. transformer is tuned by a variable condenser, as usual; but the connection between the grounded side of the variable condenser and the ground end of the coil is made through the primary or antenna winding (therefore, the primary is in series with the secondary winding and the chassis ground). This primary winding is bypassed by a fixed condenser which is across the tuned secondary circuit.

The aerial connection is optional; both a direct lead and a variable capacity coupling to the primary are provided. It is possible that changing the value of the antenna variable condenser would result in considerable improvement, with the converter connected to the "Long Ant." post. (This diagram appears on page 320 of the first volume of the Official Radio Service Manual.)

As shown on page 323 of the same manual, the "A. K. 60" used with the original converter model has a regular tapped-primary type of R.F. transformer.

(Readers might find it of interest to check the input and output circuits of the converter against the several means of connecting an adapter shown in the diagram of the Work-Rite [Walker] "Flexi-Unit" illustrated on page 203 of the October-November, 1930, issue of Short Wave Craft magazine.)

#### Antenna Design

(Q.) What are the correct length and height of an antenna for best short-wave operation? We are located about thirteen miles west of the down-town district of Chicago?

(A.) The correct design of the antenna for short-wave transmission or reception is determined by local conditions, as well as the wavelength, or wavelengths, at which the equipment is to operate, and the circuit design of the instruments.

#### Grid Leak Value

(Q.) Is the grid-leak value on short-waves the same as for broadcast waves?

(A.) Usually, higher for the short wavelengths; one or two megohms for 200 meters and up, and two to eight, below.



# CHAPTER X

## Automotive-Radio Data

### Installing Remote Controls

(Q.) Please describe in detail the manner in which auto-radio remote control units are mounted in the car and adjusted to the radio set.

(A.) As indicated in the illustration (reproduced on page 34, in Fig. 27A), there are 10 main parts to one of the best-known assemblies.

The parts referred to in the illustration bear the following classifications: (A), control head with control cable and electric cable attached; (B), two semi-circular clamps for securing the head to the steering post (one grounding set-screw in each); (C), four 8-32 x 1 1/4-ins. round-head screws (to attach clamp to control head); (D), four No. 8 internal tooth lock-washers (for clamp screws); (E), two leather spacers; (F), one brass hexagon cable-chuck (consisting of three parts); (G), one condenser pulley (with two set-screws in hub and cable clamping screw and washer); (H), one spiral spring; (I), one centering ring; (J), two keys for lock.

In mentioning the condenser pulley G, the centering ring encircles the condenser shaft with the lugs projecting through the condenser end plate. These holes should be 1/8-in. in diameter and 3/8-in. between centers. They are provided on some condensers, but will have to be drilled in some others. When the ring is in place, bend the lugs over on the inside of the plate.

The inside turn of the spiral spring is provided with an offset bend. This is locked in the slot in the centering ring and the loop on the outside turn is placed on one of the twelve projecting pins on the condenser pulley. The spring is then wound by turning the condenser pulley on the shaft. Usually about one turn provides sufficient tension.

The pulley set-screws are then tightened on the shaft, being careful that some clearance is allowed between the projecting pins and the condenser end plate to prevent binding. When the proper tension has been determined, it may be that the cable clamping screw on the pulley is not in the correct position for operation. The same tension can be maintained and the position of the clamping screw corrected by moving the loop on the outside turn of the spiral spring to a different pin on the pulley.

A minimum of 3/8-in. clear space and 9/16-in. condenser shaft extension is required at one end of the condenser for mounting the condenser pulley.

The cable chuck, which is in three

parts, can be mounted in the receiver housing or on a bracket secured to the condenser or chassis. It mounts in a 3/8-in. hole, the large jam nut fitting on the tapered end and the lock nut on the short end. This chuck may be located any distance from the condenser pulley but should be in line with the center of the groove in the pulley.

Now, turn the selector knob as far as it will go in a clockwise direction, to begin the procedure of mounting the control unit. This draws the cable into the tubular housing and protects it from injury at the free end. Keep it in this position during installation. The control head A is mounted on the steering post with the knobs projecting toward the right-hand side. The proper distance below the steering wheel can be determined by trial.

If the steering post is 1 1/2-ins. in diameter, use the leather spacers E. If 1 3/4-ins., split the spacers or wrap the post with about 1/16-in. of friction tape, under the brackets. If the post is 1 3/4-ins., spacers are not required. Use the lock washers D under the heads of the clamp screws C for securing the clamps B to the head.

Run the control cable in as straight a line as possible, avoiding any short bends.

The next step is to loosen the large jam nut on the cable chuck. Insert the free end of the cable and its tubular housing. The weatherproof braid at this end is removed to expose the metal spring; here the housing with the weatherproof covering will not enter the chuck. If it is necessary to insert the housing so that it extends farther through the chuck, remove the covering for that distance and tighten the jam nut. Be sure that the selector knob on the control head is still turned to the stop in the clockwise direction. Turn the condensers to the extreme position (against the returning action of the spring and toward

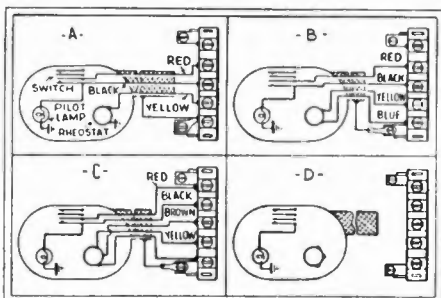

Fig. 27B

the free end of the control cable). Loosen the cable clamp-screw and insert the cable under the clamp washer, then tighten in place. Cut off any excess cable to prevent tangling with other parts of the receiver.

The standard cable has a length of 10 feet; a longer length may be required, up to 30 feet. This cable is to be cut off to suit the installation.

After the control head has been mounted and the control cable run to the set, mark the right length by cutting the weatherproof covering, being sure that enough cable is allowed, to avoid sharp bends, and in no case coil the excess into short loops.

In cutting off the outside housing it is necessary, again, to be sure that the selector knob is turned full clockwise.

With a sharp, three-cornered file, mark across one of the turns of the tubular housing until it is practically severed. Then bend it slightly, back and forth, until it breaks; do not bend sharply, as in so doing permanent injury to the inner element of the cable might result.

Mount the junction box attached to the free end of the electric cable, to the vertical dash or bulkhead, and then run the volume control and battery leads to the junction box, to wire in the electric cable.

The standard automobile cartridge-type fuse rated at 5 or 10 amperes may be used for replacing the fuse in the fuse block if one is provided on the control.

The dial light may be replaced by removing the selector knob and the two screws on the sides of the control housing. Use a standard 6- to 8-V. screw-base lamp which may be procured from the factory. As a temporary measure, a 6-V. pilot-light bulb may be procured from a radio supply house.

The several circuits in which the cable may be connected, depending upon the number of wires in the particular cable required, are shown at 27B: At A a 3-wire cable; B, 4-wire; C, 5-wire; and D, arrangement for special wiring.

**Reducing Interference**

(Q.) Can you suggest any way of reducing interference, in addition to the use of spark-plug circuit series resistors? The use of these does not entirely eliminate interference from the motor.

(A.) Apparently bypass condensers have not been applied to the several radiating circuits of the ignition wiring in the car.

Two bypass condensers, one on each terminal, at the ammeter may reduce certain forms of car interference. The receiver should not be located near the car's ignition coil, due to its strong field. Interchanging its primary connections may reduce interference. Whether the antenna lead-in shield should be grounded to reduce interference should be determined by test.

Illustrations and procedure in this and other phases of automotive radio operation will be found in the book "Automobile Radio and Servicing," by Louis Martin.

**Auto-Radio Laws**

(Q.) Is there any regulation that would prohibit my installing a radio receiver in my car?

(A.) There is no such regulation in the State of New York. However (as pointed out by Mr. Gernsback, writing in the May, 1930 issue of Radio-Craft) such regulations are in force in other states, notably Massachusetts and New Hampshire. We also note that, under the provisions of a new law in Michigan, a fine of \$1,000 or imprisonment for six months, or both, is the punishment for equipping, or using, an automobile with a short-wave receiving set unless the car is used or owned by a peace officer or unless a permit is granted by the police authorities. The law was enacted to prevent the receipt of broadcast warnings by those for whom the Police Department are instituting search. (The police cars of many municipalities are equipped with radio apparatus.) The constitutionality of these regulations is another question.

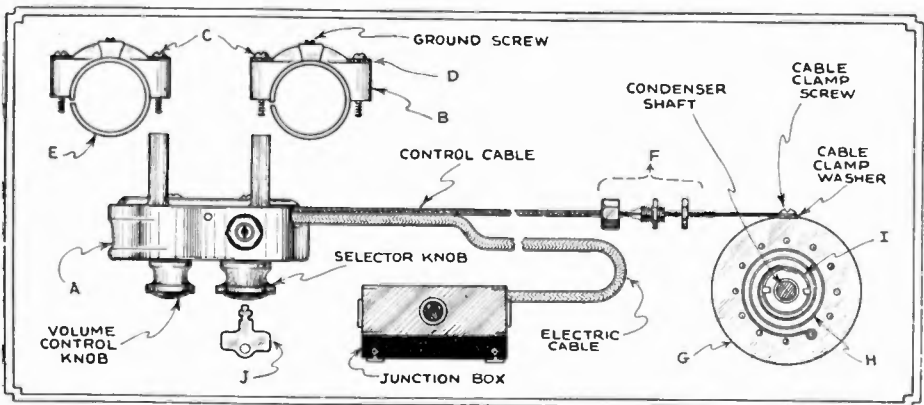

Fig. 27A

**Generator Polarity**

(Q.) In the article, "Simplified Radio Installation," in the June, 1930 issue of Radio-Craft, the author states: "If the 'A-' is grounded, the receiver is connected up as shown. If the 'A+' is grounded to the car frame, reverse the battery connections and make the car frame a negative ground, instead. This will change nothing except that it reverses the reading of the ammeter on the instrument board; accordingly, reverse the connections to the meter and everything will then be in proper shape." I beg to differ with him.

If he does not reverse the connections on the generator he will have the finest case of run-down auto battery he ever heard tell of. You see, when the positive terminal of the battery is connected to the frame, the positive side of the generator is also grounded; so that when the battery terminals are reversed those on the generator should also be reversed. I may also say that those on the generator are inside the generator case and, in most cases, the generator will have to be removed in order to make the change of connections. This pointer may save some Service Man needless work checking through a circuit that is apparently O. K.

(A.) The solution of this problem lies in the fact that the polarity of the output of the generator is dependent upon the polarity of the exciter current through the field coils of the generator of practically every car on the market (as we are advised by the manufacturer's Chief Engineer); and this polarity, in turn, is

dependent upon the polarity of the battery to which it is connected.

Installation procedure would be as follows: If the car battery has "A+" grounded to the frame of the car, the next step is to lift the battery out of the battery box and turn it half-way around (if, as may be found in a few instances, the leads are "polarized," it will be necessary to resolder the lead-ends accordingly), and then reverse the connections to the ammeter. If the meter now reads "discharge" with only the car lights turned on, all is well; if it doesn't leave the zero mark, "flash" the field coils for a couple of seconds, to kill the residual magnetism, by pressing down the cutout relay arm. The connections to a standard generator are indicated in Fig. 28. To overcome the residual magnetism of the core, the battery must, of course, be well charged; and all the connections must be tight.

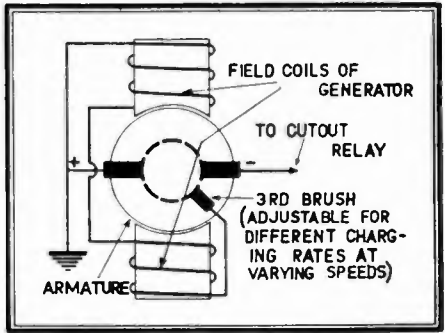

Fig. 28



# CHAPTER XI

## Sound Equipment

### Complete Tone Control

(Q.) What is the difference between a type SAF Fader and SAF-3 Mixer; both units being part of a sound movie installation? How are these to be wired into a sound system?

(A.) The SAF Fader is a distortionless attenuator to be interposed between the head amplifier disc pickup and the main amplifier, and serves to control volume in a "straight line" manner. Change-over to either disc or head amplifier is the duty of a two-way switch. Vitreous resistors are used, having the total value shown in the illustration of these units, Fig. 29.

The SAF-3 Mixer is a tone-control device which is to be connected between the sound pickup device and the main amplifier.

The following detailed data is furnished by the manufacturer, and indicates that the mixer has application also in radio receiver circuits:

"As there are always two projectors in a theatre installation, the disc equipment includes two phonograph pickups. The sound-on-film equipment is generally made up of two photoelectric cells and two head amplifiers or preamplifiers;

these are 2-stage units using a combination of resistance and transformer coupling.

"The selection or rejection of frequencies is obtained in the SAF-3 Mixer by control of inductance and impedance values, as shown in Fig. 29.

"The 'equalizer' portion of the instrument is for the purpose of adjusting the impedance match of the input and output circuits. With the equalizer set at zero, no frequency correction takes place, no matter what the setting of the 'compensator,' as the impedance of the amplifier input is lower than the impedance of the pad.

"The 'compensator' controls the amount of low, medium, or high frequency cut-off.

"With the equalizer set at half-way or 5,000 ohms, any amount of the high, medium, or low frequencies can be cut out by adjusting the compensator. When the compensator is set at zero, maximum correction occurs; however, if it is necessary to secure more correction, the resistance in the equalizer circuit can be increased. For instance, with R1 set at 10,000 ohms, and R2 at zero, the frequency band passed by the impedance-capacity combination will be greatly broadened. Now, by moving the 3-way selector switch to 'low,' 'medium,' or 'high,' only the low, medium, or high notes, respectively, will be bypassed through the impedance-capacity combination, resulting in only high frequencies being passed from input to output at the 'low' setting of the switch; low frequency selection at the 'high' setting; and in 'medium,' only the extremely low and extremely high notes will be bypassed."

This method of tone control is more convenient than the system described in "An Ideal Sound System for High Power," in the August, 1931 issue of Radio-Craft; although the tone correction has substantially the same graph as shown in Fig. 2 of the article. It is very convenient to apply to phonograph pickups and radio receiver output circuits, in addition to its use primarily in sound movie installations.

### Applications

(Q.) Are there very many applications of the modern "public-address" type of audio amplifier, aside from the generally known ones: (a) at parks; (b) at political gatherings; (c) in theatres; (d) in dance halls?

(A.) By checking over sales records, Samson Electric Company has been able

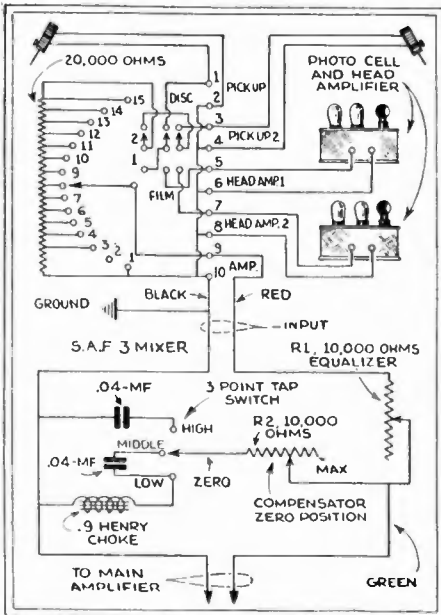

Fig. 29

to compile a representative list of applications of their own product, the "PAM" public-address unit, and we present these and additional uses:

"Airplanes, amusement parks, apartment houses, auditoriums, athletic fields, bathing beaches, banquet halls, baseball parks, brokerage offices, cabarets, charitable institutions, churches, clubs, conventions, dancing schools, encampments, factories, fairs, filling stations, flying fields, football games, hockey matches, home entertainments, hospitals, hotels, ice skating rinks, merry-go-rounds, motor cars, open-air assemblies, orphan asylums, paging systems, polo games, railroad depots, race tracks, regattas, receptions, restaurants, roller skating rinks, sanitariums, schools, stores, summer resorts, swimming pools, veterans' homes and carnivals."

The sound requirements of these various demands vary within wide limits, from one reproducer or pair of headphones to forty or fifty reproducers and perhaps fifteen hundred or two thousand pairs of headphones.

From a study of these figures it becomes evident that the chances for placing a public-address system are very numerous, for the capable technician with a little sales ability.

**Scratch Filters**

(Q.) Please furnish construction data for a "scratch" filter to be used in conjunction with a phonograph pickup.

(A.) For all practical purposes, it is only necessary to shunt the pickup leads with a fixed condenser of suitable capacity to be determined by test; choke coils are quite unnecessary.

It is recommended, however, that the Service Man double this value and connect in series with the condenser a variable resistor of 25,000 ohms. This will result more nearly in a "tone" control; at the same time, "scratch" of any type may be suitably controlled, or eliminated (as found desirable), no matter whether it is due to the use of a needle of incorrect shape, worn records, poor recording, poor matching between the pickup and the amplifier, or to peaks in the amplifier, the reproducer, or the pickup.

The required value of condenser capacity cannot be given as it will depend upon the above conditions; also, whether the pickup is of low- or high-impedance type.

**Baffle Sizes**

(Q.) Is there available any ready reference, which will indicate the size of

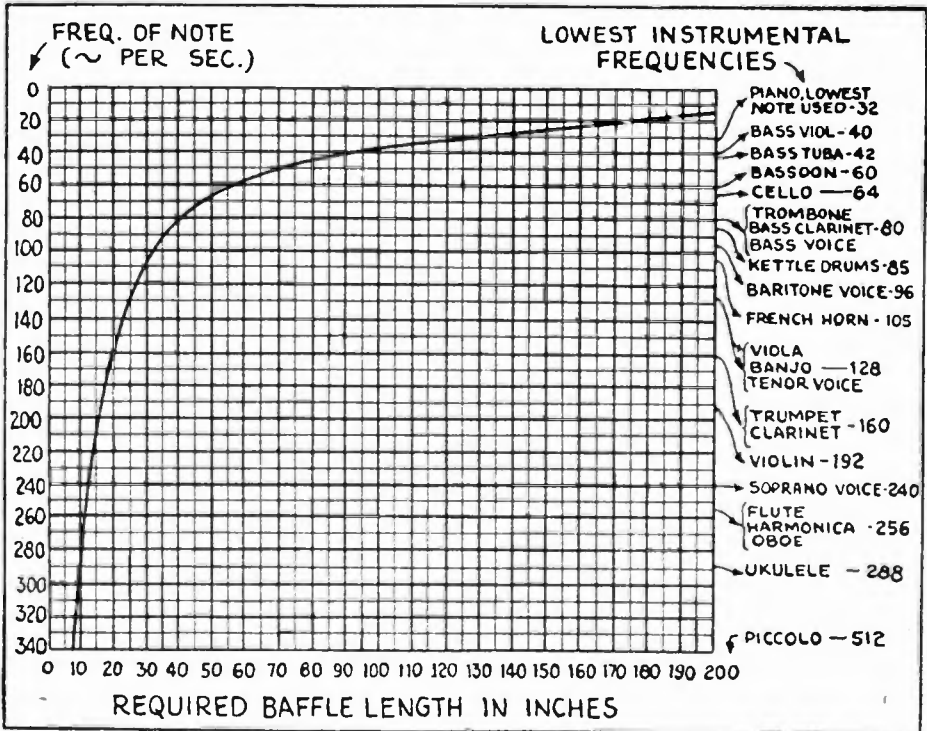

Fig. 30

baffle recommended for various cut-off frequencies?

(A.) This information appeared recently in the form of a graph which is reproduced in these columns (Fig. 30). It was developed by Mr. A. A. Ghirardi of the Pilot Radio and Tube Company; and appeared in the Spring, 1931 issue of Radio Design.

### Faders

(Q.) I have a "Super-Tonatrol," type 7. Please show this unit connected as a "fader" for swinging from one pickup or microphone to another.

(A.) The circuit for this and similar units is shown in Fig. 31. The pickups are numbered 1 and 2. This fader controls volume on only one pickup at a time.

In order to maintain a fixed volume limit, a separate control, in shunt with the output of the pickups, is recom-

mended. This is preferably a 100,000-ohm unit, indicated as R3. It may be adjustable in small steps, or continuously variable.

Each half of the fader is numbered, R1 and R2, and each has a resistance of 25,000 ohms.

For simplicity, there has been no attempt to show controls having "constant impedance" design.

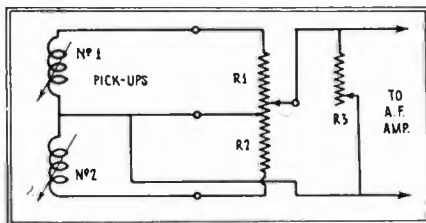

Fig. 31





# CHAPTER XII

## Home Recording

### Copying Recordings

(Q.) In commercial recording, the wax "master" is electro-plated. Test records are stamped from this; then a metal "mother" is made from this original negative (by electroplating once again); and from the metal mother is made the production negative "stamper" (or stampers) from which the composition records for commercial use are finally made. Inasmuch as, in instantaneous recording with aluminum discs, we have the equivalent of the metal mother (the first step, or the original, and the first negative from this, being eliminated) cannot a metal negative be obtained from this by electroplating; whereby the home recordist might have records stamped on regular record composition or celluloid and thus be able to obtain additional records from the original which, duplicated, might be played in the ordinary way on the regular phonograph using the regulation steel needles?

(A.) You are right in assuming that the aluminum disc is the equivalent of the metal mother. Stampers have been made from these aluminum discs by the plating process, and the results have been fairly good. The only objection is that the groove in the stamped record is as shallow as the aluminum record; and that is not as deep as the groove on the commercial record.

A better method of making copies of the original would be to "dub" (re-record) the original on a wax disc, and then obtain the stampers in the conventional manner.

Re-recording an aluminum record results in an efficiency loss of about 10%. In order to make several inexpensive copies of the original, the latter is placed on a turntable provided with an electric pickup, the output of which is connected

to the input of the usual audio amplifier; the procedure from then on is the same as in making the original.

### Amplifier Design

(Q.) Can you give me any information as to what type of amplifier to use?

(A.) Any good three-stage transformer-coupled amplifier will be satisfactory for recording; the diagram of such an amplifier is shown in Fig. 32.

The parts illustrated have the following characteristics; potentiometer R9,  $\frac{1}{4}$ -meg.; R1, R4, 50,000 ohms; R2, R5, R8, 1,000 ohms; R3, 30,000 ohms; R6, 20,000 ohms; R7, 20 ohms, center-tapped. Condensers C1, C3, C4, C6, 1.0 mf.; C2, C5, 0.5-mf. Unit T1 is a microphone transformer; and is indicated with a two-winding primary, for matching a double-button microphone into a type '27 tube. Unit T2 is a standard '27-to-'27 transformer. Components T3 and T4 are the usual input and output transformers, respectively; the latter being provided with a secondary S which exactly matches the impedance of the particular recording head which is being used.

Care must be taken to isolate this amplifier unit from the power unit, to prevent induction hum. The use of high-grade transformers will be repaid in recordings of high quality. Remember that the use of any unit of inferior quality is reflected immediately in the quality of the recordings; ordinarily by lack of extreme bass or treble notes. Test all resistors and condensers for rated values; make certain also that the units will operate under the rated loads. Use only tested tubes.

Design data and other information on this absorbing subject appear in the book, "Home-Recording and All About It," by George J. Saliba.

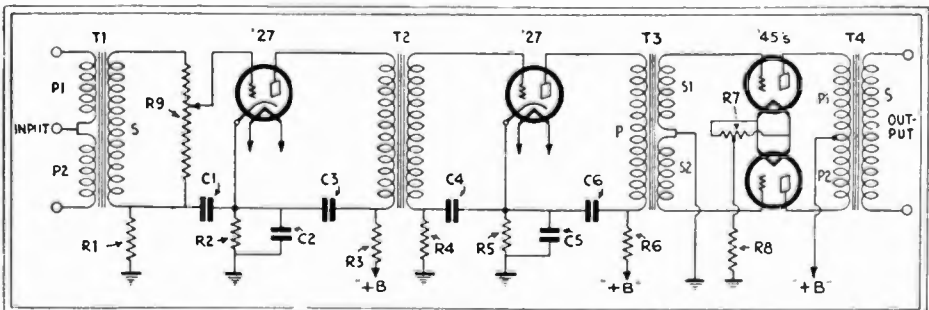

Fig. 32

### Stroboscope

(Q.) In the article, "Home Recording of Radio Programs and Speech," in the December, 1930 issue of Radio-Craft, the statement is made (page 341), that the "stroboscope" makes possible a satisfactory solution of the problem of maintaining the correct speed of disc rotation for recording and reproduction. How does such a device work; and how can it be made?

(A.) The stroboscope is a mechanical device which depends for its effectiveness upon the "inertia" of the optic nerve, or, more familiarly, the "persistence of vision." By courtesy of the Marconi Radio Co. of Canada, we are able to reproduce in Fig. 33, a stroboscope designed for 60 cycles per second.

When a disc of this type is rotated at the correct speed by a phonograph turntable, the lines appear to stand still when the disc is illuminated by an electric bulb which is lighted by an A.C. supply of the stated frequency.

### Lack of Volume

(Q.) We are using a special celluloid for recording and find it difficult to get the grooves deep enough to give us sufficient volume. We have seen "electrical transcription" records, from some California recording studios, that seem to be made on this same material; and we wonder how it is possible to overcome this lack of volume.

(A.) Your lack of volume is not due to the shallow groove. A shallow groove might make it difficult for the reproducing needle to track, but the lack of volume is due to the modulations being too small. This can be caused by several things: either the amplifier's gain is not high enough; there is incorrect impedance matching between cutting head and amplifier; or the material might be too resistant for good recording. The transcription records are "processed"—that is, a metal stamper is used to impress the sound track. In that case the hardness of the material is reduced considerably,

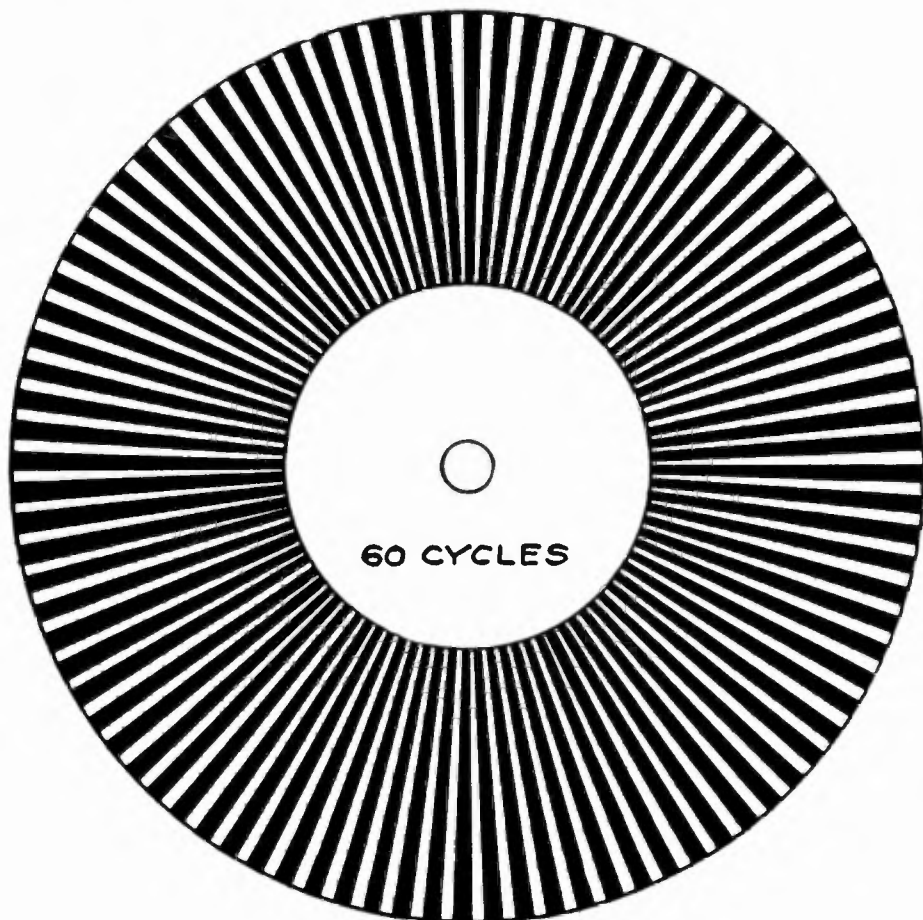

Fig. 33

by heating, so that it will take an impression. Try using celluloid that contains no pigment (coloring).

**Frequency Range**

(Q.) Will you tell me if a frequency range of 35 to 6000 cycles will record the highest and lowest frequencies?

(A.) A frequency range of 35-6000 cycles is very suitable for good recording. As a matter of fact, the maximum reproduced frequency in talking pictures is never more than 6000 cycles; while broadcasters limit themselves to about 5000 cycles.

**Matching-Transformers**

(Q.) What are the average impedance values, of the primary and secondary windings of transformers designed to match a carbon-button microphone to a vacuum-tube grid circuit?

(A.) The average values are: Primary, 200 ohms; secondary, 400,000 ohms. These values are for the usual 1,000-cycle standard.

**Tone Quality**

(Q.) I am using my radio receiver for recording, and the results are poor. When I reproduce commercial records, the volume is good; but with home-made records the volume is very low. My pickup (when recording) is connected to the plates of the output tubes. Can you tell where my trouble may be?

(A.) Evidently your trouble lies in a poor impedance match between the cutter and the amplifier output. Check your pickup to see if it is of high-impedance; the value should be around 4000 ohms.

**Recording-Power Figures**

(Q.) We would like to know how much gain it takes to make a good recording, and we would also like to know the impedance of pickups suitable for recordings.

(A.) For recording on aluminum, the level at the cutting head should be about

+20 decibels. If a carbon microphone is used, the pickup volume level is down about -36 db. It is obvious, therefore, that an amplifier having a gain of at least 56 db. is necessary.

If celluloid is to be used, the required recording level is near +36 db. and, consequently, an amplifier having a gain of at least 72 db. is necessary. A good three-stage transformer-coupled job will serve the purpose very nicely.

The impedance of the cutting head does not make any difference, so long as it is properly matched to the output of the amplifier. The use of a high-impedance cutter of the order of 4000 ohms is common practice.

**Microphones**

(Q.) Are there any convenient corrective measures that may be applied to packed carbon-button microphones? The one in question is noisy and, though sensitive, it is difficult to keep at the best operating point.

(A.) If buttons become packed because of moisture, or long standing in one position, it will often be possible to loosen the carbon granules by holding the "mike" with the diaphragm in a horizontal position, in one hand, and striking it gently against the other hand. Also, try gently striking the edge of the microphone against one hand. Note that damage may result if this procedure is followed with the current on; make certain that the microphone is disconnected from the battery circuit while undergoing this manipulation. Do not strike the diaphragm.

If the "mike" is located in an excessively moist place it may be advisable to place the unit under an electric light bulb, in front of an electric heater (at some distance), or in the rays of strong sunlight, to drive out the moisture that has caused the packing of the carbon. Most microphones are, after assembly, tested and balanced with meters; and they should not be opened or tampered with.



# CHAPTER XIII

## Test Apparatus

### Service Oscillator

(Q.) Are there any data available on the circuit details and use of an A.F. modulated R.F. and I.F. service oscillator?

(A.) The Dayrad "Type 180" portable test oscillator circuit is shown in Fig. 34. A type '30 tube is used as the oscillator. The design of this good, totally-shielded service instrument is representative of similar types of oscillators.

The procedure to be followed in using this modern service oscillator may be of interest:

First, the black lead of the shielded dummy antenna is connected to the sliding rod just below the unit marked "output control"; the red wire being connected to "ground." (The jack switch marked "550-1,500 kc." and "175-180 kc." should be turned till its pointer is in the former position.) The other end of the dummy antenna is to be connected to the set; the black wire attaches to the antenna post and the red wire to the ground. Turning the line switch on now will put the oscillator in operation.

The output meter (Weston "Model 30," type 653) is removable for observation in the most convenient position. The "output meter connector," with its adapter, serves as the connection between

the set and the meter. The latter is connected to the receiver by removing the output tube and placing this in the adapter's tube socket; the plug of the adapter is then inserted into the power-tube socket of the set. The two leads from the adapter are connected to posts C and 3 on the output meter; posts 1 and 2 are used if connection is made, where necessary, directly to the voice coil of a dynamic reproducer or a magnetic, respectively.

The intermediate frequencies calibrated on the oscillator are 170, 172.5, 177.5 and 180 kilocycles. The I.F. output of the oscillator may be smoothly varied; the vernier must be set at 50 to obtain the exact fundamental frequencies. This variation feature permits "flat-topping" tunable I.F. transformers.

Various other oscillator circuits are illustrated and described in the book, "Radio Kinks and Wrinkles; for Service Men and Experimenters," by C. W. Palmer.

### Meter Internal Resistance

(Q.) What is, approximately, the internal resistance of a 0 to 1-ma. meter?

(A.) The internal resistance of the average milliammeter of this rating, in one make, is 28 ohms. However, this value

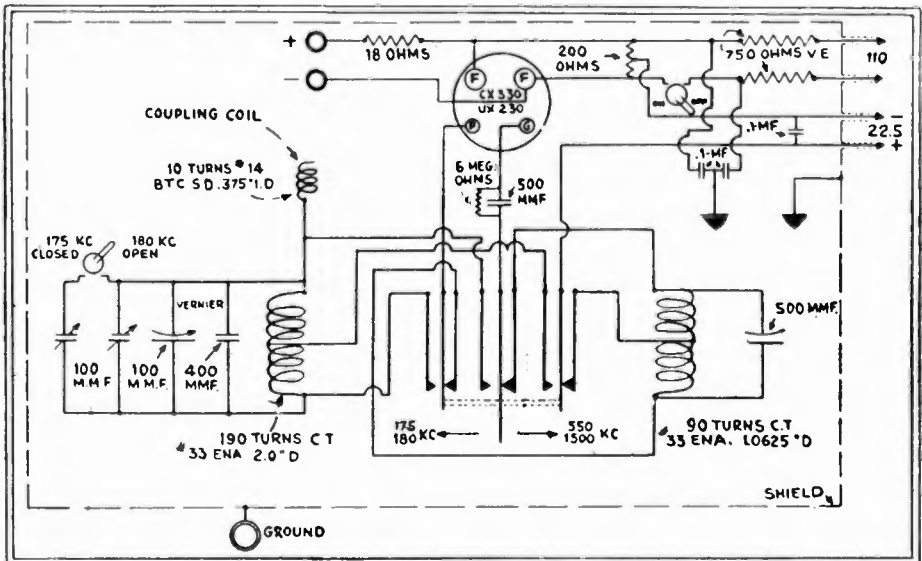

Fig. 34

may vary five percent, plus or minus. Each instrument is a hand-made unit and this causes slight variations which do not noticeably effect the scale readings. The exact constants of all meters are individually recorded and may be obtained by writing to the makers, if special laboratory work should necessitate the data.

### Aligning Cage

(Q.) What is meant by the term "aligning cage," and how is the device made?

(A.) An aligning cage is used by some radio manufacturers, to prevent the disturbing effect of radiations from powerful local stations, and the static radiations of electric machinery, from affecting the tests and adjustments which are made upon receivers in the final stages of production.

Through the courtesy of the RCA Victor Co. we show, in Fig. 35, the arrangement of an aligning cage, recommended by them. Though a powerful station broadcasting on, for instance, 1,260 kc. might cause enough interference to prevent correct alignment of the set at the 1,264-kc. point, an aligning cage can be used effectively in a service shop, as at the factory, to reduce this interference, and it will permit accurate alignment of the instrument in the shortest possible time.

The cage illustrated is built of light material, such as would be used for screen-door construction. The entire set of equipment includes amplifier, speaker

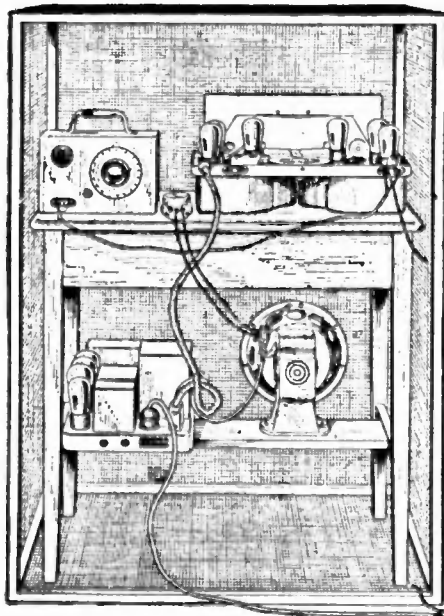

Fig. 35

and suitable plug connections, oscillator and necessary meters. If it is undesirable to use a separate amplifier and speaker, the cage can be constructed large enough to accommodate the entire cabinet.

Although the cage must be built to fit the available space, it should be large enough to permit swinging the chassis, to couple it to the oscillator. The screening should preferably be of copper, 12 meshes to the inch. The sides are carefully bonded together to give maximum screening effect, and the entire screen is grounded. In all cases the open side of the cage should be placed away from the interfering station.

### 4-Meter Set Analyzer

(Q.) Please show the circuit arrangement of a portable test set in which meters may be plugged into sockets, to give instantaneous reading in different parts of a tube circuit; with an extra receptacle, connected to test prods or probes, for making external tests.

(A.) The circuit of this tester appears in Fig. 36. This is available in commercial form as the Readrite "Model 9" Test Kit; hence the data concerning this instrument are given here. Four out of the nine meters are plugged into respective sockets. For reference, the ranges of the nine meters are given in the table in the upper left corner of the illustration; the meter receptacles are shown in dotted outlines.

The two sockets (in solid outline) are for the various 4- and 5-prong tubes which may come under suspicion; their elements are connected into the receiver circuit by means of a 5-wire cable having a 5-prong plug and a 4-prong adapter. Another adapter is required for 6-prong tubes.

A screen-grid tube under test must have its cap connected to something, of course; and the "something," when using the "Model 9" tester is the cap connection in the radio receiver. A long lead

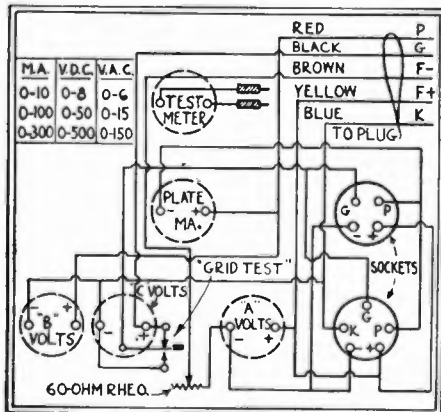

Fig. 36

for this purpose is provided. One end of it has a cap which fits the control-grid connection on the top of the screen-grid tube, and the other end has a plug over which fits the control-grid cap in the radio set.

Numerous circuits of set analyzers appear in the book, "Radio Set Analyzers and How To Use Them," by L. Van der Mel.

**Capacity Meter**

(Q.) Please show the circuit arrangement of a simple capacity bridge to use headphones and measure capacities less than one microfarad.

(A.) The circuit arrangement of an excellent bridge of this type, developed by Mr. Beverly Dudley and described in

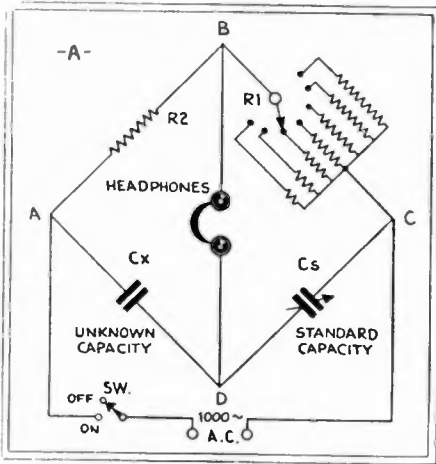

Fig. 37A

QST, is shown in its elementary form at A in Fig. 37; and in detail, in Fig. B. Its capacity range as shown is approximately 10 mmf. to 0.05-mf. Its operating graph in position 1 of the selector switch is shown in C of the same figure. However, this is only approximate, and the completed test instrument must be sent to a laboratory for calibration. (See also "Measuring Inductance and Capacity" in the June, 1931 issue of Radio-Craft.)

A device of this nature is almost indispensable to the radio Service Man. A test unit of this type eliminates guesswork as to whether condensers of 10 mmf. to 0.05-mf. are open—or have their rated capacity.

**Meter Accuracy**

(Q.) Using a 0 to 1.-ma. milliammeter with resistors of the correct value in series for operation as a voltmeter, will the accuracy of the meter be as good or better than one of the high-grade standard voltmeters?

(A.) A voltmeter can be no better than its different parts and, if any part of the assembly, exclusive of the resistor, is of inferior design, the resulting instrument will be inferior to just that extent. The usual good voltmeter, shorn of its series resistor, is simply a milliammeter with a range of 0-10-ma.; precise voltmeters, designed to read voltages in high-resistance circuits, and known as "high-resistance voltmeters," usually consume only about 1 milliamp.

**1-Meter Tube Checker**

(Q.) What are the connections within a "self-biasing" tube checker?

(A.) Figure 38 shows the schematic circuit of the commercial Dayrad "Type L" Self-Biasing Tube Checker.

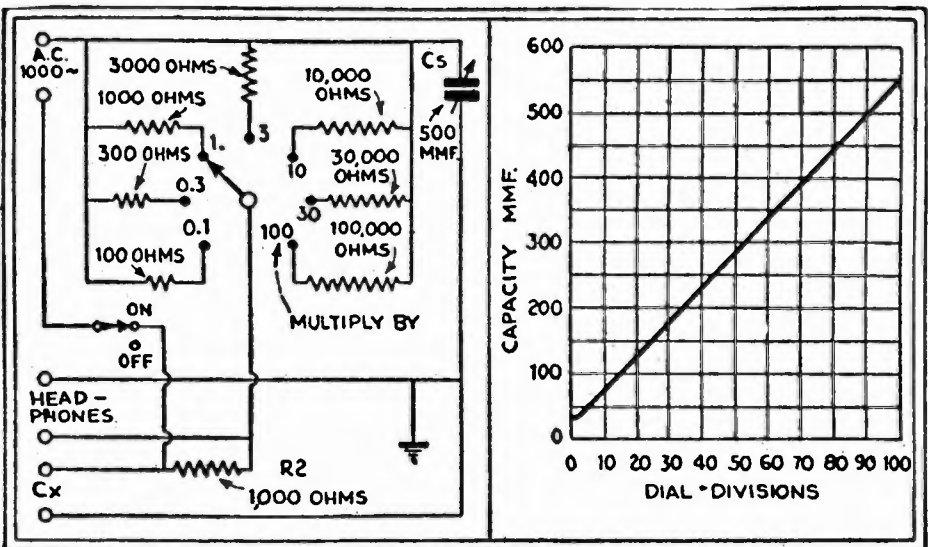

Fig. 37B

Fig. 37C

The sockets take tubes as follows: V1, '24, '27; V2, '26, '30, '31, '32; V3, X12, '36, '37, '38; V4, '45, '20, '99, '22; V5, '01A, '12A, '71A, '80; V6, '10, '50, '81. Output terminals give 3 and 15 volts.

Only the following readings are furnished. To test other types, it is only necessary to make a checkup test of three or four of these tubes to determine average readings; and include these figures in the following list. "Min." indicates the minimum difference reading, which marks the "End of Life." The tube should exceed this figure in proportion to its expectancy of service.

Type	Min.	Type	Min.	Type	Min.
'24	9	'20	2	'50	20
'27	13	'30	1	'01A	3
'45	18	'31	3½	K-12	3
'71A	18	'32	1	'26	5½
'12A	8	'22	4	'80	*34
'99	½	'10	10	'81	34

\*Each plate.

A.C. vs. D.C. Meters

(Q.) How does an A.C. meter work? Why does it indicate, steadily, on A.C.; when the needle of an ordinary D.C. meter on this supply will flutter?

(A.) The D.C. meter when measuring D.C. may be represented as shown at the right in Fig. 39 where a moving coil, indicated by the arrow and carrying the current to be measured, produces a field which reacts against the stationary field of the permanent magnet. This reaction is physical and the coil, being freely suspended, moves in proportion to the amount of current through it. However, alternating current, flowing through this winding, at the rate of, say, 60 cycles, changes polarity so rapidly and is attracted and repelled so fast, that the coil cannot follow it. If there were some means of changing the field of the permanent magnet, at the same rate as the change in the moving coil, there would be continuous repulsion; and the needle would indicate truly.

This action may be obtained by discarding the permanent magnet and substituting two coils (N, S, shown at the left). These are connected in series with the moving coil, so that alternating current through these coils changes polarity at the same rate as the current through the single moving coil. This produces continuous repulsion, and indication on the A.C. meter scale.

Characteristic Graphs

(Q.) Please show a schematic circuit for taking the "characteristic curve" of an A.F. transformer, or for determining its comparative value.

(A.) The circuit requested is Fig. 40. As shown, it is of value only for obtaining an approximation of the "gain" or voltage stepup of a particular transformer, at 1000 cycles (1 kc.), as compared to another transformer used as a standard. However, the gain of a complete stage, including such a transformer, at other frequencies may not be in proportion to this volume.

To obtain a true picture, it is necessary to make a graph of the values obtained at other frequencies; this is possible by using an oscillator adjustable to these frequencies.

The constants of T3 will be determined by the design of the oscillator and the characteristics of the tube selected as V1 (the voltages indicated are for an '01A). The milliammeter should read nearly zero, until the oscillator is started.

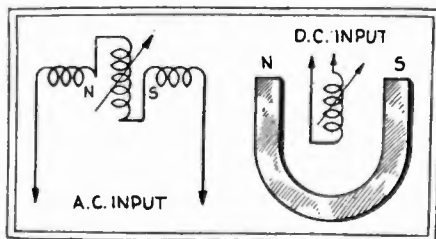

Fig. 39

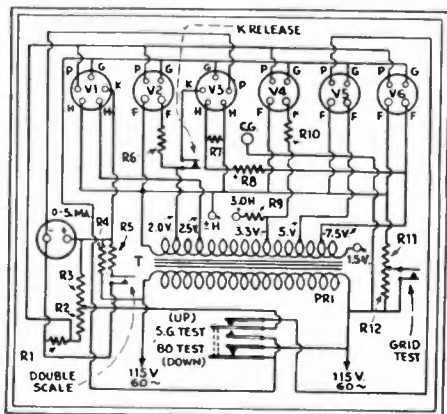

Fig. 38

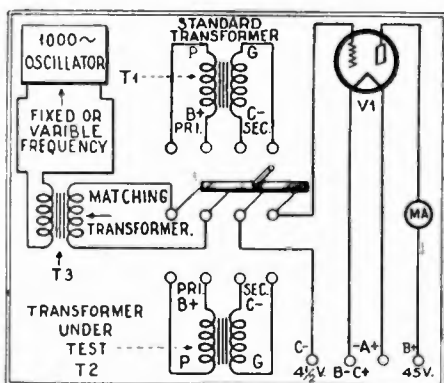

Fig. 40

# CHAPTER XIV

## General Inquiries

### Statistics

(Q.) How many radio sets are there in the United States? In New York City?

(A.) Late U. S. census figures indicate that there are approximately 14 million radio sets in operation in the United States; and that nearly one-half the population of the country, or 50 million people, can be classed as "listening public."

The figures which concern a large city are of particular interest. New York City, for instance, boasts that of its 1.7 million families, approximately 1 million are radio set owners; 70% of these sets are electrically operated. Incidentally, of the 3.1 million families in New York State, 1.8 million have radio sets. It is interesting to note that city and state figures closely agree as to the proportion of "listening public," with city interest in radio taking a bit the edge over that of the ruralites.

It is estimated that in New York, Pennsylvania and Illinois are to be found one-fourth of all the radio sets in the country; and more than one-third of the listening public.

### Tri-Color Television

(Q.) In the latter part of 1928 I read about a scheme for transmitting instantaneous pictures in colors. Red, blue and green were used, but I do not recall the details. Can you tell me in a general way the method used by the inventor, Mr. Baird?

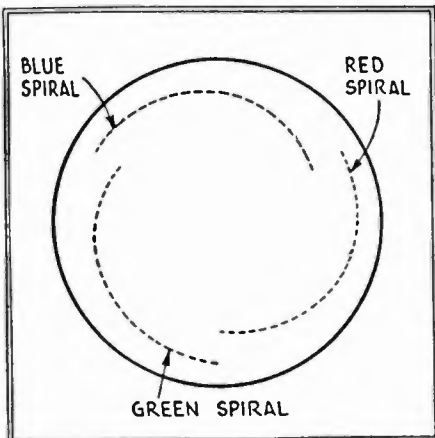

Fig. 41

(A.) Figure 41 depicts a Baird method of color television.

By having three scanning spirals instead of one, it was found possible to assign a particular color pickup and reproduction to each one and present a very creditable example of television in colors—the eventual arrangement we may expect.

The solution to the problem of obtaining three primary or primary-secondary colors was to use two separate lamps. One, the usual pink or red neon; the other, a special mercury vapor, helium vapor lamp. The latter radiations could be readily filtered into blue and green.

### Set Modernizing

(Q.) What is the usual procedure in modernizing radio receivers?

(A.) The changes necessary to modernize any given receiver depend upon the characteristics of the individual set. In general, it may be stated that the wiring and components are changed to permit operation with the latest tubes; this usually necessitates redesign of the power pack. In some cases the R.F. coils are replaced; a more modern volume control usually becomes necessary; a tone control usually improves the audio quality. Single-dial tuning may replace multi-dial operation; a power detection circuit improves the tone quality, as does the use of a pentode or other high-power output tube. Perhaps the major alteration is the use of A.C. tubes in place of battery-operated types.

Most of these changes are described in complete detail in the "Radio Service Treatise"; copies of which are available gratis by addressing an inquiry to the publishers of this book. See also the publication, "Bringing Electric Sets Up-to-Date," by Clifford E. Denton.

### Harmonic Production

(Q.) I have a coil of 85 turns of No. 26 C.S.C. wire, which is tapped at the 40th turn. I use this in an A.C. oscillator, for balancing purposes, in a unit which covers the broadcast band from 550 to 1500 kc. I now find I am able to use this contraption on the 20-, 40-, and 80-meter amateur bands without the change of coils; thus giving me a range from at least 17300 kc. (W2XK), 17.34 meters, to 560 kc. (WIBO), 535.4 meters.

Would you kindly explain this phenomenon; and could its calibration be relied upon if such is obtained?

(A.) Our inquirer has discovered the phenomenon of harmonic frequency pro-



duction, so often discussed in Radio-Craft. The statement may be recalled that, in an oscillatory circuit including an ordinary vacuum tube, there is produced not only the fundamental frequency of that circuit (due to the values of its inductance and capacity—see Table I, page 55, July 1931 issue), but also numerous other frequencies which are multiples of the fundamental. These "harmonic" frequencies are rated in their numerical sequence; the first multiple being the "second harmonic" or double the fundamental frequency; the second multiple is the third harmonic, or three times the fundamental; and so on.

We fear our correspondent did not read this July 1931 Radio-Craft; therein, on page 10, is described an "All-Wave Oscillator for Modern Servicing" which commercializes the phenomenon of harmonic-frequency production.

The practicability of calibration, obviously, is evident at least, for the 200- to 1500-kc. band specified. Further, this method is used in amateur radio transmitting work to accurately calibrate short-wave wavemeters; the signals of crystal-controlled stations are used for the fundamental; to which may be tuned (by zero-beat) a vacuum-tube oscillator, whose harmonics may be logged on graph paper for further reference.

Constancy and accuracy of calibration are largely a matter of obtaining constant current supply and uniform tube characteristics. In general, quite close work may be done.

### Battery Carbons

(Q.) I would like to use an ordinary battery carbon as a resistance. What is the average value of one which is six inches long?

(A.) About 55 ohms. It varies about five ohms each way.

### Electrolytic Condensers

(Q.) What are the dimensions of the coiled sheets of metal foil used in the 8-mf. Mershon electrolytic condenser and the 2000-mf. Elkon dry "A" condenser shown as Figs. C1 and B, respectively, in the September, 1930, issue of Radio-Craft, on page 148?

(A.) The coiled strip used in the former measures 2 in. by 36 in.; two strips are required in the latter, each one measuring 5 in. by 72 in.

### "Newton's Disc"

(Q.) I am conducting some experiments in television and would like to duplicate the physics experiment known as "Newton's Disc." By mounting on a rotatable shaft and twirling the card, all the colors of the rainbow painted on it merge into almost a clean white. Can you assist me?

(A.) A sketch of the card to which you refer is Fig. 42. We suggest you use the following water colors or oils to get approximately the right effect, which may be close enough for your work.

For red, use vermilion with a little permanent violet; orange, orange cadmium; yellow, chrome yellow; green, blue-green viridian plus a small amount of cobalt blue; blue, prussian blue and cerulean blue; violet, permanent violet and a little blue; indigo, permanent indigo. Due to optic nerve fatigue the colors will, when rotated, resolve into the sensation of white.

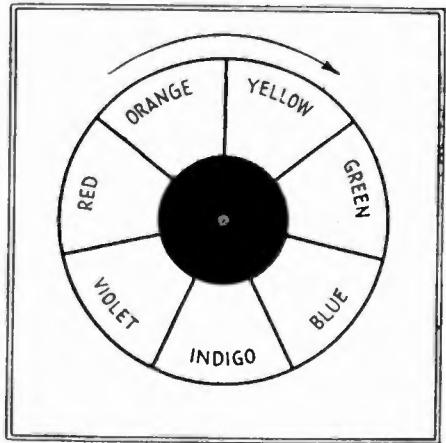

Fig. 42



# CHAPTER XV

## Experimental Circuits

### Reflex Set

(Q.) Some time ago the Carborundum Company published a reflex circuit wherein a single tube amplified both radio and audio frequencies, with detection accomplished through the use of a Carborundum crystal detector. The writer built a set according to the plans and has received the programs of WPG, WBAP, KTHS, KWKH, WGY and CFCA, among the distant listings, and about twenty-five more local ones. However, increased volume is sometimes desirable and the question is, "How can the audio output of this reflex set be increased?" The theory of reflex operation is not clear to me.

The constants of the circuit are as follows: L1 and L2 are wound on a three-inch bakelite tube to a total length of 3½-in. Coil L1 consists of 32 turns of No. 24 D.C.C. wire tapped at every eight turns, and spaced ½-in. from L2 which consists of 45 turns of the same size wire. Coils L3 and L4 are wound on a form of the same size as L1 and L2; but L3 consists of 48 turns of No. 30 D. C.C. wire, tapped at every twelve turns, while L4 has 45 turns, center-tapped. Units C1 and C2 are .0005-mf. variable condensers, preferably with grounded rotors; C3 is .0001-mf.; C4, .0005-mf.; R1, a suitable filament ballast for the particular tube used as V1; R3 (required only if uncontrollable A.F. oscillation occurs), has 50,000 ohms resistance mini-

um, and 500,000 ohms maximum (it is variable within these limits); Detector, is a Carborundum crystal.

(A.) A schematic circuit of the desired arrangement (Fig. 43) is shown in these columns. Tube V2 is the added one, arranged as a second stage of A.F. amplification; the "B" and "C" potentials shown are the correct values for a 71A tube; although any other power tube may be used if the current supply is adjusted accordingly.

For convenience, the idea of the filament-control jack has been retained; but the old jack is now shown as J2 and a new one, J1, replaces it in the former position.

If the A.F. transformer T1 has a ratio of about 4 to 1, T2 may have a ratio of 2 to 1, if of good design; otherwise, the volume may not be as great as desired. It is suggested that C5 placed as shown, with a capacity about .00015-mf., might improve the operation of the circuit. Resistor R2 is the filament ballast required for the particular power tube selected. The old circuit is shown at left of dotted line, and the added A.F. amplifier at right; this unit may be constructed in any convenient manner.

(A study of the action of a reflex circuit appears in the December, 1929, issue of Radio-Craft Magazine, in Radio Service Data Sheet No. 7.)

Other considerations are covered in the writer's book, "Modern Radio Hookups."

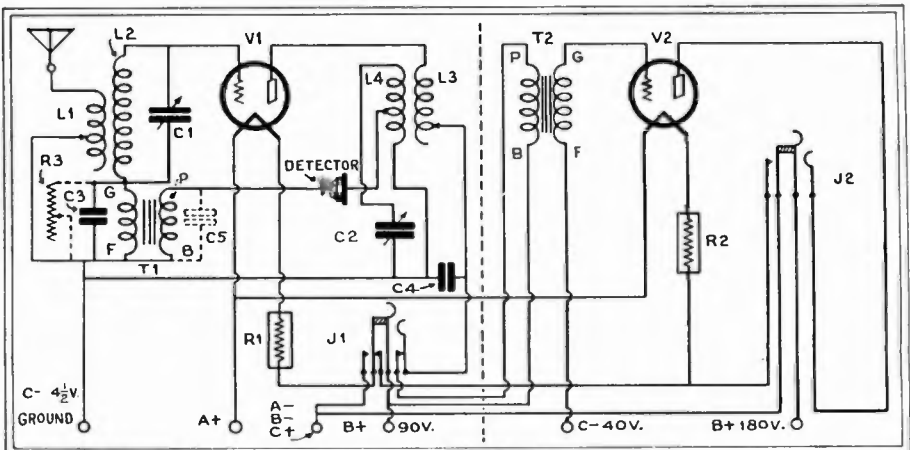

Fig. 43

**Long-Wave Receiver**

(Q.) As I would like to make up an experimental circuit to receive long-wave stations for code practice, please print details of this arrangement.

(A.) The schematic circuit of an easily-built set, a 2-tube "autodyne," and designed by the writer, is shown in Fig. 44.

Although a tuning condenser C1 of .0005-mf. capacity may be used, it is recommended that this part have a capacity of about .001-mf.; which value may be obtained by ganging two .0005-mf. units. The larger capacity will make it easier to tune in a greater number of stations with a lesser number of coils. Any type of tube may be used at V1 and V2.

Honeycomb coils may be purchased, or home-made coils scramble-wound, with No. 30 enameled S.C.C. wire, on a form an inch wide and about two inches in diameter, to the following number of turns: (25, 80-350 meters; 35, 175-550); 50, 220-750 meters; 75, 330-1030; 100, 450-1460; 150, 660-2200; 200, 1300-4000; 250, 1550-4800; 300, 2050-6300; 500, 3,000-8,500; 600, 4,000-12,000; 750, 5,000-15,000; 1,000, 6,200-19,000; 1,250, 7,000-21,000; 1,500, 8,200-25,000, meters.

The two smallest coils are listed merely for completeness; the ranges are roughly those covered with a .001-mf. condenser. Some form of mounting must be arranged so that the coils may be conveniently interchanged. The coils should be rigidly supported, so that the turns cannot move, even slightly, when the coils are interchanged.

It may be desirable to insert a resistor of about 1,000 ohms in the detector plate lead at X.

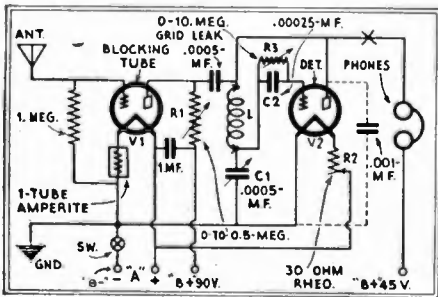

Fig. 44

Once adjusted for a given tube and plate potential, resistor R1 need not be reset. The adjustment of R3 is critical. Unit R2 controls volume and sensitivity.

Blocking tube V1 prevents radiation of interfering frequencies.

**Signal Booster**

(Q.) Please show the circuit for an A.C. screen-grid booster unit to be added to the average receiver, for use on broadcast wavelengths.

(A.) The circuit requested is Fig. 45; connect its "output" to the "Ant." post of the first R.F. tube in the set. The tuning condenser C2 will not "track" closely with the radio set dial unless it is of the same capacity and design of plates; and unless coil L2 has the same effective inductance as the tuned windings in the associated receiver.

The experimental constants may be as follows: L1, 10 turns of No. 26 D.C.C. wire on a tube 2 inches in diameter; L2, 80 to 85 turns of the same wire on a tube of the same diameter; L13, standard R.F. choke, C1 and C3, 1 mf. fixed condensers; C2, .00035-mf., variable; C4, .00025-mf., fixed; R, 1200 ohms. Resistor R is for biasing the tube.

Over-all shielding, grounded, is shown in dotted lines. The coils should not approach the can more closely than two inches at any point. It is a good idea to connect a 1 mf. condenser as shown in dotted lines.

By using one of the new "pentode" tubes as the amplifier, increased amplification may be obtained.

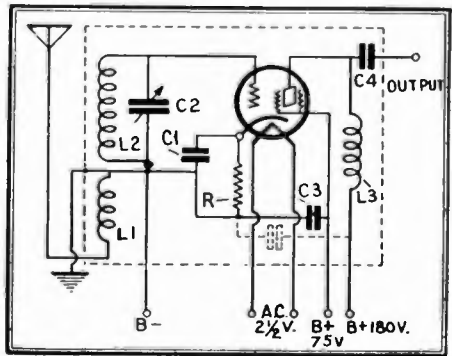

Fig. 45



# CHAPTER XVI

## Service Problems

### Aligning and Neutralizing

(Q.) Please advise as to the best method to be employed in completely balancing a radio set of advanced design. It seems to me that a well-equipped shop should be able to align these correctly, if the correct procedure is made available; whereas, at the present time, we ship such sets to the factory of the respective manufacturer.

(A.) In reply, the Service Department of the Kellogg Switchboard & Supply Co., has very kindly submitted the following detailed information on this procedure in connection with a representative set,—their "Model B" chassis, which incorporates Kellogg types 401 and 403 tubes. (The schematic circuit appears on page 199 of the Official Radio Service Manual, Vol. 1.)

A modulated oscillator tuning from 1500 to 550 kc. should furnish the signal, and an output meter should be connected at the audio output. (If this equipment is not available, circuit resonance may be satisfactorily obtained by tuning in two weak radio stations, one at either end of the band, and adjusting the aligning condensers of the detector and R.F. stages for greatest volume.)

Each aligning or trimming condenser is located nearest its associated tube, and the balancing or neutralizing condenser is nearest the coil of each stage.

After alignment of the resonant circuits has been secured, the balancing or neutralizing procedure is as follows: beginning with the R.F. stage nearest the detector tube, and using the shield top which has two holes perforated to allow the entrance of two "neutralizing sticks," the top filament connector is removed from the R.F. tube in the stage being balanced and, keeping the stage in best alignment, the balancing condenser is adjusted for weakest volume. On some stages no signal will be evident; this is the ideal point at which to leave the balancing condenser. Each succeeding stage is balanced in the same manner. After all stages have been balanced, the balancing condenser should not again be touched, but should be sealed with wax, or other suitable sealing medium.

The receiver should now have its final resonance alignment and every stage including the detector should be aligned for greatest volume. The last step is to test the receiver by tuning in stations across the entire range, noting the selectivity and sensitivity.

Kellogg receiver circuits of the series using Kellogg Type 401 tubes rarely oscil-

late, and may be considerably out of balance without being near the oscillation point. Inductive tuning is used, the left-hand knob controlling zone-switch contacts which tap the secondary of each coil and divide it into seven zones. These contacts should be cleaned if an oxide or dust has accumulated on them and prevented perfect contact. This condition may be the diagnosis if the set fades and other possible causes have been checked and eliminated.

The right-hand tuning knob controls a rotor coil for each stage, which through variometer action varies the inductance and thus tunes each zone. The contacts to these rotors should also be cleaned. The proper method of cleaning both zone and rotor contacts is to use a pipe cleaner or a special tool with special felt which has been dipped in "Carbona" or carbon-tetra-chloride; or, if the first two are not available, alcohol may be used. After the cleaning operation a very thin film of vaseline may be spread on the contacts to prevent future oxidization.

### Grounded Circuit

(Q.) What is most likely to be the trouble in an A.C. set, when the 110-volt current passes through the ground wire of the set? Set cannot be used with ground lead. Would a condenser in the ground lead help, and what capacity should it be?

(A.) This unusual phenomenon is probably due to a "ground" between the windings of the power transformer. If this transformer is carefully tested, it probably will be found that the insulation between windings has broken down. A fixed condenser of 0.25-mf. capacity may be connected in the ground lead; but it is best to have the transformer replaced or repaired. Otherwise, the insulation may break down still more, and eventually arc—setting fire to inflammables in the cabinet.

### Distortion

(Q.) I have a neutrodyne receiver, the reproduction of which seems to have a high note "fuzz." Can this be due to the neutralization not being as exact as it was?

(A.) It can be. Also:

1. The insulation of the neutralizing condensers may be leaky, causing detection in one of the R.F. stages, due to a positive potential being impressed on the grid;

2. The detector grid-leak value may have changed;

3. Defective tubes may be causing this trouble;

4. The audio transformers may need to be replaced. (This is an unusual source of distortion);

5. The reproducer may need repair. (Probably re-magnetizing, in the case of a magnetic motor; or, re-centering of the voice coil, if a dynamic unit is used);

6. Defective bypass condensers may be causing the trouble.

**Shocks**

(Q.) I have a D.C. "mains" set well insulated by antenna and ground series condensers. Why is it that I get a shock when the shield cans and radiator are touched at the same time?

(A.) Evidently the shielding of your set is grounded to the set wiring, which is connected to the lighting lines, and contact with it and the ground (radiator) completes the lighting lines circuit to ground, through your body; or discharges the isolating condensers.

**Fading**

(Q.) What is the remedy for fading signals in two receivers operated from "A" units which incorporate "dry" rectifiers? One set is an 8-tube receiver operated from a 2½-amp. "A" unit, and the other is a 7-tube set used with a 2-amp. unit of the Kuprox dry-disc type.

(A.) The trouble mentioned can be traced, usually, to: a defective "A" rectifier unit; defective "A" filter condensers, or; poor contact elsewhere in the "A" circuit. Defective units must be replaced.

Of course, this is working on the assumption that the trouble is in the "A" circuit; there are numerous other possibilities, exterior to the "A" supply.

While all tubes are "on," test the output voltage of the "A" unit with a low-scale voltmeter. If the voltage is not steady, the source of the fading has been located.

**Crackling Sounds**

(Q.) The battery cable on a radio set produces a loud crackling sound when the cable is moved in a certain position, near the input to the set. I have tested this cable for open or short circuit, but find it OK in every respect; in fact it is a new one. Sometimes merely touching the cable with the finger causes the noise.

(A.) This crackling sound is caused by loose connections (perhaps corroded contacts), partial breaks, or partial shorts.

The reason the cable tested perfect is that the tests were not carried sufficiently far; or else the trouble does not rest in the cable.

It is possible that the fault is due to poor connection at binding posts; perhaps a wire underneath a post is making intermittent contact. Corroded "A" battery clips will cause the same effect. A voltmeter placed across the filament con-

nections of a tube will quickly indicate whether the "A" supply is fluctuating. If this reading is steady, check the "B" supply with a voltmeter or milliammeter.

A broken strand of the cable conductor will occasionally cause this effect, when the strand sticks through the insulation and intermittently touches another lead.

**Ground Efficiency**

(Q.) The writer has been informed that the size of the spark obtained, when the ground wire is removed from the chassis of some Victor sets, when they are connected to the light-line, is an indication of the efficiency of the ground. Is this true? And is the ground best when the spark is large, or small?

(A.) The information is correct; the better the ground, the larger the discharging spark of the 0.1-mf. condenser bank across the power lines.

**Phono Motor Interference**

(Q.) I replaced the spring motor in my phonograph with a 110-volt A.C. synchronous electric motor. It was my intention to operate this motor and an electric phonograph pickup in conjunction with my radio set, which is provided with connections for a pickup. However, the motor causes a loud hum in the reproducer when the motor is put into operation; although there is no interference when the motor is not turning.

If the pickup head is moved about six inches from the motor, the hum stops; it can also be stopped by turning the pickup to an odd angle. The leads from the pickup are not inductively coupled to the motor, since shielding them does not reduce the hum. How can this trouble be remedied?

(A.) If grounding the frame of the motor does not eliminate the interference which is experienced from the phonograph motor, it may be necessary to shield the entire motor in the manner shown in Fig. 46. The shield is to be made from soft iron sheeting, of any convenient thickness.

Before making this shield, it may be advisable to try grounding the frame of the phonograph pickup; and shielding the A.C. leads to the motor and to the switch controlling the motor.

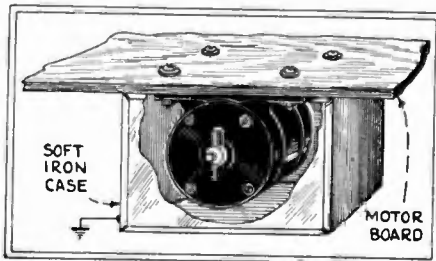

Fig. 46



### Circuit Oscillation

(Q.) An 8-tube screen-grid radio set, has developed a case of circuit oscillation. Please advise as to the probable cause of this effect; the means to correct it; and the procedure in phasing the several tuned circuits.

(A.) Although the request is terse and appears to be a simple one, the answer must necessarily be rather extensive. For our example we have selected a commercial radio set,—the Stewart-Warner "series 950" receiver, Fig. 47.

Referring to this diagram, the 0.1-mf. condenser bypassing the screen-grid of V1 may be open-circuited and therefore the cause of circuit oscillation over the entire waveband.

Circuit oscillation on the higher wavelengths may be due to an open R.F. plate bypass condenser.

Circuit oscillation throughout the tuning range, accompanied by a blurred reception, may be due to an open in the fixed condenser, bypassing the R.F. grid bias resistor.

It is to be noted that a screen-grid potential greater than 85 volts will probably cause circuit oscillation. The cause of excessive voltage at this point may be due to a lowered value of the 20,000 ohm (purple) resistor.

Each of the tuning condensers is grounded through an individual contact shoe, which makes connection with the rotor shaft. If this contact collects a considerable amount of dirt, loosens, or becomes corroded, circuit oscillation may result.

Coupling through external wires may cause circuit oscillation, due to this feedback. Such coupling may exist where the aerial comes close to the terminal strip in back of the set, or where it crosses either the reproducer leads or the 110-volt current supply cord.

Once again, it is considered advisable to point out that a poor ground may cause circuit oscillation; this is more true of sets of this design, in which high sensitivity has been achieved.

The Service Man perhaps is unaware that a simple, but infallible, test may be made to determine whether the ground is a poor one, or whether external coupling exists. Just connect an .006- to 0.1-mf. condenser inside the set, from the frame to one of the 110-volt power leads.

If, after reassembling the receiver carefully, all traces of circuit oscillation are gone, the original cause was unquestionably either outside feedback, or a poor ground. Having determined that outside leads run directly to the set and are not coupling back to other parts of the circuit, change the ground connection.

Exceptional amplification at the higher wavelengths may result in circuit oscillation at the low-frequency end of the tuning scale; a condition which is seldom apparent unless the set is tuned exactly to the station and the volume control is turned full on.

To cure this trouble first remove the bottom metal plate of the set. Note the three leads running under the large filter condenser, from the R.F. coils to the plates of the screen-grid tubes. If these leads are encased in metal braiding, the braiding should be pulled out more; see that the wire is completely shielded. If these leads are encased in brass channel-strips, the filter condenser should be removed, and the brass clinched over the wires with a pair of pliers.

Now, when replacing the filter condenser, omit the cardboard strips between the shield leads to make certain that the pressure on the leads is sufficient to insure a perfect ground. (For the same reason, if the condenser is of the large black type, it should be reversed, so that the paper back is pressed against the shields.) This should clear up the cause of the particular circuit oscillation referred to above.

**NOTE:** Make certain that the bottom plate is bolted tightly in place, as this is part of the shielding system.

Leaving the ground connected, but with the set turned on and the aerial disconnected, couple the set to an A.F. modulated R.F. service oscillator and adjust the receiver dial for 1,000 cycles; then tune the oscillator to this frequency, with the volume control of the receiver full on. (Control the volume of the oscillator by some adjustment in the oscillator or by changing coupling, but not by variation of the volume control on the set.) Carefully balance the antenna trimming knob.

Now, bring an insulated piece of metal, such as a tape-covered hack-saw blade, close to the detector-circuit tuning condenser, through the stator plates at the left side; so that the blade can make contact at its lower end with the upper left rim of the condenser frame. This added capacity should cause the signal to decrease. If there is no change of signal strength, or an increase in strength, this indicates that the circuit is out of resonance and should be aligned by the trimming condenser at the left. (The coupling condensers at the right, of 16 mmf., are set at the factory and should not be touched). Repeat this procedure for RFT3 and RFT2; the circuit of RFT1 is taken care of through the panel condenser control.

This is the check for high capacity in the tuning condensers; the test for low capacity follows the same routine, with the tuning dial adjusted off the 1,000 kc. setting by two degrees. If the signal does not become louder, carefully adjust the trimming condenser in shunt with the tuning condenser under test.

Should the receiver tune a little too broadly after a careful lineup as described above, a poor ground system may be the cause. Otherwise, the aerial is probably too long, or close to a metal roof, trees or light lines. A defective tube may also be the cause.

**Midget Set Constants**

(Q. Kindly show the complete schematic circuit and operating potentials of a representative commercial midget radio receiver which employs only four tubes, including the rectifier; a band-selector should be included in the design.

(A.) In Fig. 48 is shown the schematic circuit of an exceptionally good receiver which meets the specifications; the set is the Sears, Roebuck 4-Tube Midget Receiver.

Operating potentials are to be measured at a line voltage of 110 and with the volume control full on; and the readings (on a Weston Model 547 set-checker) should approximate the following figures: Filament potential, V1, V2, V3, 2.4 volts; V4, 5 volts. Plate potential, V1, 250 volts; V2, 65 volts\*; V3, 230 volts. Control-grid potential, V1, 2.5 volts; V2, 2.5 volts\*; V3, 16.5 volts. Plate current, normal, V1, 4 ma.; V2, 0.4-ma.; V3, 35 ma.; V4, 30 ma. (each plate). Screen-grid potential, V1, 90 volts; V2, 37.5 volts\*. Space-charge grid, V3, 250 volts. Readings (\*) are comparative only, and are not true potentials, due to the resistance of the meter.

Adjust the length of the antenna to the requirements of individual localities. To take advantage of the adjusting vanes on the variable condensers (from front to back, they are in this order: C1, C2, C3), the circuit should be aligned at 1,500 kc., 1,295 kc., 800 kc., 750 kc. and 550 kc. The degree of band selection is determined by the inductive coupling of coils L1 and L2.

The receiver diagrammed in Fig. 48 is exceptionally well balanced for the reception of most programs; however, in some instances it may be desirable to increase the proportion of "highs" in the reproduction. This may be conveniently accomplished by changing the effective value of the output bypass condenser C4 by connecting in series with it, at "X," a variable resistor of 0-50,000 ohms; of course, an off-on switch may be used instead, if satisfactory tone results when this portion of the circuit is open-circuited.

The first tube is a type '35 or '51 variable-mu, which functions as first R.F.;

this is followed by the detector, which is a screen-grid type '24 tube; the last tube in the receiver portion of the circuit is a type '47 pentode, resistance-capacity coupled to the detector; the rectifier is an '80.

In this model, "C" bias is obtained as the voltage drop across the 300-ohm section of the field coil, Ch.

**Ungrounded Sets**

(Q.) What is the explanation for an increase in signal volume when the ground wire is disconnected from a sensitive T.R.F. set. Aerial and ground have been inspected, and both seem to be in perfect condition; all tubes test up to par.

(A.) When the ground wire is removed from a radio set, the chassis no longer serves as a radio-frequency shield since it is ungrounded. Regeneration now takes place in the circuit, thus causing increased sensitivity; and perhaps the circuit may become so highly regenerative as to slip easily into oscillation. Another result of this instability is to decrease the noise-to-signal ratio, bringing in background noises not otherwise heard. Also, the hum level is often raised to an objectionable degree.

Under normal conditions, the various interfering noises picked up by the light-lines and chassis may pass directly to ground through a filter bank consisting of two center-tapped 0.1-mf. capacities, connected inside the amplifier unit. However, when the ground connection is removed, the effectiveness of the ground wire to carry off these static discharges is eliminated. Also, the signal gain obtained by removing the ground is not as noise-free when obtained in this manner, as when the volume control is advanced to obtain the same sensitivity; for it is seldom that a sufficient degree of sensitivity is not obtainable by adjustment of this control—if the receiver is otherwise properly balanced.

Signal pickup via the light-line, no longer bypassed to ground, now may back up through the set. If it is "in phase" with the antenna pickup, volume is increased; otherwise, decreased volume will be experienced.

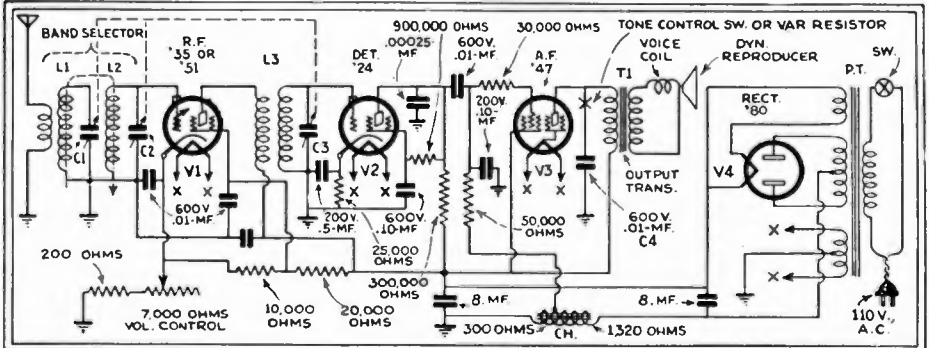

Fig. 48



**"Screen-Grid" Coils**

(Q.) Please print details for the construction of R.F. transformers of a design suitable for use as antenna and interstage units in modernizing old '01A- and '27-(tube) type receivers to the use of screen-grids or variable- $\mu$ 's. The coils should be small as possible.

(A.) This is rather a large order. In the first place, the proximity of the shield to the R.F. coil will greatly affect the tuning range of the receiver; as will the characteristics of the particular tubes used. Perhaps the greatest factor with which to contend is the minimum capacity and the capacity range of the tuning condenser, as pointed out in past issues of Radio-Craft. Furthermore, reference should be made to recent articles in Radio-Craft magazine on coil design of the latest type; in which reception at both low- and high-frequency ends of the tuning spectrum are compensated in the design of the primary winding.

However, still another, and more common design, is illustrated in Fig. 49. The object here has been to obtain good operation, though using coil forms and

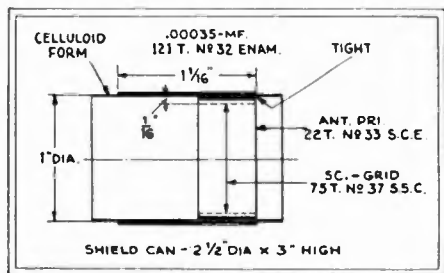

Fig. 49

shield cans of very small dimensions. The values are those of a commercial product.

The primary of the antenna coil fits tightly inside of the form, on the outside of which is wound the secondary. The primary of the screen-grid coils is to be spaced 1/16-in. from the inside of the celluloid winding form. All secondaries have the same number of turns, and are tuned by a variable condenser rated at ".00035-mf."

**Automatic Volume Control**

(Q.) How does an automatic volume control act to control the volume of a radio receiver?

(A.) As explained in detail in the article, "Automatic Volume Control," by C. H. W. Nason, in the November, 1930 issue of Radio-Craft magazine, there are numerous types of circuits; however, they all operate to vary the screen-grid, or the control-grid potential of the R.F., I.F., or A.F. tubes.

A circuit in general use is shown in Fig. 50.

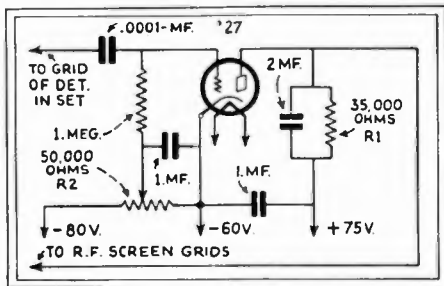

Fig. 50



# CHAPTER XVII

## Handy Reference Data

### Conversion Chart for Wavelength, Frequency, and Oscillation Constant

Wave length meters	Multiply values below by 1000	Multiply values below by 100	CL in ft L in cm	Wave length meters	Multiply values below by 1000	Multiply values below by 100	CL in ft L in cm
1	300000	1894000	0.001	200	1500	9420	11.28
2	150000	947000	.0011	203	1465	9190	11.83
3	100000	631000	.0018	210	1428	8970	12.41
4	75000	471000	.0025	215	1395	8790	13.01
5	60000	377000	.0032	220	1365	8630	13.62
6	50000	314200	.0040	225	1335	8490	14.25
7	42900	269900	.0048	230	1310	8370	14.90
8	37500	235500	.0056	235	1285	8260	15.55
9	33320	209400	.0065	240	1265	8160	16.22
10	30000	189400	.0075	245	1250	8070	16.90
15	20000	126200	.0112	250	1230	7940	17.60
20	15000	94700	.0150	255	1215	7830	18.31
25	12000	75800	.0188	260	1200	7750	19.03
30	10000	63100	.0225	265	1185	7690	19.77
35	8570	53900	.0263	270	1175	7650	20.52
40	7500	47100	.0300	275	1165	7620	21.29
45	6670	41000	.0337	280	1155	7600	22.07
50	6000	37700	.0375	285	1145	7590	22.87
55	5450	34220	.0413	290	1135	7590	23.68
60	5000	31420	.0450	295	1125	7590	24.50
65	4620	28970	.0488	300	1115	7590	25.33
70	4290	26990	.0525	305	1105	7590	26.17
75	4000	25130	.0563	310	1095	7590	27.02
80	3750	23550	.0600	315	1085	7590	27.88
85	3529	22190	.0638	320	1075	7590	28.75
90	3333	21000	.0675	325	1065	7590	29.63
95	3158	19900	.0713	330	1055	7590	30.52
100	3000	18940	.0750	335	1045	7590	31.43
105	2857	17990	.0788	340	1035	7590	32.35
110	2727	17130	.0825	400	750	4710	45.00
115	2609	16360	.0863	410	735	4590	46.00
120	2500	15710	.0900	420	720	4490	47.00
125	2400	15170	.0938	430	705	4410	48.00
130	2309	14640	.0975	440	690	4330	49.00
135	2222	14160	.1013	450	675	4260	50.00
140	2144	13740	.1050	460	660	4200	51.00
145	2076	13360	.1088	470	645	4140	52.00
150	2000	12990	.1125	480	630	4080	53.00
155	1935	12650	.1163	490	615	4020	54.00
160	1875	12340	.1200	500	600	3960	55.00
165	1818	12050	.1238	510	585	3900	56.00
170	1765	11790	.1275	520	570	3840	57.00
175	1714	11550	.1313	530	555	3780	58.00
180	1667	11310	.1350	540	540	3720	59.00
185	1622	11090	.1388	550	525	3660	60.00
190	1579	10890	.1425	560	510	3600	61.00
195	1538	10710	.1463	570	495	3540	62.00
200	1500	10550	.1500	1150	260.9	1637	372.1
210	1417	9840	.1575	1200	250.0	1570	360.0
220	1340	9240	.1650	1250	240.0	1510	348.0
230	1269	8710	.1725	1300	230.0	1448	336.0
240	1204	8250	.1800	1350	220.0	1385	324.0
250	1144	7850	.1875	1400	210.0	1320	312.0
260	1089	7500	.1950	1450	200.0	1255	300.0
270	1038	7190	.2025	1500	200.0	1200	288.0
280	990	6920	.2100	1550	190.0	1145	276.0
290	945	6680	.2175	1600	180.0	1090	264.0
300	902	6460	.2250	1650	170.0	1035	252.0
310	861	6260	.2325	1700	160.0	980	240.0
320	822	6070	.2400	1750	150.0	925	228.0
330	785	5900	.2475	1800	140.0	870	216.0
340	750	5740	.2550	1850	130.0	815	204.0
350	717	5600	.2625	1900	120.0	760	192.0
360	686	5470	.2700	1950	110.0	705	180.0
370	657	5350	.2775	2000	100.0	650	168.0
380	630	5240	.2850	2050	90.0	595	156.0
390	604	5140	.2925	2100	80.0	540	144.0
400	580	5050	.3000	2150	70.0	485	132.0
410	557	4970	.3075	2200	60.0	430	120.0
420	536	4900	.3150	2250	50.0	375	108.0
430	516	4840	.3225	2300	40.0	320	96.0
440	497	4790	.3300	2350	30.0	265	84.0
450	479	4750	.3375	2400	20.0	210	72.0
460	462	4710	.3450	2450	10.0	155	60.0
470	446	4680	.3525	2500	0.0	100	48.0
480	431	4650	.3600	2550	0.0	55	36.0
490	417	4620	.3675	2600	0.0	10	24.0
500	404	4600	.3750	2650	0.0	0	12.0
510	392	4580	.3825	2700	0.0	0	0
520	381	4560	.3900	2750	0.0	0	0
530	370	4550	.3975	2800	0.0	0	0
540	360	4540	.4050	2850	0.0	0	0
550	350	4530	.4125	2900	0.0	0	0
560	341	4520	.4200	2950	0.0	0	0
570	332	4510	.4275	3000	0.0	0	0
580	324	4500	.4350	3050	0.0	0	0
590	316	4490	.4425	3100	0.0	0	0
600	309	4480	.4500	3150	0.0	0	0
610	302	4470	.4575	3200	0.0	0	0
620	295	4460	.4650	3250	0.0	0	0
630	289	4450	.4725	3300	0.0	0	0
640	283	4440	.4800	3350	0.0	0	0
650	277	4430	.4875	3400	0.0	0	0
660	271	4420	.4950	3450	0.0	0	0
670	266	4410	.5025	3500	0.0	0	0
680	261	4400	.5100	3550	0.0	0	0
690	256	4390	.5175	3600	0.0	0	0
700	251	4380	.5250	3650	0.0	0	0
710	246	4370	.5325	3700	0.0	0	0
720	241	4360	.5400	3750	0.0	0	0
730	236	4350	.5475	3800	0.0	0	0
740	231	4340	.5550	3850	0.0	0	0
750	226	4330	.5625	3900	0.0	0	0
760	221	4320	.5700	3950	0.0	0	0
770	216	4310	.5775	4000	0.0	0	0
780	211	4300	.5850	4050	0.0	0	0
790	206	4290	.5925	4100	0.0	0	0
800	201	4280	.6000	4150	0.0	0	0
810	196	4270	.6075	4200	0.0	0	0
820	191	4260	.6150	4250	0.0	0	0
830	186	4250	.6225	4300	0.0	0	0
840	181	4240	.6300	4350	0.0	0	0
850	176	4230	.6375	4400	0.0	0	0
860	171	4220	.6450	4450	0.0	0	0
870	166	4210	.6525	4500	0.0	0	0
880	161	4200	.6600	4550	0.0	0	0
890	156	4190	.6675	4600	0.0	0	0
900	151	4180	.6750	4650	0.0	0	0
910	146	4170	.6825	4700	0.0	0	0
920	141	4160	.6900	4750	0.0	0	0
930	136	4150	.6975	4800	0.0	0	0
940	131	4140	.7050	4850	0.0	0	0
950	126	4130	.7125	4900	0.0	0	0
960	121	4120	.7200	4950	0.0	0	0
970	116	4110	.7275	5000	0.0	0	0
980	111	4100	.7350	5050	0.0	0	0
990	106	4090	.7425	5100	0.0	0	0
1000	101	4080	.7500	5150	0.0	0	0

Wave length meters	Multiply values below by 1000	Multiply values below by 1000	CL in ft L in cm	Wave length meters	Multiply values below by 1000	Multiply values below by 1000	CL in ft L in cm
8000	37.50	235.2	18010	25000	12.00	75.4	176000
8500	35.29	221.4	20340	30000	10.00	62.8	253000
9000	33.33	208.2	22900	35000	8.57	53.8	344000
9500	31.58	196.2	25410	40000	7.50	47.1	450000
10000	30.00	186.4	28160	45000	6.67	41.8	570000
16000	20.00	125.7	63400	50000	6.00	37.7	700000
20000	15.00	94.2	112000				

"TURNS-PER-INCH" of INSULATED WIRE							
B. & S.						Enm. and	
Gauge	DCC	SCC	DSC	SSC	Enm.	SCC	SSC
14	13.7	14.6	14.7	15.0	15.2	14.2	14.7
15	15.0	16.2	16.4	17.0	17.0	16.8	16.5
16	16.7	18.0	18.2	19.0	18.7	17.6	18.4
17	18.5	20.0	20.0	21.2	21.4	19.5	20.5
18	19.6	22.3	22.3	23.6	24.0	21.7	22.9
19	22.5	26.0	25.2	27.0	27.2	24.2	26.8
20	24.6	27.6	27.6	29.5	30.1	26.5	28.4
21	27.5	30.8	30.8	32.8	33.6	29.6	31.5
22	30.0	34.0	34.0	36.6	37.7	32.7	35.0
23	32.7	37.6	37.6	40.7	42.3	36.1	39.0
24	35.6	41.5	41.5	45.3	47.2	39.7	43.1
25	38.6	46.7	46.7	50.3	52.9	43.7	47.9
26	41.8	60.2	60.2	55.7	59.0	47.8	52.8
27	45.0	65.0	65.0	61.7	65.8	52.1	58.1
28	48.5	60.0	60.0	68.3	73.9	57.0	64.4
29	52.0	65.6	65.6	76.4	82.2	61.9	70.6
30	55.6	71.3	71.3	85.1	92.3	67.4	77.9
31	60.0	77.3	77.3	91.6	103.0	72.8	85.3
32	62.7	83.7	83.7	101.0	116.0	79.1	93.9
33	66.3	90.3	90.3	110.0	130.0	86.6	103.0
34	70.0	97.0	97.0	120.0	146.0	91.7	112.0
35	73.4	104.0	104.0	131.0	164.0	98.8	123.0
36	77.0	111.0	111.0	143.0	182.0	106.0	133.0
37	80.3	126.0	126.0	166.0	208.0	113.0	146.0

A Self-Perpetuating Nomograph for Determining Tube Characteristics

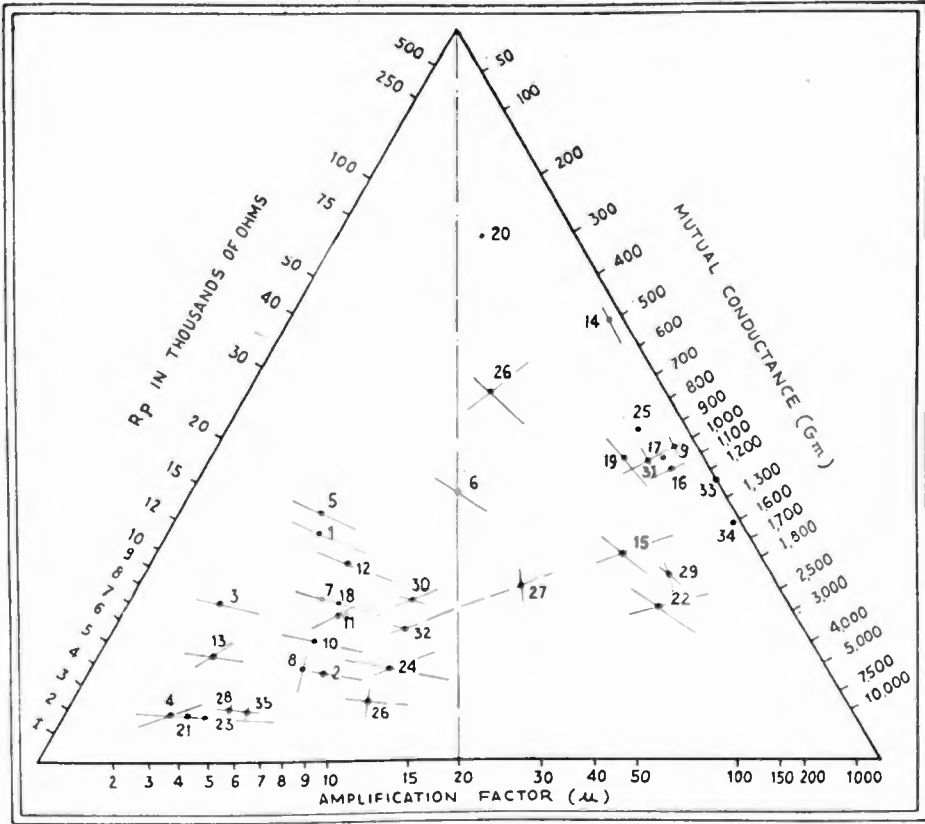

Determining Meter Shunts and Multipliers

Voltage Range Desired in Volts	Resistance in ohms.								
	100 $\mu$ a.	200 $\mu$ a.	300 $\mu$ a.	500 $\mu$ a.	1000 $\mu$ a. 1 M A	1.5 M. A.	2 M. A.	3 M. A.	5 M. A.
1	10,000	5,000	3,330	2,000	1,000	667	500	333	200
1.5	15,000	7,500	5,000	3,000	1,500	1,000	750	500	300
2	20,000	10,000	6,670	4,000	2,000	1,330	1,000	667	400
3	30,000	15,000	10,000	6,000	3,000	2,000	1,500	1,000	600
5	50,000	25,000	16,700	10,000	5,000	3,330	2,500	1,670	1,000
7.5	75,000	37,500	25,000	15,000	7,500	5,000	3,750	2,500	1,500
10	100,000	50,000	33,300	20,000	10,000	6,670	5,000	3,330	2,000
15	150,000	75,000	50,000	30,000	15,000	10,000	7,500	5,000	3,000
30	300,000	150,000	100,000	60,000	30,000	20,000	15,000	10,000	6,000
50	500,000	250,000	167,000	100,000	50,000	33,300	25,000	16,700	10,000
100	1 Megohm	500,000	333,000	200,000	100,000	66,700	50,000	33,300	20,000
150	1.5 Megohm	750,000	500,000	300,000	150,000	100,000	75,000	50,000	30,000
300	1.5 Megohm	1 Megohm	1 Megohm	600,000	300,000	200,000	150,000	100,000	Two 30,000
500	5 Megohms	2.5 Megohms	1 Meg 667,000	1 Megohm	500,000	333,000	250,000	100,000 66,700	30,000 20,000 40,000
1,000	Two 5 Megohm	5 Megohm	3 Meg 333,000	2 Megohm	1 Megohm	Two 333,000	Two 250,000	Three 111,000	Five 40,000

**OHM'S LAW — RELATIONS BETWEEN VOLTAGE, RESISTANCE, CURRENT AND POWER**

Direct Current

Where  $I$  is Current Intensity in Amperes,  $R$  is Resistance in Ohms

$E$  is Electromotive Force in Volts and  $W$  is Power in Watts, then:

$$I = \frac{R}{E} = \frac{W}{E^2} = \sqrt{\frac{W}{R}}$$

$$R = \frac{E}{I} = \frac{W}{I^2} = \frac{E^2}{W}$$

$$E = I \times R = \frac{W}{I} \quad W = E \times I = I^2 \times R = \frac{E^2}{R}$$

Alternating Current

Where  $Z$  is the Impedance in Ohms,  $E$  is Effective Electromotive Force in Volts, and  $I$  is Current Intensity in Amperes, then

$$I = \frac{E}{Z} \quad E = Z \times I \quad Z = \frac{E}{I}$$

Where  $L$  is the Inductance in Henries and  $C$  the Capacity in Farads,

$f$  is the Frequency in Cycles (per second), then in ohms,

$$\text{The Inductive Reactance } X_L = 6.283 \times f \times L$$

$$\text{The Capacitive Reactance } X_C = \frac{1}{6.283 \times f \times C}$$

$$\text{The Resonant Frequency is } \frac{1}{6.283 \sqrt{LC}}$$

The Impedance Z is

In a Capacitive Inductive Circuit: In a Circuit Having Resistance, Capacity and Inductance

$$Z = \sqrt{\left(\frac{1}{6.283 \times f \times C}\right)^2 + (6.283 \times f \times L)^2} \quad Z = \sqrt{R^2 + (6.283 \times f \times L)^2} \quad Z = \sqrt{R^2 + \frac{1}{(6.283 \times f \times C)^2}}$$

$$\text{The Resonant Frequency of a PARALLEL Circuit is } f_r = 0.159 \sqrt{\frac{C}{L}}$$

**VACUUM-TUBE FORMULAS**

$$\text{Amplification constant ("}\mu\text{"')} \mu = \frac{\text{Change in Plate Voltage (}E_p\text{)}}{\text{Change in Grid Voltage (}E_g\text{)'}}$$

$$\text{Plate Impedance (in ohms)} I_p = \frac{\text{Change in Plate Voltage (}E_p\text{)}}{\text{Change in Plate Current (}I_p\text{)'}}$$

$$\text{Mutual Conductance } g_m = \frac{\text{Change in Plate Current (}I_p\text{)'}}{\text{Change in Grid Voltage (}E_g\text{)'}}$$

When the Plate Current is measured in Amperes; the Mutual Conductance  $g_m$  in MICROMEOS =  $\frac{\mu}{I_p} \times 1,000,000$

When  $E_g$  is the Input Voltage,  $I_p$  is the Plate Impedance and  $E_p$  is the External plate Impedance or Load Impedance, the

$$\text{Voltage Amplification} = \frac{\mu \times E_g \times R_p}{I_p + R_p}$$

**POWER OUTPUT**

When  $E_g$  expresses the RMS (Root-Mean-Square) Effective Value of the

$$\text{A. C. Input, the POWER OUTPUT} = \frac{\mu^2 \times E_g^2 \times R_p}{(I_p + R_p)^2}$$

$$\text{The MAXIMUM Power Output is } \frac{\mu^2 \times E_g^2}{4 I_p} \quad \text{The MAXIMUM UNDISTORTED Power Output is } \frac{2 \mu^2 \times E_g^2}{9 I_p}$$

When  $E_g$  is the Maximum (Peak) A. C. Input Value

$$\text{The Maximum Undistorted Power Output is } \frac{\mu^2 \times E_g^2}{9 I_p}$$

**TRANSFORMER RATIOS**

The Voltage across the Secondary = The Number of Secondary Turns

The Voltage across the Primary = The Number of Primary Turns

**Table of "L-C Constants"**

This table, reproduced on Pg. 56, shows the relationship which exists between wavelength, frequency, inductance and capacity; the latter two factors are combined under the heading CL—which is generally referred to as the "L-C constant," or the "oscillation constant." The calculations follow the Bureau of Standards figure, for the velocity of light, as 299,820,000 meters per second (instead of the older one—300,000,000 meters).

**"Turns-Per-Inch" of Insulated Wire**

A very useful table, reproduced on Pg. 56, taken from the article, "I.F. Coil Design," which appeared in the April, 1932 issue of Radio-Craft.

**Bias Resistor Values**

As stated on Pg. 56, the figures given are only for a single tube. To determine the correct value for a greater number of tubes of the same type operated in the same circuit, divide the figure shown in the table by the figure for the quantity of tubes. (This data is available by courtesy of International Resistance Co.)

**Nomograph of Tube Characteristics**

This "abac," reproduced on Pg. 57 (and appearing originally in the card-insert in the August, 1932 issue of Radio-Craft) represents the following tubes: 1, WD-11, 12; 2, 12A; 3, 20; 4, 71A; 5, '99; 6, '00A; 7, '01A; 8, '10; 9, '24; 10, '26; 11, '27; 12, '30; 13, '31; 14, '32; 15, '33; 16, '35; 17, '36; 18, '37; 19, '38; 20, '40; 21, '45; 22, '47; 23, '50; 24, 852; 25, 865; 26, 211; 27, 541; 28, 845; 29, LA; 30, Wunderlich; 31, 44; 32, 56; 33, 57; 34, 58; 35, 46 (Class A). To read, draw a line from the apex which permits the desired characteristic to be indicated when the particular index dot is bisected. Other data on tubes and other equipment may be similarly plotted.

**Determining Meter Shunts and Multipliers**

In the chart under this title reproduced on Pg. 57, values are given for the total resistance required to change microameters and milliammeters into instruments for accurately measuring voltage. Since the resistance of most microammeters and milliammeters is about 40 ohms or less, the error with this assumption is the resistance of the instrument divided by the resistance given in the table. (Illustration and data, courtesy International Resistance Co.)

**Formulas**

A discussion of the formulas on Fgs. 58 and 59 will be found in the two-part article, "Simple Mathematics for the Service Man," in the September, and October, 1930 issues of Radio-Craft magazine.

**Vacuum-Tube and Socket Connections**

Although certain tube characteristics may be obtained from the nomograph on Pg. 57, the complete characteristic data corresponding to the tubes mentioned in the chart on Pg. 60 may be found in the July, 1932 issue of Radio-Craft.

**A. C. Voltage and Power:**

The Maximum Voltage  $E_m$  is 1.414 x the Effective Voltage  $E_e$

The Effective Voltage  $E_e$  is 0.707 x the Maximum Voltage  $E_m$

The Average Voltage  $E_a$  is 0.636 x the Maximum Voltage  $E_m$

The Power in an A. C. Circuit  $W = I \times E \times Z$

Where the Angle of Lag or lead  $\phi$  and the Power Factor  $\frac{R}{Z} =$

Cosine  $\phi$ , Sine  $\phi = \frac{X}{Z}$ , and Tangent  $\phi = \frac{X}{R}$

**Combinations of Resistances or Capacities:**

The Effective Sum of a Combination of Resistances (R) or of a Combination of Capacities (C) is as follows:

In SERIES In PARALLEL

Resistances:  $R = R_1 + R_2 + R_3 \dots$   $R = \frac{1}{\frac{1}{R_1} + \frac{1}{R_2} + \frac{1}{R_3} \dots}$

Capacities:  $C = \frac{1}{\frac{1}{C_1} + \frac{1}{C_2} + \frac{1}{C_3} \dots}$   $C = C_1 + C_2 + C_3 \dots$

**OSCILLATORY CIRCUIT VALUES**

Where  $\lambda$  ("lambda") is the WAVELENGTH in meters,  $L$  is the Inductance in MICROHENRIES and  $C$  is the Capacity in MICROFARADS

The RESONANT FREQUENCY in Cycles is  $f_r = \frac{159,160}{\sqrt{L \times C}}$

The DECREMENT of a Circuit is  $\delta = \frac{R}{2\pi f L} = 3.1416 \times \frac{R}{\lambda L}$   
Where the POWER FACTOR is  $\frac{R}{\lambda L}$

Reproduced, in part, from the July, 1932 issue of Radio-Craft magazine.

VACUUM TUBE and SOCKET CONNECTIONS

WD-11			230			46			BA
WX-12			232			112A			BH
44			234			120			280
56			235 251			171A			281
57			236			210			866
58			237			231			874
112A			239			233			876
199			240			238			886
200A			841			245			211
201A			864			247			841
223			Wunderlich			250			845
224			41			LA			852
224A			42			82			865
226			295 TRIPLE TWIN						
227									

# PRESENTING THE Radio-Craft Library

Presented on this page are the new books of the RADIO-CRAFT LIBRARY—the most complete and authentic set of volumes treating individually, important divisions of radio. Each book has been designed to give radio men the opportunity to specialize in one or more of the popular branches of the industry. The material contained in these books will increase your knowledge; you will find them a real help in your work and they will contribute to your money earning capacity. Read these books during your spare time at home. The authors of these books are well-known to everybody. Each one is an expert radio man; an authority on the subject—each is thoroughly familiar with the field which he represents. This is perhaps the first real opportunity that you have ever had to build a radio library of books that are authentic, right-up-to-the-minute and written so that they are easily digested and clearly understood. Mail coupon below for your books.

<p>Book No. 1 <b>RADIO SET ANALYZERS</b> And How To Use Them With Full Instructions and Descriptions of Set Analyzers, Tube Checkers, Oscillators, Etc. By L. VAN DER MEL</p>	<p>Book No. 5 <b>HOW TO BECOME A RADIO SERVICE MAN</b> How To Get Started and How To Make Money in Radio Servicing By LOUIS MARTIN</p>	<p>Book No. 8 <b>RADIO QUESTIONS AND ANSWERS</b> A Selection of the Most Important of 5,000 Questions Submitted by Radio Men During the Course of One Year By R. D. WASHBURNE</p>
<p>Book No. 2 <b>MODERN VACUUM TUBES</b> And How They Work With Complete Technical Data on All Standard and Many Special Tubes By ROBERT HERTZBERG</p>	<p>Book No. 6 <b>BRINGING ELECTRIC SETS UP TO DATE</b> With Pentodes, Multi-Mus, Dynamic Speakers—Complete Information How to Modernize A.C., D.C. and Battery Operated Receivers By CLIFFORD E. DENTON</p>	<p>Book No. 9 <b>AUTOMOBILE RADIO AND SERVICING</b> A Complete Treatise on the Subject Covering All Phases from Installing to Servicing and Maintenance By LOUIS MARTIN</p>
<p>Book No. 3 <b>THE SUPERHETERODYNE BOOK</b> All About Superheterodynes How They Work, How to Build and How to Service Them By CLYDE FITCH</p>	<p>Book No. 7 <b>RADIO KINKS AND WRINKLES</b> For Service Men and Experimenters A Complete Compendium of the Latest Radio Short-Cuts and Money-Savers By C. W. PALMER</p>	<p>Book No. 10 <b>HOME RECORDING AND ALL ABOUT IT</b> A Complete Treatise on Instantaneous Recordings, Microphones, Recorders, Amplifiers, Commercial Machines, Servicing, etc. By GEORGE J. SALIBA</p>
<p>Book No. 4 <b>MODERN RADIO HOOK-UPS</b> The Best Radio Circuits A Complete Compendium of the Most Important Experimental and Custom-built Receivers By R. D. WASHBURNE</p>		

## ALL BOOKS UNIFORM

The books in the new RADIO-CRAFT LIBRARY are all strictly up-to-date and written by men who know their subjects. The volumes are all uniform size, 6 x 9 inches, and contain on an average from 50 to 120 illustrations. Each book is printed on fine book paper, and no expense has been spared to make it an outstanding value, for its editorial contents as well as from the mechanical standpoint.

## Big Discount Offered

In order to make it possible for everyone to buy these books, the fifty (50) cents price has been made uniform for all volumes. You can buy these books separately, but you should take advantage of our special offer:

**WHEN FIVE (5) BOOKS OR MORE ARE ORDERED DEDUCT 20% FROM YOUR REMITTANCE**

Simply fill in the coupon below, and mail it to us together with your remittance. Checks, stamps or money orders accepted.

**Clip Coupon and Mail TODAY**

GERNSBACK PUBLICATIONS, INC. 96-98 Park Place, New York, N. Y.

I have circled below the numbers of books in the RADIO-CRAFT LIBRARY, which you are to send me, and have deducted 20% for ordering five (5) books or more. I have included my remittance in full, at the price of 50c each, when less than five books are ordered.

The amount of my remittance is.....(Stamps, checks or money orders accepted.)

Circle numbers wanted:      1      2      3      4      5      6      7      8      9      10

Name ..... Address .....

City ..... State ..... RQ

# The Key to every Radio Problem!

## S. GERNSBACK'S RADIO ENCYCLOPEDIA

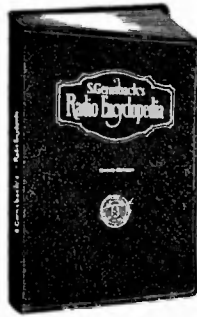

PRICE  
**\$3.98**  
POSTPAID

## SECOND EDITION! CONTENTS ENTIRELY NEW

**T**HIS book is the New Edition of the Famous First Radio Encyclopedia by S. Gernsback, the first book of its kind ever published in America. The new Second Edition—just off the press—is fully revised, rewritten, and enlarged. It is the absolutely up-to-the-minute new model of the pioneer First Radio Encyclopedia, which became the stand-by of all radio men in every part of the world. Over 39,000 copies of the first edition were sold.

It gives you an explanation of every word used in radio. These explanations—or, rather, definitions—are not brief outline information like those of an ordinary dictionary, but they give in fullest detail, and at considerable length, the meaning and application of every word, phrase, general and special term used in the science of radio. They are written in plain, everyday English, easily understood by anyone.

Practically every definition in the book is illustrated by drawings, photographs, diagrams, or charts. All you need to do is to look up as you would in a dictionary, the word or phrase about which you are seeking information. Furthermore, each page is key-indexed, for greater convenience and speed in locating any definition. All the Subject-Matter is Arranged in Alphabetical Order.

This greatly enlarged Second Edition Radio

Encyclopedia is an absolute necessity to everyone interested in Radio. It answers all radio questions, increases your knowledge and saves your time. It covers every known radio problem, and is a gold-mine of practical information for every radio man.

2,201 Radio Definitions  
1,253 Technical Illustrations  
34 Tables and Charts  
24 Pages of Appendix  
Size of Book:  
9 in. wide by 12 in. high  
352 PAGES  
Weight, 3 lbs.

Red Morocco-Keratol Flexible Binding  
Printed on strong ledger paper  
Loose-Leaf Arrangement

**ABSOLUTE GUARANTEE:** For your copy of S. Gernsback's Radio Encyclopedia send \$3.98 in form of check or money order. (Canada or foreign 35c extra for postage.) Postage prepaid in U. S. If the book does not come up to your expectation, or is not as represented, or if you do not want it for any reason whatsoever, you can return it and have your money refunded without question.

**S. GERNSBACK CORPORATION**  
98RQ Park Place New York, N. Y.



# PATENTS

**INVENTORS**  
*Get this*  
**FREE Book**

## Patent Your Ideas This Free Book Shows How

**Y**OUR idea for a practical article or an improvement upon an old one should be patented NOW. Frequently many of the thousands of applications filed in the U. S. Patent Office each year are for the same or almost the same idea. In such a case, the burden of proof rests with the last application filed. Sometimes a delay of even a few days in filing the application means the total loss of the patent. Lose NO TIME.

The entire time of my large and experienced organization is devoted exclusively to patent and trade-mark cases. We know the rules and requirements of the Patent Office. We understand the technicalities of Patent Law. We can proceed in the quickest and safest ways in preparing an application for a patent covering your idea.

The book shown here contains valuable information that every inventor should know. It tells you just how to go about obtaining a patent for your idea. With the booklet I will send you my "Record of Invention" form on which you may sketch your idea and establish its date before a witness. If a dispute arises this will be valuable to you. Send the coupon TODAY! You will receive the FREE book, the "Record of Invention" Form, and full information regarding costs.

### Strict Secrecy Preserved

All communications, sketches, etc., are held in strictest confidence and protected by steel files. Your idea will be in trustworthy hands. I have the highest references. It is probable that I can help you. Send the Coupon AT ONCE.

### Personal Service

Your case will be handled by a specialist selected for knowledge and experience in certain lines of inventions. His personal attention will be given to your idea.



Above is a view of our drafting and specification rooms. These important departments are made up of men of demonstrated skill and aptitude for the particular phases of patent and trade-mark procedure to which they give their attention.

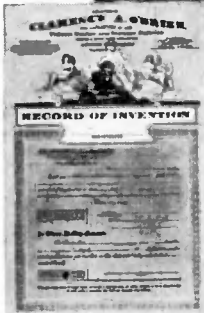

**Rush this Coupon to**

### ALSO FREE

"Record of Invention" Blank: On request I will send you FREE a copy of my "Record of Invention" blank. On this blank you can sketch and describe your invention and have it witnessed in such manner that it may be of value to you as evidence. Send coupon now and receive this form together with my free book.



**CLARENCE A. O'BRIEN**  
**REGISTERED PATENT ATTORNEY**  
**WASHINGTON, D. C.**

Clarence A. O'Brien  
Registered Patent Attorney  
26B, Adams Building, Washington, D. C.

Please send me your Free Book, "How to Obtain a Patent," and your "Record of Invention" form, without any cost or obligation on my part.

NAME .....

ADDRESS .....

(Important: Write or print name plainly)

# I will train you at home to fill a **BIG PAY** Radio Job



J. E. Smith, President, National Radio Institute, the man who has directed the Home Study Training of more men for the Radio industry than any other man in America.

**Free Book  
Tells How  
Mail Coupon!**

Get my big FREE book on the opportunities in Radio. Read how quickly you can learn at home in your spare time to be a Radio Expert—what good jobs my graduates have been getting—real jobs with real futures.

**Many Radio Experts Make \$50 to \$100 a Week**

Over 300,000 jobs have been created by Radio's growth, and thousands more will be created by its continued development. Many men and young men with the right training—the kind of training I give you in the N. R. I. course—have stepped into Radio at two and three times their former salaries.

**Many N.R.I. Men Have made \$200 to \$1000 in spare time while learning**

The day you enroll with me I send you material which you should master quickly for doing 28 jobs, common in most every neighborhood, for sparetime money. I give you the plans and ideas that have made \$200 to \$1,000 for N. R. I. students in their spare time while studying. My course is famous as the course that pays for itself.

**Talking Movies, Television, Aircraft Radio Included**

Special training in Talking Movies, Television and home Television experiments, Radio's use in Aviation, Servicing and Merchandising Sets, Broadcasting, Commercial and Ship Stations are included. I am so sure that N. R. I. can train you satisfactorily that I will agree in writing to refund every penny of your tuition if you are not satisfied with my Lessons and Instruction Service upon completion.

**64-page Book of Information FREE**

Get your copy today. It tells you where Radio's good jobs are, what they pay, tells you about my course, what others who have taken it are doing and making. Find out what Radio offers you without the slightest obligation. **ACT NOW!**

**.. NEW Radio Equipment for Broad Practical Experience Given Without Extra Charge**

With this equipment you work out many of the things you read in textbooks. From it you get the experience that tells an expert from a beginner. In a short time you have learned what would take years to learn in the field. You make experiments illustrating the important principles in the 25 best known receiving sets.

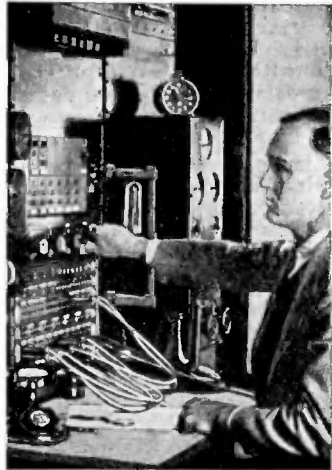

**I have doubled and tripled the salaries of many. Find out about this tested way to BIGGER PAY**



**FILL OUT AND MAIL THIS COUPON TODAY**

J. E. SMITH, President  
National Radio Institute, Dept. 2ED7  
Washington, D. C.

Dear Mr. Smith: Send me your free book. I understand this request does not obligate me and that no salesman will call.

NAME.....  
ADDRESS.....  
CITY.....STATE.....



On All Newsstands

25c The Copy

## RADIO'S LIVEST MAGAZINE

**N**EEDED to everyone interested in Radio is a radio magazine that includes in each issue all of the outstanding developments of the month. It is important that such news be carried which is most advantageous to the largest number of readers. *This is exactly what RADIO-CRAFT does.* In it you will find articles which broadly cover topics that are interesting and which should be thoroughly known by those who find radio a diversion. From the experienced radio man's point of view these articles are written, still every amateur or "ham" can get the utmost from them. Such well known authorities as Lee de Forest, C. H. W. Naşon, Sylvan Harris, Bertram M. Freed and others contribute articles regularly to RADIO-CRAFT.

Such educational articles on the following subjects are to be found in every issue:

New radio tubes	Latest in radio
Airplane radio	Money-making ideas
Radio construction	Automobile radio
Short wave sets and converters	Testing equipment
	Servicing radios

and dozens of other articles.

**RADIO-CRAFT IS FULLY ILLUSTRATED WITH PHOTOGRAPHS, DIAGRAMS AND SKETCHES. OVER 150 ILLUSTRATIONS IN EACH ISSUE**

**8**  
MONTHS FOR  
**\$1.00**

The regular yearly subscription rate to RADIO-CRAFT is \$2.50, newsstand rate \$3.00. But for a limited time only we offer you the opportunity to save money on this short term subscription. RADIO-CRAFT will be sent to you for Eight Months for only One Dollar. (Canadian or foreign subscriptions not accepted at this rate.)

**RADIO-CRAFT MAGAZINE**

98RQ Park Place

New York, N. Y.

# 96 PAGES

## OF NEW DATA HAVE BEEN ADDED TO THE

# Official Refrigeration Service Manual

**T**HE idea of electricians, radio service men and other mechanically inclined men, servicing refrigeration units is self-evident and the thought has occurred to perhaps untold thousands ever since electric refrigeration started. Yet nothing was done, because the average service man knows little or nothing about refrigeration. Compared with servicing a radio set or wiring a home for electricity, the servicing of a refrigerator is absurdly simple, once you get the hang of it.

The Official Refrigeration Service Manual has been edited by L. K. Wright, who is an expert and a leading refrigerator authority. He is a member of the American Society of Mechanical Engineers, American Society of Refrigeration Engineers, The National Association of Practical Engineers, etc.

**\$5.00** The  
Copy



In this Refrigeration Manual every page is profusely illustrated; every refrigerator part is carefully explained; diagrams are furnished of every known machine; special care is given to the servicing end. The tools needed are illustrated and explained; there are trouble shooting charts, and other service data.

Remember there is big money in the refrigeration servicing business. There are thousands of firms selling refrigerators every day and these need to be cared for often. Eventually there will be more refrigerators than radios. Why not increase your earnings with a full or spare time business by servicing refrigerators?

Here are some of the important chapters:

- Introduction to the Refrigeration Servicing Business
- History of Refrigeration
- Fundamentals of Refrigeration
- Description of All Known Types of Refrigeration
- Service Tools and Shop Equipment
- Motors
- Trouble Shooting
- Unit Parts, Valves and Automatic Equipment
- Makes and Specifications of Units
- Manufacturers of Cabinets
- Refrigerants and Automatic Equipment
- and Many other Important Chapters.

Already thousands of copies of the Official Refrigeration Service Manual have been sold; and there still remains the greatest opportunity for thousands more to learn how to make more money in a short time through openings in this new field.

**OVER 1,200  
DIAGRAMS  
450 Pages  
Flexible Looseleaf  
Binder  
Complete Service Data**

The First  
Complete Refrigeration  
Service Manual Published

**GERNSBACK PUBLICATIONS, Inc.**  
98RQ Park Place  
New York, N. Y.